

# QST

August, 1938  
25 cents

devoted entirely to

# amateur radio

In this issue—  
A Three-tube  
Superhet  
Improved  
Stability  
with E. C. O.  
A 250-watt  
56 Mc. Rig

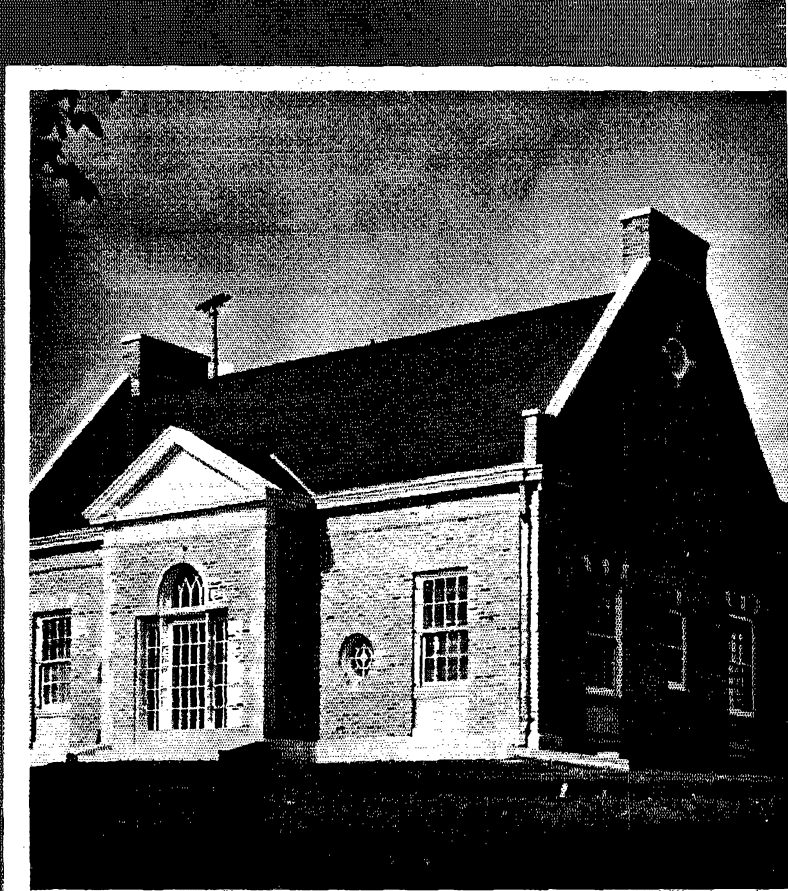

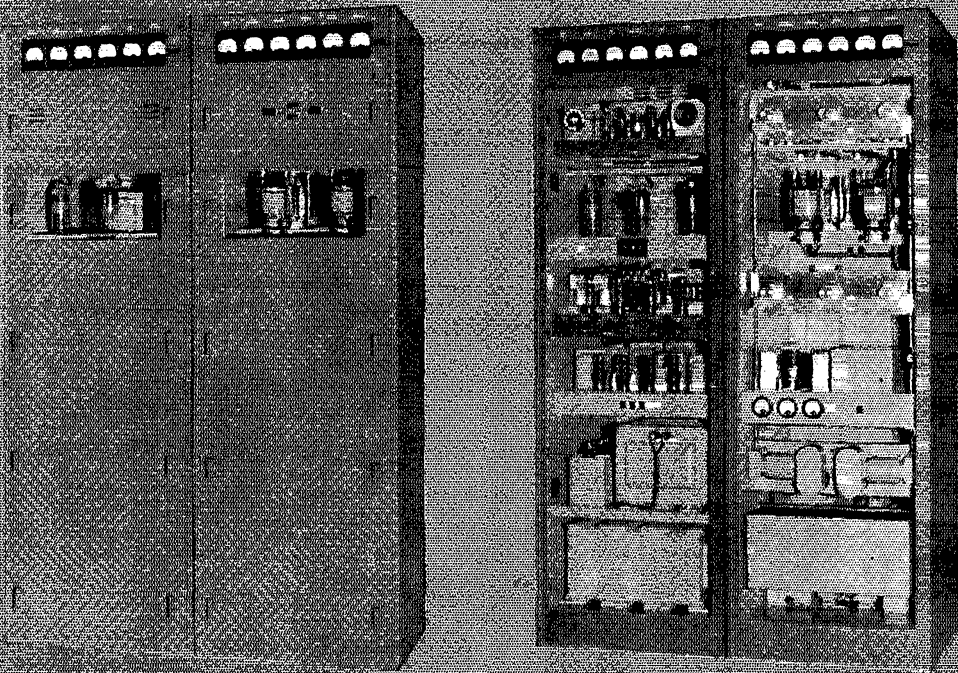

# COLLINS 203C

The 203C Transmitter has been adopted by numerous commercial airlines and governmental agencies for service in which an unattended multi-frequency transmitter is remotely controlled and operated over a telephone line. Output power of 1000 watts is instantly available on any of ten unrelated frequencies between 2000 kc and 20,000 kc by means of the Collins Autotune System. A single tone pair (the least expensive type of telephone line) serves to control completely the transmitter at a distance up to 30 miles—starting and stopping the transmitter, selecting telephone or telegraph operation, shifting to any of the ten frequencies, and carrying the telephone and telegraph signals.

Salient engineering features include positive internal pressure and air filter to insure a dust free interior, removable front and rear panels to expedite maintenance, and a thoroughly shielded oscillator compartment to permit both break-in reception and high keying speeds. Concealed tuning controls prevent accidental detuning, but are easily accessible for initial adjustment.

Several items such as automatic overload indication at the control point, a modulation limiter, and a complete complement of fifteen instruments combine with other features of the 203C to assure operation of the radio circuit with the same degree of reliability as that of a land-line dial telephone system.

## COLLINS RADIO COMPANY

CEDAR RAPIDS, IOWA

NEW YORK, N. Y. 41 WEST 42 STREET

# Introducing — the hallicrafters MODEL HT TRANSMITTER

50 WATTS PHONE OUTPUT  
100 WATTS CW OUTPUT

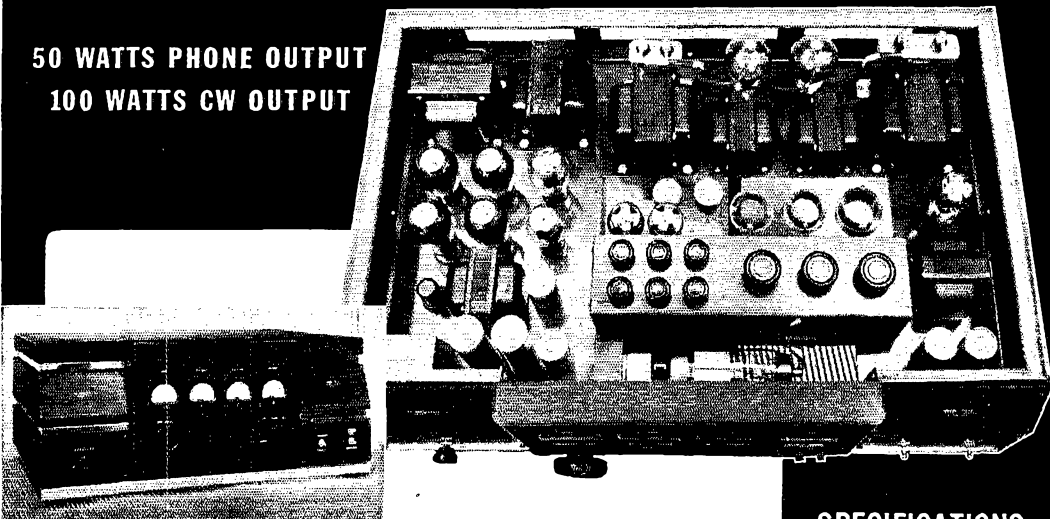

## *An Approach to an Ideal in Transmitter Design*

While many are models of workmanship, the home-built or kit-assembled transmitter necessarily suffers from lack of proper facilities for testing and correlating the component parts. Holding a license to build amateur transmitters, the Hallicrafters engineers visualized an ideal amateur transmitter, with adequate power at conservative ratings, simple to the point where even a novice could operate it — ruggedly built in the commercial style — and set to work to build it.

*The result* — the Hallicrafters Model HT. Entirely functional in design and marking a bold departure from conventional transmitter construction, the Model HT is, nevertheless, a close approach to the ideal transmitter its designers set out to build.

Conservatively rated at 50 watts Phone Output and 100 watts CW Output, in operation its output is equivalent to that of kit-constructed transmitters of 75 or 100 watt "input" phone rating.

*Utter simplicity*, compact, orderly design, convenience and versatility in operation, and absolute dependability are among the desirable characteristics of this new transmitter. Generously oversized transformers and other components are used, and its design was based on the most advanced type of tubes.

See the Model HT at your Hallicrafters dealer, or write for complete information.

*See the Hallicrafters Exhibit at the National A.R.R.L. Convention  
Chicago, September 3, 4, 5*

All Hallicrafters Equipment Sold on Liberal Down Payment Terms

## the hallicrafters inc.

2611 Indiana Ave., Chicago, U.S.A. Cable Address, "HALLICRAFT" Chicago

World's Largest Builders of Amateur Communications Equipment

### SPECIFICATIONS

#### MODEL HT-1

50 Watts Phone Carrier  
(slightly reduced at 30 MC)  
100 Watts CW Output

Frequency Range — 4u,  
3 Bands between 10 and 160  
meters, crystal controlled on  
one frequency per band.

Frequency (Band)  
Switching by single control  
in front panel switching  
all circuits. Individual  
tanks, knob controlled,  
inside cabinet and adjusted for  
particular frequency for that  
band.

R.F. Tubes — 2 — 6A6, 6K47,  
Modulator — Tubes, 6J7,  
6J5, 4 — 6L6.

Modulation Capacity 100%.  
Fidelity — plus or minus  
2 DB, 80 to 8000 cycles.

Rectifiers — 2 — 5Z3, 1 — 80,  
2 — 866.

Meters — 3, for adjustment  
and checking of operation.

Controls — All necessary  
controls on front panel.

Cabinet — Rigid steel cabinet  
of attractive design  
with adequate ventilation.

Output Terminals —  
From adjustable pick-up coils  
on separate final plate tank  
coils. Proper pick-up coil  
and plate tank automatically  
selected by Band Switch.

Dimensions — 29 $\frac{3}{4}$ " wide,  
11 $\frac{3}{4}$ " high, 19 $\frac{1}{4}$ " deep.

MODEL HT-2 — For CW  
only, less modulator and 1  
— 5Z3 rectifier tube.



# WHY DIVERSITY RECEPTION?

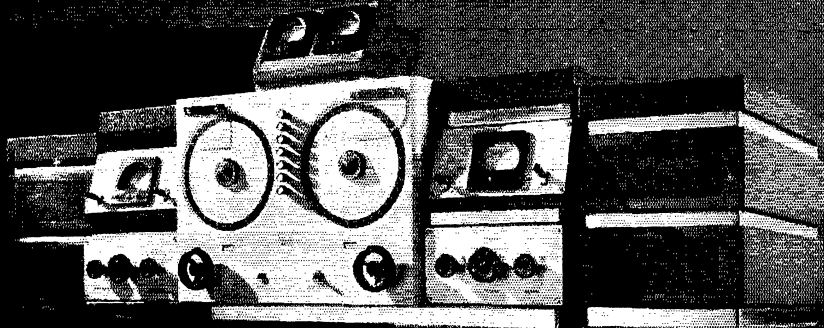

## WHAT THE SKYRIDER DIVERSITY DOES FOR AMATEUR RECEPTION!

All amateurs are more or less familiar with the principles of Diversity Reception. The idea of using two or more receivers with individual antennae for the reception of short wave signals is not new. Receiving stations built by the commercial radio companies to operate on this principle have been phenomenally successful in the reduction of fading and improvement in the quality of reception.

However, Diversity Reception as practiced commercially, where each receiver is individually tuned, the second detector outputs being tied together across a common load, and the signals combined after rectification, is not practical for amateur communications work, where ease and rapidity of tuning to a number of signals is essential.

The SKYRIDER DIVERSITY is the result of several years of intensive experimental work, directed toward one object — the development of a means to provide the highly desirable advantages of Diversity Reception for the amateur in practical and easily operable form. It is the first receiving system to offer these advantages with a single tuning control — entirely practical for amateur operation — and consists of two complete r.f., i.f. and second detector circuits with a common r.f. heterodyne oscillator, common AVC and one audio amplifier.

The principal advantages of Diversity Reception as offered by the SKYRIDER DIVERSITY are as follows:

1. Reduction of fading to negligible proportions.
2. An increase of Signal Strength over any single receiver.
3. Improvement of Signal-to-Noise ratio over any single receiver.
4. Reduction of Heterodyne Beat Note Interference.

While it has been generally understood that proper Diversity action could be obtained only with widely separated antennae, experience has proved the contrary. Fair Diversity action can be obtained with paralleled antennae separated as little as 10 feet, although it is desirable, where circumstances require antennae in such close proximity, to have them at right angles to one another or in different planes, as one horizontal and the other vertical.

The Diversity action of the SKYRIDER DIVERSITY is clearly demonstrated by the two diversity meters, which indicate the fading effect in the two separate circuits. Under normal conditions in long-distance, high-frequency reception, they will rise and fall from zero to plus 9, rather rapidly, but will seldom rise or fall in unison. In fact, they give the illusion of being oppositely geared together — as one falls the other rises and vice versa. Meanwhile the signal level meter on the main panel, reading the combined signal strength from both antennae, shows that the resultant output of both receivers remains practically stationary and indicates the improvement effected by the Dual Diversity System.

It is with a real sense of achievement that the Hallicrafters offer Diversity Reception to the amateur with the SKYRIDER DIVERSITY. For a more complete discussion write for reprint of *QST* articles by J. L. A. McLaughlin and Karl W. Miles on Diversity Reception.

See the SKYRIDER DIVERSITY at the National A.R.R.L. Convention

Chicago Sept. 3, 4, 5, 1938

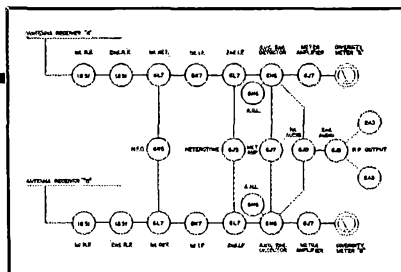

TUBE LAYOUT OF SKYRIDER DIVERSITY!

## the hallicrafters, inc.

2611 INDIANA AVE., CHICAGO, U.S.A.  
Cable Address, "HALLICRAFT" Chicago

"World's Largest  
Builders of Amateur  
Communications Equipment"



# QST

devoted entirely to

# AMATEUR RADIO

PUBLISHED, MONTHLY, AS ITS OFFICIAL ORGAN, BY THE AMERICAN RADIO RELAY LEAGUE, INC., AT WEST HARTFORD, CONN., U. S. A.; OFFICIAL ORGAN OF THE INTERNATIONAL AMATEUR RADIO UNION

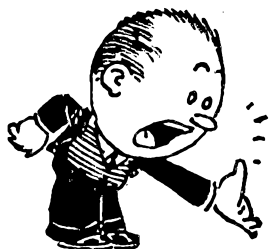

**AUGUST**  
**1938**  
*Volume XXII*  
*Number 8*



Kenneth B. Warner, General Manager of A.R.R.L. Publications; Ross A. Hull, Editor; James J. Lamb, Technical Editor; George Grammer, Assistant Technical Editor; Clark C. Rodimon, Managing Editor; David H. Houghton, Circulation Manager; Ralph T. Beaudin, Assistant Circulation Manager; F. Cheyney Beekley, Advertising Manager; Charles Brunelle, Assistant Advertising Manager.

*Editorial and Advertising Offices*

38 La Salle Road  
West Hartford, Connecticut

Subscription rate in United States and Possessions and Canada, \$2.50 per year, postpaid; all other countries, \$3.00 per year, postpaid. Single copies, 25 cents. Foreign remittances should be by international postal or express money order or bank draft negotiable in the U. S. and for an equivalent amount in U. S. funds.

Entered as second-class matter May 29, 1919, at the post office at Hartford, Connecticut, under the Act of March 3, 1879. Acceptance for mailing at special rate of postage provided for in section 1103, Act of October 3, 1917, authorized September 9, 1922. Additional entry at Concord, N. H., authorized February 21, 1929, under the Act of February 28, 1925.

Additional second-class entries to cover sectional editions authorized March 20, 1935. Copyright 1938 by the American Radio Relay League, Inc. Title registered at United States Patent Office.

## The Contents

Editorials . . . . .	7
A Three-Tube Super for Portable or Emergency Work <i>George Grammer, W1DF</i>	8
A 250-Watt Output Crystal-Controlled 28- and 56-Mc. Transmitter . . . . . <i>Abe Hass, W2KPX</i>	12
Which Directive System? . . . . . <i>Hugo Romander, W2NB</i>	16
The A.R.R.L. National Convention . . . . .	17
1938 Paley Award Goes to W9MWC . . . . .	18
56-Mc. Goes on Annual Frolic . . . . .	19
What the League Is Doing . . . . .	22
Northwestern Division Convention . . . . .	26
With the Affiliated Clubs . . . . .	27
Improving the Stability of the E.C.O. . . . .	28
Army-Amateur Radio System Activities . . . . .	31
A Four-Band 75-Watt Output 'Phone-C.W. Transmitter <i>Frederick F. Sylvester, exW2ACU</i> <i>and Richard S. Briggs, W1BVL</i>	32
Maritime Division Convention . . . . .	36
Midwest Division Convention . . . . .	36
How Would You Do It? . . . . .	37
Results, First "A.R.R.L." QSO Party <i>E. L. Battey, W1UE</i>	39
Hints and Kinks . . . . .	41
I.A.R.U. News . . . . .	43
Delta Division Convention . . . . .	69
A.R.R.L. QSL Bureau . . . . .	86
Standard Frequency Transmissions . . . . .	88
New World Globe . . . . .	90
New Hampshire State Convention . . . . .	90
Hamads . . . . .	91
QST's Index of Advertisers . . . . .	94

# Section Communications Managers of the A.R.R.L. Communications Department

All appointments in the League's field organization are made by the proper S.C.M., elected by members in each Section listed. Mail your S.C.M. (on the 16th of each month) a postal covering your radio activities for the previous 30 days. Tell him your DX, plans for experimenting, results in 'phone and traffic. He is interested, whether you are an A.R.R.L. member or get your QST at the newsstands; he wants a report from every active ham. If interested and qualified for O.R.S., O.P.S. or other appointments he can tell you about them, too.

Eastern Pennsylvania Maryland-Delaware-District of Columbia Southern New Jersey Western New York Western Pennsylvania	W3QP W3BAK W3BEI W8CSE W8QFO	<b>ATLANTIC DIVISION</b> John Buck Morgan  Edgar L. Hudson W. W. Filson Ed Preston Kendall Speer, Jr.	Blue Bell  Laurel, Delaware Audubon Tully Lowber	
Illinois Indiana Kentucky Michigan Ohio Wisconsin	W9RMM W9QG W9ARU W8DPE W8AQ W9UIT	<b>CENTRAL DIVISION</b> Leslie M. Dickson Noble Burkhart Darrell A. Downard Harold C. Bird E. H. Gibbs Aldrich C. Krones	Edellyn Farms R. 4, Box 1 116 N. Longworth Ave. R.F.D. 2 405 Broad St. 3127-A West Madison St.	Waukegan Indianapolis Louisville Pontiac Wadsworth Milwaukee
North Dakota South Dakota Northern Minnesota Southern Minnesota	W9RZA W9VOD W9IGZ W9DCM	<b>DAKOTA DIVISION</b> Ernest Bloch Dr. A. L. Russell Edwin L. Wicklund Webster F. Soules	Box 202 R.F.D. 3 3549 36th Ave., So.	Thompson Wall Kensington Minneapolis
Arkansas Louisiana Mississippi * Tennessee	W5ABI W5DKR W5GHF W4DEF	<b>DELTA DIVISION</b> H. E. Velte Eugene H. Treadaway Robert E. Barr B. G. Lowrey Smith	4415 West 12th St. 2749 Myrtle St. 673 Hillcrest St.	Little Rock New Orleans Lucedale Memphis
Eastern New York N. Y. C. & Long Island Northern New Jersey	W2LU W2AZV W2GMN	<b>HUDSON DIVISION</b> Robert E. Haight E. L. Baunach Fred C. Read	511 South Holmes St. 102 Central Ave. 1014 North Ave.	Scotia Massapequa, L. I. Elizabeth
Iowa Kansas Missouri Nebraska	W9ARE W9PB W9OUD W9FAM	<b>MIDWEST DIVISION</b> Clyde C. Richelieu Harry E. Legler Miss Letha Allendorf Samuel C. Wallace	815 Dunham St. 304 Miami St. 1015 W. 3rd St. Green St.	Burlington Hawthra Joplin Clarks
Connecticut Maine Eastern Massachusetts Western Massachusetts New Hampshire Rhode Island Vermont	W1CTI W1FBJ W1IWC W1IAH W1BFT W1HERC W1GNF	<b>NEW ENGLAND DIVISION</b> Frederick Ella, Jr. Winfield A. Ramsdell Sam Gross William J. Barrett Carl B. Evans Clayton C. Gordon Alvin H. Battison	19 Merrill Rd. 1188 Washington Ave. Pleasant St. 239 Columbia St. 80 No. State St. 192 Washington Ave. 1 Central St.	Norwalk Portland Marsfield Hills Adams Concord Providence Windsor
Alaska Idaho Montana Oregon* Washington	K7ENA W7EMT W7FL W7BNO W7FCG	<b>NORTHWESTERN DIVISION</b> Leo E. Osterman Carl Eichelberger G. A. Woodhouse J. R. MacManiman W. Beale	Customhouse Route 2 Holter Dam 1545 N. E. 48th Ave. R. 4, School Ave.	Wrangell Kuna Wolf Creek Portland Walla Walla
Hawaii* Nevada Santa Clara Valley East Bay San Francisco Sacramento Valley Philippines San Joaquin Valley	K6OOE W6BIC W6FPW W61TV W6SG W6GZY KA1GR W6LPE	<b>PACIFIC DIVISION</b> Harold C. Smith Edward W. Heim Elbert Amarante Harold J. Burchfield Alan D. Whitaker, Jr. J. L. C. Buckenham George L. Rickard Angelo V. Astone	P. O. Box 150 509 Claremont St. 454 Washington St. 2340 106th Ave. 79 Elinor Ave. 2720 22nd St. Box 849 729 Safford	Honolulu Reno San Jose Oakland Mill Valley Sacramento Manila Fresno
North Carolina South Carolina Virginia West Virginia	W4OG W4BQE W3UVA W8HD	<b>ROANOKE DIVISION</b> H. S. Carter Ted Ferguson Charles M. Waff, Jr. C. S. Hoffmann, Jr.	P. O. Box 111 1213 College St. 2607 Stuart Ave. 47 Lynwood Ave.	Winston-Salem Columbia Richmond Wheeling
Colorado Utah-Wyoming*	W9FA W7CLG	<b>ROCKY MOUNTAIN DIVISION</b> Glen Glasscock Ernest Parshall	2164 So. Corona St. 540 Peake St.	Denver Midwest, Wyoming
Alabama Eastern Florida Western Florida Georgia-Cuba-Iale-of-Pines- Porto Rico-Virgin Islands	W4DGS W4DVO W4BSJ *W4PM	<b>SOUTHEASTERN DIVISION</b> James F. Thompson L. A. Connolly Ellis R. Curry Charles W. Davis	102 Narrow Lane Rd. 719 So. Willow Ave. Box 425 2136 N. E. Boulevard Dr.	Montgomery Tampa Madison Atlanta, Ga.
Los Angeles Arizona San Diego	W6MQM W6KFC W6JRM	<b>SOUTHWESTERN DIVISION</b> Ralph A. Click Victor C. Clark Howard K. Breedlove	979 Farnam St. 747 E. Polk St. R. 2, Box 636	Los Angeles   Phoenix San Diego
Northern Texas Oklahoma Southern Texas New Mexico	W5DXA W5CEZ W5BHO W5CGJ	<b>WEST GULF DIVISION</b> Lee Hughes Carter L. Simpson Dave H. Calk Joseph M. Eldodt	125 N. Main St. 2010 So. 4th St. 6726 Ave. Q	Childress Ponca City Houston Chamita
Maritime	VE1DQ	<b>MARITIME DIVISION</b> A. M. Crowell	69 Dublin St.	Halifax, N. S.
Ontario	VE3SG	<b>ONTARIO DIVISION</b> Fred H. B. Saxon	302 Lee Ave.	Toronto, Ont.
Quebec	VE2EE	<b>QUEBEC DIVISION</b> Stan Comach	780 Brault Ave.	Verdun, P. Q.
Alberta British Columbia	VE4GE VE5HP	<b>VANALTA DIVISION</b> C. S. Jamieson J. Hepburn, Jr.	581 W. Riverside Drive 335 Foul Bay Road	Drumheller, Alta. Victoria
Manitoba Saskatchewan	VE4BG VE4SYJ	<b>PRAIRIE DIVISION</b> A. J. R. Simpson Arthur Chesworth	635 Garfield St. 1071 4th Ave., N. W.	Winnipeg Moose Jaw

\* Officials appointed to act until the membership of the Section choose permanent S.C.M.'s by nomination and election.

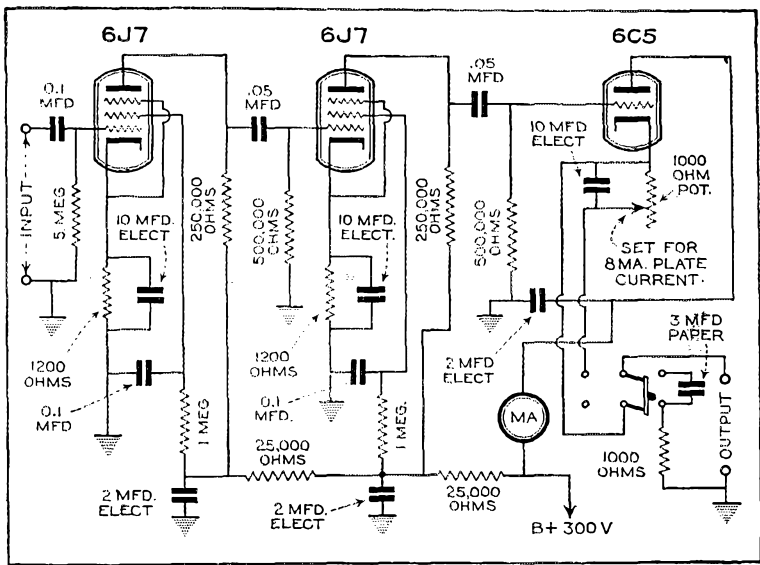

## Kandid Ken-O-Talk, No. 9

### • Standardization of Low Level Audio Equipment •

Many manufacturers of commercial transmitters are working toward the standardization of low level audio amplifier and exciter units. By doing this, it is possible to build almost any type of transmitter with only two high level stages to worry about. Usually these stages are simple and straightforward, so the really difficult part of building a unit, once done, never has to be duplicated. It is a standard part, carried in stock.

Many amateurs find their greatest pleasure in building new "rigs" from time to time as advances or changes are made in power and driver tubes. There is, however, very little pleasure in slaving over a fussy low level, high gain circuit every time a change is made.

The circuit shown above possesses numerous advantages over the conventional pre-amplifier. The first two stages are of the standard resistance coupled type, but the output stage is somewhat different. This stage is of the type sometimes called a cathode follower. The plate is connected directly to B plus and the load is connected in the cathode circuit. From an arrangement of this sort, a low impedance output may be obtained.

The principle of operation is degenerative, that is, a signal of approximately one hundred volts peak may be applied to the 6C5 grid. The cathode, not being tied to ground, follows this voltage to such an extent that the grid is never positive with respect to cathode. The available output voltage is therefore less than the input voltage.

An output of eighty volts peak into the primary of a driver transformer, designed to carry 10 MA D.C., may be obtained with the D.P.D.T. toggle, shown above, thrown to the left, and the output fed into the primary of transformer type T-261. Ample power is available to drive 6L6's to sixty watts output, or 807's to eighty watts. The output of the preamplifier is low impedance so the line may be run any desired distance to the modulator chassis. This allows the driver transformer to be at the grids of the power tubes.

If a low impedance line with no D.C. in it is required, the toggle switch is thrown to the right. This line may be worked into impedances as low as five hundred ohms, making it ideal for coupling to class A input transformers.

The gain of this amplifier is approximately 80 D.B. Its flexible output possibilities make it suitable for driving a low power modulator stage, or for coupling to the driver of a high power modulator stage.

Erratum—In Ken-O-Talk #6 the by-pass condenser from screen of the 6J7 to ground was omitted. This condenser may be a 0.1 mfd. paper type.

*F. P. Kenyon*

# The American Radio Relay League



THE AMERICAN RADIO RELAY LEAGUE, INC., is a non-commercial association of radio amateurs, bonded for the promotion of interest in amateur radio communication and experimentation, for the relaying of messages by radio, for the advancement of the radio art and of the public welfare, for the representation of the radio amateur in legislative matters, and for the maintenance of fraternalism and a high standard of conduct.

It is an incorporated association without capital stock, chartered under the laws of Connecticut. Its affairs are governed by a Board of Directors, elected every two years by the general membership. The officers are elected or appointed by the Directors. The League is non-commercial and no one commercially engaged in the manufacture, sale or rental of radio apparatus is eligible to membership on its board.

"Of, by and for the amateur," it numbers within its ranks practically every worth-while amateur in the nation and has a history of glorious achievement as the standard-bearer in amateur affairs.

Inquiries regarding membership are solicited. A bona fide interest in amateur radio is the only essential qualification; ownership of a transmitting station and knowledge of the code are not prerequisite. Correspondence should be addressed to the Secretary.

HIRAM PERCY MAXIM, FIRST PRESIDENT

## OFFICERS

*President*.....EUGENE C. WOODRUFF, W8CMP  
State College, Pa.

*Vice-President*.....GEORGE W. BAILEY, W1KH  
Weston, Mass.

*Secretary*.....KENNETH B. WARNER, W1EH  
West Hartford, Connecticut

*Treasurer*.....ARTHUR A. HEBERT, W1ES  
West Hartford, Connecticut

*Communications Mgr.*...F. EDWARD HANDY, W1BDI  
West Hartford, Connecticut

*General Counsel*.....PAUL M. SEGAL  
1026 Woodward Building, Washington, D. C.

Address all general correspondence to the administrative headquarters at West Hartford, Connecticut

## DIRECTORS

*President*  
EUGENE C. WOODRUFF.....W8CMP  
234 W. Fairmount Ave., State College, Pa.

*Vice-President*  
GEORGE W. BAILEY.....W1KH  
74 Webster Road, Weston, Mass.

*Canadian General Manager*  
ALEX REID.....VE2BE  
169 Logan Ave., St. Lambert, P. Q.

*Atlantic Division*  
WALTER BRADLEY MARTIN.....W3QV  
Box 612, Roslyn, Pa.

*Central Division*  
R. H. G. MATHEWS.....W9ZN  
100 East Ohio St., Chicago

*Dakota Division*  
FRED W. YOUNG.....W9MZN  
Apartment 16, 500 Harvard St., Minneapolis, Minn.

*Delta Division*  
E. RAY ARLEDGE.....W5SI  
P. O. Box 286, Pine Bluff, Ark.

*Hudson Division*  
KENNETH T. HILL.....W2AHC  
115 Willow St., Douglaston, L. I., N. Y.

*Midwest Division*  
FLOYD E. NORWINE, JR.....W9EFC  
120 South Fourth St., St. Louis, Mo.

*New England Division*  
PERCY C. NOBLE.....W1BVR  
37 Broad St., Westfield, Mass.

*Northwestern Division*  
RALPH J. GIBBONS.....W7KV  
c/o United Air Lines, Pendleton, Ore.

*Pacific Division*  
J. L. McCARGAR.....W6EY  
66 Hamilton Pl., Oakland, Calif.

*Ronoke Division*  
H. L. CAVENESS.....W4DW  
State College Station, Raleigh, N. C.

*Rocky Mountain Division*  
EDWARD C. STOCKMAN.....W9ESA  
618 So. Williams St., Denver

*Southeastern Division*  
BENNETT R. ADAMS, JR.....W4APU  
1512 Grove Place, Homewood, Ala.

*Southwestern Division*  
CHARLES E. BLALACK.....W6GG  
443 Main St., El Centro, Calif.

*West Gulf Division*  
WAYLAND M. GROVES.....W5NW  
c/o Humble Pipe Line, Mt. Pleasant, Texas



# "It Seems to Us — —"

OUR mail the other day contained a letter from a ham who said: "I'm pleased to see that things came out fairly well at Cairo, although I'm afraid that short-wave 'phone in the 7200-7300 band may bring about trouble. Listeners in this country may squawk when they cannot hear the announcements of such foreign 'phones."

Wowwwwwww! Let them, we say; let them squawk their bleeding heads off if they want to. Whose band is it, anyhow? We'll answer that: it's ours. Since the Washington Regulations took effect in 1929 there hasn't been a single non-amateur station with a thoroughly legal right to use a frequency between 7000 and 7300. After September 1st of next year, the extra-American regions (meaning chiefly Europe) may put broadcasting stations between 7200 and 7300 if they want to, but even in these regions the whole band remains available for amateurs, and nobody can complain if amateurs "interfere." And in the American region—north, central and south—the whole band remains exclusively an amateur band, just as it always has, ours and ours alone.

This invasion was made by European governments at Cairo on the premise that there wouldn't be appreciable transoceanic interference and in the mistaken belief that most European administrations would throw their amateurs out of the 7200-7300 portion. That is both bad engineering and wishful thinking, and is a prime example of the folly to which overzealous non-technical administrators can be carried. They did it in the face of plain warning from the American administrations that amateur radio on this side would continue full blast in these frequencies. They elected to exercise their sovereign votes to try it nonetheless. It's their funeral; let them do the worrying.

American short-wave broadcast listeners might as well understand right now that they cannot expect to hear international programs on these American amateur frequencies. They can listen for them if they want to, but when the interference comes from our operating it will be just too bad: we won't care. There are plenty of other broadcast frequencies for them to listen to, if they yearn to be propagandized.

As a matter of fact, it is probably safe to say that there will be but small use of 7200-7300 for broadcasting, even in Europe. We hope that the amateur societies in every country outside the Americas are already making representations to their governments to retain the frequencies exclusively for amateurs. Australia and New Zealand probably will want none of this kind of

broadcasting at amateur expense; we doubt if South Africa will. The chief difficulty, of course, will be in Europe, but even there we are reasonably confident that many countries will continue the whole band for amateurs. That means European interference to the transmissions from the countries that elect to use the band for broadcasting. All the uses we have heard discussed are long-distance broadcasting. Some of the smaller European states that have been unable to find a high-frequency channel may put their chief reliance on a frequency chosen from the European amateurs' band but most of the employment will be for auxiliary uses by the bigger countries. For instance, England has displayed some interest in using such frequencies for broadcasts to Egypt and India. As far as interference to us on this side of the water is concerned, it is interesting to note that the band will be useful only during the evening in Europe, say up to midnight in England. After that, there won't be audiences. So the European stuff should be ending about 7 P.M. Eastern Time or 4 P.M. Pacific Time, and at that hour it's daylight all the way across the Pacific. The interference possibilities to us therefore do not seem serious. And we doubt very much if any of the totalitarian states of Europe will even try to use such frequencies for bombarding South America with propaganda. They are already well entrenched elsewhere and they will know that the normal operations of American amateurs on these frequencies will make public reception utterly impossible.

We repeat that these are our frequencies and that every American amateur will have an uninterrupted right to their use. Their use for broadcasting in other regions will be a wholly unwarranted invasion. We hope that no American amateur will hesitate, out of misplaced sympathy for broadcasting, in making any legitimate use of these frequencies that he pleases. If we do that, we'll find that "it can happen here" too. Moreover, our signals, at the optimum paths over which we communicate to get through our own QRM, will have plenty of punch to override broadcasting interference, so our cue is not to get out of this end of the band but quite the contrary. And if some of our high-power ham rigs just happen to get on some of the frequencies used for broadcasting (as they inevitably will), that also is just too bad. We'll blast 'em off the air! We'll mow 'em down! And serve them right; bad luck to them, anyway!

K. B. W.



# A Three-Tube Super for Portable or Emergency Work

Superhet Performance with Regenerative Receiver Economy

By George Grammer,\* W1DF

*In portable emergency receivers light weight and low battery drain usually are paramount considerations, and at first thought only the regenerative receiver seems able to meet these specifications. But newer tubes and components have changed this picture, and it is now possible to get greatly improved performance in the portable set without losing the advantages so long associated with the old standby receiver. The set described here will out-perform a three-tube regenerative receiver, costs about the same, is equally light and compact, and is easy on both "A" and "B" batteries. Something to think about—and build—for that emergency station.—EDITOR.*

**T**HE regenerative receiver has had a long and honorable history in portable emergency work, but changing conditions are bound to cause it to be displaced just as it has already been displaced in regular station operation. For portable use where, nine times out of ten, the chief source of power is a 6-volt storage battery, the regenerative set offers the advantage of low battery drain in addition to light weight, compact construction and low cost. But inadequate selectivity and cranky tuning are serious objections to this type of receiver, especially during an emergency when nerves already are under a strain to which shortcomings in equipment should not be allowed to contribute.

The greater selectivity and smoother operation of the superhet-type receiver make it imperative that it be given consideration for portable

\* Asst. Technical Editor.

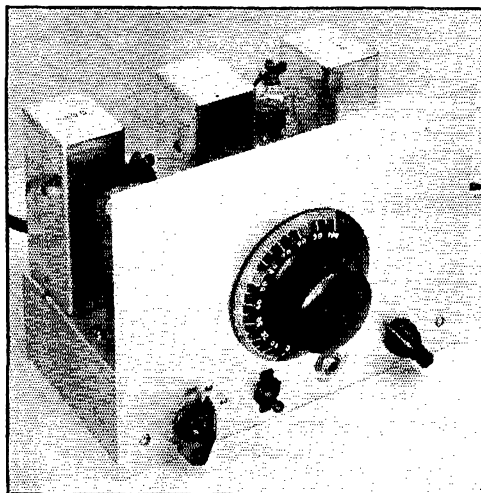

**THREE-TUBE SUPERHET FOR PORTABLE EMERGENCY USE**

Filaments are heated by a 6-volt storage battery; "B" power is from one or two blocks of "B" batteries. The set is designed for the 1.75-, 3.5- and 7-Mc. bands.

use as well as in the home station. If the superhet can be made as economical, both in battery drain and in dollar cost, as the regenerative receiver it certainly deserves a place in our emergency picture. The receiver described here represents an attempt to initiate something along these lines, and on the whole it meets any reasonable specifications for a portable emergency receiver much more completely than does the ordinary regenerator. It has only three tubes; the regenerator also requires three, if adequate audio volume and freedom from antenna effects are to be obtained. The "A" current drain, therefore, is no greater than that of the regenerative set. It does its best work with only 90 volts of "B" battery, and the "B" drain is only 15 milliamperes which, in normal operation, means a battery life of well over a year. It can even be used with a single 45-volt "B" block, although the audio output is somewhat reduced. It can be built, with tubes, three sets of coils, for about \$16, which certainly compares favorably with the cost of a three-tube regenerative set. It does not suffer by comparison on the questions of size and weight. Finally, it has regular superhet selectivity and stability, simple and straightforward circuits free from any critical adjustments, and is easy to construct and operate.

There is, of course, nothing particularly new in the idea of making a three-tube super. It happens, however, that until recently there have been no really suitable double-purpose tubes. For our purposes, the 6K8<sup>1</sup> is a great improvement over the oscillator-mixer tubes previously available, since it has a more stable oscillator section and lesser pulling effects than the older tubes. The 6C8G double triode has a 0.3-amp. heater instead of the customary 0.6 amp., and furthermore has separate cathodes for each section, thereby affording more freedom in circuit design. In the line of components, the new permeability-tuned i.f. transformers with high-stability fixed-mica trimmer condensers offer compact construction, high gain, stability comparable to air-tuned

<sup>1</sup> QST, April, 1938.

units, and low cost. The combination of new tubes and new components makes it possible to build something worthwhile for the frequencies of greatest interest in portable emergency work—1.75, 3.5 and 7 Mc. This receiver has been built for these bands only, and neither the layout nor circuit are recommended for operation at higher frequencies. The lack of preselection makes image response bad at 14 Mc. and higher, and while this response could be reduced by using a higher-frequency i.f., it was felt that for the purpose for which the receiver was designed the higher selectivity afforded by a 460-kc. i.f. more than compensated for the poorer image ratio. At 7 Mc. and lower, images do not cause much trouble.

Basically, the receiver is conventional, and therefore reliable, in design. It consists of the 6K8 oscillator-mixer, a 6K7 i.f. amplifier at 460 kc., and the 6C8G combined second detector and beat oscillator. The audio-output is taken from the plate of the second detector.

#### RECEIVER CIRCUIT

The complete circuit diagram of the receiver is given in Fig. 1. Partly to simplify construction and eliminate separate padders on each coil, which would have added an appreciable item to the cost, the antenna circuit is not ganged with the oscillator.  $C_1$  must, therefore, be separately tuned to resonance with the incoming signal if maximum signal strength is desired. The second reason for having the input tuning control separate was to permit its use as a volume control, thus eliminating the conventional bias-control resistor. With the 6K8 mixer, the slight detuning effect over the working range on  $C_1$  is no more than, if as much as, would be the case with grid-bias control of the i.f. or mixer stage.

The input coils are wound on four-prong forms. The antenna winding is adjusted for low-impedance input and is not grounded in the receiver. Antenna connections are made to a pair of flexible wires running out from the back.

In the oscillator section,  $C_2$  is the padding or band-setting condenser and  $C_3$  the band-spread tuning condenser. The coils are adjusted to give practically complete spread of each band over the tuning dial. The circuit is the familiar tickler arrangement, preferred in this case because it permits grounding the cathode. The coils are wound on five-prong forms, two prongs for the tickler, one for ground, one for the grid connection (junction of the upper end of  $L_2$  and the stator plates of  $C_2$ ) and the fifth for the band-spread tap to  $C_3$ .

On the 1.75- and 3.5-Mc. bands,  $C_3$  is connected across the whole of the oscillator grid coil, with a jumper in the coil form to make the necessary connection. On the 7-Mc. coil,  $C_3$  is tapped down as indicated in the coil table for desired spread.

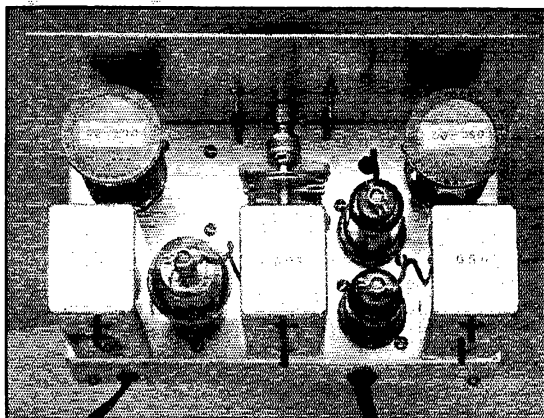

TOP VIEW OF THE THREE-TUBE SUPER

*The permeability-tuned i.f. and b.o. transformers are along the rear edge of the chassis. Plug-in oscillator and detector coils, with separate tuning controls, are used.*

In the i.f. amplifier both transformers are the interstage type, since the output transformer works into a plate detector. The plate-type detector was used for several reasons, chief among them being the fact that it does not load its input circuit as does a grid-leak detector, thus making for better selectivity; the plate current is negligible, reducing battery drain; and it can handle fairly large signals so that reasonable audio output can be secured without additional audio amplification. The bias resistor,  $R_4$ , is by-passed by an electrolytic condenser,  $C_9$ . In the plate circuit a rather large by-pass,  $C_{10}$ , is used to cut down high-frequency response and thus reduce hiss and heterodynes. It has practically no effect on a normal 1000-cycle beat-note, however, nor on the intelligibility of speech.

The second 6C8G section is the beat oscillator, using a permeability-tuned transformer made for the purpose. The grid condenser and leak are built into the transformer. The plate is fed through the b.o. on-off switch and a 50,000-ohm dropping resistor,  $R_5$ , the latter serving both to reduce the current drain and to cut down the output of the oscillator to a value suitable for good heterodyning. Although not shown on the diagram, small capacitive coupling between the b.o. and the second detector is provided by a short length of wire, soldered at one end to the cathode terminal of the beat-oscillator section and with the other end twisted for a few turns around the lead from the 6K7 plate to  $T_2$ . This additional coupling is not strictly necessary, since there is some stray coupling between the two stages, but proves helpful in practice.

In the "A" battery circuit, one side of each heater is grounded; the others are connected in parallel and to the plus-A wire in the battery cable. Parenthetically, humless reception can be obtained with a 6.3-volt filament transformer

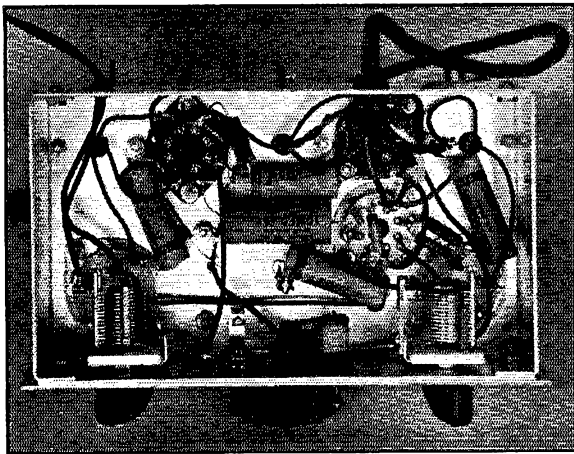

COMPARATIVELY FEW PARTS ARE NEEDED IN THE RECEIVER

In this bottom view, the detector tuning condenser is at the left and the oscillator padding condenser, with its band-setting "stops," at the right. Antenna connections are the twisted leads going through the rear edge of the chassis at the left.

instead of the battery. In the "B" circuit, screens and plates are operated at the same voltage. This not only gives best tube performance, but saves on resistors and bypass condensers and simplifies the circuit.

There is no on-off switch on the set, either for the "A" or "B" batteries. It was considered that this switching can be grouped more conveniently with the transmitter switching in a coordinated design of which this receiver is one unit.

#### CONSTRUCTION

Since no standard chassis of suitable size was available, a chassis was made up in one piece from 1/16th-inch aluminum. Dimensions before bending are given in Fig. 2. Wherever a bend is to be made the aluminum should be scribed rather deeply on both sides so that the bends will be along the right lines and will approach a right angle as nearly as possible. A bench vise will be useful in making the bends. The small lips on the short side pieces should be bent down

first then the longer sides, and finally the short sides should be folded under with the lips inside the long sides. Machine screws through the lips will make a tight and quite rigid job.

The top-view photograph shows how the parts are fitted on top of the chassis. The oscillator and detector coils are readily identified in this view. The tube just to the right of and behind the oscillator coil is the 6K8 mixer, this position being chosen for the tube so that the oscillator circuit leads would be short and therefore less likely to be "floppy." The band-spread condenser is in the center, mounted directly on the chassis; the stator connection from it drops through the chassis to the coil socket. Along the back, from left to right, are the first i.f. transformer,  $T_1$ , the 6K7, the second i.f. transformer,  $T_2$ , the 6C8G, and finally the beat oscillator transformer. The adjustment screws on the transformers project to the rear where they are readily accessible. Mounting them in this way necessitated drilling holes on the right-hand sides (from the front) of the shield cans to bring the grid leads

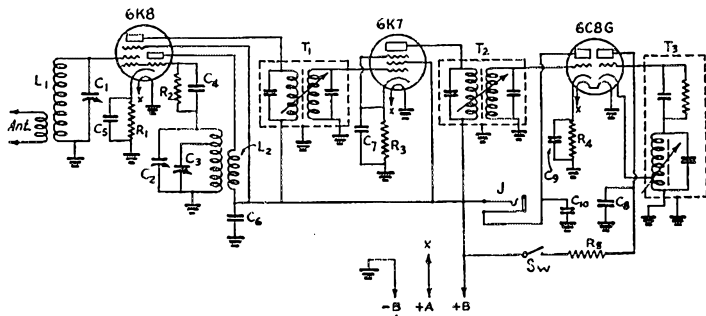

FIG. 1—CIRCUIT DIAGRAM OF THE PORTABLE 3-TUBE SUPERHET

- |   |  |  |
|---|--|--|
| $C_1, C_2$ —100- $\mu$ fd. midget variable (Hammarlund HF-100).   | $C_{10}$ —0.005- $\mu$ fd. mica.                   | former, interstage type (Sickles 6504).                            |
| $C_3$ —35- $\mu$ fd. variable (Hammarlund MC-35-S).   | $R_1$ —300 ohms, 1/2-watt.                         | $T_2$ —460-ke. permeability-tuned b.o. transformer (Sickles 6577). |
| $C_4$ —100- $\mu$ fd. midget mica.  | $R_2$ —50,000 ohms, 1/2-watt.                      | $T_3$ —460-ke. permeability-tuned i.f. trans-                      |
| $C_5, C_6, C_7, C_8, C_9$ —inc.—0.1- $\mu$ fd. paper.   | $R_3$ —500 ohms, 1/2-watt.                         | former, interstage type (Sickles 6504).                            |
| $C_9$ —10- $\mu$ fd. 25-volt elec-  | $R_4$ —10,000 ohms, 1/2-watt.                      | $T_2$ —460-ke. permeability-tuned b.o. transformer (Sickles 6577). |
|   | $R_5$ —50,000 ohms, 1/2-watt.                      | Sw—S.p.s.t. toggle switch.   |
|   | $T_1, T_2$ —460-ke. permeability-tuned i.f. trans- | J—Open-circuit jack.   |
| $L_1$ —1.75 Mc.: 70 turns No. 24 enameled, close-wound, on 1 1/2-inch form. Antenna coil 10 turns, 1/4 inch from grid coil. |  |  |
| 3.5 Mc.: 45 turns No. 22 enameled, close-wound, on 1 1/2-inch form. Antenna coil 6 turns, 1/4 inch from grid coil.          |  |  |
| 7 Mc.: 18 turns No. 22 enameled, close-wound, on 1 1/2-inch form. Antenna coil 4 turns, 1/4 inch from grid coil.            |  |  |
| $L_2$ —1.75 Mc.: 41 turns No. 22 enameled, close-wound, on 1 1/2-inch form. Ticker 13 turns, 1/4 inch from grid             |  |  |

out close to the tubes. Metal tubes in the first two stages avoid the necessity for tube shields and thus conserve some space. No shield is needed on the 6C8G.

In the bottom view, the first detector tuning condenser is at the left at the front edge of the chassis. Next to it is the 'phone jack (insulated from the chassis), then the beat-oscillator switch and, at the extreme right, the oscillator band-setting condenser. To facilitate rapid and accurate setting of this condenser for each band, it has been provided with a home-made gadget which stops the condenser at the proper setting. A disc about the size of a penny cut from thin sheet brass, with its rim smoothed down with steel wool, is soldered to the end of the condenser rotor shaft. A piece of half-inch wide brass strip, 1/16th inch thick, is fastened to the mounting angle on the condenser by a machine screw and projects slightly to the rear of the disc. A U-shaped spring made of thin phosphor bronze strip about 1/18th inch wide is soldered to the brass piece. At the free end of the spring a V-shaped projection rides against the edge of the disc. When the proper setting of the condenser is found for a band, a small notch is filed in the disc so that the "V" fits into it. When the condenser is turned, the disc slides along the spring until the "V" slips into the notch and locates the desired setting.<sup>2</sup> The "band-locater" is simple to make and is a worth-while addition to the set, although it is not absolutely necessary.

The coil sockets are directly under their respective condensers. The socket at the left near the rear edge is that for the 6C8G, and that at the right is for the 6K7. These two sockets are the ordinary bakelite wafer type. The others are isolantite (National CIR) for more stable operation at the signal frequency, and for greater rigidity in the case of the coil sockets.

The location of by-pass condensers and resistors should be apparent after a little study of the bottom view. Grounds may be made to any convenient points on the chassis. There are comparatively few parts and hence not a great deal of wiring.

The panel is 3½ by 6½ inches, and is made of 1/16th-inch aluminum. With the exception of the tuning dial, none of the controls is mounted on the panel itself but on the front edge of the chassis. The dial, however, must be fitted to the

tuning condenser after the panel is fastened in place. A fairly large hole should be drilled in the panel at the point where the tuning condenser shaft will be. The dial may then be taken apart and the mechanism connected to the condenser shaft and used as a template for locating the mounting holes. After drilling, the panel and dial mechanism may be reassembled to the chassis and condenser, and there should be no trouble with binding because of off-line shafts. It may be

necessary to saw off a quarter inch or so of the condenser shaft to accommodate the dial coupling behind the panel. This type of dial, a National Type A, 3⅝-inch, is particularly recommended because of its good vernier ratio and large tuning knob, both of which mean less fatigue over a long period of operating. The full-vision feature is also helpful in making quick estimates of the position of a signal within a band.

Complete coil data are given in Fig. 1. The oscillator coils are fairly high-C as

compared with the detector coils. In the case of the 1.75- and 3.5-Mc. oscillator coils, where the band-setting and band-spread condensers are simply in parallel, the coils were adjusted to give full spread, resulting in the use of less padding capacity on 1.75 Mc. than on 3.5 Mc. since a greater capacity change is needed to cover the range on the former band. On 7 Mc. practically full capacity of the band-setting condenser is used. The high-C circuits result in better stability, evidenced chiefly by lowered pulling effect of first detector tuning.

The 1750-2050-kc. and 3500-4000-kc. bands are spread over about 90 divisions of the 100-division dial. The 7000-7300-kc. band occupies about 65 divisions, which can be increased, if desired, by moving the tap for  $C_3$  a fraction of a turn toward the ground end of the coil. This spread is adequate, however, since the number of kilocycles per dial division is actually less than on 3.5 Mc. because of the greater width of the latter band.

#### LINING UP

Preliminary adjustment of the receiver includes both lining up the i.f. and beat oscillator and finding the proper settings of  $C_1$  and  $C_2$  for the bands. A test oscillator is desirable for the former. Such an oscillator usually can be borrowed from a service-man friend or the local radio shop if nothing suitable is available in the regular station equipment. If the station receiver has a

(Continued on page 60)

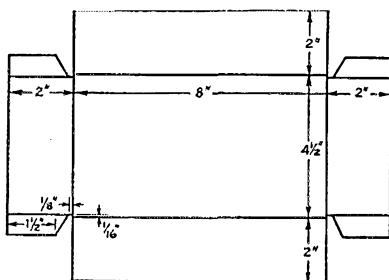

FIG. 2.—CHASSIS DIMENSIONS BEFORE BENDING

The chassis is made of 1/16th-inch aluminum. The lips on the left- and right-hand side pieces are bent down at right angles, then the sides folded down to form the chassis.

# A 250-Watt Output Crystal-Controlled 28- and 56-Mc. Transmitter

## Low-Frequency Technique Applied to Ultra-High Frequencies

By Abe Hass, W2KPX\*

**N**OW that the u.h.f. spectrum has been definitely allocated among the various services, the amateur may proceed to construct transmitters adapted to his particular frequencies, without fear of having to discard equipment at short notice. With this optimistic outlook we can now face those problems which often were conveniently shelved. That the Heavieside layer rarely reflects ultra-high-frequency waves; that the noise level in the neighborhood of these frequencies is extremely high, that occupancy near our bands by government and commercial interests is increasing, are all facts which demand consideration in the design of u.h.f. equipment.

Since we do not normally rely upon skip effect for gaining distance on 56 Mc., it becomes evident that the ordinary working area is dependent upon power output. Overcoming the high noise level in the vicinity of the receiver requires a strong signal, which in turn necessitates sufficient power output from the transmitter. To keep within the limits of the amateur bands we must have something better than the self-excited

variety of transmitter, which does not have the necessary stability. The final outcome will be a decidedly more elaborate job, but the results unquestionably make the expenditure and effort well worth while.

The transmitter to be described has been in use at W2KPX for the past several months and has given an exceptionally good account of itself. It is a self-contained r.f. unit, making a compact supplement to the regular low-frequency rig. The whole affair is mounted on a standard 10- by 23-inch chassis.

A top and front view of the unit is shown in one of the photographs, giving a general idea of the layout. From left to right we have first the crystal-controlled oscillator, then an RK-49 tube acting as a doubler or quadrupler, depending upon the output frequency desired. The next stage consists of a single 809 doubler, in turn followed by a pair of 809's in push-pull as a straight amplifier. The final or power stage consists of a pair of HF-100's in push-pull.

*The trend of the times for 56-Mc. is crystal control. QST has had several descriptions of low-power crystal-controlled 56-Mc. transmitters, portable and otherwise, but here is one which should satisfy the man who wants to put out a hefty signal on "five." It uses standard tubes and components in time-tried circuits. Furthermore, it includes both 56- and 28-Mc. output, so that its builder can get a taste of two almost totally-different kinds of operation.—EDITOR.*

### CIRCUIT AND CONSTRUCTION

The r.f. circuit diagram is given in Fig. 1.

The oscillator tube is a 6V6G in the straight pentode circuit. Crystal control was chosen because of its inherent stability, a quality essential to the proper performance of a transmitter of this type. Every amateur knows the benefits obtained by having a rig with good stability, a subject which has been dwelt upon in practically every issue of QST. As shown in the photograph, the components in this stage above the chassis are

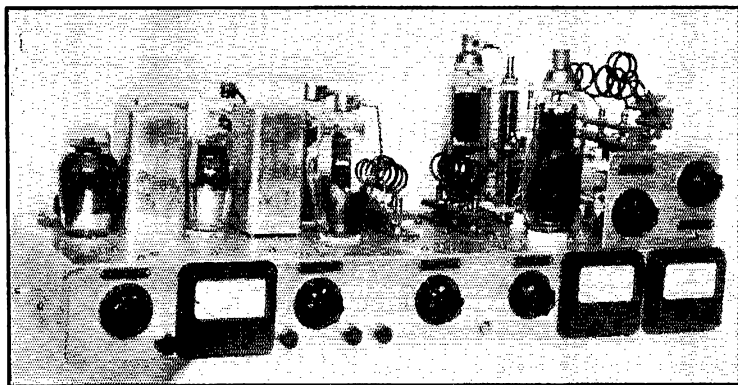

THIS 56- AND 28-MC. TRANSMITTER IS COMPLETE ON ONE CHASSIS. Normal input on both bands is 300 to 400 watts, but inputs as high as 600 watts have been used on 56 Mc.



the tube, crystal, miniature lamp, and tank coil and shield; all other components are placed underneath. This arrangement was used to make the leads as short as possible, consequently reducing stray capacities and inductances to a minimum. It may be well to mention at this point that the same care was exercised in the layout of the complete unit. The oscillator tank coil housed by the shield can is wound on a six-prong isolantite coil form which plugs into a mycalex socket mounted beneath the chassis. The shield can is fastened in place by means of four one-quarter

inch tapped rods mounted on the chassis so as to fit the inside corners of the can.

The second stage is capacity-coupled to the oscillator through a 200- $\mu$ fd. condenser. For ten-meter output a 7-Mc. crystal is used in the oscillator and the second stage acts as a doubler. For five-meter output, either a 7- or 14-Mc. crystal may be used. With the former the RK-49 is operated as a quadrupler, and if the 14-Mc. crystal is used the tube is worked as a doubler. Since a reserve of driving power is available by utilizing the 14-Mc. crystal and doubling in the second stage, it is preferable to do so. For 2 $\frac{1}{2}$ -meter operation it is highly desirable if not essential to use the 14-Mc. crystal.

In this stage, like the preceding one, very little can be seen above the chassis. The tank coil is similar in construction to that of the oscillator. From the circuit diagram it will be noticed that the output circuit of this stage uses a split-stator condenser and coil combination. The lower portion of the coil is unused at the present time but provides a source of r.f. voltage if it is ever desired to neutralize this or the following stage.

The output of the RK-49 is coupled to the 809 doubling stage through a 100- $\mu$ fd. condenser. The tank coil is

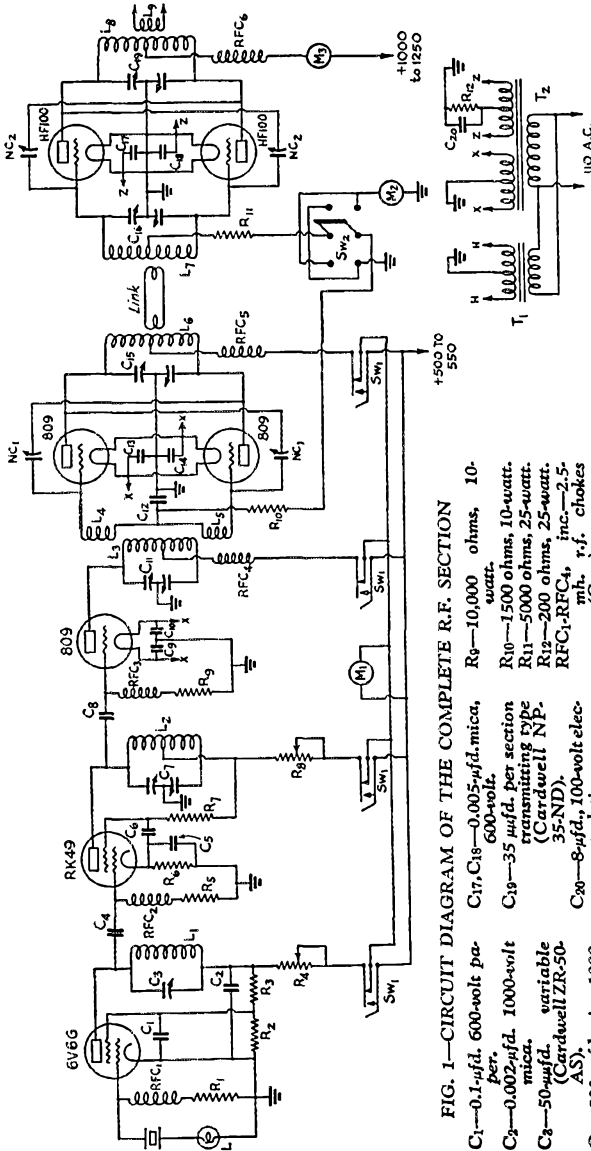
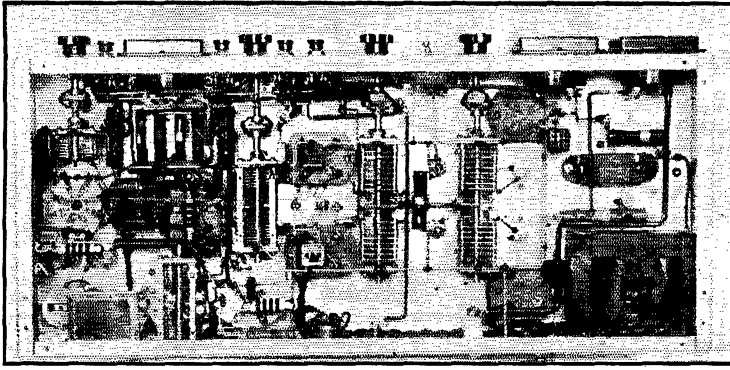

FIG. 1—CIRCUIT DIAGRAM OF THE COMPLETE R.F. SECTION

- C1—0.1- $\mu$ fd. 600-volt per section
- C2—0.002- $\mu$ fd. 1000-volt mica, variable
- C3—50- $\mu$ fd. variable (Cardwell ZR-50-AS)
- C4—200- $\mu$ fd. mica, 1000-volt
- C5—0.002- $\mu$ fd. mica, 1000-volt
- C6—0.1- $\mu$ fd. 600-volt per section (Cardwell ET-30-AD)
- C7—50  $\mu$ fd. per section (Cardwell ET-30-AD)
- C8—100- $\mu$ fd. mica, 1000-volt
- C9, C10—0.005- $\mu$ fd. mica, 600-volt
- C11—35  $\mu$ fd. per section (Cardwell ET-30-AD)
- C12—500- $\mu$ fd. mica, 1000-volt
- C13, C14—0.005- $\mu$ fd. mica, 600-volt
- C15, C16—30  $\mu$ fd. per section (Cardwell ET-30-AD)
- C17, C18—0.005- $\mu$ fd. mica, 600-volt
- C19—35  $\mu$ fd. per section transmitting type (Cardwell NP-35-ND)
- C20—8- $\mu$ fd., 100-volt electrolytic
- NC1—15- $\mu$ fd. variable (Cardwell ZT-15-AS)
- NC2—Twin neutralizing condenser with insulated coupling between units, 10  $\mu$ fd. per section (Cardwell ES-10-SD1)
- R1—25,000 ohms, 1-watt
- R2—20,000 ohms, 2-watt
- R3—10,000 ohms, 10-watt
- R4—4000-ohm slider, 25-watt
- R5—50,000 ohms, 2-watt
- R6—350 ohms, 10-watt
- R7—15,000 ohms, 10-watt
- R8—1500-ohm slider, 25-watt
- R9—10,000 ohms, 10-watt
- R10—1500 ohms, 25-watt
- R11—5000 ohms, 25-watt
- R12—2000 ohms, 25-watt
- R13—2.5-mh. r.f. chokes (Coto)
- R14—35-uh. r.f. chokes, Ohmite
- Z1—0.300 d.c. milliammeter
- M1—0.100 d.c. milliammeter
- M2—0.500 d.c. milliammeter
- M3—6.3-volt filament transformer
- T1—6.3- and 10.5-volt double-winding filament transformer (UTC)
- Sw1—S.p.d.t. push-button switch, locking type (Yasley 208L, one section used)
- Sw2—D.p.d.t. toggle switch
- L—Dial lamp, 60-ma.



THE BELOW-CHASSIS VIEW SHOWS A NEAT LAYOUT AND WIRING JOB. Particular care has been used to keep the wiring symmetrical and stray capacity and inductance low.

of the same type as the two preceding ones, but coupled to the following push-pull buffer stage through a fixed inductance wound on the tank-coil form. This type of coupling eliminates a grid tuning condenser, and with a slight amount of pruning of the grid coil very satisfactory results can be obtained. The neutralizing condensers are mounted beneath the chassis between the tube sockets. Adjustments can be made from above by means of a fibre or bakelite neutralizing rod through holes cut in the chassis. The condenser shafts are slotted to fit the rod.

To the right of the buffer tubes is the tank coil for the stage. This coil is mounted on a mycalex strip having five banana plugs, fitting into a similar jack strip bolted to the chassis. Where the jacks go

#### COIL DATA

- For 28-Mc. Output with 7-Mc. Crystal:  
 L<sub>1</sub>—17 turns No. 20 d.c.c. close-wound on 1½-inch form.  
 L<sub>2</sub>—14 turns No. 20 d.c.c. on 1½-inch form, length 1½ inches.  
 L<sub>3</sub>—6 turns No. 20 d.c.c. on 1½-inch form, length 1 inch.  
 L<sub>4</sub>, L<sub>5</sub>—4 turns each coil, close-wound on same form with L<sub>3</sub>, ¼ to ¾ inch from L<sub>3</sub> outside ends to grids.  
 L<sub>6</sub>, L<sub>7</sub>—10 turns No. 12 enamelled, diameter 1¾ inches, length 3 inches. Link 2 turns 1¾-inch diameter inside coil at center.  
 L<sub>8</sub>—8 turns No. 10 enamelled, 1⅞-inch diameter, length 4¼ inches.  
 L<sub>9</sub>—2 turns No. 10, 1⅞-inch diameter, length ½ inch.  
 For 56-Mc. Output with 14-Mc. Crystal:  
 L<sub>1</sub>, L<sub>2</sub>—8 turns No. 20 d.c.c. on 1½-inch form, length 1 inch.  
 L<sub>3</sub>—4 turns No. 20 d.c.c. on 1½-inch form, length ½ inch.  
 L<sub>4</sub>, L<sub>5</sub>—3 turns No. 22 close-wound on same form as L<sub>2</sub>, spaced ¼ to ¾ inch from L<sub>3</sub>.  
 L<sub>6</sub>, L<sub>7</sub>—6 turns No. 12 enamelled, diameter 1 inch, length 3 inches. Link 1 turn in center.  
 L<sub>8</sub>—6 turns No. 10 enamelled, diameter 1½ inch, winding length 4½ inches.  
 L<sub>9</sub>—2 turns No. 10 enamelled, diameter 1⅞ inch, length ½ inch.

Note: Coil diameters for self-supporting coils are outside measurements. L<sub>1</sub> and L<sub>2</sub> on National XR-20 forms, L<sub>3</sub> on Hammarlund CF-6 forms.

through the basic ample clearance was allowed to reduce the capacity to ground and to prevent arcing over. The grid coil for the final stage is similar in construction to the buffer plate tank. Shields were fabricated for both coils, but in operation it was found that coupling between these coils and the plate tank coil of the HF-100's was imperceptible, and the shields therefore were discarded. Coupling between the buffer plate and amplifier grid cir-

cuits is through a one-turn loop at each end, with a line made up of two No. 10 wires spaced approximately 1/16-inch apart.

The final or power stage uses two HF-100's in push-pull. These tubes were chosen because of their high ratio of transconductance to inter-

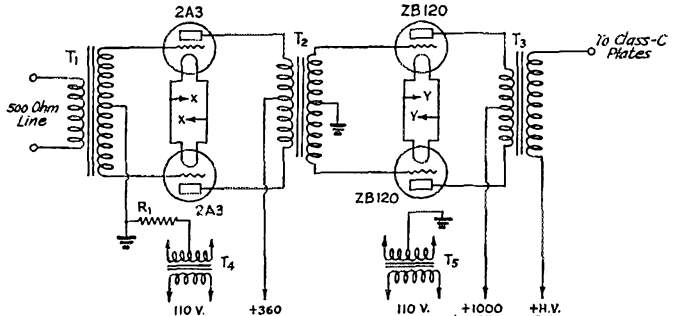

FIG. 2—MODULATOR AND DRIVER CIRCUIT DIAGRAM

- R<sub>1</sub>—800 ohms, 10-watt.  
 T<sub>1</sub>—500-ohm line-to-grid transformer (UTC-PA135).  
 T<sub>2</sub>—Class-B input transformer (UTC-PA53AX).  
 T<sub>3</sub>—Class-B output transformer, variable ratio (UTC-VM4).  
 T<sub>4</sub>—2.5-volt filament transformer.  
 T<sub>5</sub>—10-volt filament transformer.

electrode capacitance. This means that the tubes are easy to drive, and at the same time, because of the construction and low capacities, they can be operated at full ratings at ultra-high frequencies. Particular care was exercised in laying out this stage so that good overall efficiency could be obtained, especially to keep stray capacities comparable to the tube capacities. The two neutralizing condensers are ganged in one assembly and mounted in a vertical position; this was done because the tubes have side grid connections and such a mounting resulted in the shortest possible leads.

The variable antenna link has worked admirably. It has advantages over the usual type by allowing for smooth control and having a plug-in arrangement for different sizes of link coils. Once the required conditions are determined the position of the link is maintained by a locking device. Locking is accomplished by a reducing shaft-coupling ( $\frac{3}{8}$ " to  $\frac{1}{4}$ "). The  $\frac{1}{4}$ -inch side fits on the link shaft and the  $\frac{3}{8}$ -inch side on the panel bushings; by using set screws any position may be fixed.

A view of the layout beneath the chassis is given in a second photograph. The two filament transformers mounted on the rear edge supply all the tubes. While the rig was still in the experimental stage a third transformer was tried for the 809 tubes. This proved to be unsatisfactory since any position available was so situated that the introduction of the transformer caused severe unbalance. The final outcome was a transformer with two separate windings (extreme right in photograph) supplying the 809's and the HF-100's. It will be observed from the photograph that all the tank condensers are insulated from the front panel by means of an isolantite coupling. These couplings were used to insulate the condenser shaft from ground in the case of the series-fed tank circuit in the first stage, and to give a good layout and to compensate for any misalignment in the panel bushings in the other stages. In the second stage the tuning condenser has its control coming through the back of the chassis, but subsequent to the taking of the photographs the control was brought out through the front by means of a flexible shaft.

It may be well to mention at this point that ground returns are not dependent upon contacts to the chassis, because these may be a source of annoying difficulties at ultra-high frequencies. A No. 10 copper bus running almost the full length of the rig on both sides of the split-stator condensers, and having all ground connections soldered to it, has proved to be most satisfactory for this purpose. In the final stage it will be noted that the cathode bias resistor is by-passed by an 8- $\mu$ fd. condenser. Among some amateurs it is believed that the cathode bias resistor for a push-pull modulated amplifier need not have a by-pass condenser, a belief which seems to have been founded on audio amplifier practice. However, such is not the case, and experience shows that the cathode bias resistor of a modulated r.f. amplifier requires a by-pass condenser of at least 8- $\mu$ fd. to prevent degenerative effects.

Fig. 1 also shows the switching arrangement which enables reading the plate currents of all

tubes with the exception of the HF-100's. By using one meter and four push-button locking-type switches one can read the plate current of any individual tube or of all the tubes collectively. This has a distinct advantage over any plug-in arrangement by making tuning more rapid, and also during operation of the unit by allowing a quick check on any difficulties which may arise. The grid currents of the buffer or the final stage may be read through one meter by utilizing a double-pole double-throw toggle switch as shown in Fig. 1.

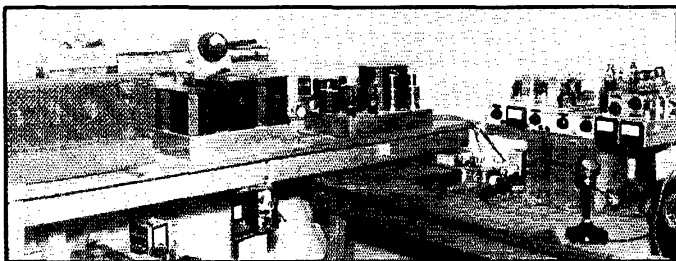

**POWER SUPPLY AND AUDIO UNITS ARE ON SEPARATE CHASSIS**  
*This layout at W2KPX is used in preference to the customary rack so that changes can be made without difficulty.*

#### ADJUSTMENT

The tuning procedure does not differ from that used with a transmitter designed for the lower-frequency bands. If a wave meter is not part of the station equipment it would be advisable to construct an absorption type with a neon indicator which can be roughly calibrated against a receiver. This will prove invaluable when quadrupling in the second stage, since it is important to distinguish between the third and fourth harmonics. Other than that no difficulty should be experienced in tuning the transmitter, and it will suffice to give the plate and grid currents under normal operating conditions.

#### Plate and Grid Current Readings

##### 56 MEGACYCLE OPERATION

(With an applied plate voltage of 500 volts to exciter portion of transmitter.)

6V6G—Oscillator—Combined screen and plate....	40 ma.
RK49—1st doubler—Combined screen and plate..	70 ma.
809—2nd doubler plate current.....	75 ma.
809's Buffer plate current.....	150 ma.
HF-100's Final amplifier plate.....	250 to 300 ma.
809's Buffer grid current.....	40 ma.
HF-100's Final grid current.....	45 ma.

##### 28 MEGACYCLE OPERATION

(The voltage for exciter portion is reduced to 360 V.)

6V6G.....	38 ma.
RK49.....	40 ma.
809.....	65 ma.
809's.....	120 ma.
HF-100's.....	250 to 300 ma.
809's (Buffer grids).....	40 ma.
HF-100's (Final grids).....	45 ma.

(Continued on page 64)

# Which Directive System?

## Factors Influencing Choice of Directive Antenna Arrangements

By Hugo Romander, W2NB\*

THE many varieties of antennas having more or less directional characteristics which have been described in radio publications in the past few years undoubtedly has led to confusion for many amateurs as to which design is most applicable to their individual needs and locations. A brief comparison of a few antennas of related design might therefore help a bit in making an intelligent choice, this comparison including two of the antennas described by Mr. J. D. Kraus in his very excellent article in the January, 1938, issue of *QST*.<sup>1</sup>

Referring to Table I, first and foremost is the simple doublet, this being the reference antenna with which all other antennas are compared. No mention need be made of the method of feed, so that this reference doublet may be either center or end fed, or single-wire fed, or simply fed from a bottle. It is of interest to observe that if this antenna is center-fed, it may be much shorter than a half wavelength without appreciable sacrifice in efficiency *provided* the losses in the wire are kept small by using larger-sized wire and improved insulation in both antenna and feeders. From a practical standpoint, this will permit shortening an antenna to about 0.2 wavelength before voltages and currents become so high that reasonable sizes of wire and the best insulation available absorb an appreciable portion of the power. Incidentally, antennas shorter than a half wavelength and hung horizontally, let us say, have a horizontal pattern somewhat broader than that of the horizontal doublet, making its "coverage" around the compass better than that of the doublet.

The second item in the table is our old friend the double Zepp, or two coaxial half-waves in phase. The gain of this antenna is 1.9 db, a rather small improvement when one considers that the length of the antenna has been doubled to obtain it. The third item is the double 230° Zepp with its gain of 3.0 db.<sup>2</sup> Here the extra length is more worth while, since a longer antenna costs little

more if one has the space available. This antenna multiplies the effective power by 2 in the broadside direction, as compared with the simple doublet.

Then there is the 1-section W8JK antenna. With this antenna there is introduced the added complication of at least two spreaders to form a "flat-top" antenna. The possible gain of 4.1 db in either broadside direction may be slightly discounted by the fact that very low radiation resistance with consequent high currents and voltages will cause some loss, but nevertheless the improvement is well worth striving for in locations where space is limited to such a short structure. If the longer 2-section W8JK antenna can be installed, however, the mechanical difficulties are practically the same but the possible gain would then be 5.5 db—equivalent to increasing the power in a simple doublet to 3.55 times its original value. Here again the radiation resistance is very low and currents and voltages are high, with resultant loss in power which must be minimized by using generous-sized wire and the best-quality insulators. Gain in both broadside directions is the same and is accomplished by restriction of the lobes of radiation in both the horizontal and vertical planes.

Finally we come to the double 230° Zepp with reflector (or director). The very attractive gain of 7 db possible with this antenna together with the fact it is of the "flat-top" variety, makes it

*Choosing an antenna system is something like choosing a tube line-up for a new transmitter—there's an embarrassment of riches. The author here discusses some pertinent points in connection with simpler directive arrays.—EDITOR.*

the logical competitor to the 2-section W8JK antenna, hence a direct comparison between these two antennas is of particular interest. For the sake of brevity, let's call the double 230° Zepp antenna the D230 antenna, hence the double 230° Zepp with reflector may be called the D230R antenna. Since the 2-section W8JK antenna is really two double 158° Zepps<sup>3</sup> operating out of phase, we might abbreviate this by calling it the 2D158 antenna.

<sup>3</sup> This figure refers to the active portion of the two-section beam in which the inner ends of the elements are folded back to meet the transmission line, i.e., the element length is approximately 30 feet for 14 Mc. The antenna also can be constructed readily to have 180-degree radiating members, but the difference in performance will not be appreciable.—EDITOR.

\* 200 Mt. Pleasant Ave., Newark, N. J.

<sup>1</sup> J. D. Kraus, "Directional Antennas with Closely-Spaced Elements," *QST*, January, 1938.

<sup>2</sup> H. Romander, "The Extended Double-Zepp Antenna," *QST*, June, 1938.

The outstanding difference between these two antennas lies in their directional characteristics. Assuming both antennas are supported horizontally, the D230R obtains its 1.5 db extra gain over the 2D158 by suppressing radiation in one broadside direction. One might expect nearly 3 db extra from this, but the 2D158 gets an extra

TABLE I

Antenna	DB Gain		Percentage
	Backwards	Forwards	Power in Single Doublet to Give Equal Signal
Single Doublet . . . . .	0	0	100
Double 180° Zepp . . .	1.9	1.9	155
Double 230° Zepp . . .	3.0	3.0	200
1—Section W8JK . . .	4.1	4.1	257
2—Section W8JK . . .	5.5	5.5	355
Double 230° Zepp with reflector . . . . .	-7.0	7.0	500

boost from the fact its vertical pattern is narrower than that of the D230R. This fact places the 2D158 at a further disadvantage to the D230R where high angles of radiation are desired, but since the flat-top type of antenna will not generally be used for frequencies lower than 7 Mc., this point will probably not be of much importance.

Another point to consider is the loss due to low radiation resistance. Since the spacing between elements across the flat-top is 0.2 wavelength for

the D230R, as compared with 0.125 wavelength for the 2D158, the radiation resistance of the D230R will be considerably higher. This will result in less copper and dielectric loss for the D230R, all other factors being equal. However, compared with the single doublet (S180), the radiation resistance of the D230 and the D230R is quite low and precautions against line losses are important.

To sum up the comparison between the D230R and the 2D158 antennas, the 2D158 will be most practical where space does not permit the longer D230R, where a bi-directional characteristic is desired, and where QRM from the opposite direction to a desired signal being received by the antenna will not be a serious factor. The D230R will offer definite advantages where space permits its larger dimensions, where transmission and reception in one general direction only is acceptable, or where transmission and reception in two opposite sectors is desired and is accomplished by bringing a separate transmission line into the operating room from the reflector to permit quick change of tuning from reflector to director,<sup>2</sup> and where QRM from a direction opposite to the desired direction is a serious factor. Perhaps one should also give consideration to the possibility of causing less QRM to others by the use of a unidirectional antenna.

## The A.R.R.L. National Convention

PLANS for the A.R.R.L. National Convention and amateur radio equipment show to be held at the Sherman Hotel in Chicago over Labor-Day week-end, September 3d, 4th and 5th, are progressing rapidly and at this early date point to the finest amateur convention ever held. The convention is to be conducted by the Chicago Area Radio Club Council, which sends us the following announcement of their plans:

Judging from advance ticket reservations and from comparison with the large convention held here two years ago, all indications are that a record crowd of between 4000 and 5000 amateurs from all the states and several foreign countries will be on hand.

The Convention Committee has outlined a program which will cover all phases of amateur radio and will include educational, entertaining and official matters. Under the educational part, the outstanding speakers in every branch of amateur radio have been invited to speak. Already such prominent men as Frank Lester, W2AMJ, on U.H.F.; Ted McElroy, the speed champion; W8JK on antennas; Fritz Franke on airways radio, and others, have indicated they will be on

hand. By convention time the program will be enriched, no doubt, by the presence of such men as Dr. Lee de Forest, John Reinartz, Boyd Phelps, Dave Evans, etc. There will be demonstrations of television, receivers, transmitters, and many group meetings for 'phone, cw, DX, uhf, AARS, NCR, and many more.

The finest entertainment ever shown at an amateur convention is planned. The floor show from the Hotel Sherman's famous College Inn will be on hand, there will be stars from N.B.C., C.B.S. and M.B.S., as well as stars from local broadcast stations, and the hit of the '36 show, SMITH, will again be on our program. A big Saturday night informal party will be held, and on Sunday evening a huge banquet with additional novel types of entertainment. Many side trips to Chicago manufacturers' plants are planned.

Mr. K. B. Warner, Secretary of the League, who has accomplished more for amateur radio than any other man, will be here in person to discuss with us the various problems of the League.

The League part of the program will be held on Sunday afternoon when you will be able to see

(Continued on page 66)



# 1938 Paley Award Goes to W9MWC

LAST June 9th Robert T. Anderson, W9MWC, of Harrisburg, Ill., was presented with the second annual Paley Amateur Radio Award by William S. Paley, president of the Columbia Broadcasting System, at a presentation luncheon at the Waldorf-Astoria in New York.

W9MWC was chosen for the award on the basis of his work during the 1937 Ohio River Valley flood, as reported in the May, 1937, issue of *QST*. In making the presentation, Mr. Paley made the following citation:

"On behalf of the Board of Awards, I present this to you . . . for meritorious performance during the 1937 Ohio River flood from January 22nd to January 25th . . . for proceeding with your amateur short wave equipment from Harrisburg to the relief of the isolated inhabitants of Shawneetown, twenty-three miles away . . . for transporting this equipment in the height of a blizzard, in a small open boat, over great areas of water running at flood force . . . for setting up your transmitter in a raging storm at 12 degrees above zero and establishing the first communication direct with relief agencies . . . for the exercise of extraordinary perseverance and ingenuity at the risk of your own life in bringing relief to eleven marooned people near Junction, sending

lowing the acceptance speech, Vice-President George W. Bailey again assumed responsibility for the permanent trophy on behalf of A.R.R.L. and expressed amateur radio's appreciation to Mr. Paley for his recognition, stating that in the search for the winner of the award many good deeds are brought to light that might otherwise have escaped attention.

The presentation ceremonies, in which a number of dignitaries participated including Rear-Admiral Woesche, Commandant of the U. S. Coast Guard and Captain Hooper, the Naval Director of Communications, were broadcast over the C.B.S. Network.

The award is made annually to the U. S. or Canadian radio amateur who, in the opinion of an impartial Board of Awards, has contributed most usefully to the American people. The Board of Awards consisted this year of the Hon. Norman H. Davis, Red Cross Chairman; Lieut.-Commander C. P. Edwards, Chief of Air Services for the Dominion of Canada; Dr. J. H. Dellinger, Chief of the Radio Section of the U. S. Bureau of Standards; Prof. A. E. Kennelly, Professor Emeritus of Electrical Engineering at Harvard University, and Rear-Admiral Woesche. The first Paley Award, given last year, went to Walter Stiles, Jr., W8DPY, for his work in the 1936 Pennsylvania flood.

According to the *St. Louis Post Dispatch*, Anderson "performed an act of heroism during the flood of last year which will be remembered for a long time along the Ohio River." It will be remembered for a long time by the radio amateur fraternity, too, for Anderson's performance is unquestionably one of the most outstanding in amateur history. —C. B. D.

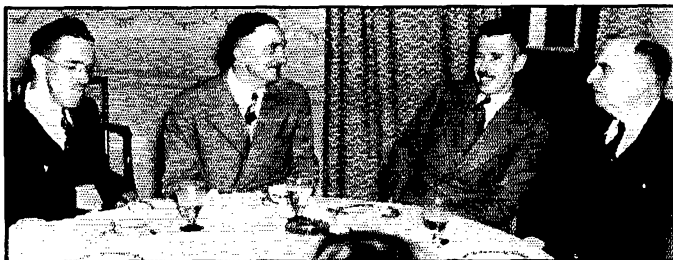

HANDY, BOB ANDERSON, WARNER AND WDRG'S DOOLITTLE TALK IT OVER

food and supplies to the 1500 isolated inhabitants of Shawneetown and bringing about their eventual evacuation . . . for cooperating unceasingly with the military and civil authorities through more than forty hours of intense activity without sleep and then again manning your station and again serving the entire southern Illinois area with the transmission of official communications throughout the duration of the emergency . . . and finally, because throughout these activities, you exemplified the highest standards of amateur radio operation."

W9MWC accepted the award "as a representative of that great body of hams whose world knows no boundaries and whose proudest and happiest moments are when they are able to render service in disasters or emergencies." Fol-

## The Cover

THIS month the picture is of the new Maxim Memorial Station now being completed at Newington, Conn. Scheduled operation of W1AW is to begin early in September.

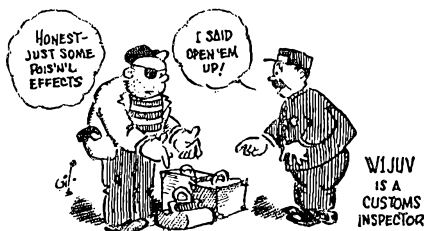

# 56 Mc. Goes on Annual Frolic

## "Five" Opened Wide for DX During May and June

**T**RUE to form, the month of May 1938 saw the 56-Mc. band take its annual DX-fling. This makes the fourth consecutive year that five meters has opened for long-distance work during May. But this year the splendid performance of the band surpassed all previous accounts and continued into the month of June. It was the most widespread 56-Mc. DX Party yet noted, with some 150 stations figuring in the 900-1500 mile QSO's, and many more stations being logged over equal distances!

We wish to extend sincere thanks to the operators who submitted reports on the unusual conditions. Unlike last year, reports were plentiful, the following sending very complete information: W1ALP AUN EKT IJ KZH HXE JKT JRS DFY HDQ GJH EHT JBF JVA KUB CLI KBL KH BPI KJT CBG W2IEK HKU HZL DVC KFB COK KTF HBO KBG IXY AOE GME W3QV DNU EZM FVS DOD BZJ FX W5AJG BHO EOO W7FPN GLH W8OKC CIR NED MST AGU PK RVT PBX EFW PNU MSK QDU QFV W9ZGD TZQ BRY ARN CCY LNV LEZ VSX USH ZJB RBK UIZ NY H. W. Swanson and Eugene Schraut.

June 5th was the banner day, and most of the reports received cover that Sunday's activities. However, let us review the preceding days of the unusual series before covering in detail results on the 5th. July *QST*, page 59, carries a preliminary summary of the 1938 five-meter DX spree.

According to reports May 12th started the ball rolling, with the West Coast getting in the first licks. F. W. Linklater, W7FPN, writes, "A letter from W7AQJ, Vancouver, Wash., tells of five opening up so that W6's came in like locals on May 12th. He worked five stations—W6IOJ, W6MKS, W6DNS, W6AVR and W6GZE—and has 'heard' cards from others. Several Portland, Oregon, stations were reported being heard, but only QSO was W7ABZ to W6IOJ." The longest distance represented in this work is W7AQJ-W6MKS/W6DNS (San Diego) . . . close to 1000 miles!

May 15th was apparently the first DX day in the east with W4EDD, Coral Gables, Fla., rolling up an impressive list of QSO's with the W1's, W2's, W3's and W8's.

May 19th is the next day for which DX was reported. W5EHM, Dallas, Texas, seemed to be the star performer, working a bunch of W8's and W9's. Conditions were good this date between W5 and W8-W9 and between W8 and W9.

On May 22d, W5AJG, Dallas, Texas, found the band open from 8:00 to 8:30 p.m. CST. He heard W9CLH and W9ANA.

May 27th found the band open (according to W9NY) from Wisconsin to the east coast from about 7:45 to 8:45 a.m. CST, and to W5 at 5:30 and 7:30 p.m. CST. In the evening W8QDU had a short contact with W5EHM. W8QFV also heard EHM. W9CCY, Council Bluffs, Iowa, heard and called (not sure of contact) W5EHM at 5:32 p.m. CST.

On May 28th "five" opened up in the southeastern part of the country and W4EDD made contact with W5EHM. East-West contacts between W9's and the east coast were quite numerous, as reported in July *QST*.

May 30th W8QDU (Michigan) had a good contact with W5EHM, and heard W8CIR, Pittsburgh. W8QFV (Ohio) also logged W5EHM. From this date on through June 6th we find DX reported for each day.

May 31st: W9NY reported 56 Mc. open to W5 for a few minutes at 1:30 p.m. CST, and open to the east coast and W5 at several other times. W9RBK, Kentucky, worked W5EHM at 1:00 p.m. June 1st: W8RVT, Springfield, Ohio, worked W5EHM at 1:05 p.m. and again at 1:25 p.m. EST. W9RBK worked W5EHM, 1:00 p.m. W5AJG worked W8EUX, W8CIR and W8OPO from noon to 12:16 p.m. CST. He heard W9ISM at 4:48 p.m. June 2d: W1HDF, Elmwood, Conn., worked W9ALE, Chicago, at about 8:00 p.m. EST. HDF also heard W9ALE between 10:00 a.m. and noon. W9RBK worked W3HKM, 1:20 p.m., heard W1EYM. June 3d: W8QFV, Blacklick, Ohio, worked W1IZY at 6:30 p.m. June 4th: W8QFV heard W1IZY, 10:40 a.m.

### June 5th

And now we come to Sunday, June 5th! This was the real history-making day. Paths taken by five-meter signals on the 5th are indicated in several representative diagrams appearing with this write-up. It will be noted that the coverage was extremely widespread. Stations in some thirty states participated in the work.

Signals covered distances in excess of 1500 miles and practically all reception and contacts were over distances greater than 900 miles. Among the outstanding DX contacts were those between W9USH, Brookings, S. Dak., and W2JCY, W2KTC, W2MO and W2DB, all close to 1300 miles. W9ZJB, Kansas City, Mo., spanned 1100 miles in contacts with W2HWX and W2ISY. Reception was reported of signals between Texas and New England (about 1560 miles), between Nebraska and Eastern New York state (1400 miles) and between Florida and New England (1300 miles). The diagrams give a striking

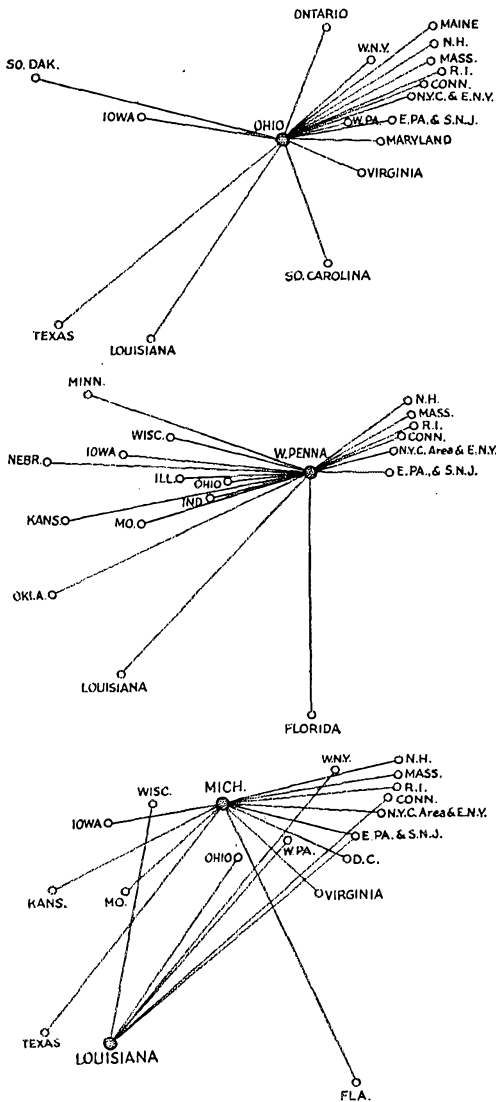

56-MC. PATHS ON JUNE 5TH

picture of distances and directions covered. W7EYN, Seattle, Wash., was reported heard by several operators in the Philadelphia region. Quoting from the "Atlantic Division Emergency News": "It has been reported by W9CCL that Sunday, June 5th, while the band was open he heard VK2NO. It has also been reported that the east coast had worked G5ML and G5BY." Although no definite reports have been received of such extreme DX as VK, or G, W1HXE heard a station signing G5ML during the morning period. W1EKT, Wakefield, Mass., was informed that W6FN and W6ITH were heard in that

vicinity, but he did not personally hear them.

On June 5th, 56-Mc. was open first from about 7:30 to 11:30 A.M. CST, with activity peaking between 8:45 and 11:00 A.M. CST. The bulk of work was between the East Coast and W8-W9, with some W4's and W5's reported by the north-eastern states.

Reported open next from 2:00 to 10:30 P.M. CST, the band's activity peaked again between 4:45 to 8:00 P.M. for East-West work, with W4's and W5's again reported in the northeast. 9:45 to 10:30 P.M. CST was reported by W9NY and W9ZGD as best for W5 in Wisconsin.

W3FVS observed that the DX peak occurred at sunset. W9NY found that in the morning period reception started with W8's and drifted to the east coast; in the afternoon-evening, reception started with the east coast and drifted somewhat closer.

Mr. J. A. Pierce, W1JFO of Cruft Laboratory, Harvard University, provides interesting data on E layer activity, measured at low frequencies on June 5th, which coincides with the 56-Mc. performance. He reports, "Our 3.5-Mc. pulse measurements show abnormal E layer reflection on June 5th from about sunset to 2050 EST. This abnormal reflection began before the end of the normal daytime E layer reflection so that we can set only an approximate time for its beginning. Abnormal reflection of this sort is very common at this time of year. The interesting thing, however, is that the intensity of this reflection, and presumably the ionization density at the lower boundary of the E layer, increased to a very high value between 1912 and 2035 EST. During this period the reflections were the strongest, as indicated by the observed number of multiples, that have occurred in at least the last two or three months. It is interesting to note that this period checks quite well with the time when the long-distance signals were being heard, and I think it is probably one of the first good correlations between E layer activity measured at low frequencies and 5-meter transmission."

The extraordinary conditions followed heavy thunderstorms in many localities. Rapid fading was extremely prevalent on DX signals, often making it difficult to get a station's call letters. The strength of local signals dropped below par during the DX periods, long-distance signals many times equalling the locals. Very short skip was noted on 28 and 14 Mc. at the time 56 Mc. was alive with DX. The most outstanding signal reported in the East was W9CLH, Elgin, Ill. A minimum of fading was reported on CLH and strength was very good. W8JIN, W8RSS, W9ARN, W9FEN, W9FP and W9NY are also reported as having outstanding signals. W1GYT, W1JQA, W1KEE, W2MO and W3EZM are named as outstanding signals by W9's.

An interesting point brought out by the various reports is that a high location, in the clear, is not

a necessity for successful 56-Mc. work. For example, W8QFV, who worked several W1's and W2's and heard scores of DX stations during the May-June periods, is surrounded on three sides by a cliff. W1HXE, who logged 68 DX stations in three and three-quarters hours, writes, "My location is one of the very lowest in the city, a little higher than our recent flood level, completely surrounded by large hills in every direction. The location and antenna are so low that I have a hard time working nearby towns of Lowell and Haverhill, nine miles away." Practically all operators who succeeded in making contacts or hearing DX were located at their regular home QTH's with normal set-ups.

According to reports received the following-listed made DX contacts on June 5th. In this list and later "heard" lists it is likely that errors in call letters have occurred because of difficulty in logging calls due to QRM, fading, poor enunciation, etc. However, all calls have been checked against the latest amateur call book and no calls are listed unless they appear in that publication.

#### Stations That Made 56-Mc. DX Contacts June 5th

W1AGR AUN BJE CMP EHT EKT EYM IAH IGJ IJ (Five W9's) IJG IUI IUR IVA IXP IYT IZY JFK JHL JKT JLI JQA JQO JUJ (Seven QSO's) JUN JXN JZE JZN KAD KCG KEE (Many QSO's) KEK KEM KH (W8 & W9) KIB KIC KJT (Six W8's & W9's) KNN KPM KUD KXF KXK LAB MJ QV W2ANM COK (Eight W8's & W9's) DB DMM GAH GHV HWX HYJ HZL ISY IXY JCY JLY KHK KHR KLZ (Ten QSO's) KNV KTC LAH LEY MO W3AIR AYF BYF (Four W9's) BZJ (Three W9's) CUD (Two W9's) DOD (Three W8's) ERA EZM (Ten W8's & W9's) FLL FOP FSS FVR (Three W9's) GEF GHO GQK (Two W9's) GQS MV NU VX W5AJG (Six W8, W9) ETQ ZS W8AGU (Three W9's & W5) CIR (Two W1's, Two W2's, Seven W9's & W5) CLS (W5 & W9) DSU EGQ EID GU JIN JLQ LL MST (W5 & W9) NED (Two W1's, W9 & W5) NF NKJ OIA OJF OPG ORA OTG PNU (Seven W1's, W2's, W3's) QDU (Six W2's & W3's & W5) QFV QKI RRH RSS RVA RVP RVT (Thirteen W1's, W2's, W3's, W8's) VO (Four W1's, One W2, Two W5's, Two W9's, One VE3) W9AHQ AHZ ARN (Fourteen W1's & W2's) CCY (W2) CLH (Many QSO's) FEN FP GGH GKO HPP IVC JRM JUE LLC (W1's, W2's) LNV (Six

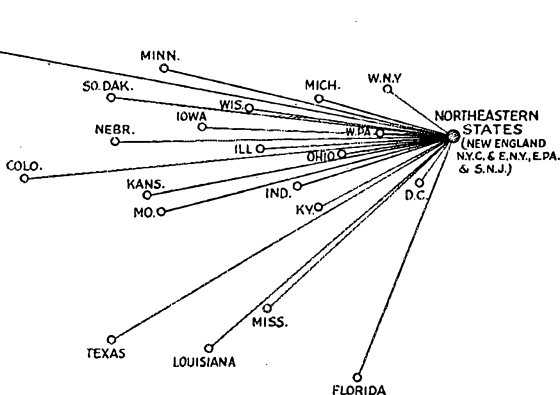

56-MC. PATHS ON JUNE 5TH

W1's, W2's & W3's) LVK LYI MXK NY OLY (Four W2's, W3's) OVK PQH QFX QHR RBK TMM (About ten QSO's) UIZ (Four W8's) USH (Four W2's) VSX (W1, W2) WLX WTV WWD YGS YGZ YMG YSV ZGD (Sixteen W1's, W2's, W3's) ZJB (Two W2's, Six W8's) ZPJ ZSS ZUX W1DCG.

The power input at several successful stations will be of interest. W5AJG ran 50 watts, crystal control; W8PNU 30 watts, long lines; W8RVT 300 watts; W8AGU 250 watts, c.c.; W2COK 65 watts, long lines; W3BZJ 75 watts, c.c.; W3EZM, 150 watts, c.c.; W9LNV, 25 watts; W8CIR 250 watts, c.c.; W9ARN 100 watts. It will be noted that moderate powered stations shared DX with those of higher power. High power was not a necessity. The opinion of most five-meter observers is that stations having stable signals (preferably crystal control) get through best. There are exceptions to the rule, of course, but quite a number of the stations making DX contacts during May and June used crystal.

Following "the big Sunday," June 5th, five-meters continued to open up on various days through the whole month of June. June 6th saw a considerable amount of activity. W8QFV, Ohio, worked W1DWR, W2LEY, KLO, FZA, JCY and LFM between 6:47 and 7:10 p.m. He heard W2ITU, DTE and IRY. Between 5:20 and 5:55 p.m. CST, W8RVT, Ohio, worked W2HJE, FZA, HYU, KYY, HKE and LFL. W8NED, Pittsburgh, reports the band open for about 10 minutes at 7:42 p.m. CST, W8CIR working a W9 at 7:45 p.m. W9RBK, Newport, Ky., heard W1JLK at 7 p.m. Between 5:30 and 6:30 p.m. CST, W2HBO, Ridgewood, N. Y., heard W8RVQ and other W8's; reports signals not as strong as on June 5th. W1KJT, Middletown, Conn., worked W9WLX, W8EGQ and W8RSS on the evening of the 6th. W1IJ heard W8EGQ at 5:30 p.m. CST.

June 8th, W9CCY, Council Bluffs, Iowa, heard W8ANT and W8AGE about 10 A.M. CST.

(Continued on page 70)

# What the League Is Doing

League Activities, Washington Notes, Board Actions—For Your Information

**F.C.C. Notes** The Federal Communications Commission is engaged in revising all of its regulations with a new uniform printing, a new numbering system, etc. Work has now commenced on the revision of amateur regulations and the League is being given an opportunity to participate in the discussions. The basic structure of our rules will not be changed, but we may well experience some new requirements based upon the observations of the monitoring stations in recent years. When the new regulations appear, late in the summer, they are expected to contain the new provisions for amateur emergency communication requested by the A.R.R.L. Board, the long-expected revision of the portable rules, and the removal of television transmission from the 1.7- and 56-Mc. bands.

There is going to be some delay in shifting our 1715-2000 band to 1750-2050. The frequencies between 2000 and 2050 kc. have to be cleared for our occupancy and the whole question of moving us is tied up with moving part of the police system, on whose behalf the original idea of moving us was generated. These stations will have to be given due notice before their frequencies are changed, so that it will probably be autumn before we are shifted.

There were about 49,600 valid amateur station licenses in the U. S. A. on June 30th, the end of the government's year, comparing with 47,444 a year previous, indicating that we maintain our steady progress.

The Commission has ruled that amateur portable-mobile stations may be operated on board American vessels, on frequencies above 28 Mc., in American waters and on the high seas—at any place except in foreign waters.

Just how pure is the plate supply of amateur transmitters supposed to be? The Commission engineers say that it is supposed to have no modulation whatever; they do not recognize any percentage tolerance of ripple. Monitoring stations are not supposed to get too "technical" and cite a fellow for having a modulation hum 100 db down from the signal, something that can be heard only with the volume control wide open. But if it can be heard at normal volume it's too much, they say.

Our Board's proposal that the Commission appoint some amateur deputy inspectors to assist in the policing of the amateur bands is viewed with considerable favor in some quarters of the Commission. The proposition is now under study and we hope for more definite word on it soon.

**Exec. Com. Minutes** Continuing the publication of minutes begun last month, we present now the minutes of the several meetings of the A.R.R.L. Executive Committee held between the last two meetings of the Board of Directors:

## MINUTES OF EXECUTIVE COMMITTEE MEETING

No. 148

July 10, 1937

Pursuant to special call, the Executive Committee of the American Radio Relay League, Inc., met at the headquarters office of the League in West Hartford, Conn., at 9:40 a.m., July 10, 1937, under the chairmanship of Vice-President George W. Bailey. Other members present were Treasurer A. A. Hebert, Communications Manager F. E. Handy, Secretary K. B. Warner.

On motion of Mr. Hebert, formal approval was given the holding of the following A.R.R.L. conventions:

Oklahoma State (West Gulf Division), Tulsa, Okla., July 17-18, 1937, auspices Tulsa Amateur Radio Club.  
Rocky Mountain Division, September 4-5, 1937, Colorado Springs, Colo., auspices Pike's Peak Amateur Radio Association.

South Dakota State (Dakota Division), September 4-5, 1937, Sioux Falls, S. Dak., auspices Sioux Falls Amateur Radio Club.

Central Division, September 4-5-6, 1937, Detroit, Mich., joint auspices Central Division Radiophone Association, Detroit Amateur Radio Association, Motor City Radio Club.

Hudson Division, Asbury Park, N. J., September 23-24-25, 1937, auspices Jersey Shore Amateur Radio Association.

Midwest Division, Kansas City, Mo., October 9-10, 1937, joint auspices Heart of America Radio Club, O.B.P., and Kaw Valley Radio Club.

Northwestern Division, Sunrise Park, Rainier National Park, Wash., August 28-29, 1937, sponsored by Director Gibbons.

On motion of Mr. Handy, affiliation was granted by unanimous vote to the following societies:

Olney Amateur Radio Club (re-affiliated) . . . . . Philadelphia, Pa.  
The Amateur Radio Communications Society . . . . . Verona, Pa.  
New Bedford Amateur Radio Association . . . . . New Bedford, Mass.  
Four Lakes Amateur Radio Club . . . . . Madison, Wis.  
Palo Alto Amateur Radio Association . . . . . Palo Alto, Calif.  
100 What Club . . . . . Modesto, Calif.  
Co-Goth Radio Club . . . . . Cozad, Gothenburg, Nebr.  
Tempe Amateur Radio Association . . . . . Tempe, Ariz.

On motion of Mr. Handy, the affiliation of the following societies was regretfully terminated for non-compliance with the regulations of the Board, with a statement of the League's willingness to re-affiliate if and when said clubs again comply with the Board's regulations.

Shamokin Radio Club . . . . . Shamokin, Pa.  
San Bernardino Radio Club . . . . . San Bernardino, Calif.



Raritan Valley Radio Club . . . . . South River, N. J.  
 St. Joseph Valley Amateur Radio Club . . . . . Mishawaka, Ind.  
 Highland Park Amateur Radio Club . . . . . Highland Park, Calif.  
 Walnut Valley Radio Club . . . . . Arkansas City, Kan.

Mr. Handy gave an extended report of his search for a location for the new headquarters station W1AW, describing many possible sites investigated in three towns and the eventual selection of a most favored one in the town of Newington, distant approximately 4.5 miles by road from the headquarters office. The members of the Committee had inspected most of these sites and all the Committee members had carefully inspected the favored site. Mr. Handy pointed out that the Board's request for additional facilities above those that had been appropriated for, particularly in the matter of directive antennas, meant that the cost of the station must be expected to go over the Board's appropriation, which itself was less than the minimum estimated cost of the station. The proposed location was on an isolated site in Newington, of approximately 7 acres extent; the tax rate was 24 mills; zoning difficulties had been adjusted satisfactorily; power would have to be run in a distance of 0.2 to 0.3 mile on poles already existing; a water line would similarly have to be run in. After extended discussion, on motion of Mr. Handy, it was unanimously voted that the Communications Manager is authorized to conclude negotiations with Miss Elsie Starr, of Hartford, Connecticut, for the purchase of a site of land in Newington by the League, subject to complete survey and search of title, being 7 to 7.5 acres, at a price of \$300.00 cash per acre, for the purpose of the Hiram Percy Maxim Memorial Station; the said piece being described as running about 350 feet on the east or front along Main Street, Newington, bounded on the south for about 900 feet by Orchard Lane, on the north for about 860 feet chiefly by property belonging to John Schwager, and running west on property of Elsie Starr to a certain distance to make between 7 and 7½ acres, the west line being approximately 350 feet in length. The Secretary was directed to arrange immediately for a search of title.

The Committee engaged in extended discussion of the desirable type of operating building. Mr. Handy presented preliminary sketches by an architect which were, however, regarded as entirely unsatisfactory. The Committee believed that an appropriate building should be of colonial style, disposed to present its longest elevation to the highway, and so planned as to permit future enlargement. After the discussion, the Communications Manager was requested to bring in definite plans and specifications for a station building along the lines discussed.

The Committee discussed a dilemma brought about by the Board's action in voting to hold a national convention next year and to hold the Board meeting at the same time and place. A constitutional limitation made it impossible to hold the Board meeting other than in the month of May, a most disadvantageous time to hold a national convention. Moreover, it has been developed that the San Francisco Exposition was not to be held until 1939. After extended discussion, on motion of Mr. Hebert and by unanimous vote, the Secretary was directed to present this matter to the Directors by letter for their further consideration, and to solicit a mail expression from each.

The meeting adjourned at 11.30 A.M.

K. B. WARNER,  
 Secretary.

## MINUTES OF EXECUTIVE COMMITTEE MEETING

No. 149

November 1, 1937

Pursuant to the requirements of by-laws the Executive Committee of the American Radio Relay League met in the Headquarters office of the League in West Hartford, Conn., at 1:45 P.M., November 1, 1937 with President Eugene C. Woodruff in the chair and Vice-President George W. Bailey, Treasurer A. A. Hebert, Communications Manager F. E. Handy and Acting Secretary A. L. Budlong present.

The Acting Secretary read a letter from the Trenton Radio Society of Trenton, N. J., suggesting that individual

members of the League be permitted to contribute towards the building of the Headquarters Memorial Station and requesting the publication of their letter in *QST* to stimulate such response. In the ensuing discussion members of the Committee were unanimous in expressing doubt as to the advisability of such action, for a variety of reasons. The Acting Secretary was, therefore, on motion of Mr. Bailey, instructed to convey to the Trenton Radio Society the Committee's regret that it did not believe such a plan would be feasible.

On motion of Mr. Handy affiliation was granted by unanimous vote to the following societies:

The 56-Mc. Minutemen . . . . . Massachusetts  
 The Mike & Key Club of Ithaca . . . Ithaca, N. Y.  
 Kalamazoo Amateur Radio Club . . . Kalamazoo, Mich.  
 Greater Cincinnati Amateur Radio Association . . . . . Cincinnati, Ohio  
 Northern Alberta Radio Club . . . Edmonton, Alberta, Can.  
 Azalea City Wireless Club . . . . . Palatka, Fla.  
 The Chair City Radio Association . . . . . Gardner, Mass.  
 VE Operators' Association . . . . . Toronto, Ontario, Can.

Rating previous informal agreement among a quorum of members of the Executive Committee, the Committee, on motion of Mr. Hebert, approved the holding of the following conventions:

Maritime Division Convention at Halifax, N. S., September 4-5-6, 1937, auspices Halifax Amateur Radio Club.

Southwestern Division Convention at Tempe, Arizona, October 23-24, 1937, auspices Arizona Section Radio Club.

Massachusetts State Convention at Boston, Massachusetts, October 2, 1937, auspices Eastern Mass. Amateur Radio Ass'n. and South Shore Radio Club.

The Acting Secretary announced that the Headquarters had recently been in receipt of a letter from Mr. Philip E. Haller, Secretary, Chicago Area Radio Club Council, stating that the clubs of the Chicago area, through the Council, had unanimously voted to request the Board of Directors of the American Radio Relay League that the national convention be held at Chicago on September 3, 4 and 5, 1938 under the Council's auspices. The letter set forth that the Council is made up of twelve of the most active clubs in the Chicago area; it listed a tentative convention committee of nine individuals, five of whom had served on the convention committee of the Central Convention Committee in 1936; it stated that at the present time \$500.00 is available in the Council's funds, pointed out that for the convention in 1936 the Council, then having no funds, had been successful in obtaining more than \$6700 and estimated that \$12,000 would be required to finance a national convention and that it was felt this amount could be obtained if the convention were held in Chicago; it also set forth the advantages of Chicago as a location for the convention. In the ensuing discussion it was brought out that the Board has already voted to hold its annual meeting next year in May at Hartford, as usual, and to postpone until then further discussion of a national convention. The President also read to the Committee a six-page opinion from the General Counsel detailing past actions of the Board with respect to the general subject of national conventions and rendering the opinion that the authorization for the holding of a national convention as contained in the 1937 minutes of the annual Board meeting is not only ambiguous but also illegal and that it is not possible to hold a national convention without an amendment to the by-laws of the League. After further discussion, however, it was the sentiment of the Committee that, considering both the Board's recent expression on the subject and the bid of the Chicago Council, the Committee considered it advisable to come to an immediate decision on the latter owing to the fact that a delay until the Board meeting in May, in the event of a decision to hold a national convention in 1938, would give insufficient time for adequate preparation and publicity. On motion of Mr. Hebert, therefore, the Acting Secretary was directed to place the matter again before the Board of Directors for a mail expression with

respect to the formal bid of the Chicago Area Radio Council and, at the same time, to ask directors to express themselves on the subject of whether or not they would be in favor of amending the League by-laws on the subject of national conventions at the 1938 meeting of the Board.

— . . . —

The Committee proceeded to an examination of the nominations for director and alternate director in the 1937 elections, its action in each case being herein detailed below by divisions.

#### *Atlantic Division*

For director, the Committee found petitions in good order for Roy C. Corderman, W3ZD, Walter Bradley Martin, W3QV, and Edward L. Thompson, W3CQS and, upon motion, all three candidates having been found eligible, ordered their names to be listed on the ballots to be sent to members.

For alternate director, the Committee found petitions for Gilbert Crossley, W8YA, Hunter J. Lohman, W8OC, Raymond E. McComber, W3CZE and Herbert M. Walleze, W8BQ. Upon examination, Messrs. Lohman and Crossley were found ineligible in the opinion of the Committee under the terms of the League's by-laws but Messrs. McComber and Walleze were found eligible whereupon, upon motion, the Committee ordered their names listed on the ballots to be sent to members.

#### *Canada*

For Canadian General Manager, the Committee found petitions in order for M. J. Caveney, VE3GG, Leonard W. Mitchell, VE3AZ and Alex Reid, VE2BE. Messrs. Mitchell and Reid were found eligible under the terms of the League by-laws but Mr. Caveney was declared ineligible because of the fact that League records disclosed he had not been, as required, a member of the League continuously for four years prior to the time of receipt of his nomination. The Committee thereupon, upon motion, declared Messrs. Mitchell and Reid eligible and ordered their names listed on the ballots to be sent to members of the League in Canada.

For alternate Canadian General Manager, the Committee found petitions for Alex Lariviere, VE2AB and John C. Stadler, VE2AP. Thereupon, both candidates being found eligible, the Committee, on motion, ordered their names listed on the ballots to be sent to Canadian members.

#### *Dakota Division*

For director, the Committee found petitions in good order for Frank A. Wowles, W9BBL, Earl R. Thornburg, W9EU and Fred W. Young, W9MZN. Mr. Thornburg was found to be ineligible, but both Mr. Wowles and Mr. Young were declared eligible and, upon motion, their names ordered to be listed on ballots to be sent to members.

For alternate director, the Committee found petitions in order for Adolph A. Emerson, W9ITQ, W. F. Soules, W9DCM, and Fred W. Young, W9MZN. The Committee was in receipt of a written communication from Mr. Young withdrawing his name as a candidate for alternate director. Upon examination it was found that both Mr. Emerson and Mr. Soules were ineligible under the terms of the by-law requiring continuous League membership for a period of at least four years prior to the receipt of their nomination, whereupon the Committee declared "no election" for alternate director in the Dakota Division.

#### *Delta Division*

For director, the Committee found a petition for but one candidate, the incumbent, E. Ray Arledge, W5SI but was obliged to declare Mr. Arledge ineligible under the terms of the by-law requiring continuous League membership for four years prior to the time of nomination. Thus, there is no election for director in the Delta Division.

For alternate director, the Committee found a petition for but one candidate, E. H. Treadaway, W5DKR. Whereupon, Mr. Treadaway being eligible, he was, on motion, declared duly elected as the alternate director of the Delta Division for the 1938-1939 term.

#### *Midwest Division*

For director, the Committee found a petition for but one candidate, the incumbent, Floyd E. Norwine, Jr., W9EFC. He being found eligible, the Committee, on motion of Mr. Hebert, declared him duly reflected as the director of the Midwest Division for the 1938-1939 term.

No petitions were received for alternate director.

#### *Pacific Division*

For director, the Committee found a petition for but one candidate, J. L. McCargar, W6EY. He being found eligible, the Committee on motion of Mr. Bailey, declared him duly elected as director of the Pacific Division for the 1938-1939 term.

For alternate director, the Committee found a petition for Elbert Amarantes, W6FBW and none for any other person. Whereupon, Mr. Amarantes being found eligible, he was, on motion of Mr. Handy, declared duly elected as the alternate director of the Pacific Division for the 1938-1939 term.

#### *Southeastern Division*

For director, the Committee found a petition for but one candidate, the incumbent, Bennett R. Adams, Jr., W4APU. He being found eligible, the Committee, on motion of Mr. Bailey, declared him duly reflected as the director of the Southeastern Division for the 1938-1939 term.

For alternate director, the Committee found a petition for Mr. S. J. Bayne, W4AAQ, the incumbent and none for any other person. Whereupon, Mr. Bayne being eligible, he was, on motion of Mr. Hebert, declared duly reflected as the alternate director for the Southeastern Division for the 1938-1939 term.

— . . . —

The Committee then proceeded to an examination of the matter of Headquarters Memorial Station, W1AW, first examining the plans submitted by architects for the proposed structure. After discussion, on motion of Mr. Bailey, the Committee voted to select and approve the plans and specifications dated October 25, 1937, as submitted by Isaac A. Allen, Jr., and Charles A. Allen, Architects, of Hartford.

Mr. Handy reported that he had been in receipt of a number of sealed bids from various contractors for plumbing, heating, electrical work, and station building and grading, and proposed that these bids be opened and examined. This was done. Extended discussion thereupon took place on the whole question of the proposed new W1AW, it being brought out by the President that the Board in its recent mail vote had expressed itself 11 to 6 in favor of proceeding with the new building on the basis recently outlined by Mr. Handy in his letter accompanying Secretary's Letter No. 358. It was found that the lowest bid in each case tallied more than the amount previously estimated by Mr. Handy. After extended discussion, the Committee although mindful of the favorable expression of a majority of the Board, was of the belief that the question should be resubmitted to the Board for additional expression of opinion on the basis of actual bids now available, both because the bids appeared to exceed the previous estimate and in response to demand from several directors for the specific bids. On motion of Mr. Bailey, and by unanimous vote, the Acting Secretary was directed to present this matter to the directors by letter for their further consideration and to solicit a mail expression from each.

Without action, the Committee discussed a proposed QSO Party (for League members only) proposed by Mr. Handy to be held some time after the first of the year, and listened to a brief résumé of the Segal-Smith hearings from the Acting Secretary, who had been in attendance.

The meeting adjourned at 6:45 P.M.

A. L. BUDLONG,  
Acting Secretary.

#### MINUTES OF EXECUTIVE COMMITTEE MEETING

No. 150

December 20, 1937

The Executive Committee of the American Radio Relay League, Inc., met at the headquarters office of the League in

West Hartford, Conn., at 2 P.M., December 30, 1937, with full attendance: President E. C. Woodruff in the chair, Vice-President G. W. Bailey, Treasurer A. A. Hebert, Communications Manager F. E. Handy and Secretary K. B. Warner. Assistant Secretary A. L. Budlong was also present.

Constituting itself a committee of tellers as prescribed in the by-laws, the Committee proceeded to an examination of the ballots cast in the 1937 elections. To aid in this work it appointed as clerks of the Committee C. B. DeSoto, Byron Goodman, C. C. Rodimon, D. H. Mix, Charles Brunelle, E. L. Batty, H. A. Bubbs, Grace Heley, and Catherine Craig. Carefully opening and counting the ballots cast, the committee found as follows:

*Atlantic Division*

*For Director:*

For Roy C. Corderman, W3ZD . . . . .	281 votes
For Walter Bradley Martin, W3QV . . . . .	679 votes
For Edward L. Thompson, W3CQS . . . . .	79 votes
Invalid ballots . . . . .	42

*For Alternate Director:*

For Raymond E. Macomber, W3CZE . . . . .	540 votes
For Herbert M. Walleze, W8BQ . . . . .	495 votes
Invalid ballots . . . . .	42

*Canadian Section*

*For Canadian General Manager:*

For Leonard W. Mitchell, VE3AZ . . . . .	114 votes
For Alex Reid, VE2BE . . . . .	202 votes
Invalid ballots . . . . .	31

*Alternate Canadian General Manager:*

Balloting had taken place between John C. Stadler, VE2AP, and Alex Lariviere, VE2AB, but after the listing of the names on the ballots, Mr. Stadler withdrew his name. Accordingly, upon advice of the General Counsel, the balloting by the members was disregarded and not counted, and Alex Lariviere, as the only eligible candidate, was declared duly elected as Alternate Canadian General Manager for the two-year term of office commencing at noon on January 1, 1938.

*Dakota Division*

*For Director:*

For Frank A. Vowles, W9BBL . . . . .	57 votes
For Fred W. Young, W9MZN . . . . .	127 votes
Invalid ballots . . . . .	11

Whereupon, the count being completed, the clerks retired from the meeting with the thanks of the Committee. Secretary Warner withdrew from the meeting for the purpose of preparing a statement of certification by the Committee of Tellers, and Assistant Secretary A. L. Budlong assumed the recording.

The Assistant Secretary presented a telegram just received from C. D. Tuska calling attention to a "New York Times" item, mentioning that the new headquarters station was being erected to the memory of Mr. Maxim as founder and first president of the League; Mr. Tuska requested that if this statement resulted from any press release by the League, a list of papers to whom sent be furnished and a correction issued stating that Mr. Maxim was only a cofounder. No action was taken by the Committee, it being the sentiment of the members that since the policy with respect to Mr. Tuska had already been defined by the Board at its 1937 meeting, the matter was one for routine handling by the headquarters.

The Committee received from the Assistant Secretary the file of Director responses on the subject of a 1938 national convention (Secretary's Letter No. 362). It was found that the following had expressed themselves in favor of holding a national convention in 1938 and had pledged themselves to vote for such amendments to the by-laws as might be necessary to bring this about, at the next meeting of the Board: Messrs. Adams, Arledge, Bailey, Blalack, Caveness, Hill, Jabs, Mathews, Noble, Norwine, Stockman and Woodruff—total, 12. Opposed to making a decision at this time and in favor of leaving the question until the next Board meeting: Messrs. Gibbons, Groves, Martin and Reid—total, 4. Mr. Culver had requested a copy of counsel's opin-

ion on this subject before making a decision and his expression had not yet been received. Of the 12 in favor of a 1938 national convention, 11 favored acceptance of the bid from the Chicago Area Radio Club Council; Mr. Hill believed this should be left until the Board meeting for decision.

The Committee proceeded to an examination of these expressions, in order to determine if it is now possible to forecast the action of the Board next year on the subject. It was found that a two-thirds vote of the Board—12 votes—is required to amend by-laws. The Committee felt it had to bear in mind in its deliberations that Mr. Jabs would not be present at the meeting next year but would be replaced by Fred W. Young, W9MZN; Mr. Budlong reported he had undertaken to obtain expressions on the national convention question from both candidates in the Dakota elections prior to the election and that the new director, Mr. Young, had expressed himself as opposed to making a decision on a 1938 national convention at this time.\* It was also determined from Cushing's Manual that the President may vote when his vote will make or break a tie, but not otherwise. These two considerations indicated that the vote as of the next Board meeting would be 10 in favor to 5 opposed, two votes short of the two-thirds majority required to amend by-laws; on the matter of awarding the bid to Chicago there would be only 19 votes in favor, a bare majority. After discussion, therefore, on motion of Mr. Hebert, it was unanimously voted that the Executive Committee, feeling that the future action of the Board with respect to a national convention in 1938 cannot now be forecast and that the matter must be left for consideration of the Board at its next meeting, and feeling, therefore, that no decision can be made at this time with respect to acceptance of the bid of the Chicago Area Radio Club Council for the holding of such possible convention, instructs the Secretary so to advise the Council in a letter which will fully explain the reasons underlying the Committee's action; and that the question is scheduled in the agenda for the determination of the Board at its 1938 meeting.

Mr. Warner here returned to the meeting and resumed the recording, whereupon Mr. Budlong withdrew from the meeting. The Committee thereupon executed a certificate filed in the archives of the League, declaring Walter Bradley Martin duly elected as director, and Raymond E. Macomber as alternate director, of the Atlantic Division; Alex Reid duly elected as Canadian General Manager; and Fred W. Young duly elected as director of the Dakota Division; all for a term of two years, commencing on noon on January 1, 1938.

On motion of Mr. Hebert, approval was granted by unanimous vote for the holding of a New England Division Convention at Hartford, Conn., on May 21-22, 1938, under the auspices of the Hartford County Amateur Radio Association.

On motion of Mr. Handy, and by unanimous vote, approval was given on application for affiliation from the Dells Region Radio Club, Wisconsin Dells, Wis., subject to the approval of Director Mathews and to be effective upon date of the receipt at this office of such approval. On the further motion of Mr. Handy, and by unanimous vote, affiliation was granted the following societies:

- Queen Anne High School Radio Club, Seattle, Wash.
- Winnipeg Radio Club . . . . . Winnipeg, Man., Can.
- Southeastern New Mexico Amateur Radio Club . . . . . Carlsbad, N. M.
- Albuquerque Communications Club . . Albuquerque, N. M.
- Loyalist City Amateur Radio Club . . St. John, N. B., Can.

Mr. Handy reported satisfactory progress on W1AW, contracts signed, builders working, ground broken, footings in, foundation to be finished in ten days, all work estimated to be completed by April 1st. At Mr. Handy's request, the Committee gave him counsel on certain matters:

Language for the memorial tablet was discussed and agreed upon.

\* After his election, Mr. Young explained that his belief that the subject should be deferred to the board meeting did not mean he was opposed to such conventions, and at his request this information was conveyed to the other members of the board.—Secretary.

On motion of Mr. Bailey, it was unanimously voted that the Communications Manager is authorized to have appropriate iron bars placed on all the windows at an estimated cost of \$140.00, and to install screens on doors and windows, and to install a cornerstone bearing the date of the building, and that the Board of Directors is requested to appropriate additional funds for these small extras at its meeting next May, over the previous authorization.

On motion of Mr. Bailey, the Communications Manager was authorized to depart from the approved design so as to arrange for six windows at the rear of the building instead of five as shown on the sketch, provided this modification can be made without additional cost.

On motion of Mr. Bailey, the Communications Manager was authorized to arrange for appropriate public liability insurance for the W1AW property.

There being no further business, the Committee adjourned at 5:11 P.M.

K. B. WARNER,  
A. L. BUDLONG,  
*Secretaries.*

MINUTES OF EXECUTIVE COMMITTEE MEETING  
No. 151

March 5, 1938

The Executive Committee of the American Radio Relay League, Inc., met at the headquarters office of the League in West Hartford, Conn., at 10:00 A.M., March 5, 1938, with the following present: President E. C. Woodruff in the chair, Vice-President G. W. Bailey, Treasurer A. A. Hebert, Communications Manager F. E. Handy and Acting Secretary A. L. Budlong. Preceding the meeting, the President and Vice-President had paid a visit to the site of W1AW, accompanied by the Communications Manager and Acting Secretary, for the purpose of inspecting work done up to this time.

Mr. Budlong presented to the Committee information collected by a headquarters committee which had made a study of possible candidates for A.R.R.L. nomination for the Paley Award. After discussion and an examination of the facts, on motion of Mr. Bailey, it was unanimously VOTED that the League's nominee for the Paley Award for 1937 is Robert T. Anderson, W9MCW, of Harrisburg, Ill., for his services in the Ohio River flood emergency of 1937.

On motion of Mr. Hebert, applications to hold A.R.R.L. conventions were approved as follows:

Maritime Division, at St. John, N. B., September 3-4-5, auspices of Loyalist City Amateur Radio Club.

Hudson Division, at New York City, June 17-18, auspices of a special convention committee approved by Director Hill.

On motion of Mr. Hebert the Committee by unanimous vote RATIFIED its previous informal approval of the following conventions:

West Gulf Division, at Carlsbad, N. M., August 25-26-27, auspices the Southeastern New Mexico Amateur Radio Club.

Atlantic Division, at Washington, D. C., June 24-25, auspices the Washington Radio Club.

Roanoke Division, at Winston-Salem, N. C., September 3-4, auspices the Winston-Salem Amateur Radio Club.

On motion of Mr. Handy, affiliation was GRANTED by unanimous vote, to the following societies:

Hamfesters Radio Club, Inc. . . . . Chicago, Ill.  
Enid Amateur Radio Club . . . . . Enid, Okla.  
Salisbury Amateur Radio Operators Club, Salisbury, N. C.  
Baton Rouge Amateur Radio Club . . . . . Baton Rouge, La.  
Fostoria Wireless Association . . . . . Fostoria, Ohio  
The Oakland County Radio Club . . . . . Pontiac, Mich.  
The York Radio Club . . . . . Elmhurst, Ill.  
Ventura County Radio Club . . . . . Ventura, Calif.  
South Eastern Nebraska Radio Club . . . . . Auburn, Nebr.

On further motion of Mr. Handy, reaffiliation was GRANTED the Fall River Amateur Radio Club, of Fall River, Mass., which had been disaffiliated last year when it fell below the required standards regarding percentage of

League members but which had since complied with such requirements and had applied for such reaffiliation.

Mr. Handy rendered a detailed report on the status of W1AW; he informed the Committee, among other things, that completion of the building had already been delayed about two weeks beyond the original contemplated date of April first by a prolonged spell of bad weather. The Committee thereupon discussed both W1AW and other matters without, however, taking any formal action thereon.

There being no further business, the Committee adjourned at 1:03 P.M.

A. L. BUDLONG,  
*Acting Secretary.*

— . . . . —

ECW8CMP  
Honored

At the banquet of the Hudson Division convention in New York on June 18th, Dr. Woodruff, our president, was awarded the gold Marconi Memorial Medal of Service by the Veteran Wireless Operators Association. The presentation was made by Mr. William J. McGonigle, president of the V.W.O.A. The citation states that the award is made to Dr. Woodruff "for his outstanding work in amateur radio, as an amateur and as an elected representative of amateurs for many years." Through him, the citation continues, the V.W.O.A. wishes to recognize "the splendid achievements of amateurs in furthering the progress of radio and the heroic efforts of many amateurs in time of emergency."

The V.W.O.A. is an organization of professional operators which has long had the custom of recognizing meritorious service rendered by wireless operators on land or sea. Earlier recipients of their gold medals have included Marconi, Anne Lindbergh and many an heroic sea-going operator. The presentation to Dr. Woodruff was broadcast over a nationwide N.B.C. net.

Northwestern Division Convention

August 27th and 28th at Sunrise Park,  
Rainier National Park, Washington

THE thirteenth annual convention will again be held at Sunrise Park, Rainier National Park. Registration fee is \$2.50 which includes a banquet Saturday evening. A pre-registration prize for registering before August 1st will be given. Information will be needed when you send in your registration as to whether or not you will want a cabin and whether with or without bedding. Cabins accommodate two persons and cost \$2.00 without or \$3.00 with bedding per night. Cabins are paid for at the Park. The Park can be reached by stage from Yakima and Tacoma for those who are not traveling by automobile. There is an admission fee of \$1.00 per car, regardless of the number of occupants.

Mail, express, telegraph, telephone or get your ticket and information from Harold W. Johnston, W7DXF, P. O. Box 527, Pendleton, Oregon, who is the convention secretary.

Remember the dates—August 27th and 28th.

# With the Affiliated Clubs

AT the 1938 Meeting of the A.R.R.L. Board of Directors it was voted "to create a recognition of the affiliated clubs having 100 per cent League membership by periodically listing in *QST* those affiliated societies whose entire membership consists of members of the League." Accordingly, an "honor roll" of affiliated clubs possessing this qualification has been established. The first listing is presented this month.

## The Affiliated Club Honor Roll

All members of these clubs are A.R.R.L. members

Bridgeport Amateur Radio Association, Bridgeport, Conn.  
 Chester Radio Club, Chester, Pa.  
 Huron Radio Club, Huron, S. Dak.  
 Kaw Valley Radio Club, Topeka, Kansas  
 New Orleans Radio Club, New Orleans, La.  
 Northern Nassau Wireless Association, Manhasset, L. I., N. Y.  
 O.B.P., Chapter No. 1, St. Louis, Mo.  
 Pendleton Amateur Radio Club, Pendleton, Oregon  
 The Portland Sevens, Portland, Oregon  
 Trenton Radio Society, Trenton, N. J.  
 Valley Radio Club, Eugene, Oregon  
 York Radio Club, Elmhurst, Ill.  
 York Road Radio Club, Glenside, Pa.

## AFFILIATED CLUB STATIONS

A study of the files of active affiliated-societies reveals many club-owned and operated amateur radio stations. In order that operators at club stations may better know other club-groups "on the air," we list here the calls of stations operated by A.R.R.L.-affiliated organizations. If the call of your club station does not appear, send us a QSL-card telling us so. Supplementary lists will appear from time to time. Keep an up-to-date list at the operating position of your society's station to further radio contacts between the affiliated bodies.

VE1LC Loyalist City Amateur Radio Club  
 VE1MK Halifax Amateur Radio Club  
 VE2DN Les Amateurs Canadiens-Francais de la TSE  
 VE3AJV Frontier Radio Club  
 VE4AAA Saskatoon Amateur Radio Club  
 VE4JI Winnipeg Radio Club  
 VE5EZ Victoria Short Wave Club  
 W1ACT Fall River Amateur Radio Club  
 W1AQ Associated Radio Amateurs of Southern New England  
 W1BKQ Worcester Radio Association  
 W1BWY Springfield Radio Association  
 W1CBA Connecticut Brasspounders Association  
 W1GIB New Haven Amateur Radio Association

W1FTS Hoosac Valley Radio Club  
 W1INM Providence Radio Association, Inc.  
 W1IXF New Bedford Amateur Radio Association  
 W1JHT Bridgeport Amateur Radio Association  
 W1JJO Holyoke Amateur Radio Club  
 W1JRQ Tri-State Amateur Radio Club  
 W1JUD Trinity College Radio Club  
 W1KVI The Portland Amateur Wireless Association  
 W1MX M.I.T. Radio Society  
 W1ZO Fellsway Radio Club  
 W2AOC Williamsburg Radio Club  
 W2GYR Intercity Amateur Radio Club  
 W2GZP Mid-Hudson Amateur Radio Club  
 W2HHE Bronx Radio Club  
 W2HJ City College Radio Club  
 W2JC Bloomfield Radio Club  
 W2JIQ Tuboro Radio Club  
 W2JLJ The Tri-County Radio Association, Inc.  
 W2SV Sunrise Radio Club  
 W3ADO Amateur Radio Club of U. S. Nava Academy  
 W3BKQ Chester Radio Club  
 W3BKX Frankford Radio Club  
 W3DBI Petersburg Short Wave Club  
 W3EDU York Amateur Radio Club  
 W3ESR Peninsula Amateur Radio Club  
 W3GKI Tri-States Radio Club  
 W3GWN The Staunton Amateur Radio Club  
 W3HEB Greater Camden Amateur Radio Association  
 W4AWO Lake Worth Radio Club  
 W4CIQ Mobile Amateur Radio Club  
 W4CUE The Birmingham Amateur Radio Club  
 W4CZU Charlotte Amateur Radio Association  
 W4DUG Tampa Amateur Radio Club, Inc.  
 W4EXU Salisbury Amateur Radio Operators Club  
 W4NC The Winston-Salem Amateur Radio Club  
 W5DPA Houston Amateur Radio Club  
 W5DYR New Orleans Radio Club  
 W5FPO Short Wave Amateur Club of America  
 W6MGJ Helix Amateur Radio Club  
 W6OT Oakland Radio Club, Inc.  
 W6SV Santa Clara County Amateur Radio Association  
 W7ADF Casper Radio Amateurs' Club  
 W7AJW Portland Sevens  
 W7AOK Broadway High School Radio Club  
 W7BMW Pendleton Amateur Radio Club  
 W7BPY Queen Anne High School Radio Club  
 W7COE Electric City Radio Club  
 W7DK Radio Club of Tacoma, Inc.  
 W7EPN Olympia Radio Club  
 W7GN Roosevelt High Radio Club  
 W8APJ Bluffton Radio Club  
 W8HXT Ludington Amateur Radio Association  
 W8LEC Gratiot County Amateur Radio Association  
 W8INE Boys' Club of St. Marys Amateur Radio Society  
 W8KYC Marietta Amateur Radio Society  
 W8LMT The Mohawk Valley Brass Pounders  
 W8MRM Motor City Radio Club, Inc.  
 W8NLG Detroit Amateur Radio Association  
 W8NTD Lycoming Radio Association  
 W8ODJ The Buckeye Short Wave Association  
 W8ON Jamestown Amateur Radio Association  
 W8OVE Cleveland Heights Amateur Radio Club  
 W8QLU Mike & Key Club of Ithaca  
 W8QWH The Amateur Radio Communications Society  
 W9AIU Egyptian Radio Club  
 W9IXR Northern Wisconsin Radio Club  
 W9KEM Hannibal Amateur Radio Club  
 W9MWJ Tri-Town Radio Amateur Club  
 W9NAA Rose Tech Radio Club  
 W9OKY Pikes Peak Amateur Radio Association  
 W9QHA Elkhart Amateur Radio Club  
 W9TFA Hamfesters Radio Club, Inc.

(Continued on page 78)

# Improving the Stability of the E. C. O.

## New Circuits Provide Greater Frequency-Generator Isolation

INTEREST in electron-coupled oscillators for transmitter frequency control is definitely increasing. And, as always, when an idea takes root in amateur circles, improvements usually are not long in coming to the front. In this case, we have two versions of an electron-coupled oscillator circuit which promise improved stability in the frequency-generating section and greater independence between this circuit and those which follow it.

The circuit resembles that of a push-pull, or perhaps more closely, that of the push-push arrangement. The operation apparently differs from that of either, however.

### A Two-Tube E. C. O.

By H. N. Beveridge, VE2KX<sup>1</sup>

THE circuit shown in Fig. 1 was developed during some experimental work on 28 Mc. last summer while attempting to secure satisfactory frequency stability with an electron-coupled oscillator at that frequency. It will be noticed that the circuit somewhat resembles a push-push arrangement. The plate circuit is tuned to twice the frequency of oscillation, therefore it is unnecessary to shield this circuit from the grid circuit. With the frequency-generating circuit operating at 14 Mc., it is possible to obtain sufficient output from a pair of 59's to drive an RK-23 at 28 Mc. with frequency stability approaching very closely that of a crystal-controlled transmitter. The improvement over the usual single-ended circuit is decidedly marked.

In the final arrangement, the oscillator and RK-23 amplifier were assembled upon one chassis, as shown in the photograph, to form an exciter which might be used to drive a higher-power final amplifier. The oscillator was completely enclosed in an aluminum box to shield its output circuit from that of the RK-23. Careful shielding is extremely important here if self-oscillation is to be avoided when the RK-23 is operated as a straight amplifier at 28 Mc. Within the shield box are the oscillator grid and plate coils and the two oscillator tubes. The coils for the oscillator, with the exception of the plate coils for 28 and 1.7 Mc., are wound on discarded tube bases. The 28-Mc. coil is self-supporting, while the 1.7-Mc. coil is wound on a  $1\frac{3}{8}$ " diameter receiving coil form. The amplifier tube and plate coil may be seen outside the shield box at the right-hand end

of the chassis. A link is provided to couple the output to an antenna coupler or a following stage.

All tuning condensers are located beneath the chassis. The controls, left to right, are: The oscillator band-spread tuning condenser; oscillator padding condenser; oscillator plate tuning condenser; amplifier excitation control, and amplifier plate tuning condenser. The oscillator padding condenser is a two-unit gang of the type used frequently in small broadcast receivers. The band-spread condenser is tapped across a small portion of the oscillator grid coil at its center to permit tuning over a range of 25 to 50 kc. either

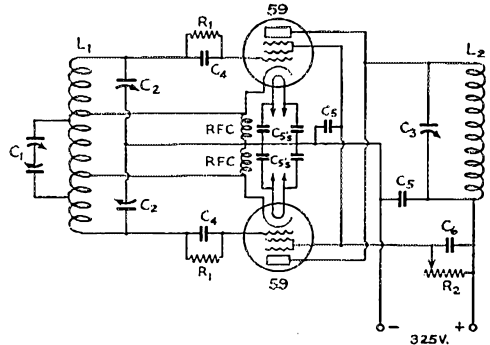

FIG. 1—THE ELECTRON-COUPLED CIRCUIT USED BY VE2KX

An amplifier is capacity-coupled to plate circuit.

- |  |  |
|--|--|
| C <sub>1</sub> —75 $\mu$ fd. per section.                                      | C <sub>5</sub> —0.01- $\mu$ fd. paper, 600-volt. |
| C <sub>2</sub> —350 $\mu$ fd. per section (broadcast-receiver, two-unit gang). | C <sub>6</sub> —0.1- $\mu$ fd. paper, 600-volt.  |
| C <sub>3</sub> —100 $\mu$ fd.  | R <sub>1</sub> —60,000 ohms.                     |
| C <sub>4</sub> —250- $\mu$ fd. mica.   | R <sub>2</sub> —50,000 ohms.                     |

- L<sub>1</sub>—1.7-Mc. output—90 turns No. 28 enam.,  $1\frac{3}{8}$ " diam., close-wound; cathode taps at 30 turns from each end; bandspread condenser across  $\frac{1}{2}$ " of winding at center.
- 3.5-Mc. output—30 turns No. 28 d.s.c.,  $1\frac{3}{8}$ " diam., close-wound; cathode taps at 7 turns from each end; bandspread condenser connected across  $\frac{1}{8}$ " of winding at center.
- 7-Mc. output—20 turns No. 28 d.s.c.,  $1\frac{3}{8}$ " diam., close-wound; cathode taps at 7 turns from each end; bandspread condenser connected across approx. 3 turns at center.
- 14-Mc. output—12½ turns No. 20 d.c.c.,  $1\frac{3}{8}$ " diam., close-wound; cathode taps at 4 turns from each end; bandspread condenser connected across  $1\frac{1}{8}$ -turn closely-coupled loop at center.
- 28-Mc. output—9½ turns No. 16 d.c.c.,  $1\frac{3}{8}$ " diam., close-wound; cathode taps at 3 turns from each end; bandspread condenser connected across  $\frac{5}{8}$ -turn closely-coupled loop at center.
- L<sub>2</sub>—1.7-Mc.—45 turns No. 28 enam.,  $1\frac{3}{8}$ " diam., close-wound.
- 3.5-Mc.—23 turns No. 28 enam.,  $1\frac{3}{8}$ " diam., close-wound.
- 7-Mc.—18 turns No. 28 d.s.c.,  $1\frac{3}{8}$ " diam., close-wound.
- 14-Mc.—6½ turns No. 16 d.c.c.,  $1\frac{3}{8}$ " diam., close-wound.
- 28-Mc.—5 turns No. 10 enam.,  $\frac{3}{4}$ " diam.,  $\frac{1}{2}$ " long.

<sup>1</sup> P. O. Box 57, Lachute Mills, Que.

side of any frequency determined by the setting of the padding condenser. At 14 and 28 Mc., the band-spread condenser is connected across a loop tightly coupled to the grid coil at its center. At the lower frequencies connection is made directly to the turns of the grid coil itself. The excitation control is in the form of a variable series resistor in the oscillator screen circuit.

The socket for the RK-23 is also sunk below the surface of the chassis and a short cylindrical shield extends from the chassis level to a line even with the lower edge of the plate of the tube. All by-pass condensers and r.f. chokes are located underneath the chassis. Closed circuit jacks are provided for each circuit so that a milliammeter may be plugged in any of them for tuning or checking plate or grid currents.

In tuning,  $C_1$  and  $C_2$  determine the frequency.  $C_3$  should be tuned for the dip in plate current. During last winter, about 200 contacts were made on 28 Mc.

## An E.C.O. of High Stability and Output

By William Guimont, W9JID<sup>2</sup>

IT is the purpose of this article to describe a new type electron-coupled oscillator which was developed during the course of some work

<sup>2</sup> Highway 3, Champlin, Minn.

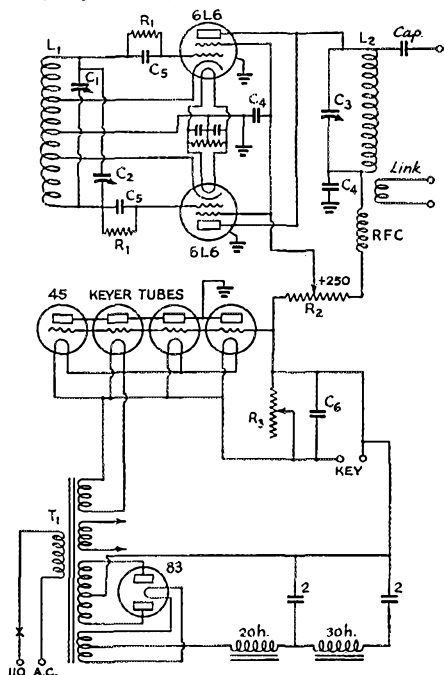

FIG. 2—THE CIRCUIT USED BY W9JID

A single-section tank condenser is used. The tube keying system eliminates all key clicks.

with the e.c.o. in connection with the construction of a transmitter for traffic work. It has proved to be superior in stability to the commonly-used single tube arrangement and the use of tubes such as the 6L6 permits appreciably greater power output from the oscillator than is normally obtained from an oscillator of this type. The circuit is shown in Fig. 2. A single-section 260- $\mu$ fd. condenser provides the necessary high capacity in the grid-screen circuit. A 25- $\mu$ fd. condenser in parallel with this permits a change in frequency of about 50 kc. without change in the setting of the main tank condenser. Since the oscillator has been built up as a separate unit and installed on the operating table this small change in frequency is about all that can be used, because a greater change will necessitate retuning the other stages of the transmitter located, in this case, several feet from the operating position.

In the course of adjustment, it was found that best stability is obtained with a small amount of excitation, therefore the cathode tap is placed very close to the center-tap of the coil. Although 6L6's have worked out very satisfactorily, it is possible that RK49's would be slightly better.

It will be noticed that a tube keying system is included in the circuit diagram. This keying system is highly recommended and has resulted in absolutely clickless keying even when working break-in close to the operating frequency.

## A Stabilized E. C. Oscillator

By John Scoville, W7FUW<sup>3</sup>

I HOPE that the diagram of Fig. 3 and the brief description which is to follow will be of benefit to those hams who may find themselves in circumstances similar to mine. I work hard to get the little rig perking right and sit down to try to work someone, only to listen on my frequency just in time to hear some guy say something like this: "Ok, OM, and tnx fer the call. Rig hr is 999 watts to a pr of 250TH's." Well, the evening is conked for me then and I can twiddle my thumbs. I don't blame the fellow with 999 watts, for I'd have that much too if I could afford it, but it is surely tough on the fellow with a small outfit. Well, the upshot of it is that I turned to the electron-coupled oscillator to solve my problem. Here is a description of the results which followed my efforts.

I tried the standard oscillator first. It worked fairly well and I received "xtal" reports about half of the time. But, I couldn't work break-in and did not even attempt 'phone because most e.c. rigs I have heard are not so hot. Then I tried push-pull e.c.o. with no better results until I arrived at the idea of the circuit shown in Fig. 2.

<sup>3</sup> Lakeview, Oregon.

Its success is dependent chiefly upon the unique construction of the grid coil.

In this special circuit, a pair of 24A's is used. The grids are in two separate circuits and the plates are connected in parallel. Because of incomplete internal shielding, 6L6's will not work satisfactorily. The types 802, RK-25 or 807 should be satisfactory if greater output from the oscillator is desired.

The construction must be very solid and the frequency-generating and output circuits very well shielded. In our construction, we took two 4" by 7" by 5" cans, which we happened to have, and soldered the bases together, bottom to bottom. Then we mounted the parts inside with the tubes and grid circuit components on one side of the partition and the plate circuit components on the other side. One reason for the necessity for complete shielding is that for 1.7-Mc. output, the frequency-generating circuit works on some frequency between 900 and 1000 kc. which might

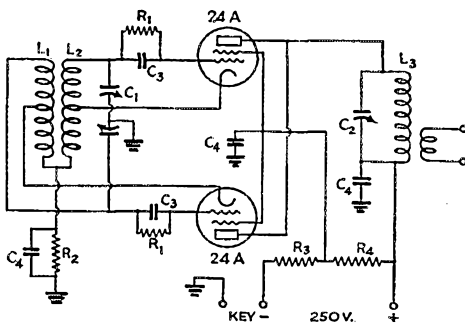
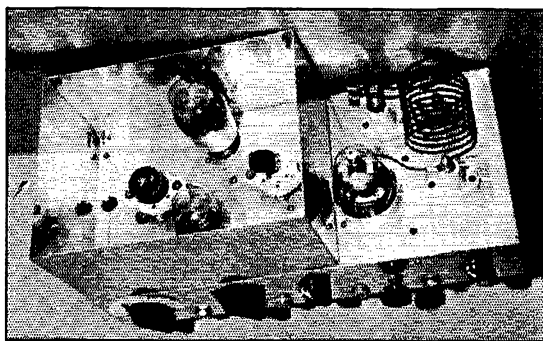

FIG. 3—THIS CIRCUIT, BY W7FUW, IS SIMILAR IN ESSENTIALS TO FIGS. 1 AND 2, BUT A SPECIAL TYPE OF GRID COIL IS USED

- |                                   |                         |
|-----------------------------------|-------------------------|
| $C_1$ —350 $\mu$ fd. per section. | $R_2$ —200 ohms.        |
| $C_2$ —100 $\mu$ fd.              | $R_3$ —75,000 ohms.     |
| $C_3$ —250 $\mu$ fd.              | $R_4$ —30,000 ohms.     |
| $C_4$ —0.25 $\mu$ d. or larger.   | $L_1, L_2$ —(See text). |
| $R_1$ —30,000 to 100,000 ohms.    |                         |

- 1.7-Mc. output—approx. 45 turns each coil No. 28 d.s.c.  $1\frac{1}{2}$ " diam.,  $1\frac{1}{2}$ " long.  
 3.5-Mc. output—approx. 25 turns each coil No. 28 d.s.c.,  $1\frac{1}{2}$ " diam.,  $1\frac{1}{2}$ " long.  
 7-Mc. output—approx. 12 turns each coil No. 28 d.s.c.,  $1\frac{1}{2}$ " diam.,  $1\frac{1}{2}$ " long.  
 14-Mc. output—approx. 6 turns each coil No. 28 d.s.c.,  $1\frac{1}{2}$ " diam.,  $1\frac{1}{2}$ " long.  
 $L_3$ —1.7-Mc.—55 turns No. 28 d.s.c.,  $1\frac{1}{2}$ " diam.,  $1\frac{1}{2}$ " long.  
 3.5-Mc.—30 turns No. 28 d.s.c.,  $1\frac{1}{2}$ " diam.,  $1\frac{1}{2}$ " long.  
 7-Mc.—20 turns No. 20 d.s.c.,  $1\frac{1}{2}$ " diam.,  $1\frac{1}{2}$ " long.  
 14-Mc.—10 turns No. 20 d.s.c.,  $1\frac{1}{2}$ " diam.,  $1\frac{1}{2}$ " long.



THE COMPLETED EXCITER UNIT SHOWING SHIELDING OF OSCILLATOR

The RK-23 amplifier circuit is conventional.

easily get into neighboring broadcast receivers. If one desires, the grid circuit may be operated at 450 kc. and the fourth harmonic picked off in the plate circuit. The output should be sufficient to drive a buffer such as ours, in which a pair of 6L6's is used.

The construction of the coils  $L_1$  and  $L_2$  requires special attention. Both are wound on the same  $1\frac{1}{2}$ " diameter form.  $L_1$  is wound first, then  $L_2$  is wound over  $L_1$  but in the opposite direction. Grid connections are made to the top ends of both coils. The wire with which the coils for the higher frequencies are wound must be small enough to permit space-winding, otherwise the capacity between coils may result in reduced output.

To check the operation, the plate circuit should be tuned to resonance as indicated by the buffer grid current. Then, touch the oscillator grid caps, one at a time, with a finger. The output, as indicated by buffer grid current, should decrease by the same amount for each tube. If one of the tubes is removed, the circuit will still oscillate,

but with much reduced output and stability. If each circuit is adjusted, with one tube at a time, so that the same frequency falls at the same dial setting with either tube, the output will be highest, but the stability will not be maximum. If one of the coils is adjusted so that the same frequency falls at a slightly different setting of  $C_1$  the stability is greatly improved and approaches very closely that of a crystal. The two circuits lock together, one pulling one way and the other the other. Loading, or tuning any condenser except that in the frequency-generating circuit, will have no more effect upon frequency than it would with a crystal oscillator, and the oscillator may be keyed as readily for break-in work. There will be less drift in frequency from changes in temperature if a high value of tuning capacity is used in the grid circuit; otherwise, there seems to be little advantage in the higher capacity. Changes in electrode voltages seem to have no practical effect upon the frequency although they do have influence upon the power output, of course.

This oscillator has been used on all bands from 1.7 to 28 Mc., 'phone and c.w., and I have yet to receive anything less than a 'T9 report. It has solved my problem when I have found myself blanketed out and it has enabled me to finish many a QSO which would have been lost otherwise. So I am passing it along to other hams.



## ● ARMY-AMATEUR RADIO SYSTEM ACTIVITIES ●

THE Florida nets of the Fourth Corps Area A.A.R.S. are particularly interesting because of the numerous times they have furnished emergency communications during the annual hurricane season. Members of these nets are veterans in emergency work, which dates back over a period of ten years, with many instances of outstanding individual accomplishment. These years of experience have taught the members of the Florida nets the necessity of proper organization and preparedness, hence they keep their net organizations active during all except six weeks of the year. Drills are attended regularly each week, not particularly for the individual pleasure derived, but because the members realize that this preparation will be rewarded by more efficient operations during emergency and a better service to the public.

In order to provide several channels for moving traffic in and out of a stricken area, there are four nets operated in the state, two on 'phone and two on c.w. In addition key stations are equipped to operate on c.w. on a National Guard frequency of 4035 kc., in addition to the two special A.A.R.S. frequencies of 3497.5 and 6990 kc. Each net is state-wide and is under the supervision of its Net Control Station, which is responsible to the State Net Control Station.

In the present set-up, W4AWO/WLRO/WXXKJ, located halfway down the east coast of Florida, acts as State Net Control Station, exercising general supervision of net activities and shouldering the responsibility of drill reports to the Fourth Corps Area Headquarters. This station is located in a storm-proof building with a transmitter on 80-meter c.w., another on 80-meter 'phone, and another on 40-meter c.w. Power for all three is supplied by a 2½-kilowatt gasoline-driven emergency power supply. There is also maintained at this station a two-ton White truck, equipped as a complete field station with a combined 'phone and c.w. transmitter of 150 watts, another 2½-kilowatt generator and the necessary sectional masts, cots, blankets and medical supplies needed to equip and maintain an emergency station in the field.

A second portable unit of lower power is maintained at this station, arranged so that it can be placed in any available car or truck together with its 350-watt gasoline-driven power plant and dispatched to any point where it may be needed.

The National Guard Officer of the state, W4COS, acts as Second Alternate State Net Control Station. The Military Department of the state has equipped six National Guard armories with complete stations which are operated by qualified amateurs who are members of the Na-

tional Guard. Through arrangements with the Adjutant General's Office of the state, these stations operate as a part of the Army Amateur Radio System, when not operating on the special National Guard frequency. In this manner coordination of the nets is maintained and duplication of effort is avoided.

W4WS, located in Deland in north-central Florida, is Third Alternate Net Control Station for the state. This station controls the 75-meter 'phone net on 3910 kc. Members of this net are experienced 'phone men, familiar with the job of effectively handling pertinent information to and from the storm area through the semi-tropical static usually encountered during emergencies. This net is responsible for dispatch of general information as to conditions in an affected area.

Another net, similar to the 80-meter 'phone net, operates on 1820 kc. in the 160-meter 'phone band. W4CQJ at Lakeland in central Florida is the Net Control Station of this net, which provides a second channel for general information to and from a stricken area. The duties of this net are similar to those of the 75-meter net and their members are "static eaters" of renown.

W4CNT is the Net Control Station of a 40-meter c.w. net, operating on 7290 kc. This net is most effective during daylight hours when conditions on both the 80- and 160-meter 'phone bands are very limited and distances such as the 500 miles between the state capitol and southern Florida must be covered.

W4AWO is the director of the c.w. net on 3875 kc., which handles traffic of an exact nature which must be transmitted with speed and accuracy. This net handles emergency traffic pertaining to National Guard details and supplies.

Certain stations in each net, with facilities to operate on frequencies of other nets, are designated as cross net stations, and act as liaison between nets. Close contact is maintained between the A.A.R.S., N.C.R., and Coast Guard.

Monday evening, September 5th, marks the opening of the 13th A.A.R.S. season. With the opening of the new season we wish to welcome the new members as well as the old. The beginning of each season finds many new members, and we hope that by joining our system each new member will find added pleasure in his hobby.

—♦♦♦—

The following cryptogram is presented for those interested in these problems. Solutions received by the Liaison Officer, A.A.R.S., 3441 Munitions Building, Washington, D. C., will be acknowledged by mail.

ANRMO BOSMY THLFO YNITR ISIEN  
LXXXX

# A Four-Band 75-Watt Output 'Phone-C.W. Transmitter

## Class-B Modulated Outfit of Low-Cost Construction

By Frederick F. Sylvester, Ex-W2ACU\* and Richard S. Briggs, WIBVL\*

**T**HE construction of a complete 'phone and c.w. transmitter covering the popular amateur bands does not represent a complicated problem. However, the cash outlay for materials becomes of major importance when the power of the rig exceeds 30 or 40 watts. The transmitter outlined here is capable of delivering in excess of 75 watts of good quality 'phone or c.w. signals on all bands from 3.5 to 28 Mc., and the actual cost of all material, including the rack, panels, hardware, tubes, and component parts, exclusive of the microphone, approximates \$75. It is interesting to note that the transmitter affords approximately 1-watt output per dollar invested. Upon examining the circuits, the reader no doubt will

Thinned black lacquer on Masonite will give a finish resembling the crackle found on commercial metal panels.<sup>1</sup> Use of chromium-plated screws on the front panels adds greatly to the appearance.

There are three units in the rack. The lower contains the speech amplifier and modulator, the center section consists of the crystal and buffer stages, and the upper unit houses the final amplifier. Through the use of plugs and jacks, only four meters are necessary for complete measurement of grid, plate and screen currents of all stages from the crystal through to the final, as well as the modulator.

The power supply consists of three separate plate supplies in one unit which, for convenience, may be placed beneath the table or desk on which the transmitter and receiver are located. On and off switching of the various filaments and plate supplies is accomplished through the use of toggle switches, either installed in the front panel of the power supply, or through remote control by connection cables through a small switch-box which may be located close to the operator.

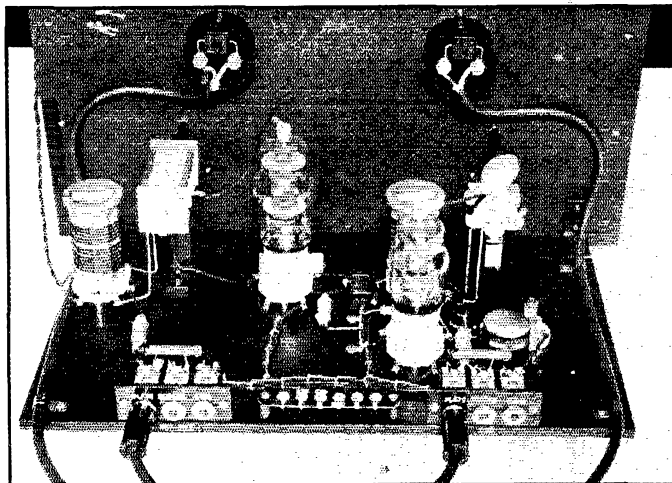

**BEHIND THE PANEL OF THE OSCILLATOR-BUFFER UNIT**  
All wiring is above the baseboard. Oscillator at right, buffer-doubler at left.

find that he already possesses many of the parts required.

The rack and panel assembly is constructed of material obtainable at any lumber yard, and the physical dimensions are exact duplicates of standard metal racks designed for amateur use. The panels, each  $8\frac{3}{4}$  by 19 inches, and bottom boards are of tempered Masonite; either  $\frac{1}{4}$ -inch or  $\frac{3}{8}$ -inch stock may be used satisfactorily.

\*Engineering Dept., Hytronic Laboratories, Salem, Mass.

### OSCILLATOR AND BUFFER

The crystal stage, which uses a type HY60 beam tetrode, operates efficiently as a straight crystal oscillator, crystal oscillator-doubler, or crystal oscillator-quadrupler. Three crystals, two chosen so that their harmonics fall within the higher-frequency bands, are necessary, as well as three sets of coils, for covering the four bands. The crystal oscillator is inductively coupled to an HY61 buffer or buffer-doubler, with tight coupling and an untuned secondary to eliminate the grid tuning condenser in the buffer stage. This method of coupling also insures stability of both the crystal and buffer stages and at the same

<sup>1</sup> Masonite panels cut to relay-rack size, finished in the customary black crackle or wrinkle, are available from many dealers in amateur equipment. — Editor.

time gives good coupling efficiency. Three coils are needed in the buffer stage.

When operating on crystal frequency, straight amplification is employed throughout, while on crystal harmonic frequencies, the crystal and buffer stages are doubled or the crystal quadrupled and the buffer doubled, as the case may be. More than sufficient excitation is obtainable for the final amplifier on each band since the tubes used in the final stage drive easily with as low as 17 ma. grid current per tube. The HY61 working as a buffer-doubler will drive the grid current of the final to well over 45 ma.

The Class-C amplifier utilizes two HY25 high- $\mu$  triodes, requiring but 45 volts of grid bias with 750 volts on the plates. Better than 75 watts of r.f. output is obtainable from these two tubes with an input of less than 125 watts. The final stage grid tank is link-coupled to the plate tank of the HY61 buffer through a variable link, providing easy adjustment of the excitation for the Class-C stage. As in the case of the crystal and

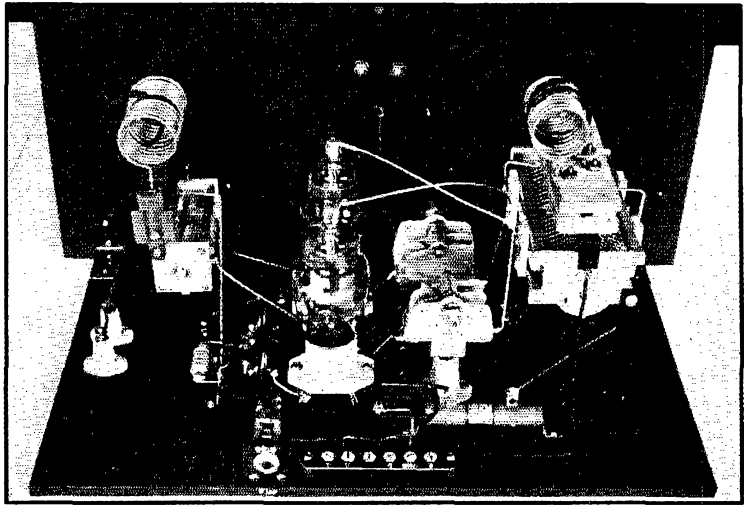

CONSTRUCTION OF THE FINAL STAGE IS SIMILAR TO THAT OF THE EXCITER

The tubes are HY25's, operated at 700 volts.

buffer stages, the final amplifier requires three sets of coils.

The modulator, shown in Fig. 2, employs a 76 speech amplifier, transformer-coupled to a pair of 45's in Class A. These in turn are transformer-coupled to a pair of HY25's operating in Class B. More than sufficient gain is available when a carbon microphone of the single or double-button variety is used. However, for use with crystal or velocity microphones, an additional speech amplifier having a voltage gain of about 1000 is

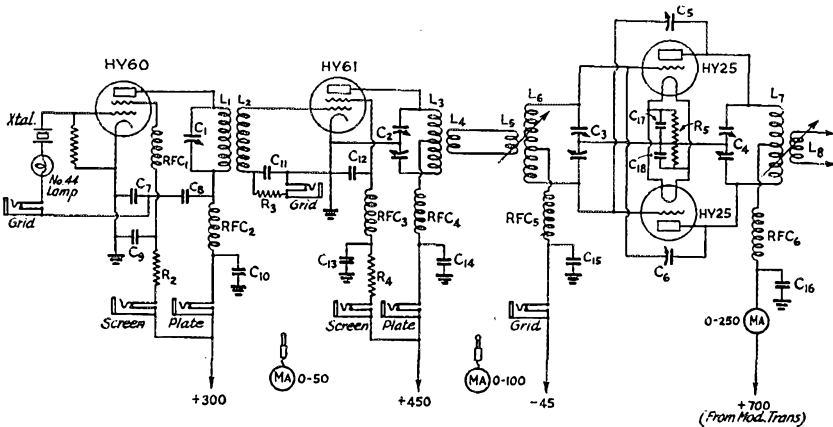
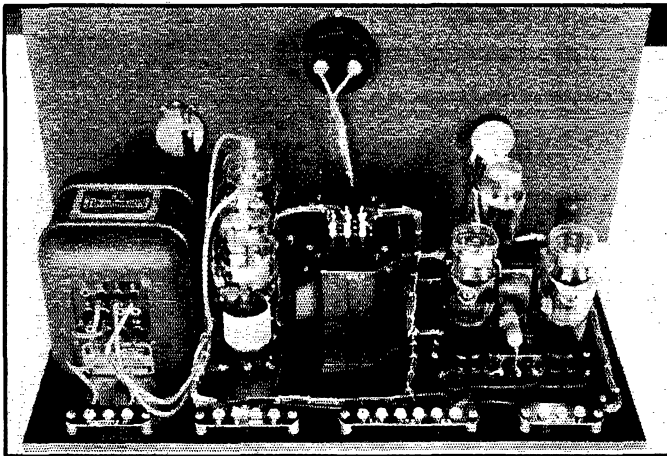

FIG. 1—THE R.F. SECTION OF THE TRANSMITTER

- |   |   |
|---|---|
| C <sub>1</sub> —100- $\mu$ fd. variable (Hammarlund MC-100S).                                       | C <sub>7</sub> —Fundamental output, 250- $\mu$ fd. (minimum) mica.                |
| C <sub>2</sub> , C <sub>3</sub> —Split stator, 100 $\mu$ fd. per section (Cardwell EU-100-AD).      | Harmonic output, 100- $\mu$ fd. (maximum) mica.                                   |
| C <sub>4</sub> —Split stator, 100 $\mu$ fd. per section, transmitting type (Hammarlund MTCD-100-B). | C <sub>8</sub> —C <sub>16</sub> , inc.—0.002- $\mu$ fd. mica, postage-stamp type. |
| C <sub>5</sub> , C <sub>6</sub> —Neutralizing condenser, 4-6 $\mu$ fd. (Cardwell NA-6-NS).          | C <sub>18</sub> —0.002- $\mu$ fd. mica, 1000-volt.                                |
|   | C <sub>17</sub> , C <sub>18</sub> —0.002- $\mu$ fd. mica, postage-stamp type.     |
|   | R <sub>1</sub> , R <sub>2</sub> , R <sub>3</sub> —50,000 ohms, 1-watt.            |
|   | R <sub>4</sub> —75,000 ohms, 1-watt.  |
|   | R <sub>5</sub> —30-ohm wire-wound (25-watt), center-tapped.                       |
|   | RFC <sub>1</sub> —RFC <sub>5</sub> , inc.—2.5-mh. r.f. choke (National R-100).    |
|   | RFC <sub>6</sub> —35- $\mu$ h. solenoid choke (Ohmite Z-2).                       |
|   | See coil table for data on r.f. coils.  |



### THE SPEECH-AMPLIFIER AND MODULATOR

Enough gain is provided for carbon microphones. The Class-B tubes are the same type as is used in the Class-C amplifier.

required to drive the modulator to full output. Inasmuch as many amateur operators use some form of carbon microphone, including transceiver handsets, the writers felt that designing the unit with available material would be entirely satisfactory, since good quality is obtainable with the newer types of inexpensive carbon microphones. Both gain and tone controls are provided on the front panel of the modulator unit. The tone control provides a simple means of reducing the hiss produced by carbon microphones. To make the speech section universal in application, no microphone transformer is shown. In case a carbon microphone is used, the secondary being connected across  $R_1$ . A crystal-microphone pre-amplifier can be connected to  $R_1$ .

Plug-in jacks provide instantaneous change-over of the two meters assembled on the crystal-buffer section front panel, permitting permanent installation of the Class-B plate-current and final amplifier plate-current meters. Continuous metering of modulator and final amplifier assures complete control as well as safe operation of the transmitter.

### POWER SUPPLY

The power supply consists of two 750-volt and one 500-volt plate transformers. The circuit is given in Fig. 3. Rectifiers for both the final amplifier and the modulator plate supplies are 866 Jrs. operated as full-wave rectifiers. Condenser-input filters are used in both cases. Plate supply for the crystal and buffer stages as well as the speech amplifier is obtained from the 500-volt transformer with an 83 rectifier. The bleeder resistor across the supply is tapped to form a voltage divider supplying the proper

### COIL TABLE

	L <sub>1</sub>	L <sub>2</sub>	L <sub>3</sub>	L <sub>4</sub>	L <sub>5</sub>	L <sub>6</sub>	L <sub>7</sub>	L <sub>8</sub>
<b>3.5 Mc.</b>								
Turns.....	28	25	30	4	4	28	26	5
Wire size....	18	22	18	18	18	16	10	10
Coil diam., in.	1 1/2	1 1/2	1 1/2	1 1/2	1 1/4	1 1/4	2 1/2	2 1/2
Coil length, in.	Close-wound		3/8		5		4	
<b>7 Mc.</b>								
Turns.....	16	11	15	3	3	16	16	4
Wire size....	16	22	16	16	16	14	14	10
Coil diam., in.	1 1/2	1 1/2	1 1/2	1 1/2	1 1/4	1 1/2	1 1/4	1 1/4
Coil length, in.	2 1/4	1 1/2	2 1/4	1 1/2	4		4	
<b>14 and 28 Mc.</b>								
Turns.....	11	7	10	3	3	10	8	4
Wire size....	16	22	16	16	16	14	14	14
Coil diam., in.	1 1/2	1 1/2	1 1/2	1 1/2	1 1/4	1 1/4	1 1/4	1 1/4
Coil length, in.	1 3/4	1 1/2	1 3/4	1 1/2	3		3	

Note.— $L_5$  and  $L_6$  are interwound. For 3.5 Mc. the coils are wound with no spacing between pri. and sec. Link coil  $L_8$  is wound at midpoint of  $L_7$ . Link coil  $L_9$  at center of  $L_{10}$ , coupling is variable. Oscillator and buffer coils are wound on Hammarlund SWF6 coil forms; final grid coils are mounted on National PB5 plugs; final plate coils on General Radio 678P plug bases.

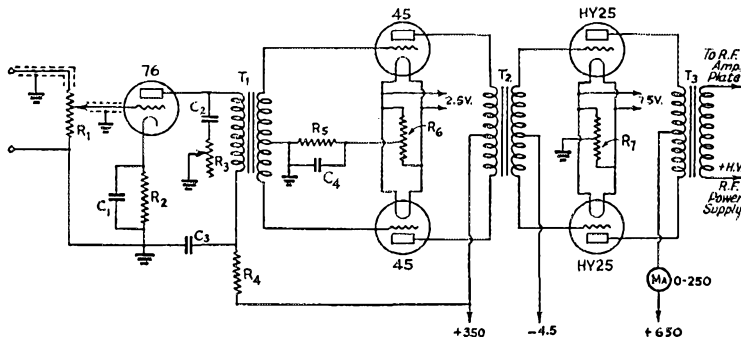

FIG. 2—MODULATOR AND SPEECH-AMPLIFIER CIRCUIT DIAGRAM

- $R_1$ —500,000-ohm potentiometer.
- $R_2$ —3500 ohms, 1-watt.
- $R_3$ —50,000-ohm variable.
- $R_4$ —5000 ohms, 10-watt.
- $R_5$ —750 ohms, 10-watt.
- $R_6$ —20 ohms, center-tapped, 10-watt.
- $R_7$ —30 ohms, center-tapped, 25-watt.
- $C_1$ —5- $\mu$ f., 25-volt electrolytic.
- $C_2$ —0.01- $\mu$ f., 600-volt paper.
- $C_3$ —2- $\mu$ f., 450-volt electrolytic.
- $C_4$ —5- $\mu$ f., 100-volt electrolytic.
- $T_1$ —Audio transformer, single plate to push-pull grids (Thordarson T-3391).
- $T_2$ —Class-B input transformer (UTC PA-53-AX).
- $T_3$ —Class-B output transformer (Thordarson 11-M-75).

voltages to the various stages. For maximum efficiency, 300 volts is applied to the crystal stage, 450 volts to the buffer stage, and 350 volts to the speech amplifier.

Although the bill of materials for construction of the transmitter is quite specific, it is not necessary to use the exact parts named. The wide variety of manufactured components makes it possible for the amateur to choose equivalent parts of other brands. As previously mentioned, probably a large percentage of the parts used are already available and may be put into service without undue complications.

#### TUNING

In tuning the transmitter for 80-meter operation, the complete set of higher inductance coils is inserted throughout. The crystal stage tuning is conventional. Resonance is obtained with the crystal plate condenser approximately at three-fourths full capacity. Considerable dip will occur at resonance and the crystal stage plate current should approximate 25 ma. In tuning the crystal stage the 0-50 ma. meter plug is inserted in the crystal plate-circuit jack provided at the rear of the exciter unit chassis.

To tune the buffer stage, the 0-100 ma. meter is plugged into the grid-current meter jack at the rear of the final-amplifier chassis. The grid circuit will tune to resonance at approximately three-fourths total capacity, and the resonance grid current will be approximately 60 ma. Upon applying plate voltage to the final amplifier, the grid current will drop to approximately 40 ma. At this point the final amplifier must be neutralized. Neutralization is most easily checked by rotating the final tank condenser and noting the reaction on the grid current. When the neutralizing condensers are properly adjusted, there should be little or no reaction on the grid current reading with plate tuning. After neutralizing, plate voltage may be applied to

the final stage. It is generally advisable to apply plate potential with caution, taking note of the no-load plate current, which should approximate 30 ma. for the two HY25's. The final-stage plate tank will tune to resonance (minimum current) at approximately seven-eighths total capacity.

Excitation to the final amplifier stage can be checked by observing the d.c. grid current. For 'phone operation, this grid current should not be less than 30 ma. and not greater than 50 ma. To adjust the excitation the link-coupling may be varied or, even better, a variable screen resistor may be used in the buffer stage to act as an excitation control. Condenser  $C_7$  in the crystal oscillator circuit must be higher in value when the circuit is operating as a fundamental oscillator

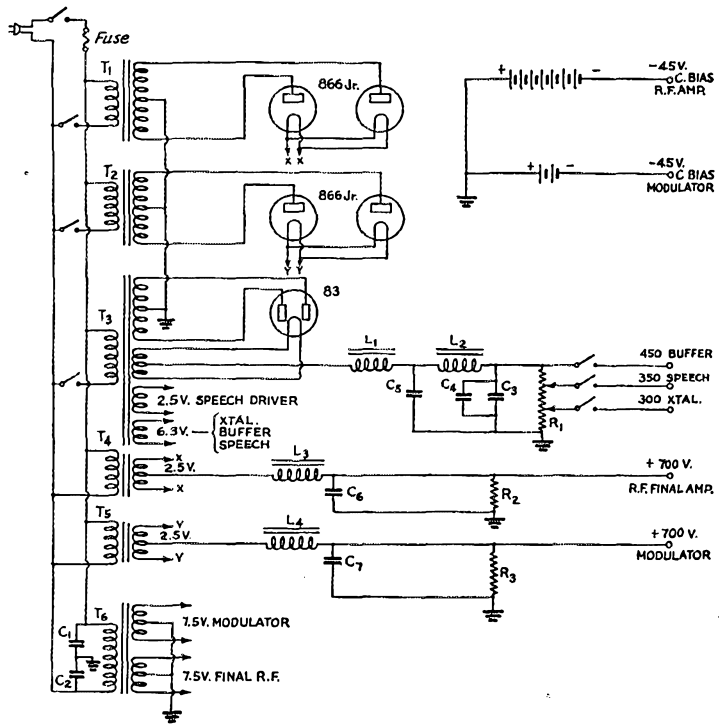

FIG. 3—POWER SUPPLY WIRING

$T_1, T_2$ —Plate transformer, 750 v., 300 ma. (UTC 20462-A).

$T_3$ —Plate and filament transformer, 500 v., 200 ma. (UTC 20757).

$L_1, L_2$ —20 henrys, 200 ma. (UTC 20462-F).

$L_3, L_4$ —20 henrys, 300 ma. (UTC 20462-G).

$C_1, C_2$ —0.1- $\mu$ fd., 600-volt paper.

$C_3$ —8- $\mu$ fd., 500-volt (working) electrolytic.

$C_4$ —0.25- $\mu$ fd., 600-volt paper.

$T_4, T_5$ —Filament transformer, 2.5 v., 10 amp. (Thordarson T-5455).

$T_6$ —Filament transformer, two 7.5-v., 5-amp. windings (Trutest K-2544).

$C_5$ —16- $\mu$ fd., 500-volt (working) electrolytic.

$C_6$ —2- $\mu$ fd., 1000-volt paper.

$C_7$ —4- $\mu$ fd., 1000-volt paper.

$R_1$ —50,000 ohms, 100-watt (IRC Type HAA).

$R_2, R_3$ —100,000 ohms, 100-watt (IRC Type HAA).

than for harmonic operation (see Fig. 1). When operating the first two stages on harmonics of the crystal, a large number of frequencies may be obtained in the final amplifier stage through using the crystal as a straight oscillator, oscillator-doubler, or oscillator-quadrupler, and by using

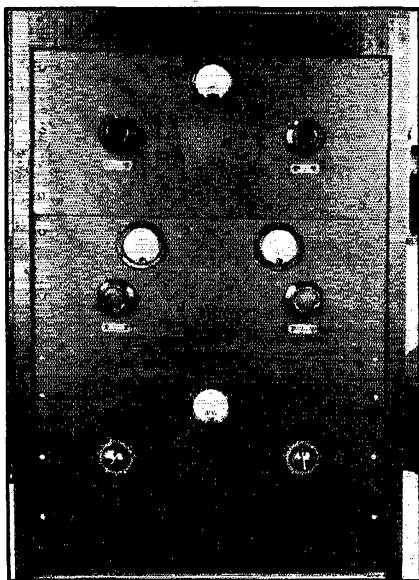

THREE RACK-TYPE PANEL UNITS COMPRISE THE R.F. AND MODULATOR OF THIS 75-WATT OUTPUT 'PHONE AND C.W. TRANSMITTER

Power supplies are not included in the home-made rack, but may be installed in any convenient location.

the buffer stage either as a straight amplifier or doubler.

Various methods of arriving at the final frequency are easily worked out and, through the use of three crystals, practically all of the amateur bands, both 'phone and c.w., can be covered. When operating on harmonics of the crystal, care should be taken to check the frequency at which the crystal tank is operating. This may be done by use of an absorption frequency meter or through comparative calibration, knowing the size of the inductance and the approximate condenser setting. The set of coils having the lowest inductance will tune both the 20- and 10-meter bands.<sup>2</sup> With doubling in both the crystal stage and the buffer, the operating settings of tuning condensers will be approximately one-fourth to one-third their maximum value. The antenna

<sup>2</sup> Care must be used to keep the circuit capacity low in order to achieve this with the tuning condensers specified. To avoid possible difficulties on this point, the authors suggest using split-stator condensers having 150  $\mu$ fd. per section and reducing the coil inductance slightly to compensate for the higher minimum capacity.—EDDOR.

network is coupled to the final tank through the link coil provided.

The plate current to the final stage should be adjusted to 150 milliamperes by means of the antenna coupling and tuning, giving a power input of 105 watts. This represents a load of 4670 ohms for the modulator. To deliver the required audio power for modulating the Class-C stage, the modulator tubes should have a plate-to-plate load of 7200 ohms, operating at 700 volts on plates and with the grids at  $-4\frac{1}{2}$  volts. The Class-B output transformer should therefore have a primary-to-secondary impedance ratio of 7200/4670, or 1.55/1; the corresponding turns ratio is 1.25/1. On the transformer specified, this ratio is most closely matched by connecting terminals 8 and 11 to the modulator plus B, 7 and 12 to the Class-B plates, 1 and 6 to the Class-C stage, and joining 2 and 3 together. The idling plate current of the Class-B tubes should be 25 ma., and on speech the current should rise to approximately 100 or 110 ma. with full modulation.

### Maritime Division Convention

Saint John, N. B., September 3rd, 4th, 5th

THE Loyalist City Amateur Radio Club is staging this year's A.R.R.L. convention. With Labor holiday excursion rates in force during the period of the convention it should make it possible for amateurs and their friends to take advantage of the reduced fares. Nova Scotia and Newfoundland amateurs and friends may travel from points in Nova Scotia via D. A. R. and Digby and thus enjoy the pleasant sail on the Bay of Fundy, via the Str. *Princess Helene*. The banquet will not take place till after arrival of the boat at 6 P.M. Atlantic Standard Time.

The Clifton House Hotel is the headquarters for the convention and the registration desk will be ready to receive the visitors at 2 o'clock Atlantic daylight time. Special guests and speakers will include His Worship the Mayor and an A.R.R.L. representative. Various contests and presentation of the Brown-Holder DX Cup, for which QSL cards are required. On Sunday a boat trip on the magnificent St. John River to attractive picnic grounds. Dinner will be provided. Monday, September 5th, five-meter hunt and visits to points of attraction. Hotel accommodation at reduced rates. Further particulars may be obtained from Secretary, H. C. Fowle, 245 Rockland Road, Saint John, N. B.

### Midwest Division Convention

Omaha, Neb., October 29th and 30th

Hotel Paxton is the place.

Watch for the publicity or write W. H. (Bill) Graham, Suite 212, Hotel Paxton, Omaha, Neb.

# How Would You Do It?

## On Eliminating B.C.L. Interference

**T**HE subject of Problem No. 18—that of elimination of interference with local broadcast reception by the amateur transmitter—should be of vital interest to all of us. A transmitter which causes general interference in the neighborhood is not only a source of difficulties between its owner and otherwise friendly neighbors, but it also may create ill-will and antagonism against the entire amateur fraternity as a group. The solutions submitted do not bring out new principles but they do demonstrate the fact

that the precautions recommended for the past several years do not involve complication and that they *are* effective.

### First Prize Solution

By Eugene L. Fegley, W8MPB\*

**Y**OUR Problem No. 18 in the June issue of *QST* hit me plumb on the nose. After spending a lot of time and dough on equipment and building the rig, I found that I had key clicks, blanketing and feed-back into the power lines. Otherwise the ole rig worked swell!

First of all, I started to work on the feed-back which was helping to blanket the b.c.l. receivers in the neighborhood. At A is the hook-up I used. The coil is wound on a large General Radio ceramic form, and the wire size is No. 12. This coil had enough impedance to act as a choke and it stopped the feed-back. Now to make this a good job and be sure that no r.f. was getting past the choke, I grounded the ground side of the power line close to the transmitter and by-passed the hot side to ground. This did surprising things in helping get rid of a lot of blanketing.

The feed-back now gone, the blanketing came next. After a little search, I found in the *Handbook* data on some low-pass filter systems. Perhaps this was just the thing I was looking for! So I built one just to see if the darn thing worked and—lo and behold—it did!

The diagram and coil data are given in Fig. B. I might add that the filter system must be designed for the lowest frequency used. If you are working on 160, the filter system must be designed for complete cut-off at 1600 kc. The one shown in the diagram is recommended for working in several bands.

Now for the key clicks which were really doing some damage. I used two types of filters, but the second one was the one that did the best work for me. In Fig. C is the one I tried first, and it helped, but it just didn't come up to what I thought it should. The second was simpler, and really worked the best for me. I use blocked-grid keying and a b.c. power pack supplies the necessary voltage. The transformer is a Bell telephone transformer which came out of a connection box. The variable resistor was adjusted until the oscillator began to draw plate current, or rather adjusted until the highest-biased tube started to draw current. In my case it happened to be the

\* 1415 Scott St., Williamsport, Pa.

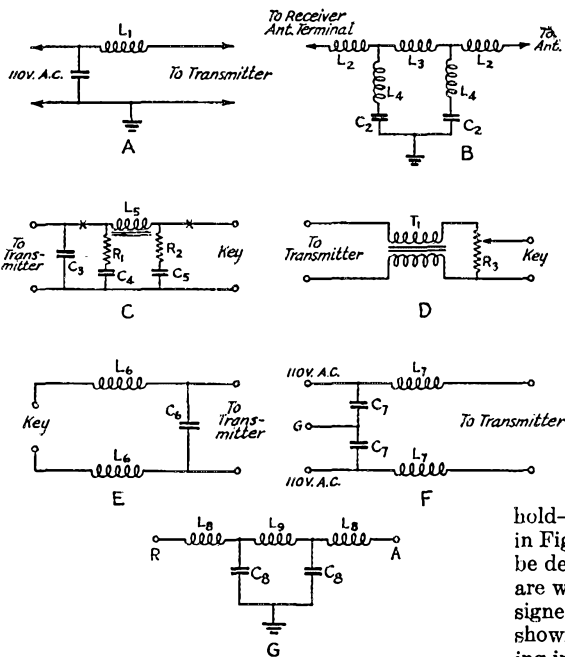

A—A simple line filter designed to prevent feeding r.f. from the transmitter back into the power lines. B—A low-pass r.f. filter to be inserted in series with the antenna of the b.c. receiver. It eliminates the necessity of tuning a wave-trap. C and D—Two types of lag circuits for eliminating key clicks. E—A key-click filter of the r.f. type. F—Another power line filter. G—A simple low-pass r.f. filter for the b.c. receiver.

C<sub>1</sub>—0.25  $\mu$ fd.  
C<sub>2</sub>—25  $\mu$ fd.  
C<sub>3</sub>—0.006  $\mu$ fd.  
C<sub>4</sub>—0.5  $\mu$ fd.  
C<sub>5</sub>—0.5  $\mu$ fd.  
C<sub>6</sub>—0.01 to 0.05  $\mu$ fd.  
C<sub>7</sub>—0.1  $\mu$ fd.  
C<sub>8</sub>—500  $\mu$ fd.  
R<sub>1</sub>—100 ohms.  
R<sub>2</sub>—100 ohms.  
R<sub>3</sub>—500–25,000 ohms.  
L<sub>1</sub>—See text.

L<sub>2</sub>—18 turns No. 28 d.s.c. 1 $\frac{3}{8}$ " diam.  
L<sub>3</sub>—29 turns No. 28 d.s.c. 1 $\frac{3}{8}$ " diam.  
L<sub>4</sub>—24 turns No. 28 d.s.c. 1 $\frac{3}{8}$ " diam.  
L<sub>5</sub>—Primary winding of bell-ringing transformer.  
L<sub>6</sub>—2.5 millihenry r.f. chokes.  
L<sub>7</sub>—180 turns No. 12 enamelled, 1 $\frac{1}{4}$ " diam.  
L<sub>8</sub>—33 turns No. 24 d.s.c. 1 $\frac{3}{8}$ " diam.  
L<sub>9</sub>—54 turns No. 24 d.s.c. 1 $\frac{3}{8}$ " diam.

oscillator. The diagram for the one I'm now using is shown in Fig. D. Now the filter of Fig. C is a really good one. The choke there is the primary of a bell-ringing transformer. The 0.006- $\mu$ fd. condenser across the input of the filter may be tried although, in some cases, it may not be needed. The X's are for r.f. chokes. The filter may be built without them since they are needed only in extreme cases.

The stuff I've just described worked very well for me, and would probably give someone else a galloping start towards getting his troubles ironed out. I spent two days getting my difficulties eliminated, and now think that it was well worth the work involved. Now the rig can be used on all bands without causing my neighbors any trouble and, of course, it saves me the cost of replacing a window if some enraged neighbor should get to the breaking point and toss a brick through the shack window!

## Second Prize Solution

By David Davidson, W1GKM\*\*

WHEN a ham moves to a new location and finally gets the rig on the air, he is naturally inquisitive about the question of interference with his new neighbors' broadcast reception. Of course, the best way to find out is to inquire, but, in the case of the b.c.l., it is sometimes better not to trouble trouble. The ham's own b.c. receiver affords the most convenient object of preliminary tests. If the interference can be eliminated from it, any complaints from outside will very frequently come from those owning receivers of inferior design.

In the writer's case, the first bit of interference at a new location was with the family's own set. Although a certain amount of tolerance was extended, inevitably there came the time when a certain favorite program was to be heard and operation had to be curtailed. The interference experienced was of the click type; the clicks were evident on the "make" and "break" of the key. The b.c.l.'s, who are in great numbers, had not yet complained, possibly because operation had been confined chiefly to the early morning and evening hours or because the interference was drowned out by local broadcast stations.

However, participation in dx and ss contests, etc., would involve evening operation, and silent hours looked none too good. Briefly, the

\*\* 34 Essex St., Hartford, Conn.

situation was this: The transmitter, with a type 10 final, was being keyed between filament center-tap and ground. The keying leads were about 20 feet long, parallel to the a.c. line which supplies the transmitter. These could not be altered. Various ideas were investigated and tried unsuccessfully. Finally an arrangement of a condenser and two r.f. chokes was tried, and this cleared up the clicks in the home receiver. This filter is described in the last several editions of *The Radio Amateur's Handbook*. The diagram is shown in Fig. E. Condenser values from 0.01  $\mu$ fd. to 0.05  $\mu$ fd. were tried and all worked equally well.

The results were so satisfactory that a test was arranged with the nearest b.c.l. The test revealed that he was getting interference, but had not noticed it until it was called to his attention, because he was a devout listener of the local b.c. station. The key-click filter successfully eliminated the clicks in his receiver also. The average b.c.l. is probably of the same type, a local-station adherent; the irate one is the dx-er or the one with the ancient tuner who has all faith in it.

The values of chokes and condensers should be consistent with the voltage and current of the keying circuit. The arrangement can be built into a wooden box and furnished with appropriate terminals. Suffice it to say, attacking the problem before the b.c.l. can do save time, trouble and jangled nerves. Above all, it tends to make a potential friend of ham radio out of an otherwise hostile b.c.l.

## Honorable Mention

By J. Dawson, W4DNA\*\*\*

YOUR Problem No. 18 which appeared in QST for June is one which I have overcome by the use of proper filters. The idea is not new by any means, but it worked to complete satisfaction to all concerned in my case.

Looking through the *Handbook* I discovered a power-line filter circuit which I thought might work. It is shown in Fig. F. I hunted around and found a nice straight broom handle, and sawed off two lengths, each 8½ inches long. In each of these, I bored mounting holes ½ inch from each

end and then bored additional holes, the size of the wire used, 1¼ inches from each end. After boiling the forms in paraffin, I wound each with 180 turns of No. 12 enameled wire, leaving a short length at each end for making con-

(Continued on page 84)

\*\*\* 1936 49th St., So., St. Petersburg, Fla.

### Problem No. 20

Sooner or later most c.w. operators come to the realization that provision for break-in operation has many advantages. Our Hero thinks so, too. Keying of the crystal oscillator is imperative if one is to work break-in near his own frequency, but unfortunately, most keyed oscillators may be detected by their characteristic chirps. These chirps may make it difficult to copy the signal of a high-selectivity receiver and may also cause unnecessary interference, if the chirp is sufficiently pronounced, at stations near the transmitter. A few of us seem to be able to produce a perfect signal even though the oscillator is keyed. Our Hero wants to know a sure-fire method of avoiding a chirpy signal while keying his crystal oscillator.



# Results, First "A.R.R.L." QSO Party

By E. L. Battey,\* W1UE

**T**HE First A.R.R.L. QSO Party, held in January, 1938, was enthusiastically received. "For A.R.R.L. Members only," it was a "family gathering," a reunion session for older members, a get-acquainted period for others. Old friendships were revived, new ones made. The spirit of the affair was one of sincere good fellowship.

"Enjoyed it, and contacted many fellows I had not QSO'd for years. A fine way to reopen old acquaintances of the air."—W2EC. "Had an FB time. Met lots of new fellows."—W9HEN. "One thing that I especially enjoyed was the meeting with a good many old-timers that I have missed for several years."—W9CWW. "Had lots of fun. Met a swell bunch of fellows."—W6EXH. "This party got W3QV and me together after years of separation and, as he said, 'It was worth the party to meet up again with one of the old gang.'"—VE3DC. "It gave a real chance to make many new friends. I worked stations I had not worked for years. It was a great pleasure to renew the friendships of the past."—W8DED. "Had nice chat with W6FQU, whom I had not worked for some time. That was worth more than all the rest of the party to me."—W6OUU. "Sure enjoyed meeting lots of old pals."—W6PFR, ex-W7DBP. "Not a winner, but friends were made and enjoyed the party."—W8FCG. "The contest was plenty of fun and I renewed many acquaintances. Ran into W8JA/3 who was formerly in Ohio when I was W8CFL. I had not heard from him for about 8 years, and it was a pleasant meeting after so many years."—W3CFL. "Worked many old friends and enjoyed every bit of the work."—W9AB.

## SCORING

Simplicity was the keynote of the rules for this QSO Party. Only contacts between A.R.R.L. members counted. Participants exchanged (1) the name of the League Sections in which they were located, (2) their A.R.R.L. membership expiration dates—month and year. One point was scored when this information was completely transmitted and acknowledged, one point when the information was received and logged. But one complete exchange of data was permitted with any member. The sum of points made by contacts was multiplied by the number of different A.R.R.L. Sections (and continents outside field organization territory) in which at least one member had been worked and at least a one-way

exchange effected. Either voice or telegraph, or both, could be used as desired—with any combination of frequencies. The party ran through a 33-hour period on the week-end of January 8th-9th, participants operating any 20 hours of the 33 for contest credit. The ease of taking part



HAL PRATT, W1EZ, HAS PROVIDED VERMONT CONTACT FOR MANY W.A.S. ASPIRANTS

*A fellow to contend with in operating contests, he made second highest score of all participants in First "A.R.R.L." QSO Party.*

and keeping score was lauded by participants as adding to the enjoyment of the party.

## THE WINNERS

Call letter pins were offered to the highest scoring members in each of the 70 League Sections and to the member leading each of the six continental areas. Sixty-eight awards are being made, the victors being G6QX K6CGK VE1EP VE2DR VE3GT VE4AHE VE4GE VE4QZ VE5QP W1BFT W1EOB W1EVJ W1EZ W1HYP W1IQF W1IZU W2DIJ W2IBT W2JKH W3BWA W3DGM W3FBM W3FQZ W4AGI W4BSJ W4CXY W4CYC W4CZA W4DWB W4EFM W5ASG W5CJP W5EGP W5FBQ W5FZD W5GHF W5WG W6CIS W6EXH W6FYR W6KFC W6MDI W6NCO W6NMZ W6OCQ W6OXQ W6UO W7CYU W7FFQ W7GLH W8CMH W8JTT W8LCN W8MOT W8OFN W9CWW W9DMY W9GBJ W9LEZ W9LQU W9MN W9MUX W9QRM W9TSQ W9UBB W9VKF W9YCR and W9YEZ. Congratulations to these winners!

## OUTSTANDING SCORERS

Thirty-seven operators made scores of over 10,000 points. The highest score was rolled up by

\* Assistant Communications Manager, A.R.R.L.

Hal Bubb (W1JTD) operating Headquarters station W1AW, of which he is Chief Operator. Hal made contacts with 197 members in 61 sections for a total of 24,034.

Another well-known "Hal"—Hal Pratt, W1EZ—made the second highest showing, 22,568 points from contacts with 202 members in 56 sections.

And, believe it or not, still another "Hal" placed third! Dr. Harold E. Stricker, W8OFN, a familiar call in "SS" and other contests, came through with 180 member-contacts in 59 sections, or 21,240 points.

What fatal charm hath this name "Hal"?! At any rate, these lads have the "contest touch" and they deserve a big hand.

Claimant to the fourth highest score is none other than our old contest shark, Vic Clark, W6KFC—19,942 points, 169 members worked in 59 sections. Among the other high scorers are W8AQ, 17,499; W3FQZ, 17,056; W9RQM, 16,907; W1BFT, 15,184; W4CYC and W5WG, 14,976; W8MOT, 13,728; W4BSJ, 13,536; VE3GT (highest scoring VE), 13,248; W4APU, 13,158; W5KC, 12,954;

W8LCN, 12,576; W1EOB, 12,446; W9MUX, 12,054.

GENERAL

Three hundred and sixty-nine League members submitted logs in the First A.R.R.L. QSO Party. Leaders in number of member-contacts were: W1EZ 202, W1AW 197, W8OFN 180, W6KFC 169, W3FQZ 165, W9RQM 160, W8MOT 156, W8AQ 154, W1BFT 146, VE3GT 145, W4BSJ, W4CYC and W5WG 144, W3ECA 140. Leaders in sections worked: W1AW 61, W6KFC and W8OFN 59, W8AQ 57, W1EZ 56, W9RQM 53, W1BFT, W3FQZ, W4CYC, W5WG and W8DOD 52, W4APU, W5KC and W8NBK 51, W7GLH and W9VKF 50. There was a small amount of radiophone operation reported. W2JDG, W6IWU and W9ZTF used voice exclusively. The bulk of party operation took place in the 3.5-, 7- and 14-Mc. c.w. bands.

In analyzing the reactions of those who submitted reports, a one word common desire in connection with the First "A.R.R.L." QSO Party is evident—ANOTHER! OK, gang, see you there!!



CHARLES A. PINE, W9CWV, KANSAS WINNER

A ham for over 16 years, CWV is an ardent DX and contest enthusiast.

SCORES

First "A.R.R.L." QSO Party, January 1938

(Scores are grouped by Divisions and Sections. . . . The operator of the station first-listed in each Section is winner for that Section. . . . Asterisks denote stations not entered in contest, reporting to assure that stations they worked get credit. . . . Listings show score, number of A.R.R.L. members worked, number of Sections worked. . . .)

ATLANTIC DIVISION		S. New Jersey		W6TKN		W8OQF		3888- 54-36		DAKOTA DIVISION	
<i>E. Pennsylvania</i>		W3FBM 7056- 98-36	W8JYR 5270- 85-31	W9VES 5950- 89-34	W9LDC 3540- 59-30	W8PBG 5805- 68-43	W8GC 1120- 28-20	W9YUBB 10461-109-48	W9YDZ 2184- 42-26	<i>North Dakota</i>	
W3DGM 111395-133-43	W3BEB 10140-138-40	W3ECG 3172- 61-26	W3AWH 1536- 32-24	W8TH 4464- 63-36	W9YX* 8- 2- 2	W9ZII 4012- 59-34	W8TRH 3584- 56-32	W9WUU 220- 11-10	<i>South Dakota</i>		
W3ECA 10610-140-38	W3EEW 10369-111-48	W3GCU 289- 12-12	<i>Western New York</i>		W9IVD 3036- 48-33	W8OFN 21240-180-59	W8AQ 17499-154-57	W9YCC 600- 20-15	<i>No. Minnesota</i>		
W3GDI 10034-114-44	W3ATR 7788- 89-44	W8JTT 11074-113-49	W8DOD 9672- 93-52	W8SXL 2790- 47-30	W8NBE 10914-107-51	W8BVM 5244- 57-46	W8NBE 10914-107-51	W9WUU 220- 11-10	W9YCR 6560- 80-41	<i>So. Minnesota</i>	
W3GDM 7728- 92-42	W3GUB 7524-114-33	W8PWU 5508- 81-34	W8RCP 3200- 50-32	W9IVD 3036- 48-33	W8BVM 5244- 57-46	W8CBC 5032- 74-34	W8PBN 1680- 42-20	W9YDZ 2184- 42-26	W9HEN 2632- 47-28	<i>Arkansas</i>	
W3EDC 6336- 98-33	W8HKS 6020- 86-63	W8RCP 3200- 50-32	W8GWT 2912- 46-32	W9CBO 1178- 28-21	W8PBN 1680- 42-20	W8PBN 1680- 42-20	W8PBN 1680- 42-20	W9YDZ 2184- 42-26	W9DNY 2352- 42-28	<i>Illinois</i>	
W3GJY 5328- 74-35	W3DGC 4088- 73-28	W8GDM 1800- 50-18	W8QKM 1440- 36-20	W9ZNV 1050- 25-21	W8PBN 1680- 42-20	W8PBN 1680- 42-20	W8PBN 1680- 42-20	W9YDZ 2184- 42-26	W9KYE 1100- 25-22	<i>Michigan</i>	
W3ADE 3480- 60-29	W3BCP 2869- 58-23	W8GDM 1800- 50-18	W8QKM 1440- 36-20	W9ZNV 1050- 25-21	W8PBN 1680- 42-20	W8PBN 1680- 42-20	W8PBN 1680- 42-20	W9YDZ 2184- 42-26	W9KYE 1100- 25-22	<i>Wisconsin</i>	
W3AOC 2304- 58-19	W3APU 1850- 37-25	W8GDM 1800- 50-18	W8QKM 1440- 36-20	W9ZNV 1050- 25-21	W8PBN 1680- 42-20	W8PBN 1680- 42-20	W8PBN 1680- 42-20	W9YDZ 2184- 42-26	W9KYE 1100- 25-22	<i>Minnesota</i>	
W3APU 1850- 37-25	W3BGD 1856- 36-23	W8GDM 1800- 50-18	W8QKM 1440- 36-20	W9ZNV 1050- 25-21	W8PBN 1680- 42-20	W8PBN 1680- 42-20	W8PBN 1680- 42-20	W9YDZ 2184- 42-26	W9KYE 1100- 25-22	<i>Wisconsin</i>	
W8ATF 1554- 37-21	W8EJU 520- 20-13	W8GDM 1800- 50-18	W8QKM 1440- 36-20	W9ZNV 1050- 25-21	W8PBN 1680- 42-20	W8PBN 1680- 42-20	W8PBN 1680- 42-20	W9YDZ 2184- 42-26	W9KYE 1100- 25-22	<i>Minnesota</i>	
<i>Mid.-Del.-D. C.</i>		W8GDM 1800- 50-18	W8QKM 1440- 36-20	W9ZNV 1050- 25-21	W8PBN 1680- 42-20	W8PBN 1680- 42-20	W8PBN 1680- 42-20	W9YDZ 2184- 42-26	W9KYE 1100- 25-22	<i>Wisconsin</i>	
W3FQZ 17056-163-52	W3BKZ 11844-126-47	W8GDM 1800- 50-18	W8QKM 1440- 36-20	W9ZNV 1050- 25-21	W8PBN 1680- 42-20	W8PBN 1680- 42-20	W8PBN 1680- 42-20	W9YDZ 2184- 42-26	W9KYE 1100- 25-22	<i>Minnesota</i>	
W3FPQ 11094-129-43	W8JA-3 6055- 97-35	W8GDM 1800- 50-18	W8QKM 1440- 36-20	W9ZNV 1050- 25-21	W8PBN 1680- 42-20	W8PBN 1680- 42-20	W8PBN 1680- 42-20	W9YDZ 2184- 42-26	W9KYE 1100- 25-22	<i>Wisconsin</i>	
W3GKZ 5544- 77-36	W3BXG 5320- 70-38	W8GDM 1800- 50-18	W8QKM 1440- 36-20	W9ZNV 1050- 25-21	W8PBN 1680- 42-20	W8PBN 1680- 42-20	W8PBN 1680- 42-20	W9YDZ 2184- 42-26	W9KYE 1100- 25-22	<i>Minnesota</i>	
W3CXL 3219- 56-29	W3C 2914- 47-31	W8GDM 1800- 50-18	W8QKM 1440- 36-20	W9ZNV 1050- 25-21	W8PBN 1680- 42-20	W8PBN 1680- 42-20	W8PBN 1680- 42-20	W9YDZ 2184- 42-26	W9KYE 1100- 25-22	<i>Minnesota</i>	
W3GAU 987- 27-21	W3DRD 84- 7- 6	W8GDM 1800- 50-18	W8QKM 1440- 36-20	W9ZNV 1050- 25-21	W8PBN 1680- 42-20	W8PBN 1680- 42-20	W8PBN 1680- 42-20	W9YDZ 2184- 42-26	W9KYE 1100- 25-22	<i>Minnesota</i>	
W3DRD 84- 7- 6		W8GDM 1800- 50-18	W8QKM 1440- 36-20	W9ZNV 1050- 25-21	W8PBN 1680- 42-20	W8PBN 1680- 42-20	W8PBN 1680- 42-20	W9YDZ 2184- 42-26	W9KYE 1100- 25-22	<i>Minnesota</i>	

<sup>1</sup> Two oprs., W9SDG and W9TWC.

<sup>2</sup> W9SDG opr.

<sup>3</sup> W1JTD opr.

<sup>4</sup> HQ staff member, not eligible for awards.

# HINTS and KINKS for the Experimenter



## Another Device for Obtaining Proper Capacity Ranges on Different Bands

USE of a split-stator condenser for a circuit requiring a wide range of capacities, and switching the sections of the condenser automatically with a four-pin plug-in coil, is suggested by W7GDB, Harold Johnstone, 427 W. Gold St., Butte, Mont.

maximum capacity of approximately 50  $\mu\text{fd}$ . across the tank circuit, and a minimum capacity of approximately half the single-section minimum capacity. For these bands, furthermore, the insulation in the condenser provides a longer leakage path than on the lower frequency bands. The maximum and minimum capacities on 40 and 80 meters are the values for a single section. On 160 meters, the sections of the condenser are

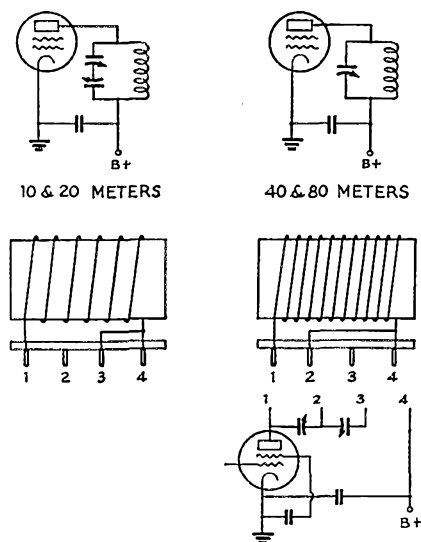

FIG. 1—THREE-CAPACITY RANGES WITH A SPLIT-STATOR CONDENSER

The three sketches at the top of Fig. 1 show the manner in which the sections of the condenser are used in a plate tank circuit. From the diagram at the top left in the figure, it can be seen that both stator and rotor of this condenser should be insulated from the base or chassis upon which the condenser is mounted and, in addition, that the condenser should be well separated from the panel unless the latter provides thorough shielding. An excellent method of mounting this condenser would be the use of standoff insulators as mounting feed and of an insulated shaft with flexible coupling for the purpose of adjustment.

The condenser used by W7GDB in this arrangement has a maximum capacity of 100  $\mu\text{fd}$ . per section. On 10 and 20 meters, this gives a

connected in parallel, resulting in a maximum and minimum capacity on this band double those for a single section, or 200- $\mu\text{fd}$ . maximum capacity on 160 meters.

The sketches in the middle of Fig. 1 show the manner in which the four contact pins of the coil are utilized for switching the condenser sections, and the circuit at the bottom of the figure shows the corresponding socket connections. As will readily be seen, this method will work equally well with tube-socket plug-in coils as with the type shown.

## Simple Modulation Indicator

THOSE 'phone amateurs using plate modulation and desiring a negative peak overmodulation indicator will appreciate the gadget diagrammed in Fig. 2. This unit may be set to indicate modulation up to 100 per cent; in other words, to give a warning signal when a peak of a predetermined amplitude up to 100 per cent is reached in the modulation.

In Fig. 2,  $R_1$  is the bleeder across the modulated amplifier plate supply, while  $R_2$  is a potentiometer in parallel with the portion of  $R_1$  between ground and the adjustable tap.  $R_2$  serves two purposes—that of a vernier control on the portion of  $R_1$  used, and that of a convenient method of adjusting from the front of panel the tap from the audio transformer primary for the proper voltage above ground on the modulated amplifier plate-supply.  $T_3$  is an audio transformer with primary connected in series with a rectifier between the modulated amplifier B+ connection and the adjustable tap on  $R_2$ . The polarity of the rectifier tube connections is such that the voltage at the B+

connection of the amplifier must be negative with respect to the voltage of the  $R_2$  tap to cause a warning flash of the modulation indicator. This indicator, a simple neon bulb with the resistor removed from the base, is shown connected across the secondary of the audio transformer.

The neon bulb is mounted in an old Readrite meter case with a frosted glass; this makes the small flashes more noticeable. The meter glass may be given a frosted appearance by grinding the surface just as crystals are ground to frequency.

If the tap on  $R_1$  is set at a point one-fourth the distance from the ground end, the control  $R_2$  may be used to set the modulation percentage for indications at any value between 75 and 100 per cent. However, on many 'phone transmitters, the plate voltage used for the modulated amplifier limits this range, for the voltage across  $R_2$ , if the tap on  $R_1$  is set at one-fourth the voltage in a transmitter with 2000-volt supply, may be as high as 500 volts. Unless a heavy duty potentiometer or a slider-type resistor mounted on the front of the control panel is used, then, care must be taken in limiting the range to a safe value for the control.

A suitable rectifier for use in this indicator is an '81 tube, with filament supplied by a 7.5-volt transformer having insulation to stand more than double the plate supply voltage. Although the inverse peak voltage on the rectifier tube will be higher than rated value, the current through the tube is so limited that the overload is not serious.

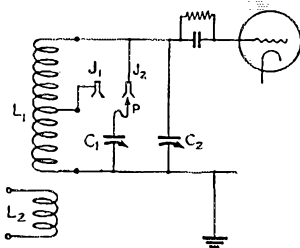

FIG. 3—GENERAL COVERAGE AND BAND-SPREAD TUNING BY USE OF PLUG AND JACKS

If the potentiometer or slider resistor used for  $R_2$  is linear (that is, if the resistance between tap and end varies proportionately with movement of the tap or rotation of the knob), this control, once the tap on  $R_1$  has been permanently set, may readily be calibrated for the modulation per-

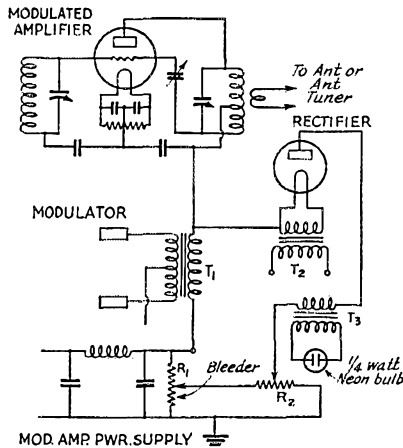

FIG. 2—A NEGATIVE-PEAK MODULATION-PER CENT AND OVER-MODULATION INDICATOR

however, this procedure involves quite a bit of expense, and the inexpensive and thoroughly practical kink diagrammed in Fig. 3 is offered as a better solution.

Five- or six-prong coil forms are necessary for the windings, and small trimmer condensers should be provided inside the coil forms—air trimmers are preferable but mica may be used. Hammarlund XP53 or similar forms are satisfactory—the large coils are easy to handle and have adequate space inside for the trimmer condensers.

The winding is made so that resonance of the coil alone falls a few kilocycles higher in frequency than the ham band to be spread. The small trimmer condenser in parallel with the winding is then used to set the high-frequency edge of the tuning range so that only a slight margin higher than the high-frequency end of the band is available on the dial.

In the immediate vicinity of the coil socket, two banana-plug jacks are mounted in the chassis in such a position that connections to the grid pin and the coil tap pin lugs of the socket will be short and direct. Making the band-spread tap on the coil is an experimental job, as the position of the tap depends on the capacity of the condenser used for tuning and on the width of the band to be covered. The tuning condenser stator is connected with a flexible wire to a banana plug.

All that is needed to make the receiver full coverage tuning rather than band-spread is insertion of the plug in the jack connected to the grid-pin lug of the coil socket. The cost of the arrangement is only a few cents, results are excellent, and the convenience is comparable to that of sep-plug-in coils for band-spread and general coverage.

—Dr. Roy R. Campbell, W4DFR  
Lenoir City, Tenn.

cent at which flashes will occur.

—Ray Harland, W7FRA  
Moscow, Idaho

## Plug and Jacks for Changing from Band-spread to General Coverage

ALMOST every ham would like to have a receiver that would cover the complete short-wave spectrum, yet would give complete dial spread of the amateur bands. In some receivers this is accomplished by winding separate coils for each purpose;

# • I. A. R. U. NEWS •

Devoted to the interests and activities of the  
**INTERNATIONAL AMATEUR RADIO UNION**

Headquarters Society: THE AMERICAN RADIO RELAY LEAGUE, West Hartford, Conn.

### MEMBER SOCIETIES

American Radio Relay League  
 Asociația Amatorilor Romani de Unde  
 Scurte  
 Associazione Radiotecnica Italiana  
 Canadian Section A. R. R. L.  
 Československá Amatérský Vysílač  
 Deutscher Amateur Sende-und-Empfangs  
 Dienst  
 Experimental Radio Society of Egypt  
 Experimenterende Danske Radioamatører  
 Federation des Emetteurs Belges  
 Irish Radio Transmitters Society  
 日本アマチュア無線聯盟 Japan

Liga Colombiana de Radio Aficionados  
 Liga Mexicana de Radio Experimentadores  
 Magyar Rövidhullámú Amatőrök Országos  
 Egyesülete  
 Nederlandsche Vereeniging voor Interna-  
 tionaal Radioamateurisme  
 Nederlandsch-Indische Vereeniging Voor  
 Internationaal Radioamateurisme  
 Newfoundland Amateur Radio Association  
 New Zealand Association of Radio Trans-  
 mitters  
 Norsk Radio Relæ Liga

Polski Związek Krotkofalowcow  
 Radio Club Venezolano  
 Radio Society of Great Britain  
 Rede dos Emissores Portugueses  
 Réseau des Emetteurs Français  
 Réseau Luxembourgeois des Ama-  
 teurs d'Ondes Courtes  
 South African Radio Relay League  
 Suomen Radioamatöörlitto r.y.  
 Sveriges Bandareamatörer  
 Unión de Radioemisores Españoles  
 Union Schweiz Kurzwellen Amateur  
 Wireless Institute of Australia

## Conducted by Byron Goodman

### Results '37 DJDC Contest

**B**ECAUSE the DASD's DJDC Contest has be-  
 come quite a popular event throughout the  
 world, we are listing some of the scores of the 1937  
 contest and the rules for the 1938 affair. (If we've  
 got it wrong it's because we don't read German  
 very well!)

Some of the high scores:

D4CDM....	865,878	W3GGE.....	61,578
D3DSR....	820,798	W3GKM.....	52,668
YM4AA....	671,207	W3AGV.....	47,376
D3CFH....	622,080	W4CEN.....	47,872
D4QET....	562,095	W4DCZ.....	26,520
D4SNP....	375,342	W4DTR.....	23,376
D4BUF....	351,302	W5FI.....	702
G2ZQ....	55,157	W6IES.....	23,232
G6YR....	53,352	W6GPB.....	1,760
GM6NH....	81,130	W7FEC.....	45
OK2OP....	58,431	W8MAH....	47,124
LU8EN....	87,516	W8DHC....	39,032
ZS1AH....	62,424	W8JMP....	21,420
VK2ADE....	179,758	W9TB.....	128,592
VK3MR....	118,048	W9VDY....	4,096
VK2JX....	91,290	W9TXG....	1,680
VK2TI....	82,376	VE1EP....	52,122
VK3KX....	56,355	VE2DF....	3,192
W1TW....	129,143	VE3AU....	28,112
W2GVX-1...	123,690	VE5MZ....	1,872
W1RY....	95,494	K5AY....	41,820
W2AAL....	58,968	NY1AE....	31,780
W2CJM....	56,466	CM2OP....	5,427
W2CYS....	52,530		

### Rules for This Year's DJDC

The DJDC 1938 is based upon radio contacts  
 between European amateurs at one side and over-

seas amateurs on the other side as in 1937. The  
 traffic consists of two parts:

1. DX-QSO between Europe, Germany in-  
 cluded, and serial numbers.

There are two classes of DX-QSO:

- (a) Overseas-Germany.
- (b) Overseas-Non-German Europe.

QTC reports can originate only from  
 DX-QSO as under (b).

2. QTC-QSO between Europe outside Ger-  
 many or overseas at one side and Germany  
 at the other side.

Time: The four weekends of August, starting  
 with the 6th. Each weekend from Saturday, 1200  
 GT to Sunday, 2400 GT.

Frequency bands: All amateur bands. There is  
 a special band scoring this time. The German  
 amateurs are unable to transmit on 56-Mc.,  
 3.6-4-Mc. and 1.75-Mc. bands. *Off-band working  
 causes disqualification.*

DX-QSO contacts between Europe, Germany  
 included, and overseas. The idea of the DJDC is  
 to get a maximum number of such contacts. Six-  
 cipher serials are to be exchanged. The first three  
 characters show the RST (or RSN) with which  
 the other amateur has been received; the last  
 three give the number of the DX-QSO. The first  
 DX-QSO has the number 001, then 002, etc.

The general call for the contest is "CQ DJDC."  
 Amateurs who don't wish to participate are re-  
 quested to avoid wasting time of the participants.

Only one DX-QSO is possible between the  
 same stations per weekend and per frequency  
 band. DX-QSO between European and German  
 amateurs is not possible.

QTC traffic: Each DX-QSO between European

stations outside of Germany and overseas may be the origin of a QTC report for each of the two partners of the respective DX-QSO.

QTC reports may be sent to Germany (and Danzig) by QTC-QSO between Non-German and German stations. QTC-QSO may be arranged by foreigners with Germany as desired. Each time as many QTC may be transmitted as there are. Overseas stations may also send QTC reports in connection with DX-QSO.

The QTC reports are to be transmitted in the following manner:

1. Call of the station worked.
2. Local time of the DX-QSO in four characters (0001-2400).
3. The received serial.

The German partner of the QTC-QSO has only to verify the correct reception of the reports, e.g., 5 QTC OK. Points may only be claimed after such acknowledgment. From the above you will see: European amateurs can work QTC-QSO with

for European foreign amateurs and the overseas amateurs, multiplied by the number of the German districts, are indicated by the final letters of the call. There are 19 districts: final letters A, B, C, D, F, G, H, I, J, K, L, M, N, O, P, R, T, U, V. The 20th district is formed by YM4-Danzig. The characters 3 or 4 are not regarded.

Hence it follows: A station outside Germany which works no German QSO receives no points. European stations, therefore, are forced to send QTC to Germany, for they can work QTC-QSO only with Germany.

In U. S. A., Canada and Australia (W, VE, VK) each district forms a country of its own. The same applies to G, GI, GM, GW, etc.

Awards: There is no world-winner. The amateurs of each prefix zone are competing among themselves. The top-scorer of each country (district area) is awarded a certificate. Two awards are given if there are five or more participants.

Each competitor who submits his log in due time will get a verification card and a report on DJDC 1938 regardless of his result.

The amateur is the participant, not the station. If there is more than one operator, each one has to submit a log of his own.

Log: There are no entrance formalities for the DJDC; just send the DASD your completed log made up according to the sample. For the DX-QSO the log must show: Date, time, frequency band, worked station, serial number sent and received, and the points claimed. For the QTC, show what German stations received them and at what time the QTC-QSO started. The heading of the log must show the name of the competitor, address, call and an abbreviated

description of the station. At the end, show the total score. Logs which reach the DASD after Nov. 30, 1938, can't be regarded. Each competitor is asked to send a log to: Contest Manager DASD e. V., Berlin-Dahlem, Cecilienalle 4.

LOG							Final score:	
DJDC 1938							Call:	
Deutscher Jahres DX - Contest 1938.							Name, Address:	
TX:		RX:		Ant:		Nr German Distr wkd:		
Date Time	Freq band	worked Station	Serial numbers		points	QTC sent to D. . .		
2354	14	W 2 (VXX)=1	550	801	578	005	2	
2358	14	PY 2 AL	547	002	308	003	2	
0235	-	D 4 BAF	-	-	-	-	4	
(Examples for a European amateur)								
Nr. German distr. wkd:						Sum of points:		
<div style="border: 1px solid black; padding: 2px; font-size: small;">                     The DASD must have the log not later than Nov. 30th 1938! (Pay safe Oms, send early!)                 </div>						Total: _____ <small>(Please enter final also in heading of Log)</small>		
I state that I have abided by the rules of the Contest and that my total score is true and proper. I know that I may be disqualified if I have hurt the rules of my license.								
							Signature _____	
Send the log to: DASD Contest manager, Bin-Dahlem, Cecilienalle 4								

Germans only. QTC reports never can show D- or YM-calls. Example: ON4AU reports to D . . . W6CUH 0515/589012. This means ON4AU has worked W6CUH at any day of the contest at 0515 his local time, when he received the serial number 589012. The serial with its first three characters means that W6CUH heard ON4AU rst 589; the latter three characters mean the 12th DX-QSO of W6CUH. At his side, W6CUH would be able to report this QSO in the following manner: ON4AU 2115/579005, which means that the QSO took place at 2115 W6 local time, ON4AU heard W6CUH with rst 579, and it was the 5th DX-QSO of ON4AU.

Scoring: For each DX-QSO may be claimed 4 points between Germany or Danzig and overseas; 2 points between Europe (except D, YM) and overseas.

Each correctly acknowledged QTC report counts two points.

The points of this scoring are summed up and,

## Strays

W7GDB says: "My power supply has so much hum in it that W7EMF calls it a 'BEE' supply."

In World Transcription Library record number 88 is "I Love You Truly."

W6LCD wonders whether there was a ham involved in the numbering.

W2KCN and W1KCN recently had an unique c.w. contact. It happened that both stations were on the same frequency—7117 kc. Both stations used low power—the input at W2KCN was 15 watts, and that at W1KCN was 12 watts.



# OPERATING NEWS



Conducted by the Communications Department

F. E. Handy, Communications Manager

E. L. Battey, Asst. Communications Manager

Visiting fellow hams can often be planned as part of vacation activity. Visiting A.R.R.L. Headquarters is also as popular an idea as ever this summertime. Until a member pays a visit to his Headquarters offices he can scarcely picture the full extent of the facilities set up for his benefit. The responsibility for representation of the whole amateur service in line with Board policy, facilities for giving technical information, editing your articles, development of equipment techniques, preparation of bulletin information for organized A.R.R.L. groups, machinery for placing your magazine in your hands promptly each month—all these and other specialized functions require the full time of nearly two score persons. The museum of apparatus used some years ago in amateur radio is alone a sufficient reason for a visit by the newer members of the fraternity. Your Headquarters is a very real place. Every amateur ought to visit it.

The new W1AW (Maxim Memorial Station), located on a seven-acre site about four miles south of the Headquarters offices, is itself the mecca of many amateur operators and visitors these days. The transmitters which you glimpsed on *QST*'s cover last month have now been moved to the station building. Installation is proceeding apace, with limited daytime operating during August. The full schedule of evening operating will start in September. Look in on W1AW and your organization Headquarters this month if you get a chance.

**Warning.** Every licensed amateur operator knows the penalties prescribed in the Communications Act—for violations of the Act—for violations of regulations made under the Act. The Act applies to all citizens. The Federal Communications Commission is increasingly active in collecting evidence against the few who infringe the rules.

Elsewhere in these columns we publish certain decisions of the F.C.C. in which you will note that, in addition to license revocations and suspensions, penalties of considerable cash fines are imposed on convicted violators. The prosecution of those that endanger the privileges of all of us by "bootlegging" or irresponsibility will be prosecuted earnestly by the F.C.C. A few words to the wise:

(1) If unlicensed, *don't* bootleg. You may not only be subject to prosecution and heavy fines, but may lose the chance to hold the valued amateur status and license.

(2) Licensed operators, who have earned the use of frequencies by simple and proper qualification, will help themselves and the whole fraternity "to keep amateur bands for amateurs" by reporting any and all unlicensed or bootleg operation to the F.C.C. for investigation.

(3) Don't allow anyone to operate *your* station unless he first shows you a valid license.

(4) Log completely and properly *every* call or transmission! It's a violation not to. (We recently examined the log of a leading DX man . . . which showed neither the power or finishing time of any of the QSO's. What sort of shape would that fellow be in if his log was called for any reason at all by F.C.C.!?)

(5) To all amateurs on vacation we suggest strict and early notification (to F.C.C.) where low-frequency portable operation is planned. Remember to take your license along if you expect to be allowed to operate at any ham stations visited.

**A.R.R.L.'s June Field Day** wins for itself classification with our major operating activities. Logs received show 25 per cent to 35 per cent more of the stations worked, in the portable (BT-X) class, than in previous events. Participation as shown by the number of logs is up proportionately. The "FD" has gone ahead in popularity with each passing year. A most important activity for clubs, some are already planning local contests in their groups for building self-powered equipment both to better their standing in the next "FD" and to aid in general communications emergency preparedness.

The scores this year will be printed so as to indicate which stations operated with but a single-transmitter-single-operator at a time. This is in order to properly credit all such entries, which are not to be compared directly with several-transmitter groups.

No August Field Day or low-power summer activity is announced this year. Experience has indicated that participation has never been close enough to the volume of June activity to justify this extra activity in the schedule. Like other big activities you can count on the Field Day as an annual event. Experience indicates July and August as the universal vacation months. Summer is also a good time for general rebuilding and tests and some local activities for those with the special enthusiasm so to prepare for bigger success in the next official activities! — F. E. H.

### PRIZES FOR BEST ARTICLE

The article by Mr. R. E. Cosier, VE3ARB, wins the C.D. article contest prize this month. Each month we print the most interesting and valuable article received marked "for the C.D. contest." Contributions may be on any phase of amateur operating or communication activity (DX, phone, traffic, rag-chewing, clubs, fraternalism, etc.) which adds constructively to amateur organization work. Prize winners may select a 1938 bound *Handbook*, *QST* Binder and League Emblem, six logs, eight pads radiogram blanks, DX Map and three pads or any other combination of A.R.R.L. supplies of equivalent value. Try your luck. Send your contribution to-day!

## Our Golden Opportunity

By R. E. Cosier, VE3ARB\*

ONE has been able to read so much during the past few years, of criticism directed at the novice, breaking into this great brotherhood of "hams," that I am prompted to submit a few words which, I hope, will give new thought on what now is a problem to more than a few.

As we all know, essentially amateur radio is the exchange of thoughts and ideas by means of radio. These contacts should be not only friendly but helpful, everyone striving towards the ideal goal of human relationship—that of helping the other fellow—so lacking in the world as a whole, to-day.

The number of beginners within our ranks is ever on the increase, and that familiar QRS is heard more and more often. QRM is also increasing until one now hears many a proposal that beginners should be placed on 300 megs., or given a dummy antenna! In other words, the beginner should be isolated from those who believe they are above that stage.

I cannot help but think that these suggestions come from the experienced of our ranks who have forgotten their own early days. However, it is not my point to criticize ideas, but rather to suggest another line of thought.

The majority of beginners venturing into our fine hobby are conscientious and will quickly correct faults in their equipment when shown how. They strive to send good clear signals and of necessity must send slowly. Their copying also is slow.

For the operator who normally sends anywhere from 20 w.p.m. up, and his "bug" setting is 20 w.p.m. or more, to QRS is a trying and tiring procedure. But his signals are merely a blur of noise to the novice, who must treat them as he would QRN, not being able to even identify a call. Many the operator thus isolates himself from the less experienced, and, a golden opportunity! Let those operators stop a moment and think. Can the beginner be given a place with the experienced? Yes.

\* 160 Hopedale Ave., Toronto, Ontario, Canada.

The beginner provides another great channel for furthering the ideals of amateur radio. From his ranks come those good fists that are a joy to hear. The future of our hobby is dependent on him. Therefore, the beginner should not be criticized, looked down upon, and dubbed "lid," but rather envied! He receives all those thrills and strivings undulled by repetition. He provides the opportunity for his more experienced fellow ham to be of service to others, to reap a rich reward in further enjoyment and happiness that must follow from his hobby. And that is not all. The veteran,<sup>1</sup> in showing the way to the beginner, also controls the destiny of amateur radio, *fostering* that true spirit and ensuring its continuance.

Shall we ban the beginner from our popular bands or shall we keep them near our frequencies and guide them?

Nothing but praise can go to the man who devotes his efforts and time to helping others. Sacrifice, tolerance and patience are required, but is it not worth while?

The beginner is one of amateur radio's biggest opportunities for carrying out the true spirit of our hobby. The experienced may reduce QRM by leading the way, giving our beginner a pattern<sup>2</sup> on which to build. That's the true amateur spirit—long may it continue!

<sup>1</sup> It is all too true that *personal responsibility* of the experienced amateur is the highest necessity for the fraternity as a whole. On every *individual*, and the veteran in particular, lies the hope of the fraternity for public understanding and appreciation of "the amateur."

<sup>2</sup> The veteran is apt to be too sophisticated in operation and too callous to the opinions of non-amateurs, and the need for consideration for fellow amateurs of other interests or of different operating abilities! All would do well by themselves and amateur radio also to study *operating*, and their own careless technique in particular—aim to set the right example—operate in a way you can justly take pride in—not sloppily or selfishly. Study Chapters 18 and 19 in the *Handbook*.

### F.C.C. Disciplinary Actions

Violations of the Communications Act involving unlicensed operation are now under investigation by the Commission or pending in Federal Courts throughout the United States. The defendants in two of these cases were recently convicted of the charge of operating an unlicensed radio station in the ultra-high frequency amateur bands and without the required operator's license from the Commission. They were:

*Theodore V. Fabian* of Pittsburgh, Pa., who pled *nolo contendere* in the United States District Court at Pittsburgh on May 26, 1938, and was sentenced by Judge Gibson to pay a fine of \$100 and costs, and was placed on parole for two years during which time he is required to report each month to the Probation Officer.

W8BIE, station license of T. V. Fabian, acquired subsequent to unlicensed operations was revoked also, under a decision of the Federal Communications Commission reported June 15, 1938, because of violation of Sections 301 and 318 of the Communications Act of 1934, as amended.

*Samuel Alfred Travetta* pled guilty to unlicensed 2½-meter operation, in the United States District Court at Washington, D. C., on June 8, 1938. On motion of defense counsel, Judge Adkins deferred sentence and referred the case to the Probation Officer for investigation and recommendation with regard to parole. Later he was sentenced for from four to eight months imprisonment and sentence suspended.

*John Evans* of Palmyra N. J. (W3ANE), on July 5th had his operator license suspended for six months. The inspector measured his phone station input with accurate instruments and found the power 1462 watts! Mr. Evans also failed to answer discrepancy reports. The log was not kept properly in accordance with the regulations. The operator was apprehended while actually operating with 1462 watts input.

A number of unlicensed 56 Mc. bootleggers have just been indicted in Atlantic City.



## Gatti African Expedition—OQ5ZZ

The tenth Gatti African Expedition will be on the air from the Belgian Congo starting about middle August. Some of the purposes of the expedition are working in the Uele, where are the greatest herds of elephants and the only station capturing, taming and training the African elephant, study, movies, photos, collections among the Manbetu and research on the Mulahu, the mysterious and still unknown fifth anthropoid. The call OQ5ZZ has been assigned the party and operation will be in the 14-Mc. amateur band. A 75-watt radiotelephone transmitter receives its power from a 4-kw. lighting plant. Word to the base camp from the expedition's exploring parties will be on 3950 kc.

## Bowdoin-Kent Island Expedition—VE1IN

The Bowdoin-Kent Island Expedition is on the air again this summer with station VE1IN. This expedition consists of scientists and students from Harvard University, Bowdoin College and other institutions. Aerial photography, meteorology, biology, oceanography and field radio research are included in the program. VE1IN works amateurs in the 3.5 and 14-Mc. bands, both 'phone and c.w. Much operation in past years has been on 3.9-Mc. 'phone.

## Archbold New Guinea Expedition—PK6XX

PK6XX, the Archbold New Guinea Expedition, has been putting a good signal into the States, and quite a number of amateurs have been making contacts. At 4:55 a.m. EST, June 3d, W4DRD, Miami, Fla., had a two-way 'phone contact with KHAHX, the call used by the "Flying Laboratory" *Guba* of the expedition; at this time the *Guba* was on the first leg (San Diego-Honolulu) of the flight to New Guinea. On June 7th W4DRD again made contact, while the plane was 750 and 900 miles from Honolulu, enroute Wake Island. Again, on June 9th, W4DRD made two-way contact with KHAHX on the last leg of the flight, Wake Island-Hollandia, New Guinea. On all contacts KHAHX used 12,420 kc., W4DRD 14,246 kc. The plane was also contacted during flight at regular intervals by W6LYY and K6OQE, W2IWT, W5FIY and W9UJS were among others to make contact. W6ANU and W6PGE assisted W6LYY in maintaining an hourly schedule.

PK6XX, the base station at Hollandia, now maintains regular Saturday night schedules. 14,009-kc. 'phone is used mostly and W4DRD reports a solid S8 signal from 4:00 to 8:00 a.m. EST. W2BVB, operator at PK6XX, will confirm all stations worked, periodically, by message to A.R.R.L. so that Century Club credit may be allowed. Hollandia is a village of approximately 350 black natives who, prior to the expedition's arrival, had never seen electric lights nor the other wonders of electricity. Their astonished faces constantly appear in windows and doorway while the station is in operation.

Among others who have reported contacts with PK6XX are W6ITH, W9BEU, W5ACY, W7FEZ and W9FK-6. W9CVL reports that W2BVB/PK6XX says he will use the commercial call P06ZA on 11,355 kc. W9FK-6 did some good work when several relatives and friends of the expedition party were at his station to talk with the base. PK6XX is on the air nearly every day and welcomes QSO's—watch 14,009 kc.

## W1OXDA

Radio operator with Captain Bartlett's Expedition to the Arctic (W1OXDA) is Don Clark, W2DBS, instead of Harold Cooper, W21KT. See page 57, July QST, for complete details.

## Briefs

In addition to the four winners mentioned in the June QST report on the 1937 A.R.R.L. Copying Bee, Harry Gross, W6FZL, also made perfect copy and has been awarded a bronze medallion in recognition of his accomplishment. Congratulations, OM!

## R Stands for . . . ?

By Zeh Bouck, W8QMR\*

REMEMBER the spelling books—I mean the first ones we ever had, just outside the nursery—where A stood for APPLE and B stood for BRONCHITIS? To this day I'm not quite certain what R stands for—and that may well be because some lads haven't quite been graduated from that same nursery.

Frankly, I'd say that R was the most misused term in ham radio—with the possible exception of CQ. But then CQ has two letters which give it somewhat of an advantage. It can be transmitted as CTK, TRQ, NNMA, KEGT, CMA, KETK, NNQ, TRTK, KEQ, CGT, NNTK, TRMA, NNGT, KEMA, TRGT . . . and occasionally CQ. Liberties taken with R are limited to ETE, AE and EN. However, the crimes against R are not so much those resulting from variations on the theme.

For some twenty years now—twenty-eight when I care to admit it—I've been trying to convince myself that R stands for RECEIVED—OKAY—that it is an abbreviation conveying the intelligence that everything transmitted has been received—copies beyond the doubt of an error. Or at least a reasonable doubt. But sometimes . . . well, I wonder.

When traffic isn't heavy, I delight in chewing the rag. I'm no stickler for formalities and set forms, but I usually open a QSO in the conventional manner—just as it is easier to start a game of chess with the Queen's Pawn opening or the Muzio gambit. And besides, the RST business makes sense—as does the QTH. However, I rarely tack on any dope concerning the weather. Weather as a topic of conversation should be used only as a last resort. Of course, when the WX is exceptional, it may be justifiably dragged in—as in the case I am about to relate.

I had just finished a sked with W8CSE, and he, somewhat sour on the QRN, hit the hay. I sent a short CQ. A W3 came back. I wasn't getting him very well, but feeling more or less obligated I returned with—

GE TKS FOR THE CALL OM—YOUR SIGS RST 379X HR IN LIVINGSTONVILLE NY—QRN BD BUT THINK I CAN PULL YOU THRU WITH THE XTAL ON THE HRO—THE XMTTR IS A CUPLA 6L6S IN THE FINAL WITH ABT 60 WATTS K

The W3 responded with two attention calls, called three times and signed three times (not at all necessary, but read on my friend, read on)—and then added:

R R R R R R

Subconsciously I glowed a bit. The ole 6L6s apparently were pushing through down his way—QRN and all. The W3 made a few BTs and continued—

OK SOLID

I had gained that impression when he sent the first R. About this time I had a vague idea that the SOLID might well describe some portion of his anatomy. A moment later I was convinced—

OK ON YOUR QRA (never QTH!) BEING IN LIVINGSTONVILLE NY OK ABT THE WX OK ON THE BD QRN OK ON UR FB RIG . . .

I wonder why he ever wasted time sending that R in the first place?

Then there is another chap I worked—a W8—under exactly the same conditions, and my opening was identical with that of the W's QSO. The W8 also came back with—

R R R R

Again I was mildly pleased, and he went on—

YOUR SIGS FB RST 589X HR IN CLOSEVILLE NY —RIG HR IS . . . etc., etc. . . WHAT R U USING?? WX BD HR HW IS WX UP UR WAY??? QRA? (once again, not QTH?) QRK?

About that time I lost most of my philosophy, not to mention patience, and cut it short.

I don't trust an R any more!

\* Ex-2PI, ex-W4FCP, Livingstonville, New York.

## O.B.S.

The following is a supplement to the list of A.R.R.L. Official Broadcasting Stations in October QST (page 50): W1EOB, W3GWQ, W8RBI, W9KHC, W9MOK, VE2HV.

# How's DX?

## How:

With a soft spot in our heart for the finer things in life, we're a pushover for odes, ballads, lyrics and such. It's a pleasure to present the result of a thunderstorm over New Jersey:

### THE POSTMAN COMETH NOT

I've worked them all from east to west.  
I've sent them all a card.  
I've sent them two, and three, and four:  
I've pleaded pretty hard.

I've worked my tongue off to the root  
I've licked so many stamps.  
I often wish I had them here—  
I'd fill them full of amps.

I've only six more cards to go,  
I've thought 'twas in the bag.  
I've met the postman every day;  
I've heard the same old gag.

I've been so sure they'd come across,  
I've hurried to the door.  
I've gotten G and D and F—  
I've gotten nothing more.

I've finally got my dander up,  
I've lost all sense of trust.  
I've sworn an oath, a mighty oath;  
I'll work six more or bust!

—W2GVZ

## Where:

One nice thing the Century Club has done for DX has been the reduction of QRM. Have you noticed how quiet the bands sound lately? But just let some juicy rare one open up, and the band really roars . . . . W8CRA was heard working CR8AA the other a.m., but we haven't any dope on the frequency . . . . W6ITH worked CR9JF on 10 'phone in April, but thought him a phoney. Reg received a card the other day . . . . Any station in Bulgaria is plenty rare, so leave it to WISZ and W2CYS to grab off LZIID (14,360 T8c). The lad's under cover and QSL's, but we'll forward your card for you . . . . It really pays to get up these mornings. W6NRE grabbed off VR1AM (7165 T9x) at Ocean Island the other a.m. . . . .



VO3R, WIKH, AND VO3X, AT ST. ANTHONY, NEWFOUNDLAND

EL2R (14,405 T7) has had the boys chasing after him the past few weeks. According to the dope he gives, he's located about 50 miles east of Monrovia, is an ex-W2, is running 500 watts into a MOPA into a 10-wavelength Vee, and will QSL via A.R.R.L. So far we've received no word from him . . . . It isn't easy to be skeptical in this warm weather, but when someone gets on signing VR6AB (14,350 T6) and tells G6KP and G6RH that he's the portable outfit of VR6AY, with W1BES at the key, we have to take it with a grain of sodium chloride, especially since W1BES has been back in this country for some time . . . . We've had several inquiries as to the QTH of OY4C (14,325, 14,430 T6), but our only suggestion is to send your card care of the OZ QSL Bureau, and keep your fingers crossed . . . . According to TF3C (14,280, 14,420 T8), who should know if anyone does, the only active stations in Iceland are 5C, 5F, 5M, 5CD, 2Z and 3C, which leaves the burden of proof with the TF2AX reported last month and the TF5B (14,415 T8) worked this month by W1BGY, W2CYS, W8RQA, W2HHF and W3FQO and others . . . . W5HBE and W9WBT worked SU2AS (14,385 T9x) and are wondering about his address . . . . That's easy; cards for SU go care of the SU QSL Bureau, but if someone were to ask where to send a card for EQ4AC (14,030 T9), worked by W9TPH, we wouldn't have such a snappy answer . . . . And all we could do about AR8MK (14,365 T9) is pass along the QTH as copied by W8LYQ and W3FQO: Dan Lunnon, Posts and Telegraph, Damas, Syria. (Boy, we hope that's good!) . . . . W2CYS says he's heard YI2FK (14,310 T8c) calling "CQ USA" in the evenings, but in vain . . . . Borrowing again from that very excellent source, G6WY's column in the *T & R Bulletin*, we see that several G's have worked AC4YN (14,120) and that you can QSL PX1A (14,300, 14,415 T6) via the R.E.F. (France) . . . . This fellow FJ8AA (14,400 T9), worked by W2BHW, W9FS, VE5SW, W9CWW and W9ARL, may be OK. He says he's on Clipperton Island (remember?) and to QSL via the R.E.F. They worked him in the early ack emma . . . . Please excuse the error last month. We mentioned ZD2A and ZD2B as legit but QSL via R.S.G.B. They should have been ZB2A and ZB2B . . . . For those of you that care about such things, we have QSO lists from I7AA, K6NVJ and PK6XX, as well as those mentioned last month . . . . Speaking of I7AA, we have a letter from a friend of his, the fellow that supplied the list, which says that some muddle-head sent 7AA a card direct, with the result that his superior raised a fuss and 7AA has had to lay low for a couple months. If he receives any more cards direct he will be put off the air permanently. We weren't kidding these last couple of months when we said that these fellows deserve some consideration, so please don't send open cards blind or to fellows that you know or suspect are under cover . . . . W4TP has one that may or may not be OK: TZ5AA (14,375 T9x), and W3EVW's ZA1C (14,395 T7) falls in the same category . . . . WIJL must have plenty on the ball. He received a QSL from XSV18M (send yours to LU2CW) and, of all people, F2PX (FP8PX)! . . . . W2BHW has a couple of nice items: he says that he heard FO8AA (14,405 T8) working K6KKR in Samoa but couldn't find the K6. Our dope, from WCFT, was that there was no active station in Samoa, but it looks like the picture has changed. Rolf also worked VQ3HJP (14,405 T7) . . . . Another VQ is VQ4KTF (14,080 T8) worked by U1BGY . . . . W8OUK has an interesting couple here: ST6AL (14,290, 14,330 T9x) and CROZS (14,290, 14,400 T6) . . . . And YSIAP (14,430 T9), heard by W2HHF, looks like a fair-to-middling bet . . . . Some of the lads were a little suspicious about the three-letter G's they worked on Field Day. You'll notice that the calls all end in "P"—that's the British "portable" designation . . . . A few more in the "Guess What" category: EY7F (14,370), heard by W9UQT, and ZK6K (14,405 T7), heard by U1EH . . . . There have been

several stations on signing ZC6 lately, including ZC6PO (14,375 T9) and ZC6KF (14,325 T7), but we're not quite sure if they're legit or not. Cards have been coming through from ZC6AA and ZC6AQ, however . . . . EA7AV (14,005, 14,410) has been on, but we can't say whether or not a card to his old address in Cadiz will reach him or not. You know how those things are these days.

**When:**

If a fellow were to go by the reports that trickle in here he might get the impression that 20 was the only band with any DX on it. We don't like to believe that, and that's why the dope from ZSIAN, via W3BGD, makes us feel better. ZSIAN says that he can hear W's down there on 3.5 Mc., which makes it a cinch for 7 Mc., and he relates how he has worked W6GRL on 28-Mc. sked when there wasn't another signal on the band. He seems to think the lads want everything their own way, and aren't willing to dig a little. So if you get tired of DX on 20, look around on one of the other bands for a while, and let us know how you make out . . . . Those Pacific Islanders are still on 7 Mc., except K6NVJ, who is waiting for replacement parts to arrive.

W9TJ, who used to work 'em with battery plate supply, has gone QRO, and some of his stuff includes ZD2H (14,300 T9), VK9DM (14,300), ZC6AQ (14,410), PJ3CO (14,430), and EL2A (14,370) . . . . W8OUK is in with some interesting material which includes LX1AO (14,340 T9x), LY1KK (14,380 T9x), YR5VV (14,405 T7), ZE1JI (14,375 T9), KA1AX (14,255 T8), U9ML (14,415 T9), OQ5AQ (14,350 T9), UX1CN (14,410 T9), and ZB1U (14,315 T9) . . . . W8RQA's contribution has U5KN (14,390 T5), CT2BE (14,405 T6), FY8AA (14,440 T7), SP1LN (14,390 T9), 11MH (14,430 T8), and SV1RX (14,400 T9x), as well as J2LL, J2JJ and J2KG at the high end . . . . W8PQQ reports F8SAB (14,390 T9x), F8BAD (14,310 T9x), VK9BW (14,400 T7), ZB1R (14,290 T9x), VS7RF (14,290 T9x) and PK1MF (14,390 T8) . . . . Down around Cuba, CM2AO grabs off OZ7PH (14,320), CN8AX (14,405), CT1ZZ (14,335), VQ8AB (14,300), XU8OL (14,340), and VQ8AS (14,315) . . . . W7GPY, who used to be W6PB, has been working KA1AP (14,150 'phone), OH5OD (14,400 T9), OK2PN (14,360 T7), KA20V (14,155 'phone), and PK1RI (14,020 'phone) . . . . At W8DOD it's LX1AG (14,432 T8) and U5HE (14,405 T9), and at W8HGG it's CT3AB (14,030) and HR7WC . . . . W9CWW has VK9VG (14,110) and CT2BC (14,145) in his list, while W5EWZ sports PK1BX (14,020) and XU6LN (14,060, 14,270 T8) . . . . W2HHF has a nice group which includes SU1TM (14,280 T9), ES7D (14,075 T9), YU7LX (14,420, 14,370 T7), VS6AO (14,350 T9), F18AC (14,405, 14,275 T9), UK1CC (14,275 T9x), and VP6RB (14,360 T9).

**What:**

Those of you that are interested in signal reports may be interested in some experiments we ran with W1SZ in connection with the New England Convention. We made a phonograph record with a constant c.w. signal on it and then faded in various forms of background noise and QRM, to see who could copy the most through QRN and QRM. The interesting thing, at least to us, was the fact that, in every case, the minute the QRN came on, the signal would appear to take a drop in strength. We knew this wasn't the case, because the signal was always fed in at a constant level, but nevertheless it sounded as though the signal was being attenuated at the same time that the noise was introduced. All of which leads us to believe that hams have trained their ears to have a sort of a.v.c. action that instantly takes care of noise peaks, reducing the response when noise gets bad. And it of course shows that the business of signal



**"HAM" WHYTE, G6WY, OF BECKENHAM, KENT, ENGLAND**  
*The No. 1 DX Century Club man resorts to no tricks to work his DX. The driver unit (6A6-6L6G) drives either a 10-20 PA or a 40-80 PA, and the antenna is the old reliable 133' straight tap, aided and abetted on occasion by half-wave doublers on 10 and 20. The receiver is a homemade 8-tube regenerative s.s. super which, according to Jim Lamb (who has heard it), is one of the smoothest-working there is.  
 (In case you can't read some of those cards on the wall, they include AC4YN, FN1C, EA9AI, and such.)*

reports is even more of an old shoes proposition than ever we had dreamed. What we need is a real method of comparing signals that gives a fellow an accurate indication of how he compares with others on the band. How about some of you brains giving it a thought?

There's another thing you may or may not know. We were running some tests with the 1851 as the first r.f. tube in a superhet, and comparing the signal/noise ratio of it with other tubes. On 20 it showed a slight improvement, about 25% better, but the interesting thing was that it was easier to get a better signal-noise ratio by cutting down the audio pass band with the old-fashioned tone control. For example, the 1851 would improve the ratio by 25%, but cutting in the tone control could improve it by 75% or more (this with the crystal at normal adjustment). These weren't aural tests: they were all made with a standard signal generator and so are reliable. Give it a try.

One more thing. W8NJP dropped in the other day for a nice chin-fling about DX, and among other things mentioned that he thought it would be a good idea for clubs to get together on the QSL-card mailing business. For example, all the fellows bring their cards going to the larger countries to the meeting, and the official bundles them together and sends them to the proper QSL Bureaus, saving postage all around. It should be a good thing in those clubs that have majority of DX-minded amateurs.

**Who:**

Consolation for this month comes from G6QX, who has been visiting throughout the East. He says, "I now know something of the QRN problem, and would say that G is a paradise compared to W on that count; the QRM from electric razors, diathermy machines, neons, power leaks, etc., has to be heard to be believed. Never would I have believed it possible to get so many power lines on the average lot as I saw in some places, short of a vertical antenna some locations are simply impossible, and the gang is to be congratulated on having the love of the craft to stick it out" . . . . G2VZ, an engineer at BBC's Checking Station at Tatsfield, has had the pleasant (?) experience of listening on 10 and hearing his own call pirated! As far as he knows, the pirate has been active only on 10 and 40 . . . . It isn't all smooth sailing for some of these smarties that sign phoney calls. W3FLH worked a fellow signing 17AC who said he was at Ras Dascian, but when Bern went back at the mug in Italian he answered in English and Q signals! It must be frightfully disconcerting, what? . . . . Then there are the lads who insist on quick QSL cards. K6BAZ has the answer: to the request of a W2 the other morning he replied that he didn't know whether bird mail would beat

fish mail or not . . . . . W3EYY claims some sort of record. With only 30% normal hearing, he has worked 69 countries, which would rate him about 230 countries with good ears . . . . . We kinda like G8MF's attitude. He says that "if some of the boys over there had a little more patience and waited until I finished my QSO's, instead of busting in, I would be able to work more, but as it is many QSO's are interrupted and therefore prolonged. I always like to finish a QSO when started." (Jeeves, what have you done with that ECO?) . . . . . Don't look now, but Mrs. W6QD just finished building a two-tube receiver of her own. Wonder why Herb doesn't let her use the big receiver once in a while? . . . . . Donald Clark, W2DBS, took over as op of W1OXDA at the last minute, since Cooper couldn't go . . . . . Gil, W1CJD, who draws those cartoons for QST, is down South America way on a boat, and pounded brass at HK1JB one evening. He's spoiled now, because he didn't have to touch the receiver all evening, there were that many fellows calling him . . . . . W3EDP, who makes odd lengths of wire really put out, has forsaken 'phone for DX and likes it. He should; he's been working VR4AD, F18AC, K6BAZ, VQ2GW, KA1AX, LZ7AN, U8WB, U9MJ, LX1AO, VR3A (QSL via G2SQ), and VP7NT, among others, for a total of 121 . . . . . W8ITH tells that FN8E (7300 T8) at Kwangchowan is on frequently, and that J2MI says J9PA in the Marshall Islands also gets on . . . . . On Field Day with only 15 watts input, W9RRS worked XU2AA (7300). Of course he was on a hill only 8600 feet high! . . . . . W6HIP claims that he has received the largest QSL card ever, and he's probably right. It's from K7ESJ, and takes the form of a Lambert Conformal Conic (whew!) Projection map 13" x 33" . . . . . VE3ADV, who is ex-G5UP, has been craking DX with things like K6BAZ, U9MI, I1LD, FT4AG (14,350 T9), FO8AA (14,403 T9x), VR4AD and CN8AX . . . . . W1CNU crawled out of the sack long enough to tell us that he has made up a rather complete loose-leaf booklet listing the DX he gleans out of these pages. He lists them by prefixes, with plenty of room for additions, and shows the reported frequencies after them. It works out well, according to Nick, although it's naturally a bit of a job. He doesn't depend on the frequencies entirely, but finds them to be fairly reliable . . . . . W8JSU bet a local he could WAC with less than 40 watts, and won in two months. Asia was the toughest, as might be expected . . . . . VK4CG (14,064) needs Nevada for WAS, as do most of us . . . . . W8GER thinks he's the last QSL Manager to get close to the CC, but he's well on the way with YN1AA, CT2BO and the like . . . . . W2IBT-6 passes it along that LU7AZ can be worked on about 3615 kc. if you get on around midnight . . . . . VE3AU, who sort of bowls over the DX when he gets on, is back, and added ZB1H and LX1AS the first day . . . . . I1IR (14,405) needs Nevada, N. D., S. D., N. M. and Wyoming for his WAS. He's 100% QSL, in case you haven't an I card . . . . . W8WQ has been having good luck with his haywire rhombic, if reports of "only W coming through" in Europe on 40 watts can be considered anything but perfect. Some of the better stuff includes TA2BS, CT2BM, EA7AV, YR5CG, YU7XU and SV1RX . . . . . We predict the finest DX conditions ever during the first week of July—we'll be 200 miles from the rig!

—W1JPE

## Briefs

During the past winter VO2J, Carbonear, Newfoundland, did a nice bit of QRR work handling train orders when trains were snow-bound, with all telegraph and telephone wires down. More recently, when a motor-boat was astray between St. Anthony and Conche on the northeast coast of Newfoundland, the Newfoundland Amateur Radio Association through VO1J established communication with VO3X, St. Anthony. Appreciation of authorities was expressed to amateurs for establishment of communication when other means were not available.

All VO stations when operating portable add the oblique stroke (DN) and the letter P to their home station calls.

## MEMBERS, DX CENTURY CLUB

	Countries
H. A. Maxwell Whyte, G6WY	(No. 5).... 134
Frank Lucas, W8CRA	(No. 1).... 125
Jefferson Borden IV, W1TW	(No. 3).... 124
Clark C. Rodimon, W1SZ	(No. 7).... 124
J. Mahieu, ON4AU	(No. 40).... 124
John Hunter, G2ZQ	(No. 6).... 123
C. E. Stuart, W6GRF	(No. 15).... 120
E. L. Walker, W8DFH	(No. 14).... 119
Douglas H. Borden, W1BUX	(No. 2).... 118
Don H. Mix, W1TS	(No. 9).... 116
Reeve O. Strock, W2GTZ	(No. 12).... 116
Walton H. Bostwick, W2GW	(No. 11).... 114
Henry Y. Sasaki, W6CXW	(No. 4).... 113
Harry G. Burnett, W1LZ	(No. 10).... 112
Jean Lips, HB9J	(No. 13).... 110
W. H. Alexander, W6KIP	(No. 28).... 110
George Grammer, W1DF	(No. 29).... 110
Keat Crockett, W9KQ	(No. 16).... 109
Onne L. Santti, W8DHC	(No. 27).... 108
C. L. Williams, W8JMP	(No. 22).... 107
Julius Wengler, W8OSL	(No. 23).... 107
Francis J. Walczak, W8DWV	(No. 17).... 106
John Marshall, W9ARL	(No. 18).... 106
Fred M. Gillett, W6HX	(No. 21).... 105
Paul de Neck, ON4UJ	(No. 31).... 105
A. Edward Hopper, W2GT	(No. 32).... 105
Glenn H. Means, W6ADP	(No. 34).... 105
John F. Dormois, W9GDH	(No. 41).... 105
Arthur H. Bean, W7AMX	(No. 26).... 104
Ralph H. Summers, W8OQF	(No. 30).... 104
Ralph E. Thomas, W2UK	(No. 33).... 104
William T. Caswell, Jr., W5BB	(No. 37).... 104
Richard J. Cotton, W8LEC	(No. 25).... 103
R. W. Weisbach, W9PST	(No. 35).... 103
R. W. Bensing, W4CBY	(No. 20).... 102
Guy Grossin, F8RJ	(No. 8).... 101
H. Hodgson, EI5F	(No. 19).... 100
Jack Claricoats, G6CL	(No. 24).... 100
Robert Holmes, G6RH	(No. 36).... 100
Wilmer L. Allison, Jr., W5VV	(No. 38).... 100
Rolf Lindenahayn, Jr., W2BHW	(No. 39).... 100
Roy W. McCarty, W9KA	(No. 42).... 100

The following have submitted proof of contacts with 75-or-more countries:

J5CC . . . . . 99	W4AJX . . . . . 88	W6ITH . . . . . 81
PAQXF . . . . . 99	W8BOX . . . . . 88	W8AU . . . . . 81
W9EF . . . . . 99	W6BAM . . . . . 87	W9FLH . . . . . 81
W1ZB . . . . . 98	W9AEH . . . . . 87	W1GCX . . . . . 80
W3EVW . . . . . 98	F8BAB . . . . . 87	W3BVN . . . . . 80
W1DUL . . . . . 97	G2DZ . . . . . 87	W3EPR . . . . . 80
W6FZL . . . . . 97	PAQZ . . . . . 87	W3FRY . . . . . 80
W1VW . . . . . 96	VE2AX . . . . . 87	W3VX . . . . . 80
W3EVT . . . . . 96	W1RY . . . . . 86	W8DGP . . . . . 80
F8RR . . . . . 96	W2HHF . . . . . 86	W1GNE . . . . . 79
W1CC . . . . . 95	W8ADG . . . . . 86	W5A8G . . . . . 79
W1JPE . . . . . 95	W1FTR . . . . . 85	W8FJN . . . . . 78
W3EDP . . . . . 95	W8CJJ . . . . . 85	W9UM . . . . . 78
W3EMM . . . . . 95	G6GH . . . . . 85	G2TR . . . . . 78
W6GAL . . . . . 95	W4BPD . . . . . 84	W1BFT . . . . . 77
PAQQF . . . . . 95	W4CCH . . . . . 84	W1EWD . . . . . 77
G6RV . . . . . 94	W4CFD . . . . . 84	W2GRG . . . . . 77
W2GVZ . . . . . 94	W8KTW . . . . . 84	W5KC . . . . . 77
W9ADN . . . . . 93	W2CYS . . . . . 83	W8BSF . . . . . 77
W4CEN . . . . . 92	W3AIU . . . . . 83	SU1WM . . . . . 77
W1ZI . . . . . 91	W3GAU . . . . . 83	W2DSB . . . . . 76
W8EUY . . . . . 91	HB9X . . . . . 83	W6GPB . . . . . 76
W3BES . . . . . 90	G5QY . . . . . 83	W8DOD . . . . . 76
W4DRD . . . . . 90	VE2EE . . . . . 83	W8LZK . . . . . 76
W2DC . . . . . 89	SP1AR . . . . . 82	G5BD . . . . . 76
W3EPV . . . . . 89	W1BGY . . . . . 82	W1ICA . . . . . 75
W8KKG . . . . . 89	W8AAJ . . . . . 82	W3CKT . . . . . 75
VK5WR . . . . . 89	W1ADM . . . . . 81	G6ZO . . . . . 75
W2CBO . . . . . 88	W6GHU . . . . . 81	PAQJMW . . . . . 75

New Century Club members this month: W6ADP W9PST, G6RH, W5BB, W5VV, W2BHW, ON4AU, W9GDH and W9KA. Congratulations, all! The Century Club and "75-or-more" listings represent the only official confirmed countries worked list in existence. Send in your confirmations when you can qualify for at least 75 countries.

## Kansas Emergency

Well, it happened! Out here in high and dry, mild climate Kansas. On the night of April 7th a good old "norther," like grandpa used to tell about, blew into Kansas, rain, sleet and snow in abundance, taking out an enormous number of communication lines in the state.

The gang got on the air immediately and went to work. W9ZMS at Wichita kept schedules all night with W9COP at Mulberry, dispatching Kans. Gas & Elec. Co. traffic. Some traffic was also handled for Phillips Petroleum at Bartlesville, Okla. The following morning a schedule was established with W9AEY at Beloit for the Cities Service and important traffic handled from there for some time. W9MPH, W5GSM/9, W9SIL and W9TFR handled press for the Wichita papers by working W9KFK in Kansas City. Wichita was without wire communications of any kind for 24 hours. W9WIN, Wichita, worked W9ZAW, Ft. Scott, and did some relaying for the Frisco R. R. W8FWY and W9QQQ, Manhattan; W9TAI, Herington; W9AWB, Hutchinson; and W9FRW, Pratt, helped find some Rock Island trains that were stalled in the drifts out in the western part of the state. W9IQV, W9KST, W9RQE and W9TBR manned the Kansas State College Radio Club station, W9QQQ, W9DKI, Great Bend; W9SRS, Salina; W9VRZ, Pretty Prairie; W9RAT, Coffeyville; W9EYY, Ottawa; W9NJS, Winfield; W9FLG, Topeka, W9GXW, Concordia; W9QCH, Winfield, were heard passing traffic along. W9ADE, Abilene worked W9WQN, White City, dispatching for Kansas Power and Light. W9WQN was forced to use emergency power (batteries) for several hours due to failure of commercial lines.

With all the telegraph and most of the telephone wires down at Colby, W9YAH handled Western Union traffic with W9HO of Salina. W9YAH was also in communication with W9CDM, Concordia, W9KTE, Norton, W9UJW, Oakley, and W9YRS, Hutchinson, handling messages for the United Telephone Co., the Rock Island R.R. and Western Union. This was all on 7 Mc. W9JDY assisted in operating at W9HO. W9YRN, Salina, was alternate for W9HO. W9NQH, Abilene, assisted in getting information on the condition of telephone lines in his section of the state. W9ATI at Herington, together with other 1.75-Mc. 'phone stations, aided the Missouri Pacific R.R.

W9FWY, Manhattan, and W9ECF, Leonardville, acted as control stations for the Kansas Cyclone network, taking traffic from over the state and relaying to Kansas City, by W.U. and later via W9QQQ, Kansas State College. W9BOE, W9ELU, W9KST and W9UGL assisted at W9FWY. W9JWY, Lyons, on 3900-cc. c.w. raised W3QV ('phone) with a rush message for Salina. W3QV forwarded the mes-

## BRASS POUNDERS' LEAGUE

(May 16th—June 15th)

Call	Orig.	Del.	Rel.	Extra Del. Credit	Total
W1IYE	19	38	1618	28	1703
W4PL	6	92	1224	83	1405
W1KQY	7	35	1280	18	1340
W1LHE	6	18	1075	6	1105
W6IOX	26	51	874	48	999
W6RN	250	145	275	275	945
W7EBQ	13	51	768	62	894
W8LMD	4	9	724	6	743
W8DH	39	116	446	116	717
W7DUE	5	9	680	9	703
W6ITH	68	163	288	156	675
W6LUJ	70	141	283	137	631
W6TTV	74	210	146	168	598
W6LLW	26	52	474	38	590
W3SN	81	74	422	—	577
W3CIZ	39	89	345	—	562
K6NXD	308	51	152	49	556

### MORE-THAN-ONE-OPERATOR STATIONS

Call	Orig.	Del.	Rel.	Extra Del. Credit	Total
W1R	1770	53	—	—	1770
W4BR	735	53	312	—	1578
W5DKR	185	150	325	325	985
W5OW	102	77	636	60	875

These stations "make" the B.P.L. with total of 500 or over. One hundred deliveries + Ex. Del. Credits also rate B.P.L. standing. The following one-operator stations make the B.P.L. on deliveries. Deliveries count!

W8IQ, 258	W7APS, 148	W6IMI, 117
W2KTR, 217	W8MTS, 147	W1KH, 114
W3QP, 217	W6KMM, 132	W6MDI, 110
W2WEL, 199	W4HZ, 131	W1JCR, 100
W6RRH, 188	W5FMO, 125	W3EDC, 100
W6PFL, 148	W1KZT, 120	W6HSA, 100
	W5MNN, 120	

A.A.R.S.

### MORE-THAN-ONE-OPERATOR STATIONS

Call	Orig.	Del.	Rel.	Extra Del. Credit	Total
WLM (W3CXL)	126	104	2520	58	2808

A total of 500 or more, or 100 deliveries Ex. D. Cr will put you in line for a place in the B.P.L.

sage by W.U. Amateur radio was the only means of communication from Lyons for several days. W3QV sent a message to W9FDO, Kansas City, Kansas via W9FMZ, arranging a schedule for W9JWY, and advised A.P. that they could send their press into Lyons via W9FDO.

The most outstanding feature of the emergency work in Kansas was that although it was possible to raise stations in almost any particular part of the state, most of the fellows were listening, getting on the air only when they were called or had a message to handle. There was an absence of needless CQ's and QRM.

—Maurice Lampl, W9UQX,  
Assistant S.C.M., Kansas

### A.R.R.L. Headquarters Operators

Hal Bubb, "Hal," Chief Opr. W1AW.

The following calls and personal sines belong to members of the A.R.R.L. Headquarters gang:

- W1AL, J. J. Lamb, "jim"
- W1AW, A.R.R.L. Headquarters Operators Club
- W1BAW, R. B. Beaudin, "rb"
- W1BDI, F. E. Handy, "fh"
- W1CBD, C. B. DeSoto, "de"
- W1DF, George Grammer, "gg"
- W1EH, K. B. Warner, "ken"
- W1ES, A. A. Hebert, "ah"
- W1GS, F. C. Beekley, "beek"
- W1JBJ, Thomas W. York, "ton"
- W1JEQ, Vernon Chambers, "vc"
- W1JFN, A. L. Budlong, "bud"
- W1JPE, Byron Goodman, "by"
- W1JTD, Hal Bubb, "hal"
- W1LJL, Thomas M. Ferrill, Jr.
- W1SZ, C. C. Rodimon, "rod"
- W1TS, Don Mix, "don"
- W1IUE, E. L. Battey, "ev"

### Hams Afloat

W2BSJ writes to say that he has been shipping in the Merchant Marine since 1926. At present he is on the S.S. *A. L. Kent*, KDLL. . . . W2BSJ is on the air with portable-mobile 56-28 Mc. rig. . . . W8MTE is operator on the S.S. *North American*, WTBA, of the Georgian Bay Lines on the Great Lakes. . . . W8SAC and W8JIO are also on the Lakes, on the Steamer *D. M. Clemson*. . . . K7GLZ is Chief Radioman on NRDS, U.S.C.G.C. *Spencer*. . . . K7BUK is operator on the S.S. *Cordova*. . . . W9LAF is a Navy man—he holds the rating of RM3c on the U.S.S. *Concord*. . . . W6ITY is operator on the S.S. *Robert Luckenbach*, W9BHP on the S.S. *Steelmaker*. . . . W9AKT is on Naval Reserve duty this summer (starting July) on the U.S.S. *Paducah*, NESG; he expects to have a 56-Mc. rig along, so five-meter operators along the shores of Lake Michigan should be on the look-out for him. . . . W5BVF has a berth on the S.S. *City of Joliet*, pounding brass as KUJR between the Gulf ports and Europe. He has visited several British amateur stations on his travels, among them G5GQ, G2FS, G6OS and G8KZ, where he is a frequent visitor. When in the States he is on the air at W5GPL, Galveston.

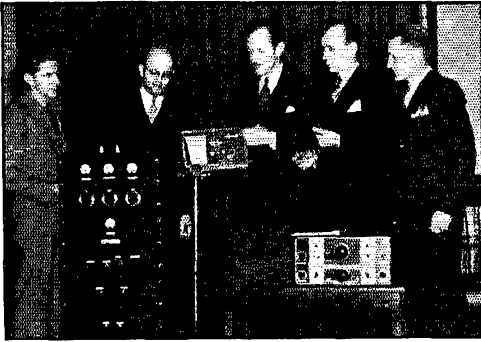

**DELAWARE VALLEY RADIO ASSOCIATION OFFICERS**

Left to right: William Hannah, W3EUH, Treasurer; Edward G. Raser, W3ZI, Secretary; Lieut. A. H. Waite, Jr., W3HKO, Chief Radio Operator of Byrd Antarctic Expedition II, and member of D.V.R.A. Board of Directors; Lester H. Allen, W3CCO, President; Edward B. Kerr, W3CCC, Vice-President.

The Delaware Valley Radio Association, Trenton, N. J., is undertaking a series of lectures and special events in an effort to better educate the general public as to the intrinsic value of amateur radio in the community. On March 1st the Association was sponsor of an educational lecture by Lieut. Waite, W3HKO, entitled "The Rescue of Admiral Byrd." The part played by amateur radio in providing communication with expeditions was explained and a demonstration of two-way amateur communication given. In the photo W3HKO is holding one of the portable tractor sets which was used to maintain communication at Little America.

**Hamfest Schedule**

August 7th, at Mt. Lebanon, Pa.: The South Hills Brass Pounders and Modulators of Pittsburgh will hold their annual hamfest at Clattys Driving Range, Bower Hill Road, Mt. Lebanon, Pa., on the afternoon of Sunday, August 7th. Among the principal speakers will be Walter Bradley Martin, W3QV, Atlantic Division Director. Plenty of good prizes and eats. Don't miss this big get-together!

August 14th, at Washington Crossing, N. J.: The Second Annual Eastern States Outing and Hamfest under the auspices of the Delaware Valley Radio Association will be held Sunday, August 14th, 10:00 A.M. to 8:00 P.M. (if rain, date will be August 21st). The place—Sullivan's Grove, Washington Crossing, N. J., 7 miles northwest of Trenton on River Road. Among the main attractions will be a Big Championship Baseball Game, Second District vs. Third District. \$1.50 per person at gate; \$1.00 each if paid before August 10th. Mail all reservations to W3ZL, 46 Marion St., Trenton. Come one, come all—OM's, OW's, XYL's, YL's, Hams to-be—a good time is in store for all.

August 20th-21st, at Valparaiso, Fla.: Jimmy Long's (W4KB) annual hamfest is scheduled for August 20th and 21st. This affair needs no introduction to the Eastern Florida gang and those in surrounding states. Be in Valparaiso at W4KB on the dates mentioned and you'll realize where this affair gets its popularity!

August 28th, near Cincinnati, Ohio: The Greater Cincinnati Amateur Radio Association and the Cincinnati U. S. Naval Reserve Unit announce their annual hamfest and stag picnic to be held August 28th at the Boone County Harvest Home Grounds, Florence, Ky. Big rag chew, red-hot program, lots of good food, contests, games, exhibits, fun for all, plenty of prizes! Advance registration \$1.00; tickets at gate \$1.25. Motor cavalcade starts 9:00 A.M. from the Naval Reserve station NEG-W8NC, Union Central Life Bldg., 4th and Vine Sts., Cincinnati. Information and registrations from W8FBF, 1974 Avonlea Ave., Cincinnati, Ohio.

August 28th, The Marin Radio Amateurs are holding their annual hamfest and picnic. This hamfest grows larger each year. A new trophy is offered for the softball tournament, an event that always meets with much enthusiasm. The gathering place is McNears Beach, out of San Rafael, Calif.

**ELECTION NOTICES**

To all A.R.R.L. Members residing in the Sections listed below: (The list gives the Sections, closing date for receipt of nominating petitions for Section Manager, the name of the present incumbent and the date of expiration of his term of office.) This notice supersedes previous notices.

In cases where no valid nominating petitions have been received from A.R.R.L. members residing in the different Sections in response to our previous notices, the closing dates for receipt of nominating petitions are set ahead to the dates given herewith. In the absence of nominating petitions from Members of a Section, the incumbent continues to hold his official position and carry on the work of the Section subject, of course, to the filing of proper nominating petitions and the holding of an election by ballot or as may be necessary. Petitions must be in West Hartford on or before noon of the dates specified.

Due to resignations in the Oregon and Hawaii Sections, nominating petitions are hereby solicited for the office of Section Communications Manager in these Sections, and the closing date for receipt of nominations at A.R.R.L. Headquarters is herewith specified as noon, Monday, August 22, 1938.

Section	Closing Date	Present SCM	Present Term of Office Ends
Santa Clara Valley	Aug. 1, 1938	Elbert J. Amarantes	Aug. 15, 1938
Ohio	Aug. 1, 1938	E. H. Gibbs	Aug. 17, 1938
Nbraska	Aug. 1, 1938	S. C. Wallace	Aug. 17, 1938
Western Mass.	Aug. 1, 1938	William J. Barrett	Aug. 17, 1938
New Hampshire	Aug. 15, 1938	Carl B. Evans	Sept. 1, 1938
Utah-Wyoming	Aug. 22, 1938	Thomson J. Rigby	June 15, 1938
Hawaii	Aug. 22, 1938	Otia Hill (resigned)	.....
Oregon	Aug. 22, 1938	Eugene E. Lovejoy (resigned)	.....
Nevada	Aug. 22, 1938	Edward W. Heim	June 14, 1938
Vermont	Aug. 22, 1938	Alvin H. Battison	April 15, 1938
So. Minnesota	Aug. 22, 1938	Webster F. Soules	April 16, 1938
Mississippi	Sept. 22, 1938	J. H. Weems, Jr.	Oct. 1, 1938
Tennessee	Oct. 3, 1938	B. G. Lowrey Smith	Oct. 14, 1938
Ontario*	Oct. 3, 1938	Fred H. B. Saxton	Oct. 15, 1938
Michigan	Oct. 3, 1938	Harold C. Bird	Oct. 15, 1938
Philippines	Oct. 3, 1938	George L. Rickard	Oct. 15, 1938
Kansas	Oct. 17, 1938	Harry E. Legler	Oct. 29, 1938

\* In Canadian Sections nominating petitions for Section Managers must be addressed to Canadian General Manager, Alex Reid, 169 Logan Ave., St. Lambert, Quebec. To be valid such petitions must be filed with him on or before the closing dates named.

You are hereby notified that an election for an A.R.R.L. Section Communications Manager for the next two year term of office is about to be held in each of these Sections in accordance with the provisions of the By-Laws.

The elections will take place in the different Sections immediately after the closing date for receipt of nominating petitions as given opposite the different Sections. The Ballots mailed from Headquarters will list in alphabetical sequence the names of all eligible candidates nominated for the position by A.R.R.L. members residing in the Sections concerned. Ballots will be mailed to members on the closing dates specified above, for receipt of nominating petitions.

3. Nominating petitions from the Sections named are hereby solicited. Five or more A.R.R.L. members residing in any Section have the privilege of nominating any member of the League as candidate for Section Manager. The following form for nomination is suggested: (Place and date)

Communications Manager, A.R.R.L.  
38 La Salle Road, West Hartford, Conn.

We, the undersigned members of the A.R.R.L. residing in the \_\_\_\_\_ Section of the \_\_\_\_\_ Division hereby nominate \_\_\_\_\_ as candidate for Section Communications Manager for this Section for the next two-year term of office.

(Five or more signatures of A.R.R.L. members are required.) The candidates and five or more signers must be League members in good standing or the petition will be thrown out as invalid. Each candidate must have been a licensed amateur operator for at least two years and similarly, a member of the League for at least one continuous year, immediately prior to his nomination or the petition will likewise be invalidated. The complete name, address and station call of the candidate should be included. All such petitions must be filed at the headquarters office of the League in West Hartford, Conn., by noon of the closing date given for receipt of nominating petitions. There is no limit to the number of petitions that may be filed, but no members shall sign more than one.

4. Members are urged to take initiative immediately, filing petitions for the officials for each Section listed above. This is your opportunity to put the man of your choice in office to carry on the work of the organization in your Section.

—F. E. Handy, Communications Manager

**ELECTION RESULTS**

Valid petitions nominating a single candidate as Section Manager were filed in a number of Sections, as provided in our Constitution and By-Laws, electing the following officials, the term of office starting on the date given.

Maritime	Arthur M. Crowell, VE1DQ	June 15, 1938
Iowa	Clyde C. Richelleu, W9ARE	June 15, 1938
Los Angeles	Ralph A. Cilek, W6MQM	July 1, 1938
Western Penna.	Edward Speer, Jr., W8CFO	July 10, 1938
Illinois	Leslie M. Dickson, W9RMN	July 10, 1938

Station Activities Page 72



# CORRESPONDENCE

The Publishers of QST assume no responsibility for statements made herein by correspondents

## For Manufactured Gear

118 Soundview Ave., White Plains, N. Y.  
Editor, QST:

Lately, there have appeared in your august publication several statements, evidently the brain-children of immature or irresponsible minds, deploring the use of factory-built radio equipment, and casting rather patronizing innuendoes against those amateurs that use such equipment. As an active amateur and member of the League, with an amateur background dating to 1912, and a commercial background dating to 1917, I take issue with such childish prattle.

At the outset let me make one point clear. I am *not* in the radio business, nor am I dependent for my livelihood upon anything even remotely connected with radio or any of its ramifications. Therefore I can establish quite definitely that I have no axe to grind in expressing these views.

I use a factory-built receiver and a partially factory-built transmitter in my station. What of it? I feel that I had my fill of messing around with various types of nondescript home-made apparatus years ago. In fact I have constructed some pretty fair rigs before some of our self-styled critics were born. Being a practical business man to-day, I now look at most things from a practical business viewpoint. I have long since given up the idea of being a Tesla or an Edison. I enjoy amateur radio for the pleasure of engaging in actual communication, and it ends right there. Such being the case, is it not only logical but prudent that I should equip myself with apparatus that I consider most efficient and dependable for the funds available for the purpose? As stated above, I have a factory-built receiver, and it happens to be one of the best. Now I challenge any of our "great experimenters" to produce an equivalent job at no greater cost. Do I hear any responses? Of course not; it can't be done. . . .

—Richard C. Kleinberger, W2GVU

Lansford, Pa.

Editor, QST:

Concerning VE4NM's letter in the June issue, I would like to sum it up in two words: "Sour grapes."

I myself have anything but a commercial layout, but I sure could go for one in a big way if—!!\$!!

Personally, I drive an automobile which I made

myself. No "robot-working," manufactured car for me! No sir! I might just as well travel by train.

—Charles Olsefsky, W8RCL

## 14-Mc. for DX Only

2014 N. Berendo St., Hollywood, Calif.  
Editor, QST:

After reading W1WV's letter in June QST . . . all I can say is that I am fed up with the whole business of dickering around about the DX situation on the 20-meter band. My blood is boiling, my grid is leaking, I—I am at a loss for words.

After plenty of careful thought and consideration, I sincerely believe that, due to conditions as they are to-day and as they always will be, the 20-meter band should be restricted to contacts outside of the U. S. *only*. This plan cannot fail—it is foolproof. More enjoyable DX will be experienced. It will create a friendly international band. Hams from all over the world will "feel at home on twenty!"

—Stanley R. Radom, W6KBY-MXZ

## García Gets D—X'ed

Calle 15 Num 1209 Vedado, Habana, Cuba  
Editor, QST:

I desire for you to say to me what you feel if it happen to you? For two year ago I have five conts. and only need Asia for to get whack but not very easy for all days I try for hooking one. Six months back from now one evening I break sleep two o'clock in morning and see ow is sleeping soundly and loud I alight down from bed and snake to shack and seat in chair in front of operating mess. I put ears in cans but only I hear nothing and weirdly noise and no sig. Then I listen very thin sea queu and is very heavy to finally to fish him out the call. It is a XU' when he stop I start calling his call but so elated I forgot to close switch of plate of T55. I notice desk light don't wink and correct error. I burn seven-pound btu calling his call and stand buy and hear to see if he listened me. Sure! he whispers CM2AO! After the gm om tnx fer ur call he say my rst is 589x I know he is a liar and I am another I tell him he is 599x he say sure will qsl tnx and please cheerio. I ascend back to bed but cannot sleep too much excitation. Next morning I send him

nice letter wid crd in envelope wid two special deliveries. For six months I wat but head so big I dont care for qso wid W Ve VK or Europe or S A or Afr. but he never send qsl. To-day in morning I have laundry boy transfer to Chinese language nice letter and go post Office to register when I come back I go front of stand of newspapers and by QST and read my XU is no Chink but damp peddler of contra-band liquor in Washington, D. C. I am very mad I think I sell my rig for nothing but afraid to morrow morning I try agn. Cu agn.

—S. E. Garcia, CM2AO

## About 56-Mc. DX

1426 South Wabash Ave., Chicago, Ill.

Editor, QST:

After having watched last night's scramble for QSO's on the 5-meter band I begin to think that better organization in handling things would increase enjoyment and results.

First of all, it may appear that the DX possibility is moving from east to west and stops with the coming of the darkness. If this is the case, then the DX possibility for an amateur in the east becomes zero while there is still a chance for the fellows on the western end to work further west.

I wonder if the broadcasting companies could be induced to broadcast for one-half of one minute, perhaps during the program change, to spread the news of the DX possibilities to the western territories, because the commercials benefit from the observation of the amateurs. . . .

After the east coast stations began to fade Chicago stations pulled the switches because they had something to "talk about," and because the excitement was over, while the real thrill might have been in store for them. . . .

—Willly Hess, W9VPC

## The Maternal Angle

Apt. D2A, University Apts., Durham, N. C.

Editor, QST:

Not being a very good composer I hardly know how to start, but I would like to tell you how very much I enjoy your QST. I read every issue through. This is not very out of the ordinary and maybe you are wondering why I am writing this. Well, if you knew my mother you would think it is funny. She is the most lovable and understanding mother in the world, but when it comes to radio she is absolutely ignorant and uninterested. I have been trying for a long time to get her to pay just a little attention to my hobby, but to her it is completely boring. What I am trying to say is that it was your magazine that did the trick. I read her K6PGQ's article in March issue and W7FKC's article in June issue and now she is a regular enthusiast. Hi! She even sits up to midnight with me sometimes when I try to get a little DX on forty.

Thanks to K6PGQ and W7FKC and you for doing what I had almost given up as hopeless.

—Charles P. Walton, W4FJS

## More on the SWL

929 First Ave., Salt Lake City, Utah

Editor, QST:

Three hours operation on 20-meter 'phone the other night brought seven SWL cards. Two had one-cent stamps tacked on for "return postage." All begged on bended knee, "Your my first Utah—" "B A Sport—" "Cause a miracle, QSL," etc.

I think the recent sentiment against the American SWL activity is well founded. Foreign SWL cards tell a good deal. They give a critical indication of the transmitting range, but as far as the signal reports given by the American SWL's, the amateur can do a much better job by operating a few hours. . . .

SWL is the first stage in the development of an amateur. But why capitalize at such an early stage? If the SWL would use the dollars wasted on postage and cards to buy a good radio manual, and if he would put his "QSL energy" into earnest study, he could take the next step into Hamdom and become a respectable citizen.

A space on my wall is reserved. Above it is a cardboard tombstone. Every SWL card that finds its way into my mail box receives a pauper burial, and any postage for "return purposes" will help buy the four tacks that hold each card in place.

—Wm. R. Turner, W6KOP

2307 Winter St., Fort Wayne, Ind.

Editor, QST:

. . . I do not own or operate a station but I am a short wavelistener. I am one of those listeners who has sent reports of station's transmissions and requested one of their call cards. I've always enclosed sufficient postage for mailing. I realize that to the operator it has become a large problem to send cards and answer all letters. If a rule was made that no QSL cards would be sent unless sufficient postage is furnished for cost of cards and mailing it would solve the problem. In the United States three cents in postage is sufficient for cost of card and of mailing. It only costs one cent to mail a card in the U. S., and this leaves two cents for the cost of the card. I believe it would be worth his while to answer the letter even if it did contain "pointless signal reports."

His phrase "pointless signal reports" interests me very much. To an operator who has owned a station a few years, they (signal reports) would mean very little, but to a beginner they are very important. These reports inform him how his transmission is received in places which he has never contacted. Well, this is all, and I hope the "listeners" will furnish sufficient postage when writing to an amateur station.

—Jack L. Flauding

621 Prairie Ave., Glen Ellyn, Ill.

Editor, QST:

In a recent letter W5BB said that something should be done about SWLs, especially b.c.l.s, who want a lot of cards to show off. I agree that there probably are many of this kind, however, there are some who are really interested.

I have just completed an 8-tube super (QST April '36) and I expect to use it when I get a license (which I plan to go after this spring). I have also put up antennas suitable for transmitting.

SWLing has given me a foundation for my knowledge (little that it may be) and there are many others who feel the same way. . . .

About the so-called "rubber stamp" SWL cards. Have you ever stopped to think that some SWLs couldn't afford anything better? I have seen many QSLs just as bad. However, I am not criticizing them. Some of the QSLs I like best are of that variety. It is not the looks of the card but the message that counts.

And remember that we spend as much postage as you do.

—Jim Tillotson

## Ham Imposters

Vandalia, Ohio

Editor, QST:

Some boys make a racket of posing as hams, usually from a long way off, and go around visiting amateurs. They usually pull a gag that they are out of money and want you to send a message through to their folks, usually out in California or some place. Then they hint that they'll stay around in the vicinity until they get their money, which of course never comes. I've had two such hitchhikers visit me, one posing as W6DDR (which isn't listed). He also posed as a commercial operator. Amateurs should be notified of these prowlers and if they can't produce their ticket then send them on their way pronto. . . .

Duke Bettelon, W8MPV



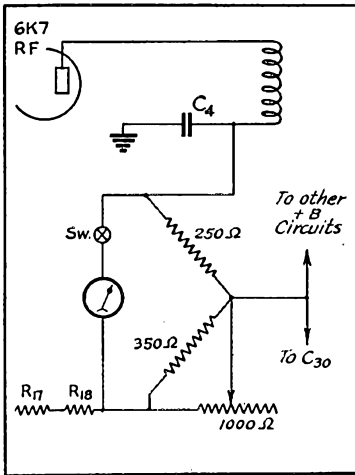

AS A RESULT of our recent announcement that all NC101X receivers are now being manufactured with S meters in place of the magic eyes formerly used, we have had a number of inquiries as to just how it is done. The circuit diagram is given herewith. The meter is a standard 0-1 milliammeter. If you have such an instrument on hand, you can easily enough make a special scale — either in “S Units” or “Microvolts.” In this latter case the accompanying calibration curve will prove useful. On the other hand, if you do not want to make your own scale and want one of the special meters such as we use on our receivers, you will find them

listed in the new No. 280 National catalog. The type number is SM80 and the net price is \$6.00 including a sloping-panel mounting case which eliminates the need for removing the magic eye and chopping a meter-size hole in the front panel of the receiver. (Such an operation is relatively easy for some fellows but not so easy, we are told, for others!) One thing more — in adjusting the meter circuit, the 1000-ohm variable resistor is set at a value which will balance the bridge circuit (that is, cause meter to show no deflection, either positive or negative, when the r.f. gain control on the receiver is set just short of maximum, or at about 9 on the scale; the a.v.c. turned on; and the receiver not tuned to any signal).

JAMES MILLEN

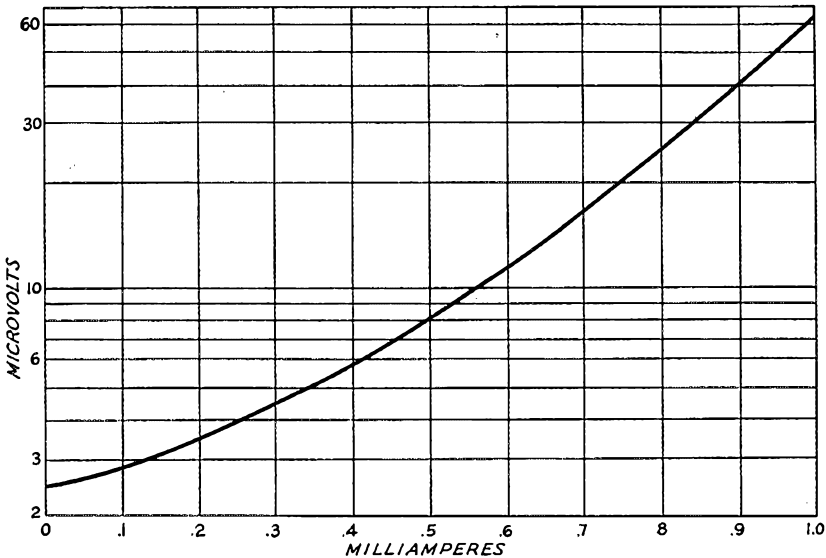



**When Temperatures are Up  
and Collars Wilt Down**

**P. R. MALLORY & CO. INC.**  
**MALLORY CONDENSERS**  
*are Unaffected*

Steamy summer days may play havoc with ordinary condensers. But they do not affect Mallory Replacement Condensers because humidity doesn't get to them!

Mallory provides a heavy metal seal around the actual condenser unit inside the carton. This protection—plus a final sealing of the carton itself—so completely safeguards the condenser that its characteristics remain unchanged despite increasing or decreasing humidity.

The humidity proof feature of Mallory Replacement Condensers is one big point of superiority. There are many others. If you are not using them, you are missing a real bet. Ask your distributor about Mallory Replacement Condensers—now!

**P. R. MALLORY & CO., Inc.**  
**INDIANAPOLIS INDIANA**

Cable Address—Pelmallo



Use  
**P. R. MALLORY & CO. INC.**  
**MALLORY**  
APPROVED RADIO  
PRECISION PRODUCTS

Use  
**YAXLEY**  
APPROVED RADIO  
PRECISION PRODUCTS

**Scores A.R.R.L. Contest**

(Continued from page 40)

<i>Louisiana</i>		<i>Missouri</i>	
W5WG	14976-144-52	W9GBJ	9030-105-43
W5KC	12954-127-51	W9VLP	5928-79-38
W6DWW	6478-79-41	W9AUB	4176-58-36
<i>Mississippi</i>		W8SBR	1600-32-25
W5GHH	2436-42-29	W9OOD	1178-31-19
W5GEA	308-14-11	<i>Nebraska</i>	
W5FIT	220-11-10	W9DMY	7452-81-46
<i>Tennessee</i>		W9ZUM	2436-43-29
W4CXY	6464-101-32	W9EUT	972-27-18
W4PL	5632-64-44	W9ZHT	240-12-10
W4DQG	2100-42-25	<i>New England Division</i>	
W4EIS	1750-35-25	<i>Connecticut</i>	
W4DDJ	897-21-17	W1HYF	7566-97-39
W4RM	336-14-12	W1KFN	5454-101-27
<i>Hudson Division</i>		W1BHM	5439-74-37
<i>Eastern New York</i>		W1CIC	3175-64-25
W2DIJ	6160-110-28	W1GME	2310-55-21
W2EWD	5965-79-38	W1JHN	1748-38-23
W2FCG	2800-50-28	W1HYF	1734-51-17
W2ISQ	2784-58-24	W1EAO	690-23-15
W2KFB	728-26-14	W1CIT	580-29-10



**HERE'S THE MAN  
BEHIND THE BUG  
AT W8OFN, DR.  
HAROLD E.  
STRICKER**

**"Doc" was third  
highest scorer and  
Ohio winner.**

<i>N. Y. C.-L. I.</i>		<i>W1AWL</i>	24034-197-61
W2IBT	11316-138-41	W1UEP	9440-118-40
W2HMJ	10684-124-43	W1T8A	5405-73-37
W2HRV	9400-100-47	W1JPE	5180-74-35
W2DBQ	8216-128-36	W1BDI	2808-52-27
W2KBR	6142-83-37	W1JBJ	2070-45-23
W2AEC	5016-66-38	W1E8A	768-24-16
W2AOD	3306-57-29	W1JFN	24-4-8
W2EIL	3078-57-37	<i>Maine</i>	
W2BGO	2806-61-23	W1IZU	5994-81-37
W2HUG	2231-49-23	W1FBJ	2990-66-23
W2KIK	1598-38-21	W1LEB	260-13-10
W2AJL	1520-38-20	W1GJL	2-1-1
W2JHB	988-26-19	<i>E. Massachusetts</i>	
W2KIX	928-29-16	W1LEV	6751-79-43
W2JCA	494-19-13	W1IQH	6587-100-33
W2KFW	468-18-13	W1LEP	4760-70-34
W2EC	324-18-9	W1IWC	4234-73-29
W2AZM	280-14-10	W1JEA	3712-64-29
W2JDG	154-11-7	W1IKU	940-28-15
W20Q*	126-9-7	W1INO	602-22-14
W2HAK*	72-6-6	W1BSG	253-12-11
W2KTH*	2-1-1	W1BSM	60-6-5
<i>No. New Jersey</i>		W1ZR	50-5-5
W2IKH	8640-108-40	<i>W. Massachusetts</i>	
W2HZY	7344-108-34	W1EOB	12446-127-49
W2JTE	6640-84-40	W1LXN	2550-51-25
W2JKG	5994-81-37	W1JAN	2106-39-27
W2KHA	3630-61-30	W1DCH	2016-48-21
W2GGW	3024-54-28	W1BIV	1350-45-15
W2ECO	2800-50-28	W1KOM	1200-30-20
W2JUC	2560-64-20	W1FPP	810-27-15
W2CW	2548-49-26	W1JAH	560-20-14
W2CFW	2400-50-24	W1BKG	220-11-10
W2KMY	1824-38-24	W1JLL	220-11-10
W2HNP	1260-35-18	<i>New Hampshire</i>	
W2HRN	702-27-13	W1BTF	15184-146-52
W2EWM*	48-6-4	W1AVJ	8774-107-41
W2JQE	18-3-3	W1HJM	7344-102-36
<i>Midwest Division</i>		W1P	6144-96-32
<i>Iowa</i>		W1AXL	1975-47-21
W9LEZ	7644-91-42	W1KIN	160-10-8
W9UOX	1820-35-26	W1HGV	80-8-5
W9YXK	1100-25-22	<i>Rhode Island</i>	
W9WVY	736-23-16	W1IQF	3528-63-28
W9BBB	510-18-15	W1JUE	2484-54-23
W9NVF	112-8-7	W1GTN	1764-42-21
<i>Kansas</i>		<i>Vermont</i>	
W9CWW	10560-110-48	W1E2	22568-202-56
W9VBQ	2016-98-46	W1JXS	1496-34-22
W9WIN	1904-35-28	W1JVS	1176-28-21
W9ZSM	360-20-9	W1KJG	380-14-10
W9UEG	160-10-8		
W9YRN	22-4-4		

(Continued on page 80)

# RK SUPER TRIODES



with extra features—greater values than ever before!

- ★ Easy to Drive
- ★ Long Life
- ★ Advanced Construction
- ★ Efficient at the Ultra Highs
- ★ Low Price!

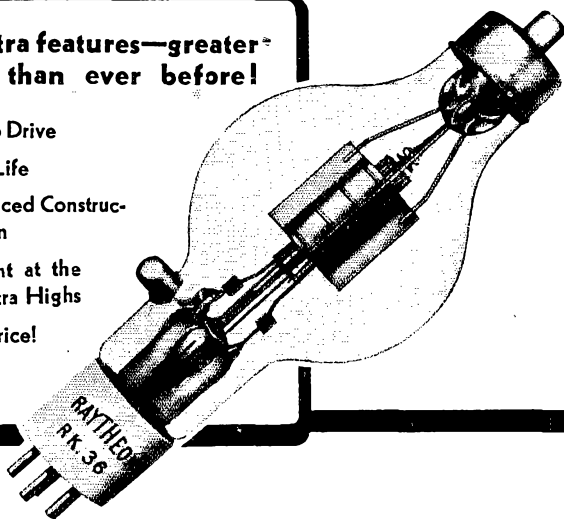

**RK36 (mu of 14) RK38 (mu of 30).** Two advanced triodes incorporating the latest engineering improvements. A pair of either type is capable of using the 1000 watts maximum input allowed by the F. C. C.! Both types conservatively rated at 100 watts plate dissipation and extremely easy to drive.

Self-supporting filament structure permits ultra high frequency operation without circulating R.F. between filament and other members. Tantalum plates and grids are all self-supported so as to decrease losses, eliminate electrolysis, reduce inter-electrode capacities and give maximum life. Extra heavy

thoriated tungsten filaments (40 watts) assure a copious supply of electrons, and are able to withstand heavy momentary overloads.

**RK35 (mu of 9) RK37 (mu of 30).** Perfect mates to RK36 and RK38 offering the same advanced features — but with 50 watts plate dissipation. These small ultra high frequency triodes, with their extra heavy thoriated filaments (30 watts) tantalum plate and grid, hard glass envelope and isolantite base are amazing value. To assure maximum insulation, lowest capacities and efficient high frequency operation, all elements are also self-supporting.

Write your nearest Raytheon office for complete technical data.

## Class C Operation

	RK35	RK37	RK36	RK38
Price	\$8.00	\$7.75	\$14.50	\$13.50

	One Tube		Two Tubes	
Filament Volts	7.5	7.5	5	5
Plate Voltage	1500	1500	3000	3000
Grid Bias	-250	-130	-540	-300
DC Grid Ma.	15	30	60	75
Power Output Watts	120	122	800	800

NEWTON, MASS.

NEW YORK

CHICAGO

SAN FRANCISCO

ATLANTA

**"WORLD'S LARGEST EXCLUSIVE RADIO TUBE MANUFACTURERS"**

**JUST OUT!** "Handbook of Amateur Tube Uses." An encyclopedia of technical information, and containing the exclusive Raytheon Temperature Color Chart, the only one available for amateur use. 50c

# RAYTHEON RK AMATEUR TUBES



SUMMER TIME IS **SPECIAL OFFER TIME** TOO  
(DURING JULY AND AUGUST ONLY)

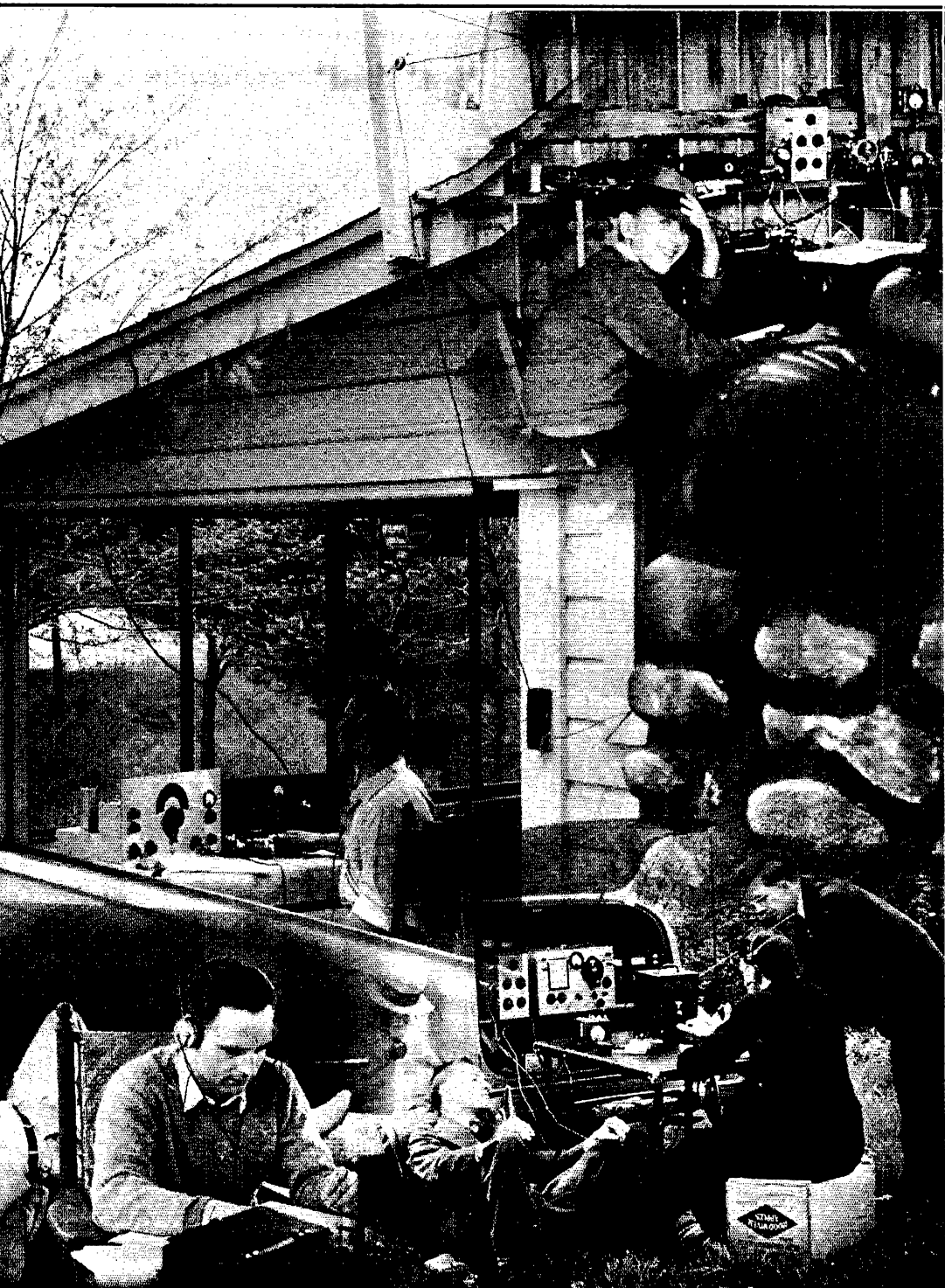

A.R.R.L. Membership }  
 QST Subscription } \$3  
 and the HANDBOOK }

\$3.25 U. S. Possessions and Canada. \$3.75 elsewhere. Order must be sent direct to A. R. R. L., West Hartford, Conn. Subscriptions may be new or extension of present one.

QST and the HANDBOOK  
 THE BASIS OF  
 EVERY AMATEUR'S LIBRARY

Say You Saw It in QST— It Identifies You and Helps QST

# FAVORITES AMONG HAMS

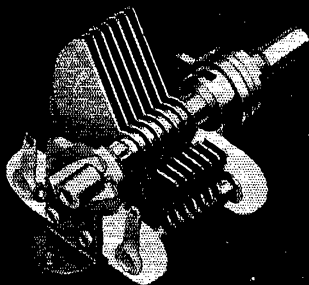

'MC' MIDGET  
CONDENSER



'S' ISOLANTITE  
SOCKET



'SWK' COIL KIT

FOR years "MC" midgets have been favorites among hams. Their outstanding features are silver plated beryllium contacts; heavy soldered brass plates, cadmium plated; Isolantite insulation. Available in a wide variety of capacities, both single and double spaced, there is an "MC" for every purpose. Use them in your receivers, low power transmitters, exciter units, monitors, and frequency meters.

"SWK" coil kits in both two- and three-winding types are designed to match the "MC-140-M" tuning condenser. This combination conveniently covers a range of from 17 to 270 meters, with no blank spots. These coils are wound with heavy silver plated wire on low loss XP-53 forms. For a minimum of losses in your receiver, use "MC" condensers with "SWK" coils and type "S" Isolantite sockets.

**Write for catalog!**

HAMMARLUND MFG. CO., INC.  
424-438 W. 33rd St., N. Y. C.

Q-8-38

Please send me 1938 Catalog

Name.....

Address.....

City.....State.....



## HAMMARLUND

Canadian Office: 41 West Ave. No., Hamilton, Ont.

## A Three-Tube Super for Portable or Emergency Work

(Continued from page 11)

crystal filter, the crystal can be borrowed and set up in a low-power oscillator to do the trick, provided its frequency is in the vicinity of 455 or 460 kc. The exact frequency is not important so long as it is near 460, the frequency for which the transformers are adjusted.

With a regular test oscillator, connect its leads to the chassis and the grid of the 6K8 (no r.f. coil in the grid circuit of the tube). Using a modulated signal, adjust the i.f. screws for maximum signal strength. As adjustments are made, reduce the output of the oscillator until, on the final check, the audio output in the headphones is moderately weak. This will avoid overloading of the receiver and will make the effect of slight changes more readily observable. An unmodulated signal will serve almost equally well, the hiss being peaked instead of the audio tone. When the adjustment is satisfactory, the beat oscillator may be turned on and, with the oscillator signal frequency unchanged, the adjusting screw on the transformer turned until a beat note of about 1000 cycles is obtained. The test oscillator frequency may then be varied on either side of zero beat and if the i.f. is properly adjusted one side should be noticeably louder than the other. In other words, the selectivity should be such that a small, but definite, single-signal effect is observed.

If an oscillator such as the crystal affair suggested above is used, the lining-up procedure will be much the same. In this case, however, it should suffice to set the oscillator somewhere near the set, without any direct coupling to the 6K8. A resistor of about 100,000 ohms should temporarily be connected between grid and ground, again with no r.f. coil in the socket. It may be necessary to put some shielding about the oscillator, or reduce its plate voltage, for the final i.f. tuning adjustments in order to get a weak enough signal.

In a pinch, the i.f. can be lined up without any auxiliary oscillator at all simply by plugging in the pair of coils covering the 7-Mc. band and tuning around for any steady signal. Usually the transformers as they come from the factory are adjusted closely enough to give fair response before regular alignment, and once a signal is heard the lining-up readily can be carried through. It will not be possible to depart greatly from the desired intermediate frequency since the tuning range is small. Of course the test oscillator method is to be preferred when it can possibly be used.

With the i.f. aligned, plug in the detector coil and set  $C_1$  at about one-fourth capacity. Then, with  $C_2$  at minimum, carefully tune  $C_2$  from minimum until the high-frequency edge of the desired band is reached. This point should be found with  $C_2$  at about half capacity on 1.75 Mc., at about  $\frac{5}{8}$  capacity on 3.5 Mc., and very nearly at full capacity on 7 Mc. The band-spread may

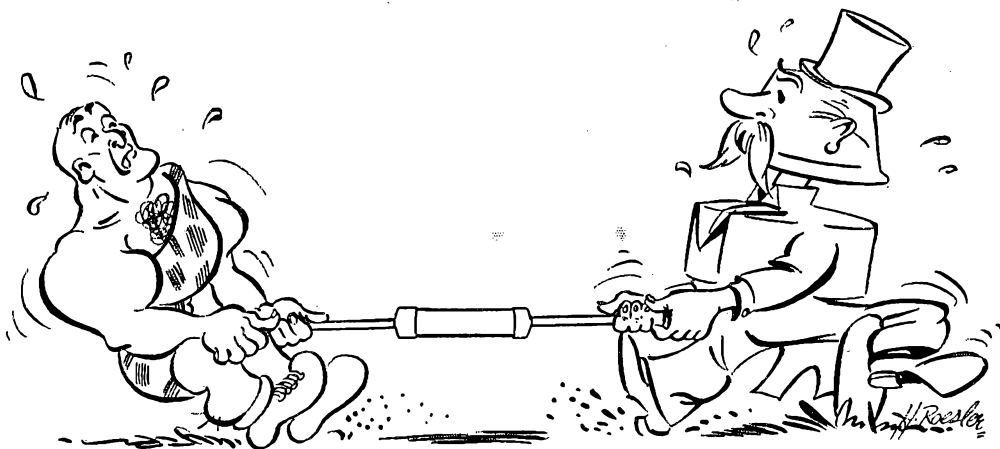

# The New End Lead (Center Lead) CENTRALAB Resistor is ★ T.P.



Now available . . . five to a card  
in one-half and one watt ratings  
. . . 100 ohms to 5 megohms.

★ **TUG-PROOF!** A mighty important reason for changing to CENTRALAB'S new Center Lead Resistors. For these new Fixed Resistors have their ends so firmly attached that you will never experience any trouble with loose ends no matter into what "tight hole" you may be forced to solder.

Yes . . . the same strong ceramic — hard as stone — and as impervious to moisture, vibration and shock, as the previous types. End leads brought out through bakelite insulation.

Baptized with fire at 2500 degrees . . . they are still the best Resistor bet of all.

For original equipment or replacements . . . select Centralab's new Center Lead Resistors.

CENTRALAB  
DIVISION OF GLOBE UNION INC.  
MILWAUKEE

# Centralab

RESISTORS

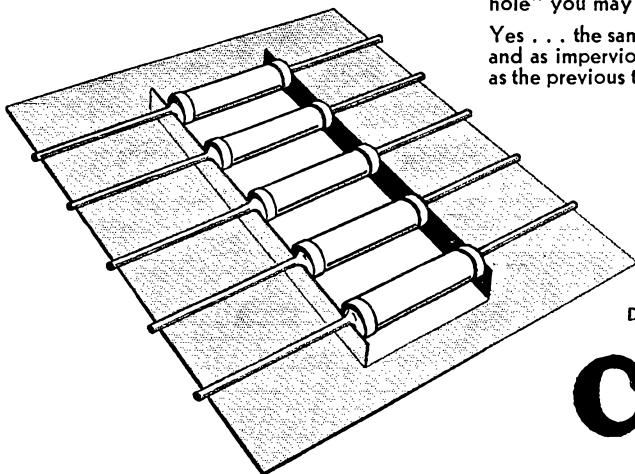



## HY615 TRIODE

Ultra-High Frequency Oscillator,  
R. F. Amplifier, Detector

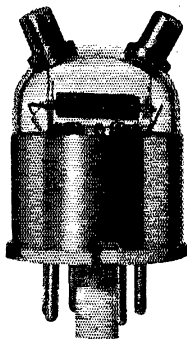

( $\frac{1}{4}$  Actual Size)

Note: Plate and Grid leads are brought out to caps in the dome of the bulb. The HY615 features short connection leads, small internal elements and low inter-electrode capacities resulting in efficient operation at ultra-high frequencies.

Heater Voltage  
(A.C. or D.C.) . . . 6.3 volts  
Heater Current . . . 0.15 amp.  
Pl. Voltage . . . 250 max. volts  
Pl. Current . . . . . 15 max. ma.  
Grid Voltage . . . . . —9 volts  
Average Amp. Factor . . . 22  
Mutual Conductance  
2200 umhos  
Pl. Resistance . . 10000 ohms

**\$2.00 Net**

Ceramic Base

## 6L6 GX

Beam-Tetrode, Power Amplifier

(Low-loss replacement for 6L6 and 6L6G)



Heater Voltage (A.C. or D.C.)  
6.3 volts  
Heater Current . . . . . 0.9 amp.  
Plate Voltage . . . 400 max. volts  
Screen Voltage . . . 350 max. volts  
Grid Voltage . . . . . —14 volts  
Plate Resistance . . . 22500 ohms  
Mutual Conductance 6000 umhos  
Amplification Factor . . . . . 135  
Plate Current . . . . . 85 max. ma.  
Screen Current . . . . . 5 max. ma.

**\$1.55 Net**

Ceramic Base

**HYTRONIC  
LABORATORIES**  
76 LAFAYETTE STREET  
SALEM, MASSACHUSETTS  
A DIVISION OF HYTRON CORP.

then be checked by tuning  $C_3$  across its scale. If the band-spread is not as described in the previous section, it may be decreased by adding a turn or two to the oscillator grid coil in the case of the 1.75- and 3.5-Mc. coils, or increased by the reverse procedure. In either case a new setting must be found for  $C_2$ . On 7 Mc. the band-spread can be increased or decreased by moving the tap toward or away from ground. If care is used in following the coil specifications, however, no adjustments of this sort should be needed.

### TUNING

With the preliminaries out of the way, actual operation of the receiver is simple. With the band-setting condenser at the proper setting (the device previously described simplifies this adjustment), tuning is done with the main dial. For c.w. reception, snap the b.o. switch to the on position, tune in a signal, and adjust  $C_1$  for maximum strength—or set the condenser at any point on the high-capacity side of resonance which gives the desired signal strength. The condenser gives adequate volume-control range, although it will not cut out a signal completely unless the signal itself is very weak. When using  $C_1$  as a volume control, always set it on the high-capacity side of resonance so that image response will be reduced.

Resonance on  $C_1$  is best detected by setting the main dial at a point where no signal is heard and then adjusting  $C_1$  for maximum background noise. If two such settings can be found, use the one with the highest capacity; the other is in resonance at the image frequency. As  $C_1$  is varied with a signal tuned in there will be a slight change in the beat-note frequency; this change will be gradual and always in the same direction until  $C_1$  has passed through resonance and approaches the oscillator frequency. In the latter region the change will be considerably greater, so the detector tuning should be kept near actual resonance or on the low-frequency side of it. The tuning is not really critical but, because of the relatively large-capacity condenser, shows a quite definite peak.

In evening operation it is seldom necessary to approach resonance with  $C_1$  since signals often have such strength that the receiver overloads. This cannot readily be avoided at the low-plate voltage used except through reducing the signal input by detuning  $C_1$ . It is quite easy to find one off-resonance setting of  $C_1$  which gives good strength on practically all signals so that the tuning is purely single control. In the daytime, with poorer transmission conditions and fewer signals, it is often helpful to tune the detector circuit for maximum strength. One setting will hold over a considerable portion of a band.

At the frequencies for which this receiver is designed images should give relatively little trouble. Naturally there will be some, but usually they are quite effectively masked by the legitimate amateur signals. Image response is practically the only disadvantage of this type of receiver, but is certainly tolerable in view of the many points of superiority over the conventional



# BUFFER · DRIVER · DOUBLER

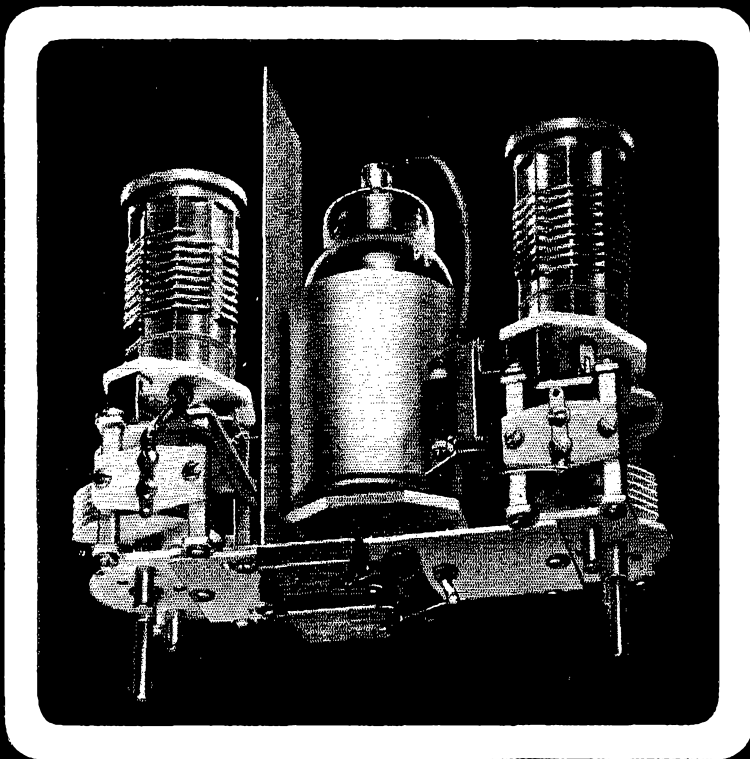

**I**N ANSWER to hundreds of inquiries, Hammarlund is glad to announce the "BD-40" buffer-driver to be used with the now-famous "PA-300." These kits are so designed that they can be assembled by the most inexperienced person. Featuring the same type of construction as in the "PA-300", the "BD-40" can be put together in a few minutes using only a screw driver and soldering iron. No intricate chassis drilling is necessary. The "BD-40" can also be used as a low power output amplifier in a beginner's transmitter. Beginners can now build "Professional" rigs. The illustration shows

the complete unit assembled and wired, ready for installation. It measures only 8¼" x 7½" x 3¼". The power output is approximately 40 watts when using either an 807 or RK-39 beam tube. See the "BD-40" and also the "PA-300" on display at your local ham store.

### Write for complete data!

HAMMARLUND MFG. CO., INC. Q-8-38  
424-438 W. 33rd St., N. Y. C.

Please send BD-40 DATA

Name .....

Address .....

City.....State.....

Canadian Office: 41 West Ave. No.  
Hamilton, Ont.



# HAMMARLUND

# NOW IS THE TIME

to lay your plans for the big rig for the Fall. Before you know it, Summer will be over, and crisp Autumn weather with its inviting tang in the air that makes the fingers itch for the key or mike, will be a reality.

## WILL YOU BE READY?

Cardwell has never before had so complete a line of variable and fixed air condensers for every purpose and power. Specified and used in almost every representative constructional article, manufacturers kit and commercial transmitter, Cardwells are your logical choice for the "big rig." Numerous couplings of all kinds, new neutralizers, fixed plug-in units, several new multi-band condensers and accessories have been recently presented to you in this column.

A few of the Cardwell "regulars", typical of the hundreds of available types now in use in all parts of the globe, are shown, by way of refreshing your memory.

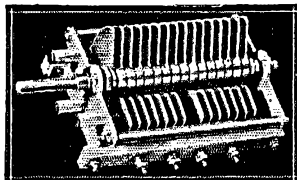

### MT-70-GD

Midway Dual—10-70 Mmfd. per section, 3000 V. .070" airgap. Many other airgaps and capacities available. Popular push pull or balanced tank circuit, low or medium power. **List. .... \$7.00**

### XE-240-KS

Capacity 240 mmf. max. Correct for antenna networks for 100-200 watt xmtrs. Airgap—.100". Plates—Buffed and polished. Peak v.—4500. Insulation—G. E. mycalex. **List. .... \$10.80**

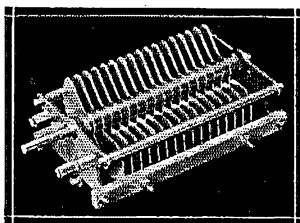

### XD-160-XD

New "X" standard dual transmitting condenser for 325 watt modulated amplifiers. 160-28 mmfd. per section. Airgap .125". Flash Voltage (per section)—5000 V. peak. Thick plates, buffed and polished G. E. mycalex insulation. Length—11-1/16". **List. .... \$19.00**

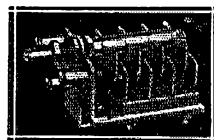
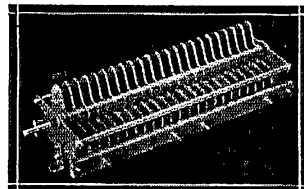

### NA-16-NS

High frequency neutralizer for low capacity tubes. Mycalex insulation; heavy buffed plates with rounded edges. Capacity range 7 to 16 Mmfd. **List. .... \$5.00**

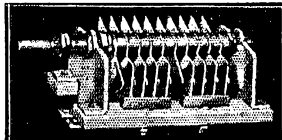

### NP-35-ND

Cap. 35-35 mmf. The best bet for the 5 meter rig. Pushpull rigs with low power deserve it—higher power requires it. Small enough for portables—big enough for high power fixed 56 M.C. stations. No closed loops. Icolantite insulation. Airgap .084". Peak flash over—4200 V. Buffed and polished plates. **List. .... \$6.00**

And don't forget the stock sizes of the G. E. mycalex bars—most convenient for all U.H.F. coil form mountings, special R.F. switches jack blocks, etc. Send for list.

## ATTENTION!

Broadcast Stations and Commercial Transmitter Manufacturers

Interesting data for you on new Cardwell "P" type, light weight, commercial variable air capacitors for H.F. transmitters. Send for data sheet.

**THE ALLEN D. CARDWELL  
MANUFACTURING CORPORATION**  
83 PROSPECT STREET, BROOKLYN, NEW YORK

portable regenerative receiver. A particular image readily can be taken out by a simple wave-trap, tuned to the image frequency, in one of the antenna leads.

For 'phone reception, the tuning procedure is the same except that the beat oscillator is off. The selectivity is comparable to that of the ordinary superhet, a point which will be appreciated by those who have used regenerative receivers for 'phone.

In conclusion, this little set seems to offer marked advantages over the regenerator for portable emergency use, and work with it so far has failed to disclose any serious defects. It does not pretend to be the ultimate, but rather the first step in what we feel is the right direction. It is possible—indeed probable—that time and continued field use will point out ways in which improvements can be made without sacrificing the fundamental requirements of compactness, light weight, battery economy, and low cost.

## A 250-Watt 56-Mc. Rig

(Continued from page 16)

Two complete power supplies are mounted on a heavy duty chassis measuring 17 by 13 by 3 inches.

The higher-voltage supply delivers 1000 and 1250 volts at 500 ma. The lower voltage system supplies 600 and 750 volts at 350 ma. This lower voltage supply has a variable auto-transformer in the primary of the power transformer so that the voltage can be varied smoothly from a low value to maximum of 750 volts. The rectifier and filter systems are conventional and need no detailed description.

### MODULATOR

The modulator unit, shown schematically in Fig. 2, consists of two push-pull stages. Two 2A3's are the drivers for the ZB-120 Class-B modulators. The input transformer to the 2A3 drivers has a low-impedance primary winding with taps. This is advantageous in two respects; first, the microphone pre-amplifier can be mounted directly on the operating table with the gain control convenient to the operator, permitting the use of a short microphone cable; second, a low-impedance link between the pre-amplifier and modulator unit is not as susceptible to stray r.f. and magnetic fields as would be a high-impedance connection. This to some extent minimizes r.f. feedback and noise on the carrier.

The drivers are self-biased with an 800-ohm 10-watt resistor in the filament return. The ZB-120 grids are coupled to the drivers through a Varimatch transformer. The plates of the modulators are coupled to the r.f. unit through a Varimatch Class-B output transformer. This transformer carries the final r.f. amplifier plate current through its secondary winding. In the diagram it will be noticed that the ZB-120 grid returns are tied to ground, but normally they are connected through meters to ground at W2KPX.

The pre-amplifier should deliver enough voltage

# WHY NOT A FIRE BRICK FOR THE ANODE?

*It will stand excessive heat, is distortion proof, is a good heat radiator (high thermal emissivity) and is very inexpensive.*

There are two very important reasons why fire clay is not suitable for anode construction: 1) It is not a good electrical conductor: 2) (most important) A heated fire brick *pays off gas*.

Every "ham" knows that gas released inside a transmitting tube destroys emission; more often causes complete failure. The ability of anode materials to withstand excessive heat is less important than that such material can be completely de-gassed. Eimac discovered this fact long ago . . . chose tantalum for tube elements and developed a new method for removing its relatively small original gas content. (1/10 that of Molybdenum and only 1/1000 that of the conventional carbon anode.)

Since that time, radio amateurs who use Eimac tubes have been favored with outstanding performance, plus complete freedom from failures caused by gas. BUT the use of tantalum alone is not wholly responsible for this fact.

Perhaps you have wondered why other tubes (even some having tantalum elements) cannot measure up to the Eimac standard? The answer is: Tantalum requires special handling. Eimac engineers developed an exclusive process which

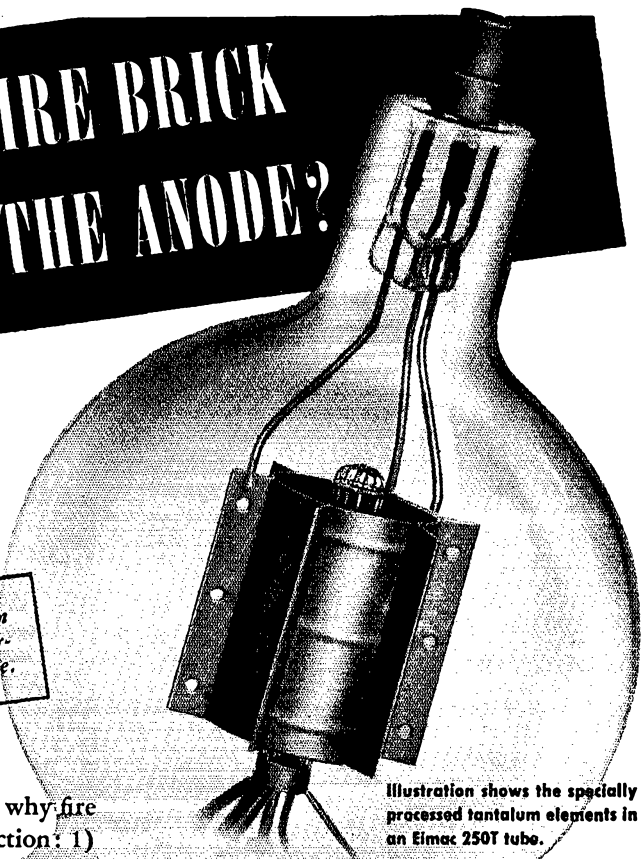

Illustration shows the specially processed tantalum elements in an Eimac 250T tube.

takes full advantage of the superior properties of tantalum, renders it completely de-gassed and eliminates the use of a chemical agent or "getter." Results speak for themselves. Eimac tubes will stand momentary overloads of 400% to 600%, without damage, where some tubes fail utterly.

Your dealer is ready to deliver an Eimac tube for your transmitter . . . from 35T to 1000UHF.

## *Eimac* TUBES

**EITEL-McCULLOUGH, Inc., San Bruno, Calif.**

**NOTE:** Amateurs who are interested in increasing the efficiency of the tank circuit in their transmitters will be wise to ask about the New Eimac Vacuum Tank Condenser. Get full information from your dealer.



**NOW**

## **this high-powered radio engineering library**

sent to you for 10 days' trial—  
at a special price and terms

These books cover circuit phenomena, tube theory, networks, measurements, and other subjects—give specialized treatment of all fields of practical design and application. They are books of recognized position in the literature—books you will refer to and be referred to often. If you are a researcher or experimenter—if your interest in radio is deep-set and based on a real desire to go further in this field—you want these books for the help they give in hundreds of problems throughout the whole field of radio engineering.

### **RADIO ENGINEERING LIBRARY**

—especially selected by radio specialists of McGraw-Hill publications

—to give most complete, dependable coverage of facts needed by all whose fields are grounded on radio fundamentals

For home-study and reference. Contains a revised selection of books culled from latest McGraw-Hill publications in the radio field.

**5 volumes, 3064 pp., 2000 illustrations**

1. Glasgow's PRINCIPLES OF RADIO ENGINEERING
2. Terman's MEASUREMENTS IN RADIO ENGINEERING
3. Chaffee's THEORY OF THERMIONIC VACUUM TUBES
4. Hund's PHENOMENA IN HIGH-FREQUENCY SYSTEMS
5. Henney's RADIO ENGINEERING HANDBOOK

#### **Special Low Price and Easy Terms**

Bought singly, the five volumes comprising this library would cost you \$25.00. Under this offer you save \$1.50 and, in addition, have the privilege of paying in easy installments beginning with \$2.50, 10 days after receipt of the books, and \$3.00 monthly thereafter. Take advantage of these convenient terms to add them to your library now.

#### **SEND THIS ON-APPROVAL COUPON**

**McGraw-Hill Book Co., Inc.  
330 W. 42nd St., New York, N. Y.**

Send me Radio Engineering library, 5 vols., for 10 days' examination on approval. In 10 days I will send \$2.50, plus few cents postage, and \$3.00 monthly till \$23.50 is paid, or return books postpaid. (We pay postage on orders accompanied by remittance of first installment.)

Name.....

Address.....

City and State.....

Position.....

Company..... QST 8-38  
(Books sent on approval in U. S. and Canada only)

to excite the 2A3's to full output, and should have sufficient gain for the type of microphone used. Any of the usual tube combinations may be used.

The normal power input to the transmitter is 300 to 400 watts, a limit set by the audio output available from the modulator. The power input to the Class-C amplifier has been run as high as 600 watts with perfectly safe operation on 56 Mc. Work also has been done on 2.5 meters.

### **The National A.R.R.L. Convention**

*(Continued from page 17)*

many of the Headquarters staff. There will be talks on operating procedure, the future of the League, what your League means to you, and many other vital subjects. All Directors will be invited as well as the whole staff at West Hartford. An open forum is planned under the direction of the President of the League.

The equipment show will be the finest strictly-amateur display ever held. You will see all that is new in amateur radio—everything from complete stations to the smallest part. All of your favorite apparatus will be on display. Plenty of time has been reserved for visiting these displays and talking over your individual problems with the outstanding engineers in amateur radio. Over \$100,000 in apparatus will be displayed.

A special program has been planned for the women which will assure them of a grand time under the guidance of a woman chairman. By all means bring your wife. There will be many parts of the program she will enjoy, especially the banquet and Saturday night party.

There will be contests galore, including code-speed contests for both men and women. All talks will be limited to 45 minutes and there will be frequent recess periods. Nothing dry and tiring.

Plan now on attending this, the finest of all and the first A.R.R.L. national convention in 14 years.

### **Delta Division Convention**

New Orleans, La., September 3rd and 4th

**T**HE New Orleans Radio Club is sponsoring the official Delta Division Convention to be held at the Hotel Jung, New Orleans, La., on September 3rd and 4th. It is a pleasure of the convention committee to extend a cordial invitation to A.R.R.L. members, radio amateurs and interested friends to attend this affair at New Orleans, "America's Most Interesting City."

Amateurs who have attended local hamfests and the Louisiana State Convention two years ago know that New Orleans can, and always does, arrange things for a good show and a good time.

Program will be complete with well known speakers, plenty of entertainment and prizes. The tentative fees have been set at \$3.25 and \$2.75 for the Y.L.'s. A very fine pre-registration prize has been set up.

If more information is desired, write Gene Treadaway, W5DKR, Secretary, New Orleans Radio Club, Hotel Jung, New Orleans, La.

The

# NC-800

NEUTRALIZING CONDENSER

— BUILT LIKE A MICROMETER —

LONG BEARINGS, threaded bearing is 1-9/32 inches long preventing eccentric operation, wobble, etc.

MICROMETER TYPE LOCK does not require screw driver or other tool for operation.

3/16 inch thick, rounded and polished aluminum plates provide for maximum breakdown voltage with a minimum of between plate spacing.

Fine, accurately machined threads — no wobble.

Heavy aluminum base with three mounting holes.

Rugged cast aluminum bearing support.

Convenient terminal locations.

Genuine Isolantite insulation.

Convenient! — Requires a minimum of chassis space.

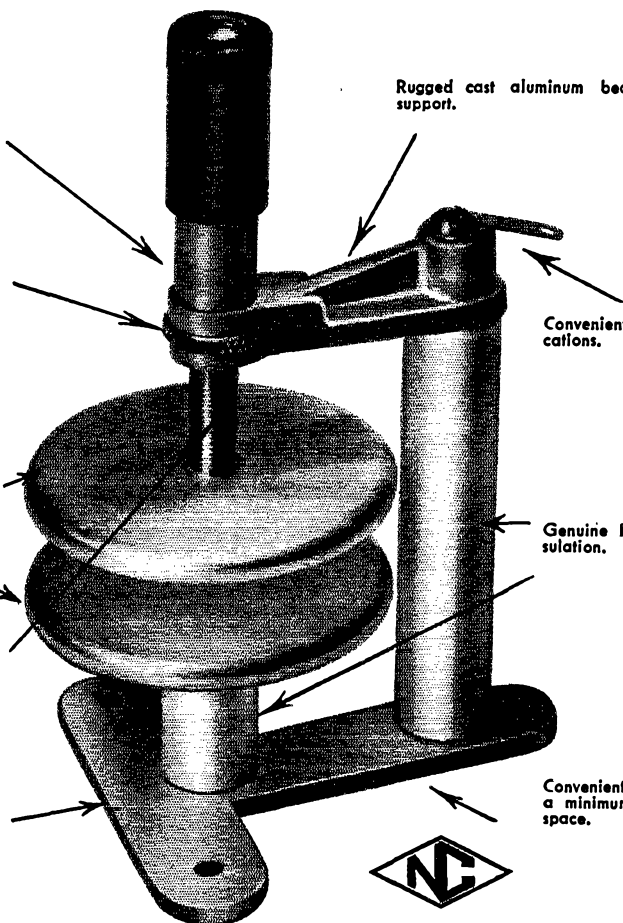

We not only are continually striving to develop and originate new and advanced products, but we are also continually trying to improve and better our older products. See the improved NC-800 at your dealer's today! — No increase in price!

NATIONAL COMPANY, INC., MALDEN, MASS.

## Station Activities

### ROANOKE DIVISION

**NORTH CAROLINA**—SCM, H. S. Carter, W4OG— Please don't forget your S.C.M. these hot summer months, for it is very hard to get up a report when no reports are received. ECH has had his call changed to DVV. AAU has W.A.C. and W.A.S., and is waiting for 28-Mc. to open again so he can use his pair of 100TH's. TJ is putting up a beam antenna. DLX is going to join N.C.R. FCB, EYF, BMR and CQ are members now. BIP has been rebuilding the rig and improving the shack. DGU is on 3.9 and 14-Mc. 'phone regularly. BBS is back on 3.9-Mc. 'phone with a new Lafayette 40-watt transmitter. DKF is working for Class A ticket. W4QI has an emergency transmitter. The Raleigh gang had a fine time on Field Day. BHR bought OC's "Signal Squirter" and swapped it off before he got home with it. ESO says all the gang there had a swell time in the Annual Field Day. FIY and FIZ are new Clinton hams. DGV is going strong on all bands with 75% of his time spent in good rag chews. DWB led the State again in traffic this month. 4NC had a swell time on Field Day; they had a 12-h.p. Austin motor running a 5-kw. a.c. generator; the entire outfit was built on a special trailer weighing about 1500 lbs. BOH, ABT and CFR have started building 56-Mc. rigs and plan to have a net going in the city soon. DCW is on regularly. AI returned from South Carolina. North Carolina has missed him for all these years. DZS is going to Fort Lauderdale, Fla., and may make it his permanent address. We hope not, but if so, best of luck, OM.

Traffic: W4DWB 83 DLX 15 OG 5 ANU 4 DCW 3 DGU-ESO 2 DGV 1.

**SOUTH CAROLINA**—SCM, Ted Ferguson, W4BQE— BNN is working mostly 28-Mc. 'phone, but has QSL from VK2FU confirming 1.75-Mc. 'phone QSO. CQU is rebuilding rig and revamping antenna system. EXJ has new 28-Mc. rotating beam, also has 56-Mc. rig on the air. EGH is working 28-Mc. 'phone and 1.75-Mc. rag chewing. EDQ says 28-Mc. short skip FB. CZA is busy with preparations for hamfest. FFO is vacationing in Virginia and working portable there. CKW is active on 14 Mc. The S.C.M. expects more reports next month and expects all OFFICIAL STATIONS to report. Don't forget the Hamfest at Charleston, S. C., Sunday, July 31st. If you miss this one you will be sorry you did. See you there.

Traffic: W4CZA 38 BNN 15 CQU 7 EDQ 5.

**VIRGINIA**—SCM, Charles M. Waff, Jr., W3UVA— P.A.M.: 3AIJ—R.M.'s: 3DJC, GTS—GPC is leaving our Section to live in Maine. Sorry, OM. Come back to see us. AQPZ/2 has moved to Bristol; new call is 3HNP. Welcome. HBH will be in operation soon at C.C.C. Camp at Morrums River. GTS still handles plenty of traffic. AIJ wants more stations in Virginia 'Phone Net Sundays. HDQ is experimenting with series modulation. FQO worked TF2AX and ST6AL for new countries, and needs only Nevada for W.A.S. The Richmond Short Wave Club sponsored an outing and Field Day in conjunction with the A.R.R.L. Field Day. Thirty-two licensed hams and numerous YL's, etc., were present at Big Meadow, on the Skyline Drive, at one time or another from Richmond, Norfolk and Washington. Almost a dozen transmitters were in evidence operating on all bands from 56 to 1.75 Mc. HNV and HNZ are new Lynchburg hams. DZW now has Class A ticket.

Traffic: W3HDQ 88 GTS 78 (WLMG 76) GPC 23 AIJ 6 8QPZ/32.

**WEST VIRGINIA**—SCM, C. S. Hoffmann, Jr., W8HDNS—A poll has been taken of DX records; more to follow in future reports, as received. Following is a list of total countries worked by W. Va. hams: KKG 117, JRL 112, AZD 105, KWI 94, OXO 91, CDV 80, GBF 76, LCN 75, MZD 74, CWY 70, QBQ 65, NCD 57, PQQ 56, ASI 56, FAA 52, PAJ 48, MIP 40. Three groups reported participating in Field Day tests, one composed of ELJ, LGB, KHB and QQZ; the second LJX, PTJ and QIB; the third JKN and ASI. HHH visited Logan; he is using 950 watts on 1.75-Mc. 'phone! ELJ was appointed S.N.C.S. of A.A.R.S., 80K resigning. OJI was appointed Official Observer. The first such appointment held in the Section for some years. KIU, with aid of RFP and DWZ, made a field survey of 56-Mc. sigs over Morgantown. KIU visited Hall, Ex-8TI, now W2KUM. MOP's O.P.S. was endorsed for another year. PHY reports KWU moving to Warren, O. KGT moved to Pittsburgh, RHS and RHM are in U.S.N.R.,

Wheeling, AWT is now a Medical Doctor. FB, OM! JM got married. Congrats! KWV has Junior operator. EHA and FEO have made their usual summer appearance after another winter's hibernation! BDP is working on television. BTV, DYB and QFN are rebuilding. KKG worked OY4C and VK9MD. BTV, KKG and the S.C.M. visited Washington, D. C., Convention. RFT and RZJ (a YL) are new Nitro hams.

Traffic: W8PTJ 58 BTV 34 HD 26 PSR 24 PHY 7 KIU 4 OXO 2.

### NEW ENGLAND DIVISION

**CONNECTICUT**—SCM, Frederick Ellis, Jr., W1CTI— The New Haven Amateur Radio Association handled 1770 messages at its booth at the New Haven Progress Exposition. Three 250-watt transmitters operating on 56, 14-Mc. c.w., 3.9-Mc. 'phone and 3.5-Mc. c.w. were used. Those participating in the setting up of the exhibit, the operators and local relay stations were JHM, KFN, KQY, GDC, JZJ, JYE, HSK, DDP, HHJ, JQK, ATH, FMV, GRF, IYF, BYW, EUG and KUM. JYE had his hands full with Exposition traffic. KQY secured very good cooperation from IGN, LHE, 2KTR, 2HCO, 3EDC, IJMY and JXP in handling Exposition traffic. LHE reported in person at C.B.A. Club meeting. JXP reports that A.A.R.S. drills shut down May 28th. BDI and AFB spent a quiet Field Day at UE's place in Granby, operating portable BDI. Portable FH at Niantic worked 64 stations; operators were EH, JFN and JPE. KFN handled over a thousand messages at GB during the Exposition, and only one at his own station. It's mutiny! CBA took part in the Field Day, June 12th, the gang setting up 7, 3.5 and 56-Mc. stations in a hay field near New Canaan. A gas-driven a.c. generator was used, but not many stations contacted, due to "hash" in the power delivered. The gang gained plenty of experience with emergency rigs, a little sunburn and a swell time. ES still maintains schedules with 3BWT and 8CMP.

Traffic: W1GB 1770 JYE 1703 KQY 1340 LHE 1105 JMY 376 JXP 177 ES 69 DMP 38 BDI 29 EH 27 DWP 3 KFN 1.

**MAINE**—SCM, Winfield A. Ramsdell, W1FBJ—GOJ has new exciter unit for the Collins 30FXC and is working some of the higher frequency bands as well as some 'phone rag-chewing. INW and LDC called on 5AUC, who has been honeymooning in Auburn. INW is building new rig with HF100 final. APR moved to Taylor Pond for the summer. KKZ has his eye on an HRO. LDC received a certificate of merit in the W/Ve contest. JCP and IQM will be working portable from Millinocket this summer. JCP has new RK-12 pushing pair of 35T's. LHD and LHI are new hams in Millinocket. DHH is going to Northeast Harbor this summer to try some portable work. IIE handled some of the New Haven tercentenary traffic; Hal says that the last radio Rifle Match with Oneida, N. Y., through 8DSS was a real success. LHC, new ham in Damariscotta, has new Hallicrafter receiver. JUJ worked seven 56-Mc. DX stations on June 5th. LHA heard 3GMZ, 9CLH, 8JLT, 9FGN and several others. KAD worked 9NY. KOU received QSL from the eighth district as being heard. CRP was out on F.D. and worked two stations. AUC has 1.75-Mc. 'phone rig at camp this summer. KJJ completed W.A.S. on 'phone and also W.A.C. on 28-Mc. 'phone. Bill will have fine array of certificates, as he is getting O.P.S. appointment shortly. LDC is new O.R.S.

Traffic: W1IE 12 LDC 3 CBU 6 GOJ 5 KOU 3 LHA 2 JCP-CRP 1 FBJ 4.

**EASTERN MASSACHUSETTS**—SCM, Sam Gross, W1IWC—AKS is still high traffic man. KZT and KH made B.P.L. on deliveries. KH worked Cincinnati, Chicago and Toledo on 56 Mc. HXE received five QSL's confirming QSO's with W8 and W9's on 56 Mc. KPW reports hearing W6, W7, W8 and W9 on 56 Mc. June 5th, all 88-9. LAZ sends in reports of N.B.A.R.A. members by message. WV has new speech equipment all finished and working. JYJ is working hard trying to make 100-watt amplifier perk. The N.B.A.R.A. enjoyed a successful Field Day using a 6L6 crystal oscillator on 7 Mc. JKT worked two W9's on 56 Mc. with s.e. oscillator, 25 watts input. KVV worked K6PDQ with 6L6 oscillator on 7 Mc. GAG is moving upstairs and will have separate room for station. KKO is putting up a vertical "Zepp" for 14 Mc. KHY is getting his T125 ready for the fall. The S.S.A.R.C. ended the season's club activities with a turkey banquet, entertainment and dance, June 16th, at Quincy. An enjoyable time was had by all, and the committee in charge is to be congratulated. The Brockton Radio Club successfully defended their "duck pin"

title and are looking for more competition. Another radio rifle match was held May 29th. The Massachusetts Rifle Ass'n of Woburn and the Connecticut Rifle and Revolver League at Simsbury, Conn., were the teams competing. Communication between ranges was furnished by IHI and IWC operating portable at Woburn, Mass., and UE (at Granby, Conn.), who drove to the Simsbury range during the match to exchange scores. A return match is planned for the near future, as the contestants were much pleased with this type of match. IHI and IWC operated during the Field Day and learned plenty about emergency equipment. JSM will operate 61.6 portable 3.5-Mc. rig on the Cape during August. LGY handles traffic on 56 Mc. AGX keeps summer schedules with HWE.

Traffic: W1AKS 320 KZT 194 KH 188 HXEX 186 AGX 85 EMG 77 LGG 60 HWE 54 KPW 48 JSM 34 LAZ 22 1EA 21 LGY 17 WV 10 LBY 7 FOI 1 JYJ 18. (April-May: W1IHI 442 JCK 313 EMG 261 JSM 149 KCT 100 EPE 45 QW 26 (CC11 57) AST 8 QE (CC1C 30).)

WESTERN MASSACHUSETTS—SCM, William J. Barrett, W1JAH—BKQ went to town on Field Day; ops were LBU, JOP, IOR, CPG, DDK, IZW, KJY, JNA and FJC. EOB is now also WLGJ; Vic reports the Field Day week-end slightly damp at HDQ's portable QTH. (Same here!) BVR was very much in evidence at N. E. Convention—doing his usual swell job. AJ reports a lil' DX and a lil' traffic—the main thing is that he reports—how about the rest of you guys?? BIV reports logging lots of W9's on 56 Mc., June 5th. New officers of Chair City Radio Club: Pres., AUN; V.-Pres., KIK; Activities Dir., ADE; Secy.-Treas., BYJ. FTS was active in the flood—I mean Field Day—ops included JJR, JAD, FFK, JAH, LFT, FZI and IKT. JAH put up new mast, aided and abetted by JAD.

Traffic: W1IOR 206 (WLGJ 28) EOB 149 (WLGJ 61) BVR 24 (WLG 85) AJ 24 JAH 9 Riv 6.

NEW HAMPSHIRE—SCM, Carl B. Evans, W1BFT—The M.V.A.R.A. operated portable during A.R.R.L. Field Day at the NYA camp in Concord. All units were 100% battery-operated. Two complete stations were in operation on 3.5 and 7 Mc. and one station on 56 Mc., using the call 1BFT-1. AEF is now using 808's in P.P. with 250 watts input. LIN is a new ham in Concord. JKH joined the R.C.C. KBR acquired an SW-3 receiver. JEH and the gang at the State Sanatorium at Glencliff will be 56 Mc. this summer with a directive antenna headed south. HJI worked U9ML for W.A.C. on 14 Mc. 7KK is looking for a schedule with a N. H. station to complete W.A.S.; he operates on 14,380 kc. with 350 watts input. The Mike and Key Club of Nashua operated portable 1TA-1 on a hill outside of town on 56 and 3.5 Mc. during the annual June Field Day.

Traffic: W1BFT 5 AEF 2 JKH 1.

RHODE ISLAND—SCM, Clayton C. Gordon, W1HRC—From IZO we have the following: "Prov. N.C.R. did an FB job at State Airport where complete station was set up for communication with Hartford N.C.R. (NIQP) in N. E. Air Tournay held 5 June. Hams who participated included CAB, IZO, GVH, GTS, HEN, IPU, KXA, DDDY, KWY, KUG. Official letter of commendation on station and communications received." Thanks, Del, for FB report. From JUC comes a report on the Newport gang. JUC advises that JSB was in town and had a long talk with his old classmate, KOE in Kingston, on 56 Mc. JFF worked a W9 in Chicago on 56 Mc. besides a W2 and W3 with his new crystal-controlled rig. JUC has new 56-Mc. receiver and is about complete on a new 56-Mc. M.O.P.A. All this 56-Mc. success has HPE scouting around to buy a new receiver. JNO was in town and paid most of the fellows a visit. KLR has been bitten by the traffic bug and says he likes it fine. ETD reversed the usual procedure and developed odd harmonics with crystal control which disappeared when using e.c. CPV in Pawtucket is also R.M. for that Section and is doing an FB job rounding up new O.R.S. and A.E.C. members. The Providence Radio Association held its Annual Test of Emergency Equipment on June 12th (The A.R.R.L. Field Day). The place selected was the residence of FAH in North Scituate. A 110-volt a.c. generator-driven by Maytag gas engine was available. A superhet receiver is almost a necessity on these parties to overcome the hash from the power plant (Hi). Everybody agrees that the only way to find out how good a set up we have is to get out and try to put it to work. Therefore, another Field Day for P.R.A. will be pulled off again this summer, with some of the technical defects which were observed on this one corrected. It is a thought that instead of an attempt to contact as many

stations as possible on a Field Day, might it not be more practical and more in line with what would be met in an actual emergency if a test were run with one other point, or a small net of points, observing how long a time a continuous QSO could be held through interference, fading or any other obstacles? Does any other club or group of hams wish to cooperate with us in running a test of this nature? Address 1GTN, President P.R.A., 26 Charles St., Cranston, R. I.

Traffic: W1KLR 46 IZO 34 QR 14 KKE 1.

VERMONT—SCM, Alvin H. Battison, W1GNF—KWB is working in St. Albans. JXS plans to operate in Barnard during July and August. KJG has worked all New England with his 5-watt 1.9-Mc. 'phone. KOO has a new SW3. JVS needs Montana for W.A.S. The Green Mt. Radio Club was quite successful in the Field Day tests despite the inclement weather on the Mt. Individual operator contacts: FSV-31, GAZ-25, BNS-19, GAN-14, AAJ-13, GAE-6, KVV-2. KUV and 2AZX engineered the generator and transmitters. LEM is the station of Ted La Pier in St. Albans. KVB visited KUY, KJG and JRU. FPS attended the Hartford Convention. The Twin State Radio Club, IIV, will be open for the summer after July 1st. JVI is operating portable at RyeGate Corners. LII is the call of Don Hoyt, Orleans. AEA, DPO, GGT and ILX qualified for A.E.C. this month. JRU and IQG are rebuilding to rack and panel at their new locations. KUY is rebuilding in order to make his whole station portable. KXL is using the low-power stages of his transmitter at present. IQG and 61JK visited at FSV. KOO visited at E.J.F. DPO is looking for O.P.S. recruits. BJP contacted Paraguay on 3.5 Mc. JZF has a new RME receiver and DB20 pre-selector. CUN in Barre operates some from FKU. GXP will be on 3.9 Mc. for the summer. BIC is building a 28-Mc. rotary beam. DQK is sporting a new 500 watt 1.9-Mc. 'phone. EZ and IZM visited Mt. Mansfield.

Traffic: W1FSV 21 GNF 12 AHN 2.

#### HUDSON DIVISION

EASTERN NEW YORK—SCM, Robert E. Haight, W2IU—IU spent two weeks in wilds of Maine. ISQ is on 14, 7 and 3.5 Mc. using 61.6 osc., 6L6 doubler and 35T final. KOI is rebuilding rig for 150 watts, all bands. GTW reports Delaware Valley B.P.A. was out for Annual Field Day operating under GTW's call. ITK schedules 8CTX Wed. nights. BLU is busy with a crack 'phone job and erecting new skywire. BJX, our new Emergency Coordinator, changed address to 358 Church St. KFB finds 3.9-Mc. 'phone FB; he works 300 miles consistently with 20 watts input. KZS gets fine results on 3.5 Mc. using 33 crystal oscillator, 1 to 1.5 watts input. ALP is grinding crystals, fixing up controls and relays for quick change from receiver to transmitter and sports new antenna, center-fed. DVC reports S.A.R.A. Field Day results were very good. DHS and JZR managed to pull in a nice total of points. ACB and KUD are rebuilding for lots of power. JZR attended Hudson Division Convention. NYC heads Section in traffic.

Traffic: W2HYC 120 (WLNK 19) LU 45 ISQ 40 KOI 3 GTW 7 ITK BLU 7.

NEW YORK CITY & LONG ISLAND—SCM, Ed. L. Baunach, W2AZV—New appointments: LR and EVA O.R.S., GUV O.P.S., KJY O.O. CHE's new QTH is 138 Rutland Ave., Rockville Centre. CFS joined the benedicts on June 18th. Congrats. LBI got his R.C.C. KYO hooked G2ZQ for his 1000th QSO in five months. CMI is located in Riverhead operating portable on 3.5-Mc. c.w. and 4-Mc. 'phone. DBQ worked SU1CH and found out that he had been waiting to have a QSO for two years; friend in Cairo had given him one of his QSL's. KYV is operating portable July 23rd to August 4th on 3.5 Mc. during a camping trip from Washington, D. C. to Vermont, and would like to QSO the gang. IHT schedules his brother, JBL, at his summer QTH. KCV did some nice operating with the N.Y.N.G. at camp. KTF is building low power rigs for 14 and 56 Mc. KXB is building the double regen super described by 1JPE in March QST. IXQ's antenna was cut down. ELK has been experimenting with '46 doubler stage. EVA needs Nevada, Utah and Wyoming for W.A.S. IYR is now located at 159 Rainbridge St., Brooklyn. KVV is using crystal control on 56 Mc. using a 28-Mc. crystal, a pair of 48's in the final with 110 volts d.c. on the plates, about 30 watts input. New station LJC is located at 2108 Quentin Road, Brooklyn. 8QPS/2 would like to hear from any of the gang interested in playing checkers over the air; he operates on 7190 kc. PF reports a new op at SC/WLN from WLW. DVU read in the paper that L. I. is sinking one inch in one hundred

(Continued on page 72)

## The pioneer is still the leader

TYPE TJ-U  
Dykanol  
Transmitting  
Capacitors

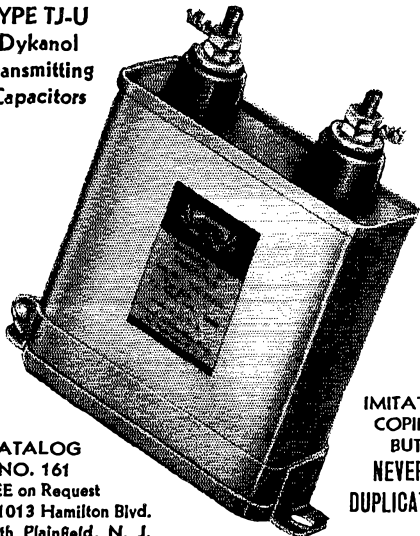

CATALOG  
NO. 161  
FREE on Request  
at: 1013 Hamilton Blvd.  
South Plainfield, N. J.

IMITATED  
COPIED  
BUT  
NEVER  
DUPLICATED

### CORNELL - DUBILIER



ELECTRIC CORPORATION

South Plainfield, New Jersey

## Your Inquiries Invited . . .

When you need amateur equipment it is to your advantage to write to Bob Henry, W9ARA. You get personal attention; terms financed by myself so you buy with less cost and more convenience; fair trade-in value for your equipment; ten day trial of all receivers; and my cooperation in every way to see that you are 100% satisfied. No wonder Bob Henry's customers are boosters. You will be too. For the newest equipment, the latest information and technical help:

WRITE TO: BOB HENRY, BUTLER, MISSOURI

### Compare Bob Henry's Terms With Others

Model and Receiver	Cash Price	Down Payment	12 Monthly Payments
The NEW NC-44.....	\$49.50	\$9.95	\$3.52
NC80X and NC81X.....	99.00	19.80	6.99
Improved NC101X.....	129.00	25.80	9.11
The NEW NC100A.....	120.00	24.00	8.48
The NEW RME-69.....	141.03	28.20	9.98
Sky Champion.....	49.50	9.90	3.49
Sky Challenger II.....	77.00	15.40	5.44
Super Sky rider.....	99.00	19.80	6.99

Also Super Pro, HRO, PR15, Breting 9, Sargents, others.

Similar terms on Harvey, RCA, RME, Bassett, Temco transmitters and National, Progressive, Utah, Stancor kits.

Special Department for Export Orders

### HENRY RADIO SHOP

211 North Main Street Butler, Missouri

## 56 Mc. Goes on Annual Frolic

(Continued from page 21)

June 9th: W9ZGD reports that at about 8:05 p.m. CST, W5EHM called QST on 28 Mc. and reported that 56 Mc. was open to the 8th and 9th districts. W5AJG was heard in Ohio S8 at 9:21 p.m. CST.

June 10th was an active day. W5EEX, Houston, Texas, worked W8VO, W8JLQ, W9UJE, W9CLH, W9LLC and W9YYY, using about 70 watts to a pair of '10's. W9ZGD, Milwaukee, worked W5EHM for the third time at 7:58 p.m. CST. W9YTI, Milwaukee, heard three W5's, including W5EHM. W5AJG, Dallas, Texas, worked W9ANA at 7:44 p.m. CST, and heard W9CLH and W8CVQ; reports band open from 7:30 to 8:30. W8PK reports band open from 7:30 to 9:00 p.m. with W5EHM the best performer. W8PK heard EHM work W8JLQ, OWO, RYK and a W9 in Indiana. W8QDU, Michigan, heard W5EEX and W5ZS, both fading badly; worked W5EHM. W8QFV heard W5EHM, W5EEV (testing) and W5EXQ, about 7:30 p.m.

June 18th: W5AJG reports "five" open from 8:00 to 11:30 p.m. CST. He worked W8VO, 11:30, and W8CIR, 11:50; heard W3BLH, W8QXV and W8IEF. W3EZM, Langhorne, Pa., worked W5EHM at 11:30 p.m. CST. W8QFV, Ohio, heard W5EHM at 10:10 p.m.

June 19th: W3EZM worked W4EDD at 7:20 p.m. CST. Eugene Schraut of Sheboygan, Wis., reports the following heard between 4:30 and 7:00 p.m.: W1KIB, IXP, W2MO, DYR, HWX, W3DYE, BUU, EZM, BIO, NU, FBH, AYF and FVR. W8QFV heard W4EDD at 9:30 p.m. W1IJ writes, "June 19th W4EDD rang the bell again, putting an S5 to 9 signal up the coast. He was first heard here from 8:22 to 9:00 p.m. EST, at which time he faded out and the band returned to normal. At 9:23 we noticed the band was upset again and went back to EDD's frequency and there he was. At 9:28 p.m. we called him and made contact. The last we heard of him was about 9:40 when he seemed to have gone out of the picture."

June 27th: W9ARN, Bartonville, Ill., reports the band opened slightly for east coast at 7:00 p.m. CST. At 7:17 W2KLZ was worked; W8ABX was heard on i.c.w. at 7:26; band out at 7:45. W8CIR, Western Pennsylvania, worked W9UOG. W8NED worked W9ZJB, W9QDQ and several other nines. W9NY worked W1IZY, 6:03 p.m. CST, W2KLZ, 6:16 p.m.; heard W2KLZ again at 7:20 p.m.; worked W5EHM at 10:49 p.m. W9VKT, Omaha, Nebr., heard W2KLZ, 7:25 p.m. CST, W8QKT, 9:10 p.m., W8CIR, 9:20 p.m.

June 28th, W5BHO, Houston, Texas, reports hearing W9CLH for very short periods of time (about one-half minute) at 8:48, 9:05 and 9:25 p.m.

June 29th, W5AJG, Dallas, W9USH, South Dakota, 11:00 a.m., heard W9ANA, Wisconsin, from 10:00 to 11:30 a.m. CST.

And that's the story as this issue goes to press.



**GIGANTIC** **BREATH TAKING**  
**COLOSSAL** *Stupendous* **STAGGERING**  
**TREMENDOUS**

That's how the movie producers would tell you that radio amateurs everywhere are cheering those two new Taylor Champs, T-40 and TZ-40. Our natural modesty forces us to admit that these new tubes are gol-darn good—we know they represent greater values for Radio Amateurs. Many thousands of these Wonder Tubes, have been bought during the past few months. Reports indicate extremely efficient operation on all ham bands from 5 meters up to 160 meters. Such outstanding manufacturers as Bassett, Utah, Temco, Thor-darson, Gross, etc., have developed fine transmitter circuits and kits which use these tubes. Reports from these manufacturers are equally enthusiastic as those received from amateurs themselves. Be fair to your Rig and your pocketbook, and remember — comparison sells Taylor Tubes.

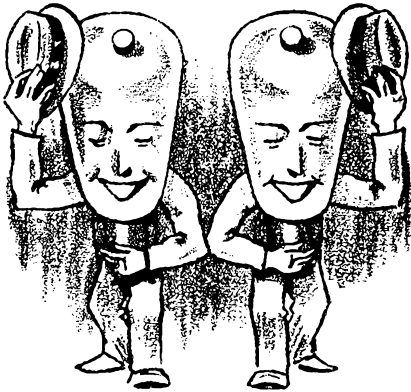

**7000**

That's how many Taylor T-40's and TZ-40's have been purchased by amateurs in a few short months. "A real championship pair."

**COMPARE !**

**T-40 RATINGS  
Class C.**

Fil. ....	7.5 Volts	2.5 amps.
Amp. Factor .....		25
Grid to Plate Cap .....		4.5 mmf.
Plate 1000 Volts .....		175 m.a.
Driving Power .....		10 watts
Price .....		\$3.50

**TZ-40 RATINGS  
Class B. Audio**

Fil. ....	7.5 Volts	2.5 amps.
Amp. Factor .....		62
Plate .....	1000 Volts	(Two tubes) . 220 m.a.
Driving Power .....		(Two tubes) . 3 watts
Plate to Plate Load .....		(Two tubes) . 6800 ohms.
Audio Output .....		(Two tubes) . 175 watts
Price .....		\$3.50

*Send for complete technical bulletin.*

*'More Watts Per Dollar'*

**Taylor** HEAVY **CUSTOM BUILT** DUTY **Tubes**

**TAYLOR TUBES, INC., 2341 WABANSIA AVE., CHICAGO, ILLINOIS**

(Continued from page 69)

years, so he is working on his emergency rig now. Unit 4 of Section 6 of the N.C.R. organized an expedition to Rock Hill, L. I., under the leadership of ADW and operated portable on 1.7, 3.5 and 7 Mc. on Field Day. IXV manages to keep the foreign schedules going FB. LAP reports regularly. AVS at Riverhead operates on the Airport Network every night at 5 p.m. EC reports A-P Net discontinued until fall. HGO keeps his once-a-week schedule with 8MCT. Heavy rains kept AZV's Field Day activity down. AOT and GGS are getting back after a long layoff. HMJ and eight of the S. I. gang operated in a tent in the wilds of S. I. during Field Day. JRF also operates in the Airport Net. KDK contemplates leaving S. I. for Army Air Corps at Mitchel Field. KMS operates on 7 Mc. with an RK49. GPY is trying to get on 7 Mc. with a P.P. 6L6 final. KMN operates 3.5 and 7 Mc. JRZ works DX on 14-Mc. 'phone and c.w. KVB keeps on 4-Mc. 'phone while COK operates 56 Mc. ELN sends the following news: CGD recently tripped to the altar. CSB also lost his bachelor freedom some time ago. The YL-2NI, who used to attend the F.T.C. (Flatbush Transmitting Club) meetings, got spliced, but not to the ex-boy friend 2CES, who got her started in ham radio. Hi! BTF will soon be back on with a corking new rack-job and a nifty super-hot receiver. BLD completed a swell new rack-job. FEO moved to Richmond Hill, Jamaica, and expects to work his old friends on 1.75 Mc. better from the new QTH. ELN will very shortly be back on 3.5-Mc. c.w. with new rig using 6L6G and parallel tens and a Hallicrafter receiver.

Traffic: W2EEL 203 PF 76 AZV 70 IHT 31 DRQ 23 FF 14 EC 13 BGO 10 BYL 8 GRJ 7 AA-CIT 6 KJY 12 LR 6 JZX 11 8QPS/2 2KCV 7 IXV-CHK 6 FLD-DIR 5 GG-FIP-AZM 4 KYV-BDR 3 KXB 4 HJT 3 HYL-AJM-AHC 2 DVU 3 HGO-LBI-HMJ 2 LAP-AGH-AGC-DOG-HAK-JBL 1.

NORTHERN NEW JERSEY—SCM, Fred. C. Read. W2GMN—Some very good work was done by radio clubs and individuals in the June Field Day, despite the dampening effects of a couple of thunder showers. Communication on 56 Mc. was especially brisk. To the best of our knowledge the greatest number of contacts for this section was made by the Jersey Shore Amateur Radio Assn. from its station at Homing Hill. GVZ is still after JX and has worked 109 countries. TP is busy making a new 28-Mc. antenna. AOG has new 56-Mc. rig. Number of Jersey hams had fine time at the Hudson Division Convention on June 17th-18th. Committee deserves congratulations. IOZ made trip to Luray, Va., and Washington. KTR has an O.R.S. appointment after only 5 months on the air. FBI L EK is new station in Woodbridge. ISW is building portable transmitter-receiver. FDI moved to Middletown, Conn. ZB is back on 56 Mc. at new location in Hillside. GYY sends CQ with cut-out of his motor boat and works the gang ashore. FOI and JOC spent two weeks at National Guard camp at Indiantown Gap, Pa. Schedules were kept with IE at Cranford on 1.75-Mc. c.w. BZJ built new exiter for Field Day contest. IQM has been active on 3.5 Mc. KHA is spending summer at Derry, N. H. Any of the fellows who want to get in touch with him may do so through IKIN. AUH is planning to use 56-Mc. 'phone. GME and HFN have been doing good DX work on 14 Mc. BMK has new preselector. Public Service Amateur Radio Club had dinner meeting, May 31st, their last meeting until fall. North Newark Amateur Radio Club discontinued meetings until fall after a very active season. DSV finds 14-Mc. conditions improving for DX.

Traffic: W2CGG 455 (April-May) KTR 360 HOZ 209 HCO 180 HCO 51 (April-May) GVZ 44 BZJ 14 KHA 25 KMI 23 ISW-CJX 6 IZV 4 HDJ 3 HQL 2 (WLNK 42) DSV 8.

#### ATLANTIC DIVISION

EASTERN PENNSYLVANIA—SCM, Jack Morgan, W3QP; Asst. SCM in charge of E.C., Miss Frances V. Rice, W3AKB; R.M.'s: 3AKB, 3AQN, 8ASW. P.A.M.'s: 3EOZ. The Frankford and York Road Radio Clubs waged intensive war on each other during the annual Field Day outing. Both seemed able to work everything within hearing, despite thunderstorms, ear-splitting static and periodic equipment trouble. 3BRZ hooked XU80L near 14,320 kc. 3DGC is bucking static on 1.75 Mc. for some summer vocalizing. 3DXC has tied in with 4PL for clearing K6 traffic; he

also has crystal switching which speeds up dodging interference. 3EEW raised Detroit on 7 Mc. with .18 watts!! 3EFH built his regular rig into a case, so that it is both the home station and the portable with no changes but antenna and power supply. 3EML ran up his total in only two weeks: Here is the fast route to K5AA and the W6 area. 8NPQ has moved to Pottsville, and provides the only O.R.S. route into that point. Nearly all report reduction or discontinuance of schedules for the summer, but the main lines continue operating: 3EML to K5AA. 3EJW to 8ASW, 3DGC, 3GDI, 3ADE and 8CDT; 3NF to WLM; 3QP to 6LUJ, 6CUU, 0A4U and VK6MO.

Traffic: W3ADE 5 3AOC 15 3AQN 97 3BES 8 3CHH 16 3DDM 15 3DGC 229 3DXC 50 3EFH 2 3EML 356 3EJW 113 3FXG 5 3GDI 14 3GYY 42 3HCT 1 3NF 101 3QP 322 3UA 14 8ASW 166 8CDT 7 8EKG 53 8NPQ 4 QLW 2 3GAG 122 3AKB 178 3ECA 34 3EDC 141 8EU 3.

MARYLAND, DELAWARE, DISTRICT OF COLUMBIA—Edgar L. Hudson, W3BAK, SCM—3CXL, 3CQS; R.M.'s: 3BWT; Chief R.M. Several of the Eastern Shore gang attended the Atlantic Division Convention at Washington, June 24th-25th. SN is installing new power supply in Collins and putting in tube keying. WU worked four new countries. GKZ returned from three weeks in New London, Conn.; he also visited Hartford and some of the HQ gang. BXC attended the New England Div. Convention in Hartford, May 2nd; he received his M.A. degree in chemistry from Wesleyan University and will go to MIT as teacher in the fall. 8EYX, together with GPK, GXI and HMX, had portable rig on the skyline drive on Field Day and had lots of fun. GXX has had his ticket a year and has worked all states and 50 countries with 100 watts. HBT is on 7 Mc. with a pair of 6L6's. EPV works 56 Mc. when DX is bad. AOO and BEN are going in for DX in a big way. CSX moved to the country. ATQ is on 7 Mc. with a 50-watter. FCX is getting built up with a new rig and new 81X receiver. BWT is rebuilding. DOG raised his power to 600 watts on 3.9-Mc. 'phone. AED rebuilt his kw. rig and is back on with FB signal. GLM, a junior at Yale, is home for summer QSO's. AXP is taking a trip to France on a French liner.

Traffic: W3CXL 227 (WLM 2808) SN 577 CIZ 562 FPQ 10 BAK 7 CDG 6 WU 3 CDG 2.

SOUTHERN NEW JERSEY—SCM, W. Walter Filson, W3BEI—BYR is rebuilding. HEH is back on with a new c.c. rig using 35-T's in the final with 400 watts. ZI still holds a few schedules. FBM secured new power supply for final and is getting better results. HJV is interested in traffic handling and is starting out with a '47 crystal and '45 final with about 40 watts. AEJ turned to rag chewing for the summer. ZX is getting going in a new location on Oak Drive, Medford Lakes. K4ENY dropped in on the gang unexpectedly, and says his two-year stay at the Virgin Islands will be terminated about October, after which he expects to be transferred to the Great Lakes. The D.V.R.A. will hold its annual outing and hamfest on Aug. 14th at Sullivan's Grove, Washington's Crossing Park, N. J. The D.V.R.A. operated from Mercer Airport on the Annual A.R.R.L. Field Day and worked 25 hours for 51 contacts. 1KTQ(3) enjoyed a shakedown cruise down along the Atlantic Coast and wound up in Cuba. The S.J.R.A. will hold its annual outing and Field Day in Aug. or Sept. Details later.

Traffic: W3ZI 88 BYR 60 (WLVN 9) FBM 40 BEI 9 HEH 8.

WESTERN NEW YORK—SCM, H. E. Preston, W8CSE—P.A.M.'s: 8CGU. R.M.'s: 8BJO, 8DSS, 8JTT. The big news of the month is the 56-Mc. DX worked by DSU. On June 5th the 56-Mc. band opened up during the evening and Fred worked 9AHZ and 9ZPJ; he heard 9ARN and 9NY. PK and AGU were also active on 56 Mc. and got in some good work. PK heard 5EHM. DSU puts in a couple of hours each Tuesday night on "five" with 100 watts input to the final. It would be greatly appreciated if anyone hearing his signal, regardless of distance, would report reception to him. NXQ moved about July first to Webster Ave., Syracuse; as soon as he settles at new QTH he will have about 100 watts on 56 Mc. JTT has been visiting in Springfield, Mass.; he has a new 65-foot stick at his Fredonia QTH. NNJ had an FB time operating MLM portable on the A.R.R.L. Field Day. The Finger Lakes Transmitting Society had an FB Field Day in conjunction with the A.R.R.L. Field Day; a self-powered rig with an RK-20 was used in a trailer at "Frozen Ocean," fifteen miles south of Auburn;

over 80 contacts were made, many of them on 3.9-Mc. 'phone; the call used was 8BDV/8. ACY worked ZD2H for his 89th country MIM. DHU is giving 14 Mc. a whirl. FUG changed QTH to 123 Holmes Road, about two miles west of the city of Rochester. JQE is working on his RK-20 rig. DSS gets on around 9 p.m. EST occasionally. Our low-power DX'er, ROI, went on 14 Mc. and the first station called, EIGG, came back and gave him 589X report MIM; he is forsaking Auburn for new QTH at Aurora. RKA has been registered as the local American Legion emergency communication unit. 4FCP/8QMR returned from Florida and is summering at Middleburg; he is very anxious to establish a schedule with Rochester. RNG shifted activity from 1.75-Mc. 'phone to 7-Mc. c.w.; one day he was QSO a VF3 and the wind blew his antenna down, pulling the transmitter right out of the window. Hi! NA worked 54 stations on 1.75-Mc. 'phone and one station on 1.75-Mc. c.w. GZP, OAM and CSE captured Class A tickets during the month. OAM joined Coast Guard as Radioman. GZP is burning up the 3.9-Mc. 'phone band. The Toothpickers, IY, CGU, FFN and GBV, still keep their noontime schedule on 3.9-Mc. 'phone. RTX in Caledonia applied for O.P.S.; he is on 1.75-Mc. 'phone. RNE in Syracuse is planning on a new transmitter; with all the advice he probably gets from PXA, NXQ, JUG, ETH and LYJ, it's a wonder the poor fellow doesn't go crazy. LYJ is president of Syracuse Radio Club and RNE is vice-president. RZX is a brand-new ham in Syracuse. KDY will show the boys how to really operate a 1.75-Mc. 'phone. REI and RKM are active in Cortland. QLT is on 28 and 14 Mc. RMR in Mt. Morris has a new SX11 Skyriider and is working plenty of DX on 7 Mc. QXS paid the S.C.M. a visit; he is on 1.75-Mc. 'phone and 3.5-Mc. c.w. JNU is working plenty of 14-Mc. 'phone. Don't forget to listen on 56 Mc. every Tuesday from 7.30 to 9 p.m.

Traffic: W3JQE 24 PLA 87 RKM 36 JTT 2 ACY 4 DHU 19 DSS 34 ROI 2 RKA 27 QMR 48 CGU 15 FCG 52 CSE 56 (WLNW 49) QXS 48.

WESTERN PENNSYLVANIA—SCM, Kendall Spear, Jr., W8OFO—R.M.'s: 8KUN, 8KWA, 8MOT, 8GBC. A.A.R.S. Liaison R.M.: 8UK. N.C.R. Liaison R.M.: 8KOB. Emergency Coordinators: McKeesport, 8DNF; Pittsburgh, 8QAN; Erie, 8AQJ; St. Marys, 8NDE; Butler, 8DDC; New Castle, 8NQO; Ohio River Region, 8RBV. New appointments: O.R.S., AVY; O.B.S., RBL. DON'T MISS THE SOUTH HILLS BRASS POUNDERS FIFTH BIG ANNUAL HAMFEST, Sunday August 7th at Clattys Driving Range, Mt. Lebanon, Pittsburgh. From noon 'til dark. Lots of eats, prizes and speakers. Tickets, \$1.00. Attendance of 1000 expected. The Pittsburgh Area Radio Council has organized with five clubs already represented. QAN is President and AVY, Secretary. Western Pennsylvania, West Virginia and Eastern Ohio Clubs are invited to join the Council. Write 8AVY for details. The Altoona Horseshoe Radio Club held its June meeting in the form of an outing and basket picnic at Ivyside Park. Over 125 attended. NRY, Chief Engineer at KQV and WJAS, and ONW of West Penn Power spoke at the June meeting of the McKeesport Mon Yough A.T.A. Pictures of the San Francisco Bay Bridge were shown at the meeting of the Amateur Transmitters Ass'n of Western Penna. in Pittsburgh. OLW, OC, FTY, ONW, AMP, OFO, CUG, UK, NDP, BSO and CFR will again handle 56 Mc. radio communication for the annual Boat Regattas September 2nd-3rd at North Park, this year being sponsored by Allegheny County during the Sequi-Centennial celebration with two complete regattas instead of one as in previous years. Ensign Hiner, FUV, and Lieut. Williams, ZAE, Commanders of Sections Two and Three of the N.C.R., are busy enlisting recruits. A card to either will bring you application blanks and details. The S.C.M. was visited by KXP, NCJ, his XYL and 3BO, DDC, DNX, BBW and RXO took part in Field Day doing nice work. CMP attended the Atlantic Division Convention. NDE is trying some 14 Mc. during the summer. UK operated portable for South Hills Brass Pounders on Field Day with PX, QAN, OKF, CKO, FCO and others assisting. CUG, CFR, BSO, NXD and Sam Nickhazy ran up a nice score during Field Day. MTK had his appendix removed. GUB completed his course at Dodge Institute and now has his First Class Telephone Ticket. AJV bought an HRO. NDP is back on the air. The XYL at NCJ made the R.C.C. and worked a YV for her first DX. POX and CUN are on 7 Mc. Over 125, including the R.I., Grinnell and XYL attended a picnic, June 12th, on BRC's farm. JSU worked 58 countries and

went W.A.C. eight times since January. MJK is on 14 Mc. for summer; his new rig is 6L6-6L6-Pr. T40's with 200 watts. RUF is on 3.5 Mc. EIS works 7 Mc. IOH has a new Vibroplex. KWA in pulling down his old antenna brought the chimney along with it. CIR worked Florida and Texas on 56 Mc. OKS, LGD, OUA, LBO, QNJ, QVN, OIR, QEN, QNY and QBK completed two weeks' active duty at the Phila. Navy Yard. QFM is back from two months' cruise on the U.S.S. *Savannah*. HHM is now 3GXV at Norfolk and OCG is 4FDO at Rocky Mount, N. C. PFW is handling Western Penna. traffic in the A.A.R.S. State Net during the summer. RQA now has 25 countries. AVY is busy with Radio Council, P.R.R. Emergency and fishing! RAU and RAZ have been hearing W1-2-3-4-5-9's on 56 Mc. KCW uses a pair of '45's TNT on 3.5 Mc. Congrats to DGL, who just got married. LBW has been rated Chief Radioman and LGD Radioman Second Class in the N.C.R. SBQ (ex 4BOU), "side kick" of 4IR, the Ole Dixie Squinch Owl, is joining the Third Corps A.A.R.S. NTJ, KYW and PMY took part in Field Day. RUE worked 5EHM on 56 Mc. FLASII—W8CMP was presented with the Marconi Memorial award at the Hudson Division Convention. Congrats. You are invited to become O.R.S. and O.P.S. during the summer period and be ready when the fall season opens. The traffic nets will be bigger and better. Don't forget, crystals are loaned gratis to active stations. A card to the S.C.M. will bring information and application blanks. Do you want a W. Pa. QSO Contest this fall with prizes? Your response and enthusiasm will determine if there will be one.

Traffic: W8FUW 162 OFO 81 DNX 69 CMP 53 DDC 35 QAN 25 NDE-UK 15 NCJ 3 JSU-MJK 2 IOH-RBI 1:

#### DELTA DIVISION

LOUISIANA—SCM, Eugene H. Treadaway, W5DKR—R.M.'s: 5BN, 5DWW, P.A.M.: 5BMM, E.C.: 5FPO. O.O.'s: 5DXK, 5FXK. EQG reports the Baton Rouge Amateur Radio Club very active. ACA is doing an FB job on 14 Mc. and is active O.R.S. FXC is on the job 100% as O.O. BYX has T55 in final, and is going strong after a lay-off of six years. BN has 250 watts int. 242-A, working 7, 14 and 3.5 Mc. CEW enjoys working DX. BMM will build several new beam antennas soon. WG and BZR were active in Field Day tests on Black Lake, about 60 miles southwest of Ruston. GIA has pair of T40's working nicely. GMF with his low power is doing a great job on 14 and 28 Mc. GUX reports for FSI, GVW and 4WD of Camp Beauregard, and says they all will be active on 28 Mc. soon. FVD reports the Louisiana Tech. Radio Club successful in its private Field Day on Black Lake with the Monroe Amateur Radio Club. Congrats, gang! EPY, our good friend of Starkville, Miss., sends 73 to the Louisiana boys. AOZ is working away on that 28-Mc. 'phone rig. GUK is sure proud of his '45's P.P. FPO, the old 'phone station, is heard on c.w. these days. CXQ is a hog for DX. DXK is plenty QRL with convention plans. CJO has a complete new plug-in transmitter. FBB has a new 16-tube R.C.A. ham receiver, and it sure is the berries. JW, EDY, FSX, EVS and FHH are going strong on 28-Mc. 'phone. DKR has new ham shack, new antenna, and is working 14 Mc. FMO has been new beam antenna. EVZ has 150T in final with 600 watts. GXQ is new active ham in Baton Rouge. BRR is big DX man. ACY has 300 watts on 3.9 Mc. FZQ has an FB rig. AKI, ML, DXB and EKU want activity on 56 Mc. Here's your chance to give it to 'em, gang. JN has new 14-Mc. antenna. FZY likes 28-Mc. 'phone. ZV is heard all day long on 28-Mc. 'phone. 9SNR quit the sea and will be heard from his station back home; while in New Orleans he was active over FPO. GLH is active 7-Mc. station. GRE is working hard for W.A.S. GMR and his 100TH are doing a nice job on 28-Mc. 'phone. BLQ has an FB new 28-Mc. 'phone rig. FWO says his new McMurdo Silver receiver perks FB. DRF does his bit of DXing. GCS likes his T55 job. FJW, EGK and DXL are active Monroe stations. BDJ gets out nicely with low power. DAQ has a swell transmitter. FSA is working away on new rig. GJO does some oping over FPO. AVO is back and active in New Orleans. Sure glad to have you back with us, OM. BSR keeps Lake Charles on the map. GIW, the L.S.U. station, is working some nice DX. ADJ comes crashing through the QRN on 1.75-Mc. 'phone. FUM is getting c.w.-minded. GAL sends some FB reports on the Baton Rouge gang. KC is active O.R.S. and O.B.S. of Plaquemine. GDU enjoys pounding brass. BQD reports active from Jonesboro, DU, our R.I. at New Orleans, is heard on 28-Mc. 'phone.

**DRESS UP and LIGHT UP  
Your PANELS  
with FRONT or REAR  
ILLUMINATION**



**TRIPLET**  
FAN TYPE  
ROUND  
SQUARE

A Style  
for  
Every Need  
Economically  
Priced

Sensitive and ultra-sensitive electrical indicating instruments. D.C. Moving Coil . . . A.C. the Re-pulsion Type. Sizes—2" to 7". Specify TRIPLET for

the finest, most up-to-date instruments in appearance, performance and economy. Write for Complete Catalog.

**THE TRIPLET ELECTRICAL INSTRUMENT CO.**  
258 Harmon Dr., Bluffton, Ohio

**RADIO COURSES**

**RADIO OPERATING:** Prepare for Gov't License Exam. • **RADIO SERVICING:** Including Short Wave • **AMATEUR CODE** • **ELECTRONICS** • **TELEVISION** •

Day and Evening classes—Booklet upon request

**NEW YORK YMCA SCHOOLS**

4 West 63rd Street, New York City

**SPECIAL TO AMATEURS**

**Piezo-Electric Crystals — \$2.50 EACH** POSTPAID

Until supply is exhausted . . . we offer 80 meter band crystals unmounted; accurate calibration, excellent oscillators. Limited quantity.

**SCIENTIFIC RADIO SERVICE**

"The Crystal Specialists Since 1925." University Park, Hyattsville, Md.

**SEE YOUR JOBBER**

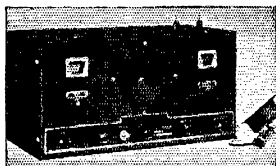

For one of our powerful portables . . . use it at home, too . . . interchangeable 6 v. d.c. or 110 v. a.c.

Write for bulletins giving complete data on our high frequency amateur equipment.

**Radio Transceiver Laboratories**  
8627 115 STREET RICHMOND HILL, NEW YORK

"Five" certainly gave the boys a work-out this year! During May and June W8CIR worked seven districts, lacking only W6 and W7! W3EZM has also worked all districts except W6 and W7, has worked 15 states and D.C. and received "heard" reports from 18 states. Who holds the records for number of states worked on "five"? Has anyone worked all districts?

56-Mc. will bear watching. Perhaps the band is open more often than we realize. The open periods this year apparently covered a wider span of time than in the past. With the advent of more stable signals and improved receivers DX may become more common, and extend more widely through other portions of the year. Experienced five-meter men believe that crystal control and more general use of good receivers will greatly improve 56-Mc. performance.

Many thanks again to those who submitted reports. To those who figured in the May-June activities—well done and keep plugging!

—E. L. B.

**Heard and Worked \* on 56 Mc. June 5th**

In Massachusetts: W3GMZ W4DNW EDD W5DRN FO FOH W8ARQ BDG CIR CQK EQG IUB IUD IVF JIN JKT JLQ\* LDJ LEU LSS NKJ NKK NSL NSS OCG OAI OIA OJF OOD ORA OSS OTG PBP PNU PPU PQQ QDU QXV RAC RDT RFC RFS RKE RMJ RSH RSM RSS RUZ RUL RUT RVA RVD RVF\* RVT\* RYM VO YX W9AAV AEA AHZ ALE ARC ARF ARN BEA CGW CJW CLH CMN CX FEN FP\* IUD KIC LRC LNV LVK LYI MKJ NY PQA PQH PTB QCY QEI QHR TMM UTS VHG WJW WLX YDD YGZ YSV\* YX ZDG ZEO ZGD ZJB ZMG ZSS ZUX. In Connecticut: W5ZS W8EGQ ENV IUD JIN JLQ NOB OJF\* OPG ORA\* QAM RSF RSS\* RVT YX W9ARN CAY CLH CX FEN\* FP GGH\* GKO HPP\* IBX IV IVC\* KEN KRX LDM LLC LLV LLX LYI\* MXX\* NY OXD PQH\* TMM UTS ZSS. In New Hampshire: W8CJW EQG JIN JLQ OJS OTG RMJ RSS RVT W9ARN CLH DQH FP PPV PQH PTB UGS ZGD ZSS. In Maine: W3GMZ W8EGQ OPO RSS W9CLH NY\* PQH. In N.Y.C. area and Eastern New York State: W8CXK EQG\* JIN\* JLQ MRK NIX NKJ\* OIA\* OTG QDU RAF REU RFC RSS RVA\* RVQ RVT YX W9ALE ARN BEA CJW CLH FCH FEN FP HFP IVD JFM LLC LNV LCK\* LYI MTN NY PMM PQH PQX QCY RBK TMM TMN UTS UTS WJW WLX YMG\* YSR YSV ZBD ZSS\* ZTB. In Eastern Pennsylvania and Southern New Jersey: W6ML ZS W7EYN W8BEA CGU CLS EQG JIM JIN JLQ\* LL\* MKJ NUJ NKJ OCY OIA\* OKG OPG\* OQG ORA OTG\* PNU\* POG PQK QDU RHR RK RKE RMJ RSH\* RSM RSS RTS RVA RVT RKO YX W9AHZ ALE ARN BEA CLH\* CX EYH FE FEN FGB FP GGH\* GNW GPS GUX GYS HPP HTT IBC IVC JUE\* LNV LVK\* LYI MXX NMF NY\* OLY\* OVK\* PNM PQH\* QCY QHR\* QHY QVB RGD TAT THR TQH USE UTF UTL UTS VSS WLX\* YGS\* YGU YGZ\* YLD YMD YMG\* YNG YSA YSB YSV ZBS ZGD\* ZJG ZJD ZSS ZUL ZUX\* W6DQH-9 W6EVO-9. In Western New York: W5EHM ZS\* W8EGQ JIN PQJ RSS YX W9AHZ\* ALE ARN CLH NY OLY PQH UIZ\* ZJB\* ZJP\*. In Western Pennsylvania: W1BJE\* IJG IVA\* IZY\* JUN QV\* W2GAH\* IX Y KLZ\* W4EDD W8ETQ\* ZS\* W9AHQ\* AHZ\* FD GKO MOW OLY QFX\* QVP UIZ\* VIZ WTV\* WWD\* ZB\*. In Ohio: W1AGR\* AJR APJ ASF AUN BJE\* COX CRV DOO ETD EYM\* FKV FVD FZU GDJ GKJ GQV GYT HM HPE IAH\* IAK IGH IJG IXO IXP IYK IZA IZY JFK JIS JLG JLI\* JLO JMT JNT JUI JUN\* JZC JZE\* KEE KEK\* KEM\* KEX KH KHK KHO KIB KNG KNH KNM KNN\* KNX KPM\* KP V KSG KTF KUD\* LAB\* LBK LGH PM SI TA W9ANM\* BKW COK DB DEJ DMM FGB HGB HYJ HZL\* JCY JMC JVV KHK\* KL KLO KLV KLX LAH LEV\* W3CGF DOD EZM\* FBC FBH FOP\* GHI GHL GHO HJM HK MV W4EDD ETC W9AJG ML ZS W8ETD W9OLY USH. In Illinois: W1ASY AUN\* BRL

# A New THORDARSON Band Switch Transmitter Kit

## Instantaneous Band-Switching From Front of Panel

Over any three pre-selected amateur bands

- ▶ 100 watts input on all bands.
- ▶ Single meter reads all plate currents as well as grid current of final stage.
- ▶ Power supply and R-F section on one chassis.
- ▶ Band-Switching feature optional, regular plug-in coils may be used.
- ▶ Tube lineup: 6L6G—6L6G—TZ-40.

### PHONE OPERATION

- ▶ Plate modulation by a separate unit using a pair of 6L6's.

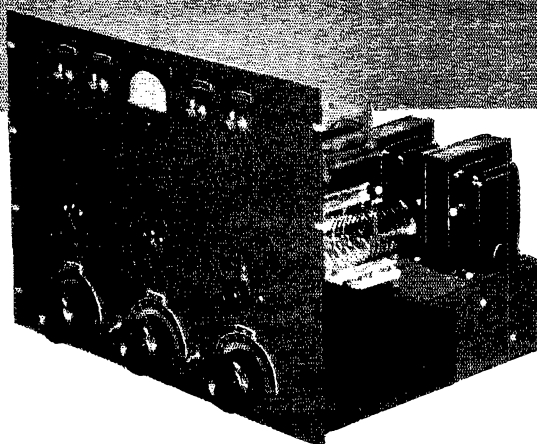

### FOUNDATION UNITS

Completely punched chassis and panels supplied by Thordarson for both units. Full constructional details, photos, diagrams, etc. Standard parts used throughout. Fits standard relay racks or cabinets.

## UNIVERSAL SPEECH AMPLIFIER

- ▶ Designed specifically for amateur transmitters.
- ▶ Sufficient driving power for any Class B modulator.
- ▶ Hum at absolute minimum.
- ▶ Output can be adapted to either Multi-Match driver transformer or 500 ohm line.
- ▶ Accommodates crystal microphone.
- ▶ Optional volume compression circuit.
- ▶ Tube lineup: 6F5—6C5—6C5—2A3's P-P.
- ▶ Foundation unit furnishing completely punched chassis, instructions, photos, etc., suitable for standard relay rack or cabinet. Also screen cover and bottom plate available.

*Foundation Units for all three items may be  
obtained from your parts distributor*

*Ask him or write to factory for free descriptive circular SD-378*

**THORDARSON ELECTRIC MFG. CO.**

**500 W. HURON ST., CHICAGO, ILL.**

*Demand "Power by Thordarson"*

IF IT'S  
**NEW** . . .  
we have it

## HALLICRAFTERS

### DIVERSITY RECEIVER DD-1

Reduces fading to almost Nil  
Increases average signal strength  
Improves signal-to-noise ratio  
Reduces H. B. N. interference.

### SKYRIDER 5-10

Continuous coverage 27 MC to 68 MC  
in two bands. Superior ultra-high  
frequency reception.

### SKYRIDER MARINE

8-tube AC-DC receiver adapted to  
marine work . . . excellent selection  
and sensitivity.

### TRANSMITTER HT

Built especially to ham requirements,  
featuring new and efficient method of  
band-changing.

## NATIONAL

### NC-44 RECEIVER

Newest 7-tube Superhet, combining  
fine performance with unusually low  
price.

### EXCITER and SPEECH AMPLIFIER

5 to 75 meters, featuring latest im-  
provements, with or without speech  
amplifier.

### NC-100A RECEIVER

An up-to-the-minute 11-tube Super-  
het, ideal for amateur use.

### NC AIR SPACED COILS

Four new models ready for your  
inspection

## THORDARSON

### 100 WATT BAND SWITCH TRANSMITTER

Band-switched from front of panel;  
regular plug-in coils may be used if  
preferred; complete with power sup-  
ply. A completely wired transmitter  
on display —

IN ADDITION, we carry a most complete  
line of Public Address equipment . . . write for the  
catalogs which interest you . . . visit our new 2nd  
floor . . . SOON

**TERMINAL**  
*Radio Corporation*  
80 CORTLANDT STREET, NEW YORK, N. Y.

CPM EYM\* GYT HM IGT\* LJ JG\* ISC IUI\* IXP\*  
IXT IYI IYK IZY JLI JMT JQA\* JQO\* JXM JXN\*  
JZN\* KCG\* KEE\* KGE KHO KIB\* KID KJE KJY  
KNM KRB KUD\* KXX\* LKB MJ\* MY SI W2DB  
DMM\* FBI GAH\* GHV\* HGB HWX\* IRY ISY IXY  
JCY\* JMC JQY KBH KHR\* KLO KLW KLZ\* LEZ  
MO\* W3BYF GEF\* GIO HG. In Kentucky: W9RBK  
worked WICMP\*, W1KUD\*, W1KXF\*, heard W1JUN  
JUZ KJT IXO JFK W2COK LBK KLV KLU ISY ANM  
W3BUU FVR. In South Dakota: W9USH worked  
W2JCY\*, W2KTC\*, W2MO\*, W2DB\*, heard W1JMT  
KID W2JMC ISY HWX W3HKN EZM GLV W8AGU  
CIR. (During the week June 1st-6th, W9USH worked  
W2AMN, W1IXP, W5EHM, W5AJG.) In Kansas:  
W9UIZ worked W8GU\*, AGU\*, CIR\*, VO\*, heard  
W1ALW JQH KIB MY IY W2JMC HW ISY W3GLV  
FCR W4DEK W8NOU OSS QAI. In Missouri: W9ZJB  
worked W2HWX\*, ISY\* W8AGU\* CIR\* GU\* DSU\*  
MST\* NED\*, heard W1JQA KEE JXN JMT SI GDJ  
JNT W2JCY JMC MO HGB DYR KLV GJK W3FOP  
FVH EZM FBH FVR CUD VX HKM W8QDU. In Iowa:  
W9CCY worked W2JCY\*, heard W1KEE SI W2MO JMC  
KJZ FKD HWX GLZ W3FKF W5ZS W8CIR CLS AGU  
QKI DK KBJ QDU NED MST W9KHC DND. In Texas:  
W5AJG worked W8VO\* QKI\* QDU\* NF\* JLQ\* W9NY,  
heard W8CIR OPO GU. In Michigan: W8QDU worked  
W2JLY\* DB\* HYJ\* LAH\* W3AYF\* FLL\* W5AJG\*,  
heard W9CCY. W8MSK heard W1SI JNT JLI JMT  
GQV W2KHR MO COK IQK AWW HWX FQM KMK  
JCY LAH LEY KTU LU FWX W3CUD FSI ERA BYS  
HKM AIR GYE HKX EZM FBH HAC GDO GKW HKN  
VX GHL GKJ W4EDD. In Wisconsin: On May 27,  
May 31, June 5, W9NY worked W1BIE\* CSR\* EYM\*  
IZY\* KAD\* KTF\* W2BVY\* W3AIR\* BYF\* CXU\*  
EVT\* FVR\* W5AJG\* EHM\* ZS\* W9CLH, heard W1IXP  
KEX SI 5CSU-1 W2DYR FQM GAH HYJ IXY JCY  
KBG KF GHR KTC KTU W3CUD DOD FAA FSI  
GHY GIO GKW GMZ HG HJX HKM VX W5ML  
(W9NY reports all stations heard by him were using crystal  
control.)

## With the Affiliated Clubs

(Continued from page 27)

W9UNL Iowa Illinois Amateur Radio Club  
W9WKR Lane Tech Radio Club  
W9YL University of Colorado Radio Club  
W9YMA Mound City Radio Amateurs  
W9YWG The Tractor City Radio Club  
W9YWX Sheboygan Radio Amateurs Club  
W9ZBX Lake Michigan Amateur Radio Reserve  
W9ZVZ South Eastern Nebraska Radio Club

### OPERATING DEMONSTRATIONS AT CLUBS

At a meeting of the Amateur Transmitters  
Association of Western Pennsylvania (Pitts-  
burgh), something new in the way of a program  
was tried with much success. Instead of having a  
speaker, Ken Speer, W8OFO, S.C.M., and  
"Shorty" Grossarth, W8CUG, gave a demon-  
stration of "How Traffic Is Handled." This sug-  
gests several ways in which interesting programs  
may be worked up. Net operation is an exceed-  
ingly interesting form of amateur activity. A  
demonstration of net operating procedure, bring-  
ing several of the net operators to the club and  
conducting a net session before the club group  
should interest all operators. It would not neces-  
sarily have to be a traffic net. There are tricks to  
the smooth operation of any form of net, which  
would be enlightening to many amateurs. If the  
size of the club group is not unwieldy, it might be  
possible for the club to sit in at a net station dur-  
ing actual operation.

Demonstrations of correct operating prac-  
tices in every day amateur communication (aside

No news... **EXCEPT**

**WE CELEBRATE OUR 2ND ANNIVERSARY**

Now entering the third year of faithful service . . . our store filled to overflow with **NEW** merchandise of interest to hams and experimenters

**WE'VE ADDED AN EXTRA FLOOR**

where, in sound-proof booths, you may inspect the very latest in Receivers, Transmitters, Speakers, Microphones, Racks of all types. Here will be found an elaborate line of PA equipment, and salesmen who talk **YOUR** language

**. . . AND TELEVISION**

On August 1st we will have on demonstration Allen B. Dumont Television Receiver. It's a date!

*outside of that, there's no news!*

**TERMINAL**  
*Radio Corporation*

80 CORTLANDT STREET, NEW YORK, N. Y.

Say You Saw It in QST — It Identifies You and Helps QST

# TRIED AND PROVEN by AMATEURS EVERYWHERE

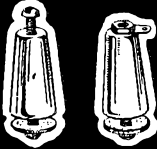

## BIRNBACH 50 AND 10 WATT SOCKETS

Designed especially for U.H.F. work.  
No. 434 — 50-watt socket. List. \$1.25  
No. 435 — 10-watt socket. List. \$ .85

## IMPROVED CONE STANDOFF INSULATORS

In a complete range of heights for condensers, coils, etc. White glaze. Write for prices and discounts.

## RO 1 TRANSMISSION CABLE

Can be used any length to 1000 ft. with negligible loss. Handles any power to 1 KW. Surge impedance of 72 ohms. No. 956 — 100 ft. spool. List price \$10.00  
250, 500, or 1000-ft. lengths also available.

## STRETCHLESS COPPERWELD ENAMEL ANTENNA WIRE

Steel case, copper covered, heavily enameled, low R.F. resistance. Fine for X-mitting doublet and directional antennae. No. 12 Gauge — 100 ft. List price \$1.58  
No. 14 Gauge — 100 ft. List price \$1.10  
*Special lengths to order*

## BIRNBACH GIANT INSULATED PLUG

No. 392 with insulated handle. Fits into recess leaving no metal to contact band. 3" overall. Red or black. List each. .50c

**BIRNBACH RADIO CO.**  
145 HUDSON ST. BIRCO NEW YORK, N. Y.

**RADIO POSITIONS** There are good positions waiting for good-type, well-trained men in radio . . . There are good opportunities for fine futures . . . but an advanced COMPLETE ACTUAL PRACTICAL TRAINING . . . as well as high type theory . . . is essential. Free Bulletin on Positions, Futures and Training.

Frank C. Jones Lectures Arthur Halloran  
Author "Radio Handbook" Author "Cath. Ray & Tel."

**PACIFIC RADIO SCHOOL**  
Dept. A, 735 Larkin Street San Francisco, Calif.

## PRECISION CRYSTALS



Crystal Holder

Highest quality crystals, one inch square, carefully ground for frequency stability and maximum output. Be sure of your transmitter frequency — use PRECISION CRYSTALS.

Crystals can be furnished with square holder as illustrated (fits G.R. type jacks) or with round holder to plug into tube socket. When ordering be sure to state the type holder desired. G.R. jacks to plug illustrated holder into — 15c pair.

Low frequency drift crystals (Type LTC) supplied within 0.1% of your specified frequency and calibrated to within 0.03% are priced as follows: 1750, 3500 and 7000 kc. bands \$3.50 each. Holder \$1.00. (State type desired.)

\*X\* cut PRECISION Crystals carefully ground for maximum power supplied within 0.1% of your specified frequency and calibrated to within 0.03% are priced as follows: 1750, 3500 and 7000 kc. bands — \$3.00 each. Holder \$1.00. (State type desired.)

\*AT\* cut crystals for commercial use quoted on at your request. When ordering our product you are assured of the finest obtainable. Now in our ninth year of business.

**PRECISION PIEZO SERVICE**  
427 Asia Street Baton Rouge, La.

from nets) would also provide worthwhile material for club meetings. Examples of correct calling, working, signing practice—proper use of CQ, QRZ (and other Q signals)—could be put across very nicely by the use of a loud speaker and two operators with keys and audio oscillator. In the case of a demonstration of voice operating, a couple of mikes would be all that was needed, unless the size of the gathering warranted a P.A. system.

Another interesting stunt for club meetings is to set up a receiver with loud speaker and tune through the bands, observing the operation of various stations, pointing out the errors, calling attention to the good operators, etc. The club group can be asked to comment on the operators logged—to tell what was wrong with the procedure used, what it should be. Newcomers and old-timers alike will profit by these various forms of operating demonstrations.

### FILM AVAILABLE

By advance request two different selections of 16 mm. movie film may be made available to any affiliated club for meeting showings. One of these films shows the functioning of the A.R.R.L. Headquarters offices. Another shows amateur station participation in the Cleveland Air Races of some years ago. Mr. A. A. Hebert, A.R.R.L. Treasurer, is custodian of the films. Requests should be addressed to him.

### GET ACQUAINTED!

Clubs are excellent places to get acquainted with radio amateurs and to participate in interesting discussion on our hobby. At A.R.R.L. headquarters there are recorded the addresses of several hundred amateur radio clubs affiliated with the League, their places and times of meetings. Why not drop in at your local club and "meet the gang"? Address the Communications Manager (enclosing 3¢ stamp, please) for data on affiliated clubs in your vicinity.

### TO MAINTAIN INTEREST

The Chester Radio Club (Chester, Pa.) has devised a workable scheme to assist in keeping up interest in club meetings. At each meeting one member is selected to make up some forty questions for the following meeting. These questions deal with the various phases of amateur radio. Teams are chosen by the president and vice-president and the questions placed in a box, each contestant in turn drawing his question and answering, if possible. Scores are tabulated and tallied at the end of the "question bee" to select the winning team. Questions run anywhere from "How many prongs has a 6L6?" to "What States are in the Seventh District?" And do the boys get stuck!

### CLUB AWARD TO BE MADE

The Federation of Radio Clubs of the Southwest, A.R.R.L., is composed of affiliated member clubs of the Southwestern Division of the League. This progressive association publishes a monthly

(Continued on page 88)



# BIG NEWS-GOOD NEWS for HAMS

## THORDARSON 100 WATT Multi-Band TRANSMITTER

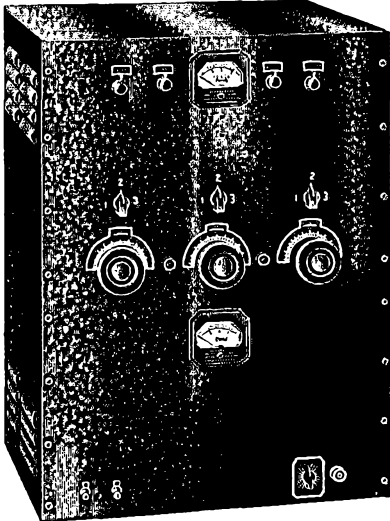

### Your CALL LETTERS IN GOLD . . . 10¢

Hams look at this! Your Call Letters in impressive three dimensional style. Big decalcomania letters nearly TWO INCHES high. Put them on your HAM SHACK door, auto window, etc. Send dime for yours today. Be sure to give your call letters.

### FREE Get This Big New HAM Bargain Bulletin!

Illustrations, prices and full details on nearly 600 separate items, sets, tubes, parts and supplel MAKE UP A \$60 ORDER and Buy All the supplies you need at present low prices AND PAY ON EASY TERMS. Write for this Special Bulletin Today.

Great terms despite ports and the...  
**NEWARK BUYS PARTS FIRM**  
**Mid-West Radio Mart Sells Out as Newark Expands Again**  
 Again Newark makes NEWS! Five months ago we announced our removal to our splendid new store, with perhaps the finest display of radio gear in America.  
 And NOW, June 17th, we buy the entire stock and good-will of Mid-West Radio Mart, formerly one of the greatest of parts supply houses! One of the greatest of parts houses has been closed. Mail orders addressed to Newark West are now being shipped to Mid-West Way — no back-orders, no excuses, every order shipped COMPLETE within 4 hours!  
 All Mid-West customers are invited to try our service — see for yourself why so many others are sending their orders to this fast-moving, well-liked organization — the one sure place to find EVERYTHING in radio supplies — the only U. S. supply house now running full page ads in QST every month of the year. Our 6% Easy Credit plan — a year to pay — is open to hams everywhere!

The city's share of the...  
 day structure would...  
 appro...

Get Yours Now on Newark's EASY TERMS  
**PAY ONLY \$10 DOWN** then a small amount on delivery, and the balance in 6, 9 or 12 months.

### LOOK AT THESE BIG FEATURES

- 100 watts input on all bands.
- Power supply and R.F. section on one chassis.
- Single meter reads all plate currents as well as grid current of the final stage.
- Modulator and power supply on one chassis.
- Bands switched from front of panel.
- R.F. lineup 6L6G-6L6G TZ-40.
- Modulator lineup — 6J7, 6F5, 6F6, 2-6L6's.
- Crystal for each band.
- Band-switching feature optional, regular plug-in coils may be used.

This self-contained 100 watt Multi-Band transmitter is available in "Foundation Unit" form with complete instructions for assembly and operation. Chassis, panels and chassis brackets are supplied completely punched for easy assembly. The entire transmitter requiring but 26 1/2" of panel space may be mounted in any of the standard cabinets or racks available on the market. Only standard parts of nationally known manufacture and highest quality are used throughout. Both the R.F. and the modulator units are supplied complete with their own power supplies. Complete band-switching is accomplished from the front of panel. Approximate Price Complete Including Cabinet but Less Tubes and Crystals. . . . . **\$136.90**

Write for Complete Circular and Time Payment Details

### Thordarson Universal SPEECH AMPLIFIER

Total approximate price **\$25.58**

less tubes and metal cover with regular type transformers and 500 Ohm output. Prices on C. H. T. Transformers on Request.

Designed to eliminate transmitter building troubles for the Ham. The 2A3 Output stage provides ample driving power. Chassis adaptable to rack-and-panel mounting or to conventional chassis type with metal screen cover and bottom. Supplied less panel, but with panel drawing and full instructions included. Easy terms when included in an order of \$60.00 or more.

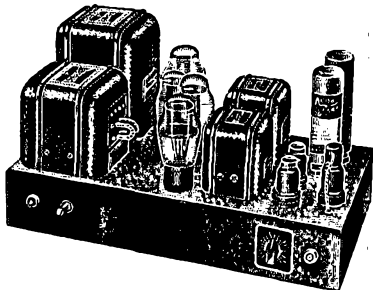

**COME TO THE AMATEUR SHOW—SEPT. 3-4-5, CHICAGO**  
 Visit our Booth and don't miss seeing Newark's HAM BARGAINS on display at our Beautiful New Store, only a few blocks from the Show!

# NEWARK

## Electric Company

323 W. MADISON ST.  
 Dept. Q CHICAGO, ILL.

# AMATEURS ENGINEERS EXPERIMENTERS

## WE CHALLENGE YOU TO PUT US ON THE SPOT!

We welcome tough assignments! The funny part of it is that we come through with that hard-to-find part in so many instances and we make such quick delivery that we've won quite a reputation for ourselves.

It's this reputation that has won so many loyal friends for us. There's no mystery about it, however. You see SUN is the Radio Parts Store of the East and we have to carry tremendous stocks to maintain the reputation that we've gained thru 16 years of honest dealings.

That's why we invite YOU to SHOP at SUN. You'll get SERVICE and you'll SAVE, too!

### AUGUST'S BEST VALUES AT SUN'S NEW HOME

● Two New National Communication Receivers: NC44 and NC510. Write for FREE Literature.

● Immediate Delivery on the NC100XA and NC101X. Other models in stock.

● HALLICRAFTERS Sky Buddy \$29.50  
HALLICRAFTERS Sky Champion.....\$49.50

● STANCOR Power Transformers, 600 volts AC at 200 MA, 0.3 volts at 2.5 amps, 0.3 volts at 4 amps. A real bargain at.....\$3.82

● G.T.C. Peewee Xmtr Kit.....\$19.95  
Kit completely wired and tested.....\$22.50

● HALLICRAFTERS Super Sky Rider SX16 and SX17 for immediate delivery. SX16...\$123. SX17...\$149.50. Write for time payment plan.

● NATIONAL NTE Exciter and speech amplifier unit in stock. Ideal for your new Xmtr. Write for free catalog.

● Complete stock of Biley Crystals: BC1...\$3.35. HF2...\$5.75. VF1...\$7.50. Write for Free Frequency Chart.

● New York's largest stock of Xmitting Tubes. Gamma-tron, Eimac, RCA, Taylor, Raytheon, Amperex, Western Electric.

## Scores A.R.R.L. Contest

(Continued from page 56)

W1FSV	192- 12- 8	Eastern Florida	
W1KVB	176- 11- 8	W4EPM	9292-101-46
<b>NORTHWESTERN DIVISION</b>		W4EBP	672- 24-14
<i>Idaho</i>		<i>Western Florida</i>	
W7FFQ	4556- 67-34	W4BSJ	13536-144-47
W7AYD	2214- 41-27	W4AXP	432- 18-12
<i>Oregon</i>		<i>Georgia-Cuba-etc.</i>	
W7GYU	180- 10- 9	W4AGI	9978-116-43
<i>Washington</i>		W4VX	6520- 83-40
W7LH	9300- 93-50	W4ECZ	4410- 64-35
W7LD	6900- 75-46	<b>SOUTHWESTERN DIVISION</b>	
W7AKP	6512- 74-44	<i>Arizona</i>	
W7CMB	2400- 40-30	W6KFC	19942-169-59
W7FZB	672- 21-16	W6MNH	1768- 34-22
W7WY*	108- 9- 8	W6GBN	1134- 27-66
W7CWN	30- 5- 5	W6OOU	96- 8- 1
W7APR*	2- 1- 1	<i>Los Angeles</i>	
<b>PACIFIC DIVISION</b>		W6OXQ	2688- 46-29
<i>Hawaii</i>		W6JD	160- 10- 8
K6CGK	855- 23-19	W6IOX*	8- 2- 2
<i>Santa Clara Valley</i>		<i>San Diego</i>	
W8NCO	6390- 71-45	W6NMZ	7216- 82-44
W8MUR	5184- 72-36	W6GTM	6642- 81-41
W8PBV	2378- 42-29	W6FQU	1152- 32-18
W8OTY	450- 15-15	<b>WEST GULF DIVISION</b>	
<i>East Bay</i>		<i>Northern Texas</i>	
W8OCQ	784- 27-14	W5FBQ	6232- 76-41
W8DHS	32- 4- 4	W5DXA	702- 20-18
W8EJA	2- 1- 1	<i>Oklahoma</i>	
<i>San Francisco</i>		W5BGR	7600- 95-40
W6GIS	7304- 83-44	W5GVP	84- 7- 6
W6GPB	4525- 63-37	<i>Southern Texas</i>	
W6IPH	2580- 43-30	W5FZD	8648- 97-47
W6NEN	1292- 34-19	W5GHI	510- 17-15
W6FFR	532- 19-14	<i>New Mexico</i>	
<i>Sacramento Valley</i>		W5CJP	4340- 64-35
W6MDI	2240- 40-28	<b>CANADA</b>	
W6EHR	1728- 36-24	<i>Maritime</i>	
W6LZE	540- 18-15	VE1EP	748- 22-17
<i>San Joaquin Valley</i>		VE1KY	504- 18-14
W6RXH	240- 12-10	VE1JK	480- 20-12
W6IWU	180- 10- 9	VE1EX	300- 13-12
<i>Nevada</i>		VE1ME	40- 5- 4
W6UO	1518- 33-23	<i>Ontario</i>	
<b>ROANOKE DIVISION</b>		VE3GT	13248-145-46
<i>North Carolina</i>		VE3AFW	11409-124-46
W4DWB	11880-135-44	VE3ES	10890-121-45
W4ESO	384- 16-12	VE3ZE	5076- 71-36
W4MR	300- 13-12	VE3AND	2394- 59-21
<i>South Carolina</i>		VE3DU	1050- 25-21
W4CZA	3720- 62-30	VE3SS	720- 24-15
W4EPJ	1584- 36-22	VE3SQ	552- 23-12
<i>Virginia</i>		VE3DC	506- 23-11
W3BWA	6864- 88-39	<i>Quebec</i>	
W3CFL	1276- 29-22	VE2DR	5880- 84-35
W3GWQ	442- 17-13	VE2HI	448- 16-14
<i>West Virginia</i>		<b>Alberta</b>	
W8LCN	12576-131-48	VE4GE	1044- 29-18
W8JJA	8342- 97-43	<i>British Columbia</i>	
<b>ROCKY MOUNTAIN DIVISION</b>		VE5QP	8096- 89-46
<i>Colorado</i>		VE5SW	3776- 59-32
W9TSQ	8326- 91-46	VE5UK	396- 18-11
W9SBB	5265- 68-39	<i>Manitoba</i>	
W9EII	972- 27-18	VE4AE	18- 3- 3
W9URH	828- 23-18	<i>Saskatchewan</i>	
W9RRS	630- 21-15	VE4QZ	1656- 35-24
W9EHC	300- 15-10	VE4MB	1475- 30-25
<i>Utah-Wyoming</i>		<b>GRAND BRITAIN</b>	
W6FYR	40- 5- 4	G6QX	144- 9- 9
<b>SOUTHEASTERN DIVISION</b>			
<i>Alabama</i>			
W4CYC	14976-144-52		
W4AFU	13158-130-51		
W4DS	608- 19-16		
W4EQC*	24- 4- 3		

# RADIO

**ENGINEERING,** broadcasting, aviation and police radio, servicing, marine radio telegraphy and telephony, Morse telegraphy and railway accounting taught thoroughly. Engineering course of nine months' duration, equivalent to three years of college radio work. School established 1874. All expenses low. Catalog free. DODGE'S INSTITUTE, Day Street, Valparaiso, Indiana



## RADIO CO.

212 Fulton Street, New York, N. Y.

Cable Address SUNRADIO NEW YORK

# Complete Kit! 14 Tubes . . . 5 Bands

## TRAFFIC MASTER

### COMMUNICATIONS RECEIVER

What a radio! A 14 Tube, 5 Band Communications Receiver with electrical band spread. Major circuit improvements. Excellent sensitivity, selectivity and signal-to-noise ratio on the amateur bands.

The Traffic Master comes to you in complete kit form — everything included except tubes and speaker — even the solder. You will have the thrill of a lifetime building this receiver — a real TRAFFIC MASTER. Ask your PARTS JOBBER.

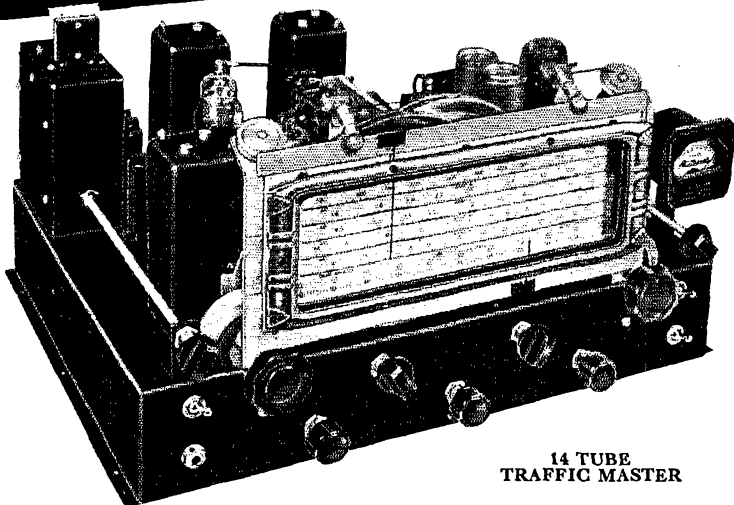

14 TUBE TRAFFIC MASTER

### 8 TUBE "TRAFFIC SCOUT" COMMUNICATIONS SUPER COMPLETE KIT

Meissner's great 8 tube, 5 band Communications Super with electrical band spread. The Traffic Scout has eleven desirable amateur features in addition to clarity and good performance. — A receiver kit that really delivers! You will enjoy building this one! Ask your PARTS JOBBER.

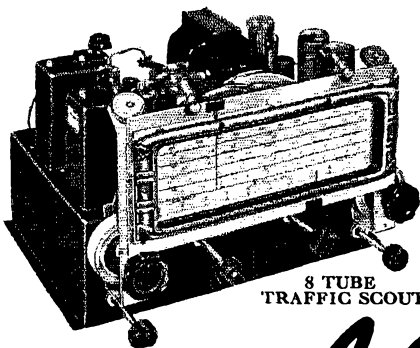

8 TUBE TRAFFIC SCOUT

### MEISSNER SIGNAL SHIFTER

*A Variable Frequency Exciter Unit for Remote Operation*

Offers convenience and utility for the amateur. An electron-coupled exciter unit that has excellent frequency stability. It's variable — you can cover any amateur band right from your operating position. For remote control operation — there's plenty of excitation available.

The Signal Shifter is completely assembled, wired and adjusted. It is ready for use (except for tubes) when you buy it. — Ask your PARTS JOBBER.

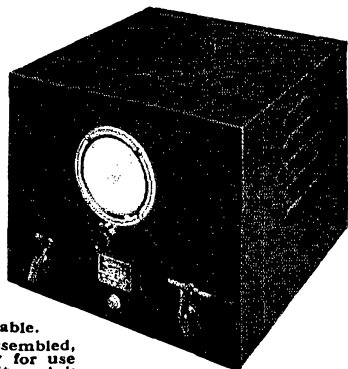

**FREE!** Meissner 1938 catalog, 44 pages filled with things you need. Complete Kits! Push Button Tuners! A Complete line of parts. Get this big FREE BOOK now, while the supply lasts. See your PARTS JOBBER, or write to us — Meissner Manufacturing Co., Mt. Carmel, Illinois.



**Meissner**

**"A FAMOUS NAME FOR TWO DECADES"**

# NEW SHURE "ROCKET"

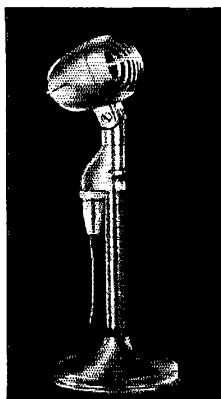

## Communications MICROPHONE

A new deluxe crystal microphone for commercial and advanced amateur radio operators. Ultra-modern streamlined beauty — plus the famous Shure "high-efficiency" speech characteristic. Gives clear, crisp speech that cuts through noise and static — doubles power on important intelligibility speech frequencies. Head finished in rich Satin Chrome — tilts to any desired angle. (Shure A91 A Baffle may be added, if desired). Equipped with new built-in Cable Connector. Desk Mount in Iridescent Gray. Ask Your Jobber or Write for New Catalog 150C.

**Model 706S.** "ROCKET," complete with Desk Stand and 7 ft. cable with plug attached. List Price..... **\$27.50**

**Model 706SH.** Same, without desk stand. List Price.. **\$25**

*Shure patents pending. Licensed under patents of the Brush Development Company*



## ACME VOLTROL . . .

For regulating voltage or testing all electronic functions this new Acme Voltrol offers many advantages. Manually operated. Continuous duty. Complete stepless control from 0 to 130 volts. Panel mounting type illustrated especially adapted for radio work. \$12.00. Write for Free Bulletin.

THE ACME ELECTRIC & MANUFACTURING CO. Cuba, N. Y.  
38 Water Street

## READ AND SEND CODE

Learn Easily at Home this Quicker Way:

No experience needed. Beginners read code quickly, copy accurately. If already an op, speed up your wpm this approved way. "Almost human!" experts call the amazing New All Electric Master Teleplex. Only instrument ever produced which records your sending in visible dots and dashes on specially prepared paper tape — then sends back your own key work at any speed you wish. Fascinating, fool-proof, gets results because you learn by HEARING as well as seeing. That is why thousands agree this method is surest and quickest. While not designated standard equipment, Teleplex is used



at many U. S. Army Posts, Naval Training Stations. Also almost all private radio schools in the U. S., American Tel. & Tel. and many foreign governments. We furnish Complete Course, lend you the New Master Teleplex, and give you personal instruction with a MONEY-BACK GUARANTEE. Low cost, easy terms. Write today for folder Q8, no obligation.

**The "Ham" SPECIAL** Standard Teleplex — a highly efficient code teacher using heavy specially prepared waxed paper tape, having two rows of perforations. Write for Free folder QT-8.

We are the Originators of this type instrument  
**TELEPLEX CO.** 72-76 CORTLANDT ST. NEW YORK, N. Y.

## With the Affiliated Clubs

(Continued from page 78)

organ known as "73." We quote an item from the September, 1937 issue of this publication.

"The federation will award a beautiful cup which any club would be mighty proud to own. Here's a chance for any club to own this cup, it makes no difference whether your club is small or large, you have an equal chance of winning.

"This cup is offered to the club complying and securing the most points during the year 1938. It will be awarded at the 1938 Convention.

"You will find that the rules are very easy for any active club, all that is needed is a little co-operation from your club members. The rules for this contest appear below, and may the best club win! Good luck.

"(1) Club must be affiliated with A.R.R.L. (2) Club making the most progress. (3) Per cent gain in membership. (4) Outstanding activity. (5) Per cent gain in average meeting attendance. (6) Per cent A.R.R.L. membership. (7) Public relations as applied to community. (8) Operating activity of members. (9) Coöperative activities.

"To qualify for this contest complete report must be forwarded to the editor of '73' at once. This report must contain the following: (1) Is club affiliated with A.R.R.L.? (2) What is membership enrollment at present? (3) How many belong to A.R.R.L.? (4) What is average attendance at present?

"We might add here that this cup is a permanent award. If won by a certain club, it remains in their custody as long as the club exists. The following year another cup will be awarded."

## MARCHING ALONG TOGETHER

(An editorial quoted from the *SARA News*, club paper of the Schenectady Amateur Radio Association.)

"The idea of hams forming an organization is certainly nothing new. There are dozens of hobby clubs in Schenectady that contribute greatly to making life in the community more pleasant. Incidentally, they furnish a means of interchanging skill, experience and information. Whether most hobby clubs exist or not, the hobbies can go on. But if there were no ham organizations, there would be no ham radio in a few years. It is largely through the efforts of organized hams that we have such unusual freedom of the airways in this country. Every ham, whether in the organization or not, shares in the benefits; every ham should share the responsibilities. To go forward in ham radio, we must all go forward together. . . .

"The summer will fly by quickly, but when the September meeting is called to order, let's all join again in the activities to the tune 'Marching Along Together.'"

## GENERAL CLUB ACTIVITIES

The Atlantic Radio Club (Pleasantville, N. J.) held a DX Contest for its members from November 15 to December 15, 1937; the first prize was an Eimac 35T. . . . The first issue of *HARC News*, publication of the Houston Amateur Radio

# A. C. RELAYS

Made by

## Allen-Bradley

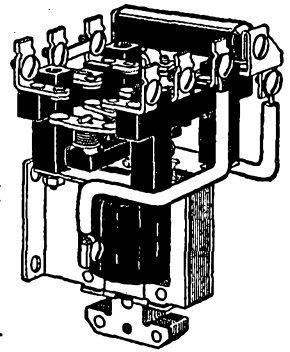
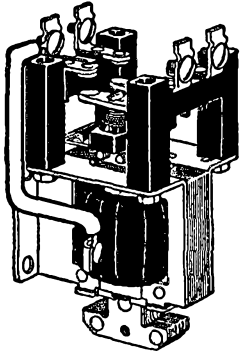

These A. C. solenoid relays are ideal for remote control of transmitters, for control of crystal ovens, and for any general remote control application except for keying. THESE RELAYS WILL NOT OPERATE IN KEYING SERVICE. Silver-to-silver double-break contacts are used throughout.

The maximum contact rating is 10 amp. at 220 v. or 3 amp. at 550 v. The relay coils are wound for 115 volts 60 cycle alternating current. Relays for other voltages can be supplied on special order. Use coupon below.

Type No.	Poles	Nor- mally	Action	Circuit Diagram	Price		Type No.	Poles	Nor- mally	Action	Circuit Diagram	Price	
					Open	In Cab.						Open	In Cab.
A107	1	Open	SP ST		\$3.50	\$4.50	A177	1	Closed	SP ST		\$7.50	\$8.50
A117	1	Closed	SP ST		4.50	5.50	A207	2	Open	DP ST		4.00	5.00
A127	1	Open and Closed	SP DT		5.00	6.00	A217	2	Closed	DP ST		6.00	7.00
A137	1	Open	SP ST		4.00	5.00	A227	2	Open and Closed	DP DT		7.00	8.00
A147	1	Closed	SP ST		5.00	6.00	A237	2	Open	DP ST		4.50	5.50
A157	1	Open and Closed	SP DT		5.50	6.50	A247	2	Closed	DP ST		6.50	7.50
A167	1	Open	SP ST		6.50	7.50	<p><b>Radiostat</b>—A stepless graphite compression rheostat for primary of 550 watt filament or plate supply transformer. Range 4 to 150 ohms. <b>Price \$6.50</b></p>						

### ORDER BLANK—MAIL WITH REMITTANCE TO

Allen-Bradley Co., 108 W. Greenfield Ave., Milwaukee, Wis.

Enclosed find money order for \$..... for which please send me, shipping charges prepaid, the following items:

..... for..... Volts..... Cycles

Name.....

Address.....



**CONVENIENT to EVERYWHERE**

## RECEIVERS IN STOCK

For immediate delivery

New National NC-100XA.....	\$142.50
New Hallicrafter 5-10.....	\$69.50
New Hallicrafter Dual Diversity	

## MEISSNER SIGNAL SHIFTER

A Variable Frequency Exciter Unit for remote operation, complete with power supply and coils for 1 band.....

.....	\$39.95
Without power supply.....	\$31.95

## BASSETT CONCENTRIC FEEDER CABLE IN STOCK

BCF-64 — 500-watt line for feeding doublets, stub lines, etc., surge impedance, 64 ohms. Per ft.....	10c
BCF-64 — 100-watt line for feeding doublets, stub lines, etc., surge impedance, 64 ohms. Per ft.....	5c
BCF-13 — 1000-watt line for feeding close spaced director type beams, surge impedance, 13 ohms. Per ft.....	7c
BCF-64 — 1000-watt line for feeding doublets, stub lines, etc., surge impedance, 64 ohms. Per ft.....	17c
Moulded End Seal for any of above....	\$1.50

New Gammatron 254.....	\$12.50
500 watt input with a single tube.	

## NEW UTC 15 WATT S-15A AUDIO AMPLIFIER

High gain, sufficient for crystal meter operation. Completely mounted on a beautiful gray crinkle chassis, ready to wire, less dust cover and tubes including

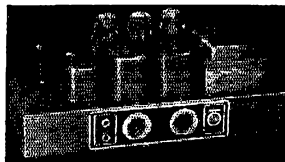

all components, accessories, etched plates, etc.	\$24.00
Dust cover.....	\$1.50

OUR *Best* VALUE IS OUR RECORD OF LOYAL SERVICE

# HARVEY

*Radio Company of New York*

103 WEST 43rd STREET • NEW YORK, N. Y.

Club, indicates that this club is on its toes and going places. FB. . . . As a result of the efficient work of its program and publicity committees, the membership of the Dayton Amateur Radio Association has grown by leaps and bounds. Any society wishing a copy of the *DARA Bulletin* should get in touch with the editor, Clem E. Wolford, W8ENH, 3228 McCall St., Dayton, Ohio. . . . The Palomar Radio Club of Northern San Diego County held its Second Annual Birthday Party at La Jolla, Calif., in February. . . . The Iowa Illinois Amateur Radio Club (W9UNL) is interested in working with other clubs to encourage more 1.75-Mc. c.w. activity. To this end, the I.I.A.R.C. would consider offering several prizes in cooperation with other societies. . . . The Marietta Amateur Radio Society transmitted the progress of the Marietta-Bethany football game through its station W8KYC, in cooperation with the Bethany College Radio Club. . . . The Richmond Short Wave Club alternates meeting activities between social affairs and technical sessions. . . . The Fort Wayne Radio Club devotes one meeting per month to social activities, including interesting speakers, free prizes, free luncheon and a good old-fashioned get-together for all hams. . . . The 1937 award in the annual contest for the Burrows Cup, a contest for local amateurs under the auspices of the Victoria Short Wave Club, was made to VE6EC. Other operating activities participated in by V.S.W.C. members included operation of the club's station, VE5EZ, at the Y.M.C.A. Hobbies Fair, collaboration in a chess contest between players in Vancouver and Victoria, and operation of a station at the Y.M.C.A. annual camp. . . . One of the outstanding demonstrations at the Queen Anne High School Open House (Seattle, Wash.) was the operation of W7BPY, station of the school's Radio Club. . . . In connection with the Tercentenary Celebration of the City of New Haven, the New Haven Amateur Radio Association through its station W1GB transmitted several hundreds of invitations from the Mayor to officials in all parts of the United States and Canada. W1GB was also in operation at the exposition handling messages for the visitors. . . . The Westlake Amateur Radio Association held a very successful hamfest during February at Cleveland, Ohio. Among the guests of honor were Central Division Director Mathews, W9ZN, and E. H. Gibbs, W8AQ, Ohio S.C.M. . . . Close to 3000 hams, hamesses and friends attended the annual hamfest of the Union County Amateur Radio Association at Newark, N. J. A full program of entertainment met with much enthusiasm. . . . The South Shore Amateur Radio Club of Quincy, Mass., installed and operated a complete amateur radio station at the four-day Leisure Show held in that city during April. The station of the club's vice-president, Ed Myrbeck, W1AKY, was operated on 1.75, 3.5 and 14 Mc., 'phone and c.w. The exhibit was received most enthusiastically. . . . Over 85 members and friends of the Merrimac Valley Amateur Radio Club (Lawrence, Mass.) were guests on January 26th of the management of broadcast station WLAW. A special program dedicated to the club was broadcast at 1 A.M. on the 27th. . . . The Fourth Annual Banquet of the Nashville Amateur Radio Club, held in January, was attended by nearly 100 members and visitors. The principal speaker of the evening was Director E. Ray Arledge, W5ST, Delta Division. . . .

—E. L. B.

## Honorable Mention Solution

(Continued from page 38)

nections. I then mounted the two coils side-by-side on a 6" by 11" baseboard, leaving a space between them for the condensers. Two binding posts were placed at each end for the power line and load, and one near the center for the ground wire. The unit was then mounted near the rig. The power leads from the rig were brought to the end of the filter opposite the condensers and connected. The power line from the switch was then connected to the remaining end of the filter at the condenser end.

This filter eliminated all interference except in one case in which an old receiver had to be

# Avoid QRM



**BLILEY Type VF1  
VARIABLE CRYSTAL UNIT**

## Use Variable CRYSTAL CONTROL

1. Frequency of crystal can be varied over a range of approximately 6 Kc. at the 80-meter fundamental.
2. Variations up to 12 Kc. possible when doubling and 24 Kc. when quadrupling to 20 meters.
3. Crystal has frequency drift not exceeding 4 cycles/Mc./°C. Frequency adjustments do not affect the operating stability.
4. Unit fits 5 prong tube socket and may be mounted in any position. It can be used to replace crystal units now in use.
5. Price, within 5 Kc. of specified minimum frequency, \$7.50; to exact integral specified Kc., \$10.00. (Furnished only for the 80-meter band.)

Be sure to read "Frequency Control with Quartz Crystals". 10c at all Bliley Dealers (15c in Canada).

Bliley Type VF1 Crystal Unit, U. S. Pat. No. 2,079,540

# BLILEY CRYSTAL UNITS

## SICKLES COILS

ALL TYPES OF RF AND IF WINDINGS

Manufactured by

F. W. SICKLES COMPANY

300 Main Street

Springfield, Mass.

## LEARN CODE RIGHT

INSTRUCTOGRAPH tapes send you typical messages Radio or Morse any speed. Easy, practical way to improve. Senior Model \$20.25 (also rented). Junior Model \$12.00 (not rented). Complete oscillator equipment less battery \$6.50. Write for details today.

**INSTRUCTOGRAPH CO.**

Dept. Q-8 912 Lakeside Place, Chicago, Ill.

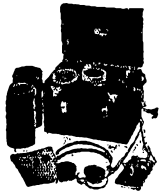

## • RADIO OPERATOR'S COURSE •

TELEGRAPHY  
TELEPHONY  
AVIATION  
TELETYPE  
TELEVISION  
TRANS RADIO  
PRESS



PRACTICAL  
EXPERIENCE  
STUDIO —  
TRANSMITTER —  
ANNOUNCING  
TYPEWRITING

Port Arthur College advertises primarily to Radio Amateurs and the training is too technical for the average student who has not selected Radio as his life's work. The opportunities for positions and advancement are unlimited for men who are interested in Radio and who plan to make this their career and are willing to make the sacrifice and effort necessary to master the training. P. A. C. maintains strict collegiate rank — only high school or college graduates are eligible for enrollment.

*If interested in details about Radio Course, write for bulletin R*

**PORT ARTHUR COLLEGE** ■ **PORT ARTHUR (World-known port) TEXAS**

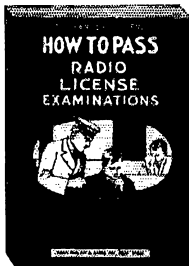

Answers  
**YOUR**  
Questions  
  
**HOW TO PASS**  
Radio License  
Examinations

By CHARLES E. DREW, I.R.E., A.I.E.E.

This book is more than just a new edition of a famous work. It has been completely rewritten, and will serve as an excellent guide to all radiomen. Important phases of the subject are given thorough treatment, so that the man who understands the content of this book will be well qualified to pass the examination for his commercial license. **\$2.00**

**ON APPROVAL COUPON**

John Wiley & Sons, Inc.  
440 Fourth Avenue, New York, N. Y.

Kindly send me a copy of Drew's HOW TO PASS, on ten days' approval. If I decide to keep it, I will remit \$2.00; otherwise I will return the book postpaid.

Name.....

Address.....

City and State.....

Employed by.....

QST 8-38

**RADIO ENGINEERING**



RCA Institutes offer an intensive course of high standard embracing all phases of Radio and Television. Practical training with modern equipment at New York and Chicago schools. Also specialized courses and Home Study Courses under "No obligation" plan.

Illustrated Catalog on request

**RCA INSTITUTES, INC.** Dept. ST-38

A Radio Corporation of America Service

75 Varick St., New York 1154 Merchandise Mart, Chicago

**How to Put New Pep in Your Equipment with TURNER'S New Crystal "Torpedo" Mike**

at this

**Amazing Low Price**

Your voice "sounds like you" when you use this expensive-looking mike. Streamline design and absence of peaks permits operation close to speaker without feedback. Model 55 needs no polarizing voltage or input transformer; works with any amplifier designed for crystal or other high impedance mike. Crystal floated to prevent noise and breakage. Handsome finish adds style to your outfit. Guaranteed for one year. Order yours today.

Only  
**8<sup>79</sup>**  
net

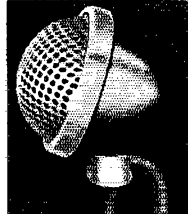

**MODEL 55** with side open coupler and 8 foot cable

Range: 50-7,000 cycles. Level -60DB. Fits any stand. Free wiring diagrams with each Torpedo. Order today.

**RADIO SUPPLY CO.**

950 South Broadway  
Los Angeles, Calif.

Licensed under patents of the Brush Development Company

treated a bit differently. A low-pass filter similar to the one described in Fig. G was constructed and inserted in the antenna circuit of the receiver affected. This took care of the obstinate receiver.

My advice to those using the circuit of Fig. F is to be sure to by-pass the primaries of all power transformers with 0.01- $\mu$ fd. condensers of at least 600-volt rating. The condensers should be placed close to the transformer terminals. If this is not done, r.f. from the transmitter may cause damage to the primaries.

**A.R.R.L. QSL Bureau**

FOR the convenience of its members, the League maintains a QSL-card forwarding system which operates through volunteer "District QSL Managers" in each of the nine United States and five Canadian districts. In order to secure such foreign cards as may be received for you, send your district manager a standard No. 10 stamped envelope. If you have reason to expect a considerable number of cards, put on an extra stamp so that it has a total of six-cents postage. Your own name and address go in the customary place on the face, and your station call should be printed prominently in the upper left-hand corner.

- W1—J. T. Steiger, W1BGY, 35 Call Street, Willimansett, Mass.
- W2—H. W. Yahnel, W2SN, Lake Ave., Helmetta, N. J.
- W3—R. E. Macomber, W3CZE, 418 10th St., N. W., Washington, D. C.
- W4—G. W. Hoke, W4DYB, 328 Mell Ave., N. E., Atlanta, Ga.
- W5—E. H. Treadaway, W5DKR, 2749 Myrtle St., New Orleans, La.
- W6—Horace Greer, W6TI, 414 Fairmount Ave., Oakland, Calif.
- W7—Frank E. Pratt, W7DXZ, 5023 So. Ferry St., Tacoma, Wash.
- W8—F. W. Allen, W8GER, 324 Richmond Ave., Dayton, Ohio.
- W9—Roy W. McCarty, W9KA, 11 South Michigan Ave., Villa Park, Ill.
- VE1—J. E. Roue, VE1FB, 84 Spring Garden Rd., Halifax, N. S.
- VE2—C. W. Skarstedt, VE2DR, 236 Elm Ave., Westmount, P. Q.
- VE3—Bert Knowles, VE3QB, Lanark, Ont.
- VE4—George Behrends, VE4RO, 186 Oakdean Blvd., St. James, Winnipeg, Manitoba.
- VE5—H. R. Hough, VE5HR, 1785 First St., Victoria, B. C.
- K4—F. McCown, K4RJ, Family Court 7, San-turce, Puerto Rico.
- K5—Norman F. Miller, K5AF, 15th Air Base Squadron, Albrook Field, Canal Zone.
- K6—James F. Pa, K6LBH, 1416D Lunalilo St., Honolulu, T. H.
- K7—Dean Williams, K7ELM, Box 2373, Juneau, Alaska.
- KA—George L. Rickard, KA1GR, P. O. Box 849, Manila, P. I.



# Crime does not pay . . . . .

especially when your department is equipped with a Harvey 2-way Police Radio system. This equipment is licensed under patents of the American Telephone & Telegraph Co., and is used in many prominent Police and Fire Services. Small departments as well as large are now taking advantage of this 2-way equipment. Inexpensive — easy to install — low maintenance cost — standard parts — crystal controlled



transmitter and receiver — meets every requirement of the Federal Communications Commission. For complete details write to Harvey Radio Laboratories, Inc., 25 Thorn-dike St., Cambridge, Mass.

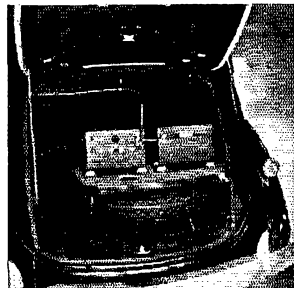

## HARVEY 2-way POLICE RADIO



**NEW HOLDER DESIGN**  
15 SECONDS TO  
INSTALL CRYSTAL

For All Bands  
GREATER STABILITY  
Plugs in 5 prong tube socket  
Beautiful Appearance

**MODEL AH HOLDER \$1.00** At your dealer  
or direct

**HIPOWER LOW DRIFT CRYSTALS:**  
within 10 kc. or Choice of stock

AH-10, 1700-3500 Kc. bands \$2.35  
AH-10, 7000-7300 " bands 3.90

WRITE FOR NEW LITERATURE

Hipower "Low Drift" Broadcast and Commercial  
Crystals Are Approved by F.C.C.

Hipower Crystal Co., 2035 Charleston St., Chicago

## VIBRATOR POWER SUPPLY

COMPLETELY FILTERED  
D.C. OUTPUT

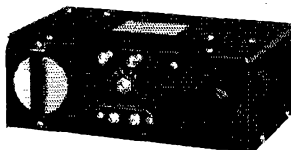

Model 31 — 6 volts DC to  
40 watts completely filtered

Unequaled for portable  
transmitters — giving  
high output of 30 to 40  
watts after filtering. In-  
expensive. Engineered  
for extra long life and  
heavy duty applications.  
Variable output ranging  
from 250 volts D.C. at

50 MA. to 325 volts at 125  
MA. Completely filtered  
for RF interference. Send  
post card for FREE illus-

trated and technical catalog. DC to AC Converters recom-  
mended by Hallicrafters and other leading manufacturers.

ELECTRONIC LABORATORIES, INC., Indianapolis, Indiana

Depend on the GOOD NAME

Ken-Rad Radio Tubes give more value and better results.  
You'll get a bigger thrill out of radio by using dependable  
Ken-Rad Radio Tubes. Look for the Good Name Ken-Rad.



**Ken-Rad Radio Tubes**  
KEN-RAD TUBE & LAMP CORPORATION - OWENSBORO, KY.  
Makers of all types of radio tubes and Ken-Rad Electric Lamp Bulbs

Say You Saw It in QST — It Identifies You and Helps QST

# NUTS

&  
BOLTS

Yes that's just about it. At the Radio Shack — items of insignificance to most suppliers are stocked by us for the convenience of our customers.

## WE SELL SERVICE

and in addition we list a few of the lines carried on hand.

*Hammarlund  
Cardwell*

*Hallicrafters*

*Birnbach*

*Triplet*

*Weston*

*Tobe*

*Dunco*

*Jensen*

*National*

*Sangamo*

*United Transformer*

*Burgess*

*Cornell-Dubilier*

## A POST CARD

— NOW —

WILL BRING YOU OUR NEW  
FALL CATALOG

*New England's Oldest Amateur Jobber*

## THE RADIO SHACK

46 Brattle Street

Boston, Mass.

## Standard Frequency Transmissions

Date	Schedule	Station	Date	Schedule	Station
Aug. 5	A	W9XAN	Sept. 2	B	W6XK
	B	W6XK	Sept. 9	A	W9XAN
Aug. 12	A	W9XAN		A	W6XK
	A	W6XK	Sept. 16	BB	W6XK
Aug. 19	BB	W6XK		A	W9XAN
	A	W9XAN	Sept. 17	BX	W6XK
Aug. 20	BX	W6XK	Sept. 18	C	W6XK
Aug. 21	C	W6XK	Sept. 23	A	W6XK
Aug. 26	A	W6XK	Sept. 30	A	W9XAN
Sept. 2	A	W9XAN		B	W6XK

### STANDARD FREQUENCY SCHEDULES

Time (p.m.)	Sched. and Freq. (kc.)		Time (p.m.)	Sched. and Freq. (kc.)	
	A	B		BB	C
8:00	3500	7100	4:00	7000	14,000
8:08	3600	7100	4:08	7100	14,100
8:16	3700	7200	4:16	7200	14,200
8:24	3800	7300	4:24	7300	14,300
8:32	3900		4:32		14,400
8:40	4000				

Time (a.m.)	Sched. and Freq. (kc.)	
	BX	
6:00	7000	
6:08	7100	
6:16	7200	
6:24	7300	

The time specified in the schedules is *local standard time at the transmitting station*. W9XAN uses Central Standard Time, and W6XK, Pacific Standard Time.

### TRANSMITTING PROCEDURE

The time allotted to each transmission is 8 minutes divided as follows:

2 minutes—QST QST QST de (station call letters).

3 minutes—Characteristic letter of station followed by call letters and statement of frequency. The characteristic letter of W9XAN is "O"; and that of W6XK is "M."

1 minute—Statement of frequency in kilocycles and announcement of next frequency.

2 minutes—Time allowed to change to next frequency.

W9XAN: Elgin Observatory, Elgin National Watch Company, Elgin, Ill., Frank D. Urie in charge.

W6XK: Don Lee Broadcasting System, Los Angeles, Calif., Frank M. Kennedy in charge.

## WWV Schedules

EACH Tuesday, Wednesday and Friday (except legal holidays), the National Bureau of Standards station, WWV, transmits with a power of 20 kw. on three carrier frequencies as follows: 10:00 to 11:30 A.M., E.S.T., on 5000 kc.; noon to 1:30 P.M., E.S.T., on 10,000 kc.; 2:00 to 3:30 P.M., E.S.T., on 20,000 kc. The Tuesday and Friday transmissions are unmodulated c.w. except for 1-second standard-time intervals consisting of short pulses with 1000-cycle modulation. On the Wednesday transmissions, the carrier is modulated 30% with a standard audio frequency of 1000 c.p.s. The standard musical pitch A = 440

## ? COMMERCIAL RADIO ?

If you are planning to prepare yourself for a job in commercial radio be sure and investigate the advantages offered by Eastern.

### EASTERN RADIO INSTITUTE

899 BOYLSTON STREET

BOSTON, MASS.

# Where to buy it

A directory of suppliers who carry in stock the products of these dependable manufacturers.



- ALBANY, N. Y.** Uncle Dave's Radio Shack 356 Broadway
- BOSTON, MASS.** Radio Shack 46 Brattle Street
- BOSTON, MASS.** Wholesale Radio Service Company, Inc. 110 Federal Street
- BRONX, N. Y.** Wholesale Radio Service Company, Inc. 542 East Fordham Rd.
- HARTFORD, CONNECTICUT** Radio Inspection Service Company 227 Asylum Street
- JAMAICA, L. I.** Wholesale Radio Service Company, Inc. 90-08 166th Street
- NEWARK, N. J.** Wholesale Radio Service Co., Inc. 219 Central Ave.
- NEW YORK, N. Y.** Gross Radio, Inc. 51 Vesey St.
- NEW YORK, N. Y.** Harrison Radio Co. 12 West Broadway
- NEW YORK, N. Y.** Wholesale Radio Service Co., Inc. 100 Sixth Ave.
- NEW YORK, N. Y.** Terminal Radio Corp. 80 Cortlandt Street
- POTTSVILLE, PENN.** E. Norwegian & George Sts. Jones Radio Company
- READING, PENN.** George D. Barbey Company 404 Walnut St.
- READING, PENN.** Jones Radio Company 104 North Ninth Street
- SPRINGFIELD, MASS.** T. F. Cushing 349 Worthington St.
- WASHINGTON, D. C.** Sun Radio & Service Supply Co. 938 F Street, N. W.



- ALBANY, NEW YORK** Uncle Dave's Radio Shack 356 Broadway

- BINGHAMTON, NEW YORK** Radio Testing Station 25-27 Sturges Street
- CONCORD, NEW HAMPSHIRE** Rear, 80 N. State Street Evans Radio
- HARTFORD, CONNECTICUT** 210 Chapel Street Stern Wholesale Parts Company
- NEW YORK, N. Y.** Harrison Radio Co. 12 West Broadway
- NEW YORK, N. Y.** Terminal Radio Corp. 80 Cortlandt Street

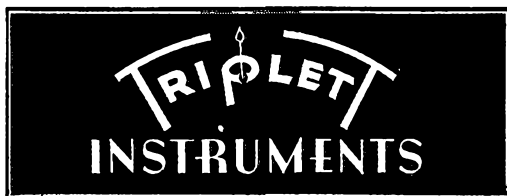

- ALBANY, N. Y.** Uncle Dave's Radio Shack 356 Broadway
- BOSTON, MASS.** Radio Shack 46 Brattle Street
- BOSTON, MASS.** Wholesale Radio Service Company, Inc. 110 Federal Street
- BRONX, N. Y.** Wholesale Radio Service Company, Inc. 542 East Fordham Rd.
- JAMAICA, L. I.** Wholesale Radio Service Company, Inc. 90-08 166th Street
- MONTREAL, CANADA** 285 Craig Street, West Canadian Electrical Supply Co., Ltd.
- NEWARK, N. J.** Wholesale Radio Service Company 219 Central Ave.
- NEW YORK, N. Y.** Wholesale Radio Service Company 100 Sixth Avenue
- NEW YORK, N. Y.** Leeds Radio 45 Vesey St.
- POTTSVILLE, PENN.** E. Norwegian & George Sts. Jones Radio Company
- READING, PENN.** George D. Barbey Co. 404 Walnut Street
- READING, PENN.** Jones Radio Company 104 North Ninth St.
- WASHINGTON, D. C.** Sun Radio & Service Supply Co. 938 F Street, N. W.



## TRANSOIL

for transmitting

### HIGHEST QUALITY OIL CAPACITORS

Ask for new complete  
Transmitting Catalog  
describing

TRANSOIL—SOLAREX—TRANSMICA

S O L A R  
MFG. CORP.



599 BROADWAY  
NEW YORK CITY

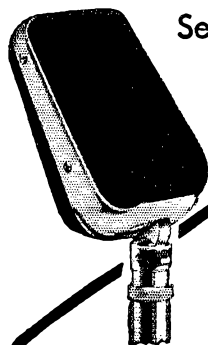

Self-Locking  
Tilting  
Head

### NEW MULTI-UNIT Dual Diaphragm CRYSTAL MICROPHONE

An outstanding achievement in microphone construction for nightclub and public address installations. Maximum amplification without feedback. Cannot be acoustically overloaded. Made in two models. MU-2 constructed with two dual diaphragm crystal units using four small diaphragms. MU-4 uses four dual diaphragm crystal units and eight diaphragms. Black and chrome. Complete with three-prong interchangeable locking connector and 25-ft. cable.

#### List Prices

MU-2 : \$29.50  
MU-4 : 39.50

Write for Literature



Astatic Microphone  
Laboratory, Inc.  
830 Market St.  
YOUNGSTOWN, OHIO  
Licensed Under Brush  
Development Co. Patents

c.p.s. is also transmitted from 4:00 P.M. to 2:00 A.M., E.S.T., daily except Saturdays and Sundays, on a carrier frequency of 5000 kc., power 1 kw., 100% modulation. The accuracy of the frequencies of the WWV transmissions is better than 1 part in 5,000,000.

### New World Globe

AMATEURS in general, and DX men in particular, will be interested to know that Rand McNally of New York, Chicago and San Francisco is now producing a world globe which may be quickly adjusted to supply all of the vital information as to great-circle bearing, distance, difference in time and conditions of daylight and darkness between any points upon the surface of the earth.

It has been designed with the requirements of radio and aviation particularly in mind. Instead of the usual arrangement in which the globe rotates on a fixed axis through the poles, this globe rests upon a cup-shaped base so that it may be set in any desired position. The globe is equipped with a fixed vertical ring and a second ring which may be rotated at right angles to the first. This second ring is divided in half and each half may be adjusted independently of the other. Both vertical and adjustable rings are calibrated in degrees while the adjustable ring also has a scale of miles and a time scale.

By centering the home location and lining it up with one of the poles and adjusting the movable ring, the great-circle bearing and distance for any other point on the globe may be determined quickly. The twelve-inch diameter globe is of good quality. The base and metal rings are finished in an attractive bronze finish.

—D. H. M.

### New Hampshire State Convention

(New England Division)

Where: At Manchester, N. H.  
When: Saturday, September 17th.  
At Hotel Carpenter.

More information may be obtained from Carl B. Evans, SCM, 80 North State Street, Concord, N. H.

## LEARN RADIO — TELEVISION —

500 Licensed graduates placed in past 7 years in shipping, broadcasting, aviation, police, etc.; we also teach radio servicing and repairing; new term Sept. 12, Nov. 7; day or eve.; 52-page catalog free; oldest, largest and best equipped.

### MASS. RADIO SCHOOL 18 Boylston Street, Boston

G. R. Entwistle, Pres.  
Established 1899

R. F. Trop, Treas.  
Hancock 8184

# HAM-ADS

(1) Advertising shall pertain to radio and shall be of nature of interest to radio amateurs or experimenters in their pursuit of the art.

(2) No display of any character will be accepted, nor can any special typographical arrangement, such as all or part capital letters be used which would tend to make one advertisement stand out from the others.

(3) The Ham-Ad rate is 15¢ per word, except as noted in paragraph (6) below.

(4) Remittance in full must accompany copy. No cash or contract discount or agency commission will be allowed.

(5) Closing date for Ham-Ads is the 25th of the second month preceding publication date.

(6) A special rate of 7¢ per word will apply to advertising which, in our judgment, is obviously non-commercial in nature and is placed and signed by a member of the American Radio Relay League. Thus, advertising of bona fide surplus equipment owned, used and for sale by an individual or apparatus offered for exchange or advertising inquiring for special equipment, if by a member of the American Radio Relay League takes the 7¢ rate. An attempt to deal in apparatus in quantity for profit, even if by an individual, is commercial and all advertising by him takes the 15¢ rate. Provisions of paragraphs (1), (2), (4) and (5) apply to all advertising in this column regardless of which rate may apply.

**Having made no investigation of the advertisers in the classified columns, the publishers of QST are unable to vouch for their integrity or for the grade or character of the products advertised.**

**QUARTZ**—direct importers from Brazil of best quality pure quartz suitable for making piezo-electric crystals.

Diamond Drill Carbon Co., 719 World Bldg., New York City.

**RADIO** engineering, broadcasting, aviation and police radio, servicing, marine and Morse telegraphy taught thoroughly. All expenses low. Catalog free. Dodge's Institute, Byrd St., Valparaiso, Ind.

**QSL'S, W2SN, Helmetta, N. J.**

**USED** receivers. Bargains. Cash only. No trades. Price list 3¢. W3DQ, Wilmington, Del.

**QSL'S**, all colors, cartoons, snappy service. Write for free samples today. W1BEF, 16 Stockbridge Ave., Lowell, Mass.

**CALLBOOKS**—Summer edition now on sale containing complete up-to-date list of radio hams throughout entire world. Also world prefix map, press schedules and new time conversion chart. Single copies \$1.25. Canada and foreign \$1.35. Radio Amateur Call Book, 610 S. Dearborn, Chicago.

**QSL'S, Cuts, Cartoons, Free samples, Theodore Porcher, 7708 Navahoe, Philadelphia, Penn.**

**100's** of Y-cut crystals, 75¢. Networks spot frequencies, \$1. Free catalog. Faberadio, Batavia, Ill.

**QSL—SWL** bargains. Fritz, 455 Mason, Joliet, Ill.

**ANTENNAS**, 102 pages antenna dope. Practical, understandable. Many arrays, directives, multibands. Complete tables eliminate calculations. Radio Antenna Handbook, continental U. S. A., 75¢; elsewhere, 85¢. Radio, 7460 Beverly, Los Angeles.

**QSL'S**, Free samples. Printer, Corwith, Iowa.

**CRYSTALS**, mounted, 80-160 \$1.25, V-cut 40 \$2.25. R9 Crystals, 338 Murray Ave., Arnold, Pa.

**QSL'S**—highest quality—lowest prices. Radio Headquarters, Ft. Wayne, Ind.

**CRYSTALS**: X-cut, 80-160 = five kilocycles, \$1.50; spot frequency, \$2.50. Special prices to Army, Navy, Red Cross and other round table nets. Three small, 80 meter blanks, including carborundum, \$1.20. Holders, 11. William Threm, W8FN, 3071 Moosewood St., Cincinnati, Ohio.

**QSL'S, SWL's**, 100-3 color—75¢. Lapco, 344 W. 39th, Indianapolis, Ind.

**AMATEUR** radio licenses, home study course in code and theory—reasonable, efficient, and thorough. Results guaranteed. American Radio Institute, 1430 N. Dearborn Parkway, Chicago, Ill.

1000 watt G.E. transformers 1100-2200-4400 volts each side c.t. Guaranteed, \$13.50. Dawson, 5740 Woodrow, Detroit, Mich.

**SELL**: Pair of RK-36, slightly used, perfect, 5 volt 20 amp. filament transformer. Best cash offer takes them. William Dean, Columbia, Tenn.

**BLILEY** crystals. W8DED.

**QSL'S**, world's finest. Samples (stamp). W8DED, Holland, Mich.

**TRADE** radio course for transceiver. Want Rider's Manuals, modern servicing instruments. Virgil Coleman, Gid, Ark.

**DOUGLAS** modulation transformers. Match all tubes. More audio per dollar, 50 watts, \$4.95 pair; 100 watts, \$7.75 pair. Postpaid in U. S. Guaranteed. For details write W9IXR, Rice Lake, Wis.

**WANTED**: good used DB20. W3FHY.

**SELLING** out. Send for list. W9IFZ.

**GROSS** c.w. 25 transmitter. Gross power supply, 40-80 meter coils, xtal, tubes, \$22.50. W5DMA, Trent, Texas.

**MODERN QSL's**, samples. W8BZK, Newark, Ohio.

**NEW** surplus government radio equipment. Real bargains—price list 3¢. Minch & Lyons, 2711 Virginia Court, Ft. Worth, Texas.

**86** consecutive QST's to date, \$12.50 c.o.d. Wencil Kopecky, 1502 K St., Cedar Rapids, Iowa.

**TRADE** National 100-X or 81-X receiver for miniature camera, enlarger. Frank Ridgway, Peru, Ind.

**FBXA**—complete with speaker, \$35. Turchin, 742 E. 176 St., N. Y. C.

**SELL**: pair RK20As, slightly used, guaranteed perfect, \$18. W4CRO, Box 339, N. Miami, Fla.

**FEATURING** Meissner signal shifters. Write—Loughnane & Co., Decatur, Ill.

**TELEPLEXES**, instructographs, omnigraphs, vibroplexes bought, sold. Ryan's, Monroe City, Mo.

**QSL'S**. Finest at lowest prices. Samples. Maleco, 1805 St. Johns Place, Brooklyn, N. Y.

**ANALYZER**, tube tester—Supreme 385 automatic, Hickok 0B-10 radio-audio oscillator, 5 meter portable fone transmitter, receiver, All Star, senior receiver, complete parts for 150 watt, 20-160 fone transmitter. All perfect—send for list. W2IBK.

**NEW**. Cartoon and individually designed QSL's drawn to your specifications at an unbelievable price: \$1. per hundred. Our samples will convince you. W8HTH, 216 Superior Bldg., Cleveland, Ohio.

**NATIONAL NC80X**, practically new, guaranteed perfect condition, with 8 meter; first \$60. takes it. Holton Harris, 1026 Erie St., Shreveport, La.

**STAMP** for list. Detroit hams look it over. W8GWA.

**SELL**: 6L6G, T20s, 100TH rig, 400 watts, \$65. New 7 metal tube receiver, \$35. W2IUW.

**DEFINITELY** controlled angle of radiation. Tilting head rotary feeds thru bearing, worm gear motor driven. W8ML.

**QSL'S, SWL's**: one color 45¢, two color 60¢ hundred, postpaid. Samples. W1FTM, 268 Piedmont, Waterbury, Conn.

**SELL** or trade. Best offer takes Gen-E-Motor, 32 volts d.c. to 110 a.c. W9GKH, Milledgeville, Ill.

**SKY** Challenger II crystal, speaker, Brush headphones. Must sacrifice at \$70. H. Peterson, 3528 S. 52 Ave., Cicero, Ill.

**HIGH** power factory-built plate transformer, 3 1/2 k.v.a. 3300-2400-1750 each side, 110-220 primary. Trade for service manuals or 25 bucks. W9DEX, 404 N. Pinet, Jefferson, Iowa.

**SACRIFICE** half kilowatt d.c. motor—500 cycle generator set. 4 kw. transformer 2000 to 4000 each side center. Variable. W2BOX.

**TUBE**, condenser tester. Ohmmeter. Dependable 305C. Tests latest tubes. Cost \$22. Offer? W2HTZ.

**FILAMENT** and plate transformers up to 1 1/2 kw. built to order. All work absolutely guaranteed. R. Laurenson, 812 Coal, Wilkinsburg, Penn.

**SELL** National 81X receiver complete with cabinet, speaker, \$70. Perfect condition. Owner in hospital. c/o W3CGU.

**CRYSTALS**: there is no substitute for dependable crystal control, Edison T9 crystals give you this dependability with economy. Fully guaranteed, high activity type X-cut: 40 and 80 meter bands, \$1.60; T9 ceramic holders, \$1.10. Prices postpaid, c.o.d.'s accepted. Commercial crystal users inquire prices. Sold by: Frank Anzalone, 1540 Broadway, Room 1502, N. Y. C.; Henry Radio Shop, Butler, Mo.; The Hargis Co., Austin, Texas; Van Radio, 464 E. 117th, No. 7, Cleveland, Ohio; Southwest Radio Supply, Dallas, Texas; Pembleton Labs., Ft. Wayne, Ind.; Casa Edison, Havana, Cuba; Radio Atlas, Tampico, Mexico; or Edison's, Temple, Texas.

**SELL**: transmitter complete—commercially designed and built, fully described in March QST, operating at present in the 20 meter band. Sacrifice for \$1,750. W9AXH.

**SELL**: Comet Pro, xtal AVC model, tubes, speaker, 8 to 550 meters. Excellent condition. First \$50. takes it. W9ARH, Box 487, Milan, Mo.

**LISTEN** for W9XA, high frequency broadcast station, Kansas City, Mo.

**FREE** air mail service. Guaranteed crystals 160-80M AT and 40M X, \$1.95; 40M AT, \$2.75; losses mounting, \$1. State frequency desired. Commercial crystals quoted. C.O.D.'s accepted. C-W Mfg. Co., 1170 Esperanza St., Los Angeles.

**FOR** sale: new National 81-X receiver complete, \$80. W4AGH.

SELL: 3000/4000 c.t. 1 k.v.a. Thordarson, \$12.; 500 v. .2 amp. Westinghouse MG set, \$12.; Johnson 350DD70, \$7.; 100D90, \$4.50, 50C130, \$4. condensers; 2 Johnson 636 plug-in inductors, \$4.; 204-A (50 hrs.), \$25.; new PA-111 UTC transformer, \$7.50; new Bimac RX-21, \$6. W9AXH.

**BARGAINS:** reconditioned guaranteed receivers shipped on ten day trial. Practically all models at big savings. List free. Write Bob Henry, W9ARA, Butler, Mo.

**BRAND** new in factory sealed cartons: Sky Chiefs, \$29; Ultra-Skyriders, \$69.; Mac-Bugs, \$5.95, ACT-20 transmitter at big discount. W9ARA.

## ANNOUNCEMENT

We wish to offer the facilities of our well equipped laboratory and machine shop for the servicing or construction of communication receivers, transmitters, and all other types of radio and electronic equipment. We design and build equipment to order. QST designs made up. Out of town orders solicited. Inquiries invited.

**FEIGHNER TECHNICAL ASSOCIATES**  
525 Woodward Avenue Detroit, Michigan  
*Twenty-two Years in Radio*

# GET THE FACTS ON CODE FROM CANDLER!

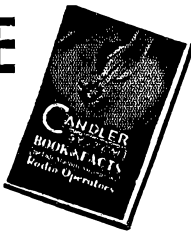

The man who has taught thousands the amazing Candler special method of real code speed. Don't spend hours alone, trying to overcome your own faults — let Candler correct them by the same method he has used to teach speed champions. Candler's expertly directed practice will help you even if you are a beginner starting to learn. Candler has the real short cut to code speed — ask any skilled "op" — and the cost is very low.

**FREE!** Write today for the big 52-page book — packed full of real helpful information, including new F. C. C. regulations, probable exam. questions. Don't delay — send for this book NOW! — There is no obligation.

**CANDLER SYSTEM CO.**  
DEPT. Q8 ASHEVILLE, NO. CAROLINA, U. S. A.

## SPEED

THE COMPLETE LINE  
OF TELEGRAPH KEYS

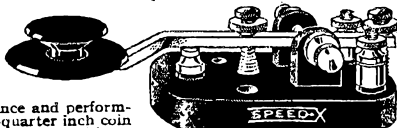

THE  
LAST  
WORD

in appearance and performance. One-quarter inch coin silver contacts — well insulated for heavy duty work. All parts chromium plated — choice of black wrinkle or chromium base.

No. 320, Black base ..... List \$3.25  
No. 321, Chrome base ..... List \$3.50  
Other models of hand keys from \$1.50 to \$3.50 list — Available at leading jobbers everywhere.

Write for new literature and amateur discounts

**LES LOGAN CO.**

646 JESSIE ST.

SAN FRANCISCO



● To the Man —  
Who is just hoping to get a  
better job!

Now is the time to do something  
about it—CREI will show you how—

Here is the opportunity for you to train yourself for a better job in Radio at home in your spare time. CREI courses in Practical Radio Engineering will give you the ability to handle the important jobs that Radio has for men who are technically trained. Constant improvements demand better men — and that means a better job for you if you train NOW!

Practical Radio Engineering offered in 3 study plans: Home Study Course, Residence Course (begins Sept. 19), Combination Home-Study Residence Course.

**FREE!** Write today for copy of our illustrated booklet — "A Tested Plan for a Future in Radio."



MAIL THIS COUPON TODAY

CAPITOL RADIO ENGINEERING  
INSTITUTE

Dept. Q-8  
3224 16th St., N.W., Washington, D. C.

Please send me complete details and illustrated 48-page booklet — "A Tested Plan for a Future in PRACTICAL RADIO ENGINEERING."

Name .....  
Address .....  
City ..... Q-8

CAPITOL RADIO ENGINEERING INSTITUTE

## TAKE A HINT from Eminent Designers

### Use OHMITE BROWN DEVILS

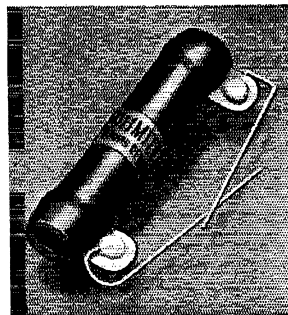

They're the same dependable, trouble-free resistors specified by eminent designers of world-famous amateur, commercial, and broadcast transmitters and receivers. Built right — and sealed tight with permanent Ohmite vitreous enamel coating — they give you time-proved protection against heat and humidity shock and vibration. Ask your Jobber for Brown Devils. Write now for New Ohmite Catalog 17.

**OHMITE MANUFACTURING COMPANY**  
4831 Flournoy St. Chicago, Illinois, U.S.A.

# OHMITE

RHEOSTATS RESISTORS TAP SWITCHES

# Your Nearest Dealer Is Your Best Friend

Your nearest dealer is entitled to your patronage. You can trust him. He is equipped with a knowledge and understanding of amateur radio. He is your logical and safe source of advice and counsel on what equipment you should buy. His stock is complete. He can supply your needs without delay. His prices are fair and consistent with the high quality of the goods he carries. He is responsible to you and interested in you.

Patronize the dealer nearest you—You can have confidence in him

## ATLANTA, GEORGIA

Wholesale Radio Service Company, Inc.  
265 Peachtree Street  
"The World's Largest Radio Supply House"

## MONTREAL, CANADA

Canadian Elec. Supply Co., Ltd.  
285 Craig St., W.  
Quality parts and equipment for discriminating buyers

## BALTIMORE, MARYLAND

Radio Electric Service Co.  
3 N. Howard St.  
Everything for the amateur

## NEWARK, N. J.

Wholesale Radio Service Company, Inc.  
219 Central Avenue  
"The World's Largest Radio Supply House"

## BOSTON, MASS.

Wholesale Radio Service Company, Inc.  
110 Federal Street  
"The World's Largest Radio Supply House"

## NEW YORK, N. Y.

Gross Radio, Inc.  
51 Vesey Street  
Fair dealings plus fair prices. Anything in radio

## BRONX, NEW YORK

Wholesale Radio Service Company, Inc.  
542 East Fordham Road  
"The World's Largest Radio Supply House"

## NEW YORK, N. Y.

Wholesale Radio Service Company, Inc.  
100 Sixth Avenue  
"The World's Largest Radio Supply House"

## BUFFALO, NEW YORK

Dymac Radio  
216 E. Genesee Street  
Ham and BCL Equipment W8RRL, W8OLB, W8GJ Cl. 2080

## NEW YORK, N. Y.

Harrison Radio Company  
12 West Broadway  
"The Friendly Ham Supply House"

## BUFFALO, NEW YORK

Radio Equipment Corp.  
326 Elm Street  
W80BK — Ham, service and sound equipment

## NEW YORK, N. Y.

Leeds Radio  
45 Vesey Street  
The Home of Radio

## ELMIRA, NEW YORK

Miller's Radio Shack  
205 Railroad Avenue  
Fine equipment for amateurs

## PHILADELPHIA, PENNSYLVANIA

Eugene G. Wile  
10 S. Tenth Street  
Complete Stock of Quality Merchandise

## JAMAICA, L. I.

Wholesale Radio Service Company, Inc.  
90-08 166th Street (Merrick Road)  
"The World's Largest Radio Supply House"

## ROCHESTER, NEW YORK

Radio Parts & Equipment Co.  
244 Clinton Avenue, North  
Complete stock amateur-BCL parts. Standard discounts

# You Are Protected When You Buy From QST Advertisers

“Advertising for QST is accepted only from firms who, in the publisher’s opinion, are of established integrity and whose products secure the approval of the technical staff of the American Radio Relay League.”

Quoted from QST’s advertising rate card.

Every conceivable need of a radio amateur can be supplied by the advertisers in QST. And you will know the product has the approval of the League’s technical staff.

## Index to Advertisers

Acme Electric & Mfg. Company	82
Allen-Bradley Company	83
Astatic Microphone Laboratory, Inc.	90
Birnbach Radio Company, Inc.	78
Bliley Electric Company	85
Candler System Company	92
Capitol Radio Engineering Institute	92
Cardwell Mfg. Corp., Allen D.	64
Centralab	61
Collins Radio Company	Cov. 2
Cornell-Dubilier Corp.	70
Dodge’s Institute	80
Eastern Radio Institute	88
Eitel-McCullough, Inc.	65
Electronic Laboratories, Inc.	87
Feighner Technical Associates	92
Hallicrafters, Inc., The	1, 2
Hammarlund Mfg. Company, Inc., The	60, 63
Harvey Radio Company	84
Harvey Radio Laboratories	87
Henry Radio Shop	70
Hipower Crystal Company	87
Hytronic Laboratories	62
Instructograph Company	85
Ken-Rad Tube & Lamp Corp.	87
Kenyon Transformer Company, Inc.	5
Logan Company, Les	92
Mallory & Company, Inc., P. R.	56
Massachusetts Radio School	90
McGraw-Hill Book Company	66
Meissner Manufacturing Company	81
National Company, Inc.	Cov. 3, 55, 67
New York Y. M. C. A. Schools	74
Newark Electric Company	79
Ohmite Manufacturing Company	92
Pacific Radio School	78
Port Arthur College	85
Precision Piezo Service	78
RCA Institutes, Inc.	86
RCA Manufacturing Company, Inc.	Cov. 4
Radio Mfg. Engineers, Inc.	95
Radio Shack, The	88
Radio Supply Company	76, 86
Radio Transceiver Laboratories	74
Raytheon Production Corp.	57
Scientific Radio Service	74
Shure Brothers	82
Sickles Company, F. W.	85
Solar Manufacturing Corp.	90
Sun Radio Company	80
Taylor Tubes, Inc.	71
Teleplex Company	82
Terminal Radio Corp.	76, 77
Thordarson Elec. Mfg. Company	75
Triplett Electrical Instrument Company	74
United Transformer Corp.	96
Wiley & Sons, Inc., John	86
Yaxley	56



# RME-69 . . .

HIGH IN VALUE  
LOW IN COST

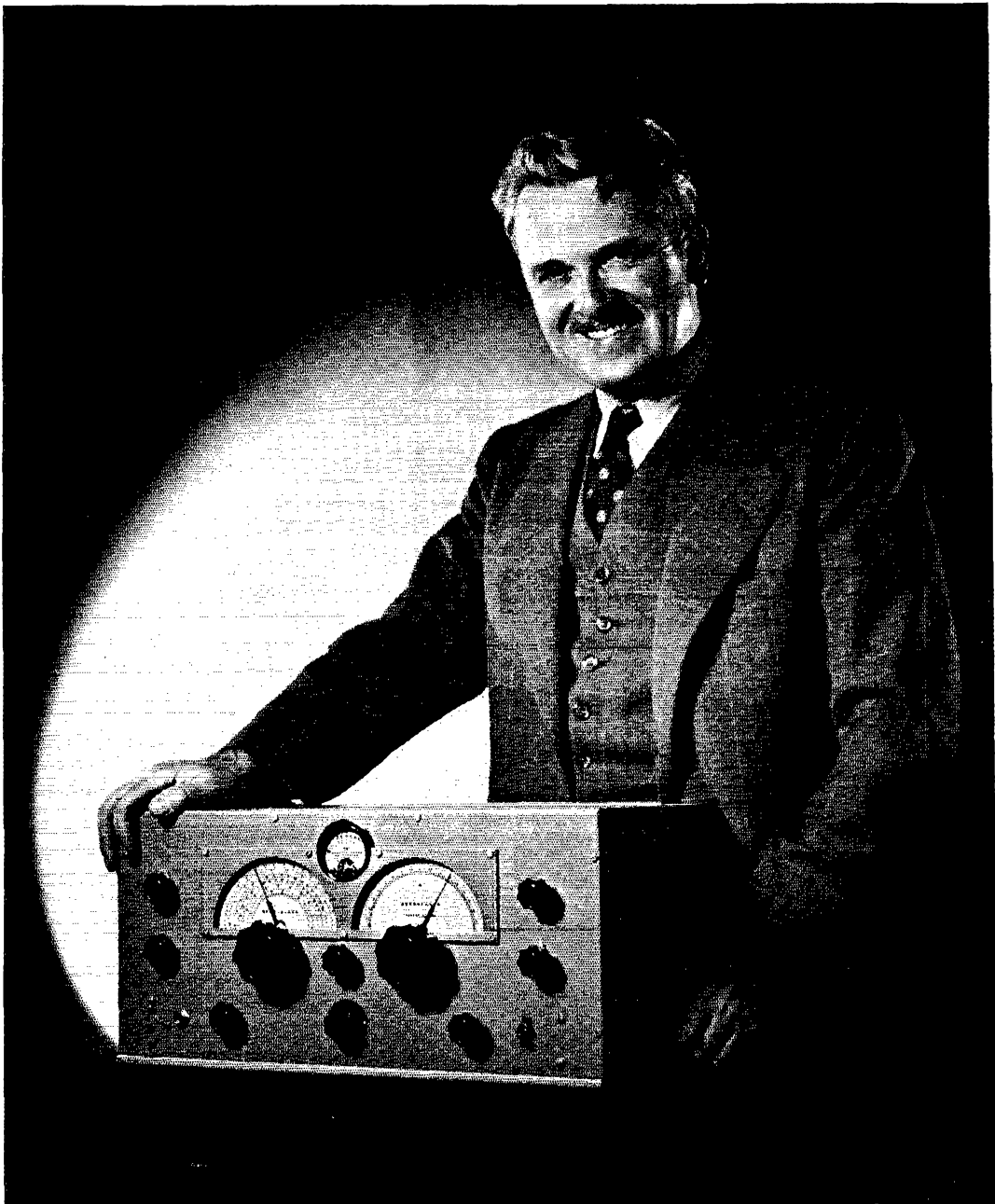

Considering the high trade-in value, low depreciation and excellent performance of this receiver, there is no better year-round investment than an RME-69. We will gladly give you the details.

**RADIO MFG. ENGINEERS, INC.** 111 HARRISON STREET  
PEORIA ILLINOIS

# They still lead the field —

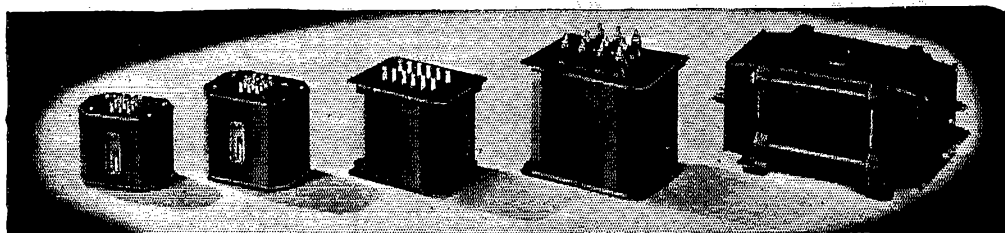

## THE VARIMATCH TRANSFORMER NEVER BECOMES OBSOLETE

ALL UTC transformers are designed for maximum flexibility. The Varimatch series are noteworthy in that they will match any audio tubes to any RF tubes within their output rating, eliminating the possibility of obsolescence as new tubes are announced. All you have to decide is the DC input to your RF stage. Then just pick the VARIMATCH output transformer that will handle the maximum audio power required. These transformers will also match the line impedance output of PA or similar amplifiers direct to the Class C tubes. ALL VARIMATCH outputs matching RF stages will carry DC in the secondary.

### VARIMATCH MODULATION TRANSFORMERS

UTC VARIMATCH Modulation Transformers Will Match ANY Modulator Tubes to ANY RF Load . . .

VM-0 Maximum audio output 20 watts . . . . .	\$3.00
VM-1 Maximum audio output 30 watts . . . . .	\$4.80
VM-2 Maximum audio output 60 watts . . . . .	\$7.50
VM-3 Maximum audio output 125 watts . . . . .	\$12.00
VM-4 Maximum audio output 300 watts . . . . .	\$19.50
VM-5 Maximum audio output 600 watts . . . . .	\$42.00

### VARIMATCH INPUT TRANSFORMERS

Varimatch Input Transformers will take care of practically every driver requirement.

PA-50AX Single 89, 53, 56, 6C5, etc. to class B 53, 6A6, 89, etc. . . . .	\$3.30
PA-51AX Single 56, 6C5, 45, 59, 6L6, 2A3, etc. to class B 46, 59, 79, or A prime 42's, 45's, etc. . . . .	\$3.30
PA-52AX Push Pull 45, 59, 2A3, etc. to class B 46, 49, 841, etc. . . . .	\$3.90
PA-53AX Push Pull 45, 59, 2A3, 6L6, etc. to class B 210, 801, 800, 35T, RK-18, 203A, ZB-120, etc. . . . .	\$4.50
PA-59AX 500 ohms line to 805, 838, 203A, 210, 800, ZB-120, etc. . . . .	\$4.50
PA-238AX Push Pull Parallel 45, 2A3, 6L6, etc. to push pull parallel 838, 203A, ZB-120, or to class B 204A, HF-300, 849, etc. . . . .	\$10.50
PA-512 500 ohms line to class B, 150T, HF-300, 204A, etc. . . . .	\$12.00



### VARITRAN VOLTAGE CONTROL UNITS

REG. U. S. PATENT OFFICE

The UTC VARITRAN makes possible continuously variable output voltage, using a sliding contact riding over the turns of an auto-transformer.

Standard units are designed for 115 volts input, 0-130 volts continuously variable output.

- |                        |                        |
|------------------------|------------------------|
| <b>FEATURES</b>        | <b>APPLICATIONS</b>    |
| ★ Smooth control       | ★ Motor control        |
| ★ High efficiency      | ★ Heat control         |
| ★ Excellent regulation | ★ Rectifier control    |
| ★ Low cost             | ★ Light control        |
|                        | ★ Line voltage control |

Model V-1, 570 Watts — 5 amp. maximum ratings, complete with cord, plug and switch, net. . . . .	\$10.00
Model V-2. Same as V-1, but uncased, with terminal strip for rack or panel mounting, net. . . . .	\$9.00
Model V-3, 850 watts maximum rating, 7.5 amps., uncased, with terminal board and provisions for mounting, net. . . . .	\$14.00
Model V-4, 1250 watts — 11 amps. maximum rating, uncased, net. . . . .	\$20.00
Model V-5, 2000 watts maximum rating, 17.5 amps., uncased, net. . . . .	\$32.00

Other sizes Automatic VARITRANS are available to maintain line voltage constant. Details and prices on request.

Licensed under U. S. Patent No. 2009013

ALL PRICES SHOWN ARE NET TO AMATEURS

## UNITED TRANSFORMER CORP.

72 SPRING STREET

NEW YORK, N. Y.

BRIDGE PLAZA, 100 WALKER STREET, NEW YORK, N. Y. CABLES: 22-144

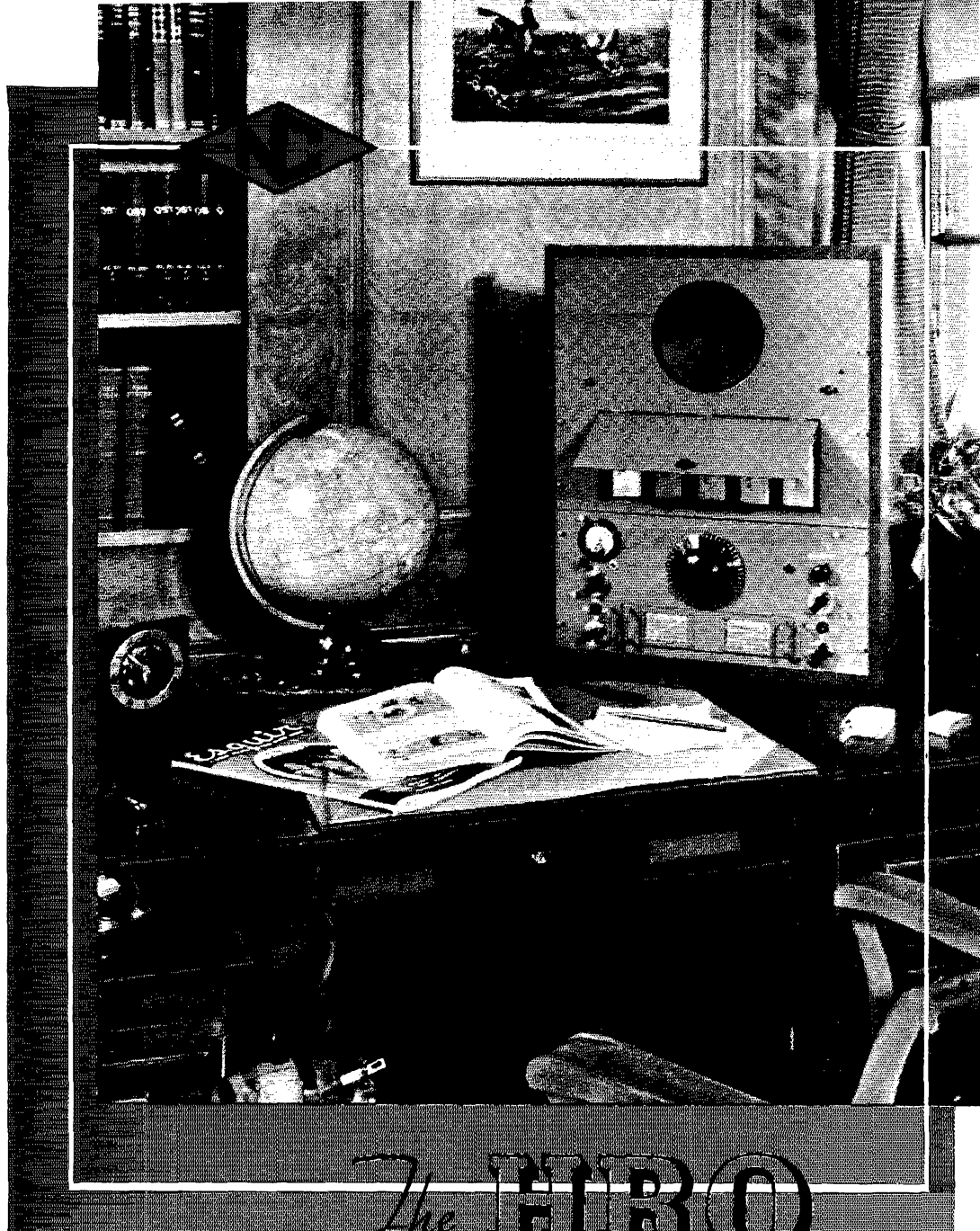

## The HRO

THIS pleasing HRO combination comes in two choices of finishes, either rich grey (as shown) or black leatherette. Net amateur prices are: HRO receiver, relay rack type, with coils covering 1.7 to 30 megacycles — \$192.00; combination panel containing matched speaker, spare coil cabinet and power supply, type SPC — \$54; table-model relay rack type MRR — \$13.50.

NATIONAL COMPANY



# New RCA Beam Power Tube Provides 130 WATTS OUTPUT\* with 1.5 Watts Driving Power

## Note these money saving features

- 1 YOU SAVE** because beam power construction for high power sensitivity makes possible use of low-priced tubes in the exciter.
- 2 YOU SAVE** because neutralization is not required with well-shielded circuits—thus eliminating expensive neutralizing condenser.
- 3 YOU SAVE** in terms of antenna watts per dollar because of high power output with high efficiency.
- 4 YOU SAVE** because rugged RCA construction provides long, trouble-free life.
- 5 YOU GAIN** flexibility for band-switching transmitters because of full power input to 30 megacycles.

Since the announcement of the RCA 814 several months ago, hundreds of amateurs and experimenters who require moderately high power have reported that this tube provides the utmost in circuit efficiency. The RCA 814, shown in actual size on this page, is a husky tetrode using electron beam principle and is designed for use as an r-f amplifier, frequency multiplier, oscillator, and plate-modulated amplifier. Low interelectrode capacitances and excellent insulation are assured because plate connection is made through a separate seal at the top of the bulb and is thoroughly isolated by the screen and shield structure. (\*For Class "C" telegraphy conditions)

*RCA presents the Magic Key every Sunday, 2 to 3 P. M.,  
E.D.S.T. on the NBC Blue Network*

Ask your distributor for your copy of RCA TT-100 Bulletin just published, for complete list of features that will appeal to the discriminating amateur.

Max. Ratings—Class "C" Telegraphy  
 DC Plate Voltage, 1250 volts  
 DC Screen Volts, 300 volts  
 DC Grid Voltage, minus 300 volts  
 DC Plate Current, 150 MA.  
 Plate Input, 180 watts  
 Plate Dissipation, 50 watts  
 Filament Voltage, 10 volts  
 Filament Current, 3.25 amperes



# Radio Tubes

FIRST IN METAL  
FOREMOST IN GLASS  
FINEST IN PERFORMANCE

RCA MANUFACTURING CO., INC., Camden, N. J. • A Service of the Radio Corporation of America

