

QST

august, 1940

25 cents

30c in Canada

devoted entirely to

amateur radio

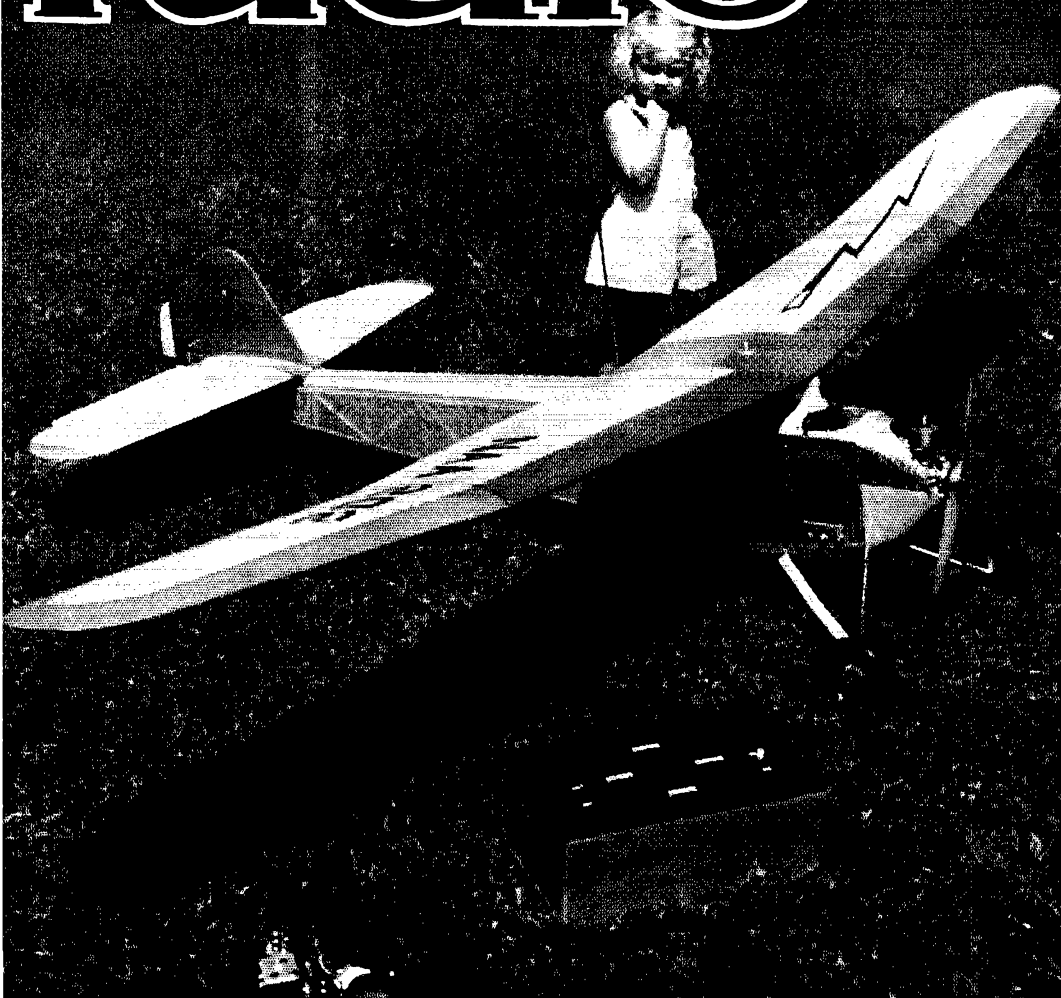

150-3000 WATTS 2-20 MC AUTOTUNE TRANSMITTERS

Every communication requirement can be met by some member of Collins versatile family of high frequency transmitters. Power output of these transmitters runs from 150 to 3000 watts, frequency extends from 2 to 20 megacycles. A₁, A₂ and A₃ types of emission are all available.

Some important features are common to each of the transmitters. For example, all models have up to 10 Autotune frequencies. Several remote control arrangements can be employed with every model.

Wide acceptance of a standardized versatile design has made possible quantity production and the consequent low prices. Even if there is need for only 2 or 3 frequencies it is still more economical to buy Collins Autotune Transmitters.

16 E 16 F 231 B 231 C 231 D

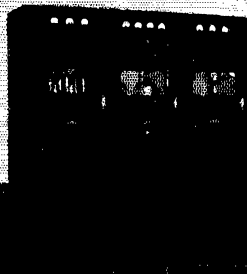
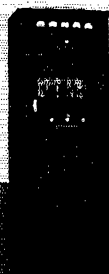

16E Rated output 150 watts
16F Rated output 1000 watts
231B Rated output 2000 watts
231C Rated output 1500 watts
231D Rated output 3000 watts

COLLINS RADIO COMPANY

CEDAR RAPIDS, IOWA

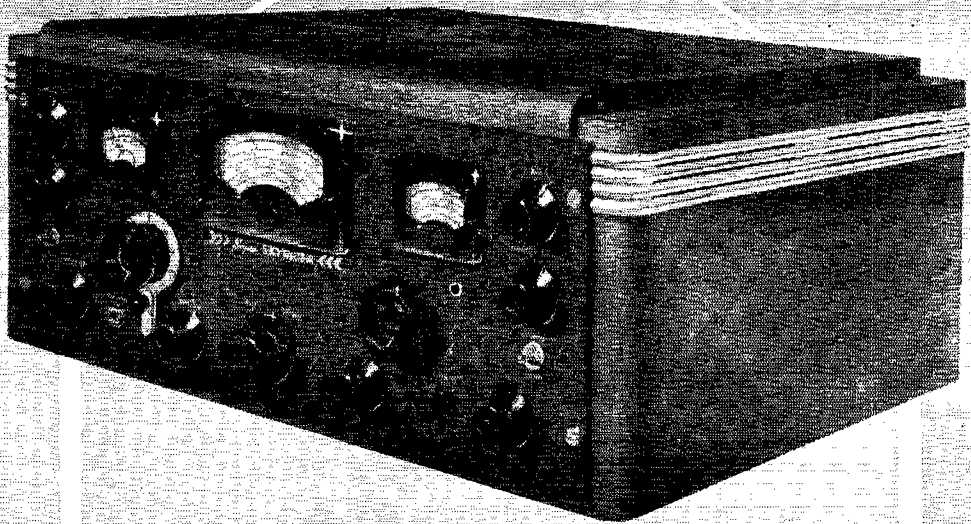

DESIGNED TO GOVERNMENT SPECIFICATIONS

A few fundamentals of the new SUPER SKYRIDER are 6 bands covering 540kc to 43mc—2 stages of preselection—high fidelity, push pull audio—band pass audio filter—a new and highly efficient crystal filter circuit—an additional and completely effective noise limiter—cadmium plated steel chassis—standard relay rack panel $\frac{1}{8}$ inch thick—machine tool, gray wrinkle, well ventilated steel cabinet. Hallicrafters-Jensen *Bass Reflex* speakers available. Sells, complete with crystal and 14 tubes, less only speaker, for \$159.50 net.

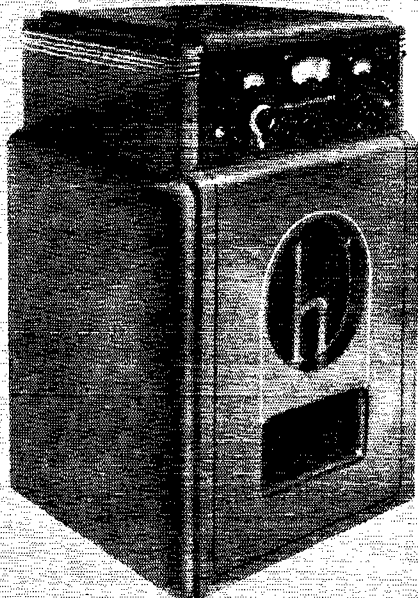

THE NEW 1941
S U P E R

Skyrider

the hallicrafters inc.

CHICAGO, U. S. A.

USED BY 33 GOVERNMENTS • SOLD TO 89 COUNTRIES

New DIRECTION FINDER

Model S-30 Radio Compass and Direction Finder covers from 200 to 3000 kc (1500 to 100 meters) on 3 bands—Beacon, Broadcast and Marine. Has provision for external speaker. Welded aluminum cabinet houses the receiver and supports the rotatable 12-inch loop antenna. Power supply in separate cabinet. Operates from 6 volts. \$99.50 NET

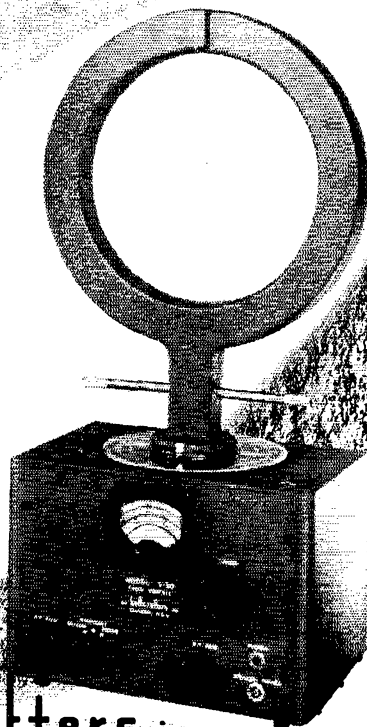

the **hallicrafters** inc.
CHICAGO, U. S. A.

USED BY 33 GOVERNMENTS • SOLD IN 89 COUNTRIES



New PORTABLE COMMUNICATIONS RECEIVER

Model S-29 Sky Traveler operates on 110 volt AC or DC of from self-contained batteries. Covers from 542 kc to 30.5 mc (553 to 9.85 meters) on 4 bands. Built-in collapsible antenna extends to 3 feet. *Battery life prolonged through self-contained charging circuit.* Automatic noise limiter, electrical bandspread, built-in speaker, etc. \$59.50 NET

AUGUST 1940

VOLUME XXIV

NUMBER 8



STAFF

Editorial

KENNETH B. WARNER, W1EH
Editor and Business Manager

CLARK C. RODIMON, W1SZ
Managing Editor

GEORGE GRAMMER, W1DF
Technical Editor

DONALD H. MIX, W1TS
BYRON GOODMAN, W1JF
Assistant Technical Editors

EDW. P. TILTON, W1HDQ
Contributing Editor, U.H.F.

VERNON CHAMBERS, W1JEQ
Technical Information Service

JAMES J. LAMB, W1AL
Research Engineer, A.R.R.L.

Advertising

F. CHEYNEY BEEKLEY, W1GS
Advertising Manager

CHARLES BRUNELLE
Asst. Advertising Manager

Circulation

DAVID H. HOUGHTON
Circulation Manager

RALPH T. BEAUDIN, W1BAW
Asst. Circulation Manager



OFFICES

38 La Salle Road
West Hartford, Connecticut

Subscription rate in United States and Possessions, \$2.50 per year, postpaid; all other countries, \$3.00 per year, postpaid. Single copies, 25 cents. Foreign remittances should be by international postal or express money order or bank draft negotiable in the U. S. and for an equivalent amount in U. S. funds.

Entered as second-class matter May 29, 1919, at the post office at Hartford, Connecticut, under the Act of March 3, 1879. Acceptance for mailing at special rate of postage provided for in section 1103, Act of October 3, 1917, authorized September 9, 1922. Additional entry at Concord, N. H., authorized February 21, 1929, under the Act of February 28, 1925. Additional second-class entries to cover sectional editions authorized March 20, 1935.

Copyright 1940 by the American Radio Relay League, Inc. Title registered at United States Patent Office.

QST

devoted entirely to

AMATEUR RADIO

PUBLISHED, MONTHLY, AS ITS OFFICIAL ORGAN, BY THE AMERICAN RADIO RELAY LEAGUE, INC., AT WEST HARTFORD, CONN., U. S. A.; OFFICIAL ORGAN OF THE INTERNATIONAL AMATEUR RADIO UNION



CONTENTS

Editorial	7
Our Cover	8
New Radio Control Gear for Model Airplanes <i>C. E. Bohnenblust, W9PEP</i>	9
A Precision Crystal Frequency Standard <i>G. M. Brown, W2CVV</i>	13
F.C.C. Orders and Interpretations	17
Radio Direction Finding <i>James M. Bruning, W3EZ</i>	19
What the League Is Doing	24
New 112-Mc. Record	26
W5CXH/6 Wins 1939 Maxim Award	27
The Fixed "Rotary" Beam Antenna <i>Arthur H. Lynch, W2DKJ</i>	28
A.R.R.L. Announces New Code Proficiency Certificates <i>F. E. Handy, W1BDI</i>	32
Designing a Wide-Range U.H.F. Receiver <i>F. W. Schor</i>	34
Naval Communication Reserve	38
On the Ultra Highs <i>E. P. Tilton, W1HDQ</i>	40
Hints and Kinks <i>Three-Band Coil — A Multi-Band Antenna System — Improved Pi-Section Antenna Coupler</i>	44
Amateurs Honor Hiram Percy Maxim	45
Club Members — Code Awards	46
Joint Pacific — Southwestern Convention	46
WWV Schedules	46
Correspondence	47
Operating News	48
Hamfest Schedule	50
Brasspounders' League	51
How's DX?	52
Northwest Division Convention	66
A.R.R.L. Affiliated Club Honor Roll	66
Station Activities	68
Silent Keys	82
New Tubes	84
Catalogs and Pamphlets	88
Hamads	91
QST's Index of Advertisers	94

Section Communications Managers of the A.R.R.L. Communications Department

All appointments in the League's field organization are made by the proper S.C.M., elected by members in each Section listed. Mail your S.C.M. (on the 16th of each month) a postal covering your radio activities for the previous 30 days. Tell him your DX, plans for experimenting, results in phone and traffic. He is interested, whether you are an A.R.R.L. member or get your *OST* at the newstands; he wants a report from every active ham. If interested and qualified for O.R.S., O.P.S. or other appointments he can tell you about them, too.

ATLANTIC DIVISION			
Eastern Pennsylvania Maryland-Delaware-District of Columbia Southern New Jersey Western New York Western Pennsylvania	W3BES W3CIZ W3CCO W8PLA W8OFO	Jerry Mathis Hermann E. Hobbs Lester H. Allen Fred Chichester Kendall Speer, Jr.	6042 Master St. 9701 Monroe St. Silver Spring P.O. 704 Quinton Ave. Philadelphia Linden, Maryland Trenton Sonyea Lowber
CENTRAL DIVISION			
Illinois * Indiana Kentucky Michigan Ohio Wisconsin	W9LH W9AB W9ARU W8DPE W8AQ W9UIT	Mrs. Carrie Jones Harry B. Miller Darrell A. Downard Harold C. Bird E. H. Gibbs Aldrich C. Krones	2407 Central Ave. 729 E. Lowell Ave. 116 N. Longworth Ave. R.F.D. 2 405 Broad St. 2702 So. 46th St. Alton Milawaka Louisville Pontiac Wadsworth Milwaukee
DAKOTA DIVISION			
North Dakota South Dakota Northern Minnesota Southern Minnesota	W9WWL W9ADJ W9IGZ W9YNQ	Anton C. Theodos E. C. Mohler Edwin L. Wicklund Millard L. Bender	Box 444 Box 149 R. F. D. 3 608 N. Huron Ave. Williston Rapid City Kensington Spring Valley
DELTA DIVISION			
Arkansas Louisiana Mississippi Tennessee	WSABI WSDWW W5EWD W4DWS	H. E. Vette W. J. Wilkinson, Jr. Jewell W. Cole William Harold Walker	4415 West 12th St. 1523 Laurel St. c/o City of McComb Water Dept. 1901 Cedar Lane Little Rock Shreveport McComb City Nashville
HUDSON DIVISION			
Eastern New York N. Y. C. & Long Island Northern New Jersey	W2LU W2AZV W2GVZ	Robert E. Haight E. L. Baunach Joseph P. Jessup	511 South Holmes St. 102 Central Ave. 131 California St. Scotia Massapequa, L. I. Ridgewood
MIDWEST DIVISION			
Iowa Kansas Missouri Nebraska	W9PIR W9UEG W9OUD W9DI	L. B. Vennard Melvin D. Kirby Miss Letha Allendorf William J. Bamer	P. O. Box 304 1015 W. 3rd St. West Burlington Arlington Joplin Tobias
NEW ENGLAND DIVISION			
Connecticut Maine Eastern Massachusetts Western Massachusetts New Hampshire Rhode Island Vermont	W1CTI W1IIE W1ALP W1JAH W1BFT W1HRC W1KJG	Frederick Ellis, Jr. H. W. Gardner Frank L. Baker, Jr. William J. Barrett Cari B. Evans Clayton C. Gordon Clifton C. Parker	19 Merrill Rd. 147 Church 21 Colby Road 239 Columbia St. 163 South Main St. 70 Columbia Ave., Gaspee Box 537 Norwalk Reno North Quincy Adams Concord Plateau, Warwick Morrisville
NORTHWESTERN DIVISION			
Alaska* Idaho Montana Oregon Washington	K7GNN W7EMT W7CPY W7DXF W7FCG	James G. Sherry Carl Eichelberger Rex Roberts Harold W. Johnston W. Beale	Route 2 Box 1088 902 N. W. DeSpain R. 4, School Ave. Chichagof Kuna Glendive Pendleton Walla Walla
PACIFIC DIVISION			
Hawaii Nevada Santa Clara Valley East Bay San Francisco Sacramento Valley Philippines San Joaquin Valley	K6FTF W6HIC W6FBW W6TI W6CIS W6MDI KAIGR W6KUT	Francis T. Blatt Edward W. Heim Albert Amarantes Horace R. Greer Kenneth E. Hughes Vincent N. Feldhausen George L. Rickard Edwin A. Andress	837 16th Ave. 509 Claremont St. 454 Washington St. 414 Fairmount Ave. 622-36th Ave. 113 South Quincy St. Box 849 2921 North Van Ness Blvd. Honolulu Reno San Jose Oakland San Francisco McCloud Manila Fresno
ROANOKE DIVISION			
North Carolina South Carolina Virginia West Virginia	W4CYB W4BOE/ANG W3GWO W8XNO	W. J. Workman Ted Ferguson Frank S. Anderson, Jr. W. D. Tabler	P. O. Box 566 1213 College St. 4703 New Kent Ave. 238 Watson Ave. Morgantown Columbia Richmond Fairmont
ROCKY MOUNTAIN DIVISION			
Colorado Utah-Wyoming	W9EHC W7CLG	Carl C. Drumeller Ernest E. Parshall	819 East Dale St. Salt Creek Electric Plant Colorado Springs Midwest, Wyoming
SOUTHEASTERN DIVISION			
Alabama Eastern Florida Western Florida Georgia West Indies (Cuba-Isle-of-Pines- Porto Rico-Virgin Islands)	W4DGS W4PEI W4AXP W4AGI CM2OP	James F. Thompson Carl G. Schaal Oscar Cederstrom Leland W. Smith Mario de la Torre	12 Clanton Ave. Waucoma Apts. Lakeview Hotel Second St. & Bruce Ave. 2010 Pennsylvania Ave. Escobar 110 (Altos) Montgomery Clermont De Funiak Springs Augusta Habana, Cuba
SOUTHWESTERN DIVISION			
Los Angeles Arizona San Diego	W6MQM W6KMM W6BKZ	Ralph S. Click Marson B. Hull Louis A. Cartwright	1038 Milwaukee Ave. 617 North Fourth Ave. 370 Nautilus Los Angeles Phoenix I. a. Jolla
WEST GULF DIVISION			
Northern Texas Oklahoma Southern Texas New Mexico	W5DXA W5GFT W5SMN W5ENI	Lee Hughes Russell W. Battern Horace E. Biddy Dr. Hilton W. Gillett	125 N. Main St. Box 290 1746 Schley Ave. Childress Enid San Antonio Lovington
MARITIME DIVISION			
Maritime	VE1DQ	A. M. Crowell	69 Dublin St. Halifax, N. S.
ONTARIO DIVISION			
Ontario	VE3SG	F. H. B. Saxon	302 Lee Ave. Toronto, Ont.
QUEBEC DIVISION			
Quebec	VE2CO	Lindsey G. Morris	Apt. 6, 4510 Girouard Ave., N.D.G. Montreal, P. Q.
VANALTA DIVISION			
Alberta British Columbia	VE4GE VE5DD	C. S. Jamieson C. O. I. Sawyer	581 W. Riverside Drive 2634 West 31st Ave. Drumheller, Alta. Vancouver
PRAIRIE DIVISION			
Manitoba Saskatchewan	VE4AAW VE4SY	A. W. Morley Arthur Chesworth	747 McMillan Ave. 1071 4th Ave., N. W. Winnipeg Moose Jaw

* Officials appointed to act until the membership of the Section choose permanent S.C.M.s by nomination and election.

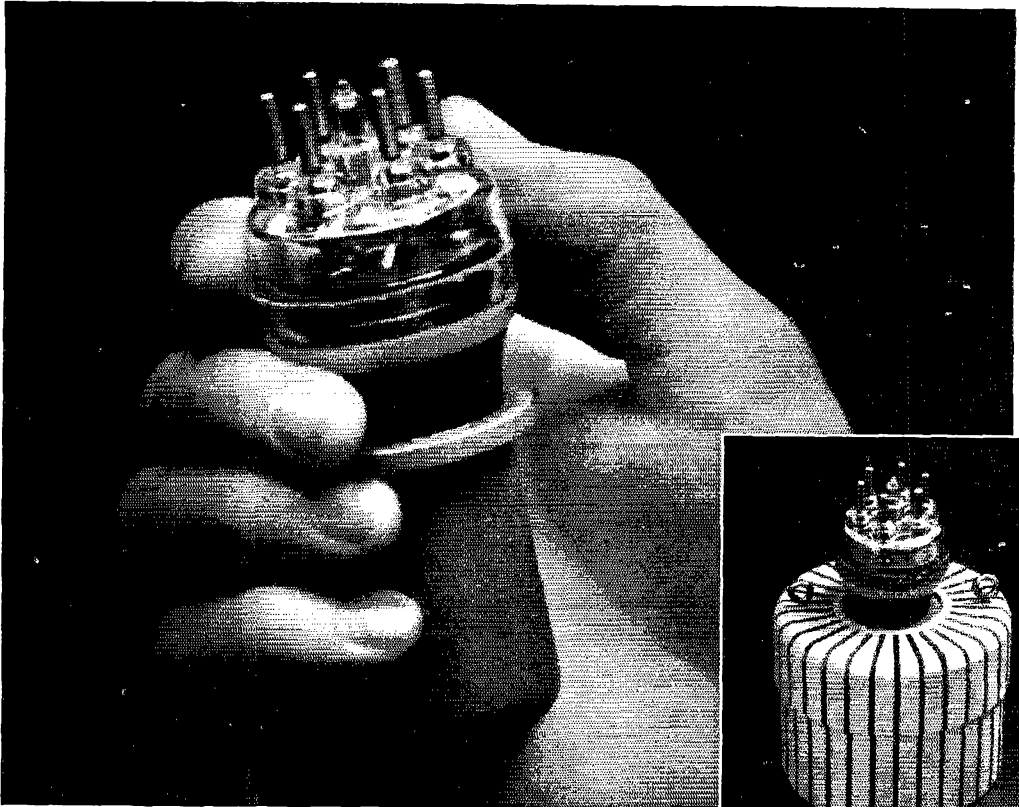

3 KW INPUT AT 120 MC*

GL-8002-R—General Electric's Latest U-H-F Achievement

NO. GL-8002-R is not a ham tube. But hams—especially you who are connected with commercial broadcasting—should know about it. It's another example of G-E leadership in tube design and construction.

GL-8002-R is not just another u-h-f triode. It solves, in itself, some basic ultra-high-frequency problems:

Small size permits short leads—both inside and outside the tube.

Center-tapped filament provides parallel feed for r-f circuits.

Three grid leads reduce common inductance, making neutralizing easy; separate leads for neutralizing and excitation.

Heavy-wall anode reduces local heating, improves cooling.

Milled radiator has uniform air passages for more efficient cooling.

Water cooled (GL-8002) takes 3 kw up to 150 mc; reduced inputs to 300 mc.

The GL-8002 is used in the G-E 1-kw television transmitter and the GL-8002-R in the 3-kw frequency-modulation transmitter. Like every other G-E transmitting tube, it is backed by 27 years of G-E tube experience. Next time you buy, try G-E, and measure the difference. General Electric, Schenectady, N. Y.

* Up to 200 mc at reduced inputs

GENERAL  **ELECTRIC**
161-5

THE AMERICAN RADIO RELAY LEAGUE

Directors

President
GEORGE W. BAILEY..... W1KH
74 Webster Road, Weston, Mass.

Vice-President
CHARLES E. BLALACK..... W6GG
1273 Main St., El Centro, Calif.

Canadian General Manager
ALEX REID..... VE2BE
169 Logan Ave., St. Lambert, P. Q.

Atlantic Division
WALTER BRADLEY MARTIN..... W3QV
Box 612, Roslyn, Pa.

Central Division
R. H. G. MATHEWS..... ex-W9ZN
4534 Dover St., Chicago

Dakota Division
FRED W. YOUNG..... W9MZN
107 Hanover St., Mankato, Minn.

Delta Division
E. RAY ARLEDGE..... W5BI
P.O. Box 286, Pine Bluff, Ark.

Hudson Division
KENNETH T. HILL..... W2AHC
175 Willow St., Douglaston, L. I., N. Y.

Midwest Division
FLOYD E. NORWINE, JR..... W9EFC
7405 Hiawatha Ave., Richmond Heights, Mo.

New England Division
PERCY C. NOBLE..... WIBVR
37 Broad St., Westfield, Mass.

Northwestern Division
RALPH J. GIBBONS..... W7KY
c/o United Air Lines, Portland, Ore.

Pacific Division
J. L. McCARGAR..... W6EY
66 Hamilton Pl., Oakland, Calif.

Roanoke Division
H. L. CAVENESS..... W4DW
State College Station, Raleigh, N. C.

Rocky Mountain Division
GLEN R. GIBSON..... W9FA
2164 So. Corona St., Denver

Southeastern Division
WILLIAM C. SHELTON..... W4ASH
Box 652, Daytona Beach, Fla.

Southeastern Division (Acting)
JOHN E. BICKEL..... W6BKY
801 E. California St., Whittier, Calif.

West Gulf Division
WILLIAM A. GREEN..... W5BKH
801 Ross St., Abilene, Texas

THE AMERICAN RADIO RELAY LEAGUE, INC., is a non-commercial association of radio amateurs, bonded for the promotion of interest in amateur radio communication and experimentation, for the relaying of messages by radio, for the advancement of the radio art and of the public welfare, for the representation of the radio amateur in legislative matters, and for the maintenance of fraternalism and a high standard of conduct.

It is an incorporated association without capital stock, chartered under the laws of Connecticut. Its affairs are governed by a Board of Directors, elected every two years by the general membership. The officers are elected or appointed by the Directors. The League is non-commercial and no one commercially engaged in the manufacture, sale or rental of radio apparatus is eligible to membership on its board.

"Of, by and for the amateur," it numbers within its ranks practically every worth-while amateur in the nation and has a history of glorious achievement as the standard-bearer in amateur affairs.

Inquiries regarding membership are solicited. A bona fide interest in amateur radio is the only essential qualification; ownership of a transmitting station and knowledge of the code are not prerequisite. Correspondence should be addressed to the Secretary.



Past Presidents

HIRAM PERCY MAXIM, 1914-1936
EUGENE C. WOODRUFF, 1936-1940

Officers

President..... GEORGE W. BAILEY, W1KH
Weston, Mass.

Vice-President..... CHARLES E. BLALACK, W6GG
El Centro, Calif.

Secretary..... KENNETH B. WARNER, W1EH
West Hartford, Connecticut

Treasurer..... ARTHUR A. HEBERT, W1ES
West Hartford, Connecticut

Communications Mgr...... F. EDWARD HANDY, WIBDI
West Hartford, Connecticut

General Counsel..... PAUL M. SEGAL
1026 Woodward Building, Washington, D. C.

Address all general correspondence to the administrative headquarters at West Hartford, Connecticut.

“IT SEEMS TO US—”

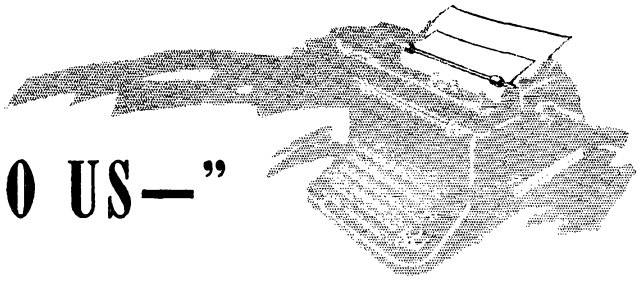

AS THE United States rolls up its sleeves for a job of work ahead, it is being said that there are disappearing from American life those things that have been done only for fun or to add zest to living, and that there will remain those things essential to our security and well-being. For many years we have remarked how the institution of amateur radio follows, in miniature, the changes in tempo and atmosphere that leave their greater mark on the national life. It is therefore not surprising that the recent fundamental gear-shifting has had its effect upon ham radio. DX and just-for-fun portable work have temporarily disappeared. The new emphasis is upon the national-defense value of the amateur — national defense and the safety of life and property.

Some aspects of amateur radio require no justification. One of these is the training-school side. At our own expense, and with great zeal, we train ourselves in the complexities of a difficult art and make ourselves proficient operators. What a nation primarily needs from amateur radio at a critical time in national history is competent radiotelegraph operators. And so it comes about that the new emphasis is upon code proficiency. Even back in May this was apparent to our Board of Directors who, at their annual meeting, stressed the importance of greater proficiency with the code and directed the headquarters officers to take steps to increase the individual amateur's telegraphing speed. Elsewhere in this issue are some announcements of interesting activities inaugurated by the Communications Department.

Our tune is changing. All of you, particularly the old-timers, remember that the League for many years has been long on telegraphing accuracy. The amateur was proud of his accuracy. He was also courteous and he adjusted his speed to what he knew the receiving operator could deal with comfortably and accurately. As we look back on it now, those practices were part of the days when life was easy. Our job then was to get messages through and to get them correctly. Perforce we adjusted ourselves to the receiving operator, knowing that otherwise he wouldn't get it straight. We encouraged the freer use of "QRS" and deplored

the false pride that wouldn't let a receiving operator ask for slower transmission.

Such practices made for accuracy but they never raised anybody's code speed. It is absolutely a fundamental that nobody ever raised his code speed without having it come at him just a little faster than he could deal with. Beginners trying to crawl from 8 words a minute up to the magic 13 know that. A competent operator trying to raise himself from 40 to 45 knows it equally well. Obviously for record correspondence accuracy must be maintained. But we now suggest to every American amateur that, outside of actual traffic-handling, he make the deliberate endeavor to gain speed for himself and to give added speed to his brother amateurs by slightly stepping up the tempo in both directions. Copying press of course will also give excellent practice — really copying it, not just reading it. Many of us, too many, do not possess *useful* code speed — say 25 words a minute or more. Those of us who are good could be better. Let the goal be for every ham to improve his performance so that the speed at which he can receive accurately is definitely increased, and continues to increase every week.

There is a job to be done here, but this subject is full of dynamite. Great care is necessary or all is lost. It should be perfectly obvious that the only justifiable increase in speed is a *slight* one, say two or three words per minute faster than would be really comfortable for the particular receiving operator. If it is anything more than this, nothing will make sense. There will be no "copy" whatever and all the fun will be lost. Therefore our new program is anything but an invitation to impress your vast speed immediately upon your bewildered correspondents. Courtesy is still necessary. Your ability to send a little faster must still be carefully adjusted to the recipient. You in turn will not want somebody shooting a mere blur at you. You will have the ambition to increase your copying speed, and you will have enough pride to work for it, so that most of the time you will be willing to invite a speed which makes you strain just a little to get it. You want to be able to control that speed rather accurately. Have the courtesy to

do the same thing for your receiving operator. If we go at this thing sensibly, the speed of the whole amateur world will go up, a little this week, a little more next week, and eventually you'll be able to send as fast as you wish — or can.

For this situation, we suggest an increased use of the Q abbreviations already available. There is "QRQ?", meaning "Shall I transmit faster?" and "QRS?", "Shall I transmit slower?" These two abbreviations and a figure constitute convenient answers. For example, "QRQ 22" would obviously mean "Transmit faster, i.e., increased speed to 22 w.p.m.," while "QRS 18" would similarly mean not only to transmit more slowly but to decrease speed to 18 w.p.m.

Another important consideration: Don't in any case send faster than you can send reasonably well. If your correspondent is capable of reading anything anybody can dish out, obviously he won't be able to increase his proficiency from working you. But you can increase your transmitting capabilities by taking advantage of such an opportunity to have somebody read you while you are still transmitting as fast as you can do so cleanly. The important thing is to stay within your limitations.

We speak here of increasing sending speed and that too is proper. Our fists need improvement as much as does our copying speed. There are as many lousy fists as there are punks who can't read at a decent speed. (Maybe there is a cause-and-effect relation!) Generally our dashes are too long and our dots too short. Bug keys have nearly ruined us and half the letters on the air are badly formed. Watch your spacing. The nearer you sound like a tape auto, the better you are. How we wish a few gents of our acquaintance would believe that! They go in for "individuality" and it is only when they forget themselves that they accidentally let loose a few letters in the shape that Old Man Morse intended. This gives them very vivid personalities but, inasmuch as the days of personal amusement are declining, it hasn't the slightest value in the world.

Another thing on which we ought to concentrate is learning to copy on a typewriter. In many of the service jobs the best pencil-pusher in the world isn't acceptable; it is required that the stuff be taken on a mill. All too few amateurs know how to do it. It is one thing to know the code and to be able to type-write, and quite another thing to put it down on the mill. An extra brain circuit has to be established and it can be done only by practice. We know some operators who can copy with a pencil at 30 words a minute, who can easily read up to 40, who have the ability to run a typewriter at 60 or 70, but who can actually copy code on the typewriter at only about 10

words a minute — simply because they have never practiced coordinating code-reading and typing. The acquisition of this ability is therefore a part of the job of whipping ourselves into better shape. Oil up that old machine and try it. We suggest tuning in for press as the best kind of copy at first, because it is sustained and at uniform speed and because the context will help to show you how you are doing.

And now you 'phone men: We are talking about you too. We think that you are going to wish that you had code speed, and we think that your Uncle Samuel is going to need it. We therefore suggest that you not spend all of your time with a mike. Ham radio has its serious side, its need to pay for its fun. Do your part by keeping yourself a proficient code operator. All 'phone men once had minimum code proficiency — at the time they first got their licenses. We think that it is incumbent upon 'phone men to make the same effort to raise their c.w. proficiency as in the case of the men who have no microphone. It may be a little tough going for some of you boys to get on the air at a magnificent 7 words per minute, but you needn't feel too ashamed of it, in the knowledge that it can happen to anybody who practices code so little, and in the confidence that it will come back quickly. And we suggest that the working up of a decent speed will give you more of a thrill of accomplishment, and more of the consciousness of doing something that needed to be done, than working Mars on 160 'phone.

We opened these remarks on a rather grim note, that some of the fun was disappearing from amateur radio. We don't really mean that, of course. It is simply that there is a change in the standards by which we gauge what things are pleasurable to do. We amateurs always get a kick out of doing the things that need to be done. Times change and the desirable thing now is better code proficiency. We're sure we'll have as much fun out of that this summer as we have had from the other things that have come along. So take a look at Handy's dope elsewhere in this issue, dig out that bottle of wrist oil, and let's go places!

K. B. W.

OUR COVER

There is something about a model plane that excites the interest of young and old alike. This is the ship which is described by W9PEP in our lead article. Clarence set the ship down on the front lawn, posed the apparatus, dragged out the sun and shot the works.

It is quite obvious that the ship's vertical is coming in for some close inspection. The control box and cable leading to the transmitter are included.

The control of machines by radio has been a fascinating field of endeavor for a long time, but not until the last couple of years has there been really fool-proof radio control of planes by amateurs. This story is the result of a mighty interesting demonstration staged at the Midwest Division Convention held at Wichita in April. Since then successful flights and landings have been executed, and as we take off to press Siegfried and Bohnenblust are vying with the best of them at the National Meet in Chicago.

New Radio Control Gear for Model Airplanes

Three-Way Control Installation for Gas-Powered Models

BY C. E. BOHNENBLUST,* WØPEP

ABOUT eighteen months ago Mr. C. H. Siegfried approached me with a request to assist him with the design and construction of radio control gear for his model gas-powered planes. Siegfried is a model builder of great ability and his planes fly — something quite vital before radio control can be applied to a plane. I became interested in the job and this article describes the gear we are using, its adjustment and operation.

The Receiver

The receiver, with minor changes, is identical to that shown in a previous issue of *QST*.¹ The use of the RK62 tube in a conventional "super-regen" circuit provides a consistent receiver which will operate the Sigma relay at distances of slightly over a mile on level ground. The circuit is given in Fig. 1.

The receiver, less the relay, is assembled in a 2¾-inch diameter aluminum shield can. A hole through the can allows the tube to protrude an inch or so. The base is fitted with a plug so that the entire receiver can be easily removed.

The antenna is coupled to the receiver by means of a three turn coil. We found this to be

somewhat better than capacity coupling. An air tuning condenser of about 15 μfd . capacity connected from the center of the coil to the plate end, with the rotor connected to the center of the coil, makes tuning easier since hand capacity is largely eliminated. A hole cut through the base of the can provides access to the tuning condenser for adjustment. The antenna is vertical and about three feet long. No potentiometer is used for plate-voltage control, nor is an r.f. choke used.

The large-size "D" flashlight cell is used for the filament supply because constant voltage for the filament is very essential for continuous, stable receiver operation. A medium-size cell might be used with satisfactory results. However, a "penlite" cell is not satisfactory. Note that but one cell (1.5-volt) is used for the filament. We have found this to be as satisfactory as higher voltages.

A five-ounce 45-volt "B" battery is used for the plate supply. This size will last for some time.

Adjustment of this receiver is simplicity itself. Starting with no signal and with loose antenna coupling, the plate current will be well below 1.5 milliamperes. Coupling is increased until the plate current is about 1.5 ma. Then, with the carrier on, the signal is tuned in. This results in a

* 836 Woodrow, Wichita, Kans.

¹ DeSoto, "Radio Control of Powered Models," *QST*, October, 1938.

◆
The gnome, "A chain is no stronger than its weakest link," still holds water when it comes to radio-controlling a ship. The author is shown giving each component the once over. Note the belt-driven generator run from the Dodge driveshaft.



◆
August 1940

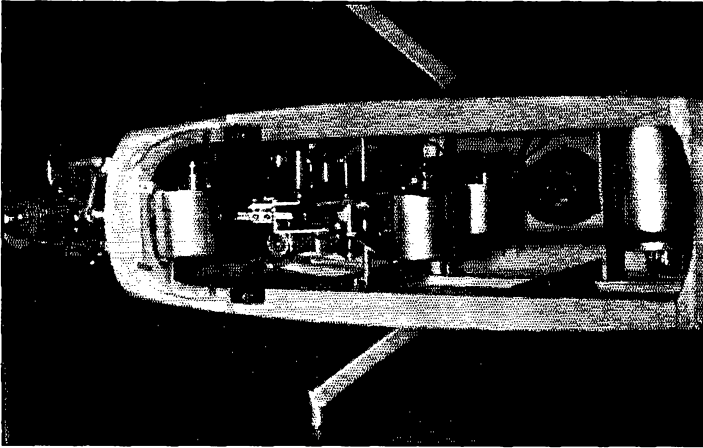

The complete control set-up installed in the model plane. The third motor (throttle control) is mounted to the left of the control mechanism. At the right are the relay and the receiver, the latter completely enclosed, except for the tip of the tube, in a shield can.

lower value of plate current. Some readjusting of antenna coupling may now be necessary to hold the plate current at 1.5 ma. with carrier off.

Try other values of grid leak until the value is found which gives greatest plate current change. To do this it is probably best to separate the

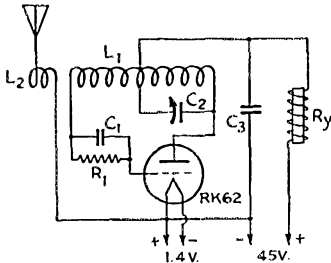

Fig. 1 — Circuit of the single-tube receiver.

- L₁ — 10 turns of No. 14, diameter ½ inch, turns spaced to cover band
- L₂ — 3 turns same as L₁.
- C₁ — 100- μ fd. mica.
- C₂ — 15- μ fd. air trimmer.
- C₃ — 0.005- μ fd. paper.
- R_y — 8000-ohm sensitive relay (Sigma).

transmitter and receiver some distance from each other.

The Transmitter

The transmitter is of conventional design, using an 807 doubler in the final for 5-meter output. Using a 500-volt power supply, about 20 watts output is obtained. An 89 with a 20-meter crystal drives the 807.

The transmitting antenna is a "J" type. This is equivalent to a vertical which gives coverage in all horizontal directions.

The Control Unit

The control unit presented by far the most difficult problem of the entire job. There are of course many methods of applying the controls, and final choice of the method used was influenced by (1) weight, (2) speed of application, (3) ease of construction, (4) consistency of operation, and finally (5) controllability.

Our first was a simple rudder control unit which operated in sequence each time the carrier was turned on. The sequence was (1) neutral, (2) right rudder, (3) neutral, (4) left rudder, (5)

A side view of the plane with the control unit in place. This shows the opposite side of the unit to that given in the other photograph. The commutators and wipers on the motors are visible through the left window, while at the right are the 10:1 gears, the escapement assembly, and the magnet which operates the escapement. The throttle on the engine is controlled by a cord driven by the electric motor mounted at the front of the plane.

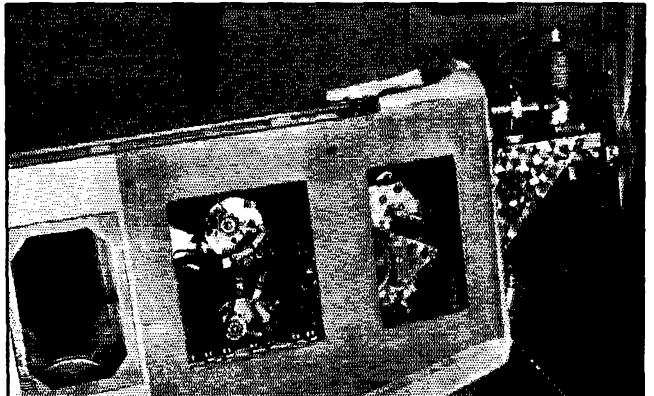

neutral, and so on. Such an arrangement has been used by several experimenters with good results, and since constructional data have appeared previously no details will be given here.

With the simple rudder control we obtained several nice flights; however, we soon concluded that we needed more controls to do the job up "brown." After much discussion we decided upon the following controls: (1) rudder right or left, (2) elevators up or down, (3) motor speed high or low, and finally (4) shut off motor.

The use of but one receiver makes a pulsing or "dialing" arrangement necessary in order to select and operate any one of several spring assemblies. Pulses for this unit must be made uniformly in order to avoid interference with the restoring feature. This will be explained later. We use an ordinary telephone dial to pulse the carrier. A switch turns on the carrier, then by dialing a number the carrier is pulsed. This rate of pulsing is about 9 per second.

Rather than using a stepping switch, actuated by an electro magnet, a dialing wheel driven by a rubber motor is used. Its rotation is controlled by an escapement. This device is lighter and the battery required to operate the escapement is smaller. Thus an overall saving in weight is effected.

Reversible electric motors were decided upon to apply the controls. Model DC-7 electric motors, manufactured by the Pittman Electrical Developments Company, Philadelphia, Pennsylvania, are used in this unit. Three separate motors were used. These motors weigh three ounces each and come equipped with reducing gear assemblies. The speed is reduced to one revolution in 18 to 20 seconds. By using but 1/20 revolution to apply the control the time required is about one second.

Motor shut-off is obtained by opening the ignition circuit sufficiently long to cause the motor to die. Then other controls may be selected.

Now for the hard part of the job. A dialing wheel about three inches in diameter carries a cam which, when the wheel is rotated, successively operates the spring assemblies. The operation of the spring assemblies in turn closes electrical circuits to the motors which apply the controls. Fig. 2 shows the circuit arrangement for motors Nos. 1 and 3. The circuit arrangement for No. 2 motor is identical to No. 1 and is not shown.

Reversible motor No. 1 has two wipers, A and B, attached. These wipers engage commuta-

tors C, D and E respectively. It will be noted that C and D are spaced apart just far enough so that wiper A can rotate to the center gap where it clears, electrically, segments C and D. Wiper A, segments C and D and the normally-closed contacts at positions 1 and 2 constitute the automatic restoring feature for motor No. 1. By tracing the circuit it will be seen that, with 1 and 2 at normal, if wiper A is in contact with either C or D, the circuit is closed to the motor so that it rotates to the gap between C and D, which is normal. The rudder is adjusted to normal with the motor in this position.

Rotation of the dialing wheel to bring the actuating cam to position 1 operates the spring assembly at that position. Operation of this spring assembly opens the restoring circuit and closes a circuit which causes the motor to rotate to the right. It will be noted that this circuit is in series with commutator segment E and wiper A which open the circuit when the motor rotates a given amount. This position is of course determined by the length of segment E and determines the amount of right rudder applied.

The control remains operated so long as spring assembly No. 1 remains operated, and when the spring assembly is released will rotate back to normal as described above.

Operation of spring assembly at position 2 results in rotating the motor to the left for left rudder control in a manner identical to that described above for right rudder control.

Motor No. 2 is an exact duplicate of No. 1 and is wired to the spring assemblies at positions 3 and 4 exactly as shown for motor No. 1. This motor controls the elevators.

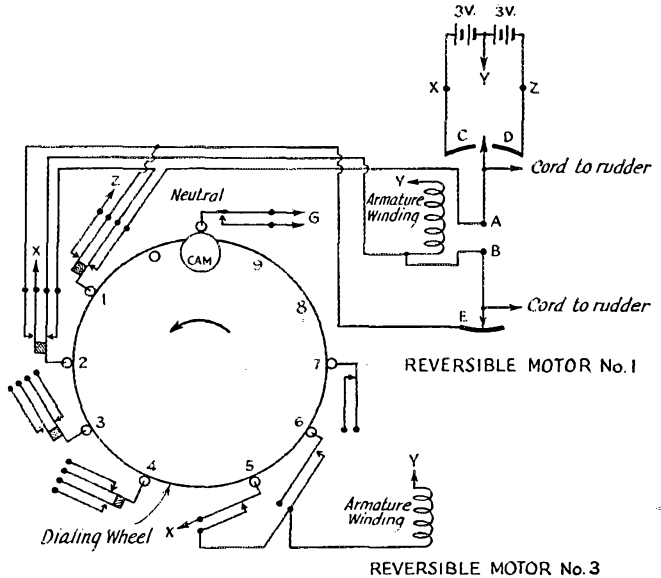
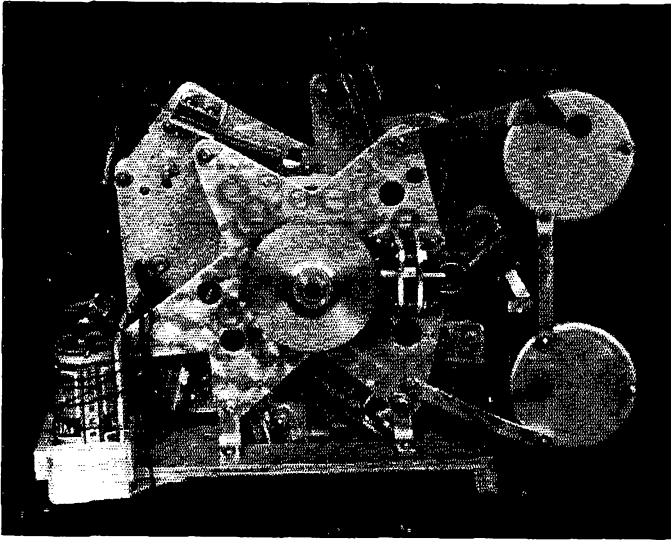

Fig. 2—The electrical circuit of the control unit. Motor No. 2 is not shown because its connections are similar to those of No. 1.



The control unit, showing batteries and two of the reversible motors. The 4:1 bevel gears are mounted on the front plate; the hook for the rubber motor is on the right-hand end of the shaft of the driving gear. Spring contact assemblies are attached to the rear dural plate. At the top, one of the assemblies can be seen riding on the rim of the dialing wheel.

Motor No. 3 rotates right or left as spring assemblies at 5 and 6 are operated, respectively. This motor is connected to the throttle and has no automatic restoring feature, since after setting the throttle at a given point it would not be desirable to have it rotate back to "neutral" automatically. This arrangement makes possible the setting of the throttle at any given point.

The spring assembly shown at position 7 is used to open the ignition circuit of the motor, which of course causes it to die.

The Mechanical System

Fig. 3 shows the gear layout and the escapement. Gear *A* is on the same shaft as the dialing wheel shown in Fig. 1. Gear *A* drives gear *B* in the ratio of 10:1. Gear *H*, driven by the rubber motor, drives gear *I*, which is also on the same shaft as the dialing wheel and gear *A*. This ratio is 4:1. Therefore 4 turns of rubber are used to turn the dialing wheel one revolution.

The dialing wheel normally cannot rotate because the "flipper" *D* strikes the edge of the escapement. When the magnet is energized the "flipper" clears and is caught by *E* of the escapement. This permits the dialing wheel to turn nearly 1/20 revolution and the cam is now located at position 0 shown in Fig. 2. One pulse of the magnet similarly rotates the dialing wheel to position 1. Likewise by pulsing the magnet the dialing wheel cam can be rotated to any position

from 1 to 9. The pulsing of the magnet obviously is accomplished by the relay in the receiver circuit.

Position 0 is left dead because in operation the carrier is first turned on by use of a non-locking switch and then the dial is operated to pulse the carrier. Because of the interval of time involved before the dial is operated, a spring assembly at position 0 would be operated an appreciable length of time.

It will be noted that the cam on the dialing wheel is at position 0-9 inclusive only when the carrier is on and the magnet operated, holding the "flipper" at *E*. Therefore the control selected is on so long as the carrier is on. When the carrier is released the "flipper" rotates to normal. However the cam *C* on the same shaft with the "flipper" closes spring assembly *G* through normally closed assembly *F*. This causes the magnet to operate

(Continued on page 70)

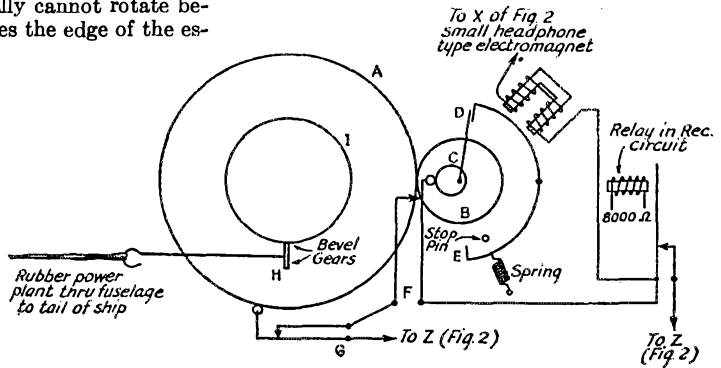

Fig. 3 — The mechanical gear system and control escapement.

A Precision Crystal Frequency Standard

Using a 1000-kc. Crystal for General Amateur Measurement

BY G. M. BROWN,* W2CVV

FOR the last year or two, the frequency standard in use at W2CVV consisted of a 100-kc. quartz bar, together with a 10-kc. multivibrator and harmonic amplifier. This unit, besides being a bit too heavy to be portable with anything less than a basket, and having a rather high temperature coefficient, had one serious fault. The harmonics, even with the multivibrator off, were separated by only 100 kc. and, unless a separate frequency standard of reasonable accuracy was available, it was exceedingly difficult to determine which harmonic was being used, particularly on the higher frequencies. Of course, one of the crystals capable of oscillating on either 100 or 1000 kc. would have answered this last objection but would have immediately added another in that, with such a crystal, the frequency of the 1000-kc. oscillator has no direct relation to that of the 100-kc. oscillator, and individual means for setting and maintaining the frequency of each oscillator "on the nose" would have to be provided.

What seemed to be required was a single precision frequency source, capable of being adjusted to WWV or some other primary standard and of putting out uniformly accurate calibrating signals with 10-, 100-, or 1000-kc. intervals.

When a sample became available of a new type of 1000-kc. crystal having a frequency temperature coefficient of less than one cycle/Mc./°C. and a grinding accuracy such that a small variable condenser across it was all that was required to put its frequency "flat on," it was immediately decided to place the old 100-kc. bar in retirement and build a new frequency standard from the ground up.

The first and most important requirement, of course, was a crystal oscillator circuit which would not detract from the accuracy capabilities of the crystal itself. A circuit which had previously been used commercially with similar crystals was tried and, since it was found to be entirely satisfactory, was used in the final model. It uses the triode section of a 6K8 as an oscillator, with a resonant choke, L_1 , in its plate circuit and the hexode section of the same tube as an electron-coupled amplifier. Since the crystal was ground to be on-frequency with 25 $\mu\text{fd.}$ across its terminals, a 50- $\mu\text{fd.}$ variable was so connected and controlled from the front panel by means of a vernier dial. Adjusting this condenser varies the frequency something like plus 75 cycles and minus

100 cycles from 1000 kc. Its setting will be found to be quite critical when an attempt is made to set to within one cycle or so of WWV and, unless a good vernier dial is used, it is recommended that the 50- $\mu\text{fd.}$ capacitor be screwdriver-controlled from inside, and a two-plate midget condenser connected in parallel with it be used on the front panel. Only a $\mu\text{fd.}$ or two of variation is necessary to take care of any drift that will normally be encountered.

No commercially-available choke seems to be suitable without modifications for L_1 . The one used in the original unit was obtained by peeling turns from a small universal-wound coil of uncertain ancestry until it was right. This produces a satisfactory coil of small size, and a coil from an old i.f. transformer would probably do for a start. The method of adjustment is covered later. If desired, a suitable solenoid which will do the job can be constructed to the following specifications:

Wire size: 0.010 inch (No. 30 enamel)

No. of layers: $1\frac{3}{4}$

Number of turns: 75

Diameter: 1 inch

Length of winding: $\frac{3}{4}$ inch (bottom layer)

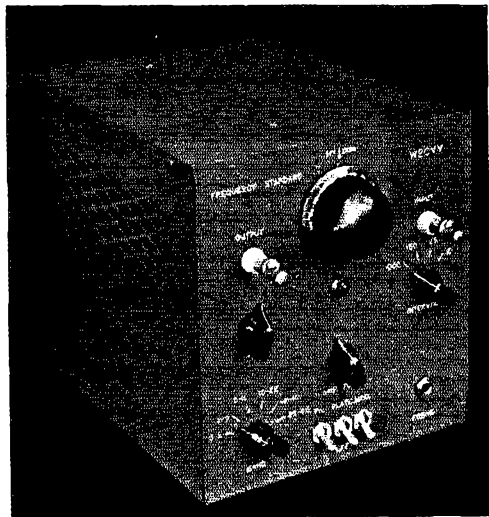

A complete precision frequency standard using a 1000-kc. crystal. The panel engravings explain the functions of the various controls. The tuning dial is used to set the padding condenser across the crystal so that the crystal is exactly on frequency.

* General Electric Company, Schenectady, N. Y.

This may require a little adjusting because of differences in stray capacitances but will not be far off. Its natural resonant frequency will be on the order of 1200-1400 kc. — its inductance about 165 microhenries.

Two separate multivibrators were used: one to step the original 1000 kc. down to 100 kc., and

the second to repeat the process with 10-ke. output. Neither of these multivibrators puts a harmonic on 3925 kc., which the writer particularly wanted to check, so resistors R_{12} and R_{23} and another point on the switch S_1 were provided to make the second multivibrator work on 25 kc.

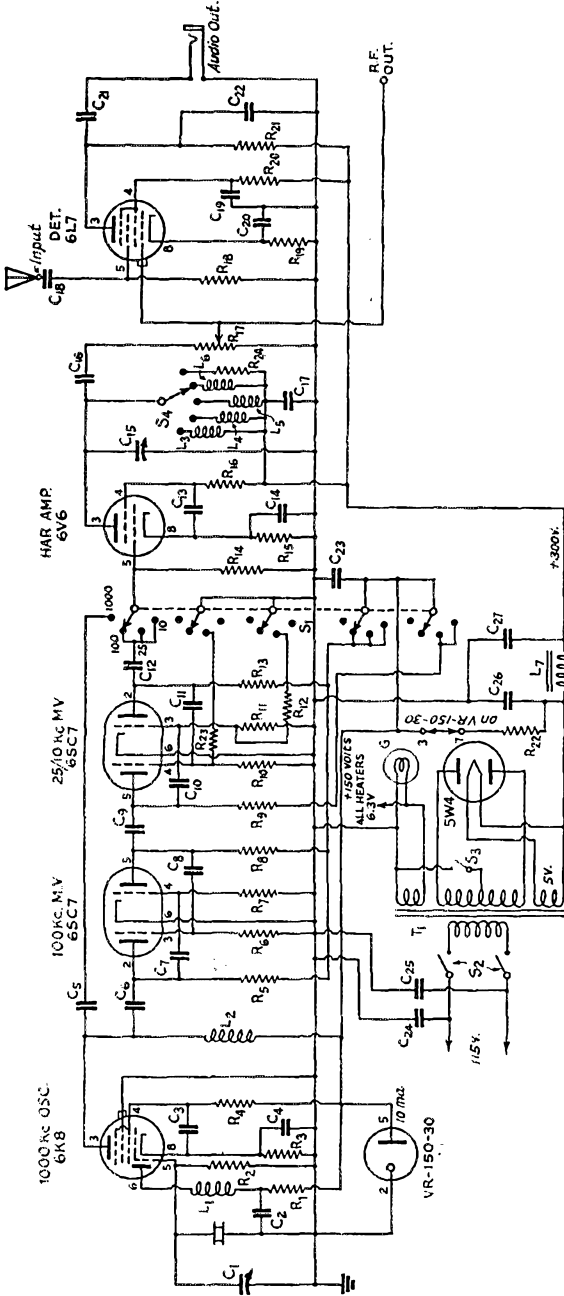

Fig. 1 — Circuit diagram of the frequency standard

- C1 — 50- μ fd. midget, or 50- μ fd. midget with 2- or 3- μ fd. midget in parallel. (See text.)
- C2, C13, C14, C24, C25 — 0.002- μ fd. mica.
- C3, C4, C15, C26, C27 — 400-volt paper.
- C5, C16 — 500- μ fd. mica.
- C6, C9 — 20- μ fd. mica.
- C7, C8 — 100- μ fd. mica.
- C10, C11 — 0.001- μ fd. mica.
- C12 — 30- μ fd. mica.
- C18 — 325- μ fd. variable. (A broad-cast tuning condenser will do.)
- C19, C22 — 0.006- μ fd. mica.
- C21 — 0.1- μ fd. 400-volt paper.
- C28, C29 — 8- μ fd. electrolytic.
- G — Indicator light.
- L1 — Oscillator plate coil. (See text.)
- L2 — 2.5-mh. r.f. choke (Millen 34100).
- L3 — 36 turns No. 22 enam., close-wound.
- L4 — 15 turns No. 22 enam., close-wound.
- L5 and L6 both wound on $\frac{3}{4}$ -inch polystyrene form as one continuous winding. A tap on the coil forms the common point.
- L5 — 7 turns No. 14, $\frac{1}{4}$ -inch diam. and spaced to occupy $\frac{1}{4}$ inch length.
- L6 — $3\frac{1}{2}$ turns No. 14, $\frac{3}{4}$ -inch diam. and spaced to occupy 1-inch length.
- L7 — 30-ma. 20-henry filter choke.
- R1 — 1000 ohms, 1-watt.
- R16 — 10,000 ohms, 10-watt.
- R17 — 25,000-ohm potentiometer.
- R19 — 500 ohms.
- R21 — 25,000 ohms, 1-watt.
- R22 — 6000 ohms, 10-watt.
- Resistors $\frac{1}{2}$ -watt unless otherwise designated.
- S1 — Interval switch. Yaxley 5-circuit 4-position rotary.
- S2 — D.p.s.t. line switch.
- S3 — S.p.s.t. plate switch.
- S4 — Band switch. Yaxley single-circuit 6-position rotary.
- T1 — Power transformer. Broad-cast receiver type. 70 to 80 ma.
- R5 — 10,000 ohms.
- R6, R7 — 40,000 ohms. (May be $\frac{1}{2}$ -watt fixed, or 50,000-ohm variable resistor. See text.)
- R11 — 62,000 ohms. (May be $\frac{1}{2}$ -watt fixed, or 100,000-ohm variable. See text.)
- R12, R23 — 15,000 ohms. (May be $\frac{1}{2}$ -watt fixed, or 25,000-ohm variable. See text.)
- R14, R18 — 0.1 megohm.
- R15 — 10,000 ohms.
- R3 — 1 meg.
- R8 — 300 ohms.
- R4, R9, R10, R13, R20 — 50,000 ohms.
- R5, R6 — 20,000 ohms.
- R7 — 40,000 ohms. (May be $\frac{1}{2}$ -watt fixed, or 50,000-ohm variable resistor. See text.)
- R11 — 62,000 ohms. (May be $\frac{1}{2}$ -watt fixed, or 100,000-ohm variable. See text.)
- R12, R23 — 15,000 ohms. (May be $\frac{1}{2}$ -watt fixed, or 25,000-ohm variable. See text.)
- R14, R18 — 0.1 megohm.

A single 1000-kc. crystal will give one all the points he needs for band-edge measurements when used with multivibrators and a harmonic amplifier. This is the story of how it is done and, incidentally, it will give you some new pointers on construction.

Incidentally, a multivibrator is not as complicated as many who are unfamiliar with its operation believe. It consists of nothing more or less than a two-stage resistance-coupled audio- or low radio-frequency amplifier, with its output fed back into its input. Anyone who has tried to get the undesired feedback out of a high-gain audio amplifier should not be surprised that such an arrangement produces oscillations. The natural oscillating or "motorboating" frequency of a multivibrator is determined by the resistance and capacitance in its coupling circuits, and to a certain extent by such other variables as plate and grid voltage, and input and output circuits.

The property of a multivibrator which makes it particularly useful is that, while it is an unstable oscillator by itself, when a small signal at its fundamental, one of its sub-harmonics, or one of its harmonics is coupled into it, it is controlled by this signal, and its frequency stability is then directly controlled by this incoming signal.

As normally used, the multivibrator is used to divide an original frequency, and is accordingly synchronized and controlled on one of its sub-harmonics. For convenience, the tenth is usually used, although others are equally feasible.

The Circuit

Referring to Fig. 1, the first multivibrator uses a 6SC7 tube. To obtain operation on 100 kc., the coupling capacitors, C_7 and C_8 , are 100 μfd . each, the two grid resistors, R_8 and R_7 , are 40,000 ohms each, and the two plate resistors, R_8 and R_9 , are 20,000 ohms each. The input and output coupling capacitors, C_8 and C_9 , are reduced to 20 μfd . each, to prevent their having too much effect on the natural frequency. These values were all determined experimentally, and variations in individual designs will probably require that one or more be changed as described later before proper operation will be obtained.

The second multivibrator is identical to the first, with the exceptions that different constants are used to obtain the different natural frequency, and two additional grid resistors, R_{12} and R_{23} , are arranged to be switched in parallel with R_{11} and R_{10} , respectively, for 25-kc. operation.

The interval switch, S_1 , is used to select the desired interval between calibrating signals. In the "1000-kc." position, plate voltage is removed from both multivibrators, and the 1000-kc. output of the oscillator is coupled directly to the grid of the harmonic amplifier.

In the "100-kc." position, plate voltage is applied to the 100-kc. multivibrator, causing it to produce a 100-kc. signal. At the same time plate voltage is also applied to one triode of the second multivibrator so that it acts as an amplifier. The 100-kc. signal is coupled from the first multivibrator through C_9 and C_{10} to the grid of this triode, where it is amplified, and is coupled through C_{12} and S_1 to the grid of the harmonic amplifier.

In the "10-kc." position, plate voltage is ap-

A view of the left-hand side of the vertical partition on which the components are mounted. The tubes, from left to right and from top to bottom, are VR-150-30, 5W4 rectifier, 6K8 oscillator, 6SC7 25-/10-kc. multivibrator, 6SC7 100-kc. multivibrator, 6L7 detector and 6V6 harmonic amplifier. The coils and resistor used in the plate circuit of the harmonic amplifier can be seen at the lower right-hand corner, near the band-selector switch.

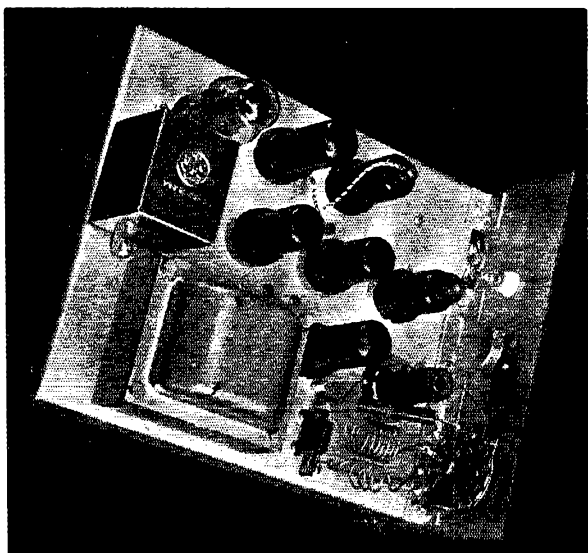

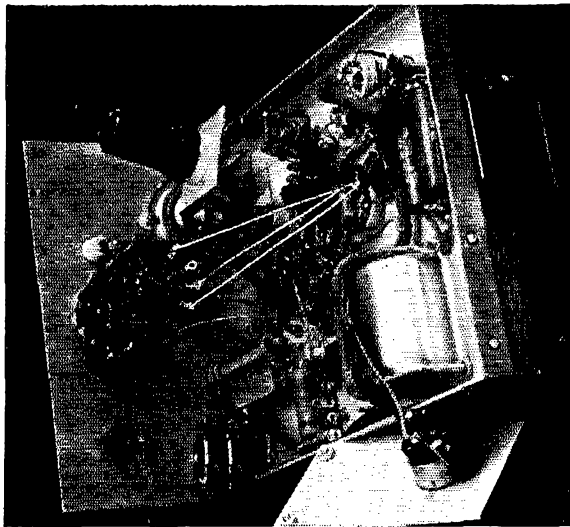

The right-hand side of the partition bears the brunt of the wiring. Note that the crystal holder (what appears to be a metal tube at the front top of the partition) is not mounted level but is tilted slightly, for reasons explained in the text. The detached plate carries the flush-mounting line socket for the 110-volt line plug.

plied to both multivibrators through a section of S_1 , and the signal is fed straight through. It appears, with a frequency of 10 kc., on the grid of the harmonic amplifier.

The "25-kc." position is practically identical to the "10-kc." one, except that the natural frequency of the second multivibrator is changed to 25 kc. by means of the resistors R_{12} and R_{23} , switched in by S_1 .

Whatever signal is coupled to the grid of the harmonic amplifier, as determined by the position of S_1 , is rich in harmonics. The plate circuit of the harmonic amplifier is tuned to the desired frequency by C_{15} and one of the coils L_3 - L_6 . The lowest frequency to which this circuit is designed to tune is approximately 2 Mc., and the resistor R_{24} is used, with C_{15} at minimum capacity, for frequencies below this. The coils as used in the original unit are capable of tuning to approximately 50 Mc. The tuning is quite broad and, at any one setting of C_{15} , harmonics can be heard over a large part of the spectrum.

R_{17} is an output potentiometer, its arm being connected to both the output terminal and the No. 1 grid of the detector (6L7). A sufficiently strong radio-frequency signal picked up on the "input" or antenna terminal is coupled to the No. 3 grid, where it will beat with the crystal-controlled signal and produce an audible beat in 'phones plugged into the output jack. Quite a strong signal is required for this, but it is very satisfactory for monitoring the frequency or keying of the local transmitter.

The power supply is built into the unit, and is quite conventional. A VR-150-30 gaseous voltage-regulator tube is used to control the plate voltage of the crystal oscillator and the multivibrators, in the interests of frequency stability.

The "B" switch, S_3 , is quite essential, since it permits the heaters to be warmed up ahead of

time and the plates turned on only while making a measurement.

The line by-pass capacitors, C_{24} and C_{25} , were found to be required to prevent a rough a.c. modulation which appeared on the note.

Construction

In working out the mechanical design of this unit, recent commercial practice was followed by using a vertical chassis. The accessibility obtained by this method of construction is much superior to that obtained with conventional design. It was found that vertical chassis construction is as well adapted to small table-mounted as to larger rack-mounted equipment.

The chassis and panel are constructed of 3/32-inch half-hard aluminum, although other materials would be entirely suitable. The chassis is bent up $\frac{1}{2}$ inch on top, bottom, and back, to provide rigidity. It is mounted vertically on the front panel by means of dural angle and machine screws. The tubes, which are of course mounted horizontally, all protrude from one side of the chassis. The VR-150-30 socket is mounted on spacers, since this tube is taller than the others, and a minimum amount of clearance is provided between the tops of the tubes and the side of the case. The power transformer is mounted on the same side of the chassis as the tubes, thus concentrating most of the heat-radiating elements on this one side, away from the crystal. Incidentally, the vertical chassis construction permits free circulation of air around the tubes, tending to keep their temperature down.

The crystal itself, which is sealed into a metal tube of the type used for 6J5 tubes, is mounted on the opposite side of the chassis from the tubes, in order that its temperature may remain as near ambient as possible. The extremely low tempera-

(Continued on page 76)

F.C.C. Orders and Interpretations

Notes for Your Guidance and Assistance

THE several recent orders of the F.C.C. putting emergency limitations upon amateur communication are here summarized for your information. We also report such interpretations as have been made from time to time, to assist you in complying and yet to allow you the widest radius of action.

It is to be noted that these limitations were effected by formal Commission orders, not by the amending of our regulations. Thus, as quickly as the international situation permits, the restrictions can be lifted by the simple repeal of the orders, with no need to wait upon another formal amendment.

Order No. 72

This order, effective June 4th, forbade the exchange of communications "with operators or radio stations of any foreign government or located in any foreign country," except that it does not apply between the continental United States and "United States citizens authorized to operate amateur radio stations in the Philippine Islands or the Canal Zone." Primary reason for the Commission's action was to prevent American amateurs from being used unwittingly as the instrumentality of alien agents. The Commission is willing to consider exceptions authorizing contacts with specified foreign stations, either by American amateurs generally or by specified American amateurs, when from genuinely patriotic motive we can urge such exception on the basis of national defense or the security of isolated citizens.

Examining now some of the details of this order, it is to be noted that there is no interruption of communication between continental United States and Hawaii, Alaska, Puerto Rico, the Virgin Islands, the small U. S. islands in the Pacific, and Antarctica. All of these territories and possessions may also freely intercommunicate. The only amateur stations in the Canal Zone are those authorized to government personnel — citizens — so we may work any such stations. With respect to the Philippines, contact is authorized with but a few of the existing KA stations, namely, those licensed to U. S. citizens. This of course covers the stations at military and naval posts, but a Filipino, while a national of the U. S., is not a citizen unless he has been naturalized. We may work any other KA known to be a U. S. citizen, and the F.C.C.'s law department tells us that there is no objection to inquiring of a KA station proffering a contact whether or not he is a U. S. citizen, provided the conversation does not go beyond that point if he is not. We shall list

in QST, as soon as possible, the KA stations that are known to be OK to QSO.

Order No. 73

This order, effective June 7th, prohibited portable and portable-mobile operation on frequencies below 30 Mc., except for the A.R.R.L. Field Day tests later in June, for which we were fortunately able to get exemption. U.h.f. operation above 56 Mc. is in no wise affected. This order arose from the feeling in F.C.C. that at such a time as this they must know precisely where every radio station is operating.

F.C.C. regulations provide for the application of portable procedure in two cases where an amateur has changed residence and moved his fixed station. One is the case of a permanent change where modification has been requested, and the other is the case of a temporary change (as so frequently occurs in summer) with intention to return to the original address. Many amateurs who were necessarily operating in "portable status" for one or the other of these reasons were perturbed over the Commission order. At the request of the League, the Commission on June 11th issued an interpretation stating that these routine provisions of the regulations are unaffected by the order, which is intended to apply only to the roving type of portable or portable-mobile. *Amateurs whose fixed-station equipment has been moved under either paragraph of Sec. 12.93 (old number 152.13) may therefore continue precisely as in the past, notifying the inspector and signing the portable designator.* In so notifying the inspector it is suggested that, to avoid confusion, you state that under the provisions of Sec. 12.93 you are applying portable procedure to your fixed station under such-and-such circumstances, such as modification of address or temporary move with intention to return.

Order No. 73A

Effective June 11th the Commission, at the urgent solicitation of the League, issued an amending order providing that No. 73 shall not apply to portable and portable-mobile stations "actually engaged in supplying or attempting to supply domestic communication in the public interest during a bona fide communications emergency when normal facilities are inadequate or non-existent." Thus we are entirely free to carry on the emergency communication that the Commission knows we alone can supply. Notice, however, that it must be a domestic emergency; you don't get to work DX just because you are trying to help out a Nicaraguan earthquake situa-

tion — hi! Notice, too, that the mere existence of an emergency does not entitle everyone to operate portable, but only those who are helping.

While the days of playing with portable apparatus just for fun are temporarily gone, we pointed out to the Commission that amateurs could not be expected to invest time and money in emergency equipment if they had no opportunity to test it, and that they could not be prepared to do a good job unless they could actually test it in the field and get out the "bugs." The amending order of June 11th therefore made another exception in favor of those "actually engaged in the domestic testing and developing of self-powered portable and portable-mobile equipment intended for use in domestic communications emergency, during the hours between sunrise and sunset, local time, on Saturdays and Sundays of each week, provided notice of such testing and developing operation shall have been given at least 48 hours in advance to the Federal Communications Commission Inspector in Charge of the district in which such operation is contemplated." This is not a completely happy outcome but it does serve the essentials, opening the daylight hours of the weekends when most of us have our leisure time. Notice that the exception is confined to self-powered emergency sets and that at least 48 hours' advance notice of such intention must be given, to permit any desirable notifications to local authorities. *The requirement of 48 hours' advance notice does not apply during emergencies*, but the usual requirement to give some advance notice in writing for portable operation below 14,400 kc. does exist even in an emergency, as it always has; but it is then only necessary to drop the notice in the mail before beginning operating.

Ten-meter portable-mobile intended for emergencies may be tested and developed weekends upon 48 hours' advance notice, and may be employed during emergencies without any notification whatever, but may not otherwise be used. Work above 56 Mc. remains entirely unimpeded.

Subtracting what we may do from the original terms of the order, it is useful to summarize what we may *not* do. We may not operate portables or mobiles from Monday to Friday, inclusive, not at any time between sunset and sunrise, unless the apparatus is for 56 Mc. and higher, or unless we are helping in an emergency. We may not operate portables below 30 Mc. nor 10-meter mobile rigs even during the daylight hours of Saturday and Sunday unless (1) the apparatus is self-powered, (2) the work is testing and developing looking to emergency-communicating ability, and (3) we have sent written notice to the Inspector at least 48 hours in advance.

Order No. 75

On June 18th the Commission adopted an order requiring all holders of operator licenses, both

commercial and amateur, to file a response under oath by August 15th to a questionnaire that is to be sent to every operator, and to furnish additional data and documents required therein. The same requirement is made of applications for new licenses and for renewal, except that it need not be submitted with a renewal application if such response has previously been filed.

Primary purpose of this order is to require positive proof of U. S. citizenship. You do not have to do anything about it until you hear from the Commission. They will send you the questionnaire by mail, together with full instructions. The form, which must be sworn to, requires data on place and date of birth, on what your citizenship is based, your military record, your absences from the country, and on the citizenship of your close relatives. Documentary evidence of citizenship must be attached. A passport-type photograph must be affixed to the form. There will also be enclosed a fingerprint form, on which you must have your fingerprints impressed in the presence of a municipal, state or federal official, and certified.

Documentary proof of citizenship may be difficult to acquire, and you would be well advised to commence work on the subject at once. If available, you must supply a certified copy of either public birth record or baptismal or other church record. If neither is available, the correspondence showing that it is not available must be submitted to F.C.C., and you may then rely upon a family record, hospital record, physician's statement or report of the Census Bureau. Only if none of the above is available, and that is established by correspondence, may you prove your case by the submission of two or more auxiliary documents, such as school records, passports, military discharge papers, affidavits of parents. All of this is explained in detail in instructions that will be received from the Commission.

In many cases, compliance with this order will be difficult and annoying in the highest degree, but compliance is mandatory, as every operator's license is subject to the orders of the Commission. At this writing, no consideration has been given special cases, and no exceptions are provided. Every operator is supposed to be a citizen and if any are found who are not citizens, obviously they should be weeded out. Actual proof has not been required in the past, and we suppose that at such a time as this we cannot object to being made to prove citizenship. In the case of the average amateur it should be simple to comply, since birth registration data should be available in the local City Hall. For information on possible interpretations, special rulings or extensions, it is suggested that you watch the transmissions of WIAW, which distributes all such news nightly.

— K. B. W.

Radio Direction Finding

Practical Dope on Loop Receiving Antennas

BY JAMES M. BRUNING,* W3EZ

Practically every A.R.R.L. convention has, as part of the program, a "treasure hunt", normally entered into by amateurs with portable receivers and some good guessing abilities. Not too much has been published in the past on accurate direction-finding systems, and that is why you should find this story a very interesting one. The Main Line Radio Club has made d.f. work its particular pet, and we are pleased to present a résumé of the club's findings after several years' experience with the game.

RADIO direction finding is a subject of increasingly greater importance in these days of commercial and military aircraft and marine travel. Its use in marine navigation has been of recognized value for many years. This phase of radio has been somewhat neglected by the majority of amateurs, probably because of unfamiliarity with the subject and a lack of knowledge of the fun, excitement and valuable training that can be had from even an elementary excursion into this fascinating branch of radio.

To foster the advancement of short-wave direction finding, and as a highly exciting summer activity, the Main Line Radio Club of suburban Philadelphia (Penna.) has, for many years, conducted annual "Hidden Transmitter Hunts." A radio-telegraph transmitter of about 100-watt power is hidden by a designated team somewhere within a radius of about twenty-five miles from a selected starting place. At an appointed time, the transmitter is put on the air and an automatic keying device sends an identifying signal and call letters of the portable station followed by a long dash. This signal is continuously repeated on the air for several hours, during which time the hunters attempt to locate the concealed transmitter. At the expiration of the allowed time, the automatic disc is removed and an operator manually transmits his location for the benefit of any unsuccessful teams. The equipment has been hidden in barns, houses, garages, airports, and even in a jewelry store! Following the arrival of all teams, the club members, along with their respective guests, congregate at some nearby refreshment place and spend a sociable evening dancing, eat-

ing, and talking (and explaining!) far into the night.

A series of ten hunts held throughout the summer usually comprises the official season. Points scored on the basis of elapsed time for each contestant, or on the order of their arrival, determine the season winner, who receives a worth-while award at a special "celebration dinner."

Competing teams must all start from the same location and locate the hidden transmitter through the use of portable direction-finding equipment carried in or mounted on their cars. Quite a varied, and sometimes weird, display of receiving equipment, loops and trick gadgets appears during each season. Good ideas or clever operating techniques are unashamedly copied by other teams in later hunts!

Some idea of the possible improvement in ability may be obtained from the following: Several years ago it was quite the rule for several hours to be consumed in finding a transmitter, regardless of its location. Winning teams now locate the hidden equipment in little over a half hour *including* the driving time! The taking of a radio bearing and its transfer to a map formerly took four to five minutes, whereas bearings are now logged and drawn in less than *one* minute. The accuracy of bearings has increased in similar proportion. Using conventional automobile maps, bearings previously triangulated within a one-inch map space. Bearings of today usually intersect right on the correct town! Rain once stopped all hunting but our equipment now functions equally well in wet or dry weather.



In the field with map and loop, W3FPP is all set for a bearing.

* Technical Chairman, Main Line Radio Club, 339 West Lancaster Avenue, Haverford, Pa.

This improvement in equipment and operating technique has been brought about by the constant search for new methods and better-working apparatus necessary to win against competition furnished by men who are more or less experts in this particular field. We feel the problems of *overland* direction finding have been largely conquered, and for any one who thinks such a task is an easy one we suggest that he try it under our conditions of actual competition. In a surprisingly large number of cases, results predicated upon known radio theory simply do not work out in practice. A complete study of the observed effects often allows one to find the "joker," but sometimes the joker is not in the deck.

To give those more or less uninitiated members of our fraternity an idea of the electrical and practical background of radio direction finding, the following story is dedicated. Commercial engineers are warned not to read further for fear of being shocked by some heresy that may not agree with Terman or Taylor!

Wave Propagation

At frequencies above 1500 kc. the ground-wave attenuates rapidly and is of little importance, except for transmission over very short distances. All waves, regardless of frequency, vary from time to time in their direction of travel. These variations have been observed on extremely long waves but are more severe as the wavelength decreases. Such variations are often caused by the phenomena of reflection and refraction of electromagnetic waves from or through banks of ionized layers of the atmosphere. As a result, the receiving equipment is influenced not only by the main wave, which we may consider as coming directly from the transmitter, but by many other waves travelling longer paths and converging at the receiver because of having been reflected or refracted by regions having such electrical characteristics as to produce a prism or lens action. Obviously, these several portions of the received signal will arrive at the receiver from various di-



W3CGM, the 1939 winner, checks the resonance of his loop.

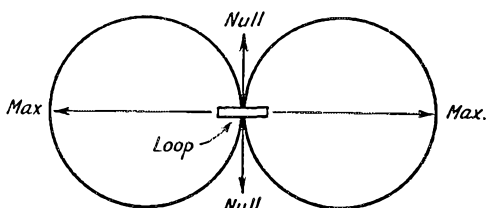

Fig. 1 — Directional characteristic of plain loop antenna.

rections and in various phases. Short-wave communication ordinarily depends upon the ability of the ionosphere to refract the high-frequency sky wave back to earth at the receiving point without excessive attenuation. As a result, the strength of the signal received from a distant transmitter depends on the transmitted frequency, conditions in the ionosphere, and the angle at which the transmitted waves enter the ionized regions.

Direction Finders

The fact that radio waves *normally* propagate away from the transmitter along a great-circle route can be utilized in direction finder or "d.f." work. A direction finder is a receiving device with which one can determine the travel line of radio waves coming from a distant station. Most practical d.f. systems make use of a loop antenna, which is essentially a large coil of any convenient shape, so mounted as to be easily rotatable. Such an antenna has the directional characteristic shown in Figure 1, as a result of phase or "time" differences between the voltages induced in the opposite vertical sides of the loop, depending on its orientation. The result is that the greatest pickup is obtained when the loop winding is in a line pointing to the transmitter. When the plane of the loop is perpendicular to the direction of travel of vertically-polarized waves, the voltages induced in the two side legs are of equal magnitude and the same phase and, being directed around the loop in opposite directions, cancel each other and result in zero response. As the plane of the loop is brought nearer to parallel with the direction of wave travel, the wave front reaches the two legs at slightly different times, causes a phase difference between voltages induced in the two legs and gives rise to a resultant voltage that acts through the loop. This resultant voltage is maximum when the plane of the loop is parallel to the direction along which the waves travel.

As a loop is rotated, the signals gradually drop from maximum to a null point which is usually well defined, and which is used to determine the unknown direction. A "d.f." set such as the above is termed "bi-lateral" and cannot distinguish between signals coming from a given direction or its reciprocal, since two distinct bearings differing about 180° can be found with such equipment.

By the addition of certain extra apparatus, to be explained later, a bi-lateral set can be converted to a "uni-lateral" d.f. — one which can determine the "sense" or absolute direction of the unknown station.

Loop Construction

Possibly the simplest and best form of loop for amateur use consists of a few turns of insulated wire wound within a thin copper or aluminum tube of an inch or so diameter. The tubing is shaped into either a square or round structure with an overall diameter of about eighteen inches. The loop proper is tuned to the desired frequency band by a small variable condenser. A pick-up link of one or more turns is placed within the shield so as to be near the loop coil. This link connects to a low-impedance twisted-pair transmission line and terminates on the doublet input terminals of the receiver. A means of turning the loop structure must be provided as well as a means for reading the rotation in terms of degrees. It is necessary that the shielding tube have a small insulating splice provided so that the metallic tube will not act as a "shorted turn". In addition, the shield is usually grounded to the car chassis and is also connected to the midpoint of the loop winding to provide electrostatic balance.

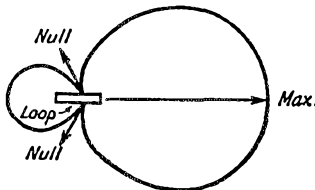
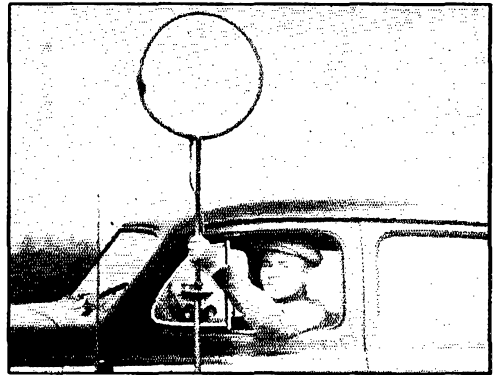

Fig. 2 — The loop characteristic modified by the introduction of some slight additional pickup from a vertical antenna.

Deviation is experienced in all d.f. work, and it is defined as the difference between the true bearing of a transmitter and its observed radio bearing. Many objects cause deviation, in addition to the effects of ionospheric refraction. Wire fences, steel bridges and buildings, even the automobile in which a d.f. set is installed, can distort the field pattern of the desired signal at the receiving point and give false readings. An automobile carrying a d.f. set gives the loop a pronounced tendency to align itself either fore-and-aft or broadsides to the car. For that reason the loop should be mounted symmetrically with respect to the car and at least higher than the highest part of the car. The accuracy of a bearing can be estimated from the kind of minimum bearings obtained. If a bearing has two sharp null points approximately 180° apart, the bearing can be considered accurate. If the minimum is broad, covering ten or more degrees, or if the "reciprocal 180-degree bearing" is not 180° from the first



It's going to be hard to hide that transmitter from W3DNZ.

null point, the true bearing cannot very well be estimated or interpolated, and the bearing is not to be trusted.

Maximum versus Minimum

Why do we use the minimum instead of maximum indication of a loop to determine the bearing? We do so because the percentage *change* in response with a small rotation of the loop is much greater in the vicinity of the loop's minimum than maximum, as an examination of the pattern in Fig. 1 shows. Add to this the fact that the human ear can distinguish changes in intensity more readily when the sound volume is low than when it is strong, and it is evident that a precision bearing can be obtained much more readily by using the minimum or null indication of a loop antenna.

Uni-Lateral Bearings

A simple loop antenna employed as described gives the bearing angle of the passing radio waves but leaves an uncertainty of 180° in the absolute direction of the transmitting station. The "sense" of the bearing can be determined by making use of a vertical antenna in conjunction with the loop. The polarity of the resultant voltage acting around the loop depends on the direction from which the waves arrive so that, if a small amount of pick-up from a non-directional vertical antenna is suitably coupled into the loop, the antenna action will cause one lobe of the loop pattern to be enlarged and the other to be dimin-

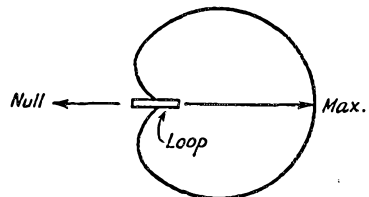

Fig. 3 — The cardioid pattern obtained when the pickup from the loop and antenna effects are equal.

ished as in Fig. 2. When the two forms of pick-up are of the same strength, the directional pattern becomes a cardioid as shown in Fig. 3. The procedure for direction finding is then to take a preliminary bearing by setting the loop for minimum response with the "sense" antenna disconnected. The uncertainty of 180° in bearing is then removed by rotating the loop 90° in a specified direction and coupling the sense antenna to the loop circuit. If the addition of the sense antenna increases the signal, the "sense" is one way, while reduction in signal indicates the opposite sense. These directions are established for the system by checking the apparatus against a known station when the direction finder is being installed.

The antenna used to obtain the sense of the bearing can be any convenient arrangement located near the loop and must be coupled so that the voltage induced in the loop circuit output will either add to or subtract from the resultant loop voltage. In certain commercial d.f. applications a rather large sense antenna is used and, since it therefore possesses directional qualities to a certain extent, it must be located far enough away from the loop not to distort the field pattern surrounding the loop. A simple arrangement is shown in Fig. 4. Here a resistance of several thousand ohms or higher is placed in series with the antenna to make the antenna current substantially in phase with the induced voltage and to a large extent independent of frequency. This current then passes through a coil inductively coupled to the receiver input. The amount of vertical antenna effect must not appreciably exceed the loop pickup, but at the same time it must be great enough to have a decided effect upon the directional characteristics of the loop itself.

Loop Errors and Their Elimination

Loop antenna bearings are accurate only when the loop is at a distance from metal objects, when the loop is electrostatically balanced to ground, and when down-coming horizontally-polarized waves are absent. Wires or metal structures intercept passing waves and produce re-radiation fields that affect a nearby loop. The resulting loop errors require that a correction curve be determined by calibrating the d.f. set.

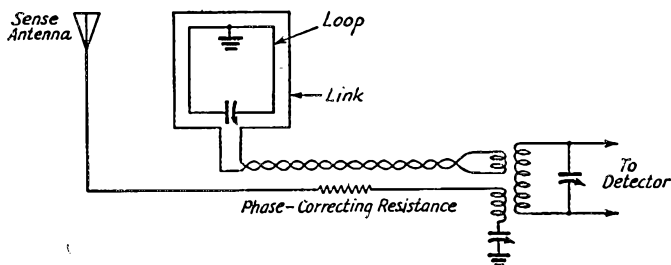

Fig. 4—A practical arrangement for obtaining "sense" of bearing.



W3FRY concentrates on a weak signal from the hidden transmitter.

The amount of correction needed will depend somewhat upon the operating frequency. A small amount of "vertical antenna action" is produced by loop unbalance and causes the angle between the two null positions to differ by less than 180° ; therefore, the presence of unbalance in a loop can be tested for by finding a null position and then rotating the loop 180° and noting whether or not a null is again obtained. It is helpful to enclose the loop in an electrostatic shield, such as a metal housing broken by an insulated bushing, as shown in Fig. 5. Such a shield insures that all parts of the loop will always have the same capacity to ground irrespective of the loop orientation or of neighboring objects. Finally, where maximum accuracy is required it is possible to compensate for residual unbalances by connecting the loop to a small balancing condenser as shown in Fig. 6. This introduces a controllable amount of compensating antenna effect. The proper adjustment of this balancing condenser is ob-

tained experimentally as the setting for which a loop rotation of 180° does not affect the null locations.

Night Effect

When horizontally-polarized downward-traveling waves are present (as at sunrise, sunset and during the night), the horizontal members of the loop have voltages induced in them that do not give a zero resultant voltage when the plane of the loop is perpendicular to the true bearing of the transmitter. This causes the minimum signal to occur at a false position, and in some cases make it impossible to obtain zero response at any loop position. Since horizontally-polarized downcoming waves are produced by the action of the ionosphere, the error is negligible near the transmitter where the sky wave is much weaker than the ground wave, but becomes of great importance as the distance is increased. When this type of error is present, the bearing of the waves as observed by the loop appears to vary continuously. At broadcast and lower frequencies, where loops are most commonly used, the sky wave is much stronger at night than in daytime, so that the error from downcoming sky waves is often termed "night effect". A similar effect occurs if the receiver picks up any energy directly, due to poor shielding, other than that picked up by the loop itself.

Compass Errors

True north is the direction of the north geographic pole. Unfortunately, the magnetic



W3BYL holds the umbrella while W3BRO takes a bearing.

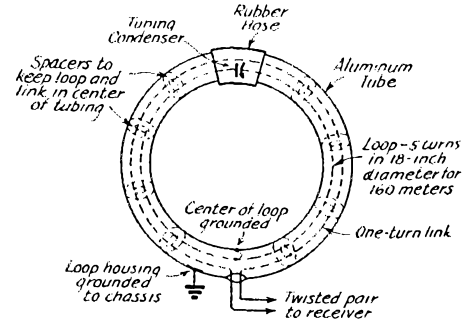

Fig. 5 — A sketch of the general constructional details of a loop enclosed in an electrostatic shield. The shield is broken, so as not to form a closed loop, and is held together by a short length of rubber hose.

compass rarely indicates true north. Instead, it points to the north *magnetic* pole which is located in Canada, northwest of Hudson Bay. Most maps are drawn on the basis of true north and, in order to plot compass readings on such a map, the "compass variation" or angle between magnetic and true north must be determined and marked on the map. Compass bearings can then be plotted in relation to this "magnetic meridian line" drawn on the chart. The compass variation is negligible over short distances, but if a map covers twenty or more miles the variation must be allowed for, usually by drawing several magnetic meridian "north" lines. When plotting on any one portion of the map, observed compass bearings are compared with the closest north line. The compass is subject also to *deviation* or error caused by nearby iron, steel, or electric circuits. The ordinary compass is of little value, for instance, when mounted in an automobile, unless expensive compensating apparatus is provided. Magnetic headphones also can cause considerable error, and the operator must not wear phones while bending over a compass to observe a bearing. The author some years ago made extensive compass checks on country and city roads and found that deviations of more than 45 degrees often occurred within a curb-line distance of one hundred feet! Such deviations are frequently caused by the proximity of below-surface iron pipes used for water and gas mains. So, when your compass points to north, don't believe it without further checks!

Reference-Point Bearings

Because of the compass errors so commonly encountered, the difficulty of translating loop angles into compass bearings and thence transferring the data to a map previously corrected for magnetic north, the necessity for allowing for any electrical errors inherent in any loop antenna system, etc., the author developed a system which, for want of a better name, is termed the

(Continued on page 88)

★ WHAT THE LEAGUE IS DOING ★

THE LEAGUE AT WASHINGTON

THE President and Secretary of the League are keeping in close touch with official Washington these days. They have had conversations with the highest-ranking officials in various branches of the government concerned with radio and have laid before them the offer of the Board of Directors of the full cooperation of amateur radio in any jobs that need to be done. They have also discussed in detail the imperative need in the national interest to maintain amateur radio, pointing out the loss to the nation if amateur radio should be unwisely hampered. We find all these agencies aware of the value of the amateur and currently satisfied with the amateur situation. Their policy is to restrict the practices that are palpably capable of causing trouble, then letting us go on. In that connection we have a couple of important suggestions:

1) We earnestly urge every 'phone amateur who values his operating rights to confine the use of his microphone to members of his immediate family and to licensed amateurs who at the time are in possession of their operator licenses. Beware of people who approach you and ask to talk over your station! And if they are strangers, turn them down cold.

2) We have heard of three hams who have been propositioned recently to provide communication for groups that meant no good. The time has come to stop trifling with this monkey business. If you are approached by the agent of a subversive group, you are asked to report the particulars immediately to the Federal Bureau of Investigation. F.B.I. does not centralize this work at Washington; they are all over the country; there may be a local office in your town. If not, communicate directly with their nearest division office in the following list:

Albany, N. Y., 707 National Savings Bank Bldg., 'phone 5-4595

Atlanta, 501 Healey Bldg., Walnut 3698

Baltimore, 800 Court Square, Plaza 6776

Birmingham, 320 Federal Bldg., 4-1877

Boston, 10 Post Office Square, Room 1016, Liberty 8470

Buffalo, 400 U. S. Court House, Cleveland 2030

Butte, 302 Federal Bldg., 2-4734

Charlotte, N. C., 914 Johnston Bldg., 3-4127

Chicago, 1900 Bankers' Bldg., Randolph 6226

Cincinnati, 637 U. S. Post Office & Court House, Cherry 7127

Cleveland, 1448 Standard Bldg., Prospect 2456

Dallas, 1200 Tower Petroleum Bldg., 2-9086

Denver, 518 Railway Exchange Bldg., Main 6241

Des Moines, 739 Insurance Exchange Bldg., 3-8998

Detroit, 911 Federal Bldg., Cadillac 2832

El Paso, 202 U. S. Court House, Main 1711

Grand Rapids, 715 Grand Rapids National Bank Bldg., 6-5337

Honolulu, 302 Dillingham Bldg., 4621

Huntington, W. Va., 700 West Virginia Bldg., 8928

Indianapolis, 323 Federal Bldg., Riley 5416

Juneau, Alaska, 515 Federal and Territorial Bldg., 618

Kansas City, Mo., 707 U. S. Court House, Victor 3113

Knoxville, 407 Hamilton National Bank Bldg., 3-7928

Little Rock, 500 Rector Bldg., 2-3158

Los Angeles, 527 U. S. Post Office & Court House, Michigan 0761

Louisville, 633 Federal Bldg., Jackson 5139

Memphis, 2401 Sterick Bldg., 8-4236

Miami, 1300 Biscayne Bldg., 3-5558

Milwaukee, 1021 Bankers' Bldg., Daly 3431

Newark, 936 Raymond-Commerce Bldg., Market 2-5511

New Orleans, 1308 Masonic Temple, Raymond 9354

New York City, 607 U. S. Court House, Foley Square, Rector 2-3520

Oklahoma City, 940 First National Bldg., 2-8186

Omaha, 629 First National Bank Bldg., Atlantic 8644

Philadelphia, 4060 U. S. Court House, Walnut 0555

Phoenix, 307 W. C. Ellis Bldg., 4-5766

Pittsburgh, 620 New Federal Bldg., Grant 0800

Portland, 411 U. S. Court House, Atwater 6171

Richmond, 601 Richmond Trust Bldg., 3-0169

St. Louis, 423 U. S. Court House & Custom House, Garfield 0360

St. Paul, 404 New York Bldg., Garfield 7509

Salt Lake City, 301 Continental Bank Bldg., Wasatch 1797

San Antonio, 478 Federal Bldg., Fannin 8052

San Diego, 728 San Diego Trust & Savings Bank Bldg., Main 3044

San Francisco, 111 Sutter, Room 1729, Exbrook 2679

Savannah, 305 Realty Bldg., 3-3054

Seattle, 800 Joseph Vance Bldg., Main 0460

Sioux Falls, S. D., 400 Northwest Security National Bank Bldg., 2385

Springfield, Ill., 1107 Illinois Bldg., 2-9675

Washington, 2266 U. S. Department of Justice, National 5303

By the way, there is nothing stirring about getting a repeal of the rule requiring the signing of the log by all people who speak over the microphone of a 'phone station. Maybe later, but not now.

This, also by the way, is no time for us to make nuisances of ourselves at F.C.C. or at the local inspectors' offices by asking dizzy questions. More than at any other time, A.R.R.L. headquarters is in touch with the situation and able to give you precise advice. Lay off the F.C.C., let Hq. front for you; ask us and we'll give you the cold dope.

See the article elsewhere in this issue on recent orders and rulings of F.C.C. in the current emergency.

RECRUITING

IN Washington we found attractive opportunities for amateurs being offered by the Army and the Navy. There will be a big recruiting effort under way soon. The Navy wants to make a big expansion in the N.C.R., needing both radiomen and signalmen, and has some interesting in-

formation to present about training opportunities. Watch the N.C.R. page in *QST*. Recruiting for the expanded Regular Army began July 1st, and we found needs for hundreds of operators in the various arms of the established service. As time goes on, we'll hear more about these things. Suffice it to say now that it's not a bad idea for an amateur to have an interesting berth lined up for himself . . . just in case.

POLL POSTPONED

MEMBERS of the League will remember that the Board, at its meeting last May, voted that a poll of amateur opinion should be taken in the August issue of *QST* on the desirability of proposing to the government that the 4-Mc. and 14-Mc. 'phone assignments be doubled.

All writing these days is filled with references to the rapidity with which this world of ours is changing. Amateur radio is not apart and exempt from these changes. Because of the new emphasis upon the national-defense value of amateur radio, the Board of Directors has reconsidered its original action on the 'phone question and has decided that it would not be in the best interests of amateur radio to propose at this time a widening of 'phone allocations, nor in the national interest. They have therefore postponed indefinitely the taking of the poll of amateur opinion on the question. This decision is subject, however, to the right of any director to raise the question anew at any time, and it is probable that it will be reexamined as soon as the international situation is sufficiently encouraging.

SPECIAL ELECTION NOTICE

To all A.R.R.L. members of the Southwestern Division:

YOU are hereby notified that a special election is about to be held in the Southwestern Division to elect a director to fill the vacancy left by the resignation of Chas. E. Blalack, W6GG, to become vice-president of the League. The election will be for the unexpired remainder of the 1939-1940 term, plus the next regular term of two years, 1941-1942, as provided in By-Law 24.

If more than one eligible candidate is named, voting will take place during the month of September, 1940, on ballots that will be mailed from the headquarters office in late August.

Nomination is by petition. Nominating petitions are hereby solicited. Your attention is invited to the pertinent portions of the Constitution and By-Laws of the League, a copy of which will be mailed any member upon request. Ten or more A.R.R.L. members residing in the Southwestern Division may join in nominating any eligible West Gulf member of the League as a candidate. The following form is suggested:

Executive Committee

**The American Radio Relay League
West Hartford, Conn.**

We the undersigned members of the Southwestern Division, hereby nominate, W6., of, as a candidate for director from this division for the remainder of 1940 and for the next following full term of 1941-1942.

(Signatures and addresses)

The signers must be League members in good standing. The nominee must have been both a member of the League and a licensed radio amateur operator for a continuous term of at least four years immediately preceding receipt by the Secretary of his petition of nomination, except that a lapse of not to exceed ninety days in the renewal of the operator's license and a lapse of not to exceed thirty days in the renewal of membership in the League, at any expiration of either during the four-year period, will not disqualify the candidate. He must be without commercial radio connections: he may not be commercially engaged in the manufacture, selling or renting of radio apparatus normally capable of being used in radio communication or experimentation, nor commercially engaged in the publication of radio literature intended, in whole or part, for consumption by licensed radio amateurs. Further details concerning eligibility are given in By-Law 12. His complete name and address, and call, should be stated. All petitions must be filed at the headquarters office of the League in West Hartford, Conn., by noon E.S.T. of the 20th day of August, 1940. No member shall append his signature to more than one petition. To be valid, a petition must have the signatures of at least ten members in good standing. Petitioners are urged to have an ample number of signatures, since nominators are frequently found not to be members in good standing.

Balloting will close at noon, October 1, 1940, and the successful candidate will take office as soon as the result can be determined.

This election constitutes an important part of the machinery of self-government in A.R.R.L., and members are urged to take the initiative and file nominating petitions immediately.

For the Board of Directors:

K. B. WARNER,
Secretary

June 4, 1940

EXECUTIVE COMMITTEE ACTIONS

ONE of the acts of the recent Board meeting was to ratify the actions of the A.R.R.L. Executive Committee in the intervening Board year. These actions are reported below, by order of the Board for your information:

At meeting No. 157, October 21, 1939, the committee, pursuant to the recommendation of the Commu-

tions Manager, declared the office of Section Communications Manager of West Virginia vacant, under the terms and provisions of By-Law 11 and directed that another election be held as provided elsewhere in the by-laws to fill the office. Affiliation was granted 16 clubs. Authorization was granted for the holding of 9 official A.R.R.L. conventions.

At meeting No. 158, November 1, 1939, the committee canvassed the balloting in the 1939 elections for director and alternate director in the 1939 elections, and took actions and made findings as already reported at page 24 of *QST* for December last. There was no further business.

At meeting No. 159, December 20, 1939, the committee canvassed the balloting in the 1939 elections for director and alternate director and certified the election of the successful candidates, as reported in detail at page 26 of *QST* for February last. The vote of the A.R.R.L. as a member society of the International Amateur Radio Union was cast in favor of admitting to membership the Burma Amateur Radio Society and the Lietuvos Trumpuju Bangu Radio Megeju Draugija (Lithuania). Approval was granted the holding of 4 division conventions. Assistant Secretary Arthur L. Budlong was directed to represent the League at the Second Inter-American Radio Conference at Santiago.

At meeting No. 160, March 1, 1940, the committee ordered the listing of 5 nominations on special ballots to choose an alternate director of the West Gulf Division. Approval was granted the holding of 6 conventions. Four clubs were affiliated. The League agreed to the admission to the I.A.R.U. of the Manchoukou Amateur Radio League and the Radio Club Argentino.

At meeting No. 161, April 1, 1940, the committee counted the ballots in the special West Gulf election and certified the winner, as reported at page 19 of May *QST*. Affiliation was granted five clubs.

K. B. WARNER,
Secretary

FINANCIAL STATEMENT

FOR the first quarter of the year, generally the best from the business standpoint, the League made a substantial gain from its operations before disbursements against Board appropriations, and only a little less than in the same quarter last year. At the direction of the Board, the operating statement is published for your information:

STATEMENT OF REVENUE AND EXPENSES, EXCLUSIVE OF EXPENDITURES CHARGED TO APPROPRIATIONS, FOR THE THREE MONTHS ENDED MARCH 31, 1940

REVENUES	
Membership dues	\$16,827.43
Advertising sales, <i>QST</i>	23,520.52
Advertising sales, Handbook	4,084.00
Booklet advertising sales	600.00
Newsdealer sales, <i>QST</i>	11,634.64
Handbook sales	13,685.83
Spanish edition Handbook revenues	24.75
Booklet sales	4,491.24
Calculator sales	361.10
Membership supplies sales	2,728.13
Interest earned	414.82
Cash discounts received	422.50
Bad debts recovered	149.17
	<u>\$78,924.13</u>
<i>Deduct:</i>	
Returns and allowances	\$ 3,461.04
Cash discounts allowed	568.22
Exchange and collection charges	145.03
Increase in reserve for newsdealer returns of <i>QST</i>	16.83
	<u>4,191.12</u>
Net Revenues	\$74,733.01

EXPENSES

Publication expenses, <i>QST</i>	\$17,500.13
Publication expenses, Handbook	9,486.40
Publication expenses, booklets	1,774.92
Publication expenses, calculators	310.40
Salaries	24,801.02
Membership supplies expenses	1,690.62
Postage	1,467.56
Office supplies and printing	1,197.57
Travel expenses, business	657.24
Travel expenses, contact	22.90
<i>QST</i> forwarding expenses	1,318.28
Telephone and telegraph	556.62
General expenses	1,216.06
Insurance	425.06
Rent, light and heat	1,166.35
General Counsel expenses	250.00
Communications Dept. field expenses	113.27
Headquarters Station expenses	264.10
Alterations and repairs expenses	240.26
Bad debts charged off	7.00
Provisions for depreciation of:	
Furniture and equipment	302.33
Headquarters Station	448.88

Total Expenses 65,216.97

Net Gain before expenditures against appropriations \$ 9,516.04

LEAGUE NOTES

MR. BLALACK having resigned as Southwestern Division director to become the vice-president, you will notice that nominations are being solicited for an election to choose a new Southwestern director, to take office October 1st. In the meanwhile, Alternate Director John E. Bickel, W6BKY, of Whittier, California, becomes the acting director.

President Bailey has appointed Directors Glasscock (chairman), Caveness and Martin to constitute the Membership Committee established by the Board at its recent meeting for the purpose of building up League membership.

NEW 112-MC. RECORDS!

LATE reports from California indicate that almost anything is apt to happen on 112 Mc. these days. During the A.R.R.L. Field Day, June 23rd, W6QZA/6 operating from a location six miles north of Mt. Santa Ynez (spot used by W6BCX in recent 200-mile record with W6OIN) contacted W6BKZ/6 on Mt. Soledad, near San Diego, a distance of 206 miles. This was followed by a contact with W6MKS (home station), Mission Beach, San Diego, a 213-mile hop.

On July 4th, W6BJI/6 operating from a plane flying near Tulare, Cal., worked W6KIN/6 on Mt. St. Helena. This is one for the gang to shoot at—255 miles! Next??

W5CXH/6 Wins 1939 Maxim Award

DAWKINS ESPY, W5CXH/6, was named the 1939 winner of the Maxim Memorial Trophy Award, which goes annually to the young amateur under 21 who has made the most outstanding record for the year in amateur radio. The selection was made from nominations by various S.C.M.'s of the outstanding candidates from their Sections.

The award consists of a bronze replica of the Wouff Hong given by Mrs. John G. Lee, daughter of Mr. Maxim, and the sum of one hundred dollars in cash, contributed jointly by Mrs. Lee and Mr. Hiram Hamilton Maxim, his son.

Although now resident in California, nomination of the 1939 winner was made from the Louisiana Section. The fifth district call, under which the outstanding work that led to his selection was accomplished, is still retained.

Dawkins Espy was born in Temple, Texas, on May 20, 1919. In the intervening time he has lived at various other points in Texas, as well as New Orleans (where he attended Tulane University) and Pasadena (where he is currently graduating in E.E. from California Institute of Technology). It was in Taylor, Texas, at the age of 13, that he received his first ticket. The first Class C in 1932 was succeeded by a Class B the next summer and Class A in 1935.

His early amateur career reads much like that of a thousand other young hams. The principal difference was that he began a little earlier and moved a little faster. By the time he finished high school and the family moved to Dallas in 1935, the preliminary self-excited rigs had given way to a 53-46-46-46 pp combination feeding a Johnson Q, 160 meters gave way to 20, and the DX bug stepped in.

While in Dallas (and, incidentally, attending Southern Methodist University) a group of the lads rebuilt the school station W5YF into a 500-watt outfit, and W5CXH rigged a radio remote control system that enabled him to work the school rig from his home, four blocks away. There was one day he was merrily working along, monitoring W5YF on twenty while he talked, of course, when suddenly the carrier went off. He never will erase the vision he had then of the school's 100TH's melting away, drop by drop, to nothing. . . .

It was after the family moved to New Orleans that W5CXH really went to town, though. There Dawkins Espy acquired just about every appointment and recognition available to an amateur. He won the state certificate for 'phone in the 1938 S.S., placed high in several other contests, was second only to W1AW in a check on O.B.S. coverage, ranked high on "Radio's" DX Honor Roll, experimented with antennas

and wrote articles about them, organized and was first president of the Tulane University Radio Club, and maintained regular activity on all bands from 5 through 160 with a 500-watt rig.

At the same time he was an honor student, in addition to dramatic work (the lead in one play, supporting parts in others) and writing for the college newspaper. In fact his extra-curricular work (meaning other than school or hamming!) throughout his career has been exceptional. In high school he played in the band, acted in Little Theatre plays, sang in the glee club, wrote on the newspaper. At SMU he played drums in the swing band (code helped him learn the drums, he says) and did glee club and newspaper work. At Cal tech the routine has been about the same, including a job on the staff of the annual and feature editor of the paper. His other hobbies are music, tennis and social life.

Not all of his radio life has been as an amateur. He has announced over five broadcast stations either regularly or intermittently, as well as over the NBC Red, Mutual and Don Lee networks. Such jobs as these, soda jerking (he once broke the store record by selling 35 cases of soda pop and received a two-bit bonus) and theatre ushering during high school days, varied by fixing radio sets in summer, took up such of his time as remained. In Dallas he also worked as a statistician (slide rule, Monroe calculator and comp-

(Continued on page 66)

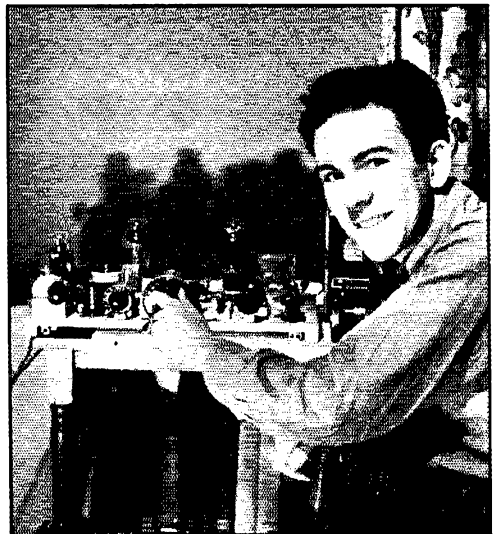

Dawkins Espy, W5CXH/6, Maxim Award Winner, shown with the 42-6L6-6L6 transmitter operated jointly with W6LHN in portable status.

The Fixed "Rotary" Beam Antenna

Variable Directivity With Fixed Antennas

BY ARTHUR H. LYNCH,* W2DKJ

IT ALL came about in the following manner. Our good friend, W2BKX, bought himself a house in Garden City, L. I., and restrictions regarding antennas are just a little bit tough in that town. George, who had been doing some excellent work with low power on 10 meters from his location on the roof of a lofty apartment in New York City, wanted to duplicate the performance in his new home. Lacking the height of his old location, we knew it would be necessary to go to some form of beam. The usual "hay rack," suitable for a three- or four-element horizontal rotary, was out of the question.

Whenever occasions like this arise we can't avoid remembering the shock we all got from the performance of the vertical 20-meter "pitchfork" antenna that was used at W2USA for so long, before the full-wave vertical rotary was erected. The former, which was the same as the antenna of Fig. 1A, was set right on the roof of the building. The roof was made of metallized roofing paper, and it furnished a very effective counterpoise. The beam, made of Premax alum-

inum units, was set up along an east-west line, and it gave us a grand signal in those directions, but we were surprised to find that the beam was not too sharp and that we were getting out in nearly all directions except at exactly right angles to a line through the elements.

That experience, coupled with the reports of others who have tried the three-vertical system¹ for securing transmission in all directions, led us to the conclusion that more might be accomplished with the method than had been considered previously. Instead of confining the beam to single-band operation we decided, in George's case, to try the same arrangement on all the bands which he would desire to work. Since the lowest-frequency band he uses is 28 Mc., the 10-meter band was used as the starting point for calculations. The use of tuned lines was dictated by the multi-band operation, but this has the advantage that the system can even be used on the next lower frequency band with, of course, some compromise in performance. However, it should be remembered that we are attempting to get the most out of the least and, while it is recognized that it is possible to design an antenna with the same number of elements which will do a better job in any one direction and on any one band, we believe that the many uses to which this system can be put warrants its consideration by anyone with limited antenna space.

The pitchfork antenna has, of course, a null along the line at right angles to the plane of the elements. This null can be overcome by using a third element as shown in Fig. 1B. By selecting the proper pair of elements, the signal can be radiated most effectively in any desired direction while still retaining the gain of the system. Naturally, either pair of elements can be used with equal effectiveness along a line making an angle of 45° with the line of the plane of the elements, but in any other direction a particular pair will be more effective.

If room is available for the erection of two separate beams a half wavelength or more apart and at right angles to each other, it would be well worthwhile, and the directional pattern would be nearer the pure theoretical one than is possible with the compromise system using three elements. Many of the houses in the larger cities have roof space of 25 by 40 feet or more, which is plenty of room for the use of two pitchfork antennas, as

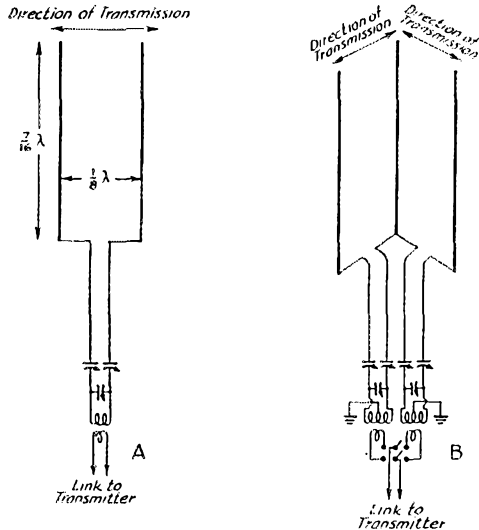
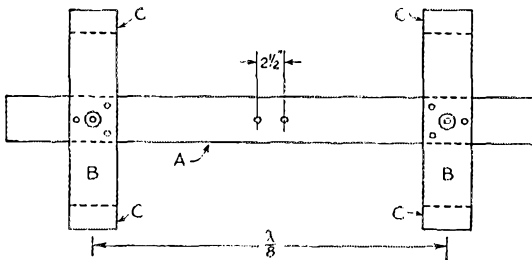

Fig. 1 — The fundamental "pitchfork" antenna system, such as is used at W2USA, is shown at A. Two pitchfork antennas can be combined, as at B, to give coverage in directions along two lines at right angles to each other. The elements are vertical in both cases.

¹ Lynch, "Feeding Vertical Antennas," QST, Jan., 1939.

shown in Fig. 2. When less space is available, it is necessary to go to the system shown in Fig. 1B.

In W2BKK's case it was necessary to use the compact system using three elements (Fig. 1B). Since the mechanical arrangement used on that job may be of help to others, it is given in more than ordinary detail later in this story. At first, consideration was given to the possibility of using a single antenna coil for each band and placing the antenna relay at the ends of the four lead-in wires, using link coupling to the antenna coil from the final tank and tuning the feed line with two series condensers and a third condenser in parallel. However, the final arrangement shown in Fig. 2C is very much more effective and easy to control, although it requires a bit more apparatus. In addition to providing suitable operation on any one band it allows the use of both antennas at the same time, for general coverage use when calling CQ.



For convenience, the two transmission lines are carried by the same separators. Old-fashioned cage antenna spreaders (which are still available in some radio stores) can be used, or curtain rings of celluloid, bakelite or well-varnished wood can be drilled to take the wires.

Whether the triangular set-up with three vertical elements or the two spaced pitchfork antennas are used has no bearing on the feed system or the tuning of the two antennas and, for this reason, the two cases have not been treated separately. When two separate pitchforks

Although the antenna systems described in this story are not exactly brand new, many of the ideas regarding installation and operation are, and you're bound to garner food for thought from these pages. The amateur with a lack of roof space will find it particularly to his liking.

are to be used on only one band, a quarter-wave matching section and any type of non-resonant line is probably the best method of feed — the tuned line is described in this case because we were interested in multi-band operation.

Mechanical Details

Where two elements are to be used in a single pitchfork set-up, which is all that is required in many locations, it may be well worthwhile to

Fig. 3 — Plan view of the supporting framework of the 14 Mc. pitchfork antenna at W2USA. The members are made of 3-inch by 10-inch stock; A is 10 feet long, B is 4 feet long, and C is 5 inches long. For 28 Mc., the members can be 2-inch by 4-inch stock, with A 6 feet long, B 2 feet long, and C 4 inches long. In either case, the supports are held fast by sandbags laid on them.

take a page from the book of construction of W2USA and use the simple framework shown in Fig. 3. If two separate pairs of verticals are used, two similar frames can be used. This form of construction makes the use of nails, lag-bolts or other fastening directly to the roof unnecessary. Sand bags will do very well for anchors. If a coarse bag is used, it will be found advisable to use coarse sand. In some instances, we have found it desirable to add a little cement, so that the bags will take the form of the supports and harden in that shape.

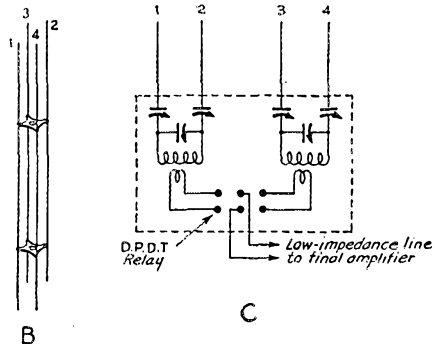
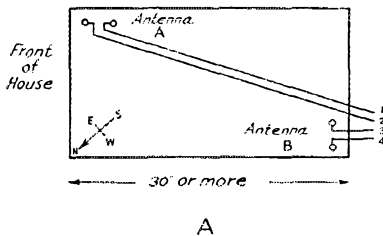

Fig. 2 — If room is available, two pitchfork antennas can provide good coverage by separating them on the house-top, as shown at A. Suggested construction of the feed line is illustrated at B, and the antenna coupling detail is shown at C.

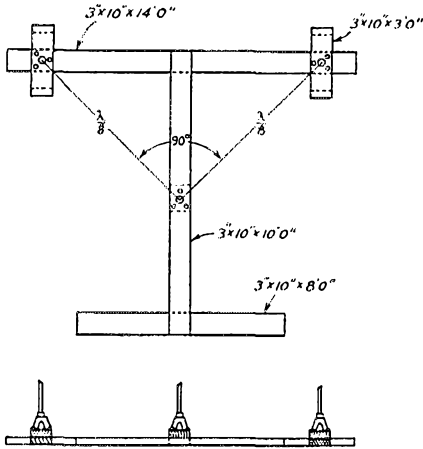

Fig. 4 — Plan view of the supporting platform for a three-element 14-Mc. fixed "rotary" beam set on a flat roof. The frame can be held in place by sandbags.

Where three verticals are to be used to provide the "rotary" effect and they are to be set up on a flat roof, the layout shown in Fig. 4 will be found desirable. Where 20 meters is the "fundamental" frequency of the system, the vertical elements will be approximately 29 feet high, and the supporting structure should be reasonably heavy. Planks of warp-free, well-dried, solid wood, 3 inches thick and 10 inches wide, are suitable for this use. The lengths are indicated in the drawing.

Where 10 meters is to be the lowest fundamental frequency, the vertical elements will be of lighter material, less than 15 feet high and only 4 feet 4 inches apart. For that reason regular 2

by 4 stock, half the lengths indicated in Fig. 3, will do very nicely on 28 Mc. It will be noted that plenty of room has been provided for the use of sandbags, since their liberal use may be warranted if the array is going to be subjected to high winds. The blocks at the ends of the small members are made of the same lumber which is used for the other members and provide equalization for those portions of the structure which are above roof level.

Hinges

Where we have a flat roof to deal with, the problem of the fixed "rotary" beam, except for the manner of running the transmission lines away from the structure, is relatively easy. However, where we have to set one of the three vertical assemblies on a peaked roof, we have a horse of another color. In the accompanying drawings, Figs. 5 and 6, two alternative methods are shown. In the side elevation, it can be seen how the weight of the assembly is distributed and how the outside ends of the cross member are supported by the roof.

Most of us are not sufficiently clever with carpenter's tools to make such a structure without having the joints badly askew. It is really surprising to find what a great help strap hinges can be in such circumstances. A quarter of an inch here or there or a badly cut angle on the end of a supporting strut would ordinarily throw the whole beam out of kilter, while hinges, used as indicated in the top view, permit us to do the trick quite easily. Before attaching the hinges to the various members, we should be sure to place them so that they will ride over the centers of the roof studs, where the weight will be carried

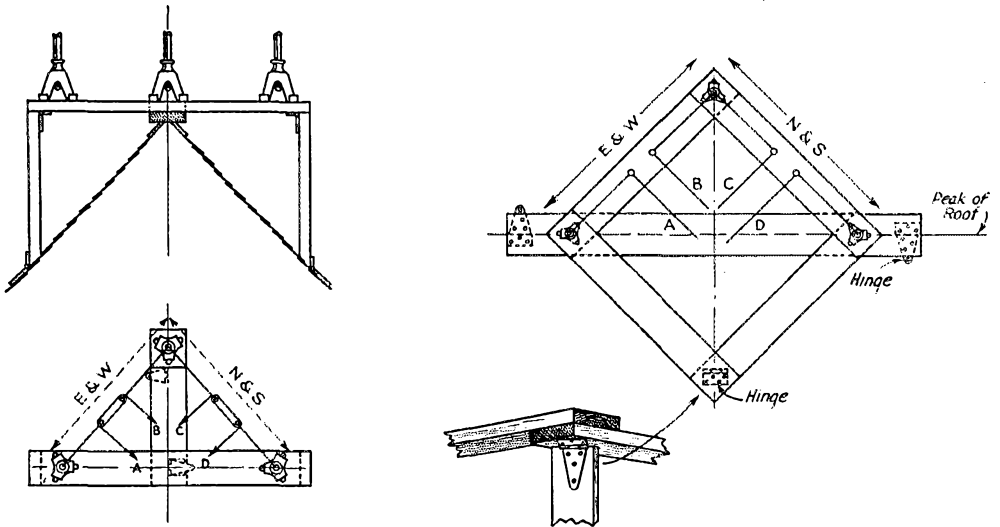

Fig. 5. — Two different methods for mounting the three-element fixed "rotary" on the peak of a roof. The use of hinges offsets any minor lack of carpentry skill.

without the possibility of punching a hole through the shingles or other roofing material. Another important advantage resulting from the use of hinges for this purpose is that it is difficult to make screws or bolts hold when we put them through one surface into the butt-end of another member, while using the hinges makes it possible to set the screws into side surfaces at all times, with better distribution of the stresses and providing greater strength as well as ease of assembly.

The assembly which we designed for use at W2BKX's new location is a simple square made of two by four stock. It wasn't the easiest thing in the world to set it up, because the house doesn't aim just right to get the proper directions for the beam without putting the supporting frame at a cock-eyed angle with relation to the roof lines. Then, too, the roof is slate (and, besides, it's George's *new* house), so we couldn't go banging nails here and there, as we have been accused of doing on other occasions. (The story is much exaggerated and we have not done any such thing. The bedroom ceiling fell down as the result of what we know was a poor roofing job, but which we can never prove was not the direct result of our excursions about the roof.)

Fig. 6 gives the details of the assembly, and it will be seen that we have again gone very strongly for the use of hinges. Even a poor carpenter can do a fairly respectable job of setting up such an assembly by using hinges generously and a spirit-level frequently. The 6-foot planks of 2 by 6 were first laid side by side along the peak of the roof, after they had been held together by a couple of hinges. That gave us the support for most of the weight and the rest was relatively easy. More hinges, attached to the ends of a pair of 2 by 4's which were in turn attached to the outside west wall of the house, gave us the bracing for the ends, and other hinges held the remainder of the framework to the two long planks. The sandbag draped over the east end of the whole job goes a long way toward holding things under control, even in a high wind.

In this case, the matter of bringing the transmission lines down has been made relatively simple because they drop in a straight line to a point outside the radio room window. Insulators, suitably disposed along the small cross strut give the lines a good start. The feed line is made up

Fig. 6—The framework used to support the three-element 29-Mc. antenna at W2BKX. The small side view more clearly shows how the hinges simplify construction.

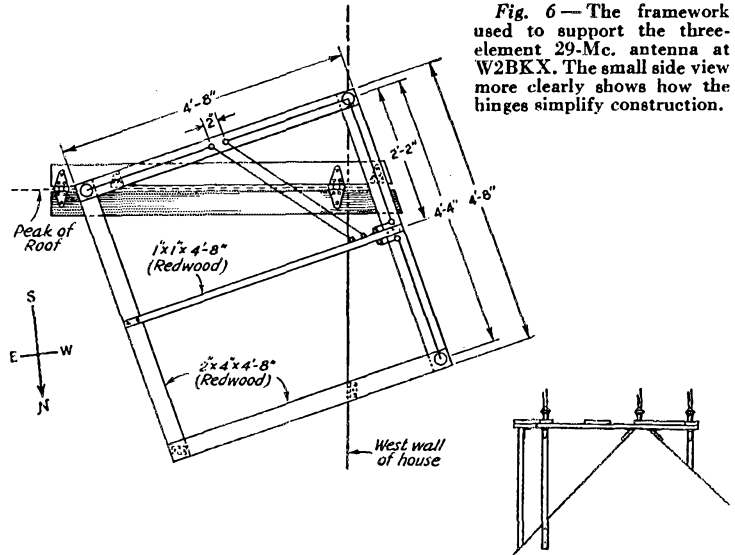

as previously described (Fig. 2-B), and is run down the side of the house. A bracket outside the window supports the other end of the line.

The Counterpoise

Reference has been made to the effectiveness of beams of this nature being improved when it is possible for us to erect them adjacent to flat metal roofs, where the roofing acts as a counterpoise. However, very much the same effect can be had, even when we are located in a frame house having a shingle or other form of non-metallic roof. If it is possible to get into the attic, it is only necessary to procure some metallized insulation paper, which carries the trade name "Reynold's Metallation," and tack it up on the rafters. It comes in two kinds. One has metal on only one side and the other type has aluminum foil on both sides. We "got it wholesale" so nothing was too good and, instead of providing ourselves with the usual size counterpoise, we covered the whole inside of the attic, using the bi-metal type of paper, of course. It works very well for what we set out to do with it, and it really does hold the heat out in summer and in during the winter. It brings another blessing by carrying any possible leaks in the roof to some portion which is not graced by some form of antenna support. So, if you think a counterpoise would be of any advantage to you, it might be a good idea to "sell" the family the idea of insulating the attic. But be very careful that they don't hook you with the idea of using some form of non-metallic wall board and then let you have the job of finishing off the attic, which has been under consideration for so long, leaving you without your counterpoise.

A.R.R.L. Announces New Code Proficiency Certificates

First Test Transmissions from WIAW to be August 5th and August 30th; Daily Tape Sending from WIAW to Help Your Copying Ability

BY F. E. HANDY,* WIBDI

THE present times are a challenge to the ability, usefulness, and qualifications of every United States citizen, and the present offers no exception to radio amateurs. Our country is faced with serious international problems. Every institution and every individual must look toward fundamentals. The law of the survival of the fittest is the law of the hour. Easy-going habits that are based exclusively on selfish and non-useful practices must gradually be foregone in favor of or at least with emphasis on the useful and the productive things. For all citizens, life is likely to require increased alertness and responsibility. The future may call for every man to prove himself a man, to pull his own weight, to conquer difficulties by personal effort, to assume proper obligations to others and to ourselves, to demonstrate and augment our possible service to our nation and ourselves.

This is not too tough a picture for us amateurs at all. We have spent much of our attention in field organization efforts; we have an Emergency Corps; for many years our *training values* and plans for service have followed the precepts of our founders. We have always maintained an eager pride in our code ability. Only in recent years have some of us permitted it to slip back from the top. Amateur radio has never lost sight

of the necessity to demonstrate public service. Our organization always has been noted for its measures of self-regulation, for intelligent self-discipline and self-training. Amateurs then welcome the opportunity to accept the challenge of the hour. We present herewith plans for a project that will enable every radio amateur to check his code proficiency, to better that code proficiency, and to receive a certification of his receiving code speed, with a further award for every improvement that the certificate recipient can demonstrate up to a top of 35 w.p.m.!

This new program is going to be a whale of a lot of fun. Whatever our initial speed, it will be our private program, and that of every other red blooded and patriotic American amateur to add five words per minute (copying ability, by ear) to that speed! The League will give a certificate to any United States F.C.C.-licensed radio amateur who demonstrates that he can copy perfectly by ear for at least one minute, plain language Continental code at either 15-, or 20-, or 25-, or 30-, or 35-words-per-minute, all copy to be of special monthly transmissions to be scheduled from your A.R.R.L. station, WIAW.

There will be two objectives: (1) To copy by ear, write down by pencil and paper, or better yet, right on a "mill" what is sent, to qualify for a certificate and rating on the best one can now

* Communications Manager.



◆
One of these Proficiency Certificates may be awarded to *you*. Try for it, by copying WIAW at 10:15 p.m. EDST (8:15 p.m. CST) August 5th (or 30th). If you can take 15 w.p.m. by ear and prove it this handsome lithographed certificate is yours! If you can do 20-, 25-, 30-, or 35 w.p.m. your certificate will so state! Every F.C.C. amateur operator licensee is eligible.
◆

Progress in proficiency in code reception will be shown after the initial test and certificate award, by a separate dated and initialed Endorsement Certification to be added in a space provided. Silver Endorsement Stickers (a distinctive design for each speed) will be issued for 35 w.p.m. work or progress from any lower speed to 20-, 25-, 30- or 35 w.p.m. All United States amateur operators may try for the progressive endorsements!



do. (2) To put in a few minutes a day operating our station at the best speeds we can, also listening and copying PX and practice transmissions to train our powers of coordination, in order to win from the League the conspicuous endorsement that will be awarded to go on that first Proficiency Certificate whenever we can boost our speed honestly to another 5 w.p.m.!

WIAW Practice Transmissions

Effective daily except Friday, starting August 1st, WIAW will transmit a schedule of practice material, as follows, after a 3-minute "QST" call:

Speed	Starting Time (EDST)
15 w.p.m.	10:15 P.M.
20 w.p.m.	10:20 P.M.
25 w.p.m.	10:25 P.M.
30 w.p.m.	10:30 P.M.
35 w.p.m.	10:35 P.M.

Frequencies (Simultaneous)

1761-3825-7280-14254-28600 kcs.

The tape transmissions will be of plain language material, accompanied by identification of the station, and the speed will be briefly indicated. The groups of practice material will be sent at constant speed, each group taking about four minutes, allowing one minute to adjust the sending device to the new speed. Look for the QST call on any of the frequencies indicated, daily except Friday, just before 10:15 P.M. EDST. (9:15 P.M. EST, 8:15 P.M. CST, 7:15 P.M. MST, 6:15 P.M. PST.) Write down all you can copy at any of the speeds used.

For practice we likewise recommend that interested amateurs copy the A.R.R.L. Official Messages, which are sent on all the above mentioned frequencies, on the following time and w.p.m. speed schedules:

Starting Times (P.M.)				Speeds (W.P.M.)						
EDST	CDST	MDST	PDST	M	T	W	Th	F	Sat	Sun
8:30	7:30	6:30	5:30	20	15	25	15	20	—	20
Midnight	11:00	10:00	9:00	15	25	15	20	15	15	—

The mid-evening practice material is not read on voice since it is simply for practice and any recipient can tell how much he is getting just by looking at his paper. The Official Message is re-

peated on three 'phone frequencies, in turn, immediately after the conclusion of the radiotelegraph schedule and can be used for a check, if desired. The time required for voice transmission on the lower frequencies can be estimated in each case from the relative length of the particular code transmission. Voice transmissions should be looked for in the following order:

1806-, 3950.5-, 14237-Kcs.

August 5th and August 30th, First WIAW Proficiency Certificate Award Runs

At the usual practice time (10:30 P.M. EDST) on the above dates, WIAW will follow a five-to-ten minute explanatory "QST" message, by a special transmission, at consecutive increasing speeds, through the usual ranges, for all interested amateurs to copy. This text, that received successfully by ear at the highest speed you could copy, should be sent in to A.R.R.L. for checking. In all cases send your original copy (if not mark if you copied the material initially by hand, or on a typewriter, please). In all cases, attach a statement to your copy certifying over your signature, that the copy submitted is direct copy, made from reception of WIAW by ear, without any kind of assistance, personal or mechanical. You may expect to receive acknowledgement, direct from the League, and if you qualified on a test date and transmission, your certificate, or the appropriate endorsement sticker, if you qualified for a particular speed. We expect a high volume of interest in this new amateur activity. Our limited personnel will be unable to do extensive checking and corresponding. No copies of the official texts will be given out, and no copies submitted will be returned. Decisions and awards will be final and must be accepted as such. There will always be another test period coming up, to re-demonstrate higher code proficiency!

A word of caution: Send in your original paper! In A.R.R.L. Copying Bees of the past, more individuals have failed because of attempting to re-copy than the average amateur would suspect. To insure some measure of overcoming fading or QRM and QRN, we suggest that on the important dates, amateurs may use "split headphone" reception (one 'phone on each of two receivers set on different WIAW frequencies) to minimize transmission difficulties. We also request the cooperation of all amateurs who use the frequencies of WIAW, especially on the dates and at the times of monthly qualification schedules, in avoiding transmission themselves at such times, to help keep interference levels low.

A record is going to be started showing every certificate award and endorsement issued, and we know that every real ham is going to try to get his Code Proficiency Certificate just as soon as possible. QST will carry information on the awards made.

(Continued on page 30)

Designing a Wide-Range U.H.F. Receiver

Circuit Features of a F.M./A.M. Receiving System

BY F. W. SCHOR*

A NUMBER of u.h.f. receivers covering narrow frequency ranges have been built with a fair measure of success, but the problem of covering from 27 to 145 Mc. in a single receiver, together with provision for operation on either amplitude- or frequency-modulated transmission, proved intriguing indeed.

The receiver as finally completed incorporates all the usual controls found in a communications receiver plus a switch for detecting either amplitude or frequency modulation. The sensitivity varies from one to four microvolts over the entire range, and the selectivity can be varied to provide adequate separation on a crowded 28-Mc. band or it can be broadened to where a wobbling 2½-meter signal can be received without losing a single word. Such a wide-range coverage in a single receiver has been justified not only by the increasing popularity of the 10-, 5- and 2½-meter bands, but by the recent assignment of numerous frequencies for aircraft use ranging all the way from 75 to 140 Mc. There are only a few f.m. bands at present but many more are expected to show up as the advantages of such service is realized.

Acorn tubes are used for the r.f. converter and oscillator, as can be seen in Fig. 1. Three bands are used to cover the range from 27 to 145 Mc. An 1852 followed by an 1853 provide the i.f. amplification at 5.25 Mc. Fig. 2 shows how the signal splits following the 1853. One part enters the limiter, also an 1852, followed by the discrim-

* Hallicrafters, Chicago, Ill.

inator detector circuit incorporating a 6H6 double diode and de-emphasis circuit to reduce the high frequency emphasis put in at the transmitter. The other part enters a highly-selective diode transformer feeding a 6H6 diode which provides detection and an automatic noise-limiting action. Either type of detector can be switched to a push-pull audio amplifier which furnishes sufficient audio power for any normal use.

The photograph of the r.f. end of the receiver shows that ordinary ceramic switches are used for band-changing. Through careful design and placement of parts, very little trouble was experienced with the system. The switching of high-frequency circuits, particularly those of the oscillator, has often been condemned because it is claimed that the frequency at any one setting of the tuning dial will vary depending upon the direction in which that switch position is approached. This variation is due to the play between the insulating switch rotor carrying the common contact and the switch shaft. Cementing the rotor to the shaft removes this difficulty. The cement can be peeled off easily if it is later desired to remove the switch shaft.

The tuning condenser used has a range of 55 $\mu\text{mfd.}$ and a minimum capacity of only 6 $\mu\text{mfd.}$, thus requiring that all circuit capacities be kept as low as possible if the full range is to be covered. The rotors of the condenser sections are electrically insulated from each other to prevent common coupling between circuits, and heavily silver-plated wipers and contacts are used.

The coils are mounted close to the switches to

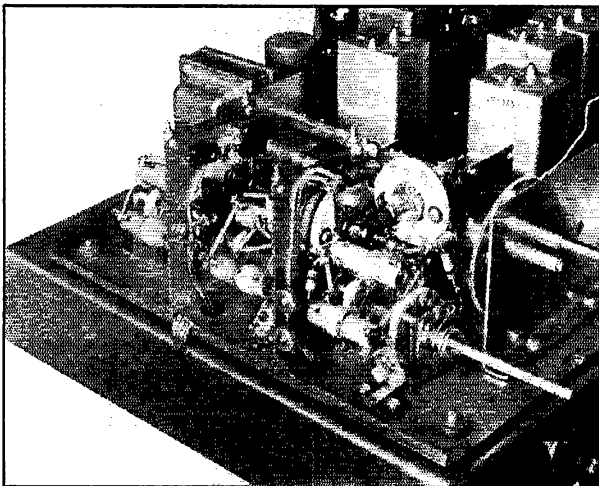

A close-up of the tuning section of the receiver under discussion shows how closely the parts have been fitted together. The coils just visible at the left-hand side are the antenna coils, the next are the r.f. transformers between r.f. amplifier and mixer grid, and the coils in the foreground are those of the oscillator. The oscillator tube sits up above the coils—the amplifier and mixer sockets mount on the shield partitions. A metal cover fits over this entire assembly when in use.

The commercial design of a f.m./a.m. receiver covering the range from 27 to 145 Mc. is not exactly a pushover, and that's why we think you'll find this description of some of the methods rather interesting.

keep the leads as short as possible, and the sizes of the coils then become not unreasonable for the frequencies covered. The coils for the 27- to 50-Mc. range are 5 turns of No. 22 celanese-covered wire on a half-inch diameter bakelite form, 2 turns on a similar form suffices for the 48- to 85-Mc. range, and the coils for the 84- to 145-Mc. range consist of two turns of No. 14 wound on a 1/4-inch diameter bakelite rod. The antenna coupling coils are adjusted to match a 75-ohm line at the low-frequency ends of the band. At the high-frequency ends, the matching impedance more closely approaches 150 ohms. However, even a 400-ohm line can be used with but little sacrifice in antenna gain throughout most of the range.

By-pass condensers to the screen, heater and cathode of the 956 r.f. amplifier tube are soldered within 1/8 inch of where the leads emerge from the bakelite shells around the condensers. The grid terminal of the variable condenser is only 1/4 inch away from the switch terminal. Although the 956 is normally rated at 250 volts plate supply, this particular one is operated at 150 volts to assure long life. Screen and cathode voltages are normal.

The plate of the r.f. amplifier feeds into the primary of the proper r.f. transformer selected by the band-change switch. All primaries are resonated below the low-frequency end of the band and are coupled to the secondary through a 10- μ fd. condenser. In switching it is necessary to short-circuit the primaries of the higher-frequency bands, because the primary of the second band resonates at 35 Mc., which falls in the range of the first band, and the primary of the third band resonates at 65 Mc., which falls in the second band. The resonant periods of the primaries are determined by the total inductance from the plate of the tube to the plate-supply by-pass condenser as tuned by the total capacity including

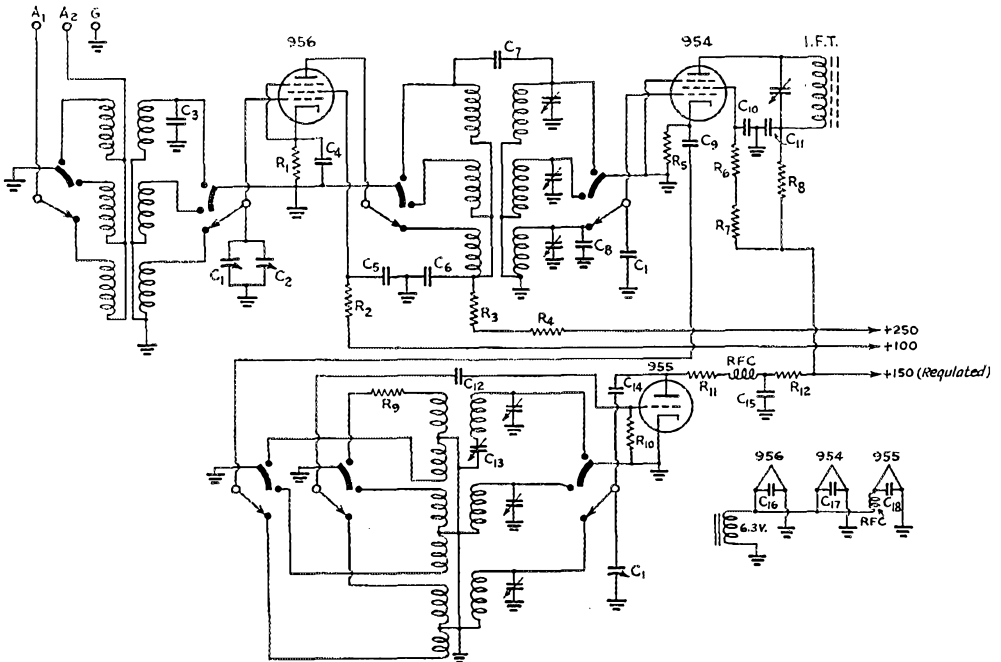

Fig. 1 — Circuit diagram of the front end of the wide-range u.h.f. receiver.

- C₁ — 60 μ fd. per section, three-gang tuning condenser
- C₂ — 15- μ fd. antenna trimmer
- C₃ — 5 μ fd.
- C₄, C₆ — 0.002 μ fd. mica.
- C₅, C₉, C₁₀, C₁₅, C₁₆, C₁₇, C₁₈ — 300 μ fd.

- C₇, C₈ — 10 μ fd.
- C₁₁ — 0.01 μ fd.
- C₁₂ — 0.001 μ fd.
- C₁₃ — 450- μ fd. pad.
- C₁₄ — 50 μ fd.
- R₁ — 250 ohms.
- R₂, R₃, R₆, R₈ — 1000 ohms.
- R₄ — 10,000 ohms, 2-watt.

- R₅ — 2000 ohms.
- R₇ — 0.1 megohm.
- R₉ — 35 ohms.
- R₁₀ — 20,000 ohms.
- R₁₁ — 5000 ohms.
- R₁₂ — 300 ohms.

All resistors 1/2-watt unless otherwise designated.

the output capacity of the tube plus all wiring and switch capacities to ground.

The secondary coils of the r.f. stage are identical to those of the antenna stage except that the inductance is about 3% higher. This is because of the loading effect of the primaries which reduces the apparent inductance of the secondaries. All of the r.f. primaries are wound with No. 34 s.s.e. wire and are spaced approximately $\frac{1}{8}$ inch away from the low-potential side of the secondary. In designing these r.f. coils, turns were removed from the primaries until they were resonant at the frequencies indicated above. The primary for the first band resonates at 18 Mc. Primary resonance is most easily determined by connecting a vacuum-tube voltmeter across the secondary and then feeding in a signal from a variable-frequency signal generator to the grid of the preceding tube. A decided resonance peak will be observed at the primary resonance. It will be found that tuning the secondary affects the value of this peak voltage but does not affect its frequency. Care must be taken not to confuse the secondary resonances with that of the primary.

A 954 acorn tube is used as the mixer. Both plate and screen supply are fed from a VR-150 voltage regulator tube. A cathode bias resistor of 2000 ohms is used. The method of injecting the oscillator voltage differs radically in this receiver from that used in most high-frequency receivers. A pick-up coil varying from $\frac{1}{2}$ turn to 2 turns is closely coupled to the oscillator coil and connected to the cathode through a 300- μ fd. condenser. This coil impresses a voltage varying from 1 to 3 volts between cathode and ground and provides unusually uniform conversion over the entire frequency range. Great pains were taken to keep the cathode circuit impedance as low as possible to prevent degeneration from the plate to grid circuits and consequent loss of conversion.

As a matter of fact, the cathode coupling method of conversion was originally proposed for this receiver and was rejected after the first attempts to use it had failed. Connecting directly from the cathode of the converter to a tap on the oscillator coil loaded the oscillator circuit too heavily and also made the cathode impedance

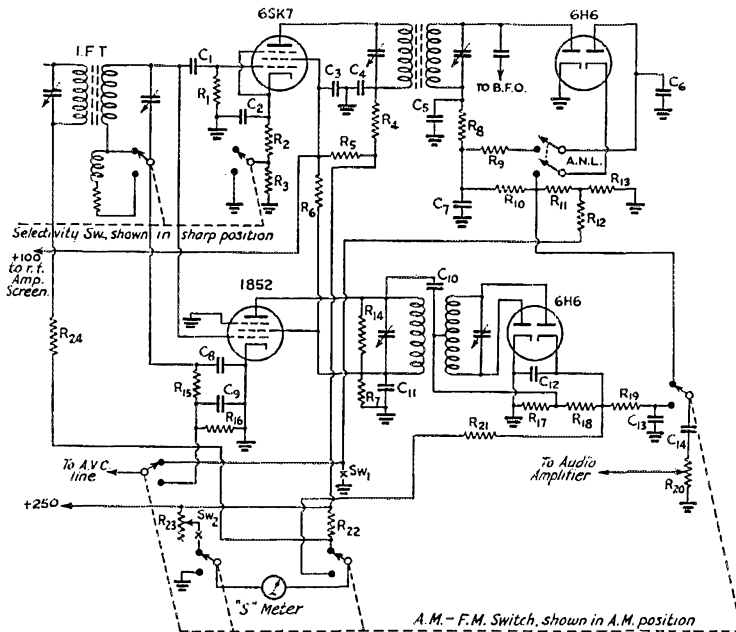

Fig. 2 — The two detection systems used in the a.m./f.m. receiver.

- | | | |
|---|--|--|
| C ₁ , C ₅ , C ₇ , C ₁₂ — 50 μ fd. | R ₃ — 5000 ohms. | R ₁₄ — 15,000 ohms. |
| C ₂ , C ₃ — 0.02- μ fd. paper. | R ₄ — 1000 ohms. | R ₁₉ — 0.2 megohm. |
| C ₄ — 0.01- μ fd. paper. | R ₅ — 7500 ohms, 10-watt wire-wound. | R ₂₀ — 0.5-megohm audio gain control. |
| C ₆ , C ₁₄ — 0.05- μ fd. paper. | R ₆ — 2000 ohms. | R ₂₁ — 0.6 megohm. |
| C ₈ — 100 μ fd. | R ₇ — 20,000 ohms, 2-watt. | R ₂₂ — 17 ohms, $\frac{1}{2}$ -watt wire-wound. |
| C ₉ , C ₁₃ — 500 μ fd. | R ₈ , R ₁₅ — 50,000 ohms. | R ₂₃ — 1500-ohm wire-wound S-meter adjustment. |
| C ₁₀ — 25 μ fd. | R ₉ — 1.0 megohm. | |
| C ₁₁ — 0.002 μ fd. | R ₁₀ , R ₁₇ , R ₁₈ — 0.1 megohm. | |
| R ₁ , R ₁₂ — 0.5 megohm. | R ₁₁ , R ₁₃ , R ₁₆ — 0.25 megohm. | |
| R ₂ — 300 ohms. | | All resistors $\frac{1}{2}$ -watt unless otherwise designated. |

high. Using a resistance common to both oscillator and mixer cathodes for injecting the oscillator voltage into the mixer also kept the oscillator for operating over the entire range.

Screen injection was tried next but the conversion ratio proved comparatively very low. Suppressor injection also gave extremely low conversion gain. Both of these methods have been used successfully for narrow range operation where high oscillator voltages are available. However, high oscillator output was not available in our case.

Another popular method of coupling the oscillator to the mixer is by means of a small capacity, usually 1 to 2 $\mu\text{fd.}$, between their respective grid circuits. Only a small voltage at the grid of the 954 is required for good conversion. This method worked admirably at the high-frequency end of each band but the conversion gain dropped to 1/20 normal at the low-frequency end of the band. Increasing the coupling capacity to improve performance at the low-frequency end of the band pulled the oscillator circuit out of its normal tracking curve at the high-frequency end of the band.

The cathode coupling method was next reconsidered. It was found that the impedance of the cathode circuit depended primarily upon how closely its parallel resonance approached that of the signal frequency. In addition to revising the entire layout to provide extremely short cathode-circuit leads, an effort was made to reduce the cathode to ground capacity. The 954 socket was spaced away from the shield, an opening in the shield was made just behind the cathode terminal, and the suppressor was connected directly to ground instead of to the cathode. With the natural resonant frequency of the cathode circuit well above the signal frequency and using the separate oscillator pick-up coil described above, fairly uniform gain was secured over the frequency range of all three bands.

The oscillator is a 955 acorn tube with its plate supply fed from the VR-150 voltage regulator. A Hartley circuit was first tried but gave considerable hum modulation. This was found to be due to a modulation of the cathode to ground impedance due to the heater-cathode emission. This emission takes place at a frequency of 120 cycles from the ungrounded side of the heater. The author was surprised to find that hum modulation was still present in the output of the receiver even after both plate and heater supplies of the oscillator were operated from a battery source. The signal generator was suspected, and, when it also was operated from batteries the hum modulation completely disappeared. The signal generator also used the Hartley circuit! The above experiences definitely pointed to the fact that the cathode had to be kept at ground potential at these frequencies.

The plate-tuned oscillator shown was decided

upon and gave hum-free operation together with comparative freedom from parasitics. It allowed easy control of the parasitics through the use of low-value series carbon grid resistors shown in the tickler circuit. As usual, extremely short heater and cathode ground connections were used. The plate supply was fed through a 5000-ohm resistor in series with an r.f. choke to reduce the loading effect of the resistor upon the tuned circuit. The plate circuit is by-passed to the condenser frame at this point and connected through a 300-ohm resistor to its voltage supply. The tuning condenser used has ball bearings between the shaft and front plate, and it was necessary to provide a short wiper to the frame to prevent loading effects due to the varying resistance of the ball-bearing contacts across a small portion of the oscillator inductance. The 955 socket is mounted directly to the gang condenser to keep lead lengths short, and the entire r.f. unit is floated on point supports to prevent microphonics and to reduce mechanical shock disturbances.

Something should be said here about the possibilities of undesirable resonant circuits which occur when working with ultra-high-frequency circuits. Every lead, no matter how short, is an inductance and has its own natural period when tuned by its capacity to ground. For this reason, all voltage supply leads have a 1000-ohm resistor connected in series as they leave the oscillator and r.f. stages. These resistors not only decouple the element supplied but also act to reduce very greatly the Q of any tuned circuit that may be formed. Thus absorption from circuit wiring is minimized.

One interesting case of absorption occurred in the oscillator circuit when a two-inch lead from the padder condenser of the lowest-frequency band resonated with the capacity of its plates to the metal casing at a frequency of 135 Mc. It took some time to locate it but the cure consisted of mounting the case on a bakelite insulator to remove it slightly from the chassis.

Because of the comparatively high i.f. frequency, there is no perceptible interaction during alignment between the oscillator and signal circuits except at the extreme high-frequency end of the lowest-frequency band, and here it is necessary to rock the gang condenser during alignment.

From this point, the plate of the 954 mixer feeds into the first i.f. transformer. A frequency of 5.25 Mc. was chosen to give good image ratio and a clear channel. An 1852 is used as the first i.f. amplifier tube and an 1853 is in the second stage. The first three i.f. amplifier transformers are of the expanding type. To provide maximum selectivity and stability in the sharp position, 100- $\mu\text{fd.}$ variable air condensers are used across both primary and secondary. The coils are universal wound of No. 28 double-celanes-covered solid wire over an iron core and give a Q of 150.

(Continued on page 85)



NAVAL COMMUNICATION RESERVE NOTES

Join the Naval Communication Reserve

BY LIEUT. COMDR. WILLIAM JUSTICE LEE, U.S.N.R.

EARLY in June, K. B. Warner, the managing secretary of the American Radio Relay League, visited the Navy Department and while there discussed with certain officers the question of building up the strength of the Naval Communication Reserve. At his suggestion, I have undertaken to tell the membership of the League something of the opportunities which are offered in connection with enlisting in the Naval Communication Reserve. It is logical to suppose that at this time particularly, every young American of military age is giving thought to the desirability of preparing himself for some particular branch of the military or naval service.

The members of the American Radio Relay League, being licensed radiotelegraph operators, are especially interested in communications. Most men would prefer being employed in some activity in which they are personally interested and, with this idea in mind, it is believed that many members of the League will wish to join the Naval Communication Reserve and prepare themselves for the possibility of active duty in communications.

At the present time the Naval Communication Reserve is composed of radiomen, signalmen, telegraphers, and yeomen, and men in seaman rates who are training, drilling, and studying with the idea of qualifying as petty officers in one of these specialties. It is not within the scope of this article to go into much detail as to all of the requirements for enlistment and for qualification in the various ratings. However, there are some especially interesting things which should be mentioned in this connection.

A licensed amateur radiotelegraph operator who now holds a Class A or B amateur license and who has not had any previous Naval or Naval Reserve experience, can be enlisted as a seaman first class in the Naval Communication Reserve. At such time as he can pass the professional examination prescribed for enlisted men of the Navy for radioman third class, he may be advanced to this rating. Amateur radiotelegraph operators who hold an amateur Class C license may be enlisted as seaman second class and

advanced to seaman first class as soon as they can qualify by examination.

At the present time the age limits for first enlistments in this class of the Naval Reserve are 17 to 35 years. However, ex-servicemen who were honorably discharged may be reënlisted in their specialty up to the age of 50 years.

All men must qualify physically prior to being enlisted. The physical requirements call for good health and no physical defects which would interfere with the performance of duty afloat or ashore, and are in general the same as for men of the regular Navy.

The enlistment of qualified radiotelegraph operators as seaman second class, for later qualification as signalmen third class, is especially desired. At the present time a much larger number of men are required for signalman duties than for radioman duties. The duties of a signalman on board ship are most interesting and include many forms of signaling such as is carried on with searchlights, yardarm blinkers, blinker guns, semaphore, and flag and sound signals. The fact that an amateur radio operator has already learned the International Morse Code should be a great asset in qualifying for a signalman rating.

Some men prefer radio duty and others prefer signal duty. However, there is one particular attraction to signaling, and that is that signalmen are stationed on the signal bridge platform, or on the flag bridge, and from this point of vantage can actually see what is taking place, and watch maneuvers which are executed in conformity with the signals which they themselves are transmitting.

There used to be a joke which all of us have heard at one time or another which read, "Join the Navy and see the world through a porthole." A signalman who joins the Naval Reserve and is ordered to active duty will see the world, and not all through a porthole by any means.

While no one can predict what turn the international situation will take, it does seem fairly obvious to us all that the defensive forces of the U. S. will be very rapidly expanded. Certainly there will be a great demand for all our present radiomen and signalmen, and for many hundreds or even thousands more. How much better it

The opinions expressed are those of the writer and do not necessarily reflect those of the Navy Department.

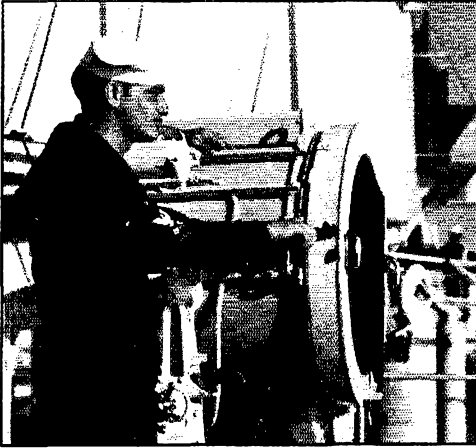

Signaling by searchlight

will be to join the Naval Communication Reserve now and have time to qualify for a rating, than later on, should the necessity arise, to be subject to selective service and drafted for some duty which had nothing to do with communications. For my part, I cannot recommend too highly that every member of the League who reads this article should give this matter his earnest consideration. All members of the League who are interested may communicate with the Commandant of their Naval District or with the Commanding Officer of their local Naval Reserve organization and ask for information as to how and where to enlist.

Assuming that you, as a member of the League, have applied for enlistment, have been accepted, and have enlisted as a seaman first class for radioman third or signalman third, and that you desire to qualify at an early date, the Department is prepared to order you to a month's instruction at a training school at Norfolk, Virginia, San Diego, California, or some other convenient location. You do not have to volunteer for this duty unless you wish to, but assuming that you do so desire, you may be ordered to these schools where you will receive an intensive 30-day period of instruction in naval procedure and be afforded the opportunity thereafter for active duty. This active duty may be performed in ships of the Atlantic Squadron on the Atlantic Coast, or in ships of the U. S. Fleet on the West Coast, and in some cases at shore naval radio stations. Prior to leaving the school and transfer to duty, you will be given the opportunity to qualify by taking a written examination for radioman third class or signalman third class, and if you pass the examination you can be advanced to these ratings immediately prior to transfer from the school.

At present the capacity of these schools is somewhat limited and consequently the men who are accepted for enlistment and who volunteer for duty will be given preference in order.

The length of such active duty will be for the period of the present limited emergency or such shorter time as you may be willing to serve, but in any case not less than six months' duty after transfer from the training station. It is hoped that men who volunteer for duty afloat will enjoy this duty and will wish to continue on with it as long as their services are needed by the Navy.

One important request is that applications or questions in connection with this article should not be directed to the Navy Department or to the author of this article. The Commandant of each Naval District is the responsible official who will be prepared to reply to inquiries and to give whatever information is necessary so that each member of the League will know whom to see and where to go. The Commandants of the several Naval Districts and their addresses are given at the end of this article and the proper thing to do is to write to the nearest Commandant.

It is desired to emphasize again that every member of the League who is in good physical health and eligible for military service might well give consideration to joining the Naval Reserve, and should make inquiry to find out whether he is qualified. If so, he can apply for enlistment in the Communication Reserve. Even though it may not be possible for members of the League to volunteer for active duty or for training at this time, they may nevertheless enlist in this branch of the Naval Reserve and attend local drill activities. At present, the Communication Reserve has Communication or Radio units located in 306 different cities in the U. S. Several thousand members of the League already belong to the Naval Communication Reserve and any reservist will be pleased to supply information regarding the unit to which he belongs.

A list of Commandants follows:

- Commandant, 1st Naval District, Navy Yard, Boston.
- Commandant, 3rd Naval District, Federal Building, 90 Church Street, New York.
- Commandant, 4th Naval District, Navy Yard, Philadelphia.
- Commandant, 5th Naval District, Naval Operating Base, Norfolk, Va.
- Commandant, 6th Naval District, Navy Yard, Charleston, S. C.
- Commandant, 7th Naval District, Navy Yard, Charleston, S. C.
- Commandant, 8th Naval District, Navy Yard, Charleston, S. C.
- Commandant, 9th Naval District, Naval Training Station, Great Lakes, Ill.
- Commandant, 11th Naval District, Naval Station, San Diego, Calif.
- Commandant, 12th Naval District, Federal Office Building, Civic Center, San Francisco.
- Commandant, 13th Naval District, 553 Federal Office Building, Seattle, Wash.
- Commandant, Navy Yard, Washington, D. C.



ON THE ULTRA HIGHS



CONDUCTED BY E. P. TILTON,* WHDQ

WHILE even the most optimistic see little in the current state of world affairs to arouse enthusiasm, the recent F.C.C. rulings prohibiting foreign contacts and curtailing low-frequency portable activity are proving to be clouds with a silver lining for occupants of the Ultra-Highs. Mobile operation on Five, at a low level since the advent of the stabilization regulations, is experiencing a boom as a result of the appearance of scores of former 28-Mc. mobile rigs on 56 Mc. The trend toward u.h.f. from the lower frequencies has been tremendously accelerated by the sudden demise of foreign DX. There's plenty of room on the Ultra-Highs for every licenced amateur in these United States, plenty of fascinating possibilities for the experimentally inclined, and plenty of fun for everyone — so come on down, gang! The more the merrier!

If May was an exciting month on Five, June turned out even better. During these two months 56 Mc. was "open" for sporadic-E skip more than half the time, with the character of the openings considerably improved in June over the frequent, but spotty and uncertain, openings of May. As is usually the case as the summer advances, skip has become shorter and the signals have come through for longer periods and with considerably greater strength, indicating more intense ionization.

Interspersed with the skip-DX sessions were numerous nights when inversion bending held the stage. In the East, June 17th and 18th were peaks

for this sort of work. On Monday, June 17th, the entire Atlantic seaboard was treated to the kind of night that happens only once or twice in a season, when everybody works everybody else within a radius of 150 miles or more. Low-powered stations, normally limited to a working radius of a few miles, suddenly find themselves working out to 100 miles or more with ease, and everyone has a grand time generally.

In direct contrast to the rapidly varying signals heard during skip-DX sessions, practically no variation in signal strength was noted during the evening, unless it was that everyone seemed to grow louder as the night wore on. Some idea of the fortunate state of affairs may be gained from the work of W3AZG, Colwick, N. J., who, with only twelve watts input to an RK-34, a half-wave vertical antenna, and a super-regen receiver, worked W1's CLH, KHL, KLJ and HDQ; all over 100 miles. W3FBH, Riverton, N. J., with 16 watts input, also to an RK-34, did equally well. From W3CGV in Wilmington, Del., to the gang around Boston — everyone who

* 329 Central St., Springfield, Mass.

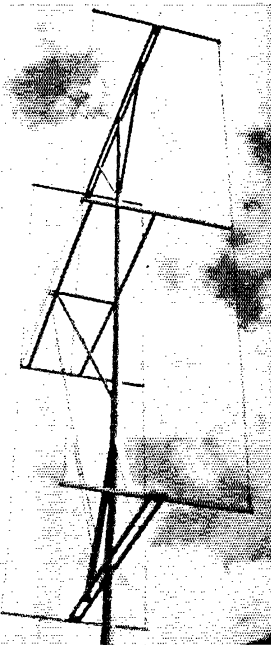

Probably the most popular beam of all is the old standby, 4 half-waves in phase, with reflectors. At the left is the array of W7FDJ of Houlton, Oregon. At the right is the solidly-built structure of W1AZ, East Longmeadow, Mass. Slip rings in the feeders, just below the array, permit continuous 360-degree rotation.

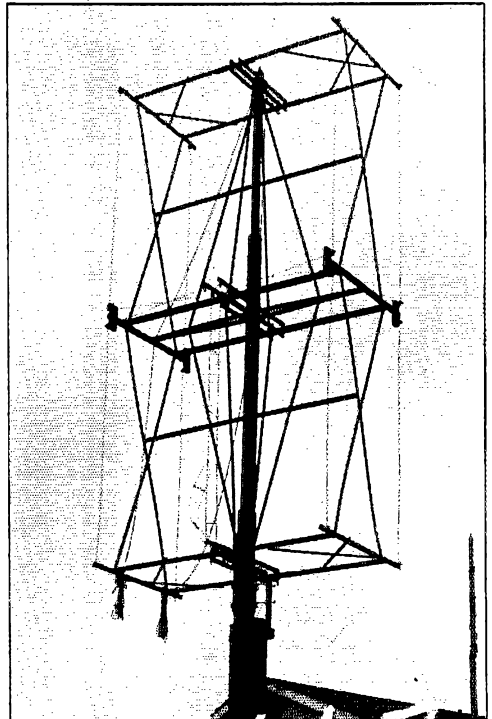

QST for

ever had a five-meter rig, it seemed, was on that night, making the most of this sample of inversion bending at its best.

In the Middle West long-range work (without the benefit of skip) is being done, too. This is a welcome sign, for it means that the true possibilities of Five are being recognized; that this year, when skip ceases to be with us, we shall still be having daily activity in many areas where it has been thought impossible to work out on Five.

On June 20th, W9BDL, Marshall, Ill., and W9ANH and W9ZHL of Terre Haute, Ind., were able to contact Ozark Five-Meter Net of Eastern Missouri, a distance of 125-175 miles. Members of the Ozark Net include W9's GHW, Kirkwood; WAL, OWD, and VAV, St. Louis; NKW, Wellston; EET, Sullivan; and NYV, Beck; all of Missouri. These boys get together regularly on Five, with a view to extending the daily working range and increasing the regular activity. Contact has been made with the Central Illinois Net; W9's ZHB, ARN, Inc. Nice going, gang, and keep up the good work.

HERE AND THERE:

THAT guy in Kansas City has done it again! Not content with being the first to work all call areas on Five, completing the Grand Slam in August, 1939, Vince Dawson, W9ZJB, has turned the trick again in 1940! On June 23rd, at 2:37 p.m., Vince heard W7ACD, Shelley, Idaho, on 28 Mc. say that he was listening on Five. A cross-band contact, with W9ZJB transmitting on 56 Mc., followed, lasting until 3:10 p.m. At 3:20, Vince went up to 28 Mc. and hooked W7GBI, changing back to Five to complete another cross-band contact. W7GBI then dropped to Five to make it two-way, contact being maintained on c.w. for about 30 minutes. W9AHZ of Kansas City also worked W7GBI, making it WACA for George also. We have rumors that W9ZD, Kansas City, and W9USH-USI of Brookings, S. D., have also worked all call areas, but details and confirmation are lacking at the moment.

Five really opens up in W4! A certain well-known W4 turned on his receiver and hearing a number of his 28-Mc. friends in the 8th and 9th call areas coming through with good signals he warmed up his ten-meter rig and gave forth a "CQ-Ten." No answer! Another CQ, and again no result. Somewhat surprised at this unaccustomed negative result he tried a few individual calls. Still no contacts. He was just about to "do a job" on the rig when he noticed that his converter was switched to the five-meter range!

W4FLH, Miami, who had worked 7 call areas and 18 states up to June 16th, says that 1940 has been a red-letter year on Five. He reports contacts on Five on many nights when Ten appeared to be dead. Contacts, for the most part, have been quite solid and reports well above those received when operating on 28 Mc.

Following the Florida hamfest at Lake Worth, June 16th, W4GJO took his friends W4BRB and W4FNR out to show them how DX is worked on Five. They caught the band wide open and even though they were operating on a busy highway in West Palm Beach a solid contact was made with your conductor, a distance of nearly 1200 miles. The mobile rig of W4GJO consists of a 6F8-G oscillator-doubler, driving an RK-56 final, running 15 watts input. A quarter-wave radiator on the back bumper is fed with a home-made coaxial line. The receiver is a Skyrider 5-10 operated with a Vibropack. "Grid" is now located in New Salem, Mass., for the summer. He brought along a 100-watt home rig for use in New Salem, but has been too busy exploring New England's hills with the mobile rig to get the big job going. While operating from Mt. Wachusett, Princeton, Mass., a contact was made with W9ZHB, Zearing, Ill., on June 27th. Grid reports that everywhere he went after he got up

W6QLZ, W3RL SET NEW 1940 DX RECORD FOR 56 Mc.!

As we go to press there comes news of a new 1940 DX record, set on June 27th by W6QLZ, Phoenix, Arizona, and W3RL, Herndon, Virginia. This hop, approximately 2000 miles, was made at 8:15 a.m. (MST) when the 56-Mc. band was otherwise apparently dead at Phoenix.

At 10:45 the same morning, W6QLZ worked W8QQS, Saginaw, Michigan, on c.w., distance approximately 1650 miles. Signals, as reported by W6QLZ: W3RL-589X, W8QQS-549X.

On the evening of June 26th, Clyde heard the *second harmonic* of K6MVV, *Waialua, Hawaii*, working W5FXB on 28 Mc.! This proves that K6-W6, 7 work is definitely possible on 56 Mc. Who's going to be the first to make it?

to Philadelphia on the trip north he was stopped by 56-Mc. fellows and bawled out for not coming back to their frantic calls on the night of June 16th!

W4GJO/4, 3, 2, 1 is one of the converts to Five as a result of the ban on mobile work on Ten. Here in Western New England we find W1's KK, DNT, CNF, and IPL likewise transplanted to Five. Another we hope to hear from on Five is W7GOH of Midwest, Wyoming, who has been doing a swell job with mobile equipment on 28 Mc. With Wyoming a state which has never, to our knowledge, been represented on Five, Pickett should find himself in plenty of demand when 56 is open.

Would anyone like to work Vermont? The Green Mountain State is now represented on Five by W1MEP, but you'll have to really "bear down" on this one. Located in a fire tower on remote Glastonbury Mountain, MEP and his able assistant, NEH, are miles from the nearest a.c. line. The rig is a 1J6-G crystal oscillator driving a 1F5-G final, modulated by another 1F5-G. Input is about one watt, supplied by dry batteries. Let's see some of you W4's and W9's knock off this one! The frequency is 57,486 kc. W9ZHB has already accepted the challenge and declares that he will work W1MEP, if he does nothing else the rest of the summer!

How many of you need W7? Practically everyone, aside from the fortunate W9's in Kansas City mentioned above, so we list the calls and frequencies of W7's known to be active on Five: EGV, Prescott, Ore. — 150 watts, Sterba beam, freq. 56,824; FFE, Houlton, Ore. — 150 watts, long wire, freq. 58,188; FDJ, Houlton, Ore. — 160 watts to HF-100, 8-element H (see photo), freq. 57,100; AXS, Mercer Island, Wash. — 400 watts to 100 TH; DYD, Bothell, Wash. — 100 watts to 812, H arrays for 5 and 10, and 8JK horizontal; CEC, Everett, Wash. — 300 watts to HK-54's, 3-element beam; ANI, W. Seattle — equipment unknown; EUI, Kirkland, Wash. — 75 watts to 801's, series-modulated with four 50's in parallel, extended H, 2 half-waves in phase, 32' vertical; GBI, Great Falls, Montana — 500 watts to 250 TH, X-H array, DM36-SX16.

W7's AXS and EUI report contacts with f.m. at each end, with indifferent results. Both were using super-regen receivers, so that the real value of f.m. could not be realized. The effectiveness of the s.r. receiver depends greatly upon its selectivity. In most cases the signal will appear to be slightly under-modulated when f.m. is used, unless very wide deviation is used in the transmitter. Rapid growth of interest in f.m. awaits the development of a simple receiver which will permit the noise-discrimination and high-fidelity characteristics, which have caused such a furor in commer-

U.H.F. DX RECORDS

Two-Way Work

- 56 Mc.: W1EYM — W6DNS, July 22,
1938. 2500 miles.
- 112 Mc.: W6OIN/6 — W6BCX/6, April
28, 1940. 200 miles.
- 224 Mc.: WIKLJ — WIHDF, May 18,
1940. 13 miles.

cial circles, to be realized in amateur work. A step in this direction is the construction of a separate i.f. and second detector unit such as recently described in *QST*.¹ A unit of this sort, which will do a good job on a.m. signals as well, is not too difficult or expensive to build and may be used with any converter unit, commercial or home-built.

After we went out on a limb last month with the statement that skip is getting longer on Five, along comes W3RL, Herndon, Va., with a contact with W4AUU in Macon, Ga., under the 600-mile mark. Another instance of exceptionally short skip is the reception of W3BZ, Danville, Va., by W1LLL and W1HDQ on June 24th. W3RL reports a big day on June 13th, listing contacts with ten W9's, W5EHM, W5AJG, and W4's FLH, FVW and EDD. The band was open from 11 A.M. to 8 P.M. Dick has been hearing W3's HKM, HOH, FQS, BZJ, DI, and FBH, and W2AMJ and W2GHV, the last two being over 200 miles distant. If some of these would use c.w. more frequently, contacts would be possible almost any night. The two-stage acorn preselector at W3RL is a big help in pulling through the signals over this 200-mile path.

W4AUU, Macon, Ga., reports that the DX season started on April 30th, with reception of W4EDD and W4FLH — more skip in that territory below 600 miles. DX was worked during May on the 1st, 2nd, 5th, 6th, 17th, 18th, 19th and 21st, with June showing openings at least as frequently. On June 9th, when Ten was open to W1, 2, 3, 5, 8, and 9, Five was open for W5 only, and EEX, DXB, VV and EHM were worked between 10:10 and 11:14 A.M. On June 1st, Jim heard W6QLZ, Phoenix, Ariz., on 28 Mc. say that he was going to Five. Listening on the harmonic of Clyde's 28-Mc. frequency, Jim heard a station calling CQ-Five. The signal was very weak and positive identification was not possible, however. On the 4th, W4AUU heard the harmonic of W7GLX on Five, but still no W7 signals have been heard anywhere in the East, that we know of. Jim is hearing W4FBH and some of the rest of the gang around Atlanta. Though this is a matter of only 80-90 miles, no contacts have ever been made. Softly (so W9ZHB won't hear) we venture the comment that this looks, to us, like a job for a vertical beam!

W4EQM, Langdale, Ala., has erected a 3-element "plumber's delight" and is really going places now. He worked eight states in five call areas on June 4th, and was one of the first to come in and the last to go out for the boys of W1 on the night of June 24th.

Why be torn between horizontal and vertical, asks W9UD0, Union, Ill. Roy is in a spot where he works the die-hard advocates of both types, so he has a beam which works in either position, enabling him to work the vertically-polarized Chicago area (60 miles) and the horizontal gang, W9ZHB, W9ARN, and others in Central Illinois (up to 110 miles), and W9HAQ, Davenport, Iowa, 120 miles. During a recent contact with your conductor, Roy swung the beam from one position to the other while we listened with both horizontal and vertical arrays at W1HDQ. While there appeared to be a very slight discrimination, favoring horizontal-to-horizontal or vertical-to-vertical, the difference was only a small fraction of that noted on similar tests over extended local paths, both at W9UD0 and W1HDQ.

¹"A Complete 56-Mc. I.F. System," Goodman, *QST*, April, 1940.

U.H.F. MARATHON

W5AJG WINNER OF MAY AWARD WITH 590 POINTS

Call	Contacts Through		Cumulative Score	States 1940
	56	112		
W1AIY	19		63	2
W1BCT		3	6	2
W1CGY	7		20	3
W1CLH	54		175	8
W1CUC	24	5	38	2
W1DJ	75		108	4
W1EHT	48		65	2
W1EKT	63		113	5
W1ELP ¹	46	61	169	4
W1GJZ	87		279	8
W1HDF	42	11	185	7
W1HDQ ²	108	28	646	16
W1IEP				1
W1JJR	40		140	7
W1JLK	66		160	6
W1BJ	1	27	43	2
W1KIJ	128	7	618	15
W1EVQ		68	146	1
W1LCC	13		16	2
W1LLL	72		389	14
W1LPP	46		75	4
W1LZY		60	128	2
W1MBS		74	150	1
W2ADW	5	7	41	3
W2AMJ	116		484	17
W2BZ	32	103	290	5
W2COT	62		86	5
W2CTK	23	57	151	5
W2DZA	17	15	32	2
W2GHV	71		271	14
W2LAL	48		67	4
W2LXO		73	162	3
W2MIL		16	82	1
W2VK		20	40	1
W3AC	53		142	5
W3BYF	41		101	14
W3CJ	155	17	750	17
W3CGV	56		127	7
W3CYW	16		122	7
W3DI	66		308	12
W3EIS	22		63	5
W3FJ	13		88	6
W3FSM		29	60	2
W3FX	34	24	82	2
W3HOH	159		410	12
W3RL	49		344	17
W4FBH	48		417	15
W5AJG	59	2	616	17
W5VV	16		152	8
W6IOJ	16	62	207	3
W6KTJ	5	1	7	1
W6BQR		60	128	1
W6MKS		16	144	1
W6OVK	6		24	2
W6QQ	20		77	4
W6QLZ	10	12	59	5
W6QNU		50	146	1
W6RVL	1	123	331	1
W6SLO	2		2	1
W6SNU	2		2	1
W6SNT	1		1	1
W7GSJ		4	8	1
W8MHM	19	6	57	5
W8NKJ	26	15	99	3
W8PKJ	27		100	10
W8QDU	52	21	415	10
W8QQS	20		135	6
W8RUE	39	12	157	10
W8SNN	20	14	28	5
W8TTU			131	5
W9ARN	41		393	14
W9VWU	16		136	9
W9ZJB	41		313	12

¹ Frequency modulation used exclusively at W1ELP.
² Not eligible for award.

To conserve space, stations not reporting for two consecutive months have been deleted. These will be re-listed upon receipt of further reports.

W9ZHB has a beam in the works which should really tell the story. Not only will this one be capable of being operated either vertical or horizontal, but it will be possible to tilt it in a horizontal position to determine the angle of the re-

(Continued on page 83)

★ I. A. R. U. NEWS ★

Devoted to the interests and activities of the

INTERNATIONAL AMATEUR RADIO UNION

Headquarters Society: THE AMERICAN RADIO RELAY LEAGUE, West Hartford, Conn.

MEMBER SOCIETIES

American Radio Relay League
Asociatia Amatorilor Romani de Unde
Scurte
Associazione Radiotecnica Italiana
Bunua Amator Radio Society
Canadian Section A.R.R.L.
Ceskoslovenski Amateri Vystlaci
Deutscher Amateur Sende-und-Empfangs
Dienst
Eesti Raadio Amatooride Uhing
Experimental Radio Society of Egypt
Experimenterende Danske Radioamatorer
Federation des Emetteurs Belges
Irish Radio Transmitters Society
日本アマチュア無線聯盟 Japan

Lietuvos Trumpuju Bangu Radio Megeju
Draugija
Liga Colombiana de Radio Aficionados
Liga Mexicana de Radio Experimentadores
Magyar R6vidhullamu Amat6rk Orszagos
Kgyesulete
Manchoukuo Amateur Radio League
Nederlandsche Vereniging voor Interna-
tionaal Radioamateurisme
Nederlandsch-Indische Vereniging voor
Internationaal Radioamateurisme
Newfoundland Amateur Radio Association
New Zealand Association of Radio Trans-
mitters
Norsk Radio Relte Liga

Polski Zwiasek Krotkofalowcow
Radio Club Argentino
Radio Club de Cuba
Radio Club Venezolano
Radio Society of Great Britain
Rede dos Emissores Portugueses
Reseau des Emetteurs Francais
Reseau Luxembourgeois des Ama-
teurs d'Ondes Courtes
South African Radio Relay League
Suomen Radioamat6riliitto r.y.
Sveriges Sändareamat6rer
Union de Radioemisores Espanoles
Union Schweiz Kurzwellen Amateure
Wireless Institute of Australia

CALENDAR

THE JUNE issue of the I.A.R.U. Calendar, while acknowledging the fact that international amateur radio is virtually in a state of complete suspension, reports a determination on the part of Headquarters to continue to function in normal fashion, as far and as long as possible. The Calendar will be issued regularly to all member-societies of record.

"Inevitably," says the Secretary's report, "world conditions will result in general dormancy on the part of the Union membership as a whole. But in the conviction that this dormancy will be only temporary, and that amateur radio can and will eventually be restored as an international institution, we shall continue to maintain the functions of the Union for whatever present value they may have, and in particular that there may be a rallying point against the time when the ranks of international amateur radio may be reformed."

We are pleased to announce the acceptance into membership of the *Manchoukuo Amateur Radio League*, Manchoukuo, and the *Radio Club Argentino*, Argentina, as the member-societies for their respective countries. We extend a hearty welcome to these new members.

The sole proposal in the current Calendar concerns itself with an application for membership from the *Liga de Amadores Brasileiros de Radio Emissao*, Brazil, whom the Headquarters has recommended for acceptance.

The Calendar reports a request from the A.R.R.L., in view of this government's recent prohibition of foreign amateur contacts, that member-societies whose amateur stations are still on the air refrain from attempting to contact amateur stations with W, K or N prefixes.

NEW OFFICERS

THE Union's Constitution provides that the officers of the member-society serving as the Headquarters society shall be also the officers of the Union. With the election of George W. Bailey, W1KH, as president of the *American Radio Relay League*, and Charles W. Blalack, W6GG, as vice-president, these gentlemen automatically assume similar titles in the Union.

NEWS AND NOTES

WE ARE SORRY to record the closing of all Uruguayan amateur stations. Although many South American countries sharply restricted their amateurs' operations several months ago, until now to our knowledge none has deemed it necessary to order a complete shut-down. . . . According to A. G. Hull's column in the "Radio World" (Australia), examinations for amateur licenses are still being held in that country as usual. Although of course no use can be made of the licenses at present, much encouragement is being given to those interested in acquiring now the necessary ability. . . . The tenth annual meeting of the *Associazione Radiotecnica Italiana* was held in Bologna on May 26th, with about thirty delegates in attendance. Technical speakers and trips to radio manufacturers' plants were features of the meeting. A special tribute was paid to the immortal Guglielmo Marconi.

Strays

Plywood panels may be given a finish which will resist finger marks by the use of ordinary black shoe polish. After allowing a coat of black shoe dye to dry, the polish is applied with a shoe brush and polished to the desired degree. A semi-gloss finish results. — WSERV.



HINTS AND KINKS FOR THE EXPERIMENTER



THREE-BAND COIL

IF YOU are bothered with a multiplicity of plug-in coils for your exciter or portable and don't care to go to band switching, this compromise may solve the problem.

The coil form is made in the time-honored manner using a 7- or 8-prong octal base from one of the "G" series of tubes. The coil is wound for the lowest-frequency band desired and tapped for the two next higher-frequency bands. The plug and socket are wired as shown in Fig. 1. The socket must have two keyways cut in it, one between pins 1 and 2 and one between pins 2 and 3. This can be done with a small hacksaw blade or file. To change bands, merely pull out the coil

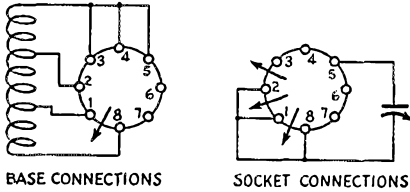

Fig. 1 — Base and socket connections for the 3-band coil.

and plug it in another keyway. Unused turns are automatically shorted.

Should the base have insufficient length for the necessary winding, a section of tubing of the correct diameter may be cemented over the base.

— Arlo Sullivan, W7CMY

A MULTI-BAND ANTENNA SYSTEM

WHERE one antenna must be used on several bands, the usual procedure is to use a tuned open-wire line for the feeder. This makes one more tuning adjustment whenever bands are changed and usually requires retuning if different frequencies in the same band are used. A system which is in use very successfully at W8QZP retains most of the advantages of open-wire fed lines, but eliminates tuning adjustments. It is necessary only to switch matching sections when changing to different bands. Final loading remains quite constant over wide frequency variations within a single band, which is a particularly desirable feature when several crystals or e.c.o. control is used.

If the antenna is made one-half wave long at the lowest frequency, it may be fed at one end with a quarter-wave open-wire line which is connected to a low-impedance cable of any length running to the transmitter. The quarter-wave line may be regarded as a "Q" section. The impedance of the matching section should be the geometrical mean of the antenna impedance at its end and the impedance of the cable. For an antenna impedance of 2500 ohms and a twisted-pair cable of 100 ohms impedance, the matching section should have an impedance of 500 ohms. In practice, the usual 600-ohm line works very well. At higher harmonic frequencies, the matching section becomes a half-wave or multiples of a half-wave in length. The impedance at the end of the section is then the same as the impedance

Fig. 2 — Matching-section arrangements suggested by W8QZP to eliminate tuning of antenna system. At A the switching is done with a double-gang rotary switch, while ordinary d.p.d.t. switches are used in the scheme shown in B.

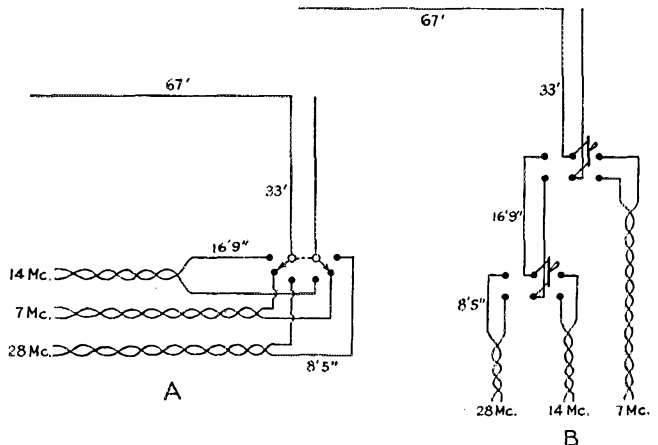

at the end of the antenna. Another section of 500-ohm line, one-quarter wave long at the higher frequency, may be switched on to the end of the first in place of the low-impedance cable to provide a match for a second section of low-impedance cable which is run to the transmitter. The impedance at the end of the antenna remains fairly constant when it is operated at its harmonics so that 500- or 600-ohm matching sections can be used for all bands.

Switching may be done manually or by means of antenna-switching relays. The matching sections may be connected to the end of any of the lower-frequency sections so that considerable latitude is possible in the location of the various sections. The switches must have good contacts and good insulation, since the current is high when a voltage node appears at the switch and the voltage is high when a voltage loop appears at the switch. The switches should be enclosed in a protective housing for safety, especially if they are easily accessible.

No difficulty should be experienced in the adjustment of this system, since the usual formulas for antenna length and length of the quarter-wave sections as given in the A.R.R.L. *Handbook* are satisfactory, under normal conditions, without any alteration.

The sketches of Fig. 2 illustrate two possible methods of switching. Fig. 2B uses ordinary double-pole double-throw switches of the knife type for manual operation, or antenna-switching relays for remote control. Fig. 2A uses a two-pole multi-contact switch of the band-switching type. The proper cable may be selected at the transmitter either by means of a band switch or by a plug-and-jack arrangement. Probably the least expensive system is the one in use at W8QZP in which ordinary d.p.d.t. porcelain base knife switches are used at the ends of the lines and four-contact tube sockets with two contacts in parallel at the ends of the low impedance lines. A short line from the link on the final tank coil terminates in a tube base which is plugged into the desired socket. The low-impedance lines used at W8QZP are No. 14 duplex cable of the type used for conduit wiring. The open wire lines are ordinary 600-ohm lines of No. 14 wire spaced 6 inches. — *Omar Snyder, W8QZP*

IMPROVED PI-SECTION ANTENNA COUPLER

IN TRYING the improved pi-section antenna coupler described by Mr. R. B. Jeffrey in January 1940 *QST*, some difficulty was experienced in making the amplifier load up properly when a single-turn link was used on the lower frequencies. It appeared that the input condenser, C_1 , did not have enough capacity to work into such a low impedance, so the same remedy that Mr. Jeffrey applied to the output of his coupler was also applied to the input, namely, the use of an induc-

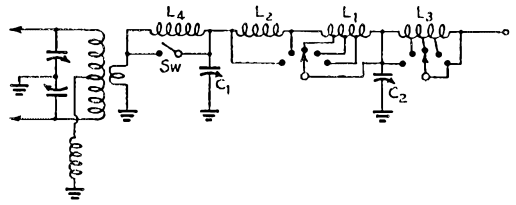

Fig. 3 — Input extension of pi-section filter for low-impedance input.

L_1 — 75 turns 3 in. diam. with 5 or 6 evenly-spaced taps.

L_2 — 10 turns, 1 in. diam. L_3 — 30 turns, 3-in. diam. with 5 or 6 evenly-spaced taps. L_4 — 8 to 10 turns, 1½ in. diam. C_1 — 500 μ fd. C_2 — 200 μ fd.

tance to extend the range. This is made clear by the diagram of Fig. 3. L_4 is the inductance that was used at the input of the coupler and may be eight or ten turns of large wire close-wound on a 1½" form. The value is not critical, but it may be well to try various sizes to find a value which will permit easy adjustment of the coupler on several bands. It may be necessary to provide a switch to short-circuit the coil on the higher frequency bands where C_1 will have sufficient capacity to work from a single-turn link. Adjustment of the coupler is similar to that of the original.

— *Donald Clark, W1MJU*

Amateurs Honor Hiram Percy Maxim

AT 3 P.M. on Sunday, May 26th, a group of amateurs gathered in Hagerstown, Md., to place a floral tribute at the grave of our beloved leader, Hiram Percy Maxim.

The placing of a wreath on the "Old Man's" grave was at the suggestion of William W. Brantly, one of the most active members of the Washington Radio Club. The Club adopted Mr. Brantly's proposal and through its President, Fred W. Albertson, arrangements were made for the laying of the wreath.



F. W. Albertson and J. L. Reinartz place the wreath

His cheery smile, his hearty handclasp, his fatherly advice can be no more, but the memory of his work for us will live on in the hearts of all amateurs.

An address at the grave was delivered by Lt. John I. Reinartz, a close personal friend of Mr. Maxim. Mr. Eppa Darne, W3BWT, spoke briefly.

Club Members—Code Awards

RADIO CLUBS. Attention! Note herewith a reproduction of a CLUB AWARD (Code Proficiency Certificate). This is independent of the A.R.R.L. Hdq. program for awarding proficiency certificates which is described elsewhere in this issue. The above certificate is devised to enable clubs to extend suitable recognition to individuals over the signature of officers and witnesses in connection with radio club programs of any nature that will extend code proficiency.

Most forward looking radio clubs organize 'round-the-table code classes each fall, as a sound way to insure new blood in the club, and to increase their memberships. This year we suggest that the radio club continue to do this *and in addition adopt an auxiliary program* to enable those who at present can do 15 and 20 w.p.m. to increase proficiency to some 5 or 10 w.p.m. above present levels. Both our sending "fists" and receiving ability need this attention.

CLUB AWARD certificates like that shown above will be furnished gratis by the League to bona fide radio clubs (1) that undertake to conduct code classes and qualifying tests (2) that schedule local competitions between large or small groups of amateur operators to stimulate interest in code proficiency. As the blank places on the certificate will indicate, there is considerable latitude in the manner of conducting rating tests. The League will not send code or cipher for over-the-air tests at this time, but this *can* be used in addition to plain language in qualifying candidates for Club Award certificates where over-the-

air signals are not necessary, and groups gather 'round the table for instruction and tests.

All amateur radio clubs are invited to apply to the League for a suitable supply of Club Award Certificates, after inaugurating such a program as suggested above. A newspaper announcement of the Club program and plans will show the patriotic and preparedness aims of the association and meet with a favorable public reaction, in addition to bringing excellent attendance at your fall meetings. The Club Award certificates may be given for either sending proficiency or receiving proficiency. — F. E. H.

Joint Southwestern-Pacific Convention

**Municipal Auditorium, Long Beach,
Calif., August 31st-September 2nd**

THE largest turnout for any west coast gathering is the optimistic expectation of the Associated Radio Amateurs for Joint Southwestern and Pacific Division A.R.R.L. Convention, to be held at the Long Beach Municipal Auditorium over the Labor Day weekend. Outstanding activities are being planned, including valuable prizes (an RME 99 is the advance registration prize), a boat trip around the harbor and free tickets to the amusements on the famous Long Beach "Pike," exceptional technical talks, the inevitable "beer bust" and smoker, and a real banquet dinner. Special activities are being planned for YL's and guests. Tickets are now on sale at \$3.00 each from E. P. Woolcock, W6EZL, Secretary of the A.R.A., P.O. Box 275, Long Beach.

WWV Schedules

EXCEPT for the special broadcasts of WWV using 20 kw. as described below, WWV is now running a continuous schedule (day and night) on 5000 kc. with a power output of 1 kw. This continuous transmission is modulated with the standard pitch in music, 440 cycles per second.

Each Tuesday, Wednesday and Friday (except legal holidays), the National Bureau of Standards station, WWV, transmits with a power of 20 kw. on three carrier frequencies as follows: 10:00 to 11:30 A.M., E.S.T., on 5000 kc.; noon to 1:30 P.M., E.S.T., on 10,000 kc.; 2:00 to 3:30 P.M., E.S.T., on 15,000 kc. The Tuesday and Friday transmissions are unmodulated c.w. except for 1-second standard-time intervals consisting of short pulses with 1000-cycle modulation. On the Wednesday transmissions, the carrier is modulated 30% with a standard audio frequency of 1000 c.p.s. The accuracy of the frequencies of the WWV transmissions is better than 1 part in 10,000,000.





CORRESPONDENCE FROM MEMBERS

The publishers of *QST* assume no responsibility for statements made herein by correspondents.

"SAY IT WITH WORDS . . ."

Editor, *QST*:

. . . It is my sincere hope that every ham will read "Say It With Words," and read it thoughtfully. . . .

— Carroll Tigner, W5ABM

NR 225 W3EEW CK 10 PHILADELPHIA PA MAY 30
K B WARNER ARRL
CONGRATULATIONS ON A THOROUGH AND
SENSIBLE PROGRAM FOR PHONE BANDS

— W3EEW

Whitewater, Wis.

Your article . . . is leading us away from ham radio into the realm of broadcasting. Are we on the air to amuse the b.c.l.s who happen in our bands?

— M. C. Sauré, W9MIJ

Austin, Texas

. It has long been needed. . . .

— Wilmer Allison, W6VV

Springfield, Ill.

. . . You're advocating too much crispness, efficiency, colorless brevity. . . . Why be so blasted efficient? Let's get some fun out of operating!

— S. P. Wright, W9PYW

NR 30 W8CJL CK2 AKRON OHIO MAY 24
K B WARNER ARRL
AMEN BROTHER

— W8CJL

Springfield, L. I., N. Y.

. . . From to-day on I shall try in every way to adhere to your suggestions. . . .

— Dorothy Hall, W2IXY

1810 Spear St., Logansport, Ind.

Editor, *QST*:

I read with considerable interest your article "Say It With Words" that appeared in the June issue. To me, that article was a marvel of clear, straightforward, precise, misleading logic. It went straight from its simple premise to its logical conclusion; but since the premise was faulty, the conclusion was even further from the truth.

Your first error, Mr. Editor, lies in this: you have failed to take into account the peculiar psychological makeup of the ham; you have overlooked the mental and spiritual urges that first enlisted him in the amateur ranks; you have, in short, failed to consider the actual nature of the material upon which you are trying to work.

The really good ham is, *per se*, a socially maladjusted creature. He is a man who is not at ease with his fellows, who has unsatisfactory success with his *femmes*, and whose ego is in desperate need of inflation. Amateur radio appears to him as the perfect sublimation. He may not be able to knock his woman over the head and drag her to his lair, but he certainly can knock the daylights out of the b.c.l. receivers. He is powerful. Stentor was a pip-squeak compared to the lordly amateur who can hurl his mumbled inanities over mountains, deserts, and oceans. He is wise. Does not every

visitor at his shack say, "How you can make a pile of wire and other junk like that work is beyond me". He is an orator. By the simple expedient of turning on his transmitter and flipping the standby switch, he may secure and hold the floor for as long as he wishes. Finally, he is mysterious. He deals in what is still the black art of radio. He talks with people in the far-off corners of the earth. He speaks an unknown tongue that is made up of numerals, dits and dahs, three letter combinations, etc.

Surely, my friend, you are not so foolish as to think that he will give up all this without a struggle. Why it would be as easy to persuade a doctor to give up his confusing use of his long medical terminology, a lawyer to forego his Latin, or a lodge-member to surrender his ceremonial dress! To ask a ham to eschew the abracadabra that he uses is to deny him his very reasons for being a ham. Strip him of his jargon, and he becomes merely another half-baked individual playing with electricity.

Please do not do this to us, mister. You are a great man; perhaps you are even a good man. Surely you can understand how much our mystery means to us. Take away our frequencies if you will; reduce our power if you must; but spare our glamour, our mystery, our jargon!

— John T. Frye, W9EGV

CODE PROFICIENCY

18030 Waltham St., Detroit, Mich.

Editor, *QST*:

Re the official broadcasts on board meeting, etc.: the portion about A.R.R.L. pushing "better code proficiency in the ham ranks" is a very good idea. . . .

We have worked with thousands of operators in the past twelve or more years of active brass pounding — amateur and commercial — and the best method of ham preparedness in the president's program is to encourage amateur message handling. In radio message handling, as in all lines of endeavor, experience counts. The one way to get experience is to get experience. . . .

Our own Michigan "QMN" Net on 3663 kc. has turned out more good operators in the past few years than would be possible by any other method. The net type of traffic handling gives all those willing to get on the air a chance to listen to the better operators and learn many short cuts from them and also to listen to the slower men and find out what *not* to do. Any man who has worked in a net becomes alert and equipped to know what is going on. . . .

For the sake of continued amateur radio we must encourage, by every means possible, more and better operators in the amateur ranks!

— Kenneth F. Conroy, W8DYH

BOUQUET

Elmhurst, Ill.

Editor, *QST*:

The press dispatches from Washington during the past few days have carried mighty testimony to the fact that the A.R.R.L. is representing the amateur and his interests in Washington and that the position of the League as the representative of the American amateurs is recognized by the authorities in Washington. The exception of the A.R.R.L. Field Day tests from the original order banning portable operation and the subsequent liberalization of the original order should alone be sufficient answer to those individuals who have taken it upon themselves to inform the

(Continued on page 87)



OPERATING NEWS

F.C.C. Prohibits Foreign Contacts.

Dating from June 4th, *U. S. amateurs are prohibited from engaging in foreign communications.* See the full text of Order No. 72 in the editorial in July *QST*. It is unlawful to exchange communications with a foreign country, or with operators or stations of a foreign government. We may continue to contact licensed amateurs in the territories and possessions, who may also communicate with each other. Some amateurs have asked if Cuba was a foreign country. It is! The KC4- and the NY- K5- (Canal Zone) stations may be worked, of course. In the Philippines it must first be ascertained that the operator is a U. S. citizen. One may safely inquire of the KA- stations, whether the station is operated by a citizen before engaging in any other exchange of communications, according to advices from Washington. The order is intended to exempt post stations, such as KA1HR, in the Philippines.

All the F.C.C. orders are subject, on violation and conviction, to the penalties provided by law. We already have been told about the amateur who was contacted by break-in procedure, by a D4-, on his own frequency, shortly after the new prohibition was in effect. It obliges us to say that absolutely no communications or contacts, be they ever so brief and fleeting, may be made with any foreign country or station, by subterfuge or otherwise. Work with foreign countries is unlawful. It will not be tolerated. There is surveillance.

Precautions Brought Up to Date. The *code of precautions* we talked about and set forth last month on this page has already become out dated. Just as this department was nicely buttoned up, along came the F.C.C. with a handful of orders. Part of our precautions are covered by Order 72, mentioned above, but we have a couple of additional provisos that now really belong in the self-adopted A.R.R.L. rules of conduct to safeguard the amateur service during this trying period. We print herewith a new precautionary list, which also has been sent to every League Official Observer. These observers are on the job, watchful to see that the new regulations, and each point of the precautionary code are as thoroughly observed as possible. Based on their reports, warning advices are sent any individuals necessary. *It is further requested that every amateur who reads these lines not only do his part by observance, but that he also make himself part of the monitoring patrol of radio amateurs that assures that necessary steps are taken to inform hams of the new requirements in to-day's operating!*

Send A.R.R.L. the name and call of any ama-

teur who is uninformed, or non-coöperative, or misunderstands the present precautions, so we may take steps to send him information.

KC4USA-B-C of the U. S. Antarctic Service. We have just received a list of the calls of stations worked on 14-Mc. 'phone by KC4USA at the West Base. Clay Bailey has requested us to hold all QSL's received until his return a year or so hence, at which time he expects to handle the whole batch in business-like fashion. At present the colonists are digging in for the long winter night. Previous request *not to call or answer the KC4's on their own frequencies is repeated.* If one interferes with the efficient personal contacts of the operators with their friends here at home, he can hardly be surprised if he fails to raise the station. Courtesy always pays dividends. A.R.R.L. also earnestly requests on behalf of the expeditioners that amateurs working Antarctica give the contact no publicity whatever, outside of amateur circles. *Kindly do not under any circumstances report U. S. Antarctic Service expedition contacts to any local newspaper or press representative.* There are proper political reasons, and arrangements that any and all publicity be released by competent authority, behind such a request. The operators very much value the personal amateur station contacts, and will be permitted to continue working amateurs if this publicity matter is controlled. We want to keep working the KC4's, so please respect their wish!

POINTS IN EXTENDING A.R.R.L. CODE OF CONDUCT FOR ALL U.S. RADIO AMATEURS

1. Do not talk about the war over the air, even among ourselves, or discuss any happenings that might have a military significance (our signals may be intercepted by belligerents).
2. Do not use any code or cipher*; use plain language, English recommended.
3. Do not permit anyone except members of your immediate family, or other licensed amateurs who at the time are in possession of their F.C.C. licenses, to use the microphone of your 'phone station.
4. Sign each transmission with your assigned call; follow every F.C.C. regulation with utmost care.
5. Scrutinize domestic traffic offered you by strangers; if you are approached by any agent of a subversive group or an agent of a foreign country, communicate immediately with the nearest office of the F.B.I. or via A.R.R.L.

* One exception, authorized AARS/NCR drills

Say It with Words. Sensible voice operating practices recently received a needed boost in a *QST* article under this caption. A number of pledges to follow the suggested practice have been received. A few random comments, that will be of interest follow. Radiotelephone operators should review the article starting on page 56, June 1940 *QST*, for points that will permit improvements in existing technique for voice communication.

"May hams soon adopt these procedures that will present the amateur to his fellows and the public as an individual of intelligence. W5AMB. "Many of the 75 meter gang are using 'Calling any amateur 'phone station' in lieu of the outmoded CQ." W4AGL. "I heartily agree in dropping the silly use of c.w. characters that convey little and do not save time on 'phone." W5IYC. "Amen brother." W8CJL. "We would all like to see 'hi' go out the window on the 'phone bands." W2MYH.

F.D. Results. Anyone who listened to the bands on June 22nd-23rd must have been convinced that 70% of the amateur world consisted of portable amateur stations! Last year proved the Field Day to be A.R.R.L.'s biggest operating event. Early reports indicate that this year's activity dedicated to the public interest annual testing of emergency-powered rigs may be even ahead of last year, conducted this time under special dispensation of the F.C.C. excepting us from Order No. 73. One group is said to have rolled up about 600 contacts in the week-end test! The real spirit is evident in reports from several who entered individually with emergency gear that worked at the 5-10 watt level, making several contacts proving the efficacy of the equipment for establishing contact out of their area in case of practical need. FB!

Get Your Code Proficiency Certificate. Elsewhere in this issue a new A.R.R.L. Award, available to every licensed ham who can do something above the license requirement itself, is announced. The first chance at the new recognition in amateur radio will be available in attempting to copy a run from W1AW on August 5th, at different speeds. Then will follow regular practice transmissions (daily except Friday) in addition to our daily automatic transmissions of the Official Message (O.B.S. transmission) to all amateurs. Two objectives will be (1) to get an A.R.R.L. certification of the highest transmitted speed that you can copy correctly, (2) to practice definitely to improve that speed by 10 or 15 w.p.m. so you can win a further certification by endorsement of that first award. A second official test will be run off August 30th from W1AW and other tests at monthly intervals are planned to help you attain this second objective. Look into this business. You will find it good fun. Aim to get a fully endorsed Proficiency Certificate as soon as possible!

--- F. E. H.

ARTICLE CONTEST

Which do you consider "the most interesting amateur band"? If you have followed the contest articles in the past few issues of *QST*, you know what some of the gang have to say on this subject. We are inviting more articles for the C.D. contest based on various individuals' ideas of the most interesting band. What is *your* choice?

Leroy May, W5AJG, wins the prize this month with his article boosting 56 Mc.

Send in your article on why such-and-such-a-band is, in your opinion, the best available. Each month we will print the most interesting and valuable article received on this subject. Please mark your contribution "for the C.D. contest." Prize winners may select a 1940 bound *Handbook, QST* Binder and League Emblem, six logs, eight pads radiogram blanks, DX Map and three pads, or any other combination of A.R.R.L. supplies of equivalent value. Try your luck!

The Most Interesting Band

BY LEROY MAY, W5AJG *

SAY, you "old timers" with the jaded metabolism and low blood pressure, you who say Ham Radio doesn't carry the "thrill" it once did, fifteen or twenty years ago. You who have worked 300 through 10 meters and think you have worked "all bands" and all phases of amateur radio. You who, perhaps, work eight hours a day (or more) with commercial radio and find it a tough job to get that "thrill" at home on the rig. You, who haven't worked up enough enthusiasm in ten years to answer a QSL card. Know what you need?

R—Elixir 56 Mc.

I, personally, will guarantee it. Have been licensed here at W5AJG for 18 years and have worked my share of all common bands, 'phone, c.w., spark, traffic, ragchew, etc. Had just about decided that certain "thrill" was gone forever, — then about three years ago I tried 56 Mc. Boy, there was a band that really kept me interested. Since then, I have had more fun, more thrills and more heartaches than in many a year. On 56 Mc. I have worked Canada, eight of the U. S. call areas (all but W7) and 32 states of the 48. The going is now getting a little tough, but it is to be W.A.S. on 56 Mc. or bust.

Ask any of the boys working on 56 Mc. if his heart didn't skip a beat when he heard the 56-Mc. band open for several districts. Why, I have worked old timers who have recently gone 56, whose voices were so excited they could hardly sign their calls. Here at W5AJG, in one sitting, on May 2nd of this year, I succeeded in working 51 different stations in 15 different states. Now don't tell me that isn't a thrill. You experience it yourself before you pass judgment. This type of work has been repeated again and again in the past three years, and it still carries the same kind of "punch." As for QSL's, I had come to the point where I considered this practice rather silly and for the newly active hams only, but 56 has changed all that. I fight for them now like I did in '22, and that space on the wall I have reserved for that W7 call area drives me nuts. Excuse please, — I always go off the deep end when talking 56. The XYL says the "low-frequency radio widows" think they have experienced the height of something or other in their OM's ham activities, but, as a matter of fact, they are quite lucky. An U.H.F. widow really leads a rough life.

To simmer down a bit and get away from the purely DX type of skip characteristics, there are other interesting angles to 56 Mc. It is an excellent band for local work (up

* R4, 9428 Hobart St., Dallas, Texas.

to 50 miles or so) to relieve, say, the 160-meter band — for pre-skip work out to perhaps 250 miles, and now an ideal band for "F.M." experimentation. Is it not versatile? Yes, if you will but scratch a little below the surface, you will see many possibilities for outstanding pioneering, skillful research, a full share of thrills and not a few headaches (and who desires a leadpipe cinch in all that he does, all the time?) on 56 Mc. As Ross Hull stated in the January 1929 issue of *QST*, "... the 28,000-kc. band is at once the most engaging and most baffling problem that the amateur has faced for many years. Of course, any problem is, to the amateur, engaging if it is baffling, but this one would seem to possess a rare combination of the expected and the unexpected. . . ." That statement was made over eleven years ago. To-day, we think we have cracked the 10-meter band. Can we say as much eleven years from now of the 56-Mc. band?

"TRY FIVE FOR A THRILL."

U. S. CITIZEN-STATIONS IN P. I.

Under F.C.C. Order No. 72, only U. S. citizens authorized to operate stations in P. I. may be worked by U. S. amateurs. Mr. George L. Rickard, the P. I. S.C.M., sends us the following list of stations licensed to U. S. citizens by the P. I. government: KA1AB 1AR 1BB 1BN 1BS 1CG 1CO 1CS 1CW 1DM 1GC 1JH 1JP 1JJ 1JM 1LB 1ME 1MN 1OZ 1PO 1PM 1RV 1TW 1VL 1XR 1XS 1YL 1ZL 3BW 3KK 3RA 4LH 7FS 7HB 8AA 8ED 1AK 1FA 1RK 1CM. We are advised by Washington officials that Order No. 72 is not intended to prohibit operation between U. S. amateurs and any of the military-post-operated amateur stations, such as KA1HR, KA1HQ, etc.

— . . . —

The call W8USA has been assigned for use at the National Scoring Meet, Elmira, N. Y. Authorization for the special call is good until August 1st.



"Doc" A. L. Walsh, W2BW president, W2USA Radio Club, Inc. takes a trick at W2USA while "Joe" Meditz, W2CKQ and "Dan" Lindsay, W2PL look on. Joe and Dan are the W2USA custodians, and official handshakers. They invite all amateurs to visit the station. Be sure to bring your ticket, if you wish to operate. W2USA will provide a free pass for admission to the World's Fair to any licensed amateur who volunteers to take a shift on the regular operating schedule. Write to W2USA, attention of Dan Lindsay, offering your services and advising that you will be at the fair grounds at a certain time on a certain date, at either the L. I. RR or the I.R.T. Gate, and Dan will fix you up.

By mid-June one-thousand-odd licensed hams had visited W2USA since its opening on May 11th. At least half of the visitors actually operated the rigs. Dr. Woodruff, W8CMP, retiring A.R.R.L. president, was among the visitors, as were several League Directors, including W6GG, the new vice-president

Hamfest Schedule

August 3rd, 4th and 5th, at Jenny Lake, Wyo.: The Eighth Annual WIMU Hamfest (Wyoming, Idaho, Montana, Utah) will be held August 3rd, 4th and 5th at the usual spot — Jenny Lake, near Moose, Wyo. All amateurs are invited, and are urged to bring along the YF and junior operators. Most of the gang bring their own camping equipment and eats. A limited number of cabins are available for those not wishing to camp out. Those desiring cabins should communicate with L. D. Branson, W7AMU, Casper, Wyo., regarding facilities.

August 4th, near Chicago, Ill.: The Seventh Annual Hamfest and Picnic of the Hamfesters Radio Club of Chicago will be held at the Frankfort Park picnic grove on Sunday, August 4th. The location is on U. S. Route 45, one mile north of U. S. Route 30, just southwest of Chicago. The principal gate prize is to be a 500-watt Thordarson transmitter, valued at over \$400. It will be followed by an RME-99 receiver, and other valuable prizes too numerous to mention. An unusually fine program of entertainment includes well known stage and radio stars. Contests have been arranged to attract the interest and participation of everyone present. There will be technical and equipment exhibits, and a demonstration by one of the Club's crack emergency communications groups. There will be dancing in the evening to the music of one of Chicago's big-name bands. Hamfesters Club picnics in the past have attracted hams from a radius of over 700 miles, and this year's attendance is expected to surpass the record crowd of 3500 who attended the 1939 picnic. All hams and their families and friends are cordially invited to attend.

August 4th, near Pittsburgh, Pa.: The South Hills Brass Pounders and Modulators are holding their Seventh Annual Hamfest on August 4th at Silent Brook Grove, near the Swimming Pool at South Park, Allegheny County, on Route 88 out of Pittsburgh, Pa. There will be the usual lunch and prize drawing included in the admission price of one dollar.

August 11th, at Trenton, N. J.: The Delaware Valley Radio Association announces its Fourth Annual Outing and Hamfest for Sunday, August 11th. The place: Trenton State Fair Grounds, Trenton, N. J. Activities start at 10 A.M., continue all day. Admission: Adults, \$1.50; children, 50¢ . . . nothing else to buy; eats and drinks included. There will be sports of all kinds, outdoor dancing, and gifts and prizes for OM's, YM's, YL's, XYL's, SWL's, etc. For tickets or further details see W3EUH, General Chairman, 904 Edgewood Ave., or W3CCO, 704 Quinton Ave., Trenton, N. J.

August 11th, at Waterloo, Wis.: The Rock River Radio Club in announcing its Fifth Annual QSO Party says, "You've attended the rest, now attend the best." This all-day hamfest will be held August 11th at Fireman's Park, Waterloo, Wis. Registration: In advance, 75¢ per person; \$1.00 at the gate. Included are generous prizes, entertainment, contests, speakers, rag chewing, etc. Bring your own lunch, or eats available at a nominal charge; beverages free. Send advance registrations (remittance not necessary) to Lester H. Miller, W9OFL, 275 S. Madison St., Waupun, Wis.

— . . . —

Amateur's License Suspended

The Federal Communications Commission on June 4, 1940 adopted an order suspending the amateur radio operator license with Class "B" privileges of Harry S. Krop, W8MJQ, Corning, New York, for a period of 6 months, because licensee caused interference to broadcast station WOR, failed to keep a proper log, communicated with an unlicensed radio station and operated on the 3900-4000-kc. 'phone band without the proper class of radio operator license.

— . . . —

The 4th Annual Hamfest of the San Joaquin Valley Radio Club was held in Fresno, Calif., on April 20th, with a record attendance of 550. It was a great success from every standpoint.

Albany to New York Outboard Motorboat Race

AMATEUR radio provided communications during the Outboard Motorboat Race from Albany, N. Y., to New York City on Sunday, May 12th. The Naval Communication Reserve gang at N. Y. C. and other points, in conjunction with the Albany Radio Club and the Mid-Hudson Amateur Radio Club (Poughkeepsie) set up an extensive network, which followed the progress of the boats down the Hudson River, reporting positions, trouble, etc., to the main control station at Dyckmann Street in New York. Considerable traffic was handled for race officials and participants.

There were two main circuits along the river, one operating on 3590 kc. between Albany, Poughkeepsie and New York City, the other on 3550 kc. between Newburgh, Verplanck, Tarrytown and N. Y. C.

At the starting location, which was the Yacht Club at Albany, the Albany Radio Club handled the busy circuit. Fully 100 boats crossed the starting line. Equipment at Albany consisted of a 28-Mc. rig located at the Yacht Club, running approximately 60 watts on c.w., which was picked up by W2AWF (located about four miles uptown in Albany) on an SX24 receiver. The output of the receiver actuated a relay, which in turn keyed his regular rig on 3590 kc. running about 200 watts. The judges and starting line were located at the extreme south end of the Yacht Club, approximately 300 feet from the message center and radio gear. This distance was bridged by a land telephone line, by means of which messages from the various officials, boat crews, etc., were relayed to the operating position from whence they were put over the air or over the P.A. system, if one of the boat crews was wanted. Synchronization of all time pieces used in the race was periodically checked via the land line with the official starter, then via 3590 kc. with Poughkeepsie and New York. This phase of the radio participation was greatly appreciated by all the officials of the Middle Atlantic Outboard Motor Boat Association, as heretofore this checking of watches was very difficult.

Another feature of the Albany participation was contact on 7 Mc. with a portable rig located at the Castleton Bridge, some five miles south of Albany. This Castleton contact proved of the utmost importance as it is found that it is generally in the first five miles that contestants drop out, if they develop trouble. On this score valuable service was rendered to both the boat crews and judges. As the various boats passed Castleton Bridge and also the halfway mark, Poughkeepsie, the results were transmitted back to Albany and announced over the P.A. system to the crowd waiting at the Yacht Club. Amateurs participating at the Albany end, all members of the Albany Radio Club, were as follows: The 3590-kc. circuit was handled by Larry King, W2GSM,

At the Albany Yacht Club

The Albany Radio Club set up this portable installation on the top floor of the Albany Yacht Club to handle radio communications at the starting point of the Albany to New York Outboard Motorboat Race, May 12, 1940. Otto Boos, W2MTF, Dorothy Knapp, W2MIY, and Alfred Soback, W2LLK, were at the operating positions when this photo was taken.



Brass Pounders' League

(May 16th-June 15th)

Call	Orig.	Del.	Rel.	Extra Del. Credit	Total
W9QIL	56	177	977	160	1370
W6DH*	169	248	452	223	1092
W8GZ	15	48	930	43	1036
W4PL	12	25	972	23	1032
W7EBQ	16	63	872	48	999
W3QP	295	258	2	253	808
W3GKO	9	22	708	16	755
W5FDR	162	84	347	78	671
W6LUJ	0	0	653	0	653
W6IOX	17	34	516	32	599
W3EML	65	125	226	122	538
W9ZTU	221	155	0	151	527
W2LSD	257	69	158	22	506
W3BWT	52	39	381	31	503
W2SC	22	90	310	80	502

MORE-THAN-ONE-OPERATOR STATIONS

Call	Orig.	Del.	Rel.	Extra Del. Credit	Total
KAIHR	960	799	352	764	2875
KAIHQ	318	274	612	262	1466
WSOW	97	188	644	84	1013
W2USA	865	40	44	22	971

These stations "make" the B.P.L. with total of 500 or over. One hundred deliveries + Ex. Del. Credits also rate B.P.L. standing. The following one-operator stations make the B.P.L. on deliveries. Deliveries count.

W6KMM, 222	W9ZFC, 150	W6IG, 121
W1KKS, 206	W7GVH, 138	W9TKX, 116
W6PCP, 183	W6MDI, 134	W6QCX, 115
W7APS, 182	W2LZR, 133	W3HRS, 103
W3CIZ, 164	W9BHY, 123	More-than-one-opr.
W9OMC, 154	W5CWW, 124	W1AW, 177

A.A.R.S.

Call	Orig.	Del.	Rel.	Extra Del. Credit	Total
WLTW (W9QIL)	42	101	276	91	510

MORE-THAN-ONE-OPERATOR STATIONS

Call	Orig.	Del.	Rel.	Extra Del. Credit	Total
WLM (W3CXL)	157	153	2513	98	2921

A total of 500 or more or 100 deliveries + Ex. D. Cr. will put you in line for a place in the B.P.L.

* April-May.

and Dean Cortright, W2LEI, with Elmer Wirsing, W2AWF, guarding his rig at his home address. Jim Murphy, W2HCS,

(Continued on page 66)



How's DX?

HOW:

THE turn of events last month made our long harangue about the working of Europeans look rather silly, but it happened that the pillar had been turned in and set up in type before the word came through from the F.C.C. about the ruling. Production schedules being what they are, we didn't have time to modify our remarks to fit more closely the new situation.

With that out of the way, the next question that arises is, "What to do about it?" We don't mind telling you right at the start that we're not going to let somebody else's war spoil all our fun and, after a week-end enjoyably spent in the DXCC Round-Up (more on that later), we have a firm conviction that a majority of the gang feels the same way. First off, we are still permitted to work the Pacific islands and, if you must know the truth, there are a few of those guys out there we haven't worked yet, so we're going to go after them. Judging from the early yawning activity by some of the lads, we are not alone.

We've always had a warm spot in our ticker for long-haul traffic, ever since the days when we used to get up before breakfast out on the west coast and handle the stuff with P. I. and Guam, and, unless we're completely damp, that phase of ham radio should have the same appeal to-day, combining, as it does, the best features of DX and traffic handling. There will be the added virtue that we won't be worrying every ten minutes about what DX we're missing. Long-haul skeds make perfect reasons for high-gain fixed antennas, and catch-as-catch-can DX chasing sometimes discourages that type of skywire, particularly when you don't know where your next country is coming from.

Elsewhere in this issue you'll find an announcement of the code proficiency awards to be made for copying ability. We'll confess that we can copy 35 w.p.m. if it's sent slowly enough, but if you and Jeeves think we aren't going to bone up for one of those awards you have us wrong. From what we know of some of the DX operators, there are a lot of them that are going to have less trouble with that award than some of the alleged high-speed artists, but that doesn't go for all of them, naturally.

The grapevine tells us that some of the DX gang is casting jealous eyes at the u.h.f. bands and some of the records hung up by the faithful group of workers down there. With the hand-picked locations of many of the C-Clubbers, there's no reason why the one-digit bands shouldn't see a crop of neophytes investigating their vagaries.

There you have a few angles, so don't go moping around with a face with dimensions sufficient for a rhombic and moaning, "What to do till the DX comes?"

As for the chatter on these pages, we'll try and keep that up as long as we have material. Our main object will be to keep the DX gang informed as to what their former competitors and hair-getter-intos are doing. If that doesn't pan out we'll open a millinery shop and make exclusive hats for gals from insulators, tangled antenna wire and an engraved QSL card we were saving for AC4YN.

DXCC ROUND UP:

THE Round Up, held on 20 over the week-end of June 29th-30th, drew out a lot more stations than we had expected and, for a first venture, was quite a success. All we have to go on right now is our own experience and the remarks garnered from those we worked, but practically everyone was quite keen about the idea and said he'd like to see more of them. An unofficial count shows that there were about 50 C-Clubbers on the air over the week-end and, mister, if you don't think those guys can chew the rag, you just don't know! Personally, we never had so many swell contacts outside of a real face-to-face get-together. Next month we'll tell you more about it, after the gang sends in its comments

and number of contacts. We would like to know how many want to put a contest angle on the thing but, personally, we're afraid that would take away the gab factor which made this particular meeting so pleasant. But it's up to youse guys.

WHERE:

It would appear that **KH6SHS** (14,397) rates No. 1 on the list. A flock of fellows have worked him already, and cards have come through from him. We have it that he was off for a while but should be back on when this gets to you Next in line is **KE6SRA** (14,330-14,380, e.c.o.) who has worked a mess of the men and has sent in a list of contacts up to June 8th. SRA is Roger Parnell of the U. S. Navy, and can be addressed Naval Station, Johnston Island, c/o Postmaster, Honolulu. He rates right up with **F18AC**, **VU7BR** and some of those other 100% QSL-ers in his eagerness to see that the lads get CC credit for the contact. There was some delay in his list reaching us because the ship that took his list came back by way of one of the other islands out there. Roger has a lot of cards he wants to send out, but the boat that brought them left the same day and he didn't have time to make them all out. He's on in the early hours **W1KHE** passes along dope from **K6QYI** that **K6OLU** was planning a trip to Midway and Wake via the airways, with a few days stop at each place, but we have no further dope on him **W2GT** says old Lem Hobdy, **K6MV**, is now signing **KG** on Palmyra and is on both 'phone and c.w. Ed gives the address as Warner Hobdy, c/o Hawaiian Dredging Co., Honolulu, T. H. Someone was saying Lem didn't have a b.f.o. in his receiver, so he's probably on 'phone most of the time. On 'phone he hugs the edges of the 'phone section **W9ANS** reports working **KC6QA** (14,230 T9) during the early part of June —dunno if he's still on or not **W6ITH** says those who claimed **HA8C** on 20 'phone a BL were wrong, or else someone sends cards for fun. Could be — take **TA1AA** for example **W6SN** gives the address of **OQ5BF** as Ecole Professionnelle, Leopoldville, Belgian Congo, in case you're after a pasteboard.

WHEN:

FOR what it's worth, we'll list a few frequencies for those that like to look around. **W6PMA** reports **K7TP** (7050), **K7QI** (7030), **K7IEB** (7105), **KAIHQ** (7100) and **K7EXE** (7035), and **W7BIZ** adds **KAIPO** (14,300).

Next month we'll list a few rare W9's here for the benefit of a certain W6 with a two-letter call who must go unnamed because of the way he treated **W1SZ** during Roddy's recent western trip.

WHAT:

A nice letter from **W8QQE** and his mob says they would like to see the column used as a clearing house for general information on gear, antennas and stuff as used by outstanding DX stations. We're happy to do it — tell us what you want and we'll go after it. Personally, we think that the lull "for the duration" is an ideal time to really crank up the gear to 101% efficiency, and ideas will be welcome.

WHO:

KF6JEG (14,360 or so) is on c.w. more now, and is looking around for Delaware for his WAS **W9HLF** passes along the dope that **KB6RWZ** is back on with 400 watts to a pair of 75T's, which will be boosted to 800 watts when a new bias resistor arrives **YN1OP**, whose new address is E. H. Andreas, P. O. Box 118, Managua, Nicaragua, says that **YN9G** never was in Nicaragua, which is another good reason for not giving CC credit for him. The other reason, and the one used by the CC moguls,

(Continued on next left-hand page)

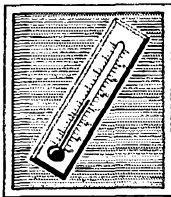

Low temperature drift is particularly important in a communication receiver. For one thing, drift makes the tuning wander off while answering a CQ, so that the QSO is lost while re-tuning. Fortunately, this problem has been licked in the best of the modern communication receivers, and we certainly do not advise any amateur to try to improve on the factory job. However, if you feel the urge to build a receiver or a frequency monitor or other equipment, the dope below will be interesting.

The first thing, of course, is to use parts with the lowest possible drift. Almost any air condenser is better than an adjustable mica condenser, for instance. Quality condensers intended for such work, such as the National PW Tuning Condenser and the W-100 Padding Condensers, are specially designed to have very low drift. Good coil forms should be used, and they should support the winding throughout its entire length.

If good parts are used, the remaining drift will be low enough so that it can be compensated by using the small fixed condensers specially developed for the job. When one of these condensers forms part of the tuning capacity in a circuit, its negative coefficient will balance the positive coefficient of the other parts of the circuit. The difficulty with using these condensers is that they will give exact compensation for only one value of tuning capacitance, which usually means one frequency in any one coil range. This means that only partial compensation can be achieved on general coverage. However, if a separate coil system is used for the bandspread ranges, as in the HRO, so that the whole tuning range of the main condenser covers one amateur band, then the receiver is so nearly "fixed frequency" that it can be nicely compensated. This is important, because it is on bandspread that even a slight drift is annoying. It is one of the main reasons why we are using bandspread of the HRO type in the new medium priced amateur receiver now getting its finishing touches.

One other point must be mentioned. When a receiver is first turned on, different parts will heat up at different rates. Transformers, tubes and resistors get warm first, with heat gradually spreading to coils and condensers. This makes the location of the compensator very important. If it is close to the high frequency oscillator, it will do a very good job. If additional compensators are used in the RF and Detector stages also, as in the new receiver mentioned above, the drift can be made negligible after the first minute or so.

What size of compensator should be used? To answer this, let's take an actual case. Suppose that the frequency varied from 14,000 KC to 14,025 KC when the temperature changed 30° C. Suppose the compensator chosen has a rated coefficient of .0006 mmf/mmf/°C. Expressed as a fraction of the operating frequency, this 25 KC drift amounts to .00006 KC per KC per Degree C, approx. This is a frequency ratio (KC) and it must be changed to a capacity ratio (Mmf). Capacity varies as the square of the frequency so the change can be made simply by multiplying by two (when the ratio is small, as it will be). So we get .00012 Mmf per Mmf per Degree C as the coefficient of the circuit. It must be balanced by the negative coefficient of the compensating condenser (.0006), which we find is five times the circuit coefficient in the example chosen. That means that the compensating condenser should be one-fifth the capacitance of the other circuit capacitance.

JACK IVERS





HOT OR COLD, Mallory Condensers stand up—that is the secret of their popularity. There are temperature limits which must be observed for any type of condenser. When the operating temperatures are near these limits it is essential condensers with extra durability be used to insure satisfactory performance and freedom from break-down.

Mallory Condensers have an added factor of safety—special constructional features which provide longer life. You benefit from this extra, deluxe quality—yet thanks to modern production methods, Mallory Condensers cost no more.

There is an economical, long life Mallory Condenser for every filter circuit application—types ranging from transmitting and television capacitors of 6,000 volts to low voltage bypass condensers of 4,000 mfd. capacity. There are ultra compact FP (Fabricated Plate) and etched plate filter condensers for radio receiver service. All are built for easy installation. Complete information is in Catalog Form M-770, available without charge from your distributor, or from the factory.

Amateurs, servicemen, and experimenters are urged to discuss their condenser problems, whether for original application or for replacement service. The advice of Mallory Condenser experts is yours for asking. Address, Application Engineering Section, Wholesale Division.

P. R. MALLORY & CO., Inc.
INDIANAPOLIS INDIANA
 Cable Address—Pelmollo

Use
P.R.MALLORY & CO. Inc.
MALLORY
 APPROVED
 PRECISION PRODUCTS



was that he wasn't licensed in Nicaragua. ("How could he be licensed in Nicaragua if he wasn't there?" — Jeeves.) They knew he wasn't licensed but they didn't know he wasn't there. ("Ok." — Jeeves.) There was some delay on that second batch of VU7BR cards, but apparently they got through. However, if you didn't get one and your DXCC credit, we have a list of all those sent out, and so can credit you from the list W2LXY writes to say that VK4HN, op at PK6XX, is in the States now. His address is Tanque Verde Ranch, P. O. Box 1831, Tucson, Ariz., in case you want to renew an old friendship. He would like to hear from those he worked. No, we don't know if he brought his log with him W6SN received a letter from ex-OE1FH saying that Frits — call him Fred now — is in Adelaide, hobnobbing with the VK5 gang, and was married in January. His mail address is still the same: c/o Electrical Institute, Sydney, Australia W6EJA has been skedding KA1CO regularly since 1933 K4KD finally reached his objective of working WAS on 3.5, 7 and 14 Mc., but still needs a few cards to show it W1KHE tells us that the day or so after the F.C.C. order he heard a certain w.k. W with more brass than brains frantically calling W2MCHH with as much horsepower as if he was calling AC4YN. He finally raised HE2MC and continued to use the call of W2MCHH, much to the surprise of our Haitian friend, who probably hadn't heard of the order yet. The method is recommended most highly as a way to get us all closed down — grab a handful of tar and feathers and follow us! That's all this trip — we're going home to listen for W4YNAC.

— W1JPE

Another dodge! Do not be tricked into working any foreign stations by answering *any* station that does not send the proper international prefix in front of his call. It is said that one of the German stations has been trying to trick W stations into establishing communication since Order No. 72 went into effect, by using its call *without any prefix*. Only unwary operators can be taken in by such methods. It is unlawful to communicate with operators or stations of any foreign country or located in any foreign country.

About Code Proficiency: A lot of hams think that it is easy to copy 20 or 25 w.p.m. Perhaps, but many of the gang are interpreting that word "copy" to mean that the words are merely noted mentally as they flow out of the 'phones or speaker. Actually we are obliged to say that the word "copy" refers to aural reception and interpretation *and the writing down accurately* all the intercepted code signals. That puts a different story on "code proficiency." A.R.R.L. is going to help every interested ham to find out for himself just what he can copy in the basic art in which all amateurs are tested initially by Uncle Sam. It will all be plain language reception of signals keyed from a tape to insure perfect stuff for the test. See what you can do!

Two Top Receivers!

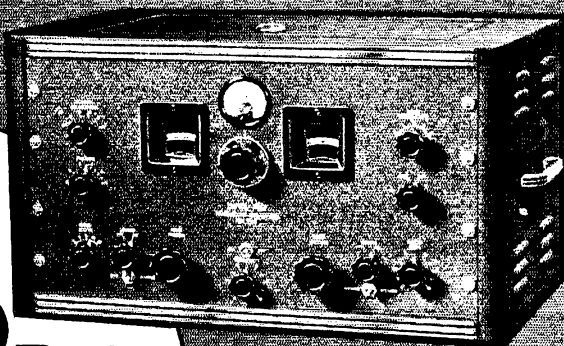

*
*
SUPER-PRO
and
HQ-120-X

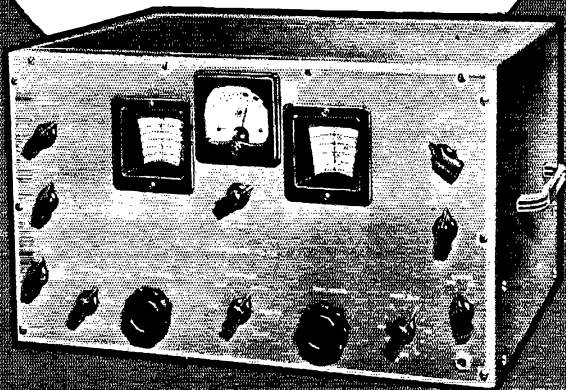

THE "Super-Pro" has the approval of civil and military communications experts. They have found the "Super-Pro" to meet practically every requirement in both commercial and governmental services. These experts are old friends of the "Super-Pro." . . . Many have been using them for years. The new Series 200 has been even more widely accepted as the top receiver for communications service. Electrically, it has many outstanding features such as, variable band width in addition to the variable selectivity crystal filter, and a noise limiter that is really effective. Mechanically, the "Super-Pro" is built to stand the wear and tear of continuous duty.

BECAUSE Hammarlund designs and manufactures precision equipment for military and civil use in aeronautic, marine, and land services, we have the engineering facilities to produce receivers with mechanical and electrical features not found in the ordinary receiver. The "HQ-120-X" is a shining example of this fact. Examine every detail of the "HQ." Note that it does not follow the design of production type broadcast receivers. It is really a special receiver and is not made on a mass-production basis. Try it in your own shack and you will agree it's tops. Write for booklets.

HAMMARLUND MFG. CO., INC.
424-438 WEST 33rd ST., NEW YORK

CANADIAN OFFICE: 41 WEST AVE., NO., HAMILTON, ONT.



BLILEY



CRYSTAL UNITS

• Each Bliley Quartz Crystal Unit represents the fruits of constant research, the application of careful engineering, the results of long experience, and the skill of highly trained specialists. It is no wonder, therefore, that Bliley Crystal Units are the choice of engineers, manufacturers, experimenters, and amateurs in all parts of the world.

Catalog G-11 describes precision-made crystals and mountings for all frequencies from 20 kc. to 30 mc. Circular A-7 covers units for amateur applications. Write for your copy.

BLILEY ELECTRIC CO.
UNION STATION BLDG., ERIE, PA.

(Continued from page 51)

assisted at the key or on the receiving end as the occasion arose. The 7-Mc. circuit at Castleton was handled by Ray Ainsworth, W2BSB, Andy Swider, ex-K6UKR, and J. D. Thomas, assisted by three observers with field glasses. Dorothy Knapp, W2MIY, handled the Albany end of the 7-Mc. circuit. Otto Boos, W2MTF, chairman of the committee for the event, made all necessary arrangements, including setting up of equipment and assisting in general. Omer Martratt, W2ITQ, assisted by George Jones, W2HYO, and Bill Paley, arranged for and set up the various antennas. Spencer McCarty, W2GTI, assisted by Joe Johnson, W2JBQ, handled the land line at the judges' stand. The other end of the land line, located at the message center, was handled by A. J. Sobeck, W2LLK. All equipment used was supplied by the Club members.

The Mid-Hudson Amateur Radio Club handled the half-way point, Poughkeepsie. Facilities there took two forms. At the Poughkeepsie Yacht Club, working the Albany and New York points on 3590 kc., was Robert Wingood, W2IYH, as chief operator, assisted by Ransford Ferris, W2AFI, and James White, W2AXX. The transmitter consisted of a 6V6, 6L6 and T55, with about 125 watts input. Receiver was an SX24, with a couple of Sky Champions as auxiliaries. W2CGT was the call used. The second part of the Mid-Hudson participation consisted of boat-to-Yacht Club contact, to assist each boat's refueling crew by giving them a few minutes advance notice when their man was approaching the Yacht Club. On a small power boat, cruising in the vicinity of Crum Elbow, in the Hudson River about four miles north of the Poughkeepsie Yacht Club, was Daniel G. Lawrence, W2CGT (president of the Mid-Hudson A.R.C.), assisted by Edward W. Pritchard, operating a 28-Mc. portable-mobile 'phone outfit, consisting of a 6V6 and 807, modulated by a 6L6 and powered from a Vibropack. The receiver used was a 3-tube regenerative operating on 1.75 Mc. This unit used the call W2GZP.

As each boat approached and passed the W2GZP group, their observers spotted the boat's identifying number, and W2GZP immediately flashed this number via 28-Mc. 'phone to a relay station located at the Hudson River State Hospital Yacht Club, on the river bank about a mile south of Crum Elbow. At this point Paul Grant, W2AGZ, was operator, assisted by Fred Wohlfahrt. They picked up W2GZP on a Sky Champion receiver and relayed (not rebroadcast) the information on a 1.75-Mc. transmitter, consisting of P.P. '45's final, with Class B modulation. Call used by this unit was W2AGZ, and it was, in turn, picked up at the Poughkeepsie Yacht Club and acknowledgments made via the Mid-Hudson Club's portable rig on 1.75 Mc. Frank White, W2EDT, and William Chrystal, W2DOS, presided over this equipment. Gurdon R. Abell, Jr., and Clinton Wallwork assisted these fellows and also aided the 3590-kc. crew at the P.Y.C. The boat-to-Yacht Club circuit saved considerable time and confusion, since it gave each boat's refueling crew about 5 minutes advance warning that their man was coming in. In previous years, before radio service was available, all the refueling crews had to crowd around the float and dock, straining to see which boat was arriving, and getting in each other's way.

The set-up at the finishing line at Dyckman Street, New York City, was manned by N.C.R. personnel and used the call N2LC. Two transmitters and two receivers were in operation. One unit was engaged in operation on 3590 kc. with Poughkeepsie and Albany. Watch on this frequency began at 6:00 A.M. to enable the finishing line group to receive from Albany the last-minute race entries. The second unit was on 3550 kc. and received all movement reports from N.C.R. personnel at Roseton (Newburgh), Verplanck and Tarrytown. Lt. (jg) W. J. Rooke, N2LC, was in charge of operations at N. Y. C. He was assisted by Lt. (jg) P. B. Collison, Commander of Unit Four, Section Three, 3rd Naval District, N.C.R. Chief Radioman Walter Germann of the 3rd Naval District N.C.R. Headquarters Staff was Supervisor of the Watch. Edgar C. Powell, RM2c, Unit 5, Sec. 5, and R. J. Astey, RM3c, Unit 4, Sec. 3, acted as operators with CRM Germann taking over the controls at times. Lt. Collison stood listening watches while Lt. Rooke was busily engaged forwarding reports as received by radio to news reporters and to the P.A. system, which kept hundreds of people on the dock informed at all times as to the location and status of all boats.

At Roseton, an outlying section of Newburgh below Poughkeepsie, a portable was set up by J. H. Smith,

(Continued on next left-hand page)

*Here's Another
Century Club Member
with a Completely
Eimac Equipped Station*

Wilmer Allison W5VV

Here is one of the outstanding amateur stations in the country. W5VV has consistently been among the leaders in the fifth district . . . in fact this station has won the DX contest in the fifth district the past four times. The first three times on CW, but last year stepped out ahead on fone.

Wilmer Allison has worked a total of 150 foreign countries with 136 of them confirmed. The station operates on 5, 10 and 20 meters using a full KW on 10 and 20 and 700 watts on the 5 meter band. All finals use inductive tuning and are completely free from parasitics.

Wilmer says: "I can't help but feel these rigs are very efficient. Even the five meter rig runs cool at 700 watts input on fone and the minimum unloaded plate dip is 60 mils." Wilmer says further: "Naturally I favor Eimac tubes. They are easy to neutralize, easy to drive and I like their ruggedness and endurance."

No one is better qualified to recommend Eimac tubes than Wilmer Allison. He's been

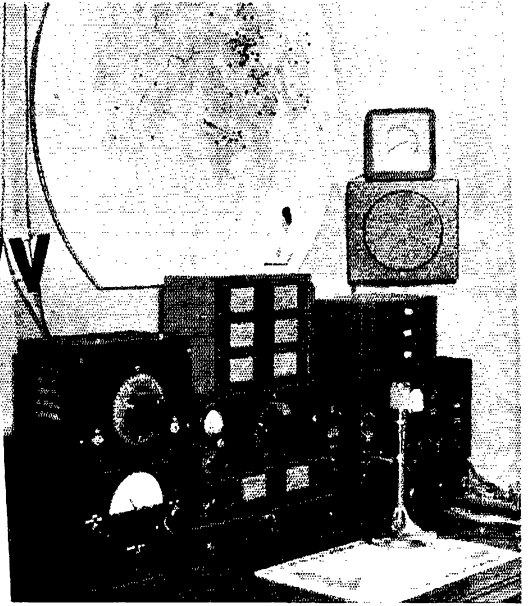

using them since the first Eimac tubes were made. Right now his transmitter has 2 pairs of Eimac 250TH's driven by 2 Eimac 100TH's in the ten and twenty meter units and a pair of 100TH's in the final of the five meter rig. Eimac Vacuum Tank Condensers are used in the ten and twenty meter units with great success. Going all the way with Eimac tubes has brought real results for Station W5VV. Why don't you consult your nearest Eimac dealer, or write direct today for information about these Vacuum tubes with a proven record for better performance.

Eimac TUBES

EITEL-McCULLOUGH, INC.,
San Bruno, California



California, Nevada
HERB BECKER, 1530 W.
104th St., Los Angeles, Cal.
Wash., Ore., Idaho, Mont.
GENERAL SALES CO.,
Verner O. Jensen, 2603-07
Second Ave., Seattle, Wash.
Colo., Wyo., New Mexico,
Arizona, Utah
RICHARD A. HYDE,
3253 Quirman St., Denver,
Colo.

N. Caro., S. Caro., Georgia,
Tenn., Flor., Ala., Miss.
JAMES MILLAR, 316
Ninth St. N. E., Atlanta,
Georgia
N. Y., N. J., Penn., Md., Del.,
Dist. of Cal., Maine, N. H.,
R. I., Conn., Mass.
ADOLPH SCHWARTZ,
14726 Elm Ave., Flushing,
New York

Texas, La., Okla., Ark.
J. EARL SMITH, 2821
Live Oak St., Dallas, Texas
Chicago, Illinois, Wisconsin
G. G. RYAN, 549 W.
Washington Blvd., Chicago,
Ill.
Ohio, Mich., Ky., Ind., Minn.,
Mo., Kan., Neb., Iowa
PEEL SALES ENGINEERING CO., E. R. Peel
134 E. Erie St., Chicago, Ill.

HARD TO GET ?

...SORRY

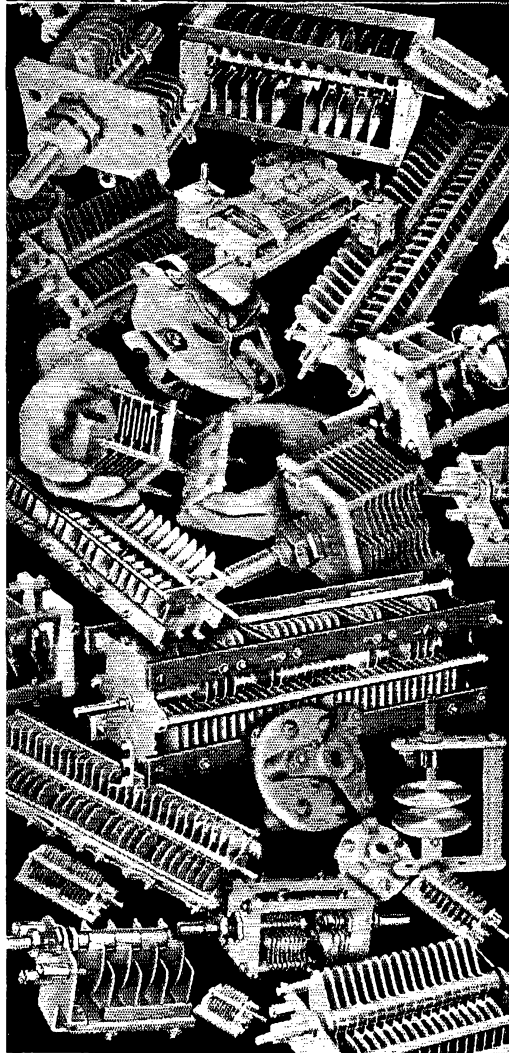

If your dealer says "sorry, they are on order but out of stock," when you ask for some CARDWELL product, don't blame him — it's probably our fault.

The demands on CARDWELL facilities by Uncle Sam must be met.

We ask your consideration when deliveries are slow, and thank you for the friendly patience you have shown.

**THE ALLEN D. CARDWELL
MANUFACTURING CORPORATION**
83 PROSPECT STREET, BROOKLYN, NEW YORK

W2BCR, and Henry J. Abreu, W2CIF, with the help of a couple of non-hams. They worked with the 3550-kc. N.C.R. circuit, reporting boats as they passed Roseton. Identification of boats was made through field glasses. W2BCR/2 used 175 watts input to an HK54 final and a Hammarlund Super Pro receiver.

Next point south on the 3550-kc. circuit was Verplanck's Point, where a portable unit already set up in a truck belonging to Robert L. Fischer, N2LA, and manned by Fischer, Archie Bunting, RM1c, N2ISJ, George Bisset and his son Harold, drove to a point close to the river, at 7:30 in the morning. The antenna was erected by attaching a rope to the end of the wire, throwing the rope over the arm of a pole, and driving the truck down the road until the rope and 132-foot wire was taut. The rig consisted of an 89 crystal-e.c. oscillator and an 807 operated from batteries with an input of 16 watts. This is N2ISJ's regular rig. Receiver was N2LA's SX25, operating from the same batteries. Operating was done alternately by N2LA and N2ISJ, while the identification of the boats was done by George Bisset and his son. As the boats passed their numbers were passed to the finish line in N. Y. C. As much as could be seen of stalls, breakdowns, beaching, etc., was also reported to New York. The call N2LA was used at Verplanck.

At Tarrytown, also in the 3550-kc. circuit, a portable station signing N2LDS/2 was set up at the Tarrytown Yacht Club by Allen C. Sheldon, N2IDY, V. F. Stokes, N2JAI, and Edward B. Chapman, N2LDS. The Commodore of the Yacht Club provided a motorboat on which a 1.75-Mc. 'phone rig was installed by Wm. F. Hoisington, W1LAS, his XYL, and N2IDY. The boat was operated by the Commodore and the rig by W1LAS, and lay offshore between Tarrytown and Nyack reporting the outboards as they passed. This unit was in contact with the main station, N2LDS, at the Yacht Club by 1.75-Mc. 'phone. The rigs used for this work belong to W1LAS and consist of a combination transmitter and receiver. The 3550-kc. rig at the Yacht Club was N2LDS' Browning e.c.o. unit.

The entire cooperation by radio amateurs went off very smoothly and Mr. Charles F. Chapman, Chairman of the Race Committee and Commodore Harry Birdsall, Sr., both of the Middle Atlantic Outboard Motor Boat Association, expressed complete satisfaction with the results.

We wish to express appreciation to the following for the very excellent reports submitted, from which the above account was prepared: A. J. Soback, W2LLK, Sec'y Albany Radio Club; Archie Bunting, W2ISJ, for the N.C.R. participants; and D. P. Love, W2BJX, Sec'y Mid-Hudson Amateur Radio Club.

O.B.S.

The following is a supplement to the list of A.R.R.L. Official Broadcasting Stations in October QST (page 76): W1INW, W3GNU, W3HAE, W3HNX, W4BOW, W4ERX, W4GQH, W5HVN, W7YG, W9CGK, W9MWR, W9TQD.

Something new in emergency communication work was experienced last April by three members of the Associated Amateur Radio Operators of Denver (Colo.). While cruising the countryside in their car, testing portable-mobile equipment in preparation for a club activity, W9VTK and W9WYX came upon an automobile, which had just overturned following a crash into the side of a mountain. The four occupants were seriously injured, and immediate aid was needed. Through W9BQO, Denver, with whom they were in contact, VTK and WYX sent word to the State Highway Patrol, and in less than five minutes an ambulance was en route to the scene of the accident. A letter of appreciation from the Chief of Police to the amateurs concerned reads in part as follows: "I have been informed of the splendid manner in which you three gentlemen handled this matter and took it upon yourselves to advise the proper police authorities, and which prompt action on your part undoubtedly avoided more serious consequences in this unfortunate accident."

W9TBF of Pender, Nebr., did outstanding work when heavy rains brought flood conditions to six counties in Nebraska late this Spring. Although flood waters were swirling past his home and had completely covered the front porch, TBF stayed at the controls and provided Pender with its only contact with the outside during the height of the disaster.

(Continued on next left-hand page)

for Every Application

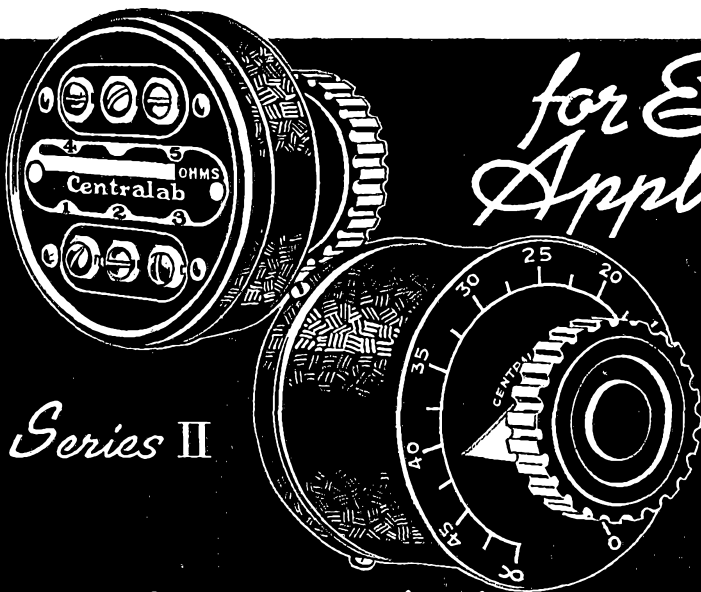

Series II

Centralab SOUND PROJECTION CONTROLS

CENTRALAB SERIES II

Controls are the finest for input circuits in broadcast stations, public address systems, and recording apparatus of new or old design. Will prove faultless in the most critical service.

The curve chart above shows the change in impedance and attenuation plotted against clockwise rotation for a "T" pad attenuator. The impedance characteristic (dotted line) is substantially the same at any setting. The attenuation curve (solid line) varies from infinity at zero rotation to zero Db. at full rotation. No insertion loss.

Electrostatic and electromagnetic shielding provided by a black finished steel case. Bakelite screw type terminal strip on back of case. All resistance elements insulated from shaft and bushing. Single hole mounting. Mounting bushing 3/4" long with 2 locknuts and lockwashers. Case diameter 2 3/4". Depth back of panel "T" Pad — 2 3/8"; Gain Control — 1 3/8". Maximum load dissipation 1 watt.

For detailed information, write for technical booklet.

CENTRALAB: Division of Globe-Union Inc.
MILWAUKEE, WISCONSIN

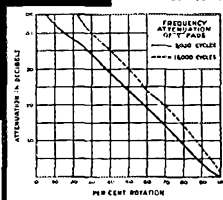
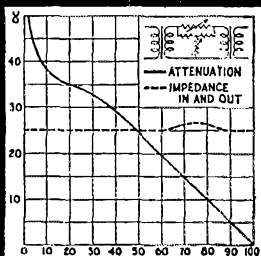

ECONOMY P/A CONTROLS

These controls are intermediate to the series II line and the older series I types. As their name implies, they are economy controls designed primarily for inexpensive sound equipment, where original cost is a limiting factor. They are designed for all types of fading and mixing systems. All units have soft aluminum shaft 2 1/4" from end of 3/8" brass bushing. Small diameter bakelite case same dimension as Standard Radiom. Non-rubbing contact for smooth, quiet operation. Limited to input applications. Maximum power rating for all units one watt.

BRIEFS

At least two of the eleven preliminary winners in the R.C.A. Opportunity Scholarship Competition are radio amateurs. George F. Smith, W5GSD, and R. K. Moore, W9JKI, together with the nine other winners, will receive a one month's trip, with all expenses paid, to New York and Camden, where they will compete for a \$4000 scholarship in electrical and radio engineering. The competition in which the preliminary winners were selected was conducted in 17,000 high schools. The eleven students will spend four weeks inspecting and studying R.C.A. facilities in and around New York and at Camden, N. J. On or about August 31st, the judges will select the student who in their opinion is most likely to succeed in the field of radio science. He will be awarded the \$4000 grand prize scholarship in the college of his choice. The other ten preliminary winners will each receive a cash award of \$100.

— . . . —

Amateur radio gave real aid when a wind, snow and sleet storm hit Eastport, Maine, and vicinity on April 21st. Edward Sprague (call unknown) provided the only means of communication with Eastport on Sunday, the 21st. Operating a station at Quoddy Head, beginning at 11 a.m., Sprague relayed to Coast Guard stations at Southwest Harbor the calls for help sent by Eastport residents. Other amateurs assisting in the work were W1LIC of Ellsworth, W1AUC of Bar Harbor, W1HKP of West Jonesport, and W1EWN of Portland.

— . . . —

W3BEK reports on the important part played by amateur radio in the Hobby Show sponsored by the Central Y.M.C.A., Norfolk, Va. The Norfolk Radio Club set up three transmitters: one on 3.5 Mc. for traffic; one on 7 Mc. for c.w. rag chewing; and one on 1.75 Mc. for local 'phone contacts. For the latter band, the popular emergency-portable transmitters were used in order to demonstrate their effectiveness for local communication. The club's permanent equipment, with 100 watts, was used on 7 Mc., and W3HAE's 300-watt rig served on 3.5 Mc. Message handling gained the spotlight from the beginning, and the traffic flowed smoothly out to the A.A.R.S. and A.R.R.L. trunk lines and nets. More than 275 messages were filed and dispatched with Buster Etheridge, W3HAE, doing the bulk of the "bug swinging," although assisted at times by the able fists of W3IKV and W3RZ. The 'phone men had their inning on 1.75 Mc. with many contacts. During one QSO, W3II from his home station started a radio quiz. Visitors to the show were allowed to answer his questions "over the radio," and a highly interesting feature resulted. The dispatching of traffic, the display and operation of equipment and the explanations of the nature and functions of the Radio Amateur, brought delight to hundreds of visitors during the week of the show.

— . . . —

The Mid-South Radio Association cooperated with the National Guards in controlling traffic at the Jaycee Air Show held May 19th at Memphis, Tenn. Transmitters and receivers were stationed at the entrance of roads leading to the airport and orders were given by radio.

— . . . —

W2KUD, Schenectady, N. Y., worked all districts on 14-Mc. 'phone in a single evening from 7:49 p.m. E.D.S.T. to 11:40 p.m., on May 18th. Stations worked were W1ZR, W2KAP and W2EEG, W3LN, W4DAL, W5FNH, W6AWD, W7FKW, W8OKU and W9LAK. Incidentally, W2KUD, Roy Jordan, was recipient of the 1940 Schenectady Amateur Radio Association silver plaque award for meritorious service to amateur radio.

— . . . —

According to a newspaper clipping received from W3CCO, S.C.M. Southern New Jersey, "Many stories have been told about the man who fell asleep at the switch — but here's one about a radio ham who fell asleep at his microphone." In the midst of a three-way conversation about a fishing trip, silence from station W3GVM (R. M. Feger, Gloucester, N. J.) was followed by deep snoring. "Mrs. Gertrude Spingler, listening to the conversation, became alarmed and notified the Camden police who in turn notified Gloucester police. A patrolman found the broadcaster sleeping in front of his open microphone. 'I guess the heat made me doze off,' Feger said."

(Continued on next left-hand page)

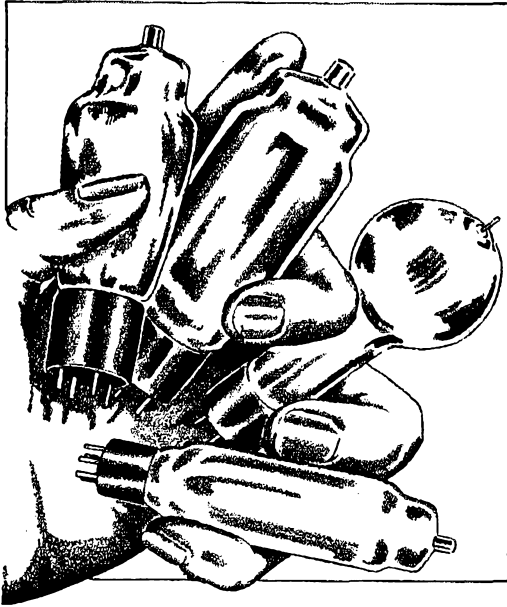

WHAT MAKES SOME TUBES *better* THAN OTHERS?

Many factors effect a tube's characteristics — its life, the power a transmission or a rectifying tube can handle, etc. — but, other factors being equal, tubes with SPEER Graphite Anodes will handle more power and last longer because of their superior ability to dissipate the heat of operation.

At 510° C., Graphite's heat dissipating value is 70% higher than tungsten, 76% higher than molybdenum, 88% above tantalum, 97% to 99% above nickel.

Buy tubes with SPEER Graphite Anodes for longest useful life and power. Write for booklet and list of makers.



"IT'S THE LAST WORD
IN RECEIVERS," Says
W8CPC

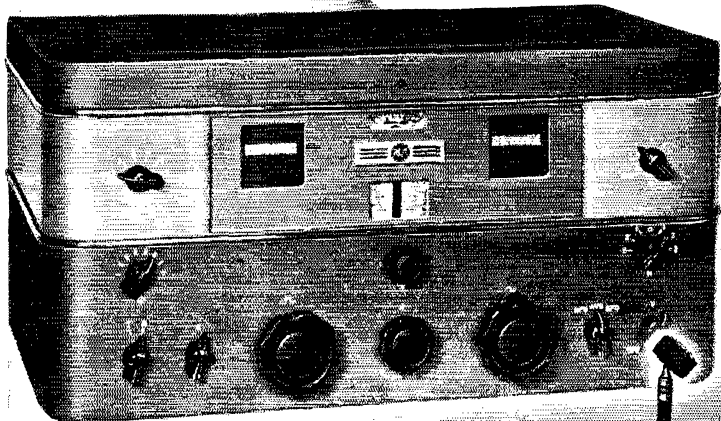

AR-77

COMMUNICATION RECEIVER



In this receiver, RCA engineering has gone the limit to provide the utmost in signal-getting ability, noise-free operation, stability, convenience and economy. Frequency coverage, 540-31,000 KC in six ranges—dual R-F alignment: stay-put tuning; negative feedback in audio amplifier; uni-view dial; calibrated bandspread for 10, 20, 40 and 80 meter bands; accurate signal re-set; variable selectivity in six steps with crystal filter; improved image rejector; adjustable noise limiter and many other features.

Net Price, \$139.50 f.o.b. factory.
8" Speaker in matched cabinet, \$8.00.

"I have been using the AR-77 for about a month and find that it is even finer than your announcement led me to expect."

... So writes Dr. Burton T. Simpson, W8CPC of Buffalo, an old-timer in the amateur game and still one of the best-known voices on the air. He adds: "The AR-77 is extremely sensitive and certainly brings the signals in, even under bad conditions. The noise limiter is particularly valuable because of its manual adjustment which can easily be regulated to best advantage to meet local conditions in separating signal from noise. I am more than pleased with the outfit and believe it is the last word in receivers!"

TRY IT TODAY! Dr. Simpson is one of the many well-known amateurs who have accorded enthusiastic praise to the AR-77—the most sensitive, the most stable receiver RCA has ever produced. Write for descriptive folder, but, above all, visit your nearest RCA distributor and test its superiority for yourself. You be the judge!



for Amateur Radio

RCA MANUFACTURING COMPANY, INC., Amateur Division, CAMDEN, N. J. • A Service of the Radio Corporation of America

ABBOTT—MRT-3

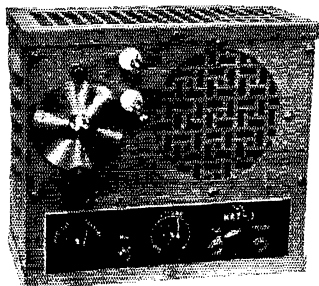

2½ Meter
Hi-Power
Mobile
Transceiver
20 Watts Input
Price
\$47.00 List
Less — 40%
to Amateurs

The unit you need for your car operates from car battery and vibrator power supply.

Real transmitting tube Hytron HY-75 used in the R.F.
EXTREMELY COMPACT

Size 9" long — 8" high — 4" deep. Self contained PM dynamic speaker.

FIXED STATION OPERATION

AC power supply is available for fixed station operation from 110 volts A.C.

NOTE: Portable and mobile operation on 2½ meters is permitted by the F. C. C.

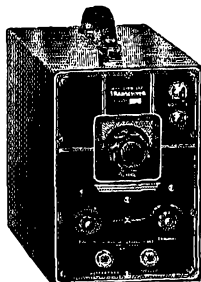

DK-2
2½ METER
BATTERY TRANSCIVER
Ideal for summer portable operation — simple and convenient.
List Price \$27.50
LESS TUBES AND BATTERIES
40% Discount to Amateurs

GENERAL: The DK-2 is a completely self-contained 112 mc. radio-telephone transmitter and receiver, for use in your car, plane, boat, or while being carried, for portable work. It is very simple to operate. The working

range is between 2 to 30 miles depending on the location. Astonishing results have been obtained.

BATTERY REQUIREMENTS: Three 45 volt B batteries like Burgess 5308; and four No. 6 dry cells, or two Burgess 2F2H batteries.

SEE IT AT YOUR FAVORITE DEALER

Write for bulletin

ABBOTT INSTRUMENT, INC.

51 Vesey Street

New York City



A KNOCK OUT

Universal's "KO" model, just out, super microphone value. Hi-output crystal unit. Output level 48 db. below one volt per bar. Freq. range 50-6000 CPS. Incl. 10 ft. cable. Accessories enables "KO" to be suspended, as hand mike, desk or floor stand. At your dealer or jobber.

\$16.25
LIST

Universal Microphone Co., Ltd.

INGLEWOOD, CALIFORNIA

A Ham-Made Army

The city of Sioux City, Iowa, is the home of some seventy amateur operators. In this middle western trade center the National Guard has established a signal corps troop, the only one of its kind in the entire United States. This unit is the first National Guard Division-Headquarters signal corps troop ever to be organized. The division of which this troop is a part embraces troops from Oregon, Washington, Utah, Montana, Dakota, Iowa, and Missouri. A glance at the duties of this signal corps troop will indicate why amateurs were selected as the key men.

The unit is stationed at Division headquarters and handles all communications on the Major General of the Division to his three Brigadier Generals in charge of the brigades in the field. Men in the headquarters troop will maintain contacts by means of radiotelephone, radiotelegraph, land line telephone and telegraph, and carrier pigeon. The very nature of this work demands that the troop be expert in its various jobs, and that the whole unit be equipped and trained for mobile operations. It has, therefore, been designated as a troop of cavalry, completely motorized for rapid movement. Personnel consists of sixty men, some raw recruits, some men transferred from infantry, and eight amateur radio operators. These hams are Stephen C. Dier, W9DWV; Bruce Morrow, W9F80; Henry Hildebrand, W9KZE; Howard Hamm, W9RJE; Donald Perasso, W9YQY; Carl Gray, W9EUEH; C. W. Hoyt, W9DWN; and Cliff Taylor, W9EQN.

In command is Captain Dier (W9DWV), who is in every sense a "ham's ham." Steve Dier began operating about 1912. When calls began to be issued Steve drew 9MS. War interrupted his amateur activities. Stationed in New Mexico with a machine gun outfit when a call came for radio operators, Steve responded and eventually wound up as an operator at General Headquarters in France. He became chief operator of the first Army intercept station, later being put in charge of all operators. He was discharged in 1919, got his present call, and promptly forgot about all things military until he was called upon to organize and command a new troop. Carl Gray (W9EUEH) has been commissioned Lieutenant and is second in command. Technical Sergeant is Cliff Taylor (W9EQN). All the non-technical men must be taught radio from the ground up. The men have been allowed to select which type of work they wish to do, and the platoons have been organized accordingly. Instruction to all men, whether they will finally be assigned to radio or land line, must begin with fundamental electricity and the allied subjects. The teachers are the amateurs. To quote Captain Dier, "Our back bone is the radio amateur. They are our key non-commissioned officers and instructors."

Tentative equipment plans provide for several portable transmitters having a range of about seventy-five miles c.w. and thirty-five miles 'phone. Bolstering these will be one or two high-power, gas-driven, truck-mounted transmitters for base operation in the field. It is also expected that a high-power station will be erected at the armory in Sioux City. This will provide a means of training the men in actual construction and operation of radio equipment before they are turned loose in field maneuvers. Classes have already begun. In the end the new signal troop will be a fast, clean operating bunch of military communications experts. In short, a "Ham-Made Army."

— Paul Sperting, W9QOK

Tech. Sgt. Edwin G. Bevan of Fort Knox, Ky., points out that mail congestion, a source of grief for the members of the fast and frequent traveling 7th Cavalry Brigade, need not worry them, or the widows left at home, this year, for a ham radio operator at the Fort keeps constant contact with the travelers daily. The ham at Fort Knox is Mrs. E. O. Helland, wife of Tech. Sgt. Helland of the 13th Cavalry. Sgt. and Mrs. Helland operate W9ZTU. Mrs. Helland has worked out a daily schedule with the brigade. She goes on the air at 1:00, 5:45 and 7:00 p.m., and has contact with both the 1st and 13th Cavalry station operators in the South. Pvt. Troutman (W8AWX/9) of Headquarters Troop, 1st Cavalry, handles all 1st Cavalry traffic for W9ZTU, while Sgt. Helland takes care of all traffic sent via the 13th Cavalry. For the first twelve days the troops were away from Fort Knox, Mrs. Helland handled a total of 288 messages.

(Continued on next left-hand page)

Frequency Modulation



EXTENDED RANGE - HIGH FIDELITY

There is now available a complete family of special Jensen products for Frequency Modulation and Television receivers as well as for monitoring and studio work. ¶ The new 15" dual-unit model in Permanent Magnet design has a built-in filter network—shows an extended high frequency response up to 14,000 cps. The 8" and 12" PM models are extended to 10,000 cycles. ¶ All three available in the standard "M" type *Bass Reflex* enclosure—the two larger also available in the new Walnut "CA" type *Bass Reflex* enclosure. All extremely modestly priced. ¶ Jensen Radio Mfg. Co., 6601 S. Laramie, Chicago.

Jensen
Bass Reflex

The New TURNER Microphone Models

See These
Before You
Buy!

Hang It!
Hold It!
Use it
on
Desk
or
Floor
Stand



TURNER Hand-D

CRYSTAL or DYNAMIC

Microphones do the Job of
Several Mikes—at Low Cost

Ideal for voice, music pickup or auto use.
POSITIVE CONTACT SLIDE SWITCH
on both Crystals and Dynamics permit off-
operation. Won't blast from close speak-
ing. Rich, brushed chrome finish. Complete
with 7 ft. removable cable set, diagrams and
chamoisette mike bag.
9D Dynamic Hi-Impedance, List \$25
9X Crystal, List \$22.50

The Turner "Challenger"

Challenges comparison in performance,
appearance and price. Finished in rich,
brushed chrome.

CX Crystal gives crisp, clear performance.
Crystal impregnated against moisture. Level
-50DB. Range 50-7,000 cycles. With dia-
grams and 7 ft. cable, List \$15

CD Dynamic, with high level dynamic cartridge.
Same in appearance as CX. Level -52DB. Range
40-8,000 cycles. Packed with diagrams and 7 ft. cable.
200 or 500 ohms or hi-impedance, List \$16.50
Crystals Lic. Under Patents of The Brush Development Co.

904 17th St. N.E.

TURNER

Cedar Rapids, Iowa



GETTING ACQUAINTED

WITH

RADIO

By ALFRED MORGAN

A new book designed to give the lay-
man interested in radio a complete
understanding of the fundamentals
and more technical aspects of the
subject. Here are chapters on: radio's
development, radio waves, antennas,
the functions of the tube, etc., plus
instructions for building simple re-
ceiving and transmitting sets and how
to obtain a license to operate. Ex-
planatory drawings. \$2.50

D. APPLETON-CENTURY COMPANY

35 W. 32nd St., New York

ELECTION NOTICES

To all A.R.R.L. Members residing in the Sections listed below:
(The list gives the Sections, closing date for receipt of nominating petitions for Section Managers, the name of the present incumbent and the date of expiration of his term of office.) This notice supersedes previous notices.

In cases where no valid nominating petitions have been received from A.R.R.L. members residing in the different Sections in response to our previous notices, the closing dates for receipt of nominating petitions are set ahead of the dates given here-with. In the absence of nominating petitions from Members of a Section, the incumbent continues to hold his official position and carry on the work of the Section subject, of course, to the filing of proper nominating petitions and the holding of an election by ballot or as may be necessary. Petitions must be in West Hartford on or before noon of the dates specified.

Section	Closing Date	Present SCM	Present Term of Office Ends
Philippines	Aug. 1, 1940	George L. Rickard	Oct. 15, 1938
Idaho	Aug. 1, 1940	Carl Eichelberger	June 15, 1939
Alberta *	Aug. 1, 1940	C. B. Jamieson	Feb. 18, 1940
Kentucky *	Aug. 1, 1940	Darrell A. Downard	April 15, 1940
Maritime *	Aug. 1, 1940	Arthur M. Crowell	June 15, 1940
W. Penna.	Aug. 1, 1940	Kendall Speer, Jr.	July 10, 1940
Santa Clara Valley	Aug. 1, 1940	Eilbert J. Amarantes	Aug. 15, 1940
Ohio	Aug. 1, 1940	E. H. Gibbs	Aug. 17, 1940
W. Mass.	Aug. 1, 1940	William J. Barrett	Aug. 17, 1940
So. Minn.	Aug. 15, 1940	Millard Bender	Aug. 22, 1940
Utah-Wyoming	Aug. 15, 1940	Ernest E. Parshall	Aug. 22, 1940
New Hampshire	Aug. 15, 1940	Carl B. Evans	Sept. 1, 1940
Tennessee	Oct. 1, 1940	William Harold Walker	Oct. 14, 1940
Michigan *	Oct. 1, 1940	Harold C. Bird	Oct. 15, 1940
Ontario *	Oct. 1, 1940	Fred H. B. Saxon	Oct. 15, 1940
Kansas	Oct. 15, 1940	Melvin D. Kirby	Oct. 29, 1940

* In Canadian sections nominating petitions for Section Managers must be addressed to Canadian General Manager, Alex Reid, 169 Logan Ave., St. Lambert, Quebec. To be valid such petitions must be filed with him on or before the closing dates named.

1. You are hereby notified that an election for an A.R.R.L. Section Communications Manager for the next two-year term of office is about to be held in each of these Sections in accordance with the provisions of the By-Laws.
2. The elections will take place in the different Sections immediately after the closing date for receipt of nominating petitions as given opposite the different Sections. The Ballots mailed from Headquarters will list in alphabetical sequence the names of all eligible candidates nominated for the position by A.R.R.L. members residing in the Sections concerned. Ballots will be mailed to members as of the closing dates specified above, for receipt of nominating petitions.
3. Nominating petitions from the Sections named are hereby solicited. Five or more A.R.R.L. members residing in any Section have the privilege of nominating any member of the League as candidate for Section Manager. The following form for nomination is suggested: (Place and date)

Communications Manager, A.R.R.L.

38 La Salle Road, West Hartford, Conn.

We, the undersigned members of the A.R.R.L. residing in the Section of the Division hereby nominate as candidate for Section Communications Manager for this Section for the next two-year term of office.

(Five or more signatures of A.R.R.L. members are required.)

The candidates and five or more signers must be League members in good standing or the petition will be thrown out as invalid. Each candidate must have been a licensed amateur operator for at least two years and similarly, a member of the League for at least one continuous year, immediately prior to his nomination or the petition will likewise be invalidated. The complete name, address, and station call of the candidate should be included. All such petitions must be filed at the headquarters office of the League in West Hartford, Conn., by noon of the closing date given for receipt of nominating petitions. There is no limit to the number of petitions that may be filed, but no member shall sign more than one.

4. Members are urged to take initiative immediately, filing petitions for the officials for each Section listed above. This is your opportunity to put the man of your choice in office to carry on the work of the organization in your Section.

— F. E. Handy, Communications Manager

ELECTION RESULTS

Valid petitions nominating a single candidate as Section Manager were filed in a number of Sections as provided in our Constitution and By-Laws, electing the following official, the term of office starting on the date given.

Los Angeles Ralph B. Cllick July 1, 1940

In the Alabama Section of the Southeastern Division Mr. James F. Thompson, W4DGS, and Mr. C. C. Atkinson, W4ECL, were nominated. Mr. Thompson received 70 votes and Mr. Atkinson received 38 votes. Mr. Thompson's term of office began May 22, 1940.

In the Virginia Section of the Roanoke Division Mr. Frank S. Anderson, W3GWQ, and Mr. W. L. Turner, W3BEK, were nominated. Mr. Anderson received 62 votes and Mr. Turner received 44 votes. Mr. Anderson's term of office began May 27, 1940.

In Alaska we are awaiting final word on eligibility of the candidate before making final announcement.

BUY ON EASY TERMS • MAIL ORDERS PROMPTLY FILLED • Write for FREE CATALOG

★ \$5.00 with your order—puts this NEW SUPER SKYRIDER in your home!

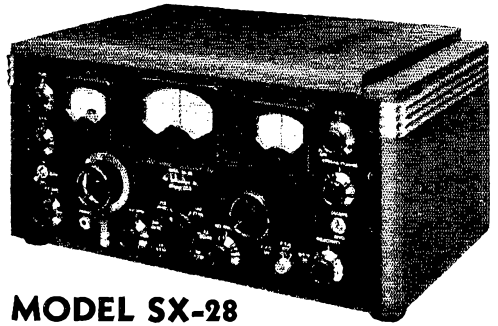

MODEL SX-28

This new communications receiver sets new standards for receiver performance. Frequency Range 540 KC to 43 MC.

FEATURES . . .

- ★ 15 tubes ★ 6 bands for the most satisfactory I/C ratio ★ 2 RF stages ★ Push-pull, and high fidelity audio output ★ 6-stop wide range variable selectivity
- ★ Band pass audio filter ★ Wide angle "S" meter ★ Phono jack ★ Adequate headphone output ★ Improved signal to image and noise ratio ★ 80-40-20-10 meter amateur bands calibrated ★ Temperature compensated high frequency oscillator

Cash Price \$159.90

LIBERAL TIME PAYMENT PLAN

\$15.90 down—and \$12.70 per month for 12 months

★ Pay Express Company \$10.90 making total of \$15.90 down payment

Yachtsman
-AHoy

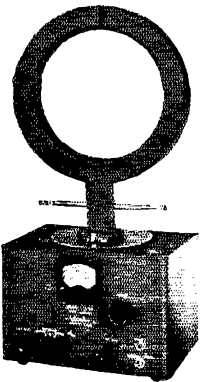

Radio Compass—Model S-30

This model S-30 Hallicrafter Radio Compass and Direction Finder will enable you, at all times, to check your position against Beacon, Broadcast, or Shore Radio Phone Stations.

Coverage from 200 to 3000 KC (1500 to 100 meters)

Frequency Range

Beacon Band	220 to 540 KC
Broadcast Band	535 to 1340 KC
Marine Band	1200 to 3000 KC

Net Price \$99.50

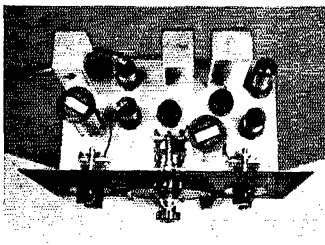

SKY TRAVELER — Model S-29

Take it with you — Use it at home — The Sky Traveler is a true Universal receiver. Operates on either 110 V AC or DC, or from its self-contained battery. Receiver covers from 542 KC to 30.5 MC (553 to 9.85 meters). Self-contained Antenna. Electrical Band Spread. Sensitivity below 2 Microvolts on all Bands. One Stage Preselection. Improved Automatic Noise Limiter.

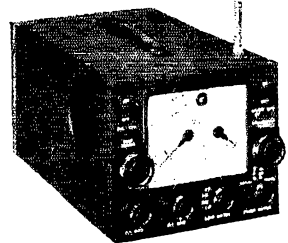

Cash Price \$59.50

LIBERAL TIME PAYMENT PLAN

Down Payment \$5.95
Per month for 12 months \$4.73

Kit of Parts for the

QST Regenerative Single-Signal Super
Described in October '38 QST by George Grammer
All parts as specified and of nationally advertised manufacturers.

Complete kitless tubes and power supply. NET PRICE **\$19.56**

Kit of 6 Raytheon tubes for above kit. NET PRICE **\$3.95**

Crackle finish hinged top cabinet supplied at \$1.57 extra

The **RADIO SHACK**
167 WASHINGTON ST., BOSTON, MASS., U.S.A.

RADIO TRAINING



PORT ARTHUR COLLEGE — not privately owned, not operated for profit, a college built and endowed by the late capitalist-philanthropist, John W. Gates — offers the most thorough practical Radio training in America. P. A. C. owns Radio Station KPAC, which is equipped with the very latest type 1000-Watt high fidelity RCA transmitter, operating on 1220 kc. with directional antenna system. The college is authorized to teach RCA texts. Additional equipment consists of the latest type Marine and Airways Transmitter installation complete; SOS Automatic Alarm; Marine Direction Finder, two-way Television Transmitter and Receiver; Trans-radio Press Receiving Equipment; laboratory facilities where every phase of practical radio assembly technique is taught. Students assemble composite transmitters, audio amplifiers, RF amplifiers, etc. The Radio training covers thoroughly Airways, Press, Announcing, Teletype, Typewriting, Laboratory and practical experience at KPAC transmitter, control room and studios. Announcing is an optional part of this training; nevertheless a number of students annually make successful announcers.

Port Arthur College pioneered the teaching of radio with its first classes in 1909, and for thirty-one years has maintained an active Employment Bureau that is successful in placing graduates in airways, broadcast and marine radio industries.

If interested in details about the Radio Course, write for Bulletin R

PORT ARTHUR COLLEGE
PORT ARTHUR (World-Known Port)
TEXAS

MICROMETER FREQUENCY METER

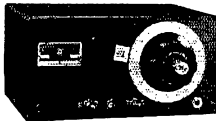

... a precision, heterodyne-type, band spread instrument for police, relay-broadcast, aviation

stations • will monitor several transmitters, from 1.5 to 56 mc. • calibrations give percentage deviation • accuracy better than 0.01% • net price, Type 103, \$90.00; Type 105 with crystal calibrator, \$135.00 • ask for Engineering Data sheets.

LAMPKIN LABORATORIES • BRADENTON FLA., U. S. A.

W5CXH/6 Wins 1939 Maxim Award

(Continued from page 27)

tometer) and in New Orleans as estimator for a local electrical contracting firm.

A full program — but the sort of thing one might logically expect from a fellow like Dawkins Espy. His record to date justifies the assertion that he is a fitting recipient of the Maxim Award.

A.R.R.L. AFFILIATED CLUB HONOR ROLL

All members of these are A.R.R.L. members

- Asheville Amateur Radio Club, Asheville, N. C.
- Associated Amateur Radio Operators of Denver, Colo.
- Bridgeport Amateur Radio Association, Bridgeport, Conn.
- Chester Radio Club, Chester, Pa.
- Connecticut Brass Pounders Association, Noroton Heights, Conn.
- Dells Region Radio Club, Portage, Wis.
- Detroit Amateur Radio Association, Detroit, Mich.
- Glendale Amateur Radio Society, Glendale, Calif.
- Hi-Q Radio Club, Lynn, Mass.
- Intercity Radio Club, Galion, Ohio
- Iowa-Illinois Amateur Radio Club, Burlington, Iowa
- Baton Rouge Amateur Radio Club, Baton Rouge, La.
- M.A.K. Amateur Radio Association, Mass.
- Mike & Key Club of Ithaca, New York
- O.B.P., Chapter No. 1, St. Louis, Mo.
- Radio Club of Tacoma, Inc., Tacoma, Wash.
- Short Wave Amateur Club of America, New Orleans, La.
- The L/C Club of New Jersey, Jersey City, N. J.
- The T9 Club, Beverly, Mass.
- Trenton Radio Society, Trenton, N. J.
- Valley Radio Club, Eugene, Oregon
- Winston-Salem Amateur Radio Club, Inc., Winston-Salem, N. C.
- York Radio Club, Elmhurst, Ill.
- York Road Radio Club, Glenside, Pa.
- The 56-Mc. Minutemen, Winchester, Mass.

NORTHWESTERN DIVISION CONVENTION

August 24th and 25th
 Walla Walla, Washington

Under the auspices of the Walla Walla Amateur Radio Club. For further details write Chairman Wilbur Beale, W7FCG, c/o Marcus Whitman Hotel.

5 Meters for Fun—

NEW THRILLS— NEW "DX" RECORDS

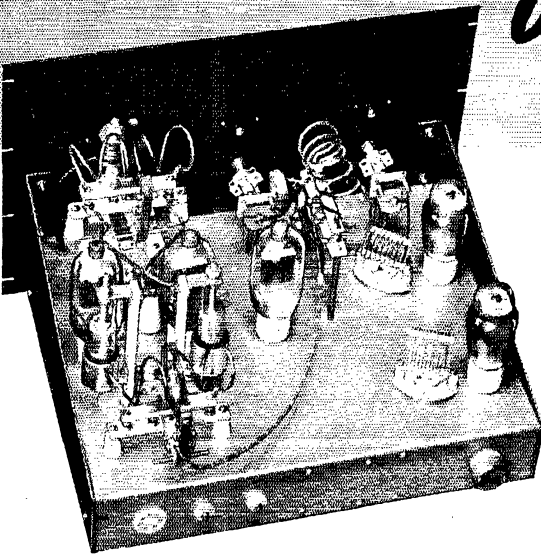

with TAYLOR'S 5 Meter Rig!

Here's a rig that will provide new thrills. "Hams" who formerly confined their operations to the lower frequencies will find Taylor's 5 Meter Rig an ideal performer.

No one yet has been credited with working all states on 5 Meters. Perhaps you can be the first. There's loads of fun in pioneering on 5 Meters and making new contacts on this friendly band.

250 Watts Input Using TAYLOR T-21's and TZ-40's

The Taylor 5 Meter Rig incorporates the best ideas gathered from discussions with hundreds of amateurs in all parts of the country. In addition to providing outstanding performance on 5 Meters, its efficiency is very good on 10 and 20. First described in the 1939 Taylor Manual, this rig has proved so popular that it was included with the 1940 manual. So enthusiastic have been the comments from ama-

teurs who have constructed this rig that the decision was made to make this transmitter available for easy low cost construction. For a limited time only, a complete set of chassis with all socket and other large holes already punched, will be furnished FREE of charge through your distributor when you purchase the complete set of Taylor Tubes for this transmitter.

1940 Manual

Complete technical information on the construction of this transmitter is given on pages 38 to 45 in the 1940 edition of the Taylor Manual now available FREE at your parts distributor or for 5c in coin or stamps direct from the Taylor Tube Co.

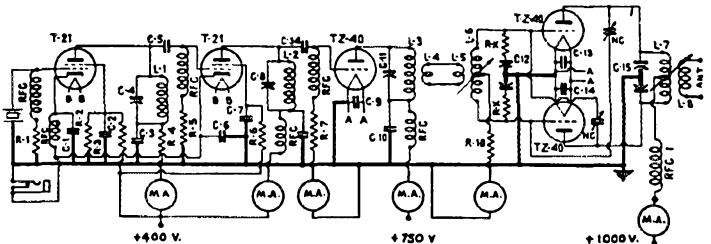

Taylor HEAVY **CUSTOM BUILT** DUTY **Tubes**

TAYLOR TUBES, INC., 2341 WABANSIA AVE., CHICAGO, ILLINOIS

Station Activities



ATLANTIC DIVISION

EASTERN PENNSYLVANIA — SCM, Jerry Mathis, W3BES — All regular schedules quit for the summer but maintaining contacts through A.A.R.S. skeleton nets — 3AKB. Expect to do a little work on the ultra-highs this summer — 3AOC. The E. Pa. Net is closed for the summer and will resume Sept. 1, 1940. I made a trip to see 8ATH, Memorial Day, and was treated swell — 3AQN. I spent most of my time on 56 Mc. working many stations in Penna. and New Jersey, but heard some W9's and W4's — 3BRZ. 3BXE built a most gorgeous Field Day rig. June 3rd the Lancaster Transmitting Society held a very successful QSO party with 3AXT, who was operating portable from Key West. Those participating included 3AJH, APO, CHV, DFI, DRO, DXL, EWR and HAN — 3DRO. Rebuilt the old receiver, and it works much better; now building an e.c.o. unit — 3GOW. I am still building, but should be on for the next O.R.S. party — 3GRF. Rebuilding rig and going on 7 Mc. — 3INH. Trying to get arranged in new location and doing a little rebuilding while the junk is torn down — 3KJ. My O44U schedule is gone, but at least have some KA's — 3QP. Down on the farm till Sept. 1. Whoopee, will be on more now — 8EU. Anxious to try out emergency equipment — 8QGG. 8UQM works 3.5 and 7 Mc., and has a traffic bug. FLASH! A bit of Field Day dope — 3BKX/3 approx. 8000 points, 600 contacts. 3QV/3 approx. 300 contacts. 3GYV (opr. at 3QV/3) scouted the 3GAG/3 group at 5 a.m. on Sunday, only to find them all asleep. (He should have swiped their logs.) We still need an Emergency Coordinator for Harrisburg area.

Traffic: W3AKB 91 AOC 2 AQN 29 BRZ 3 BXE 2 DRO 5 EEW 176 EML 538 GKO 755 GKR 5 HRS 138 HZK 82 INH 26 QP 808 WSASW 163 QGG 32 SNZ 12 UGM 5 W3BKX/3 5.

MARYLAND-DELAWARE-DISTRICT OF COLUMBIA — SCM, Hermann E. Hobbs, W3CIZ — R.M.'s: 3CXL and 3CDQ. Chief R.M.'s: 3BWT, Regional Coordinator: 3ZD. CME of Cumberland has become a member of A.A.R.S. Phone 3.9-Mc. Net. HLX of Dundalk and EIZ of Burtonsville expect to sign up soon. EQK has a new Hallicrafter S-20R. IEM joined the F.T.S.; has new rig nearing completion. ICT is putting up a new Zepp antenna. WU, QSL Manager, has a bunch of FB QSL cards on hand and wishes their owners would send in their stamped envelopes for them. On May 26th the Washington Radio Club held annual dinner and election of officers. The new officers are IBS, pres.; GKP, vice-pres.; FVD, corres. secy.; BWT, recording secy.; FUE, treas.; FMC, ZD, EEN, executive committee. Rear Admiral Hooper, U.S.N., spoke on "The Value of Amateurs to Their Country." On May 26th Washington Radio Club members attended the joint meeting of the Hagerstown and Cumberland Radio Clubs at Hagerstown, in conjunction with a meeting of the Potomac Valley Net. Talks were given by George S. Humphrey, operating vice-pres. of the Potomac Edison Co., Mr. Bernard of the U. S. Weather Bureau, and Gordon Stone of the Red Cross. In the afternoon, the entire body proceeded to Rose Hill Cemetery, to Hiram Percy Maxim's grave, where a wreath was laid on the last resting place of "The Old Man," and a memorial ceremony conducted by FMC and IBS.

Traffic: W3BWT 503 CDG 4 CIZ 456 EQK 32 IMN 6 ICT 35 WU 2 DXD 4 CXL 124 (WLM 2921).

SOUTHERN NEW JERSEY — SCM, Lester H. Allen, W3CCO — Ass't S.C.M. and A.A.R.S. Liaison R.M., Ed G. Raser, W3ZI, N.C.R. Liaison R.M., Ed B. Kerr, W3CCC, Regional Coördinator in charge of Emergency Coördination, Ted Toretti, W3BAQ. R.M.'s: 3BEI, 3BYR, 3EUE, P.A.M.'s: 3GNU. Section Net frequencies: O.R.S., 3700 kc.; O.P.S., 1980 kc. EUH reports the Delaware Valley Radio Assn.'s Hamfest plans completed and a good time in store for those who attend. The latest development is the arrangement of a baseball game between the O.R.S. and O.P.S. of our Section, this game to be played just previous to the big 2nd District vs. 3rd District game. This is your chance to root for your favorites in this big double-header ball game. 2GVZ, the S.C.M. from up North Jersey way, will be on hand to do the official umpiring. Anyone wishing further

information or tickets for the D.V.R.A. Hamfest, contact Bill Hannah, W3EUE, 904 Edgewood Avenue, Trenton, GNU, new O.B.S., will be on daily at 6:45 p.m. on 1962 kc. EDP is new O.R.S. IEL and ITU are latest enrollees in the A.E.C. Supporting Division. ACC and GCU are now owners of Class A tickets. ABS is experimenting with new 6-element beam on 28 Mc. IOW and ISY are working out FB on 7 Mc. IDY built a new transmitter for 3.5 Mc. using 150 watts input. IKG, Phillipsburg's latest ham, is active on 112 Mc. using a rod oscillator with a pair of 76's in P.P. GEV is building a new r.f. final for 1.75-Mc. phone. FBZ sends along a newspaper clipping concerning one of the boys in Gloucester falling asleep at the mike; this must be a new wrinkle over the old one, "Falling asleep at the switch." Maybe GVM can tell us a little more about the incident. How about it, Bob? It has come to our attention that EDP has W.A.C.'d in 1 hour and 58 minutes. Anyone else in our Section that has bettered this time? BAQ staged a one-man Field Day recently when he operated his new portable gear, gas engine and all, from a light Ford truck. Over 30 stations were contacted and results were very gratifying. ZI will operate portable for three weeks at Dexter Airport near Watertown, in western New York State, during the Army maneuvers being held in that area from August 3rd to the 24th. Listen for 37I/8 on 3535 kc., the N. J. State Net frequency, for contacts and traffic. GQX finished a new gas-driven power plant for F.D. work. FBC and GPS will accompany Ray on all expeditions. CCC is all lined up for a trip to Puerto Rico as radioman aboard a destroyer. HKO returned home from an 8 months' lecture tour through the middle western states. ARR gave up phone operations and is back on 3.5 Mc. CFT, one of the local N.C.R. members, is all set to take the yearly cruise aboard a destroyer. CCO and EUH are putting the finishing touches on the AQ kilowatt transmitter. HW and ZI were appointed Assistant Emergency Coördinators for Trenton area. The entire Emergency set-up in Southern N. J. has been reorganized by BAQ, who is in charge of Emergency operations. ATF is experimenting with a Radio Printer machine. CFS reports working out FB on 3.9-Mc. phone. EED is rebuilding after being off the air for several years. FB, LES, ARN is now Class A and is heard on 3.9-Mc. phone. HVO had a Y.L.R.L. visitor when FXZ and her hubby MG dropped in for a chat; Pauline and Mary kept schedules all last winter. With less than 20 watts input, IOK is adding new states to his W.A.S. list quite rapidly. IRI has completed low power job for 7 Mc. ITU is latest call in Trenton. Congratulations, Dave. ITR is youngest licensed operator in Trenton, just 15 years of age. ISZ moved into the country where he can experiment with antennas. FXN still holds down A.A.R.S. Net and has schedules with BWT. HOH was high scorer in recent 56-Mc. relay for this Section. OQ is doing a bit of development work on Marine transmitters. GCU lists his Official Broadcast schedules as follows: Tues., Thurs. and Sat. at 1 a.m. E.D.S.T. on 3742 kc. HTJ completed a Stancor 60P rig and sounds FB; Frank can be heard on 1.75-Mc. phone using this rig any evening. GLG has 500 watts on 3.9-Mc. phone and uses only to contact his brother, ICMO, twice weekly. SW is looking for recruits in the N.C.R. for this coming fall. Your support is urged in sending in news for this column and also your traffic totals. Will look forward in seeing you all at the D.V.R.A.'s Hamfest August 11th. Until next month, 73.

Traffic: W3ZI 89 CCO 124 EUH 75 CFS 63 GCU 41 OQ 40 ATF 35 ARN 33 CFC-FIS 28 BWF 26 IOK 24 AEE 23 HPX 11 ITU 10 IHO-IFT 5 VE 4.

WESTERN NEW YORK — SCM, Fred Chichester, W8PLA — R.M.'s: 8BJO, 8CSE, 8DSS, 8FCG. P.A.M.'s: 8CGU, 8RVM. E.C.'s: 8FNT, 8GWY, 8SBV, 8SMH, 8RVM. Net frequency: 3720 kc. FCG tops the net for traffic handled. KYR received a "Certificate of Service" from Western Union. DLU has a new YL op. Congrats, Marvin. IIO celebrated his 20th anniversary of becoming a radio amateur; he operated under the call letters 8AIN from 1920 to 1932. Nice going, Bob. SUI won the 112-Mc. award of the KBT Radio Club. The prize, a plaque, will be presented at the Oct. 11th meeting. MFB is attending college at Ann Arbor, Mich. PSX vacationed in Florida. NWH visited the World's Fair station 2USA. DLK and MQX built portable 3.5-Mc. rigs for Field Day. FQS, of Niagara Falls, won the Five Meter Club silver cup for the longest DX contact in the 56-Mc. contest. KBT Radio Club and the Five Meter Club held a soft-ball game at Ellicott Creek Park on June 28th. KDY is now a grandfather. QLT, home from college, is keeping the 7-Mc. band hot. The neighbors are enjoying the new, high-power, 1.75-Mc. phone rigs of THC

and SEF. SHC is trying to work 14 Mc. The Central New York Radio Club held its Field Day operations in the Live-stock Building on the N. Y. State Fair grounds. TDT is the son of CQW. The Rochester Amateur Radio Ass'n held its annual picnic at Westminster Park on July 14th. Newly elected officers of the club: DOD, pres.; UPH, vice-pres.; NCM, secy.; RQX, treas. Officers of the newly formed R.A.R.A. YL auxiliary are: TUQ, pres.; MC, vice-pres.; Mrs. PDF, secy.-treas. DFN won the Beaucaire Trophy by taking advantage of the extra points allowed for portable operation. DOD and SFD joined the F.T.S. ATH and ANQ are going to the West Coast during their vacation in August. TUQ worked K5AY and K7GTB on 7 Mc. 1FNY and his YL visited DOD over July 4th week-end. UPH will be on with a new rig using a 75T in the final. ILO and KMY were married June 8th. (Not to each other!) PPB and MNV also took the step recently. UNY is working hard on the new St. Lawrence Valley Net. OSO and THC applied for membership in the Emergency Corps.

WESTERN PENNSYLVANIA — SCM, Kendall Speer, Jr., W8OFO — Ass't S.C.M. in charge of Emergency Coördination, R. M. Francis, W8AVY. Inasmuch as this is my last QST report as Section Communications Manager I wish to extend my sincere thanks to all the amateurs in Western Pennsylvania for their splendid cooperation in my two terms of office. I hope you will give the same support to my successor. New O.R.S.: RBC, TTD. The XYL at NCJ is now a member of the R.O.W.H. Congrats. NCJ is keeping summer traffic schedules on the high end of the 7-Mc. band. SWT is on 14 Mc. regularly. RAT says QEL is building 500 watts portable-mobile. BWP rebuilt his rig into a cabinet. TXQ worked PY, CM and XE with 75 watts input before Order No. 72! PYO and RBI are on 3.9- and 14-Mc. 'phone. JQW is back on 1.75 Mc. ASE is building portable. RYC wants the O.P.S. gang to try u.h. frequency during the summer. The Warren County boys operated Field Day with 3 rigs, using the call SVT/8. MJK is all set up at new location. USV, a new amateur at Berlin, uses 40 watts to a 6L6. RBM traded his SX24 for an SX25. RAU says RDZ is going to rebuild with HK24's. New amateurs: Uniontown-UHG and Brookville UMZ. The Horseshoe Radio Club held its annual basket picnic at Lakemont Park, Altoona, on July 14th. ZD operated Field Day at the old WJAS transmitter location 15 miles west of Pittsburgh, with three officers and eleven enlisted men of the N.C.R. operating three rigs. Lieut. B. P. Williams of the N.C.R. at Pittsburgh advises that unlimited enlistments as Radiomen, Signalmen and Yeoman are now open in the N.C.R. The new age limits are 17 to 35 years. Drop in at the Old Federal Building any Monday or Thursday evening, Room 504. OFO visited the Philadelphia Navy Yard and the New York World's Fair on the week-end of June 8th. HKU says TOJ, SVT and JSQ have been experimenting with 112 Mc. RIT, IYI, SNA, NWY, MKH, TFI manned IYI's transmitter at the Greensburg High School Hobby Show. It's a baby girl at 1VQ. Congrats. MKH has a new XYL and an HQ120X. OFM relayed a message to a girl in Hawaii and then met her personally. OUT has his beam up again. SWT has Class A ticket. TTD contacted 30 states with 15 watts. ROA takes part in the Chair Warmers party on 1.75 Mc. every Monday night. Shut-ins are invited to participate. RAU revamped the rig using a 6L6 oscillator, HK24 buffer and a pair of HK54's final. DNK is the proud father of a baby girl. DRA added a Collins coupler with much improvement to signal strength. ADY replaced his T55's with 810's. KYD uses a 110CM Stancor with excellent results. The Horseshoe Radio Club has been assigned the call QZF which was the call of a member who passed away about a year ago. The club has started a CODE CLASS, week days from 7 to 9 p.m.

Traffic: W8NCJ 137 CMP 35 RAT 6 OFO 4 SFV 2 BWL 1. (April-May: W8NCJ 235 RAP 110 TWI 31 CMP 30 HKU 20 RIT 18 OEM 16 OUT 8 RAT-TTD-OFO 4 ROA 3 PER 2 RAU 1.)

HUDSON DIVISION

EASTERN NEW YORK — SCM, Robert E. Haight, W2LU — LSD, King of the F.T.S. traffic boys, is king of the month with nice total. F.T.S. boys are operating 2USA daily, 600 watts. KWG is keeping 3.5 Mc. active at West Point. MHW schedules 2USA daily. MIY operated at Albany Club F.D. station; Dot is on 3565 kc. LU helped boys at S.A.R.A. F.D., using 2ACB-2 on 3.5 Mc. JRG operates on 7095.24 kc. KUG is still putting up 1.75-Mc. antenna at new QTH. LLU has new portable nearly com-

pleted. JKT reports from Honolulu, where he is radio striker on the U.S.S. *Saratoga*. S.A.R.A. completed a bang-up Field Day with seven transmitters on all bands, using 25 watts input on transmitters. W2ACB, E.C., and his Ass't E.C. are to be commended on their excellent showing. Vacations being in order, let every member of E.N.Y. enjoy a pleasant vacation and come back ready to help E.N.Y. keep in line. 73. — LU.

Traffic: W2LSD 506 KWG 144 MHW 86 MIY 45 LU 40 JRG 16.

NORTHERN NEW JERSEY — SCM, Joseph P. Jessup, W2GVZ — Ass't S.C.M. in charge of Emergency Coördination, Les Baglee, W2JMX. R.M.'s: 2BZJ, 2CGG, 2GVZ. P.A.M.: 2HNP. Section Net Frequency: 3630 kc. (Net closed until Sept.) New A.E.C. registrations: FDL, FXV, GW, GYR, JQA, KMO, LEU, LHJ, LSR, MHJ, MHK, MMZ, MPQ, MRZ, NBL. The Inter City Amateur Radio Club came through in great shape with ten A.E.C. registrations. Many thanks, and I hope all of the clubs will help to boost A.E.C. registrations. Right now is a splendid time to demonstrate our usefulness, and this is one way of doing it. The Freehold Amateur Radio Club is now signing MZA on 1.75-Mc. 'phone, and is now an Affiliated Club. KM is proud to announce the arrival of his first son. The N.N.J. Traffic Net got together and swapped lies at home of HCO. Those attending the Annual Net Hamfest (miniature) were CMC, GRG, GVZ, HCO, IYQ, JUU, KHA, LMN, LXI, MKW. GRG was a ringer, but came in his capacity of O.O. He placed second for the country in accuracy in the latest O.O. measuring tests. Accidental traffic during the summer can be put on the N. J. A.A.R.S. Net on 3535 kc. between 7 and 7.30 p.m. daylight time. The following will be on that net all summer: DYQ, GVZ, ILE, KHA, LDB, LMN, 30CC, 3FXN, 3ZI. Any of them will take traffic for points in the U. S. and U. S. possessions. GW, who stands high in the DX C.C. on c.w., also rang the bell with DX C.C. on 'phone. He also registered in the A.E.C. How about the rest of the DX gang coming into the A.E.C.? SN delighted the heart of the power company by sending the flock of recent Official Broadcasts many times over. By the way, don't forget to thank the O.B.S. gang when you copy a broadcast, because it is a thankless job. MRJ and MTO operated portable on 1.75-Mc. 'phone at Emerson High School Radio Club at a Parent Teachers Ass'n exhibit. AGH has a nice combined receiver and transmitter and 60-watt vibrapack under way. JMX held a meeting of the Emergency Coördinators but, through a variety of circumstances, only GMN, HNT, JME, JMX and LOP got there. The A.E.C. registration is close to 200 for the Section. We need YOU in it more than ever now. There are also plenty of jobs open for qualified stations as O.R.S., O.P.S., O.B.S. and O.O. You are cordially invited to apply now, so that the fall season can get a fast start. Please tell me what else you are doing besides sitting with your fingers crossed, so that we can keep this column going. KHA was high man in N. J. in A.A.R.S. contest. JME just got 100th card for DX C.C. C2M is proud pop of a baby YL. HLC has moved to third district. MZF is on 28-Mc. 'phone from Montclair. JRU had to revamp his final on account of winning a transformer at hamfest. HXI will be active on traffic all summer. BZJ has a 600 watt emergency generator.

Traffic: W2GVZ 162 (WLNI 33) JUC 101 KHA 71 IYQ 59 LXI 30 MKW 29 BZJ 27 ILE 22 JUU 18 HXI 19 MNT 13 JRU 7 CJX 6 CIZ 4 MAX 9 IZV-MRJ 3 MEO 1. (April-May: W2LAG 2.)

NEW YORK CITY AND LONG ISLAND — SCM, E. L. Baunach, W2AZV — KXB, LYC, LYH and VG are out for O.R.S. NBF, new Seaford station, is LID's brother. At a recent E.C. meeting at DBQ's, plans were set up for complete coverage of the Section with key stations at various points for communication with Red Cross headquarters in Brooklyn and Manhattan. Mr. Drowne, Red Cross Field representative, was there and gave an instructive talk on the work that the Red Cross does in time of emergency, and praised the amateurs for the fine work that has been done in the past. The Suffolk R.C. reported looking for a big day in the Field using the call AVS. MBO is a newcomer to the Nitwit Net on about 1810 kc., which is still open to all who want to join. LPJ is getting set for a big fall season in the Section Net. DOG worked hard getting portable gear set up at Baiting Hollow for Field Day with the Suffolk gang. PF says that the A.A.R.S. nets will continue in operation during the summer on an informal basis in the Second Corps Area.

(Continued on page 78)

YEARS AHEAD

TRIPLET

1941 Model 1696-A MODULATION MONITOR

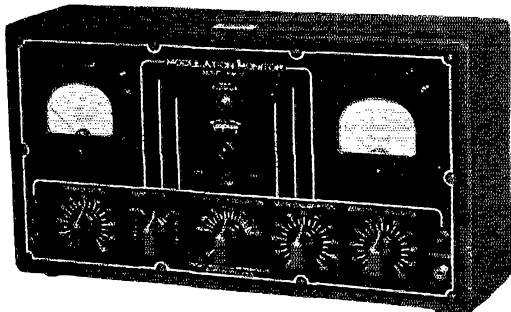

You've solved your problem of getting maximum efficiency from your transmitter when you invest in a Model 1696-A Modulation Monitor. Plug it into your AC line — make simple coupling to the transmitter output and the monitor shows:

● Carrier Reference Level ● Per cent of Modulation ● Instantaneous Neon Flasher (no inertia) Indicates when per cent of modulation has exceeded your predetermined setting. Setting can be from 40 to 120 per cent.

Helps comply with FCC regulations. Has two RED DOT Lifetime Guaranteed Triplet Instruments. Modernistic metal case. Model 1696-A — Amateur Net Price.....\$34.84

Also available as a rack panel mounting unit

For More Information — Write Section 258, Harmon Drive

THE TRIPLET ELECTRICAL INSTRUMENT CO.

Bluffton, Ohio

NOW READY! A B&W 5-BAND TURRET for Your 100-WATT RIG!

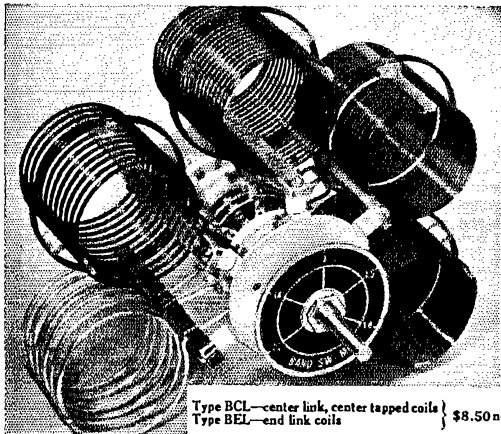

Type BCL—center link, center tapped coils } \$8.50 net
Type BEL—end link coils

THESE B&W 100-watt Turrets set new highs in fast, positive band switching on the commonly used amateur frequencies, 10 to 160 meters. Several new features, including a specially-designed switch, make them equal in efficiency to the best individual plug-in coil systems.

They're extremely compact — 7 1/4" high; 7 1/4" wide; depth behind panel, 4 1/4"; shaft extension, 1". They may be used with tubes operating at 1,000 to 1,250 volts and a maximum input power of 165 watts. Each unit comes complete with frequency-marked dial plate, lock washer and nut. It may be mounted directly on the panel in a single 3/4" hole. See them at your jobbers', or write for complete technical data.

BARKER & WILLIAMSON

Radio Manufacturing Engineers • ARDMORE, PENNSYLVANIA

New Radio Control Gear for Model Airplanes

(Continued from page 18)

and thus the escapement is automatically operated until the cam on the dialing wheel reaches neutral, whereupon assembly *G* is opened. This stops the dialing wheel at neutral. Note that spring assembly *G* shown in Fig. 3 is the same assembly as shown in Fig. 2.

The automatic restoring of the dialing wheel to neutral as described above does not interfere with dialing so long as "carrier off" time interval of the pulsing is not too great. Pulsing the carrier means simply cutting the carrier off for a short time (about 1/18 sec.) and then restoring the carrier. The carrier is left on about 1/18 sec. and this cycle repeated as desired for the various controls.

During the "carrier off" intervals of pulsing, the magnet is released and the "flipper" rotates to normal. This closes spring assembly *F* which operates the magnet even though by this time the carrier may not be on again. However in order to avoid interference the carrier must be on again before assembly *F* opens. If interference is experienced, shorten the "carrier off" time of the pulsing or add some weight to some of the moving parts to build up inertia which of course will slow down the speed of rotation of the dialing wheel.

One turn of the dialing wheel (four turns of the rubber power plant) is required for each operation. It will be noted that all the spring assemblies are operated when selecting a control; however, the time closed is so short that the controls are not applied. If a control would be slightly applied in this manner, the restoring device would immediately bring it back to neutral.

Reviewing the operation we have this sequence:

1. Carrier is turned on. Cam on dialing wheel rotates to position 0.
2. Carrier is pulsed; cam is rotated to positions 1-9 corresponding to the number of pulses.
3. With carrier left on cam is held at that position which applies control.
4. Carrier is turned off. Cam wheel rotates back to neutral, and simultaneously the control applied restores to neutral.

The operation of the spring assembly at position 7 when the dialing wheel is restoring to neutral is but momentary and not of sufficient time to kill the motor.

The weight of the unit is two pounds. The receiver and batteries bring the total weight up to 3 1/2 pounds. The ship has a wing spread of 12 feet and weighs 13 1/2 pounds complete with the radio and control unit.

This solution of the control-unit problem, I feel, is all that the experimenter could expect from a performance viewpoint. However, I do believe that the same performance could be duplicated in a strictly mechanical unit without the use of the electric motors. Such a solution would be lighter and less costly. I hope to have something along this line in the near future.

Own the **NEWEST**

Skyrider SX28 by

hallicrafters

for only **\$15.95** down, balance easy terms

\$12.68 per month for 12 months or \$25.36 per month for 6 months

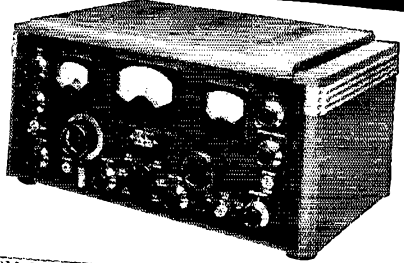

15 tubes, 6 bands, 540kc. to 43mc. 2 stages preselection. Adjustable noise limiter. High fidelity audio. Band pass audio filter and other features as advertised in July *QST*. Cabinet or play rack mounting. Panel of 1/2" steel mureoco. Machine tool, grey wrinkle steel cabinet. Designed to government specifications. SX 28 complete, less speaker, cash price.....\$159.50

YOUR CALL LETTERS IN GOLD, 10c

Put these big shadowed decalcomania letters on your Ham Shack door, auto window, etc. Nearly 2" high. Send dime for yours today. Be sure to give call letters.

SPEAKERS

Regular PM 23 speaker in metal cabinet.....\$12.00
Hallicrafters Jensen bass-retex enclosure 30" high, 16" deep, 22 1/2" wide.....\$29.50
Hallicrafters Jensen bass-retex enclosure 23 1/2" high, 10 1/2" deep, 17 1/2" wide.....\$19.50

hallicrafters HT-6 \$9.90 down

\$7.83 per mo. for 12 months or \$15.66 per mo. for 6 months

Main features include 25 w. output, clickless keying, 6 bands 160 to 5 meters. Coils for any 3 bands may be plugged in, pre-tuned, and switched from front of panel control properly connecting all circuits from crystal to antenna. Uses any high level, high impedance mike.

HT-6, with tubes, less coils and crystals...\$99.00 cash

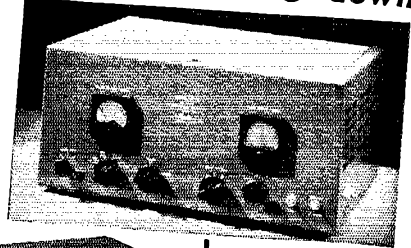

FREE BULLETIN

8 pages, illustrated. Just out, and full of Ham bargains, details of NEW CONTINUOUS TIME-PAYMENT PLAN. Every item a real guaranteed value... and savings well worth while.

How To Order

Send 10% down payment with your order. We ship immediately upon credit approval. You pay balance plus 6% carrying charge in equal, monthly payments. Order today, direct from this ad.

We have all other Hallicrafters sets and transmitters in stock. Just send your order... or write for New Hallicrafters Catalog.

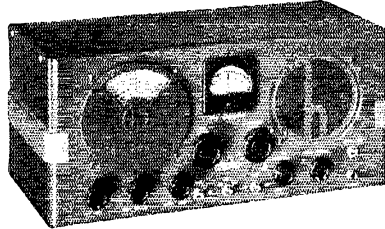

\$4.95 down **\$5.90** per month

EIGHT MONTHS TO PAY!

New Sky Champion S20R

Only recently available on Newark's Payment Plan. You can add a few extra parts or supplies and make your order total over \$50 and pay only 10% down if you wish. **Cash price, \$49.50** complete.....

★ ★ ORDER TODAY DIRECT FROM THIS AD ★ ★

NEVER BEFORE A BARGAIN LIKE THIS!
Oil filled, oil impregnated
FILTER CONDENSERS

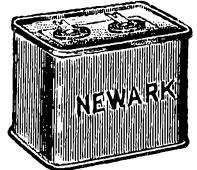

Previously advertised at \$1.00. Never offered before at this low price.

1000 v. DC, 1 mfd. size 1 3/4 x 1 x 4". Weight 1 1/2 pound.....**59c**
Very special.....
2 mfd, 1000 v. DC.....\$1.00
4 mfd, 3000 v. DC, size 4 1/4 x 3 1/4 x 3 3/4" (2 3/4 lbs.).....\$3.75

Write for Bulletin Listing Other Condenser Bargains

NEWARK

Electric Company

323 W. MADISON ST.

Dept. Q CHICAGO, ILL.

(Continued from page 89)

JBL tried a hand at operating USA. LGK finished building his four-tube t.r.f. autodyne receiver and is getting FB results. EYS is spending his time rag-chewing on 7 Mc. With the A-P trunk line down for the summer months, EC is operating on 7260 kc. NAZ, ex-9CHD, a member of the Y.L.R.L., is now located in N. Y. C.; the OM is MSC. HNJ received his commercial ticket. HMJ is now with the Eastern Airlines operating at WEEM, Miami Springs, Fla.; his QTH is 181 East 3rd St., Hialeah, Fla. LYC is trying for a commercial second-class ticket. KI is keeping his schedule with 3BWT, 3698 kc. daily. HRT wants all licensed operators to get in touch with him so he may write to the N. Y. State Motor Vehicles Bureau to request a special license plate for those who have cars and call letters. Ex-TI is now one of the benedicts and is living in Washington, D. C. DBQ is working feverishly on getting self-powered stations for emergency operation. LYC is now a self-powered A.E.C. member using a 6L6 job run from batteries. CKQ sends in USA's traffic total via special delivery. Again an urgent appeal is made to all stations of the Section that are not members of the A.E.C. to join up and be prepared. We can never tell what may happen. AZM and LBI are doing active duty at Floyd Bennett Field for the N.C.R. IXQ is going the limit in building precision frequency measuring equipment for O.O. work. MYI is a new ham at 2290 Davidson Ave., N. Y. C.

Traffic: W2USA 971 LZR 463 ITX 428 SC 502 LPJ 295 DBQ 145 (WLNB 35) AZV 93 LGK 65 LR 50 BGO 48 KI 45 MT 36 PF 35 IOP 30 KXB 23 CHK 17 BYL 11 CET-IRC 10 AZM-AEU 9 AA-NAZ 8 CIT 7 DW-BMG 6 ADW-AVS 5 DLR-HNJ-BDN 4 EC-AYI 3 DOG-LYH-CTN-ELK 2 FAQ-HGO-LWE 1. (April-May: W2USA 187.)

NEW ENGLAND DIVISION

CONNECTICUT -- SCM, Frederick Ellis, Jr., W1CTI -- AW B.P.L.'s on deliveries and maintains schedules with 6CIS, 2USA, 3NF, 3BWT, 6CDA and WCFT. KKS B.P.L.'s on deliveries and found time to visit AKS. LWE and TY. TD, Regional Coordinator for the Railroad Net, says the net will be working in fine shape by fall. FB/1 contacted 304 stations Field Day from their Woodbridge location. 2MQB/1, 1MJY/1 and LOC are in Portsmouth, Va., with a new call, 3IVO. Look for them and give 'em a buzz. KQY had an addition to his family June 6th. What did you name her, Ed? Chickenpox in the family barred KQY from the hospital, but, with the aid of GRF and a couple of 112-Mc. transceivers, contacts were made to his wife's room in the hospital to KQY in his car. CSY is changing his signal shifter to osc. keying. 8MYW is operating on 56, 112 and 224 Mc. exclusively for the summer. CBA/1 took part in the Field Day tests and had worked 32 stations on 3.5 Mc. when the gas engine burned out a bearing and they had to QRT. Operators were BCG, CTI, IOV and IWT. B.A.R.A., JHT/1, was set up in Bethel, Conn., and indications are that they ran up a high score, but no report has been received at this writing. INP is in charge of magnalux inspection of Pratt and Whitney Aircraft Co. In his department are FUP, IJO, EJT and ex-8ADQ. INQ also works for P.W.A. Co.

Traffic: W1AW 435 KKS 263 ITI 49 TD 36 CTI 35 BDI 28 GB 23 KQY 6 CSY-JTD 2 W2MQB/1 8.

MAINE -- SCM, H. W. Castner, W1IIE -- I had a most interesting visit in Rockland, and everyone gathers around RU. I dropped in on GKC, and there was a room full of hams all building and fixing rigs. Also visited MMR, a bran' new ham and a good one. LKP is building an e.c.o. and adding a buffer stage. BFA (MOF) is on 28 Mc. and ran up 191,880 points in the DX contest using 14- and 7-Mc. bands. BGZ is in Portugal aboard ship. CUZ is now in Rye, N. H., on 28 Mc. Capt. "Carl" LOZ had a fine chat with Capt. "Fred" K6QYI. VF is hoping to go on a cruise with the N.C.R. and at present maintains schedules with BWR. LWG has been grid-moding on 1914 kc. with 25/50 watts. MKB is on 7 Mc. and works for the A.P. QH reports a lot of interest from Bangor. AQL had a fire and lost some of his rig. LCU had a sad accident, broke his leg and is in the Eastern Maine General Hospital. We all hope you are better, Laurel. BNZ is op on a United Fruit boat. QH and PQ visited in Portland and saw some of the hams at WGAN. On invitation of the boys at the Waterville Amateur Radio Club, I went up for a visit at their regular meeting on May 10th and, by golly! there's a live bunch. They have a fine club room and a whale of a lot of interest. They are

making all sorts of plans for emergency preparation, and all you have to know is that HSE is President and "Jap" Haines Secy.-Treas., to explain why this is one of the most active clubs in the state. Fellows, I feel confident that it is most timely advice when I say that by forming a local club and affiliating with A.R.R.L. and getting all the excellent helps they send you, you all get more out of Ham Radio personally. A movement is on foot to increase our operating efficiency, and we hope everyone will try to improve in operating. This office has all sorts of helps for the asking. I have been accorded the honor of serving for another year on the Planning Committee! In case you have forgotten, we have a national committee of 75 prominent hams. We are trying to find out just where and how to improve all our bands and usages. We want the opinion of everyone who reads this. Write me any ideas you have for improvement and I'll pass them along. Some of you boys and girls are not members of the American Radio Relay League. I cannot resist reminding you that but for the League we would be undoubtedly off the air long before this. We owe the League real support and I sincerely urge membership. LIP is working all bands but at present is on 14 Mc. 'phone with 25 watts. KSL is on 7 Mc. with a new "QSL Forty." EOP is on 3.9-Mc. 'phone. The Maine A.A.R.S. Net has closed for the summer. A group of Skowhegan hams visited the New Hampshire hams at Colebrook; among those present were LJK, MEV, MQI, LBJ, LYS and MQC.

Traffic: W1IIE 4 LKP 3 LYK 5 VF 1 LWG 10 MKB-HSE 2.

EASTERN MASSACHUSETTS -- SCM, Frank L. Baker, Jr., W1ALP -- We wish to congratulate KH, a member of our Section, as our new Pres. of A.R.R.L. Best of luck and wishes from the whole gang, to a real ham and a swell guy. On May 25th an Emergency meeting was held at the Red Cross Headquarters in Boston, with the following present: ALP, HXE, JJJ, AHP, IPA, JXQ, QW, SS, BDU, JNU, LBH, JIX, JKR, TY, IN, KOG, JCK, JSM, MKW, MHC, LIO, JLL, LZW, MME, DTP, CB, DEX, GCU, LUG. Mr. Rice, Red Cross Director of Disaster Relief, spoke about the necessity of communication during an emergency. SS brought up several good points, and various subjects were discussed. Another meeting is to be held in Sept. Keep this in mind, gang. Check your certificates for endorsement, O.R.S., O.P.S., E.C., etc. AAR is new O.R.S. S.S.A.R.C. of Quincy held its annual banquet; prizes and certificates were given to all past officers. New officers 56-Mc. Minutemen: EHT, pres.; EKT, vice-pres.; IIQ, secy. AAL in Attleboro is active again on 14, 3.5, 7 Mc. Welcome, Ray. LQQ and MQE are on 112 Mc. LMB got his W.A.E. cert. LEU has new 112-Mc. rig. MOX has gone back to Calif. MQO is interested in a Night Owl Net on 28 Mc. MRK is going to have a 4-element beam. SI is active on 56 Mc. AQH has new Jr. op. Congrats. Welcome to new ham in Winthrop, MQB. Parkway Radio Club had a fine meeting showing Coast Guard pictures; GTN spoke on some of the highlights of Directors' Meeting. BDU reports F.T.S. quite active, which helps to keep up the totals. MEZ will be on c.w. A.A.R.S. meeting was attended by LSA, MEZ, LNN. HWE is active with schedules and traffic. IN, KH and ELP are on f.m. on 56 Mc. The Eastern Mass. Club just closed its 16th year. FB, hope you have many more. CTW has DX record, 1.5 watts, Buffalo, 1.5 hours on 7 Mc. ALY has a yen for 56 Mc. IIQ is on 56-Mc. i.e.w. FSK is on 7 Mc. and dabbling with 28-Mc. 'phone. JGQ has KSN, LMJ, IPS, JUB and TY signed up in Emergency Corps. FB, WI is looking for O.R.S. between 2 and 6 a.m.; will take traffic for K6's. O.B.S. is keeping GAG busy. Welcome to new hams, MUC in New Bedford, and MTB, sister of JDO. South Shore and East Mass. Clubs are working on Boston Hamfest. Watch for date. Club Secy's, please send me the dope on your club and members. This is your column. Notice to O.R.S., O.P.S. and others: I must receive your reports, on or before the 18th of each month, if you want to be included in my report, as I have to mail it on the 20th. Please do your part. Thanks. FGT joined N.H.R.R. Net. LGH applied for O.P.S. MTQ, new ham in No. Easton, is only 12 years old. FB, young feller.

Traffic: W1EPE 200 (WLGs 10) BDU 164 JCK 158 (WLGV 55) AAR 95 AGX 39 AAL 32 HWE-LNN 21 WI 20 EHT 10 HUV 5 ALP-MKN 4 KTE 3 IXL 1 KH 10 JYJ 35 FWQ 36 LWL 121 AKS 162 EMG 54.

WESTERN MASSACHUSETTS -- SCM, William J. Barrett, W1AJH -- BIV leads a rather small parade this month. Among those at the Boston meeting of the A.A.R.S., June 15th, were AZW, BVR, IOR, EOB, JXE,

BIV, KIK, FNY, LHY and JAH. IOR reports that BKQ is about ready to go with its new quarter kw. BVR had busy month with A.R.R.L. Board Meeting and wind-up of A.A.R.S. active season. IIP is still at WHAI. AJ worked a few K6's, and is laying out new final. KZU is running HY75 on 112-Mc. portable-mobile. BNL says that W1XTG, new f.m. station of WTAG, is now on 43.4 Mc., and now BNL is building f.m. outfit for mobile use. KJK reports from Md., and hopes to be back in West. Mass. soon. GZL reports plenty of 112-Mc. activity in his neighborhood. MRS. a new ham in Holyoke, starts in with 200 watts on 1.75-Mc. 'phone.

Traffic: **W1BIV 74 (WLGN 16) JAH 50 (WLGH 22) IOR 45 BVR 9 (WLG 56) IIP 7 AJ 3 GZL 7.**

NEW HAMPSHIRE — SCM, Carl B. Evans, W1BFT-DMD — The M.V.A.R.A. participated in 100% emergency power and using the call DMD/1. 230 contacts were made, three of them W6's in California. BFT, JBA, JCA, LBD, LIN and LVG were operators. The Manchester Radio Club and the Nashua Mike & Key Club also participated, using the calls LVK/1 and TA/1 respectively. KPL has taken unto himself an XYL. Congrats, Homer! MPD is new ham in Concord, being the XYL of LFO. IJB is now working at WRPT, N. H. State Police. The Farmers' Net Annual Outing was held at Lakeport, N. H., on June 23rd, with 75 present, including KH, the new A.R.R.L. President. A most enjoyable time was had by all. MOF is new Dover ham. MOI is new Manchester ham. CCM is rebuilding, and his XYL, IQT, has recently joined the Y.L.R.L.

Traffic: **WIKIN 107 LIN 2.**

RHODE ISLAND — SCM, Clayton C. Gordon, W1HRC — CPV schedules 2USA three nights a week on 7250 kc., and remarks that AQ is having the towers painted. IZO is confining all activities to N.C.R. work on 3680 and 2096 kes. JNO has a three-way schedule with MLZ and HA at 7:30 a.m., Mondays through Fridays; got BUI to help him put up new 1.75-Mc. Zepp. MNX and MMG are new hams in Newport. MEK has new home-made superhet and 100-watt rig on 3.5 Mc. KZN went on 1.75-Mc. 'phone, but BCL didn't like the quality, so went right back to 7-Mc. c.w. pronto. EOF is on 7 Mc. The P.R.A. visited the Westerly Radio Ass'n on the evening of June 19th, at which time the Norwich, Conn., gang also joined in the visit. Speeches were made by GTN (on the Board Meeting), JEZ (on the Emergency Coördinator's job and such), JP (on P.R.A.'s Field Day preparations and 112-Mc. activities), and your S.C.M. talked on and on and on, as usual, about A.R.R.L. appointments and "why don't we get more reports for QST?" etc., and wound up with a blast against tolerating the "bootleggers, if any." DET described the merits of a "Rotating Flush Bowl Ball Antenna." Their second Annual Hamfest was announced and all invited, and a lunch of sandwiches, coffee, cupcakes, doughnuts and cheese was served, in addition to which Ernest Palmer passed out bottles of soda pop. MOK is running code classes for the prospective hams down that way, in addition to his experiments on 112 Mc. KRQ is also on 112 Mc. with good results locally. KRF is out of R. I. State College for the summer; at present he is visiting his brother, Sam, who is one of the operators on the *Yankee Clipper*; and, when that is over, will go to Maine for the rest of the summer, as usual. AGJ is on 14-Mc. 'phone with 100 watts and new 1/2-wave Zepp. LZD (David Payne from over in Bradford) has 812's in P.P. running about 375 watts in his new final on 7 and 14 Mc. FOV and BOS have built a portable-emergency outfit using 6J5 Pierce-Osc.; 6L6 Final; 6L6 Modulator with a combination 6-v.-110-v. power supply. Your S.C.M. has finally got back home and has achieved the removal of enough dust from the rig to fire it up once on 7 Mc. by inhaling rapidly, then forming the circle with the lips and exhaling with increased rapidity, and then immediately retreating to the far corner of the cellar to await a favorable opportunity for a second attack. Here's hoping you all have a pleasant vacation.

Traffic: **W1UNI 337 CPV 132 INT 58 GTN 50 LDL 34 IZO 31 IEG 29 KWA 28 AOP 20 BOY-LWA 15 KKE 11 KZN-LAB 5 KIV 2.**

VERMONT — SCM, Clifton G. Parker, W1KJG — KWB is now located at St. Albans, employed by WQDM. KIE has new multi-stage e.c.o. exciter unit which is giving fine results. MLJ is still active on Vt. Traffic Net. Reports are that DQK is having good results with his top-loaded vertical. MCQ is temporarily off the air and now receiving treatment at the Veterans' Hospital, White River Jet. KUY returned from college for the summer vacation and is

active on 3.5 Mc. JRJ acquired a pair of 812's and extras for new final. Visitors at KJG were MMV and XYL, KUY and KXL. JXS, CBW and KJR have been down for Class A exams. JXS is on at Bethel this summer and busy with plans for a 3-band exciter to driver his RK20 final. FPS is busy with A.E.C. work. KOO has been heard from around the Section with portable. LYA has registered in A.E.C. ND is active week-ends and heard quite regularly on 1.75-Mc. 'phone late Saturday evenings. KXY has returned from winter maneuvers and is now stationed at Fort Ethan Allen. DPO passed away June 15th at Washington County Hospital. Another OT has had a long fight against long odds, and will be remembered by many. "30." Del. MJU visited MLJ and MMV. FSV continued activity with the A.A.R.S.

Traffic: **W1KWB 7 MLJ 26 KJG 53 MJU 15 MCQ 1 FSV 9.**

ROANOKE DIVISION

NORTH CAROLINA — SCM, W. J. Wortman, W4CYB — AKC has returned to the ranks of the traffic men, and takes top honors. WE, operated by FXU, has been very active at the University, and will be on all summer. DWB is rag-chewing on 7 Mc. New O.P.S. is ESB who reports another one for Ripley — FSF having trouble in eliminating himself from his neighbor's electric refrigerator when he comes on the air. GVW is a new Goldsboro ham. FWT returned home from college. DGV has 100TH's on the air. OG visited New York World's Fair. NC worked Field Day from Hanging Rock. DCQ and BOH are both now married. DVU has a new daughter. Lightning visited ZH and did considerable damage to HQ120X and transmitter. APP is on 1.75-Mc. 'phone. BHA joined the ranks of the Benedicts on June 15th. GG is new president of Greensboro Club, EIW is new vice president. MR is active on 7 Mc. Several of the Greensboro gang plan the 6L6 low-power transmitters for local practice in copying and sending c.w. Seems like a good idea. Congratulations to QI for third place in the April O.P.S. party. We report with regret that AAK will be convalescent for about four months, after his recent operation.

Traffic: **W4AKC 77 WE 60 DMB 3 ESB 3 DGV 5 DGU 2.**
SOUTH CAROLINA — SCM, Ted Ferguson, W4BQE/ANG — GCH now operates 7 Mc. CQU is renovating his shack. COL took some good shots of the hamfest at Columbia. GMO has his R.C.C. EDO operates 3.5, 7 and 14 Mc. FXH likes his traffic. EZF reports his 325-watt 1.75-Mc. rig works FB. FWO visited EZF. GIM has new home-built crystal mike. CSP sticks to 1.75-Mc. 'phone. FVF has a pair of HK24's. DYC changed his QTH to Pittsburgh, Pa., and hopes to keep schedule with CPB. ACH is now at Ware shoals. GTW operates 1.75-Mc. 'phone. GCW can be heard on 1.75 Mc. EXH reports 56 Mc. wide open these nights; has heard W8's and 9's. EOD has returned to 1.75-Mc. 'phone.

Traffic: **W4FXH 116 EDO 45 GCH 34 EZF 12 CQU 9 DNR 8 COL 1.**

VIRGINIA — SCM, Frank S. Anderson, Jr., W3GWQ — HWJ is working hard on publicity for the Roanoke Division Convention. AGH has 100 watts on 14, 7, 3.5 and 1.75 Mc., both 'phone and c.w. Most of FEM's time on the air is with the A.A.R.S. Net. IKN is using new rig. IQC is using 807 final with 50 watts input. HBH is using 807 with 32 watts and has half-wave antenna on 3.5 Mc., 45 feet high. BZE and HAE are new Route Managers. GWQ has been working c.w. lately. EHL and IKN want O.R.S. HWJ wants O.P.S. GWQ wants to thank those who supported him for S.C.M., and will do all he can to fulfill his duties as such. Also I would like to have some nominations for Emergency Coördinators from those cities in the state which do not have any.

Traffic: **W3BZE 281 HBH 82 IQC 49 FEM 29 IKN 17 HWJ 15 HJW 4.**

WEST VIRGINIA — SCM, W. D. Tabler, W8OXO — KWL built new T40's final for 56 Mc. TNC is building a new all-band rig with final 250TH's. Ultra-high activity is in full swing in the Morgantown area. BTV has his 75-foot poles in the air, but is having a little difficulty about overhanging property lines! QHG and his XYL are the proud possessors of a new junior op. Congratulations. New hams: Moundsville, UVC. USI is spending summer in Philadelphia. Another father and son combination is ADI and PHY. UTO is building a 500-watt rig. A few more West Va. ham occupations: JKN is professor at West Va. Wesleyan; JJA high school math. professor; EYV high school English professor; KXC and FEO are miners; AKQ is railway agent and telegrapher.

Traffic: **W8OXO 90 TDG-TNC 6 UNH 4 PHY 3. (April-May: W8PSR 92 ORD 13.)**

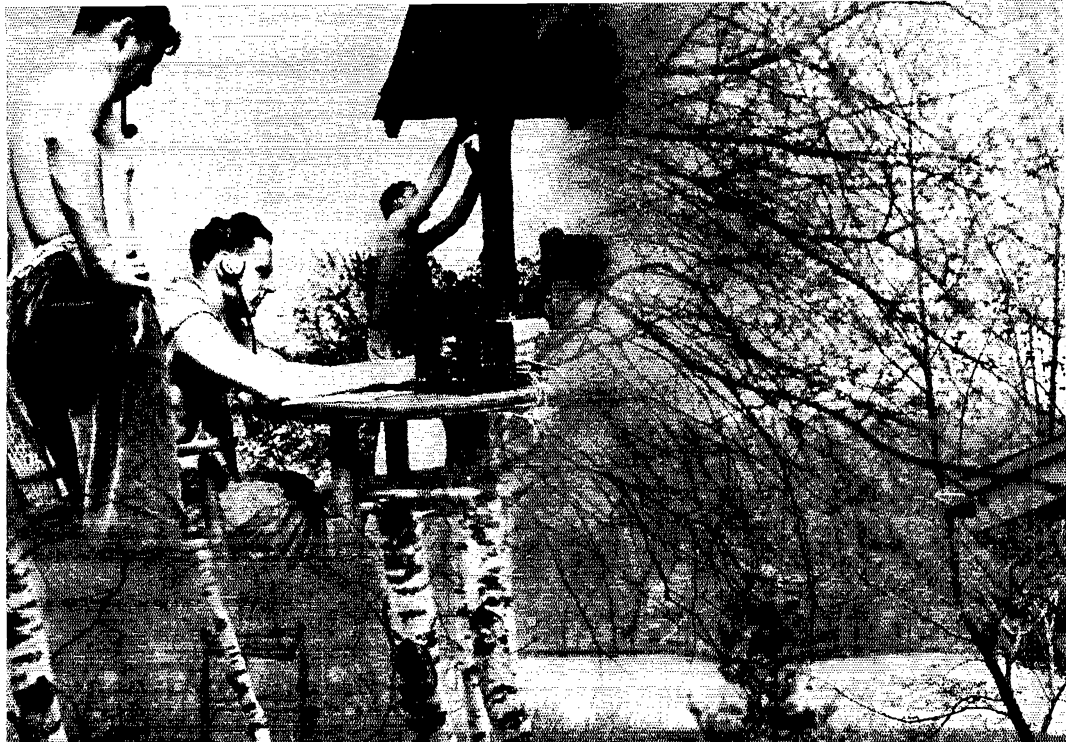

SUMMER TIME IS SP

QST AND THE HANDBOOK
ARE THE BASIS OF
EVERY AMATEUR'S LIBRARY

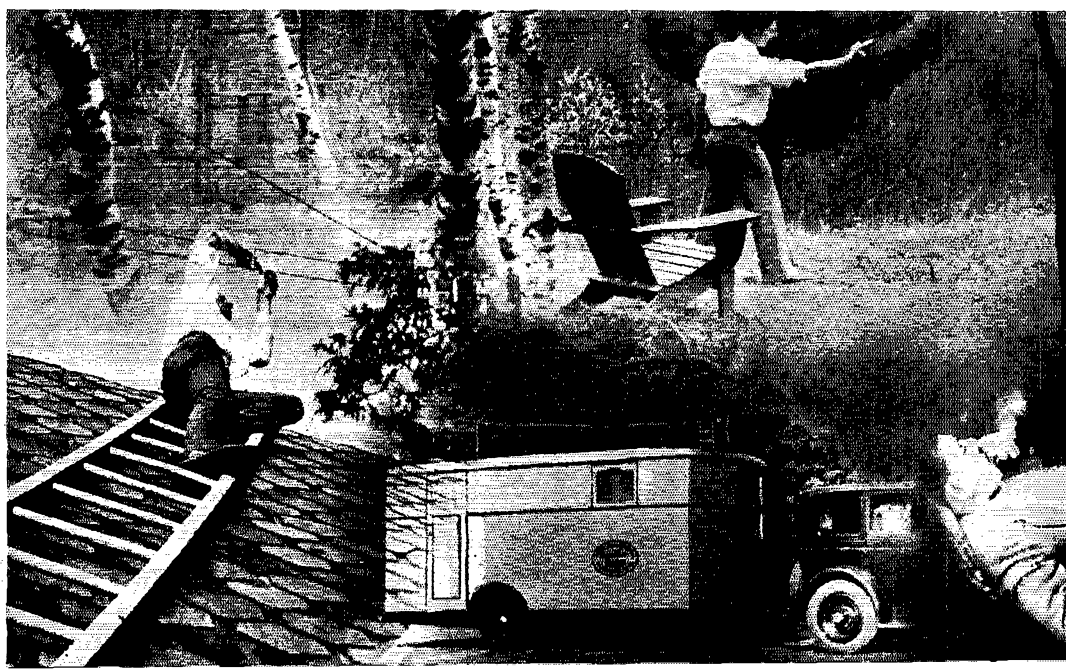



ECIAL OFFER TIME

A.R.R.L. Membership
QST Subscription
and the HANDBOOK

all for **\$3.00**

During July and August only

\$3.25 U. S. Possessions, \$3.75 elsewhere - U. S. funds. Only direct orders to A.R.R.L., West Hartford, Conn., U. S. A., can be handled at these special rates.

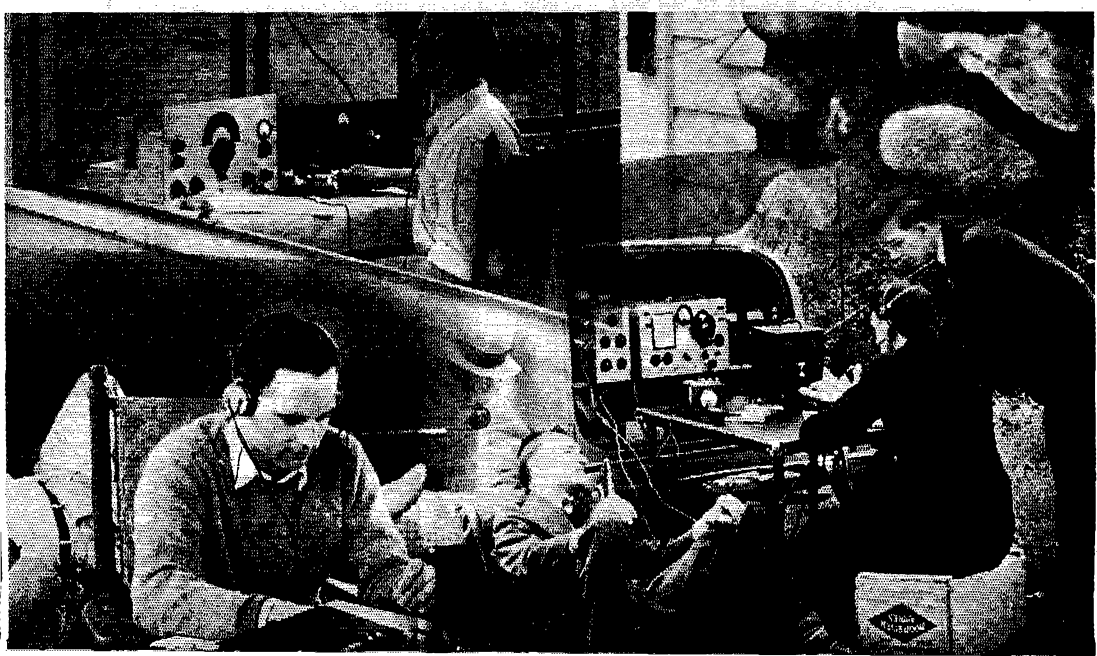



Everything sold by us carries a **SATISFACTION** guarantee that is backed by our 12 years of service to radio men.

MEISSNER Signal Splicer

can increase signal strength from 2 to 3 "R" points by efficiently matching your antenna to your receiver **\$3.95 net**

2 1/2 Meter Transceiver Kit

with drilled panel and chassis complete with recommended parts and tubes as described by Mr. Vernon Chambers W1JEO in April QST. Kit supplied completely assembled and ready for wiring.

\$14.95 net

Set of batteries consisting of four Eveready long life Mini-Max B Batteries and one 6 Volt A Battery..... **\$4.72 net**

NEW HALLICRAFTER S-27

Ultra High Frequency — 27 to 145 MC.
Frequency Modulation — Amplitude Modulation.. **\$175.00 net**

UNIVERSAL 820 Hand Set

with 2000 ohm receiver and single button microphone. Ideal for the 2 1/2 meter job..... **\$5.88 net**

New low price on MEISSNER FM Receiver

covering the newly assigned frequencies. Completely wired and factory tested..... **\$38.85 net, less tubes**

New PRECISION Series 832

31 Range AC, DC Multi-Range Tester. Measures up to 2400 volts AC and 1200 Volts DC. Decibel Ranges from -10 to +62 DB etc. **\$14.95 net**

MARION METERS

0-1 MA movement..... **\$2.85 net**
Shunts, multipliers, and scale for converting to Volt-Ohm-Milliamperes **\$1.75 net**

W2JLJ W2LJA W2KWY

OUR *Best* VALUE IS OUR RECORD OF LOYAL SERVICE

HARVEY

Radio Company of New York

103 WEST 34th STREET • NEW YORK, N. Y.

CABLE ADDRESS: "HARADIO"

Precision Crystal Frequency Standard

(Continued from page 16)

ture-coefficient of the crystal, together with this isolation from heat-radiating components, means that the frequency drift caused by temperature variations is practically nil.

It will be noticed from the photographs that the bracket on which the crystal socket is mounted is not exactly square with the rest of the chassis. This is not an error, but was made that way so that the crystal holder itself, inside the metal shell, would not be exactly level. Thus the crystal slides to one corner of the cell and stays put. The crystal is tilted and rotated approximately 20°.

The actual mechanical and wiring layout is not particularly critical, because of the relatively low operating frequency, but some attention should be given to keeping the leads connecting to the crystal, the adjusting condenser, C_1 , and the crystal oscillator tube as short and rigid as possible, since any shift in this part of the circuit will affect the frequency stability.

Adjustment

If reasonable care in construction is taken, no particular difficulty should be experienced in placing the unit in operation, providing the following steps are taken in order:

1. Adjust the crystal oscillator plate coil, L_1 .

This can best be done by connecting a milliammeter in series with the low side of R_1 , to read crystal oscillator plate current. Switch S_1 should be placed in the "1000-kc." position and plate power applied. If the crystal does not oscillate, its plate current will read 5 ma. or more. When it is oscillating properly, its plate current drops to less than 2 ma. If the crystal does not oscillate when power is applied, it is probably caused by the plate circuit of the triode not being resonated to the proper frequency. This can be checked by temporarily substituting for L_1 a coil-condenser combination capable of tuning to 1000 kc. A broadcast coil and condenser is satisfactory. Tuning this circuit through resonance should cause the plate current of the 6K8 triode to dip, as in a conventional crystal oscillator circuit. If this occurs, but the crystal still will not oscillate with the choke in the plate circuit, the choke probably has the wrong inductance. If the choke must be adjusted, it is first necessary to find out whether it has too much or too little inductance. This can be determined by connecting a small variable condenser across the choke, and swinging it through its range. If at some setting of this condenser the crystal goes into oscillation, it means that the choke does not have enough inductance, and either more turns must be added or another choke be used. If no point of oscillation is found, it is probable that the choke has too much inductance, and turns must be removed. It is best to remove a few turns at a time, and the choke tried in the circuit, to insure not removing too many turns, since it is easier to remove them

(Continued on next left-hand page)



The **FIRST LINE OF RESISTANCE**



*W*hen the going gets tough outside, we come to appreciate the value of protection.

In the unpredictable times ahead, it is reassuring to be able to turn to an organization which has devoted its life to that job—which takes nothing for granted.



The Defense forces, as well as thousands of amateurs and industrial concerns, count us in their "first line". We know our job for we have made nothing but resistors for fifteen years. If you want 50 million insulated resistors a year, or only one that will work at a hundred megacycles, if you want a "bleeder" for 1,000,000 volts or just a compact one for your portable rig, look to IRC.

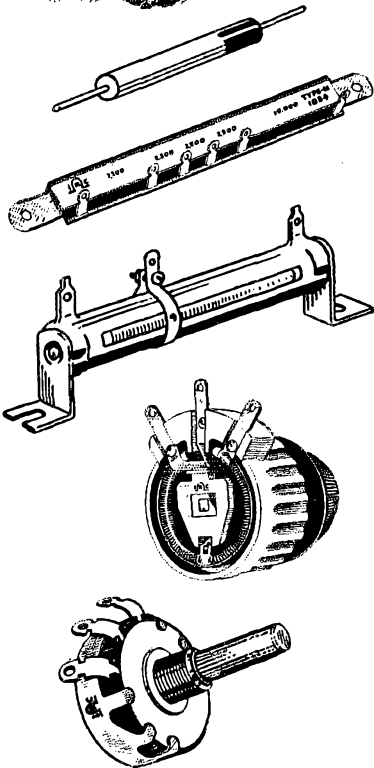

FB REPORTS KEEP ROLLING IN on the NEW PRECISION #832 31 Range Rotary Selective AC-DC Multi-Range Tester



★ LARGEST METER ever provided (3 1/2 inches is the ACTUAL WIDTH) in such a compact instrument only 7" x 4 1/2" x 3" overall.

★ A single Master Rotary Range Selector allows ALL measurements to be made from ONLY TWO polarized tip jacks, except for the two highest voltage ranges.

★ RANGES • 6 DC voltage ranges at 1000 ohms per volt: 0-6, 0-150, 0-60, 0-1200 volts • 6 AC voltage ranges at 500 ohms per volt: 0-12, 60, 300, 600, 1200, 2400 volts • 3 DC current ranges to 600 ma. • 3 OHMMETER on internal battery • 8 DECIBEL ranges (-10 to +22 DB) • 6 OUTPUT ranges to 2400 volts.

★ IT'S "PRECISION" BUILT! — 1% wire wound bobbin — 1% matched metallized multipliers — individually sealed calibrating controls — telephone cabling wiring, etc.

COMPARE THIS "PRECISION" VALUE at only \$14.95 net
This is only one of the more than 40 models comprising the complete "Precision" line of dynamic mutual condenser tube testers, combination set testers, multi-range testers, signal generators, etc. Prices start as low as \$10.95.

Ask for the PRECISION TEST EQUIPMENT 1940 CATALOG

PRECISION TEST EQUIPMENT

Standard of Accuracy SEE THEM AT YOUR JOBBER

PRECISION APPARATUS COMPANY
647 Kent Avenue Brooklyn, New York
Export Div.: 458 Broadway, New York, U. S. A. — Cables: Morhanex

RADIO COURSES

Start September

RADIO OPERATING • BROADCASTING • CODE
RADIO SERVICING • TELEVISION

• ELECTRONICS — 1 year day course; 2 years eve.
Day and Evening Classes — Booklet upon request

NEW YORK YMCA SCHOOLS
4 West 63rd Street, New York City

SICKLES COILS

ALL TYPES OF RF AND IF WINDINGS

Manufactured by
F. W. SICKLES COMPANY
300 Main Street Springfield, Mass.

EASY TO LEARN CODE

It is easy and pleasant to learn the modern way — with an **Instructograph Code Teacher**, ideal for the beginner or advanced student. • Many tapes available ranging from alphabet for beginners to typical messages on all subjects. Speed range 5 to 40 WPM. • Always ready, no QRM, beats having someone send to you.

FOR SALE OR RENT

STANDARD with 10 tapes and book of instructions, A.C. motor \$24.50
With spring-wound motor \$18.50

JUNIOR with 5 tapes and book of instructions (not rented) \$12.00

RENTAL Standard with 10 tapes and book of instructions \$3.00 first month, \$2.25 each additional month. Reference or \$10 deposit required. All rental payments may be applied on the purchase price should you decide to buy the equipment.

Write for details today

INSTRUCTOGRAPH COMPANY
Dept. O, 4701 Sheridan Road, Chicago, Illinois
Representative for Canada:
Radio College of Canada, 54 Bloor St. West, Toronto

than to put them back on. When the crystal starts oscillating, C_1 should be swung through its range, and a final adjustment made on L_1 until the plate current stays at a low value over the range of C_1 , indicating a stable operating condition.

Under this condition, listening to the output on a receiver should reveal a harmonic of the crystal every 1000 kc. This is as good a time as any to set the fifth harmonic of the crystal to zero beat with WWV, or the fundamental to zero beat with a 1000-kc. broadcast station, by adjusting C_1 .

2. Adjust the first multivibrator for 100-kc. operation.

S_1 should be placed in the "100-kc." position, energizing the first multivibrator. Under this condition, listening to the output on a receiver will indicate that a new group of signals is present, equally spaced between the original 1000-kc. points. If the builder is lucky, there will be nine such new signals between each original 1000-kc. point, indicating that the first multivibrator is operating on 100 kc. It is probable, however, that the multivibrator will be operating on some other sub-harmonic than the tenth when first tried, and its natural frequency must be adjusted. This is most readily done by adjusting the value of one or more of the resistors, R_5 , R_6 , R_7 or R_8 . One convenient method is to substitute for R_6 or R_7 a variable resistor having a maximum value somewhat greater than the nominal value of the resistor which it replaces. This resistor can then be varied, and it will be found that, over a certain portion of its range, the multivibrator will operate at the proper frequency. The variable can be set at the center of this range, and left in the circuit, or it can be replaced by a fixed resistor of the same value. When adjusting the multivibrators, it should be kept in mind that increasing the capacity of a coupling capacitor or increasing the value of a plate or grid resistor lowers the natural frequency, and vice versa.

3. Adjust the 10-kc. multivibrator.

When the first multivibrator is operating properly, the interval switch, S_1 , should be placed in the "10-kc." position and the adjusting operation repeated on the second multivibrator by varying R_{10} or R_{11} , until it is operating on 10 kc.

4. Adjust the 25-kc. multivibrator circuit.

The final circuit to be adjusted is the 25-kc. multivibrator. This should be done by adjusting R_{12} or R_{23} with S_1 in the "25-kc." position, until it is operating on the correct frequency.

5. Check the harmonic amplifier.

The operation of the harmonic amplifier should next be checked. This can best be done by connecting the "R. F. Output" terminal to the antenna terminal of a high-frequency receiver. S_1 should be placed in the "100-kc." position, S_4 to the lowest frequency coil, and R_{17} advanced to about the center of its range. Now tune in on the receiver one of the harmonics of the 100-kc.

(Continued on next left-hand page)

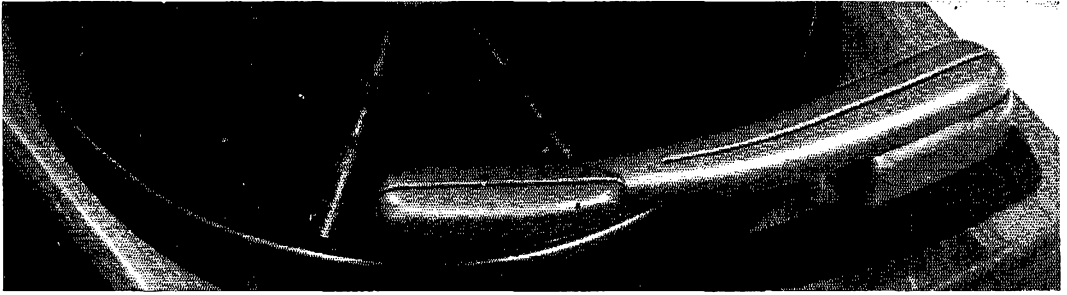

LOW PRESSURE CRYSTAL PICKUPS

Everyone who employs phonograph reproduction and especially those now interested in home recording, will welcome these new Astatic Low Pressure Crystal Pickups . . . sensation at the recent National Radio Parts Show. Models FP-18 and FP-38 are curved offset arms, cartridges of which are equipped with permanent sapphire points. Only one ounce stylus pressure. This is equivalent to approximately one-third of that necessary in conventional pickups. Records retain newness for hundreds of plays. Wear-distortion and surface noise reduced to negligible minimum. Needle changing no longer necessary. List Price \$16.50.

- ★ PERMANENT SAPPHIRE STYLUS
- ★ LONG RECORD LIFE
- ★ NO MORE NEEDLE CHANGING

*Astatic Crystal
Products Licens-
ed Under Brush
Development Co.
Patents.*

NEW
CATALOG
NO. 40
AVAILABLE

ASTATIC MICROPHONE LABORATORY, INC.
In Canada: Canadian Astatic, Ltd.
Toronto, Ontario
YOUNGSTOWN, OHIO

New Exams

NEW LICENSE MANUAL

The new examinations are based on the multiple-choice type of questions. This of course requires an entirely different approach on the part of the applicant studying to take the examination for license. The NEW "License Manual" has been written to make it as easy as possible for the individual to acquire the necessary knowledge to pass the examination with flying colors. Whether you are going up for your Class B or your Class A ticket, "The License Manual" will provide the most direct path to getting that ticket. If you are one of the thousands who always wants a "License Manual" around the shack for ready reference for amateur regulations, it will please you to know that the regulations are very thoroughly indexed.

Price 25c postpaid (no stamps, please)

AMERICAN RADIO RELAY LEAGUE
WEST HARTFORD, CONNECTICUT

"Time Is Money—

Mr. Engineer
Mr. Purchasing Agent
Mr. Manufacturer
Mr. Amateur
Mr. Exporter

"Time is Money —

that is why it is actually profitable to procure all your development and limited production components from Harrison Radio Co.

One stop service that offers complete stock, rush delivery, and technical assistance. Concentrated purchasing that eliminates duplication of ordering, auditing, and disbursement procedure. Prices that in most cases are as low or lower than your present costs.

Advise us of your requirements. Information, catalog, and literature given without obligation.

HARRISON RADIO COMPANY

12 West Broadway
New York City

Telephone WOrth 2-6276

Cable—"HARRISORAD"

multivibrator in the range of 2 to 4 Mc., and adjust C_{15} for maximum input to the receiver. By tuning in various harmonics of the 100-kc. multivibrator on the receiver, and adjusting C_{15} to maximum signal on each one, the range of each coil, L_3-L_6 , can be determined. If more calibration points are desired, S_1 can be placed in the "25-kc." or "10-kc." position. It will be found, however, that as the higher frequencies are reached, the 1000-kc. harmonics are strongest, although the others can be heard up to at least 50 or 60 Mc.

6. Check the operation of the detector.

If a strong radio-frequency signal is available, such as that from a test oscillator, it can be connected to the "Input" terminal, and the operation of the 6L7 detector checked. It will be found that the best operation of the detector occurs in the lower-frequency bands, although high-frequency signals can be monitored if they are of sufficient strength.

One of the most useful functions of a frequency standard such as this is in calibrating a variable-frequency oscillator. By using the proper procedure, in five or ten minutes calibration points having a frequency error of only a few cycles can be obtained every 10 kc. from 3500 to 4000 kc., or over any similar band.

The most satisfactory method found for making such a calibration is as follows:

1. Place S_1 in the "1000-kc." position, and tune in the 4000-kc. harmonic on a receiver. This is best done with the antenna removed from the receiver, and the "Output" terminal connected directly to the receiver antenna post.

2. Couple the uncalibrated oscillator to the receiver also, and adjust the coupling until a strong heterodyne between it and the standard is produced. Adjust the uncalibrated oscillator to zero beat with the 4000-kc. harmonic. This is of course the 4000-kc. calibration point.

3. Place S_1 in the "100-kc." position. This will not affect the 4000-kc. point, although it will probably reduce the signal strength and it will cause signals to appear every 100 kc. over the band.

4. Now set the uncalibrated oscillator to zero beat with the 3900-, 3800-, 3700-, 3600-, and 3500-kc. harmonics in turn. It will probably not be necessary to reset the receiver to each of these frequencies, since the various signals will mix in the receiver circuits and produce heterodynes anyway. This will produce a skeleton calibration, with points every 100 kc.

5. Next place S_1 in the "10-kc." position, and repeat the previous step, this time obtaining the final calibration, with a point every 10 kc. The 100-kc. points obtained in step 4 will be found useful in keeping track of which 10-kc. harmonic is which.

A.R.R.L. Announces New Code Proficiency Certificates

(Continued from page 33)

It is one thing to be able to hear some signals coming in and get the gist of the information

(Continued on next left-hand page)



QUALITY TRANSFORMERS to Specifications

U.S. DEPARTMENT

FOR over two generations Thordarson has been producing transformers to the rigid specifications of engineers in U. S. Governmental Departments. ¶ The laboratories of great industrial firms depend upon Thordarson for transformers to go into their better products. ¶ Thordarson equipment has been specified for years in Radio Beacon Systems, high fidelity broadcast stations, sensitive geophysical apparatus, highly technical communications receivers, and radio communications systems. ¶ Thordarson transformers are known and respected the world over for efficiency in intricate circuits and meticulousness in matching specifications.

Transformer Specialists **THORDARSON** *Since 1895*
CHICAGO, U. S. A.

QUALITY

Plus

VALUE



PAT.
APP.
FOR

Kenyon Plug-in Transformers stand the acid test. Compare them in any way you want and you'll find that they give PLUS value all the way. Judge for yourself.

1. Over 20 different types
2. Uniform response 30 to 20,000 cycles. (No. D. C. in primary)
3. No wire sizes smaller than No. 44. (assuring absolute dependability)
4. Positively Submersion-Proof (3/8" lap on all sealed joints)
5. Humbucking construction employed (not practical in smaller sizes)
6. 11-prong base allows maximum electrical versatility plus more rigid mechanical mounting — a "first" by Kenyon.

Send for the new Kenyon Catalog which gives complete data on the more than 20 different types of plug-in transformers as well as Laboratory Standard transformers, broadcast and industrial transformers, etc. Many graphs, charts and valuable data. It's yours for the asking.

KENYON TRANSFORMER CO., Inc.

840 BARRY STREET

NEW YORK, N. Y.

Cable Address: "KENTRAN"—New York

conveyed. It is quite another to *write down ACCURATELY* all that is sent! One cannot consider himself an operator in the truest sense until he can transcribe accurately. Sending well is an art that the writer considers even more difficult, especially if this hand transmission is to be maintained at an even tempo for any considerable period.

Practice makes perfect. A few minutes each day in emulating tape sending (by hand) and in reception of code that is moving along *just a little above* the speed one can copy comfortably, with full accuracy, will pay big dividends in a very (surprisingly) short time. Operating and more operating is recommended. Experience counts.

Amateur message handling and transcription is highly recommended. If you can do so at all, get into a net or a Trunk Line; operate in every A.R.R.L. activity that you can; put aside your "mike" for a spell, if you have at all neglected your c.w. and start your code ability on the up grade from where it is. Regardless of where we start, it is nothing to be ashamed of. Everybody will be doing it! The first A.R.R.L. certificate may be obtained at a 15 w.p.m. aural receiving ability. This is only a couple of w.p.m. above the skill required in initial license qualification tests.

All nets and scheduled traffic operating will help you, by giving a chance to listen to the better operators. Break-in work, how to learn what NOT to do, how to "copy behind" may all come with just a little practice. Any operator with net experience behind him is a more alert operator. Putting down everything you hear *on paper*, is our most earnest recommendation. See if you can get it down fully and correctly. Copy good amateur sending, and select non-amateur transmissions that are stepping along at the useful speed, just above what you can take "solid" to boost ability to copy. Competence counts.

You can be guaranteed a thrill as the application of a little vigor and energy reward any efforts put forth. There's opportunity for you in this new A.R.R.L. program. It's an obligation to one's self to nail down a Code Proficiency Certificate (in some range) just as soon as possible. It will show the visiting brethren a thing or two, and it also will exemplify an amateur's patriotism as well as his ability. So be on deck on August 5th and 30th . . . so we'll be sending you yours.

Silent Keys

It is with deep regret that we record the passing of these amateurs:

Jack Langridge, ZL2LG, Gisborne, New Zealand

Delbert W. Miller, W1DPO, North Ferrisburg, Vt.

Elmer C. Piersig, W3FEB, Philadelphia, Penna.

Jerry M. Reed, W9ZXU, Colorado Springs, Colo.

Peter G. Spencer, G8MH, Bushey, Herts, England

On the Ultra Highs

(Continued from page 42)

ceived signal. Pictures and details should be ready by next month. Ed reports a 66-db signal from W6QLZ on June 16th at 11 A.M. This is the earliest in the day and earliest in the season that W6 sigs have ever been heard, according to Ed.

A letter from W7GUR, Portland, Ore., lists contacts made on 28 Mc. during May and June. While Ten is outside our prescribed territory, we find this of interest to the 56-Mc. gang, as most of the contacts are obviously sporadic-E skip and, as such, serve to show what might be done in the same territory on Five if sufficient stations were active in the right places. Ten was dead for W7GUR only on May 4th, 6th, 8th, 9th, 24th and 26th. June was open every day except the 7th, up to the date of the letter, June 9th.

Watching Ten for signs of possible DX on Five is not always reliable. W4EDD, hearing Ten dead, decided to do a little work on the 56-Mc. rig. during the evening of May 21st. Following a period of testing, Robbie stood by on Five and was surprised to hear W9SQE calling him. This was followed by contacts with three other Chicago stations. During this entire period only one signal was heard on Ten. Robbie had DX contacts on Five on May 30th, June 2nd and 9th. Most successful contacts have been with W8 and W9 in 1940, with W1 in only seldom and for short periods. During a contact with your conductor on Ten on June 10th, when 28 Mc. showed very little sign of short skip and Five was apparently dead, we got Robbie to shift to Five; whereupon he surprised both of us by coming through quite nicely, in an apparently dead band, for several minutes around 7:30 P.M.

W5AJG, Dallas, Texas, winner of the Marathon Award for May, listens on 7 meters, and finds this territory to be a more reliable indication of possible DX conditions than is 28 Mc. Watching Ten can easily fool you, says Leroy, unless you study the combinations of different lengths of skip, the different types of fade, and other signs, until you are familiar with the combinations which seem to produce skip in your own territory. Five opens up frequently early in the morning, around 7-7:30, long before Ten shows signs of life, but 7-meter monitoring never fails at such times. "Watching Ten for possible openings on Five is excellent — if you know what to look for. There is no magic formula, however. It's just like learning to ride a bicycle — you have to learn for yourself, by experience." With 18 years of commercial and amateur radio experience in back of him, Leroy ought to know. His record of consistent DX work on Five would certainly indicate that he does.

DX of the year, to date, appears to be a contact between W5VY and W1DEI which took place on June 20th. Though this is some 1700 miles, it may be exceeded before the season is over. W6QLZ has heard several eastern stations including W4EQK, W8RUE and W8CIR. Any of these would be a 1940 record if two-way contact could be made. After long periods when no signals were heard, Clyde is really working them now, his Marathon score for June having gone over 200 points at this writing.

Over in Santa Clara, Cal., W6BPT worked W6AHH, San Francisco, for the first two-way contact between home stations on Five in these two cities. W6AHH also heard W6OHJ in San Jose. W6BPT now works W6IWS in Santa Cruz regularly. BPT uses an H array, while the skywire at IWS is 6 half-waves in phase. While all of these contacts are over relatively short distances, the indirect paths over mountainous country involved make them very creditable going.

112 MC.:

THE coming of summer has brought a considerable increase in the distances being covered by 112-Mc. stations in all parts of the country. As reported last month, the California W6's lead in this department, with contacts in excess of 100 miles being made quite frequently. W6MKS heard both ends of the W6BCX-W6OIN QSO of April 21st from his home location in San Diego. First indications of the band "opening up" for home-station work between San Diego and Los Angeles came during the latter part of April. Between then and May 15th, W6MKS worked W6's KWH, MAK, POT, SDJ, BQR, OZV, QNU, VJ, IOJ, CFY, RDR, RVL, FNN, and RUS; all over 100 miles distant, all being in the area around Los Angeles.

During May 9th to 15th, conditions were particularly conducive to temperature inversions, with extremely hot weather only a few miles inland and cool sea breezes blowing

PINCO

A
SIZE
FOR
ANY
JOB



DYNAMOTORS

Pinco Dynamotors are as much "at home" on tough jobs as on ordinary ones. No wonder they are specified by governmental and commercial users universally for aircraft, marine and broadcast service, police units, sound systems, auto radios, etc. Available in a wide variety of types and frames for any requirement. Highest efficiency and regulation. Capacities: 5 to 850 watts. Input, 6 to 110 volts; output, up to 1750 volts. Specify "Pinco" — and be sure of thousands of hours of dependable, quiet service. Mail coupon for complete information.

PIONEER GEN-E-MOTOR CORP.

CHICAGO, ILLINOIS

Export Department: 25 Warren St., New York, New York
Cable Address: SIMONTRICK, New York

Pioneer Gen-E-Motor Corp.

Dept. R-6H, 466 W. Superior St., Chicago, Ill.

Please send information on Pinco Dynamotors,
Motor Generators and special power supply units.

Name.....

Address.....

City..... State.....

RADIO

ENGINEERING, broadcasting, aviation and radio telegraphy and telephony, Morse telegraphy and railway accounting taught thoroughly. 48 weeks' engineering course, equivalent to three years of college radio work. School established 1874. All expenses low. Catalog free.

DODGE'S INSTITUTE, Day Street, Valparaiso, Indiana

READ AND SEND CODE

Learn Easily at Home
This Quicker Way

No experience needed. Beginners read code quickly, copy accurately. If already an op, speed up your wpm with this approved, amazing, all Electric Master Teleplex Code Teacher. Only instrument ever produced which records your sending in visible



dots and dashes on specially prepared paper tape — then sends back your own key work at any speed you wish. Fascinating, fool-proof — yet results because you learn by HEARING as well as SEEING. That is why thousands agree this method is surest and quickest. While not designated standard equipment, Teleplex is used at many U. S. Army Posts, Naval Training Stations. We furnish Complete Course, lend you the New All Electric Master Teleplex, and personal instruction with a MONEY-BACK GUARANTEE. Low cost, easy terms. Write today for folder Q-8, no obligation.

“HAM”
SPECIAL

TELEPLEX CO., 67-69 Park Place, New York

In Canada, Write

Canadian Electronic Institute, Toronto, Ontario

MEET THE GANG!!

AS "OM to OM", we here at SUN think we have something "on the line" for you. We are continually offering you technical information, advice, and help. For the men who take care of your technical requests and provide the prompt service on your requirements — we thought their picture might prove of interest. Of course, those of you who have already met them will instantly recognize their beaming (?) countenances. To those who have not as yet met them, we thought you would like to know who they are. So here they are, every one, amply qualified to solve the most complex radio problems.

From left to right —

Jack Grand — who has been with SUN almost since its inception. A real old-timer who knows his meters. (Look at that pose, will you.)

Ed Magad — specialist in home radio, television and frequency modulation circuits. Loves seeing what makes them "tick."

H. Kahn — for many years associated with Leeds Radio. Now brings his vast experience and background to SUN.



Ed Berliant, WZJEH — Our strong, silent man. Widely known throughout amateur radio circles. Expert technician and fundamentalist. Has covered the globe with CQ.

Ed Riny, WZLFV — cut his teeth on a telegraph key 'way back in —. Well, — 'way back. (My, isn't he handsome!)

Sam Schwartz — founder and sole-owner, whose progressive-mindedness has placed SUN RADIO foremost among amateur supply houses.

Joseph Pohlmuller — familiarly known as "J. P." Trouble-shooter par excellence.

Bill Green, WZDXC — the YL's Prince Charmant for theories and principles. (Darned if we can stick him.)

Joseph Schwartz — a little of this and a little of that, with a special leaning towards television.

Gene Gerber, WZGCK — well-steered in theory, fundamentals and their practical application. Always bright's gift to radio.

John Heddacus, Ex-W4DJM and Ex-2BZT — a good man gone wrong. Well-versed in all radio applications. Specializes in public address.

"You'll Find Sun Service Is Best"
NEW P.A. CATALOG JUST OUT
 SEND FOR YOUR COPY TODAY
NEW YORK'S OLDEST "HAM" HOUSE
 ■ ESTABLISHED 1922 ■

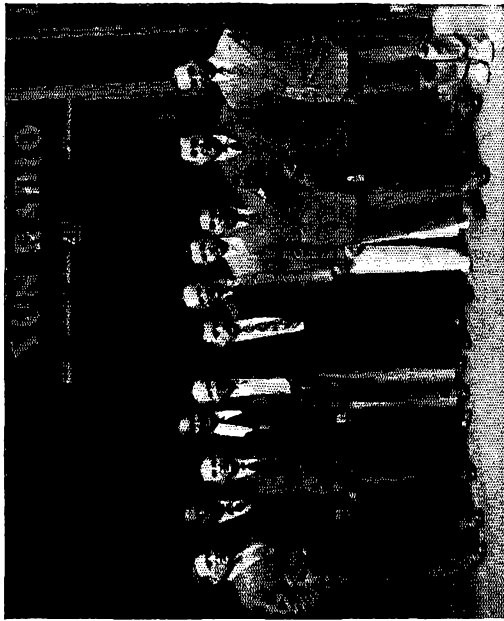

in along the coast. W6MKS is located right at the water's edge, his antenna being only about 45 feet above sea level. The path to Los Angeles is entirely over salt water, a favorable condition for long-range work, but at 100 miles a considerable amount of bending is required even over flat terrain. Under ideal conditions, power seemed to make little difference. On one occasion, during a contact with W6RVL, Eric reduced power from 75 watts to 4.5 watts with very little change in signal. On May 14th, when the band was particularly good, contact was made with W6RDR/6, 105 miles, when RDR was running ¼ watt to a battery-operated transceiver!

The rig is a pair of HK-24's. For receiving, a t.r.f. super-regen, 954 r.f., 6J5-G a.r. detector, 6J5 quench oscillator, 6J5 audio, with concentric lines in r.f. and detector circuits, is used. The antenna at W6MKS is a 3-element vertical beam, the radiator of which is a multi-wire doublet with 400-ohm feeders. The multi-wire doublet, incidentally, is giving nice results for a number of the gang, among them being W2CTK, who reports results far exceeding those obtained with his former delta-matched vertical.

At W1HDQ, we had the good fortune to catch 112 Mc. in one of its hot spells on the evening of June 14th. Contacts were made with W2's KYT and KZP on Long Island, about 120 miles; and LXO, West Orange, N. J., about 130 miles. The last is believed to be the first New Jersey-Massachusetts QSO on 112 Mc.

From Chattanooga, Tenn., comes word of activity by the Lookout Amateur Radio Club on 112 Mc. Using flea-power portables having an input of about ¼-watt, W4ESQ and W4FVM in moving automobiles, W4DLJ riding a bicycle, and W2MEX/W4FEE carrying a rig on a shoulder strap, have been covering distances of about a mile on all sorts of terrain. These little rigs were demonstrated at the Rome, Ga., hamfest on June 2nd.

★ NEW TUBES ★

NEW 1.4 VOLT OUTPUT TUBE

KEN-RAD announces the type 1T5GT, a 1.4-volt, 50-ma. filament-type beam power amplifier tube designed for battery-operated radio receivers. Ratings and characteristics for operation as a Class A₁ amplifier are as follows:

Plate voltage.....	90 max.
Screen voltage.....	90 max.
Grid voltage.....	— 6
Peak a.f. grid voltage.....	6
Plate current.....	6.5 ma.
Screen current.....	1.4 ma.
Transconductance.....	1150 μmhos.
Load resistance.....	14,000 ohms
Total harmonic distortion.....	7.5 p.c.
Power output.....	0.17 w.

NEW RECTIFIER-BEAM POWER-OUTPUT TUBE

RAYTHEON announces the Type 117M7GT, a two-section tube for service as both rectifier and beam power-output amplifier in applications where it is desired to connect the heater directly across the 115-volt power line. The heater draws 0.09 amp.

The rectifier section is rated at a maximum a.c. (r.m.s.) plate voltage of 117 and d.c. output current of 75 ma. The internal voltage drop at maximum rated load current is 22.

The audio section has an output rating of 1 watt with 8% total harmonic distortion. Recommended operating conditions are: plate and screen voltage — 100, grid bias — 5.5 volts, load resistance — 2000 ohms. The plate resistance is given as 15,000 ohms and the transconductance as 6500 μmhos.

Designing a Wide-Range U.H.F. Receiver

(Continued from page 37)

Litz wire gave lower Q values. A conical winding over an iron core gave a Q of 165 but could not be used because of the winding and assembly difficulties involved. The coils are spaced 1 3/8 inches apart between centers. The expanding winding consists of a single turn around the iron core in series with the low potential side of the secondary and in the expanded position provides ample band width for wide-band f.m. reception.

The grid of the third i.f. transformer is coupled to both the grid of the 1852 limiter tube and the grid of the 6SK7 i.f. amplifier. The 1852 limiter is operated without bias and with reduced plate and screen voltages. For small signal amplitudes impressed upon its grid, this tube acts as an amplifier. As the signal voltage increases, the grid rectification causes a current to flow through the biasing resistor which makes the grid negative and keeps the plate current from increasing. As a result, the output voltage reaches a saturation value as the input voltage is increased. It was noted that further increase of input voltage reduced the output voltage. Applying a small amount of a.v.c. voltage to the i.f. amplifier resulted in a very flat output characteristic. A double resistance-capacity filter circuit is used, with one set of RC values to respond to rapid voltage variations while the other responds to slow changes.

In most f.m. receivers a 6SJ7 tube or its equivalent is used as the limiter tube and gives excellent results in this capacity. The 1852 was chosen for this receiver because the low impedance of the 5.25-Mc. primary required a tube of higher transconductance to give sufficient output for the audio amplifier used. The low primary impedance of the discriminator transformer was due to the 50- μ fd. air tuning condenser chosen as the minimum value necessary for good circuit stability.

Increasing the coupling in the discriminator increases the range over which it will operate, while loading the transformer with a resistance across either primary, secondary or both, serves to make the response more linear. Too much damping again reduces the range. There is an optimum value of coupling and loading which gives a linear characteristic over the required range. A simple method of obtaining the correct values is to disconnect the condenser from primary to the secondary center-tap and operate the transformer exactly as a normal diode i.f. transformer in an ordinary superhet. Connect a signal generator to the grid of the limiter tube and tune the primary and secondary to the correct i.f. frequency. Then vary the coupling and the load resistor until a flat-topped selectivity curve is obtained whose width across the flat top is equal to the total frequency-band response required. In this case, we used somewhat more than twice 75 kc. Leaving the coupling and loading resistance unchanged, the transformer is recon-

GET THE FACTS ON CODE FROM CANDLER



THE system which has taught thousands the amazing Candler special method of real code speed. Don't spend hours alone, trying to overcome your own faults—let the Candler system correct them by the same method used to teach speed champions. Candler's expertly directed practice will help you even if you are a beginner starting to learn. Candler has the real short cut to code speed—ask any skilled "op"—and the cost is very low.

FREE! Write today for the big 52-page book—packed full of real helpful regulations, probable exam questions. Don't delay—send for this book NOW!—There is no obligation.

CANDLER SYSTEM CO.
DEPT. Q-8 ASHEVILLE, NO. CAROLINA, U. S. A.

RADIO TECHNOLOGY



RCA Institutes offer an intensive course of high standard embracing all phases of Radio and Television. Practical training with modern equipment at New York and Chicago Schools.

Illustrated Catalog on request

RCA INSTITUTES, INC. Dept. ST-40

A Radio Corporation of America Service

75 Varick St., New York

1154 Merchandise Mart, Chicago

Piezo-Electric Crystals Exclusively

- Quality crystals of all practical frequencies supplied SINCE 1925. Prices quoted upon receipt of your specifications.

Our Pledge: **QUALITY FIRST**

SCIENTIFIC RADIO SERVICE

"The Crystal Specialists Since 1925" University Park, Hyattsville, Md.

TAKE THE NEW RADIO EXAMS IN YOUR STRIDE

Newly-written, low-cost, home-study courses, under supervision of Arthur R. Nilson, twenty years co-author of technical radio books. Thousands of professional radiomen use Nilson and Horning textbooks to keep up to date. Now Arthur R. Nilson will give you direct, detailed lessons, step by step.



**POLICE
AIRCRAFT
FORESTRY
BROADCAST**

SEND FOR FREE 16-PAGE BOOKLET "What the Modern Radioman Must Know." Make this step toward your successful radio career... now!

NILSON RADIO SCHOOL

51 East 42nd St., New York, N. Y.





E. H. Kietzke
Pres. CREI

MR. RADIOMAN: What Are You Doing About "Tomorrow"? Start Training NOW in Practical Radio Engineering

● Don't sit back and watch the other fellow get ahead. Radio pays no "favorites." The GOOD men get the GOOD jobs. TECHNICAL TRAINING makes it possible for YOU to get ahead to a better job and better pay. Preparing yourself today is the best insurance for a better job tomorrow! We can help you get ahead as we have helped hundreds of other ambitious men.

Write for FREE Booklet

To help us send complete details, please state briefly your radio experience, education and present position — and if interested in home study or residence course.



*CREI Technical Training
Plus Your Own Experience
Prepares You for a
Future in a Field Where
Training Pays!*

CREI courses are planned for the man who realizes that technical training is necessary to advance in radio. Every phase of practical RADIO and TELEVISION ENGINEERING is covered. If you combine your own radio experience and knowledge with CREI training, you should be equipped to take advantage of every opportunity to improve yourself. Write today for details.

Capitol Radio Engineering Institute
Dept. Q-8, 3224 16th St. N.W., Washington, D.C.

Fish Don't Perspire!

- A sleeve has no vest.*
- A fly can't bird, but a bird can fly.*
- You can't tie a railroad tie.*
- How long is a piece of string?*
- How high is it up?*
- Which end of a rope is the short one?*

You can't find information like that, or the answers to questions like that, in the RADIO AMATEUR'S HANDBOOK. But if you want clear information on any radio problem, with no nonsense — and if you want to keep in touch with the latest, hot-off-the-bench developments in the radio art — you'd better take advantage of the *Special Offer*, as outlined on pages 74 and 75 of this magazine. July and August only.

nected as a discriminator. It will be necessary to retune the circuits of course, but a check of the frequency response voltage will indicate the correctness of the constant chosen. What we have done was simply to maintain a nearly zero phase angle over the operating frequency band.

As all standard f.m. broadcast transmissions have greater modulation with increasing audio frequency, a de-emphasis circuit having a time constant of 100 micro-seconds and consisting of a series resistance of 0.1 megohm and a shunt capacity of 0.001 $\mu\text{fd.}$ are used as shown (R_{19} and C_{13} , Fig. 2). It is not sufficient to merely use a shunt capacity across the diode resistors, for the low d.c. resistance of the diode prevents even a fairly large capacity from becoming effective.

The amplitude modulation part of the receiver is normal in all respects. A standard noise limiter diode has been incorporated. Due to the relatively wide frequency pass of a 5.25 Mc. i.f. amplifier, the higher frequency components of noise pulses appear in the diode circuit, thus preserving to a greater degree the steep wave-front of the noise pulse. As this type of limiter is most effective on pulses having a steep wave front, the limiting circuit becomes very effective in reducing a variety of noises.

A dual purpose "S" meter is another feature. When operated in the a.m. position, the "S" meter operates as the well-known carrier-level meter. Operating in the plate circuit of a tube whose screen voltage is controlled by the VR-150 voltage regulator, the S-meter pointer is practically unaffected by line voltage changes but quickly responds to plate-current variations produced by the a.v.c. voltage whose value depends upon the strength of the received signal.

When the receiver is switched to the f.m. position, the S-meter is used as a tuning meter. More so than in any other type of receiver, accurate tuning is a requisite of distortionless f.m. reception. The zero-current position of the meter is located about 25% of the meter-scale distance from the right end. The "S" meter is now connected as a voltmeter across the total discriminator diode load resistors. When the receiver is perfectly tuned, no voltage appears across these resistors because of the balanced discriminator action. In using the meter, therefore, the pointer will first swing in one direction as the signal is tuned in. It reaches a peak and then swings back in the other direction, passes the zero line and reaches a peak on the opposite side and then comes back to zero. When it crosses the zero line while swinging across it, the receiver is perfectly tuned. The carrier level of an f.m. signal can be compared simply by switching to the a.m. position and noting the S-meter reading.

Unusual pains were taken to make the cabinet and mounting as sturdy as possible. The panel is made of $\frac{1}{8}$ -inch thick steel, and a large heavy bracket on each side of the chassis supports the front panel. The completed chassis assembly can fit into either a rack mounting or the cabinet for which it was designed.

Correspondence Department

(Continued from page 47)

amateur that A.R.R.L. is not — according to their story — on its toes in protecting amateur interests.

Speaking for the members of the York Radio Club of this city (100% A.R.R.L.) may I extend our congratulations to you on a job well done.

— J. H. Platz, W9GY

ENDORSEMENT

5106 Wilshire Blvd., Los Angeles, Calif.

Editor, QST:

I take the liberty of enclosing herewith copy of a letter which I am sending to the Commissioners of the Federal Communications Commission, to certain Congressmen and to the President.

It occurs to me that you may care to publish this letter in your forthcoming issue of QST.

— Lee de Forest

(Dr. de Forest's letter is reproduced below.)

My understanding of the Federal Communications Commission's recent action in prohibiting communication by radio amateurs with others outside of the United States and its possessions, and in prohibiting communication of radio amateurs from 30-megacycle mobile and portable installations, impels me to write a word of commendation for such action in this emergency, and also to offer certain suggestions.

The action of the Commission in permitting radio amateurs to continue with mobile operations on the ultra-high frequencies, which could not be harmful and which are only good for short distances, was thoughtful and meritorious.

I wish to urge, however, that all governmental authorities, the Federal Communications Commission especially, now give every consideration to radio amateurs so that their legitimate activities, so long as we are not at war, may not be further impaired, so that they may continue operation with one another from fixed locations within the United States and its possessions. I offer, as my reason for these suggestions, the fact that my own wide acquaintance with this amateur group convinces me that for the most part these young men are true, red-blooded Americans, willing to "do or die" for their country and flag, and are ready and willing at all times to volunteer their services and their equipment itself, in any emergency.

I believe, and I feel that you will agree with me, that the thousands of modern and ultra-modern installations of radio telephone and telegraph apparatus operated by these amateurs in all parts of the United States and its territories actually constitute a most valuable reserve force both of equipment and capable men, serviceable for communication centers in any contingency that might arise.

I further feel that by permitting the amateurs to continue with their work in radio we are building up practical training and experience in these men far better than could be done in any school of training, both as regards technical ability and for the handling of radio telegraph code messages.

A great majority of these licensed radio amateurs maintain equipment which is quite portable in nature and which permits far greater power output in proportion to the size and weight than most commercial equipment available for government use in emergency to-day. By their continued day and night activities (frequently far into the night and early morning hours) these men constitute a real value to the government in emergency. . . . Take the amateurs off the air, take away their privileges of carrying on communications with one another, and it is self-evident that their interest in radio would then not be sufficient, purely from a listening angle, to afford such a widespread group of monitors as the nation now enjoys.

It is my belief, therefore, that rather than further curtail American amateurs and their activities, they should be encouraged by their government to more closely organize themselves into a vast reserve army of expert communication men operating high-class communication equipment, in cooperation or association with regular Army and Navy communication activities. Actually I believe that the American radio amateurs are already to a large extent regimented of their own volition along these very lines. . .



DUMMY ANTENNA

Use this Ohmite Dummy Antenna to check R.F. power, determine transmission line losses, check line to antenna impedance match — then tune up to best efficiency. Non-inductive, non-capacitive, constant in resistance. Mounts in standard tube socket. Available in 100 watt and 250 watt sizes.

Write for Free Dummy Antenna Bulletin 111

OHMITE MANUFACTURING CO.
4864 Flournoy Street ★ Chicago, U.S.A.

Be Right with **OHMITE**
RHEOSTATS • RESISTORS • TAP SWITCHES

AUTOMATIC SENDERS

Type S — Sends 4 to 60 W.P.M. 10 rolls of double perforated tape made up of carefully selected and arranged matter for the most practical results. **\$20.00**

Type J — Sends 6 to 60 W.P.M. Practise tape and 5 rolls of blank tape. Make your own special tapes with built-in tape perforator. **\$12.50**

If your dealer can't supply you, write us

Gardiner-Levering Co. Haddon Heights, N. J.
New Jersey, U. S. A.

WANTED

ELECTRICAL ENGINEER with basic ability in electronic work, particularly tubes. Should have about 5 years' experience with development and manufacturing problems. Write:

Box EE, Advertising Dept., QST
West Hartford, Conn.



AMATEUR RADIO LICENSES

Day and Evening Classes in Code and Theory

HOME STUDY COURSES

Reasonable, Efficient and Thorough, Hundreds of Licensed Students Now on the Air

American Radio Institute, 1123 Broadway, New York, N. Y.

TERMINAL AMPLIFIERS

Speak for Themselves!

Radio amateurs will find Terminal public address amplifiers ideal for low-cost speech input stages. Terminal amplifiers incorporate inverse feedback circuits and provide attenuation of bass and treble frequencies for wide-range and speech-range audio response. They are manufactured for us to our own rigid specifications.

TERMINAL 8 Watt Amplifier

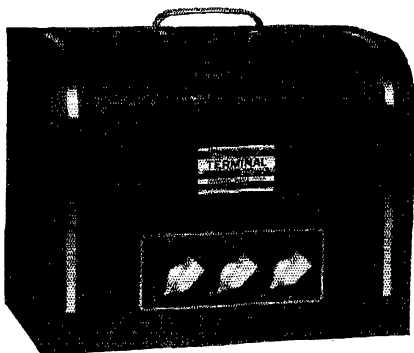

Delivers 8 watts undistorted. Complete mixing of mike and phono input. Excellent frequency response. Tubes:

1-6J7, 1-6F5, 1-6L6G, 1-5Y4G. Choice of output impedances.

Model T-8. 8 watt amplifier, less tubes..... **\$13.95**

Kit of Matched RCA Radiotron tubes \$2.55

TERMINAL 20 Watt Amplifier

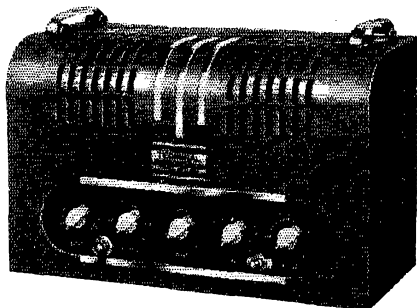

20 watts output. Complete mixing of 2 mike and 1 phono inputs. Hi-Fi response. Tubes: 2-6J7,

2-6N7, 2-6L6G, 1-5U4G. Choice of output impedances.

Model T-20. 20 watt amplifier, less tubes..... **\$29.95**

Kit of matched RCA Radiotron tubes \$5.53

FREE P. A. CATALOG!

Lists hundreds of buys! Write or call for your copy today!

TERMINAL *Radio Corp.*

68 West 45th St. • 80 Cortlandt St.
2 stores in NEW YORK CITY
Vanderbilt 6-5050 • Cable: TERMRADIO

Catalogs and Pamphlets

American Phenolic Corp., 1250 W. Van Buren St., Chicago, Ill.

FOLDER describing new "AN" series of universal cable connectors of aluminum and high-grade bakelite. There are 4 types of shells in 18 sizes for cables from 3/16-in. to 2 1/2-in. diam., male and female elements with from one to 42 contacts with current ratings from 5 to 200 amperes.

Irvington Varnish and Insulator Co., 24 Argyle Place, Irvington, N. J.

BULLETIN covering the outstanding features of a new low-cost, extruded insulating tubing Irv-O-Lite, Type XTE-30. Sizes, colors and prices are listed and samples are included.

Premax Products, Highland Ave., Niagara Falls, N. Y.

A CIRCULAR of Monel metal collapsible antennas and insulating fittings designed particularly for marine and other services in which heavy corrosion is likely to be experienced.

Radio Direction Finding

(Continued from page 25)

taking of "reference point bearings." In this system the compass is *eliminated*, loop errors are largely cancelled out, and the actual plotting of the observed bearing becomes a matter of seconds instead of minutes! The operator using this system first takes a bearing against a known location such as a prominent broadcast station and draws a line on the map from his location to that of the known station or "reference point." A radio bearing is then taken on the unknown station and its angular displacement in relation to the "reference line" is drawn. The unknown station must then be located somewhere along this second line. If, for example, an unknown station is 30° "to the right" of the known station, a pencil line is drawn at that angle to the "reference line." If the loop is mechanically or electrically unbalanced, due to a bent loop, bent index pointer, stray pickup, or similar defect, the error is automatically cancelled out because the plotted lines merely indicate *relative* directions rather than *absolute* directions, which, after all, would necessitate surveyor's instruments.

Hunting Methods

At the start of a "hunt," the operator tunes in a known station for use as a reference point and the bearing is noted and drawn. Usually, the reference lines have been previously inked in for a number of strategic locations. A bearing is then taken on the unknown station and is plotted as so many degrees off the first reference line. The operator then drives to a second location some distance away and repeats the process. The plotted lines normally intersect. If the angle of intersection is very acute, or the lines do not intersect within the limits of the map, one or both

(Continued on next left-hand page)

Where to buy it

A directory of suppliers who carry in stock the products of these dependable manufacturers.



ALBANY, N. Y. Uncle Dave's Radio Shack 356 Broadway
ATLANTA, GEORGIA 265 Peachtree Street
 Radio Wire Television Inc.
BOSTON, MASS. Radio Shack 167 Washington Street
BOSTON, MASS. 110 Federal Street
 Radio Wire Television Inc.
BRONX, N. Y. 542 East Fordham Rd.
 Radio Wire Television Inc.
BUTLER, MISSOURI 211-215 N. Main Street
 Henry Radio Shop
CHICAGO, ILL. 833 W. Jackson Blvd.
 Allied Radio Corp.
CHICAGO, ILL. 901-911 W. Jackson Blvd.
 Radio Wire Television Inc.
CINCINNATI, OHIO 1103 Vine Street
 United Radio, Inc.
DETROIT, MICH. 325 E. Jefferson Ave.
 Radio Specialties Co.
DETROIT, MICHIGAN 11800 Woodward Ave.
 Radio Specialties Co.
HARTFORD, CONNECTICUT 227 Asylum Street
 Radio Inspection Service Company
HOUSTON, TEXAS 4021 Huey Street
 R. C. & L. F. Hall
INDIANAPOLIS, INDIANA 34 West Ohio Street
 Van Sickle Radio Supply Co.
JAMAICA, L. I. 90-08 166th Street
 Radio Wire Television Inc.
KANSAS CITY, MO. 1012 McGee Street
 Burstein-Applebee Company
NEW YORK, N. Y. Harrison Radio Co. 12 West Broadway
NEW YORK, N. Y. 100 Sixth Ave.
 Radio Wire Television Inc.
NEWARK, N. J. 24 Central Ave.
 Radio Wire Television Inc.
SCRANTON, PENN. 519-21 Mulberry Street
 Scranton Radio & Television Supply Co.
WASHINGTON, D. C. 938 F Street, N. W.
 Sun Radio & Service Supply Co.

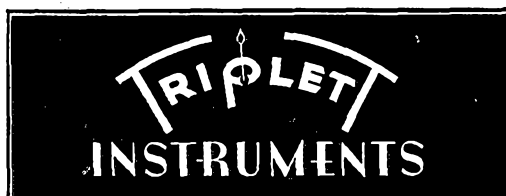

ALBANY, N. Y. Uncle Dave's Radio Shack 356 Broadway
ATLANTA, GEORGIA 265 Peachtree Street
 Radio Wire Television Inc.
BOSTON, MASS. Radio Shack 167 Washington Street
BOSTON, MASS. 110 Federal Street
 Radio Wire Television Inc.
BRONX, N. Y. 542 East Fordham Rd.
 Radio Wire Television Inc.
BUTLER, MISSOURI 211-215 N. Main Street
 Henry Radio Shop
CHICAGO, ILLINOIS 833 W. Jackson Blvd.
 Allied Radio Corp.
CHICAGO, ILL. 901-911 W. Jackson Blvd.
 Radio Wire Television Inc.
CINCINNATI, OHIO 1103 Vine Street
 United Radio, Inc.
JAMAICA, L. I. 90-08 166th Street
 Radio Wire Television Inc.
LITTLE ROCK, ARKANSAS 409 W. 3rd St.
 Beem Radio Company
MINNEAPOLIS, MINNESOTA 1124-26 Harmon Place
 Lew Bonn Company
NEW YORK, N. Y. 100 Sixth Avenue
 Radio Wire Television Inc.
NEWARK, N. J. 24 Central Ave.
 Radio Wire Television Inc.
SCRANTON, PENN. 519-21 Mulberry Street
 Scranton Radio & Television Supply Co.
WASHINGTON, D. C. 938 F Street, N. W.
 Sun Radio & Service Supply Co.

Listings on this page do not necessarily imply endorsement by QST of the dealers or of other equipment sold by them.

readings may be in error. If either of the first two sets of bearings is thought to be doubtful, the operator drives to a third location and repeats the process. If the plotting of three "unknown" lines results in the formation of a dot where the three lines cross, a perfect "fix" has been obtained and the operator drives to that location. If the three-line intersection forms a small triangle, the transmitter is quite likely within the area enclosed. If a large triangle has been formed, the transmitter location is still probably within its designated limits, but in this case it may be advisable to take a fourth and even fifth bearing from other locations before driving to the indicated area. It is important that a good "fix" be obtained before dusk, as bearings taken after that time are notoriously unreliable because of the night effect.

After arriving at the designated area, the problem of triangulation is repeated, but now the bearings are not necessarily plotted. If the area is small, or in unsettled territory, the operator makes mental note of his bearings as he drives along, and so continuously narrows his search. When the transmitting antenna is approached, the signal strength will suddenly increase while the receiver is still several wavelengths away. This increase is very noticeable. In some cases the receiver will "block" if sufficient r.f. gain control has not been provided. If this happens the operator can note, while driving in a straight line, the approximate limits between where his receiver commenced to block and where it resumed oscillating. The transmitter will probably be midway between those limits. If the receiver does not block, the operator continues "triangulating" until he has determined the transmitter location. This is not always as easy as it may sound, since the radiation is not from a point source but rather from a "line base." If you consider the electrical length necessary for an antenna to resonate on, for example, 160 meters, and assume the station to be hidden in one of a group of adjoining buildings, the difficulties are obvious. In such cases the best procedure is to drive some distance away from the blocking or induction field area and take several very careful bearings, noticing whether the lines cross at the

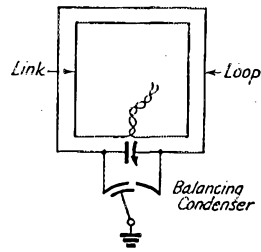

Fig. 6—A loop-balancing condenser can be added for complete capacity balance to ground.

head or in the middle of a particular block. Further readings taken at right angles will determine if the transmitter is on one or the other side of the street.

Field-strength measurements, while helpful, are very misleading. If a field strength meter is carried *across* rather than *along* one of the major transmitting lobes of the radiating system, the observed field strength readings will be much greater at a distance of several hundred yards than when almost under the transmitting antenna but within one of its null zones. In practical direction finding, as in anything else, the skill and experience of the operator is one of the chief factors.

Conclusions

Some of the precautions, practices and beliefs, reached by the Main Line Radio Club, after many years of this activity, are listed for the guidance of any others contemplating such an event.

1. Notify the District Radio Inspector of the proposed portable operation and follow the legal requirements for portable operation.
2. Keep the hunts within a 25-mile radius of the starting point.
3. 160 meters seems the best compromise between interference, skip, signal strength, and reliability of bearings.
4. 100 watts of input assures a good signal throughout hilly country.
5. Run the hunts in the summer and start at approximately 7 P.M. Night effect becomes pronounced around 7:30 P.M. and preliminary bearings must be completed before then.
6. Make up a set of *complete* rules before the season and adhere strictly to them, in order to prevent future misunderstandings and possible hard feelings.
7. Provide a worth-while award for the winning team.

The Main Line Club started several years ago to give silver loving cups as prizes. These cups are now prized possessions in the ham-shacks of W3CGM, W3EOZ and the author. If your club is looking for a real, honest-to-goodness, interest-stirring, blood-warming activity, this is definitely IT.

Meanwhile, the author is working on a new finder that burns a red light when you approach the hidden station and rings a bell when you pass the right house. But then you wouldn't be interested in it. . . .

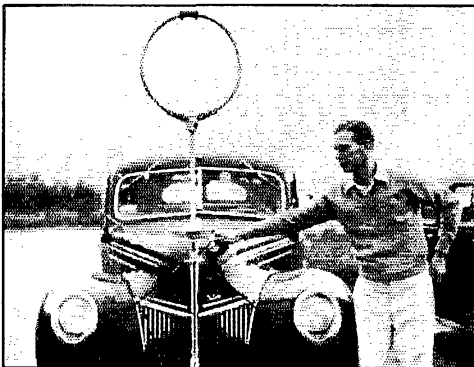

W3EZ adjusts his "rotator."

HAM-ADS

(1) Advertising shall pertain to radio and shall be of nature of interest to radio amateurs or experimenters in their pursuit of the art.

(2) No display of any character will be accepted, nor can any special typographical arrangement, such as all or part capital letters be used which would tend to make one advertisement stand out from the others.

(3) The Ham-Ad rate is 15¢ per word, except as noted in paragraph (6) below.

(4) Remittance in full must accompany copy. No cash or contract discount or agency commission will be allowed.

(5) Closing date for Ham-Ads is the 25th of the second month preceding publication date.

(6) A special rate of 7¢ per word will apply to advertising which, in our judgment, is obviously non-commercial in nature and is placed and signed by a member of the American Radio Relay League. Thus, advertising of bona fide surplus equipment owned, used and for sale by an individual or apparatus offered for exchange or advertising inquiring for special equipment, if by a member of the American Radio Relay League takes the 7¢ rate. An attempt to deal in apparatus in quantity for profit, even if by an individual, is commercial and all advertising by him takes the 15¢ rate. Provisions of paragraphs (1), (2), (4) and (5) apply to all advertising in this column regardless of which rate may apply.

Having made no investigation of the advertisers in the classified columns, the publishers of QST are unable to vouch for their integrity or for the grade or character of the products advertised

QUARTZ — direct importers from Brazil of best quality pure quartz suitable for making piezo-electric crystals.

Diamond Drill Carbon Co., 719 World Bldg., New York City.
QSL's — samples. Brownie, W3CJL, 523 No. Tenth St., Allentown, Pa.

CRYSTALS, mounted, 80-160, \$1.25, V-cut 40, \$2.25. R9 Crystals, 338 Murray Ave., Arnold, Pa.

QSL's, Maps, Cartoons. Free samples. Theodore Porcher, 7708 Navahoe, Philadelphia, Pa.

USED receivers. Bargains. Cash only. No trades. Price list 3¢. W3DQ, Wilmington, Del.

CALLBOOKS — Summer edition now on sale containing complete up-to-date list of radio hams throughout entire world. Also world prefix map, and new time conversion chart. Single copies \$1.25. Canada and foreign \$1.35. Radio Amateur Call Book, 610 S. Dearborn, Chicago.

CRYSTALS: famous P.R., mounted in latest Aismag 35 holders — 40, 80 meter PR-X, 160 meter PR-Z, \$3; 40, 80 meter PR-Z (low drift), \$3.50; 20-meter PR-20, \$4.50; unconditionally guaranteed. Immediate shipment. Wholesale Radio Labs., Council Bluffs, Iowa, W9GFQ.

SHURE 5B double-button carbon mikes — \$3.49, postpaid; mike rings with springs, 49¢; combination — \$3.75 postpaid. W8RRL, Dymac Radio, 1531 Main St., Buffalo, N. Y.

1000 watt G.E. transformers 1100-2200-4400 volts each side c.t. Guaranteed. \$13.50. Dawson, 5740 Woodrow, Detroit, Mich.

TELEPLEXES, instructographs bought, sold. Ryan's, Hannibal, Mo.

MACAUTO code machines: low monthly rental 50,000 words practice tapes. Write N. C. Ayers, 711 Boylston St., Boston, Mass. Granite 7189-W.

QSL's. W8JOT, Box 101, Rochester, N. Y.

BARGAIN — 500 watt phone-CW transmitter. W. E. relay rack 72" high; black crackle panels. \$150 cash f.o.b. W9WYI. If you want to buy, sell, or trade equipment, write to Radio and Electrical Division of Lubbock Real Estate and Brokerage Service, Box 803, Lubbock, Texas. W5DV; W5HQD.

SELL 112 mc. transceiver complete with handset antenna power supply \$20, reound Dodge generator 110 a.c. \$15, portable transmitter 6 v. d. c. or 110 a. c. supply \$20. Other items. W9ERU.

QSL's? — SWL's? America's finest. Quickest service. Samples? W8DED, Holland, Mich.

SX-10 Ultra Skyriider, crystal filter, noise silencer, like new, \$60. W8HGA.

NATIONAL 101X receiver, slightly used, \$85. WICEG.

CRYSTALS — police, marine, aircraft, amateur. C-W Mig. Co., 1170 Esperanza, Los Angeles.

DOUGLAS Universal modulation transformers. Designed for use. 50 watts \$4.95. 100 watts \$7.75 pair. Postpaid. Year guarantee. Free circular. W9IXR, Box 349, Rice Lake, Wis.

QSL's. 300 2 colors, \$1.75. Maleco, 1805 St. Johns Place, Brooklyn, N. Y.

CASH buys my station, 400 watt fone and CW xmitter complete with all accessories including 4 element rotary beam. All in perfect shape, dirt cheap at \$195 f.o.b. W3EYT.

CRYSTALS in plug-in heat dissipating holders. Guaranteed good oscillators. 160M-80M AT \$1.25, 40X \$1.65, 80M vari-frequency (5 kilocycle variance) complete \$2.95. State frequency desired. Marine-craft crystals 2738, 2670, etc., .01% accuracy, lowdrift, mounted \$5.75 each. C.O.D.'s accepted. Pacific Crystals, 1042 S. Hicks, Los Angeles.

WANTED: All-wave receiver. Write William, 1444 Riverside Ave., Baltimore, Md. What have you?

SUPER Defiant receiver, complete — never used. Cost \$99.50. First \$35 takes it. Snyder, 200 Janice Drive, Wilkinsburg, Pa.

WANTED: Collins 30 or Temco 350 phone transmitter. Cash. W6ZAE.

CRYSTALS AT cut 80 — 40 meter ± 5 kc. \$1.35 postpaid. Guaranteed. Holders 70¢. W9IXR, Box 349, Rice Lake, Wis.

COMMERCIAL radio operators examination questions and answers. Two dollars per element. G. C. Waller, W5ATV, 6540 Washington Blvd., Tulsa, Okla.

SACRIFICE 500 watt Utah transmitter, complete. Cash and carry \$65. W2CLE, Box 92, Rockland, Mass.

RECONDITIONED receivers at lowest prices. Write for big list. Easy terms. Over 100 sets. Write to Leo, W9GFQ, today.

CRYSTALS, commercial or amateur: police, aircraft, marine and all types of low drift for commercial services at attractive prices — send for catalog. For the amateur: those time-proven, fully guaranteed T9 crystals, 40, 80, and 160 meter bands, \$1.60 postpaid — close frequency choice. T9 ceramic holders, \$1. C.O.D.'s accepted. Sold by: our dealers previously listed and Eidson's, Temple, Texas. Dealer territory still available, inquire.

COLLINS 30FXC, 300 watts, fone, CW. Beautiful commercial job. \$400. W2LVZ.

QSL's, SWL's. 100 — 3 color — 75¢. Lapco, 344 W. 39th, Indianapolis, Ind.

COMPLETE twenty meter 3 element rotary \$30. New DeLuxe 400 watter on steel. Best offer. Pickup. Photos. W5AUB, Tupelo, Miss.

CRYSTALS: 80-160 meter AT cut \$1, three blanks \$1. QSO Crystals, Indiana, Pa.

SELL — Utah kit number 1, eighty watts xmtr, factory wired Triplett meters. Oscar Bonter, State Road Hill, Meadville, Pa.

TRANSMITTER headquarters: modulators for 70 watts of R.F. or less only \$25 complete with tubes. 70 watt transmitters complete for \$35. Other bargains. For best deal write Leo, W9GFQ, Council Bluffs, Iowa.

HALLICRAFTERS 5-10 receiver in factory carton \$45. Complete mobile public address, new \$85. Want late 2 1/4 x 3 3/4 Speed-Graphic. W7DXY.

CRYSTAL blanks, X-cut, 40, 80, 160, three for \$1.20, including carborundum. William Threm, W8FN, 1833 Elm St., Cincinnati, Ohio.

NEW SX23 month old \$79; RCA-175 \$49; HRO Jr. 4 coils \$79. Ultra Skyriider \$45. W6MVK.

FOR sale: two 300-watt plate-modulated transmitters, ranges 1.7-4.5 Mc. and 7.0-30.0 Mc. Each mounted on Western Electric 6-foot rack complete with Western Electric speech equipment. A.C. operated. \$125. each. W8OCV.

NEED cash sell HQ-120X new \$100, Meissner DeLuxe Shifter \$32.50, meters, tubes, parts. All replies answered. W4CCH, Security National Bank, Tarboro, N. C.

MOTOR bargains. All-steel Hi-Torque rotators. Rotary Array Service, W8ML.

WRITE Bob, W9ARA, for best deal on all amateur receivers, transmitters, parts. You get largest trade-in allowance, best terms (financed by myself), fairest treatment, lowest prices. Write. Henry Radio Shop, W9ARA, Butler, Mo.

BARGAINS: New \$7.50 Mac bugs \$5.95; new Howard 460s complete with crystals \$59.95; SX-23s \$79.50; complete stock of new Guthman transmitters, receivers, preselectors, frequency meters, etc., at special bargain prices. W9ARA, Butler, Mo.

SUPER Pro's \$99, HQ-120Xs \$99, RME-69s \$79, NC101Xs \$69, HRO Jr. \$59, Patterson PR-15s \$59, NC81Xs and NC80Xs \$49, Skyriider 5-10s \$39, PB7XAs \$19, Sky Buddies \$15, SW3s \$9, many other models. All reconditioned and guaranteed. Free trial. Terms. Write for free list. W9ARA.

WE have started speed classes for licensed amateurs and others residing in New York and vicinity. Speeds are from 15 to 60 w.p.m. Classes meet Tuesday and Friday nights. American Radio Institute, 1123 Broadway, Watkins 9-7159 and Academy 2-7400.

ALL models Hallicrafters in stock, \$29.95 up. Write for trade-in allowances on new and used receivers. Easy terms. Seeli's Radio, Hartford, Conn.

HENRY RADIO SHOP

BUTLER, MISSOURI

I sell all makes and models of receivers, xmtrs, parts. I want to help you get the best apparatus for your use and to see that you are 100% satisfied. I guarantee you can't buy for less or on better terms elsewhere. Write and tell me what you want and how you want everything handled. Bob Henry W9ARA

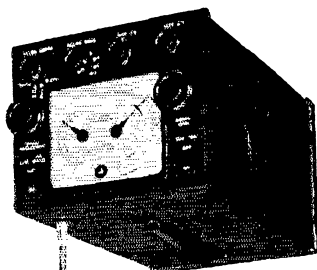
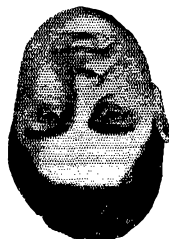

5-29 9-tube portable - that's metal - operating from 110V AC-DC or self-contained batteries. I tune 9-200 meters. Send \$5.00 deposit. I'm shipped on freight plan.



I'm 5X-24, the 9-tube with electrical bandspread and freq. meter tuning from 43.5 to .54 MC, costing only \$69.50. Try me or any other set on Bob's free trial plan.

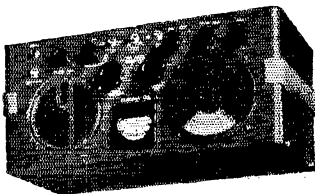

I'm the 9-tube 5AB, giving top performance at \$49.50. When ordering me or any other set state whether you prefer self-met from W9ARA's world's largest stock or from local store.

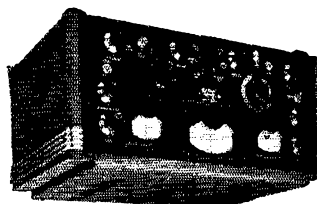

For top performance on all bands, buy me - Halli Crafters' latest and finest - the 5X-28. Terms \$12.50 a month. Write to W9ARA for information on me or any receiver.

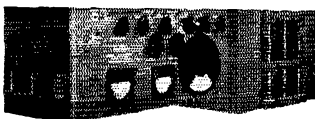

For top performance at medium cost, buy me, the 5X-25. Terms only \$7.00 a month. W9ARA gives you the best trade for your old set on any new one. Write him!

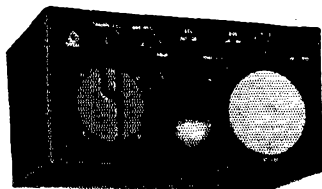

I'm 519R and a lot of radio for \$29.50. Terms, \$2.08 a month. Bob finances all terms himself, so you buy with less cost - no red tape - quicker delivery. Write Bob for details.

Your Nearby Dealer Is Your Best Friend

Your nearby dealer is entitled to your patronage. He is equipped with a knowledge and understanding of amateur radio. He is your logical source of advice and counsel on what equipment you should buy. His stock is complete. He can supply your needs without delay. His prices are fair and consistent with the high quality of the goods he carries. He is responsible to you and interested in you.

One of these dealers is probably in your city — Patronize him!

<p>ATLANTA, GEORGIA Radio Wire Television Inc. 265 Peachtree Street "The World's Largest Radio Supply House"</p>	<p>JAMAICA, L. I., NEW YORK Radio Wire Television Inc. 90-08 166th Street (Merrick Road) "The World's Largest Radio Supply House"</p>
<p>BALTIMORE, MARYLAND Radio Electric Service Co. 3 N. Howard St. Everything for the Amateur</p>	<p>NEWARK, N. J. Radio Wire Television Inc. 24 Central Avenue "The World's Largest Radio Supply House"</p>
<p>BOSTON, MASS. Radio Wire Television Inc. 110 Federal Street "The World's Largest Radio Supply House"</p>	<p>NEW YORK, N. Y. Radio Wire Television Inc. 100 Sixth Avenue "The World's Largest Radio Supply House"</p>
<p>BRONX, NEW YORK Radio Wire Television Inc. 542 East Fordham Road "The World's Largest Radio Supply House"</p>	<p>NEW YORK, N. Y. Harrison Radio Company 12 West Broadway Harrison Has It! Phone WOrth 2-6276 for information or rush service</p>
<p>BUFFALO, NEW YORK Radio Equipment Corp. 326 Elm Street W8PMC and W8NEL — Ham, service and sound equipment</p>	<p>PHILADELPHIA, PENNSYLVANIA Eugene G. Wile 10 S. Tenth Street Complete Stock of Quality Merchandise</p>
<p>BUFFALO, NEW YORK Dymac Radio 1531 Main Street — Cor. Ferry Open Evenings GA. 0252</p>	<p>PROVIDENCE, RHODE ISLAND W. H. Edwards Company 85 Broadway National, Hammarlund, Hallicrafter, Thordarson, Taylor, RCA</p>
<p>HARTFORD, CONNECTICUT Radio Inspection Service Company 227 Asylum Street What do you want? We have it. Radio exclusively</p>	<p>RICHMOND, VIRGINIA The Arnold Company Broad at Harrison St. W3EQO — "The Virginia Ham Headquarters" — W3FBL</p>
<p>HOUSTON, TEXAS R. C. & L. F. Hall 4021 Huey Street (W 9-2713) "Specialists in Amateur Supplies"</p>	<p>SCRANTON, PENNSYLVANIA Scranton Radio & Television Supply Co. 519-521 Mulberry Street Complete Stock of Quality Amateur Supplies</p>

YOU CAN BE SURE
WHEN YOU BUY FROM

QST

ADVERTISERS

“Advertising for *QST* is accepted only from firms who, in the publisher’s opinion, are of established integrity and whose products secure the approval of the technical staff of the American Radio Relay League.”

Quoted from QST’s advertising rate card.

Every conceivable need of a radio amateur can be supplied by the advertisers in QST. And you will know the product has the approval of the League’s technical staff

Index to Advertisers

Abbott Instrument, Inc.	62
American Radio Institute	87
Appleton-Century Company, D.	64
Astatic Microphone Laboratory, Inc.	79
Barker & Williamson	70
Bliley Electric Company	56
Candler System Company	85
Capitol Radio Engineering Institute	86
Cardwell Mfg. Corp., Allen D.	58
Centralab	59
Collins Radio Company	Cov. 2
Dodge’s Institute	83
Eitel-McCullough, Inc.	57
Gardiner-Levering Company	87
General Electric Company	5
Hallcrafters, Inc., The	1, 2
Hammarlund Mfg. Company, Inc.	55
Harrison Radio Company	80
Harvey Radio Company	76
Henry Radio Shop	92
Instructograph Company	78
International Resistance Company	77
Jensen Radio Mfg. Company	63
Keynon Transformer Company, Inc.	82
Lampkin Laboratories	66
Mallory & Company, Inc., P. R.	54
National Company, Inc.	Cov. 3, 57
New York YMCA Schools	78
Newark Electric Company	71
Nilson Radio School	85
Olmite Mfg. Company	87
Pioneer Gen-E-Motor Corp.	83
Port Arthur College	66
Precision Apparatus Corp.	78
RCA Institutes, Inc.	85
RCA Mfg. Company, Inc.	Cov. 4, 61
Radio Mfg. Engineers, Inc.	95
Radio Shack, The	65
Scientific Radio Service	85
Shuler Supply Company	88
Sickles Company, F. W.	78
Solar Mfg. Corp.	87
Speer Carbon Company	60
Sun Radio Company	84
Taylor Tubes, Inc.	67
Teleplex Company	83
Terminal Radio Corp.	88
Thordarson Electric Mfg. Company	81
Triplett Electrical Instrument Company, Inc.	70
Turner Company, The	64
United Transformer Corp.	96
Universal Microphone Company, Ltd.	62
Wholesale Radio Laboratories	84
Yaxley	54

Let's talk about
the new
RME-99
Communication Receiver

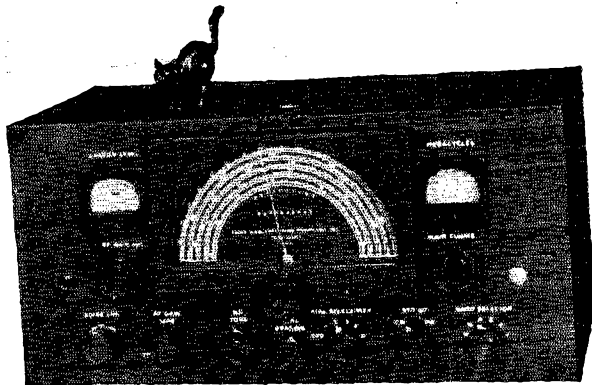

Among the many questions which have been fired at us by amateurs who have seen the RME-99 for the first time, the most persistent has been, "Is the RME-99 a better receiver than the RME-69?"

We can answer this query best by asking a question or two in return. Which is better, an automobile built in 1935 or one built in 1940? Or which is better, a radio tube of the '01A variety or one of the Loktal series?

The answers to these questions are perfectly obvious. So, also, is the answer to the original question . . . after you have had your first taste of communications reception as introduced by the new RME-99.

We don't like to brag, but it's the truth, when we say the new "99" is the finest piece of receiving apparatus we have ever devised. And this statement is made without the least hesitation or fear of contradiction.

The other day we were talking to one of our jobbers who holds a "ham" ticket. Among other things he commented on the extremely good signal-to-image ratio the "99" provided when tuning the 28 megacycle amateur band. Since he knew that this receiver had only one stage of radio frequency preselection, he was quite curious to learn in what manner we were able to produce this remarkable feat.

When we told him that this good ratio was gained through use of precision wound coils held to extremely close tolerances, we're afraid he was disappointed. Apparently, he had expected us to pull some trick circuit from our sleeves to account for this favorable result.

So it is, throughout the design of the "99". Every day you will discover new and startling innovations concerning this fine instrument. It truly has been a receiver of pleasant surprises. If you'd like to learn more about it, why not drop us a line, today; we'll be more than pleased to send you all the information.



Radio Mfg. Engineers, Inc.

One-eleven Harrison Street
Peoria, Illinois

Leaders in TRANSFORMER DEVELOPMENT and DESIGN



Since the inception of the United Transformer Corporation, UTC designs have set a standard for the field. The major improvements in transformer design listed below substantiate that UTC leads—others follow.

1933

HIGH PERMEABILITY CAST SHIELD (TOP AND BOTTOM MOUNT)



Used by UTC since 1933, the HIGH PERMEABILITY CAST SHIELD was a definite forward step in high quality transformers.

1936

TRI-ALLOY SHIELDING



The combination of Linear Standard frequency response and internal TRI-ALLOY magnetic shielding is a difficult one to approach. That is why these units are used by G.E., R.C.A., Philco, Western Electric, Westinghouse, M.G.M., Walt Disney studios, and other discriminating organizations.

1933

HUM BALANCED COIL STRUCTURE



Used by UTC in practically all High Fidelity designs, hum bucking and hum balanced transformers are now accepted as standard practice in the transformer field.

1937

OUNCER AUDIO UNITS



Extremely compact AUDIO UNITS for portable applications were a problem until the development of the UTC OUNCER UNITS. Fifteen types take care of practically all applications. Units not carrying DC are flat from 40 to 15,000 cycles. Another UTC-pioneered advance.

1934

LINEAR STANDARD AUDIO UNITS



Flat from 30 to 20,000 cycles... a goal for others to shoot at.

1938

UNIVERSAL EQUALIZERS

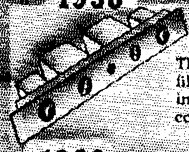

The UTC UNIVERSAL EQUALIZERS, ATTENUATORS, and SOUND EFFECTS FILTERS fill a specific need of the broadcast and recording field. Almost any type of audio equipment can be equalized to high fidelity standards.

1934

PORTABLE UNITS



The UTC HIPERM ALLOY group of transformers were brought out to take care of portable high fidelity requirements.

1939

PLUG-IN AUDIO UNITS

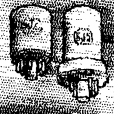

The manufacture of UTC PLUG-IN components was commenced in 1937. In 1939, a simple octal base structure was developed. Fifteen stock items are now available in this housing similar to our OUNCER UNITS.

1935

ULTRA COMPACT AUDIO UNITS

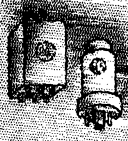

Developed originally for Aircraft and Hearing Aid Devices, in 1936, an entire series of these units were released for Broadcast Station applications. ULTRA COMPACT AUDIOS are HUM BALANCED, weigh from 4 1/2 to 5 1/2 oz, and are guaranteed ± 2 DB from 30 to 20,000 cycles.

1940

NEW ITEMS



The UTC research laboratory will develop new items and improve standard designs in 1940. While some of these developments are described in our advertisements, many are applied to customer's problems. May we cooperate with you on your problem?

Imitation is the sincerest form of flattery

UNITED TRANSFORMER CORP.
 150 VARICK STREET
 EXPORT DIVISION, 100 VARICK STREET
 NEW YORK, N. Y. CABLES: "ARLAB"

QST for August, 1940, EASTERN Edition

PRINTED IN U.S.A.
 RUMFORD PRESS
 CONCORD, N.H.

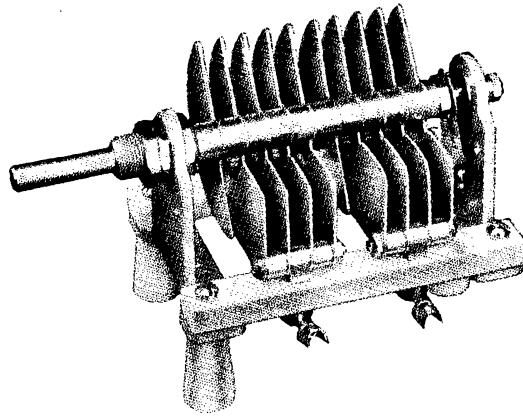

NATIONAL - Type TMH

RELEASED 1938

Very compact construction • Aluminum plates .040" thick with polished edges • Isolantite insulation with long leakage path • Excellent power factor • Mounts on panel or on removable standoff insulators • Made by National Company, Inc., Malden, Mass.

Capacity	Min. Cap.	Air-Gap	Catalog Symbol	List Price	Amateur Net
50	9.	.085	TMH-50	\$3.50	\$2.10
75	11.	.085	TMH-75	4.00	2.40
100	12.5	.085	TMH-100	4.75	2.85
150	18.	.085	TMH-150	6.00	3.60
35	11.	.180	TMH-35A	5.25	3.15
DOUBLE SECTION					
35-35	6-6	.085	TMH-35D	5.50	3.30
50-50	8-8	.085	TMH-50D	6.00	3.60
75-75	11-11	.085	TMH-75D	7.25	4.35

NATIONAL COMPANY, INC., MALDEN, MASS.

TAKE A LEAF FROM THE COMMERCIAL BUILDER'S NOTEBOOK

For two years the Type TMH Condenser has found growing favor with commercial builders. They like its compactness, its performance and its price. Now it is available to amateurs for the first time, with many new sizes added to the stocked models. Ask your dealer to show it to you!

64.3 INPUT WATTS* PER DOLLAR

and that's only part of the story!

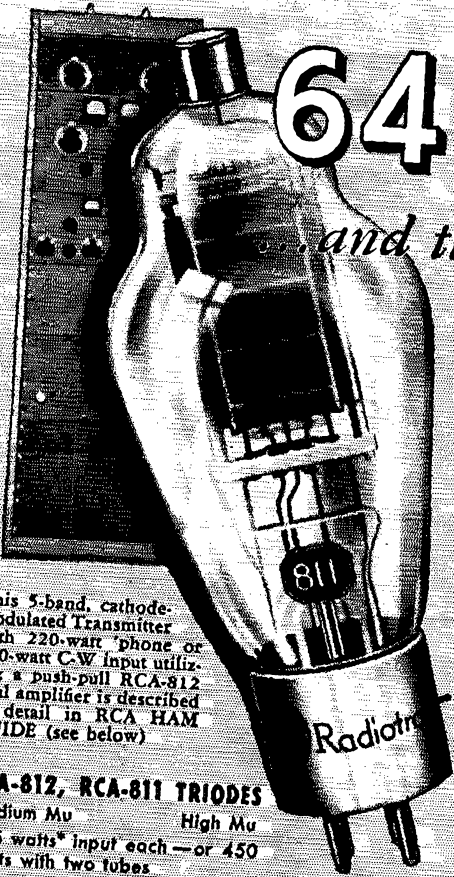

This 5-band, cathode-modulated Transmitter with 220-watt phone or 450-watt C-W input utilizing a push-pull RCA-812 final amplifier is described in detail in RCA HAM GUIDE (see below)

RCA-812, RCA-811 TRIODES

Medium Mu High Mu
225 watts* input each — or 450
watts with two tubes

Max. plate dissipation, 35 watts*
170 watts output with only 6.5
watts of grid drive

60-Mc operating at full ratings
—up to 100 Mc at reduced input.

\$3.50 EACH, Amateur Net

Listen-in to conversations on the air. Tune in on the talks across jobbers' counters. Ask other hams the next time your gang has a get-together. You'll find that, in a few short months, RCA-811 and RCA-812 Triodes have won a popularity that is unique among tube developments of recent years.

At rated values, these tubes offer just about all that any amateur could ask for—just the thing for present day conditions where most amateurs are looking for maximum results at an absolute minimum outlay of cash. But don't forget! Outstanding as their ratings are, they are still conservative. The new Zirconium-coated plates not only have very exceptional heat-dissipating qualities, but also function as highly effective "getters". Thus, the tubes can stand stiff temporary overloads and still come back for more. They not only give you real performance, but above all, they bring you the full measure of protection and dependability for which RCA Transmitting Tubes have long been famous.

No wonder many thousands have already been sold to set a new RCA sales record. No wonder the 811's and 812's are continuing as the most popular tubes in Radio's best-known line.

**ICAS Ratings for Class C Amateur Telegraphy.*

Here's the Data You Want ... the Way You Want It!

Now ready—the RCA Ham Guide! Contains 48 richly illustrated pages chock full of timely new circuits, new construction features and complete data on all RCA Amateur Transmitting Tubes—all compiled in handy, easy-to-use form that any ham can put to immediate use. Tells what to do and exactly how to do it. Has plenty of help for the newcomer plus a whale of a lot of indispensable material for the old-timer. It's the Guide they're all beginning to talk about—a "must" item for every shack.

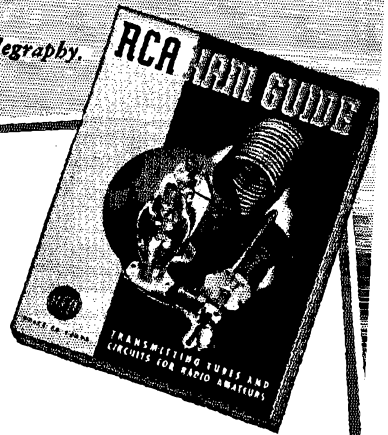

RCA HAM GUIDE 15c Amateur Net Price

Available through RCA Power Tube Distributors, or direct from RCA Commercial Engineering Section.



Transmitting Tubes

For PERFORMANCE PLUS