

QST



June, 1943

25 cents

35c in Canada

devoted entirely to

amateur radio



In This Issue:

Inverse Feed-Back

WERS Transmitter-Receiver

Building a Manual Tape Perforator

Pre-Induction High School Radio Course

PUBLISHED BY THE AMERICAN RADIO RELAY LEAGUE

Designs for War... Transformers

The requirements in war transformers differ considerably from those of commercial units. The UTC engineering staff has pioneered many of the design features which make possible modern war transformers. A few typical designs are illustrated.

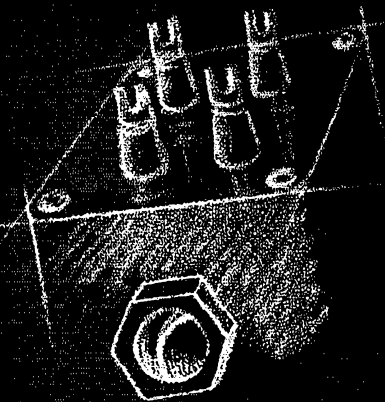

This transformer is tunable . . . ideal for signal frequency amplifiers.

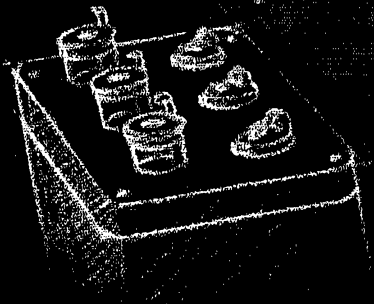

This oil filled transformer is hermetically sealed with glass high voltage terminals solder-sealed to case.

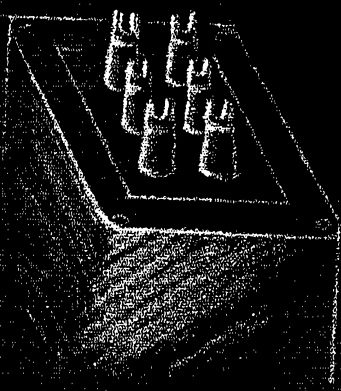

Designed for minimum amplitude distortion . . . this unit has distortion under .01% for a power range of 100:1 . . . Q over 150.

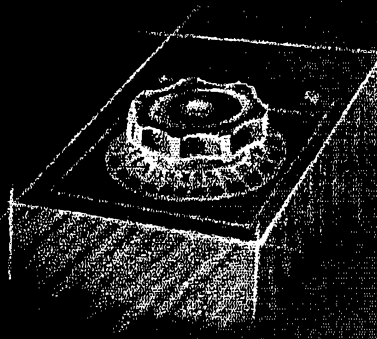

This Varitran supplies fixed filament and bias voltages, as well as variable plate voltage all in one unit.

May we design a War Unit to your application?

UNITED TRANSFORMER CO.

150 VARICK STREET



NEW YORK, N. Y.

EXPORT DIVISION: 100 VARICK STREET NEW YORK, N. Y. CABLES: "ARL"

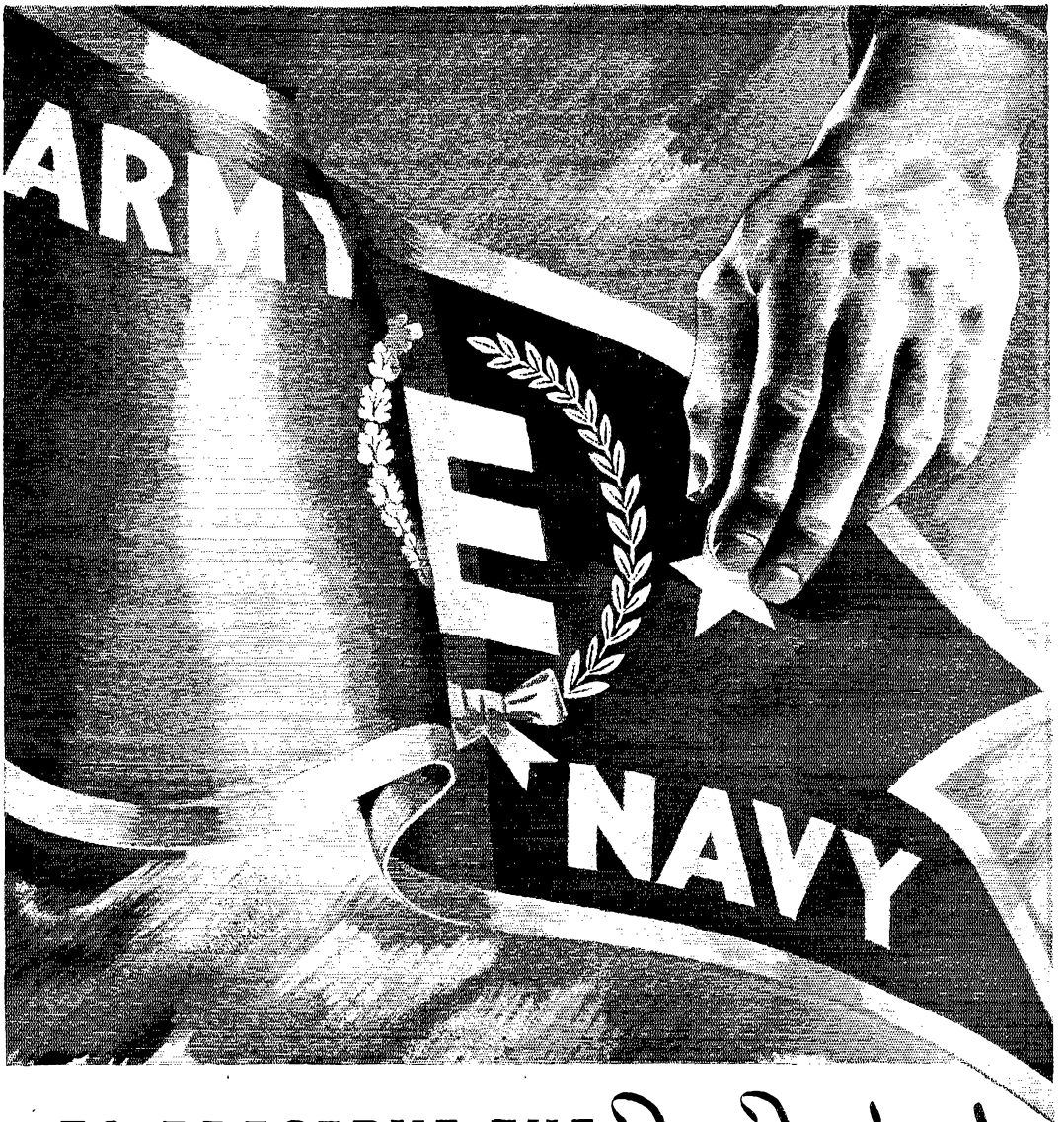

TO PRESERVE THE *Four Freedoms!*

...freedoms that are uppermost in the heart of every American. Workers in industry have toiled unceasingly to build peak production to enable their country to be the world's best equipped fighting forces to protect these freedoms.

The Hallicrafters employees have twice been cited by their country for excellence in production... once with the Army-Navy "E" Burgee... and now the addition of a star to this Burgee for continued excellence in producing communications equipment so vitally needed by our boys on all fronts.

This new honor will serve as an additional incentive to greater production.

hallicrafters
CHICAGO, U. S. A.





*Thanks
for the
Response!*

Not long ago we placed an advertisement asking for meters . . . the need was so great and the existing supply so small that Hallicrafters appealed to you for aid.

Your response was so gratifying that Hallicrafters want to take this means . . . because we cannot

thank each of you . . . of showing a sincere appreciation of your aid to your country's effort toward winning this war in order that all of us may enjoy our freedom the real American Way!

BUY MORE BONDS!

hallicrafters

CHICAGO, U. S. A.



JUNE 1943

VOLUME XXVII

NUMBER 6



STAFF

Editorial

KENNETH B. WARNER, W1EH
Editor and Business Manager

CLINTON B. DESOTO, W1CBD
Executive Editor

GEORGE GRAMMER, W1DF
Technical Editor

DONALD H. MIX, W1TS
BYRON GOODMAN, W1JPE*
Assistant Technical Editors

EDWARD P. TILTON, W1HDQ
Contributing Editor, U.H.F.

WALTER E. BRADLEY, W1FWH
VERNON CHAMBERS, W1JEQ*
Technical Information Service

LOUISA B. DRESSER
Editorial Assistant

JAMES J. LAMB, W1AL*
Research Engineer, A.R.R.L.

Advertising

F. CHEYNEY BECKLEY, W1GS
Advertising Manager

Circulation

DAVID H. HOUGHTON
Circulation Manager

RALPH T. BEAUDIN, W1BAW
Asst. Circulation Manager

*On leave of absence



OFFICES

38 La Salle Road
West Hartford, Connecticut

Subscription rate in United States and Possessions, \$2.50 per year, postpaid; all other countries, \$3.00 per year, postpaid. Single copies, 25 cents. Foreign remittances should be by international postal or express money order or bank draft negotiable in the U. S. and for an equivalent amount in U. S. funds.

Entered as second-class matter May 29, 1919, at the post office at Hartford, Connecticut, under the Act of March 3, 1879. Acceptance for mailing at special rate of postage provided for in section 1103, Act of October 3, 1917, authorized September 9, 1922. Additional entry at Concord, N. H., authorized February 21, 1929, under the Act of February 28, 1925. Additional second-class entries to cover sectional editions authorized March 20, 1935.

Copyright 1943 by the American Radio Relay League, Inc. Title registered at United States Patent Office.

QST

devoted entirely to

AMATEUR RADIO

PUBLISHED MONTHLY, AS ITS OFFICIAL ORGAN, BY THE AMERICAN RADIO RELAY LEAGUE, INC., AT WEST HARTFORD, CONN., U. S. A.; OFFICIAL ORGAN OF THE INTERNATIONAL AMATEUR RADIO UNION



CONTENTS

It Seems to Us	7
Splatter	8
Teaching Radio in High School <i>James Perkins Saunders, W1BDV</i>	9
Notes on Inverse Feed-Back . . . <i>Philip C. Erhorn, W2LAH</i>	13
U.S.A. Calling!	18
A Hand Perforator for Code-Practice Tape <i>George Grammer, W1DF</i>	20
CD-WERS in the State of Maryland . . . <i>Thomas F. McNulty</i>	25
"Take It Off — !" "Sourdough"	28
In the Services	29
An Economical Transmitter-Receiver for WERS <i>Paul F. Magee, W3AED</i>	32
Missing in Action	34
Circulation Statement	34
Happenings of the Month	35
Watts — Or Decibels? <i>McMurdo Silver</i>	37
Prisoners of War	38
Dessie Belle and Johnny <i>Heber H. Clewett, W6QE</i>	39
Hams Teach AAF Pilots at Maxwell Field <i>Lt. Thomas E. Campbell, W4GKU</i>	40
Elementary A.C. Mathematics <i>George Grammer, W1DF</i>	42
On the Very Highs <i>F. P. Tilton, W1HDQ</i>	47
Who Killed the Signal? <i>Clinton B. DeSoto, W1CBD</i>	48
Army-Navy Announce Radar!	51
Experimenters' Section	52
Hints and Kinks <i>Substituting Pin Jacks for Rotary Switch in V.O.M. Circuits — Mica-Trimmed Tank Condensers in WERS Gear — Convert- ing an Out-Dated B.C. Receiver to a Communications Job — Using Transformers with 2.5-Volt Windings for 6.3-Volt Heaters</i>	53
Correspondence from Members	56
Operating News	59
Honor Roll	59
Amateur Activities	62
The Month in Canada	68
Silent Keys	72
Ham-Ads	92
QST's Index of Advertisers	94

Section Communications Managers of the A.R.R.L. Communications Department

Reports Invited. All amateurs, especially League members, are invited to report communications activities, training plans, code classes, theory-discussion groups, civilian-defense building or planning each mid-month (16th of the month for the last 30 days) direct to the SCM, the administrative official of ARRL elected by members in each Section whose address is given below. Radio Club reports and Emergency Coordinator reports representing community organized work and plans and progress are especially desired by SCMs for inclusion in *QST*. ARRL Field Organization appointments, with the exception of the Emergency Coordinator and Emergency Corps posts, are suspended for the present and no new appointments or cancellations, with the exception named, will be made. This is to permit full efforts of all in Emergency Corps plans.

ATLANTIC DIVISION			
Eastern Pennsylvania	W3BES	Jerry Mathis	6208 Master St. Philadelphia
Maryland-Delaware-District of Columbia	W3CIZ	Hermann E. Hobbs	9701 Monroe St. Linden, Maryland
Southern New Jersey*	W3GCU	Ray Tomlinson	Silver Spring P. O. Trenton
Western New York	W8MC	William Bellor	623 E. Brown St. Rochester
Western Pennsylvania	W8CKO	E. A. Krall	186 Dorsey Rd. East McKeesport
CENTRAL DIVISION			
Illinois*	W9QLZ	George Keith, Jr.	Box 22-A, R.F.D. 2 Utica
Indiana	W9VMV	LeRoy T. Waggoner	1721 Winton St. Indianapolis
Kentucky	W9ARU	Darrell A. Downard	116 N. Longworth Ave. Louisville
Michigan	W8DPE	Harold C. Bird	R.F.D. 2 Pontiac
Ohio	W8CBI	D. C. McCoy	Normandy Lane, R. R. 7 Dayton
Wisconsin	W9RH	Emil Felber, Jr.	1625 N. 18th St. Milwaukee
DAKOTA DIVISION			
North Dakota	W9YVF	John W. McBride	420 West 12th St. Sioux Falls, South Dakota
South Dakota	W9QVY	P. H. Schultz	118 N. Yankton Ave. Pierre
Northern Minnesota	W9FUZ	Armond D. Brattland	War Production Training School Glenwood
Southern Minnesota	W9YNG	Millard L. Bender	608 N. Huron Ave. Spring Valley
DELTA DIVISION			
Arkansas	W3GED	Ed Beck	2503 Bishop St. Little Rock
Louisiana	W5DWW	W. J. Wilkinson, Jr.	Room 313, Jefferson Hotel Shreveport
Mississippi	W5HAV	P. W. Clement	524 Santini St. Biloxi
Tennessee	W4SP	James B. Witt	R.F.D. 6, Shady Dell Trail Knoxville
HUDSON DIVISION			
Eastern New York	W2LJH	Robert E. Haight	356 West 34 St. New York City
N. Y. C. & Long Island	W2AZV	E. L. Baumach	102 Central Ave. Massapequa, L. I.
Northern New Jersey*	W2IIN	John J. Vitale	106 Orchard St. Elizabeth
MIDWEST DIVISION			
Iowa	W9AED	Arthur E. Rydberg	
Kansas	W9AWP	A. B. Unruh	1617 S. Seneca St. Mitchellville
Missouri*	W9OUD	Letha E. Allendorf	1015 West Third St. Wichita
Nebraska	W9POB	Roy E. Olmsted	Trimble House Joplin
NEW ENGLAND DIVISION			
Connecticut	W1KOY	Edmund R. Fraser	48 Willow St. West Haven
Maine*	W1AGL	G. C. Brown	379 No. Main St. Brewer
Eastern Massachusetts	W1ALB	Frank L. Baker, Jr.	40 Atlantic St. North Quincy
Western Massachusetts	W1JAH	William J. Barrett	239 Columbia St. Adams
New Hampshire	W1FTJ	Mrs. Dorothy W. Evans	71 N. Adams St. Manchester
Rhode Island	W1HRC	Clayton C. Gordon	70 Columbia Ave., Gaspee Plateau, Warwick
Vermont	W1KJG	Clifton G. Parker	Box 537 Morrisville
NORTHWESTERN DIVISION			
Alaska	K7GNN	James G. Sherry	P. O. Box 486 Homer
Idaho	W7AVP	Don D. Oberbillig	Box 1088 Boise
Montana	W7CPY	Rex Roberts	117 Federal Glendive
Oregon	W7GNI	Carl Austin	513 N. Central Beast
Washington*	W7FWD	O. U. Tatro	
PACIFIC DIVISION			
Hawaii	K6ETF	Francis T. Blatt	837 16th Ave. Honolulu
Nevada	W6BIC	Edward W. Helm	509 Claremont St. Reno
Santa Clara Valley	W6IUZ	Earl F. Sanderson	400 Acadia Ave. San Bruno
East Bay	W6TT	Horace R. Greer	414 Fairmount Ave. Oakland
San Francisco	W6CIS	Kenneth E. Hughes	590 35th Ave. San Francisco
Sacramento Valley	W6MDI	Vincent N. Feldhausen	113 South Quincy St. McCloud
Philippines	KA1GR	George L. Rickard	Box 849 Manila
San Joaquin Valley*	W6M1W	Ralph C. Lowry	315 Santa Barbara Modesto
ROANOKE DIVISION			
North Carolina	W4CYB	W. J. Wortman	P. O. Box 560 Morgantown
South Carolina	W4BQE/ANG	Ted Ferguson	1213 College St. Columbia
Virginia	W3AKN	Walter G. Walker	217-51 St. Newport News
West Virginia	W8JRL	Kenneth M. Zinn	P. O. Box 132 Clarksburg
ROCKY MOUNTAIN DIVISION			
Colorado	W9CNL	Stephen L. Fitzpatrick	P. O. Box 1101 Kiowa
Utah-Wyoming	W7GZG	Henry L. Schroeder	663 N. 10th St. Laramie, Wyoming
SOUTHEASTERN DIVISION			
Alabama	W4GBV	Lawrence J. Smyth	808 Winona Ave. Montgomery
Eastern Florida*	W4BYR	Frank C. Fassett	1712 Hills Ave. Tampa
Western Florida	W4AXP	Oscar Cederstrom	115 No. Baylen St. Pensacola
Georgia	W4FDJ	Ernest L. Morgan	R.F.D. 4 Lyons
West Indies (Cuba)	CM2OP	Mario de la Torre	Escobar 110 (Altos) Habana, Cuba
(Puerto Rico-Virgin Islands)	K4KD	Everett Mayer	24 Lindberg St. Santurce, P. R.
SOUTHWESTERN DIVISION			
Los Angeles	W6QVV	H. F. Wood	723 No. Las Palmas Ave. Hollywood
Arizona	W6RWV	Douglas Aitken	341 S. Mt. Vernon Ave. Prescott
San Diego	W6BZE	Richard Shanks	4033 S. Hempstead Circle San Diego
WEST GULF DIVISION			
Northern Texas	W5IAU	N. R. Collins, Jr.	2230 W. Amherst Dallas
Oklahoma	W5GFT	Russell W. Batter	Box 290 Enid
Southern Texas	W5MN	Horace E. Bidly	1746 Schley Ave. San Antonio
New Mexico	W5HJF	J. G. Hancock	110 S.E. Nevada St. Fortales
MARITIME DIVISION			
Maritime	VE1DQ	A. M. Crowell	69 Dublin St. Halifax, N. S.
ONTARIO DIVISION			
Ontario	VE3EF	Flying Officer Donald R. Gunn	c/o Canadian Bank of Commerce New Toronto, Ont.
QUEBEC DIVISION			
Quebec	VE2CO	Sub-Lieutenant L. G. Morris	c/o Room 604, 1111 Beaver Hall Hill Montreal, P. Q.
VANALTA DIVISION			
Alberta	VE4GE	C. S. Jamieson	581 W. Riverside Drive Drumheller, Alta.
British Columbia	VE5DD	C. O. I. Sawyer	2634 West 31st Ave. Vancouver
PRAIRIE DIVISION			
Manitoba	VE4AAW	A. W. Morley	32 Carlton St. Winnipeg
Saskatchewan	VE4SY	Arthur Chesworth	1071 4th Ave., N.W. Moose Jaw

* Officials appointed to act until the membership of the Section choose permanent SCMs by nomination and election.

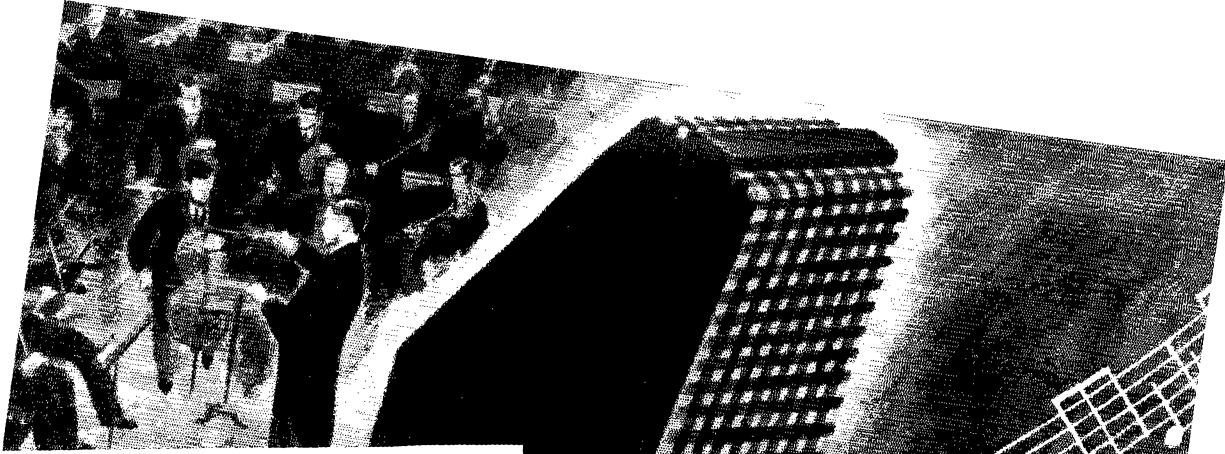

Electronic briefs: **FM**

Radio is simply a method by which electrical energy is transmitted through space. By varying the intensity or frequency of this electrical energy, an intelligible signal can be created. The principle is the same whether dot dash code messages or voice and music are being transmitted. In the case of voice and music transmission the radio wave must be varied (modulated) at the same speed as the vibrations of the voice or music. The characteristics of electrical energy which can be varied or modulated are three: voltage, frequency and phase. Radio transmitters which vary the intensity (voltage) are called amplitude modulated and those which vary the frequency are called frequency modulated. The differences of these two systems can be understood easily by visualizing a beam of light. An audible signal can be transmitted by varying the light intensity (amplitude modulation) or by varying the color of the light beam (frequency modulation).

Static and other man-made electrical disturbances are identical in character to the amplitude modulated signal. Hence these disturbances are extremely bothersome to AM broadcasts. On the other hand these electrical disturbances do not essentially vary in frequency and consequently do not interfere with FM transmission. Another fortunate characteristic of FM is the fact that the stronger of two signals predominates, thus eliminating much inter-station interference and cross-talk. Further, and of great importance, the fidelity of tone can be made nearly perfect even when the heaviest of musical scores is being broadcast.

In frequency modulation as in all things in the field of electronics, vacuum tubes are the most important component. Eimac tubes have the distinction of being first choice of most of the leading electronic engineers throughout the world. They are consequently first in the most important new developments in electronics... FM for example.

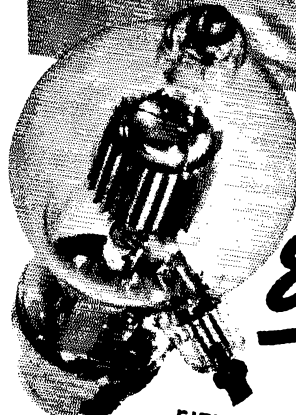

Follow the leaders to

Eimac

REG. U. S. PAT. & TM. OFF.

TUBES

EITEL-McCULLOUGH, INC.
SAN BRUNO, CALIFORNIA

Export Agents: *Frazar & Hansen* 301 Clay Street, San Francisco, California



Army-Navy "E" Award for Achievement in the Production of War Material

THE AMERICAN RADIO RELAY LEAGUE

Directors

President
GEORGE W. BAILEY W1KH
2101 Constitution Ave., N. W., Washington

Vice-President
CHARLES E. BLALACK W6GG
Box 108, Yuma, Ariz.

Canadian General Manager
ALEX REID VE2BE
240 Logan Ave., St. Lambert, P. Q.

Atlantic Division
WALTER BRADLEY MARTIN W3QV
Address correspondence to the Acting Director:
HERBERT M. WALLEZE W8BQ
P. O. Box 18, Drums, Pa.

Central Division
GOODWIN L. DOSLAND W9T8N
11831 Longwood Drive, Chicago

Dakota Division
TOM E. DAVIS W9VVA
915 W. Becker Ave., Willmar, Minn.

Delta Division
E. RAY ARLEDGE W58I
340 N.E. 20th Terrace, Apt. 7, Miami, Fla.

Hudson Division
ROBERT AKERIDGE KIRKMAN W2DSY
250 Albert Place, Eiberson, N. J.

Midwest Division
FLOYD E. NORWINE, JR. W9EFC
7405 Hiawatha Ave., Richmond Heights, Mo.

New England Division
PERCY C. NOBLE W1BYR
37 Broad St., Westfield, Mass.

Northwestern Division
KARL W. WEINGARTEN W7BG
3219 N. 24th St., Tacoma, Wash.

Pacific Division
J. L. McCARGAR W6EY
66 Hamilton Pl., Oakland, Calif.

Roanoke Division
H. L. CAVENESS W4DW
2607 Vanderbilt Ave., Raleigh, N. C.

Rocky Mountain Division
C. RAYMOND STEDMAN W9CAA
925 So. Gaylord St., Denver

Southeastern Division
WILLIAM C. SHELTON W4ASR
527 Revilo Blvd., Daytona Beach, Fla.

Southwestern Division
JOHN E. BICKEL W6RKY
1834 E. Whittier Blvd., Whittier, Calif.

West Gulf Division
WAYLAND M. GROVES W5NW
% Humble Pipe Line Co., Hawkins, Texas

THE AMERICAN RADIO RELAY LEAGUE, INC., is a non-commercial association of radio amateurs, bonded for the promotion of interest in amateur radio communication and experimentation, for the relaying of messages by radio, for the advancement of the radio art and of the public welfare, for the representation of the radio amateur in legislative matters, and for the maintenance of fraternalism and a high standard of conduct.

It is an incorporated association without capital stock, chartered under the laws of Connecticut. Its affairs are governed by a Board of Directors, elected every two years by the general membership. The officers are elected or appointed by the Directors. The League is non-commercial and no one commercially engaged in the manufacture, sale or rental of radio apparatus is eligible to membership on its board.

"Of, by and for the amateur," it numbers within its ranks practically every worth-while amateur in the nation and has a history of glorious achievement as the standard-bearer in amateur affairs.

Inquiries regarding membership are solicited. A bona fide interest in amateur radio is the only essential qualification; ownership of a transmitting station and knowledge of the code are not prerequisites.

All general correspondence should be addressed to the Secretary at the administrative headquarters at West Hartford, Connecticut.



Past Presidents

HIRAM PERCY MAXIM, W1AW, 1914-1936
EUGENE C. WOODRUFF, W8CMP, 1936-1940

Officers

President GEORGE W. BAILEY, W1KH
Washington, D. C.

Vice-President CHARLES E. BLALACK, W6GG
Yuma, Ariz.

Secretary KENNETH B. WARNER, W1EH
West Hartford, Connecticut

Communications Manager F. E. HANDY, W1BDI*
Washington, D. C.

Treasurer DAVID H. HOUGHTON
West Hartford, Connecticut

General Counsel PAUL M. SEGAL
1026 Woodward Building, Washington, D. C.

*On leave of absence. Address correspondence to the Acting Communications Manager, George Hart, West Hartford, Connecticut.

"IT SEEMS TO US—"

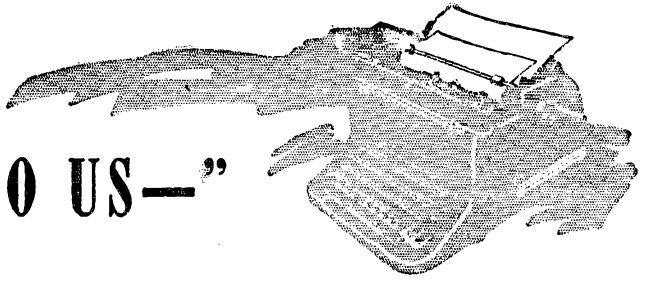

IN THE SERVICES

ONE manifestation of zeal in the war effort for which we have little enthusiasm is the self-acclaim certain firms and organizations seem inclined to bestow on themselves in their advertising publicity. "Just look at *our* accomplishments!" they cry. "See, *we* are winning the war!" — and single-handed, too, their claims seem to imply. Oddly enough, those institutions with the most outstanding records of accomplishment don't seem to find it necessary to indulge in such self-adulation.

To the best of its ability *QST* has deliberately avoided the breast-beating role. If any of that feeling has shown through our narrative accounts of amateur service in the war it has only been the result of a desire to tell the whole story, to give credit where due. Not that there haven't been amateur contributions aplenty to shout about, or that we aren't bursting with pride over the accomplishments of the ham fraternity. It just doesn't seem to us that now is the time to boast of these things. We've got the war to win, first; the cheering can come later.

And yet, short of such self-exploitation, there is undeniably a certain merit to the recording of outstanding war service even now. If presented neither boastfully nor vaingloriously but as a simple statement of fact, such a report can supply mutual inspiration and encouragement through the stirring picture of unity and determination it displays. It's good for the morale — our own and that of our fellow-citizens.

The foregoing reflections stem from a recent examination of what may at first glance seem only a vaguely related detail. That detail is the mechanical problem involved in publication of the lists of amateurs "In the Services" presented monthly in *QST*. If you've been following this department — and its pages seem to be as thoroughly thumbed as any in the magazine — you're probably aware that it has always bulged its allotted space. Currently, because of space reductions enforced by paper conservation regulations, the problem has become even more acute. We believe we now have found a solution (for details see "Splatter" and the department itself in this issue), but in the finding of it we've had occasion to do quite a bit of thinking about the subject as a whole. And that's the point of this piece — not the

mechanical problems involved in publishing these "In the Service" lists, but the basic import of the listings themselves.

What is that import? Stop and think about it for a moment. Every issue, month in and month out, for more than two years, we've been publishing several hundred names of amateurs in uniform (we've not yet been able even to begin publication of the names of the many additional amateurs in essential civilian activities, as we hope some day to do) — and still there are thousands of unpublished names in the files, and still those files grow by additional hundreds of listings monthly.

When these lists are analyzed they indicate clearly (1) that just about every solitary radio ham in the nation eligible for military service is now in uniform, and (2) that practically every remaining amateur, ineligible for military service by reason of age, physical disability or dependency, is engaged in work directly supporting the war effort, chiefly with government or allied agencies.

More than a year ago — on March 15, 1942, to be exact — an official count disclosed no less than 14,813 amateurs in the Army and Navy as of that date. Although no more recent official count has been made, the best available evidence indicates that this number has now increased by not less than 50 per cent — and possibly it has doubled. Consider that amateur licenses are distributed through every age group from 14 to 80, subtract those not of military age, the several thousand YLs and a normal percentage of physically-disqualified from the pre-war total of 58,000 licensees — and, if proof is required that practically every eligible amateur is now in uniform, there it is.

As for the second classification — those who, although for one reason or another still in multi, are serving as valiantly as any wearing the khaki or blue — our service records indicate that for every three hams in Army and Navy there is another in government service (in such agencies as OSRD, FCC, CAA, OWI, OCD-CAP, in the Maritime Service, as civilian employees of Army or Navy), and at least one more (or possibly one and one-half) in essential civilian occupations — research, engineering, instruction, administration, manufacturing, procurement. Moreover, many of

these remaining on the home front are doing double duty in spark-plugging WERS networks and corollary civilian defense activities.

It is doubtful that any comparable body in American life can show as high a proportion of direct participation in the war effort. Talk about your production records — here's a manpower contribution unsurpassed in both extent and performance. If ever there was a body consecrated with all its soul and hands and heart to the cause of Victory, it is amateur radio.

But quantity alone is by no means the whole story. Every loyal American citizen *wants* to serve; it is the relative utility of the special skills he has to offer that is the measure of his contribution. And there is scarcely any more valuable accomplishment one can offer his country than a proficiency in radio technique. The competent radio engineer or operator or technician is not only a man with intricate and extensive training; he must have a high order of native intelligence and industry to begin with. Proof of that may be found in the assignment policies of the military classification centers, where only men with the highest qualifications are selected for radio assignments. No technical specialty in the armed forces rates a higher priority on top-flight manpower than radio.

It is in such company that the amateur stands — and he stands head and shoulders above his fellows without amateur experience. Were it not for the bedeviling incompressibility of leaden type (and the fact that a number of vital military secrets would be involved), we could recount scores of tales illustrating the

superiority of the man with amateur background — incidents showing how his ingenuity and versatility, his avidity for learning, unquenchable curiosity and inborn disregard for the cant of the "impossible" have carried him far ahead of the rote-encumbered professional engineers and the text-conscious theoreticians whose vision has a minimum declination that never lets them see the solid earth.

One day, of course (and this is a promise!), *QST* will chronicle the far-reaching developments of these amateurs — men whose calls usher bright memories from the dear old days of DX and roundtables and "hr msg pse." But even without unveiling guarded secrets we can substantiate our case by pointing to the self-same "In the Service" lists that inspired this discussion — to the Army colonels and majors, the Navy captains and commanders, whose amateur backgrounds constituted a major qualification for their rise in the service. We could cite the heroic —

But wait a moment. We ourselves are now verging perilously close on that same fault of premature boasting we deplored at the outset. It's an easy trap to fall into; somehow the perspective changes when you're talking of your own people. . . .

Anyway, we've said enough — for now. There's the record in facts and figures of what amateur radio, as one body in American life, is doing to ensure the preservation of that way of life. As an organization we're In the Services — now and for the duration.

C. B. D.

★ SPLATTER ★

OUR COVER

IT SEEMS almost like a page from the past to see an apparatus picture on *QST's* front cover again. However, George Grammer's homemade tape perforator was not only a logical choice editorially but photogenic as well, and so for variety's sake here it is.

IT'S SQUEEZED

THERE'S a saying in the publishing game that printing type isn't made of rubber, although, as noted editorially above, the growing requirements of our "In the Services" department (not to mention paper rationing, etc., etc.!) have often made us wish it were. If type can't be compressed like rubber, however, it can be condensed, and beginning with this issue the format of our ITS department is being changed to use a special condensed type face that permits the running of three columns per page and more names per column. The type isn't any smaller or less legible; the characters are merely squeezed a little closer to-

gether. Since the result is an increase of nearly 70 per cent in the number of names that can be printed on a page, we hope you'll approve.

FOOTNOTES

AN EVEN half dozen new non-staff contributors to *QST* this month, plus two previously introduced via this column — McMurdo Silver (March '43) and "Sourdough" (May '43). Presenting:

James Perkins Saunders, WIBDV, (p. 9) is our idea of the ideal high-school science instructor. Principal qualifications: Licensed amateur since 1920; 35 w.p.m. ARRL code proficiency certificate; SS winner; recipient of four Navy Day letters; RCC; AEC. Supplemental qualifications: S.B. in electrical communication engineering (MIT); Ed.M. (Boston University Graduate School of Education); instructor at Northbridge Senior High since 1930 (mainly biology and photography; incidentally, he supplied the pictures accompanying his article); assistant principal since 1941. What more could you ask? . . . It was because **Philip Erhorn, W2LAH**, is a dyed-in-the-wool music lover with a sensitive ear for fidelity that he became interested in inverse

(Continued on page 38)

Teaching Radio in High School

**Pre-Induction Training at Northbridge (Whitinsville, Mass.)
Senior and Junior High Schools**

BY JAMES PERKINS SAUNDERS,* WIBDV

PEARL HARBOR and the events following have had a profound influence upon the people of these United States. Practically all of our normal activities have undergone reorganization and adjustment to war-time tempo. Not one of the least affected has been the field of secondary education. To do everything possible to aid the war effort, high schools have added many special courses aimed to prepare the boys and girls of America for useful places in our armed services or in related war activities. Some of these were added as "defense" courses before Pearl Harbor; others have since been introduced as a result of the War Department's request for pre-induction training.

At Northbridge Senior High School radio instruction is of long standing, although until recently it was rather irregular and consisted almost entirely in helping budding hams procure their tickets by informal discussions of radio problems after school hours. No classes were held, nor was there a radio club, for the number of interested students was quite small. The limited activity of those "days of old" may be compared with the present program as described here.

This program has developed quite naturally as world conditions showed the increasing need for radio operators and personnel. December 7th was the day that gave it final impetus. Considerable planning was carried out during the spring of 1942, correspondence with ARRL Headquarters bringing us much fine material and many suggestions. I was put in touch with others who had been conducting defense courses in their high schools, notably Lawrence Mansur, W1NDI, of Cranston, R. I. As a result of all this material, our plans were completed, student interest surveyed and all made ready for regular courses with the start of the school year in September.

The courses are entirely voluntary on the part of both the instructor and the students. The work in radio communication is divided into six parts, as follows: (1) Beginning code classes conducted over the RCA sound system to most all rooms in the senior and junior high schools; (2) advanced code classes over the sound system to special rooms in both the senior and junior high schools; (3) a class learning "blinker" reading; (4) a class copying code on the "mill"; (5) a class developing high speed in copying code directly from the tape to the typewriter by sight only; (6) a radio theory class, with the attainment of an amateur license as the goal.

* Assistant Principal, Northbridge Senior High School, Whitinsville, Mass.

Code Instruction Over Sound System

In planning the code instruction it seemed desirable to conduct the classes simultaneously over the sound system instead of in small groups. It was just as easy to work with forty rooms full of students as with one. Since the code lessons would be given for the senior high students, it was logical to include the junior high students as well, for it merely meant the throwing of one switch on the sound system.

The time from 8:05 A.M. to 8:20 A.M. was set aside exclusively for code instruction. Master tapes controlling the classroom bells were repunched to a new schedule, which took two minutes off each of the seven classes during the day and one minute from the lunch period, to make up this 15-minute period. In this way no one class suffered appreciable curtailment.

The ARRL course for teaching code was followed, using groups of seven letters at a time until that group had been mastered, then advancing to the next group of seven letters while at the same time constantly reviewing the last set. The students were urged to get acquainted with the *sound* of each letter, rather than to try to analyze the *dits* and *dahs*. After the seven letters in any group had been learned, simple words and short sentences were introduced to give the student an early feeling of accomplishment.

Every afternoon I type out my "script" for the next day. Every word spoken and every character sent is "down in black and white." It is almost

As part of its Civilian Training Program, the War Department last year requested high schools to institute pre-induction training courses in various specialized fields such as electricity, aviation, machinery — and, of course, radio. This article describes the practical installation of a radio course complying with that program. The success of this course was due in large measure to the interest and enthusiasm of the instructor, WIBDV. With equal administrative devotion, however, any school should be able to duplicate his results.

The nation's need for pre-trained military and maritime radiomen continues. High schools not now offering radio training, or meeting with inferior results, are urged to apply the lessons in this article to their planning for the coming 1943-1944 term.

like a network broadcast, where a certain time limit must be met. This system can be recommended as conducive to better and snappier work.

Weekly Progress Check

Since the code work was all on a strictly voluntary basis, it was desirable that some sort of progress check be made from time to time. This was accomplished by sending a test set of letters, words and sentences approximately once a week and having each room teacher report on a special form as to the number of students working on code and the percentages obtained in the test.

The first test report showed a total of more than 250 students in both buildings. This number naturally dropped, as students became discouraged or fell behind because of absences or because they used the code period to study other subjects on days when exams were scheduled for those subjects. By mid-year the number who had completed all the work on the letters, numerals and punctuation had dropped to about 75. At this time a new beginners' class was started with an enrollment of over 250, and the other students who had completed a half year's work were put into an advanced class.

Signal Corps Tapes

Through the interest and kindness of Principal Payson H. Reed and Superintendent of Schools Harrie J. Phipps, a McElroy Graphic Keying Unit, tape puller and set of twenty-five Signal Corps tapes were purchased. The advanced class is now working from these tapes. The output of the tape machine (see Fig. 1) is sent over a second channel in the sound system to special rooms in both the senior and the junior high buildings during the regular code period. The student assistant in charge of the machine copies what is sent and then reads the material back over the mike for checking.

The speed of the tape is adjustable so that it can gradually be speeded up to suit the abilities of the students. By the end of the year the advanced students should be able to copy Army tactical messages from the tapes at speeds of between 15 and 20 words per minute. By this time, too, the second beginners' class will be able to copy at least 5 to 7 w.p.m. Year by year the number of students will increase, and the abilities of those who have worked several years should be proportionally greater.

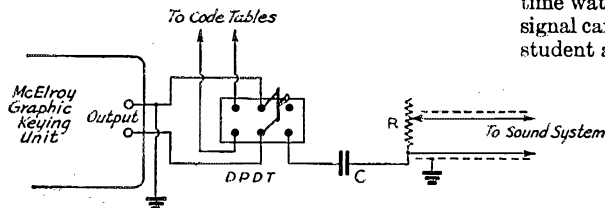

Fig. 1 — Circuit for connecting code machine to sound system for distribution to classrooms. The coupling condenser, C , is 250 $\mu\text{f.d.}$ R is a 30-ohm filament rheostat which controls output.

Multiple-Channel Code Tables

For operating practice, a group of laboratory tables in one room have been wired up as code tables. The circuit used is that given in the ARRL booklet, *Learning the Radiotelegraph Code*, with several changes. The output of the code machine is sent along the circuit originally intended for the oscillator output. (In fact, the tape machine can be used as a very fine oscillator by merely tilting back the exciting lamp over the photocell.) A separate circuit has been added for another oscillator, however, so that two outputs are available at each position. Fig. 2 shows how, by means of a d.p.d.t. switch, a student may choose either the tape machine for receiving practice or the regular oscillator for sending practice, or pair up with other students for practice in message handling and procedure.

The novel part of this arrangement is that the student can listen to a letter correctly sent by tape, flip the switch to the sending position and send the letter to himself, trying to imitate the sending of the tape. As a result the students acquire correct habits of character formation. It is possible to listen in on the monitoring switch to hear what is going on at any position, or to break in and send directly to any student involved in difficulty.

In building these code tables we were, of course, confronted with material shortages, so that much of the wiring, switches and even keys had to be homemade. Examples may be seen in some of the photographs. The boys in the class who were also taking machine-shop work turned out some fine keys. The d.p.d.t. switches were made in the vocational school out of old switch blades cut down to shape. In fact, the whole assembly is a product of home talent — but, in good old ham fashion, it works!

Advanced Instruction

A special class of boys and girls in the senior high is in session from 8:20 A.M. to 9:03 A.M. Part of the time is devoted to code practice, which consists of receiving from the tape machine or the instructor, and sending individually or in groups for experience in traffic handling.

At this time, too, practice in blinker reading is given. The output of the McElroy unit is sufficient to light a 2- or 3-volt lamp, mounted on one of the upright posts of the code tables where the whole class can see it. At first the students listen to the signal through the headphones, at the same time watching the lamp. Then, when desired, the signal can be switched off, either by the individual student at his position or by the instructor for all positions, so that reading is done by sight only.

Another phase of the radio training is giving the senior typists who have worked with code over the sound system special drills in copying code directly on the mill. This instruction is given two or three days a week during the regular typing period when the teacher in that class is kind enough to allow me to take over.

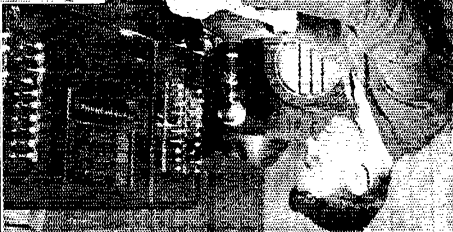
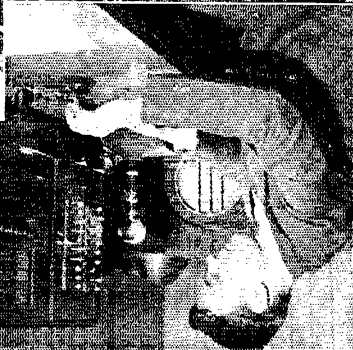
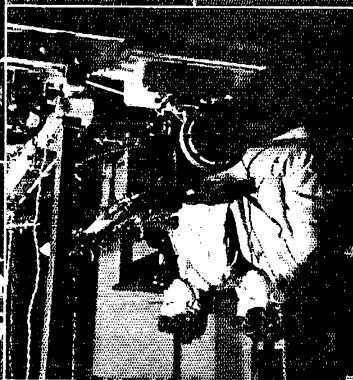
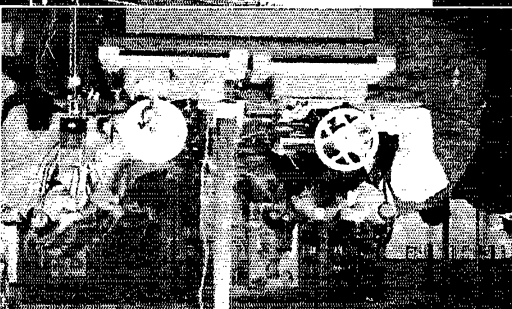
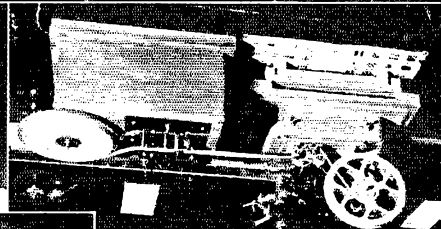
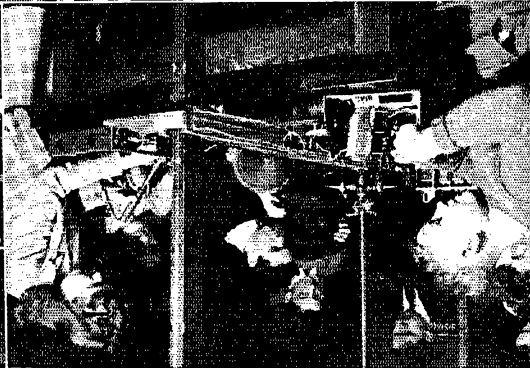
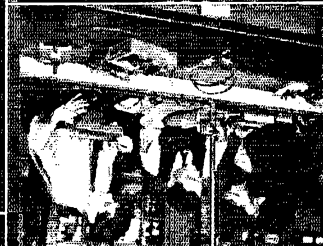
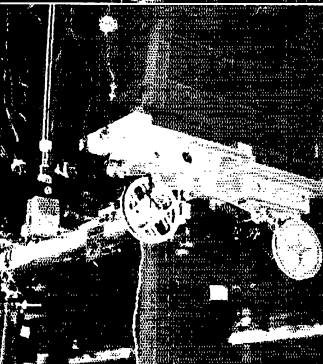
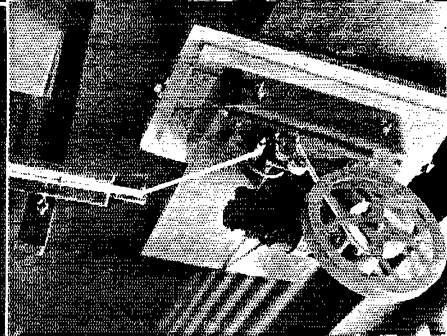
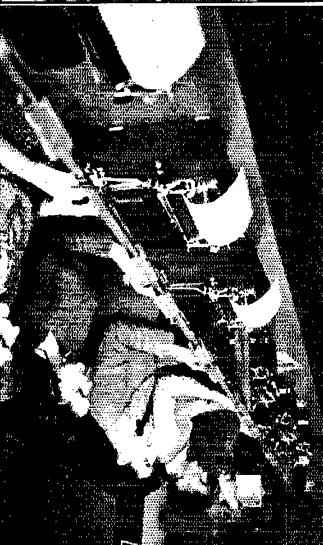

This group of senior typists is also being taught to copy directly from the tape by sight only, as is done regularly in high-speed work. For a tape guide, the woodworking department made up a wooden channel in two sections, about 12 feet long over all. The tape is held in place by metal pins (made from nails with the heads cut off) as well as by its angular placement. A small metal pulley (turned out in the machine shop by one of the boys) is used to change the direction of the tape as it leaves the channel to be taken up by the tape puller. Sliding "blindners" have been constructed which can be placed on the channel and so adjusted that the space through which the tape is viewed can be made smaller and smaller as the student progresses in ability. The whole arrangement has been made portable so that it can be taken down or set up at a moment's notice, and consequently does not interfere with the use of the tables for the regular typing classes.

So interested are the students that they sit with eyes glued to the tape and work like trojans for the whole period! When the bell rings they hate to stop. One of the boys said, when the period ended one day: "Boy, this is fun! I like it a lot." A girl came to me the other day and wanted to know if I would set up the machine so she could work on it after school — and she stayed for a long time getting extra practice. It is quite a thrill to find high school students so interested that they ask for more.

Theory and Lab Instruction

Radio theory is taught to the group of boys and girls in the senior high who showed special aptitude and interest enough to give up their study period. This is carried on during the 8:20 A.M. to 9:03 A.M. class in addition to the advanced code practice. The instruction follows rather closely the ARRL outlines and is based on *The Radio Amateur's Handbook* (Defense Edition), *A Course in Radio Fundamentals* and *The Radio Amateur's License Manual*. Since the course is not part of the regular curriculum, these books are purchased by the student himself. This system has advantages

in that, if the student actually spends his own money on the books, he is all the more interested in seeing the thing through. By the end of the year a good percentage of those studying theory hope to have ham tickets.

Members of the theory class have rounded up several defunct radio sets which have been dismantled for parts. In this way they learned to recognize a transformer when they saw one, distinguish a resistor from a condenser, and so on. You should have seen the students dive into those old sets, almost disappearing inside the chassis, and come out smiling with some resistor or other part. With the parts obtained they were able to build up oscillators, power supplies, detector circuits, etc. The woodworking department made us about a dozen breadboards such as is shown in one of the photographs.

Our latest endeavor is building a siphon tape recorder, as described in *QST*.¹ As soon as the "bugs" are all ironed out we plan to use it in the advanced class to record the students' sending, which will be played back on the McElroy unit to show them where their mistakes lie. The recorder will also be used to make straight language tapes for the advanced group, the Signal Corps tapes being mostly cipher groups and tactical messages using cipher groups.

Navy Approval

All in all we feel that we are doing unusual work in the field of training in radio communication for a school of our size (total enrollment of both the junior and senior high schools being less than 1000). In this connection, a great deal of credit should go to the other departments of the school for their assistance in solving our many problems.

When the Navy heard of our work they thought it of sufficient interest and value as a war effort to send a delegation of Navy officers from the Naval Training School (Radio) in Boston to inspect the setup. As they put it, "You are doing splendid work in code, and you surely have every individual in the school 'code-minded.'"

It has been a lot of work, but it was worth it. I get so excited about the course and its possibilities that I find myself spending many extra hours here at school working on it. If anything could be a substitute for ham radio, this is it. My XYL thinks it is even worse now than before the war. Then, at least, I was in my "shack" — at home! But "once a ham, always a ham," they say — and a ham has to be fooling around with something connected with radio, hasn't he? And when he is also aiding his country's war effort — well, that makes a double reason.

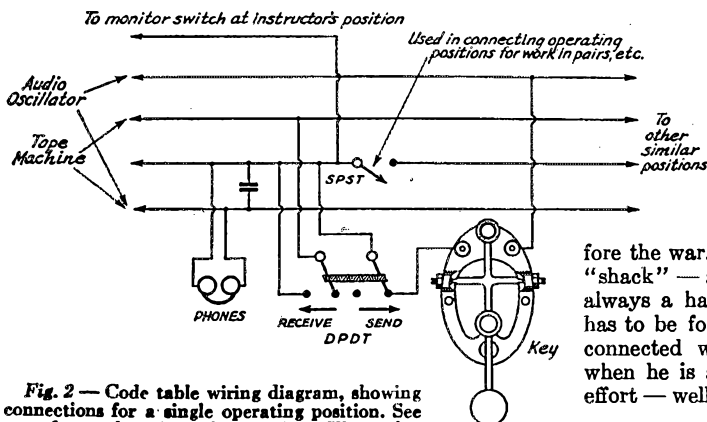

Fig. 2 — Code table wiring diagram, showing connections for a single operating position. See text for explanation of operation. The value of the condenser shown across the headphones should be chosen to give a comfortable volume level in the 'phones.

¹Gilliam, "A Siphon Tape Recorder for Radio Telegraph Signals," *QST*, April, 1943, p. 18.

Notes on Inverse Feed-Back

Characteristics, Circuits and Design Considerations

BY PHILIP C. ERHORN,* W2LAH

Here is a helpful discussion of the principles and applications of inverse feed-back, a subject of special interest now that home experimenting is pretty largely confined to audio-frequency systems. While the circuits given are primarily intended to be illustrative, they are also practical, and the circuit values suggested furnish a basis from which further work can be carried on.

INVERSE or negative feed-back principles were set down quite a few years ago, but only recently have modern high-gain tubes made feed-back popular in the quest for better fidelity of reproduction, stability and noise reduction in audio circuits. In contrast to positive feed-back, which produces distortion, increased gain and oscillation, inverse feed-back offers:

- 1) Improved linearity of response.
- 2) Stabilized impedances.
- 3) Reduced gain.
- 4) Improved phase shift and phase distortion.
- 5) Reduced harmonic distortion.
- 6) Improved load capacity.
- 7) Stabilized amplification with changes of circuit constants.
- 8) Reduced noise.

To apply inverse feed-back in the general sense, a small portion of the output of an audio amplifier is returned to the input and added to the signal voltage, but in phase opposition so that degeneration rather than regeneration is produced. If the amplitude of this feed-back voltage approaches that of the signal input voltage, then the output waveshape of the amplifier will resemble the input waveshape more and more. Nonlinear components appearing in the output of the amplifier will be fed back and again amplified, but in a manner such that the original components will be largely cancelled. Because of this cancelling effect on amplitude excursions the linear response band will be extended in scope. Noise, distortion and other imperfections in the input signal will not be reduced by feed-back, since the corrective action is limited to those circuits over which the feed-back is applied. However, the application of feed-back to an amplifier will give it much improved fidelity of reproduction, so that the additive action of its own faults will be minimized.

*205 Kilburn Rd., Garden City, L. I., N. Y.

Types of Feed-Back

Inverse feed-back may be subdivided into two fundamental types, voltage feed-back and current feed-back. A combination of the two is generally spoken of as "bridge" feed-back. Voltage feed-back occurs when the feed-back voltage is proportional to the output voltage. This, the most frequently used type, provides a reduction in the internal resistance of the amplifier, giving an effect similar to that resulting from lowering the plate resistance of the output tubes. When feeding a loudspeaker whose impedance varies greatly over the audio range, an impedance-stabilizing effect is observed, reducing cone resonance and "hangover" effects. Current feed-back occurs when the feed-back voltage is proportional to the output current. It has the effect of raising the internal resistance of the amplifier, and is much less desirable with a speaker load. It is of value in certain types of "gainless" phase inverters. Bridge feed-back is sometimes used for specific overall application, but it is not easy to proportion the amounts of each type without the use of laboratory instruments and reference to involved mathematics.

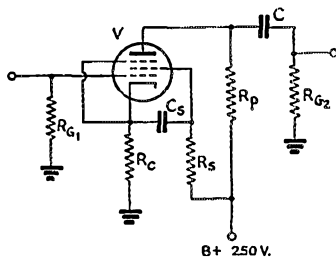

Fig. 1—A single-tube current-controlled feed-back circuit.

V—6J7, 6C6, etc.
C—0.1 μ fd., 450 v., paper.
C_s—0.5 μ fd., 450 v., paper.
R_{G1}, R_{G2}—500,000 ohms, $\frac{1}{2}$ watt.
R_C—2000 ohms, 1 watt.
R_S—1.0 megohm, 1 watt.
R_P—100,000 ohms, 1 watt.

Figs. 1, 2, and 3 are examples of single-stage feed-back. In Fig. 1 the feed-back occurs across the unby-passed cathode resistor, R_C . This is an example of current feed-back; that is, feed-back which tends to maintain the output current constant with variations in inherent amplification. There is no improvement of frequency distortion (the range of flat frequency response is not extended) because the inherent variation in amplification results from the variation in load im-

pedance with frequency, hence the output voltage of the amplifier varies with frequency even though the output current is constant. However, amplitude distortion is greatly reduced, as is the gain of the stage. This type of feed-back circuit

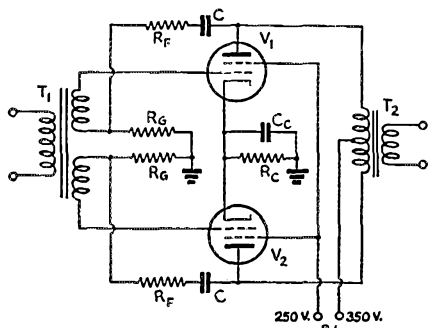

Fig. 2 — Voltage feed-back in a transformer-coupled push-pull stage.

- V_1, V_2 — 6L6, 6F6, etc.
- C — 0.5–1.0 $\mu\text{fd.}$, high quality (preferably 1000 v. rating, although 450 v. will do).
- C_s — 25 $\mu\text{fd.}$, 50 v., electrolytic.
- R_s — 250 ohms (Class AB₁).
- R_1 — 500,000 ohms, variable. When feed-back is set, a fixed resistor of proper value may be substituted.
- R_2 — 25,000 ohms, 1 watt.
- T_1 — Driver plate or line to push-pull grids (split sec.).
- T_2 — Push-pull plates to line or v.c. (6600 ohms p-p).

is not suitable for use with an output transformer because it tends to make the magnetizing current sinusoidal and thereby actually increases the distortion in the output voltage. Note that the suppressor grid and the screen by-pass condenser, C_s , are returned to the cathode, so that feed-back is not also applied to these elements.

Fig. 2 shows a push-pull stage in which the feed-back is taken off both plates and returned to the grid circuit. This is an example of voltage feed-back. Resistors R_1 and R_2 set the amount of feed-back used. The condensers, C , are blocking condensers of at least 0.5 $\mu\text{fd.}$ and must be of good quality. In this circuit the distortion generated by the tubes and that caused by core saturation of transformer T_2 are reduced. The low-frequency response is improved, but the leakage reactance of the secondary of T_2 prevents the high frequencies from being improved. Fig. 3 shows another example of voltage feed-back, affecting the driver as well as the output stage. Amplitude distortion in V_2 is reduced and the low frequency response improved. The feed-back voltage varies with frequency in a manner such that frequency distortion in V_1 is also improved. Amplitude distortion is not reduced. In this case the feed-back resistor, R_f , must be larger in value than R_p and R_p must be less than R_c .

Feed-Back Over More than One Stage

Figs. 4 and 5 are examples of feed-back over two stages. In Fig. 4, R_f and R_1 form, in effect, a voltage divider. R_c is the normal cathode bias resistor and C_s a normal by-pass condenser. Less degeneration takes place in V_1 than in the circuit

of Fig. 1. Amplitude and frequency distortion are reduced in both stages and the circuit is quite stable. Fig. 5 shows a different method of returning the feed-back to the input circuit. Because the winding capacity of T_1 is in shunt with R_c and some phase shift will be added by T_2 , the amount of feed-back which can be used is limited to a greater extent than in Fig. 4.

Fig. 6 shows a circuit with feed-back over three stages. No blocking condenser is necessary since the feed-back voltage is picked off the secondary of transformer T_2 . To obtain the right polarity the proper end of the secondary of T_2 must be selected; if oscillation occurs, reverse the feed-back and ground connections. Since the secondary of the output transformer, T_2 , is also included within the feed-back loop, both high- and low-frequency response will be improved. Amplitude distortion is greatly reduced. The use of a phase inverter tube, V_2 , obviates the necessity for an interstage transformer and helps reduce inherent phase shift. Resistor R_2 is the normal bias resistor, and R_1 and R_2 are generally made equal in value. The large amount of current feed-back reduces the effective gain of the stage to unity or somewhat less. The feed-back resistor, R_f , may be variable so that control over the amount of feed-back used can be easily secured. If the secondary of T_2 is of voice-coil impedance, the low output voltage may limit the amount of feed-back obtainable before oscillations occur at the extremes of the frequency range. With line impedances (of the order of 500 ohms) sufficient output voltage should be available for all purposes.

Effect of Phase Shift

The gain of the amplifier as a whole will be reduced by feed-back, and to realize useful output the gain without feed-back must be in excess of the desired gain. The excess gain is then put to work producing feed-back. Loss of gain in a power amplifier where high power output is necessary

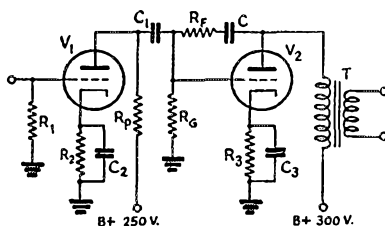

Fig. 3 — A simple voltage feed-back system for a single-tube output stage.

- V_1 — 6C5, 6J5, etc.
- V_2 — 76, 6P5G, etc.
- C — 0.5–1.0 $\mu\text{fd.}$, high quality (preferably 1000 v. rating, although 450 v. will do).
- C_1 — 0.1 $\mu\text{fd.}$, 450 v., paper.
- C_2 — 25 $\mu\text{fd.}$, 25 v., electrolytic.
- C_3 — 25 $\mu\text{fd.}$, 50 v., electrolytic.
- R_1, R_2 — 500,000 ohms, $\frac{1}{2}$ watt.
- R_3 — 3000 ohms, 1 watt.
- R_4 — 5000 ohms.
- R_f — 500,000 ohms, variable. When feed-back is set, a fixed resistor of proper value may be substituted.
- R_p — 100,000 ohms, 1 watt.
- T — Plate to line.

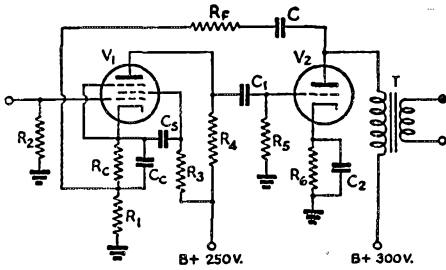

Fig. 4 — Feed-back over two stages.

- V_1 — 6J7, 6C6, etc.
- V_2 — 2A3.
- C — 0.5–1.0 $\mu\text{fd.}$, high quality (preferably 1000 v. rating, although 450 v. will do).
- C_c — 25 $\mu\text{fd.}$, 25 v., electrolytic.
- C_s — 0.5 $\mu\text{fd.}$, 450 v. paper.
- C_1 — 0.1 $\mu\text{fd.}$, 450 v., paper.
- C_2 — 25 $\mu\text{fd.}$, 50 v., electrolytic.
- R_1 — 100 ohms (may be varied).
- R_2 — 500,000 ohms, $\frac{1}{2}$ watt.
- R_3 — 1.0 megohm, 1 watt.
- R_4 — 100,000 ohms, 1 watt.
- R_5 — 500,000 ohms, $\frac{1}{2}$ watt.
- R_6 — 750 ohms (Class A1).
- R_c — 2000 ohms, 1 watt.
- R_f — 500,000 ohms, variable. When feed-back is set, a fixed resistor of proper value may be substituted.
- T — Plate to line (2500 ohms).

may be offset by increasing the input signal. This can be done in the low-level speech stages where extra gain can be realized cheaply and with low distortion.

Loss of gain is not the real criterion for setting the maximum amount of usable feed-back. Because of practical design limitations an amplifier will produce phase shift at various frequencies in varying degrees, the harmonics lagging the fundamentals. The fact that phase shift is not linear as to frequency is the cause of phase distortion. Phase shift and phase distortion are usually considered of little consequence when associated only with audio amplifiers, but in the case of a feed-back amplifier phase shift and its attendant distortion assume quite some importance.

The amplifier will have an inherent amount of phase shift which must be added to the shift caused by the feed-back network. It can be shown that if, for some arbitrary frequency, this combined shift equals 180 degrees, then the gain of the amplifier must have been reduced by feed-back to an extent that the product of this gain multiplied by the fraction of the output voltage applied to the input circuit is less than one, or instability in the form of oscillation will take place. Thus the usable percentage of feed-back is directly dependent upon the phase shift inherent in the amplifier.

The causes of inherent phase shift in an audio circuit may be brought out by a specific example. The total cathode current of a tube with a bypassed cathode resistor is the sum of the currents in the resistor and the condenser. Vectorially it can be shown that the current in the by-pass condenser causes a phase difference between cathode current and cathode voltage. This phase difference, which will not be constant with respect to

frequency, causes a phase shift between the signal input voltage to the stage and the signal output voltage. The result is phase distortion of the signal.

In a similar manner the plate-circuit decoupling condenser, the output condenser of the "B" supply, and a screen by-pass condenser will cause a phase shift to occur. "B" batteries, as they age, will produce the same effect as a condenser. Further, the interelectrode capacities of a tube, particularly the output capacity, will cause a phase shift. Coupling condensers contribute unless their reactance is small compared with the value of the following grid resistor. Resonance in transformer windings, leakage reactance and stray capacities such as wiring capacities or the capacity of a condenser to its own grounded metal case, are all factors contributing to inherent phase shift. The design of an amplifier eliminating the disadvantages of these capacities can become involved, and is not to be taken up here. However, such design will bear investigation by the prospective builder who would use large amounts of feed-back.

A fact which should be emphasized is that for proper corrective action feed-back should take place not only over the audible range of frequencies but also at the harmonics of these frequencies, many well out of the audible range. Hence a large phase shift at some super- or sub-audible frequency can become of real consequence if the harmonic voltage of some audio frequency is present in any amount. The application of inverse feed-back will tend to reduce phase shift and phase distortion over a wide response band, but a large shift at a remote frequency where the gain is fairly substantial will still have a limiting effect on the usable feed-back, since the amplifier must not be allowed to oscillate at any frequency, audible or inaudible.

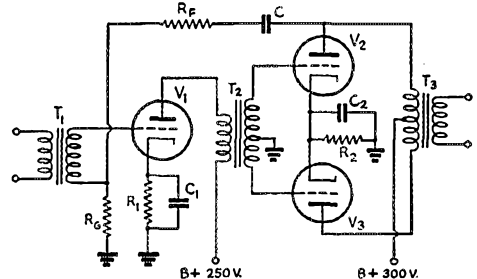

Fig. 5 — Feed-back over two stages in a transformer-coupled amplifier with push-pull output stage.

- V_1 — 6SF5, 6C5, etc.
- V_2, V_3 — 2A3s.
- C — 0.5–1.0 $\mu\text{fd.}$, high quality (preferably 1000 v. rating, although 450 v. will do).
- C_1 — 25 $\mu\text{fd.}$, 25 v., electrolytic.
- C_2 — 25 $\mu\text{fd.}$, 50 v., electrolytic.
- R_1 — 3000–5000 ohms, 1 watt.
- R_2 — 750 ohms (Class AB1).
- R_f — 500,000 ohms, variable. When feed-back is set, a fixed resistor of proper value may be substituted.
- R_0 — 100 ohms (may be varied).
- T_1 — Driver plate or line to grid.
- T_2 — Single plate to push-pull grids, center-tap, 1:1 or step-down.
- T_3 — Push-pull plates to line, v.c. or Class-B grids, 5000 ohms p-p.

Reduction of Distortion and Noise

Because of non-linearity of tube characteristics and associated devices, harmonics and combination frequencies are generated within an amplifier. When the amplifier is operated well within its limits of power output the total distortion will be reasonably small, and ordinarily only the second harmonic will be of any importance. An amplifier on the verge of overloading will have higher order harmonics present, even in amounts exceeding the second harmonic.

Inverse feed-back reduces the percentage of all harmonics present by a proportion effectively equal to the reduction of overall amplification. It can be shown that, because of distortion and cross-modulation of the harmonics fed back, in an amplifier operated at its overload point this is not strictly true, although the overload point will be extended by feed-back. For an amplifier in its general application to use, however, the first statement holds.

The output of an amplifier may be increased as the square of the gain reduction due to feed-back, for the same percentage distortion allowed without feed-back. For example, if 1 per cent distortion is allowed without feed-back and feed-back reduces the gain of the amplifier three times, then the output can be increased nine times for the same 1 per cent distortion with feed-back, provided the extreme capabilities of the amplifier are not exceeded. Do not forget that any distortion produced in the external circuits supplying the increased signal voltage necessary for increased output will not be reduced by this feed-back.

Examining a power amplifier with intent to apply inverse feed-back, several interesting facts may be brought out. The power output stage itself is the source of a large percentage of noise and distortion. Feed-back over this stage alone should produce marked improvement in the output. However, if the feed-back loop is returned to the input of the power stage, any amount of it will reduce the gain to such an extent that the output of the driver must be excessive and the distortion produced therein may offset the benefits given by feed-back. Much more satisfactory results will

occur if the feed-back is applied over the driver stage as well, relying on the speech amplifier to supply the gain lost. Since the speech amplifier generally has to supply voltage output rather than actual power output, it may be assumed that little distortion arises. However, since nothing is to be lost except gain, feed-back may also be applied over at least three stages of the speech amplifier. The linear-response range will be increased and any distortion present will be reduced. If after such application of feed-back the output level of a microphone or pick-up head is too low for the gain remaining, a pentode stage external to the feed-back loop may be added. This should give enough gain for the usual purpose. Where feed-back is desirable over more than three stages, considerable trouble with instability will occur. To get around this trouble the feed-back may be split, applying one loop around two stages and another around the remaining stages. In a somewhat remote case, a third loop could then be added over all of the stages.

Equalizing

The flat frequency-response range resulting from the application of inverse feed-back may be modified to give more pleasing response to the ear, particularly if the signal source is a poorly equalized pick-up. By suitably altering or adding to the constants of the feed-back loop itself, feed-back may be reduced for both high and low frequencies with negligible reaction of one on the other. The gain at these frequencies will be increased, giving a peaked response easily adjustable to the individual taste. Referring to Fig. 6, if a condenser and an inductance of suitable values are tied across the cathode resistor of V_1 in parallel, the condenser will by-pass some of the high-frequency feed-back to ground, and the choke will similarly reduce the low-frequency feed-back. This method of equalization has none of the distortion and loss characteristics so generally found with usual bass and treble boosting circuits. Unless tremendous boosting is wanted, there will still be a small amount of feed-back present at the boosted frequencies.

While feed-back has its best corrective action for amplifiers with pentodes or beam tetrodes

Fig. 6—A three-stage amplifier with over-all feed-back loop.

- V_1 — 6J7, 6C6, etc.
- V_2 — 6J5, 76.
- V_3, V_4 — 6L6, 6F6, etc.
- C_1 — 0.5 μ d., 450 v., paper.
- C_2, C_3, C_4 — 0.1 μ d., 450 v., paper.
- C_5 — 25 μ d., 50 v., electrolytic.
- C_6, C_7 — 8.0 μ d., 450 v., electrolytic.
- R_1, R_2 — 50,000 ohms, 1 watt.
- R_3 — 1.0 megohm, 1 watt.
- R_4, R_6, R_7 — 100,000 ohms, 1 watt.
- R_5 — 500,000 ohms, 1 watt.
- R_8 — 250 ohms, Class AB₁.
- R_9 — 25,000 ohms, 1 watt.
- R_{-1} — 2000 ohms, 1 watt.
- R_{-2} — 3000 ohms, 1 watt.
- R_{-7} — 500,000 ohms, variable. When feed-back is set, a fixed resistor of proper value may be substituted.
- T_1 — Low-impedance mike, p.u. or line to grid.
- T_2 — Push-pull plates to line or v.c. (6600 ohms p-p).

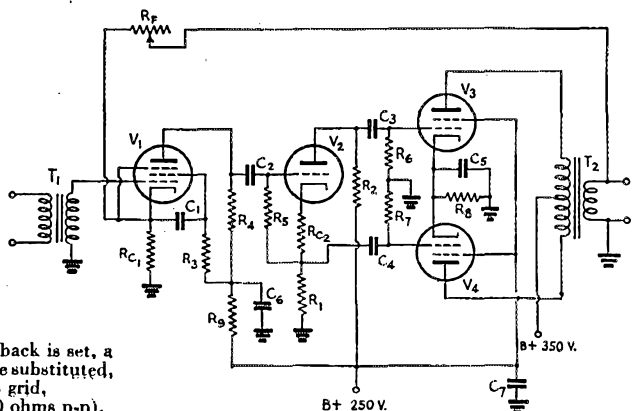

such as the 6L6 in the output stage, there is no reason why it should not be used with a triode output amplifier, particularly if Class-B triodes are used and a power-type driver is required. If equalization is wanted in an amplifier set-up feeding a speaker and used for record play-back, or for feeding a cutter and used for instantaneous recording, excess gain might be incorporated in the pre-amplifier. The pre-amplifier is then equalized by means of selective feed-back as just pointed out. This practice will allow a maximum amount of feed-back to be used over the power amplifier where it is needed greatly at all frequencies. In an ideal arrangement, the gain may be controlled by a "T" pad inserted in the line between the output transformer of the pre-amplifier and the input transformer of the power amplifier.

Negative Feed-Back at R.F.

Although generally only used in commercial applications, feed-back may be applied over an entire radiotelephone transmitter. A small percentage of the carrier signal is rectified and introduced into one of the speech input stages. This is known as r.f. inverse feed-back, and Fig. 7 illustrates a simplified circuit suitable for amateur use. The rectifier must be free from hum and distortion, not only to produce a balanced output representative of the carrier, but also because any noise and distortion originated by the rectifier will have a return path to appear on the carrier signal. If the rectifier is balanced, the carrier frequency will be cancelled in its output to the audio circuits. Because of the possibility that large amounts of phase shift will be present in the various stages within this feed-back loop, only quite small amounts of feed-back may be used. To make available somewhat large amounts the linear response band must be widened. This may be done easily for the audio circuits by applying separate feed-back to them. The problem of widening the r.f. stages is much greater, but generally may be brought about by raising the L/C ratio of the tuned circuits, so long as too low a value of circuit Q does not result. It is easier to apply r.f. inverse feed-back to a high-frequency transmitter than a low-frequency one, since the frequency where a sizable envelope phase shift occurs will be very high and will have a more remote effect. Class-B modulators are a considerable source of phase shift and distortion, and usually rectified r.f. feed-back is applied only to transmitters using grid-bias modulation. As pointed out previously, audio feed-back will provide a very worthwhile improvement for Class-B stages, and the tubes will tend to adjust themselves to the linear operating portion of the dynamic characteristic curve regardless of ageing and bias voltage variations.

In a feed-back amplifier the plate-supply voltage may vary over a considerable range without materially affecting the amplification. Constants of the circuits may be changed in value and the tubes themselves may be replaced without serious effect on the output, either in quality or quantity. Voltage regulation of the power supply need not be other than ordinary, and noise, in the form of

hum from a poorly-filtered supply feeding the power output stage, is greatly reduced. However, it must be noted that hum and other noises, such as microphonics, induced in low-level stages will be only very slightly reduced by feed-back if there is any amount of gain after the stage where the noise occurs.

All the foregoing has served to present a few interesting and vital facts concerning the practical uses of feed-back. For a mathematical and more thorough theoretical treatment, the appended bibliography will serve as an excellent guide. Several practical articles are also included.

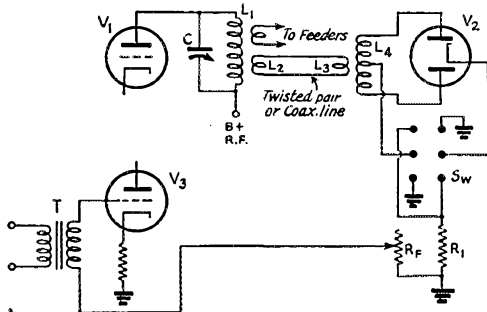

Fig. 7—Application of negative feed-back to a transmitter.

- V₁, C, L₁ — Final r.f. output stage.
- V₂ — 84/6Z4 (must be located near V₂).
- V₃ — Speech amplifier stage.
- R₁ — 10,000 ohms, 1 watt.
- R₇ — 10,000 ohms, variable to set amount of feed-back.
- L₂, L₃ — 1- or 2-turn loop coupled to "cold" end of tank coil and to L₄ with twisted pair of coaxial line.
- L₄ — Center-tapped coil broadly tuned to carrier frequency.
- Sw — D.p.d.t. polarity reversal switch. If "ringing" occurs reverse switch.

Bibliography

- Fundamentals of Radio*, by W. L. Everitt and others, 1st edition, 1942, Chaps. 7 and 12.
- Fundamentals of Radio*, by F. E. Terman, 1st edition, 1938, Chaps. 8 and 9.
- The Radiotron Designers Handbook*, F. Langford Smith, editor, 3rd edition, 1941, Chaps. 6 and 8.
- "Feed-Back Amplifier Design," by F. E. Terman, *Electronics*, January, 1937.
- "Practical Feed-Back Amplifiers," by J. R. Day and J. B. Russell, *Electronics*, April, 1937.
- "An Amplifier Without Phase Distortion" (an editorial review), *Electronics*, June, 1937.
- "Applying Feed-Back to Broadcast Transmitters," by L. G. Young, *Electronics*, Aug., 1939.
- "A Flexible Equalizing Amplifier," by E. G. Cook, *Electronics*, July, 1942.
- "Inverse Feed-Back," by B. D. H. Tellegen and V. C. Henriquez, *The Wireless Engineer*, August, 1937.
- "Some Properties of Negative Feed-Back Amplifiers," by L. I. Farren, *The Wireless Engineer*, January, 1938.
- "Distortion in Negative Feed-Back Amplifiers," by J. Frommer (correspondence), *The Wireless Engineer*, January, 1938.



U.S.A. CALLING!



COMMISSIONS—MEN

OUTSIDE of highly specialized fields, it is now the general rule that the various military services make their own officers by the process of selecting likely candidates from their own enlisted ranks and sending them to officer schools. Except in occasional special cases, it is no longer possible for persons other than engineering graduates to obtain commissions direct from civil life. However, that is emphatically not true in the engineering branches for which highly specialized schooling is necessary — which of course in the case of our readers means the electrical engineering field. Numerous opportunities there remain and the applicant who has a college degree in electrical engineering or physics can generally get a commission in short order in the service of his choice. Our latest information is here summarized:

In the Army — aside from the Air Forces, concerning whose needs we have no late information — most communications personnel is furnished by the Signal Corps, and it is in that arm that most of the commissions are available. The Signal Corps still has need for EEs, particularly those qualified in radio and electronics. Correspondence should not be with that corps, however, since the procurement function has been taken over by what is called the Officer Procurement Service. Last month we published, on page 27, a list of the addresses and telephone numbers of these district offices all over the country, and to that we invite your attention. Applications are urgently desired from men qualified as radio engineers and electronic physicists, which occupations have been classified as "scarce," and men in this group between the ages of 22 and 45 are eligible for commission. In other branches of EE, men must have reached the age of 35. If you are available, please seek further information from the Officer Procurement District nearest your home.

There is one specialized branch of the Signal Corps in which the solicitation of personnel is handled by a man who happens to be president of ARRL: George W. Bailey, of the Office of Scientific Research & Development, 2101 Constitution Ave., N. W., Washington, D. C. This is the Electronics Training Group. It consists of young men between the ages of 18 and 35 who are in combat physical condition and who are graduates of an accredited college, either in EE or in science with an electronic-physics major. These fellows deal with an immensely interesting microwave radio development which we are not permitted to discuss in any detail. Selecting only men with the best available technical education, the Signal Corps builds on top of that an exceed-

ingly comprehensive course in the technique of this new art. The training is invaluable for the future, as well as being one of the most interesting activities in the war. The schooling is at the best technical universities, some of it in England. Commission is as a second lieutenant, but of course there is plenty of opportunity for promotion after schooling. Interested persons are requested to exchange full information with Mr. Bailey at the address above.

The Navy is seeking graduate electrical engineers, between the ages of 18 and 25, for commission in three classes of specialists. One is the Aviation Volunteer class, dealing in general with functions of the type mentioned in the preceding paragraph. Another group is the Communication Volunteers, in which most of the NCR gang are serving, and of course dealing with communications. The third is the Engineer Volunteer, which has functions in both fields. You can obtain full particulars from The Commandant of your Naval District.

Despite the fact that the Headquarters gang is represented in the Coast Guard, we have no data on their radio needs. Tight little bunch, that Coast Guard crowd. Almost makes a fellow the more eager to crash them.

The only direct radio commissions in the Marine Corps seem to be those in its Aircraft Warning Service, open to college graduates, between the ages of 20 and 45, who have either degrees or special training in the appropriate subjects. After special technical training of a sort you can readily guess, these officers see action with troops, discharging the special functions of their new art. Solicit particulars from The Commandant, Headquarters, U. S. Marine Corps, Washington.

Mr. Bailey has contact with all of the above matters and is in position to give advice to candidates who may be in doubt about their qualifications. He can assist men with EE or physics degrees to become located in the service of their preference. He can also tailor some jobs to fit well-qualified candidates over 35 years of age, at various places in the armed forces, and frequently can make a berth for a man possessing long experience in the technical side of commercial radio in lieu of holding a sheepskin.

ENLISTMENTS—MEN

ALTHOUGH the voluntary enlistment of men between the ages of 18 and 38 is prohibited, there are attractive opportunities in most branches of the armed forces for volunteers outside these limits. Moreover, men between the stated ages who are about to be selected in the draft may wish to be in some service other than

the Army. The Navy, Marine Corps and Coast Guard have quotas which govern the number of men accepted for induction, but provided the quota is not filled a would-be draftee can generally get in the service he prefers if he meets its standards. In communications work in the services nothing can take the place of actual experience in operating and repair work. All the services are therefore definitely interested in applicants who possess amateur experience, and the display of your FCC operator license will be a powerful help. You can get information on the opportunities in the various services, and on procedures for induction through Selective Service, by applying at the local recruiting station of the service in which you are interested.

ENLISTMENTS—WOMEN

WOMEN are playing an increasingly important part in this war, through their participation in the women's auxiliaries of the various branches of the armed forces. They are turning in an excellent performance and the auxiliaries are being expanded and new radio schools opened up for their training. Women in uniform, with skill in communication, relieve a man in uniform for duty on a hotter front.

The regulations vary slightly in the different services as concerns age limits, marital status, etc. We recommend that interested candidates shop around at the local recruiting offices of the Army and Navy to obtain fuller particulars. Applicants are being sought by the Army WAACs, the Navy's WAVES, the Coast Guard's SPARS and the Marine Corps' Marines. (Almost seems that we ought to write that last word with all-caps too, but the Marine Corps says it is content to call its women simply marines.)

The procedure in these services is much the same. After a brief basic training course, the women destined for communications are sent to special technical schools which have been set up for that purpose. Swell training in radio. Those who are licensed YL amateurs are exceedingly likely to get a rating immediately after the completion of basic training. Those who, in addition, are college graduates are prime candidates for a quick commission.

While there are ample provisions for women in every service, some may prefer civil duty in laboratory or industry. Those who do are invited to exchange particulars with George W. Bailey, 2101 Constitution Ave., N. W., Washington.

MARITIME SERVICE

THERE is a pressing need for radio operators in the U. S. Maritime Service and for the other vessels of our merchant marine. The service that an amateur can here render is one of the most important that a man can give toward the winning of this war. For full information, see our lengthy article "QST Returns to Gallups Island" in our May issue, particularly page 90 thereof. Every man entering the Maritime Service now does so as an apprentice seaman, enlist-

ing at the nearest enrolling office of the USMS. Although proficient amateurs go through the course in less than the regular time, the usual apprentice seaman gets five weeks of basic training and then, if found to have special aptitude, is sent to a preliminary school at Huntington, Long Island, for two months and then on to the famous school at Gallups Island for four additional months. This service affords magnificent training and an opportunity to play a vital part in the war program. If you live in a major city, there is probably a U. S. Maritime Service enrolling office near you. If not, write for further information to The Commandant, U. S. Maritime Service, Washington, D. C.

CIVIL OPPORTUNITIES

THE U. S. Civil Service is seeking men and women for a large variety of positions in the service of the Federal Government. We would like to refer readers to numerous items in this category which have appeared in this department in recent months. The positions include radio inspectors and monitoring officers and intercept officers of FCC, and technical & scientific aides for government laboratories. In almost all of these positions there is a considerable number of pay grades, with varied qualifications for initial appointment, so that generally there is a place where any applicant will fit. The details of these positions are published in Civil Service bulletins known as "Announcements," which are to be found in the office of the Civil Service secretary at any first- or second-class post office, or at the numerous regional offices of the Civil Service Commission. There are many attractions to being in the Federal service and the experienced amateur is almost certain to find something in the lists which is attractive. Visit your post office.

Attention, radio engineers and physicists! This country is still in serious need of upper-echelon brains in its technical leadership. The kind of men we are here talking about are unquestionably enjoying good business connections at present, but may feel that they are not exerting their full capabilities toward the winning of the war. It has been established that many men in such positions would relish an opportunity to engage in absolutely confidential correspondence to make a quiet investigation of the opportunities to employ their highest skills in the most important manner. An arrangement has been set up for that specific purpose whereunder the president of ARRL, George W. Bailey, with wartime duties at the Office of Scientific Research & Development, 2101 Constitution Ave., N. W., Washington, is in position to engage in personal correspondence with such men. You are invited to see previous references to this subject on page 35 of March QST, page 39 of the April issue, page 28 last month, and write to Mr. Bailey.

The manpower situation in the broadcast industry, with particular reference to technicians, is growing more serious each day. All available persons who have a first-, second- or third-class

(Continued on page 34)

A Hand Perforator for Code-Practice Tape

Building a Practical Punching Device from Junk-Box Materials

BY GEORGE GRAMMER,* WIFE

THE Wheatstone-tape code-reproducing machine which appeared some time ago in *QST*¹ was originally described with the thought that it would be of interest to those who had access to prepared tape. However, the relative simplicity of the reproducer evidently appealed to some who did not already have such tape, immediately raising the question of where it could be obtained. Aside from suggesting the few sources from which especially-prepared code-practice tapes could be secured, and intimating the possibility that old tapes might be begged from some of the commercial users, there was little we could recommend.

But the existence of the question did give us reason to consider the possibility of putting together a tape perforator, one which could be built at little or no expense with only the facilities available in the average home workshop. After a period of trial and error a perforator was evolved which does produce usable tape, is simple in operating principle and is not difficult to build — at least not for one who has the ability to do reasonably good work with a drill, hacksaw and file. That the design is successful is entirely attributable to the mechanical bent possessed by F. C. Beekley, *QST*'s advertising manager, for "Beek" supplied the ideas and did most of the actual construction. The writer's rôle is simply that of reporter, a rôle forced on him because the man to whom the credit belongs could not be persuaded to punch a typewriter with the same enthusiasm that he puts into work on a drill-press.

It is well known that a dot on Wheatstone tape consists of two holes on a line at right angles to the axis of the tape, and that a dash consists of two holes on a diagonal line making an angle with the tape axis such that the lengthwise space occu-

ried by the dash holes is the same as that occupied by two consecutive dots. The length of a dash, on the tape, is therefore twice that of a dot, and the tape must be moved twice as far through the perforator to accommodate a dash. A practical hand perforator should be capable of punching both holes for either type of character at will, and should simultaneously move the tape along so that the proper amount of space will be provided for the character. In addition, provision should be made for spaces between letters and between words. Regular Wheatstone tape also has a series of center holes used by the pulling mechanism in the transmitter, but these holes are not necessary for the code reproducer previously described because the puller operates by friction. Probably it would not be a difficult design problem to include punches for the center holes, but their omission greatly simplifies the construction in that less painstaking work is required to get the various parts to fit with sufficient accuracy.

The several photographs show the perforator both assembled and with the sections taken apart. The materials are pieces of quarter-inch square brass rod, half-inch brass angle strip, a hacksaw blade, and various brackets, springs and pieces of metal from the junk box. Part of the assembly is on a sub-base of 3/16-inch bakelite, while the main base is quarter-inch tempered Masonite, 4½ inches wide by 6¾ inches deep. Except for the punch itself, none of the dimensions are particularly critical, and even in the punch some departure is permissible unless one wants the holes to be exactly the same as in regular Wheatstone tape. While it is desirable to approximate Wheatstone spacing as closely as possible, there is sufficient leeway in setting up the contacts on the reproducer to take care of reasonable variations, so that even this part of the job requires no more than ordinary care in following specifications.

Punch Details

The basic punch mechanism is shown in Fig. 6 and the essential parts comprising it in Fig. 5. Fig. 7 is a dimension drawing of the punch. The punch arm is a 3-inch piece of ¼-inch rod with a

Fig. 1 — Although not a high-speed device, tape can be punched with this perforator at least as fast as the average beginner can copy it. This view is taken from the side on which the puller is installed.

*Technical Editor, *QST*.

¹"A Code Machine Utilising Wheatstone Tape," *QST*, November, 1942.

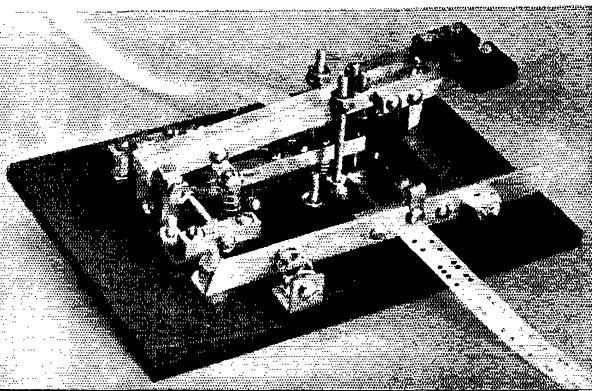

machine-screw pivot at one end. This screw, which is threaded into the rod and locked in place with nuts, is $1\frac{3}{4}$ inches long and was made from a 2-inch 6-32 screw by cutting off the head and filing the ends to conical points. The points can be formed quite readily if a drill-press is available by placing the screw in the chuck and holding a file against the end as the screw rotates. The same method can be used with a hand drill by fastening the drill in a vise and having another person turn it. The points can be smoothed by using fine sandpaper or steel wool. The pivot arm should be fairly long so that the punch arm will have little tendency to swing out of line laterally when the punch is in operation.

The trunnions are 6-32 machine screws threaded into $1\frac{1}{8}$ -inch lengths of square rod, the latter being held to the base by machine screws threaded into the bakelite. Lacking a means for boring a conical hole in the ends of the trunnion screws, the screws were simply hollowed out by drilling shallow holes with two or three different sizes of drills to simulate a conical depression. To bring the punch arm to about the right height, the trunnions are mounted on a piece of bakelite which in turn mounts on the main bakelite base, as shown in Fig. 6. A $\frac{1}{2}$ -inch hole should be drilled under the end of the punch arm in the upper bakelite piece so that the arm will be free to swing upward without having its rear end strike the bakelite.

Details of the punches are shown in Figs. 5 and 7. There are three punches altogether, spaced at the vertices of a small right-angled triangle. The single punch toward the rear is force-fitted into the punch arm by grinding the punch rod to a somewhat conical shape and driving it into a slightly undersized hole. The other two punches are free to move in the guide holes at the end of the arm. In Fig. 5 the punch arm is upside down to show the fixed punch, which normally faces downward. The punches are pieces of the shank of a No. 45 drill, this size of drill being approximately the same diameter as the holes in Wheatstone tape. The same size drill should be used for drilling out the two guide holes at the end of the punch arm, but a slightly smaller hole should be drilled to take the fixed punch. Care should be taken to drill the holes at the right distances from each other (see Fig. 7) and to make them exactly perpendicular to the arm.

Each of the free punches has a flat filed near the upper end. A flat piece of metal, seen just above the end of the punch arm in Fig. 5, fastens to the punch arm with two small machine screws and has its front end inserted into the flats when the parts are assembled, as shown in Figs. 6 and 7. When pressure is exerted on one of the free punches the upper lip of the flat pushes on the metal piece and thus forces the arm downward so that this punch and the fixed punch at the rear both go through the tape. The other free punch, however, has no pressure exerted on it and simply rests on the tape while the arm moves downward. By exerting pressure on one free punch, but not both, it is therefore possible to punch either a dot or a dash, depending on which punch is selected.

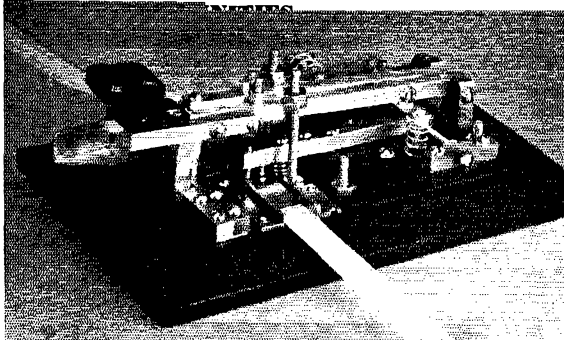

Fig. 2 — The tape enters the perforator from this side, running under the stripper in a channel formed from UM-type condenser-mounting angle brackets.

Die and Tape Guides

The die is a piece of hacksaw blade, $2\frac{1}{4}$ inches long and slightly less than $\frac{1}{2}$ inch wide, having three holes drilled in the middle to the same dimensions as the holes in the punch arm. Here again accurate drilling is required so that the punches will enter the holes without binding. At the ends of the die are countersunk mounting holes for 4-36 machine screws. The heads of the mounting screws must be filed down to be flush with the top of the die so that the tape will move freely over it. The driving slots in the screws disappear in the filing process, but it is nevertheless easy to tighten the nuts when assembling the die to the base. The mounting holes in the bakelite base should be oversized so that the die can be moved about a bit to align the holes with the punches. While a close fit between the holes and punches is necessary for making a clean cut in the tape, the punches should nevertheless enter the holes as easily as possible. To attain this, accurate alignment between the punches and the holes is necessary, and it is also necessary that the punches be as nearly vertical as possible with respect to the surface of the die at the instant they enter the holes. The punches need only penetrate about the thickness of the hacksaw blade — further travel is neither necessary nor desirable — and once the assembly is completed the ends of the punches may be ground down to the right length. The cutting faces of the punches should be perpendicular to the axes; a skew face is likely to leave the punched-out section of tape still attached at the point where the heel goes through. However, the performance of the punch will be improved if the face can be ground cylindrically concave or in the shape of a hollow V. The cutting edge in such a case then "slices" the tape rather

If you can't get Wheatstone tape for code-practice purposes, it's not too much of a job to make your own perforator. The chief ingredients are time and a little patience; the actual materials can be found in most any ham scrap pile. Here's the dope on one way to go about it, plus some revisions in the code machine described in QST last winter.

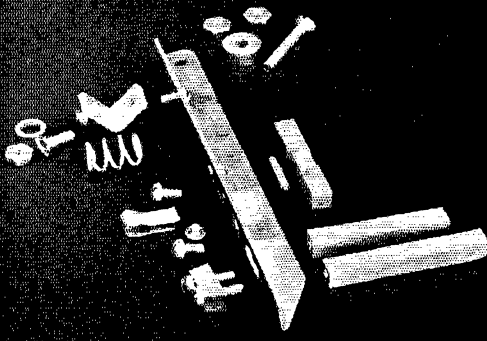

Fig. 3 — The puller mechanism dismantled.

than making a simultaneous cut all around the circumference, reducing the amount of pressure required.

The back stop for the punch arm is a 6-32 screw threaded into the bakelite base and fastened underneath with a lock nut. The stop should be set so that the ends of the punches just clear the tape, thus permitting the punch to be operated with a minimum of motion. The arm is held against the back stop by a spring taken from a small battery clip. A machine screw threaded through the base from the bottom acts as a retainer for the spring and also serves as an adjustable stop for the downward motion.

The tape is kept in position in moving through the perforator by the guides shown in Fig. 6. These are mounting brackets of the type furnished with National Type UM condensers. The unneeded material on the vertical side is cut off, leaving about $\frac{1}{8}$ inch to serve as a guide. The holes in the bakelite base for the mounting screws should be drilled a little oversize so that the guides can be moved about slightly. This will permit adjustment so that the tape can be kept from moving sidewise but still can move freely through the perforator.

An important part of the punch is the stripper, the thin metal piece having a shape somewhat like a flattened I. This has three holes, drilled in the same positions as the three punch holes in the die but larger in diameter so that the punches do not touch the metal. The stripper prevents the punched tape from adhering to the punches when they rise out of the die and thus clears the punch for the next operation. It is placed over the die with just enough space between the two to permit the tape to move through, the proper spacing be-

Fig. 5 — Component parts of the punch mechanism.

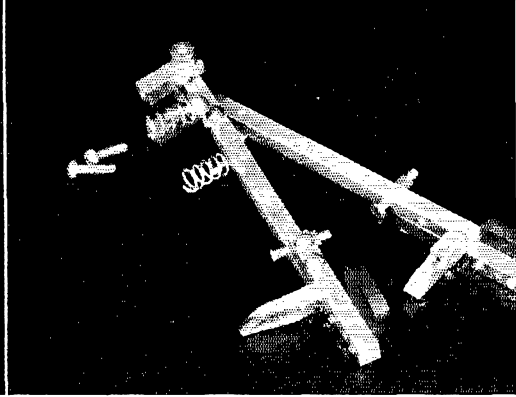
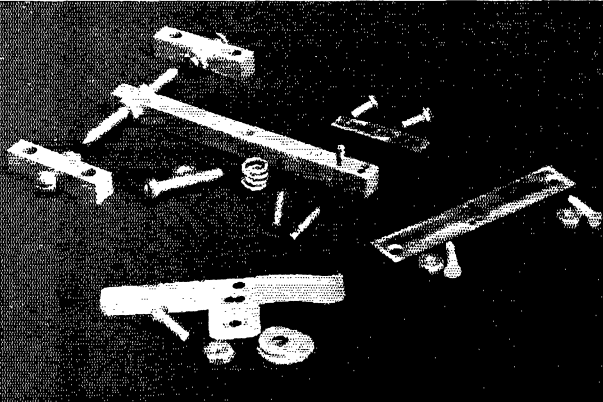

Fig. 4 — Operating levers with spacing wedges.

ing secured by placing thin washers under the mounting tab. A rounded lip is bent in the right-hand end (as viewed from the top) so that a little pressure is exerted on the tape at the point where it enters. This is an aid to proper operation of the spacing mechanism, as described later.

It is of course necessary to cut a hole in the bakelite base under the punches so that the "confetti" can fall through. A half-inch round hole is large enough.

Operating Levers

The punches are operated by the two arms shown in Fig. 4. These are $\frac{1}{4}$ -inch square brass rods, one $4\frac{5}{8}$ inches long and the other $4\frac{3}{8}$ inches long. The arms are pivoted between a pair of $\frac{7}{8}$ -inch high posts of the same material, using a bearing formed by a machine screw running through holes at the rear ends of the arms. While the bearing should not be tight, there should be little or no play because any sidewise movement is undesirable in the absence of front guides to keep the arms in the proper positions. One arm, that on the right-hand side as viewed from the front, is used for making dots and the other for making dashes. The "pusher" which presses down the proper punch when the lever is depressed is a 6-32 round-head machine screw with the head filed flat. It is threaded into the arm and locked in place with a nut. Since the clearances were small, special nuts had to be made for this purpose by drilling and tapping a short length of hexagonal bar (actually a small mounting pillar found in the junk box).

Two-inch pieces of square rod are fastened to the side of each arm, at the front, to extend the arms so that some operating leverage is obtained.

Fig. 6 — Punch assembly, with back-stop bars.

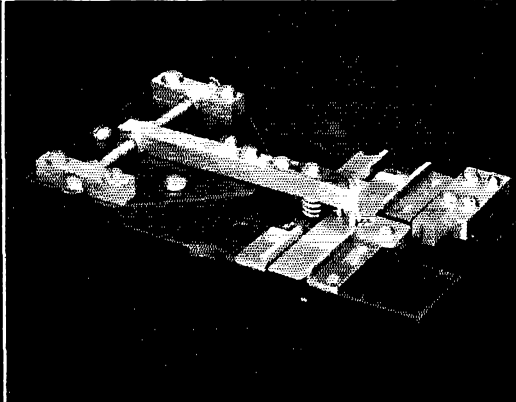

Small pieces of bakelite are fastened on these for use as key knobs. The extension pieces are used in preference to longer single arms so that the keys can be separated a little for operating convenience. The dash knob is made a bit larger than the dot knob for ready identification.

The operating arms have a spring return, the springs being mounted about an inch from the pivoted end. As shown in the photographs, the springs are held in place by small L-shaped brackets fastened by machine screws threaded into the arms. A half-inch machine screw extends through the spring to keep it in place.

Back stops for the operating levers are provided by 2-inch machine screws extending upward through the base on either side of the arms, just back of the punch. Nuts on the machine screws form the actual stops, the height being conveniently adjustable.

Pulling Mechanism

The mechanism which pulls the tape is shown taken apart in Fig. 3 and assembled in Fig. 1. The moving arm is a 5½-inch length of ½-inch L-shaped brass strip, pivoted at the rear end on a machine screw running through the main base. The top of the lower side of the arm is brought flush with the die by means of a collar, shown between the pivot end of the arm and the machine-screw bearing in Fig. 3. This can be filed to the proper height. The pivot hole in the arm should be just large enough to clear the screw so that the arm can turn freely but will have little play at the bearing. The arm is pressed against the edge of the bakelite base by a spring, again taken from a battery clip, mounted from a small L-shaped bracket as shown in Fig. 1.

The actual puller is a "one-way" device which grasps the tape when the arm is swung outward but which simply slides back over the tape when the arm returns to its normal position. It is formed by the filed-out brass piece and roller, together with the small flat spring, shown in Fig. 3. A dimension drawing is given in Fig. 8. The roller rests in a slanting slot, as shown in the drawing. When the arm is moved outward the surface of the arm tends to slide along the tape. Friction draws the roller toward the narrower end of the

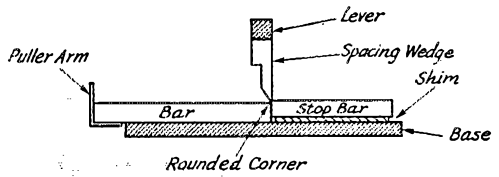

Fig. 9 — Spacing arrangement showing dot wedge.

slot, forcing it down on the tape and thus preventing the tape from sliding and causing it to be pulled along by the arm. The flat spring pressing against the roller makes this action more positive. When the arm returns inward the friction tends to force the roller outward, thereby causing it to release its grasp so that the tape does not move.

The successful operation of this puller depends chiefly on keeping the tape firmly in place during the return stroke of the arm. The stripper accomplishes this by holding the tape flat against the die and thus preventing it from folding back on itself when the puller arm moves inward. The pressure lip on the far end of the stripper prevents the tape from sliding in the reverse direction. The end of the stripper should extend over the puller arm to keep the tape flat over the whole length of its travel to the actual pulling device. If this is done there will be little or no tendency for the tape to back up on the return stroke. With proper spring tension the roller will grasp the tape practically at the instant the arm starts to move outward, so that there is negligible slack. The spring should not be too stiff; the one actually used in this perforator is made of copper 6 mils (0.006 inch) thick. The pressure should be adjusted (by bending the spring) until the operation of the puller is wholly positive.

Spacing Device

The spacing mechanism consists of the ¼-inch square bars shown to the right of the puller arm in Fig. 3, the two smaller bars mounted at the right on the front of the base in Fig. 6, and the wedge-shaped pieces on the ends of the operating arms in Fig. 4. The bars on the base and those on the arm are end to end when the operating levers are up and the puller arm is pressed back against

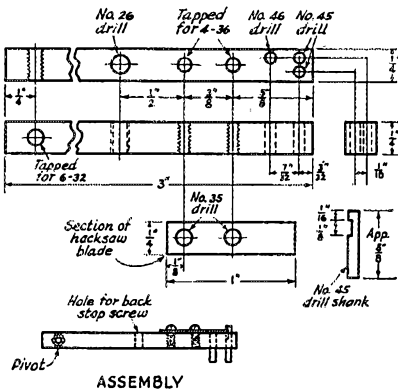

Fig. 7 — Detail drawing of the important punch parts.

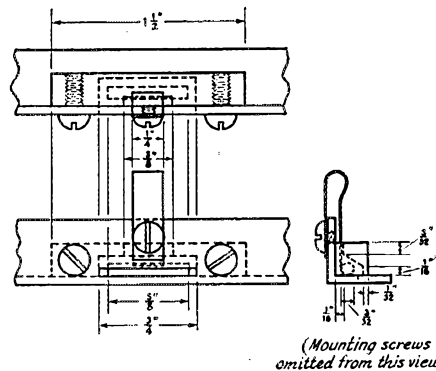

Fig. 8 — Dimension drawing of the puller assembly.

the base in its normal position. One bar of each pair is $\frac{1}{4}$ -inch longer than the other, this being the width of the operating levers. The lengths of the pieces should be such that the junction of the inner bars is just under the inner edge of the dash-lever and the junction of the outer bars is just under the outer edge of the dot-lever arm.

The operation of the spacer is indicated by the sketch of Fig. 9. The flat edges of the spacer wedges normally rest against the surfaces of the small bars on the base. When a lever is depressed the wedge forces the bar on the puller arm outward until the flat section is reached, when further movement of the arm ceases. As the lever is further depressed, the push rod on the lever arm makes contact with the appropriate punch and forces it through the tape. When the pressure is released the springs force the arm upward, the punch clears the tape and the spring return on the puller arm forces the bar back to its original position, setting the perforator for the next character.

The spacer wedge for the dash lever is just twice as wide as that for the dot lever, so that the tape moves twice as far for a dash as for a dot. The actual thickness required in the wedges will depend upon their position with respect to the tape and the total leverage of the puller arm. In the perforator shown the thickness needed for the dash spacer is slightly over a quarter inch, so that it was necessary to pound the $\frac{1}{4}$ -inch rod with a hammer to distort it into slightly larger thickness. The only requirement to be met is that the tape should move $\frac{2}{10}$ inch for a dash and $\frac{1}{10}$ inch for a dot. Slightly larger movement can be used if desired, and will make the tape somewhat more sturdy because there will be a little more paper between consecutive holes. It is best to make the wedges a little thicker than necessary and then file them down to proper size. It is easy to check on the relative thickness of the two wedges by observing the spacing between consecutive holes

when making a dot followed by a dash and a dash followed by a dot. If the spacing is uniform the two spacer wedges are correctly adjusted.

The stop bars mounted on the bakelite base are shimmed up with a piece of metal about $\frac{1}{32}$ -inch thick so that they are slightly higher than the bars on the puller arm. The back stops on the operating levers are then adjusted so that the wedges just catch against the stop bars. This keeps the levers in the correct position to force the bars apart when the key is depressed.

To make a space equal in length to the period occupied by a dot, the dot lever is simply pressed down until the push rod touches the punch and is then released before a hole is made. This is not at all confusing from an operating standpoint since there is a definite stop when the rod touches the punch. To make a space between words the dot lever is operated in this fashion three times.

A typical section of punched tape is shown at the top of page 20, together with a sample of Wheatstone tape containing the same copy. The spacing is slightly greater on the homemade tape, but not enough greater to make any appreciable difference in the operation of the reproducer even without making compensating adjustments in the latter. It has been found that after almost no practice it is possible to punch tape accurately at the rate of about six words per minute. While this is not by any means high speed, quite a bit of practice tape can be turned out in a sitting or two. It is more difficult than it might seem at first thought to increase the speed appreciably. One reason is that the force required to cut through the tape, although not excessive, makes it necessary to press the levers firmly, while at higher speeds the tendency is for the operator to lighten the pressure. We have toyed some with the idea of using solenoids to do the actual work, reserving the operating keys for control purposes only, but

(Continued on page 74)

Fig. 10 — Front view of the rebuilt reproducer, showing the revamped tape-pulling system.

Fig. 11 — The bearing arrangement used allows the driving shaft to follow any wobble in the driving disc.

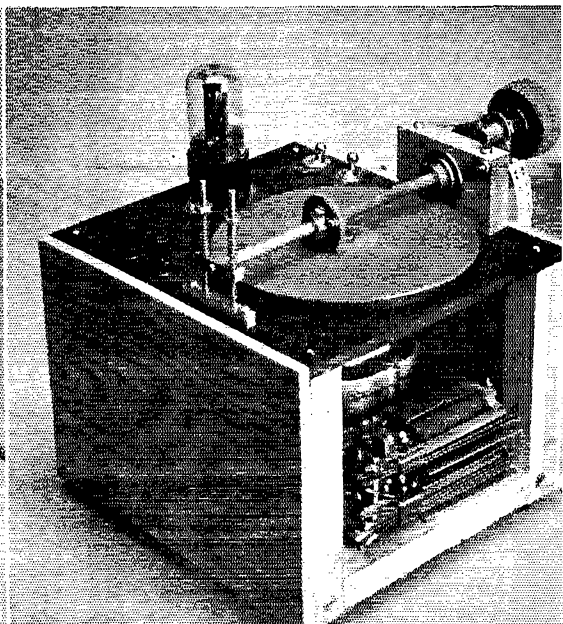
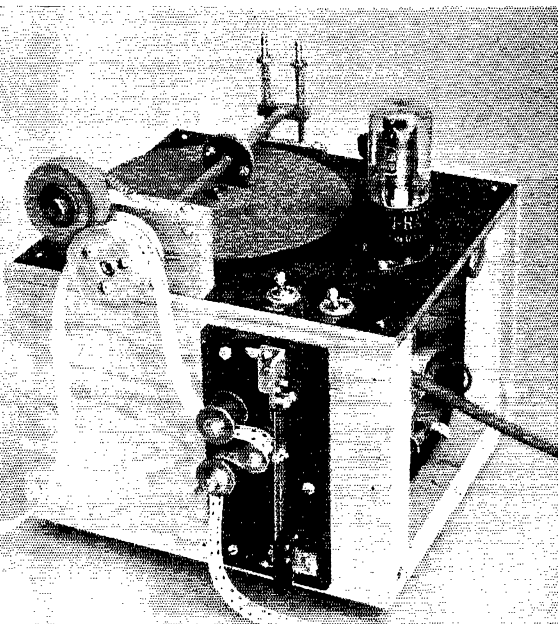

CD-WERS in the State of Maryland

An Example of Centralization of CD-WERS Activities at a State Headquarters

BY THOMAS F. McNULTY*

Given the proper cooperation by both state government and local personnel, CD-WERS can be centralized at a state headquarters which will take much of the administrative load from the shoulders of local radio aides. State governments are not eligible to become CD-WERS licensees, but they can accomplish much by establishing a focal point around which local activity can revolve. This article illustrates how such centralization has been achieved in the State of Maryland.

ALTHOUGH CD-WERS licenses are issued on the basis of district warning areas or individual communities, civilian-defense communications officials of the State of Maryland early recognized the advantages to be realized from the setting up of a state headquarters for centralization of activities within the state. Steps were immediately taken to establish such a headquarters for coordination of the prospective licensees into a state network of supplementary radio communication.

It had proved a comparatively simple matter to enlist the aid of experienced men, both amateur and professional, but it was felt that no great service could be expected from a series of independently-operated units or groups and that more could be accomplished by having a network of integrated or relay stations throughout the state.

With this thought in mind, it became necessary to get some actual operating data on what had been done on 112 Mc. Estimates of practical ranges varied from two to forty miles. It was finally decided that fifteen miles might be the average range, and subsequent experiments proved this to be a rather fair figure for all except the very low-powered walkie-talkie.

The problems of the War Emergency Radio Service in the State of Maryland were originally outlined as follows: (1) experienced personnel, (2) construction of units, (3) training of auxiliary personnel and (4) operational procedure. At the first meeting, held in August, 1942, committees were formed to take care of the technical details — construction, procurement, training and recruiting. It was decided to have as few meetings as possible after the general outline became known, so that maximum time could be devoted

to actual work. Generally speaking, these plans have been followed without change.

From the interested men in Baltimore City, names of possible recruits in outlying territories were turned over to the director for personal contact. Two or three communities had some activity already under way, and it was a simple matter to integrate these activities with those proposed by state headquarters. Cooperation among the various interested sections of the state has been a keynote of the success of our organization throughout. Ideas were exchanged by personal contact and through correspondence, and problems were solved without having to duplicate efforts.

Equipment Procurement

Realizing in the beginning that, without priorities or money, any thought of manufactured equipment would be out of the question, plans were laid for construction of the simplest types of units with the smallest number of parts. Among the men who volunteered to aid in this work was James O. Procter, W3BZL, one of the top officials in the War Vocational Training Program in the state. Through his efforts we were privileged to



WJRO-6, control station for the "State of Maryland Net." The equipment includes frequency-measuring apparatus, a cathode-ray oscilloscope, modulator and power supplies. The walkie-talkie on table was built by Alfred Freitag, W3HDZ. B.c. receiver is used to monitor WBAL; speaker on wall monitors State Police net. Telephones are connected to switchboard in office and direct to Warning Center. Seated, at left — Hal Kemp, W3EEI, radio aide for Baltimore City, and Ray Rock, W3EKZ, asst. radio aide. Standing, left to right — State Director Thomas F. McNulty; Goma C. Gooch, in charge of construction of WJRO-6 and his associates, David C. McGibbon and Ed Mueller. Foreground — Richard Whitehorn, engineering design; John Gezi and Al Allison.

* Director, War Emergency Radio Service, Maryland Council of Defense, 203 Calvert Bldg., Baltimore, Md.

use the facilities of schools engaged in the Army Signal Corps training course. Also through this source we were able to enlist the help of school teachers and children all over the state in collecting old radios, whose parts were disassembled and segregated by the beginner Army students and made available to our own corps. The radio aides in the various communities were encouraged to follow through on the administrative details and to delegate constructional problems to an assistant.

Meanwhile a campaign was inaugurated to obtain parts from manufacturers working on radio contracts. Many parts which would not pass government inspection were excellent for our purposes. This idea developed to a point where it was found necessary to appoint a procurement officer, whose duty it was to ferret out salvage materials at such plants. After a thorough explanation had been made to the authorities, excellent cooperation was obtained.

Once the proper channels were opened, a tremendous flow of materials was obtained from the salvage piles of manufacturers. Tubes remained somewhat of a problem, but this was circumvented by the use of circuits built around obtainable tubes. Antenna construction was an early bugaboo, but a good supply of coaxial cable was found in salvage heaps which worked out excellently after it had been checked and spliced.

Much has been written on the technical difficulties surrounding the War Emergency Radio Service, but, generally speaking, these technical details are not so difficult as the procurement of parts and materials. Any of the well-published circuits seem to work well, and we have adopted any circuit that would fit the materials at hand, as far as possible steering away, however, from the transceiver type of unit which breeds operational difficulties later.

In the country sections it was found that some money might be had from civilian defense funds, and in addition to promoting enthusiasm among

the amateurs, city and county officials were invited to sit in on meetings so that a thorough explanation could be made to them of the value of the service. This program resulted not only in financial aid but also in much favorable publicity which in turn made the task of building the organization easier.

Organization

Points to be covered were considered from the standpoint of military and wartime importance. No attempt was made to incorporate Air Raid Warden Messenger Service in the system. Four factors were considered:

1) How vulnerable were commercial communications and how could we use our system to reinforce them?

2) How much could be done in the emergency medical service field to facilitate the handling of casualties in the event of actual bombing raid?

3) How could we render proper service to military targets whose ordinary means of communication could be immediately disrupted by bombing?

4) How could we arrange our stations so as to form a relay network to and from all parts of the state?

The last of these questions was the most important and the one most immediately concerning us. We were faced with the problem of having many men in communities such as Baltimore City and Prince George's and Baltimore Counties and, to some extent, in Allegany and Washington Counties, with very few men in the more sparsely settled counties. It was immediately apparent that the most aid had to be given those individuals who had no trained help in their own communities. An auxiliary training course was pretty well standardized and turned over to these men. Money was obtained for them from their various county funds to purchase manufactured equipment and parts. Radio aides were encouraged as far as possible to visit one another and exchange ideas directly. They were also brought together here in Baltimore as a group, shown the facilities available and encouraged to create the same type in their own communities. In order completely to cover that part of the state where there is no trained personnel, units are being assembled wherever there is experienced personnel and installed and maintained by amateurs in nearby counties. Auxiliary operators are being trained to operate these units.

It was felt that the whole system should be made as liquid as possible, so that help could be dispatched quickly and effectively to nearby communities. After units were thoroughly tested, locations in hospitals, medical command posts and target areas were assigned to those well located geographically to handle them, while others were encouraged to construct portable mobile units for their cars as well as walkie-talkies.

Since, after the sets were installed in their permanent locations, it was found best to work with a two-frequency plan, one for control stations and another for the portable-mobile units, police



The main control station of WJWM, Prince George's County. Foreground — Radio Aide Perry E. Wightman. Background — Network Engineer H. H. Lyon.

department procedure was followed so that the stations would not be in the midst of a gabfest when there was work to be done. Incidentally, this resulted in more enthusiasm rather than less.

Radio aides were, for the most part, picked on recommendation by local directors of civilian defense. This was true in Allegany, Prince George's, Wicomico and Baltimore Counties, and this office suggested the radio aide for Baltimore City, Washington, Montgomery and Talbot Counties. A complete character record is kept in the Maryland Council of Defense office so as to relieve the radio aide of responsibility of this task. In short, by setting up a central office, much of the detail work is done which would normally take a great deal of time from the technically trained men.

State Headquarters Avoids Duplication of Effort

If a state network is used as a basis, much duplication of effort may be avoided. Licenses may be set up by areas rather than for communities. The group which works in the vocational training school is often visited by amateurs from the counties, who may bring a completed unit to be tested or checked or may want direct technical assistance. Parts from the general supply are given out only after an order is received from the local radio aide, so that there are three checks — one through the radio aide, one through the disbursing agent and another through the procurement officer.

Over 150 units have been completed and are in operation throughout the state, and about 75 more are in the course of immediate construction. It is felt that a minimum of 300 units will be necessary to cover the state completely. In addition to this, we have a personnel of over 1000 at present, about 600 of which are licensed and the other 400 in training.

It is intended that every control station will have 24-hour operation. This is arranged so that volunteers may serve one stretch of four hours

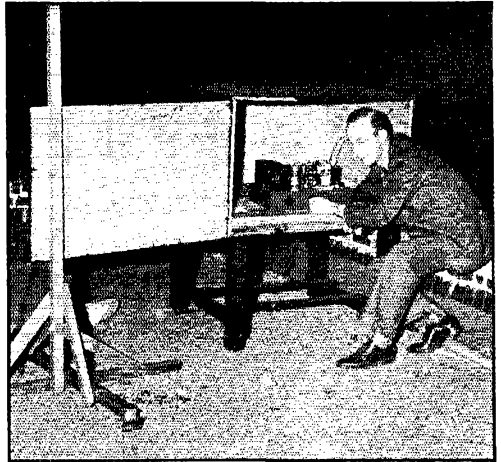

The crystal-controlled transmitter of WJGS-1, Baltimore County control station, is remotely operated from the building below. R. A. Dieffenbach, W3JAS, asst. radio aide and asst. director of WERS, at the controls.

every week. Personnel in the other fixed stations is selected from the immediately available persons in the vicinity, so that in the event of an air raid all fixed stations can immediately be manned and portable-mobile units will go on duty as soon as the operators in charge of these units can get to them. In addition, receivers on WERS frequencies are being installed* in key defense plants so that they may be alerted immediately in the event of a raid. These receivers will, of course, be operated 24 hours a day.

The typical CD-WERS station in Maryland is administered by the following personnel:

The *radio aide* is in entire control of all facilities in his licensed area, as set forth by law. He is a member of his local defense council and has complete autonomy for communications under his control. The communications officer of the local defense council may suggest and recom-

(Continued on page 78)

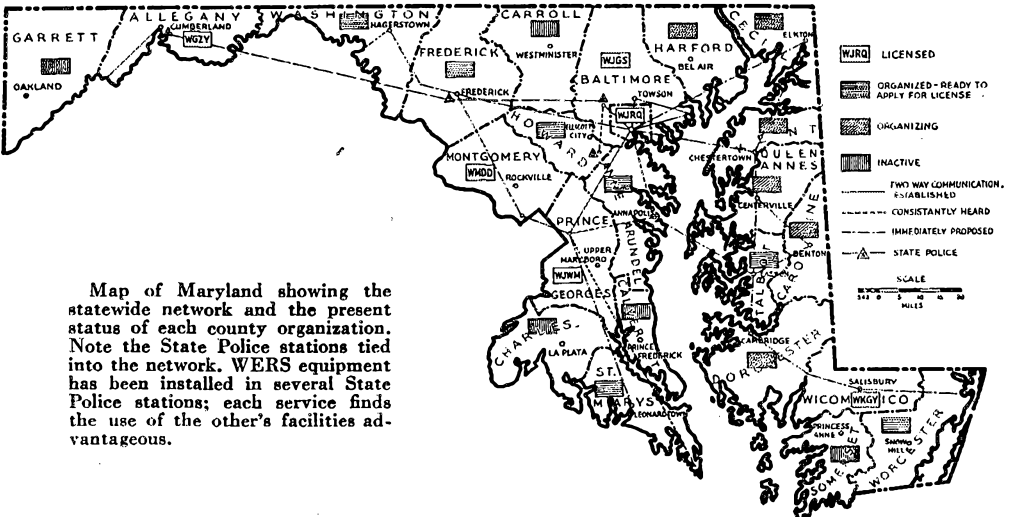

Map of Maryland showing the statewide network and the present status of each county organization. Note the State Police stations tied into the network. WERS equipment has been installed in several State Police stations; each service finds the use of the other's facilities advantageous.

"Take It Off—!"

BY "SOURDOUGH"

Sourdough continues with the theme of automatic off-frequency prevention by offering an idea for a gravity-operated circuit-breaking relay.

SORRY to disappoint you, Corporal Doakes, but this article has nothing to do with burlesque. Remember last month we whipped up a limiting gadget which would close a relay the second the transmitter frequency reached the edge of the band? Well, this thing is designed to tie onto the relay circuit and take the transmitter off the air -- bingo!

Let's look at what we want to do. When that relay goes shut we want the transmitter to stop sending before the FCC begins reaching for the pink tickets. The surest way to take the transmitter off the air is to cut the power to the final.

We want to go off automatically, but the reset should be manual. An automatic reset is too complicated to make and is an invitation to go back on at an off-frequency setting. If the ham has to take the trouble to do a manual reset he is much more likely to try and save himself the trouble and hence not clip the edges quite so closely.

If we break the final power supply we want a device that will handle the current, make good contact and snap open instantly so that an arc cannot form. We also want something simple and inexpensive that can be made with the normal ham quota of tools and skill.

Look at the drawing, Fig. 1. The vertical rod (1) can be made of bakelite, lucite or any insulating material which will not warp and which will provide good-enough d.c. insulation. The rod is the moving part and is actuated by gravity. There is a lot to be said for gravity — it doesn't change with temperature, get out of adjustment or rust.

The contactor disc (2) is a bit of 1/8-inch copper or brass. It would be a good idea to spend a few cents to have it silver-plated. Before plating, solder one of those brass collars with a set screw (available in normal times as standard radio hardware) concentric with the disc. The collar should have the right internal diameter to take the rod — one-quarter inch would be a good value.

It will be seen that the rod (1) is free to slide up and down through the box and shelf. The box can be of wood or metal, in any convenient size or shape. The shelf can be of masonite. The two holes passing the rod should be lined up carefully.

Mounted on the shelf are two stand-off insulators (3). Each insulator carries a spring contact (4) as shown. You old-timers will be able to dig up an old rheostat or stud switch from which the contact leaves can be taken. The contact leaves

should be of phosphor bronze, as we will need a good degree of tension to keep them biting hard on the contact disc. It will now be clear that if we push up hard on the bottom of the rod it will drive the disc up against the contacts, and if we push hard enough we will bend the contacts and thereby store up a counter force in the contacts. This force will be useful as it will serve to snap the disc assembly away when released. This snap will give the quick acceleration we need to break so quickly and cleanly that an arc will not have time to form.

The latch (5) should be made out of a bit of thin flat spring steel. It should be bent in the form shown and bolted to the bottom of the box in such a position that the lip just does not touch the rod.

The magnet (6) can be taken from a retired doorbell or simply wound up on a steel bolt. It is secured to the box with an angle strip or any other simple means and positioned as shown so that it will pull the latch away from the rod.

Collar (7) should be placed loosely on the rod. The rod is then pushed hard up against the contacts (4), and when these are under heavy tension the collar (7) is pushed snug down onto the latch and the set screw tightened.

Now we are all set to go. The rod is being pushed down hard by the contacts but the collar (7) is caught by the latch (5) and the assembly is locked. When juice is applied to the magnet (6)

(Continued on page 38)

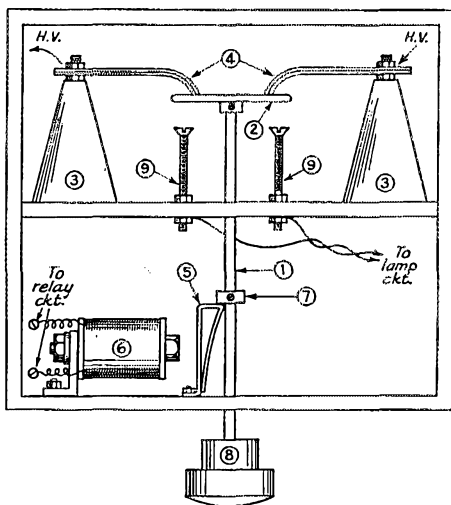

Fig. 1 — Sketch of gravity-operated relay constructed from odds and ends. Although the high-voltage supply is indicated as the circuit being interrupted, it would be readily possible to use the relay to break the primary circuit of the plate transformer instead.



IN THE SERVICES

ANOTHER addition appears this month — YLs in the Service! We have one WAAC and four WAVES, and although it's a small beginning we are very proud to list them. There must be more who have not reported. How about SPARS and Marines? Will you let us hear from you?

Does "address unknown" after your call and name leave you with an incomplete feeling? It does us. This is an SOS for better QTH, and we count on you to QSP by return mail.

Having only a few additions to the list and limited space available, we will be listing VE hams every other month. So far we have received no pictures of Canadians in the armed forces — and we'd like to have some.

See "Happenings of the Month" for your Amateur War Service Record blank. Please complete and mail it!

NAVY — SPECIAL DUTY

GENE MCCARTHY, W8TBU, RM3c and a dry-land sailor in the Navy, says they never miss chow call — even if it's ham!

- 2BNJ, Cabanillas, RM1c, Washington, D. C.
- 2DDU, Stolzenberger, RT3c, Corpus Christi
- 3JNK, Hart, RT2c, Corpus Christi, Tex.
- 3GZQ, Brearley, Lt., Washington, D. C.
- 3HZM, Wagoner, RT2c, San Francisco, Calif.
- 3HQ, Fane, RT2c, New London, Ct.
- 3RL, Peck, address unknown.
- 4BTE, Lawson, RT2c, Charleston, S. C.
- 4DAJ, Sapp, RT2c, Charleston, S. C.
- 4BVI, Carver, RT2c, Charleston, S. C.
- 4FRE, Kennedy, RT2c, Portland, Ore.
- 4FZO, Bacon, RM2c, Mayport, Fla.
- 4GFX, Wooten, RT2c, Charleston, S. C.
- 4OCU, Weidlich, Lt. (jg), Corpus Christi, Tex.
- 5ADL, Talbutt, Lt., Corpus Christi, Tex.
- 5HPU, Maxwell, RT2c, Algiers, La.
- 5INV, Harrig, RT2c, Corpus Christi, Tex.
- 5JOX, Dorset, ARM1c, Corpus Christi, Tex.
- 5KEB, Dolese, RM3c, Algiers, La.
- 5KQP, Bramlett, Lt., Algiers, La.
- 6ARL, Westerfield, RT2c, San Francisco, Cal.
- 6DIS, Zervantian, Corpus Christi, Tex.
- 6DTY, Williams, ART2c, Corpus Christi, Tex.
- 6GNP, Hallett, Corpus Christi, Tex.
- 6MCR, Ming, ARM1c, Corpus Christi, Tex.
- 6PLI, Gleue, RT2c, San Francisco, Cal.
- 6PNV, Paine, Corpus Christi, Tex.
- 6PVE, Matthews, RT2c, New London, Ct.
- 6RPR, Vierra, RT2c, New London, Ct.
- 6TRA, Lenhart, RT2c, San Diego, Cal.
- 6KHQKH, Welsh, RM1c, Algiers, La.
- 6UHE, Stewart, Ens., Corpus Christi, Tex.
- 7COE, Long, Brunswick, Me.
- 7DBS, Badger, Lt. Cmdr., Corpus Christi
- 7DKY, Shoulders, RT1c, San Francisco, Cal.
- 7FQN, Varnes, Corpus Christi, Tex.

- 7GMC, Rose, CRM, San Francisco, Cal.
- 7GOF, Davis, RT2c, New London, Ct.
- 7GPR, Fagan, Corpus Christi, Tex.
- 7HMY, Ashley, RT2c, College Station, Tex.
- 7HRO, Logan, Stillwater, Okla.
- 7HXK, Wallis, RT2c, Chicago, Ill.
- 7ILS, Brennrick, RT2c, Algiers, La.
- ex-7OZ, Nichols, ARM1c, Pasco, Wash.
- 8AHD, Borts, RM2c, Noroton Hts., Ct.
- 8AHK, Froudfit, RM2c, Algiers, La.
- 8EBR, Pioring, Ens., Ithaca, N. Y.
- 8ERC, Morcroft, Lt., Boston, Mass.
- 8GMB, Green, RT2c, Great Lakes, Ill.
- 8KG, Dinger, address unknown.
- ex-8LXC, Hassell, RT2c, Chicago, Ill.
- 8MWZ, Mace, RT1c, Algiers, La.
- 8NIV, Faulkner, Lt., Cambridge, Mass.
- ex-8PVB, Hassetl, RM1c, San Francisco, Cal.
- 8QBW, Boden, RT3c, Grove City, Pa.
- 8SPF, Riegel, Lt., Boston, Mass.
- 8TBS, Belshaw, RT2c, Chicago, Ill.
- 8TCT, Kriz, Corpus Christi, Tex.
- 8TJI, Smith, Corpus Christi, Tex.
- 8UEN, Moore, Corpus Christi, Tex.
- 8VHV, O'Connor, Corpus Christi, Tex.
- 8VLK, Justavick, RT3c, Corpus Christi, Tex.
- 8WWT, Johnson, Corpus Christi, Tex.
- 9CEY, Morin, address unknown.
- 9CKF, Flanders, RT2c, Chicago, Ill.
- 9CQN, Heubach, RT2c, Chicago, Ill.
- 9DKO, Reynolds, RM2c, Algiers, La.
- 9FBG, Lawliss, RT2c, Corpus Christi, Tex.
- 9GSQ, DeWitt, Ens., Cambridge, Mass.
- 9IEW, Caldwell, Corpus Christi, Tex.
- 9JWT, Burrows, Lt., Cambridge, Mass.
- 9LDM, Seddon, Lt. (jg), Hanover, N. H.
- 9LTP, Moran, Lt. (jg), Boston, Mass.
- 9MNV, Norris, RT2c, Corpus Christi, Tex.
- 9NLU, Alexander, SoM3c, San Francisco, Cal.
- 9OPT, Hurst, address unknown.
- 9PAR, Johnson, address unknown.
- 9PDU, Krasner, RT2c, Chicago, Ill.
- 9PLU, House, Corpus Christi, Tex.
- 9QZ, Wilson, Lt. (jg), Cambridge, Mass.
- 9RL, Beane, Lt. Cmdr., Miami, Fla.
- 9SGJ, Robbins, Corpus Christi, Tex.
- 9SJC, Lescro, RT2c, College Station, Tex.
- 9SJM, Walcop, RM2c, Algiers, La.
- 9TAF, Antrim, ARM1c, Philadelphia, Pa.
- 9TQA, Miller, Lt. (jg), Cambridge, Mass.
- 9TQA, Field, RE, Algiers, La.
- 9UKT, Prewitt, RT2c, San Francisco, Cal.
- 9UXW, Shepard, Lt., Cambridge, Mass.
- 9VPL, Moor, RT2c, Norfolk, Va.
- 9YFZ, Mundy, RT2c, Chicago, Ill.
- 9ZRL, Baumgartner, Lt. (jg), Algiers, La.
- 9ZTL, Muggli, RT2c, Chicago, Ill.
- 9ZZR, Elmquist, Corpus Christi, Tex.

Operator's license only:
 Carrick, RT2c, San Francisco, Cal.
 Erwin, RT1c, San Diego, Cal.
 Kocian, Sealco, Grove City, Pa.

WAVES

- 1NHN, Schall, Sea2c, Madison, Wis.
- 1NRU, Saltonstall, RM3c, Washington, D. C.
- 1NBA, Myer, Sea2c, Madison, Wis.
- Bradford, RM3c, Seattle, Wash. (op. license only).

ARMY — GENERAL

IN the communications section of a Coast Artillery battalion out in San Francisco, a M/Sgt. and ex-ham — Milt Carlson, W9JPR — is sponsoring a little contest to stimulate interest in radio and help a bit in winning the war. The first man to get a

Class "B" amateur license receives a prize of \$10.00, second man, \$5.00, and third man, \$5.00 — and he's putting up the money himself! How about that for recruiting?

- 1CGY, Paige, Pvt., Camp Hale, Colo.
- 1EPG, Windsor, Lt., Camp Wallace, Tex.
- 1HKY, Griffiths, T/5, foreign duty.
- 1IKI, O'Neill, Pfc., Bangor, Me.
- 1LXE, Lyons, Pvt., Camp Bowie, Tex.
- 1NTE, Merriam, Cpl., address unknown.
- 2BQH, Howland, Lt. Col., address unknown.
- 2CDJ, Magee, W/O, Ft. Monmouth, N. J.
- 2DAX, Leonard, Pvt., Ft. Ontario, N. Y.
- 2DFO, Hart, Capt., foreign duty.
- 2EGN, Brown, Capt., foreign duty.
- 2EVZ, Wolf, address unknown.
- 2GQV, Schnipper, Pfc., foreign duty.
- 2HGO, Fogarty, address unknown.
- 2HGN, Prosehl, foreign duty.
- 2HYZ, Sealander, foreign duty.
- 2IAT, Boyce, Pfc., foreign duty.
- 2KKW, Lang, S/Sgt., Camp Shelby, Miss.
- 2LZM, Sinofsky, Pfc., Hawthorne, Cal.
- 2MGG, Santangelo, Sgt., foreign duty.
- 2MIG, Berzin, T/Sgt., Camp Davis, N. C.
- 2NWW, Romer, Lt., Camp Hood, Tex.
- 3AFC, Eubank, T/Sgt., Camp Chaffee, Ark.
- 3AOR, Siegel, Lt., foreign duty.
- 3CIE, Osborne, Major, foreign duty.
- 3GYL, Simpson, Pvt., Ft. Meade, Md.
- 3HCP, Munro, Capt., Edgewood Arsenal, Md.
- 3HOM, Smith, Pvt., Camp Gruber, Okla.
- 3IDF, Chant, Sgt., foreign duty.
- 3OM, Baumgardner, T/Sgt., Ft. Monroe, Va.
- 4BED, Jopling, Cpl., address unknown.
- 4BNN, Furr, Sgt., address unknown.
- 4CAU, Royal, T/Sgt., Ft. Benning, Ga.
- 4CCR, Johnson, T/Sgt., foreign duty.
- 4CJG, Coley, Capt., foreign duty.



Fred Catel, W9DTK, one of the first amateur and commercial operators in the country (1909) and president and chairman of the board of directors of the Milwaukee Radio Amateurs Club, Inc., is now a full-fledged Commander. As communications officer at the world's largest Naval Air Station in Corpus Christi, Tex., he has supervision over all telephone, telegraph, and radio facilities. What ham wouldn't smile? *Official U. S. Navy Photograph.*



A YL WAVE! One of the first to take the oath, Norma Schall, WINHN, of Dedham, Mass., (sister of WJLI) had her boot training at Hunter College in New York. Now holder of a Sea2c rating, she is studying radio at the University of Wisconsin in Madison.

4CRG, Boles, Capt., foreign duty.
 4DQE, White, W/O, Ft. Jackson, S. C.
 4EI, Gloyer, Col., Camp Gruber, Okla.
 4FVM, Von Schaaf, Sgt., Ft. Jackson, S. C.
 4GAG, Porter, S/Sgt., Camp Stoneman, Pa.
 4GIP, Salisbury, Sgt., Ft. Belvoir, Va.
 4HWF, Hesel, Lt., address unknown.
 4IBT, Cohen, W/O, Ft. Benning, Ga.
 5BPL, Thomas, T/Sgt., foreign duty.
 5DVB, Andersen, 2nd Lt., Dallas, Tex.
 5GXC, McAfee, Lt., Ft. Sill, Okla.
 5HZL, Reid, M/Sgt., Camp Shelby, Miss.
 5JVS, Hays, S/Sgt., Walnut Ridge, Ark.
 6BJJ, de la Laing, Lt., Ft. Sill, Okla.
 6DAN, Ritter, 2nd Lt., address unknown.
 6BVQ, Perry, Cpl., Ft. George G. Meade, Md.
 6HXU, Seitz, Lt., foreign duty.
 6JYS, Weber, Pvt., Chicago, Ill.
 6JVR, Watson, Pvt., Camp Carson, Colo.
 6JZE, Francisco, Camp Hood, Tex.
 6MNQ, Kawai, Sgt., Camp Hale, Colo.
 6OSW, Blosser, POW.
 6OUT, Mahan, T/Sgt., Cambria, Cal.
 6PLA, Stokes, address unknown.
 6PWU, Craig, S/Sgt., Camp Davis, N. C.
 6SJB, Hall, address unknown.
 6STK, Sinclair, address unknown.
 6STW, Olsen, address unknown.
 6TAH, Russell, address unknown.
 6TQT, Kochenderfer, address unknown.
 6TTJ, Gagean, address unknown.
 6UPP, Conway, Lt., Pendleton, Ore.
 6USB, Fisher, Pvt., Camp Wallace, Tex.
 ex-7AIC, Andrew, Capt., foreign duty.
 7CJG, Holmes, Cpl., foreign duty.
 7COV, Gallatin, Capt., Ft. Sill, Okla.
 7DAE, Welch, Lt., Camp Sutton, N. C.
 7ELW, Petersen, Pfc., address unknown.
 7ERK, Bendetson, Col., address unknown.
 7FLS, Coleman, Pvt., foreign duty.
 7FQK, Middleton, Capt., address unknown.
 7GLF, Ustick, Cpl., foreign duty.
 7GMM, Stafford, T/Sgt., foreign duty.
 7HRP, Slabekorn, Cpl., Los Angeles, Cal.
 7HTH, Carlson, Cpl., Camp Swift, Tex.
 7IKI, Miller, Pvt., foreign duty.
 7IOX, Gray, S/Sgt., foreign duty.

K7IPN, Sulzman, Lt., foreign duty.
 7JBI, Wade, Lt., address unknown.
 7LI, Wauchope, Capt., Ft. Stevens, Ore.
 8AWX, Troutman, T/Sgt., Ft. Knox, Ky.
 8GVN, Moore, S/Sgt., foreign duty.
 8GZF, Double, Sgt., Ft. Bragg, N. C.
 ex-8LXL, Purdy, W/O (JG), Camp Stewart, Ga.
 8JHR, Zimneck, Pvt., New York, N. Y.
 8JIN, Ringland, T/Sgt., Kansas City, Mo.
 8MAN, Cassidy, Major, address unknown.
 8QFG, Dadd, Lt., Aberdeen, Md.
 8QPI, Lukacs, Sgt., foreign duty.
 8QXV, Berlesky, Lt., Ft. Harrison, Ind.
 8QZF, Nash, Pvt., Milwaukee, Wis.
 8RPT, Mirsalia, Pvt., address unknown.
 8TLQ, Conrad, Pvt., Camp Pendleton, Va.
 8TZK, Matthews, Pvt., foreign duty.
 8UBS, Harris, T/4, foreign duty.
 8VHV, Baumbain, Sgt., address unknown.
 8WJY, Watson, Pvt., Camp Gordon, Ga.
 8WRG, Popkiewicz, address unknown.
 9AEG, Devlin, T/Sgt., Ft. Cronkhite, Cal.
 9AGR, Craig, Lt., foreign duty.
 9AKO, Smith, Lt., Washington, D. C.
 9ASB, Anderson, Sgt., POW.
 9BBT, Harman, Cpl., foreign duty.
 9CKH, Fox, Pvt., address unknown.
 9CPO, Vaudrin, Pfc., Ft. Leonard Wood, Mo.
 9CZF, Abel, Cpl., Ft. Benning, Ga.
 9DJC, Behnke, Pvt., Ft. Riley, Kansas.
 9DZD, Davison, T/Sgt., Denver, Colo.
 9HWM, Hampshire, Lt., address unknown.
 9GRV, Moloney, Lt., foreign duty.
 9GYG, Wipf, Capt., foreign duty.
 9GYS, Malm, T/Sgt., foreign duty.
 9HZL, Hill, Lt., address unknown.
 9IED, Feigel, Pvt., address unknown.
 9IIN, Russell, Lt., address unknown.
 9JNA, Kinne, Sgt., foreign duty.
 ex-9JPR, Carlson, M/Sgt., San Francisco, Cal.
 9KDN, Hagen, Sgt., Camp Sibert, Ala.
 9KDV, Crane, Pvt., Westerly, R. I.
 9KNV, White, Lt., foreign duty.
 9EQI, Sexton, Pvt., Ft. Harrison, Ind.
 9LOB, Olgren, Pvt., address unknown.
 9NOP, Berquist, foreign duty.
 9NQO, Wacyky, Pvt., address unknown.
 9PFE, Galas, Sgt., Camp Gruber, Okla.
 9PIF, Fox, Lt., address unknown.
 9QCK, Zimbon, Lt., Camp Van Dorn, Miss.
 9QKG, Fulkerson, Pvt., Washington, D. C.
 9QMJ, Ricks, Cpl., Camp Atterbury, Ind.
 9RBN, Blanton, Capt., address unknown.
 9RO, Woolsey, Lt., foreign duty.
 9RQO, Moran, S/Sgt., foreign duty.
 9SJ, Reid, Capt., address unknown.
 9SRT, Anderson, Lt., address unknown.
 9TCE, Bischoff, Sgt., foreign duty.
 9UCG, Shaw, Lt., Palm Springs, Cal.
 9URX, Vaughn, address unknown.
 9UWT, Hammer, Pvt., address unknown.
 9VIZ, Deegan, S/Sgt., Martinez, Cal.
 9WCC, Kanning, Lt., Crossville, Tenn.
 9WNQ, Schlingerman, Pfc., POW.
 9WNT, Anderson, Camp White, Ore.
 9WQF, Gedney, Cpl., Ft. Benning, Ga.
 9YIK, Williams, S/Sgt., foreign duty.
 9YSO, Horak, T/5, Kansas City, Mo.
 9YUK, Finney, address unknown.
 9YZU, Sylvester, Cpl., Ft. Stevens, Ore.
 9ZEC, Sivin, Sgt., Ft. Sill, Okla.
 ex-9ZJJ, Todd, T/Sgt., Camp Hood, Tex.

Operator's license only:

Anker, Pvt., Ft. Totten, N. Y.
 Atkinson, Pfc., Ft. Ord, Cal.
 Austin, Pvt., Ft. Barrancas, Cal.
 Bale, T/Sgt., Camp Carson, Colo.
 Bryan, Cpl., Jacksonville, Fla.
 Hakens, T/3, foreign duty.
 Holster, Camp Knight, Cal.
 Immerman, T/Sgt., Camp Adair, Ore.

WAAC

Lehman, Aux., Des Moines, Iowa (op. license only).

COAST GUARD

1BBM, Bates, RT, Chelsea, Mass.
 1LZB, Barbato, RM2c, address unknown.
 1MVN, Porter, RM1c, foreign duty.
 1NVH, Comstock, Lt. Cmdr., Chicago, Ill.
 2HFU, Rutson, RM1c, Hialeah, Fla.
 2LIY, Siems, BM1c, Port Newark, N. J.

2OQB, Yoka, RM1c, Stapleton, L. I.
 3HTM, Clausen, RM2c, Manassas, N. J.
 3HVS, Scales, Lt., New Orleans, La.
 3ILL, Hearon, Atlantic City, N. J.
 3JXX, Lewis, RM3c, address unknown.
 4FWS, Lahey, RM1c, Tampa, Fla.
 4HVM, Fuller, GRM, address unknown.
 5KIU, Ray, RM1c, foreign duty.
 6AVY, Baker, RT1c, Wilmington, Cal.
 6BWC, Parr, RT2c, Wilmington, Cal.
 ex-6DCP, Terry, ARM3c, Mills Field, Cal.
 6EIV, Zirkle, RT2c, Wilmington, Cal.
 6LRN, Watkins, RM1c, Wilmington, Cal.
 6OBQ, Riddell, RM2c, foreign duty.
 6OOG, Futchik, RM1c, Wilmington, Cal.
 6QJJ, Brunk, Santa Barbara, Cal.
 7DCO, Barnes, address unknown.
 7GEJ, Barnett, Lt., Seattle, Wash.
 8KAY, Paradis, RM2c, Atlantic City, N. J.
 8RSL, Zilio, Sea2c, address unknown.
 9AAM, Ocha, Marquette, Mich.
 9INN, Fanckboner, AS, Atlantic City, N. J.
 8JVZ, Adams, GRM, address unknown.
 9OMI, Shafer, RM2c, address unknown.
 9ONP, Strohker, RM2c, address unknown.
 9VFO, Levin, RM1c, address unknown.
 9ZEN, Vasicak, RM3c, Wilmette, Ill.

Operator's license only:

Miller, RM3c, St. Louis, Mo.
 Rooney, address unknown.
 Sporre, Atlantic City, N. J.

ARMY — AIR FORCES

“ARMY radio is second only to the ham bands for DX and swell QSOs” — so says an Air Forces amateur at Miami Beach. We figure it's all okay in the Air Forces as long as you aren't on ground duty too long!

1AKF, Luckingham, Lt., Merced, Cal.
 1BDZ, Krueger, address unknown.
 1DW, Hall, Capt., foreign duty.
 1FOU, Johnson, Lt. Col., Washington, D. C.
 1HCB, Rich, Lt., foreign duty.
 ex-1RQM, Thayer, S/Sgt., Scott Field, Ill.
 1KGV, Fraters, M/Sgt., foreign duty.



A ham of the footlights and frequencies is Merwin Beam, W1M0Q, of Somerville, Mass. Active for many years in stock companies, “Billy Dale” — as he was known to you on Ten — is now working as RT2c in the Coast Guard, stationed at Portsmouth, N. H.

1KHE, Briggs, Lt., Dodge City, Kansas.
 1KNI, Robbins, Pvt., Miami Beach, Fla.
 1KOY, Lydon, Lt., Miami Beach, Fla.
 1LWB, Nelson, Pvt., Scott Field, Ill.
 1MDN, Kaski, Pvt., Wilmington, Del.
 1MEK, Young, Pvt., Gowen Field, Idaho.
 1NJE, Hammons, Capt., Arlington, Va.
 1NRK, Rodiger, A/C, New Haven, Ct.
 2BMK, Thomas, Major, Washington, D. C.
 2BZS, Dangerfield, Capt., Farmingdale, L. I.
 2IPB, Wood, Cpl., Hamilton Field, Cal.
 2JEM, Romer, Capt., Mitchel Field, N. Y.
 2JGB, Martin, Lt., Davis-Monthan Field, Ariz.

2KCY, Perry, Lt., foreign duty.
 2KFI, Hogue, Sgt., foreign duty.
 2LJJ, Grossman, Pvt., Grotton, Ct.
 2LNI, Gensler, Pvt., address unknown.
 2MDM, Altman, Pfc., Scott Field, Ill.
 2MGV, Stenger, Sioux Falls, S. D.
 2MIB, Evans, Lt., Patterson Field, Ohio.
 2MOM, Percy, A/C, New Haven, Ct.
 2MOQ, Ickowski, 2nd Lt., address unknown.
 2NCY, Rauser, Lt., Scott Field, Ill.
 2NDR, Harris, Pvt., Farmingdale, L. I.
 2NHI, Stenger, Sgt., Cochran Field, Ga.
 2NSI, Haight, Sgt., Cochran Field, Ga.
 2NXV, Bowen, A/C, San Antonio, Tex.
 2NXZ, Grainger, Sgt., Mitchel Field, N. Y.
 3FHO, Powell, Orangeburg, S. C.
 3HUG, Fullman, foreign duty.

3IEM, Cann, Pvt., Miami Beach, Fla.
 3IYM, Robb, Lt., Twenty Nine Palms, Cal.
 3JNZ, Hales, Pvt., Atlantic City, N. J.
 3JWP, Axford, Lt., Patterson Field, Ohio.
 ex-3QR, Shannon, Capt., Dalhart, Tex.
 4BWC, Williamson, Sgt., Key West, Fla.
 4DAQ, Jordan, Capt., foreign duty.
 4DSU, Buchanan, Scott Field, Ill.
 4EAM, Long, Pvt., Keesler Field, Miss.
 4ECF, Britton, Lt., foreign duty.
 4EFG, Andrews, Capt., foreign duty.
 4FCH, Stanley, Sgt., Dale Mabry Field, Fla.
 4FVI, Reid, S/Sgt., Pope Field, N. C.
 4GIS, Barker, Cpl., Boca Raton Field, Fla.
 4HHH, King, Cpl., Boca Raton Field, Fla.
 4HYF, Putnam, T/Sgt., foreign duty.
 4KU, Reid, Major, Salina, Kansas.
 5AA, Munro, M/Sgt., Scott Field, Ill.
 5DXL, McCoy, Lt., Sarasota, Fla.
 5EEX, Leediker, Lt. Col., address unknown.
 5FAG, Hill, 2nd Lt., Randolph Field, Tex.
 5GLP, Kindred, 2nd Lt., Randolph Field, Tex.
 5GQL, Beeler, Capt., Bolling Field, D. C.
 5GTL, Carlisle, S/Sgt., Minneapolis, Minn.
 5HOP, Melton, Sgt., Kelly Field, Tex.
 5HZN, Hornsby, Duncan Field, Tex.
 5IGV, Parkerson, W/O, Orangeburg, S. C.
 5IVU, Dittrich, Cpl., Foster Field, Tex.
 5JRE, Discher, Cpl., Cochran Field, Ga.
 5JWN, Harvey, W/O, Kirtland Field, N. M.
 5KMU, Wallace, Pvt., Hondo Field, Tex.
 5MA, Skelton, Cpl., Love Field, Tex.
 5VV, Allison, Lt. Col., Bolling Field, D. C.
 6ALX, Wolfe, Cpl., Deming, N. M.
 6CDE, Hanson, Sgt., Williams Field, Ariz.
 6FAY, Stone, address unknown.
 6KSC, Reiser, Sgt., Miami, Fla.
 6MBZ, Abbott, Capt., Hamilton Field, Cal.
 6MMM, Schofield, Pvt., Merced, Cal.
 6NHZ, Hahn, Pvt., Merced, Cal.
 6OWM, Stoeckel, Cpl., Mather Field, Cal.
 6OYO, Parsons, A/C, New Haven, Ct.
 6PUJ, Wong, Pvt., McClellan Field, Cal.
 6QVI, Mitchell, Capt., Hamilton Field, Cal.
 ex-6KRHO, Call, M/Sgt., Scott Field, Ill.
 6RIU, Bonner, Cpl., Silver Springs, Md.
 6RSN, Sargent, Sgt., Topeka, Kan.
 6SEH, Morrison, Pfc., Truxav Field, Wis.
 6SEY, Seely, Pvt., Chanute Field, Ill.
 6SHY, Larsen, Pvt., Atlantic City, N. J.
 6SMU, Rast, T/Sgt., Farmingdale, L. I.
 6SQP, Hanson, Lt., Lubbock, Tex.
 6SVU, Smith, Sgt., Presque Isle, Me.
 6TTK, Bourdet, Cpl., Silver Springs, Md.
 6UBB, Taylor, Cpl., Camp Crowder, Mo.
 6UMV, Morgan, Pfc., Scott Field, Ill.
 6URC, Rawlins, foreign duty.
 7CDW, Hanley, T/Sgt., Kelly Field, Tex.
 7GCT, Greer, Cpl., Ephrata, Wash.
 7HQO, Farris, Sgt., Stockton Field, Cal.
 7ILV, Honey, Pvt., Gardner Field, Cal.
 7INS, Simon, Cpl., Presque Isle, Me.
 7IPS, Jones, Sgt., Pecos, Tex.
 8ADR, Reynolds, Pvt., Truxav Field, Wis.
 8BHL, Cooper, Pvt., Gravelly Point, D. C.
 8DSB, Herrle, Pvt., McClellan Field, Cal.
 8HTZ, Pfeister, Pvt., Cochran Field, Ga.
 8KJW, Taylor, Pvt., Truxav Field, Wis.



A group of hams now using their knowledge of radio as instructors at the Air Forces Institute, Scott Field, Ill., are here seen discussing a point with Capt. Jim Lattig K6UQK (seated), veteran of Pearl Harbor and director of the school. L. to r. — Roy Robinson, Belleville, Ill.; Julius Goldspiel, an ex-W2; Paul Chamberlain, W8DDE; Aldrich Zmeskal, W9UWU, and Otis Wright, W5GIL. *Official U. S. Army Air Forces Photograph.*

8LMK, Lochner, Pfc., Scott Field, Ill.
 8NDG, Young, Pvt., Chicago, Ill.
 8OQC, Lusty, Lt., Austin, Tex.
 8PKA, Mazur, Lt., Morrison Field, Fla.
 8QGE, Sampson, Cpl., Valparaiso, Ind.
 8QOU, Lang, Sgt., foreign duty.
 8ROV, Skinner, Pfc., Scott Field, Ill.
 8SFR, Foy, Pfc., Selfridge Field, Mich.
 8SFR, Makovec, S/Sgt., Colorado Springs
 8STJ, Cook, Hammer Field, Cal.
 8SXQ, Knull, Pvt., Atlantic City, N. J.
 8TDA, Koskela, Pvt., Hammer Field, Cal.
 8UEP, Whalen, Pvt., Portland, Ore.
 8UMU, Beach, Sgt., Miami Beach, Fla.
 8UXH, Sambalino, Pvt., Atlantic City, N. J.
 8VAC, Scott, address unknown.
 8VBC, McCollum, Pfc., Gravelly Point, D. C.
 8VJY, Martini, Pvt., Kingman, Ariz.
 8VOH, Williams, T/Sgt., foreign duty.
 8VTK, Redpath, Pvt., Amarillo Field, Tex.
 8VTH, O'Rourke, foreign duty.
 8WDF, Hollowell, Pvt., Sioux Falls, S. D.
 8WVM, Clonson, Cpl., Mitchel Field, N. Y.
 8WVF, Carson, Pvt., Columbus, Ohio.
 8XKG, Nickell, Cpl., Scott Field, Ill.
 8ANA, Wollaege, Lamona Field, Tex.
 8ANS, Gonsior, Pvt., Chicago, Ill.
 8APZ, Shea, Sgt., Kelly Field, Tex.
 8BUD, Blostein, Sgt., Miami, Fla.
 8BYC, Courtney, Pvt., Clovis, N. M.
 8CGR, Laakko, Pvt., address unknown.
 8CHK, Courtney, Cpl., Chanute Field, Ill.
 8DIF, Wood, Pvt., Dale Mabry Field, Fla.
 8DII, Zander, Sgt., Drew Field, Fla.
 8EEZ, Smith, S/Sgt., foreign duty.
 8EIG, Laird, Sgt., address unknown.
 8EUV, Wennberg, Pvt., Atlantic City, N. J.
 8FEK, Vidmar, Pvt., Kelly Field, Tex.
 8FEB, Gladson, Sgt., Richmond, Va.
 8FWD, Woodward, Pvt., Dalhart, Tex.
 8HBY, Merling, Pfc., Eagle Pass, Tex.
 8HBY, DeBoth, Cpl., Silver Springs, Md.
 9KHY, Straghan, 2nd Lt., Scott Field, Ill.
 9LRV, Cossette, 2nd Lt., Randolph Field, Tex.
 9LSR, Miller, Lt., Gunter Field, Ala.
 9MGH, Trinko, address unknown.
 9MIO, Schuster, Pvt., St. Petersburg, Fla.
 9MKH, Lindgren, Pvt., Goodfellow, Tex.
 9MRK, Kubik, Pvt., Sheppard Field, Tex.
 9NG, Lyons, Cpl., Scott Field, Ill.
 9NIG, Muehling, Pvt., Scott Field, Ill.
 9NUE, Bethal, Cpl., Foster Field, Ill.
 9NWQ, Medlock, W/O (ig), Las Vegas, Nev.
 9OMD, Quick, Capt., Carlisbad, N. M.
 9PTU, Dickinson, Major, foreign duty.
 9RTU, Cawvey, T/Sgt., foreign duty.
 9SO, Gainer, foreign duty.

9TQN, Brovet, Pvt., Patterson Field, Ohio.
 9URF, McGuire, Pvt., Hondo, Tex.
 9URG, Morman, Pfc., Key Field, Miss.
 9VSK, Buchanan, Pvt., McClellan Field, Cal.
 9WVA, Johnson, Lt., Kelly Field, Tex.
 9WQA, Wonnell, A/C, San Antonio, Tex.
 9WUU, Johnson, Pvt., Atlantic City, N. J.
 9YBV, Ellis, Pvt., Patterson Field, Ohio.
 9YIV, Hamblen, T/Sgt., Scott Field, Ill.
 9YR, Holte, 2nd Lt., address unknown.
 9YUN, Green, Lt., Will Rogers Field, Okla.
 9ZUW, Duke, S/Sgt., Scott Field, Ill.
 9ZXY, Peckens, Hammer Field, Cal.

Operator's license only:
 Galassi, Pvt., Sioux Falls, S. D.
 Huber, Pvt., Perrin Field, Tex.
 Kahout, Sgt., foreign duty.
 Lacey, Pvt., Gowen Field, Idaho.
 Merkel, address unknown.
 Schluter, Pfc., Chicago, Ill.
 Shapiro, Pvt., Scott Field, Ill.
 Vogts, Pvt., Farmingdale, L. I.
 Wheaton, Sgt., George Field, Ill.

HAM HOSPITALITY

THE Victorian Division of the Wireless Institute of Australia invites amateurs of the United Nations in service to attend its general meetings, held at 191 Queen Street, Melbourne, on the first Tuesday of each month. 'Phone F 6997 (evenings only) or write to Box 2611W, GPO, Melbourne.

Many W hams have had enjoyable QSOs with members of the New South Wales Division of WIA. Their meetings are held at the YMCA Buildings, Pitt Street, Sidney, on the third Thursday of each month. 'Phone Chairman Priddle, VK2RA, at BW 6006, or Secretary Ryan, VK2TI, at FX 3305.

An Economical Transmitter-Receiver for WERS

An Easily-Built Station Unit of Sturdy Design

BY PAUL F. MAGEE,* W3AED

This transmitter-receiver is as simple to operate as a transceiver, almost as inexpensive to build and uses parts which, if not plentiful, are at least among the easier ones to get. The cabinet can be readily locked to meet the FCC requirement that the apparatus be inaccessible to unauthorized persons.

DURING the recent fall and winter the writer spent a good deal of time experimenting with various circuits suitable for WERS communication, the object being to arrive at an arrangement which would be simple, practical, sturdy and easily constructed. In view of the present difficulty in obtaining materials, a description of the equipment which resulted will, it is hoped, be of interest to WERS groups.

To obtain flexibility in operation as well as transmitter stability, it was decided that separate transmitter and receiver circuits should be used, but that on the other hand the transceiver idea of using the same audio system for both should be incorporated so that the number of parts could be kept to a minimum. The complete circuit diagram is shown in Fig. 1. The superregenerative detector is conventional, using a 6J5GT oscillator tube with the circuit tuned by a 15- μ fd. variable

condenser. If such a condenser is not available an ordinary 3-30- μ fd. trimmer could be substituted to provide padding capacity for band-setting while the actual tuning could be done by means of a copper disc or plate arranged to be swung with respect to the coil axis, as suggested previously in *QST*.¹

The transmitter oscillator circuit is the familiar ultratradion, the tank circuit consisting of 2 turns of quarter-inch copper tubing with the ends flattened and drilled for mounting on stand-off insulators or strips of low-loss insulating material. The tank condenser is a 3-30- μ fd. trimmer with an additional piece of mica inserted between the plates to provide extra insulation against voltage break-down. The transmitter is set on frequency by means of a screwdriver, no tuning controls being brought out to the front panel.

The audio-frequency section consists of a 6J5GT pre-amplifier and a 6V6GT, the latter being used as the modulator for transmitting and as the speaker output tube in receiving. Plate current is fed to the tube through the center tap of the output transformer, one side of the primary connecting to the tube and the other to the oscillator. This provides a 1-to-1 ratio with approximately the same current flowing in each side of primary, to avoid core saturation.

Changing from transmitting to receiving presented a problem, especially if the customary 4-

¹ Goodman, "Receivers for 112-Mc. Emergency Work," *QST*, January, 1942.

*315 N. Main St., Berlin, Md.

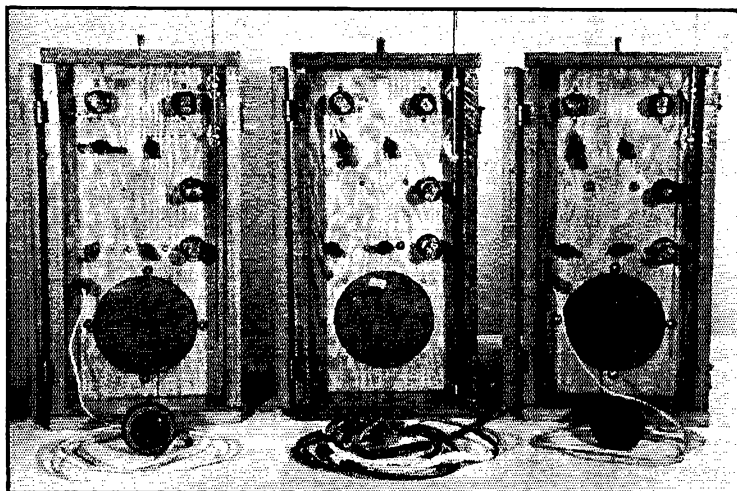

Three transmitter-receiver units built to the same design. Providing the advantages of separate transmitters and receivers with the economy of the transceiver, these sets are sturdy in construction and easily assembled. The receiver tuning control is just below the detector tube at the upper left. The smaller knob at its right is the send-receive switch. The regeneration control and audio volume control are in line horizontally above the speaker.

pole 2-position switch was to be used, since one set of contacts had to be allotted to the antenna circuit and another to transferring the plate voltage from the oscillator to the detector. This problem was solved by connecting the plate-voltage switch arm in the "hot" lead of the audio output circuit, as shown in Fig. 1, and providing a filter to eliminate the audio component from the voltage applied to the detector. This filter is comprised by resistors R_4 and R_5 and condensers C_8 and C_9 . The circuit has given no feedback troubles. The remaining two sections of the switch are used to open the speaker circuit on transmitting and to disconnect the microphone circuit in reception.

Microphone voltage is obtained from the drop across the 200-ohm section of the 6V6GT cathode resistance.² If the power-supply voltage is much lower than that indicated on the diagram, it might be advisable to interchange the 200- and 250-ohm resistors.

Since a combination microphone and coupling transformer of the type used in transceivers is now practically unobtainable, the detector is coupled to the audio amplifier by the system shown in the diagram. R_3 is the plate resistor, coupled through C_6 to the 100,000-ohm volume control connected across the secondary of the microphone transformer. Moving the volume control arm changes the audio output. In addition, the proportion of the developed audio voltage that is fed to the grid of the audio tube also is varied because of the voltage-divider action of the volume-control resistor in conjunction with the secondary of T_1 . It might be advantageous to connect a by-pass condenser (0.001 μ d. or less) from the volume-control arm to ground to help eliminate the quench frequency

²"Boosting Transceiver Performance," Hints and Kinks, QST, December, 1942.

from the grid circuit of the audio tube, although in the units actually built so far no trouble has been experienced from this source.

Construction

The method of construction is illustrated by the photographs. The case is of wood, 20 $\frac{1}{4}$ inches high, 10 inches wide and 11 $\frac{1}{2}$ inches deep, these being outside dimensions. The panel is of plywood, backed by an 11 \times 8 $\frac{1}{2}$ -inch metal plate where the components are mounted. The speaker is larger than is necessary for the purpose, but since it was on hand it was used in preference to securing a new one. The cone is protected by a piece of wire screening. Tubes plug in through the panel, for ventilation and accessibility; the panel is recessed in the box sufficiently so that the front door can be closed and secured when the set is not in use. This door, incidentally, is hinged so that it can be swung completely back against the side of the cabinet and is thus well out of the way when operation is going on.

The vibrator power supply mounts on the bottom behind the speaker, as shown in the rear view. This view also shows how the components are arranged on the panel. The oscillator tube socket is in the upper left corner and the detector socket is at the upper right. The receiver tuning condenser is just below the detector socket, with the send-receive switch to its left at the center. The output transformer is below the switch, and the modulator tube is to the left of this transformer. The audio amplifier is in the lower left corner, with the volume control centered to its right, concealed by the microphone transformer mounted over it. The detector regeneration control is in the lower right-hand corner of the panel, with the microphone jack just below it.

The front view shows the tubes and control knobs. The rod antenna mounts on the two stand-

Fig. 1 — Circuit diagram of the easily-constructed and economical WERS transmitter-receiver.

- C_1 — 15- μ d. variable
- C_2 — 3-30- μ d. trimmer (see text).
- C_3, C_4 — 50- μ d. mica
- C_5, C_7 — 0.0025- μ d. mica
- C_6, C_8 — 0.05- μ d. paper
- C_9 — 0.5- μ d. paper
- C_{10} — 0.01- μ d. paper
- C_{11} — 20- μ d. electrolytic, 50 volts
- C_{12} — 8- μ d. electrolytic, 450 volts
- R_1 — 10 megohms, $\frac{1}{2}$ watt
- R_2 — 10,000 ohms, 1 watt
- R_3 — 50,000 ohms, 1 watt
- R_4, R_5 — 25,000 ohms, 1 watt
- R_6 — 50,000-ohm volume control
- R_7 — 0.1-megohm volume control
- R_8 — 1000 ohms, $\frac{1}{2}$ watt
- R_9 — 0.1 megohm, 1 watt
- R_{10} — 0.5 megohm, $\frac{1}{2}$ watt
- R_{11} — 250 ohms, 1 watt
- R_{12} — 200 ohms, 1 watt
- L_1 — 3 turns No. 10, diameter $\frac{1}{2}$ inch i.d.; coupling coil 2 turns
- L_2 — 2 turns $\frac{1}{4}$ -inch copper tubing, diameter $\frac{1}{4}$ inch i.d.; coupling coil 2 turns same as L_1
- T_1 — Single-button mic. transformer
- T_2 — Universal output transformer
- S — 4-pole double-throw switch
- RFC — App. 70 turns No. 28 enameled, or Ohmite Z-1

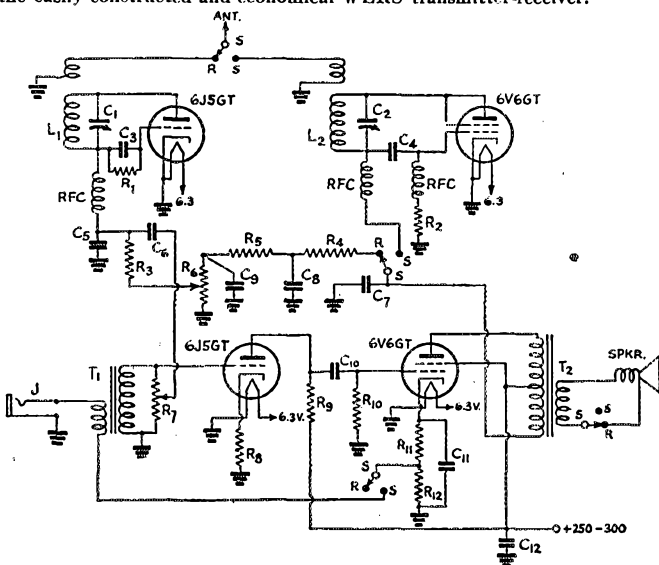

off insulators in the upper right corner and projects through a hole in the top of the case. The lugs holding the antenna rod were obtained from an electrical contractor and are of the type usually used in making electric stove connections. When the screws are loosened the antenna can be slid down into the box.

The microphone is mounted inside a 1½-inch section of 1¾-inch diameter automobile water hose with a 2-inch diameter section slipped over it. The shock-absorbing properties of the rubber mounting prevent damage to the microphone in case it is accidentally dropped.

No provision has been made for switching the battery circuit, the clip connections on the battery being used instead. The filament lead is a length of rubber-covered shielded wire with the shield connected to the chassis (metal panel) and the inside wire to the filaments. The vibrator-supply connections to the battery are formed by a separate pair of No. 14 wires, with no connection between these leads and the filament leads except at the battery clips. The vibrator-supply chassis is not connected to the transmitter-receiver chassis except through the battery leads; the only direct connection between the supply and the set is the "B" lead. With this method there is no trace of vibrator hash either when receiving or on the transmitted carrier. In fact, it is possible to interchange vibrator power-supply units whether or not they have built-in "A" filters.

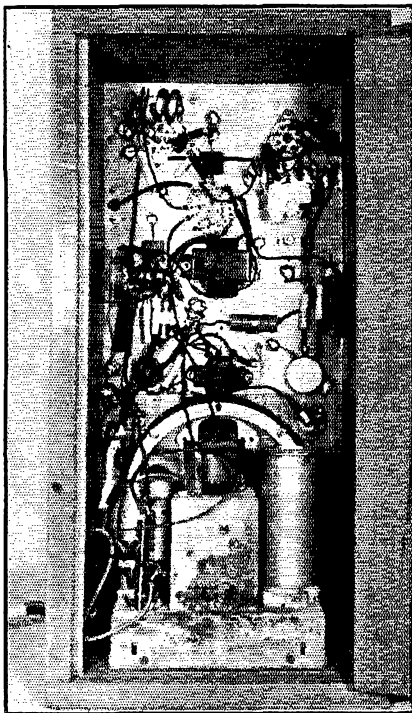

The vibrator power supply occupies the space behind the speaker, as shown in this rear view. The r.f. circuits are arranged for short leads; other parts are placed for accessibility and ease of wiring.

The layout of these outfits is such that patterns easily can be made and the sets can be readily assembled by persons not familiar with radio. The one place where some familiarity with apparatus construction is desirable is in the wiring, but there is relatively little wiring to be done. An experienced ham can handle that part of it with no trouble.

U. S. A. Calling!

(Continued from page 19)

radiotelephone operator license, or other qualifying radio experience, and who are not now employed in the broadcast industry, are requested to register with the National Association of Broadcasters. Broadcasting has been designated by the War Manpower Commission as an industry essential to the war effort. Amateurs, retired technicians and others who are at present outside the professional fraternity for one reason or another, are asked to hit the victory trail by registering their name, age, experience, preferred location for job, time available, salary desired and other pertinent data with Howard S. Frazier, director of engineering, NAB, 1760 N St., N. W., Washington, D. C. The NAB has already registered experienced personnel available from 37 states and the District of Columbia as a result of the appeal in March *QST*, but even more are needed to fill the constantly-widening gaps. This is a good chance right now for hams to get on the stove and start cooking with r.f.

The ARRL Personnel Bureau continues to receive a heavy load of calls for radio personnel from defense industries and other civilian activities, both government and private. Many opportunities are here for the experienced amateur to contribute more usefully to the war effort, to increase his knowledge and his earning power. The League brings together the prospective employer and employee by means of data which the amateur registers with ARRL. If you have last October's *QST* handy, see the form on page 38 as a guide, or write Headquarters for a blank.

Missing in Action

ARNOLD LEON TANGEN, USMM, W9YNX, of Grand Forks, N. D., and Pvt. Harry T. Simms, W7HBD, of Butte, Mont., are reported missing in action.

CIRCULATION STATEMENT

PUBLISHER'S STATEMENT OF CIRCULATION AS GIVEN TO STANDARD RATE AND DATA SERVICE

This is to certify that the average circulation per issue of *QST* for the six months' period July 1st to and including December 31, 1942, was as follows:

Copies sold	45,547
Copies distributed free	544
Total	46,091

K. B. Warner, Business Manager,
D. H. Houghton, Circulation Manager
Subscribed to and sworn before me
on this 17th day of March, 1943
Alice V. Scanlan, Notary Public

HAPPENINGS OF THE MONTH



KILOWATT XMTRS & V-O-M'S WANTED

ONE of the government war agencies, which shall be nameless, has appealed to us to locate certain radio apparatus which they need at once for work in foreign parts. The ARRL Apparatus Bureau has been unable to fill these requirements from the existing registrations. If any of you fellows have any of the required gear, here is your opportunity not only to send it to war duty but to exchange it for cash money with which to buy War Bonds with which to acquire a better post-war station with which to regale your heart, etc.

The main requirement is some 1-kw. factory-built 'phone transmitters. Homemade jobs, however good, not considered; must be factory-built, of some standard commercial model. Must be capable of a full kilowatt input. Please register with ARRL, stating make and model number; describe condition accurately; detail any alterations that have been made; give frequency ranges for which coils exist; name your price securely crated and delivered to local transportation agency.

Also needed are a considerable number of volt-ohm-milliammeters. Any meter of reputable make is acceptable if it reads 0-1000 volts a.c. or d.c., ohms up to 1 megohm or so, and has a current range of about 0-500 ma. If the make is Triplett, Weston, Jackson, Hickok, Precision or Radio City Products, give the model number. If of any other make, name it and state the ranges in volt, ohms and ma. Please state your price, packed for shipment.

These registrations may be made by letter or post card addressed to the Apparatus Bureau,

American Radio Relay League, 38 LaSalle Road, West Hartford, Conn.

THE AMATEUR'S WAR RECORD

FOR the future of amateur radio, it is highly desirable that ARRL headquarters have statistics on what the amateur is doing in this war. For that purpose, and for no other purpose than supplying data for our department devoted to those "In The Services," we are endeavoring to compile a record of all participating hams. As the League's field covers both Canada and the United States, we're as much interested in VEs as we are in Ws and Ks. While we particularly desire the dope on amateurs in the armed forces and the merchant marine, we equally want the information on those in war-radio work in the Civil Service. We are also expanding our records to take in amateurs who are applying their skill in the radio and electronic manufacturing industry, but only providing their personal labors are 100 per cent devoted to war work. And by amateurs we mean the new ones with operator license only, as well as old-timers with station calls.

We print on this page a form which may be either cut out or reproduced. It lists the essential data we need — we don't want any that may be restricted. However, that much, with some indication of who you are and what you're doing, is highly necessary to preserve our future interests. Won't you do your part by reporting in to ARRL headquarters?

RENEW YOUR LICENSE:

LEAGUE headquarters most earnestly urges you to maintain your amateur status by keeping your operator license in force. You will

AMATEUR WAR SERVICE RECORD

Name

Present mailing address

Rank or rating

Branch or bureau: Signal Corps, AAF, Buships, WAVES, etc.
If civilian industry, give title and company.

Call, present or ex; or grade of op-license only

SERVICE

- Army
- Navy
- Coast Guard
- Marine Corps
- Maritime Service
- Merchant Marine
- Civil Service
- Radio industry, 100% war

save yourself much fuss and feathers later if you do so, and meanwhile there are many ways in which it may prove valuable to have this attestation of radio proficiency. Remember your date and file renewal application sixty days before expiration. You get the blanks from any FCC Radio Inspector-in-Charge, you attach your old license, and you mail the works to FCC at Washington. If you change address, you should simply file application for modification. If you have a station license, apply in that respect the same as for the operator license. All you'll get from FCC will be a new operator license with the station side left blank, but the fact that you have the station application on file will preserve your status and stand you in awfully good stead later.

BIG EIMACS WANTED

THE Aluminum Company of Canada, Ltd., is badly in need of some Eimac 250TL (or equivalent) tubes for the maintenance of an important transmitter at one of its remote plants where the only communication is by radio. There is involved not only the wartime production of aluminum but the maintenance of a weather-reporting service for the Canadian Government and an observation post, so it is worthy of our help. Amateurs willing to sell their 250TLs are requested to address Mr. J. Hillwood, General Purchasing Department, Aluminum Company of Canada, Ltd., 1700 Sun Life Building, Montreal, Quebec, stating age of tubes and price desired, and describing condition.

COPPER SCRAP SHORTAGE ACUTE

THE country is said to be seriously short of copper. The output of mined ores cannot meet demands because of manpower shortages, and scrap is depended upon as a source for approximately 40 per cent of the copper. Scrap refineries are reported to be operating at only a fifth of capacity. Another appeal is made to radio amateurs to dig out and turn in their copper, brass and bronze scrap. The stuff we fellows are likely to have around, particularly copper wire, is almost pure and can be used in place of virgin copper. It is particularly prized. Considering that a transmitting antenna is considerably more of a hazard these days than an asset, we again recommend that those made of pure copper wire be taken down and turned in—along with the copper-bearing stuff from the junk box. Where? If it's a small amount, we suggest donating it to a local charity which collects waste material; if you have a goodly poundage, sell it to a scrap dealer. Either way starts it back to the refineries.

ARE YOU LICENSED?

When joining the League or renewing your membership, it is important that you show whether you have an amateur license, either station or operator. Please state your call and/or the class of operator license held, that we may verify your classification.

Splatter

(Continued from page 8)

feed-back. His work in the CBS sound effects and engineering maintenance departments (he is now on studio control for the CBS international short-wave stations) coupled opportunity with incentive. For encouragement add a wife who is very lenient when it comes to radio gear around the house and a small daughter with prospects of a good mike voice, and the formula for success is complete—said success being Phil's first published article (p. 13). . . . **Thomas F. McNulty** (p. 25) reports as follows: "I cannot remember when radio was not a hobby. As early as age seven I was presented with a Gilbert Electrical Set and sometime during 1917 or 1918 received a Gilbert Wireless Set. Early in 1919 the Gilbert Co. sent me a galena crystal and, with 50 feet of aluminum wire, an old telephone receiver and a Murdock fixed condenser, I was rewarded immediately by hearing NAA. Before I was thirteen, I had received my first amateur license (3VS) and became a member of ARRL. After two years as reporter on Baltimore papers, I entered the insurance business in 1924 and I became inactive in radio until 1930, when I was again licensed as W3NB. . . ." . . . About all our sleuths have been able to dig up on **Paul F. Magee, W3AED**, is that he spent practically all this past fall and winter in the basement of his Maryland home figuring out the simplest and most economical circuit for his standardized-construction WERS transmitter-receiver (p. 32). Since then he has gone into production—total output to date, five units. . . . We hasten to explain that **Heber H. Clewett, W6QE**, doesn't have trouble getting to sleep nights, isn't subject to bad dreams, etc. His *Dessie Belle* (p. 39) is not an idle brainstorm but a calculated piece of instruction material originally created for his Pomona Junior College radio class. . . . **Lt. Thomas E. Campbell, W4GKU**, entered the Air Corps in July, 1942, after assorted experience including teaching, serving as Assistant State Director of Education for Georgia and doing radio production and advertising work in Detroit. Previous to his assignment to the Maxwell Field Pre-Flight School (p. 40), where he is chief code instructor, he was a civilian instructor teaching physics in AAFP-FS. On the air first in 1916, after the World War I shut-down he did not return until 1931. His current call, W4GKU, was assigned while he was instructing at Thorsby Institute in Alabama.

FEEDBACK

IT was probably inevitable, at that. It just wouldn't be possible to describe a speech unscrambler without scrambling the circuit diagram.

Anyway, in the de-inverter circuit on p. 18 of the March issue, the 6K6 plate condenser, C_6 , should not be grounded but should cross over to R_4 and R_6 with no connection to the T_2 ground lead. And the screen voltage on the 6L7s should, of course, be +125 volts instead of -125.

Watts—Or Decibels?

It's the Signal at the Receiver that Counts

BY McMURDO SILVER*

It's what the transmitter accomplishes at a distant receiver that counts, not the kilowatt-hours it adds on the monthly power bill. Here's a speculative plea for using reason instead of emotion in planning post-war transmitters.

THE question propounded above is one which seems worthy of serious consideration in advance of the return to active operation by all amateurs. It has to do with the spending of money to build amateur transmitters to put out all the power that can be afforded, without anything but mostly hopeful thought about how much more *useful* the signal received therefrom at a distant point will be. For a long time it has seemed to the writer that the problem of transmitter power should be thought of in terms of how much money must be spent to provide a *useful* increase in signal strength at the receiving end of the chain. His time during the past three years having been entirely devoted to the design and production of military equipment, the experience so gained now causes him publicly to put this question.

For the average amateur, the question of how much power his transmitter is going to have, either at any given moment or in the event of a financial windfall, seems to be most frequently answered by how much he can afford to put into its cost. As a consequence, "bigger and bigger" seems to have been established in many amateur minds as the exact equal of "better and more efficient," on the assumption that even an extra watt of r.f. squeezed out of long-suffering "bottles" means a worth-while gain in effective signal strength at a distant receiver. That this long-beloved thought is not wholly true is evidenced by the mass of material which has appeared in print on the subject of better antenna systems.

It is well recognized that a low-powered transmitter with a good antenna can equal a powerful transmitter working into a poor radiating system — but the conclusion still seems to be that, if this is true, then more power into the better antenna will result in more DX. So the merry-go-round whirled gaily about in the pre-war past, while we one and all now dream of the happy day when we may blast the ether wide open with a "California" — or will it be "corn-fed"? — kilowatt. The same old tendency probably will be prevalent, to spend money where it most easily can be seen — on the bigger "power-house," in preference to the radiator.

At all times the fundamental aim of most ama-

*140 East 28th St., New York City.

teurs seems to have been to put out a good, clean, readable signal that would reach half-way 'round the globe. Even on the very-high frequencies the object was the same, although the chances of attaining it in any marked degree were relatively slight. And happy indeed was the operator who could marshal the required shekels to put the legal limit of power into his final stage. By comparison, the chap whose "all" is but a measly hundred watts seemed destined to take a decidedly back seat. Yet such was not *proved* to be the case, either in nightly operation or in the DX contests. And who has forgotten the legend of the W who worked, or at least was heard, 'way down in Australia with only dry batteries powering a midget '99 tube — literally no "watts" output — or input, either? Admittedly this was in the nature of a freak, but it gives pause for profitable thought, nevertheless.

The power put out by a transmitter must produce power at the receiver to operate either headphones or loudspeaker. So let's think acoustically for a moment or so. Experience has taught that an increase of 1 db. in electric power fed to a reproducer makes substantially no change in what the listener hears — nor does a 2 db. increase become really noticeable. At a 3 db. increase in power the ear *begins*, in the case of most of us, to be able to notice a slight increase in volume. The same situation applies, substantially, to the process involved in turning the Edison Company's power into a readable signal miles away via the link of amateur radio.

Looking up a decibel chart (or hunting up a "log" table, to do it the hard way) we find that to get the 3 db. increase which just convinces the receiving operator that we really have "upped" power means that we must double transmitter power output. Whatever your transmitter power may have been or may be in the future, doubling it is a costly process when the best you are justified in hoping for will be an improvement of less than one S unit at the end of the circuit.

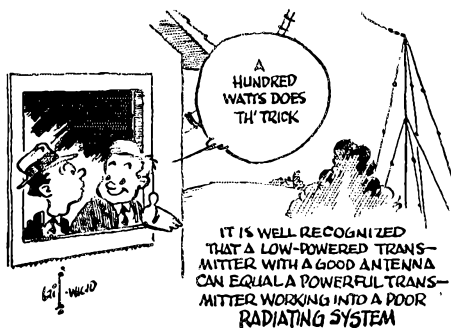

Considering the readings upon the distant receiver's S meter, 3 db. doesn't mean very much, if anything, in terms of a signal more likely to get through QRM or QRN. Yet lives there the amateur whose chest has not nearly burst with pride as he contemplated the result of rebuilding his transmitter to double its former power? And if the unpleasant truth were told, how many have been disappointed that the costly doubling of power didn't seem to waken noticeable enthusiasm for the new "rock-crusher" among distant listeners — that, in the light of absolute truth, the DX worked didn't seem to take the expected jump to astronomical distances?

If by enlarging the transmitter one could get a 10-db. increase, that would definitely be worth shooting for in terms of signal-strength improvement at the receiving end — the *only* place it counts. But a 10-db. increase is a power increase of just 10 times — a rather sizable dollar jump for most operators. It is believed that if this age-old desire to boost transmitter power were looked at only in terms of decibels of increase in the strength of the signal to which the receiving operator listens — a rational measure of what hard-earned dollars are spent to buy — increasing power by double what it was at first would not appear at all enticing. True, bigger tubes, bigger transformers and filter reactors and the louder "bang" of bigger filter capacitors blowing are most impressive — but they don't impress a single thing upon the receiving operator unless the power increase is big enough to mean an honest, *real* signal-strength increase to his ears.

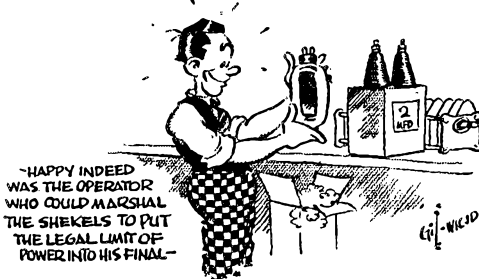

To the writer, any desire to increase transmitter power by less than three times at a single jump — about 5 db. effective increase — seems like a terrible waste of good money. To jump 25 watts to 50 watts seems all but meaningless, as it does to jump 500 watts to one kilowatt. But to jump 10 watts to 100 watts (10 db. increase) means a real, noticeable gain in signal strength at the *only* point where it counts — at the receiver listening to your signal. Better, indeed, to put fewer dollars into improving the radiating system, where little cost but some ingenuity and study can pick up several decibels gain so cheaply as to be almost as free as air.

The "rule-of-thumb" when contemplating increasing transmitter power could seem to be put fairly well as "three times power increase or nothing." It might better be stated "ten times increase or nothing."

Then the question arises, of course, as to what is a good, optimum power to start with, grow up to, or settle down in comfort with? While many opinions already exist, here goes for another — "without prejudice," as the British would say. Coupled with a few dollars spent on a good radiating system, 100 watts r.f. output into such a system appears to make good sense, even in that happy future when foreign DX may again be possible. If 100 watts were set as a desirable limit and time and effort were spent upon improving antenna systems — and operating technique — what a happy world this would be! No longer would the nearby "rock-crushers" lift the roof off while failing to accomplish their owners' aim of doing the same in Africa; no longer would intra-family relations be severely strained by the cost of amateur radio; and even QRM would diminish pleasurable indeed. All of which makes the so-recently-announced-as-mostly-to-be-only-in-military-service-as-yet HY67 beam-power tube, rated at 100 watts r.f. output Class-C telephony and presumably the result of commercial airline demand for a bigger, tougher 807, look very attractive indeed. For, like all beam power tubes, it's a "pipe" to drive.

No, this isn't a paid "sales puff" for its makers — just a compliment for filling in the open gap in the previous tube picture with the really sensible "bottle" needed to make possible a two- or three-tube, all-band, 100-watt transmitter at reasonable cost — so reasonable that, even after applying the rule-of-thumb suggested above and refusing to think in terms of one watt less than a 3 times power increase for the next power-upping step, the wise amateur may stick to that desirable optimum of so easily and sweetly obtained transmitter power — 100 watts into the antenna.

“Take It Off — !”

(Continued from page 28)

the latch is pulled back and the whole rod assembly drops away, open-circuiting the contacts.

Suppose we put a knob (8) at the bottom of the rod. When the time comes to reset we push up on this knob. The collar will slide up the sloping face of the latch below the lip. When it passes the end the latch will snap shut and we are on the air.

As a bit of trimming we can put two long machine screws (9) through the panel under the disc. When the rod assembly drops, the screws (9) will act as stops and will also complete a circuit through the disc (2), perhaps lighting a warning lamp to show that the circuit is broken.

P.O.W.

It is reported that Glenn Blosser, W6OSW, of Willits, Calif., and Robert Lally, ex-W8AAO, of Canton, Ohio and Wheeling, W. Va., are being held as prisoners of war. W6OSW was captured in Tunisia by the Germans, while W8AAO was taken by the Japanese.

Dessie Belle and Johnny

BY HEBER H. CLEWETT,* W6QE

Although *db* was expecting him that evening, Johnny Short-wave had a date with Lucy Static. He did not have the *P* to $\sim\sim\sim$ charms. Lucy had asked him to $\text{---}(\text{M})\text{---}$ near the $\text{---}(\text{G})\text{---}$ sign at the corner, but luck was against him and he missed $\text{---}|\text{---}$ with the streetcar. He went to a 'phone booth and tried to *W6XYZ* her, but although he could hear $\text{---}(\text{O})\text{---}$ ringing, no one answered. Poor Johnny was about to $\text{---}\sim\sim\sim\text{---}$ with despair, and decided to walk out to Lucy's Ω , but again he was disappointed, for he found that Lucy had left to visit her ∇ . He $\text{---}|\text{---}$ his teeth and began to whistle off- $\text{---}|\text{---}$ as he walked back to town. His thoughts were of Lucy. With eyes clear as $\text{---}|\text{---}$, her smile seemed to $\text{---}\sim\sim\sim\text{---}$ into an angel, but of late something seemed to $\text{---}(\text{A})\text{---}$ affection for him. She had accused him of stepping out with *db*, and even though her *C* for forgiveness was great, now

she had probably seen fit to $\text{---}(\text{E})\text{---}$ his tardiness with the wiles of her rival, although there was really $\text{---}|\text{---}$.

Johnny paused to watch a window- $\text{---}|\text{---}$ in a department store who was busy displaying new clothes the store had to $\text{---}|\text{---}$. Passing a cafeteria, Johnny was $\text{---}|\text{---}$ he couldn't re- $\text{---}\sim\sim\sim\text{---}$ a $\text{---}(\text{F})\text{---}$ of food, and since he had a little $\text{---}\sim\sim\sim\text{---}$ in his pocket, he decided to $\text{---}|\text{---}$ his plans, and he stepped in. The sight that met his eye made him re- $\text{---}\sim\sim\sim\text{---}$ stunned to the $\text{---}\sim\sim\sim\text{---}$ by the *Z* of a band of hoodlums who were committing a-*Na Cl* and $\text{---}|\text{---}|\text{---}|\text{---}|\text{---}|\text{---}$ upon the proprietor. The victim was, however, a $\text{---}|\text{---}$ and between his shouting and the general din and commotion, Johnny had to $\text{---}|\text{---}$ his ears. Using the store's furniture as a $\text{---}\sim\sim\sim\text{---}$, he made a wide- $\text{---}|\text{---}$ to $\text{---}|\text{---}$ the ruffians, ran out a side door, and darted through a $\text{---}\sim\sim\sim\text{---}$ of side streets to the police station.

*704 E. Jefferson Ave., Pomona, Calif.

Hams Teach AAF Pilots at Maxwell Field

Student Fliers Learn Morse Code at Pre-Flight School

BY LT. THOMAS E. CAMPBELL, * W4GKU

In connection with the accompanying article, Lt. Campbell writes, "Since reading the story by Clint DeSoto in *QST* for January, 1943, on his visit to the Army Air Forces, some of us here at the Army Air Forces Pre-Flight School (Pilot), Maxwell Field, Alabama, thought we'd like to express our belief that the cultivation of our hobby — amateur radio — will help defeat the Axis. This article is intended as a testimonial to the fact that the radio amateurs of America are doing their part. Although many are not fit for actual combat duty, they are fit for duty as instructors. They 'keep 'em flying' while others fly 'em!'"

HERE at Maxwell Field, one of the greatest pre-flight schools in the world, we are proud to boast that the future pilots of the Army Air Forces receive the best training that can be had anywhere. This is made possible in part by radio amateurs who are serving their country by helping to train our student pilots in the art of radio communication.

It is well-known that the foremost single method of communication in the Air Forces is radio. Without radio the talents of the pilots of our Army, Navy and Marine Air Forces would be of little value.

*U. S. Army Air Corps, Maxwell Field, Ala.

A group of instructors at Maxwell Field. Rear row, left to right — Pvt. W. M. Speed, W4NP; Pvt. T. G. Hancock; Pfc. R. Plak, ex-W8SPL; M/Sgt. J. W. Marley, W4EW; and Pvt. W. E. Lincoln. Front row, left to right — Pvt. H. C. Rhode, ex-W1AKP, ex-W1HH; Cpl. G. Prestigiacomo; Pvt. A. A. Romane, W1JOS; Pvt. P. Washburn, W1BN; and Pvt. R. G. Kenworthy, ex-W9FUU. *Official U. S. AAF (Southeast Training Center) Photos.*



But, you may ask, why should a pilot have to know code? Isn't that the job of the radio operator? The answer is simple. The Air Forces strive for teamwork, and flying is a team business. Every member of the crew must be a jack-of-all-trades, able to do any job on the plane should the man to whom that particular job is entrusted be put out of action.

Code Training for Pilots

In the pre-flight school great emphasis is placed on learning the code. The future pilots jam 147 hours of classroom work into 49 week days, and 50 hours of this work is on code alone.

Members of the cadet lower class must attain a code proficiency of 6 words per minute by the end of their 4½-week period as lower classmen. When the cadet becomes an upper classman he must step up his code to a minimum of 8 words per minute aural and 6 visual. After he attains 8 words he is not allowed to rest on his laurels but is put into a group striving for 10 words per minute. A majority of the cadets are able to take 10 words when they leave for primary flight training.

Code is taught entirely by sound from the first day until the last, and writing it out is avoided at all costs. All rooms are equipped with headsets and keys or loudspeakers. Tape machines, automatic keys, bugs and handsets are also used.

Most salient feature of the code school is the aptitude test which is taken by all incoming

cadets. The cadet is given a sheet of paper which lists numbers from 1 to 78 with a "yes" or "no" answer choice, all based on 78 groups of sounds. If they sound alike, the answer is "yes"; otherwise, "no." The test starts rather simply, with something like a pair of *didahs* for "a"—the answer, of course, being "yes"—and gets progressively harder. Not even men who really know code can make a perfect grade on the test. For instance, paired groups of three numbers each might be run together without a break and, unless one is able to retain sounds, it is difficult to get. So exacting is the aptitude test that it is practically possible to predict the date when a cadet will reach the required proficiency. The test also makes it possible to single out men requiring individual help.

Instruction for Instructors

The success of code training depends of course upon the instructors, and in order that the program may function efficiently they must be thoroughly familiar with their subject and with the methods of teaching it. To help them become better qualified for their positions here, and at the same time raise the standards of the code school, a night school for instructors has been organized. Classes are held three nights each week. Instruction is given in the organization of the department, class discipline and procedure, and sending and receiving code. One of the more important topics is class procedure, it being our aim to have every instructor use the same methods of teaching.

Good sending is the first requirement of a code instructor. In order to standardize the department we have adopted the policy of sending 20-w.p.m. characters for all speeds, with the exception of 6-w.p.m. visual which is considerably slower. Instructors are taught to use both the hand key and the bug, developing a proficiency of at least 16 w.p.m. on each. Three nights a week the instructors get practice in receiving code. The standard receiving speed every instructor must attain is also 16 w.p.m.

So far the results of this night school have been quite favorable, as shown by the constantly improving efficiency of the instructors. We believe that "being on the ball" as instructors inspires the cadet to do his utmost.

Many of the instructors are amateurs. Among them are Capt. J. M. Williams, W4HKG; Lt. T. E. Campbell, W4GKU, M/Sgt. J. W. Marley, jr., W4EW; S/Sgt. H. P. Hoy, W8NQY; Cpl. J. J. Disch, W9MIC; Pfc. R. Plak, ex-W8SPL; Pvt. A. A. Romane, W1JOS; Pvt. W. M. Speed, W4NP; Pvt. R. G. Kenworthy, ex-W9FUU; Pvt. A. C. Girard, W1EJV; Pvt. H. C. Rhode, ex-W1AKP, ex-W1HH, and Pvt. P. Washburn, W1BN.

◆ The author, Lt. Thomas F. Campbell, W4GKU, ex-W4ENK, who is chief code instructor at the Army Air Forces Pre-Flight School (Pilot), Maxwell Field, Alabama.



◆ Of course, the International Morse code is not the only subject taught at the pre-flight school. Every phase of military aviation is embraced. Basic courses are given for general and specific information in customs and courtesies, safeguarding military information, War Department publications and chemical warfare defense. Other courses cover maps, charts and aerial photographs, aircraft recognition, communications, and ground, air and naval forces. Refresher courses are given in mathematics and physics. A stiff physical-training program is designed to build up the muscles used in flying.

In these other branches of study hams also play a part as instructors. Among them are Lt. W. A. Hallam, W8JKN; Lt. F. B. Ferris, W9RGF, and Lt. R. J. Tyrell, W9HM.

(Continued on page 74)

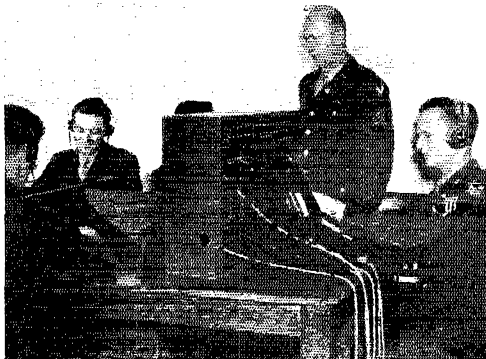
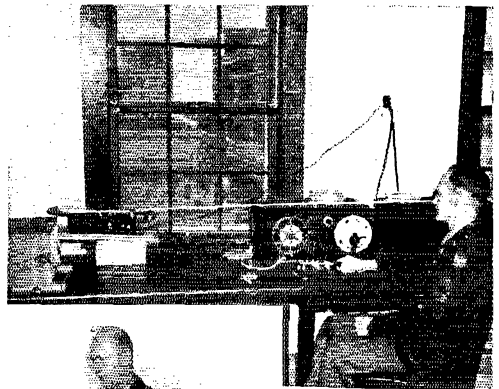

Above — Code instruction at Maxwell Field is from tape-recorded hand sending. Here M/Sgt. J. W. Marley, W4EW, is seen making a practice tape. Left — One end of a typical code table, showing instructor's master switchboard. Instructing are S/Sgts. H. P. Hoy, W8NQY (standing), and J. H. Edrington.

Elementary A.C. Mathematics

Part V*—Reactance and Impedance

BY GEORGE GRAMMER,** WIDF

THE basic idea in Ohm's Law is that in any metallic circuit in which the conditions remain unchanged the current flowing will be proportional to the voltage applied. This statement may be written

$$I \propto E$$

the symbol \propto meaning "varies with." Since it is known that the current will not be the same in different circuits having the same voltage applied, nor in similar circuits constructed from different materials, an equality can be made out of the statement above by introducing a constant, G , called the *conductance* of the circuit, giving

$$I = GE$$

an expression which states that the current is proportional to the circuit property, conductance, as well as to the applied voltage. However, it is frequently more convenient to use the reciprocal of the conductance in actual work. This reciprocal is called the *resistance* of the circuit, so that if R represents resistance then $G = 1/R$. Substituting $1/R$ for G in the expression above gives the familiar form of Ohm's Law, R being expressed in ohms.

The question now arises as to what happens to the current in an a.c. circuit containing only capacity or inductance, resistance being excluded, when the amplitude of the applied voltage is varied. Let us assume that an alternating voltage is applied to a condenser. It will be remembered from the discussion in connection with Fig. 21 that the quantity of electricity stored in the condenser is proportional to the capacity of the condenser and to the voltage across its terminals at the instant considered; that is, $Q = CE$. Current is the rate at which a quantity of electricity is moved past a point in a circuit, so the current flowing in the condenser will be the rate at which the condenser is either acquiring or losing its charge. Since $Q = CE$, the rate of change of CE must equal the rate of change of Q , which in turn equals the current. While for any given condenser C is a fixed quantity and hence has no rate of change, it is obvious from the equation that the larger C is made the larger Q becomes for a given voltage, hence the rate of change of Q is directly proportional to C . The actual change causing the current flow is the change in the applied voltage as it varies throughout its cycle. Using the rate-of-change notation previously introduced, we can write dQ/dt to indicate the rate of change of Q

with respect to time, and dE/dt to indicate the rate of change of E . Then

$$I = \frac{dQ}{dt} = C \frac{dE}{dt}$$

In other words, the current — that is, the rate of change of the quantity of electricity — is equal to the capacity of the condenser multiplied by the rate of change of the applied voltage. Fundamental units — amperes, farads, volts — are used, of course.

We now want to reduce the expression dE/dt to one more easily used; in other words, to determine what the actual rate of change of the voltage is in any given case. It will be remembered that the expression describing an alternating voltage is $e = E_{max} \sin \omega t$, where e is the instantaneous voltage, ω is $2\pi f$, and E_{max} is the amplitude of the voltage. Phase is neglected here, since we are concerned with only one voltage and consequently can select the beginning of the cycle as our starting time. Using instantaneous values, the current will be

$$i = C \frac{de}{dt} = C \frac{d(E_{max} \sin \omega t)}{dt}$$

Like the condenser capacity, E_{max} is a fixed quantity under any given set of conditions and hence has no rate of change. Again, however, it is obvious that the larger E_{max} is the greater the rate of change in voltage must be, other things being equal, because the voltage must vary between wider limits as E_{max} is made larger. Thus the rate of change of voltage is directly proportional to the maximum voltage, so we can rewrite the equation as follows:

$$i = CE_{max} \frac{d(\sin \omega t)}{dt}$$

thus reducing the problem to one of finding out how rapidly $\sin \omega t$ varies.

We have already determined that the curve obtained when the rate of change of a sine curve is plotted graphically is a cosine curve. The curve representing the rate of change of the expression $\sin \omega t$ will have the *shape* of the curve $\cos \omega t$ and the phase relationship of the cosine to the sine. But it would be wrong to assume that $\cos \omega t$ is equal to the rate of change of $\sin \omega t$. The maximum value of the cosine is always 1, whereas it should be evident that the rate of change of a sine wave is limited only by the maximum frequency we can generate. For example, consider the two sine curves in Fig. 29, one having three times the angular velocity of the other. If the "slower" curve is assigned an angular velocity of 1, it will

*The series began in *QST* for February, 1943.

**Technical Editor, *QST*.

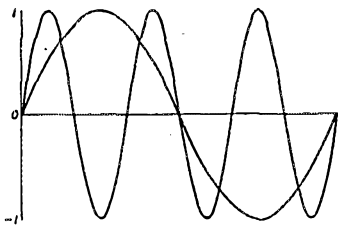

Fig. 29

be described by the expression $\sin t$. The angular velocity of the other curve then becomes 3, so that its expression is $\sin 3t$. But the maximum values of $\cos t$ and $\cos 3t$ are exactly the same, 1, which would indicate that the rate of change is the same in both cases. Obviously, the rate of change of $\sin 3t$ is three times as great as that of $\sin t$, since its cycles are being generated three times as rapidly, so we must write the expression for its rate of change as $3 \cos 3t$. In general terms, the rate of change of the function $\sin \omega t$ is equal to $\omega \cos \omega t$. That is,

$$\frac{d(\sin \omega t)}{dt} = \omega \cos \omega t$$

When this is substituted in the expression for i , the equation of the instantaneous current becomes

$$i = \omega C E_{max} \cos \omega t$$

The current is a cosine function of the voltage, as we found previously, and hence leads the voltage by 90 degrees. We are not concerned with the phase angle between current and voltage at the moment, but only with the relationship between their amplitudes. Remembering that the cosine curve is identical with the sine curve in all respects except phase, we can, by neglecting phase, set $E_{max} \cos \omega t$ equal to $E_{max} \sin \omega t$. The latter will be recognized as the expression for the instantaneous value of the voltage. The instantaneous value of the current is equal to $I_{max} \sin \omega t$, and since the ratio of the effective to the maximum value is always the same for a sine wave, we can substitute the effective values directly, obtaining

$$I = \omega C E$$

where I and E now represent effective values. The current flowing in a condenser is therefore proportional to the angular velocity, the capacity, and the applied voltage.

By comparing this expression with the earlier version of Ohm's Law, it is evident that the two are alike if G and ωC are interchanged. The quantity ωC , corresponding to conductance in the resistive circuit, is called the *susceptance* of the circuit, and is usually represented by the symbol B . Its reciprocal is called *reactance* and is represented by the symbol X , so that $X = 1/B$. In the condenser circuit $X = 1/\omega C$, or $1/2\pi fC$. Since reactance has a restricting effect on current flow in much the same way that resistance does, it is also expressed in ohms. The difference is that no energy is consumed in reactance.

Inductive Reactance

In the case of a circuit containing only inductance the analysis is much the same. We found previously that the voltage generated in an inductance is proportional to the amount of inductance, and to the rate of change of the current flowing. Using instantaneous values,

$$e = L \frac{di}{dt}$$

where di/dt represents the rate of change of current. The expression for the instantaneous current is $i = I_{max} \sin \omega t$, and making the substitution gives

$$e = L \frac{d(I_{max} \sin \omega t)}{dt}$$

By reasoning similar to that in the condenser case, this leads to

$$e = L I_{max} \frac{d(\sin \omega t)}{dt}$$

This expression has the same form as that for the condenser, so we may omit the various steps and go directly to the final result, using effective values:

$$E = \omega L I$$

If this is rewritten in the form $I = E/\omega L$, it is evident that the alternating current flowing in an inductance is proportional to the applied voltage and inversely proportional to the angular velocity and inductance.

This is similar to the expression $I = E/R$ for Ohm's Law, so that the quantity ωL corresponds to R and is expressed in ohms. It is called reactance, just as in the condenser case, although it is of a different type since the current in an inductance lags 90 degrees behind the voltage while that in a condenser leads the voltage by 90 degrees. In both cases, however, the reactance dissipates no energy.

Resistance and Reactance Combined

With the phase and amplitude relationships between current and voltage established for resistive, inductive and capacitive circuits, it becomes possible to determine phase and amplitude relationships in more complex circuits. It will be convenient to represent inductive reactance by the symbol X_L and capacitive reactance by X_C , so that for the three cases

$$I = \frac{E}{R} \quad I = \frac{E}{X_L} \quad I = \frac{E}{X_C}$$

We may take first the simple case of a series circuit containing resistance and inductance, as shown in Fig. 30. As a specific example, we assume that the resistance, R , is 15 ohms and that the reactance, X_L , is 25 ohms, the current, I , being 2.5 amperes. Since the circuit elements are in series the current is the same in both, consequently we use the current as a reference in constructing a vector diagram. In constructing the diagram we can use effective values directly, instead of maximum values as in the previous examples, because the ratio of effective to maximum

is constant and the shape of the vector diagram will be unaffected if all the scale values are multiplied by a fixed factor. The voltage drop across the resistance will be $E = RI = 15 \times 2.5$, or 37.5 volts. The voltage drop across the reactance will be $E = XI = 25 \times 2.5 = 62.5$ volts. The

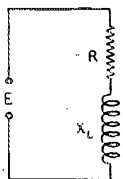

Fig. 30

voltage across the resistance will be in phase with the current and that across the inductance will lead the current by 90 degrees. The two voltages may be laid off to scale, as shown in Fig. 31, and the total voltage may be found by the parallelogram method. It is found to be approximately 73 volts.

It will be observed that the two individual voltages correspond to the base and altitude of a right-angled triangle and that the resultant voltage corresponds to the hypotenuse. They may in fact be drawn that way, as in the diagram to the right in Fig. 31. Since the lengths of the sides are scaled to the voltage values, the right-triangle rule may be used to find the value of the resultant voltage. Thus

$$E^2 = E_R^2 + E_{X_L}^2 \text{ or } E = \sqrt{E_R^2 + E_{X_L}^2}$$

Substituting the assumed values gives

$$E = \sqrt{37.5^2 + 62.5^2} = 72.9 \text{ volts}$$

The phase angle between voltage and current is approximately 59 degrees, as measured from the vector diagram with a protractor. By trigonometry, the tangent of the phase angle is E_{X_L}/E_R , or

$$\tan \theta = \frac{E_{X_L}}{E_R} = \frac{62.5}{37.5} = 1.667$$

From a table of trigonometric functions the angle is found to be $59^\circ 2'$.

It will be recognized that this solution is simply a special case of the more general method of vec-

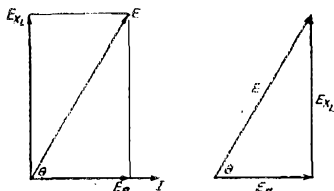

Fig. 31

tor addition described earlier. The simplification results because one vector lies along the X axis and the other along the Y axis, so that it is unnecessary to break them down into sine and cosine components.

In analyzing the effect of inductance and capacity on current flow, it was found that the

quantity termed reactance had an effect analogous to that of resistance in a resistive circuit. That is, given a fixed value of reactance in a circuit, the current will be directly proportional to the applied voltage. Since this is also true of resistance, a combination of reactance and resistance should exhibit the same direct proportionality between voltage and current. That this is so is shown by the triangle of Fig. 31, for if a larger or smaller value of current is used the reactance and resistance voltage vectors will increase or decrease proportionately in size. Then the resultant voltage must also increase or decrease in the same proportion, since all such triangles will be similar. Consequently the voltage and current in a complex circuit follow a law similar to that for simple reactive or resistive circuits; that is, $I \propto E$.

In the voltage triangle,

$$E = \sqrt{E_R^2 + E_{X_L}^2}$$

and since $E_R = IR$ and $E_{X_L} = IX_L$, substitution gives

$$E = \sqrt{I^2 R^2 + I^2 X_L^2} = \sqrt{I^2 (R^2 + X_L^2)} \\ = I \sqrt{R^2 + X_L^2}$$

The quantity $\sqrt{R^2 + X_L^2}$ evidently occupies a position analogous to that of resistance in Ohm's

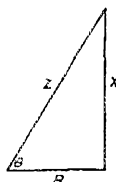

Fig. 32

Law. It is neither resistance nor reactance but a combination of both, so it is called by a separate name, *impedance*, but since it has a comparable effect on current flow its unit is the ohm. It is identified by the symbol Z , and the generalized form of Ohm's Law for a.c. circuits can be written

$$I = \frac{E}{Z}$$

The fact that $Z = \sqrt{R^2 + X_L^2}$ indicates that there is a triangular relationship between the three quantities, R , X and Z . Thus the impedance of a circuit can be found by constructing a right triangle with the resistance as the base and the reactance as the altitude, both being drawn to the same scale of ohms; the length of the hypotenuse of the triangle represents the impedance on the same ohms scale. Since the impedance triangle is similar to the voltage triangle, the former also gives the phase angle of the circuit, as indicated in Fig. 32. Consequently,

$$\tan \theta = \frac{X_L}{R} \text{ or } \theta = \tan^{-1} \frac{X_L}{R}$$

A little thought will show that an infinite number of different right triangles can be constructed with the same length of line for the hypotenuse. Consequently the value of the impedance in

ohms does not represent complete information about the circuit. However, since a right triangle is uniquely determined when one side and one angle (in addition to the right angle) are known, the behavior of the circuit can be predicted if the impedance and phase angle are given.

A circuit having resistance and capacity in

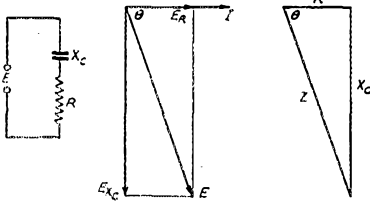

Fig. 33

series can be treated by the same method as in the inductance case. Such a circuit is shown in Fig. 33, with its vector diagram and impedance triangle. Since the voltage across a condenser lags 90 degrees behind the current, the vector representing the condenser-reactance voltage is drawn downward. However, the triangular relationships are like those in the inductance case, and the same method of solution is used. For example, if the current is 4 amperes through a circuit having 16 ohms resistance and 45 ohms capacitive reactance, the voltage across the resistance will be 64 volts and that across the reactance 180 volts. Drawing a vector diagram to scale will give the approximate values 190 volts and 70 degrees for the impressed voltage and phase angle, respectively. Using the triangular rule the voltage is

$$E = \sqrt{64^2 + 180^2} = 191 \text{ volts}$$

and the phase angle is found from

$$\tan \theta = \frac{E_C}{R} = \frac{180}{64} = 2.813$$

to be 70° 26'. The impedance of the circuit is

$$Z = \sqrt{R^2 + X_C^2} = \sqrt{16^2 + 45^2} = 47.7 \text{ ohms.}$$

The phase angle also can be found from

$$\tan \theta = \frac{X_C}{R} = \frac{45}{16} = 2.813$$

L, C and R in series

With inductance, capacity and resistance in series there are three voltage vectors to be considered, but there is no fundamental change in the method of solving the circuit. Taking the circuit in Fig. 34 as an example, let us suppose that the current is 2 amperes, R is 12 ohms, X_L is 10 ohms and X_C is 20 ohms. The corresponding voltages across the circuit elements are $E_R = 24$ volts, $E_{X_L} = 20$ volts and $E_{X_C} = 40$ volts. The vector diagram is constructed as in Fig. 34. The inductance voltage vector is drawn upward, since the voltage leads the current by 90 degrees, and the capacity voltage vector is drawn downward because the voltage lags the current by 90 de-

grees. The vector sum of these two is the numerical difference between them, since they are oppositely directed. However, the complete diagram can be constructed by successive addition. This is indicated in the figure, where E_R is first added vectorially to E_{X_L} and the sum of these two is then added to E_{X_C} to obtain the total voltage. The result is exactly the same as though the difference, E_X , had first been taken between E_{X_L} and E_{X_C} and the total voltage found by adding E_X vectorially to E_R .

E_X is the total or net reactance voltage of the circuit, and from the considerations above the actual reactance voltages present may be combined into one equivalent voltage which may be used in the formula $E = \sqrt{E_R^2 + E_X^2}$ to find the applied voltage. Obviously the same reasoning applies to the relationship between resistance, reactance and impedance in such a circuit. The impedance triangle is constructed by making the altitude equal to the difference between the inductive and capacitive reactances; the altitude is drawn upward if the inductive reactance is larger than the capacitive reactance, and downward if the capacitive reactance is larger. Although it makes no difference in the numerical results whether the altitude is drawn upward or downward, the direction does indicate whether the phase angle is positive or negative. Since a negative angle indicates a preponderance of capacitive reactance, it is conventional to call capacitive reactance "negative," while inductive reactance is

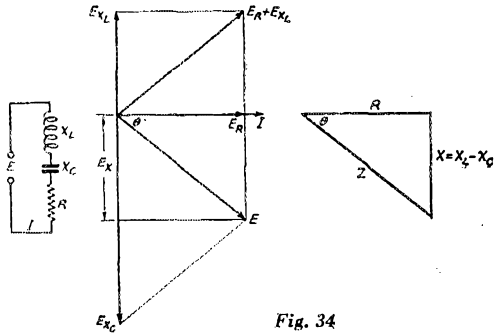

Fig. 34

called positive because of its association with a positive phase angle.

In this example, therefore, we can find the numerical values by subtracting E_{X_C} from E_{X_L} , obtaining a value of -20 volts. The negative sign indicates that the net reactance is capacitive, so that the voltage will lag behind the current. Using -20 volts for E_X and substituting,

$$E = \sqrt{E_R^2 + E_X^2} = \sqrt{24^2 + 20^2} = 31.2 \text{ volts}$$

The impedance of the circuit is

$$Z = \sqrt{R^2 + X^2} = \sqrt{12^2 + 10^2} = 15.6 \text{ ohms}$$

and the phase angle can be found from

$$\tan \theta = \frac{X}{R} = \frac{10}{12} = 0.833$$

This is the tangent of $39^\circ 48'$. Note that the negative sign associated with the reactance disappears when the quantity is squared.

It is of interest to observe that, looking into the circuit terminals from the source of voltage, the circuit appears to consist of a 12-ohm resistance in series with a capacitive reactance of 20 ohms. So far as the source of energy is concerned, a condenser having a reactance of 20 ohms could be substituted for the combination of inductance and capacity actually present and the current as well as the phase angle would be exactly the same as in the actual circuit. The simpler circuit is therefore *equivalent* to the more complex one from this standpoint.

If more than one inductance or capacity is in series in the circuit the voltages across each reactance of the same kind will have the same phase relationship to the current. That is, the voltage across each inductance will lead the current by 90 degrees and that across each capacity will lag the current by 90 degrees. The inductance-voltage vectors therefore all have the same direction, since the same current flows through all parts of the series circuit, and consequently can be added numerically to find the total inductance voltage in the circuit; similarly with the condenser voltages. The same result will be secured by adding all the inductive reactances together and multiplying by the current, and by adding all the capacitive reactances together and multiplying by the current. Hence all the inductive reactances in series may be "lumped" into one equivalent reactance, and all the capacitive reactances into one equivalent reactance, in determining the impedance and phase angle of the circuit. If the voltage drops across individual coils and condensers are wanted, the individual reactances must of course be used in the calculation.

In the preceding examples it was assumed that the current was known and that the applied voltage was to be found, since this assumption represented the easiest method of approach. In the practical case it is more likely that the applied voltage will be known and that the value of the current, as well as voltages across the individual circuit elements, will be wanted. We handle such a problem by means of the impedance triangle. The method is to solve first for the circuit impedance, then substitute the value of impedance so found into the equation $I = E/Z$, thus obtaining the current. The voltages across the circuit elements can then be found by multiplying the current by the resistance or reactance in each case.

Taking the circuit of Fig. 34 as an illustration, suppose that the applied voltage is 100 volts. The impedance was determined to be 15.6 ohms, so that

$$I = \frac{E}{Z} = \frac{100}{15.6} = 6.42 \text{ amperes}$$

Then

$$E_R = IR = 6.42 \times 12 = 77.0 \text{ volts}$$

$$E_{X_L} = IX_L = 6.42 \times 10 = 64.2 \text{ volts}$$

$$E_{X_C} = IX_C = 6.42 \times 20 = 128.4 \text{ volts}$$

Resonance

When resistance, inductance and capacity are in series, a special case of importance in radio practice occurs if the inductive and capacitive reactances are equal. Since the net reactance in the circuit is the difference between the two, the net reactance is zero when the two reactances have the same value. In this case the circuit as viewed from the input terminals shows only resistance, of a value equal to the actual resistance in the circuit. Consequently the phase angle is zero and the power factor is $\cos 0^\circ$, or 1; all the volt-amperes supplied by the source of e.m.f. are dissipated in the resistance. Such a circuit is said to be "resonant."

In general, any circuit having resistance, inductance and capacity in series will be resonant at some a.c. frequency, since the reactance of a condenser decreases with increasing frequency, while that of an inductance increases with increasing frequency. The frequency at which resonance occurs can be found by setting the reactances equal, so that

$$X_L = X_C \text{ or } \omega L = \frac{1}{\omega C}$$

Consequently,

$$\omega^2 LC = 1 \text{ and } \omega = \frac{1}{\sqrt{LC}}$$

Since $\omega = 2\pi f$,

$$2\pi f = \frac{1}{\sqrt{LC}} \text{ and } f = \frac{1}{2\pi\sqrt{LC}}$$

L and C are of course in the fundamental units, henrys and farads, while f is in cycles per second.

(Part VI will appear in an early issue. — Editor.)

Strays

Under Order L-265, released April 24 by the WPB, owners of radio and electronic equipment requiring repair, including b.c. receivers, must turn in all defective parts to be replaced before new parts may be purchased. Production of electronic equipment for non-military purposes may be undertaken only upon specific authorization of WPB.

W2HOJ (interviewing an applicant for a job):
 "Do you understand Ohm's Law and its uses?"

Applicant: "I'm sorry, but I have studied only the technical side of radio — not the legal side."
 — *W3FVZ*.

 Around the edge of our store window we have written, in dots and dashes, the words: "Welcome Hams." To the average passerby it looks like some sort of decoration, but it has attracted a surprising number of hams in the service passing through town. — *VE3AJ5*.



ON THE VERY HIGHS



CONDUCTED BY E. P. TILTON,* W1HDQ

SPRING again! This season of the year means many things to many people, but to the ham the first mild days awaken the urge to put up a new antenna. Spring, 1942, found us floundering; we'd been put off the air and we were rather tired of waiting for information from Washington that would indicate what our war-time rôle was to be. But 1943 presents quite a different picture, and all over the country new antennas are going up. No fancy arrays to help us snag elusive prefixes or work some of those hard-to-get states — just plain vertical dipoles in most cases, but even in this seemingly simple job we've been finding problems to tax our ingenuity.

Most WERS station locations are in the basements of buildings, located for safety considerations in the event of bombing, and many times the spot is the lowest place in town — hardly the sort of thing one would pick out as an ideal 112-Mc. QTH. Thus we are forced to run feeders much longer than usual amateur practice, and, with steel-frame buildings all around, that feed line had better be flat if we expect to have any energy left to make the long climb up to the antenna!

Here in hilly New England we are confronted with the necessity of working over plenty of ridges, so the antennas have got to be as high as possible, and they have got to perform correctly if we are to have a consistently-satisfactory signal for WERS work. In our WKHF network we have several stations operating in poor locations but with antennas highly elevated, covering hops of five miles or more over high hills with S8 to S9 signals. Something better than a simple halfwave dipole is frequently necessary. Vertical stacking, as in the case of the extended double-Zepp, has been found very helpful. The antennas of WKHF-1 and WKHF-16, shown in the accompanying photographs, have 200 feet and 130 feet of feeders, respectively. The two stations are situated about five miles apart with a hill about one

hundred feet high intervening; yet S8 signals are maintained both ways with power input running only 10 to 15 watts. It is of interest to note that substitution of an extended double-Zepp for the multi-wire doublet shown in the photo resulted in an increase of two S units in the signal strength over this difficult path.

Initial operation at WKHF-1 was done with an antenna about thirty feet above the ground level in a downtown location. Our signal was only barely audible at several of the nearer points in the area we have to serve. Moving this same antenna up to the roof of an adjoining building, 75 feet higher up, brought the signal up to a solid S9 at these locations and extended our range many miles in all directions, despite the fact that it meant using more than 200 feet of line and going around several sharp angles. Strong signals are now heard from adjacent warning districts twenty miles or more north and south of Springfield, paths over which 112-Mc. work was never dreamed of in the free and easy days before December 7, 1941.

Back in the fall of 1941 there was much discussion, out in Arizona, of the possibility of working on 2½ over the mountains from Phoenix or Tucson to the California coast. W6QLZ and W6OVK were hard at it preparing a series of tests, with both portable and fixed stations, in an attempt at breaking our existing 335-mile record. Now comes word from W6SLO, via W6OVK/1, that the control tower at Tucson Airport contacted a similar control tower at Santa Monica, Calif., on March 9, 1943. Both transmitters and receivers are crystal-controlled on a frequency just outside the high end of the 112-Mc. band. The power at each end was about 25 watts, and the distance — *about 400 miles!* We know from the experiences of W2MPY, the amateur record-

(Continued on page 80)

Antennas that bloom in the spring: *L. to r.* (1) The antenna of WKHF-16 dominates the city of Chicopee, Mass., from the belfry of the City Hall. The folded doublet shown has since been replaced with an extended double-Zepp, with improved results. (2) Tom Chapman, W1KK, and Joe Manning, W1GKY, putting the finishing touches on the Chicopee antenna. Their perch is 125 feet above ground. (3) Extended double-Zepp at WKHF-1 is more than 100 feet above ground, fed with 200 feet of open line. (4) Jess Richardson, W1CKJ (standing), and Howard Gourley, W1APP, rest up after erecting the new antenna for WKHF-1 atop the Hotel Kimball in Springfield.



HOTEL

KIMBALL

Who Killed the Signal?

A Radio Mystery Serial

BY CLINTON B. DE SOTO,* WICBD

Chapter 5 — "Danger In the Dark"

Synopsis:

The characters in this story, which interprets radio principles in the guise of a detective-mystery yarn, are radio parts living on the chassis of a receiver standing silent and dark, dust-covered from disuse. The Signal is dead — murdered by an unknown hand. The Great Sleuth, an amateur detective and therefore a good one, was called in on the case, along with his three assistants — Ohm Meter, Volt Meter and Milly Am Meter. At first, lanky, brown complexioned Power Cord seemed a logical suspect. Then Volt Meter discovered Cord's helper, Power Plug, asleep on the floor beside the wall socket — a derelict from duty. Even when Plug plugged himself in and the lights gleamed again inside the cabinet, however, the set still refused to function. Following the path of the current, the Sleuth continued his investigation, interviewing in turn Power Transformer, Rectifier Tube and finally Filter Choke and Filter (Miss "Electrolytic") Condenser. At first the rumor Ohm Meter picked up that Filter Condenser had been serving "rough" current to the set seemed like a promising lead, but then Volt and Milly Am Meter tried the current and found it pure. The Sleuth and his minions resumed their search.

So complicated was the maze of wiring that the Sleuth obtained a circuit diagram — a sort of map or chart of the set. With its aid they traced the current to Output Tube, who described the amplifying process by which he made the Signal strong, and thence to Output Transformer, a very sharp character indeed, and his puppet stooge, Loud Speaker. Antagonized by Output Transformer's jive talk, the Sleuth tried unavailingly to pin the crime on him, but the sly, quick-witted Transformer talked his way clear. Thwarted, the Sleuth began his investigation anew at the Antenna terminal, where the Signal first entered the set.

Finding himself stymied by his lack of expert knowledge, the Sleuth called in Signal Generator, a versatile mimic capable of imitating any signal, and Output Meter, an expert on a.c. They attempted to send an artificial signal through the set (the Sleuth meanwhile interviewing R.F. Tube), but without success. Somewhere along the route the artificial signal, too, was lost. Meanwhile the Sleuth learned that the Variable Condenser gang was romantically linked with three Coils, and that the r.f. amplification of the set depended on this relationship. Could it be that one of these Coil-Condenser teams had had a falling out of tune and were no longer working together?

The story continues. . . .

RECHARGED with confidence by this new solution, the Sleuth and his helpers set to work with a will. Even the three Meters lost their apathy and their movements became alert and responsive.

"Looks to me like R.F. Mixer Tube over there is the next suspect to be questioned," said the Sleuth from the depths of the circuit diagram.

Wordlessly, Signal Generator reached out that incredibly long, thin arm and took hold of Mixer

* Executive Editor, QST.

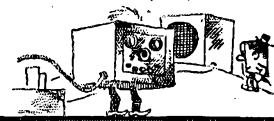

SIGNAL GENERATOR'S
EYES FLICKERED AND
THE HUMMING COULD
BE HEARD AGAIN

Tube's top cap. Signaling to Output Meter, who was waiting up by Speaker's housing, Signal Generator's white-irised round eyes flickered and the faint 400-cycle humming could be heard again.

The Sleuth and his minions watched tensely while Signal Generator again struggled to force the artificial signal through the set. But there was no response. Once Output Meter's pointer-like nose twitched, but it was only a nervous reflex.

Signal Generator tried again and again. Finally, eyes dulled with fatigue, he gave it up. His broad, angular shoulders sagged in defeat. "It's no use," he conceded wearily. "Now I can't get any signal at all through — not even a faint one."

The Sleuth's face reflected his disappointment. Milly attempted to lighten her chief's despair. "Oh, don't be discouraged, Boss," she said sympathetically. "After all, this isn't the first solution that hasn't worked. We've still got plenty of other possibilities to investigate."

"Sure, Boss," Volt added his encouragement. "Those coils and condensers aren't the only parts without an alibi. Anyway, you remember Signal Generator said right at the start he doubted that your theory would account for the Signal's death."

"I can't understand it," the Sleuth said sadly. "I was so sure my theory was right. Yet according to the circuit diagram these resonant-circuit Coil-Condenser teams all work ahead of R.F. Mixer Tube. If my theory had been right — that one of them is responsible — the Signal shouldn't have had any trouble going the rest of the way."

Volt studied the diagram over The Sleuth's shoulder. "Aren't you overlooking something here, chief? They aren't the only Coil-Condenser combinations in the set. Look — here are some more, next to I.F. Tube."

The Sleuth looked where Volt was pointing. "But those I.F. Trimmer Condensers aren't members of the Variable Condenser gang," he objected. "They're free lances, so to speak. I don't think that a single Condenser, working alone, could kill the Signal. Do you?" The Sleuth turned to Signal Generator for confirmation.

"Well," the worldly-wise signal impersonator scratched his head doubtfully, "you never can tell. Many's the time I've seen a puny little Resistor get all heated up over something and do more damage than old Power Transformer himself could do."

"Why don't you ask one of those Tubes up there about it?" Volt suggested. "They seem willing enough to talk."

Almost as though this had been a cue, a faint voice whispered, "This is Mixer Tube talking. R. F. Tube has told me why you are here. If you'll come up to see me maybe I can help. . . ." The whisper trailed off into inaudibility.

"What's the matter with him? Has he got laryngitis?" demanded Ohm.

"It's de-amplification," Signal Generator explained. "He's sending a message to us backwards through the set. If it were going the other way it would be amplified and made stronger, but this way it's stepped down and made weaker."

"I didn't think such a thing was possible," the Sleuth demurred.

"It isn't," retorted Signal Generator with a malicious gleam. "But go on up there anyway."

Mixer Tube was waiting. He proved to be affable and friendly — a good mixer, as his name implied.

"What have you got to tell me?" the Sleuth asked.

"I've been listening to that artificial signal you've been sending up here, and I thought I might give you a lead," he smiled in friendly fashion. "To start with, I want you to know that



I've been trying to help you all along. I've been doing my best to change the frequency of your signal, but this fellow Oscillator Tube —"

"You've been doing *what?*" the Sleuth broke in incredulously.

"Why, trying to change the signal's frequency, of course," Mixer Tube repeated.

"Why on earth should you do that?"

"Because it's my job. I'm the official frequency changer for the set. Now, as I was saying —"

"You'd better tell me more about this frequency-changing business," the Sleuth interrupted ominously. "All this time we've been trying to give the set exactly the frequency it wants, and here you go and change it on us. You've got some explaining to do, young fellow. Talk — and talk fast!"

"But that's just the point," Mixer Tube said quickly. "I'm *supposed* to change the frequency of the signal, but I haven't been able to."

"Why are you supposed to change it?" the Sleuth demanded sternly.

"So the tuned circuits that I.F. Tube works with can handle it, of course. This set is a super-heterodyne, as you should know. That means that any signal it receives, regardless of its frequency, is changed to another fixed frequency called the intermediate frequency."

"Why, for Heaven's sake?"

"For convenience, principally. It's easier to give every signal uniform handling that way, regardless of its frequency or amplitude. Makes it a lot easier to control amplification and selectivity and all that."

The Sleuth was still unconvinced. "It seems to me that involves a lot of useless complication. Why wouldn't it be better to handle each signal at its own frequency?"

"Well, just as an example, take those tuned circuits around R.F. Tube. Generally speaking,



the lower the frequency of a signal the more they amplify it. This puts a high-frequency signal at a disadvantage, of course. The intermediate-frequency amplifier, on the other hand, gives all signals equal amplification regardless of their original frequency — and usually a lot more amplification per stage, too, because it works on an even lower frequency still. Much the same is true when it comes to selectivity; again, an r.f. amplifier is sharper at the lower frequencies. In fact, an ordinary r.f. stage just doesn't have what it takes to select one signal from the other if the frequencies are fairly high. But the i.f. amplifier is equally choosy with them all."

The Sleuth wavered. "That seems reasonable enough, at that," he said finally. "But tell me — how do you accomplish this frequency changing? Sounds like a difficult job."

"Oh, it isn't, really," Mixer Tube replied deprecatingly. "I'm only sort of a bartender. I take a couple of signals, mix 'em together — and there you are!"

"A couple of signals? But the set is supposed to receive only one signal at a time."

"True enough — only one signal coming in from the outside. The other signal is supplied locally. It's generated by this fellow Oscillator Tube I wanted to tell you about. He —"

"But why are two signals required?"

Mixer Tube sighed. "Because we use the age-old heterodyne principle," he explained patiently, "which may be summed up as saying that if you mix two different things together you get a third. In this case we merely beat one signal against the other."

"Rather rough treatment, isn't it?"

"Of course not — they don't mind it a bit. Say, you know what a beat note is, don't you?"

"Only," said the Sleuth, "that it's what is heard when two musical notes of different pitch are played simultaneously."

"Right. If the frequencies of the two tones are close together the sound seems to rise and fall in intensity, doesn't it? That's the combination or beat frequency. By the way, did you ever see a pair of unsynchronized windshield wipers?" Mixer Tube asked with apparent irrelevance.

"Yes, but — oh, I think I see now what you mean. If the respective speeds are slightly different, every dozen strokes or so they both sweep across at the same instant, but the rest of the time each goes its own way."

"Correct. Suppose one is making 120 strokes per minute and the other 150. The first makes one

complete cycle in 0.5 second, the other in 0.4. Putting it another way, in two seconds the first makes 4 strokes, the other one 5. Thus every two seconds the faster one gains one full stroke on the other, and on the next stroke both appear to be in synchronism. Since that happens every two seconds, there are 30 such synchronized strokes per minute."

"And 30 is the difference between their respective speeds — 120 and 150 strokes per minute," the Sleuth added eagerly.

"Nice figuring. Now suppose that, instead of windshield wipers, we have a.c. voltages of two different frequencies. The same process occurs except that here it's more important than just an interesting visual effect. At any point the two voltages add together to make a third. When they are in synchronism their peaks add together, making the total voltage the sum of the two. Half-way along the cycle the two also add up — but in opposite polarity, so that they cancel out and the result is zero. At all other points proportionate percentages of each voltage add up, making a smooth rise from zero to maximum, with the result that a new voltage at the beat or difference frequency is added to the two voltages originally in the circuit."

"Why, of course," the Sleuth assented. "I see now. So that's how you change the frequency of the incoming signal. You take the Signal from R.F. Tube, mix it with another voltage of the right frequency, and pass the mixture along."

"Right."

"But how do you mix the two voltages?" the Sleuth pursued.

"Well, you see, basically I'm an amplifier like R.F. Tube there — with a couple of added features. I take the Signal in on my control grid, and it varies or modulates my plate current as in any tube. However — and here's where the added features come in — in addition to the usual control, screen and suppressor grids, I have a fourth one called the injection grid. This is also a kind of control grid, and it takes the voltage from the local oscillator and modulates my plate current a second time. By the time that electron stream reaches my plate it's quite a mess, carrying not only the input Signal and the local signal but their beat-frequency combinations as well."

"But if all those frequencies get into your plate circuit, how do you ever separate them to get the one you want?"

"Oh, I leave that up to I.F. Input Transformer. His primary is my plate load impedance, you know, and he has a pair of tuned circuits inside him tuned to the intermediate frequency. He uses his sense of selectivity to pick out the beat or heterodyne voltage, rejecting all the others."

"How does he get rid of the other voltages?"

"Passes them straight down to ground through his low capacitive reactance. There's very little left of them after that, I can tell you."

"This is all very interesting, I must say." The Sleuth's face glowed with interest. "Now tell me more about the local signal — where you get it, and so on."

"That's what I've been trying to tell you all along, but you've insisted on going off on these tangents," Mixer Tube retorted petulantly. "I have to depend on Oscillator Tube for the local voltage and ever since the current failed he just hasn't been supplying me any."

The Sleuth looked at Mixer Tube for a moment before the significance of this statement dawned. Then he asked excitedly, "And that's why the Signal isn't getting through?"

"Well, it's the reason I haven't been able to pass along this artificial test signal of yours, anyway. Although —"

"What? You numskull! Why didn't you tell me that in the first place instead of letting me waste all this time?" the Sleuth shouted in fury, instantly the ruthless troubleshooter tracking a hot lead.

"But that's just it — you wouldn't let me!" Mixer Tube defended himself, unawed by his questioner's rage. "Anyway —"

But the Sleuth was gone. Coat tails flying, down the chassis he ran, sliding to a halt before Signal Generator and the waiting Meters with something less than his accustomed dignity.



"I've got it at last!" he proclaimed breathlessly, steadying himself to regain his balance. "It's Oscillator Tube! He quit supplying the heterodyne voltage to Mixer Tube!"

Signal Generator pursed his lips. "Well, at least that theory sounds more reasonable than your other one," he observed. "It might explain why I could get through weakly to Output Meter when I was feeding through R.F. Tube but not otherwise."

"What's that got to do with it?" the Sleuth demanded in annoyance.

"Well, with both R.F. Tube and Mixer Tube amplifying my signal, even though it didn't get changed to the intermediate frequency it was strong enough so a little of it got through the set, even though that i.f. amplifier crew did their best to kill it."

"So what? We needn't worry about that now — all we've got to do is arrest our man."

"But first we'd better make sure he is our man, hadn't we?" Signal Generator demurred mildly. "Suppose I try sending a signal through at the intermediate frequency. If it survives, then we can be pretty sure of the answer."

"You're wasting time!" the Sleuth snapped. "Why, it's obvious that Oscillator Tube is guilty — it couldn't be anyone else. I'm going up there right now and grab him!"

"Yeah — and so was Output Transformer guilty, and Power Cord and those Coils and Condensers," Ohm muttered nastily in the background. The Sleuth did not hear him, however.

(Continued on page 80)

Army-Navy Announce Radar!

In all probability there is scarcely an amateur anywhere who does not know the meaning of the word "radar" and at least something of the purpose of the device it identifies, if not of its principles. Alternately in the past the subject of guarded disclosures and of tight censorship, the term is one which in recent months *QST*, in common with other technical publications, has not been permitted so much as to mention, even for recruiting purposes.

On April 25th, however, the first "official" announcement of radar was made in the form of a joint release by the War and Navy Departments describing its early development. For the record as well as for the information of our readers, this release is reproduced herewith:

BASIC STORY OF "RADAR" TOLD IN JOINT ARMY-NAVY STATEMENT

The early development of radar was described by the War and Navy Departments to-day. This joint announcement was made in line with the policy to give the American people as much information as possible without endangering our own forces or helping the enemy.

The term "radar" means radio-detecting-and-ranging. Radars, then, are devices which the Allies use to detect the approach of enemy aircraft and ships, and to determine the distance (range) to the enemies' forces. Radar is used by static ground defenses to provide data for anti-aircraft guns for use in smashing Axis planes through cloud cover, and by airplanes and warships.

It is one of the marvels made possible by the electron tube. Ultrahigh-frequency waves traveling with the speed of light can be focussed, scan the air and sea. When they strike an enemy ship or airplane, they bounce back. Radio waves travel at a constant speed of 186,000 miles per second. Thus a small space of time is required for such signals to travel to a reflecting surface and return to a receiver, so that, with means provided for measuring this time interval, it is possible to determine the distance to a given target. Radars operate through fog, storms, and darkness, as well as through cloudless skies. They are, therefore, superior to both telescopes and acoustic listening devices.

Radar is used for both defense and offense. In fact, the British, who call their similar apparatus the radiolocator, say it was instrumental in saving England during the aerial blitz of 1940 and 1941. At that time the locators spotted German raiders long before they reached a target area, and thus gave the RAF and ground defenses time for preparation. Since then radar has stood guard at many danger points along United Nations frontiers and at sea, warning of the coming of aerial and sea-borne enemy forces, and contributing towards victory in combat. The new science has played a vital part in helping first to stem and then to turn the tide of Axis conquest.

It was first discovered in the United States in 1922, when scientists observed that reception from a radio station was interfered with by an object moving in the path of the signals. Accordingly, a radio receiver was set up on the banks of a river and the effects on signal reception caused by boats passing up and down the river were studied. The experiment of installing the receiver in a truck was also tried, and it was observed that similar disturbances were produced in the receiver when the truck moved past large buildings. Development work was immediately undertaken so that the new discovery might be used for detecting vessels passing between harbor entrances, or between ships at sea.

So far, it had been necessary to have the moving object pass between the radio transmitter and the receiver. This obviously limited the possible fields of application. In 1925 it was found that the surface of an object, or target, would act as a reflector of high-frequency radio waves. In other

words, the radio signals sent out by a transmitter could be made to strike a target, and then "bounce" back to a receiver. This made it possible to have both the transmitter and the receiver at the same location.

By 1930, research engineers were able to pick up reflected signals from planes passing overhead. By 1934, they had developed a satisfactory means of measuring the distance between the radar transmitter and the target. Since then other advances in the field have been made, some of which, after the war is over, will undoubtedly contribute to the security and comfort of a world at peace.

In order to prevent information which might facilitate development of radar from reaching the enemy through publicity originating in the United States, it has been decided that no further items on the subject will be released until the Army and Navy are convinced that the enemy already has the information from some other source.



Army-Navy Time Signals

In addition to local War Time, Longines time announcements from b.c. stations now also include the time in terms of the 24-hour clock. This is in cooperation with the desire of the Army and Navy to promote an understanding of 24-hour time by civilians and to benefit those of the armed forces who make use of the time signals, since all activities of the Army and Navy are now conducted according to the 24-hour clock. In all cases Army-Navy time corresponds to local War Time, except that A.M. and P.M. designations are eliminated and the hours of 13 o'clock to 24 o'clock are substituted for the usual P.M. hours. For instance, announcements of 3 P.M. local War Time will also include the announcement of 15 o'clock Army-Navy time.

— . . . —

According to *Telecommunications Reports*, the Costello Committee of the House of Representatives, investigating draft deferment in the government, in its report expressed concern "over the number of draft-eligible young men hired by the FCC . . . particularly in the case of junior and assistant monitoring officers and radio operators. . . . These monitoring employees, Mr. Fly testified, were hired because they were experienced radio operators or technicians. The Commission had tried to find women replacements, the FCC chairman told the committee, but found few qualified. The Commission had literally covered the field and had enlisted the aid of the American Radio Relay League in an effort to obtain qualified personnel not subject to the draft, Chairman Fly said. In defense of the many young monitors employed by the FCC in the Foreign Broadcast Intelligence Service, its director, Robert Leigh, testified that youthful monitors are necessary because almost nobody over 40 years of age has the acute hearing necessary in listening through the static."



EXPERIMENTER'S SECTION

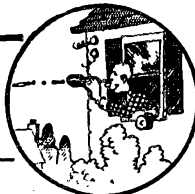

Address correspondence and reports to ARRL, West Hartford, Conn.

PROJECT A

Carrier Current

FIG. 1 shows the circuit diagram of a c.c. transmitter-receiver in use here. The receiver consists of a regenerative detector and single-stage audio amplifier preceded by an untuned stage of r.f. with the hot side of the power line tied directly to the grid. The detector is quite conventional. The coil was wound on a piece of cardboard tubing about one and one-half inches in diameter. It is scramble-wound with wire salvaged from an old speaker field. The secondary, L_2 , was wound on first and covered with a layer of friction tape. The primary, L_1 , was wound close to the grid end, and the tickler, L_3 , close to the ground end. Then the whole thing was given another covering of friction tape. The r.f. chokes used in the original model were standard 2.5-mh. manufactured units,¹ but we ran out of these and instead wound about two hundred turns of No. 32 wire on a piece of half-inch dowel.

¹ A 2.5-mh. choke has a reactance of only about 2300 ohms at 150 kc. An inductance of 25 to 80 mh. should reduce choke losses. — EDITOR

The transmitter is a regulation Hartley oscillator using a 6L6G. With the plate voltage available, the input runs about 12 watts. The note is really crystal d.c. and sure sounds sweet. Of course the key is hotter than a firecracker as it stands now, but we are planning to put in a keying relay to remove that danger.²

The power supply is common to both the receiver and transmitter, the receiver running all the time, and acting as a bleeder for the supply. When the transmitter is keyed, of course, the receiver gives out some very nice clicks, but that isn't too annoying. Grounding the detector grid during periods of transmission results in a hum in the 'phones that makes a swell monitoring tone.

Nothing in either the receiver or transmitter is shielded, but shielding would no doubt improve the selectivity.

(Continued on page 72)

² If the system shown in the circuit diagram is used, all ground connections shown must be made to the chassis and not to actual ground; otherwise the key will short-circuit the line. The chassis must not be grounded. This arrangement also has the added disadvantage that the chassis will then be "hot" with respect to ground by the amount of the line voltage. It would seem to be a better plan to place C_{14} between the arm of S_1 and the ungrounded side of the line. The chassis may then be grounded and the danger of shock or short-circuit removed. — EDITOR

Fig. 1 — Circuit diagram of W6RLJ's transmitter receiver for carrier-current communication.

- C_1 — 700- μ fd. variable, see text
- C_2, C_3, C_4 — 0.01 μ fd.
- C_5 — 250- μ fd. mica
- C_6 — 0.25 μ fd.
- C_7, C_8 — 500 μ fd.
- C_9 — 0.1 μ fd.
- C_{10}, C_{11} — 0.002 μ fd.
- C_{12} — 0.006 μ fd.
- C_{13} — 250- μ fd. mica
- C_{14} — 0.1 μ fd.
- C_{15}, C_{16} — 8 μ fd.
- R_1 — 75,000 ohms, 1 watt
- R_2 — 1000 ohms, 1 watt
- R_3, R_4, R_5 — 50,000 ohms, 1 watt
- R_6 — 2 megohms, $\frac{1}{2}$ watt
- R_7 — 50,000-ohm variable
- R_8 — 0.25 megohm, $\frac{1}{2}$ watt
- R_9 — 0.1 megohm, $\frac{1}{2}$ watt
- R_{10} — 2500 ohms, 1 watt
- R_{11} — 15,000 ohms, 1 watt
- RFC — 2.5 mh.
- S_1 — S.p.d.t. toggle
- S_2 — S.p.s.t. toggle

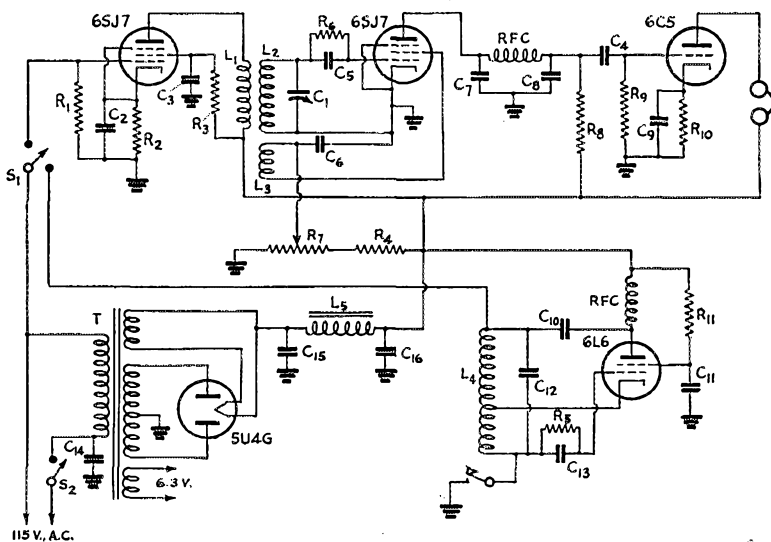

- T — Power transformer: 350-0-350, 5 volts, 6.3 volts
 - L_1 — 100 turns No. 32 wire, $1\frac{1}{2}$ in. diam., see text
 - L_2 — 300 turns No. 32 wire, $1\frac{1}{2}$ in. diam., see text
 - L_3 — 75 turns No. 32 wire, $1\frac{1}{2}$ in. diam., see text
- Ground connections shown in the diagram indicate connections to the chassis and not to actual earth.



HINTS AND KINKS FOR THE EXPERIMENTER

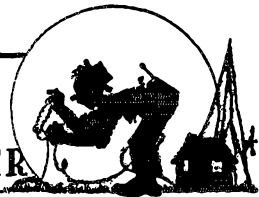

SUBSTITUTING PIN JACKS FOR ROTARY SWITCH IN V.O.M. CIRCUITS

SINCE multi-position gang switches are often difficult to obtain without priority these days, several fellows have been stumped when it came to building the volt-ohm-milliammeter shown in Fig. 1821 on page 393 of the current edition of *The Radio Amateur's Handbook*. To solve this difficulty, we figured out a way by which headphone tips and jacks may be used as a substitute switching arrangement. The circuit is shown in Fig. 1. Since several of the switch points in the original circuit were tied together, it is possible to dispense with some of the contact points in the revision.

All voltage readings are made with tip No. 1 in a neutral position. For resistance measurements up to 250,000 ohms, tip No. 2 should be placed in the 250,000-ohm jack, leaving tip No. 1 in neutral position. Without changing the position of either tip, the 2.5-megohm range is obtained by using an external 45-volt battery. For measuring resistances up to 500 ohms, tip No. 1 should be plugged in the 500-ohm jack and tip No. 2 in the low-ohm-ma. jack. Leaving tip No. 2 in this same position and removing tip No. 1 to neutral, the 1-ma. range can be covered. Additional current ranges require merely plugging tip No. 1 in the 10- or 100-ma. jacks, while tip No. 2 is in the low-ohm-ma. jack. — W. E. Bradley, W1FVH.

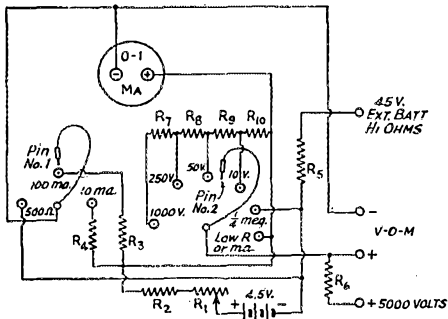

Fig. 1 — Pin-jack arrangement which may be used as substitute for ganged multi-point switch in v-o-m circuits. The following values apply to the circuit shown in Chapter 18 of the 1943 *Radio Amateur's Handbook*.

- R₁ — 2000-ohm wire-wound variable
- R₂ — 3000 ohms, ½ watt
- R₃ — 100-ma. shunt, 0.33 ohms
- R₄ — 10-ma. shunt, 3.6 ohms
- R₅ — 40,000 ohms, ½ watt
- R₆ — 4 megohms, 4 watts (four 1-meg. resistors in series)
- R₇ — 0.75 megohm, 1 watt (0.5- and 0.25-meg. resistors in series)
- R₈ — 0.2 megohm, ½ watt
- R₉ — 40,000 ohms, ½ watt
- R₁₀ — 10,000 ohms, ½ watt

MICA-TRIMMER TANK CONDENSERS IN W.E.R.S. GEAR

I HAVE been working with v.h.f. in a military capacity and have run into the same snag that a good many of the fellows in defense work have run into, said snag being the lack of proper parts. Here are two uses I have found for the small 3- to 30- μ fd. trimmer condensers.

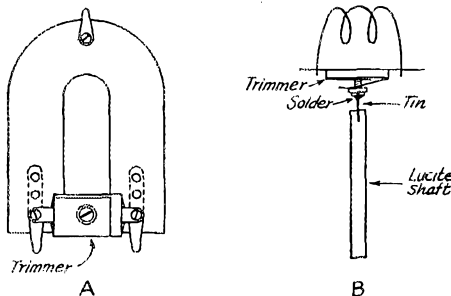

Fig. 2 — Substituting mica trimmers for air condensers in WERS gear. A shows the trimmer applied to the high-C horseshoe tank described in *QST* for December, 1941. The horseshoe is supported by three stand-off insulators, one at each end and one at the center of the curved portion. For the 112-Mc. band, the horseshoe should have an over-all width of 2 inches and length of 2½ inches. The opening at the center is ½-inch wide, making the width of the conductor ¾ inch. The inductance may be adjusted by changing the position of the trimmer on the horseshoe.

B shows the trimmer applied to a receiver. A shaft is attached to the trimmer adjusting screw.

The high-C oscillator, described in a recent issue of *QST* and in the 1943 *ARRL Handbook*, which uses the U-shaped tank circuit, can be made more compact without any appreciable losses in efficiency by the use of a 3- to 30- μ fd. trimmer condenser across the tank instead of the large split-stator variable, which, by the way, is quite hard to obtain. Care should be taken to reach the desired frequency with the trimmer almost all the way closed in order to maintain the desired high-C tank.¹ The U tank circuit may be made adjustable either by drilling holes, as shown in the drawing of Fig. 2-A, or by slotting it to fit the hardware which mounts the trimmer and soldering lugs and tank itself on the stand-off insulators. The U tank in the set I built was mounted on Plexiglass as was the tube and other parts. The assembly can then be put in a cabinet if desired. The high-C transmitter using the trimmer condenser still shows good

¹ Hieronymus, "WERS Gear, 1942 Style," *QST*, Nov., 1942, p. 36.

modulation capabilities and frequency is apparently just as stable as with the variable condenser recommended in the original oscillator.

A trimmer of the same type may be put to use as a tuning condenser in the $2\frac{1}{2}$ -meter receiver or transceiver by soldering a small piece of tin to the head of the set screw and then cementing this tin to a shaft after inserting it into a slot cut for this purpose as shown in Fig. 2-B. It is not difficult to get the screw head to take the solder if it is thoroughly cleaned and scraped before attempting to solder. Any noise that may result from a metal washer or no washer at all between the screw head and movable plate may be eliminated by substituting a fiber or ceramic washer.

The trimmer which was used in a transceiver as a tuning condenser allows the transceiver to superregenerate over three full turns of the trimmer set screw, and it works very nicely. It is used in conjunction with a 1G4G oscillator and a 1T5GT with only $67\frac{1}{2}$ volts on the plates. The inductance will be approximately the same in most cases where the trimmers are substituted.

-- S/Sgt. J. H. Hearne, Hensley Field, Texas.

CONVERTING AN OUT-DATED B.C. RECEIVER TO A COMMUNICATIONS JOB

THE average communications receiver offers an excellent proving ground for a wide

variety of technical theories and practical kinks, yet a great many hams who have spent a goodly sum for a commercial receiver have never ventured beyond replacing a tube or soldering in an exact replacement. Probably the main advantage of the homemade job is that you're not afraid to tear in and try something new. But with parts at a premium (if you can get them at all) not much construction of this type is being attempted at the present time.

The receiver at this shack has been the subject of much experimentation, yet it cost little and used incredibly few parts. An old broadcast receiver—in this case a Fada Model 99 which was about to be discarded—was secured from a friend. The first step was to dismantle it completely. (A previous attempt merely to rewire the r.f. and i.f. stages was wholly unsatisfactory.) After cleaning and repairing, the old receiver yielded an $18\frac{1}{2} \times 11 \times 2\frac{1}{2}$ -inch chassis, a power transformer, a four-gang variable condenser, two audio transformers, a loud speaker with a torn cone and many smaller usable components. After a schematic of the new receiver was drawn up, a general plan was made of the layout. Both circuit and plan were made as similar as possible to those of the original receiver, to save parts and make necessary fewer additional holes in the chassis.

It was necessary to condition several of the parts, such as removing plates from the variable condenser and sawing and drilling the chassis. The r.f., oscillator and i.f. coils were wound by hand on tube bases and forms from the b.c. receiver. The set wiring was done with No. 16 wire from an old field coil. By running the power wiring parallel to the sides of the chassis with right angle bends, an extremely neat job resulted. Of course, all wires carrying r.f. were run in straight lines.

The circuit used in any particular case is, of course, dependent on the original receiver and on your own ideas. A brief description of some of the irregularities in the circuit of my receiver might help to show a few of the possibilities for innovations.

The r.f. stage, the circuit of which is shown in Fig. 3-A, is conventional except for the gain control. When the gain control is moved to the right the screen is by-passed but degenerative feed-back is introduced by reducing the effect of the cathode by-pass condenser. In this condition the tuning of the stage is broad and the gain reduced for receiving a strong signal with good fidelity. For weak stations and greater selectivity, the gain control is moved to the left. Here it reduces the effect of the screen by-pass condenser, causing regeneration.

Inverse feed-back was applied to the first audio grid directly from the voice coil

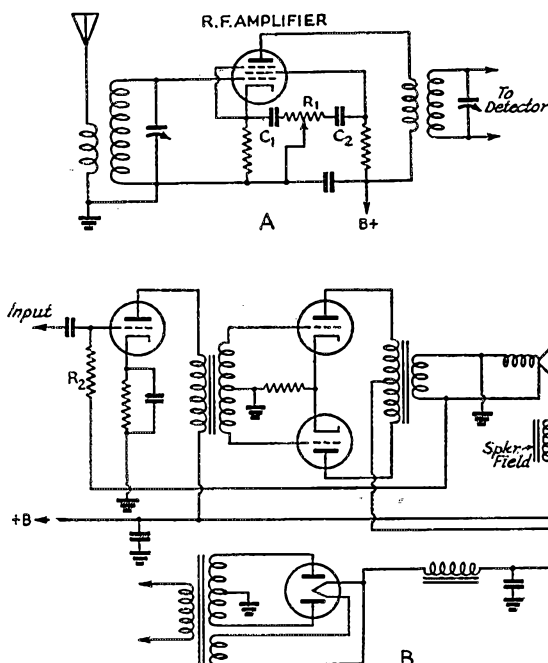

Fig. 3 — Hints for improving homemade receivers.

(A) Combined regeneration-degeneration control for variable selectivity in r.f. amplifier. R_1 is a volume control with a resistance of 5000 to 10,000 ohms. C_1 and C_2 are the usual cathode and screen by-pass condensers.

(B) Negative feed-back audio circuit to improve fidelity and reduce hum. R_2 is the usual grid resistor in the driver stage of the audio amplifier (usually the first audio stage).

as shown in Fig. 3-B. This reduces distortion* in all parts of the audio system and also reduces hum from the ripple in the "B" supply and speaker field current.

Those amateurs who cannot actually help fight this war can still aid their country by becoming as proficient as possible in the fields of research and construction of radio and electronic equipment. Certainly this type of experimentation is one way to help develop and improve these skills. — *William Davidson, W2OKY/9.*

— —

USING TRANSFORMERS WITH 2.5-VOLT WINDINGS FOR 6.3-VOLT HEATERS

Now that there is a trend toward using any old parts that can be salvaged, I would like to pass on an idea for using obsolete b.c. power transformers with 2.5-volt filament windings for tubes with 6-volt heaters.

By replacing the usual 80 rectifier with a tube using an indirectly-heated cathode, such as an 84 or 6X5, the 5-volt winding can be connected to one half of the 2.5-volt winding, giving a total of 6.3 volts.

When using the windings in series, they must be connected in phase. If the first connection gives less than 5 volts, reverse the leads to one of the windings. The total current drain should be limited to about 2 amperes, since this is usually the rating of the rectifier-filament winding. As the current drain of 6-volt tubes is small, this will be sufficient for the average equipment to be powered by such a supply. — *R. R. Robinson, W8MGV*

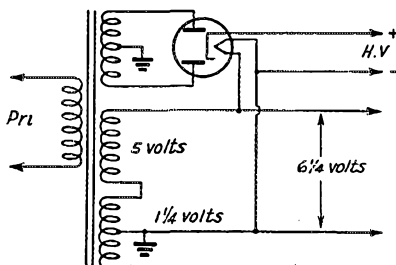

Fig. 4 — Scheme for using 5-volt winding and half of 2.5-volt winding on old transformers to obtain 6.3 volts for operating newer-type tubes. The substitution of a rectifier with an indirectly-heated cathode is required.

— —

SWITCHING ON OR OFF FROM FOUR LOCATIONS

HAVING the urge to act after reading the editorial suggestion by C. B. D. in the February issue, we are passing the following on to *Hints and Kinks*:

Some of us remember the first time we wired our rigs so that we could switch them on or off from either of two positions. For a while we had a feeling of real satisfaction. Of course, our wiring was nothing more than the common "three-way" switching circuit used in hall lighting.

Many occasions arise when it would be most convenient to be able to switch from more than

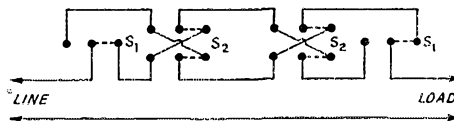

Fig. 5 — Circuit for controlling transmitter or other device from any one of four positions.

S₁ — S.p.d.t. toggle switch
S₂ — D.p.d.t. toggle switch

two positions. The circuit shown in Fig. 5 permits control from four locations and requires only standard switches found in knife, toggle and snap-switch types.

Two single-pole double-throw switches and two double-pole double-throw switches (wired as reversing switches) are needed. Note that in the diagram all switches are shown switched to the right and that the circuit as shown is off. Switching at any of the four positions puts the circuit on. This may be followed by switching to "off" from that or any other of the four positions. — *Charles F. White, Washington, D. C., and Robert J. Hearon, Arlington, Va.*

IF YOUR COPY OF QST IS LATE —

Bear with us and the nation's transportation systems. We are both doing our best — *QST* is being printed one to three days earlier to help keep deliveries on schedule — but unavoidable wartime delays do occur.

ARRL Members:

1. Slowness of delivery is beyond our control; your copy is mailed at the same time as all others for your vicinity.
2. Don't write us about non-delivery until at least the 10th of the following month; your copy is on the way.
3. Renew early and keep your file intact; the supply of replacement and back copies is sharply limited.
4. Please allow plenty of time for acknowledgment of new and renewed membership-subscription entries.

Newsstand Readers:

Because of paper limitations, newsstand quotas are unavoidably reduced. To make sure of getting your copy, buy it from the same dealer each month. That way we can allocate available copies to maximum advantage.

Overseas Members:

Note the expiration date on your membership-subscription certificate and renew 3 to 4 months in advance. We can no longer backdate renewals or supply missing issues. All entries are now being made effective with the issue of *QST* current as of the date new or renewal order is received.

Under present conditions *QST* is mailed overseas at the subscriber's risk and we cannot duplicate copies.



CORRESPONDENCE FROM MEMBERS

The Publishers of *QST* assume no responsibility for statements made herein by correspondents.

THE MARINE CORPS ACKNOWLEDGES

Headquarters U. S. Marine Corps
Washington, D. C.

Editor, *QST*:

It is with pleasure that I acknowledge the article by Clinton B. DeSoto, "*QST* Visits the Marine Corps," which was published in the April issue. The clear and concise presentation of radio communications in the Marine Corps with respect to the problems involved in training of personnel as well as difficulties encountered in combat is gratifying to all Marines. It is believed that the manner in which the article was presented will give the readers of *QST* a deeper insight into the importance and responsibilities of combat radio communications, which will benefit the Marine Corps in its future procurement of radio operators and technicians.

— Lieutenant General T. Holcomb,
The Commandant, U. S. Marine Corps

"ELECTRONICS" VS. "RADIONICS"

41-73 Gleane St., Elmhurst, N. Y.

Editor, *QST*:

I am a great admirer of your magazine . . . but I'm afraid "something must have slipped" in "Correspondence from Members" in the April '43 issue. There you published a letter from E. F. McDonald, jr., concerning the terms *radionics* and *electronics*. Mr. McDonald is probably a good radio engineer and manager, but does not appear to know too much about etymology. He has made several mistakes, I believe. *Radio* is a word derived from the Latin equivalent of "to radiate," but you will see that words like "radius," "radiate," "radiation" all contain the *i* after the ancient root *rad* (*rad-i-us*, for instance). The Greek word *ion* (*ιων*) is therefore *not* contained in the word *radio*. So cancel the "wandering."

Then he states that the first syllable of the word *electric* (*electronics*) is derived from the Greek root meaning "amber." However, the Greek word actually is *elektron*, and *electron* has for a long time been understood to mean the negative charge of an atom, which, when in motion, causes a flow of electric current. If, then, we add the syllable *-ics* to the word *electron*, like in *phys-ics* or *mathematics*, we find the real meaning of the genially-contrived word *electronics* to be "the science concerned with moving negative atomic charges." (Here, too, there is no trace of the *ion*, the "wandering.") The artificially-contrived word *radionics* would

only mean "the science concerned with radiations," which, in my opinion, would be a very incomplete definition of all that which is included in electronics.

We have been using many hundreds of thousands of words "of British origin" — almost the entire American language, in fact — without bothering to find a substitute for every one of them. At a time like this, when Britain is closer to us than ever before, should we let the origin of such an important and well-derived word like *electronics* make us reject it and substitute a competitive "ersatz" word like *radionics*?

— Harry W. Neugebauer

University of Michigan, Ann Arbor, Mich.

Editor, *QST*:

Referring to the communication in *QST* for April, page 47:

Radionics does not spring from the Latin, "to radiate" and the Greek *ion* (to wander or travel), as Mr. McDonald asserts. The Latin word is *radius*, which means the "spoke" of a wheel, "radius" of a circle, and "ray"; but it does not mean "to radiate." There is no Greek verb *ion*, "to wander or travel." *-on*, "thing," or *-ion*, "little thing," cannot properly be added to a Latin word. Scientific terms are not properly made by combining elements of English words. This is the habit of commercial advertisers and the inventors of names for commercial products. Examples of sound scientific terminology are *keno-tron*, meaning "empty device" and *di-ode*, "two road (thing)." To know how good these terms are one has to have some standards in language. Scientific terms are not properly made by ganging up, nor by finding a term "that will win friends and influence people." That is a business man's idea. Words, including personal names, are not mere jumbles of syllables, though that seems to be the idea in the Middle West. *Radionics* is made up slap-dash from *radio* and *onics* (stolen from electronics). Like *heatatrola* and *hatateria*, it will "win friends and influence people." Finally, *radionics* would seem to mean "the science of things pertaining to radio"; whereas the meaning we want is "the science of things pertaining to the electron."

Elektron meant "amber." From this was made the adjective, *electr-ic*, and the noun, *electr-ic-ity*. From the last named was made in turn *electr-on*, "the thing behind the 'amber' effect"; then the adjective, *electr-on-ic*, and the noun, *electr-on-ic-s*, "the science of things pertaining to the electron." That, after all, is the sense you want.

— W. H. Worrell, W8SKW

Editor, *QST*:

. . . I do not like to disagree with Prof. Worrall, but believe the following will be of interest to all concerned.

Due to the discussion now going on about the words *radionics* and *electronics*, it seems advisable to evaluate the etymology and semantics of each. Those who favor "radionics" have given as much thought to it from a standpoint of scientific construction as anyone could ask for. Language is a growing thing, not static. In particular, English (especially the American version) is a composite which has borrowed words from nearly all tongues. In transliteration foreign words are sometimes changed in spelling. Even words which always belonged to the English language have been altered in spelling, as anyone who reads Spencer or Chaucer will realize. Examples of words that have been accepted, such as "fluoroscope" and "dictograph," are a combination of Greek and Latin.

Ray, *radiation*, *radiate* and the English word *radius* all spring from a Latin root which also appears in the first syllable of *radionics*. *Radiate* appears in the Latin form as *radiatus*, which is the past participle of the Latin *radiare*, meaning "to emit rays from," and in turn is derived from the Latin *radius*—rod, ray. The word *ion* comes from the Greek *ion*, neuter of *ion*, present participle of *ienai*, meaning "to wander" or "go." The literal translation of the word *radionics* is "wandering" or "traveling" radiation.

Now let us consider the implied scientific meaning of the word *radionics*. *Ion* is used to indicate a charged particle and its use here combined with radiation is self-explanatory. It is a broad term which, in view of the present state of the art, covers current and future developments.

The early physicists believed atoms to be made of protons and electrons. They were not aware of the possibility of wave mechanics. Now scientists have found in nuclear physics a number of other entities, such as the positron, neutron and deuteron, etc. In the future, when atomic disintegration and ultrahigh-frequency techniques come out from behind closed doors, perhaps there will be other particles that may be used as building blocks and controlled as electrons are now.

In coining scientific words, the suffix *-on* is used to form nouns in physics, denoting the presence of a charged particle. This appears to be a contraction from *-ion*. The first syllable tells something as to behavior or character. Examples are photon, neutron, positron, rumbatron, magnetron, cyclotron.

Also the noun suffix *-ion*, signifying act or process, state or condition, gives another interpretation. In view of all this, the word *radionics* takes on greater significance. We have in it radiation, charged particles, a coverage for future developments in radio technique, an act or process using ultimate particles. Radionics has three important points: (1) The literal translation is de-

scriptive. (2) Scientific connotation is broad and accurate. (3) It implies radio techniques as thought of by laymen, scientists and engineers.

Electronics comes from a Greek root. The Greek word for amber is *elektron*. Thales discovered in 546 B.C. that when amber was rubbed it took on new properties, attracting grass, hair, etc. Stoney in 1891 first used *electron* to indicate a unit charge. Since he was thinking of it in connection with the univalent ion, it might be either positive or negative. It is easy to see how he may have arrived at this terminology. By simply changing one letter, he had a word whose first syllable, *elec-*, indicated electricity with the historical significance of the attracting properties of amber, and the *-on* suffix necessary to show charged particles. The literal translation becomes "wandering amber." Our words, *electricity*, *electrical*, etc., all come from the same Greek origin, *elektron*. (Note the use of the first syllable.) It certainly follows then that Stoney, conscious of charged particles, wanted the *-on* ending to carry its full significance.

Electronics' three important points are as follows: (1) Literal translation is not descriptive. (2) The scientific connotation can stand for only this particular charged particle, negative in character. (3) Absence of anything that will directly indicate radio techniques.

A letter on the subject of radionics and electronics was sent to the editors of a number of publications in all parts of the country, as well as to physicists and deans of engineering schools. Replies from this sample survey are as follows:

Out of 68 editors, 56 preferred radionics, 6 were neutral, 6 thought electronics the better word. According to scientific opinion, as shown by 202 replies of the physicists and others engaged in this field, 131 preferred radionics, 57 preferred electronics and 14 were neutral.

— Elizabeth Kelsey, *Engineering Correlator*,
Zenith Radio Corporation

UNIONS AND THE MARITIME SERVICE

1715 Maiden Lane, Springfield, Ohio
Editor, *QST*:

Have just finished reading the article in May *QST* . . . [on] the training of radio operators for the U. S. merchant marine.

The article is interesting as far as it goes, but the paragraphs outlining privileges, quarters, messing facilities and base-pay status should have been followed by an explanation of how this "Utopia" came about. For "Utopia" it was, to the operators who were going to sea in the '30s.

These good conditions and wages did not come about through the good-heartedness of the War Shipping Administration or any other governmental agency, nor through the fact that a "national emergency" existed and marine radio operating had to be "dressed up" to make it an attractive service.

It was done individually and collectively through the membership of the American Com-

munications Association, who for over ten years fought for and obtained, the hard way, the privileges and fair wages that are now an accepted standard in the merchant marine. The high standards and wages obtained in the communications company's point-to-point services and marine coastal stations were obtained the same way.

Give credit where credit is due.

— *R. P. Letsinger, W6EGR*

PROPERLY CLASSIFIED

Ephrata Air Base, Ephrata, Wash.

Editor, *QST*:

. . . No doubt you have heard that the Army tries to classify men into the type of work they are best suited for. Believe it or not, it actually happened with me. Aside from being in the radio business for the past three years, I have held a ham ticket and was active on several bands for over twice that time. Also, in the months before Uncle Sam beckoned I spent a great deal of time at another of my major interests — flying. My job now is a combination of both: control tower operator, directing air traffic.

As a graduate of the Army Air Forces' great radio school at Scott Field, Ill., I feel that I have accomplished something thus far and sincerely hope that all who might read this have been as fortunate in being assigned to a task as pleasant and as much to their liking and ability as I have.

Boy! Won't the ether waves hum with tall tales and exciting adventure when we can once again sit down for an unending evening of friendly ragchewing? That's the day I'm looking forward to!

— *Cpl. Robert D. Greer, W7GCT*

FROM ONE RUMPUS TO ANOTHER

U. S. Naval Air Station, Cape May, N. J.
Editor, *QST*:

. . . You will remember, I'm sure, the call KH6SHS that started such a rumpus from American Samoa during the spring of 1940. Ever since that time I have had no opportunity to go on the air, and when war was declared that settled things for good. . . .

I have joined the Naval Air Force and now hold the rating of aviation chief radioman. I won't say where I've been, but it sure is fun to meet up with fellas all over the world who have held amateur licenses and who still have the same enthusiasm for research, handling traffic and just plain chewing the fat. . . .

I'd like to make a recommendation to all ex-hams who are now in Uncle Sam's Navy. Go to the Navy's finest radio school at Bellevue, D. C., and then start all over with hamming principles! It works wonders, and the technical knowledge gained is of inestimable service to your country. Most of our top grads at the school were ex-hams. . . .

— *ACRM J. J. Petranek, USN*

THINKING NOT RESTRICTED

519 E. Melbourne Ave., Peoria, Ill.

Editor, *QST*:

You are to be congratulated on the high quality maintained by "our" magazine since the war. Working under unusual difficulties, you are doing a remarkable job.

Our operating has been restricted, but our thinking has not. Our learning and experimenting continues at an even faster pace for many of us. We are glad to see *QST* coming out each month — just about as thick as ever — and with the latest news of our great fraternity.

I like, especially, your articles on new apparatus and theory. — *Cyrus Rohrer, jr., W9EKL*

BUSILY ENGAGED

Fort Canby, Wash.

Editor, *QST*:

. . . Am busily engaged with Uncle Sam as a Signal Corps radio engineer — exact duties unmentionable. . . . It is highly interesting work and my twenty-odd years of ham experience actually have done some real good. Heretofore I just played with radio. Now I am thoroughly enjoying putting my radio experience to good use for our national defense.

Speaking of national defense, I would like to state that your "Defense Edition" of the *Handbook* helped me greatly in presenting radio fundamentals to a group of soldiers whom I was teaching at the Presidio at San Francisco before coming to Fort Canby. Keep up the good work. . . .

When this confounded war is over and I can speak, I would like to tell you and the rest of hamdom just what our very pleasurable hours of ham radio have meant to us — all of us. I did not realize at first just what hams could do until I got started doing. Now, due to a wide variety of experience all over the country, from going to school and teaching school, from servicing and maintaining complete unit installations, I have had an opportunity to see how the radio ham has gone to work for his country in so many ways — not necessarily all in the field of communication. . . . — *Porter Evans, W6BF*

HE DID SOMETHING ABOUT IT

Millington, Tenn.

Editor, *QST*:

. . . I want to express my gratitude to you there at Headquarters for keeping *QST* going and for the splendid work that you do through it in behalf of national defense. Without *QST* amateur radio would literally die. Before the war I did not belong to the ARRL, but after the declaration I decided that it was my duty to join.

QST has been a wonderful help to me in catching up on my radio fundamentals. I thought that I knew a *little* about radio, but after studying the issues of *QST* for the past two years I decided that I didn't. So I proceeded to do something about it. . . . — *C. Moss Mangum, W4HYB*



OPERATING NEWS



GEORGE HART, WINJM
Acting Communications Manager

CAROL A. KEATING, W9WWP
Assistant Communications Manager

Ninth Regional CD-WERS. Not long ago we had a communication from an official of OCD's Ninth Regional office, who stated that amateurs on the West Coast were not giving as much support to WERS as he knew they were capable of giving. He asked us for a list of our officials in the Ninth Region, which we were glad to send him. By this time he has probably already been in touch with some of you SCMs, Assistant SCMs and ECs out there. We hope that he was well received.

But this business of non-participation — is it true? Our WERS map here at Headquarters shows a total of 14 licensees in the Ninth Civilian Defense Region, comprising the states of California, Oregon, Washington, Idaho, Nevada, Arizona, Utah and Montana. This compares to approximately 40 licensees in the New England states alone. Most large West Coast cities, such as San Diego, Los Angeles, San Francisco, Portland, and Seattle, are unlicensed. Oakland is

a notable exception. Let us summarize a bit. Our latest advices show that the 14 licensees are as follows: In California — Culver City, San Mateo County, Pacific Grove, Inglewood, Oakland and Vallejo; in Oregon — Bend and Oregon City; in Washington — Tacoma, Snohomish County, Spokane County and Olympia; in Montana — Great Falls; in Arizona — Maricopa County. The other states of the region have no licensees. Four other communities have reported to us that they are organizing: Medford, Ore.; Sacramento, San Francisco and Los Angeles, Calif. Six other ECs have reported that there is little hope of any CD-WERS activity in their communities. From all the rest — silence.

Thirteen licensees, and most of them in comparatively small towns, isn't such a good showing for an area as critical as the West Coast. How about a little more activity? If CD-WERS is under way in other areas not mentioned above we have not heard about it, and we should like to.

Honor Roll

The American Radio Relay League War Training Program

Listing in this column depends on an initial report of the scope of training plans plus submission of reports each mid-month stating progress of the group and the continuance of code and/or theory classes. All Radio Clubs engaged in a program of war radio training are eligible for the Honor Roll. Those groups listed with an asterisk teach both code and theory. Those listed with two asterisks teach theory only. Others conduct only code classes.

- **Amateur Radio Researchers, Bell, Calif.
- *Associated Amateur Radio Operators of Denver, Colo.
- *Bell Radio Amateurs, Denver, Colo.
- *Bloom Radio Club, Chicago Heights, Ill.
- *Buckeye Radio Association, Akron, Ohio
- *Central New York Radio Club, Syracuse, N. Y.
- *Central Oregon Radio Klub, Bend, Ore.
- *Chair City Radio Association, Gardner, Mass.
- *Detroit Amateur Radio Association, Detroit, Michigan
- *Dutchess County Sheriff's Emergency Radio Corps, Poughkeepsie, N. Y.
- *Edison Radio Amateurs' Assn., Detroit, Mich.
- *Electron Club, Denver, Colo.
- *Flood City Radio Club, Johnstown, Pa.
- *Goshen (Ind.) Amateur Radio Club
- *Hampden-Sydney College Radio Club
Hampden-Sydney, Va.
- *Hamilton (N. J.) Township Radio Club
- *Hillsborough Twp. ARRL Radio School, South Branch, N. J.
- *Iowa-Illinois Amateur Radio Club, Burlington, Iowa

- *Jersey Shore Amateur Radio Assn., Long Branch, N. J.
- *Joliet (Ill.) Amateur Radio Society
- Kalamazoo (Mich.) Amateur Radio Club
- Knoxville (Tenn.) Radio Communications Club
- *Marietta (Ohio) Amateur Radio Society
- *Milwaukee Radio Amateurs' Club, Milwaukee, Wis.
- *MIT Radio Society, Cambridge, Mass.
- *New Haven (Conn.) Amateur Radio Assn.
- *Olympia (Wash.) Radio Club
- *Randolph-Macon Academy Communications Club, Front Royal, Va.
- *Recreation Radio Club, Fitchburg, Mass.
- Rose Polytechnic Institute Radio Club, Terre Haute, Ind.
- *St. Paul (Minn.) Radio Club
- Schenectady (N. Y.) Amateur Radio Assn.
- Shy-Wy Radio Club, Cheyenne, Wyoming
- *South Jersey Radio Assn., Merchantville, N. J.
- **Spokane (Wash.) Radio Operators' Club
- Tucson (Ariz.) Short Wave Assn.
- *Walnut Hills High School Radio Club, Cincinnati, Ohio

Drop us a line, and while you are at it, drop a line to your SCM and get him to report activity. If you are endeavoring to get something started and are having trouble, get in touch with your regional communications officer, Mr. A. C. Ray Birch, Office of Civilian Defense, 1355 Market St., San Francisco.

We at ARRL Hq would like to keep in closer touch with our West Coast members and other amateurs. If your SCM hasn't been reporting perhaps it is because he hasn't been receiving reports from the members of his section. Try him and see. If he is simply inactive, why not build a fire under him? Write us your troubles, anyway, and you will see that we are eager to help where we can.

— G. H.

BRIEFS

Two of the Chicago area radio clubs are keeping "alive" in good fashion. The *Chicago Suburban Radio Association* has been building 2½-meter crystal-controlled WERS transmitters. Special mention for their work in the design and construction of these transmitters, which have been used as the nucleus of the City of Chicago's WERS set-up, goes to 9PEQ, 9PNV, 9MAT, 9MNW, 9PK, 9USJ, 9RLM and 9FCN.

The *Society Radio Operators* holds open-house meetings once every two months with top-rank speakers, lecturers and entertainers. The average attendance totals 150 guests. Of the club's 19 members, 7 are in the Service, and all 7 hold officer ratings.

Earlier this year, at the annual meeting of the *Chicago Area Radio Club Council*, seven affiliated clubs out of a possible nine were represented, which further proves that amateur radio is not "dead" in and around Chicago. In addition to planning WERS for the Chicago area, the Council has been functioning in a more quiet way by disseminating information of licensing of all rigs to hams and others in possession of transmitters, lending its card mailing list to the Army and Navy and others entitled to its use, furnishing information and answering questions of, about and to the Service commands as well as keeping abreast of latest CAP developments. Further information about the Council will be furnished on request by the Secretary, M. Warren Clark, W9YDV, 2916 N. Albany Ave., Chicago, Illinois.

The real ham spirit of "do or die" has been exemplified by E. G. Graf, W8SJV, the radio aide for Tonawanda, N. Y. Finding that he was unsuccessful in obtaining aid from the few hams remaining at home, he decided to call on the local Civilian Defense authorities for help in organizing WERS in Tonawanda. The communications chairman wasn't interested because he thought Boy Scouts could serve as messengers in all such emergencies. Not to be dissuaded, W8SJV then asked for a chance to address the OCD and war council at one of their meetings. After a lot of discussion, the council finally decided to grant permission for WERS efforts in the town, but stated that all expenses would have to be paid by W8SJV. He then recruited 19 women for a class in basic radio law, to become WERS operators; called his own DK3 into service; purchased a TR4 for the local control station; built a wavemeter and a Lecher wire system for frequency measurement, and is now using all of his own equipment to build four transceivers for special calls and other transmitters and receivers for the network. On March 29th the license was received from FCC, the call being WKNL. Since that time the local authorities have evinced a little more interest, and a local ham and a serviceman have offered assistance.

We doff our hats to W8SJV for the finest example of single-handed WERS effort that has come to our attention here at Headquarters!

W3HVD, 4801 Kenwood Ave., Baltimore, Md., and the Rev. Albert E. Martin, 3705 Ridgcroft Rd., Baltimore, Md., would like to swap QSL cards with any ham or SWL. They both guarantee 100 per cent returns in the form of hand-drawn QSLs.

ELECTION NOTICES

To all ARRL Members residing in the Sections listed below: The list gives the Sections, closing date for receipt of nominating petitions for Section Manager, the name of the present incumbent and the date of expiration of his term of office. This notice supersedes previous notices.

In cases where no valid nominating petitions have been received from ARRL members residing in the different Sections in response to our previous notices, the closing dates for receipt of nominating petitions are set ahead to the dates given herewith. In the absence of nominating petitions from Members of a Section, the incumbent continues to hold his official position and carry on the work of the Section subject, of course, to the filing of proper nominating petitions and the holding of an election by ballot or as may be necessary. Petitions must be in West Hartford on or before noon of the dates specified.

Due to resignations in the Missouri, Eastern Florida and San Joaquin Valley Sections, nominating petitions are hereby solicited for the office of Section Communications Manager in those Sections, and the closing date for receipt of nominations at ARRL Headquarters is herewith specified as noon, Tuesday, June 15, 1943.

Section	Closing Date	Present SCM	Present Term of Office Ends
East Bay	May 14, 1943	Horace R. Greer	May 26, 1943
Vermont	May 14, 1943	Clifton G. Parker	June 2, 1943
Maine	May 14, 1943	Ames R. Millett	June 7, 1943
Alaska	June 1, 1943	James G. Sherry	June 14, 1942
No. Minn.	June 1, 1943	Millard L. Bender	Aug. 22, 1942
No. New Jersey	June 1, 1943	Edward Gursky, Jr.	Oct. 15, 1942
West Indies	June 1, 1943	Mario de la Torre	Dec. 16, 1942
Missouri	June 15, 1943	Robert C. Morwood (resigned)
Eastern Fla.	June 15, 1943	Carl G. Schaal (resigned)
San Joaquin Valley	June 15, 1943	Antone J. Silva (resigned)
Hawaii	June 15, 1943	Francis T. Blatt	Feb. 28, 1941
Sacramento Valley	June 15, 1943	Vincent N. Feldhausen	June 15, 1941
Nevada	June 15, 1943	Edward W. Heim	Nov. 1, 1941
Oklahoma	June 15, 1943	R. W. Battern	Nov. 1, 1941
New Hampshire	June 15, 1943	Mrs. Dorothy W. Evans	Sept. 1, 1942
San Francisco	June 15, 1943	Kenneth E. Hughes	July 5, 1943
So. Carolina	Aug. 16, 1943	Ted Ferguson	Aug. 25, 1943
Eastern Penna.	Aug. 16, 1943	Jerry Mathis	Aug. 28, 1943

1. You are hereby notified that an election for an ARRL Section Communications Manager for the next two-year term of office is about to be held in each of these Sections in accordance with the provisions of the By-Laws.

2. The elections will take place in the different Sections immediately after the closing date for receipt of nominating petitions as given opposite the different Sections. The Ballots mailed from Headquarters will list in alphabetical sequence the names of all eligible candidates nominated for the position by ARRL members residing in the Sections concerned. Ballots will be mailed to members as of the closing dates specified above, for receipt of nominating petitions.

3. Nominating petitions from the Sections named are hereby solicited. Five or more ARRL members residing in any Section have the privilege of nominating any member of the League as candidate for Section Manager. The following form for nomination is suggested:

(Place and date)

Communications Manager, ARRL
38 La Salle Road, West Hartford, Conn.

We, the undersigned members of the ARRL residing in the Section of the Division hereby nominate as candidate for Section Communications Manager for this Section for the next two-year term of office.

(Five or more signatures of ARRL members are required.)

The candidates and five or more signers must be League members in good standing or the petition will be thrown out as invalid. Each candidate must have been a licensed amateur operator for at least two years and similarly, a member of the League for at least one continuous year, immediately prior to his nomination or the petition will be thrown out as invalid. The complete name, address, and station call of the candidate should be included. All such petitions must be filed at the headquarters office of the League in West Hartford, Conn., by noon of the closing date given for receipt of nominating petitions. There is no limit to the number of petitions that may be filed, but no member shall sign more than one.

4. Members are urged to take initiative immediately, filing petitions for the officials of each Section listed above. This is your opportunity to put the man of your choice in office to carry on the work of the organization in your Section.

— George Hart, Acting Communications Manager

ELECTION RESULTS

Valid petitions nominating a single candidate as Section Manager were filed in a number of Sections, as provided in our Constitution and By-Laws, electing the following officials, the term of office starting on the date given.

Mississippi	P. W. Clement, W5HAV	April 1, 1943
Western Penna.	E. A. Krall, W8CKO	April 1, 1943
Rhode Island	Clayton C. Gordon, W1HRC	April 15, 1943
Utah-Wyoming	John S. Duffy, W7DIE	April 15, 1943

Wartime Radio in High Schools

BY GLADDEN ELLIOTT,* W6MLL

ARTICLE CONTEST

The article by Mr. Gladden Elliott, W6MLL, wins the CD article contest prize this month.

We invite entries for this contest. Regarding subject matter, we suggest that you pick a topic of current interest. Amateur radio is a broad field and our ways of contributing to the war effort need discussion and emphasis. Perhaps you would like to write on Radio Training programs, club methods boosting code proficiency, Emergency Corps registering for CDC selections and WERS activity, organizing or running a radio club, getting local groups QSO by light beam or wired wireless or ground currents now radio is out!

Each month we will print the most interesting and valuable article received. Please mark your contribution "For the CD contest." Prize winners may select a bound *Handbook* (Radio Training Course or regular edition), *QST* Binder and League Emblem, or any other combination of ARRL supplies of equivalent value. Try your luck!

AT FIRST GLANCE there seems very little that the small or medium-sized high school can do in the way of direct war training. As a general rule, shop facilities are too limited to accomplish much, and funds are not available to add new or additional items. The Nogales High School, being in this category, found that radio training offered the opportunity that we had sought — something that we could give our students that would greatly assist our nation in wartime. Continual appeals by radio broadcasts and newspapers for radio operators proves that our contention was right.

Our school was particularly fortunate in that it had three licensed amateur operators on its faculty: W6MKZ, W6KSO, and W6MLL, to start its radio training program. (The school which is not so fortunate, may be able to obtain needed assistance from hams who live in the community.)

Through their efforts classes have been organized in code and radio theory. Both type classes have been given high school credit and have, as a result, proven extremely popular. Code classes are now conducted on two levels, one for beginners and one for advanced students. They are conducted before and after school to give all students an opportunity to participate. The radio theory class, which carries full high school credit, is offered during regular school hours.

The beginning code classes are conducted along the plan suggested by ARRL. Additional practice, and an accurate means of testing, is afforded by the use of tape machines. Headphone outlets are provided for a dozen students by the simple expedient of stringing wires along the baseboards of the room. Two nails are driven in the baseboard beside each desk, each one about one and one-half inches above the other. Wire is strung from nail to nail, with the insulation scraped from the wire at each nail, and it is twisted around the nail. The wire is terminated at the output of the audio oscillator, which is used to produce the code practice signals. Headphones are fastened to the nails by the use of battery clips. (When class is over, the headphones are stored in a convenient drawer so that the equipment will be out of the way.) An audio oscillator is connected to a loudspeaker for use of training groups larger than twelve.

As the group advances in code ability, other factors are introduced in the course. Procedure, similar to that used by the Army, is followed in advanced work. Class instructions are given in message handling, similar to the methods used in the Army Amateur Radio System. ARRL net "Q" signals are used in place of the Army "Z" signals. The text of the license manual is used for code drills, so that the student may familiarize himself with the license examination questions and radio laws at the same time he is learning the code.

Students get practice in sending on a code table constructed out of old wooden typing tables, which have been wired according to the plans in October *QST*. With this table, students may send to themselves or others, and they are permitted to practice anytime during the day, using headphones to prevent disturbing noises. Students are encouraged to get additional practice in sending, receiving, and procedure by sending messages to each other.

Code tests are given twice a month. Copy must be made for one minute without an error before the student is given credit for attaining any one given speed. ARRL code certificates are awarded for attaining fifteen or more words per minute.

The radio theory class is conducted similar to a science class. The text used is "Understanding Radio," by Herbert Watson and Herbert Welch, published by McGraw-Hill. This book is supplemented by the defense edition of the ARRL *Handbook*, to bring the course up to date. The material in this course, when supplemented by the *Handbook*, is the same as outlined by the ARRL and Navy elementary radio theory courses. As individual laboratory projects, each student is encouraged to construct a short-wave regenerative receiver out of an old radio, and to put in some time listening to a short-wave receiver in the classroom.

The simple experiments of the course are readily performed by using physics class equipment and additional parts are obtained from obsolete alternating current receivers. The cost of equipment has been well under twenty-five dollars, with the tape machine and audio oscillator being the most expensive items. Most of the equipment, such as old radio receivers and headphones, was readily obtained from citizens as loans or donations.

At the close of the school year the students are given the opportunity to take the tests for amateur licenses. In any event they will certainly be of greater potential value to the nation than other students who have had no specialized training.

BRIEFS

Patience must be its own reward. R. C. Barnes, W2RP, this last year received a QSL confirming a nine-year-old QSO with W4DZ. "Better late than never," says W4DZ.

W9SCH suggests playing radio tick-tack-toe when we are back on the air again. The only new requirement would be a designation scheme for the squares to facilitate playing:

A	B	C
D	E	F
G	H	K

He says it would be quicker than chess or checkers, and would be easy enough and familiar enough for any amateur to play.

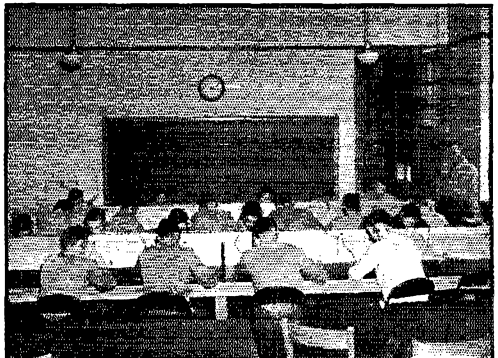

A scene that should be typical throughout the nation's high schools this coming term. W7AMU teaching his code class at Caspar (Wyo.) High School.

* 218 Loma St., Nogales, Arizona.



ATLANTIC DIVISION

EASTERN PENNSYLVANIA — SCM, Jerry Mathis, W3BES — 3AOC is teaching advanced theory course at the Naval Aircraft factory, along with 2LZK and 3DZ. During a recent visit to Washington, he met 3CFE, 3AKB and 3GUV. 3GRF is pounding brass at WAR along with 3DZR and 3GUF. Lower Merion worked a very interesting problem with their 2½ meter WERS portables, entailing relaying of messages between stations shielded from each other. This was accomplished by an intermediate relay point that could work both ways. They have also made contact on 1½ meters. During a recent surprise alert, 100% of their units reported for duty. Haverford also handled incidents on the same night. 3KT is presently stationed at Boston. 3JBC is in the Signal Corps and is in South Carolina. 3DXZ is a master sgt. now. 8SNA, one of the regular ORS gang, is operating at WDAS in Phila. 3IRS is chief at WHAT. The Phila. WERS can put on up to 111 units. 3IXN had a very fine visit with Bailey, 1KH, while in Washington recently. 3BES is making phonograph records to send to the various members of the Frankford Radio Club who are stationed away from home. GRF says that the lads handling the high speed circuits in the Army are going to be "hot stuff" when the war is won, and are going to be hard to snout under in the contests. He also states that his days of flea power are over. 3AXR is back from overseas. 3EKK is a lt. in the Army, home from Florida, on leave. 3CND is a capt. in the armored forces. 3CBT is a lt. in the air transport branch, and states that all of the officers in his outfit are hams. The ARRL is especially interested in getting full reports on the WERS activities of all communities in order that a record may be compiled. This record will be a strong claim to our rights as radio amateurs should the occasion to use it arise. ECs and radio aides should get report blanks from hq. or their SCM. 73.

MARYLAND-DELAWARE-DISTRICT OF COLUMBIA — SCM, Hermann E. Hobbs, W3CIZ — The WERS license for the District of Columbia was finally issued on March 25th, and a test proved successful in covering a distance of 12 miles. The call is WJDC. They have some surplus equipment which can be obtained from them by contacting the radio aide. The Montgomery County WERS also obtained its license, the call being W3MD, and a test run was held May 3rd. The gang is short of equipment for construction, especially peanut tubes. EYX is with the Navy Dept., Phila., Pa. 5JFJ was a recent caller in Washington. INVO, ex-2ESO, ex-4GNQ, is located in Waltham, Mass. 2LVH is located at 1008 Euclid St., NW, Wash., D. C.

SOUTHERN NEW JERSEY — Acting SCM, Ray Tomlinson, W3GCU — Asst. SCM, Edw. G. Raser, ZI; Regional EC in charge of Emergency Coördination, Theodore Torretti, BAQ; ECs: Somerville and Vicinity, including Southbranch, Stanley Case, ABS; Asst. EC for Hamilton Twp. and radio aide for WERS, H. Dallas Fogg, ASQ. Hamilton Twp. application for WERS still in FCC. ABS reports program for Hillsboro and Branchburg Twps. is still bottled up for approval in Trenton OCD. Hillsboro-Branchburg set-up now has seven complete 2½ meter rigs ready to go. EBC has moved to Bound Brook, thereby nullifying his EC appointment covering Somerville and vicinity. ABS has been appointed and has accepted EC job for Somerville and vicinity, including Southbranch. He may be addressed: Mr. Stanley Case, W3ABS, Route No. 4, Southbranch, N. J. ACC and ABS spend quite a lot of time listening in on 2½ meters Sundays and Wednesdays, and have heard Brooklyn, N. Y., which is an airline distance of approximately 50 miles. New Brunswick, Metuchen and several others come in fb with R9 plus signals over a distance of 17 miles. ASQ and several others are working out nicely on wired wireless communication throughout Hamilton Square and surrounding territory. ACC and ABS maintain regular wired wireless skeds. JAG is doing a lot of listening on wired wireless. The Hillsboro Twp. radio school, now in third session, has one student up to 25 per and set to take license exam for ham ticket. Hamilton Twp. instruction now covers

seven volunteer fire companies, with ASQ covering two classes in some three nights weekly. There are now 35 ready for exams in Hamilton Twp. SJRA classes, with FDF in charge, are progressing nicely. BWR and BO, former members of SJRA, now in the Services, wish to extend their 73 to all the gang. SJRA welcomed two more new members at their regular meeting April 15th. EEQ, now in Omaha, says the room he now occupies was the former radio shack of the landlady's son. Our hearty congrats to the Queen City Emergency Network, of Cincinnati, on their excellent progress in WERS set-up there. And, speaking of WERS progress, let's hear from some more of our own section members! Due to illness, GCU had to give up editorship of "DVRA News," which was taken over by the associate editor, ZI, with the able assistance of JAG. Best luck 'til next month and 73.

WESTERN NEW YORK — SCM, William Bellow, W8MC — Rochester has quite an influx of out of town hams: 9KRA, 71CC, 6RWG, 9TYG, Joseph Paterchok, LSPH, and Edward Pederson from western Pennsylvania. Tonawanda, N. Y., has received its CD-WERS license with the call WKNL. The radio aide, SJV, has built and donated the equipment for 12 stations. Aided by one other ham, OWT, and one other operator, he is conducting a class in basic radio for 16 women. Corp. Bob Maverman, and ex-SWL of Rochester, is studying radio mechanics at air corps technical school at Tomah, Wisconsin. He tells us the hams played a large part in the development of a control net system. DFN has built up a little transmitter for WERS using an 1852 as ECO on 10 meters, and an 1852 to 2½ meters, driving an 815 final.

WESTERN PENNSYLVANIA — SCM, E. A. Krall, W8CKO — Asst. SCM in charge of EC, Theresa McLaughlin, VYU. ECs are needed in many areas of W. Pa., and progressive amateurs are invited to participate. MHE has done outstanding work in his attempts to get WERS of Allegheny County on a working and substantial basis. MP, Electrical Engineer in charge of the electrification of one of Pittsburgh's largest steel mills, has been transferred to the Chicago district. UVD of Jeanette has to look into a mirror to see another ham.

CENTRAL DIVISION

ILLINOIS — Acting SCM, George Keith, Jr., W9QLZ — JVC is in the thick of it in North Africa. CXT has joined the Marines. OXA promoted to capt., Air Forces. ZEN pounds brass for Coast Guard and likes it. NIU, WOO, KTA, KSZ, LIG, PBY and NOO are enrolled in ESMWT course in radio at LaSalle. LIG has commercial 'phone second class ticket. NIU, NGG and QLZ have first class 'phone and second class telegraph commercial tickets. NGG is pounding brass for Ill. state police and is stationed at French Village. NIU, engineer for LaSalle County police comms. system, is dabbling in fb FM equipment. Where's Elmer, W9DBO? ILH has moved to California and QLZ has been asked to keep the SCM job going until she returns. ASB's father recently was notified that he was captured by the Japs on the Philippines with the Army artillery corps. Ex-UPG (now 8VKJ), now a CG ensign, studying Diesels at Cornell. IHN, in Honolulu with the FCC, reports STG listed as missing, JNC in Yukon Territory in Canada, and BRD in Washington, D. C. It is hoped that the section will cooperate by sending news early in the month to insure being received at ARRL in time for publication. Give news about yourselves, except restricted info, members in the Services, their rank, address, etc. Geo./QLZ.

INDIANA — SCM, LeRoy T. Waggoner, W9YMW — Gary has joined the rapidly growing list of Indiana communities that are licensed for WERS. The CD-WERS call is WKMR. EGQ advises that the initial license covers five fixed, four mobile, and two spare transmitters. Terre Haute CD-WERS has progressed to the application for license stage. LVH has built the control center rig. The two other transmitters were built by YXT and ANH. EMQ writes that Anderson CD-WERS operators have been designated "Hdqrs. Staff" of the local CDC. SVH advises initial plans are completed and application for Elkhart County CD-WERS license has been made. Vincennes has nine prospective WERS ops anxiously awaiting licensing. Marion hams propose to operate CD-WERS on a county-wide basis. Valparaiso, says W9HDB, will have CD-WERS very soon. KYQ, lone ham at New Castle, is going in for CAP-WERS with the Newcastle Squadron. LPQ informs that CD-WERS call letters for Sullivan will soon be a reality. EBB,

former member of the Calumet Area Emergency Net, and now doing radio research in Washington, D. C., would like to hear from the old gang. QTH, 2409 Naylor Road, SE. ZYJ is training recruits for Uncle Sam. HUV says NXU, home on furlough recently, goes for Army flying in a big way! GVW had to lose a lot of avoirdupois to get his feet off the ground. AUN and DKP are very active on wired wireless. Indiana amateurs are active in CD, CAP, and State Guard WERS. Let's have reports from each of these branches! 73, Roy.

MICHIGAN — SCM, Harold C. Bird, W8DPE — Lansing WERS is functioning smoothly. Those participating are: PLE, GSP, RGS, UGO, UJS, CQT, SDB, SLQ, IZB, UXS, VDC, VCZ, VIZ, VRV, SPV, WDA, WCZ and AHV. Detroit reports about 30 students ready to graduate from Thomas A. Edison Post School. WERS in that locality doing very nicely. JIJ states that between watch repairing and teaching code classes, he is plenty busy, and takes alarm clocks home at night to repair. OCC reports the burning of the plant where he works. He has been busy rewiring new quarters and getting machines back in action. NXT is very busy pulling teeth. DSQ still coasting along and hoping. GP keeps busy with code classes at school. IFT wishes he could send in good traffic report. VZZ held a meeting at his house as he expects to leave for camp before long. IHR still on job minus a couple of his teeth. BIU, radio aide for Center Line, Mich., reports WERS in that locality progressing smoothly and invites us to visit them. MV missed making Naval officer by fifty pounds and says this should be a lesson to fat men. SEY attended first club meeting in about two years. RJC sent in renewal for QST. Please send in your WERS activity reports. This column is limited now due to space. Thanks. 73, Hal.

OHIO — SCM, D. C. McCoy, W8CBI — Floods threatened the Ohio Valley around the 20th of the month. Cincinnati and Dayton WERS units were in touch with each other during the danger period and both units kept in touch with the Red Cross to be of any assistance. VUS has just been appointed EC at Pomeroy and negotiations are under way for one at Marietta, to replace VZ, now in the Navy. AVH suggests a state wide relay on 2 1/2 meters. Cincinnati — The Cincinnati WERS went into action on Feb. 25th during a blackout. The Walnut Hills high school radio club reports 5 members have passed their third class 'phone; Dick Rose, secy., passed class B amateur, and Charles Edelson, pres., passed 1st class radiophone. PNJ says he finally got all his cards for 10 meter WAS after 5 years of effort. Says TYM, TKH and QUM were WERS ops in his zone for the last blackout. SJFC is at Wright Field as civilian employee. Lima — CXN has resigned as EC as he is expecting induction into the Army soon. Toledo — RRZ reports license received, call letters WKJF, on March 4th. ESN reports a meeting of the CARMARS, at which Mr. Claude Caldwell gave a lecture on FM, and Mr. Glenn Snow showed some motion pictures. Chillicothe — VUS has been appointed as EC for the Pomeroy WERS area. Columbus — QMN reports city license now includes all of Franklin County. A special demonstration for the disaster officials of the local Red Cross chapter was held on March 28th. 41 operators have been licensed, papers for 5 more are in hands of the FCC, and about 100 students will soon be given 3rd class 'phone permit exams under direction of DMN, RHH and LCO. It is the writer's sad duty to record the death of TWO, who passed to eternal rest on March 10th. Charlie has been engaged in the radio business for the past 21 years, selling and repairing radios, and operating as an amateur in more recent years. He was one of the founders of the Miami Valley emergency net and was always active in its affairs. Severely handicapped by infantile paralysis, his activities are an example for those of us who are blessed with our full physical capacities. TOZ has been called to the Army. RHH will take over his duties. MFV writes from Kelly Field that he has graduated from another radio school and is awaiting assignment to another post. He can be reached for the time being, at Kelly Field, c/o 3rd Communication Squadron. SVI has graduated from radio school, and is now at Drew Field, Fla. SPL was in town on a brief leave. IX is on sea duty now, somewhere in the Pacific. WOX and AZH are struggling to get the latter's PM equipment built for WERS operation. VWL, LCO and ENH are chief operators for fixed stations in the Dayton WERS system. Eaton — PRS is local radio aide for the Eaton defense council. SID is working long hours but has been planning with PRS for county WERS activities. VYE has two Abbott TR4s ready, one for installation in his car and the other for fixed

operation in the home town. Piqa — Warm weather will allow some experimental work on antennas, according to WKN. Cleveland — AVH reports direct communication between Akron and Cleveland control centers and messages exchanged. Over 100 operators have been licensed and more are in training. 73, Dan.

WISCONSIN — SCM, Emil Felber, Jr., W9RH — The MRAC-Shorewood High School evening classes report Petty Officer Bahr of the Wisconsin recruiting staff, U. S. Navy, and 35 of the personnel in the recruiting office appeared for the first period of instruction. On the opening night for this Navy class 6MPL of Oakland, Cal., was a visitor to the class. Instructors still are GPI, CCD and HWO, who is a regular instructor at the school. ALG, EC of Chippewa Falls, reports that WERS there is getting a start. Ernest Wendt, formerly a member of the Chippewa QRR Club, now with the Signal Corps at Washington, D. C., has obtained a class B license. Jack Selden, also a member of the QRR Club, received a class B ticket. LEC, at La Crosse for approximately a year, has been transferred to Chippewa Falls as manager of the Western Union telegraph office. ZVO is an instructor in shop radio at AAPT, Madison. GIT has several classes in radio theory and shop at the radio school at Ashland. ALG is teaching code and elementary radio theory to would-be hams and young men near military age who are going into the Signal Corps. NVJ, former EC of Sheboygan, writes that he is an instructor at Madison and has been promoted two grades since being there. Said with all those hams there it's just like a hamfest every day. Wanted: a volunteer from Sheboygan to take over the EC job. RBI moved from Wisconsin Dells to Arlington, then to Madison, where WIBA is his present employer. Also, he has been teaching ESMWT radio classes in Portage, Beaver Dam, and Madison for about a year. VDY, who is with Raytheon at Boston, met quite a few Milwaukee hams there and they got together one evening to talk about home, etc. His QRA is R.C. Schmidt, 31 Otis St., Watertown, Mass. The MRAC's recordings, which were sent to the members in the Services, received some fine comments and another set is being made. With each record the club sends four pictures that were taken while the recordings were being made. DIJ, a sgt. with the Sig. Corps, was home for a couple of days leave. DII is now a corp. JWT of the Marines received another silver bar to add to his earlier one. The recording of the loss of another famous Milwaukee ham, Herman Fritchel, Jr., ex-OSS, who drowned at Hawaii when he was caught in an underflow, is herewith made. For a number of years he was the clerk called "Fritz" behind the ham counter of our local radio store. A real amateur, his smile will be missed by many when they return. Herbert Wareing, NY, has been appointed radio aide for Milwaukee. Lumber has been donated by IZO to construct 19 cabinets for the fixed stations, and the work of building and painting is being supervised by our president, CDY. The EC, SYT, completed first design and construction model of unit, including osc., modulator, receiver (with RF stage), and two power supplies. Each unit is built very compact, on its own chassis, so it can be taken out and replaced with the least loss of time. 73, Emil.

DAKOTA DIVISION

SOUTH DAKOTA — SCM, P. H. Schultz, W9QVY — BJV would like to hear from the old S. Dak. gang. He is now in N. Africa and is asst. div. signal officer. Anyone wishing his address just drop me a card. YNW says he remains active, and would like to hear from the S. Dak. gang. His address is R. O. Bray, CRM, U. S. Naval Station, Tutuila, Samoa. ZNM and XYL send 73 from RFD No. 1, Onalaska, Wisc., care H. W. Schilling. Would like to hear from the old gang. He is now with CAA near that location, after spending 14 mo. in Ohio and then being transferred to Wisc. CAA is looking for more help. Write CAA regional office at K. C., Mo. Dick Swain of Sioux Falls has completed training at Treasure Island and is assigned as an instructor. Rules and regs on QST matter are being revised so get dope to me by 16th so it can be edited before it is sent to hdqtrs. Wat say, gang? How about more news? 73, Phil.

NORTHERN MINNESOTA — SCM, Armond D. BRATTLAND, W9FUZ — BCT is a lt. in Navy, now stationed at Brunswick, Me., while the new jr. op. is keeping his YF, MSW, busy at home. IBD has been moving his family to new location at Dayton, O. EPD paid a visit to the twin cities from Mt. Vernon, Ill. POU, now living near St. Paul, is working in radio department at ordnance plant. QPL, a tech. sgt., is married and at Ft. Monmouth. OOO is at Clearwater, Fla. WNI down at Gulf Port, Miss. HZV is

with KSTP. CYX with Navy department since Pearl Harbor, is now stationed with family near Chicago. IZG, former SCM this Section, has been driving to Morris each week and teaching radio to CPT. WCI is now bo operator at St. Cloud. WCC reports from Crossville, Tenn., where he is post Chaplain. A fb report from BMX says St. Paul Radio Club still operates four nights a week, teaching code and theory. ZWW is now on West Coast. QFQ is transferred to Winona. MPI is with Bureau of Investigation. BHY, capt., wing staff communications officer CAP, says reports of activity from all outlying points will be appreciated. With hook-up between CAP and Minnesota Forest Fire Patrol, it is likely to mean an active summer for communications men in these organizations. 73, Army.

DELTA DIVISION

ARKANSAS—SCM, Ed Beck, W5GED—KKL is lining up for an EC appointment and it is hoped that others will soon follow suit. HYP was last reported well satisfied working for FCC. HYQ to start pounding brass at Camp Robinson soon. HDR is reported as having been in serious accident in foreign service recently and is progressing nicely. CNX, formerly of Hot Springs, also is operating at Camp Robinson. GWA has been on the key at KASP for several months. FUW recently recovered from a severe attack of Malaria. AY, among numerous other things, has been busy for several weeks with field strength measurements of the KLRa installation. FPU put in a very nice victory garden and then decided to accept an out-of-town position. JHL has been busy moving his workshop from the basement to the attic. FXF visited briefly with GED while passing through Little Rock en route to a teletype assignment. CVO and DQB are located just across the bay from each other in their respective duties on the West Coast and both have been promoted there. HML and GRL, now 3JHF and 3JHG, staff sgt. and tech. sgt. respectively, are well pleased with their particular duties at WAR. Let us hear from more of you fellows, regardless of who, what, and where you are! 73 and all the best—Ed, W5GED.

TENNESSEE—SCM, James B. Witt, W4SP—DFB sends in nice letter. GEN has moved to Nashville. James A. Rogers, Jr., will try for class B. ACU calls on local phone now for his qso's. PGJ says that they have converted all DK3s for mobile operation and they work fb. Elizabeth W. Fitzell, Harry Frasier, Everett Crawford and Paul W. White have received restricted radiotelephone licenses. Come on gang with the reports!

HUDSON DIVISION

NEW YORK CITY AND LONG ISLAND—SCM, E. L. Baunach, W2AZV—If you want to see this section represented in these columns, you must report to the SCM on the fifteenth of every month. NYC, due to its large population, is in great need of a large number of WERS operators. Those of you who are not registered should get in touch with your boro radio coordinator. BO, boro radio coordinator for Brooklyn, reports there are 25 licensed units, 19 of which are operating. A great many v.l.f. tubes are needed, such as HY75, 955 and 9002, and more equipment is wanted. DZH, radio coordinator for Bronx, says there are 16 licensed units in the boro, operated by DM, DSG, FRK, IN, KIY, KRS, LKP, MXG, NSX, OCO, ODO, OES and OCJ. DZH has taken a leave of absence and IN has taken over. There are approximately 87 WERS stations in NYC. 20 are fixed, 29 are portable, and 38 are portable-mobile. The operating frequencies are: city control, 112.250; Brooklyn, 112.550; Manhattan, 112.850; Richmond, 113.150; Queens, 113.450; and Bronx, 113.750 Mc. The following are operating the Manhattan unit: AKF, ANZ, BR, CYN, CKO, DRO, DPP, EGD, EWH, GHL, HLL, HWH, IGO, ISO, JKB, JXH, JZO, KBW, KXB, LUC, LUM, LWP, MCE, MPL, MPC, MQM, MID, NAZ, NDD, OAA, and OFO. HGO is now in the Army. ELK is busy doing defense work, and is now located in Baldwin. DOG, BFA, LVN, ADW and their Yfs attended KOA's birthday party, and made recordings. MVR, Cpl. James Geras, 97th Service Sqdn., Army Air Base, Murco, Calif., is chief radio mechanic for all radios in his Lockheed P-38 pursuit division.

NORTHERN NEW JERSEY—Acting SCM, John J. Vitale, W2IIN, EC. After a long silence, NNJ breaks thru the ice, and here we are. Now it is up to the ECs, radio-aides, and yourself to keep your SCM advised as to "wat's cookin'." A post card or letter will do the trick. Phone, if you wish, El 2-9473. LI in Union, N. J., is the radio aide for WKNJ WERS. His technical committee comprises ZB,

IHR, CIA and CRW. EUI, EC and radio aide for Roselle, N. J., with CQD, reports that they expect the license any day. Cranford has BYD as EC and radio aide, also expecting to hear from FCC for license. Millburn, N. J., has been licensed as WLLH. LV has moved to Washington, D. C., and is engaged in war duties there. LCR has been busy on installation work for police radio in this state. EUI, CQD, EUR and BWV are applying their radio skill to the aircraft industry. IIN, BWI, HB and NWT are connected with shipbuilding program. IKD is wearing a cpo uniform as a sparks. LUJ is 2nd lt. in Signal Corps at Hunter Field, Savannah, Ga. OBG is in foreign service as 1st lt. MLW is away, engaged in aircraft communication duties. JBI and AJC are at Ft. Monmouth. LTP is now Army sergeant. LIQ in Army radio in Florida. OFR is in Navy, while JOS has returned from duties in Navy. GMN moved to Rahway, N. J. CQD is active with the American Red Cross Chapters in Union County, in communications. MMX is in Army. If you are connected with State Guard WERS or Civil Air Patrol WERS, let's hear from you for this column. Your group should be active now with WERS, and the radio aide or one of his assistants should be ARRL EC. Why not check up on this matter and write me for appointment of EC, if there is no EC in your locality?

MIDWEST DIVISION

IOWA—SCM, Arthur E. Rydberg, W9AED—The Des Moines Radio Amateur Assn. WERS work is continuing with fair progress. Some equipment has been loaned from local police. URK, radio aide, says some of the fellows do not realize that they cannot operate WERS on their ham license and that a new permit is required. WTD is now commander of the Burlington CAP squadron, and TMY is the new communications officer, with QVA as his deputy. FKA is commander of the CAP detached flight at Mt. Pleasant. He and his XYL, along with FSH, have passed written exams for their private pilot's licenses. The Iowa-Illinois Amateur Radio Club continues its code and theory classes each Friday evening. ALC has graduated from Bell labs. in NYC and is home awaiting a call from the Signal Corps. ESF has left for Signal Corps at Birmingham, Ala. QOQ and HIM are attending the Philco School at Philadelphia. The following were in Burlington on leaves from duty in armed forces: WNL, corp. tech. of the Signal Corps, attached to the Air Forces at Drew Field, Tampa, Fla.; QGU, RT2c of the Naval Radio School at the University of Chicago, and NLA, cpl. tech. of the Signal Corps at Ft. Lewis, Wash. has just finished a special school at Lexington, Ky. TLL and Miller are experimenting with carrier current.

KANSAS—SCM, Alvin B. Unruh, W9AWP—VWV will continue as EC for Zone 4, Leavenworth and Jefferson counties. The appointment of PAH for Zone 19, Riley, Clay and Geary counties, has also been renewed. HNI writes from Brownsville, Texas, where he is junior flight radio officer for Pan-American Airways. PLK, who installed the original Wichita Police radio before going to the Kansas Highway Patrol, has been transferred from Wichita to Paola. Ex-9PPC, a captain in the Signal Corps, visited home folks after a year in England. He is now stationed in New Jersey. YBC is teaching at Camp Crowder, Mo. YCL and GEM are in Calif. FEHW is teaching in motor school, San Antonio. FBY, QPK, LQQ and KXD are all working for Unc. Sam at air field in Spokane. YFS is in aviation corps. Thanks to STC for Salina news. CIK, formerly of WBBZ, and brother BYC are both in Air Corps. BYC is ARO at Clovis, N. M., and CIK is radio instructor at Chanute Field, Ill. Congrats to BYC and YF—a junior op has been added! FZW is teaching radio to Army boys in Georgia. OZN has accepted job with Wichita Police, where some new CW rigs will hit the air soon. Ex-TAE, now a W5, is chief op. for Delta Airways at Atlanta. OAQ is sgt. in f.a. at Ft. Sill, and may receive orders to OCS. Old "Sweepstakes and DX hound" CWV is now chief eng. of Mo. River dist corps of engineers. VWV works at Ft. Leavenworth and reports business is good! BGW is now master sgt. and recently returned from a far north Air Force mission. Rumor has it that Harvey annexed himself a wife. PAH taught code to CAA and WTS students and now has been "loaned" by chem. dept. to physics to teach AAF students on KSC campus. YUQ is with Naval Research labs. OTV is in Sig. Corps. HYZ went to U. of N. C. The appointment of FER as EC for Zone 23, Ellis, Rooks and Russell counties, has been renewed. Rufus has built a gadget which fellow hams call "the baby squaller." KWA is now operating KVGB. Note to FLG: FER would like your address. 73, Abie.

MISSOURI — Acting SCM, Letha Allendorf, W9OUD — ENF is taking the junior instructors course at Camp Crowder. Cpl. BLV, at the same camp, is teaching code and tlc. and has increased his own code speed to 30 w.p.m. Jim Harvey is in the Navy and wants the address of A.Y.M. now with the Merchant Marine. FBG, RT2c, is completing his instruction with the Navy at Corpus Christi and is expecting to be shipped soon. WIS is teaching code, blinker, semaphore, engines, and flight theory at Wm. Jewell College to Navy cadets at the Naval Flight preparatory school. Thanks to NDX for the following: LDP, student instructor, AAFRIS St. Louis U., is going to AAFRTTC radio school, Madison, Wis. upon completing course; QAZ, instructor AAFRIS staff, is going to the Signal Corps; YUB, instructor AAFRIS staff, has gone to a job as maintenance man for FM equipment at a Hercules TNT plant; TPK, instructor AAFRIS staff, has gone to the Army; NBE, shopman AAFRIS, is now with Raytheon, Walcham, Mass.; MBE, instructor AAFRIS, is with USNIS, Farragut, Idaho. JWJ is teaching science at the Normandy Junior High and has a class of 15 for code after school. MCA, science teacher in a St. Louis high school, has three classes in code and theory with 115 students. JWJ says also that YCB is with Raytheon, and that ZMV and BPZ are with the Coast Guard unit at St. Louis. SAA, instructor AAFRIS, has gone to Raytheon; AMD, instructor, is reported in the Navy; SNJ, instructor, still at the school, and ex-PPX, instructor, will be at Scott Field in May. 4HLN made one successful round trip to England as op on a tanker. Lots of luck to you all and let's have more news! 73.

NEBRASKA — SCM, Roy E. Olmsted, W9POB — To save space and paper, we are requested to submit brief reports to this column. Would like to have some new applications for EC appointments. RVZ writes from Ft. Omaha that the operator staff includes ZMO, LSI, IMM, AVX, FSR and RVZ. He adds that RWO is missing in action in Africa and BDQ is now stationed at a Naval air station in R. I. GFI reports to say that JBK is in the Service but has no address yet. QFT is serving in Navy in South Pacific. FQB sez HTE is somewhere across the Pacific. LPA is leaving for BC engineering job at Juneau and Ketchikan. EW, chief transmitter engineer at WOW, is about due for 10 year service award. RQR asks about YNO, YEN and DI. He is doing advanced flight training on Texas coast. KPA, now at Juneau, is operating for PAM. UDH and YOP visited your SCM during past month. OHU transferred from Ft. Bridger to Lincoln Airways Station. I have the addresses of many Nebraska amateurs in service or doing war work but prefer to keep them out of this column for security reasons. Will send the dope to friends who send request to me. Regards to all of you, wherever you are. Pop.

NEW ENGLAND DIVISION

CONNECTICUT — SCM, Edmund R. Fraser, W1KQY — ALW, district radio aide Norwich warning district, writes 12 units in operation, has substituted 7A4s for 7F7s in TR4s with increased quality. A hamfest was held Apr. 10th with QV, FLH, IED, KYV, Lt. Cmdr. Knight and four other hams in attendance. CTI, Asst. SCM and R.A. for Norwalk, submits report that class for restricted permits is under way. New Canaan using quarter wave antennae mounted on top of cars with excellent results. MIQ and AXB experimenting with antennae systems. New Canaan using 6V6s in place of HY75s in TR4s. IM, district radio aide Bridgeport warning district, says modification of license will bring total units to 78. 40 candidates have been examined for restricted permits. SG-WERS has been licensed under call letters of WKMV with Bert Dow in charge of that area. KQY has joined State Guard as tech. sgt. Lt. Stiles, WIDUC, from Texas, is busy teaching radio. COB is attending S.C. school in Florida and MHF is in Manchester. DBM, district radio aide Middletown, has received license for that area. Waterbury is getting under way with Bristol securing 8 TR4s. 2FKF, formerly from Verona, N. J., is now 2nd Lt. in S.C. at New London. During test radio silence all New Haven district units were silenced in 20 seconds from time WJLH-1 sent out silence signal. T.S. McCabe and Lambert from Bristol were recent visitors observing the N. H. WERS set-up.

EASTERN MASSACHUSETTS — SCM, Frank L. Baker, Jr., W1ALP — PZX reports from Spokane, Wash. that NRY of Natick is attending the WAVE officer's school at Northampton. MYL is now working at Raytheon and studying at nights. KUP is in the Army and is located at Duxbury, Mass. KQV is in Texas. KUA is in Penn. BQR

is in the Signal Corps, as a civilian, in Boston. BUS is in Conn. MDN writes from Montreal, Canada. We are sorry to hear of the death of JPD. William Sadowski of Amesbury, and wish to extend our sympathy to his family. MQX writes that he is now in the Navy and is RM3c. NIC of Chelsea is now a corporal in the Army Air Force down in Tampa, Florida. MLL, recently married a girl from Presque Isle, Me. JNM, NKA, NTW, ALP, SH and MLL are working in Presque Isle, Maine. VT is working at Harvard Univ. We hear that IIQ, now in the Army, has just been married. BJU is chasing over the country on special work. HUV is a special fireman and cop. LIO, our Newton EC, reports that the hams are rallying around and helping out in the WERS work. HPC is at key position, HUG control, MHC at the log and LIO on the hi-relay. FVL operates one portable and DYS and ANV operate fixed stations. Lincoln, Mass. will be on the air with one station at present. KON expects to be through at Harvard soon. NAH from Graniteville is at USNTS at Sampson, N. Y. for boot training. MJE reports that Danvers has been on 2½ for several weeks. IPA is working for a housing project and is traveling around New England. WERS units in Lowell and Lawrence were reported used in a hunt for a lost Army flyer.

NEW HAMPSHIRE — SCM, Mrs. Dorothy W. Evans, W1FTJ — Congrats to JCA, who has taken unto himself a YF. BLA is a corporal now, and has been fortunate in being able to follow the study of radio. He wants to extend his regards to the gang here. DUK is now in Florida. ITF is busy with set-up of WKLW at Northwood. ARM has been made Wing 12 communications officer of the Civil Air Patrol at Laconia, and advises that they are getting set for 2½ meter work there. He would like to hear from any of the gang who would be interested in helping out as well as getting some recreation from their hobby. We think this is a fine idea and urge the boys to contact ARM. MRD is now in the Navy as RM2c.

VERMONT — SCM, Clifton G. Parker, W1KJG — NJM, ARRL Acting Communications Manager, was a visitor at a meeting of the New England Defense Communications Council at Montpelier, held April 8th. On April 11th, CGV, EKTU, MLJ and KJG attended a conference at the state armory in Barre, when plans for 2½ meter equipment and operating personnel for use by the State Guard were considered. Standard type units were agreed upon. Four completed typical units with interchangeable power supplies were exhibited, completed by the Barre gang. CBW is now in training with Northeast Airlines, Inc. and may be reached at 73 Maverick St., Apt. 50, East Boston. A card arrives from FSV telling of his induction on April 1st. LYD now located at Camp Campbell, Kentucky, and reports recent range activities.

NORTHWESTERN DIVISION

MONTANA — SCM, R. Rex Roberts, W7CPY — BIZ reports from Helena that they are beginning work on WERS set up for Helena community. Fred Wamble, ex-4ENO, is chief engineer at KGOV in Missoula.

OREGON — SCM, Carl Austin, W7SNJ — GTW, just back from the land of snow and 40 below, says he prefers Oregon. FHX, well known on 75 fone, is in Veteran's Hospital in Portland, but expects to be out in a few weeks. After trying for many months to get a transfer to radio, QP says he has finally made the change and is now in communications. BGM has moved from Ft. Wayne to Albany, N. Y., and mentions testing out a twelve thousand hp motor for G. E. ENC, who has been in Alaska with ACS for the past two and one-half years, was out on leave, and visited his folks and many of the Oregon gang before returning. ENC is a sergeant, and has charge of a station. EKA is reported as being with ACS in Alaska. BUB, formerly in charge of KFAR in Fairbanks, is now at MIT. CBF, Augie, now has charge of KFAR. Leo Mickel, LSPH, secy. of CORK, reports an average attendance of 20. Phyllis Coe passed class B exam. ARZ, radio aide for KFNX, reports fairly reliable communication more than 5 miles from mobile units. DBZ is radio aide for Medford, and waiting for license. HVX ready for bc ticket, as soon as he can get to Portland for exam. GSI doing radio service work in spare time. GSL working spare time in newspaper shop. HHH helping GNJ in bike shop. BS built a super. 73.

WASHINGTON — Acting SCM, O. U. Tatro, W7FWD — BSB deserves great credit for his organization at KFNH, and also EVW, police department technician for the technical work and operating organization. Others at KFNH include EPB, FVY and IYL. Tacoma's problem now is to

train more operators. Please report any other WERS setup in the state to me. KX is now full commander, somewhere in the north in charge of an important base. GEV is now a full lt. ECA is hopping around for the Navy; his last hop was to the north. DDY is still with the state highway department, and CMX is with the state patrol. ANN has been in the Navy for a couple of years and we regret to report the loss of their two-year-old daughter. BG, ARRL director, has fully recovered from an accident he had at the plant during a practice blackout. HJN was recently enjoying his first leave in eleven months. He is located at Camp Wheeler, Ga. He left Ft. Lewis as a sergeant, and is now a 1st lt., with prospects bright for capt., soon. EPV, who is heading a magazine that is doing much to hold the local ham fraternity together, advises that the Oroville Club still meets regularly and at present is studying theory.

PACIFIC DIVISION

SANTA CLARA VALLEY — SCM, Earl F. Sanderson, W6IUZ — Received interesting letter from Frank Williams, JWI-RDF, now serving in the CTC in England. NGA promoted to RM1c. MOV is teaching in San Jose. ACV has new job in Defense Training Plan. HBB is teaching at San Jose State. LCS taking course with the Signal Corps. Your SCM would appreciate having a report from any person or group participating in WERS activities. This column is based on your reports, fellows, and unless information is forwarded sufficient to continue it, the SCV section report will be discontinued.

EAST BAY — SCM, Horace R. Greer, W6TI — EC: QDE. EC v.h.f.: FKQ. Asst. EC v.h.f.: OJU. OO v.h.f.: ZM. WERS for Oakland has been called into action on several tests and everything worked fb. The following SARO members are in the service: Navy radio, Ens. EHS; Ens. FAQ; Lt. (jg) QWX, Lt. (jg) IPK, Lt. (jg) OCZ, Lt. CBX; Army radio, T. Sgt. IMA, Mst. Sgt. AVX, 2nd Lt. LCH, 2nd Lt. LFW, 1st Lt. ZF and Capt. QVI. Working for the govt. in radio as civilians: DMY, GPY and MUC. Another day closer to victory, "TI."

SAN FRANCISCO — SCM, Kenneth E. Hughes, W6CIS — Asst. SCMs: RBQ and GPB. ECs: DOT and RBQ. Radio aide DOT advises that San Francisco WERS is well under way under the call KGCW. We need all the operators we can get, so how about it, you San Francisco hams? Wire or phone Bill Ladley, 200 Naylor St., San Francisco, Randolph 8340. IPI, Sgt. in the Army, in North Africa. WB returned recently from another eastern trip. RBQ now has two sons serving in the Navy. 9EKY, in town en route to the East Coast from K6, visited RBQ. Art Monsees is a 1st. Lt. in the Air Corps at Chico, Calif. 30X, regional communications engineer for OCD, is helping our radio aide establish WERS in San Francisco. He has eight western states under his wing. 73, Ken, CIS.

ROANOKE DIVISION

VIRGINIA — SCM, Walter G. Walker, W3AKN — 5FDR has recently arrived at the Norfolk Naval Air Station and can be reached c/o SOSU-2, N.A.S., Norfolk, Va. 9DMP has recently moved to Norfolk and wants to contact someone in that vicinity having a common interest in WERS. The only activity I can give you this month is the three way contact between GGF, IIF and AKN by wired wireless during the last week in April. The airline distances are about 1.5, 3 and 4 miles respectively. Freq. used was about 160 kc., rigs a la March 1942 QST, HJW has been devoting most of his time to reading up on radio theory. GGI now at Boca Raton, Fla., and states in his last letter that the boys down there are considering wired wireless on a frequency near 50 kc.

WEST VIRGINIA — SCM, Kenneth M. Zinn, W8JRL — The code class in Wheeling, tutored by ADI and Ralph Gould, manager of Cameradio Co., certainly is progressing and from all indications will turn out several good operators. LCN, RT2c, USNR, is now located at the Naval Armory, Michigan City, Indiana. BTV, Y1c, is located at the Navy recruiting office in Greensburg, Pa. CYV, RM1c, USN, who has been in the South Pacific for the past nine months, was home for a week in March. The Wheeling Radio Club held a dinner meeting in his honor March 26th. Lt. (jg) Robert Laley, ex-AAO, formerly of Wheeling, is a Jap prisoner in the Philippines. He served near Manila until he was transferred to Wake Island. CSF has moved from Wheeling to St. Clairsville, O. He is a transmitter engineer for WVVA. GHB is working for the Navy Dept. at Blaw-Knox Co. in Martins Ferry, Ohio. HD has recovered from a serious ill-

ness. MZD has moved to the lake for the summer. Earl Weimer, formerly BSY-ZW, is home for a visit from the Army. Also home on leave is AZD of the Navy. Thanks to the boys who came through with the news this month. Keep it up, and let's hear from the rest of you! 73, Ken.

ROCKY MOUNTAIN DIVISION

COLORADO — SCM, Stephen L. Fitzpatrick, W9CNL — BQO is teaching code classes and working on WERS organization. He has moved to a new location at 2641 South Lafayette Street, Denver, Colorado. TRR is still teaching radio. YXU is teaching code classes. CAA is still teaching radio theory. OWP drove 120 miles on March 31, on two months pleasure allowance of gas to attend a meeting of the Bell Radio Amateurs in Denver. QFN has been promoted to warrant officer at Fort Logan, Colorado. GYY of Boise, Idaho, has moved to Denver and was voted in as a new member of BRA. ACB is president of the BRA, with TRR as vice-president and Paul W. Kirkpatrick as secretary. Meetings are held every three months. OMs, let's make this column grow! Best regards, CNL.

SOUTHEASTERN DIVISION

EASTERN FLORIDA — Acting SCM, Frank C. Fassett, W4BYR — EPW now has side line in radio service business. LF is back from Texas and located at McDill Field as fmn.. A.C.E. FGQ has left police radio in Bradenton and is now with WSPB, Sarasota, ACZ has been made exec. officer in FDF at WPB. GJI has been appointed EC and radio aide for WPB CDC. FGX still at Galveston as top man for Radiomarine. AGM is very active with his navigating. Sixty-five in the WPB area are cramming for radio tel. third tickets. ES is EC in Dade City, and also very busy with Navy duties. Miami all set with emergency net consisting of: MD, BYF, AZJ, KK, ES and GZY, latter in Homestead. All have 350 watt gas engine sets loaned by Red Cross. CZX is draftsman at Embry-Riddle. 3NR is director of training at Embry-Riddle. EWU is running shipyard, repairing naval vessels. 5DRR left Miami and is now with USN, Miami. CM2TW is with RMO USN, Miami. CKD is in Veterans' Hospital at Bay Pines. AKI gone to Boston for advanced Naval training in shush gear. EWX is now 1st lt. with 15th Bomber Wing, USA. COTCX has been ill. Word from KK to effect that Dade City WERS application is in. Col. W. H. Baird has been made Commander of Dade City defense council. IH has just graduated as lt. from AAF training school at Miami. DDB expects induction around first of May. HGO was in Tampa recently on a visit to the RI for class A ticket. Sanford has received WERS license, the second in Florida. DEN has received commission as capt. in SC. GEE is now corp. with 3rd Air Force, Tampa. AFU is leading double life meeting the dead line and working at TASCOC. BOT has quit following the dogs (working, not betting) now that Springs track is closed for season. ERU was last seen cutting a rug. A number of the Tampa gang report having received their FCC xmttr certificates. EX-Va, D. M. Brown at WFLA, was recently commissioned 1st lt., First Signal Co., PDF for Florida West Coast, with hdqtrs in Tampa. AKJ visited folks in Tampa recently and has been capt. since last December. FYI is now RT1c and sees he's meeting lots of hams in the Navy. CRA is in Oklahoma City. DQW is improving from recent illness. GNS is at U. of Florida taking radio. UY expects call any day now from the Merchant Marine as radio op. RQ is taking over UY's police radio job, also holding down the job of comm. ofr. for Upper Pinellas CDC. Upper Pinellas and Clearwater were first to receive WERS license in Florida. EIA made CRM, USN, at Jupiter, and is the first to do so at that station.

WESTERN FLORIDA — SCM, Oscar Cederstrom, W4AXP — The section was saddened by the reported loss at sea, during a training flight, of Lt. Comdr. Archibald W. Greenlee, Ex-K6NYD, HGM. He was stationed at Pensacola Navy Yard for several years, and was a very popular officer and an outstanding amateur. He operated mostly on the higher frequencies. His loss is a great one to both ham radio and aviation. The section extends its sincerest sympathies to his family. MS reports that GGN has received the Navy Cross for action in the Midway battle. One of the highlights of this month's report is the ham meeting held at the Spring Street USO. This meeting was largely due to the efforts of 9NLF and 9FHD. The Navy was represented by everything from a lt. comdr. down to a RM2c and there were several civilians present. 5BKH, 9CFL, PE, GBM, 5BZB, UW of WCOA, CQF, 5GOK, 9KSF, 60VS, George Wall, DeForest Fisher, Floyd Grice, VR, and Carl Eubanks were



We receive a letter:

“Enclosed is a picture of an NC-200 taken on an ‘unnamed’ tropical island. This particular set did a darn good job of operation at W3JCE for a year and a half and it worked well in New Zealand on 220 volts 50 cycle with a lamp bank in series; the exact amount of resistance required was estimated by the brilliancy of the pilot light.

“Later on, the set was landed through the surf and handled pretty roughly if the $\frac{3}{4}$ -inch deep scars on the packing box are used as an indication. The set was operated on 6 volt storage batteries and 225 volt B for several weeks until AC became available. Its reception of broadcast programs from the States 7000 miles away was excellent. In fact, the only thing it wouldn’t do was translate Japanese. The NC-200 was by far the best radio on the island except for one ‘RAS’ and I guess you know who built that.

“When I received my orders to come back to this country, it almost broke my heart to part with ‘Baby,’ but I sold it because a good radio means a lot out there. I will be going back before long and I have a chance to buy another NC-200 from a friend of mine. . . .” *The letter asks if we can overhaul this NC-200, and then adds:* “Naturally I don’t want to take a set to the South Pacific that isn’t working well when we may have to use it on something important.

“We guarded 500 kc with ‘Baby’ for three weeks after Rickenbacker was lost—and it was our boys who found him. So what say?”

73’s

Major J. E. MORRIS, USMC
(W3JCE)

Thanks a lot for the letter, Major. We have a paternal feeling for Baby and are glad that she is behaving herself in the Marine Corps. Her sisters are doing a job, too, but until the war is over, most of their activities are not for publication.

NATIONAL COMPANY.



in attendance. Another American family gone 100% in the service of their country is Lt. PE of the Navy and his xyl who is a member of the WAACS. 5FDR has moved up to Pennsylvania. GRI passed through here. 6CBY is stationed here at NAS. Lt. Veasey, a W4 from Memphis, is here at NAS. This station is alive with hams and if they would just come out and let us know who they are it would be fine. Charles Swick's wife presented him with a 6½ pound YL. Bobbie Heeley took class C and 3d class comm. exams. Carl Eubanks took 3d class comm. exam. BCZ took a swing around the section in the interest of the Lively Vocational Training School of Tallahassee. DAO is building a 100 kc. osc. for freq. measuring. The OM wishes to thank the gang for this very fine report. 73 and luck to you all, from "The Old Maestro" AXP.

SOUTHWESTERN DIVISION

LOS ANGELES — SCM, H. F. Wood, W6QVV — The Los Angeles city application for WERS work has been approved by the local CD, so we hope that ere long we can be ready to go. You will be notified just as quickly as we get the full approval of FCC. Register your u.h.f. equipment with me or Walt Matney at once because we will want to know about all of the equipment there is available in the territory. We also need more operators, so those of you that have held off on account of uncertainty about licenses and rumors, please get in touch with us and sign up. EQM is the duly appointed radio aide, and QVV has been appointed the deputy aide for L.A. SQC is defense coordinator for Inglewood, and MSO is radio aide. RNN of the Inglewood Club reports 35 attended their last regular meeting, even with 20 serving in the armed forces. They are still meeting twice a month and going to town. How's about the rest of the clubs? AM reports the Long Beach WERS meeting now once a month with RO in charge. DEP is now a lieutenant in the Navy, and was reported in Long Beach early in April, as was MFJ. UKL, capt., is still studying. OYY now a sgt. in the Marine Corps photo section at Quantico, Va. He would be glad to hear from his friends. Let's hear from you soon. 73, Ted, W6QVV.

ARIZONA — SCM, Douglas Aitken, W6RWW — OMH and SSV are both in the Navy, and NZU is attending the Naval Academy at Annapolis. Any more of the gang we've missed? Tucson keeps on with their good code training work, having recently graduated 4 at 20 wpm and have 6 who can average 31 wpm, including a YL. Their club is figuring on a big ham picnic. SOB's son is now in the Navy. Two of the gang have married — LAI at Tucson, and PNN at Phoenix. QLZ has been home on furlough. RPS is in a hospital for treatment. NGJ and LSK are figuring on the commercial exams. TVU is now a shavetail. The Salt River Valley WERS is in the building process. Operators include BUX, HRH, IXC, LSK, MAE, NEL, NGJ, OAS, ROP and SXP. A V-mail letter from PQQ, some place with the Pacific Fleet, sends his regards to the whole gang. He has an ART1c rating. MLL says you have to be mighty particular how you place the components in wired wireless to get away from AC hum troubles. IDR has been instructing in radio theory. GS is doing the swing shift at Marana. Reports have many hams from other districts in various training centers in the state. Let's hear from you fellows! Ex-NXO writes that he is in the 6th CA high speed communication center, and is married. I am attempting a card index of all the Arizona gang in service, so will all of you please send your military addresses, so I can pass them along to those who want to know where you are? A postal card won't take long, so let's have it! Vy 73 to all — Doug.

WEST GULF DIVISION

NORTHERN TEXAS — SCM, N. R. Collins, Jr., WSIAU — FIV is attending school for American Air Lines in New Orleans. He has his 2nd class phone and telegraph commercial tickets and expects to be transferred out very soon. ESC has completed his training and is now an operator for American Air Lines. ALA reports that IYO and ISM are now working at Lockheed. JJF has been appointed assistant radio engineer at El Paso. ARQ has been appointed communication officer at Midland. EVI has been transferred to Florida. Sorry to hear that GOB is in a Naval Hospital in Calif. How about all you hams, both at home and in the armed forces, sending a card to let me know what's doing? 73. — N. R.

NEW MEXICO — SCM, J. G. Hancock, W5HJF — CXP is winding homemade output transformers to keep 'em going in the Southwest Pacific. JWA is playing chess be-

tween watches aboard ship. DER and ISN are back in Clovis. HJF lost his last antenna mast in a recent wind-storm. Gang, the job is getting hard without reports. Let's try to keep up all the interest we can, and keep a line in here. Won't you drop me a line now and then? 73 and hope to see you on the air soon. — Jake.

The Month in Canada

NOVA-SCOTIA—VE1

From L. J. Fader, 1FQ:

It is about time I sent along a bit more news regarding the VE1 gang. Unfortunately, I still do not receive much information. However, I am going to pass along what I have and hope that maybe the gang will send along some news.

INP was the leading telegraphist on a Canadian corvette lost by enemy action in the Mediterranean. Fortunately, Bill was a survivor. After floating around in the water for an hour and a half he was picked up and landed in England. He is at present spending a well deserved leave in Halifax, and apparently suffered no serious injury as a result of his trying ordeal. One loss he did suffer was some ham equipment he had on board which he was fixing up in preparation for getting back on after the war.

We regret to report that ICS was lost on a destroyer in enemy action last year. He spent a short time with the Marine section of the RCMP previous to the outbreak of war, and then joined the Navy when hostilities broke out. He has a brother, IJS, who is also a radio operator in the Canadian Navy.

Our good friend, John Harris, 1KJ, suffered a harrowing experience not long ago. John is with the RCAF, and was out in an Air Force marine craft which ran into difficulty. We understand he is now home on leave convalescing from this adventure, and hope to see him around soon fit as a fiddle and rarin' to go.

It has been reported that our good friend, Ron Hart, 1MZ, who is in the Reserve Army Signal Corps, is going around displaying his first hook. Congratulations, Ron; keep up the good work. Banner Edwards, 3PD, of Ottawa, had the pleasure of being on board one of the Canadian Naval ships out on the West Coast last year, and was present at the making of a movie now showing throughout Canada and the States called "The Commandos." The ship he was on was used in making the movie. He also spent some time in the Aleutian Islands and visited Alaska. Recently he passed another course with flying colors, and was placed in charge of a naval station ashore.

ONTARIO—VE3

From Len Mitchell, 3AZ:

THE Wireless Association of Ontario, which was organized in 1913, is still functioning in spite of the many handicaps experienced by amateur organizations during wartime and has been very fortunate in obtaining capable speakers on interesting subjects despite conditions. Some of the outstanding subjects presented in the current season have been: "Inter-Communication Systems," by Al Rosenthal, B.A.Sc.; "Frequency Modulation," by L. W. Elliott, B.A.Sc.; "Reflection of Radio Waves," by E. Olson, B.A.Sc.; a group of science educational films prepared by the General Electric Co., and "Ultrahigh-Frequency Technique," presented jointly by R. G. Anthes, B.A.Sc., and M. C. Patterson, B.A.Sc. U.h.f. was well covered in two meetings held during the month of April. The average attendance this season has been 83 and the Association welcomes any person interested in the radio art, especially members of the armed forces who may be located in or near Toronto. The following executive officers have been elected for the 1943-44 season: president, Bob Humphries, 3ALC; vice-president, Alf Edmunds; secretary-treasurer, Bill Winter, 3APA.

Flight Lt. Dave Gwinn, 3IX, has just returned to Canada to take up special work in this country after two years service overseas.

ALBERTA—VE4

From W. W. Butchart, 4LQ:

THANKS to 4ZI of Barons for waking up Bill Savage, 4EO, of Lethbridge, long enough to shoot along a very nice chunk of Lethbridge news:

(Continued on page 70)

ESSENTIAL

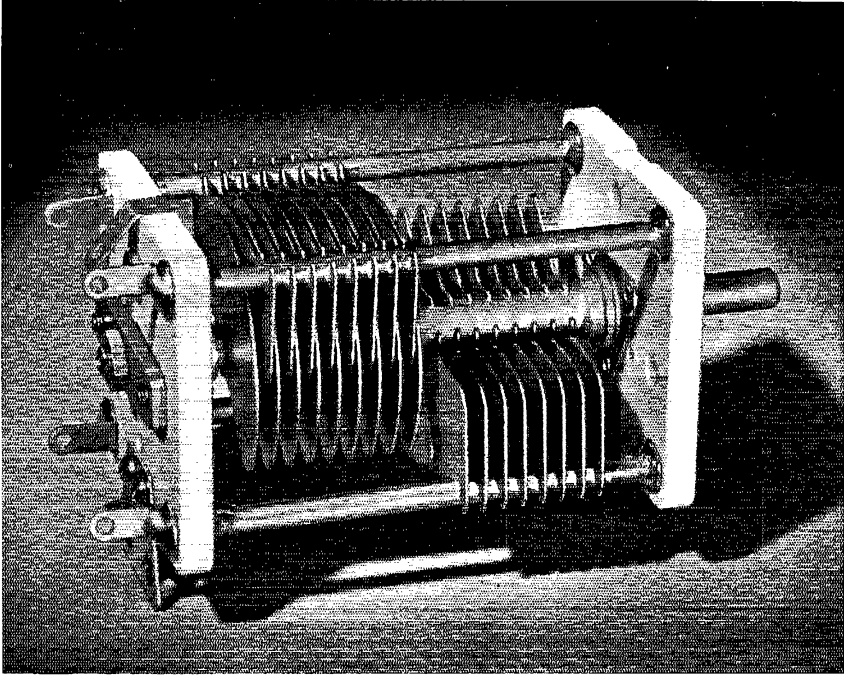

Scientifically designed for aviation

HAMMARLUND variable condensers have become an essential part of our war effort because they meet the ever changing demands of modern military equipment. Solve your problems with Hammarlund condensers.

THE HAMMARLUND MANUFACTURING CO., INC.

460 West 34th Street, New York, N. Y.

Polarize

It is fundamental that two terminals of a source of electrical energy have, at any instant, opposite nature. This is known as polarity; plus for one terminal, minus for the other.

Light, also, is subject to polarization. In this case, however, polarization refers to the planes of the vibrations. Normally the vibration planes are helter-skelter, but, it is possible to bring about vibration all in a single plane parallel to the direction of propagation. This is plane polarized light.

Plane polarized light is a valuable tool in the manufacture of quartz crystals. Quartz will rotate the plane of polarization of plane polarized light passing through it along the optic axis. If the rotation is to the right, the quartz is termed right-handed; and vice versa. Whether a piece of quartz is right or left-handed must be known to the crystal cutter. Also, crystal blanks must not be cut from portions of quartz containing physical strains. Under plane polarized light, strained portions are revealed as irregular areas of beautiful colors.

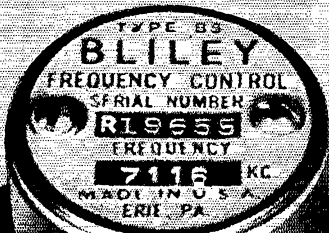
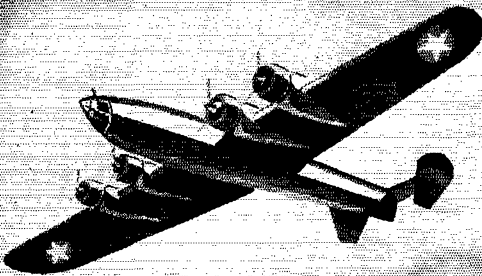

BLILEY ELECTRIC CO., ERIE, PA.

The Month in Canada

(Continued from page 68)

4AA is still throwing switches on the CPR. 4AF has just finished installing a new 1000-watt job for CJOC, where he is chief engineer. 4ABM works for the City of Lethbridge Light and Power Dept. 4ACS is with CP Telegraphs at Princeton as repeater man. 4AQQ is a Lt. in the RCN radio division, at present located on the West Coast. 4AHD is in the AGT switchroom at Lethbridge. Ralph of 4AIH is a radio op with the RCN on the West Coast. 4AIP is an Army Lt. stationed "somewhere in Canada." 4ALH is in the RCAF. Roy, 4ALI, is still throwing switches on the CPR. (Seems to us that ALI is AEV's old sidekick — LQ.) 4ANG is attending Varsity in Edmonton. 4AOX is station electrician with TCA. 4DB is firing boilers at the power plant at Sentinal, turning out the kw. 4DN still makes his QTH at Glenwoodville, in the CP station. 4OE is a sergeant in the radio division, RCAF, stationed at Halifax. 4OF is still radio repairman with TCA. Bob, 4OG, is a captain in an anti-tank regiment overseas. 4OL is still running a service station. 4OZ is in the W/T end of the RCAF overseas. Pete, 4SJ, is still farming. Twins arrived to bless his household. 4EO passed some very pertinent remarks about the circuit SJ used. 4UF is servicing teletype machines for a Lethbridge broker. 4VN has turned into a budding plumber. (Note by EO: "What some hams will do to earn money!") 4MF is a sergeant in the RCAF wireless division at Halifax. 4EO runs a rifle and revolver club for a hobby.

And now, as 4EO is a modest sort of chap, I think we should tell you that his wife has become an expert rifle shot under the coaching of her OM. She puts EO's scores to shame now, and has come first in four Dominion matches and won a Canadian championship.

Another batch of news from 4ZI brings word of 4JJ. He has designed himself some very compact radio equipment which caught the eye of the Calgary RI to such an extent that Jessop was asked to have it ready for a rapid dash to Calgary on emergency ARP call. ZI says that he himself has been doing a spot of plumbing the last two months. 4WZ has gone into politics, having been elected councilman in his enlarged Municipal District.

And now for a round-up of Alberta and Edmonton news: 4ADD, district signal officer of Calgary, has 5 "Quacks" (CWACs) working for him now. Jack says it begins to look like a harem around the DSO's office. 4CY is a 2nd Lt. in the RCCS (Res.) at Calgary. Yes, boys, he is the same Sammy Lichinsky we knew back in the good old "daze." 4GD (Geraniums and Daffydills) is sgt. in the same outfit. 4GS is in the Calgary Airport Control Tower, working for the Department of Transport. We regret to say that 4BV was the victim of a heart attack a week or two ago. He is making progress along the road to recovery. 4BW, 4HT and 4LQ wrote their special-to-arm examinations for the rank of Lt.

A former Edmontonian, Cyril N. Hoyler, is working with the RCA Research Department in Princeton, N.J. He had the call W3VG before Pearl Harbor. Cyril remarks that he always reads the VE4 column in the "Canadian corner." Thanks, OM — your letter is very much appreciated.

The NARC held a social evening on April 3rd with 37 in attendance. All report having a swell time. Forty-five minutes of home movies in Kodachrome and twenty minutes of Kodachrome transparencies was followed by a sleight-of-hand performance by 4BW, who incidentally proved to the gang that the "Old Master" has been keeping his hand in shape. Refreshments topped off the evening. 4XE's YF is now stationed in Edmonton as recruiting sergeant with the CWAC. 5AEB of Kaslo, B.C., a flight sergeant with the RCAF, is still stationed in Edmonton. 5MJ, also with the RCAF in Edmonton, is from Vernon, and prior to the war was a great 75-meter 'phone man. 4ALO arrived at the party safely convoyed by 4HF. ALO is just recovering from a spot of sickness that had him pinned down for a couple of weeks. 4EY and his YF turned out for the evening and proudly displayed a picture of their junior YL op. The Cable brothers of 4YX fame attended in full force. 4VJ donated coffee for the affair, and ably directed preparations for the evening. 4AOC, Ken Smith, and his YL showed up. Ken is just finishing up at Varsity in electrical engineering this year. Hilda, 4WH, had to leave the party early in the evening owing to other commitments. By the way, boys, Hilda had an Aussie observer in tow that evening! 4HM's presence was missed.

Of interest to the 75-meter 'phone gang is the news that 4GM is back in Canada.



GEEWIZ,
A FELLOW'S
GOTTA TAKE
OFF ONCE IN
AWHILE

IF THE
FELLOWS
AT THE FRONT
TOOK OFF WE'D
BE OUTA
LUCK!

OUR boys can't beat the Axis if we on the production front can't stay on the job long enough to produce the weapons they need. Elmer is right—where would we be if *they* took days off.



HAMMARLUND

THE HAMMARLUND MFG. CO., INC., 460 WEST 34TH ST., NEW YORK, N. Y.

MALLORY TECHNICAL DATA

Series Connected Capacitors

The wartime scarcity of high-voltage filter condensers has increased the popularity of using series-connected lower voltage units to achieve a required working voltage rating. This practice has much to commend it, particularly when series-connected dry electrolytic capacitors are substituted for high-voltage transmitting capacitors. The substitution provides economical dependable replacements that conserve raw material. However there seems to be some misunderstanding about the procedure to be followed. The requirements for satisfactory operation with series-connected electrolytic condensers are quite different from the requirements for paper-dielectric capacitors.

PAPER-DIELECTRIC CAPACITORS

It will be apparent that if two equal value paper-dielectric condensers are connected in series, and one has an insulation resistance of 500 megohms, while the other has an insulation resistance of 2,000 megohms, the voltage division will be such that 80% of the voltage will be across the higher resistance condenser. By shunting each capacitor with a $\frac{1}{2}$ megohm resistor, the division of voltage becomes practically perfect, so that the working voltage of the pair becomes twice that of a single unit. Note that the resistance value of the shunt resistor is very small in comparison with insulation resistance of the condensers.

ELECTROLYTIC CAPACITORS

Figure 1 shows why $\frac{1}{2}$ megohm shunt resistors are worthless with dry electrolytic capacitors. The initial leakage of the typical dry electrolytic capacitor graphed below represents an equivalent insulation resistance of only about $\frac{1}{4}$ megohm. A $\frac{1}{2}$ megohm parallel resistor will not have much effect.

Fortunately, however, commercial experience has shown that voltage dividers are unnecessary with electrolytic capacitors provided the correct installation is made.

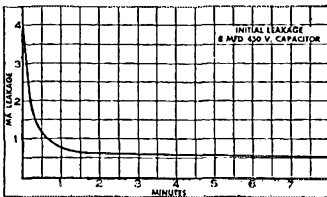

Figure 1

Initial leakage current of a representative Dry Electrolytic Capacitor

The requirements for the satisfactory performance of series-connected dry electrolytic condensers are simple. Just use the following rules:

1. Select capacitors of the same value and rating.
2. Select capacitors of the same make and type.
3. Select capacitors of the same age, as shown by the code dating.
4. Operate at a working voltage that does not exceed 80% of the combined working voltage of the individual units.

The leakage resistance of a dry electrolytic capacitor varies inversely with the applied voltage, so that after a period of use automatic equalization of voltage occurs.

It should be noted that when two equal value capacitors are connected in series, the effective capacity is one-half that of a single unit.

P. R. MALLORY & CO., Inc., Indianapolis, Indiana
Cable Address—PELMALLO

P. R. MALLORY & CO. INC.
MALLORY



Silent Keys

It is with deep regret that we record the passing of these amateurs:

- W2BZ, Samuel Jackson, jr., USN, New York, N. Y.
- W2DFC, William B. Simpson, Rye, N. Y.
- W2KCU, Ernest H. Wechsler, USMM, New York, N. Y.
- W2NGC, Joseph Smith, RM3c, USN, Hillside, N. J.
- W4AGS, Clarence E. Armstrong, Niceville, Fla.
- W4HGM, ex-K6NYD, Lt. Comdr. Archibald W. Greenlee, USN, Pensacola, Fla.
- W8ALU, Dr. J. A. Carnes, Massillon, Ohio
- W8HCP, E. M. Early, Dover, Ohio
- W8JFZ, James W. Seegar, Dayton, Ohio
- W8KZF, Steven W. Stokasa, USAC, Detroit, Mich.
- W8TWO, Charles Martindale, Dayton, Ohio
- W8VP, J. Clayton Nicholson, Cambridge, Ohio
- VE1CS, S. R. Kenney, RCN, Halifax, N. S.

Experimenter's Section

(Continued from page 52)

All condensers are tubulars except the transmitter tank condenser, the grid condensers and the variable used for detector tuning. The latter is a two-section gang, 365 μ fd. per section, with both sections in parallel.

Very good results have been obtained with the outfit and on a whole it is quite satisfactory. No very great distances have as yet been attempted, but the amount of signal received during tests leads us to believe that we will be able to span considerable lengths of wire. Operation is on c.w. only at the present time, because so far only c.w. hams have come around. However, we may eventually use 'phone.

That's about all the dope from here, so 73 for now and hope to hear from some other fellows in the San Joaquin Valley soon. — *Albert F. Weber, W6RLJ*

I am converting an old 12-tube superhet into a carrier-current rig. I wonder if you would print my name and address in the Experimenter's Section, since I would like to get in touch with anyone in the Bay area interested in c.c. — *Bill Hetrick, 1609 Rose St., Berkeley, Calif.*

Don't let your operator's license expire!

Centralab

Ceramic TUBULAR Capacitors

Provide Controlled Temperature Compensation

Centralab manufactures small purpose capacitors, widely used in high frequency circuits where the ultimate in stability and retrace characteristics are essential. Centralab capacitors consist of a thin wall ceramic tube, spacing two tubular silver plates, one inside and the other outside the ceramic. The temperature coefficient of these capacitors is determined by the ingredients of the ceramic dielectric and can be controlled within very close limits.

Available in capacities from 1 mmf to 860 mmf. Greater capacities can be obtained by paralleling two or more units without affecting temperature

coefficient or tolerance of capacity.

Temperature coefficient from zero to $-.00075\text{mmf}/\text{mmf}/^{\circ}\text{C}$ which is maximum negative. Thus in addition to units with zero temperature coefficient that are the most stable of all commercial capacitors, others with a uniform rate of negative change are available to compensate for normal positive drift of other circuit components.

Flash tested at 1400 volts D.C. Recommended working voltage 500 volts D.C. Power factor will average .05% with .1% the passing limit. Power factor does not increase with age. Leakage resistance more than 10,000 megohms.

CENTRALAB • Division of Globe-Union Inc.

Milwaukee, Wisconsin

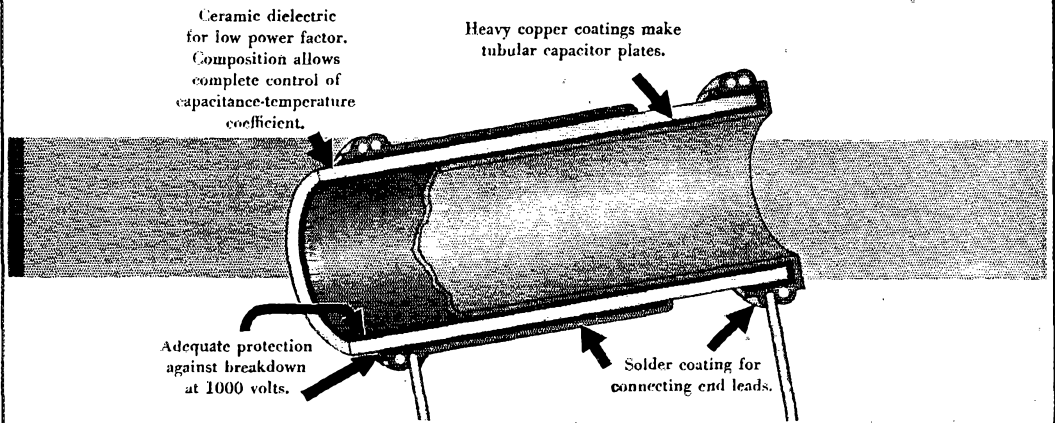

TRIPLETT

Combat line

INSTRUMENTS

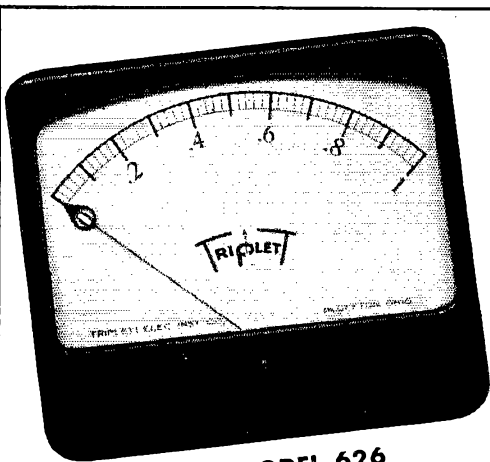

TRIPLETT MODEL 626
with long 5.60" scale

This illustration is $\frac{1}{2}$ actual size. Note long scale and minimum panel space required.

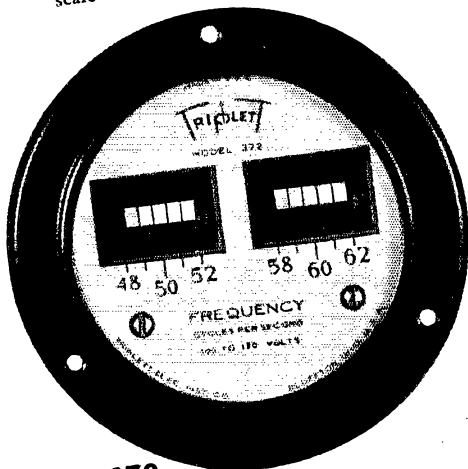

MODEL 372

Vibrating Reed
Frequency Meter.
This illustration is
 $\frac{3}{4}$ actual size.



A WORD ABOUT DELIVERIES

Naturally deliveries are subject to necessary priority regulations. We urge prompt filing of orders for delivery as expeditiously as may be consistent with America's War effort. TRIPLETT ELECTRICAL INSTRUMENT CO., BLUFFTON, OHIO

Hams Teach AAF Pilots

(Continued from page 41)

Maxwell Field

The site for Maxwell Field was originally selected by Wilbur Wright in 1910 for aerial experimentation. During the first World War the field was used for repair work, and in 1921 it was known as the Montgomery Air Intermediate Depot. In 1922 its name was changed to Maxwell Field, in honor of Lt. William C. Maxwell, an Atmore, Ala., boy who crashed to his death in the Philippines while serving with the 3rd Aero Squadron.

From 1931 to 1942 Maxwell Field was used as a tactical school. Its roster during this time is a star-studded one, and it isn't straining the imagination to say that the astounding success of the Air Forces to-day had its origin in this tactical school. Brig.-Gen. Caleb V. Haynes, now heading the bomber command in China, went through the school when a captain. Lt.-Gen. Millard F. Harmon, commanding officer of all allied Air Forces in the Pacific, is a former commandant. Generalissimo Chiang Kai-shek's son, Chiang Wega, is an alumnus. A captain by the name of Chennault — to-day you know him as Major-Gen. Claire L. Chennault, whose American Volunteer Group revolutionized pursuit aviation in China — taught pursuit aviation in the tactical school, and it was here that he developed his famed "flying trapeze" stunt.

For a time Maxwell Field was a giant pre-flight school for pilots, navigators and bombardiers, but to-day it concentrates only on pilots. Its present commandant is Col. Elmer J. Bowling, who is a rated balloon and balloon observer pilot as well as a combat observer.

To all radio amateurs, we here at Maxwell Field say *didididah* for Victory — and we believe it won't be long until we can say *didididah-didah*.

A Hand Tape Perforator

(Continued from page 24)

the additional complications probably are not worth the effort in view of the fact that this type of perforator is hardly likely to be used for quantity production of tape. But those who have the time and the scrap materials necessary to put it together will find that it will produce perfectly-useable tape when none is available by other means.

Reproducer Changes

In the course of several months' use of the original code machine it became increasingly apparent that some improvement in the tape-pulling mechanism would be quite desirable. The chief disadvantage of the old system was that a considerable nuisance factor was involved in changing speed; further, only a series of fixed speeds was available. Also, the strap arrangement required careful adjustment so that the tape would be held

TAYLOR TUBES

...Veterans in Freedom's Cause!

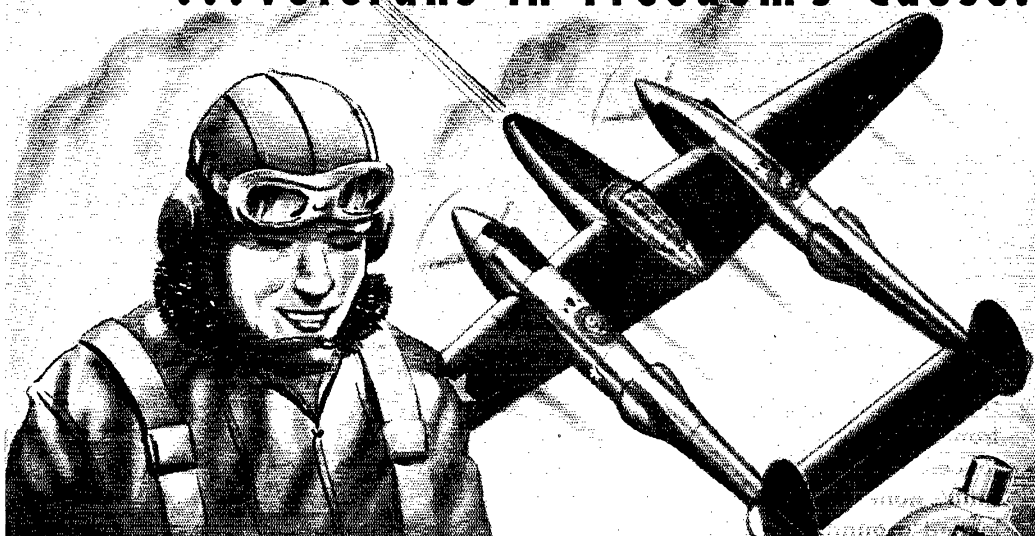

... WHEN YOU'RE IN THE THICK OF IT You Realize the Value of Superior Equipment

Long before America herself was at war, Taylor Transmitting Tubes proved they could stand up under the gruelling stress of actual combat on many Allied Battlefronts.

Today, thousands of Uncle Sam's fighting communications men know the assurance of Taylor dependability — know that Taylor Tubes deliver maximum power and extra hours of performance far beyond the needs of normal service.

With each passing day, the growing production of Taylor Tubes becomes an increasingly decisive contribution toward Victory. With this goal attained, Taylor will again supply many advanced types of "More Watts Per Dollar" tubes to peacetime America.



Taylor HEAVY **CUSTOM BUILT** DUTY *Tubes*

TAYLOR TUBES INC., 2312-18 WABANSIA AVE., CHICAGO, ILLINOIS



PAMPERED DARLINGS

Don't look so sad, pooch. Before this war upset everything, many an ABBOTT was a "pampered darling" too . . . cozily nestled in a protected radio shack . . .

Now, ABBOTT transmitters and receivers are subjected to many front line rigors and inconveniences. But they are tough little units, none the worse for being kicked around.



This is an ABBOTT TR-4, one of our standard models — a compact and efficient ultra high frequency transmitter and receiver. It is only an indication of the type of apparatus that we can and do produce. Our facilities may be of assistance, if you have a problem within the scope of our activities.

ABBOTT
INSTRUMENT, INC.
8 WEST 18 STREET • NEW YORK, N. Y.

against the driving wheel with sufficient tension to prevent slipping and yet not so much that it would act as a brake. The machine has now been rebuilt to use a new pulling system which is shown in Figs. 10 and 11. The contact mechanism and the electrical system are the same as in the old machine, hence need no present discussion.

In the new system a large driving disc, fastened to the motor shaft, turns a smaller disc which can be moved along the radius of the large disc to change the gear ratio and thus vary the speed at which the tape is pulled. The large disc, cut from an old bakelite panel, is 5 inches in diameter and has a piece of rubber taken from a scrap inner tube glued to its upper face. A piece of 1/4-inch round tubing with a thread cut in one end is used as a shaft, set in a panel bearing mounted in the top panel of the unit. This shaft is coupled to the motor shaft underneath by means of a flexible shaft coupling of the type used with variable condensers.

The horizontal shaft on which the small driven disc is mounted is 1/4-inch brass tubing, 7 1/2 inches long, with a short piece of 5/32-inch rod forced in one end to make a bearing at the rear. The rear bearing is simply a hole in a 1-inch piece of 1/4-inch square brass rod. The two vertical rods are 1/8-inch brass, threaded top and bottom for 6-32 nuts and mounted 3/4-inch apart in a 1 1/4-inch piece of square rod which in turn is mounted to the panel. The bearing piece is drilled so that it can slide freely up and down the vertical rods. Springs, with tension adjustable by the nuts on the rods, press the bearing piece down so that the driven disc is held firmly against the large one. This arrangement allows the rear end of the shaft to ride up and down with any wobble in the large disc, avoiding the binding and slipping which would occur if fixed bearings were used. The front end of the shaft goes through a ball bearing (taken from an old roller skate) mounted between wooden blocks. The ball bearing is quite "sloppy" — just what is needed in this case to allow for wobble.

The driven disc is formed by cutting two 1-inch diameter discs from thin iron (stovepipe iron) drilling 1/4-inch holes in the center, and then cutting two slightly larger discs from the scrap inner tube. The two rubber discs are used as the filling in a sandwich, with the iron discs on the outside. The parts are held together by half of a shaft coupling of the type which bolts to an isolantite disc. The set screw in the coupling is also used as a set screw on the shaft to hold the driven disc in the position selected.

The pulling wheel consists principally of an old bakelite knob about an inch in diameter and slightly more than a half-inch wide. This was used principally because it had a set screw which offered a convenient means for attaching it to the shaft. To provide friction for the tape a rubber strip is glued to the edge, and two 1 1/2-inch diameter metal discs were provided to keep the tape from slipping off. The pressure wheel is a piece of sponge rubber cut from an old kneeling pad and

THESE HAMS ARE DOING VITAL WORK

W1AUF	Harry Graves	W6FTT	Carl Boltz
W1BCG	Cedric W. Root	W6JMI	Robert J. Hagerty
W1HML	Charles Newman	W6KW	John R. Griggs
W1IPL	Milton Mix	W6OOT	Joseph A. Strong
W1NBL	Richard Patten	W6TEH	Byron Frankenburger
W1TWW	Jefferson Borden, 4th	W8CJR	Edward Doherr
W1N1	Victor C. Serreze	W8CLS	Ashley Farrar
W2BRI	James J. Tynan	W8OWU	Oscar P. Kusisto
W2CUZ	Donald B. Whittemore	W9BEU	Elmer F. Koehler
W2IDN	Vincent Bashore	W9BMU	Howard L. Harvey
W2KBY	Louis Morrison	W9HPN	Joseph Otto
W2---	Robert Dixon	W9DKT	Austin G. Anderson
W3AOH	Henry J. Geist	W9DUD	Wells K. Chapin
W4APJ	Charles L. Herman, Jr.	W9EFC	Floyd E. Norwine, Jr.
W4BIK	William D. Pease	W9EKY	Richard K. Rohan
W4CNY	Thomas J. Kelly	W9EZX	Herman T. VanAllen
W4CPG	Russell A. Patterson	W9HWE	Robert Shirley
W5DXW	Willis F. Johnson	exW9VMM	James Cole
W5GGW	Hohart G. Alexander	W9LBM	Charles E. Dewey, Jr.
W6BGH	Karl Pierson	W9SAA	Alois S. Engleman
W6EPW	Vern Milton	W9---	James McPaul

W9 — Roy Peck

These boys are really performing a service for the armed forces, some at bases in U.S.A., others at allied bases out of the country. They are receiving training in an advanced radio technique—training that will be invaluable in the postwar electronic world. In the course of their travels and duties they are renewing many ham friendships and making more new ones. Raytheon is proud of the performance of these boys in the Field Engineering group.

Hams who have had years of practical experience in building and re-building amateur rigs are "naturals" for this work of supervising the installation and maintaining some vital radio equipment. If you are not putting your radio ability to full use, and don't mind travelling, drop a line to Clark C. Rodimon, W1SZ, at the address below.



RAYTHEON MANUFACTURING COMPANY

Seyon Street, Waltham, Mass.

OFFICIAL U.S. NAVY PHOTO



FOR OUTSTANDING MERIT IN MICROPHONE PRODUCTION

The Army and Navy "E", symbol of outstanding achievement, has been awarded to Shure Brothers. It is the highest badge of honor for the victories of the soldiers on the production front that must come before the victories of the soldiers at the fighting fronts. Shure Brothers are united in the determination to do their utmost to hasten the day of final victory for the democratic forces.

SHURE BROTHERS • 225 W. HURON ST., CHICAGO
Designers and Manufacturers of Microphones and Acoustic Devices



(Continued from page 76)

ground to approximately circular shape by holding it against a grindstone. The grinding process is slow, but it works; scissors are of practically no value for this kind of job because of the flexibility of the rubber. A stove bolt through the center, with washers on each side of the rubber, forms a shaft, and this in turn fits into a bearing made from the sleeve of a junked 'phone jack. The shaft is not fastened in this bearing but simply rides in it so that the pressure wheel is free to stay in the puller wheel. A spring is fastened to the bearing to keep the two wheels in contact. Between them, the two provide enough friction to make a quite positive pulling arrangement; slippage is rare unless the tape becomes jammed for some reason.

Using the pulling wheel and discs described, together with the motor previously used, the speed range is from about 6 to 45 words per minute, adjustable to any speed within the range. The effective diameter of the pulling wheel with the rubber covering is about 1 1/8 inches. Adjustment is a matter of seconds, a distinct improvement over the old method.

CD-WERS in Maryland

(Continued from page 27)

ment, but, since FCC regulations delegate to him certain responsibilities, the radio aide is a free agent and may conduct local CD-WERS in the manner in which he thinks best results will be obtained.

Assistant radio aides may be named by the radio aide, to carry out whatever functions the radio aide may designate.

Executive operators are men holding amateur Class B or higher licenses. It is their duty to operate portable-mobile units and to take the place of less-experienced personnel whenever the situation seems to warrant.

Operators are placed in charge of fixed or portable units.

Auxiliary operators constitute the personnel of fixed and portable units and are under the direct supervision of the operators. Several auxiliary operators are provided for each unit, to be available twenty-four hours a day.

Technicians are those who have technical knowledge of radio but who are not licensed by FCC. Radio servicemen and others technically qualified but not able to be assigned to any definite operating unit can be placed in this classification.

Raymond Rock, W3EKZ, has been placed in full charge of construction. Perry E. Wightman has been appointed state procurement officer. Harold Kemp, W3EEI, is radio aide for Baltimore City and co-chairman of the technical committee. His co-chairman is Frank E. Lyon, W3HAL, radio aide for Baltimore County. The State of Maryland has materially assisted by allowing the use of state road trucks to pick up materials donated and, through its State Board of Education, in the use of school facilities.

HELPS FOR RADIO TRAINING COURSES



★ ★ ★

Hints & Kinks

Amateurs are noted for their ingenuity in overcoming by clever means the minor and major obstacles they meet in their pursuit of their chosen hobby. An amateur must be resourceful and a good tinkerer. He must be able to make a small amount of money do a great deal for him. He must frequently be able to utilize the contents of the junk box rather than buy new equipment. Hints and Kinks is a compilation of hundreds of good ideas which amateurs have found helpful. It will return its cost many times in money savings — and it will save hours of time.

Price 50 cents

The Radio Amateur's License Manual

To obtain an amateur operator's license you must pass a government examination. The License Manual tells how to do that — tells what you must do and how to do it. It makes a simple and comparatively easy task of what otherwise might seem difficult. In addition to a large amount of general information, it contains questions and answers such as are asked in the government examinations. If you know the answers to the questions in this book, you can pass the examination without trouble.

Price 25 cents

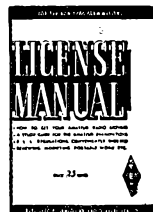

How to Become a Radio Amateur



Universally recognized as the standard elementary guide for the prospective amateur. Features equipment which, although simple in construction, conforms in every detail to present practices. The apparatus is of a thoroughly practical type capable of giving long and satisfactory service — while at the same time it can be built at a minimum of expense. The design is such that a high degree of flexibility is secured, making the various units fit into the more elaborate station layouts which inevitably result as the amateur progresses. Complete operating instructions and references to sources of detailed information on licensing procedure are given.

Price 25 cents

Lightning Calculators

RADIO, Type A — This calculator is useful for the problems involving frequency, wavelength, inductance, capacity, etc. It has two scales for physical dimensions of coils from one-half inch to five and one-half inches in diameter and from one-quarter to ten inches in length; a frequency scale from 400 kilocycles through 150 megacycles; a wavelength scale from two to 600 meters; a capacity scale from 5 to 1,000 micro-microfarads; two inductance scales with a range of from one microhenry through 1,500; a turns-per-inch scale to cover enameled or single silk covered wire from 12 to 35 gauge, double silk or cotton covered from 0 to 36 and double cotton covered from 2 to 36. Using these scales in the simple manner outlined in the instructions on the back of the calculator, it is possible to solve problems involving frequency in kilocycles, wavelength in meters, inductance in microhenrys and capacity in microfarads. Gives the direct reading answers for these problems with accuracy well within the tolerances of practical construction. \$1.00

OHM'S LAW, Type B — With this concentrated collection of scales, calculations may be made involving voltage, current, and resistance, and can be made with a single setting of a dial. The power or voltage of current or resistance in any circuit can be found easily if any two are known. This is a newly-designed Type B Calculator which is more accurate and simpler to use than the justly-famous original model. It will be found useful for many calculations which must be made frequently but which are often confusing if done by ordinary methods. All answers will be accurate within the tolerances of commercial equipment. \$1.00

ABOVE PRICES ARE POSTPAID • PLEASE DO NOT REMIT IN STAMPS

AMERICAN RADIO RELAY LEAGUE, INC., West Hartford, Connecticut



Listen
YOU MONKEYS
 ...WE'VE GOT A STORY
 TO TELL YOU

You won't believe this but miracles have been accomplished by the Radio Industry — it's a safe bet that five years' work have been compressed into one year so far as deliveries are concerned — Technically, we have the accomplishments of twenty years at hand now.

We are proud to be part of this dynamic fight by our Industry, that is contributing so much to victory.

★
BUY WAR BONDS and STAMPS

The **RADIO SHACK**
 ★ 167 WASHINGTON ST. ★
 BOSTON, MASS., U.S.A.

Who Killed the Signal?

(Continued from page 60)

He was already up on the chassis, bearing down on Oscillator Tube with menacing purposefulness.

"You're under arrest!" he barked. "It is my duty to inform you that anything you say may be used as evidence against you," he rattled off, formula-fashion.

Oscillator Tube, plain and transparent-looking, with a dome-shaped head, looked up in surprise. "I beg your pardon?" he said.

"You're under arrest," the Sleuth repeated, less belligerently.

"What for?"

"For the murder of the Signal. Come with me."

Oscillator Tube did not move. "Just how am I supposed to have murdered the Signal?" he asked.

"You stopped supplying the local signal voltage to Mixer Tube. And if that isn't murder, it is manslaughter. Anyway, you're under arrest." The Sleuth reached for the glass-garbed Tube's wrist with opened handcuffs.

"Did Mixer Tube tell you I murdered the Signal?" Oscillator asked quietly, drawing back.

"He — well, maybe he didn't say exactly that, but he did say he was no longer getting voltage from you — and that's the same thing."

"Not quite," Oscillator Tube denied. "It's true I haven't been sending out the voltage since the power failed, but the Signal died some time before that, I understand."

"You admit you're not delivering the voltage, though," the Sleuth accused harshly. "And that's why our test signals failed to get through."

"Yes, and I'm sorry — although I don't think it was really my fault. But I didn't kill the Signal — that is, the real Signal. I think Mixer Tube will tell you that, if you'll ask him."

"That's right," said a voice behind them. The Sleuth whirled swiftly; it was Mixer Tube standing there. He had been listening to the conversation. "I tried to tell you before, but you were gone before I could say anything."

The Sleuth was wordless. In silent apology he stuffed the opened handcuffs into the deep pocket of his long jumper.



IN SILENT APOLOGY SLEUTH STUFFED THE HANDCUFFS INTO THE DEEP POCKET OF HIS JUMPER

Oscillator Tube was not one to harbor a grudge, however. "In a way, I'm sorry to disappoint you," he said, smiling. "While you're here, though, maybe you can help me out with my problem. Then perhaps in return I can give you a tip that may be of help in yours."

The Sleuth looked puzzled. "What is your problem?" he asked.

"Well, the truth is, I myself don't know why I haven't been able to supply the local signal voltage to R.F. Mixer Tube. I've been making it just as always, but it doesn't seem to work any more."

"You'd better ask someone else to help you,"

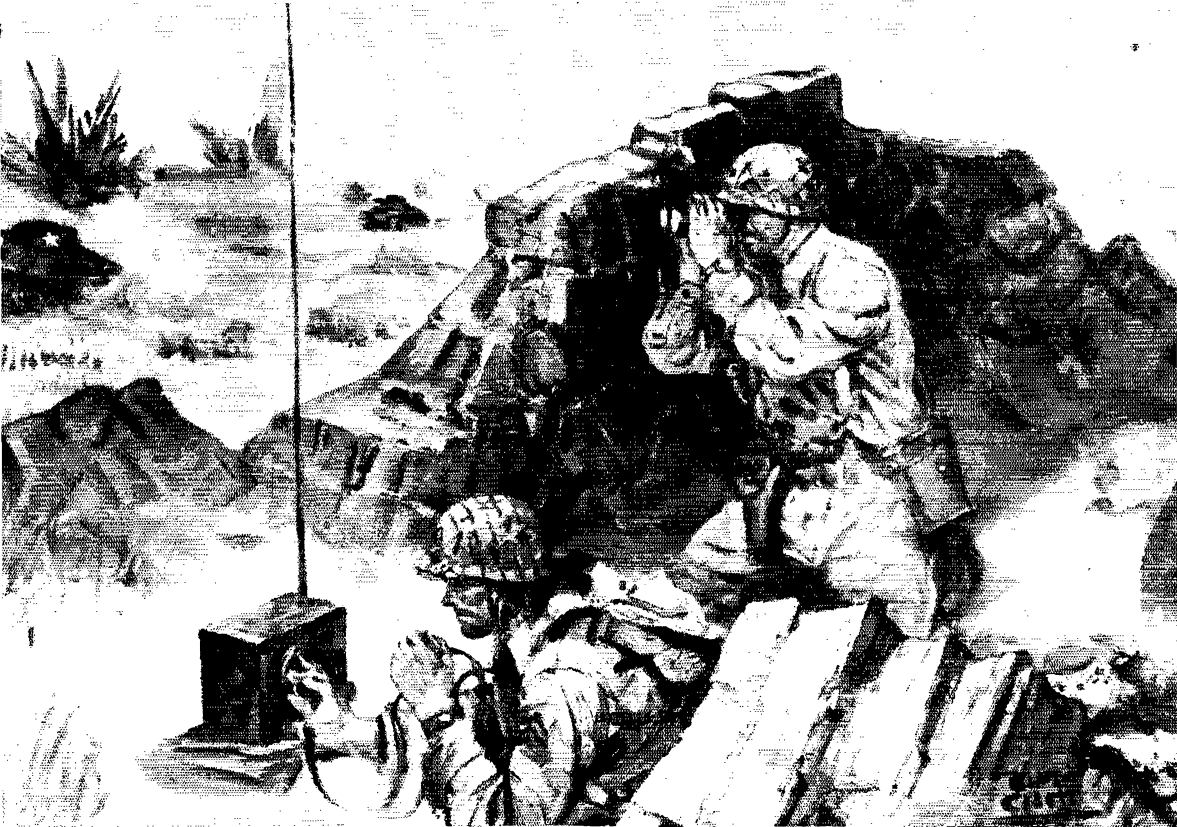

E·L IS OUT THERE, TOO...

Out where the "fighting front" becomes grim reality instead of a glib phrase, **E·L** units are powering the "Walkie-Talkie" that serves as the voice and ears of our advance forces.

It's a marvelously efficient two-way radio, of course. But the Signal Corps knew that it couldn't be the useful, reliable instrument it is, unless it had a power supply that would keep it operating, under all conditions . . . whether in the destructive heat and grit of the desert, the paralyzing arctic cold, or the corroding humidity of the jungle.

Such a power supply did not exist until Electronic's engineers designed a special, high-voltage vibrator power supply, combined with storage bat-

tery, in a single, incredibly light and compact unit.

Behind this and other **E·L** power supply achievements are years of intensive development of the technique of *vibrator type* power supplies, and the most extensive research anywhere on power supply circuits. They have not only produced amazing advances for many military purposes, but promise revolutionary benefits for products of peace.

Wherever electric current must be changed, in voltage, frequency or type—for war or peace—**E·L** Vibrator Converters will give the same outstanding service that has singled them out for battle duty today.



Power Supply using rechargeable, non-spill storage battery for operation of "Walkie-Talkie" radio equipment. Input Voltage: 4 Volts; Output: Numerous Voltages, supplying plate and filament requirements of the equipment. Width, 3 1/2"; Length, 6 1/2"; Height, 4 3/4".

... and **E·L** will be here when peace comes!



• Mobile, two-way radio telephones will be at work in peace-time on big construction projects . . . on farms . . . in countless other places. **E·L** products will be on the job then, too, solving the power supply problem!

Electronic

LABORATORIES, INC.

E·L ELECTRICAL PRODUCTS—Vibrator Power Supplies for Communications . . . Lighting . . . Electric Motor Operation . . . Electric, Electronic and other Equipment . . . on Land, Sea or in the Air.



NOW—a really high-powered RADIO ENGINEERING LIBRARY

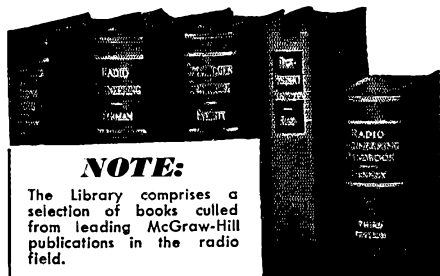

NOTE:

The Library comprises a selection of books called from leading McGraw-Hill publications in the radio field.

- ➔ especially selected by radio specialists of McGraw-Hill publications
- ➔ to give most complete, dependable coverage of facts needed by all whose fields are grounded on radio fundamentals
- ➔ available at a special price and terms

THESE books cover circuit phenomena, tube theory, networks, measurements, and other subjects—give specialized treatments of all fields of practical design and application. They are books of recognized position in the literature—books you will refer to and be referred to often. If you are a practical designer, researcher or engineer in any field based on radio, you want these books for the help they give in hundreds of problems throughout the whole field of radio engineering.

5 volumes, 3559 pages, 2558 illustrations

- Eastman's **FUNDAMENTALS OF VACUUM TUBES**, 2nd edition
- Terman's **RADIO ENGINEERING**, 2nd edition
- Everitt's **COMMUNICATION ENGINEERING**, 2nd edition
- Hund's **HIGH FREQUENCY MEASUREMENTS**
- Henney's **RADIO ENGINEERING HANDBOOK**, 3rd edition

10 DAYS' FREE EXAMINATION

SPECIAL LOW PRICE

EASY TERMS

Special price under this offer less than books bought separately. Add these standard works to your library now; pay small monthly installments, while you use the books.

SEND THIS EXAMINATION COUPON

McGraw-Hill Book Co., 330 W. 42 St., N. Y. C.

Send me Radio Engineering Library for 10 days' examination on approval. In 10 days I will send \$3.00 plus few cents postage, and \$3.00 monthly till \$24.00 is paid, or return books postpaid. (We pay postage on orders accompanied by remittance of first installment.)

Name.....

Address.....

City and State.....

Position.....

Company..... QST-6-43

the Sleuth replied despondently. "I'm afraid I'm not much good at shooting trouble.

"Don't be so discouraged. You'll break this Signal case yet—I promise you that. But first, see if you can help me, won't you?"

"Oh, all right," the Sleuth shrugged wearily. "Suppose I get my assistants in on this, too. They may be able to help."

He waved a command, and the three Meters trooped obediently up the chassis. The Sleuth explained the situation briefly, then turned back to Oscillator Tube. "Now tell us your story," he directed.

"First you'll want to know how I generate the local signal, I suppose," Oscillator Tube began. "Of course, as you know from my name, I'm an oscillator—in fact, a self-oscillator. The difference between an amplifier and an oscillator is that the amplifier merely builds up or enlarges a signal he gets from someone else, while an oscillator creates his own signal. I'm the creative type, you see—supply my own signal, amplify it, and then deliver the power from it.

"All that with your one little set of elements?" Milly asked in honeyed tones.

"Well, not quite," Oscillator Tube confessed. "I have a number of associates who help me. There's Oscillator Coil and his mate, Variable Condenser, and Grid Leak and Grid Condenser—"

"What do they do?" Volt interrupted sharply, glancing at Milly.

"Each has his own job. To start with Grid Leak, he's in my grid circuit, in series between my grid and cathode—which is grounded, by the way; I have no cathode bias. He helps me start my oscillations by building up a biasing voltage from my static grid current flow."

"Don't you mean plate current?" Volt questioned.

"No, I mean grid current. You see, when my grid is at the same potential as my cathode—when there's no negative bias to repel electrons—a few of the electrons traveling to the plate will stop off on the grid wires that lie directly in their path, not bothering to go around. Not many, but enough to make a nice little flow of current. To complete the circuit there must be a return connection from the grid back to the cathode, of course—which is where Grid Leak comes in."

"He's right in line with this return current flow, eh?"

"Yes. And being what he is (he's actually a member of the Resistor family, you know), he doesn't let that current through without building up a nice little voltage drop from it."

By this time the Sleuth, his gloom cast off, was completely absorbed. "I'll wager I know what happens then. The voltage drop built up across this Resistor has its negative end toward your grid. That puts a negative potential on the grid and stops any further current flow."

"Very good," Oscillator Tube nodded approvingly. "Almost as soon as the current starts up it kills itself off by its own voltage drop across Grid

CRYSTALS

"SHORT ORDERS"

If it's a "Rush" phone us, and your order for special crystals will go into work immediately under a competent crystal engineer personally charged with the responsibility for your project.

Our full facilities, including latest electrical and optical equipment, X-ray orientation, etc. - are at your service. John Meck Crystals are "Good Will Ambassadors of the Future" to acquaint you with our Family of Activities in the field of Sound and its Projection. That's why "Short Orders in a Hurry" are welcome.

phone

CRYSTAL SERVICE DIVISION
PLYMOUTH THREE THREE

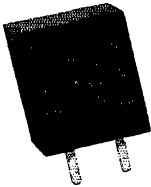

JOHN MECK INDUSTRIES

PLYMOUTH, INDIANA



Keep 'em Sending!

Genuine Easy-Working "Lightning Bug"

VIBROPLEX

Reg. Trade Marks: Vibroplex, Lightning Bug, Bug

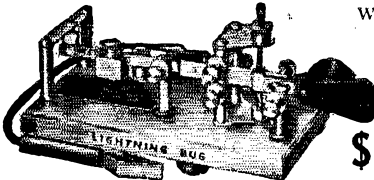

World's Finest
Semi-Automatic
Key

Standard finish
ONLY

\$13⁹⁵

De luxe finish with
PATENT JEWEL
MOVEMENT, \$17.50

To-day more than ever before telegraphing calls for the utmost in sending skill and endurance to withstand the strain of long operating periods under adverse operating conditions. Day after day on land, sea and in the air Vibroplex is demonstrating its ability to develop sending skill to a remarkable degree, and at the same time almost completely eliminate tiresome effort. No wonder that tens of thousands of experienced operators use only the Genuine Easy-Working Vibroplex.

The "Lightning Bug" model illustrated is one of the smartest, smoothest, easiest-to-operate (BUG) keys Vibroplex has ever produced.

The "BUG" trade mark identifies the Genuine Vibroplex.

It's TOPS on any sending assignment. Don't guess! Play safe with Vibroplex. Remit by money order or registered mail. Write for catalog.

FREE
Catalog

THE VIBROPLEX CO., Inc.
833 Broadway NEW YORK, N. Y.

NEWARK does it again!



a NEW, lucky buy in

FILTER CONDENSERS

9 mfd. **\$3²⁵** NO PRIORITY
2000 v. D.C. **REQUIRED!**

The best condenser and the biggest value Newark has ever advertised. An improved type. Oil Filled and oil impregnated. Quality built by a reliable manufacturer and Guaranteed at rated voltage. Complete with porcelain insulators and mounting brackets. Neat gray enamel finish. Not illustrated, but you'll be delighted! Size 1 3/4" x 3 3/4" x 4 1/2" high.

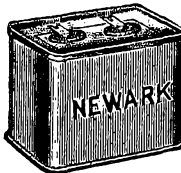

Still have limited stock of the old reliable NEWARK SPECIAL filter condensers. Oil filled and impregnated. Thousands of them have been sold.

Mfd.	DC.	Size	Price
1	1000	5 x 3 3/4 x 1 3/4	\$.59
2	2000	4 3/4 x 3 3/4 x 1 3/4	1.50
4	3000	5 x 3 3/4 x 3 3/4	3.75

ORDER TODAY DIRECT FROM THIS AD
Sorry — NO CATALOGS for the Duration!

NEWARK Electric Company
323 W. MADISON ST.
CHICAGO, ILL.

You CAN HELP!

We supply radio apparatus for war use. You can help fill this need by selling your equipment to us. We pay highest cash prices without delay or red tape.

Write and tell us what receivers, meters, parts, etc., you have. If in a hurry telephone or telegraph. This is the easiest and quickest way to send your apparatus to war. And we pay you more, too. We promise you a better deal. So let us know what you have.

We also have a store at 2335 Westwood Boulevard, West Los Angeles, Calif.

HENRY RADIO SHOP

BUTLER, MISSOURI

"World's Largest Distributor of Communications Receivers"

**NOW . . . THE MATH YOU NEED
to solve everyday radio
and electrical problems
IN THIS NEW BOOK**



Out of the U. S. Navy Radio Materiel School at Anacostia Station comes a complete home-study text that teaches you mathematics from elementary algebra through quadratic equations, logarithms, trigonometry, plane vectors and elementary vector algebra with direct applications to electrical and radio problems.

MATHEMATICS for ELECTRICIANS and RADIOMEN

Based on more than 8 years' experience teaching mathematics to U. S. Navy electricians and radio operators. By N. M. Cooke, Lieutenant, S. G., U. S. Navy, 604 pp., 6 x 9, \$4.00.

10 DAYS' FREE EXAMINATION

McGraw-Hill Book Co., Inc., 330 W. 42nd St., New York, N. Y.
Send me Cooke's Mathematics for Electricians and Radiomen for 10 days' examination on approval. In 10 days I will send you \$4.00 plus few cents postage or return book postpaid. (We pay postage if you remit with order.)

Name.....
Address.....
City and State.....
Position.....
Company..... QST — 6-43

Leak. But don't forget that Grid Leak isn't working alone. He has Grid Condenser there working side by side with him, and the very first thing he does with this voltage is to charge her with it. He gives her just as much voltage as he can build up in the short time the current is flowing."

"What happens when it stops flowing?"



GRID LEAK HAS GRID CONDENSER THERE WORKING SIDE BY SIDE WITH HIM

"Then she starts unloading and pours her charge back into him. But — and get this, because it's important — when the current flow begins the voltage has its negative end toward the grid. However, when Grid Condenser discharges the voltage back into Grid Leak she pours it out the other end, so to speak. The polarity is therefore reversed, and in this second step it's the positive end that's on the grid."

"Like a complete cycle of alternating current, eh?" said the Sleuth.

"That's exactly what it is. And that's what I use to start my oscillations — my self-starting signal, I sometimes call it."

"Well, if that starts 'em, what keeps 'em going?" Ohm asked, flicking his test leads idly.

"That's something else again," Oscillator Tube replied. "To start with, the Sleuth has pointed out the effect on the grid current flow of this voltage drop across the grid leak. But what is the effect on the plate current?"

"Why, the plate current would be high at the very start when there was no bias on the grid and then would fall as the voltage drop built up," the Sleuth answered.

"And on the second half of the cycle — when Grid Condenser is discharging?"

"Just the reverse, I suppose. The grid voltage would be positive instead of negative and so the plate current would go even higher."

"In other words, the plate current reproduces the grid-voltage cycle — just as though it were one cycle of an input signal which I'd been given to amplify," Oscillator Tube affirmed.

"You still haven't said what keeps 'em going," Ohm persisted stubbornly.

"I'm coming to that," Oscillator Tube said impatiently. "Now, Sleuth, do you remember what R.F. Tube said about feed-back — the coupling back of a signal from the plate of a tube to its grid through the interelectrode capacity?"

"Yes. That was why he had that screen grid — to prevent it."

"Well, in his work feed-back, whether in himself or between his associates, is undesirable. It handicaps his amplification. In my case, however, feed-back is essential, because I want the signal in my plate circuit to be coupled back to my grid. That's the way I work; without it I couldn't oscillate.

"Now, young man," he continued, addressing himself to Ohm, "to answer your question, I keep

Have You a Copy?

"A COURSE IN RADIO FUNDAMENTALS" By **GEORGE GRAMMER**

In Book Form

THE MATERIAL in this volume was prepared in response to the demand for a course of study emphasizing the fundamentals upon which practical radio communication is built. It originally appeared serially in QST and so great was the enthusiasm with which it was received that it is now published under one cover. The course is equally as valuable for those studying at home as for the teaching profession, many members of which have found themselves in the (to them) new field of radio technician training without the benefit of a planned course, nor the time to put in to thorough preparation.

It has been said by the planners of military and pre-service training for radio technicians and mechanics that their objective is to provide, as nearly as possible, the practical experience possessed by the radio amateur with a background of basic fundamentals. The objective in preparing this course, therefore, was to accent those principles most frequently applied in actual radio communication. "A Course In Radio Fundamentals" is a study guide, examination book and laboratory manual. Its text is based on the "Radio Amateur's Handbook" of 1942 or subsequent editions. Either the special edition for war training purposes or the Standard

Edition may be used. References contained in the "Course" are identical in both editions.

The material is divided into thirty-six study assignments. With each assignment there is a series of questions designed to bring out the most significant points in the text. When problems of a mathematical nature are included, the answers are given at the end of the book. In cases where more than routine methods are required, the complete solution is given. Where feasible, experiments accompany each assignment to best illustrate the principles being studied. Anyone undertaking the course may be assured that, if he follows its precepts literally and exactly, performs the experiments and examines himself honestly with the test questions, he cannot fail to learn the principles of radio and will be well equipped to undertake specialized and advanced training in any branch of radio communications or electronics. Instructors using this material may be confident that their students will receive thorough training in the essential fundamentals of radio.

PRICE 50 CENTS POSTPAID (No Stamps, Please)

AMERICAN RADIO RELAY LEAGUE, WEST HARTFORD, CONNECTICUT



RADIO OPERATORS WANTED

Be a "key" man. Learn how to send and receive messages in code by telegraph and radio. Army, Navy and Commerce need thousands of men. Expansion of air commerce and freight after war should create an even bigger peace-time demand for operators. The famous Candler System, maker of world's champions, teaches you the "knack" of sound sense and sound consciousness that is the secret of speedy sending and receiving. Good pay, adventure. Learn at home quickly.

FREE 52-PAGE BOOK

explains extra course of training. Rush name for it today. It's absolutely free.

CANDLER SYSTEM CO.

Dept. 4-G, P. O. Box 928, Denver, Colo., U. S. A.

Craven House, 121, Kingsway, London, W. C. 2



LEADERSHIP
is just a word!

but

THORDARSON'S LEADERSHIP
IS AN ACCEPTED *fact!*

Today, in any language, the word Thordarson means the finest transformers that human skill can create.

The prized Army-Navy "E" award has been granted to Thordarson for excellence in producing material for furthering the war effort.

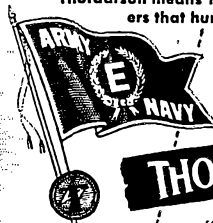

THORDARSON

ELECTRIC MFG. COMPANY
500 WEST HURON ST., CHICAGO, ILL.

Transformer Specialists Since 1895

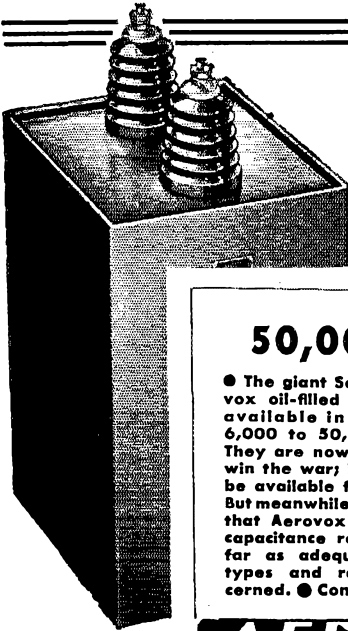

50,000 V.

● The giant Series '20 Aero-vox oil-filled capacitors are available in ratings from 6,000 to 50,000 v. D.C.W. They are now being used to win the war; later, they will be available for civilian use. But meanwhile, just remember that Aerovox can meet ALL capacitance requirements so far as adequate choice of types and ratings is concerned. ● Consult our jobber.



In many capacities and voltages from 6,000 to 50,000. To 30,000 v. for continuous service in rectifier filters, etc. 50,000 v. for intermittent service.

MATHEMATICS FOR RADIO AND COMMUNICATION

by **GEORGE F. MAEDEL, A.B., E.E.**

Chief Instructor, RCA Institutes

To master the technicalities of radio — to read engineering literature intelligently — you must have the mathematical groundwork covered by these absorbing books prepared for home study. Book I (314 pp.) covers the algebra, arithmetic, and geometry; Book II (329 pp.) covers the advanced algebra, trigonometry, and complex numbers necessary to read technical books and articles on radio.

MAEDEL PUBLISHING HOUSE
593 East 38 Street, Brooklyn, New York

Room 101

Send me MATHEMATICS FOR RADIO AND COMMUNICATION as checked below. I enclose payment therefor with the understanding that I may return the book(s) within 5 days in good condition and my money will be refunded.

Name.....

Address.....

- Book I at \$3.75 plus 6c postage
- Book II at \$4.00 plus 6c postage
- Books I and II at \$7.75 postage prepaid

Foreign and Canadian prices 25 cents per volume higher

the oscillations going by feeding part of the a.c. voltage, set up in my plate circuit by that first Grid Leak-Condenser cycle, back to my grid circuit. That supplies the second cycle, and it in turn supplies the third, and so on. As long as enough voltage is fed back from my plate to my grid, I can keep oscillating forever."

"What's your trouble, then?" the Sleuth asked. "Hasn't there been enough voltage feeding back?"

"No, that isn't it. I've had no trouble keeping the oscillations going, and as far as I know the frequency has been all right, too."

"That reminds me — just how do you control the frequency of those oscillations? I know they have to be timed exactly, but how do you do it?"

"Oscillator Coil and Condenser are in control of that operation," Oscillator Tube waved at the pair. "They work in my grid circuit, too, you know — just down the line from Grid Leak and Grid Condenser. Once the oscillatory cycle has been started by the d.c. drop across Grid Leak, it becomes an alternating current signal, as I pointed out. Oscillator Coil and Condenser aren't interested in the d.c., of course, but they take charge of the a.c. with a firm hand."

"Is that a pun — 'take charge'?" Ohm asked suspiciously.

"Sorry---it wasn't meant to be. Anyway, when this alternating voltage is fed back from the plate to their grid circuit they behave just like any of these selective circuits. If the voltage has the right frequency they give it a lot of impedance on which to build itself up. If the frequency isn't right, they just pass it to ground through their reactances. It's very much like the system R.F. Tube was telling you about."

"What happens to the voltage when you finally have it made?"

"I pass it along to Mixer Tube through Oscillator Coupling Condenser and a dumb half-watt Resistor she has working with her."

"Why can't you hand it along direct?"

"The Condenser blocks off the d.c. on my grid and lets only the a.c. through. Mixer isn't interested in current, though; what he wants is voltage. So the a.c. goes from Condenser to ground through this Resistor. In doing so, of course, it makes an a.c. voltage across the resistance drop — and that's what Mixer uses."

"I see. Now let's check our facts. You make a.c. current for the local signal. Right? So far as you know you've been putting out this current at the right amplitude and frequency and so on. Right? This Coupling Condenser takes the current from you — and as far as you know it's been going out as usual. Right? But Mixer Tube hasn't been getting the voltage that's supposed to result from this current when it flows through the resistor. Right?"

Oscillator Tube nodded his head emphatically at each clipped query. The Sleuth turned to Ohm Meter. "Give me an immediate report on that half-watt Resistor over there," he ordered.

Head bent, Ohm strode over to the recumbent



**WHEREVER
SUPERIORITY
MEANS
LIFE
THERE WILL
BE A
KENYON**

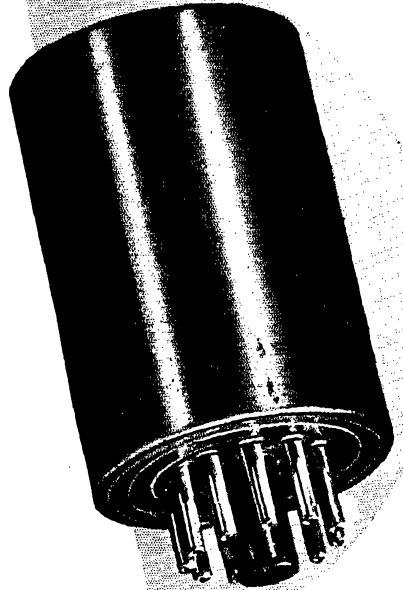

KENYON TRANSFORMER CO., INC.

840 BARRY STREET
NEW YORK, N. Y.

THE RADIO AMATEUR'S LIBRARY

Many requests are received for the complete list of our publications. The list follows:

Title	Price
QST.....	\$2.50 per year*
List of Stations.....	Discontinued
Map of Member Stations.....	Discontinued
Operating an Amateur Radio Station	Free to members; to others 10¢
The Story of The A.R.R.L.....	Discontinued
The Radio Amateur's Handbook	
a. Standard Edition.....	\$1.00**
b. Special Defense Edition.....	\$1.00
The Log.....	35¢ each; 3 for \$1.00
How to Become a Radio Amateur.....	25¢
The Radio Amateur's License Manual.....	25¢
Hints & Kinks for the Radio Amateur.....	50¢
Lightning Calculators:	
a. Radio (Type A).....	\$1.00
b. Ohm's Law (Type B).....	\$1.00
Amateur Radio Map of the World.....	\$1.25
Two Hundred Meters and Down: The Story of Amateur Radio.....	\$1.00
Building an Amateur Radio-telephone Transmitter.....	Out of print
A.R.R.L. Antenna Book.....	50¢
Emergency Communications Manual.....	10¢
The Minilog.....	25¢
Learning the Radiotelegraph Code.....	25¢
A Course in Radio Fundamentals.....	50¢

*In the United States and Possessions—other Countries \$3.00 per year.

**Postpaid in Continental U. S. A. — \$1.50, postpaid, elsewhere.

(No stamps, please)

The American Radio Relay League, Inc.
WEST HARTFORD, CONNECTICUT

what is a TERMINAL?*

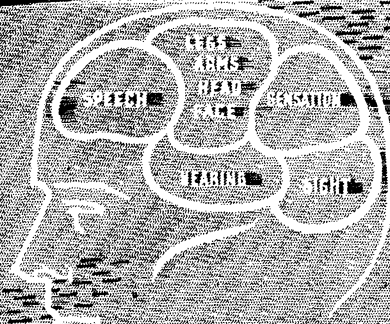

*THE MIND is a terminal for external impressions and internal ideas. A War Bond booth is a terminal for Bonds and your extra cash. And TERMINAL (be sure *your* mind gets *this* idea!) is a terminal for all radio and electronic supplies and those who want them. TERMINAL Radio Corp., 85 Cortlandt St., New York, N. Y. Telephone: WOrth 2-4415.

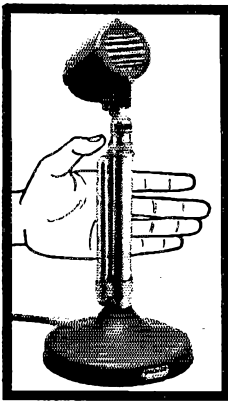

MICROPHONE CONTROL at the Finger Tips

● Unaffected by variations in temperature, sturdy and dependable, Astatic GDN Series Dynamic Microphones, in high and low impedance models of 50 to 50,000 ohms, are now serving efficiently in many war-time radio communication applications. Made with

tilting head and interchangeable plug and socket connector. Recommended for use with Astatic Grip-to-Talk Desk Stand embodying relay operating OFF-ON switch for remote control of transmitters and amplifiers.



THE ASTATIC CORP., Youngstown, Ohio

IN CANADA:
CANADIAN ASTATIC, LTD., TORONTO, ONTARIO

● "Three-Way" Transmitter-Receivers for CD and Military Use

Write for Circular CD

● Radio Remote Control Equipment for Models and Industry

The Radio Control Instruction Manual, 25c postpaid

RADIO CONTROL HEADQUARTERS, INC.

P. O. Box 214

Deal, New Jersey

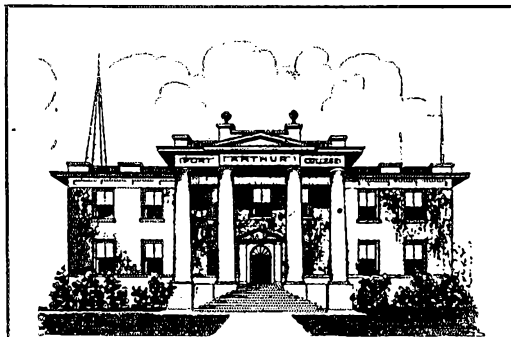

Founded in 1909

Pre-Induction "RADIO"

A maximum of thirteen weeks to prepare for military service — code — printing — typing — procedure — and fundamentals of tube and transmitter servicing. If interested, write for details.

PORT ARTHUR COLLEGE

PORT ARTHUR, TEXAS

Resistor. The examination was brief but intensive. Returning, Ohm spread his probes in a gesture of negation. "Checks OK," he said. "I can't find anything wrong with him."

The Sleuth puffed thoughtfully. "Are you oscillating now?" he asked Oscillator Tube.

"I'm bouncing," was the reply.

"ARE YOU OSCILLATING NOW?" SLEUTH ASKED.
"I'M BOUNCING," WAS THE REPLY



"Good," the Sleuth said, taking the pipe from his mouth. "Volt, just check that voltage on Oscillator Tube's grid for me will you?"

"I can only check d.c.," Volt reminded him.

"Yes, I know. But there's supposed to be a d.c. voltage across Grid Leak."

Nodding, Volt Meter hoisted himself into position. His pointer moved slowly up over perhaps ten per cent of his scale.

"Hey, he's too heavy a load for me," Oscillator Tube protested.

"That's enough, anyway," the Sleuth said. "We know now that you're delivering all right. Now, Volt, see if you can find any indication of voltage on Mixer Tube's grid."

Again Volt got himself into position, but this time there was no response.

"There's the culprit," the Sleuth pronounced sternly, pointing at the diminutive Output Coupling Condenser, who cowered wanly. "By elimination, it can't be anyone else. She isn't passing the current along."

"Is that true?" Oscillator Tube asked the tiny Condenser.

"Y-yes, sir. Ever since the power failed and it got so c-cold and damp I-I've been too sick to do anything. I don't know what's wrong — I just can't seem to work any more. . . ." The frail voice trailed off weakly.

"Hmmm," Oscillator Tube spoke with measured kindness. "I didn't suspect her before because I knew she was such a loyal and willing worker, and I didn't know she'd been sick. It did get cold and damp in here when the power was off — it's a wonder more parts aren't sick. Well, we'll get someone else for her job and let her have a rest. She's earned it."

He turned to the Sleuth. "And now I must thank you for helping me with my problem. It was a masterful job of detective work," he said warmly.

"Only a little logical deduction and the process of elimination," the Sleuth answered comfortably. "That combination can't fail, if you apply it intelligently."

"Oh, yeah? Then *who killed the Signal?*" It was Ohm's rasping murmur in the background. The Sleuth's complacent smile faded.

"That reminds me," Oscillator Tube bridged the awkward pause. "I promised to help you solve your case if you'd help me with mine, didn't I?"

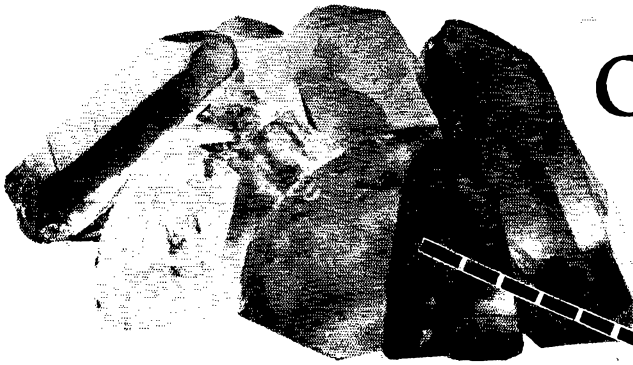

Our Birthday Gift for War ... and Peace!

WE'RE YOUNG in years — old in experience — here at Scientific Radio Products, Inc. For we've just passed our first "birthday."

During one four months' period we produced more crystals — perfect ones — than the entire United States made a couple of years ago. And we are constantly "upping our production!"

Right now, we have one important customer — Uncle Sam . . . he's taking our output. But our facilities are such that we can supply the same quality crystals for other important needs.

Write us today!

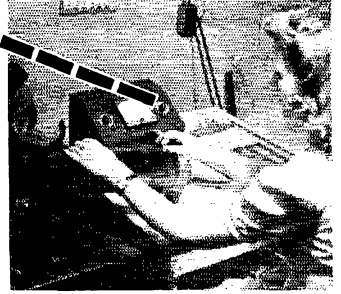

Scientific RADIO PRODUCTS CO.

738 W. Edwy.

LEO MEYERSON W9GFG
E. M. SHIDELER W9IFI

Council Bluffs, Iowa

MANUFACTURERS OF PIEZO ELECTRIC CRYSTALS AND ASSOCIATED EQUIPMENT

MASTER COURSE IN RADIO COMMUNICATION



Fits you for a job, advancement or license examination. Course by A. R. Nilson for home study covers same scope as resident school course. Every Nilson graduate to date has commercial license, or a good radio job.

FREE circular 3-Q gives full information. Write today.

NILSON RADIO SCHOOL, 51 East 42nd St., New York

RADIO ENGINEER

Experienced in the manufacture and testing of ultra-high frequency apparatus; must be capable of taking complete charge of war projects. Splendid opportunity. War workers at highest skill need not apply. Inquiries will be kept confidential. Please state age, experience and salary expected. Box 45, QST.

RADIO OPERATORS' CODE MANUAL (WITH TOUCH TYPING)

A complete and thorough self-study and classroom text in code transmission and reception with touch typing procedure. Comprehensive instruction in the construction of code practice equipment and devices, 166 pages, 40 illustrations and touch typing charts. Flexible paperbound edition \$2.00 post-paid or write for descriptive circular.

WAYNE MILLER

The Engineering Building, Chicago, U.S.A.

DON C. WALLACE

Radio Field Engineer

Representing Eastern Radio Manufacturers
in the Western Territory

4214 Country Club Drive (W6AM)

Long Beach, Calif.

Phone 434-59

★ COAST-TO-COAST ★

WARTIME RUSH SERVICE

for

**PURCHASING AGENTS
ENGINEERS • EXPEDITERS
PROCUREMENT OFFICERS**

★ ★ ★ ★ ★

**RADIO PARTS, TUBES and
ELECTRONIC EQUIPMENT**

— Available FROM STOCK!

FREE 800-PAGE CATALOG!

If you have not already received a copy of our 800-page buying directory and are actively engaged in the war effort doing purchasing, specifying, expediting or research, write to us today on your company letterhead for a free copy of "Radio's Master Encyclopedia." Address Dept. Q-6.

New York's Oldest Radio Supply House

SUN RADIO CO.
212 FULTON ST., NEW YORK CITY

— Telephone BR 47-1840 —

IMPORTANT PLEASE STATE, WHEN ORDERING,
WHICH EDITION YOU WISH

The Radio Amateur's HANDBOOK

"the all-purpose volume on radio"

Text,* data book, operating manual — it is all these and more. As a text it is probably more used in radio schools and colleges than any other single volume. As a practical constructional handbook, it stands in a class alone. As an operating manual, it provides information available from no comparable source.

Standard Edition

Geared to war needs, the latest Edition of THE RADIO AMATEUR'S HANDBOOK is the largest ever published. In addition to the established features it includes a comprehensive 50-page chapter dealing with the vitally-important War Emergency Radio Service plus other new material — all added without sacrificing the essential information in previous editions which made the HANDBOOK the world's most valuable and widely-used radio book. Retained is the highly successful treatment of fundamentals which was an innovation of the 1942 edition. Stripped to essentials, the theory and design sections cover every subject encountered in practical radio communication, sectionalized by topics with abundant cross-referencing and fully indexed. An ideal reference work, the 1943 Edition also contains all the constructional information on tested and proved gear which has always been the outstanding feature of the HANDBOOK.

\$1 IN CONTINENTAL U. S. A.
\$1.50 ELSEWHERE

Special Defense Edition

This edition of the HANDBOOK is designed especially for use in radio training courses. It eliminates those portions of the regular edition which are not useful for instruction purposes and has added chapters on mathematics, measuring equipment and code instruction. The first chapter covers the elementary mathematics necessary for the solution of all formulas and interpretation of graphs appearing throughout the text. A four-place log table is included in the Appendix.

\$1 POSTPAID ANYWHERE

* The book "A Course in Radio Fundamentals" is based on the text of either of the above mentioned editions of the HANDBOOK — PRICE 50 cents.

**AMERICAN RADIO
RELAY LEAGUE, INC.**

West Hartford, Connecticut, U. S. A.

(Continued from page 88)

Well, here's my tip. It took a good piece of detection to solve this problem of mine, and I think you'll find that to be the answer to yours. Detective work — that's what you need."

The Sleuth stared, first in perplexity, then with anger succeeding bewilderment as Ohm's mocking laughter sounded in the background.

"He's ribbing you, Boss," Ohm chortled. But after a moment an expression of thoughtful concentration replaced the rage on the Sleuth's face.

(To be concluded.)

On the Very Highs

(Continued from page 47)

maker, what an extreme temperature inversion can do to 112-Mc. signals; here is a sample of what *can* happen out where they have the world's best natural inversion setup. Some interesting things are going to happen on the "very highs" when the current unpleasantness is over.

This should serve to remind us that there is plenty of activity in the region around the 112-Mc. band these days. Airfields and planes the country over are using this 116-plus channel for communication regularly. We should bear that in mind when we assign our WERS frequencies. Already we've heard WERS signals close enough to the channel used by fighter planes at a local field so that there was interference between the two on a super-regen. A word to the wise — better be sure of those frequency standards!

Not much news from our gang in the services this month. As reported previously, Vince Dawson, W9ZJB, is now in the Air Corps. Most fellows get sent far from home when they go into uniform, but for Vince, getting the call meant going back home! He had the good fortune to be assigned to training at Fort Leavenworth, only thirty miles from home. Vince would like to hear from any of the gang. Address: Pvt. G. V. Dawson, jr., AAF, Sherman Field, Fort Leavenworth, Kansas.

Cpl. Mallory, W1MEP, is all through training at Fort Monmouth and is assigned temporarily to Drew Field, Florida. He warns not to write him there, however, as he expects to be on the move again soon.

Another Horsetrader, W1KJT, writes from North Africa that the affair there is no picnic, but it's not all fighting, either. Johnny reports that a couple of months ago a group of more than twenty hams got together at an unnamed airfield for a real American-style hamfest. Johnny is piling up a great store of yarns for the boys back home when it's all over. After more than nine months in North Africa he's really missing the old carefree life of the States. Naturally he'd like to hear from the gang. Write to Cpl. John T. Bibisi, 1st Signal Co., APO 1, New York City.

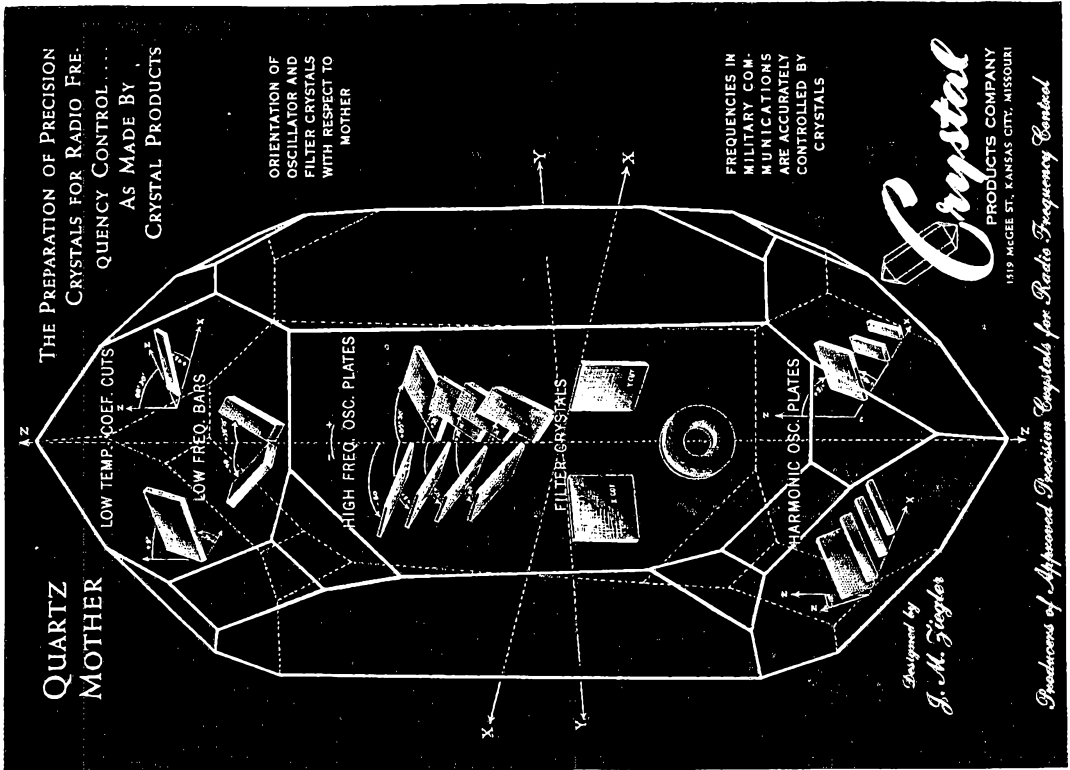

RADIO CODE *Taught without instructors by the Voice Code Method*
 A set of 10 phonograph records comprising a complete radio course up to 16 words per minute.
 Simple and Economical ■ Complete Set \$20.00
AMERICAN RADIO INSTITUTE 44 EAST 23rd ST. NEW YORK CITY
Teaching Radio Since 1935

LEARN RADIO
 60-page catalog on request. Oldest, largest and best equipped in New England. New classes now forming. Write for new catalog.
MASS. RADIO SCHOOL
 18 Boylston Street Boston, Massachusetts

RADIO TECHNOLOGY
 RCA Institute offers an intensive two-year course of high standard embracing all phases of Radio and Television. Practical training with modern equipment. Also shorter specialized courses in Commercial Radio Operating, Radio and Television Servicing, and Aviation Communications.
 For Free Catalog write Dept. ST-43
RCA INSTITUTES, INC.
 A Radio Corporation of America Service
 75 Varick Street New York City

HARVEY RADIO LAB'S, Inc.
 Manufacturers of Radio Transmitters
ELECTRONIC APPARATUS
 447 CONCORD AVENUE, CAMBRIDGE, MASS.

Going ^{*}WERS?



Get Your Equipment in Shape for **WARTIME SERVICE**
 ORDER PARTS NOW WHILE AVAILABLE

Send Today for **FREE Radio BARGAIN BOOK**

Largest stock parts and rigs on hand... but they're going fast. Better hurry! Send today for free illustrated catalog, low prices, terms. Write to Leo, W9GFQ.



* Wartime Emergency Radio Service
WHOLESALE RADIO LABORATORIES
 714 West Broadway
 Council Bluffs Iowa

HAM-ADS

(1) Advertising shall pertain to radio and shall be of nature of interest to radio amateurs or experimenters in their pursuit of the art.

(2) No display of any character will be accepted, nor can any special typographical arrangements, such as all or part capital letters be used which would tend to make one advertisement stand out from the others.

(3) The Ham-Ad rate is 30c per word, except as noted in paragraph (6) below.

(4) Remittance in full must accompany copy. No cash or contract discount or agency commission will be allowed.

(5) Closing date for Ham-Ads is the 25th of the second month preceding publication date.

(6) A special rate of 7c per word will apply to advertising which, in our judgment, is obviously non-commercial in nature and is placed and signed by a member of the American Radio Relay League. Thus, advertising of bona fide surplus equipment owned, used and for sale by an individual or apparatus offered for exchange or advertising inquiring for special equipment, if by a member of the American Radio Relay League takes the 7c rate. An attempt to deal in apparatus in quantity for profit, even if by an individual, is commercial and all advertising by him takes the 30c rate. Provisions of paragraphs (1), (2), (4) and (5) apply to all advertising in this column regardless of which rate may apply.

Having made no investigation of the advertisers in the classified columns, the publishers of QST are unable to vouch for their integrity or for the grade or character of the products advertised

* * * * *

QUARTZ — direct importers from Brazil of best quality pure quartz suitable for making piezo-electric crystals. Diamond Drill Carbon Co., 719 World Bldg., New York City.

COMMERCIAL radio operators examination questions and answers. One dollar per element. G. C. Waller, W5ATV, 6540 Washington Blvd., Tulsa, Okla.

TELEPLEXES, Instructographs bought, sold. Ryan's. Hannibal, Mo.

WHY not turn your unused equipment into ready cash which may be applied towards new and better equipment after the war? Leo, W9GFC, offers you the best cash prices for communications receivers and test equipment. Write today for large illustrated catalog. Wholesale Radio Laboratories, 744 W. Broadway, Council Bluffs, Iowa.

WANTED: Hallicrafter S-29, Sky Traveler. Charles Smith, 85 Kingsboro Avenue, Gloversville, N.Y.

USED equipment wanted. Highest cash prices paid for receivers, transmitters, meters, parts, etc. I promise you the best deal. Let me know what you have. Bob Henry, W9ARA, Butler, Mo.

IN stock: Mac No. 200 keys, \$2.25, Signatone code oscillators \$11.85; condensers, resistors, panels, chassis, transformers. Vibroplexes, radio supplies of all sorts. Your inquiries and orders invited. Henry Radio Shop, Butler, Mo.

WANTED: Signal generator, Hickok, either 188X, 188, 177X. Oscillograph R.F. 0-5. Electronic multimeter, R.C.P. Co. 662 or other. Walter Waechter, 95-07 Creeskill Place, Jamaica, L.I., N.Y.

SUPREME reconditioned instrument 1250 volts DC, two megs. Rest offer over \$15 takes it. W9JMG, 520 West Empire, Freeport, Illinois.

RIDER manuals, test equipment, etc., wanted. Sell or trade: early Rider volumes. Cannady, 38 West Anderson, Aurora, Missouri.

HY 75, HY 615, 9002, in good condition, wanted. Louis J. Silva, W6TNM, 9500 Granada, Oakland, California.

WANTED — Tube & Set Tester. W2JZI.

WANTED: Super-pro HQ 120-X. SX-28. James Fernane, 10 Cottage Street, Medfield, Mass.

VOLT-OHMETER wanted. State details, price. George Kravitz, 7919 20th Avenue, Brooklyn, N.Y.

SELL — Transmitter tubes, parts. Send for list. Albert Smith, 2304 Sherman Avenue, Evanston, Illinois.

WANTED — Late model Hammarlund Super-pro. Good condition. Write W8RHP, 2710 Lakeview, Rocky River, Ohio.

URGENTLY needed radio tubes RK-49, RK-37, RK-38, RK-47. Please dispatch your list showing quantities, condition and prices. Bodnar Police Radio, Tuckahoe, N.Y.

FOR SALE — National 101X Receiver, complete with speaker. perfect. \$75. W6WY, 1901 Park Drive, Los Angeles, Calif.

V.O.M. wanted. Must be modern. Write to William Heer, Elmira, OHIO.

NC81X for sale. Excellent condition. With speaker. Best offer gets it. Paul E. Gardner, New England, No. Dakota.

WANTED: Sargent Marine Receiver. 15-9000 meters. Milt Abell, 1639 Monterey Av., Detroit, Mich.

GOOD quality cutting head wanted, 8 Ohm (or higher, with transformer); also lead screw and associated apparatus, such as Rek-O-Cut. SELL: 40 Ft. Amphiphenol copper tubing concentric cable. New. \$10. R. E. Leo, W6PBV, General Delivery, Inverness, California.

WANTED: Late Scott Phantom or McMurdo Silver Masterpiece, in good condition. Ralph Ashworth, Charlton City, Massachusetts.

SELL — Deluxe Par-Metal 36 3/4" gray cabinet DL3513, 2 19" racks 62" gray, heavy duty, standard drilling. Steel cabinets, boxes, gray. Amplifier Bud BPA-500. Fifty variable Cardwell, Hammarlund, Bud, APC size to 1100 mmf., some dual, some wide spaced. Taylor Tubes, Mica transmitting condensers. Large 220 V.A.C. full wave Tungar charter. Thordarson plate and filament transformers including T19P66. Other parts. Priced to sell. Condition good to perfect. What do you need? W9BQZ, Lawson, 341 Spring Avenue, Webster Groves, Missouri.

WANTED — RCA 955 tube. W2BMT, 8121 91st Avenue, Woodhaven, N.Y.

WANTED — SX28, SX32, or Super-pro in reasonably good condition; will pay cash. O. G. Villard, Jr., 21 Chauncy Street, Cambridge, Mass.

FOR SALE — Patterson PR-16, good as new, guarantee. Price fifty dollars here. Master Teleplex, used less than 5 hours, price forty dollars here. E. E. Conzelman, Scandia, Kansas.

SELL — Jensen PM 12 B Speaker, Speed-X Jr. Bug, W9DPB, Gerard, Mason City, Iowa.

WANTED — Good used Howard Model 430 — Cash. Meissner Deluxe Shifter. Trade CB-OCX Signal Generator, and Cash. T/S H.N. Christianson W9QKN, 502 CA AA Hq Btry, 1st Bn, Paterson, N.J.

SELL old issues Wireless Age, Proceedings I.R.E. QST, & Bell System Technical Journal. Want QST for Dec., 1915, May-June 1916, also old issues Amateur Radio Call Books & A.R.R.L. Handbooks. W. L. Holst, W9MD, 2553 Winnemac Ave., Chicago, Ill.

WANTED — RME-99 receiver, in good condition. C. L. Janik, 9 Rockefeller Plaza, N. Y. Phone Columbus 5-4251.

FOR SALE, Abbott DK-3, 2 1/2 Meter Transceiver, good as new, used only 60 hours, tubes and hand set. O. H. Ford, W5HXH, Granite, Okla.

WANTED: S-27 Hallicrafter. Will pay your price. W1HFB, Dresser, Long Hill, Conn.

WANTED — Pocket Volt-Ohm-Milliammeter, Triplet 666S, Supreme 542 or similar. W3JMA, Rushworth, 533 South Longwood, Baltimore, Md.

QSL Printing Press wanted. Barrett, 201 1/2 Decatur St., Oildale, Calif.

NEED crystals immediately? Call or order from Eidson's. Very prompt delivery on small or medium quantities. You will like our time-proven type E62 and E64 Steatite units, suitable for frequencies in the 1600 to 10,000 kilocycle range. All orders subject to priority. "Eidson's", Temple, Texas. Phone 3901.

WANTED: Hallicrafters Model S-27. Abbott TR-4. HY-75 tube. William S. Burkhardt, Route 15, Amity Rd., Lockland, Ohio.

WANTED — For 100% War Radio Work. Radio Engineers, Mechanical Engineers, Test Engineers. Qualified engineers having transmitter and receiver manufacturing experience. Excellent opportunity for applicants presently not engaged at highest skill. This is not only a war job but post-war as well. Write, giving full details of age, education, experience, and salary. Hamilton Radio Corp. 510 6th Ave., New York City.

QST'S prior to July, 1919, wanted, also Grebe CR-18 Receiver. W2ELN, 89-19 78th St., Woodhaven, L. I., N. Y.

WANTED: Small compact self-contained CW or phone transmitter. Give full details. W1BB

WANTED — Meissner DeLuxe Signal Shifter Model 9-1050. Frank Huberman, 673 Conn. Boulevard, East Hartford, Conn.

**THAT ECHOPHONE EC-1
IS SENDING THEM LIKE MY DRAFT
BOARD SENT ME!**



Echophone Model EC-1

(Illustrated) a compact communications receiver with every necessary feature for good reception. Covers from 550 kc. to 30 mc. on three bands. Electrical bandspread on all bands. Six tubes. Self-contained speaker. Operates on 115-125 volts AC or DC.

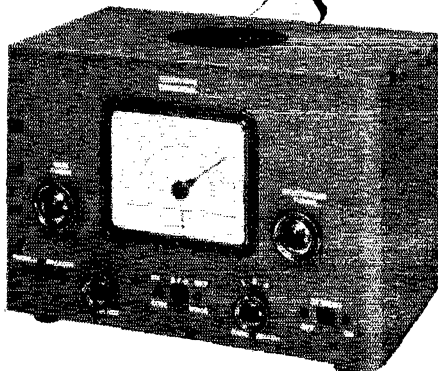

ECHOPHONE RADIO CO., 201 EAST 26th ST., CHICAGO, ILLINOIS

Designed for

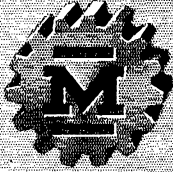

Application

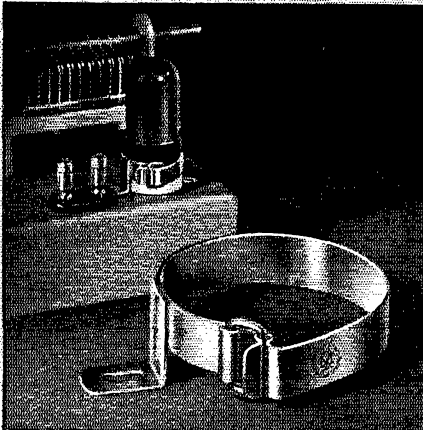

THE 33087 TUBE CLAMP

Still another exclusive Millen "Designed for Application" product. Easy to use, easy to install, effective in function. Available in special sizes for all types of tubes. Single hole mounting. Spring steel, cadmium plated.

**JAMES MILLEN
MFG. CO., INC.**

MAIN OFFICE AND FACTORY
**MALDEN
MASSACHUSETTS**



Index to Advertisers

	Page
Abbott Instrument, Inc.	76
Aerovox Corporation	86
American Lava Corporation	**
American Radio Institute	91
Amperex Electronic Products, Inc.	**
Asatic Corporation, The	38
Ayers Automatic Code Machines	**
Barker & Williamson	**
Bliley Electric Company	70
Browning Laboratories, Inc.	**
Candler System Company	85
Capitol Radio Engineering Institute	**
Cardwell Manufacturing Corp., Allen D.	**
Centralab	73
Clarostat	**
Crystal Products Company	91
Dodge Telegraph & Radio Institute, The	**
Echophone Radio Company	93
Eitel-McCullough, Inc.	5
Electro-Voice Manufacturing Co.	**
Electronic Laboratories	81
Galvin Manufacturing Corp.	**
Hallcrafters Company, The	1, 2
Hammarlund Manufacturing Co., The	69, 71
Harvey Radio Company	**
Harvey Radio Laboratories, Inc.	91
Harvey-Wells Communications, Inc.	**
Heintz & Kaufman, Ltd.	**
Henry Radio Shop	84
Instructograph Company	**
Jensen Radio Manufacturing Company	96
Ken-Rad Tube & Lamp Corp.	**
Kenyon Transformer Co., Inc.	87
Knights, James, Co.	**
Maedel Publishing House	86
Mallory & Co., Inc., P. R.	72
Massachusetts Radio School	91
McElroy Manufacturing Corp.	**
McGraw-Hill Book Co., Inc.	82, 84
Meck, John, Industries	83
Meissner Manufacturing Company	**
Melville Aeronautical Radio School, Inc.	**
Metropolitan Technical School	**
Millen Manufacturing Co., James	94
Miller, Wayne	89
National Company, Inc.	67, Cov. III
Newark Electric Company	83
Nilson Radio School	89
Ohmite Manufacturing Company	**
Oxford-Tartak Radio Corporation	**
Port Arthur College	88
RCA Institutes, Inc.	91
RCA Manufacturing Co., Inc.	Cov. IV
Radio Control Headquarters, Inc.	88
Radio Manufacturing Engineers	**
Radio Shack Corporation	80
Raytheon Manufacturing Company	77
Scientific Radio Products Co.	89
Shure Brothers	78
Standard Transformer Corporation	**
Sun Radio Company	89
Taylor Tubes, Inc.	75
Terminal Radio Corporation	87
Thordarson Electric Manufacturing Co.	85
Triplett Electrical Instrument Co., The	74
United Transformer Company	Cov. II
Universal Microphone Company	**
Vibroplex Company, Inc., The	83
Wallace, Don	89
Wholesale Radio Laboratories	91
Wilcox Electric Company	**
Vaxley (Mallory)	72

All of the above advertisers are cooperating with the A.R.R.L. to permit publication of an editorially adequate (OST) during this period of war-rationing of paper. Using less advertising space but at higher rates, they continue their customary support of (OST). Some are using smaller space in each issue and some are using space only every second or third issue. Of the latter, those whose advertising does not appear in this particular issue are indicated by the ** above.

QST

Probably you have noticed that in the May and June issues of *QST* much less space is devoted to advertising than has been the case in previous recent issues. One might suspect that this is because we have been unable to sell as much space as heretofore. Quite the contrary; it is the effect of one of the finest pieces of coöperation we have ever seen.

Like all other magazines, *QST* is rationed. We must use less paper than we did last year. What with circulation growing, owing to the great new military interest in radio, any reduction in paper means considerable reduction in the number of pages. But as you have seen, and will continue to see in future months, *QST* has many important editorial jobs to do which are directly related to the war effort. Reducing the number of pages we could use for editorial material was a sad prospect.

So we put it up to the advertisers. We told them we needed to *cut in half* the number of pages we could devote to advertising if we were to continue an editorially adequate magazine. And then we told them, “. . . *but we must have the same number of dollars we have had in the past if QST is to operate at a profit so that the League will be financially able to undertake the job of post-war rehabilitation of Amateur Radio. In other words, we want you to use half the space at twice the rate!*”

Well, the rest of the story is short but very sweet. We doubled *QST's* advertising rates and rationed advertisers to approximately half the previous space they had been using. Almost without exception, *QST* advertisers said, “Okay, we'll go along with you.” The result is that, in this and in the previous issue of *QST*, over twenty-five pages in each issue have been, in effect, bought and paid for by *QST* advertisers and then turned back to us to use for editorial material. *QST* looks thin, but it contains just as much editorial material as it would if it were twenty-five pages thicker.

Some advertisers are using half-pages instead of pages, or quarter-pages instead of halves; some are using space only every other month and some are using customary space now and small space later in the year, or vice-versa. But every advertiser you see in *QST* this year is coöperating with us in this plan, and will continue to do so for the duration. It's good that we have such friends.

Some day, when the war is won and we've settled down to the pleasant pursuits of peace, we'll try to think up suitable words for a toast to *QST's* advertisers. Their generous coöperation is helping tremendously to get us through these dark days of war and out into the sunshine of an even finer post-war Amateur Radio.

F. C. B.

The American Radio Relay League, Inc.

Better SPEECH REPRODUCTION FROM THE SKYWAYS!

No matter what the operating conditions
JENSEN speech reproducers bring in those
important orders — and maintain passenger comfort
— installed JENSEN speech reproducers at their
bases for sky-to-ground communications
because they know quality is an essential
and reliability a must.

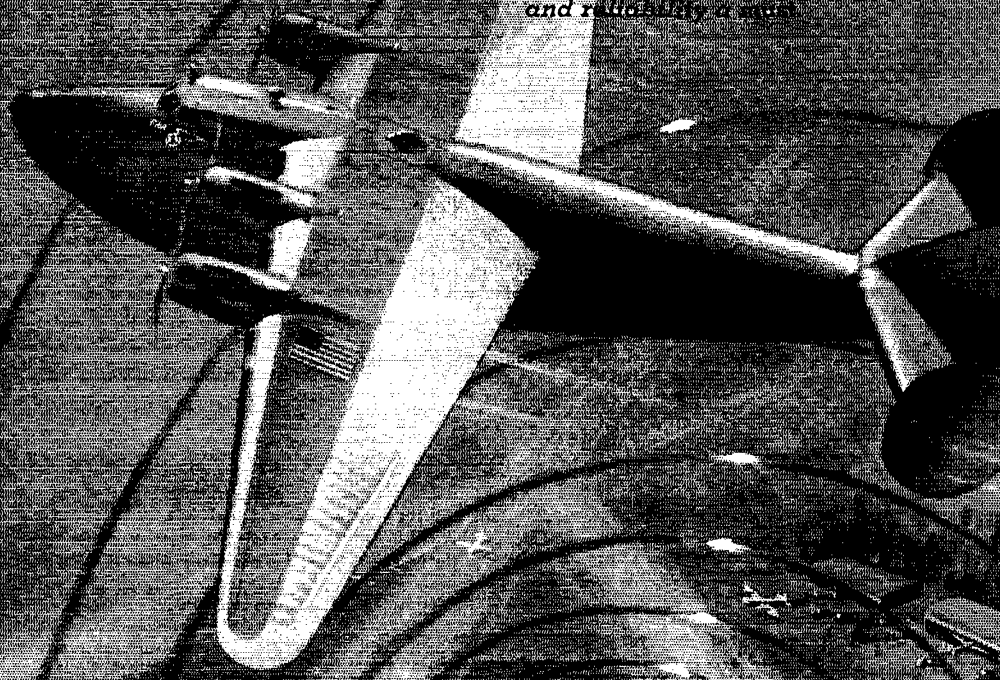

Jensen RADIO MANUFACTURING COMPANY

200 SOUTH LEXAMIE AVENUE
CHICAGO, U. S. A.



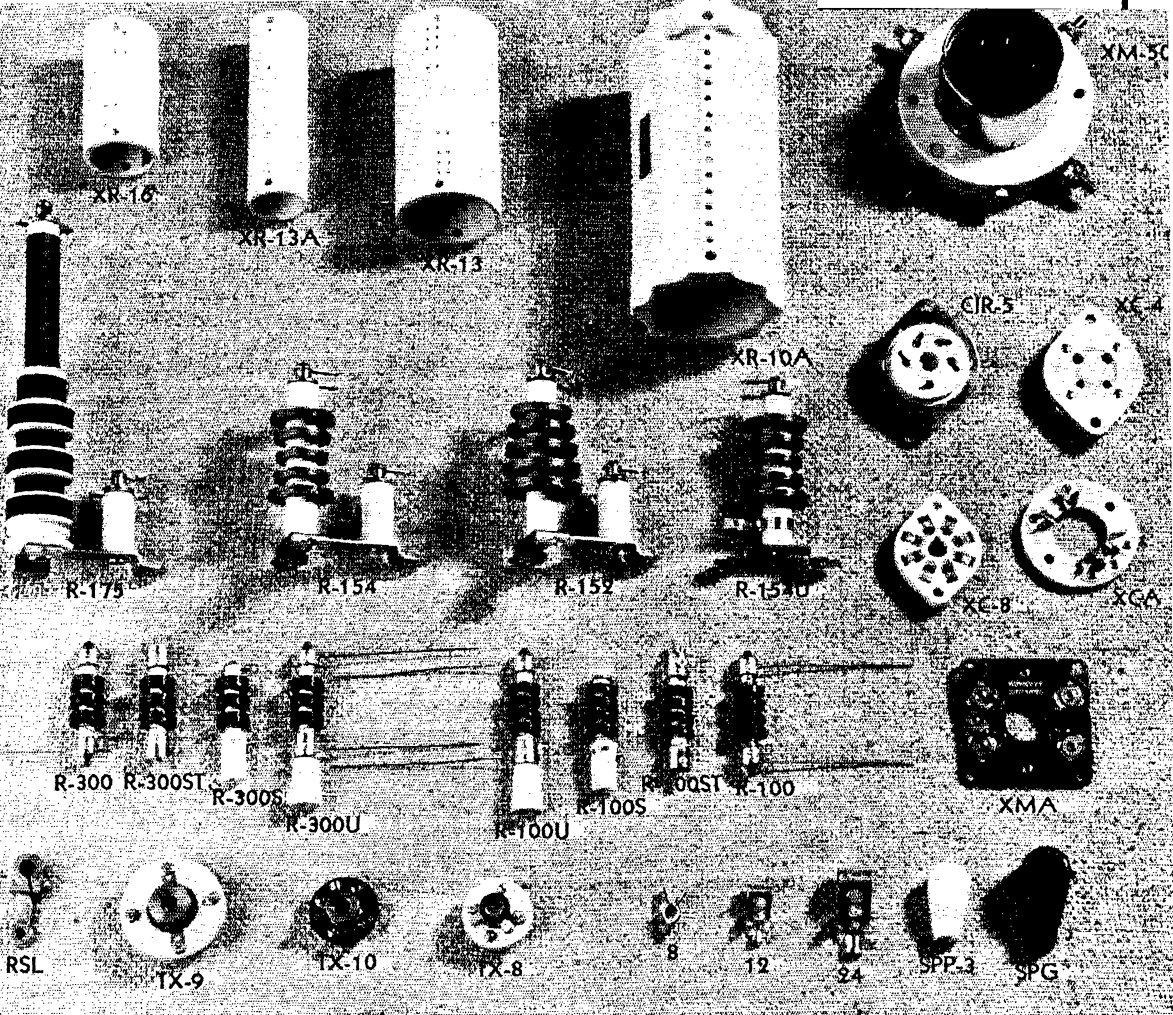

AVAILABLE FOR REASONABLY PROMPT DELIVERY



Enlarged manufacturing facilities have enabled National to offer reasonably prompt delivery on many small parts to those who have the necessary priorities. The sockets, coil forms, RF Chokes, Grid Grips, couplings and rotor shaft locks shown in the photograph above are available on especially good delivery schedules, and in the case of a few items, limited quantities may even be shipped from stock.

NATIONAL COMPANY, INC.

MALDEN, MASS., U. S. A.

THE TUBES THAT LAUNCHED A MILLION BROADCASTS

Probably no tubes in Radio history have launched more top flight broadcasts—and launched them more successfully—than the RCA-892 (water-cooled), and the RCA-892-R (air-radiation-cooled) types.

Prior to the war, these famous tubes led the field on a watt-per-dollar basis. This economy factor is still important, but war emergency conditions now make it secondary to their proved ability to last longer and to perform more dependably. Both types can be rebuilt under the RCA Plan (see below).

These are the RCA standard tubes for

5 kw broadcast requirements, or for driver stage needs in 50 kw transmitters. Both have double-unit filaments permitting operation from 2-phase a.c., thus minimizing hum. Both can be operated from single-phase a-c or d-c filament supplies. Both are designed for class B and class C services—and the RCA-892 has also found widespread use in the most modern induction heating applications.

Complete technical information gladly sent upon request. Write to RCA, Commercial Engineering Section, Harrison, N. J.



HAVE YOUR OLD TUBES REBUILT BY RCA!

RCA Types 207, 891, 891-R, 892,
and 892-R

Actual use over a long period of time has proved the efficiency of these RCA Rebuilt Tubes beyond question. Ratings or characteristics are in no wise impaired. If your station uses any of the five listed types, write today for details.

"Electrons in Action at RCA"

Modern electronic tubes could not be produced in quantity without employing equally modern tubes in the operations used in their manufacture. This promisingly illustrated page book tells the story of electrons in action at RCA and contains many valuable hints on possible electronic applications in your field. Ask for Booklet No. 122150.

BOOKLET FREE!



LONGER LIFE
GREATER ECONOMY
HIGHER OUTPUT

RCA-892 Water-cooled Triode
\$285.00

RCA-892-R Air-radiation-cooled
\$410.00

*Rebuild price \$50 less if old radiator in good condition is returned, postpaid to our Jersey City, N. J. warehouse.



RCA RADIO-ELECTRONIC TUBES

RCA Victor Division - GEORGIA ELECTRIC CORPORATION - B.F. AMERICA - Camden, N. J.