

QST

april, 1945

25 cents

35c in Canada

devoted entirely to

amateur radio



In This Issue: Principles of Radar • Video Amplifier Design • Wide-Range V.H.F. Tank Circuits
230 Watts from a Single 815 • Orienting Directional Antennas • Aircraft Transmitter for CAP
The "Para-Talkie" • Automatic Antenna Switching Methods • Radio Amateurs in Navy Radar

98% HERMETIC PRODUCTION



The need for maximum dependability in transformer products has swung UTC production into high gear on Hermetic designs. Work at our Varick Street plant, for example, is now 98% Hermetic.



(ALL PLANTS)



hallicrafters equipment covers the spectrum

● Hallicrafters equipment covers the radio spectrum. From low to ultra high frequencies there is a Hallicrafters receiver ready to meet your special requirements. Although certain equipment operating in the ultra high frequencies cannot be described at present for security reasons, the characteristics of Hallicrafters standard line of receivers may be disclosed. This line includes:

Model S-37. FM-AM receiver for very high frequency work. Operates from 130 to 210 Mc. Highest frequency range of any general coverage commercial type receiver.

Model S-36. FM-AM-CW receiver. Operates from 27.8 to 143 Mc. Covers old and proposed new FM bands. Only commercially built receiver covering this range.

Model SX-28A. Operates from 550 kc to 42 Mc continuous in six bands. Combines superb broadcast reception with the highest performance as a versatile communications receiver.

Model S-22R. Completes Hallicrafters coverage in the lower end of the spectrum. Operates from 110 kc to 18 Mc in four bands. A.c./d.c. operation.

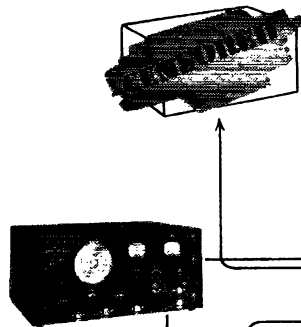

Model S-37.



Model S-36.



Model SX-28A.



Model S-22R.

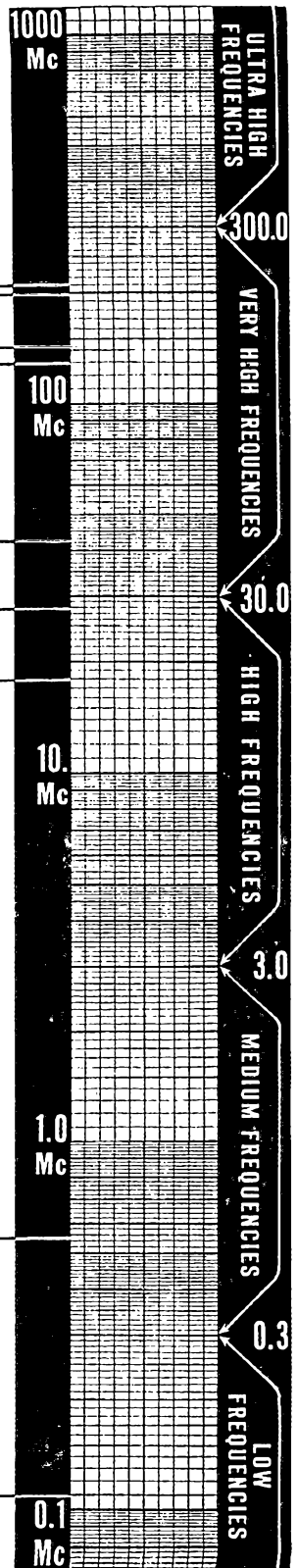

BUY MORE WAR BONDS TODAY!



hallicrafters

THE HALLICRAFTERS CO., MANUFACTURERS OF RADIO
AND ELECTRONIC EQUIPMENT • CHICAGO 16, U. S. A.

Whoever you are—

whatever you do—

YOU NEED hallicrafters EQUIPMENT in high frequency development work



• Illustrated: The new Hallicrafters AM/FM receiver, Model S-36A, designed for maximum performance on the very high frequencies. Provides continuous frequency coverage from 27.8 to 143 Megacycles.

Rail and motor lines, maritime services and universally expanding aviation are planning new or improved communications systems to keep up with the forward pace. In these and many other fields of science there is an urgent demand for the latest developments in very high frequency and ultra high frequency apparatus. In your work in these fields, look to Hallicrafters for advanced communications and electronics equipment.

THE HALLICTRAFTERS CO., MANUFACTURERS OF RADIO AND ELECTRONIC EQUIPMENT, CHICAGO 16, U. S. A.

BUY A WAR
BOND TODAY!



APRIL 1945

VOLUME XXIX

NUMBER 4



STAFF

Editorial

KENNETH B. WARNER, W1EH
General Manager of A.R.R.L.
Publications

CLINTON B. DeSOTO, W1CBD
Editor

A. DAVID MIDDLETON, W2OEN
Assistant Editor

GEORGE GRAMMER, W1DF*
Technical Editor

DONALD H. MIX, W1TS
Acting Technical Editor

J. VENABLE FITZHUGH, W5VL
BYRON GOODMAN, W1JPE*
Assistant Technical Editors

EDWARD P. TILTON, W1HDQ
Contributing Editor, V.H.F.

WALTER E. BRADLEY, W1FWB
VERNON CHAMBERS, W1JEQ*
Technical Information Service

LOUISA B. DRESSER, LSPH
Assistant to the Editor

JAMES J. LAMB, W1AL*
Research Engineer, A.R.R.L.

Advertising

F. CHEYNEY BEEKLEY, W1GS
Advertising Manager

Circulation

DAVID H. HOOBTON
Circulation Manager

RALPH T. BEAUDIN, W1BWA
Asst. Circulation Manager

*On leave of absence



OFFICES

38 La Salle Road
West Hartford 7, Connecticut

Subscription rate in United States and Possessions, \$2.50 per year, postpaid; all other countries, \$3.00 per year, postpaid. Single copies, 25 cents. Foreign remittances should be by international postal or express money order or bank draft negotiable in the U. S. and for an equivalent amount in U. S. funds.

Entered as second-class matter May 29, 1919, at the post office at Hartford, Connecticut, under the Act of March 3, 1879. Acceptance for mailing at special rate of postage provided for in section 1103, Act of October 3, 1917, authorized September 9, 1922. Additional entry at Concord, N. H., authorized February 21, 1929, under the Act of February 28, 1925.

Copyright 1945, by the American Radio Relay League, Inc. Title registered at U. S. Patent Office.

QST

devoted entirely to

AMATEUR RADIO

PUBLISHED, MONTHLY, AS ITS OFFICIAL ORGAN, BY THE AMERICAN RADIO RELAY LEAGUE, INC., AT WEST HARTFORD, CONN., U. S. A.:
OFFICIAL ORGAN OF THE INTERNATIONAL AMATEUR RADIO UNION



CONTENTS

It Seems to Us	9
Splatter	10
Practical Design of Video Amplifiers — Part I Elliott A. Henry, W9FEN	11
A New Type of Dry Cell	16
Happenings of the Month	17
VWOA Celebrates 20th Birthday	19
Radar Techniques — Part I Clinton B. DeSoto, W1CBD	20
Radio Amateurs in Navy Radar Lt. (jg) Charles Lillie, USNR, W1JTG	24
230 Watts from One 815 Lt. Hulen M. Greenwood, AC	26
In the Services	30
The "Para-Talkie" Lt. Arthur H. Copland, CAP	34
In QST 25 Years Ago This Month	37
Automatic Antenna Switching Alfred K. Robinson, ex-W7DX	38
Hams Afloat Jack Nelson, W3FU	42
Ready! Aim! Fire! W. E. Marquart, W9CKT	43
New Transmitting Tube — 4-125A	45
Hams on the Alaska Highway Major Lloyd D. Colvin, SC, K7KG	46
Wide-Range Tank Circuits for V.H.F. and U.H.F. Morrison L. Gable, W9RLM, and Cyrus T. Read, W9AA	48
Gold Stars — W51ZP, W2MKW	49
Hams in Combat Invasion Hams Capt. John Brawley, SC, W9GYZ	50
Hints and Kinks Transmit-Receive Antenna Switching Using Gas-Filled Tubes — A Vacuum-Tube Volt-Ohmmeter — Equip- ment Nameplates from Hand-Drawn Negatives	52
Strays	54
Correspondence from Members	55
Operating News	57
Press Schedules	59
The Month in Canada	60
Amateur Activities	62
WWV Schedules	82
Silent Keys	98
Ham-Ads	101
QST's Index of Advertisers	102

☐ All material appearing in QST conforms with the "Code of Wartime Practices for the American Press" of the U. S. Office of Censorship.

☐ All material involving military security has been reviewed by appropriate military, naval or other competent authority

ORIGINAL AWARD JULY 27, 1942

SECOND AWARD FEB. 13, 1943

THIRD AWARD SEPT. 25, 1943

FOURTH AWARD MAY 27, 1944

FIFTH AWARD DEC. 2, 1944

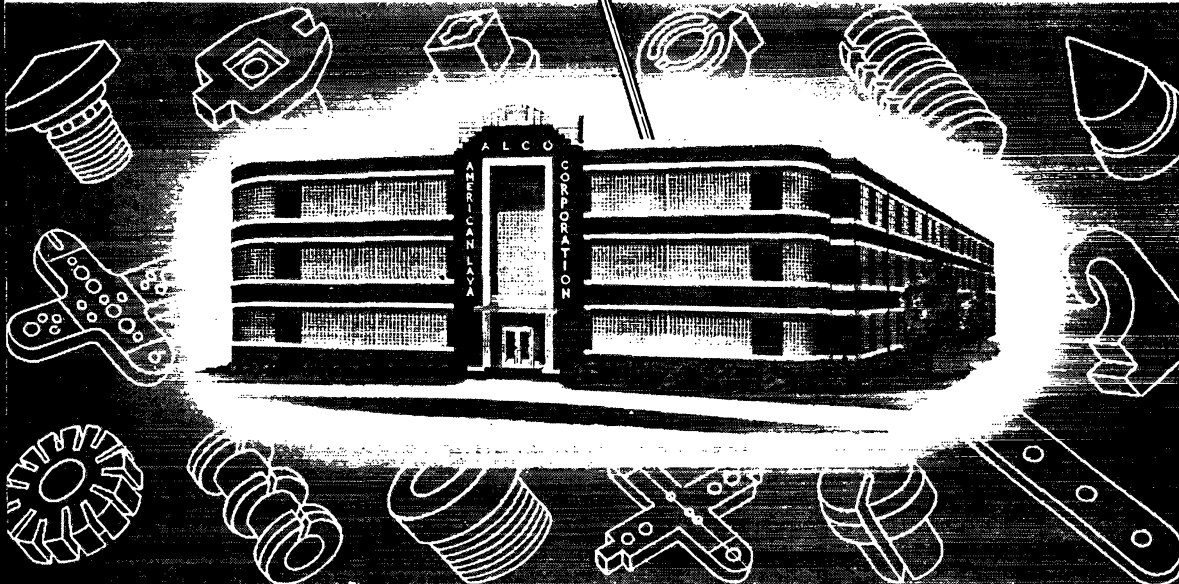
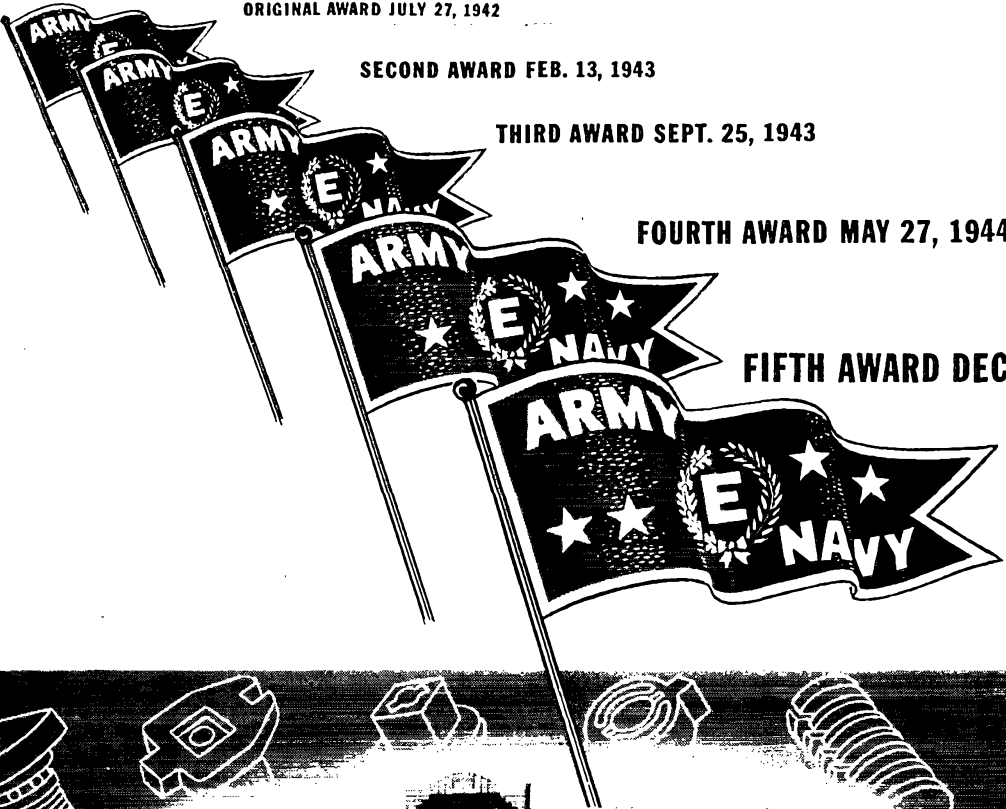

For the fifth consecutive time, the men and women of American Lava have earned the Army-Navy "E" Award "for continued excellence in quantity and quality of essential war production." All of us are very thankful that the necessary knowledge, experience and skill were available at American Lava to maintain the high standard of quality of ALSIMAG products, while meeting production schedules that once seemed incredible.

AMERICAN LAVA CORPORATION • Chattanooga 5, Tennessee
43RD YEAR OF CERAMIC LEADERSHIP

ALSIMAG
TRADE MARK REG. U. S. PAT. OFFICE

CERAMIC INSULATORS

- For Use in:**
- Electronic Devices
 - Electrical Circuits and Appliances
 - Gas and Oil Heating
 - Automotive Equipment
 - Chemical Processes



THERMEX meets the demand for high frequency equipment for pre-heating of plastic preforms. Preforms are placed on this drawer which slides into unit shown below.

THERMEX MODEL 2-P

Of course it uses Eimac tubes

This compact Thermex unit measures 28 inches by 28 inches, stands 47 inches high, and weighs only 614 pounds. It is a practical and flexible piece of equipment with built-in heating cabinet and removable 12 inch by 15 inch drawer-electrode.

Being completely automatic, there is nothing to do but plug this Thermex in and load and unload the preform drawer. No dials, no tuning, not even a button to push. Closing the preform drawer all the way in, turns on the high frequency power and timer. At the end of the prescribed time, which may be anywhere from 5 to 10 seconds up to 2 minutes, the red indicating light goes out, the operator removes the tray and unloads the preforms into the mold cavities.

The Thermex Model No. 2-P, which is illustrated, operates at a frequency of 25 to 30 megacycles using 230 volt 60 cycle single phase current. It has an output in excess of 3400 BTUs per hour, and it uses a pair of Eimac 450-TH tubes. The use of electronic heating has increased production for many plastic manufacturers who

have been leaders in utilizing the science of electronics.

The Thermex Division of the Girdler Corporation of Louisville, Ky., is a leader in supplying equipment for this and other industrial applications. It's natural that Eimac tubes are used, since these tubes are first choice of leading electronic engineers throughout the world.

Follow the leaders to

Eimac
REG. U. S. PAT. OFF.
TUBES

EITEL-McCULLOUGH, Inc.

985 San Mateo Avenue, San Bruno, California

Plants located at: San Bruno, California and Salt Lake City, Utah

Export Agents: Frazier & Hanson, 301 Clay St., San Francisco 11, California, U. S. A.



Eimac has received 7 ARMY-NAVY "E" AWARDS for production efficiency • San Bruno 5, Salt Lake City 2

Section Communications Managers of the A. R. R. L. Communications Department

Reports Invited. All amateurs, especially League members, are invited to report communications activities, training plans, code classes, theory-discussion groups, civilian-defense building or planning each mid-month (16th of the month) for the last 30 days direct to the SCM, the administrative official of ARRL, elected by members in each Section whose address is given below. Radio Club reports and Emergency Coordinator reports represent community organized work and plans and progress are especially desired by SCMs for inclusion in QST. ARRL Field Organization appointments, with the exception of the Emergency Coordinator and Emergency Corps posts, are suspended for the present and no new appointments or cancellations, with the exception named, will be made. This is to permit full efforts of all in Emergency Corps plans.

ATLANTIC DIVISION				
Eastern Pennsylvania	W3BES	Jerry Mathis	623 Crescent Ave. 9701 Monroe St.	Glenside Gardens
Maryland-Delaware-District of Columbia	W3CIZ	Hermann E. Hobbs	Silver Springs P. O. 623 E. Brown St.	Linden, Maryland
Southern New Jersey	W3GCU	Ray Tomlinson	186 Dorsey Rd.	Trenton 10
Western New York	W8MCC	William Bellor	703 Broadway	Rochester
Western Pennsylvania	W8CKO	E. A. Krall		East McKeesport
CENTRAL DIVISION				
Illinois	W9NUX	David E. Blake, II	4501 N. Malden St.	Chicago 40
Indiana	W9EGQ	Herbert S. Brier	385 Johnson St.	Gary
Kentucky	W9ARD	Darrell A. Downard	116 N. Longworth Ave.	Louisville 12
Michigan	W8DPE	Harold C. Bird	R.F.D. 2, Box 228	Pontiac 2
Ohio	W8MFP	Carl F. Wiehe	122 St. Albert St.	St. Bernard 17
Wisconsin	W9RHJ	Emil Felber, Jr.	1625 N. 18th St.	Milwaukee 5
DAKOTA DIVISION				
North Dakota	W9QVF	John W. McBride	620 North Menlo Ave.	Sioux Falls, South Dakota
South Dakota	W9QVY	P. H. St. Yankton	208 N. Yankton Ave.	Pierr
Northern Minnesota	W9RUZ	Armond D. Bratland	2802 So. Western	Los Angeles 7, Calif.
Southern Minnesota	W9YNU	Millard L. Bender	608 N. Huron Ave.	Spring Valley
DELTA DIVISION				
Arkansas	W5GED	Ed Beck	2503 Bishop St.	Little Rock
Louisiana	W5DKR	Eugene H. Treadaway	P. O. Box 44	LaPlace
Mississippi	W5HAV	P. W. Clement	524 Santini St.	Biloxi
Tennessee	W4SP	James B. Witt	R.F.D. 6, Shady Dell Trail	Knoxville
HUDSON DIVISION				
Eastern New York	W2HZL	Ernest E. George	2044 Lexington Parkway	Schenectady 8
N. Y. C. & Long Island	W2AZV	E. L. Baunach	102 Central Ave.	Massapequa, L. I.
Northern New Jersey	W2CQD	Winfield G. Beck	617 Spruce St.	Roselle
MIDWEST DIVISION				
Iowa	W9PJR	Leslie B. Vennard	2712 Washington St.	Burlington
Kansas	W9AWP	A. B. Unruh	1617 S. Seneca St.	Wichita 12
Missouri	W9OUD	Mrs. Letha A. Dangerfield	Box 123	Butler
Nebraska	W9FQB	Arthur R. Gaeth	6105 N. 37 St.	Omaha 11
NEW ENGLAND DIVISION				
Connecticut	W1KOY	Edmund R. Fraser	48 Willow St.	West Haven 16
Maine	W1AOL	G. C. Brown	379 No. Main St.	Brewer
Eastern Massachusetts	W1ALP	Frank L. Baker, Jr.	91 Atlantic St.	North Quincy 71
Western Massachusetts	W1JAH	William J. Barrett	239 Columbia St.	Adams
New Hampshire	W1FTJ/4	Mrs. Dorothy W. Evans	1435 Snowden Ave.	Memphis 7, Tennessee
Rhode Island	W1HRC	Clayton C. Gordon	70 Columbia Ave., Gaspee	Plateau, Providence 5
Vermont	W1NLO	Burtis W. Dean	P. O. Box 81	Burlington
NORTHWESTERN DIVISION				
Alaska	K7GNN	James G. Sherry		Homer
Idaho	W7AVP	Don D. Oberbillig	P. O. Box 486	Boise
Montana	W7CPY	Ear Roberts	Box 1088	Glendive
Oregon	W7GNI	Carl Austin	1137 Federal	Bend
Washington	W7FWD	O. U. Tatro	513 N. Central	Olympia
PACIFIC DIVISION				
Hawaii	K6ETF	Francis T. Blatt	837 16th Ave.	Honolulu
Nevada	W6CW	N. Arthur Sowle	Box 2025	Reno
Santa Clara Valley	W6LUZ	Earl F. Sanderson	600 Acacia Ave.	San Bruno
East Bay	W6T1	Horace R. Greer	414 Fairmount Ave.	Oakland 11
San Francisco	W6RBO	William A. Bradley	200 Taylor St.	San Francisco 12
Sacramento Valley	W6MDJ	Vincent N. Feldhausen	113 South Quincy St.	McClood
Philippines	KA1GR	George L. Rickard	Box 849	Manila
San Joaquin Valley*	W6BXB	Edward H. Noack	811 West Magnolia St.	Stockton
ROANOKE DIVISION				
North Carolina	W4CYB	W. J. Wortman	P. O. Box 566	Morganton
South Carolina	W4BOE/ANG	Ted Ferguson	3422 Rosewood Drive	Columbia 25
Virginia	W3KEN	Walter G. Walker	217-51 St.	Newport News
West Virginia	W8JRL	Kenneth M. Zinn	P. O. Box 132	Clarksburg
ROCKY MOUNTAIN DIVISION				
Colorado	W9VGC	H. F. Hekel	2743 Julian St.	Denver 11
Utah-Wyoming	W7DIE	John S. Duffy	P. O. Box 293.	Medford, Oregon
SOUTHEASTERN DIVISION				
Alabama	W4GBV	Lawrence J. Smyth	808 Winona Ave.	Montgomery
Eastern Florida	W4IP	Robert B. Murphy	3302 S.W. Grapeland Blvd.	Miami 33
Western Florida	W4AXP	Oscar Cederstrom	408 S. Pine St.	Warrington
Georgia	W4FDJ	Ernest L. Morgan	R.F.D. 4	Lyons
West Indies (Cuba)	CM20P/	Mario de la Torre	Escobar 110 (Altos)	Habana, Cuba
(Puerto Rico-Virgin Islands)	K4KD	Everett Mayer	24 Lindberg St.	Santurce, P. R.
SOUTHWESTERN DIVISION				
Los Angeles	W6QVV	H. F. Wood	429 So. Fairview	Burbank
Arizona	W6RWV	Douglas Aiken	341 S. Mt. Vernon Ave.	Prescott
San Diego	W6CHV	Ralph H. Culbertson	7172 Eads St.	La Jolla
WEST GULF DIVISION				
Northern Texas	WSALA	Jack T. Moore	5712 Berkshire Lane	Dallas 9
Oklahoma	WSAYL	Ed Oldfield	2141 N.W. 35th St.	Oklahoma City 6
Southern Texas	WSJC	James B. Rives	1721 Kentucky Ave.	San Antonio 1
New Mexico	WSHJF	J. G. Hancock	110 S. E. Nevada St.	Portales
MARITIME DIVISION				
Maritime	VE1DQ	A. M. Crowell	69 Dublin St.	Halifax, N. S.
ONTARIO DIVISION				
Ontario	VE3EF	Wing Commander Donald R. Gunn	c/o Canadian Bank of Commerce	New Toronto, Ont.
QUEBEC DIVISION				
Quebec	VE2CO	Lieutenant L. G. Morris	211 Bolton St.	Ottawa, Ont.
VANALTA DIVISION				
Alberta	VE4GE	C. S. Jamieson	581 W. Riverside Drive	Drumheller, Alta.
British Columbia	VE5DD	C. O. I. Sawyer	2634 West 31st Ave.	Vancouver
PRAIRIE DIVISION				
Manitoba	VE4AW	A. W. Morley	26 Lennox St.	St. Vital
Saskatchewan	VE4SY	Arthur Chesworth	1084 Redland Ave.	Moose Jaw

*Officials appointed to act temporarily in the absence of a regular official.

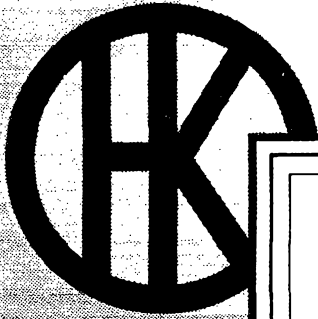

*These are the reasons
Heintz and Kaufman endorses*
TUBE STANDARDIZATION

**STANDARDIZATION IS A
WARTIME NECESSITY**

Colonel C. C. Irwin, commanding officer of the Signal Corps Standards Agency, recently stated that a majority of Signal Corps contractors are heartily cooperating with the standardization program sponsored by his agency to the end that approved component parts and materials are used wherever possible in equipment supplied to the Signal Corps.

"However, there are some," Colonel Irwin said, "fortunately only a few, who view this program as an attempt to put an unsound theory into practice. Such is, of course, not the case. Standardization is vitally necessary, not only to relieve bottlenecks in production and distribution; to facilitate maintenance by providing interchangeability of parts; but more important, to reduce equipment failures in the field.

"There is no theory in a Gold Star.

"If the reasons behind the laconic phrases 'killed in action,' 'missing,' and 'plane failed to return' could be explained, it is quite probable that equipment failures would bulk large among the reasons.

"It is not expected that the use of approved standard component parts will eliminate equipment failures, but it most certainly will reduce them."

**EQUALLY ADVANTAGEOUS IN
THE POSTWAR PERIOD**

Joint Army and Navy Specifications ("Jan-1A specs") have already established standards of electrical similarity and physical dimensions for vacuum tubes. Heintz and Kaufman will voluntarily continue to apply these engineering standards to postwar Gammatrons as the benefits are so obvious that we believe the designers of com-

munications equipment will insist upon their continuation:

1. Standardization of specifications will facilitate equipment design and production, since it assures the designer that there will be no physical or electrical changes made in the tube type he has selected. Often such changes have necessitated extensive redesign of equipment.

2. It will assure performance where performance is vital . . . in air transport and marine communications, in navigation and direction finding.

3. By establishing rigid electrical and physical requirements and tests, tube failures will be materially reduced. Such failures often reflect on the manufacturer of equipment, and must be guarded against just as carefully in peacetime as in war.

**STANDARDIZATION DOES NOT
LIMIT NEW DESIGN**

Standardization of the specifications for current Gammatron tube types will not restrict the development of additional types to meet future needs. Watch for the list of 22 types of Gammatron tubes which will be available indefinitely under our voluntary standardization program.

HEINTZ AND KAUFMAN LTD.
SOUTH SAN FRANCISCO • CALIFORNIA

KEEP BUYING  WAR BONDS

Gammatron Tubes

THE AMERICAN RADIO RELAY LEAGUE, INC.,

is a noncommercial association of radio amateurs, bonded for the promotion of interest in amateur radio communication and experimentation, for the relaying of messages by radio, for the advancement of the radio art and of the public welfare, for the representation of the radio amateur in legislative matters, and for the maintenance of fraternalism and a high standard of conduct.

It is an incorporated association without capital stock, chartered under the laws of Connecticut. Its affairs are governed by a Board of Directors, elected every two years by the general membership. The officers are elected or appointed by the Directors. The League is noncommercial and no one commercially engaged in the manufacture, sale or rental of radio apparatus is eligible to membership on its board.

"Of, by and for the amateur," it numbers within its ranks practically every worth-while amateur in the nation and has a history of glorious achievement as the standard-bearer in amateur affairs.

Inquiries regarding membership are solicited. A bona fide interest in amateur radio is the only essential qualification; ownership of a transmitting station and knowledge of the code are not prerequisite, although full voting membership is granted only to licensed amateurs.

All general correspondence should be addressed to the Secretary at the administrative headquarters at West Hartford, Connecticut.



Past Presidents

HIRAM PERCY MAXIM, W1AW, 1914-1936
EUGENE C. WOODRUFF, W8CMP, 1936-1940

Officers

President..... GEORGE W. BAILEY, W1KH
Washington, D. C.

Vice-President..... CHARLES E. BLALACK, W6GG
Yuma, Arizona

Secretary..... KENNETH B. WARNER, W1EH
West Hartford, Connecticut

Communications Manager..... F. E. HANDY, W1BDI*
Chevy Chase, Maryland

Treasurer..... DAVID H. HOUGHTON
West Hartford, Connecticut

General Counsel..... PAUL M. SEGAL
1026 Woodward Building, Washington 5, D. C.

*On leave of absence. Address correspondence to the Acting Communications Manager, Charles A. Service, W4IE, West Hartford 7, Connecticut.

Directors

President
GEORGE W. BAILEY..... W1KH
1530 P St., N.W., Washington 25, D. C.

Vice-President
CHARLES E. BLALACK..... W6GG
Box 108, Yuma, Ariz.

Canadian General Manager
ALEX REID..... VE2BE
240 Logan Ave., St. Lambert, P. Q.
Alternate: Leonard W. Mitchell..... VE3AZ
78 Raglan Ave., Toronto, Ont.

Atlantic Division
WALTER BRADLEY MARTIN..... W3QV
25 Arbutha Rd., Abington, Pa.
Alternate: Herbert M. Wallez..... W8BQ
P. O. Box 18, Drums, Pa.

Central Division
JOHN A. KIENER..... W8AVH
3462 Edison, Cleveland Heights,
Cleveland 21, Ohio
Alternate: Earl S. Nelson..... W8DS
22551 Hadden Rd., Euclid 17, Ohio

Dakota Division
TOM E. DAVIS..... W9VVA
915 W. Becker Ave., Willmar, Minn.
Alternate: Aaron E. Swanberg..... W9BHY
1487 Breda St., St. Paul 4, Minn.

Delta Division
E. RAY ARLEDGE..... W5SI
340 N.E. 20th Terrace, Apt. 7, Miami 37, Fla.
Alternate: Samuel H. Dowell..... W5ERV
1057 Mildred St., Shreveport 15, La.

Hudson Division
ROBERT AKERIDGE KIRKMAN..... W2DSY
Werah Pl., R.F.D. No. 1, Box 61, Long Branch, N. J.
Alternate: George Rulfs, Jr..... W2CJY
38 Brookwood Drive, Manhasset, L. I., N. Y.

Midwest Division
FLOYD E. NORWINE, JR..... W9EFC
7405 Hlawatha Ave., Richmond Heights 17, Mo.
Alternate: C. A. Colvin..... W9VHR
% Omaha & Council Bluffs St. Railway Co.,
Omaha 2, Nebr.

New England Division
PERCY C. NOBLE..... W1BVR
37 Broad St., Westfield, Mass.
Alternate: Clayton C. Gordon..... W1HRC
70 Columbia Ave., Warwick, R. I.

Northwestern Division
KARL W. WEINGARTEN..... W7BG
3219 N. 24th St., Tacoma 7, Wash.
Alternate: R. Rex Roberts..... W7CPY
110 W. Brennan St., Glendive, Mont.

Pacific Division
J. L. McCARGAR..... W6EY
66 Hamilton Pl., Oakland 12, Calif.
Alternate: Elbert J. Amarantes..... W6FBW
1675 Dale Ave., San Jose, Calif.

Roanoke Division
H. L. CAVENESS..... W4DW
2607 Vanderbilt Ave., Raleigh, N. C.
Alternate: J. Frank Key..... W3ZA
Box 707, Buena Vista, Va.

Rocky Mountain Division
C. RAYMOND STEDMAN..... W9CAA
925 So. Gaylord St., Denver 9, Colo.
Alternate: Howard R. Markwell..... W9TFP
355 Monroe St., Denver 6, Colo.

Southeastern Division
WILLIAM C. SHELTON..... W4ASR
527 Revillo Blvd., Daytona Beach, Fla.
Alternate: William P. Sides..... W4AUP
Fleming Road, Montgomery, Ala.

Southwestern Division
JOHN E. BICKEL..... W6BKY
1834 E. Whittier Blvd., Whittier, Calif.
Alternate: Eldridge E. Wyatt, Jr..... W6ARW
P. O. Box 3597, Long Beach 3, Calif.

West Gulf Division
WAYLAND M. GROVES..... W5NW
Box 1314, Seagraves, Texas
Alternate: Jennings R. Poston..... W5AJ
Box 246, Mabank, Texas

"IT SEEMS TO US —"

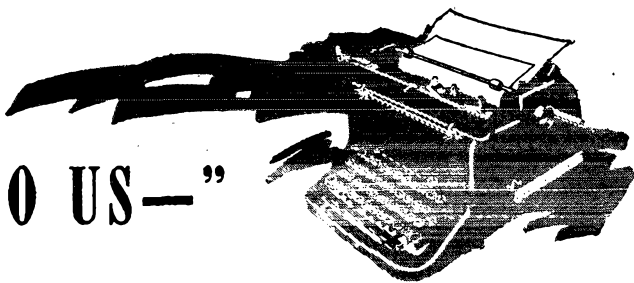

TROPOSPHERIC DX

WE'RE likely to think of the impetus the radio science has received from wartime urgencies as being largely a matter of new applications, ingenious new circuits, and much better components and materials. There is another branch of the art in which at least equally great progress has been made: man's knowledge of propagation, the behavior of waves, and the ability to predict performance. Many things have been learned that were not dreamed of when the war began. Naturally, such information is of the highest military value and consequently is closely guarded. By the time we need it — when we're back on the air — we shall find that we have as much to master in this field as in circuit technique, and probably to our greater profit.

Only occasionally during the war is any such information "unclassified" and released. Such an occasion was the FCC hearing last autumn on postwar allocations, when the military services permitted some of the things to be talked about which bore upon immediate allocation problems. There are new and better figures for this and that, and much to interest the physicist. What immediately caught our attention, though, was the flat statement that the range to be had through tropospheric propagation increases with frequency. This refers to what we amateurs have called air-wave bending, the extended ranges attributable to the bending of waves in the lower atmosphere, as first explored by Ross Hull and reported in *QST*.

To be sure, you can find the statement in *QST* that tropospheric DX increases with frequency. Notably you can find it in the summary of our prewar operations which Ed Tilton wrote in his column a year ago. It is, in fact, something we all accept as concerns the comparison between the 28-Mc. band and 56 Mc. But most of us have nothing in our personal experiences to bear it out when it comes to the higher bands. For instance, how many of us have believed, consciously or unconsciously, that we can get greater tropospheric extensions of range on 112 Mc. than on 56 Mc.? Almost none of us, we fancy. Then why is that, since it is now clearly indicated?

It seems to us that the answer plainly lies in the inadequacy of the equipment we used in the 112-Mc. band before the war, and in the

differences in the way we occupied and employed the bands above 28 Mc. The 10-meter band was almost purely a DX band, and when it wasn't open for DX it was pretty generally left alone. The 5-meter band had a regulation requiring stabilized transmitters, which tended to confine occupancy to the more serious workers who had a real heart-interest in the band and who installed higher-powered transmitters and first-class receivers. They did notable work, as we all know, with many contributions to our knowledge. The 2½-meter band contained the great mob of v.h.f. fellows, most of them working purely local ranges because there never was any sporadic *E* in this band. Some serious work was undertaken on 112, of course, and some goodly DX records established, but we had fewer of our keener experimenters there and the power was generally much lower and the receiver problem much more difficult to handle. There we think is the solution. Practical considerations always masked the answer. For the comparison of 56 and 112 to mean anything, transmission would have to be over the same path, with antennas at each end having precisely the same gain and pattern on both bands and supplied with identical power, and with receivers that could be adjusted to identical input sensitivity. So far as we know, that comparison was never tried — the war interfered as we were about at that stage. When we do try it we may expect the 112-Mc. signal to be the better; that is to say, under fixed conditions we may expect greater DX on 112 than on 56 — again excluding occasional sky-wave manifestations.

Isn't that a dainty dish? The story goes right on up from there, of course: 220 Mc., 420 Mc., 1125 Mc., 2500 Mc., and so on, increasing in the attainable range for given power and sensitivity as the frequency goes up. We don't yet know much of anything about *how much* the effect increases, and of course the necessary conditions for the effect won't exist for some of us and will never be constant for any of us. But it is pleasing news that the *direction* of the effect is such as to help overcome the increased difficulty which experimenters always have in achieving power and receiver sensitivity on each successively-higher band. Definitely it is something on which to hang some postwar hopes.

It is by now practically certain that our postwar bands above 60 Mc. are going to be located at the points in the spectrum first proposed by IRAC, rather than as a continuation of our harmonic family. Some of the OMs seem to be wondering howcum, and whether everything is as it should be. The assignments in the higher reaches of the spectrum have the appearance of being a confused jumble, with no particular pattern. Why couldn't our narrow bands have been fitted into the table at regularly-recurring intervals?

Well, we'll start by saying that we have been unable to locate anything foreseeable in the art which dictates any particular desirability of a harmonic relationship in this part of the spectrum, so we haven't cared too much about that aspect. Then we want to quote FCC, which you'll remember embraced the IRAC plan for u.h.f. and s.h.f. In its report on proposed allocations the Commission calls attention to the fact that the proposed amateur bands are adjacent to proposed Government bands, and says: "The reason for this is to locate the amateur bands at points where in time of war or national emergency they may be used for the expansion of essential Governmental radio services. It is felt that this arrangement of contiguous Government and amateur bands is more important than the preservation of strict harmonic relations between the amateur bands."

We accept that reasoning, for it means a great deal of strength and support for us in future. We admit we don't know what dictated the choice of the locations for the Government bands. We suppose sheer happenstance controlled in some cases, as a new device was developed and put into use. Some

of the assignments probably have some fixed relationship to others, or represented the optimum frequency for a certain job, or the best working frequency of some particular apparatus, or something of that sort. The point is that the Government assignments represent services that are working, doing things in the war, and the military forces properly intend to keep them there as Government activities. Government has all these frequencies during the war. Afterward it will have to contract, letting civilian services have some of the bands. But at the same time it must arrange a quick ability to expand anew when the next national emergency comes, and without disturbing essential civilian services which are by then established in these higher ranges. Is it not therefore perfectly logical, and in keeping with our relationships with the military services in other parts of the spectrum, that they should write in amateur bands alongside their own? In time of peace we occupy those ham-bands, do what we can to advance the art. They have enough for their peacetime needs, too. If war comes again, we get closed for security reasons and they take over, materially widening their bands for increased needs. It's a sound, sensible arrangement. It means that we shall have the unceasing support of the military services in these assignments, against the rapacity of the commercials, for the military regard them as theirs in wartime. In other words, it's a simple extension of the same philosophy that has long led to the protection of our DX frequencies by the armed forces. It is therefore an arrangement that promises great strength for the higher amateur allocations through the long years to come.

K. B. W.

★ SPLATTER ★

OUR COVER

HERE is an authentic action shot from one of the genuinely important action centers of this war — the battle-bloodied island of Bougainville, only a year or so ago a bitterly contested battleground, today a major base for Allied air thrusts against remaining Japanese strongholds in the Pacific. The scene is the AAF information center — the focal center of all air activities. Within these sandbagged walls all tactical combat and antiaircraft control information . . . offensive or defensive; radar, radio, or wire . . . is filtered, logged, recorded, coordinated, relayed — every bit of it bad news for the Nips.

FOOTNOTES

ALPHABETICALLY first among the month's seven additions to the roster of QST authors is

Major Lloyd D. Colvin, SC, K7KG, who takes us on an enlightening trip along the historic Alaskan Military Highway (p. 46). A licensed amateur since 1929, Major Colvin has held several calls, the most active being W7KG, K7KG, W7YA, W6TG and W6AHI. In civilian life he was an electrical engineer for Pacific Gas and Electric in San Francisco, from which he has been on leave of absence since entering active duty in 1940. He is a graduate in both power and communication engineering from the University of California, a member of AIEE and IRE, and holds both radiotelephone first and radiotelegraph second class licenses. A member of ARRL since 1929, charter member of AARS, formerly ORS, RCC, and holder of a 35-w.p.m. code proficiency certificate, it seems quite in order that his main activity these days is preparing his XYL to pass the exam for her amateur ticket in anticipation of a joint ham station in the good new days after the war. . . . Second on the list is Lt. Arthur H. Copland, CAP, with his CAP-

(Continued on page 94)

Practical Design of Video Amplifiers

Part I—Causes of Frequency Attenuation; Low-Frequency Correction

BY ELLIOTT A. HENRY,* W9FEN

SINCE a thorough understanding of the underlying causes of trouble or limitations of performance of any circuit leads to an easier comprehension of the methods of overcoming these limitations, this article, while dealing particularly with the design of video amplifiers, will be prefaced by a discussion of the factors limiting the frequency range of the conventional RC (resistance-capacity) coupled amplifier.

Since pentode tubes are used almost universally in such amplifiers the discussion which follows

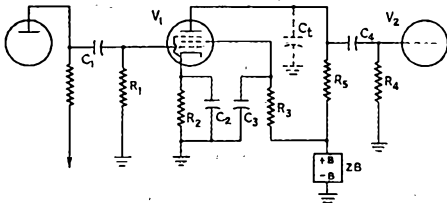

Fig. 1—Conventional RC-coupled amplifier stage.

will be based primarily upon their use, with the assumption that the value of the grid resistor is much greater than that of the plate load impedance, as is the case in video amplifiers. However, since triodes are used occasionally, sufficient data are included to cover the compensation of triode amplifier stages as well.

In order better to understand the frequency-response limitations of conventional RC coupled amplifiers, let us examine the plot of output voltage vs. frequency for a typical amplifier circuit, such as that of Fig. 1. A representative response curve for such a circuit is shown in Fig. 2. At zero frequency, f_0 , the output voltage is zero. As the frequency is increased the output voltage rises to a maximum at a frequency somewhat higher than f_1 , remains essentially constant

until the frequency is somewhat lower than f_2 , and then continually decreases as the frequency is further increased. The two frequencies, f_1 and f_2 , considered the useful limits of the pass-band of an audio-frequency amplifier, are the frequencies at which the output of the amplifier falls to 70.7 per cent of the output over the mid-frequency range. This loss of response below f_1 and above f_2 results from the change of reactance (X_C) of condensers in the circuit with change in frequency. Either the high or low frequencies will be attenuated, depending upon the location or function of the various condensers, including stray circuit capacities. In order to demonstrate this more clearly, high- and low-frequency attenuation will be considered as separate problems.

Unequal gain in an amplifier is referred to as *frequency distortion*, because a complex wave passing through the amplifier will have its wave-shape altered or distorted if all of its harmonic components do not receive the same degree of amplification. If the phase delay is not proportional to frequency, the wave may be further distorted. This is called *phase distortion*.

In the following discussion, major emphasis is placed upon the frequency response rather than

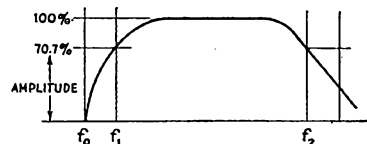

Fig. 2—Gain vs. frequency plot of Fig. 1.

upon the phase characteristics of amplifiers. This is necessary for two reasons: first, to confine the mathematics to simple algebra; second, an amplifier, compensated in accordance with the design data herein presented, will be corrected for both frequency and phase distortion, and it is perhaps easier to visualize results in terms of frequency

* RCA Victor Division, Radio Corporation of America, Camden, N. J.

In the past few years many excellent articles and papers have been published in various technical magazines on the subject of video amplifiers and the many types of compensation used to extend the frequency range of resistance-capacity-coupled amplifiers. The majority of these articles have dealt with the mathematical analysis or have had primarily a theoretical approach. A few have presented a generalized introductory discussion of the subject. Between these two extremes a wide gap exists in the published information on this subject. In preparing this material it has been the author's purpose to bridge that gap by presenting both the underlying principles and practical design data in which mathematics has been confined to simple algebra. Other information pertinent to the subject, such as data on certain types of vacuum tubes, is included for the sake of completeness.

response rather than those of phase characteristic. The importance of the phase characteristic of a video amplifier cannot be overemphasized. For example, an amplifier stage with a response curve such as that shown in Fig. 2 would not be suitable for video work, since the phase angle would increase 45 degrees at f_1 and decrease 45 degrees at f_2 in respect to the mid-frequency value. Therefore a change in the phase angle of 90 degrees over the operating range, f_1 to f_2 , would result. General practice indicates that the frequency response should drop not more than 2 per cent at f_1 and f_2 if these frequencies are to be considered the limits of the useful pass-band of a video amplifier.

Low-Frequency Attenuation

Low-frequency attenuation, or low-frequency distortion as it is sometimes called, may be introduced in any one of four places or any combination of the four. Referring to Fig. 1, these four places or networks are: the grid resistor-condenser coupling network, R_1C_1 or R_4C_4 ; the cathode-resistor by-pass condenser network, R_2C_2 ; the screen-resistor by-pass condenser network, R_3C_3 ; and the internal impedance, Z_b , of the power supply. How the grid resistor-condenser combination acts to reduce the gain at low frequencies may be seen by referring to Fig. 3.

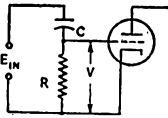

Fig. 3—Grid-coupling network.

With E_{in} constant, the voltage, V , impressed from the grid to cathode may be expressed as $\frac{V}{E}$, and is equal to the resistance, R , divided by the impedance of R and C , or

$$\frac{R}{\sqrt{R^2 + X_C^2}} = \frac{V}{E} \quad (1)$$

Since the reactance of a condenser is inversely proportional to frequency, the ratio of resistance to impedance, and thus $\frac{V}{E}$, decreases as the frequency decreases. This means that the voltage available to drive the following stage is less at low frequencies than at high frequencies and, with the tube gain equal at both frequencies, the output voltage will be down in the same proportion as the input voltage. This ratio, $\frac{V}{E}$, expressed in percentage, is the coupling efficiency of the grid resistor-condenser combination.

For example, let us assign values to R and C in Fig. 3 and, with a constant input voltage, E_{in} , see how V varies with frequency. If

$$\begin{aligned} C &= 0.05 \text{ } \mu\text{fd.}, \\ R &= 250,000 \text{ ohms,} \\ E_{in} &= 10 \text{ volts,} \end{aligned}$$

and the two frequencies are

$$\begin{aligned} f_1 &= 30 \text{ cycles and} \\ f_2 &= 1000 \text{ cycles,} \end{aligned}$$

then, at f_2 ,

$$X_C = \frac{1}{2\pi f C} = 3184 \text{ ohms.}$$

From equation (1),

$$\begin{aligned} \frac{V}{10} &= \frac{(25)(10^4)}{\sqrt{[(625)(10^8)] + [(10.1)(10^9)]}} = \frac{250,000}{250,020} \\ &= 1 \text{ (approximately).} \end{aligned}$$

Therefore, $V = 10$ volts (approximately), which means a coupling efficiency of practically 100 per cent at 1000 cycles.

At f_1 , $X_C = (10.6)(10^4)$ ohms.

$$\frac{V}{10} = \frac{(25)(10^4)}{\sqrt{[(625)(10^8)] + [(112)(10^8)]}} = \frac{25}{27.2} = 0.92.$$

So, $V = 9.2$ volts and the coupling efficiency is 92 per cent at 30 cycles. Therefore, the output voltage of the stage will be 8 per cent lower at 30 cycles than it is at 1000 cycles, all other factors being equal.

Low-frequency distortion may result from the constants of the cathode resistor-condenser combination, R_2C_2 of Fig. 1. This effect is caused by degeneration, since the impedance in the cathode circuit varies with frequency, and the gain of a stage with cathode degeneration is reduced by the factor

$$\frac{1}{1 + G_m Z_k} \quad (2)$$

In other words, the gain of a stage, other things being equal, is

$$A = (A_1) \left(\frac{1}{1 + G_m Z_k} \right) = \frac{A_1}{1 + G_m Z_k}, \quad (3)$$

where

A is the actual stage gain,
 A_1 is the stage gain without degeneration, and
 Z_k is the cathode-circuit impedance (impedance of R_2C_2 in parallel) in ohms.

This impedance, Z_k , is detailed in Fig. 4 and is given by

$$Z_k = \frac{R X_C}{R^2 + X_C^2} \quad (4)$$

Thus if, in Fig. 1, $R_2 = 1000$ ohms, $C_2 = 10 \text{ } \mu\text{fd.}$, $G_m = 5000 \text{ } \mu\text{hos}$, and the stage gain without degeneration = 10, the actual gain at 1000 cycles may be found as follows:

$X_C = 15.9$ ohms at 1000 cycles,

$$Z = \frac{(1000)(15.9)}{\sqrt{10^6 + 253}} = \frac{15,900}{1000.125} = 15.9 \text{ ohms}$$

(approximately), and

$$A = \frac{10}{1 + [(0.005)(15.9)]} = \frac{10}{1 + 0.0795} = 9.25,$$

which represents a loss of gain at 1000 cycles of 7.5 per cent.

Now let us see what the gain of the same stage is for a frequency of 20 cycles.

$X_C = 800$ ohms (approx.) at 20 cycles.

$$\begin{aligned} Z &= \frac{(10^3)(800)}{\sqrt{10^6 + [(64)(10^4)]}} = \frac{(8)(10^5)}{\sqrt{(164)(10^4)}} \\ &= \frac{(8)(10^5)}{1260} = 625 \text{ ohms.} \end{aligned}$$

$$A = \frac{10}{1 + [(0.005)(625)]} = \frac{10}{1 + 3.125}$$

$$= \frac{10}{4.125} = 2.42.$$

Thus the output of the stage at 20 cycles under these conditions will be only about one-fourth the output at 1000 cycles.

The effect of R_3C_3 in Fig. 1 is similar to that of the cathode degeneration mentioned above. Since the screen current is only about 10 per cent of the plate current and the screen-plate transconductance is only about 12 per cent of the control-grid or cathode-to-plate transconductance, however, the effect is much smaller, and usually can be made negligible by making the time constant of R_3C_3 at least three times as long as the period of the lowest frequency to be passed, or

$$TC = RC > \frac{3}{f}, \quad (5)$$

where C is in farads,

R is in ohms, and

f is the lowest frequency in the pass-band.

The total impedance of the screen circuit is essentially the reactance of C_3 . In the case of cathode degeneration, if the product of $G_m Z_k$ equals 1, the gain will be reduced 50 per cent. However, the effect of the screen is so much less that a reduction of gain at the lowest frequency of only 2 per cent would result if $G_m Z_s$ is made equal to 2 (G_m being the control-grid-to-plate transconductance).

For example, it is desired to pass 30 cycles with a 6F6 in the circuit of Fig. 1.

$$Z_s = X_{C_s} \text{ (approximately) and } X_{C_s} G_m = 2.$$

$$X_{C_s} = \frac{2}{G_m} = \frac{(2)(10^6)}{2500} = 800 \text{ ohms.}$$

$$X_{C_s} = 800 \text{ ohms at 30 cycles} = 6.64 \mu\text{fd.}$$

In practice the next-larger commercial size, or 8 $\mu\text{fd.}$, would be used. To determine R_3 ,

$$RC = \frac{3}{f} = \frac{3}{30} = 0.1$$

$$R = \frac{(0.1)(10^6)}{8} = \frac{10^5}{8} = 12,500 \text{ ohms.}$$

Therefore, a value of 12,500 ohms or larger should be used for R_3 .

In the event that the value of the screen voltage-dropping resistor, R_3 , as determined above, should be too large to allow the proper screen current, R may be set by the screen requirements and the by-pass condenser, C_3 , determined from equation (5), using R selected and solving for C .

The fourth place where low-frequency distortion may occur is in the internal impedance of the power supply, Z_b . Unless a regulated power supply of the electronic type is used, the impedance is essentially the reactance of the output filter condenser and will vary with frequency, as

outlined previously. A method for making the effect of this impedance negligible is by the use of RC filters. Such filters, if properly designed, also may provide correction for either R_1C_1 or R_2C_2 in Fig. 1, but not for both at the same time. Design data for these correction networks will be given in the section which follows.

Low-Frequency Correction

Of the four places or networks where low-frequency distortion may be introduced, two, R_3C_3 and Z_b , can be made negligible by proper design. In addition to making negligible the internal impedance of the power supply, correction may be made for either R_1C_1 or R_4C_4 by the addition of an RC filter, C_5R_5 in Fig. 5.

To correct for R_1C_1 or R_4C_4 , the procedure is as follows. The grid resistor (R_1 or R_4) is made as high as permissible; 500,000 ohms is a convenient value. A nominal value, such as 0.1 $\mu\text{fd.}$, is chosen for the coupling condenser, C_1 or C_4 . It is desirable to keep this value large, but not so large that trouble may be encountered from leakage and "hang-over" effects. The time constant of the grid resistor-condenser network, R_1C_1 or R_4C_4 , then is made equal to the time constant of R_5C_5 , and R_5 made greater than 20 times the reactance of C_5 at the lowest desired frequency. For example, if, in Fig. 5, R_4 is 500,000 ohms, C_4 is 0.1 $\mu\text{fd.}$ and R_5 is 1000 ohms, and correction to 30 cycles is to be made, the time constant of R_4C_4 will be 0.05 seconds or 50,000 microseconds. Leaving TC in microseconds will give an answer directly in microfarads.

$$TC = RC = (0.1)(500,000) = 50,000$$

$$C_5 = \frac{50,000}{1,000} = 50 \mu\text{fd.}$$

$$R_5 > 20 X_{C_5} \text{ at 30 cycles} = (20)(106) = 2120 \text{ ohms or greater.}$$

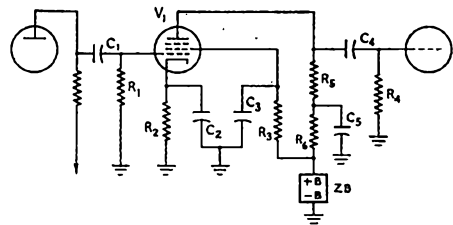

Fig. 5 — Amplifier stage with low-frequency correction.

What actually happens is that, as the voltage across R_4 decreases as a result of the rising reactance of C_4 (as the frequency is decreased), the reactance of C_5 also increases. As a consequence, the parallel impedance of C_5R_5 is added to R_5 as part of the plate load impedance. Where the plate load is small in comparison to the plate resistance, the gain from grid to plate is given by

$$A = G_m Z_p, \quad (6)$$

where

A is the stage gain,

G_m is the transconductance in mhos, and

Z_p is the plate load impedance,

Since the time constants of C_4R_4 and C_5R_5 have been made equal, the voltage across the plate load impedance will rise in proportion to the loss of voltage across C_4 , and the voltage across R_4 will remain constant.

It might be pointed out that, although at times it is expedient to make either C_4 or R_4 somewhat lower in value to permit the use of a standard-size condenser for C_4 , this should be done with caution. If the values of C_4 or R_4 are reduced the amount of correction necessary is increased, and errors become magnified. Good practice demands good design first, so that minimum correction need be used.

If it is desired, C_5R_6 may be used to compensate for the frequency distortion of R_2C_2 instead of R_1C_1 . To see how this can be done, reference again is made to Fig. 5. It has been shown previously that the impedance in the cathode circuit varies with frequency, and therefore the a.c. voltage developed across this impedance, according to Ohm's Law, will be

$$E = IZ \quad (7)$$

Consequently, the voltage is a function of frequency. This voltage will appear across the plate load resistor, R_6 , amplified by the stage gain. Now the plate current flows through both R_2C_2 and R_6C_5 , so the same kind of distortion will be generated in both circuits if the time constants are equal. But, since the current flows through these networks in opposite directions, the distortion across R_6 resulting from R_2C_2 will be cancelled by the distortion from C_5R_6 , if the distortion components are equal in magnitude. This condition is met when

$$R_2C_2 = R_6C_5$$

and
$$\frac{C_2}{C_5} = \frac{R_6}{R_2} = A, \quad (8)$$

where A is the stage gain, as defined in equation (6) for pentodes and equation (11) (which follows) for triodes. For example, if values are assigned in Fig. 5 such as 200 ohms to R_2 , a nominal value of 100 μ f. to C_2 and a stage gain of 10, and values for C_5 and R_6 are to be determined, then

$$\frac{C_2}{C_5} = \frac{100}{C_5} = 10, \text{ and } C_5 = 10 \mu\text{f.}$$

$$\frac{R_6}{R_2} = \frac{R_6}{200} = 10, \text{ and } R_6 = 2000 \text{ ohms.}$$

The second condition may be checked by substituting in equation (8).

$$\frac{(200)(100)}{1} = \frac{(2000)(10)}{1}$$

Therefore, both conditions have been met. There will be no frequency distortion from plate to ground resulting from R_2C_2 , and the phase delay will be proportional to frequency. However, more about phase delay later.

We now find ourselves in the position of being able to make negligible two of the four circuits causing low-frequency distortion and of being able to compensate for either of the other two, but not both. Without compensation, as previously

explained, the only way of minimizing the effects of the coupling efficiency of R_1C_1 or R_4C_4 , Fig. 5, is by increasing the value of either the resistor or the condenser, or both. There are limits as to how far this can be carried, and generally the reactance of the coupling condenser cannot be kept low enough at the lowest frequency to give completely satisfactory results. So it is good practice generally to utilize C_5R_6 to compensate for R_1C_1 or R_4C_4 , and to use other means to minimize the effects of R_2C_2 , Fig. 5.

Three methods have been used in practice to accomplish this. First, R_2C_2 is eliminated, the cathode is grounded directly, and fixed bias is applied to the tube through the grid resistor. Second, the cathode by-pass condenser, C_2 , is eliminated and the consequent loss in stage gain accepted. The gain will be reduced by the factor given in equation (2), but the reduction in gain will be constant at all frequencies so that, other factors being equal, there will be no low-frequency distortion. The third method is simply to make C_2 very large and accept what comes out. This is not so bad as it sounds, since 1000- μ f. low-voltage electrolytics are available at reasonable cost and certainly are less expensive than the additional stage which might be required to bring up the over-all gain of the amplifier. The reactance of a 1000- μ f. condenser at 30 cycles is 5.31 ohms, which will cause negligible distortion in the average circuit.

High-Frequency Attenuation

It has been pointed out that there are four places, or networks, in the conventional amplifier where the low-frequency output may be restricted, and actually only one place where correction may be applied (the effects at the others being made negligible, however). The opposite is true for high-frequency limitations. We have only one (or what may be summed up and treated as one) network responsible for the reduction of output at the higher frequencies (f_2 and higher in Fig. 2), but there is a choice of several correction circuits. For an explanation, reference again is made to Fig. 4. The resistance, R , is in parallel with a capacity, C . The impedance of this network is given by

$$Z = \frac{RX_c}{\sqrt{R^2 + X_c^2}} \quad (9)$$

Obviously, therefore, the impedance, Z , will be a function of frequency.

Now if R of Fig. 4 represents the plate load resistance of an amplifier stage, such as R_6 in Fig. 1, and C represents the total shunt reactance across this load resistor, such as C_t in Fig. 1, the effective load impedance for any frequency can be calculated. Equation (6) shows that, whereas the plate load impedance is much less than the plate resistance of the tube, the gain of the stage is directly proportional to the plate load impedance. In other words, if the G_m of a tube is 9000 μ mhos and the load impedance is 1000 ohms the gain is 9, while if the load im-

pedance were raised to 2000 ohms the gain would be 18. It is this shunt reactance in parallel with the plate load resistor that limits the high-frequency response of the amplifier. This reactance, in Fig. 1, is composed of the output capacity of V_1 plus the input capacity of V_2 and the stray circuit capacity, all summed up as C_L .

Circuit and Stray Capacities

Before taking up the problem of compensating for this condition methods for determining C_L should be discussed, since all systems of high-frequency compensation depend upon accurate knowledge of this capacity.

The input capacity of a tube, C_{in} , is defined as the capacity from the grid to all other elements, and the output capacity of a tube, C_{out} , as the capacity from the plate to all other elements. This is emphasized because of the usual practice in tube manuals of listing the static inter-element capacities of triodes and summing up the capacities up into C_{in} and C_{out} for multi-grid tubes. A good reason for this is that the dynamic capacities of triodes are more subject to variations than screen-grid tubes. Therefore, when dealing with triodes the grid-plate capacity, C_{gp} , should be added to the plate-cathode capacity, C_{pk} , in determining the total output capacity, C_{out} for triodes.

$$C_{out} = C_{pk} + C_{gp}$$

In the case of a 6J5, where the tube manual lists C_{pk} as 3.6 $\mu\text{fd.}$ and C_{gp} as 3.4 $\mu\text{fd.}$, the output capacity is $3.6 + 3.4 = 7.0 \mu\text{fd.}$

In determining the effective or dynamic input capacity of a triode, the "Miller Effect" must be considered. When a triode is acting as an amplifier, the grid and plate voltages are out of phase; that is, if the grid voltage is changed one volt in the positive direction and the gain is ten, the plate voltage will decrease ten volts. This gives a net change of eleven volts between the grid and plate and results in a capacity current in the grid circuit eleven times above the normal capacity current. This is known as the "Miller Effect," and from the above it can be seen that the dynamic input capacity is a function of the stage gain. The dynamic input capacity of a triode is given by

$$C_{in} = C_{pk} + [C_{gp}(1 + A)], \quad (10)$$

where C_{in} is the dynamic input capacity,
 C_{pk} is the capacity from grid to cathode,
 C_{gp} is the capacity from grid to plate,
 A is the stage gain.

From equation (10) it is evident that the stage gain must be known before the dynamic input capacity can be determined. The gain of a triode is given by

$$A = \frac{\mu Z_L}{Z_L + R_p}, \quad (11)$$

where A is the stage gain,
 μ is the amplification factor of the tube,
 Z_L is the plate load, and
 R_p is the plate resistance of tube.

For example, let us determine the stage gain and dynamic input capacity of a 6J5 working into a 20,000-ohm plate load. From the tube manual the plate resistance is 6700 ohms, μ is 20, C_{pk} is 3.4 $\mu\text{fd.}$, and C_{gp} is 3.4 $\mu\text{fd.}$

From equation (11),

$$Z_L = R_L$$

$$A = \frac{(20)(2)(10^4)}{[(2)(10^4)] + [(67)(10^2)]} = \frac{(4)(10^5)}{(2.67)(10^4)} = 15 \text{ (approx.)}$$

From equation (10),

$$C_{in} = 3.4 + [3.4(1 + 15)] = 3.4 + 54.4 = 57.8 \mu\text{fd.},$$

which is quite an increase from the static capacity.

Where the load of a triode is in the cathode instead of the plate circuit, as in a cathode-follower stage, the dynamic input capacity is given later by equation (31) in the cathode-follower section. The grid-to-cathode capacity of any amplifier tube, C_{gk} , is modified, where cathode degeneration exists, by the factor $(1 + G_m R_k)$ when the cathode is not by-passed, and by $(1 + G_m Z_k)$ when the cathode is partially by-passed, Z_k being given by equation (4). This reduction factor is seen to be the same as for the reduction of gain with cathode degeneration.

$$C_{eff} = C_{gk} \left(\frac{1}{1 + G_m Z_k} \right) = \frac{C_{gk}}{1 + G_m Z_k}, \quad (12)$$

where

C_{eff} is the effective capacity grid to cathode,

C_{gk} is the grid-to-cathode capacity without degeneration,

G_m is the transconductance in mhos, and

Z_k is the cathode impedance.

If the pentode screen is by-passed to the cathode, the entire input capacity may be degenerated. This, however, reduces the effective shielding of the screen grid. For example, let us determine the dynamic input capacity of an 1852 with an unby-passed 160-ohm cathode resistor ($Z_k = R_k$).

From equation (12),

$$C_{eff} = \frac{11}{1 + [(0.009)(160)]} = \frac{11}{1 + 1.44} = \frac{11}{2.44} = 4.52 \mu\text{fd.}$$

With the screen by-passed to ground the effective input capacity would be about 10 per cent higher.

Determining the stray capacity is perhaps the hardest part of the job. There are no hard and fast rules for determining these strays. Sometimes the capacity of individual components to ground are measured and summed up but generally they are estimated as closely as possible, which may involve a bit of "cut and try." Nominal variations usually are compensated for in critical or very wide-band amplifiers by using a "peaking coil" with a variable high-permeability iron core and adjusting the inductance during alignment of the amplifier. A close approximation of the stray capacity in a well-designed layout is 10 to 15 $\mu\text{fd.}$

Another method of determining C_L is by measuring the gain of the uncompensated amplifier

stage of Fig. 1 in the mid-frequency range (between f_1 and f_2 , Fig. 2) and then measuring the frequency at which the gain drops to 70.7 per cent of the mid-frequency level. This will be at f_2 in

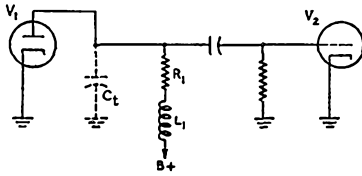

Fig. 6 — Shunt-peaked stage.

Fig. 2. In an uncompensated amplifier the magnitude of C_t , which, with a given plate load resistor, will cause the gain to drop to 70.7 per cent of the mid-frequency gain, is given by

$$C_t = \frac{1}{2\pi f R}, \quad (13)$$

where C_t is in farads,
 f is in cycles, and
 R is in ohms.

Essentially, this states that when the shunt reactance across the plate load resistor and its resistance are equal, the response will drop to 70.7 per cent of the mid-range value from equation (4).

For example, by using the circuit in Fig. 1, with 1000 ohms at R_5 and a wide-range vacuum-tube voltmeter connected from plate to ground, C_t can be determined by measuring the voltage across R_5 , with a constant voltage input to the grid of V_1 , at around 2500 cycles, and then increasing the frequency until the voltage is 70.7 per cent of the initial value. This frequency then can be substituted in equation (13) and the equation solved for C_t . The value thus determined will include the input capacity of the v.t.v.m., which must be subtracted from the calculated C_t . To minimize error in the input voltage, to the grid of V_1 resulting from shunt reactance across the grid, R_1 should be made very low in value (50 to 100 ohms) while making the measurements.

As a practical example, if 10 volts is measured across R_5 at 2500 cycles and 7.07 volts at 2 Mc., then substituting in equation (13),

$$C_t = \frac{10^{12}}{(6.28)(2)(10^6)(10^3)} = \frac{10^3}{12.56} = 79.6 \mu\text{fd.}$$

But from this capacity must be subtracted the capacity of the vacuum-tube voltmeter. Assuming this capacity to be 22 $\mu\text{fd.}$, C_t is $79.6 - 22 = 57.6 \mu\text{fd.}$ This value includes all circuit and stray capacities, and may be used as the basis for calculating the high-frequency compensation networks, as outlined later. When the peaking coil, L_1 , is installed care should be used in its mounting to disturb the circuit as little as possible. A good practice is to have a coil of the same physical size mounted in place but shorted out during the above measurements. If the peaking coil is placed as in Fig. 6, the effect of the capacity of the coil to ground is minimized.

Part II will appear in the May issue of QST.

A New Type of Dry Cell

P. R. MALLORY & Co. of Indianapolis, Ind., has announced the development of a dry battery of radically new type designed particularly for improved performance in tropical climates. In addition to features which resist the effects of moisture and high temperatures, the cell has other unusual characteristics. Whereas the voltage of the conventional cell drops throughout the operating life, the voltage of the new cell, within practical limits, remains substantially constant up to the end of the cell life. Also, unlike conventional cells, the new cell, within the rated current range, possesses the same ampere-hour service life whether the battery is operated intermittently or continuously. Under normal conditions, no recovery time is required.

The new cell is especially adaptable where the factors of small size and weight and longer life outweigh that of greater cost. It is not expected that it will compete in the field of low-cost flashlight cells, its most logical applications being in the direction of hearing aids and portable radio equipment. Also, it will not, at present, replace standard cells where they must be operated at temperatures below zero F.

An important ingredient of the new cell is mercury. Whereas the conventional cell is encased in a zinc can which serves as the negative terminal, the new cell has a steel case which is the positive terminal. A carbon rod serves as the positive terminal of ordinary cells. It is surrounded by a composition of sal ammoniac and the depolarizer manganese dioxide. In contrast, the "inside" of the new cell consists of layers of zinc and specially-impregnated paper wound in the form of a spiral, the zinc being the positive terminal. The usual type of cell is porous and requires "breathing" space, while the new cell may be fitted into closely-machined enclosures, if necessary, without impairing its performance.

In one Signal Corps battery, 72 cells are fitted into a tube less than one foot long and 1½ inches in diameter. This battery delivers 93.6 volts.

Strays

Our hats are off to Lt. Charles D. Houchin, W9OUQ, who has received the Purple Heart after being twice wounded in action in the Mediterranean theater. He received his first commendation from his commanding officer after receiving wounds in the battle for Tunisia. Recently, while serving on an Italian battlefield, he was wounded again, and received, in addition to the Purple Heart, a commendation by the commanding general of the Third Air Force. Lt. Houchin, who has been in service for more than three years and overseas for eighteen months, has served in North Africa, Sicily and now in Italy.

HAPPENINGS OF THE MONTH



ALLOCATION NEWS

LAST MONTH we gave you FCC's proposed postwar allocation of the frequencies above 25 Mc. After a two-week postponement, the oral arguments on the proposal began before the Commission on February 28th and lasted several days, with around a hundred people in attendance. A considerable percentage of the interests appearing were generally in favor of the allocation, including aviation, television and ourselves.

The major protest came from f.m. organizations, who objected to the proposed move to 84-102 Mc. and desired to remain in the general vicinity of their present location. FCC proposes the change both because the propagation qualities of the higher frequencies should provide a superior service and to find room to expand the f.m. assignment from its present width of 8 Mc. to 18 Mc. — 90 channels. F.m. challenged the propagation data and wanted the expanded width of 18 Mc. near its present spot. Dr. E. H. Armstrong, the inventor of f.m., proposed 48-66 Mc. for f.m., with our 5-meter band being displaced to 44-48 Mc. instead of at 50-54 Mc. as shown in the FCC table in our last month's report. Another f.m. proposal was to occupy 46-64 Mc., with our band presumably to be split into two 2-Mc. slices, one at 44-46 and the other higher up. All these proposals also involved shifting television to the higher end of the 44-102 range. Television objected, supporting the Commission's proposals.

So, you may be sure, did ARRL. We were represented throughout the arguments by Messrs. Segal, Warner and Grammer, with President Bailey on tap as needed. Last month we mentioned that we were not sure we would take the stand and make a formal appearance before the Commission, being satisfied with its plan; but, our 5-meter band being under attack, we did appear in argument, supporting the FCC proposal and protesting the f.m. suggestion. We said that the FCC intention to shift us to 50-54, while acceptable to us, was as far as we could go. We pointed out that that immediate vicinity is a unique transition spot in the spectrum, where the observations of amateurs are of great value, and that the band was very precious to us in this location because it is so uniquely erratic and unpredictable. In other words, we love it for the very qualities that make it an undesirable assignment for activities that must render a regular and reliable service. The 5-meter gang will note, incidentally, that sporadic *E* should be "sooner and oftener" on 50-54 than on 56-60, and that there is a better opportunity for the appearance of F_2 transmission.

What happens now is that FCC will again go into a huddle with itself, take note of the argu-

ments, decide whether changes should be made in its proposals — and then come out with a definite allocation order. All this is expected before the end of March, and it should pretty well decide what our postwar assignments are to be in this range. Not entirely, because it is not yet apparent how high in the spectrum allocations will become the concern of international conferences, and it is also to be kept in mind that the FCC allocations above 450 Mc. are "on an experimental basis, pending adequate showing as to need and technical requirements." But it will be all we need to begin the planning of our own postwar world above 25.

Below 25 Mc. — the more important part of the spectrum for us — the work is still in process. RTPB Panel 2, representing the industry, has resumed meetings to formulate recommendations to FCC. The Commission, again checking its way along with IRAC, is expected to follow the same course as it did above 25 Mc.: bring out a report containing a proposed allocation, and set dates for briefs and arguments on the part of those who wish to offer opposition. Some announcement on this is also expected before the end of March.

In the case of these frequencies below 25, a joint FCC-IRAC determination is only the beginning for such users as ourselves, since these of course are DX frequencies and necessarily subject to world agreement. The next step will be their study by the committees formed by the Department of State to draft proposals for international conferences. That will probably await the announcement by FCC of its plan for the whole of the spectrum, meaning that these meetings should be under way in April. There, too, ARRL is participating. There is to be an inter-American regional conference in Rio this summer, and a world conference may come sooner than many realize. As for the plans of amateurs, our Board of Directors is contemplating a special meeting to examine FCC's figures for proposed allocations in the region below 25 Mc. as soon as they are announced.

Watch this department in *QST* each month for further news.

RENEWING COMMERCIAL LICENSES

As a convenience to many licensed and formerly-licensed radio operators now in military service or employed in war industries distant from their homes, who do not have actual possession of their licenses and cannot ascertain their expiration dates and therefore cannot file timely applications for renewal, FCC, by its Order 124, dated January 2, 1945, extended for a period of one year from date of expiration the time within which applications for renewal of commercial

operator licenses (other than Temporary Emergency Radiotelegraph Second Class licenses) may be accepted, provided application is filed prior to December 31, 1945.

This order should not be construed as authorizing continued operation under the terms of any radio operator's license after the expiration date thereof. The actual operation of transmitting equipment of any station for which a license is necessary may be carried on only by a person holding a valid operator's license of the proper class.

Under the terms of this order, renewal applications filed with the Commission will be acted upon in the order in which they are received, and such renewals as are issued will be dated accordingly. It is suggested that applications for renewal be filed at the Commission's field office where the original license was issued.

ENGINEERS WANTED

To expedite the development of ground communication systems fitted to the peculiar needs of the Army Air Forces, a development project known as the Watson Laboratories has been permanently established by the AAF at Red Bank, N. J. Its tasks are so great that it is in need of many more engineers. At the moment of writing, it reports that it has approximately 325 openings for radio and radar engineers, to be filled at the earliest possible date. These are war service appointments under the Civil Service Commission, in professional classifications carrying salaries from \$2600 to \$5600 per annum.

Complete information regarding these positions may be obtained from the New York office of the Civil Service Commission or by direct inquiry of Chief, Personnel & Administrative Division, 4151st AAF Base Unit, Red Bank, N. J. Qualified persons in position to contemplate such employment are invited to write.

NOBLE REELECTED

THE balloting early in the winter in the New England Division resulted in a tie between the incumbent, Percy C. Noble, W1BVR, and Frank L. Baker, jr., W1ALP, necessitating another balloting. In the re-run of this election, the results of which were canvassed on February 20th, Mr. Noble won easily, receiving 738 votes to Mr. Baker's 361.

Mr. Noble is thus returned to the Board of Directors for the 1945-46 term. He is a member of two Board committees, the Postwar Planning Committee and the Finance Committee.

ARE YOU LICENSED?

When joining the League or renewing your membership, it is important that you show whether you have an amateur license, either station or operator. Please state your call and/or the class of operator license held, that we may verify your classification.

BAILEY ELECTED EXECUTIVE SECRETARY OF I.R.E.

GEORGE W. BAILEY, president of ARRL and IARU, and chief of the scientific personnel office of the Office of Scientific Research & Development for the last four years, has been elected to the new post of executive secretary of the Institute of Radio Engineers.

Mr. Bailey will continue his present work with OSRD, under Dr. Vannevar Bush, while gradually assuming his new responsibilities with IRE. It is expected that he will take over full time on the new job about the first of next year. The Institute plans a greatly expanded program of activities after the war, and the creation of the new managerial post is in consonance with those plans.

Mr. Bailey will continue his duties as president of ARRL, there appearing to be no conflict in the interests of our two societies but rather the contrary.

STATE GUARD ON "80"

THE WERS regulations have been amended to permit State Guard stations to use two frequencies in our 80-meter band during the war, on voice emission and with power output not exceeding 5 watts. A 3655 kc. channel is available in certain states, 3825 kc. in the other states, and both frequencies in the territories and possessions. Special applications and endorsements are necessary for operation on these frequencies.

H.F. LIFEBOAT RADIO

THE traditional lifeboat radio installation is on 500 kc. During the early months of this war, after Pearl Harbor, many merchant vessels were torpedoed in remote waters and their 500-kc. signals never heard, crews eventually coming to land after distressing weeks in lifeboats. It was obvious that a DX frequency was indicated, and that even the few watts of an emergency transmitter could cover the thousands of miles to a coastal station if the frequency were right, thus permitting rescues.

Last year the Coast Guard and FCC carried out experiments over many months, utilizing, among other equipment, an experimental high-frequency portable transmitter of typical amateur construction which, in response to a request for voluntary cooperation to expedite matters, the League built and lent to the Commission's engineering department. The operation and utility of this transmitter were demonstrated to Commission engineers by QST's Acting Technical Editor, Don Mix. After initial tests using this set, further tests with other equipment were conducted by the Coast Guard in cooperation with FCC and interested manufacturers, and several conferences were held on the subject.

The Commission has now issued extensive amendments to its Rules Governing Ship Service, providing that all new lifeboat radio installations must be compulsorily equipped for high frequency in addition to 500 kc. The lifeboat regulations also require special means for the use of efficient

AMATEUR WAR SERVICE RECORD

Name

Call, present or ex; or
grade of op-license only

Present mailing address

SERVICE

- Army
- Navy
- Coast Guard
- Marine Corps
- Maritime Service
- Merchant Marine
- Civil Service
- Radio industry,
100% war

Rank or rating

Branch or bureau: Signal Corps, AAF, BuShips, WAVES, etc.
If civilian industry, give title and company.

antennas for operation on these frequencies. The changes seem all to the good, and the League is happy to have been able to play its small part in effectuating this further wartime aid to those who go down to the sea in ships.

YOUR WAR SERVICE RECORD

NEAT little 3 X 5 cards now fill dozens of filing drawers at ARRL Hq. in our record of the amateur radio contribution to the war effort. Hundreds of "coupons" and numerous letters come in every week to add to the list. But, do you know, we don't believe we've got half of you fellows yet.

We do want to get all of you listed, because this list supplies the ammo to prove the case for amateur radio if any further proving becomes necessary — as well as supplying the data for our column of you fellows "In the Services." It is important that this record be as nearly complete as possible, and the very rate at which we still receive entries proves that the task is nowhere near done.

How about you? If you are using your amateur radio know-how anywhere in the war effort, we want the simple facts on you that are shown on the small form reproduced at the top of this page — and on your ham associates, too, if you can spare the time to include the dope on them. Canadian as well as U. S., and civilians as well as those in uniform. We want no classified information — just the simple facts called for in our form. It will only take you a moment. TU.

NOTICE TO MEMBERS DISCHARGED FROM THE MILITARY SERVICES

THE requirement of continuous membership in the League for eligibility to ARRL offices has been waived for members serving in the uniform of the United States. See particulars on page 23 of *QST* for July last. Those desirous of taking advantage of this arrangement are asked to claim the right when renewing membership, stating the beginning and ending dates for their military service.

VWOA Celebrates 20th Birthday

The Veteran Wireless Operators Association celebrated its twentieth anniversary at the annual VWOA "dinner-cruise," Feb. 17, 1945, at the Hotel Astor in New York. By saluting television the VWOA kept pace with the ever-changing world of electronics. Outstanding personalities of the television, radio and other electronic fields were present, together with high-ranking officers from the armed services.

As is their custom, the VWOA again presented awards for contributions to the world of electronics. This year the Marconi Memorial Service Award was bestowed upon the Television Broadcasters Association and accepted by the Association's president, J. R. Poppele. R. Morris Pierce, ex-9WJ, received the Marconi Memorial Medal of Service for his invaluable work in the European theater. The Marconi Memorial Medal of Achievement was presented to Dr. Allen B. DuMont, ex-W2AYR/W2AHD, for his continued contributions in the field of television. Orin E. Dunlap, jr., received the Marconi Memorial Medal of History for his recording of the age of wireless in his numerous books. Congratulatory messages were received from Admirals King and Nimitz and Generals Eisenhower, MacArthur and Vandergrift, each of whom intimated that "pressing business elsewhere" kept them from attending. Major General H. C. Ingles, Chief Signal Officer, Major General Frank E. Stoner, Chief of the Army Communications Service, and other officers paid tribute to the meritorious performance of radio operators in the war and praised the unceasing effort of the men who now form a considerable part of the background of radio, the former professional wireless operators.

Among the many interesting facts presented, none was more revealing than the statement by Major General Stoner that "for every bullet fired from an American gun, four words are transmitted by Army Communications."

— A. D. M.

For years the nation's press, both lay and technical, has been unable to print even broad generalities concerning a subject already reasonably familiar to a substantial cross section of the public — radar. The British lifted the veil in early 1941 to publicize a program for enlisting civilian U. S. technicians to maintain the lifeline of radiolocation stations which proved England's salvation during the devastating days of the blitz. Again, in April, 1943, a joint release by the U. S. Army and Navy defined the art and, in popular terminology, explained its applications. But after each tentative disclosure U. S. censorship promptly renewed its ban on discussion of the topic. Later, use of the term "radar" was conceded; but only the word itself could be mentioned. Military agencies prohibited linking the term and applicable techniques in print. The purpose was not to conceal its existence from the enemy — the Germans not only had a radiolocation system in operation several years before the outset of war, but they learned much of what the Allies knew concerning the subject from documents captured in the fall of France. One reason was a pious hope that the possibility of disclosures, inadvertent or otherwise, concerning the tactical employment of radar could be minimized by inhibiting discussion of the subject as a whole. The other reason was that, following the first tentative revelations, a wave of contention arose among conflicting claimants for the credit of its conception and development. Indeed, internecine disputes over who was "first" — U. S. vs. British, Army vs. Navy, laboratory vs. laboratory, manufacturer vs. manufacturer — began to resemble another world war in miniature, with the advertising columns of every magazine and newspaper their theater of operations, mimeograph machines and printing presses their heavy ordnance, and millions of words, spoken and written, their missiles. So, again the lid was clamped down — tight.

Now, however, it seems to be loosening up once more. The first intimation of this was a softening of British technical censorship around the first of the year, climaxed by the appearance in the February *Wireless World* of a piece by NPL's and RSGB's Dr. R. L. Smith-Rose. In his article, openly titled "Radiolocation," some of the fundamental principles were rather plainly discussed. Following this breaking of the ice, the U. S. Office of Censorship, consonant with its customary common-sense policy, moved over its own "Off Limits" sign. At this writing it is understood that the Joint Chiefs of Staff are considering the matter, and announcement of a more realistic Army-Navy policy is expected.

It must be understood, of course, that only the top pages of the file will be exposed to public view. Radarelectronics has become a broad field, with diverse applications. Many of these applications, those customarily categorized as "electronic devices," will remain in the highly secret category until the termination of hostilities — and possibly for some time thereafter. But the elementary principles of radar at last may be treated rationally — which, if no longer exciting, is at least refreshing.

Radar Techniques

I—Primer Principles

BY CLINTON B. DE SOTO,* WICBD

EVERY American — adult or adolescent — astute enough to keep up with the adventures of Buck Rogers, Smilin' Jack, and Terry and the Pirates is well aware of the existence of radar — and probably of its operating principles, as well.

He has been told that radar is "a radio wave with an echo" — that a radar beam is a sharply focused radio searchlight which searches out any object coming within range of its "owl-like eye."

Whether it be considered as an "eye" or as an "echo," assuredly radar is a means for projecting the range of human senses far beyond their normal limitations. There is logic in the thought that, as sound radio is to the ear and television to the eye, so radar — even though it employs other sensory organs — may be regarded as an extension of the sense of touch.

The word radar, by official account, was coined from the initial letters of the prosaic phrase

* Editor, *QST*.

"radio detection and ranging." As a military weapon, radar is utilized both defensively and in attack. Defensively, it performs the duty, first, of detecting a trespassing enemy and, second, establishing his precise location. In its offensive role radar scouts out the prey of pilots of interceptor fighters and the commanders of naval patrol craft; it aims antiaircraft artillery and the big guns of the battlewagons; it controls devices which automatically align searchlights, navigate air and seacraft, and perform many other functions.

The purpose of this series is to discuss the techniques employed in radar, within the limits circumscribed by military restrictions — to explain radar systems in general, to present diagrams and simple circuits illustrating the derivation of the generic units, and to suggest elementary methods employed to achieve the required effects.

Admittedly, to the thousands of radio amateurs directly associated with this new art (many of

whom, incidentally, have made major contributions to its development) there will be little we can say that will be novel or useful. Even to those who, while not directly engaged in radar work, have access to the literature on modern technical trends, these articles will in all likelihood have only incidental interest.

There remains, however, the many stay-at-home civilian hams (and also some of those in military service) who do not have access to such specialized technical information, and it is for their benefit that this series is written. For them we shall endeavor to interpret the broader aspects of the technique and evolution of the art. Moreover, to ensure comprehension even by the neophyte, the explanations will go back to the underlying principles. Thus this initial discussion concerns itself only with a generalized summary — a “primer class” treatment of the subject. Details of component units and certain aspects of the theory involved will be dealt with in somewhat more detail in subsequent installments.

Radio Location

Military radar systems must be capable of (1) searching an assigned area, which may range from the relatively small frontal-fire arc of a night-fighter interceptor pursuit to the entire expanse of horizon surrounding a warship or a long-range bomber, and (2) supplying data for the accurate (and, preferably, automatic) determination of the quantities necessary to give an exact “fix” on enemy air or seacraft: (a) direction or bearing (azimuth); (b) altitude (elevation), and (c) distance (range), as shown in Fig. 1.

The prospective peacetime applications of radar are beyond prediction. Among the more obvious are those relating to navigational aids and collision prevention. In some of these uses it will be a case of radar replacing radio. Radar d/f is distinguishable from familiar radio direction-finding practice by an invaluable quality, described thus by Dr. Smith-Rose: “An intrinsic feature of the art is that no cooperation whatsoever is required of the object being detected. . . . The latter, be it an aeroplane, ship, building or human being, is merely required to reflect or scatter some of the radiation which reaches it. . . . The detected object is thus merely a source of secondary radiation which results from its being illuminated, as it were, by the incident radiation from the primary sending station.”

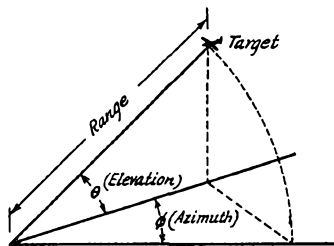

Fig. 1 — To establish the location of the target in space, three quantities must be determined: distance (range), bearing (azimuth), and altitude (elevation).

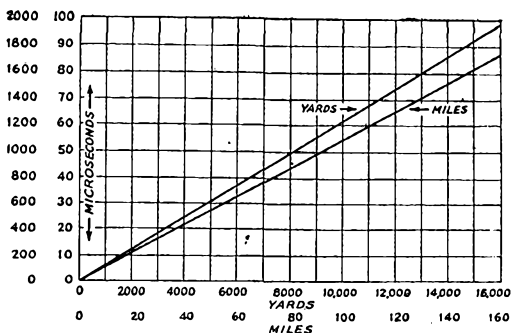

Fig. 2 — Time intervals for return of reflected signals.

Ordinary radio d/f requires that the object of the search transmit a signal so that a bearing can be taken. If the mobile transmitter aboard the ship or aircraft fails, or radio silence is imperative, or an enemy bomber fails to “cooperate” and does no transmitting — well, then no radio bearing can be taken. Radar systems, however, require of the wanderer only that he serve as a reflector — a form of assistance which not only can be, but in wartime usually is, rendered involuntarily.

Apart from that significant difference, the two methods are essentially similar. The procedure in taking a radar bearing may be simply that of rotating a directive antenna for maximum response, in either the horizontal or vertical plane, and then reading the angle of azimuth or elevation on a calibrated scale to establish direction.

The third item of information required to establish the exact location of a target, as shown in Fig. 1, is the distance to the object. Here radar displays another unique quality — its ability to measure the distance to any object in the field of its beam, like a searchlight with a coupled range-finder, without triangulation.

Modus Operandi

This ability is predicated on three technical factors which characterize radar: (1) radiating energy in extremely short pulses spaced by comparatively long quiescent intervals; (2) concentrating the radiated energy in a very sharp (highly directive) beam; and (3) utilizing electronic devices, which can register and measure split-microsecond intervals precisely, to determine the transit time of reflected pulses or “echoes.”

Because the velocity of propagation or “speed” of a radio wave is constant in space, and very nearly so in air, the time taken by a pulse in traveling any given distance represents an accurate measure of that distance.

The process may be described as akin to sending a messenger out into space, traveling at a known rate of speed, and therefore requiring a given time to reach a given point and return. The radar messenger is a pulse of r.f. energy; its speed is approximately the same as the velocity of light; and the time required to make the round trip over any given distance and back is shown in Fig. 2.

A typical arrangement for the measurement of

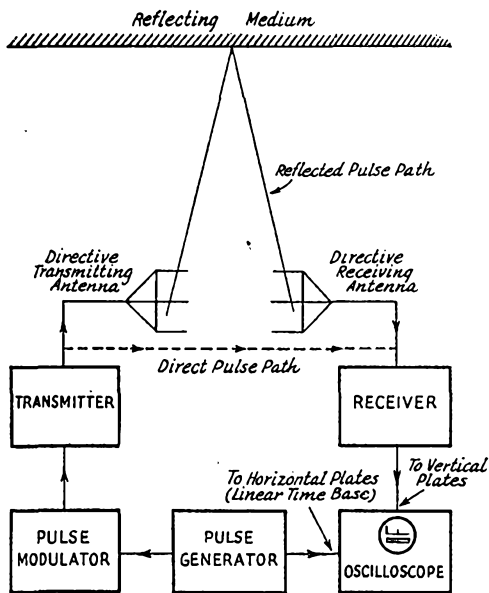

Fig. 3 — Block diagram of a simple radar system.

distance or range by means of reflected pulses is illustrated in block diagram form in Fig. 3. Although bearing only slight resemblance to current practice, it illustrates the mechanics of radar in readily comprehensible fashion.

Modulated by the pulse generator, the radar transmitter radiates short pulses of r.f. The interval between individual pulses is made somewhat greater than the total time required for the wave to travel to a reflecting target at maximum range and back to the receiver.

The transmitting antenna emits radiation beamed in the approximate direction to be explored. Whenever this radiation strikes a surface having characteristics of electrical conductivity or dielectric constant appreciably different from those of air, some of the energy will be reflected or scattered back towards the receiver.

While the power radiated from the transmitting antenna is concentrated principally in the beam, reducing the local field to a minimum, the direct

radiation is sufficient to energize the receiver. If the distance between transmitter and receiver is small, transmission of this direct wave, indicated by the dash line in Fig. 3, is practically instantaneous. The direct radiation from the transmitter therefore establishes the starting time of the exploring pulse.

Both direct and reflected pulses are picked up by the receiving antenna and generate corresponding pulses of signal voltage in the receiver input circuit. After being amplified and rectified, both signals are applied to the vertical deflecting plates (Y axis) of the cathode-ray tube indicator. There the pulses register on the screen as vertical deflections of the horizontal timing trace.

The appearance of the screen is shown in Fig. 4. By comparing the distance between the direct and the reflected pulse indications on the screen, using a known time base, the distance traveled by the reflected wave can be read on a calibrated scale. The horizontal (X axis) deflection is synchronized with the transmitted pulses, giving a known horizontal time base which is adjusted so that the direct pulse indication coincides with 0 on the scale.

The vertical amplitude of the pulse deflection or "pip" is, of course, proportional to the relative amplitude of the received signal. Thus the height of the trace tends to vary with distance, and may also serve to indicate, to some extent, the size or composition of the target. Moreover, if the target under observation is moving, the change in its relative position will be indicated by a movement of the pip along the base line.

Timing the Radio Echo

It is evident that the accuracy of such measurement will be greatly dependent upon the accuracy of the scale calibration — which, in turn, is dependent upon the accuracy of the timing base.

The key to the entire system is the pulse generator, which times each and every step in the operating sequence. For this reason the pulse source must be capable of delivering a continuous series of precisely identical pulses at an exact and unvarying repetition rate.

These control pulses synchronize both the transmitter-modulator and the receiver-indicator functions. Each pulse going in the transmitter direction is applied to the modulator input and serves to release r.f. power from the transmitter for a period precisely equal to the duration of the pulse. Similarly, in the receiver direction each pulse triggers a sawtooth sweep-voltage generator which supplies the horizontal time base for the cathode-ray tube indicator. Since the resulting sweep frequency is identical to the pulse repetition rate, the cathode-ray beam makes exactly one traverse of the screen along the X axis in the interval between each transmitted pulse.

The cathode-ray tube is comparable to a split-second stop watch, in which the "sweep hand" makes a complete revolution in terms of thousandths of a second and reads time in microseconds (millionths of a second). What this means can best be appreciated by pointing out that, if an

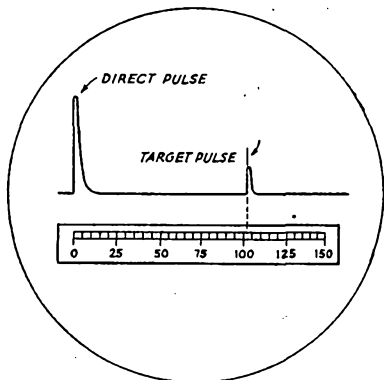

Fig. 4 — Timing (direct pulse) and target (reflected pulse) "pips" on the cathode-ray tube indicator screen.

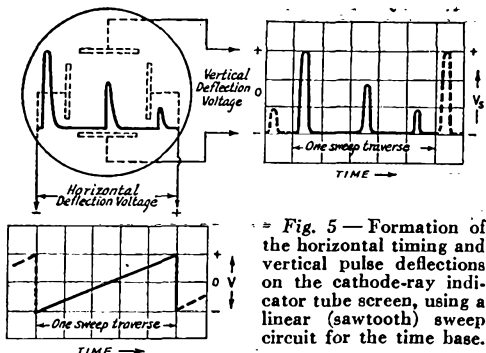

Fig. 5 — Formation of the horizontal timing and vertical pulse deflections on the cathode-ray indicator tube screen, using a linear (sawtooth) sweep circuit for the time base.

ordinary 12-hour clock were speeded up to a comparable rate, the hour hand would be making several revolutions *per second* rather than two per day.

Obviously, only an electronic instrument can meet such an exacting requirement. The cathode-ray tube therefore is used to measure the time interval as a function of voltage. As explained above, the distance or range is then found by translating that quantity into a function of time.

Cathode-Ray Tube Indicator

At the risk of emphasizing the obvious, let us take a backward glance at some fundamentals of cathode-ray tube operation.

A cathode-ray tube, as has been explained in so many places at so many times, is in effect a two-dimensional voltmeter with an essentially weightless, massless, inertialess pointer. This pointer is a sharply focussed electron beam which impresses its transient indication on the fluorescent material of the screen, creating a luminous spot wherever it strikes. Normally centered on the screen, the spot from the cathode-ray beam will be deflected, moving up or down, left or right, in instantaneous response to the influence of an external electric or a magnetic field. In so moving it leaves a visible line or trace. Because of the inherent retentivity of the fluorescent screen and the persistence of vision of the human eye, this luminous trail will remain visible for 0.1 second or longer.

That, of course, is the principle of the cathode-ray oscilloscope. By translating any dynamic quantity — electrical or mechanical — into voltage, its characteristics can be reproduced as a visual image on the screen of the oscilloscope. And that is just what is done in the radar indicator; the required quantities — time, distance, bearing, etc. — are translated into corresponding voltages which trace characteristic patterns on the cathode-ray tube screen.

To establish the relationship between voltage and time, the external circuits are so arranged as to apply to one pair of deflection electrodes (usually the horizontal or X axis) a voltage which increases linearly over a predetermined interval of time. At the end of this interval it will "fly back" rapidly to zero, and then repeat its relatively slow linear traverse across the screen. This action is pictured in Fig. 5, where the vertical (Y axis) deflection voltage depicts three received pulses.

If the linear movement of the beam as it is visually apparent on the screen is directly proportional to the amplitude of the deflection voltages, the screen may be calibrated rectilinearly in terms of voltage. Thus, with a linear time base, a rectilinear-coordinate scale can be obtained.

It must be understood that the total length of the horizontal base line bears no relationship to the time scale; it is controlled solely by the peak value of the sweep voltage. Nor is the amplitude of this voltage related to the time interval; it serves only to establish the length of the trace. Regardless of the numerical length of the trace, its proportional parts will always bear the same relationship to the total time interval. Thus, for a repetition rate of, say, 1000 (0.001 second), 10 per cent of the trace will represent 100 microseconds, 5 per cent will be 50 microseconds, etc. — whether the trace itself be 0.5 inch or 5 inches long. Thus any scale may be arbitrarily divided off into linear units and attached to the cathode-ray-tube screen; the beam deflection is made to correspond to the scale calibration simply by adjusting the sweep amplitude to match the scale length.

Provided the time base is perfectly linear, the possible accuracy of measurement is limited only by the accuracy with which the scale calibration can be read — in effect, the number of intervals into which the scale can be divided. This, in turn, is limited by the maximum base length, which obviously must be somewhat less than the diameter of the cathode-ray tube screen.

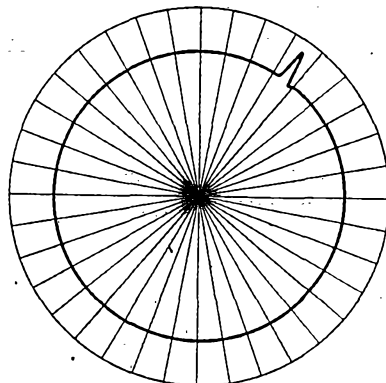
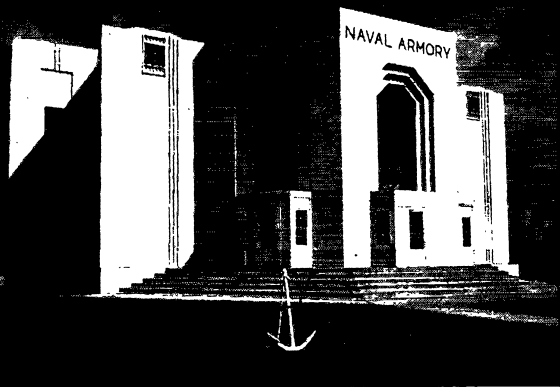

Fig. 6 — Use of a polar-coordinate time base multiplies the effective scale length by a factor of 3 or more.

A three-fold longer trace and consequent better accuracy can be achieved by using a polar-coordinate scale. With such a scale the circumference of the screen, not the diameter, determines the maximum scale length.

To obtain a polar scale, the timing-axis trace must appear as a circle rather than as a straight line. This requires that a circular sweep be used instead of a linear sweep. The signal deflection voltage then is applied radially to alter the shape of the circular trace, causing either a "tooth" or a notch to appear in the circle, as shown in Fig. 6.

This article is Part I of a series. Part II will appear in the May issue of QST.



The Naval Reserve Armory at Michigan City, Ind., one of four schools at which pre-radio courses are given under the Navy's radio technician (radar) training program.

Radio Amateurs in Navy Radar

**An Opportunity to Receive Valuable
Radio Training While Serving
Your Country**

**BY LT. (jg) CHARLES LILLIE,*
USNR, WJTG**

LEISURE conversation here at Radio Chicago turns again and again to the postwar future of amateur radio. Those of us who used to work DX on 5 meters are already dreaming up rigs capable of operating at 300 or 400 megacycles and higher, while the 10- and 20-meter gang are arguing the pros and cons of the still hypothetical 21-Mc. band.

It would be interesting to know just how many hams are now serving with the Navy. There must be several thousand in the radio technician bracket alone, for every school in this training program can point to a sizable group among its officers, instructors, students and graduates.

Here at Radio Chicago, our visual aids officer is Lt. (jg) Al Rogers, an ex-lawyer whose 350-watt rig on 28- and 14-Mc. 'phone was heard under the call W9OZE, Waukegan. Lt. (jg) Arnold Schwemin, W7EWM, in charge of barracks, pioneered on 112 Mc. and worked 10- and 20-meter 'phone from Clarkston, Wash., while Ensign George Dean, W7EAV, pre-radio coördinator of instruction, spent his evenings in Seattle, trying to push 35 watts of 160-meter 'phone eastward over the Cascade Mountains.

CRT Ernest Sindelar, W8OOF, in charge of radio theory classes, and CRT Lloyd Alexander, W8VQ, in charge of laboratories, head the list of radio amateurs now teaching at Radiq Chicago's primary school. Among the students may be found returned fleet men such as RT1c Victor Langello, formerly attached to the cruiser *Boisé*,

* Education Officer, USNTS, Radio Chicago, 190 North State St., Chicago 1, Ill.

and CRM Oliver Arden, W6LPF, a veteran of five years of motor torpedo boat duty, together with recently enlisted men such as S2c John Birch, W8SEN, of Elgin, Ohio.

It might prove interesting to follow a typical student through the radio technician training program and see just what he learns in ten to twelve months. Upon qualification for RT by virtue of the Eddy Test, the new recruit is sworn in as a seaman first class, two pay grades above the normal entrance level. Four to eight weeks of indoctrination training at Great Lakes follow immediately and, after boot leave, the embryo radio technician goes directly to a pre-radio school in the Chicago area. These include former city-owned high schools and junior colleges such as Wright Junior College, Theodore Herzl School and Hugh Manley School, as well as the Naval Armory in Michigan City, Ind.

Pre-Radio Training

The function of pre-radio training is to bring men of widely varying background to a common level of knowledge in three and one-half weeks' time. Assuming that all students have some mathematical background, it is possible to provide a comprehensive review of high school algebra in this short period. In addition, the basic theory of electricity is introduced from the electron concept, and the student then studies simple direct current circuits, Ohm's Law in all its phases, power, voltage, and current measurements.

Practical examples of all theoretical problems are demonstrated by visual aids and actual labo-

The Navy is still accepting men for radio technician (radar) training and, in fact, the need for such men is great. Seventeen-year-old high school seniors may take the written qualifying examination (Eddy Test) at any time prior to their eighteenth birthday. In addition, all inductees who pass their pre-induction physical examination and meet Navy standards may take the Eddy Test, and those who pass are assured of assignment to the Navy for radio technician training. A highly technical background is not necessary to qualify, but a knowledge of high school mathematics and physics is essential. Experience with amateur radio will prove of extreme benefit, too. All Navy recruiting stations are prepared to administer the Eddy Test and tell you more about Navy radar, so here is a direct invitation to every amateur not currently engaged in war work to visit his nearest Navy recruiting officer at once for detailed information about the radio technician program.

ratory experiments. The student must be able to hook up and analyze *each type* of circuit himself and he will do just this in the lab. Proper shop technique is taught in separate classes during this early phase of the training program. Furthermore, the slide rule is introduced as a mathematical short cut. Every man learns its operation thoroughly as he watches his instructor manipulate a twelve-foot giant rule hanging on the wall and follows along with his own Navy issue rule of standard size. Such large scale models of all types of equipment, together with the use of carefully selected motion pictures, form a most effective method of presenting new material.

Pre-radio instructors are graduate radio technicians, many of whom are also radio amateurs. These men must successfully complete a specialized teacher training course at Radio Chicago before they are considered qualified for platform or laboratory duty.

Graduates of pre-radio school are assigned to one of several primary training centers located at Radio Chicago, 190 N. State St., Chicago; Stillwater, Okla.; Gulfport, Miss.; Takoma Park, Md.; Houston, Texas; Dearborn, Mich., and Great Lakes, Ill.

Radio Theory and Practice

Primary training is of three months' duration. The mathematics course stresses vector analysis and formula solution as important tools for the practical engineer, while the electricity course begins with Kirchhoff's Laws and goes into a.c. from sine wave generation into a.c. power and a.c. circuits, finally terminating on the threshold of radio theory. A practical course on rotating machinery teaches the do's and don'ts of this type of power supply, while daily laboratory classes again closely parallel theory lectures. Radio theory itself is introduced by a detailed study of the vacuum tube. Then follows a study of audio amplifiers, tuned circuits, detectors, oscillators, rectifier power supplies, and finally the complete superheterodyne receiver, together with Class-C amplifiers and the complete transmitter. The laboratory course concludes with the construction

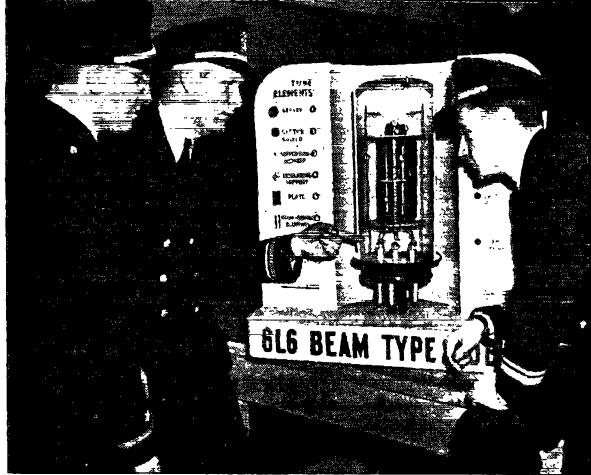

The author, W1JTC, shows Ensign George Dean, W7EAV, just what a 6L6 really looks like, while visual aids officer, Lt. (jg) Al Rogers, W9OZE, looks on.

of a working superhet, while lab is further tied in with theory by means of a third-month course in servicing techniques. Upon graduation from primary school the student has received a complete education in general radio theory and typical circuits. He is now ready to go on with the study of specific types of Navy equipment at a secondary training school.

Secondary schools are located at Washington, D. C. (Bellevue); Treasure Island, Calif.; Chicago (Navy Pier), and Corpus Christi, Texas. The latter school is devoted exclusively to the study of aviation radio matériel. The Corpus Christi graduate will be an aviation radio technician and may expect a limited amount of flight time in Navy aircraft while testing equipment under airborne conditions. The other schools are more concerned with shipboard equipment, although aircraft gear is also taught as a necessary part of the curriculum.

Throughout secondary training great emphasis is placed on the need for a thorough understanding of the theory and practice of all Navy electronic equipment including radio receivers and

(Continued on page 98)

Left — CRT Sindelar, W800F, chief radio instructor at Radio Chicago, demonstrates the electronic voltmeter to students. Left to right: RT1c Langello; RT2c Shaw, W1NEU; S2c Birch, W8SEN; CRM Arden, W6LPP, and RT1c Diegan, W8BTU-W6EAF. Right — A group of Radio Chicago instructors gathered around a giant working model of a multivibrator. Left to right: ART1c Lewis, W9QUW; CRT Sindelar, W800F; CRT Alexander, W8VQ; ART1c McIntyre, W8TSR, and ART1c Dunlap, W90GG.

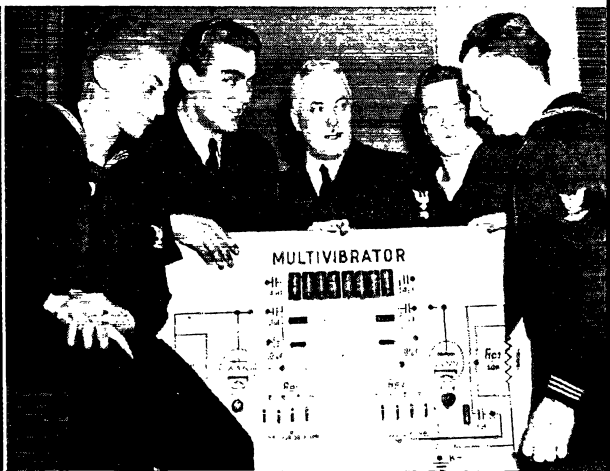
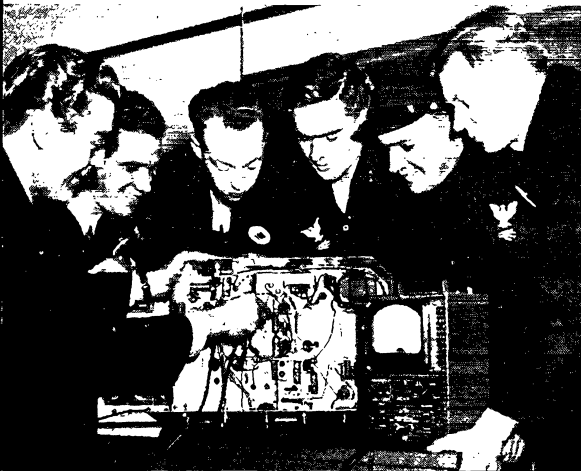

230 Watts from One 815

A High-Efficiency Class-C Amplifier Circuit

BY LT. HULEN M. GREENWOOD, AC*

THIS is one of those things one dreams about — except that in this case the dream came true. It has been shown that it is entirely practicable to obtain plate efficiencies upwards of 90 per cent from Class-C amplifiers. This in itself is a notable technical achievement, for it means, in practice, that a power input can be applied to a tube equal to 10 times its rated plate dissipation! We are indebted to Prof. Robert I. Sarbacher for the details of the circuit.¹ The idea originated with Dr. E. L. Chaffee of the Cruft Laboratory, Harvard, who has very kindly assisted in the preparation of this article.

Requirements for High Efficiencies

Considering efficiency in general, high efficiency means that θ_p , the angle of plate current flow, must be between 120 degrees and 150 degrees; the minimum instantaneous plate voltage, e_{bmin} , must be small; the plate-supply voltage must be high, and the maximum instantaneous plate current, i_{bmax} , must be high. But for high power output we want a large angle of plate-current flow and a large positive grid swing. For low driving power, we want a small

In this article, the author describes an interesting method of increasing the plate-circuit efficiency of a Class-C amplifier to values approaching ninety per cent. The material is based upon the work of Prof. Sarbacher formerly of Harvard University and involves the introduction of a third-harmonic voltage into the plate circuit of the amplifier.

angle of plate-current flow, θ_p , and a small positive grid swing. The maximum positive-voltage grid potential, e_{cmax} , should be less than e_{bmin} . Some of these conditions are exactly opposing, so we must compromise. In this discussion we shall use a family of curves in the $E_b E_c$ plane, called "constant-current" curves. A little study will show that they are far more useful for this purpose than the other types of curves.

In Fig. 1 such a chart is shown for the RCA type 815. Let us just disregard most of the lines on the chart and concentrate on the straight load line. This straight line is the conventional load line for a Class-C stage. At the Q point, E_c is -45 volts and E_b is 500 volts. This is the way we are supposed to set it up, according to the tube manuals. The grid swings up to +11 volts; the curves do not tell us what the minimum instantaneous plate voltage is, but we will assume it is 50 volts and thus fix point A₁. Under these conditions, the push-pull stage takes an input of 75 watts and puts out 56 watts.

Now the total swing of the grid on the positive half-cycle of the driving voltage is from -45 to +11, or 56 volts. Plate current flows as soon as the grid gets up to -31.5 volts and continues up to +11 (and back down again to -31.5 volts, of course). So $\theta_p/2$ is $(42.5/56)(90) = 68.2$ degrees, and plate current flows for 136.4 degrees. We notice that the plate voltage, e_b , is about 390 volts when plate current starts to flow. This high value is not so good, because the voltage across the tube should be low when current is flowing. The voltage across the load is $500 - 390 = 110$ volts, so most of the power at that point is wasted inside the tube. If we could only get e_b lower in some way, we could increase the efficiency.

Introduction of Third-Harmonic Voltage

Suppose we made the plate voltage vary along with the grid voltage. Then we could get the curved line QA₁. Now the value of e_b at the

* 112 W. 32 St., Austin, Texas.

¹ Sarbacher, "Power-Tube Performance in Class-C Amplifiers and Frequency Multipliers as Influenced by Harmonic Voltages." *Proc. I.R.E.*, Nov. 1943.

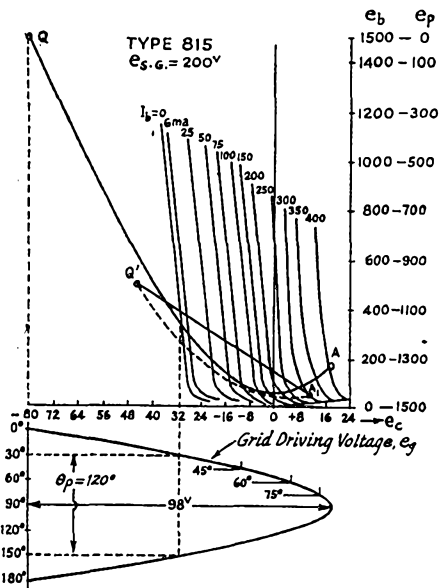

Fig. 1 — Constant-current characteristics and excitation-voltage curves for one section of a type 815.

Table I

θ_1°	$\sin \theta_1$	E_1	θ_3°	$\sin \theta_3$	E_3	E_p	E_b	I_b	P_b
0	0.0000	0.000	0	0.000	0.00	0.000	1500	0.000	0.000
15	0.2588	430	45	0.707	235	665	835	0.000	0.000
30	0.5000	830	90	1.000	332	1162	338	0.000	0.000
45	0.7070	1173	135	0.707	235	1408	92	0.075	6.8
60	0.8660	1436	180	0.000	000	1436	64	0.260	16.7
75	0.9659	1604	225	-0.707	-235	1369	131	0.364	47.6
90	1.0000	1660	270	-1.000	-332	1328	172	0.415	71.3
105	0.9659	1604	315	-0.707	-235	1369	131	0.364	47.6
120	0.8660	1436	360	0.000	000	1436	64	0.260	16.7
135	0.7070	1173	45	0.707	235	1408	92	0.075	6.8
150	0.5000	830	90	1.000	332	1162	338	0.000	0.000
165	0.2588	430	135	0.707	235	665	835	0.000	0.000
180	0.0000	0.000	180	0.000	0.00	0.000	1500	0.000	0.000

Maximum value comes at approximately 50 degrees where E_p equals (0.872) (1500). E_1 max. is 1660 volts; value of E_1 at any angle is ($\sin \theta_1$) (1660). E_3 max. is 332 volts; value at any angle is ($\sin \theta_3$) (332). E_p is sum of E_1 and E_3 . E_b is $1500 - E_p$. $P_b = E_b I_b$.

beginning of plate-current flow is only 250 volts; the voltage across the load, e_p , is also 250 volts, and we are really getting somewhere. Fig. 2 shows the relations in the plate and grid circuits graphically.

Through the use of some very devious mathematics Prof. Sarbacher shows that, if we insert a third-harmonic voltage into the plate circuit in phase with the fundamental alternating component, the load line will be just as shown. Fig. 3 shows the experimental circuit which was set up for a type HK-54. There are variations on this circuit which can be found in the original article.

Let's see what happens to the plate voltage when we combine a fundamental sine wave with its third harmonic. In the case of the 815, we will make the amplitude of this third harmonic just 20 per cent of the amplitude of the fundamental. When these two sine waves are combined the result can be plotted in tabular form as shown in Table I, taking the amplitudes of the two waves at regular intervals. θ_1 is the angle associated with the fundamental; $\sin \theta_1$ gives its instantaneous amplitude. θ_3 is the angle of the third harmonic at the same instant we take θ_1 . Naturally, the third harmonic will have progressed three times as far in degrees in the same time interval as the first harmonic; thus $\sin \theta_3$ gives its instantaneous amplitude. The value of e_p shows the instantaneous amplitude of the resultant wave.

Power-Input Calculations

Before we fill in the column for e_p , we must figure out the operating limits. We said earlier that we could run 10 times the rated plate dissipation to the tube. However, we must not exceed the rated average plate current, or the tube will be

short-lived. So we will use a power input of approximately (10) (12.5) = 125 watts. The family of curves shown in Fig. 1 is for only one of the two triode units in the tube; hence, the total power input to both units will be (2) (125) = 250 watts. Then $E_{pb} = 250/0.075 = 1667$ volts. We could use a power input of 250 watts in what follows, but 1667 volts is a peculiar value, so let us take 1500 volts and be satisfied with an input of 225 watts.

We now fix the minimum instantaneous plate voltage, e_{bmin} , at 50 volts. This means that the plate voltage, e_b , will vary between 1500 and 50 volts, or a net change of 1450 volts. We notice in the table that the maximum value of the resultant wave is 0.872. This means that a fundamental component of amplitude 1000, combined with a third harmonic of amplitude 200, has a maximum value of 872. Suppose we had wanted a resultant whose amplitude is 1000. We would have had to begin with a fundamental larger than 1000, or $1000/0.872 = 1146$, to be exact. Now we want our resultant wave to have a maximum of 1450 volts, so we need a fundamental amplitude of $1450/0.872 = 1660$ volts. Then the third harmonic will be 20 per cent of this or 332 volts in amplitude, and we can fill in the columns for e_1 , e_3 and e_p . Curves for the two components and their resultant are shown in Fig. 4.

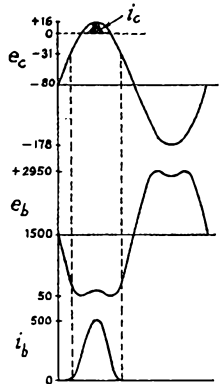

Fig. 2 — Curves showing relationships in plate and grid circuits.

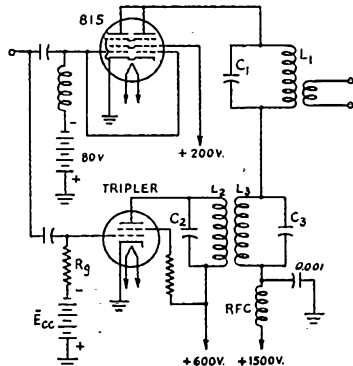

Fig. 3 — Circuit of the high-efficiency amplifier. L1C1 — Tuned to fundamental frequency. L2C2, L3C3 — Tuned to third harmonic.

Grid-Biasing Voltage

Having fixed the plate-supply voltage at 1500, we must fix the grid bias. To do this, we fix the angle θ_p . We make it 120 degrees. The alternating voltage on the grid is E_g , and the instantaneous grid voltage is e_g . Grid and plate currents flow

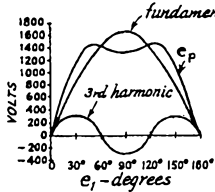

Fig. 4 — Resultant of the combination of fundamental and 20 per cent third-harmonic voltages.

only during the positive half-cycle of E_g , so we will talk only about that 180 degrees of the grid-voltage cycle. If plate current is to flow for 120 degrees, it will start when the grid has traveled for 30 degrees and on to 150 degrees, then stop. What is the value of e_g at any instant during the cycle?

We prepare another tabulation, as shown in Table II. Now we may plot our curved load line. From a little experimenting, we find that I_{bmax} must be around 400 ma. Therefore, we choose a value of grid voltage which will give this current, and it comes out about +18 volts. Plate current will cut off at about -31 volts. So, from -31 to +18 corresponds to the interval between 30 degrees and 90 degrees on the grid-voltage cycle.

A sine wave has reached half its maximum value when it reaches 30 degrees (i.e., $\sin 30$ degrees is 0.500), so the top half of the grid voltage, E_g , is $31 + 18 = 49$ volts. Hence the total grid swing on the positive half-cycle is $(2)(49) = 98$ volts; thus we need a driving voltage of 98 volts. To get the answers, we find the instantaneous grid potential, e_g , at intervals of 15 degrees, starting at 30 degrees, and then we can fill in Table II as shown. To find I_b at the required intervals, simply go up vertically from say, +18 volts on the E_e axis, until you intersect the load line and read off the current. It will be necessary to interpolate between the current lines in filling in the column for I_b .

Now, we must analyze the plate-current pulse for the power output. Prof. Chaffee has derived some very simple equations for doing this. We notice that the plate currents in Table II are labeled A, B, C, D, and E. In the equations

below, we substitute the currents wherever we find the letters.

$$\text{To find the average plate current, } I_{av}, \\ I_{av} = 0.0833 (0.5 A + B + C + D + E)$$

To find the harmonic currents in the output, peak values are

$$I_1 = 0.0833 (A + 1.93B + 1.73C + 1.41D + E) \\ I_3 = 0.0833 (A + 1.41B - 1.41D - 2E)$$

$$\text{Power input} = (I_{av})(E_{bb})$$

Power output at the fundamental frequency is

$$P_1 = \frac{(I_1)(E_1)}{2}$$

Power output at the third harmonic is

$$P_3 = \frac{(I_3)(E_3)}{2}$$

Taking our particular case, we have

$$I_{av} = 0.0833 \left(\frac{415}{2} + 364 + 260 + 75 + 0 \right)$$

$$= (0.0833)(906.5) = 75.5 \text{ ma.}$$

$$I_1 = 0.0833 (415 + 703 + 450 + 106 + 0) \\ = (0.0833)(1674) = 139.5 \text{ ma.}$$

$$I_3 = 0.0833 (415 + 514 - 106) = (0.0833)(823) \\ = 68.5 \text{ ma.}$$

$$P_{in} = (0.0753)(1500) = 112.5 \text{ watts.}$$

$$P_1 = \frac{(0.1395)(1660)}{2} = 115.7 \text{ watts.}$$

$$P_3 = \frac{(0.0685)(332)}{2} = 11.36 \text{ watts.}$$

Plate Dissipation

The power dissipated at the plate is the average plate current times the average plate voltage when the tube is conducting. In Fig. 5 we have plotted the shape of the plate current and plate voltage (voltage from plate to ground) from values taken from Table I. The instantaneous power dissipated at the plate is the product of the two curves and is plotted separately in Fig. 6. About the easiest way to find the average power is to count up the squares under the curve and divide by the length of the base line. This gives the average power over 180 degrees, and we divide by 2 to get the average over 360 degrees. We have 63 spaces and the base is 18 spaces long, so the average over 180 degrees is 3.5 spaces high. Each space vertically represents 5 watts, so the average power is 17.5 watts or, over 360 degrees it is 8.75 watts.

No doubt some of these figures are confusing. We are taking only 112.5 watts from the battery, yet we are getting out 115.7 at the fundamental plus 11.36 at the third harmonic, and wasting 8.75 in the tube plate to cap the climax. Apparently, we put in 112.5 and get $115.7 + 11.36 + 8.75 = 135.8$ watts! This is an efficiency of $135.8/112.5 = 121$ per cent. There is a joker in all this lovely scheme, as might be suspected. The auxiliary tube, which supplies the third-harmonic voltage in the plate circuit, is Poor Richard, for it has to supply the third-harmonic

Table II

θ_p°	$\sin \theta$	E_g	E_e	I_b	I_c	I_o	P_o
30	0.500	49.0	-31.0	E 0.00	0.000	0.000	0.000
45	0.707	69.3	-10.7	D 75	0.000	0.000	0.000
60	0.866	84.9	4.9	C 260	0.012	0.035	
75	0.966	94.7	14.7	B 364	0.075	0.110	
90	1.000	98.0	18.0	A 415	0.086	1.500	
105	0.966	94.7	14.7	364	0.075	0.110	
120	0.866	84.9	4.0	260	0.012	0.035	
135	0.707	69.3	-10.7	75	0.000	0.000	
150	0.500	49.0	-31.0	0.00	0.000	0.000	

Value of E_g at any angle is $(98)(\sin \theta)$. E_g is absolute voltage along e_g axis of constant-current family. A, B, C, D, E are values of current for analysis. $P_o = E_e I_o$.

power and some additional power for the plate of the 815, or $11.36 + 8.75 = 20.11$ watts. Also, the 815 puts out power at the fundamental at a level 3.2 watts higher than the plate input from the battery, so Richard has to supply that too, a total of 23.32 watts. Then the overall efficiency is $115.7/132.61 = 87.4$ per cent.

Remembering that the family of constant-current curves is for only one unit of the tube, the results may be multiplied by two. The power is then (2) (115.7) = 231.4 watts. The plate dissipation is (2) (8.75) = 17.5 watts. The auxiliary tube supplies 46.64 watts at the third harmonic; the power input is (2) (112.5) = 225 watts from the "B" supply, 1500 volts at 150 ma.

Auxiliary-Circuit Considerations

The auxiliary tube may well be an oscillator, if desired, since oscillators will give much higher efficiencies than triplers. However, it would be difficult to keep it oscillating exactly at the third harmonic unless it were synchronized by voltage from the driver tube. This can be done, but it is

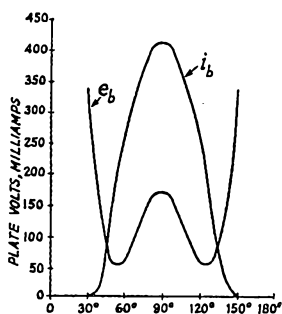

Fig. 5 — Curves plotted from the data of Table I.

not too reliable. A better solution perhaps is to use a larger percentage of third-harmonic voltage. If we change the operating conditions slightly, so that e_{max} is +16 volts, plate current will start to flow at -32 volts, and the grid swing will be 48 volts, the bias -80 volts and the driving voltage 96. Then the power input is 110 watts, P_1 is 109 watts, P_3 is 14.2 watts, the plate dissipation, P_b , is 13.4 watts and the auxiliary tube must supply 26.6 watts, or (2) (26.6) = 53.2 watts. So, we see that the solution is not to increase the percentage of third harmonic. We may decrease the grid drive, which will decrease the power output, the maximum plate current, the grid driving power and the efficiency. It will also decrease the power at the third harmonic. We have to pay the gander some sauce if you want to pay the goose!

We haven't considered the grid power yet. Fig. 6 shows the curve of grid power — not the power wasted in the bias supply — for the operating range. The instantaneous values of grid voltage and current are shown in Table II. The results are $I_{av} = 10.8$ ma., power dissipated in the grid = 0.057 watt, driving power = (80) (0.0108) = 0.865 watt. Any old oscillator you pick out will supply this "flea-power."

Practical Adjustments

Let us say that we have hooked up the circuit and are ready to go ahead. Apply driving power to the 815 and the auxiliary tube. Now we shall apply about 500 volts to the 815. We remember that the third-harmonic voltage has to be in phase with the fundamental voltage across the main tank circuit. How can we be sure it is? Well, if it isn't, we shall have plenty of excess plate dissipation in the 815 as the plate voltage is increased. If the 815 appears to run too hot, the leads to coil L_2 should be reversed.

Assuming that the 815 is running cool as a cucumber, let us increase the plate voltage to about 1000; being sure to keep sufficient grid drive, as near to 10 or 11 ma. as possible. We note whether the plate current is approaching 150 ma. (2×75 ma., remember) in normal fashion. If a peak-reading vacuum-tube voltmeter good at r.f. is available, it should be connected across the third-harmonic tank to make sure we are getting the 332 volts we are supposed to have. It goes without saying that the auxiliary tank should be tuned to resonance at the third harmonic before going very far with this tuning-up process! If the plate current appears to be running too high at 1000 volts, and was all right at 500 volts, it may be that the voltage across the auxiliary tank is not 332.

Now, assuming that things seem normal, let us couple in the load, remembering that for good circuit efficiency, the coupling should be pretty tight and the secondary circuit should have low Q ; i.e., it should be heavily loaded. We can't get 225 watts into the antenna if the circuit efficiency (the efficiency with which the load is coupled into the plate circuit) is practically 80 per cent. So, we couple up fairly tight and load the secondary. If the plate current rises in a well-behaved fashion, we can increase the plate voltage to 1500.

The author chose the 815 because it is easy to drive, is inexpensive (\$4.50), and its published curves allow one to construct from them families of constant-current curves that go to sufficiently-high values of peak current. Most static curves published do not show the necessary high peak currents. These principles apply to triodes as well. If an attempt is made to work out the circuit, these things should be remembered:

1) The minimum instantaneous plate voltage must exceed the maximum instantaneous positive grid voltage.

(Continued on page 92)

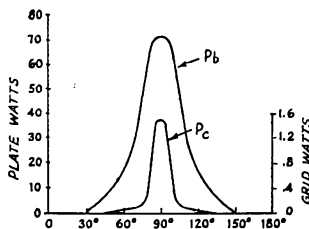

Fig. 6 — Curves showing relative values of instantaneous grid and plate dissipation.



How about some more group photos, fellows? Notice the two large shots and one small one in this issue and consider the collective interest for readers of *QST*, not to mention the sentimental value to the subjects themselves in later years. We know the difficulties in getting a gang together, but there are ways and means. Right after chow time most men are available and willing, or public relations officers can usually arrange an alternate time and get permission for all hands to be present for a photo.

NAVY—AERONAUTICS

1QCR, Turner, ART2c, Corpus Christi, Texas
 21MI, Jardine, Lt., New York, N. Y.
 21SK, Alden, Lt., Belleville, N. J.
 2MYC, Swanson, ARM1c, Brooklyn, N. Y.
 3ARK, Kupp, Lt. (jg), Patuxent River, Md.
 ex-3EEM, Proudfoot, ARM1c, Oakland, Calif.
 3HNI, Casselberry, ACRM, foreign duty
 3INA, Schiavone, Ens., Corpus Christi, Texas
 3IQL, McWilliams, AM1c, Norfolk, Va.
 4DYK, Christian, ART3c, Corpus Christi, Texas
 4GZO, Gaskin, Ens., Clinton, Okla.
 4HCV, Stuckey, ART2c, Corpus Christi, Texas
 4ICA, Boggs, ART1c, Patuxent River, Md.
 6ABJ, Anderson, Lt., Moffett Field, Calif.
 6AOU, Sprecher, Lt. (jg), Corpus Christi, Texas
 6HZN, Cobb, ACRT, foreign duty
 6OVI, Snider, Lt. Comdr., San Diego, Calif.
 6PUD, Whitaker, ACRT, Corpus Christi, Texas
 6QAW, Godbey, Lt. (jg), foreign duty

6SHZ, Bowman, ARM2c, foreign duty
 7GXH, Buettner, A/C, Iowa City, Ia.
 7HAW, Robischon, ART1c, San Diego, Calif.
 7HRJ, Brockway, ART3c, Seattle, Wash.
 7I1H, Bonsall, ARM3c, foreign duty
 8SYQ, Kirkby, ARM2c, foreign duty
 8TYW, Gillett, ART1c, foreign duty
 8UVL, Vincent, ART1c, foreign duty
 9FEM, Harris, ACRM, foreign duty
 9LRH, Ayres, ACMM, Anacostia, D. C.
 9LUF, Hobelman, ART2c, Corpus Christi, Texas
 9LYW, Carr, ART1c, Patuxent River, Md.
 ex-9MWM, Gillette, ART1c, Corpus Christi, Texas
 9NPH, Condo, A/C, Pensacola, Fla.
 9QCA, Gray, ART2c, Corpus Christi, Texas
 9QYK, Sjolund, Ens., foreign duty
 9UZD, de Stwolinska, Lt., Gainesville, Ga.
 9VKJ, Parker, AMM3c, Jackson Hts., N. Y.

Operator's license only:

Boynnton, ARM2c, Seattle, Wash.
 Hall, ARM1c, Norfolk, Va.
 Linville, ART1c, Jacksonville, Fla.
 Rakowski, ART2c, Corpus Christi, Texas
 Silbermintz, ART3c, Corpus Christi, Texas
 Stedman, ART1c, Corpus Christi, Texas

ARMY—SIGNAL CORPS

ex-2HVH, Klass, 2nd Lt., Ft. Monmouth, N. J.
 21FG, Kors, S/Sgt., foreign duty
 21FQ, Dalton, M/Sgt., foreign duty
 2LBC, Spiletic, T/Sgt., foreign duty
 ex-2LMX, Hartley, Pvt., foreign duty
 2LPT, Levine, Cpl., foreign duty
 3GLL, Housel, Lt., Audubon, N. J.
 31PV, Power, T/3, foreign duty
 ex-3SZ, Little, T/Sgt., foreign duty
 ex-4CQD, Dodd, Capt., Robins Field, Ga.
 4FXI, Walker, T/3, foreign duty
 5EHY, Hawkins, Sgt., foreign duty
 5FYD, Norris, Pfc., Camp Shelby, Miss.
 5GDM, Rumbaugh, Lt., Tinker Field, Okla.
 5KYZ, Farmer, T/Sgt., foreign duty
 5IGN, McDermott, T/4, foreign duty
 5JWP, Sisson, Sgt., Camp Chaffee, Ark.
 6E1Y, Hall, T/4, foreign duty
 6HCX, Krentz, Lt., foreign duty

6NNN, Murray, T/4, foreign duty
 7ELY, Bennyhoff, T/4, foreign duty
 7GOE, Dodd, S/Sgt., foreign duty
 8T1XB, Wakeman, Sgt., foreign duty
 81EF, Bossman, S/Sgt., foreign duty
 8QEW, Steckiel, S/Sgt., foreign duty
 8QLZ, Stone, T/3, La Plata, Md.
 8SDN, Beckman, Lt., Asbury Park, N. J.
 9GGW, Jaacks, Sgt., foreign duty
 9GSO, Resetaritz, 2nd Lt., Ft. Monmouth, N. J.

9JGL, Jones, 2nd Lt., Ft. Monmouth, N. J.
 9MBW, Call, Major, Washington, D. C.
 9MDK, Bacon, 2nd Lt., Ft. Monmouth, N. J.
 9NDQ, Schnittker, T/5, Robins Field, Ga.
 9QMA, Hoffman, M/Sgt., foreign duty
 9VDA, Schwartz, Sgt., foreign duty
 9YGO, Borella, T/5, foreign duty
 ex-9YUB, Erickson, T/5, foreign duty
 9ZCC, Jones, Lt., foreign duty

Operator's license only:

Davmitt, M/Sgt., foreign duty

NAVY—SPECIAL DUTY

1KUK, Roberts, RT3c, Washington, D. C.
 2JSE, Cisek, RT3c, Chicago, Ill.
 2KKP, Witt, S1c, New York, N. Y.
 5FGB, Montgomery, RT3c, foreign duty
 5JNQ, Gilliland, CRT, foreign duty
 6FZA, Margo, Ens., Norfolk, Va.
 ex-6MH, Line, Lt., Washington, D. C.
 7HKW, Boyd, RT1c, foreign duty
 8MNW, Wyman, S1c, Houston, Texas
 8QQD, Merle, S1c, Stillwater, Okla.
 8OTX, Kasmarik, RT2c, Chicago, Ill.
 8TMG, Bratten, CRT, Chicago, Ill.
 ex-9NRB, Huston, Lt., foreign duty
 9PEG, Davis, RT3c, Chicago, Ill.

Operator's license only:

Clinton, CRT, foreign duty
 Kaprocki, RT3c, foreign duty
 La Ross, S1c, Gulfport, Miss.
 McLean, S1c, Takoma Park, Md.
 Pottenger, S1c, Del Monte, Calif.
 Rudson, RT1c, foreign duty
 Skeehan, RT3c, foreign duty
 Stolz, RT1c, foreign duty
 Wishart, S1c, Treasure Island, Calif.



These amateurs in the Navy, on duty in North Africa, got together on short notice for this photo. *L. to r., standing:* ACRT Knickerbocker, W9EZG; ACRM Ivory, W8FVP; ACRM Cobb, W6HZN; ACRM Harris, W9FEM; ACRM Tarditi, W2BPV; Lt. (jg) Godbey, W6QAW; ACRM Caves, W6ERC; ART1c Earle, W7CAL; ART2c Higgins, W8VNE; ACRT Louden, W9EGP, and ACRT Harnisch, W2KZI. *Kneeling:* ACRM Dmitruk, W9NUN; ART1c Victor Gillett, W8TYW; twin brother ART1c Vincent Gillett, W8UVL, and ART1c Peadar, W5HHR.



Bearing up under the rigors of a Florida winter, the following amateurs in the AAF are assigned to Auxiliary Field No. 9, Eglin Field. *Left to right, standing:* 1st Lt. Morrell, W1AJN; 2nd Lt. Walker, W4DNR; 1st Lt. Arnold, W1NOH; 1st Lt. Benson, W9VZR; 1st Lt. Ransdell, W9YGD; 1st Lt. Petersen, W9ZAR; 2nd Lt. Kessinger, W5KFN; 2nd Lt. Wiscavage, operator license; 2nd Lt. Kunath, W9LOV; S/Sgt. Robertson, ex-W9GYW; Sgt. Dunbar, W7BYS; Capt. Littlewood, W9WEN. *Kneeling:* Capt. Praun, W6MEV; 1st Lt. Ballou, W1KKN; Sgt. Sperath, W9ZPQ; S/Sgt. Chase, operator license; Sgt. Miklas, W8SKE. Missing from picture but stationed at the same field are: 2nd Lt. Reidel, W5EWI; 2nd Lt. Brown, W8GSZ; 1st Lt. Neely, W4BJE; 2nd Lt. Papp, W2LBG; Capt. Tietz, W9QDL; Sgt. Broyles, W9KCH, and 1st Lt. Raney, W3EQZ.

ARMY — GENERAL

2KUX, Player, T/Sgt., foreign duty
 2KWV, Anderson, Lt., Ft. Belvoir, Va.
 2LRP, Kalish, Cpl., foreign duty
 3EDC, Apfelbaum, Pvt., foreign duty
 ex-3QWB, Haag, M/Sgt., Ft. Bliss, Texas
 3GYI, Brader, Pvt., Camp Howze, Texas
 3HVG, Halscheid, Pvt., foreign duty
 3MI, Felsenheld, Major, Peapack, N. J.
 4ERW, Smith, Pvt., Ft. George G. Meade, Md.
 ex-5EPW, Gearhiser, Lt. Col., foreign duty
 ex-6QOM, Martin, Lt., foreign duty
 6SEW, Porep, Pvt., foreign duty
 7COR, Lowry, Sgt., foreign duty
 ex-K7GCI, Dahle, Pfc., Milwaukee, Wis.
 7HFZ, Eurich, Capt., foreign duty
 ex-8AQL, Brestle, S/Sgt., Miami Beach, Fla.
 8UHO, McWhirter, Pvt., foreign duty
 8VAY, Hill, Pvt., Ft. Knox, Ky.
 8VRR, Klinko, Pvt., Camp Blanding, Fla.
 8WJD, Ward, Sgt., Camp Livingston, La.
 9AXK, Campbell, Capt., Ft. Warren, Wyo.
 9BDA, Cotter, Pvt., foreign duty
 ex-9CTL, Hermann, S/Sgt., foreign duty
 9JCP, Hyland, T/Sgt., Springfield, Mo.
 9QCL, Murray, Sgt., foreign duty
 9QNT, Warichak, S/Sgt., Ft. Sheridan, Ill.
 9UHO, Montgomery, T/5, foreign duty
 ex-9ZWD, Ishmael, S/Sgt., Holtville, Calif.

Operator's license only:

*Chevnoff, Pfc., Sioux Falls, S. D.
 Jollif, Sgt., foreign duty
 Miller, Cpl., Oconomowoc, Wis.
 Thomas, Pvt., Camp Wheeler, Ga.

NAVY — GENERAL

ex-1GP, Lewis, Lt., Princeton, N. J.
 1JVA, Allen, CPO, Washington, D. C.
 1KH4, Parrish, RM1c, Everett, Mass.
 1LZE, Gibson, RM1c, foreign duty
 1MMY, Eggers, Sic, Atlantic City, N. J.
 1MQB, Everbeck, Sic, foreign duty
 1MUX, Stites, Ens., Washington, D. C.
 1MWK, MacLeish, RM2c, foreign duty
 1NTA, Clark, EM3c, foreign duty
 2DO, MacArt, Lt. Comdr., foreign duty
 2IEB, Morrow, Sic, Camp Bradford, Va.

2NYK, Paccione, RM2c, foreign duty
 2RV, Candido, Comdr., Washington, D. C.
 3BZI, Steelman, A/S, Bainbridge, Md.
 3GYN, Kinney, MM1c, foreign duty
 3HCK, Bittner, CRM, foreign duty
 3HXQ, King, Lt. Comdr., Washington, D. C.
 3ISE, Shreve, Ens., Princeton, N. J.
 3IZR, Blankenbiller, F1c, foreign duty
 4AIJ, Elton, Lt. (jg), Cambridge, Mass.
 4COO, Jones, Lt. (jg), Charleston, S. C.
 4FGC, Flynn, RM1c, foreign duty
 4JZ, Grange, Comdr., foreign duty
 x-4PQ, White, Sp(T), Yukon, Fla.
 5DYS, Dudley, Sic, foreign duty
 ex-5GEM, Meyer, Ens., Washington, D. C.
 5KIB, Adams, Sic, Shoemaker, Calif.
 5KPO, Wright, Ens., Anacostia, D. C.
 ex-6DWN, Sherman, Sic, Mare Island, Calif.
 6OHT, Krell, Sp. (S) 3c, San Francisco, Calif.
 6OSQ, Dowden, RM1c, foreign duty
 6VH, Brown, Lt., Washington, D. C.
 7AWD, Patterson, CM1c, Camp Endicot, R. I.
 7FPZ, Smith, Lt. Comdr., Seattle, Wash.
 7GE, Grenfell, Lt. (jg), Cambridge, Mass.
 8JFP, McLaughlin, RM3c, Romney, W. Va.
 8KUG, Love, Lt. (jg), foreign duty
 8OEF, Geltz, Ens., address unknown
 8QDI, Siff, Lt. (jg), foreign duty
 8RMF, Detrick, Lt., Key West, Fla.
 8UJV, Dussinger, CRM, foreign duty
 8UJW, Gwyer, Sic, Great Lakes, Ill.
 8WNF, Freitag, S2c, Madison, Wis.
 9CEZ, Dean, EM3c, Great Lakes, Ill.
 9ENZ, Berger, Chicago, Ill.
 9KVF, Bohnet, CEC, foreign duty
 9NMW, Winslow, A/S, address unknown
 9NXF, Berk, RM2c, Wildwood, N. J.
 9QED, Ebert, Ens., Washington, D. C.
 9RTM, Goldberg, Ens., Princeton, N. J.
 9SRK, Norman, MaM3c, Great Lakes, Ill.
 9TNR, Brolley, Ens., Princeton, N. J.
 9UNR, Rice, Sic, foreign duty
 9VPS, Grabowski, EM3c, San Diego, Calif.

Operator's license only:

Green, Ens., Princeton, N. J.
 Kendall, F1c, foreign duty
 MacCready, HA1c, foreign duty
 Perryman, RM3c, foreign duty

ARMY — AIR FORCES

1AJN, Morrell, Lt., Eglin Field, Fla.
 ex-1FTH, Wenden, S/Sgt., foreign duty
 1ILD, Vargas, Major, foreign duty
 2KPA, Deeg, Sgt., foreign duty
 2KZH, Kanze, Lt., Victorville, Calif.
 3ANP, Sanford, Cpl., foreign duty
 4BJE, Neely, Lt., Eglin Field, Fla.
 4DRX, Groves, 2nd Lt., Romulus, Mich.
 4HRB, Minor, Lt., Ellington Field, Texas
 5ILL, Morgan, Capt., Scott Field, Ill.
 5JQJ, Clark, S/Sgt., foreign duty
 ex-6BPK, Green, Lt. Col., foreign duty
 6QUQ, Pearson, S/Sgt., foreign duty
 K6QY, Williams, Major, Osborn, Ohio
 K6RW, Boma, M/Sgt., foreign duty
 6SYJ, Perry, Capt., George Field, Ill.
 6TNU, Farnsworth, Pfc., Will Rogers Field, Okla.
 6UKQ, Miller, S/Sgt., foreign duty
 7HTE, Robertson, T/Sgt., Avon Park, Fla.
 8KTT, Passoja, Lt., foreign duty
 8VDK, Lach, Pfc., Thomasville, Ga.
 9BZM, Fry, M/Sgt., foreign duty
 ex-9GYW, Robertson, S/Sgt., Eglin Field, Fla.
 ex-9JJE, Richie, Cpl., foreign duty
 9KXA, Le Brun, S/Sgt., Homestead, Fla.
 9N1Q, Chase, S/Sgt., Yuma, Arizona
 9NPL, Beams, foreign duty
 9OUU, Bush, Sgt., foreign duty
 9QZG, Walden, M/Sgt., foreign duty
 9SGS, Demko, Pvt., Scott Field, Ill.
 9YGD, Ransdell, Lt., Eglin Field, Fla.

Operator's license only:

Buntain, Cpl., Eglin Field, Fla.
 Cross, Cpl., Sheppard Field, Texas
 Dimsdale, T/5, Ft. Dix, N. J.
 Garey, Sgt., foreign duty
 Gragg, Cpl., Godman Field, Ky.
 Hildum, 2nd Lt., Mitchel Field, N. Y.
 Hunt, Pfc., foreign duty
 Kaiser, T/Sgt., Hamilton Field, Calif.
 Laase, Sgt., Victorville, Calif.
 Lehr, Sgt., foreign duty
 Straythorne, Sgt., Westover Field, Mass.
 Sykes, Lt., Sheppard Field, Texas
 Svien, S/Sgt., Sioux Falls, S. D.
 Wilson, Cpl., foreign duty

MERCHANT MARINE AND MARITIME SERVICE

1HYF, Amundsen; 1IZY, Mullen; 1LBT, Chandler; 2CFZ, Goldstein; 2CKQ, Medits; 2ECL, Weintraub; 2GTW, McKinney; 2KMZ, Krushins; 2LUX, Novotny; 2NGM, Klein; 4IIP, Pomaroy; 6MPD, DeBiddle; 6ULB, Williams; 8VOV, Peters; 8WSM, Yochelson; 9BLD, Vavak; 9FQE, Nielsen, and 9OKQ, Althouse. Crenca, Polshaw, Mitchell, Stephenson and Trout hold operator's license only.

100 PER CENT WAR WORK—INDUSTRY

Western Electric Company

THE large majority of these amateurs are field engineers in different parts of the world and their addresses are not available. We therefore list only their names and calls.

1BOZ, Prue	2IZC, Kenny
1HR, Gray	2JAO, Brinkerhoff
1JRP, Maasz	2JEL, Van Atta
1KJU, Litchfield	2JFY, Faber
1KUW, Allen	2JKA, Brown
2ABN, Okker	2JEC, Cook
2AOF, Cahalan	2JST, Waters
2ATQ, Grossefingher	2JWK, Skutnik
2AWD, Gallo	2JXE, Dunkel
2AYJ, Poucel	2KBH, Stratton
2BGT, Wilsey	2KGC, Stahl
2BGZ, Whiteside	2KIH, Ganguzza
2BQV, Scull	2KQO, Bean
2BSF, Neuenhaus	2KQZ, Vanderbilt
2BXI, Simpson	2KRU, Measnikoff
ex-2CGK, Tiffany	2LKK, Weiss
2CH, Sprink	2MEP, Conlin
2CIA, Sole	2MHL, Zmetronak
2DGL, Paitin	2MKD, Bedoin
2DIB, Cloyd	2MNY, Walker
2DMY, Coeyman	2MYE, Vogel
2DVF, Jordan	2NGW, German
2EOC, Griffith	2NJS, Feldman
2EEG, Stark	2NRI, Davis
2ERK, Smith	2NYO, Ghigliotti
2EUO, George	2OBG, Jacobs
2EWA, Patzig	2OGS, Huste
2GLF, Dolid	2OPC, Bailey
2GNM, Richards	2OQP, Voorhees
2GZS, Ahlstrom	2SU, Daly
2HWU, Kuhn	3AFI, Kirby
2IWT, La Hiff	3AXC, Bremner
2IWU, Rowland	3BO, Kressel
2IXA, Halligan	3CHE, Smith



3FVZ, Diehl	8JH, Leedy
3IZM, Lee	8KXD, Stahl
3JLM, Shackell	8MBI, Seastrom
3ZD, Corderman	8MLK, Kaiser
4AFZ, Gerrard	8MMC, Briggs
4AWP, Dalton	8OAD, Andras
4BZ, McMasters	8OLK, Dushane
4CUZ, Buning	8PQF, Blake
4CWY, Wescoat	8RB, Stringfellow
4DD, Chamberlin	8RIZ, Morrison
4EKL, Wheeler	8RQD, Hart
4GCC, Landolina	8SES, Wood
4GCM, Taylor	8TVF, Zamites
ex-5DVF, Thomas	8TWR, Zamites
5EN, Boulton	8TWF, Keisling
5FOS, Jonas	8TXM, Redhammer
5EPC, White	8VQN, Shaw
5JEC, Beitel	8VRQ, Fowler
5JMP, Gable	8VQR, Bailey
5MS, Nelson	8VRF, Bladec
5PU, Behrendt	8VRF, Carraker
5WR, White	8VZG, Coan
ex-6AGZ, Gibbs	ex-9BBZ, Lovell
6BEZ, Wagener	9BJE, Switzenberg
6CCX, Miller	9BJE, Gessland
6CGQ, Watts	9BST, Wickline
6CZL, Heineman	9BUR, Parks
6DEI, Moore	9CBL, Vaikutis
6DES, Pitzer	9CFY, Fedorov
6DMY, Sharp	9CRG, Philippsen
6EAU, Cook	9DCQ, Sutter
6EDX, Dougherty	9DMU, Holland
6GPY, Tynes	9DPS, Pomeroy
6GXQ, Martin	9DWW, Bronoski
6HJJ, Anderson	9EAL, Shaleen
6HXH, Ringer	9EYP, Hill
6JAB, Wilson	9GGI, Hessler
6KEY, Shirer	9GGX, Fasick
6KID, Sorber	9GJR, Harder
6LCG, Williams	9GPD, Mall
6LCJ, Townsend	9GVW, Anderson
6LTA, Franklin	9HKE, Kean
6MPJ, Brodersen	9HSB, Beard
6NZG, Dodge	9IWR, Pulliam
6PKK, Cooper	9IYN, Harding
6PKZ, Cottrell	9JGF, Sechler
6PLD, Carpenter	9JXW, Fulton
6SE, Jones	9JYP, Davis
6SER, Burggraf	9JZE, Frost
6SFQ, Reineking	9KPY, Piety
6SNJ, Cassasa	9LXH, Divis
6TS, Willis	9MCP, Schoen
6TXA, Tippitt	9MKQ, Buhner
6ZCB, Zint	9MSX, Fisher
7ATK, Benzon	9MWY, Dunkin
7BN, Johnson	9NOJ, Pree
7CH, Gander	9NT, Paige
7DLG, Meydenbauer	9NT, Bridgman
7DZA, Haase	9OJL, Harrison
7EKM, Dillon	9OPZ, Russell
7HGN, Gibbs	9OSM, Snow
7JL, Young	9OZA, Ulm
7WP, McPherson	9PAE, Lund
8AAC, Gray	9PEQ, Bohnsack
8AVQ, Baller	9PFL, Brown
8AWU, Chrysler	9PSP, Stanton
8BQJ, Davie	9PTR, Burns
8CM, Van Cott	9QKF, Eggers
8CP, Murphy	9RFS, Russell
8DBC, Makinson	9RIY, Bernath
8DKA, Augustus	9RKO, Borowski
8DQM, Warnock	9RPJ, Beaudine
8EUN, Thomas	9RRY, Bandy
8FNP, Larson	9RYF, Von Jennings
8FTS, Shiber	9TH, Lewis
8GUB, Prewitt	9TWAJ, Phillips
8HZC, Hubbard	9WC, Conrad
8IIP, Semkow	9WQE, Shopen
8ITA, Elia	9WYC, Wilson
8IWN, Graul	9ZYZ, Hagerty

Lt. Col. Robert Herzberg, SC, W2DJJ, who has been stationed overseas for three years, states that his hq. has more hams per square fox hole than any other in the ETO. The last count showed almost seventy ex-brasspounders, the majority engaged in communications work. They are planning a hamfest soon.

CIVIL SERVICE

1AEO, Aaltonen, Navy Dept., radio technician, Portsmouth, N. H.
 1AEU, Morgan, Navy Dept., radio technician, Portsmouth, N. H.
 ex-1AGV, Welch, Navy Dept., radio Technician, Portsmouth, N. H.
 1BBH, Houghtaling, Navy Dept., radio technician, Portsmouth, N. H.
 1BNC, Woodman, SC, radio engineer, Boston, Mass.
 ex-1BQQ, Libbey, SC, radio engineer, Boston, Mass.
 1CAY, Goodwin, Navy Dept., radio technician, Portsmouth, N. H.
 1CBB, MacGown, SC, radio engineer, Bangor, Me.
 1CKY, Meader, Navy Dept., radio technician, Portsmouth, N. H.
 1DSX, Rainville, Navy Dept., radio electrician, Boston, Mass.
 ex-1DWU, Knightly, Navy Dept., radio technician, Portsmouth, N. H.
 1EEJ, Dutch, Navy Dept., radio technician Portsmouth, N. H.



For six years in prewar days Major Frank Breene, W6FOY, left, and S/Sgt. Pat Gould, W9DHP, maintained regular skeds on 20, although they never met. Came war and "greetings" and, in course of time, Pat arrived in the China-Burma-India theater. Visiting his general hospital for a minor ailment, Pat saw a familiar name on the bulletin board — "Major Frank Breene, dental officer." This was the result! *Official U. S. Signal Corps photograph.*

1EIO, Goodwin, Navy Dept., radio technician, Portsmouth, N. H.
 1GKK, Reuther, Navy Dept., electrician engineer, Portsmouth, N. H.
 1GIU, Foye, Navy Dept., radio technician, Portsmouth, N. H.
 1HSC, Cann, Navy Dept., radio technician, Portsmouth, N. H.
 1IQJ, Smith, Navy Dept., radio mechanic, Quonset Point, R. I.
 1IWW, Ross, Navy Dept., radio technician, Portsmouth, N. H.
 1JES, Newhall, SC, Chicago, Ill.
 1KAS, Stone, Navy Dept., radio technician, Portsmouth, N. H.
 1KEX, Richardson, Navy Dept., radio technician, Portsmouth, N. H.
 1KSS, Lines, Navy Dept., radio technician, Portsmouth, N. H.
 1LB, Leave, Navy Dept., electrician, Portsmouth, N. H.
 1LJZ, Mould, radio mechanic, foreign duty
 1LNG, Foote, Navy Dept., radio technician, Portsmouth, N. H.
 1LVR, Stenbeck, Navy Dept., inspector, Bridgeport, Conn.
 1MQZ, St. Martin, Navy Dept., radio mechanic, Providence, R. I.
 2IQW, Gray, SC, Chicago, Ill.
 3BTW, Smith, Atlantic City, N. J.
 ex-3TS, Meighan, SC, Chicago, Ill.

4QP, Gullodge, SC, radio engineer, Miami, Fla.
 4VR, Purdy, Navy Dept., instructor, Pensacola, Fla.
 5CPV, Hardin, AAF, radio engineer, Wright Field, Ohio
 5HKJ, Sanders, SC, radio instructor, State College, Miss.
 5HLK, Perkins, War Dept., radio & telegraph operator, San Antonio, Texas
 5ICA, Hollinger, CAA, aircraft communicator, Coal Valley, Pa.
 5IDN, Bond, San Antonio, Texas
 5IFU, Pittman, Navy Dept., radio mechanic, Corpus Christi, Texas
 5IJP, Cockburn, SC, radio mechanic, San Angelo, Texas
 5IZO, Thompson, SC, Camp Polk, La.
 5JME, Ard, AAF, electrician, Oklahoma City, Okla.
 5JOV, Hunsaker, CAA, foreign duty
 5JRF, Hayton, AAF, Oklahoma City, Okla.
 5JZJ, Williams, Port Arthur, Texas
 5KEA, Akers, AAF, San Bernardino, Calif.
 5MZ, Graham, CAA, radio electrician, foreign duty
 ex-5QP, Moore, SC, instructor, West Palm Beach, Fla.
 5VN, Crays, CAA, aircraft communicator, Ft. Worth, Texas
 6AKZ, Doherty, Navy Dept., radio mechanic, San Diego, Calif.
 6ALR, Emm, SC, radio engineer, San Bernardino, Calif.
 6AQE, Garello, Navy Dept., electrician, Oakland, Calif.
 6AQO, Uecker, AAF, radio engineer, Walnut Creek, Calif.
 6ARO, Nordberg, Navy Dept., radio mechanic, Los Angeles, Calif.
 6AV, Neabitt, Navy Dept., radio engineer, Lodi, Calif.
 6AW, Richardson, electrician, San Francisco, Calif.
 6AWA, Wagner, Navy Dept., field engineer, foreign duty
 6BAS, Burnett, Navy Dept., radio engineer, San Diego, Calif.
 ex-6BCE, Barrett, CAA, airway engineer, foreign duty
 6BF, Evans, Navy Dept., design engineer, Piedmont, Calif.
 6BQH, Minton, Santa Monica, Calif.
 6BTJ, Bruhns, Navy Dept., Berkeley, Calif.
 6BWX, Pearce, CAA, aircraft communicator, Lovelock, Nev.
 ex-6CBF, Barnes, SC, general foreman, Riverside, Calif.
 ex-6CDZ, Lipman, AAF, San Bernardino, Calif.
 6CL, Ayers, SC, foreman, Los Angeles, Calif.
 6CNI, Smead, SC, radio mechanic technician, Los Angeles, Calif.
 ex-6COS, Seeley, Navy Dept., San Francisco, Calif.
 6DEY, Maxson, FCC, monitoring officer
 ex-6DTO, Cassens, AAF, radio mechanic, San Bernardino, Calif.
 6DXM, Galbraith, Forestry Dept., Alhambra, Calif.
 6FFW, Stewart, SC, radio mechanic, Los Angeles, Calif.
 6FLE, Foote, Navy Dept., radio engineer, foreign duty
 6FYE, Dille, SC, radio engineer, San Francisco, Calif.
 6HDY, Phillips, AAF, electronics inspector, San Bernardino, Calif.
 6HFE, Perinotti, SC, inspector, Quincy, Ill.
 6HKD, Jaque, AAF, instructor, San Bernardino, Calif.



Capt. Stephen Loyzim, AC, WIBEQ, is now a communications officer somewhere in the ETO. His ham experience has served him well and his promotion has been rapid since enlistment in May, 1942. Steve is married and the father of two daughters, who are studying for ham tickets. His wife, Eunice, is WINJJ and his brother, John, is W1EJI. Steve's own station was active on all bands.

HAM HOSPITALITY

FROM the January, 1945, issue of *Amateur Radio*, the official organ of the Wireless Institute of Australia, we reprint a list of several WIA Divisions which have not previously appeared in this column. Visiting amateurs in these sections looking for contacts should drop a line to the WIA at the following addresses:

Western Australian Div., Box N 1002, G.P.O., Perth
 Queensland Div., Box 1524V, Brisbane
 South Australian Div., Box 284D, Adelaide
 Tasmanian Div., Box 547E, Hobart

The City of Belfast YMCA Radio Club writes us that visiting amateurs in Belfast may contact any of the following, who will put them in touch with all the boys who are still active:

City of Belfast YMCA Radio Club, GI6YM, City YMCA, Wellington Place. Club nights Wednesday and Friday, 8 P.M.
 Frank A. Robb, GI6TK, Hon. Sec'y, YMCA Radio Club, 60 Victoria Ave., Sydenham
 Jack N. Smith, GI5QX, 19 Hawthornenden Drive, Belmont. Phone Belfast 63323
 Robert S. Holden, GI5HU, 260 Grosvenor Rd.
 Robert Barr, jr., GI5UR, 4 Dunkeld Gardens, Oldpark
 J. J. Hargen, 2DHB, Hon. Sec'y, NWIRTS, 8 Epworth St., Park Ave., Londonderry, Co. Derry, N.I. Meets first Tuesday every month.

The following amateurs are still in N.I. and meetings with them can be arranged:

GI2KR, 3SG, 3CM, 3KN, 5TK, 5UW, 5UR, 5QX, 5ZY, 5JN, 5NJ, 5HU, 5SJ, GHV, 6YW, 6YM, 6TK, 8LF, 8MI, 5DX, 8GK, 8PA, 6WG and 5WD.

L. W. Ensor, ZS6BJ, Hon. Sec'y, Radio Amateurs Society (S.A.), P.O. Box 2327, Johannesburg, South Africa, advises the society has had to relinquish its former quarters at 107 Grand National Bldg. but visiting amateurs may get in touch with him direct. He also states that press of duties makes it impossible for him to correspond with *QST* readers but he would be glad to publish requests for correspondents in *Ham Chatter*, the official organ of the society.

Durban and Pretoria report renewed amateur activity. Any overseas men in those parts should write or call on the following:

W. E. D. Bennett, ZS4W, 8 Innes Mansions, Innes Rd., Durban
 W. H. Dibble, ZS6AG, Sec'y, Pretoria Radio Club, Box 440, Pretoria.

A "hams wanted" ad in a Brisbane, Australia, newspaper by Eric Neale, VK4EN, produced immediate results, as shown in this snapshot. True ham hospitality was enjoyed by all hands. Pictured here are, left to right, rear row: Sgt. Cheslow, W2JFY; T/Sgt. Held, W2KLD; the host, VK4EN; Pfc. Costopoulos, W4GKZ, and Sgt. Hermann, W6URB. Front row: Cpl. Hathaway, W1BUU, and S/Sgt. Penick, W5GWI. See W6URB's letter in Correspondence from Members, page 56 in this issue, for further details.



The para-talkie is given a test in the field by Lt. Ralph Berkhausen, CAP, using the special parachutist's antenna attached to his leg.

The "Para-Talkie"

A Parachutist's Transceiver

BY LT. ARTHUR H. COPLAND,* CAP

When parachute instructors of a Michigan CAP wing wanted some means of communicating with student jumpers in the air, the radio crew set out to solve the problem. The result was the development of the tiny transceiver unit described in this article. The acorn-type detector-oscillator tube and the two miniature audio tubes operate from a pair of midget-sized 33-volt "B" batteries and a single flashlight cell. A rig of this type also will find many applications in WERS and ham work on terra firma.

COMMUNICATIONS problems in the v.h.f. band shared by CAP and WERS seem, for the most part, to parallel those experienced in OCD-WERS operation. One CAP Group — Parachute Group 9 of Michigan Wing — by virtue of the unique nature of its curriculum, however, confronted its communications personnel with an unusual problem to solve.

Parachute instructors clamored for some means of communicating with student jumpers to provide a greater measure of safety and, at the same time, to give the student the advantage of receiving direct instructions in manipulating his 'chute to control his descent. Limited success along these lines was effected by the use of directional loudspeakers, but the disadvantages were many. Two-way radiotelephone contact seemed to be the only answer to the need, but to our knowledge this had never been successfully accomplished between

*Communications Officer, Parachute Group 639, 18419 Santa Rosa Dr., Detroit, 21, Mich.

'chutist and ground. No enlightening technical information on v.h.f. equipment for parachute being found in the books, the group communications staff set out to do a little pioneering.

Existing units of the walkie-talkie type would not serve for obvious reasons. Any set carried by a parachute jumper must be small and light, and yet it must be rugged enough to withstand the shocks of landing. A whip antenna could not be used because it would be a hazard; therefore the antenna would have to be of flexible material and radiate efficiently while being carried close to the body. Power and transceiver controls would have to be placed so that they could not be shifted accidentally.

Experimental Tests

With the above problems in mind, a basic experimental circuit was set down on paper and technicians of our squadron communications sections were directed to work out their own concepts of the ideal parachutist's transceiver. That's when the fun began! Dreams like this, we found, were not easy to make come true. Many of the boys were doomed to disappointment when their pet creations either were rejected by the parachute instructors as a hazard to the jumper or could not be persuaded to develop any acceptable degree of signal strength. Eddie Pietrasik, deputy communications officer of Hamtramck Squadron 639-3, was the ingenious lad who developed the neat, sturdy transceiver which is the subject of this article.

After exacting ground tests, an aerial test was made during a routine CAP maneuver. Equipped with the new transceiver, Lt. Ralph Berkhausen bailed out at 3500 feet and established continuous two-way contact with Lt. James Allen on the ground from the instant his 'chute filled until he hit the field. Lt. Allen, the group's master parachute instructor, who was using an Abbot DK-2,

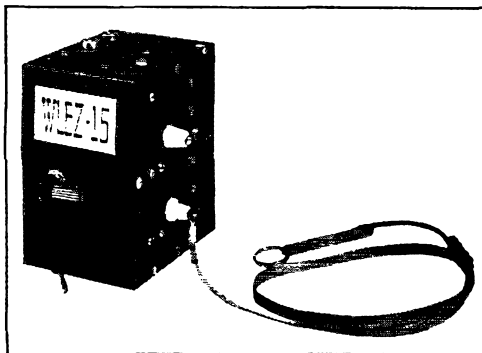

The "para-talkie" with flexible braid antenna attached. The change-over switch is in front, the power switch on the bottom, and the headphone and mike connectors on top. The extra stand-off insulator is provided for supporting a whip-type antenna for ground use.

was exultant. Communication had been perfect. Here at last was the perfect instruction medium which he and his staff had so long hoped for. To his knowledge, and to ours, this was the first time two-way radiotelephone had been used successfully by parachutists. It was he who christened the unit the "para-talkie."

The para-talkie is fastened under the jumper's right arm, near the belt, by means of webbing straps threaded through slots in the rear plate of the case. The straps buckle over the left shoulder and under the right groin. Microphone and headphone cords are attached at the rear top of the case. They run under the 'chute harness to the jumper's overall opening, then inside the coveralls to emerge from the collar near the 'chutists ear. A tiny lapel crystal mike, clamped on the inside of the helmet chin strap, is used as a throat mike. Lightweight headphones with headband removed are attached inside the helmet.

The antenna is a piece of flat metal shield braid, approximately a quarter-wavelength long. A lug is securely soldered at one end and this is attached to the lead-in near the bottom front of the case, the braid running down to the toe of the 'chutist's right boot. At the boot there is a special harness and an adjustable expansion spring which keeps the braid taut and also compensates for long or short legs. This is insulated from the braid by a short polystyrene bar.

The set is pre-tuned to 115.75 Mc. Before the jumper leaves the airplane he turns on the set by snapping a toggle switch on the bottom of the case. The controls normally are in the "receive" position. He can then hear transmissions from the ground transmitter. To talk to his instructor he presses the "push-to-talk" lever at the right side of the case. The "receive" position is automatically returned when he releases the lever.

Fig. 1 — Circuit diagram of the para-talkie.

C₁ — Isolantite-insulated midget tuning condenser, 3 plates, with slotted shaft.

C₂ — 50- μ fd. mica.

C₃, C₄ — 0.005- μ fd. mica.

C₅, C₁₀, C₁₁ — 0.1- μ fd. paper.

C₆ — 500- μ fd. paper.

C₇ — 0.002- μ fd. paper.

C₈ — 10- μ fd. 75-volt electrolytic.

C₉ — 0.01- μ fd. paper.

R₁, R₁₂ — 5 megohms, 1/2 watt.

R₂, R₄ — 25,000 ohms, 1/2 watt.

R₃ — 0.5 megohm, 1/2 watt.

R₅ — 10 megohms, 1/2 watt.

R₆ — 1 megohm, 1/2 watt.

R₇ — 3 megohms, 1/2 watt.

R₈ — 2 megohms, 1/2 watt.

R₉ — 450 ohms, 1/2 watt.

R₁₀ — 1,000 ohms, 1/2 watt.

R₁₁ — 25,000 ohms, 1 watt.

L₁ — 1 turn No. 14 bare copper wire,

1/2-inch inside diameter.

L₂ — 4 turns No. 14 bare copper wire,

1/2-inch inside diameter, spaced to fill 1/2-inch winding length.

L₃ — Modulation choke, 30 henrys, 5 ma. (Thordarson

74C30 can be used if space is available.)

RFC₁, RFC₂ — V.h.f. choke, 55 turns No. 30 d.s.c., wound

on 3/8-inch polystyrene rod (or Ohmite Z-1).

S₁ — Pole of 4-pole, double-throw rotary wafer switch

with spring return and lever.

S₂ — Pole of d.p.s.t. toggle switch.

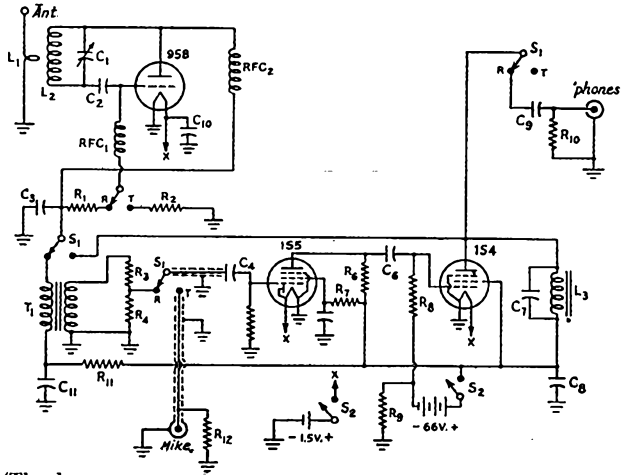

A 'chutist is aided in his descent by instructions received via the para-talkie, which he carries strapped to his body.

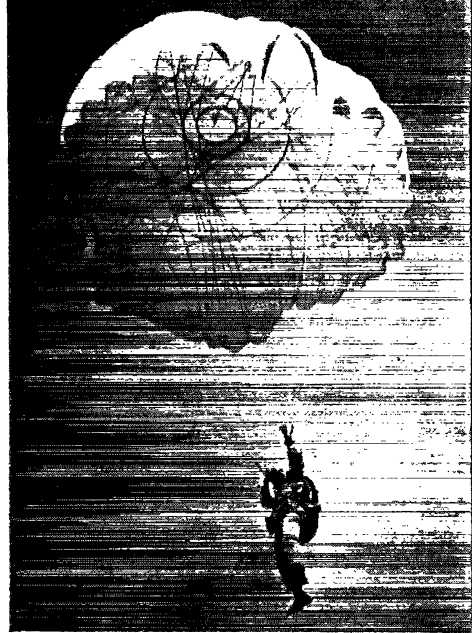

Circuit Details

The circuit diagram of the transceiver is shown in Fig. 1. The oscillator-detector circuit is built around a 958 acorn tube which operates as an ultraudion when transmitting. Resistor R₂ develops bias voltage for the grid. Condenser C₁₀, connected across the filament terminals of the 958, was necessary to eliminate a tendency toward spurious audio-frequency oscillation.

The receiving circuit is the usual self-quenched superregenerative-detector type, with a positive exciting voltage applied to the grid of the 958 through the resistor R₁. C₃ is in the quench frequency-determining circuit and the capacity

Headphones used are Brush Type BJ. Any good quality light weight type may be substituted. The microphone is an Astatic L-I. The "B" batteries are Burgess XX22E and the "A" battery a No. 2 flash-light cell.

necessary, dependent to some degree upon the inductance of the primary of T_1 , might vary from the value indicated with a different transformer. Two stages of audio are used, with transformer coupling between the detector and the first stage and resistance coupling between the first and second stages. Full gain is not required for receiving. The grid of the first audio amplifier is fed from a voltage divider across the secondary of T_1 , tapped down as indicated, so that the voltage amplification realized from the 1S5 does not over-drive the grid of the 1S4. This arrangement also helps to guard against r.f. on the grid of the 1S5. The 1000-ohm resistor, R_{10} , shunting the 'phones is another attenuating device to hold the volume down to a level where the headset can be worn with comfort. In early stages of the development of this rig, a switching arrangement was used which cut out the 1S5 and coupled T_1 directly to the grid of the 1S4 through C_6 . The revised circuit arrangement, although employing considerable attenuation, is much more satisfactory.

Modulation is accomplished by employing a choke in the common high-voltage line to the modulator tube and the 958 plate. This choke has a d.c. resistance of 1000 ohms and is by-passed by C_7 to avoid oscillation in the 1S4. Grid bias for the 1S4 and 1S5 is obtained by the voltage drop across R_9 between negative "B" and "ground." The antenna-coupling turn is placed at the grid end of the tank and coupling is adjusted for the maximum antenna loading which will allow the tube to maintain stable superregeneration when the switch is in the "receive" position.

Construction

The unit is contained in a standard $4 \times 5 \times 6$ -inch steel box with removable sides. Most of the components are mounted directly on one of these removable sides, to make the job of assembling and wiring easier.

To permit the shortest leads possible, the acorn detector-oscillator tube and the tuned-circuit

components are grouped close to the change-over switch mounted on one of the fixed sides of the box. C_1 is mounted on spacers, with its shaft opposite a quarter-inch hole through which it is adjusted by a screwdriver. L_2 is self-supporting, its ends being soldered directly to the terminals of C_{11} with the grid side going to the rotor terminal. L_1 also is self-supporting, being mounted at the grid end of L_2 . An extension lead at one end goes directly to the small feed-through insulator which serves as the antenna terminal, while the other end is soldered to a lug fastened to the case. RFC_2 is supported by the heavy leads with which it is fitted, one being soldered to the plate terminal of the 958 socket while the other goes to the switch terminal. RFC_1 is mounted similarly underneath the change-over switch.

The audio transformer, T_1 , is in one corner next to the change-over switch. The two audio tubes are placed opposite S_1 , leaving sufficient space behind them for the two 33-volt "B" batteries which are held in place with metal straps. Space for the miniature modulation choke, L_3 , is found next to the 1S4 output tube. The single-cell "A" battery is clamped against the bottom end of the case with a U-shaped metal strap.

Two cable connectors are set in the top of the case. One is for the headphone connection and the other for the microphone cord. It is important that a shielded 'phone cord be used. The power toggle switch, S_2 , is mounted on the bottom end. The side of the case which was removed for the photographs is slotted for the web straps by which the unit is fastened to the operator.

The para-talkie has held up well under repeated tests, our only casualty being one cracked lead-in insulator. Careful selection of parts and a painstaking wiring job probably are responsible for its stable operation, the frequency shift from "receive" to "transmit" being negligible. Its general performance as a portable rig on the ground, using a whip antenna, is superior to commercial transceivers with considerably greater power input.

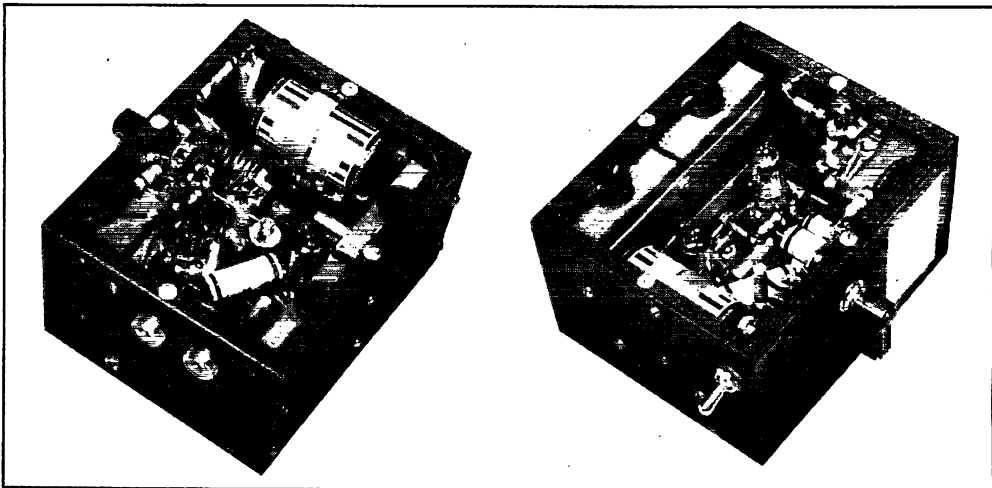

These views of the "para-talkie" show the arrangement of components inside the $4 \times 5 \times 6$ -inch steel box.



25 YEARS AGO THIS MONTH

Whoops! — 88 pages in our issue for April, 1920. A house ad proclaims that "this issue contains more paid radio advertising than ever appeared in a radio periodical before. Its circulation is 10,000 copies."

The leading technical article is on "The Vacuum Tube as a Detector and Amplifier," by L. M. Clement, reporting the wartime development work of Western Electric Co. M. B. West, pre-war 8AEZ, from his vast fund of practical information again contributes "Some Notes on Improved Transmission." The editor has a piece on spark, too, on "Multiple Transmitters," publicizing several ideas that have been reported for the use of dual transmitters with a single gap and antenna in the quest to get a kilowatt input on 200 meters. But amateur continuous-wave telegraphy for relay work has at length arrived, as reported by the editor in "The Advent of Amateur C.W." We know at least twelve stations that are doing good work on c.w., probably the most interesting being that done by 2ZL, the station of our traffic manager, J. O. Smith. He is even junking his spark set as outgrown. With much less power, he is putting traffic into Boston, something that can't be done with a spark, and has had loud and steady signals in Chicago for a week at a time. It is extremely hard to tune in c.w. signals and still harder to hold them, but enclosing the receiver in a metal screen or backing the panel by a grounded metal plate will prevent disturbance from the operator's hands, while vernier-driven condensers solve the difficulty of extremely exact tuning.

S. Kruse, an assistant engineer at the Bureau of Standards, lightheartedly reports his radio adventures in lighthouses in Chesapeake Bay under the title "Radio Lighthouse Keeping." Further humor is contributed by The Old Man in a piece on "Rotten Weather Relays," while a chap who signs himself "A Boiled Owl" answers TOM's recent article on "Our Rotten Hours." It is our opinion, we say in an editorial, that we radio men have quite a sparkle to our humor. "Somebody told us the other day that all sorts of people not identified with wireless read our *QST* every month just for the quality of the humor and the enjoyment they derive from getting into contact with our splendid ARRL spirit of fraternalism."

The League is going to do something about fading. Traffic Manager Smith has an article on "Variation of Strength of Amateur Station Signals," reporting that the League is interested in gathering together "all possible information, from which it will endeavor to work out some theory in explanation of the rise and fade in the strength of amateur signals at night." All amateurs with any information on this subject are

requested to make it available for study by the League. In this very issue, Charles J. Lowry of Toronto has a long letter reporting his own wartime observations on fading.

The New England Amateur Wireless Association and the Massachusetts Institute of Technology Radio Club gave a combined dinner at MIT on February 12th with over 350 amateurs present from all over New England. "The guests wore tags bearing their calls and many new friends were made. At the conclusion of the program the toastmaster called upon various amateurs with well-known calls to stand up so folks would know what they looked like. This was very interesting."

"Who's Who" introduces our new vice-president, who is also manager of our Atlantic Division, Charles A. Service, jr., and also Frederick E. Terman, our superintendent for the San Francisco district, operating 6AE at Stanford University. Although now only twenty years of age, Mr. Terman's first station was erected in 1916. He has been heard often in Denver and in Wyoming.

New legislation threatens, the Radio Law of 1912 being regarded as outmoded. There is a pending bill to establish a "National Radio Commission" of four men representing Navy, War, Commerce and Post Office, who would have the right to assign wavelengths and formulate technical regulations. The League regards this with considerable uneasiness. It also comes out that following the signing of the EU-F-GB-I Protocol at last year's meeting of the Inter-Allied Economic Commission in Paris, an international radio conference is planned to be held in Washington. We don't like the proposals and our Board of Direction is holding a special meeting.²

¹ At the same meeting of the Board, Arthur A. Hebert, of Nutley, N. J., was elected treasurer of the League.

² Our Board decided that it wanted an allocation of 150 to 250 meters for general citizen stations and a longer wavelength between 350 and 375 meters for special citizen stations. "The reservation of a special longer wavelength was desired to facilitate vacuum tube transmission, the extreme difficulty of operating such equipment on 200 meters being realized."

Strays

The Signal Corps has completed development of a new radio receiver to be used for morale and recreational purposes. The receiver, known as the R-100/URR, provides reception of medium- and short-wave broadcasts and operates from self-contained batteries or from alternating or direct-current power sources. It will not be issued for use in continental United States except as specifically prescribed by the War Department.

Automatic Antenna Switching

A Simplified System for Instantaneous Selection from a Number of Units

BY ALFRED K. ROBINSON, * EX-W7DX

THE Field Division monitoring stations of the Federal Communications Commission must be able to determine quickly and accurately the operating frequencies of all classes of radio stations, including those of the Army, Navy, and other government agencies. They must be able to make bandwidth and modulation measurements and many other technical studies, such as channel-occupancy surveys, wave-form analyses, keying checks, emission tests, and a great number of other tasks of a highly specialized nature. To accomplish these duties requires apparatus capable of the greatest possible degree of accuracy. Since standard equipment is not always available, the Commission's field inspectors often must design and construct special apparatus which may be required for a particular application.

This has been true in the case of the antenna systems required. The Commission's monitoring

* 2116 West Division, Grand Island, Neb.

stations require a wide variety of antennas. For instance, as many as seven medium and low-frequency double-ended Beverages, nine double-ended high-frequency rhombics, four multiple doublets, several simple doublets, beams, verticals, and long-wire antennas are used at a single location.

Antenna Requirements

The necessity for such extensive antenna systems is not hard to understand when one considers the large number of stations on the air with their multiple-frequency assignments and duplicated channels. An example of how valuable these antennas become is apparent from the fact that with a single Beverage, elimination of practically all except those stations located on a line with the antenna is possible. Also there is the probability of being able to select as desired either of two stations on such a line if one is in one direction and the other in the opposite direction, even

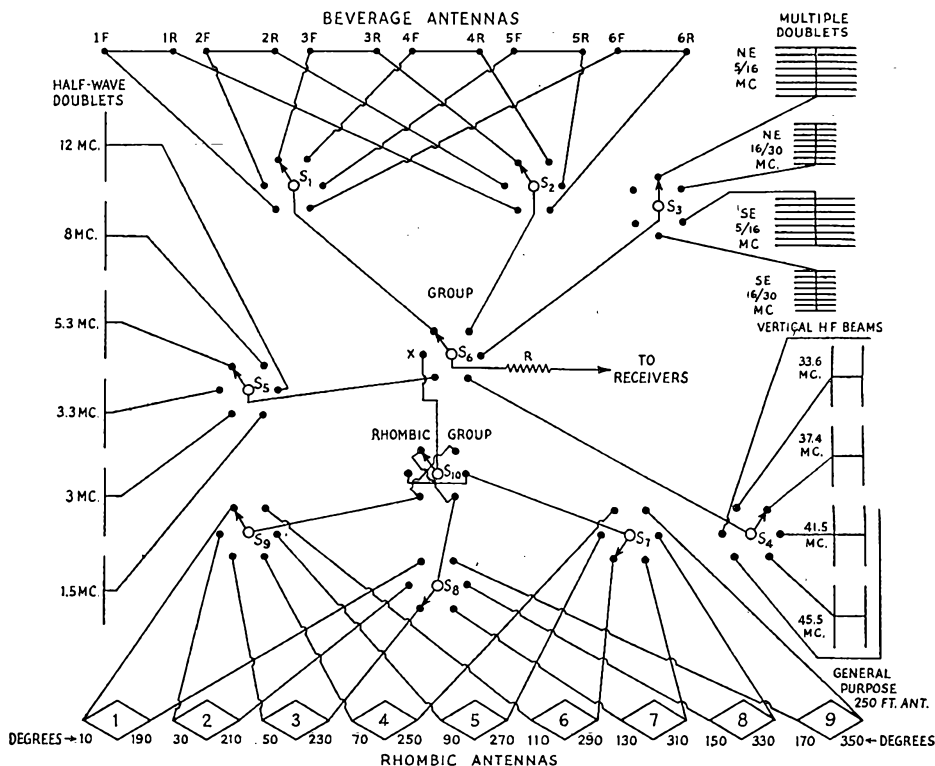

Fig. 1 — Antenna-feeder switching system. Only one feeder wire is shown in each case; connections for the second wire are duplications of those shown, and are made through a second section of each of the three-gang switches. (Connections to the third switch section are shown in Fig. 2.) R is a 200-ohm resistor.

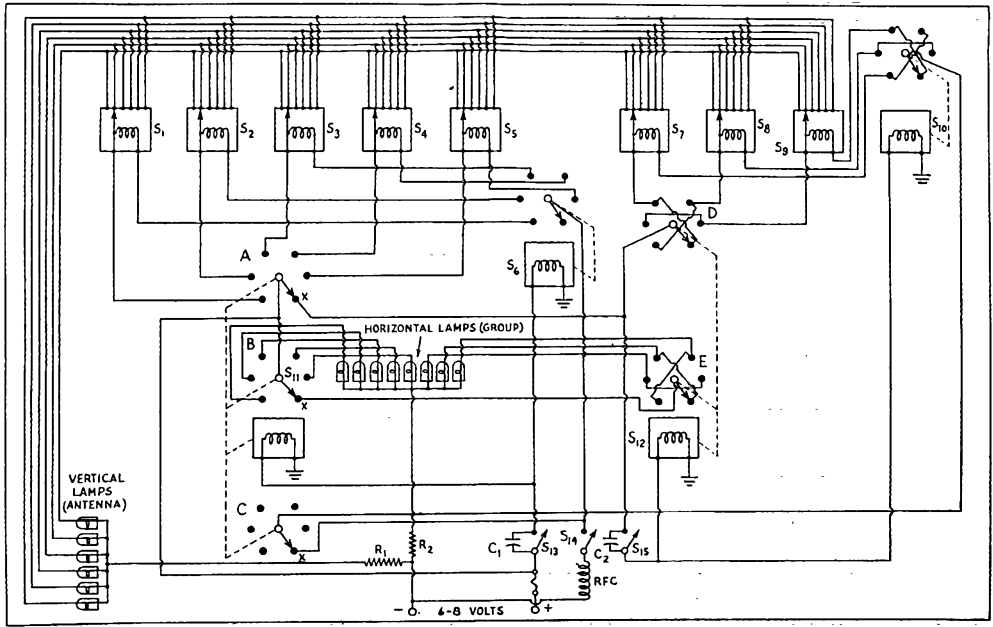

Fig. 2 — D.c. circuit of the third switch section. The negative terminal of the battery is grounded at the chassis. C_1, C_2 — 0.5 μ f. RFC — 80 turns No. 16 wire on a 2-inch diameter form. R_1, R_2 — 15 ohms. A, B and C are sections of S_{11} , while D and E are sections of S_{12} (see Fig. 1).

though one of these stations is several hundred miles farther away.

Administration, which has made use of such engineering, has eliminated the necessity for several times as many monitoring stations as are now in use to monitor the bands properly.

Since measurements and observations vary over wide frequency ranges and because antennas designed for low-frequency operation are seldom suitable for high frequencies, there is a need for some type of switching arrangement whereby any antenna may be made instantly available if full use is to be made of the receiving facilities.

Transmission-Line Switching

Such a switching system, essentially automatic, is shown schematically in Figs. 1 and 2. These drawings show antenna-feeder and direct-current control circuits respectively. Notably there are no "dead-end" feeder lines connected to the receiver at any time. The system takes care of a total of forty-six antennas with the possibility of adding two more immediately. By making slight modifications the system could be extended to include eighteen more if necessary.

As indicated in Fig. 1, the antennas are classified and divided into eight groups with six of one class to each group. This is done for several reasons: the inspector can more quickly select the antenna group most likely to produce without having to set up each separate antenna; switching is accomplished without "dead-end" feeder lines; better isolation between each individual feeder line and still greater isolation between groups of antennas is provided; the use of comparatively small automatic switches becomes practical and

these can be mounted at the best possible point in relation to antenna termination, with a corresponding decrease in antenna feeder-line interaction. Another highly desirable reason for the grouping method of switching is to permit the best antenna of any particular class to be compared with the best antenna of other classes without switching through several other antennas.

In order to keep the efficiency of the antennas at a maximum, open-wire feeder lines are used throughout. A short distance from where the transmission lines connect to the switches, the wire spacing is reduced to 3/16 inch. Such a line is practical when using dual-hole Lucite beads commercially manufactured for two-wire coaxial cables, and these make a very neat installation. The impedance is maintained approximately by the use of smaller-diameter wire. The advantage of close spacing is obvious, since the possibility of interaction because of the feeder-line connections at the switches is reduced to a minimum.

R.F. Circuit Details

Each of the numbered switches in Fig. 1 consists of three sections ganged together on the same

In this article the author describes the switching system which has been developed for controlling the forty-odd receiving antennas at the FCC's Grand Island (Neb.) Monitoring Station. With this system it requires only a matter of seconds for the operator to select any desired antenna by simply pushing a couple of buttons on the control panel.

shaft. Each section has six positions and is operated by a 6- to 8-volt d.c. "stepping" solenoid which continues to rotate the switch arm, contact by contact, so long as the solenoid circuit is held closed. Fig. 1 shows only the first section of each switch. It is seen that these switches control the selection of one of the two transmission-line wires to the various antennas. The second switch sections (not shown) control connections to the other transmission-line wire in exactly the same manner. Connections to the third sections are shown in Fig. 2. These third sections of each switch control connections to the vertical and horizontal lamps on the control panel which indicate which antenna of the forty-odd available is in use at any given time.

Returning to Fig. 1, it will be seen that the various antennas are arranged in groups. Any one of six Beverage antennas may be selected by S_1 and S_2 . Since a Beverage antenna is directional, its direction depending upon to which end of the antenna the receiver is connected, provision is made to switch the receiver to either end. S_1 controls connections to the "forward" end of each antenna, while S_2 controls the connections to the "rear" ends. Connections to any one of four multiple doublets are made through S_3 and blank contacts are available for the addition of two more antennas to this group.

In the next group, controlled by S_4 , are four h.f. beam antennas, a vertical antenna and a 250-foot general-purpose antenna. Similarly, S_5 controls a group of six half-wave doublets. Connections to either end of any one of nine rhombic antennas are controlled by S_7 , S_8 , S_9 and S_{10} . The switching of this group will be discussed later.

Connections to any desired group of antennas are set up by the "group" switch, S_6 . Thus, to connect the receiver to any desired antenna, the "group" switch is first turned to the desired group and then the "antenna" switch for that group is turned to the desired antenna.

Since more than six connections are required for the rhombic antennas and since these antennas are used to a considerable extent on high frequencies to determine the "sense" of a signal (direction from which a signal is arriving at a bi-

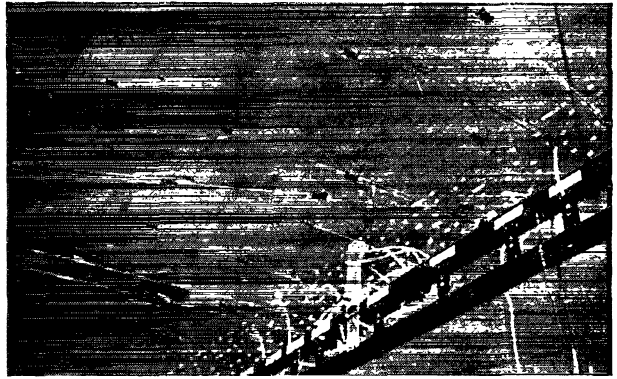

Transmission-line anchors, showing the jack connectors used for "patching" circuits when required.

directional antenna), this group is provided with a separate "group" switch, S_{10} , which connects to X on the first group switch, S_6 . This permits around-the-compass rhombic directivity without the necessity for going through other groups while doing so. S_{10} selects any one of the three rhombic antenna switches, S_7 , S_8 or S_9 , while the latter each provide for six different connections to the rhombic antennas. Here also connections may be made to either end of each antenna.

Control Panel

The control and indicator panel is shown in Fig. 3. It is only $5\frac{1}{4}$ inches high and of standard rack length (19 inches). Antenna designations are marked on the panel in tabulated form with an indicator lamp opposite each row of "antenna" designations and one above each column of "group" designations. This system simplifies considerably the wiring, besides saving on those parts which are so scarce and difficult to secure these days. The simultaneous lighting of one lamp in the vertical row and one in the horizontal row serves to indicate which antenna is in use. Thus, to select any particular antenna, the "group" push-button switch, S_{13} (Fig. 2), is held closed until the horizontal lamp lights indicating the proper group. The "antenna" push-button switch, S_{14} , is held closed until the vertical lamp lights which indicates the desired antenna in that group. Thus, when the fifth horizontal lamp from the left and the third vertical lamp from the top are lighted, the 3.3-Mc. doublet is in use.

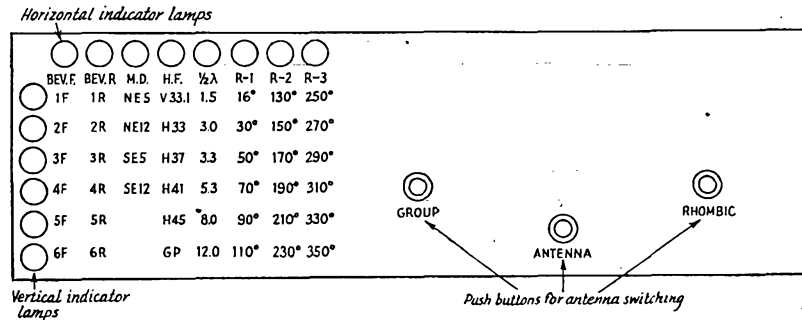

Fig. 3—Arrangement of the control and indicator panel used with the antenna-switching system.

When any of the rhombic antennas is to be used, the "group" push-button switch, S_{13} , is held closed until one of the last three lamps in the horizontal row lights, indicating that the "rhombic group" switch is connected in the circuit. Then the "rhombic" push-button switch, S_{15} , is held closed until the indicator lamp shows the desired rhombic group, after which closing the "antenna" push-button switch, S_{14} , will select the desired antenna in that group.

Control and Indicator Circuits

Referring to Fig. 2, two operating circuits are required, one for the solenoids which operate the rotary switches and a second which furnishes voltage to light the indicator lamps. The numbered switches in Fig. 2 are ganged with the correspondingly numbered switches of Fig. 1.

To begin with, it should be noted that when the "group" switch, S_{13} , is closed the solenoids of S_6 and also of an additional three-gang switch, S_{11} , are energized, so that these two switches turn in unison as though they were ganged on the same shaft. Lamp voltage is fed to arms A and B of S_{11} . Arm A , through its contacts, delivers this voltage to the arms of the first five antenna-indicator switches operated by S_{14} via S_6 , and thence through the contacts of these switches to the vertical row of indicator lamps. Arm B , on the other hand distributes voltage to the first five lamps in the horizontal "group" row.

When section A of S_{11} is in the position marked X , it delivers lamp voltage to one arm of an additional switch, S_{12} , which operates in unison with the "rhombic" switch, S_{10} , and thence through the contacts of S_{12} to the arms of the last three antenna-indicator switches, S_7 , S_8 and S_9 . The contacts of these switches are connected to the

vertical row of lamps as shown in Fig. 2. Voltage from X also is fed through the "rhombic" push-button switch, S_{15} , which energizes the solenoids of S_{10} and S_{12} simultaneously.

When arm B of S_{11} is in the position marked X , voltage is fed to the arm of section E of S_{12} and thence to the last three lamps in the horizontal row.

When the arm of section C of S_{11} is in the X position, voltage is fed through the "antenna" push-button switch, S_{14} , to the arm of S_{10} and thence to the solenoids of S_7 , S_8 and S_9 .

Components

Study of the diagrams will show that very few parts are used, considering the job that is accomplished. Twelve three-gang switches, three push-button switches, fourteen lamps and sockets, a source of d.c. power, a few feet of close-spaced transmission line and other wire are all that is necessary for a workable system. The switches are of the three-section, six-position, low-loss wafer type fitted with a "stepping" solenoid, as mentioned previously. They are particularly well suited to this use, since two of the sections to the rear of each unit are well removed from the solenoid winding and have practically no other metal in the immediate vicinity.

A few refinements have been added, such as condensers C_1 and C_2 and the r.f. choke, RFC , to prevent any possibility of clicks in the receivers from the "make" and "break" of the push-button switches. Resistors, R_1 and R_2 in Fig. 2 are connected in series with the lamps to prolong their life. The several units are provided with octal plugs and sockets so that they may be removed readily for service or rearrangement.

(Continued on page 80)

◆ One of the monitoring bays at the FCC station at Grand Island, Nebraska. The antenna-switching panel is in the right-central rack, just above the row of Key-type switches at the bottom.

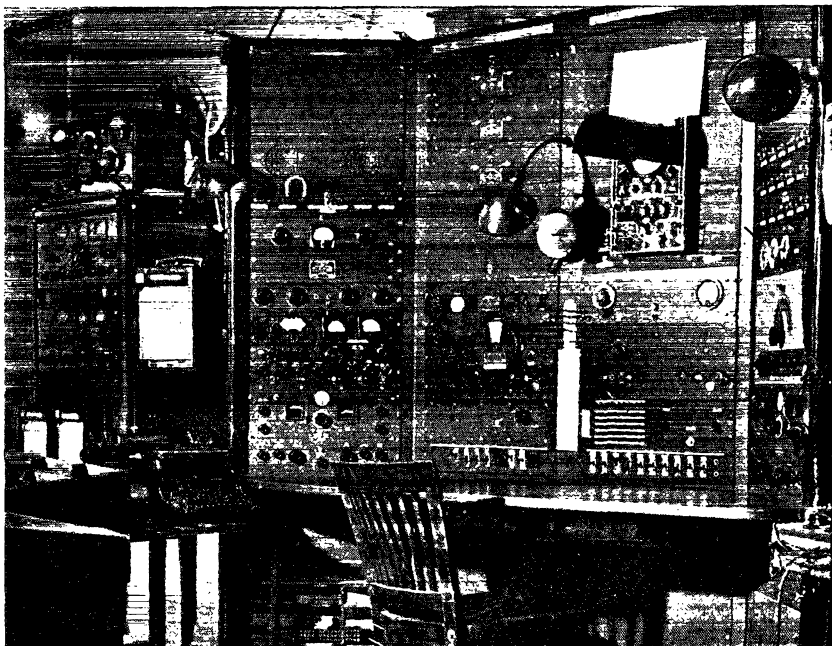

Hams Afloat

What to Take on That First Trip at Sea

BY JACK NELSON,* W8FU

A HAM starting out on his first trip as a ship's operator usually has no idea where he is bound, because of wartime secrecy, so it is hard to know what sort of clothing to take along. However, you won't go wrong if you take some dungarees, a work shirt, and some old shoes. These are good to wear when working on storage batteries and any other dirty jobs that may come up. Don't forget to take a pair of swimming trunks. I still remember how it feels to dive off the 27-foot deck of a Liberty with only my shorts on. Ouch! Don't be afraid of taking too much clothing along; you'll have plenty of locker and drawer storage-space, and there are no moths aboard to eat up the woolens. And who knows? You might have liberty in one of those ports where they pay fabulous sums for old pants, shirts and suits. Then you can unload what you don't need.

The ship's store aboard a merchant-man is called the "slop-chest." Here you may buy shirts, pants, shoes, candy and smokes — in fact, most anything needed on a trip — and prices are generally quite low. Some slop-chests do not have much good candy — so if you are able to take some extra candy bars, so much the better.

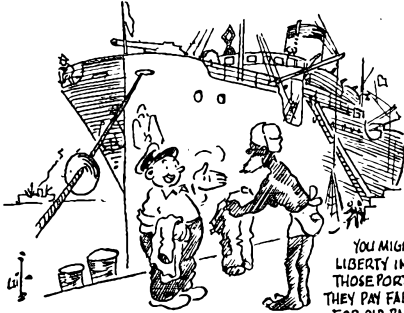

YOU MIGHT HAVE LIBERTY IN ONE OF THOSE PORTS WHERE THEY PAY FABULOUS SUMS FOR OLD PANTS, SHIRTS AND SUITS

Purchases on board are usually on credit, so you won't need much money. When you reach a port you are given a "draw" of money for use in port; most pursers will give out up to \$50. This money is deducted from your final pay. Do not take along your electric razor; they are not allowed aboard ship. (Besides, lots of ships have 110-volt d.c. only.) Do not bring a receiver along, either, for they cannot be used unless they happen to be of an approved nonradiating type.

Towels and soap are furnished by the steward's department, so you need not have much with you, but be sure to carry along plenty of stamps and stationery. Stamps are hard to get at some ports, and the stationery available is sometimes low in grade and high in price.

*75 Minaville St., Amsterdam, N. Y.

A pair of slippers or clogs will be very handy. An outfit of khaki suntan slacks, suntan shirt, and uniform cap will take care of all requirements in tropic or semi-tropic climes. When you join the Maritime Service you are given a blue uniform complete with topcoat. However, you must have six months seamtime in order to join this Service. Uniforms are not required on ordinary runs.

You have been a land-lubber all your life. Suddenly you find yourself a "Sparks" aboard a merchant ship. You have always had opportunities for spending any leisure time available while ashore. Now things will be much different. When you formerly finished your daily eight hours at the shop, office or store, you could go home, tinker with a rig, go for a swim, see a show, dance, and do many other normal things that help spend time. Now — after your radio watch is over there is no place to go. No show to see, no dance, etc. So you have a problem — "How can I spend my extra seven hours?" Here are some answers:

Cards? Take a straight deck and a pinochle deck. Most of the officers play any game — poker, pinochle, rummy, hearts. Solitaire helps out while on radio watch.

Chess? Checkers? Take along your checker-board and chessmen, or any other portable games you may have at home.

Buy a flock of those two-bit pocket-library books and some magazines. Your ship may have a library, but you can't tell how good it will be.

Here is probably the best chance you will ever get to study. Take those radio, mathematics, and any other study books you have.

Get out a daily newspaper, using carbon-paper to make five or six copies at once — one each for the officer's mess, crew mess, Navy mess, and two or three extra copies. Get radio press news (be sure it is authorized for general release) and include jokes and stories (get these from the gang) and scuttlebutt. Your shipmates will go for such a paper and it helps pass those extra hours.

Or get together a group of three or four of your mates and just talk. You'll be surprised how the time goes by and the different points of view you get when talking with new friends.

Many times you will be anchored offshore for days. Take along fishing tackle and have lots of fun fishing in different parts of the world. No license is required, and you can use galley meat for bait. (At one port we found American cheese to be the fishes' favorite dish. Hi!)

Do you like to whittle things out of wood? Do you go in for model airplane or boat building? Don't forget your plans, plenty of kits and extra parts, and your favorite modeling tools. Model building is an excellent shipboard hobby.

Ready! Aim! Fire!

A Practical Method of Orienting Directional Antennas

BY W. E. MARQUART,* W6CKT

Directive antenna patterns represent a subject in which every amateur is going to be increasingly interested when we get back on the air. This article describes a simple method for determining the bearing of any point on the earth's surface in relation to one's own location.

WHEN the filaments go on again in amateur transmitters all over the world, the emphasis will be not on getting more and more power out of the rig but on radiating more *useful* power from the antenna. Some of the most encouraging remarks made by amateurs whom the writer has met in his work in the Signal Corps have been expressions such as: "When I get back on the air, you can bet I'm going to have an antenna that is an antennal!" or, "Watch me use a directional antenna and knowledge of ionospheric propagation to put my signals where they belong!" or, "Knowing what I do now about transmission lines, I'll really get the energy into the antenna, even though it is hundreds of feet away," etc.

It is a pleasant experience to talk to amateurs about postwar plans and to see how they visualize putting into effect their acquired knowledge when, once again, they are permitted to get on the air. It is generally accepted that one of the surest ways of improving station performance after the war is to "put the signals where they are." Perhaps we can profit by applying, inversely, the old baseball adage of "Hit 'em were they ain't."

Advantages of Antenna Directivity

According to FCC regulations, a radio amateur is "... engaged in point-to-point communication, . . ." Notice that it stipulates *point-to-point* communication. Perhaps our newly employed techniques will enable us actually to engage in point-to-point communication, rather than to broadcast power in all directions, hoping that enough of it reaches one point on the earth's surface to maintain reasonably reliable contact. If for no other reason, think of the reduction in the inevitable bedlam of QRM that we must look forward to! In addition, consider the tremendous gain in effective power at the receiver — which, after all, is the primary measure of the effectiveness of the station.

The problems of designing and building a really efficient directional antenna and transmission line are not beyond the capabilities of the average amateur. Much material has appeared in *QST*,

* 2123 26th St., South, Arlington, Va.

The Radio Amateur's Handbook and *The ARRL Antenna Book*, furnishing sufficient information so that any ham should be able to erect some sort of "pointing signal squirter," ranging from a single wire to complex steerable arrays. It is especially easy on the high and very-high frequencies, but reliable DX communication will demand directional antennas for all frequencies, including 7 and 3.5 Mc. The antennas will fall into two main classes: (1) rotatable arrays, or (2) fixed-direction antennas, such as rhombics, Vees, long-wires, etc.

Deciding what antenna we are going to use for working each band of frequencies is just the start of the battle, especially for the fixed-direction type of antenna. Point-to-point communication might be likened to a rifle marksman's "Ready, Aim, Fire!" One thing is clear — you must know your target and *aim* for a bull's-eye. You get *ready* by designing and building your signal squirter, *aim* by proper orientation of the antenna system, and *fire* by grabbing the key or mike.

Equipment Requirements

This article gives a simple but reasonably accurate method for aiming your antenna and incidentally obtaining a good perspective of the world as you will know it on 40, 20, and 10 in the year "V."

Similar means, if not the identical methods, have no doubt been used by many DX hounds in the past, and no claim to originality is advanced — merely the hope that by the written word others may benefit. If, by erasing the myth that the use of higher mathematics is necessary to orient a great-circle path on this "terrestrial globe," one more ham puts a signal where he wants it when he wants it, the effort and printer's ink will have been worth while.

The material needed to build the simple equipment required is readily obtainable, and the end result is a finished product that will be an asset to any ham's shack, in addition to being an invaluable aid to effective station operation. It consists, briefly, of a globe having a pivot at the location of the station, around which a pattern of your beam may be rotated. It includes a reasonably accurate method of determining the direc-



Fig. 1 — Globe with 15° celluloid beam pattern attached.

tion of this beam for proper orientation of either a rotating or fixed array. Fig. 1 shows the revamped globe as it looks when completed.

The first step is to obtain a globe. The larger its diameter, the more accurate the results will be.

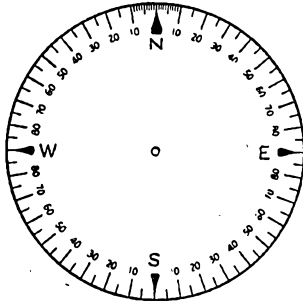

Fig. 2 — Calibrated directional orientation disc, with compass points, cut from a sheet of transparent celluloid.

A minimum size probably would be one 12 inches in diameter. The author uses a 14-inch globe, a Victory model of compressed-paper composition, which adapts itself admirably to "revamping according to plan." Next, a transparent celluloid sheet should be obtained (about 6 × 24 inches for a 14-inch globe), and a 3-inch diameter circle cut out in one corner. Be sure to cut this as near one corner of the sheet as possible so that sufficient material will remain for additional cut-outs. This circle should then be marked with the four principal directions of the compass and intermediate points, as shown in Fig. 2.

Celluloid can be marked easily by scratching it with a sharp stylus, filling the scratches with India ink, and finally covering all with a thin layer of collodion (clear nail polish will do, if the OW isn't looking!). This procedure, if carefully followed, will result in a satisfactory and permanent job. Punching a small hole in the exact center of this disc to give a snug fit over a Nu-Way snap fastener or reasonable facsimile will complete that part of the equipment, as shown in Fig. 3.

The characteristic radiation pattern of the beam should next be cut out of the remaining part of the celluloid sheet, as illustrated in the sketch of Fig. 4. Because it is impractical to have a separate pattern for each different possible radiation pattern, a compromise must be made. By

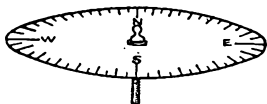

Fig. 3 — The transparent orientation disc complete with snap-fastener mounting.

using a 15-degree pattern, you will show the areas of main coverage of a well-designed antenna and have a better picture of actual coverage than if a single line is used. This 15-degree angle may be drawn on paper by using a large protractor, or by obtaining a sheet of paper approximately 24 inches long and constructing a right-triangle according to the measurements shown in Fig. 5. This angle is then placed under the celluloid sheet as a guide for cutting out the beam pattern of Fig. 4.

Assembly

A straight line with markings at 500- and 1000-mile intervals then is laid out on the pattern to facilitate measurement of distances between the home station and whatever country the beam is covering. The distance markings are easily calculated from the scale of miles printed on the globe. If a larger or smaller globe than the 14-inch size is used, the pattern should be cut accordingly, although the above dimensions may be used to obtain a 15-degree pattern, regardless of its ultimate length. A small hole is punched at the apex of the angle of correct size to snap over the Nu-Way snap fastener shown in Fig. 3. Markings are protected by a coating of collodion, as previously described.

After the circle and beam pattern have been cut out and marked, you are ready to start putting them together. In assembling the pieces, the key point is to determine accurately the location of your station on the globe. After this is checked and rechecked, a small hole should be punched at the exact spot. The snap fastener and celluloid disc previously made are then screwed into the

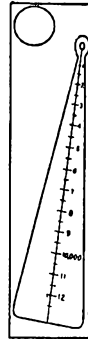

Fig. 4 — Celluloid 15° beam pattern.

globe, after placing rubber cement on the threads and that part of the underside of the circle between the fastener and the "N" marking. A snug and permanent fit is necessary.

Before the cement has time to set, the "N" on the circle must be oriented directly north. A thread stretched between the fastener and the North Pole on the globe will facilitate this operation. Because of the compound curves involved, the disc will not conform to the surface of the globe unless corrected for this curvature. If desired, the disc could be slit and a thin triangular piece removed, allowing it to conform approximately to the curvature of the globe, but the results would not be worth the difficulties of computing the degree markings on the circumference. Furthermore, a certain amount of error probably would be introduced when attempting to make a correction for the compound curvatures.

Determining Desired Antenna Direction

The globe now is ready to be used in determining the desired direction of the antenna. By placing the beam pattern on the center post and rotating it around the globe, a clear picture of the approximate coverage of the beam is obtained. The beam is rotated until the center line outlines the path along which you desire to pump your signals, and the degree of deviation from one of the four cardinal directions of the compass, as indicated by the intersection of the center line and the circumference of the disc, is noted. This is the proper azimuth reading along which to beam your antenna.

If your antenna is a rotating array, this azimuth reading can be transferred directly to the

control wheel used to rotate the array. For those desiring the ultimate in design, a number of possible innovations suggest themselves. The author intends to have the revamped globe rotate on a new axis running through the station's spot on the sphere, and to mount it near the operating table in his postwar shack. (After all, which is more important — *your* location or the North Pole? Hi!) The beam pattern will be stationary, facing the operator, and the rotation of the globe will be synchronized to the antenna mechanically or by electrical means using selsyn motors. Thus a continuous picture of the terrestrial coverage of the beam along the great-circle route will be maintained.

Orienting the Antenna System

The azimuth readings obtained from the globe are very useful in properly orienting rhombic and similar permanently located antennas before starting their construction. It is necessary to be careful in transferring this determined direction to the actual location of the antenna supports, however, to prevent possible inaccuracies in orientation. A surveyor's transit is almost a necessity, and the ham should beg, borrow or otherwise obtain one if humanly possible.

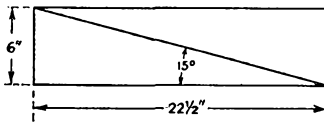

Fig. 5 — Laying out an exact 15-degree angle.

As the first step, a stake is driven into the ground at the location of the pole which will support the station end (feed point) of the antenna. The transit is then centered over this point and true North determined either by the compass or by night exercises in conjunction with our old friend, the North Star.¹ It then is a simple matter to set the 'scope on the desired azimuth, squint through it, and, with the help of the OW or little brother, set up a line of stakes marking the main axis of the antenna.

If a transit proves absolutely unobtainable, a substitute may be constructed by calculating the proper triangle, using simple trigonometry, and building a wood model at least three feet on a side. After determining true North (or East, South, or West, as applicable), the triangle is supported horizontally and one side is carefully lined up with this direction. Sighting along the other side then will line up the axis of the antenna in the desired direction.

In the process of orienting a permanent directional antenna, it is impossible to place too much stress on the necessity for accuracy of measurement; a few degrees error will throw the beam off quite a few hundred miles on the other side of the earth. Even though the beam may be broader than calculated, it is desirable to use all possible care in centering it on the objective. You may be sure the results will amply repay you for the

¹ Budlong, "True North from Old Sol," *QST*, Jan., 1938.

small extra amount of effort and patience required to do the job right.

A judicious selection of frequency for optimum ionospheric propagation, plus a correctly designed and constructed array aimed at the target, will enable you to concentrate all your power within a zone a few degrees wide instead of spreading it out thinly over the entire globe.

New Transmitting Tube

The Eimac 4-125A

EIMAC announces a newly developed very-high-frequency tetrode for medium-power operation under the type designation 4-125A. Its physical size (seated height, 4 $\frac{3}{8}$ inches; bulb diameter, 2 $\frac{1}{2}$ inches) is small for its 500-watt maximum input capability. So, too, is its grid driving-power requirement of only 2.1 watts as compared with the power-output rating of 375 watts. A pair of these tubes operating in a conventional push-pull circuit with a kilowatt input will deliver 750 watts output with 4 watts of grid drive anywhere in the region from 1 Mc. to 120 Mc.; 500 watts is obtainable at 150 Mc. and 350 watts at 215 Mc.

Neutralization is unnecessary up to 100 Mc. When neutralization is required, the conventional method (cross-feed from plates to grids) is not recommended. Instead, a variable condenser is connected from each screen to ground. Since this arrangement represents a series-tuned circuit, a change in the adjustment of this condenser is necessary for any appreciable change in output frequency. Screen voltage is applied through individual r.f. choke coils.

The screen grid is supported by two posts connected to an internal screening disc, which in turn is supported by two rugged leads going through the base to two prongs on the tube. An external base shell overlaps the edges of the internal shielding disc, making almost complete shielding possible by grounding this shell. The plate connection is made to the cap on the top of the tube. Base connections are as follows: Pins No. 1 and 5 — filament; pins No. 2 and 4 — screen; Pin No. 3 — control grid.

Typical operating data for Class-C telegraph service are as follows:

Filament voltage.....	5.0 volts
Filament current.....	6.3 amp.
Grid-plate capacity (without shielding; base-shell grounded).....	0.03 μ fd.
Input capacity.....	10.5 μ fd.
Output capacity.....	3.0 μ fd.
Plate voltage.....	2000 3000
Plate current.....	200 167
Screen voltage.....	350 350
Screen current.....	25 50
Grid voltage.....	-150 -150
Grid current.....	8 8
Power output.....	300 375
Power input.....	400 500
Plate dissipation.....	100 125
Peak r.f. grid input voltage.....	260 270
Driving power (approx.).....	2 2.1
Power gain (approx.).....	150 178

— W. E. B.

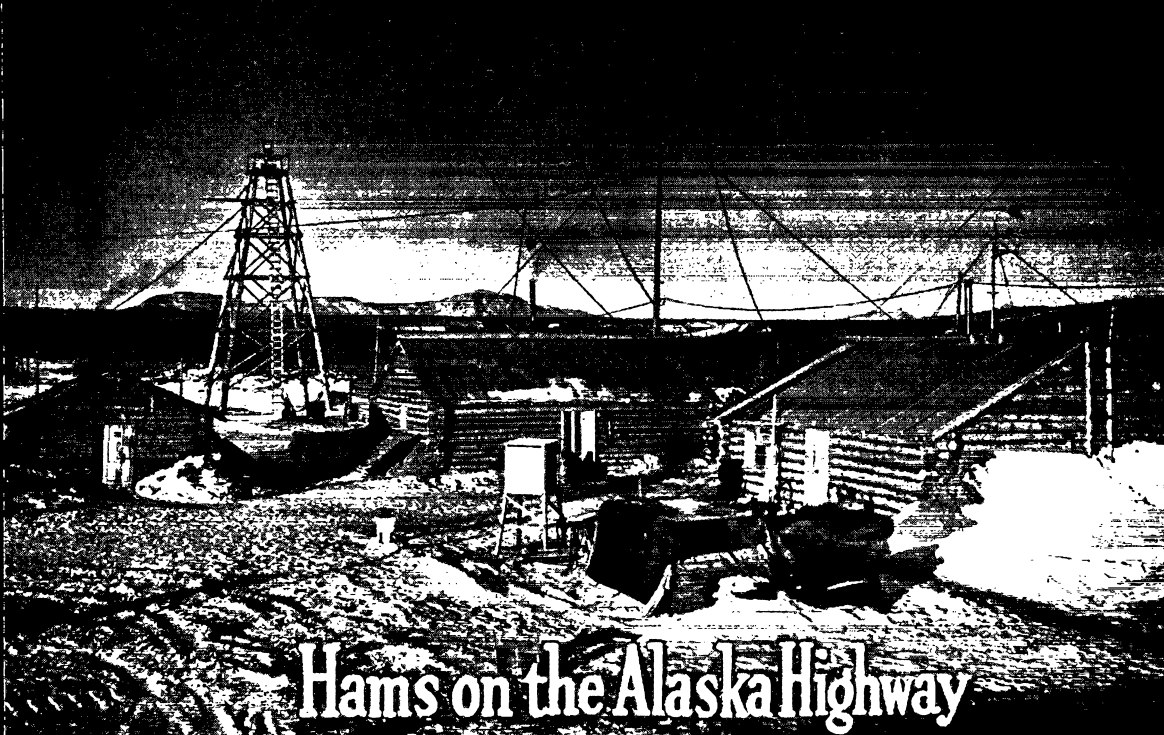

Hams on the Alaska Highway

Establishing Signal Corps Radio Stations at 72 Degrees Below Zero

BY MAJOR LLOYD D. COLVIN,* SC, K7KG

THE question always asked of troops returning from the Alaska Highway is this: "How cold is it up there?" Prior to my assignment in October, 1942, as a radio engineer on the Alaska Highway I had spent nearly two years in various parts of Alaska. I thought I knew what cold was — but I had a surprise coming. During the winter of 1942 the weather along the route followed by the Highway has been officially described as perhaps the coldest ever experienced in that area. The temperature dropped to 72° below zero.

At the time of my arrival at Army Highway Headquarters, located in Whitehorse, Yukon Territory, the temperature was 25° below zero. That first night I slept with two other officers in a tent near the airfield. In the morning, after considerable hunting, we found enough wood to build a fire in a small stove near the center of the tent and heated some water. When the water was boiling I took some in a pan to the entrance of the tent, where I could see better, and started to shave. Before I had finished shaving, ice had formed all around the edge of the pan!

My first job was supervision of the building and operation of a large high-speed radio station at Whitehorse to serve the Army Headquarters. The installation consisted of a multiposition operating

room near the headquarters establishment, with remote receiving and transmitting stations.

The Army troops and contractors had moved into Whitehorse faster than supplies could follow them. There seemed to be a scarcity of everything except cold weather. Transportation — or the lack of it — was the biggest problem, however. I had been instructed to get the station on the air at the earliest possible date, but work on signal facilities was at a standstill because of the lack of transportation. The distance from the operating room to the receiving station was three miles, while the distance from the operating room to the transmitting station was six miles.

Neither the buildings nor the antennas at either site had been completed. With the extreme cold that prevailed it was imperative that some kind of a vehicle be obtained to get the Signal Corps personnel to and from work.

In my search for transportation I saw everyone from second lieutenants to the commanding general. All were very sorry, but all available Army transportation that would run was needed to haul

food and clothing to keep the men alive.

In desperation I started a canvass of the stores in the village of Whitehorse, asking, "Does anyone know of a civilian who has a car or truck that could be rented or bought?" The village fire chief



*APO 722-A, o/o Postmaster, Seattle, Wash.

"... a large high-speed station at Whitehorse ..."

was finally located. His job as fire chief was only a part-time duty, but he had an old Ford pick-up, painted red, which he used to take him to what had previously been the very infrequent local fires. After considerable persuasion I talked him into renting this vehicle to me. I had no authority to make such a contract, but the Army eventually paid the bill.

With the aid of our new "fire wagon," work was resumed. The vehicle was too small to take all the men to either the receiver or the transmitter sites in one load, but by making shuttle trips we managed to get everyone to and from work. In spite of the cold the radio station was completed and on the air in a few weeks.

Eventually we received several Army vehicles for Signal Corps use. However, our troubles were not over. These cars and trucks originally belonged to the first engineer troops who worked on the highway. The vehicles had already taken a terrific beating before they were turned over to the Signal Corps, and only one of them would run.

All repair work had to be done out in the open because no garage could be found for the vehicles and no material was available with which to build one. The temperature was 50° below zero

when we started to repair the trucks. After several days of such work, I started out one morning to see how the work was progressing. The temperature was only about 20° below and I had on several coats, a parka, shoe-pacs with two pairs of heavy woolen socks, and two pairs of gloves — but I still felt cold. When I reached the vehicles I found one of the Signal Corps mechanics wearing about half the amount of clothing I had on, with no gloves, handling metal parts with his bare hands. He was whistling and appeared to be in the best of spirits. Turning to me, he said, "Good morning, sir. Much warmer this morning, isn't it, sir?"

On another occasion, after we had one vehicle repaired and were in high hopes it would run, we discovered we had no antifreeze for the radiator. Not having a car available that would run, I walked a mile to a quartermasters' warehouse where I could draw Prestone. It was one of our coldest days. After two trips I got enough antifreeze to fill the repaired car — but when I finally got the cans open, the pure Prestone was frozen solid! I was mad enough to fight the whole war alone.

We found that the oil would freeze in the cars unless we let them run all night. The latter plan was reasonably satisfactory except when a drop of water got into the gas line. When this happened...

... transportation was the biggest problem ..."

Official U. S. Army Signal Corps Photographs



opened the engine would stop and everything would freeze up.

During most of that first winter some supplies had to be flown in by airplane. The Air Corps had very little covered storage space, and as a result many tons of the equipment and supplies unloaded from planes were left in the snow near the edge of the airfield.

Much of Christmas Day of 1942 was spent on the airfield in the hope that the incoming planes would bring Christmas packages for the men in the radio section. Just as I was about to leave the field I accidentally kicked the snow off a box half buried in a drift. Imagine my surprise when I saw

my name on the box! Except for that lucky kick, the box might have remained there until spring.

Hoping it would turn out to be a Christmas present, we rushed the box to the radio station and hurriedly opened it. Imagine my mixed feelings of disappointment and joy when it turned out to be a much-needed communications receiver for the station. One of the men lifted the receiver out of the box,

placed it on a table — and then gave a terrific yell. The metal chassis was so cold that when he let go pieces of flesh were pulled off his hands! After warming up the receiver, first over a fire and then in the conventional manner, it was found in perfect operating order.

Yes, the weather was cold during the building of the Alaska Highway. But, as in so many other parts of the world, the U. S. Army Signal Corps, with its high percentage of amateur radio operators and technicians, is providing communications there of which we can all be proud.

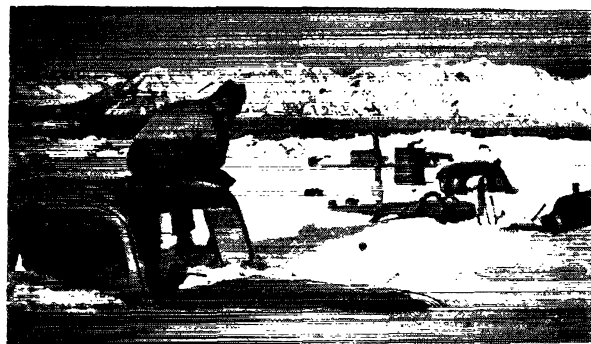
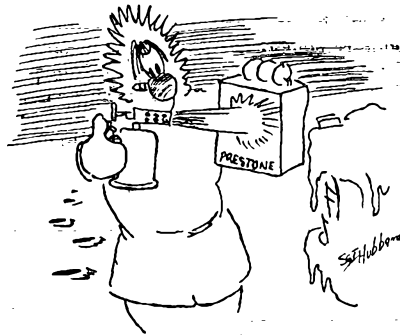

Wide-Range Tank Circuits for V.H.F. and U.H.F.

Simplified Mechanical Design for Amateur Construction

BY MORRISON L. GABLE,* W9RLM, AND CYRUS T. READ,** W9AA

WHEN amateur radio gets under way again there will be many new devices to build, new techniques to learn, and whole new regions of the spectrum to explore. Some of the new devices will, of course, be modifications and refinements of prewar equipment. Others, while actually operating on the same fundamental principles as the more familiar amateur gear, will appear as strange as though they had come direct from Mars via Buck Rogers' rocket ship.

Contrary to popular opinion, not all postwar construction will require the amateur builder to take a course as a master plumber. The wide-range tank circuit shown in the illustration can be made with simple tools and will prove a most useful gadget in exploring the new frequency assignments and in trying out new circuits. An amateur version of one of the wide-range circuits described by engineers of the General Radio Co. last October at the National Electronics Conference in Chicago, it was built from junk-box materials. While this particular model was made with the help of a lathe, it should be possible to make one with nothing but a set of drills, a hacksaw, and a couple of half-round files.

* Electronic Engineering Department, Minneapolis Honeywell Regulator Co.

** Director of Sales Engineering, The Hallicrafters Co.

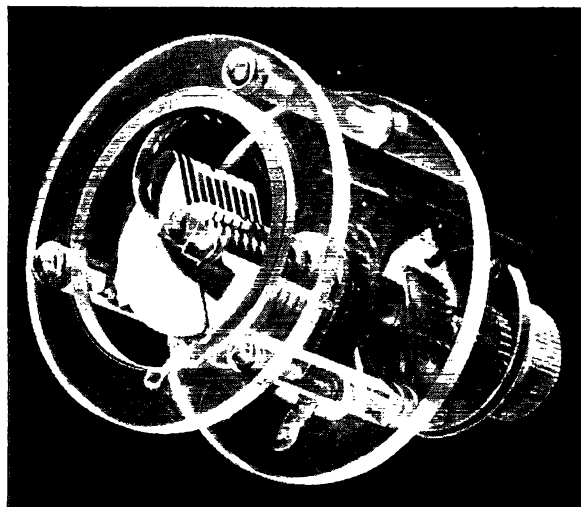

Rear-end view of the wide-range tank circuit covering the span from 65 to 380 Mc. The inductance is concentric with the inner edge of the rear supporting ring, which is made of plastic material.

This article describes a ham-built version of one of the simpler of the several types of wide-range tank circuits which have been developed for v.h.f. and u.h.f. research work. Many of these devices are complicated mechanically and require specially machined parts, but the one shown here is simple enough to be duplicated easily by any amateur possessing an average complement of tools.

This tank circuit comprises an ordinary single-bearing midget variable condenser, with a maximum capacity of 100 $\mu\text{mf.}$, and a continuously variable inductance, both of which are actuated simultaneously. The inductance consists of a phosphor-bronze wiping contact mounted on the end of the condenser rotor and a circular segment of soft copper, one end of which is connected to the stator plates of the condenser. This copper ring is 2 inches in outside diameter and has a cross section $\frac{1}{8}$ -inch square. The entire unit is supported in a framework made of Plastiglas held together with self-tapping plastic screws. Any easily worked plastic with good high-frequency characteristics could be used. The gear assembly in the background is merely a temporary vernier tuning arrangement and should be replaced by a good dial with a high gear ratio if, for example, the device is to be used as an absorption frequency meter.

Application

The primary need for such tank circuits in the commercial field will be in the development of postwar television receivers which will have to cover a wide range of frequencies, but they should also have many applications in the amateur field, not only as absorption-type frequency meters but as tank circuits for the exciter and intermediate stages of v.h.f. and u.h.f. transmitters. Properly designed, they should enable the postwar amateur transmitter to operate on several of the new bands without having to change circuit elements. This particular model was checked as a frequency meter against frequency standards in the Hallicrafters'

laboratory and was found to cover a range of 65 to 380 Mc. in its present form.

For maximum range and performance there are several improvements which could be made without too much difficulty. In common with all other v.h.f. equipment, all metallic parts of the circuit itself should be silverplated, to reduce high-frequency resistance and increase the Q. A small silver "button" on the sliding spring contact would make the tuning action more positive and help to eliminate variations in the dial reading.

Extending Tuning Range

Two things might be done to increase the range of the unit, which is not quite so wide as in the model described at the National Electronics Conference. The minimum capacity of the condenser could be lowered by filing off the small metal tabs which hold the rotor plates to the shaft. This operation would not seriously weaken the condenser and should raise the upper frequency limit to at least 400 Mc.

The lower limit of the frequency range could be extended by using a condenser with — believe it or not! — a smaller maximum capacity than the one shown. This statement probably requires explanation, but it is easily understandable when some of the phenomena connected with operation at these frequencies are considered. If the condenser is too large the capacitive reactance of the circuit will decrease too fast as the capacity is increased, and a point will be reached where the inductive reactance of the conductive path through the condenser plates becomes equal to the capacitive reactance at the frequency in use. Beyond this point the capacity of the condenser merely functions as a by-pass and might as well be infinite. The inductance of the condenser in series with the variable inductance itself determines the resonant frequency of the circuit. With this mode of operation, the resonant frequency jumps to a much higher value which is of no practical use. The cure is to use a smaller condenser in which the capacitive reactance will always have a greater value at any setting than the inductive reactance through the plates.

If this device is to be used as a wavemeter in connection with circuits of reasonable power, a miniature socket for an indicator lamp can be built in as part of the wiper assembly. For use in oscillator and similar circuits, adequate r.f. coupling can be secured with a pick-up loop one-half inch in diameter at the end of a coaxial line.

Strays

Radio Palau is back on the air again, this time under the capable management of the U. S. Marines. Four months ago this station was one of the important Japanese propaganda stations. It is now operated by a group of hams and professional radiomen who work on their off-hours to furnish a 12-hour entertainment program.

★ ★ ★ ★ ★ ★ ★ ★ ★ ★ Gold Stars

T. JAMES B. KELTNER, AC, W5IZP, 22, died November 7, 1943, when his plane crashed while on a mission over France.

Keltner enlisted in the National Guard in June, 1940, and was called to active duty in November of that year. He was a communications sergeant with the 56th Cavalry Brigade and was on duty at Ft. Bliss and Ft. McIntosh before his transfer to the Air Corps in January, 1942. He received flight training at Kelly Field, Waco, and Victoria, winning his wings at Foster Field in November, 1942. He went overseas the following February and joined his squadron in North Africa. The squadron, in operation against the enemy since January, took part in the battles of the Kasserine Pass, Gafsa-El Guettar, and in the final fighting in the Medjes El Bab and Cap Bon sectors.



W5IZP obtained his amateur license in May, 1940. His activities included much portable operation on 3.5 and 7 Mc. at camps before the war.

T. WILLIAM MILLER, AC, W2MKW, 19, was killed, with two companions, when their airplane crashed near Syracuse, N. Y., July 2, 1944.

W2MKW first became interested in amateur radio while attending high school. With the assistance of W9SAG/W2KHA, he soon went on the air on 3.5- and 7-Mc. c.w. and 1.75-Mc. 'phone. He became active on the N. J. AARS net and was a member of the Bayonne High School Radio Club, W2GYO.



With the shut-down in December, 1941, W2MKW's interest turned to aeronautical engineering and in the summer of

1942 he enlisted in the Air Corps as an aviation cadet. His early training took him through camps in Kentucky and Mississippi and he received basic flying instruction at Indiana Central College. He won his wings at Pampa Army Airfield, Texas, and had started multi-engine bomber training at Syracuse, N. Y., when the fatal accident occurred.

Throughout his military service W2MKW credited amateur radio with making his training far easier and giving him an advantage that his associates did not have.

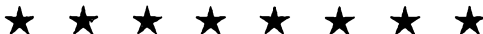

Hams in Combat



It was a long, hard trek from the Normandy beachhead to Germany — the route the invasion hams of VII Corps traveled.

Invasion Hams

BY CAPT. JOHN BRAWLEY,*
SC, W9GYZ

MANY were the hams who landed in the initial stages of the invasion of France. Some waded through the surf at H-hour, carrying radio equipment with which to establish the first communications from the assault forces to the headquarters ships. Some manned the sets aboard those ships and communicated with the various elements of the invasion forces, including the airborne troops who had parachuted with their equipment down behind the enemy lines sometime before H-hour.

The airborne link was probably one of the most important QSOs ever held by radio. The suspense and tension aboard the floating headquarters was terrific as the hour grew nearer for radio silence to be broken by the paratroopers. Operators strained their ears for the first *dit dah* signifying that the airborne forces had landed successfully. For many it was their first combat experience and their first live messages. But when the tension was broken and signals started coming through, these operators copied them. They were handed messages to transmit — and they sent them. QRM mounted — but these lads fought through and over and around it. Searching out the signals, they stuck to them with the tenacity of a DX hound on the trail of an XU. They weren't all hams, by any means — but they were all well-trained operators, and they did a superb job.

There were many other communications needs to be met. There was the great concentration of ships to be controlled by radio and blinker; there was split-second firing data to be radioed to the warships from shore fire-control parties; there was the enormously complex job of control by the convoy commanders and the beachmasters to time the arrival of landing craft at the beach where they would disgorge their cargoes of men and matériel. There were calls for air support,

*APO 307, c/o Postmaster, New York, N. Y.

and there was the tremendous job of coordinating the fighting forces on the beaches.

One radioman off a headquarters ship started ashore shortly after H-hour. He was carrying a portable voice set. As he neared the beach the LCVP was forced aground. He made his way ashore through waist-deep water, only to find that his radio set had been damaged by the brine. Without hesitation he climbed aboard the first returning craft and went back for another set. Again he plunged through enemy fire to the beach, where he put the set in operation. Twice through that withering fire — and not a scratch!

Major Charles T. Wesner, ex-W9BIM, waded to the beach with a radio set under each arm and a bottle of scotch tucked into the front of his trenchcoat. There was considerable unfriendly activity on the beach, and in his haste to clear the area he lost the bottle of scotch. Needless to say, he did not tarry long enough to pick it up. "It was a snap decision," declared the major, "but the scotch had to go. War certainly *is* hell!"

Later Major Wesner and I together "liberated" a town in Belgium. Armored units had been advancing ahead of us all day. The natives were deliriously happy to see the Allies come and the Germans go. Belgian, American and British flags decorated the streets. Hastily prepared banners were strung up, reading: "Welcome les *Liberateurs*" and "*Viva les Americains.*" Crowds of civilians lined the roadsides, waving, cheering, heaping our vehicles with fruit and flowers, shouting "*Viva la Amerique! Vive les Allies! Vive la Belgique!*" In fact, they yelled "*vive*" everything. Seeing "PRESTONE '44" lettered on the radiators of our vehicles, they shouted, "*Viva la Prestone!*"

Major Wesner and I rode our jeep gaily through the holiday atmosphere. After a while we arrived at this little village. Although we didn't know it then, we were the first Americans to enter the town. Before long we were stopped by a civilian. Although we spoke no French and he spoke no

English, we soon realized that the villagers wanted us to join them in the celebration. We permitted ourselves to be dragged (ahem!) to the civilian's home. From the basement he brought dusty bottles of champagne, while his wife took shiny glasses from the cupboard. People began coming in from all over the village. By the time the champagne was poured there were more customers than there was wine. Everyone shook hands and kissed everyone else.

The problem of language didn't bother us very long. I raised my glass and shouted, "Hello CQ! CQ twenty-meter 'phone!" "Vive la Amerique!" they responded in unison, and we all had another round of drinks. Major Wesner raised his glass and said, "Brawley, we'd better be on our way." "Vive la Belgique!" they yelled, and then we had a round of kisses.

Personally, while I hold no strong objection to unpremeditated kissing I do feel that, even on the spur of the moment, it is my privilege to select my opponent. But such was not the case here. I was constantly pursued by an elderly gentleman who hadn't shaved for several days. Each time I spotted a likely subject and moved closer to make myself available, I was intercepted by the oldster with the "five-o'clock shadow."

We weren't accustomed to such demonstrative people. When we left our jeep looked like a float in a Mardi Gras parade. It was covered with wreaths, bouquets, streamers and flags. The Belgians are surely a friendly and hospitable race.

We have a versatile radio crew in the VII Corps. The first press news from the beachhead was flashed back on c.w. by our operators with their 399. As fast as the reporters handed in their copy it was transmitted direct to London.

We also furnished radio facilities for psychological warfare purposes. During the peninsular campaign, when the fortress of Cherbourg was being assaulted by VII Corps, we took SCR-399s up to the front lines and broadcast an ultimatum to the enemy. Handling the technical side of these broadcasts were T/4 John F. Wilson, T/4 Albert Yokym, W8SGW, and T/4 James Coleman. To insure a proper audience, we picked up German operational frequencies and put the 399s right on zero-beat. Then our interpreters read the ultimatum in German, Polish and Russian. The broadcasts went on all night. To prevent the enemy from pinpointing our transmitters and knocking them (and us) out with artillery fire, we stopped in any one spot only long enough for one brief transmission.

Since I have been in the service I have yet to meet a ham who has not been benefited by his amateur experience. Nor have I met one ham who hasn't been able to contribute something tangible to his branch of service. There are many others to whom immense credit must go, as well — the technicians and commercial operators who made radio a business instead of a hobby, and those men who learned radio in the service schools.

Take, for example, Major Gene M. Ranvier, the radio engineer who interviewed me upon my arrival in Iceland. The memory of our meeting is still vivid. He chose to discuss the design and application of a proposed v.h.f. automatic relay circuit. The only image the words "automatic relay" conveyed to me was that of a mythical ambidextrous operator who could copy with his right hand and simultaneously transmit with his left. To add to my confusion, Major Ranvier

(Continued on page 86)

We were the first Americans to enter the town . . . and the villagers wanted us to celebrate with them.





HINTS AND KINKS FOR THE EXPERIMENTER



TRANSMIT-RECEIVE ANTENNA SWITCHING USING GAS-FILLED TUBES

It is generally conceded that the best receiving antenna is a good transmitting antenna. This is especially true when a directional antenna or beam array is used.

Several methods have been evolved for switching the antenna from transmitter to receiver, the most common being a manually operated switch. Occasionally the operator, excited over a new DX contact, forgets to throw the manual switch when transmitting. Even an automatically operated relay fails sometimes. Moreover, many amateurs are reluctant to part with the price of a satisfactory relay.

In some installations a more suitable method is electrical switching of the antenna by the use of a gas-filled tube to short-circuit the receiver input.

In the case of an end-fed half-wave antenna with which open-wire feed is used, as shown in Fig. 1-A, it is common practice to employ a shorted quarter-wave stub for impedance matching. To obtain electrical switching a gaseous tube may be inserted at point X. This tube may be a simple neon- or argon-filled bulb.

When the transmitter is on, the r.f. voltage will fire the gas-filled tube. This shorts the stub, thus providing the required high impedance at the antenna end of the stub. The tube also shorts the other quarter-wave section to the receiver, preventing current flow to it during transmission. When the transmitter is shut off and the tube is no longer conducting, the section then becomes an open half-wave stub to the receiver. Since the

majority of receivers have an input impedance in the neighborhood of 300-600 ohms, a very good match can be obtained. There is no particular disadvantage in leaving the transmitter coupled to the stub, because little energy will be lost to it. Since the stub has been altered from a quarter-wave to a half-wave untuned line, it is no longer at an optimum transfer point.

For voltage-fed antennas which lead directly into the operating room, an arrangement such as that shown in Fig. 1-B may be used. When the transmitter is on the tube fires, shorting the tuning circuit to ground; when the key is raised or the final plate voltage is turned off, the circuit opens, thus connecting the antenna to the receiver.

The chief advantage of electrical antenna switching is that it may be installed and forgotten. The cost of a gaseous tube is well within the reach of any ham. A neon bulb of sufficient current rating must be chosen, as they can be popped by overloads even at r.f.

I used this method successfully on a rig operating with an input of 500 watts on 7 Mc. The end-fed half-wave antenna was fed by an untuned 600-ohm line with a quarter-wave stub shorted by a 2-watt argon bulb. No difference in transmitter operation could be detected when the bulb was replaced by a shorting bar. However, in adjusting this type of feed system the resistance of the bulb requires that it be shifted in its location on the stub from the spot that would be correct for a regular shorting bar.

Perhaps a more satisfactory method would be to use an 866, the maximum peak plate-current rating of which is 1000 ma. From this characteristic it is obvious that, with the cathode cold and its leads shorted, the tube could conduct the normal antenna current safely. The striking voltage is approximately 15 volts at 60 cycles and probably even less at r.f., even when the tube is cold, since there is a certain amount of residual vapor in combination with the condensed mercury. — Lt. Carroll E. Humphrey, W5HVT

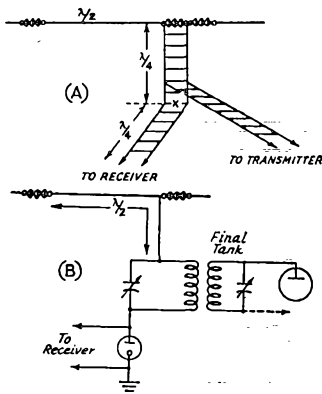

Fig. 1 — (A) End-fed half-wave antenna using open-wire feeders and a quarter-wave stub. Gas-filled tube for antenna switching is connected at point X. (B) Voltage-fed antenna with gas tube connected across receiver terminals in series with antenna tank coil and ground.

A VACUUM-TUBE VOLT-OHM-METER

Most radio experimenters and servicemen are finding it hard to obtain the more elaborate and expensive testers. The circuit shown in Fig. 2 may be found of value in the construction of a simple and practical unit for use with other test equipment on hand, filling the need for a high-range ohmmeter and high-impedance input voltmeter for testing modern receivers. The basic microammeter required may be that in the regular volt-ohmmeter which every radioman should

have available. The 200-microampere meter used in this volt-ohmmeter was originally obtained from a General Electric photocell light meter and is now also serving in a portable volt-ohmmeter of conventional design.

The entire v.t.v.m., including batteries, should be built up in a wooden box to prevent leakage to the circuit under test, which might occur with a metal cabinet. The unit is readily portable and light in weight if small batteries are used.

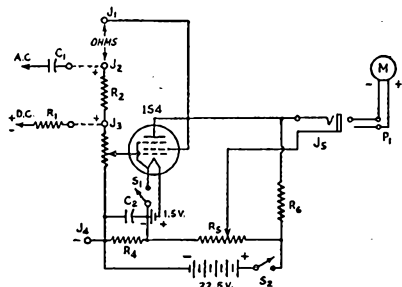

Fig. 2 — V.t. volt-ohmmeter with plug-in meter.

- C₁ — 0.1- μ fd. 600-volt (in a.c. test-lead).
- C₂ — 50- μ fd. 150-volt electrolytic.
- R₁ — 0.33 megohms (in d.c. test lead).
- R₂ — 15 megohms.
- R₃ — 1-megohm volume control.
- R₄ — 2000 ohms.
- R₅ — 20,000-ohm potentiometer.
- R₆ — 12,500 ohms.
- J₁, J₂, J₃, J₄ — Tip jacks.
- J₅ — 'Phone jack.
- M — 200 microamperes.
- P₁ — 'Phone plug for meter.

As seen in Fig. 2 the unit can be used as an a.f. signal tracer by plugging 'phones or a magnetic speaker into J₅, in place of the meter, and connecting the input to J₃ and J₄. This assumes that the tube is operated sufficiently high on the linear portion of the $E_p I_p$ curve so that audio distortion is not excessive. If the tube is biased near the cut-off point the a.c. sensitivity will be slightly greater, but the unit cannot then be used successfully as a signal tracer in a.f. circuits except with a meter as the indicator.

The 20,000-ohm potentiometer, R₅, furnishes bucking voltage to balance out the residual current in the meter for zero-setting adjustment, and also furnishes bleeder current of about 1 ma. through the cathode resistor for initial bias. If desired, R₄ may also be made variable to adjust the maximum scale reading, but with a little experimentation a fixed resistor of the right value can be found. The 1-megohm grid input control, R₃, may be calibrated for use as a voltage divider to increase the voltage range. It also serves the purpose of "zero-ohms adjuster." The voltage-divider resistors were chosen arbitrarily so that no calibration chart or graph is needed for the d.c. and "high-ohm" ranges, since the readings can be obtained by applying a multiplying factor to the regular volt-ohmmeter reading. The d.c. scale is practically linear, so the error introduced will be negligible for ordinary testing purposes. However, the a.c. scale resembles a square-law curve, so a calibration chart should be drawn utilizing

any reasonably accurate calibrated source of variable voltage that may be available.

In the meter described the full-scale sensitivity on a.c. is about 2.1 volts and on d.c. 1.125 volts, which is raised to 1.5 volts by the isolating resistor in the test lead and multiplied to approximately 18 volts by the 15-megohm resistor. The 1-megohm potentiometer can be used to multiply the maximum input up to about 300 volts on the high range. Resistances up to about 1000 megohms may be measured with a fair degree of accuracy. No low ranges are provided, since most existing instruments measure up to 1 megohm or so. If the meter used is not marked with an ohms scale, a chart may be made by testing several resistors having known values of resistance or by using the following formula:

$$R_x = R \frac{(I_M - 1)}{I}; \text{ where } R_x \text{ is the unknown resistance indication,}$$

R = initial resistance in circuit,
 I_M = full scale current reading.
 I = current reading with unknown resistance across "ohms" terminals.

If a 1-ma. meter is used the plate voltage should be increased to 45 or 67.5 volts and the bias resistor adjusted for proper operation. Since the bleeder current increases with voltage, the bias resistor will probably be near the correct value. The reason for increasing the voltage is not to increase the plate current but to maintain a linear characteristic over the increased current range.

A shunt should be placed across the meter for protection during the preliminary phases of adjustment. — Roy McCarthy, W9GEJ.

EQUIPMENT NAMEPLATES FROM HAND-DRAWN NEGATIVES

WHITE-ON-BLACK paper nameplates are suitable for use on transmitter, receiver, frequency-meter and other instrument panels. Obviously, they are best applied in the case of equipment having a black panel or cabinet.

A negative is made of tracing paper. The printing may be either typewritten or hand-lettered on the negative. If typewriting is to be used, the type should be cleaned with a small brush and carbon tetrachloride, and a dense and fairly new ribbon should be used. The tracing-paper should be backed with a piece of carbon-paper (carbon side facing tracing-paper). Hand-lettering should be done with black drawing ink. Border and other lines should be drawn with drawing ink and a ruling pen. Slightly sharper lines will result on the finished job if the lines are drawn on the reverse side of the negative — i.e., the side that will be next to the sensitized paper.

Photographic paper is then exposed through this negative, and developed and fixed in the usual way. A double-weight paper stock with a velvet surface is suggested and should be the "hardest" available e.g., Azo No. 5. The time of exposure is not critical and with an ordinary printing box, 10 seconds will be about correct. — Earl Schoenfeld, c/o U. S. Forest Service Radio Laboratory, Route 9, Box 155, Portland, Oregon.



STRAYS



Frank A. Robb, GI6YM, honorary secretary of the Belfast YMCA Radio Club, notifies us that the hamfest held in London last September and reported in these pages (December, 1944, *QST*, p. 45) as the "first" Anglo-American hamfest was not actually the first at all. GI6YM states that the first Anglo-American hamfest of the war took place at the Belfast YMCA on November 4, 1942, when 72 amateurs signed the register. He adds that seven other meetings have been held at the YMCA, at one of which 29 U.S. amateurs, representing all nine call areas, were present.

According to its 1944 annual report, RCA is now building more than two hundred new tube types not manufactured by any other concern before the war.

It is reported from Belgium that at least two well-known Belgian hams, ON4UU and ON4AU, have come through the war safely.

W9WID wrote recently: "I have done some research in the field of electrical bugology having been prompted originally by the May, 1944, *QST* article on transformer lice.

"While out in the field one day I chanced across a scene which proved to be a whole colony of carefully controlled specimens. To date I have not ascertained whether the REA was forced to confine the colony of transformer lice in a coop or whether they have found a beneficial use for these creatures. At any rate, this snapshot gives positive proof of the existence of this governmental venture into the control or raising of the Species *Transformus Pediculosis* of the family *Taurus Exeretus*."

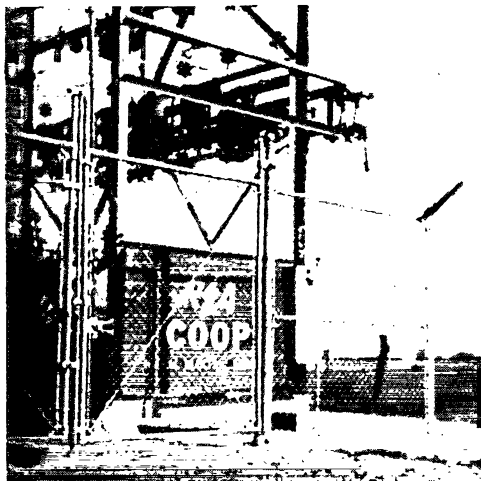

When the management and employees of Electronic Corporation of America in New York sent a congratulatory cablegram recently to "General Douglas MacArthur, Manila, Philippine Islands" on the occasion of the recapture of that metropolis, the message was returned to the senders with a Western Union request for the addressee's Army serial number and APO!

WILIG reports the existence of the "QSL Laundry" in Philadelphia, Pa. The familiar symbol was derived from the initials of the original name of the Quick Service Laundry.

A "non-creeping" liquid which quickly strips finishes from metal, known as Fidelity Stripper No. 306, has been developed by Fidelity Chemical Products Corporation of Newark, N. J. Developed especially for the quick removal of insulating coatings from wires, it also does a thorough job of removing baked-on enamels from objects which cannot or should not be submerged.

The liquid stripper is applied by brush at room temperature. Usually in less than a minute it causes the finish to puff and leave the metal, which is then wiped clean. Since there is no residue or corrosive action, the stripped part may be soldered or refinished immediately.

Designed to meet a wide range of specifications, a new type of vacuum capacitor has been developed by Industrial and Commercial Electronics of Belmont, Calif. Units are available in capacities ranging from 10 to 110 μfd . in steps of 1 μfd ., accurate within $\pm 1 \mu\text{fd}$. Special units are available having tolerances held to 0.1 μfd .

A two-decade electronic counter designed for industrial and laboratory use has been announced by the Potter Instrument Co. of Flushing, N. Y. The counter is actuated by a closing contact or by sine-wave or pulse input, as from a photo-cell, at rates up to 1000 cycles per second. Each decade divides by ten, giving a scaling factor of 100. The count for 0 to 99 appears on two banks of neon lamps. A telephone-type relay is connected to the counter output, its contacts closing once for each 100 input cycles. An electro-mechanical counter may be connected to this relay to extend the count as many places as desired.

The unit can be used as an interval timer by connecting it, through an electronic switch, to a known external frequency source such as 60-cycle a.c. As the switch is closed and opened the unit counts the number of cycles which pass in the switch-closed time interval, giving a reading in terms of the known frequency.



CORRESPONDENCE FROM MEMBERS

The Publishers of *QST* assume no responsibility for statements made herein by correspondents.

A TRIBUTE FROM A SIGNAL CORPS OFFICER

Washington, D. C.

Editor, *QST*:

I know first-hand from World War I and now through World War II how much the radio amateur has contributed both to science and to the defense of his country.

As Winston Churchill said of the RAF, so American citizens truthfully can say of the hams: "Never have so many been helped by so few." I do not know what the Signal Corps, with all of its responsibility of procuring and developing radio, radar and all the other communications equipment, could have done without them.

— Major George R. Call, *SC*

HAM RADIO AND THE SHUT-IN

258 Glenlake Ave., Toronto 9, Canada

Editor, *QST*:

I belong to that large army known as "shut-ins," who are now convalescing at home.

Having left the hospital four months ago, I send every copy of *QST* along to my former ward-mates. They all agree with me that there is something wonderful in reading about other hams. They sketch out plans for the stations they would like to own, and daydream about what they would do if they were pounding a key.

My doctor (who was once bitten by the ham bug himself) says there is nothing that . . . keeps a patient's mind off himself, as to get interested in radio — particularly amateur radio. I agree with him 100 per cent!

One of my biggest thrills was when Bill Winter, VE3APA, came to see me. Now I was going to meet a real amateur. Well, I can tell you that I wasn't disappointed in our three-hour visit. He said he would see about getting me out to the next WAOO meeting. Sure enough — three other hams came in their car and took me to one of the University of Toronto buildings to meet and hear a swell bunch of fellows.

The point I wish to bring out is this: there must be thousands of other civilians shut-ins who would love to see a brother ham who can speak the radio lingo, lend them copies of *QST* and other ARRL books, or perhaps bring along a code-practice oscillator — so they can get the feel of a key. . . .

— Clark Pollock

EX-GIS IN THE MERCHANT MARINE

c/o Postmaster, New York, N. Y.

Editor, *QST*:

For the benefit of all hams and ex-GIs, CDD'D or medically discharged, who are desirous of ob-

taining a position as radio officer in the merchant marine but who harbor doubts as to their physical qualifications, I can say that there are no restrictions. Anyone who can pass the FCC's commercial license exam is eligible to become a ship's "sparks."

After I lost my right wing while in service (AACS) I made innumerable inquiries regarding the above, but the only answers I ever got were indefinite.

If any of you "dit-happy-lads" from the Caribbean AACS area who may read this care to write me,* a letter will be appreciated and answered. This is "KP callin'!"

— Andrew Romanisky

POSTWAR DREAMS

Somewhere in the Aleutians

Editor, *QST*:

Just finished reading W6ANN's letter, entitled "Crystal Ball," in January *QST*, and found myself dreaming along with him.

Stationed up here at an armed forces radio station in the Aleutians, I find myself planning just how I'm going to revamp that exciter unit and rebuild my audio unit with a four channel mixer (low impedance, of course) to permit different types of mikes to suit the occasion. A ribbon mike, for instance, to give my raspy vocal chords a pleasing mellow tone when working some YL operator (that I'll call my "Sinatra Velocity Job"); a mike with equalization or audio filter to remove all low frequencies to give me complete concealment, especially when the fellow whose crystal holder I'm using is listening on the band (especially good when BCLs recognize your voice).

As to antennas, in order to satisfy my cravings I'm going to have to rent an Indian reservation some place where I can have fixed beams for all countries and two good rotary arrays for 10 and 20. Feeders of coaxial or open-wire line will all feed to a central tuning house where they are connected by relays. With the aid of a pilot-light signal we can determine whether the European, the Asiatic or the South American beam is in use.

Here's what I dream about — a good dual-diversity receiver with properly phased sky-wires and my present rig with the old Vibroplex or a mike, my log book open with plenty of sharp pencils, the warm glow of the bottles in the final and the blue haze of the 866s, plus the smell of fresh coffee on the fire. Man, oh, man — that's my hobby, and it sounds good to me!

*Correspondence will be forwarded if addressed c/o ARRL Hq., Editorial Dept., West Hartford 7, Conn.

Seriously, though, I hope the boys will have plenty of crystals or v.f.o.s and will spread out a bit. If we have the same bands (and if ARRL has anything to do with it, we shall) I hope fellows will try all parts of the band rather than crowd like iron filings to a pole-piece at the ends of the band. How's a guy going to separate you when you're about ten deep in one spot?

— Ed. Wolfe, W2DFW

STORY OF A JAP. CRYSTAL

Rt. 2, Box 93, Ojai, Calif.

Editor, *QST*:

Under separate cover find, not a time bomb, but a 1223-kc. crystal from a Japanese field transmitter for your collection. . . .

In the early days of the Guadalcanal campaign and during the battle of the Tannaru River, I was regimental communication officer of the 164th Infantry. Naturally, I was interested in Japanese signal equipment. The portable transmitter from which this crystal was taken was removed from the back of a dead Jap. A .50-caliber machine gun bullet had gone through the transmitter — and, incidentally, the Jap. It was one of the first pieces of Japanese equipment captured.

As we were cut off from our source of supplies for a month and a half, the Jap transmitter and receiver were gradually absorbed into our own gear. The crystal is the sole remaining part. . . .

I saved a trunk of small odds and ends. After I had been in the hospital for several months and someone said, "You can go home now," however, I left everything I couldn't carry in my hands. Twenty-six months in the South Pacific makes one soft in the head, I guess.

Incidentally, hams appear in the queerest places, and it always is a signal officer's dream to get them in his outfit (by hook or by crook). . . .

— Capt. Elmer E. Carter, SC (Ret.), W9ANL

ON THE "CALLING FREQUENCY" IDEA

2260 Boas Street, Penbrook, Harrisburg, Pa.

Editor, *QST*:

I see . . . that W8FU likes the idea of using a "calling frequency." Several years before the war I advanced this plan and it was considered a good idea by a few of the boys, but was given up because of strong protests from the nets using whatever spot we chose for our calling frequency.

Before closing down we had e.c.o.s that were very stable and we could shift our frequency very rapidly and fairly accurately. I believe this idea, brought to life again by W8FU, has good possibilities. . . . Maybe more of the boys are of the same opinion.

One of the greatest advantages would be the ease with which traffic could be picked up and cleared. While working or reading the receiver could remain tuned to the calling frequency, and it would take only a matter of seconds to fire up the transmitter if a station was heard calling with QTC — your section. Likewise, a short call using a directional CQ would often bring an answer

resulting in a relay of traffic. Stations with limited time on the air could participate in traffic handling and still not have to maintain schedules.

I don't believe the QRM would be too great if stations answering a CQ heard on, say, 3600 kc. would simply say "QSY up ten (or down)" or shorter yet "up ten" or "down ten" and immediately shift off the calling spot. If QRM is still too bad, a further move could be made.

— Lewis E. Elicker, jr., W3ADE

"LOW-LEVEL" LEARNING

Williamsport, Pa.

Editor, *QST*:

McMurdo Silver's article on carbon microphones reminded me of one definition of an amateur — "one who learns by trying." The operator who does not some day try a "low-level" mike and *make it work* is throwing away part of his chances for the joy of conquest.

The carbon mike is a swell way for an operator new at the game to start out. He will get good results almost immediately, which is encouraging and gives him a chance to get the rest of the rig going. But if its usage is to limit the scope of amateur investigations, I present the following:

Once the r.f. equipment is in shape, it is time to return to the audio section and do a real job on it. Learn something about the requirements of high-gain high-fidelity circuits. It's no picnic. The problems make one more alert to all phases of communications and the training acquired is invaluable, as many have found in this war.

Sure, we want economy, simplicity, and maximum efficiency; but let's learn something, too. Some of us will try our hand at television and f.m. after the war, but results will be mediocre if we avoid the simple problems and then try to solve the complex intricacies of television. We'll need a good deal of experience on wide-range amplifiers to make low-frequency sync pulses work and to preserve sharp wave-fronts.

The average inquisitive and aggressive ham won't buy a factory-built rig. He wants to build it his own way and work out the bugs himself. Why should the audio system be an exception? Are we going to let industry do all our thinking while we sit at a mike and gas about the swell Burp & Co. transmitter we bought?

Let's get down to work!

— Myron O. Schilling

HAM HOSPITALITY

Somewhere in the Philippines

Editor, *QST*:

It seems that my letter published in "Correspondence from Members" attracted some attention there in the States. I received a letter from an old ham buddy of mine who used to pound brass with me in Brisbane, Australia, and who was discharged from the Army as being over age. He told me he had seen the story and pictures and that it made him "homesick" for the old

(Continued on page 84)



OPERATING NEWS



CHARLES A. SERVICE, W4IE
Acting Communications Manager

LULLIAN M. SALTER
Asst. Communications Manager

FCC Notice. The FCC recently has received reports of certain activities of persons associated with some stations in the War Emergency Radio Service, and has issued the following notice to communications officers of Civil Air Patrol and State Guard stations and to radio aides of Civilian Defense stations requesting cooperation in connection with the work of the Commission's Radio Intelligence Division:

It has come to the attention of the Commission that, in some cases, the communications officer or radio aide responsible for the supervision of the operation of radio transmitters authorized under the license of the Associated Civil Air Patrol, State Guard, or Civilian Defense station license, are conducting operations for the purpose of locating stations in their territory which they believe to be operating illegally.

Although the Commission appreciates the interest of these officials in endeavoring to assist in the enforcement of law, it should be understood that these actions may seriously interfere with the normal operations of the Radio Intelligence Division of the Commission, and possibly of other governmental agencies, in attempting to locate an unauthorized station and apprehend the persons involved.

Accordingly, it is requested that such efforts as may have been undertaken in this regard be discontinued, but that any reports or information coming to your attention regarding unauthorized stations be forwarded immediately to the nearest official of the Commission's Radio Intelligence Division.

We urge each WERS operator to give the FCC his fullest cooperation in this matter.

Press Schedules. A list of commercial press schedules is now available, upon request to Headquarters, to anyone desiring to improve his code speed. This is only a partial list of the many stations which can be used for code practice and we would appreciate knowing of additional stations heard or any changes in the published schedule. When sending in additions, please give the call, time (GMT), frequency (kc.), origin and speed. It is our intention to publish revised or supplementary lists of commercial press schedules from time to time.

SCM Reports. During the past few weeks complaints have been received from members of several Sections regarding the lack of SCM reports in *QST*. In many cases the fault lies with the members themselves who do not advise the SCMs of their activities. In other cases, the SCM no longer is able to perform the duties of his office and has neglected to appoint an Acting SCM to carry on in his stead. The main duty of an SCM these days is to submit a report each month on the activities of the members of his Section for publication in Amateur Activities. Have you written to your SCM lately telling him where you and your amateur friends are and what you are doing? If you have sent news to your SCM

which was not published within a reasonable length of time, let us hear about it.

While we are on the subject of SCMs, we'd like to express our gratitude to those men and women who faithfully send in reports each month even though their terms of office have long since expired. These SCMs deserve your support.

SCM Nominations. We call your attention to the Election Notices in this month's issue containing the names of thirty SCMs whose terms of office have expired. Is your Section listed? Why not get five *full* members of the League to sign a petition for a qualified amateur in your Section and send it in to us before the announced closing date. Please make sure that your candidate has been a licensed amateur operator for at least two years and a *full* member of the League for at least one continuous year immediately prior to his nomination. If you think your SCM has done a good job, send in a petition for him. If not, send in a petition for another member of your Section.

WERS Licenses. Recently it was suggested that a list of WERS stations be published so that unknown nets may be identified when heard. This information is restricted and cannot be published in *QST* or released to unauthorized persons in any way, but we now have ready for issuance to recognized WERS officials, mimeographed sheets containing the names, calls and number of operator permits of 271 CD-WERS, 14 CAP-WERS and 11 SG-WERS licensees. Copies of this list are available to qualified WERS personnel only, and it is necessary that the radio aide make request for, distribute and be responsible for same.

— L. M. S.



These hams from various parts of the world met recently in the European Theater of Operations. *Left to right, front row:* W. O. Throssell, G2HJR; Sidney Berg, W2IID; S. R. McDowell, VU2FV. *Back row:* Lt. A. Jones, G3RV; S. T. Phillips, G8DL; Capt. C. J. Black, G6XR; Capt. N. Balke, VE5BM; Major G. N. Wilford, AC8HB, and Capt. C. R. Thornton, VE2AR.

Each month under the accompanying heading we shall publish the story of an outstanding WERS organization as an item of general interest to all WERS participants. Contributions are solicited from any radio aide or WERS participant, whether he be an amateur or a WERS permittee. Descriptions of organizations which have already been featured in *QST* articles will not be considered. The story may describe the organization in general, how it came into being, how it was set up and how it operates; or it may describe some particular phase of the organization which makes it unusual or unique. Contributions should be brief (two or three typewritten pages, double-spaced, is maximum) and may include photographs if desired, although only one photograph will be printed with each story. Each story must be released for publication by the radio aide of the licensee, in writing. Address your contribution to the Communications Department, ARRL, and mark it: "For WERS of the Month."

WERS of the Month



To San Mateo County, California, goes the distinction of receiving the first radio license west of the Mississippi under the War Emergency Radio Service granted by the Federal Communications Commission as an adjunct to the Civilian Defense. Since receipt of its license San Mateo County has actively engaged in drills at least once each week and has participated in eight tri-city defense drills. Several incidents have been handled completely by radio without the use of telephone service whatever.

Administratively, KFHM, the official WERS station in San Mateo County, operates under a county radio aide supported by an advisory council and city or community radio aides who are directly responsible for their individual municipalities.

Physically, the organization consists of a county radio control which at all times monitors not only through the assigned broadcast stations but also directly through the Fourth Interceptor Command. In each of the communities embraced by San Mateo County territorial limits, there is a local radio control which monitors the county radio control.

Working out from the radio controls in each community are mobile units. Each mobile unit is equipped with a walkie-

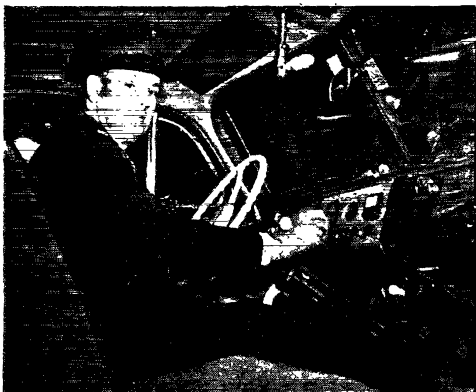

Lt. J. Steventon, W6CLS, acting radio aide, operating WERS mobile unit KFHM-25, San Mateo County.

talkie which is a self-contained battery supply transceiver. In the event of an actual emergency, the mobile unit is dispatched to the scene and if it cannot approach directly to the scene of the incident, the walkie-talkie is sent on so that it may communicate with the mobile unit and the latter, in turn, communicate with the radio control.

In addition to the mobile units, fixed stations have been set up at important centers, such as Police Headquarters, Fire Headquarters, Casualty Centers and Hospitals.

The equipment which, of course, is all adapted to the 112-116-Mc. band, has been donated almost entirely by amateur operators and other citizens who have become interested in the movement. Training classes, covering not only the operation but also the construction of the transmitters and receivers used in this service, are conducted through the courtesy of San Mateo Junior College. To an increasing extent the operators are women, all of whom must, of course, comply with the FCC regulations which demand at least a restricted radiotelephone license. More than sixty operators have been prepared and given actual experience in the field. An interesting sidelight is that the present group of WERS operators includes persons from twenty-seven different States in the Union.

In every instance, the local radio control station is located in the same building with the Civilian Defense "horseshoe." While the War Emergency Radio Service in San Mateo operates independently of other radio services, it cooperates wholeheartedly with the local police and other authorities.

In connection with the periodic Civilian Defense tests during which actual incidents are simulated, KFHM has participated in several tests where at least a portion of the incidents have been reported entirely by radio.

The value of the WERS is attested by the fact that many of the local communities have agreed to undertake the maintenance of the equipment used.

The program's success is due to the excellent leadership of John I. Steventon, acting radio aide, and the genuine interest of James Torney, Adult Center Director; C. S. Morris, president of San Mateo Junior College, and the Radio Department Faculty of San Mateo Junior College, headed by Jacob H. Wiens and assisted by Robert Reimus, Cyril Miller and John Hecomovich. The cooperation of all units in the actual field work is largely due to the coordination work done by Henry Boer, who is in charge of field operations.

BRIEFS

Connecticut Wing, Civil Air Patrol, has need for instructors in International Morse Code and allied communications subjects in order to completely carry on the work of training boys and girls in the AAF Civil Air Patrol Cadet program. It is thought that many ARRL members who no longer are able to be on the air would like to help in this program. If you are interested in this work and reside in or near the following cities or towns, please write to Capt. Frank B. Hales, CAP, Communications Officer, 56 Woodside Ave., Waterbury 61, Conn., for further information: New Haven, Stamford, Manchester, Willimantic, Simsbury, Bridgeport, Greenwich, Norwich, Putnam, Torrington, Danbury, Hartford, New London, Enfield, New Britain.

The 11th Regiment, New Jersey State Guard, has openings in its headquarters detachment for a number of men to operate Signal Corps and WERS type equipment, according to R. W. Gast, ex-W2WG, communications chief. The communications unit employs Signal Corps field telephones and switchboards, v.h.f. radio transmitters and receivers and other signal equipment. WERS operation is conducted under the call WKZF. The State Guard is a military organization of citizen volunteers between the ages of 17 and 55. Uniforms and equipment are furnished, and gasoline rations are obtainable for necessary driving. The detachment drills on Thursday nights at the East Orange Armory on Orston Parkway near Park Avenue. Men who are interested are invited to appear any Thursday at 8:00 P.M. Here is an opportunity to perform part time military service while carrying on your regular civilian job.

Lester Reiss, 1230 Park Ave., New York 28, N. Y., s/sgt. in the 22nd Regiment, New York State Guard Communications Section, 168th St. and Ft. Washington Ave., writes their need for good radio men in that organization.

ELECTION NOTICES

To all ARRL Members residing in the Sections listed below:

The list gives the Sections, closing date for receipt of nominating petitions for Section Manager, the name of the present incumbent and the date of expiration of his term of office. This notice supersedes previous notices.

In cases where no valid nominating petitions have been received from ARRL full members residing in the different Sections in response to our previous notices, the closing dates for receipt of nominating petitions are set ahead to the dates given herewith. In the absence of nominating petitions from full Members of a Section, the incumbent continues to hold his official position and carry on the work of the Section subject, of course, to the filing of proper nominating petitions and the holding of an election by ballot or as may be necessary. Petitions must be in West Hartford on or before noon on the dates specified.

Due to resignations in the San Joaquin Valley and Utah-Wyoming Sections, nominating petitions are hereby solicited for the office of Section Communications Manager in these Sections, and the closing date for receipt of nominations at ARRL Headquarters is herewith specified as noon, Tuesday, May 1, 1945.

Section	Closing Date	Present SCM	Present Term of Office Ends
Western Penna.	Mar. 15, 1945	E. A. Krall	April 1, 1945
Mississippi	Mar. 15, 1945	P. W. Clement	April 1, 1945
Rhode Island	Apr. 2, 1945	Clayton C. Gordon	April 15, 1945
San Joaquin Valley	May 1, 1945	Antone J. Silva (resigned)
Utah-Wyoming	May 1, 1945	John S. Duffy (resigned)
Hawaii	May 1, 1945	Francis T. Blatt	Feb. 28, 1941
Sacramento Valley	May 1, 1945	Vincent N. Feldhausen	June 15, 1941
Alaska	May 1, 1945	James G. Sherry	June 14, 1942
Southern Minn.	May 1, 1945	Millard L. Bender	Aug. 22, 1942
New Hampshire	May 1, 1945	Mrs. Dorothy W. Evans	Sept. 1, 1942
West Indies	May 1, 1945	Mario de la Torre	Dec. 16, 1942
Western Fla.	May 1, 1945	Oscar Cederstrom	Oct. 1, 1943
Idaho	May 1, 1945	Don D. Oberbillig	April 15, 1944
South Dakota	May 1, 1945	P. H. Schultze	May 18, 1944
Alabama	May 1, 1945	Lawrence Smyth	May 22, 1944
Los Angeles	May 1, 1945	H. F. Wood	July 1, 1944
Arkansas	May 1, 1945	Edgar Beck	Aug. 17, 1944
North Dakota	May 1, 1945	John McBride	Aug. 17, 1944
Virginia	May 1, 1945	Walter G. Walker	Oct. 15, 1944
New Mexico	May 1, 1945	J. G. Hancock	Oct. 15, 1944
Santa Clara Valley	May 1, 1945	Earl F. Sanderson	Oct. 15, 1944
Tennessee	May 1, 1945	James B. Witt	Nov. 15, 1944
Georgia	May 1, 1945	Ernest L. Morgan	Nov. 29, 1944
Kentucky	May 1, 1945	Darrell A. Downard	Dec. 15, 1944
Western New York	May 1, 1945	William Beller	Feb. 15, 1945
North Carolina	May 1, 1945	W. J. Wortman	May 3, 1945
Washington	May 15, 1945	O. U. Tatro	May 27, 1945
N.Y.C. & L.I.	June 1, 1945	E. L. Baunach	June 9, 1945
No. Minnesota	June 1, 1945	Armand D. Bratland	June 15, 1945
So. New Jersey	June 15, 1945	W. Raymond Tomlinson	June 22, 1945

1. You are hereby notified that an election for an ARRL Section Communications Manager for the next two-year term of office is about to be held in each of these Sections in accordance with the provisions of the By-Laws.

2. The elections will take place in the different Sections immediately after the closing date for receipt of nominating petitions as given opposite the different Sections. The Ballots filed from Headquarters will list in alphabetical sequence the names of all eligible candidates nominated for the position by ARRL full members residing in the Sections concerned. Ballots will be mailed to full members as of the closing dates specified above, for receipt of nominating petitions.

3. Nominating petitions from the Sections named are hereby solicited. Five or more ARRL full members residing in any Section have the privilege of nominating any full member of the League as candidate for Section Manager. The following form for nomination is suggested:

Communications Manager, ARRL
38 La Salle Road, West Hartford, Conn.

We, the undersigned full members of the ARRL residing in the Section of the Division hereby nominate as candidate for Section Communications Manager for this Section for the next two-year term of office.

(Five or more signatures of ARRL full members are required.)
The candidates and five or more signers must be League full members in good standing or the petition will be thrown out as invalid. Each candidate must have been a licensed amateur operator for at least two years and similarly a full member of the League for at least one continuous year, immediately prior to his nomination or the petition will likewise be invalidated. The complete name, address and station call of the candidate should be included. All such petitions must be filed at the headquarters office of the League in West Hartford, Conn., by noon of the closing date given for receipt of nominating petitions. There is no limit to the number of petitions that may be filed, but no member shall sign more than one.

4. Members are urged to take initiative immediately, filing petitions for the officials of each Section listed above. This is your opportunity to put the man of your choice in office to carry on the work of the organization in your Section.

— Charles A. Service, Jr., Acting Communications Manager

ELECTION RESULTS

Valid petitions nominating a single candidate as Section Manager were filed in a number of Sections, as provided in our Constitution and By-Laws, electing the following officials, the term of office starting on the date given.

Michigan	Harold C. Bird, W8DPE	Feb. 3, 1945
Southern Texas	James B. Rives, W5JC	Feb. 15, 1945
Iowa	Leslie B. Vennard, W9PJR	Feb. 15, 1945

Press Schedules

The following list of press schedules has been compiled for code practice purposes. All stations listed have been checked by the ARRL monitoring station. However, as these schedules are subject to change without our knowledge, we would appreciate knowing of any changes in the time or rate of speed of these transmissions or any additional stations transmitting code so that we may revise our list from time to time. When sending in additions, please give the call, time (GMT), frequency (kc.), origin and speed. The contents of these messages must not be divulged to anyone other than the addressee. PLEASE DO NOT USE THESE TRANSMISSIONS FOR ANYTHING BUT CODE PRACTICE.

Time (GMT)	Time (EWT)	Call	Freq. (kc.)	Origin	Speed
0030	8:30 P.M.	WBG3	7,340	New York	30
0030	8:30 P.M.	WBG7	7,620	New York	30
0030	8:30 P.M.	WCL	9,390	New York	30
0030	8:30 P.M.	WCX	7,850	New York	35
0030	8:30 P.M.	WJS	15,700	New York	35
0100	9:00 P.M.	WDD	7,510	New York	30
0100	9:00 P.M.	WHL	10,750	New York	30
0105	9:05 P.M.	KROX	17,880	San Francisco	25
0200	10:00 P.M.	WGEX	7,000	New York	30
0200	10:00 P.M.	WLWR	6,370	New York	30
0200	10:00 P.M.	WRUX	5,985	New York	30
0300	11:00 P.M.	WLWR	6,370	New York	30
0305	11:05 P.M.	KROX	9,850	San Francisco	25
0505	1:05 A.M.	KROX	9,850	San Francisco	25
0900	5:00 A.M.	KMH	8,350	Los Angeles	16
0900	5:00 A.M.	KROX	5,980	San Francisco	25
1200	8:00 A.M.	WCW2	15,860	New York	30
1200	8:00 A.M.	WCX	7,850	New York	35
1200	8:00 A.M.	WJS	15,700	New York	30
1200	8:00 A.M.	WLWR	12,967	New York	35
1400	10:00 A.M.	WCW2	15,860	New York	30
1430	10:30 A.M.	WCX	7,850	New York	35
1430	10:30 A.M.	WJS	15,700	New York	35
1440	10:40 A.M.	WCL	9,390	New York	25
1500	11:00 A.M.	WGEX	17,880	New York	30
1500	11:00 A.M.	WLWR	12,967	New York	30
1505	11:05 A.M.	KROX	9,850	San Francisco	25
1515	11:15 A.M.	KHF4	15,700	Los Angeles	35
1515	11:15 A.M.	KJE6	7,350	Los Angeles	35
1615	12:15 P.M.	WCX	7,850	New York	35
1615	12:15 P.M.	WJS	15,700	New York	35
1800	2:00 P.M.	WCX	7,850	New York	35
1800	2:00 P.M.	WJS	15,700	New York	35
1815	2:15 P.M.	KROX	11,140	San Francisco	25
1900	3:00 P.M.	WCX	7,850	New York	35
1900	3:00 P.M.	WJS	15,700	New York	35
2000	4:00 P.M.	KJE	15,850	Los Angeles	16
2015	4:15 P.M.	KROX	17,880	San Francisco	25
2045	4:45 P.M.	WLWR	12,967	New York	45
2100	5:00 P.M.	WCX	7,850	New York	35
2100	5:00 P.M.	WJS	15,700	New York	35
2115	5:15 P.M.	WJP	8,810	New York	25
2200	6:00 P.M.	WCL	9,390	New York	20
2200	6:00 P.M.	WCX	7,850	New York	35
2200	6:00 P.M.	WGEX	7,000	New York	30
2200	6:00 P.M.	WHL	10,750	New York	25
2200	6:00 P.M.	WJS	15,700	New York	35
2200	6:00 P.M.	WLWR	9,550	New York	30
2305	7:05 P.M.	KROX	17,880	San Francisco	25
2330	7:30 P.M.	GAY	8,910	England	25
2330	7:30 P.M.	WXC	7,850	New York	35
2330	7:30 P.M.	WJS	15,700	New York	35
2400	8:00 P.M.	WEV	5,270	New York	30
2400	8:00 P.M.	WQW2	7,730	New York	30

The Month in Canada

QUEBEC—VE2

From Lt. L. G. Morris, VE2CO:

GROUP Captain Edgar Wurtele, ex-VE2FD, has been appointed commanding officer of the RCAF's Lachine station. FD joined the RAF in 1935, has 2400 flying hours to his credit, and has flown over fifty types of planes. In 1941 he was given command of the 1st Canadian Torpedo Bombing Squadron, later became OC of the RAF station at Patricia Bay, B.C., then returned to England in charge of a station in the Canadian Bomber Group. In June, 1944, he transferred to the RCAF.

Congrats to Jack Little, 2HP, on the arrival of a baby girl. Bob Prissick, 5TD-ex-2CX, is now serving with the Army overseas. Jack Warr, ex-2EX, has been promoted to the rank of acting lieutenant commander. Harry Ashdown, 2IO, was in a plane crash in Iceland, but escaped without injury. Harry suffered a broken leg in a crash in B.C. several years ago.

ONTARIO—VE3

From L. W. Mitchell, VE3AZ:

THE first general meeting of the WAOO for the new year was held in Room 21, Electrical Bldg., University of Toronto, on Thursday, February 15, 1945, with fifty-five in attendance. President Bob Humphreys, 2ALC, was in the chair and introduced the guest speaker, T. S. Farley of T. S. Farley Ltd., Hamilton, Ontario, whose paper was entitled "Design and Manufacture of Radio Coils." This paper covered the problems encountered in the design of radio coils, the application of these principles to actual design, and a discussion of manufacturing and test methods. Various coils also were displayed, which were enthusiastically examined by all. A hearty vote of thanks to Mr. Farley for his excellent paper was tendered by Alf Edmonds.

Newcomers to the WAOO meeting were Orville Anderson, 3AEJ, and C. L. Skelding, 3ADU. Ash Chown, 3IW, was on deck again after a considerable absence. He has recently returned to his civilian duties after serving as a Government investigator since the outbreak of hostilities. Floyd Gribben 3LR, also dropped in at the meeting. He has been in Toronto on a visit but has since returned to his work in Montreal. George Perrin, 3JT, of Oshawa, who is at present working in a Toronto war plant, is seriously considering taking unto himself an XYL. We wish them both lots of happiness. The proposed postwar conference which the Toronto district hams were going to hold in the Spring, has been postponed until a later date. The major, Art Potis, 3MT, was recently transferred to another war plant in Toronto. We know he misses the YLs who used to keep him company during the long ride down to work each morning.

ALBERTA—VE4

From W. W. Butchart, 4LQ:

A LETTER from 4AEN, Geo. Marion of Edmonton, reveals that he has been doing more than a little traveling since last reported as being at Charleston, S. C., with the RCN technical crew. Yes, he has been at sea on an RCN



NARC Secretary-Treasurer Hilda Hughes, VE4WH, opens her gift at the farewell party given in her honor, while Mrs. Bert Stollery, XYL of VE4HJ, and Ken Angus, VE4VJ, president of NARC, look on.

ship, possibly a corvette or destroyer. 4DR, Doc. J. J. Dobry of Cardston, visited Edmonton in February while scouting around for staff for his clinic in Cardston, and while in the city he spent a couple of interesting hours with 4BW, Ted Sacker, and 4HM, Chas. Harris, leaving behind two very interesting reels of 8-mm. movie film, which HM and EA, Roy Usher, showed at the Edmonton Ciné Club meeting. As Doc's QTH is quite close to Waterton and Glacier National Parks he has many excellent shots of them taken both in summer and winter. Paying a visit to 4HM a few days ago, I discovered him poring over a new steel chassis. Charlie is very keen on experiments with input circuits, and judging from results, his experimenting is all to the good.

The NARC has lost its secretary-treasurer, Hilda Hughes, 4WH, popular young YL, who represents one of the chief reasons that the club has held together during the war years. She has been transferred to the Vancouver Branch of the Royal Bank, and by the time this item appears in *QST* it will be no secret that she is getting married this Spring. The NARC recently held a farewell party in her honor, and presented her with a table cloth and napkins. Amongst those in attendance were 4EA, Roy Usher; 4YX, Cecil Cable; 4VJ, Ken Angus; 4HJ, Bert Stollery, and XYL; 4XF, Pat Sullivan, and XYL; 4HM, Chas. Harris, and YF; 4LQ, Bill Butchart, and XYL.

While on a business trip to Rocky Mountain House I (LQ) paid a visit to the Alberta Forestry Service Radio Station, and saw AOZ's rig sitting on the operating table doing its stuff. You chaps will probably recall that I made mention some time ago, of Slim's rig pinch-hitting at Rocky after the big commercial rig was knocked out of action by a direct hit of lightning. And speaking of 4AOZ, Slim Marsden of Milo, he writes to say that he has sold his business in Milo and intends to locate in fields where the wind doesn't blow every day! Other news items from Slim's letter are as follows: 4AMA, Ed MacDonald, of Grassy Lake, is a civilian radio technician with the RCAF at different points in Saskatchewan and Manitoba, and is now stationed at the d/f station in Portage LaPrairie, Man. Also at the same station relieving AMA we find 4TD, Cec Morton of Vegreville. Then 4AP is at No. 2 Flight Hangar, while 4UV, Max Frazer, is in the Maintenance Hangar at the same station. 4TI, Novakoff, is a technician at No. 5 Hangar, and 4AMT, Matin Murray, who has been overseas and returned, is with the radio crew at No. 2 Flight Hangar. Brandler Parsons of Edmonton, formerly connected with CFRN, CJCA and 4ASX, is a pilot at the same station. 4ANI, Geo. Brockie, drives a supply truck for the Manitoba school for cripples. 4APZ, Alvin Campbell, of Innisfail, has been pinch-hitting for his brother by taking over his shift as projectionist at the Burdett theater. Jock Palmer, former ham of Lethbridge, Calgary, etc., who was chief pilot instructor at EFTS, High River, until that station closed down, has opened a radio shop in High River and he employs four ex-pilots from the station. Thanks for that dope, Slim.

Our old pal 4AQQ, Tommy McLaughlin of Edmonton, is working for Western Airlines of this city, and is a member of the Edmonton Ciné Club, which organization boasts at least four Edmonton hams among its membership: 4BV, 4AQQ, 4EA and 4LQ. Tommy says that Norm. Reidford, 4ANH, of Edmonton, is getting his discharge from the RCAF and will take a course in electrical engineering at the University of Toronto. He also advised that, to the best of his knowledge, 4YD, Pete Fair of Peace River, is now stationed in Mossbank, Saskatchewan. Roy Cable of 4YX is a sub-lieutenant in the RCN, making his Hq. in Halifax. 4ATH, Stan Mitchell, of Edmonton, phoned the other evening and said that he had met W9PKO, M. R. Mayhugh, after he had seen PKO's call on a car on Jasper Avenue. Our Stan made himself known and found out that PKO is working in Edmonton for North West Airlines at No. 3 Hangar, American Air Base, Edmonton Municipal Airport, and that he would like to meet members of the Edmonton ham fraternity, if possible. The Edmonton boys may get in touch with him by addressing a card or letter to the above noted QTH. 4HF, Ed. Gilbert, of Tomahawk, possessor of the famous "pretzel-bender" rig on 160 'phone, is at present in Calgary studying for his commercial ticket. 4WE, Minnie Nichols of Edmonton, is operating for TCA at Moncton, N. B./S Ron Mathews of Kaslo, B. C., now is a married man, and is stationed at AOS, Winnipeg. 4WX, Norm. MacDonald of Calgary, at present a radio officer aboard a ship stationed at Vancouver, was ashore long enough over the Xmas holidays to get himself married, at least. Congrats, Norm!



MANY READERS of this page who are interested in high quality reproduction have asked us to give a circuit diagram for the type of amplifier we have been describing on this page. We are happy to oblige, and the diagram for the output stage is given below.

This diagram is quite conventional, and has no tricky features. However, some comments are in order. It is marked with 2A3s in the output, but 6A3s and 6B4-Gs can of course be used, as they have identical characteristics. The only differences are in the filament voltage and the basing.

★ ★ ★

Usually 2A3s in a push-pull output stage are operated as a Class-AB₁ amplifier. In the circuit given below, they are operated Class A. This results in lower distortion and better speaker damping, and minimizes the effects of using tubes which are not a matched pair. On the other side of the ledger, we must admit that Class A gives only 7 watts of output as against 10 or 15 watts for Class AB₁. Furthermore, the no-signal plate current is 120 ma. instead of 80 ma. For a high fidelity amplifier such as this, we think the advantages outweigh the disadvantages. Seven watts of power are ample for home use.

The Class-A amplifier requires 45 peak volts to drive the grids positive, as compared to 62 volts for the Class AB₁. This makes it sound practice to drive the output from a single tube through a coupling transformer. High-fidelity audio transformers do not have much step-up ratio. Usually the ratio is about one-to-one from the plate to either grid. In the circuit shown, this would require a total peak swing of 90 volts on the plate of the 6J5. This, a 6J5 should be able to deliver with very low distortion. However, if the output tubes required much more swing than this, we would recommend two 6J5s in series (i.e. in push-pull).

We have not listed components as we would in peacetime. Use the best transformers and the best speaker you can get, and give the speaker a good baffle. The size of the by-pass condensers should be generous, and may well be larger than specified on the diagram.

So much for the output stage. We will discuss the input end of the amplifier next time.

WILLIAM A. READY

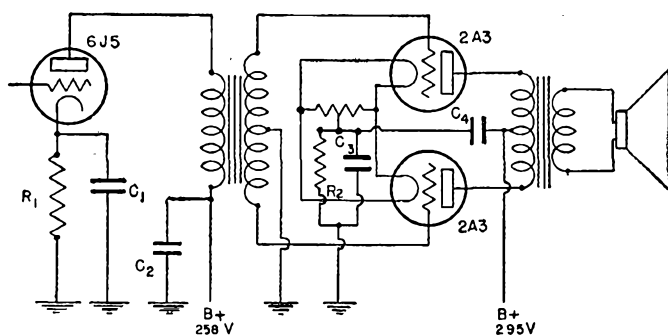

- R₁ 900 OHMS
- R₂ 375 OHMS
- C₁ 25 MFD
- C₂ 10 MFD
- C₃ 25 MFD
- C₄ 10 MFD



AMATEUR ACTIVITIES

ATLANTIC DIVISION

EASTERN, PENNSYLVANIA — SCM, Jerry Mathis, W3BES — 3CL is home on a short furlough from Brazil. Two letters from 3GHM state that he is on the broad Pacific. 3AQN reports by home-recording discs. He has cut 2500 discs in the past two years, set up an OCD wired wireless system, recorded for the York scrap drive and cut 300 discs for service men's families to be sent overseas at Christmas. Paul solicits QSOs via home recording. 3HRE says that Easton WLRs has moved its control station to the top floor and the shortening of the feed line should enable it to put out a better signal. He also states that a line of WERS units exist that can relay from Philadelphia to New York City, but the complete operation of the proposed net has not been attempted. Dick Hanak (LSPII) writes that he is enjoying his seagoing life in the merchant marine. 3DMQ has made his first trip across in the merchant marine. 3GYV writes from Italy that he is playing around with photography. 3EFH, former NCS of TL "C," is back in Philadelphia. 3DVC has a very FB shack well under way and is also building a super frequency-measuring device. Lower Merion WERS tests are well attended and the interest is high. 3DGP and 3GC won the Army-Navy "E." 3AGV has recovered from an industrial accident in his arm. 73, Jerry.

MARYLAND-DELAWARE-DISTRICT OF COLUMBIA — SCM, Hermann E. Hobbs, W3CIZ — D.C. Notes of the Washington Radio Club has proved to be quite a popular feature of radio activities in this vicinity, and one that would prove equally attractive along similar lines for other clubs. ASE now is located at Langley Field control tower and says that the work is very interesting and that he has met quite a few hams in the AACS. The Club code class, held each week on Sat. at 7:30 p.m. at C.R.E.I., has reached a speed of seven or eight w.p.m. Since a few beginners have shown an interest in the class, a second class is being contemplated. If sufficient interest is shown the new class will be started in the near future. A recent visitor to one of the code practice classes was Comdr. QV, director of the Atlantic Division. FZ is experimenting with radio-controlled model boats. GQM is back in the States after eighteen months at sea. 60GZ is EYX's boss. G2JK gave a very interesting talk about ham life in Great Britain at a recent meeting of the Washington Radio Club. CDQ spent three weeks in Miami but was ill most of the time. She is the first YL to be president of the W.R.C. FPQ is the proud father of a jr. operator. 8MOW is flying high in his new Fairchild. 8NMX expects to be on furlough soon, after 2 years below the Equator. GKP says his hi-f amplifier won't work unless plenty haywire. It feeds back whenever it is neat enough to put in the living room. ZD, who is working for the Western Electric Co., Newark, N. J., sends his 73 to the gang, JJD, ex-6NQB, 7HXK, who has been in the merchant marine for a year, sends in an interesting letter from somewhere in the Central Pacific. Mail addressed to his home address, 212 Douglas St., N. E., Washington, D. C., will be forwarded to him.

SOUTHERN NEW JERSEY — SCM, Ray Tomlinson, W3GCU — Asst. SCM, Ed. G. Raser, W3ZI. Regional EC for So. N. J., Technical Radio Advisor for N. J. State Defense Council, N. J. State Radio Aide and Radio Aide for Hamilton Twp. WERS, ASQ. EC for Somerville and vicinity, including Southbranch, and Radio Aide for Hillsboro/Branchburg Twp. WERS, ABS. Assistant Radio Aide for Hillsboro/Branchburg Twp. WERS, ACC. State Aide Dallas Fogg reports some WERS units making revisions and changes toward the betterment of their organizations. Hamilton Twp. Radio Aide ASQ reports the newly organized Hamilton Twp. WERS Operators' Association has taken hold and is now functioning very nicely. Last minute changes were made in some of the committees and a licensed amateur has been placed on each of the committees as advisor as follows: JOL, ITS, GCU, FMU, AXU. Radio Aide ASQ acts in an advisory capacity on all committees. On the regular test period, Wed. evening, Feb. 7th, a visiting delegation from Ewing Twp. was entertained by a demonstration given by the Hamilton Twp. WKPX network. Ewing Twp. officials were greatly impressed with the WKPX or-

ganization and it is expected that another demonstration will be forthcoming in the near future for the enlightenment of others of our neighboring officials. No report has been received from Hillsboro or Bridgewater Twp. The Delaware Valley Radio Association has several new members. This organization has made a place within its membership for radio servicemen and technicians other than the amateur fraternity, and has accepted ten or twelve of these servicemen into membership. At the same meeting at which the servicemen were accepted, JOL and HW were also annexed to the fast-growing organization, bringing to fourteen the total of new members. The D.V.R.A. Bond Wagon is rolling along nicely since being "greased" up by CCO. A contest of somewhat extensive proportions is on with the forming of three teams, two of them being divided up among the men, and the third, which was on the top of the heap in the Jan. series, being composed of the members of the D.V.R.A. Ladies' Auxiliary. Disheartening news comes with the loss of President EED to the merchant marine. Les obtained his 2nd-class commercial ticket last month, got himself a membership in the Radio Operators' Union, and shipped as radio operator on Feb. 19th. Pop Yoder got that excellent work bench Les had when he "broke up," and convinced Vice-President Vince Wagner that the printing of the D.V.R.A. News should be his headache. JOL is working at local h.c. WTTM, part time as studio technician and part time as transmitter engineer. A letter received recently from JAG, also in the merchant marine, tells us Pierre is OK and doing swell. He says the gear he is working with is Mackay, and he is having a swell time with the lil u.h.f. one-half watt 'phone-c.w. portable gear aboard. Pierre's letter, dated December 26, 1944, extends Season's Greetings to all the gang, and gives his QTH as, Ens. Pierre Williams, chief radio operator, c/o Postmaster, N. Y. The South Jersey Radio Assn. (SJRA) has started publication of a monthly rag similar to the D.V.R.A. News, and their new paper contains many items of interest for this column. We would appreciate it if the SJRA would submit news published in their new paper to this office for publication in this column. 73, Ray.

WESTERN NEW YORK — SCM, William Bellor, W8MC — We hear that DKN now is behind the war effort in a big way. Fred is a manufacturer of radio-testing equipment and has a sub-war contract. DFN has just completed a new three-stage 112-Mc. transmitter and a 112-Mc. superhet, using a 6J6 tube as mixer. RDX and TEX are working together on a job in a radio war plant. NCM gave a nice talk on out-phase modulation at a recent meeting of the RARA. We have the following information from Charlie Fox: AYI is communications chief of the Third Regiment, New York Guard, Syracuse, N. Y. Lt. Bob. Aller, WFBAL-AWP, is doing a swell job as communications officer. Among other things he designed, and practically built by himself, five walkie-talkie units which were very successfully used during maneuvers at Camp Smith last summer. S/Sgt. DWJ is working for General Electric Co. installing and testing radar equipment. They have a weekly program that includes code practice, flag signaling, fundamentals of radio and care and use of equipment. Their communications sections has also cooperated in several problems with the local WERS and CAP units. The group is eager to hear from anyone interested in their activities. MNW is back in a war plant after receiving his honorable discharge from the Navy. 2EZC, formerly of Lynbrook, L. I., now lives in Binghamton. He invites correspondence from PK, AFQ, RSV and the rest who used to operate on 3905 kc. 73, Bill.

WESTERN PENNSYLVANIA — SCM, E. A. Krall, W8CKO — We are indebted to AOE for sending in a report for Western Pennsylvania this month. Lt. IYQ, now a prisoner of war in Germany, writes that he is becoming accustomed to doing KP and odds and ends around camp and that he is spending some of his spare time studying radio and brushing up on his math. TVA, located in Fortaleza, Brazil, with the AACS, still insists that one good American blonde is worth a handful of senoritas. However, Gus tells us he is willing to trade for some good old Pennsylvania snow. TTD reports that he is doing all right as radio instructor at Central Signal Corps School, Camp Crowder, Mo., and says he is going to be the AARS chief brasspounder. He has met many hams from all parts of the country at the school. VYU, Greensburg's pretty YL operator, still is QRL with radio engineering at Carnegie Tech., but finds time to sit in at a local broadcast station in her spare time. KCV still is slapping those mosquitoes around in New Guinea. Art says he wishes he could hear a 2 1/2-meter signal on the air. What has

(Continued on page 84)

CONTACT!

Behind bombing missions and dog fights

at every one of our invasion points

you'll find Super-Pro receivers

on twenty-four hour duty with the AACs

under almost impossible

operating conditions.

CRYSTAL
SELECTIVITY

BAND
WIDTH

LIMIT
OFF

REAL
TUNING



ESTABLISHED 1910

THE HAMMARLUND MFG. CO., INC., 460 W. 34TH ST., N.Y.C.
MANUFACTURERS OF PRECISION COMMUNICATIONS EQUIPMENT

(Continued from page 68)

become of the gang from the ole Pennsylvania ARRS net? Let's hear from CDG, DML, JUC, OUH, PER, UKL, USV, MJK, NDE and RAP. If anyone knows the addresses of these boys, AOE, 509 Beechwood Ave., Farrell, would appreciate hearing from you. Mercer County has ten licensed WERS stations, and all are active three nights a week for 2½-meter drills. Two channels are being used for 'phone, and one for i.e.w. The boys have been working the gang from Youngstown, Ohio, which is about fourteen miles airline distance, and have been hearing signals from Warren, Ohio, a distance of eighteen miles. Four-element beams are being used at this correspondent's station, at present running an m.o.p.a. using 6V6 oscillator and 815 amplifier, cathode-modulated, crystal microphone. Reports indicate broadcast quality. FXK, Greenville's only active amateur, reports being QRL with CAP code instruction, besides acting as supply and communications officer with a lieutenant commission. Greenville also reports hearing the Mercer County WERS gang at times. This shows that Greenville may soon be tied up with WERS activities through CAP. TTD has added the following to AOE's report: S/Sgt. TTN, in Northern Solomons, claims to be acquiring radio knowledge. He has been building sets and likes the Tiny Tim circuit of QST. UVD is nicely settled and enjoying farm life and is awaiting the signal to build some tall towers on the hilltop at his new location. OMG has been discharged and is back at his old QTH working and studying. When last heard from Pvt. TWI was doing experimental work for the government, WRK/1 writes to Headquarters that he would like to hear from the gang in Erie and vicinity. His address is: Franklin A. Munro RM1c, 84 Van Zandt Ave., Apt. 7, Newport, R.I.

CENTRAL DIVISION

INDIANA — SCM, Herbert S. Brier, W9EGQ — KMY says, "This is supposed to be a combat zone, but it seems more like the States." AHJ, radio operator in the merchant marine, has been lucky; weather has been perfect on all his trips. EOC holds down two jobs; he has three transmitters waiting for the day. JXK has spent several months in the hospital. He uses an SX-24 to help pass the time. ZNC reports from "somewhere in Germany" that it won't be long now. TTY, in Hawaii, built a crystal set, which cost \$174.80; \$170.00 of which was for a radio course to acquire the skill to build it. EHT now is SAD2c, and has a new address. MPB is back in Indiana Harbor with a medical release after three years in Hawaii. YMV says, "All I can tell you is that I am in the Pacific, and that not all Alaska Steamship Co.'s ships go to Alaska." EGV gets the "screaming willies" when he sees Indiana labelled as being in the North Temperate Zone. PUB loves the efficiency of the Navy! After flying B-24s for a year in the Central Pacific, he and the rest of the crew are going to elementary B-24 school. He has been awarded a commendation ribbon for excellent service in the line of his profession as a combat aircrewman of a Navy patrol bomber. EBB has met a WAVE who knows me; lucky girl! The gang at NRL are trying to make a ham of her. SNF gloats that with only twenty-six more promotions, he will equal "Old Blood and Guts" in rank. UZW, back in the States after two and one half years in New Zealand, Fiji Islands, Guadalcanal, Australia, New Guinea, New Britain, Russell Islands and Peleliu, got married. He saw a captured "J" in '42 on Guadalcanal. PQL says that CRZ is not the only one ready to come home after thirty months in the Pacific, but that the road to Tokyo is longer than some people think. UMK reports swimming in a bay patrolled by a man-eating shark. NXU attends a communications school in Illinois. HUV has been chief cook and scullery maid during the illness of his mother. He also sent AB some popcorn. OOG had a real treat on his furlough; his mother offered him a few cans of Spam! He is in the New Equipment Introductory Division of the Signal Corps. MVZ, Gary radio aide, is starting a radio class to help WERS operators and others to get ham tickets. ILL is stationed in the Aleutians. ONQ, one of Mishawaka's WERS stalwarts, now is in the Army. He left a "beautifully built" 112-Mc. superhet for AB to line up. AB has postponed his visit to EQQ for another month. If he makes it this time, it will be less than a year since he started procrastinating. TBM has him beat; he started seven years ago! PLW is wishing for an f.m. receiver. BHC works for Allison. GVV and JYP are doing field radio work. LVT says Marion gave up trying to get WERS, after losing three radio aides and getting the application back five times! KBL works with very short waves, but the first chance he

gets, he will go back to 40 and 80 meters. The more letters and cards you send, the more news there will be in this section of QST; so . . . 73. Herb.

MICHIGAN — SCM, Harold C. Bird, W8DPE-8VZZ writes that if we could hook up now both of us would be working extreme DX. 8FWU writes that he copies coded groups for practice. 8UXS sends a very nice letter from down New Orleans way. He asks the gang to write him at Route 2, Box 317, Lansing, and his wife will forward. Tom says that he is making trips to the vicinity where 8QK is; also that he is working both I/F and H/F and that the equipment gives a few more funny ideas as to how he would like to build his postwar rig. Graham C. Whitehead, an ex-ham, of 2812 Roberts St., Saginaw, writes that he would like the boys to send him some QSL cards. Graham is a shut-in doing service work and also is studying and practicing for both ham and commercial tickets. 8SWI writes a very interesting letter on the activities of WERS in Detroit: "We are continuing to have practice drills and simulated incidents on Monday and Wednesday evenings of each week, and on Sundays we devote the two-hour period to testing new equipment and also make any adjustments that may be required at a particular station. During the past year we have cooperated closely with the Michigan State Troops in their maneuvers and simulated incidents." Fred says that additional operators are needed and any hams in the Detroit area that are interested should contact Radio Aide A. C. Lyman, 607 Shelly Street, Detroit 26. We have received a couple of letters from Louis Gerbert, who is in Boston for a short time going to school. 8WEL, one of the operators at WKAU-4, makes a practice of writing several letters nightly to hams and acquaintances in the services, and has received more than 600 letters and souvenirs from all battlefronts. Lt. 8SPF was home on leave during the holiday season and renewed old acquaintances. Jack is electronic maintenance officer on a large aircraft carrier. At a recent meeting of the DARA we were honored by the presence of our old friend, 8FR. Pete received and answered several messages of welcome in the round table network which preceded the business meeting. The DARA committee is planning a St. Patrick's Day dinner, which should be a huge success. The club also is doing a lot of postwar studying concerning the future of the club, operation on the new frequencies and ideas for the betterment of the club and amateur radio in general. The Oakland County Radio Club, which is operating WERS station WKYM, has acquired a club room which they intend to use as a meeting place and also as a laboratory where the boys can go and tinker when they wish. The laboratory idea has been a topic of discussion at every meeting since the club finished its electronic course. In the next QMN Bulletin you will receive a report card which I hope you will return to the address printed on the front. Thank you, 73. Hal.

OHIO — SCM, Carl F. Wiehe, W8MFP — QQ reports Columbus WERS activity continues. Aid is being rendered to OPA as a sideline. A code class is in action. VMA reports Cincinnati WERS and club activities are stimulated by intra-zone activity contests. Zest is added by changing the rules monthly. Postwar plans are being formulated. PZA reports that OFF has shipped out as operator with the merchant marine, GD is reported in Washington after two years in the So. Pacific. WV, promoted from lt. comdr. to capt., was in town with films from the So. Pacific. EFW shipped out as 2nd lieut. PBZ, back in civvies, exhibited a German key at the club meeting. AVH is getting gray over the coal shortage. DS is branching out in the insurance business for himself. WJJE, Cleveland WERS, is active and is planning a transmitter hunt. A letter was received from JRS, at Ft. Monmouth, N. J., and a Christmas card was received from AKA, a lt. overseas. PZA wants the address of Ens. Carol Conrad, a Navy nurse. The Cleveland club's CRA Bulletin for Jan., featuring a picture of their new emergency transmitter and club station, was a model of perfection. WERS, under AVH, is installing three transmitters for Cleveland Red Cross. Don Hoffman, of Youngstown, reports ex-FRY, now a lt. comdr. on the honorary retired list of USNR, is home in Youngstown after 4½ years in the Navy. He is back at police station WPDG, which he helped to build fifteen years ago. A card from ENH says that he now is ART3c in school at Corpus Christi, Tex., and has acquired a radiotelephone 1st-class ticket for use after the war. CBI reports Dayton WERS still going strong. Time will probably improve results obtained in the scheduled WERS contacts between WJTW, Dayton; WKOD, Hamilton; and WKHO, Cincinnati. VAY now is trying to

(Continued on page 66)

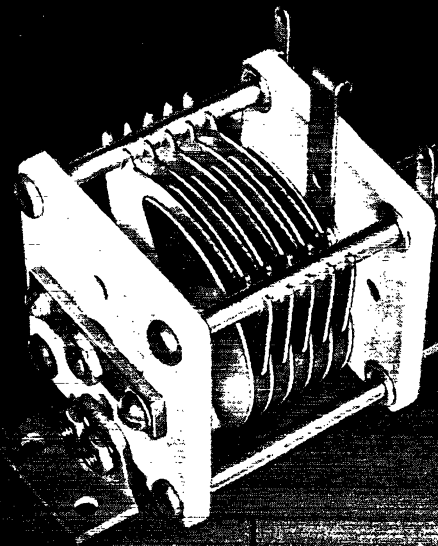

HIT AND RUN

The speedy little PT boat won its place by performance, and that's the way Hammarlund variable condensers did it — by top performance in every branch of communications.



THE SIGN OF QUALITY



ESTABLISHED 1910

THE HAMMARLUND MFG. CO., INC., 460 W. 34TH ST., N.Y.C.
MANUFACTURERS OF PRECISION COMMUNICATIONS EQUIPMENT

OFFICIAL U.S. NAVY PHOTO

(Continued from page 64)

squeeze in and out of tanks at Ft. Knox, Ky. SVI has "captured" a Jap 807 and tuning condenser to bring home from Netherlands East Indies. CBI has been appointed an industry member of the Army Q.M. Technical Advisory Committee on Frozen Fruits and Vegetables. He has been concentrating on frozen food and low-temperature research for Frigidaire for the past five years. Letters from clubs and individuals have been coming in expressing satisfaction with the election of AVH to the Central Division directorship and assuring him of their continued support. 73.

WISCONSIN — SCM, Emil Felber, jr., W9RH — The EC of Madison, UFX, reports he lost his best fishing partner when PCX left for Brazil to teach in the Air Force. HMG remodeled his home and plans on a deluxe shack in the attic. UFX, AVM and HMO are instructing at Navy school. Zindara, a CRM, is in charge of theory and shop practice. RM2c JEK is instructing in procedure. Lt. Wes Kelly, Navy (operator license), was home on a thirty-day leave. WCW and the OM, a CRT (operator license), were home on leave in Glendale, Calif. PCN will graduate from Annapolis this summer. UFX sold his complete rig to WHA. JDA still is churning butter. HZS and FVX are experimenting with wired wireless for a morale builder. FVX has been very ill. WXD, teaching in California, now sports a CRT rating and is married. MFR left Navy school, and is a distributor for a hearing aid. MRY was promoted to lieutenant. UFX is busy making his own flies for trout fishing in the Chippewa Flowage around Hayward. T/Sgt. OEB, located in England for the past two years, saw a list of twenty-five called on the wall while in a certain room in a Red Cross Club in Liverpool. He added his to the list. Capt. JWT, USMCR, in the Southwest Pacific, is growing a garden on his island. RNZ reports his new address is 205 5th St., Neenah. He would like to meet some of the local hams. Ex-EBI, formerly of Round Lake, Ill., now is living in Milwaukee and is a new member of the MRAC. T/Sgt. Eugene Berens has been transferred from Nebraska to New Mexico. ACRM JPS has been assigned to an aircraft carrier for Pacific sea duty. GQO reports his eyes are coming along fine. SYT's next assignment will be somewhere in Italy. Lt. RRT is in Italy and passes the *MRAC Bulletin* on to his friend. RPW, who has been shifted to France. RM2c is at an amphibian base in California. Cpl. W. Heinrich now is located in the Marianas. Capt. KVX dropped a line to the *Bulletin* editor, HRM, and reports all OK. Sgt. CRK is receiving the club mail in Italy. Sgt. Gil Rink sends 73 from Paris to the gang. S/Sgt. KCY, in No. Africa, reports he's acquiring a Boyer accent. RM1c ZUX has been reported as missing in action during a Naval battle when his destroyer mine sweeper was sunk near the Philippines. Dan Geller of WTMJ, who is an RCA technical engineer with the Bureau of Ships, has returned for a visit from the Southwest Pacific. Ed Thornley, WERS operator of Unit No. 12, has enlisted in the Navy as RT3c and is at boot camp. Pfc. John Holmes is located in New Caledonia and sends 73. We are looking for more reports from the boys at home. What say? Regards, *Emil*.

DAKOTA DIVISION

NORTH DAKOTA — SCM, John W. McBride, W9YVF — We received a swell letter from Sgt. SBF, of Sioux Falls, sent from "Somewhere in France." He would like to hear from some of the old gang. How about it, fellows? DHW, of Dickinson, was discharged from the Paratroopers and is now in St. Paul working for a radio distributor. BMR, of Wahpeton, is back in the harness again. He has a class of twenty enrolled in radio mechanics at the State School of Science. GZD, of Carrington, has returned from the Southwest Pacific and now is in the electrical engineering department at the U. of North Dakota; he is also operator-technician at KILO. He writes that HSR, of Hatton, who also served with him in the radio section overseas, has returned and is now with the N. S. Power at Hatton. GZD's brother, RT1c OCI, of Carrington, is serving with the Navy in the So. Atlantic. ILT, of Hanks, is located with the Army Post Office Service, in New Guinea. DNI, of Lidgerwood, is in the Southwest Pacific. Drop us a line and give us any dope you can about yourself or any of the boys you may meet or hear from. 73, *John*.

SOUTH DAKOTA — SCM, P. H. Schulta, W9QVY — BZI, who has seen plenty of action, was home from the Southwest Pacific because of the serious illness of his father. Capt. USH, of Brookings, now back in the U. S. A., writes a very interesting letter about his work with the 14th Air Force in China. He is a radar instructor and likes

the job very much. He has married and would like to settle down and get on the air again. His brother, USI, is a major with the Signal Corps and when last reported on was in New Guinea. Bob would like to hear from the old gang. His address: Capt. Robert M. Mattison, 4525 AAFBU, Robins Field, Warner Robins, Ga. YMB, of Moberidge, was a caller on the SCM recently. He is now a pfc. in the Tank Corps at Ft. Knox. Please send in news. Even though only an item, it will be of interest to someone. 73, *Phil*.

NORTHERN MINNESOTA — SCM, Armond D. Bratland, W9FUZ — LDR, chief operator at NWA, has a new home and a swell location for postwar hamming. LPL is progressing in his training as navigator. He reports that JHF was hospitalized some time ago as a result of malaria but is out again. JHK is taking a course in teletype at Chanute Field. JNC reports his progress in radar and has probably completed his studies by now. Last reports on FVO places him somewhere in New Guinea in fixed station operation. An interesting letter from MZN, former Dakota director, places him in Riverside, Ill. Previously with the CAA pilot training program, Fred now is working for Utah Radio Products as assistant production engineer on a Navy project. He is vice-president of the Chicago Suburban Radio Assn., and reports into 13th district WERS net. He reports that CYX is in charge of all Navy electronics in the area as a civilian and that Rex Munger is still footloose. FYT reports the death of CGG of Wheaton after a short illness. FUZ, with the merchant marine, finds time to think about the old days and look forward to the new with a better station than ever. A long letter from BBL, CRT with the Coast Guard, in charge of the repair shop at St. Louis, has splendid equipment and states that all of the higher-rated men have a ham background. He has built a 25-watt transmitter on 2½ and a superregen. and listens to St. Louis WERS. The only 2½-meter activity here, Frank, is the CAP set-up with some twenty units. The call is KHBI. RPT made a trip to Chicago to attend the CAP communications meeting and flew back with Col. Johnson of the Air Force — the national CAP commander. MTH is building equipment for CAP and keeps busy as group communications officer, St. Paul group. HNB of Minneapolis is another ardent CAP member who keeps busy constructing. The cadets show an intense interest in the activities, and with TLE and other hams instructing them in theory and code will progress rapidly when they eventually go into the services. VVA still is at Willmar and is now a full-fledged pilot. IPN and FEW were observed looking over some equipment at Halls and probably are lining up their gear. HZV still is at KSTP and manages to keep very busy. How about some news? 73, *Army*.

DELTA DIVISION

LOUISIANA — SCM, Eugene H. Treadaway, W5DKR — It's been several months since we have had a section report in *QST*. I have written to those in the section and in the armed forces for whom I had addresses. Please, gang, wherever you are, try to find a few minutes to pen me a few lines. Let's do all we can to have a Louisiana section report in good old *QST* each month. I always enjoy hearing from each and everyone of you and the gang will enjoy knowing what we are doing these days. 73, *Gene*.

HUDSON DIVISION

NORTHERN NEW JERSEY — SCM, Winfield G. Beck, W2CQD — Hi, gang. JMM sends a postcard telling us he is now radio technician for N. J. State Police in the No. New Jersey area. His home QRA is 5 Ridgehurst Road, West Orange. A chummy epistle from Walt Hampton, president of the Freehold Amateur Radio Club, MZA, says that the club is showing a bit of activity with meetings every Tues. at 8 P.M. in the clubroom at 4 Bennet St. Most of the boys are in the services but seven are left and are holding the fort and buying themselves with code practice and building 2½-meter receivers and a frequency meter. Walt promises that with the approach of warmer WX a regular code class will be started again. RM3c LSX, U. S. NAAF (Communications) Ayer, Mass., sends a letter with the following news on his three pals from Cranford. Sgt. LQR is somewhere in England. He's been visiting historical spots in and around London and had a "blitzing" time of it. 2nd Lt. MDA, busy at OCS in Australia, is going places in the Signal Corps. He really deserves it, too; he's been out there two years or more. MCX writes to Bud from Ceylon frequently and has sent a nice collection of postage

(Continued on page 68)

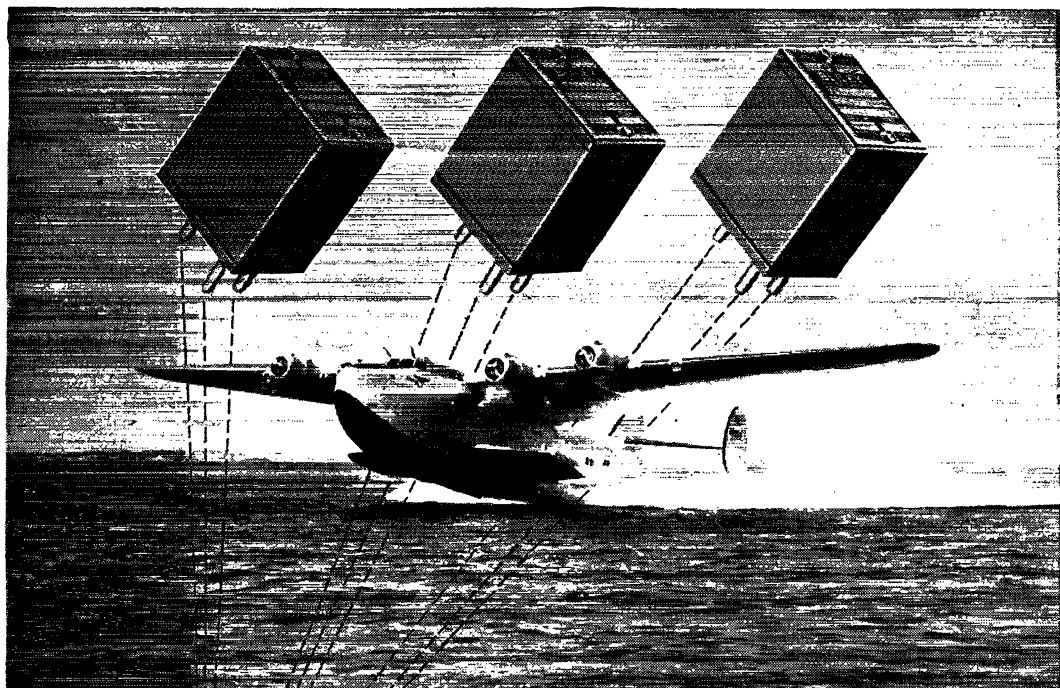

BLILEY CRYSTALS, of course, fly with Pan American

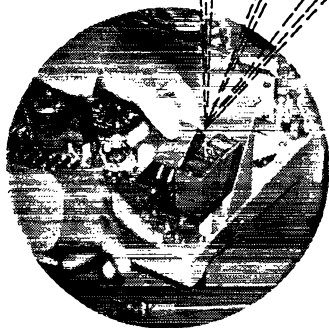

Do more than before . . .
buy extra War Bonds

Bliley *acid etched** crystals persistently show up wherever there is an important communications job to be done, such as the combination two-way telephone and telegraph and range finder systems of Pan American World Airways. In peace and in war Bliley crystals have flown millions of world-wide miles with their famous Clippers.

Bliley crystals are pre-conditioned for just such rugged assignments. In the Bliley Electric Company plant there

is a large section where Bliley *acid etched** crystals receive their pedigree. Here each crystal gets "the works". Its activity and frequency are *proved* under tough laboratory created service conditions of altitude, humidity, temperature, immersion, shock and vibration.

But licking tough assignments is a tradition with Bliley engineers and craftsmen. This background of research and skill has been responsible for the distinguished record of Bliley Crystals in every field of radio communication. Whatever your crystal problem may be—specify Bliley.

+

*Acid etching quartz crystals to frequency is a patented Bliley process.
United States Patent No. 2,364,501



A new star has been added

Bliley CRYSTALS

BLILEY ELECTRIC COMPANY • UNION STATION BUILDING • ERIE • PENNSYLVANIA

(Continued from page 66)

It seems that Pete is putting a lot of his radio brainstorms to work in the lab. over in Ceylon. His pop buys the parts on Radio Row and sends them to him. Bud has renewed his c.w. and 'phone ticket. GO still has radio repair business in Roselle, as have EUI and HFP. CSL still is at Weston and CQV is at Western Elec. AZL is dividing his time between Prudential in Newark (days) and EUI'S radio business and a YL in Nutley (evenings, of course). Your SCM "drug" out the ole e.c.o. and 6L6-807 stages 't'other evening and played around a bit. What a strange feeling! Couldn't seem to figure out what all those knobs and dials were for! C U next month. 73, W7in.

MIDWEST DIVISION

IOWA — SCM, Arthur E. Rydberg, W9AED — KFHR. Polk County WERS, has had its license renewed for another year. Drills are continuing very satisfactorily, with a good percentage of the members reporting each drill night. New members are being added each week. Interest remains high with the construction of more crystal-controlled transmitters, receivers with r. f. stages to prevent radiation, and improvement on antennas. SEJ, control station operator, plans a new receiver with more selectivity as stations become more numerous. MMZ leaves WERS to take a government job in Pearl Harbor. URK has a new transmitter with an RK34 in final. UOP is on with an 815 that puts out a nice signal. WHG is building a resistance-coupled superheterodyne for WERS reception. YAW left Camp Crowder for the Pacific. KGIL, Linn County WERS, has applied for a renewal of its license. Twenty-five new transmitters will be completed soon which will make a total of about forty-five transmitters and thirty-five operators. Drill periods average about 30 to 40 per cent of the licensed transmitters on the air. The net also has four mobile transmitters and the operators are wondering how they can keep trees and telephone poles from modulating the carrier as the car goes by. The new members of the executive committee of the Linn County Radio Club are: VTD, executive chairman; Mervil Powlishta, membership chairman; Mrs. Frank Bucacek, financial chairman; GIM, activities chairman. YDX is back from a lengthy stay in the East. ZQL now has 1st-class telephone and 2nd-class telegraph licenses. JIH got his 1st-class telephone ticket. WQJ is the EC for Linn County. EAI, Navy instructor for Navy pre-radio in Chicago, says hello to all his Des Moines friends. XSX, radio operator AACs, is home on leave after twenty-nine months in Alaska and would like to hear from TJR and MJP. PJR reports the Iowa-Illinois Radio Club meets on Friday night and still has its code classes. CTQ, Navy ensign, on Leyte with the first wave, had a tough time of it. SHY is back from down under; he was in radar. NLA is in the Dutch Indies with the Signal Corps. WNL, married last fall, is home from the Pacific area on medical leave. TMY is on the road for Burl Instrument Co., doing 100 per cent war work. WTD is drilling for oil in Illinois. PJR lost his oldest son, who was with Patton, last Sept. SWD, AEP and AHP have renewed their EC certificates. 73, Art.

KANSAS — SCM, A. B. Unruh, W9AWP — NHB now is RM1c serving with the Navy in the So. Pacific. 7NL, of Boeing-Seattle, was a Boeing-Wichita visitor on business. (Electronics, of course.) DJL, YOS and WKA pooled their ideas and came up with a four-element rotary for v.h.f. communication with aircraft. BCY, although serving nine hours daily as electrical engineer at one of the war plants, is helping to relieve the manpower shortage by standing a four-hour watch at b.c. station KANS. GSW constructed a speech amplifier which will probably show up in a postwar rig. KNQ, an AAF civil service inspector at Boeing, returned from Army school at San Antonio, Tex., where he pursued technical information on the air position indicator. 5HRQ is an electrician in flight service at Wichita war plant. YLY is returning to the merchant marine after a visit home to help welcome a new jr. operator, a YL, into the YLY household. They say no news is good news, but how about putting it down on paper and sending it in, so we can see it in black and white? 73, Abie.

MISSOURI — SCM, Mrs. Letha A. Dangerfield, W9OUD — MFM tells us that he has crossed each of the big oceans three times since leaving his law practice for the merchant marine and our last letter was written while he was in sight of the rock which is supposed to carry an insurance sign — but doesn't. SPI is quite the country farmer these days, running the 300-odd-acre plantation — cotton, we believe, is the result of his labor. KIK has been busy with

American Legion affairs, but sends us a note about his brother UAB, with OWI in Hawaii, and OWD, who is serving in his second World War and is back in the States at present. He is part owner of a St. Louis radio shop. FTD received an invitation to the Heart of America Radio Club meeting, but was unable to make it from the So. Pacific. In a recent column a note about FTD gave his call as FYD. Apologies. JWJ reports a reunion of the gang that used to go ice skating together — ZWM, chief radio technician in Coast Guard; TCG, with RCA in Indianapolis; ONW, teaching radio at Scott Field; JWJ, who has a code and theory class on Tues. evenings for the boys of the Naval Training School, operates WERS station KFPJ-8, teaches code for forty-five minutes before school every day to fourteen boys, and is taking a correspondence course from M. Y. in wild life conservation. Others of the ice skaters were BPZ, GYZ and YCB, who is a Raytheon engineer in Honolulu. VWW/8UUA gave us the QTH of KAG and would like some dope on the ham in Pittsburg, Kans., who was a member of the National Guard. Any information will be gratefully accepted. The address is requested for ZWK, now in Hawaii. MBE, of the old Missouri net, is doing something with radar for the Navy in the So. Pacific; he desires to contact FOR/FIR and would like to hear from other members of the gang. OUD had another fine letter from G2HKU, who would like to correspond with more U. S. hams. Will be very glad to share his address with you boys and girls. OUD and BMS have been listening to press just to keep in practice. Lots of luck and best regards.

NEBRASKA — SCM, Arthur R. Gaeth, W9FQB — The KHKN net copied 88 signals from airplanes over Lincoln. WOA, KAAJ-1, has a TR4, and says that only two others in Lincoln are interested in WERS. Cliff Allwine, KHKN-39, copied signals from airplanes near St. Joseph, Mo. EKK, KHKN-2, copied KAAJ-1 signals 81 with rapid fade on Jan. 11th, and works LIQ, KHKN-61, in his mobile rig near Gretna, which is about twenty-eight miles from Omaha. W5ABI, KHKN-13, had landlady trouble regarding antennas for 2½ meters, so fish poles, feeders and all followed Santa Claus up the chimney; now Henry does very well from his semi-basement apartment. ZPZ, KHKN-33, visited the KHRW radio side in Sioux City, Iowa, and found some 815s gathering dust in a radio store there. RM1c EUF, attached to the Pacific Fleet, flew over Omaha and reports that he was surprised to hear so much activity on 2½ meters in the Midwest. Capt. HTE also was surprised at the amount of WERS activity, and years for some himself. GEU, KHKN-37, formerly of Sioux Falls, So. Dak., is a new member of the KHKN net. UEV, KHKN-30, has more r. f. in the shack than in his folded doublet. VKT, KHKN-9, has a garden in the attic, where he raises antennas. UPD, KHKN-6 and 31, is selling all surplus equipment and is building a crystal rig with an 852 in final for 2½ meters. FQB, KHKN-48 and 10, finally went in for more soup with an HY615, which two weeks later was exchanged for an HY75. EUT is building an FB receiver for 2½ meters, and really swings a mean pen with reference to YDC and Joe Herold (technical supervisor WOW) in the *Broadcasters Journal*. YDC, KHKN radio aide (the "old ghost," as EKK calls him), was able to get out of the hospital long enough to preside at the AK-SAR-BEN Radio Club meeting in January. He is very much improved, we are glad to report, and says that he is busy issuing new WERS permits and that SPM and MJI, both located in Plattsmouth, Sarpy County, have applied for permits. The AK-SAR-BEN Radio Club formally adopted a resolution to affiliate with the ARRL at their Jan. meeting, and enjoyed ninety minutes of very FB pictures, with ZPZ as operator and the Signal Corps Depot gang as sponsors. In addition, Pfc. 1LQW, ex-WJQA-11, and Sgt. 8ALP, now attached to the Signal Corps Depot at Ft. Omaha, were very welcome guests, and LQW gave a very interesting talk and answered lots of questions regarding WERS activities back East. Lt. BZV reports reading QST in Corsica, and would like to hear from some of you guys. Sgt. NYU is stationed on the same island. Ex-HZR, now K6AMH, located at present in Maryland, reminisces about code classes in 1929, via WJAG, and includes a letter to forward to GAS, somewhere in the Pacific. M/Sgt. VHP, home from Italy on a thirty-day furlough, was seen browsing around radio shops. Cpl. ZFC, 4127 AAF Base Unit, Sec. B, Main Post T-6, McClellan Field, Calif., is flying high. JCK has traveled all over the country and spent some time in the Hawaiian Islands during the last two and one-half years.

(Continued on page 70)

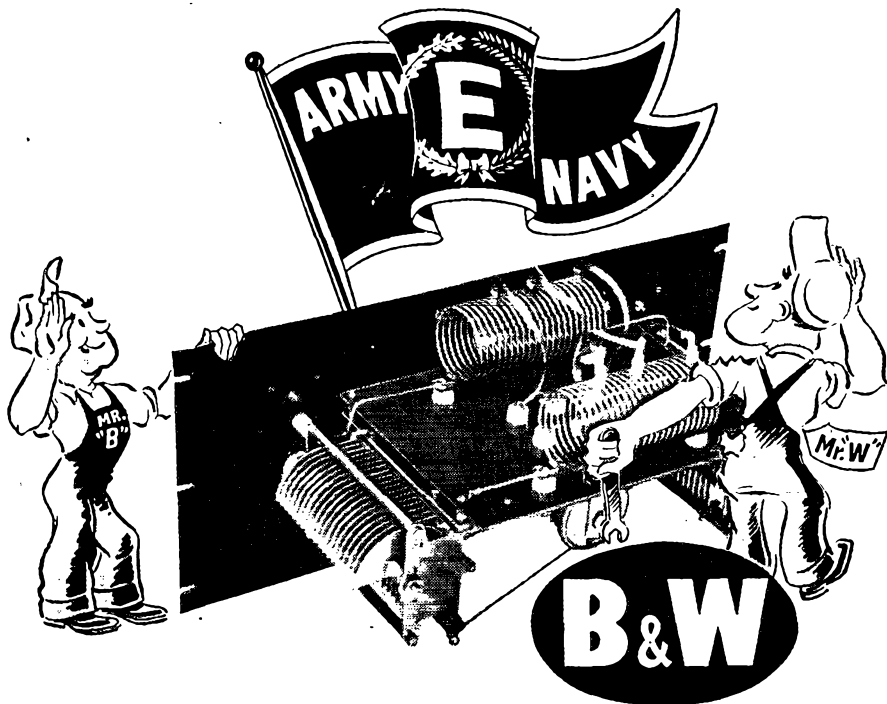

NOW OUR SIGHTS ARE SET *for the Stars*

Ever since the war began—and for some time previous—B & W engineering has been achieving in days what would normally have taken months. Production was quickly doubled and redoubled. Then it was doubled again.

Somewhere along the line, we began catching up with the tremendous demand placed upon us or the coveted Army-Navy "E" burgee would not now be here.

We're proud of this recognition. We were more than pleased when the Flag arrived—even though there was time for no more than a fervent 20-minute salute. There are still Air Inductors, variable capacitors and special electronic assemblies to be produced—in more intricate designs and in larger quantities than seemed possible only a few years ago. There are still stars to be added to our "E" burgee. There is still a war to be won!

BARKER & WILLIAMSON

AIR INDUCTORS • VARIABLE CONDENSERS • ELECTRONIC EQUIPMENT ASSEMBLIES

235 FAIRFIELD AVENUE, UPPER DARBY, PA.

Export: LINDETEVES, Inc., 10 ROCKEFELLER PLAZA, NEW YORK, N. Y., U. S. A.

(Continued from page 68)

Then he bought a copy of *QST* and now he inquires of carrier current, WERS and club activity. SHEP reports that SHH (brother-in-law), who has served three years with the Coast Guard on both oceans, is now RT2c and is home on a thirty-day furlough. BYR is in the Navy and is assigned to a university in Seattle. NNU, formerly of Kansas City, Kans., and later a civil service employee at Ft. Omaha, now is in Belgium. QUQ, in the USNR before Pearl Harbor, now is on a short layover in San Francisco. UEW bought a new home, choppers and photography equipment. 73, Art.

NEW ENGLAND DIVISION

CONNECTICUT — SCM, Edmund R. Fraser, W1KQY — IJ, Madison, received his radiotelephone 2nd-class license and is working for McMurdo Silver in Hartford. ELG has received his restricted radiotelephone permit and is working part time at broadcast station WNHC with AGT and TD. GDG is chief engineer of the station. ANN, a well-known Connecticut ham, has retired as captain in the Signal Corps and now is resuming radio activities as consultant engineer. ALW has opened up a radio store in Norwich. CSX has taken over a factory in Derby where he is kept plenty busy. KDO has resumed his former job as assistant manager of the New Haven airport. EAO, state radio aide, attended a radio meeting in New York. FMV regrets he was unable to attend the VWOA annual cruise held in New York. QV now is working at Templeton. NRR now is in the Pacific as a radio operator with the merchant marine, having graduated from Gallups Island. HMN, a former member of GB, has been advanced to captain in the Signal Corps. Jack has been doing a long stretch somewhere in the Pacific, having started the hard way as a private. Ernest Mongillo, a GB member now in the services, has been awarded the Purple Heart for an injury received while under action in Germany. Jack Naughton has left G.E. in Syracuse for Raytheon. TD reports letters from BSS and DDX, both GB members. The former is in the Army and is awaiting assignment from Oregon. He has attended about ten radio schools and thinks very highly of f.m. The latter is an ACRT in the USN at Panama and writes they had fourteen inches of rain in three days. *QST* has been arriving regularly every month, keeping him up to date on ham activities. Word has been received indirectly that APA and HMZ, both in the Signal Corps, are awaiting overseas assignment. LEI, Milford, was home recently on furlough and now is somewhere in the Pacific as a s/sgt. in the Signal Corps. WERS News: Middletown: Our hats are off to DBM, hard-working district radio aide for WKNQ, who still can find time to experiment with WERS receivers and transmitters. Waterbury: WKWG-70 has been kept very busy with traffic on Monday nights during interdistrict test periods. WKWG-62 and 50 have been putting in a very consistent signal at WJLH-1. The latter is a new unit in Naugatuck. Stamford: CTI writes that BCG is back in New Canaan and is working nights from 6 p.m. to 6 a.m. WJQA-23, 31 and 61 are the most active units in that district. CTI is using WJQA-17 portable for the winter months. Bridgeport: IM, district radio aide, has moved to a new QTH. WKAO-1, 4, 62, 64 and 55 are very active, being heard consistently in New Haven. Frank Sanchione, Bridgeport radio aide and operator at WKAO-4, is doing a fine job increasing activity in that district. New Haven: Steve Tabor, West Haven radio aide, has entered the services. Steve was tendered a farewell party recently at the QTH of MVH by the WJLH radio aides and assistants. His services will be sorely missed, as he was one of the most active members of WJLH. Steve Van Een (LSPH), former West Haven radio aide, now is working with Hammerlund in New York. IND and MVH both are busily engaged in building superhet receivers for 112.1 Mc. Ex-SF is reported out of the hospital and well on the way to recovery. BW and Dunbar looked after Branford units during ex-SF's illness. LTZ, East Haven radio aide, has been gifted with two new operators, the Misses Kelly and Keyes, who are doing a fine job of operating at the control center. The Misses Jackson, Doyle, Desmond and Terrill have been taking turns keeping WJLH-1 on the air during Mon. and Wed. night test periods. Hamden WERS units with JQK and Dickerman, radio aide and assistant respectively, report that they still are maintaining their splendid average of having fifteen operators and twelve units in operation during test periods. Mary Creaven, ex-Hamden operator now in the WAVES, telephoned during a recent visit home that she had finished training and had been transferred to Washington as a specialist in communication. WERS activity in the Waterbury, Bridgeport

and New London districts is gradually increasing with units preparing themselves for possible floods. GM, FCC Inspector, Boston district, expects to be in New Haven about Mar. 19th to hold examinations. 73, Ed.

MAINE — SCM, G. C. Brown, W1AQL — The CAP in Maine is busy organizing a patrol to assist in finding lost planes, etc. FBJ, a lieutenant, is in charge of the radio section in the Portland vicinity. A nice letter was received from IVZ, Flash is in Greenland as a CRM and says that 2HFO, 4FJY, ex-BCPS and 8KNP are in his outfit. MDK writes from the U. S. Employment Service in Portland and says that there are openings for hams as radio technicians, engineers and draftsmen. Ens. EBJ is home on shore leave after an extended trip to England with the merchant marine; his brother, Ens. ERO, is with the Maritime Commission. AKR is overseas again after a short visit with his wife. Your SCM spent a couple of weeks in Rockland recently. Most of the gang from down that way are working in the Bath Shipyard. LYK sent in his EC certificate for endorsement, accompanied by a couple of news items to the effect that LOZ is a colonel and is in France and that Mr. and Mrs. DEG are receiving congrats on the birth of a son. AUC still is in the State of Washington. CPL now is working at b.c. station WRDO in Augusta and has moved to 108 Water St., Hallowell. To those ECs who have certificates which have expired — send them in for endorsement. 73, "GC."

EASTERN MASSACHUSETTS — SCM, Frank L. Baker, jr., W1ALP — JGQ writes that he has lost another WERS operator. MXJ now is in the Navy and is located at Sampson, N. Y. Lt. GFW, of the USMCR, is home from the So. Pacific on furlough with three battle stars. NSS' folks write that he is in the Central Pacific as manager of radio repair work. 4ALJ, a Lt. (jg), is located at M.I.T. We hear that KEF now is a married man. KNX writes from Norfolk, Va. He has been on active duty with the Navy for four years and now is stationed with the Fleet Adm. Office at the Navy Yard as a CRT. BKE now has three sons in the services. NAX is back at M.I.T. DIU is working at WBZ, S1c (RT) Donald Jameson (LSPH), of Lowell, is in the Navy and is located at Great Lakes, Ill. JXZ is a grandfather. Congrats to NHN on being the first YL operator to become RM1c in the WAVES. 2ONY is living in So. Boston and working at Fore River Shipyard. HX still is located at Wright Field. FI gave a talk at the meeting of the South Shore Amateur Radio Club on the sixteen months he spent in the Pacific. Those present were: HHU, 4HRW-ex-9UTN, HJG, 5JLO, MMU, IS, MMH, ALP, IHA, LZW, CCL and FWS. NKW says he sold all his gear and bought War Bonds. He wants to contact 9LUN, 4CDC and 9WML. IHL says that they have started up a little local club and he has been elected president. They meet on the first Friday of each month at each other's homes and invite the XYLs. MJ, MDH, EKT and LVV are the present members. LVV is at radio school in Pearl Harbor and can do 25 w.p.m. on cypher groups. MDH is working at G.E. EKT still is at M.I.T. MJ is with the telephone company. IHL still is a paper machinery engineer. They operate WERS on the first Sunday of each month. WKXH-9, 10, 11, 14 and 7 were on recently. ZN still is working at the Boston Navy Yard. MQH is looking for a QTH with more elevation for postwar plans. MON says that he and LSR, JQA and LWI chew the rag over the land 'phone. GPZ is in the Army and now at Corpus Christi, Tex., utilizing his ham experience. AGR is working with ZK in conjunction with Massachusetts State Guard. MON has charge of the public address system at three plants of Barbour Welding Co., Brockton. LID writes from somewhere in the Netherlands East Indies and says most of his work is on amplifiers and audio systems. MIH writes that he spent a week at Christmas time in St. Albans, Vt. He met Bob English (LSPH), a radio operator in the Air Corps, and visited KXP's folks. The OT-5 held its meeting recently at the home of AKC. Those present were: GM, PK, AKN, DVC, ZK, AKC, HHU, Phil Robinson, Chas. Harris and Guy Entwistle. At an election of officers Chas. Harris was elected president and DVC secretary-treasurer. We hear that Oscar Olson of Reading, a radio operator for Pan-American, is missing in Trinidad. 73, Frank.

WESTERN MASSACHUSETTS — SCM, William J. Barrett, W1JAH — MIM reports from Ogdensburg, N. Y., where she is with the U. S. Immigration Border Patrol. Lee reports that hubby, LDV, is back in the Pacific, where he took part in the Lingayen Gulf landings. LXE now has an APO number and is overseas. MND is with the infantry in France. KJO now has an XYL and at last reports was op-

(Continued on page 72)

People who make Collins radio

A few of the more than 3000 specialists who design and produce high quality radio communication equipment in the Collins plant.

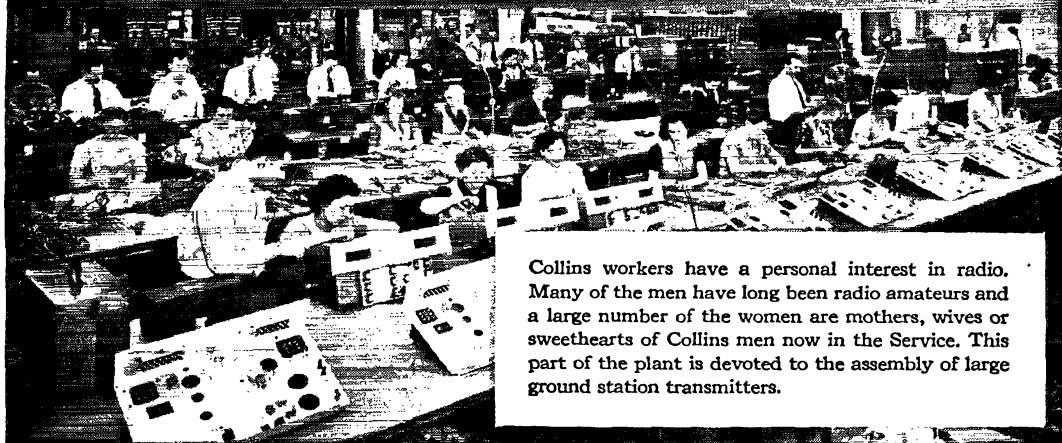

Collins workers have a personal interest in radio. Many of the men have long been radio amateurs and a large number of the women are mothers, wives or sweethearts of Collins men now in the Service. This part of the plant is devoted to the assembly of large ground station transmitters.



The technicians who wire the critical r.f. circuits in the exciter unit understand why each wire must be located and terminated with great care, exactly as engineered.

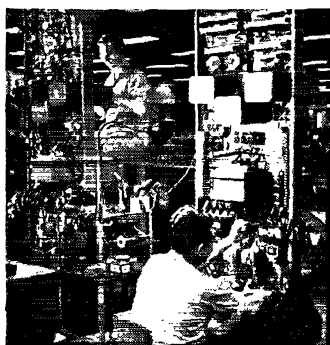

These men know what it means to the field service man to have cables neatly positioned so that component terminals are accessible and item numbers in full view.

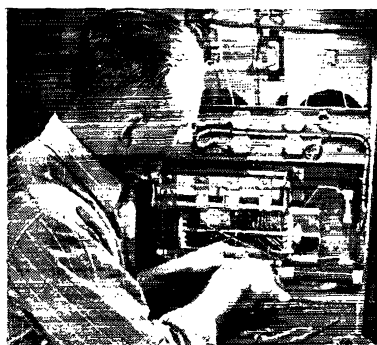

Collins is a radio man's radio organization. Men of high technical integrity have come here from all parts of the country because Collins standards are their own ideals of excellence.



Skilled mechanics assemble and synchronize the heavy duty Autotunes used on the output network of the 3000 watt Collins 231D ground station transmitter.



First line craftsmen assemble the Collins pi output network, which matches into a wide variety of single wire and vertical antennas.



Collins final-test men check every transmitter function critically, from the operator's point of view.



IN RADIO COMMUNICATIONS, IT'S...

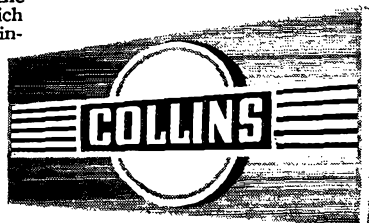

Collins Radio Company, Cedar Rapids, Ia., 11 W. 42nd St., New York 18, N. Y.

(Continued from page 70)

erating at a b.c. station in Worcester. MCF still is a Jap prisoner in Shanghai. Lee suggests that members of the Recreation Radio Club gang in Fitchburg drop her a line and she will keep me posted on the Fitchburg news. The Worcester WERS gang held a meeting recently to arrange renewal of the license, with about twenty of the gang present. The radio aide is C. C. Margerum; IHI is his deputy. The district communications officer is R. F. Atwood, Earl Lawson is local communications officer and Herman Gruzen is his deputy. Arrangements have been made for a state relay station to operate on 112.5 Mc., located at WGTR in Paxton. This would tie in the WJBB network with other sections of the State. This location, tested with a mobile unit, yielded reliable reception of the following WERS stations: WJQH-4, WLSO-27, WKXH, WJRG-17, WLDC-5, WKHF-2, WKWG-62-70. Thanks to Dick Atwood for the Worcester report. The Pittsfield Radio Club held a joint meeting with the local Hi-Y club to hear a talk by Leon Beeler, executive secretary, Region I, Massachusetts Committee on Public Safety, on "Radio in Civilian Defense and Public Emergencies." IZN introduced the speaker and explained to the Hi-Y gang the purpose and activities of the club. MKR now is stationed at Easer Field, La., following a furlough home after several years in the So. Pacific. 8PPJ now is living in Lenox and is working in the G.E. Plastics Lab. MPU couldn't find a place to live in Florida, so returned to Pittsfield. BNL now is with WSAI in Cincinnati. KVN recently spent twenty-one days with his parents after more than three years in the So. Pacific. He has returned to California for reassignment. AZW has returned to work after a long siege with serious burns. JOP reports from Worcester, where he is spending a short leave after completing boot training at Great Lakes. He is due for radio technician training at Chicago at the end of his leave. How about some news from Springfield? 73.

NEW HAMPSHIRE — SCM, Mrs. Dorothy W. Evans, W1FTJ/4 — CMB has been home on leave after two years abroad with the Navy. APK recently ran down a wireless record player that was interfering with the Dover city police radio. CFG was home on leave over the holidays; he still is on sea duty in the Atlantic. JSL is officer in charge of high-powered transmitter and is getting ideas for his postwar ham rig. APQ has been presented with the Bronze Star. MLO was home from West Point for Christmas. KKQ sends word that she recently had a three-way get-together with 3CDQ and 9RNO down in Florida. MUW is keeping plenty QRL with her jr. operator while JMY is overseas. Even though FTJ and BFT are in the so-called "sunny South" for a while, they long for New Hampshire and the snow. How about some news from you fellows? The new QTH is 1435 Snowden Ave., Memphis 7, Tenn.

VERMONT — SCM, Burtis W. Dean, W1NLO — FSV is with the Navy in the So. Pacific. Bob and the XYL are the proud parents of a daughter, Jean Elizabeth, born Jan. 31st. KJG, on a recent business trip to Utland, stopped in at AVP's radio shack. Park and Bill had a regular old-fashioned rag-chew. 8CEX/3, formerly of the WCAX engineering staff and now with NBC, has joined the N.A.B.E.T. and is taking a math course at Rutgers U. and a course in television at Radio City. NDL has been experimenting with carrier-current with FB results. AVP recently visited GAN and NLO. Ed Rybak (LSPH), former member of the WCAX engineering staff and recently with Bell Aircraft, is now chief engineer of WENT in Gloversville, N.Y. How about a line from some of you guys? 73, Burt.

NORTHWESTERN DIVISION

IDAHO — SCM, Don D. Oberbillig, W7AVP — Fred Tintinger, an ex-W7 now living in Fairbanks, recently visited Boise with Leonard Walker. Tommy Jeo writes from ETO. AQK, whose new QRA is Troy, Mont. recently visited Boise. KJ is teaching radio at night school. BAR is living in Caldwell and operating a service shop. HPH is busy with CAP communications. CUG is working at Stibnite in the assay office. BJZ is having tube trouble, like all servicemen.

MONTANA — SCM, Rex Roberts, W7CPY — The Butte Amateur Radio Club still is active and plans to have a radio theory class going by the time you read this. Several of the club members are planning c.c. rigs and work already has been started on some of them. EQM has built the push-pull oscillator per January QST. 9DVT now is in the armed services and is located in Texas. Richard Babcock is a new member. DXQ hopes that tubes and parts come back soon or the BCLs will have him in the nut house. 73, Rex.

OREGON — SCM, Carl Austin, W7GNJ — ENC, formerly stationed in the Aleutians, now is at Anchorage, where he is acting as transmitter attendant for ACS. His letter was accompanied by a clipping announcing that ACS had installed telephone service. It is not clear whether ACS has installed modulators, or whether this is land wire. Ed also mentions that AST, who had a kw. of 75, is his NCOIC. Feeling in no mood to provide voice modulation after climbing out of bed at 3 a.m., ARZ now takes care of this frequency-checking chore by means of a transcription. Now if he can rig an electric clock to turn the transmitter on and off! ALU is back in the States for a time, after making ports throughout the world as radio operator for the merchant marine. He says those amateurs who are 4F are missing a good bet by not getting into this service. The physical requirements are not strict and the need for operators is great. HKE still is in Louisiana, and has taken unto himself an XYL. Because of an infection he no longer is flying, and has transferred to radio. He requests any and all tips on "how to get the XYL interested in ham radio," and is impatient to get back on 80. Your SCM is interested in tips on "how to dish up dirt on Oregon hams who never report their doings and whereabouts." 73, Carl.

WASHINGTON — SCM, O. U. Tatro, W7FWD — IOQ reports that WERS has come to life in Everett and eight or ten attend each Wed. night drill. KFNW still is looking for the KANR (Bremerton) signal. KFIQ, Olympia, has only two stations ready for immediate action and drills are to be resumed. HXK, of the merchant marine, reports, "Hit the Med. twice, one a good long shuttle run. Hit Bari, Brindisi, Taranto, Naples and Piombino, Italy; Augusta, Sicily; Marseille, France; Oran, No. Africa, and Gibraltar. Met hams in Naples and got a ride from airport to Foggia; they were radiomen gunners on a fortress. You can't help but run into hams if you call out CQ!" Jack would like to hear from BG, EHQ, HJN and others of Tacoma, and he looks forward to reading the action news in QST. His mail will be forwarded from 212 Douglas St., N. E., Washington, D. C. Miriam Brown (LSPH) is recovering from a major operation. Ken Hager (LSPH), a radio man in the motorized tank division, U. S. Cavalry, was reported "missing in action" in Belgium Dec. 17, 1944. Ken started radio with the Olympia Radio Club code classes and received a 20 w.p.m. certificate. IJZ has received a medical discharge from the Navy and now is in the Radiation Lab. of M.I.T. as an RT and wireman. DLN, rejected from the J.A. Combat team on account of bad teeth now is teaching radio at Ft. Snelling. CWN is planning to rebuild his rig. HML still is "tonsil tossing" at T.I. and says Lt. Comdr. GEV is now "down under." IOQ is putting on the Red Cross drive at Everett. HWG now has 2nd-class commercial and Class A amateur tickets and is studying for 1st-class commercial license. He is with the State Forestry Dept. Who, in or near Spokane, will volunteer to give me information about Spokane hams? Many amateurs in the service read the Section news. You'll be adding to their comfort if you keep your SCM advised. 73, Tate.

PACIFIC DIVISION

NEVADA — SCM, N. Arthur Sowl, W6CW — Asst. SCM, Carroll Short, jr., W6BVZ. S/Sgt. TPR reports from Teheran, Iran, that the umbrella he was using for an antenna leaks badly so now is radiating only a ground wave. He sends his regards to the gang. Write the SCM for his complete address. UQY reports from 227 S. Seneca Rd., Oak Ridge, Tenn., where he is with Clinton Engineering Works. He says there are 250 hams there with him. John sends his hello to all the boys in the South. UIZ, our youngest ham, can be heard on local b.c. station KOH operating and spinning platters. TNL still is with the railroad pushing fuses around the sparks shops. QAY is contemplating a b.c. station in Reno and has applied for a construction permit. No reports have been received from the rest of the gang since last November. I have asked, pleaded, threatened and now I am begging. Please send me your reports. 73, Art.

EAST BAY — SCM, Horace R. Greer, W6TI — EC, QDE; EC v.h.f., FKQ; Asst. EC v.h.f., OJU; OO v.h.f., ZM. Because of a death in the family of EE the WERS meeting scheduled for Feb. 15th was postponed. The next meeting will be held the third Thurs. in March. LJC writes, "At Sea — A couple of lines by way of a QST report. Still doing a good business for Uncle's Gray Line and seeing lots of interesting spots. Occasionally meet a few hams. Anyone given out new transmitter designs or ideal rigs they'd like to have for postwar? Think it would be material for some swell

(Continued on page 74)

Working together, they form a complete high speed automatic code transmitting assembly ... for stationary or mobile applications

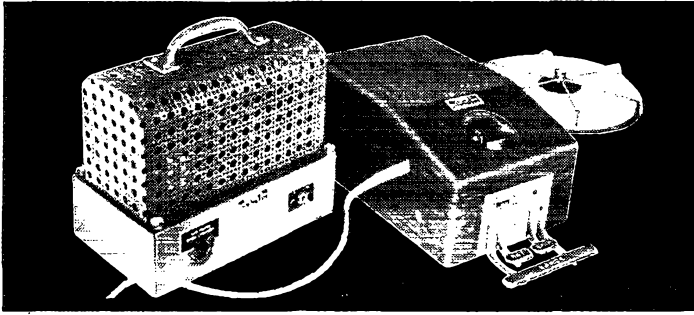

**McElroy Wheatstone
Code Tape Perforator
Model PFR-443-A**

A lightweight, compact, self-protected instrument comprising two units: the Keying Device and the Electronic Drive. The PFR-443-A prepares clean and accurate tapes for transmission up to 300 words per minute. Experienced operators can maintain speeds of between 30 and 40 words per minute in International Morse as well as all codes known throughout the world. Created and built by McElroy, it's available, for immediate delivery, at only \$275.00.

**McElroy Automatic
Transmitter
Model XTR-442-G**

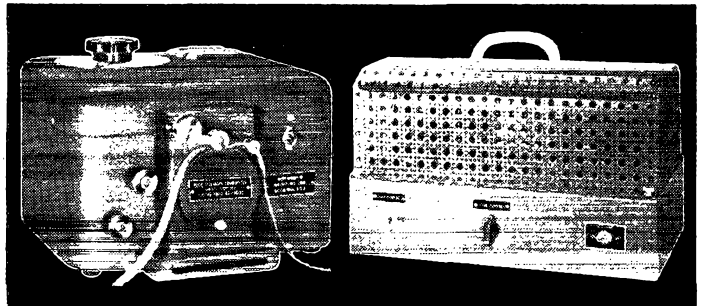

Opens and closes any keying circuit to form mechanically precise signal elements in response to Wheatstone perforated tape. Speed range on first set of gears, from 10 to 60 words a minute . . . for speeds from 50 to 300 words per minute, simply shift the gear. New type auto head and new operating arrangement of microswitch make for longer life of the instrument. The speed remains constant, unaffected by temperature rises or voltage fluctuations. \$490.00.

These McElroy instruments may be purchased individually, or together, as desired

McElroy engineers never copy...never imitate. We create...design...build...deliver. We are never satisfied with mediocrity.



McElroy
MANUFACTURING CORP.
82 BROOKLINE AVE., BOSTON, MASS.

BUY... AND HOLD... MORE WAR BONDS

P. R. MALLORY & CO. Inc.

MALLORY

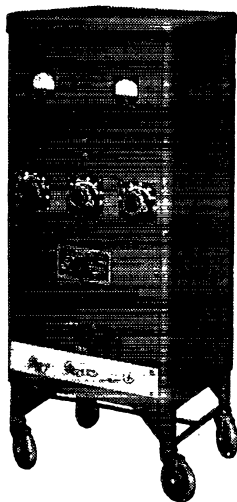
DC Power Supplies



PORTABLE

Mallory Portable Supply Units (available in Types VA 1500, VA 3000 and VA 4500) are designed for operation from 3-phase 208-230 volt, 60 cycle AC. Also available at a slight increase in price are 460 volt, 3-phase, 60 cycle AC units. All VA Power Supplies have adjustable output voltage, excellent regulation (10-15%) and extremely low ripple characteristics—approximately 3% at full loads, lower at light loads.

STATIONARY

Mallory offers a complete line of Stationary Rectopower* Supplies for bench or wall mounting. These lower output power supplies are designed to operate from 115 volt, 60 cycle AC, single phase. Output varies from 6 volts 10 amperes DC, to 32 volts 25 amperes DC.

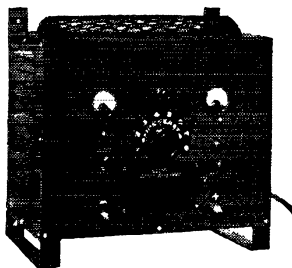

*Reg. U. S. Pat. Off.

All Mallory DC Power Supplies are equipped with Mallory Dry Disc Rectifiers which have no moving parts, and are silent in operation. Units shown are part of the complete line of Mallory power supplies and battery chargers. For information see your Mallory distributor or write direct.

P. R. MALLORY & CO., Inc.
INDIANAPOLIS 6 INDIANA



P. R. MALLORY & CO. Inc.

MALLORY

(Continued from page 78)

QST articles. How about it?" In a letter FCF reports, "How I would love to be working with the gang on WERS. We are kept busy in our radio school training new operators for our P.W. net. In our postwar ham activity, I would like to see sectional branches of the League run on the same basis as a club — but working out of League Headquarters in West Hartford. Please give my 73 to the gang. Would like to hear from the gang." His QRA is Sgt. E. H. Nickell, P.O.W. Camp S.C.U. 1920, Coolidge, Ariz. Received first copy of *Mid-Pacific Chapter S.A.R.O. News* the other day from Sid Glasson, USNR, stationed at Honolulu. The first meeting of this group was held Feb. 2, 1945 with the following members present: NZG, CBX, OCZ, FAQ, LCG, PSN and Ens. R. D. Ogg. Regular meetings are planned. The first meeting was a great success and was held at the Senior Officers' Bachelor Quarters at Honolulu, T. H. Officers elected were: Pres., NZG; secy-treas., OCZ. Let's get the news in so I can pass it on to the gang. "Another day closer to victory." 73, TI.

SAN FRANCISCO — SCM, William A. Ladley, W6RBQ — Phone RA. 8340, ECs, DOT and KZP. O.O. u.h.f., NJW. Lt. QL visited in San Francisco this month as he passed through for discharge. Jim was injured in the line of duty and expects to reside at Colton. He joined the armed forces for the second time in 1940, having served as an officer years ago. 5FDR has returned to duty after having received the Congressional Medal of Honor in Washington. He will continue his air activities, flying between San Francisco and Pearl. Glenn Glasscock now is a commander and is located at Pearl. GWD is on the coast for Submarine Signal looking for amateurs for field engineering work. Hama interested, please contact RBQ. IZR is with R.C.A. at Inverness. QJC is now retired and living at Markleville, Alpine County. Keep this in mind for postwar contests. NKE reports in from Mare Island. HJP still is reporting in regularly from various Pacific Islands. Merchantman radio operator 9IHN passed through on his way home for a short visit. S/Sgt. K6TMM, along with ex-K6PIT of K6 traffic fame, are back in the U.S.A. EAR still is in Seattle as Army operator. RXV and 5HAT check in as they leave for Pearl. AWA now is with Submarine Signal as field engineer somewhere in Africa. An old timer, ex-NQB, 7HXX, now 3JJD, writes in from somewhere in the Central Pacific; he sends regards to all San Francisco Radio Club members, also EY, LLW and PGB. John has just about made the seven seas in his wanderings. KGCW, WERS for San Francisco, has been renewed. State Guard WERS is making steady progress with fifteen members now enlisted in the Guard. A license application now is in the hands of the FCC. If you would really like to see what a group of hams are willing to do for their country visit the State Guard any Wed. night. A letter comes through from 9VND telling of his exploits in the So. Pacific, where he is a field engineer with Raytheon. He and Cis have been bunking together. WN advises a meeting of hams will be held soon at LV. LES has purchased a summer camp home on the Russian River. RBQ's son Jerry arrived home after an eight-month cruise in the Pacific. 73, Bill.

SAN JOAQUIN VALLEY — Acting SCM, Edward H. Noack, W6BXB — Your Acting SCM sent out cards to the hams in our district with very fine responses from EXM, RFX, now in San Diego, and QFR, of Fresno. Where are the other sections in this district? PDX and RQN are at Hammer Field. BLU is an operator on an oil tanker with the Maritime Service. RFX is at the Navy repair base in San Diego. RHN now is in Taft in the mortuary business. SQP now is a lat looie and a flying instructor in the Army Air Corps at Fort Worth, Tex. CLN still is doing mechanical work. GSY is a farmer, EXM also is farming and is doing radio work when he can get parts. 9YFI, formerly of Wahoo, Nebr., now in Fresno, says he is waiting for the war to end so he can have a California kw. and get in the BCLs' hair. BJL, BIL and LBC are at KRBU, the Highway Patrol on the Bay Bridge. The following on the Fresno district was reported by 6QFR: We are glad to see TO back at his old stand, Davis Radio, again looking like himself and feeling chipper after several months of illness. IHV has been down with flu, and all of us look forward to seeing "CQ" blown with the cigarette holder which is Bill's constant companion. GCF has turned into a rabid camera fan — we are waiting to look at some of his "post cards." NOH has gone in for "boating" in a big way. He reports that he has been besieged with orders for the postwar rig, but between boats, OPA and a few ham gatherings he patiently awaits the day he can show the boys "how the hog ate the cabbage." BWK, "Willie on the Pickle Barrel," still modulates the maps for Fresno. His side kick, GWM, occasionally warms

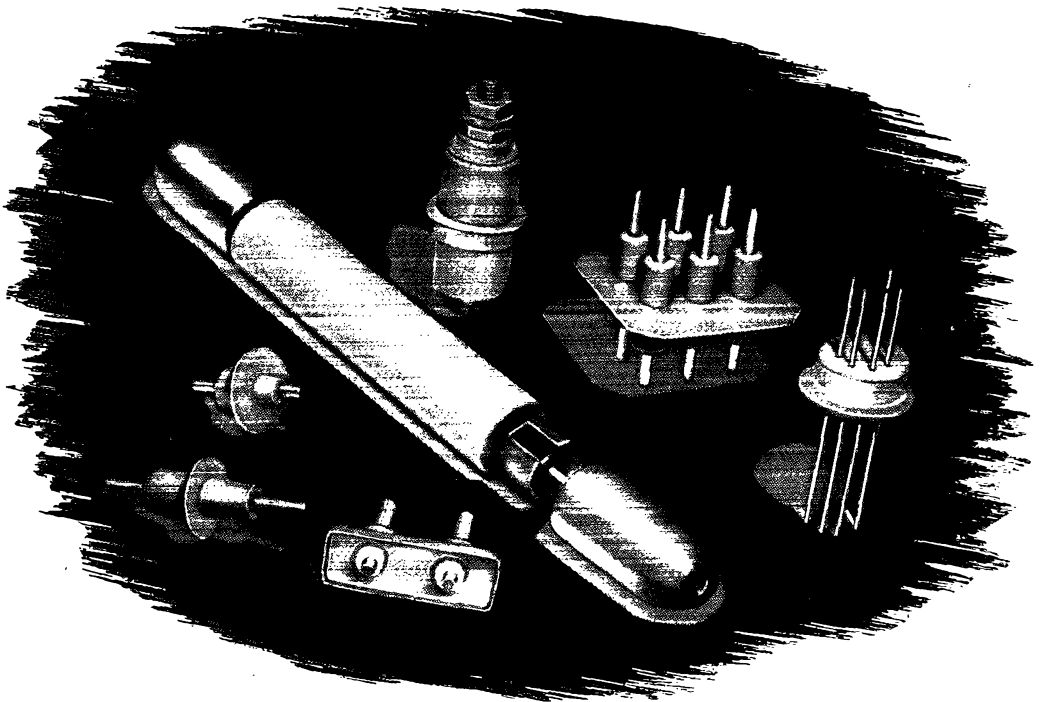

STEATITE AND STEEL PERMANENTLY BONDED TOGETHER

● SEALEX Bushings developed by General Ceramics and Steatite Corporation are the answer to the problem of hermetically sealing all types of communication equipment.

SEALEX Bushings will contain air at 50 pounds per square inch after a thermal change test of 25 cycles from -65°C to $+125^{\circ}\text{C}$.

Available in single terminal and multiple terminal designs for high and low voltage requirements.

Contact General Ceramics and Steatite Corporation for help in solving your hermetic sealing problems.



SALES REPRESENTATIVES
 H. W. GEBHARD
 737 No. Michigan Ave., Chicago, Illinois
 J. J. PERLMUTH & ASSOCIATES
 942 Maple Avenue, Los Angeles, Calif.
 MICA COMPANY OF CANADA LTD.
 P. O. Box 189, Hull, Quebec



KEASBEY
 NEW JERSEY

PORTABLE POWER PROBLEMS

THIS MONTH—UNITED AIR LINES' RADIO SIGNAL TEST



DIRECTIONAL INTENSITY of radio signals from all United Air Lines transmitter stations is measured at intervals with portable Field Strength Test Meters, powered by Burgess Industrial Batteries. Control of exact radiation from transmitters maintains perfect communication between ground and flight crews, assuring safe, accurate guidance of planes into airports.

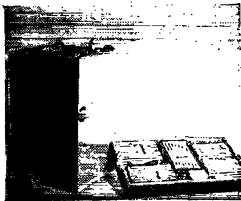
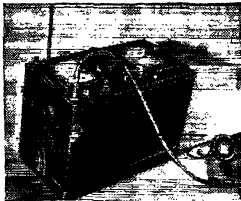

TEST METER records full volt intensity of radio signals, showing how far and in what direction radiation extends from a specific antennae or station. Burgess Industrial Batteries are the standard of quality for commercial uses—they meet every requirement in the operation of test and control instruments. Production of industrial batteries is severely limited today by very urgent war needs, and the types you require may not be immediately available. Burgess Battery Company, Freeport, Illinois.



Keep Your Red Cross At His Side!

BURGESS BATTERIES

(Continued from page 74)

up a UV-201A (very prewar) — all that was left after Uncle Sam got through with Bill and Spec. Saw MYP and he talks a swell recipe for killing potato bugs and squash bugs, and has the latest on tomatoes. BVM has moved to Delano and is associated with CBS. LOO has taken Don's place at KMJ. KPW still is confusing the telephone company, but promises some postwar endeavors which will be something. KB jams the ether with his market news at Salinas — he recently was rocked on his heels when he met a major with an older ham call than his. QFR has been teaching Boy Scouts and building model aeroplanes; he occasionally lends a hand to Mac Dorothy, engineer at KARM. KUT and JPU were reported in Fresno. PCF is with Uncle Sam; we understand he is a "looiie." DWE has been transferred to San Diego. How about sending us a line? The SCM had a birthday Mar. 9th. Drop him a card with some news and guess his age.

SOUTHEASTERN DIVISION

ALABAMA — SCM, Lawrence J. Smyth, W4GBV — GOX was home for a fifteen-day furlough. While here he went to Atlanta and got his 1st-class telephone and 2nd-class telegraph licenses. Don't fail to ask GOX why he didn't take his exam on his first trip to Atlanta. Congratulations are in order for EW; his new XYL is a WAC, stationed at Maxwell Field. HDI is in Montgomery recently; he has been stationed at Great Lakes, studying radar. EFD has solved the transportation problem for himself; he now rides to and from work on a "motorbike." Yours truly, GBV, is back at work, after spending two weeks in the hospital and the same length of time at home. DPX still is somewhere in France. 73, Larry.

EASTERN FLORIDA — SCM, Robert B. Murphy, W4IP — Our old friend, Lt. HJQ, is on the high seas again, having left Grove City last month. HKJ reports the following activity around PAA A&O Division: 8ONC/IFG is a captain with A&O. AF is a navigator. 6TVU is headed for the CBI. DZN is working for Walders in Miami. GIB is chief operator for A&O. HKP is back in the States after a tour of duty as a Navy civilian technician. HMQ is at Saranac Lake and we all hope for a speedy recovery. VV is flight engineer. FVW is working in the local post office and has just completed a wire recorder. ECV is in charge of the stereograph department, *Miami Herald*. Pauley, call unknown, has taken upon himself a YF. Thanks, HKJ, for the report. AKV writes from APO 862, New York City and says it sure is cool where he is. He sends his 73 to KK and all the others. PEI comes through with a book. He enjoys reading our report and is still ACL dispatcher with a good outlook for c.w. days again. A real surprise comes from Ens. BRB, USMS, just back from ETO. While on his trip he met Lt. (jg) DGW in Bristol, GW3VL and GW8WU of Cardiff, Wales, and Lt. (jg) 3HTG/4. The latter is sporting a pair of torpedo stars for two tankers. RT3c AB now is on some K6 sandpile. BRB is getting hot on 112 Mc. and is looking forward to increasing interest in WPB. BRB has been on stations 4XID, WKDL, KKEJ, KBWU, WOB and KOWZ. ES made one business trip to Washington and now is in Cuba on another. He has promised to get some information from Cuban amateurs, especially around Camaguey, and I may get someone to correspond with monthly. ASR still is plugging along with his broadcast job and has his hands full as director. ANP seems to have been frozen in. GWJ is a crew chief for the line crew shop of PAA and is getting lined up for 112-Mc. receiver in a quiet way. K4HO0 has been transferred to Balboa. IHJ has gone to Guatemala. CM28G has been hospitalized with appendicitis. DZH almost had to have a passport to get a trip to Georgia for PAA. 9EEY is starting out in the local WERS net with a new receiver. GWJ, a crew chief at PAA Line Crew, also is interested in 2¼-meter work. Kincaid and Williams, in the shop, also are getting interested and have 2¼-meter receivers for listening to the regular run of WERS work here in Miami. BYF and 1KVB are doing very good work with the WERS organization in Miami. IEV has made up the dual front-end job as described in Jan. QST and really likes it, according to reports I have received from GWJ. IEV has recently grooved into the job as foreman of overhaul shop at PAA. GNT has made up a very nice signal generator and has been doing some nice work installing radio equipment. 3CM left Miami for the North. IBS is acting crew chief of the Cuban section of the overhaul shop, PAA. EYI still holds down the fort at St. Pete and comes through with the following report: ATB now is in charge of the police and water department radio systems. Link has been chief engineer at WSUN for many years.

THE *Postwar* MIRACLE
THAT WILL *Really*
HAPPEN . . .

JENSEN SPEAKERS
WITH

ALNICO 5



Among all the miracles that have been talked about for a great and glorious postwar era, here is one thing on which you can really count: JENSEN Speakers will be built around the wartime developed **ALNICO 5** JENSEN naturally pioneered in the use of this remarkable new magnet material which weighs only a fraction of other magnetic alloys of equal strength. Thus JENSEN postwar speakers with **ALNICO 5** will be lighter and more compact, but still as highly efficient and rugged as ever. JENSEN military loud speakers are now using **ALNICO 5** in great quantities.

And as soon as conditions permit, **ALNICO 5** will become a feature of JENSEN PM Speakers.



Jensen

SPEAKERS WITH

ALNICO 5

Specialists in Design and Manufacture of Acoustic Equipment

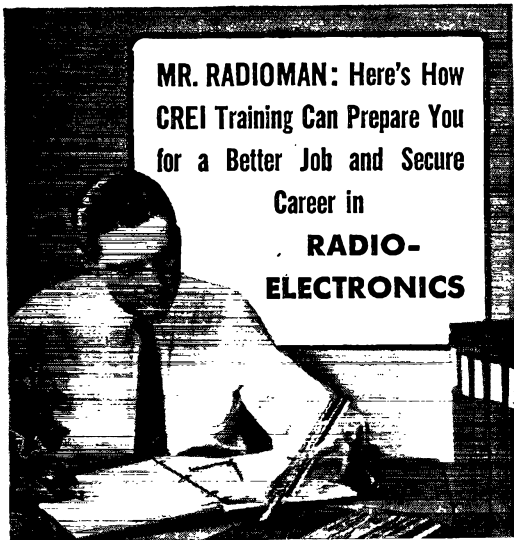

**MR. RADIOMAN: Here's How
CREI Training Can Prepare You
for a Better Job and Secure
Career in
RADIO-
ELECTRONICS**

**CREI Offers a Planned Program of Home Study
in Practical Radio-Electronics Engineering That
Equips You to Cope with Current and Post-War
Technical Applications and Problems and Helps
to Assure You of a Secure, Post-War Future.**

What do you know today about U.H.F. circuits, cavity resonators, wave guides, Klystrons, Magnetrans and other tubes? U.H.F. as well as all other basic principles of modern, practical radio-electronics engineering are covered in CREI home study courses. CREI can show you the way by providing the "tools" to build a secure foundation for your future based on our proved method of home study training. You learn not only *how* . . . but *why!* Easy-to-read and easy-to-understand lessons . . . each student having his personal instructor . . . corrections, criticisms and suggestions on each lesson examination . . . these are only a part of the successful CREI method of training for which thousands of professional radiomen have enrolled since 1927.

Investigate CREI home study training now, and prepare for security and happiness in the coming New World of Electronics! *Write for all the facts today.*

● **WRITE FOR FREE 36-PAGE BOOKLET**

If you have had professional or amateur radio experience and want to make more money—let us prove to you we have something you need to qualify for a better radio job. To help us intelligently answer your inquiry—please state briefly your background of experience, education and present position.



Capitol Radio Engineering Institute

Home Study Courses in Practical Radio-Electronics Engineering for Professional Self-Improvement

Dept. Q-4, 3224 16th St. N. W., Washington 10, D. C.
Contractors to the U. S. Navy, U. S. Coast Guard and Canadian Broadcasting Corporation
Producers of Well-trained Technical Radiomen for Industry

(Continued from page 76)

FZW is based in Florida again after a time in California. KK still is very busy in his profession and keeps his hand in with a receiver at home. CO2CG is enjoying his stay in Miami; his wife and baby arrived from Havana last month to join him. 2CG is with the PAA overhaul shop. BRB wants to stir up the 2 1/2-meter men in West Palm Beach and BYF is stirring it up here. Let's try to get these two groups on the air. CUL, OM, and 73. *Merf.*

WESTERN FLORIDA — SCM, Oscar Cederstrom, W4AXP — It's Lt. A. P. Ludwig now. Congrats on a well-earned promotion. Lt. Ludwig is ex-6BRG and now is stationed at N.A.S., Atlanta, Ga. Lt. (jg) Eddie Collins, our outstanding ham and former SCM, has been visiting here. Eddie came out to N.A.S., visited his former haunts and paid a visit to Delson and some of the A and R gang. Eddie spent most of his leave here visiting the hams. He spends part of his spare time getting postwar gear together. Chief Stahell is busy in Squadron 7 radio shop and has met several hams who are in the squadron. H. E. Whaley, RM3c, has composed two more poems entitled "To the Unfortunate Civilian" and "A Shipmate Speaks." EJE, an officer in the Naval Air Force and a Class A ham, paid us a visit. He worked 10- and 20-meter 'phone from Charlotte, N. C. 6PNI took 5AX, a lt. (jg) and 3HXD, a lt. comdr., for a hop. Joe Hicks, our instructor at Ellyson Field, became the proud daddy of a brand-new baby YL, Evelyn Peck, on Feb. 4th. She has a brother, Joe, jr. ECM, our blind operator at DeFuniak, is a new poppa of a girl named Joyce Lee. VJ, ex-9DZS, electrical engineer at N.A.S., formerly of Tampa and an ex-FCC man, pays the communications training office and shop an occasional visit. He is an old-timer at the game. When AXP, ECT and FJR get together a good rag-chew takes place and carrier line communication usually get aired out. Joe R. Miller, RM2c and one of the old gang from here and Corry Field, writes from San Francisco that he enjoys our section news in QST. He works in a Navy radio school. AXP, jr., is joining the radio game. He has just received another promotion. Red Flowers acquired an APO, New York, address. We like to hear from you boys in the services — so write, please. The Old Maestro turned another page at the half-century mark on Jan. 30th and hopes to go the other half. Wonder what ham radio will be like in 1957? 73 to all from *The Old Maestro*.

GEORGIA — SCM, Ernest L. Morgan, W4FDJ — EGT enjoyed a furlough at home between Navy schools and reassignment. He suffers from nostalgia when he reads of the action in P. I. ERS still is in the hospital in Philadelphia. AET visited his mother and called on FDJ before going to the Pacific area. FVI is in France; he has been overseas for two years but still is looking forward to getting home and back on 40 meters. He asks the gang around Atlanta to write him. Ask me for his address, youse guys. 73, *Pop*.

SOUTHWESTERN DIVISION

ARIZONA — SCM, Douglas Aitken, W6RWW — RWW is back in the hospital, and OAS has been asked to write this month's report for him. We are sorry to hear of your illness, Doug, and wish you a speedy recovery. 9AVO, ex-KFC, paid us a short visit recently; he met quite a few of his old amateur friends and got a real thrill out of the WERS drill. He hopes some day to meet all his old ham friends via the good old c.w. PDA, while still working for the R.R., is working extra shifts at the sheriff's office in Winslow as radio operator. IGO is out of the hospital well on the road to recovery. NEL has been having his teeth pulled and says the XYL is feeding him baby food. QLZ is with us again and is working as broadcast operator for KPHO in Phoenix; he is back in WERS work as strong as ever. FZQ has been made a captain since the picture shown in Feb. QST was taken. A code class started by the Radio Club of Arizona, which meets at the YMCA every Saturday night, has met with poor response; most of the fellows attending can copy 20 w.p.m. or better. WERS license KFRS for Maricopa County has been renewed and the boys really are showing an interest in the drills. TJH, of Tucson, writes that they are interested in WERS there and might make a try at getting a license. 73, *George*.

SAN DIEGO — SCM, Ralph H. Culbertson, W6CHV — Asst. SCM, Gordon W. Brown, W6APG. The first official meeting of the WERS organization was held at the San Diego Police Department on Feb. 9th. Applications were filled in for operators and stations by the following members: APG, BHF, BKZ, CHV, DUP, EDJ, ELL, EOP, EWU, EZM, FMJ, HRI, LYF, MHL, NBJ, NDD, OIN, OXQ, OZH, QKI, QJK, RGY, ROZ, SFO, SVB, UOQ, 11RL,



FOR MOBILE SHORTWAVE OPERATION E-L VIBRATOR POWER SUPPLIES

● Among the most valuable new developments for the amateur are Electronic Laboratories Vibrator Power Supplies for mobile and portable applications to allow efficient operation of powerful two-way radio from your car or any non-fixed source of power.

Much of the effective work of the amateur before the war, and of the War Emergency Radio Service which has performed such a vital function in the communications field, was made possible because of portable and mobile rigs. After the war, Vibrator Power Supplies, which have stood the test of the most rugged combat use in military service, will be available to provide trouble-free mobile operation both for emergency service and regular use.

Pioneering in current conversion, E-L has developed many exclusive advantages both in the light and heavy-duty power supply field. These include: constant output voltage despite wide fluctuations in input voltage; multiple input and output voltages in one unit; power outputs up to

1000 watts, and any wave form, including pure sine wave. When planning your new layout, consider the advantages that E-L Power Supplies can offer.

For the transit, railroad, aviation, electrical and electronic fields, as well as the amateur field, Electronic Laboratories are proving the superior dependability and service of Vibrator Power Supplies in comparable military uses today.

Give your name to your distributor for early supply when civilian production is permitted.

E-L Standard Power Supply Model 307

This typical Inverter unit, Model 307, is ideal for operating receivers and transmitters from the 6 volt DC auto battery. Specifications: Input, 6 volts DC; Output, 115 volts AC; Output Power, 100 watts; Frequency, 60 cycles; Load Power Factor, 80 to 100 per cent. Dimensions: $10\frac{3}{4} \times 7\frac{1}{2} \times 8\frac{3}{4}$ inches. Weight: $23\frac{1}{2}$ pounds.

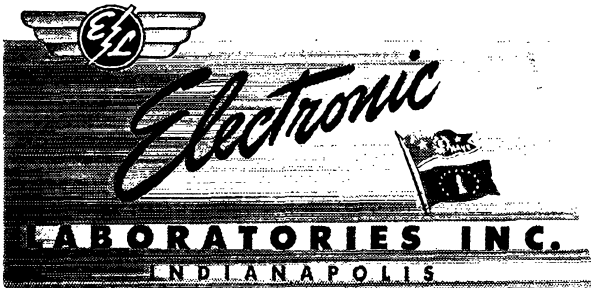
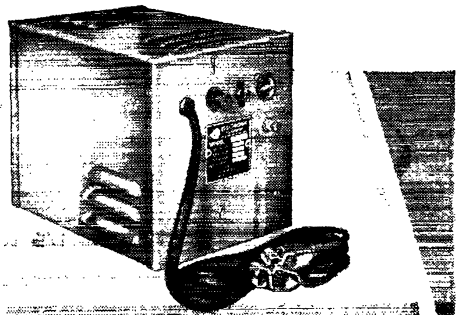

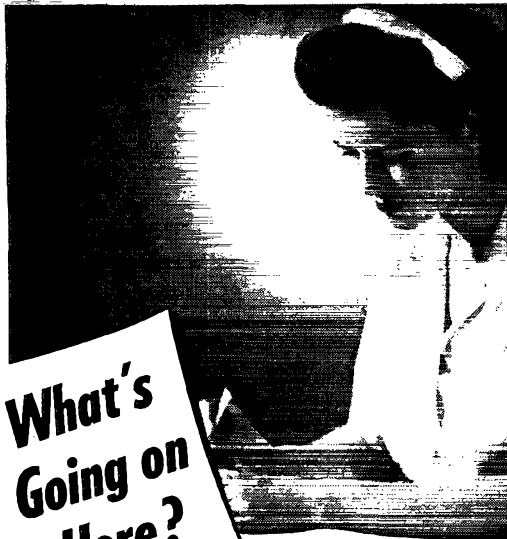

**What's
Going on
Here?**

The *what* we can tell you about. The *how* is one of those many little secrets about instrument manufacture Simpson has learned through more than 35 years of experience. This particular operation has to do with the making of pivots, those critical parts around which the accuracy of any electrical instrument revolves. Only by means of this and other Simpson-developed processes can we make pivots which in strength and hardness, and in their perfect contour, measure up to Simpson's standard.

The Simpson plant is full of such refinements and shortcuts—all aimed at the twin purpose of improving performance and reducing cost. Added to the basic superiority of the patented Simpson movement they provide the fullest measure of accuracy and stamina, and dollar value.

Only Simpson's long familiarity with the problems of instrument manufacture could achieve so many noteworthy solutions. Nothing less can promise so much for the electrical instruments and testing equipment you will use in the years to come.

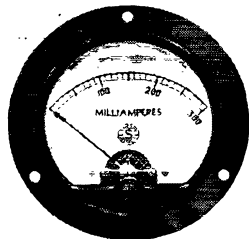

SIMPSON ELECTRIC CO.
5200-18 W. Kinzie St., Chicago 44, Ill.

Simpson

INSTRUMENTS THAT STAY ACCURATE

(Continued from page 78)

8CPX, 8VHN and 9ITS. The main topic of discussion was types of equipment. All fixed stations are to be crystal-controlled. Locations of the control stations were decided upon. All of the gang present were very enthusiastic and are set to get going as soon as the license is granted. GVU is home on a short vacation after attending Officers Training School in Florida. He is now a colonel in the Signal Corps and is stationed in Italy. 73, *Ralph.*

WEST GULF DIVISION

NORTHERN TEXAS—SCM, Jack T. Moore, W5ALA —FKH is overseas. AQS recently built a two-tube "super blooper" so as to hear what goes on in the world from down on the farm. BNQ, the "Lancaster scientist," reports further on his research work. Dale now is working on a private communications system where the positive peaks will be on one carrier and the negative peaks on another carrier. BNQ advises that as soon as this project is put where the Class-B audio into the Class-B amplifier was buried, he will start a new project—a high-speed continuously rotating beam, in an attempt to have gain in all directions at the same time, using 4" pipe for elements. JIE reports from Sioux Falls, So. Dak., where he has been stationed for the past sixteen months as an instructor in radio theory for combat crew radio operators. CDU has received a letter from EN, who is in Africa working for Western Electric. JXH is working at the Dallas radio range station. CDU also advises that DWR is a 2nd lieutenant in the Signal Corps and is located in Philadelphia. VV has been awarded the Air Medal for a flight successfully completed into the Arctic Circle in Jan., 1942. Three planes started on the mission but only the plane VV was in reached its destination. Because of an injury to the expedition's radio operator, VV served in that capacity himself. AJG is planning a 21-Mc. rig. IXM was in Dallas on week-end leave and advised that he was being transferred to the West Coast for six months' further Naval training. David also reports that OW is a civilian technician for the Army at Albuquerque, DQD is teaching at M.I.T., HXA is an ensign and is attending school at M.I.T., JIZ is going to midshipmen's school at Columbia when he graduates from S.M.U. 6ITK is an engineer for Lockheed's Dallas Modification center. ACU is in the Army and is located at Love Field. The SCM is all set to put ALA on the air with an SX-24 and HT-6 just as soon as the whistle blows. HWK is a WAC stationed at Love Field. 9ZJB now is located in Dallas and is working with VV. The Dallas unit of CAP has been authorized by WERS to set up a 500-watt transmitter for training purposes. IUQ visited San Antonio recently and had a chat with several hams that work for the telephone company. Bill says he is plenty busy these days. KJF reports that he has a jr. operator and that JQY now is a grandpa. FBI is a petty officer in the Pacific area. JXY is assistant foreman of the assembly line at North American's Dallas plant. JFK is working in Washington. EVI has moved from Ascension Island to Brazil and hopes to be home soon. FKB is working for Philco. IAU, S1c in the Navy, is going to radar school in Chicago. CJJ is also in Naval radio school in Dearborn, Mich. HB is in charge of the radio station at North American in Dallas, and is assisted by FBX. Ex-H8G is in the radio business. HCS' present QTH is Panama with Uncle Sam's Navy. RG reports business is plenty heavy. Fellows, IXM wins the *Handbook* for the best unsolicited report sent in this month. 73, *Jack.*

NEW MEXICO—SCM, J. G. Hancock, W5HJF — We regret to report that RM2c JWA, USN, was killed on Feb. 15th. Jack received his Class C license in May 1941 and was appointed ORS less than two months later. He was active in all League activities and ranked second in New Mexico in the 1941 Sweepstakes. After Pearl Harbor he helped HJF organize and instruct a class in code and theory. He acquired his Class A license in 1943. *Jack.*

BRIEFS

Comdr. Gerald C. Gross, W3GG, now is Assistant Nava Attaché, American Embassy, Bogotá, Colombia.

Congratulations to Lt. George Hart, WINJM, former Acting Communications Manager, who became the proud father of a son, Frederick Louis, on January 6th.

W8CYT says the Chinese radio engineers are so eager to read his *QSTs* they sign a waiting list to read them in turn.

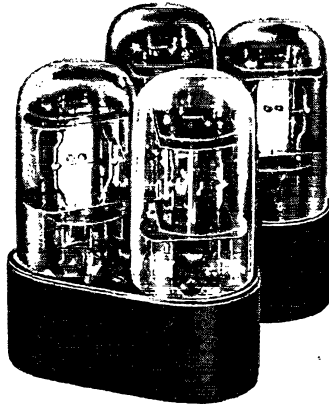

Crystal gateways for your voice

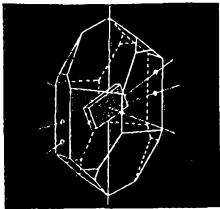
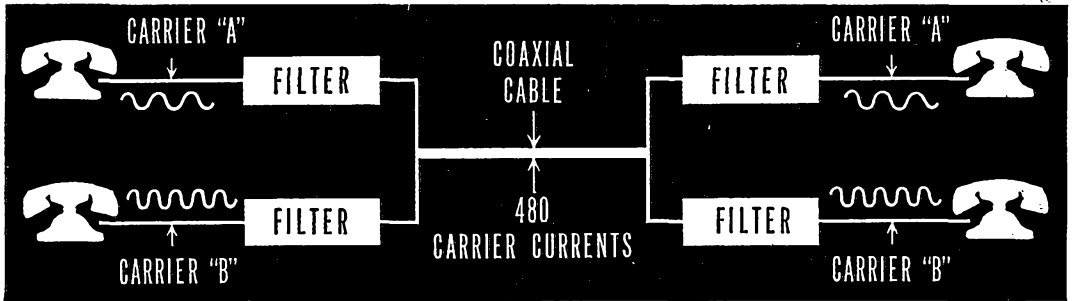

Four hundred and eighty telephone conversations over a coaxial cable was one of the last peacetime achievements of Bell Telephone Laboratories. In this multi-channel telephone system, each conversation is transported

by its own carrier current. At each end of the line are crystal gateways; each opens in response to its own particular "carrier" with the message it transports. In telephone terminology, these gateways are filters.

The ultra-selective characteristic of these filters is made possible by piezo-electric quartz plates, cut in a special manner from the mother

crystal, and mounted in vacuum. Each set of plates is precisely adjusted so that the filter responds only to the frequency of its assigned channel, rejecting all others. In the coaxial terminal equipment, such crystal gates sort out messages for delivery to their four hundred and eighty individual destinations.

In recent years, Bell Telephone Laboratories research has provided the Armed Forces with many types of electrical equipment in which frequency is controlled by quartz crystals. Notable is the tank radio set which enables a tank crew to communicate over any one of 80 different transmission frequency channels by simply plugging in the appropriate crystal. The future holds rich possibilities for the use of quartz crystals in Bell System telephone service.

BELL TELEPHONE LABORATORIES

Exploring and inventing, devising and perfecting for our Armed Forces at war and for continued improvements and economies in telephone service.



Available from Stock

The Cardwell Capacitors illustrated are available from jobber stock, on low priority, while the supply lasts.

Since Cardwell is still engaged 100% in vital war production, this is indeed an exceptional opportunity to obtain immediate delivery on familiar catalog numbers of Cardwell Standard Transmitting Capacitors, as well as more interesting special items.

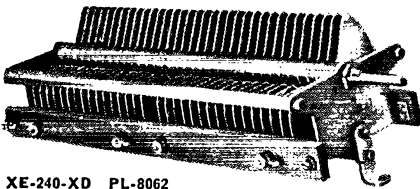

XE-240-XD PL-8062

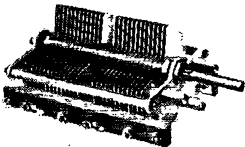

MR-260-BD PL-7013



EOY-2.8-SD1 Midget
Dual Neutralizer Con-
denser PL-6266
Airgap .111"
Max. Cap. Approx. 2.8
per section

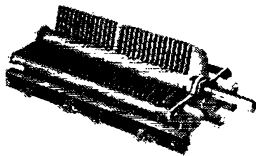

MO-180-BD PL-7031



ER-200-AS Spec., Insulated Shaft Extension
PL-6207

Because the specific capacitors shown here are subject to prior sale, and will not be available indefinitely, we advise immediate action. However, a complete listing (periodically revised) of other immediately available Cardwell products of equal merit and versatility will be sent upon request.

CARDWELL  CONDENSERS

**THE ALLEN D. CARDWELL
MANUFACTURING CORPORATION**
81 Prospect Street, Brooklyn 1, N. Y.

WWV Schedules

STANDARD-FREQUENCY transmissions are made available as a public service by the National Bureau of Standards over its standard-frequency station, WWV, on the following schedules and frequencies:

2.5 Mc. — 7:00 P.M. to 9:00 A.M. EWT (2300 to 1300 GMT).

5.0 Mc. — Continuously, day and night.

10.0 Mc. — Continuously, day and night.

15.0 Mc. — Continuously, day and night.

The 10- and 15-Mc. radio frequencies are modulated simultaneously at accurate audio frequencies of 440 and 4000 cycles. 5 Mc. carries both audio frequencies during the daytime but only 440 cycles from 7:00 P.M. to 7:00 A.M., EWT, while 2.5 Mc. carries only the 440-cycle modulation. A 0.005-second pulse may be heard as a faint tick every second, except the 59th second of each minute. These pulses may be used for accurate time signals, and their one-second spacing provides an accurate time interval for physical measurements.

The audio frequencies are interrupted precisely on the hour and each five minutes thereafter, resuming after an interval of precisely one minute. This one-minute interval is provided to give the station announcement and to afford an interval for the checking of radio-frequency measurements free from the presence of the audio frequencies. The announcement is the station call (WWV) sent in code, except at the hour and half hour, when it is given by voice.

The accuracy of all the frequencies, radio and audio, as transmitted, is better than a part in 10,000,000. Transmission effects in the medium may result in slight fluctuations in the audio frequencies as received at a particular place; the average frequency received, however, is as accurate as that transmitted. The time interval marked by the pulse every second is accurate to 0.00001 second. The 1-minute, 4-minute and 5-minute intervals, synchronized with the second pulses and marked by the beginning and ending of the periods when the audio frequencies are off, are accurate to a part in 10,000,000. The beginnings of the periods when the audio frequencies are off are so synchronized with the basic time service of the U. S. Naval Observatory that they mark accurately the hour and the successive 5-minute periods.

Of the frequencies mentioned above, the lowest provides service to short distances and the highest to great distances. In general, reliable reception is possible at all times throughout the United States and the North Atlantic Ocean, and fair reception over most of the world.

Information on how to receive and utilize the service is given in the Bureau's Letter Circular, "Methods of Using Standard Frequencies Broadcast by Radio," obtainable on request. The Bureau welcomes reports of difficulties, methods of use, or special applications of the service. Correspondence should be addressed to the Director, National Bureau of Standards, Washington, D. C.



2 complete NEWARK RADIO STORES



FOR BETTER . . . FASTER SERVICE ON RADIO AND RADAR PARTS . . .

For better, faster service on communications and sound equipment, radio and radar parts, electronic accessories and supplies, order ALL the things you need from the NEWARK ELECTRIC COMPANY store nearest you. Our recently opened New York store, as well as the famous Chicago store, are BOTH at your command with large stocks of radio equipment representing all the big manufacturers. Your inquiry will receive prompt and intelligent attention. We ship on short notice, right from our shelves wherever possible, promptly advising delivery date on any unfilled part of your order.

NEW METERS

(General Electric)

0-500 DC Ma, 2" round **\$3.50**

0-8 RF Ammeter, 2" round **\$4.00**

Bakelite Cases

Immediate shipment on Priority L265 or better

SPECIAL OFFER of Oil Filled, Oil Impregnated FILTER CONDENSERS

To celebrate the opening of NEWARK in New York, we feature this brand new offer of quality filter condensers. Guaranteed at rated voltage. No Priority Required.



Mfd.	DC	Size	Weight	Price
1	1000 V	5 x 3 1/4 x 1 1/4	10 oz.	\$.59
2	2000 V	4 1/4 x 3 1/4 x 1 1/4	2 1/4 lb.	1.50
6	1000 V	4 1/4 x 2" rnd can	12 oz.	1.00
2 MFD and 4 MFD in one can				
	600 V	4 3/4 x 2 1/2 x 1 1/4	14 oz.	\$.80

THORDARSON TRANSFORMERS

(Power Transformers and Chokes)

Immediate delivery on Priority L265 or Better

T-70R61	770 V. C.T. at 70 MA. 115 V. 60 Cycle 6.3 V. C.T. at 2.5 A; 5 V. at 2 A. 4 1/4 lbs.	\$3.36
T-70R62	700 V. C.T. at 145 MA. 115 V. 60 Cycle 6.3 V. at 4.5 A; 5 V at 3 A. 8 1/2 lbs.	4.41
T-45556 or T-92R21	leads out of side. 778 V. C.T. at 200 M.A. 115 V. 60 Cycle 6.3 V. C.T. at 5 A. 5 V. at 30 amp. 9 lbs.	5.29
T-13C27	10 H. 40 M.A. 475 ohm 1600 V. Insulation 3/4 lb.	.76
T-13C30	8 H. 150 M.A. 200 ohm 1600 V. Insulation 2 1/4 lbs.	1.41
T-45557 or T-74C29	leads out of side. 15 H. 150 M.A. 200 ohm 2000 V. Insulation 5/4 lbs.	2.82

Newark

ELECTRIC CO.

CHICAGO

323 W. Madison St.
DEArborn 0083

★ ★ ★ ★

NEW YORK

115-117 W. 45th St.
BRYant 9-4735

I WANT WHAT I WANT

When I Want It



That's the demand of industrial buyers today — so we're set to give you just what you want in radio and electronics — and to deliver it when you want it.

"Same-day" shipments from our diversified stocks plus our close contact with all sources of supply save time for you on those R-U-S-H orders. For help in a hurry, call CAPitol 7530.

BUY MORE BONDS

The **RADIO SHACK**
★ 167 WASHINGTON ST. ★
BOSTON, MASS., U.S.A.

Correspondence

(Continued from page 58)

gang and that he had to write and let me know he had seen it. The ham I'm referring to is W4CZH, Herbert Hanson, and he is doing radio repair work in Mobile, Ala.

I have another ham friend in Brisbane — Eric Neale, VK4EN. How we happened to meet is rather an interesting story. He inserted an ad in a Brisbane daily stating that he wanted to meet some American hams if there were any in town. Some of our gang spotted the ad and, after contacting him as soon as we could, he invited a group of us to his home.

We hopped a train and rode out to the suburb of Woolwin, and found VK4EN's home located on high ground in a beautiful spot for radio work. He met us at the door and after introductions all around we settled down for a good rag-chew. Mrs. Neale called us to lunch and of course during the meal radio was the main topic. After the luncheon we adjourned to the living room for more radio talk. We compared rigs we had used and discussed military and commercial operation.

VK4EN's job, by the way, is with the Postmaster General's Dept., which controls all radio and telegraph communication in Australia. He told us about their various circuits and just how his office worked there in Brisbane.

We got on the subject of bug keys and Mr. Neale showed us his, which made automatic dashes as well as dots. We had an audio oscillator with us and my old Vibroplex, so we practiced sending and receiving. Believe me, if you work VK4EN after this war you had better be on the ball, as he is a fast c.w. man. We asked him what kind of DX he had worked and he brought out a stack of QSL cards that would warm the heart of any old DXer. We ran across cards from W4AJY, W5FZY, W6ANN and W6HWH among the W section, and the other countries were myriad. . . .

As the afternoon drew to a close Mrs. Neale snapped a photo of the gang. [See page 33. — Ed.] We each held a QSL card representing our district. W4GKZ held his own, as he was the only one who had any of his personal QSL cards along. Several of us had to work the four to midnight shift so we reluctantly took leave of the Neales. . . .

No matter where you go in the world you find hams are all the same, and it makes me feel pretty good to belong to such a swell fraternity. I'm sure when peace comes the ham brotherhood will be larger and stronger than before.

I have been in the Philippines since the invasion, and though the Js tried their best to make a Silent Key out of me they didn't succeed. The first ham I met here was W2IUS from Teaneck, N. J., an old 20-meter 'phone man. W5HAQ, Lt. Robert E. Wick from Texas, came in at the same time as I did; in fact, we were on the same boat.

It seems no matter where you go — in the Army, Navy or Marines, in the remotest corners of the globe — the hams are there doing a great job. I am looking for KA hams now. . . .

—Sgt. Jack Hermann, W6URB

HERE'S ONE OF THE SECRETS OF HIGHER FIDELITY

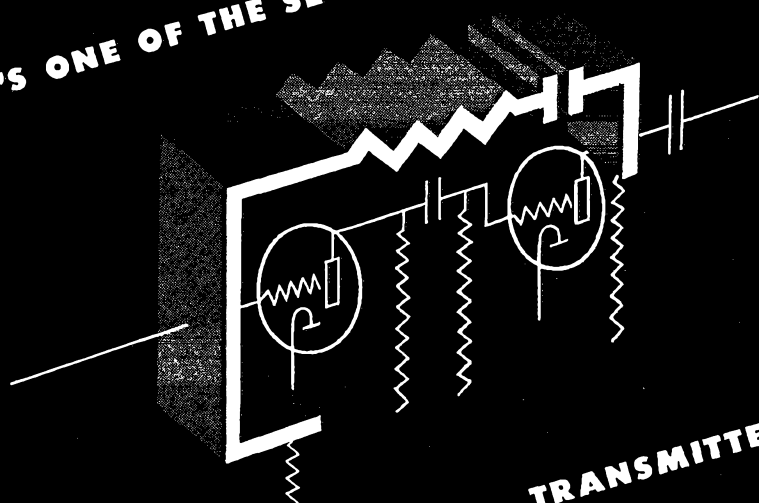

IN WESTINGHOUSE

TRANSMITTERS

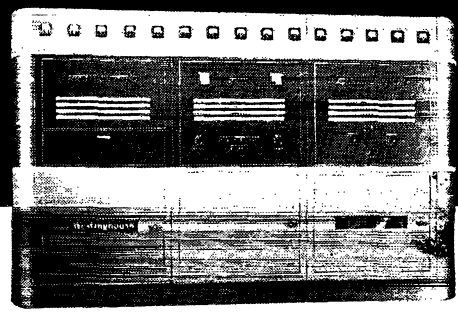

Here's one of the secrets of the higher fidelity in Westinghouse 5 and 10kw transmitters: it's called equalized audio feedback (see drawing) and it's an outstanding contribution to higher signal fidelity.

Equalized audio feedback strengthens the already high fidelity of the audio and modulation circuits in Westinghouse transmitters, and reduces audio distortion to even lower limits. The system is independent of any variation in rectified antenna output.

Control-simplicity, economy and high fidelity are natural partners of the solid dependability you find in the complete line of Westinghouse transmitters . . . 5, 10 and 50kw AM and 1, 3, 10 and 50kw FM. Your nearest Westinghouse office has all the facts on these newest achievements in faithful transmitter operation designed by Westinghouse . . . the oldest name in broadcasting. Westinghouse Electric & Manufacturing Company, P. O. Box 868, Pittsburgh 30, Pa. J-08110

Easy operation is another keynote of the smartly-styled Westinghouse 5kw transmitter . . . one master switch puts the transmitter on the air and cuts off power at close of broadcast day. Controls reset automatically whenever overloads occur in any circuit for any reason.



Westinghouse
PLANTS IN 25 CITIES . . . OFFICES EVERYWHERE

Electronics at Work

XXV—RADIO'S 25TH ANNIVERSARY—KDKA

Wanted ENGINEERS

Radio

- ★ Electrical
- Electronic
- ★ Mechanical
- ★ Factory Planning
- Materials Handling
- Manufacturing Planning

Work in connection with the manufacture of a wide variety of new and advanced types of communications equipment and special electronic products.

Apply (or write), giving full qualifications, to:

R.L.D., EMPLOYMENT DEPARTMENT

Western Electric Co.

100 CENTRAL AVENUE, KEARNY, N. J.

★ Also: C.A.L.

Locust Street, Haverhill, Mass.

Applicants must comply with WMC regulations

FIELD SERVICE ENGINEERS

for

Domestic and Foreign Service

MUST POSSESS GOOD
KNOWLEDGE OF RADIO

Essential Workers Need Release

HAZELTINE CORPORATION

58-25 Little Neck Parkway
Little Neck • Long Island

U. S. War Bonds for Stories of War Service

QST wants reports on the experiences of radio hams in active service on the battlefronts — for immediate publication in this section, where feasible, or to be held confidential where security considerations so require.

Do you have a story of war service to tell — either your own or that of someone you know? Then write us a letter giving full details, including photographs, clippings and other substantiating data where available. If your story is published in *QST*, you will receive a \$25 U. S. War Bond. Please indicate clearly on the report if it is available for publication in its entirety, if names, dates or places should be deleted, or if all information must be held confidential.

Hams in Combat

(Continued from page 51)

then threw in a few queer-sounding geographical locations, such as "Hvalfjorder" (pronounced KWAL-four-ther) and "Budayeyri," by way of orientation.

"Amazing, isn't it?" was all I could say when he had finished.

Major Ranvier did much for radio communications in Iceland. When he didn't have the proper spare parts for repairs, he improvised, often by redesigning the circuits to fit the available parts. He had a most practical, common-sense approach to a problem which invariably produced results.

While in Iceland I also met Glen Davidson, W9DDU; John R. Swink, W8TEF; Wm. Brooks, W8FKT; Walter H. Bales, W9ADH; James A. Shanks, W9JCI, and Joseph Palm, OPLO. There were others, too, but their calls slip my memory. We fought the battle of boredom and the peculiar atmospherics that play havoc with all radio communications in Iceland. In the postwar era, when you QSO Iceland, don't be surprised if the TF suddenly does a fade-out in the middle of a QSO. The air goes completely dead in a matter of seconds. Sometimes it stays dead for several hours; sometimes for only a short while. The result is unpredictable, intermittent communication. We usually blamed the northern lights for this phenomenon. In fact, we blamed the aurora for almost every radio trouble — including power failure!

Iceland is cold and stormy in the winter months — and so is the North Atlantic! No one knows this better than Lt. James A. Shanks, W9JCI, who spent several hours in a small lifeboat after his ship was torpedoed somewhere off the coast of Iceland. The torpedo hit during the early morning hours, in pitch dark and bitter cold. The ship listed badly but Lt. Shanks and other passengers launched lifeboats before the ship went down. They drifted in darkness through the rough seas for over four hours. Soaked to the skin by spray, by dawn they were nearly frozen.

PREVIEW OF A STARTLING NEW FARM TYPE BATTERY

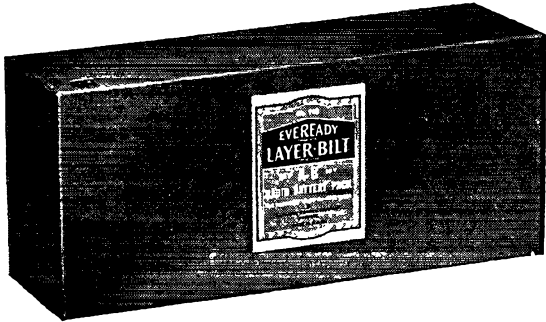

OLD

The present No. 748 1½-volt "A," 90-volt "B" A-B Pack
Dimensions, 15 13/16" x 6 15/16" x 4 15/32"
Weight, 23 lbs., 11 oz.



NEW

The New No. 758 1½-volt "A," 90-volt "B" A-B Pack
Dimensions, 10 11/16" x 6 13/16" x 4 1/8"
Weight, 16 lbs., 13 oz.

30% SMALLER, LIGHTER -BUT SAME CAPACITY!

THIS GIVES YOU an advance look at the latest "farm-type" radio battery to be developed by National Carbon Company. A revolutionary construction makes this smaller, lighter "Eveready" "Mini-Max" battery a reality. Actually it is a good 30% more compact than the present No. 748 A-B Pack. Yet not one bit of capacity has been sacrificed in achieving a valuable reduction in size and weight.

The advantages of this more compact battery will be obvious to you. The way is paved for smaller, less expensive battery-operated radio sets. And these sets will have the advantage of being far easier to move about from room to room. The way is likewise paved for sets of the present size utilizing the space saved by the new battery to use larger speakers giving improved receptivity and tonal qualities. Both add up to a greater demand for farm-type radios and an important increase in business for you.

This newcomer, known as the "Eveready" No. 758 A-B Pack, is only one of many improved types of "Eveready" batteries which will appear after the war. Look to National Carbon's exclusive construction, used in the "Mini-Max" battery, for more and equally important news to the trade.

"EVEREADY"

MINI-MAX
TRADE-MARK

RADIO "B" BATTERIES

NATIONAL CARBON COMPANY, INC.
Unit of Union Carbide and Carbon Corporation

UCC
General Offices: NEW YORK, N. Y.

The trade-marks "Eveready" and "Mini-Max" distinguish products of National Carbon Company, Inc.



IRC METALLIZED TYPE BT RESISTORS

Unexcelled in such essential characteristics as stability, low noise level, low voltage coefficient, mechanical strength, humidity protection, and insulation—IRC type BT resistors have a proven record of performance in millions of applications. Today, after more than a decade of use, these small, sturdy units are recognized as standard around the world. Available in all wanted ratings.



INTERNATIONAL RESISTANCE CO.

401 N. BROAD ST., PHILADELPHIA 8, PA.

IRC makes more types of resistance units, in more shapes, for more applications, than any other manufacturer in the world.

Phone, Wire or Write

WHOLESALE

Radio-Electronic Parts
Tubes, Sets and
Equipment

R. G. SCELİ & CO.

227 Asylum St. Hartford, Conn.

Telephone 2-1144

W9JCI almost qualified for Silent Keys before their flares were sighted by a Coast Guard cutter.

Another Signal Corpsman, Lt. William Valentine, was aboard the ship with W9JCI. When the torpedo struck he made his way below deck to the sick bay to help get the patients into the lifeboats. Disregarding his own safety, Valentine stayed aboard until all the launchable boats were filled. By then the ship was sinking fast. A few seconds before it went down Valentine climbed to the bridge, cut loose a small life raft, and slid with it into the sea. He was picked up several hours later, nearly dead from exposure and fatigue — but on the raft with him were three other survivors he had fished from the sea. Upon reaching Iceland Lt. Valentine was awarded the Soldiers' Medal. His citation read "for extraordinary heroism" — and justly so.

However, Iceland isn't always a land of ice and snow. In the summer it is a beautiful place where the sun shines twenty-three hours each day. The Icelanders are an intelligent, progressive people. Indeed, at times I felt they were a bit too progressive. Once I paid 20 kronur for a bunch of grapes. To satisfy my curiosity, I counted the individual grapes and divided by the rate of exchange. They had cost me the equivalent of ten cents each! Another time I bought a genuine hand-made Icelandic souvenir in a curio store. It seemed a steal at 150 kronur (\$10.00) — until I found, marked inconspicuously on the bottom, the label "Made in U. S. A."

Icelandic hams seemed to be as scarce in person as they used to be on the air. Unscrupulous DXer that I am, if I could have found one I'd have tried to snare a QSL card — or at least arrange a postwar schedule. In the past I've spent many fruitless hours at Babler Park in St. Louis County pounding out answers to Icelandic CQs on 14-Mc. c.w. But even in Iceland I couldn't raise a TF.

There are other foreign hams whom I hope to meet in person while I am in Europe — particularly ON4HC, whom I once talked to from W9JWJ at Ferguson, Mo. The fact that I couldn't work him on the same band at home, with 300 watts as compared with W9JWJ's 30, is better not discussed. I think he discovered that W9JWJ is a YL and picked his QSO accordingly.

The following amateurs of VII Corps are currently living on the German side of the Siegfried line:

- W1BLO, Pvt. Eugene J. Gaumont, SC
- W1GKJ, M/Sgt. Lionel Simon, SC
- W4EVH, S/Sgt. Ralph Jenkins, SC
- W4IDI, Cpl. Edward Talley, SC
- W5FRP, Colonel John H. Sampson, FA
- W5KHZ, CWO Hilton J. Allen, AUS
- W8QMK, T/4 Chester E. Riker, FA
- W8UBF, T/3 Mitchell A. Paniwozick, SC
- W9MNS, T/3 Irving E. Olsen, SC
- W9YVR-ex-W5GQQ, Capt. Alexander S. Turner, SC
- K5AT, 1st Lt. Francis X. Knopp, SC

(Continued on page 90)



The Greeks gave us a word for it . . . now we give it to you

WHEN Sperry first developed its velocity-modulated, ultra-high-frequency tube, the word "KLYSTRON" was registered as the name of the new device.

This name—from the Greek, as coined by scientists of Stanford University—is an apt description of the bunching of electrons between spaced grids within the tube.

"Klystron" is a good name. So good, that it has come into widespread use as the handy way to designate any tube of its general type, whether a Sperry product

or made by another manufacturer.

This is perfectly understandable. For the technical description of a Klystron-type tube is unwieldy, whether in written specifications, in conversation, or in instructing members of the Armed Forces in the operation of devices employing such tubes.

These conditions have prompted many requests from standardization agencies—including those of the Army and Navy—for unrestricted use of the name Klystron. In the public interest, Sperry has

been glad to comply with these requests . . .

From now on, the name KLYSTRON belongs to the public, and may be used by anyone as the designation for velocity-modulated tubes of any manufacture.

Sperry will, of course, continue to make the many types of Klystrons it now produces, and to develop new ones.

On request, information about Klystrons will be sent, subject to military restrictions.

SPERRY GYROSCOPE COMPANY, INC. GREAT NECK, N. Y.

Division of the Sperry Corporation

★

LOS ANGELES • SAN FRANCISCO • NEW ORLEANS
HONOLULU • CLEVELAND • SEATTLE

GYROSCOPICS • ELECTRONICS • RADAR • AUTOMATIC COMPUTATION • SERVO-MECHANISMS

Why WARD LEONARD VITROHM RESISTORS AND RHEOSTATS

are universally recognized as outstandingly superior products.

- **FINEST MATERIALS OF TIME-TESTED QUALITY**
- **DESIGN AND MANUFACTURING "KNOW-HOW"**

Over fifty years experience in the development and building of wire-wound resistors and rheostats.



WARD LEONARD

ACCEPTED MEASURE OF QUALITY
WARD LEONARD ELECTRIC CO.
Radio and Electronic Distributor Division
53 West Jackson Blvd., Chicago, Ill.

Now—a really high-powered



RADIO ENGINEERING LIBRARY

- especially selected by radio specialists of McGraw-Hill publications
- to give most complete, dependable coverage of facts needed by all whose fields are grounded on radio fundamentals
- available at a special price and terms

5 VOLS.
3319 PAGES,
2289
ILLUSTRATIONS

1. Eastman's Fundamentals of Vacuum Tubes
2. Terman's Radio Engineering
3. Everitt's Communication Engineering
4. Hund's High Frequency Measurements
5. Henney's Radio Engineering Handbook

THESE books cover circuit phenomena, tube theory, networks, measurements, and other subjects—give specialized treatments of all fields of practical design and application. They are books of recognized position in the literature—books you will refer to and be referred to often. If you are a practical designer, researcher or engineer in any field based on radio, you want these books for the help they give in hundreds of problems throughout the whole field of radio engineering.

Free Examination • Special Low Price • Easy Terms

McGraw-Hill Book Co., 330 W. 42nd St., New York 18
Send me Radio Engineering Library, 5 vols., for 10 days' examination on approval. In 10 days I will send \$3.00, plus few cents postage, and \$3.00 monthly till \$24.00 is paid, or return books postpaid. (We pay postage on orders accompanied by remittance of first installment.)

Name.....
Address..... Position.....
City and State..... Company..... QST-4-45

(Continued from page 88)

K5GQO—ex-W2MAP-KAIUS, WOJG, William R. Scott, AUS
OPLO, T/Sgt. Joseph T. Palm, SC

Obviously, the hams mentioned in this account represent only a fraction of the total of those doing their bit in the ETO. Even in VII Corps undoubtedly there are other hams who have not been included but who have also experienced the long, hard trek of VII Corps from the Normandy beachhead to the interior of Germany.

Antenna Switching

(Continued from page 41)

To expand further the usefulness of the available antennas and to provide an auxiliary for the automatic switching system, all antenna-feeder lines are brought in to General Radio jacks, thus making it practical to "patch" to any antenna manually. The transmission lines brought to these terminal jacks are well spaced to avoid coupling. The jacks make excellent points to connect the close-spaced lines from the switching relays.

The rhombic antennas shown in the diagrams belong to the Radio Intelligence Division of the FCC, which has been doing such excellent work in keeping radio channels clear of unauthorized transmissions and locating sources of interference to important wartime communication circuits.

Since the rhombics are used by the RID independently of the Field Division of the Commission, the connections to these antennas must be made in a manner such as not to disturb in the slightest their use by this agency. To accomplish this a 250-ohm carbon resistor is inserted in each leg of the transmission line coming from the rhombic-group relay. Extensive tests on several frequencies have shown no interference to the RID and no perceptible loss of signal for monitoring purposes.

While the usefulness of an automatic switching system for rapidly selecting the most desirable aerial is readily apparent, a few of the more unusual results include those noted when propagation conditions are acting up. At such times good reception of a wanted signal often is possible on an antenna whose directivity and theoretical design are both unfavorable. Normally such an antenna would never be selected by manual means, but the automatic system is so rapid that an inspector having difficulty with a signal will run through all antennas in a matter of seconds. Quite frequently the switching system has been used to select one signal free from interference from as many as five other signals on the same frequency.

Although many other similar instances could be given, suffice it to say that the Field Division of FCC, through its monitoring stations, has been able, by use of highly skilled inspectors and such specialized apparatus, to reduce the number of spurious emissions, off-frequency signals, and undesirable operating practices to a point where the increase in efficiency of communication channels is a very gratifying contribution to the war effort.



"CONTROL OF THE AIR"
has a new meaning today

Yes, we're talking about a different kind of air control than that established by Allied fighters and bombers. For the air today is full of high-frequency impulses, launched by varied types of radio and electronic equipment and performing varied functions of communication, detection, ranging and safeguarding. From compact mobile radio sets to highly intricate radar equipment, Delco Radio products are helping to bring new "air supremacy" to America's armed forces. Delco Radio Division, General Motors Corporation, Kokomo, Indiana.

KEEP BUYING WAR BONDS

Delco Radio
DIVISION OF
GENERAL MOTORS

DeLuxe SPEED KEY

Model
CP 810

Amateur
Net Price
\$9.75

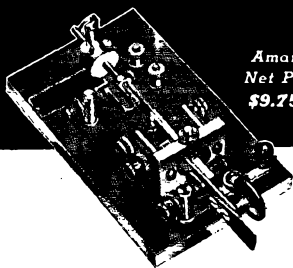

One of the finest commercial or amateur bugs available. Chrome finished base and super-structure. Springs made of selected blue spring steel for uniform performance in all keys. Nine points of adjustment to suit the most critical touch. Fully adjustable. Silver contacts 3/16" diameter.

MODEL CP 510 SPEED KEY • Similar to above except the base is Battleship gray wrinkle finish. Amateur Net Price **\$6.75**

TELEGRAPH Apparatus Co.

325 WEST AURON STREET • CHICAGO 10, ILL.



IT'S HERE . . .

UNIVERSAL'S new D-20 dynamic microphone is ready. It is designed for indoor or outdoor use with frequency range of 30 to 8,000 cycles at -54 db as referred to one volt per bar. Suitable for recording, p. a. systems, transmitters or wherever a full-ranged dynamic microphone is needed. Includes 25 ft. cord, detachable connector and dust-proof cover. 50, 200, 500 and 40,000 ohms. Priority required.

UNIVERSAL MICROPHONE COMPANY
Inglewood, California

230 Watts from One 815

(Continued from page 89)

2) The average plate current value must not be exceeded.

3) The peak allowable emission from an oxide filament is 150 ma. per watt of filament power; for a thoriated tungsten filament, 50 to 100 ma. per watt.

4) When using tetrodes, the plate voltage should not be permitted to fall too far below the screen potential and the screen voltage should be supplied from a separate source.

5) It is not necessary to push things to the limit; the circuit can be so designed that the auxiliary tube supplies only 5 or 10 watts, with resulting efficiencies in the plate circuit of the main tube of about 88 to 92 per cent. The over-all efficiency then will be very close to 90 per cent, although the allowable power input will be less than in our "souped-up" 815.

If anyone is interested, I have derived constant-current curves for the 809, 811, 813 tubes, with accompanying circuit conditions which I will gladly furnish to anyone sending a stamped self-addressed envelope.

Radio Amateurs in Navy Radar

(Continued from page 26)

transmitters, direction finders, and underwater sound gear. Laboratories are completely equipped with all the latest models of such equipment, and every student has the opportunity to perform actual experiments on the same gear he will later maintain at sea. It should be stressed that the graduate radio technician's duties are concerned solely with maintenance and engineering. No operating is involved, for men are trained in operating techniques at other schools far less technical in their scope.

It is apparent that RT graduates will hold a highly responsible position on the fighting team. Successful performance of duty naturally will lead to advancement. Advancement from the start of training is rapid and may be summarized as follows: Enlistment or induction as seaman first class. Generally the RT reaches the rate of third class petty officer in the early months of secondary school. Those specially qualified students are then graduated as second class petty officers. Further advancement to first class or chief petty officer is contingent upon satisfactory performance of duty with the fleet. Men with college background who display outstanding ability in secondary school may also be considered as officer prospects.

The need for radio technicians in the Navy is still great, and I can assure every amateur that the training he will receive in this program is second to none in the field of practical radio engineering. What is more, by serving in this capacity you will be adding one more page to the enviable record of amateur radio's total contribution toward the winning of this war.

PAVING THE WAY for postwar amateur development, particularly on the ultrahighs (microwaves) and other prospective new techniques, the 1945 Edition of the "Radio Amateur's Handbook" includes diversified material new to its scope, while still retaining its time-proved treatment of the orthodox theory and

NEW 1945 EDITION

The Radio Amateur's Handbook

practice of amateur radio — refined, modernized, reorganized for maximum convenience whether used as text, reference or constructional manual. This Edition of the "Handbook" contains more pages and more information per page than any "Handbook" yet published. . . . Every subject encountered in practical radio communication is covered, arranged for maximum convenience to the reader, sectionalized by topics with abundant cross-referencing and fully indexed. . . . More than ever the ideal reference work, the 1945 edition also contains practical constructional information on tested and proved gear — always the outstanding feature of the "Handbook." . . .

\$1 *Postpaid in Continental U. S. A.*

\$1.50 Postpaid Elsewhere . . . Buckram Bound \$2.00

American Radio Relay League, Inc., West Hartford 7, Conn., U. S. A.

PREMAX



Premax Antennas

Tested in War...
Ready for Peace

PREMAX PRODUCTS
DIVISION OF CHISHOLM-RYDER CO., INC.
NIAGARA FALLS, N. Y.

Premax Products

Division Chisholm-Ryder Co., Inc.

4519 Highland Avenue • Niagara Falls, N. Y.

RF Inductors • RF Chokes • IF Transformers
Condensers • Mica Molded Condensers • Trimmer
Condensers • Miscellaneous Apparatus

The F. W. Sickles Co., Chicopee, Mass.



SICKLES *Electronic Specialties*



Founded in 1909

**RADIO TELEPHONY
RADIO TELEGRAPHY
PRE-INDUCTION RADIO**

Courses ranging in length from 3 to 9 months. Dormitory accommodations on campus for men and women students. Approved by Texas Department of Education with authority to issue a maximum of 60 semester credits for complete training. *If interested, write for details.*

PORT ARTHUR COLLEGE PORT ARTHUR TEXAS

Splatter

(Continued from page 10)

WERS "para-talkie" (p. 34). He received his initiation into the mysteries of radio serving as a signaler in the Canadian Expeditionary Forces for three years of World War I (with nine months in the front lines) and radio has been one of his pet hobbies ever since. Then WW II came along and he entered the CAP shortly after it became an auxiliary of the Army Air Forces. In the intervening years he had been patiently awaiting the opportunity to become a ham. Radio work in the CAP finally aroused his enthusiasm to the pitch required to make the effort to obtain his Class A and radiotelephone second class tickets last year. "The biggest thrill I've had in radio was when, as group communications officer of the CAP Parachute Group, I watched the men stick to their job of designing and building the much-needed 'para-talkie' until they had licked every one of the vexing problems confronting them," he reports. . . .

Morrison L. Gable, W9RLM, also took a long time to make the jump. He became interested in amateur radio in 1932, but kept putting off getting his license until 1940. This does not imply that his radio education suffered a similar lapse, however, for Gable is now an electronic engineer in the aeronautical division of Minneapolis-Honeywell. Before going to the Twin Cities W9RLM spent some time as an instructor in the Signal Corps Training School in Chicago. There he met one **Cyrus T. Read, W9AA**. A result of the ensuing friendship is their collaboration on the article describing wide-range v.h.f. tank circuits (p. 48). W9AA, during 1944 an assistant secretary of ARRL and long a prominent Chicago amateur, is, of course, no stranger to *QST*'s pages, having been in and out of them for many years — including an initial appearance in *Splatter*, December, 1943, page 110.

Lt. Hulen M. Greenwood, AC (p. 26), was born in Texas, where every field is a flying field. But, paradoxically, his prime ambition is to get duty at Wright Field, Ohio. Here is a report on his progress to date: Leaving Texas University with a B.A. in physics in 1937, he dug an oil well (it was a dry one), did radio servicing and construction, and finally enlisted in the Air Corps in 1940. Having been interested in radio since 1932 and a ham since '37, by some strange quirk of fate he got into aircraft radio maintenance. That was at Randolph Field — in Texas. Later he was transferred to Ellington Field — also in Texas. From there he went to Labrador and Greenland with the AACS. In '43 he came back to Kelly Field — still in Texas. (Somewhere along the trail he obtained radiotelephone first, radiotelegraph second and Class B licenses.) Accepted as an aviation cadet, Greenwood next went to New Haven to take the communications officers course at Yale. Commissioned in August of '44, Lt. Greenwood is now attending radar school in Boston — and still trying to get out to Wright Field. . . . The radio career of E. A. Henry, W9FEN (p. 11), started in 1922 with a cigar-box

Unfailing Dependability

TURNER
99 and 999
Dynamic Microphones

Built to stand up and deliver under the most difficult acoustic and climatic conditions, Turner 99 and 999 are the choice of discriminating users who want utmost in dependability and performance. For indoor or outdoor use in arctic cold, desert heat or tropic humidity, they're precision engineered to faithfully reproduce all gradations of tone and volume without distortion or blasting. No. 999 has same appearance as 99 except equipped with Balanced Line features for critical applications. Both available in 30-50, 200, 500 ohms, or hi-impedance. Range 40-9,000 cycles. Level -52 DB. Gun metal type finish.

Write for FREE Turner Catalog giving specifications and prices on Nos. 99 and 999 and all other Turner Microphones

The TURNER Company

917 17th St., N.E. • Cedar Rapids, Iowa, U.S.A.

TURNER

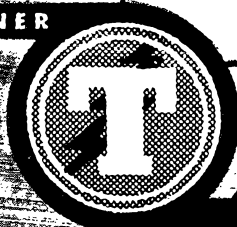

TURNER

Pioneers in the communications field

Microphones

RADIO-ELECTRONICS

Co-educational training in Airline, Merchant Marine, Press Communications, Electronics, Television. FREE booklet. Address Registrar, Ex-Servicemen. Request FREE copy, G.I. bill of rights
"A Radio School managed by radio men."
45 West 45th Street, New York 19, N. Y.

MELVILLE RADIO INSTITUTE

INSTITUTES

Offer thorough training courses in all technical phases of

RADIO and TELEVISION

WEEKLY RATES DAYS-EVENINGS

VETERANS: RCA Institutes is approved under G. I. Bill of Rights
For Free Catalog write Dept. ST-45
RCA INSTITUTES, Inc.
A Radio Corporation of America Service
75 Varick Street, New York 13, N. Y.



Electricity

FOR RADIO AND ELECTRONIC APPLICATIONS

Onan Electric Generating Plants supply electric service for electronics applications and general uses, mobile, or stationary. Driven by Onan-built, 4-cycle gasoline engines, they are of single-unit compact design and sturdy construction.

65 models, sizes from 350 to 35,000 watts. A.C. types: 115 to 660 volts, 50, 60, 180 cycles, 1 or 3-phase; 400, 500 and 800 cycles, 1-phase. D.C. types: 6 to 4000 volts. A.C.-D.C. combination types available. Write for engineering assistance and literature. Model shown is from A.T.C. lightweight series.

Over 250,000
Now In Service

D. W. ONAN & SONS

2623 Royalston Ave., Minneapolis 8

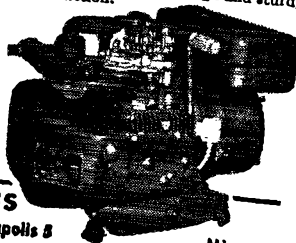

Minnesota

THIS **HARVEY** REGULATED OF CAMBRIDGE POWER SUPPLY 106 PA

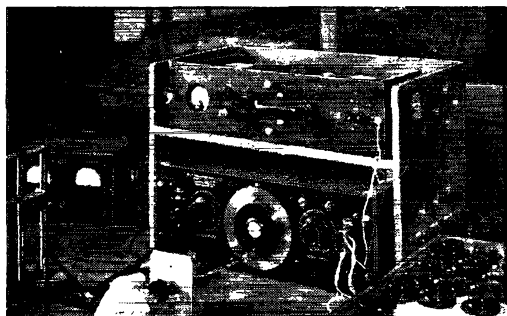

Helps Check the Quality of MURDOCK-Made Head Sets

The W. J. Murdock Company of Chelsea, Massachusetts, relies on a HARVEY Regulated Power Supply 106 PA to determine that head sets manufactured by them for the Armed Services meet Signal Corps and Navy Department Specifications.

The HARVEY 106 PA, teamed with a wide range beat frequency oscillator, supplies a constant D.C. voltage for an amplifier testing the output of Murdock type R14 head sets. Input is three volts. Earphones are tested at four frequencies within the range of 500 to 2500 kc., to check various decibel readings within that range.

If you need a constant, thoroughly dependable source of D.C. power, better look into the HARVEY Regulated Power Supply 106 PA. Write for new bulletin.

HARVEY RADIO LABORATORIES, INC.

451 CONCORD AVENUE CAMBRIDGE 38, MASS.

RADIO

Courses Qualifying for Service Technician • Laboratory Technician • Electronic Television • Communications Operator • Register Now for New Classes Starting First Monday of each month, Day-Eve. Classes • Consideration Given to Veterans Eligible for Training Under G.I. Bill

AMERICAN RADIO INSTITUTE

101 West 63d St.

New York 23, N. Y.

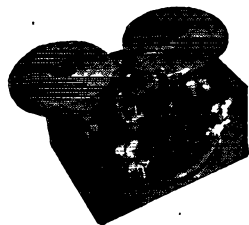

"The Choice of Those Who Know"

MASTER

THE CODE

with

Master Teleplex

ALL AC OPERATED. The only all-in-one instrument that will record your own sending and repeat it back to you. Records signals from the air and repeats back at any speed. The perfect instructor for both sending and receiving.

A postcard will bring Booklet N-12 giving full details of ten day **FREE TRIAL**

TELEPLEX CO. 107 Hudson Street
Jersey City 2, N. J.

crystal receiver and progressed through the super-blooperdyne and all the other 'dynes until January, 1926. By this time his interest was sufficiently aroused to cause him to enlist in the Navy as a radioman. After attending the Naval Radio Operating School at San Diego, he spent the major portion of his hitch as an operator in the Asiatic Fleet. By the time he hit the beach again he had learned enough radio to obtain an amateur license in April, 1930. The next few years were spent on 7-Mc. c.w., passing through the various stages from flea to high power. In 1935 the 'phone bug bit hard enough to get W9FEN on 56-, 28- and 14-Mc. 'phone. Of all the phases of amateur radio, he likes rag-chewing and construction best. Which, obviously, constitute excellent qualifications for his present job as an engineering group leader in the Test and Measurement Equipment Section of RCA Victor at Camden. . . .

Next, we present **W. E. Marquart, W9CKT** (p. 43). He has been licensed ever since he was 11 years old — which was in 1920. During the twenties, Marquart, then familiarly dubbed "TYS" after the TOM-famed Young Squirt, was ARRL district superintendent for South Dakota. Now he is in charge of civilian technical and shop training in OCSigO at Washington — which shows what can be accomplished in a mere quarter century. Yet W9CKT confides that an outstanding highlight of his entire radio career was the ARRL Dakota Division convention of 1929, held in Huron, S. Dak. There not only was he initiated into ROWH, but he also met ARRL Treasurer "Pop" Hebert, 1ES, representing Hq., who presented his own personal ARRL pin to 9CKT. "That," Marquart emphasizes, "was indeed a memorable occasion for a 14-year-old Young Squirt!" . . . This month's oldest old-timer is **Alfred K. Robinson, W7DX** (p. 38), who obtained his first amateur call in 1913 when he was 13 years of age. That call was 7AT. Since then he has been, successively, 7AL, 7US, 6AOJ, 7KQ, W7KQ and now W7DX. His ownership of this call is justified by the 129 DX countries worked on 20-meter 'phone. A sea-going op for six or seven years, Robinson had a preliminary brush with the Japs in connection with the disaster suffered by the SS *Wenatche* in the Orient. Under the very noses of the Japs, who were holding up regular communications, Robinson operated an undercover station which pushed through the news and effected rescue of the *Wenatche* by an American freighter. Leaving the sea in 1928, Robinson joined the Bureau of Navigation of the Dept. of Commerce, later transferring to the new FCC with the rest of the Radio Division, where he remained until 1941. That year he joined the ACS as a radio engineer, designing, constructing and installing radio stations in Alaska. In 1943 he rejoined the FCC and is now senior inspector at Grand Island. Incidentally, his son, Oliver, was one of the youngest U. S. hams ever licensed, becoming W7IBK when he was 9 years old. Although still only 16, Oliver is now a radio op on a Liberty ship somewhere in the South Pacific.

You'll
HEAR
MORE



from Astatic • In speeding up wartime production and discussing new postwar products and markets, executives, engineers and sales chiefs of The Astatic Corporation meet in frequent round table conferences. As a result, Astatic Microphones, Phono Pickups, Cartridges and other products of tomorrow will incorporate many advanced ideas for improved sound detection, pickup and reproduction. That's why we say: "You'll HEAR MORE from Astatic" . . . hear more concerning these new products and hear more from the efficient operation of the products themselves.

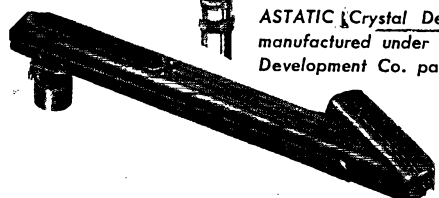
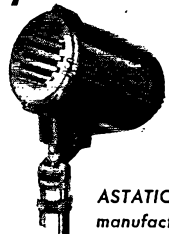

ASTATIC Crystal Devices manufactured under Brush Development Co. patents.

THE Astatic CORPORATION
 CONNEAUT, OHIO
 IN CANADA: CANADIAN ASTATIC LTD., TORONTO, ONTARIO

THE BOSTON TRAVELER, MONDAY, JANUARY 23, 1909.

MARVELOUS WORK OF WIRELESS SAVED HUNDREDS FROM DEATH

SURVIVORS OF REPUBLIC ARE **Republic Founders in**

Just How I was Rescued

IKE DAN'S AT RIDE

Back in the early 1900's most people thought radio didn't have much of a future . . . until January 23, 1909. On that day the S. S. Florida rammed the Republic off Nantucket. 1500 people were saved — by radio. An alert wireless operator named Jack Binns sent out the distress signal of that day — CQD — which brought other vessels to the rescue. Radio had proved its worth . . .

Today the Marine Radio Service is one of the most highly developed aspects of radio communications. It is one of the fields served by Harvey-Wells, producers of excellent communications equipment for marine craft, aviation, public services, transportation and allied industries.



Harvey-WELLS

ELECTRONICS
 SOUTHBRIDGE, MASSACHUSETTS

operators or the public.

1923 1924 1925 1926 1927 1928 1929 1930 1931 1932 1933 1934 1935 1936 1937 1938 1939 1940 1941 1942 1943 1944 1945

SERVICE THROUGH THE YEARS!

America's MOST COMPLETE Source of Supply for

RADIO PARTS TUBES INDUSTRIAL ELECTRONIC EQUIPMENT

OVER 10,000 ITEMS AT YOUR FINGERTIPS!

★ Telephone BRclay 7-1840 ★

SUN RADIO & ELECTRONICS CO.
212 Fulton Street, New York 7, N. Y.

FREE 800-Page Catalog!

Authorized purchasing agents and engineers who write on company stationery can obtain our massive buying guide free of charge.

Write Box QA

LEARN RADIO

Pre-Military training for beginners. Catalog on request. We teach all technical branches of radio. Lic. by the Comm. of Mass. Dept. of Education.

MASS. RADIO SCHOOL
18 Boylston Street Boston, Massachusetts

COMMERCIAL RADIO INSTITUTE

A RADIO TRAINING CENTER FOR 24 YEARS

Resident Courses Only • Pre-Induction, Broadcast, Service, Aeronautical Television, and Marine telegraphy classes now forming for April 16th. Literature upon request. Veteran training.

Dept. B., 38 West Biddle Street, Baltimore 1, Maryland

COMPLETE RADIO TRAINING!

All branches of communications, including television and FM courses from 6 to 18 months' duration. HIGH SCHOOL GRADUATES 17 YEARS OF AGE—prepare for radio operating positions in the U. S. Merchant Marine in 6 months. Complete pre-induction radio training in 3 months. Information supplied to Veterans on radio engineering training.

Write for particulars
VALPARAISO TECHNICAL INSTITUTE
Dept. T Valparaiso, Indiana

RADIO-TELEVISION-ELECTRONICS

Prepare now for ever-increasing post-war opportunities. Day and Eve. Sessions. Enroll now for new classes. Consideration given to Veterans eligible for training under the G.I. Bill.

RADIO-TELEVISION INSTITUTE
480 Lexington Avenue, New York 17 (46th Street)
Plaza 3-4585 Licensed by New York State

Silent Keys

It is with deep regret that we record the passing of these amateurs:

W1IWW, Augustus K. Ross, Dover, N. H.
W2EVA, Roy R. Neira, Long Island City, N. Y.
W2HWH, Robert J. Woytisek, Jackson Heights, L. I., N. Y.
W2ITR, Lt. Joseph M. Hyland, Jackson Heights, L. I., N. Y.
W6SPE, Pfc. Leslie E. Haughs, San Francisco, Calif.
W7GTR—ex-W7AKI, Darrell G. Warner, Pendleton, Ore.
W7BHH, Lt. Comdr. William O. Beach, Seattle, Wash.
W7FAL, Earl L. E. Stillings, Molallo, Ore.
W8ACW, George F. Gurnea, Flint, Mich.
W8ADI, Arbie B. Creighton, Wheeling, W. Va.
W8AIT, Charles H. Davies, Pittsburgh, Pa.
W9VLM, Kenneth H. Smith, Michigan City, Ind.
VE5RS, Richard D. Smith, Vancouver, B. C.
G4IT, E. H. Paulton, Worthing, Sussex, England.

Strays

The deaths of two good friends of amateur radio, whose names have been tradition in the game from the early spark days to the present time, occurred recently. Dr. Charles F. Burgess, founder of the Burgess Battery Company and inventor, among a great many other things, of the process for electrolytic purification of iron, died Feb. 13th, within a few days of which occurred the death of C. H. Thordarson, founder in 1895 of the pioneering Thordarson Electric Manufacturing Co.



RECEIVING SENDING CODESPEED *without strain*

CHAMPIONS ENDORSE CANDLER WAY

Get skill, accuracy, speed with the highly endorsed Candler System. Learn to send and receive by telegraph or radio code. Government service and commerce need thousands of better trained operators. Air commerce, mail, freight, etc., demand expert, reliable operators. Good pay. Get the Candler System, the maker of champions. It teaches you the "knack" of sound sense, alertness, speedy sending and receiving without strain. Adventure—good pay. Learn at home or wherever you are. Rush name today for free book.

FREE! **CANDLER SYSTEM CO.**
Dept. 4-D, Box 928, Denver 1, Colorado, U.S.A. and at 121 Kingsway, London, W.C. 2, England

Another **DX** FIRST!



For more than a year DX Crystals have been automatically deep-etched by a new process. Both the method and machines were perfected by DX Engineers so that all DX Xtals can have the nth degree of stability and endurance necessary to wartime operation

Think about DX Products for your new receivers and transmitters.



DX CRYSTAL CO.

GENERAL OFFICES: 1200 N. CLAREMONT AVE., CHICAGO 22, ILL., U. S. A.

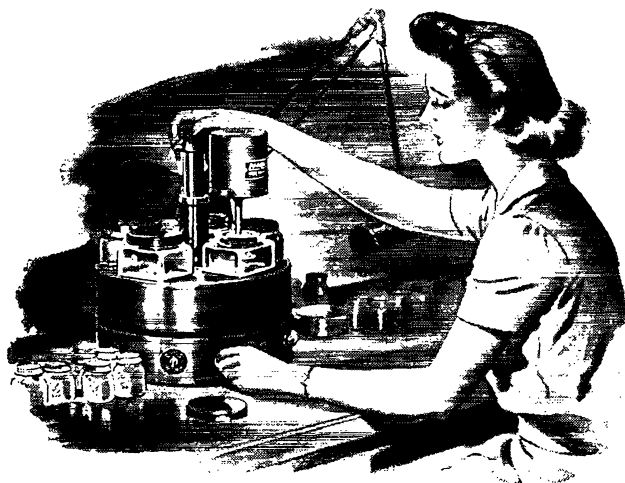

EVERYDAY IS WASHDAY AT Triplett

The special equipment and solutions with which jewels are washed typify the Extra Care provisions that are routine in Triplett plants in the making of fine electrical measuring instruments. Through them Triplett maintains in mass production the hand-made quality of fine instruments.

Extra Care in our work puts Extra Value in your Triplett Instruments

Precision first
...to last



Triplett

ELECTRICAL INSTRUMENT CO. BLUFFTON, OHIO



**"IT COULD BE SERIOUS THIS
TIME—HOGARTH NEVER BEFORE
TRUSTED ANYONE WITH HIS
ECHOPHONE EC-1"**



ECHOPHONE MODEL EC-1

(Illustrated) a compact communications receiver with every necessary feature for good reception. Covers from 550 kc. to 30 mc. on 3 bands. Electrical bandspread on all bands. Six tubes. Self-contained speaker. 115-125 volts AC or DC.



ECHOPHONE
"The Ears of the World"

ECHOPHONE RADIO CO., 540 NORTH MICHIGAN AVE., CHICAGO 11, ILLINOIS

HAM-ADS

(1) Advertising shall pertain to radio and shall be of nature of interest to radio amateurs or experimenters in their pursuit of the art.

(2) No display of any character will be accepted, nor can any special typographical arrangements, such as all or part capital letters be used which would tend to make one advertisement stand out from the others.

(3) The Ham-Ad rate is 30c per word, except as noted in paragraph (6) below.

(4) Remittance in full must accompany copy. No cash or contract discount or agency commission will be allowed.

(5) Closing date for Ham-Ads is the 25th of the second month preceding publication date.

(6) A special rate of 7c per word will apply to advertising which, in our judgment, is obviously non-commercial in nature and is placed and signed by a member of the American Radio Relay League. Thus, advertising of bona fide surplus equipment owned, used and for sale by an individual or apparatus offered for exchange or advertising inquiring for special equipment, if by a member of the American Radio Relay League takes the 7c rate. An attempt to deal in apparatus in quantity for profit, even if by an individual, is commercial and all advertising by him takes the 30c rate. Provisions of paragraphs (1), (2), (4) and (5), apply to all advertising in this column regardless of which rate may apply.

Having made no investigation of the advertisers in the classified columns, the publishers of *QST* are unable to vouch for their integrity or for the grade or character of the products advertised

LOOKING for a magazine by and for amateurs in other fields? Copy, 15¢. Amateur Scientist's Magazine, 45Q No. Evergreen, Memphis, Tenn.

IN Order to complete my file of *QSTs*, will make generous offer for any issues published before 1930. W9MHV, 3335 Summit St., Omaha, Nebr.

WILL swap pistol or cash for late model tube tester; any range microammeter 0-1 milliammeter. Cash for *QST* or Radio News back copies. T. A. McIntire, 364 Wilmington, No. Carolina.

SELLING code transmitter. Elmer Attig, 939 Rose Avenue, Des Moines, Iowa.

WANTED: Good recorder with 8-ohm magnetic cutter, a.c. driven turntable, amplifier not needed. State price, make and condition. W7IEY, Box 105, Rupert, Idaho.

WANTED: Ohmmeter and tube tester. Give complete information in first letter. Joseph Brejcha, 1237 So. 57th Court, Cicero, Ill.

TRADE: D104 microphone for a.c.-d.c. v.l.o.m. in good condition. Mike, factory overhauled. Gordon Wilkinson, Tule Lake, Calif.

INSTRUCTOGRAPH with ten rolls tape, oscillator, earphone and key, all perfect condition, \$20. Mrs. E. B. Fryinger, 5430 Harper Ave., Chicago, Ill.

WANTED: NC200 receiver, record changer, signal generator, tube tester. State make, condition and price. B. E. Harris, R #1, Nampa, Idaho.

FOR SALE: New Hallicrafters SX28A in box without priority —\$223. Want new SX25. S. J. Schulmerich, 60 Elm Drive, Lansdale, Pa.

CHANGING frequency? Immediate delivery of Eidsaon fine crystals; low-drift commercial types available throughout the 100-12,000 k.c. range. Also repair and regrounding, and crystals supplied to your holders. Ten years of satisfaction and fast service! Send for free folder L-5, mention your needs. "Eidsaon's", Temple, Texas.

WANTED: SX28 receiver. Will pay ceiling price, \$135.00 or trade. WIDXT, 334 Stanley St., New Britain, Conn.

WANTED: 10 ma and 100 ma Triplett 2" round case meters, Model 221. W1BB.

SELL or swap: Abbott DK3 transistor complete, less batteries in new condition, for a National ACSW3 receiver complete. John S. Marvin, W8VQZ.

UTC SC-100 bandswitch Xmr with tubes, \$100. 400 watt p.p. rack final, with 10 meter coils, 500 m.a. hv. power supply. Pair HK54s, Amperex 211-Hs, 809s and 803. W6UPZ, Box 145, AAB, Ft. Sumner, N.M.

OSCILLATOR units — factory built, 90-145 Mc. use as exciter or modulator for low-power transmitter. Uses 9002 and 9003 tubes, \$11.95, less tubes. Write for full details. J. W. Hofferth, 621 N. Wisner St., Jackson, Mich.

BEST offer takes 52 issues *QST*, 1920 to 1928. E. L. Gerard, Mason City, Iowa.

TUBES! 375 of 'em! Send stamp for list and prices. Fox, 307 Nc. Kingston Ave. Rockwood, Tenn.

WANTED: Scott Philharmonic. Condition unimportant if all transformers and r.f. section are good. Ben Lew Wilson, 107 W. White St., Bay City, Mich.

WANTED: Echophone EC-1 or similar. Overseas request. Sgt. Bernard Bath, Signal Corps Office, 930 York St., Cincinnati 14, Ohio.

FOR SALE: 1000-watt transmitter. Final Class C, pp. T200s. Modulators pp. Class B, T322s. Complete in two standard relay racks. What am I offered? For more information, write A. J. Fischer, W9LRX, 721 Center St., Des Plaines, Ill.

WANTED: Complete Candler course. R. J. Sanvick, Veterans' Home, Napa Co., Calif.

WILL pay top price for one good 807 tube. J. W. Fowler, W4ELO, 584 Holderness St., Atlanta, Ga.

WANTED for overseas serviceman Hallicrafters S29. Pay cash or trade S20R or SX24. Charles Perkins, USN, Box 194, Bisbee, Ariz.

WANTED: *QSTs* December 1915 through December 1923. Advise condition and price. Meek, W6LMY, 1121 Hamilton Lane, Burlingame, Calif.

BUILD radio, complete kit with tubes, \$10.95, details. Radio, 9418J Ave. "A", Brooklyn, N. Y.

FOR SALE: Radio station equipment WIHPT consisting of Thordarson Rack transmitter c.w. and phone (Universal all-wave), one Patterson receiver, field strength meter; high-voltage National condensers and transformers for power supplies. Miscellaneous equipment all in perfect condition. If interested a complete list will be given. Communicate with Mrs. Wm. K. Bowers, 19 River St., West Newton, Mass.

QUARTZ — Direct importers from Brazil of best quality pure quartz suitable for making piezo-electric crystals. Diamond Drill Carbon Co., 719 World Bldg., New York City.

COMMERCIAL radio operators examination questions and answers. One dollar per element. G. C. Waller, W5ATV, 6540 Washington Blvd., Tulsa, Okla.

WHY NOT turn your unused equipment into ready cash which may be applied towards new and better equipment after the war? Leo, W9GFG, offers you the best cash prices for communications receivers and test equipment. Write today for large illustrated catalog. Wholesale Radio Laboratories, 744 W. Broadway, Council Bluffs, Iowa.

CRYSTALS available — all types, including 100 kc., 465 kc. and 100 kc. Broadcast and Aircraft given prompt attention. Scientific Radio Products, Council Bluffs, Iowa.

IMMEDIATE shipment on priority: new SX28As, \$223.00; SX25s, \$94.50; PM23s, \$15.00. In stock without priority: Trimm #65, Dependable headsets, \$2.28; #100 Featherweight \$6.00; meter rectifiers, \$1.95; coils, transformers, etc. Instructographs for rent. Write for our catalog. Henry Radio Shop, Butler, Mo.

HIGHEST prices paid for used receivers, test equipment, bugs, oscillators. What have you? W9ARA, Butler, Mo.

NEED Dec. 1915 and May 1916 issues *QST*. Pay any price. Also want old Call Books and Handbooks. W. L. Holst, W9MD, 2553 Winnemac Ave., Chicago, Ill.

CRYSTALS: complete units or blanks. All types. Your specifications and tolerances. One or one million. Refinishing and repairing of your present units. Rex Bassett, Incorporated, Ft. Lauderdale, Fla.

FABERADIO crystals will be available to amateurs immediately after hostilities cease. Faberadio, Sandwich, Ill.

RADIO TESTS — Pre-examination Tests for Radio Operators. Tests your knowledge before you appear for commercial radio operator license examinations. Avoids failures. Guides your preparation. Saves your time. Worth investigating at once. Also books for home study. Write for free circulars 5Q. Nilson Radio School, 51 E. 42 St., New York 17, N. Y.

SELL: 2 Collins 4A xtra. W3QP.

RCA New tubes in stock. 811, \$3.50; 803, \$25.00; 3AP1/908, \$6.00; 955, \$2.75. Also HK-24G, \$6.00. Taylor 866A tubes in stock, \$1.50. Van Sickle Radio, Indianapolis 6, Ind.

PROMPT Repair Service on meters and electronic instruments. Braden Engineering Co., 3317 Kenmore Ave., Dayton 10, Ohio.

FRITZ for better QSLs after victory! 1213 Briargate, Joliet, Ill.

METERS: 1 ma. 3 in. Weston, G.E. and W.E., available without priority. Practically new, limited supply, 47. V.o.m. scales, \$1 extra. Ideal foundation meters. 5010 Alcott St., Dallas 6, Texas.

Designed for

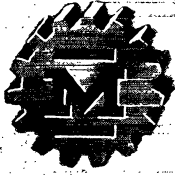

Application

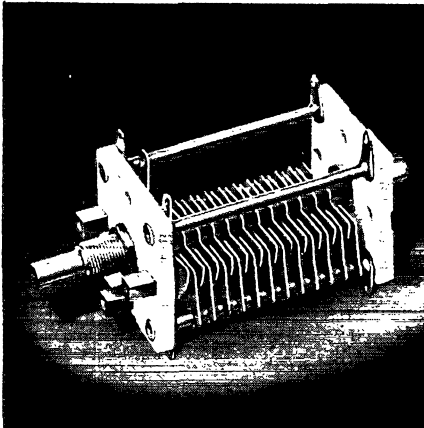

The 23000 Series Variable Air Capacitors

"Designed for Application," double bearings, steelite end plates, cadmium or silver plated brass plates. Single or double section. .020" or .060" air gap. End plate size: $1\frac{7}{8} \times 1\frac{1}{2}$. Rotor plate radius: $19/32$ ". Shaft lock, rear shaft extension, special mounting brackets, etc., to meet your requirements.

JAMES MILLEN MFG. CO., INC.

MAIN OFFICE AND FACTORY

MALDEN
MASSACHUSETTS



Index to Advertisers

	Page
Abbott Instrument, Inc.	**
Aerovox Corporation	**
American Lava Corp.	4
American Radio Institute	96
American Tel. & Tel. Corp.	81
Amperex Elec. Products, Inc.	**
Astatic Corporation, The	97
Ayers Automatic Code Machines	**
Barker & Williamson	69
Billey Electric Co.	67
Brach Manufacturing Corp.	**
Browning Laboratories, Inc.	**
Burgess Battery Company	76
Candler System Company	98
Capitol Radio Engineering Institute	78
Cardwell Mfg. Corp., Allen D.	52
Centralab	**
Clarostat Mfg. Co., Inc.	**
Collins Radio Company	71
Commercial Radio Institute	98
Communications Products Co.	**
Crystal Products Co.	**
Delco Radio, Div. Gen. Motors	91
DX Crystal Company	99
Echophone Radio Co.	100
Eitel-McCullough, Inc.	5
Electro-Voice Mfg. Co.	**
Electronic Laboratories	79
Galvin Mfg. Corp.	**
Gardiner & Company	**
General Ceramics & Steatite Co.	75
General Electric Co.	103
Genlee Tool Company	**
Hallcrafters Co., The	2
Hammarlund Mfg. Co., The	63, 65
Harrison Radio Company	**
Harvey Radio Co.	**
Harvey Radio Laboratories, Inc.	96
Harco Steel Construction Co.	**
Harvey-Wells Communications, Inc.	97
Hazeltine Electric Corp.	86
Heintz & Kaufman, Ltd.	7
Henry Radio Shop	**
Hytron Corporation	**
Instructograph Company	**
International Resistance Co.	88
Jensen Radio Mfg. Co.	77
Ken-Rad Tube & Lamp Corp.	**
Kenyon Transformer Co., Inc.	**
Knights Co., Inc.	**
Maedel Publishing House	**
Mallory & Co., P. R.	74
Massachusetts Radio School	98
McElroy Mfg. Corp.	73
McGraw Hill Book Co., Inc.	90
Meek Industries, John	**
Melnsner Mfg. Co.	**
Melville Radio Institute	95
Metropolitan Technical School	**
Millen Mfg. Co., James	102
National Carbon Company	87
National Company, Inc.	61, Cov.
Newark Electric Co.	83
New York YMCA Schools	**
Nilson Radio School	**
Ohmite Manufacturing Co.	**
Onan Electric Co., D. W.	95
Oxford-Tartak Radio Corp.	**
Philco Corporation	**
Pioneer Gen-E-Motor	**
Port Arthur College	94
Premax Products	94
RCA Institutes, Inc.	95
RCA Manufacturing Co., Inc.	Cov. IV
Radio Manufacturing Engineers	**
Radio Shack Corporation	84
Raytheon Mfg. Co.	**
Ramsey Publishing Co.	**
Radio-Television Institute	98
Scell, R. G., & Co.	88
Scientific Radio Products Co.	**
Shure Brothers	**
Sickles Co., F. W.	94
Simpson Electric Co.	80
Sperry Gyroscope Co.	89
Sprague Electric Co.	**
Standard Radio Electronics Co.	**
Standard Transformer Co.	**
Sun Radio & Electronics Co.	98
Taylor Tubes, Inc.	**
Telegraph Apparatus Co.	92
Teleplex Company	96
Terminal Radio Corp.	**
Thordarson Elec. Mfg. Co.	**
Triplet Elec. Instrument Co., The	99
Turner Company, The	95
United Transformer Co.	Cov. II
Universal Microphone Co.	92
Vaiparaiso Technical Institute	98
Vibroplex Company, Inc., The	**
Ward Leonard Electric Co.	90
Wallace Co., William	**
Western Electric Co.	86
Westinghouse Elec. & Mfg. Co.	85
Wholesale Radio Laboratories	**
Wilcox Electric Co.	**
Vaxley (Mallory, P. R.)	74
Zenith Radio Company	**

All of the above advertisers are cooperating with the A.R.R.L. to permit publication of an editorially adequate QST during this period of war-rationing of paper. Using less advertising space but at higher rates, they continue their customary support of QST. Some are using smaller space in each issue and some are using space only every second or third issue. Of the latter, those whose advertising does not appear in this particular issue are indicated by the ** above.

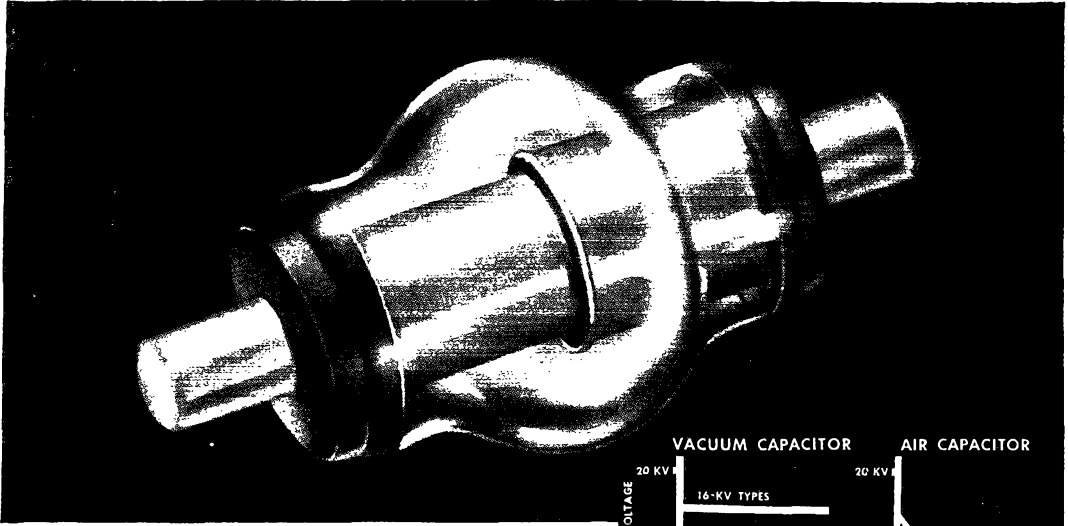

The 16,000-v Type GL-1L22 illustrated above—4 11/16" long, 2" diameter—has only 10 per cent of the volume of an air capacitor with similar rating . . . At the right are two curves showing the breakdown voltages of vacuum capacitors and air capacitors at successive altitudes. Note that air capacitors show a steady drop. However the figures for G-E vacuum capacitors, sealed against atmospheric changes, remain constant at all times.

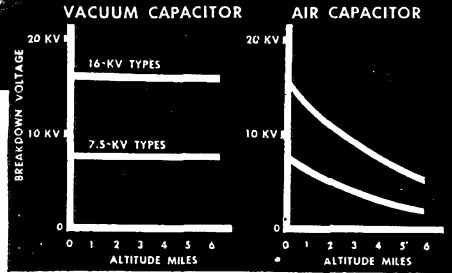

G-E VACUUM CAPACITORS

- are $\frac{1}{10}$ the size of air capacitors
- are unaffected by external conditions

G-E vacuum capacitors are designed for service where voltage peaks run up to 16,000 v, a range that is common in military, aviation, and other radio equipment, and in special applications such as diathermy. They are small in size and compactly built. This fact underscores their usefulness in high-frequency circuit design, where space-saving is important because of short lead-lengths.

Since vacuum capacitors are completely sealed in, variations in air-density due to changing altitudes or other causes have no effect on voltage breakdown, which re-

mains constant at all times. Likewise, temperature or humidity changes do not influence performance, nor can foreign particles affect these capacitors in any way.

Consult the table at the right to select the right capacitors for your own use. For further details telephone your nearest G-E office or distributor, or write direct to *Electronics Department, General Electric, Schenectady 5, N. Y.*

Hear the G-E radio programs: "The World Today" news, Monday through Friday, 6:45 p. m., EWT, CBS. "The G-E All-Girl Orchestra," Sunday 10 p. m., EWT, NBC. "The G-E House Party," Monday through Friday, 4 p. m., EWT, CBS.

G-E VACUUM CAPACITORS

Type	Peak voltage, volts (a-c, d-c, or r-f)	Capacitance, micromicrofarads	Price
GL-1L32	7,500	6	\$8.50
GL-1L21	7,500	12	8.50
GL-1L36	7,500	25	8.50
GL-1L38	7,500	50	8.50
GL-1L33	7,500	100	10.00
GL-1L31	16,000	6	9.25
GL-1L25	16,000	12	9.25
GL-1L22	16,000	25	9.25
GL-1L23	16,000	50	9.25
GL-1L24	16,000	100	11.00

GENERAL ELECTRIC

161-D4-8880

MEMO TO *Purchasing Dept.*

For postwar, recommend we standardize on Solar's hermetically-sealed, patented special twist-prong base Type DY electrolytic. They're properly protected against moisture.

E.M.

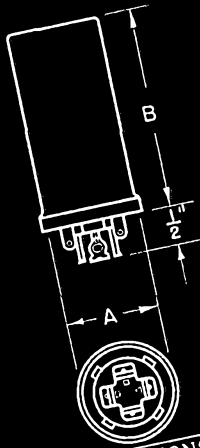

ENGINEERING
SPECIFY
Solar
DEPARTMENT

LEADING MANUFACTURERS
EVERYWHERE

PART NO.	SOLAR PART NO.	CAPY MFD.	WKG. VOLTS	DIMENSIONS	
				"A"	"B"
51 B50-1	DY-61	20*20	150	1"	2"
51 B50-2	DY-92	20*20	450	1"	3-3/8"
51 B50-3	DY-94	10*10	450	1"	2-1/2"
51 B50-4	DY-132	15*10*20	350-350-25	1"	2-1/2"
51 B50-5	DY-141	10*10*20	450-450-25	1"	3"

DRAWN *E.O.H.* DATE *1/4/45*
 TRACED *M.* DWG. No. *51 B50*
 APPROVED *J.C.* ISSUE



Prominent engineers consistently show their preference for Solar Capacitors. Solar pledges continued production of superior quality capacitors to merit that preference. Solar Manufacturing Corporation, 285 Madison Avenue, New York 17, N. Y.



CAPACITORS &
ELIM-O-STATS

7754



NATIONAL RECEIVERS ARE THE EARS OF THE FLEET

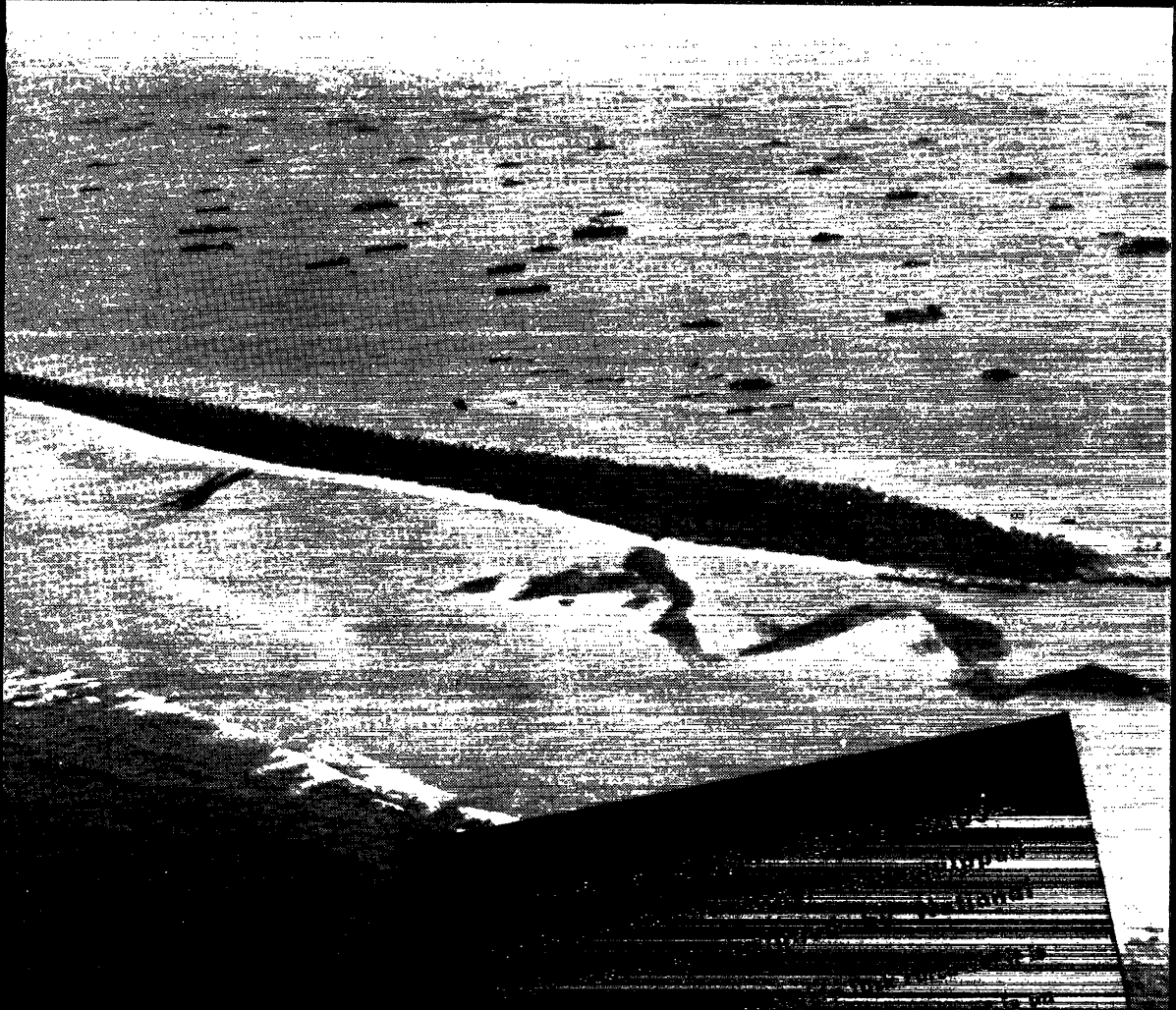

OFFICIAL U. S. NAVY PHOTOGRAPH

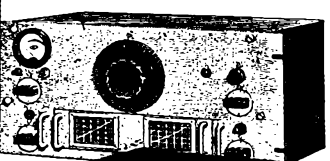
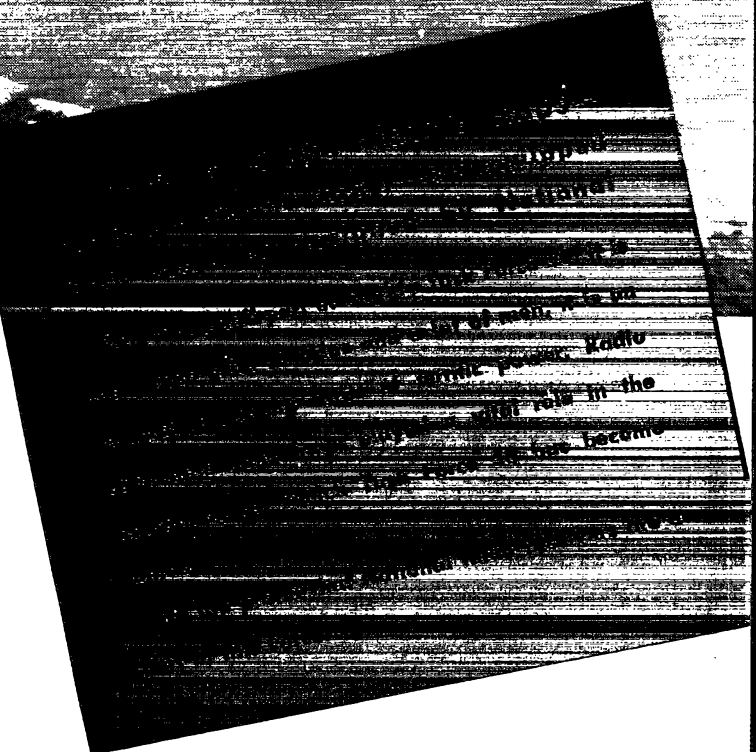

HRO

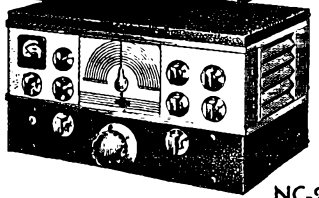

NC-200

NATIONAL COMPANY

MALDEN  MASS, U. S. A.

NATIONAL RECEIVERS ARE IN SERVICE THROUGHOUT THE WORLD

How RCA Tubes Kept

Chennault's Tigers Flying

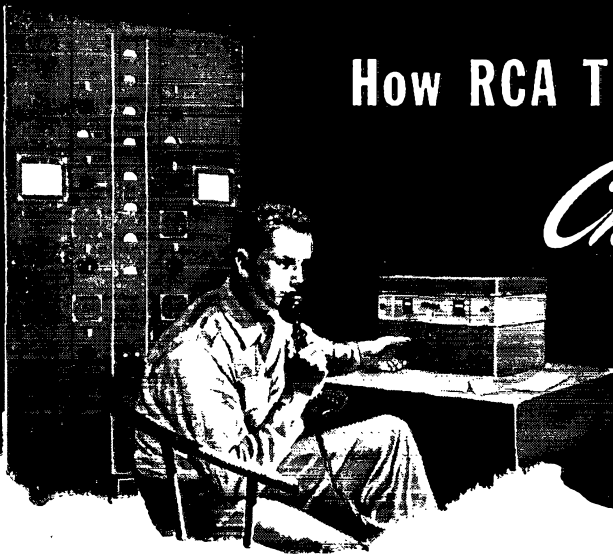

RADIO amateurs will be glad to know that equipment which they helped develop is performing important jobs in the war.

According to a recent news report by a former Communications Officer of General Chennault's 14th Air Force, amateur-type equipment carried the burden of American Air Force ground communications during the fighting retreat up the Burma Road.

Bombed from pillar to post, driven from cave after cave, temple after temple, communications men kept one jump ahead of the Japs. In this ordeal, their equipment was transported by truck and by oxcart over 2000 miles of the world's roughest terrain—through bomb craters, jungle mire, and over jagged mountain trails.

There were no replacement tubes or parts. Equipment had to last, and last, and last—while taking merciless punishment. Some of the original RCA-802, 813, 872 and 5Z3 tubes were still in service after nearly three years of constant use.

This is but one example of the splendid war record of American radio men, many of them former hams—and of the yeoman service RCA amateur-type equipment is performing on far-flung battlefronts.

You can expect great things from RCA postwar, for all of our war-born "know-how" will be applied to building better equipment for America's Radio Amateurs.

THE FOUNTAIN-HEAD OF MODERN TUBE DEVELOPMENT IS RCA

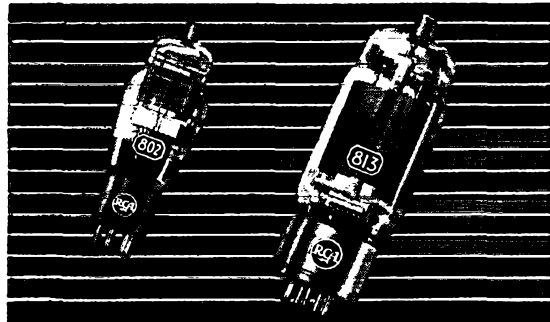

RCA-802's and 813's took a three-year beating on the Burma front!



62-6436-60

RADIO CORPORATION OF AMERICA

RCA VICTOR DIVISION, CAMDEN, N. J.