

QST

may, 1946

25 cents

35c In Canada

devoted entirely to

amateur radio



PHOTO COURTESY OF THE AMERICAN RADIO RELAY LEAGUE

SEE!



PANADAPTOR Eliminates "Blind" Operation

The PANADAPTOR brings a revolutionary change in amateur techniques. It provides "eyes" for your receiver. Panoramic Reception allows you to see not only the one signal heard through your receiver, but *simultaneously every signal in the 200 kc portion of the band surrounding that signal*. Through the use of another sense — sight — the PANADAPTOR introduces new methods, new efficiency. . . .

USE YOUR EYES

TO find holes in those crowded bands . . . locate weak signals . . . to find your sked among the QRM and tell him where to shift frequency . . . to see quick answers to your CQs. . . .

TO observe signal characteristics, your own and others . . . to measure percentage modulation, to detect splatter . . . to sort 'phone and CW. . . .

TO facilitate netting operations . . . see the station which is off frequency in the net (instead of being absent) . . . to see break-ins . . . to see calls from auxiliary nets. . . .

TO aid your ears . . . use all your faculties to improve your station operation and efficiency . . . to enhance the pleasure you get from radio.

THE PANADAPTOR IS YOUR SEEING EYE, use it and you'll find you get more out of any phase of radio operation be it traffic handling, DXing, experimenting. . . .

PANADAPTOR Model PCA-2
Now Available at Leading Radio
Parts Jobbers. Ask for demonstra-
tion. Amateur Net Price, complete
with ten tubes and accessories for
115 V., 50-60 cycle operation.

\$99.75

ONE YEAR GUARANTEE
against defects in parts or
workmanship (excluding
tubes). Panoramic Handbook
with full installation, operat-
ing, application and mainte-
nance instructions furnished
with each PANADAPTOR.

You must SEE the Panadaptor in operation to realize how it can revolutionize, simplify and improve the operation of your rig. Contact your radio parts jobber, NOW!

Write to us for a free descriptive booklet.

PANORAMIC

CABLE ADDRESS
PANORAMIC, NEW YORK



RADIO CORPORATION

242 WEST 55TH ST. New York 19, N.Y.

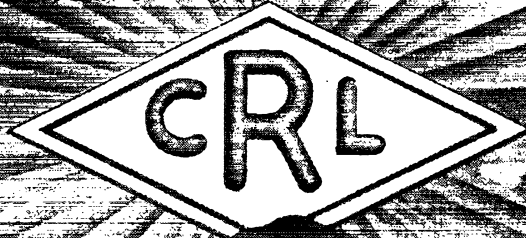

The Mark of Quality

With the dawn of the new electronic era CENTRALAB again dominates the scene. The "CRL IN THE DIAMOND" identifies a group of QUALITY components engineered to the exacting requirements of the new electronic age . . . always specify CENTRALAB.

Centralab

Division of GLOBE-UNION INC., Milwaukee

PRODUCERS OF



Ceramic Trimmers
Bulletin 695



Variable Resistors
Bulletin 697

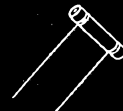

Tubular Ceramic
Capacitors
Bulletins 630 and 586



Selector Switches
Bulletin 722



Ceramic High Voltage Capacitors
Bulletin 814



THE COUNTERSIGN OF DEPENDABILITY IN ANY ELECTRONIC EQUIPMENT

NOW...

**LONGER LIFE, BETTER PERFORMANCE
WITH EIMAC 3-250A TRIODE**

**NEW NON-EMITTING GRID!
NEW LOW-TEMPERATURE PLATE!
NEW FILAMENT STRUCTURE!**

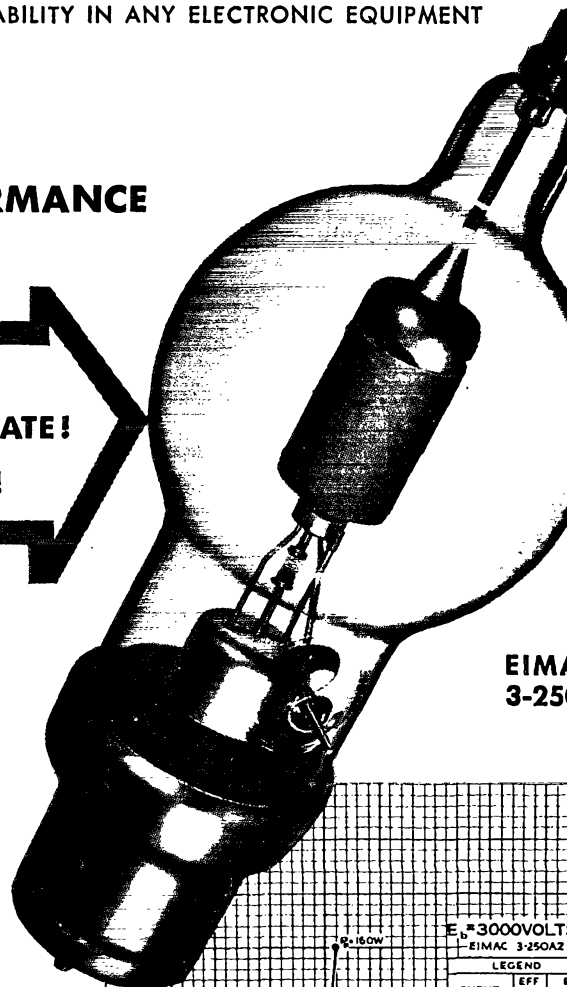

**EIMAC
3-250A**

Read the history of amateur Dx work and you'll find Eimac 250T has an enviable record over the past decade. Its performance was so dependable that it was drafted for war duty. Today it emerges as Eimac 3-250A with a new low temperature plate, a new non-emitting grid, and a new filament structure which make it even more desirable for amateur use. The new 3-250A is interchangeable with the old Eimac 250T. The new elements result in better performance and even longer life in a tube that has long been famous for its long life and stamina. This new tube is available in both low mu (3-250A2) and high mu (3-250A4) tube versions.

Its outstanding performance characteristics are exemplified by its low driving power requirements. For example, in Class C telegraphy, with 3000 plate volts on a single tube, the Eimac 3-250A2 will deliver 750 watts output with only 29 watts (approx.) of driving power. (See chart.)

You can depend upon Eimac year in and year out for leadership in vacuum tube developments.* That's one reason why Eimac tubes are today, and have been for years, first choice of leading electronic engineers throughout the world.

*Ask your dealer to give you a copy of "Eimac Electronic Products" just off the press. Or write direct.

Follow the leaders to



EITEL-McCULLOUGH, INC., 1212M San Mateo Avenue, San Bruno, Calif.
Plants located at: San Bruno, Calif. and Salt Lake City, Utah
Export Agents:
Frazar and Hansen, 301 Clay St., San Francisco 11, California, U. S. A.

CALL IN AN EIMAC REPRESENTATIVE FOR INFORMATION

ROYAL J. HIGGINS (W9A10), 600 S. Michigan Ave., Room 818, Chicago 5, Illinois. Phone: Harrison 5948.
V. O. JENSEN CO., 2616 Second Ave., Seattle 1, Washington. Phone: Elliott 6871.
M. B. PATTERSON (W5CI), 1124 Irwin-Kessler Bldg., Dallas 1, Texas. Phone: Central 5764.

ADOLPH SCHWARTZ (W2CN), 220 Broadway, Room 2210, New York 7, N. Y. Phone: Cortland 7-0011.
HERB BECKER (W6QD), 1406 S. Grand Ave., Los Angeles 15, California. Phone: Richmond 6191.
TIM COAKLEY (WIKKP), 11 Beacon Street, Boston 8, Massachusetts. Phone: Capitol 0050.

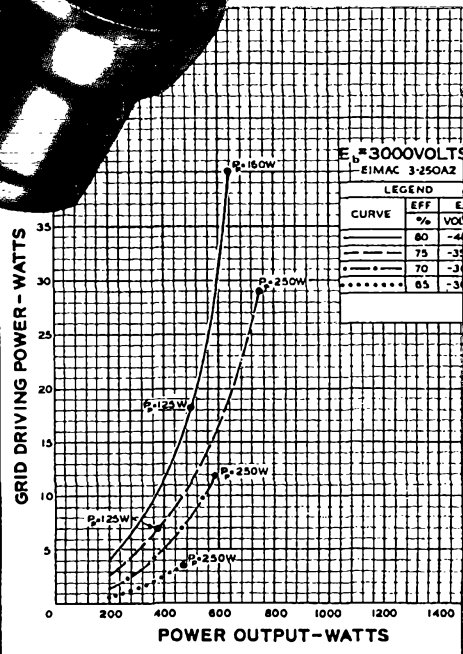

ELECTRICAL CHARACTERISTICS

	3-250A2	3-250A4
Filament	Thoriated tungsten	3-250A2 3-250A4
Voltage	5.0 volts	5.0 volts
Current	10.5 amperes	10.5 amperes
Amplification Factor (Average)	14	37
Direct Interelectrode Capacitances (Average)		
Grid-Plate	3.1 uuf	2.9 uuf
Grid-Filament	3.7 uuf	5.0 uuf
Plate-Filament	0.7 uuf	0.7 uuf

MAY 1946

VOLUME XXX

NUMBER 5



STAFF

Editorial

KENNETH B. WARNER, W1EH
(Managing Secretary, ARRL)
Editor

GEORGE GRAMMER, W1DF
(Technical Director, ARRL)
Technical Editor

DONALD H. MIX, W1TS
BYRON GOODMAN, W1JPE
Assistant Technical Editors

A. DAVID MIDDLETON, W2OEN
Department Editor

EDWARD P. TILTON, W1HDQ
V.H.F. Editor

WALTER E. BRADLEY, W1FWH
Technical Information Service

Production

RALPH T. BEAUDIN, W1BAW
Superintendent

ELSIE C. HOCHMEISTER
Assistant

Advertising

F. CHEYNEY BEEKLEY, W1GS
Advertising Manager

Circulation

DAVID H. HOUGHTON
Circulation Manager

RALPH T. BEAUDIN, W1BAW
Assistant Circulation Manager



OFFICES

38 La Salle Road
West Hartford 7, Connecticut

Subscription rate in United States and Possessions, \$2.50 per year, postpaid; all other countries, \$3.00 per year, postpaid. Single copies, 25 cents. Foreign remittances should be by international postal or express money order or bank draft negotiable in the U. S. and for an equivalent amount in U. S. funds.

Entered as second-class matter May 29, 1919, at the post office at Hartford, Connecticut, under the Act of March 3, 1879. Acceptance for mailing at special rate of postage provided for in section 1103, Act of October 3, 1917, authorized September 9, 1922. Additional entry at Concord, N. H., authorized February 21, 1929, under the Act of February 28, 1925.

Copyright 1946 by the American Radio Relay League, Inc. Title registered at U. S. Patent Office.

QST

devoted entirely to

AMATEUR RADIO

PUBLISHED, MONTHLY, AS ITS OFFICIAL ORGAN, BY THE AMERICAN RADIO RELAY LEAGUE, INC., AT WEST HARTFORD, CONN., U. S. A.; OFFICIAL ORGAN OF THE INTERNATIONAL AMATEUR RADIO UNION



CONTENTS

It Seems to Us	11
Noise Limiting in C.W. Reception <i>George Grammer, W1DF</i>	13
New Tuning System for the Amateur Receiver <i>W. J. Halligan, W9WZE and Norm Foot, W9GQP</i>	18
A Remote-Indicating Field-Strength Meter <i>E. P. Tilton, W1HDQ</i>	21
We Have New Regulations	23
A.R.R.L. QSL Bureau	30
A Two-Meter Crystal-Controlled Converter <i>Calvin F. Hadlock, W1CTW</i>	31
Attention: Ten-Meter Operators!	35
Happenings of the Month	36
In QST 25 Years Ago This Month	39
A Wide-Range Test Oscillator <i>Charles F. Lober, RT1c, USCG, W8ICO</i>	40
Power Control Circuits in Amateur Transmitters <i>Myron E. Lawson, W9BQZ/2</i>	43
Radio Propagation Work at the National Bureau of Standards <i>Newbern Smith, ex-W3QY and Richard Silberstein, W3JQB</i>	45
1946 V.H.F. Marathon <i>F. E. Handy, W1BDI</i>	51
Silent Keys	52
Operating the 807 <i>Donald Mix, W1TS</i>	53
The World Above 50 Mc.	55
W6MBA/Tinian	59
Hints and Kinks	60
How's DX?	62
The Cliff-Dweller's Antenna . . . <i>C. G. Peterson, W2KJU</i>	64
A DX Record: To the Moon and Back <i>Herbert Kauffman, W2OQU</i>	65
Foreign Notes	69
An Umbrella-Type Antenna <i>Alfred K. Robinson, ex-W7DX</i>	70
A Selective Pulse Communication System <i>Arthur R. Knight, ex-W8BDE and Howard Storck, ex-W8BYN</i>	74
Correspondence from Members	76
Operating News	78
Station Activities	84
New Apparatus	
V.H.F. Ground-Plane Antenna	136
WWV	154

hallicrafters

New design, new utility in a great new communications receiver . . .

Here is Hallicrafters new Model S-40. With this great communications receiver, handsomely designed, expertly engineered, Hallicrafters points the way to exciting new developments in amateur radio. Read those specifications . . . it's tailor-made for hams. Look at the sheer beauty of the S-40 . . . nothing like it to be seen in the communications field. Listen to the amazing performance . . . it beats anything in its price class. All around, up and down, through and through it's a true Hallicrafters-built ham job.

Ask your local distributor about when you can get an S-40—the up and coming leader in the popular price field.

INSIDE STUFF: Beneath the sleek exterior of the S-40 is a beautifully engineered chassis. One stage of tuned radio frequency amplification, the S-40 uses a type 6SA7 tube as converter-mixer for best signal to noise ratio. RF coils are of the permeability adjusted "micro-set" type identical with those used in the most expensive Hallicrafters receivers. The high frequency oscillator is temperature compensated for maximum stability.

From every angle the S-40 is an ideal receiver for all high frequency applications.

\$79⁵⁰
(APPROXIMATELY)

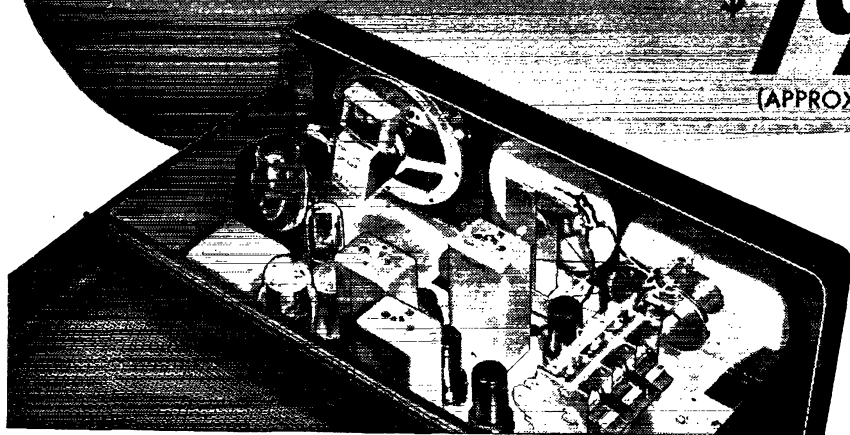

Interior completely accessible. Entire top turns back on piano hinge.

COPYRIGHT 1945
THE HALLICRAFTERS CO.

new Model S-40

Listening range from 550 kc. to 42 Mc	Separate electrical bandspread with inertia flywheel tuning	New beauty and perfect ventilation in the perforated steel top	Self-contained, shock mounted, permanent magnet dynamic speaker	Standby receive switch
---------------------------------------	---	--	---	------------------------

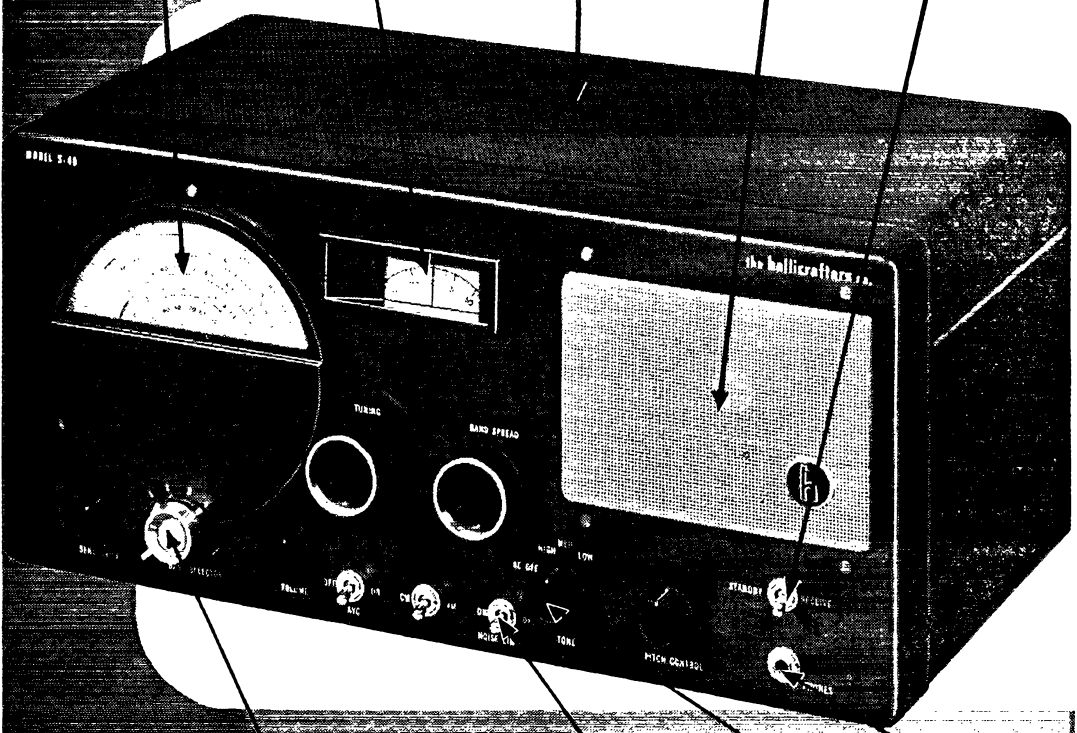

All controls logically grouped for easiest operation. Normal position for broadcast reception marked in red, making possible general use by whole family.	Automatic noise limiter	3-position tone control	Phone jack
---	-------------------------	-------------------------	------------

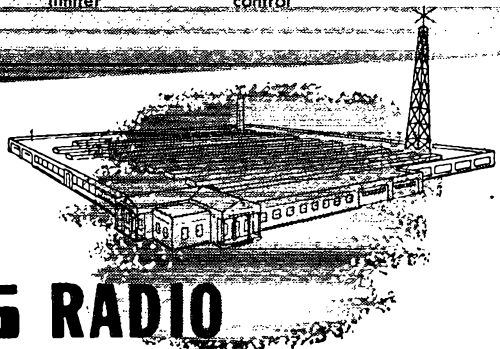

hallicrafters RADIO

THE HALLICRAFTERS CO., MANUFACTURERS OF RADIO AND ELECTRONIC EQUIPMENT, CHICAGO 16, U. S. A.

Sole Hallicrafters Representatives in Canada: Rogers Majestic Limited, Toronto-Montreal

Section Communications Managers of the A. R. R. L. Communications Department

Reports Invited. All amateurs, especially League members, are invited to report station activities on the first of each month (or preceding month) direct to the SCM, the administrative ARRL official elected by members in each Section. Radio Club reports are also desired by SCMs for inclusion in QST. All ARRL Field Organization appointments are now available to League members. These include ORS, OES, OPS, OO, and OBS. Also, where vacancies exist SCMs desire applications for SEC, EC, RM, and PAM.

ATLANTIC DIVISION				
Eastern Pennsylvania Maryland-Delaware-District of Columbia Southern New Jersey Western New York Western Pennsylvania	W3BES W3CIZ W3GCU W8UPH W8NCJ	Jerry Mathis Hermann E. Hobbs Ray Tomlinson Charles I. Otero R. R. Rosenberg	623 Crescent Ave. 9701 Monroe St. Silver Springs P. O. 623 E. Brown St. 4158 Ridge Road, West 927 East 23rd St.	Glenside Gardens Linden, Maryland Trenton 10 Spencerport Erie
CENTRAL DIVISION				
Illinois Indiana Kentucky Michigan Ohio Wisconsin	W9NUX W9EGO W5IEZ/9 W8DPE W8MFP W9RH	David E. Blake, II Herbert S. Brier Joseph P. Colvin Harold C. Bird Carl F. Wiehe Emil Felber, Jr.	4501 N. Malden St. 385 Johnson St. 1653 Beechwood Ave. R. F. D. 2, Box 228 1224 St. Albert St. 1625 N. 18th St.	Chicago 40 Gary Louisville 4 Pontiac 7 St. Bernard 17 Milwaukee 5
DAKOTA DIVISION				
North Dakota South Dakota Northern Minnesota Southern Minnesota	W9EVP W9QVY W9FUZ W9OMC	Raymond V. Barnett P. H. Schultz Armond D. Brattland Vernon G. Pribyl	406-17th St. 118 N. Yankton Ave. 2802 S. Western 560 Brown St.	Bismarck Pierre Los Angeles, Calif. Hutchinson
DELTA DIVISION				
Arkansas Louisiana Mississippi Tennessee	W5GED W5DKR W5HAV W5P	Ed Beck Eugene H. Treadaway P. W. Clement James B. Witt	2503 Bishop St. P. O. Box 44 524 Santini St. R.F.D. 6, Shady Dell Trail	Little Rock LaPlace Biloxi Knoxville
HUDSON DIVISION				
Eastern New York N. Y. C. & Long Island Northern New Jersey	W2HZL W2KDC W2CQD	Ernest E. George Charles Ham, Jr. Winfield G. Beck	2044 Lexington Parkway 151-06 84th Drive 617 Spruce St.	Schenectady 8 Jamaica, L. I., 2 Roselle
MIDWEST DIVISION				
Iowa Kansas Missouri Nebraska	W9BYR W9AWP W9OUD W9FQB	Leslie B. Vennard A. B. Urrah Mrs. Letha A. Dangerfield Arthur R. Gaeth	2712 Washington St. 1401 S. Seneca St. 411 Moffett Ave. 6105 N. 37 St.	Burlington Wichita 12 Topeka Omaha 11
NEW ENGLAND DIVISION				
Connecticut Maine Eastern Massachusetts Western Massachusetts New Hampshire * Rhode Island Vermont *	W1KQV W1AQL W1ALP W1JAH W1AXL W1HRK W1NDL	Edmund R. Fraser G. C. Brown Frank L. Baker, Jr. William J. Barrett John H. Stoughton Clayton C. Gordon Gerald Benedict	48 Willow St. 379 No. Main St. 91 Atlantic St. 239 Columbia St. 3RD 2. 70 Columbia Ave., Gaspee 23 Foster St.	West Haven 16 Brewer North Quincy 71 Adams Claremont Providence, Providence 5 Montpelier
NORTHWESTERN DIVISION				
Alaska Idaho Montana Oregon * Washington	K7CBF W7AVP W7CPV W7BEE W7FWD	August G. Hiebert Don D. Oberbillig Rex Roberts Cliff Tice O. U. Tatro	c/o K FAR P. O. Box 486 Box 1088 McKay Dam 513 N. Central	Fairbanks Boise Glendive Pendleton Olympia
PACIFIC DIVISION				
Hawaii Nevada Santa Clara Valley East Bay San Francisco Sacramento Valley Philippines San Joaquin Valley	K6RLG W6CW W6BPT W6TI W6CVP W6MDI KA1GR W6FSQ	Howard S. Simpson N. Arthur Sowle Roy E. Pinkham Horace R. Greer Samuel C. Van Liew Vincent N. Feldhausen George L. Rickard James F. Wakefield	2068 Wells St. Box 2025 1061 Fremont St. 414 Fairmount Ave. 215 Knowles Ave. 113 South Quincy St. Box 849 1548 L St.	Wailuku, Maui Reno Santa Clara Oakland 11 Daly City McCloud Manila Fresno
ROANOKE DIVISION				
North Carolina South Carolina Virginia West Virginia	W4CVB W4BQE/ANG W3AKN W8JM	W. J. Wortman Ted Ferguson Walter G. Walker Donald B. Morris	c/o Duke Power Co. 3422 Rosewood Drive 217-51 St. 303 Home St.	Charlotte 1 Columbia 25 Newport News Fairmont
ROCKY MOUNTAIN DIVISION				
Colorado Utah-Wyoming	W9VGC W6LLH	H. F. Hekel Victor Drabble	2743 Julian St. 1024 Oak St.	Denver 11 Ogden, Utah
SOUTHEASTERN DIVISION				
Alabama Eastern Florida Western Florida Georgia West Indies (Cuba) (Puerto Rico-Virgin Islands)*	W4GBV W41P W4MS W4HYW K4KD	Lawrence J. Smyth Robert B. Murphy Lt. Edward J. Collins Thomas M. Moss Everett Mayer	808 Winona Ave. 3302 S.W. Grapeland Blvd. 1215 N. 12th Ave. 570 Oak Drive P. O. Box 1061	Montgomery Miami 33 Pensacola Hapeville San Juan 5, P. R.
SOUTHWESTERN DIVISION				
Los Angeles Arizona* San Diego	W6QWZ W6MLL W6CHV	Ben W. Onstenk Gladden Elliott Ralph H. Culbertson	9631 3rd Ave. 1408 West Fresno 7172 Eads St.	Inglewood Tucson La Jolla
WEST GULF DIVISION				
Northern Texas Oklahoma Southern Texas New Mexico	W5ALA W5AYL W5JC W5HJF	Jack T. Moore Ed Oldfield James B. Rives J. G. Hancock	4529 Fairway Ave. 2141 N.W. 35th St. 1721 Kentucky Ave. 110 S. E. Nevada St.	Dallas 4 Oklahoma City 6 San Antonio 1 Fortales
MARITIME DIVISION				
Maritime	VE1DQ	A. M. Crowell	69 Dublin St.	Halifax, N. S.
ONTARIO DIVISION				
Ontario	VE3EF	Dr. Donald R. Gunn	1007 Lakeshore Road	New Toronto, Ont.
QUEBEC DIVISION				
Quebec	VE2CO	L. G. Morris	4114 Hingston Ave.	Montreal 28, Que.
VANALTA DIVISION				
Alberta British Columbia	VE4GE VE5DD	C. S. Jamieson C. O. I. Sawyer	581 W. Riverside Drive 2634 West 31st Ave.	Drumheller, Alta. Vancouver
PRAIRIE DIVISION				
Manitoba Saskatchewan	VE4AAW VE4SY	A. W. Morley Arthur Chesworth	26 Lennox St. 1084 Redland Ave.	St. Vital Moose Jaw

*Officials appointed to act temporarily in the absence of a regular official.

CQ CQ CQ de ALSIMAG

**FREE Bulletin No. 545
on RF and UHF
INSULATION**

This booklet briefly describes AlSiMag products, tells how they are made, and gives you useful information about technical ceramic insulators. Includes convenient open wire antenna feeder data and a chart giving mechanical and electrical properties of the more frequently used AlSiMag ceramics. Free on request. We would like hams to know more about AlSiMag RF and UHF insulation, though NO sales of AlSiMag are made direct to hams. All sales are made to manufacturers or to ham supply houses.

AMERICAN LAVA CORPORATION

CHATTANOOGA 5, TENNESSEE
43RD YEAR OF CERAMIC LEADERSHIP



Original Award July 27, 1942
Second Award February 13, 1943
Third Award September 25, 1943
Fourth Award May 27, 1944
Fifth Award December 2, 1944



AMERICAN LAVA CORPORATION, CHATTANOOGA 5, TENNESSEE
PLEASE SEND FREE COPY OF ALSIMAG BULLETIN NO. 545 TO:

NAME _____

ADDRESS _____

What!

No zero
adjuster?

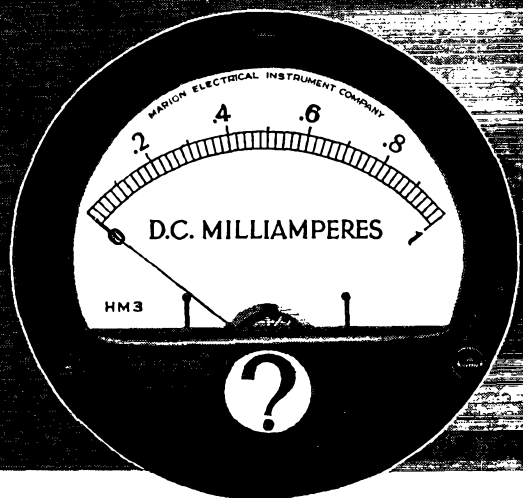

This is the invariable first reaction of engineers and consumers when meeting Marion Glass-to-Metal Truly Hermetically Sealed Instruments face-to-face. Let us begin by saying that zero adjusters correct for mechanical changes in an instrument caused by drift of the hair springs, ageing of the moving system, and are often used to correct (but incorrectly) errors brought about by unbalance of the moving system. Marion "hermetics" eliminate the need for zero adjustment for the following reasons:

Drift-free Springs: Marion "hermetics" use special silvered beryllium copper hair springs which are essentially drift-free. And the instruments as a whole are thoroughly aged at 170° to 180° F for at least 48 hours, assuring permanent "set" to the components of the moving system. These factors permit overloads far in excess of normal specifications, without permanent zero shift of the instrument.

"Apologist for Error": When a panel instrument is overloaded and its pointer is slammed, re-setting with the zero adjuster does not correct the error caused by the unbalance of the moving system. It only apparently corrects this error, and conceals its magnitude. Slammed instruments should be repaired or replaced if stated accuracy is to be maintained, and not just covered up by that apologist for error, the zero adjuster.

Independent Tests . . . by private and governmental laboratories in the United States and Canada prove that Marion "hermetics" sustain zero setting under severe and continuous shock, vibration, temperature and humidity cycling. Maximum permanent zero shift recorded on any "hermetic" by any laboratory has been 1/2 of 1% after completion of any and all combinations of the foregoing tests.

Marion Glass-to-Metal Truly Hermetically Sealed 2½" and 3½" Electrical Indicating Instruments

Write for 12-page brochure



MARION ELECTRICAL INSTRUMENT CO.
MANCHESTER, NEW HAMPSHIRE

EXPORT DIVISION

458 BROADWAY • NEW YORK 13, N. Y., U. S. A.

CABLES: MORHANEX

IN CANADA: THE ASTRAL ELECTRIC COMPANY, SCARBORO BLUFFS, ONTARIO

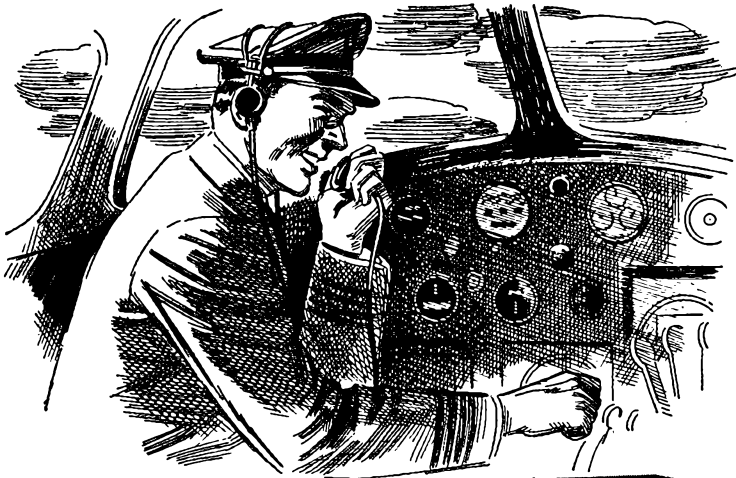

●
The Collins
17K-1 Transmitter

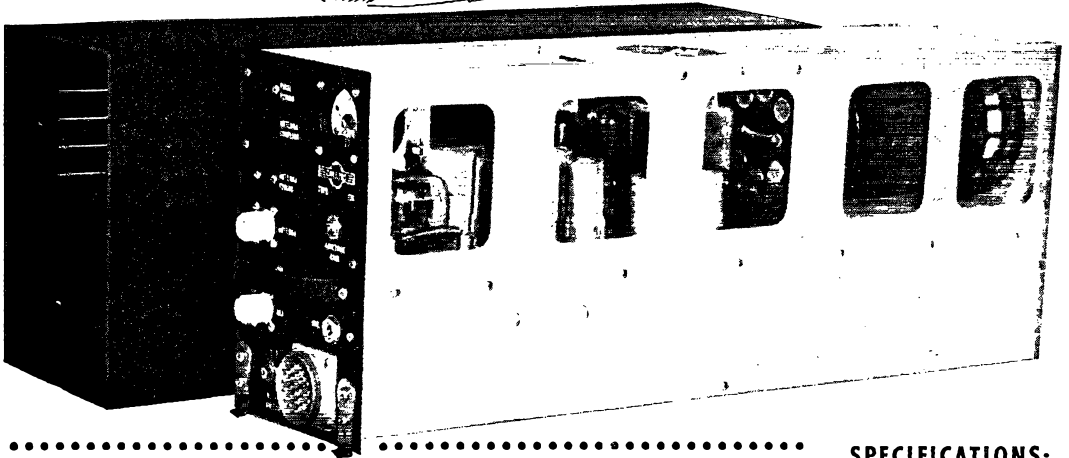

.....

Lightweight VHF for Aircraft

The 17K-1 is a five frequency, crystal controlled radio transmitter for commercial and itinerant aircraft use in the 122-132 mc band. The complete transmitter, including a dynamotor power supply, is housed in a single $\frac{1}{2}$ ATR unit cabinet. Transmitter, control box, and interconnecting cable weigh less than 20 pounds.

Remote control facilities allow complete freedom in locating the 17K-1 in the plane. An antenna transfer relay is available, if desired, in order to operate a receiver from the transmitting antenna.

The power output, adequate for the VHF range, is conservatively rated at 5 watts. Total power drain is held to a minimum during both stand-by and operation.

The audio circuit employs peak clipping to raise appreciably the effective modulation level and allow full use of the carrier power.

The 17K-1, thoroughly engineered and flight tested, enables its owners to obtain maximum benefit from the new VHF aircraft frequencies. Write today for early delivery. The Collins Radio Company, Cedar Rapids, Iowa; 11 West 42nd Street, New York 18, N. Y.

SPECIFICATIONS:

- Frequency range: 122-132 mc.
- Size: $\frac{1}{2}$ ATR unit.
- Total weight: less than 20 pounds.
- Number of frequencies: five.
- Frequency control: quartz crystals.
- Power output: 5 watts minimum.
- Type of emission: voice modulation.
- Output impedance: 50 ohm concentric line.
- Power source: 12 volts d-c or 26.5 volts d-c.

.....

IN RADIO COMMUNICATIONS, IT'S ...

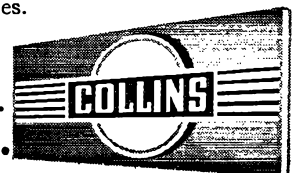

THE AMERICAN RADIO RELAY LEAGUE, INC.,

is a noncommercial association of radio amateurs, bonded for the promotion of interest in amateur radio communication and experimentation, for the relaying of messages by radio, for the advancement of the radio art and of the public welfare, for the representation of the radio amateur in legislative matters, and for the maintenance of fraternalism and a high standard of conduct.

It is an incorporated association without capital stock, chartered under the laws of Connecticut. Its affairs are governed by a Board of Directors, elected every two years by the general membership. The officers are elected or appointed by the Directors. The League is noncommercial and no one commercially engaged in the manufacture, sale or rental of radio apparatus is eligible to membership on its board.

"Of, by and for the amateur," it numbers within its ranks practically every worth-while amateur in the nation and has a history of glorious achievement as the standard-bearer in amateur affairs.

Inquiries regarding membership are solicited. A bona fide interest in amateur radio is the only essential qualification; ownership of a transmitting station and knowledge of the code are not prerequisite, although full voting membership is granted only to licensed amateurs.

All general correspondence should be addressed to the Secretary at the administrative headquarters at West Hartford, Connecticut.



Past Presidents

HIRAM PERCY MAXIM, W1AW, 1914-1936
EUGENE C. WOODRUFF, W8CMP, 1936-1940

Officers

President.....GEORGE W. BAILEY, W1KH
Washington, D. C.

Vice-President

Secretary.....KENNETH B. WARNER, W1EH
West Hartford, Connecticut

Communications Manager.....F. E. HANDY, W1BDI
West Hartford, Connecticut

Treasurer.....DAVID H. HOUGHTON
West Hartford, Connecticut

General Counsel.....PAUL M. SEGAL
1026 Woodward Building, Washington 5, D. C.

Directors

President
GEORGE W. BAILEY.....W1KH
1530 P St., N.W., Washington 25, D. C.

Vice-President

Canadian General Manager

ALEX REID.....VE2BE
240 Logan Ave., St. Lambert, P. Q.
Alternate: Leonard W. Mitchell.....VE3AZ
78 Raglan Ave., Toronto, Ont.

Atlantic Division

EDWARD G. RASER.....W3ZI
315 Beechwood Ave., Trenton 8, N. J.
Alternate: J. Victor Brotherson.....W8BHN
1743 Ottawa Drive, Erie, Pa.

Central Division

JOHN A. KIENER.....W8AVII
3462 Edison Rd., Cleveland Heights,
Cleveland 21, Ohio
Alternate: Earl S. Nelson.....W8DS
22551 Hadden Rd., Euclid 17, Ohio

Dakota Division

TOM E. DAVIS.....W9VVA
915 W. Beecher Ave., Willmar, Minn.
Alternate: Harold B. Love.....W9ZRT
Box 426, Mandan, N. D.

Delta Division

GEORGE S. ACTON.....W5BMM
Plain Dealing, La.
Alternate: Samuel H. Dowell.....W5ERV
1057 Mildred St., Shreveport 15, La.

Hudson Division

ROBERT AKERIDGE KIRKMAN.....W2DSY
Werah Pl., R.F.D. No. 1, Box 61, Long Branch, N. J.
Alternate: George Rulfs, Jr.....W2CJY
38 Brookwood Drive, Manhasset, L. I., N. Y.

Midwest Division

FLOYD E. NORWINE, JR.....W9EFC
7405 Hiawatha Ave., Richmond Heights 17, Mo.
Alternate: C. A. Colvin.....W9VHR
% Omaha & Council Bluffs St. Railway Co.,
Omaha 2, Nebr.

New England Division

PERCY C. NOBLE.....W1BVR
37 Broad St., Westfield, Mass.
Alternate: Clayton C. Gordon.....W1HRC
70 Columbia Ave., Warwick, R. I.

Northwestern Division

KARL W. WEINGARTEN.....W7BG
3219 N. 24th St., Tacoma 7, Wash.
Alternate: R. Rex Roberts.....W7CPY
110 W. Brennan St., Glendive, Mont.

Pacific Division

J. L. McCARGAR.....W6EY
66 Hamilton Pl., Oakland 12, Calif.
Alternate: Elbert J. Amarantes.....W6FBW
1675 Dale Ave., San Jose, Calif.

Roanoke Division

H. L. CAVENESS.....W4DW
2607 Vanderbilt Ave., Raleigh, N. C.
Alternate: J. Frank Key.....W3ZA
Box 707, Buena Vista, Va.

Rocky Mountain Division

Acting Director:
HOWARD R. MARKWELL.....W9TFP
355 Monroe St., Denver 6, Colo.

Southeastern Division

WILLIAM C. SHELTON.....W4ASR
527 Revilo Blvd., Daytona Beach, Fla.
Alternate: William P. Sides.....W4AUP
Fleming Road, Montgomery, Ala.

Southwestern Division

JOHN E. BICKEL.....W6BKY
1834 E. Whittier Blvd., Whittier, Calif.
Alternate: Eldridge E. Wyatt, Jr.....W6ARW
P. O. Box 3597, Long Beach 3, Calif.

West Gulf Division

WAYLAND M. GROVES.....W5NW
% Humble Pipe Line Co., Odessa, Texas
Alternate: Jennings R. Poston.....W5AJ
P. O. Box 848, Curundu, Panama Canal Zone

"It Seems to Us..."

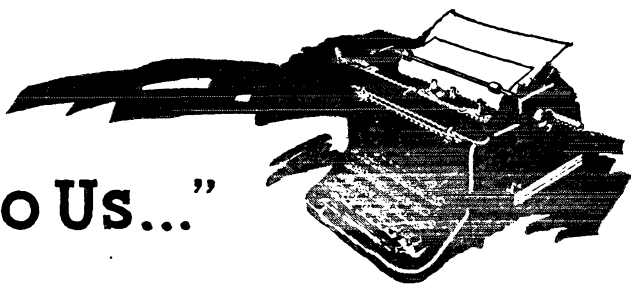

MORE OF 80

This has been the longest week of our life, these endless last few days of waiting for April 1st to roll around and unlock the 80-meter band. Time and again we've eyed that FCC order but it's absolutely adamant: "... may be used for amateur station operation on and after, but not before..." But it's the last week-end now, and we think we'll live. By the talk we hear, a bunch of the boys will be waiting up for the witching hour of 3 A.M., E.S.T. We hope their clocks are exactly right, for if we hear other fellows opening up twenty seconds or fifteen or ten ahead of what our clock says, it's going to be hard to convince ourselves that our clock hasn't suddenly developed a dry bearing.

And as of course you all know now, the band opening was widened at the last moment in two important respects:

1) Instead of being just 3700-4000 kc., it became 3625 to 4000 kc.

2) Instead of being confined to continental United States, it included Alaska, Puerto Rico and the Virgin Islands — although unhappily Hawaii and the Pacific area generally are still temporarily excluded through some Army needs.

These developments came about in late March through further ARRL representations and some rather special coöperation from the armed forces and FCC. Our president went to see the Army again and said he thought they ought to make an effort to improve their schedule for vacating 80. They were willing to try, and the Navy said it thought it could match anything the Army could do. As we understand it, the Signal Corps is now moving out of the remainder of our band altogether. The big user of these frequencies is the Air Forces, which have several important airground channels there. Some AAF generals were flown to Washington for a two-day conference, as a result of which it was decided that AAF could clear us down to 3625 now and would shift

their remaining channels out of our band as soon as crystals can be delivered for replacement frequencies and rhombic antennas can be altered. Clearance by the military services of the frequencies down to 3625 kc. was given to FCC through IRAC on March 28th and next day FCC took special action to issue its Order 130-E to make the expanded band available to us on the scheduled opening date of April 1st.

We can now look forward to the rest of the band coming back to us much sooner than was contemplated at the February conference. If all goes as presently planned, we should be enjoying our whole 3500-4000 stretch by early May, thanks to AAF flying technicians around the globe to recut their diamonds in the least possible time. Then we can open up our trunklines and nets and really be in business again — training operators, handling traffic, and rendering emergency communication service.

ELEVEN METERS

Our new band from 27.185 to 27.455 Mc. was activated with a bang by middle March and was promptly dubbed by the gang the 11-meter band. By reason of its having been assigned in the first instance for industrial and medical apparatus, we had expected to call it the "QRM band," but one of the most amazing things about our limited experience with it to date is that there is very little QRM so far. (Sometimes there seems to be much more in the 10-meter band, where there isn't supposed to be any!)

But perhaps the biggest surprise is how much better 11 seems to be than 10. We all know the differences between 28 and 30 (29.7, we mean) but the little gang who are already calling "CQ 11" report it very much better, both in coming in earlier and staying longer and in increased ease of getting excitation, which latter in turn means increased modulation capability. As W6AM writes us:

The 11-meter band is certainly a dream, and it seemed just like old times to be running i.c.w. It is a lot more useful for United States communication than the 10-meter band, and as yet it has just about enough hams in it to make it of maximum interest.

Incidentally, if the QRM is going to be bad, this is one band where operation toward the edges would seem justified. The QRM apparatus is assigned the center frequency of 27.32 Mc. and is given the wide tolerance of plus or minus a half a per cent. By the time the noise-makers get settled on a sound technical basis, most of the rumpus ought to be in the middle of the band and the edges relatively free.

But what if the interference doesn't prove bad? Our regulations for this band were drafted with the thought that it would be a sort of half-world in which anything might go. Thus A2 emission has been authorized and so has A \emptyset , or unmodulated carriers. You will remember that our regulations provide that, except for brief tests, a 'phone station may not emit a carrier on frequencies below 144 Mc., unless modulated for the purpose of communication. This band now becomes an exception, and carrier-on operation or what we have fondly called duplex 'phone is now permissible. It was thought that such provisions as this would encourage occupancy and that anything should be encouraged in a near-worthless band. But if the QRM is not going to be severe, and if the band is going to perform notably better than 10, are we sure we're smart? Wouldn't it be a shame to smear a really good little band with such things as this? We might be wiser to confine operation to A1 and A3 and get provisions for A \emptyset and A2, if we must have them, at the top end of 10, above 29 or 29.5 Mc.

Let's be thinking this over as we get more experience with 11.

DX QSLs

Honestly, fellows, you ought to visit one of the area managers of ARRL's QSL Bureau System and see for yourselves what a vast number of prewar foreign cards there are — waiting for the American addressees to submit envelopes. A large handful picked at random from the files would almost make the old DX Century Club — if they were all yours! Some of the cards confirm early contacts with Ws who have since dropped out of ham radio, yet many are for presently-active hams who simply haven't taken the trouble to submit an envelope, the procedure for which is described elsewhere in this issue.

There are a lot of choice calls like KC4USC, PK6XX, PJ5EE, I1MH, URS-3-156 (Russian SWL), YU7AY, LY1KK, U3BX . . . and

dozens of others. Many are from countries which may not be heard on the air for a long time, if ever. Maybe some of the foreigners you've been cussing for not QSLing actually sent cards via the bureaus. If you've ever worked any DX, send a stamped, self-addressed No. 10 envelope to your district manager, whose address is to be found in the article mentioned. If you're overseas, submit envelopes self-addressed to a home QTH. If you held other calls in previous years, send an envelope to the appropriate manager for each call. Cards for portable operation outside the home district should be obtained from the home-district manager, e.g., W9IIL/K7 should send his envelope to the W9 manager.

Do it now! And make certain that you keep a fresh envelope on file at all times. The stuff coming in now for Ws is plenty interesting. Get yourself a good start in the postwar DXCC!

Edwin

Strays

Have you heard Dinah Shore's new transmission-line song? Sure, "Co-ax Me a Little."

— . . . —

W8QBJ contributes this squib clipped from an advertisement in the Cincinnati *Post*: "Genuine US Signal Corps key with switch to close *contracts*." (Italics ours.)

W8QBJ suggests that maybe some of the boys could use this key to advantage in their business.

— . . . —

W9LQE discovered a most unusual triode in the RCA guide for transmitting tubes. This tube takes 750 volts on the grid and only 200 on the plate.

— . . . —

Frank E. Wooley, of Irvington, N. J., reports that the Public Service Electric Corporation of New Jersey recently quoted their animated cartoon character as follows: "I am your little friend, Reddy Kilowatt. I make my voltage high so I can come to your house with greater speed!"

Every day, new laws!

— . . . —

A recent news release reported a test in which "24 fifteen-candlepower incandescent bulbs consumed 25 *ammeters*, while ten 42-inch fluorescent lights consumed only twenty-three."

Not very hungry, eh?

Noise Limiting in C. W. Reception

A Review of Principles and an Application

BY GEORGE GRAMMER,* WIDF

NEARLY ALL current models of communication receivers include noise-reducing circuits of one type or another. The majority of these are amplitude limiters designed to chop off noise peaks that rise above the desired signal. Usually they are "automatic" in operation — that is, self-adjusting so that 100%-modulated signals of differing carrier levels can be accommodated without chopping off the desired modulation along with the noise.

These circuits, like automatic gain control, give all the breaks to 'phone reception. It is common experience to find that a noise limiter whose performance is all that could be asked on 'phone seems to be almost wholly ineffective in code reception — often there is no limiting at all except on unusually strong noise. The reason, well known to those whose business it is to design receivers but perhaps less so to the ordinary user, is the same one that prevents using the conventional type of a.v.c. on c.w. — the b.f.o. puts in such a strong carrier at the second detector that the operating point is shifted far outside the normal range. In a way, this state of affairs is absurd because the nature of c.w. reception is such that it ought to be possible to use limiting much more effectively than on 'phone.

* Technical Editor.

¹ For further references on noise and noise reduction, see Leland E. Thompson, "A Detector Circuit for Reducing Noise Interference in C.W. Reception," *QST*, April, 1935; J. J. Lamb, "A Noise-Silencing I.F. Circuit for Superhet Receivers," *QST*, February, 1936; H. A. Robinson, "Audio Output Limiters for Improving the Signal-to-Noise Ratio in Reception," *QST*, February, 1936.

There is an answer to noise limiting in c.w. reception that is not in the least novel, but it is not compatible with the automatic limiting that is such a desirable feature in 'phone work. It is simply this — the clipping should not be done at the second detector but in a later audio circuit where the rectified d.c. from the beat oscillator cannot appear and consequently cannot affect the clipping level. Beyond that, the chief problem is to get an effective limiting circuit. However, it appears to be equally important that the user should understand just what limiters can and cannot do, because sometimes miracles are expected where none are possible. For this reason it is desirable to review some of the principles of noise reduction,¹ with special reference to c.w. reception as accomplished in the ordinary superheterodyne receiver.

Noise Characteristics

To make an improvement in signal-to-noise ratio possible by amplitude limiting, the noise voltage must have higher amplitude than the signal, but the energy must be contained in a pulse of very short time duration. Much of the noise that mars reception meets this requirement. A typical example is the highly-damped oscillation set up by the spark discharge in an automobile ignition system. The r.f. oscillations might look something like the picture at A in Fig. 1; each group is associated with a single spark discharge and although the maximum amplitude is large the oscillations decay so rapidly that there is a long silent period between groups. A con-

◆

A crystal diode noise limiter for use between receiver and headphones. Built in a 4 by 4 by 2 inch box, it contains the limiter crystals, bias cells, headphone jack, and on-off switch, and is provided with a cord and plug to connect to the receiver headphone output.

Although primarily intended for c.w. reception, the limiter also is highly effective on 'phone signals when the audio volume level is properly set and the r.f. gain is automatically controlled.

◆

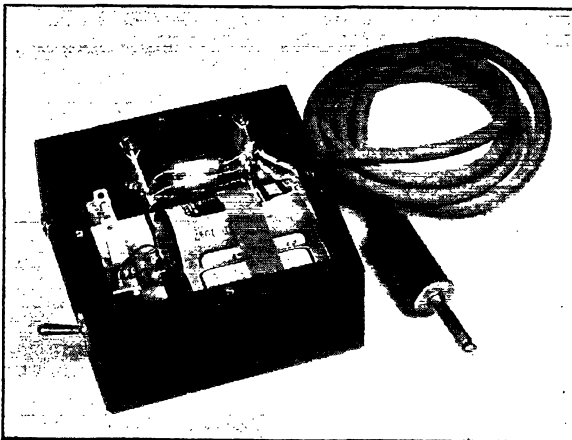

tinuous wave of low amplitude is shown at B. If everything in the damped oscillation greater in amplitude than the c.w. signal is clipped off, only the part contained within the two horizontal dashed lines in Fig. 1-A will remain. This repre-

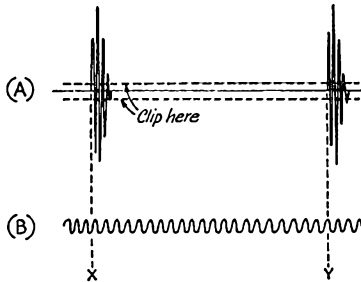

Fig. 1 — Representation of noise impulses compared with a continuous carrier.

sents a relatively small part of the noise energy, so the signal-to-noise ratio has been improved by limiting.

If the noise alone is rectified at the second detector the result is a unidirectional pulse which reproduces the envelope of the r.f. oscillation. A series of such rectified pulses is depicted at Fig. 2-A. If the output of the detector is observed on an oscilloscope through a coupling means, such as a condenser, that transmits only the a.c. but not the d.c. component the noise will look like the drawing at the right, provided the low-frequency response of the system is good. The pulses are all on the same side of the a.c. axis of the audio-frequency output.

However, when a carrier is present along with the noise, the two are combined by a process quite like that of ordinary modulation, so it is helpful to visualize the noise as modulating the carrier. Since the phase of the carrier and noise is variable, a noise pulse may modulate the carrier either

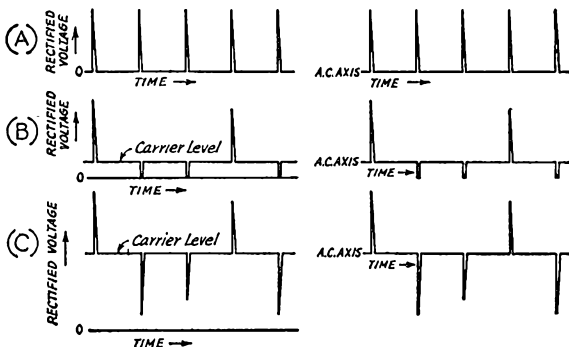

Fig. 2 — Noise pulses at the second detector, left, and with the d.c. component removed (audio only), right. (A) no continuous carrier present; (B) with low-amplitude carrier; (C) with high-amplitude carrier such as that from the beat-frequency oscillator.

up or down, with a resultant amplitude that depends on the phase as well as on the amplitudes of the carrier and noise. The noise in Fig. 2-A might modulate a low-amplitude carrier in the fashion shown in Fig. 2-B, giving the a.f. output shown at the right of the figure. There are now noise pulses on both sides of the a.c. axis, those below the axis being limited by the carrier amplitude.

When the carrier amplitude is high, as in the case of the beat-frequency oscillator, it may take a quite husky noise to modulate it completely. The same noise on a strong carrier is indicated in Fig. 2-C, the phases being assumed to be the same as in Fig. 2-B. In this case there is no limiting of the downward modulation and the a.c. output, at the right, contains pulses of high amplitude on both sides of the a.c. axis.

An incoming signal modulates the b.f.o. carrier just as the noise does. When the signal and b.f.o. frequencies differ slightly, the output contains the audio-frequency beat note superimposed on the rectified carrier. A weak signal, along with the noise impulses, will give a pattern after rectification such as is shown in Fig. 3, and everything above the dashed line can be clipped off at the

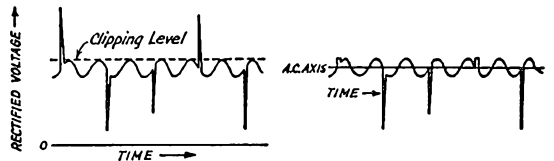

Fig. 3 — Noise and signal resulting from beat reception. Left, at second detector; right, audio only, after amplitude limiting as ordinarily accomplished at the second detector.

second detector without clipping the signal itself. However, the audio output is as shown at the right in Fig. 3; the downward noise pulses are unaffected by the clipping and to the ear there is little if any reduction in noise. If the noise is really to be clipped, the limiting circuit has to be equally effective on both the positive and negative peaks, and to be most useful it should cut off at exactly the same value of voltage above and below the axis.

Noise Pulses and Selectivity

Fig. 1 gives a qualitative picture of noise and signal, but is by no means accurate in a quantitative sense when the circuit in which the oscillations exist is an i.f. amplifier operating in the vicinity of 450 kc. The number of cycles in the damped oscillation — and therefore the length of time the oscillation persists, since the frequency is fixed — is primarily a function of the Q of the circuit; the higher the Q the larger the number of cycles before the oscillation ampli-

tude decays to a given fraction of the maximum amplitude. The normal 456-kc. i.f. amplifier has an effective Q of such magnitude that even when excited by a single pulse, several hundred cycles will occur before the amplitude dies down to 1 per cent of its maximum value. Since Q and selectivity are directly related, an increase in selectivity brings with it an increase in the time required for damped oscillations to die down. This has an important bearing on noise reduction.

The noise that remains after full clipping will interfere to the extent that it tends to wipe out part of the beat note, and this in turn is a function of the length of time during which the noise exists. If the noise pulse is very short it may wipe out only a cycle or two of a beat frequency which usually lies between 500 and 1000 cycles per second, and the loss of one or two cycles is not likely to be noticed. On the other hand, if the time duration of the noise pulse is great enough the signal may be unreadable even though the maximum noise amplitude is limited to that of the signal. Since the time duration of the r.f. noise oscillations increases with the selectivity of the i.f. amplifier, the rectified envelope of the noise pulse likewise lasts longer, and the effectiveness of a limiter decreases when the receiver selectivity is increased.

The seriousness of pulse lengthening depends upon the original strength of the pulse and the rate of pulse recurrence. The stronger the pulse the longer the time required for the amplitude to die down to a fixed level, and if the pulses occur in rapid succession they may even overlap when lengthened out by selectivity. The rate of recur-

rence of most noises seems to be in the neighborhood of 120 per second (many noises are associated with the power-line frequency) so the time during which the noise pulse amplitude is comparable to that of the desired signal has to be held to considerably less than $1/120$ th second if limiting is to do any good.

The effect of selectivity on the shape of noise pulses can be observed quite readily on an oscilloscope if a recurrent pulse is available for examination. Fig. 4 shows progressively increasing selectivity from normal i.f. to the maximum available with a crystal filter. Note that the selectivity reduces the maximum amplitude in addition to increasing the time duration. It is entirely possible for the maximum pulse amplitude to be reduced to such an extent that it does not exceed the amplitude of the desired signal — in which event, although limiting is useless, there is nevertheless an improvement in the signal-to-noise ratio. The effect is readily observable by switching a crystal filter in and out when there is ignition noise of moderate strength; it usually makes the difference between copying and not copying a weak signal. Yet with normal i.f. selectivity and a good limiter it would be possible to clip the noise pulses so effectively they would not even be heard. It would be easy to interpret this last statement to mean that high selectivity is somewhat of a handicap in the presence of impulse noise, but despite the fact that there are occasions when it becomes possible to copy a signal with normal i.f. selectivity, plus limiting, and impossible to copy the same signal through a crystal filter, it would not pay to jump to such a conclusion.

Continuous Noise

In the final analysis all noise is of a pulse-like nature, but when the pulses are random and occur so frequently that they overlap even though they are of extremely short duration, the result is a hiss-like noise of more or less uniform average intensity. This is the familiar receiver hiss, much of it generated in the circuits and tubes, but some of it similarly random noise picked up by the antenna. The energy distribution does not meet the requirements stated earlier because the total noise does not exist in short, high-amplitude bursts with relatively long silent periods between; it is continuous in time and there is no sense in expecting a limiter to reduce it.

On the other hand, this is the very type of noise that is reduced by increased selectivity; it is spread out over the whole frequency spectrum and the higher the selectivity the smaller the amount of it that is passed by the selective circuits. Weak signals that are unreadable in the hiss noise with normal i.f. selectivity become readable with a crystal filter because the selectivity reduces the noise without changing the signal strength. When impulse noise is added to

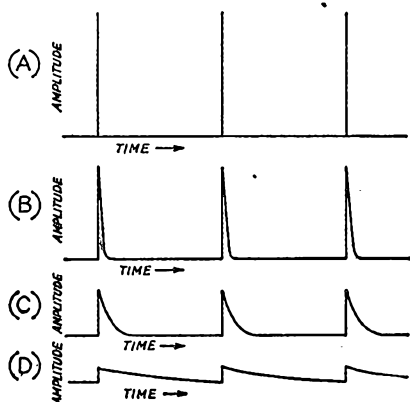

Fig. 4 — Effect of increasing selectivity on the shape of noise pulses. (A) shows the pulse as it might appear with normal i.f. selectivity, (B) with a broad crystal filter, (C) and (D) with progressively increasing selectivity. These drawings, although not to true amplitude scale, show the effect of high selectivity in decreasing the amplitude of a pulse. They were made from oscilloscope patterns using a loran signal, the pulse intervals being approximately $1/16$ th second. With maximum selectivity (D) most of the pulse interval is required for the pulse amplitude to decrease to a negligible value.

the hiss it may or may not be possible to copy such a signal through the filter, but it certainly will not be possible without it even though the limiter does a perfect job of taking out the noise impulses. However, if the signal can be copied through the hiss with normal i.f. selectivity a good limiter usually will prevent impulse noise from interfering; whether or not the same signal can be copied with the crystal filter is a matter of the amplitude and character of the noise and the degree of selectivity. Ultimately, the noise pulses passing through the filter may result in a continuous "ringing" through which no signal can be copied, simply because the pulses are of such amplitude and have been lengthened to such an extent that they overlap to produce what is practically a continuous wave. This requires a noise amplitude such that with normal i.f. selectivity and without limiting, the signal is so deeply buried in noise as to be completely undiscernible to the ear. But if the noise is of the high-amplitude, short-duration character a good limiter will not only make the signal audible but make it perfectly readable.

This makes a convincing demonstration of the

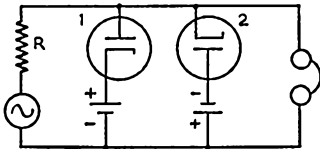

Fig. 5 — The fundamental shunt diode clipper circuit for limiting on both sides of the a.c. axis.

usefulness of a noise limiter, but the occasions when it can be done are relatively infrequent. The more common case is the one where the noise amplitude is such that either the crystal or normal-i.f.-plus-limiter will make the signal readable. With the filter, the limiter gets only an occasional chance to work because the noise amplitude is reduced by the selectivity; the result is that the impulse noise is there even though it may not prevent making perfect copy. With the normal-i.f.-plus-limiter the noise may be eliminated almost 100 per cent but the hiss is much stronger and the selectivity against other stations is much reduced. Which is better depends upon the operator's likes and the conditions — noise and other interference — existing at the moment.

There are at least two other types of noise that tend to be continuous and therefore hard to handle with a limiter insofar as increasing signal readability is concerned. One is natural static; if it is stronger than the signal the latter is likely to be blotted out completely for the duration of the crash. The other is associated with some electrical devices in which the sparking appears to be practically continuous during the half of each a.c. alternation when the voltage is highest, with

the result that for about half the time the noise pulses are overlapping. When a limiter is applied on such a noise the residue is a throttled-sounding buzz.

A Practical Limiter for Headphone Reception

It was mentioned earlier that to be successful an audio limiter — meaning, here, one which operates on a.c. only and not on the rectified d.c. at the second detector — should clip on both sides of the desired signal and should cut off sharply at the same amplitude on either side. A single diode limiter, whether of the series or shunt type, can cut off the peaks on only one side. Limiters of other types — saturated amplifiers, for example — probably do not do a really clean job of clipping and do not clip at the same voltage above and below the axis. A good limiter has to provide a sharp "slot" through which nothing larger than the signal can pass.

There are several ways in which the slot characteristic can be obtained, but the simplest makes use of the shunt diode arrangement. Two diodes are required, one to cut off the positive peaks and the other the negative, and both must be biased to be nonconducting up to a certain level of applied voltage. The fundamental circuit is shown in Fig. 5. The diodes are connected across the load, shown here as a headset, with their plates and cathodes reversed. The two battery voltages, which should be equal, determine the amplitude of signal that will be passed. When the voltage from the audio signal source is positive and becomes larger than the voltage of the battery associated with diode No. 1, that tube will conduct. If the diode resistance when conducting is low compared to the impedance of the headset and also low compared to the internal resistance, R , of the audio source, the voltage across the headset will remain constant at the value of the battery voltage no matter how high the voltage of the audio source goes. The action is similar on the negative half-cycle, when diode No. 2 does the conducting. The audio output voltage can be set at any desired level by changing the battery voltage; the peak-to-peak audio output voltage is equal to the sum of the voltages of the two batteries.

It can be seen that the effectiveness of this limiter depends upon having a low-resistance path through the diodes and bias source during the conducting period. "Low resistance" is used in a relative sense, since the value that will work depends entirely on the load and source resistances. It is not a hard condition to meet with a headset as a load — and fortunately most code operators prefer headset to loudspeaker reception. The average 2000-ohm headset has an impedance in the neighborhood of 20,000 ohms at 1000 cycles, so a short-circuit of a few hundred ohms is practically perfect. The series resistance, R ,

usually is the plate resistance of the amplifier tube to which the headset is connected; if it is not high enough, more resistance can be added without materially lowering the signal volume. A total resistance of about 30,000 ohms is sufficient with low-resistance diodes.

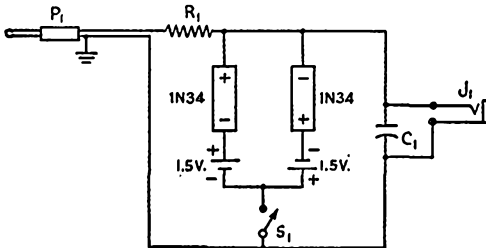

Fig. 6 — Practical clipper circuit for headphone reception.

C₁ — 0.005 μ fd. P₁ — Headphone plug.
 J₁ — Single-circuit jack. R₁ — 15,000 ohms, $\frac{1}{2}$ -watt.
 S₁ — S.p.s.t. toggle.

The two sections of a 6H6 or a 6AL5 may be used as the diodes and will work quite well. However, even better performance can be secured with the new 1N34 germanium crystal diodes.² The high forward conductance of these crystals makes them ideal as limiters in this circuit, as shown by practically perfect leveling of the signal peaks in oscilloscope patterns. With the tube diodes some of the stronger peaks get through. Aurally, the difference is not so marked as in the oscilloscope pictures, but the better performance of the crystals is observable. The crystals also have the advantage of not requiring any auxiliary power such as a heater supply, and thus are independent of the a.c. line.

For a bias source there is nothing better than a pair of flashlight cells. A 1½-volt cell on each diode will pass a 3-volt peak-to-peak audio signal, which represents a good headset level — not ear-splitting, by any means, but ample volume for the average pair of ears. The low internal resistance of the dry cells makes them well suited to the purpose, because it would be undesirable to introduce appreciable resistance at this point. Since no current is taken from them the cells will last their shelf life.

It is not necessary to do anything to the receiver to use a limiter of this type. One can be built as an entirely separate unit, an example being shown in the photograph. It is equipped with a 'phone plug to go into the receiver 'phone jack, and the 'phones are simply transferred to the black box. The circuit, Fig. 6, differs but little from the fundamental circuit shown in Fig. 5; a series resistance, R₁, is included to take care of cases where the internal resistance of the audio

² A second detector circuit with automatic limiting using these crystals, devised by W. F. Frankart, W9KPD/6, is described in *Hints & Kinks*, this issue.

source is low — for example, when the headphones are connected to the loudspeaker output. There is also an on-off switch.

Getting the most out of a unit of this type is a matter of experimenting with the receiver gain and selectivity. The audio level must be at least 3 volts peak-to-peak before limiting will occur, but this requirement is easily met by the headphone output of almost any receiver. The r.f. and audio gain controls should be adjusted so that the weaker signals are up to the 3-volt level; in general, it is better to use maximum audio gain and do any necessary regulating with the r.f. control since this tends to prevent overloading in the r.f. circuits. The limiting level easily can be checked by means of the on-off switch.

With proper adjustment of the receiver gain controls most ignition noise can be made to disappear, but unusually strong noise of this type may leave a soft growl that will not bother any but very weak signals. The previously-mentioned "heavy" noises of long time duration usually are accompanied by sharp pulses that are readily clipped, even though the best that can be done to the body of the noise is to limit its volume. Nevertheless, tests have shown that the limiter does a good job on the spark type of noise set up by electric razors and oil-burner ignition systems — many signals that disappear in the noise without the limiter become readable with it switched in. Regularly-recurrent noises of this sort usually have a lower tone pitch than is used for beat-note reception, and a reasonably good operator does not have too much trouble copying the signal under such circumstances. The miscellaneous pops and crackles that ordinarily accompany high-frequency reception likewise are limited, and since they are usually of the nature of pulses they disappear to the point of hardly being noticed. It is only when the limiter is switched out that one begins to appreciate how much random racket is tolerated in ordinary operation.

A device such as the one pictured is very convenient, but handicaps the limiter to some extent because the headset — or any inductive device such as a transformer — causes the downswing of the pulse to overshoot the axis. The amount of noise energy thus redistributed is put largely, if not wholly, within the limits of the "slot." For the same reason the limiter performance is slightly better if the headset works directly out of the detector or a resistance-coupled audio stage rather than from the power output stage where it is usually transformer-coupled to the plates. The best spot for the limiting circuit would be between the second detector and a following amplifier tube, with the headset and any tone control or audio filter circuits completely disassociated from the limiter circuit proper.

(Continued on page 118)

New Tuning System for the Amateur Receiver

Split-Stator Tuning for Improving V.H.F. Performance

BY W. J. HALLIGAN, * W9WZE AND NORM FOOT, * W9GQP

• Here's a new tuning arrangement that promises higher gain in receiver r.f. stages operating in the v.h.f. region, particularly in amplifiers covering a continuous frequency range. It makes use of our old friend, the split-stator condenser — but with a difference.

THE NEW ERA of amateur radio now opening presents many opportunities to the amateur builder. Equipment for the new v.h.f. and u.h.f. bands requires new techniques and there are innumerable modifications and improvements to be made in gear for the traditional frequencies. One item, however, which has escaped general notice is the possibility of extending the tuning range of the standard communications receiver into the v.h.f. region without in any way impairing its efficiency. As a matter of fact, the system to be described offers several advantages throughout a large part of the normal high-frequency range as well.

The principal problem in securing a wide tuning range in a communications receiver is that large minimum capacitances often reduce the coil inductance at v.h.f. to the vanishing point and prevent the realization of any appreciable r.f. gain. If the tuning capacitors are made small enough to provide sufficiently low minimum capacitance, the maximum capacitance becomes too small to offer any effective tuning range on the lower-frequency bands. The solution lies in the split-stator condenser, long a favorite device in amateur transmitters.

The gain of a tuned r.f. amplifier is directly proportional to the Q of the tuned circuit associated with it. In general, Q will be increased if the inductive reactance of the coil can be increased — that is, the inductance made larger — so any way in which this reactance can be increased is well worthwhile. The split-stator tuning circuit, Fig. 1, reduces the minimum capacitance to a value sufficiently far below that obtainable by any conventional means to make it possible to use nearly twice the number of turns in the inductance for any given frequency. Including the lessened effect of tube input loading and bandspread condenser minimum capacitance, the over-all minimum can

be made approximately one-third that of the usual circuit.

In practice this device makes it possible to secure tuning ratios of three to one, even at frequencies as high as 150 megacycles. A convenient formula for determining the effective capacitance change needed to achieve any given tuning ratio is:

$$C_{\text{eff}} = (f_r^2 - 1) C_0$$

Where:

C_{eff} is the capacitance change needed.

C_0 is the minimum capacitance of circuit.

f_r is the tuning ratio.

Decreasing the minimum capacitance by a factor of three makes possible a marked improvement in performance at the higher frequencies. For example, if the minimum capacitance of a circuit is 45 $\mu\text{fd.}$ and the desired tuning ratio is 3 to 1, the capacitance change required becomes:

$$C_{\text{eff}} = (9 - 1) 45 = 360 \mu\text{fd.}$$

When the minimum capacitance is reduced to 15 $\mu\text{fd.}$ the necessary change for the same tuning range is:

$$C_{\text{eff}} = (9 - 1) 15 = 120 \mu\text{fd.}$$

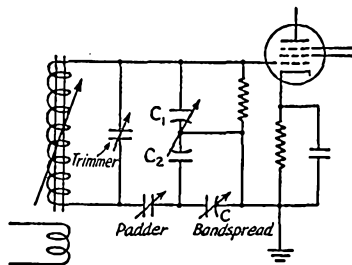

Fig. 1 — The split-stator tuning circuit as applied to the grid of an r.f. amplifier or mixer. The split-stator condenser, C_1 C_2 , is not necessarily of the "balanced" type having identical sections.

By consulting an ARRL lightning calculator it is evident that a much larger coil can now be used to cover the desired frequency range. At a frequency of 50 megacycles, for example, using the capacitance figures in the first example permits less than two turns on a form $\frac{1}{2}$ inch long and $\frac{1}{8}$ inch in diameter — practically no coil at all; whereas the same frequency using the second

*The Hallicrafters Co., 2611 Indiana Ave., Chicago, Ill.

example requires the use of three-and-a-half turns on the same form. This not only means much higher inductive reactance because of the greater number of turns but in practical cases permits the use of a powdered-iron slug for easier adjustment, giving still higher coil Q and even greater gain.

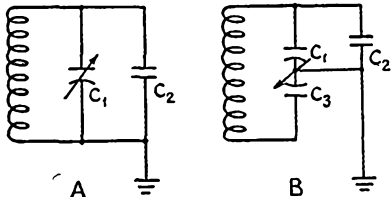

Fig. 2—In this diagram C_2 represents the input capacitance of the tube used with the tuned circuit. The effect on minimum capacitance of the circuit is reduced in the split-stator circuit at B because C_2 is in series with one section, C_3 , of the tuning condenser.

Other Advantages

Obviously it would be possible to use a standard variable capacitor of good quality and having maximum and minimum capacitances meeting the requirements of the above example, but such a condenser would be entirely inadequate for tuning the lower-frequency bands. In addition, the split-stator circuit offers many other advantages which are not evident at first glance.

With this arrangement a very large portion of the circulating r.f. current is confined to the actual tuned circuit and flows through the shaft of the condenser instead of through the wiper contacts, frame and chassis. This reduces the r.f.

resistance of the circuit, raises the Q correspondingly, and decreases noise caused by imperfect contact in rotor bearings or wipers. Another outstanding advantage in practical applications is the improved isolation between stages because most of the r.f. is confined to the coil and condenser, with ground currents in the chassis kept to a minimum. This reduction in stray inter-stage coupling is a real help in making a pair of tuned r.f. stages operate smoothly at v.h.f.

The split-stator circuit makes it possible to use tubes having a fairly high input capacitance at higher frequencies than usual, because the tube capacitance does not load the circuit to anything like the extent that it does in the conventional arrangement. This can be understood by referring to Fig. 2. The conventional circuit is shown at A with the tuning capacitor and the input

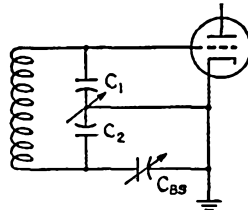

Fig. 3—Fundamental r.f. amplifier circuit.

capacitance of the tube in parallel across the inductance. In contrast, the split-stator circuit of B shows the tube to be in shunt to only one section of the tuning condenser.

For optimum efficiency it has been found best to make one section of the tuning condenser about

⋈

A tuning unit employing the split-stator circuit. The gang at the right incorporates the split-stator condensers, each one being divided in the ratio of approximately 4 to 1. The band-spread gang is at the left. The receiver in which this unit is used has two r.f. stages preceding the mixer.

⋈

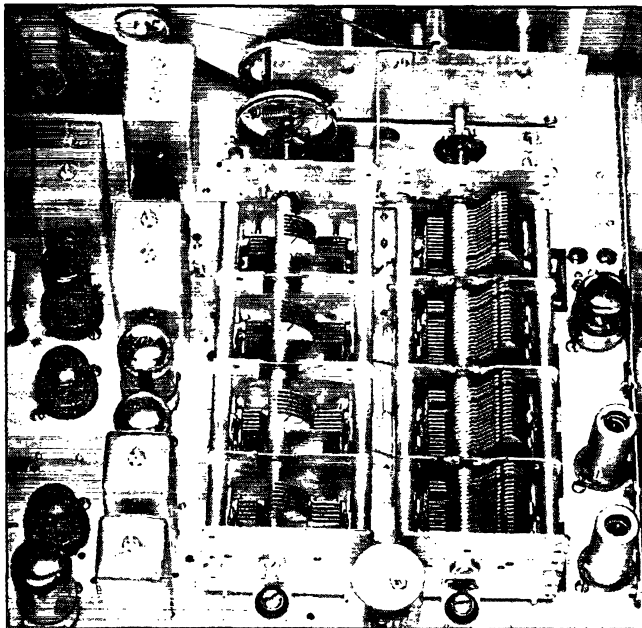

four times the capacitance of the other. As the condenser is tuned toward minimum capacitance, however, these values tend to approach each other so that at the lowest point they are nearly equal. Under these conditions, if the minimum capacitance of each section is $20 \mu\text{fd.}$, for example, and

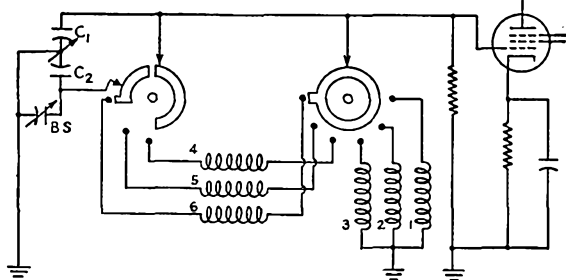

Fig. 4—Band-switching circuit, using split-stator tuning on three ranges and ordinary tuning on three additional low-frequency ranges.

the input capacitance of the tube is $10 \mu\text{fd.}$, the advantage is obvious. Assuming it is possible to secure a minimum condenser capacitance of $10 \mu\text{fd.}$ across the coil, in the conventional circuit shown at A the addition of the tube input capacitance would increase the total to $20 \mu\text{fd.}$ With the circuit of B, assuming a much poorer condenser with a minimum capacitance per section of $20 \mu\text{fd.}$, the total capacitance across the coil is:

$$C_{\text{total}} = \frac{(C_1 + C_2) C_3}{C_1 + C_2 + C_3} = \frac{(20 + 10) \times 20}{20 + 10 + 20} = \frac{600}{50} = 12 \mu\text{fd.}$$

In the first case the addition of the tube causes an increase of 100 per cent in minimum circuit capacitance, in the second an increase of only 20 per cent.

Smoothing Out the Gain-Frequency Curve

All of the factors considered so far are helpful in increasing the inductive reactance of the circuit, thereby raising the input voltage at the grid of the tube and providing greater gain per stage. There is another advantage, however, which is of real value in the design of practical receivers: that is, the tendency of this circuit to maintain more uniform gain from minimum to maximum frequency than is possible with the usual arrangement. In normal tuned r.f. amplifiers the gain is greatest at the high-frequency end of the tuning range because of the higher inductive reactance of the coil.

In the split-stator circuit the tendency for the large and small sections of the condenser to approach the same minimum capacitance reduces the gain at the high-frequency end of the tuning range. Fig. 3 shows the fundamental r.f. amplifier circuit. When this circuit is tuned to the high-

frequency end (minimum capacitance) the capacitances C_1 and C_2 are approximately equal. Note that the minimum capacitance of the bandspread condenser serves to balance the tube input capacitance. Under these conditions it is obvious that approximately one-half of the voltage developed

across the tuned circuit will be applied to the grid of the tube. When tuned to the low-frequency end, however, the situation is altogether different. At this point C_2 is four times larger than C_1 , and as the r.f. voltage applied to the tube is a function of the reactance across which the tube input circuit is connected, approximately $\frac{1}{5}$ of the total r.f. voltage is applied to the tube. It must be remembered that, while inductive reactance at a given frequency increases as the value of the inductance itself increases, capacitive reactance increases as the capacity in the circuit has the same effect as tapping it across $\frac{1}{5}$ of the coil.

Band Switching

The full benefit of this split-stator tuning system is only realized, of course, in a multiband receiver designed to cover a wide range of frequencies. A basic diagram showing how band-switching is accomplished in a six-band receiver of this type is shown in Fig. 4. Two switch wafers are necessary because both ends of the coils are "hot." It will be seen that only the three higher bands use the split-stator circuit, the other three being connected in the customary manner with both sections of the tuning condenser in parallel

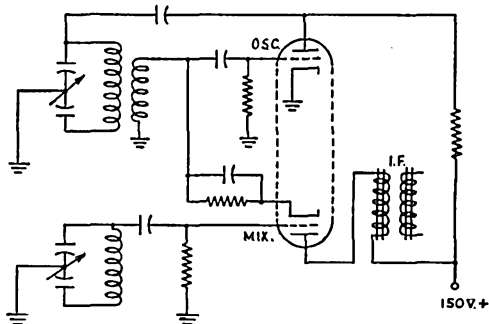

Fig. 5—Basic oscillator and mixer circuit used with split-stator tuning in a wide range (540 kc. to 110 Mc.) receiver.

to provide the greatest possible maximum capacity for the lower frequencies. For clarity no primary windings, iron cores, trimmers, padders, and so on are shown.

The actual tuning assembly used in a commercial receiver using this circuit is shown in the photograph. The receiver in which this unit is

(Continued on page 133)

A Remote-Indicating Field-Strength Meter

BY E. P. TILTON,* WIHDQ

THE ALMOST universal use of directional antenna systems for v.h.f. work makes the possession of a good field-strength meter a "must" for any serious worker in this field. Directional arrays can be "cut to formula" and erected without adjustment, but good performance by this procedure is largely a matter of luck. To attain maximum performance with parasitic arrays, and to know whether they are performing as they should, a good indicating device must be used.

The field-strength meter has been thought of as a "junk-box" proposition, thrown together in haywire fashion from whatever parts might happen to be on hand, but if one considers all the angles it is easy to see that there is little justification for this technique. By no other means can so much return be obtained from a small investment as by the erection of a good antenna system. It is a well-established fact that a low-powered station with a high-gain antenna will out-perform a kilowatt rig and an inferior skywire. Surely, then, the investment of a few dollars in a good field-strength meter is an economically-sound approach.

A common fault of most field-strength meters is their sensitiveness to body-capacity effects. At the frequencies for which such devices are most used, movement of the user in the vicinity of the pick-up antenna causes all manner of variations in the meter indication, due to the body acting as a "parasitic element." Unless a very large meter is employed or field glasses are used to read it, just getting near enough to take a reading will render the indications inaccurate. In addition,

*V.H.F. Editor.

◆
For remote indication, the pick-up unit is separated from the meter compartment and set up at a distance from the antenna system. The meter, which is connected to the pick-up unit by a long extension cord, may then be used wherever convenience dictates. The pointer at the left of the meter unit is the shunt switch. The two controls on the top of the pick-up unit are the band switch (left) and tuning control. The resistor-shorting switch is on the right side.

◆

• Today, more than ever before, the accent is on antennas. Here is a handy gadget to help you get the most out of that new parasitic array. Its two-piece construction makes antenna adjustment a one-man job.

when the meter is integral with the rest of the unit its use in connection with antenna or transmitter adjustments is a time-consuming task, if the meter is set up at a point remote from the antenna or transmitter position, as it must be for accurate work.

The unit about to be described is made up in two sections, one containing the usual tuned circuit, crystal rectifier, and antenna connection, and the other housing a microammeter for registering the rectified current from the crystal. The two units are fitted with matching plug and socket, permitting them to be used together in the conventional way, or they may be interconnected by means of a cable which can be any length up to several hundred feet. This arrangement allows the pick-up unit to be set up out in the field to pick up radiation from the antenna under test, while the meter unit is placed at a convenient point near where adjustments are to be made. Antenna adjustment thus becomes a one-man job, and it can be done more quickly and accurately by one man than by two using the conventional approach.

Several other features are included for maximum convenience and usefulness. Three coils are used, so that measurements may be made on 28, 50, and 144 Mc. with the snap of a switch. A re-

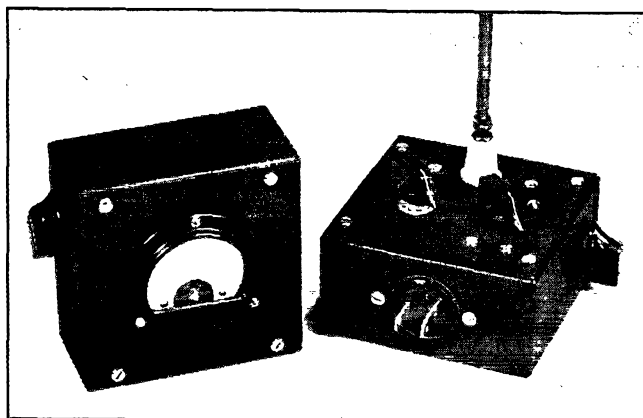

sistor is inserted in series with the crystal and meter, to lessen the loading effect on the tuned circuit and to make the response of the crystal more linear with variations in radiated power. As the use of the resistor reduces the sensitivity of the device somewhat, a switch is provided to short out the resistor in case measurements are to be made with extremely low power or at great distances from the transmitting antenna. A 100-microampere meter was chosen in order to give high sensitivity, and a shunt is available to multiply the range of the meter by three. This shunt is also provided with a switch so that low or high readings can be taken without making a trip to the pick-up unit.

The crystal is the 1N21 type, commonly used as a mixer in microwave radar equipments and now available in large quantities at low cost on the surplus market. Germanium crystals, designed especially for such applications, may be used with good results, but the 1N21 was selected because of its lower cost. With the resistor, R_1 , in the circuit the current indication is substantially linear with variations in field strength except at very low levels; thus a good field pattern can be taken simply by recording the meter indications as the antenna is rotated. If one wishes to go further, the meter can be calibrated by connecting the input terminal to a good v.h.f. signal generator and calibrating it in terms of the generator output required to give indications at regular intervals. The front, back and side readings from a directive array may be spotted on such a calibration curve and the antenna performance determined with reasonable accuracy.

The two units are housed in standard 2 by 4 by 4-inch steel boxes with front and back removable. In the pick-up unit all parts except the resistor shorting switch and connecting plug are mounted on the top panel, permitting easy wiring of the assembly. The interconnecting plug and socket are the polarized type, with one prong on the plug

slightly larger than the other. The plug will fit a standard a.c. outlet, so the interconnecting cable (ordinary rubber-covered lamp cord) doubles as a long a.c. extension cord when not in use for its intended purpose.

The antenna connection is a steatite feed-through bushing fitted with a G.R. "banana plug" socket. A convenient pick-up antenna is made by drilling and tapping a $\frac{1}{4}$ -inch rod for $\frac{3}{32}$ thread to take the threaded end of a G.R. plug. The length of the antenna will vary the

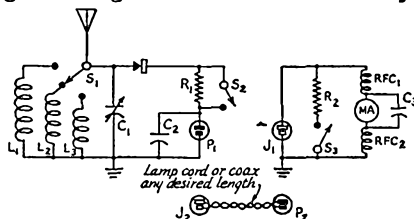

Fig. 1 — Wiring diagram of the remote-indicating field-strength meter.

C_1 — 25- μ fd. midget variable.

C_2, C_3 — 0.001- μ fd. mica.

R_1 — 1000 ohms, $\frac{1}{2}$ -watt.

R_2 — 250 ohms, $\frac{1}{2}$ -watt.

S_1 — 3-position wafer-type switch.

S_2, S_3 — S.p.s.t. snap switch.

P_1, P_2 — Polarized plug, two-pole, retainer-ring type (Amphenol 61-MP).

J_1, J_2 — Universal receptacle, two-pole, retainer-ring type (Amphenol 61-F).

L_1 — 28-Mc. coil — 7 turns No. 22 enamel, $\frac{1}{4}$ -inch long, on $\frac{3}{4}$ -inch dia. form. (National PRF-1)

L_2 — 50-Mc. coil — 6 turns No. 22 enamel, $\frac{3}{4}$ -inch long, on $9/16$ -inch dia. form (National PRE-1).

L_3 — 144-Mc. coil — 3 turns No. 18 enamel, $\frac{1}{4}$ -inch long, $\frac{3}{8}$ -inch dia., self supporting.

RFC_1, RFC_2 — 2.5 mh. choke (National R-100).

sensitivity of the unit. If measurements are to be made with high power levels, a rod a few inches in length will suffice. For maximum pick-up on 50 or 144 Mc. a resonant rod may be used, though this would be a bit cumbersome for 28

(Continued on page 124)

◆ Interior views of the two parts of the field-strength meter.

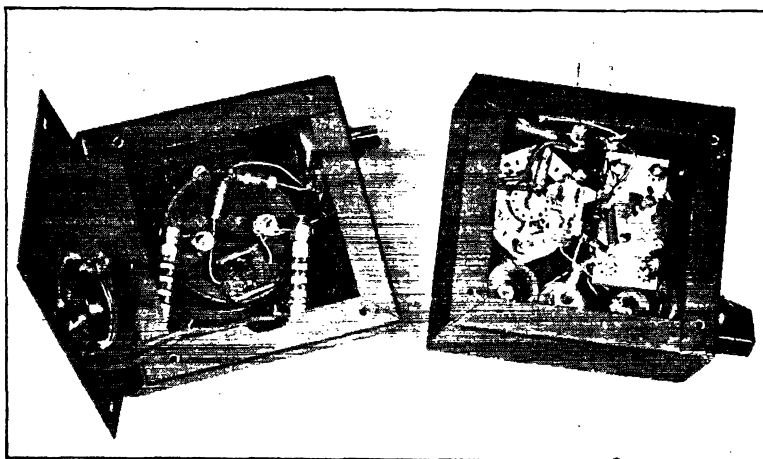

We Have New Regulations

FCC Polishes and Clarifies Our Rules New 'Phone-Operating Procedure Specified

EFFECTIVE on April 1st, FCC on March 27th adopted a complete new text for Part 12 of its rules and regulations, "Rules Governing Amateur Radio Service." This is a job that has been in process since midwinter and which we have told you was in prospect.

There are many little changes with which you must become familiar and a few important ones which we shall point out in this article. The whole text has been gone over so thoroughly in the process of clarifying meaning that, even where there is no change in the import, the language is entirely different. It is therefore the duty of every amateur to read the entire text carefully and get firmly in mind the extent of the privileges and the limitations of amateur radio. We are constantly surprised at the number of amateurs who do not know that a certain thing can be done or who think that something can be done that is not authorized. It has probably been a long time since you read through the full text of our rules, so here is the ideal time to acquire that detailed familiarity which is essential to strict compliance and the avoidance of "tickets."

The more important changes are now discussed below. While some of them are more restrictive than prewar practices, many of them constitute a liberalization of our rules.

Licensing Matters

With licenses now issued for a term of five years, it is specified that renewal applications must be filed not more than 120 days before expiration nor later than the expiration date. The proof of use of a station license, by citing three contacts, previously necessary as a condition for renewal, is abandoned; but this ability to cite three contacts is still required for the renewal of an operator license and it is specified that they must occur in the last six months of the five-year term. Moreover — and here is a quite important change — *these contacts must be by means of radio-telegraphy* and must be with other FCC-licensed amateur stations. It is felt in Government circles that it is necessary for amateurs to retain some practical working proficiency with the code, and this requirement sets, as a minimum standard, the requirement to demonstrate this ability every five years — failing which the applicant will not get a renewal but must requalify by reexamination.*

* ARRL is advised by FCC that this requirement is not immediately applicable, since all proof-of-use of operator licenses is currently suspended by Order 77-E and will probably continue suspended for at least the remainder of this year. C.w. contacts therefore will not be required in the first postwar renewals of old licenses.

The amateur examination remains the same but it is now provided that an applicant who fails the test may take another examination after 30 days, instead of waiting the 90 days previously required. There is a much clearer definition of the code test: it must be copied free of error for a continuous period of at least one minute during a test period of five minutes. There is a sharp reduction in the credit allowed for the holding of commercial licenses. While commercial radiotelegraph licenses still count for the code test, no credit is allowed any commercial license for the theory part of any amateur examination. The technical practices of amateur and commercial stations are so different that FCC believes that even an experienced commercial operator must demonstrate knowledge of amateur techniques. As a further development of this reasoning, the only credit allowed for the advanced — 'phone examination for a Class A license is the previous possession of such a Class A ticket, and that must have been within the preceding two years. Now that license terms are to be five years, if this figure still read the preceding five years it would imply (in the course of a few years) a theory examination taken as long as ten years previously — which is too long a gap to assure current knowledge.

'Phone Matters

There is considerable confusion in identifying the calls of 'phone stations when the operating procedure of some fellows is to say "A from B" and others say "B to A." FCC now regularizes this matter by requiring that *'phone stations state the calls in the same order as is done in telegraphy*: first the call of the station called, then the words "this is" or the word "from" instead of the letters "de," and then the call of the calling station. An example of correct procedure is shown in the regulations and it is to be noted that the voice transmission ends with the word "over."

Whereas c.w. stations operating portable or mobile, or in portable status pending modification, indicate their location only by a diagonal mark and the number of the call area in which they are temporarily operating, 'phone stations are to make a concise "announcement" of their geographical location. See the example in Sec. 12.82.

Much confusion in identification has been caused under bad-reception conditions by the use of geographical place names in the phonetic identification of the letters in calls. We have all experienced this and got excited over the possibility that a guy was in Zanzibar or Tokyo, or got

ourselves badly messed up between the Californias, Indianas and Susquehannas. (We ourselves have been tempted to kid this situation by announcing myself as "W 1 East Hartford, located in West Hartford.") The Commission takes this particular bull by the horns now and says that phonetic aids to identification may be used but that, to prevent confusion, *these shall not embrace the names of countries, states or cities.* We think all hands will agree that this is decidedly to the good. It does invalidate our present ARRL word-list but the Communications Department will be up with a new one soon.

On the liberalizing side, there is an important new gain in the abandonment of the complicated old requirement that an unlicensed person, speaking over the microphone, had to hand it over to the licensed operator at the beginning and end of each transmission to do the signing. While a licensed operator must still control the emissions and turn the carrier on and off, and sign off the station at the end of the QSO, an unlicensed person may now do all of the intermediate talking, including the stating of the calls of the two stations concerned at the beginning and end of each such intermediate transmission. And while the signatures of licensed operators manipulating the equipment must still be entered in the log, only the name of an unlicensed person speaking over the mike need be entered, not his signature.

Portable & Mobile

The clumsy term "portable-mobile station" is now abandoned throughout our rules in favor of what everybody knows is meant, "mobile station," as contrasted to a portable station.

The 28-Mc. dividing line for these matters is now specified as 25 Mc., a point where FCC draws a certain natural line in allocations. Mobile operation may occur on any *authorized* amateur frequency above 25 Mc., and thus *our new 11-meter band is opened to mobile work.* Advance notice of portable operation is required on authorized frequencies below 25 Mc., and thus no notice is required for 11-meter portable work, any more than for 10.

Answering a question that is frequently asked us, there is no prohibition against the operation of amateur mobile stations on the high seas, on authorized frequencies above 25 Mc.

Allocations

All the amateur allocations are shown in the new rules in their full widths but there is a footnote explaining that the frequencies and types of emissions which may actually be used by amateurs are only those specified in Order 130-D, and that the use of additional frequencies will be authorized from time to time by modification of that order.

There are certain details in which the new rules differ from our current authorizations in

Order 130-D, and it is expected that the latter will be altered to conform to the new rules in its next modification. For example, in the 10-meter band, amplitude-modulated 'phone (A3) is to be authorized all the way up to 29.7 Mc., instead of stopping at 29.5 as at present; and f.m. is to begin at 29 Mc. (instead of 28.95). Any type of emission, including pulse transmission, is to be authorized on frequencies above 1215 Mc., and amateurs are to possess rights on all frequencies above 30,000 Mc. However, we emphasize that these rights are not effective until Order 130-D is so amended.*

The old border-line frequency of 112 Mc. is of course now changed to 144 Mc. Below this figure, adequately-filtered d.c. power supply is required. Below this figure, unmodulated 'phone-carriers are not permitted, except in the 11-meter band. Below this figure, when employing amplitude modulation no simultaneous frequency-modulation is permitted, and vice versa.

Interference

There is an interesting specification that, in addition to all the requirements of the rules, an amateur station must be operated "in accordance with good engineering and good amateur practice." It is traditionally required of amateur stations that they must not have spurious radiations of sufficient intensity to cause interference in receiving equipment of modern design. The specification of such equipment is now made to read "of good engineering design, including adequate selectivity characteristics." Good!

Quiet hours in the past have been applicable only to the protection of standard broadcasting. With many new types of broadcasting coming up, and with increased amateur operation on v.h.f., the requirement for possible quiet hours is expanded to protect "the domestic broadcast service," so as to include television broadcasting and f.m. broadcasting. It is made clear (as was always actually the case) that quiet hours are to be observed by the amateur of his own initiative when he knows that he is causing general interference on apparatus of modern design. This apparatus is redefined now as "receivers of good engineering design including adequate selectivity characteristics." Since no ill-adjusted amateur station should be allowed to run amok and ruin any other radio service, there is a new specification in this section that deserves attention: "In general, such steps as may be necessary to minimize interference to stations operating in other services may be required after investigation by the Commission."

Now for the text itself. We again urge that every amateur forthwith study it in detail.

— K. B. W.

*The two changes in the 10-meter band were made later by Order 130-E, effective April 1.

RULES GOVERNING AMATEUR RADIO SERVICE

DEFINITIONS

§ 12.1. *Amateur Service.* The term "amateur service" means a radio service carried on by amateur stations.

§ 12.2. *Amateur operator.* The term "amateur operator" means a person interested in radio technique solely with a personal aim and without pecuniary interest, holding a valid license issued by the Federal Communications Commission authorizing him to operate licensed amateur stations.

§ 12.3. *Amateur station.* The term "amateur station" means a station used by an amateur operator, and it embraces all radio transmitting apparatus at a particular location used for amateur service and operated under a single instrument of authorization.

§ 12.4. *Amateur portable station.* The term "amateur portable station" means an amateur station that is so constructed that it may conveniently be moved about from place to place for communication, but which is not operated while in motion.

§ 12.5. *Amateur mobile station.* The term "amateur mobile station" means an amateur station that is so constructed that it may conveniently be transferred to or from a mobile unit or from one such unit to another, and is ordinarily used while such mobile unit is in motion.

§ 12.6. *Amateur radio communication.* The term "amateur radio communication" means radio communication between amateur stations solely with a personal aim and without pecuniary interest.

AMATEUR OPERATORS

LICENSES — PRIVILEGES

§ 12.21. *Eligibility for license.* The following are eligible to apply for amateur operator license and privileges:

Class A — Any citizen of the United States who within five years prior to receipt of his application by the Commission has held, for a period of a year or more, an amateur operator license issued by the Commission.

Class B — Any citizen of the United States.

Class C — Any citizen of the United States whose actual residence, address, and amateur station are more than 125 miles airline distant from the nearest location at which examinations are held at intervals of not more than three months for class B amateur operator license; or who is shown by physician's certificate to be unable to appear for examination because of protracted disability; or who is shown by certificate of the commanding officer to be in the armed forces of the United States at a military, naval or Coast Guard station and, for that reason, to be unable to appear for examination at the time and place designated by the Commission.

§ 12.22. *Application for amateur operator license.* Each application for amateur operator license shall comply with the Commission's Rules and Regulations and shall be made in writing on Form 610 (application for amateur operator and/or station license). The application shall be filed with the district field office of the Commission if personal appearance is required for operator examination. If personal appearance is not required, the application shall be sent instead to the Commission, Washington 25, D. C. All applications for class C operating privileges shall be sent to the Commission, Washington 25, D. C.

§ 12.23. *Classification of operating privileges.* Amateur operating privileges are classified as follows:

Class A — All authorized amateur privileges.

Class B or C — All authorized amateur privileges except the use of type A-3 emission on the frequency bands 3900 to 4000 kc. and 14,150 to 14,250 kc.

§ 12.24. *Scope of operator authority.* Amateur operator licenses are valid only for the operation of licensed amateur stations; and, on a temporary basis, for the operation of experimental stations (except class 2 stations) in the experimental service licensed for operation exclusively on a frequency or frequencies above 450 Mc. if such services are performed without compensation, direct or indirect, paid or promised.

§ 12.25. *Availability of operator license.* The original operator license of each operator shall be kept in the personal possession of the operator while operating an amateur station. When operating an amateur station at a fixed location, however, the license may be posted in a conspicuous place in the room occupied by the operator. The license shall be available for inspection by any authorized government official whenever the operator is operating an amateur station and at other times upon request made by an authorized representative of the Commission, except when such license

has been filed with application for modification or renewal thereof, or has been mutilated, lost, or destroyed, and application has been made for a duplicate license in accordance with section 12.26. No recognition shall be accorded to any photo-copy of an operator license.

§ 12.26. *Duplicate license.* Any licensee applying for a duplicate license to replace an original which has been lost, mutilated, or destroyed, shall submit with the application the mutilated license or a statement setting forth the facts regarding the manner in which the original license was lost or destroyed. If, subsequent to receipt by the licensee of the duplicate license, the original license is found, either the duplicate or the original license shall be returned immediately to the Commission.

§ 12.27. *Renewal of amateur operator license.* An amateur operator license may be renewed upon proper application showing that within the last six months of the license term the licensee has lawfully operated an amateur station or stations licensed by the Commission, and has thereby communicated by radio telegraphy with at least three other such amateur stations in the United States. The applicant shall qualify for a new license by examination if the requirements of this section are not fulfilled. Application for renewal of an amateur operator license shall be filed not more than 120 days prior to date of expiration of such license and not later than the date of expiration.

§ 12.28. *Who may operate an amateur station.* An amateur station may be operated only by a person holding a valid amateur operator license, and then only to the extent provided for by the class of privileges granted under the license. When an amateur station is used for telephony, the station licensee may permit any person to transmit by voice, provided that during such transmission call signals are announced as prescribed by section 12.82 and a duly licensed amateur operator maintains actual control over the emissions, including turning the carrier on and off for each transmission and signing the station off after communication with each station has been completed.

§ 12.29. *License term.* An amateur operator license is valid normally for a period of 5 years from the date of issuance of a new, renewed, or modified license.

§ 12.30. *Order of suspension.* No order of suspension of any operator's license shall take effect until 15 days' notice in writing thereof, stating the cause for the proposed suspension, has been given to the operator licensee who may make written application to the Commission at any time within said 15 days for a hearing upon such order. The notice to the operator licensee shall not be effective until actually received by him, and from that time he shall have 15 days in which to mail the said application. In the event that physical conditions prevent mailing of the application at the expiration of the 15-day period, the application shall then be mailed as soon as possible thereafter, accompanied by a satisfactory explanation of the delay. Upon receipt by the Commission of such application for hearing, said order of suspension shall be held in abeyance until the conclusion of the hearing which shall be conducted under such rules as the Commission shall deem appropriate. Upon the conclusion of said hearing the Commission may affirm, modify, or revoke said order of suspension.

§ 12.31. *Proceedings.* Proceedings for the suspension of an operator's license shall in all cases be initiated by the entry of an order of suspension. Respondent will be given notice thereof together with notice of his right to be heard and to contest the proceeding. The effective date of the suspension will not be specified in the original order but will be fixed by subsequent motion of the Commission in accordance with the conditions specified above. Notice of the effective date of suspension will be given respondent, who shall send his operator license to the office of the Commission in Washington, D. C., on or before the said effective date, or, if the effective date has passed at the time notice is received, the license shall be sent to the Commission forthwith.

EXAMINATIONS

§ 12.41. *When examination is required.* Examination is required for the issuance of a new amateur operator license, and for a change in class of operating privileges. Credit may be given, however, for certain elements of examination as provided in section 12.46.

§ 12.42. *Elements of examination.* The examination for amateur operator privileges comprises the following:

Element 1. Code test. Ability to send and receive, in plain language, messages in the International Morse Code at a speed of not less than 13 words per minute, free of omission or other error for a continuous period of at least 1 minute, during a test period of 5 minutes, counting 5 characters to the word, each numeral or punctuation mark counting as 2 characters.

Element 2. Amateur radio operation and apparatus, including telephone and telegraph.

Element 3. Provisions of treaties, statutes, and regulations affecting amateurs.

Element 4. Advanced amateur telephony.

§ 12.43. *Elements required for various privileges.* The examination for class A privileges will include all of the examination elements specified in section 12.42.

The examination for class B and class C privileges will include elements 1, 2, and 3 specified in section 12.42.

§ 12.44. *Manner of conducting examination.* The examinations for class A and class B privileges will be conducted by an authorized Commission employee or representative at locations and at times specified by the Commission.

Each examination for class C privileges will be conducted and supervised by not more than two volunteer examiners, whom the Commission may designate or permit the applicant to select; in the event the examiner for the code test is selected by the applicant, such examiner shall be the holder of an amateur operator license with class A or B operating privileges, or shall have held, within the 5 years prior to the date of the examination, a commercial radiotelegraph operator license issued by the Commission or within that time shall have been employed in the service of the United States as the operator of a manually operated radiotelegraph station. The examiner for the written test shall be at least twenty-one years of age.

§ 12.45. *Additional examination for holders of class C operating privileges.* The Commission may require a licensee holding class C operating privileges to appear for a class B examination at a location designated by the Commission. If the licensee fails to appear for the class B examination when directed to do so, or fails to pass such examination, the class C operator license previously issued shall be subject to cancellation and, upon cancellation, a new license will not be issued for the class C privileges.

Whenever the holder of class C amateur operating privileges changes his actual residence or station location to a location where he would not have been eligible to apply for class C privileges in the first instance, or whenever a new examining location is established in an area within which the holder of class C amateur operating privileges would not have been eligible, because of such examining location, to apply for class C privileges, such holder of class C privileges shall appear within 4 months thereafter at an examining location and time designated by the Commission and be examined for class B privileges. If, under such circumstances, the licensee fails to appear for the class B examination, or fails to pass such examination, the class C operator license previously issued shall be subject to cancellation and, upon cancellation, a new license will not be issued for the class C privileges.

§ 12.46. *Examination credit.* An applicant for class A privileges who holds an amateur operator license authorizing class B privileges will be required to pass only the examination element No. 4, advanced amateur telephony.

An applicant for class A privileges will be given credit for examination element 4 if within two years prior to the receipt of his application by the Commission he held class A privileges.

An applicant for any class of amateur privileges will be given credit for examination element one if within five years prior to the receipt of his application by the Commission he held a radiotelegraph first or second class operator license.

No examination credit for other classes of licenses or privileges shall be allowed.

A holder of an amateur operator license authorizing class C privileges will not thereby be accorded an abridged examination for either class B or class A privileges.

§ 12.47. *Examination procedure.* When taking an examination for amateur operator license, or for additional amateur operating privileges, the applicant shall write in longhand, by means of pen and ink. Diagrams shall be drawn either with pen and ink or with pencil; likewise, code tests shall be written with either pen and ink or with pencil. Applicants unable to comply with these requirements, because of physical disability, may dictate their answers to examination questions, and if unable to draw required diagrams, may dictate a detailed description essentially equivalent. If the examination or any part thereof is dictated, the examiner shall certify the nature of the applicant's disability and the name and address of the person(s) taking and transcribing the applicant's dictation.

§ 12.48. *Grading.* Code tests are graded as "passed" or "failed," separately for sending and receiving tests. Failure to pass the required code test for either sending or receiving will terminate the examination.

Seventy-four per cent is the passing grade for written examinations. For the purpose of grading, elements 2 and 3

(required for class B and class C privileges) are considered to be a single examination and element 4 (required, in addition to the other elements, for class A privileges) is considered to be a separate examination.

§ 12.49. *Eligibility for reexamination.* An applicant who fails examination for amateur operator privileges may not take another examination for such privileges within 30 days, except that this limitation shall not apply to an examination for class B operating privileges following an examination for class C privileges.

AMATEUR RADIO STATIONS

LICENSES

§ 12.61. *Eligibility for amateur station license.* A license for an amateur station will be issued in response to proper application therefor to a licensed amateur operator who has made a satisfactory showing of control of the transmitting station for which license is desired and of control of the specific premises upon which all of the station apparatus is to be located, at a designated fixed location. An amateur station license may be issued to an individual, not a licensed amateur operator (other than an alien or a representative of an alien or of a foreign government), who is in charge of a proposed amateur station located in approved public quarters and established for training purposes in connection with the armed forces of the United States, but not operated by the United States Government.

§ 12.62. *Eligibility of corporations or organizations to hold license.* An amateur station license will not be issued to a school, company, corporation, association, or other organization, nor for their use except that in the case of a bona fide amateur radio organization or society a station license may be issued to a licensed amateur operator as trustee for such society.

§ 12.63. *Application for amateur station license.* (a) Each application for an amateur station license shall comply with the Commission's Rules and Regulations and shall be made in writing, subscribed and verified on Form 610 (application for amateur operator and/or station license), Form 602 should be used where the applicant is in charge of a proposed amateur station located in approved public quarters and established for training purposes in connection with the armed forces of the United States, but not operated by the United States Government.

(b) One application and all papers incorporated therein and made a part thereof shall be submitted for each amateur station license and shall be filed with the district field office of the Commission if personal appearance is required for operator examination in connection with the application for station license. If personal appearance is not required, the station application shall be sent to the Commission, Washington 25, D. C.

§ 12.64. *Location of station.* Only one fixed location will be authorized and designated in the license for each amateur station. Unless remote control of the transmitting apparatus is authorized, such apparatus shall be operated by a duly licensed amateur operator present at the location of such apparatus.

The granting of authority to operate by remote control is contingent upon the filing of a proper application, supported by (1) a showing of the applicant's control of the control point, (2) a description of the means which will be employed to control emission, (3) a description of the equipment and method for monitoring the emissions and (4) a statement of the precautions which will be taken to prevent access by unauthorized persons to the premises on which the controlled transmitting apparatus is located.

§ 12.65. *License period.* The license for an amateur station is valid normally for a period of 5 years from the date of issuance of a new, renewed, or modified license.

§ 12.66. *Authorized apparatus.* An amateur station license authorizes the use under control of the licensee of all transmitting apparatus at the fixed location specified in the station license which is operated on any frequency or frequencies allocated to the amateur service, and in addition authorizes the use, under control of the licensee, of portable and mobile transmitting apparatus operated at other locations.

§ 12.67. *Renewal of amateur station license.* An amateur station license may be renewed upon proper application filed not more than 120 days prior to date of expiration of such license and not later than the date of expiration.

§ 12.68. *Availability of station license.* The original license of each amateur station or a photo-copy thereof shall be posted in a conspicuous place in the room occupied by the licensed operator while the station is being operated at a fixed location or shall be kept in his personal possession. When the station is operated at other than a fixed location,

the original station license or a photo-copy thereof shall be kept in the personal possession of the station licensee (or a licensed representative) who shall be present at the station while it is being operated as a portable or mobile station. The original station license shall be available for inspection by any authorized government official at all times while the station is being operated and at other times upon request made by an authorized representative of the Commission, except when such license has been filed with application for modification or renewal thereof, or has been mutilated, lost, or destroyed, and application has been made for a duplicate license in accordance with section 12.26.

§ 12.69. *Revocation of station license.* Whenever the Commission shall institute a revocation proceeding against the holder of any radio station license under section 312 (a), it shall initiate said proceeding by serving upon said licensee an order of revocation effective not less than 15 days after written notice thereof is given the licensee. The order of revocation shall contain a statement of the grounds and reasons for such proposed revocation and a notice of the licensee's right to be heard by filing with the Commission a written request for hearing within 15 days after receipt of said order. Upon filing of such written request for hearing by said licensee the order of revocation shall stand suspended and the Commission will set a time and place for hearing and shall give the licensee and other interested parties notice thereof. If no request for hearing on any order of revocation is made by the licensee against whom such an order is directed within the time hereinabove set forth, the order of revocation shall become final and effective, without further action of the Commission. When any order of revocation has become final, the person whose license has been revoked shall forthwith deliver the station license in question to the inspector in charge of the district in which the licensee resides.

§ 12.70. *Modification of station license.* (a) Order to show cause. Whenever the Commission shall determine that public interest, convenience, and necessity would be served, or any treaty ratified by the United States will be more fully complied with, by the modification of any radio station license either for a limited time, or for the duration of the term thereof, it shall issue an order for such licensee to show cause why such license should not be modified.

(b) Contents of order to show cause.—Such order to show cause shall contain a statement of the grounds and reasons for such proposed modification, and shall specify wherein the said license is required to be modified. It shall require the licensee against whom it is directed, to be and appear at a place and time therein named, in no event to be less than 30 days from the date of receipt of the order to show cause why the proposed modification should not be made and the order of modification issued.

(c) Failure to appear.—If the licensee against whom the order to show cause is directed does not appear at the time and place provided in said order, a final order of modification shall issue forthwith.

CALL SIGNALS

§ 12.81. *Assignment of call signal.* (a) The calls of amateur stations will be assigned systematically by the Commission with the following exceptions:

(1) A specific unassigned call may be reassigned to the most recent holder thereof;

(2) A specific unassigned call may be assigned to a previous holder if not under license during the past five years;

(3) A specific unassigned call may be assigned to an amateur organization in memorandum to a deceased member and former holder thereof;

(4) A specific call may be temporarily assigned to a station connected with an event, or events, of general public interest.

(b) An amateur call will consist of a sequence of 1 or 2 letters, a numeral designating the call area, and 2 or 3 letters. The call areas are as follows:

- 1 — Maine, New Hampshire, Vermont, Massachusetts, Rhode Island, Connecticut.
- 2 — New York, New Jersey.
- 3 — Pennsylvania, Delaware, Maryland, District of Columbia.
- 4 — Virginia, North and South Carolina, Georgia, Florida, Alabama, Tennessee, Kentucky, Puerto Rico and Virgin Islands.
- 5 — Mississippi, Louisiana, Arkansas, Oklahoma, Texas, New Mexico.
- 6 — California, Hawaii and Pacific possessions except those included in area 7.
- 7 — Oregon, Washington, Idaho, Montana, Wyoming, Arizona, Nevada, Utah, Alaska and adjacent islands.
- 8 — Michigan, Ohio, West Virginia.

9 — Wisconsin, Illinois, Indiana.

0 — Colorado, Nebraska, North and South Dakota, Kansas, Minnesota, Iowa, Missouri.

§ 12.82. *Transmissions of call signals.* (a) An operator of an amateur station shall transmit the call of the station called or being worked and the call assigned the station which he is operating at the beginning and end of each transmission and at least once every 10 minutes during every transmission of more than 10 minutes' duration. In the case of stations conducting an exchange of several transmissions in sequence, with each transmission less than 3 minutes' duration, the call of the communicating stations need be transmitted only once every 10 minutes of operation as well as at the beginning and at the termination of the correspondence.

(b) In addition to complying with the requirements of paragraph (a) above, an operator of an amateur station operated as a portable or mobile station using radiotelegraphy shall transmit immediately after the call of such station, the fraction-bar character (DN) followed by the number of the amateur call area in which the portable or mobile amateur station is then being operated, as for example:

Example 1. — Portable or mobile amateur station operating in the third amateur call area calls a fixed amateur station: W1ABC W1ABC W1ABC DE W2DEF DN 3 W2DEF DN 3 W2DEF DN 3 AR.

Example 2. — Fixed amateur station answers the portable or mobile amateur station: W2DEF W2DEF W2DEF DE W1ABC K.

Example 3. — Portable or mobile amateur station calls a portable or mobile amateur station: W3GHI W3GHI W3GHI DE W4JKL DN 4 W4JKL DN 4 W4JKL DN 4 AR.

When telephony is used, the call of the station shall be preceded by the words "this is" or the word "from" instead of the letters "de," followed by an announcement of the geographical location in which the portable or mobile station is being operated.

Example 4. — Portable or mobile amateur radiotelephone station operating in the third call area calls a fixed amateur station: W1ABC W1ABC W1ABC "this is" or the word "from" W2DEF W2DEF W2DEF operating portable (or mobile) three miles north of Bethesda, Maryland, over.

(c) When telephony is used, the transmission of call prescribed by subsections (a) and (b) of this section may be made by the person transmitting by voice in lieu of a duly licensed operator provided the licensed operator maintains the control required by section 12.28.

(d) When using telephony phonetic aids to identify the call of the station may be employed. To avoid confusion, however, the names of countries, states, or cities shall not be used for this purpose.

PORTABLE AND MOBILE STATIONS

§ 12.91. *Requirements for portables and mobile operation.* An amateur station may be operated as a portable station on any authorized amateur frequency and as a mobile station on any authorized amateur frequency above 25 Mc.

§ 12.92. *Special provisions for portable stations.* Prior to operating an amateur station as a portable station, the licensee shall give written notice to the inspector in charge of the district in which the portable operation is intended. This notice shall state the station call, the name of the licensee, the date or dates of proposed operation, and the contemplated portable station location as specifically as possible. An amateur station operated under the provisions of this section shall not be operated during any period exceeding 1 month without giving additional notice to the inspector in charge of the radio inspection district in which the station is intended to be further operated, nor for more than 4 consecutive periods of 1 month each at the same location. This section does not apply to operation on frequencies above 25 Mc.

§ 12.93. *Special provisions for non-portable stations.* The specific provisions of these rules relative to portable stations are not applicable to a non-portable station except that —

(a) An amateur station that has been moved from one permanent location to another permanent location may be operated at the latter location, in accordance with the provisions governing portable stations (including notice to the inspector in charge of the district in which the station is located) for a period not exceeding 4 consecutive months, but in no event beyond the expiration date of the license, provided a formal application for modification of license to change the permanent location has been filed with the Commission.

(b) The licensee of an amateur station who changes residence temporarily and moves his amateur station to a tem-

porary location associated with his temporary residence, or the licensee-trustee for an amateur radio society which changes the normal location of its amateur station to a different and temporary location may use the station at the temporary location if the station is to remain there for a period of not more than 4 months and the following requirements are met:

(1) Advance notice in writing shall be given by the amateur station licensee or licensee-trustee to the Commission in Washington, D. C., and to the inspector in charge of the district in which the station is to be temporarily operated.

(2) Similar notice shall be given for each change in station location and for transfer of the station to the former permanent location, or to a new permanent location, before the transmitting apparatus is operated.

(c) When the station is operated under the provisions of this section the calling procedure specified in section 12.82 shall be used, including transmissions of the fractional bar character when telegraphy is used followed by the number of the amateur call area in which the station is being operated. When telephony is used, an announcement shall be made of the geographical location in which the station is being operated.

USE OF AMATEUR STATIONS

§ 12.101. *Points of communications.* An amateur station may be used to communicate only with other amateur stations, except that in emergencies or for test purposes it may also be used temporarily for communication with other classes of stations licensed by the Commission, and with United States Government stations. Amateur stations may also be used to communicate with any radio station other than amateur which is authorized by the Commission to communicate with amateur stations. Amateur stations may be used also for transmitting signals, or communications, or energy, to receiving apparatus for the measurement of emissions, temporary observation of transmission phenomena, radio control of remote objects, and for similar experimental purposes.

§ 12.102. *No remuneration for use of station.* An amateur station shall not be used to transmit or receive messages for hire, nor for communication for material compensation, direct, or indirect, paid or promised.

§ 12.103. *Broadcasting prohibited.* An amateur station shall not be used for broadcasting any form of entertainment, nor for the simultaneous retransmission by automatic means of programs or signals emanating from any class of station other than amateur.

§ 12.104. *Radiotelephone tests.* The transmission of music by an amateur station is forbidden. However, single audio-frequency tones may be transmitted for test purposes of short duration for the development and perfection of amateur radiotelephone equipment.

ALLOCATION OF FREQUENCIES *

§ 12.111. *Frequencies for use of amateur stations.* (a) The following bands of frequencies are allocated for use by amateur stations:

(1) Below 25 Mc.	(2) Above 25 Mc.
1,750 to 2,050 kc.	28 to 29.7 Mc.
3,500 to 4,000 kc.	50 to 54 Mc.
7,000 to 7,300 kc.	144 to 148 Mc.
14,000 to 14,400 kc.	1,215 to 1,295 Mc.
	2,300 to 2,450 Mc.
	5,250 to 5,650 Mc.
	10,000 to 10,500 Mc.
	21,000 to 22,000 Mc.

(b) The band of frequencies 420 to 450 Mc. is allocated for use by amateur stations (and temporarily by other services for special air navigational aids) subject to the limitation of 50 watts peak antenna power.

(c) The band of frequencies 235 to 240 Mc. is allocated for use by amateur stations until January 1, 1949; the frequency band 220 to 225 Mc. is allocated for use by amateur stations beginning January 1, 1949.

* The frequencies specified in these rules may not be used by amateurs except pursuant to and subject to the limitations and restrictions prescribed by Commission Orders. The frequencies and types of emission which may be used by amateurs as of April 1, 1946, 3:00 A.M., Eastern Standard Time, are prescribed in Commission Order No. 130-D. The use of additional frequencies will be authorized from time to time by modification of Order No. 130-D. The assignment and use of all frequencies below 25 Mc. contained in these regulations are subject to change in accordance with the Commission's final report of allocations below 25 Mc., in Docket Proceedings No. 6651.

(d) Amateur stations may be operated with types A-0, A-1, A-2, A-3, A-4 and special emission for frequency modulation on the frequency band 27,185-27,455 Mc. (allocated for operation of scientific, industrial and medical apparatus).

§ 12.112. *Use of frequencies above 30,000 Mc.* Licensed amateur stations may be operated, subject to further order of the Commission, with any type of emission authorized for amateur stations, on any frequency or frequencies above 30,000 Mc.

§ 12.113. *Individual frequency not specified.* Transmissions by an amateur station may be on any frequency within any authorized amateur band. Sideband frequencies resulting from keying or modulating a carrier wave shall be confined within the authorized amateur band.

§ 12.114. *Types of emission.* All bands of frequencies allocated to the amateur service may be used for the transmission of type A-1 emission, and for type A-0 emission for short periods of time when required for authorized remote control purposes or for experimental purposes.

§ 12.115. *Frequency bands for additional types of emission using amplitude modulation.* The following additional types of emissions using amplitude modulation may be used on the following bands of frequencies:

28.1 to 50 Mc.	29.7 Mc.	— A-3 — —
50 to 144 Mc.	54 Mc.	A-2, A-3, A-4 —
144 to 235 Mc.	148 Mc.	A-2, A-3, A-4 —
235 to 420 Mc.	240 Mc.	A-2, A-3, A-4 —
420 to 1,215 Mc.	450 Mc.	A-2, A-3, A-4, A-5
1,215 to 2,300 Mc.	1,295 Mc.	A-2, A-3, A-4, A-5
2,300 to 5,250 Mc.	2,450 Mc.	A-2, A-3, A-4, A-5
5,250 to 10,000 Mc.	5,650 Mc.	A-2, A-3, A-4, A-5
10,000 to 21,000 Mc.	10,500 Mc.	A-2, A-3, A-4, A-5
	22,000 Mc.	A-2, A-3, A-4, A-5

Any type of emission may be used by amateur stations on amateur frequency bands above 1215 Mc.

§ 12.116. *Additional bands for radiotelephony.* Amateur stations may be used for radiotelephony with amplitude modulation (type A-3 emission) in the frequency bands 3900 to 4000 kc. and 14,150 to 14,250 kc., provided the station is licensed to a person who holds an amateur operator license endorsed for class A operating privileges, and actual operation and control of the station is maintained by an operator holding class A privileges.

§ 12.117. *Frequency modulation.* The following bands of frequencies may be used by amateur stations for frequency-modulated radiotelephone transmissions and for radiotelegraph transmissions employing carrier shift or other frequency modulation techniques:

29 to 52.5 Mc.	29.7 Mc.	1,215 to 2,300 Mc.
52.5 to 144 Mc.	54 Mc.	2,300 to 5,250 Mc.
144 to 235 Mc.	148 Mc.	5,250 to 10,000 Mc.
235 to 420 Mc.	240 Mc.	10,000 to 21,000 Mc.
	450 Mc.	21,000 to 22,000 Mc.

EQUIPMENT AND OPERATION

§ 12.131. *Maximum authorized power.* Except on frequencies within the band 420-450 Mc. (where peak antenna power shall not exceed 50 watts), each amateur transmitter may be operated with a power input not exceeding 1 kilowatt to the plate circuit of the final amplifier stage of an amplifier-oscillator transmitter or to the plate circuit of an oscillator transmitter. An amateur transmitter operating with a power input exceeding 900 watts to the plate circuit shall provide means for accurately measuring the plate power input to the vacuum tube or tubes supplying power to the antenna.

§ 12.132. *Power supply to transmitter.* The licensee of an amateur station using frequencies below 144 Mc. shall use adequately filtered direct-current plate power supply for the transmitting equipment to minimize modulation from this source.

§ 12.133. *Purity and stability of emissions.* Spurious radiation from an amateur station being operated with a carrier frequency below 144 Mc. shall be reduced or eliminated in accordance with good engineering practice. This spurious radiation shall not be of sufficient intensity to cause interference in receiving equipment of good engineering design including adequate selectivity characteristics, which is tuned to a frequency or frequencies outside the frequency band of emission normally required for the type of emission being employed by the amateur station. In the case of A-3 emission, the amateur transmitter shall not be modulated to the extent that interfering spurious radiation occurs, and in no case shall the emitted carrier wave be amplitude-modulated in excess of 100 per cent. Means shall be employed to insure that the transmitter is not modulated in excess of its modulation capability for proper technical operation. For the purposes of this section a spurious radiation is any radiation

from a transmitter which is outside the frequency band of emission normal for the type of transmission employed, including any component whose frequency is an integral multiple or submultiple of the carrier frequency (harmonics and subharmonics), spurious modulation products, key clicks and other transient effects, and parasitic oscillations. When using amplitude modulation on frequencies below 144 Mc. simultaneous frequency modulation is not permitted and when using frequency modulation on frequencies below 144 Mc. simultaneous amplitude modulation is not permitted. The frequency of the emitted carrier wave shall be as constant as the state of the art permits.

§ 12.134. *Modulation of carrier wave.* Except for brief tests or adjustments, and except for operation in the band 27.185 to 27.455 Mc., an amateur radiotelephone station shall not emit a carrier wave on frequencies below 144 Mc. unless modulated for the purpose of communication.

§ 12.135. *Frequency measurement and regular check.* The licensee of an amateur station shall provide for measurement of the emitted carrier frequency or frequencies and shall establish procedure for making such measurement regularly. The measurement of the emitted carrier frequency or frequencies shall be made by means independent of the means used to control the radio frequency or frequencies generated by the transmitting apparatus and shall be of sufficient accuracy to assure operation within the amateur frequency band used.

§ 12.136. *Logs.* Each licensee of an amateur station shall keep an accurate log of station operation, including the following:

(a) The date and time of each transmission. (The date need only be entered once for each day's operation. The expression "time of each transmission" means the time of making a call and need not be repeated during the sequence of communication which immediately follows; however, an entry shall be made in the log when signing off so as to show the period during which communication was carried on.)

(b) The signature of each licensed operator who manipulates the key of a radiotelegraph transmitter or the signature of each licensed operator who operates a transmitter of any other type and the name of any person not holding an amateur operator license who transmits by voice over a radiotelephone transmitter. The signature of the operator need only be entered once in the log, in those cases when all transmission are made by or under the supervision of the signatory operator, provided a statement to that effect also is entered. The signature of any other operator who operated the station shall be entered in the proper space for that operator's transmission.

(c) Call of the station called. (This entry need not be repeated for calls made to the same station during any sequence of communication, provided the time of signing off is given.)

(d) The input power to the oscillator, or to the final amplifier stage where an oscillator-amplifier transmitter is employed. (This need be entered only once, provided the input power is not changed.)

(e) The frequency band used. (This information need be entered only once in the log for all transmission until there is a change in frequency to another amateur band.)

(f) The type of emission used. (This need be entered only once until there is a change in the type of emission.)

(g) The location of the station (or the approximate geographical location of a mobile station) at the time of each transmission. (This need be entered only once provided the location of the station is not changed. However, suitable entry shall be made in the log upon changing the location. Where operating at other than a fixed location, the type and identity of the vehicle or other mobile unit in which the station is operated shall be shown.)

(h) The message traffic handled. (If record communications are handled in regular message form, a copy of each message sent and received shall be entered in the log or retained on file at the station for at least 1 year.)

§ 12.137. *Retention of logs.* The log shall be preserved for a period of at least 1 year following the last date of entry. The copies of record communications and station log required by section 12.136 shall be available for inspection by authorized representatives of the Commission.

SPECIAL CONDITIONS

§ 12.151. *Additional conditions to be observed by licensees.* In all respects not specifically covered by these regulations each amateur station shall be operated in accordance with good engineering and good amateur practice.

§ 12.152. *Restricted operation.* (a) If the operation of an amateur station causes general interference to the reception of transmissions from stations operating in the domestic broadcast service when receivers of good engineering design including adequate selectivity characteristics are used to receive such transmissions and this fact is made known to the

amateur station licensee, the amateur station shall not be operated during the hours from 8 o'clock p.m. to 10:30 p.m., local time, and on Sunday for the additional period from 10:30 a.m. until 1 p.m., local time, upon the frequency or frequencies used when the interference is created. (b) In general, such steps as may be necessary to minimize interference to stations operating in other services may be required after investigation by the Commission.

§ 12.153. *Second notice of same violation.* In every case where an amateur station licensee is cited within a period of twelve consecutive months for the second violation of the provisions of sections 12.111, 12.113, 12.115, 12.116, 12.117, 12.132, or 12.133, the station licensee, if directed to do so by the Commission, shall not operate the station and shall not permit it to be operated from 6 p.m. to 10:30 p.m., local time, until written notice has been received authorizing the resumption of full-time operation. This notice will not be issued until the licensee has reported on the results of tests which he has conducted with at least two other amateur stations at hours other than 6 p.m. to 10:30 p.m., local time. Such tests are to be made for the specific purposes of aiding the licensee in determining whether the emissions of the station are in accordance with the Commission's rules. The licensee shall report to the Commission the observations made by the cooperating amateur licensees in relation to the reported violations. This report shall include a statement as to the corrective measures taken to insure compliance with the rules.

§ 12.154. *Third notice of same violation.* In every case where an amateur station licensee is cited within a period of twelve consecutive months for the third violation of sections 12.111, 12.113, 12.115, 12.116, 12.117, 12.132 or 12.133, the station licensee, if directed by the Commission, shall not operate the station and shall not permit it to be operated from 8 a.m. to 12 midnight, local time, except for the purposes of transmitting a prearranged test to be observed by a monitoring station of the Commission to be designated in each particular case. The station shall not be permitted to resume operation during these hours until the licensee is authorized by the Commission, following the test, to resume full-time operation. The results of the test and the licensee's record shall be considered in determining the advisability of suspending the operator license or revoking the station license, or both.

§ 12.155. *Answers to notices of violations.* Under title III of the act. — Any licensee receiving official notice of a violation of the terms of the Communications Act of 1934, any legislative act, Executive order, treaty to which the United States is a party, or the Rules and Regulations of the Federal Communications Commission, shall, within 3 days from such receipt, send a written answer direct to the Federal Communications Commission at Washington, D. C., and a copy thereof to the office of the Commission originating the official notice when the originating office is other than the office of the Commission in Washington, D. C.: Provided, however, that if an answer cannot be sent nor an acknowledgment made within such 3-day period by reason of illness or other unavoidable circumstances, acknowledgment and answer shall be made at the earliest practicable date with a satisfactory explanation of the delay. The answer to each notice shall be complete in itself and shall not be abbreviated by reference to other communications or answers to other notices. If the notice relates to some violation that may be due to the physical or electrical characteristics of transmitting apparatus, the answer shall state fully what steps, if any, are taken to prevent future violations, and if any new apparatus is to be installed, the date such apparatus was ordered, the name of the manufacturer, and promised date of delivery. If the notice of violation relates to some lack of attention or improper operation of the transmitter, the name of the operator in charge shall be given.

§ 12.156. *Operation in emergencies.* In the event of widespread emergency conditions affecting domestic communication facilities, the Commission may confer with representatives of the amateur service and others, and if deemed advisable, declare that a state of general communications emergency exists, designating the area or areas concerned (normally not exceeding 1,000 miles from center of the affected area), whereupon it shall be incumbent upon each amateur station in such area or areas to observe the following restrictions for the duration of such emergency:

(a) Transmissions, other than those relating to relief work or other emergency service, such as amateur station networks can provide, shall not be made within the 1750-2050 kc. or 3500-4000 kc. bands. Incidental calling, testing and working, including casual conversation or remarks not pertinent or necessary to constructive handling of the emergency situation, shall be prohibited.

(b) Frequencies within the bands 2025-2050 kc., 3500-3525 kc. and 3975-4000 kc. shall be reserved for emergency calling channels, for initial calls from isolated stations or first

calls concerning very important emergency relief matters or arrangements. All stations having occasion to use such channels shall change, as quickly as possible, to other frequencies for carrying on their communications.

(c) A 5-minute listening period for the first 5 minutes of each hour shall be uniformly observed for initial calls of major importance, both in the designated emergency calling channels and throughout the 1750-2050 kc. and 3500-4000 kc. bands. Only stations isolated or engaged in handling official traffic of the highest priority may continue with transmissions in these listening periods. No replies to calls or resumption of routine traffic shall be made in the 5-minute listening periods.

(d) The Commission may designate certain amateur stations to assist in promulgation of its emergency announcement, to police the 1750-2050 kc. and 3500-4000 kc. bands and to warn non-complying stations observed to be operating therein. The operators of these observing stations shall report fully to the Commission the identity of any stations failing to comply, after notice, with any of the pertinent provisions of this section. Such designated stations will act in an advisory capacity when able to provide information on emergency circuits. Their policing authority shall be limited to the transmission of information from responsible official sources, and full reports of non-compliance which may serve as a basis for investigation and action under section 502 of the Communications Act. Such policing authority shall apply only to the 1750-2050 kc. and 3500-4000 kc. bands. Individual policing transmissions shall refer to this section of the rules by number (12.156) and shall specify briefly and concisely the date

of the Commission's declaration and the area and nature of the emergency. Policing observer stations shall not enter into discussions with other stations beyond the furnishing of essential facts relative to the emergency.

(e) The special conditions imposed under this section will cease to apply only after the Commission shall have declared such emergency to be terminated.

§ 12.157. *Obscenity, indecency, profanity.* No licensed radio operator or other person shall transmit communications containing obscene, indecent, or profane words, language, or meaning.

§ 12.158. *False signals.* No licensed radio operator shall transmit false or deceptive signals or communications by radio, or any call letter or signal which has not been assigned by proper authority to the radio station he is operating.

§ 12.159. *Unidentified communications.* No licensed radio operator shall transmit unidentified radio communications or signals.

§ 12.160. *Interference.* No licensed radio operator shall willfully or maliciously interfere with or cause interference to any radio communication or signal.

§ 12.161. *Damage to apparatus.* No licensed radio operator shall willfully damage, or cause or permit to be damaged, any radio apparatus or installation in any licensed radio station.

§ 12.163. *Fraudulent licenses.* No licensed radio operator or other person shall obtain or attempt to obtain, or assist another to obtain or attempt to obtain, an operator license by fraudulent means.

A.R.R.L. QSL BUREAU

FOR THE convenience of American and Canadian amateurs, the League maintains a QSL-card distributing system which operates through volunteer "District QSL Managers" in each call area. To secure such foreign cards as may be received for you, send your district manager a standard No. 10 stamped, self-addressed envelope. If you have reason to expect a considerable number of cards, put on an extra stamp so that it has a total of six cents postage. Your own name and address go in the customary place on

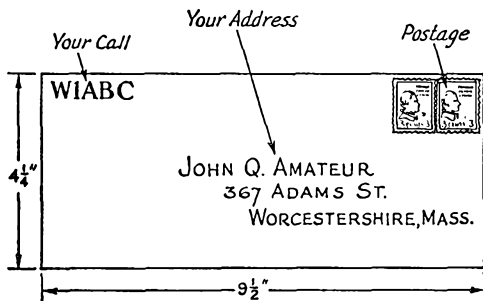

the face, and your station call should be printed prominently in the upper left-hand corner. If you have held other calls in previous years, submit an envelope for each such call to the proper manager — there are many thousands of un-called-for cards in the files. All incoming cards are routed by Hq. to the home district of the call shown in the address. Therefore, cards for portable operation in other districts should be obtained from the home district manager. Amateurs in the new WØ area should send envelopes to the

W9 Manager until their calls are actually modified to carry the zero designator.

(See the "Foreign Notes" section of this issue of QST for the method of handling outgoing cards from W-K-VE amateurs to foreign countries.)

W1 — Jules T. Steiger, W1BGY, 231 Meadow St., Willimansett, Mass.

W2 — Henry W. Yahnel, W2SN, Lake Ave., Helmetta, N. J.

W3 — Maurice W. Downs, W3WU, 1311 Sheridan St., N. W., Washington 11, D. C.

W4 — Edward J. Collins, W4MS, 1215 North 12th Ave., Pensacola, Fla.

W5 — L. W. May, jr., W5AJG, 9428 Hobart St., Dallas 18, Texas.

W6 — Horace R. Greer, W6TI, 414 Fairmount Ave., Oakland, Calif.

W7 — Frank E. Pratt, W7DXZ, 5023 So. Ferry St., Tacoma, Wash.

W8 — Fred W. Allen, W8GER, 1959 Riverside Drive, Dayton 5, Ohio.

W9 — F. Claude Moore, W9HLF, 1024 Henrietta St., Pekin, Ill.

WØ (as established) — Alva A. Smith, W9DMA, 238 East Main St., Caledonia, Minn.

VE1 — VE1FQ will resume service soon.

VE2 — C. W. Skarstedt, VE2DR, 3821 Girouard Ave., Montreal 23, P. Q.

VE3 — W. Bert Knowles, VE3QB, Lanark, Ont.

VE4 — c/o ARRL.

VE5 — H. R. Hough, VE5HR, 1785 Emerson St., Victoria, B. C.

K7 — J. W. McKinley, K7GSC, Box 1533, Juneau, Alaska.

A Two-Meter Crystal-Controlled Converter

A New Approach to 144-Mc. Reception

BY CALVIN F. HADLOCK, * WICTW

A REVIEW of the development of the 144-Mc. converter to be described may prove interesting and will help to show where and to whom its construction will be beneficial. It is admitted that a couple of hams out in East Jaffrey working each other with very little outside interference would not feel the need of such a unit. However, in cities where the ham population may be quite dense something better than normal superregen selectivity is needed, and the addition of this unit ahead of the present superregenerative receiver may be an inexpensive answer to the QRM problem on two meters. Since the writer had a National One-Ten receiver already available it was used, although any superregenerative or f.m. receiver that will tune around thirty megacycles should work well.

Two events led to the construction of the converter. The first was the acquisition of a house located on top of Arlington Heights, a suburb of Boston. At an elevation of nearly 350 feet, one can look out over practically the entire area which is commonly called Greater Boston. The second event was, of course, the temporary re-opening of the 2½-meter band shortly after V-J Day with the resultant mad scramble to get back on the air. The writer made it in a single Sunday afternoon and the transmitter certainly looked it.

The receiver problem was easily solved by dragging the old faithful One-Ten off the shelf. This is a superregenerative receiver using a 954

r.f. stage, 955 superregenerative detector and two audio stages. When put into use, it became apparent immediately that my problem was not to bring in the stations but to cut out the ones that were not wanted. What with everyone on a single band, coupled with the fact that I can "see" every antenna within ten or twelve miles, S9 plus signals were a dime a dozen and about five such signals filled the entire band. They came in layers, and the bottom layers could not be heard until the top layers went off. Something better in the line of selectivity was needed quickly, but too

much selectivity could not be used because practically every station was using a modulated oscillator.

Since the One-Ten was available, it seemed probable that a good way to improve its selectivity would be simply to lower the frequency at which the receiver operated through the use of a converter to change the 112-Mc. signal to somewhere around 30 to 40 Mc. There are two ways of doing this. One is to set the One-Ten dial to a fixed frequency and tune the h.f. oscillator of the converter. The other would be to use a fixed high-frequency oscillator on the converter and tune the intermediate

frequency amplifier, which in this case would be the receiver. Since the receiver already has a very fine dial on it, it was decided to use the latter system. Although a self-controlled fixed-frequency oscillator could be used, it was decided that crystal-controlled excitation would be an added touch of refinement, to eliminate any possible

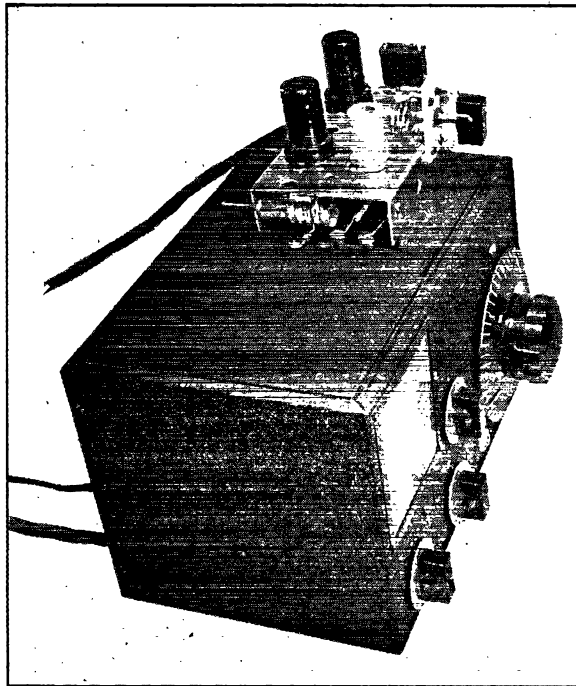

The original 112-Mc. converter is shown here in its operating position atop the One-Ten receiver. The 144-Mc. unit with 7-Mc. crystal is similar in appearance.

*c/o The National Co., Malden, Mass.

• While these simple converters were designed to increase the selectivity of the One-Ten, they should be ideal to extend the tuning range of f.m. superhets like the S-27 and S-36 to include the 144-Mc. band. The fixed-tune converter idea represents an easy way of obtaining 2-meter coverage with any receiver which will tune to around 30 Mc. or so, and the fact that no ganging of condensers is required should encourage those who are ordinarily deterred from any attempt at receiver work by a fear of the mechanical and electrical complications involved in tracking a series of tuned circuits.

drift and allow accurate calibration of the dial. With present-day technique, this exciter should be relatively simple.

Accordingly, the converter shown mounted atop the One-Ten was developed. More detailed description of the components of this circuit will be given when we arrive at a description of the units used on 144-148 Mc. The crystal frequency, which is around 7 or 8 Mc., is tripled in the plate circuit of a 6AC7 oscillator and tripled again by a second 6AC7. This ninth harmonic is then

coupled loosely into the grid of a 6AK5 mixer tube, beating with the signal to produce the i.f. voltage which is fed into the antenna post of the One-Ten receiver, which then receives it and demodulates it in the usual manner.

Avoiding "Birdies"

In selecting a crystal frequency, it must be remembered that harmonics of that crystal must not fall in or too near the edges of either the i.f. or r.f. bands to be used. If they do, dead spots will occur in the range to be covered exactly as though a strong carrier was being received. The first crystal frequency used was 8.444 Mc., the ninth harmonic of which was 76 Mc. This exciter frequency beating with the signal frequencies between 112 and 115.5 Mc. produced an i.f. range of 36 to 39.5 Mc. The fourth and fifth harmonics straddled the i.f. range while the 13th and 14th harmonics straddled the r.f. range. The i.f. range was covered by using the "F" coils plugged into the receiver. This setup worked very well and, with the able assistance of Mert Porter, WINBI, who did most of the operating at WICTW, W1DHX in Fall River, more than 50 miles to the south, was worked solid right through the middle of the local QRM.

A "bug" showed up, however, which had to be

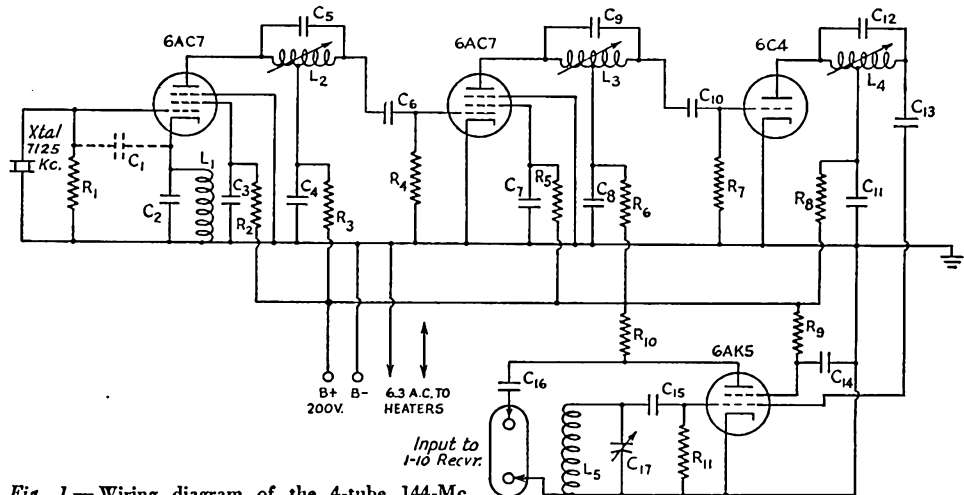
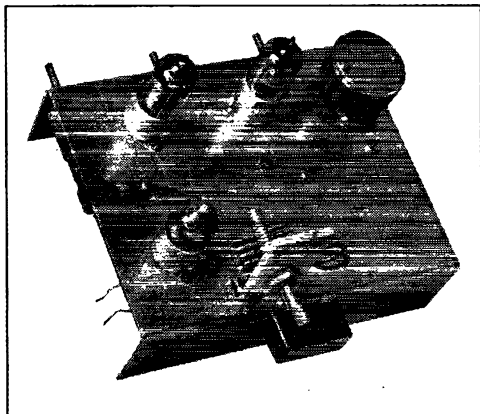

Fig. 1 — Wiring diagram of the 4-tube 144-Mc. converter using 7-Mc. crystal.

- C₁ — 3 to 5 μ fd. (if needed).
- C₂ — 50 to 100 μ fd., ceramic or mica.
- C₃, C₄, C₇, C₈, C₁₁ — 500 μ fd. mica.
- C₅, C₉, C₁₂ — 10 to 25 μ fd., ceramic or mica.*
- C₆, C₁₀, C₁₆ — 100 μ fd. mica.
- C₁₃ — 2 μ fd., ceramic or mica.
- C₁₄, C₁₅ — 50 μ fd., mica.
- C₁₇ — 15- μ fd. variable (National UMA-15).
- R₁ — 250,000-ohm, $\frac{1}{2}$ -watt.
- R₂ — 50,000-ohm, $\frac{1}{2}$ -watt.
- R₃ — 1000-ohm, $\frac{1}{2}$ -watt.
- R₄ — 100,000-ohm, $\frac{1}{2}$ -watt.
- R₅ — 50,000-ohm, $\frac{1}{2}$ -watt.
- R₆ — 1000-ohm, $\frac{1}{2}$ -watt.
- R₇ — 100,000-ohm, $\frac{1}{2}$ -watt.

- R₈ — 1000-ohm, $\frac{1}{2}$ -watt.
 - R₉ — 750,000-ohm, $\frac{1}{2}$ -watt.
 - R₁₀ — 5000-ohm, $\frac{1}{2}$ -watt.
 - R₁₁ — 100,000-ohm, $\frac{1}{2}$ -watt.
 - L₁ — 750- μ hy. pie-wound choke (National SA-2868).
 - L₂ — XR-50 coil form, ungrooved, 11 turns No. 22 enam. closewound, center-tapped.
 - L₃ — XR-50 coil form, ungrooved, 5 turns No. 16 enam., spaced $\frac{1}{2}$ -dia., of wire, center-tapped.
 - L₄ — XR-50 coil form, ungrooved, 3 turns copper strip 3/32-inch wide, spaced 3/32-inch, center-tapped.
 - L₅ — 1 $\frac{1}{2}$ turns of No. 14, $\frac{1}{2}$ -inch in diameter.
- * C₅, C₉ and C₁₂ should be selected in value so that plugs are fairly well out from center of coil at resonance.



Top view of the three-tube 144-Mc. converter using 10-meter crystal. Space is provided at the right of the mixer for addition of an r.f. stage.

cured. In the middle of the band at 114 Mc., there was a spot at which the background noise became very strong. It was apparent after a little figuring that at this spot the third harmonic of the superregenerative detector at 38 Mc. was being received as a signal at 114 Mc. In order to eliminate this, a new crystal at 7.91 Mc. was selected so that its harmonics straddled the i.f. and r.f. ranges and also relocated the i.f. range so that no harmonics of it were to be found in the r.f. range. This new crystal, multiplying by nine to 71.2 Mc., gave a new i.f. band from 40.8 to 44.3 Mc. This setup continued in use very satisfactorily until the band was shifted to 144-148 Mc.

Designs for 2 Meters

With the shifting of the band to two meters, it became necessary to rebuild the converter. To use the same order of intermediate frequencies as before, it became necessary to multiply to a higher frequency in the excitation stages. Also, it was considered desirable to use a crystal of a frequency which would be readily available to amateurs in case others cared to duplicate the apparatus. After checking harmonics carefully, a crystal was used whose frequency was 7.125 Mc. The 16th harmonic of this crystal would give an excitation frequency of 114 Mc. The beat note produced by combining this with the signal frequencies of the 144-148-Mc. band would produce an i.f. band of 30 to 34 Mc. which could be covered with the "F" coils in the One-Ten receiver. The circuit of this converter is shown in Fig. 1. Since this setup will operate well on the present two-meter band, details of its construction and operation will be given.

The chassis is made of aluminum bent-up into a U-shaped channel, 6 inches long by 4½ inches and 1½ inches high.

The crystal oscillator-multiplier stage is iden-

tical with that previously used except that the plate circuit quadruples to 28.5 Mc. instead of tripling as before. The control grid, screen grid and cathode operate as an ordinary Pierce triode oscillator circuit. The plate tank circuit then passes the fourth harmonic to the grid of the second 6AC7 tube. The 750- μ hy. choke and the 47- μ fd. condenser between cathode and ground are not particularly critical but should be adjusted for optimum operation. If the crystal is sluggish, adding a 3-5- μ fd. condenser directly from the control grid to the cathode will usually make it oscillate harder. All components are small, the ½-watt resistors and small mica or ceramic condensers being grouped around the tube sockets to produce a compact assembly. The oscillator-quadrupler tube is mounted beside the crystal. Between it and the second 6AC7 is mounted the first exciter plate tank coil.

The second 6AC7 will now double to 57 Mc. instead of tripling as before. Its plate tank coil is mounted beside it near the edge of the chassis. This tank is then connected to the grid of an additional doubler stage whose output is on 114 Mc. It was not considered advisable to use another 6AC7 at such a high frequency so a type 6C4 triode was used instead. The 6C4 is an excellent tube at these frequencies and easily gives enough output to produce good conversion efficiency when coupled to the 6AK5 first detector. The 6C4 is located in front of the second multiplier tank toward the front of the chassis. Between it and the 6AK5 can be seen the third multiplier tank coil. The 6AK5 is located in the front middle of the chassis next to the r.f. input tuning condenser. The plate and ground connections which connect the converter to the input posts of the receiver are located close to the 6AK5 and the

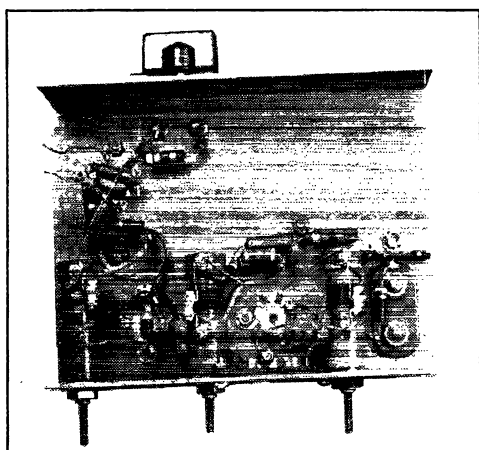

Bottom view of the three-tube 2-meter converter. Note the fixed-tune tank circuits mounted along the back edge of the chassis. The two short leads at the upper left connect to the antenna terminals of the One-Ten receiver.

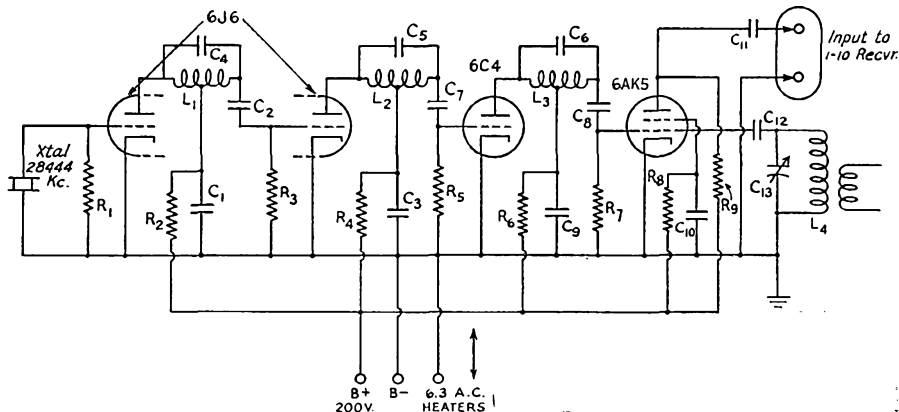

Fig. 2 — Schematic of 3-tube 2-meter converter, using 28-Mc. crystal.

- C₁, C₈, C₉ — 500-μfd. mica.
- C₂, C₇ — 100-μfd. mica.
- C₄, C₆ — 15-μfd. (10 to 20) ceramic or mica.*
- C₅ — 20-μfd. (15 to 25).*
- C₈ — 2-μfd. ceramic or mica.
- C₁₀, C₁₂ — 50-μfd. mica.
- C₁₁ — 100-μfd. mica.
- C₁₃ — 15-μfd. variable, National UMA-15.
- R₁ — 20,000-ohm, ½-watt.
- R₂ — 5000-ohm, ½-watt.
- R₃ — 100,000-ohm, ½-watt.
- R₄ — 5000-ohm, ½-watt.
- R₅ — 100,000-ohm, ½-watt.
- R₆ — 5000-ohm, ½-watt.

- R₇ — 250,000-ohm, ½-watt.
 - R₈ — 750,000-ohm, ½-watt.
 - R₉ — 5000-ohm, ½-watt.
 - L₁ — XR-50 coil form, ungrooved, 11 turns No. 22 enam., closewound, center-tapped.
 - L₂ — XR-50 coil form, ungrooved, 5 turns No. 16 enam., spaced ½ dia. of wire, center-tapped.
 - L₃ — XR-50 coil form, ungrooved, 3 turns copper strip, 3/32-inch wide, spaced 3/32-inch, center-tapped.
 - L₄ — 1½ turns of No. 14 copper wire, ½-inch in diameter.
- * C₄, C₅ and C₆ should be selected in value so that plugs are fairly well out from center of coil at resonance.

whole converter literally sits on the antenna and ground posts. A double plug, National type FWF, can be used for making the connections as a matter of convenience. In some cases, it may improve the sensitivity of the converter to ground the proper point of the converter chassis, as found by trial, directly to the top cover of the One-Ten receiver cabinet.

Circuit Details

A word about the r.f. tanks used in the exciter circuits is now in order. As will be noted from the circuit diagram, these are tuned by small ceramic or mica fixed condensers. The frequency is varied by means of iron-core slugs made of special powdered iron developed for high-frequency use. The position of the core is varied by means of the screws projecting outside the front and back sides of the chassis. Conventional tank circuits might be substituted but these forms (National XR-50) are compact and handy. The centertap of the coil is by-passed to ground while the plate is connected to one end and the grid to the other. This connection is convenient and places the tube capacities in series across the tuned circuit instead of in parallel.

Decoupling resistors are used in the various plate circuits to reduce leakage of undesired harmonics. The value of the grid resistor in the crystal oscillator has been made high to insure strong oscillation and high harmonic output. The

optimum value of the grid resistor in the multipliers for best harmonic output is about 100,000 ohms. If a triode is used as first detector, the plate voltage should be reduced by using a large plate resistor to get maximum mixer sensitivity. In the case of a 6F4, the best plate voltage would be about 20 volts. If a screen grid tube such as a 6AK5 tube is used, the same procedure should be followed with respect to the screen voltage. In the circuits using the 6AK5 with 200 volts plate supply, about ¾-megohm gave the best conversion sensitivity. It will be noticed that parallel feed is used in the plate circuit of the 6AK5 mixer. This is handy mechanically and places a load across the antenna coil which produces smoother operation of the receiver.

The mixer input tuned circuit is a conventional coil and condenser coupled to the antenna in the usual manner. It tunes very broadly and need not be retuned except for reception of very weak signals.

Simplification

It seemed that it should be possible to simplify the converter, as the three stages in the exciter section somehow seemed more of an elaboration than should be necessary. If the third multiplier could be eliminated and the entire exciter confined to the back half of the chassis, the mixer could be moved over to make room for an r.f. stage to be added later. A 20-meter crystal,

14,215 kc., and a 10-meter crystal, 28,444 kc. were found in the writer's prewar collection. The former could be used with only two tubes by using a pair of 6J6s and doubling three times, but this would require four tuned circuits. If the 10-meter crystal were used, we could use two miniature tubes and limit the number of tanks to three as before. This setup was tried and worked very well. The circuit diagram is shown in Fig. 2. One half of the 6J6 serves as a ten-meter crystal oscillator, doubling in the second half, and then doubling again in a 6C4. When first tried the 10-meter crystal refused to oscillate. Remembering that it had been inactive for over three years, I washed it in carbon tetrachloride after which it oscillated freely. The grid of the second half of the 6J6 was excited to about twenty volts and it in turn, after doubling in the plate circuit, drove the grid of the 6C4 to about 25 or 30 volts. The 6C4 in turn produced about 10 volts of fourth harmonic on the grid of the 6AK5 before the r.f. input tank was connected. When the input tank circuit was connected to the 6AK5 grid and set to approximately the 2-meter band, the exciter voltage developed on the detector grid dropped to about 1 volt after retrimming the 6C4 plate tank. This is sufficient to give good conversion when using grid-leak injection. A very high resistance voltmeter should be used for checking the grid voltages. The writer used a 500,000-ohm resistor in series with a 100-microampere meter with the resistor lead to the grid as short as possible to prevent detuning. It is also advisable to use a wavemeter to check harmonics — it is awfully easy to get lost in the harmonics, especially when using the 7-Mc. crystal.

Approximate checks were made on the sensitivity of the over-all setup as compared to working straight through the One-Ten on 2 meters. The converter-receiver combination appears to have equal or slightly better sensitivity than the One-Ten alone, on the basis of the input required to give a 6-db. reduction in background noise. Since improved selectivity was the object rather than improved sensitivity, the converter accomplishes its purpose.

The selectivity is quite broad as compared to low-frequency communications receivers. At 10 db. down, it is about 200 kc. wide. Certainly, no transmitter in a crowded v.h.f. section has any right to take up any more space than that! The average modulated oscillator is readable by detuning off the center of the carrier, although quite often it is necessary to detune so far that the background noise comes up to make an S8 signal sound like S4. The poorest oscillators are just out of luck, while crystal or v.f.o. stations like W8CLS/1, W1AKD, W1CWZ, W1EL and W3BSY/1 really stand out and are truly beautiful to listen to. A stable S9-plus signal like W3BSY/1 can be tuned in and out completely in nine of the 150 dial divisions, although Harri-

son lives less than a quarter of a mile away. It is interesting to note that the modulated-oscillators using QST's so-called "strap" oscillator tank have considerably better than average stability. It should be pointed out that the dial of the One-Ten receiver can be calibrated with respect to the 144-148-Mc. band with the aid of harmonics of the crystal oscillator and a little interpolation.

In closing, it should be pointed out that the unit described is not the ultimate. The present unit might possibly be reduced to two tubes by using a 6J6 in place of the 6C4 and using the second half of it as a first detector to replace the 6AK5. The addition of a good r.f. stage would be very much worthwhile. This might well be a broad-band fixed-tune affair, to avoid adding mechanical complications. Also, it should be remembered that this is only one approach to the subject of 2-meter receivers and it is hoped that interest will be stimulated in further investigation of the subject. Let us anticipate that some day all that has been accomplished on 5 and 2½ meters will also be accomplished and surpassed on this new 2-meter band.

Attention: Ten-Meter Operators!

THIS ISSUE carries the story of the work at the National Bureau of Standards in accumulating and analyzing radio propagation data¹ with the ultimate aim of increasing the scope and accuracy of predictions of radio transmission conditions. It becomes evident on reading the account that one reason — probably the determining one — why so much progress was made during the war period is simply this: The volume and variety of regularly-contributed data were increased tremendously by the establishment of new ionosphere-sounding stations in widely different parts of the world and by observing programs such as the one in which ARRL coöperated.²

Quantity and variety are just what amateurs are in a position to supply. Simply because we exist in large numbers over practically the whole face of the globe, we can collect data that could not be obtained otherwise without the expenditure of astronomical sums of money. Furthermore, the data needed are generated by the normal operation of amateur stations.

It seemed such a shame for the possibilities to go to waste that we recently put to the Bureau the question of how amateurs could help. The

¹Smith and Silberstein, "Radio Propagation Work at the National Bureau of Standards," this issue.

²Gautier, "The NBS-ARRL Radio Observing Projects," QST, April, 1946.

(Concluded on page 158)



Happenings of the Month

BOARD MEETING

The ARRL Board of Directors will have its annual meeting at Hartford on May 10th. Your director (name and address in the front of any *QST*) will be glad to have your suggestions for the betterment of the craft.

At this writing the Board's agenda are still incomplete and we do not know with finality what topics will be up for discussion. There is a proposal, sponsored by several directors, to rearrange the thirteen ARRL divisions in the United States into ten new ones coinciding with the new FCC amateur call areas. One defect in the ARRL system is that there is gross inequality in the number of amateurs contained in our various divisions, each represented by a single director's voice. Since the redistricting of call areas has been done on a basis much closer to uniform population distribution, we would come much closer to proportional representation in our affairs on such a plan. On the other hand, the areas and the traveling distances would be increased in some of the more sparsely populated divisions. . . . A major question at this year's Board meeting, of course, will be the matter of accelerating the return of the amateur bands. . . . Unquestionably, also, the question of the division of operating privileges between types of emission and classes of operator license will be up for attention. The war years having intervened since our rules were last overhauled in such respects, it may be expected that they will come in for a thorough discussion with a view to re-adjusting our regulations to fit the modern scene.

Your director would like to know how your thinking goes on such subjects and to have the benefit of any other suggestions you care to offer. Write him.

PROSPECTS

With the opening of 60% of the 80-meter band, ARRL efforts now concentrate on the return of the remainder of that band and of 40 and 20. The work of clearing our bands progresses, and we are getting particularly pleasing cooperation from the AAF. It takes time, and unfortunately the international situation does not inspire the too-rapid tearing down of circuits, but we are hoping to improve on the estimated dates, particularly concerning the rest of the 80-meter band. The outlook for 40 and 20 continues to be the expectation of the return of substantial parts of each by midsummer. There are indica-

tions of considerable bustle, particularly concerning 20, both in Washington and in the various theaters. Since this is an Allied problem, indications from other countries are useful indexes, and the signs here are good too: RSGB reports signs of activity in England and we learn that the French Government is making a move intended to result in the return of 20 to its amateurs.

It is pretty disgusting to listen in on 14 Mc. and be able to hear the amateurs of practically every country on earth except the Allies, enjoying the current quite grand performance of this band. You of course wonder how that can be. The answer is that most of this operation is in countries that either have had small stake in this war or have small continuing obligations in the present picture — so they feel free to cut their hams loose, while the Allied countries still have the military establishments and the bases and the millions of men overseas. While we feel that the military are collaborating with us as well as their system permits, we agree with you that these matters move with appalling slowness, and that there are probably many circuits being maintained for which there is not true justification. By midyear, however, there should be a very great improvement in the situation.

Don't get your hopes too high for any early action on the proposed new 21-Mc. band. This is a United States proposal but it is in a portion of the spectrum subject to international treaty and, at least theoretically, it cannot be made available to us until the effective date of the next revision of the international regulations by a world conference. It is hoped to hold that conference within a year but the effective date for a 21-Mc. ham band is possibly as far away as late 1947. As a matter of fact, FCC has not yet issued its final decisions for the U. S. proposals for postwar allocation below 25 Mc. — and you may note that it coppers itself in all allocations below 25 Mc. by pointing out that they remain subject to these final determinations. However, there is every reason to believe that the 21-Mc. U. S. proposal will remain firmly in the picture. ARRL has been hard at work building up support for this proposal in the leading amateur countries of the world, with quite encouraging results: support has been promised in many quarters and prospects are excellent that some other major nations will in fact sponsor the same proposal.

The FCC (or FCC-IRAC) decisions on frequencies below 25 Mc. will be of further interest in indicating the final fate of 160, on which

ARRL now has a brief pending before FCC. Meanwhile, British amateurs were opened on 1800-2000 kc. on March 15th but with power restricted to 10 watts and with the band subject to abrupt withdrawal if there be interference to other services, particularly to loran operated in those parts by U. S. services. However, the action of the British Government points up the suggestion in the ARRL brief that a shared use of this band is possible. And, as we said therein,* it is not yet demonstrated that loran is the ideal permanent system nor that it is in the right place in the spectrum.

(For later news on the 80-meter band, see "It Seems to Us . . .")

RENEWAL APPLICATIONS

On the editorial page in March *QST* we told you that FCC would like to receive renewal applications from amateurs in certain regions during March and April. Last month we were obliged to tell you that licensing was proceeding so slowly that you should QRX for further word. We can now report that the situation is so improved that, although there remains a goodly backlog, FCC can look ahead to the time when it can entertain certain renewal applications. Consulting with the FCC staff, we now suggest that renewal applications be filed by the following groups at the following times:

1) Amateurs whose calls are to be changed to WØ upon renewal may file during the month of May. This embraces the states of Colorado, Iowa, Kansas, Minnesota, Missouri, Nebraska, North Dakota and South Dakota.

2) Amateurs living in all other areas where calls are to be changed upon renewal may apply during June. This embraces Alaska, Arizona, Hawaii, Kentucky, W9 Michigan, Nevada, W3 New Jersey, W8 New York, the Pacific possessions, W8 Pennsylvania, Puerto Rico, Utah, Virginia, Virgin Islands.

3) Amateurs living in areas not enumerated above are requested to continue to stand by for further word.

All those applying for renewal should remember to attach any valid FCC licenses held, station or operator or both.

Don't worry about the May 15th date for the expiration of our present operating authority. It will surely be extended.

RECENT ASSIGNMENTS

FCC on March 13th and 29th assigned three additional bands for amateur use. Although you already know the story through WIAW, here are the details for the record.

The band 235-240 Mc. was opened immediately for A1-2-3-4 and f.m. This is our new 1¼-meter band. It is an interim assignment,

expected to be effective until January 1, 1949, pursuant to a small Anglo-American treaty which makes temporary provision in that part of the spectrum for radar distance indicators. About the first of 1949 these devices are to be removed from that neighborhood and we may expect to be shifted to the band permanently earmarked for us, 220-225 Mc.

FCC also opened for our use the band 27.185 to 27.455 Mc. This is what we have called the "QRM band," primarily assigned for scientific, industrial and medical apparatus, but which FCC in its allocation decisions said we might be free to make such use of as we could. It is open for AØ-1-2-3-4 and f.m. emissions, thus permitting so-called duplex 'phone operation. These are the only amateur frequencies below 144 Mc. where either unmodulated carriers or A2 operation are permitted. This subject is further discussed in an editorial this month.

The big news, of course, was the opening of most of the 80-meter band on April 1st. First stipulated in Order 130-D of March 13th to be 3700-4000 kc. and open only in continental United States, it was expanded by Order 130-E on March 29th to cover 3625-4000 kc. and be available not only in continental U. S. but in Alaska, Puerto Rico and the Virgin Is. For the history of this matter, see this month's editorial page. These are our first frequencies below 25 Mc. since our reactivation. The whole range is open to c.w., and the portion 3900-4000 kc. is available for A3 'phone to stations whose licensees have Class A operating privileges and provided the station is operated by a Class A operator. Real c.w. operating fun is here again! Still denied Hawaii and the Pacific area generally, it is hoped that this band can be opened there soon.

Effective April 1st two changes were made in the 10-meter band to accord with our new rules of that date. For no good reason, a.m. 'phone had been denied the top 200 kc. of this band, but now it has them and the assignment now reads 23.1 to 29.7 Mc. Get up on that top edge, some of you fellows! The portion open to f.m. has heretofore started with the odd figure 23.95 Mc. This was rounded out to an even 29 Mc., and f.m. 'phone and telegraphy may now be used in the top 700 kc. of the band.

Some of our previous f.m. authorizations have been confined to telephony, although some others included telegraphy. All these now have been uniformly expanded to cover f.m. emissions which are either "radiotelephone transmissions" or "radiotelegraph transmissions employing carrier shift or other frequency-modulation techniques."

Because Order 130-E recites all our operating authorizations as of April 1st, we quote its "ordering" portion as a summary of the score to that date:

* *QST*, p. 24, August, 1945.

IT IS HEREBY ORDERED THAT the second ordering clause of Order No. 130-A, as amended by Orders No. 130-B, 130-C and 130-D, be and it is hereby further amended to read as follows:

2. (a) The following frequency bands are available for use for amateur station operation, subject to the limitations and restrictions set forth herein:

(1) 3625 to 4000 Kc., using type A1 emission, and, on frequencies 3900 to 4000 Kc., type A3 emission, subject to the restriction that A3 emission may be used only by an amateur station which is licensed to an amateur operator holding Class A privileges and then only when operated and controlled by an amateur operator holding Class A privileges. This band may be used for amateur station operation on and after, but not before, April 1, 1946, 3:00 A.M. Eastern Standard Time. Use of this band is restricted to amateur stations within the continental limits of the United States, the territories of Alaska and Puerto Rico, and the Virgin Islands.

(2) 27.185 to 27.455 Mc., using types A0, A1, A2, A3 and A4 emissions, and also special emissions for frequency modulation (radiotelephone transmissions and radiotelegraph transmissions employing carrier shift or other frequency modulation techniques). This band is subject to use also for operation of scientific, industrial, and medical apparatus.

(3) 28.0 to 29.7 Mc., using type A1 emission.

(4) 28.1 to 29.7 Mc., using type A3 emission.

(5) 29.0 to 29.7 Mc., using special emission for frequency modulation (radiotelephone transmissions and radiotelegraph transmissions employing carrier shift or other frequency modulation techniques).

(6) 50.0 to 54.0 Mc., using types A1, A2, A3 and A4 emissions and, on frequencies 52.5 to 54.0 Mcs., special emission for frequency modulation (radiotelephone transmissions and radiotelegraph transmissions employing carrier shift or other frequency modulation techniques).

(7) 144 to 148 Mc., using types A1, A2, A3 and A4 emissions and special emissions for frequency modulation (radiotelephone transmissions and radiotelegraph transmissions employing carrier shift or other frequency modulation techniques). The portion of this band between 146.5 and 148 Mc. shall not be used, however, by any amateur station located within 50 miles of Washington, D. C., Seattle, Washington, or Honolulu, T. H.

(8) 235 to 240 Mc., using types A1, A2, A3 and A4 emissions and special emissions for frequency modulation (radiotelephone transmissions and radiotelegraph transmissions employing carrier shift or other frequency modulation techniques).

(9) 420 to 430 Mc., 1215 to 1295 Mc., 2300 to 2450 Mc., 5250 to 5650 Mc., 10,000 to 10,500 Mc., and 21,000 to 22,000 Mc., using on these six bands, types A1, A2, A3, A4 and A5 emissions and special emissions for frequency modulation (radiotelephone transmissions and radiotelegraph transmissions employing carrier shift or other frequency modulation techniques). Peak antenna power on the band 420 to 430 Mc. shall not exceed 50 watts.

(b) No frequencies other than those assigned in this order shall be used for amateur operation.

CANADIAN ASSIGNMENTS

The Canadian Department of Transport matched FCC on March 13th in the matter of the band openings reported in the item above and went then one better: It opened to Canadian amateurs, on April 1st, the additional frequencies 3500-3700 kc., with a maximum power *output* on these frequencies of 50 watts, and subject to the condition that there be no interference to U. S. military radio services. The geographical distance from the remaining U. S. military operations makes possible the contemplation of an operating privilege for the relatively small number of Canadian amateurs that we in this country

ARE YOU LICENSED?

• When joining the League or renewing your membership, it is important that you show whether you have an amateur license, either station or operator. Please state your call and/or the class of operator license held, that we may verify your classification.

cannot yet enjoy. This proposal was submitted to and approved by our War Department. The Canadian action should have the collateral effect of speeding the return of these frequencies to U. S. amateurs too.

With this one exception, the frequency limits in Canada and the United States are now the same, although the assignment of the 11-meter band is on a temporary basis, possibly awaiting the ratification of the next world conference, and 10-meter 'phone is authorized only subject to station inspection and approval.

The authorized types of emission in Canada vary somewhat from the U.S. F.m. 'phone is permitted only above 52.5 Mc. and f.m. telegraphy only above 144 Mc. The 10- and 11-meter bands are open only to A1 and A3. There are no provisions for A4 and A5. The provision for 75-meter 'phone, confined to stations entitled to that privilege, is temporarily restrained to the frequencies 3900-4000 kc. until the whole band is released to U. S. amateurs. At that time, qualified Canadian amateurs will be authorized to use A3 on 3800-4000 kc., the same as prewar, and the power limitation on 3500-3700 will be removed.

The Canadian Government is prepared to join the United States Government on a moment's notice in the return of the amateur 7- and 14-Mc. bands.

The Canadian operator license exists in but one grade, the Amateur Certificate of Proficiency in Radio, and remains in force indefinitely or until new examination may be required by a change in law or treaty. All amateur station licenses expire on March 31st each year and must be renewed for the following 12 months.

All amateur calls with the suffix RI apparently are being reserved for the use of Canadian radio inspectors and the few amateurs with that combination are suffering a change of calls.

ATTACH YOUR CURRENT LICENSE

Whenever you have an existing valid FCC license, either operator or station, and are an applicant for either type — new, renewed or modified — you *must* attach and return it (or them) to FCC with your application. That is because any of these actions of FCC results in automatic extension of the existing license, so

the old one(s) must be surrendered. Failure to return the old license is causing hundreds of amateurs delay in getting new tickets. If you have just an operator license now, and are applying for a station license, you still must return the operator ticket, because FCC is going to give you a new *combination* license for a new term of five years. You'll save yourself an awful lot of grief and delay if you remember this.

NOTICE TO MEMBERS DISCHARGED FROM THE MILITARY SERVICES

The requirement of continuous membership in the League for eligibility to ARRL offices has been waived for members serving in the uniform of the United States. See particulars on page 39 of *QST* for July last. Those desirous of taking advantage of this arrangement are required to claim the right when renewing membership, stating the beginning and ending dates of their military service.



IN *QST* for May, 1921, the leading technical article, "The Antenna" by John C. Stroebel, Jr., 8ZW, deals with the flat-top Marconi antennas commonly used these days. . . . A western amateur challenges our claim that a c.w. set can be put in as cheaply as spark, mile for mile. Editor Warner accepts the challenge in "The \$100 C.W. Set," recommending four UV-202s, push-pull in pairs, self-rectifying, in a Hartley circuit, as being capable of out-performing any 1-kw. spark. Incidentally, each tube requires a \$2 rheostat and a \$1.75 socket. . . . F. S. Huddy, III, reports on three different c.w. transmitter circuits in "C.W. For the Amateur." . . . L. W. Hatry, 5KN, of Port Arthur, Texas, describes his regenerative tuner in a letter to the editor. . . . Walter S. Lemmon, in a Radio Club of America paper, explains the synchronous "Resonator Converter," a device to change direct current to any desired voltage and alternating frequency.

Station descriptions include Gordon Hight's 4BQ at Rome, Georgia, which boasts a 125-foot tower supporting the high end of a 90-foot 8-wire cage antenna 8½ feet in diameter. . . . 3XM, at Princeton (until recently 3DH) has a 40,000-volt transformer weighing 500 pounds, a glass-dielectric condenser weighing 300 pounds and an antenna slung between a 150-foot steeple and a hundred-foot stack. 3XM's signals have been copied in all but eight states.

There is a vast display of interesting advertising. New gear advertised includes the Tuska moulded variometer, Cunningham tubes, the

Westinghouse RA-DA combination receiver, a Magnavox speaker for "radiophone concerts," and the new A-P rectifier tube which will pass 75 ma.

Irving Vermilya, IHAA, has the operating honors with 608 messages handled, the greatest number ever reported for a single month. . . . The Washington's Birthday Relay, under 9XE, was successful and a message from President Harding was relayed by Citizen Radio to all parts of the country. . . . 1AW won a close decision over 1TS and 4EA as the best recorder in the January QSS tests. . . . Phillip R. Coursey reports the failure of the February transatlantic test, in which 25 U. S. amateurs transmitted coded signals listened for by 250 British amateurs. While no American was unquestionably heard, many extremely faint 200-meter c.w. signals, too weak to read, were received. Some of the British contestants used as many as eight or ten stages of amplification. Oscillating receivers caused much QRM. We have tested most British circuits and know them to be inferior to our variometer-tuned regenerators, and "we would bet a new spring hat that if a good U. S. amateur with such a set and an Armstrong Super could be sent to England, reception of U. S. amateurs would straightway become commonplace."

The Second District Convention in New York City was the biggest amateur radio affair ever held as over five thousand persons attended exhibits and meetings during the three-day conclave in March. One of the features of the convention was the reception, via NAA, of a message of greeting and good wishes to the amateurs from President Harding.

ARRL is paying off its bonds, reimbursing those good amateurs who, two years ago, lent their League the hard coin to purchase *QST* and to get going again. When we get through, our bank balance is going to be as low as a 60-cycle growl. But we'll get by and gradually we'll accumulate a reserve for new work. One of the first things we want to do is to publish a real textbook helpful to every amateur and to the new people "who, in increasing numbers, are taking up Citizen Wireless."

Attention, Foreign Hams

• When you hear such an American call as WIUE/1 it means that WIUE is operating in portable or mobile status somewhere in the W1 area. The greatest likelihood is that he is operating his home fixed station at a different location than shown on his prewar license and is applying the rules for portable status while awaiting license modification. He has to sign that way — every time — but the /1 is not part of his actual call and you don't have to use it in calling him.

Even some W amateurs don't seem to know that.

A Wide-Range Test Oscillator

A Generator Delivering Sine- or Square-Wave Output

BY CHARLES F. LOBER, RT1c, USCG, * WSICO

WIDE-RANGE oscillators generating signals at frequencies extending from those low in the audio range into the low- or medium-r.f. region have many uses in the laboratory and on the test bench. The one shown in the photographs has been tested thoroughly and considerable time was spent in its construction and overcoming original weaknesses.

The frequency range of an oscillator of this type is practically unlimited. As described, it covers from 17 to 218,000 cycles per second, and delivers a power output of about one watt. Either sine-wave output with very good wave form or square-wave output may be obtained which makes it useful for a wide variety of applications. A square-wave generator is very useful in checking distortion in audio amplifiers and in television work and, should the unit be used for code practice, the square-wave output provides a tone much more pleasant and untiring to copy. This type of wave snaps the speaker or headphone diaphragm back and forth much more sharply than a sine wave.

The frequency stability of this unit is excellent. No consequential drift in frequency is encountered from the time the tubes become warm enough for cathode emission until the unit has been in operation for several hours. Power tools running off the same line may cause sufficient voltage fluctuation to vary the output amplitude slightly, but no frequency shift is noticeable.

The Circuit

The circuit diagram is shown in Fig. 1. The operation of the oscillator depends upon inverse feedback. The output of the 6K6 is fed back to the 6SJ7 exactly 180 degrees out of phase. With care in construction and spacing, no phase shift will be encountered. Frequency is determined by the capacitance of the tuning condensers and the values of the resistors in the Wien bridge circuit. As a result, changes in temperature or voltage have negligible effect on the frequency.

The variable condenser, C_1 , used to tune the

Wien bridge circuit was obtained from a broadcast receiver. One of heavy construction and good insulation should be chosen. All contacts should be thoroughly cleaned and the insulating material should be free from dirt and corrosion. The gang should have four sections of 450 to 500 $\mu\text{f.d.}$, per section. Two sections at each end of the condenser are connected in parallel to form the two legs of the bridge.

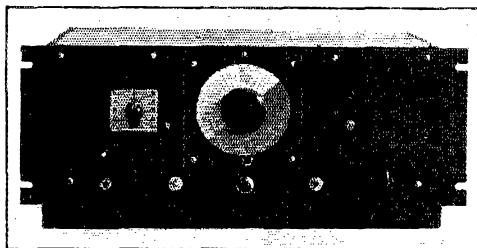

This test oscillator is designed for rack mounting. The dial is constructed from a National movement as described in the text. The range switch is at the left.

An important factor is the ratio of maximum to minimum capacitance of the variable condenser to obtain maximum frequency range for each band. The minimum capacitance should be as small as possible, striving towards a ten-to-one ratio. All padders should be removed or opened.

A mica padder, C_2 , is used to balance the two sections to compensate for capacitance to ground and tube capacitance.

The frame of the condenser is insulated from ground, and because it is at grid potential and on the lowest-frequency bands may be 15 megohms above ground, no attempt should be made to use the instrument without a metal cabinet completely enclosing the unit.

The dial is a National Velvet with the knob in front of the usual dial plate in back of a piece of celluloid four inches square. The calibration is marked on a piece of paper cemented to the face of the dial. A diagonal across the celluloid serves as the index.

Adjustments

Resistors R_1 and R_2 are determining factors in the accuracy and wave-form of this instrument. Of primary importance is the close match between each pair of resistors. Each pair should be matched within at least 0.5 percent. If each band is calibrated separately, the exact value is not critical, except that each pair should be matched. If the same dial calibration is used, and resistors have exact values of 10 megohms, 1 megohm, 100,000 ohms, 10,000 ohms, etc., a switch plate marked $\times 1$, $\times 10$, $\times 100$, etc., can be used. Under these conditions the condenser ratio must be ten to one, otherwise complete frequency coverage cannot be obtained.

The three-watt lamp, R_4 , is used to control

* U.S.C.G., 230 Old Customhouse, St. Louis, Mo.

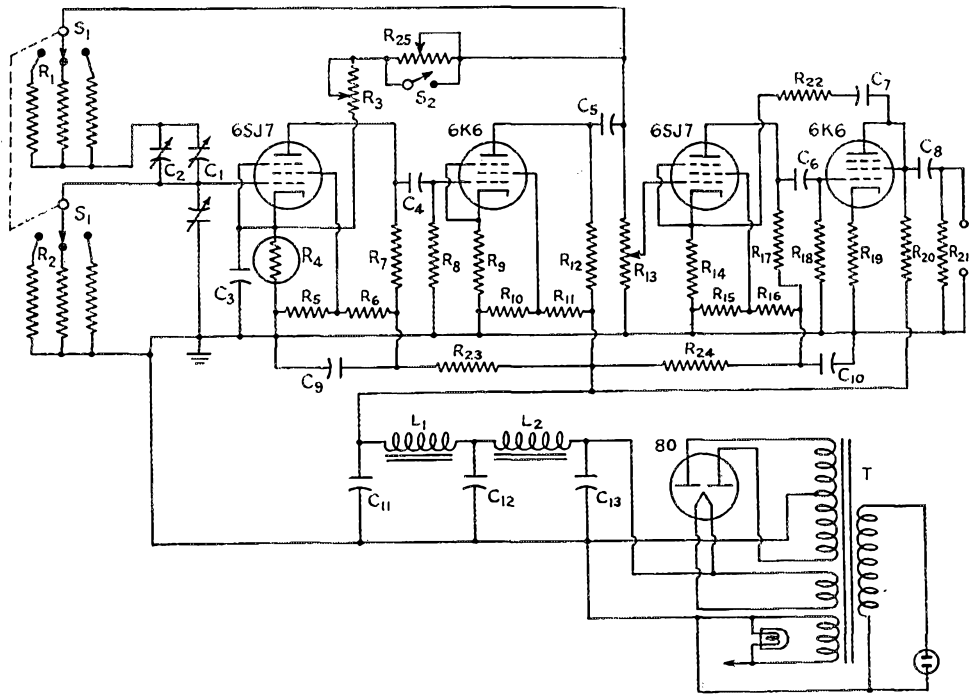

Fig. 1 — Circuit diagram of the wide-range test oscillator.

- | | | |
|--|--|--|
| <p>C₁ — 4-section broadcast condenser, 500 μfd. per section, two sections in parallel in each half.</p> <p>C₂ — 50-μfd., mica padder.</p> <p>C₃ — 50-μfd. mica.</p> <p>C₄, C₆ — 0.01-μfd. 400-volt paper.</p> <p>C₅, C₈ — 40-μfd. 450-volt, electrolytic.</p> <p>C₇, C₁₁, C₁₂, C₁₃ — 16 μfd., 450-volt, electrolytic.</p> <p>C₉, C₁₀ — 10-μfd. 450-volt electrolytic.</p> <p>R₁, R₂ — Matched within 0.5 per cent, values as follows:
 15 megohms — 17 to 130 cycles
 5 megohms — 50 to 380 cycles
 1 megohm — 230 to 1750 cycles
 0.5 megohm — 400 to 3000 cycles
 0.1 megohm — 2100 to 16,000 cycles</p> | <p>50,000 ohms — 4200 to 33,000 cycles</p> <p>10,000 ohms — 20,000 to 132,000 cycles</p> <p>5000 ohms — 38,000 to 218,000 cycles</p> <p>(If the unit is built for four ranges, use 10 megohms, 1 megohm, 0.1 megohm and 10,000 ohms.)</p> <p>R₃ — 10,000-ohm variable.</p> <p>R₄ — 3-watt, 110-volt candelabra lamp.</p> <p>R₅ — 35,000 ohms, 1 watt.</p> <p>R₆ — 75,000 ohms, 1 watt.</p> <p>R₇ — 50,000 ohms, 1 watt.</p> <p>R₈ — 0.5 megohm, 1 watt.</p> <p>R₉ — 500 ohms, 2 watts.</p> <p>R₁₀ — 50,000 ohms, 2 watts.</p> <p>R₁₁ — 10,000 ohms, 2 watts.</p> <p>R₁₂ — 10,000 ohms, 10 watts, wire-wound.</p> | <p>R₁₃ — 25,000-ohm potentiometer</p> <p>R₁₄ — 5000 ohms, 1 watt.</p> <p>R₁₅ — 25,000 ohms, 1 watt.</p> <p>R₁₆ — 50,000 ohms, 1 watt.</p> <p>R₁₇ — 50,000 ohms, 1 watt.</p> <p>R₁₈ — 0.5 megohms, 1 watt.</p> <p>R₁₉ — 500 ohms, 2 watts.</p> <p>R₂₀ — 2500 ohms, 10 watts, wire-wound.</p> <p>R₂₁ — 10,000 ohms, 1 watt.</p> <p>R₂₂ — 3000 ohms, 1 watt.</p> <p>R₂₃ — 10,000 ohms, 1 watt.</p> <p>R₂₄ — 4000 ohms, 1 watt.</p> <p>R₂₅ — 10,000-ohm variable.</p> <p>S₁ — 2-pole rotary (number of positions depends upon number of bands used).</p> <p>S₂ — S.p.s.t. toggle switch (square-wave switch).</p> <p>L₁, L₂ — Filter choke.</p> <p>T — Power transformer.</p> |
|--|--|--|

the feedback automatically. No glow will be noticed on the higher-frequency bands, but on the low-frequency bands a slight color will show. It is almost impossible to get good wave form without this bulb, and it should not be placed near a resistor which may get hot since its operation will be effected.

The value of R_3 is very critical. The correct value may vary from 1000 to 3500 ohms, depending chiefly upon the characteristics of the particular bulb used at R_4 . A good method of selecting the correct value is to check with an oscilloscope, noting the wave form. At values too high, harmonic distortion is very pronounced. As the

value is reduced, the wave approaches a perfect sine-shape. As the value is decreased still further, the output falls off and if too low, oscillation may cease or may not be constant over the entire capacity range. Slightly different settings may be noticed on different bands, but the low-frequency bands are more critical and should be favored. A setting will be found which gives good results on all bands. This resistor is placed underneath the chassis, since once adjusted for the particular bulb in use, no further attention should be necessary.

Resistor R_{25} will have some value at which square waves will be most nearly approached.

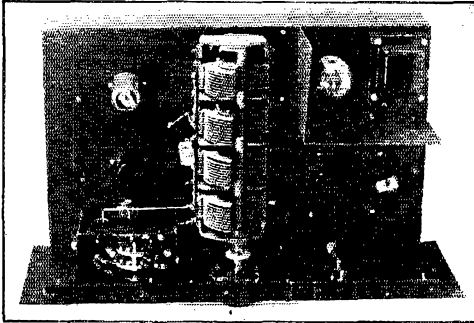

Plan view of the chassis showing the tuning condenser at the center, power supply in the upper right-hand corner and the shielded range switch in the lower left.

The value is not as critical as in the case of R_3 , but should be adjusted in the same manner. These two resistors are the only ones which may cause headaches, since their values can upset the unit to a high degree.

Variable output is obtained by the use of R_{13} . Variations in output power results in no frequency change because of the use of the isolation amplifier. A 6SJ7 and a 6K6 are used in this amplifier. The power output is limited to about 1 watt by the triode connection and heavy inverse feedback. This is done with the idea of providing an amplifier with as little frequency discrimination as possible. As near as could be determined very little difference in gain is noticeable between the highest and the lowest frequencies.

Transformer output could be substituted for the capacity-resistance output circuit shown but the frequency range of the oscillator will be reduced, of course. On the lowest frequencies, resonant peaks may cause trouble, while the high frequency output will be limited unless a good output transformer is used.

If it is desired to use the oscillator for code practice, a key jack can be inserted between this lamp and ground. Very good keying can be obtained except at the very-lowest frequencies where rapid keying is not possible because of the thermal action of the bulb in its rather slow heating and cooling. This causes a slight frequency drift until the bulb reaches its normal color. On normal code-oscillator frequencies from 200 to 2000 cycles or higher, this action is not noticeable.

Calibration

In calibrating the instrument, a capacity checker should be used to balance the sections of the gang condenser. All of leads except the lead to grid of the tube should be disconnected and the mica trimmer adjusted until both sections have the same capacity.

The best method of calibration is to use another oscillator and an oscilloscope. One oscillator should be connected to the vertical plates and

the other to the horizontal plates. At identical frequencies a single oval pattern will appear on the screen. To calibrate out of the range of the oscillator used as a standard, ratios or harmonics may be used. With the standard at 20,000 cycles, if five waves appear on the screen, the second frequency will thus be 100,000 cycles, etc. The oscillator used as a standard should be matched against 60-cycle power frequency to check its calibration. 60-cycle power waves also can be used to check calibration of the new oscillator up to the point where ratios become so great that the possibility of error becomes high.

Power Supply

The power supply is standard, except that good filtering is required; 250 volts at 65 Mc. will handle the requirements. If the power supply is built on the same chassis with the unit, it should be shielded on top of the chassis as well as below.

Trouble may be encountered on the low-frequency bands if pick-up from the power supply occurs. The output of the oscillator will beat with stray pick-up from the 60-cycle source and cause "wowing" or wave distortion. This will be particularly noticeable if the cabinet is removed during operation. A shield around the frequency-determining resistor bank also will be advisable.

If care is taken in calibration, and good construction is followed, an extremely accurate instrument can be built, which will hold its calibration indefinitely.

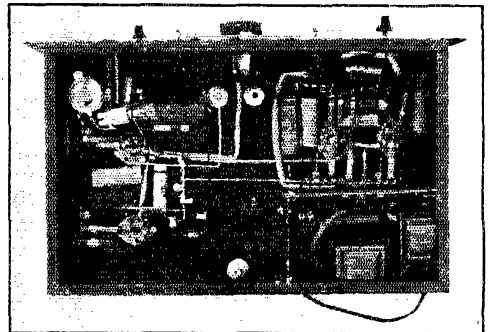

Small components are placed underneath the chassis. The filter chokes are in the shielding compartment in the upper left-hand corner.

About the Author

Sometimes it's almost impossible to obtain information for this column and in the case of Chas. F. Lober, W8ICO, the results of our unceasing efforts hit a new low in the statistical department. The sum total of our information consists of two facts: (a) OM Lober hails from Mansfield, Ohio and (b) he is an RT 1/c aboard a Coast Guard destroyer escort stationed at Balboa.

Power Control Circuits in Amateur Transmitters

A Suggestion on Power-Supply Interconnecting Wiring

BY MYRON E. LAWSON,* W9BQZ/2

• This story is intended for newcomers to amateur radio or old hands planning a new rig. The author confesses that most of it has been scattered through the pages of past issues of *QST*, but it is a good symposium of "what every new ham should know," and it may even give some old timers a few helpful hints.

WITH so many amateurs returning to activity and so many new hams joining our ranks, this seems like a good time to do a little rehashing of the subject of the 115-volt wiring in a typical amateur transmitter. No high hopes are held that every reader will agree with the recommendations, nor is that the intention, but it is felt that the general ideas can serve as a good guide for newcomers to the game.

The writer has never been greatly impressed by the often-recommended technique of placing the plate-supply primary switch in one side of the line after the filament supply switch "so the plate power cannot be applied until the filament switch is on." This precaution is of limited value because it does not prevent such improper operation as

(a) Closing the plate switch immediately after closing the filament switch before the filaments have reached the correct temperature.

(b) Closing the plate switch first through error and then switching both plate and filament power on together with the filament switch.

(c) Turning off the rig by opening the filament switch. This is probably the worst of all because no immediate harm is done, yet there is no warning of the trouble to come when the filament switch is thrown the next time.

True, the suggested circuit also has these same defects, but at least the operator's caution is not influenced by the belief that the circuit is fool-proof. In the new transmitter planned at W9BRZ it is proposed to equip the filament switch with a narrow vertical "ring" guard over the switch handle. One is not likely to reach under a guard to operate a switch without thinking twice, even during those early morning skeds. Probably the real answer is for some benevolent manufacturer to make available to us a pair of switches mounted together and so constructed that No. 2 cannot be

closed until No. 1 is closed and No. 1 cannot be opened until No. 2 is opened. Also, No. 1 should have a 20- to 30-second timer delaying the operation of No. 2 when No. 1 is first closed. Some will prefer more elaborate relay and/or vacuum tube circuits here, but it should be remembered that convenience is obtained in this way only at the expense of more possible points of failure.

The diagram in Fig. 1 shows how the filament circuits of a complete transmitter can be wired. A single plug, mounted at the rear of the transmitter, is used to take the power from a flexible power line which ends in a receptacle at the transmitter. A Master Filament Switch, probably mounted on the panel of the largest and heaviest power supply, must be closed before any filament circuit in the transmitter can be energized. Separate filament switches on the power supplies and r.f. units are normally closed, but they are included for use at times when every unit in the transmitter is not in service, as during c.w. and low-powered operation. The filament switches on r.f. units can be omitted if these units are always

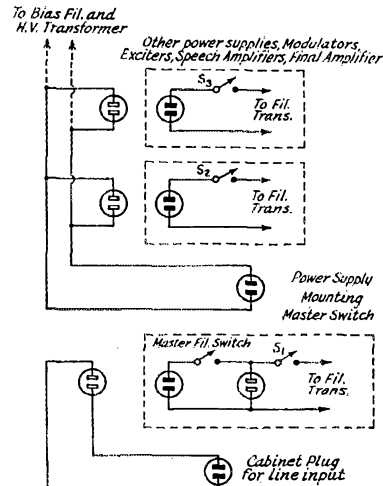

Fig. 1 -- The filament circuits are controlled by one Master Filament Switch mounted on one of the power supplies. The individual filament switches, S₁, S₂ and S₃, might be omitted on r.f. units that are used all of the time, but they are recommended on equipment that is not always in use, such as speech amplifiers and modulators. Plugs are shown with solid contacts; open contacts indicate receptacles.

* 1382 Park Ave., Plainfield, N. J.

in use. If a bias supply is used, its filament and high-voltage circuits should be turned on with the filaments on the other units, since the lag in its

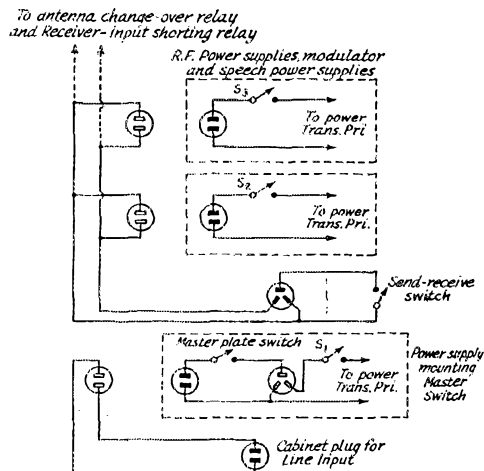

Fig. 2 — A single Master Plate Switch mounted on one of the power supplies has to be closed before the Send-Receive Switch takes over its function of switching the primaries of all plate transformers and the antenna change-over and receiver-shortening relays. A further refinement, not shown in the diagram, is a 'Phone-C.W. Switch that opens the primaries to the modulator and speech power supplies and controls a high-voltage relay that switches the plate lead of the final amplifier from one terminal to the other of the secondary of the modulation transformer.

filter might exceed the lag in a plate-supply filter.

The plate-supply and send-receive switching is shown in Fig. 2. Here, nothing in this circuit can be energized until the Master Plate Switch is closed. Individual switches in each power-transformer primary are provided for limited operation as mentioned in the preceding paragraph. The Send-Receive Switch controls the primaries of all power transformers, and it would also handle an antenna send-receive relay and a relay used to short the input of the receiver during "transmit." A further refinement, for the operator who requires quick switching from 'phone to c.w. and back, would be a 'phone-c.w. switch controlling a relay that opens the modulator and speech power supplies and a high-voltage relay that switches the plate lead of the final amplifier from the "hot" end of the modulation-transformer secondary to the "cold" end. This latter relay must be insulated well enough to ground to stand better than twice the final plate voltage. For this reason, it is probably a luxury item that would be included only in the more elaborate transmitters.

The reason for the dual wiring system is to keep the voltage drop caused by the plate transformer loads confined to the house wiring, in order to minimize the effect on filament voltages. Where this scheme is used a few words of caution are indicated. Do not run twin cables to wall sockets

on different house-wiring circuits that are separately fused! The house fuse in the line to the filament transformers and bias supply may be blown, leaving the plate power on. Also, precautions should be taken against plugs working loose from the wall sockets. A good trick where locking-type plugs and sockets are not used is to place a small screw hook adjacent to the wall socket and tie a loop of stout cord to the plug neck or to the cable at the plug. The loop should be just long enough to slip over the hook when the plug is seated properly.

Another rule worth repeating here is that when "looking" at the end of a wire or cable toward the source of power, the connector should be a receptacle. Aside from the danger of shock from live plug tips, it is very easy to blow a house fuse by shorting the plug on the chassis or cabinet while attempting to insert the plug in a socket.

For wiring the power circuits, No. 12 wire is adequate up to powers of about 600 watts. Above this, the plate power leads should be of No. 10 wire.

While we are touching on some phases of the subject of safe design practices, it might be timely to take a look at Mr. H. H. Massy's article in *Hints and Kinks* of April, 1942. For those who do not have this issue of *QST* handy, Mr. Massy pointed out that where the power-supply negative high voltage is connected to the chassis and distributed to other chassis through a ground wire, the full plate voltage can appear between the power-supply chassis and the chassis connected to the cathode of the tube having the positive high voltage on its plate, if the ground wire becomes disconnected. In the new transmitter planned by the writer this principle will receive full consideration.

Other protective devices that can be incorporated are listed below:

1. Overload relays with through-panel reset buttons in the high-voltage and modulator power supplies.
2. Underload relay with winding in one side of the modulation transformer secondary lead and the contacts in the driver plate-supply primary lead.
3. The usual two-colored pilot lights on each power-supply panel to indicate when the filament and plate circuits are on.
4. The cabinet rack grounded to a good water-pipe ground and the ground wire continued up the side of the cabinet, connected to each chassis under a wing nut. The ground wire should be about No. 10 or a heavy copper bus.
5. Bleeder resistors of ample size on each power supply output.
6. A test pick always connected to ground and ready to use each time the cabinet door is opened, to check for charged filter condensers before anything is touched. The wallop from a discharging filter may be brief, but so is lightning!

Radio Propagation Work at the National Bureau of Standards

Progress in the Field of Forecasting Transmission Conditions

BY NEWBERN SMITH,* EX-W3QY, AND RICHARD SILBERSTEIN,* W3JQP

THIS IS the story of the war job done by the National Bureau of Standards on radio propagation. Centralizing the basic work in this field for the Army and Navy, it developed techniques for predicting the best frequencies to be used anywhere in the world at any time of day, and put out such predictions as a regular service.

Some of the value of this work may be judged by the story — a typical one — of an engineer who shall be nameless, just returned from overseas, who asked a radio propagation instructor to kick him. It seems that he and some other engineers had just spent two months conducting transmission tests 24 hours a day in an attempt to determine the best frequencies for use over a certain transmission path during the Teheran Conference. He then found out that he could have obtained the answer after 15 minutes of paper work if the IRPL predictions had been available to him at the time.

Research in radio propagation at the National Bureau of Standards began with the work of Dr. L. W. Austin in 1909 on the then prevalently used low and very low frequencies; the famous Austin-Cohen formula was published in 1911. Early in the next decade radio engineers and amateurs discovered that higher frequencies than those previously used were capable of transmitting over great distances using phenomenally low power. The amateurs in fact pioneered in this discovery. It was proved that these waves were not traveling over the earth's surface but were leaving the earth obliquely and being reflected back to places at great distances from the transmitter. It appeared that reflection of these "sky waves" was taking place from an ionized region of the upper atmosphere whose existence had been suggested some time before by Kennelly in this country and by Heaviside in England. This region was at first called the "Kennelly-Heaviside layer," but was later found to consist of several layers, the whole region being subsequently called the "ionosphere."

Because of its interest in radio wave propagation the Bureau began studying the ionosphere in the 1920s. By means of pulse equipment of the type used by Breit and Tuve to obtain echoes

• Providing a perennial topic for conversation both on and off the air, there is probably no more fascinating subject in radio than "conditions" — the state of wave propagation at the moment. There is probably also no subject with more tantalizing ramifications. Climaxing a long period of investigation, accelerated wartime research has brought the prediction of radio propagation conditions to a high degree of practical accuracy. This article, a general survey of the propagation work done at the National Bureau of Standards, tells what has been accomplished so far in a field of vital interest to every amateur.

from the ionosphere (equipment and techniques which were later destined to be incorporated in radar), the regular reflections obtained from directly overhead were measured and the heights of the ionosphere on various frequencies were obtained thereby at various times of the day. It was found that at any given time of day, radio waves above some value of frequency striking the ionosphere at vertical incidence would no longer be reflected but would pass on through. There seemed to be some relationship between these "critical frequencies" observed at vertical incidence and frequencies which, for transmission at oblique incidence to places at a given distance along the earth's surface, became critical in the sense that above a certain value for that distance they also would not return to earth but were said to "skip." The practical result of "skipping" was that in radio communication, operating frequencies which were too high for prevailing conditions in the ionosphere would not be received.

An exhaustive mathematical study was made at the Bureau of the relationship between oblique- and vertical-incidence reflection from the ionosphere and a fairly exact relationship was developed which has stood the test of time. Just before the war a rapid empirical method was developed at the Bureau whereby "maximum usable frequencies" for radio transmission over any distance could be evolved, by use of distance factors, from critical frequencies observed at vertical incidence on ionosphere recorders.

*Interservice Radio Propagation Laboratory, National Bureau of Standards, Washington 25, D. C.

Meanwhile, during the 1930s it was noted that average or median values of critical frequencies followed regular diurnal and seasonal characteristics and furthermore that their 12-month running average had a linear relationship to the 12-month running average of sunspot numbers. Thus it became possible by estimating sunspot-cycle trends to predict average or median maximum usable frequencies for any period in the future. In the years just prior to the war the Bureau was publishing, both in *QST* and in the *Proceedings of the Institute of Radio Engineers*, predictive charts of maximum usable frequencies for use in the United States, based upon vertical-incidence data received at Washington. They appeared in *QST* under the title "Predictions of Useful Distances for Amateur Radio Communication," and in *Proc. I. R. E.* under the title "The Ionosphere and Radio Transmission." Also, at this time, data were being received from the ionosphere stations operated by the Department of Terrestrial Magnetism, Carnegie Institution of Washington, at Huancaayo, Peru, and Watheroo, W. Australia, and studied to determine probable effects of geographic location.

Another activity which began in the early

1930s was the continuous recording of received field intensities of broadcast and short-wave stations throughout the world. These records furnished direct relationships between the ionospheric measurements and actual radio propagation conditions. Many interesting effects were discovered in this way, such as the relationship of sudden disturbances of the ionosphere to solar hydrogen flares. The records also afforded valuable data for checking maximum usable frequencies and modes of propagation. Another very important use of the records was in the study of absorption of the energy in radio sky waves.

By use of these continuous field-intensity recordings and with the help of data furnished by amateur radio operators cooperating in a project jointly sponsored by the Bureau and ARRL, it became possible to determine rough constants for the calculation of sky-wave absorption on different frequencies and thus to predict roughly distance ranges and lowest useful high frequencies.

Thus it is evident that at the beginning of the national defense emergency period the Bureau was in a good position to render a service to the armed forces as well as to the commercial radio companies in predicting the best usable frequen-

◆

Ionosphere field stations are to be found in all parts of the world, from Arctic wastes to tropical islands. Wide geographical distribution is needed for the accumulation of data to be used as a basis for predictions of world-wide propagation conditions.

◆

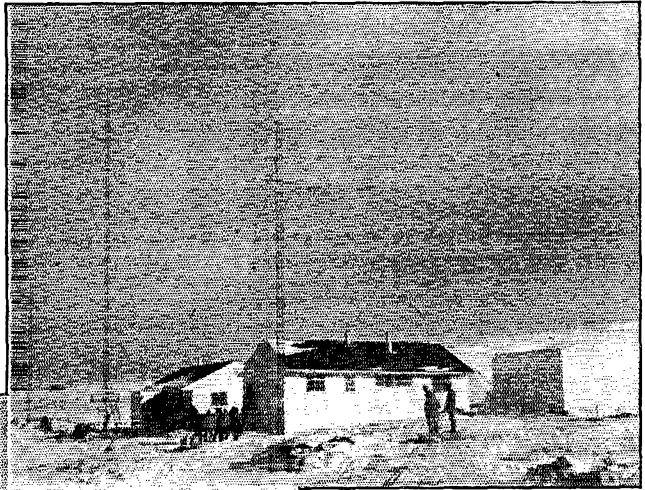

◆

Above: A view of the Clyde, Baffin Island, field station now operated by the Canadian Government. Left: The station at Christmas Island, established by the Department of Terrestrial Magnetism, Carnegie Institution of Washington.

◆

cies for radio sky-wave transmission at any time of day anywhere in the world. The National Defense Research Committee recognized the bearing of this upon direction-finding problems and in 1941 granted funds for the purpose of studying the correlation of direction-finder errors with ionospheric conditions. These studies were begun in July, 1941, with the cooperation of the Navy and the FCC in furnishing data taken in spare minutes at their direction-finder stations, and with the establishment of four new ionosphere stations in the North American area, in accordance with a program laid out at the National Bureau of Standards. Funds were also granted at this time for the preparation of a radio propagation handbook for use by communications people.

Through the efforts of Bureau members, as well as of radio propagation experts in the Armed Services and elsewhere, particularly in the Office of the Chief Signal Officer, the Army and Navy recognized the great advantages in many instances of using sky waves as compared to ground waves, the importance of using predictions of usable frequencies in the allocation and assignment of frequencies, and the necessity for the use, by communication networks in the field, of frequencies properly assigned on the basis of ionospheric conditions at different times of the day in different months and in different parts of the world. Previously, frequencies had been chosen in many instances with no regard to or knowledge of propagation effects, resulting at times in complete failure in the achieving of objectives.

During the emergency period, techniques of predicting maximum usable frequencies for the Washington area were extended to the data from the other laboratories, and a method was adopted of representing predictions at different latitudes in the form of a world chart which could be used, to a first approximation, for the prediction of radio propagation conditions anywhere in the world. In the winter of 1941-2 the first radio propagation handbook was compiled, to be followed by another in the summer of 1942. These handbooks contained the newly-evolved world charts as well as charts of distance ranges and descriptive information on the use of the material.

An important development at the Bureau during this period was the two-control-point method of solving long-path transmission problems. This method was also arrived at independently in England by K. W. Tremellen. The technique was described recently in *QST*.¹

Observed ionospheric data for the Washington area were reported monthly, along with predictions for that area, in the regular NBS report, "High Frequency Radio Transmission Conditions." The first predictive world chart in these reports appeared as predictions for March, 1942. The above-mentioned reports were later issued as

"Radio Propagation Conditions" and then as the IRPL-D series, "Basic Radio Propagation Predictions." Also, data observed at other ionosphere stations were subsequently reported and were eventually issued as a separate report, "Ionospheric Data."

By the time of the termination of the direction-error project in July, 1942, the usefulness of ionospheric data obtained at stations in different parts of the world, not only for direction-finding work but also for any radio work involving sky waves, was generally acknowledged. Accordingly, the ionosphere station network set-up for the direction-error project was recognized as of importance in radio communications in general, and although direction-finding research also continued, the Bureau was named the centralizing agency for the United States for the compilation, dissemination and analysis of all ionospheric data.

It soon became evident that world-wide cooperation with the United Nations was going to be necessary to effect adequate exchange of basic data between nations and to coordinate practices and techniques so as to increase the amount of useful timely data for the predictions both here and abroad. The result was that in the summer of 1942 the Combined Chiefs of Staff, acting through the Combined Communications Board, set up the Interservice Radio Propagation Laboratory at the National Bureau of Standards, which, operating directly under the Army and Navy, was to cooperate with the British Inter-Services Ionosphere Bureau and the Australian Radio Propagation Committee. In December, 1942, the Officer-in-Charge of the British Inter-Services Ionosphere Bureau, together with representatives from Australia and Canada, visited the Bureau to discuss plans for future cooperation.

The various radio propagation projects sponsored by NDRC at the Bureau were gradually placed under the newly-formed IRPL, and coordination was effected with British, Australian, New Zealand and Canadian wave-propagation groups. Later on, data were also exchanged with the USSR. In April, 1944, an International Conference on Radio Wave Propagation was held in Washington to discuss exchange of data, coordination of efforts, and standardization of techniques. Representatives of Great Britain, Australia, New Zealand and Canada attended.

The following paragraphs summarize the progress of radio propagation work at the Bureau after the creation of IRPL. The activities discussed are in the sequence in which they are taken up:

1. Basic radio propagation predictions.
2. Study of ionospheric absorption.
3. Forecasting of ionosphere and radio propagation disturbances.

¹ William R. Foley, "Forecasting Long-Distance Transmission," *QST*, February, 1946.

4. Radio traffic data analysis.
5. Ionosphere field-station activity.
6. The IRPL handbook and the monthly publications.
7. The IRPL training course.
8. Postwar expansion.

In the work of basic ionospheric data analysis, prediction methods were greatly improved and eventually there was evolved a simple nomographic method for predicting critical frequencies and maximum usable frequencies for transmission by reflection from any regular ionosphere layer for any part of the world at any state of the sunspot cycle, and in any month.

Worldwide trends of sporadic-*E* were also determined to a fair degree of accuracy and prediction charts of *E_s* were issued. Examples of these charts are shown on pages 44 and 45 in the January, 1946, issue of *QST*.²

Another development was the discovery of the "longitude effect." Ionospheric data in the same season at the same latitude were found to vary with longitude since this seemed dependent upon geomagnetic latitude. It was found expedient to divide the world, accordingly, into three zones, East, Intermediate and West (E, I and W) and to issue world charts of maximum usable frequency (m.u.f.) for the three zones.

The ionospheric absorption constants which had earlier been determined were revised as a result of the sustained study of continuous field-intensity records. Atmospheric radio noise ("static") maps of the world were made, based on thunderstorm activity and on observations by numerous investigators. The maps showed five "noise grades," and charts of minimum field in-

² E. H. Conklin, "The Bright New World — of Sunspots," *QST*, January, 1946.

tensity required for communication were calculated for each noise grade for various hours of the day. Techniques were developed for the rapid determination of a *lowest* useful high frequency (L.u.h.f.) over any path in any month at any time of day, as determined by radiated power, absorption, and required field intensity. It was now possible to calculate not only an *upper* limit of useful high frequency, the maximum usable frequency (m.u.f.) which was determined by the limits of skip, but also a *lower* limit of useful high frequency (l.u.h.f.) as determined by the factors mentioned. The L.u.h.f. determinations were more accurate at very short and very long distances than at intermediate distances and were less accurate than m.u.f. predictions.

At the same time studies were made of the factors determining ionosphere and radio propagation disturbances. During the waning part of the last sunspot cycle it was usually possible to forecast disturbances on a 27-day recurrence basis, coinciding roughly with the solar meridian passage of large sunspots. At the beginning of the new sunspot cycle, however, the correlation became much poorer. A radio-disturbance forecasting service was begun and operated, together with a radio-disturbance warning service, telling the users of propagation data of the actual or imminent onset of disturbances. The onset of major disturbances, which originate in the auroral zones, was observed by daily monitoring of the North Atlantic path, which traverses the auroral zone. Stations in North Europe and Iceland were observed aurally in radio receivers and visually on a cathode-ray-indicator type of direction finder, at the receiving station at Sterling, Va. Contributory evidence on radio disturbances observed at ionosphere stations in the north auroral zone, and certain radio traffic observations and ob-

• We understand that the National Bureau of Standards has been deluged with replies to the announcement in the March issue regarding the need for men to operate ionosphere field stations, but that there may still be some openings for top men of the radio-engineer supervisor type, qualified to take responsibility for the operation of an entire station.

The Bureau also needs highly experienced physicists and radio engineers to take charge of radio propagation research projects on all frequencies in laboratories and field stations in the Washington area.

It is desired that candidates, when writing, state whether they are interested in working at the remote stations or at Washington. The overseas jobs are for the most part on island locations from the Arctic to the equator but a differential of 25 per cent increase in pay is granted for these jobs.

As in all Federal appointments, preference is given to candidates in the following order:

1. Ten-point veterans
2. Five-point veterans
3. Present Federal employees
4. Former Federal employees

It is expected, however, that the number of candidates with the necessary qualifications will not be large, so that persons not in the above categories need not hesitate to apply.

servations of solar and terrestrial magnetic phenomena which were telephoned or telegraphed to the Bureau daily, were weighed before the issuance of a disturbance warning.

The forecasts and warning services are continuing and, in addition, disturbance warnings applicable chiefly to the North Atlantic path are now issued daily over station WWV at 20 and 50 minutes past each hour. If a warning is in effect, indicating that a radio propagation disturbance is anticipated or in progress over the North Atlantic Path, six Ws follow the WWV time announcement. If conditions are quiet or normal, eight Ns follow the time announcement.

Post-facto analyses of radio traffic data were made so as to afford a continuous check on predictions. Traffic logs of commercial companies were received and analyzed regularly, as were observations by Army, Navy and FCC listening posts, and by amateurs. An account of this work appears in the April issue of *QST*.³

The Department of Terrestrial Magnetism, Carnegie Institution of Washington, was requested by the Army and Navy to establish ionosphere field stations in certain areas of the Atlantic, the Caribbean and the Pacific. These stations were manned in part by Army and Navy and in part by civilian personnel. As in the case of the other cooperating stations, daily and monthly data were forwarded to IRPL by radio, with monthly tabulations following by air mail or boat.

In the Washington area, the original NBS propagation station at Meadows, Md., was dismantled when the Army took over the region for an airport, and the activities were moved to Sterling, Va. At the Sterling station of IRPL one or more ionosphere recorders are and have always been in continuous operation, with new types of recorders under development. Continuous field-intensity recordings were and are being made of nearby and distant stations on 16 recorders. A standard field-intensity recorder, acting on a monopole erected over a large ground mat, was put into use whereby the other recorders could be calibrated in microvolts per meter. Four direction finders of different types were operated in connection with propagation studies, one having an attachment, developed at the Bureau, for continuous recording. Work was also done on the measurement of polarization of down-coming waves and of ground constants.

In November, 1943, the IRPL Radio Propagation Handbook, Part I, was issued, superseding earlier handbooks. This handbook, appearing also as Army manual TM 11-499 and Navy manual DNC-13-1, gave some general theories of radio wave propagation, chiefly on sky-wave frequencies, and described all of those techniques mentioned above which had been developed up to the

time of issuance. Tables, charts, nomograms and maps for the use of these techniques were included.

Beginning in September, 1944, with predictions for December, 1944, the radio propagation predictions were issued in reports of the IRPL-D series, "Basic Radio Propagation Predictions," an outgrowth of the earlier monthly reports "Radio Propagation Conditions." The D series was issued as a supplement to the Handbook (also being issued under special Army and Navy numbers). Each issue of the D series gives complete information enabling the user to calculate best sky-wave operating frequencies over any path at any time of day for the month of prediction. The techniques given are improvements on those outlined in the Handbook; some of the IRPL techniques and explanatory material were given in Foley's recent *QST* article,¹ and Figs. 6, 7 and 9 of the article are from the report IRPL-D15. The charts in January *QST*² are also from IRPL reports.

The reports of the IRPL-D series were distributed during the war to the Armed Services and to commercial organizations associated with them. Since the material is now declassified, it is expected that these and other IRPL reports will be made available to the public on a regular subscription basis from the Superintendent of Documents, Government Printing Office, at a small price.

A series of unscheduled reports giving the results of research developments is the IRPL-R series. For example, a typical recent R report is IRPL-R25, "The Prediction of Solar Activity as a Basis for Prediction of Radio Propagation Phenomena."

Another monthly publication is the IRPL-F series, "Ionospheric Data," which succeeded a previous report series under the same name. In it appear tables and graphs of monthly observations of basic data at the different ionosphere stations throughout the world and also articles discussing scaling practices, results of data analysis, and similar matters. This publication is chiefly of interest to scientific groups.

During the war IRPL also issued quarterly tables of monthly predicted usable frequencies for ships, aircraft and submarines under various IRPL, Army and Navy symbols, and nomograms for rapid approximate calculations of usable frequencies were also issued to certain users.

Another service to the Armed Forces was a two-weeks training course given in January, 1944, to a group of Army, Army Air Force and Navy officers and enlisted men and a few civilians. These men were taught basic principles of radio wave propagation by scientists and engineers from the Bureau staff and the staffs of cooperating groups in the Armed Forces and in civilian scientific bodies. The lectures were supplemented by drill in the solution of typical propagation problems. Those who took the course subse-

³ T. N. Gautier, "The NBS-ARL Radio Observing Projects," *QST*, April, 1946.

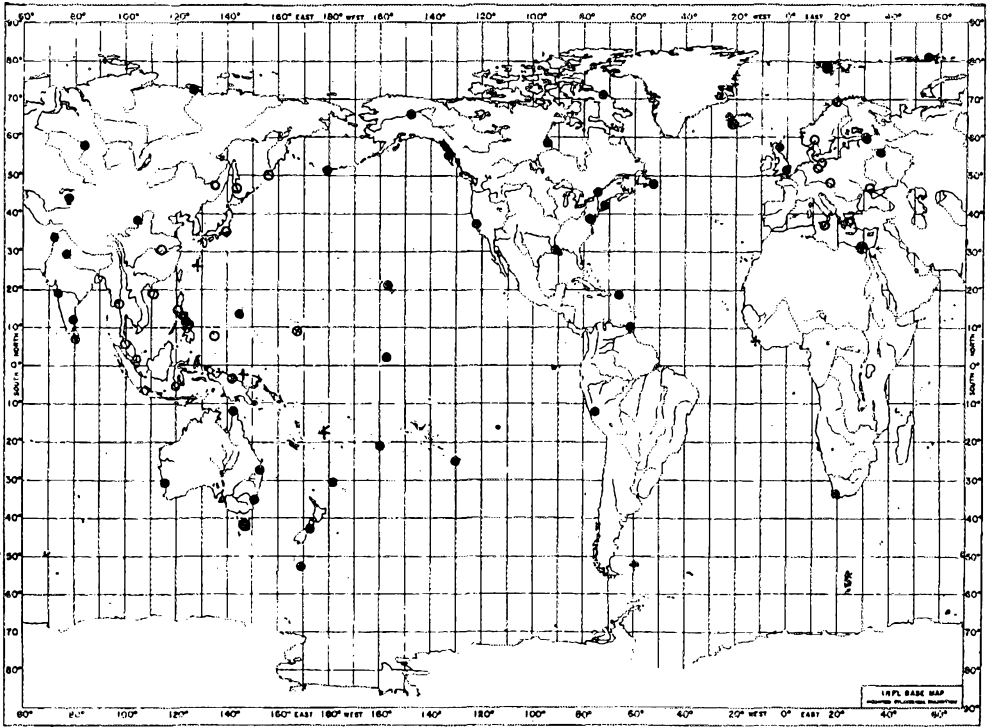

WORLD WIDE DISTRIBUTION OF OBSERVING STATIONS, JANUARY 1946

- - OPERATING IONOSPHERIC STATIONS
 - - ENEMY IONOSPHERIC STATIONS
- ⊗ - ABANDONED IONOSPHERIC STATIONS
 - + - PROPOSED IONOSPHERIC STATIONS

Fig. 1

quently organized similar courses for military personnel, organized problem-solution groups, or went into the theaters of war as communications officers.

With the end of the war has come an expansion of IRPL activities. The laboratory has been designated as the centralizing agency, for the United States, for all basic data and research in radio propagation. Data from new ionosphere stations were added to those from older stations for analysis. The total number of ionosphere stations which had been established by the United Nations and from which data were regularly being received was 45 in January, 1946. In addition several former enemy stations which had been taken over by the United States and British forces were also sending in data. Fig. 1 is a map showing the worldwide distribution of existing and proposed stations as of January, 1946.

It is now planned that most of the ionosphere field stations which were established by Carnegie Institution and the Army and Navy during the war will be taken over and operated by the Bureau. In addition, research activities are being expanded to include basic theoretical and experimental investigations of radio propagation on all

radio frequencies from the very low frequencies to the microwaves.

In the past, radio amateurs have pioneered and rendered unstinting assistance in the advancement of the study of radio propagation. Many old-timers will remember how the frequencies above 1500 kilocycles ("below 200 meters" in the parlance of that day) were given to the amateurs because they were considered to have little practical value. What happened is apparent from an examination of the issues of *QST* around 1922 to 1925, which bristled with accounts of first contacts between U. S. amateurs and those in foreign countries on the higher frequencies. Many of the personnel on the Bureau staff who were responsible for the developments described herein are radio amateurs or ex-amateurs. There is no doubt that amateurs will continue to play a large rôle in the future in these studies, so important to commercial and amateur radio as well as to national defense.

**SWITCH
TO SAFETY!**



1946 V.H.F. Marathon

May 1 to December 31, 1946, Inclusive-All W/VE Work Counts for Points in Scoring Extra Credit for F.M. and Regular Activity

BY F. E. HANDY, * WIBDI

ANOTHER popular prewar ARRL contest returns! The Marathon is a running competition based on cumulative operating results in the v.h.f.-u.h.f.-s.h.f. bands. This activity is designed to increase interest, occupancy, and enjoyment in all these bands. It will give appropriate recognition to the outstanding workers in these frequency ranges.

The contest rules are detailed below. They are based on study of information and suggestions received in the last such competition and include consideration of suggestions from various sources.

(1) Solid bronze-medallion awards will be engraved with the calls of the winners for each of four frequency groupings (50-54 Mc., 144-148 Mc., 235-240 Mc., 400-and-above Mc.) for their leading scores based on their station operations covering the last eight months of 1946.

(2) The high monthly scorer will receive certificate recognition for the leading results reported covering his operations for each designated calendar month.

(3) In addition special certificates will go to the Marathon Leaders for each ARRL Section for the whole period May 1 to December 31, 1946, inclusive.

The certificate award is reproduced herewith. As a separate feature from the Marathon, additional bronze-medallions are being offered for the three amateur operators demonstrating confirmed contacts to show the three highest numbers of STATES WORKED by any W- or VE- amateur between March 1 and December 31, 1946, inclusive. (See full details of this separate competition and reproduction of the medallions in the Operating News section, this issue.) The record of "states" worked will appear from time to time with QST's monthly reports of Marathon results. Reports for this separate feature may be sent in with Marathon scores.

All awards will be determined on the evidence submitted, and in accordance with the decisions of an award committee consisting of the VHF Editor, the ARRL Technical Director, and the ARRL Communications Manager.

Rules

1. The Contest is open to all U. S. and Canadian licensed radio amateurs, and will take into account operating and experimental work re-

*Communications Manager, ARRL.

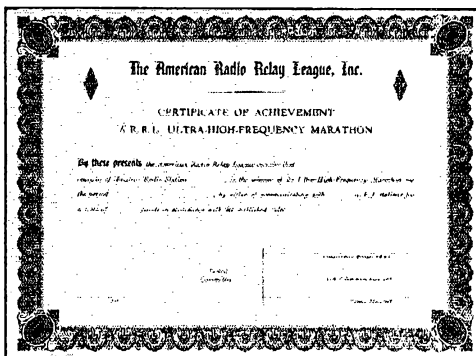

ported at monthly intervals during the contest period May 1 to December 31, 1946, inclusive.

2. Contact Points. Contacts may be scored for each completed QSO sufficiently good to permit exchange of intelligence with a station! *One contact only, per band, per year, per different station, counts in the claims.* Points claimed depend on distances measured by a great circle line between stations as follows:

Under 25 miles.....	1 point
25 to 75 miles.....	2 points
75 to 250 miles.....	5 points
250 to 500 miles.....	25 points
500 to 1500 miles.....	10 points
Over 1500 miles.....	50 points

3. Multipliers.

50-54 Mc. contacts.....	1
144-148 Mc. contacts.....	2
235-240 Mc. contacts.....	10
Contacts above 400 Mc.....	15

The frequency band of one's transmitter shall determine contact multipliers allowed (1, 2, 10, or 15) and permits cross band work to count.

4. Frequency Modulation Multiplier. For all contacts made in which the transmitter of the claimant is adjusted for and uses controlled FM, the points may be figured as in Rules 2 and 3 for various frequency bands, and then a multiplier of two in addition to any other factors may be applied. To earn this multiplier *contacts must be initiated on FM.* The factor of two may not be applied if contact is established on AM and then the transmitter is switched to FM. The use of FM at stations contacted does not affect your own score. Claims for a given station in a given band may include either an FM or AM credit, but not both.

5. Special Credit for Regular Activity. Additional credits, *one for each contact* with a different station, and not to exceed three points per day, may be claimed by each contestant as a bonus for regular activity. Total number of points claimed per month under this rule may not exceed 50. The same station may be worked on different days. Contacts for a particular day may be made on any band above 50 Mc. Contacts for which this special credit is claimed need not be listed in your regular Marathon report. Logs showing such QSOs must be kept available for call (in proof of the points, if requested by the award committee). This monthly credit is added after the score has been determined under Rules 2, 3 and 4.

6. Extra Portable or Portable-Mobile Credits. In addition to credit for work with a fixed or permanent amateur station, one extra credit for communication with that same station operating portable or portable-mobile, may be claimed for a given band. Such stations may be considered to be *different stations* when they operate afield. If more than one contact is made under these conditions, only that for the greatest distance is counted. All locations of temporary stations of portable or portable-mobile character must be accurately defined to permit a valid claim. Fixed-portable stations, or those using the portable designator *because of operation at a new address* and not actually portable or portable-mobile, may not be counted additionally if they have been worked while located at a previous location; if the new location is at a greater distance, however, the QSO with the second location is then claimed.

A portable or portable-mobile equipment may be used by the competitor himself, and when duly controlled and operated by this individual, points in addition to those attained by contact with particular stations included in claims resulting from operation at his fixed station may be granted. Only one such additional credit for each station worked both from the home location and the portable or portable-mobile location shall be allowed. Where more than one contact is made in portable status, the extra credit claimed shall be that for the contact over the greatest distance.

7. Reporting. Monthly claims must be made in the form of a "stations worked" list, *showing station calls, locations (city & state), distances and points for each QSO and giving claimed total of all credits for a given reporting month (1st to 31st inclusive).*

Reports must be sent *at once* after each reporting month for claims to be allowed, *i. e.* reports for a particular month must bear a postmark *not later than* the 8th of the following month. Special mimeographed report forms available from the ARRL Communications Department, should be used (or facsimile of such forms) in making monthly reports.

8. Proof of contact in writing from any stations contacted may be required as prerequisite to credit whenever thought necessary by the award committee. FCC logs may be submitted as necessary to straighten out points in doubt.

Each competing score shall be that obtained by one operator, operating equipment under his individual control. Club stations may take part. The highest one-operator score shall be submitted. Reports from other club station operators may be submitted for mention.

The Award Committee may declare "no award" if fewer than three entries turn up in any classification or may declare "duplicate awards" if circumstances warrant. ARRL staff members may participate but are ineligible for awards. It is not required that an amateur be a League member to take part fully. All licensed W/VE hams are invited to report their worked lists and point claims for each reporting month as explained in Rule 7. Decisions of the Award Committee shall be final.

Mail all reports to ARRL Communications Department, West Hartford, Connecticut.

Silent Keys

IT is with deep regret that we record the passing of these amateurs:

W4BCB, F. C. Nedley, Tallahassee, Fla.
W6JPN, Halford M. Postle, Van Nuys, Calif.
W6NRJ, John G. Hoser, Los Angeles, Calif.
W6RBI, Richard F. Poag, Long Beach, Calif.
W7HTD, Lt. (jg) Paul D. Searles, Beaverton, Ore.
W8CPC, Dr. Burton T. Simpson, Buffalo, N. Y.
W8MJB, George J. Geary, Point Marion, Pa.
W8ONX, S/Sgt. Roy Bixler, Salem, Ohio
W9WLK, Dwight J. Stebbins, Morris, Minn.
XU3MA, Dr. Wm. Malcolm, New York, N. Y.
Ernest A. Moreau, Detroit, Mich.

Strays

ATTENTION — S/SGT. J. D. WHEATON and PVT. LEIGH ROBARTES JR. The Victory Stamps awarded for your Crystal Ball contributions await you at ARRL HQ. Please send us your correct mailing addresses.

Operating the 807

Some Pointers on Eliminating Common Troubles

BY DONALD MIX,* WITS

ALTHOUGH THE 807 is one of our most popular low-priced transmitting tubes, it is probably the source of more trouble than all other types put together, except perhaps the poorly-screened 6L6. This situation arises not so much as a fault of the tube, but in the way it is handled. Treated properly, it can be a pleasure to operate, but if it isn't given consideration, it will get even with you by putting parasitic signals all over the band (and outside too) not to mention putting the bite on your pocketbook for replacements.

One of the chief reasons for its reputation as a bad actor among those who have had sad experiences with this and other r.f. beam tubes is the one which makes it so desirable — namely, high power sensitivity. For efficient operation at full power, the manufacturers recommend a driving power of one-quarter watt, but appreciable output can be obtained with much less excitation. The considerable advantage over a triode of equivalent output rating, which may require as much as five watts, is readily appreciated. However, a very low excitation requirement means that a very small amount of feedback will cause self-oscillation. For this reason the input and output circuits must be much better isolated, if trouble is to be avoided, than in the case of a triode whose power sensitivity is much lower.

Satisfactory reduction in coupling between the two circuits at the operating frequency is not difficult if it is done correctly. Metal construction which provides shielding and a means of obtaining a good common ground connection is almost a necessity. Since the portion of the grid lead which passes through the glass seal and the base of the tube is not shielded, an external shield should be provided to eliminate the capacity between this wire and plate-circuit components which may be placed near-by. If the chassis is 3 inches or more in depth, the socket may be lowered on brackets so that only the top portion of the tube protrudes above the chassis, which then provides an effective shield. If the socket is to be mounted on the chassis, it should be sub-mounted so that the grid terminal is underneath and the lower portion of the tube should be enclosed in a cylindrical shield extending from the chassis up to the level of the bottom internal ceramic washer. A long looping plate lead should be avoided, elevating the tank condenser, if necessary, to permit a short plate lead. If the lead must be long for some reason, it should be

• This article discusses some of the practical operating characteristics peculiar to the 807 and other beam tubes. Suggestions for avoiding many of the troubles often experienced with tubes of this type are included.

kept well spaced from the bottom portion of the tube.

It is preferable, particularly at frequencies above 14 Mc., to place the driver plate-circuit components, or those for the grid tank circuit if link coupling is used, below the chassis, keeping the plate tank coil and condenser above. If parallel plate feed is used, the r.f. choke and blocking condenser also should be above the chassis. When plug-in coils are used it is usually not feasible to place the grid tank coil underneath the chassis, although the layout may permit the grid tuning condenser to be placed there. If space is available, plenty of room should be left between the two tank circuits. In any case, the grid and plate coils should be placed with their axes at right angles.

Unfortunately the tank circuits formed by the coils and condensers are not the only ones present. Leads, r.f. chokes and by-pass condensers can combine to form circuits which will cause oscillation all too readily at frequencies considerably removed from the operating frequency. R.f. chokes may combine with by-pass condensers to form a low-frequency t.p.t.g. oscillator circuit, but since the 807 screening is very effective at these frequencies it is seldom that sufficient coupling will occur to cause this type of parasitic oscillation. The most common trouble is oscillation in the v.h.f. region where the screening is not effective because the coupling is usually external to the tube. The leads to the screen by-pass condenser and to the cathode by-pass condenser also should be as short as possible. At high frequencies it is sometimes possible to avoid trouble by substituting mica by-pass condensers of smaller capacitance for the usual 0.01- μ f. paper condensers. If oscillation persists, one way to suppress it which has been found effective is to place a 50-ohm, 1-watt resistor between the screen terminal of the tube socket and the by-pass condenser, the voltage being fed in at the by-pass condenser end. This alone, or in combination with a v.h.f. choke in series with the grid, is usually sufficient to suppress any tendency to

* Assistant Technical Editor.

ward instability. Depending upon the length of the leads determining the frequency, the proper size of the choke may vary somewhat above or below 10 turns of No. 18 wire wound on a $\frac{1}{4}$ -inch diameter. A few turns either one way or the other may make considerable difference.

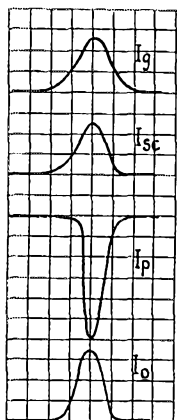

Fig. 1—Tuning characteristics of an 807 with proper electrode voltages, excitation and loading.

TANK CAPACITANCE →

Beam tubes are much less tolerant than triodes in the matter of excitation. The manufacturer's recommendations should be followed closely both in regard to biasing voltage or grid-leak resistance, and screen voltage or screen-voltage-dropping resistance. Fig. 1 shows a group of tuning characteristics for an 807 amplifier in which the various voltages and currents have been adjusted properly. A slight rise in grid current occurs at the point of minimum plate current. The screen current also shows a very slight rise at the same point. Maximum output is coincidental with minimum plate current.

If the tube is under-excited, the curves do not look so pretty, as will be noted from Fig. 2. Here the grid-current side of minimum plate current and a decrease on the high-capacitance side, in respect to the grid current at the point of minimum plate current. The screen current shows a slight irregularity also on the low-capacity side. Probably the most annoying characteristic is that maximum output occurs not at plate-current minimum but at a point on the low-capacitance side of minimum where the input runs higher. The plate-current dip no longer is an indication of maximum output.

While some increase in power output is possible by running the grid current in excess of the recommended value if the tube is heavily loaded, it is not to be recommended, because grid and screen dissipation increase rapidly—often with disastrous results to the tube.

Beam tetrodes differ considerably from triodes in the matter of off-resonance plate current. When using a triode whose rated loaded plate

current is 100 ma., it is not uncommon to have plate currents of 150 to 200 ma. when the plate circuit is tuned off resonance. On the other hand, the off-resonance plate current of a beam tube may be only a few milliamperes higher than the rated loaded value. However, the output does not flatten off with the beam tube as it does with the triode when the loaded plate-current value approaches the off-resonance value. In fact, it is possible to load the tetrode to the point where no noticeable dip is obtained without encountering this flattening off of output.

Our experience with beam tubes has been that they will not stand up under the relatively terrific temporary overloads which a triode of equivalent power rating will withstand when the plate circuit is detuned, especially with the grid current above normal. Several 807s which were tried started to disintegrate rapidly when the plate current was tuned off resonance while the grid current was about twice the recommended value. This means a grid current of only 6 ma. instead of 3 ma., a value which is easily obtained if a close check is not kept on the driver adjustment. In some cases the grid current reversed, causing a \$1.95 display of fireworks before the high-voltage switch could be pulled.

Increasing screen voltage over the manufacturer's recommendations seldom results in increased output. In fact, the tendency is for the screen and plate power both to increase while the output may actually decrease after the optimum value of screen voltage has been reached.

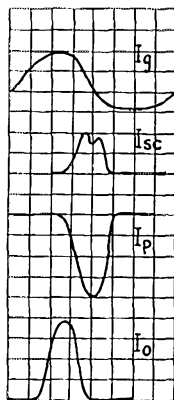

Fig. 2—Tuning characteristics of an 807 with less than adequate excitation.

TANK CAPACITANCE →

So far as efficiency and tuning characteristics are concerned, it seems to make little difference whether the bias and screen voltages are obtained from fixed sources, from a grid-leak and voltage-dropping resistor, or from a combination of the two, so long as the rated grid current is used. If, in the case of the 807, an extra 50 volts is available from the plate-voltage supply, cathode-resistor biasing may be used with identical results.

(Concluded on page 188)



The World Above 50mc.

CONDUCTED BY E. P. TILTON,* WIHDQ

MAY! THAT magic month for poets, gardeners and v.h.f. enthusiasts is upon us again, and May, 1946, has a special appeal. Not only does it represent the opening of the spring DX season, our first since 1941, but we are sailing in uncharted waters this time. Ever since it appeared that a new band was in prospect, to replace our old 56-Mc. assignment, we've speculated on the possibilities of this new 6-meter band. Now we're on the verge of finding out what it will do.

In the years since sporadic-E skip was first observed, workers on the five-meter band learned to watch the frequencies between 28 and 56 Mc. to tell whether Five was going to open up too. As the old assignment was near the top of the range where such skip occurs, we often observed skip signals on 28 Mc., on the police frequencies, and even into the f.m. and television bands just below our five-meter band, without any DX contacts resulting for us. The displacement of our assignment six megacycles lower in frequency should change that picture appreciably. We know that scores of old hands at catching openings will be watching the new band closely for the first sign that indicates a chance for DX work. They should have had their first taste before this appears in print.

As this material is being prepared there has been no sporadic-E work in the new band, and short skip has not been in evidence to any great degree on 28 Mc. Few contacts have been made by auroral reflection on 50 Mc., though there were a series of brilliant auroral displays and a considerable magnetic disturbance during March 23rd, 24th, and 25th. Auroral "fuzz" was noted on all 50 Mc. signals from more than a few miles away, and several WIs were reported heard in New Jersey, but the only contact known to have been made, at this writing, was between W8CLS/1, Waltham, Mass., and W3HDJ, Delanco, N. J., at 9:30 p.m. on the 25th. W1AEP, WILLL, W1HXP, and WIHDQ were among those who were in there trying. Past experience on 56 Mc. has indicated that the likelihood of auroral DX is greatest when there is a pronounced auroral curtain in the northern sky, rather than a diffused display as existed during the period mentioned above. A similar condition

* V.H.F. Editor.

RECORDS

Two-way Work

56 Mc.: W1EYM-W6DNS
2500 miles — July 22, 1938

112 Mc.: W1BJE-W3FYB
355 miles — September 6, 1945

144 Mc.: W6OIN/6-W6UID
100 miles — January 10, 1936

224 Mc.: W6IOJ/6-W6LEN/6
135 miles — August 18, 1940

400 Mc.: W6IOJ/6-W6MYJ/6
60 miles — September 14, 1941

5250 Mc.: W2LGF/2-W7FQF/2
31 miles — December 2, 1945

occurred in September, 1941, when the most brilliant auroral display in recent history produced only a brief flurry of DX signals on 56 Mc., at the beginning and ending of the show, when the display was confined to the northern sky. Some of the strongest aurora-reflected signals ever heard on 56 Mc. have come through at times when no aurora was visible at all, during daylight hours, or at times when cloudy skies prevented visual observation.

It is quite possible that the effect of the magnetic disturbances on 50-Mc. propagation may be appreciably different from the familiar 56-Mc. pattern; thus it is more important than ever that anything unusual be reported. Let's hear about it, gang!

May is good news to the 2-meter men, too. Signals are at last beginning to filter through from points up to 100 miles and more, after the long winter period during which we did well to work a distance of 25 miles. At WIHDQ we've been experimenting with various 144-Mc. arrays within the limits imposed by the rigors of a New England winter. With anything up to six elements, horizontal or vertical, we merely raised the level of our signal at stations we were already able to work with simple dipoles. The reliability of our coverage (up to about 40 miles) was improved by any of several arrays tried, but none of these broke down the path to several points near the 100-mile mark, from which we'd been hearing weak signals from time to time. We were deter-

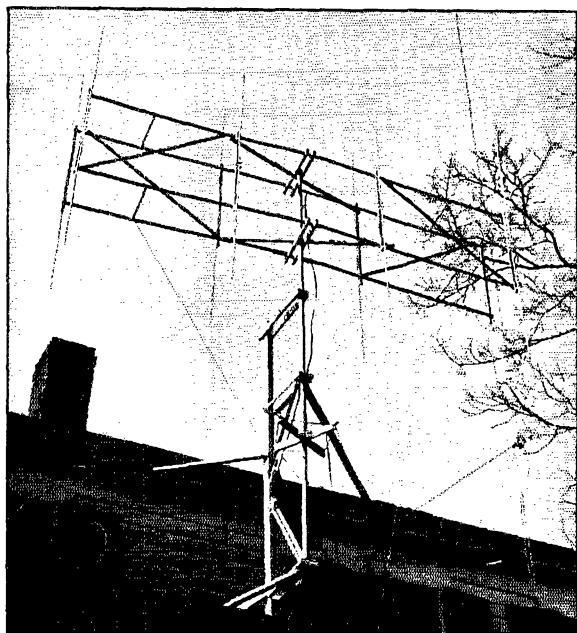

Detail photo of the 16-element array at W1HDQ, showing supporting structure and "rotating mechanism." Sash cord wrapped three times around the criss-cross pulley permits 360-degree rotation.

mined that, come spring and antenna weather, we'd put up the "beam to end all beams," and push a 2-meter signal into Eastern New England and the New York area, or know the reason why.

By the second warm spring day, the 16-element array pictured on our front cover had blossomed forth on the front porch roof at Selden Hill — the same old porch roof that took such a beating back in the heyday of the late Ross Hull. The result on 144 Mc. was a furor in Eastern New England not unlike that created back in 1934, when Ross' 56-Mc. beams began pumping a walloping signal into the Boston Area on Five. During the week-end period including March 15th, 16th and 17th, stations in five states were contacted, several of them being more than 100 miles distant, and all over hills nearly 1000 feet higher than the elevations at each end of the path. The signal strength at semi-local range was also raised to a new high, and a number of stations in difficult locations were worked for the first time. The stations listed below were among the first raised.

- * W1LPO Newport, Rhode Island 85 miles
- * W1ME New Bedford, Mass. 105 miles
- * W2JWO Patchogue, Long Island 80 miles
- W1DHX Fall River, Mass. 90 miles
- W1MGL Norfolk, Mass. 85 miles
- * W1JDF Salem, New Hampshire 115 miles
- W1ZE Mattapoisett, Mass. 110 miles

* Indicates first contact with that state from W1HDQ.

All these stations, and many others worked since, were not weak barely-readable signals — they really pounded in, at levels of S7 or better, and frequently peaked over S9. Monday morning's mail brought numerous reception reports from points beyond our previous working range, the most distant being from W1IPA/1, who reported hearing us S6 while working portable-mobile near Dennis, on Cape Cod, more than 140 miles distant! The contact with W1JDF is 144-Mc. history, as it represents the first work between Connecticut and New Hampshire on that frequency.

The response was tremendous. "How about sending us the dope on that beam?" was a standard query. W1LPO wanted to know "Is the band open, or are you opening it with that array?" The best answer was to switch to our comparison antenna, a folded dipole, for a test transmission. Though the signal from W1HDQ had been running consistently above S7, it was inaudible in Newport when the folded dipole was used, though the loading was identical with the two antennas. Repeated tests showed that we could get through weakly with the simple antenna, when conditions were riding a peak, but under the

same conditions the 16-element was giving us "local" characteristics — the difference being in the vicinity of 12–14 db., which is close to the theoretical gain for such an array.

Actually the phenomenal difference in signal with and without the array stems in part from the fact that a superregenerative receiver has a steep sensitivity characteristic in the range between inaudibility and what is commonly called S9 — the point at which all background hiss is suppressed. This is true of all receivers, though to perhaps a lesser degree; i.e., only a small change in level is required to make a tremendous difference in the apparent strength, when no a.v.c. is used, as in c.w. reception. With 'phone reception on a communications receiver we *see* rather than hear the difference by watching the variation in S-meter reading. When you pour it on with a high-gain v.h.f. array, the boys with the superregens really *hear* the difference, and it sounds like plenty!

No black magic was used in connection with this 16-element array. It is a perfectly straightforward setup, the conventional eight half-waves in phase, shown in Fig. 1, with eight reflectors spaced approximately two-tenths of a wavelength in back of the curtain of driven elements. The reflectors were omitted from the diagram for the sake of clarity. The cumbersome nature of the structure required to support such an array would make its construction out of the question for any

lower frequency, but for 144 Mc. the outside dimensions of the array are only $1\frac{1}{2} \times 7\frac{1}{2} \times 10$ feet, and the supporting frame can be made feather light. The entire frame of our array is made of $\frac{1}{2} \times \frac{3}{4}$ -inch spruce, and with elements mounted, the whole structure weighs less than 10 pounds!

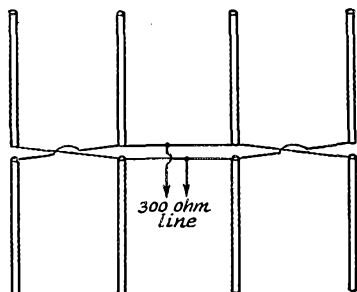

Fig. 1 — Schematic of the radiating portion of the 16-element array. Reflectors are omitted for clarity. Radiators are 38 inches long, reflectors 40.5 inches. Cross-over or phasing sections are also 40.5 inches long. Reflectors are mounted 17 inches in back of each radiator.

The center pole (a $1\frac{1}{2}$ -inch rug pole 10 feet long) turns in three bearings which are mounted on braced arms extending out about two feet from a vertical "two by three," which is braced in position on the porch roof. An improvised pulley made of two pieces of 1×2 -inch "ferring" notched in the ends and fastened criss-cross fashion near the bottom of the center pole serves as a "rotating mechanism." Sash cord wrapped three times around this "pulley" and run over to the window on small dime-store pulleys allows the beam to be rotated more than 360 degrees before reversal is required. To keep the array from twisting in high winds light sash cords are attached near each end of the supporting structure. These cords are brought through the window near the rotating ropes and are pulled up tight and fastened when the antenna is not in use.

The elements are of $\frac{7}{16}$ -inch soft aluminum tubing for light weight. To stiffen the structure, and to help to maintain alignment, inserts were turned down from $\frac{1}{2}$ -inch polystyrene rod to fit tightly into the elements at the point where the cross-over or phasing wires are connected. Similar inserts are used for the reflector elements also. The interconnecting phasing sections are of No. 16 wire, spaced about $1\frac{1}{2}$ inches. The feed-line, connected at the center of the system,

is Amphenol Twinlead, 300 ohms impedance.

That the match at this point is fairly close is indicated by the fact that the array will load with any length of line, and the standing-wave ratio on the line is low enough to be inconsequential, so that no matching transformer need be used. One word of warning; don't expect an array of this sort to show up impressively when tested with a neon bulb — we were sure that this one was no good at all until we listened on it a bit. Then our doubts were dispelled in a hurry!

Though it is difficult to find evidence of r.f. in such a system with a neon bulb, there is no lack of field strength in the right places, as the field pattern shown in Fig. 2 will demonstrate. This was taken with the remote-indicating field-strength meter described elsewhere in this issue. The small circle represents the field around our comparison antenna. The dotted line shows the pattern of a 5-element parasitic array, the mounting of which did not permit complete rotation. A look at the solid line representing the field pattern of the 16-element array shows why ease of rotation is a "must" — at 10 degrees either side the power begins to drop sharply, and at 20 degrees it is down almost to zero; in fact, the pickup in these nulls is not appreciably greater than with no antenna connected to the receiver. This is of untold value in working DX when other stations are active locally. No ham antenna is apt to be perfect, and this one is no exception — note the considerable minor lobes resulting from other antennas and house wiring. Still, the front-to-side ratio is

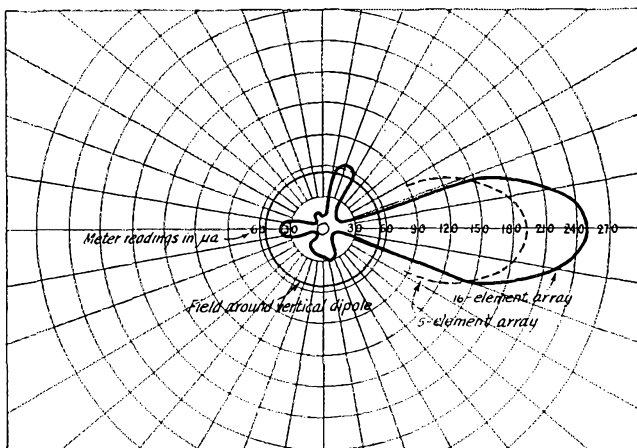

Fig. 2 — Field pattern of the 16-element 144-Mc. array, showing comparisons with a 5-element parasitic array and a simple folded dipole.

sufficient to make all but the strongest of locals drop completely out when they move into a null as the antenna is rotated.

Interest in the possibilities inherent in the use of such high-gain arrays at both ends of long v.h.f. paths is high, and early reports indicate

WHO WILL MAKE THE FIRST 50-MC. W.A.S.?

In the period just before the outbreak of war, several 56-Mc. operators were close to having worked all 48 states on five meters. The moving of the assignment in this range to 50 Mc. brings W.A.S. within the realm of possibility for almost any v.h.f. worker. It will not be done easily nor quickly, and the man who makes it will have done some real promotional work to get stations on the band in the hard-to-get states.

To recognize the outstanding effort involved in working all 48 states on 50 Mc., ARRL announces a permanent W.A.S. Contest for 50-Mc. workers. A suitable award, as yet to be selected, will be given to the first operator who makes two-way contact with all the 48 states.

The contest is open to all W and VE operators. Contacts must be made by a fixed station operating in one state (mobile contacts made on tours do not count) and must be two-way work on 50 Mc. No cross-band work will count, though this is acceptable for Marathon scoring. Send in your states-worked total, with details of new contacts made, by the 8th of each month. Scores will be listed regularly in *QST*, but stations not reporting regularly will be dropped from the list — there will be no "dead wood" in the *QST* listing. *QSL* cards or other "proof of contact" will be required.

Records for the contest may start with March 1, 1946, the date the 50-Mc. band was opened to amateur operation. The contest will continue until someone makes the grade!

that the New England coast will soon bristle with 16-element arrays. For our part, we feel that the array in its present form is fine, but we think it will be really hot when we turn it over horizontal and get that sharp pattern in a vertical plane! This will be done after its vertical performance has been more fully explored.

Another 16-element array has been producing excellent results at W3HWN, Mechanicsburg, Penna. With only 60 watts input to a crystal-controlled 829, Paul worked W3GMY, Vineland, N. J., on March 17th, a distance of more than 120 miles! Both stations were working from home locations and taking part in the 144-Mc. DX contest sponsored by the Lancaster Radio Transmitting Society and the York Amateur Radio Club. Contact was first established at 10:27 A.M. and W3GMY was heard thereafter for most of the day. Also heard at W3HWN were W1IRV/3, Mt. Ephraim, N. J., and a W8R?? in New York. In addition to the above, 33 stations were worked, the majority being over hops of 40 miles or more.

Preliminary reports received on the 144-Mc. contest indicate that it was a huge success. One of the high-scoring stations was W4HXA/3, who with the help of W3KAK set up a complete station at an 1100-foot elevation in the Welsh Mountains, near Mt. Airy, Penna. With an m.o.p.a. rig consisting of a 6J6 oscillator, 832-A buffer, and 829-B final, 42 stations were contacted, including several in New Jersey, some of them around 100 miles distant. The antenna was a "J" fed with 300-ohm line, mounted atop a 70-foot mast. W2KAR/3 had an 815-829 m.o.p.a. and a square-corner reflector. He worked 21 stations, including some in New Jersey. W3AQN/3 at Mt. Pisgah had 30 contacts with an HY-75 rig operated from a gas engine driven generator. W3BKB, York (829 xtal) made 25 contacts, and 20 or more were made by W3LN (829 m.o.p.a., square-corner antenna), W3GGT (8-watt rig, 3-element beam), W3DRO, W3EDO, and W3BTP. A fine time was had by all, and another similar contest is planned for early summer.

The W3HWN-W3GMY work is the record dis-

tance thus far reported for 144 Mc. two-way work, and will be listed as such when confirmation is obtained from W3GMY, but it barely edges out a contact reported by W6JXZ, Van Nuys, California, who worked W6OIN at San Diego on March 4th. This hop is close to 120 miles, and is impressive when one considers the elevations in between the two, the intervening terrain running up well over 1000 feet from sea level. Stations in Long Beach and Los Angeles are worked regularly, the distance being about 30 miles, also over elevations up to over 1250 feet, with signals at the S9 level most of the time. The receiver at W6JXZ uses a 6AK5 triode-connected mixer, with a 3-inch diameter coaxial line 14 inches long as the tuned circuit. The oscillator is a 6C4. Three stages of i.f. at 10 Mc. are used, two with 6SG7s and one with a 6SH7. The whole setup is home built, including the air-tuned i.f. transformers.

W6JXZ points out that the ratio between the diameter of the driven portion of a folded dipole and that of the parallel sections provides a flexible means of matching the center impedance of a parasitic array to almost any sort of line. Following this line of thought, the match at the center of the 3-element array described in March *QST* in the article entitled, "Need There Be Line of Sight?" would be better if all components of the radiating element were made of the same diameter material, rather than using two wires in parallel with a driven section of tubing. A similar match might also be obtained with a 2-section dipole by making the driven section one-third of the diameter of the parallel section.

We've been asking for more information on v.h.f. DX heard or worked during the war period. Here are three more reports. At the Greenville, S. C., C.A.A. station, Ellis Huguley, LSPH, has contacted aircraft over Washington, D. C., on 116.1 Mc., a distance of more than 400 miles. Planes at 3000 feet or more can be worked over a radius of 150 miles, and craft as low as 500 feet above the Atlanta airport, 140 miles away have

(Continued on page 128)

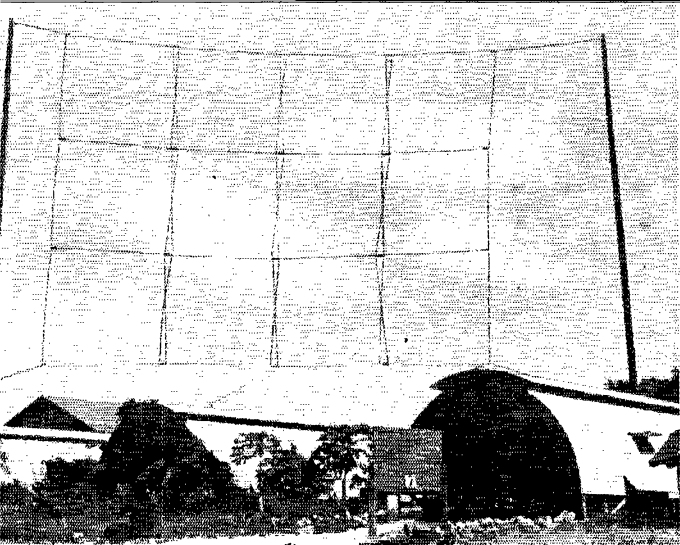

W6MBA/Tinian

THE POST-WAR ten-meter activity has brought forth few stations more outstanding than W6MBA/Tinian. This busy and widely-sought-after station turned in a performance that will be long remembered by those fortunate enough to effect a QSO and its signal will be recalled with longing by those who burned up countless kilowatts — and failed.

For W6MBA/Tinian passed from the amateur scene on March 5th when the station's prime-mover — Winton W. Smith, 2nd Lt. AC, W6MBA, of Los Angeles, closed the station preparatory to his transfer to Manila.

In response to an urgent plea by W2OEN/1 during a QSO, W6MBA air-mailed the accompanying photographs of his Tinian layout, and a letter from which we quote:

"The first thing to do is to explain the suffix, Tinian. We are authorized to operate on ten meters. However, we have to use the suffix of *Tinian* instead of that used by the boys on Guam. The reason is that Tinian is a former Japanese possession. I might add, though, that it is not advisable to sign out *Tinian* and so, on c.w., it is often dropped for the KB6 of Guam.

"The rig at W6MBA/Tinian consists of a pair of HK24Gs, in the final, running about 150 watts on 'phone and 170 watts on c.w. Actually, we took an old Army transmitter and tore out the r.f. section and built the new transmitter, utilizing only the power supplies and the modulators. A pair of 809s do the job on that.

"The receiver is a Hammarlund Super-Pro that was never meant for ten meters. One of the low-frequency bands was torn out and new coils wound for ten meters. During the process of rebuilding the receiver, an additional stage of pre-selection (a 6AG5) was built into the receiver. This gave us a receiver that out-performs any others we have tried against it.

"The antenna, of course, is our pride and joy. Actually, it is a stacked collinear broadside beam, consisting of four sets of collinear elements, each

having four half waves. This gives us sixteen half waves in phase. The collinear elements are spaced a half wave apart. This "four-by-four" (as the Zs call it) is slung between a pair of eighty-foot poles and is so orientated that its beam is directed 47 degrees east of true north. The center of the beam cuts the California-Oregon border and comes out at Miami. The feed system is a quarter-

(Concluded on page 138)

The operating position at W6MBA/Tinian. The cabinet houses a pair of HK24Gs and the associated transmitting equipment. A monitor and an aircraft receiver rest on the shelf above the Super-Pro.

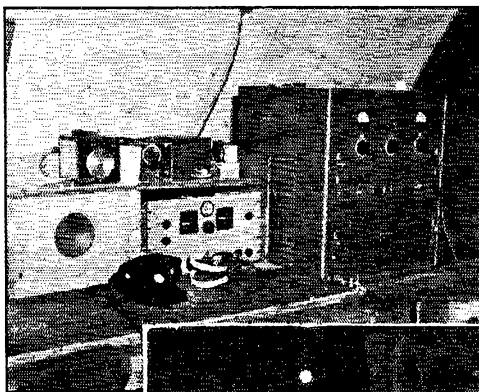

W6MBA leans on a BC-610 and we can almost hear him saying: "Now, if only I had this on ten meters!"





Hints and Kinks

For the Experimenter



AN OPERATING CONSOLE FOR THE AMATEUR STATION

MOUNTING equipment in a console desk was suggested by looking over many commercial installations which tend toward this arrangement. Such a console was built at W9EYN several years ago and has been a source of great satisfaction. Nearly every visitor to the shack contemplates construction of something similar when they realize all the advantages possible. The design makes a hit with the XYL also, since most of the unsightly equipment that usually clutters up the operating table is neatly mounted out of sight. An entire station may be built into such a console, depending on size and how much auxiliary equipment it is desired to locate at the operating position. At W9EYN, it was decided to mount only the receiver, exciter, speech amplifier and monitor in the desk — with, of course, the necessary power and bandswitching controls for a remotely-located transmitter.

There are many possible arrangements for equipment. It would seem logical to mount the receiver in the center panel with sufficient space remaining for power controls, monitor, modulation indicator, and similar accessories. The v.f.o. may be located on one side with speech input con-

trol and speech amplifier on the opposite. There is ample space for power supplies, as well as other units not requiring direct control, in the rear lower section of the desk. Lower side cabinets have room for log books, QST files, and other station necessities.

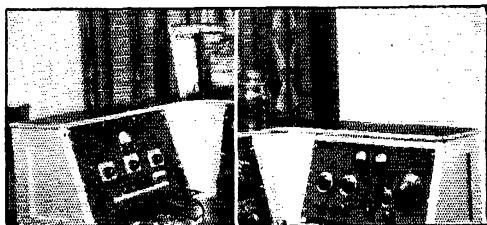

A close-up of the left-hand panel of the console. The controls for the speech amplifier and the audio circuits are located on this panel. The right-hand panel contains the v.f.o. and the exciter. The dials at the right of the central panel control switching circuits for the remotely-located transmitter.

As to construction, it is suggested that the console be made in detachable sections. It becomes a rather large piece of furniture and difficulty might be experienced if it had to be moved. In the desk at W9EYN there are six sections. Three lower units make up a U angle which is

bridged by the operating table top. Three upper sections mount the panel equipment. The sections may be made up in the form of open framework, with spaces not filled by equipment paneled in with plywood or other type material. Angle iron strips can be used to mount the panel-supported equipment. Each side section should have removable cabinet-type doors to allow access in rear. The back of the console might be left open. A shelf across the back lower section affords plenty of space for power supplies.

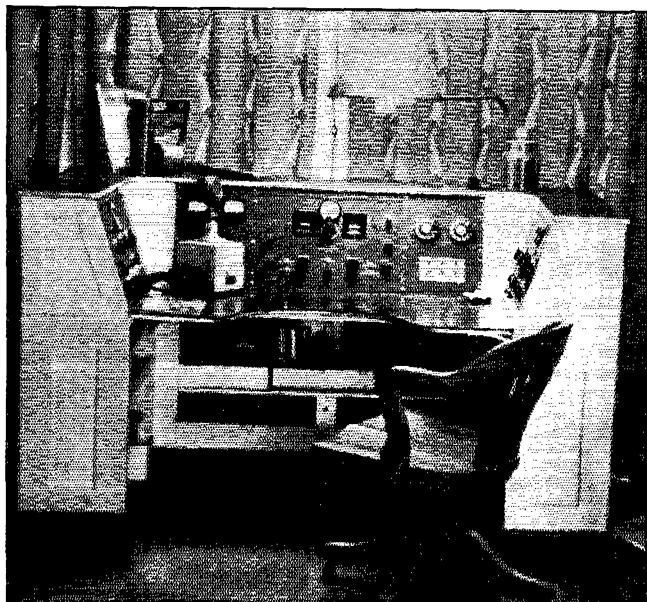

◆
Front view of the console at W9EYN. The panels beneath the writing shelf have been removed to show the space available for power supplies and other units not requiring adjustment.
◆

Complete constructional details are not given here, but Fig. 1 supplies suggested measurements. The operating table top is lower than usual. This allows a more comfortable position for the arms and shoulders. A semicircular cutout is made in the front of the table to allow the operator to reach controls conveniently, and the position is excellent for a key or bug located at one side. The suggested dimensions allow the mounting of two 19-inch panels in the center, and one 19-inch panel to the right or left.

If good wood is used the desk might be finished in natural grain and a really nice piece of furniture constructed. The desk at W9EYN got a coat of flat paint which has been since regretted. To further trim and finish the project, cover the table top and upper shelf with battleship linoleum, securing the edges with metal strip available for the purpose. — *Joe Rohrer, W9EYN.*

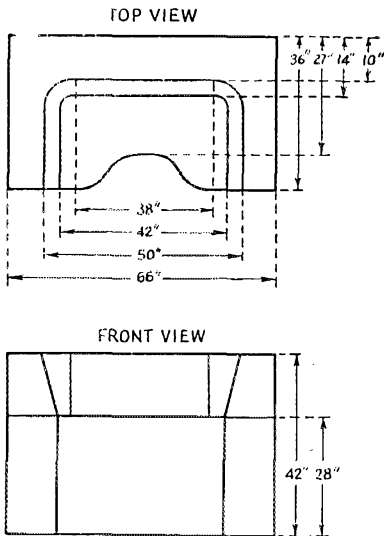

Fig. 1 — Outline dimensions and layout of the console built by W9EYN. Note the low (28 inches) writing shelf that offers a high order of operating convenience and comfort.

A NOISE SILENCER USING GERMANIUM CRYSTALS

MANY STATIONS are bothered by ignition and other noises often to the point of spoiling what would be a good QSO. As a result of the war, there has been developed a diode that has characteristics such that a remarkable noise silencer can be made in most communication receivers with a minimum of change. The diode is the new 1N34 Sylvania germanium crystal that exhibits polarized nonlinear current-voltage characteristics. This diode starts to work with much less signal than the typical vacuum-tube diode and

has less electrostatic capacity, making it more suitable for a high-frequency i.f. amplifier. The circuit shown in Fig. 2 is in use by the writer and a brief description follows.

Fig. 2 — A second detector and noise limiter circuit utilizing germanium crystal rectifiers instead of tubes.

- C_1, C_2 — 50. μ fd. mica.
- C_3, C_4 — 0.1. μ fd. paper.
- R_1 — 47,000 ohms.
- R_2 — 0.27 megohm.
- R_3 — 0.1 megohm.
- R_4 — 0.33 megohm.
- R_5 — 1 megohm.

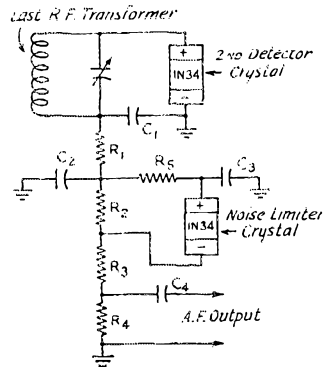

© In the schematic the diode load resistor is the series combination of R_1 through R_4 . C_1 and C_2 in combination with R_1 make up the r.f. decoupling network.

Resistor R_2 is where the noise is dissipated. As can be seen, the 1N34 germanium diode is connected in shunt across the resistor after first being connected through a 0.1 second constant RC network. R_3 is an audio decoupling filter before the audio output network R_4 plus C_5 .

This silencer is remarkably effective on noise of pulses of steep wave front and short duration such as are emitted by automobile and aircraft ignition systems. — *Wm. P. Frankart, W9KPD/6.*

RELAY COIL TRANSIENT REDUCTION

AFTER I installed a Model 750 Advance overload Relay in series with a ground return from my final amplifier, I found that when I adjusted it to kick out at 320 ma., under steady-state conditions, it would not handle the transients due to normal turning on and off of the plate power supply. If I adjusted the threshold so that it would withstand the transient voltages, then it would not kick out, except under extreme conditions of steady overload. Since the d.c. resistance of the relay coil was only 6 ohms, I was afraid that I might have trouble slowing down the transient, especially since I did not know what the wave form of the transient looked like. To be on the safe side, I shunted the field coil with a 3000- μ fd. 10-volt Mallory condenser, and found that the transient was completely tamed. It is quite possible that a lower value of capacitance would do the same trick. — *D. W. Atchley, jr., W1HKK.*

How's DX?

How:

DX contacts, like the dreams in that popular song, are getting better all the time. Every week countries crop up that give even the jaded old timers a new lease on life, and the fact that it isn't always the easiest stuff in the world to work just makes the game a little more exciting. The 10-meter band always was the craziest and most wonderful band we have, and if you can stand off the men in the white jackets long enough you can run up a good total.

Lately we have had reports from fellows working stations a few hundred miles away when the beam antennas were not pointed at each other, and the conjecture has been that possibly the signals were going around the world, particularly since the signals have a very hollow sound to them. The ionosphere boys, whose business it is to study these things and find the answers, call this effect "scattering" and say that these signals are reflections from a distant point, as shown in Fig. 1 on page 60 of the January, 1946, *QST*, and we are in no position to argue with them. On 28 Mc. one also runs into reflections from the aurora — both borealis and australis — but this is generally recognized by the fluttery characteristics it gives the signals. So, round-the-world signals on 7 and 14 Mc., but probably not on 28.

What:

There are plenty of guys to welcome back this month, and a few juicy new ones to report. W3ASW starts the stuff rolling with VP6YB

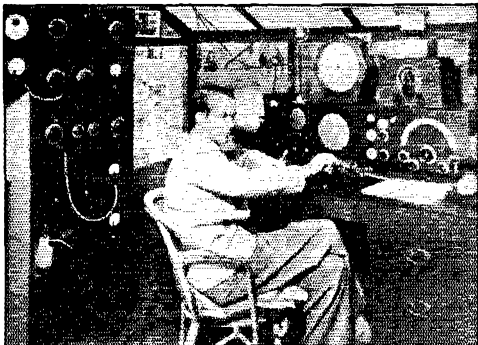

G8IG can afford to sit back and take things easy for a while. On February 28th he made WAC and WBE in 9½ hours by working, between 0822 and 1750 GCT, W4YA/XZ, XU1YQ, W8CJR/XU, XU1YK, ZS6FN, LU4EC, G3FJ, G6CU/ZC2, WIEN and VE3LC. The final amplifier is a T55, modulated by TZ20s in Class B, and the antenna is three wavelengths long, fed by 100-ohm line a quarter-wavelength from one end.

Attention, Foreign Amateurs

• We W amateurs have a new band at 11 meters. When the 10-meter band is open, listen for us on 11 also. Communication often should be better on 11 than 10, particularly when 10 is almost but not quite open. Your reports on their relative performance will be welcomed. Our exact limits are 27.185 to 27.455 kc.

(28,150 f), although the VP6 sometimes gets covered up by LU7AZ and VK2GU W8QFL is back and in business, starting off by raising W9EWY/VS6 (28,000) on a CQ, which is going to make anything else he does seem easy by comparison W2JJC heard VU2WP (28,080), the first report we've had on VU activity, and in the worked column there are I1KN (28,000), YR5C (28,050), and ON3A (28,100) W9YXO likes three-element beams. In the ten days after he got his up, he worked 28 countries, including LA4K (28,220), LA4P (28,220), OZ7CC (28,090), OZ2M (28,090), ZS2AL (28,050), ZS6AM (28,085), HB9CE (28,040), FA8B (28,015), OQ5AQ (28,005 T7), VQ3EDD (28,050), ZS5BZ (28,085) and ZP1A (28,050). No, Jeeves, that doesn't mean 250 countries in a month with a 9-element beam, so put down that catalog W8P MJ has HB9CV (28,160 T8), HH5E (28,120 T9) and TG9FG (28,040 T7) to add to the roster, and W7EYS comes up with XU1YM (28,180 f), WINQM/J5 (28,300 f), VK4LP/VK6 (28,430 f), VK5BF (28,390 f), W6RJG/J9 (28,410 f), KA1AF (28,380 f), TG9RC (28,080 f), PY2QK (28,200 f) worked and G6OM (28,095 f), WINNS/VO (28,120 f), VK7LJ (28,250), ZS1T (28,050 f), heard Old timer W7VY even takes a shot at the stuff, working W4YA/XZ (28,000), VK5FM (28,045), ZS5B (28,080) at 9 p.m. PST!, G8RQ (28,060) and LU1EP (28,000) for WAC and W2OAA/J8 (28,060), KA1AG (28,025) and XU1YU (28,080) for the fun of it WIHKK managed to get in a few 'phone contacts between arguments with the friendly neighbors who insist that his new rotary is not "a thing of beauty and a joy forever," and seems to be doing better with the DX than with the neighbors. As proof; ZP2AC (28,290), ON4SFA (28,200), SV1EC (28,260), OZ5BW (28,230), SU1MW (28,050) and XAAL (28,410). ZD4AC (28,730) was heard W2GNQ says GM3TR (28,065, 28,255 f), in the Orkney Islands, uses only 7 watts input and would like the gang to give a look W6ITH has his usual long list that looks like a

fugitive from the Call Book, and this month it includes 'phones like FA8JD (28,030), FA8NF (28,090), HK4JD (28,010), VO5TOM (28,090), HC1FG (28,000), CE2CE (28,095), TG9HS (28,120), ZE1JF (28,140), and lots of Pacific stuff Some of the more mellow 'phone stuff from W2MPA this month includes GM6SR (28,500), W9DCH/J (28,300), at Iwo, GW6JW (28,200), W2KQT/KB6 (28,100), XABY (28,300) in Greece, LX1DP (28,200), GI5YZ (28,150), XACR (28,050) in Greece, PAOJM (28,250), DXEH7 (28,600) in Poland and W7GXR/KB6 (28,150). In the heard column are included such as KA1AB (28,300), HB9J (28,300), W5HKB/J (28,200) and VE4AEV/VP8 W6AM found time to scare up W2ILE/K6 (28,035) on the Line Islands, 1900 miles south of Hawaii, and Don adds that he had a swell 11-meter QSO with K6TKA (K6CGK at key) using i.c.w. both ways. Hmmm, guess that's the first K6 we've heard of with i.c.w.!

Where:

Unfortunately for all, a number of foreign stations are saying "QSL via ARRL" and then forgetting to send in their address so that we can do some mighty sharp forwarding. Chief mystery man in this category is PJ3X (28,000), with PX1B (28,000) running a close second, so if either of them reads these pages here's hoping they will send in their addresses. (Why don't you work them and tell them yourself? — *Jeeves*) If we weren't so busy with other things we would swing the beam around and work them, but we like to think that they read the column. (If you haven't tried to raise them, why was the light bill so high last month? — *Jeeves*) (It got dark early!) (Not *that* early!) Here are some addresses, forwarded by the gang, that may partially solve some of your QSL-ing problems for the nonce: YR5X (28,150 T8) and YR5B via HB9AG; OQ5BQ (28,000), Maurice Plumen, Box 222, Leopoldville, Belgian Congo; YV5AP, C. Nouel, Avensa, La Guaira, Venezuela; PY2AJ, Box 446, Santos, Brazil; XU1YO (28,005 f), 700 Brewster Ave., Redwood City, Calif.; CX4CX (28,140 f), Jose Goylet, 1012 Blancos, Montevideo; CX2CO (28,125 f), Ricardo Sierra, Presidente Berro 2741, Parque de los Aliados, Montevideo; VQ4ERR (28,030 f), P.O. Box 1313, Nairobi, Kenya; G6ZO/I (28,000) and XAAZ, 2GHQ, Signals CMF, Caserta, Italy Via W2JIL, we learn that G8MF, who spent 3 months in a German prison camp, will QSL all prewar contacts that didn't get his card. His address is Tom de Putron, "Beverley," Les Hubits, St. Martins, Island of Guernsey, Channel Islands LZ1ID is on signing LZ1XX, and will QSL as soon as possible. Yours for him can go via us XU1YV (28,020) puts through a nice signal via a 6-element Sterba. He is ex-ARRL-Director W3QV, and QSLs go to his home address.

Why:

That squib elsewhere in this issue asking for dope on 28-Mc. skeds, the information to be used by the BuStan in their prediction work, is certainly tailored to fit the average good DX station. All it requires is a daily sked with some distant station and a record of the times contact was made and when it wasn't. It is the sort of

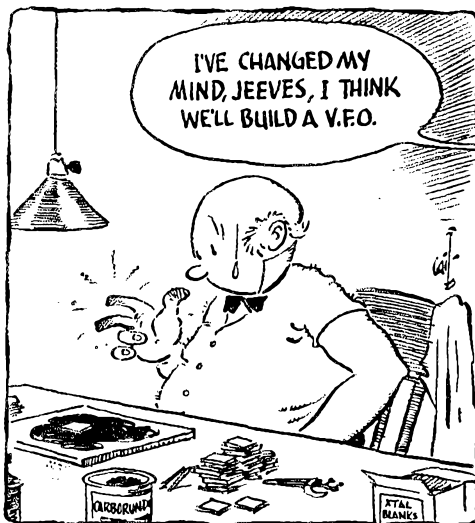

dope we've carried around in our heads and formed a sort of instinct about, but the ionosphere boys have to be a little more exact than, "Oh, the VKs should start coming through in November." Given several hundred schedules — a pushover for the DX gang — they will get information that they can get no other way. When you get through here, look up that squib and start figuring on a sked with your most reliable DX contact.

For what it may be worth, here is how W1DLC tuned his 3-element beam. The job is 28 feet off the ground, the elements are 3/4-inch tubing and the radiator is fed delta match. Dick says, "Perhaps you have noticed that when you connect a beam to a receiver there is one point somewhere, either in the band or out of the band, where the noise peaks up. Of course, this is its resonant frequency. I simply kept lengthening my elements with the 4% shorter ratio and 5% longer ratio being maintained, until I got the beam peaked on 28,010 kc., starting from the figures in the *Handbook*. The result was that the driven element was lengthened to 17 feet 5 inches. This may or may not be the reason I get out fairly well, but it works." It sure does, and only 180 watts.

Who:

Last month we mentioned that W6MBA/KB6 had a nice antenna, and elsewhere in this issue

(Continued on page 138)

The Cliff-Dweller's Antenna

While There's Wire There's Hope

BY C. G. PETERSON, * W2KJU

THE HAM WHO is an apartment dweller in the city is often up against what appear to be insurmountable handicaps when he tries to put up a decent skywire. Small roof space and nearby steel and concrete buildings are the worst headaches. Even the smallest roof will accommodate a half-wave on 14 Mc., but the real problem is what to do for an antenna for 40 and 80. It would appear that the c.w. traffic man and rag chewer is out of luck, but even in the worst cases some sort of compromise antenna can be made to function decently. You may not be able to get out quite as well as your country cousins, but stick with it, brother, and read on. Deep down in the abyssmal darkness glows the faint filament of hope!

The first look at my present QTH back before the war gave me the screamers — but the lease was already signed. The outlook for ham radio was black. Our apartment is on the second floor rear of a five-story building located in the middle of a block, and a sixteen-story building towers behind it. The only open space is over a one-story building adjacent to our house.

The first antenna tried was a 40-meter single-wire-fed Hertz running from the roof across the "taxpayer" to a garage. The far end of the antenna was attached to a structure on the roof of the garage which housed the elevator-lifting machinery. The antenna was cut to resonate at the center of the 40-meter band. At this time the rig was running about 30 watts input, but even considering the low power, results were pretty dismal. Loading was difficult — and from the looks of the log, radiation was practically nil.

The book says that single-wire-fed works best when the antenna is erected over good conducting earth and when the transmitter is well grounded. The lack of a good ground at this location accounted in part for the poor results obtained, but I had a strong suspicion that the large masses of iron in the vicinity of the antenna were responsible for a poor impedance match between the flat top and the feeder.

Next, two 15-foot poles were put up on the roof about 50 feet apart. A 40-meter dipole was strung between the poles with about 9 feet at each end of the antenna sloping down towards the roof. The antenna was intentionally made a little long to enable pruning to the center of the 40-meter band. A jumper was placed across the insulator at the center of the antenna.

• Surrounded by tall buildings in a city location? Well, maybe a little attention to detail will help get you out. Here's how one ham solved such a problem in the days before Pearl Harbor.

Cut and Try

A Hartley oscillator whose tank circuit would resonate at 40 meters was constructed in a cigar box using a Type 30 tube with a 22½-volt battery for the plate supply. A low-range milliammeter was inserted between the grid leak and ground and a piece of curtain rod was fastened to the cigar box to serve as an antenna. A calibrated receiver was used to determine the setting of the tank condenser at 7150 kc. The oscillator was then placed near one end of the 40-meter dipole and the tank condenser was rotated until the grid current dipped. This showed that the antenna was taking power at the frequency of the oscillator. A few inches at a time were trimmed from each end of the antenna until the oscillator grid current dipped at 7150 kc. This method of cutting an antenna to frequency is described on page 40 of the 1939 edition of the *ARRL Antenna Book*, and is a simple method for determining the electrical length of a "hunk of wire" with several bends in it that is strung in the vicinity of grounded objects.

The jumper across the insulator at the center was then removed and the twisted-pair feeders were attached. The rig was fired up and we were able to get out at last, in spite of the 16-story apartment building looming within 100 feet of the antenna. In the first few hours of operation all U. S. districts, K4, CM, and PY were worked. Joy and happy day!

Success Again!

The 40-meter doublet was used for about a year, and then we got the urge to try 80 and 20. An 80-meter Zepp was erected with about 80 feet of it on the roof, none of it being any higher than the two 15-foot poles that supported 50 feet of its length. The remaining length of the antenna was run down to the roof of the one-story building next door. The antenna was cut to resonate at 14,350 kc. using the previously-described method except for one minor change. All trimming of the

* 1258 Third Avenue, New York 21, N. Y.

(Continued on page 154)

A DX Record: To the Moon and Back

How the Moon-Radar Feat was Accomplished

BY HERBERT KAUFFMAN,* W2OQU

• In late January the newspapers and radio were full of the latest news sensation — “communication” with the moon. Lots of people had dreamed about it, but the practical realization came about as the result of hard work on the part of engineers at the Signal Corps Laboratories. There were hams in the picture, naturally. Here is the story of how it was done, written by the first man to hear a signal from the moon.

MAN HAS long dreamed of communicating with one of the heavenly bodies such as Mars or Venus or — more reasonably — the moon. The coming of radio and radar has given such encouragement to that dream that now — although the planets remain for the present unattainable — we *have* sent a radar pulse to the moon and received the echo back here on earth.

At the Evans Signal Laboratory, one of the combined group of Government laboratories comprising the Signal Corps Engineering Laboratories with headquarters at Bradley Beach, New Jersey, a $\frac{1}{4}$ -second pulse of 111.5-Mc. energy was beamed at the moon on the 10th of January, 1946. Two and one-half seconds later a faint “beep” was heard in the loud speaker. That was the voice of the moon, the first time it had been heard upon the earth, and the writer was fortunate enough to be the first man to hear it.

It came about this way. Dr. Harold Webb, one of my associates, was watching the oscilloscope at the time. He had not heard the beep. I said to him, “Did you hear that beat?” He said, “No.” Then I heard another beat, but Dr. Webb did not hear that either, so we turned up the audio gain, whereupon we both had no difficulty in hearing it.

At first we told no one of our success, not even Lt. Col. John H. DeWitt, jr., W4ERI and ex-W4FU, the officer in charge of the project and the man primarily responsible for the triumphant culmination of an experiment that many thought

* 15 Garfield Ave., Avon-by-the-Sea, New Jersey.

Decidedly not a back-yard antenna, the directive system used in the moon-signal experiments has a power gain of 200 and uses 64 phased dipoles. The transmitter and receiving equipment is housed in the buildings at the foot of the tower.

would never be successful. But the next day our results were confirmed; four other persons saw and heard moon echoes and Col. DeWitt was told that his plans and calculations had borne fruit at last.

The first question reasonably asked may be, “How do you know it is the moon?” Later on we will show that under the circumstances it *had* to be the moon, because the technical characteristics of the system would not allow a radar echo to return from anything except an object such as the moon, and at a distance of about 240,000 miles or so from the earth. It is possible that many people may still be skeptical, and to such folks I can only say that since that memorable day of January 10, 1946, we have received echoes day after day, at all hours of the day and night, and under all sorts of meteorological conditions. I do not mean we have received echoes without fail, every time we shot for the moon. We have not; indeed, that is one of the reasons for the continuation of the study. We want to find out *why* we do not, and what frequency or frequencies (if any) will make echoes receivable all the time.

In May, 1940, Col. DeWitt was chief engineer of WSM in Nashville, Tennessee. With typical amateur inquisitiveness he kept thinking about getting echoes from the moon and actually set up equipment using the same frequency and about the same power we use now. However, because of equipment limitations he failed to

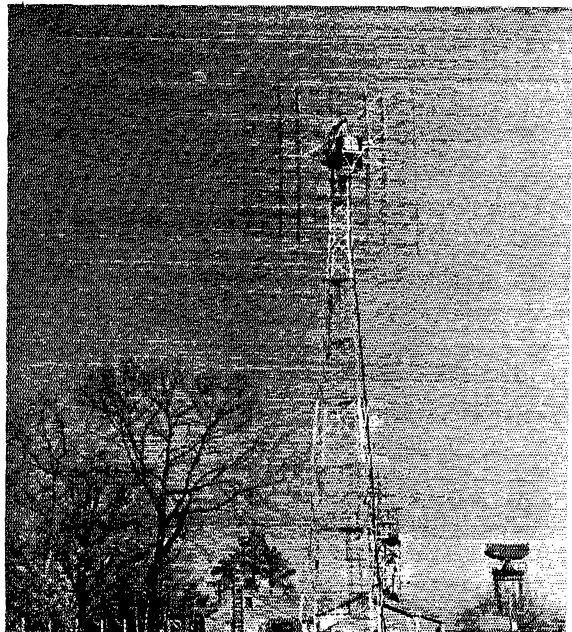

achieve success. The idea remained with him all during the war, but as director of the Evans Signal Laboratory the more pressing need for getting vital radar equipment out into the field made it impossible for him to try again.

Shortly after V-J Day, Col. DeWitt issued instructions to modify certain standard radar equipment for the moon investigation. Changes were made immediately to allow us to send out a long pulse. The transmitter was driven as hard as possible so we could get considerably more power from it, and an ordinary telegraph key was connected in the circuit to turn it on and off.

In a few days we were ready. It was decided that a one-second pulse every four seconds would be satisfactory, so about ten minutes before moonrise I started to key the transmitter, continuing for thirty minutes with no observable results. After operating for about ten days, it became evident that the TR system¹ was not working satisfactorily; the TR tubes were not protecting the receiver from the strong transmitted pulse. Engineers from the Antenna Design Section were called in, and J. Ruze, head of the section, and A. Kampinsky designed a system using quarter-wave step-up transformers on the 250-ohm line with open spark gaps on the ends of the quarter-wave TR and ATR. But the gaps would not last because of the unusually long pulses, although normally they work very well on conventional radar sets where the pulses are very short and the average power is low.

The next step was to design a mechanical TR system using an electro-mechanical keyer which

¹ The automatic transmit-receive switching system used in radar sets. It normally employs gas tubes that ionize during the transmitted pulse, acting as a temporary conductor to change the transmission-line or wave-guide configuration in such a way that the receiver is protected during the time the transmitter is operating. At the end of the pulse the tubes deionize, opening the channel to the receiver.

would close shorting bars on the transmission line, the keying being so arranged that the shorting bars would have to be closed before the transmitter would go on. But still we did not succeed in getting a response from the moon.

The head of the Research Section of the Laboratory, E. K. Stodola, W3IYF, and two of his assistants, Dr. Harold Webb and J. Mofensen, now part of the moon-radar group, decided that if two antennas could be mounted side by side on the same tower the additional 6 db. gain that could be realized in the two-way system would be an advantage, so engineers from the Mechanical Design Section were consulted. Under the able direction of J. Zorowitz this rather difficult feat was accomplished. Now instead of 32 dipoles we had 64. The phasing of the dipoles was done by F. Haacke, P. Hartman and F. Elacker, ex-W2DMD.

During the time that the new antenna was being assembled and installed it was decided to utilize the narrowest band-pass possible in the receiver, to design an electronic keyer and sweep generator in order to operate a nine-inch cathode ray oscilloscope, and to measure the receiver sensitivity. Elaborate equipment was brought into the test area for the latter purpose and it was found that 0.04 microvolts would equal the receiver noise, showing that the receiver was many times more sensitive than our ham receivers — although it should be noted that the band-width used (about 50 cycles) is much too narrow for voice communication. Equipment was also set up to measure the efficiency of the transmitter, which was found to be fifty per cent. The power input to the final stage of the transmitter was about 8000 watts, so that 4000 watts went into the antenna. Since the antenna had a power gain of 200, this was equivalent to 800,000 watts in a nondirectional antenna. Calculations made in the labora-

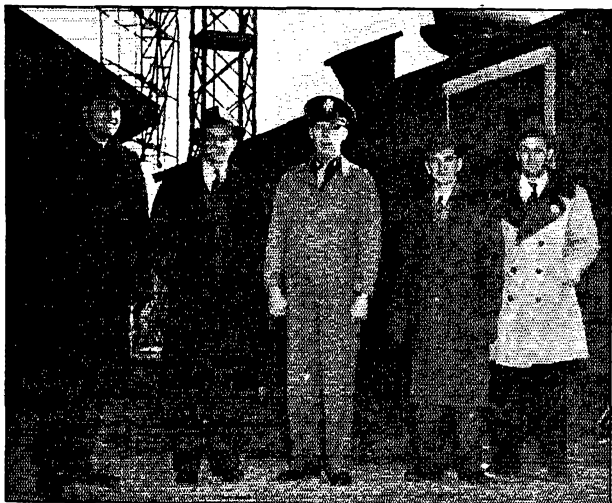

◆
Here's the group that holds the new DX record. Left to right, J. Mofensen, Dr. H. Webb, Lt. Col. J. H. DeWitt, ex-W4FU, E. K. Stodola, W3IYF, H. P. Kauffman, W2OQU.
◆

tory by W. McAfee and his Mathematical Analysis Section showed that theoretically, using the above figures, the moon would reradiate 3 watts. It was calculated that the received signal after passing through the sensitive receiver would be about 16 db. above the noise.

Tests were made daily after the new antenna and keyer were installed, without success until January 10 when I heard that first faint beep from the speaker.

To appreciate the techniques used it is necessary to understand the Doppler effect. Have you stood near a railroad while a train came thundering down the track with its whistle blowing? Did you notice that the sound suddenly dropped in pitch (or frequency) as the engine went by? That is a familiar example of the Doppler effect. If the source of waves, either sound or radio, moves with respect to the observer, the frequency will be shifted either higher or lower, depending on whether the object is approaching or receding. The amount of shift depends on the frequency used and the speed of the source with respect to the receiver. The effect is the same when the waves travel out from the source and are reflected back from a moving object. In our case the moving reflector is the moon, with additional movement contributed by the rotation of the earth.

To receive an echo from the moon obviously is not just a matter of turning on the transmitter and receiver and waiting. The exact time of moonrise or moonset at Belmar, N. J., where the equipment is located, must be computed daily, as must also the optical angle of rise or set on the horizon. The latter changes from day to day and varies about fifty degrees during the month. The orbital velocity of the moon, which also changes from day to day, must likewise be calculated and added to or subtracted from the earth's tangential speed so that the Doppler shift can be computed. The change in frequency caused by the Doppler effect is about 33 cycles per hundred-miles-per-hour of object speed at a frequency of 111 Mc. It is necessary for us to know this change so the receiver tuning can be set to pass the received frequency through the narrow band-pass.

Referring to the block diagram, Fig. 1, notice that the transmitter and a major portion of the receiver are both controlled by the same crystal, which has a fundamental frequency of 516.2 kc. This frequency is multiplied up to 12.39 Mc. as can be seen by following the arrows through the various blocks. At this point the signal is keyed by an electronic keyer and then goes through a coaxial line to the transmitter. All the stages preceding the keyer function continuously; this is necessary because frequencies are taken from the multiplier to operate the receiver heterodynes, and the receiver must operate during the time the transmitter is silent.

The 12.39 Mc. signal is fed to an 807 tripler which drives a pair of 257-B buffers in push-pull.

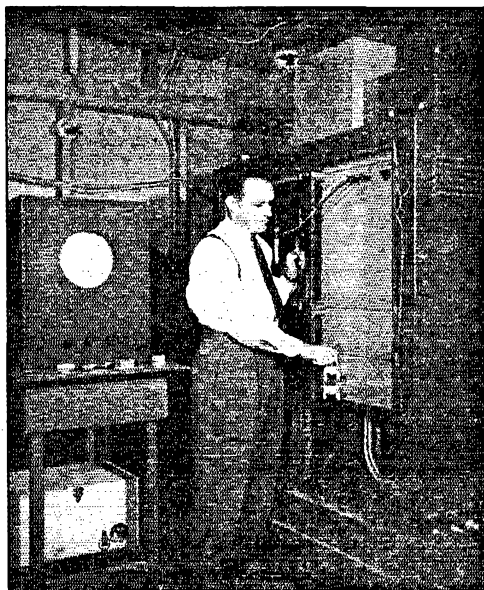

The author adjusting one of the receiver controls — the variable air-gap crystal holder that sets the fourth heterodyne to the proper frequency to compensate for Doppler effect.

These in turn drive a pair of 450-TH push-pull triplers which excite a pair of 1000-Ts as push-pull final amplifiers, feeding a balanced 250-ohm open line to the antenna. The standing-wave ratio on this line is less than 1.1 to 1.

It might be pointed out here that the grid and plate tank circuits of the 807 and the 257-B tubes use conventional coils and condensers and that the grid circuit of the 450-THs also is coil-and-condenser tuned. However, the plate circuit of this stage and the grid and plate circuits of the 1000-Ts are parallel lines with movable shorts for tuning them to resonance.

The receiver, which employs a quadruple heterodyne circuit, obtains its heterodyne injection voltages from a separate series of multipliers working from the transmitter crystal. In fact, the receiver basic frequency is obtained from the transmitter multiplier, as can be seen by following the arrows on the block diagram. The injection for the last mixer is obtained from a separate crystal operating at a fundamental frequency of 516.265 kc., multiplied three times before it is injected into the last mixer. The frequency can be varied 400 cycles above or below the 1.545 Mc. last intermediate frequency by adjusting the air gap on the crystal holder. This variable crystal is necessary so that the injection to the last mixer can be set quite exactly to give a resultant final intermediate frequency of 180 cycles, because at this very low intermediate frequency the narrow band-pass filter is only 50 cycles wide. The beat between the incoming signal and this variable

crystal is so adjusted that the resultant beat falls in the center of the narrow-band filter. As explained, the Doppler shift changes from day to day and from moonrise to moonset, so it is necessary to adjust the last heterodyne injection frequency to compensate for this change.

To show how this crystal is set let us assume that the next moonrise will give a Doppler shift of 296 cycles. To this figure we add 180 cycles,

a distance of more than 44,000 miles, because the one-quarter second pulse sent out into space is 44,000 miles long, as compared a pulse length of a few hundred yards with the usual aircraft-detection radars. The received signal follows the transmitted pulse by about 2.5 seconds, which is equal to about 235,000 radar miles (one direction only).

At the present time an old radar set using

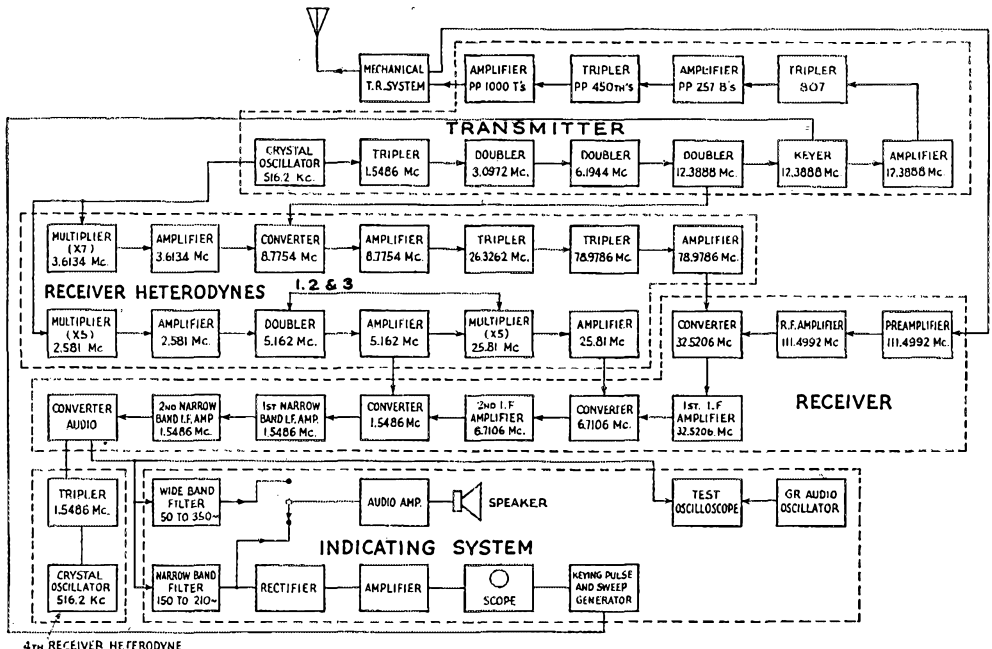

Block diagram of the equipment used in the tests. The transmitter and receiver are both controlled by the same crystal.

which is the center of the band-pass filter of the final i.f. amplifier. This gives a resultant frequency of 476 cycles. We then compare an accurate audio oscillator with the heterodyne between the third harmonics of the two crystals by observing the audio frequency, which has been set to 476 cycles, on one set of plates of an oscilloscope and the heterodyne beat on the other set of plates. The crystal is adjusted until a 1-to-1 Lissajous pattern is observed on the 'scope. With this adjustment only an object moving at the proper speed to shift the carrier frequency by 296 cycles will be able to pass through the narrow band-pass of the receiver.

Now let us see why it was the moon that we received and not any other object. From the above analysis, any other object in space would have to be moving at the exact speed for which the receiver has been adjusted. Another object moving either faster or slower than the moon would create a different audio frequency and would not pass through the narrow band-pass filter if the difference was more than 50 cycles. Furthermore, such an object would have to be at

water-cooled tubes is being modified with Clarence Holritz, W9BBD/2, making the necessary calculations as to efficiency, bias and drive necessary to get an expected 50,000 watts output — more than ten times the power obtained from the present transmitter. The present low-power transmitter will be used as a driver. A high-voltage rectifier has been acquired from one of the other Sections of the Laboratory and this rectifier is capable of delivering 10,000 volts at 10 amperes continuously. The present low-power transmitter is being operated with about 4300 volts at 2 amperes to the final tubes. It is expected that much useful information will be gathered during the coming months in our studies of wave propagation — information which someday may be useful to the amateur. It is hoped, too, to study propagation at other frequencies than the one used so far.

Beyond the individuals mentioned above, so many have been associated with the "Diana" project that it is impossible to name all those who contributed to its success.

Foreign Notes

AUSTRIA

From OE3WB we hear that:

"The *Oesterreichischer Versuchssenderverband* (Austrian Union of Amateur Radio Stations) which had to cease activities in 1938 because of the annexation of Austria by Germany, has now been reestablished in its original form and its members hope that their voices will soon be heard again on the air. For the time being they can regrettedly greet their friends by means of *QST* only, as the Austrian amateur sender law has not come into force again so far. We are sorry to say that only a few well-known hams will be heard again and that these will partly have to rebuild their stations.

"Among them will be: Heitler, OE1ER; Strunz, OE1EZ; Polacek, OE1FP; Lehrner, OE3FL; Schedl, OE3FS; Blaschek, OE3WB; Tax, OE6AX; and Doppelhofer, OE6DK. Carl Martin, OE1CM, who made WAC in 1926 and who had been president of O.V.S.V. for many years, died in the autumn of 1945. Nothing definite is known so far about the winner of the first WAS in Europe, Archduke Anton, OE3AH, who is supposed to be in Rumania at present. Haas, OE1FH, who had been our most famous DX-ten-meter man, emigrated to Australia in 1938; we are now eagerly expecting his first message.

"Our president is now E. Heitler, OE1ER, one of our eldest and most successful OE hams, and we are sure that his personality will guarantee new achievements for our society."

AUSTRALIA

Along with reactivation above 28 Mc., our VK friends have new regulations. Changes of note from pre-war rules include an increase in the minimum age to eighteen years; a 14-w.p.m. code test; two classes of licenses, one with power limit of 100 watts and the other with 50 watts; and a strict ban on musical entertainment of any kind.

Reflecting the gradual return to peacetime conditions, "Amateur Radio" is once more appearing in printed form and is enlarged in size. The *Institute* hopes to obtain permanent quarters for its federal executive which will include workshop and laboratory, library and a technical information service available to all members.

CUBA

Most hams know already, but we want to record the fact that Cuban hams have been returned to the air. The first license was issued to the society's headquarters station, CO2RC. Hereafter, licenses will be issued only to Cuban citizens eighteen years of age or over, and persons between eighteen and twenty-one years must have written approval of parents or guardian! Licenses will be issued to citizens of other countries who extend a similar privilege to Cuban citizens.

NETHERLANDS

The combined-society group of V.E.R.O.N. is pleased to announce, after a conference with gov-

(Concluded on page 158)

◆

Here are four of the more than 200 American servicemen-hams operating with D4 calls in the European Theater. Left to right: Major Floyd Wickenkamp, D4AAU, ex-W7JG; Capt. Thomas MacClure, D4ABX; Lt. Bruce Blackburn, D4AAS, W4DWU; and Lt. Ralph Edwards, D4ABW.

◆



An Umbrella-Type Antenna

A Directive System Employing Sloping-Vee Elements

BY ALFRED K. ROBINSON,* EX-W7DX

• This article describes an umbrella-type directive antenna designed for use at one of the FCC monitoring stations. It consists essentially of a grouping of sloping-Vee antennas arranged so that complete coverage in any desired direction is possible by proper selection of wires in the "umbrella." Only a single mast is required.

A UNIQUE antenna has been installed at one of the government's primary monitoring stations. This antenna, resembling an umbrella in physical construction, combines high gain, around-the-compass directivity, low-angle radiation, and wide frequency range with economy both in material and installation costs.

Installation was made under the direction of the Equipment and Projects Section of the Field Division, Engineering Department, Federal Com-

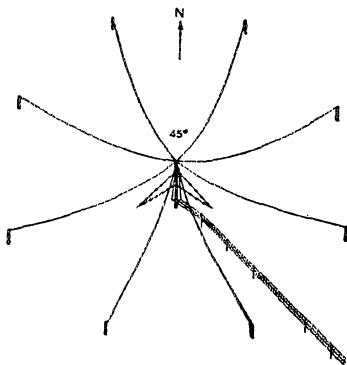

Fig. 1 — Sketch showing constructional details of the umbrella-type antenna. The far end of each wire is supported on a short post and the wire is terminated to ground with a resistor.

munications Commission. This Section is charged with the general instructions to the field in connection with monitoring or equipment operation and utilization. The antenna is one of the many results of the Division's efforts to improve continuously upon the technical equipment under its supervision.

* 613 So. Flower, Santa Ana, Calif.

¹ For a complete discussion of all principles involved, see Terman, "Radio Engineers' Handbook," chapters on propagation of radio waves and antennas, and *The ARRL Antenna Handbook*.

The design of an antenna suitable for a monitoring station differs greatly from the requirements of commercial radio installations, either transmitting or receiving. In practically all such instances the problem is to receive or transmit specifically as to distance, frequency and direction. The monitoring-station antenna design is a great deal like that with which the amateur is confronted; namely, to receive on as many frequencies, from as many directions as possible, while still retaining a directive pattern to eliminate interference and to take advantage of the gain usually provided by utilizing directivity.

Fig. 2 — Horizontal pattern of 4-wavelength wire. The solid-line pattern is for a vertical angle of 10 degrees, while the dashed lines indicate the change in pattern for a vertical angle of 25 degrees.

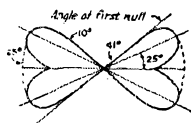

Like the Commission, the amateur is faced with an economic problem; the cost of the overall installation, necessary land, etc., usually are prime factors. In the following description of the "umbrella" antenna it must be remembered that the location influenced the design; also it should be kept in mind that considerable compromise is possible both as to height and length of the elements. Many modifications readily will suggest themselves to the average ham.

The umbrella antenna consists of eight equally-spaced wires radiating at intervals of forty-five degrees from the top of a central 90-foot pole as shown in Fig. 1. Each wire slopes from the top of the pole to the ground, where it is terminated electrically through a non-inductive 400-ohm resistance to ground. This value is chosen arbitrarily since its value, plus the ground resistance, should equal the characteristic impedance of the wire and naturally its value will depend upon the ground resistance encountered at a particular installation.

In reality the umbrella antenna consists of predetermined combinations of sloping-Vee antennas. For normal operation two adjacent wires are used in the form of a single sloping Vee.

Theory of Operation

No claim is made that any new theory is involved.¹ However, certain well established principles have been adopted in a somewhat new and practical application.

To visualize the final results, one must analyze

the applied theories step by step. First consider the long single wire in space with maximum lobes as indicated in Fig. 2. The angles for the wire length in use (four waves in this instance) may be determined from the chart of Fig. 3. The minor lobes are eliminated for simplicity.

Fig. 3— Graph showing positions of maximums (solid lines) and nulls (dashed lines) as a function of antenna length in wavelengths. The dotted line shows the angle at which maximum phase addition occurs.

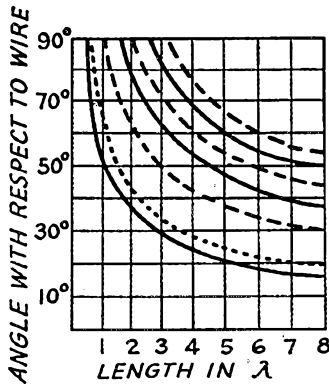

When this antenna is placed in proximity to earth, as shown in Fig. 4 (A), the earth may be considered of infinite conductivity for all practical purposes. The reason for this is that the main lobe, even with considerable attenuation from earth effect, will have the same general shape. Losses are principally reflected in modification of the minor lobes. The included lobe is out of phase with its reflected lobe, thereby tending to cancel. On the other hand, that portion of lobe A radiated towards earth is reflected in phase with the upper part, resulting in accentuation. The maximum radiation then is the vector sum of the direct radiated portion and the reflected portion, neglecting the earth losses. This is shown by the solid lines of Fig. 4 (B). The lobe is lifted slightly (approximately 3 degrees) above ground to represent an effect of ground losses.

With the wire terminated at r through a non-inductive resistor having a value equal to the characteristic impedance of the wire, the antenna becomes practically uni-directional. Transmission is in the direction of the arrow T , reception from the direction of the arrow R in Fig. 4 (A). This termination also eliminates standing waves from the wire rendering it non-resonant; practical operation over a wide range of frequencies results.

So far only vertical directivity has been discussed. The next step is to see what happens in the horizontal plane. Essentially the same results are possible in the horizontal plane as in the vertical if, instead of the "image" antenna which results from ground reflection, another wire is substituted and oriented as the image would be, except in the horizontal plane. Fig. 5 (A) represents such a substitution with the back lobes cancelled by the terminating resistors r_1 and r_2 , the side lobes phased out and the major lobe accentuated.

The resulting horizontal pattern is approximated in Fig. 5 (B). The dotted lines show the field strength of a single lobe of the wire in space, the dashed lines show the accentuation because of reflection, and the solid line the resulting gain with two wires oriented as in Fig. 5 (A).

The terminating resistors, r_1 and r_2 , each should have a value of approximately 400 ohms for a ground resistance of 55 ohms, giving an over-all impedance of around 465 ohms. This value is only representative; the resistor value should be adjusted to a compromise with the best front-to-back ratio over the widest frequency range.

It should be stated here that even at optimum frequency, slight compromise can be made in pole height and vertical tilt angle. This is possible since it can be shown that the optimum tilt angle is not critical, provided the length of the legs is two or more full wavelengths long.

At the optimum frequency and angle as selected on the basis of four full wavelengths, this antenna will have a gain something less than a possible 10 db. over a single half-wave dipole.

With the height of the pole, length of the legs, and tilt angles thus fixed, certain changes may be expected as the frequency is shifted. Reference to Fig. 3 shows that increasing the frequency so that the wire length is five or more full waves changes the angle of the main lobe only slightly with respect to the wire. A very small decrease in the angle of incidence will result; hence a slight narrowing of both the vertical and horizontal portions of the lobe. However, a considerable increase in gain is derived. Evidently, then, no harm results by raising the frequency until a point is reached where the vertical angle has narrowed beyond practical limits.

Going in the other direction (decreasing frequency) it is obvious (also from Fig. 3) that a gradual increase in the angle of incidence results. Correspondingly the gain decreases and the lobes, both vertical and horizontal, broaden out. How-

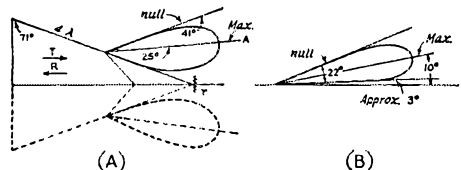

Fig. 4— Sketch showing (A) the radiated lobe and the ground-image lobe of a single slanting-wire antenna and (B) the resultant.

ever, this is not necessarily a disadvantage. Higher-angle radiation is permissible at the medium-high frequencies since the critical angle of transmission is normally greater.

In the horizontal plane it is possible to broaden the angle by selecting alternate antenna wires instead of adjacent ones, hence worth-while gain and directivity are still available on lower fre-

quencies. In this connection it should be pointed out that Fig. 3 shows that the unterminated wire of one wavelength would have maximum lobes at 54 degrees. Because of the different type of current distribution, the terminated wire of this same length would have the main-lobe maximums at 45 degrees. For two wavelengths or more, the difference from this effect is negligible. Thus using alternate wires at the lower frequencies still results in gain when the frequency is such as to make the wires each one wavelength long.

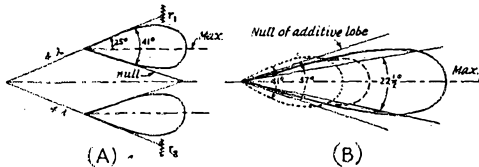

Fig. 5 — The individual lobes of the Vee antenna at (A) combine to form the pattern shown at (B).

The foregoing analysis is based on an optimum tilt angle for proper aiming of the lobes. For maximum phase addition, the angle with respect to the wire would be slightly greater resulting in a small increase in the angle of incidence and a sharpening of the directional pattern. The dotted line in Fig. 3 gives the values considering this effect.

Elimination of Standing Waves

The front-to-back ratio, as noted from the graphs of Fig. 6, is extremely good. To attain such pronounced differences with legs of this short length on the frequencies indicated requires that a directional antenna of this type be terminated properly. A very simple method of attaining proper termination can be had by using a "grid-dip" meter. The grid-dip meter consists of a simple variable-frequency oscillator with a sensitive milliammeter in the grid circuit. As the plate is loaded, a pronounced dip will take place at the frequency to which the load is tuned. By connecting the transmission line through a small coupling coil to the grid-dip meter all resonant points on the transmission line will be evidenced by a pronounced dip. As the proper termination is approached, these dips flatten out so that the meter reading remains almost constant as the frequency is varied over wide ranges; the reading will be that of a moderately loaded condition. This procedure eliminates the necessity for energizing the antenna with a strong oscillator and checking transmission lines by loops or other means.

Practical Results

Because of the automatic antenna-switching system² which selects instantly any antenna on the reservation, comprehensive tests of the capabilities of the Vee with respect to other antennas

² Robinson, "Automatic Antenna Switching," *QST*, April, 1945, p. 38.

available were possible. Considerable gain was noted over simple doublets cut to the frequency under test. This gain at times spelled the difference between a copiable signal and an inaudible signal. In addition, during periods of heavy atmospheric noise received on the simple doublet would preclude reception of even the strongest signals whereas the Vee would discriminate against the storm unless the latter was in line with the station being received. Almost exact duplication of signal strength was noted between the rhombics and the Vee at distances of approximately 1500 miles at frequencies of 8 Mc. and higher. At frequencies below 8 Mc. and at distances of 1500 miles or less, the Vee generally is equal to or superior to the rhombic. For distances greater than 1500 miles, the rhombic is increasingly better, almost in the same proportion as the Vee is better on less-distant stations. In order to attain even better results it would be necessary only to extend the length of the legs a few hundred feet.

Fig. 6 indicates relative signal strength, based on receiver R units, of standard-frequency station WWV at 5, 10, and 15 Mc. There are two graphs for the 5-Mc. signal, Fig. 6 (A), showing the pattern using adjacent legs of the Vee and Fig. 6 (B), the pattern with two alternate legs; that is, one free leg between. Apparently theory holds very closely in practical operation since alternate legs on this frequency are necessary for proper lobe alignment. Other tests run with a local signal generator confirm the graphs of Fig. 6 for other directions and frequencies.

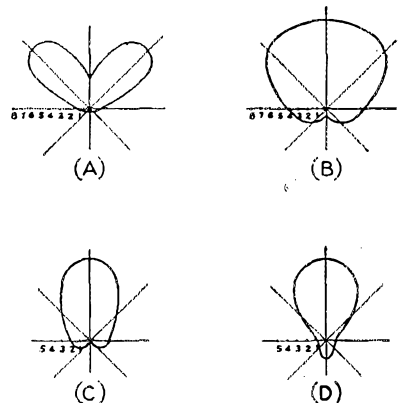

Fig. 6 — Various patterns obtained with the umbrella-type antenna: (A) for adjacent wires at 5 Mc., (B) for alternate wires at 5 Mc., (C) for adjacent wires at 10 Mc., (D) for adjacent wires at 15 Mc.

Switching System

In order that any combination of wires may be used to form the Vees with the included angle desired for the frequency in use, four remotely-controlled stepping relays are installed in a water-

tight box at the top of the pole. These relays are composite and were constructed locally since selsyn motors were not available on the market at the time of construction. Each relay consists of a single-pole, eight-position, low-loss-type rotary switch with a solenoid mounted with a mechanical

ratchet so that each activation causes the relay to set up another contact. Each of the eight contacts is paralleled with the respective contacts of the other relays. The relays are paired, with the two selector arms from one pair connected to a transmission line, the impedance of which should match the average characteristic impedance of the antenna wires. The water-tight box with the relays installed is shown in the photograph. Of note is the fact that the wires are kept clear of the sides of the box as much as possible and are no longer than necessary.

The exact position of each relay on the pole is indicated at the operating position by a lamp on the indicating panel. The lamps are arranged

in the form of a circle and are mounted on polar coordinate paper marked in degrees with due North straight up, East to the right, etc. There are two circles of lights, one for each pair of antenna relays. Each circle of lamps is connected in such a way that the lights will be oriented in exactly the same way as the antenna legs. In other words, each circle of lights will always have two lights on unless both relays are connected to the same antenna leg, in which case only one lamp, that to which it is connected, will light. Four push buttons are installed on the control panel, one for each set of relays. A set comprises one indicating-light relay on the control panel and one antenna relay on the antenna pole. The double-pole, double-throw switches are connected so that in the "off" position each set of relays may be operated independently, while in the "on" position each pair is operated simultaneously. In other words, if adjacent wires are used for reception, it is only necessary, when this switch is closed, to operate a single push button and adjacent pairs will be set up throughout.

Pole Construction

The optimum angle for the slope of the wire was obtained by the erection of a 90-foot pole. To obtain such a height two smaller poles were spliced together since the cost of a pole with an over-all length of 96 feet is prohibitive in this section of the country. A properly designed spliced pole is equal in every way to that of the single pole.

To support the transmission line from the antenna box and the transmission line terminations from the station, a double cross-arm assembly was installed about ten feet off the ground at the base of the pole.

Ground

Because of the dryness of the soil in this section, it was necessary to construct a special type of ground connection in order to be assured of reasonable resistance stability for termination of the antenna wires. Essentially, this consists of 8 to 12 No. 14 wires driven some 15 to 20 feet directly down into the ground.

Lightning Protection

To guard against the frequent electrical storms prevalent in this section of the country a lightning rod was installed on top of the pole extending above the center of the antenna some six feet. This rod with its independent ground at the base of the pole provides a safety factor for the resistors, relays and transmission lines. In addition lightning arrestors were placed across the control lines.

Strays

While W4GVD/9 and W5DTL/9 were visiting W9APX, W6OUW, Inglewood, Calif., was called and raised. His signals were 5-9 with 180 watts input. He decreased his input to 40 watts and the signal was still reported S9. The power at W6OUW was lowered until the input was only 0.16 watts (20 volts at 8 ma.) and the signals were still readable in East St. Louis, Ill., on 28.7 Mc.

— W5DTL/9

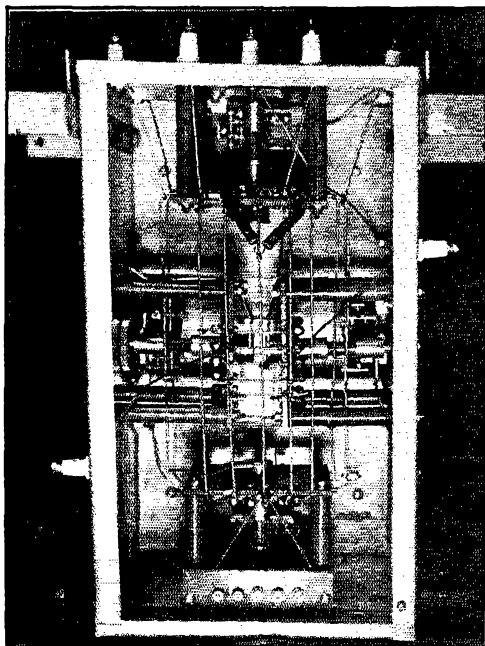

Relays for selection of Vees mounted in a weather-proof box.

A Selective Pulse Communication System

Multiple Station Operation on the Same Frequency

BY ARTHUR R. KNIGHT,* EX-W8BDE AND HOWARD STORCK, EX-W8BYN

IN THE old days, amateurs derived much pleasure from experimentation. The authors believe that there are now many amateurs who would be interested in testing a new communications system for the sheer pleasure of such experimentation. This is written in the hope that it will be a basis for such work and, although this article deals only with pulse code communication, one can easily visualize voice communication using time-modulated pulse systems or other pulse schemes.¹

The system to be described is the subject of a patent disclosure by Arthur R. Knight. So far as patent rights are concerned, all hams and amateur organizations are hereby given all rights pertaining to amateur communication.

The dream of all radio operators has been some method or system whereby they could receive some one desired transmitting station at will to the exclusion of all others with, perhaps, the elimination of natural static and man-made noise. This dream may be partially realized with the system herein described, at least, to an extent undreamed of before developments of World War II made it possible.

Time Selection

In this system, literally thousands of stations may operate simultaneously on the same frequency of transmission and reception without interfering with each other. The various stations all transmit on exactly the same frequency; all receivers are tuned to this common frequency. Various stations are selected or "tuned in" by selecting manually on each receiver the exact instant in time when intelligence from any one chosen station will reach the receiver. Where transmitters are at fixed locations, the receiver may be calibrated as to stations, or in miles, or in any other suitable measurement of distance.

• You won't get much out of this article if you are interested only in how many turns it takes to hit the 28-Mc. band, because it doesn't have a single circuit constant in it. But if you are interested in something new, in one of the many possibilities of pulse communication, this story introduces the concept of "time selection," as contrasted to our familiar frequency and space selectivities.

At any one point on such a dial the same station will always be received. Furthermore, the radar principle of pulsing is used which enables one to secure in the neighborhood of one kilowatt of peak radio frequency power into the antenna using an ordinary five-watt r.f. unit with suitable power supplies and controls.

Our system is based upon synchronization from some accurate signal source, and upon the time it

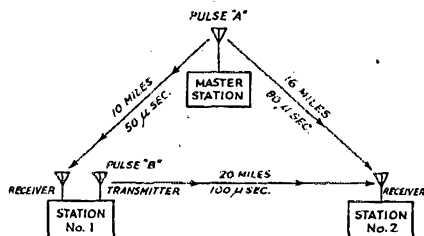

Fig. 1—A block diagram showing the principle of selective pulse communication. Master Station sends a special pulse which is received at both No. 1 and No. 2. No. 1 relays this pulse and it is tuned in by opening a "gate" in the receiver at No. 2 at the proper instant.

takes radio frequency energy to travel from one place to another. For the purpose of explanation, one method of accomplishing these results will be described and other methods of accomplishing the same results will be suggested. The simplest way of explaining the idea is not the most practical way of accomplishing the desired results. Anyone familiar with transient techniques may easily visualize the equipment necessary. Much has already been published on such techniques, or the authors may be consulted for further information.

For discussion purposes, assume a transmitter which radiates r.f. pulses of energy 500 times a second. Further assume that the time duration of the radiated energy is only one microsecond. The transmitter is "working" only one-two thousandths of the total time between radiated pulses. This transmitter will be referred to as the "Master Station," and the pulses radiated by this transmitter will control all circuits for all stations desiring to communicate with each other. All reception will be accomplished during the time the transmitter is not working.

Assume that two radio stations, No. 1 and No. 2 of Fig. 1, desire to communicate with each other. All receivers and transmitters are tuned to the

* 1657 Hearthstone Drive, Dayton 10, Ohio.

¹ "Forms of Pulse Modulation," *QST*, Dec., 1945.

same frequency. Station No. 1 transmits intelligence to station No. 2 in the following manner:

1) The Master Station radiates a one-microsecond pulse "A."

2) This pulse is received at No. 1 approximately 50 microseconds later, because No. 1 is located 10 miles from Master Station.

3) The pulse from Master Station is received at station No. 2 approximately 80 microseconds after initiation, since No. 2 is located 16 miles from Master Station.

4) Since No. 1 is transmitting, the key there is closed and pulse "B" is immediately radiated, neglecting delay in the equipment. It is received at station No. 2 approximately 150 microseconds after "A" was initiated or 70 microseconds after "A" reached station No. 2.

5) When pulse "A" is received at station No. 2, it initiates a "gating" circuit in the i.f. or video amplifier which is manually controlled with reference to time. This gate circuit is moved out approximately 70 microseconds so that the gate is opened for slightly more than one microsecond, thus coinciding with the arrival of pulse "B." The pulse is then passed through the receiver and the signal is heard as an audio tone through distortion in the audio amplifier.

The above paragraphs explain the basic theory. It is important that they be thoroughly understood before proceeding with this discussion. A number of things are to be noted. It is necessary for all equipments to be controlled by the same master timing station. When transmitting, the energy is simply amplified and relayed. This type of equipment is called a "transponder." Intelligence is created by keying the transponder output into dots and dashes. The important point at the receiving station is the gate which allows only the desired intelligence to pass. That gate is in the amplifier only. The receiver receives all signals. This is necessary so that the pulse from the master station can start the gating action.

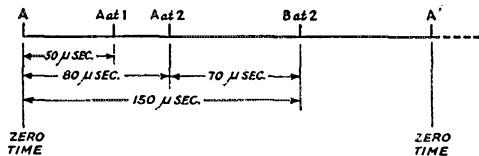

Fig. 2 — The time relations of the signals in Fig. 1.

Practical Details

The above is only a rough outline of the basic theory which disregards many things, such as the delay in each equipment. Furthermore, if such a system were used, the control energy "A" would necessarily need to be of a distinguishing nature so that the equipments would not oscillate within themselves, or between each other. This could be overcome by various tricks; for example, two pulses could originate at the master station a few

microseconds apart and then paired-pulse interrogation could be used to operate the gate, or a long pulse could be used as "A" and a pulse filter could be used to control the gate. In this connection, it should be noted that the starting pulse does not need to be the same, but the cycle of repetition must be the same. There are other reasons against using the same r.f. for synchronization. First, if the stations are physically close together, they will all be crowded at the start of the time cycle. Second, synchronization transmitters are not available. Third, the coverage, for synchronization purposes, would not be as great as some of

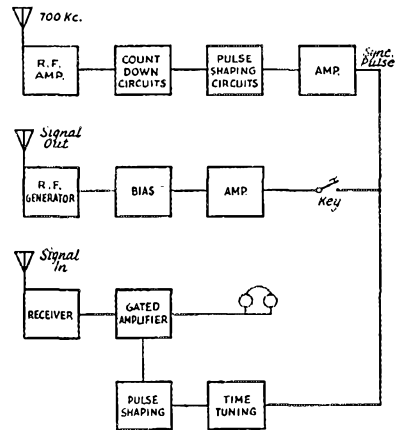

Fig. 3 — Block diagram of a typical station using selective pulse communication.

the standard stations now on the air. Fourth, a standard unit can be designed for synchronization purposes which can operate on any low frequency station, such as a reliable broadcasting station or WWV, and the transmitted frequency then "counted down" to a selected synchronization frequency by one of the highly accurate systems which may be put to such use.²

Perhaps a better understanding of the system may be had by making reference to a block diagram of a proposed "ham" station necessary to practice this system. Fig. 3 represents such a station. This station differs from the ordinary radio station in that it has an auxiliary receiver from which synchronizing energy is secured. In this particular case, the r.f. energy from WLW (700 kc.) is counted down by one of the methods referred to above.

Once the synchronization pulse is available, the transmitter is the height of simplicity; all that is necessary is to amplify the synchronization pulse to a sufficient degree to unbias the transmitter.

The receiver is somewhat more complicated than the transmitter. It must be so designed that it can present output pulses without too much

(Concluded on page 144)

² Morecroft, "Electron Tubes," page 438; Batcher and Movlie, "The Electron Engineering Handbook," page 331.



Correspondence From Members -

The Publishers of *QST* assume no responsibility for statements made herein by correspondents.

TRIBUTE TO XUSMA

610 West 143, N. Y. 31, N. Y.

Editor, *QST*:

I am enclosing reports of the death of Dr. William Malcolm, ex-XUSMA and XUSMA, otherwise known to amateurs of several continents as "Old Man River" (OMR).

Dr. Malcolm's personality, his devotion to the radio art, and the historical chances which gave him unique opportunities, easily make him one of the outstanding amateurs of all time. A DX man, he continuously and conscientiously handled semi-local traffic between his station at Chefoo and Shanghai for many years. During the early stages of the Japanese war (1937-39) it was the only radio output from the North China port, and he handled astronomical numbers of messages at that time. His station also had a hand in pirate adventure, being instrumental in rescuing school children held aboard a pirate ship in notorious Bias Bay, Hongkong.

Forced to leave Chefoo, the doctor, approaching 80 years of age, went on the air with XU3MA, an 807 driving a pair of 807s on c.w. only, on ten and twenty. His equipment, built into an office desk, was a fine piece of living-room furniture, a point he stressed as necessary to the household security of amateur radio. "Many an enthusiastic young ham," he wrote, "has been completely discouraged by being ostracized by the OW to the garret or cellar, and thought he had become tired of radio when as a matter of fact he had only become tired of cold fingers and cold feet!" Active organizationally as well as on the air, he was a member of the committee of the International Amateur Radio Association of China until his departure for the States in 1940, and was an unflinching contributor of entertaining articles and artwork to its magazine, *QSO*. For Dr. Malcolm was an artist of no mean ability, and many of his lengthy series of radio cartoons, "Technical Terms Illustrated" have been printed (with or without credit) in United States magazines.

Dr. Malcolm achieved his success with key and pencil despite the handicap of a crippled right hand, due to an infected knife wound. This cut off a promising surgical career, though it resulted, as he afterward said, in his being "kicked upstairs" to more important work. He used and cherished throughout his life a side-swiper key which was a present from the late Colonel Claire Foster, the famous W6HM, who suffered an identical handicap. Unable to continue on the air after his return to the states, he maintained his interest in amateur radio, especially attempting to contact former XU hams, and fully intended going back on the air as soon as DX bands should be opened. He is one of the century's leading hams, and may well have posed as model for the author of "The Amateur's Code."

— Fred Shunaman, ex-XUSWG, Editor *QSO*

CANADIAN VETS

3rd Floor, Veteran Block, Regina, Sask.

Editor, *QST*:

Veteran VE operators will be interested in plans for a radio section of the Canadian Legion B.E.S.L. This Command is preparing a survey preparatory to detailed planning for a radio section, which will include club and library facilities, study assistance, "on-the-air" meetings for the members and branches throughout Canada and a general range of activities of interest to radio amateurs, especially to those who have served with the armed forces. All ARRL members

who are eligible for Legion membership will be able to get full details very soon from the nearest secretary, whether they are Legion members or not. The main qualification is a genuine interest in radio and naturally, eligibility for Legion membership. This is an excellent chance for those who want to maintain their service friendships via amateur radio.

Get in touch with the nearest Legion office, leave your name and address and a brief record of your radio experience and ask the secretary to notify you when he receives further details, which will be supplied from the Sask. Provincial Command office. As there are hundreds of branches throughout Canada it may take a little time to supply them all with complete details. B.E.S.L. secretaries outside Canada are requested to write direct to this office for details as the plans call for a world-wide organization with attention being concentrated on Canada for a start. However, details will be supplied to other branches in case they are in a position to do their own local organizing. It is important that the survey be completed as soon as possible and veteran VE operators or those who are interested in becoming hams are therefore urged to check with their local Legion secretaries (or this office) as quickly as they possibly can.

— D. H. Leitch, VE4FS

RUMORS

1409 Mango Court, Corpus Christi, Texas

Editor, *QST*:

I believe it is not only bad taste to spread rumors on the air regarding frequency allocations, but also harmful.

— S. T. McNeal, W6KSV, ex-W6LDJ, W6BBB

P. O. Box 1200, Ft. Worth, Texas

Editor, *QST*:

A report, or it may be just a rumor, is going around among some licensed radio amateurs over the air that the representatives of the governments of the United States and Great Britain are now in session, talking of the possible diversion to commercial use of the bands formerly allocated to the amateurs in the 20 and 40 meter locations.

If this is true, I am sure that the ARRL is on the job and doing everything possible to prevent such sabotage of the amateurs' frequencies. However, some of the local operators thought it worth while to write you and see if there is any truth in the reports. . . .

— R. E. Cowan, W6CF

(Editor's Note: The rumor is entirely without foundation. The United States and United Kingdom are two of the strongest supporters of amateur radio, fully realizing its wartime and peacetime value.

There have been many conferences concerning future radio frequency allocations, and there are more to come. That is one of the reasons we have a League — to represent the amateur service at such meetings and to keep in close contact with all activities possibly affecting us.

Sincere thanks to W5CF for writing Hq. for information instead of spreading further what seems like alarming news. We urge the continued cooperation of all amateurs in not spreading incomplete or inaccurate information over the air. One thing is a pretty certain bet: the wilder the rumors, the greater probability of their being untrue.)

1006 Ligonier St., Latrobe, Pa.

Editor, *QST*:

Our short-wave editor states that he heard an announcement over WIAW to the effect that (and I quote) "Amateur band 14,200 was open to all amateurs with 50-kilowatt power by authority of the FCC." It has been brought to our attention that this statement is obviously incorrect, and we would like to have the official statement of that announcement direct from you to clear this up to our members.

— Art Hankins, Editor, Victory Radio Club

(Editor's Note: The pertinent part of the WIAW bulletin said, "FCC ORDER 130-B OPENS 420 TO 430 MEGACYCLES TO LICENSED AMATEURS WITH PEAK ANTENNA POWER LIMITATION FIFTY WATTS.")

REPORT FROM HA

Sarisap, Esztergom VM., Hungary

Editor, *QST*:

The Budapest radio just now communicated the reopening of postal traffic between U.S.A. and Hungary. After a long silence I am glad to get contact again with the hams of foreign countries and especially with my old radio friends of the states.

Maybe you are interested in the present situation of amateur radio in Hungary. Briefly, it is hopeless for quite a long period, I think — not only because we didn't get back our licenses as yet, but also our equipments are ruined or disappeared. The former government has collected all ham equipments and there is no sign where they are now. To build a new one is very hard; prices are above the Heaviside layer and we are also financially ruined. (We hams have never been millionaires!)

Many of the HA hams are dead or disappeared. During wartime a new generation has grown up, with a great interest in ham radio. We hams could not get together with the old fellows outside so we made local rag-chews on 'phone (till 1942). That was interesting for the non-amateurs, who have listened, and many of them are now learning code, etc., to get a license when the government makes it possible again. Of course, we old hams are ready to spring into the ether again as quickly as it will be allowed. At the least, I'll make a good old Hartley or t.p.t.g. from an old receiver. Hi!

Our general hope is that ARRL or IARU with its great influence will end our long silence soon. Please protect us to get back our license — if not earlier, after the peace treatment; which we hope will come soon.

To say something personal about myself for those who are my old ether friends: During wartime I got my diploma as physician. I married and now am a proud father of a girl. In the winter of this year I was arrested for ten days because of amateurism, but I left free without difficulties. During the offensive of Budapest I was in Buda with my XYL. (Buda is that part of Budapest which lies on the right of the Danube and which was liberated at least.) We were continuously bombarded and shot by the artillery from 30 Dec. 1944 to 12 Feb. 1945. For 3 weeks I could not visit my parents, living in the same street, only 6 houses away. I left Budapest last April and moved into the village of Sarisap, about 40 km. distance from Budapest.

— Dr. Kahle Frigyes, ex-HA7P

MARCONI

108 Novar Dr., Glasgow W.2, Scotland

Editor, *QST*:

The letter in your December, 1945, issue touches an old controversy beyond the compass of a letter to the Editor. Marconi was an *initiator*, not the inventor of radio. None of the components used by him were conceived by him. (The coherer was devised by Branly.) Clerk-Maxwell announced the existence of electro-magnetic waves in 1863, and Hertz in 1888 produced these waves by an oscillator devised by him. The principle of tuning was demonstrated to the British Association at Oxford (England) in 1894 by Sir Oliver Lodge and patented by him in 1897. The thermionic valve was invented

by Ambrose Fleming in 1904. Edison patented a system of wireless before Marconi's time as the telegraph wires running alongside railroad tracks were utilized for transmitting news to traveling trains by means of electro-magnetic waves. This was too far ahead of the times and was not a commercial success.

The British Admiralty achieved wireless communication some months prior to Marconi and perfected their system independently.

— C. G. Wisdom

KA UNDERGROUND

Apartado 15 bis, Mexico, D.F., Mexico

Editor, *QST*:

The writer, formerly chief operator of W6USA, has been asked to write to you in behalf of Luis Fernandez, KALFH, 1131 M. H. del Pilar, Sy-Quia Apts., Malate, Manila, Philippine Islands.

During the dark days of the Jap occupation of Manila, Mr. Fernandez aided the allied guerillas materially by providing radio parts for the construction of a transmitter, at great risk to his life. Night after night, as many as 20 people crowded into a small room in the basement of the Fernandez home to listen to short-wave news broadcasts from the United States. When the Japs discovered his radio equipment they confiscated everything in sight including several hundred QSL cards. Luis put a very high value on his American cards and has asked me to petition you to publish a request for amateurs that have in the past contacted him on the air: please send their cards again to replace those stolen by the Japs.

I am sure that you will agree with me that amateur stations operated by brave men like Luis Fernandez have done a great deal towards giving amateur radio the splendid name it has acquired during the war.

— R. C. Hansen

"PLACE OF HONOR"

218 Havelock St., Toronto, Ont.

Editor, *QST*:

It is with great pleasure and personal satisfaction that I renew my membership to ARRL and subscription to *QST*. Both have been of invaluable aid to me during the past trying years and have helped me do what I think was a good job on the government radio project I was engaged in during the war.

In visiting the various radio plants up here I was impressed and somewhat amused at the high place of honor occupied by *QST* and the *Handbook* in all engineering and test departments. I know for a fact much of the elaborate equipment manufactured was started on its way by an idea gleaned from our two valuable publications.

Now that we once more are applying ourselves to domestic and more peaceful occupations there is no need for me to say, "keep up the good work." As hams we should not be content to rest on our past laurels but rather like a lot of inquisitive little boys and girls we will have to find out what makes these wonderful new radio creations tick.

— Bob Humphreys, W6SALC

W4ERI, PLEASE NOTE

700 Ralph St., San Francisco, Calif.

Editor, *QST*:

On page 48 of September, 1921, *QST* appears the following limerick:

A whimsical lad called Maloney,
A ham in the art of Marconi,
Once essayed to tune
A spark from the moon.
With suspicion guarded
He's always now guarded —
Beware lest you follow Maloney!

— Vernon Howard, W6ERS

(Continued on page 146)



Operating News



F. E. HANDY, WIBDI, Communications Mgr.
E. L. BATTEY, WIUE, Asst. Comm. Mgr.

J. A. MOSKEY, WIJMY, Communications Asst.
LILLIAN M. SALTER, Communications Asst.

3625-4000 kc! The operating business is looking up! A few short months ago we were wondering what "10" would be like. 28 Mc. seemed erratic at first. We liked some of its surprises. The "BW" party found conditions excellent. Reports of BW-operations are still pouring into ARRL Hq. We write these words just as W1AW goes on the air with the first news of the welcome contents of FCC Order No. 130-D. By the time you read these lines many amateurs will have been on "80" three or more weeks, ourselves included. A few of the gang who could hardly wait for April One have been tuned up all set to throw the Big Switch. Now more gear is slated to come out of storage. No "band warming" will be needed for eighty. The band is guaranteed to be hot. See you there!

U. S. hams will start with all the c.w. brethren able to use 3625-4000 kc. of our lowest frequency band, but of course steering clear of the busy 3900-4000 kc. 'phone band (VEs and U. S. Class A only). 3625-4000 k.c. must perform for all our other lower frequency bands which is quite some assignment. VE's can also use 3500-3625 kc. with a temporary 50-watt limit, provided they do not interfere with U. S. military uses. In the event of flood disaster or other emergency it is good that we have these low frequencies to supplement and handle area links from the ARRL Emergency Corps v.h.f. community nets that ECs have under way. Remember that in emergency FCC may "declare" the emergency to aid in our organized amateur service. (See FCC regs., par 12.155. They require no transmissions except those related to emergency service in this band.)

Transmission conditions are still generally excellent, so the QRM in 3625-4000 kc. is likely to be fierce. At certain hours especially, 28 Mc. and 3.5 Mc. will carry a heavy load! This is to recommend that all users employ the frequencies with tolerance and courtesy at all times.

Amateur traffic will now start to flow in more volume. Formal and informal schedules, N-E-S-W etc., will be made. Friendly medium distance QSOs will be more easily accomplished. The top reports of organized work will be mentioned in QST. Report all you do. Some traffic and voice operators, we hear, may be up with the birds at 3 A.M. EST to help "open the band" April first!

And *no fooling!* A "new" ham phones to ask if he can visit our station to see what ham gear and 3.5-4 Mc. operating is like. You bet he can!

Re Nets. Before the war scores of ARRL Nets were listed in an ARRL Directory of Nets — traffic nets, section nets, proficiency nets, emergency nets, 'phone nets, c.w. nets, river nets, regular nets, summer nets, winter nets, early nets, late nets, AEC nets, county nets, spot frequency nets, general nets, directed nets, free nets, and so on. We like nets. Expect to belong to one or more. But we must all recognize that 375 kc. isn't enough for all our nets and ARRL Trunk Lines.

The informal five-point nets, or a simple series of schedules with hams in several different directions from our station on 3 or 4 days per week will facilitate relaying. Such schedules promote friendships and can aid in emergencies. Net operation represents an efficient use of frequencies for work with a purpose. But most of the large *spot-frequency* nets must defer *that* form of operation. So many crystals are in the part of the band still coming to us! Even time sharing will not make enough frequencies for all the nets. There will be no "immediate" new Net Directory. However, be sure you tell ARRL about your plans. A master frequency plan providing for each ARRL Section, based on prewar use, and designed to avoid conflicts with TEs and other known nets can be consulted by Section planners. But operation under the plan must await the return of the rest of this band. General resumption of ARRL Trunk Lines will await that action. W1AW will undertake limited two-way work, when possible on 3950 kc. 'phone and 3825 kc. c.w., but will continue to use its special authorization, 3555 kc. in this band for official bulletins until other frequencies are cleared.

27,185 to 27,455 kc. All FCC-licensed amateur stations may now use this band for AØ A1 A2 A3 A4 and FM voice or telegraph emissions. The new authorization is a *shared* use of frequency with medical and industrial users. Two more significant facts about the band, which is a new-comer to the family of ham bands: (1) It is the only band below 144 Mc. on which amateurs may use *duplex* voice work. (2) It is the lowest band in which A-2 emission is specified. A "genuine" QRM-band, the many possible uses make it sound attractive. Give it a whirl and let's know

how you find it. (We're also looking for OES reports on first use of the newly allocated 235-240 Mc.)

VHF Marathon. Attention of all amateurs working in 50-54 Mc., 144-148 Mc., 235-240 Mc., or any higher frequency amateur bands is invited to the announcement of the rules for the 1946 competition. Scores will be determined by the number of QSOs, DX and consistent activity. See details elsewhere in this issue. Monthly results will be featured in *QST*. Not only OES, but all v.h.f., u.h.f., s.h.f. workers are invited to get the reporting forms and participate.

About Reactivation of ORS and OPS Appointments. Effective May first any ORS and OPS who has submitted activity reports to his SCM covering two consecutive months of his postwar amateur station operation, and presented his certificate for SCM-endorsement may have his appointment renewed. (SCM sends usual Form 4 endorsement card to ARRL HQ. for record purposes.) At any time within 24 months of May 1, 1946, prewar ORS or OPS may report and apply for reactivation, SCMs automatically issuing endorsements on receipt of the second such activity report. Leadership posts, Route Manager and Phone Activities Manager, in these groups are being reviewed by SCMs. Member-amateurs with an active or continuing interest in organizing and coordinating section traffic schedules and voice activities are wanted where prewar RMs and PAMs are not available to carry on their assigned functions in ORS/OPS groups. SCMs must endorse certificates of prewar RMs or PAMs (notifying Hq. on Form 4) to validate these old appointments.

Appointment Applications Invited. With the above announcement the ARRL Field Organization again offers appointment activity in all departments. An abbreviated description of each type SCM-appointment appears with the announcement of the new Official Experimental Station appointment (See pages 66 and 80, March 1946 *QST*). Ask ARRL for a copy of Operating an Amateur Radio Station and an application form for the appointment you are interested in and qualified for.

28 Mc. Ideas: Sportmanship vs. QRM. Not only in the "BW" (see claimed scores this issue) but in many periods when 28 Mc. has been good, we have found desirable DX signals under a bunch of locals engaged in rag chews, or under certain unmodulated carriers from local sets being tuned up or tested. When stations are stacked two or three deep this needless QRM is almost inexcusable. GOOD SPORTSMANSHIP requires amateurs to refrain from local work in a DX band or from excessive tuning up, when the DX conditions are right and signals are coming through.

WIJNO writes to invite additional attention of 28 Mc. operators to (1) possible harmonics of

their stations falling in the television channels (2) possible excessive frequency drift of some crystals and the danger of drifting off-frequency if one starts but 25 kc. from a band-edge (3) danger of FCC citations from direct radiation from links and low-power driver stages at 14 or 21 Mc. "Better check up," he says. He also suggests increased use of "10" for short haul phone work, and use of vertical antennas for non-directional local work at night and other times, all of which is sound doctrine.

ARRL "FD" to be June 22/23. Dates for this once-a-year outing for testing emergency powered portables can be announced now that we have more frequencies to facilitate plans: Count on June 22/23. Full details in next *QST*. See you in the FD!

— F. E. H.

FLASH!

CODE PROFICIENCY PROGRAM RESUMES

Headquarters station W1AW has just received temporary authorization for use of 3555, 7145, and 14,230 kc. on an unlimited time basis to provide one-way transmissions pertaining to amateur radio matters and in order to permit resumption of international Morse code transmissions as a part of the ARRL Code Proficiency Program. 29,150 and 52,000 kc. frequencies will also be used.

The CP program will be similar to that in effect in 1941 and detailed information will follow in June *QST*. Practice transmissions will start May 1 (see W1AW Schedule).

To permit direct comparison of one's fist and tape sending, *QST* will list in advance the text to be used for practice on two of the five weekly practice runs. The following tabulation indicates material to be used in the program during May and to June 18th. To get sending help hook up your own key and buzzer or audio oscillator, turn to the *QST* material, tune in W1AW, and attempt to send right in step with the tape signals. Adjust your spacing in the manner the received signal indicates necessary for improvement.

Date	Subject of Practice Text
	March <i>QST</i>
May 2	<i>Need There Be Line of Sight?</i> p. 47.
May 7	<i>Technical Topics</i> , p. 59.
May 10	<i>Official Experimental Station</i> , p. 66.
May 13	<i>Operating News</i> , p. 80.
	April <i>QST</i>
May 15	<i>Good Operating Pays Off</i> , p. 31.
May 21	<i>A Band Pass 28-Mc. Converter</i> , p. 44.
May 23	<i>Crystal Grinding Without Tears</i> , p. 58.
May 29	<i>The Postwar Naval Reserve</i> , p. 54.
May 31	<i>The World Above 50 Mc.</i> , p. 60.
June 4	<i>The Circular Band Theorem</i> , p. 65.
June 6	<i>Technical Topics</i> , p. 67.
June 10	<i>Listening Post in the Philippines</i> , p. 70.
June 12	<i>Stabilizing the 144-Mc. Transmitter</i> , p. 24.
June 18	<i>Qualifying Run, 10:00 p.m. EDST.</i>

Get started on practice material from W1AW now. The W1AW bulletins "to all radio amateurs" will give additional practice at 15 and 25 w.p.m.

The first certificate-qualifying run is scheduled for June 18 at the usual CP transmission hour, 10:00 P.M. EDST. Following an initial issue of certificate, the ARRL program will award additional recognition by progressive sticker-endorsements at each higher speed attained. All amateurs are invited to participate in the Code Proficiency Program and to submit copies made during the June 18th *qualifying* run.

NEW W1AW OPERATING SCHEDULE (Effective May 1, 1946)

Official ARRL Bulletins containing latest FCC information relating to amateur operation and reactivation, and other bulletins on matters of general amateur interest are transmitted on regular schedules, as follows:

Frequencies: 3855, 7145, 14,280, 29,150, and 52,000 kc.

Times: 8:00 and 11:30 p.m. EDST, Monday through Friday. (0000 and 0330 GCT, Tuesday through Saturday.)

Starting at the times indicated, bulletins are transmitted by telegraph simultaneously on all frequencies. Bulletins are sent at 25 w.p.m. and repeated at 15 w.p.m. to facilitate code practice. Telegraph bulletins are followed by voice transmissions on each frequency in turn. Changes from this schedule will be announced by the operator.

Code Proficiency Program: Practice transmissions at five speeds, 15 through 35 w.p.m., are made Monday through Friday, on the above listed frequencies, starting at 10:00 P.M. EDST (0200 GCT, Tuesday through Saturday). Approximately ten minutes practice is given at each speed. First certificate-qualification run is scheduled for Tuesday, June 18.

General Operation: Frequencies- 3950 kc. (voice), 3825 kc., 29,150 kc., 28,245 kc., and 52,000 kc. W1AW engages in two-way work with amateurs as progress on constructional projects permits. The station is not operated on legal national holidays.

BRIEFS

The Milwaukee Radio Amateurs' Club will hold its 17th Annual Stag QSO Party at the Republican Hotel, Saturday, May 11, at 6:30 P.M. Admission is \$3.50 in advance, \$4.50 at the door. Tickets are available from Ralph O. Koenig, W9RUF, 1311 South 5th Street, Milwaukee (4), Wisconsin. The Party includes dinner, entertainment, famous Milwaukee refreshments, and all ticket stubs go into the box for prize drawings.

WHO CAN WORK MOST STATES ABOVE 50 MC. IN 1946?

Awards! What W or VE amateur operator using any frequency above 50 Mc. will work most of the 48 United States from March 1st to the end of 1946? Three suitably inscribed solid-bronze medallions, engraved with the call of the winner and the number of states he works will be awarded by ARRL. All work credited must be that from one location, with the transmitter on 50-54, 144-148, 235-240, or above 400-Mc. amateur bands.

A *location* is defined as "from places in one community, no two of which are more than 25 miles apart." The District of Columbia counts for Maryland.



Required: Written confirmations from the stations contacted, one such confirmation for each state claimed. Report new states at once, but hold confirmation cards and letters until the end of the year, when the *leading* operators must submit evidence to support claims, including postage sufficient for the return of any such communications desired returned. All amateurs competing for these awards should report their number of states (and progress) with their Marathon scores, from month to month, for *QST* mention. Monthly progress tables will appear from time to time. See that your call is there!

How many States can you work above 50 Mc. in 1946?

KAIHR ON THE AIR

A radiogram via W7ETN brings word that KAIHR, Manila, returned to the air March 13th, with A-2 on 28,700 kc., and is open for traffic. Old time message-pushers will remember KAIHR as one of the most active traffic stations in the islands. Operators are W5DUI, W7HOB, and W9CHZ.

EARLY CLAIMED SCORES — BAND WARMING PARTY

The 28 Mc. band has hardly cooled off as we write this, but reports on the Band Warming Party are pouring in. We have scanned the logs and taken off the claimed high scores, which we present for the information of all. Early reports indicate that practically all activity was on 28 Mc., although several logs show some operation on 144 Mc. W6ULE worked 144 Mc. exclusively, making 26 contacts in the Los Angeles area.

It appears that the gang in the western sections had things pretty much their own way, although we assure you those scores were not made by relaxing in an easy chair! Old time contest men who participated in the BW agree that it was the most grueling affair they have encountered, yet nonetheless enjoyable. QRM reached new proportions, at least equalling anything ever heard in prewar days. But judging by the enthusiastic comments on the logs, hams can take it. They want more — contests, not QRM! You will recognize some prewar contest-masters in the list, among them W3BES and W8OFN . . . all still in there pitching.

We got a wonderful break on conditions for both domestic and DX contacts. It was a "band warming" in every sense of the word. Here are the highest (unchecked) scores so far reported. Listings show score, number of contacts, multiplier, and indication of whether c.w., 'phone, or both were used (cw; f; cw/f).

W6RBQ.....	49822-409-58-cw/f
W6TT.....	47216-400-52-cw/f
W6WB.....	42983-406-53-cw/f
W6MBA/Tinian.....	42075-385-55-cw/f
W6MLY.....	40704-338-53-cw/f
W4EPT/K6.....	34599-308-57-cw/f
W3ITO/5.....	34470-354-44-cw/f
W6BXL.....	31519-360-43-cw/f
W3BES.....	31000-301-40-cw/f
W6PKC.....	25272-325-39-cw/f
W6IKQ.....	24910-240-53-f
W5FRD.....	24820-323-34-cw/f
W7FNK.....	23547-251-47-cw/f
XE1FG.....	22936-239-47-cw/f
W8OFN.....	22736-220-49-cw/f
W6LKC.....	20548-234-44-f
VE4ALO.....	20080-246-40-cw/f
W9IU.....	19383-233-39-cw/f
W9BEZ/5.....	19371-207-33-f
W6CHEV.....	18180-201-45-cw/f
W1DCE/6.....	17640-191-45-cw
W6OKK.....	15708-177-44-cw/f
W2OIQ/6.....	15614-138-37-cw/f
W6SIG.....	15200-178-40-cw
W6SRU.....	14120-172-40-cw
W7HZE.....	12636-164-39-f
W3EHW/1.....	12587-155-41-cw
W2JRE.....	12390-188-30-cw/f
W2JXH.....	12390-187-30-cw/f
W7RT.....	11620-128-35-cw
VE3KE.....	11285-142-37-cw/f
VE1EP.....	10804-141-37-cw
HK1AB.....	10620-150-36
W3HWT.....	10592-138-32-cw/f
W2VL.....	10508-134-37-cw/f
K4KD.....	10032-132-37-cw/f

W5HGG.....	9792-150-32-cw
W1BFT.....	9758-122-34-cw
VE4GD.....	9418-139-34-cw/f
VE4SO.....	9019-111-29-cw/f
W2HMJ.....	8640-134-30-cw
W1DLC.....	8208-109-36-cw/f
W5CX8.....	8181-126-27-cw/f
W9JRI.....	8106-172-21-cw/f
W4FLJ.....	7714-127-29-cw/f

FIELD DAY — JUNE 22-23 MAKE YOUR PLANS NOW!

Yessir! There will be a Field Day this year. Mark your calendar, dig out the portable/emergency gear, check the trailer (if you are fortunate enough to own one!), pick the site for your operations, get your special antennas cut to length, check the portable masts to see if all the pieces are still around, and break the news to the family that the June 22-23 week-end is reserved for ham radio. Clubs particularly will want to make plans early. It is *the* ham outing of the year. ARRL Emergency Corps members will find the FD an unexcelled opportunity to test emergency equipment, including auxiliary power supplies. We expect that some Emergency Coordinators will take advantage of the Field Day to expand AEC plans. Don't miss this fun-in-the-great-outdoors activity. Full details June QST.

BRIEFS

W2KGW, operating fixed-portable at Stevensville, Newfoundland, has had several ragchews by 28 Mc. 'phone with his wife in Westfield, N. J. On February 13th we heard one of these contacts. Some angles involved struck us as examples of "rotten operating." Here's how it went. W2KGW/VO called "CQ Westfield, N. J.," whereupon answers poured in from New England to Pennsylvania. To many of the gang, a directional CQ meant nothing compared with the possibility of raising a VO! We commend W2KGW's patience in dealing with the non-New Jersey answers. After several attempts, W2MYH, Summit, N. J., was raised. He got W2KGW's YF on the land line and a relayed telephone call was tried. This proving unsatisfactory, Mrs. W2KGW set out for W2MYH's shack. That's when bedlam started. So many stations were calling W2KGW/VO on W2MYH's frequency, that KGW was finally obliged to announce, "I give up. Take it easy, fellows." By the time his wife reached W2MYH the interference had reached such proportions that contact was impaired. It was rather pitiful to hear the unnecessary jamming by horners-in while a GI was trying to talk with home. There was no excuse for the mad rush to work W2KGW/VO while he was in contact with another station. Common courtesy in operating would have dictated that a fellow be permitted to complete his contact before others tried breaking in for a routine QSO. Let's show a bit of the old-time ham spirit of cooperation, fellows!

MEET THE SCMS

The San Joaquin Valley Section has elected a new Section Communications Manager — James F. Wakefield, W6PSQ, Fresno, California, fresh from the Air Corps, and Army Signal Corps.

A Californian by birth, "Jim" first saw the light of day in Fresno on November 1, 1920. The amateur radio bug took its initial bite in 1935, and continued to nip until 1938, when FCC issued W6PSQ.

The present W6PSQ is designed for operation on 3.5, 7, 14, and 28 Mc. c.w., and 14, 28, and 144



Mc. 'phone. Transmitter line-ups: 6AG7-6L6-PP TB35s, 200 watts; 6A6-6L6-813, 200 watts, TZ40s in modulator; 6AG7-6L6-832-829, 25 watts. Receiver is an HQ-120X. In addition, portable/emergency equipment is available: Transmitting-6AG7-6L6, 12 watts, portable-mobile; HY-75, 5 watts. Receiving-6K8 converter with auto

radio, and 9002 super-regen. Antennas include 3-element rotary, half-wave off center fed, half-wave co-ax.

"Jim" is active in the San Joaquin Valley Radio Club, having served on the Board of Directors, and held the offices of president, secretary, and treasurer. He has been active in ARRL organization work, holding appointment as Official Observer. His operating proficiency is indicated by his 25 w.p.m. receiving speed.

Hobby time is shared by ham radio, photography, and flying, as well as active participation in the sports of swimming, trap shooting, skiing, tennis, and skeet shooting. The favorites, aside from hamming, are skiing and flying.

The daily bread comes from association in the firm of Wakefield & Hopper, Real Estate and Insurance. When not busy in this field, "Jim" is devoting his first efforts to the new SCM office. We know that the SJV Section will go places under his leadership. Welcome to the family, "Jim."

BRIEFS

In case you have been wondering how those D4s put in such healthy signals with 25 watts, you will be interested to know that on March 1st the D4 GI stations received authorization to use up to 500 watts! Also, they are now permitted to use 'phone on all of the 28 Mc. band.

FIRST AEC DRILL?

P. C. Yeomans, W2OHE, Brooklyn, N. Y., Emergency Coordinator for Kings County, writes that his group has been holding 144 Mc. drills and tests under the new ARRL Emergency Corps set-up since its origin. W2OHE asks, "Are we first?" Operation of the reorganized AEC was described in December, 1945 *QST*. Local simulated emergency tests and regular drills under the leadership of ECs is the foundation upon which the new AEC is building. We recommend 144 Mc. for these drills, where practicable. Is W2OHE the first EC to actually have his group organized and working on the air? Let us know the date of the first AEC tests in your locality.

A radiogram from W2FI, handled entirely on 144 Mc. February 25th, with routing via W2AEF-W2LPA-W2IQI/1-W1HDQ, reports active emergency net operation that date in Nassau and Suffolk Counties, New York. W2FI was Control Station, with 19 stations (3 mobile) represented.

Have you joined the ARRL Emergency Corps? If you have been unable to get hold of an application form locally, a postal to your SCM or to Headquarters will bring you one, together with the address of your Emergency Coordinator, if appointed. Get in on the interesting AEC activities.

SEND YOUR CONTRIBUTIONS FOR PRIZE ARTICLE CONTEST

The CD Article Contest is open to all radio amateurs. The first winning article in the postwar series appeared in April *QST*. It is a continuing contest, with entries considered for publication each month.

The author of each article used is awarded a \$10 prize, consisting of \$5 in Victory Stamps, and \$5 in ARRL supplies or publications (except *QST*).

Your contribution must be on a subject of interest to amateur radio operators. That is the only limitation, except that the length should be not over 500 words. Snappy articles of moderate length are usually most acceptable. Entries are judged on originality and value to the fraternity.

Write on any topic of interest to you as a radio amateur. There is an almost limitless variety of subjects in the fields of ham operating and organization. Send as many contributions as you like. Please mark your article "for the CD Contest."

— . . . —

A group of Seattle amateurs have formed a QSO club, the "ADDDC." The only requirement for membership is the ability to operate on 28338 kc. At last count there were 20 members. To learn the meaning of "ADDDC" one must get on the frequency, and then meet a member personally. W7JEF (ex-W6DKM, KA1AC, XU8CC) reports that the members hold lunches each Monday.

CANADIANS ORGANIZE AFARS

The Canadian Minister of National Defence for Air, and the Air Council, RCAF, have approved organization of the Air Force Amateur Radio System (AFARS) to be formed by the RCAF, and certain VE amateurs. A trans-Canada chain of amateur stations will be set up and operated by qualified operators, who will be trained in RCAF procedure, both c.w. and 'phone. The object is: (a) to provide a backlog of trained radio amateurs in the event of emergency, (b) to acquaint these amateurs with the latest developments in service communications and electronics, (c) to provide a service for localized emergency operations, and (d) to foster mutual interests between the amateurs and the RCAF.

No reserve status will be required on the part of any member nor will there be any liability for service or call. Full membership is open to any Canadian citizen over the age of seventeen. The organization is aimed at encouraging good operating between AFARS members and amateur clubs located at RCAF stations. In some fifteen areas throughout Canada, Net Control Stations will be set up. Each of these "squadrons" will consist of one or more "flights" of not more than twenty radio amateurs each. Each "flight" will operate on a spot frequency between 3505 kc. and 3825 kc. with crystals loaned by RCAF. 3625 kc. will be the general AFARS frequency for inter-squadron working and for official broadcasts. The "flights" will be associated with local RCAF Auxiliary Units to improve their technical knowledge, and operating ability, and will have one parade, or "roll call" night, on the air, each week for each "flight."

The organization of the system is being undertaken by A/C Keith Russell (retired), VE3AL, an active figure in Canadian amateur circles for the past twenty-eight years. At his request the following amateurs have volunteered to get things started in their areas: Halifax, VE1JH; Montreal, VE3JI and K. R. Patrick, 1001 Lenoir Street; Ottawa, VE3KE; Toronto, VE3ADR and VE3GT; Hamilton, VE3CJ; Winnipeg, VE4AAW;

WITH THE AFFILIATED CLUBS

• ARRL Affiliated Clubs, please note: The QST "With the Affiliated Clubs" section will be resumed soon. It is reserved for worthwhile ideas and information of interest and value to all clubs in planning activities and maintaining interest. Photographs will be used, if satisfactory and pertinent to the subject matter. Secretaries and activities managers are invited to submit material for consideration. With your cooperation we can develop a useful idea exchange medium, which will aid all societies.

Regina, Don Leitch, 2450 Broder Street; Calgary, VE4GD; Victoria, VE5XX. Those interested should contact the organizer in their area. At the outset, operations will be restricted to c.w., but radiophone also will be used later. Although the AFARS idea has been considered for many years, its present fruition is largely due to the efforts of Noel Eaton, VE3CJ (ex Wing Commander, RCAF). Other amateurs who assisted in the early planning are VE3GT, VE3ADR (ex Flight Lieutenant, RCAF), and VE3EF (ex Wing Commander, RCAF).

BRIEFS

Here is proof that 28 Mc. is reliable for schedules, at least in some quarters. W6TPN/7, Centralia, Washington, writes, "I've pushed traffic for years on 7 Mc. c.w., but during the last three months I have run the most consistent and reliable schedule I ever had, and it has been on 28 Mc. 'phone. I schedule W9YM/KB6 (Guam), daily and haven't missed more than two schedules due to QSB. We handle an average of 300 messages per month. The record, however, is really held by W6QKB/KB6, who has had more than 81 person-to-person schedules in three months without a single failure!" Can anyone match this performance?

Interest in amateur radio is high at the Eastern Signal Corps Training Center, Fort Monmouth, N. J. Plans include formation of the Fort Monmouth Radio Club, and facilities for round-the-clock operation in the ham bands. Space for a club room and station has been allotted, and several transmitters already are being installed. FMRC will be open to all radio amateurs of the ESCTC command. Since many ham stations in the theaters are operated by Signal Corps personnel, the Fort Monmouth school expects to keep close contact with former students. Valuable training in radio practice will be given through the handling of traffic, as well as technical training in building and maintenance of the equipment.

W6TEF/7, Kalispell, Montana, and W4HSQ, Oneida, Tenn., are keeping daily schedules on 28 Mc. 'phone, at 11 A.M. and 3 P.M. CST. Each station has 150 watts input, half-wave doublet antennas, and RME-45 receivers. Contacts have been consistent, with reports averaging R5 S5/6. W6TEF and W4HSQ are both located in the mountains. Let us hear of any other reliable schedules on 28 Mc. or higher frequencies, as well as outstanding work on other bands.

W6MBA/KB6 and XU1YU have regular traffic for the States. Here's a chance to arrange a schedule and get in on some overseas relaying.

Station Activities



REPORT YOUR ACTIVITIES

• All operating amateurs, especially ARRL members, are invited to report to the SCM on the first of each month, covering station activities for the preceding month. Radio Club news is also desired by SCMs for inclusion in these columns. The addresses of all SCMs will be found on page 6.

ARRL members are invited by SCMs to make application for the following appointments: ORS, OES, OPS, OO, OBS. Leaders are needed in several Sections to handle important SEC and EC posts. The SCM would also like to hear of your interest in RM or PAM appointments. Send all inquiries and applications to the SCM for your ARRL Section.

ATLANTIC DIVISION

EASTERN PENNSYLVANIA — SCM, Jerry Mathis W3BES — 3AQN reports that the York gang is getting swell newspaper publicity for their emergency network. They have made successful field tests in conjunction with the Red Cross. 3AOC sends in the first postwar formal activities report and is rarin' to go on 3.7 Mc. for traffic. 3KBB is old-timer IBOA, of New Haven, Conn. 3EAN/4, of Jacksonville, Fla., says that he wishes the fellow using his call would stay in the band because he got two off-frequency reports from the FCC when he wasn't on. 3FZA moved to Chicago where DX is good. He can't hear the Philadelphia stations there but can tell they are on by the DX stations calling them. 3DGM worked 3QV, who is signing XUIYV in China. 3HXA has been mowing down the DX on 'phone and c.w. with his new 8JK beam. 3JBC is getting out well on 28 Mc. with a new three-element beam. 3GET is using 3GHM's NC-101X. 3ILK has a new converter for 28 Mc. 3BES made 31,000 points in the Band Warming Party. The Lancaster and New York Clubs are sponsoring a 144-Mc. contest which is creating plenty of activity. 3KT has a new daughter; also several new countries. 3AGV and 3KT are running a close race for the first 28-Mc. WAS. 3DGM worked WAC in one day. 3IXN has a swell-sounding 'phone on 28 Mc. The Frog Hollow net continues to attract a lot of attention. 3EWZ and 3HRD are hard at work on 144 Mc. 3DGM christened the new 27-Mc. band a few moments after the WIAW broadcast. 3CJI is on 28 Mc. from O4AAK. 2AQN is DXing on 144 Mc. 3EDO and 3KBA have mobile rigs on 144 Mc. The YARC of York has reorganized and 3BIL is the new president. 3BXR, GZX, JNT, and JOH are active on 28 Mc. 3IXG has a new SX-25. 3IPB is a new member of the YARC. 3GZZ, FHG, and BXR are all set for 3.9 Mc. 3EKK reports the opening of the 144-Mc. band for short skip DX. 3HIO is experimenting on super-high frequencies. Former ORS/OPS are invited to send in formal activities reports, write for report forms, and send in certificates for endorsement. 73. *Jerry.*

MARYLAND-DELAWARE-DISTRICT OF COLUMBIA — SCM, Hermann E. Hobbs, W3CIZ — IVZ, formerly with Jansky & Bailey Radio Engineers, has moved to the West Coast and now is head of the technical department of the School of Radio Arts, Hollywood, Calif. His address is 1584 Cross Roads of the World, Hollywood 28, Calif. BTA spoke at the DARC meeting on BCI, BCC, SVS, and 2OAM were visitors. DOH is going on 144 Mc. at Arlington, Va. KAP and KAT are new calls in Wilmington. CGV has a new 28-Mc. antenna and is evolving some "DX." DRD and IYE have coaxial antennas on 28 Mc. DQZ and KAT are on 144 Mc. DA and DPA are running a kw. on 28-Mc. 'phone. HC moved his rig from the linen closet to the spare

room and now has room to entertain visitors. JEW is on 28-Mc. 'phone and c.w. HGA and DUK, also K8TEB/3, are rebuilding. GL made a recording at the DARC meeting. W8UUQ/3 is on 28 Mc. with a thirty-watt 'phone input to a dipole antenna and has worked eleven of the thirty-three districts that he has heard. He is planning to erect a rotary on 28 Mc. and rebuild so that it will work on 3.5 Mc. 73.

SOUTHERN NEW JERSEY — SCM, Ray Tomlinson, W3GCU, — Section EC, BAQ; ECs, ABS and JNZ. At the February meeting of the DVRA, Mr. Oliver Wright, prowar BBO, gave a very interesting talk on antennas and feeder systems. New officers of the DVRA are: CCO, pres.; EED, vice-pres.; ZI, secy.; H. L. Yoder, treas. 1KIQ/3 signs W2OQN, 3ASG now signs W2ORH. ABS reports further progress with the new 144-Mc. emergency net being formulated with the cooperation of the N. J. State Forest Wardens. Stan is on 28,352 kc. JNO is using a new four-element beam. Following are new officers of the Hamilton Twp. Radio Club: Bill Fry, pres.; Fred Muhs, vice-pres.; Earl Van Horn, secy.; and GCU, treas. Classes are held each Tuesday at 7:30 p.m. under the tutorship of ARN and Jack Rittman. HTJ is clicking FB with the DXers with good reports both ways on the Ds and Gs. Frank is running 300 watts into a beam. 2KBI is on 28 Mc. in Neptune City. 3EPE has a nice signal on 28 Mc. CCO reports working some choice DX on 28-Mc. 'phone: LU7AZ, Buenos Aires; W4HUT/PY7, Natal, Brazil; HP1A, Panama City; G4JZ, Cheltenham, England; and O4AAK, Lima, Peru. The DVRA W3AQ transmitter is in daily operation. Code and theory classes will be conducted under the tutorship of HAZ. AFH has his new rotating mechanism in operation on his beam. HTJ replaced the saddle on his beam and raised the unit ten feet. During the ARRL Band Warming Party EDP worked LU7AZ, K6CGK, K4KD, XE1FG, XE1A, XE1D, ZS6AA, and ZS4AA. Traffic: W3CCO 8. 73. *Ray.*

WESTERN NEW YORK — Charles I. Otero, W8UPH — The Radio Association of Western New York has been formed at Buffalo. The first regular meeting was honored by the presence of Senator James Mead. Officers are SD, pres.; QLK, vice-pres.; UXL, treas.; and OSN, secy. The Jamestown Amateur Radio Assn. is active again and has great plans for the near future. Several wives and families in this section have been put in touch with their husbands and relatives in the armed forces overseas through the facilities of RTX, NOL, and PAM. This is an FB service which should be expanded. RTX traffic schedules with 9YM/KBB at Guam are very successful. When conditions do not permit direct handling, 6TPN/7, at Centralia, Wash., stands by and takes over relaying to RTX. They seldom miss. 1LDV/8 and 1MIM/8, at Ogdensburg, and 9AQ8/8, at Canton, N. Y., are ready for traffic on 3.5 Mc. c.w. LDV and his XYL, MIM, will be on twenty-four hours if necessary. TCB is teaching school at Troy. EWE is rebuilding, OSH is planning a new 1/2-kw. rig, and TBZ is tearing his hair out trying to work on 28 Mc. Now that the 3.5-Mc. band is open TBZ is happy again. There is a 144-Mc. gang at Buffalo on the air regularly. PLU, NOR, and BSM are now crystal-controlled. The boys on 144 Mc. are swinging to superheta. EBF is leaving for the West Coast. First W2 calls reported are TXB and his XYL, WOW, and PES, and OSK. LVZ, writing from San Diego, says the Navy is OK with him, so he shipped back as CRM (PA). CYD reports there is a good emergency net operating on 146 Mc. throughout Onondaga County. Thanks for Bulletin on activities of the new ERCA at Syracuse. The "Old Timers Night" at the Rochester Amateur Radio Association was a big success. MUH entertained the gang with his rare ability to read the mind. SJV, EC for the Niagara Frontier, paid us a visit to discuss organization plans. Ed is doing a wonderful job and is determined to have the best organization for EC work in this section. In order to tie in with his plans we need someone in Batavia. How about dropping me a card? OGC and TEX helped OQC get the "mice" out of the filaments, but Lank is building a new and more powerful rig. For those interested in OES work, I have blanks available. VUY, back from the services, is on again with an FB signal. We are not getting enough news from the field. How about more? 73. *Charlie.*

WESTERN PENNSYLVANIA — SCM, R. R. Rosenberg, W8NCJ — Section EC, AVZ. New appointments: OBS; MPO and RAT. OO; TVA. BOY has 20-watt, 28 Mc. 'phone rig and reports Warren news: VMW is constructing new rig. KYW is purchasing new receiver. ESR has moved to Philadelphia and is with RCA. LTQ is home after duty

(Continued on page 86)



★ ★ ★

LIKE crystal filters, noise limiters require some understanding on the part of the operator if they are to be used effectively. However, they are much simpler and easier to understand than the filter, and their use requires less skill.

Noise limiter design is based on the fact that most of the objectionable noise picked up by the antenna consists of pulses of large amplitude and very brief duration.

The pulse lasts such a short time that the ear would scarcely notice it if the noise were as brief as the pulse.

However, the objectionable noise pulse is strong, though brief, and it acts like a hammer blow on the speaker diaphragm. This blow sets the diaphragm in vibration, and these vibrations die out slowly. Thus an electrical disturbance of short duration produces a sound of long duration.

We have mentioned that the amplitude of the noise impulse is large. It is commonly very much greater than the signal. If we arrange a circuit in the receiver so that the maximum amplitude is limited, then any amplitude greater than this value will be "chopped off." Thus if the signal has a peak value of one volt at the detector, and if the detector will pass a peak signal of just one volt and no more, then the signal will pass through unaffected. However, if a noise pulse with an amplitude of ten volts arrives, then nine volts of it are "chopped off" and only one volt is passed. Since the energy varies as the square of the voltage, the blow on the speaker (and the noise you hear) is greatly reduced.

The level at which the detector limits the voltage is called the "threshold." Obviously, if the threshold is too low, it will clip the signal and result in distortion. On the other hand, if the threshold is too high, it will not be fully effective in reducing noise. Some receivers have a fixed threshold, adjusted at the factory to a compromise value. We prefer to provide a "Threshold Control" which can be turned down until distortion just begins to appear. This insures optimum results.

A noise limiter is quite a simple device and we hope this very brief description will clear up some misunderstandings about it. For instance, very often amateurs will write us that noise limiters cause audio distortion. The answer, of course, is to turn up the threshold control until distortion disappears.

If you would like to know more about noise limiters than we have been able to tell on this page, you will find plenty of good descriptions in radio textbooks and handbooks. Try page 165 of the 1946 ARRL Handbook, for a start.

WILLIAM A. READY



(Continued from page 84)

with merchant marine. PEC is still in the services. NTJ took the fatal step after release from the Army. T/5 TWI/4 was elected secretary of radio club at Oak Ridge, Tenn., where he is stationed. TVA logged the following local stations on 28 Mc. from his new Pittsburgh QTH: IZG, JCM, NKI, OIX, OMY, OVZ, PGV, RAS, SHK, and AOE. JCM works European DX with 20 watts to 816 final using cathode modulation. VNE has Class A ticket and is working 28 Mc. c.w. UVD has completed new receiver with 6C8G tube, and transmitter with 809 final. OUH is cleaning up his 3.5-Mc. crystals. 9LEZ/8 and SNC are employed at the same plant in Meadville. SNC was recently discharged from the Army. QWD is attending Allegheny College after release from Navy. MIE is on 28 Mc. with vertical antenna. UTQ is constructing modulator for his 28-Mc. transmitter using 809 final. QKI dropped around to visit Erie fellows after his release from the Army at Sheppard Field, Tex. UUG has remarkable DX record on 28 Mc. with thirty-four countries worked since November 15th. DNO has been elevated to chairman of Pittsburgh Area Radio Club Council. MPO was elected vice-chairman. DX amateurs in Pittsburgh area having good success on 28 Mc. are: MBC, UUG, OMY, PGV, MTY, RAS, MGZ, and RZC. MPO, president of Amateur Transmitters' Assn., of Western Pennsylvania, reports club news: NUG is in charge of program planning. OB gave an instructive talk on WX forecasting at February meeting. BSO and BWP were lucky to get first two postwar receivers delivered in Pittsburgh. NRW is building a "plug-in front end" (r.f. detector and oscillator) for receiving on 50 and 28 Mc. RAS has set his rotary beam way up in the sky, with the aid of 3" pipe set in concrete and braced alongside the shack. CKO erected new beam antenna 25 ft. above his garage. TFU works locals with only 8 watts input. 73. Ray.

CENTRAL DIVISION

ILLINOIS — SCM, David E. Blake, II, W9NUX — Representatives at the Chicago Area Radio Club Council annual meeting were: CRTA — WL, ADF, and YDV; CSRA — MAT and PNV; Hamfesters Radio Club — KBO; Illinois Ham Club — SG, UJR, HPX, and MD; LMARC — TIJ and MCS; Northwest ARC — LIP; York Radio Club — KA and GY. Visitors included NVX, LVD, and 8NUI. The new officers of the Council are: SG, chairman; TLQ, vice-chairman; YDV, secy.; KA, treas. Plans for a National ARRL Convention are being made. Contests and other activities are in the making under LIP's direction and much is to be expected. See HXE in the "Ham Shack" at Allied. News via JVI: Orchids to 6BBQ, Pasadena, who got a message back to Chicago 24 hours after W9 arrived at Pasadena. TZL is on 28-Mc. c.w. JUW is rebuilding for 28-Mc. phone with 812s by 811s. LUW is doing service work. KZD works W6s on 28-Mc. phone. CWU writes from the Pacific. Rex is s/sgt. in the Marines. Ex-BC is an engineer. His dad, AZW, railroad telegrapher, is awaiting Rex for help on the kw. Old ZAK has retired, and is at Delaware, Ohio. OQZ is heading home from Italy. GYD has p.p. T20 nearly ready for 28 Mc. YZO had a poor QTH in St. Louis but urged by his XYL, built 807 on 28 Mc. GHB is back in Jacksonville. The Starved Rock Radio Club, MKS, is planning a prewar quality hamfest to be held June 9th at Camp Ki-Shau-Wau, near Starved Rock State Park, Ill. The SRRC is going to build rigs, towers, and additions to the clubhouse and will have one rig on 3.5 and 7 Mc. and another on 14 and 28 Mc. QLZ is the club president. The Chicago Suburban Radio Association reports PK as outstanding DX man on 28 Mc. with over thirty countries; UIG is second, and MAT third. KZV maintains daily schedules with K6S and is always R9 plus with 60 watts and a Lazy H antenna. KDI does the same with 45 watts and an 8JK antenna. New club officers are: TQL, pres.; PK, vice-pres.; BGC, secy.; FCN, sgt. at arms. JVI is going to be his old active self on all bands, 144 Mc. and up, and has been reappointed EC for Greene County. Application for OES appointment has been received from EJX. The Cahokia Amateur Radio Club is active. ZYP is rebuilding. EBX is building a soundproof studio in the basement of his home. NMY is getting ready for 7 Mc. APX has found a use for his beam antenna besides transmitting ("his said that it makes a good chicken roost). Capt. ex-6HJP, of San Francisco and of California kw. fame, is in the Army Air Forces and is assigned to HQ, the Army Airways Communications System at Langley Field, Va. He is stationed with George Hart.

1NJM, of the ARRL. He hopes to obtain a W9 call and operate that kw. from Chicago. DBO is ready and waiting for 14 Mc. SMD reports lack of equipment is the biggest drawback, but lots of prospective hams are asking to be organized. He still is working on plans for a club to be formed soon. Hams now enrolled at Elmhurst College include KWN, VYQ, and SCH. Plus a couple of active SWLs, these constitute the "extra curricular electronics group" on the campus. They have a rig at the school on 3.5 Mc. Hamfest No. 1 was sponsored by the Quad City Amateur Radio Club. Let's have more of these all over the State. The 144 Club, in Chicago, is under way. Get on 144 Mc. and learn more about it. 73. Dave.

INDIANA — SCM, Herbert S. Brier, W9EGQ — AB worked a Z8 and has the DX fever again. IU is working dozens of DX stations each week. HUV worked Burma for his best. VV bought a home with an acre of ground. OKR built two receivers and is building a new transmitter. EGV and MBM had their rigs for 3.9 Mc. tuned up weeks before the band opened. DPL is attending classes and teaching at Valpo Technical Institute. DLI has a 144-Mc. beam. PQL has a folded doublet on 144 Mc. YNK/9 works 144 Mc. from Valpo. YWE visited PQL. He is building a new low-frequency transmitter. MVZ, CWO, and HUV are OOs. DGA worked Tinian and PJ for his best DX. He will be in the Indiana net when it is organized. NWN has his three-element beam 50 feet high. 8NLW is in Logansport, and is building a 75-watt v.h.f. mobile rig. KMY and ILU are on 319 Mc. PMT is communications manager of Fort Wayne Radio Club. He reports new officers are: Van Bowman, pres.; UUN, vice-pres.; WJF, secy.-treas. UUN, USU, REW, PWZ, PWF, PMT, UJE, MQ, DJU, VKH, JRR, EFW, GOX, TJN, AMM, ZEZ, NAH, MRS/9, SBF/9, YQV, CLF, KCD, QCY, ODW, VVJ, TBM, TCZ, CXJ, DJJ/9, PSV, BKH, SVH, and 8TDN/9 are on 28 Mc. in and near Ft. Wayne. PMT is building a 300-rig. DJU ordered a 28-Mc. beam. VKH uses his farm to raise antennas. GOX and EFW, the XYL, erected a four-element beam. ODW does well with 100 watts. YQV got delivery of NC-200 receiver. PWF has SX 23 and plumber's delight rotary. UJE and CLF built 28-Mc. receiving equipment. DJJ/9 gets out well with 5 watts. 8TDN/9 has seven 807s in his exciter. AMM runs 600 watts c.w., and is building modulation equipment. MVZ works K6 and CQs. EGG bought a modulation transformer. QG has a 7-Mc. Zepp to work 3.5 Mc. c.w. When sending further reports, please include traffic totals. Appointments are open for OES, OO, OBS, EC, and SEC. Are you qualified? 73. Herb.

KENTUCKY — SCM, Joseph P. Colvin, W5IEZ/9 — FS reports hearing BAZ on 28-Mc. c.w. KRY and JML are working ground-wave DX. JML is operating also on 52 Mc. and wants information on ground plane antennas. Lexington and Louisville, please note. 4IKO is a new license in Kentucky. 6TTI, ex-9JIT, is back home and itching to get on 3.5 Mc. Others in his vicinity are FRH, JJS, JWW, KUY, and KLO who, because of mountain difficulties, are setting up to get started on 3.5 Mc. Owensboro hams are on the ball. ZUZ would like to contact his prewar friends, QRA: Lafayette, Ky. 2KVA/9 is at 330 West Thirteenth, Owensboro. MMY is ready for emergencies. NEP exchanged his RKZO for an 814. CHL is with G.E. engineers. FVF is planning a b.e. station. FXA has returned to Princeton. CXD is active with T55s and NC-100XA after seven years QRT. EIS has taken the moth balls out and uses 35T. He wants to see CNE sometime. ARR is in Kentucky with 807s. KWO has an SX-28 and a Collins Autotune 250-watt transmitter. BAZ is now an OES in addition to other functions. BAZ, TXC, and ELL are burning lots of watts. LPB is running flea power. IEZ is modulating an e.c.o. because of BCL trouble. Louisville is going crystal on emergency net at 50.5 Mc. Twelve have been ordered. The Midnight Net is active with MRF, GOM, YAL, MLI, LPB, KDB, CDO, and others active. YQN is knocking off Gs and Ds by the bunch. ARTS still meets the 2nd Sat. night at Canary Cottage. 73. Jos.

MICHIGAN — SCM, Harold C. Bird, W8DPE — SOCC reports that by using an 1852 directly in r.f. stage in place of 6SK7 on an 8-20R receiver very good results are obtained. 9VJJ reports on the Marquette County boys; 9BZH is working plenty of DX on 28 Mc. with 40 watts and inverted Q. 9VJD has a new 28-Mc. four-element beam. 9YLS has three-element beam for 28 Mc. The Hiawatha Radio Club has been reactivated and now is holding regular

(Continued on page 88)

FULLY SHIELDED

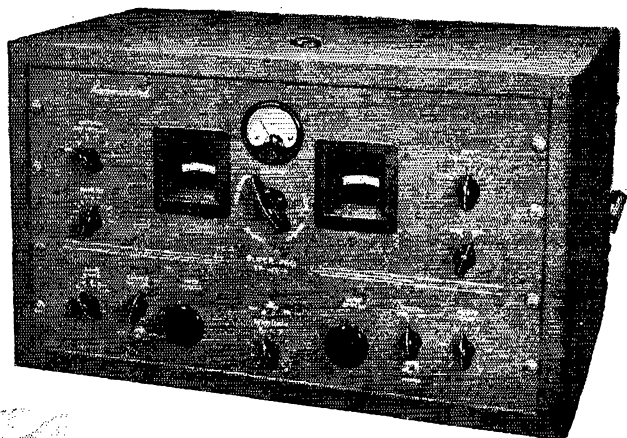

The "Super-Pro's" high-fidelity amplifier provides excellent broadcast quality — fine for use with record players when DX isn't coming through.

"SUPER PRO"

Series 400

.54-30 MC.

If you are troubled with spurious beats and images from powerful stations, you need a "Super-Pro." Complete shielding right up to the antenna terminals is one of the many features of the new Series 400 "Super-Pro."



HAMMARLUND

THE HAMMARLUND MFG. CO., INC., 460 W. 34TH ST., NEW YORK 1, N. Y.
MANUFACTURERS OF PRECISION COMMUNICATIONS EQUIPMENT

(Continued from page 88)

meetings. 51GW, at Greenville, Miss., has written asking to be placed on traffic trunks when they are reactivated. He used to work 9BRD, DPE, ILH, DIR, QLZ, YZH, OUD, 8DDJ, 5FDR, and 5OW on the trunks. 8ONK asks if QMN will be on the 3700-ko. band when it is opened. He wants ORS appointment again. 8UGR has his rig on 28 Mc. and is waiting to go on 3.5 kc. as soon as we get started. Paul renewed his EC appointment but because of work had to decline appointment as Chief EC of Metropolitan Detroit. 8NQ has receiver going on 28 Mc. using battery supply to eliminate tunable hum but has not been successful in getting his transmitter to function on 28 Mc. He hears very little c.w. but plenty of 'phone. 9SBW, formerly of Marquette, is at Ann Arbor attending U. of M., where he is operating portable. His sky wave contacts are not so good but many ground wave stations have been worked. The Oakland County Radio Club held its first postwar meeting on March 8th at which time the following officers were elected: Harold C. Bird, pres.; Chester Birwell, vice-pres.; Louis Young, secy-treas. After the meeting a general hamfest took place. The club will hold meetings the first Monday of each month. The Detroit Amateur Radio Association held its monthly meeting March 14th. At this meeting Kenneth F. Conroy, our Bulletin editor of long standing, was presented by the club with a new HQ-120 receiver, complete with speaker. The occasion was held in strict confidence by the members for three months. The surprise was well worth the efforts of the club. Ken's wife, Polly, was so overcome she could not enjoy the luncheon served. Your SCM will accept applications for ORS, RM, and the various other appointments, and will give them consideration as these appointments are reinstated. 73. Hal.

WISCONSIN — SCM, Emil Felber, jr., W9RH — SZL reports Racine Megacycle Club is having large turnouts at its meetings, which are held the second and fourth Mondays of each month at the Vocational School. SZL is ready to go back in the traffic nets. UFX is owner of the Sportsmen's Inn at Stoughton. The University Radio Club is working with the Four Lakes Radio Club and meetings are held the second and fourth Mondays of each month at 701 East Johnson St., Madison. MSJ, Y3c, hopes to be back at Kaukauna soon; he has spent quite a little time in the American Embassy in London; DDD, of Kewaskum, received his discharge from the Signal Corps after a year's hospitalization. He served three years in India and China where he was chief operator of WVWH. He now is attending Iowa State College at Ames, Iowa, and sends regards to the gang at home. The MRAC will hold its annual election of officers May 17th, and club meetings will be adjourned May 23rd until fall. SYT is preparing the gang for a Field Day. GIL and FJE were the first Milwaukee stations to operate on the new 27000-kc. band. 73. Emil.

DAKOTA DIVISION

NORTH DAKOTA — SCM, Raymond V. Barnett, W9EVP — A correction: PDN says his brother, RPM, was with TCC, not the ATC. PDN possesses a new RME-45 receiver. EVQ, with CAA at Dickinson, says PGO, senior aircraft communicator in charge there, has 280 watts on 28 Mc. OKM will be active on 3.5 Mc. as will YJL with pair of T55s. EOY, NVK, and RHV are rebuilding. HDD is collecting ham gear. AFK and ZKL are active on 28 Mc. CYN has installed a new three-element beam. ZTL is getting his share of DX with 100 watts. ABQ gets out FB with battery power. BBD is working portable W2 at Eatontown, N.J. FKP moved to Fargo. PDN will be active soon. DXC has his new rig on the air and ZRT hopes his new transmitter will arrive soon. PJT called on his brother, KZL, recently to inspect the WRL 70 transmitter and the 8-20R receiver. GJJ's official broadcast schedule will be 6 p.m. Mon., Wed., and Fri. on 3955 kc. 73. Ray.

SOUTH DAKOTA — SCM, P. H. Schultz, W9QVY — WUU, of Alcester, is operating his old rig on 28-Mc. 'phone and c.w. The Huron Club has reorganized with ILL as secy-treas., LBU, vice-pres., and Jack Foasberg, ex-ABY, who is relicensed and ready to go on the air, as pres. BAE is with the power company at Bismarck, N.D. New members are ZTR, Sioux City, and YTN, Kansas City. ILL is in radio service business. His XYL has operator license. IK operates radio service for Gamble store. MNI is assistant operator at KABR. QVY visited EOJ recently. When sending in calls please give name as it has been some time since we've heard the call and attached handle. FOQ is in repair business at

Redfield, ACT, of Sioux Falls, is doing some DX. So far he has four Gs, a ZS, an L and several others to his credit. EKT, Sioux Falls club secretary, says the club is very active and plans to give code and refresher courses for hams. 73 Phil.

SOUTHERN MINNESOTA — SCM, Vernon G. Pribyl, W9OMC — Congrats to ANU on his jr. operator. GBZ now has an XYL and is going to settle down and do some real work on frequency measurement with all the latest equipment. Your SCM is active on 28- and 3.5-Mc. 'phone and c.w. and wants traffic schedules. The following news was sent in by ZT: JRI, JHF, and LPL are home from the services. JNC is with the Army in Texas but expects to become a civilian again soon and says he has a pair of 813s to build a rig around. He also says he is very interested in finding someone to play around "a.h.f." with him as he is now radar-minded. Any takers? A club known as the Fairmont Radio Club recently was organized in Fairmont with twenty members. At the first meeting RPT was elected president and Jack Furtney, secretary-treasurer. Don't forget to send those ORS and OPS certificates to your SCM for endorsement. Report your activities — they are needed badly. 73. Vern.

DELTA DIVISION

ARKANSAS — SCM, Ed Beck, W5GED — This month's A report was written by W6JIC. IYW has his mobile rig working in fine shape. JPY has new HT-4E rig working on 28 Mc. and is getting some fine reports. IWL has new antenna and is getting some very encouraging reports. ARX has new QTH. GWT completely rebuilt his rig and ended up with an 814 in the final. ICS has been overhauling p.p. HY-51A rig getting ready for 3.9 Mc. 'phone. GAS recently was elected president of the local club. GQG has a new 807 rig on and is working some pretty good DX. DXJ has his rig on and is doing fine with his 807 but is dreaming of more power, maybe a kw. GWA is making plans for the future. Ex-HNU is waiting for his new ticket. HY8 got in one full day of operating recently using JIC's rig. He will be on as soon as he can get a new receiver. JIC has a new HQ-129X receiver, and has gotten the bugs out of the doubler stages by using 802s from 3.5 down to 28 Mc. Had QSO recently with 9RXX/4 by remote control. JAP is laboring to get new rig together. The Fort Smith Radio Club meets on the 2nd and 4th Thursdays of each month. Visitors are welcome. DQV is waiting for a new receiver and is building a small portable rig to use locally with big rig at home. 73.

HUDSON DIVISION

NEW YORK CITY AND LONG ISLAND — SCM, Charles Ham, jr. W2KDC — All of our emergency nets appear to be short on paper work but long on steady operating and drills. Only two ECs heard from officially. Nassau reports through CET that FI still has control Mondays at 9 on 145 Mc. An average of eighteen stations check in, including NDC and 9TWS/2, John having 120 watts crystal. KNA works across the pond (Long Island Sound) regularly. A message from FI to 1HDQ and return took one hour via AES and LPA. Another message to LPA in Ronkonkoma got good assistance from GZ, who has a five-element beam on his car plus an air-cooled 6J5 hanging out the window. BGO had a bad few weeks of it during the illness of his XYL. He did get a list of AEC members in Bronx: MED, OJA, MGA, NXQ, OJR, MLL, AD, and LKP, the EC. AD worked several Gs the other day. Manhattan AEC members are LVQ, JRE, 8EA/2, DPP, IFL, LFM, OFO, and JXH, the EC. The latter and JRE are working good 28-Mc. DX. Manhattan sports seven fixed, two mobile, and one pack set. AVW is assistant EC for Eastern Suffolk, including Riverhead, Easthampton, Southold, and Shelter Island. He is on 144 Mc. exclusively. OQI is newest postwar call there. FCH and LUD are on 144 Mc. while EBT keeps 28 Mc. hot. OCZ is out of the Army and using a new TR-4 which works fine on a ground plane antenna; Bob is back at New York Telephone. 2EC says the Atlantic-Pacific trunk line will resume on April 1st on 3815 kc., temporarily on Monday-Friday at 9:30 p.m. EST. 9FS is net control with 2EC, New York outlet. LKP worked 4GCJ/K7 at Anchorage, Alaska. OBW changed QTH from rented house to his own in Bellerose Manor and is reading his 3.5-Mc. bandswitch job. GWQ has big plans for p.p. 250Ts as soon as his giant transformer arrives. RT awaits

(Continued on page 90)

Many Thanks for Waiting!

ABOUT the middle of September, 1945, we decided to bring out the new "HQ-129-X." Then followed the usual survey of required engineering time, tooling requirements and availability of materials. By the middle of October, it looked as though we would have the "HQ-129-X" in our dealers' stores before December 1st—but we were wrong. Strikes, reconversion in our own plant, reconversion and OPA troubles in suppliers' plants, shortages of critical materials, and finally a nation-wide industrial breakdown put our schedule months out of line.

Sure, we could have started earlier, but we were finishing up essential war work and we felt that that was our first duty. Nevertheless the "HQ-129-X" turned out to be a better receiver than we had planned . . . The delay made additional time available to conduct further engineering and now we are in production, and have made substantial deliveries on what we believe is the greatest buy ever offered to the amateur or shortwave enthusiast.

We know that a lot of you have waited months for your new receiver when you could have purchased others which were immediately available. Believe us, we are especially grateful for that confidence and support . . . The new "HQ-129-X" will live up to *all* of your expectations.

We are rapidly increasing production and the many thousands of back orders are speedily being filled.

Lloyd A. Hammarlund, President,
The Hammarlund Manufacturing Company, Inc.



HAMMARLUND

460 West 34th Street, New York 1, N. Y.

(Continued from page 88)

7 Mc. but will need help to get skywire back up. 1MRZ/2 reports activity at Easthampton. He, WH, and BTC work for Mackay Radio. 1JW7/2 and KXSX are with Coast Guard while NMZ is with Western Union. All the above are on 28 Mc., some on c.w. BTC and 1MRZ/2 have 144-Mc. rigs but complain of no activity. Ex-CRZ, also at Mackay, awaits new ticket. KMJ, 427-44th Way, Long Beach, Calif., is out of the Army and misses IRV at Massapequa, who is shipping his rig out to Don. KMJ is only yards from 6AM and says California kilowatts are not underrated. MDQ says his 28-Mc. antenna elements, which were reported missing, were removed by unknown persons. Pete is waiting for a new rig from Temco, 2KR; he then will deliver his present rig to MIN who in turn has promised his. LUS worked Nebraska on 3 watts, and NCT worked a PY, both on 28-Mc. 5JSZ/2 is an expert on Haiti voodooism. BSL is back at Radio Transceiver Labs. IOT bought an HRO sans coils. OG has neighbor trouble, no antenna allowed. CTO is buying HQ-129X. CNJ is interested in 235 Mc. LFX is touring Pennsylvania on his job, no radio. LFY is looking for new QTH. The Sunrise Radio Club, under call SZ, is rebuilding for 144 Mc. CJY has Super Pro. A hamfest is scheduled for April 26th under the auspices of North Shore Radio Club. See LKC, etc. CPT is back from Alaska and at CAA, La Guardia. All club secretaries please contact me. There are many requests for help from local hams.

NORTHERN NEW JERSEY—SCM, Winfield G. Beck, W2CQD—From "Hank" Greenberg, official publicity man for Union County Amateur Radio Association, comes the following dope: The Union County Amateur Radio Assn. gives instructions in code and theory every Thursday at 7:00 p.m. at the YMCA in Elizabeth. LCR works out FB on 28 Mc. with a vertical and ground screen under it. EUI, a real pioneer in ham radio, was on 50 Mc. when it opened and was rewarded with a W1 contact in Connecticut. MLW is on 144 Mc. and red hot for his 3.5-Mc. c.w. AU hops on 28 Mc. once in a while for a QSO or two. AU gave a demonstration of the Collins Autotune at UCARA. HMV is working out on 28-Mc. 'phone and c.w. KG is on 28 Mc. with 50 watts and will have a kw. on soon. Some of the boys from UCARA attended a meeting of Tri-County Amateurs in Plainfield in March and heard a very interesting lecture on antennas and feed systems. LIQ and GUH have been honorably discharged from the Army. MAJ is working out nicely on 28-Mc. 'phone and is building a three-element rotary beam. MUP works out nicely on 144 Mc. after lots of experimenting. 8UYO/2 put a noise silencer in his National receiver. LTP is building a kw. and a two-element beam for 28 Mc. LFR, who was construction chief in Africa and Italy for the Radio Intelligence Division of OSS, is trying to get enough stuff together for a few hundred watts on 3.5 Mc. JTA sends the following news: JJX is going to open a service shop in a great big way. JJM is with the communication force of the State Police. IIW is sadly bent with the problems of the new rig. The Livingston Radio Club is reorganizing, and is being given full backing by the local government and population. CQD is at the Radio Shack. JTA is home again and getting a new rig on the air. JQF is active on 144 Mc., as is EWL. MO is on in the usual high-power style, with DX galore. HKV is back from over there, and keeps a daily schedule with a GI in Germany. BCN dropped a post card with the following dope: MRG has a 30-watt crystal rig, with five crystals on 144 Mc. and is altering an 8C-40 receiver. JOQ, MWZ, and KWP, all Newark cops, are doing good on 28 Mc. KQB is doing plenty of DX on 28 Mc. OKE has been inducted in the U. S. Army. OLV will be heard with a much stronger signal on 28 Mc. EDM is doing some nice operating on 28 Mc. The Northern N. J. Emergency Corps will use the tower of the Krueger Brewery for location for u.h.f. rig which did such good DX work in WERS on 112 Mc. NLJ and TR report fine progress on BCI, Inc. Swap night was held at the last meeting of the JSARA. Each member brought some piece of gear for which he had no immediate need. This was auctioned off and a handsome profit was made for the club. AER, now in Washington, D. C., has changed YL to XYL. 1FZX announces affiliation of the Monmouth County Amateur Radio Association with ARRL. MCARA has twenty-eight members and promises to start things around Eatontown. Please send along some "stuff" for the column. 73. "Win."

MIDWEST DIVISION

IOWA—SCM, Leslie B. Vennard, W9PJR—ALC is 160 lbs. of all man. Don't know how the "her" slipped in the March report. The Council Bluffs Club is going again. Officers are: JRY, pres.; UQJ, vice-pres.; and SEE, secy-treas. SEE now is local EC, as QAQ is going to have a 6 call soon. UQJ has a 50-ft. pole for his beam. The Council Bluffs gang helped QAQ take down his 40-ft. tower and beam and moved it to SEE's back yard. JRY is on with a kw. and going great guns. YFF has revamped a 20P. He has put an HK24 in and is on 28 Mc. PGG is working with KNZ in the Radio Shop, it's now W0PDM. LCD is having converter trouble. QUF is busy in school. VEY is experimenting with 144-Mc. antennas. W0AHX has 50 watts on 28 Mc. WNL is first OES in Iowa. SWY is home from the Navy and is trying to get a rig together. ROW has moved to Marion and turned farmer. ARE visited the Burlington Club in February and joined the AEC while here. ECs, get some reports in, please. 73. Les.

KANSAS—SCM, Alvin B. Unruh, W9AWP—ZHH writes from Narasarsuak, Greenland, where he is based. He pounds a key in a PBY Catalina Patrol Plane. QQJ is in the Army's corps of engineers, Electronics Division of the Atomic Bomb Project, in New Mexico. He is getting a rig together to work the Kansas boys. KCS writes from the U. S. Naval Hospital in Virginia. He reports hearing strong signals from the Kansas 28-Mc. gang. He is set for 3.5-Mc. c.w. and expects to live in Miami, Fla., when he "graduates" from the hospital. IFR is operating a radio shop in Chanute after working through the war in shipyards. He has 28-Mc. rig with 815 final. LYN is also active there with 807 final. They plan to organize a radio club. GLV, in Goessel, is building a beam antenna of the flat-top variety. LOX also is active there. QQT, QUU, VBQ, and AWP, as well as others, worked in the Band Warming Contest. GUO and WQF have new beams. OZN and DJL have purchased new homes. Now that some frequencies suitable for network operation are again available, your SCM will welcome applications for ORS and other appointments. 73. "Abie."

MISSOURI—SCM, Mrs. Letha A. Dangerfield, W9OUD—28 Mc. finally is drawing out the old gang. JQP contacted G3D0 and reported that he and ZXX, in Butler, had a three-way QSO with 801Y on a ship 700 miles from San Diego, the latter relaying for the two Missouri stations. DEA is located in Joplin with the CAA and has an HT-4 for use when he can manage for an antenna. GUG and SOM are temporarily out of the game. TGN is now on 28-Mc. 'phone. OUD and BMS have the Stancor P-60 dusted, mounted in the rack and ready for the opening of 3.5 Mc. KXL reports that DNF is back from the Navy and has 40 watts on 28 Mc. LA1 has a pair of 801s on 28 Mc. ZJB, ex-3FSL, who is head of the amateur division of Wilcox Electric, has a new four-element beam and has made the first application for OES appointment. DDX is bidding his time on 28 Mc. with a watchful eye on the lower bands. 6UUA, ex-9VWV, is back in Kansas City and active on 28 Mc. BCD is trying to get his Stancor 10-P on that band. UMM and TJP are working on 28-Mc. c.w. GYD is building a Thordarson 56- and 28-Mc. rig. YZD traded his Breting 9 in on an SX-25. AEJ, home from the Navy, expects his hamming to be limited by his attendance at Washington U. WJT is working fine DX in Chicago with 55 watts to an 807 on 28 Mc.; he is building a 500-Mc. transmitter and as an instructor in radar and antennas thinks he may be able to help the gang with their antenna problems. A fine bunch of reports, gang. Thanks a lot; keep them coming. CU on 80. 73.

NEBRASKA—SCM, Arthur R. Gaeth, W9FQB—RQK reports that UBN held an FB hamfest at his home on Feb. 22nd. Present were DNW, SAI, TMK, and RQK. EXP is on with T50s in the final. DNW is having "landlord and antenna" trouble. RQK put up a four-section flat-top beam and then worked K6, KB6, and K7. SAI is anxiously waiting for the AARS to get going, and in the meantime copies W1AW to keep up with the latest ham news. UDV is working the 4 p.m. to midnight trick at UAL. DYG had UFD build up a rig to help his Signal Shifter out, which wound up with about 150 watts to a single T55 in final, modulated by pair of HY307s. RQS hooked ZS6FN, and VE10D, and W6QJW/K7 on Tinian Island. EKK reports OK1 working for him as assistant engineer and BYR out of the Navy and going to work for him. UPC was

(Continued on page 88)

A MICRO-THIN METAL FILM

**MEANS
SUPERIOR
CRYSTAL
PERFORMANCE**

First for amateur frequencies...

BLILEY TYPE AX2 PLATED CRYSTALS

We are justly proud of the technical accomplishments represented in the AX2 *plated* crystal. Its advanced development and pace-setting design again demonstrate Bliley's leadership in the manufacture of crystals for amateur frequencies.

Primary electrodes in the AX2 *plated* crystal unit consist of a micro-thin metal film which is deposited directly on the major surfaces of the quartz crystal by evaporation under high vacuum. This film exhibits extremely high adhesion to the crystal and can almost be considered as a chemical bond to the quartz. Since the crystal is chemically cleaned before plating the film provides a coating which protects the crystal surface against contamination.

Secondary electrodes, under spring pressure, are used to clamp the crystal in posi-

tion and to provide a medium for thermal dissipation.

Under rigid comparative tests with unplated crystals, AX2 *plated* crystals show—

- better grid current stability over a wide temperature range.
- improved frequency stability under high drive conditions.
- substantial improvement in keying characteristics.

Type AX2 *plated* crystals, for the 40-meter band, are available now from your Bliley distributor—frequency selection from stock at \$2.80 each. Prices and information on type AX2 *plated* crystals for the 20-meter band will be released shortly. Keep in touch with your Bliley distributor for latest information.

**Bliley
CRYSTALS**

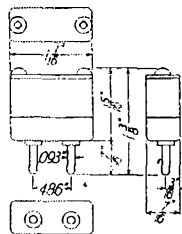
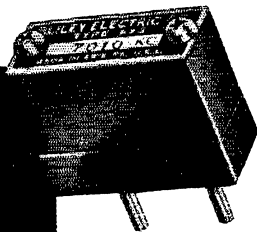

(Continued from page 80)

QRT because of appendix removal. VHR, first WØ in Omaha, hooked eleven Ga in a row on Feb. 14th. CDZ finally got tied up in a matrimonial knot. RUH put up two half-waves-in-phase with open-ended stub on 28 Mc. FUV built closed spaced beam. HGV changed T40s to a pair of T55s. QUA purchased an HT-9. IJF purchased an HQ-129X. LTL is working for Western Electric in Los Angeles. QUQ moved to California. The Ak-Sar-Ben Radio Club raffled off its 144-Mc. transmitter at its last meeting and VIG was the winner. PPY, KBZ, BQP, and ARG were visitors. 8WJV/9 gave a very instructive demonstration on the theory of crystal phasing. How about traffic reports and inquiries regarding AEC? 73. Art.

NEW ENGLAND DIVISION

CONNECTICUT — SCM, Edmund R. Fraser, W1KQY — Sgt. BGJ writes from Windsor Field, Bahamas, that Maine is the only New England State coming through consistently on 27 and 28 Mc. ON reports ITX and MLT have new rotary beams for 28 Mc. 3EHW/1 is running 600 watts to a new coaxial vertical antenna. NPG has completed his new rig with 8005s in the final and is experimenting with beam constructed of rain-spouting. EAF has completed new rig with p.p. 812s. LPN reports successful results with delta-matching transformers. ON has a new four-element beam and attended the Norwich hamfest with DLM. Matry Lee, secy. of the Norwalk Amateur Radio Assn., reports the club celebrated its seventh anniversary Mar. 12th with a fine spaghetti dinner at LRT's QTH. CTI has lined up most of the former Nutmeg Net members for the opening night of the 3.5-Mc. band. EAO reports using JAN coaxial running through the house, on 28 Mc. and working out fine. GC, FMV, and BIC report similar results. HDQ, 20EN/1, and IJ have been appointed OES. LZM has purchased an HT-9 to keep in step with JAK and CUX. APA will operate jointly with ACV with an 813 final. JZJ has been keeping close tabs on his XYL through MVH, EUG, and KAT from D4ABC, where he is stationed. MVH contacted D4ABL and relayed a message from Lt. Paradis to his XYL in Groton. The following day KQY and MVH contacted D4ABL, operated by 2JYW of Newark. Lt. Paradis was called to the radio, and MVH phoned his XYL at Groton while KQY operated MVH's rig. A 40-minute successful QSO was held. BSS and JHN, now out of the services, are operating on 28 Mc. 4FFD/1 reports his folded dipole performing excellent on 28 Mc. LVX has completed his new crystal and band-switch rig using 6L6 oscillator — 807 buffer-doubler with 814 final, all mounted on same chassis including two power supplies. EUF is working on new e.c.o. after buying new receiver. TD received his 1st-class radiotelephone commercial license. KAT has worked twenty-seven countries on 28 Mc. His latest additions are Norway, Sweden, and Egypt. ECs, please mail your reports to EAO, Section EC. 73. Ed.

MAINE — SCM, G. C. Brown, W1AQL — BZS writes that he has been discharged from the U. S. Coast Guard and is back on his old job at WGAN, Dick Whitehurst, of Portland, writes that he has been released from the Army and is all set to get his ham ticket. ACW is on 28 Mc. with a pair of 807s in the final and has a rig under construction which will have a pair of G.E. 805s in the final. Red also sends in the following items: CPS is on 28 Mc. with 807s. GCB is on 28 Mc. and is awaiting the arrival of an SX-25. 9VIN/1 is working a lot of DX. HXQ is an XYL now. LYR is building a 28-Mc. rig. HYI is about ready to get on the air with a pair of 807s. ACW and CPS are doing regular tricks at WAGM. LYW writes that he is on 28 Mc. with a 40-watt 'phone rig. TO is going to town on 28 Mc. CMO and KNJ are active on 28 Mc. LTS is working portable in Florida and contacting the Maine gang. MNR is tearing his hair trying to get his rig to work on 28 Mc. A nice letter was received from LKP, who is anxious to renew his ORS, OPS, and OBS tickets. Your SCM's term expires next June and he does not wish to serve beyond that time. Get your thinking caps on and be ready to nominate your candidates when the time arrives. Watch for election notices. 73. "GC."

EASTERN MASSACHUSETTS — Frank L. Baker, jr., W1ALP — The Eastern Massachusetts Amateur Radio Assn. started up again on March 6th. FSK was the presiding officer and MPP the secretary. 5BDB spoke on antennas. This club plans to hold meetings on the first and third Wednesdays of each month at the Inst. of Geographic Exploration, Harvard U. The Brockton Radio Club elected the following: MON, pres.; LJT, vice-pres.; MQH, secy.;

IZB, treas. LWI, MQH, LJT, JKR, IZB, FRZ, ECX, LSR, and MON are on 28 Mc. MON worked thirty-eight states during Band Warming Contest. IID, who is OBS, OO Class 3, and our first OES, is on 144 Mc. IID requests that the gang on 144 Mc. try some horizontal antennas. DBH is on 144 Mc. and will be on 28 Mc. as soon as he can get a receiver. IKK and DNL are working at State College in Pennsylvania and are on 28 Mc. JOJ, in Ipswich, is on 144 Mc. 2FLN/1 is on 28 Mc. in Lynn. 7HFY, and 5FWD are on 28 Mc. 9ACV is stationed at the Squantum N.A.S. JDO says his sister, MTB, and her OM, 6CSU, are living in Minnesota and will be on 28 Mc. soon. 5HQN is living in Waltham and is on 28 Mc. He made 7308 points and worked fifteen countries in the recent contest. All prewar ORS and OPS are invited to renew appointments by sending certificates to the SCM for endorsement with the second station activity report. We are sorry to have to report the death of MLN on March 10th. MQO writes that he is out of the Coast Guard and is on 28 Mc. 5GNV, activities manager of the Raytheon Amateur Radio Club, gives us the officers as follows: 9CPD, pres.; 8MHL, vice-pres.; 9TXG, secy.; 5FWD, treas. The club has about 200 members, a 100-ft. tower, and a kw. on 28 Mc. MRQ, who is on 28 Mc., says he was issued the first RCC since the war. Arline Berry, secy-treas. of the Waltham Amateur Radio Assn., writes that they have twenty-seven licensed members and seven SWLs. Their station, MHL, will be on 28 Mc. and 144 Mc. Other officers are: JCI, pres.; LSD, vice-pres.; After each meeting code classes are held for the SWLs and interested Boy Scouts. SS, secy. of the MAK Amateur Radio Assn., says the club meets at members' homes once a month. CB is president. ZZC is on 28 Mc. ALP has a rig going on 28 Mc. IL, IRX, BLR, JZQ, and CWZ are on 144 Mc. FDN is pounding brass on 28 Mc. RX will be on 28, 50, and 144 Mc. with an m.o.p.a. JDO has 400 watts on 28 Mc. The South Shore Amateur Radio Club has been holding regular meetings twice a month. LQI of the Valpey Crystal Co. gave a talk at one meeting. JYB reports the first meeting of the Hi-Q Radio Club was held on March 1st, with the following present: TY, RD, ALB, ALG, JIX, NEW, IQO, KDM, JYB, BSG, JBO, CF, BKE, and BSM. Monthly meetings are being held. MVQ, secy. of the Yankee Radio Club of Salem, reports meetings are held the second Thursday of each month at Bell Studio, YMCA, Salem. MAL says he is on 28 Mc. and will be on 3.9 Mc. later. JGQ, EC for Lynn, wants any ham willing to help in the Emergency Corps to call him at LY2-5492. Traffic: WIJXU 1, MRQ 2, 5HQN/1 3, HNN 1.

WESTERN MASSACHUSETTS — SCM, William J. Barrett, WIJAH — NWH is first to apply for OES appointment. Bob reports IHL, HRN, KJO, HIB, and NWH waiting for the weather to permit mobile 144-Mc. work. CH has worked forty-two countries and WAC three times. JQJ has new three-element rotary working. BCT has applied for OES appointment. KP6SJJ/1, ex-KFV, reports from Springfield. Bob has ten countries since getting out of the Navy. He reports CQR, EVZ, FOI, KZU, NH, CCH, and LRE active on 28 Mc. FOI had excellent results with Class B linear on 28 Mc. Hank had a visit from NLL, who is out of the Marines and studying electrical engineering at Union College. GZL is sporting new RME-45 and SR-20. Les also has new Onan gas-electric generator for operation from summer home at South Hadley. IEQ and his new XYL are located in Springfield. KZU and EVZ have new SX-25. The Pittsfield Radio Club now has W1, 2, 4, 6, 7, and 8 represented in its ranks. LUD, BKQ, KVN, IFE, LKO, IZN, and 7EZT/1 received high praise from local ski club for consistent and accurate work in furnishing 144-Mc. channels for timing ski races. 144-Mc. drills are held every other Monday night. 73. Bill.

NEW HAMPSHIRE — Acting SCM, John H. Stoughton, W1AXL — Well, gang, here is Old No. 4 kicking the rudder bar trying to keep a straight course on our first report. It is going to seem strange not to see Dot's handle and call at the beginning of the report. We all are sorry to learn that she had to give up her duties as SCM. We owe her a vote of thanks for the great job she has done for us in New Hampshire. From the bottom of our hearts we say, "Thanks, Dot, for a job well done." It seems good to have BFT back with us, giving the usual fast and efficient service. ANS has blossomed forth with a new RME-45. KKQ is studying hard at the photography business. JCA has received his 2nd-class 'phone and telegraph tickets. IOC and

(Continued on page 84)

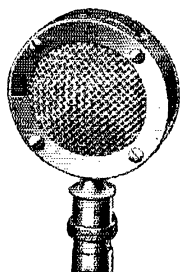

*A*mateurs **ACTIVE AGAIN...**

Warming up short wave bands

With all old amateur station licenses that were valid between Pearl Harbor and Sept. 15, 1942, temporarily reinstated, and the FCC now issuing new station licenses, "ham" activities are on the upswing and short wave bands, long forbidden to the amateur, are getting warmed up. Astatic Microphones, in many new and time-tested models ideally suited to amateur requirements, are now in production and will soon be available in sufficient quantity to meet the ever-increasing amateur demand. Keep in touch with your Radio Parts Jobber for new and improved models in Astatic Microphones, Phonograph Pickups and Recording Heads.

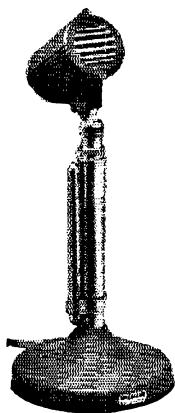

THE
Astatic
ASTATIC CORPORATION
CONNEAUT, OHIO
IN CANADA: CANADIAN ASTATIC LTD., TORONTO, ONTARIO

The Name is Vibrapack*

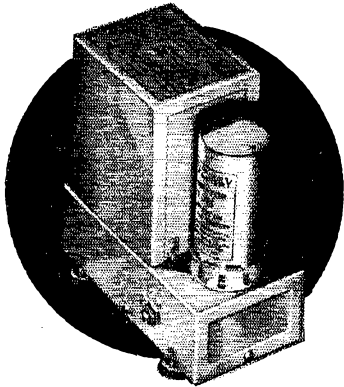

... and it's the Perfect Portable Power Supply

Vibrapacks—the famous Mallory vibrator power supplies—are better than ever. Hermetically-sealed Mallory Vibrators are now standard equipment with cataloged Vibrapacks.

Hermetically-sealed vibrators assure longer life and greater dependability—moisture and corrosive fumes are sealed out—ionization breakdowns are prevented.

When you need high voltage from a low voltage DC source for powering mobile, aircraft or portable electronic equipment, specify Vibrapack. Features include nominal input voltages of 6, 12 and 32 . . . nominal output voltages from 125 to 400 . . . models available with switch for four output voltages in approximate 25-volt steps . . . heavy-duty models with 60 watt capacity. Ask your Mallory distributor for descriptive literature, or write us direct.

*Reg. U.S. Pat. Off. for vibrator power supplies

P. R. MALLORY & CO., Inc.
INDIANAPOLIS 6, INDIANA

P. R. MALLORY & CO. Inc.
MALLORY

(Continued from page 98)

XYL, KAW, are back in Boscawen once again. May 4th is the date for HFO. He's to be married then and FYH is to be best man. Some of the gang are asking if the ole New Hampshire Net is to get going again soon. How about it, fellers? We hear that FFL is back in the U. S. Well, gang, how about dropping us a card on the 1st of each month giving us the news? The QTH is RFD 2, Claremont.

RHODE ISLAND — SCM, Clayton C. Gordon, W1HRC — The Rhode Island gang is modest to a fault — not a word has been received from anybody for this report. At the PRA meetings the majority of the active-on-the-air hams respond to "station reports" with "nothing to report." Exceptions are as follows: AFO has finished a new e.c.o. using an 802 oscillator. LWA has erected a 3.5-Mc. centered Zepp and is working on e.c.o. NDQ has a new cabinet for a rig and has been gazing into his crystal ball for ideas to fill it. KKE has gone in for toy electric trains. LFB has been experimenting with superregenerative receivers, attempting to reduce the hiss level, and gave a talk at the PRA meeting describing his experiments with injecting the squelch voltage into the grid circuit of the detector. An interesting side-light on this talk was brought out in the fact that nobody present knew for sure what frequency the hiss was, or from what principle it was derived. Neither did they know the exact function of the squelch voltage in relation to plate voltage-plate current-grid voltage values in the detector. Other clubs may find this subject a hot one for an evening quiz.

VERMONT — Acting SCM, Gerald Benedict, WINDL — QQ's new QTH is Richford; he is now with Border Patrol. NDL and MMV have new receivers. MLJ is on 28 Mc., e.c.o. with 200 watts. AD has an 807 with 50 watts on 56 and 28 Mc. IDW has a new rig for 56, 28, and 14 Mc. with 150 watts. CBW has a new farm near Danville. KJR has new jr. operator. We need more activity reports from this area. Get them in by the 1st. Will all Vermont hams please send complete QTH to your Acting SCM? 73. *Jerry.*

NORTHWESTERN DIVISION

ALASKA — SCM, August G. Hiebert, K7CBF — The reactivated Arctic Amateur Radio Club, Fairbanks, meets the 2nd and 4th Tuesdays of each month in the High School building. Members voted to consolidate with the school "Hamateur Club" and help with code practice, theory, and design of junior operator equipment. EGN, HXV, HMS, CBF, HCU, and 3JWS, in Fairbanks, have been giving Statewide boys DX opportunities. Just arrived from the Aleutians are 8QHG, 6QYE, and 2JKN, the latter anxious to confirm Dec. 3rd contact with 5HZM as being first ever made from Amchitka. Others active throughout Alaska are 2MAX, 9QEG, 3EUC, and 6QJW in the Aleutians; GNN, GBF, EYI, FTA, and EXH on the Mainland. IUN amazes the Eskimos working 80 above Honolulu from 40 below Kotzebue. JES is postwar call of 6SYS. HMW, IGW, GRF, and FTO are out of the armed forces. Only known Alaskan XYL is FZL, Fairbanks, whose father is EMU, Pilot Point.

IDAHO — SCM, Don Oberbillig, W7AVP — 3IOS/7 is about ready for 28 Mc. with a pair of HY30s. He would like W3s to listen for him. AHS hopes to increase power soon. GQD is working 28-Mc. DX. DOH has been working DX with 100 watts. CRL is back at the post office in Moscow. GGH is busy in his radio repair shop. HKG is living in Moscow. AVP is waiting for 3900-ke. phone.

MONTANA — SCM, R. Rex Roberts, W7CPY — Section EC, BWH. You will note the new Section EC for Montana. George has a fine plan worked out for Montana emergency net. Montana hams are really getting out on 28 Mc. Best DX reported to the SCM is contact with Okinawa and Guam by EQM at Butte. The Butte and Anaconda Clubs held a joint meeting at the home of EQM, attended by twenty-seven, plus FEG and 9HKF/7 as visitors from Missoula. 7CDW and BKB are home from the services. Livingston plans a Field Day to be held in June. CVQ is back in his prewar shack. ISU got on 14 Mc. too soon but is now on 28 Mc. using cathode modulation. JBK was home on 30-day leave from the Aleutians. BWH has quit operating in the theater and is in refrigeration business on his own. CBY is the proud papa of a new YL. The Great Falls Club is meeting regularly but needs a suitable meeting place. DSS and CPY both use 3.9-Mc. antennas on 28 Mc. and report practical coverage as good or better than most of the antennas and beams made up for the 28-Mc. band. Thanks,

(Continued on page 98)

AMPHENOL

Covers the Spectrum

WITH CABLES AND CONNECTORS FOR EVERY FREQUENCY

Amphenol serves the electrical and electronic industries with the most complete line of cables, connectors, plugs and fittings for every application. No matter what the need—from high-current, low-voltage cables and connectors such as are used in power lines, to high-voltage, high-frequency components required in the upper regions of the spectrum—there is an Amphenol product for the job. Amphenol cables and connectors are used in Radar, F.M., Television, Standard Broadcast, electronic controls and equipment... and in numerous industrial applications.

Amphenol connectors are engineered and constructed so as to afford the absolute minimum of loss of power, potential or waveform even at the highest frequencies. These components reflect the greatest advancement in all phases of electrically correct design and mechanically correct manufacture. Amphenol makes the most complete line of cables, connectors, plugs and fittings for the most efficient transmission of power at all frequencies.

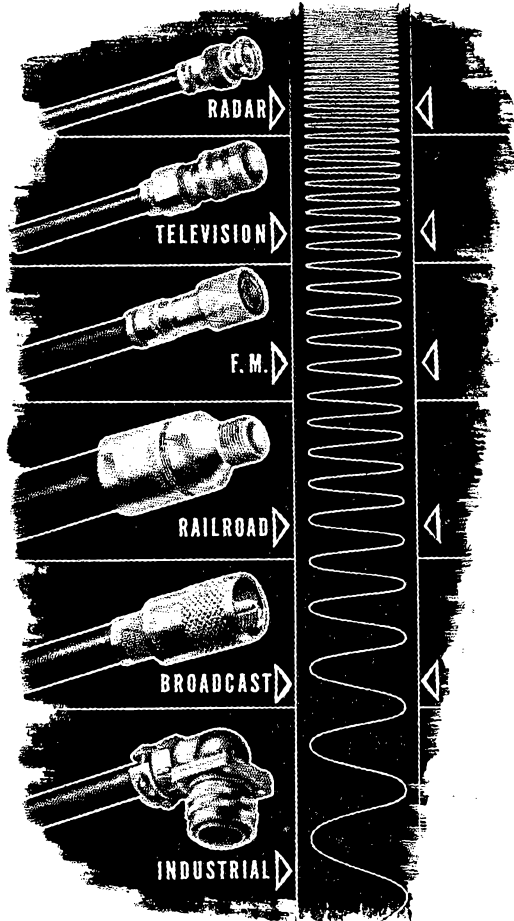

AMERICAN PHENOLIC CORPORATION
CHICAGO 50, ILLINOIS
In Canada • Amphenol Limited • Toronto

COAXIAL CABLES AND CONNECTORS • INDUSTRIAL
CONNECTORS, FITTINGS AND CONDUIT • ANTENNAS
RADIO COMPONENTS • PLASTICS FOR ELECTRONICS

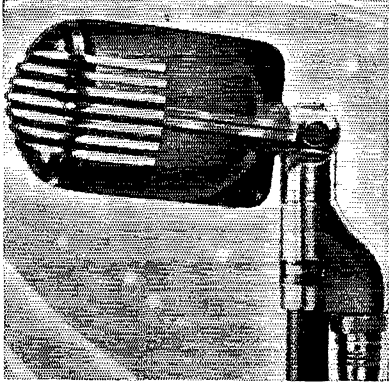

Does the Shure Stratoliner Crystal Microphone have a high output level?

The Stratoliner Crystal has an output level of 49.7 db below one volt per bar. This makes it ideal for Transmitters, Recording, and other general-purpose use.

Can the Stratoliner be used for both semi-directional and non-directional pickup?

The swivel head permits pointing the microphone at the source of sound for semi-directional pickup. Pointing the microphone upward, gives non-directional pickup in the horizontal plane. In this position performers can group around the microphone.

What are other advantages?

The Stratoliner Crystal is equipped with a cable connector which permits quick change of various detachable cables. The high output level permits fairly long lengths of cable to be used. Genuine Bimorph Crystal.

Is it as expensive as it looks?

The list price is only \$21.35... although its appearance would lead you to believe the price is much higher.

Crystal Microphones licensed under patents of The Brush Development Company

SHURE BROTHERS

Designers and Manufacturers of
Microphones and Acoustic Devices
225 W. Huron St., Chicago 10, Illinois
Cable Address: SHUREMICRO



(Continued from page 84)

gang, for FB reports. 73. *Res.*

OREGON — Acting SCM, Cliff Tice, W7BEE — Owing to the suddenness of the appointment, and the fact that there are no reports available for comment from other parts of Oregon, the data here must consist of the doings of the local bunch. The Pendleton Amateur Radio Club has been reactivated with a membership of eighteen licensed hams and a couple of excellent prospects. Officers elected for the coming year are: BEE, pres.; EQI, vice-pres.; BUS, treas.; MQ, secy.; BDN, OO. Meetings are held the first Tuesday in each month and visitors are more than welcome. Active hams here are EQI, who is manager of the local broadcast station, BKD, MQ, GKM, and BEE. BUS, one of our implement dealers, and our treasurer, is in the ring for nomination to the position of mayor here. BEE has a mobile transmitter in the back of the car with an input of forty watts but still lacks the converter to enable operation with the car receiver. While the Southwest Pacific has been coming in good he has been able to transmit Valentine Greetings from hams in Guam and Okinawa to their wives in the States. Will the correspondents of the various clubs in the State please pass along news. It is necessary if this report is to be made. 73. *Clif.*

WASHINGTON — SCM, O. U. Tatro, W7FWD — EEN has been appointed EC for Spokane and vicinity and all amateurs in this area who desire to aid in Emergency Corps activity should contact him. DSR, 5EII/7, and 9FEG/7 have added government surplus high-voltage transformers to their shacks. EKP and 5FCP/7 finally made 28 Mc. HZE operated portable from North Idaho. 9FBY/7 was on 3.5 opening day with 200 watts and 812a. The SROC entertained about sixty hams with dinner, refreshments, movies, and prizes. CEIAO walked off with prize for being the farthest from home. HCE, EC, reports that portable activity around Yakima is now great enough to warrant Emergency Corps organization. GR and EEX are now Mr. and Mrs. Active on 28 Mc. are FIV (c.w.), ALH, ECR, and CAM. AWX visited the RI in Portland for 2nd-class telegraph ticket and Arch McArthur for a ham ticket. Five new ARRL members and two new full members reported at the last YARL meeting, where a demonstration was given of four-way, 144-Mc. QSO with US and CAM at home stations, AWX operating mobile. GMC is completing a neat 144-Mc. mobile set. HCE has about completed an e.c.o. in one of FCZ's aluminum cabinets and is substituting a 446A lighthouse tube for the 7A4 in the 144-Mc. rig. JBH, EC, reports the SARC is affiliating with the ARRL. The Club entertained over ninety hams and XYLs from Snohomish, Skagit, and Whatcom Counties, and from Vancouver, Victoria, and Chilliwac, B.C. VE5US and DPU gave talks on radar. MH, 6SYR, and ILR were first, second, and third in the code contest. 6TPN/7 reports he and CQJ are the only hams in Centralia on 144 Mc. and they successfully contact CKZ and AQB, of Aberdeen, evenings on ground carrier. CQJ has 120 watts with an 8JK rotary beam and works Tinian and Guatemala. 6TPN/7 schedules 9YM/KB6, and 6QKB/KB6, Guam; 6NFL/J5, and 2JE/J5, Okinawa, daily on 'phone for traffic using only 65 watts and eight half-waves in phase. Since that band opened he has worked fifteen countries and handled 386 messages. JFB has a new shack on her glassed-in front porch. She reports CHZ is on 28 Mc. and has about completed a kw. transmitter and is using a beam. 9UYQ/7 has just completed a beam and has worked his old Wisconsin QTH. IOQ, EC, found that bleeders are hot even when the transmitter won't work. ER is on 28 Mc. and opened on 3.5 Mc. GEV is in Shanghai and is trying to reach home via FWR on 28 Mc. 73. *Tats.*

PACIFIC DIVISION

NEVADA — SCM, N. Arthur Sowle, W6CW — Asst. SCM, Carroll Short, jr., W6BVZ. No reports were received in February and March. No doubt everyone is very busy getting equipment on the air and preparing for the new frequencies. Your SCM cannot gather news and report it unless you send it in. A few months of this and then you decide the SCM is not active. However, you don't consider that YOU are responsible for not submitting your reports. Let's keep the Nevada section represented. Send in your reports. 73. *Art.*

SANTA CLARA VALLEY — SCM, Roy E. Pinkham, W6BPT — The Santa Clara County Amateur Radio Assn. held its monthly dinner meeting at Vahl's club on March

(Continued on page 100)



Here's the u-h-f pair you've been waiting for!

*Famous
lighthouse
tubes*

Type
2C40

Type
2C43

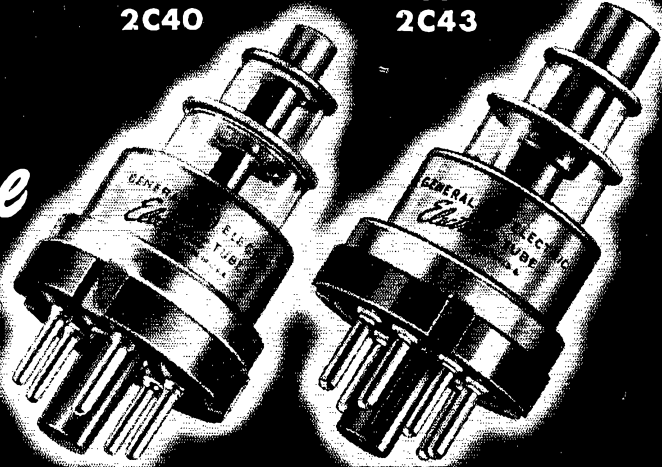

Type 2C40—ratings for typical operation

	Class A r-f amplifier	CW oscillator
Frequency	1,200 mc	2,400 mc
Plate voltage	250 v	250 v
Plate current	17 ma	20 ma
Power gain	12 db	—
Power output	—	0.2 w

Type 2C43—ratings for typical operation

	CW oscillator	Plate-modulated amplifier
Frequency	1,200 mc	425 mc
Plate voltage	360 v	350 v
Power output	1.5 w	5 w

NOW you can have G-E Lighthouse Tubes to work the u-h-f bands! Types 2C40 (receiving) and 2C43 (transmitting) are a celebrated team in the same frequency range—from 200 to 3,370 megacycles. Between 200 and 600 mc these small, compact G-E triodes give unmatched efficiency. Above 600 mc no other general-purpose tubes in their power-class are available.

Type 2C40's principal use is as a CW amplifier and oscillator for the full range of 200 to 3,370 mc. Type 2C43 is mainly employed as a CW amplifier and oscillator from 200 to 1,500 mc, or a plate-pulsed amplifier over the full frequency range.

Much has been written and said about the amazing job that lighthouse tubes—a G-E "first"—did during the war. *More* will be quoted in months to come about their unrivalled peacetime performance! Your G-E tube distributor will give you prices and information, or write *Electronics Department, General Electric Company, Schenectady 5, N. Y.*

The ultra-highs await the adventurous ham pioneer!

You'll get a thrill out of exploring the new bands that Types 2C40 and 2C43 open up! And in doing this, you'll be blazing a trail like other amateurs who, from the start, have led the search for new frontiers in radio . . . But remember—the ultra-highs require new methods, a revamping of your present rig! While Types 2C40 and 2C43 can be used in conventional tube circuits, and also will perform in long-line circuits from 150 to 600 mc, their top u-h-f performance is attained only by utilizing concentric transmission-line resonators. *G.E. is at your service should you need advice on circuits in this class.*



GENERAL ELECTRIC

161-E10-8850

ELECTRONIC TUBES OF ALL TYPES FOR THE RADIO AMATEUR

High Power Beam Tetrode

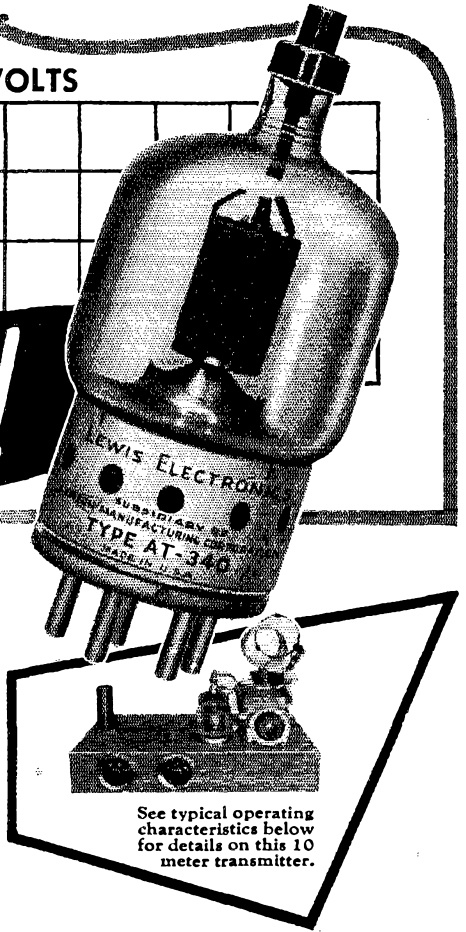
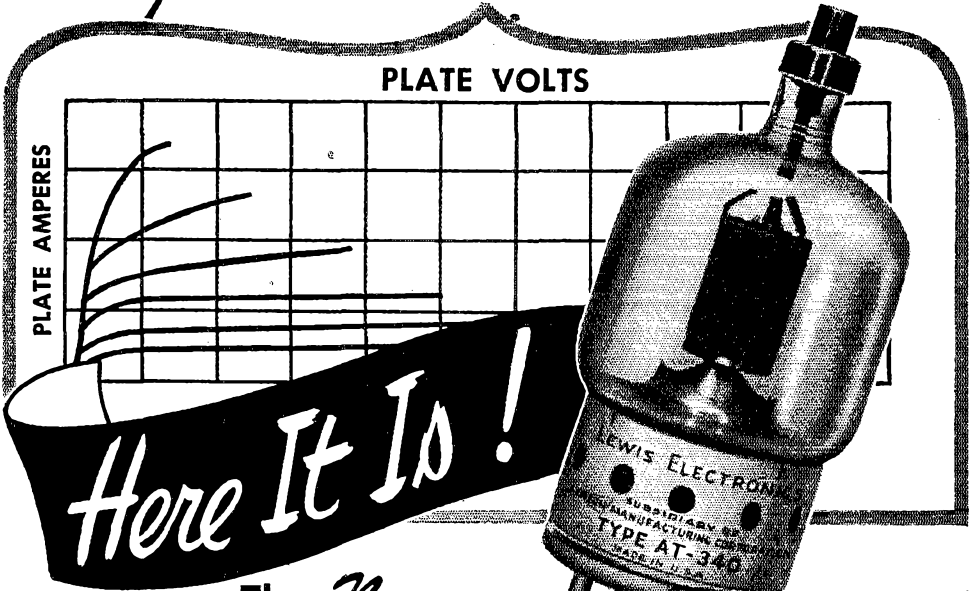

The New AT-340

Here's the easy way to handle a one kilowatt input on the ham bands—two AT-340's—driven by a single 6L6, or any low powered all band exciter. The unusually high power gain of AIREON'S new tetrode makes this possible, and incidentally, you'll note the special price to hams makes it easy on the pocket-book too.

The AT-340 is very conservatively rated at 150 watts plate dissipation, and its full power top frequency is 120 megacycles. Uses a giant 5-pin metal-sleeve base and top plate connection.

Typical operating characteristics shown at the right should be compared with existing types to fully indicate the superiority of the AT-340 as to price and performance.

Tubes and specifications now available.

Typical Operating Conditions Class "C"— 2 Tubes

Fil.	5.0 volts 7.5 amps
Plate	3000 volts 333 ma
Grid	150 volts 12 ma
Screen	400 volts 20 ma
Plate Dissipation	150 watts
Plate Input	1000 watts
Driving Power	4.75 watts

Ham Net \$17.00
Ham Special \$30.00 pair

Lewis

Subsidiary of **Aireon**
MANUFACTURING CORPORATION

ELECTRONICS
LOS GATOS • CALIFORNIA

You Can Depend on These Famous Names

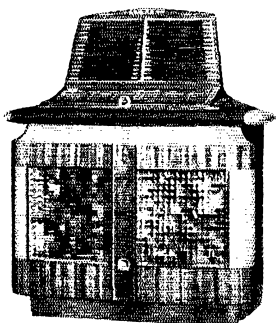
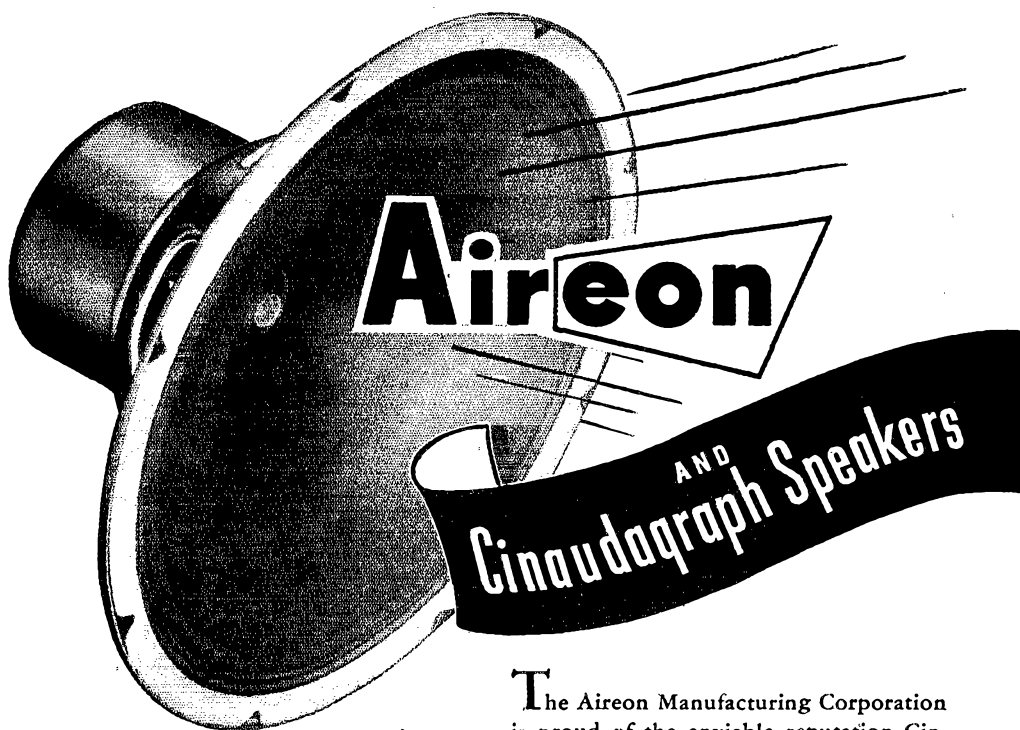

"Electronic" Tone Quality

Aireon Electronic Phonographs, achieve a tone quality never before approached in coin-operated music. Heart of their sensational performance is the specially designed 15-inch, 12,000 cycle Cinaudagraph Speaker which carries a maximum range of harmonics and tone.

The Aireon Manufacturing Corporation is proud of the enviable reputation Cinaudagraph Speakers have attained for high fidelity, superior performance and ruggedness. This standard of perfection will not only be maintained in Cinaudagraph Speakers but will be extended through the exceptional research, engineering and production facilities of Aireon. Recognition and acceptance of Cinaudagraph Speakers by leading radio manufacturers is an assurance of their high fidelity performance.

A complete line of speakers from two-inch units for portable radios to fifteen-inch models for commercial phonographs and public address systems is produced at the Slater, Missouri plant. You are invited to write us about your speaker requirements.

Cinaudagraph Speakers, Inc.

MANUFACTURED AT SLATER, MISSOURI

Subsidiary of **Aireon** Manufacturing Corporation

SALES OFFICES: 1401 FAIRFAX TRAFFICWAY,
KANSAS CITY 15, KANSAS



READY NOW

A NEW LINE OF

CARDWELL

MIDGET CONDENSERS

for

U. H. F.

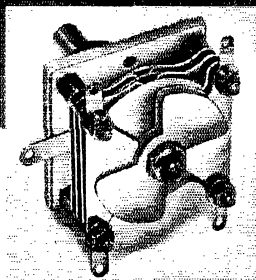

PL-6113
(Type ER-14-BF/S)
Range: 14-11 mmf. (approx.)
(Minimum capacity loaded by
circular rotor plates — for a
High "C" circuit.)
Amateur Net: \$2.40

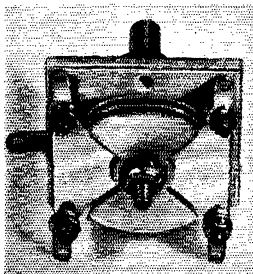

PL-6076
(Type ER-6-BF/S)
Range: 6-2.5 mmf (approx.)
Amateur Net: \$1.62

The "Butterfly" rotor plates with 90 degree stators insure:

ELECTRICAL SYMMETRY LOW DISTRIBUTED INDUCTANCE

Features

- Circular plates for low loss fixed minimum permits adjustable band spread.
- No moving contacts.
- Plates easily removed to change capacity range.
- Isolantite Insulation.
- Single Hole Mounting.
- Small size—made to fit standard Cardwell Trim-air hardware.

Other sizes available. Inquiries will be promptly answered



**THE ALLEN D. CARDWELL
MANUFACTURING CORP.**

MAIN OFFICE: 81 PROSPECT ST., BROOKLYN 1, N.Y.

(Continued from page 96)

11th with a very good attendance. H. P. Fehler gave a talk on the mechanics of hearing and hearing aids. MOV's XYL won the door prize for ladies, which was a pair of Nylons. SCCARA is having local round table of all club members on the 1st and 3rd Mondays at 8 P.M. QLP is doing a fine job as control station. Anyone having surplus equipment on hand, please list it with SCCARA's trading post of the air, thus enabling more stations to get back on the air. 9FAV/6, UGF, and QLP have RME-45s. KG is using condensers in the middle of the elements of beam for tuning. 7LXQ/6, CFK, and BPT have new beams working. NOE/6 is working portable-mobile on 28 Mc. NYS moved into new shack. LFD is rebuilding high-power rig for 3.9-Mc. phone. TBK has a schedule with Guam. PVV and IUZ are back on 28 Mc. SYW reports Cleave Amendt is on the air in Munich, Germany, using D4ADE on 29.2 Mc. W1WV/6 has worked WAC from his location in Menlo Park; he also has worked thirty-five states. He is using 137-ft. single wire 25 ft. high. JSB has a schedule every evening with 6NDW/KA1. This is a good outlet for P.I. traffic. Well, gang, this is my first report as SCM. Any station wishing OPS or OBS appointment, please contact me. Traffic: W1WV/6 12, 6SYW 8, 73. "Pinkie."

EAST BAY — SCM, Horace R. Greer, W6TI — SEC, EE; EC, QDE; EC v.h.f., FKQ; Asst. EC v.h.f., OJU; OO v.h.f., ZM; OO, ITH; OBS, TT, IDY, ZM, ITH. With the second highest score in the Pacific Division, TT took first honors in the East Bay Section with 47,218 points in recent ARRL contest. Elvin had 400 QSOs showing 54 'phone to c.w. contacts, 337 'phone to 'phone and 9 c.w. to c.w., working 52 sections and with 43 hours operating time. A new Hammarlund HQ-129X receiver, a pair of Eimac 250THs in the final running 800 watts input and a 28-Mc. Johnson Q antenna comprised the outfit. IKQ had 24,910 points, showing 230 QSOs with 53 sections and 42 hours working time, with 600 watts input to a pair of Eimac 250THs, a Hammarlund Super-Pro receiver and a rotary antenna. PYH and others were very much in the contest, which seemed to be enjoyed by almost everyone. EE still is working on new radio room. NO is building shack. KZN has been elected chief operator for the Oakland Radio Club. The ORC meets the 1st and 3rd Thursdays of each month. At the last minute the ORC U.H.F. contest was called off and will be held at a later date. The following new officers were elected at the February SARO meeting: GPY, pres.; VX, vice-pres.; QWX, treas.; DDO, secy.; EHS, communications manager; and OCZ, SARO News editor. The following members have been on the net on 29,400 kc. every Monday evening: BEZ, BUY, DDO, CHE, EHS, NQJ, PFM, NPP, OCZ, OMC, PB, QWX, S8N, and CEO. The call AEX, which belonged to Dave who recently passed away, is being applied for to be used as the club call letters. This is a nice gesture on the part of the gang. LMZ has a pair of VT127As in final. EJA worked G8ZO/I in Italy and W4YA/XZ in Burma in Feb. and Mar. on 28 Mc. c.w. ITH now has General Radio primary frequency standard in operation for 1:10,000,000 measurements. Call him for check. On March 20th, EY and TI journeyed to Sacramento to take in the reorganization of the Sacramento Radio Club. They sure have a swell gang. How about those reports? Traffic: W6ITH 132, EJA 12, 73. "W6TI."

SAN FRANCISCO — SCM, Samuel C. Van Liew, W6CVP — Phone, Randolph 6457. Asst. SCM, 6GPB; ECs, 6DOT, KZP; OO, 6NJW; OBS, 6FVK, KNE. We are proud to report many fine scores in the BW Contest in this section. RBQ and WB ran neck and neck to a photo finish for a likely first for this section. OZC was up top also until his receiver went out. The whole gang extends sympathy for this heartbreaking turn of luck, OM. With many hours to go OZC still turned in 365 contacts. Many other fine scores were made. The San Francisco Radio Club held its second meeting Mar. 22nd. An interesting talk by Harry Mandoli, an Eimac engineer, on a 500-watt Class B1 modulator unit using Eimac tubes of latest design, was enjoyed by all. The raffle winner of our first meeting, 6NPT, received his prize, an HK-354 donated by Associated Radio Co. The raffle winner of this meeting was George Carrol, who received a Milan e.c.o. donated by San Francisco Radio and Supply Co. Our membership continues to grow, so sign up. DJI is building new radio shack and new transmitter. RBQ repainted shack and is rearranging operating position. Our new 27-Mc. band, just one week old, already has been tried by many with good results. Among these are WB,

(Continued on page 108)

Announcing
NEW
PR

SUPER
10-METER
CRYSTALS

Available for the FIRST
Time at Your Jobber's

The new Z5 unit, when used in our simple circuit, is no more critical than an ordinary 40 or 80 meter crystal. High power output without damage to crystals is now possible with the new P R Super 10 meter crystal. P R Super 10 meter crystals, with a temperature coefficient less than 2 cycles per M. C. per degree centigrade, are now available at your favorite jobber's.

P R crystals can "take it" and really "put out." Every P R crystal is *unconditionally guaranteed*. See your jobber today — ask him for a copy of the descriptive booklet on P R 10 meter crystals.



PETERSEN RADIO COMPANY

2800 WEST BROADWAY — TELEPHONE 2760

COUNCIL BLUFFS, IOWA



for U. H. F.

JOHNSON 122-101 SOCKET

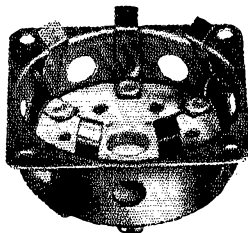

FOR TOP
PERFORMANCE
FROM
826-829
832
TRANSMITTING
TUBES

Latest addition to the famous line of JOHNSON Tube Sockets is the 122-101. A ceramic wafer socket with aluminum base shield and JOHNSON superior contacts — the 122-101 is designed to really "take it"!

Socket is designed so that by-pass capacitors may be mounted directly on the tube socket base. Button mica capacitors are available in a range of capacitances enabling the tube to be used at its highest frequency.

Grid terminals are designed so that connecting wires may be isolated from other circuits.

Grid terminals are specially constructed to permit small grid coils to be mounted directly on the terminal ends, thus eliminating connecting leads.

Holes are provided for adequate ventilation of the tube.

Built-in retainer springs hold tube securely in place under conditions of heavy vibration and shock.

Your JOHNSON Distributor has, or soon will have the JOHNSON 122-101.



Shown at left are JOHNSON 228 and 275 tube sockets. The 228 socket is ideal for many tubes including the "Tuf-20", and the 275 socket is designed for tubes including the 4-125A, RK28, 125M, 803 and X404. See these sockets and other outstanding JOHNSON products at leading radio-electronic distributors everywhere.



There is a JOHNSON Tube Socket for every stage of the "ham" transmitter many of these same sockets are being widely used in commercial communication and industrial electronic equipment JOHNSON means the ultimate in amateur, industrial and broadcast components.

WRITE FOR CATALOG 968J

JOHNSON

a famous name in Radio



E. F. Johnson Co. Waseca, Minn.

(Continued from page 100)

KNH, EQA, and URA. Many are preparing for the opening of 3.5 Mc. The State Guard communications detachment still is functioning. NYQ and MEZ report good DX west on 28 Mc. with many contacts to Okinawa, Tinian, China, XUIYM, Yo Cocoe, G6CU, portable ZC2. Traffic: RBQ 53, NYQ 42, KNH 32.

SACRAMENTO VALLEY — SCM, Vincent N. Feldhausen, W6MDI — This month's report was submitted by GZY. The first regular meeting of the reorganized Sacramento Amateur Radio Club was held March 20th at the Southside Clubhouse in Sacramento. The following officers were elected: GZY, pres.; AK, vice-pres.; MGC, secy.; AP, treas.; EJC, sgt. at arms. Honored guests were TI, East Bay SCM, and EY, Pacific Division Director. EY gave a talk on League activities and TI explained the operation of his QSL Bureau. Regular meetings will be held on the 3rd Wed. of each month. BVK is using a pair of HK54s with 200 watts input on 144 Mc. and a 16-tube superhet. KME, dividing his time between 28 Mc. and 144 Mc., uses an HY75 with 34 watts input in a fixed and mobile rig on 144 Mc., and a pair of 35Ts on 28 Mc. EJC has been working some choice DX on 28 Mc. IZE has returned home from overseas. It is hoped that PIV now is fully recovered. Sacramento hams active on 28 Mc. include: AP, 4JY/8, IMV, OLV, PNC, BYB, IJSU/6, MBY, and OOR. Those active on 144 Mc. include CLV, GAK, GZY, RKM, and TJA. QKJ is busy building a rig for 28 Mc. AJD, of Roseville, is building a new shack. AYZ, of Courland, has been very active on 28 Mc. Sacramento hams on 144 Mc. would appreciate schedules with stations in the vicinity of Sacramento on that frequency and are willing to conduct tests with any station attempting to work into Sacramento.

SAN JOAQUIN VALLEY — SCM, James F. Wakefield, W6PSQ — BVM reports the following boys working for CBS at Delano: BRP, ex-2CTC, BVM, BYH, GNR, and MJG. BVM has 25 watts on c.w. GNR is on 'phone with 750 watts. MJG has 500 watts c.w. with good results, namely 4YA/XZ in Burma and G8ZO/1. OKK reports from Escalon with the following dope: SQP, using 60 watts into a three-element beam, was the first California station to work into VK-Land. OKK has 31-foot tower with three-element rotary and running 125 watts into a T55 final. KBP has a pair of 75Ts at new QTH. DTY, in Bakersfield, is on c.w. but says activity is slack. OXE's new XYL arrived from G-Land. ICG is in Guatemala working for American Airlines. FPW returned to active duty with the Navy. PDX and JPU opened 50 Mc. with a contact on March 17th using surplus Navy MBFs. The San Joaquin Valley Radio Club, in Fresno, now boasts 110 members. First new call issued in this area is UWD, Fresno. HYG is building 150-watt rig using HK154. LTA just finished an FB exciter using four 6L6s and a 6CS, starting on 3.5 Mc. and all the way down. RSD is high DX man in Fresno using a pair of TW150s running cool at 500 watts into a revised Mims Squirter. SUV has 300 watts into a pair of T55s and a center-fed Zepp in the attic. GCF has new National 1-10 receiver on 144 Mc. All appointments are open in the section. If interested, please drop me a line. 73. Jimmie.

ROANOKE DIVISION

VIRGINIA — SCM, Walter G. Walker, W3AKN — FQP now has forty-one countries worked on 28 Mc. with about twenty verified by QSL cards. PK has a new 28-Mc. beam antenna and is getting good results. NT is building a high-powered 28-Mc. transmitter. BEK and IIF have new 28-Mc. vertical doublet antennas. AJA is going strong on 28 and 144 Mc. IAG still has trouble with his 813 final amplifiers oscillating on 28 Mc. as well as other feed-back trouble. MT is assembling parts for a new rack and panel 28-Mc. transmitter to run 300 watts input. IFJ has been released from the Army and has a 40-watt transmitter on 28 Mc. GGP is experimenting with different types of tubes in his 28-Mc. final amplifier in an attempt to get best results. AKN is rebuilding his transmitter for high power to operate on the 28- and 3.5-Mc. bands. HZU, at Langley Field, is getting his 28-Mc. rig set up. The Richmond Radio Club is going strong and held a state-wide hamfest on April 13th and 14th. The Norfolk Radio Club and the Portsmouth Radio Club are holding weekly meetings and planning big doings for the coming summer season. The Peninsula Amateur Radio Club is in the process of reorganization with a suitable meeting place being sought. Please let me

(Continued on page 104)

C
O
N
D
E
N
S
E
R
S

I
N
D
U
C
T
O
R
S

T
U
B
E
S
O
C
K
E
T
S

I
N
S
U
L
A
T
O
R
S

A
N
T
E
N
N
A
S

**Wherever the circuit
calls for a diode**



**Investigate the
Sylvania 1N34
G_x Crystal Diode**



FEATURES

1. Small size (actual size shown in illustration).
2. Elimination of heater supplies. Removes possible source of hum; permits both terminals to be connected far above ground potential.
3. Compact pigtail construction. Permits the 1N34 to be soldered into place, without use of sockets.
4. Rugged construction. Units will withstand vibration and shock more successfully than conventional vacuum tube diodes.
5. Low forward resistance value.
6. Low shunt capacitance (about 3 micromicrofarads for unit mounted in place in circuit, compared with about 15 micromicrofarads for a 6H6 under similar conditions).

APPLICATIONS

In general, the features of the 1N34 suggest its use in *lightweight and portable equipment*, for frequency ranges up to 500 mc. Potential fields of application include:

Field strength meters. Typical circuit diagram is shown below. Useful in delivering propagation characteristics of rotary beam antennas.

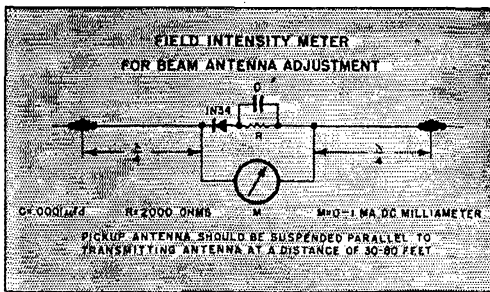

- | | |
|-----------------------------|------------------------|
| Meter rectifiers. | S-meter rectifiers. |
| Detectors. | Discriminators. |
| Clippers. | Series noise limiters. |
| Polarized relay rectifiers. | Modulation indicators. |
| Absorption wave meters. | |

Now in stock at Sylvania Distributors

For further technical information on the 1N34, write direct to Sylvania Electric.

Inquiries and suggestions on new applications are invited.

Visit us at the Chicago Radio Show — Booth 86

SYLVANIA ELECTRIC

Electronics Division, 500 Fifth Ave., New York 18, N. Y.

MAKERS OF ELECTRONIC DEVICES; RADIO TUBES; CATHODE RAY TUBES; FLUORESCENT LAMPS, FIXTURES, WIRING DEVICES; ELECTRIC LIGHT BULBS

For Low Drift and High Activity . . .

Choose

C.T.C. CRYSTALS

"Crystals You Can Count On"

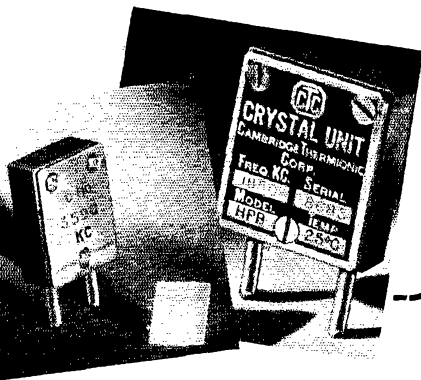

Mathematical dimensioning, X-ray orientation, mechanical lapping, etching to final frequency—these important features are but a few of the 21 vi al checks and tests that are your assurance of fine performance and long life from every C.T.C. Crystal.

C.T.C.'s quality Crystals are now available for immediate delivery for amateur frequencies in the 20, 40 and 80 meter band. They are available in two types of holders—"C" to fit actual sockets and HPB to fit 5 or 6 prong sockets. Kilocycle spread of the C.T.C. crystal assemblies include—20 meter band—14,000-14,750 kc; 40 meter band—7000-7300 kc; 80 meter band—3500-4000 kc.

For complete information on C.T.C. Crystals You Can Count On write for free bulletin.



CAMBRIDGE THERMIONIC CORP.

451 CONCORD AVENUE

CAMBRIDGE 38, MASSACHUSETTS

(Continued from page 108)

have the information on your individual doings, fellows. for news is hard to gather except from contacts on the 28-Mc. band after the band folds for DX. 73. *Wall*.

WEST VIRGINIA—SCM, Donald B. Morris, W8JM—Any amateur who is interested in OES, OBS, OO, EC, SEC, ORS, and OPS appointments may obtain information by contacting the SCM. Any prewar ORS or OPS may renew his appointments by sending in his certificate with his second station activity report. Let's get a lot of activity started in the State and please report on the 1st. Watch for the MARA gang on their old Net frequency of 3770 kc. PQQ, back in civvies from the ETO, visited ARRL before resuming studies at W.V.U. NTV, still in the Navy at Frisco, hopes to get home soon. MIS is back on 3995-kc. 'phone with a nice signal. We regret to announce the passing of two well-known amateurs from Wheeling, AAO, who died in a Jap prison camp, and ADI, who succumbed to a stroke. ELO and ETV are back in civvies after service with the Navy. K8J, active with the Ferry Command during the war, has married and moved to Washington, D. C. SPY brought along captured Jap and German gear to the last MARA meeting and gave a very interesting talk on its operation. KWL, GBF, and EHA are snagging the DX on 28 Mc., with KWL handling traffic from Germany. Traffic: W8KWL 2, GBF 1. 73. *Don*.

ROCKY MOUNTAIN DIVISION

COLORADO—SCM, H. F. Hekel, W9VGC—EHC/5 will be found on 3.5 Mc. as soon as he can get the low-down on what his permanent location is going to be. Rumors now have a new move in store for him. He expects to be moving to Oklahoma City again. The Denver Council of Radio Amateurs has formed another club in Denver known as the Denver Radio Club with MMF, pres.; JVA, vice-pres.; YTY, secy. March 23rd was the first of a series of hamfests (or would you call it a FEAST?) in Denver with meat and butter without ration points. Some of the old-timers still were among the missing as they are in other parts of the country and a lot of new faces were seen. TLM was head man and the only one who could get up and try to out-talk TFP and get away with it. When you send in your request for a renewal for this business tell them that if TFP loses his job you want your money back. 2NT/9, Denver, is another OBS and WTN, Pueblo, is the only OBS down there. Let's have some in the other parts of the State. We need you to spread the glad tidings when they are published by WIAW as we still stand a good chance of getting the rest of our frequencies back. You may be the only one able to spread the good news in your community so send in your application for OBS. WYX holds the rating of Section EC for Colorado and needs a lot of ECs. Send your applications to him at 2058 So. High St., Denver 10. I have just found out that springtime in the Rockies is a lot nicer than the Mississippi Valley at high tide. 73. *By Heck*.

SOUTHEASTERN DIVISION

ALABAMA—SCM, Lawrence J. Smyth, W4GBV—Asst. SCM, Col. Fred J. Elser, W6ANM/4—AUP, GBV, 6ANM/4, and DXB (who says he will be on with 250 watts and oil cups on his bug) have made active preparations for the 4-Mc. band on April 1st. A number of the Montgomery fellows have installed beams on 28 Mc. GBV worked a ZS within a few hours of getting his beam up. 6ANM/4 worked Tinian Island. AUP worked Norway with only 25 watts! FYF is now with Majestic in Illinois and is on 50 Mc. IDZ is out of the services and back in Montgomery after working portable in California. AAO is now at San Juan, P. R. working a portable K4. Former SCM DGS is now with Raytheon. FCI is back on the air in Birmingham. FMW is married and back on 28 Mc. AUP and HEG engaged in a cross-Montgomery QSO on 144 Mc. Old-timer DGO was observed at a recent Montgomery Club meeting. Lt. Col. Harry Copland was a recent visitor to the Montgomery Club. He exhibited several very interesting old radio documents, including a 1915 ARRL relay station appointment signed by H. P. Maxim and C. D. Tuska. This section notices the great ease with which England can now be contacted on 28 Mc. Let's have some news, gang. 73. *Fred*.

EASTERN FLORIDA—SCM, Robert B. Murphy, W4IP—The gang is going along nicely with the organizing of the Florida Net and the "Hurricane Net." GVC, as

(Continued on page 108)

Announcing!



**EFFICIENT,
New
SYLVANIA
R. F. AMPLIFIER
TUBE**

TYPE 7AG7

**TYPICAL OPERATING CHARACTERISTICS
CLASS A1 AMPLIFIER**

Plate current	6.0 Ma.
Plate resistance	0.75 megohm
Screen grid current	2.0 Ma.
Mutual conductance	4200 micromhos

Direct Interelectrode Capacitances

Grid to plate	.005 micromicrofarad Max.
Input	7.0 micromicrofarads
Output	6.0 micromicrofarads

TYPICAL OPERATING CONDITIONS

Heater voltage	6.3 volts
Heater current	0.150 ampere
Maximum plate voltage	250.0 volts
Maximum plate dissipation	2.0 watts
Maximum screen grid voltage	250.0 volts
Minimum external negative grid voltage	1.0 volt
Maximum screen grid dissipation	0.75 watts
Maximum heater-cathode voltage	90.0 volts

HERE'S a new sharp cut-off r-f pentode amplifier designed especially for 6.3 volt and a-c/d-c series service in television and FM receivers.

The tube may be operated with full plate voltage on the screen grid to produce high input resistance as a result of reduced electron transit time. Identical voltage requirements for plate and screen grid also eliminate the need of screen grid filter resistors and by-pass capacitors in some circuit applications.

Visit us at the show • Booth 86

SYLVANIA ELECTRIC

Emporium, Pa.

MAKERS OF RADIO TUBES; CATHODE RAY TUBES; ELECTRONIC DEVICES; FLUORESCENT LAMPS, FIXTURES, WIRING DEVICES; ELECTRIC LIGHT BULBS

Now **SALES AND
FROM A**

THORDARSON

TRANSFORMERS
TRU-FIDELITY AMPLIFIERS

MEISSNER

COMPONENTS • KITS
SERVICE EQUIPMENT

Important!

• The Electronic Distributor and Industrial Sales Department of Maguire Industries, Incorporated, was formed primarily to offer better, faster service . . . to assume all merchandising, sales and customer relation duties and responsibilities essential in marketing the combined, precision-built products of the Thordarson Division, Meissner Division and Radiart Corporation.

RADIART

VIBRATORS
RUST-PROOF AERIALS

**ELECTRONIC DISTRIBUTOR AND
INDUSTRIAL SALES DEPARTMENT**

SERVICE... SINGLE SOURCE!

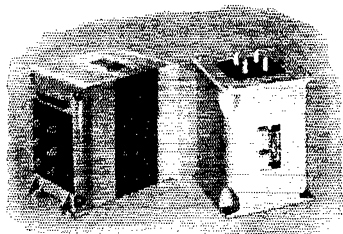

THORDARSON

QUALITY-BUILT ELECTRONIC PRODUCTS

TRANSFORMERS

- For all requirements... communications, sound amplifier, industrial, experimental and amateur.

TRU-FIDELITY AMPLIFIERS

- Advanced tone compensation, conservative ratings, multiple input channels, low hum level, etc.

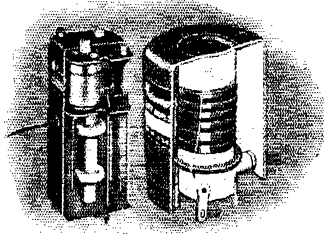

MEISSNER

COMPONENTS

- Standard, plastic and Ferrocart transformers; antenna, R. F. and oscillator coils; accessories.

SERVICE INSTRUMENTS

- Meissner Analyst... a complete servicing instrument; Signal Calibrator... self-contained and portable.

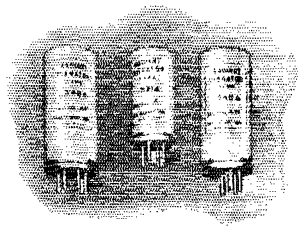

RADIART

VIBRATORS

- Exact duplicate Vibrators, individually engineered... long life, low noise level, minimum interference.

RUST-PROOF AERIALS

- A complete line, newly designed to fit all cars... cowl, hood and under hood types. Many exclusive features.

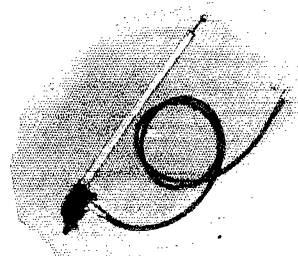
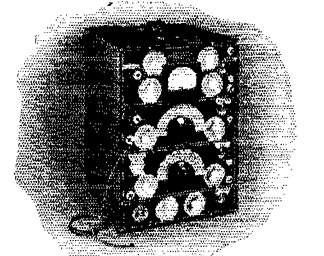
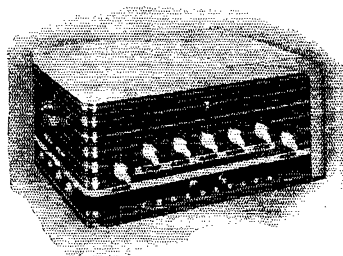

WRITE TO THE ADDRESS BELOW FOR MORE COMPLETE DETAILS!

MAGUIRE INDUSTRIES, INC.

936 NORTH MICHIGAN AVENUE, CHICAGO 11, ILLINOIS

Complete — Ready for Operation

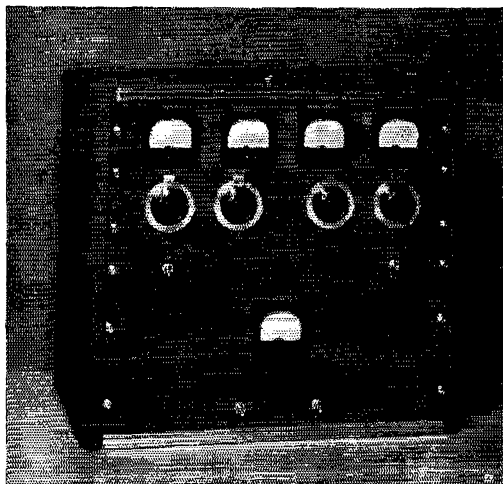

THE HARVEY MODEL 100-T TRANSMITTER

*Includes everything required to go on
the air on 'phone and CW*

READY FOR IMMEDIATE DELIVERY

The HARVEY 100-T Transmitter is a plate modulated unit of effective power (175 watts input on CW, 130 watts input on 'phone) that provides real "on the air" performance. It has everything you want—appearance, 5-band operation, quick frequency shift, reliability and ease of tuning.

The HARVEY 100-T is built to the same high standards of quality that have made HARVEY Transmitters known and respected throughout the world.

For complete information on the 100-T and other HARVEY Transmitters write for free Transmitter Bulletin.



HARVEY RADIO LABORATORIES, INC.

451 CONCORD AVENUE
CAMBRIDGE 38, MASSACHUSETTS

(Continued from page 104)

SEC, stands ready to help anyone wanting to get into this set-up. Now that the 3700-4000-kc. band is on the go, let us get our old 3875-kc. c.w. net going and the 3910-kc. 'phone back up with the old Knights of the Kiloycles taking the lead. GVC is in Orlando, the center part of the State and will make an excellent contact for us. EYI comes through with the following information: DBA resigned from Motorola to accept a job with Federal Radio Co.; GGJ has a new Motorola transmitter; IK has the bug and is going on 28-Mc. 'phone; HPM has resigned his position with the Police Department to take a job with Florida Power; EZG takes HPM's place with the Police Department; GFE and EPW report making WAC in two weeks on 28-Mc. 'phone and EYI is waiting for the 14-Mc. 'phone band to pop open. VV has worked all countries except China, Russia, Norway, and Sweden. FVW is working out with his portable mobile nicely on 28 Mc., as is VV. They keep the band hot while coming to and from their work. QN is getting lined up as OO. VP5EM writes from Kingston, Jamaica, that the gang down that way are all getting on the air and working some nice DX. AAO, in San Juan, is working DX with a rain-water pipe down drain on the side of the house. CNZ is back from a trip to Port of Spain as a radio instructor for PAA. BYF sends in the first message-handling report. BYF acted as host for members of a family in Miami while they listened to their brother in Switzerland. NB and 1KVB have been having a "yooping" good time with their c.w. rigs. New calls are coming through for the LSPH boys. IJC and IJP are up-and-coming hams. Traffic: W4BYF 27. 73. *Merf.*

WESTERN FLORIDA — SCM, Lt. Edward J. Collins, W4MS — DAO has his four-element beam up and had an FB QSO with LX1DP. BKQ keeps schedule with FA8NF. AXP was heard by FA8NF. EGN is on and having a big time. 7IQJ is our first OES. HIZ is getting out FB on 28 Mc. VR is getting rig set for 3.7 Mc. UW is on with nice signal. HJA is pounding c.w. 9ZAR keeps the band hot with his electronic keyer. We regret to record the death of ECB. LT has been working into Pensacola on ground wave. KB is getting rig back together for 4-Mc. 'phone. QK is building a larger final. EQR has 250TH in final. MS worked 8VOK/KA1 as well as FA8NF. AXF worked TG9FG for her first DX. DZX is having receiver trouble. 9MN has his rig here. FJR likes high speed code. JV has raised his antenna and gets out better. 3HNX has 840 watts on 28 Mc. CNK took the Class C exam. HYB is trying to get a transmitter location. 73.

GEORGIA — SCM, Thomas M. Moss, W4HYW — Again, I urge you to apply for Full or Supporting Membership in the Emergency Corps. We need you for this important service! ECs are needed in most of our counties. A Section EC is urgently needed. EWY is EC for Chatham, and CLA for Early. DSA, EC for Glynn, who served with AACs in the AAF, now is a "civvie" and says that his DX luck is making him wonder if he wants to go back to work. He reports BB and BO active at Brunswick, and advises that FWA now is 9ZGA. OOs (all classes) still are needed. HYW is OO (IV). If you work above 50 Mc., you are urged to write for application for appointment as Official Experimental Station. See March QST for details. FDJ advises that GGF is back from the Navy, and that DNY reached K8 to be DX from KA or J. Let us hear from you, DNY. Activities reports are welcome from clubs and individuals. Will appreciate a note from all club secretaries regarding reactivation plans. FWD is chief engineer at WGAU/WMUO. ABD is EC for Murray. The Amateur Radio Club of Savannah elected new officers as follows: EWY, pres.; AUF, vice-pres.; GMA, secy-treas. Meetings are held the second Tuesday and last Thursday of the month. The club has three 54-Mc. rigs manned by ALW, ESE, and 2ILS/4, as well as two mobile rigs handled by 9GZR/4 and 2DGM/4. EWY teaches code and theory at Savannah Vocational Tuesday and Thursday nights. 73. *Tom.*

WEST INDIES — Acting SCM, Everett Mayer, K4KD — K4HTD, HZM, GIG, and EJG, being called by the W gang, apparently are on 28 Mc. again. W6PQE/K4, W4GJM/K4, and W4DYX/K4 have started up on 28 Mc. W4IEN/K4 has another rig on and has ordered an HT-9. K4JA erected a vertical dipole with the aid of K4RJ, K4HLP, and K4HEB. W8VRD/K4 has a new vertical antenna. W4BZA/K4 installed a "non-rotary" four-element beam and is busy making it rotary. K4HEB has a

(Continued on page 110)

*Only with Westinghouse
can you gain the full benefit of
this mark of greater dependability*

**more supervisory controls
than any other type of
transmitter . . .**

Your job has become easier because Westinghouse AM transmitter controls include everything from one master switch to a complete indicator lamp system. And the soundness of Westinghouse design is backed by more experience in actual station operation than any other manufacturer. Write today for the full story. Westinghouse Electric Corporation, P. O. Box 868, Pittsburgh 30, Pa.
J-08149-A

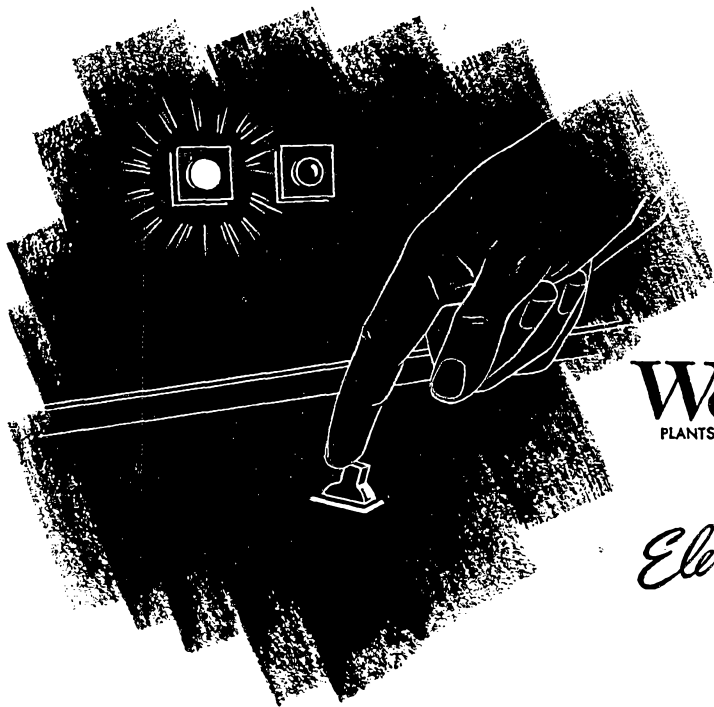

Westinghouse
PLANTS IN 25 CITIES... OFFICES EVERYWHERE

Electronics at Work



STATION TESTED*

proof of an added Quality!



*Pres. W. A. Kuehl is shown at his amateur radio station W9EZN. With the war over, Walt is again pursuing his favorite hobby.

DRAKE RADIO SOLDERING IRONS

Yes, Drake irons are *right for radio*. And these sturdy irons have proved their dependability and worth in use on countless other jobs, too, for over 25 years. That's why we say — whatever your needs, you are certain to find a Drake iron that fills the bill exactly!



600-10—the Drake No. 600-10 is ideal for those all important connections when rewiring your rig. Get back on the air fast. Make good dependable connections with this 100 watt $\frac{1}{4}$ " tip.



400—the Drake No. 400 is the perfect iron for work in small places. Only 9 inches long. It is especially designed for tight corners and delicate connections. 60 watt, $\frac{1}{4}$ " tip.



Ask your nearest supplier or write for the name of the distributor nearest you . . . and give yourself the advantages of these superior irons.

DRAKE ELECTRIC WORKS, INC.
3656 LINCOLN AVE. CHICAGO 13, ILL.

(Continued from page 108)

new HRO receiver and worked LU. K4KD worked OQ5BQ on 28 Mc. c.w. W5EVN/K4 has been active. K4ESH, 500 watts to RK33a, vertical antenna, has worked 17 countries on 28-Mc. c.w. Among the first Cuban licenses issued are CO2RC (Radio Club de Cuba), CM8CK (Minister of Communications), and CO2PLL. Heard on 28 Mc.: CO2RG. Heard on 14 Mc.: CO2MA, 2GY, 2EH, SRL, and 8MP. 8JG is getting ready for 14-Mc. work. CO2LL has worked a number of foreign stations on 14 Mc. 73. *Et.*

SOUTHWESTERN DIVISION

LOS ANGELES — SCM, Ben W. Onstenk, W6QWZ — Reorganization of AEC in this area continues with following new EC appointments: PTR, KEI, FFN, GVT, ULE, and EQM. Boundaries, frequencies, and operating procedures were discussed at a meeting of ECs held in Los Angeles Hall of Justice recently. All interested in AEC are urged to contact 8WLG/6, the SEC, at 618 E. Buckthorne, Inglewood, or your SCM. The Santa Monica AEC is putting its MBFs on 61.84 Mc. under the direction of PTR. Centinela Valley AEC continues to hold regular Monday night drills on 144 Mc. plotting the City of Inglewood dead spots by means of mobile units under the guidance of MSO. The Foothill Radio Club will sponsor AEC activities in its area under FFN. The Glendale Radio Club is starting AEC in that area under ULE. KEI is in the process of organizing the AEC in San Fernando Valley. As we go to press, there are signs of AEC activity in the Colton area through the Citrus Belt Amateur Radio Club. At this time we are anxiously awaiting word from the Santa Barbara gang as to their plans. New appointments as OBS: QL, ASW, IWE, and 2OIQ/6. GM is now OO in San Bernardino. UQG, QFT, and JZE, in Ventura County, are looking for contacts on 144 Mc. They have a nightly schedule and will be looking for you fellows. K4HTU is all alone now at Victorville, no QRM for forty-two miles and plenty of room for the sky-hook. UFJ carried his 3.5-Mc. antenna in the back of his car for 4½ years. QIL is at the key going strong again after several years in the Navy. NPX and OJC are on 144 Mc. in Beaumont. Ex-3BFU is starting up again with a kw. and lives right next door to yours truly. Woe is me! The Amateur Radio Researcher's Club meets the 2nd and 4th Thurs. at 8416 San Carlos St., South Gate. The Citrus Belt Radio Club meets the 1st Fri. at IOOF Hall, 100 E. "I" St., Colton. The Glendale Radio Club meets the 1st and 3rd Wed. at Spar Heights Community House, 3311 Downing St., Glendale. The Inglewood Amateur Radio Club meets 1st and 3rd Fri. in Veterans Memorial Hall, Centinela Park, Inglewood. The Foothill Radio Club meets the 2nd Thurs. at YMCA Building, 134 West Badillo St., Covina. The Associated Radio Amateurs meets 2nd Tues. at Bowling Green Club House, Long Beach Recreation Park. The Mike and Key Club will meet every other Wed. starting May 1st at 1011 Pine St., Santa Monica. The United Radio Amateurs Club of Wilmington meets the 2nd Fri. Call MDX or ANN for information. The Pasadena Radio Club will meet every other Fri. starting May 3rd at the Livingston Hotel, Green and Los Robles, Pasadena. Call KEI or SRJ for further information on San Fernando Radio Club. Wave propagation data on u.h.f. and v.h.f. is urgently needed by the ARRL. Appointments are being made for this work. My QTH is 9831 3rd Ave., Inglewood.

ARIZONA — Acting SCM, Gladden Elliott, W6MLL — At the Radio Club of Arizona meeting QLZ demonstrated a 145-Mc. rig and beam. NVS reported on his experiences as a commercial operator. KMM is on low-power 'phone and c.w. MDD has an 815 final on the air. MGJ has a new four-element beam up. PKZ did a fine job in the contest. FZQ has been transferred to Florida. 9UV is located a half block from QNC. PMJ and ROD both have new Aircoops and plan 144-Mc. operation. FZQ is near Manchester, N. Y. and wants to work the gang. PDB is relaying a lot of East Coast traffic across the Pacific. Marsh has a 250TH in that rig. 5GZR/6 is on 'phone and c.w. at Fort Huachuca. RLC is running 300 watts to TW75s and 200 watts on 146 Mc. with a pair of HK24s. 5JZQ and 5JGV are on 28-Mc. 'phone at Douglas. 5HMX/6 has a new Millen exciter. 7GYK/6 succeeded QWG as secretary of the Tucson Short Wave Assn. The club will conduct code and theory classes. GS and OZM are on the air. RNB is building a couple of rigs for other fellows. IGC has a pair of 812s on 10. OWX runs 450 watts on a pair of T56s. 5JDL/6 is on at Ryan Field. UPH is getting

(Continued on page 114)

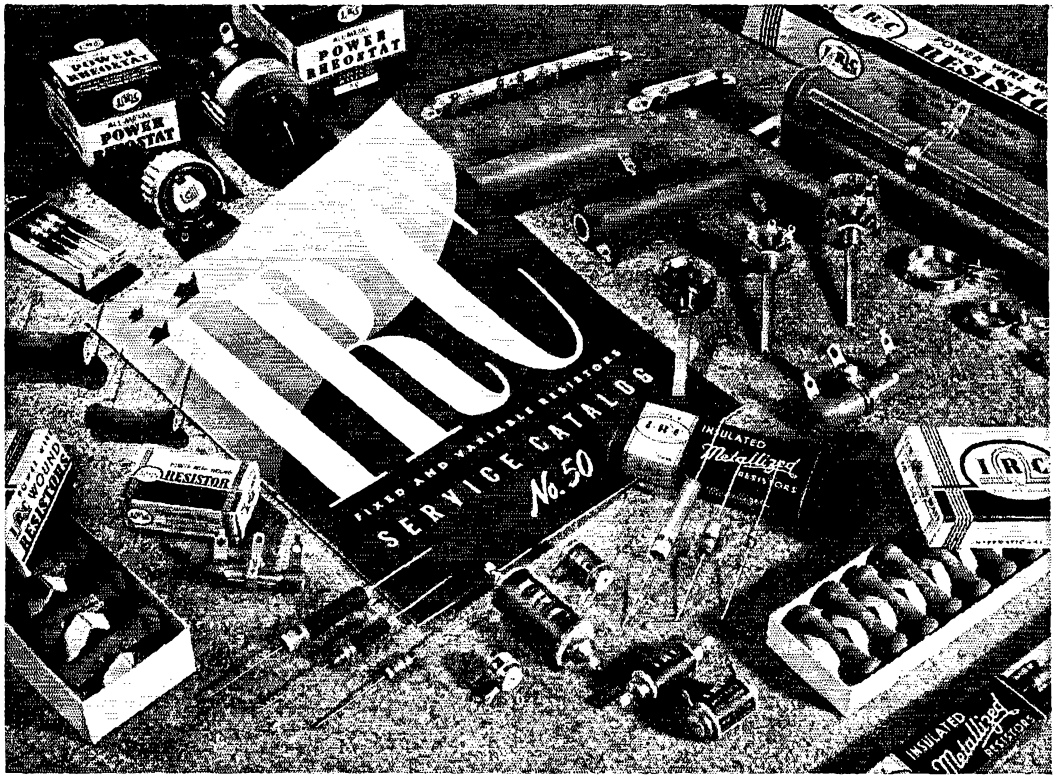

WHEREVER THE CIRCUIT SAYS Ω

IRC Catalog 50 lists a resistance unit for every ham-rig requirement. Your local IRC Distributor has a copy waiting for you! . . . and he now can give you prompt service on IRC products. Drop in, look around—you'll find his store headquarters for the best in electronic parts and equipment of all kinds.

INTERNATIONAL RESISTANCE CO.

401 N. BROAD ST., PHILA. 8, PA.

In Canada: International Resistance Co., Ltd.
11 King St., W., Toronto

IRC MAKES MORE TYPES OF RESISTANCE UNITS, IN MORE SHAPES, FOR MORE APPLICATIONS THAN ANY OTHER MANUFACTURER IN THE WORLD.



TEMCO ANNOUNCES

A 75/100 Watt Sensatio

Series GA MULTI-FREQUENCY VFO and CRYSTAL PHONE—CW TRANSMITTER

For those who prefer and appreciate fine equipment Temco announces a new line of custom built quality transmitters designed and engineered to peerless standards—*featuring maximum frequency flexibility and unusual operational simplicity.* Unexcelled in craftsmanship, these units range from 75 to 750 watts output and operate within the 3.5, 7, 14, 21 and 28 megacycle amateur bands but are also available for operation on any five harmonically related bands for other forms of communication.

As a result of standardized engineering Temco has developed a basic 75/100 Watter which in itself provides a complete multifrequency radio telephone and telegraph unit. For power output ratings in excess of 75/100 watts, this basic unit serves as an exciter for a series of power amplifiers of 150 to 750 watts output.

No Additional Expense For Signal Shifting Unit

An exceptionally stable Variable Frequency Oscillator plus direct crystal control makes it *unnecessary to employ any external equipment* to obtain the frequency flexibility needed as greater channel congestion occurs.

The VFO tuning dial and final amplifier plate circuit adjustment dial *are the only tuning controls required throughout any one frequency band.* Changing from VFO to crystal control is accomplished from the front of the panel by a three position switch. The transmitter accommodates two crystal holders affording operation on two crystal controlled frequencies.

All Tuning Adjustments Are External

In changing frequencies it is only necessary to set the band switch—plug in the correct final

amplifier coil unit—set the VFO dial to the desired frequency or select the desired crystal and tune the final amplifier plate circuit to resonance.

Thus when using crystal control the transmitter becomes a one dial unit inasmuch as *the crystal oscillator does not require any tuning whatsoever.*

For telegraph operation, break-in keying of the VFO and buffer stage is accomplished by the grid block method thus insuring distinctive clear-cut, clickless keying.

The speech amplifier input is designed to use a high impedance crystal or dynamic microphone. Three meters measure final amplifier grid and plate current and modulator plate current. Four separate power supplies are provided. All controls are at the front and the entire design permits ready accessibility to all components and provides for minimum space requirements so that the unit can be placed in any convenient location adjacent to receiving equipment.

With Mike, Key and Antenna You're ON THE AIR

The Model 75/100 GA is designed to give a most conservatively rated power output of 100 watts on CW telegraphy and 75 watts on telephone. All Series GA transmitters are furnished *complete with one set of tubes and coils for five band operation.* In addition a built-in relay transfers antenna from transmitter to receiver. The only accessories needed are a microphone, telegraph key and antenna installation.

See your dealer for complete information or write directly to Temco.



TRANSMITTER EQUIPMENT

MANUFACTURING COMPANY, INC.

345 Hudson St. • New York 14, N.Y.

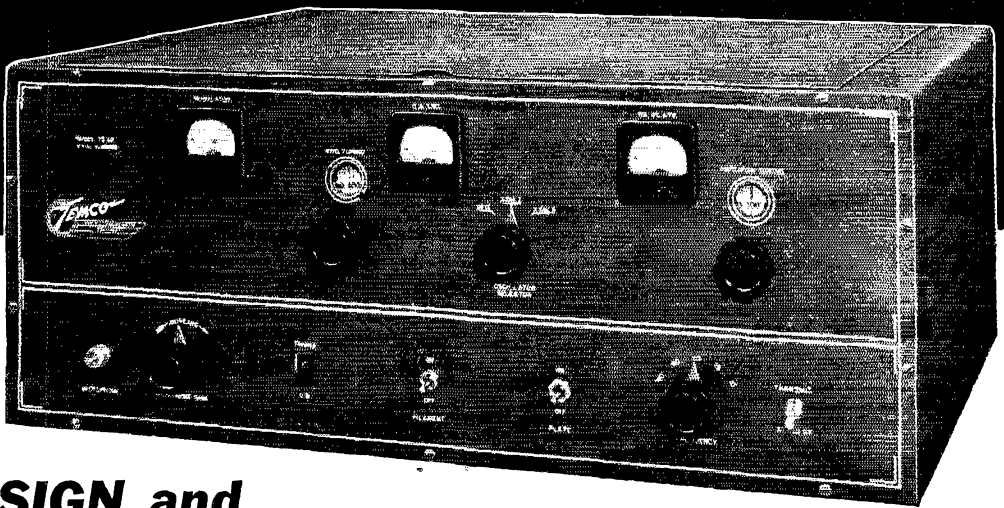

DESIGN and ENGINEERING FEATURES

Rated Output Power: 75 watts on radio telephone—
100 watts on radio telegraph.

Frequency Range: 3.5—7—14—21—28 m.c. amateur bands. (Other harmonically related bands within the range of 2 to 30 m.c. can be supplied on special order.)

Type of Modulation: High level Class AB₂.

Modulation Capabilities: 100%.

Emission: A-1 and A-3.

Input Level: From high impedance crystal or dynamic microphone, level of approximately—55 db.

Audio Frequency Response: ± 2 db from 200 to 6000 c.p.s.

Noise Level: —45 db below 100% modulation.

Audio Distortion: Less than 8% at 85% modulation.

Frequency Control: Variable frequency oscillator or crystal control with positions for two crystals.

Front of Panel Controls: VFO dial—Final amplifier tuning dial—VFO or crystal selector switch—Exciter

band selector switch—Audio gain control—Filament power switch—Plate power switch—Transmit-standby switch—Phone—CW switch.

Metering: PA grid current—PA plate current—Modulator Plate current.

Tube Complement:

Type	Function
1—6J5	VFO
1—6AC7	Class A amplifier or crystal oscillator
1—6L6	3.5 m.c. buffer or 7 m.c. doubler
1—6L6	14 m.c. doubler
1—6L6	21 m.c. tripler
1—6L6	28 m.c. doubler
1—8T4	Final amplifier
4—6L6s	Class AB ₂ modulators
1—6J5	Modulator driver
1—6SJ7	Speech input
2—866	High voltage rectifier
2—5Z3	Low voltage rectifier
1—80	Low voltage rectifier

Power Consumption: Approximately 400 watts.

Power Factor: Approximately 90%.

Measurements: Approximately
29" wide, 20" deep, 13"
high.

Power Source: 110-115 volts
50/60 cycles AC.

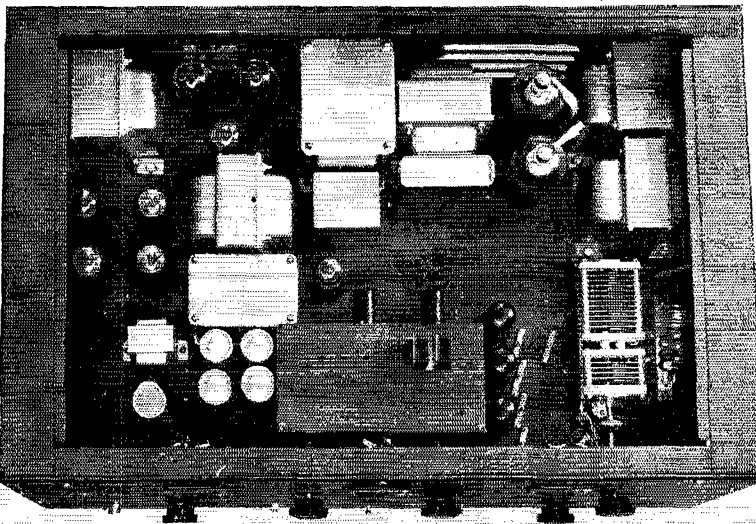

DEALERS

...interested in carrying
this line of custom built
quality Temco Series GA
Transmitters are invited
to write for details of this
interesting franchise.
Several excellent territories
still open to live wire
merchandisers.

JAMES KNIGHTS

"Stabilized"
Crystals



CRYSTALS

GOOD QSO'S AT BAND ENDS

BAND end operation often results in better QSO's but it also places critical reliance on your crystal. JK "Stabilized" Crystals are especially processed to prevent drift due to aging in service or on the shelf. Their low temperature-drift characteristics (usually less than 1 P.P.M. per degree centigrade) plus their vibration, moisture and dust proof mountings, make band edges as safe as center-of-the-band operation. Listed below are three of the most popular types of JK "Stabilized" Crystals. They are built so you can install them and forget about them.



H43 — Any frequency between 2000 KC and 30000 KC. Dimensions: 1.4" x 1.2" x .5" Fin spacing: 3/4". Pin diameter: 3/16". Price: \$2.80 for 40 and 80 meter types.

H23 — Any frequency between 2000 KC and 9000 KC. Dimensions: 1.3" x .7". Fin spacing: 3/4". Pin diameter: 3/16". Price: \$2.80 for 40 and 80 meter types.

H73 — Any frequency between 2000 KC and 30000 KC. Dimensions: 1.8" x .5". Fin spacing: 3/4". Pin diameter: .09". Price: \$2.80 for 40 and 80 meter types.

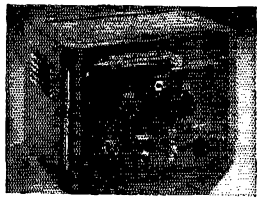

HOW OFTEN HAVE YOU NEEDED A FREQUENCY STANDARD?

To check band edges, transmitter frequency, received signal frequency, signal generator for aligning receiver? With a frequency range from 100 KC to 500 MC in convenient steps, the JK FS-344 covers the whole range of generally useful bands. Continuous frequency stability is maintained with two JK "Stabilized" Crystals. The FS-344 will become one of the most used pieces of equipment in your shack. Price complete with tubes and JK "Stabilized" Crystals. **\$79.50**



JAMES KNIGHTS
"A Radio Researcher
Since the Early Days"

The men of the James Knights Company have grown up with Ham Radio. Because of their work with piezo quartz since it first came into use as a frequency control, they know what is expected of a good Ham Crystal. You can depend on JK "Stabilized" Crystals.



LEON A. FABER
W5DAX — "An Active Ham Since 1913"

The JAMES KNIGHTS Co.

SANDWICH, ILLINOIS

Write for New Illustrated Folder

Crystals for the Critical

(Continued from page 110)
good results on 28-Mc. c.w. TDJ has a new tube tester that will test 807s. 73. GC.

SAN DIEGO — SCM, Ralph H. Culbertson, W6CHV — Asst. SCM, G. W. Brown, W6APG. Activity is increasing rapidly in this section. 9WSC/6 is on 28 Mc. with frequency modulation and worked a W4 with an R8 report in the early morning before the band was open. OFT has 425 watts input and finally worked VK3AKR for his first Australian contact. HAM reports activity in Santa Ana growing with the Orange County Radio Club going strong. New officers are: DEY, pres.; TIK, vice-pres.; FCT, secy. Meetings are held on the 2nd Wed. of each month. LKC reports OFT has an FB portable-mobile rig in his car running about 40 watts and working swell. MMZ is now an ensign in the Navy and is stationed at Kodiak, Alaska. He will be on the air soon with his own call but at present is operating with 6SMF/K7 and wants all the old gang to be on the lookout for him. JOY has a new rig on 28-Mc. c.w. running about 150 watts, and has worked VK4HR and VK3QL. HBN, formerly located in Los Angeles, is a new ham in Ramona operating on 28-Mc. 'phone. LKC finally made WAC on 28 Mc. by working ten different "G" stations in England and Wales. LKC is building a 28-Mc. portable-mobile rig in his car. He reports hearing a station in Russia on 28,700 kc. around 7:30 to 8:30 p.m., but says the fellow never talks English and you can't work them if you can't understand them. Local stations participating in the Band Warming Party included 3IXF/6, LKC, LJU, and CHV. FGU has received his old call back after about six years off the air. MHL has received an FB new shack. MBU and NXR are proud papas. MBU has a new 1-kw. rig for 28 Mc. under construction. Traffic: W6BAM-4, LKC 7, CHV 5. 73. *Ralph*.

WEST GULF DIVISION

NORTHERN TEXAS — SCM, Jack T. Moore, W6ALA — HZB reports that he and HYE are roommates at Texas A. & M. Jack says a radio club has been organized at the college with the following officers: GSS, pres.; KQZ, secy-treas. The club has a 100-watt 'phone and c.w. rig and NC-101XA and HRO receivers. Power will be increased to 500 watts soon. JAC, enroute from Swan Island, stopped off in the U. S. long enough to buy a Luscombe to fly to K4-Land. AMK sends the following news: GGQ, LM, DQF, and AMK are the active Temple hams; LM is planning an f.m. job for 28-Mc. c.w.; AMK had to borrow a crystal in order to get on the 27-Mc. band; JIB is returning from the Navy to work for AMK; IMMN/5 is on 28 Mc. at Camp Hood and also via portable-mobile. GER reports from Mannheim, Germany, that he is operating D4ACN on 28 Mc. and would like to contact Dallas. LY is planning a 250-watt rig and hopes to have it on the air soon. JIZ/K7 is on the air and also is looking for a home QSO with Dallas. EVI reports that BNQ works DX via lamp light and if his reports are down he just turns the wick up a little higher and everything is OK. JQY is using a "plumber's delight" on 28 Mc. RG is working all kinds of DX on 28-Mc. c.w. The Dallas radio supply houses are furnishing swell door prizes for the Dallas Amateur Club meetings. 73. *Jack*.

OKLAHOMA — SCM, Ed D. Oldfield, W6AYL — IPY, formerly of Tulsa, writes that he is on 28-Mc. 'phone and is located at Duncan. He is working for a refinery as electrical supervisor. KDH recently returned to civilian life after spending three years in the AAF, communications; six months of that period were spent in Greenland. He is employed in radio service at his home in Cleveland, Okla. KHH, who is in the Navy, visited his brother, 4GYO/5, at Tulsa. 9SKE/5, of Tulsa, is trying to form a Naval Ordnance Lab. net; he works on 3.9 Mc. FXD talked to the Tulsa Club on rotary beams and AYF also gave an equally interesting dissertation on phase inversion at the TARC meeting March 7th. 9YHE/5 is buying a new home. New and out-of-district club members at Tulsa are 1NIV, 4GYO, 9CTV, DQI, NLB, PQG, SKK, WZZ, and YHE. The TARC meets first and third Thursdays at Radio, Inc. and invites all amateurs to attend. 73. *Ed*.

SOUTHERN TEXAS — SCM, James B. Rives, W5JC — EHM has a 300-watt mobile rig on 28 Mc. powered by a gas engine in the back of his car. HHO is operating on 28.7 Mc. in the Tokyo area and desires an outlet for traffic to Texas. Capt. BHO is on terminal leave in Houston going back to work for the power company, and is active on 3.7 Mc. 2NDA/5 has moved to San Antonio to assume his

(Continued on page 116)

READY
for you NOW

ALLIED'S NEW 1946 CATALOG

of Radio Parts and Equipment

Everything for the Veteran and the Beginner!
Includes Latest Communications Receivers

Here's your latest, most complete Buying Guide for everything in radio! Includes newest receivers, Ham gear, code apparatus, parts, kits, tubes, tools, books, test instruments, public address and other equipment. Over 10,000 items available from the largest and most complete stocks under one roof. Nationally known makes. Finest values. Fast, efficient service from one reliable central source. Our experienced staff of licensed radio amateurs is glad to help you.

Free... Send for it today



**FOR EARLIEST DELIVERY... ORDER YOUR
Communications Receiver**

Now from **ALLIED**

Time-Payments • Trade-ins Accepted

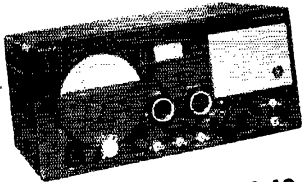

NEW HALLICRAFTERS 5-40

Simple to operate. Frequency range 550Kc. to 44Mc. in 4 bands. Wide vision main tuning dial accurately calibrated. Separate electrical band-spread dial, inertia flywheel tuning. Beat frequency oscillator. Automatic noise limiter. Separate RF and AF gain controls. Three position tone control. "Micro-set" permeability adjusted coils in RF section. Internal dynamic speaker. Net. **\$79.50**
Model SM-40 External "S" Meter, \$15



NEW PRECISION RME 45

Delivers peak reception on all frequencies—500 to 33,000 Kc. Full vision calibrated dial using one control for two-speed tuning. Five Amateur bands with ample band spread. DB calibrated signal level meter. 5 step variable crystal filter. Automatic Noise Suppression. Stable, variable pitch beat oscillator. Net, with Speaker **\$186**

Other Models

Hallicrafters SX-25.....	\$94.50
RME DB-20.....	59.30
RME VHF-152 Converter	86.60
Hammarlund HQ-129 X.	129.00
National NC-2-40C.....	225.00
National HRO.....	197.70
Hallicrafters SX-28A.....	223.00
Hallicrafters S-36A.....	307.50
Hammarlund 400X.....	318.00
Hammarlund 400SX.....	318.00
Hallicrafters S-37.....	591.75
Hallicrafters BC-610	
(HT-4).....	500.00
Hallicrafters HT-9.....	225.00

Net P.O.B. Chicago
Prices Subject to
Possible Change

ALLIED RADIO

Everything in Radio & Electronics
833 W. Jackson Blvd., Chicago, Ill.

ALLIED RADIO CORP., D. L. Warner W91BC
833 W. Jackson Blvd., Dept. 27-EE-6
Chicago 7, Illinois

- Date.....
- Enter order for.....Model.....
- Enclosed \$..... Full Payment Part Payment
(Balance C.O.D.)
- Send literature on Receivers and Time Payment Plan.
- Send FREE new 1946 Allied Catalog

Name.....

Address.....

City.....Zone.....State.....

In this NEW WORLD OF ELECTRONICS



NEW DEVELOPMENTS
SPELL *New Opportunities!*

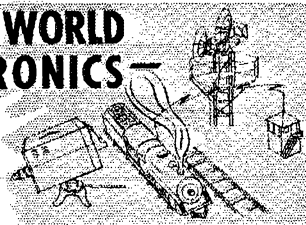

A FEW YEARS AGO broadcasting was born—many of the first radiomen to enter that field have long since arrived at the top of their profession.

TODAY, the techniques of this New World of Electronics, war-developed and now released, offer greater opportunities than ever existed in the early days of broadcasting.

MICRO-WAVE RELAY SYSTEMS, TELEVISION, FM broadcasting, mobile communication systems for trains, automobiles, busses and trucks, many industrial applications—these are only a few of the new developments and new techniques which offer marvelous, exciting opportunities to you who are alert—and are qualified!

YOU HAVE THE OPPORTUNITY to "get in on the ground floor"—where promotion will be rapid—where you can go to the top, IF—you have the foundation of technical knowledge which is so vital to an understanding of the new techniques. Your first step toward success in this new world of electronics is your resolution to acquire a formal, fundamental technical knowledge. CIRE courses of home study training are planned to do that job. **Mail the coupon today!**

CIRE HOME STUDY COURSES COVER THE FIELD OF RADIO-ELECTRONICS—TELEVISION, ULTRA-HIGH FREQUENCY TECHNIQUES, AM AND FM BROADCASTING, COMMUNICATIONS ENGINEERING—from simple treatment of fundamentals, through preparation for FCC commercial radio operators' license examinations, up to and including complete high level quantitative treatment of advanced radio-electronics and communications engineering. **Choose the course best suited to your needs, and start with the section you are qualified to enter. You pay for only the section or sections you need. Use the "Pay-as-you-go plan" patterned after ethical, educational practice.** These features are unique, with Cleveland Institute, and represent the best in the modern, post-war concept of home study training.

Many CIRE students of advanced engineering courses today are broadcast chief engineers. Graduates of CIRE courses are eligible for the top jobs in radio-electronics.

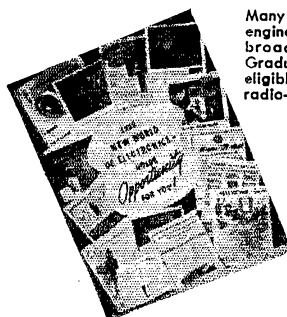

Write today for free, descriptive booklet—**"THIS NEW WORLD OF ELECTRONICS HOLDS OPPORTUNITY FOR YOU."** No obligation—no salesman.

Cleveland Institute of Radio Electronics
Contractors to the Canadian Broadcasting Corporation

Successors to: NILSON RADIO SCHOOL, Founded 1939
SMITH PRACTICAL RADIO INSTITUTE, Founded 1934

QT-5, Terminal Tower Cleveland 13, Ohio

Cleveland Institute of Radio Electronics
QT-5, Terminal Tower, Cleveland 13, Ohio

Gentlemen: Please send information about your home study courses in Radio Electronics.

Name.....
Address.....
City..... State.....

(Continued from page 114)

duties as chaplain at Kelly Field and has 200 watts 'phone on 28 Mc. 2HVJ/5 is now signal officer at Kelly Field. IRJ is pounding brass for Eastern Airlines. FNA has erected some telephone poles for that new antenna system. HBH is out of the services and teaching drafting at Texas U. GKI has a new rig using a pair of TZ40s. EBP is working over his 101X receiver. GKX has a new rig on 28 Mc. 2LNY/5 has been assigned KTL for his call in this area and has an 813 on 28 Mc. Lt. EUL is on terminal leave and ready to get back on the air in San Antonio. FDR has moved to Oakland, Calif. HEN is now stationed in Manila. FEZ has received his discharge from the Navy. BKJ is active on 28 Mc. 3IVT/5 reports regularly for the Galveston district and is interested in ORS appointment. HIF has moved from Fort Worth to Corpus Christi and is in the instrument section of Sinclair Refining Company; he has a kw. on 28 Mc. IYS is in the Navy and stationed at Cocco Solo, C. Z. HTC has been discharged from the services and has returned to San Antonio. Contact BUV for emergency appointments. 73. Jim.

NEW MEXICO—SCM, J. G. Hancock, W5HJF—KCW is getting eight out of ten tries with his p.p. 807a on 28 Mc., including K6s and Js. ISN is not doing so bad either with his 28-Mc. quarter-wave doublet with K6s and KB6s on his log. 4DWB is active on 28 Mc. from Santa Fe and is anxious to get back in ORS activities. ICD, ex-8LYG, is a patient in the National Military Home in Los Angeles. His complete address is: George G. Doty, Box 83, V. A. Branch, Los Angeles 25, Calif. Some of the material for this write-up has been carried over from last month when this report got in too late. (SCM definitely wasn't off fishing either!!!) Would appreciate hearing from all you LSPHs as you get your new station calls. 73. Jake.

CANADA

MARITIME DIVISION

MARITIME—SCM, A. M. Crowell, VE1DQ—At the March meeting of the HARC, the news of the return of some more of our frequencies was announced by the R.I. Loud cheers, especially from the "80-meter boys," greeted this official dope. A program committee under NQ, and a technical and QRM committee under ET, were appointed. LZ, the new treasurer, replaces OB, who resigned. Interesting technical films were screened and refreshments served to a full house of about fifty. President EK was in the chair as the club adopted its new constitution. KS, our first OBS, is on 28904 kc., Mon., Wed., Sat. at 1300 AST and will revise schedule when new frequencies are available. JU has been released from the Navy and is going on 28 Mc. using Sky Champion receiver. QF, also active on 28 Mc., is building a 200-300-watt job. KS is awaiting his new HT-9 Hallicrafters transmitter. ET is sporting new RME-45. Will all former holders of OBS, ORS, OPS, and those interested in new appointments, PLEASE get in touch with the SCM? And gang, let's make with those reports. 73. Art.

QUEBEC DIVISION

QUEBEC—SCM, L. G. Morris, VE2CO—The first MARC meeting since 1940 was held Feb. 21st at "B" Corps Signals Armory, with over one hundred hams in attendance. BE, the CGM, spoke on the reactivation of amateur radio. The following call-sign changes have been reported: 3JI to 2SM; 3LR to 2XR; 2CR to 3BDT, Toronto; 4PH to 2WW; 5ADS to 2FY; 4BM to 2WM. EM finally put up an outdoor skyhook on 28 Mc. and worked a D4 on his first CQ. JK is now with TCA in Ottawa and has call 3BDX. DR, IE, JJ, and LV have new receivers. BO managed to get an apartment, but it's too small for ham radio. JO is back from overseas holding the rank of captain in the RCA. DO, DJ, and BB are civilians again. ID has moved to Shawbridge. Additions to the gang on 28 Mc. are: NA, CU, NR, PX, IC, LJ, and NT. KH, AL, and BU are on 54 Mc. while AX and GN appear to be the sole occupants of 144 Mc. SM7YG is temporarily located in Montreal and visits DR for rag-chews in his native tongue. EX is a staff sergeant in the RCAF.

VANALTA DIVISION

ALBERTA—SCM, C. S. Jamieson, VE4GE—TM has FB rig on 28 Mc. and lattice tower all built for his new rotary beam. GD is trying out new AR-88 receiver. AAD (Concluded on page 118)

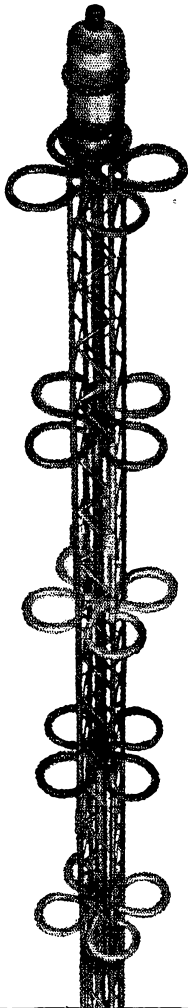

NEW!

Western Electric CLOVER-LEAF antenna for FM BROADCASTING

12 OF THE MANY IMPORTANT FEATURES:

- | | |
|--------------------------------|---|
| 1. High gain | 7. No multiple transmission lines |
| 2. Circular azimuth pattern | 8. No phase correcting lines or networks |
| 3. Simple to install | 9. No balancing lines |
| 4. Minimum maintenance | 10. No field or factory antenna tuning |
| 5. Exceptionally rugged design | 11. No insulators — full lightning protection |
| 6. 50 KW power capacity | 12. No end seals |



Western Electric's new 54A Antenna can really dish out horizontally polarized waves in concentrated form. It's the high gain CLOVER-LEAF Antenna, designed by Bell Telephone Laboratories for FM broadcasters in the 88-108 mc band.

Radiating units shaped like clover leaves are spaced at half wavelength intervals. Power gains ranging from 1.30 with two units up to 4.70 with eight units are readily achieved.

Each radiating unit consists of four curved elements, which are connected by clamps along a feed conductor. The usual phase reversal occurring at half wavelength points along such a feed line is compensated for by merely reversing the elements in adjacent units. This eliminates insulators, end seals and the need for multiple transmission lines, phase correcting lines and balancing lines.

The impedance of the 54A Antenna is matched to the impedance of the coaxial transmission line by means of a unique low-loss transformer which utilizes the base section of the tower and antenna feed conductor. This transformer is set to proper adjustment at the time of installation.

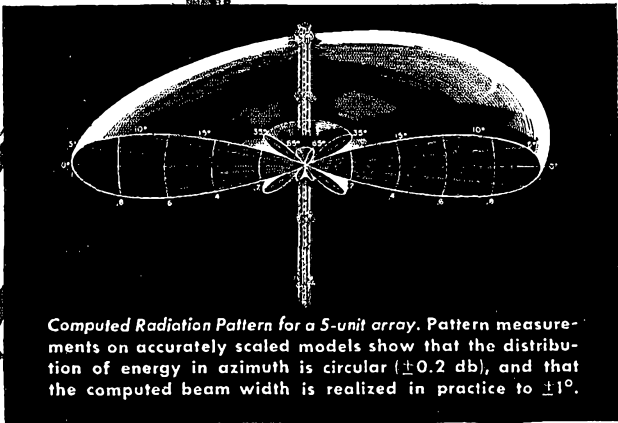

VALPEY CRYSTAL TYPE CM 5

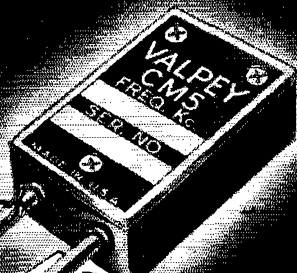

Ready for immediate delivery and furnished in your choice of two frequency ranges: —

12,500 KC to 13,500 KC (inclusive) which is $\frac{1}{4}$ of new 6 Meter Band
Amateur's Net Price \$3.50

6,250 KC to 6,750 KC (inclusive) which is $\frac{1}{8}$ of new 6 Meter Band
Amateur's Net Price \$2.80

also NEW LOWER PRICES

Valpey Type Cm-5 in: —	
80 and 40 Meter Band	
Amateur's Net Price . . .	\$2.80
20 Meter Band	
Amateur's Net	\$3.50
10 Meter Band	
Amateur's Net	\$4.50

VALPEY CRYSTAL CORP.
HOLLISTON, MASS.

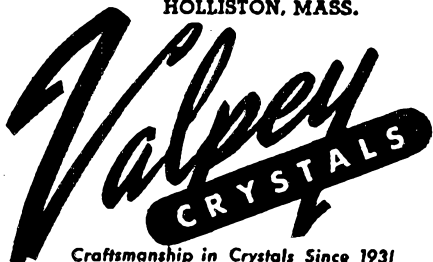

Craftsmanship in Crystals Since 1931

(Continued from page 116)

will be using VE6JF for new call. LX still prefers a good c.w. QSO to 'phone! ITA is operated by the Provincial Institute of Technology and Art in Calgary. PG and ACF plan to operate a small rig from their cabin on Highwood River this summer. OD is getting rig lined up for early action. AOC's new call is 3AVT. ALO and EY have daily schedule with GY at Fort Saskatchewan. EA built preselector for his receiver. HM gets out FB on 28-Mc. 'phone. ABL's new call will be 6WS. ASX will sign 6GS. ANQ will use 6EL after April 1st. John Gerrie's new call is 6JG. ALO will sign 6AL. LG intends to rebuild the heap to use an 813. HF, in Yukon at Lac la Barge, will be on the air soon with 807s in the rig. UP is getting out an FB signal. JP is interested in the AFARS set-up. AEA hit 28 Mc. recently and is trying to iron out the bugs in the heap. HC, ex-5MJ, will sign 6MJ from now on. ADW has rig on 28 Mc. using 807 final. AAZ is looking forward to getting back on 3.5 Mc. How about you chaps contributing a spot of news? 73. VE6LQ, ex-4LQ.

PRAIRIE DIVISION

MANITOBA — SCM, A. W. Morley, VE4AAW — The past month has been an important one in Winnipeg. At a meeting held March 8th, at which over seventy-five Winnipeg hams were present, it was decided to form one big club to be known as WARC. Officers pro tem are: BQ, pres.; AAI, vice-pres.; SO, secy.; and Miss F. Tod, treas. Ham radio needs a strong organization in Winnipeg and everyone should support it. New AEC member is AP at Brandon. EE has new jr. operator. AFY is busy on 28 Mc. IF is working DX. From Portage comes word that ALT is signing VE7. LV is working with receiver. UB is working out of town. AMT has p.p. 809s. AN, ex-ANI, runs 100 watts. ALE has returned home and reports that "while away I took unto myself one XYL." RB, at Killarney, runs 6L8-807. Locally 28 Mc. is being worked to the bone. New calls appear daily and with the mix-up of changing calls it's hard to tell who's who. By the time this appears 3.5 Mc. will be wide open. Look for me there. New call is AM. 73. Art.

SASKATCHEWAN — SCM, Arthur Chesworth, VE4SY — The regular meeting of the MJARC was held recently with a full attendance. All members reported some activity and a lecture on antennas was given by ACO which was very much enjoyed. We understand the Regina club is meeting every month but no reports have been received from that city. The Moose Jaw club decided to postpone the holding of a hamfest until more interest and activity is shown in outside points. PK reports getting his rig on 28 Mc. with 15 watts and working an LU the second day. FB, Pete! All Saskatchewan district calls will be changed to VE5 on April 1st. 73.

Noise Limiting

(Continued from page 17)

The a.v.c. action on signals is very marked, and is a feature that grows on one with continued use. It is a tremendous aid to operating comfort to be able to tune across a band without having one's eardrums blasted by strong signals when the gain is set to give reasonable volume on the weak ones. In addition, both slow fading and the rapid kind that puts a "warble" on the signal disappear, leaving a steady signal of "local" character except when the strength drops below the limiting level — and, aside from very weak signals, the percentage of time during which this occurs is low. There are some disadvantages to a.v.c., too, because the a.v.c. action is similar to a.v.c. on 'phone — that is, a strong signal close by in frequency may take control and blot out the desired weaker signal. This is because the beat note from the unwanted signal is the stronger of the two,

(Continued on page 180)



Powerful Graphite Anode Tubes

Pioneered-Championed and Revolutionized

by UNITED

Through progressive steps of refinement UNITED graphite anode high vacuum tubes have been developed to such an extent that today they set a new high standard for constancy, efficiency and long life at heavy duty. Here are the up-to-date facts about these tubes which represent a revolutionary contribution to electron tube advancement.

BASIC ADVANTAGES OF GRAPHITE

1. Graphite will stand temperatures higher than ANY other material. It has NO melting point, hence no physical distortion from overloads.
2. Being highly porous, Graphite can be EFFECTIVELY degassed through its entire mass.
3. Because it is almost a perfectly black body Graphite has high thermal emissivity and conductivity. Operating temperatures are therefore low in relation to energy dissipated thus preventing distortion of grid and other parts.

UNITED REFINEMENTS IN TUBE DESIGN AND PROCESSING

1. Crystal clear glass envelope resulting from isolated "getter trap" (patent pending) increases efficiency 10 to 20%.
2. New type graphite, machined to our specifications is free from amorphous particles.
3. Zirconium impregnation of graphite anode greatly increases service life of the tubes.

Type V-70-D

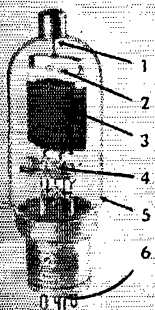

\$5.90

TWO HUSKY AMATEUR TYPES

Designed as high power renewals for soft glass tubes with 6.3 and 7.5 volt filaments, these "huskies" will take full rated inputs without a blush. They are especially desirable as replacements for tubes of 40 to 55 watts plate dissipation. The V-70-D or 812-H will perk up the old rig with new healthy watts and with little or no revamping.

- | | |
|---|--|
| 1. Ground Tungsten Seal Rod | 4. UNITED Getter Trap (Patent Pending) |
| 2. Genuine India Lava | 5. NONEX Hard Glass |
| 3. Zirconium Impregnated Graphite Anode | 6. High Grade Ceramic Base Insert |

Type 812-H

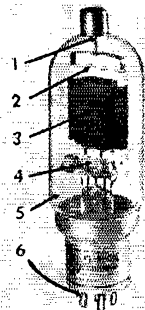

\$5.90

Type	Filament		Max. Plate Dissipation	Capacitances uuf			Max. input per tube	Max. Plate	
	Volts	Amps		cgp	cgf	cpf		Volts	Mils
V-70-D	7.5	3.25	85 Watts	4.5	4.5	1.7	300 Watts	1750	200
812-H	6.3	4.0	85 Watts	5.3	5.3	0.8	300 Watts	1750	200

UNITED ELECTRONICS COMPANY
 AMATEUR RADIO DEPARTMENT

42 SPRING ST. • NEWARK 2, N. J.

Transmitting tubes EXCLUSIVELY Since 1934

AS NEW GEAR HITS THE MARKET . . .

You can be dead sure that . . . just as fast as new gear appears on the post-war market . . . the Radio Shack will bring it to you. And it's happening *right now!* Receivers, transmitters, and accessories are being delivered in ever-increasing quantities. Keep your eye on the Radio Shack for a wide variety of exciting post-war developments.

RECEIVERS GALORE

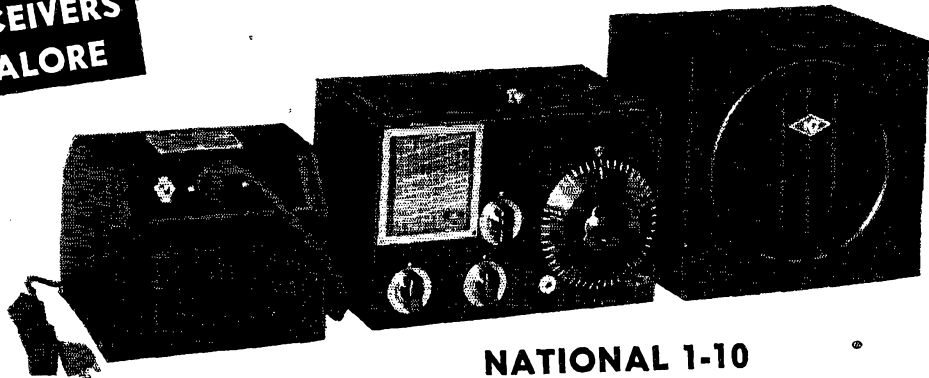

NATIONAL 1-10

The experimenters' choice . . . available now to fill your need for a receiver covering one to ten meters, this 4-tube super-regenerator with one tuned r-f stage is furnished complete with six sets of easily changed coils.

Receiver and coils	\$56.10
Kit of four tubes	9.37
Power supply type 5886	19.50
Matching speaker	10.95

Immediate shipment from stock.

ORDER THESE FAMOUS RECEIVERS FROM THE RADIO SHACK

NATIONAL

- () N-240C \$225.00
More HRO's soon available

HAMMARLUND

- () Super-Proto be announced

R. M. E.

- () RME-45 complete\$186.00

HALLICRAFTERS

- () S-22R Skyrider Marine \$74.50
- () S36-A VFH FM-AM—
Complete\$322.00
- () S-39 Sky Ranger\$110.00
- () SX-25 Super Defiant—
Complete\$109.50
- () SX-28A Super Skyrider—
Complete\$238.00

All prices are for complete receivers and are net F. O. B. Boston

NATIONAL NC-46

A post-war design by National . . . price to be announced.

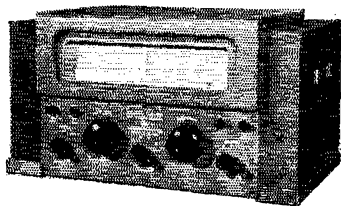

ORDER THESE RECEIVERS NOW

We will immediately telegraph confirmation of your order for prompt shipment from new stock.

NATIONAL DIAL—type ACN

You can get same-day shipment on this old favorite full-vision dial. Net price only \$3.00

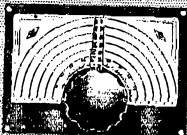

SEND FOR FREE
RADIO SHACK

108-PAGE CATALOG

YOU'LL FIND IT AT THE RADIO SHACK

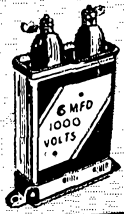

SPECIAL OIL CAPACITOR

1000 volts 6 mfd. only **\$1.19**

UFH ACORN TUBES—Types 954-955-956

Six tubes same type or assorted\$2.95
Isolantite socket for acorn tubes48c each

SUPER SPECIAL TUBE VALUES

Type 832—JAN inspected\$5.95 ea.
Type 3C24/24G Eimac 1.95 ea.

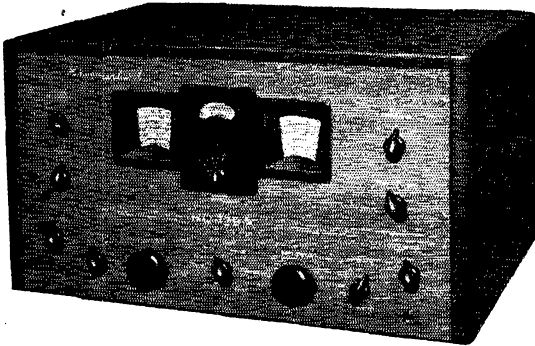

HAMMARLUND HQ-129-X

Deliveries have started on this super-value. This professional receiver has many new features . . . but the same old price. **\$129**
Receiver, complete with tubes and built-in power supply
Matching speaker\$10.50



ABBOTT TR-4

You all know this famous transmitter-receiver for 2-meter work. Order it today from the Radio Shack. **\$43**
Net price
Kit of tubes for TR-4 **\$8.30**

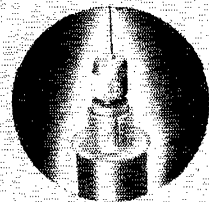

COAXIAL DIPOLE

For the 144-148 mc. band. For fixed-station or mobile use—matches 50-55 ohm co-ax cables—continuously adjustable—immediate delivery from Radio Shack only.

Net price **\$12.50**

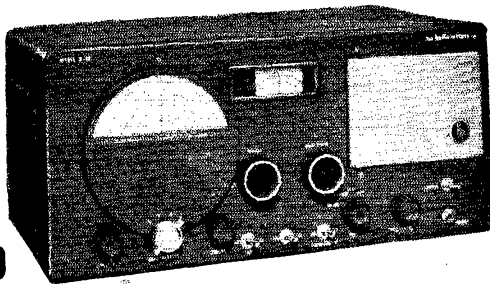

price complete **\$79.50**

HALLICRAFTERS S-40

Here's a post-war design built for your convenience. Wholly self-contained • covers .54 to 42 mc. • electrical band-spread • built-in speaker • phone jack • ANL • stand-by switch • power supply.

TIME PAYMENTS

You can equip your station on easy time payments when you buy at the Radio Shack. Write for details—*litting material needed.*

BCNU at Framingham
N.E. ARRL Convention—May 4th

The RADIO SHACK

★ 167 WASHINGTON ST. BOSTON, MASS.. U.S.A. ★

EVERYTHING FOR THE HAM

WRITE

Leo, W9GFQ

For Fast Delivery!



Get Leo's own personal, sudden-service on your radio needs. Leo will help you get back on the air quickly with first delivery on anything in radio.

HAM NEEDS

Transmitting tubes, condensers, mikes . . . everything for the Ham. One of the country's largest stocks of Ham equipment. Write Leo, W9GFQ, today, and be first with the latest. We invite inquiries for special equipment of all kinds.

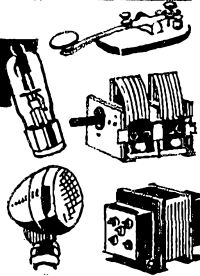

TRANSMITTERS

For peak performance and more dollar for dollar value, get a WRL Transmitter Kit . . . designed in Leo's own laboratories . . . tested and proven. Available in 15, 35, 70, and 150 watt kits as well as kits custom built to your own specs. Write Leo today for complete details, prices and terms.

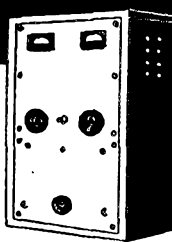

RECEIVERS

Here are just a few of the many well-known receivers offered by Leo:

- Hallcrafters SX-25 \$ 94.50
- Hallcrafters S-20R \$ 60.00
- Hallcrafters SX-28A \$223.00
- Echophone EC-1A \$ 29.50
- Hammarlund HQ-129X \$129.00
- National NC-2-40C \$225.00

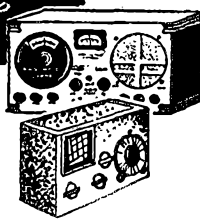

FREE! NEW 52 PAGE FLYER

52 pages packed with real buys in radio, electronic, and general merchandise. Write for details of our trade-in plan and easy terms.

- Giant Radio Reference Map (size 3 1/2" x 4 1/2") 15c
- Handy Tube-Base Calculator 25c

Address Dept. QST-5
Council Bluffs, Iowa



Formerly Wholesale Radio Laboratories

(Continued from page 118)

even though it may be well up in the audio range and be practically inaudible in the average headset. The purpose of the condenser in Fig. 6 is to give a tone-control effect, reducing the high-frequency response and thus preventing to some extent the taking-over of control by an interfering signal having a high-pitched beat note. It is purely a compromise, since it also tends to lower the effectiveness of the limiter on impulse noise. After considerable listening we decided it was worth-while to have it rather than not.

Limiting the beat-note amplitude causes considerable distortion of the beat-frequency waveform and thus introduces harmonics that are not present in the ordinary beat note. The aural effect is a change in the character of the tone. Considering the very drastic change in waveform that occurs when a strong signal is limited, it was expected that the distortion might prove to be an annoyance and that something might have to be done about it. However, the average magnetic headset is sufficiently peaked in the normal beat-note range so that, especially in conjunction with the shunting condenser, the distortion is not particularly noticeable. It shows up more with a crystal headset because of the better high-frequency response that is characteristic of that type.

Used behind a crystal filter the limiter does not ordinarily have a great many opportunities to go to work on ignition noise, because in the average location the noise amplitude seldom seems to get up to the signal amplitude through the filter. However, it is very helpful in eliminating strong transient noises caused by switching electrical devices on and off, and the a.v.c. on signals is especially desirable. In both respects limiting tends to reduce the ear fatigue resulting from the piercing character of both signal and noise in reception with high selectivity.

New Tuning System

(Continued from page 80)

used has continuous coverage from 540 kilocycles to 110 megacycles. The two tuned r.f. stages employ type 6AG5 tubes and a type 7F8 dual triode functions as oscillator and mixer. The basic circuit arrangement for the oscillator and mixer stages is given in Fig. 5. It has been necessary, of course, to introduce other innovations in order to cover such a wide range in one receiver. One of these is the use of dual i.f. transformers. Two i.f. channels are provided, 455 kc. and 10.7 Mc., and the change-over is accomplished automatically by the receiver band switch in the vicinity of 30 megacycles.

A few additional practical suggestions are in order for the amateur who plans to use this circuit. All trimmer condensers must be completely insulated from the chassis because both ends are "hot," just as in the case of the coils.

(Continued on page 124)

NEW

... and Individually Marked



OHMITE

Little Devil

INSULATED COMPOSITION RESISTORS

½ Watt • 1 Watt • 2 Watt • ±10% Tolerance

NOW . . . OHMITE makes available to you three *Little Devils* of exceptional ruggedness and stability!

Millions of these tiny molded fixed composition resistors have been used in critical war equipment and in the nation's foremost laboratories. They meet Joint Army-Navy Specification JAN-R-11, including salt water immersion cycling and high humidity tests. They can be used at their full wattage ratings at 70°C (158°F) ambient temperature. They dissipate heat rapidly—have low noise level and low voltage coefficient.

Ratings for maximum continuous RMS voltage drop are high: 500 volts for the ½ watt unit—1000 volts for the 1 watt unit—3500 volts for the 2 watt unit. Units have high insulation breakdown voltage.

Little Devils are completely sealed and insulated by their molded plastic construction. Leads are soft copper wire, hardened immediately adjacent to resistor body—strongly anchored—and hot solder coated.

Light, compact, easy to install. All units color coded. Resistance value and wattage are marked on every unit for quick identification. Available from stock in Standard RMA values from 10 ohms to 22 megohms. Order them now!

Available Only Through OHMITE Distributors

OHMITE MANUFACTURING CO.

4863 FLOURNOY STREET, CHICAGO 44, U. S. A.

Meet Joint Army-Navy Specification JAN-R-11
AVAILABLE FROM STOCK IN STANDARD
RMA 10% TOLERANCE VALUES

TYPE	SIZE		RESISTANCE RANGE	MAXIMUM VOLTS	LIST PRICE
	LENGTH	DIAM.			
½ Watt	¾"	¼"	10 Ohms to 22 Meg.	500	13c
1 Watt	⅞"	⅜"	10 Ohms to 22 Meg.	1000	17c
2 Watt	1½"	⅝"	10 Ohms to 22 Meg.	3500	25c



Send Now for
BULLETIN No. 127

Gives complete data and list of RMA values. Includes dimensional drawings and handy color code. Write for it today!

Be Right with

OHMITE

RHEOSTATS • RESISTORS • TAP SWITCHES • CHOKES • ATTENUATORS

XTALS • XTALS • XTALS

Mounted Low-Drift

3.5 M.C. and 7.0 M.C.

XTALS

± 5KC your specified frequency anywhere in 3.5 and 7.0 MC bands. Fits octal socket — has stainless steel electrodes — moisture resistant phenolic case and neoprene gasket seal.

Send cash or money order. No C.O.D. accepted.

①

Only

\$1.50

EACH

Postpaid in U. S. A.

COMMERCIAL EQUIPMENT CO.

1416-18 McGee St., Kansas City 6, Mo.

XTALS • XTALS • XTALS

(Continued from page 188)

Padder condensers should be connected in series with the coils at the end away from the grid. To reach the higher frequencies of which this circuit is capable a great deal of care must be taken in mechanical design and layout. The band switch should be placed directly under the main tuning gang and all leads should be kept as short and direct as possible. In the unit pictured, the leads from capacitor to band switch are of copper strip, silver plated to reduce r.f. resistance. The coils for the two highest bands may be placed between switch wafers and supported directly on the band switch. For the lower frequency bands a little extra lead length is unimportant and coils may be mounted in the usual manner on the chassis, progressively farther from the switch as the frequency is decreased. The band-spread condenser is connected in parallel with the larger section of the split-stator condenser to reduce the effect of its minimum capacity in the same way that the tube loading capacity was reduced.

While it is unlikely that any but the most experienced amateur builders will attempt the construction of an elaborate receiver such as the one shown here, this split-stator tuning arrangement offers endless possibilities. It should be entirely practical to add a stage or two of tuned preselection to the v.h.f. superregenerative rig by this means, and many other applications will occur to the experimenter. The advantages of low minimum capacity, higher gain per stage, more uniform gain throughout the tuning range, and the possibility of using cheaper tubes at higher frequencies should make this circuit a "natural" for all h.f. and v.h.f. purposes.

Field-Strength Meter

(Continued from page 88)

Mc. As many v.h.f. antennas are vertical, the socket was mounted for maximum convenience when using vertical pick-up antennas. For work with horizontal arrays the pick-up unit can be placed on its side, or a horizontal pick-up antenna may be made by attaching the plug near the center of a piece of rod stock. The antenna length may affect the tuning range of the coils in the pick-up unit, as the antenna is directly coupled to the hot end of the circuit. The coil sizes given resonated when a 24-inch rod was used for a pick-up antenna for all bands.

The r.f. chokes contained in the meter unit are possibly an unnecessary precaution, as the interconnecting cable is by-passed at both ends, but we were taking no chances with an expensive meter and the chokes are cheap insurance.

Constructed recently when some conclusive data was required on the performance of the 16-element 144-Mc. array shown on our cover, this unit has turned out to be the handiest gadget we've had in many a day. The determination of

(Continued on page 152)

HAM GEAR

at Newark Electric

Last issue this column advised you to latch on to a Mallory Vibrapack, stow your ham gear in the old gaswagon, head for the countryside — and enjoy a few QSO's while communing with Mother Nature.

And what should you take along to accompany your Vibrapack? Well, some batteries for one thing, plus a darned good receiver. Speaking of receivers, have you seen the new RME-45?

The first thing you notice about the RME-45 is its smart appearance. Black panels against the crackle gray of the cabinet, the red traveling pointer mounted over the translucent rear-illuminated main scale, and 6 bands covering a range from 550 kc. to 33,000 kc., make the "45" the sharpest receiver in your section of town.

And the good looks of the RME-45 is indicative of its general all around engineering excellence. You demanded *real* selectivity — which in a superheterodyne is determined primarily by the sharpness of its i.f. amplifier stages. As the frequency band which the i.f. amplifier will pass is narrowed, the selectivity of the receiver increases.

This is illustrated by the curve which shows the selectivity of the RME-45 receiver at 1000 kc. With the crystal filter out of the circuit, (Curve A), a signal with a frequency 2 kc. higher, or 2 kc. lower, than 1000 kc. is passed with full strength by the i.f. amplifier. With the crystal filter in the sharpest position, (Curve C), the same signal is down 60 db (strength of 1/1000).

Tuning the receiver simply amplifies and then converts the received signals of the different frequencies into the i.f. frequency of the receiver. Band spread, often confused with selectivity, is a slowing down of the rate at which this tuning is done.

To obtain the correct amount of band spread — neither too much nor too little — RME properly coordinated three factors:

1. Rate of turn of the tuning knob.
 2. Distance of dial (or pointer) travel.
 3. Rate of rotation of the tuning condenser gang.
- And the band spread dial is directly calibrated in frequency.

Now, having found the solution of the band spread problem, let's look at the choice of attaining this coordination of factors by electrical or mechanical means. There are two great features of mechanical band spread which electrical cannot offer. They are: (1.) Use of only one set of tuning condensers, thus avoiding the circuit losses which are inevitable when adding another set of condensers in parallel. (2.) Single dial control with its accurate calibration and logging.

The designers of the RME-45 added a further improvement — two speed tuning. The small concentric knob turns five times while the larger one turns once. A band is covered at the correct rate of speed by using the large knob and the desired station is easily tuned on the nose by using the small one. CW operators will like the effortless way in which the small knob gives the peak of a signal with the crystal filter in.

CAL-O-MATIC tuning, that's what RME has termed their new system. It is a mechanism wherein automatic tuning and calibration of the scale go hand in hand. And that also means better calibration of the entire frequency range of the receiver without any further adjustment to be made, once the receiver comes out of the test room. All calibration points, main and bandspread, are determined automatically as tuning proceeds. No dials to preset, no padders to be preadjusted, no recheck points to observe. The stations are logged, and there you have it.

Why not drop us a line for all the dope on the RME-45? And while you're at it, tell us how you like this HAM GEAR column and what you'd like us to write about next issue.

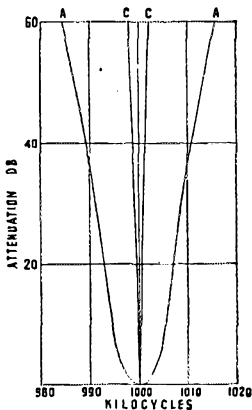

New York

Chicago

Newark *ELECTRIC* Company

115-117 W. 45th St.
NEW YORK 19
Bryant 9-4735
(ADOLPH GROSS)

212 Fulton St.
NEW YORK 7
Bryant 9-4735
(HY KAHN)

323 W. Madison St.
CHICAGO 6
DEArborn 0083
(SAM PONCHER)

Address N. Y. C. Mail to 45th St.

You can GET it at

NEWARK!

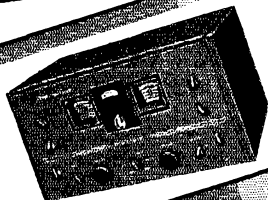
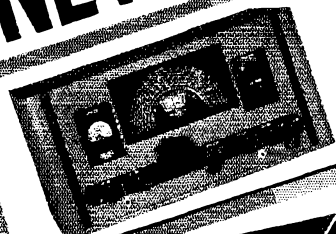

EASY
TERMS
LIBERAL
TRADE-IN
ALLOWANCES

NOW

panadaptor

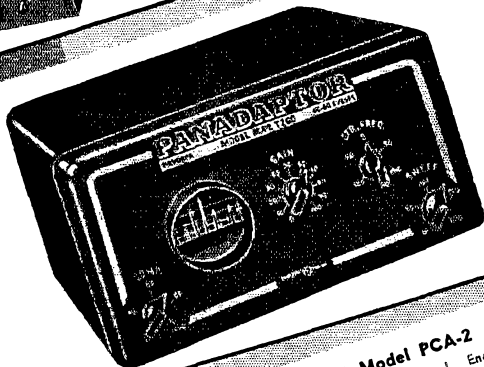

Newark **ELECTRIC** Company

115-117 W. 45th St.
NEW YORK 19
BRyant 9-4735
(ADOLPHI GROSS)

212 Fulton St.
NEW YORK 7
BRyant 9-4735
(HY KAHN)

323 W. Madison St.
CHICAGO 6
DEArborn 0083
(SAM PONCHER)

"Service is the Foundation of our Business"

RME-45
Top selectivity and sensitivity
550 Kc to 33,000 Kc. 5 amateur
bands. Xtal filter. Single dial
with two speed tuning. DB signal
level meter.
PROMPT DELIVERY
Your Cost **\$166.00**

**HALLICRAFTERS S-40
SKY CHAMPION**
New design, increased utility, in
this new communications receiver.
540 Kc to 42 Mc continuous in
4 bands. Self-contained PM
speaker.
DELIVERING NOW!
Your Cost **\$79.50**

HAMMARLUND HQ-129-X
Another fine Hammarlund receiver. Full range 540 Kc
to 31 Mc. Adjustable S-Meter. Variable Selectivity
Crystal Filter. Many exclusive patented features.
IMMEDIATE DELIVERY!
Your Cost **\$129.00**
10" PM Speaker in Cabinet **\$10.50**

PANADAPTOR Model PCA-2
Here's a new and wonderful device! Enables
SIMULTANEOUS reception of many radio
signals, continuously selectable from a broad band
of frequencies down to a single frequency. Now, for
the first time, with the PANADAPTOR connected
to your receiver, you can see up to 700 Kc of the
band at once. It's a MUST for MODERN radio
checks! Complete with tubes and accessories, for
115 V 60 cycles.
IMMEDIATE DELIVERY!
Your Cost **\$99.75**

**WE ALSO
STOCK**

HALLICRAFTERS
SX-28A \$223.00
S-22-R 74.50
SX-25 94.50
SX-36A 307.50
S-37 591.75
PM23 spkr. 15.00

HAMMARLUND
Super-pro

NATIONAL
NC-46

HRO 225.00
N-2-40C 15.00
Speaker 15.00
*to be announced

NEWARK!



SIGNAL CORPS HEADSETS

Quality headset at a BARGAIN price! 8,000 ohms impedance. Rubber cushions. Adjustable headband. Built to Sig. Corps specs. 2,000 ohms DC.

Your Cost, **\$1.95**
WHILE THEY LAST!

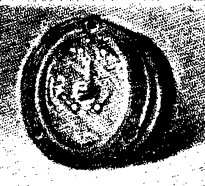

WESTERN ELECTRIC 4" MICRO-AMMETER

Another HOT VALUE! Galvanometer type meter, with zero center, 150-0-150 micro-amps. Can be easily reset to use as 5000 ohm per volt basic test meter. Panel opening 3 3/4".

Your Cost, **\$4.95**
WHILE THEY LAST!
Blant Dial Scale for above 15c ea.

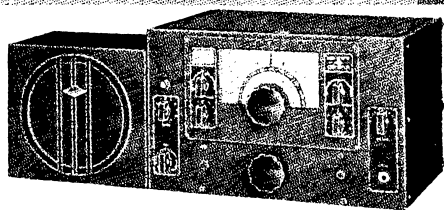

Hams! Here's a SMASH VALUE for YOU!

NATIONAL NC-100-ASD

Built to Sig. Corps Standards. 10-tube super. 200 to 400 Kc and 2300 to 30,000 Kc in 5 bands. Phone, CW, MCW. Includes separately cased PM Speaker. 115 V. 60 cy.

Your Cost, **\$115.00**
Spare Parts Kit..... \$4.95

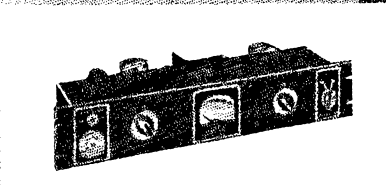

New! MILLEN 90800 TRANSMITTER-EXCITER "50 WATT"

This flexible unit is ideal for low power transmitter, or as exciter for higher power PA stages. Supplied with coils for 10 meter output with 40 meter crystal, unless otherwise requested. Uses 807 and 6L6 tubes.

Your Cost, Complete with coils for one band, **\$37.50** less tubes.
Milen 90700 frequency shifter now in stock!

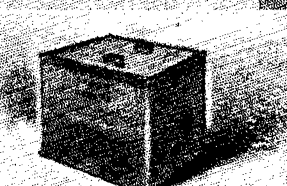

FILTER CONDENSERS

CAP. MFD.	WORKING VOLTS D.C.	H	W	D	YOUR COST
1	1500	2-3/16	1 3/4	1"	\$.79
4	1000	3 1/2	2 1/2	1 1/2	1.50
4	3000	3 3/4	3 1/4	3-5/16	3.75
8	2000	4 1/2	3 3/4	2 1/2	2.75
.15	4000	2 7/8	1 3/4	1	.59
.25	2000	3 3/4	1 3/4	1	.69
1.5	1000	2 7/8	1 3/4	1	.59
10	3000	4 7/8	3 3/4	3 1/4	4.75
13	1000	3 3/4	3 1/2	1 3/4	2.25
15	3000	4 3/4	4 1/8	3 3/8	5.25
8	3000	3 7/8	5 1/8	3 3/8	3.95
2-4	600	4 7/8	2 1/2	1 1/2	.80
5-5-15	1000	4 5/8	3 1/2	1 3/4	1.75

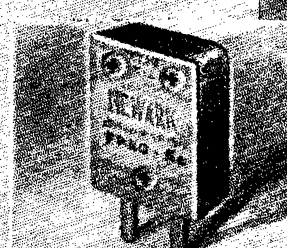

SENSATIONAL BUY!

40 and 80 METER CRYSTALS

Precision cut, low drift, accurately calibrated to within plus or minus 500 cycles of specified freq. Type X-1 for 80 Meter Band. Type X-2 for 40 Meter Band. Holder fits octal socket. Specify frequency range desired. We'll fill from nearest stock value.

Your Cost, **88c**
Each
Three for \$2.40

NEW YORK
NEWARK ELECTRIC Company
CHICAGO
115-117 W. 45th St.
NEW YORK 19
BRYant 9-4735
(ADOLPH GROSS)
212 Fulton St.
NEW YORK 7
BRYant 9-4735
(HY KAHN)
323 W. Madison St.
CHICAGO 6
DEARborn 0083
(SAM PONCHER)

"Service is the Foundation of our Business"

Quality PRODUCTS
Since 1923



**CERAMIC—
PORCELAIN & STEATITE
INSULATORS**

for every
purpose

BIRNBACH RADIO CO., Inc.

145 HUDSON ST. NEW YORK, 13, N. Y.

Operating the 807

(Continued from page 54)

Beam tetrodes of the 807 size and smaller make good frequency multipliers, but tube life is quite apt to be short unless suitable precautions are taken. For efficient operation both bias and excitation should be increased. However, there seems to be little point in going beyond twice the normal values for either doubling or tripling at least. The point to be watched is that of keeping plate and screen dissipation within the ratings. This may mean a considerable reduction in power input and a corresponding reduction in output from the values used when the tube is operating as a straight amplifier, since the efficiency of a doubler or tripler seldom exceeds 40 per cent or so. With the higher grid current, added precaution is necessary, of course, when it comes to detuning of the plate circuit to avoid damage to the tube.

For 'phone work the tetrode may be not so well suited as an output amplifier, since the screen as well as the plate must be modulated. Unless a special modulation transformer with a dual secondary is available, this means that a fair amount of audio power must be thrown away in the screen circuit. However, since audio power usually comes cheaper than power at r.f., this may not be considered too much of a disadvantage, although it must be taken into consideration.

Above 50 Mc.

(Continued from page 58)

been worked. Planes in the vicinity of Knoxville, Tenn., have been contacted at 1000 feet, a distance of 140 miles, even though elevations over 6000 feet intervene between the two points.

From Marianna, Florida, WINWE was able to contact aircraft near Langley Field, Virginia, on 126 Mc., a distance of about 600 miles. Grid, formerly W4GJO, now plans to return to Florida, and hopes to pull off something like this on 144 Mc. one of these days.

The prize in this department goes to J. H. Faulkner of Los Angeles who heard plenty of stuff when he was serving aboard a Navy tanker in the Pacific. While 200 miles from Samoa in September, 1944, he picked up a ship which was then in the North Atlantic, just south of Iceland. The frequency was 80 Mc.!

Of late we've been gratified to note the general trend toward improved gear on 144 Mc. More and more the 2-meter band is coming of age. Crystal control or its equivalent, once considered all but impossible for such a high frequency, is being used by an ever-increasing number of stations. And it pays off — at least 80 percent of the stations heard at W1HDQ from distances beyond 75 miles are using crystal or m.o.p.a. rigs, and superhet receivers are becoming increasingly popular. Even simple m.o.p.a. combinations us-

(Continued on page 180)

HOW TO PASS Commercial Radio Operators'

FCC LICENSE EXAMINATIONS...

How To Pass
FCC
LICENSE
EXAMINATIONS

CLEVELAND INSTITUTE
OF RADIO ELECTRONICS
Terminal Tower - Cleveland, Ohio

FREE BOOKLET

Tells you the Government Requirements for all classes of commercial licenses. Saves you many hours of random, undirected study. Assures a minimum of time in getting your ticket!

Don't Delay—
Write Today!

CLEVELAND INSTITUTE OF RADIO ELECTRONICS

Successors to Nilson Radio School, founded 1939;
Smith Practical Radio Institute, founded 1934

QT-5 TERMINAL TOWER CLEVELAND 13, OHIO

MAIL THIS COUPON

Cleveland Institute of Radio Electronics
QT-5 Terminal Tower, Cleveland 13, Ohio

Gentlemen: Please send your FREE Booklet,
"How to Pass FCC License Examinations."

Name.....

Address.....

City.....State.....

REGULATION

§12.136. LOGS. Each licensee of an amateur station shall keep an accurate log of station operation, including the following:

(a) The date and time of each transmission. (The date need only be entered once for each day's operation. The expression "time of each transmission" means the time of making a call and need not be repeated during the sequence of communication which immediately follows; however, an entry shall be made in the log when signing off so as to show the period during which communication was carried on.)

(b) The signature of each licensed operator who manipulates the key of a radiotelegraph transmitter or the signature of each licensed operator who operates a transmitter of any other type and the name of any person not holding an amateur operator license who transmits by voice over a radio-telephone transmitter. The signature of the operator need only be entered once in the log, in those cases when all transmissions are made by or under the supervision of the signatory operator, provided a statement to that effect also is entered. The signature of any other operator who operated the station shall be entered in the proper space for that operator's transmission.

(c) Call of the station called. (This entry need not be repeated for calls made to the

same station during any sequence of communication, provided the time of signing off is given.)

(d) The input power to the oscillator, or to the final amplifier stage where an oscillator-amplifier transmitter is employed. (This need be entered only once, provided the input power is not changed.)

(e) The frequency band used. (This information need be entered only once in the log for all transmission until there is a change in frequency to another amateur band.)

(f) The type of emission used. (This need be entered only once until there is a change in the type of emission.)

(g) The location of the station (or the approximate geographical location of a mobile station) at the time of each transmission. (This need be entered only once provided the location of the station is not changed. However, suitable entry shall be made in the log upon changing the location. Where operating at other than a fixed location, the type and identity of the vehicle or other mobile unit in which the station is operated shall be shown.)

(h) The message traffic handled. (If record communications are handled in regular message form, a copy of each message sent and received shall be entered in the log or retained on file at the station for at least 1 year.)

The

Convenient v v v Complete

ARRL LOG BOOKS

Regular Log, 8½ x 11, 35 cents each • Three for \$1.00

Mini-Log, 4 x 6¼ • 25 cents each

American RADIO RELAY LEAGUE

WEST HARTFORD, CONNECTICUT, U.S.A.

"When I put in a Ward Leonard Resistor... it stays put!"

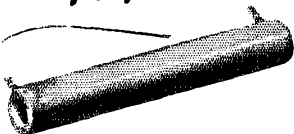

The proven dependability of all Ward Leonard Resistors is of utmost importance to the amateur. Now that they are available from stock, there is no reason to put up with substitutes. Send for Bulletin today.

WARD LEONARD

RESISTORS • RELAYS • RHEOSTATS

Electric Control Devices Since 1892

WARD LEONARD ELECTRIC COMPANY

Radio and Electronic Distributor Division

53B WEST JACKSON BLVD. CHICAGO, ILLINOIS

OMs here are your Kits!

DESIGNED FROM YOUR SUGGESTIONS
IN CRYSTALAB'S HAM CONTEST

 CRYSTAL KIT No. 1	 CRYSTAL KIT No. 2
<ul style="list-style-type: none"> * 15 blanks to precision tolerances * 5 between 7005 and 7050 KC * 3 between 7050 and 7250 KC * 3 between 7250 and 7240 KC 10 Holders — CRL-16 10 Complete sets of springs, electrodes, covers, gaskets and screws 10 additional electrodes for slight freq. change 10 pieces of lintless cloth 1 box of fine abrasive for finishing 1 box of medium abrasive for rough lapping 1 piece of plate glass for lapping Blueprints of selector switch Photographs of selector switch INSTRUCTION BOOKLET All components suitably boxed. 	<ul style="list-style-type: none"> * 7 blanks to precision tolerances * 2 between 7005 and 7050 KC * 3 between 7050 and 7250 KC * 3 between 7250 and 7240 KC 5 Holders — CRL-16 5 complete sets of springs, electrodes, covers, gaskets and screws 10 pieces of lintless cloth 1 box of fine abrasive for finishing 1 box of medium abrasive for rough lapping 1 piece of plate glass for lapping Blueprints of selector switch Photographs of selector switch INSTRUCTION BOOKLET All components suitably boxed.
<p>★ BLANKS FOR OTHER BANDS AVAILABLE</p>	

Specialists in Special Crystals

SEE YOUR LOCAL RADIO DEALER

CRYSTAL RESEARCH
LABORATORIES INC.

75 ALLEN ST. HARTFORD 3, CONN. PHONE 7 3215

(Continued from page 128)

ing a tube like an HY-75 driving an 829 sound vastly better than the modulated-oscillator type of rig, even when superregenerative receivers are used. Narrowing down the band occupied by each transmitter must be accomplished, if 144-Mc. work in the heavily-populated areas is to become anything more than a mass of QRM. It's not hard to get stability of 144, and it's definitely worth-while.

As to superheterodyne reception, we find the a.m./f.m. technique gaining ground. W1DTW, West Greenwich, R. I., uses a 6AK5 r.f., 955 mixer, two 1852 i.f. stages, and 6SJ7 limiter, 6H6 a.m./f.m. detector, and two stages of audio. He was among the first to report hearing W1HDQ after the 16-element array was installed. W1HDF and some others in the Hartford area are using converted BC-406 receivers with excellent results. This is a radar receiver with a wideband i.f., and a 2-channel r.f. section which can be converted to 144 Mc. without too much trouble. It is broad enough to receive all but the worst oscillator rigs, and the quality on reasonably-stable signals is superb.

W1IND, North Haven, Conn., has a superhet using a radar i.f. strip at 30 Mc., and is hearing signals which cannot be touched by many of the superregens in that area.

W9FST, Peoria, Ill., has a converter using a 6AK5 r.f., 9001 mixer, and 9002 oscillator. His rig is crystal controlled on 144.06 and 145.1, with an 832 in the final, running 25 watts input. Only locals have been worked thus far, but he is looking for contacts beyond the horizon and would like some test schedules.

There is quite a flurry of interest in 425 Mc., too. W1LAS brought two portable 425-Mc. stations to Hq. recently and demonstrated them for us most convincingly. As one of them will work from a portable power supply, Bill hopes to work some DX with the pair of rigs this summer. 1BBM, North Harwich, Mass., is on with a little 6C4 rig, and is working W1ARC at a distance of 3½ miles, though there are heavy pine woods between the two. The signal is comparable to that obtained on 2 meters over the same path. W1KB writes that W1KBQ, Haverhill, Mass., has a lighthouse rig, and that W2CLK/1 at Danvers will go to 425 when he has some company.

In Washington, D. C., several stations are on 425, according to W3CUD/3 who has been working cross-band, 144-425, with W1HJI/3. They are about five miles apart. W9NIM/3 has both transmitter and receiver going, and more stations are expected soon.

In years gone by we've always wanted a marker station that would be on at specified times, in order to tell when the 5-meter band was open. Now we have it on Six. W1AW is running the nightly broadcast schedule, both c.w. and voice, on 52 Mc. each evening Monday through Friday. Watch that spot, boys, and let us know what you hear!

(Continued on page 128)



RME Owners Say!

Mr. and Mrs. Fay O. Wood
PHONE L-508
1110 LAUREL ST. ELKHART, IND.

18 Feb. 1946.

Radio Mfg. Engineers Inc.
Mr. L.A. Morrow,
Sales Manager,
Peoria 6, Ill.

Dear Mr. Morrow:

How many cylinders should a motor car have ?

How many tubes does a receiver need ?

How long should a man's legs be ?

Abe Lincoln never had a 16-cyl. car nor a 16-tube radio, yet he seems to have answered all three questions when he did say that " a man's legs should reach from his hips to the ground ".

Multi-tube receivers are impressive to look at, but mine didn't give me the performance, clear reception, and the ample band spread that I expected.

All who had the foresight to pay a few more dollars for RME-69's at that time were very smart I would say.

Never again will I be fooled by the number of the tubes in a set.

In other words - RME- 45 for me.

Yours very truly,

Fay O. Wood.

Fay O. Wood.



FINE COMMUNICATIONS EQUIPMENT

RADIO MFG. ENGINEERS, INC.

Peoria 6, Illinois U. S. A.



Extras
at No Extra Cost!

ELECTROX RECTIFIERS

Get the extra dependability and longer life, inherent in ElectroX Rectifiers—full and half wave low capacity copper oxide rectifiers, for test sets, instruments, and other electronic applications which must stand up under exacting service.

Made by one of the oldest manufacturers of dry disc rectifiers — time proven — trouble-free — they cost no more!

At your parts supplier,
or write for descriptive
Circular 446

ELECTROX DIVISION **SCHAUER MACHINE CO.**
2049 Reading Rd. Cincinnati 2, Ohio

CLEAN ACCURATE HOLES

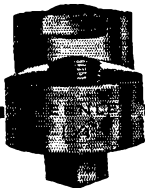

cut in radio chassis

Greenlee Punches make this tough job easy. No reaming, filing or tedious drilling. Tool has three parts: *punch* cuts through chassis, *die* supports metal to prevent distortion, *cap screw* is turned with wrench to cut holes. Sizes for holes 3/4" to 3 1/2". Ask your radio supply or electrical jobber or write for folder and prices. Greenlee Tool Co., 1865 Columbia Ave., Rockford, Illinois.

WRITE FOR FREE FOLDER



(Continued from page 150)

You asked for it, and here it is! The V.H.F. Marathon, popular long-term contest in 1940 and 1941, is back. Because of unsettled conditions as to bands which might be available, it could not be started sooner, but it gets under way on May 1st, with the best part of the year yet to come up. Write for those reporting forms without delay, and get started with the opening gun. You will have the satisfaction of knowing how your work stacks up with that of others, and, more important, you will be helping to provide a permanent record of amateur achievement in the v.h.f. field.

W6MBA/Tinian

(Continued from page 69)

wave shorted matching stub, fed with a 600-ohm line that is almost flat.

"The rig is located in the communications Quonset hut of the 504th Bomb Group. I am a B-29 navigator who has been doubling as a communications officer since the end of the war.

"I guess that I am overly proud of the station, and what we have done with it — 1035 contacts in one month (February), 45 states and a BW contest score of 42,075 points."

Well done, W6MBA/Tinian! And many thanks!

How's DX?

(Continued from page 65)

there is a picture of the station. From W9YXO we learn that this is also the station used by W6PUZ, W6TSL, W8RXL, W2MUC, W5DBT, W5ILN and W9CPJ. Thus the picture you see is not of one station but of eight. Only QST brings you this special service — eight pictures for the price of one! Carlton Marsh, W4YA/XZ, sends a very nice letter expressing his appreciation to the hundreds of stations who made it possible for so many GIs in Burma to get messages back to their folks or to talk directly with them. Marsh, who is also ex-9ASA, will be glad to QSL all contacts, from his home address at 711 Forrest Ave. W., East Point, Ga. W1DLC keeps piling on the countries. This month he gets up to 51, with HZ1FZ, LI2JU in Libya, and YX2XG in Iraq. If those guys are fakeroos, they deserve to be burned in oil, because names of countries like those should be spoken reverently and never bandied about! Incidentally, Dick made WAC in 8 hours and 15 minutes on Feb. 17, working ZS6EQ, F8AZC, ZC4C, PY2AC, W6TZB/K6 and W1BPX That shades W6GTI a little. John's WAC took 10 hours, on March 9, and was with G6ZO/I, ZS6FN, PJ3X, W1UE, VK3HT and XU1YY Early in March W1AS had "over 40 countries," and later in the month W1CH had 48. W3FQP is up to 38 Some DX at W4FON, without benefit of frequency: VO2KJ, VK2RA, OA4AB, FM8AC, HK1AB and W6KAT. Ditto at W6OKK: F3XN,

(Concluded on page 134)

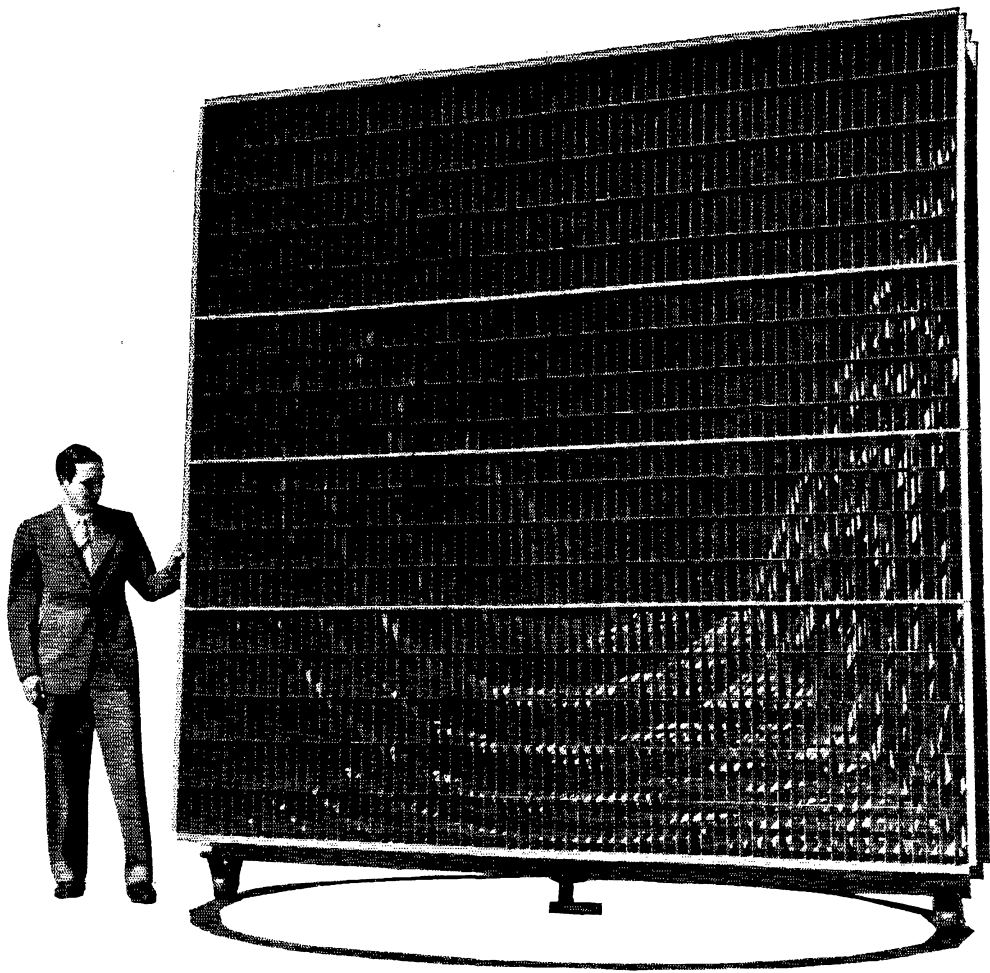

● **A "SEARCHLIGHT" TO
FOCUS RADIO WAVES**

In the new microwave radio relay system between New York and Boston, which Bell Laboratories are developing for the Bell System, giant lenses will shape and aim the wave energy as a searchlight aims a light beam.

This unique lens—an array of metal plates—receives divergent waves through a waveguide in the rear. As they pass between the metal plates their direction of motion is bent inward so that the energy travels out as a nearly paral-

lel beam. At the next relay point a similar combination of lens and waveguide, working in reverse, funnels the energy back into a repeater for amplification and retransmission.

A product of fundamental research on waveguides, metallic lenses were first developed by the Laboratories during the war to produce precise radio beams.

But how to focus waves is only one of many problems that Bell Telephone Laboratories are working on to speed microwave transmission. The goal of this and all Bell Laboratories research is the same — to keep on making American telephone service better and better.



BELL TELEPHONE LABORATORIES

Exploring and inventing, devising and perfecting for continued improvements and economies in telephone service

Now!
A Better Soldering Tool...

THE VANAITA KWIKHEAT
THERMOSTATIC SOLDERING IRON

Has Built-in Thermostat Control!



6 TIP STYLES

- #0—\$1.25
- #1—\$1.25
- #2—\$1.25
- #3—\$1.25
- #4—\$1.25
- #5—Selling Pat for fixing—\$1.25

HOT, READY FOR USE ONLY 90 SECONDS after plugging in! Kwikheat is the only soldering iron with a thermostat built into the tool itself*—maintaining the proper level of heat for most efficient, economical operation. SAFE! ... Cannot overheat—ECONOMICAL! ... Lasts longer—saves tips and requires less retinning. **POWERFUL**—225 watts—yet exceptionally light weight (14 oz.). Well-balanced with cool protecting plastic handle. Modern streamlined design. Six interchangeable tip styles adapt one Kwikheat iron to all your soldering jobs. You will be proud to own America's finest and most versatile soldering tool... from tip to plug Kwikheat is in a class by itself. Ask your dealer to demonstrate the quick-heating feature now!

*patented
Kwikheat Iron complete with #1 tip... \$11.00
Set of 5 tips consists of #0, 2, 3, 4 and 5 \$ 5.50



Dept. Q-5, Kwikheat Division of
SOUND EQUIPMENT CORP., 3903 San Fernando Rd., Glendale, 4 Calif.

Adson
RADIO CO.
Dept. Q—221 FULTON ST. N. Y. 7, N. Y.
EVERYTHING FOR AMATEURS AND SERVICEMEN
COMPLETE LINE OF ELECTRONIC EQUIPMENT



Founded in 1909

RADIO TELEPHONY
RADIO TELEGRAPHY

Courses ranging in length from 7 to 12 months. Dormitory accommodations on campus. Advanced students eligible for practical training at K-PAC, 1 KW broadcast station owned and operated by Port Arthur College. New students accepted monthly. If interested in radio training necessary to pass F.C.C. examinations for first-class telephone and second-class telegraph licenses, write for details.

PORT ARTHUR COLLEGE PORT ARTHUR TEXAS

(Continued from page 138)

G5PP, G5XA and TG9JF. Among those heard: GI2TX, LX1SI, GW6JW, FA8GT No doubt you heard LU7AZ knocking 'em off in the BW Party. He wasn't fooling, to the tune of 595 stations in 64 sections! It's a good thing for some of the perennial winners that Milo isn't eligible for the SS! G6BW writes that his call, mentioned in the January issue, must have been pirated, since the real 6BW has not been back on yet W9CSB/6 is ready to believe all those things the Calif. C of C has been saying. On March 18, in a dead band at 1800 GCR, a CQ brought a reply from OQ5AE! No fake, the OQ said Bud was the only signal coming through at the time. It must be that good old California air! And as W7RT puts its, these days you never know who's calling you until after the " / " sign!

Predictions:

Best bets for the month of May seem to be South Americans and excellent VK contacts for the West Coast, otherwise the band will probably be a little sour judged by the past few months. The European and Asian contacts should be spotty if any, and the Africans will be in but not for long. And don't forget, you can help the IRPL to make these predictions more accurate by keeping a sked or two and gathering some information.

Where no maximum usable frequency is shown it means the 28-Mc. band should be open during the period — a single time indicates when the corresponding m.u.f. is reached.

Path	Max. Usable Freq. (Mc.)	Time (GCT)
Washington — S. F.	26.5	0130
Washington — Rio		1500-0000
Washington — Paris	22.5	1930
Washington — Manila	20.2	2330
Washington — Sydney		0000-0130
Washington — Johannesburg		1730-1800
S. F. — Rio		2000-2300
S. F. — Paris	20.5	2130
S. F. — Manila		0130-0330
S. F. — Sydney		2000-0500
S. F. — San Juan, P. R.		2330-0100
S. F. — Johannesburg	23.5	1830
N. Y. — San Juan, P. R.		1830-0000

— W1JPE

Cliff-Dweller's Antenna

(Continued from page 64)

antenna was done from the free end, and the frequency of the oscillator was determined at every change in antenna length by connecting the live feeder to the antenna post of the receiver and temporarily clipping the feeder on the flat top, to feed the oscillator signal to the receiver so the frequency could be measured directly. It should be pointed out that the feeders must be disconnected from the antenna when tuning for the dip in grid current.

An 80-meter antenna cut for the high-frequency end of the 20-meter band is slightly long

(Concluded on page 136)



MR. RADIOMAN:

**Here's How Capitol Radio Can Prepare You
Now for a Better Job and a Secure Career in
Radio-Electronics . . . !**

**Add CREI Technical Training
To Your Present Experience
—Then Get That Better Radio
Job You Want—More Money!**



CREI home study training in Practical Radio-Electronics Engineering equips you with the ability to go after — *and get* — a better job in radio-engineering that offers security, advancement and importance.

In our proved course of home study training, you learn not only *how* . . . but *why!* Your ability to solve tough problems on paper, and then follow with the necessary mechanical operation, is a true indication that you have the *confidence* born of *knowledge* . . . confidence in your ability to get and to hold the type of radio job you want.

CREI courses have been studied by more than 10,000 professional radiomen — so don't say YOU haven't the time. CREI courses are designed to be studied in the most crowded schedules — without interfering with your present work, yet helping you as you progress lesson by lesson.

Now you can read what these typical CREI students have to say. They are men who had the initiative to get started on their own better-

ment program toward better jobs and more money. You have the same opportunity. It costs you nothing but a moment's time to send for complete details in free book.

"I give CREI full credit for my securing the position as Asst. Chief Engineer. . . ."

— W. H. Meiners, 420507

"In the past 7 months I have received 3 increases in salary and a promotion that can be partly credited to CREI. . . ."

— C. B. McKnight, 401101

"There are many times where what I am studying in the course works right in with the immediate problems of my job. . . ."

— C. I. Carpenter, 411024

WRITE FOR FREE 36-PAGE BOOKLET

If you have had professional or amateur radio experience and want to make more money—let us prove to you we have something you need to qualify for a better radio job. To help us intelligently answer your inquiry—please state briefly your background of experience, education and present position.



CREI Training for Veterans is Approved Under the "G.I." Bill

CAPITOL RADIO ENGINEERING INSTITUTE

E. H. RIETZKE, President

Dept. Q-5, 3224 — 16th Street, N. W.,—Washington 10, D. C.

Branch Offices:

New York City (7), N. Y.
170 Broadway

Chicago (2), Ill.
30 N. LaSalle St.

San Francisco (2), Calif.
760 Market St.

San Diego (1), Calif.
316 G Street

MEMBER: NATIONAL HOME STUDY COUNCIL • NATIONAL COUNCIL OF TECHNICAL SCHOOLS

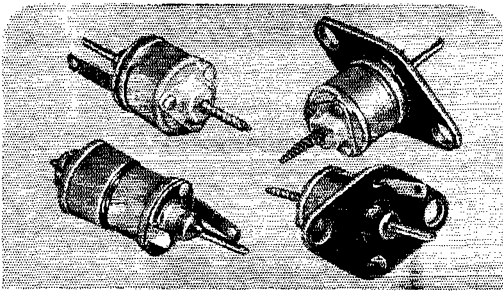

New ULTRA COMPACT HIGH-Q AIR CAPACITOR

Of unusually high-Q, extraordinary mechanical and electrical stability, easy of adjustment, small in size and useful to beyond 300 megacycles for trimming or tuning, a new air-dielectric capacitor is now available.

Produced at the famous Philips works in Holland, it is brought to American amateurs and experimenters through SILVER jobbers.

Less than one-half inch in diameter, less than 1 7/16" in length, SILVER Model 619 capacitor provides 3 to 30 mmfd. with air and high quality ceramic insulation. Rotor and stator are one piece, low inductance, multiple aluminum cups. Rotor meshing with stator gives a linear capacitance range of 27 mmfd. over three full rotations. Adjustment is permanent by virtue of retention springs; vibration does not affect capacitance since a long rotor bearing sleeve closely hugs a matching central ceramic insulator.

Model 619 capacitors have two solder terminals, are so light they may be mounted directly by connecting leads, though each is supplied with a low-loss phenolic mounting plate.

Price 30c. each, net at your favorite jobber.

OVER 35 YEARS OF RADIO ENGINEERING ACHIEVEMENT

McMurdo Silver Company

1240 MAIN ST., HARTFORD 3, CONNECTICUT

YES! IMMEDIATE DELIVERY

ON THESE HIGH QUALITY ITEMS!

PLATE TRANSFORMERS

From one of the greatest makers! Rated at 2 KVA. Primary 105/110/115, 60 Cycle. Secondary 6200 V ct. 11" x 14" x 10" high. **\$39.95**

Freight Prepaid Anywhere In Continental U. S. A.

MEISSNER 5 and 10 Meter Converter

The famed high-frequency converter, designed to give full coverage of the 5-meter (56 to 60 MC) and 10-meter (28 to 30MC) bands. Operates on 110-volt, 60 cycle supply. **\$51.50**

F.O.B. St. Louis

TWIN LEAD TRANSMISSION LINE

The perfect lead-in wire, extruded with Amphenol Polyethylene Dielectric. Tough, inexpensive—repels water, resists acids, alkalis, oils—doesn't become brittle in sun.

75 Ohm Line.....2c per foot
150 Ohm Line.....3c per foot
300 Ohm Line.....3 1/2c per foot

From 1 foot to 1000!

WHAT WE ADVERTISE — WE DELIVER!

Send for Our Bargain Flyer — Out Every Month

WALTER ASHE RADIO CO.
1125 PINE STREET ST. LOUIS 1, MO

(Continued from page 134)

for proper operation on 80, but we were able to work out quite well on the low end of the 80-meter band. Maybe our QRO to 75 watts had something to do with it! Foreign contacts were forbidden by the time this antenna was erected, but we did work K7 and K6 on 20 c.w.

Although an antenna strung high and in the clear still can't be beat, the ham who has a location that would make strong men weep need not throw in the sponge. If you must contend with an antenna that has several bends in it or is strung near metal objects, by all means check its resonant frequency. The formulas for the length of an antenna strung in free space are not accurate under these conditions, and their use will result in mediocre performance in most cases.

NOTE: Since there may be some radiation from the test oscillator, it should not be used on any band in which operation is not authorized.

New Apparatus

V.H.F. Ground-Plane Antenna

EXCEPT in the case where a very short feed line is used, one of the greatest sources of reduced efficiency in the v.h.f. region is feed-line losses. To match a line properly into an antenna requires some equipment and considerable "know how," and it is often neglected by the enthusiastic amateur who is anxious to get back on the air. Several low-loss coaxial cables were developed during the war which are admirably suited for work in the v.h.f. range, but unless they are correctly terminated they have little advantage over an open line.

The "ground-plane" antenna is a useful non-directional antenna for general work, but it is usually a one-band affair. A new two-band ground-plane antenna kit, for the 144- and 220-Mc. amateur bands, has just been announced, and several of its features make it interesting to serious v.h.f. operators. Through careful design and testing the antenna shows at 146 Mc. only 0.3 db. reflection loss with 50-ohm cable and 0.8 db. loss with 72-ohm cable. At 223 Mc. the loss is even less, amounting to 0.15 db. with 50-ohm line and 0.45 db. with 72-ohm cable. The slight loss is substantially constant over the amateur bands, resulting in no one sharp "peak" efficiency.

The kit can be assembled easily in about five minutes. Normally the antenna would be for the 220-Mc. band, but extensions are included which need only to be screwed into the ends of the radiator and the six ground radials for operation on the lower frequency. For the amateur interested in a non-directional antenna for 144 and 220 Mc. which requires no tailoring of elements, this antenna kit seems to be a very practical solution. It comes complete with a type "N" UG-21/u silver-plated weatherproof connector that can be used with RG-8/u, RG-9/u or RG-10/u 50-ohm cable or with RG-11/u 72-ohm cable. The kit is manufactured by Workshop Associates, 66 Needham Street, Newton Highlands 61, Mass.

at your service

THE EXTENSIVE FACILITIES
AND EXPERT PERSONNEL
OF NEW YORK'S MOST PROGRESSIVE

RADIO SUPPLY HOUSE TERMINAL HAS IT!

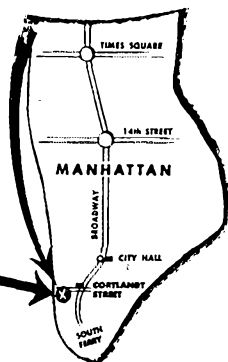

SHOP WITH CONFIDENCE

Terminal has kept its lead in New York by maintaining a complete stock of quality radio parts and equipment. Fair prices and friendly service assure you of the **BEST VALUES** at **TERMINAL!**

• • •

Visit our "SPECIALS" Department
Countless values of selected quality parts and equipment at unbelievably low prices!

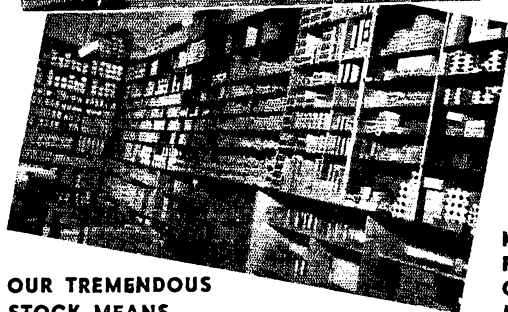

**OUR TREMENDOUS
STOCK MEANS
FASTER SERVICE**

**MAIL &
PHONE
ORDERS
PROMPTLY
FILLED**



TERMINAL RADIO CORP.

**85 CORTLANDT STREET, NEW YORK 7, N. Y.
PHONE WORTH 2-4415**

DeLuxe
SPEED KEY

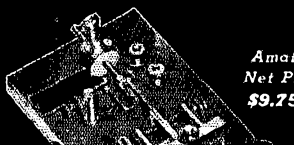

Model
CP 810

Amateur
Net Price
\$9.75

One of the finest commercial or amateur bugs available. Chrome finished base and superstructure. Springs made of selected blue spring steel for uniform performance in all keys. Nine points of adjustment to suit the most critical touch. Fully adjustable. Silver contacts 3/16" diameter.

MODEL CP 510 SPEED KEY • Similar to above except the base is Battleship gray wrinkle finish. Amateur Net Price \$6.75.

TELEGRAPH
Apparatus Co.

412 SOUTH GREEN ST. CHICAGO 7, ILLINOIS

RADIO COURSES

- RADIO OPERATING
- RADIO SERVICING
- REFRIGERATION SERVICING
- CODE
- ELECTRONICS

Personal Counselling Services for Veterans
Write for Latest Trade & Technical Catalog

Y.M.C.A. TRADE & TECHNICAL SCHOOLS
4 W. 64th Street New York City

RCA INSTITUTES, INC.

Offer thorough training courses in all technical phases of

RADIO AND TELEVISION

WEEKLY RATES DAYS—EVENINGS

VETERANS: RCA Institutes is approved under G. I. Bill of Rights
For Free Catalog write Dept. ST-45

RCA INSTITUTES, INC.
A Radio Corporation of America Service
75 Varick Street, New York 13, N. Y.

ELECTRICITY
FOR RADIO AND ELECTRONIC APPLICATIONS

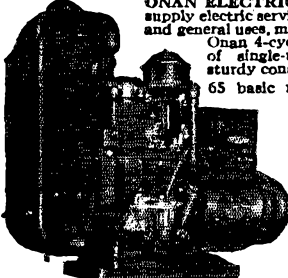

ONAN ELECTRIC GENERATING PLANTS supply electric service for electronics applications and general uses, mobile or stationary. Driven by Onan 4-cycle gasoline engines, they are of single-unit, compact design and sturdy construction.

65 basic models ranging in capacity from 350 to 35,000 watts. Standard A.C. models, 115-volt, 60-cycle, single-phase. Standard D.C. models, 32 to 115 volts. Special voltages to 660 A.C., and 0 to 4000 volts D.C. 5 KW to 35 KW units available in 3-phase. High frequencies to 800 cycles. Combination A.C.—D.C. types. Write for detailed literature or engineering assistance.

D. W. ONAN & SONS 2636 Royalston Ave. Minneapolis 8, Minn.

Foreign Notes
(Continued from page 69)

ernmental authorities, that the 5- and 10-meter bands will be opened soon. For convenience, at present the society is handling applications for transmission permits. Pre-war license holders will not be required to pass a new examination, but must obtain the permit. When frequencies are released, the power limit is expected to be 100 watts, quite an increase compared to former regulations. At the meeting, V.E.R.O.N. was represented by President Engers, PAØYM, and Mr. Baumbarten, PAØBB, of the editorial committee of "Electron."

NORWAY

"5 and 10" are open in LA-land, and over 100 amateurs have had their licenses renewed — after a very careful investigation of their personal lives during the war. There is, of course, great difficulty in obtaining parts; the Germans confiscated not only all equipment they could find, but the headquarters files and records as well.

SWEDEN

From SM7MG we learn Swedish hams are back as of mid-March, with unusually liberal privileges for a starter: 3500-3635 kc., and the pre-war bands at 20, 10, 5, 2½ and 1¼ meters. Maximum input is 50 watts. Present authorization is only for the year 1946.

QSL BUREAUS

With this issue we resume the practice of publishing, regularly in the May and October issues of QST, a list of QSL bureaus of the world. Cards for countries indicated may be sent to the addressees shown for local distribution:

- Alaska: J. W. McKinley, Box 1533, Juneau.
- Antigua: A. Tibbits, 27 St. Mary's St., St. Johns.
- Argentina: Radio Club Argentino, Av. Alvear 2750, Buenos Aires.
- Australia: W.I.A., Box 2611 W, G.P.O., Melbourne.
- Belgium: Baptiste, 158 Avenue Charles-Quint, Brussels.
- Brazil: L.A.B.R.E., Caixa Postal 2353, Rio de Janeiro.
- British Honduras: D. Hunter, Box 178, Belize.
- Colombia: L.C.R.A., P. O. Box 1268, Bogota.
- Cuba: James D. Bourne, Lealtad 660, Habana.
- Czechoslovakia: C.A.V., Vaeclavske Nam 3, Prague II.
- Denmark: E.D.R., Box 79, Copenhagen K.
- Eire: 17 Butterfield Crescent, Rathfarnham, Dublin.
- Finland: Tatu Kolehmainen, Kasarminkatu 25.C.12, Helsinki.
- France: R.E.F., 1 Rue des Tanneries, Paris 13°.
- Germany: (D4 calls only) Signal Division, Hq. USFET, APO 757, o/o Postmaster, New York, N. Y.
- Greece: C. Tavaniotis, 17-s Bucharest St., Athens.
- Great Britain: A. Milne, 29 Keechill Gardens, Hayes, Bromley, Kent.
- Italy: A.R.I., Viale Bianca Maria 24, Milan.
- Luxembourg: R.L., rue Neyperg 33, Luxembourg.
- Mexico: L.M.R.E., Av. Juarez 104-22, Mexico D.F.
- Netherlands: V.E.R.O.N., Postbox 400, Rotterdam.
- Newfoundland: N.A.R.A., Box 680, St. John's.
- New Zealand: N.Z.A.R.T., P. O. Box 489, Wellington C-1.
- Norway: N.R.R.L., P. O. Box 898, Oslo.
- South Africa: S.A.R.R.L., P. O. Box 7028, Johannesburg.
- Switzerland: U.S.K.A., Postbox, Berne.
- Uruguay: R.C.U., Casilla 37, Montevideo.
- Venezuela: R.C.V., Apartado 981, Caracas.

BUILT TO ORDER



Designers of mobile equipment and amateur vhf enthusiasts asked for this driver tube. The 2E30 (outgrowth of the Hytron development type HD59) is a filamentary-type beam tetrode. Standby current is eliminated. Yet the 2E30 is ready to operate a second after electrode potentials are simultaneously applied.

In vhf equipment, the 2E30 is ideal as a class C oscillator, frequency multiplier, or audio frequency amplifier. Important to you—the 2E30 is a transmitting tube—not just a re-hashed receiving type.

Check its versatility and its many features. Quite possibly you will discover that the 2E30 was built to order for you too.

HYTRON TYPE 2E30

Instant-Heating Miniature Beam Tetrode
GENERAL CHARACTERISTICS

Filament	Oxide coated
Potential, a-c or d-c 6.0 ± 10% volts	
Current 0.7 ampere	
Grid-plate capacitance 0.5 mmfd	
Input capacitance 10.0 mmfd	
Output capacitance 5.0 mmfd	
Max overall length 2 5/8 in.	
Max diameter 3/4 in.	
Base T-5 1/2 min button 7-pin	

ABSOLUTE MAXIMUM RATINGS

D-c plate potential 250 volts max
D-c screen-grid potential 250 volts max
D-c plate current 60 ma max
D-c screen-grid input power 2.5 watts max
Plate dissipation 10 watts max

OUTPUT—TYPICAL OPERATION

Output, class A ₁ power amplifier 4 watts
Output, class C oscillator 7.5 watts†
Output, class C doubler (80 to 160 mc) 3 watts†

†Useful power output delivered to load under normal circuit efficiency. Total plate power output (including power actually lost in circuit and by radiation) is at least two watts higher.

FEATURES THE 2E30 OFFERS YOU

- Designed, manufactured, and tested for transmitting
- Special testing controls assure interchangeability*
- Oscillator, frequency multiplier, or a-f amplifier
- Filament power is fully adequate for transmitting
- 1/10 watt driving power for 4 watts output at 80 mc
- 10 watts plate dissipation—surplus reserve for vhf
- Miniature bulb saves space and has low base losses
- Low lead inductance and capacitance—ideal for vhf
- High efficiency at low plate potential—250 volts
- Instant-heating filament—approximately one second

*For example, characteristics are tested at positive grid potentials.

TYPICAL CIRCUIT FOR VERSATILE HYTRON 2E30

Extremely Compact Driver Giving 3 Watts to Load at 160 Mc

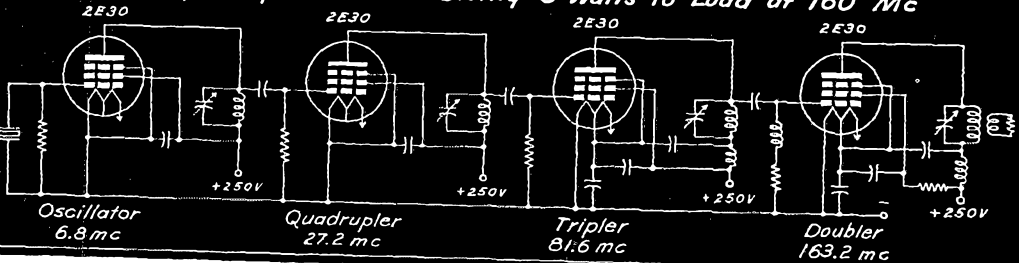

OLDEST MANUFACTURER SPECIALIZING IN RADIO RECEIVING TUBES

HYTRON

RADIO AND ELECTRONICS CORP.



MAIN OFFICE: SALEM, MASSACHUSETTS

PLASTICON* CAPACITORS

* PLASTICONS — plastic film dielectric capacitors.

OBSOLETES PAPER CONDENSERS!

Smaller, lighter, more economical. Specified by Signal Corps, Air Corps and Navy for more severe operating conditions than oil-paper capacitors. Closer tolerances, wider temperature range, greater safety factor, longer life.

Condenser Products Company 1375 NORTH BRANCH STREET
CHICAGO 22, ILLINOIS



INTRODUCING THE TELEX "MONOSET"



The under-the-chin headset designed to replace the old-style over-the-head phones.

Radically different in design, the TELEX "Monoset" is made to wear under the chin instead of over the head. So small and light—weighs only 1.3 oz.—it eliminates ear pressure and head fatigue of ill-fitting old-style headsets. . . . Replaceable plastic ear tips. . . . Fully adjustable to all head sizes. . . . Feather-light plastic cord. . . . Rugged tenite construction.

The high-fidelity performance of the TELEX "Monoset" matches that of the finest headsets produced today. . . . Frequency response from 50 to 3,000 cycles per second. . . . Maximum sound pressure output ranging from 300 to 400 dyns per sq. cent. . . . Available in three impedances: 128, 500 and 2,000 Ohms.

JOBBER AND DISTRIBUTORS WANTED

If your dealer can't supply you, order direct from Telex, Inc., Electro-Acoustic Div., Minneapolis 1, Minn. (Specify impedance when ordering).

\$18.50

Including plastic cord and standard phone jack.

TELEX INC. ELECTRO-ACOUSTIC DIV. MINNEAPOLIS 1, MINNESOTA

IT'S RIGHT...



for
VERSATILITY

for
**MODERN
BROADCASTING
TECHNIQUE**

for
DEPENDABILITY

for
**EASY
OPERATION AND
SHOWMANSHIP**

The **GATES** 1-KILOWATT TRANSMITTER

It has everything you want in performance—modern broadcasting technique from circuit developments, now incorporated, which are the result of proved laboratory tests. It is versatile to meet all demands. Yes, and it is dependable under all circumstances. In addition to these mechanical perfections which Gates engineers assure, the BC-1E Transmitter combines easy operation and beauty in appearance to make your Station outstanding in showmanship. It is **RIGHT** for the 1-Kilowatt Station. Investigate it!

CONDENSED SPECIFICATIONS

FREQUENCY RANGE: 530 to 1600 K. C.

FREQUENCY STABILITY: Plus or minus 10 cycles maximum.

POWER OUTPUT: 1000 Watts. May be operated as 500 Watt Transmitter. Power reduction for night operation may be incorporated to suit requirements.

POWER SUPPLY: 230 Volts, 60 Cycles, single phase, regulation not to exceed plus or minus 5%.

FREQUENCY RESPONSE: Within 1½ Db. from 30 to 10,000 cycles.

DISTORTION: Less than 3% from 50 to 7500 cycles. 0-95% modulation.

NOISE LEVEL: 60 Db. below 100% modulation.

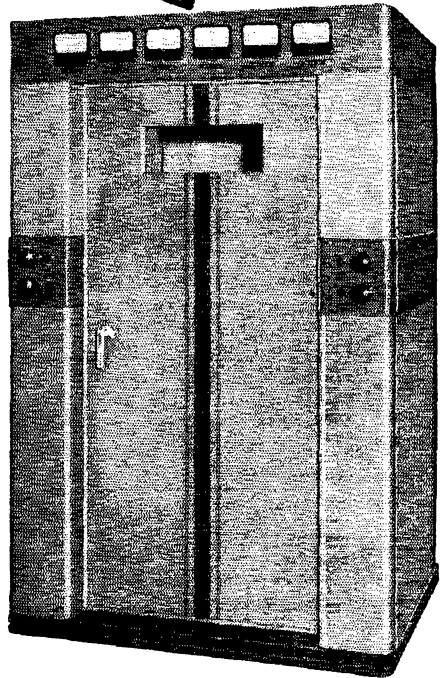

WRITE FOR COMPLETE SPECIFICATIONS

NEW YORK OFFICE:
9TH FLOOR, 40
EXCHANGE PLACE

GATES

**RADIO CO.
QUINCY, ILL.**

SOLD IN CANADA BY:
CANADIAN MARCONI CO., LTD.
MONTREAL.

EXCLUSIVE MANUFACTURERS OF TRANSMITTING EQUIPMENT SINCE 1922

REBUILDING?

A B & W tank assembly with its exclusive double stator tuning capacitor will give your rig new efficiency. The coil assembly mounts *directly* on the tuning condenser. Tubes may be mounted directly behind. Plate leads will be shortened to a few inches. Built-in neutralizing condensers at the rear permit two short grid leads, thus making a far more compact, more efficient assembly than would otherwise be possible.

And don't forget the famous B & W Air Inductors. New types! New, improved designs! Ask your distributor today!

Write for new B & W catalog!

IMPORTANT!

All B & W 10-meter coils will operate on the 11-meter band. 5-meter coils will operate on the 6-meter band.

B&W

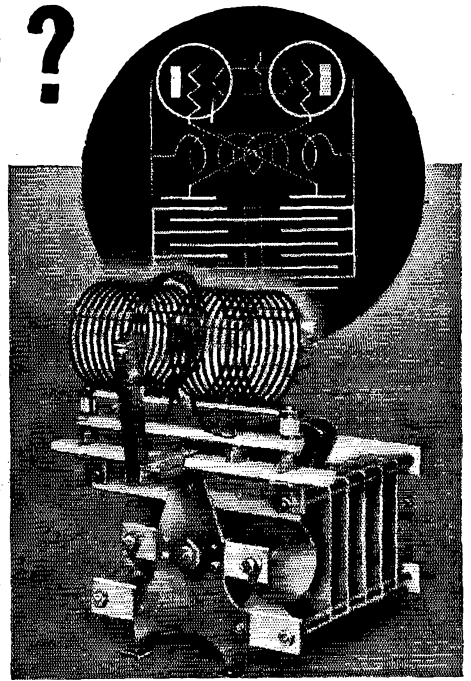

BARKER & WILLIAMSON • 235 Fairfield Ave., Upper Darby, Pa.

EXPORT: Lindeteves, Inc. • 10 Rockefeller Plaza, New York 20, New York, U. S. A.



World's Largest DISTRIBUTOR OF SHORT WAVE RECEIVERS

Do business with the biggest and one of the best in the field. Enter your orders for the following:

Skyrider Jr. 541.....	\$33.50
Hallcrafters S22R.....	74.50
Hallcrafters S39.....	110.00
Hallcrafters SX-25.....	94.50
Hallcrafters SX-28A.....	223.00
Hallcrafters S36A.....	415.00
Hallcrafters S37.....	591.75
Hallcrafters S40.....	79.50
National N-2-40C.....	225.00
National One-Ten.....	56.10
National HRO Sr.....	197.70
RME-45.....	166.00
Hammarlund HQ129X.....	129.00
Hammarlund Super Pro.....	318.00
HT-9 transmitter.....	225.00
HT-6 transmitter.....	110.00
HT4E BC-610 transmitter.....	695.00

Some models are available for immediate shipment. As more and more receivers become available Bob Henry will be able to serve you better and better. By dealing with the world's largest distributor of short wave receivers you are assured of the fastest delivery possible and the best of service.

Enter your reservation now. You can trade in your present receiver. You can order on our 6% terms. You can depend on Bob Henry also for a wide assortment and the best values in crystals, transmitting tubes, microphones, test equipment, etc. Your inquiries welcomed.

Bob Henry
W9ARA

BUTLER, MISSOURI

HENRY RADIO SHOPS

LOS ANGELES 25, CALIF.

"WORLD'S LARGEST DISTRIBUTOR OF SHORT WAVE RECEIVERS"

Still Going Strong!

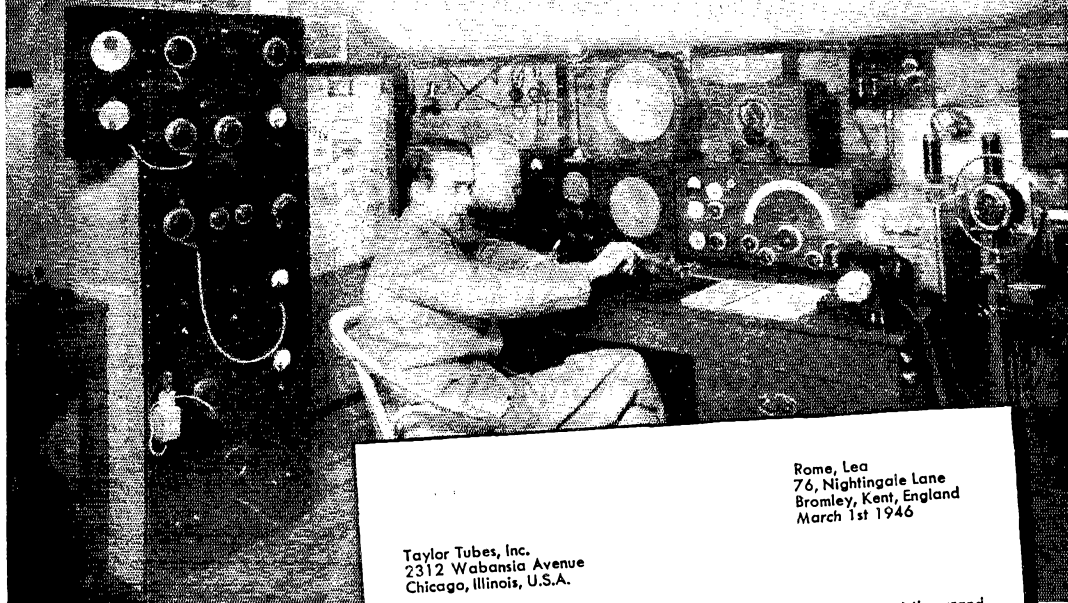

Congratulations, Mr. Allen of England, on a fine performance record. Your splendid operating achievements are a challenge to all amateurs. We are proud that Taylor Tubes played their part well and that they are living up to their reputation of performance and dependability.

**"MORE WATTS
PER DOLLAR"**

Rome, Lea
76, Nightingale Lane
Bromley, Kent, England
March 1st 1946

Taylor Tubes, Inc.
2312 Wabansia Avenue
Chicago, Illinois, U.S.A.

Gentlemen:

I am sure you will be interested to learn of my satisfaction and the grand results I have had with my transmitter using your tubes.

The line-up of the rig is a 6L6 tri-Tet Osc. TZ20 Doubler, T55 P.A. and a couple of TZ20's working in Class B in the modulator. The T55 runs with 1000 volts on the anode at about 80 ma.

Prior to the close down over here in 1939 using the above line-up I had WAC Fone and CW-WBE Fone and CW gained the British Empire Radio Transmission Award, which is the most difficult of the RSGB awards. I also worked all States in America on Fone and have the ARRL certificate endorsed 4th Station in Great Britain to qualify for this award.

On February 28th I think I established a record in Great Britain for 10 meter DX by working WAC and WBE within 9 hours 30 minutes, as below:

STATION	COUNTRY	MY RST	GMT
W4YA	Burma Rd.	4/6	0822
XU1YQ (W8SJA)	China	6/8	0847
W8CJR	Shanghai	3/5	0852
XU1YK (W2LNQ)	Pekin	5/9	0916
ZS6FN	Johannesburg	5/8	0954
LU4EC	Olivia, S. A.	3/4	1035
G6CU	Cocas Is.	7	1147
G3FJ	Slough Eng.	7	1052
W11EN	Attleboro, Mass.	9	1737
VE3LC	Ottawa	7	1750

Can you wonder that I write in praise of your tubes most of which I was using in 1937?

I am enclosing a photograph of my station, and if you care to use it with any of this letter you may do so.

Again, congratulations on your outstanding tubes.

C. G. ALLEN—G81G

Taylor HEAVY **CUSTOM BUILT** DUTY **Tubes**

TAYLOR TUBES INC., 2312-18 WABANSIA AVE., CHICAGO 47, ILL.

Pulse Communication

(Continued on page 76)

THE RADIO AMATEUR'S LIBRARY

● Many requests are received for the complete list of our publications. The list follows:

Title	Price
QST.....	\$2.50 per year*
List of Stations.....	Discontinued
Map of Member Stations.....	Discontinued
Operating an Amateur Radio Station Free to members; to others.....	10¢
The Story of The A.R.R.L.....	Discontinued
The Radio Amateur's Handbook	
a. Standard Edition.....	\$1.00**
b. Special Defense Edition.....	\$1.00
The Log.....	35¢ each; 3 for \$1.00
How to Become a Radio Amateur.....	25¢
The Radio Amateur's License Manual.....	25¢
Hints & Kinks for the Radio Amateur.....	50¢
Lightning Calculators:	
a. Radio (Type A).....	\$1.00
b. Ohm's Law (Type B).....	\$1.00
Amateur Radio Map of the World.....	Out of print
Two Hundred Meters and Down:	
The Story of Amateur Radio.....	Out of print
Building an Amateur Radio-telephone Transmitter.....	Out of print
A.R.R.L. Antenna Book.....	50¢
The Minilog.....	25¢
Learning the Radiotelegraph Code.....	25¢
A Course in Radio Fundamentals.....	50¢

* In the United States and Possessions — other Countries \$3.00 per year.

** Postpaid in Continental U.S.A.
— \$1.50, postpaid, elsewhere

(No stamps, please)

**THE AMERICAN
RADIO RELAY LEAGUE, INC.**
West Hartford 7, Connecticut

ASK FOR OUR BARGAIN BULLETIN

Phone, Wire or Write

WHOLESALE

**Radio-Electronic Parts
Tubes, Sets and
Equipment**

R. G. SCELİ & CO.

317 Asylum St. Hartford, Conn.

Telephone 2-1144

BRANCH: 84 ELM ST., BRIDGEPORT, CONN.

distortion. Any good superheterodyne receiver will be good enough to start with because the pulse shapes need not be too accurate unless a very crowded condition exists. For example, the pulses can be fifty microseconds long, provided the stations are separated by more than fifty microseconds. There is nothing special about the gated amplifier, except that it is biased "off" and nothing can get through it until it is unbiased by a pulse. The multivibrator is of special design, in as much as it generates square waves, the width of which can be adjusted by a potentiometer controlling the proper time-constant circuits. This square wave is then applied to peaking and pulse shaping circuits and amplified to furnish a bias pulse for the gated amplifier which can be moved with reference to time.

Since it is reasonable to assume that many hams will work in the ultra-high frequency bands, an additional suggestion might be in order calling attention to a method of using the system outlined herewith to secure greater than line-of-sight communication. This idea proposes that amateurs, when not using their stations, make transponder equipments out of them by simply connecting the receiver to the transmitter, through a suitable delay so that the equipment will not oscillate. These stations will transmit everything that they receive. By leaving the station "on the air" it will act as a relay station for all other signals and such a relay station can be made to relay a great number of messages during the same period of time. The message-handling capacity will be limited only by the pulse shapes, widths and separation and the repetition cycle.

With reference to the elimination of natural static and other types of r.f. noise, all such types of interference are of a "damped wave" nature of a relatively long time duration. Consider a pulse width of a microsecond for the gate. This means that any interference which could pass through this gate would have to appear at the time of the gate and, further, it would have to have a component of noise greater than a megacycle since the width of the gate is the time of one cycle of one-megacycle energy.³ Further, it would have to repeat itself in exact time phase with the synchronization signal for a number of cycles before it could be noticed.

Although two antennas are shown in Fig. 1, for reasons of simplicity of explanation, only one antenna is necessary for both receiving and transmitting. Both receiver and transmitter can be connected to the same antenna by means already described in the literature.

In this article we have attempted to outline roughly a method which is new and different and which involves circuit tricks of the radar art. Of necessity the article is very brief, but at least it calls attention to something new.

³ This discussion neglects the noise generated by the opening and closing of the gate, which would not require that the noise components be higher than 1 Mc. — Ed.

If you have this **HARVEY** Outfit ...you're set for your new station

Millen
50-watt Exciter

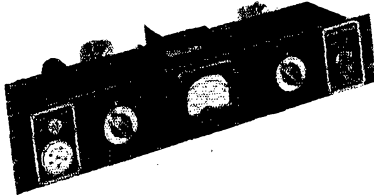

Millen ECO

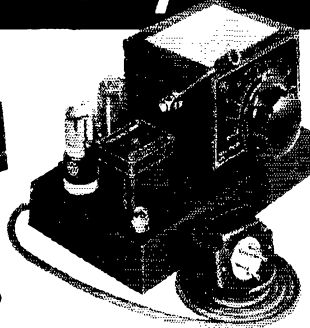

Panadaptor

And any good communications receiver.

Choice of **HAMMARLUND, HALLICRAFTER, NATIONAL, RME...HARVEY can deliver it**

Millen 90800 Xmitter-Exciter

Flexible exciter for high power, or use alone as a 50-watt rig, 10-20-40-80 meter bands. Regularly supplied for 10 meters using 40 meter xtal or ECO. Coils for all bands are available... specify band when ordering. 6L6 and 807 not included. **\$37.50**
 Bliley Xtals, 40 or 80 meter. **\$2.80**
 Extra Coils, per band. **\$3.10**
 Tubes **\$3.10**

Millen 90700 ECO

A pre-war favorite, now back again, and better than ever. Finger-tip control of frequency, big band spread, built-in power supply, 40 or 80 meter output, also ideal for use with the Millen 90800. **\$32.50**

Panadaptor

Featuring Panoramic reception which enables simultaneous visual reception of many radio signals—you can see up to 200 KC of the band at once. Also use as second receiver for 3-way QSO'S, check drift, modulation, distortion, A.M. F.M, complete with tubes. . . . **\$99.75**

Harvey "Hits" of the month

- 832 P.P. Beam Power, V.H.F. **\$4.95**
- Johnson Socket for 832 or 829. **\$1.05**

HAMFESTIVAL OF VALUES

Specially Priced! Brand New! **CARTER GENEMOTOR POWER SUPPLY** . . . for 6-volt portable operation on 2½, 5 and 10 meters — 6 volts input; 350 volts, 150 ma pure DC output. Rated for continuous operation. Has two-4 mfd oil-filled condensers, 20 henry filter choke, self-contained relay for push-to-talk operation. Screw terminal strip for easy connections. **\$29.50**

Amphenol Lo-Loss 83 series coaxial cable connectors, complete assembly inc. chassis connector, right-angle connector, cable and plug. Cat. price \$7.00—Harvey's **\$1.50**

RG-11/U, 72 ohm coaxial cable, min. length 100 feet; per foot **12¢**
 Long sought, hard to get, stealite Loktal sockets. **18¢**

The item all have been waiting for—radiating fin tube coolers—mfd. by Sharpnack Eng. Co. Increase efficiency of those overloaded tubes—6L6 size, **39¢**; 6F6 size, **34¢**; 6V6GT size. **35¢**

Thordarson 75C49 chokes, 8 henry, 120 ma, 200 ohms, tropical impregnated. **\$1.08**

Telephone stand, single button carbon mike, with push-to-talk switch and plug. **\$4.95**

The Workshop Associates amateur ground plane antenna for 144-148 and 220-225 mc. **\$11.75**

Leave it to HARVEY for what you need, when you need it, and at prices you can afford to pay.

Telephone  Longacre 3-1800

Millen 90610 VHF Freq Meter, 105-150 mc. **\$6.00**

In stock, new Taylor TB35. **\$10.00**

HARVEY

RADIO COMPANY

103 West 43rd St., New York 18, N. Y.

IMMEDIATE . . . DELIVERY



AMATEUR
NET \$11¹⁰

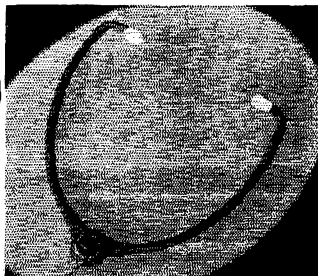

THE TELEX MONOSET

DESCRIBED ELSEWHERE IN THIS ISSUE. CHOICE OF 128 OHM—500 OHM—2000 OHM.

ANOTHER IN THE PARADE OF POST-WAR FIRSTS AT THE LARGEST HAM SUPPLIER IN THE NORTH CENTRAL SECTION.

LEW BONN COMPANY • ELECTRONICS •

12.11 LASALLE—MINNEAPOLIS 5—MINN.
BRANCH IN ST. PAUL

TELEVISION TECH—MATH SERIES

Television Tech announces publication of a new radio math series. Series begins with BASIC RADIO MATH by Edward M. Noll. First book teaches you what to do with a formula and basic radio algebra and trig. It shows you how to use math with practical examples of radio circuit calculations. Send one dollar and nine cents in stamps to:

TELEVISION TECH ENTERPRISES

Dept. C • • • Box 94, Hatboro, Pa.

RADIO

RADIO Technician and Radio Communications courses. Register now for new classes starting first Monday of each month. Day and Evening Classes.

AMERICAN RADIO INSTITUTE

101 West 63d St. New York 23, N. Y.
Approved under GI Bill of Rights

◉ TRANSMITTING TUBES RECTIFIERS CATHODE RAY TUBES

We have been appointed a sales agent by Defense Supply Corporation of Government surplus tubes and rectifiers. All are first grade Government tested and inspected tubes—not rejects.

The following types are immediately available:

828 (HF Triode)	Cathode Ray Tubes
VT 127A (HF Triode)	5AP1
304 TL	5BP4
872A M. V. Rectifier	5AP1

Trade discounts to dealers on standard packages • Write for prices

LEWIS ELECTRONICS 16 Lyndon Avenue
Los Gatos, California

Correspondence

(Continued from page 77)

NEWCOMERS

508 E. Bodine Ave., Clinton, Mo.

Editor, *QST*:

After reading your article about the boys with radio knowledge returning home from military service, I look back to World War I when I was discharged from the Army. I think the boys will try to forget the mess they have been in and let by-gones be by-gones. I know most of them did in the other war. If the old-timers will show them some interest, the way the amateurs do things, they will in most cases respond and many will take up amateur radio as a hobby and find out what fun really is.

I intend to invite all the boys from Clinton that were in the Signal Corps out to my shack and talk the whole thing over with them. I want to make them feel welcome to join our gang on the air. I had a class of eight boys and did all I could to teach them theory and code; five of them went into the Signal Corps as operators. I am sure these boys, when they return, will be out to see about getting on the air with a rig of their own. Now if each and every amateur will show these boys some consideration, they will see it the amateur way, and not the Army way.

I have been on the air for twenty years. Started in with a pair of UV-202s in a Hartley self-excited circuit, and have tried about everything under the sun when it comes to amateur radio. I have enjoyed every minute of it, and I think I can help some of the boys over some of the bumps and make the hobby more pleasant. I hope all the old-timers feel the way I do about the youngsters coming home from this awful nightmare, and show them interest and consideration. Then we will all feel better about it.

— M. W. Clark, W9DCD

3626 Penniman Ave., Oakland, Calif.

Editor, *QST*:

In your *QST* magazine you mention that you desire to get members of the armed services who had radio training while in service interested in amateur radio. I am one of the many who desire to become an amateur.

Before entering the Army, I admit I had little desire to do so, due mostly to having never come closer to the radio world than dialing our home receiver. However, while in the Army I attended a school in Kansas City, completing the five-month course for operators. Long before its completion I was a goner. I am proud of what I accomplished in the short time we had. My test speed was 30 w.p.m. but practical speed was 25, both code groups and plain text, and both with typewriter and pencil. My theory grades were high also.

However, as luck would have it, in Panama they had an excess of radio operators so it was a teletype for me for the duration. Nevertheless, I have no intentions of letting my new skill be wasted. My theory and practical maintenance experience is too meager for obtaining a license, but I intend to correct that. I want to get in on the fun in the new world opened up to me.

— Raymond McLaren

39 Gettsville Rd., Snyder, N. Y.

Editor, *QST*:

Have just been reading W5KPY's letter, "The Newcomers," in March *QST*, in which he advocates a vast association of missionaries to spread the gospel of ham radio. Apparently he feels that ham radio no longer holds the inherent power to attract newcomers of its own accord, and that the 150,000 amateurs now anticipated will not be a number sufficient to carry on our time-honored hobby.

Possibly the graduating classes of the amateur radio schools functioning in major cities are not large enough to suit W5KPY; it may be that we are falling behind in our mass production of radio amateurs. A few weeks ago, the *New York Times* advertised a "complete ham station" on sale at Gimbel's department store. I am sure that W5KPY can make it popular enough to be sold at the neighborhood drug store.

(Continued on page 148)

**PRECISION
MOVEMENTS**

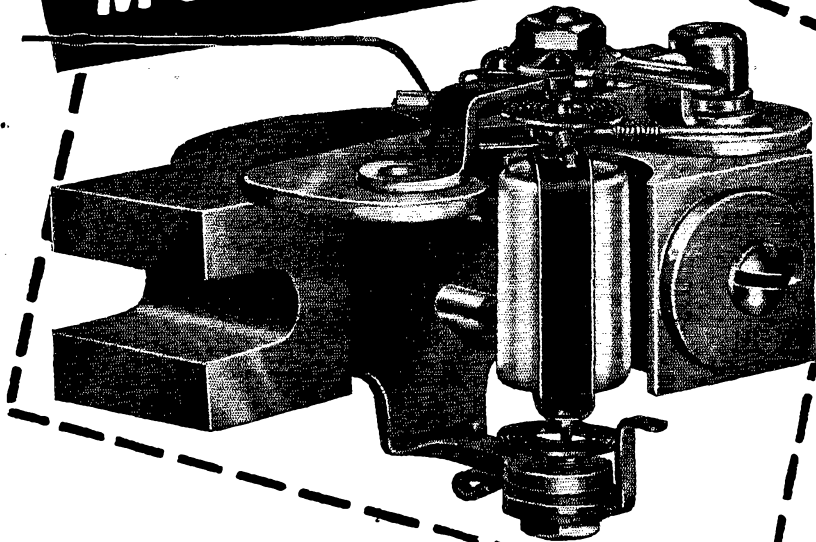

Burlington **PANEL INSTRUMENTS**

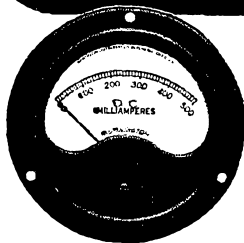

The heart of every Burlington Instrument — and the reason for its high degree of dependability — is the Burlington Precision Movement.

Design, material, and manufacturing processes are selected in such a manner that Burlington gives you a rugged instrument — which may be subjected to rough usage — and still retain its original calibration characteristics. All DC instruments employ Alnico magnets which are known to be more highly resistant to shock, heat, vibration, and stray fields than any other magnetic material. All ranges AC and DC are available in $2\frac{1}{2}$ " , $3\frac{1}{2}$ " and $4\frac{1}{2}$ " sizes, both square and round, flush mounting.

*Engineering Service Furnished for Specialized Applications. No Obligation
Write Today for Further Information*

BURLINGTON INSTRUMENT COMPANY • 806 Fourth Street, Burlington, Iowa



**STANDS UP
IN HARD
SERVICE**



**CERAMIC
CAPACITORS**



**WIRE WOUND
RESISTORS**

CHOKE COILS



**ELECTRICAL REACTANCE
CORPORATION
FRANKLINVILLE, N. Y.**

COMPLETE RADIO TRAINING!

Prepare now to accept a responsible position in Commercial Radio. New developments will demand technicians with thorough basic training, plus a knowledge of new techniques discovered during the war. Training open to high school graduates or those with high school equivalency. Courses 6 to 18 months' duration in RADIO AND ELECTRONICS. Approved Veteran training in Radio. Write for Particulars.

VALPARAISO TECHNICAL INSTITUTE
Dept. TN Valparaiso, Ind.

**Pre-Exam Tests for FCC Commercial
Radio Operator Examinations**

Determines your weak points — enables you to brush-up before taking the FCC Exam. Prepared by A. E. Nilson, famous co-author Nilson & Hornung's RADIO OPERATING QUESTIONS AND ANSWERS.

CLEVELAND INSTITUTE OF RADIO ELECTRONICS
QT-5 Terminal Tower Cleveland 13, Ohio

**RECEIVING SENDING
CODES *Speed* without
*strain***

CHAMPIONS ENDORSE CANDLER WAY

Get skill, accuracy, speed with the highly endorsed Candler System. Learn to send and receive by telegraph or radio code. Government service and commerce need thousands of better trained operators. Air commerce, mail, freight, etc., demand expert, reliable operators. Good pay. Get the Candler System, the maker of champions. It teaches you the "knack" of sound sense, alertness, speedy sending and receiving without strain. Adventure — good pay. Learn at home or wherever you are. Rush name today for free book.

FREE!

CANDLER SYSTEM CO.
Dept. 4-E, Box 928, Denver 1, Colorado, U.S.A.
and at 121 Kingsway, London, W.C. 2, England

(Continued from page 148)

All of which must bring the old-timer to realize that ham radio is not what it used to be. Until now, amateur radio has been one grand fraternity. You could honk out a CQ to the automobile ahead of you with the call sign above the license plate, or you could drop in on an out-of-town ham — a total stranger — and be treated as one of the family. But when ham stations become as numerous as family telephones, and hams become as indifferent toward each other as the average camera fiends, the spirit will be gone.

A word about this "vast, untapped store of potential hams" existing in the services: The undersigned was an Army radio instructor at Fort Monmouth for two years. The only worthwhile operators turned out of Fort Monmouth were those who were commercial or amateur operators before their induction, with a few very outstanding exceptions. Ninety per cent of them had been forced into it and were not even interested. In fact, it would be exceedingly dangerous to approach them on the subject. Let us remain thankful that this "vast store" remains untapped.

By all means, we should not let our interest in amateur radio become selfish. Give the beginner a hand whenever it is needed. But let him choose his own hobby. High pressure salesmanship should not be required. The undersigned received his ham license before he was acquainted with any other radio hams, and likewise thousands of others were not necessarily helped by another. There must be a few individualists left in the country. Let's make room for the genuine hams and keep out the rabble.

In passing, I would suggest that the code speed requirement for Class B license be raised to 15 or 17 w.p.m., and that the publication of government examination questions and answers be prohibited.

— Harry O. Brunn, jr., W8MXT

(Editor's Note: Although perhaps unintentionally, W8MXT in his fourth paragraph cites what seems to us irrefutable testimony why there *should* be more amateurs: If there had been many more hams available for his and other military classes, the "worthwhile" output would have been much higher, resulting in a better-trained and more efficient military communications service, and conceivably could have shortened the war.)

LORAN FEEDBACK

P. O. Box 911, Ft. Lauderdale, Fla.

Editor, QST:

I trust that Alexander McKenzie, WIBPI, will not object to a little "feedback" regarding his splendid article on Loran. After all, he — or those who designed the Loran indicator — certainly used a lot of feedback. The first sight of the picture on the indicator with the sweep speed switch on position eight used to give my students quite a shock, especially those on the early morning shift who had just gotten back to camp after a rough weekend in town following payday. I doubt if even Kilroy ever wrote that he had seen anything like it before.

The apparent errors to which I refer are the locking pulses for the A and B₁ delay multivibrators and the block diagram on page 65 of the February issue of QST. Output pulses from the first counter are spaced at 50 microsecond intervals, so would not go to the 500 microsecond amplifier. And, at least in the models of Loran equipment with which I am familiar, locking pulses for the A delay circuit were spaced 2500 microseconds apart.

However, the purpose of this letter is not to criticize but to express an appreciation for the splendid article Mr. McKenzie has written. It is the most informative article on Loran of the several I have seen. It gives the answers to a number of questions which had arisen during the more than a year which I spent teaching operation and maintenance of Loran airborne equipment to at least 400 AAF radar maintenance men. . . .

— Chester Park, W9WJC

WANTS "CALLS HEARD"

920 Alpha St., Inglewood, Calif.

Editor, QST:

I would like to see QST again publish a list of calls heard. I know that you folks believe it is out-moded but I also

(Continued on page 150)

LONG SCALE, WIDE RANGE VOLT-OHM-MILLIAMMETER

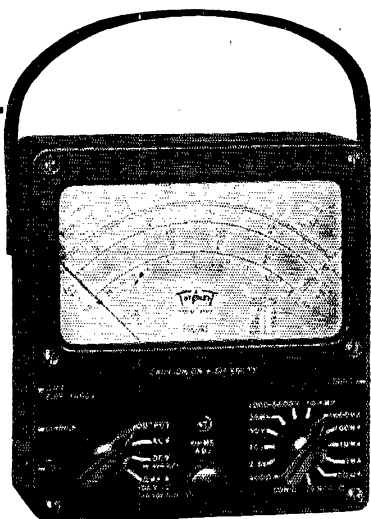

**DOUBLE SENSITIVITY
D.C. VOLT RANGES**
0-1.25-5-25-125-500-2500 Volts.
at 20,000 ohms per volt for greater accuracy on Television and other high resistance D.C. circuits.

0-2.5-10-50-250-1000-5000 Volts.
at 10,000 ohms per volt.

A.C. VOLT RANGES
0-2.5-10-50-250-1000-5000 Volts.
at 10,000 ohms per volt.

OHM-MEGOHMS
0-400 ohms (60 ohms center scale)
0-50,000 ohms (300 ohms center scale)
0-10 megohms (60,000 ohms center scale)

**DIRECT READING OUTPUT LEVEL
DECIBEL RANGES**
-30 to +3, +15, +29, +43, +55, +69
DB

**TEMPERATURE COMPENSATED
CIRCUIT FOR ALL CURRENT
RANGES D.C. MICROAMPERES**
0-50 Microamperes, at 250 M.V.

D.C. MILLIAMPERES
0-1-10-100-1000 Milliamperes, at 250 M.V.

D.C. AMPERES
0-10 Amperes, at 250 M.V.

OUTPUT READINGS
Condenser in series with A.C. Volts for output readings

ATTRACTIVE COMPACT CASE
Size: 2 1/4" x 5 1/4" x 6". A readily portable, completely insulated, black molded case, with strap handle. A suitable black, leather carrying case (No. 629) also available, with strap handle.

LONG 5" SCALE ARC
For greater reading accuracy on the Triplet RED • DOT Lifetime Guaranteed meter.

**SIMPLIFIED SWITCHING
CIRCUIT**
Greater ease in changing ranges.

Write for descriptive folder giving full technical details

Precision first . . . to last

Triplet

ELECTRICAL INSTRUMENT CO., BLUFFTON, OHIO

HERE'S THAT NEW
**TRIPLET
625-N**



HAM HEADQUARTERS FOR Equipment and Information

EXTRA SPECIALS

- 24 G Tubes. Limited Supply.. \$1.90 net
- 3-3 MFD. 600 W. V. Oil Filled Condenser.....99¢ net
- Leach Relay. Low Loss D.P.D.T. 6V. D.C. Coll. \$1.75 net
- SHURE T 17 B Mike with Relay Switch. \$3.10 net

Mail Orders Promptly Filled

Amateurs To Serve You

Write Dept. QST

W6SCQ • W8WLG/6 • W6NAT • W6SSU

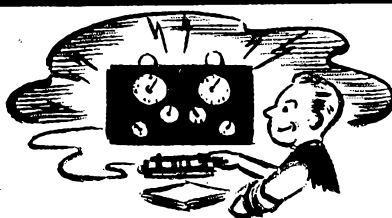

FOR YOUR NEW RIG

Monitor Crystals. 7 MC. Band. Type 43B.....\$2.80 net

Also Complete Line of:

National Johnson Ohmite Taylor	Eimac Jones Amprx Advance	Barker- Williamson Hallcrafters
---	------------------------------------	---------------------------------------

Radio Product Sales Company

238 WEST 15TH STREET

LOS ANGELES 15, CALIFORNIA

PRospect 7471



ARMY-NAVY Official HEAD PHONES

\$249



**EXTRA
SPECIAL
VALUE**

Limited quantity of these head phones. Highly sensitive, 8000 ohms impedance. Bi-polar magnets, bakelite shell and cap. Adjustable head band. Cord connects from one side out of the way. One of our many special features. Write today for complete catalog.

BURSTEIN-APPLEBEE CO.
1012T McGee, Kansas City 6, Mo.

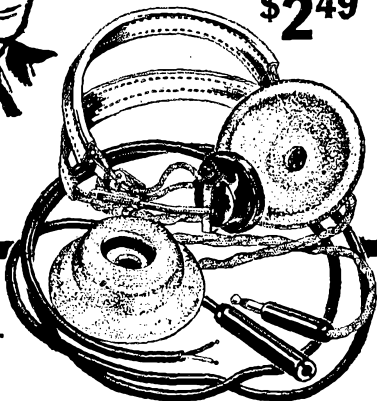

COMMERCIAL RADIO INSTITUTE

A RADIO TRAINING CENTER FOR 26 YEARS

Resident Courses Only • Broadcast, Service, Aeronautical, Television, and Marine telegraphy classes now forming for July 1st.
Literature upon request. Veteran training

Dept. B, 38 West Biddle Street, Baltimore 1, Maryland

AMATEUR GEAR HATRY & YOUNG

8 Connecticut and
Massachusetts Ham Stores

Hartford	C	Stamford
New Haven	O	New London
Bridgeport	N	Waterbury

BOSTON—MASS.—LAWRENCE

The **ELECT** in Electronics

(Continued from page 148)

know the feature is sorely missed by all of the hams I've talked to. Would it be too much to publish one list from each continent every month?

Am holder of first class commercial tickets so probably am as much interested in matters technical as the average ham. I know for a positive fact that *QST* was much more treasured when it contained description of stations and lists of calls heard than it is now. How about trying a couple of such issues and leaving the heavy stuff for *Electronics* or the *IRE Proceedings*?

— George Dery

SAFETY

1305 Spring Rd., Cleveland, Ohio

Editor, *QST*:

In *QST* the ARRL has stressed safety in xmtrs, such as enclosing all parts in a grounded metal box with interlocks on all doors. My little 100-watt rig has these features but the r.f. output is fed through insulators in the rear. This is a hazard.

Having trouble with feedback, I was switching from a 10-meter beam to an inside dipole with the hope of finding the trouble. Finally I was too impatient and tried to change antennas without turning off the xmtr and received a very good shock and a few burns on my fingers.

Now my feeders are of No. 12 insulated wire and they go into the box without feed through insulators. If I wish to change antennas I must open the lid, thus opening the interlock and killing the plate transformer.

— William H. Prosser

BREAK-IN

623 No. Broadway, Barnesville, Ohio

Editor, *QST*:

Now that hams are eagerly remodeling and building new rigs to get back on the old stand-by bands of 80, 40 and 20, I think it is a very good time for all operators to seriously consider making their rigs work with a break-in system. It's no go for just a few to have it — every station should use it. ARRL should point out to hams the advantages of everyone using break-in and, if necessary, get the FCC to make it a requirement. It cuts down QRM and speeds up the handling of traffic; also makes a "rag chew" more enjoyable. It is advantageous to be able to break an operator when he is sending to you. You may want to have him QJZ while you answer the telephone or door-bell, QRT or QBJ, etc. I got used to using break-in when I was an operator with AACB and I don't think I could get away from it now.

— R. W. Harrison, W8FYV

ADDRESSING QSLs

8902 Colby St., Lincoln, Neb.

Editor, *QST*:

We are at it again, thanks to the great effort of the Hq. gang in getting the bands opened at this early date.

We are also at it again — but now I am referring to the practice of not addressing QSL cards. I have been a ham for better than 20 years and I know what it is to want a particular card and never have it come — when probably it was lying in the post office waiting to be destroyed at the expiration of the time limit stated by postal laws and regulations for the retention of one-cent cards. These cards are not returnable, unless you state that return postage is guaranteed (in case of non-delivery) in which case they would be returned to you postage due. If fellows knew that Uncle Sam does not give directory service to one-cent cards, I believe they would not waste their money and Uncle's time by sending QSLs "blind" — not to mention the disappointment to the addressee.

What brings this on? Well, I am a postal clerk in the Lincoln post office and know whereof I speak. This date the directory section handed me two QSLs, one addressed simply "Amateur Radio Station W8VYX, fixed portable, Lincoln, Nebr." What say, gang, that we get off on the right foot and either address them correctly or don't mail them at all, especially to the larger cities. By doing so we can save ourselves a good cussing from the intended recipient whom we promised we would send some "wall paper."

— John H. Leacock, W8ED1

"ZOWIE!"

WE'RE BACK ON 80 METERS!"

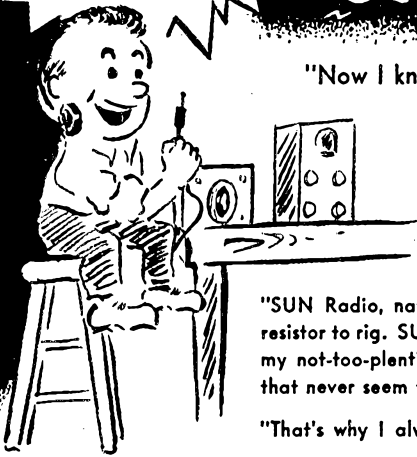

"Now I know the war is really over. 80 meters! After almost 6 long years. All I've been thinking of is night-time DX, and now it's mine for the receiving.

"But it was worth the wait. New techniques, new ideas, and new equipment were developed. Now I'm fixin' to get things that never existed before, in addition to reconditioning and overhauling my present equipment.

"SUN Radio, naturally, is going to supply me with all my equipment — from resistor to rig. SUN makes it easy for me to get parts, and this means that I spend my not-too-plentiful spare time building and QSOing — not waiting for parts that never seem to come.

"That's why I always CALL SUN FIRST."

NEW BAND SWITCH ASSEMBLY WITH 80 METER COIL

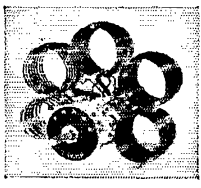

Bud's very latest: XCS-1. Coils for 10, 15, 20, 40 and 80 meters. 100 watts. Coils center tapped and center linked. A must for every up-to-the-minute ham.

Net\$8.25

ELECTRO-VOICE'S AMAZING NEW "CARDAX 950" MIKE



See March QST, page 107, for complete technical data.

Net ...\$22.20

HQ129X
 Now on display
SEE and HEAR
HAMMRLUND'S
 sensational new receiver
 at SUN Radio
NOW!

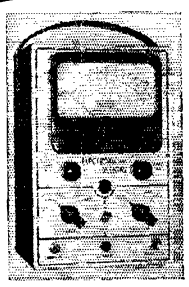

BUILT FOR W A R, YOURS IN PEACE

V.T. Voltmeter-Ohmmeter, Model 100. Mfg. by Electronic Designs. *Electronic Ohmmeter Range: 0-1000 Megohms. AC-DC Ranges: to 1000 volts.*

Net\$47.50

FREE OFFER

Condensed chart of Graphical Symbols for Electronic Diagrams as standardized by the RMA (includes those until recently kept secret). Just ask for it. Address Dept. ER 5.

Detailed Technical Data For All The Above Items Sent On Request.

Note our ONE and ONLY address

SUN RADIO & ELECTRONICS CO., INC.

122-124 DUANE ST. NEW YORK 7, N. Y. BARCLAY 7-1840



For Better Reception

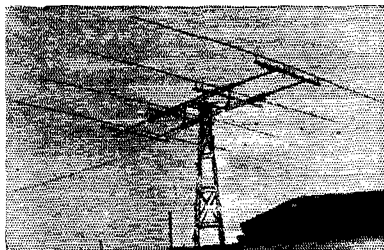

IT'S PREMAX

Premax Vertical Antennas are available in steel, monel, aluminum and stainless steel . . . the tested and tried designs that were so successful in the services of the army and navy. See your jobber . . . or write for complete information on the type of antenna you require.

Premax Products

Division Chisholm-Ryder Co., Inc.

4615 Highland Avenue

Niagara Falls, N. Y.

The HFM-25 Transmitter

Special attention to details and the use of impregnated or oversized parts make types HFM the outstanding jobs for dependability.

- Six bands with two crystals
- 36 watts r.f. amplifier
- Small cabinet 8½ x 12 x 6½, 6 v. Mobile — 110 v. Fixed, Portable

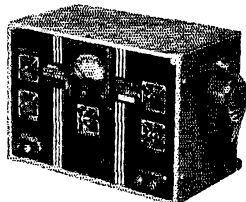

HANDIE-TALKIE 144
Delivery from stock

Write for bulletins listing complete new line

RADIO TRANSCEIVER LABORATORIES

116-23 Jamaica Ave.

Richmond Hill 18, N. Y.

EASY TO LEARN CODE

It is easy and pleasant to learn or increase speed the modern way — with an Instructograph Code Teacher. Excellent for the beginner or advanced student. A quick, practical and dependable method. Available tapes from beginner's alphabet to typical messages on all subjects. Speed range 5 to 40 WPM. Always ready, no QRM, beats having someone send to you.

ENDORSED BY THOUSANDS!

The Instructograph Code Teacher literally takes the place of an operator-instructor and enables anyone to learn and master code without further assistance. Thousands of successful operators have "acquired the code" with the Instructograph System. Write today for full particulars and convenient rental plans.



INSTRUCTOGRAPH COMPANY

4709 SHERIDAN ROAD, CHICAGO 40, ILLINOIS

(Continued from page 124)

field patterns of rotary arrays has always been a rather hit-or-miss proposition heretofore. If we got a good reading out in front and a weaker one off the sides and back we'd gone just about as far as we could. With this remote-indicating unit we not only are able to get fairly definite dope on the performance of our v.h.f. beams, but we've found it most useful in making transmitter adjustments for maximum output, both in the fixed station and with the mobile rig.

Attention 10-Meter Operators!

(Continued from page 35)

following reply from Dr. E. U. Condon, Director, points the way:

"Regarding suggestions of ways in which amateurs in general might help contribute useful propagation information, there are a number of them. For example: Carefully-kept logs of 28-Mc. stations attempting regular long-distance contacts or schedules with stations in specific areas like the Mid-Pacific, Europe, South America, and across the United States, are desirable if regularity is maintained as to days of the week as well as time of day. Failure to establish communication would be as important as a successful contact. A major purpose of this would be to obtain statistical information to determine reliability of sporadic-E in carrying long-distance propagation during months like June and July, when the regular F_2 m.u.f. would not be high enough to propagate 28 Mc. on many days of the month (as will be true this year). These results would then be compared with those for other months like February, when in these latitudes there is little sporadic-E but the regular F_2 m.u.f. is high. Comparison would also be made with results for in-between months."

That's just about the whole story. If your operating is fairly regular, it should be an easy matter to make schedules with one or more stations. But remember that it is just as useful to the Bureau to know that no contact was possible as it is to know that your signals were the best on the band. "No contact" may be the result of a missed sked or poor conditions; if you don't hear the other fellow you usually can tell, from other signals, whether or not you could have worked him if he had been there. And, of course, it's always possible to check up later and make a notation in the log accordingly.

Dr. Condon's letter was received just at press time, and to avoid a delay of another month in getting started we're running this note in advance of arrangements to handle the data. More next month on the form in which the Bureau wants the dope and where to send it. Meantime, make some schedules and keep a full log!

HARRISON HAS IT!

ALL STANDARD LINES

We are Factory Authorized Distributors for the top quality manufacturers and we now have in stock lots more new, latest improved production Ham gear! Visit our stores today, for *everything* you need. We promise you fresh, clean material — quicker — at the lowest current prices — and, above all, our sincere desire to be of friendly, helpful service.

MAIL ORDERS? — Certainly! Just list *everything* you want and include deposit or full amount. (Please add postage if you want parcel post shipment.)

73 de

Bill Harrison, W2AVA

TEMCO 75-GA TRANSMITTER

A post war transmitter of exceptional quality and dependability, incorporating many features of advanced design. — High stability VFO for crystal-like output in any part of every Amateur band covered — Single dial tuning to simplify operation — Band switching of factory tuned exciter stages — crystal selector switch — voltage regulated oscillator power supply — etc. Conservatively rated output of 75 Watts phone and 100 Watts CW.

Engineered and constructed to highest standards of performance this TEMCO Transmitter is a sound investment for the discriminating Amateur.

Complete, with tubes, VFO, and coils for five **\$495** band (10, 15, 20, 40, and 80) operation.

Place your order now for delivery in May

(Literature supplied upon request)

NEW SOLDERING TOOLS

Kwickheat — Built-in thermostat — 225 watt element — heats in 90 seconds. Net price, with tip, **\$8.91**

Weller Speed Gun — Trigger control gun type iron — 5 second heating — wire loop tip. **\$12.95**

Met-Elec Soldering Gun — For operation on 6 volt battery or transformer. **\$2.94**

With transformer for 115 V. AC. **\$6.43**

ABBOTT TR-4A

New improved 144 Mc. transmitter-receiver in stock. Less accessories. **\$43.00**

PANADAPTOR

Panoramic tuning adaptor. Easily attached to any standard communications receiver.

Harrison has it! **\$99.75** In stock.

A POST CARD will put your name on our mailing list to receive new catalogs, bulletins, additional HSS bargains, and details of how you may obtain a copy of "Electronic Parts and Equipment," our new 800-page Buyers' Guide. Please send it today!

MILLEN ECO

No. 90700. Compact, low drift, frequency shifter that plugs in, in place of crystal. Accurately calibrated. Built-in good regulation power supply.

Complete with tubes. **\$32.50**

Corlab GROUND PLANE ANTENNA

Still the best made job for 2 meters! Solid, sturdy, adjustable, proven in service. Model GP-144. **\$8.82**

Shur Antennae, Beams, and Mounts IN STOCK.

MILLEN 50 WATT TRANSMITTER-EXCITER

No. 90800. Output on four bands with one crystal or ECO. 6L6 — 807. Compact, versatile. **\$37.50** Less tubes.

TELESCOPING ANTENNA

Signal Corps AN29-C. Sturdy, lightweight, brass antennae. Extends to 9' 10", closes to 15". 3/4" base diameter. Weighs only 30 oz. Good for mobile or rotary beam elements. **\$1.98** HSS

Subject to prior sale or price change without notice.

HARRISON HAS IT!

HSS — HARRISON SELECT SURPLUS

Your assurance of good, usable, guaranteed, surplus material at sensationally low prices — top value always! Come in and browse thru our large, *entirely separate* HSS Department (Harrison Select Surplus).

SIGNAL CORPS RECEIVERS

Here's one of the hottest jobs to come out of the war — the BC-342! Two RF stages — two IF stages — exceptionally low noise level — high sensitivity — ten tubes — crystal filter — AVC — BFO — calibrated precision dial — 4500 division vernier bandspread — beam power output to phones or speaker — 9 1/2" x 18" panel — metal cabinet. Covers 1500 KC to 18 MC. (Use with 2, 5 and 10 meter converter for *top efficiency on all bands*.)

Complete with tubes, speaker in metal cabinet and instruction manual — ready to operate on 115 volt 60 cycle AC.

A damn good, dependable, modern communications receiver at a sensationally low price. Slightly used, but checked by the factory and fully guaranteed. (AND WE HAVE THE GOOD ONES, WITH ALL THE BEST FEATURES!) HSS **\$69.75**

For mobile, marine, etc. or emergency service — Model BC-312, operates on 12 Volt Battery. **\$49.25**

Just a few left!

HALLICRAFTERS BC-610 TRANSMITTERS

Complete with coils for 20, 40 and 80, speech amplifier, tubes, etc. **\$500.00** (See our April *QST* page 117.)

FIELD STRENGTH METERS

Signal Corps I-149 Indispensable for tuning up beam antennae. Also can be used as foundation for 50,000 ohm per volt multimeter. Operates on all frequencies. Complete ready to use. **\$13.90**

REVERSIBLE MOTORS — FB for UHF Beams

Totally enclosed motor and gear box. 3 RPM right angle drive shaft with ball thrust bearing. Runs on 24 to 30 volts AC or DC. Single wire reversing. Light weight aluminum construction. 3 1/2 lbs. 5 3/4" x 3 1/4" x 5" overall. Navy material — brand new! Autotransformer for 115 Volt AC. **\$14.90** **\$2.25**

MORE! — 15 TUBE UHF RECEIVERS

We have just secured more of those FB Signal Corps Model BC-406-A 205 Mc. receivers. These are all brand new, and sealed (also contain an 11 watt .65 RPM motor).

Six acorn tube RF circuit, four IF stages, 115 volt 60 cycle operation. Chassis 10 1/2" x 25 1/2", in metal case. Complete with tubes: 5 — 954, 1 — 955, 4 — 6SK7, 2 — 6S17, 2 — 6N7, 1 — 5T4.

Full instructions and diagrams for easy conversion to a hot 10 (also 6 and 2) meter superhet receiver are included.

Parts alone are worth much more than our **\$29.75** low HSS price.

HSS RECEIVERS

NATIONAL model NC-100-ASD. Brand new, in original crates, complete with tubes, speaker in cabinet, and spare parts. **\$115.00**

Model RBL-3. Long wave, 15 to 600 KC, seven tube receiver. Two RF stages, regenerative detector, noise limiter, two audio stages. 115 volt 60 cycle operation. Complete with **\$49.75** tubes.

HANDSETS

Latest, improved type. 200 ohm single button mike, high impedance phone. With push switch, cable, and plug. HSS **\$4.45**

HSS CONDENSERS

Oil filled, compact cylindrical type, mounts in 1/4" hole. Just the thing for transmitters, amplifiers, etc. Guaranteed at full rated DC working voltage. 2 Mfd. — 1000 Volt — FOUR for **\$2.34**. (Regular price of one.) Standard rectangular type, with stand off insulator terminals. Oil filled. 8 Mfd — 1000 Volt — **\$2.80**. Flat type, lug terminals, oil filled. 2 Mfd. — 600 Volt — FOUR for **\$2.12**.

HAM HEADQUARTERS
Since... 1925!



HARRISON RADIO CORPORATION

12 WEST BROADWAY • NEW YORK CITY 7

BARCLAY 7-9854

JAMAICA BRANCH — 172-31 Hillside Ave. — REPUBLIC 9-4102

W. D. BRILL CO.

198 10th St., Oakland (7), Calif.

PLACE YOUR ORDER NOW
FOR THE NEW

HQ129X and **SUPER PRO**

We Carry a Complete Line of
the Most Sought of Ham Gear

*Mail Orders Given Prompt
and Careful Attention*

SEND YOUR NAME AND
CALL LETTERS IN FOR
OUR NEW MAILING LIST

W6KLO W6SSN W6FJX

WWV Schedules

STANDARD-FREQUENCY transmissions are made available as a public service by the National Bureau of Standards over its standard-frequency station, WWV, on the following schedules and frequencies:

2.5 Mc. — 7:00 P.M. to 9:00 A.M. EST (0000 to 1400 GMT).

5.0 Mc. — Continuously, day and night.

10.0 Mc. — Continuously, day and night.

15.0 Mc. — Continuously, day and night.

The 10- and 15-Mc. radio frequencies are modulated simultaneously at accurate audio frequencies of 440 and 4000 cycles. 5 Mc. carries both audio frequencies during the daytime but only 440 cycles from 7:00 P.M. to 7:00 A.M., EST, while 2.5 Mc. carries only the 440-cycle modulation. A 0.005-second pulse may be heard as a faint tick every second, except the 59th second of each minute. These pulses may be used for accurate time signals, and their one-second spacing provides an accurate time interval for physical measurements.

The audio frequencies are interrupted precisely on the hour and each five minutes thereafter, resuming after an interval of precisely one minute. This one-minute interval is provided to give Eastern Standard Time in telegraphic code and to afford an interval for the checking of radio-frequency measurements free from the presence of the audio frequencies. The announcement of the station's services and of the station's call (WWV) is given by voice at the hour and half hour.

The accuracy of all the frequencies, radio and audio, as transmitted, is better than a part in 10,000,000. Transmission effects in the medium may result in slight fluctuations in the audio frequencies as received at a particular place; the average frequency received, however, is as accurate as that transmitted. The time interval marked by the pulse every second is accurate to 0.00001 second. The 1-minute, 4-minute and 5-minute intervals, synchronized with the second pulses and marked by the beginning and ending of the periods when the audio frequencies are off, are accurate to a part in 10,000,000. The beginnings of the periods when the audio frequencies are off are so synchronized with the basic time service of the U. S. Naval Observatory that they mark accurately the hour and the successive 5-minute periods.

Of the frequencies mentioned above, the lowest provides service to short distances and the highest to great distances. In general, reliable reception is possible at all times throughout the United States and the North Atlantic Ocean, and fair reception over most of the world.

Here's a New **POWER CUTTER KIT**

with a cutting range of 5/8" to 2-1/2"



Two Bruno Adjustable Hole Cutters in one convenient kit. High speed steel blades cut clean, fast holes in metal, wood, plastics. Quickly adjustable and easily sharpened. Designed by tool engineers to operate efficiently in bench drill, drill press or portable drill. Ask your jobber, or write Dept.

POWER CUTTER KIT CONTAINS			
MODEL	SHANK SIZE	EXPANSION	PRICE
100	1/4" straight shank	5/8" — 1 1/2"	\$3.00
101	3/8" straight shank	1" — 2 1/2"	\$5.00
		5/8" — 2 1/2"	\$8.00*

*Four Trade Minimum \$7.85



TOOLS

9330 Santa Monica Blvd.
Beverly Hills, Calif.

EXTRA!

Open up the 425mc. band in your town. Transmission line tuner, frequency range 400-500 mc. Consists of: two 1/4 inch copper tubes 5 inches long; High-Q shorting plate moved by underset threaded rod running thru linen bakelite block on shorting plate; heavy linen bakelite mounting block; crank-type knob; complete instructions, with tested and operating circuits as used with the tuner. For acorn receiver, acorn osc., and 3012 or 8025 tube with 10 watts output. Amateur net, assembled, \$8.50. Six element beam peaked on 425 mc. \$5.50.

U. H. F. RESONATOR CO.

Guion Road, Rye, N. Y.

Telephone Rye 2030

The 1946 HANDBOOK

THE LATEST EDITION of The Radio Amateur's Handbook is postwar in content, containing 688 pages of the kind of material which has made The Handbook world famous ➤ With the suddenness of peace it meant much redoing of the Handbook but this was done ➤ Retained is the highly successful treatment of fundamentals which was an innovation of the 1942 edition ➤ Stripped to essentials, the theory and design sections cover every subject encountered in practical radio communication, sectionalized by topics with abundant cross-referencing and fully indexed ➤ An ideal reference work, this Edition also contains all the constructional information on tested and proved gear which has always been the outstanding feature of the HANDBOOK.

POSTPAID IN
CONTINENTAL U.S.A.

\$1

\$1.50 ELSEWHERE
BUCKRAM BOUND \$2

AMERICAN RADIO RELAY LEAGUE

» » » » » » »

**WEST HARTFORD 7
CONNECTICUT**

HAM-ADS

(1) Advertising shall pertain to radio and shall be of nature of interest to radio amateurs or experimenters in their pursuit of the art.

(2) No display of any character will be accepted, nor can any special typographical arrangement, such as all or part capital letters be used which would tend to make one advertisement stand out from the others.

(3) The Ham-Ad rate is 30¢ per word, except as noted in paragraph (6) below.

(4) Remittance in full must accompany copy. No cash or contract discount or agency commission will be allowed.

(5) Closing date for Ham-Ads is the 25th of the second month preceding publication date.

(6) A special rate of 7¢ per word will apply to advertising which, in our judgment, is obviously non-commercial in nature and is placed and signed by a member of the American Radio Relay League. Thus, advertising of bona fide surplus equipment owned, used and for sale by an individual or apparatus offered for exchange or advertising inquiring for special equipment, if by a member of the American Radio Relay League takes the 7¢ rate. An attempt to deal in apparatus in quantity for profit, even if by an individual, is commercial and all advertising by him takes the 30¢ rate. Provisions of paragraphs (1), (2), (4) and (5), apply to all advertising in this column regardless of which rate may apply.

(7) Because error is more easily avoided, it is requested signature and address be printed plainly.

Having made no investigation of the advertisers in the classified columns, the publishers of QST are unable to vouch for their integrity or for the grade or character of the products or services advertised.

QUARTZ—Direct importers from Brazil of best quality pure quartz suitable for making piezo-electric crystals.
Diamond Drill Carbon Co., 719 World Bldg., New York City.

AMATEUR radio licenses. Complete code or theory preparation for passing amateur radio examinations. Home study and resident courses. American Radio Institute, 101 West 63rd Street, New York City.

WRL Transmitters kits—15, 35, 70, and 150-watt units—low priced. All makes of receivers, both new and reconditioned. Leo offers best trade-in deal, and easy time payment plan. One of the country's largest parts supply houses. Write today for free catalog, special radio map offer, tube-base calculator offer, and other items. Leo, at World Radio Labs, Dept. HA, Council Bluffs, Iowa.

RADIO tubes, parts, condensers, free bargain lists. Potter, 1314 McGee, Kansas City 6, Mo.

YOUR station call plate beautifully cast in aluminum, size 2" x 5 1/4", two styles, Type P, with tapped bosses for panel mounting, Type P for desk use. Price either type, \$1.50. Duplicates of same type, 75¢ each. Print your call plainly, P & H Sales Co., 619 Jasper Street, Kalamazoo 31, Mich.

HAM crystals: \$2.50 within 10 kc. of specified frequency; excellent oscillators guaranteed; 3500 kc. to 8000 kc.; Army type, FT 243 holders. L. Klipp, 277 Broadway, N.Y.C. 7.

SELL or trade: Echophone EC1, SX-25; 212Ds, 852, 211 tubes; filament transformers, sockets; Instructograph, 2 1/2 meter superhet, dynamic mike, crystal mike, Triplett 1295 modulation indicator; Mallory V-brapack, Supreme tube checker #85, Motorola 801; 300 watt Class B Utah 45 unit Solar CB analyzer 50 Watt amplifier. H. Richards W8IV, Argyle, N.Y.

NATURAL color bakelite tubing: 3' lengths, 3/4", 5/8" and heavy 3/4" OD. Impervious to moisture, ideal for high insulators, spacer coils forms and insulation. Any three lengths, 75¢ postpaid. Bud Slocum, W8JO, Roscommon, Mich.

LAPEL pins, gold-filled. Your call. Dollar postpaid. Posey, W4HEV, Box 1574, Greenville, S.C.

FOR sale: several 100T5 tubes, 100-watt plate dissipation, to 300 Mc., with 144 to 148 Mc. push-pull parallel line oscillators available; 5" army oscilloscope; 2 µd, 3000 volt working, Mallory condensers; Garrard RC 30A record-changer; new ounce crystal, 10", 12", intermixed, Garrard cabinet, as new; open frame transformer, 3500, 2500 volts, C.T. 300 milliamperes. New items: 60 cycle xfmrs; 5.0 volts at 60 amps; 5.1 volts, 180 amps, both Amertran. Cased, 900 volts C.T. grounded, at 300 milliamperes; 6.3, 6.3, 2.5, 5.0, filament windings, beautiful, Chokes: 7.75 h, 75 ohms, 300 milliamperes; 13.1 h, 58 ohms, 300 milliamperes; 3 h, 45 ohms, 400 milliamperes. R.f. chokes, millihenry, 500 milliamperes, Meissner 391-3022, Meters: 100, 1000 milliamperes, Weston Model 301, D.C. 8 volts, 4, 8, 16, 150, 750 volts; with no series resistors, 300 voltages, 4 and 150; both models 476 a.c.; Westinghouse, 150 volts, a.c.; 100 microamps, d.c., both 2 1/2" dia. G.E. 200 microamps, 3 1/2", multiscala, 1/2000 fuses mounted; Marion 1-0-1 milliamperes, d.c.; circuit breakers made by H & H, hand reset, 5 amps, 115 volts, a.c.; 12 gauge Stevens shotgun, 3" chamber, single barrel, full choke, 2 user bugs. Make offers if interested. Write, then, Two very good commercial rcvrs from 350 kc. to 450 Mc. F.O.B. Gunning Bradford, W2HAF, 705 St. Marks Ave., Brooklyn 16, N.Y.

SURPLUS radio equipment at bargain prices. Send for complete catalog. Charles Picart, 733 13th St., San Diego, Calif.

ROTARY beam antenna indicators. Use 2 Bendix AV20 Selsyns as automatic antenna direction indicators. Many other uses for these instruments. Price \$7.50 per pair, instructions included. General Developments, 521 Fifth Ave., N.Y.C.

NEW gross 100-watt 40-band transmitter, complete, \$90. Carl Vermilya, Ottawa, Ohio.

SELL, new: Western Electric 19C audio oscillator, 20-15,000 cycles, Has db meter. Output - 4 to +6 db into 600 ohm line, \$150. Hewlett-Packard 325B noise distortion meter, \$330. Westinghouse meters, 2" bakelite case 0-5 amp. r.f., \$3.25, 0-1 ma. movement, \$2.95, 3" square case, 0-15 ma., \$3.25. C-D dykanolas, 1 µd, 200 v., \$1.15, 5 µd, 150 v., \$1.00, 5 µd, 1000 v., \$1.75. Jack Krinsky, W2HQW, 4603 Church Ave., Brooklyn 3, N.Y.

CRYSTALS: 40-meter mounted units, low drift (2 cy. /°C./Mc.) within 5 Kc., \$2.50. Aircraft and marine units. Send specifications. Immediate delivery. Nebel Laboratory, 1104 Lincoln Place, Brooklyn 13, N.Y.

ROTO-SHOW motors 3 rpm, will turn 200 lbs. Completely enclosed. Not reversible. Uses link feed. Quantity limited. While they last, \$19.95. Jefferson Radio Co., 1375 Jefferson Ave., Buffalo 8, N.Y.

ONE Hallcrafters Super Defiant high frequency communications receiver. Used very little, practically new. Morris, Dublin, Ga.

SELL: thousand watt and 360-watt medium frequency composite AM transmitter complete. Details: State Division Purchase & Printing, Richmond, Va.

RECEIVERS: RME, Hammarlund, National, Conklin Radio, Bethesda, Md.

CRYSTALS: Precision low drift x-ray oriented units manufactured by latest and most scientific methods. Optical holder mounting type 400A for five prong socket or type 100A of which plug in a single octal socket. Your specified frequency: 3500 Kc to 4000 Kc, \$2.60; 6250 Kc to 7425 Kc, \$2.60; 12,500 Kc to 14,850 Kc, \$3.30. Rex Bassett, Inc., Ft. Lauderdale, Fla.

CO-AXIAL cable available RG 8/U (new material) in 29' lengths, with end fittings, \$3. per length. C. F. Moretti, Boulevard, Peekskill, N.Y.

QSLs, samples. H. L. Carter, Jr., W8JOT, 749 S. Plymouth, Rochester 8, N.Y.

QSLs? SWLs? Immediate service! Samples? Biley crystals? "CQ" Magazine, \$2.50 year. Sakers, W8DED, Holland, Mich. (Veteran).
NEW C.D. TY 20020 2 µd 2000 v.d.c. condenser with mtg. feet, \$1.75. Harry Sherwood, 3505 87th St., Jackson Heights, N.Y.

C. FRITZ for better QSLs, also JK stabilized crystals, 1213 Briar-gate, Joliet, Ill.

QSLs, Samples. Glenn Print, 1042 Pine Heights Ave., Baltimore 29, Md.

SURPLUS mobile UHF police transmitters, receivers, dynamotors. Exceptionally reasonable. Inquire: Telectron, 1988 East 59th, Cleveland 3, Ohio.

WESTINGHOUSE generators, brand new. Inputs: 12 or 5VDC. Outputs, 1000 or 500 v.d.c. at 400 Ma., \$25. John Zubas, 173 Warburton, Yonkers, N.Y.

SELL 600 watt, 10-meter phone xmt and SX-28 receiver. Excellent condition. Harry B. Brown, W4HYZ, Jellicoe, Tenn.

SALE: Signal Corps BC-186, BC-187, BC-188 receivers, transmitters and modulation units. Write W4LACV, P.O. Box 593, Bridgeport 1, Conn., for information.

BARGAINS for the DX rag-chewer! 750-watt phone, W1KWH, all highest class components and complete from mike to antenna. Cost over \$1200. Sacrifice for \$700 cash, crated, f.o.b. Danville. Photo for stamp. Nathaniel C. Smith, RFD 3, Danville, Ill.

FOR SALE: complete 160-meter phone xmt, including 4 Weston and Jewell meters; Thordarson and Acme Delta transformer and chokes; National, Hammarlund and REL condensers; 211 in final with 2 extra 511s, \$250 f.o.b., Stafford Springs, Conn. For information, call Glastonbury 542 or write Charles Stevens, 20 Deming Road Glastonbury, Conn.

FOR SALE: S-20-R, price: \$50. New condition. W3BQP, 250 Ballymore Rd., Springfield, Pa.

NEW Dumont K1003P4 cathode ray television tube; Thordarson T-17R33 television transformer; Thordarson T-17C40 filter reactor and 2 Westinghouse 5µd 10,000 v. television capacitors. Make me offer or will consider trade. Need W4IF receiver or converter for 144 Mc. N. BBTY, P.O. Box 994, Lancaster, Pa.

WANT modulation transformer to match PF100ths to 12,000 ohm load. Prefer T-17 or Thordarson. VARI-match, R. Morrison, W4FEK, 237 Singdale Dr., NE, Atlanta, Ga.

BLILEY VF-1 80 and 40-meter xtals in original cartons, \$4.50. Send card for frequencies. Tel-Electro Lab, 541 Oakwood Ave., Roselle Park, N.J.

SELL T125 and socket, \$9. Biley LD2-3525KC, \$3; BC3-1989KC, \$2. W9CHF.

WANTED: August and September 1945 QST; also Thordarson T-19P60 transformer, but of trade. Hines, R14HK-718, and 3E29 tubes. H. A. Albright, 1123 N. Main, Rochester, Michigan.

WANTED for cash: FBXA 10-meter coils. General coverage coils. National Pre-selector coils. W6PDO/S, 914 No. El Paso St., El Paso, Texas.

NEEDED: coil sets and/or blank forms for National "AGS" receiver. FB7-EX forms are same. State details. Sturham, W2MME, Box 382, New Market, N.J.

WANTED: RCA TRK-5 or Meissner 10-1153 television chassis, less tubes. D. Russell, Jr., 221 W. Allen La., Phila., Penna.

WANTED: Hammarlund exciter tanks, type ETU-20, ETU-10. Will purchase, or what do you need? W3GHD, 139 Campbell Ave., Havertown, Pa.

HALLCRAFTERS SX-15, Sky Challenger, completely overhauled and checked at Hallcrafters factory in Feb. 1946. Unused during 4 years in service, xtal filter, 545KC-38 Mc. Best offer. W3EKS, M.C.C., Haverford, Pa.

TRADE commercial 12-tube receiver, perfect condition, broadcast to 65 mc. for U.S. or Canada amp collector. Also have pre-selector and other transmitter receiver equipment. Callanan, 6825 N. Olcott, Chicago 31, Ill.

SELL or trade: McElroy RRD900-742 recorder and TP890-742 tape puller, both perfect. Price, \$65; 3 rolls practice tape, \$1 ea. Want: HRO, PW-O driver. R. N. Hayes, Box 174, Hawley, Texas.

SARAN plastic rope for antennas: 16 strand, weatherproof, strong; 50' or more, 3 1/2¢ per ft.; 24-strand, 5¢ per ft. J. O. Ellison, W8COW, 2825 Cooper, Saginaw, Mich.

WANTED: used receiver. W8VCW.

WANTED to buy: coils for HRO, 10-, 20-, 40- and 80-meters. Write Geo. Williams, W4EYK, 720 Broadway, Columbus, Ga.

WANTED: Meissner signal shift, signal spotter, National 1-10, CRR scope; D-104 mike, 832, 813, 814 tubes; 1500 to 2000 v. 500 Ma. power supply. Cash or trade. Haynes, 2413 Mallory, Flint 4, Mich.

SELL: National SW-5 receiver; 6 coils, B power pack, tubes, phones, A-1 condition — \$25. C. Horn, 325 E. 163rd St., New York City 56

FOR SALE: TR4 complete on 2 meters, \$40. New HK354, \$18. W2MID, 100 W. 94th St., New York City 25.

WILL trade new 56P1 cathode ray tube for volt-ohmmeter or recording equipment. Frank Arams, Alaska Communication System, Ketchikan, Alaska.

FOR cash, half K. w. spark transmitting condenser. Rotary spark gap with motor. Interested in other spark gear, receiving and transmitting. State price, condition. George C. Stary, 431 Depot St., Latrobe, Pa.

FOR SALE: Meissner signal booster (pre-selector) excellent condition, \$43. W. MacFarlane Jr., 1138 Palma Ave., Schenectady, N.Y.

SOLD mine to Signal Corps. Want National NC-200 in good condition. Trade RME-99 and cash for clean job. W9ERU, 2511 Burrum Road., Rockford, Ill.

FOR SALE: Mallory VP-557 vibrator power supply. Excellent condition. Cost \$40.50 new. Best offer. Harold Byler, 900 S. Pecan Street, Brady, Texas.

FOR SALE: two new RCA 813s, \$12 ea. Wanted: 1/2" and 1/4" aluminum tubing for beam elements. G. Scott, WINBK, Houlton, Me.

SWAP pair 8012s for V.O.M. Steven Kocik, W8OPC, 3653 East 114th St., Cleveland 5, Ohio.

SELL QST Jan. 1931 to Jan. 1946, 15 year run, complete, good condition, make offer. Also Argus prismatic telescope, coated lenses, 20-pole, \$74.50. Freeland offset stand, \$7.50. Will trade for good radio or what gear have you? E. Gudschnick, 620 Grant, Bay City, Mich.

SELL or trade visual frequency monitor, RCA type, EX-4180, complete, less crystal. Want HRO. Mail reply W9UWE.

MICROPHONE, hand dynamic, \$7 new and guaranteed. W9NFV, Olson, 3831 N. Fremont, Chicago 13, Ill.

CRYSTALS: low-drift high activity, 80 and 40-meter units, airgap mounted in dustproof holders. Within 5 Kcs. \$7.50. Exact, \$3.50. Nebel Laboratory, 1104 Lincoln Pl., Brooklyn 13, N.Y.

TRADE or sell 76 xtals, 5706.667 to 8173.333 Kcs. Dick Whitehurst, 4 Spring Street, Portland 3, Me.

CANADIANS QSLs, samples. Mack, Box 166, Trenton, Nova Scotia.

MY excellent metal rotary beam for 6- and 10-meters, cost less than \$12 to construct. Entire assembly raised and lowered in 10 minutes. Send 50c for detailed plan. Good used converter for 6 and 10-meters \$15. Several rebuilt pre-selectors, \$13.50 and \$16. W8LYI, Box 122, No. Kingsville, Ohio.

IN STOCK: Hallcrafters S-41, \$33.50. Millen Exciter, 90800, \$37.50. War surplus B19-235 Megacycles transceiver, 25-watt 2 to 8 Mc. Xmt, Rcvr and inter-communication; 5 mikes and phones, tubes and antennas. Cost Government \$1,000. Special, \$78.50. The old reliable for "ham" receivers, xmts and parts. We'll trade. Fred Radio & Supply Co., Asheville, No. Carolina.

WESTERN Electric 0-15-75-150 Ma. with shunts, in case, \$4.75. Public address speakers, 25-watts, Bargain. Hammarlund, Hallcrafters, RME receivers, xmts and parts. Write for particulars. Technical Equipment Co., New York 6, N.Y.

750-watt phone or kilowatt code transmitter for 10, 20, 75, \$500. Handsome rig, splendid phone quality, best parts; custom-built by Bartlett, Portland. Ask for details and photo. Hayden Anderson, WIFDL, Dover-Foxcroft, Maine.

ORDER your call-sign now! 2 1/4" x 8", cast aluminum with polished border and Roman letters. Send \$2 to JC Mfg. Co., 1695 Third St., Palo Alto, Calif.

SALE: New Hallcrafters SX-25 and matching speaker. Perfect condition. Bought recently. A. Ogawa, Adams B-47, Cambridge 38, Mass.

SAVE money; big free list aircraft radio equipment: transmitters, BC-430, 457, 458, etc., \$50 and up. Receivers BC-429, 455, 348, etc., \$50 and up. Big stock dynamotors, varied sizes. Hand mikes, head-phones, amplifiers and hundreds of other items at prices never heard of before. Big free sales list. Send post card to E. "Tex" Helm, 319 So. Canyon St., Carlsbad, New Mexico.

CRYSTAL units, complete. Guaranteed high activity, 3.5 to 10 Mc. Within band, \$1.50. specified frequency, within 500 c., \$3. R. M. Lindsay, Box 4922, Warrington, Fla.

CLASS B multi-tap driver and Class B modulation transformers, also several power transformers. WSHXC, Box 109, Blackwell, Okla.

COMMERCIAL radio operators examination questions-and-answers. One dollar per element. G. C. Waller, W5ATV, 6540 E. Washington Blvd., Tulsa 15, Okla.

METERS repaired, calibrated. Budd, 38 Glendenny Ave., Jersey City 4, N.J.

HAMS: now while rebuilding your rig, have your meters reconditioned or converted. All work guaranteed. We also buy, sell, or trade. Haseltime Instrument Labs, 4135 No. Meade Ave., Chicago 34, Ill.

PERSONALIZED QSL cards. Your photo on your card, price: 500 cards, \$7.50; 1000 cards, \$10. Samples on request. Albraun Studio, 1742 N. Palmer St., Milwaukee 12, Wis.

FOR SALE: band-switching 75, 20, or 10-meter 1000-watt phone or c.w. transmitter. Line-up Exciter 6L6-6L6-807. Buff. 100th. Final pr. of 250THs Mod. 4 ea. 203Zs. Complete except for xtals. Sacrifice. Write for details. H. C. Goff, 1885 So. Grant St., Denver 10, Colo.

THE Trading Post: Send post-card listing parts for sale or trade and receive our stock list. Route 1, Box 754, Memphis, Tenn.

MICROWAVE equipment designed and built to your specifications. Radar Engineers, 1319 Second Ave., Seattle, Wash.

PARATROOP all-metal folding antenna in original triple-packed dehydrated container as used in War. New. Real buy for Ham-auto experimenter. 18" to 15 ft. Opens with a snap of the wrist. Worth \$10. Prepaid, \$1.49. Western Electric fixed xtal detector, 76-S. No adjusting, constant loud signal, rare buy, very scarce. Cost Govt \$6.00. Prepaid, 99c. Free list, War Surplus Bargains, Radio City Labs, 30 Church St., New York City 7.

QSLs. Write for free samples. Dossett, W9HUO, 857 Burlington, Frankfurt, Indiana.

QSL cards. New designs, 10¢, \$2.25, govt. post-cards. Samples. Victorian Press, 9 Dix St., Waltham 54, Mass.

WAR surplus: new top quality radio parts at a fraction of original cost.sylvania, type IN21, high frequency plug-in type receiving crystal, 98c; condensers, Centralab 50 µfd, 3000 v.d.c. silver ceramics, 29c; famous make, 1 µfd 600 v.d.c. metal encased oil impregnated tubulars, 19c each; 10 for \$1.70, 100 for \$16.00, 10,000 Ohm 10-watt IRC type AB resistor, 19c; shipping extra. Write for circular listing many other outstanding values. Erie Supply Co., 88 Exchange St., Rochester, N.Y.

CRYSTALS: low-drift, etch finished to your exact frequency, 40 and 80-meters (The new FT-243 with socket, \$2.50. Regular ham size to fit 8-prong socket, \$2.80, 24-hour service. Tedford Crystal Labs, 1626 Chase St., Cincinnati 23, Ohio.

GOVERNMENT surplus, steel tower with insulated cable, base plate, \$1.10 per foot. Power only, 75c per ft. Immediate shipment. Ace High Vertical Radiator Co., 206 Commerce Bldg., Sioux City, Iowa.

MILLIAMMETERS for sale: 0-10, 0-100, or 0-250 Ma. ranges. 3/16" flush panel type, 160' scale, Well-known make, \$3.50 c.o.d. Riebeck Electronics, 626 Newark Ave., Kenilworth, N.J.

AMPLIFIERS: Signal Corps VO-3-B audio oscillator amplifiers, 1 6J5, 1 6SN7, 2 6L6s, 1 5UA tubes included. Completely metal encased. Four to five hundred OHM tapped output, inverse feedback, makes fine speech amplifier or P.A. system with little change. Original cartons, instructions and schematic enclosed. \$20. Radio Hospital, 1021 King St., Alexandria, Va.

SIGNAL shifter coils, all bands, including 15-meters. Immediate shipment. \$4.00 per set, prepaid for cash. Inquire Ione Bandspread. Rodgers & Harris, 727 Main St., Mt. Carmel, Ill.

IDEAL inductance, seamless dead soft, 1/4" outside aluminum tubing. Ten foot coil \$1 postpaid in U.S.A. Hunt, W8HJM, Rd 3, Cortland, N.Y.

CODE equipment. Radio code set! Sends a real radio signal! Shipped complete with telegraph key, high frequency buzzer and instructions. Only \$1. For two-way communication or practice order two sets. Satisfaction guaranteed. Immediate shipment. Please include 20c postage. Rathert Electric Co., Dept. S1, Cresco, Iowa.

ACORN tubes with sockets, \$3.25; battery operated transceivers, phone, c.w., test equipment, etc. A. Polacek, 4809 So. Latrobe Ave., Stickney, Ill.

SURPLUS: amateur, experimental. Lectronic. 5832 Hegerman, Philadelphia.

TRADE: Westinghouse 1000-volt 6 µfd oil condensers for transmitting parts. W8JM, SCM, 303 Home, Fairmont, West Va.

FOR SALE, cheap: General Electric 872A rectifiers, \$5 apiece. Also Gammatron VT-127A triode transmitting tubes, \$10 apiece. Brand new. Never removed from boxes. D. G. Burzar, 10463 Dunier Lane, Los Angeles 34, Calif.

QSLs: SWLs. Meade, 1507 Central Ave., Kansas City, Kans.

QSLs. Samples free. Radio Headquarters, 1217 So. Calhoun Street, Fort Wayne 2, Indiana.

WANTED: Condenser, Hammarlund MTC 350-C. J. P. Gehegan, W2ODO, 740 East 243rd St., Bronx, 66, N. Y. C.

Only Vibroplex Has It!

JEWEL
Movement

VIBROPLEX

Reg. Trade Marks: Vibroplex, Lightning Bug, Bug

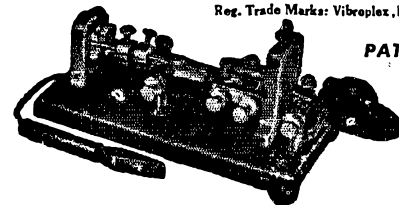

PATENTED!

EXCLUSIVE!

GENUINE
"ORIGINAL"
DELUXE
MODEL

\$19.50

America's finest radio key—the deluxe performer that sets new standards of sending excellence and operating ease. The jewels used in Delux Vibroplex keys are the same as those placed in the finest made watches and precision instruments, providing watch-like precision, feather-touch action, lifetime service and ease of operation unapproachable by any other key. Chromium finished base. Bright machined parts. Colorful red switch knob, finger and thumb piece, DIE CUT contacts and main spring, 3/16" contact Circuit closure cord and wedge. Delux finish also available in "Lightning Bug" and "Blue Racer" models. Order NOW! Money order or registered mail. FREE catalog.



The "BUG" Trade Mark identifies the Genuine Vibroplex.

Accept No Substitute

THE VIBROPLEX CO., Inc.

833 Broadway

New York 3, N. Y.

Designed for

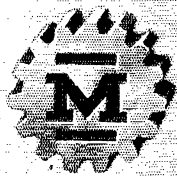

Application

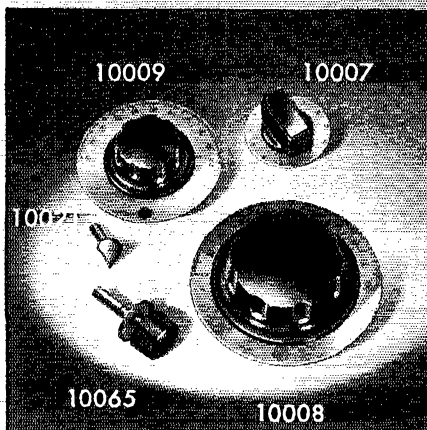

The Millen Group of Plain Dials

The No. 10007, 8, and 9 group of nickel silver plain dials with specially designed matching knobs have accurately reamed brass bushings so as to insure concentricity. The dials themselves are insulated from the hubs by means of spacer ring molded as part of the knob. The small 10007 unit is available with either 180° standard scale or 280° for potentiometer use. No. 10065 is vernier drive device for use with No. 10008, 3½" dial. The knobs are also available less dials, for other uses.

JAMES MILLEN MFG. CO., INC.

MAIN OFFICE AND FACTORY
MALDEN
MASSACHUSETTS



Index to Advertisers

	Page
Adson Radio Company	134
Aireon Manufacturing Corp.	88, 89
Allied Radio Corporation	115
American Lava Corporation	95
American Phenolic Corporation	146
American Radio Institute	136
Ashe Radio Co., Walter	93
Astatic Corp., The	142
Barker & Williamson	133
Bell Telephone Laboratories	128
Birnback Radio Co.	91
Billie Electric Co.	146
Bonn Co., Lew.	154
Brill Co., W. D.	154
Bruno Tools	147
Burlington Instrument Co.	150
Burstein-Applebee Co.	104
Cambridge Thermionic Co.	148
Candler System Co.	135
Capitol Radio Eng. Institute	100
Cardwell Mfg. Co., Allen D.	1
Centralab	116, 128, 148
Cleveland Inst. of Radio Electronics	9
Collins Radio Company	124
Commercial Equipment Co.	150
Commercial Radio Institute	140
Condenser Products Co.	130
Crystal Research Laboratories	110
Drake Electric Company	2
Eitel-McCullough, Inc.	148
Electrical Reactance Co.	97
Gates Radio Company	132
General Electric Company	4, 5
Greenlee Tool Company	87, 89
Hallcrafters Co., The	153
Hammarlund Mfg. Co., The	145
Harrison Radio Co.	108
Harvey Radio Co.	150
Harvey Radio Laboratories	142
Hatry & Young	139
Henry Radio Shop	152
Hytron Elec. & Radio Corp.	111
Instructograph Co., The	102
International Resistance Co.	114
Johnson Co., E. F.	134
Knights Co., The James	146
Kwikheat Soldering Irons	106, 107
Lewis Electronics	94
Maguire Industries	8
Mallory & Co., P. R.	136
Marion Elec. Instrument Co.	158
McMurdo Silver Co.	85, Cov. III
Millen Mfg. Co., The James	125, 126, 127
National Co., Inc.	138
Newark Electric Co.	123
New York Trade & Technical Schools	138
Ohmite Manufacturing Co.	138
Onan & Sons, D. W.	Cov. II
Panoramic Radio Corp.	101
Peterson Radio Co.	134
Port Arthur College	152
Premax Products	131, 159
Radio Mfg. Engineers	149
Radio Products Sales Co.	120, 121
Radio Shack Corp., The	152
Radio Transceiver Laboratories	138
RCA Institutes, Inc.	Cov. IV
RCA Mfg. Co.	144
Scell & Co., R. G.	132
Schauer Machine Co.	96
Shure Brothers	160
Solar Capacitors	151
Sun Radio & Electronics Co.	103, 105
Sylvania Electric Products	143
Taylor Tubes Co.	138
Telegraph Apparatus Co.	146
Television Tech. Enterprises	140
Telex, Inc.	137
Terminal Radio Co.	112, 113
Transmitter Equipment Mfg. Co.	149
Triplett Elec. Instrument Co.	154
UHF Resonator Co.	119
United Electronics	148
Valparaiso Technical Institute	118
Valpey Crystal Co.	157
Vibroplex Company	130
Ward Leonard Elec. Co.	117
Western Electric Co.	109
Westinghouse Electric Corp.	122
World Radio Laboratories	122

Announcing the RME 84

High in Quality — Low in Cost

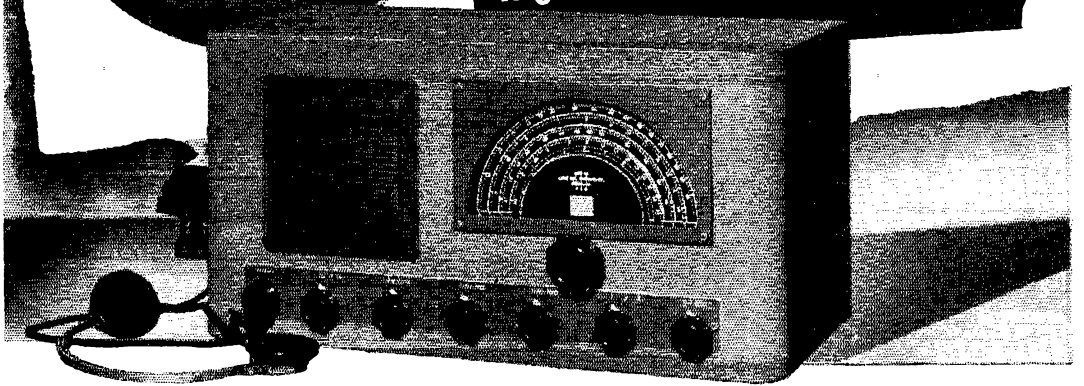

HERE'S the new RME 84 you'll be hearing a lot about during future QSO's. It's a precision instrument built to RME's tradition of expert engineering and quality components.

No compromise has been made with quality. An all gear and planetary tuning mechanism is used—no strings, no pulleys! Tubes are the new "lock-ins" resulting in high signal to noise ratio and exceptional performance in the higher frequency ranges.

For sensitivity and selectivity, compare the RME 84 with anything in its price class.

NET PRICE **\$98.70**

Features

- Four tuning ranges .54 to 44 MC.
- One Preselection Stage
- Smooth Vernier Tuning Control
- Bandspread Scale, arbitrarily calibrated from 0 to 100
- Bandspread, positively geared to main tuning control for accurate logging—no backlash!
- Automatic Noise Limiter
- Beat Frequency Oscillator—continuously variable by panel control
- Self Contained Shock Mounted PM Speaker
- Headphone Jack
- Standby, Receive & B F O Switch
- Antenna Input Terminals, provision for doublet or single wire
- Cabinet of heavy prime furniture steel beautifully finished in two-tone grey
- Plug connection provided for low drain battery operation.
- Eight tube superheterodyne circuit

Specification Sheet
on Request



RME

FINE COMMUNICATIONS EQUIPMENT

RADIO MFG. ENGINEERS, INC.

Peoria 6, Illinois U. S. A.



Capacitor

Quality...

TO SOLAR, "CQ" means *Capacitor Quality* because the Solar by-word is "Quality Above All". For all rigs — large or small — Solar manufactures every type of capacitor: from tiny tubulars for vest pocket receivers to solder-sealed high-voltage oil papers for 1 KW transmitters. All types are reliable in every climate!

Before choosing capacitors for that new transmitter or receiver, get Solar's free, new 36-page book SC-1. It's a complete catalog that belongs in every ham shack. It shows dimensions, capacitances and working voltages of every capacitor for ham use in the Solar line.

Send a post card for it TODAY.

SOLAR CAPACITOR SALES CORP.

285 Madison Avenue, New York 17, N. Y.



ELECTROLYTIC, PAPER AND MICA CAPACITORS

© 1975

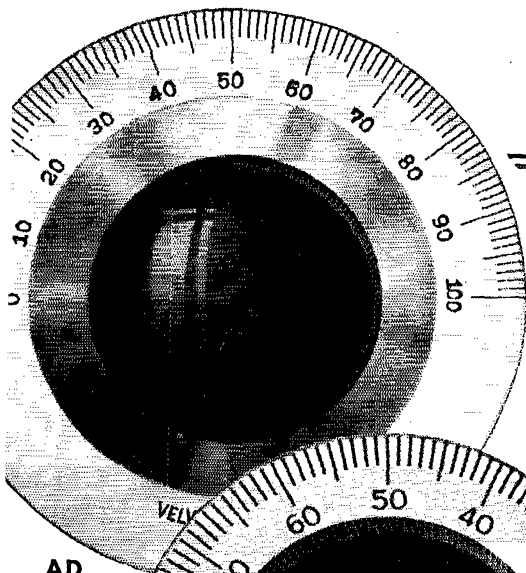

AD

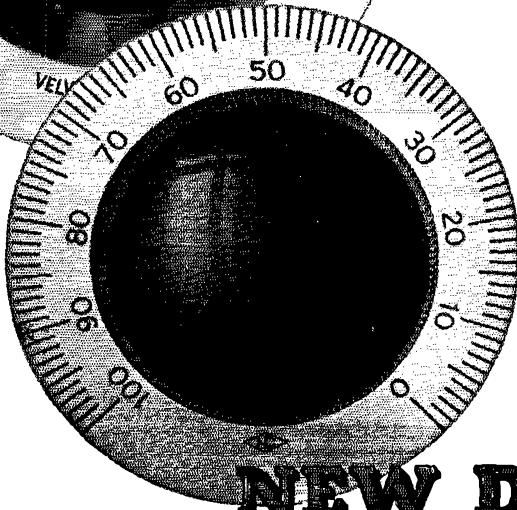

AM

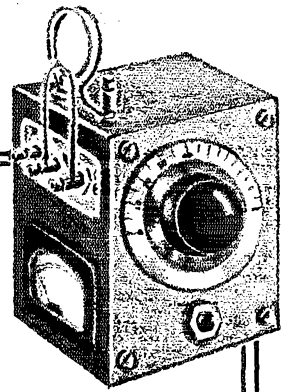

NEW DIALS

Wartime requirements for accurate smooth-working dials resulted in the design of these two new models. Both make use of the time-tested "Velvet Vernier" drive unit which for more than twenty years has been a favorite because of its incomparably smooth action and sensitive control. The Type AM Dial is three inches in diameter and is available with 2, 3, 4, 5 or 6 scale. The four-inch Type AD Dial is made with 2, 3, 4 or 5 scale.

Both are handsome in appearance and moderate in cost.

DIAL SCALES			
Scale	Divisions	Rotation	Direction of Condenser Rotation for increase of dial reading
2	0-100	180°	Counter Clockwise
3	100-0	180°	Clockwise
4	150-0	270°	Clockwise
5	200-0	360°	Clockwise
6	0-150	270°	Counter Clockwise

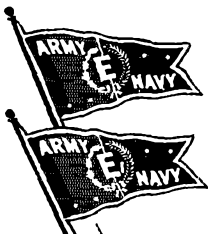

THE *BIG 3* IN POWER RECTIFIERS



RCA 5R4-GY full-wave, high-vacuum rectifier. Delivers 250 ma. dc at 700 volts, in full-wave circuit. Will handle transmitters up to 175 watts input.



RCA 816 half-wave, mercury-vapor rectifier. Two tubes in full-wave circuit deliver 250 ma. dc at 1600 volts and will handle transmitters up to 400 watts input.

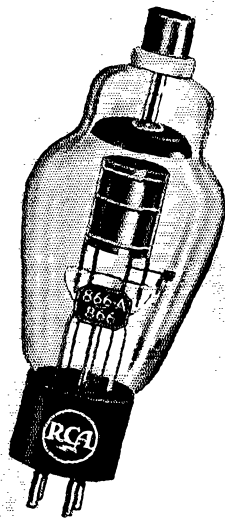

RCA 866-A/866 half-wave, mercury-vapor rectifier. Two tubes in full-wave circuit can deliver 500 ma. dc at 3200 volts—more than enough power for a full kilowatt.

These Time-Proven RCA Types Meet Practically All Amateur Transmitter Requirements

NAME your power, and the chances are that one of these three RCA tube types will supply it at less cost and over longer trouble-free periods. Their unusual performance records in prewar rigs and in wartime service point them up as the *preferred types* for current amateur transmitter designs.

RCA 5R4-GY has a heavy-duty coated filament that draws 2 amps. at 5 volts. Fitted with a low-leakage Micanol base, the tube can handle peak inverse voltages up to 2800 volts at 650 ma. peak current per plate.

RCA 816 employs an edgewise-wound coated ribbon filament that draws 2 amps. at 2.5 volts. High-voltage insulation is provided by bring-

ing the plate lead out at the top of the glass envelope. Rated peak inverse voltage is 5000 volts at 500 ma. peak plate current. Internal drop is approximately 15 volts.

RCA 866-A/866 combines the best features of the earlier 866 and 866-A types. Its edgewise-wound filament, drawing 5 amps. at 2.5 volts, has enormous emission reserve—hence, greater *useful* life. This tube has the ability to withstand a peak inverse voltage of 10,000 volts at 1000 ma. peak plate current.

You can count on RCA's Big 3 in power rectifiers for dependability and extra-long life. For further details, see your local RCA Tube Distributor.

THE FOUNTAINHEAD OF MODERN TUBE DEVELOPMENT IS RCA



TUBE DEPARTMENT

RADIO CORPORATION of AMERICA

HARRISON, N. J.