

December, 1946  
35 Cents

# QST

devoted entirely to

# amateur radio

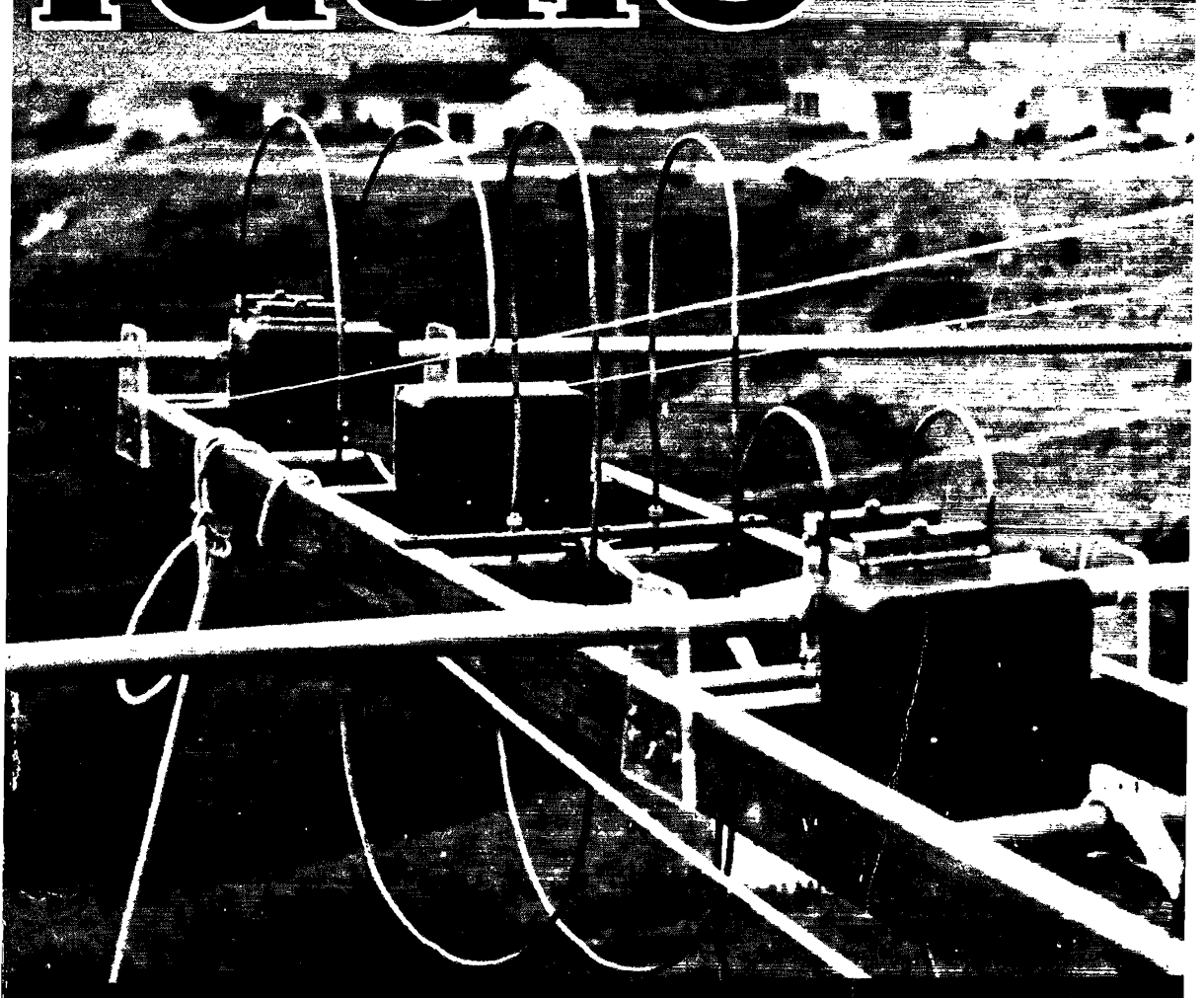

AMERICAN RADIO RELAY LEAGUE

FOR  
HEARING AIDS  
VEST POCKET RADIOS  
AIR BORNE DEVICES

UTC  
SUB-OUNCER SERIES

UTC Sub-Ouncer units are 9/16" x 5/8" x 7/8" and weigh only 1/3 ounce. Through unique construction, however, these miniature units have performance and dependability characteristics far superior to any other comparable items. The coil is uniform layer wound of Formex wire . . . On a molded nylon bobbin . . . insulation is of cellulose acetate . . . leads mechanically anchored (no tape) . . . core material Hipermetalloy . . . entire unit triple (waterproof) sealed. The frequency response of these standard items is  $\pm 3$  DB from 200 to 5,000 cycles.

Type	Application	Level	Pri. Imp.	D.C. In Pri.	Sec. Imp.
SO-1	Input	+ 4 V. U.	200 50	0	250,000 62,500
SO-2	Interstage 3:1	+ 4 V. U.	10,000	0	50,000
SO-3	Plate to Line	+ 23 V. U.	10,000 25,000	3 mil. 1.5 mil.	200 500
SO-4	Output	+ 20 V. U.	30,000	0 mil.	50
SO-5	Reactor 50 H.Y. at 1 mil. D.C. 3000 ohms D.C. Res.				

UTC  
OUNCER SERIES

The standard of the industry for seven years. The overall dimensions are 7/8" diameter by 1-3/16" height including lugs. Mounting is effected by two screws, opposite the terminal board side, spaced 11/16". Weight approximately one ounce. Units not carrying D.C. have high fidelity characteristics being uniform from 40 to 15,000 cycles. Items with D.C. in pri. are for voice frequencies from 150 to 8000 cycles.

Type	Application	Pri. Imp.	Sec. Imp.
0-1	Mike pickup or line to 1 grid	30, 200, 500	50,000
0-4	Single plate to 1 grid	8,000 to 15,000	60,000
0-5	Single plate to 1 grid, D.C. in Pri.	8,000 to 15,000	60,000
0-6	Single plate to 2 grids	8,000 to 15,000	95,000
0-8	Single plate to line	8,000 to 15,000	50, 200, 500
0-9	Single plate to line, D.C. in Pri.	8,000 to 15,000	50, 200, 500
0-12	Mixing and matching	50, 200	50, 200, 500
0-13	Reactor, 200 Hys-no D.C. 50 Hys-2MA D.C. 6,000 ohms		

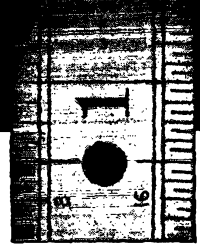

*United Transformer Corp.*  
150 VARICK STREET NEW YORK 13, N. Y.  
EXPORT DIVISION: 13 EAST 40th STREET, NEW YORK 16, N. Y., CABLES: "ARLAB"



# Here's the u-h-f pair you've been waiting for!

*Famous  
Lighthouse  
tubes*

Type  
2C40

Type  
2C43



**NOW** you can have G-E Lighthouse Tubes to work the u-h-f bands! Types 2C40 (receiving) and 2C43 (transmitting) are a celebrated team in the same frequency range—from 200 to 3,370 megacycles. Between 200 and 600 mc these small, compact G-E triodes give unmatched efficiency. Above 600 mc no other general-purpose tubes in their power-class are available.

Type 2C40's principal use is as a CW amplifier and oscillator for the full range of 200 to 3,370 mc. Type 2C43 is mainly employed as a CW amplifier and oscillator from 200 to 1,500 mc, or a plate-pulsed amplifier over the full frequency range.

Much has been written and said about the amazing job that lighthouse tubes—a G-E "first"—did during the war. *More* will be quoted in months to come about their unrivalled peacetime performance! Your G-E tube distributor will give you prices and information, or write *Electronics Department, General Electric Company, Schenectady 5, N. Y.*

### Type 2C40—ratings for typical operation

	Class A r-f amplifier	CW oscillator
Frequency . . . .	1,200 mc	2,400 mc
Plate voltage . . . .	250 v	250 v
Plate current . . . .	17 ma	20 ma
Power gain . . . .	12 db	—
Power output . . . .	—	0.2 w

### Type 2C43—ratings for typical operation

	CW oscillator	Plate-modulated amplifier
Frequency . . . .	1,200 mc	425 mc
Plate voltage . . . .	360 v	350 v
Power output . . . .	1.5 w	5 w

### The ultra-highs await the adventurous ham pioneer!

You'll get a thrill out of exploring the new bands that Types 2C40 and 2C43 open up! And in doing this, you'll be blazing a trail like other amateurs who, from the start, have led the search for new frontiers in radio . . . But remember—the ultra-highs require new methods, a revamping of your present rig! While Types 2C40 and 2C43 can be used in conventional tube circuits, and also will perform in long-line circuits from 150 to 600 mc, their top u-h-f performance is attained only by utilizing concentric transmission-line resonators. *G.E. is at your service should you need advice on circuits in this class.*



# GENERAL ELECTRIC

161-K10-8850

ELECTRONIC TUBES OF ALL TYPES FOR THE RADIO AMATEUR

*For Christmastime  
Giving or Receiving*

There is nothing finer  
than a

**TEMCO TRANSMITTER**

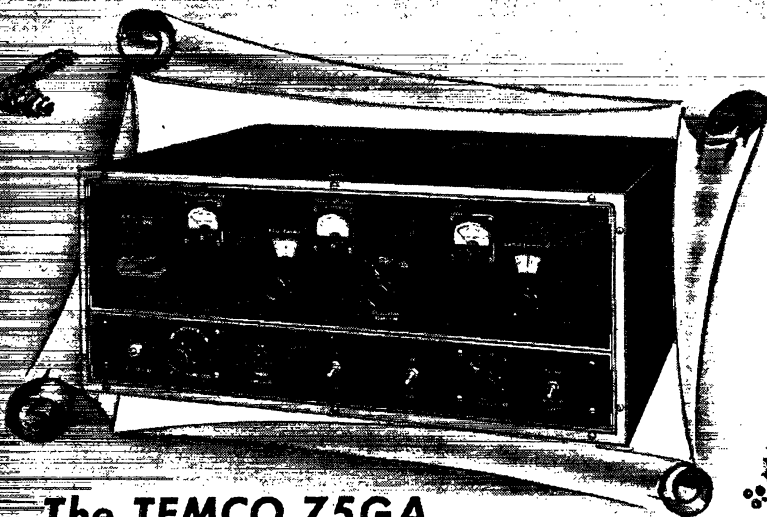

**The TEMCO 75GA...  
is a gift for generations to enjoy**

A complete 125 watt input telephone—150 watt  
input CW transmitter embodying all the refinements  
preferred by most discriminating amateurs. \$495.

*Everything at your fingertips and everything in one cabinet*



**TRANSMITTER EQUIPMENT  
MANUFACTURING CO., INC.**  
345 HUDSON STREET • NEW YORK 14, N.Y.

DECEMBER 1946

VOLUME XXX

NUMBER 12

★  
STAFF

**Editorial**

KENNETH B. WARNER, W1EH  
*(Managing Secretary, ARRL)*  
Editor

HAROLD M. MCKEAN, W1CEG  
*Assistant to the Editor*

GEORGE GRAMMER, W1DF  
*(Technical Director, ARRL)*  
Technical Editor

DONALD H. MIN, W1TS  
BYRON GOODMAN, W1DX  
*Assistant Technical Editors*

EDWARD P. TILTON, W1NDQ  
*V.H.F. Editor*

RICHARD M. SMYTH, W1FTX  
C. VERNON CHAMBERS, W1JEQ  
*Technical Assistants*

WALTER E. BRADLEY, W1PWH  
*Technical Information Service*

**Production**

RALPH T. BEAUDIN, W1RAW  
*Superintendent*

NANCY P. PORTEUS  
*Assistant*

**Advertising**

F. CHEYNEY BEEKLEY, W1GS  
*Advertising Manager*

**Circulation**

DAVID H. HOUGHTON  
*Circulation Manager*

RALPH T. BEAUDIN, W1RAW  
*Assistant Circulation Manager*

★

**OFFICES**

38 La Salle Road  
West Hartford 7, Connecticut

Subscription rate in United States and Possessions, \$2.50 per year, postpaid; \$3.00 in the Dominion of Canada, \$4.00 in all other countries. Single copies, 35 cents. Foreign remittances should be by international postal or express money order or bank draft negotiable in the U. S. and for an equivalent amount in U. S. funds.

Entered as second-class matter May 29, 1919, at the post office at Hartford, Connecticut, under the Act of March 3, 1879. Acceptance for mailing at special rate of postage provided for in section 1103, Act of October 3, 1917, authorized September 9, 1922. Additional entry at Concord, N. H., authorized February 21, 1929, under the Act of February 23, 1925.

Copyright 1946 by the American Radio Relay League, Inc. Title registered at U. S. Patent Office.

# QST

devoted entirely to

# AMATEUR RADIO

PUBLISHED, MONTHLY, AS ITS OFFICIAL ORGAN, BY THE AMERICAN RADIO RELAY LEAGUE, INC., AT WEST HARTFORD, CONN., U. S. A. OFFICIAL ORGAN OF THE INTERNATIONAL AMATEUR RADIO UNION.



## CONTENTS

"It Seems to Us . . ."	17
Silent Keys . . . . .	18
Single Control in the Bandswitching Transmitter <i>Joseph H. Harms, W2JME</i>	19
A Plan for the Ten-Meter Band . . . . .	26
"No, I'm Not on the Air" . . . . . <i>Julian N. Jablin</i>	28
A Unique Five-Band Antenna System <i>J. A. McCullough, W6CHE</i>	29
Five Are Better than Three . . . <i>W. W. Basden, W5CX5</i>	32
The Most Inexpensive Transmitter <i>Byron Goodman, W1DX</i>	33
Happenings of the Month . . . . .	36
What About the BC-375-E? . . . . .	38
The World Above 50 Mc. . . . .	43
Design of Cathode-Ray Tube Circuits <i>Walt Knoop, Ex-W9KHC</i>	45
Foreign Notes . . . . .	51
Postwar Ham Shacks . . . . .	52
Technical Topics Those Excellent C. W. Signals . . . . . 54 Standing Waves — Good or Bad? . . . . . 56	
Hints and Kinks . . . . .	58
How's DX? . . . . .	59
Correspondence from Members . . . . .	62
Operating News . . . . .	64
Station Activities . . . . .	76
ARRL QSL Bureau . . . . .	162
QST Index for 1946 . . . . .	189



# WIN A NEW SYLVANIA MODMETER!

**TYPICAL EXAMPLE** of one of the many applications for which the 1N34 crystal diode has been used can be read about in detail in an article in your QST for September, titled "A Combination Test Meter." This device uses no batteries, tubes.

**ALL YOU HAVE TO DO** is jot down your ideas on further applications of Sylvania's two new germanium crystal diodes—the 1N34 and 1N35. Send to Dept. 6X, address below. For every idea—see example below—published in Sylvania Electric's QST advertisements—Sylvania will award to the contributor one X7018 Modulation Meter! See your September QST for full description of this sensational meter.

Sylvania assumes no further obligation with respect to any use made of the entries or the ideas expressed therein. In the event of duplicate entries, only the first entry will be considered.

## EXAMPLE OF PRIZE-WINNING CRYSTAL DIODE KINK

Bothered by ignition noise? Insert P1 in head-phone output jack of communications receiver adjusted for code reception. Insert headphones in jack J1. Adjust receiver volume control to clip noise peaks but pass code signal.

- CI 0.005 mfd.
- J1 Single circuit jack
- P1 Headphone plug
- R1 15,000 ohm ½ watt
- S1 SPST toggle

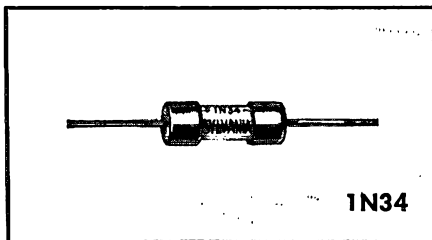
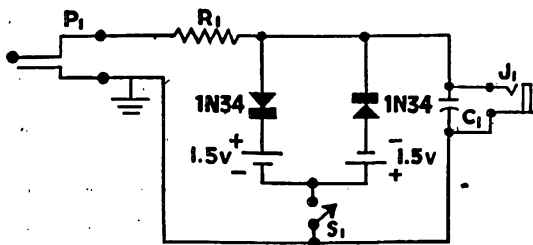

See your May QST for further applications and features of the 1N34 crystal diode.

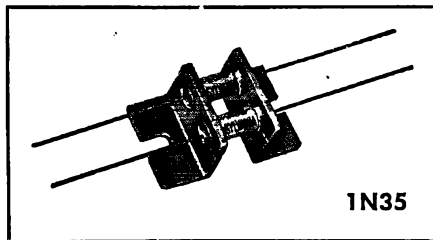

Your July QST will give full details of this new germanium crystal duo-diode.

# SYLVANIA ELECTRIC

Electronics Division . . . 500 Fifth Avenue, New York 18, N. Y.

MAKERS OF ELECTRONIC DEVICES; RADIO TUBES; CATHODE RAY TUBES; FLUORESCENT LAMPS, FIXTURES, WIRING DEVICES; ELECTRIC LIGHT BULBS

# *A PROFESSIONAL TRANSMITTER for the Amateur!*

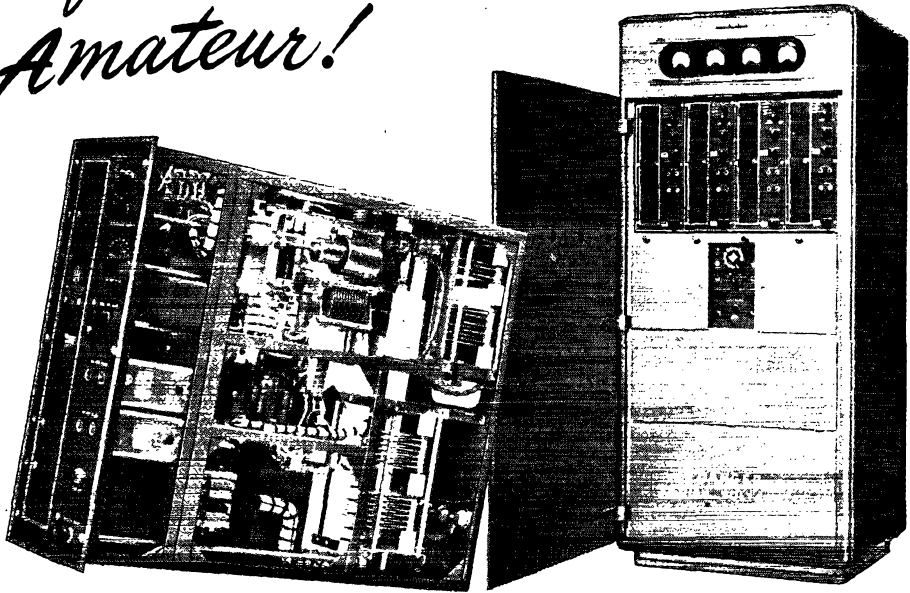

The latest developments in communication science are incorporated in the Wilcox 99A Transmitter. This advanced multi-frequency, 400 Watt carrier unit is now in use by major airlines in the United States. Rectifier, Modulator, Remote Control equipment, and four R.F. Transmitter Channels are housed in one modern steel cabinet. Bands can be instantly selected by telephone dial. Write for complete information.

## **WILCOX STAFF DEVELOPING AMATEUR EQUIPMENT**

A staff of 22 licensed amateurs under the direction of "Vince" Dawson, W9ZJB/3JSL, is developing amateur equipment of the same high quality that has brought fame and universal use to Wilcox commercial and airline products. Watch for these developments from Wilcox.



*Amateur Division of*  
**WILCOX ELECTRIC COMPANY, INC.**  
14th AND CHESTNUT STS. • KANSAS CITY 1, MO.

## Section Communications Managers of the ARRL Communications Department

Reports Invited. All amateurs, especially League members, are invited to report station activities on the first of each month (for preceding month) direct to the SCM, the administrative ARRL official elected by members in each Section. Radio Club reports are also desired by SCMs for inclusion in QST. All ARRL Field Organization appointments are now available to League members. These include ORS, OES, OPS, OO, and OBS. Also, where vacancies exist SCMs desire applications for SEC, EC, RM, and PAM. In addition to station and leadership appointments for Members, *all amateurs* are invited to join the ARRL Emergency Corps (ask for Form 7).

ATLANTIC DIVISION			
Eastern Pennsylvania	W3BES	Jerry Mathis	623 Crescent Ave. 9701 Monroe St.
Maryland-Delaware-District of Columbia	W3CIZ	Hermann E. Hobbs	Silver Springs P. O.
Southern New Jersey	W2GCU	Ray Tomlinson	623 E. Brown St.
Western New York	W2UPH	Charles I. Otero	4158 Ridge Road, West
Western Pennsylvania	W3NCJ	R. R. Rosenberg	927 East 23rd St.
CENTRAL DIVISION			
Illinois	W9AND	Wesley E. Marriner	624 College Ave.
Indiana	W9SWH	Ted K. Clifton	550 Eben St.
Kentucky	W5IEZ/4	Joseph P. Colvin	1653 Beechwood Ave.
Michigan	W8DPE	Harold C. Bird	R. F. D. 2, Box 228
Ohio	W8PNO	William D. Montgomery	1290 Coolidge Ave.
Wisconsin*	W9ARE	C. C. Richelleu	4901 S. 30th St.
DAKOTA DIVISION			
North Dakota*	W0KZL	Wilfred H. Rova	811 Sixth St.
South Dakota	W0QVY	P. H. Schultz	118 N. Yankton Ave.
Minnesota*	W0OMC	Vernon G. Pribyl	15 Glen St., South
DELTA DIVISION			
Arkansas	W5IIC	Marshall Riggs	4405 Howell Ave.
Louisiana	W5DWV	W. J. Wilkinson, jr.	Room 313, Jefferson Hotel
Mississippi	W5HAV	P. W. Clement	524 Santini St.
Tennessee	W4FLS	James W. Watkins	220 North Howell St.
HUDSON DIVISION			
Eastern New York	W2HZL	Ernest E. George	2044 Lexington Parkway
N. Y. C. & Long Island	W2KDC	Charles Ham, jr.	151-06 84th Drive
Northern New Jersey*	W2IIN	John J. Vitale	57 Sayre St.
MIDWEST DIVISION			
Iowa	W9PJR	Leslie B. Vennard	2712 Washington St.
Kansas	W0AWP	Alvin B. Unruh	842 N. Terrace Drive
Missouri	W0ODU	Mrs. Letha A. Dangerfield	411 Moffett Ave.
Nebraska	W0PQB	Arthur R. Gaeth	6105 N. 37 St.
NEW ENGLAND DIVISION			
Connecticut	W1QOY	Edmund R. Fraser	90 Atwater St.
Maine	W1AOL	G. C. Brown	379 No. Main St.
Eastern Massachusetts	W1ALP	Frank L. Baker, jr.	91 Atlantic St.
Western Massachusetts	W1AZW	Prentiss M. Bailey	62 Dexter St.
New Hampshire	W1AXL	John H. Stoughton	RFD 2
Rhode Island	W1HRC	Clayton C. Gordon	70 Columbia Ave., Gaspee
Vermont	W1NDL	Gerald Benedict	23 Foster St.
NORTHWESTERN DIVISION			
Alaska	K7CBF	August G. Hiebert	c/o KFAR
Idaho	W7IWM	Alan K. Ross	1017 East Jefferson St.
Montana	W7EQM	Albert Beck	18 Laird St.
Oregon*	W7BEE	Cliff Tice	McKay Dam
Washington*	W7EHQ	Lloyd Norberg	P. O. Box 281
PACIFIC DIVISION			
Hawaii*	KH6EL	John Souza	Box 2025
Nevada	W7GX	N. Arthur Sowle	1061 Fremont St.
Santa Clara Valley	W6BFT	Roy E. Pinkham	414 Fairmount Ave.
East Bay	W6I1	Horace R. Greer	215 Knowles Ave.
San Francisco	W6CVP	Samuel C. Van Liew	5240 Jay St.
Sacramento Valley	W6MGC	John R. Kinney	Box 849
Philippines	KA1GR	George L. Rickard	1548 L St.
San Joaquin Valley	W6PSQ	James F. Wakefield	
ROANOKE DIVISION			
North Carolina	W4CVB	W. J. Wortman	c/o Duke Power Co.
South Carolina	W4BOE/ANG	Ten Ferguson	3422 Rosewood Drive
Virginia	W4IHK	Walter R. Bullington	1203 E. Brookland Pk. Blvd.
West Virginia	W8JM	Donald B. Morris	303 Home St.
ROCKY MOUNTAIN DIVISION			
Colorado	W0QYT	Glen Bond	2550 Kendall
Utah-Wyoming	W7LLH	Victor Drabble	1024 Oak St.
SOUTHEASTERN DIVISION			
Alabama	W4GBV	Lawrence J. Smyth	808 Winona Ave.
Eastern Florida	W4IP	Robert B. Murphy	3302 S.W. Grapeland Blvd.
Western Florida	W4MS	Lt. Comdr. Edward J. Collins	1215 N. 12th Ave.
Georgia	W4HYW	Thomas M. Moss	570 Oak Drive
West Indies (Cuba)	KP4KD	Everett Mayer	P. O. Box 1061
(Puerto Rico-Virgin Islands)*			
SOUTHWESTERN DIVISION			
Los Angeles	W6QWZ	Ben W. Onesti	9631 3rd Ave.
Arizona	W7MLL	Gladden C. Elliott	1408 West Fresno St.
San Diego	W6CHV	Ralph H. Culbertson	7172 Eads St.
WEST GULF DIVISION			
Northern Texas	W5DAS	N. C. Settle	2911 Elm St.
Oklahoma	W5AYL	Ed Oldfield	2141 N.W. 35th St.
Southern Texas	W5JC	James B. Rives	1721 Kentucky Ave.
New Mexico	W5JHF	J. G. Hancock	110 S. E. Nevada St.
MARITIME DIVISION			
Maritime	VE1DQ	A. M. Crowell	69 Dublin St.
ONTARIO DIVISION			
Ontario	VE3DU	David S. Hutchinson	827 Lovett St.
QUEBEC DIVISION			
Quebec	VE2SU	Gordon F. J. Phelan	4829 Isabella Ave.
VANALTA DIVISION			
Alberta	VE6LQ	W. W. Butchart	10740-107 St.
British Columbia	VE7WS	W. W. Storey	3915 W. 32nd Ave.
PRAIRIE DIVISION			
Manitoba	VE4AM	A. W. Morley	26 Lennox St.
Saskatchewan	VE5SY	Arthur Chesworth	1084 Redland Ave.

\*Officials appointed to act temporarily in the absence of a regular official.



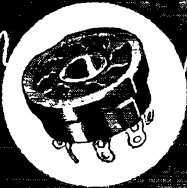
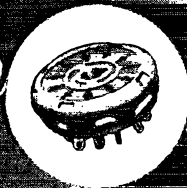

# Amphenol Components

— ACROSS THE GLOBE —

## and the Frequency Spectrum, Too!

In the eyes of amateurs and professionals of every nation Amphenol components represent the last word in electrical and mechanical design and correct manufacture.

From high voltage, high-frequency uses in the temperamental top segments of the spectrum, down through the high-current, low-voltage industrial applications — there are Amphenol cables, connectors, plugs and fittings designed and built to hold to the irreducible minimum loss of power, potential or waveform.

For Radar, Television, F.M., Railroad, Broadcast and Industrial use, Amphenol components speak the universal language of scientific efficiency, and they are available in the most complete line available from any one source in the world today. Write today for prompt attention to your needs.

**AMERICAN PHENOLIC CORPORATION** • Chicago 50, Ill.  
In Canada • Amphenol Limited • Toronto

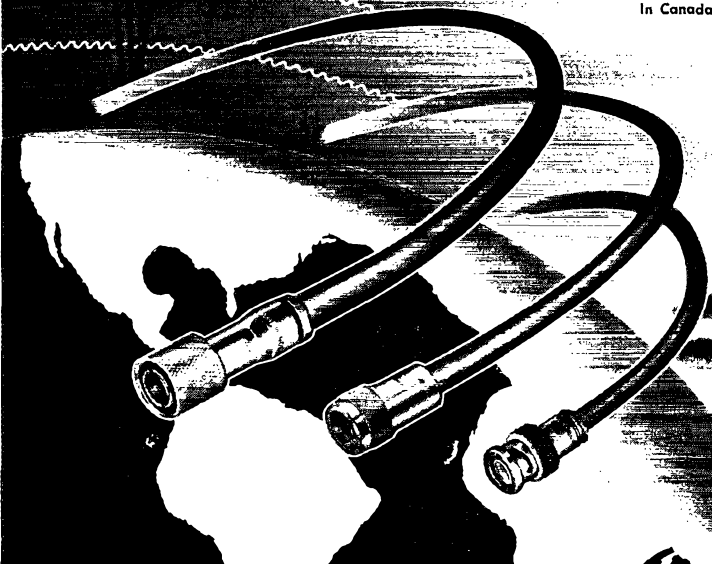

COAXIAL CABLES AND CONNECTORS • INDUSTRIAL CONNECTORS, FITTINGS AND CONDUIT • ANTENNAS • RADIO COMPONENTS • PLASTICS FOR ELECTRONICS

# Hallicrafters PRESENTS THE

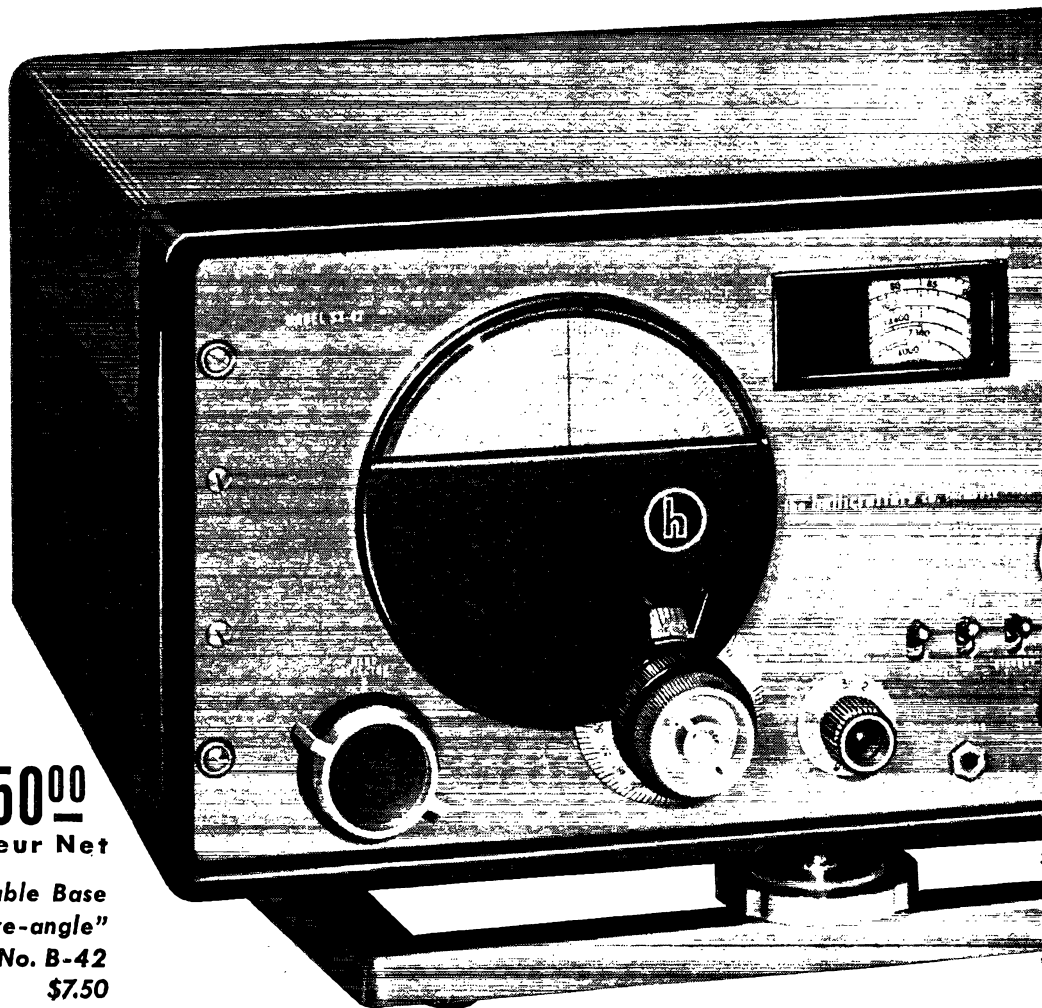

**\$250<sup>00</sup>**

**Amateur Net**

*Adjustable Base  
for "eye-angle"  
tuning No. B-42*

**\$7.50**

# SX-42

Opening a new chapter in amateur radio... read all about it in this 8-page section

In Model SX-42 Hallicrafters sets a new high standard of receiver performance and versatility. Covering all frequencies from 540 kilocycles to 110 megacycles, the SX-42 combines in one superbly engineered unit a top-flight standard and VHF communications receiver, standard, short-wave and FM broadcast receiver, and high-fidelity phonograph amplifier.

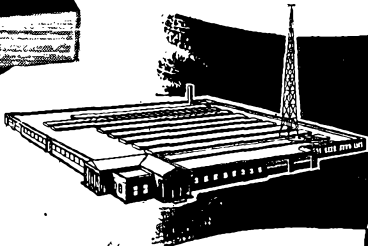

## hallicrafters RADIO

THE HALLICTRAFTERS CO., MANUFACTURERS OF RADIO AND ELECTRONIC EQUIPMENT, CHICAGO 16, U. S. A.

Sole Hallicrafters Representatives in Canada:  
Rogers Majestic Limited, Toronto-Montreal

BUILDERS OF

*kyfone*

AVIATION RADIOTELEPHONE

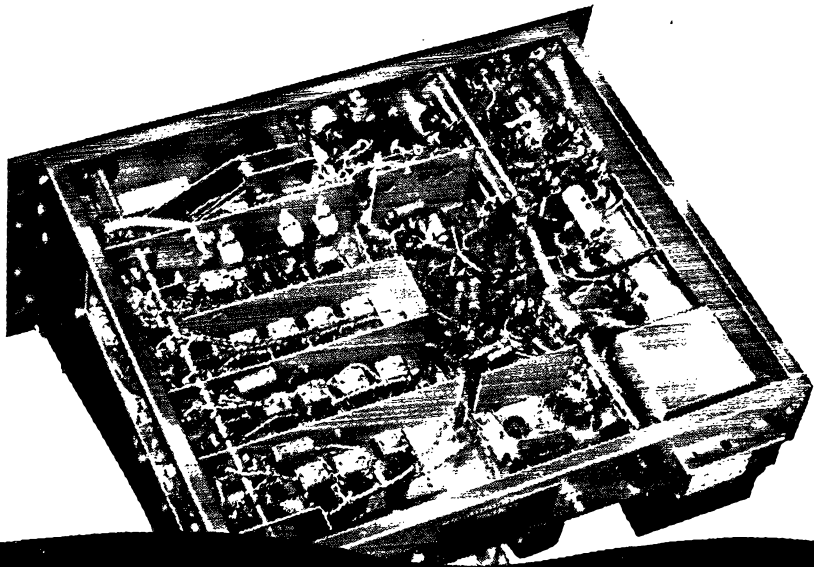

**Greatest continuous frequency coverage  
of any communications receiver . . .**

**FROM 540 kc. to 110 Mc. IN SIX BANDS**

The tremendous frequency range of the SX-42, greater continuous coverage than has ever before been available in a receiver of this type, is made possible by the development of a new "split-stator" tuning system and the use of dual intermediate-frequency transformers. Reception of amplitude modulated and continuous wave telegraph signals is provided for throughout the entire range of the SX-42. In addition, a discriminator and two limiter stages are available on bands 5 and 6 (27 to 110 megacycles) to permit the reception of frequency modulated signals. Musical reproduction of true high fidelity is assured by an audio system with a response curve essentially flat from 60 to 15,000 cycles and an undistorted output of eight watts.



**hallicrafters  
SX-42**

ULTRA HIGH  
FREQUENCIES

300.0

VERY HIGH FREQUENCIES

30.0

HIGH FREQUENCIES

3.0

MEDIUM FREQUENCIES

0.3

LOW  
FREQUENCY

100  
Mc

10.  
Mc

1.0  
Mc

0.1

BAND 6—55 to 110 megacycles

BAND 5—27 to 55 megacycles

BAND 4—15 to 30 megacycles

BAND 3—5 to 15 megacycles

BAND 2—1.62 to 5 megacycles

BAND 1—540 to 1620 kilocycles

**Ready to take**

**IN THE HAM SHACKS  
OF THE WORLD . . . .**

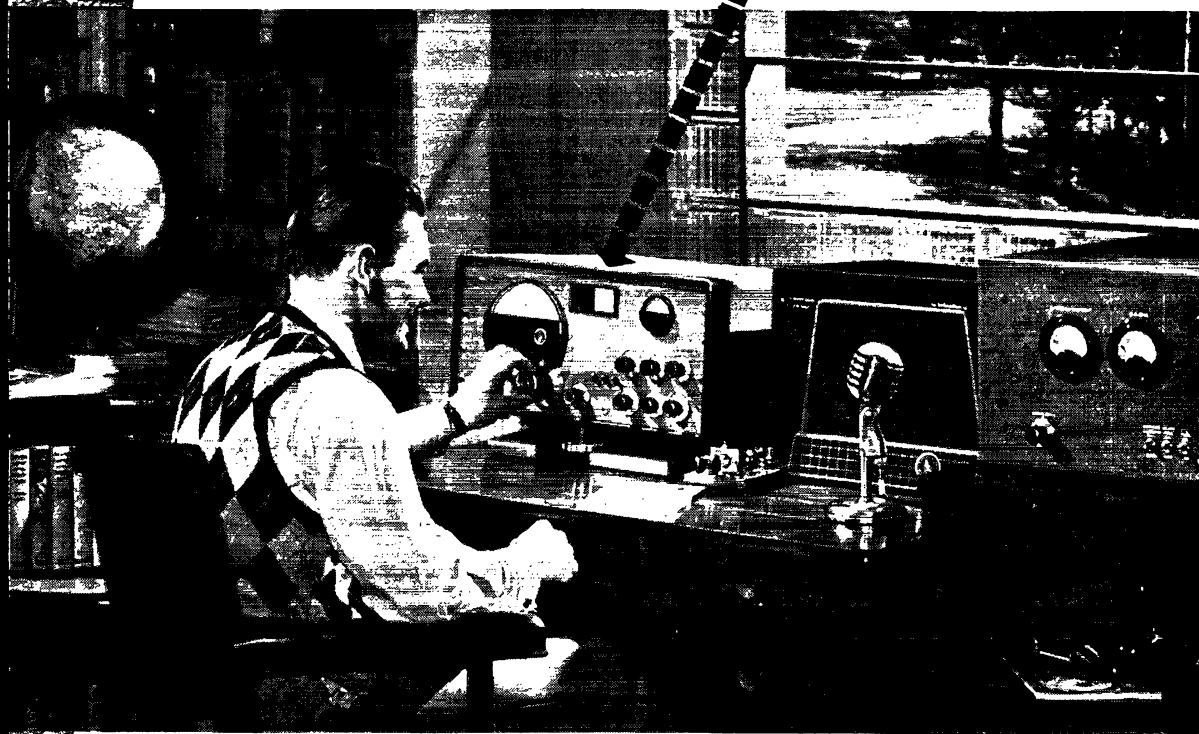

its place—



hallicrafters  
SX-42

The many new and ingenious circuit features which make possible the amazing versatility of the SX-42 stem directly from Hallicrafters long experience in the design and production of VHF and UHF communications equipment. The newly developed "split-stator" tuning system used on the three higher bands provides a far greater gain per stage than is possible with older methods. Each I-F transformer contains windings for both 455 kilocycles and 10.7 megacycles and the changeover is accomplished automatically between bands 4 and 5. As band 4 runs to 30 megacycles and band 5 starts at 27 megacycles, it is possible to use either narrow-band standard communications receiver performance or wide-band FM performance on the amateur frequencies from 28 to 29.7 megacycles. A type 7A4 tube functions as a beat frequency oscillator for CW reception. When the receiver is switched to FM, however, this tube becomes a direct-current amplifier to operate the FM tuning meter. This meter performs as a normal carrier level indicator for AM reception. A four-position switch on the panel selects the desired mode of operation—PHONO, FM, AM or CW.

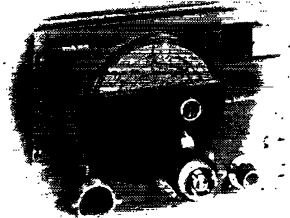

## Combinations that will unlock a new world of radio



The controls of the SX-42 are arranged for maximum convenience and simplicity of operation. MAIN TUNING and BANDSPREAD knobs are mounted coaxially, focusing the tuning functions in a single precision-built unit. BANDSWITCH and VOLUME are located at either side of the main dial. Auxiliary controls such as CRYSTAL PHASING, SENSITIVITY, etc., are logically placed so that those most frequently used are in the most accessible positions. Hallicrafters new system of color coding makes it possible for the entire family to enjoy this fine receiver. The normal control positions for standard broadcast reception are indicated by tiny red dots

while FM adjustments are in green.

The main tuning knob is provided with a precision vernier scale which is separately illuminated through a small window in the one-piece Lucite main dial housing. The main tuning dial is calibrated in megacycles and is marked with the numbers in the new FM band of 88 to 108 megacycles. The bandspread dial is calibrated for the amateur 3.5, 7, 14, 28, and 50 megacycle bands. An additional logging scale is provided on this dial for use in other ranges. The small locking knob mounted coaxially with the main and bandspread tuning knobs permits either to be rotated freely while holding the other firmly in position.

### FEATURES EVERY HAM WANTS

1. Continuous frequency range—540 kilocycles to 110 megacycles in six bands.
2. Wide vision main tuning dial accurately calibrated.
3. Separate electrical bandspread dial calibrated for amateur 3.5, 7, 14, 28, and 50 megacycle bands.
4. Beat frequency oscillator functions throughout entire range of receiver. CW pitch adjustable from panel.
5. Four-position switch selects mode of operation, PHONO, FM, AM, or CW.
6. RECEIVE/STANDBY switch.
7. Series type automatic noise limiter.
8. Push-pull final audio stage delivers over 8 watts with less than 8% harmonic distortion.
9. Audio amplifier response curve is essentially flat from 60 to 15,000 cycles.
10. Red markings for broadcast reception and green markings for FM reception simplify operation for general use.
11. Connections for coordinated operation with Hallicrafters transmitters.
12. Separate SENSITIVITY (RF) and VOLUME (AF) controls.
13. Four-position tone control provides LOW, MED, HI FI, and BASS.
14. Special socket for use of external power supply.
15. High frequency oscillator temperature-compensated to reduce drift.
16. "Micro-set" permeability-adjusted coils in RF section.
17. AVC switch.
18. "Airodized" steel top provides full ventilation and swings open on full-length piano hinge for greatest accessibility.
19. Wide band FM, AM or CW available from 27 to 110 megacycles.
20. Six-position selectivity switch with crystal filter operates on frequencies between 540 kilocycles and 30 megacycles.
21. Combination carrier level meter and FM tuning indicator. BFO tube performs dual function as FM tuning indicator amplifier.
22. New FM band marked with channel numbers in addition to megacycle calibration.
23. Dual intermediate frequency transformers; 455 kilocycle IF for standard operation, 10.7 megacycle IF for VHF and FM operation.
24. "Split-stator" tuning makes possible superior performance in VHF range.
25. Chassis and panel can be removed as a unit for rack mounting.
26. Crystal phasing control.
27. Antenna input impedance matches 300 ohm line.
28. 7F8 dual triode used as oscillator and converter provides excellent signal to noise ratio.
29. Two limiter stages for maximum quieting on FM.
30. Two tuned RF stages using miniature tubes for superior VHF performance.
31. Phonograph input connections on rear of chassis.
32. Type VR-150 voltage regulator tube provides maximum stability in high frequency oscillator, converter, BFO, and FM tuning meter circuits.
33. MAIN and BANDSPREAD tuning controls and dial lock are mounted coaxially as a single precision-built unit.
34. Main tuning knob provided with precision vernier scale, separately illuminated through small window in one-piece Lucite dial housing.

COPYRIGHT 1946 THE HALLICRAFTERS CO.

*Because of the precise and thorough engineering that must be done on the SX-42, and because the parts supply has not been continuous, top production peaks have not yet been reached. In the immediate future deliveries will necessarily run behind the demand. Meanwhile see your local distributor for demonstration and to place your order.*



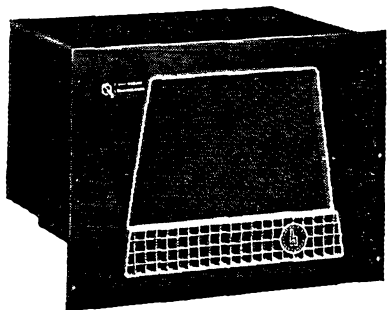
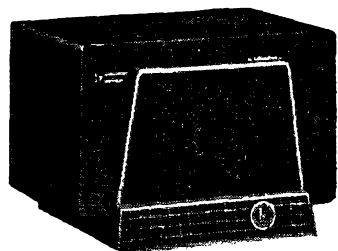

## NEW MATCHING SPEAKERS

The R-42 and the R-45 (the rack mounting version of the R-42) represent one of the greatest innovations in speaker design in recent years. This is the first speaker of its size to offer the splendid advantages of the bass reflex principle. Now in this sleek, highly functional design, matching the new line of Hallicrafters receivers, the bass reflex feature is available in a compact speaker that offers a new high quality of reproduction. The speaker size is 8 inches, with extra heavy magnet. Two-position switch on front panel for communications or high-fidelity reception. Terminals on rear for 500/600 ohm line. R-42, size: 12½" deep, 11¾" high, 17" wide. R-45, size: 12½" deep, 12¾" high, 19" wide.

R-42 Speaker \$25.00    R-45 Speaker \$27.50  
All prices Amateur Net

## EXTRAORDINARY VERSATILITY

**CONTROLS:** BAND SELECTOR, MAIN TUNING, BANDSPREAD, and selective DIAL LOCK, VOLUME and POWER OFF, AVC, NOISE LIMITER, RECEIVE/STANDBY, SELECTIVITY, TONE, SENSITIVITY, CRYSTAL PHASING, RECEPTION, CW PITCH. "S" meter adjustment on rear of chassis.

**EXTERNAL CONNECTIONS:** Antenna connections for doublet or single wire antenna. Input impedance matches 300-ohm line except on broadcast band which is designed for use with ordinary single wire antenna. Output terminals to match 500 or 5000 ohm speaker. Phone jack on front panel. Phonograph input connector on rear of chassis. Socket for use of external power supply. Remote standby switch connections provided for in power socket. Power cord and plug.

**PHYSICAL CHARACTERISTICS:** The Model SX-42 is housed in a steel cabinet of true functional design. Panel and chassis are assembled as

a unit and may be removed for servicing or for mounting in a relay rack. Panel is finished in deep gray, top of cabinet is of "aerodized" steel, silver gray finish, and swings open on a full-length piano hinge for maximum accessibility. Main dial housing is a single piece of Lucite fabricated by an injection molding process. Panel lettering is a light gray with incidental red and green markings for standard AM and FM reception. Dials are a light translucent green and are indirectly illuminated.

**FIFTEEN TUBES:** 1—6AG5 1st RF amplifier; 1—6AG5 2nd RF amplifier; 1—7F8 converter; 1—6SK7 1st IF amplifier; 1—6SG7 2nd IF amplifier; 1—6H6 AM rectifier and noise limiter; 1—7H7 1st FM limiter amplifier; 1—7H7 2nd FM limiter; 1—6H6 FM discriminator; 1—6SL7 audio inverter; 2—6V6 audio output tubes; 1-7A4 beat frequency oscillator and FM tuning meter amplifier; 1—VR-150 voltage regulator; 1—5U4G high voltage rectifier.

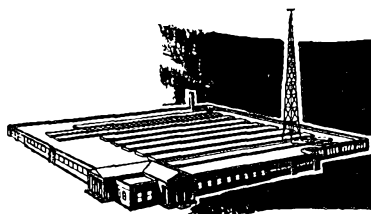

# hallicrafters RADIO

THE HALLICRAFTERS CO., MANUFACTURERS OF RADIO AND ELECTRONIC EQUIPMENT, CHICAGO 16, U. S. A.

Sole Hallicrafters Representatives in Canada:  
Rogers Majestic Limited, Toronto-Montreal

BUILDERS OF

*Skyfone* AVIATION RADIOTELEPHONE

# THE AMERICAN RADIO RELAY LEAGUE, INC.,

is a noncommercial association of radio amateurs, bonded for the promotion of interest in amateur radio communication and experimentation, for the relaying of messages by radio, for the advancement of the radio art and of the public welfare, for the representation of the radio amateur in legislative matters, and for the maintenance of fraternalism and a high standard of conduct.

It is an incorporated association without capital stock, chartered under the laws of Connecticut. Its affairs are governed by a Board of Directors, elected every two years by the general membership. The officers are elected or appointed by the Directors. The League is noncommercial and no one commercially engaged in the manufacture, sale or rental of radio apparatus is eligible to membership on its board.

"Of, by and for the amateur," it numbers within its ranks practically every worth-while amateur in the nation and has a history of glorious achievement as the standard-bearer in amateur affairs.

Inquiries regarding membership are solicited. A bona fide interest in amateur radio is the only essential qualification; ownership of a transmitting station and knowledge of the code are not prerequisite, although full voting membership is granted only to licensed amateurs.

All general correspondence should be addressed to the Secretary at the administrative headquarters at West Hartford, Connecticut.



## Past Presidents

HIRAM PERCY MAXIM, W1AW, 1914-1936  
EUGENE C. WOODRUFF, W8CMP, 1936-1940

## Officers

**President** ..... GEORGE W. BAILEY, W2KH  
Washington, D. C.

**Vice-President** ..... J. LINCOLN McCARGAR, W6EY  
Oakland, California

**Secretary** ..... KENNETH B. WARNER, W1EH  
West Hartford, Connecticut

**Communications Manager** ..... F. E. HANDY, WIBDI  
West Hartford, Connecticut

**Treasurer** ..... DAVID H. HOUGHTON  
West Hartford, Connecticut

**General Counsel** ..... PAUL M. SEGAL  
1026 Woodward Building, Washington 5, D. C.

## Directors

**President**  
GEORGE W. BAILEY ..... W2KH  
1530 P St., N.W., Washington 25, D. C.

**Vice-President**  
J. LINCOLN McCARGAR ..... W6EY  
66 Hamilton Place, Oakland 12, Calif.

**Canadian General Manager**  
ALEX REID ..... VE2BE  
240 Lorain Ave., St. Lambert, P. Q.  
**Alternate:** Leonard W. Mitchell ..... VE3AZ  
78 Raglan Ave., Toronto, Ont.

**Atlantic Division**  
EDWARD G. RASER ..... W2Z1  
315 Beechwood Ave., Trenton 8, N. J.  
**Alternate:** J. Victor Brotherson ..... W8BITN  
1743 Ottawa Drive, Erie, Pa.

**Central Division**  
JOHN A. KIENER ..... W8AVH  
3462 Edison Rd., Cleveland Heights,  
Cleveland 21, Ohio  
**Alternate:** Earl S. Nelson ..... W8DJS  
22,551 Hadden Rd., Euclid 17, Ohio

**Dakota Division**  
TOM E. DAVIS ..... W0SW, ex-W9VVA  
915 W. Becker Ave., Willmar, Minn.  
**Alternate:** Harold B. Love ..... W9ZRT  
Box 426, Mandan, N. D.

**Delta Division**  
GEORGE S. ACTON ..... W5BMM  
Plain Dealing, La.  
**Alternate:** Eugene H. Treadway ..... W5DKR  
P. O. Box 44, La Place, La.

**Hudson Division**  
ROBERT AKERIDGE KIRKMAN ..... W2DSY  
Address correspondence to the Acting Director:  
GEORGE RULFES, JR. ..... W2UJY  
38 Brookwood Drive, Manliusset, L. I., N. Y.

**Milwest Division**  
Acting Director:  
C. A. COLVIN ..... W9VHR  
% Omaha & Council Bluffs St. Railway Co.,  
Omaha 2, Nebr.

**New England Division**  
PERCY C. NOBLE ..... W1BVR  
37 Broad St., Westfield, Mass.  
**Alternate:** Clayton C. Gordon ..... W1HRC  
70 Columbia Ave., Warwick, R. I.

**Northwestern Division**  
KARL W. WEINGARTEN ..... W7BG  
3219 N. 24th St., Tacoma 7, Wash.  
**Alternate:** R. Rex Roberts ..... W7CPY  
110 W. Brennan St., Glendive, Mont.

**Pacific Division**  
WILLIAM A. LADLEY ..... W6RBQ  
200 Naylor St., San Francisco 12, Calif.  
**Alternate:** Elbert J. Amarantes ..... W6FBW  
1675 Dale Ave., San Jose, Calif.

**Roanoke Division**  
H. L. CAVENESS ..... W4DW  
2607 Vanderbilt Ave., Raleigh, N. C.  
**Alternate:** J. Frank Key ..... W3ZA  
Box 707, Buena Vista, Va.

**Rocky Mountain Division**  
Acting Director:  
HOWARD R. MARKWELL ..... W8TFP  
355 Monroe St., Denver 6, Colo.

**Southeastern Division**  
WILLIAM C. SHELTON ..... W4ASR  
527 Revillo Blvd., Daytona Beach, Fla.  
**Alternate:** William P. Sides ..... W4AUP  
Fleming Road, Montgomery, Ala.

**Southwestern Division**  
JOHN E. BICKEL ..... W6BKY  
1834 E. Whittier Blvd., Whittier, Calif.  
**Alternate:** Eldridge E. Wyatt, Jr. ..... W6ARW  
P. O. Box 3597, Long Beach 3, Calif.

**West Gulf Division**  
WAYLAND M. GROVES ..... W5NW  
% Humble Pipe Line Co., Odessa, Texas  
**Alternate:** Jennings R. Poston ..... W5AJ  
P. O. Box 848, Curundu, Panama Canal Zone

## "It Seems to Us..."

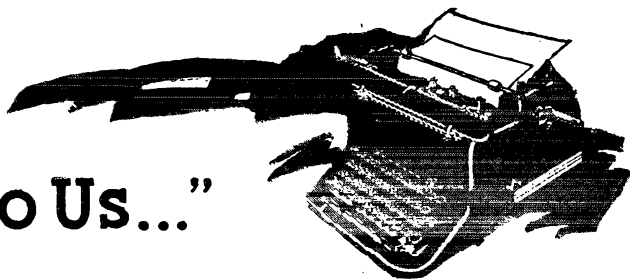

### FORTY

The forty-meter band is justifiably one of our most popular bands. A great many amateurs prefer it to any other, and our prewar occupancy surveys year after year showed it to have more stations per kilocycle than either 80 or 20. Small wonder, then, that many questions are being asked us these days about the foreign broadcast carriers in this band and what, if anything, can be done to get them out. This matter has had an interesting history which it would seem many of us have forgotten, so we believe it will be profitable to review it here.

Ever since the first international radio conference that dealt with short waves, the frequencies 7000-7300 kc. have been exclusively amateur all around the world — until the conference of Cairo in early 1938. At that conference there was a terrific rumpus about short-wave broadcasting. A war was coming on and most of the foreign nations, particularly in Europe, wanted more broadcasting frequencies on which to put out their propaganda, and they fought like mad for them. The United States was hard put to it to preserve our 7- and 14-Mc. bands, particularly against the onslaughts of the European nations. At the end it was decided that in the American hemisphere the amateur band should remain 7000-7300 but in other regions the exclusively-amateur part would be only 7000-7200, while 7200-7300 in those regions would be marked as both amateur and broadcasting. This arrangement left it to the pleasure of the individual country whether the last hundred kilocycles of the band would still be given amateurs, would be diverted to broadcasting, or would be shared between the two. Earlier it had been proposed to make this alternative arrangement available only in Europe but the administrators of some countries on other continents — even of countries as friendly to amateurs as Australia — asked to be included in the option. Thus the American region became the only one in which the whole 7000-7300 range is amateur beyond

peradventure. Thus also you cannot tell, until you inquire, whether the amateur assignment of a given non-American country ends at 7200 or 7300. Many such countries have continued the whole band to amateurs. Incidentally, you can now see how it was that the League, asked to name which half of the 7-Mc. band it preferred to have returned first by the military, named the top half — so that as many amateurs as possible, all around the world, would be reestablished all the way up to 7300.

As a consequence of the treaty provision described above, we have no legal room for complaint if we hear a broadcasting station between 7200 and 7300 in any country outside the Americas. Such nations have the option of denying these frequencies to hams and they are lawfully entitled to use them for broadcasting.

With thousands of amateurs using the frequencies for their own work in every quarter of the globe, we cannot see that they have any appreciable value for broadcasting. The chief result seems to be mutual interference. The strong carriers of these powerful stations of course cause destructive interference to our c.w. telegraph work. Some nights the best we can do is to wedge our VFOs carefully between these carriers. And even then it's not much of a go except for schedules, since it is unpleasantly discouraging to tune a c.w. receiver through this part of the band with the gain up. And woe to the chaps with fixed crystal frequencies if they fall on any of these strong carriers — nobody hears them. Now this interference is a great deal more destructive to c.w. than it would be to telephony. It takes a 'phone to compete with another 'phone. When the philosophy gradually evolved in amateur circles that 'phone is entitled to some of the 40-meter band, the position was automatically indicated: it should be the 7200-7300 part, since it is obvious that 'phone can make much more effective use of it under the existing circumstances than can c.w. We would have asked for some such 'phone assignment right

from the start except that a half of the band is too narrow a range to support both 'phone and c.w. activity properly. That is why the League's request is that 7200-7300 be opened to 'phone when we again have the entire band. Incidentally, a somewhat similar arrangement was on the way when war came. That time, instead of being without our 160-meter band, we were lending most of the 80-meter band to the military for training purposes, and the necessary rearrangements involved opening the high end of 40 to 'phone. A poll of amateur sentiment showed that we had found then, as we have again, that 'phone is much more able to compete with the foreign broadcasters. That arrangement was dated to go into effect on December 15, 1941, but Pearl Harbor, a week before, washed it out and closed us down and necessitated a fresh start.

While we're talking about 7200-7300 we'll remark that the situation in Great Britain seems an odd one. Amateurs there always had the whole band. Since the war ended the British government has opened 7150-7300 to amateurs the same as the United States and Canada have, yet the BBC stations between 7200 and 7300 continue merrily on. They shouldn't, since it is obviously England's policy to assign the whole band to amateurs. We can only think that it is an unsettled hang-over from the war. The RSGB is working on the problem of getting them out and we join them in hoping for results.

The situation above 7200 does not, however, tell the whole story. There are also broadcasting stations between 7000 and 7200, including 7150-7200. This is contrary to the Cairo regulations, to which every major nation is a party. Any such operation in derogation of the treaty is justifiable only on the legal fiction that a state of war still exists. We recall that in 1939 or '40, after the war had started in Europe but before it came to us in the States, we had occasion to protest the operation of BBC stations on frequencies below 7200. England was fighting a desperate war and BBC, a government agency, regretted that the requirements of the war effort made necessary a violation of the treaty, but promised that they would remove themselves after the war. Propaganda broadcasting is a weapon and we must expect that during a war, when our frequencies are held by our governments, some of them will be used for that purpose. But there would seem to be no more justification today for their continued use for broadcasting than there would be for their continued use by the military services. We are on the eve of the return of the rest of our bands. When they come back to us the League will feel that that action constitutes a declaration that the war is over, as far as concerns those bands, and

at that time we shall expect all broadcasting to cease between 7000 and 7200 kc. The treaty will again be in full force and there will be no room for derogations. This will be the common feeling of the amateur societies of all the world.

Next year there will be another world conference, another world allocation ladder. The United States has proposed that 7000-7300 again be exclusively amateur everywhere. Doubtless there will be the usual flock of positive ideas to the contrary. The broadcasting pressure ought to be a little less, because the war is over, every nation is poor, and there is small incentive to propagandize neighboring states at great expense; most countries want only to be left to live in peace. But we suppose that only means that there will be pressure from some other quarter — it's always that way at international conferences.

Anyway, 40 is a great band, and soon it should be wider and cleaner and more interesting than it ever has been before.

*Abbey*

### Silent Keys

IT IS with deep regret that we record the passing of these amateurs:

- Ex-W1MW, Hugh Codman, Cambridge, Mass.
- W4FJS, Charles P. Walton, Raleigh, N.C.
- W4FRI, Thomas W. Sparrow, Auburn, Ala.
- W4HDQ, Fred D. Bland, Birmingham, Ala.
- W6FGI, Harry M. Gray, Los Angeles, Calif.
- Ex-W7DYK, Mason H. Mears, Medford, Oregon
- W9JEE, Harold E. Tibbets, Hebron, Nebraska
- W9JWL, Gertrude Culver, New Haven, Ind.
- K6AGI, Wah C. Chock, Honolulu, T.H.
- K7GLD, Frank C. Spoon, Pilot Pt., Alaska
- Ex-KA1AB, ex-KA8AA, Capt. Thomas A. Wallace, Rizal, P.I.
- VE1JP, Leslie G. MacKeeman, Bathurst, N.B.
- VE3IW, A. L. Chown, Toronto, Ont.
- Ex-VE4AG, Clifford W. Ferg, Winnipeg, Man.

# Single Control in the Bandswitching Transmitter

*A 3.5-to-30-Mc. Exciter with Broad-Band Driver Circuits*

BY JOSEPH H. HARMS, W2JME \*

**E**VER since the introduction of the bandswitching receiver it has undoubtedly been the ambition of every amateur to have a companion unit — a transmitter that could be shifted from band to band by the flip of a switch and whose frequency could be varied throughout all bands without the necessity for operating more than one control. In such a unit, the output should remain relatively constant and should be great enough — 50 to 60 watts — to suffice either for low-power work or for driving a high-power final amplifier. In addition, the unit should of course be arranged for either VFO or crystal control, and should operate with any crystal in the 3.5–4.0-Mc. band without any adjustment of the oscillator tank circuit.

Naturally, such a unit can be realized. However, attempts in the past have either been based on band-pass filters with one or two capacity-tuned circuits, or else ganged tuning of the cir-

\* 3008 Ludlow Road, Lake Parsippany, R.D. 2, Morris Plains, N. J.

cuits. Both methods required special techniques and equipment for alignment. The "pipe dream" transmitter to be described was developed with the purpose of simplifying such a unit without sacrificing any of the desirable features listed above.

Many different schemes were tried and rejected for various reasons before the unit shown was evolved. The most promising-looking approach was to use some form of broadly-tuned circuit in each stage, sacrificing efficiency for uniform output over each band. This requires very low-*C* circuits, the capacitance in fact being only the residual tube and circuit capacitances. Essentially, the unit consists of a 6L6 crystal oscillator (or input amplifier, if VFO is used) operating on 3.5–4 Mc., followed by a 6L6 7-Mc. doubler, a 6L6 14-Mc. doubler or 21-Mc. tripler, and a fourth 6L6 as a 27–28-Mc. doubler. The 6L6s have sufficient power capacity to operate at low efficiency and give the necessary output for driving the final tube, an 807, without running at

The bandswitching single-tuning-control exciter. Three separate units, power supply, VFO, and transmitter occupy separate chassis mounted side by side on a relay-rack panel. The VFO dial is in the center, with the 807 milliammeter to the left and 807 plate-tank band-setting condenser to the right. Controls along the bottom, from left to right, are the a.c. line switch, transmitter plate-supply switch, VFO on-off switch, combined VFO band-selector and crystal selector switch, on-off switch for 100-kc. oscillator, meter switch, and transmitter bandswitch. The knob at the extreme right is to control a crystal switch incorporated in the transmitter proper.

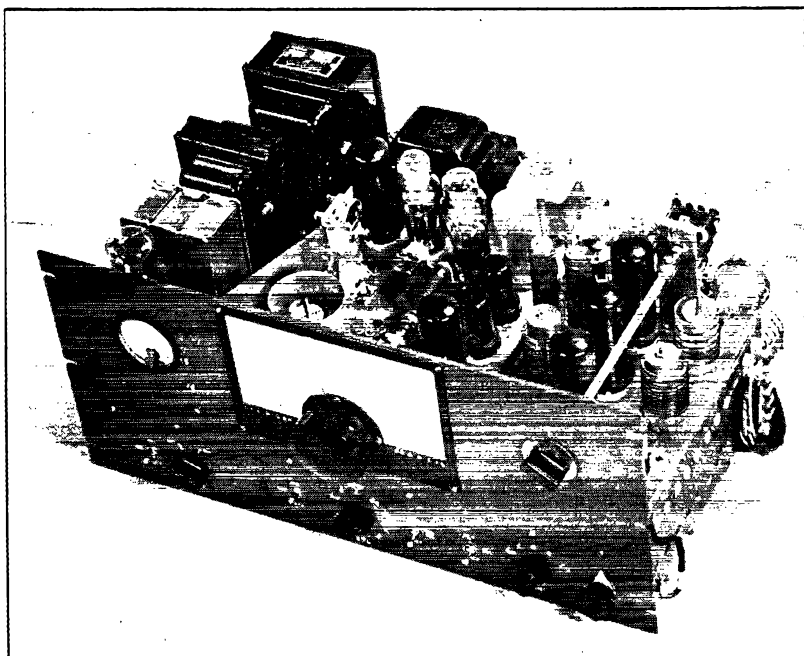
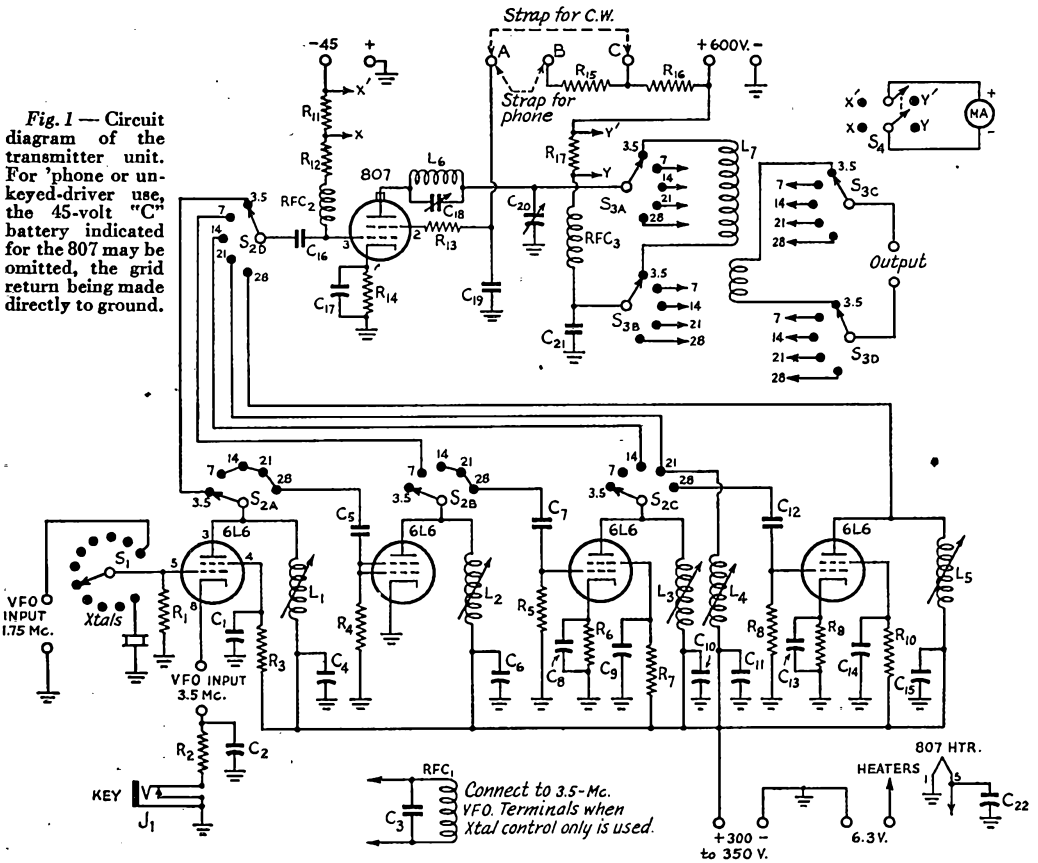

Fig. 1 — Circuit diagram of the transmitter unit. For 'phone or unkeyed-driver use, the 45-volt "C" battery indicated for the 807 may be omitted, the grid return being made directly to ground.



- $C_1, C_2, C_4, C_6, C_8, C_9, C_{10}, C_{11}, C_{13}, C_{14}, C_{15}, C_{17}, C_{22}$  — 0.01- $\mu$ fd. paper.  
 $C_3$  — 200- $\mu$ fd. mica.  
 $C_5, C_7, C_{12}, C_{16}$  — 40- $\mu$ fd. mica.  
 $C_{18}$  — 30- $\mu$ fd. ceramic trimmer.  
 $C_{19}, C_{21}$  — 0.005- $\mu$ fd. mica.  
 $C_{20}$  — 100- $\mu$ fd. variable (Hammarlund MC-100-M).  
 $R_1$  — 50,000 ohms,  $\frac{1}{2}$  watt.  
 $R_2, R_6, R_9$  — 300 ohms, 1 watt.  
 $R_8, R_7, R_{10}$  — 30,000 ohms, 5 watts.  
 $R_4, R_5, R_8$  — 15,000 ohms, 1 watt.  
 $R_{11}, R_{12}$  — 50 ohms, 1 watt.  
 $R_{12}$  — 7000 ohms, 2 watts.  
 $R_{14}$  — 660 ohms, 10 watts.  
 $R_{15}, R_{16}$  — 20,000 ohms, 25 watts.  
 For c. w. operation only terminal B must be connected to ground.  
 $R_{17}$  — Shunt to increase meter scale to 150 ma.

- $L_1$  — 50 turns No. 22 enam., close-wound on  $1\frac{1}{16}$ -inch diam. form.  
 $L_2$  — 23 turns No. 22 enam., close-wound on  $1\frac{1}{16}$ -inch diam. form.  
 $L_3$  — 12  $\frac{1}{2}$  turns No. 20 enam., length  $1\frac{1}{2}$  inches, diam.  $1\frac{1}{16}$  inches.  
 $L_4$  — 9  $\frac{1}{2}$  turns No. 20 enam., length  $1\frac{1}{2}$  inches, diam.  $1\frac{1}{16}$  inches.  
 $L_5$  — 5  $\frac{1}{2}$  turns No. 20 enam., length  $1\frac{1}{2}$  inches, diam.  $1\frac{1}{16}$  inches.  
 $L_6$  — 5 turns No. 16, spaced wire diam., coil diam.  $\frac{1}{2}$  inch.  
 $L_7$  — 3.5 Mc.: 38 turns No. 20, length 2 inches, diam.  $1\frac{1}{2}$  inches, with 8-turn link.  
 7 Mc.: 22 turns No. 16, length 2 inches, diam.  $1\frac{1}{2}$  inches, with 5-turn link.  
 14 Mc.: 8 turns No. 16, length

- $1\frac{3}{8}$  inches, diam.  $1\frac{1}{2}$  inches, with 2-turn link.  
 21 Mc.: 6 turns No. 16, length 1 inch, diam.  $1\frac{1}{2}$  inches, with 2-turn link.  
 28 Mc.: 4 turns No. 16, length  $1\frac{1}{2}$  inches, diam.  $1\frac{1}{2}$  inches, with 2-turn link.  
 $J_1$  — Closed-circuit jack.  
 MA — 0-15 d.c. milliammeter.  
 RFC $_1$ , RFC $_2$ , RFC $_3$  — 2.5-mh. r.f. choke.  
 $S_1$  — Single-circuit 11-position ceramic wafer switch.  
 $S_2$  — Two 2-circuit 5-position ceramic wafers (ganged with  $S_3$ ).  
 $S_3$  — Four 2-circuit 5-position ceramic wafers, 1 circuit unused on each wafer (ganged with  $S_2$ ).  
 $S_4$  — D.p.d.t. toggle.

NOTE:  $L_1$  to  $L_5$ , inclusive, wound on Millen 46100 forms, tuned by brass slugs as described in text.  $L_7$  coils are Millen 43002 series modified as above.

excessive plate dissipation. Broadly-resonant circuits, inductively tuned by means of slugs in the coils, are used with all the 6L6s, but the 807 has a conventional tuned tank circuit. Originally the

coils used were constructed on a variometer principle, and although they worked as well as the slug-tuned type later adopted, they were considerably more difficult to build and not as easy to

• There has been a lot of talk during the past year about using broad-tuning circuits in multiband ham transmitters, with the object of getting rid of tuning controls. But until W2JME came along with the transmitter described here, it seems to have been just talk.

Here's a practical approach to the problem of the single-control transmitter, one that is well within the electrical and mechanical capabilities of the ordinary amateur. Besides doing its intended job and doing it well, this transmitter is free from the spurious output frequencies that have only too frequently accompanied similar attempts at broad-banding.

Don't let the photographs of W2JME's transmitter mislead you into thinking that this is a complicated set-up. The transmitter itself is the small unit on the right; the rest is VFO and power supply!

mount or tune. (This change-over, incidentally, accounts for the various unused holes and slots that are visible in the photograph!)

The power output from the unit is sufficient to light a 60-watt lamp used as a dummy load to almost full brilliancy. On 3.5, 7, 14 and 21 Mc., the VFO or crystal frequency can be varied from one end of the band to the other with practically no detectable change in lamp brilliance; this with the 807 plate tank condenser set at about the center of the band. On the 27- and 28-Mc. bands this also applies to well over half the band; only a slight touch of the 807 plate condenser is required to provide maximum output throughout the band. Even with no retuning there is sufficient output over the entire band for practical use. It is really a thrill to be able to switch from band to band and be all set to transmit without plugging in a coil or retuning any intermediate stages.

The complete unit shown in the photographs consists of three individual sections mounted on a common relay-rack panel  $8\frac{3}{4}$  inches high. Looking at the front view, on the left is the power supply for the transmitter unit, in the center the VFO-crystal unit with its own power supply, and on the right the "pipe dream" transmitter itself. Inasmuch as the power supply is entirely conventional and the VFO is largely so except for a few novel features, most of the following will describe the transmitter section.

It should be pointed out that this transmitter can be driven either by the VFO shown — in which case crystals, if also desired, are mounted on the VFO unit and omitted from the transmitter — or by any VFO that furnishes either 80- or 160-meter output. In the latter case, if

crystal control is also desired, the crystals may be connected as shown in the transmitter diagram, Fig. 1. If only crystal control is required, follow the transmitter diagram and forget the VFO entirely.

#### Transmitter Circuit Details

As shown in Fig. 1, the 807 output tube always operates as a straight amplifier. This tube is driven from any of the four 6L6s. A common bandswitch selects the proper coil and associated coupling link in the 807 plate circuit, connects the output from the proper driver tube to the grid circuit of the 807, and connects the proper driver-doubler tubes together if more than one is required for the band selected. Because of the low values of grid-leak resistance used and the fact that cathode bias is employed in the 6L6 stages, the plate currents of the tubes not in the circuit for a particular output frequency selected remain approximately the same as the "in use" plate currents, thus maintaining the same load on the power supply at all times. This value of plate current will be approximately 40 ma. per 6L6. One 6L6 furnishes both 14- and 21-Mc. drive; this is accomplished by paralleling a second coil with the 14-Mc. coil so that the two together resonate in the 21-Mc. band, with the tube acting as a tripler in this instance. (For the present, we know that the 21-Mc. band doesn't exist, but it was easy to include and we're hoping for the future!)

In an attempt at maximum simplification the 6L6s were originally connected as high- $\mu$  triodes with the control grid tied to the screen and the cathode grounded, in accordance with data given in an RCA pamphlet. However, except for the 7-Mc. doubler this scheme did not work out too well, probably because of insufficient excitation for the tube when operating as a triode at the higher frequencies. But as it does work very well in the 7-Mc. stage, and since it does save a number of parts, it was retained there. The other 6L6s are operated as conventional doublers except for the lower value of grid resistor employed. R.f. chokes were tried in all of the usual locations but only those shown were found to be necessary so all others were omitted.

The plate coils employed in all of the 6L6 stages are perhaps the most unusual feature of the circuit. They are of the slug-tuned type, and although extremely simple to build and adjust are just about perfect for this job of band-passing. Any appropriate coil forms can be used. In this instance Millen Type 46100 were selected because they were a convenient size —  $1\frac{5}{16}$  inches outside diameter and  $1\frac{7}{8}$  inches long. The important feature is that they also have a bottom, which is required for mounting the screw for the slug.

The slugs were cut from 1-inch diameter brass rod and are approximately  $\frac{5}{8}$  inch long. However,

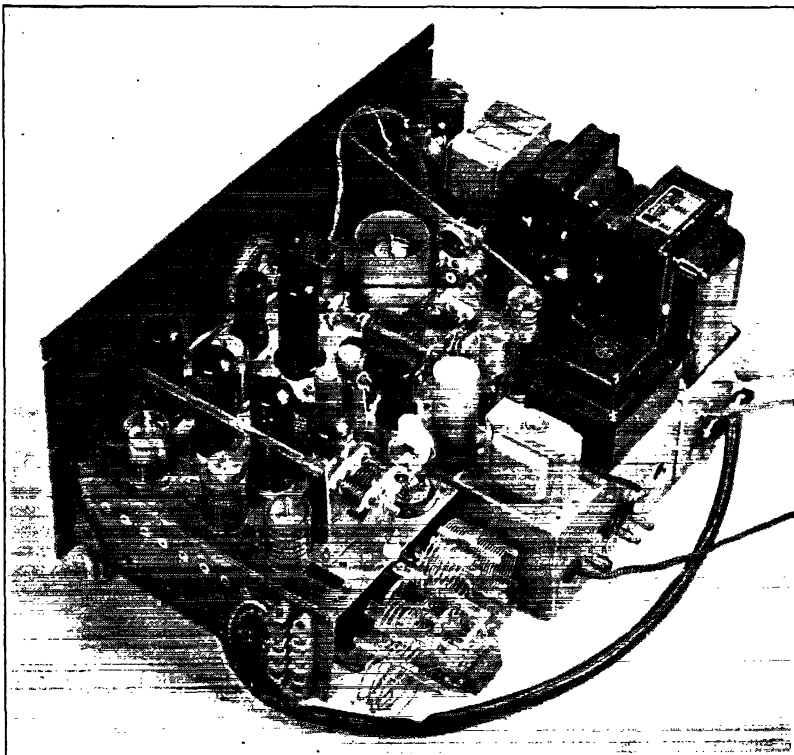

◆

The separate chassis for the three units are easily distinguishable in this rear view. The layout of the transmitter unit is described in the text. On the VFO chassis the tubes, from the panel toward the rear, are the 6F6 100-kc. oscillator, 6L6 output stage, 1853 buffer, and 6SJ7 oscillator. The 100-kc. crystal, 6L6 plate coil, and mounting for crystals are on the right-hand side of the VFO chassis. Power for the transmitter comes through the cable terminating in a connection strip in the foreground.

◆

these dimensions are not critical. The slugs should be drilled through the center and tapped with an  $\frac{3}{16}$  tap. A screwdriver slot sawed across the top of the slug will be useful later for adjustment. An 8-32 bolt  $2\frac{1}{2}$  inches long is run through a hole tapped or drilled through the center of the bottom of the coil form and a nut run down to lock the bolt securely. Then the slug is threaded on the bolt and run up or down as required to tune the circuit to resonance. Once the slug has been adjusted to the proper point another nut run down the bolt will serve to lock it. It should be mentioned here that the bolt holding the slug is left "floating" — that is, it is not connected to the chassis or any part of the circuit.

Winding information for the coils is tabulated under Fig. 1. Holes are drilled through the sides and bottoms of the coil forms and approximately eight-inch leads left so that direct connections can be made after the coils are mounted.

Using this type of coil in the 3.5-Mc. circuit permits any crystal in the 3500–4000-kc. band to be switched in with no tuning required to make it oscillate — and with low crystal current.

When a VFO is used, it should be connected in place of one of the crystals if it furnishes 1.75-Mc. input, and to the terminals in the cathode circuit of the 3.5-Mc. 6L6 if it furnishes 3.5-Mc. input. When only crystal control is desired, a tuned

circuit consisting of a 2.5-mh. r.f. choke shunted by a 0.0002- $\mu$ fd. condenser is connected across the VFO input terminals in the cathode. In most cases a strap across these terminals will do just as well, particularly with modern crystals, but the choke-condenser combination encourages some of the crankier crystals to start and improves their keying ability.

#### Layout & Construction

The chassis for these units are homemade because it was desirable to have them deeper than the usual type; however, standard sizes no doubt could be made to do the job. They are all  $3\frac{1}{2}$  inches high. The power supply is mounted on one  $4\frac{3}{4}$  inches wide by 13 inches deep, the VFO on one 6 inches wide by 13 inches deep, and the transmitter chassis is 6 inches wide by 10 inches deep, with the rear open. This is done so that the 807 plate coils and bandswitch can extend through. The  $\frac{5}{16}$ -inch rod which appears in the bottom view of the transmitter chassis is fastened across the bottom near the back to strengthen it.

The bandswitch is a Centralab K123 switch index assembly with six 2-circuit 5-position shorting-type ceramic wafers. The rear four wafers accommodate the plate tank coils and associated links for the 807. Only the upper circuit is used on these four wafers. The two front wafers serve



to switch between the 6L6s and between the 6L6s and the 807 grid circuit, as shown in Fig. 1. Through bolts,  $9\frac{1}{2}$  inches long, were used in place of the 7-inch ones that come with the kit, but there is no real necessity for this because a good layout with reasonably short leads is still possible with the shorter bolt length. Two homemade angle brackets, one near the index plate and the other just ahead of the four wafers used for the 807 plate tank coils, furnish a means for mounting the switch to the chassis. Shorting-type switches are used rather than the nonshorting type, to prevent burning of the contacts if the bandswitch should accidentally be operated without turning off the high-voltage supply.

On the side of the transmitter chassis nearest the VFO unit, going from the panel toward the rear, are the 3.5-Mc. coil, the 21-Mc. coil, the two resistances forming the screen resistor for the 807, and the 807 itself. Down the center are the 6L6s for 3.5, 7, 14-21, and 28 Mc., respectively. In back of these is the tuning condenser used to set the 807 plate coil in the band. This condenser could be omitted and slug-tuned circuits used for the 807; however, since the unit is used at times as a low-powered c.w. or 'phone transmitter, a condenser is incorporated so that the circuit will be satisfactory for modulation and for working into an antenna. In normal operation, the condenser need only be set once, at about the middle of the band, and then left alone even though the frequency is varied across the band. On the right side of the chassis are the 7-, 14-, and 28-Mc. coils.

No shielding was found to be necessary in this unit, although there is enough room on the chassis to permit using coil shields if for some reason they should be needed. If crystals are to be used, the crystal switch is located to the right of the bandswitch with the crystal sockets on the adjacent side wall of the chassis. Otherwise, the switch and crystals can be omitted and only provision for VFO connections made.

The meter switch for reading either grid or plate current to the 807 is located to the left of the bandswitch. No provision is made to read

current to the 6L6s. These currents can be checked after the unit is completed and can be rechecked at any time by inserting a milliammeter in the high-voltage lead to all the 6L6s and reading the total current to these tubes.

The quickest and best way to build this unit and get it working is to wire up one tube at a time, starting with the 3.5-Mc. stage. An absorption wavemeter is a "must." The crystal-detector type of wavemeter described in the ARRL *Handbook* will be ample for this job, and will always be a useful piece of equipment to have in the shack. After the 3.5-Mc. stage is wired and the filament supply and a plate supply of 300 to 350 volts connected, run the slug down until a 0-100 milliammeter in the plate lead, or a flashlight bulb in a single turn of wire loosely coupled to the plate tank, indicates that the circuit is oscillating. It should then be checked with the wavemeter to determine if the frequency is in the 3.5-Mc. band and also to see if any frequency other than the right one is present. With the number of turns shown, the 3.5-Mc. band should be the only one that can be found.

After the 3.5-Mc. circuit has been checked, wire the others in sequence and test them for correct frequency as outlined above. Of course, the change in loading caused by the addition of a succeeding stage will necessitate some slight retuning of the slug in the previous stage. To do this retuning, simply leave the flashlight loop on the tank of the stage being checked and adjust the slug of the preceding tank for maximum brilliancy of the flashlight bulb.

After all of the 6L6 stages have been roughly lined up, the 807 should be wired and tested. As the photograph shows, the 807 is mounted so that the chassis forms a shield between the grid and plate element. In addition, a parasitic trap for high frequencies is connected to the plate cap. This trap consists of five turns of No. 14 wire with an inside diameter of  $\frac{1}{2}$  inch and spaced the diameter of the wire, tuned by a mica padder of 3-30  $\mu\text{f.d.}$  The padder is normally set for about half capacity, but should be adjusted as required to eliminate any parasitics. These can usually be

Bottom view of the transmitter unit, showing the location of the bandswitch. The optional crystal switch is in the upper left corner. The cross-rod in the center strengthens the chassis, a desirable arrangement because the chassis rear is open to allow the bandswitch to extend through. A portion of the shield plate covering the VFO oscillator section is visible at the bottom center.

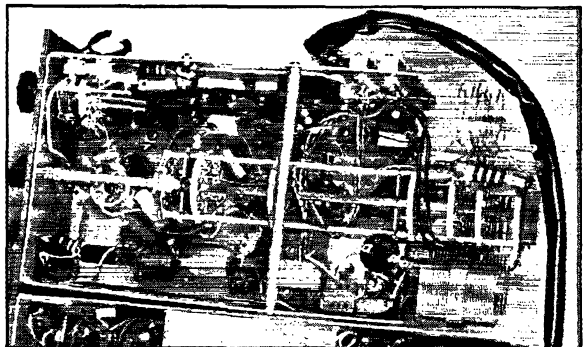

detected by a purplish glow in a neon lamp touched to the plate cap with the excitation removed. Adjusting the padder should eliminate them. In addition, as "an ounce of prevention" a 50-ohm resistor is included in the screen-grid lead at the socket terminal. Together with customary by-passing of screen and heater leads right at the socket terminals, the trap and resistor have entirely discouraged the 807 from going on any frequency excursions on its own. At least this has been the case with the several models built.

The plate coils for the 807 are standard Millen 75-watt units modified by removing the plug-in base and changing the link turns on the 7- and 28-Mc. coils to the number shown under Fig. 1. The 21-Mc. coil was made by modifying a 14-Mc. coil to the number of turns shown. These coils are then mounted directly to the terminals of the rear four wafers of the bandswitch, as shown in the photographs. Coils with end links are preferable, but as center-link coils happened to be available they were used in this unit. Naturally, homemade coils to the specifications listed will work satisfactorily, but we have found it rather difficult to make good self-supporting coils.

The 100- $\mu$ fd. plate condenser for the 807 is supported on an angle bracket that grounds the rotor. This is satisfactory for c.w. and for driving another stage, but if 'phone operation is contemplated a double-spaced condenser should be used to prevent flash-over on modulation peaks. The screen-supply resistors for the 807 are connected to the terminal strip in such a way that by strapping they can be made to form either a series screen resistor for 'phone operation or a voltage divider for c.w. operation.

When checking the 807 stage a 60-watt lamp should be connected across the output terminals to serve as a dummy load — otherwise 807s don't last too long. With the dummy connected, turn the bandswitch to the first position, where the 3.5-Mc. 6L6 supplies drive to the 807. Although

the 807 will take a maximum plate voltage of 750, 500 volts or less should be used for testing. With the meter switch reading plate current, tune the 807 plate tank condenser for minimum plate current. Next, turn off the high voltage and switch the meter to read grid current. (Always turn off the plate voltage before turning the meter switch, to prevent possible damage to the meter and switch.) Then turn on the high voltage and adjust the slug in the 6L6 plate circuit for maximum grid current to the 807. For this position of the bandswitch the grid current will be about 10 ma., but will be progressively lower at the higher frequencies.

Next, turn off the plate supply and set the bandswitch to the position that provides 7-Mc. drive to the 807. Adjust as above, except that now both the 3.5- and 7-Mc. tuning slugs must be adjusted for maximum grid current to the 807. The same tuning procedure is followed for lining up the 14-, 21-, and 28-Mc. stages. Readjustment of the slugs will tend to cut down the grid current from the original high value obtained from each of the first adjustments. However, this condition is actually desirable, because a milliampere or two is sufficient drive for an 807 and values too far above this are not desirable. Therefore the final adjustment of these slugs should be the one of "stagger" tuning of the stages so that there will be at least a milliampere or so of drive to the 807 on all bands at all frequencies.

In reality the tuning of this unit is the same as that of any multistage transmitter except that everything is tuned up only once, then the slugs are locked and left that way. After that you just flip a switch to go from band to band. If the coil data and other values given in Fig. 1 are followed, less trouble should be experienced than with a conventional transmitter.

### The VFO Unit

As mentioned before, any VFO can be used to drive the transmitter. However, a brief descrip-

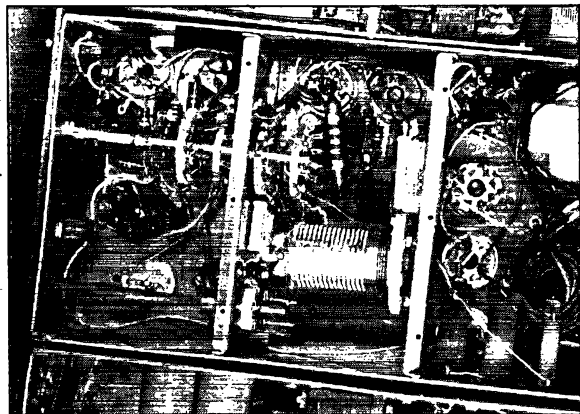

The space below the VFO chassis is divided into three compartments by cross-shields, isolating the oscillator section from the remainder of the unit. The oscillator coil is in the lower center, with the compensating condensers at the left and the bandspread switch wafers above. The ceramic condensers just above the coil socket are 200- $\mu$ fd. units paralleled to form the 600- $\mu$ fd. condenser specified in Fig. 2. The compartment at the left contains the 6L6 output stage and 6F6 100-kc. oscillator. The power supply is at the right.

tion of the one used here might be of interest since it incorporates several novel features. As shown in Fig. 2, it is basically the same as several that have been very fully described in past issues of *QST*, having a very lightly-loaded oscillator followed by several untuned isolating stages. Provision has been made for optional crystal control, break-in keying, and complete bandspread of each of the amateur bands. In addition, a 100-kc. crystal oscillator is mounted on the VFO chassis so that 100-kc. check-points are readily obtained. The 100-kc. oscillator circuit is identical with the one shown in the *Handbook* except for the omission of the 1000-kc. tuned circuit, so no further description is required.

The power supply for the VFO is also from the *Handbook* and makes use of two VR-150-30s as regulators. Originally some question arose as to the advisability of mounting it on the same

chassis with the VFO but it hasn't caused interference of any type and it certainly makes for a more compact self-contained unit.

The crystals are connected in the grid circuit of the 6L6 stage and are selected by a ganged switch which also grounds the VFO oscillator when the crystals are cut in. However, the stability and reset characteristics of the VFO are such that crystals are seldom used. If the crystal-control feature is omitted from the VFO, a single two-circuit five-position switch wafer can be used in place of the three single-circuit eleven-position wafers at present required. (The bottom view shows four wafers; however, the second wafer from the front panel is unused.)

Break-in keying of the 6SJ7 oscillator is obtained by grounding the grid circuit using a midget relay mounted adjacent to the main tun-

(Continued on page 128)

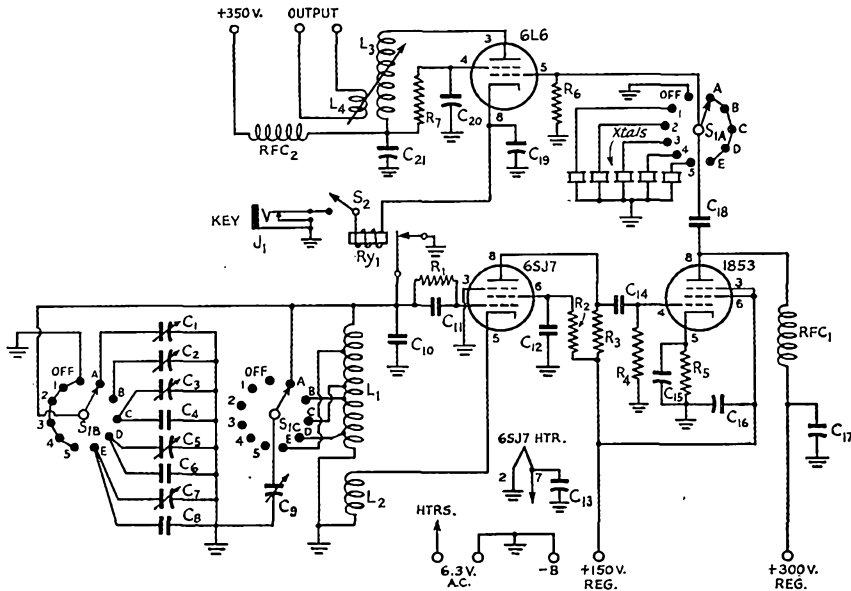

Fig. 2 — The variable-frequency oscillator circuit.

- C<sub>1</sub>, C<sub>2</sub>, C<sub>3</sub>, C<sub>5</sub>, C<sub>7</sub> — 5-25- $\mu$ fd. ceramic trimmer (Erie 554-NPO).
- C<sub>4</sub> — 150- $\mu$ fd. ceramic (Erie NPO).
- C<sub>6</sub> — 170- $\mu$ fd. ceramic (Erie NPO).
- C<sub>8</sub> — 100- $\mu$ fd. ceramic (Erie NPO).
- C<sub>9</sub> — 325- $\mu$ fd. variable (Hammarlund MC-325-M).
- C<sub>10</sub> — 600- $\mu$ fd. ceramic (three 200- $\mu$ fd. Erie NPOs in parallel).
- C<sub>11</sub> — 15- $\mu$ fd. mica.
- C<sub>12</sub> — 0.001- $\mu$ fd. mica.
- C<sub>13</sub>, C<sub>15</sub>, C<sub>16</sub>, C<sub>17</sub>, C<sub>19</sub>, C<sub>20</sub>, C<sub>21</sub> — 0.01- $\mu$ fd. paper.
- C<sub>14</sub>, C<sub>18</sub> — 40- $\mu$ fd. mica.
- R<sub>1</sub> — 0.33 megohm,  $\frac{1}{2}$  watt.
- R<sub>2</sub> — 10,000 ohms, 1 watt.
- R<sub>3</sub> — 65,000 ohms, 1 watt.
- R<sub>4</sub> — 0.1 megohm, 1 watt.
- R<sub>5</sub> — 500 ohms, 1 watt.
- R<sub>6</sub> — 50,000 ohms, 1 watt.
- R<sub>7</sub> — 30,000 ohms, 5 watts.
- L<sub>1</sub> — 24 turns No. 20, length 2 inches, on  $1\frac{3}{8}$ -inch diam.

- ceramic form (see photograph); bandspread taps, counted from ground end, as follows:
  - (A) 3.4-4 Mc.: total coil
  - (B) 3.85-4 Mc.: 11 turns
  - (C) 7.0-7.3 Mc.: 12 turns
  - (D) 14.0-14.4 Mc. and 21-21.5 Mc.: 10.5 turns
  - (E) 28-30 Mc.: 16.5 turns.
- L<sub>2</sub> — 4 turns No. 20 enam. interwound with L<sub>1</sub> at ground end.
- L<sub>3</sub> — 50 turns No. 22 enam. close-wound on  $1\frac{3}{8}$ -inch diam. form, tuned by brass slug.
- L<sub>4</sub> — 8 turns No. 22 enam. close-wound at ground end of L<sub>3</sub>.
- J<sub>1</sub> — Closed-circuit jack.
- RFC<sub>1</sub>, RFC<sub>2</sub> — 2.5-mh. r.f. choke.
- Ry<sub>1</sub> — Midget relay, s.p.s.t., normally closed, 300-ohm coil (C.P. Clare).
- S<sub>1</sub> — Three-gang ceramic switch, each wafer 1 circuit, 11 positions.
- S<sub>2</sub> — S.p.s.t. toggle.

# A Plan for the Ten-Meter Band

THE ARRL Board of Directors has under study a plan for an improved subdivision of the 10-meter band which it intends to consider finally at its annual meeting next May. It wants to know what members think of the scheme in its present form, and has directed that it be presented in *QST* for that purpose. You are asked to study this proposal and are invited to write your division director your opinion of it, pro or con, with any suggestions that occur to you for its improvement. Your director's address is to be found in a directory in the front of this issue. He wants to hear from you. This is your opportunity to express yourself and to participate in the effort to arrive at a decision of maximum usefulness to amateur radio.

The plan under contemplation relates exclusively to the organization of the 10-meter band. It is not intended to propose any break-down of the 11-meter band but, rather, to leave the latter free throughout its width to all normal types of emission, including AØ for duplex 'phone.

At the outset there are two basic facts that should be got clearly in mind as foundation pieces for the examination of this proposal:

1) The 10-meter band, because of its nature, is a problem apart from all other bands. The 3.5-, 7- and 14-Mc. bands are "older," more nearly organized and stable, more nearly predictable in performance. Whether our regulations for these last three bands are considered jointly or separately, at least they constitute a class apart from the 10-meter band. The performance of the latter varies not only more widely daily and seasonally but so radically during the 11-year solar cycle that there are likely to be periods of years on end when there is no consistent  $F_2$ -layer DX. At other times it is a super-DX band. At any unpredictable time, sporadic-*E* short skip may give it valuable modest-distance characteristics. On top of this, at the moment it is the lowest-frequency band open to Class B 'phone and it houses a big population of 'phone men who additionally use the band for local work. Thus the band is unique both in its diversity of performance and in the diverse interests of its occupants. It truly needs to be considered separately from other bands.

2) The second need is to realize how huge this band is. It is 1700 kc. wide at a spectrum location where stability is easily achieved, so this figure may be rigidly compared with the widths of other bands. It is more than three times the width of the whole 80-meter band, nearly six times the width of 40, more than four times the width of 20. Its

width is 4.25 times the *average* of these three bands. It is nearly one and a half times as wide as the *total* of these three bands. It will accommodate 1.41 times as many stations as 80-40-20 combined! Few of us realize how huge it really is. Its width is such that it will support a much more complicated organization or break-down than is given by merely determining at what frequency 'phone operation should begin, an elementary organization that wastes most of the space because it is not used. Moreover, to capitalize upon its potentialities it is essential to break it down into blocks for different purposes. It is the only place we can find the room for some of the things we need to do, and such provisions are the only way to get the distributed occupancy we need for the effective use of the band's great width. If the provisions of the proposed plan seem to you a little complicated and extensive, remember that you are dealing with the equivalent of four ordinary bands and that whenever it is broken down into blocks of the needed size there are bound to be more units than we customarily think of in one band. Again emphasizing the unique nature of "10," this is only to say that you can't have comprehensive provision for all the facilities we'd like to have in this wide band without some detail — detail which we have substantially lacked in the past and the lack of which has made us suffer.

Now to our muttons. Everybody recognizes that the three main factors in 10-meter allocation are (1) the desire on the part of 'phone operators to work in the low-frequency portion of the band, (2) the habit of foreign 'phone stations of working in our c.w.-only assignment, and (3) the necessity for some adequate assignment for c.w. work free of interference from these foreign 'phones. There are some other factors that ought to be taken into account in any planning: (4) Because 10 has lost population since the other bands opened, it is desirable to have an attractive arrangement that will invite renewed occupancy; (5) it would be an operating convenience to know where to look or go for different types of operation, such as DX or local rag-chewing, and a successful plan might accomplish some of this by providing encouragements at the proper places in the band; (6) we definitely need provision for experimentation with newer developments in communication. All these factors were taken into study in the Board's present plan. The possible advantages of time-sharing and distance limitations were considered but have been abandoned

	28,000	28,100	28,150	28,250	28,350	28,500	28,800	29,000	29,500	29,700
C.W. TELEGRAPHY (A1)	████████	████████	████████	████████	████████	████████	████████	████████	████████	████████
A.M. 'PHONE (A3)		████████	████████	████████		████████	████████	████████	████████	████████
NARROW-BAND F.M. 'PHONE			████████	████████		████████	████████	████████	████████	████████
DUPLEX 'PHONE							████████	████████	████████	████████
WIDE-BAND F.M. 'PHONE								████████	████████	████████
STONE-MODULATED TELEGRAPHY		████████	████████					████████	████████	████████
FREQUENCY-SHIFT TELEGRAPHY		████████						████████	████████	████████

as impracticable. As you will see by the chart, the plan now under study provides for some deliberate overlapping of subbands to permit intercommunication between different modes on the same frequency, and it contemplates the introduction of two types of emission which we do not now have in the band, duplex 'phone and tone-modulated telegraphy. The chart will show you the proposed assignments for each type of emission. By frequencies, the following is the proposed organization of the band:

- 28,000 to 28,100 kc — C.w. only<sup>1</sup>
- 28,100 to 28,250 kc. — C.w., tone-modulated telegraphy,<sup>2</sup> frequency-shift telegraphy
- 28,150 to 28,350 kc. — C.w., a.m. telephony, narrow-band f.m. telephony<sup>3</sup>
- 28,350 to 28,500 kc. — C.w. only
- 28,500 to 29,700 kc. — C.w., a.m. telephony, narrow-band f.m. telephony
- 28,800 to 29,700 kc. — Duplex telephony
- 29,000 to 29,700 kc. — Tone-modulated telegraphy, frequency-shift telegraphy, wide-band f.m. telephony

All amateurs familiar with the past history of 10-meter subdivision know that there is some competition between c.w. and 'phone. We might as well be frank about it. When the c.w. men had only the first 100 kc. exclusive, they found it full of foreign 'phones and nothing left for them. When the 'phone limit was raised to 28.5 Mc. to increase the space both for foreign 'phones and for c.w. work, American 'phone amateurs com-

plained bitterly about their loss of the "best frequencies." That was the main problem that had to be tackled in this new plan. The proposed solution involves two exclusively-c.w. bands. 'Phone (both a.m. and narrow-band f.m.) would be allocated 28,150-28,350 and 28,500-29,700 kc. This provides a 200-kc. 'phone assignment near the low-frequency end and thus meets the present demand for 'phone near 28,000. It also provides a clear space between 28,350 and 28,500 in which foreign 'phones can work without U. S. 'phone interference. If foreign 'phones occupy that range it will leave the first 150 kc. of the band fairly clear for c.w. DX. Of course we have no way of forcing foreign 'phones to move there but if they still prefer to occupy the region just above 28 Mc. the probability is that the 28,350-28,500 segment will be reasonably clear for c.w. DX. If they occupy both segments the interference at least will be spread thinner, so that there will be a measure of relief for the c.w. man. In either case, the U. S. 'phone assignments would gain the immense advantage of having three band-edges, reducing to perhaps as little as a third the present piling up at the edges and thereby immeasurably improving communication possibilities.

The very heart of this plan, then, is this establishment of two c.w. segments near the low-frequency end. While by no means sure-fire, it seems to offer some hope in the c.w. man's problem of the foreign 'phone — as against the certainty that a single small c.w. band would be overrun. It equally helps the 'phone man because it permits 'phone to come close to the 28,000 end, and with three band-edges the congestion will be much less than when all the 'phones attempting to work DX pile up at a single edge. Moreover, the overlapping allocation of 'phone and "special telegraphy" would discourage, it is believed, foreign 'phone operation in the first 150 kc. of the band and would encourage it to come in the 28,350-28,500 region where it chiefly is today.

(Continued on page 128)

<sup>1</sup> C.w. appears throughout the band because it is the basic mode of operation for which all amateur stations are equipped. From the legal standpoint it is essential, in our protection, that we avoid a situation in which many amateurs would not be licensed to operate on certain frequencies. To protect us, the Board has always held it to be a fundamental that every amateur license must authorize c.w. operation on every amateur frequency. But in practice, the technical effects are such that the 'phone allocations are practically self-exclusive.

<sup>2</sup> A2 emission, modulation not to exceed 100%.

<sup>3</sup> Narrow-band f.m. telephony is defined in this plan as f.m. in which the significant sidebands occupy no more spectrum space than the sidebands of a.m. telephony having the same audio modulating frequencies.

# "No, I'm Not on the Air"

BY JULIAN N. JABLIN \*

**T**HE Army made me a radio operator. I say this advisedly, despite profane evaluations of my ability by various radio sergeants and the friendly sneers of buddies of mine who hold ham tickets. The Army made me a radio operator, I maintain, and the FCC supports my claim with a Class B operator license, but you don't hear me on the air. Why? Let me tell you the story.

I came back from four years of mishandling various SCRs with the desire to continue amusing myself with radio. To this end I bought a — well, let them do their own advertising in the back of the book, and we'll call it a Pearlworth Ultra-Obnoxious. With this QRM-sifter I was able to hear Tommy Handley on the BBC, all the press stations in the world, and the boys on ten-meter 'phone, which was all we had at the time. It was a happy life. I prepared to get a ticket and do a little talking on my own.

The FCC examination was a pushover. I copied for a minute at 13, remembered that you had to remove plate voltage while neutralizing, QTH had to do with a station's location, and it was all over. All over, that is, except that someone had left a comma off my birth certificate some twenty-odd years back. The Commission was fussy about things like that. The examiner, a decent guy, promised to hold my papers until I had the facts of my birth straightened out.

Local statistics bureaus being what they are, it was about three months before I emerged from a maze of affidavits, certificates of compliance and fifty-cent fees. By that time, I discovered, regulations had been changed, proof that I had been born was no longer necessary, and my exam had been sent to Washington. However, when I had taken the exam, I hadn't filled the form for a station license, so I sent that in, and sat to await a station call.

In the meantime, I was collecting various equipment which, when put together, would become a 6L6 Tri-tet oscillator, an 807 amplifier, and a modulator, so that I could go on ten-meter 'phone. I had all the small parts, and was saving money for some of the bigger items, when two cousins came to town with the idea of going to town. Together with a YL I knew, we made the rounds, and when I awoke the next morning I found that I was 37 bucks in the red. No radio parts for a while!

I was listening to the boys on ten, and wishing to get on the air myself, when my operator ticket came up from Washington — without a station license. The local wing of the FCC sug-

gested another application, which I mailed.

The transmitter was progressing slowly. I started backward, building the modulator first, so that I could use it as a phonograph amplifier when I was not on the air. I had already received another letter from the Commission, this one with a ream of mimeographed orders and changes in orders. From the reading I did, I gathered that I should have sent my operator license with the station application. This I did; by now, Washington had three applications from me on file, and I expected any day to get three station calls.

School started about this time, and I attended evening sessions four nights a week at the local university. At times, after I came home, I'd switch the set on for a few minutes of c.w. practice, but the instant reaction from my mother, who was usually just about to fall asleep, convinced me that a three-room apartment was no place to pursue ham radio without a pair of 'phones. I honestly tried to get a pair, but every time I had three dollars something happened between the house and the radio store, and the money went for something else. I began to consider seriously a sound-proof pup tent pitched in the living room.

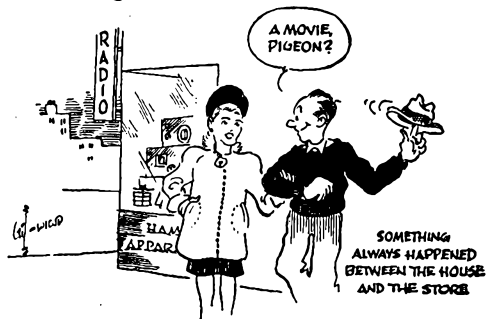

One night the tenant next door asked my dad about my radio activities. This neighbor had been a third-assistant cook in a Navy communications school twenty years back, so, of course, he knew all about it. In parting, he mentioned that my receiver was interfering with his wife's b.c.l. set, and I'd better do something before someone — not as considerate as he — complained to the FCC and had my license revoked. A few of the other neighbors were asking discreetly about my rig. I didn't know what to do about it. Obviously, my receiver was not causing any QRM. The people complaining neglected to consider an automatic elevator, some 40 electric refrigerators and

(Concluded on page 132)

# A Unique Five-Band Antenna System

## Combining the Four-Element Rotary and the Vertical

BY J. A. McCULLOUGH,\* W6CHE

• Ordinarily, all-band operation is not associated with the multielement rotatable beam antenna. This article describes a novel and practical way of adapting such an antenna for effective operation on three bands. When the supporting tower is used as a vertical antenna for the lower frequencies, the single structure will serve for all bands from 28 to 3.5 Mc.

**M**ULTIBAND operation with a single antenna is not unusual, of course. However, such systems commonly are limited to simple long-wire antennas. By combining a three-band rotary antenna with a steel tower, an exceptional antenna results for the five lowest-frequency bands. Not being a rabid 'phone man or a dyed-in-the-wool c.w. man, but one who enjoys both, the maximum possible versatility in this station's operation was desired. The fact that the famous "autotuned" transmitter used at the Golden Gate Exposition in 1939 had somehow come into our possession added a little fuel to the fire of a desire to provide a suitable companion antenna system.

The story of this antenna is told chiefly, not with the thought that someone would attempt to copy it, but rather to discuss some interesting ideas which seem to work out satisfactorily, although apparently they are not in wide use at present. In brief, the system consists of a single set of four rotatable elements for use on the 14-, 21-, and 28-Mc. bands and a steel tower insulated from ground which acts as a vertical for 80- and 40-meter operation. The beam elements also are used for top-loading the tower at 3.5 Mc. Contrary to usual practice a resonant transmission line is used to feed the close-spaced array. These rather unorthodox ideas were used not with the thought of being "smart," but rather to obtain some very definite objectives.

Prewar success with a two-element twenty-meter beam had more or less crystallized thinking along the lines of a similar antenna of three or

\* Eitel-McCullough, Inc., San Bruno, Calif.



Looking up at the 3-band rotatable. The "snubbers" which brace the elements against swaying are strips of  $\frac{3}{4}$ -inch square wood strip insulated from the elements by small pieces of polystyrene.

four elements. The writer had never operated much on ten prewar, but the fact that it was the only band open for awhile necessitated its use, and it was not long in dawning that in neglecting this band a good bet had been overlooked. The desire for a rotary beam on ten and twenty, as well as the new fifteen-meter band "if and when," really threw confusion into the design department. Logically, three separate stacked three-element beams should have been the choice, but the horrible thought of all those unused elements wasting away when operating on any one band, plus the fact that there always would be the question of whether or not any distortion of the pattern would take place because of the proximity of the unused elements, made this arrangement seem less desirable. When the idea of "switching" the elements first struck, it seemed rather involved and hopeless but, as we wore through several layers of scratch paper, things began to look a little brighter. By splitting each of the twenty-meter elements in the center, stubs could be used for phasing the elements for 28- and 21-Mc. operation. The practical success of the plan, it seemed, depended only upon suitable relays. We were somewhat discouraged when a great deal of searching disclosed the fact that no available relay would fill the bill in every respect. Even discounting the requirement of a waterproof box, we couldn't find any relay which had low enough resistance, as well as the necessary insulation. But by this time our enthusiasm for the project was so high that there was no turning back; in fact by now we had decided to add a fourth element to the twenty-meter beam because of the saving in hardware effected by the elimination of the two extra three-element beams. Our only hope of completing the project was to make our own relays. The basic unit is a 110-volt

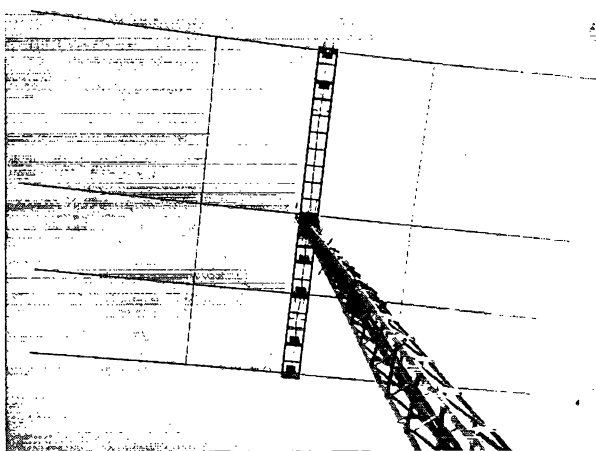
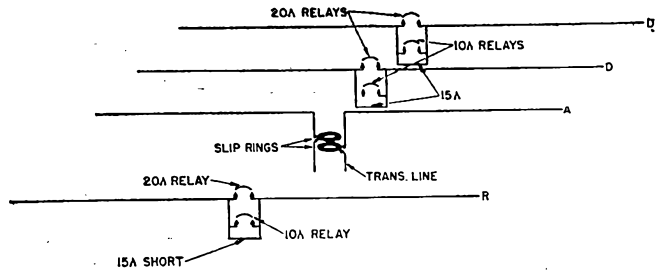

Fig. 1 — Schematic of the three-band four-element rotatable system, indicating the stubs and shorting relays in the parasitic elements.



a.c. solenoid-type Model RG-40 made by the Square "D" Company. The relay was designed originally for breaking four independent 15-ampere circuits. The armature has four separate sets of spring-loaded double contacts. Since the insulation of the fixed contacts was not satisfactory, this part of the relay was discarded. The armature section was mounted on a polystyrene square to provide insulation for the fixed contacts. The fixed contacts consist of  $\frac{3}{8}$  by  $\frac{3}{4}$ -inch pieces of copper buss, separated by a distance equal to that dictated by the separations of the double contacts of the armature. All four of the contacts on the armature short the two copper busses together with a current-carrying capacity equivalent to 60 amperes at 60 cycles. The movement of the armature is such that a clearance of better than  $\frac{3}{8}$  inch results in the unenergized position. Fortunately, the antenna system is such that with the relays energized, the relay is at a low-voltage point, so that the insulation of the armature is unimportant.

With the relay problem out of the way, we proceeded with the design. The general idea of the system is shown in Fig. 1. The parasitic elements as well as the driven element must be divided into two equal insulated sections so that the sections will be phased properly for 21- and 28-Mc. operation. This, then, calls for relays to short the two sections of the 14-Mc. parasitic element with the result that the system is a conventional beam for this band. If the beam is to be used only on ten and twenty, no additional relays are necessary, the stubs being adjusted to phase the elements for ten-meter operation by moving the shorting bar approximately  $\frac{1}{4}$  wavelength from the antenna. With the thought that the fifteen-meter band may open some day, it was decided to put in additional relays to permit operation on this new band. The stubs for fifteen-meter operation are longer than those for ten-meter operation, of course, so in this case the shorting bar is adjusted for fifteen meters and the second set of relays is placed in each stub so as to short this extension at the effective quarter-wavelength point for ten-meter operation.

#### Construction

The elements and relays are supported on a 20-ft. ladder fitted with trussing wires from ver-

tical supports at the center. The parasitic elements, as mentioned previously, as well as the antenna are split at the center to permit operating the two halves in phase at 21 and 28 Mc. Each section of each element consists of a full 12-foot length of  $1\frac{1}{2}$ -inch dural with an adjustable 6-foot extension of 1-inch tubing. The sections are supported on pieces of half-inch Lucite sheet stock. Element spacing is 5 feet between directors and between director and the driven element, and 10 feet between the reflector and the driven element. This works out to spacings of 0.1 and 0.2 wavelength for 15 meters, 0.07 and 0.14 for 20 and 0.14 and 0.28 wavelength for 10 meters. This brings all spacings near the top of the curve for gain. The 20-meter relays are mounted close to the centers of the elements and are connected to the ends of the elements with 1-inch copper ribbon

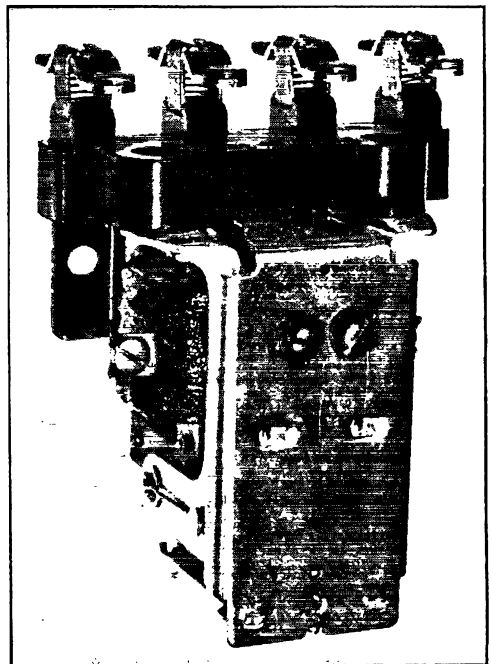

Shorting relays of the type used for band-changing with original fixed contacts removed. Alterations are described in the text.



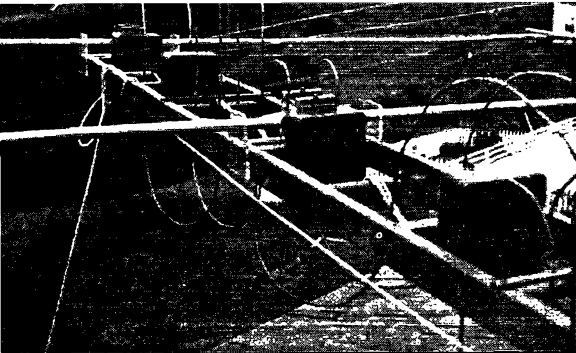

wrapped around the dural tubing. The 10-meter relays are mounted about midway between elements and the copper-tubing stubs are looped up and down as required to bring the shorting points at the relay terminals to which they are connected with 1-inch copper strip. The remainder of each stub is folded in a similar manner and terminated at a copper bar spanning the ladder. The control wiring is sheathed and brought to the center of the ladder. Then it is passed down through the rotator shaft to the base of the tower where it terminates at three slip rings. The leads between the station equipment and the slip rings are carried through a plug which is disconnected when the tower is operated with the lower end "hot."

#### **Feeding the Antenna**

With the antenna itself out of the way, the feeding problem was staring us in the face. Many weird ideas were dreamed up for switching stubs in and out, but to maintain a flat line it got really complicated. By this time we were toying with the idea of a resonant line. According to the boys on the air, standing waves on a transmission line seem to be placed in the same category as leprosy. However, the more we figured, the less apparent became the reasons for this phobia about standing waves. True, losses do go up as the standing-wave ratio is increased, but until this ratio becomes ten to one or so, no appreciable amount of power is lost in conventional lines. Of course, on the higher frequencies the solid-dielectric "coax" does have more loss than does a good open-wire line, and this loss, of course, is aggravated by an increase in standing-wave ratio. The problem here was to feed power into a load of approximately five ohms with the antenna operating on twenty, and into one of several thousand ohms when the antenna is operating on ten, with some in-between value for fifteen meters. If the antenna is five ohms at 14 Mc., then, with a kilowatt input, the current flowing at the center of the antenna will approximate fourteen am-



Close-up view showing the mounting of the elements and relays. The complete assembly is mounted on a 20-foot ladder center section, with trussing wires used for additional support.

The 1/4-inch copper stubs are folded to bring the shorting relays at the proper point.



peres and the same order of current will occur at each current-maximum point on the line. With this high order of current, it becomes apparent that we cannot stand a line with a surge impedance too high, but, at the same time, we must feed voltage at the ends of the two half-wave ten-meter sections when using the 28-Mc. band.

A line having a surge impedance of about 180 ohms was the final compromise, since it was figured that the standing-wave ratio would be approximately the same whether operating on ten or twenty meters. We estimate the standing-wave ratio to be about 35 to 1. By using a line with large-diameter conductors (1/2-inch copper tubing), we feel we have minimized the resistance losses. The line is mounted on 4-inch stand-off insulators with essentially no dielectric other than air appearing between the conductors, which should result in low insulation losses in spite of the high-voltage points. The close spacing (1 1/8 inches center to center) should keep the radiation losses low, particularly since care was taken to see that the line was symmetrical as to ground. With the beam actually in operation, we feel that the losses are comparable to the more conventional feeder systems. The resonant line makes for a great deal of flexibility since the antenna section of the beam can be resonated to any frequency, including 80 meters, although the radiation resistance becomes so small at low frequencies that extremely-high voltages and currents appear on the line. On 40, however, such

*(Continued on page 154)*

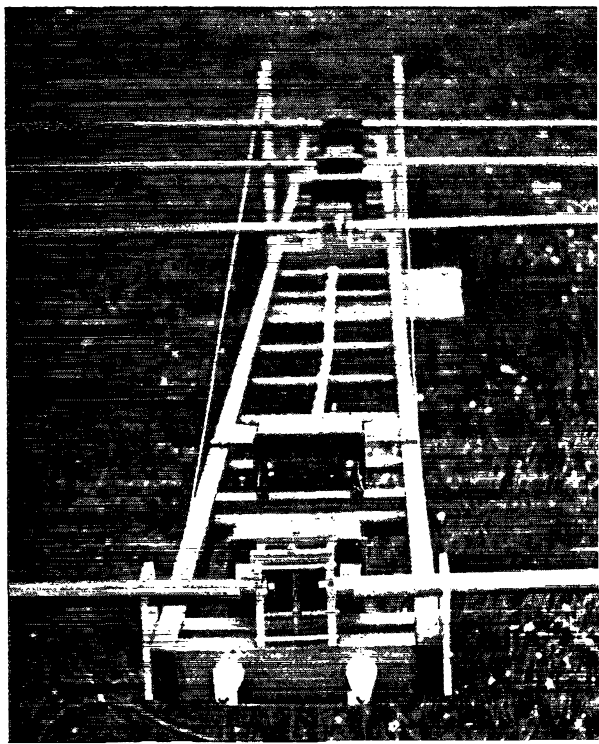

# Five Are Better than Three

## Some Experiences with a Five-Element Rotary

BY W. W. BASDEN,\* W5CXS

• Here is a story of a new type of five-element beam. We admit we don't have any performance figures beyond the results of W5CXS, the designer, but the antenna has paid off plenty "on the air" for him.

THERE'S a contraption down in the tail end of Texas that is the gosh-awfullest looking thing you ever saw. On first look it might be something Orson Welles dreamed up for "The Man from Mars." After another look it might be something to hang the wash on. No one but a ham could actually identify it, and he might be stumped for a moment.

It's called a "five-element rotary beam." Yes, that's right, a *five*-element rotary beam. Somewhere, though, the guy that built it got off the beam track and forgot (?) to follow the established precedent of putting the elements in a line. At first he wasn't even certain himself just why, but there was a bee buzzing around in his bonnet.

The whole thing started with just an ordinary run-of-the-mill three-element beam that worked pretty well, considering the kilowatt jobs that had the bad habit of sneaking up from behind and hitting this little 120-watter over the head. Something had to be done to fix these guys up, but good.

That old bee was still buzzing around in this guy's bonnet — a few more elements on that three-element job might do the trick, if they were put where they would do the most good — so a lot of good hard cogitating was done by this fellow (and very little paper work). Why not mount two more elements, one *above* and one *below* the first director? Well, why not? The whole idea is to lower the angle of radiation and shove the old signal out where these DX boys can reach out and grab it without straining a muscle, and the local boys around the country won't have to clean out their ears to hear it.

This aforementioned guy, being a little on the lazy side, finally built up energy enough to get this world-shaking project under way. The junk yard supplied a few pieces of beat-up aluminum for those other two elements, the fella at the electrical supply house wouldn't sell four lil' ole insulators for less than a buck (prewar total 40 cents), and the lumber yard did a little more

gouging for the one-by-fours.

Finally all the necessary extra parts were found and made ready. Then a problem came up out of the far blue yonder — the beam was 21 feet off the ground and this fellow darned well wasn't going to take the pole down after sweating around a coupla hours by his lonesome — the other hams in town were even lazier than he was — getting the thing up. The only available ladder was sixteen feet long, so about six feet was added, and if you think it made a good steady ladder you oughta try it sometime. Oh well, this guy was an adventurous soul, anyhow.

The ladder, after a lot of grunting and groaning, was finally raised up on the front end of the three-element beam, the beam being tied down so it wouldn't rotate (this guy thought). The one-by-fours were cut and nailed together to form a rectangle the width of the framework that supported the elements and about six feet eight inches long, to hold those extra elements one-tenth of a wave above and below the first director. The insulators were screwed in the top and bottom of aforesaid rectangle and the elements put on with brass safety wire, the stuff that's used on airplanes.

Then the trip was started up the ladder (remember, the beam was tied down so it wouldn't rotate). The wind was blowing like a banshee, and if you have never tried walking up a ladder with about thirty feet of aluminum and a few feet of one-by-fours in both hands, this guy says you oughta try it. All went well for two thirds of the way up and then the doggone beam started rotating without benefit of any outside help (except

(Continued on page 138)

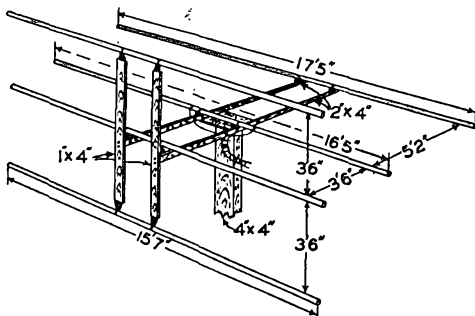

The five-element 28-Mc. beam at W5CXS is different from the usual three-element beam in that director elements have been added 0.1 wavelength above and below the normal director. Delta-match feed was used, and the line is tapped on the radiator 13 inches each side of center.

\* 634 S.E. Jefferson, Brownsville, Texas.

# The Most Inexpensive Transmitter

*A Complete Crystal Oscillator for \$3.95*

BY BYRON GOODMAN,\* WIDX

• The title to this story reads like "there must be a trick to it." There is, but it rates as the neatest trick of the year, and it does offer a mighty practical transmitter for the impecunious amateur or the v.h.f. enthusiast who wants a crack at c.w. on the lower frequencies without putting out a lot of the green stuff. And if the recent rigs in *QST* have been too elaborate and expensive for the new ham, this transmitter goes far in the other direction.

WHEN a letter from R. O. Deck, jr., W9JVI, asked, among other things, if we would be interested in a complete transmitter for less than five dollars, we replied, in our best cynical manner, "Sure, we'd like to see a *complete* transmitter for five bucks." — knowing full well that we had him and that it was impossible. He even had the effrontery to tell us that during the first week he had it on the air — at his father's shack, W9PHE — they had worked both coasts!

The reply came in due time and, for anyone who hasn't tasted crow, we don't mind saying that it *can* be eaten and, in this case, gladly. W9JVI's idea was one of those things that you could kick

yourself around the block for not having thought of before. He built a simple crystal oscillator, with crystal but *minus* the tube. He then removed the audio tube from the receiver, plugged the tube in the oscillator and the power cable from the oscillator into the empty tube socket in the receiver and there he was! Simple? Of course it's simple, but so are most good ideas. The necessity for working only with headphones in the receiver is no shortcoming — most c.w. men don't use loud-speaker output anyway. And if you're not going to use the 'speaker output tube and the power it consumes, where is a better place to use them than in the transmitter?

Our letter of congratulations to W9JVI and a request for a story brought the transmitter itself for examination. It was tested and did all that was claimed for it, but it was built on metal, so we decided to try some simplification because many beginners might like to duplicate it and might find the metal work a bit difficult. The transmitter to be described was built in the *QST* lab, but we can take no credit for the basic conception — that all belongs to W9JVI. If this story helps anyone to get on the air for a minimum outlay of cold cash, send your thanks to R. O. Deck, jr., W9JVI, Roodhouse, Ill.

The transmitter can be used with any receiver that uses a 6F6 or 6V6 audio tube and has the headphone output taken off ahead of the output

\* Assistant Technical Editor, *QST*.

◆

The "most inexpensive transmitter" is as easy to build as it is easy on the pocketbook. By using wood for the chassis and simplified construction throughout, the transmitter can be built with very few shop tools. Using a 3.5-Mc. crystal, operation in the 3.5- and 7-Mc. bands is possible by changing the plate and antenna coils.

◆

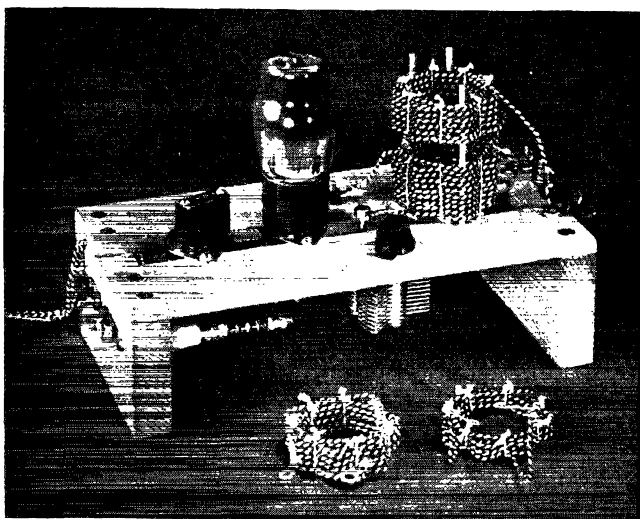

tube. Many receivers these days take the head-phone output from the output transformer, and it is well to investigate this point before planning to use the receiver for the transmitter power supply. However, the Hallicrafter S-15, S-16, S-17 and S-18 are all satisfactory in this respect, as are the receivers described in the Receiver Chapter of *The Radio Amateur's Handbook*. But even if you don't have one of the receivers listed above, the transmitter can be used with a 6L6 and a separate 350-volt power supply to put out a good signal. If desired, it can be used to get on the air with low power, and later an amplifier with an 807 or similar tube can be added for more punch. In any event, it won't go to waste around the shack!

### The Circuit

To get the most use out of the transmitter, it obviously should be capable of working on at least two bands with the same crystal. The original version of W9JVI used the grid-plate circuit, but the *QST* version uses the Tri-tet circuit because it gives a little better operation on the second harmonic. The circuit is shown in Fig. 1 and will be familiar to anyone who knows crystal-oscillator circuits. The cathode circuit,  $L_1C_1$ , is fixed-tuned to roughly 8 Mc., although provision is included for adjusting it, as will be mentioned later. The plate circuit,  $L_2C_4$ , is tuned to either the 3.5- or 7-Mc. band, depending on which is being used. Any crystal between 3.5 and 3.9 Mc. will work in the rig, but if one wants two-band operation the crystal frequency should be between 3500 and 3650 kc., since other crystals would double to outside the 7-Mc. band. No

provision is included for tuning the antenna output, since by judicious selection of feeder length and the size of  $L_3$ , the coupling coil, sufficient power can be coupled into the antenna. The antenna problem will be discussed later.

The r.f. choke, *RFC*, in the grid return, is not absolutely essential but its inclusion is highly advisable because the oscillator will key better with it in the circuit. A mica condenser,  $C_1$ , is used in the cathode tank circuit to tune the coil, but the other two fixed condensers,  $C_2$  and  $C_3$ , are common paper replacement types. The tuning condenser,  $C_4$ , is the least expensive one that can be found, although if one had an old broadcast tuning condenser he could substitute it for the more compact one specified.

### Construction

To minimize the tools required for the construction of the transmitter, a simple chassis of wood was built and finished with clear lacquer. Shellac is a suitable substitute for the lacquer, or the whole thing can be dipped in hot paraffin. Two  $1\frac{3}{4}$  by  $9\frac{3}{4}$ -inch strips of  $\frac{1}{4}$ -inch-thick wood were fastened with screws to the two  $4\frac{1}{2}$  by  $2\frac{1}{2}$  by  $\frac{3}{4}$ -inch end pieces, leaving enough separation between the strips for the Amphenol MIP octal sockets used for the crystal and the tube. Wood screws can be used to mount the sockets, or they can be bolted to the wood strips with 6-32 machine screws. The key of the tube socket should be mounted toward the front of the transmitter, for convenience in wiring the plate circuit to the tuning condenser. The tuning condenser, unfortunately, doesn't have a long mounting shank on it, and it is necessary to drill a clearance hole for the shank and then dig away — or counterbore — clearance for the nut. The two Fahnstock clips for the antenna are secured under two of the screws used for fastening the wood strips to the right-hand end piece, and the other two clips used for the key leads are held down by machine screws on the left-hand end piece. The r.f. choke is held in place on the left-hand end piece by a machine screw. The four wires used for a power cable are brought out at the rear left under the wood strip — a half-round hole is filed in the end piece to clear the wires.

The plate coil and antenna coil are held in place on three small sticks set in the top of the chassis — penny suckers are a good source for these sticks, and one has no difficulty finding help in removing the candy from the sticks. The plate coil connects, at the bottom, to a brass machine screw soldered to a lug which is sweated to the stator terminal of the tuning condenser, and the screw is built up most of its length by adding nuts or small spacers to it. The screen end of the coil, the top end of the winding, is fastened to a brass screw that runs through the rear wood strip. The coil ends have lugs soldered to them to

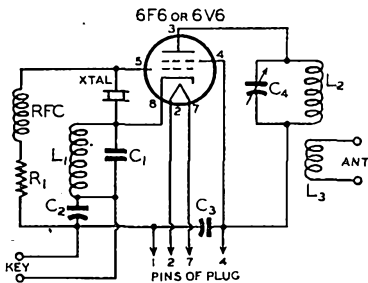
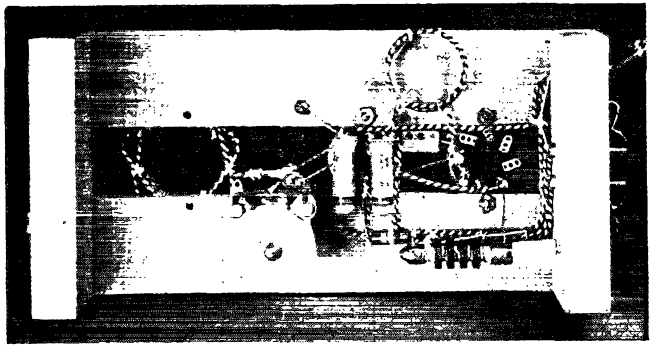

Fig. 1 — Wiring diagram of the inexpensive transmitter.

- $C_1$  — 470- $\mu$ fd. mica.
- $C_2, C_3$  — 0.01- $\mu$ fd. 600-volt paper.
- $C_4$  — 140- $\mu$ fd. variable (Hammarlund SM-140 or Bud MC-1876).
- $R_1$  — 0.1-megohm 1-watt composition.
- $L_1$  — 5 turns No. 18 d.c.c.,  $1\frac{1}{4}$ -inch inside diameter, close-wound.
- $L_2$  — 3.5 Mc.: 19 turns. 7 Mc.: 12 turns.
- $L_3$  — 13 turns and 6 turns. Requires experiment — see text. See text for  $L_2$  and  $L_3$  winding instructions.
- RFC* — 2.5-mh. r.f. choke (National R-100U).

A minimum of parts are used in the simple transmitter. Note the cathode coil between the tube and crystal sockets — its inductance can be changed by squeezing the coil out of round.



facilitate band-changing, but this refinement isn't absolutely necessary. The antenna-coil ends similarly fasten to two brass screws supported by short lengths of heavy wire (antenna wire, for example), and the wire is sweated to the Fahnestock clips and to the heads of the screws.

Wiring the little oscillator isn't much of a job. As can be seen from the photographs, the wiring is done with the same wire that was used for the coils, because a single 50-foot roll of No. 18 bell wire, available in any "5 & 10" or hardware store, suffices for the whole rig with some to spare. To insure good electrical connection, the wire is soldered at every connection, which means that the wire is soldered to the heads of the brass machine screws used for the key leads and the screen end of  $L_2$  before the screws are put in place. One key lead, one end of  $R_1$ , the outer foil connections on  $C_2$  and  $C_3$ , and the lead to Pin 1 of the power plug are all connected to Pin 1 of the tube socket. At the crystal socket, two adjacent pins (e.g., 1 and 8) are bonded together for the grid side of the crystal and the next two pins (e.g., 2 and 3) are bonded together for the cathode side. This permits plugging the crystal into either Pins 8 and 2 or 1 and 3. The connection can be elaborated still further by bonding Pins 4 and 5 with 8 and 1 and tying 6 and 7 to 2 and 3, in which case the crystal can be plugged in any way and it will make the proper connection.

The cathode coil, consisting of 5 turns of No. 18 bell wire, is wound on a  $1\frac{1}{4}$ -inch diameter form and then removed and tied with string at a number of places. One might think that the coil would fall apart when it is removed from the form, but the wax on the insulation of the wire helps to bond it until a few pieces of string have been tied in place. The cathode coil is mounted by its leads only but, being short, they offer adequate support.

The plate and antenna coils are wound in a simple fashion in vogue many years ago, but still practical for anyone trying to save on coil forms. Incidentally, the coils are mighty good electrically, all showing  $Q_s$  of over 300 when tested in the lab, just in case anyone wants to scoff. They

are wound by equally spacing seven nails on a 2-inch diameter circle, driving the nails completely through the board used so that the heads are flush against the board. Small spikes can be used, or nails of the "8-penny" size will be satisfactory if a thin board is used. One end of the wire is secured to a nail and the wire is threaded over alternate nails, so that the coil repeats itself every two turns. When the required number of turns have been made, the end of the wire is wrapped around a nail and the coil tied together with string at the seven cross-over points. The result is an inexpensive coil having fair mechanical properties and good electrical ones, and it is difficult to build one any more cheaply. Soldering lugs are soldered to the ends of the coil for ease in changing bands, though this isn't absolutely necessary, as mentioned earlier.

The four wires coming out the side of the chassis that go to the power plug are twisted together slightly and cabled with string to form a neat cable, and the cable plug is simply the base from an old glass octal-base tube that has outlived its usefulness and which one can chisel from a serviceman or radio store. Break the tube and chew out the glass from inside the base with a pair of pliers, being careful not to break the bakelite of the base. It will help in making connection to the proper pins if a small drill, slightly larger than the diameter of the No. 18 wire, is run through the pins before the wires are inserted and soldered in place. A drill larger than No. 56 is satisfactory.

### Tuning

After checking the wiring, plug in a crystal and connect the 7-Mc. coil in place. Place the audio tube from the receiver in the transmitter and plug in the power cable, and connect a key to the clips on the side of the transmitter. Set the tuning condenser,  $C_4$ , at about 40 per cent meshed and turn on the power to the receiver. When the tube has had time to warm up — about 30 seconds — close the key and touch a neon bulb to the plate end of  $L_2$ . Or a small 10-watt electric lamp can be

(Continued on page 140)



# Happenings of the Month

## THE REST OF 40 & 20!

On November 2d, nearly a month before the target date that had been under contemplation during the year, FCC restored to us the remaining halves of our 40- and 20-meter bands. The additional frequencies so released are available only for Type A1 emission (c.w. telegraphy) until further notice. The band limits are now the Cairo ones, 7000-7300 and 14,000-14,400 kc. The restoration was made by means of Order No. 130-J, which for convenience recapitulated all authorized frequencies and types of emission. No 'phone is authorized yet in the 7-Mc. band. The Class-A 'phone assignment in the 14-Mc. band remains 14,200-14,300 kc. until further notice.

Canada took simultaneous and nearly identical action, the only differences being that the 14-Mc. 'phone allocation there is 14,150-14,300 kc. Since the releases to us required clearance by the Allied powers, we assume, as we go to press, that the restoration to amateurs is general throughout the democratic nations.

This gratifying action puts us in possession of all our "good" prewar frequencies except the 160-meter band, the fate of which remains in grave doubt. Amateurs everywhere will hail with delight the full recovery of our two best DX bands. We think it was a rather special occurrence, as it involved the collaboration of many persons and agencies. These being long-distance bands employed by the Allied military forces, joint action had to be arranged with the British. On this side, Colonel O. K. Sadtler, S.C., was designated by the Chief Signal Officer as liaison officer between the Army, the Navy, FCC and the League, and it was his untiring efforts in this capacity that resulted in the release, particularly in this anticipation of the original date. You fellows would be well pleased with the philosophy of the American military forces in this connection; it was simply that these were amateur bands, borrowed for a war, and the war was over, so they should be returned now; it was that simple. Again we were given extraordinary action to facilitate the return. Many messages were exchanged with theater commanders around the world to effect the clearance. When the U.S. military released to IRAC, the latter committee dealt with the matter within the hour by telephone and turned over to FCC. The Commission, consistent with its previous policies, lost no time in lifting the restrictions, authorizing its Order 130-J within a few hours by circulation amongst the Commissioners, rather than waiting until the

following week's formal meeting. Finally we should mention that the President and the Secretary of the League have maintained personal contacts with this situation over the months since V-J Day, and that having our spokesmen in personal touch facilitated this early action.

There will be disappointment that the Commission, in restoring the prewar bands, did not simultaneously act on the League's pending requests for rearrangement of the 'phone assignments. The latter matter is suffering some delay and *has not yet been decided by FCC*. Primary reason is the enactment by Congress of a new law, effective in September, called the Administrative Procedure Act, affecting the actions of all of the Government's regulatory agencies such as FCC. Designed to protect the public from possible arbitrary actions that would possess the power of law, the act requires henceforth the advance publication of intended changes in technical regulations, with a waiting period during which aggrieved parties may request an opportunity to be heard before the issue is settled. Overload had prevented FCC from dealing earlier with the matter of 'phone assignments, and of course it was felt that this should not be permitted to delay the reopening of the bands to their full widths for c.w. at least. We estimate that a decision in the 'phone matters should come in late January. WIAW will announce any further changes in regulations.

### To All VE Amateurs:

• The question of the division of our frequency bands (when they have been returned in full) between c.w. and telephony is one which merits the serious consideration of all amateurs. In order that the wishes of the Canadian amateurs on this subject may be made known to the authorities at Ottawa, it is requested that each and every one of you advise me — preferably by postal card — of your views. After allowing sufficient time for this canvas to be completed, the results will be tabulated and forwarded to our authorities for their consideration before issuing our 1947/8 licenses.

ALEX REID, VE2BE  
Canadian General Manager  
240 Logan Avenue  
St. Lambert 23, P. Q.

## NOTICE TO READERS

• The Publishers regret that rising production costs have made it necessary, effective with last month's issue, to increase the newsstand price of *QST* to 35 cents a copy.

While there is no change in League membership dues in the operating territory of the League (the United States and Canada), the League regrets that these rising production costs now make it necessary to increase membership dues in all other countries (including subscription to *QST*) to \$4 a year.

Incidentally, this issue of *QST* is the greatest in number of pages—and also number of copies printed—in our history. We grow!

## WHAT BANDS AVAILABLE?

Below is a summary of the U. S. amateur bands on which operation is permitted as of November 10th. Future changes will be announced by W1AW broadcasts. Figures are megacycles. AØ means an unmodulated carrier, A1 means c.w. telegraphy, A2 is m.c.w., A3 is a.m. 'phone, A4 is facsimile, A5 is television; FM means frequency modulation, both 'phone and telegraphy.

3,500-	4.0	- A1	
3,850-	4.0	- A3, Class A only	
7,000-	7.3	- A1	
14,000-	14.4	- A1	
14,200-	14.3	- A3, Class A only	
27,185-	27.455	- AØ, A1, A2, A3, A4, FM	
28.0	- 29.7	- A1	
28.5	- 29.7	- A3	
29.0	- 29.7	- FM	
50.0	- 54.0	- A1, A2, A3, A4	
52.5	- 54.0	- FM	[band is only
144.0	- 148.0	- AØ, A1, A2, A3, A4, FM; except	
144.0	- 148.5	within 50 mi. of Washington, Seattle and	
235	- 240	- AØ, A1, A2, A3, A4, FM [Honolulu.	
420*	- 430*	- AØ, A1, A2, A3, A4, A5, FM	
1,215	- 1,295	} AØ, A1, A2, A3, A4, A5, FM, Pulse	
2,300	- 2,450		
3,300	- 3,500		
5,650	- 5,850		
10,000	- 10,500		
21,000	- 22,000		
All above 30,000			

\* Peak antenna power must not exceed 50 watts.

## PREWAR DX QSLs

Going . . . going . . . gone! On January 1st the hammer falls on all foreign QSL cards confirming prewar contacts with W and VE amateurs who have not applied for them under ARRL's bureau distribution system. Under authorization of the Board of Directors, unclaimed cards will be destroyed after that date to make way for the huge influx of new cards in postwar DX activities.

There are still some thousands of choice cards in file, many confirming contacts as far back as

the early thirties. By means of regular notices since the July issue, *QST* has attempted to notify all present and former amateurs of the possibility of QSLs being on hand for them. This is your last chance. The procedure to obtain cards is simple. Send a self-addressed stamped envelope, stationer's size No. 10, to the QSL Manager of the home district indicated in your call. His address is in the QSL Bureau notice elsewhere in this issue. If there are cards on file for you, your manager will mail them back, at which time you should send him another envelope to keep on file for possible future cards.

There is little consolation in having your choice old cards converted into ashes in a hallowed urn on the QSL Manager's mantelpiece. Get them before January 1st. Send an envelope now!

## PACIFIC ELECTION RESULTS

William A. Ladley, W6BRQ, of San Francisco, has been chosen director of the Pacific Division in a special election to elect a successor to J. Lincoln McCargar, W6EY, who was elevated to the Vice-Presidency at the Board's meeting last May. Mr. Ladley took office immediately, for the remainder of the 1946-1947 term. Elbert Amaranter, W6FBW, continues as the alternate director.

In the election Mr. Ladley received 621 votes, to 380 for his opponent, Horace R. Greer, W6TT.

Mr. Ladley has been active in amateur affairs in the Bay Counties for many years, having been the SCM for the San Francisco Section for 1944-45, and presently operates on both c.w. and 'phone. Businesswise he is president of the Pacific Felt Company, manufacturers of batting and upholstery.

## MIDWEST CHANGES

Director Floyd E. Norwine, jr., WØEFC, for many years the Midwest Division's member of the ARRL Board of Directors, has been compelled by the pressure of his business affairs to resign his posts in ARRL, and President Bailey has reluctantly accepted. The alternate director, C. A. Colvin, W9VHR of Omaha, becomes the director for the remainder of the 1946-47 term.

To succeed Director Norwine as chairman of the Board's Planning Committee and Regulations Committee, President Bailey has named Professor Hugh L. Caveness, W4DW, director of the Roanoke Division.

## YOUR EXPIRATION DATE?

The extensions of amateur licenses begin to expire on December 8th. From now on, we must all remember to keep informed on our expiration dates and file renewal applications in time—or go off the air. If there have been no extraordinary happenings in your case, your prewar station

(Continued on page 140)

## What About the BC-375-E?

**W**e've had a flood of questions about the BC-375-E, an Army transmitter that has appeared in large quantities on the present war-surplus market. "What is it?"—"Will it make a good transmitter for my home station?"—"Is it worth the price [about \$50, with tubes] being asked for it?"—"Is it easy to convert for a.c. operation?" These seem to be the questions most frequently asked. To get the answers to these and a few questions we had in our own minds, we bought one, took it into the lab, and went to work on it. The following may not answer all questions, but it should supply enough information to permit some evaluation of the situation.

The BC-375-E is an aircraft transmitter, using an MOPA circuit, with a 211 oscillator driving a 211 amplifier to produce 45 to 75 watts output over a wide range of frequencies, including the 3.5- and 7-Mc. amateur bands. A 210 speech amplifier driving Class B 211s is used for 'phone

operation. The equipment is designed for operation from a 24/28-volt d.c. source capable of supplying about 600 watts for c.w. operation, 840 watts for 'phone. A dynamotor rated at 28 volts at 20 amperes input furnishes the plate power required, while the filaments are supplied directly from the 24/28-volt batteries. Seven plug-in tuning units are used to cover the frequency range. The plug-in units, the dynamotor and, in some instances, an antenna tuning unit are included in the price.

The d.c. power-supply requirements present the first problem. Four 6-volt 100-ampere hour batteries would cost about \$30 at present market prices, and a suitable battery charger perhaps another \$8 or \$10. The cost, plus the inconvenience of having to recharge the batteries frequently because of the heavy drain, makes battery operation of the equipment a rather unattractive possibility. A few purchasers have shown some interest in using the dynamotor, driving it by

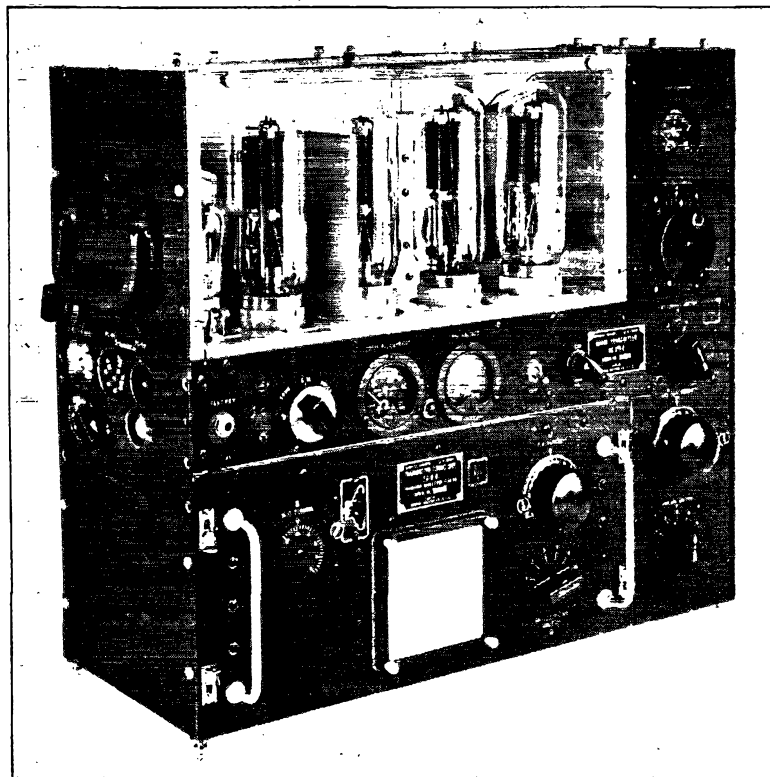

Front view of the "modified" BC-375-E. The tuning controls remain unaltered, but along the meter panel several changes have been made. At the extreme left is the new key jack, next to it the tuning control for the grid circuit of the first 211, which now operates as a buffer-doubler. Just to the left of the nameplate is the meter switch. On the left side of the case are an audio gain control, a bandswitch for the grid of the first 211, a power plug for the preamplifier, and a new microphone jack.



coupling its shaft to an a.c. motor. When you stop to consider that the motor required would have to be at least a 1-horsepower job, if 'phone operation was desired, and that it would be necessary to drive the dynamotor shaft by means of a V-belt and pulleys to obtain the rated 5000-r.p.m. shaft speed, this method also seems costly and impractical. The motor would cost \$40 or \$50, and would require a pretty husky power line to run if the usual single-phase 220-volt grounded-neutral house wiring circuit were to be used, and there aren't very many ham shacks that have 2- or 3-phase stuff available. The cost of a suitable selenium rectifier supply also seems prohibitive.

### Converting for A. C.

Therefore, forgetting that a dynamotor had been included in the purchase price, we set about "converting" the transmitter for fixed-station use from rectifier power supplies. A look at the circuit diagram in the instruction book supplied with the equipment convinced us that it should not be a difficult job to unground one side of the filament circuits and rewire them in parallel for operation from a filament transformer. Perhaps we should say *transformers*, because the requirements are 10 volts at 13 amperes for the four 211s, to say nothing of the 7.5-volt 1.25-ampere needs for the 210 speech amplifier. Armed with the usual assortment of ham tools, we started the job. We had not gone far, however, before we began to learn things about the BC-375-E, things that were not apparent at first. The equipment was designed for a specific purpose, and we have no doubt that it fulfilled that purpose. But it was not, apparently, designed with any thought of making it easy to work on. Consequently, when we attempted to do what, on paper, seemed to be a simple rewiring job, we found that we had our hands full. Before we could reach the tube sockets, several parts had to be removed — including the modulation transformer, which is something in the nature of a major operation. Without detailing the steps here, let's say that the rewiring was accomplished, with difficulty, and with the aid of about every socket and open-end wrench we could find, plus a little old-fashioned brute force. In the course of these operations, the entire filament voltage-compensating circuit was removed, as it is not needed in a.c. filament operation. To avoid using a separate filament transformer for the 210 speech amplifier, Resistors 1191 and 1192 were wired in parallel instead of in series, resulting in about 7 volts at the socket of the tube, which is adequate for the sort of operation involved.

### Some Other Changes

While the rig was still opened up, and before the modulation transformer was put back, we installed a meter-switching circuit to permit measurement of oscillator plate current, amplifier

grid current, amplifier plate current, and modulator plate current. The usual system of inserting 22-ohm resistors in the d.c. leads of the circuits to be measured, and switching the meter across each resistor in turn, was used. The meter switch was mounted on the front panel in the hole vacated by the toggle switch originally used for filament compensation. The keying relay was disabled by turning the contact-spacing adjustment screw all the way in, leaving the relay permanently in the transmit position. The relay will not operate on a.c. The keying lead was disconnected from the relay, and was brought out to a closed-circuit jack installed on the front panel in the hole formerly occupied by the "Test Key," which was not considered essential for ham use. The "On-Off" switch was rewired so that it would break the B- lead instead of actuating a relay in the dynamotor unit.

With these changes behind us, we were rapidly becoming familiar with the schematic diagram and the wiring diagram. The use of the latter is essential, because circuit tracing from the schematic alone is next to impossible.

### Performance as an MOPA

We hooked up a d.c. power supply capable of giving 1000 volts at 250 ma., and with the tuning unit that covers the 3000-4500-kc. range plugged in, set the dials for 3500-kc. output in accordance with the calibration charts supplied with the unit. The "conversion" had not upset the calibration too much, but the fact remains that we did have to retune to hit the desired frequency. Using a 150-watt lamp bulb as a dummy load, we were able to load the final amplifier satisfactorily, obtaining about 60 watts output with 100 watts input. When keyed, however, the oscillator "yooped" badly, and nothing we could do in the nature of retuning seemed to help. In addition, tuning the antenna circuits pulled the oscillator frequency a good many kilocycles away from where we started, indicating that more isolation between the antenna circuits and the oscillator was needed. These faults convinced us that the stability of the BC-375-E as an MOPA rig is just not good enough to meet the FCC requirements for amateur stations, and it does not appear to be capable of improvement without extensive modification. The low-C oscillator circuit seems to be the main cause of this instability. It is another illustration of how Army requirements frequently have no relationship to ham requirements; what the Army needed was a transmitter that would put out a signal that would be within a small percentage of a specified frequency under some rather trying operating conditions. The *quality* of the signal as judged by amateur standards was of secondary importance. The result no doubt was just about what was desired, but the signal isn't the kind that a self-respecting ham would care to have on the air!

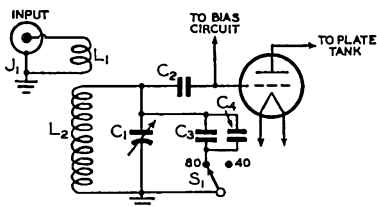

Fig. 1 — The tuned circuit used to permit link-coupling to the grid of the first 211 tube. Padding condensers are used to provide bandwitching.

- C<sub>1</sub> — 100- $\mu$ fd. receiving-type variable (Millen 22100).
- C<sub>2</sub> — 0.0022- $\mu$ fd. mica.
- C<sub>3</sub> — 22- $\mu$ fd. mica.
- C<sub>4</sub> — 47- $\mu$ fd. mica.
- L<sub>1</sub> — 3-turn link, part of L<sub>2</sub>.
- L<sub>2</sub> — 22 turns No. 20 enameled, spaced to occupy 1 1/4 inches, 1 1/4 inches diam., air-wound. (National AR-16-40 E, with 4 turns and plug-in base removed.)
- J<sub>1</sub> — Coaxial connector (Jones S-101).
- S<sub>1</sub> — 5-position single-pole ceramic switch (4 positions not used). Centralab 2501.

### Stabilization

The solution to the stability problem was found in using a separate oscillator, external to the equipment because of space limitations, and changing the first 211 from an oscillator to a neutralized amplifier. Therefore, a tuned circuit, shown in Fig. 1, was installed in the grid of the former oscillator, with a link terminating in a small coaxial connector mounted on a plate that covered the hole formerly occupied by the remote-control connector. The grid coil and its tuning condenser fit behind the front panel, the condenser shaft coming out of the hole in the panel from which the "Tone-C.W.-Voice" switch had been removed. A rotary switch was installed with its shaft coming out through the side of the transmitter to switch padding condensers into the circuit, permitting the same coil to be used for either the 3.5- or 7-Mc. bands.

The neutralizing circuit, shown in Fig. 2, was installed in the tuning unit. A 50- $\mu$ fd. transmitting-type variable condenser, mounted as shown in the photograph, with its shaft protruding out of the rear of the tuning unit, did the job nicely. A similar circuit was installed in the 6200-7700-kc. tuning unit, to permit operation in the 40-meter band. In this case it was possible to neutralize with the plates of the 50- $\mu$ fd. condenser at almost minimum capacitance, so it would be possible to use a smaller condenser if available.

Using the "Longfeller" 6F6-6L6 transmitter described in *QST* for July, 1946, as an exciter, we were able to

obtain an entirely stable signal from the transmitter. For 3.5-4-Mc. operation the first 211 works as a neutralized amplifier while output in the 7-Mc. range is obtained by using it either as a doubler from 3.5-Mc. excitation, or as a neutralized amplifier from 7-Mc. excitation. The doubling efficiency of the circuit is low, but can be improved materially by increasing the bias on the tube by adding a 50,000-ohm 10-watt resistor inside the tuning unit. It should be connected in the same manner shown in Fig. 3, the diagram of the 10-12.5-Mc. tuning unit.

To obtain output in the 14-Mc. band, it was necessary to modify the coils in the tuning unit supplied for the 10,000- to 12,500-kc. range, and to remove the grid condenser, C<sub>x</sub>, shown in Fig. 3. The simplest way to change the coils is to short one turn at the "cold" end of each. Unless straight-through operation of the first 211 is desired, installation of the neutralizing circuit in this tuning unit is unnecessary. The efficiency of the doubler in this band is poor, even when the bias is increased by insertion of a 0.1-megohm 10-watt resistor in the same manner as in the 7-Mc. unit. The long r.f. leads apparently cause the loss of efficiency at these frequencies, because the tubes themselves are capable of reasonably efficient doubling, even up to 28 Mc. To get ade-

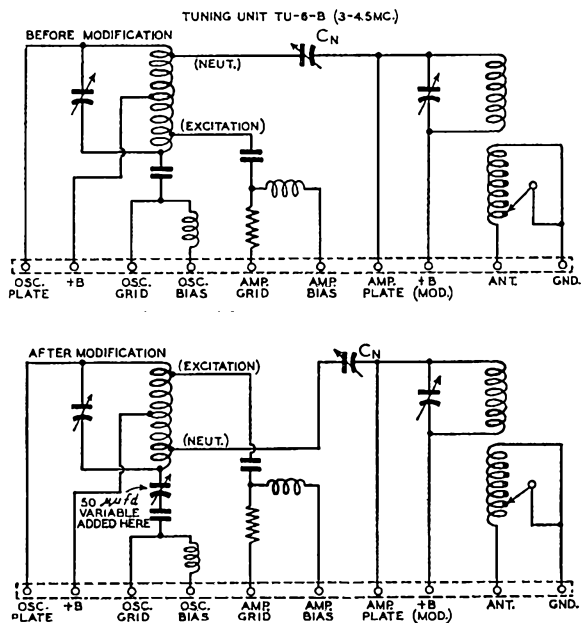

Fig. 2 — Simplified circuit diagram of the tuning unit used to cover the 3000-4500-kc. range. The addition of a 50- $\mu$ fd. variable condenser as shown in the after-modification portion of the sketch permits use of the unit as a neutralized amplifier. Output of the transmitter can be increased substantially by rearrangement of the excitation and neutralization taps on the oscillator coil as shown. The keyed terminals at the bottom of each sketch connect the tuning unit to the tube circuits.

quate drive for the final amplifier at 14 Mc. (35 to 40 ma.) it was necessary to use an 807 running at about 50 watts input as the exciter in place of the 6L6 used in the lower-frequency bands.

### Boosting the Output

With the changes outlined so far, we were able to get about 60 watts output in the 3.5- and 7-Mc. bands and somewhat less at 14 Mc., in each case running about 100 watts input to the final. This output can be increased to something over 100 watts, however, by rearrangement of the taps on the "oscillator" coils in the various tuning units. As originally designed, the drive at the grid of the final amplifier is low — too low to permit full utilization of the power capabilities of the 211 tubes used. The excitation taps on the coils are placed near the "cold" end of the tank, a desirable situation when the first tube was used as a self-excited oscillator, but no longer necessary for stability when the tube is used as an amplifier-doubler. By shifting this tap to the plate end of the coil, as shown in the after-modification sketches of Figs. 2 and 3, and at the same time placing the tap from which the neutralizing voltage is obtained near the cold end, several times as much driving power can be obtained. For example, with the taps in their original positions the grid current to the final (using the 7-Mc. coils) was measured at 15 ma. When the taps were shifted, this figure was increased to 45 ma. While 15 ma. might be adequate for c.w. work, it is insufficient for true Class C operation of the tube, a requirement if satisfactory 'phone operation is to be obtained.

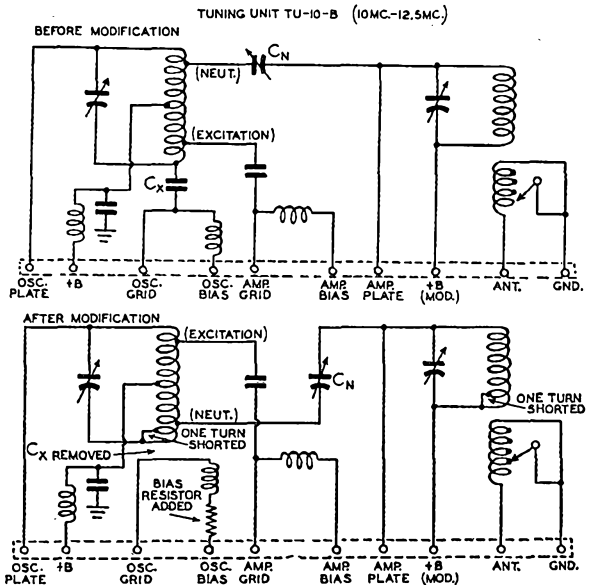

Fig. 3 — Circuit changes needed for modification of the 10,000-12,500-kc. tuning unit to permit coverage of the 14-Mc. band. One turn at the cold end of each coil is shorted, the grid condenser  $C_x$  is removed, and the excitation and neutralization taps on the oscillator coil are rearranged as shown in the "after" sketch. Unless operation as a neutralized amplifier in the 14-Mc. band is desired, addition of a neutralizing condenser is not required.

Shifting the taps is not a difficult operation, the main consideration being that the excitation tap and the neutralizing tap must always be kept an equal number of turns on either side of the "center-tap." The exact location of the taps must be determined by trial. The location that gives maximum amplifier grid current with minimum detuning of the buffer, when the final is tuned to resonance, is best.

◆ Inside view of one of the tuning units after modification. The neutralizing condenser, mounted on small ceramic stand-off insulators, is in the center. The taps on the former oscillator coil are relocated as described in the text. ◆

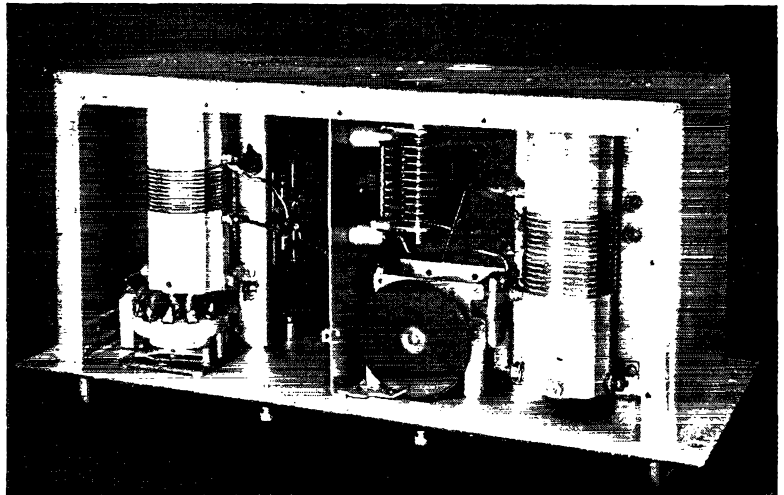
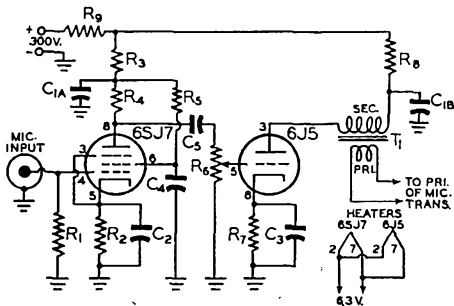

Fig. 4 — Circuit of the preamplifier used with the BC-375-E to permit use of a crystal microphone. If desired the transformer could be omitted, with normal resistance coupling being used between the 6J5 and the 210.

- C<sub>1A-B</sub> — Dual filter condenser, 2 × 8 μfd., 450 volts.
- C<sub>2, C3</sub> — 10-μfd. 25-volt electrolytic.
- C<sub>4</sub> — 0.1-μfd. 600-volt paper.
- C<sub>5</sub> — 0.01-μfd. 600-volt paper.
- R<sub>1</sub> — 2.2 megohms, ½ watt.
- R<sub>2</sub> — 1000 ohms, ½ watt.
- R<sub>3</sub> — 15,000 ohms, ½ watt.
- R<sub>4</sub> — 0.1 megohm, ½ watt.
- R<sub>5</sub> — 0.22 megohm, ½ watt.
- R<sub>6</sub> — 1-megohm potentiometer.
- R<sub>7</sub> — 2200 ohms, ½ watt.
- R<sub>8</sub> — 5000 ohms, ½ watt.
- R<sub>9</sub> — 10,000 ohms, 10 watts.
- T<sub>1</sub> — Microphone transformer, s.b.-to-single-grid type.



### 'Phone Considerations

In considering the audio system of the transmitter, it would seem that the set was not designed to operate at high modulation percentages, nor does it seem possible that linearity could be obtained with the low r.f. drive available for the amplifier. Using a carbon microphone, we were unable to approach 100-per-cent modulation, even with the transmitter running at 100 watts input, without shouting; in fact, the percentage seemed to be closer to 50. The trouble lies in the fact that there just isn't enough amplification ahead of the modulator grids to drive them the way they should be driven if anywhere near full output is to be obtained.

To get around this problem, we built a small two-stage preamplifier comprising a 6SJ7, resistance-coupled to a 6J5, with the output of the 6J5 arranged to feed the low-impedance primary winding of the microphone transformer. The circuit is shown in Fig. 4. If desired, the preamplifier can be external to the transmitter, but there is sufficient room for mounting it inside if the choke and condenser used to filter the microphone voltage in the original set-up are removed. To obtain an approximate match between the output of the 6J5 and the primary of the micro-

phone transformer, an old microphone transformer was used with its high-impedance secondary connected as the plate load for the 6J5 and its primary directly connected to the primary of the transformer in the set. With this preamplifier sufficient drive can be obtained from a crystal microphone.

Best results in 'phone operation can be obtained, however, only after revision of the biasing circuits of the Class B stage and the 210 speech amplifier. In the original circuit, biasing voltages are obtained by tapping on the grid leak of the final amplifier tube. Thus, bias on both stages changes with the amplifier grid current. To eliminate this possible source of trouble, a small 75-volt bias supply was used for the 211, and a 45-volt battery for the 210. Under these conditions, we were able to obtain 108 watts of audio from the secondary of the modulation transformer — enough to modulate a Class C input of 200 watts. We didn't attempt to get more than this, because the transformer just doesn't look large enough to handle more. (Ratings for the transformer are not included in the instruction book, but at 108 watts output with a 400-cycle sine wave, the transformer did not heat appreciably.) The audio quality of the rig, with the

(Continued on page 148)

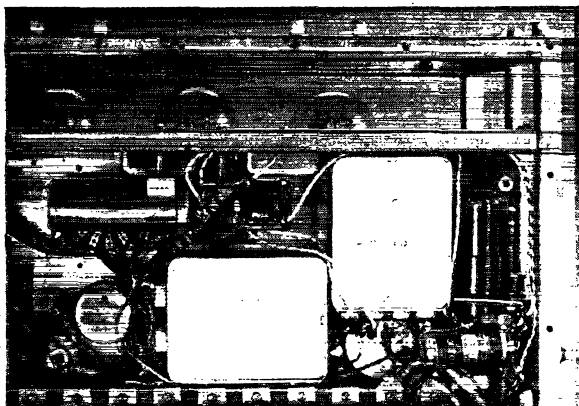

View of the upper right-hand corner of the rear of the transmitter chassis. The 2-stage preamplifier is crowded into the space formerly occupied by the microphone filter components in the upper right corner, with some of the "overflow" mounted on the shield partition just above the driver transformer. The audio gain control comes out of the right-hand side of the chassis.



# The World Above 50 Mc.



CONDUCTED BY E. P. TILTON,\* WIHDQ

**W**E THOUGHT we'd seen everything! We've lived with temperature inversions and sporadic-*E* skip for years; aurora effect, with its fuzzy c.w. and unintelligible 'phone is becoming widely recognized; the possibility of long-distance work via *F*<sub>2</sub> skip is well known, and countless v.h.f. workers are on the lookout for it — but then along comes old Giacobini-Zinner — and we have "ionization by cosmic dust" as a new means of v.h.f. propagation.

The display of meteors, forecast for October 9th, had been well publicized, and v.h.f. enthusiasts were on the lookout for unusual propagation conditions throughout the evening. By about 8:30 p.m. a peculiar rumble was noticeable on all 50-Mc. signals coming from beyond the horizon. Signals from points in a range from 200 to 1200 miles began to fill the 6-meter band, causing a degree of QRM never before experienced in this normally wide-open space. Several workers, noting the similarity of the signals to those heard during aurora sessions, switched to c.w. only to find that the slow flutter cut the dashes into bits, rendering c.w. practically unreadable. Owners of directional arrays headed them into the north, from force of habit, only to find that the signals were, for the most part, coming from their normal directions. Signals came in from all distances up to about 1200 miles, but there was no apparent skip, and very little fading of the sort normally associated with *E*-layer ionization. Reception was a continuous succession of short bursts of varying intensity, coming so close together that voice modulation was fairly readable. The period lasted for more than three hours, during which there was only a slight change in the character of the signals heard.

Most 50-Mc. workers have experienced "shooting-star" effect, that startling change of signal level which may be heard on weak signals coming from near the edge of the working range. Occasionally an S1 signal will practically tear the 'speaker apart for a brief instant, as a meteor hurtling into the ionosphere leaves a moving trail of ionization behind it, reflecting the signal briefly.<sup>1</sup> The session of October 9th was a prolonged succession of such bursts, occurring over a wider area and for a longer period of time than

ever before in the history of v.h.f. work. Since ionization begins when such particles enter the outer regions of the earth's atmosphere (at the time when the heat of collision with gas molecules causes incandescence) the 50-Mc. DX and the visible display of "shooting stars" occurred simultaneously. Because the ionization developed at about 50 miles over the earth, the approximate height of the *E* layer, the majority of the signals heard came from points normally covered only during sporadic-*E* ionization. It extended lower, however, permitting work over distances down to and including those worked by means of temperature-inversion bending.

W1PFJ, Waltham, Mass., worked W3OMY, Pittsburgh, WØIFB, Solon, Iowa, W8SFG, Hubbard, Ohio, W8JLQ, Toledo, W8VIB, Three Rivers, Mich., W9PK, Downers Grove., Ill., and W9QUV, Moline, Ill.

W8CIR/1, Boston, Mass., worked the same stations and heard a station in St. Cloud, Minn., and W2OPQ, Schenectady, N. Y.

W2BYM, Lakehurst, N. J., worked W8SFG, W3OMY, W9PK, W8CYX, Ferndale, Mich.; and W4GJO, Orlando, Fla., and heard WØNFM and WØIFB, Solon, Iowa.

W2EUI, Roselle, N. J., worked W8SFG, WØIFB, and W9PK, and heard W3OMY and WØs in Missouri.

W3OMY, Pittsburgh, Pa., worked W2IDZ, Succasunna, N. J., W8CIR/1, W1PFJ, W1HDQ, W2BYM, W1AEP, Springfield, Mass., W1JLK, Woods Hole, Mass., and WØJQC, Ft. Riley, Kansas. He heard W5FRD, Ft. Worth, Texas, W3JAY, Philadelphia, WØNFM, and many W1s and W2s not positively identified.

W3RUE, Pittsburgh, heard W8CIR/1, W1PFJ, W1HDQ, W1LLL, W1IYO, W2BQK, W2BYM, W2AMJ, W3JAY, W8SFG, WØHAQ, WØNFM, WØIFB.

W8SFG, Hubbard, Ohio, worked W2OPQ, W1HDQ, W1KJC, Wethersfield, Conn., W1LLL, Hartford, W1JTB, Shrewsbury, Mass., W2BYM, W2COT, Maplewood, N. J., W1IYO, Milford, Conn., W1DBM, Norwalk, Conn., W2EUI, W1PFJ, W8CIR/1, WØHAQ, Davenport.

W8VIB, Three Rivers, Mich., worked W1PFJ, W1HDQ, W8CIR/1, WØCHI, Grand Junction, Iowa. He heard W1LLL, W1AEP, W2AMJ, W2APU, W2BQK, W3JAY, W8NZ, W8SFG, W9PK, W9QCY, WØSV, WØNFM.

\* V.H.F. Editor, *QST*.

<sup>1</sup> "Listening in on the Stars," Oswald G. Villard, W6QYT, January, 1946, *QST*.

W9ALU, Metamora, Ill., heard W1PFJ, W2BYM, W0SV, W0DWU, W0DZM, W0ZJB, W0CHI, and W0URQ.

W0SV, St. Cloud, Minn., worked W0ZJB, Gashland, Mo., W0YUQ, Manhattan, Kans., W9ZHB, Zearing, Ill., and W9QUV. He heard W0NFM, W0IFB, W2BQK, W2AMJ.

W0ZJB, Gashland, Mo., worked W0s QIQ, ORA, SV, DWU, and URQ, all in Minnesota, W0HAAQ in Davenport, and W5FRD, Ft. Worth. All the Illinois and Iowa stations, normally heard at low levels, were heard with good strength.

W0NFM, Solon, Iowa, worked W2IDZ, W1HDQ, W1LLL, W1KJC, W1KMZ/3, Washington, D. C., W8CIR/1, W2AMJ, and W2BQK. Many others in Minnesota, Illinois, Missouri and Kansas were heard.

Observers in different sections turned in diverse reports as to the direction of arrival of the signals. In the East the directivity of the antennas was normal. In Ohio and Western Pennsylvania, signals were heard in almost any direction the antenna was aimed. The fellows in Minnesota heard signals loudest with their beams aimed south, while in Kansas and Missouri north was about the right direction!

This session was a fine example of the opportunity we v.h.f. enthusiasts have for making observations of peculiar propagation phenomena. Reports of such propagation vagaries, supplied by countless amateurs over all the years since the first v.h.f. DX was heard or worked, comprise, in sum, a considerable contribution to the present store of knowledge of the ionosphere. Because there are so many of us, our reports have great value, even though each of us may know little of the cosmic phenomena in back of our observations.

The month of October, normally not a period

## RECORDS

### Two-way Work

50 Mc.: W6OVK-W2BYM  
2500 Miles — June 14, 1946  
144 Mc.: W3HWN-W1MNF  
390 Miles — September 29, 1946  
420 Mc.: W6FZA/6-W6UID/6  
170 Miles — September 28, 1946  
2300 Mc.: W1JSM/1-W1ILS/1  
1.6 Miles — June 23, 1946  
5250 Mc.: W2LGF/2-W7FQF/2  
31 Miles — December 2, 1945  
10,000 Mc.: W4HPJ/3-W6IFE/3  
7.65 Miles — July 11, 1946  
21,000 Mc.: W1NVL/2-W9SAD/2  
800 feet — May 18, 1946

when skip-DX is expected, provided several other good openings, on the 7th, 12th, 13th, 16th, 17th, 23rd, 24th and 26th, that we know of. The 16th and 17th were exceptionally good days, with the number of stations heard and worked reaching the proportions of a summer opening. W5AJG worked W8QYD, W8DAL, W4EDD/3, W4HVV, W9ZWF, W9ZHB, W9PK, W9PIV, W9UNS, W9UIA, W0IFB, W0YUQ, and W0JCQ on the evening of the 16th. The 17th looked like a potential double-hop opening to W7QAP, Tucson, Ariz., who worked 6s, 7s and 0s, while the Eager Beavers of Kansas and Missouri were working east, but nothing east of Iowa was heard in Arizona. W6FPV, Van Nuys, Cal., worked W9ZHB, W0YUQ, W0NFM, and W0DZM during this same period, unusually long skip for a fall opening. W0NFM, Solon, Iowa, worked both ways that night, his contacts including W4HVV, W7QAP, and W6FPV.

(Continued on page 160)

The Midwest Division Convention at Topeka, Kansas, served as a gathering point for 50-Mc. men from far and wide. Left to right: Graybill, W9ZHB, Brown, W0NFM, Shirling, W0AHZ, Harnishfeger, W9QCY, Addison, W0PKD, Medlin, W0OTV, Keefe, W0HAQ, Turner, W9QUV. Back row: Ramsey, W0JCQ, Robinson, W4EDD, Milner, W0IFB, Hester, W7KAD, Tilton, W1HDQ, Keller, W7QAP, Simpson, W0YUQ, Dawson, W0ZJB.



# Design of Cathode-Ray Tube Circuits

## Practical Procedure for Building Your Own C.R. Indicator

BY WALT KNOOP,\* EX-W9KHG

• The cathode-ray tube has earned a place as one of the "indispensables" in the well-equipped amateur station. This article reviews the operation of the tube in easily-understandable style and tells how to go about designing your own power supply and control circuits.

**F**EW electron-tube types have experienced such a growth in application since the beginning of the war as the cathode-ray tube. This unique device serves as the indicator on practically all radar sets, is used in test oscillographs or "scopes" for maintenance, adjustment and trouble shooting on all types of radio gear, and also performs a valuable function as the indicator on panoramic receivers and direction finders. Its use in television receivers is, of course, by now "old stuff." With thousands of hams familiar with the value of the tube, it is considered worth while to review the principles of its operation, and to describe the circuit-design factors that need be considered in building your own gear.

There are two basic types of cathode-ray tubes in general use: the electrostatic-focus-and-deflection type, and the magnetic-focus-and-deflection type. The latter is used under fixed conditions of operation: that is, where the deflection frequencies are well stabilized, as in television receivers where the sweep frequencies are fixed, and other similar applications in military equipment. For general purposes such as test oscillographs and panoramic receivers, use of the electrostatic-deflection type is mandatory so we shall concern ourselves with this type only.

*The most important basic fact to remember about the cathode-ray tube is that it is a means of plotting a curve of some rapidly-changing phenomenon with respect to some other phenomenon.* In a test oscillograph, curves are plotted of voltage amplitude as it changes with time, and in a panoramic receiver, voltage is plotted against a frequency coördinate. In the trapezoidal type of modulation monitoring, the r.f. signal amplitude is plotted against the audio or modulating signal.

How is this accomplished? Fig. 1 is a simplified sketch of the electrodes or "gun structure" within the glass envelope on the face end of which

is coated a fluorescent salt or "screen." The spiral-wound heater, operated at 6.3-volts a.c. in most types, raises the temperature of the nickel cathode sleeve, the end of which is coated with a barium-oxide compound. The active cathode surface is roughly equivalent to the size of a pin head. Even though the total emission from this surface is only in the order of one milli-ampere, the quantity of material furnishing this emission is so small that caution must be used to maintain high cathode efficiency and long life. Fifteen years ago a c.r.t. life of fifty hours was considered normal; today 2000 hours is not exceptional under proper operating conditions.

The electrons emitted from the cathode surface are drawn toward the screen by the first anode or focusing electrode, which operates at a positive voltage with respect to the cathode. However, the passage of electrons is controlled by the grid or modulating electrode which is a cylinder surrounding the cathode with a cover plate or "aperture cup" welded to the upper end of the cylinder. The electron stream must pass through this aperture on its travel toward the first anode, and by varying the negative voltage or grid bias on this electrode the magnitude of the current

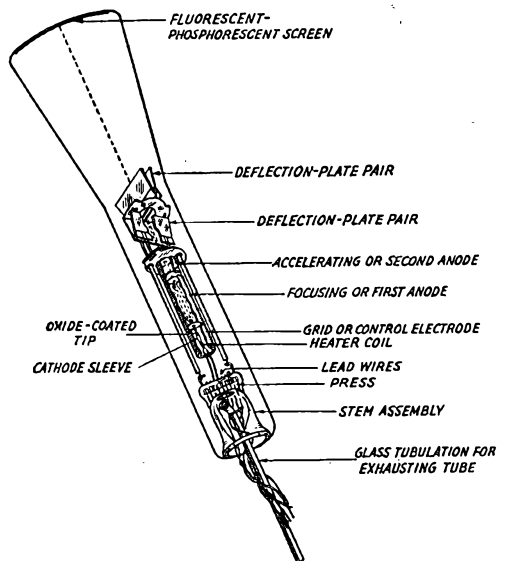

Fig. 1 — Construction of a typical cathode-ray tube with electrostatic deflection.

\*Gawler-Knoop, Inc., 1060 Broad St., Newark 2, N. J.

can be controlled as in the case of the ordinary triode. Most c.r.t. types have a cut-off bias in the order of  $-40$  to  $-50$  volts under typical operating conditions, and it should be noted that a tolerance in cut-off bias of  $\pm 50$  per cent should be provided. The adjustment of grid bias controls the intensity or brightness of the pattern on the face of the tube, just as the grid bias controls the plate current of an amplifier tube, and at cut-off the pattern is completely extinguished. The grid should never be operated at a positive voltage with respect to the cathode since such a condition, while it may cause a greater pattern brilliance, will in a short time cause cathode deterioration and drastic loss of emission, as well as causing excessive spot size.

After passing through the grid aperture the electron stream is caused to converge and then expand again in cross-sectional area by the electrostatic field set up between the grid and the first anode. The point of maximum convergence is called the "cross-over" point, and it will assume greater significance later on in our discussion. The focusing electrode or first anode operates at a positive potential in the order of 400 volts with respect to the cathode. Variation of this voltage is the means used to focus the pattern on the screen. The first anode contains a series of apertures to form an electron lens system in conjunction with the second anode or accelerating electrode. In passing through these apertures on their way up the tube, a considerable number of the electrons in the stream are collected by the anode parts to form a first-anode current in the order of 250 microamperes. Since the stream current is controlled by the grid bias (brightness control) and since the first-anode voltage is usually derived from a potential divider and bleeder, any adjustments in the brightness level require a readjustment of the focus control to maintain sharp focus. Furthermore, the combination of the focus-voltage tolerance (usually  $\pm 20$  per cent) required by the tube manufacturer and the variations in bleeder current, require adequate attention in designing the power-supply bleeder to provide sufficient focus-voltage range to operate the tube satisfactorily. This will be discussed in detail later on as we go through the design considerations of a typical power supply. Recently the tube manufacturers, in cooperation with the Army and Navy, have changed many of their gun structure designs to provide a zero first-anode current, a characteristic used some time ago in the older television tubes. This simplifies bleeder design since variations in bleeder current are largely eliminated. These new tubes bear an "A" designation after the type number, such as 5CP1A.

After passing through the first-anode barrel or cylinder the electron stream is further drawn toward the second anode or accelerating electrode, which in the 5-inch tubes usually operates

at a positive voltage of approximately 1500 with respect to the cathode. The electric field created by the voltage difference between the first and second anodes forms a condensing lens system for the electron stream, creating an image of the "cross-over" section of the stream on the screen of the tube, thus resulting in a sharp pin-point of light called the "spot." The second-anode potential imparts a high velocity to the electrons in the stream, providing them with a high kinetic energy which is converted into light when the electrons impinge on the fluorescent screen. The higher the accelerating potential the greater the brightness of the spot.

At this point, we now have an "electron gun" shooting a stream of electrons at the fluorescent screen to create a tiny pin-point of light. This corresponds to a motionless pencil, serving no useful purpose. Since we desire to trace a graph on the screen, some means must be provided to move the spot up and down and back and forth, corresponding to an active pencil tracing a curve. This is accomplished by means of two deflection-plate pairs, 90 degrees from each other, through which the beam passes after leaving the second anode.

Since the beam is composed of electrons, a positive charge on a surface adjacent to the beam will tend to pull the beam nearer that surface, and correspondingly, a negative charge will tend to push it away. Thus, by varying the voltage on a single plate of a pair, and connecting the other plate of the pair to the second anode, we can bend the beam toward or away from that plate; and if we connect an alternating voltage between the plate and the anode the beam will be deflected back and forth in accordance with the voltage variations. This type of deflection is called "single ended," and is a little cheaper but not as satisfactory as making both plates of a pair do some work by applying a voltage to one plate which is equal in magnitude but opposite in polarity to the voltage applied to the other plate. Thus, a push-pull amplifier feeding a deflection-plate pair will result in "balanced" deflection with a more uniform focus condition over the whole face of the tube. Examples of these two deflection methods are shown in Fig. 2. It should also be noted that by using a push-pull or balanced-deflection scheme, the instantaneous plate-voltage swing of each deflection-amplifier tube need only be half as great for the same amount of beam deflection.

Since a single pair of plates causes the beam to move back and forth, the other pair, at 90 degrees to the first pair, will similarly make the beam move up and down, thus providing the two coordinates for plotting a graph. In analyzing a c.r.t. specification sheet the deflection sensitivity in millimeters per volt d.c., or the deflection factor in d.c. volts per inch deflection, is stated for a given accelerating potential. The higher the accelerating potential the "stiffer" the beam be-



comes, because the velocity of the electrons is greater and therefore the time for passage of an electron through the plate structure is less, so the plates have a lesser opportunity to exert their influence. In designing circuits, therefore, a compromise must be made between permissible brilliance and deflection-amplifier output requirements.

The more modern tube types employ a third anode or "intensifier" formed by a conductive coating such as graphite on the inner bulb surface adjacent to the screen. Connection to this surface is made through a contact sealed in the side wall of the envelope. Intensifier-type tubes are operated at a lower second-anode voltage so that deflection takes place while the electrons are traveling at lower velocities, and then the final high velocity is imparted by the intensifier field after deflection. While the deflection sensitivity is reduced somewhat by the intensifier voltage, the reduction is not nearly so great as would result from the application of the same voltage to the second anode. This type of design provides the highest beam intensity with the least reduction of deflection sensitivity.

The fluorescent screen coated on the inside surface of the face end of the bulb usually produces a green trace (P1) or a white trace (P4). Other special color and light-decay or persistence characteristics are sometimes used for special purposes, but the green or the white is best suited for ham work. The screen is susceptible to burning if a bright-stationary pattern, line or spot is allowed to remain on the face for more than a few seconds. The screen is more susceptible to burning when low accelerating voltages are used, contrary to popular impression.

#### Power-Supply Design

So much for the theory of operation. Now, let's run through a typical power-supply design problem.

**Problem:** We wish to employ a cathode-ray tube to be used in a panoramic receiver having a 400-volt supply for the receiving-tube plates and a 6.3-volt winding for the heaters. A five-inch screen is desired to present the frequency-spectrum panorama on as large a scale as is economically practical. Good deflection sensitivity is important because we don't have large signal values, and a high-intensity display is obviously desirable.

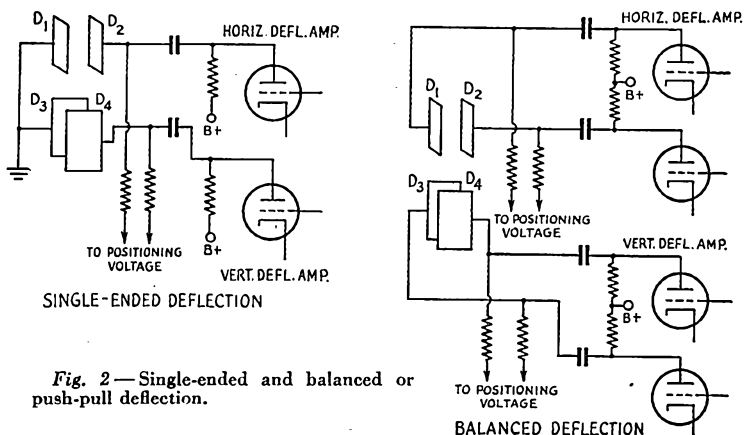

Fig. 2 — Single-ended and balanced or push-pull deflection.

**Selection of Tube Types:** A review of the available 5-inch tube types indicates the Type 5CP1 as being the most modern design. It is an Army-Navy preferred type having excellent light-output characteristics and incorporates an intensifier for maximum deflection sensitivity. Furthermore, it is produced by several manufacturers.

**Power Transformer:** The power transformer is usually the stumbling block of most experimenters working with cathode-ray tubes. Fortunately, there is obtainable a transformer used in commercial oscillographs which fulfills our requirements very nicely. The 5CP1 was designed to be operated at high accelerating potential. When used in the circuit shown in Fig. 3, the transformer will supply approximately 1400 volts positive to operate the intensifier and 1100 volts negative for the cathode. The second anode is connected to ground, thus providing a total accelerating potential of 2500 volts with respect to cathode. The transformer  $T_1$  indicated in Fig. 3 not only provides voltages for the cathode-ray tube, but for the other receiving-tube plates and heaters as well.

**Rectifiers and Filters:** Half-wave rectifiers are all that are needed for the high-voltage supply because the load current is small — less than 2 milliamperes. The 2X2 rectifies the positive cycle of the a.c. available at the 1100-volt (r.m.s.) secondary and is followed by a simple RC filter. Assuming an  $IR$  drop of 100 volts across the filter resistor  $R_{10}$  and across the 2X2, we can expect a d.c. potential of  $1100 \times 1.4$  (a.c.-peak factor) — 100 = 1440 volts available at the intensifier.

The 80 rectifies the negative cycle of the a.c. available at the 900-volt tap on the secondary. Assuming a 150-volt drop across the two filter sections and the 80 rectifier, a d.c. potential of  $900 \times 1.4 - 150 = 1110$  volts is available at the "hot" end of the bleeder string.

Simple resistance-capacitance filters are used in both high-voltage circuits because they are

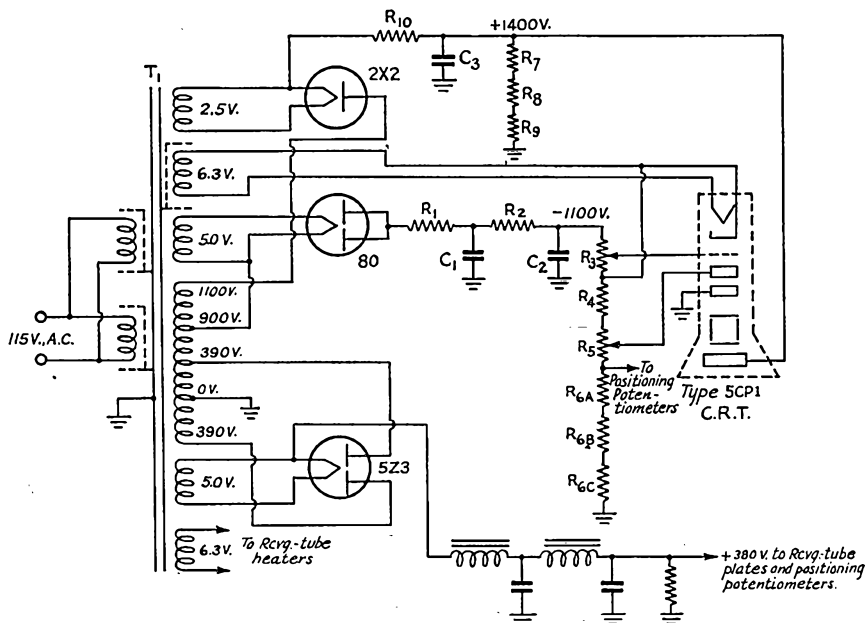

Fig. 3 — Example of power-supply circuit design discussed in the text. **Caution:** The potentiometers associated with the cathode-ray tube electrodes operate at a dangerous potential with respect to ground!

- $C_1, C_2$  — 0.5  $\mu$ fd., 1500 volts.  
 $C_3$  — 0.05  $\mu$ fd., 1600 volts.  
 $R_1, R_{10}$  — 10,000 ohms, 1 watt.  
 $R_2$  — 50,000 ohms, 1 watt.  
 $R_3$  — 75,000-ohm potentiometer.

- $R_4, R_{6A}, R_{6B}, R_{6C}$  — 0.25 megohm, 1 watt.  
 $R_5$  — 0.25-megohm potentiometer.  
 $R_7, R_8, R_9$  — 5 megohms, 1 watt.  
 $T_1$  — Combined c.r.t. and receiver power-supply transformer (DuMont Type 20-64).

entirely adequate, the current drain being so small, and they are considerably less expensive than the more common LC filters. The schematic indicates the component values used; they are not particularly critical. The voltage ratings of the capacitors are chosen to allow for variations in line voltage. Peak surge values of current through the rectifier sections are limited by the input resistances,  $R_1$  and  $R_{10}$ , which are 10,000 ohms each.

It will be noted that the single tapped-secondary provides voltages for the high-voltage positive and negative supplies as well as the 400-volt system for the other receiving tubes of the equipment. Thus a single transformer is all that is needed.

**The Bleeder:** The bleeder, consisting of  $R_3, R_4, R_5$ , and  $R_6$ , is used to achieve good voltage regulation and thus minimize defocusing and variations of pattern size with changes in intensity or brightness-control setting. It also serves as a voltage divider to provide the proper electrode voltages for the cathode-ray tube. The design of the bleeder is all important and will be discussed in detail in the following paragraphs.

First of all, a value of bleeder current must be chosen. Currents of 1 to 3 milliamperes are usually used, so let us select 1 milliampere as being good

practice. By employing Ohm's Law, we find the total value of the bleeder resistance to be

$$R_{\text{bleeder}} = \frac{1100 \text{ (d.c. voltage across bleeder)}}{0.001 \text{ (bleeder current)}} = 1,100,000 \text{ ohms}$$

The potentiometer  $R_3$  is the intensity or brightness control used to furnish an adjustable bias to the grid of the c.r.t. The value of this potentiometer must be high enough to extinguish the beam completely and to allow for tolerances from tube to tube. The 5CP1 specification sheet indicates a maximum cut-off bias of -67.5 volts with 1500 volts on the second anode. Since the cut-off bias is directly proportional to the second-anode potential and we are using 1100 volts, a simple proportion gives:

$$\frac{67.5}{1500} = \frac{E_{\text{cut-off}}}{1100} \quad E_{\text{cut-off}} = 49.5 \text{ volts}$$

So the intensity potentiometer should have a

$$\text{value of } R_3 = \frac{49.5}{0.001} = 49,500 \text{ ohms.}$$

The nearest standard-size potentiometer is 50,000 ohms, but since we desire some bias to spare so the intensity control doesn't have to be turned all the way to zero to turn off the beam, it is bet-

ter to select a 75,000-ohm potentiometer for  $R_3$ . Remember that this potentiometer must be insulated from the chassis for at least 1100 and preferably 2000 volts, for safety's sake!

The focus potentiometer, consisting of  $R_4$  and  $R_5$ , is a little tricky since it must provide sufficient voltage range to focus the beam under two conditions — at nearly cut-off bias when there is no first-anode current, and at the specified brightness level when considerable first-anode current is being drawn. The first case is the easier. Since the first anode draws no current, the idle current through the bleeder is not disturbed. The 5CP1 specification sheet indicates a first-anode focus-voltage range of 345 to 518 volts with respect to the cathode, at 1500 volts on the second anode. Consequently, in our circuit with approximately 1100 volts on the second anode, this range will be

$$\frac{345}{1500} = \frac{E_{min}}{1100} \quad E_{min} = 253 \text{ volts}$$

$$\frac{518}{1500} = \frac{E_{min}}{1100} \quad E_{min} = 380 \text{ volts}$$

Therefore  $R_4 = \frac{253}{0.001}$  (minimum first-anode voltage) (bleeder current) age  
 $= 253,000$  ohms

250,000 ohms is nearest standard size. This will provide a minimum potential of 250 volts for the first anode with respect to cathode. Potentiometer  $R_5$  must provide a voltage range of 380–250 = 130 volts.

$$R_5 = \frac{130}{0.001} = 130,000 \text{ ohms}$$

for zero first-anode current.

The 5CP1 specification sheet indicates a maximum first-anode current of 500 microamperes when the tube is operating at minimum brightness of 3 foot-lamberts. The effect on bleeder values caused by this first-anode current can be most easily evaluated by setting up the equivalent resistance of the first anode (when drawing current) as a shunt path across  $R_4$ . The minimum value of focusing voltage is used for this condition. This equivalent circuit is shown in Fig. 4.  $R_4$  and  $R_{equiv}$  in parallel can be replaced by a single resistance equal to

$$\frac{1}{\frac{1}{R_4} + \frac{1}{R_{equiv}}} = \frac{1}{\frac{1}{250,000} + \frac{1}{442,000}}$$

$$= 160,000 \text{ ohms}$$

Since our previous calculation for  $R_4$  was 253,000 ohms the difference in resistance must be furnished by  $R_5$ :

$253,000 - 160,000 = 93,000$  ohms and our previous calculation for  $R_5$  was 130,000 ohms. So when the first anode draws current,  $R_5$  must now be  $130,000 + 93,000 = 223,000$  ohms. The nearest standard size is 250,000 ohms.

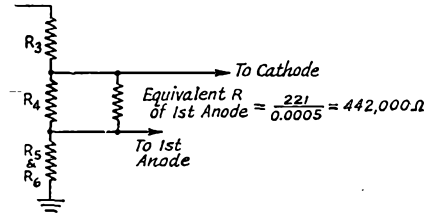

Fig. 4 — Calculation of effective resistance between terminals of  $R_4$  when current is flowing to the first anode of the c.r.t.

The value of  $R_5$  may be calculated, since the voltage across it should be

$$1100 - 380 \text{ (max. 1st.-anode } E) = 720 \text{ volts}$$

$$R_5 = \frac{720}{0.001} = 720,000 \text{ ohms}$$

It is not recommended that more than 500 volts appear across any one resistor in the bleeder string, so  $R_5$  is broken up into three 250,000-ohm resistors, comprising a 750,000-ohm total value.

The calculations may be checked by adding up the individual calculated resistances of each unit in the string.

$$\begin{aligned} R_3 &= 50,000 \text{ ohms} \\ R_4 &= 250,000 \\ R_5 &= 250,000 \\ R_{5A} &= 250,000 \\ R_{5B} &= 250,000 \\ R_{5C} &= 250,000 \\ \hline &1,300,000 \text{ ohms} \end{aligned}$$

This checks pretty well with the original 1,100,000-ohm figure for the entire bleeder, much of the 200,000-ohm difference being caused by the increase in size of  $R_5$  to handle the maximum first-anode current condition.

Fig. 5 — Sweep conditions used in example (see text).

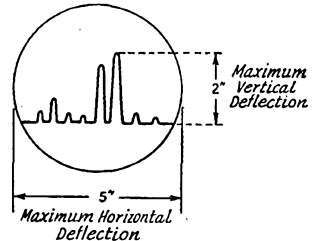

**Deflection System:** Now that the c.r.t. power supply is established, a few words about the deflection voltages are in order. Let us decide that we wish to spread the horizontal deflection over the full five-inches of the c.r.t. screen and the vertical signal deflection two inches above the horizontal baseline as illustrated in Fig. 5.

The c.r.t. specification sheet indicates a deflection factor of 55 d.c. volts per inch for plate-

pair  $D_1D_2$ , the horizontal sweep usually being connected to this pair because, being nearer the screen, it is less sensitive than  $D_3D_4$ . The deflection factor for plate-pair  $D_3D_4$ , which provides the vertical deflection, is 48 d.c. volts per inch. These figures are for 1500 volts on the second anode and with the intensifier tied to the second anode. Since the deflection sensitivity is inversely proportional to the second-anode potential (deflection factor directly proportional) the factors for our circuit are:

$$D_1D_2 = 55 \times \frac{1100}{1500} = 40 \text{ d.c. volts per inch} \\ \pm 20\% \text{ tolerance}$$

$$D_3D_4 = 48 \times \frac{1100}{1500} = 35 \text{ d.c. volts per inch} \\ \pm 20\% \text{ tolerance}$$

The addition of the intensifier voltage will reduce the sensitivity, or increase the factor. Applying an additional voltage to the intensifier which is equal to the second-anode voltage—in other words, doubling the total accelerating voltage—will reduce the deflection sensitivity by approximately 20 per cent.

Since in our case the intensifier voltage with respect to the second anode is 1400 volts, the reduction due to the additional accelerating potential is approximately  $20\% \times \frac{1400}{1100}$  or about 25%.

The maximum deflection signals needed then are:

$$D_1D_2 = 40 \text{ d.c. volts/inch} + 25\% \\ = (40 + 25\%) + 20\% \text{ tolerance} \\ = 40 \times 1.25 \times 1.2 \\ = 60\text{-volts peak}$$

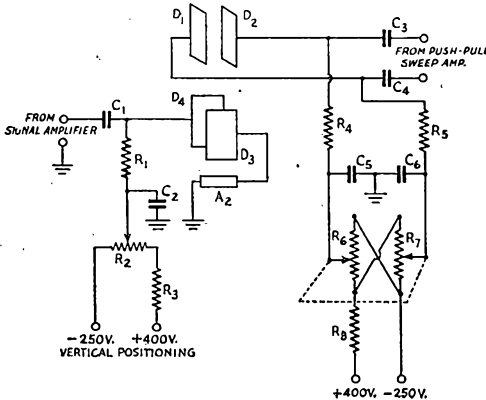

Fig. 6 — Positioning circuits for single-ended and balanced deflection.

$C_1, C_3, C_4$  — 1  $\mu$ fd.  
 $C_2, C_5, C_6$  — 0.05  $\mu$ fd.  
 $R_1, R_3, R_4, R_5, R_8$  — 1 megohm.  
 $R_2$  — 4-megohm potentiometer.  
 $R_6, R_7$  — 4-megohm dual potentiometer.

$$\text{and } D_3D_4 = 35 \text{ d.c. volts/inch} + 25\% \\ = (35 + 25\%) + 20\% \text{ tolerance} \\ = 35 \times 1.25 \times 1.2 \\ = 53\text{-volts peak}$$

In our particular application, the vertical deflection will only be upward from the baseline across the center of the tube, so we can achieve some simplicity and a saving in cost by using single-ended deflection on the vertical axis and grounded deflection plate  $D_3$  to the second anode.

Referring to Fig. 6, the circuit formed by  $R_1, R_2$  and  $R_3$  provides for the insertion of an adjustable d.c. voltage to deflection plate  $D_4$  for vertical positioning of the c.r.t. beam in the single-ended fashion, and  $R_4, R_5, R_6, R_7$  and  $R_8$  make similar provision in the balanced or push-pull circuit.  $R_2$  with  $R_3$ , and  $R_6$  with  $R_7$  and  $R_8$ , act as potential dividers.  $R_1, R_4$  and  $R_5$  are coupling resistances,  $C_2, C_5$  and  $C_6$  serve to by-pass any signal voltages to prevent their appearing in the power supply, and  $C_1, C_3$  and  $C_4$  are d.c. blocking and coupling capacitors for the signal circuits.

Horizontal- and vertical-positioning controls are necessary because the beam usually will not fall right on the center of the screen because of manufacturing tolerances, minute leakage currents, and the effect of the earth's magnetic field.

#### A Few Precautions

Now for a few general comments on construction practice. Every effort should be made to minimize magnetic fields in the vicinity of the c.r.t. Chokes and transformers should be located as far away as possible, and should be oriented so the field that does exist has a minimum effect on the beam. Trial and error will indicate the best points of location and angles of mounting. It is best to surround the c.r.t. with a high-permeability magnetic shield, such as mu-metal. In working with mu-metal remember that after it is bent or reworked to shape, it must be annealed to restore its high permeability.

Do not scratch the glass envelope of the c.r.t. Ordinarily the bulb will withstand pressures of three or four times atmospheric pressure, and most tube manufacturers run quality tests on this and other characteristics, but a scratch will greatly weaken the bulb.

Do not allow a stationary pattern to remain on the screen except at very low brightness levels, to prevent burning of the fluorescent material.

Do not apply a positive voltage on the c.r.t. grid (with respect to the cathode). A few seconds of positive grid voltage will strip the cathode surface, which cannot be repaired.

Above all, remember you are working with high voltages. The author has found it worth while to work with one hand in his pocket as much as possible. Do not be misled by negative potential points. They are just as lethal as positive points. Do not skimp on insulation, and make your parts

(Concluded on page 180)



# Foreign Notes



## NETHERLANDS PROPOSALS

On September 8th, V.E.R.O.N. held its first postwar meeting, attended by more than 150 members. The convention, after lengthy discussion, decided to recommend a division of amateur bands as between 'phone and c.w., a decision important to the rest of the amateur world since it represents the second instance of a country outside the United States and Canada being willing to restrict its voice operators to anything less than the entire band. Earlier this year, the Swiss society voted to assign the band segment 3500-3635 kc. for c.w., and the channels 3685-3950 kc. for voice, both effective September 1st. The Netherlands proposals affect all bands, and are as follows:

'Phone	C.W.
3600-4000	3500-3900
7150-7300	7000-7300
14,100-14,400	14,000-14,400
28,200-29,700	28,000-29,700

Traffic Manager Gortz, PAØGN, points out that on 20 meters the practical effect will be 14,100-14,200 for voice work outside the United States, the top half of the band being used by W 'phones. Practical effects of the 10-meter proposal will be similar, i.e., non-U. S. A. voice work from 28,200 to 28,500, and W 'phones above the latter figure. They also suggest f.m. privileges be available above 29,000 kc.

V.E.R.O.N. proposes that these band divisions be considered for adoption by member societies of the International Amateur Radio Union since, of course, nothing will be achieved if but one European country observes such allocations. Some of these proposals may have to be revised in the light of what develops at the next world telecommunications conference, now scheduled for the middle of next year. The PAs add, incidentally, that they are requesting their government to change the 5-meter assignment to that of the United States — 50 to 54 Mc.

At the convention it was further agreed that, rather than each European society conducting its own DX contest on uncoordinated dates, one society be chosen to sponsor a yearly all-inclusive affair, with "Europe competing with the rest of the world."

## LATVIA

From a Latvian ham now in exile in Sweden, we have an outline of the events affecting amateur radio in that country during the war years.

He says that in 1940 occupation authorities liquidated the meeting place of the *Radio Club of Latvia* in Riga, canceled all amateur licenses and confiscated equipment. As the battle line was forced eastward and a second invader arrived, Latvian hams to a man were active in the underground struggle for freedom. Some were not so fortunate as our informant, but were deported to Russia. We are told that the YL fraternity has by no means given up hope of returning to the air eventually. Good luck, OMs!

## NEW ZEALAND

ZL amateurs gathered in Wellington this past summer for their annual meeting, the agenda for which included discussion of a proposed new constitution. After some amendments, the new rules were adopted. Among other things, they provide for discarding of the former ballot system and the conduct of society business at the annual general meeting; permanent headquarters located in Wellington; formation of an Executive Council, elected by the membership; a management committee, appointed by the Council, to carry out routine work of the society. It was decided that the time was not yet opportune for N.Z.A.R.T. to employ a paid secretary. A proposal to increase the power limit from 100 to 250 watts above 28 Mc. was rejected.

A committee reported on the progress of the association's handling of war-surplus gear. The arrangement was found so unsatisfactory from all standpoints that it was agreed to discontinue the service and advise members to contact local equipment dealers for future surplus gear.

## MARCUSE HONORED

Honorary membership in the *Radio Society of Great Britain* has been conferred upon Gerald Marcuse, well known to the amateur world as G2NM. A prime mover for the Society's founding, he has served as honorary secretary, G.P.O. liaison officer, and president. In 1925 he was elected a vice-president of IARU, which he helped to form in Paris. R.S.G.B. considers him primarily responsible for the inauguration of Empire broadcasting, since long before the British Broadcasting Corporation began a regular short-wave service "Gerry" was transmitting regular programs from the amateur station at his home, persuading his professional friends to sing and play before his microphone. Once the skeptics

(Concluded on page 108)

*QST* is happy to return to its pages the Station Descriptions department, a feature traditional since the days of spark. With post-war planning and rebuilding culminating in Ham Shacks of permanence and technical excellence, we plan to show here, from time to time, representations of noteworthy amateur radio stations.

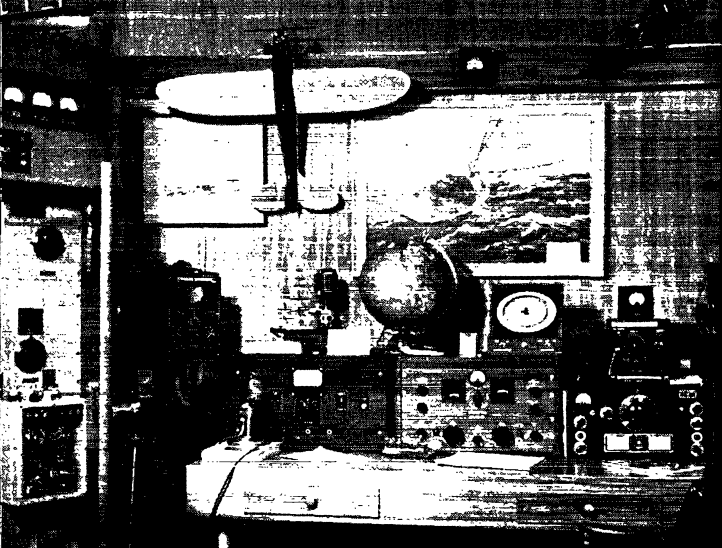

**WICPI**

*Wakefield, R. I.*

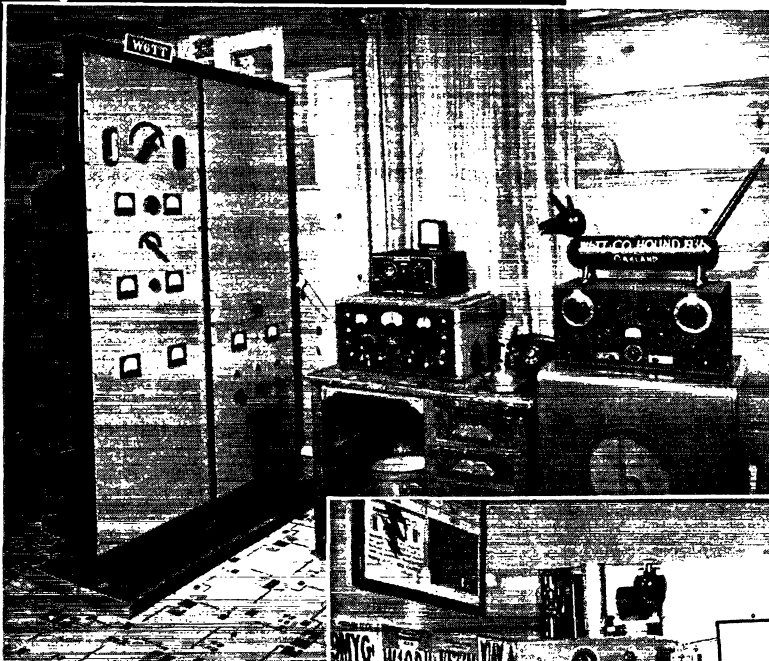

**W6TT**

*Oakland, Calif.*

**KP4AU**

*San Patricio,  
Puerto Rico*



**WINKW**

*East Lynn, Mass.*

# Postwar Ham Shacks

## W1CPI

To complete your picture of W1CPI perhaps we had better tell you right here at the start that the station of O. W. Greene, jr., is located high on a hill overlooking Narragansett Bay, at Wakefield, R. I. A pair of 80-foot steel towers elevate an ever-changing assortment of antennas, while a 54-foot self-supporting steel mast carries a Gordon 20-meter 3-element beam to round out the layout.

Although W1CPI has built many receivers and transmitters since starting in the game in 1914, his duties in recent years as president of Green Plastics, Inc. have kept him increasingly busy, with the result that the postwar W1CPI, resplendent with "boughten" gear, would make a handsome coverplate for any radio journal.

A Temco transmitter with motorized band-switching and VFO tuning operates on 10, 20, 40 and 80 meters, with a choice of either c.w. or 'phone. Two Eimac 4-250-As in p.p. in the final run at the legal limit on all bands. A pair of 100-THs comprise the modulator. Receivers in use are a Super-Pro 400-SX and an HRO. An LM-15 frequency meter, beam position indicator and Du Mont 'scope are companion units. "Skipper" is an OPS and is EC for Southern R. I.

## KP4AU

SINCE 1942, when Virg Meador pulled stakes here in the States to take up wartime duties at the Civil Aeronautical Administration's point-to-point transmitter station at San Juan, Puerto Rico, the blow of leaving sunny Cisco, Texas — and W5EVN — has been softened by a steady diet of radio and more radio . . . amateur and commercial.

KP4AU voices a transmitter with two complete r.f. sections, one on 14-Mc. 'phone, the other for similar work on 28 Mc. Each r.f. section begins with a VFO feeding a 6L6-807 exciter, which in turn drives a push-pull 813 final stage. A common 1600-volt power supply feeds upward of 500 watts to either final amplifier, while a low-voltage supply alternately powers the exciters. Class-B 811 modulators do double duty in supplying the audio needs for both sections.

The antennas at KP4AU are a four-element close-spaced beam for 28-Mc. transmission and reception on all frequencies, and a 14-Mc. half-wave doublet.

At the receiving position may be seen the Hallicrafter SX-25 which works with a Meissner Signal Booster ahead of it, a Thordarson oscilloscope, and an LM frequency meter.

## W6TT

MEET the East Bay Section champ, gang! Yes, 400 is a lot of contacts in any contest, and with this performance during the Band Warming melee, a score surpassed only by one other West Coaster was rolled up by W6TT. Elvin Feige has had plenty of practice for battles of this sort, however, for he has never missed an ARRL SS or DX contest since their inception.

The transmitter is a neat double-rack job lining up as follows: 807 crystal oscillator or 802 ECO driving an 807 buffer-doubler which, in turn, feeds a 4-125-A buffer-doubler to drive a pair of 250-THs in the p.p. final stage. Normal input runs at 800 watts. Both 'phone and c.w. are employed, and when the former is used a pair of 250-TH modulators go to work.

The receiving position boasts a Hallicrafter SX-28-A used in conjunction with a Panadaptor, which make it possible for Elv to both hear and see our sigs.

## W1NKW

HAROLD W. RYALL'S W1NKW in East Lynn, Mass., is about the best answer we've ever seen to the perennial question, "Where to put the ham shack?" Located in a closet 38 inches wide by 34 inches deep, the shack displays a compact, efficient arrangement that for operating convenience rivals many a more elaborate and spacious set-up.

A lone 6L6 crystal oscillator — with every one of its 20 input watts delivering — puts out a husky signal on 80-, 40- and 20-meter c.w., as evidenced by the rag-chewing and DX activity of the station. The oscillator-transmitter and its associated power supply are built on a single chassis and located on the top shelf. Alongside the rig are the antenna change-over relay and spare receiver coils.

A National HRO receiver is installed atop another shelf, clearing the desk top and providing extra space for the bug, keys, log and accessories. To the left of the HRO is a homemade monitor. Immediately below is a master-control toggle switch that excites relays for switching the antenna, 'phones, receiver and monitor.

If W1NKW in any fashion borrows on a tightly-crammed shipboard installation, it can be attributed to both the housing shortage and OM Ryall's "hitch" in the USCG as a radioman. He was 1PAY/1APY back in the spark days. Nowadays a mailman by occupation, W1NKW holds RCC, OTC and CP (35 w.p.m.) certificates, as well as commercial tickets he has never used.

# • Technical Topics —

## Those Excellent C.W. Signals

ANY philosopher looking for proof of the adage "History repeats itself" has to go no farther than one of the present c.w. bands. Admittedly there are a few excellent signals that might be considered as representing good 1946 technique, but altogether too many of them are not much of an improvement over the so-called "selfishcited" and "prehistoric" signals of the late 20s and early 30s. In those days signals suffered from chirps, clicks, drift and too much modulation. Fifteen years later, c.w. signals have been improved to the point where their only shortcomings seem to be from chirps, clicks, drift and too much modulation. It shouldn't be necessary to remind any amateur that the present regulations (§12.133) could put a large number of colored tickets in the hands of the c.w. men any time the FCC feels mean and decides the paper shortage is no more. So rather than force the hand of the FCC, let's take a look at some old principles that may have been forgotten.

Better yet, let's take a look at one of the bands before we continue. It doesn't matter much *which* band, because we'll find those poor signals on any. Tune across the band and just count the number of signals that are a real pleasure to copy — discounting the fist, of course, because that's another story. If you find more than 50 per cent that are really sweet sounding, don't read any farther. But we'll give you odds the percentage doesn't run that high. And when you find one you like, listen closely to see what makes it nice to copy. You will find that it suffers from none of the ailments ascribed above to "prehistoric" signals.

### Chirps

A chirp is a change in frequency during a dot or dash and is most prevalent in transmitters where the oscillator is keyed, although keying a later stage is by no means insurance that a chirp cannot develop. Keyed crystal oscillators will chirp when tuned for maximum output instead of for best keying, and some crystals key better than others. Generally the regenerative crystal oscillators, like the Tri-tet and grid-plate, will key better than straight triode or tetrode oscillators and are somewhat less critical in adjustment. Keyed self-excited oscillators require high-*C* tank circuits and careful adjustment of the feedback. Either crystal or self-excited oscillators key best when they are capable of oscillating with only a few volts on the plate (and screen) and when they are lightly loaded. If a shunt-connected grid leak is used, an r.f. choke should be used in

series with the leak to reduce loading, and the value of the leak should be high.

If a stage following the oscillator is keyed and the oscillator is running all of the time, a chirp can be introduced if the oscillator is sensitive to load changes introduced by keying, if there is insufficient isolation, or by changes in the voltages applied to the oscillator resulting from the fluctuation in line or supply voltage caused by keying. Neutralization or further isolation will cure the first condition, and the use of VR tubes or other means of stabilization will help if voltage regulation is causing the trouble.

Detecting a chirp on one's own signal requires that a stable receiver or monitor be available, and the listening can best be done on 28 Mc., where the chirp will be accentuated by frequency multiplication. If you are running a kilowatt on 7 Mc. and your receiver dial lights blink every time you hit the key, there is a good chance that your receiver is chirping when you try to listen to the harmonic on 28 Mc., and the receiver should be moved to a spot where the line voltage isn't affected. Also, steps should be taken to insure that the receiver isn't overloading while observing the signal, and it may be necessary to short the input terminals of the receiver while making the tests. Run with the audio gain wide open and the r.f. gain backed off. Tune in the signal at a low beat note and, while sending slow dashes, listen closely on both "make" and "break" for any changes in pitch. Try tuning on both sides of zero beat, to see if the signal sounds the same on either side, in case you missed a slight chirp when listening on one side only. This "tuning on both sides" is an important point, and will often show up faults that otherwise would be missed. And do the listening yourself — the other fellow may not want to hurt your feelings!

### Key Clicks

There is, of course, no standard on the maximum permissible amount of key click, and opinions differ somewhat as to what is desirable or undesirable. It might be said that if you don't interfere with any broadcast receiver and no nearby ham has cut down your antenna in a blind rage, your clicks are not bad, but the signals you like to copy are usually the ones with no objectionable clicks on either "make" or "break." Most of the c.w. men who pay attention to the fine points of good keying say that they like their signals "firm" on "make" and "soft" on "break," with no clicks adjacent to the signal



frequency on either make or break.

Clicks are caused by turning the signal on and off too abruptly, and it is generally necessary to slow up this process by introducing some delay. Series resistors and shunt capacitors, necessary to the circuit for other reasons, often introduce some incidental lag but generally it isn't enough for complete shaping. When an oscillator is keyed, the grid leak and grid condenser affect the keying shape when cathode keying is used, by introducing a shaping characteristic of their own, and for this reason it is generally advisable to key an oscillator in the negative or positive plate lead, if any lag circuits are to be used.<sup>1</sup> On the other hand, a driven amplifier can be keyed in the cathode or plate circuit with equal response to lag circuits, because of the constant excitation. Lag circuits generally consist of a small iron-core choke in series with the key and a condenser across the key. If a small current is being keyed, the choke will be large and the condenser will be small, and vice versa for the keying of a high-current circuit. Transformer primaries and secondaries can be used for the chokes. Making the choke larger will make the "make" softer, and increasing the value of the condenser will soften the "break." Small 2.5-mh. r.f. chokes in series with the condenser and placed right at the key will cut down radiation and clicks caused by sparking at the key. A tube keyer<sup>2</sup> is a deluxe method of shaping the signal, and eliminates a large portion of the experimental work necessary with choke-and-condenser combinations. Primary keying has many faithful followers and is an excellent system for reducing clicks, although two stages should be keyed<sup>3</sup> if the signal is to remain T9 and not be too soft.

To check for clicks, tune in the signal on your receiver with the input shorted and the r.f. gain reduced, and turn off the b.f.o. When making a series of slow dashes, a slight thump will be heard on "make" and practically none on "break" if the keying is about right, and no clicks will be heard with the receiver tuned away from the signal. However, if the keying is made too soft it will be difficult to copy the signal when it is weak or when sending at high speeds. Personally — and we have found many who share this opinion — we like a signal that is soft enough to start to run together at around 45 w.p.m. and so is crisp enough for all normal sending.

If the oscillator is being keyed, the introduction of lag will show up any tendency to chirp even more than if no shaping is used, because the voltage is rising and falling relatively slowly as the oscillator is keyed on and off and it is easier to observe the chirp. Thus an oscillator that keys well with shaping circuits to remove the clicks is

one of the most difficult pieces of equipment to achieve, and the difficulty increases with the operating frequency. Good keyed oscillators on 14 and 28 Mc. are a very *rara avis* indeed.

### Drift

Drift is one of those things that you're a chump to tolerate unless you are a rare piece of DX, in which case the Ws will put up with anything to get a contact. If your frequency drifts during a QSO the other fellow stands a good chance of losing you and, in this day and age, he can't be blamed for giving you up quite quickly. He has to retune his receiver all of the time he is trying to copy you, and that isn't fun in our crowded bands that require the crystal filter in most of the time. The cure for drift is obvious, of course — cut down the input to the oscillator until it doesn't drift, or else redesign it so that it stays put. Don't check your drift against your receiver — which may have some drift of its own — check it against a low-drift crystal or some other standard of which you can be sure.

### Modulation

Here is a beautifully controversial subject that has been the axis of many a heated debate. There seems to be one school that will accept only the pure d.c. signal and consider anything else a violation — and then blithely overlook the p.d.c. signal with a 100-cycle chirp and clicks extending 10 kc. either side! The other school will tolerate a small amount of modulation provided the signal has no clicks or chirps. This latter school is well represented by many of the West Coast signals and, in all fairness, it must be admitted that those who adhered closely to their code certainly took up no more room in the band than anyone else and had beautiful signals to copy. Actually the slight amount of modulation was noticeable only when the signals were S8 and S9. Unfortunately, a few eager beavers abused the thing and came up with signals that were modulated so heavily that they were T5 even when they were S3. Here again there is no FCC standard, but any time they want to tag you they can because the definition of A1 is "Telegraphy on pure continuous waves." If you must have a few per cent modulation, for sentimental reasons, be sure that it doesn't bother anyone even when you're S9 and you won't have any trouble.

However, if you are plagued with a rough and broad signal, look for too much ripple on your oscillator or final plate supply, and buy up a few  $\mu$ fd. of these excellent condensers that are kicking around in surplus these days. If the oscillator gives a T9 signal and the final supply is well-filtered, you'll have to put in a chopper wheel somewhere along the line to get a modulated signal. Chopper wheel? Oh, that goes back to the early 20s, so we may get to it in a few more years.

— B. G.

<sup>1</sup> Goodman, "Some Thoughts on Keying," *QST*, April, 1941.

<sup>2</sup> Goodman, "Tube Keying," *QST*, June, 1941.

<sup>3</sup> Perrine, "More DX Per Dollar," *QST*, March, 1937.

## Standing Waves—Good or Bad?

HERE seems to be a feeling in some quarters that there is something malignant about standing waves on a transmission line. By some magic, all your troubles are supposed to clear up if only you can get that "perfect" match, judging by the tales that go the rounds these days. There are, in fact, cases where elimination of standing waves may mean the difference between success and failure, but there are plenty of others where the time spent in trying to get rid of them might be used to better advantage.

It is true that line losses increase as the standing-wave ratio becomes greater. Numerically, the ratio of line loss with standing waves to the loss in the same line perfectly matched<sup>1</sup> is shown in Fig. 1. With a standing-wave ratio of 10, for ex-

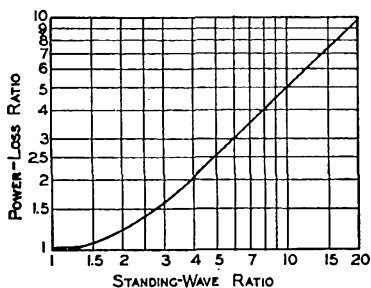

Fig. 1—The increase in line loss over the loss in a perfectly-matched line as a function of the standing-wave ratio. For higher standing-wave ratios the loss ratio is practically equal to one-half the standing-wave ratio.

ample, the line loss is approximately 5 times as high as when the standing-wave ratio is 1. This may or may not be serious. Suppose we have a perfectly-matched line which loses 2 watts out of every 100 watts put into it. Then with a 10-to-1 mismatch, giving a standing-wave ratio of 10, the loss will increase to 10 watts. The line is still 90 per cent efficient, and there is certainly no cause for concern. On the other hand, if the loss in a perfectly-matched line is 10 watts out of 100, a 10-to-1 mismatch will increase the losses to 50 watts and the efficiency will drop to 50 per cent. Here we *do* have something to worry about.

This simple illustration should make it obvious that the standing-wave ratio alone is no criterion of line efficiency. It becomes of importance only when considered in conjunction with the loss in the same line if the line were perfectly matched. The loss we are talking about is the actual total

<sup>1</sup> From Meagher & Markley, *Practical Analysis of Ultra-high-Frequency Transmission Lines*, published by RCA Service Company, Inc., Camden, N. J. The equation of the curve is

$$\frac{1+R^2}{2R}$$

where  $R$  is the standing-wave ratio.

loss in watts in a line of a definite length, not the loss in decibels per unit length. The latter is convenient for comparing different types of line when properly matched, but it gives no indication at all of the increase in losses with standing-wave ratio.

To determine the effect of standing waves in a particular case, it is first necessary to find the power lost in the line when it is properly terminated. To take a concrete illustration, suppose we have 65 feet of line that has a rated loss of 1.0 db. per 100 feet at the frequency to be used. The actual loss will be 65/100 of 0.1 db., or 0.65 db., corresponding to a loss of 14 watts if the input is 100 watts. If the line has an impedance of, say, 150 ohms and is terminated in a resistive load of 50 ohms, the standing-wave ratio will be 3 to 1. From the curve of Fig. 1 the loss ratio is 1.65, so the actual loss will be  $1.65 \times 14$ , or 23 watts. Because of the mismatch the line efficiency has dropped from 86 per cent, the maximum possible value, to 77 per cent. In decibels, the loss is now 1.13 db., an increase of 0.48 db. over the perfectly-matched case. In view of the fact that 1 db. represents the least detectable change in signal strength under ideal listening conditions, there cannot be much argument over the assertion that, *in this particular case*, a 3-to-1 mismatch is inconsequential.

The italics in the last sentence above are important. A specific illustration such as this does not warrant drawing a general conclusion that a 3-to-1 mismatch is negligible in *every* case. If we say that we can tolerate a loss up to 1 db. because any smaller ratio cannot be discerned by the receiving operator, then the standing-wave ratio that is permissible depends entirely on the kind of line in use, its length, and the frequency. Remember that it is the *total* loss in the line that counts. This loss will be greater the longer the line and the higher the frequency. A standing-wave ratio that might cause a negligible increase in loss on a short line or at low frequencies may consume most of the input power if the line is long or is operated at v.h.f. Good matching, then, becomes more important as we increase either frequency or line length.

Some representative cases are shown in Fig. 2, where the loss in db. is plotted as a function of standing-wave ratio. Curve A shows the calculated loss at 28 Mc. in 100 feet of 300-ohm Twin-Lead line which, when terminated in its characteristic impedance, has a loss of 0.84 db. The standing-wave ratio can be almost as high as 4 to 1 before the line loss increases by one decibel, so it would be expected that the line could be terminated in any value of resistance between about 75 ohms and 1200 ohms before a listener could detect any difference in the signal strength. Such a range covers a lot of antenna systems.

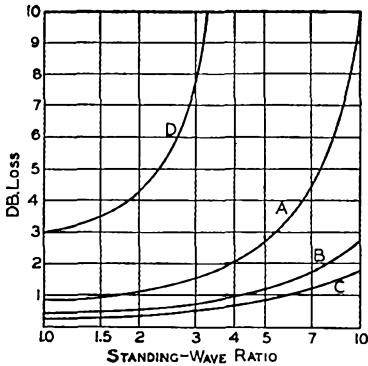

Fig. 2 — Loss in decibels in a number of lines as a function of standing-wave ratio. The transmission lines and operating conditions associated with the curves are described in the text.

Curve B is for 50 feet of the same type of line at the same frequency, and when compared with Curve A shows how marked an effect the line length has on the losses. With perfect matching the loss would be 0.42 db., and the loss does not increase by one decibel until the standing-wave ratio is about 6 to 1. With the shorter line, therefore, the terminating resistance can lie anywhere between 50 ohms and 1800 ohms; only outside this range will there be a noticeable change in the signal strength as compared to a 300-ohm load. At the 4-to-1 ratio tolerable in the case of the 100-foot line, the loss in the 50-foot line is only 0.52 db. greater than it is with perfect matching.

The effect of frequency is indicated by Curve C, which is for 100 feet of 300-ohm Twin-Lead operating at a frequency of 7 megacycles. The rated loss of 0.3 db. with perfect matching increases to 1.3 db. at a standing-wave ratio of 7.5 to 1, so the line can be terminated in any resistance between 40 ohms and 2250 ohms without noticeable loss in signal strength. Curve C, incidentally, is practically identical with a curve for 100 feet of open-wire line operating at 28 Mc., assuming a loss of 0.1 db. per wavelength for the open-wire line.<sup>2</sup> Comparison with Curve A gives some idea of the improvement to be anticipated when air-insulated line is substituted for a line with solid dielectric. Losses in solid coaxial cable such as RG-11/U are practically the same as in 300-ohm Twin-Lead.

All of the above discussion has been on the basis of the *increase* in line loss caused by a mismatch. Perhaps a more sensible way to look at the question is to assume that the *total* line loss should not exceed one decibel; in other words, to limit the line loss to a figure such that it cannot cause a perceptible decrease in the strength

<sup>2</sup> The theoretical loss is about 0.1 db. per hundred feet at this frequency in a line constructed of No. 12 wire, but actual losses run somewhat higher. If the line is well balanced, the figure used above should be conservative.

of the signal. To meet such a specification the standing-wave ratio in the case of the 100-foot line of Curve A should not exceed 1.6 to 1, and for the air-insulated line of Curve C should not exceed 6 to 1. The 50-foot line of Curve B could tolerate a standing-wave ratio of 4 to 1. It is worth noting that it will be impossible to keep the line loss below 1 db., even with perfect matching, if the line exceeds a certain length; in the case of the 300-ohm line this length would be 120 feet at 28 Mc. The only remedy is to arrange things so the line can be shorter or to use a line having lower inherent losses. The polyethelene dielectric material developed during the war is excellent stuff, but it is not perfect. At v.h.f. it is quite possible to lose nearly as much in a long line, even with good matching, as is gained in a beam antenna. Readers may remember some remarks of Ed Tilton's on the subject of height *versus* line losses a few months ago.<sup>3</sup>

Curve D is of considerable interest because it illustrates a practical point of some importance and also represents a situation in which the curve of Fig. 1 falls down. Curve D is calculated on the basis of Fig. 1 and a 100-foot 300-ohm Twin-Lead line operating at 144 Mc., where the rated line loss is about 3 db. Using the method of calculation previously outlined, the total input to the line is dissipated in the line itself when the standing-wave ratio is a little less than 4 to 1. No higher standing-wave ratio than this could exist, even if the end of the line were short-circuited or left open. Actually, things don't happen in quite that way. The loss ratio in Fig. 1 is calculated on the assumption that the standing-wave ratio is the same everywhere along the line, but the fact of the matter is that in a line such as is represented by Curve D the standing-wave ratio varies along the line, being greatest at the far end and least at the input end. Although Curve D is therefore not to be taken too literally, it does have two lessons to offer: There is a definite limit to the standing-wave ratio that can exist at any given point along a line in which the losses are high; and any checking of standing-wave ratio on such a line should be done as close as possible to the antenna if the check is to mean anything. It emphasizes again, too, the importance of keeping a v.h.f. line short if the plus decibels in the beam are not to be swamped by the minus decibels in the line.

Below 30 Mc. and with lines of reasonable length it hardly seems necessary to worry much about getting that "perfect" match if a little forethought is exercised. Take the case of the popular 3-element close-spaced array, for instance. Guesses as to the impedance at the center of the driven element seem to range anywhere from 8 ohms to about 12 ohms; possibly there

(Continued on page 164)

<sup>3</sup> Tilton, "Need There Be Line of Sight?" *QST*, March, 1946.



# Hints and Kinks

## For the Experimenter



### CONVENIENT TIE-POINT SUBSTITUTE

MANY times it proves inconvenient to mount a tie-point inside a chassis at a place where several components have a common junction point. This is especially true in experimental work where it may be found necessary to add components for which no mounting provisions could be made in advance planning. A simple, yet rugged substitute can be made by forming a few inches of uninsulated small-gauge wire, such as No. 20, into a coil as shown in Fig. 1, and inserting the leads from the components involved.

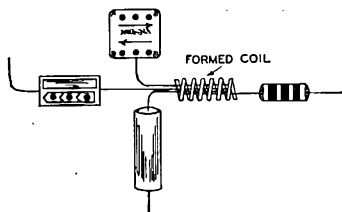

Fig. 1 — A simple way of making a neat connection out of what might otherwise look like a rat's nest.

Solder is flowed in around the "coil" which then becomes a joint that is solid enough to be permanent. If later changes are found to be required, the component involved can be disconnected by simply pulling it out of the coil while heat is being applied to the joint. The inside diameter of the coil can be made large or small, depending upon the number of leads to be joined.

### ROTARY BEAM ANTENNA FOR 2-METER WORK

THE construction of the rotary beam antenna shown in Fig. 2 is a little unusual, but the results obtained with it have more than justified the trouble encountered in its construction. The beam is the design of Russ Patterson, W4CPG, who made numerous tests with it from various fixed and mobile locations in this area. Using the beam, signals that were S4 to S5 on a comparison "J" antenna came up to S9 and better. The beam seems to be about 30 degrees wide, and has a fairly high front-to-back ratio, although not so high that nothing can be heard off the back of it.

The radiator and matching stub are constructed of 1/2-inch thin-wall tubing, the spacing between them being two inches, center to center. Other dimensions are shown in the diagram. The supporting arm for the reflector and director is a single piece of tubing, which is soldered

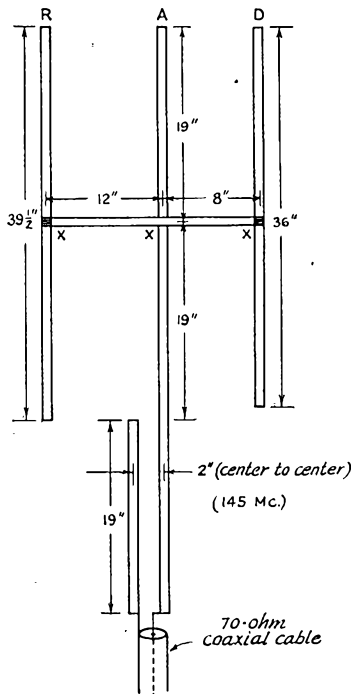

Fig. 2 — A beam antenna of unusual design for use in the 2-meter band.

directly to the radiator. Thus soldered joints appear at all points marked X. The entire assembly was mounted on a rotatable support with ceramic stand-off insulators.

Results obtained at both fixed locations and in mobile conditions with the antenna mounted on a car have been equally good. The center frequency obtained with the dimensions shown is 145 Mc.

— J. Wayne Clark, W6CAN

### Strays

What price a good QTH?

A Connecticut court recently awarded damages of \$4652 to a resident radio engineer, because in condemning one-fifth acre of the engineer's farm for a superhighway, the State Highway Department had devalued the property as a radio receiving location.



# How's DX?



## How:

Back in October the outstanding characteristics of "DX hogs" were catalogued in this column and, if the letters received are any indication, we managed to hit the ball on the schnozz, for once. We were afraid at the time that we might sound a little preachy and get in what hair is left on the heads of the DX gang. Instead, the keen-eared lads all seem to go along with us in a genuine desire to see some downright good house-cleaning. The biggest squawk, of course, was about the *porcus DXus* who eases out of the band to land a lulu, but W4JV, an OO down in Florida, comes up with the prize suggestion on that deal. Sending in a list of porkers he clocked outside of the band, he suggests that we publish the list under the heading of "Pig Pen"! How about that? Brother! — talk about your squeals and groans — it would make an ordinary hog wallow sound like the 1200-Mc. band and smell like Chanel No. 5!

The one that bothers Jeeves' boss a lot, however, is this caper concerning calling a DX station on the frequency of the W working the foreigner while the QSO is still in progress. If it weren't a prewar trick we would consider it an outgrowth of the meat-market-and-department-store technique so highly developed during the war by sharp-elbowed women and so thoroughly abhorred by men. True, it is practised by a minority who consider themselves above anything so basic as fair play but, as we see it, there is only one way to stop it. Suppose most of the foreign stations each kept a little list alongside the log book, outlined in black and headed "Pig Pen." And suppose every time one of these DX stations had a QSO broken up by a DX hog piling in the operator were to jot down, lightly and politely, the call of the stinker, for future reference. And then suppose that the DX station just *never* worked that guy! That's right, *never* — which is considered a fairly long time in most circles. Would the idea finally seep through the skulls of our hard-headed hogs that they are wasting their time and *killing their chances* by calling before the QSO is finished? We don't know, but we will gladly give space here to list any and all foreign stations who will lend a hand to a quick elimination of our undesirable ones. And if any foreign station lacks paper and pencil for the list, we'll be glad to furnish it for free.

Maybe the idea is no good. Maybe the DX hogs, unable to work anyone, would list the countries they had been heard in, as indicated by the countries that wouldn't answer their calls.

"Hmmm, Jeeves, I guess we are really getting out — no one ever comes back to us!" [What do you mean, "Getting out?" Keep up that stuff and they'll be putting you back in! — *Jeeves*]

## What:

With each winter season comes two things — the need for selecting a Christmas present for Uncle Abercrombie, and 80-Meter DX. As proof of the latter, VE1EP worked GI5UR (3510) and G8TK (3515) and heard G5TZ (3530) and G2HN (3535). Running 60 watts to a 6L6 c.o., W2LG worked PAØNG (3545) and G3ACP (3540). W8AQ did right well by scaring up XE1A (3565) and ZL1KI (3520), during the CD QSO Party. W3QV says G5UM told him the Gs are allowed 3500 to 3635 kc., and 3685 to 3800 kc. We still don't know what to get Uncle Ab.

On 40, some of the lads are doing a nice job. For example, W2ITD has knocked off TA1DB (7140) who says QSL via HB9U, UB5AL



(7140), LX1AX, HB9EU, ON4ZQ, GI5HU, PAØWAL, FA1RA, Fs, Gs, VKs and ZLs. W6SAE/J9 was heard. . . . . VE1EP got UG6AB (7130), and W2FQS wangled PY1AM (7100), HB9GA (7140), XAEY (7140), OZ2N (7140), YR5C (7140), VP4TR (7140), HH3VE (7100) and HH2FE (7055) . . . . . Running 60 watts to one of those Russian tank sets, W2VFG worked HC-1PC (7290), VO4F (7250), G8DV (7280) and F8ZW (7210) . . . . . W1ODU and W2MYY worked PK1VHN (7130), who told W1ODU he

was in an aeroplane over Egypt at the time. That we believe, because we were following the plane in a P-80, riding side-saddle.

Ten meters came in for considerable play, by the gang who keeps an ear on all bands and by die-hards disgusted with the QRM on 20. That signal in the high end that sounded like the ignition on your car — when the car was new and hitting regularly and you could rev it up — and caused considerable speculation among the gentry, was nothing but a British search radar. The fading on it wasn't as serious as one might suspect — the periodic change in strength is a result of the antenna rotation. By the nature of the beastie it extended well down toward the low end of the band, but it offers a good check on conditions to Europe. . . . . W5FRD has been grabbing his share on 10 c.w.: CR7AD (28,075), ZE1JJ, (28,210), ZD4AB (28,030), OK1WF (28,030) HB9DO (28,080), GC8NO (28,050), HE1CE (28,120) in Liechtenstein, UA3KBC (28,150), I1KN (28,000), F8EO (28,000) and OZZN (28,000) VR2AF (28,240) was worked on 'phone. . . . . W4BPD knocked off ZB2A (28,110), on c.w. and HR1MB (28,400), SU1HF (28,200) and XZ2DN (28,175) on voice, and heard HP1A (28,240), VP1AB (28,110), J9AAK (28,300) and VU2AQ (28,175) on 'phone. . . . . W2CYS scared up VS9AP (28,210), G6IA (28,100) on the Isle of Man, on 'phone, and VU2BC (28,035), ZC6FP (28,030) and SP5Y (28,120) on code. . . . . W9RBI has one of those "lousy postwar locations," but manged OQ5BL (28,415), I1AW (27,310), J9LG (29,200 and 28,480), and OX1Z on voice, and VQ2FR (28,060) and OK1AW (28,080) on key. . . . . W6IDY believes he has proof of the sensitivity of some receivers, because VS9AB (28,230) came back on 'phone. Other worked stuff includes VQ4ASC (28,310), LA8M (28,230) and SM5WK (28,320). . . . . Good stuff at W6VFR during the month included VQ3-EDD (28,200 f), LX1SI (28,280), VQ3TOM (28,000 T8c), PZ1RM (28,135 f & c.w.) and FA-3JY (28,170 T9C). FA3JY will probably win the "Fist-of-the-Year" award. . . . . WIAM

heard ARLC (28,250 f) in Syria. . . . . W9KOK is up to 73 on 10, with such as ZP2AC (28,450), VP9R (28,250), W2CDJ/J2 (28,400), W3GKJ/KJ6 (28,720), W1LTQ/TF (28,490), W8CJR/C1 (28,370), KA1ABA (28,400) and J2AAP (28,410), on voice, while W1HKK nabbed VP1AT (28,200), W6VID/KJ6 (28,650) and VU2LR (28,390) via the same medium. . . . . W5KUC has W8WHW/KG6 (28,380), KZ5AB (28,160) and VP9F (28,300) in the "worked-on-'phone" column, while W2KIK comes up with LX1BO (28,140), VU2PK (28,300), VU2CQ (28,325) and YR5V (28,220) in that same part of the log. . . . . Incidentally, a lot of foreign 'phones are beginning to listen for 11-meter W 'phones and replying on the low end of 10. A word to the wolves should be sufficient.

Twenty was somewhat spotty but that didn't hold anyone down too much. W5ASG in Arkansas worked V08AD (14,090), EA9AI (14,165), W5LJJ/Manus (14,100) in the Admiralty Group, ZD4AB (14,120), ET1JJ (14,040) and EK1AA (14,045), while W6GAL busied himself with VK4OS (14,140) in Papua, PK5LK (14,130), VR2UH (14,180), VR2AA (14,170 T9c), OQ5BR (14,130), EL5B (14,140), VP3JM (14,080), ZK1AB (14,240), CR7VAL (14,080) and F1CC (14,090), and heard VQ6GH (14,070), VQ4KTH (14,180), ZD8A (14,080) and W6VKV/16 (14,100). . . . . At W2CYS it was HE1CE (14,080), K6HOT/KC6 (14,110), and W5HHO/J2 (14,160), while VE1EP got UA9CB (14,075), OQ5AU (14,185) and UA9CR (14,050), with LZ1PT (14,075) and TAIN (14,045) heard. . . . . At W2ITD we find J2AAO (14,120), W3EKK/J2 (14,115) and OQ5CE (14,175 T7), with HZ1A (14,095) heard. . . . . W4BPD has a whale of a long list, from which can be gleaned ES5K (14,045) SV1EC (14,080), SP2RD (14,080), VS9AX (14,075) in Aden, UA0KAA (14,080), G5KW/Rhodes (14,080), ET3Y (14,055), XABU/Duodecanese (14,080), GEI (14,095) in Kenya, VS6HM (14,050) and VU2FM (14,120) worked, and YA5AX (14,155 T5) and VS9AN (14,180) heard. . . . . ZS2X gives us a taste of what DX is like down his

This picture of the modest station of Jack Sharples, G3FJ, is not much of a key to its performance unless you study some of the cards closely and are then told that on September 27th he made WAC on 10 'phone in 37 minutes, working PK1AM, VU2AQ, W1CIB, CE1AH, SU1HF and G2CDI. Jack runs 25 watts to an 807 final, the receiver is a Sky Champ and the antenna a three element rotary. DX stands at 58 countries on 10 and a total of 85.



way by listing VP8AD (14 to 14.15) in South Georgia, VP8AM (14,400) in the Falklands, VQ8AB (14,120), ZS3B (14,300) in Southwest Africa, CR6AS (14,200), OE4WN (14,050), and UD6AB (14,030). Rex says ZS4P should be on soon in Basutoland . . . . . W4BRB latched on to VK7LZ (14,150), VP5AA (14,095), LX1AX (14,090), W6TMY/Saipan (14,130 T6) and W6VDG/KW6 (14,140) . . . . . NY4CM, who is ex-W8LZK/NY4, worked VQ3HJP (14,090) and heard VQ4AD (14,135), UD6KBA (14,070), UA9DP (14,060). Mac says W4IEN/NY4 is now NY4AB on 10 and 20 'phone . . . . . W6WKU, ex-W9KHD, garnered OX1AA (14,075), VQ2GW (14,080), PK6HA (14,085), OK1FF (14,085), PK6TC (14,050), PZ1FM (14,140), ZE1JI (14,175) and CR9AN (14,060), while W6PB knocked off UA9BP (14,055), XAEG (14,065), YR5V (14,040), VS1BX (14,060), UA3AF (14,055) and UA3GI (14,060) . . . . . At W0YXO new ones include OX2K (14,055), J2EUG (14,070) and HI8X (14,150), while VU2AA (14,025) got away.

The chin-chin boys got their share of the gravy, too. W6GAL snagged PK6AW (14,370), PK5AR/CR10 (14,360) in Timor, VS2BE (14,180), and W6ONP/KW6 (14,220), while W6ITH added FG3FP (14,350) in Dakar, F7AE (14,350) in Casablanca, CN8BA (14,140), VP4TB (14,370) and ZP2AA (14,005) . . . . . At W1HKK, Dana got UA9CB (14,090) to try 'phone, XU1YO (14,160) and lots on 28 Mc. . . . . W2MPA lists C1SU (14,180), SU1CX (14,350), PZ1UD (14,305), W9CAC/TF (14,240), YV5ACW (14,390) and XU1YY (14,300) as worked, with PK4DA, ET1Y (14,300) and VS1BD heard . . . . . W1GKK's best include YN1LB (14,335), W5IBE/J5 (14,340), HC2HP (14,225), with ZB1AB (14,305) and C8YR (14,310) heard . . . . . W9VND has an imposing list of worked stuff grabbed in the last 30 hours before taking down his 2-element rotary and returning the clothes-line to his mother, best of which are J9AAR (14,215), YV7AA and VP2MY.

#### QSL:

Don't forget that January 1st is the deadline on getting your old cards from the QSL Managers, per the notices posted the last few months in QST. After that date unclaimed prewar cards will be given to Jeeves for his stamp collection.

Speaking of QSLs, several fellows are asking that everyone take a little more pains with his cards, in making certain that the information on the cards includes (1) the band on which the QSO took place, and (2) whether 'phone or c.w. was used. The information is quite vital, of course, for all awards requiring confirmation, and many 'phone men lose out because any card that doesn't state otherwise is assumed to be for a code contact, and the special 28-Mc. WAC can't be given except for proof of the band used. These remarks

apply to WAS awards, too, some of which are endorsed for 'phone or one particular band.

#### WHEN:

A few more fellows liked the idea of listing "times" and submitted some samples, so here goes on a noble experiment. Remember, of course, that these are normally good for the call area of the contributor or thereabouts, and we won't guarantee that you'll find the station at the same time every day, just in case you were planning to sue. All times are GCT.

W7HXG/6 in Berkeley starts the thing going with some 28-Mc. c.w. dope: W2QVJ/KP6 (2320), CR9AG (2150), ZL2MG (0200), G6ZO (1640), ON4DM (1720) and LU9AX (2120) . . . . . More of the same, from W5EWZ: G2AJB (1340), and OK1WF (1400). On 14,185, OA4AH (2325), and on 7190, VK3FA (1310) . . . . . At W5ACL in Houston, between 14.0 and 14.2 Mc.; CN8MI (2335), EI6G (2330), ET1JJ (2345). F3JR (0000), F8CC (1300), LX1AX (0300), OQ5AV (2140), OX2MJ (1950), PZ1FM (1310), UA3AM (0545), VP3JM (1315), VQ8AD (1420), YS8UJ (0430) and ZS6DO (0000) . . . . . At W7EYS in Bellingham, on 20 c.w.: LU6AF (1615), G3ADG (1430), I1NZ (1530) and ZS1CN (2145). On voice: KA1SS (1020) and VQ4ERR (1040) . . . . . At Fargo, N. Dak., W0OUH gets the following on 20: UA3KAH (2040), UA9CF (0330), UA0KAA (1700), SM5VR (2120), KW6EA (0900) and XAEG (1630).

#### WHERE:

A few months ago we asked for the present addresses of a number of DX stations for whom we have cards on hand, and the gentry were quite helpful in sending in the prewar addresses of many — all of which we already had! What we want is the present location, not the address on a prewar card, and the only ones who came to light were PJ1BV and PJ5EE . . . . . The gang has been mighty helpful about sending in addresses, and we'll try to list those requested most often, space permitting. PZ1G, G. Lichtveld, Maagdenstraat 36, P.O.B. 184, Paramaribo, Surinam. FG3FG, c/o Pan-American Airways, Dakar, Fr. West Africa, APO 622, c/o PM, Miami, Fla. . . . . From W5ACL: YS8UJ, undercover. He QSLs but gives no return address. YR5V and all YRs, Box 326, Bucharest, Rumania . . . . . From W2OXZ: VS9AB, Stn. Engr. AMWD, R.A.F. Stn., Khormaksar, Aden, Arabia . . . . . From W4QN: VQ8AD or VQ8AF, P. O. Box 155, Port Louis, Mauritius . . . . . From W9VND: VP2MY, Frank Derisile, Monterrat Island, B. W. I. . . . . From W6GAL: VR2AA, c/o R.N.Z.A.F., Lauthala Bay, Suva, Fiji Islands. PK6AW, Bob Westerveld, 45 Dreef, Rotterdam, Holland. PK5AR,

(Continued on page 166)



# Correspondence From Members -

The Publishers of *QST* assume no responsibility for statements made herein by correspondents.

## A TIP FROM F.C.C.

Federal Communications Commission,  
Washington 25, D.C.

Editor, *QST*:

The September issue of *QST* had a short article concerning elimination of 10-meter broadcast interference by methods requiring minor modification of the broadcast receiver. The Commission's Field Engineering and Monitoring Division's experience with BCI complaints indicates that modification of the receiver should be undertaken only if other methods fail to eliminate or reduce the interference to a satisfactory value. A method which has been found particularly valuable for reduction of 10-meter QRM is described below:

A quarter-wave stub is connected to the power line where the receiver is plugged in, offering a very low impedance to the unwanted r.f. signal being carried on the power line, and effectively preventing it from being carried into the receiver.

The stub is made of a 5-foot 7-inch length of twisted-pair lamp cord, each wire of which is connected to a side of the line, with the other ends of the stub wires securely taped to prevent a short-circuit. Any method of making this connection which is *electrically and mechanically safe* may be used. The stub is then laid out parallel to the receiver power cord, and either twisted around it or fastened to it to make a four-wire cable. If the receiver cord is not long enough, the excess stub wire may be folded back, or inserted into the back of the receiver.

If a different type of wire is used, it may be necessary to change the length of the stub somewhat, since the propagation factor may be different than that for lamp cord. The length given above is a good compromise value, and has been found generally effective in the 11- and 10-meter amateur bands.

— George S. Turner, Chief  
Field Engineering & Monitoring Division

## SIGNAL REPORTS

5633 Santa Cruz Ave., Richmond, Calif.

Editor, *QST*:

Why do hams use the QSA-R method of reports? I looked up the meaning of QSA and R. Now, as I see it, giving reports of QSA5, R9, is the same as saying, "signal strength 5, readability 9." The way it is used, however (and I do it, too), the report given is supposed to indicate readability of 5 and signal strength of 9 and, according to my research, is just the reverse of the true intended meanings.

I believe it would be much simpler to give a report correctly and more clearly, also. If the Q method is to be used, use it in its entirety by reporting QRK5, QSA5. On the other hand, the R method can be used on 'phone equally as well with a report being given as R5, S9 . . .

— Paul W. Heeder, W6PGZ

[Editor's Note: ARRL standard procedure is the RST — Readability (1 to 5), Strength (1 to 9) and Tone (1 to 9) — System. For voice stations only the first two are used.]

## CONTRA-POLAR FREQUENCIES

65 Victor Ave, Obetz, Columbus 7, Ohio

Editor, *QST*:

There seems to be a growing interest for information about the generation of "Contra-Polar Frequencies" (less than zero c.p.s.). I have done considerable experimentation

along these lines and have the following information to pass along to those who might be interested.

I find that c.p.f. may be most easily produced by taking a conventional oscillator and replacing the usual coil and condenser tank components with reactance tubes, such as are used for modulators in f.m. circuits. One, of course, is phased for inductive-reactance properties and the other is phased to present capacitive reactance. The d.c. bias on the control grid of each of these reactance tubes is made variable over a considerable range so that the amount of artificial reactance can be varied down to and beyond zero. These bias controls then become "tuning" controls. It then becomes a relatively simple matter to find the proper adjustments where strong oscillations will take place at c.p.f. All by-pass condensers and neutralizing condensers in amplifier stages require special treatment. In order for them to present a negative reactance effect, the plates or surfaces must be coated with "Notholyte." This material can be gleaned from the trash heap of the nearest cyclotron laboratories. It is a useless by-product of atom-smashing, it being the material that holds the electrons and protons in place. The stuff can easily be recognized by the fact that it casts no shadow, except in total darkness.

For 'phone work, conventional speech circuits may be used. However, for proper minulation (term for negative f.m.), a special type of microphone is needed. One of the most satisfactory devices tried was one manufactured by the "Nary-A-Sound" corporation, which is actually a loud-speaker type of unit which has a high output of silence and is designed to be placed in noisy office locations, etc., where it will cancel and absorb objectionable sounds and noises so the office workers can function more efficiently. Some of these large-scale units were used by the armed services to overcome battle noises. The Army type was called an M-1 "latrinaphone," and the more widely used Navy type was known as a "headphone."

Many advantages are offered in power-line applications of the c.p.f. principle. I have constructed a device which converts the normal a.c. power to a negative 60 cycles. The oven of the electric range is on a separate switch and when not needed for regular use, it can be used as extra refrigerator space for bulky foods. For the photography hobbyist who does not have the space for a regular darkroom, a 100-watt lamp, or two at the most, plugged into the c.p.f. outlet will adequately darken any room in the house. With a couple good-size floodlights, films can safely be developed on a bench out in the backyard at high noon. If one stays out on the beach too long and comes home looking like a boiled lobster, a few minutes spent under a sunlamp plugged into the negative 60-cycle outlet will remove all excess painful sunburn. One must be careful, though, not to stay under too long and develop a "prison pallor."

I can't give technical details on this power-line device at present until patent rights are settled. The power company is fighting the application, being considerably irked by the fact that instead of sending the usual bill, they have to mail me a check every month for the electricity I have used.

— John R. Diddine, W8NPP

## AUTOMATIC ANTENNA TUNING

401 Dryades St., New Orleans 13, La.

Editor, *QST*:

Re your editorial, "Midsummer Daydreaming," this station has used from time to time semi- and full-automatic tuned antennas. The usual ganged xmtr was used. The antenna has always been the long-wire type,  $\frac{1}{4}$  wave on the



lowest frequency against ground. The first attempt (copied from the aircraft trailing wires) was just a crank and drum of metal to wind up or reel out the antenna wire. Later this drum was motor-driven thru a pin-ball machine 50/1 gear box and the switch hand-controlled. . . .

How to make it automatic with the single-dial xmtr was the problem. One solution was a small hole drilled at 250 on the plate-current meter scale, just beneath a spot where the spade of the needle passes. A photoelectric cell and mirror did the rest thru a relay. I pasted a small piece of black paper on the spade about 1/4-inch diameter. When plate current fell off about 25 mils the p.e. cell would go to work. One thing wrong with the drum idea is that it must go all one way before returning, upon closing contacts at the end toward which the cam is sliding — but it worked OK here. Oh yes — you need a weight and a pulley on the far end of the antenna. . . .

— R. E. Steiner, W5AVO

## PRINTING CODE

5120 Westbury Ave., Apt. 1, Montreal, P. Q.

Editor, *QST*:

I notice on page 39 of September *QST* that FCC is allowing hand-printing of the code test for those who in the future take the initial step to ham radio. The Department of Transport examines future VE brass pounders in this country and never do I remember them making any distinction in the method one should use to take the code exam.

In my own case, I adopted the "printed word" when I first began to study the code. I have used the same method ever since my first QSO in 1931 and wouldn't think of ever using longhand. In all my travels since I have yet to see a ham using anything but sprawling, scribbled longhand. Visitors to the shack in the past were awed when I began printing my copy. To convince them that it was easy after a bit of practice was rather difficult.

I find the printing method far quicker and much easier on the shack stationery, the reason being that the great majority of the letters can be made by straight lines, whereas in longhand there are endless curves and loops. In addition, a lot of space on the copying pad is saved because all the printed characters are the same height. You'll find space-saving on the scratch pad really something in an S.S. contest — or perhaps you like the operating table knee-deep in paper! For those who like to postpone log entries from the copy pad, the printed word, you'll find, can be easily read a week from now! Give the idea a good try, fellows, and you'll never go back to the old method.

— Floyd G. Gribben, VE2XR

## FUTURE EXAMS

Box No. 33, Amagansett, L. I., N. Y.

Editor, *QST*:

This talk of late in *QST* regarding c.w. vs. 'phone seems to be squarely up to FCC and boils down to only one possible solution: Reissue all amateur licenses as soon as possible with just the simple requirement of a code test of 22 w.p.m. for Class B holders and 30 w.p.m. for holders of Class A tickets — you know those chaps, "Had a swell party here last night, OM, boy did we get tight, unquote. The only alternative is for FCC to have another type of examination to do away with all code requirements and have the applicants take an oral reading test with words like Charlie, Queen and Uncle thrown at them together with a color quiz, red and green only ("Switch to Safety," you know). Let us face the facts, gentlemen: the future amateur examination will have to be either one or the other. Really quite simple, ain't it?

— William J. Penney, W2CRZ

## CODE-PROFICIENCY PROGRAM

1911 Danville, Houston, Texas

Editor, *QST*:

. . . I wish to take this means of thanking you and the staff at WIAW for reinstating your code-proficiency program, for it was only through this medium that I was able to increase my code speed sufficiently to pass the amateur

examination. I tried having another amateur send code to me; I tried Instructograph; I tried phonograph records — all of which were good, but not sufficient. On May 1st when you started this program I jumped on it immediately and was ready to take my exam on June 4th. I believe this is a good program, and should never be done away with.

— Henry A. Rankin, W5LLH

— . . . —

## "HOW MUCH INDUCTANCE?"

Station Rd., West Town, Bristol, England

Editor, *QST*:

With reference to an article in your June issue (which has just come to hand), "How Much Inductance?" by G. H. Floyd, I noted that he found an easy method to measure the inductance of iron-cored coils within an accuracy of 15%. I am afraid that I do not see eye-to-eye with his statement.

His method will give the inductance at the voltage of measurement only, as the inductance to a.c. for no air gap and zero d.c. polarizing current is:

$$L = \frac{1.225 \mu H^2 A 10^{-8}}{1} \text{ henrys}$$

where  $\mu$  is the incremental permeability, being dependent on the core material and the magnitude of the a.c. flux density in the core.  $B_{max}$  is dependent on  $E$ , so it would appear that the measured inductance is dependent on the applied e.m.f. which I have found to be also true in practice.

. . . I think that Mr. Floyd would have been more correct, if he had qualified his statement by letting the unsuspecting ham in the next block also know that the value he gets by the method will only hold for the conditions of test it is made under. For, if the unsuspecting ham with his 60-henry (approx) choke uses it, for example, with d.c. flowing or with an a.c. potential less than the test condition of 110 volts, some of his "henries" will have gone home.

— F. H. Stanton

[Editor's Note: Author Floyd, when asked for comment, replied as follows: "Mr. Stanton's observations are certainly true regarding inductance measurements but I believe one point has been missed — namely, that the writer was discussing larger transmitting chokes. If a choke of this type were used in a 2,000-volt power supply with 5% ripple, 100 volts a.c. would be present across the choke, which is approximately the same a.c. voltage used for measurement. Also the presence of the d.c. current materially affects the inductance, as Mr. Stanton points out, but most large chokes are designed so that they do not operate near saturation and for this reason the writer believes the error would not be excessive."]

— . . . —

## ALTERNATE SIGNAL PATHS

47 Keeney Ave., West Hartford, Conn

Editor, *QST*:

For us DX creatures of the wee small hours, this is an example of how not to keep healthy. But it was enormously interesting while it lasted.

At 0534 EST this morning I raised VK6KW, Perth, Australia, with my 3-element rotary pointed about 20 degrees west of true north. After exchanging Readability-5 Strength-7 reports, with really solid reception at both ends, he informed me that his 3-element was pointed at me directly over the South Pole. Bracing myself for a signal blackout, I swung my beam around to due south, whereat his signal lifted to an S8. He reported a similar boost in mine. At that point we were both fringing the twilight zone around the downstairs end of the globe. We then decided to mix it up seriously with the old planet. With 6KW transmitting, we both rotated our beams around to north, I passing through west and he through east. He was audible at all times but dropped off rapidly in transit. However, when we both reached north he was back up to an S4, at which time we were again in the twilight zone, this time "roaring" over the North Pole. We double-checked the same operation while I transmitted, with equal results, though my signal ap-

(Continued on page 172)



# Operating News



F. E. HANDY, WIBDI, Communications Mgr.

E. L. BATTEY, WIUE, Asst. Comm. Mgr.

J. A. MOSKEY, WIJMY, Communications Asst.

GEORGE HART, WINJM, Communications Asst.

LILLIAN SALTER, Communications Asst.

**Operating Talk.** November *QST* invited attention to the Readability . . . Strength . . . method of reporting as the proper equivalent in voice work to the well known c.w. RST. In the editorial discussion examples of misunderstanding, resulting from careless operating habits and use of a hybrid procedure were given. Some hams may recall the days when QSA, VY QSA, and VY VY QSA were the only three report levels required or expected. Then in another period QRZ (obsolete meaning), QRK, and QSA served us well. Most hams will agree, we think, that we can very well forget hybrid and obsolete procedures of past decades in favor of our straightforward new word tools, when signal reporting is required.

We haven't yet, on return from a long field trip, reached the bottom of our mail bag, but we have turned up a few requests for clarification of other operating exchanges. In the hope that brief comment may further general understanding, we venture some questions and answers. W2NAZ got us started on this subject.

Does "QSY down" mean meters or kilocycles, wavelength or frequency? These days we talk *frequency*, usually kc. or Mc.

When you asked for 10 P.M., who calls first? Operators concerned should arrange *beforehand* which station will call first and for how long. A time check with WWV or other standard should be made by both for reasons of efficiency in operation and courtesy.

How far is "DX"? What does the call CQ DX mean?

DX is merely radio shorthand for "distance." This then is almost as bad as asking, "How high is up?" Admittedly any such call as CQ DX invites loose usages. It can always be interpreted literally as a general call for a station at any "distance." It is a wishful rather than practical call for use by most stations in the North Americas. Before getting too deeply into this thing, a tip: The way to work "DX" in our opinion is not to use this wishful and popular call at all (in our continent) but to use our best tuning skill — and listen — and listen — and listen. Hear the desired stations first; use skill; time your calls well. (You have to hear them before you can work them.)

But to get on with our story. The CQ DX call means slightly different things to hams in different bands. (a) CQ DX on v.h.f. is a general call, ordinarily used only when 50 Mc. is open, i.e., under favorable "skip" conditions. The call may be used in looking for new states and countries, distances beyond the common range of the station, which may depend on special conditions, 50-Mc. skip, duct

phenomena, etc. on 144 Mc. and up. In any bands, particularly at line-of-sight frequencies when directive antennas are used, *directional* CQs such as CQ W5, CQ NE, etc., are the preferable type of calls. (b) CQ DX on our 7-, 14-, and 28-Mc. bands may be taken to mean "general call to any foreign station," i.e., any station in a foreign continent. Experienced amateurs in W/VE-land normally leave this call to overseas amateurs, and *answer* such calls. (c) CQ DX used on 3.5 Mc. under winter-night conditions may be used as just explained. At other times, under average 3.5-Mc. propagation conditions, this call may be used in domestic work when looking for new states or countries within one's own continent, perhaps applying especially to stations at distances over 1000 miles.

**Standing-by.** There was more than a successful ARRL Simulated-Emergency Test during October! A Florida hurricane which came a week before our test dates offered a direct threat of dire emergency to Tampa and the Florida West Coast. With the winds there already at a mile-per-minute clip, amateur radio networks were mobilized and placed on stand-by operation. Both 'phone and c.w. stations were on the job. See station listings in the Florida Station Activities reported elsewhere in this issue. On word from Director Shelton and W1AW, amateurs both north and south monitored a 20-kc. 'phone-band channel, cleared to permit the low-level emergency-powered emergency-network stations in Florida to do their stuff. Organized amateur radio facilities were standing by. We're proud of the readiness of amateurs to do this emergency job, but glad that this particular hurricane petered out so that disaster was averted.

ARRL was called upon in October to supplement or assist in the communications plans for the Oahu-Cairo flight of the AAF B-29 *Dreamboat*. Our amateur service would function as a stand-by facility in the event of any emergency or failure of official government facilities. Some hams may remember that 16 years ago ARRL arranged successful network communications for a midwinter test flight (Mich. to state of Washington) of the Army Air Forces. In 1946 the flight plan was different, through the sub-Arctic, airborne for 40 continuous hours over the top of the world. However, amateur cooperation was as readily achieved.

Col. Shannon (W3QR) was recalled to active duty to handle air-ground communications from the *Dreamboat*. *Operating News* is happy and proud to record on another page this month the

calls of all those amateurs assisting in this organized operating work as indicated in special reports to us. Besides direct ARRL-AAF flight cooperation, it should be noted that Alaskan and European weather sequences for the *Dreamboat* were relayed by amateur radio, through KH6CT, on numerous occasions before the flight was cleared. FB!

**AEC Blueprints.** All League Emergency Coordinators can note from the Florida incident the importance of *advance* formulation of each *Community Plan*. All stations in the amateur service should be enrolled in the AEC, so full cooperation, understanding, and support of sound emergency-operating principles can be depended on, in distant or local emergency. Specific AEC stations require assignments *before* emergency to maintain liaison with typical local agencies to be served; other amateurs should participate in advance drills or tests, establishing local networks, and still others should be readied for outside contact in the event of any possible disaster.

The neatest thing we've seen that exemplifies the above statements is an actual blueprint, sent us by W3AQN, EC at York, Pa. It lists in diagram form and tabulation all York amateur stations in the AEC (calls, telephone numbers, frequencies), gives both the agencies served and amateurs assigned for liaison or operating purposes, and clearly shows probable dispositions of mobile, portable, and fixed amateur-service facilities, using 144 Mc. and our lower frequencies. In the case of York, each AEC member has a copy of this Plan. ECs: Data on the plan for amateur emergency-communication service for *your* city or town should be set down on paper. ARRL Hq. will appreciate a copy.

**Official Observer Activities.** Seldom a week goes by that we do not note in OO reports constructive action in monitoring and notification of amateurs of off-frequency operation, radiating harmonics, having splatter, overmodulation, key clicks, unstable signals, bad notes, etc. One Observer has not only a splendid file of "thank you" letters, but reports no "second notices" at all necessary. November *QST* observed the need for a campaign for high-quality signals, and we must stress that ham prestige for law-abiding sportsmanlike operating is more important than ever in connection with coming allocation conferences and the general postwar situation. More Observers still can be appointed to good purpose. A word to Hq. requesting information of the different classes of OO appointment, and an application form to be sent your SCM, will bring you the whole picture. For some of this story see page 73 of July *QST*.

It is now planned to arrange for the first postwar ARRL Frequency Measuring Test to qualify Class I precise frequency-checking observers. This can be held in 1947, as soon as we have at least 25 new candidates ready to take advantage

of the Test. Present Observers — Class II, III, and IV — who would like to become Class I Observers, and newly-interested amateurs with 100-kc. bars and appropriate frequency-dividing equipment should advise ARRL Hq. by postal card of their interest and readiness for participation in such a test to expedite the F.M.T.

**Start Some Traffic.** Originations are *the* thing in the amateur-traffic field. At Christmas and New Year's, many amateurs will turn to the yellow insert in ARRL log books and select ARL-check (numbered) messages to suit their needs. (A Copy of CD Form 3 containing this information will be sent to any amateur station gratis on request.) But our thought was about originations in general, *not* just seasonal messages. Did you ever stop to think that if no one *started* any messages there wouldn't be any to handle? Postwar traffic has started spontaneously, some from overseas, some from the many hams with friends who have changed address or are beyond present "local" horizons in amateur radio. Amateur radio organization and cooperation and, incidentally, our name — American Radio Relay League — came about through ham traffic handling. Traffic nets are building up. To get all the enjoyment and value we can from this phase of our hobby, *all* amateurs should be encouraged to start a friendly word by writing and originating messages. Even those *not* traffic hounds would like to send word to folks now out of their local circles.

**Start a Message.** Invite others to do the same through your station. Use the General Traffic Frequencies (3575-3600 and 7150-7175 kc.) and the period 6:30-8:30 P.M. daily. This is a profitable deal all around. It's fun for both the fellows handling the traffic and the friend receiving the message. And think of the thrill, when one morning the answer shows up in your hands!

— F.E.H.

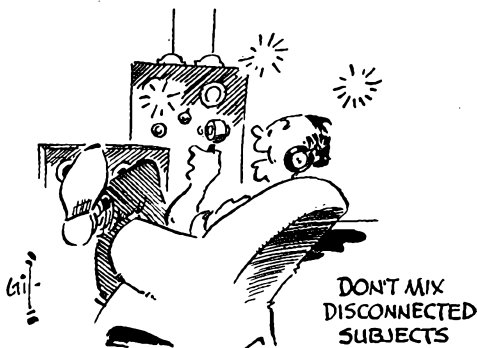

In voice operating, make connected thoughts and phrases. This gives increased intelligibility and results. Short transmissions, with breaks to listen, are most effective. Speak clearly at a steady rate, not too fast for the fellow who makes notes to assist his replies.



## The "Dreamboat" Flight

When the B-29 Pacusan *Dreamboat* left the ground at John Rodgers Field, Naval Air Station, Honolulu, on its nonstop flight to Cairo, the crew had the comfortable knowledge that they were backed up not only by the extensive Army Air Communications Service system but also by the active ears and facilities of radio amateurs at strategic points the world over.

Cooperating with Lieut. Col. F. J. Shannon, W3QR, communications officer and chief radio operator of the *Dreamboat*, ARRL through advance letters, bulletins and telegrams alerted a selected group of amateurs. Among them were W1FH, W1CH, W6GRL, W6KIP, W7EYS, W7CGL, W4FU, W9NDA, VE1EP, VE4RO, VE8MM, KL7AE, KL7AF, VO1I, VO2N, G2MI, G6CL, the Radio Society of Great Britain, and the Newfoundland Amateur Radio Association. Special bulletins from W1AW requested the cooperation of all amateurs in guarding the *Dreamboat* frequencies and preventing interference on the amateur channels. W1AW transmitted the take-off time as soon as known.

### KH6CT

In Hawaii, George W. Spare, KH6CT, was the key station both prior to the flight and after the take-off. Colonel Shannon used KH6CT's facilities as the nucleus for advance preparations. Much valuable weather information and other data were provided by amateur radio. KH6CT reports, "EL4A and FG3FP were consistent with their schedules, meeting me every day. The Canadians up north were wonderful: VE8MV, VE3BFH, VE7TQ, VE7EF. Among the American ham fraternity, the following really cooperated and worked diligently right up to the end of the flight: W1FH, W7EYS, W9NDA, W7CGL,

K6RVU/W6, W6QJT, and W7ELJ/KL7. Our thanks to each of them! After the take-off and just prior to it, it was something to behold . . . hams removing other hams from my frequency (14,204 kc.). The frequency was kept clear for about two-and-one-half hours . . . something, we'll all agree, in the congested 100-kc. 'phone band."

Official take-off time was 1621 GCT on October 4th. KH6CT immediately announced the fact by a QST to all amateurs. The *Dreamboat* used the call 4061. KH6CT's log shows contacts between 4061 and the following amateurs: W7EYS, KH6CT, W7CGL, KH6EZ, EL4A, FG3FP. These amateurs handled routine messages, weather reports, position reports, and cooperated in many ways to aid flight communications. KH6CT maintained practically continuous watch on 11,445 and 14,350 kc. throughout most of the flight.

### W7CGL

A continuous *Dreamboat* watch was maintained at W7CGL, Zenith, Washington from 7:00 A.M. PST, October 4th, until 8:00 A.M. PST, October 5th. Operators were Louis R. Huber, W7CRJ, Joseph H. Schobert, W7CGL, and Robert D. Hoffman, W7DL.

Not long after the take-off, the following comments of Colonel Shannon were intercepted at W7CGL: "It's a mighty fine feeling to take off and know you have so many people listening for you. The cooperation of radio amateurs has been marvelous."

The log of W7CGL is a running story of *Dreamboat* communications, but this account is concerned only with the amateur radio angle. Much of the news reaching the press and radio networks

came through W7CGL. Thirteen position reports were copied during the 26-hour watch. Several personal messages from crew members were received and placed on Western Union wires.

Excerpts from W7CGL's log (GCT):

October 4th —

- 1644 Worked Army 4061; his frequency approximately 14,208 kc. Shannon says he is going to 11,445 kc.  
1820 Heard several amateur radiophones keeping 14,205 kc. channel clear for 4061.  
1921 Confusion and interference among several stations on 11,445 kc. It's not so well policed as is the amateur frequency of 14,205 kc.  
1934 4061 goes to 14,205 kc. and calls several amateurs. KH6CT gets him and suggests 4061 go to 14,350 kc. 4061 goes to 14,350.  
1941 4061 working KH6CT. Shannon, using voice, lauds cooperation by radio amateurs, then suggests as many ham 'phones as possible work him. Works W6SCJ/KP6 on Palmyra Island. Gives some messages to KH6CT for delivery around Hawaii. Shannon continues giving messages, and tells names of crew members. He gives directions for hams to follow in asking for QSL cards. His address: 4418 North Fifteenth St., Philadelphia 40, Pa.  
2000 Shannon says flying at 1000 feet altitude . . . says airplane weighed "well over 150,000 pounds at take-off."  
2300 4061 goes to 14-Mc. band and gives short call. W7CGL (Huber at key) raised 4061 almost immediately. Shannon, using voice, gives position report: "At 2300Z our position was 43:45 North and 146:45 West. We are flying at 1000 feet at a speed of 215 knots, on a course of 27 degrees." This contact lasted 35 minutes.  
2346 4061 worked W6ITH (4061 on 14,350 kc.).  
2350 4061 worked W7GUL.  
2353 4061 worked KH6CT.  
2356 4061 worked VE7EF.

October 5th —

- 0720 Hoffman copies position message from 4061. 66:30 North, 120 West. 4061 signals getting much weaker and we hear fewer transmissions.  
0906 Sheriff's office telephones asking what frequencies to listen on (state-patrol operator has heard some of *Dreamboat's* signals — 'phone).  
0930 "4061 V WZJ QSV." "WZJ V 4061 QTH 71 N 103 W at 0900Z HW." (NOTE — Abbreviated transmission, Shannon obviously knowing how his signals have been silenced by aurora borealis, as was learned by us later; but Shannon could no doubt see the aurora.)  
0953 Can barely hear 4061 . . . his dashes all shot, and

Lieut. Col. Frank J. Shannon, W3QR, communication officer and chief radio operator, Pacusan *Dreamboat* flight, nonstop Hawaii to Cairo, Egypt, October 4-6, 1946.

Joseph H. Schobert, W7CGL, and Louis R. Huber, W7CRJ, at W7CGL, Zenith, Washington. They established what is believed to be the longest amateur radio contact with the *Dreamboat* during its flight — 35 minutes.

some of the dots missing, so that his signal is unreadable.

- 1046 "4061 V KCJ QSV." Think can hear 4061 come back, but it's too badly cut up to be sure.  
1130 We've been shifting back and forth, from 8200 to 11,445 kc., and so on, trying to hear 4061, but without much luck.  
1202 Joe says he can hear 4061, unreadable.  
1600 Everybody off watch. It's up to somebody else from here on.

## W7EYS

One of the outstanding amateurs in *Dreamboat* communication work was Bob Donovan, W7EYS, Bellingham, Wash. He summarizes his participation as follows:

"September 5th: Hooked KH6CT and had a nightly schedule with him until *Dreamboat* took off for Cairo. W9NDA, K6RVU/W6, W1FH, W7CGL, and myself were generally there on 14,204-kc. 'phone or c.w., depending on conditions, each night waiting for KH6CT to announce the verdict of the 1700 HST weather conferences. W9NDA and W1FH lost lots of sleep that month! Lots of credit should go to the following stations: KL7AD, Tanacross, for spending over an hour feeding me the entire Alaskan weather sequence so that I could get it over to KH6CT; VE7EF for finding and giving to KH6CT the frequencies of all the Canadian Department of Transport range and radio facilities along the flight route; EL4A for furnishing direct to KH6CT the European weather each night on 14-Mc. 'phone; W0TGL, who was right on 14,204 kc. and did his best to keep the channel clear the day the *Dreamboat* took off.

"On September 24th, KH6CT, W6QJT, and I, all on 14,204-kc. 'phone, at 11:35 p.m. PST, worked the *Dreamboat* while they were sitting on the mat at Hickam Field. Frank (Col. Shannon) took off, and we QSOed him again from about 1200 until 1240. At 1405, I worked him again as they were going in for a landing, and after they rolled up to the hangar he was S7 on 'phone. On October 2nd, the same gang worked the *Dream-*

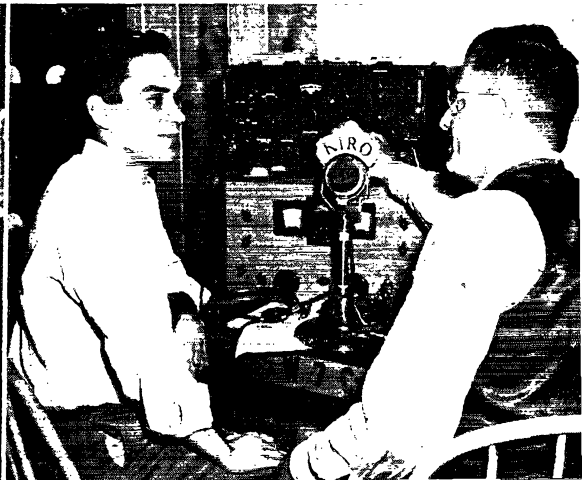

boat again, with W7EYS handling four messages from the ship in flight over Oahu. On October 3rd, KH6CT advised us that Col. Irvine had ordered the crew to bed and that it looked like the real thing. We made a schedule for 0500 GCT the next day.

"On October 4th, we met as scheduled, and at 0825 GCT I heard the *Dreamboat* calling KH6CT, a little off our frequency. CT didn't answer, so I called and Frank came right back, S9 both ways, and reported that they had left Hawaii at 0822 PST and were headed north at 1000 feet. KH6CT then called 4061 and Frank shifted to 14,204 kc., and we all read him 5-9. He was copied without interruption on 11,445, 14,204, and 14,350 all the way across the Pacific. He was worked again at 0847 PST and 0926 PST on 14,204. He was then copied 100 per cent from that time until 1945 PST, when the erratic final amplifier of W7EYS got tired and quit!"

### OTHERS COÖPERATING

The accounts of *Dreamboat* communication work at KH6CT, W7CGL, and W7EYS include several mentions of work by other amateurs. It is possible to record additional amateur coöperation. G2MI reports that he followed the *Dreamboat* on 4220 kc. from Iceland to Geneva. The plane worked G8KP at 1755 GCT, October 5th. G8IG and GM2UU worked 4061 at 0715.

A listening watch was maintained by VE1OK, VE1PQ, and VE1EP from 1800 to 2400, and from 0500 to 2300, on 14-Mc. frequencies. D4ADN heard 4061 on 11,445 kc. and monitored the 14-Mc. frequencies for a long period. W7IHA, running 9 watts on 14-Mc. 'phone, reports a contact with the plane at about 3:50 P.M. PST, while she was about 1600 miles north of Honolulu, and 1400 miles west of the mouth of the Columbia River. This is probably the low-power record of the flight. W1FH heard the *Dreamboat* over Alaska on 14,350 kc. working VE7EF at about 7:10 P.M. EST, and for about a half hour thereafter. W1FH maintained a listening watch practically all night on 11,445 kc. Others coöperating, either before or during the flight: W7DET, W6PWR, VE8AW, VE7ZM, W2LFR, VE7EL, VE8MQ.

Many amateurs other than those mentioned in this account are believed to have put in many hours of listening in connection with the flight, although their calls are not known. It was another example of amateur initiative, coöperation and know-how. Our congratulations to all who participated!

— . . . —

### BRIEF

There's a family reunion nightly when Don Getchell, W1GKA, Burlington, Vt., brother Bill Getchell, W1HRE/2, Brooklyn, N. Y., and father Mel Getchell, W1HRD, Medford, Mass., hold a round table on 3710 kc.

### W1AW OPERATING SCHEDULE

#### Operating-Visiting Hours

Monday through Friday, 8:30 A.M.—1:00 A.M.

Saturday, 7:00 P.M.—2:30 A.M.

Sunday, 3:00 P.M.—9:00 P.M.

Official ARRL Bulletins containing latest FCC information relating to amateur operation and reactivation, and other bulletins on matters of general amateur interest, are transmitted on regular schedules, as follows:

Frequencies: 3555, 7145, 14,150, 28,060, and 52,000 kc. (Voice—3950, 7145, 14,280, 52,000 kc.)

Times: Monday through Friday, 8:00 and 11:30 P.M. EST. (0100 and 0430 GCT, Tuesday through Saturday)

Sunday, 1:00 A.M. and 8:00 P.M. EST (0600 Sun. and 0100 Mon. GCT)

Starting at the times indicated, bulletins are transmitted by telegraph simultaneously on all frequencies. Bulletins are sent at 25 w.p.m. and repeated at 15 w.p.m. to facilitate code practice. Telegraph bulletins are followed, in turn, by voice transmissions, except that 3950 is substituted for 3555 kc., and 14,280 is substituted for 14,150 kc. Changes from this schedule will be announced by the operator.

**Code-Proficiency Program:** Practice transmissions at five speeds, 15 through 35 w.p.m., are made Monday through Friday on the above-listed frequencies, starting at 10:00 P.M. EST (0300 GCT, Tuesday through Saturday). Approximately ten minutes practice is given at each speed. Next certificate-qualification run is scheduled for Sunday, December 15th.

**General Operation:** W1AW engages in two-way work with amateurs as follows:

Monday through Friday, all times EST —

11:00 A.M.—11:30 A.M.	28,060 kc. c.w.
11:30 A.M.—12 noon	29,150 kc. voice
3:00 P.M.—3:30 P.M.	14,280 kc. voice
3:30 P.M.—4:00 P.M.	14,150 kc. c.w.
6:00 P.M.—7:00 P.M.	7250 kc. c.w.
7:00 P.M.—7:30 P.M.	3950 kc. voice
7:30 P.M.—8:00 P.M.	3555 kc. c.w.
9:30 P.M.—10:00 P.M.	3555 kc. c.w.
12:15 A.M.—1:00 A.M. (Tues.—Sat.)	7250 kc. c.w.
<i>Saturday and Sunday (excepting dates of official ARRL activities)</i>	
Saturday: Midnight—1:00 A.M. (Sun.)	3555 kc. c.w.
Sunday: 1:45 A.M.—2:30 A.M.	7250 kc. c.w.
6:00 P.M.—7:00 P.M.	3950 kc. voice
7:00 P.M.—8:00 P.M.	7250 kc. c.w.

The station staff:

John T. Rameika, W1JJR, "JR"  
Thomas W. York, W1JBJ, "TY"  
Wm. H. Matchett, W1KKS, "BM"

W1AW is not open on national holidays.

### BRIEF

W5LGG, W5LFM, and several others are boosting a new club called "WATC," Worked All Texas Counties. With a goal of 254 counties, these lads have much ambition!

## TEST YOUR RECEIVING ABILITY

W1AW conducts practice transmissions nightly Monday through Friday, 10:00 p.m. EST, at speeds of 15, 20, 25, 30, and 35 w.p.m. Once each month a special transmission is made to enable you to qualify for a Code Proficiency certificate or endorsement sticker indicating progress above your first certified speed. See W1AW schedule for details on frequencies.

The next qualifying run will be on December 15th. The text transmitted on that date, received successfully by ear at the highest speed you can copy, should be sent to ARRL for checking. To avoid errors in recopying, send your original copy. *Attach a statement certifying over your signature that the copy submitted is direct copy, made from reception of W1AW by ear, without any kind of assistance, personal or mechanical.* If you qualify, you will receive your certificate, or appropriate endorsement sticker for certificate you already hold. Those who qualified in the past should submit copy only if speed is higher than indicated on certificate or endorsement sticker.

QST lists in advance the text to be used on several of the CP schedules. This makes it possible to check your own copy. It also provides a means of obtaining sending practice since it permits direct comparison of one's fist and tape sending. To get sending help hook up your own key and buzzer and attempt to send right in step with the tape transmissions. Adjust your spacing in the manner indicated as necessary for self-improvement.

Date	Subject of Practice Text from October QST
Dec. 2nd:	"It Seems to Us. . .," p. 11
Dec. 5th:	A Medium-Power Bandswitching Transmitter, p. 13
Dec. 10th:	A New Kind of Skyhook, p. 24
Dec. 13th:	A Simple "Wien Bridge" Audio Oscillator, p. 29
Dec. 15th:	Qualifying Run, 10:00 p.m. EST
Dec. 16th:	A Soup-Can Wavemeter for the 24-Cm. Band, p. 33
Dec. 18th:	Impedance Matching with an Antenna Tuner, p. 38
Dec. 27th:	Amateur F.M., p. 40
Dec. 30th:	Traffic Plans, p. 61

## BRIEF

Why, when we call a directional CQ, do we invariably get answers from *all* directions at once? Why, when we call CQ North, do we get answers from the South? Why, when we call CQ South, do we get answers from the North? Why, for further example, when we call CQ St. Louis, do we get answers from such spots as Wisconsin, Indiana, North Dakota, Maine, etc.? This "improper answering" of Directional CQs has happened to everyone who ever sent one. When we're calling CQ Nevada, we're looking for a Nevada station; when we're calling CQ East, we don't want answers from the West. Why do fellows persist in answering a directional CQ not directed at them? *Why?*

## GENERAL TRAFFIC PERIOD

6:30-8:30 P.M., Your Local Time

## GENERAL TRAFFIC CHANNELS

3575 to 3600 kc. 7150 to 7175 kc.

ARRL recommends the above-mentioned hours and frequencies for use by those amateurs who have an occasional message to send but are unable to keep regular schedules or participate in organized networks. ORS and other active traffic handlers will monitor the General Traffic Channels, particularly during the General Traffic Period. They will be watching for your directional CQ to the state your message is addressed (for example: CQ Illinois, CQ Oregon, etc.). If you wish to break into message handling, it should be possible for you to use the general period and channels to pick up traffic from fellows like yourself for relay or delivery. No ARRL nets will be registered in the General Traffic Channels. Those frequencies have been purposely kept free to aid the casual message handler. Use the facilities provided and let us hear of your results.

## BELGIAN PLANE CRASH

Russ Mack, VO2RM, Gander Airport, Newfoundland, aided in maintaining communications with the rescue party following the serious crash of a Belgian plane in mid-September. VO2RM was asked by the Controller of Radio (Air) to maintain a listening watch on 3017.5 kc. for the land rescue party, which was enroute to the scene of the crash. This watch was kept for two hours before the battery-operated station was heard contacting the local Newfoundland government station. All traffic was copied solid at VO2RM in spite of weak signals although the government station could not make 100-per-cent copy, and "fills" were provided by telephone. Later VO2RM was assigned the call "Gander Radio Two" and relayed traffic from the rescue station by radio to government "Gander Radio One." This proved faster than local telephone. VO2RM and Gander Radio One were two miles apart and both approximately 20 miles from the rescue station. All traffic was relayed using VO2RM's ten-watt 'phone transmitter on the 75-meter band.

## BRIEF

W3QP called CQ. Two stations answered, about same signal strength, same frequency, in the same town (Miami), and with very similar calls (W4ITO/4, W4IMI/4). "Just goes to prove that Florida is a one-way state, as advertised," says W3QP.

## HAWAII — DECEMBER 7, 1941

In July 1941 an AARS net was formed in Hawaii at the suggestion of the Chief Signal Officer, Washington, D. C. K6JFV was first Net Control Station. K6OTH was NC2 and later took over as NCS with K6SDQ as NC2. Other net stations were K6TSK, RLG, MVX, TAI, REF, RGZ, BJJ, QXR, HOT, and RDB. Drills were held each Monday evening.

On the morning of December 7th, the "unusual" happened. When the guns started thundering on that Sunday morning, many at first thought that it was merely more maneuvers, but the fact that all guns of every size and type were in action awoke us to the realization that something out of the ordinary was happening. The broadcast stations soon told us the worst.

K6OTH went on the AARS frequency and called net stations. The islands of Maui and Kauai were asked to stand by. K6OTH then reported to the Signal Office at Fort Shafter. About five minutes later, a telephone call came with a message to Kauai. This was transmitted and an acknowledgement from the Commanding Officer on that Island phoned to Fort Shafter. After that, messages continued to come through by telephone, if in plain language, or by messenger if in code. The Signal Office at Fort Shafter was so loaded that the AARS net handled the traffic to the Island of Kauai. K6OTH stayed on from the morning of the 7th until TSK relieved him at 4 p.m. on the 8th. SDQ also helped out. K6BJJ stood by on Maui.

The gang on Kauai did a fine job. Although they lived in widely scattered spots, were all blacked out and could not use car headlights, they arranged and kept 24-hour watches. K6TAI and K6REF kept their transmitters on in shifts with K6RDB and K6QXR as relief operators. At dusk on December 7th and each night thereafter, an MP arrived at K6OTH's shack for guard duty. The net was on 24 hours daily until December 18th, when traffic eased to a point where the Signal Corps handled it without help. The net was not closed but was asked to make frequent checks and keep in operating readiness in case of call. On December 27th the Net Control post was taken over by K6TSK. Checks were made nightly for a while and later reduced to twice a week.

In June 1942, K6TSK left for the mainland and K6OTH again took control. The net was kept in operating condition with weekly checks until July 1944, when orders came through to stop operations as it would not again be required. As drills had been carried on in the 3.5-Mc. amateur band under regular station calls, these calls were used to save confusion for several months after December 1941. The net eventually switched over to the regularly-assigned Army calls. K6OTH reports splendid cooperation from all members on the net. They are all justifiably proud of the fact

that they were ready when called upon and able to have a part in helping the Signal Corps in an emergency.

Our thanks to Hugh C. Rea, K6OTH, for the above story.

## EMERGENCY NETS

William G. Meurer, W4NRA, ARRL Emergency Coördinator, Cincinnati, Ohio, reports the Cincinnati Emergency Net holding drills each Tuesday evening on 29.4 to 29.65 Mc.

— . . . . —  
A group of Texas amateurs gathered at Cuero, Texas, on September 15th with the object of reorganizing the Texas Gulf Coast Emergency Net. Among those present were W5LGG, W5FNY, W5HJY, W5CIX, W5EYV, W5ZX, W5IVU, and W5FAR. It was decided to use frequencies of 3860 kc. (voice) and 3840 kc. (c.w.), with drills at 7:00 A.M. Saturdays and 6:30 P.M. Mondays. Bob Cooper, W5EYV, was elected president of the Net, and David G. Cadena, W5FAR, secretary. It was further voted that W5FAR, Refugio, Texas should be Net Control Station, with sub-controls at San Antonio (W5FNY), Houston, Corpus Christi, Cuero, and Harlingen.

— . . . . —  
The Inglewood, California, AEC Net, under W6MSO, holds weekly drills and incidents each Monday evening on 146.5 Mc.

— . . . . —  
The Radio Association of Erie (Pa.) has supplied all active AEC members with transceivers, and the following stations are active on 144 Mc.: W3/8 QJ, AAQ, AQY, JWZ, KKK, KKT, KQP, NMP, NBV, NCJ, RHK.

— . . . . —  
In the Nassau County (New York) Emergency Corps Net, 45 stations are heard quite regularly on the 144-Mc. band. W2FI is control station.

— . . . . —  
ARRL Emergency Corps members in Stratford, Connecticut, hold regular drills on Thursday evenings and Sunday mornings, under the leadership of Emergency Coördinator Keeling, W1OGQ, and with the full cooperation of the Stratford Amateur Radio Club. In July the club sponsored a test of the disaster network in connection with local Red Cross officials. 144 Mc. is used by the group.

## BRIEF

WØTJR and W9PYI are convinced that history *does* repeat itself. On June 29, 1941, W9PYI called CQ on 7 Mc. at 7:50 A.M. He was answered by WØTJR, then W9TJR. On June 29, 1946, at 7:50 A.M., W9PYI was again calling CQ, this time on 3.5 Mc. The result was another QSO with WØTJR. It was just one of those interesting ham radio coincidences — no prearrangement of any kind!



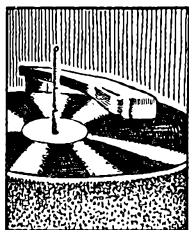

A CIRCUIT diagram for a high grade phonograph amplifier appeared on this page last month. As promised, we are giving you some pointers on it.

First of all, if you don't happen to have a magnifying glass and would like to have a larger copy of the diagram, write us a post card and we will send you one. We had to make the diagram pretty small to get it on the page.

-As shown, the output circuit is a conventional Class AB amplifier using 2A3's with self bias. This can be changed to straight Class A by making the cathode bias resistor (R23) 375 ohms instead of 850 ohms and by selecting a power transformer which will deliver 295 volts to the 2A3's. The straight Class A amplifier is less efficient than the more usual AB arrangement and draws more plate current, but in a really high performance job we prefer Class A for reasons given in earlier pages.

Because of the large amount of bass boost, you may find that you have some trouble from hum. This is the principal reason why the tone control circuits are located in high level circuits rather than at the input. The two chokes used as low pass filter inductances (CH1 and CH2) will have to be inclosed in a shield of magnetic material. We used ordinary sheet steel for it, of the kind used in chassis. It should be located away from the power transformer and chokes. The resistor and condenser network used for bass compensation also must be shielded, but magnetic material is not required.

This bass compensation circuit requires some explanation. As you probably have guessed from looking at it, it wastes a lot of gain and there is a considerable insertion loss even at the lowest frequencies. Some circuits which make use of a resonant tuned circuit to build up the bass are much more efficient in this respect, but all such circuits that we tried resulted in a very "boomy" bass without clarity or quality. The circuit given does not cause bass notes to "hang over" and gives clean, clear reproduction.

The bass compensation network shown provides about 30 db rise at 50 cycles. This is likely to be more than you will require. The switch will reduce it at will and you can select the amount that sounds most pleasing to your ear.

WILLIAM A. READY



# for really effective **NOISE SUPPRESSION**

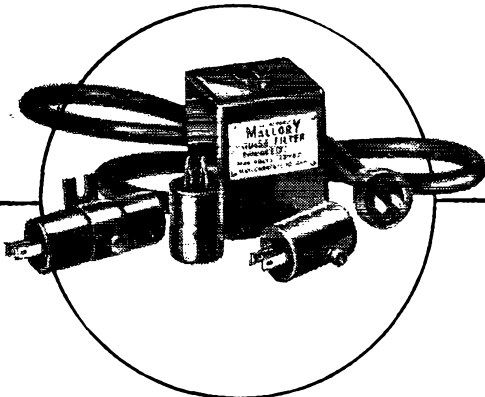

One of the simple laws of radio communication is this: "you can't work a station unless you can hear it." Almost as bad as no signal at all is one so garbled with "man-made" static that you have to strain every nerve to hear it.

Fortunately, it's easy to eliminate "man-made" static. The proper Mallory Noise Filter on the offending appliance will eliminate the noise entirely or reduce it to a whisper. Ask your Mallory distributor for a free copy of the Mallory Noise Filter Folder. It lists the entire line and gives recommendations.

For detailed information on eliminating noisy reception, see Chapter 10 of the Mallory Technical Manual. Personal help on radio noise problems is yours for the asking. Just write the Engineering Application Section of our Wholesale Division.

**P. R. MALLORY & CO., Inc.**  
INDIANAPOLIS 6, INDIANA

**P. R. MALLORY & CO. Inc.**  
**MALLORY**

## ELECTION NOTICE

(To all ARRL Members residing in the Sections listed below:)

You are hereby notified that an election for Section Communications Manager is about to be held in your respective Sections. This notice supersedes previous notices.

Nominating petitions are solicited. The signatures of five or more ARRL full members of the Section concerned, in good standing, are required on each petition. No member shall sign more than one petition.

Each candidate for Section Communications Manager must have been a licensed amateur for at least two years and similarly a full member of the League for at least one continuous year immediately prior to his nomination.

Petitions must be in West Hartford, Conn., on or before noon on the closing dates specified. In cases where no valid nominating petitions were received in response to previous notices, the closing dates are set ahead to the dates given herewith. The complete name, address, and station call of the candidate should be included with the petition.

The following nomination form is suggested:

Communications Manager, ARRL (Place and date)  
38 La Salle Road, West Hartford, Conn.

We, the undersigned full members of the .....  
..... ARRL Section of the .....  
Division hereby nominate .....  
as candidate for Section Communications Manager for this  
Section for the next two-year term of office.

Elections will take place immediately after the closing dates specified for filing of nominating petitions. The Ballots mailed from Headquarters to full members will list in alphabetical sequence the names of all eligible candidates.

You are urged to take the initiative and file nominating petitions immediately. This is your opportunity to put the man of your choice in office.

— F. E. Handy, Communications Manager

Section	Closing Date	SCM	Present Term Ends
Philippines	Dec. 16, 1946	George L. Rickard	Oct. 15, 1938
San Diego	Dec. 16, 1946	Ralph H. Culbertson	Apr. 15, 1946
Maine	Dec. 16, 1946	Grover C. Brown	June 15, 1946
Maritime*	Dec. 16, 1946	Arthur M. Crowell	.....
West Indies	Dec. 16, 1946	Mario de la Torre	Deceased
Washington	Dec. 16, 1946	O. U. Tatro	Resigned
Md.-Del.-D.C.	Dec. 16, 1946	Hermann E. Hobbs	Resigned
Minnesota**	Dec. 16, 1946	Vernon G. Pribyl	.....
Hawaii	Jan. 2, 1947	Howard S. Simpson	Resigned
Michigan	Jan. 15, 1947	Harold C. Bird	Feb. 3, 1947
Southern Texas	Feb. 3, 1947	James B. Rives	Feb. 15, 1947

\* In Canadian Sections nominating petitions for Section Managers must be addressed to Canadian General Manager, Alex Reid, 169 Logan Ave., St. Lambert, Quebec. To be valid such petitions must be filed with him on or before the closing dates named.

\*\* Effective Oct. 15th ARRL resectionalizing action has been completed. We announce a Minnesota Section, combining Northern and Southern Minnesota. All reports, applications for appointment, etc., from any Minnesota amateur should be sent Acting SCM, Vernon G. Pribyl, W9OMC, 15 Glen St., South, Hutchinson, Minn., pending action of members pursuant to the above notice.

## ELECTION RESULTS

Valid petitions nominating a single candidate as Section Manager were filed in a number of Sections, as provided in our Constitution and By-Laws, electing the following officials, the term of office starting on the date given.

Northern Texas N. C. Settle, W5DAS Oct. 15, 1946  
Wisconsin C. C. Richelieu, W9ARE Oct. 16, 1946

In the Illinois Section of the Central Division, Mr. Wesley E. Marriner, W9AND, and Mr. Dayton L. Warner, W9IBC, were nominated. Mr. Marriner received 309 votes and Mr. Warner received 292 votes. Mr. Marriner's term of office began September 30, 1946.

(Concluded on page 74)

# HQ · 129 · X

*backed by 36 years of know-how*

Many thousands of amateurs are using the new HQ-129-X communications receiver. Rarely has a new product been so widely approved in so short a time. The reason is simple—36 years experience and a record of high accomplishment build confidence. The HQ-129-X is an outstanding value from the standpoint of performance and cost.

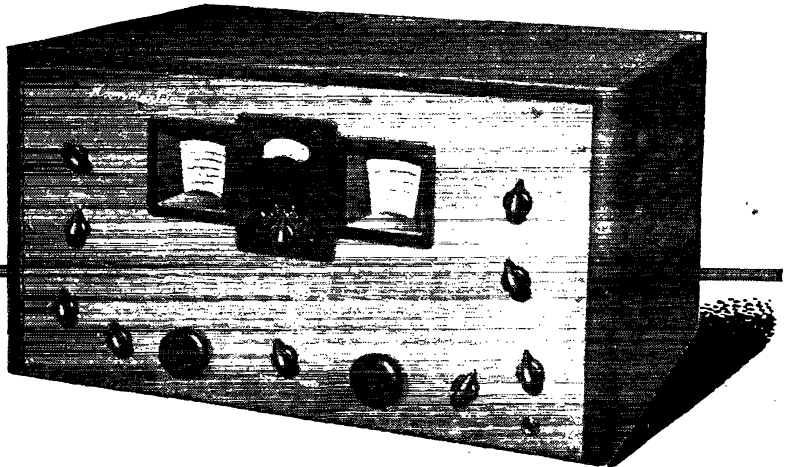

## HAMMARLUND

THE HAMMARLUND MFG. CO., INC., 460 W. 34<sup>TH</sup> ST., NEW YORK 1, N. Y.  
MANUFACTURERS OF PRECISION COMMUNICATIONS EQUIPMENT

*see*  
the HQ-129-X  
at your dealer's.

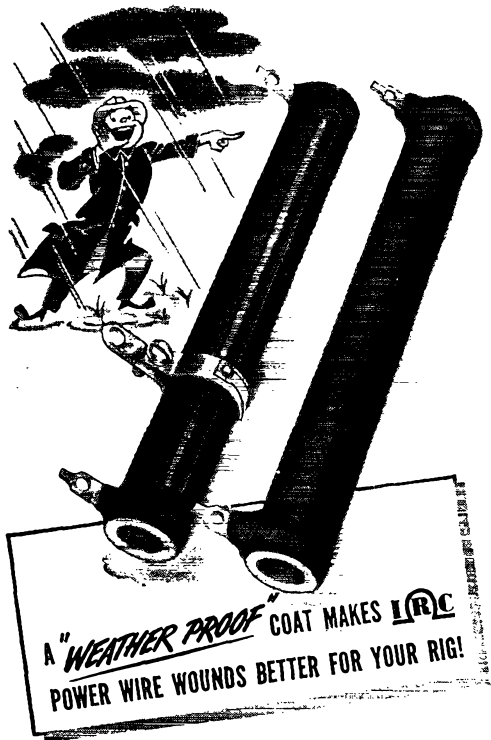

For protection against atmospheric moisture and corrosion, IRC Fixed and Adjustable Power Wire Wound Resistors have a coarse finish, special cement coating that makes them better for your rig.

This rugged coating is dark and rough, dissipates heat rapidly, does not deteriorate under any reasonable overload. It guards the winding against the inroads of moisture and corrosive action, contains no chemically active ingredients, no salts, to attack the wire. The cement is crack proof, is cured and hardened at low temperature to prevent the temper from being baked out of winding and terminals.

IRC Fixed and Adjustable Power Wire Wound Resistors are strong on tough, non-porous ceramic forms, have extreme mechanical strength. They are available from 10 to 200 watts.



FREE CATALOG!

IRC Catalog 50 lists a resistance unit for every ham-rig requirement. It's available at your local IRC Distributor.

REGISTERED FOR PERFORMANCE  
FIXED & VARIABLE RESISTORS

## INTERNATIONAL RESISTANCE CO.

401 North Broad St., Philadelphia 8, Pa.  
In Canada: International Resistance Co., Ltd., Toronto, licensees

(Continued from page 72)

In the Western Massachusetts Section of the New England Division, Mr. Prentiss M. Bailey, W1AZW, and Mr. William J. Barrett, W1JAH, were nominated. Mr. Bailey received 68 votes and Mr. Barrett received 57 votes. Mr. Bailey's term of office began September 30, 1946.

### THE YOUNGEST HAM?

Donald Joe Choice, W5LVZ, of El Reno, Oklahoma, was awarded a prize for being the youngest ham at the West Gulf Division Convention held at Oklahoma City, September 21st-22nd. This "OM" is 10 years old! He is the son of W5LTB and received his Class B ticket in mid-September. According to data so far available, W5LVZ is the "youngest active ham." Any challengers?

Not a grey-beard by any means is Richard O. Bremigan, W9RQT, Homewood, Illinois. Richard is 12 years old and received his license July 26th. He is active on 7- and 3.5-Mc. c.w. with 12 watts to a crystal oscillator.

### BRIEFS

The Washington Radio Club is now holding a membership drive, to last until December 15th, and invites all hams and other radio hobbyists in the area to its meetings, which are held the second and fourth Saturday of each month at 8 P.M. The Club now meets in a new location, in the Columbia Bowling Alleys building on 14th Street above Park Road, N.W. Code classes are in progress. Further information may be obtained by calling LUDlow 5223.

W9UYU heard W9JXB calling CQ on 28-Mc. c.w. They had worked before on 'phone; so UYU swung up to the c.w. band and gave JXB a shout. After contact was established, they found that it was the first c.w. contact for each of them. JXB was using a "liberated" German key, and UYU an ex-Japanese key!

### BRASS POUNDERS' LEAGUE

(September Traffic)

• W7FST makes the BPL with a traffic total of 793 and W1AW with 104 "deliveries plus extra delivery credits."

A message total of 500 or more, or 100 "deliveries plus extra delivery credits" will put you in line for a place in the BPL. The Brass Pounders' League listing is open to all operators who qualify for this monthly "honor roll."

In counting traffic for your monthly report to the SCM, count one point each time a message is handled by radio. That is, one point if you originate the message and forward by radio; one if received by radio and delivered; two points if received by radio and forwarded by radio. In addition, an extra point may be claimed for each delivery made by mail, telephone, in person, by messenger or external means other than radio. This extra credit is not allowed for a message received for yourself or a party on the immediate premises.

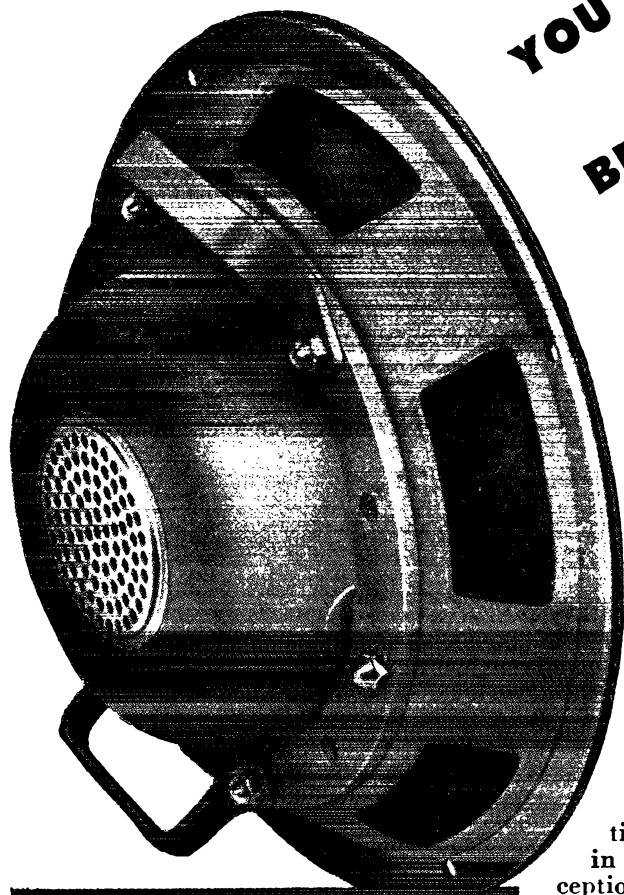

**YOU WON'T  
BELIEVE IT  
TILL YOU  
HEAR IT!**

**NEW**  
*Western Electric*  
**728B LOUDSPEAKER**

The first time you hear this revolutionary Western Electric loudspeaker in action, you'll get an entirely new conception of sound reproduction. It delivers speech and music with such "presence," such emotional quality, that you'll find it hard to believe you're listening to *reproduced* sound!

New design features, developed by Bell Laboratories scientists, make the 728B ideal for broadcast studios and sound systems where high quality reproduction is a "must."

For complete technical details and information on delivery, talk to your Graybar Broadcast Equipment Representative—or write Graybar Electric Company, 420 Lexington Ave., New York 17, N. Y.

**TECHNICAL DATA**

**FREQUENCY RANGE:** 60 to 10,000 cycles.

**IMPEDANCE:** 4 ohms.

**EFFICIENCY:** At a distance of 100 feet on axis, the 728B will produce a level of 81 db above  $10^{-16}$  watt per sq. cm. at 30 watts. This level is on a basis of a warble frequency covering a range from 500 to 2500 c.p.s.

**COVERAGE ANGLE:** 50 degrees.

**POWER CAPACITY:** 30 watts continuous.

**DIMENSIONS:** Diameter 12-11/32"; depth 4".

**WEIGHT:** Approximately 17 pounds.

**BAFFLE HOLE DIAMETER:** 11".

**MOUNTING:** An enclosure of approximately 2½ cubic feet of space is required.

— QUALITY COUNTS —





• All operating amateurs are invited to report to the SCM on the first of each month, covering station activities for the preceding month. Radio Club news is also desired by SCMs for inclusion in these columns. The addresses of all SCMs will be found on page 6.

**ATLANTIC DIVISION**

**EASTERN PENNSYLVANIA** — SCM, Jerry Mathis, W3BES — 3BKU is back from J/9 and finds the going a bit rougher here without his BC-610. 3ID operates on 3G06 kc. and 144 Mc. ØFSA/3 now is 3LUZ. The new officers of the West Philadelphia Radio Association are: 3ITZ, pres.; 3EVH, vice-pres.; 3LUZ, secy.; 3IUD, treas. 3BET is doing a fine job of traffic-handling on 14-Mc. 'phone. Ex-80ML now is 3OML and is on with a new e.c.o. 3QEW now is member of the RCC. 3BXE is our new SEC. We trust that we will have more activity along EC lines now. 3QP is planning a super antenna. 3GMK has his new e.c.o. perking and will be in the next CD Contest with it. 3HTI helped 3LDV get going in the Get Acquainted Party. Our sincere sympathies to 3EU, who reports the death of his father. His brother, 3RNW, also has been ill for several weeks. The net result was very little activity on the part of 3EU, which is understandable. 3KCD has a new jr. operator. 3HRD now is in the land of J/3 and has heard every place in the world but the East Coast of U. S. A. He loaned his home station to 3HLU. 3DMQ is in Ft. Belvoir, Va. 3AGV has a new vertical for 14 Mc. and is working out fine. Most of the Frankford Radio Club boys are DXing very seriously now but the CD Party and the SS will certainly put a stop to such doings. The York Road Club is holding an anniversary banquet at the Casa Conti in Glenside. 3KT has a pair of VT125As getting his DX for him. 3ENX is working the rare spots with a pair of 810s. 3GHD is experimenting with all sorts of antennas. ØEHR/3 has a new modulator using 811s and is trying his luck on 14-Mc. 'phone. He made close to 70,000 points in the Get Acquainted Party. 3GQW has a new center-fed Zepp up for the CD Party and SS. 3UA made a tour of the S.E.N. and is helping to line up ECs for those counties. 3BXE is sold on a vertical antenna for general operation including DX. Reports are better this month. Keep them coming. Traffic: W3BET 76, 3QP 28, 3LUZ 16, 3BES 6, 3BXE 6, 3ID 4, 3QEW 3, 73, Jerry.

**SOUTHERN NEW JERSEY** — SCM, W. Raymond Tomlinson, W2GCU — SEC: 2BAQ. ECs: 2SAK, 2PSZ. The new code and theory classes of the DVRA are in full swing with 2SOR and ex-8BRJ in charge. Old Zed Eye is doing himself proud with the new high-powered rig assigned to his custody because of lack of operating room at 2SOR, adding to his WAC contacts with one from Shanghai, a couple of VKs, and some Gs. 2HAZ made WAC. HWO's son now is 2RBV. An interesting talk was given by 3CJI at the September meeting of the DVRA. Following DX was worked by 2RSP during September: OQ5AE, G5JZ, G5KJ, ZB2A, PY9AT, KP4BO, ZS6EJ, ZS6EQ, VE7AFA, LU1EC, XE2FE, HK3AB, CX4CS, and YV5AM. 2PSZ is building a very super-duper rig for 3.9, 14, 28, and 50 Mc., all in one rack. 2JAG is looking for QSOs on 3.5-Mc. c.w. 2ORA has his T240 final with a three-clement beam set up on the beach at Atlantic City. 2IMA will become one of the 144-Mc. operators in the Forestry Emergency Net under the direction of EC, 2SAK. 2FXN is working into the Connecticut ORS Net as well as the NNJ Net. The new ham in Succasunna is 2IDZ, not IOZ. The SJRA boys report some hot stuff on 144-Mc.: 2PFQ, 3GQS, 3BYJ, and 2PAU all report working 8Y10/4 working mobile along Skyline Drive, Va. 2BV reports numerous contacts on his TR-4 with stations as far up as Cape Cod. 3HWN is using three-element beam and doing swell on 144 Mc. 2RBF is building new rig for 144 Mc. using 829 final. 2EQ has worked sixty-

(Continued on page 78)

## Don't Let Others Put You OUT of the Picture!

### Here's How CREI Prepares You NOW for a BETTER JOB and a SECURE CAREER in RADIO-ELECTRONICS!

Add CREI Technical Training to Your Present Experience—Then Get That Better Radio Job You Want  
 —Make More Money—Enjoy Security

Never before have men like you had so many chances to step into brand new jobs in brand new fields. FM, Television, Facsimile and other electronic communications systems for both government and industry will require thousands of highly trained expert radio communications engineers and technicians.

NOW is the time to take the time to prepare yourself for these important career jobs. CREI home study training can show you the way by providing you with the "tools" with which to build a firm foundation of ability based on a planned program of modern technical training. In our proved method of instruction you learn not only how but why! This is real, honest-to-goodness practical engineering training that leads to better jobs and more rapid promotions. It costs you nothing to read the interesting facts. Write for free booklet today.

**VETERANS! CREI training is available under the "G.I." Bill!**

**CAPITOL RADIO ENGINEERING INSTITUTE** Q-12  
 Dept. Q-12, 16th & Park Road, N. W.  
 Washington 10, D. C.

Gentlemen: Please send me FREE BOOK describing the new CREI home study courses in Practical Radio and Television Engineering. I am attaching a brief resumé of my experience, education and present position.

NAME .....

STREET .....

CITY ..... ZONE ..... STATE .....

CHECK  Practical Radio Engineering  
 COURSE  Practical Television Engineering  
 I am entitled to training under the G.I. Bill.

Now...

a complete line of

# OHMITE RESISTORS

for the Radio Amateur

## "RITEOHM" PRECISION RESISTORS

Six types—including non-inductive hermetically sealed glass units. Tolerance  $\pm 1\%$ . Five types available from stock in  $\frac{1}{2}$ - and 1-watt units, 0.10 to 2,000,000 ohms.

## NON-INDUCTIVE RESISTORS

For r. f. circuits where practically constant resistance and impedance are required. Available in vitreous-enamel type and in hermetically sealed glass type with vacuum tube base.

## "DIVIDOHM" ADJUSTABLE VITREOUS ENAMELED RESISTORS

Used for multi-tap resistors or voltage dividers and for obtaining odd resistance values quickly. Winding is exposed along one side for contact with adjustable lugs.

## "BROWN DEVIL" AND LUG TYPE VITREOUS ENAMELED RESISTORS

A dependable general-purpose resistor. Available in ratings from 10 to 200 watts. Smaller sizes have tinned copper wire terminals.

## "LITTLE DEVIL" INSULATED COMPOSITION RESISTORS

An extremely small, sturdy resistor. Three sizes— $\frac{1}{2}$ , 1, and 2 watt, in 10 ohms to 22 megohms. Tolerance  $\pm 10\%$ . Easy to install. Available only from Ohmite distributors.

Write for Catalog 18  
Contains helpful information  
for the radio amateur.

**OHMITE MFG. CO.**  
4864 Flournoy St., Chicago, 44  
U. S. A.

Be Right with

# OHMITE

RHEOSTATS  
RESISTORS • TAP SWITCHES

STOCK OR SPECIAL UNITS AVAILABLE



# CARDWELL

## V.H.F. Oscillator Kit

P. L. 20,024

\$10.80

AMATEUR NET

Price includes 3 sets of coils covering 144-148 M. C., 220 - 225 M. C., 420 - 450 M. C. bands — less 6F4 tube.

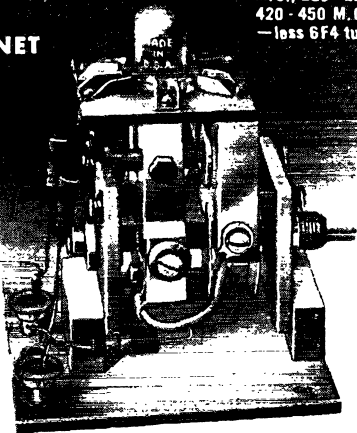

### IT HAS MANY INTERESTING APPLICATIONS FOR HAMS

Although only introduced this year, the Cardwell V.H.F. Oscillator Kit is successfully used by hundreds of amateurs for many purposes.

For example: W2NPP used the kit in a V.H.F. transmitter and found the "output extremely steady." As a detector unit in a super-regenerative 2 meter receiver, the P. L. 20,024 apparently really "went to town" under 2NPP's guidance because he reports excellent signal strength, "selectivity is fine and... never had so many stations before."

And W1MGW similarly advises that he uses V. H. F. oscillator kit, P. L. 20,024 in a super-regen. receiver with a separate quench oscillator, and reports, "sharper tuning than with ordinary super-regen. and far greater frequency stability, even with oscillator tank heavily loaded"... and, "the darn thing oscillates with less than 20 volts on the plate."

That's all we have room for here—but why not get one yourself and see what you can do with it?

SEE YOUR DEALER TODAY

**THE ALLEN D. CARDWELL**  
MANUFACTURING CORP.

MAIN OFFICE & FACTORY

97 WHITING STREET, PLAINVILLE, CONN.

(Continued from page 76)

eight countries and 20XX has twenty-four. 3JYT is operating portable on 14 Mc. from Greenland signing W3JYT/OX. 2QDY is on 3.9-Mc. 'phone. 2QHM is building an e.c.o. 2PAZ is reported on 144 Mc. 2RRP is building a new 1-kw. rig for 14 Mc. 2RLL has new TR4A. Here is another raft of new calls: 3ITD/20TH-8RVM/2OUY-LSPH/20WA-LSPH/2OXF-3ILX/2OZO-new/2PAB-3BYX/2PAC-1IRV/2PAU-3FTQ/2PAZ-3JVS/2PBV-3AUA/2PBW-9ENK/2PBX-new/2PDA-LSPH/2PEJ-LSPH/2PEN-3JTJ/2PFQ-new/2PFT-3FCQ/2PK-3IOF/2PKF-3ABQ/2PKT-3GLZ/2PLD-4HHB/2PLF-LSPH/2PML-3EEC/2PMS-LSPH/2PNA-LSPH/2PNO-3BWI/2POC-3GFT/2PPO-3GPU/2PRG-3EDN/2PSY-3JNZ/2PSZ-3COT/2PTM-new/2PUJ-3EPT/2PWD-3DAJ/2PWW-3HDJ/2PWP-3GYM/2PZD-3FBH/2PZK-3FLU/2PLZ-3GMT/2PZZ-3BPH/2QAC-3AGZ/2QBI-3JAU/2QCU-new/2QDC-3HLY-2QDY-3BCC-2QEN-3GYM/2QER-3GZS/2QHM-new/2QKA-3IIE/2QLB-new/2QLM-new/2QLP-3HOH/2QVH-3FBZ-2QXG-3HEO/2QYG-3IZP/2QYM-3IFT/2QZF-3IAS/2RBF-3FMD-2REB-new/2REK-3FDF/2RFU-3DYR/2RFV-3AVJ-2RG-3AEJ/2RGT-3HND/2RIL-new/2RIM-3IST/2RIV-1ND/2RMP-3IIC/2RQC-9EPA/2RRP-3HUZ/2RSO-3IXL/2RHD-3HKY/2SAI-LSPH/2SGG-3VX/2VX-3ZX/2ZX-3BZI/2BZI-3CHP/2RIK-3HVQ/2QZV-3EO/2KE-3ACC/2ACC-3ESG/2ESG-3EED/2SOR-3GNU/2SFT-3AZZ/2AZZ-3GQT/2GQT-3HUY/2HUY-3ABS/2SAK. Traffic: W2FXN 48, 2BEI 3, 2RYB 3, 73. Ray.

WESTERN NEW YORK — SCM, Charles I. Otero, W2UPH — The following EC appointments have been made: SB, Dunkirk; WHK, Tonawanda; 8CYD, Syracuse; PJF, Angelica; RHJ, Glens Falls; TEP, Lowville. More ECs are urgently needed to cover Western New York properly. RPO gave a talk on "Fixed Station Communications" at a meeting of RAWNY. KWS is in Massachusetts on a business trip. PPE is active with the CAP. OUJ is crystal-controlled on 144 Mc. with a rotary beam. PAQ is heard regularly on 3.9 Mc. in the morning. UXL, QDN, and OUJ are on 28 Mc. with new HT-9. FMH has an HT-9 on 3.9 Mc. RPO is experimenting with an eighteen-element rotary on 144 Mc. UHI is active on 7-Mc. c.w. FSB has a 610E on 28 Mc. TBD is experimenting with rotary and "V" beam pointed at England. 8KBS now is PJM. 2UCF is Class A, just back from Japan, and is on 3.5 and 7 Mc. c.w. using a Jap airplane transmitter with 50 watts. This Jap rig uses a 6F6 v.f.o. driving a pair of Jap 807s. The Rochester Amateur Radio Association opened up for the season. The executive committee has been busy planning an attractive program. The Sidney Amateur Radio Club holds monthly meetings on the third Monday of each month. GFD, ex-STEW, has the same call he had in Poughkeepsie a few years back. 2CYV, ex-8FOB, has a new SX-25, RZP, ex-8KKP, also has a new SX-25. UPT is ex-8UPT, ex-2CDM; RMB is ex-8LUR; SYN is ex-8SYN; RGI is ex-8ARX; RXX is ex-8FSX; PVP is postwar call in Bainbridge; SHZ is ex-8MTZ; TSX is ex-8TSX. 8UG gave an interesting talk at the last meeting of the SARC on v.h.f. tubes and their applications. A new-comer at Olean is 2SHT, who is on 7-Mc. c.w. with a single 6L6. 4JLK, ex-8NEL, is back at Alexandria, Va. Irv wants to contact his friends around the Buffalo area. KBT Club, please take note. Irv is on 14 Mc. PJF and QCP have been appointed OPS and OO. About 100 fellows, their wives and families, attended the Ham's Picnic sponsored by the Oneida Amateur Radio Club. RXW, ex-8NNJ, president of the club, expects to have many interesting meetings during fall and winter. The club meets the third Wednesday of each month at the Hotel Oneida. The following changes have been made in the Oneida area: 8ABN is 2QXE, 8MLM is 2OVT, 8VJP is 2VJP, 8BEX is 2QXF, 8FVY is 2PGU. VJP and QXE are working 144-Mc. mobile. OVT is on 3.9 and 28 Mc. 'phone. RXW is building 300-watt 'phone transmitter for 3.9, 14, and 28 Mc. and a mobile rig for 28 and 144 Mc. ADV reports the following changes in the Elmira area: PTS was 8CJJ, PUM was 8KBS, RQH was 8MXC, QXH was 8OCP. SBV is building a new 'phone rig and PMJ is on 28 Mc. VLG and PMJ helped ADV solve his antenna problems. ERM was 8QIV from Ithaca. The boys are busy with the reactivation of the Elmira Club. The most popular job in town is held by SNW, who is manager of the meat department at a local store. 73. Charis.

WESTERN PENNSYLVANIA — SCM, R. R. Rosen-

(Continued on page 80)



# SPRAGUE TRADING POST

*is coming Back!*

## Your Own Swap, Buy or Sell Advertisement Run FREE—Send it in today!

Have you any parts or equipment you'd like to trade or sell to some other radio man who could put them to good use?

Are there any hard-to-get items you'd like to buy? Want to get a radio job — or to hire a helper?

If so, write up your advertisement in brief form, rush it to Sprague. We'll run it **ABSOLUTELY FREE OF CHARGE** in the famous Sprague Trading Post that will start again next month in seven leading radio publications: **RADIO NEWS, RADIO CRAFT, QST, SERVICE, RADIO SERVICE DEALER, RADIO MAINTENANCE** and **RADIO & TELEVISION RETAILING.**

This famous Sprague service needs no introduction. During the war over 12,000 individual free classified advertisements were run for our friends. Everything, from parts and equipment to complete radio shops, was bought, sold and exchanged as a result.

In discontinuing The Sprague Trading Post at the close of the war, we thought there was no longer any need for it. But we were wrong! Hundreds of letters flooding in from all parts of the country tell us so. "*We need this sort of thing now as much as we ever did!*" is the gist of what our service and amateur friends say, "*Start it going again!*"

And so we're doing it! Send in your swap, buy or sell advertisement today!

Sincerely yours,

Harry Kalker  
Sales Manager

**THIS IS THE WAY YOUR  
FREE AD WILL LOOK**

**FOR SALE** — Standard model all-wave signal generator, \$25; modern tube tester with adapters, \$27.50; popular phono motor, \$15; power transformers and other parts. Write for list. **YOUR NAME and ADDRESS HERE.**

**WANTED** — Input i-f transformer and oscillator coil assembly for Model 15 Majestic. Will pay cash or trade. What do you need? **YOUR NAME and ADDRESS HERE.**

**HELP WANTED** — Need radio service man for busy dealer store in small Midwestern city. Well equipped shop. Write giving full details of experience. **YOUR NAME and ADDRESS HERE.**

**INSTRUCTIONS:** Print or type your advertisement CLEARLY. Hold it to 40 words or less including name and address. Confine it to radio subjects only. **MAKE IT EASILY UNDERSTANDABLE!** No commercial advertisements are acceptable. Sprague reserves the right to reject any copy that, in our opinion, does not fit in with the spirit of this free service. Your advertisement will be run in the first possible issue of at least one of the seven magazines on our list.

Write it now. Mail it to  
Dept.  
**SPRAGUE PRODUCTS COMPANY**  
North Adams, Mass.



**CAPACITORS AND \*KOOLOHM RESISTORS FOR EVERY RADIO SERVICE AND AMATEUR NEED**

\*Trademark Reg. U. S. Pat. Off.

**STATION TESTED\***

*... an added  
proof of Quality!*

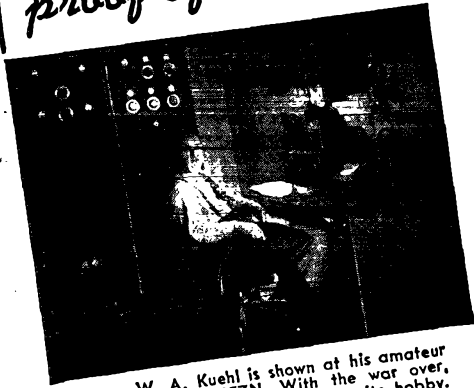

\*Pres. W. A. Kuehl is shown at his amateur radio station W9EZN. With the war over, Walt is again pursuing his favorite hobby.

## DRAKE RADIO SOLDERING IRONS

Yes, Drake irons are *right for radio*. And these sturdy irons have proved their dependability and worth in use on countless other jobs, too, for over 25 years. That's why we say—whatever your needs, you are certain to find a Drake iron that fills the bill exactly!



**600-10**—the Drake No. 600-10 is ideal for those all important connections when rewiring your rig. Get back on the air fast. Make good dependable connections with this 100 watt  $\frac{3}{8}$ " tip.



**400**—the Drake No. 400 is the perfect iron for work in small places. Only 9 inches long, it is especially designed for tight corners and delicate connections. 60 watt,  $\frac{1}{4}$ " tip.



Ask your nearest supplier or write for the name of the distributor nearest you . . . and give yourself the advantages of these superior irons.

**DRAKE ELECTRIC WORKS, INC.**  
3656 LINCOLN AVE. CHICAGO 13, ILL.

(Continued from page 78)

berg, W3NCJ — Section EC: AVY. New appointments: PAM: BWP. OES: WBM. 144-Mc. activity continues at high level in Erie, where the most active stations are: AAQ, AQY, BHN, GV, KKK, KKT, KLD, KOH, KQP, KZU, LTK, LTN, NBV, NHD, NMP, QKI, QN, RHK, TXZ, WBM, and 9EXW/3. Frequent DX contacts are being made with 2RPO near Buffalo, N. Y. NBV has worked several 144-Mc. stations in Dearborn, Mich., and Buffalo, N. Y. LTN and QKI are experimenting with beam antennas and have been conducting numerous portable/mobile tests from hills near Pennsylvania/New York State Line. New Erie amateurs include LPA, operating 28-Mc. 'phone and LJJ, NMP's XYL. The Radio Assn. of Erie station call is LTK. The South Hills Brass Pounders and Modulators has been reactivated with Ed Lips, pres. LFQ is chairman of the publicity committee. KWN, formerly 8GJM, is constructing 28-Mc. beam. MHQ reports his 400 watts on 14-Mc. 'phone not reaching out too well. BL, formerly BK, is having trouble with 14-Mc. beam antenna. IRK is constructing transmitters for other amateurs. TFW runs 30 watts to 807 final and is using half-wave Zepp on 7 Mc. While on vacation BWP visited 4GVC and 4EWY. UHO has erected 28-Mc. beam job. The Venango County EC, LOF, reports the Fort Venango Mike & Key Club is constructing portable transmitter for emergency work. VQX has 500 watts on 14-Mc. 'phone and two-element rotary beam. LKC is operating 28-Mc. 'phone. LID, operating 14- and 3.9-Mc. 'phone, worked W8SR/VP9 on 3.9 Mc. TWI/4, Oak Ridge, Tenn., operates on 28-Mc. 'phone with 15 watts input to vertical "J" antenna. VYU finds time to work c.w. on 3631 kc. KEW is installing p.p. 35Ts in final. CB has a new receiver. MIE and UVM are on 3.5-Mc. band. LTC reports that 8YA, Pennsylvania State College, is being revamped. LTC has met several amateurs at college, including KCI, KBO, and LNW. HKU has rebuilt his entire transmitter on small metal chassis to eliminate trouble from harmonic radiation. TVA/9 is temporarily operating portable from Atlanta, Ind. TOJ submits ORS net report: Twelve net sessions held, seventeen messages handled, with following stations reporting: KWL, LQQ, MJK, VYU, and TOJ (NCS). Recent call changes include: 3CB/W8CA, 3GV/8GU, 3QN/8QJ, 3LJI/8IOH, 3LOF/8HUL, 3LOI/8IZY, 3KRG/8AIG, 3BL/8BK, 3LFO/8AUC, 3KWN/8GJM, 3UL/8UK, 3KWL/8AOE, 3KQD/8EYY, 3LQQ/8AXD, 3LID/8AEG, 3LKC/8ITF. Traffic: W3MJK 30, BWP 19, TOJ 12, VYU 5, NCJ 4, KEW 2. 73. Ray.

### CENTRAL DIVISION

**ILLINOIS** — SCM, Wesley E. Marriner, W9AND — Post-war ORS renewals: WFS, YTV, and NUF. ZZU celebrated the anniversary of his discharge from the Navy by getting married. CKM is on the air with new HQ-129X and Millen exciter. ZRB and EIP tuned up new 70 foot high 14 Mc. beam at GNU. Activity is increasing on the ILN Net. Frequency is 3765 kc. Get a rock or tune the e.c.o. there and join the gang. NDA reports DX poor in September. Send in now for appointments and renewals. Received SCM appointment on deadline date for report to ARRL. Thanks, and please keep the reports rolling in. Traffic: W9NDA 51. 73. Ws.

**INDIANA** — SCM, Ted K. Clifton, W9SWH — Number one event in Indiana the past month was the 25th Anniversary Banquet of the Fort Wayne Radio Club, held on September 21st at the Fort Wayne Chamber of Commerce. IPEK, ex-9YMV, who was down for the banquet, visited some of his old friends while in Indiana. MKM is leading in the traffic count but he got the card in a day late. All reports should be received by the SCM the 4th of the month. Ervin is moving his traffic on 7 Mc. PMT and FMJ, of Fort Wayne; RCB, of North Liberty; and MBL, of New Castle; are applicants for ORS appointment. MBL is after OES appointment. NGS will be back soon on the QIN. MVZ can work New Haven on 3.9 Mc. now. Purdue has YB back on the air now. The station has been off since the transmitter caught on fire in June. DKR, of Sharpville, has Class A ticket now but no modulator. Look for TRN, of Goshen; on 3915 kc. KMY and PQL are at Valpo Tech. South Bend has formed a new radio club with twenty-five hams attending the first meeting. DUU is new call in Fort Wayne. QLW is still working the choice DX. Zane E. Sprague, formerly UZW of Covington, now is 6UWL at La Mesa, Calif., where he is a civilian instructor for the Navy. 2QLS/9 works North Carolina on 14 Mc. using his bed

(Continued on page 88)

# KEEP UP-TO-DATE ON BLILEY CRYSTALS AND YOU'RE UP-TO-DATE ON

*Frequency Control*

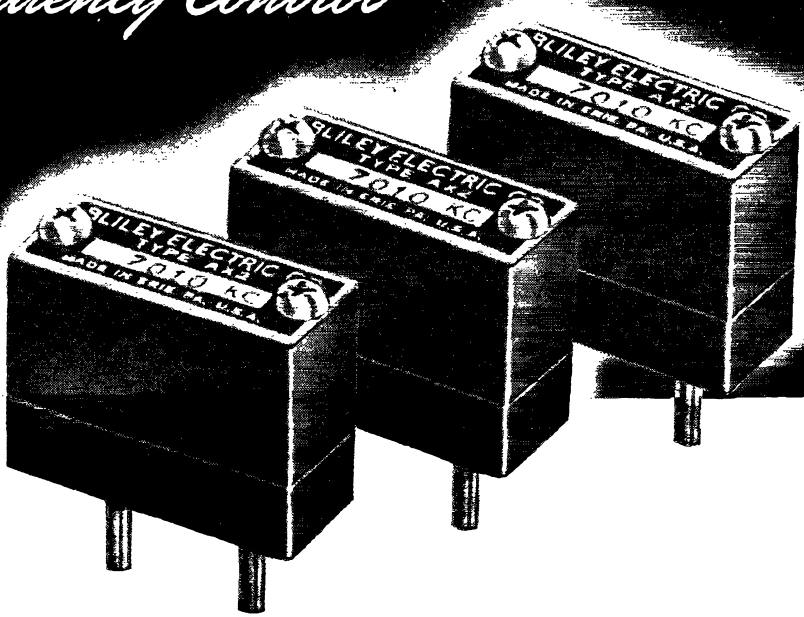

Type AX2, the *first* plated crystal for amateur frequencies, is just one example of the advance design and extra quality you have come to expect from Bliley crystals.

Modern crystal oscillator circuit design dictates low drive conditions for maximum frequency stability. With high activity type AX2 plated crystals maximum frequency stability is easily obtained since less excitation is required to secure necessary output from your oscillator.

Every Bliley type AX2 plated crystal is carefully tested for high activity, frequency precision, and full load conditions. Each unit is made to "Techni-quality" standards by Bliley craftsmen who have pioneered in frequency control for over fifteen years.

Bliley type AX2 plated crystals for the 20, 40 and 80-meter bands are available from your favorite distributor. Ask for a copy of Bulletin 31 which describes these units.

**Bliley**  
CRYSTALS

Type AX2 units, 20-meter band, \$3.95 Each  
Type AX2 units, 40-meter band, \$2.80 Each  
Type AX2 units, 80-meter band, \$2.80 Each

BLILEY ELECTRIC COMPANY • UNION STATION BUILDING, ERIE, PENNSYLVANIA

## TYPE-1000 Antenna Relay

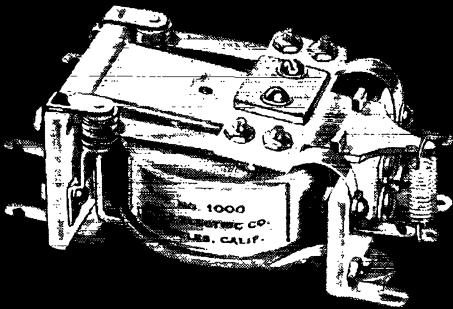

by **ADVANCE**

This sturdy, compact, ceramic-insulated, type "1000" relay makes an excellent antenna changeover relay for transmitters up to 400 watts. Due to its small size it is ideal for use in close spaced open-wire transmission lines. It is well suited for compact marine, aircraft, mobile communication sets or fixed operations. To safely handle R.F. power, high dielectric "Ceramic Steatite" insulation is used throughout. All contact terminals are adequately spaced. All parts are replaceable; no connections are riveted on this model. Available for either AC or DC power—DPDT, DPST and other combinations as desired.

Amateur Net Price (At Your Jobber)  
Type 1000 (As illustrated) \$4.95

Write for Catalog and Price List

# Advance Relays



**ADVANCE**  
**ELECTRIC & RELAY CO.**  
1260 West 2nd Street  
Los Angeles 26, Calif., U. S. A.  
Phone Michigan 9331

## Mass. Radio School

271 Huntington Ave., Boston 15, Mass.

For over 27 years the educational radio center of New England. Prepares for all U. S. Government Radio Operators' Licenses. Also gives Radio Technician Training. Approved courses for Veteran Training under G.I. Bill.

Licensed by Commonwealth of Mass.,  
Department of Education

(Continued from page 80)

springs as an antenna. DLI, of Hobart, is back on the net. NZZ will be unable to be ANCS because of change in hours. NUU is with the Blackhawk Valley boys. The Mishawaka gang met at the home of ONB this month. HUV's best DX is W6OCA/J3. MDX, licensed since Pearl Harbor, has WAC already, using BC-610 with 500 watts to six half-waves on 28 Mc. EHU is building a new final with pair of TZ40s. GZB is on 14-Mc. 'phone. MML and KOP, of Vincennes, are on 28-Mc. 'phone. GZT is new station at Montgomery. He works 3.5-, 14-, and 28-Mc. 'phone. DGC, of Vincennes, is waiting for a new crystal and should be on 14-Mc. 'phone shortly. Plans are being made to get SAL back on the air at Valpo Tech. at new location. YWE has a station back at Knox now with the call of EPZ (YWE is at South Bend). The Fort Wayne Radio Club meets the first and third Fridays of each month. Traffic: W9MKM 22, DHJ 8, ENH 5, UKT 3, HUV 2. 73. Ted.

MICHIGAN—SCM, Harold C. Bird, W8DPE—8FWU reports receiving his Old Timers Certificate. 8NXT has been active during the past month using a three-element beam on 28 Mc. He still is trying to lick 3.5-kc. problems. 8UGR reports that 8YCJ is using a Millen exciter on 3.9-Mc. 'phone. Paul has completed his new rig using 6V6 oscillator, 807 buffer, and 811 p.p. final running about 250 input. 8KOS reports that 8YJU is a new amateur in his city. Bob is using 814 in final working on 7 Mc. and says IAE is working 'phone. 8FX is so busy with QMN work he does not find much time for operating. He reports regularly on QMN. 8SWF writes that he is running QSL Bureau in his town at the request of the local post office. 8WVW reports six-element 28-Mc. beam with three pairs of co-linear elements working good DX in the few days it has been in operation. Ray also is working up a world-wide CAA net. Ex-8QHC now is known as 6UVA in Baldwin Park, Calif., running sixty watts to pair of RK49s on 3.9-Mc. 'phone, also 7201 and 14,355 kc. Curt would like to hear from the Grand Rapids boys. 8KOX reports from Washington, D. C. His call is 3KTR and he operates mostly on 28 Mc. but expects to work 7 Mc. also. Nat would like to contact the Michigan gang. 8WET has been doing a nice job on the QMN net lately. 8IWG is trying to work Asiatics on 28 Mc. 8OCC is rebuilding his band-switching transmitter. 8TRP is trying to get schedules. 8DIV is working 144 and 28 Mc. and reports good results. 8OUI has been tied up with his police work. 8RPM/8 is on 28 Mc. from Lake Orion. 8LDS is working 28 Mc. from Keego Harbor location. 8WYT can be worked on 3.5 or 7 Mc. and would like to hear from the gang. 8ZHB has a new call and is working on 7 Mc. He can be contacted in the early morning hours after midnight. 8PVB reports the following from Rogers City: PVB, BMF, and YBR are playing with 144-Mc. rigs. WVB's big transmitter is being overhauled. DMS reports several amateurs in Alpena starting up. 8ZCI writes from Ludington and asks us for dope on QMN net as he is interested in getting started in traffic work. Well, fellows, now that the season is well upon us and the nets are getting well organized, let's have those traffic and activity reports. Traffic: W8SAY 161, 8DAQ 133, 8SCW 83, 8UGR 55, 8FX 29, 8JUQ 29, 8TRP 28, 8ABH 27, 8WVL 24, 8DPE 18, 8WET 16, 8PVE 13, 8SCL 11, 8KOS 9. 73. Hal.

OHIO—SCM, William D. Montgomery, W8PNQ—All Ohio amateur radio clubs, please send details on your club to the SCM if you have not already done so. Include information on any publications you put out. Also, clubs who have no EC in their areas, please recommend someone for the job to the SCM. ORS and OPS applications are requested. A note to the SCM will bring application blanks. Get on the bandwagon, fellows. Recent ORS renewals include CBI, MPG, QE, AQ, AYS, DAE, LCY, LZE, ROX, RN, SJF, WE, and ZFA. OPS renewals are AQ, EQN, OZH, AVH, CBI, CDR, JFC, NDN, PUN, AYS, PNJ, and THH. QBF has a new jr. operator, born Sept. 13th. THJ reports that he and ICQ represent Piqua's 3.9-Mc. activity, that EGP and ALZ now have their Class A tickets, and that the Piqua Radio Club is really getting back into the swing of things. New officers, according to PFC, are JEL, pres.; NAC, vice-pres.; PFC, secy.; A. Heighton, treas.; and TEH, asst. treas. The club meets every Monday evening, with code classes before each meeting. From "Drips From the Grid Pan" and TAJ, we learn that JJM has a 60-ft. tower under his 14-Mc. beam. LYQ has a new jr. operator. THH has about recovered from his argument with a street car, and reports that his recovery is due entirely to the use of Dr.

(Continued on page 84)

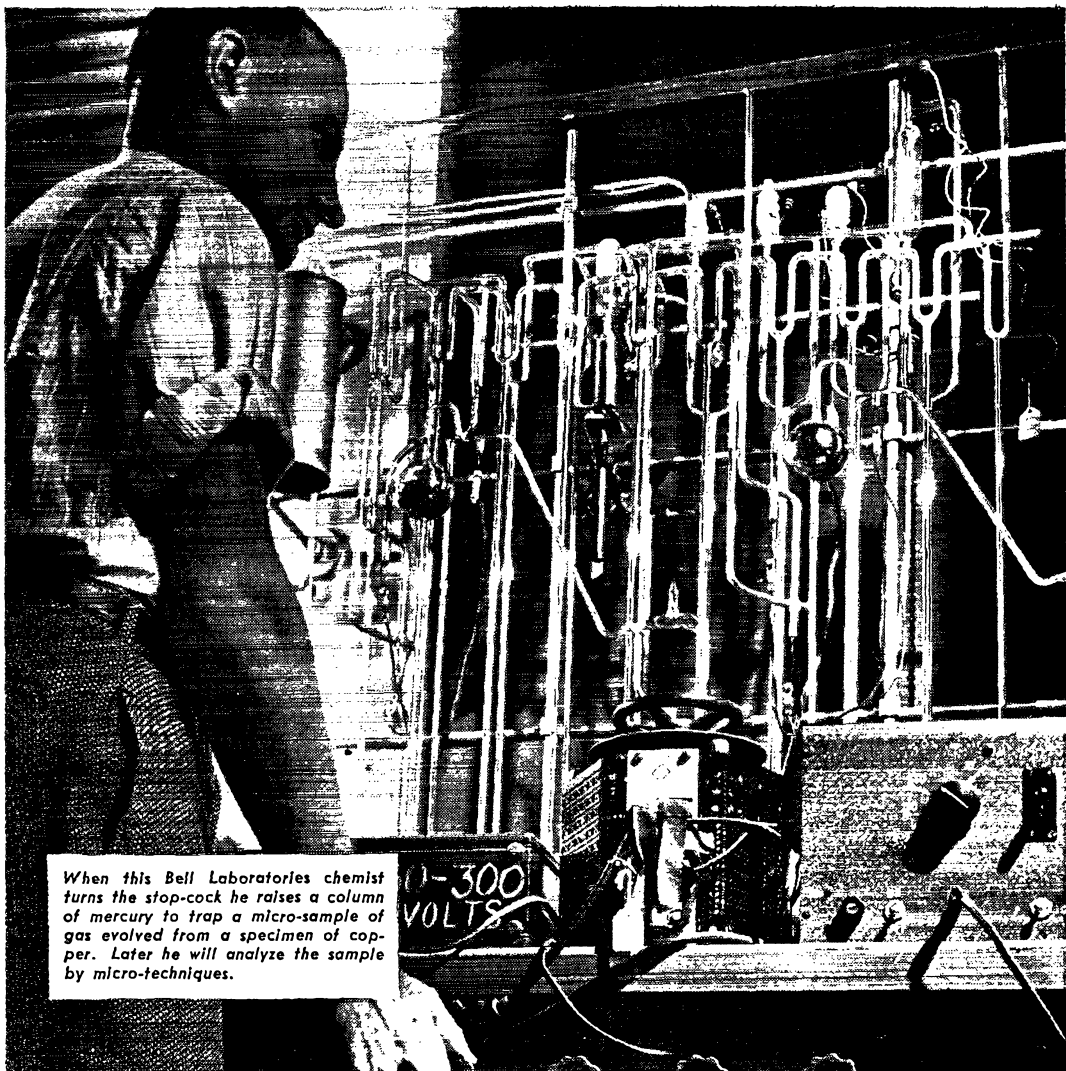

When this Bell Laboratories chemist turns the stop-cock he raises a column of mercury to trap a micro-sample of gas evolved from a specimen of copper. Later he will analyze the sample by micro-techniques.

## **Trapping poisons by micro-chemistry**

Touch of a finger-tip—or even the dust in apparently clean air—can carry enough contamination to ruin an electron tube. Bell System scientists found this out through micro-gas analysis using new and original techniques.

They determined what could destroy the cathode's power to give off electrons, and how much—to the millionth of a gram. Then, with Western Electric, they developed a manufac-

turing technique to keep out these destroyers. Bell Telephone Laboratories scientists established the world's first industrial micro-chemical laboratory more than 16 years ago for the Bell System. Today micro-chemistry is constantly at work, helping to raise still higher the standards of telephone service and performance.

**BELL TELEPHONE LABORATORIES**

*Exploring, inventing, devising and perfecting for continued improvements and economies in telephone service*



*in* **NEW YORK**

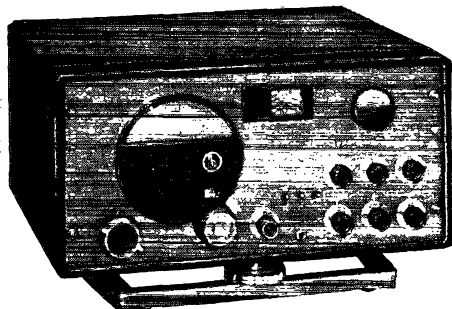

**hallicrafters sx-42**

**\$2500** AMATEUR  
NET

ADJUSTABLE BASE  
MODEL B-42 \$7.50

**TERMINAL RADIO CORP.**

85 Cortlandt St. • New York 7, N. Y.

Tel. WOrth 2-4415

(Continued from page 88)

Meyer's Megacycle Mixer. ZAU reports that ZDA is a new ham in Osborn who would like traffic schedule with Cleveland and Toledo. EQN reports that the Dog House Net had its third picnic near Springfield on Sept. 21st, with EQN acting as temporary chairman. New officers elected include STZ, pres.; TRX, vice-pres.; DZO, secy.; PUN, treas. OG moved his antenna eight feet and that night worked two ZLs. From Cleveland we hear that QV has been elected trustee of the CRA Club, and is looking for help in getting the club transmitter on the air. PWY is vice-president of Assembly Products. JNF and the boys did an overnight job of getting a 28-Mc. mobile rig, complete with antenna, built and installed in the car of 7JGW for his trip West. JFC reports from Hamilton that he finally got a 'phone contact with China, XU1YY, and that YFS is a new ham in Middletown. From the Toledo Radio Club Bulletin we learn that QUO has a new jr. operator. From Cincinnati, MFP reports that the results of the September 144-Mc. Hidden Transmitter Hunt of the GCEN are: First, Clif Schmidt; second, R. Zimmerman; and third, H. Weller. This was the toughest hunt to date, as the finders had to cross the Ohio River, and then talk an armed guard into letting them explore Ft. Thomas. The hiders were PNQ and BCJ. They have been barred from hiding any more transmitters. NDN says that the GCARA kindly donated an automatic key to the Red Cross Outcall Memorial Station of the QCEN. 4NRA, EC for the Cincinnati area, requests that all hams interested in emergency work contact him at once. MGR reports that over sixty-five door and general prizes were awarded to lucky hams at the GCARA stag hamfest Sept. 8th. There were 223 paid admissions to the hamfest, the weather was fine, and a swell time was had by all. JIN, CLM, and FGX are well on their way to the Century Club, with over seventy countries worked apiece. Traffic: WBRN 16, ZAU 14, EQN 13, NOT 9, PUN 7, LCY 2, PBX 2, PNJ 1. 73. *Bill.*

WISCONSIN — SCM, C. C. Richelieu, W9ARE — RQM has new HY75 with 829 Amp. on 144 Mc. CIH, as OO reports thirty-one off-frequency and harmonic discrepancies. NVJ is on 14-Mc. 'phone with "V" beam. EWC had get-together for all the Central Wisconsin gang at his "farm" near Hilbert on Sept. 30th. DDG and HNX are building three-element beams for 28 Mc. LXC is on 14-Mc. 'phone with BCI. UJM and BTA are rebuilding. LFK is new RM. Please get in touch with Carl Thoms, 5460 N. 41st St., Milwaukee, if interested in traffic network. HHM has new narrow-band f.m. unit and has new 28-Mc. rig in car. ANA is mobile 28 Mc. YPP reports the Madison club conducted code and study groups during the summer and as a result, AWO, AWT, BAP, CJO, and YPP received their tickets. HCR, LNM, OME, RBI, RNK, and UFX attended the Hamfesters' picnic at Chicago Sept. 1st. The GROUND-HOGS organized their 28-Mc. ground wave DX group at a get-together at QHR's place in Watertown, Sept. 15th. HCR just rebuilt to 4D32. The Madison Club has provided CTD, a patient at Lake View Sanitarium, with a 28-Mc. rig. FXV, a blind ham in Madison, is working on 28 Mc. Your SCM worked CTD, together with RI, FXV, BAS, and AWO on mobile 28 Mc. while going through Madison. He also worked NRV, fully 35 miles ground wave, with 25 watts input and a vertical whip antenna. GPI has a mobile rig. D4ABK, in Bremen, is John Pettigrew, of Milwaukee, and is eager for contacts on 28.3 Mc. WHZ is Shorewood Hi, active on 144 and 28 Mc. 144 Mc. is attracting big attention in the Milwaukee area with PYM holding consistent 144-Mc. contacts with Valparaiso and Hobart, Ind. BSS is active on 28 Mc. GVL talked on narrow-band f.m. at October 10th meeting of the MRAC. Code classes have started at MRAC. MRAC presented HRM, club secretary, with new Meck 100-watt transmitter in appreciation of his untiring efforts on behalf of MRAC. DXI and GDD are active in Superior. Let's continue these FB reports, gang. 73. *Rich.*

#### DAKOTA DIVISION

**SOUTH DAKOTA** — SCM, P. H. Schultz, W8QVY — South Dakota and Minnesota hams met at Watertown on Aug. 25th to form a new club. BJV was chairman of meeting at which AZE, of Bellingham, Minn., was elected pres.; DKJ, of Aberdeen, S. D., vice-pres.; and EOJ, of Madison, S. D., secy-treas. WKI won a Hallicrafters S-40 receiver. TI and DB were hosts at second meeting. WUU sends in report in reply to request to contact western Iowa and Minnesota hams for emergency net. ZBU reports that ZAL is not in

(Continued on page 86)

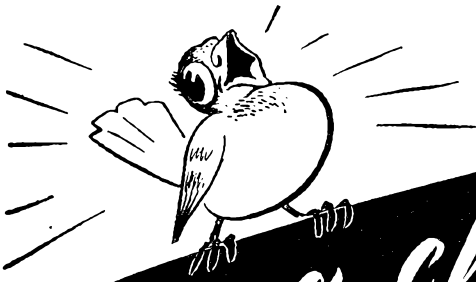

not a chirp in  
a Carload!

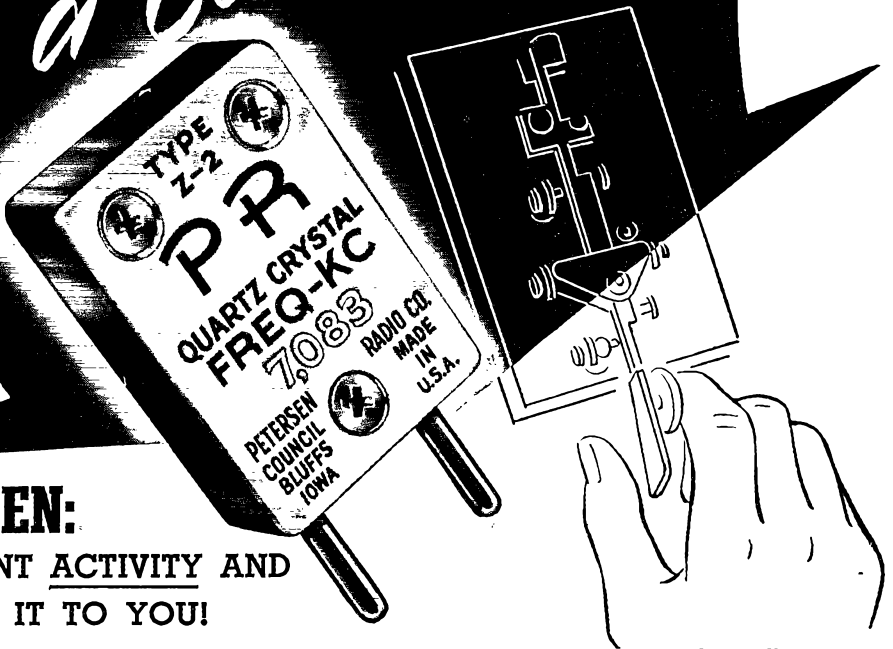

**CW MEN:**  
YOU WANT ACTIVITY AND  
PR GIVES IT TO YOU!

Chirpy signals... due to sluggish crystals... are a thing of the pre-war past for amateurs who insist on PR Crystal Controls. Yes—PRs follow your bug at high speed—on the highest frequencies. You get perfect keying activity without sacrifice of crystal output by excessive "backing off." This means more excitation to the final, higher input potential, more watts in the antenna, better final efficiency... clean keying with the weights off!

PR Crystal Controls are unconditionally guaranteed. Low drift at all frequencies... less than 2 cycles per MC. Accurate within .01 per cent. Exact frequency (integral kilocycle) at no extra cost! Gasket sealed against contamination. Stable under the most severe high power output conditions. Available for ALL BANDS at your jobber now! Accept no substitute! Petersen Radio Company, 2800 West Broadway, Council Bluffs, Iowa. (Telephone 2760)



SINCE 1934

**PR** Precision  
CRYSTALS

**10 METERS**  
PR Type Z-5.

Harmonic oscillator. Ideal for "straight through" mobile operation. High activity. Heavy drive without damage in our special circuit .....\$5.00

**20 METERS**  
PR Type Z-3.

Harmonic oscillator. Low drift. High activity. Can be keyed in most circuits. High power output. Just as stable as fundamental oscillators .....\$3.50

**40 & 80 METERS**  
PR Type Z-2.

Rugged, low drift fundamental oscillators. High activity and power output with maximum crystal currents. Accurate calibration \$2.65



PREFERRED  
BY ENGINEERS

# BURGESS BATTERIES

RECOGNIZED BY THEIR  
STRIPES • REMEMBERED  
BY THEIR SERVICE

(Continued from page 84)

the best of health and has gone to California for an indefinite stay. Several EC appointments have been made and we can use more. Drop me a line. FVB and OEO are new hams at New Underwood. OEO is looking for HP1A trying to contact his brother. He thinks that some 50-Mc. activities from Black Hills clubs would help set up a net across the State. Anyone interested drop a line to ØOEO, at New Underwood. The Bear Butte Amateur Radio Club is latest ARRL affiliate. EOJ visited BHARC. ADJ and YOB have HQ-129s. IWT, GCW, TZJ, OPS, and ANW are at School of Mines. BJV is OPS. 73. Phil.

**NORTHERN MINNESOTA** — SCM, Armond D. Brattland, W9FUZ — This likely will be my "Swan Song" as SCM, for "commuting" between Bemidji and California has taken too much time. I would like to see Minnesota have one SCM of a united Minnesota Section. In completing work as Acting SCM I stress that point. Hope Vern has a chance to take over. Lots of luck. A report from ØCZO says he has 125 watts on all bands. Particularly active at Duluth are ØOOF, ØYUB, 6VTP/Ø, and 9BWE on 14 Mc. WSB has new converter on 28 Mc. YUP has p.p. 812s on 28 Mc. and NRV is a new call there. ØRCT is busy on 7 Mc. YKD has new all-band rig on the air. CWB has new shack. Ex-AZJ, now 1OTN, sends his 73 to the section and MSN gang, and is looking for contacts. KQA is on 14 and 3.9 Mc. Wally Lamb, at Thief River, has call ØPHD and reports YKV has vertical on 14 Mc. FBI is at U. of M. Ex-PTU, a major in the Signal Corps, is 8YDQ. He is one of old AARS faithfuls and hopes to see the gang on 28 and 14 Mc. OOK is building up a rig at Atlanta, Ga., and will be looking for Minnesota contacts. JRI is using his old rig for exciter and is pushing a pair of 250THs. Visiting FUZ at Bemidji this fall were BHY, ZWW, BCT, MSW, and TOX. 73. Army.

**SOUTHERN MINNESOTA** — SCM, Vernon G. Pribyl, W9OMC — ANU is Class A and has new NC-240-D. IXR informs us of the passing of FNH. QIN has a three-element 28-Mc. rotary and is working on 50-Mc. rotary. ZMQ is putting up a folded dipole for 28 Mc. and is working with the Iowa net. PAL and IYB have three-element 28-Mc. beams. HNB has a BC-342 and is active on 3.5- and 7-Mc. c.w. JNC is on with 500 watts to a pair of 813s. 3KAI/Ø, Minneapolis, is building a swell ham shack and service shop in his basement. MBY blew his 812s so ISH sold him a new pair. IXR is active on 28 Mc. FAJ and OMC helped GBZ get up his antenna. The Jackson County Amateur Radio Club net is active. JRI, YXO, SBO, and NCS took a portable rig to a lake near Duluth for a week and worked HC5, HC1, HE2, and a J6 on 7 Mc. and an XE1 and KP4 on 14 Mc. The Minneapolis Radio Club is planning a club station. YXO has a three-element rotary on 14 Mc. and has fifty-five countries. NCS has new 500-watt rig and thirty-five countries and has WAC. BHY and ZWW visited the Fairmont Radio Club. VE4LC visited the Fairmont gang. CYA is on 7-Mc. c.w. OCF is on 14-Mc. 'phone. RPT is active on 3.5-Mc. c.w. The get-together at Rochester was a real affair. VVA got back his old call, ØSW, and has a pair of VT127As in the final and reports he has been heard on 3.9-Mc. 'phone and 3.5-Mc. c.w. in New Zealand. HEO has a new HRO-5-TA-1 and is building kw. rigs for all bands. The Minnesota 3.9-Mc. 'phone band meets every Sunday at 9:00 a.m. with BHY as control station. NCS is net control for the MSN and is scheduling drill for Tuesday evenings at 7:00. Traffic: WØJNC 3. 73. Vern.

### DELTA DIVISION

**ARKANSAS** — SCM, Marshall Riggs, W5JIC — I sure am well pleased with your response in the way of reports each month. Let's have more. EA is getting ready to handle traffic in a big way. ARX has a new shack in his new QTH. AQF is on with p.p. 4-125A. EGY is burning the oil on a p.p. 4-250 rig. KVN and LGH are 28-Mc. fans de luxe. AXP has BC-610 on all bands. AVH and ERD are trying to work some 814s to death. JPY has new beam on 14 Mc. HYS has got an antenna that will take some of the r.f. out of his BC-610. HPL is in the midst of construction. LCO is on 28 Mc. and sure going to town. BMM visited with Texarkana and Ft. Smith clubs. ICS, JIC, BMM, and EA attended Oklahoma City Convention. JIC is a new uncle. He has three-element beam on 28 Mc. How about traffic reports, boys? 73. Marshall.

**LOUISIANA** — SCM, W. J. Wilkinson, jr., W5DWW — HHV is QRL work and has had his appointments cancelled.

(Continued on page 88)



# 50% smaller SAME POWER

## New UNITED Z-225

### Mercury Rectifier

- Saves Power Supply Space
- Solves Temperature Problems

A compact version of the type 866-A with identical characteristics and ratings, UNITED Z-225 is the exclusive solution for power supply problems wherever space and weight factors are of importance. Overall clearance dimensions considered, it occupies less than  $\frac{1}{2}$  the cubic space required for types 866-866A and permits good engineering practice rather than space limitations to govern circuit selection.

In contrast with tubes into which mercury is "dumped," the UNITED Z-225 is entirely free of excess mercury. Casual examination will reveal little or no mercury. Wherever 866-866A tubes are crowded and operating under poor temperature conditions the use of the Z-225 is indicated. In such cases it permits greater space for free circulation of air and consequently cooler operation.

Type Z-225 is another outstanding development of UNITED ELECTRONICS COMPANY—notable producers of mercury rectifiers and graphite anode tubes with the famous "Isolated Getter Trap."

## UNITED ELECTRONICS CO.

NEWARK, 2



NEW JERSEY

Transmitting Tubes EXCLUSIVELY Since 1934

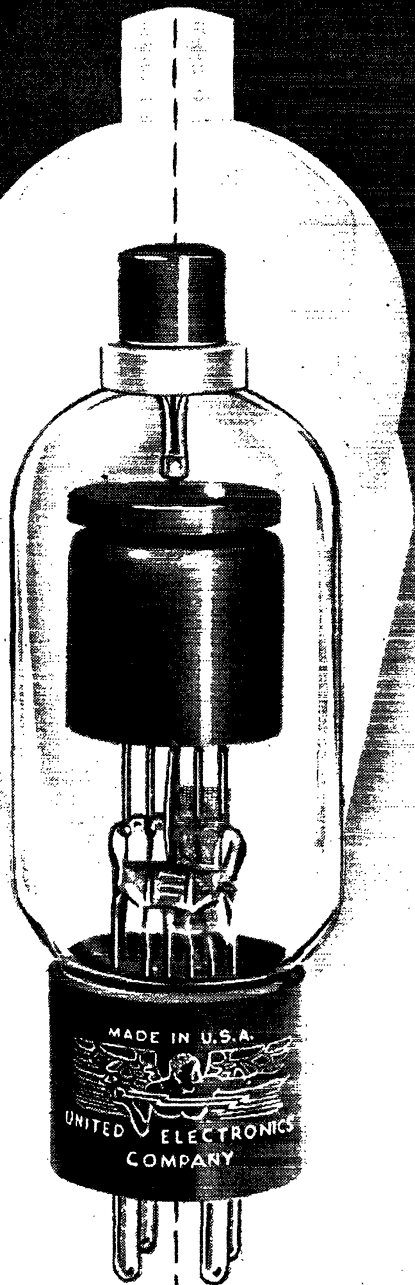

\$1.95 ea.

866-866A silhouettes  
and new Z-225 shown  
actual size.

Filament Rating . . . 2.5 M .5 amp.  
Condensed Mercury Temperature  
—Range 25 to 60 C.  
Supply Frequency up to 150 cycles  
Max. Peak Inverse  
Voltage . . . . . 10,000  
Max. Peak Plate  
Current . . . . . 1.0 amp.  
Average Plate Current . . . . . .25 amp.

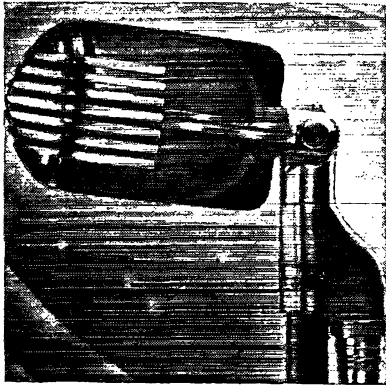

## Does the Shure Stratoliner Crystal Microphone have a high output level?

The Stratoliner Crystal has an output level of 49.7 db below one volt per bar. This makes it ideal for Transmitters, Recording, and other general-purpose use.

## Can the Stratoliner be used for both semi-directional and non-directional pickup?

The swivel head permits pointing the microphone at the source of sound for semi-directional pickup. Pointing the microphone upward, gives non-directional pickup in the horizontal plane. In this position performers can group around the microphone.

## What are other advantages?

The Stratoliner Crystal is equipped with a cable connector which permits quick change of various detachable cables. The high output level permits fairly long lengths of cable to be used. Genuine Bimorph Crystal.

## Is it as expensive as it looks?

The list price is only \$21.35... although its appearance would lead you to believe the price is much higher.

*Crystal Microphones licensed under patents of The Brush Development Company*

# SHURE BROTHERS, Inc.

Microphones and Acoustic Devices

225 W. Huron St., Chicago 10, Illinois

Cable Address: SHUREMICRO



(Continued from page 88)

HEJ and HEK are planning a trip to California using mobile all the way. OVARC will have a booth at Ouachita Valley Fair. HOS has 300 watts and a new SX-25. DXL is building a new rig for EGK. Visitors are welcome at Monroe Radio Club meetings, City Hall, each Thursday. LUU is proud of first VE on 7 Mc. JET is active on 7 Mc. in early morning. KUZ is on 3.9-Mc. 'phone. GND is back on 7 Mc. and has a new HRO. Frank, who is handicapped by blindness, is looking for a call from all of you on 7183 or 7202 kc. KQT is building a California kw. KTE is working on Section Net and KUG wants in on the traffic. QH is working 28-Mc. DX. CEW has been using c.w. on 3.5 and 7 Mc. IOP got a new transformer. LQO is on 7-Mc. c.w. with a new rig. JPJ continues his search for hams to take part in CAP training. CGC has been working plenty on 3.5 and 7 Mc. Ex-5HQN is active on 7 Mc. as 1OJIM. All c.w. men who are interested in Section Traffic Net, drop a line to KTE, R.M. 'Phone men write CEW, PAM. GHF reports following active: BZR, GCS, DXF, AXD, DHE, ACY, KC, BPL, KUZ, FSX, LBZ, JWI, IZO. ZV is running 75 watts on 28 Mc. IXL, JPJ, and IVS are new additions to 27 Mc. LMR has received his ticket. JYK is having modulator trouble. KTK and LLJ are latest additions to 28-Mc. gang. New officers of Delta Radio Club are: HOU, pres.; KTB, vice-pres.; KTK, secy.; KTE, act. mgr.; JPJ, EC. BSR is EC for Lake Charles. JFR will assist him. IYL has new 150-watter. JBW has 750 watts. Traffic: WSDWW 33, GHF 6.

### HUDSON DIVISION

**E**ASTERN NEW YORK — SCM, Ernest E. George, W2HZL — The Adirondack Radio Club of Saranac Lake has opened its doors for business again after three years of inactivity. Meetings are held bi-monthly. Officers are: OWB, pres.; QFA, vice-pres.; QII, secy.; PDF, treas. The Mid-Hudson Amateur Radio Club held a 144-Mc. Field Day at Mount Everett in southwestern Massachusetts. Present were CGT, EDT, KGU, BJX, MZP, DOS, LDS, and IXK. Results were not exciting, but a lot of fun was had. NTJ has been working DX from Mount Beacon. Other end of DX contact from 1LAS/2 reported last month was 2HES/1. Cross district QSO in reverse! The Schenectady Hamfest, held Oct. 5th, was attended by 304. Quite a gang! There was a super-swell list of prizes, too, following a "House of Magic" show. Technical session was highlighted by L. M. Leed's talk on "Antennas." **WARA BAND SPREAD** is the new publication of the Westchester Amateur Radio Association. The club held its hamfest on Oct. 18 at Scarsdale Casino. Beams, rotary and otherwise, are budding all over the Westchester area with up to five elements from 144 to 14 Mc. They're all doing it. Westchester soon will be heard outside of Westchester.

**NEW YORK CITY AND LONG ISLAND** — SCM, Charles Ham, jr., W2KDC — Brooklyn's very active EC, OHE, reports continuing interest and five new stations on Monday evening tests. He can be reached at NA8-6229. The Brooklyn gang sends 73 to PFA, now in W6-land. ODS and BPV remembered radio during vacation, and took handie-talkies with them. Those interested in the 3.5-Mc. net should contact BO. NXT solved antenna problem with a six-element beam. JSJ is going crystal on 144 Mc. NQQ changes from 28 Mc. to 144 Mc. with just two switches. 4GLP/2 did some record work on 144 Mc. AUF prefers mobile operation. In Long Island's largest county, Suffolk, DOG, at Riverhead, continues paper work with the Red Cross. He also has regular Monday evening tests, but they come after band (not spectrum) practical KOA, in Greenport, soon will be on 144 Mc. OQI is ready for anything with 12-volt supply. ADW has lost faith in New York stores; a package supposed to hold an HY75 arrived empty! FCH has never missed a drill. DOG is working on gas engine for emergency power. OEO is on 144 Mc. and many of the gang have worked Pennsylvania and Massachusetts. In Queens, the EC net has stabilized at sixteen full and two supporting stations, made up of fifteen fixed and three mobile. BSP, the EC would like to hear from the gang on forming a 3.5-Mc. net. 9CNU/2 is the latest to be added to the roll call. The County has been divided geographically and includes three nets: green, yellow, and orange. In the Bronx, LNO has been added to the 3.5-Mc. net and all interested stations should be on each Sunday at 3 p.m. on 3.6 Mc. to talk things over. From Staten Island, Asst. EC GHK is struggling with the hills on 144 Mc. and reports AMO is most active, having

(Continued on page 90)

SUPERIOR IN ENGINEERING HIGH FIDELITY IN PERFORMANCE

# The New GATES FM

## 250 WATT TRANSMITTER

*... is here ...!*

This is an outstanding FM Transmitter—in engineering, in design, in performance—assured by GATES "Know-How" of 24 years standing and months and months of pre-testing in the GATES laboratories of those features declared best for FM transmission, which it incorporates.

### ...WITH THESE BUILT-IN OPERATING ADVANTAGES

This Unit provides ALL features you want most. Besides its vertical chassis for easy accessibility, the three-quarter length front and full-length rear doors, plus modern styling, it gives you:

#### DIRECT CRYSTAL CONTROL

... eliminating the necessity of specially designed motors or critically tuned circuits—an important engineering accomplishment.

#### SIMPLIFIED ADJUSTMENTS

Only a limited number of components and controls are used—for simplicity of adjustments and ease of operation.

#### THE BASIC UNIT FOR ADDED POWER

Permits increase of power by the addition of a 1 KW or a 3 KW amplifier constructed in a matched cabinet. Hence obsolescence is obviated.

#### FORCED AIR COOLING

... is used throughout on all power amplifier tubes to secure long life.

#### EXCEEDS ALL FCC STANDARDS

All requirements of the Federal Communications Commission are exceeded by the characteristics of this FM Transmitter.

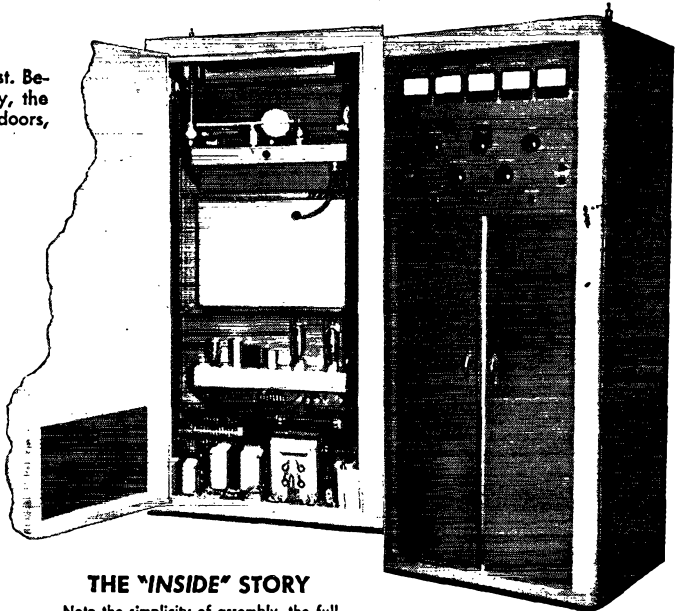

#### THE "INSIDE" STORY

Note the simplicity of assembly, the full length door exposing the inter-unit construction—and how accessible all parts are thus rendered.

#### MODEL BF-250A

The modern, streamlined cabinet is beautiful in appearance with all controls at eye level. Two large doors extending to control Panel, are easily opened. This Unit will add "showmanship" to any Broadcasting Studio.

**GET THE FULL SPECIFICATIONS...!  
THEN PLACE YOUR ORDER!**

NEW YORK  
OFFICE:  
9th Floor, 40 Exchange Place

**GATES**  
**RADIO CO.**  
QUINCY, ILLINOIS

SOLD IN CANADA BY:  
Canadian Marconi Co. Ltd.,  
Montreal

**EXCLUSIVE MANUFACTURERS OF RADIO TRANSMITTING EQUIPMENT... SINCE 1922**

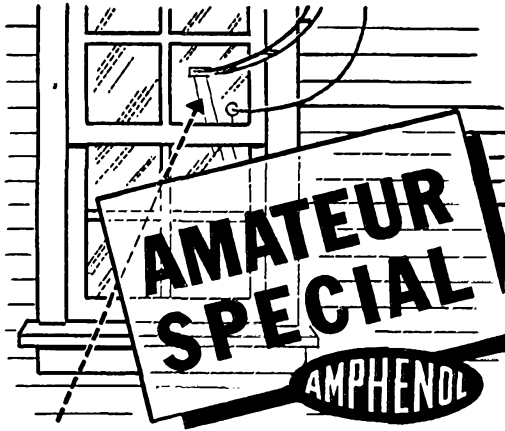

## Clear Plastic WINDOW PANE

● End the problem of bringing your lead-ins through the window. Substitute a sheet of easily drilled, clear Amphenol Polystyrene "912A" for the regular window pane. No more broken glass—no drilling of window sash. Use putty, same as with glass. Easily trimmed to required size.

12" x 16" x 3/32" Sheet  
Clear Polystyrene Plastic

**\$222**  
EA. NET

**AT YOUR DEALER**

AMERICAN PHENOLIC CORPORATION  
Chicago 50, Illinois • Toronto, Ontario, Canada

in **OAKLAND**

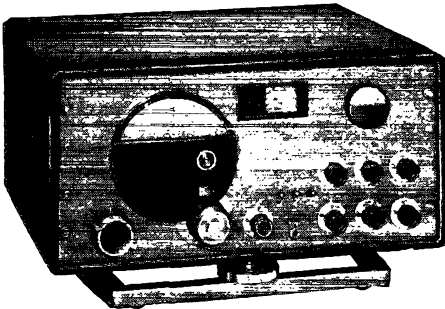

**hallicrafters SX-42**

**\$250.00** AMATEUR  
NET

ADJUSTABLE BASE  
MODEL B-42 \$7.50

**W. D. BRILL CO.**

198 TENTH ST. • OAKLAND 7, CALIFORNIA

W6KLO

W6SSN

W6FJX

(Continued from page 88)

acquired an HQ-129. CF is erecting a three-element broadband beam. FQS moved to Dover, N. J., and QNI is ex-1HQ. GMG is rebuilding and LEC promises 500 watts on 28 Mc. HIY is back from the Coast and OFD has 144 Mc. super. The Queens Radio Amateurs are active again and have elected 2LPJ, pres.; AOD, vice-pres.; and GXC, secy. All communications should be addressed to the latter. 3HVD, of Baltimore, desires to know of a W2 on 3.9-Mc. 'phone who underwent a successful eye operation recently. Contact the SCM. AYJ regularly is on three low-frequency bands. Bob has run into slight XYL trouble, however. JBP is trying a folded dipole on 14 Mc. Arthur Szerlip (LSPH), now on SS *Swishelm* as radio operator, is in Asiatic waters. He listens to W6s and has LU4AJ on board. IXZ is QRL at school but may sneak a QSO or two. Don has thirteen states with rig running from d.c. line. ITX, formerly of Stony Brook, now is at Pleasantville, N. Y., and would like to QSO the old Long Island gang. HBP should be home from the Navy by now, and will live in Elmhurst. NAZ still likes 7 Mc. best, possibly because of her QRN location in mid-town Manhattan. The YLRL has a 28-Mc. round table now and then. Ex-2MNF, now 3JZW, in Washington, is looking for the old gang on 14, 28, or 7 Mc. PRE and SKV have applied for ORS appointment. SNT is using an 807 on 3.5-Mc. 'phone and c.w. Charlie held calls 3UVA, 9JIQ, and 1NBZ before he settled in Flushing. IOP is on 14 Mc. most of the time. Larry has a BC211 as v.f.o. and plans a three-element beam. RQJ is trying narrow-band f.m. on 28 Mc. and works some DX on 14-Mc. c.w. Ex-3GQR/2, now RTQ, is building and has 829B on 28-Mc. 'phone. OWG is working on bigger "tx. and rx." BO worked a J2 and KA1 on 7169 kc. on two different nights. Mac is on practically all night for traffic on 7160 kc. EC is back on T.L.A.P. at 9:30 P.M. Monday-Friday (twenty stations Coast to Coast). HXT is working on 7-Mc. doublet and 28-Mc. vertical. Traffic: W2BO 35, EC 30, IOP 15, IXZ 14, NAZ 13, DOG 5, JBP 2, OWG 2, RQJ 2.

NORTHERN NEW JERSEY — SCM, John J. Vitale, W2IIN — Aast. SCM: NKD. SEC: GMN. COT reports that the Horsetraders' Shindig (50-Mc. boys) was held in New York City with COT, ZD, 3NOH, 1HDO, 4EDD, BYM, AMJ, and seventy-five others. The Somerset Hills Radio Club's annual hamfest was held Nov. 14th. COT has joined the horizontal trend on 50 Mc. with a three-element beam. IZP has appeared on 50 Mc. IEP has regained his old call. PJJ operated an Army BC-187 on 3.5 Mc. in New Hampshire during the summer. FXN, ex-3FXN, is an addition to Northern New Jersey net. CGG reports that more stations are needed, especially in the northern end of the State. A reorganization meeting of the NNJ Net was held in Elizabeth on Oct. 16th at the invitation of the SCM. CJX has been getting his new transmitter broken in. RUH, ex-CEN, is on 144 Mc. LAO/3, of the Navy, is ORS. The MCARA meets every other Thursday at Vail Homes Community House. Newly-elected officers for Union County Amateur Radio Association were installed by SOX, ex-3ABI, Hudson Division Director candidate. They are MUP, pres.; GIZ, vice-pres.; NKD, secy.; LIQ, treas.; and PIX, sgt. at arms. The XYL of PIY was admitted to UCARA membership and was honored by the outgoing president, IIN, on being the one-hundredth member. Every Thursday code and theory classes are conducted at the Elizabeth Y.M.C.A. from 7 to 9 P.M. AEC tests in Elizabeth on Oct. 12th were FB until LKN and his sixteen-element beam broke them up. Those cooperating were IIN, NKD, GMN, PIY, PIX, PDT, Mrs. PIY, ABN, Don Scher, and Al Rupeika. The Elizabeth Fire Department gave us the use of a number of their fire houses. The Inter-City Amateur Radio Association (Tuesdays) in Irvington is reorganizing, headed by FDL. The Bloomfield Radio Club (Wednesdays) meets at Community House. LQP is on 7 and 3.5 Mc. with an 807 final. The NNJ net is on 3630 kc. every night at 7:30. CGG is the RM and is on the same frequency at 8:00 A.M. every day in a net taking traffic for Japan. HXU is on 14 Mc. with 50 watts. BQQ is on 144-Mc. mobile and 14 Mc. AGW is working 14-Mc. DX. NIY keeps schedules with 1UE and is on 3.5 and 7 Mc. PIC is on 7 Mc. running 300 watts. BRC reports sunspots KOed DX on 7 Mc. Those same spots got NKD a ZL MIG, on 3.5 Mc., reports 8WSF/2 now is RTR. GHO is rebuilding a final to his 807. KXD, ex-GI, is using JKH's power. LTP has schedule with EL4A. MWJ is on all bands with 60 watts. Murray Gillis,

(Continued on page 92)

# 3 ways a winner!

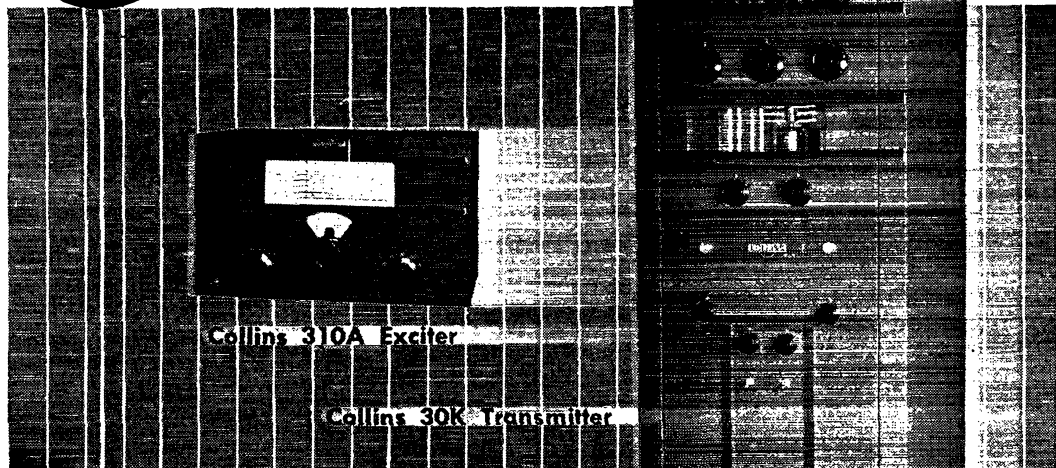

1

**RELIABLE**—The Collins 30K is designed to give continuous satisfactory service on the amateur bands. When you want to go on the air, just throw the switch. The components utilized in the 30K are rugged and long lasting. They are built to back you up when the DX starts coming through.

2

**EFFICIENT and CONVENIENT** — The 30K is designed specifically for amateurs. It utilizes modern circuits and wartime electronic developments. It's easy to operate. The 310A exciter is placed right on the operating desk. PTO (permeability tuned oscillator) control gives you accurate *direct reading* frequency control. The 30K is rated at 500 watts input on cw or 375 watts on phone.

3

**ATTRACTIVE**—Both transmitter and exciter are finished in St. James gray. You'll be proud of their up-to-date, pleasing appearance. They will give a professional look—and performance—to your ham shack.

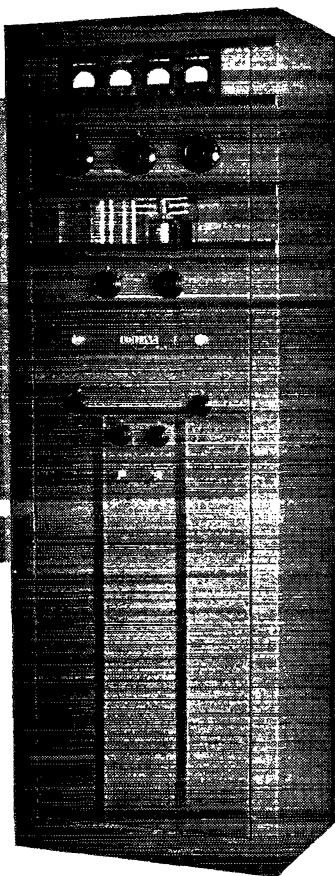

There are several more reasons why the 30K is a winner. For instance, the PTO is accurate to within 2 kc on twenty meters, and the audio circuit contains a speech clipper for more effective modulation. We suggest that you write for an illustrated descriptive bulletin. The 30K and 310A come complete with tubes and interconnecting cable.

FOR RESULTS IN AMATEUR RADIO, IT'S...

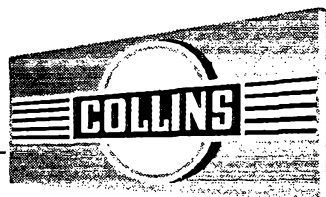

**COLLINS RADIO COMPANY, CEDAR RAPIDS, IOWA**  
11 West 42nd Street New York 18, N. Y. 458 South Spring Street, Los Angeles 13, California

# in CHICAGO

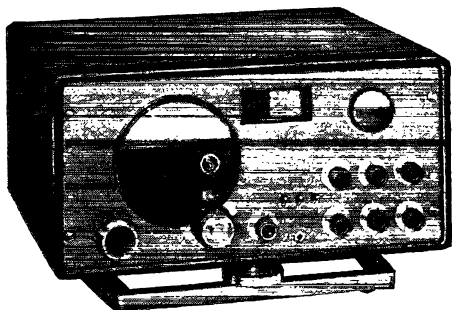

## hallicrafters sx-42

**\$2500** AMATEUR  
NET

ADJUSTABLE BASE  
MODEL B-42 \$7.50

## "CHI-RAD"

415 South Dearborn Street  
Chicago 5, Illinois  
Tel. Harrison 2276-7

(Continued from page 80)

chief operator on S. S. *William W. McKee*, will contact IIN from various ports on the way to Yokohama, Japan, through local hams. 4VA, with Collins, and NAB, with Panoramic, want clubs to get on their mailing lists. A move is in progress between clubs for the exchange of speakers at their meetings. ZD, of Somerset Hills Radio Club, is being scheduled for UCARA, and EUI, of UCARA, will be speaker at Somerset. The SCM, the Assistant SCM, and the SEC, with several traffic-handlers of the NNJ net, will attend meetings of various radio clubs to stimulate interest in the net. Clubs are urged to send the SCM names of the secretaries, meeting nights, and locations. Individuals are urged to submit activity reports and news items of interest. Traffic: W2CGG 58, NKD 33, BRC 6, CJX 4, GVZ 3, IIN 3, BZJ 2, LQP 2. 73. *John*.

### MIDWEST DIVISION

**KANSAS** — SCM, Alvin B. Unruh, W0AWP — A surprising number of the old gang were seen at the Midwest Division Convention in Topeka Oct. 5-6. The noisiest group was the more than thirty members of the 50-Mc. gang, hailing from Arizona to New England. This group was aided and abetted by 1HDQ, of ARRL staff. A note of sorrow was injected into the gathering by the absence of an old familiar face at conventions in the Midwest, that of J. R. Evans of Great Bend. 0DKI passed away the 25th of September. He was one of the oldest of old-timers in the section, and his passing will be keenly felt by his many friends. DVP, formerly of Burlington, Iowa, is working both coasts on 7 Mc. from Ft. Dodge with a 7-watt Signal Shifter. PNN has 807 with 60 watts and had 200 contacts in first month and a half. OUU has HT-9. OZA put up 3.9-Mc. half wave, and now works 28 to 3.9 Mc., c.w. and 'phone. Several reports have been received of fine long haul "local" work on 28-Mc. 'phone during evening hours — distances of 50 to 100 or more miles have been covered repeatedly and four or five cities have been hooked up on round tables. Among the boys doing such work are JBO, TTU, QQT, LOU, and KUU. PKD is OES, and will be heard on 50 Mc. KEI is new ORS in Liberal. John Reinartz addressed a special meeting of the Wichita club. Your SCM finally is getting caught up with his correspondence and will welcome your letters and applications for appointments. Traffic: W0VBQ 41, PNN 10, OZA 3.

**MISSOURI** — SCM, Letha A. Dangerfield, W0UD — ZIS has finished four-element beam and a field strength meter using N34 and 40 microamp. meter. ASG is operating mobile portable from his car. FGR is back on 28 Mc. using his 250THs and five-element rotary. ZJG has been working 3.9 Mc. with a kw. and is getting S7 to 8 reports from Alaska and is building three-element beam for 28 Mc. YHZ reports hearing ham signals on 11.75 Mc. and suggests checking third harmonics from 3.5 Mc. MFN is working 3.5-Mc. c.w. and SPY was on 3.9-Mc. 'phone until the rig broke down. QXO and YSM are helping to organize the Missouri traffic net on 3755 kc. ZVS plans on net operation as soon as he starts working days; he has a small rig on 7 as well as 3.5 Mc. GCL is rebuilding. EYM is DXing on 14, 27, and

### MO QSO REUNION PARTY

Dec. 21 and 22 — Saturday and Sunday before Christmas.

Call — CQ MO for all Missouri and ex-Missouri hams.

Suggest use of 80 and 75 principally, but this is not a contest so try any band you can work.

See how many of the gang, old and new, you can contact. You will find some old friends under new calls in other states.

Do not send in your logs, but let us know how you like it. We might make it an annual event.

73 and have fun at the MO. QSO PARTY.

W0UD Mo. SCM

28 Mc., working 3.9 and 3.5 Mc. also. KNQ moved to Jefferson City and is setting up his station. GBJ is DXing on 14 Mc. NNH and CKK are interested in the traffic net.

(Continued on page 84)

# BUILT TO ORDER

Designers of mobile equipment and amateur vhf enthusiasts asked for this driver tube. The 2E30 (outgrowth of the Hytron development type HD59) is a filamentary-type beam tetrode. Standby current is eliminated. Yet the 2E30 is ready to operate a second after electrode potentials are simultaneously applied.

In vhf equipment, the 2E30 is ideal as a class C oscillator, frequency multiplier, or audio frequency amplifier. Important to you—the 2E30 is a transmitting tube—not just a re-hashed receiving type. Check its versatility and its many features. Quite possibly you will discover that the 2E30 was built to order for you too.



**NOW AVAILABLE  
AT YOUR JOBBER'S  
AMATEUR NET PRICE \$2.25**

## HYTRON TYPE 2E30

Instant-Heating Miniature Beam Tetrode  
GENERAL CHARACTERISTICS

Filament	.....	Oxide coated
Potential, a-c or d-c	.....	6.0 ± 10% volts
Current	.....	0.7 ampere
Grid-plate capacitance	.....	0.5 mmfd
Input capacitance	.....	10.0 mmfd
Output capacitance	.....	5.0 mmfd
Max overall length	.....	2 1/8 in.
Max diameter	.....	3/4 in.
Base	.....	T-5 1/2 min button 7-pin

### ABSOLUTE MAXIMUM RATINGS

D-c plate potential	.....	250 volts max
D-c screen-grid potential	.....	250 volts max
D-c plate current	.....	60 ma max
D-c screen-grid input power	.....	2.5 watts max
Plate dissipation	.....	10 watts max

### OUTPUT—TYPICAL OPERATION

Output, class A <sub>1</sub> power amplifier	.....	4 watts
Output, class C oscillator	.....	7.5 watts†
Output, class C doubler (80 to 160 mc)	.....	3 watts†

†Useful power output delivered to load under normal circuit efficiency. Total plate power output (including power actually lost in circuit and by radiation) is at least two watts higher.

## FEATURES THE 2E30 OFFERS YOU

- Designed, manufactured, and tested for transmitting
- Special testing controls assure interchangeability\*
- Oscillator, frequency multiplier, or a-f amplifier
- Filament power is fully adequate for transmitting
- 1/10 watt driving power for 4 watts output at 80 mc
- 10 watts plate dissipation—surplus reserve for vhf
- Miniature bulb saves space and has low base losses
- Low lead inductance and capacitance—ideal for vhf
- High efficiency at low plate potential—250 volts
- Instant-heating filament—approximately one second

\*For example, characteristics are tested at positive grid potentials.

## TYPICAL CIRCUIT FOR VERSATILE HYTRON 2E30

Extremely Compact Driver Giving 3 Watts to Load at 160 Mc

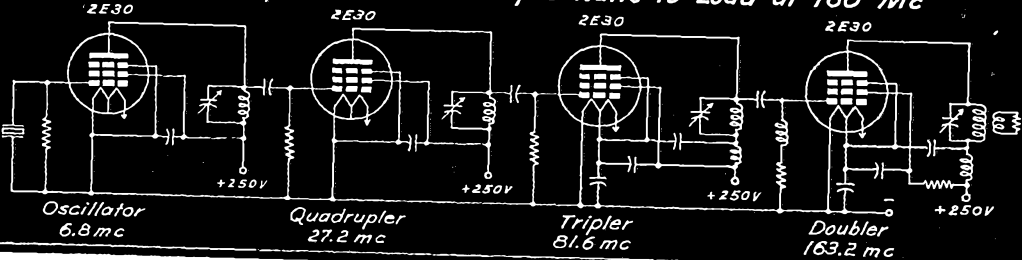

OLDEST MANUFACTURER SPECIALIZING IN RADIO RECEIVING TUBES

# HYTRON

RADIO AND ELECTRONICS CORP.



MAIN OFFICE: SALEM, MASSACHUSETTS

## New Intermediate Type ANTENNA CHANGE-OVER RELAY

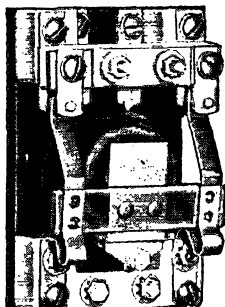

Designed for efficient, automatic transmitter or receiver antenna control. Fully insulated. Double Pole, Double Throw Silver Contacts. Available with fixed or adjustable normally closed contacts. 6 volts DC or 115 volts 60 cycle AC.

Authorized Distributors  
Everywhere

Send for complete Amateur  
Relay Catalog D-111

**WARD LEONARD ELECTRIC CO.**

Radio and Electronic Distributor Division

53B W. Jackson Blvd., Chicago 4, U.S.A.

# WARD LEONARD

RELAYS • RESISTORS • RHEOSTATS

Electric control  devices since 1892

# in OAKLAND

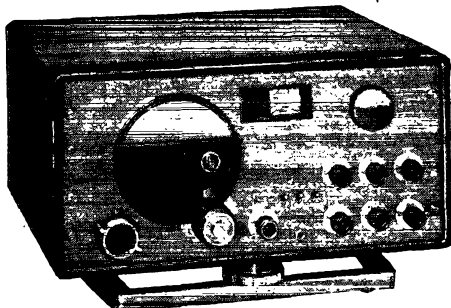

## hallicrafters sx-42

**\$2500** AMATEUR  
NET

ADJUSTABLE BASE  
MODEL B-42 \$7.50

WE ARE PIONEER JOBBERS IN THE ELECTRONICS INDUSTRY

## E. G. WENGER COMPANY

1450 Harrison Street • Oakland 12, California  
Tels. Glencourt 1020 • Enterprise 10105

(Continued from page 98)

LOUD finds that the noise limiter described in May QST protects her ears from her own signal on spot frequency work. Missouri traffic net now meets daily at 7 p.m. CST on 3755 kc. — net call MON. Come and bring your traffic. The MO. QSO Party will be Dec. 22nd and 23rd, principally on 3.5 and 3.9 Mc., but since it is not a contest any band will do. Call will be "CQ MO," and all Missourians in and out of the State are welcome. Traffic: WØGBJ 4. 73.

NEBRASKA — SCM, Arthur R. Gaeth, sr., WØFQB — RQK reports as follows: Those present at recent hamfests were BIW, UBN, DNW, SAI, TMK, LKE, CVC, GPX, BBI, OHU, EXP, RQK, UHT, and YYB. DNW is building an antenna mast. GPX has new HQ-129X. LKE has a new RME-45. OHU and UBN are on 7 Mc. Laurence Geis, our OES, now is ØOKF. EWO maintains schedule with HYR on 3640 kc. TQD reports: DMY built v.f.o.; DI is active with Signal Shifter, 811 final, and BC-348; SQT is active with 6L6 rig; TQD is picking off Europeans and Africans on 28 Mc. during noon hour. LJO squirts 50 watts from an 807 rig into a 65-foot center-fed, tuned transmission line, multi-band antenna, receiver is postwar SX-25. LZO hooked WIAW on 7 Mc. with a 6C5-6L6, 20 watts, and SX-24. MLB reports the gang organizing a radio club in Kearney. ESX is rebuilding rig for 14 and 7 Mc. YDZ plans a 50-watt rig for 7 and 3.5 Mc. FMW has Sky Buddy, dynamotor, 720 volts of "B" batteries, and a 100-watt rig for AEC activity. Special Agent ØØ reports VKT and ZZG planning crystal receiver construction. ZAB has a BC-348Q with a converter for 28 Mc. YMU reports JED has three-element beam for 14 Mc.; DHO is active on 14 and 3.9 Mc.; PDH is on 3.9 Mc. FQB built Twin-Three beam for 28 Mc. ZZG has conduit for three-element beam on 28 Mc. The Southeast Nebraska Radio Club held an informal dinner, with an interesting talk by John Reinartz. LJO was host to an organization meeting of the Hastings Radio Club. GBK, WWV, LZO, UZF, BRO, and LJO were present. The Ak-Sar-Ben Radio Club signed up eight out of ten visitors at last meeting. RM and PAM appointments are available. Traffic: WØTQD 31, ØBQP 11.

### NEW ENGLAND DIVISION

CONNECTICUT — SCM, Edmund R. Fraser, W1KQY — Have you applied for AEC membership? If not, contact your local EC or your SEC, R. W. Woodward, W1VW, 41 Middlefield Drive, West Hartford. Club News: Wallingford — Plans are under way for organizing a radio club. Torrington — BIH reports that organization of the radio club is progressing. KXB is helping new hams to construct their rigs. New Haven — "GB," the NARA celebrated its 30th anniversary of foundation and its 20th year of affiliation with ARRL Oct. 12th. Speakers were: GM, UE, PEK, FWH, BVR, and QV, who acted as master of ceremonies. The committee consisted of KQY, LTZ, JQK, ATH, AMM, and HMZ. The following officers recently were elected: HMZ, pres.; EUG, vice-pres.; ATH, secy.; JQK, treas.; KQY, OKX, and LTZ, directors. Stratford — Joe Diets reports KBZ now is Class A. The SARC has received ARRL Charter of Affiliation. Visitors at SARC were OGS, Bridgeport EC, and JVQ, secretary of Bridgeport Radio Amateur Club, who discussed emergency communications with OQY. The three-element 14-Mc. beam is working successfully at Red Cross Headquarters. General news: KKS writes that OAK has new two-element beam on 28 Mc. ODY has twenty-nine countries on 28 Mc. using 80 watts to p.p. 813s and two-element beam. JPE now is DXU. TD, with assistance from JHN, KQY, KUK, and HMZ, lowered his 52-foot mast, painted and replaced the guys. CTI resigned as EC and RM. VB has assumed duties as RM of Nutmeg Net, appointing UE, LFK, ITI, EFW, and 8HCO/1 as net control stations. These stations report into New England Net at 7:45 p.m. on 3640 kc. Stations interested in traffic handling, please contact Walter Glover, W1VB, Newtown. New ECs: LRT, Norwalk; OGS, Bridgeport; KXM, Windsor and Windsor Locks; KJC, Wethersfield. BGJ is experimenting with beams on 14 Mc. using 813 final. BTU is active on 3.5 and 28 Mc. GSP is having good results on 144 Mc. PEF, ex-6NQY, is running 500 watts to p.p. HK-54s and says within three blocks of him are QV, 700 watts; PEB, ex-KA1CM, 750 watts; MFV, 100 watts; LYV, 125 watts; and IWD, 75 watts; all working on 14 Mc. Can-

(Continued on page 98)



*in* WASHINGTON

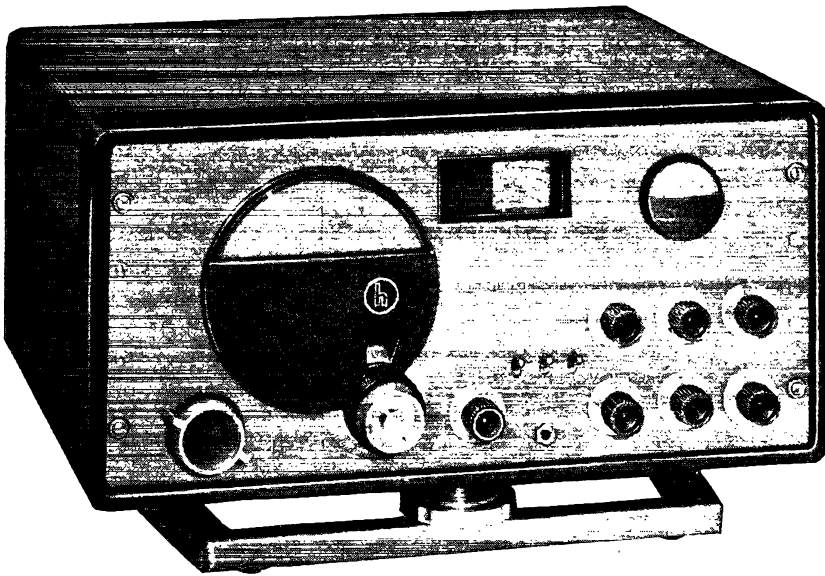

# hallicrafters SX-42

**\$250<sup>00</sup>** AMATEUR  
NET

ADJUSTABLE BASE,  
MODEL B-42 \$7.50

**SUN RADIO**  
OF WASHINGTON, D. C.  
938 F STREET, N. W. WASH. 4, D. C.

# in COUNCIL BLUFFS

One of THE LARGEST  
Radio and Electronic  
Equipment Houses  
IN THE MIDWEST

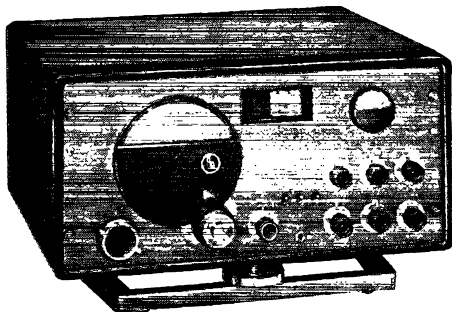

## hallicrafters sx-42

\$250<sup>00</sup> AMATEUR  
NET

ADJUSTABLE BASE  
MODEL B-42 \$7.50

As an amateur, I know your needs. I will give your requests my own personal attention and service. Fast delivery from the heart of the nation. Lowest time payment plans in the country. Write today — Leo I. Meyerson, WOGFQ (Formerly Wholesale Radio Laboratories, Address Dept. QST-12A, Council Bluffs, Iowa).



Formerly Wholesale Radio Laboratories  
Address Dept. QST12, Council Bluffs, Iowa

(Continued from page 94)

cellations: ECs: ALW, EER, and CTI. OBS: EER. RMs: CTI. Appointments: ECs: LRT, OGS, KXM, and KJC. ORS: LKF, CTC, CJA, and NJM. OPS: CTC. OO: AW (Class 2, 3, and 4). Traffic: W1AW 118, UE 84, VB 48, LOP 43, LFK 31, CTI 30, 8HCO 1/26, EFW 20, DAV 9, JMY 6, AMQ 5, ITI 5, ORP 5, TD 4. 73. Ed.

MAINE — SCM, G. C. Brown, W1AQL — OKU and FBJ had a field day on 144 Mc. recently. Both are located in Portland and worked IZY/1, in East Freetown, Mass. and BKR in Westford, Mass., also several stations in Rhode Island and New Hampshire. OKU says that he and JOL will be at the U. of M. this fall. LKP expects to go high frequency this winter. BWB is having his troubles with 144 Mc.; he can't seem to work out of Kennebunk. EZR sends in the following: KYM is back from overseas and has opened up a radio sales and service business. LCM and LWX operate the Marquis Radio Co. KEA is in the radio sales and service business. TO is chief engineer at Augusta's new WFAU. OCU operates York Radio Co. LDN is chief engineer at WCOU, assisted by HUX and LRZ. Ex-ATA has applied for renewal. DBQ has a new HQ-129X and is on 7 and 3.5 Mc. HMS is making plans for 1/2 kw. on 28, 14, 7, and 3.5 Mc. LPA and family are looking for a place to live. LOZ is modulating an HY-75 on 144 Mc. LSK is representative for Radio Service Lab., of Portland, and EZR has a similar position with Radio Supply, Inc., of Auburn. A nice letter was received this month from FV, an old-timer from the spark and galina-crystal days. His rig is a 6L6 pushing a pair of 807s, also an HQ-129X. MGP says that DEG is in Newton Highlands, Mass., on 3.9-Mc. 'phone. MIR is pounding brass on USAT. Joseph Connolly and is on an Atlantic run. CJ is in Malden on 3.9-Mc. 'phone. AKR and QH were in Bangor recently. BUZ has his prewar rig on the air again. Traffic: W1OKU 6, LKP 2. 73. "GC."

EASTERN MASSACHUSETTS — SCM, Frank L. Baker, jr., W1ALP — New ECs: FIK, Lincoln; OBK, Chelsea. New OES: PFL, ex-9UQP, JSM. OBS: OUD. BB renewed his ORS/OPS appointments. EPE and LM have renewed ORS appointments. MRQ is an ORS. Club news: The Brockton Amateur Radio Club started up on Oct. 7th and will meet on the 1st and 3rd Mondays. We are glad to welcome the El Ray Amateur Radio Club as an ARRL affiliate. New officers are: STQR, pres.; Louis Jantsen, vice-pres.; Wally Scofield, secy.; Edward Hayward, treas.; ILS, act. mgr.; LNX, chief engineer. The Eastern Mass. Amateur Radio Assn. held election of officers: HNN, pres.; OLV, ex-3BSY, vice-pres.; MPP, secy.; ILR, treas.; AJW, FSK, and HWC, board of directors. The club meets on the 1st and 3rd Wednesdays at 2 Divinity Ave., Cambridge. The T9 Club met at ISX's shack on Oct. 4th. The South Shore Amateur Radio Club held its first regular meeting with a talk by PFJ, ex-8CLS, on 50-Mc. antennas. New officers of Waltham Amateur Radio Club are: PDK, pres.; GAW, vice-pres.; JOX, secy-treas.; IHL, acting for JOX until Jan. JDU, secretary of the Merrimack Valley Amateur Radio Club, writes that they held an outing at Salem, N. H., with JNU winning an HQ-129X. On 144 Mc.: OQX, LGC, PBM, NME, OGU, AGX, and 9PCN. KTU is on 3.5-Mc. c.w. GOU worked Russia for his postwar WAC. BDU says the New England net on 3.5-Mc. c.w. is coming along, but more traffic is needed. AHP has signed OTP, DHX, JJZ, GDJ, and NXH for the Emergency Corps. OTO, LOU, OJQ, and NYO are on 144 Mc. AHP says that the Fall River Amateur Radio Club will meet in the Red Cross headquarters. KZT is active again on 3.5-Mc. c.w. MTQ writes that the Northeastern U. radio club has started up again with LJW, pres. The Massachusetts Net is active on 3745 kc. again. If interested write BDU. NXT, with a portable rig in Revere, made twelve contacts with his transceiver with an HY-615 and 2 watts input. OKK has a small walkie-talkie on 144 Mc. KMW has one on his bike. AWX has a rig on 10 f.m. on 29016 kc. and is looking for DX. DRL is on and worked across the Mediterranean. OEK has a five-element Yagi on 144 Mc. and has a rig on 3.5-Mc. c.w. IID has 150 watts on 144 Mc. and a six-element beam. IWO has new NC-240. EMG has RK4D32 going again. OMM is building a beam for 28 Mc. LQQ got a QSL from VS9AN. OUD received a card from VR2AB; he has a 4D32 in his rig. ZR has a new Meissner 150 rig and is on 'phone and c.w. on 14, 7, and 3.5 Mc. MRQ has 300 watts on 'phone and c.w. PEJ holds calls in W2, 4, 5, and 6 call areas. ONV worked three new countries on 14 Mc., making twenty-seven. OAD is on 3.5 Mc.

(Continued on page 98)

**When they come across your frequency  
...they'll STOP...they'll LISTEN  
...result QSO**

The clear call of the CARDAX gets attention. Modulation is clean . . . cuts thru QRM. True voice quality makes them *want* to work you. This means more QSO's . . . and more pleasure from your rig.

Designed to give your signal the last db of performance . . . the CARDAX is a deluxe microphone that pays big dividends for DX or rag-chewing.

The CARDAX, Model 950, lists at \$37



# THE CARDAX

The only cardioid crystal microphone with dual frequency response and high output. Ask your distributor or write for Cardax Bulletin.

**ELECTRO-VOICE, INC., BUCHANAN, MICHIGAN**

Export Division: 13 East 40th St., New York 16, N.Y. Cables: Arlab

*Authorized Distributors Everywhere*

Patent Pending. Licensed under Brush Patents.

NO FINER CHOICE THAN

***Electro-Voice***

Send for Catalog No. 101. Gives data on today's most complete microphone line. Includes handy selection guide.

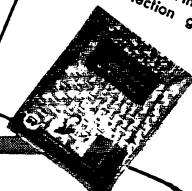

*in* DENVER



**hallicrafters sx-42**

**\$25000** AMATEUR  
NET

ADJUSTABLE BASE  
MODEL B-42 \$7.50

**INTER-STATE RADIO & SUPPLY CO.**

1639 Tremont Pl. • Denver, Colo.

"Denver's Pioneer Radio Distributor"

Established 1921

*in* CLEVELAND

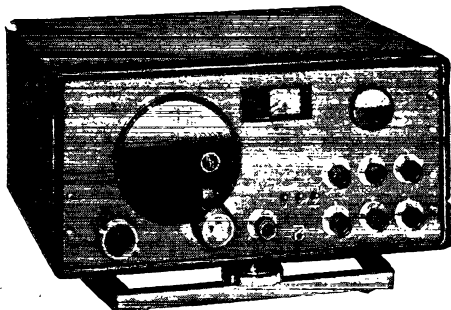

**hallicrafters sx-42**

**\$25000** AMATEUR  
NET

ADJUSTABLE BASE  
MODEL B-42 \$7.50

**Northern Ohio Laboratories**

2073 West 85th St. • Cleveland 2, Ohio

H. A. Tummonds • W8BAH • Tel. WO 2756

Wholesale Radio Distributors

(Continued from page 86)

OJT is on 144 Mc. JXM is on 28 Mc. with 80 watts and three-element beam and has worked G8s and Z8s. KLO, MON, ECX, and MQH are back on 28 Mc. ONB is on 144-Mc. mobile. MBG took a trip to Ohio. KH writes that he now has call 2KH. ORT has been getting out well lately with HT-9 and a new Meissner job owned by ILP. MNF worked some DX on 144 Mc. recently. Thomas H. Hefty, of Oslo, Norway, who is the son of the former president of the NRRL, is going to M.I.T. and would appreciate hearing from anyone who QSOs any LAs in Oslo. Traffic: W1BDU 66, EPE 29; LM 27, KZT 14, NXY 13, EMG 8, BB 6, OUD 6, OEK 5, LID 1, MRQ 1.

WESTERN MASSACHUSETTS — SCM, Prentiss M. Bailey, W1AZW — Well, here you are with a new SCM. I would like to thank all of you who voted for me and wish I could personally shake your hand. I hope I can carry on the good work as successfully as Bill has done for years. JAH also would like to convey his thanks to the boys who voted for him. The Western Massachusetts Net is perking in great style, and with BVR as NCS it is snappy and efficient. After five years of inactivity IJT is on 14 Mc. with 300 watts. FOI reports that JWV has new HT-9. NLL is chief operator at Union College Radio Club. EOB has new receiver. BIV is building e.o.o. so he can report in WM net. NKN reports the Worcester Radio Assn. now is affiliated with ARRL. The Pittsfield Radio Club has moved into new quarters at 84 Wendell Ave. JLT has new 14-Mc. vertical. BKG has equipped a 7-foot model plane with radio control. NGE took the fatal step during the month. LUD, the EC for Pittsfield, has signed up a goodly number of the boys for the Emergency Corps. 8DMW/1 has new call — IPFD. LKO has 300 watts on 14 Mc. MKR is back in Dalton and will be working at G.E. for the next four months. IHI and LTA are active Worcester members of WM net. Traffic is starting to build up in the section and it is gratifying to note that more and more of the boys are reporting into the net. Let's keep it on the increase. How about some of the newer boys coming out? It's a chance to build up that code speed and get some good operating practice. Net is on 3760 kc. Mondays, Wednesdays, and Fridays at 7 p.m. Drop a line to BVR if you are interested. Traffic: W1JAH 24, IHI 22, EOB 20, FOI 14, AZW 6.

NEW HAMPSHIRE — SCM, John H. Stoughton, W1AXL — We still are watching the mail around the first of each month for those reports. What's the matter with you guys and gals? There are over seventy-five hams in this little New Hampshire Section and we receive only three or four reports each month. A pretty poor average we would say. 6WKK, ex-1BLA, reports from California. He is on 28.64-Mc. 'phone and is looking for his old friends in New Hampshire. If we can get a report from the West Coast it seems as though some of the local gang could get that pencil out and give us the low-down on traffic, etc. BWR now is located at Northwood. LCD, of Allentown, is on 7.1 Mc. with a pair of HY51a. He is working for his Class A ticket and expects to be on 3.9 Mc. 'phone soon. 4HMS/1, at Keene, is rebuilding his antenna tuner to make it band-switching from 3.5 to 28 Mc. He has camouflaged the rig so he can sneak it past the landlady! We welcome PFU who has just received his Class B ticket. He is located at Concord and will be on the air with a 35T in the final. We expect to have all the necessary EC appointments soon. Watch next month's report for a complete list. Contact your EC and become a member of the AEC. 30. #4.

RHODE ISLAND — SCM, Clayton C. Gordon, W1HRC — DWO has new Bendix frequency meter and has applied for OO appointment. (Postman's holiday stuff.) 5BKH/1 now is in East Greenwich and formerly was Class 1 OO for North Texas and Western Florida Sections. He will continue as an OO for our Section, concentrating mostly on 14-Mc. observations. 2IUQ, formerly of Far Rockaway, L. I., now is 1MIJ, of Providence, operating on 7, 28, and 144 Mc. He works for EZW. OJW is a new ham in Providence. He has joined the NAARO and is active with p.p. 6L6s 60 watts on 3.5 and 7 Mc. CPI has new Temco kw. band-switching job on 3.5, 7, 14, and 28 Mc. and complains that South County is neglected in these reports. How about you South County fellows forming an association down there and appointing a secretary to collect the news and send it in once a month? INU is new ORS and wants to organize an R. I. net. QR is receiving some fine compliments from the Nutmeg Net on his faithful attendance. EZW is on 144 Mc. with TR-4.

(Continued on page 100)

*Listen*  
...it's a  
**Jensen**  
SPEAKER!

RA-151 REPRODUCER

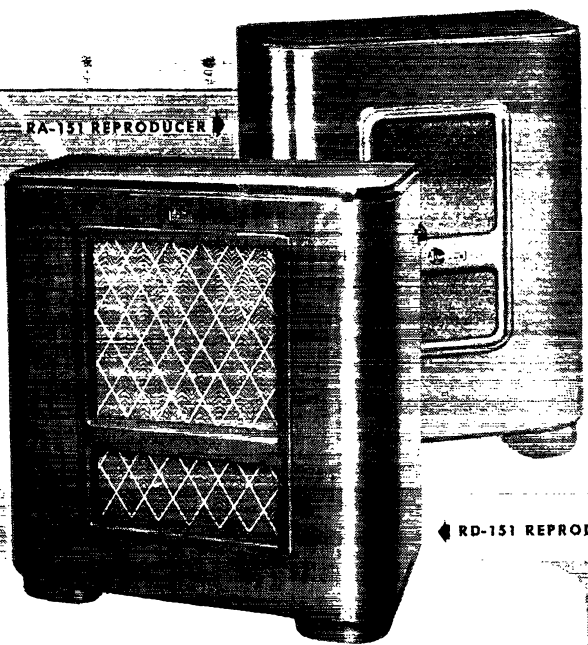

RD-151 REPRODUCER

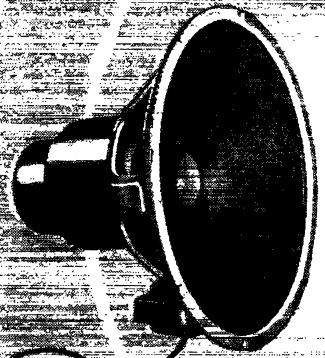

WITH  
HIGH-FREQUENCY  
RANGE CONTROL



Jensen High Frequency Control gives you the kind of reproduction you want when you want it... all the way from two-way system high fidelity to conventional single speaker performance. Now you can adjust for best results on every program, every record, every type of service.

**Now you can hear ALL program material at its best with the new JENSEN Coaxial Reproducers**

- ★ Two articulated, coaxially mounted speakers
- ★ JENSEN Bass Reflex\* Cabinets for full low register
- ★ High-Frequency Range Control for all-purpose flexibility
- ★ Beautifully styled walnut and utility cabinets
- ★ Built-in Frequency-dividing Network

\*Trade Mark Registered

Never before have you been able to buy such performance . . . such versatility . . . at so low a cost. JENSEN now brings you the ultimate in reproducers with top performance so fine, so nearly ideal acoustically that obsolescence is eliminated for years to come. Yet you can instantly adjust response for most pleasing results with every type of program material in use today. Ideal for professional and home use for FM-AM reception and monitoring, transcriptions, commercial phono records . . . for practically every moderate-level high-quality application.

JENSEN MANUFACTURING CO., 6611 S. Laramie Ave., Chicago, U.S.A.  
In Canada: J. R. Longstaffe, Ltd., 11 King St., Toronto



**Jensen**  
SPEAKERS WITH

*Designers and Manufacturers of Fine Acoustic Equipment*

**ALNICO 5**

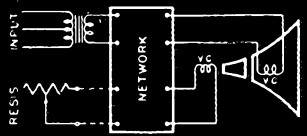

Separate coaxially-mounted speakers for low and high frequencies, with integral two-channel network. (Range control not shown.)

USES "2-WAY" PRINCIPLE



JENSEN  
BASS REFLEX

Acoustically-correct Bass Reflex Cabinet gives smoothly extended low register. Better than an "infinite" baffle . . . efficiently uses back radiation too.



in **PHILADELPHIA**

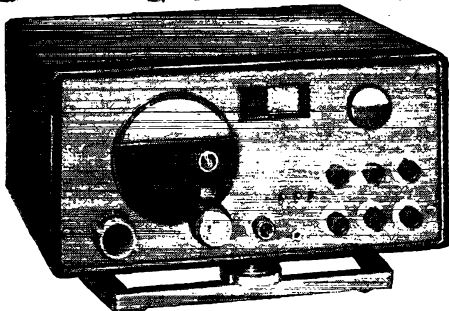

**hallicrafters sx-42**

**\$25000** AMATEUR  
NET

ADJUSTABLE BASE  
MODEL B-42 \$7.50

**Radio Electric**  
SERVICE CO. OF PENNA., INC.

7TH AND ARCH STREETS, PHILA. 6, PENNA.  
Branches at 5133 Market St. and 3145 N. Broad St., Phila.  
Also in Wilmington, Del., Easton, Pa., Allentown, Pa. and  
Camden, N. J.

in **MADISON**

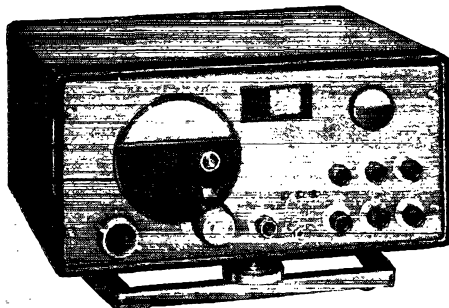

**hallicrafters sx-42**

**\$25000** AMATEUR  
NET

ADJUSTABLE BASE  
MODEL B-42 \$7.50

**SATTERFIELD RADIO SUPPLY**

INCORPORATED

326 W. Gorham Street • Madison 3, Wisconsin

Tel. Fairchild 1643

(Continued from page 98)

PCQ is on 28 Mc. and wants you to know it is Doc. Davenport. Our OO comments in his report that he is most concerned about the great number of 'phones on 3.5 and 14 Mc. that crowd the edges and have side-bands outside the amateur frequencies. Traffic: WIDWO 16, QR 15.

VERMONT — SCM, Gerald W. Benedict, WINDL — 4DZV/1 now is 1PAL and is ORS. PAL is building new 807 final. NNW is new 'phone in Rutland. AD has new 144 Mc. beam. We need one or two more OOs for Vermont. AVP is doing excellent work as OO. The Vermont Convention was very successful for the short time available for preparation. No more reports this month, gang, simply because you did not send them in. 73. Jerry.

#### NORTHWESTERN DIVISION

ALASKA — SCM, August C. Hiebert, K7CBF — The Arctic Amateur Radio Club is sponsoring code and theory classes in the Fairbanks High School building, with club secretary DT (an XYL if you please!) and CBF giving code, 5KPY/KL7 alternate, and 7IWM/KL7 giving theory. GLD, believed to be the only Alaskan Eskimo amateur, passed away last month in Pilot Point. The newly-arrived Task Force Frigid at Ladd Field is organizing a company station for State-side traffic-relaying purposes. The call, temporarily at least, will be 5LEF/KL7, under whose direction the station is being installed. DB, at Valdez, reports interest in a traffic net on 3.5 Mc. along the southeastern coast. The well-known XYL/OM team at Ugashik, HUT and HAI, now has new KL calls, AX and AV, respectively. Two new operators are working out of GBF on all bands, 7HUC and 6QYR. CQ reports State-side contacts on 3.5 Mc. with his HT-9. Traffic: K7CF 15. 73. Augie.

IDAHO — SCM, Alan K. Ross, W7IWU — New ORS is JMH. New EC is 5CAJ/7. The Gem Traffic Net is in operation Mondays, Wednesdays, and Fridays at 9 p.m. MST on 3743 kc. JMH is RM and NC. ECs, ORS, OPS, OBS, and OOs are needed. It is suggested we all supply ourselves with the booklet, *Operating an Amateur Radio Station*, which gives valuable information on operation and qualifications for the various SCM appointments. Who is active on 50 Mc. and below? 5CAJ/7 is building up 75 watts crystal-control on 144 Mc. FOF wants the DX to look for him around 29 Mc! DOH is on 27 Mc. K7ENC/7 was heard on from Weiser. DKM is back from the Navy. CUG is increasing power. AVP travels around the State and picks up some reports for me. K7HMI is in Jerome. ABK is busy with bus station. BDL works for KSEI. ACD flies his own plane. Report in, fellows. We all want to know what you are doing. The Gem State Radio Club, Boise, meets the first Wednesday of each month. Traffic: W7JMH 20, IWU 5. 73. Alan.

MONTANA — SCM, Al Beck, W7EQM — Section EC: BWH. Twelve members of the Butte Club attended dinner in Meaderville with F. E. Handy as guest. GTE has gone to Adak, Alaska. FEE is on 3.5-Mc. c.w. IVI is moving to Denver. EJF has a new rig. CPY paid the Butte boys a visit. FIN is new Billings secretary. The Billings club reports thirty-three members, nineteen licensed. EJD is operating on 7 Mc. IRN has only a rotary beam in Billings. IWW is building kw. job for 28, 14, and 3.9 Mc. JLD and HVB are rebuilding. Thanks, gang, for FB reports. Traffic: W7EDJ 6. 73. Al.

OREGON — Acting SCM, Cliff Tice, W7BEE — On the trip through Bend, BEE looked up Carl Austin and the XYL, HHH. QP of Klamath Falls, was contacted and promised to send data on activities there. JAA sent in a comprehensive report on Salem. The Salem Amateur Radio Club has been reorganized with the following officers: AXJ, pres.; DZT, vice-pres.; GBW, secy-treas. Former K6CIB, now near Salem, is W7JKU, and the Salem members enjoyed a picnic at his ranch near Lyons a short while ago. Another newcomer, 9QHV, is working 3.9-Mc. 'phone evenings. Two of the Salem bunch show what amateur radio can do; 7FRT and 7KDU are both blind. ASG is increasing power to a kw. FMX is using a new rotary beam on 14 Mc. and GBW has a new jr. operator. ARZ has moved to Hood River, and AWE has received his old call back. JAA and the XYL, with AGZ, went to Yellowstone Park and took along a 144-Mc. rig in the car. 7FBX reports nine hams in Forest Grove, three quite active. They are FBX on 7 Mc., 9ZOU/7 on 14 Mc. with a half-kilowatt and a rotary beam, and HDY on 14 and 28 Mc. BUS and BDN, in Pendleton, have

(Continued on page 102)

One of the Most Versatile  
 "HAM" Transmitters Yet Offered

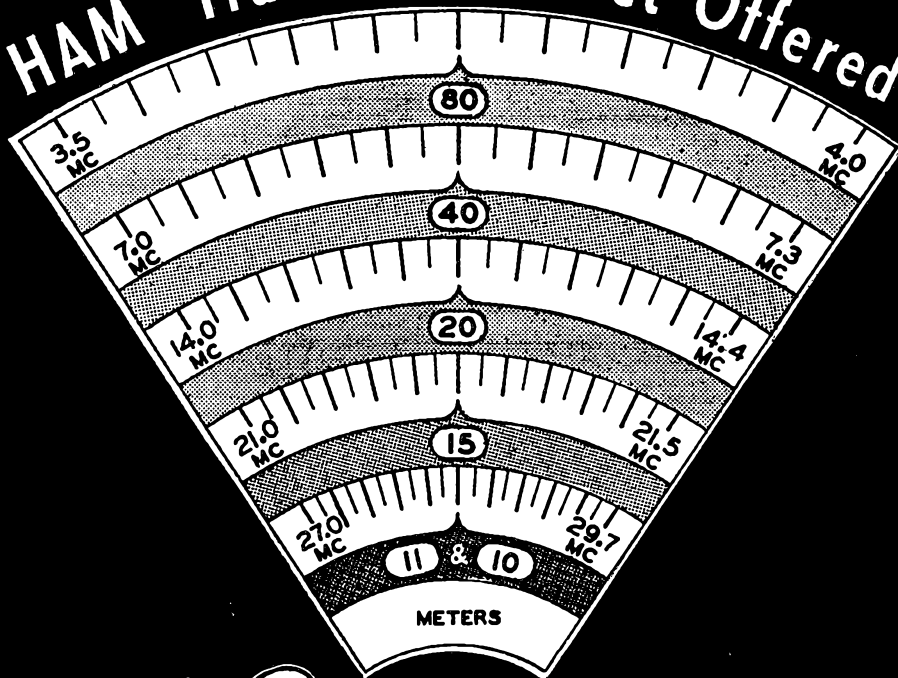

*Supreme*

Built for  
 the Present - - -  
 and the  
 Future

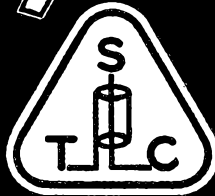

Price  
 \$450.00  
 Complete  
 with Tubes  
 and Coils

MODEL AF-100

6-BAND AMATEUR TRANSMITTER

100 WATTS — AM, FM, CW AND ICW

Write for detailed information and Catalog

**SUPREME TRANSMITTER CORPORATION**

260 WEST ST.

NEW YORK 3, N. Y.

# in HARTFORD



## hallicrafters sx-42

**\$250.00** AMATEUR NET | ADJUSTABLE BASE MODEL B-42 \$7.50

### R. G. SCELİ & CO.

317 Asylum St. • Hartford, Conn.  
Telephone 2-1144

# in SAN FRANCISCO

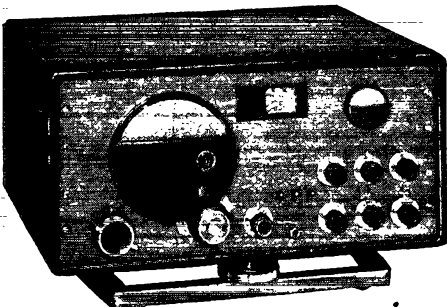

## hallicrafters sx-42

**\$250.00** AMATEUR NET | ADJUSTABLE BASE MODEL B-42 \$7.50

### ZACK RADIO SUPPLY CO.

1426 Market Street • San Francisco, Calif.

(Continued from page 100)

surplus Army rigs revamped and are working 7- and 3.5-Mc. c.w. The activities of BUS may be slightly restricted for a while because of a little local QRM — a baby girl born a short while ago. KR is getting a real ham shack fixed up. BKD is on 28 Mc. occasionally. JOG has his license and is on 3.5-Mc. c.w. IMS has moved to Salem to work at KSLM. FPT is on the air. MQ and the XYL, GPO, keep the new transmitter hot most of their spare time. BEE worked 28-Mc. mobile locally in Everett, where he visited recently. 73. *Cliff.*

WASHINGTON — Acting SCM, Lloyd Norberg, W7EHQ — Tate has dropped the reins and put the bit in my teeth. With your cooperation I can keep it going. A vote of thanks to Tate for a splendid job well done. Hereafter send reports to EHQ at Steilacoom. Appointments: EOP, HAD new ECs. RT works 144 Mc. and is looking for contacts. ETX and DSZ are shooting for Century Club on 14 Mc. DXZ, QSL Bureau, 5023 So. Ferry, Tacoma, wants envelopes from the DXers. He doesn't want stacks of W6, W9 cards to distribute. DGN is on 3.5 Mc. with fifty watts. HAD reports the Bremerton gang is reestablishing the club. DP reports CBN is on 3.9 Mc., DRD and ERO are getting some choice DX, and EQN's XYL has new call, KCU. JBH reports FXD on 3.9 Mc. BBP has new HT-9 but no coils. CZY reports GHZ, JFB, JFC, FXD, JKB, JXY, DYD, DF, IOQ, EUX, CSK, and CZY are on 144 Mc. SQ has new HT-9 on 28 Mc. HPU is mobile on 28 Mc. and is working for ETX. IMB is back farming. CMX is secretary of APCO. IGM's XYL, Manila, has new call and new rig. Vashon Island is Radio Island. Listen on broadcast band or 28 Mc. FUL is on with 6L6. FID, AQB, and CKZ divide the 14-Mc. 'phone band. FYO is mobile on 28 Mc. CGL has a pair of 450Ts in final. Look out, California! SCM visited IGM and Manila and saw the six-element reason why he gets out on 28 Mc. KAT is on 28 Mc. with new HT-6. Please send in more reports. Traffic: W7CZT 7. 73. *Lloyd.*

### PACIFIC DIVISION

HAWAII — Acting SCM, John F. Souza, jr., KH6EL — The Hilo Amateur Radio Club had a bang-up shack warming on Sept. 11th and initiated their new club house donated by KH6EJ, ex K6N2Q. Among those present were: K6SNP, K6KDV, KH6EJ, KH6EX, ex-K6NPE, K6MML, KH6AU, ex-K6EDH, and KH6EL. K6MML and KH6FE, ex-K6OQM, are on 28 Mc. KH6FE, ex-K6OQM, has new custom-built all-band Windsby. K6ROJ, the old standby on 28 Mc., is KH6FD. KH6BW is trustee for KH6DF, Navy Electronics School Amateur Radio Club. KH6DF has facilities available for operation and experimentation on all bands up to and including 10,000 Mc. Code classes are in full swing. Rigs used are: Navy TCS (65 watts) on 7 and 3.5 Mc., BC-610 on 14 and 7 Mc., Navy TBS on 28 Mc. with 200 watts being built for 28 Mc. A Navy TDT (50 watts out) is all set for 144 Mc. KH6EW is building e.c.o. K6SDM is using home-built "Band-Spotter" crystal calibrator. KH6CT, ex-K6IQN, schedules G stations nightly on 14-Mc. 'phone. K6ICL is converting BC-610 for 28 Mc. 73 and Aloha. *Johnny.*

NEVADA — SCM, N. Arthur Sowle, W7CX — Asst. SCM, Carroll Short, jr., W7BVZ. RM: 7PST. ECs: 7JU, 7TJY. Asst. EC: 6OPP. OBS: 7JUO. OES: 7TJL. 6IAJ and 7TKV, using battery-powered equipment, recently worked a lot of DX from Mt. Charleston. The best was 3JBB, Maryland. Southern Nevada AEC is active. Applicants are invited to contact 7JU, ex-6MRT, or 6OPP. 7MWF has 6L6G crystal oscillator and is getting out FB. He reports 7JSD, 9WTW/7, 6DVJ, and 7RXG are active in Las Vegas. 7ONG has a pair of VT127As but only 200 watts on them; he also has a new Super Pro and an FB all-band e.c.o. 7BXD expects to be on with a pair of 35Ts. He has an Army surplus receiver to supplement his Bretting. 7JOU, ex-W6GSB, has a new NEVADA kw. final and expects to help put Nevada on the map in the SS. 6AIJ is active on 7 and 14 Mc. 7JU is completing his p.p. 803 final. 7BVZ is looking for a BC-610. All of the above from Southern Nevada. The rest of the State take note. 7CX is in the new shack and has a pair of 55-footers. Traffic: W7CX 7. 73. *Art.*

SANTA CLARA VALLEY — SCM, R. E. Pinkham, W6BPT — Assistant SCM, Geoffrey Almy, 6TBK, PAM: QLP. LFD put up a 72-ft. wooden tower for his rotary beam. OKQ is working Europe and Africa with R9 reports on his new 14-Mc. beam. 1WV/6 now is a full-fledged W6.

(Continued on page 104)



“Мы разсуждали об американском оборудовании”  
 “We’ve Been Discussing American Equipment”



**K**

**KEN-RAD  
TUBES**

For more and clearer QSO's



THE friend in Moscow you've never seen will query you on behalf of his group, "Are American receivers as efficient as we hear? How is DX on the various bands?" His signal, travelling thousands of miles, will be clearer because of the Ken-Rad all-metal tubes you're using. *War-tested*, the Ken-Rad features of compactness, short lead lengths, and self-shielding design now are available to improve your rig's performance. Type 6SK7—popular high-gain receiving tube—is one of many efficient, stable types about which your Ken-Rad distributor or dealer gladly will give you complete information.

**Characteristics of Type 6SK7**

Heater voltage	6.3 v	Max screen voltage	100 v
Heater current	0.3 amp	Amplification factor	1,600
Max plate voltage	250 v	Transconductance	2,000 mhos

176-EG-8850

**KEN-RAD**

DIVISION OF GENERAL ELECTRIC COMPANY

OWENSBORO, KENTUCKY

Type 6SK7

**\$1.20**

Make the nearest Ken-Rad distributor or dealer your preferred source for amateur tubes

# PRE-EXAM TESTS

For Commercial  
Radio Operator

## FCC LICENSE EXAMINATIONS



### Don't Take A Chance!

Avoid Failure On FCC Commercial Radio Operator License Examinations!

Use NILSON'S COMPLETE PRE-EXAMINATION TESTS AND COACHING SERVICE

Enables You to

REHEARSE the FCC license examinations • PRACTICE the procedure • PRACTICE the multiple-choice examination methods used by FCC • CHECK your knowledge • LOCATE your weak points • CORRECT your weak points before taking the actual examination  
Prepared by Arthur R. Nilson, Famous Co-Author of Nilson and Horning's Radio Questions and Answers.  
Use Coupon or write for Descriptive Folder  
No obligation

### CLEVELAND INSTITUTE OF RADIO ELECTRONICS

Successors to Nilson Radio School, founded 1939;  
Smith Practical Radio Institute, founded 1934.

QT-12 TERMINAL TOWER

CLEVELAND 13, OHIO

### CLEVELAND INSTITUTE OF RADIO ELECTRONICS

QT-12, Terminal Tower, Cleveland 13, Ohio

Gentlemen: Please send information about Pre-Exam Tests.

Name .....

Address .....

City .....

## in DENVER

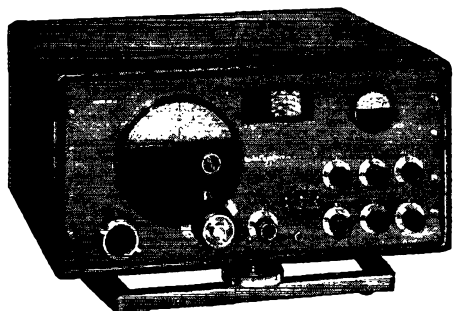

### hallicrafters sx-42

\$25000 AMATEUR  
NET

ADJUSTABLE BASE  
MODEL B-42 \$77.50

### RADIO PRODUCTS SALES CO.

1237—16th Street • Denver 2, Colo.

Tel. Cherry 6591

(Continued from page 108)

His new call is 6ZZ, 7IKU/6 also has his new call. Lee now is signing 6WUI, CFK still is trying to load his folded dipole on 14 Mc. TBK and 9FAV/8 made a trip to Fresno with RBQ to attend the hamfest given in honor of F. E. Handy. RBQ has become a member of SCCARA. While on vacation DZE went fishing and hunting, and we don't mean for DX. NX is working 28 Mc. portable-mobile with FB results. ZZ expects a BC-610 soon. Watch Miles work DX. JYQ now has a Class A ticket. LCF is QRL teaching school and hasn't much time for 14 Mc. LXA is erecting a dural tower for his 14 Mc. beam. LZL is working for Jennings Radio. DBK is building a bigger and better 100 Mc. oscillator at EI's Lab. TBK won the prize for being the oldest ham at Marin Hamfest. The SCCARA had an FB booth at the Santa Clara County Fair in September. The Club plans many activities for the coming season. It is planned to start a code class, find a permanent meeting hall, and sponsor a contest of interest to all its members. Anyone in the Santa Clara Valley interested in radio is invited to join the SCCARA and enjoy the privileges that go with membership in an amateur club. Traffic: W6DZE 10, TBK 9, ZZ 3. 73. Pinky.

EAST BAY — SCM, Horace R. Greer, W6TI — Asst. SCM, C. P. Henry, 6EJA. SEC: EE. RM: ZM. EC: QDE. EC: u.h.f.: FKQ. Asst. EC, u.h.f.: OJM, OO: u.h.f.: ZM. OO: ITH. OBS: TT, IDY, ZM, ITH, RMM, UZX, AKB. AED and IKQ are putting up new four-element rotary 14 Mc. beams. PB has new three-element 14 Mc. beam. BUY, with the help of GPY, PB, TI, and OCZ, tuned up his new three-element 14 Mc. rotary beam and it now works FB. VBJ is getting to be an old rag-chewer on 3.9 Mc. 'phone. UHM has new four-element rotary 144-Mc. beam. QLH has his new four-element rotary for 14 Mc. up and it sure looks FB. RCE has converter in car and Stancor 10-P on 28 Mc. 'phone. KPO is building new portable rig for country home, 1 kw. with pair of 4-250THs in final. KQK has new rig with same tubes in final. ZM is home and getting around FB. GPY now is on radio project 11,003. JLM is in new QRA at last. IJA has 9 watts portable-mobile on 28 Mc. TT now has seventy-five countries since the war. DUB is getting to be a big DX man on both 'phone and c.w. WP has new 500-watt rig on 28- and 14-Mc. c.w. and 'phone with pair of 35Ts in final. CRF has new four-element 144-Mc. beam up but not much luck yet. EOL is starting new club in Vallejo. NRM is designing new v.f.o. for all c.w. bands. KEK worked four Europeans on 14-Mc. c.w. with his 807 final. ITH is getting new countries right and left on all 'phone bands. EJA has a TR-4 on 144 Mc. The University of California is starting a new radio club for registered students and will sign W6BB. NRM has a BC-348Q receiver with an 807 in a final transmitter with 30 watts and is a new ORS appointee. A nice letter was received from J2EAR reporting that he is on 28 Mc. and off 14 Mc. because of the collapse of his 475 foot "V" beam. CLZ reports that Venezuela is the place to hear DX but he can't get on the air and hopes to be back in California soon. WGO reports that he received his license on Aug. 31st at 3.40 P.M. and was working a W2 by 3.56 P.M. with 25 watts with the filaments still cold. TI is giving 7 Mc. a try. Let's get in those reports. Traffic: W6ITH 24, CRF 15, NRM 10, TI 6, KEK 4, EJA 2. 73. "TI."

SAN FRANCISCO — SCM, Sam C. Van Liew, W6CVP — Phone JU. 7-6457. Asst. SCM, Joseph Horvath, 6GPB. RM: RBQ. ECs: DOT, KZP. OO: NJW, WB. OBS: FVK, KNH, DJI, OZC, BYS, ORS: RFF, BIP, ATY, RBQ, CVP. OPS: OZC, NYQ. NYQ is giving up hamming for the building trades, project, and summer home near San Jose. He has a good radio location with plenty of power leaks. KNH finds time to build 144-Mc. crystal-control rig for home location. DOT, now on 7-Mc. c.w., has new 348Q receiver. NJQ is back on 14-Mc. 'phone. Ed O'Meara returned to the fold with transmitter on 3.5-Mc. 'phone. TKI is running super power on 14 Mc., 5 watts. Stan Johnson threatens to return to the air. WN has new HRO receiver. MZ again is using his right fist for sending, the broken wrist is OK now. The WB, NYQ, DOT, and MZ community is going to be blest with another happy addition. LGN is moving nearby. ONT is on Wake Island. K6MV, ex-W6MV, soon will be on and is eager to contact his many friends in this area. He sends his best regards to all the gang. JP is back in San Francisco after six years in the Army. He is employed in the Electric Dept. of the P.G. & E. He has a new HRQ receiver and for the present may operate from QTH in Los Altos. KP6AB and KP6AA are leaving for Palmyra, where

(Continued on page 108)

*in* **NEW YORK**

## MATCHING SPEAKERS

R42 \$25.00 — R45 \$27.50

Adjustable Base for  
"Eye-Angle" Tuning — \$7.50

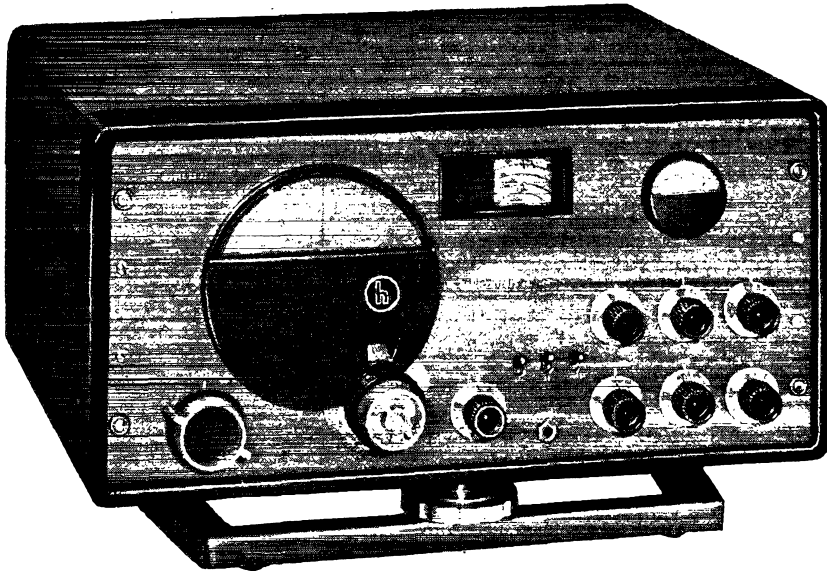

Send your name,  
address and  
remittance to  
me, NOW for  
quickest deliv-  
ery to almost  
any part of the  
world!

73 de

*Bil Harrison,*  
W2AVA

# hallicrafters SX-42

**\$250<sup>00</sup>** AMATEUR  
NET

ADJUSTABLE BASE,  
MODEL B-42 \$7.50

## HARRISON HAS IT!

**HAM  
HEADQUARTERS**  
*Since  
1925!*



**HARRISON RADIO CORPORATION**

12 WEST BROADWAY • NEW YORK CITY 7

BARCLAY 7-9854

JAMAICA BRANCH — 172-31 Hillside Ave. — REPUBLIC 9-4102

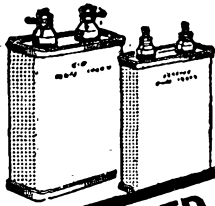

10 MFD.—1000 volts,  
No. 17A268.....\$3.95  
4 MFD.—1500 volts,  
No. 18A227.....\$2.94  
Plus 20c each postage  
and pkg. charges.

## OIL FILLED • HI-VOLTAGE CONDENSERS

### EXTRA SPECIAL VALUE

Limited quantity of these fine condensers with ceramic insulated terminals. Place your order at once.

## 18 YEARS IN RADIO

Latest developments in radio and electronic parts and devices, newest "Ham" gear, gadgets to delight the heart of the experimenter, bargains in selected war surplus radio items. Some of the best values we have offered in our 18 years in business.

### WRITE FOR CATALOG

Get on our mailing list and receive our bulletins and catalogs as issued.

**BURSTEIN-APPLEBEE CO.**  
1012T McGee, Kansas City 6, Mo.

in **CHICAGO**  
in **NEW YORK**

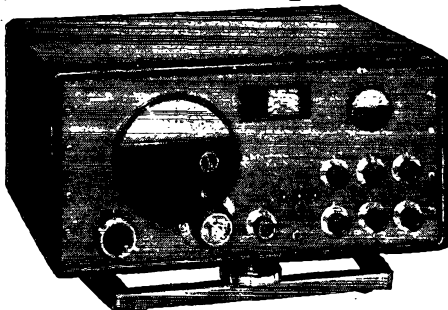

## hallicrafters sx-42

\$250<sup>00</sup> AMATEUR  
NET

ADJUSTABLE BASE  
MODEL B-42 \$7.50

NEW YORK  
Offices & Warehouse  
242 W. 55th St., N.Y. 19

**NEWARK** CHICAGO  
323 W. Madison St.  
Chicago 6, Ill.  
**ELECTRIC COMPANY, INC.**

New York City Stores: 115-17 W. 45th St. & 212 Fulton St.

106

(Continued from page 104)

they will operate under these new calls, and are anxious for schedules. BIP has been working portable W7 in Tonopah. He has finished his job there and now will operate from home QTH. VQB is proud possessor of second harmonic — a boy, his first. Now watch those v.h.f. records go with the aid of the jr. operator. RBQ is on Trunk Line Atlantic-Pacific Monday, Tuesday, Wednesday, and Friday at 8 p.m. Bill is our Route Manager and those interested in traffic nets should contact him. WB has been handling traffic from Wake Island on 14-Mc. 'phone, also traffic with J9. The San Francisco Radio Club held its monthly meeting Sept. 27th. Ex-K6SMP, now W6SMP, gave a swell talk on antennas and methods of feeding. Tom is a consultant engineer and antennas are a specialty. The club approved a motion by a good majority to affiliate with the League. The Marin County Radio Club's annual Hamfest was a huge success. Nearly 600 hams, wives, children, and friends attended. Sports, Bingo Games, and dancing were provided, in addition to the strictly ham activities. A fine list of prizes was distributed to the holders of lucky tickets, including two BC-375 transmitters, a Millen exciter unit, a 250TH and 4-260A transmitting tubes, and nearly a hundred more fine prizes. The Marin County Radio Club provided radio communication for the annual dipsea, cross-country race of Sept. 8th. Portable rigs on 3.9-Mc. 'phone were used with good results. OEI is completing a new home in Santa Venitia. RTH, AP photographer, recently returned from photographing the Bikini atom bomb tests. OZC has a new OBS appointment as well as a new four-element rotary beam. PVC is on 28 Mc. with a BC-610. GFW is working mobile on 28 and 144 Mc. In the first twelve months of activity after the war OZC has had 4019 QSOs. Both the San Francisco Radio Club and the Marin Radio Club have a membership of well over 100. GPB, president of the Marin Club, and MZ, president of the San Francisco Club, have been doing a swell job. Traffic: W6BIP 50, WB 36. Sam.

### ROANOKE DIVISION

**SOUTH CAROLINA** — SCM, Ted Ferguson, W4BQE/  
**ANG** — Thanks to the members of the Charleston Amateur Radio Club for an FB "fest" on Sunday, Sept. 1st. Nice going, fellows. New officers of Palmetto Amateur Radio Club, Inc., of Columbia are: FMZ, pres.; FAV, vice-pres.; BEN, secy. & treas.; BQE, trustee. A new club in this section is the Sumter Amateur Radio Club, Sumter, and officers are: GFP, pres.; HSM, vice-pres.; GTW, secy. and treas. The SCM and SEC visited this club recently and found them up and coming. We had an enjoyable time. GFP is EC for the Sumter area. HJR is a regular 7-Mc. guy. Thanks to EZF for nice letter and dope. FNS still is trying to get his 3.5-Mc. c.w. net going. How about giving him a lift, fellows? GCW is regularly on 3.5-Mc. c.w. GUZ, XYL of EZF, is tracing bugs in her 807 final. JEF is EC for Aiken area. CZA has been appointed RM for the Eastern Section of the State. Give him your support, fellows. BQE has his B-25 beam going with full rotation and change of angle of radiation. KGX is Columbia's newest ham. Welcome, George, to the fraternity. HMG is sporting a new 28-Mc. beam atop an FB pole and is becoming a c.w. hound. Gang, your SCM would appreciate a report from you. He certainly cannot read your minds and to put you in this report he needs to read your cards and letters. Let's have 'em and thanks, gang. Traffic: W4HJR 2, 73. Ted.

**VIRGINIA** — SCM, Walter R. Bullington, W4JHK — EOP came out second in the first postwar ORS Party. Congrats, Chas! JAQ is new ham in Phoebus. His 20-watt rig is doing fine on 3.5-Mc. c.w. KCM got his SX-28 peaked up and now is on 7 Mc. hunting DX. JHK is rebuilding. AGH is on 3.9-Mc. 'phone. CYW is experimenting on 50 Mc. and has two West Coast contacts to his credit. IZC just received his 1st-class radiotelephone, 2nd-class radiotelegraph, and Class A licenses. Congrats, Ed! IMP is studying optometry at Ohio State University. BZE is getting the bugs out of his new band-switching exciter. He also is new secretary-treasurer of the Richmond Amateur Radio Club. ITK is on 3.5-Mc. c.w. with an 829 final. The SCM wants reports from the Norfolk and Roanoke clubs and all ORS and OPS. Let's fill up our space next month. Traffic: W4EOP 15, 73. Monk.

**WEST VIRGINIA** — SCM, Donald B. Morris, W8JM —

(Continued on page 110)



● To enjoy this hobby to its fullest extent means keeping your rig up to date and in good working order. Amateurs, the world over, have long used and enjoyed the dependable and highly efficient performance of Astatic Crystal and Dynamic Microphones. When repairing or modernizing your present equipment, examine Astatic's many fine microphones with desirable voice range characteristics. Included are the old favorites and new streamlined models with excellent qualifications for ham activities.

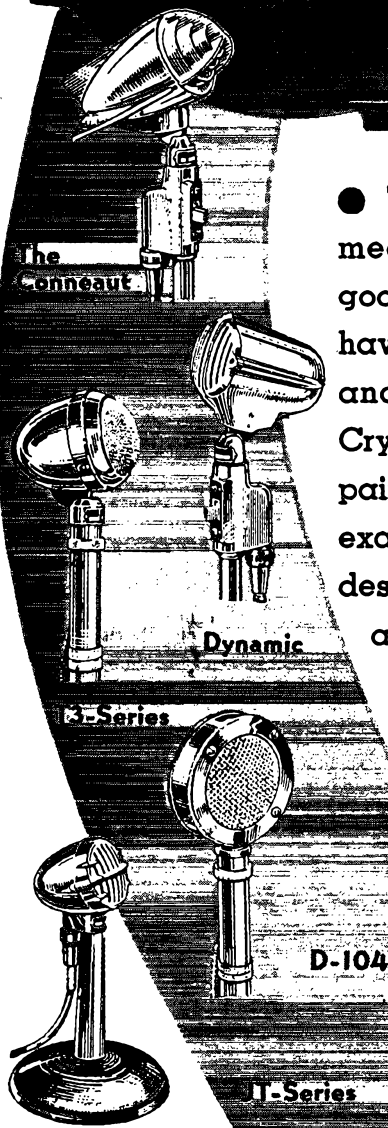

**THE Astatic CORPORATION**  
 CONNEAUT, OHIO  
 IN CANADA CANADIAN ASTATIC LTD TORONTO ONTARIO  
 Astatic Crystal Devices Manufactured under Brush Development Co. patents.



# Newark has what

SELECT FROM THESE GIFT SUGGESTIONS

If He's a radio ham, you'll make a "gift-hit" with any of these items. Look them over. Tell us what you want. Our huge stocks and prompt service will assure delivery before Christmas.

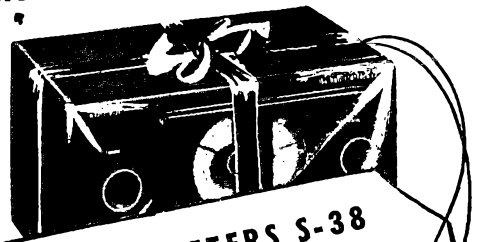

## HALLICRAFTERS S-38

A now famous and popular Hallicrafters receiver. Four tuning bands, 540 kc to 32 Mc. Self-contained PM dynamic speaker.

**\$39.50**

Model S-40 at 79.50



## N-C 46

A National receiver that has plenty. Four coil ranges cover from 550 kc to 30 Mc.

**\$97.50**

Speaker  
Model NC-240D with speaker **240.00**  
National HRO-5TA-1, complete with pack and speaker. **306.71**

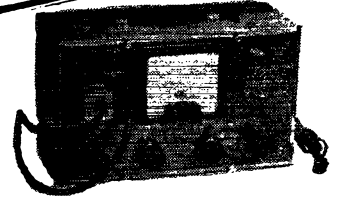

## VOMAX V. T. V. M.

Universal multi-meter with frequency range of 20 cycles to over 100 Mc. Newark has full line of Silver and other standard makes of test equipment.

**\$59.85**



## HAMMARLUND HQ-129X

Another fine Hammarlund receiver. Full range 540 kc to 31 Mc. Patented variable crystal filter.

**\$173.25**

Super-pro SPC-400 SX 1.25 to 40 Mc.

**310.05**

SPC-400X .55 to 30 Mc. **342.00**



## RME-45

Top selectivity and sensitivity. 550 kc to 33,000 kc. Five amateur bands. Xtal filter.

**\$198.70**

*he wants for a Merry Xmas*

DELIVERY GUARANTEED BY CHRISTMAS

**HALLICRAFTERS SX-42**

Great new Hallcrafters receiver. Covers from 540 kc to 110 Mc continuously in six bands. Limited quantity available for immediate delivery.

**\$2500**



**NEWARK CRYSTALS**  
Swell gift package—a set of 3 assorted Newark crystals for \$2.40 postpaid. 88 cents a piece. Select from our QST ad, October, page 91.

**GON-SET CONVERTER**

For fixed or mobile use—Gon-Set 10 meter. converter. Complete bandspread.

**\$3995**

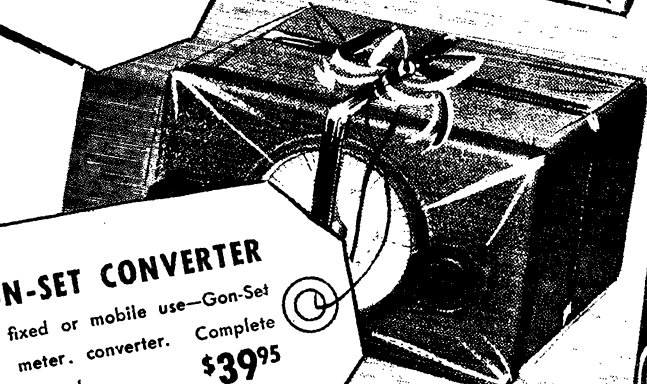

Newark has a bagful of appropriate gifts for the radio ham. Make him happy at Xmas by getting him something at Newark Now!

*Also Available*  
**For Immediate Delivery**

- Panadapter ..... \$ 99.75
- Abbott-TR-4B (less tubes) 52.00
- National 1-10A (less power supply and speaker) ..... 67.50
- Meck, Model T60-1 Transmitter ..... 150.00
- SONAR FM Exciter..... 39.45
- TEMCO 75-GA Transmitter ..... 495.00
- Millen Exciter Model No. 90800..... 37.50
- HYTRON HQ-75 Kit wired ..... 11.95
- NEW BLILEY CCO Crystal Controlled Oscillator ..... 69.50

★ MAIL ORDERS  
FILLED WITHIN  
24 HOURS!

★ We have many more items that will make ideal Xmas gifts.

**NEW YORK** Offices & Warehouse 242 W. 55th St., N.Y. 19  
**NEWARK** ELECTRIC COMPANY, INC.  
**CHICAGO** 323 W. Madison St. Chicago 6, Ill.

New York City Stores: 115-17 W. 45th St. & 212 Fulton St.

★ Newark carries complete stocks of radio and electronic parts.

\$2

# FIRST

FOR THE  
GREATEST NAMES  
IN  
HAM RADIO



Here they are—the newest Post-War "Ham" Receivers with all the latest improvements in technique and design.

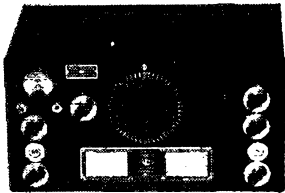

**NATIONAL HRO-5TA-1 • Net \$274.35**  
697 Power Unit \$20.36 • MCS Speaker \$12

A Receiver, designed for the Amateur, to provide dependable communications, under most severe conditions. New Noise Limiter incorporated. Band spread on all "Ham" Bands—Coverage 1.7 to 30 MC.

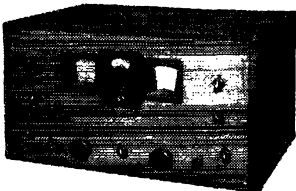

**HAMMARLUND HQ-129-X • NET \$173.25**  
Price Includes Cabinet Speaker

A "Ham" Receiver with the professional touch, providing flexibility of operation. Six bands for easy location of stations. Has all "Ham" features with sensitive and stable performance.

**HALLICRAFTER S-40 • Net \$79.50**  
With Built In Speaker

Performance and beauty are combined in this outstanding Receiver value. Many circuit refinements never before available at this price. Electrical Bandspread Dial—Coverage 540 KC to 43 MC.

HAM RADIO SUPPLIERS SINCE 1919

# CAMERADIO CO.

963 LIBERTY AVE. • PITTSBURGH 22, PA.

(Continued from page 106)

New officers of Charleaton Radio Club are: LS, pres.; SHU, secy.; HI, VAN, SHU, and CFB, board of governors. CSF has completed new receiver for f.m.-a.m. reception in the v.h.f. bands. LXF has new RME-45 and put a message into Morgantown from the Marshall Islands. LII has new HQ-129 and likes traffic work. VAN completed new 28-Mc beam which the gang says "is a honey." TDJ/SPY reports several 50-Mc. contacts with stations in Ohio and Pennsylvania. MOP has installed three new antennas and is active on all bands. GBF, BTV, and JM visited hams in Princeton and Bluefield, attended Fayette Radio Club meeting at Montgomery, and visited with CFB at Clay. DFC has new transmitter and new antenna poles and is active in the 3770 Net. New stations: YDN, near Elkins on 3770 kc. YPR, Princeton, on 28 Mc. MARA officers for next year are: GBF, pres.; SPY, vice-pres.; YGL, secy.; FMU, act. mgr. The Club held a swell picnic at Jackson Mills, a Weiner roast at Fairmont, and a week-end QSO Party at Cooper's Rocks. YCK is new OO and ORS. YPO, during one night's operation, worked twenty-five stations on 3.9-Mc. 'phone. The MARA Net is active on 3770 kc. at 7:30 p.m. nightly. Any station having traffic may clear it by coming in and calling the NCS. To reduce QRM and save time it is requested that stations refrain from rag-chewing until the Net has been cleared. Your cooperation and suggestions will be appreciated by RMs DFC and BTV. Traffic: W8LXF 10, GBF 9, DFC 5, JM 5, YCK 1, GQE 1. 73. Don.

## ROCKY MOUNTAIN DIVISION

**COLORADO**—SCM, Glen Bond, W9QYT—8IIQ writes from Santa Fe, N. Mex., that he is operating there on 28-Mc. 'phone with a pair of 35Ts 250 watts but moving to Atlanta, Ga., soon and will be on 28- and 14-Mc. 'phone. #WVAP, in Loveland, is building a new 3.5-Mc. rig for QSP to Denver so, fellows, please watch for Mac and take his traffic. He is on 7 Mc. now with 100 watts. #EHC made a flying trip to Colorado to take his family back to Oklahoma. Ex-9TTF now is 6WVB in Los Angeles. Ex-4AXG, in Canon City, now is #DRB and expects to have his 28-Mc. beam up soon. 5HYT, from Amarillo, Tex., visited in Denver recently. He has a swell 28-Mc. rig in his car with 40-watt input Gonset converter for receiver. I heard him working several East Coast stations with FB reports. #IQZ is active on all bands, both c.w. and 'phone. Watch for Mitch with his official bulletins. #FPZ has been sending code practice on 28 Mc and there has been lots of good comment. Keep it up, OM. I'm sure more people copy you than you think. I wonder if the AAROD has talked Artie Davis out of the bottle he won at the transmitter hunt for their club transmitter. Anyone wishing to get in on any of the traffic nets, please drop me a card. We need a net station in every town, also an EC to take care of and organize emergency nets. Come on, fellows, I need your help. Traffic: W9WVAP 6. 73. Glen.

**UTAH-WYOMING**—SCM, Victor Drabble, W7LLH-7CKI just finished a snazzy three-element beam for 14 Mc. 7MAV is rebuilding. 7JNS just got his ticket. 6GQC moved to Ogden. 7DTB went back to c.w. to work DX on 14 Mc. after eight years of 'phone operation. 8IFB now is 3LTJ and is running 35 watts to a 6L8 on the 14-Mc. band; he is using a folded dipole antenna. 7EVH is heard on 3.9-Mc. 'phone running 100 watts to 50T into a Zepp antenna. 7JET operates from his trailer home with 60 watts to an 807 and a half-wave doublet antenna. 7JHL puts 8 watts into an 807 and gets R9 reports from Pennsylvania; he also has an FB 144-Mc. rig. 9OWZ has three rigs on 144 Mc., including a 955 walkie-talkie. 7ICZ is sporting a new BC-348 receiver and a Collins ART-13 transmitter with 200 watts into a ¼-wave vertical on 3.5, 7, and 14 Mc. 7E2C uses a 7-Mc. Zepp and his rig is on 14- and 28-Mc. o.w., running 250 watts. 7EUZ is rebuilding his '46 Field Day portable using e.c.o. 807s for 99 watts input using his new 348P receiver. 9RHF will be on 28-Mc. 'phone with 25 watts to an 807. 7HDS is on all bands using 250 watts to an 810 into a center-fed-Zepp. 7HDS also is Cheyenne EC. 7MQL is getting the bugs out of his 144-Mc. rig. 6MDP is OO. He usually is on 3825 kc. 7UOM has a tough time finding a ¼-HP motor to drive his rotary beam antenna. Traffic: W7FST 793. 73. Vic.

## SOUTHEASTERN DIVISION

**EASTERN FLORIDA**—SCM, Robert B. Murphy, W4IP—Members of the 'Phone Emergency Net and  
(Continued on page 112)



**Bob Henry says:  
MOST MODELS  
IN STOCK**



**FOR  
IMMEDIATE  
DELIVERY**

*Most models listed below are in stock . . . ready for immediate delivery:*

Hallcrafters 538 complete . . . . .	\$39.50
Hallcrafters 540 complete . . . . .	79.50
Hallcrafters 536A . . . . .	307.50
Hallcrafters SX 42 . . . . .	250.00
Hallcrafters SP44 . . . . .	99.75
Hammarlund HQ-129X and speaker . . . . .	168.00
Hammarlund SP-400-X and speaker . . . . .	342.00
National NC-2-40D (complete with speaker) . . . . .	241.44
National HRO-5TA1 and HRO-5RA1 . . . . .	274.35
National NC-46 . . . . .	97.50
National 1-10A with tubes and coils . . . . .	67.50
RME-45 complete . . . . .	198.70
RME-84 complete . . . . .	98.70
RME DB-20 complete . . . . .	68.20
Pierson KP-81 complete . . . . .	318.00
Panoramic panadapter complete . . . . .	99.75
Temco 75GA transmitters . . . . .	495.00
Meck 60T transmitters . . . . .	150.00

*The new Hallcrafters and Collins receivers, transmitters, VFO, etc. as fast as available. Prices subject to change.*

The delivery situation is much improved. I can make immediate delivery of most receivers and other apparatus. Take advantage of the extra service and selection you get by dealing with me, based on my reputation as the world's largest distributor of short wave receivers. Send me your order now. Send five dollars and I will ship at once C.O.D. Or order on my 6% terms. I finance the terms myself to give you better service and save you money. Trade-ins accepted. Tell me what you have to trade, and let's make a deal.

Besides having all amateur receivers and transmitters, I also have a complete stock of all other amateur apparatus and parts, also test equipment, etc. I have real bargains in the really good war surplus such as SCR-211's, BC-610, BC-342, BC-348, BC-312, parts, etc. Write, phone, wire or visit either of my stores.

*Bob Henry*  
W9ARA

Butler, Missouri

**HENRY RADIO STORES**

Los Angeles 25, Calif.

**"WORLD'S LARGEST DISTRIBUTORS OF SHORT WAVE RECEIVERS"**

*in* HOUSTON  
*in* BEAUMONT  
*in* GALVESTON  
*in* DALLAS

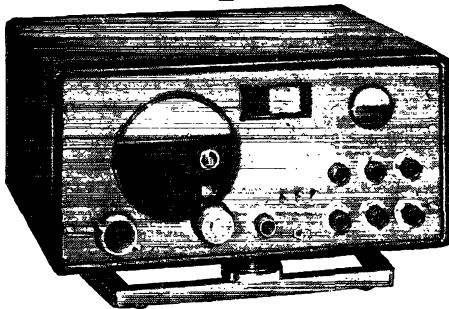

## hallicrafters sx-42

**\$2500<sup>00</sup>** AMATEUR  
NET

ADJUSTABLE BASE  
MODEL B-42 \$7.50

**R. C. & L. F. HALL, INC.**

1306 Clay Avenue • Houston, Texas

**R. C. & L. F. HALL OF BEAUMONT**

961 Pearl Street • Beaumont, Texas

**R. C. & L. F. HALL OF GALVESTON**

1803 Tremont St. • Galveston, Texas

**R. C. & L. F. HALL**

2123 Cedar Springs Ave. • Dallas, Texas

(Continued from page 110)

the good old reliable "Knights of the Kilocycles" were on the job and tracked that old hurricane right to its lair on October 7th. The 'phone emergency net was headed up by our Phone Activities Manager, ACZ, DPD, CQZ and DQW did a nice job of relieving him. KCQ, GMA, and ASR did a wonderful job clearing the 3910-kc. 'phone channel. NN and CFC gave barometer readings to the Weather Bureau. WINK and WSPB put amateurs on the air. Among those who took part were: ASR, BN, CFC, DWH, HKJ/3, AFO, PB, PT, IMJ, CUZ, DBA, DQW, GWH, JAL, JAS, NN, IEZ, EEZ, CPW, EVB, GZY, DAH, DPD, NMV/5, CPG, FWZ, FJU, ACZ, 3HNX, and BIW. As the storm came in through Tampa, each net was properly alerted by ACZ, and FWZ handled everything just fine until ASR could take over. The following c.w. stations were emergency powered and constantly on the alert: IML, FVW, FCL, IKI, DUW, IMI, CFC, NB, and our Route Manager, BYF. Mac had emergency operators ready for the Police and Red Cross in the event of real emergency. ACZ will be glad to recommend any of you interested for OPS and BYF will be glad to have you in his c.w. net. Let me have your applications for ORS and OPS appointment. CQZ says KET is in the Emergency 'Phone Net. KES is new ham at PAA School. AYV is getting set up as an OO. KCV is EC in Key West and reports IWM is new OO. KDH, JHL, KFO, and IVN are trying to form an amateur club. DOO is getting into the AEC; he has emergency power only. DQW had HAD as a guest. CUZ's good signals come out of a Meissner 150B rig. CFP works 28-Mc. band mostly. IE is moving his shop. AFO says IEZ has a Class A ticket. AGL is making up a new v.t.v.m. JVJ is applying for the honor of youngest ham; he is 14 years old. Director ASR requests that you send him your gripes so that can be ironed out to the best advantage of all concerned. I am definitely on 7 Mc. with an e.c.o. Give me a call. Traffic: W4BYF 37, IML 27, BNR 14, DQW 5, AFO 2, IP 2, KCV 1. 73. *Merf.*

WESTERN FLORIDA — SCM, Edward J. Collins, W4MS — Our newest ham, KIK, is on with an HT-9. JV blossomed forth on 14-Mc. 'phone. EQR is proud owner of an HQ-129X. DAO is enjoying 7 Mc. while working on new 28-Mc. rig. 2OTU now is 4BCC. HJA now owns four-element beam. HIZ is doing an FB job on 28 Mc. and wants more activity on 144 Mc. EQR has ordered a VHF-152 and is getting ready for 50-Mc. activity. QK is working on 7 Mc. 1DBT, now 4KAS, is doing an FB job on 14-Mc. 'phone. LT holds sway at Panama City on most bands. ACB has been on 7 Mc. while GAA is being worked on 28 Mc. AXP sounds FB on the 7-Mc. band. FHQ keeps 7 Mc. hot around 7161 kc. 8MEI is set to go on several bands. JFD is operating at Shalamar. MS has been on 28 Mc. and enjoyed QSO. VR is heard on 3.9-Mc. c.w. 7CEV/4 flies in week ends from Tennessee and operates on 28 Mc. CNK is eager to try 50 Mc. Quite a bit of interest is being worked up on a Gulf Coast 50-Mc. Net for storm work. All interested parties please contact MS. 73.

GEORGIA — SCM, Thomas M. Moss, W4HYW — We regret to report Mr. Benjamin Weinberg and Mr. G. C. Hawkins, of Hapeville, as "Silent Keys." Both CAA communications officials were killed when a CAA aircraft en route Washington to Atlanta, crashed near Commerce. YC is now OBS, OPS, and ORS. JBM, of YC, also is ORS. BOL is our new OO (I). DV has a monopoly on South Americans. We hear that no ham in Augusta can work one without his consent. FDX made postwar WAC and WAS on 14-Mc. 'phone. HRR explains the S-9 report for FDX in VK as a backward reading, thinking of the side of the road used for driving in VK. IEB is on 27-Mc. 'phone. AAY has charge of new Richmond County police f.m. system. WBBQ is new b.c. station for Augusta, operated by DV. He wants to try it on 28 Mc. BZH is engineer with Augusta police radio system. EZU is on 28 and 3.9 Mc. ETW has a beam on 28 Mc. Thanks to FDX for Augusta news. 2PYM is in Atlanta. 9JUV was visiting Atlanta. BRF, a major in the Signal Reserve, and his XYL, IKA, are in Arlington, Va. GJM now is KP4BC. 6OHN got on 28-Mc. 'phone while stopping in Atlanta on way to Los Angeles. JLT is out of the Navy and on 28 Mc. in Atlanta. GXU has been transferred to Miami. IYN (instead of IYF) is with CAA in Atlanta. DLG, BZ, BIN, and IKY are with WAGA. It's a jr. operator at IRA. New hams turned out by Savannah Club are: JZU, JOY, JOP, JOZ, JNL, KOP, and JNN. The gang there is going to 144 Mc. for local round tables.

(Continued on page 114)

# PLASTICON\* ASG Silicone-Filled GLASSMIKES



1-3/8 x 3-1/2

## FOR HIGHER VOLTAGES

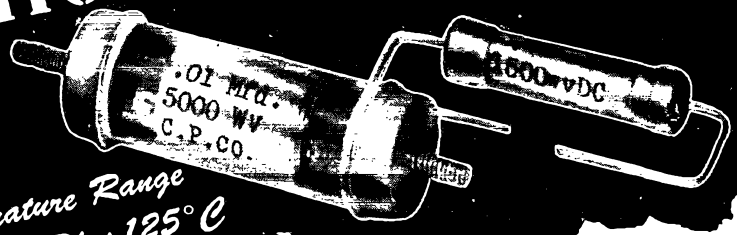

*Extreme Temperature Range  
from Minus 60° C to Plus 125° C*

From 600 to over  
30,000 Volts

*Modern functionally designed capacitors. Metal ferules are soldered to silver bands fused to each end of heavy-walled glass tubes. This vacuum tight assembly is fungus-proof and passes Signal Corps, Air Corps and Navy thermal cycle and immersion tests.*

### Applications

- For low and medium power coupling and bypass circuits where mica capacitors have previously been required
- Television and Oscilloscope Circuits
- Vibrator Buffer and Arc Elimination
- Geiger Counter and Instrument Capacitors

\* PLASTICONS: Plastic-Film Dielectric Capacitors

Write for illustrated literature featuring our complete line of Glassmike Capacitors.

Order from your jobber: If he cannot supply you, order direct



# Condenser Products Company

1375 NORTH BRANCH STREET • CHICAGO 22, ILLINOIS

*in* **DAYTON**  
and COLUMBUS

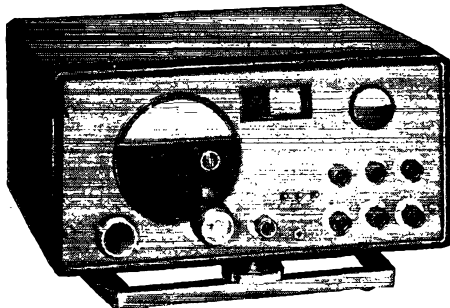

**hallicrafters sx-42**

**\$250<sup>00</sup>** AMATEUR NET | ADJUSTABLE BASE MODEL B-42 \$7.50

**HUGHES-PETERS, INC.**

300 W. 5th at Perry • Dayton 2, Ohio  
Ad 8277

*in* **NEWARK**

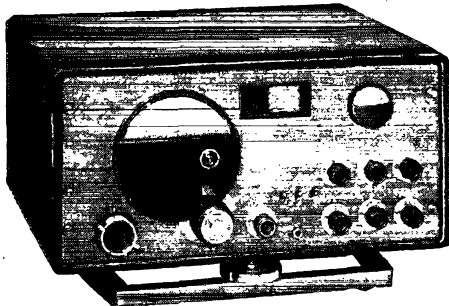

**hallicrafters sx-42**

**\$250<sup>00</sup>** AMATEUR NET | ADJUSTABLE BASE MODEL B-42 \$7.50

**CONTINENTAL SALES CO.**

195-201 Central Ave.  
Newark 4, New Jersey

(Continued from page 112)

It's a jr. operator for ESE of WSAV. 2ILS now is 4JCA. Thanks for news. Traffic: W4HYW 23. 73. Tom.

WEST INDIAS — Acting SCM, Everett W. Mayer, KP4KD — AM worked F8AH, IIRM, and several Gs on 28-Mc. 'phone and now has nineteen countries on 'phone. He held schedules with W2NFR on 27 Mc. BK, our OO, is on 7- and 14-Mc. c.w. with p.p. 813s looking for old W4 district QSO (especially Athens, Ga). W4CRO, in Puerto Rico on business, works CF's rig on 7-Mc. c.w. AZ has returned to Puerto Rico with PAA. BJ is working on exciter for p.p. 813 final. CD is on 14-Mc. c.w. and 28-Mc. 'phone in Ft. Brooke. AC and CJ got on 28-Mc. c.w. CN is on 28-Mc. 'phone with old AU rig. CE works 3.9-Mc. 'phone and 3.5-Mc. c.w. About twenty of the KP4 gang have signed up with the U. S. Coast Guard Auxiliary, forming Communications Flotilla Nr. 2, of which AU is flotilla commander; JA, vice-commander; and CE, training officer. Cuban appointees, please send in certificates for endorsement. New applications and reports are solicited. Looks like the gang is too active on the air to spare five or ten minutes monthly to get in a report to the SCM. How about it, gang? 73. Ev.

**SOUTHWESTERN DIVISION**

LOS ANGELES — SCM, Ben W. Onstenk, W6QWZ — The Inglewood Amateur Radio Club elected MSO, as pres.; REE, vice-pres.; QVS, corresponding secy.; EKM, recording secy.; AKQ, treas.; QXB, sergeant at arms. The Citrus Belt Amateur Radio Club elected UZL, pres.; SET, vice-pres.; PPJ, secy.; HDY, treas.; RSP, trustee. The Pasadena Short Wave Club elected Art Casebeer, pres.; Johnny Rothrock, vice-pres.; Robby Houston, secy. DFO, as OO, logged twenty off-frequency stations in ten days. VTC's XYL is WIJ. AM WACed in one hour and nineteen minutes on Sept. 25th. OGM broadcasts QSTs nightly except Thursdays at 8:30 p.m. on 3.9-Mc. 'phone. INH is running HK54s on 3.5 and 7 Mc. SN complains about too much v.h.f. news in this column and wishes to see more about the old-timers. Sorry, can't write what I don't get. SN uses a half-wave vertical and a long wire two full waves long tied together at the tank and says it gives him more directional gain than either of the two singly. The first meeting of Council of Radio Clubs was attended by FFN, CRY, ANN, FL, MEP, LSO, RTR, MYC, MSO, QIR, WNN, AOA, AQJ, DLL, HHJ, SRJ, KEI, UYE, WXG, LGO, RO, EQM, OGM, UXN, TZD, and QWZ.

ARIZONA — SCM, Gladden C. Elliott, W7MLL — About fifty stations took part in the Arizona QSO Contest on Oct. 5-6. Among the high scorers were QWG, KMM, TCQ, BMC, MNH, and MLL. NRI works 3.5-Mc. c.w. with a 20-watt portable from Jacobs Lake. QLZ will be on v.h.f. from the Mission Ranch again. QAP and KAD have 100 per cent QSOs between Tucson and Douglas on 50 Mc. GYK is at a new QTH and has an FB 28-Mc. rig. Other 28-Mc. mobiles are OWX, JPY, TDV, and JZP. QNO ran 144 Mc. tests from Frisco Peak while visiting in Northern Arizona. 144-Mc. activity is reported in the Verde Valley, Winslow, Williams, and Phoenix. 3865-kc. net stations are DFE, OAS, MWQ, OIF, QWG, RMB, and NRI. 3515-kc. net stations are TCQ, QWG, MLL, MNH, BMC, RU, JPY, and JOH. LHS has a small rig at the U. Ex-5GZR is KAG, now in Tucson. PDA has moved back to Phoenix. SNB is running 1614-kc. propagation tests. REO is airborne on 144 Mc. Ex-9IWR is JZZ and ex-61GC is JYK. TCQ and MLL handle nightly traffic for TCQ's XYL. JHB worked VQ4ERR and knocked off an XU at 1:30 a.m. NZS is on 3.5-Mc. c.w. The Radio Club of Arizona holds FB meetings the first Friday of every month with lots of YLs and XYLs present. OWX, SMZ, and MLL were visitors at October meeting. The Tucson Club now is the Old Pueblo Radio Club. 73. GC.

SAN DIEGO — SCM, Ralph H. Culbertson, W6CHV — LUJ reports little traffic activity but he worked ZS1CS, ZS6CH, ZL2MM, and 6TMY/Saipan, and says the biggest kick of the month was resuming rag-chews with prewar CUU and NRP. MKW reports MRP on 3.9 Mc. at Huntington Beach. BFE is on 7 Mc. at Tustin. TIK and UPP are on 28 Mc. at Orange. ADT is rebuilding and will be on shortly with a big rig. HAA and MQF are on 14 Mc. in Santa Ana. QG is active on 50 Mc. DEY, HWJ, PHJ, VKN, and MKW are active on 144 Mc. HWJ, using 6C4, worked OIN on Mt. Soledad on 144-Mc. mobile. ALO, MTC, VKN, and WWX are on 28 Mc. 9JHD/6 is on 28 Mc. at

(Continued on page 118)

# Merry Christmas

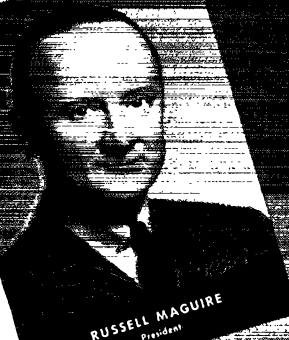

RUSSELL MAGUIRE  
President



ODEN F. JESTER  
Vice President  
& General Sales Manager

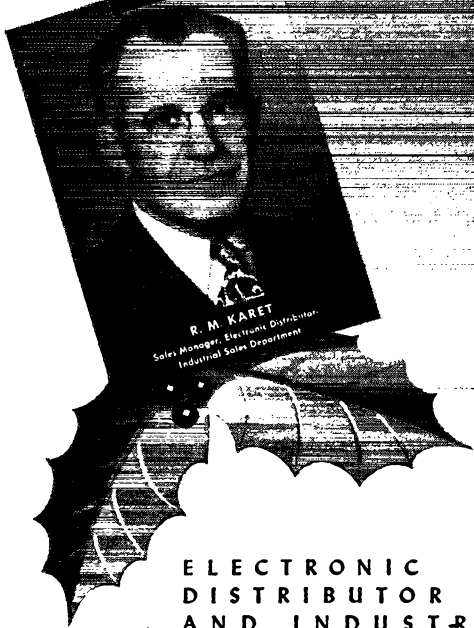

R. M. KARET  
Sales Manager, Electronic Distributor,  
Industrial Sales Department

We pause at this age-old season of good-will to greet our many friends in the radio and electronic industries and to extend to all of them our best wishes for a Merry Christmas and a Happy New Year. A year has passed since the formation of the Electronic Distributor and Industrial Sales Department . . . a year during which we have developed into a smoothly functioning organization known from coast to coast for the quality of our three great lines - Thordarson, Meissner and Radiart. We are proud of this success, and we are grateful to those in the industry who have helped to make it possible.

Now as we stand at the beginning of a new year we are firmly resolved that the products and services of these member companies will continue to reflect the wealth of engineering skill and production know-how which has distinguished them in the past.



ELECTRONIC  
DISTRIBUTOR  
AND INDUSTRIAL SALES DEPARTMENT  
936 N. MICHIGAN AVENUE • CHICAGO 11, ILLINOIS

MEISSNER • THORDARSON • RADIART

**YOUR FIRST CHOICE**

# *in Standard Amateur Receivers*

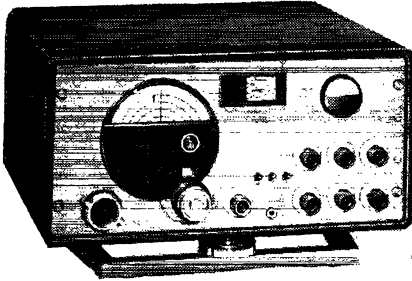

**NATIONAL HRO-5TA-1**

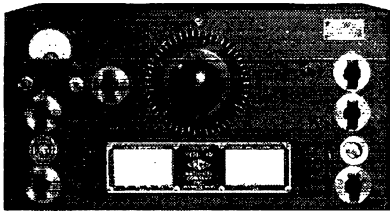

This latest version of your old favorite HRO has all the value features that make this National receiver famous, PLUS new ANL circuits that make it even more efficient. It's *the* receiver for the ham who wants professional performance. Furnished complete with 11 tubes, speaker, power supply, and plug-in coil sets for the popular amateur bands. Net price, complete, **\$306.71**

**THE NEWEST HALLICRAFTERS SX-42**

Covering all frequencies from 540 kc to 110 mc, this versatile receiver combines in one superbly engineered unit a standard and VHF communications receiver for broadcast, short wave, and FM reception and a high-fidelity phono amplifier. Enter your order now and be one of the first to enjoy this superlative receiver. Net price complete with R-42 bass reflex speaker, **\$275.00.**

**Two Old Favorites**

**HAMMARLUND HQ-129-X**

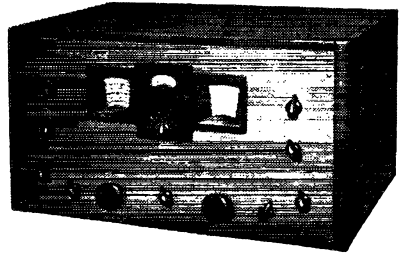

A host of new circuit features are offered in the post-war model of this world-famous receiver. Its variable crystal filter, embodying an exclusive, patented Hammarlund circuit, provides wide-band crystal selectivity for the crowded amateur phone bands and for single signal code work. Net price, complete with tubes, power supply, and matching speaker, **\$173.25**

**And we're delivering all these POPULAR RECEIVERS**

**HALLICRAFTERS**

- S-36A VHF FM-AM ..... **\$307.00**
- S-38 Complete ..... **39.50**
- S-40 Complete ..... **79.50**
- S-41G Complete ..... **33.50**

**NATIONAL**

- NC-2-40-D Less Speaker... **\$225.00**
- NC-46 Complete ..... **107.40**
- NC-1-10-A Complete ..... **101.93**

**R. M. E.**

- RME-45, Complete ..... **\$198.70**

**HAMMARLUND SUPER-PRO**

- SPC-400-SX ..... **\$310.05**
- SPR-400-SX (Rack model) **320.55**
- SPC-400-X ..... **334.05**
- SPR-400-X (Rack model) **344.55**
- Speaker, in matching cabinet **18.45**

**TIME PAYMENTS**—All these receivers may be ordered on the usual Radio Shack time payment plan. We'll gladly quote terms for payment over 6, 9, or 12 months.

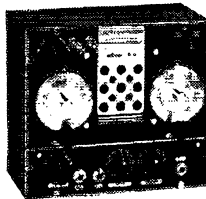

**NEW Abbott TR-4B**

Here's the post-war model of this popular 2-meter rig; now available for prompt shipment.

- Net price ..... **\$52.00**
- Kit of tubes ..... **\$ 9.18**

**Accessories for your Ham Shack**

Sonar Exciters ..... **Net \$39.45**  
 Gonset 10-meter Converter, **Net \$39.95** And the complete line of Workshop Associates antennas — in stock for immediate delivery.

**THORDARSON 8-WATT AMPLIFIER Type 30 W08**

Ideal for P. A. service . . . 30 db output at 4, 6, 8, or 500 ohms . . . Flat  $\pm 1$  db from 50 to 15,000 cycles . . . separate mike, phonograph, and tone controls . . . uses 2-6J7's, 1-6L6G, 1-5Y3GT.  
 Net price ..... **\$25.95**  
 Kit of tubes ..... **\$ 3.26**

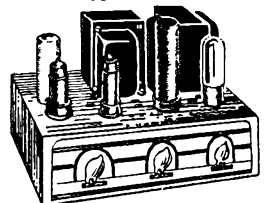

**YOUR FIRST CHOICE**

# *in Selected Surplus Specials*

**MINE DETECTOR! PIPE LOCATOR!  
DIVINING ROD! TREASURE FINDER!  
or what have you!**

Here's a device for which many possible uses will suggest themselves to the amateur's imagination. The TM says it is able to detect "the presence of nonuniformities near the surface of the earth, whether rocks, air pockets, pools of water", or mines, by indicating variations in radiation resistance of the antenna system. It's a lot of useful gear, including ear-plug-type phones, tubes, spare parts, carrying case, and the complete technical Manual giving circuits and all the operating dope.

Net price, only .....\$20.00

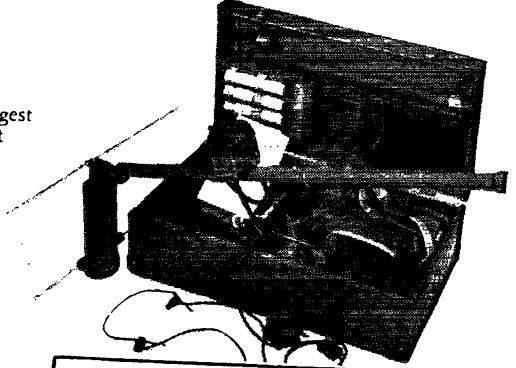

**A R T—13 SPEECH AMPLIFIER & DRIVER**

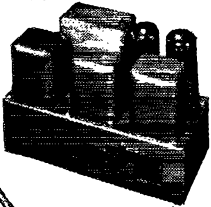

A compact, 3-watt amplifier that is fine business as speech amplifier and driver in a ham rig, or can be used as phono amplifier. Easily converted to self powered 110 volt operation—instructions furnished. Net price, amplifier only, **\$2.95**; kit of 2 tubes, **\$1.60**.

**SPECIAL COMBINATION OFFER**

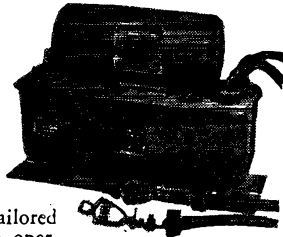
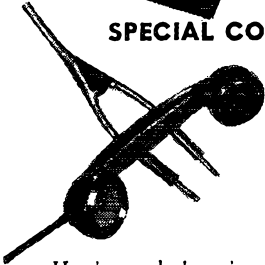

Here's a deal we've tailored specially for you mobile operators . . . and it's a real value. Item 1 is a 500-volt 160 mil dynamotor operating from 6 to 12 volts D. C., complete shock-mounted assembly including breakers, relays, filters, and cables. Item 2 is a radiophone handset with 200-ohm mike, 2000-ohm phone, push-to-talk switch, heavy rubber cord, and separate mike and phone plugs. Both items brand new — combination price only **\$17.90**. Dynamotor only, **\$14.95**. Handset only, **\$3.95**.

**SUPERSPECIAL**—1000 volt 4 mfd. mineral oil impregnated xmtg capacitor.  
While they last .....\$1.19

In our exceptionally large surplus stock, you'll find bargains in panel meters, transformers, condensers, relays, test instruments, and other wanted items much too numerous to list. Write today to get your name on our mailing list, and be sure of getting your first choice in these remarkable values.

New catalog in preparation—  
register now for this valuable handbook

**TUBE SPECIALS**

**KEN-RAD 829-B**

Brand new JAN-inspected tubes .....**\$4.95** each

**ALSO**

- 24G .....**\$1.95**
- 807 ..... **1.35**
- RCA-813 ..... **9.95**
- 838 ..... **4.95**
- 832 ..... **5.95**
- GE 872A ..... **2.95**
- GE 211 ..... **4.95**
- VT-127A ..... **3.45**

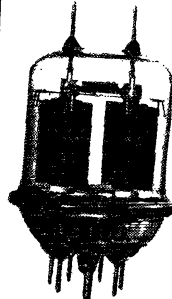

**Acorn Tube Special**

954 — 955 — 956 — 957  
Six for **\$2.95**, same type or assorted.  
Isolantite socket for acorn tubes, **48c**.

**CAPACITOR SPECIALS**

G.E. 4000 volt 2 mfd,  
Pyranol Xmtg Capacitor.  
**\$5.95**



**ALSO**

Mfd.	Volts d-c	Net ea.
.1	2000	<b>\$0.49</b>
2	1000	<b>.71</b>
2	600	<b>.59</b>
4	600	<b>.71</b>
8	600	<b>1.19</b>
10	600	<b>1.29</b>

*The* **RADIO SHACK**  
★ 167 WASHINGTON ST. BOSTON, MASS., U.S.A. ★

**AMATEURS! Leo W9GFQ Offers**

## Immediate Delivery

On His New, Exclusive, Low Priced

# WRL GLOBE TROTTER TRANSMITTER KIT



Jay Leibach, W8VJW Sandusky, Ohio Says: "May I congratulate you on turning out such a hot little rig as the Globe Trotter. It's amazing the way this flea power transmitter bucks the heaviest QRM."

Many other actual field reports of amateurs using the Globe Trotter testify to its excellent performance. It's the hottest ham equipment on the market today. The WRL Globe Trotter is capable of 40 watts input on C.W. and 25 watts input on phone on all bands from 1500 KC through 28 Megacycles. Incorporates the Tritet Oscillator using a 40 meter Xtal; Heising choke modulation; three bands, all pretuned; 10, 20, and 80 meters; two power supplies, one for 807 final and modulator tubes, one for speech amplifier and oscillator stage.

**40 WATT INPUT**  
Cat. No. 70-300..... **\$69.95**

Complete including all parts, chassis panel, streamlined cabinet, less tubes, coils, and meter.

No. 70-312 same as above, wired by our engineers..... **\$79.50**

1 Set Coils, Meter, Tubes..... **\$15.15 Extra**

For Fast Delivery order your receiver now from World Radio. Easy Payment Plan Available.

RME 45 (Immediate Delivery)..... **\$198.70**

Hammarlund HQ129X..... **\$173.25**

Hammarlund SPC-400-SX..... **\$323.25**

Hallcrafters S-38..... **\$39.50**

Hallcrafters SX42..... **\$250.00**

RME 84..... **\$98.70**

## TELESCOPING ANTENNA

Perfect for 10 meter beams. Telescopes up to 12 feet. Cat. No. 0-255..... **\$3.95**

We can supply all types of modulation transformers up to 210 watts audio.

★ All prices quoted are domestic. Write for export prices.

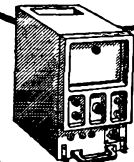

### AUDIO AMPLIFIER

Cat. No. 0-73  
less power supply... **\$3.45**

Output rated at 8 watts; freq. response, 200 to 1800 cycles; 2 mke input; low impedance and carbon mic.; output impedance 2000 to 5000 ohms; 2 powerful 1619 tubes

## FREE! OUR LATEST FLYER

Packed with real buys in radio, electronic, and general merchandise.

Giant Radio Map (Size 31 ft. x 41 ft.)..... **15c**

Handy Tube-Base Calculator..... **25c**

Tube and Circuit Book..... **10c**



Formerly Wholesale Radio Laboratories  
Address Dept. QST12, Council Bluffs, Iowa

(Continued from page 114)

Trabuco Canyon and has new RME-45, BWO, HWJ, DHP, and MKW continue activity on 3.9 Mc. VAD occasionally is active on 3.9 Mc. from Orange. VQI is on 3.9 Mc. at Imperial Valley with an HT-9. 5KFA/6, of Imperial Valley, is on 3.9 Mc. with a pair of 807s. 1DCE/6 wishes to say 73 to all the San Diego gang; he is going to Washington, D.C. His rig and family are staying at Imperial Beach. BOS reports lots of activity around Escondido on 50 Mc. He is running about 150 watts and has an FB four-element beam working Oregon, Washington, Iowa, and Michigan. NXR is active on 50 Mc. with a small rig. BOS and WNN have been doing some FB experimenting with antennas on 50 Mc. BWI reports he has a new FB Motorola rig running about 150 watts with a new rotary four-element beam. The San Diego Radio Club put on an FB hamfest at the Imig Manor Hotel in San Diego October 12th. The main door prize was a KP-81 receiver and the ladies' door prize was a new washing machine. An FB time and dinner was enjoyed by all those attending. OES certificates have been issued to WNN and JUM. WNN also has been appointed OO. ACW has moved to Alameda and will be on 14-Mc. 'phone soon. APG has completed an FB 28-Mc. beam. He is working some FB DX and reports are very gratifying. Traffic: W6LUJ 2. 73. Ralph.

## WEST GULF DIVISION

**NORTHERN TEXAS** — SCM, Jack T. Moore, W5ALA — SEC: DAS. PAM: ECE. RM: CDU. LUD hopes to be on 7 Mc. soon with a Millen exciter and an NC-240D. George sends the following about the Fannin County hams: QN is working a lot of DX on 14 Mc. with 225 watts and an HRO. ATG and GML are active on 3.9 Mc. KYL is working 3.5-Mc. c.w. and has a new HQ-129. BYX and DZ report the organization of the Central Texas Amateur Radio Club. Meetings are held the second Thursday of each month. Officers are: ATW, pres.; KRZ, vice-pres.; DZ, secy.; HOF, treas.; BIN and AMK, activities manager. BYX is interested in contacting other CAA hams on the air as he is trying to start a CAA net on 7160 kc. His address: 2608 Alexander, Waco. BYX sends the following news: JUN is active on 3.5-Mc. c.w. and 'phone and is building a new all-band rig. LUO, DZ, and ATW have HT4s. UF is running a kw. on c.w. BYX has been appointed OBS and ORS. CDU, new OO, is conducting code class over the air for the Dallas Radio Club. HBE, new OBS, has a new two-element beam for 14 Mc. DAS has made the following EC appointments with ECE, IYJ, and QA acting as assistant SEC: Abilene, QA; Brownwood, HPG; Bloomberg, HFG; Celina, HIP; Dallas, ATM; Denton, KPV; Dodd City, ATG; Decatur, GLW; Ft. Worth, OJ; Honeygroves, GML; Henderson, IYJ; Jacksonville, CBZ; Lancaster, BNQ; Lubbock, JQD; Lamesa, DSV; Munday, KOW; Midland, DYK; Odessa, GNH; Plano, GSZ; Palmer, AQS; Plainview, KOA; Pampa, IJQ; Ranger, ECE; Rule, PO; Sweetwater, DUZ; Waco, BYX. The Northern Texas ECs hold a drill each Monday night on 3900 kc. at 8 p.m. JFF has a new HQ-129 receiver. FFX is OO. Jack.

**SOUTHERN TEXAS** — SCM, James B. Rives, W5JC — We received a very interesting letter from GAB, now located in Tokyo using the call J2AAF and operating on 14130-kc. 'phone and 7160-kc. c.w. He is eager to contact stations in this section. LMA has moved to Austin, where he is attending Texas University and operates on 7 Mc. between studies. CX is the new EC for Brownsville. EUL was reassigned an old two-letter call and now is signing BE. GCJ has been appointed EC for San Angelo and is active on 7 and 28 Mc. with 125 watts input. Other active stations there are 6TYC/5 and JIC. LCU is the new EC for Harlingen. FNY now is EC and KTL and HJY are assistant ECs for San Antonio. HJY attended the hamfest at Cuero and assisted in organizing an emergency net. New officers for the San Antonio Radio Club are as follows: GKI, pres.; KTL, vice-pres.; JSL, secy.; Henry Velte, treas.; HJY, sergeant at arms. LDD has a classy new QSL card. MN is a member of the Hit and Bounce Net, which handles traffic between the Far East and the East Coast during the wee small hours of the morning. 4CW has moved from Memphis to Brownsville and his new call is CX. 8DV has moved from Toledo to Brownsville and has been assigned the call DX. CX and DX just returned from a visit to Havana, where they met many of the CO/CM gang. HIF reports the following for Corpus Christi: FBC has a new DB-20. GEL

(Continued on page 120)





# THREE OF MANY NEW AMATEUR ITEMS



## MODEL 800 RECEIVER

MODEL 800 • 144-148 and 235-240 mcs. U.H.F. receiver. E. P. Tilton's Feb. 1946 QST design modified to Byron Goodman's inductive r.f. tuning, built-in PM speaker, 88" bandspread, all in new "ATOM-X" construction. Factory built or kit for easy home construction, compact.

## MODEL 700 TRANSMITTER

MODEL 700 xtal controlled transmitter. 144-148 and 235-240 mcs. 6AQ5 Tritet drives 6C4 doubler, 6C4 doubler/tripler, 832 longline push-pull final. Built-in 14 watt 6AQ5 push-pull voice modulator. New "ATOM-X" construction, size only 5" x 10" x 5 1/4". Matches MODEL 800. Makes serious home-station or mobile rig. Factory built or kit.

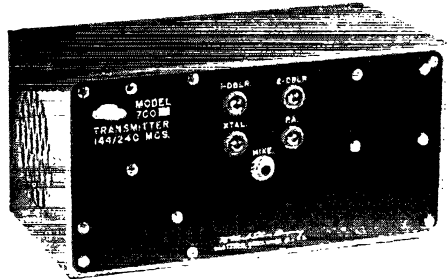

## HI-Q AIR CAPACITORS

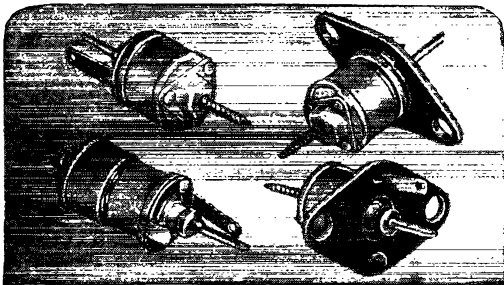

Of unusually high-Q, extraordinary mechanical and electrical stability, easy of adjustment, small in size and useful to beyond 500 megacycles for trimming or tuning, a new air-dielectric capacitor is now available.

Less than one-half inch in diameter, less than 1/16" in length, SILVER Model 619 capacitor provides 3 to 30 mmfd. with air and high quality ceramic insulation. Rotor and stator are one piece, low inductance, multiple aluminum cups. Rotor meshing with stator gives a linear capacitance range of 27 mmfd. over three full rotations.

Produced at the famous Philips works in Holland, it is brought to American amateurs and experimenters. Price 30c each, net, at your favorite jobber. **SEND FOR FREE CATALOG**

OVER 35 YEARS OF RADIO ENGINEERING ACHIEVEMENT

# McMurdo Silver Co., Inc.

1249 MAIN STREET • HARTFORD 3 • CONNECTICUT

In Canada—McMurdo Silver Division, General Radionics Ltd., 465 Church St., Toronto, Ont.



**... PRECISION IS BASIC**  
**WITH Burlington INSTRUMENTS**

These are the features that make Burlington Instruments your logical choice—Alnico Magnets used in all DC Instruments—Large clearances for all moving parts—Perfectly aligned Jewel Supports—Phosphor bronze control springs—Ceramic pointer stops—non-shifting balance weights.

All ranges AC or DC available in 2½", 3½", 4½" sizes, rectangular and round.  
 Inquiries solicited.

**BURLINGTON INSTRUMENT COMPANY**  
 812 Fourth Street Burlington, Iowa

*in* **PHILADELPHIA**



**hallicrafters sx-42**  
**\$250.00** AMATEUR NET | ADJUSTABLE BASE MODEL B-42 \$7.50

**CONSOLIDATED RADIO COMPANY**  
 612 Arch Street • Philadelphia 6, Pa.  
 Tel Lombard 7871

(Continued from page 118)

is operating a mobile 28-Mc. rig in his car. HP is rebuilding. FBC has a new vertical "J" antenna. LVU has a new three-element rotary. HIF and 6EPZ/5 are working some nice DX. LUJ is a new signal heard from Rockport and is interested in EC work. 73. Jim.

**NEW MEXICO**—SCM, J. G. Hancock, W5HJF—4DWB, who worked on the atomic bomb at Los Alamos, has accepted a research fellowship at the U. of Indiana. GXL is active on all bands between shifts as manager of b.c. station KFUN and sends the following report on the Las Vegas gang; JQP is active on 28-Mc. 'phone with his BC-610. LQX, ex-8TSQ, works 14- and 28-Mc. c.w. HPZ gets on 28-Mc. 'phone occasionally. 9EMU has moved to Hot Springs and has set up a b.c. station. FAG and GGX are heard, apparently using 3.9-Mc. 'phone as a link for v.h.f. experiments. LWH is a new ham in Portales and is erecting a 28 Mc. three-element beam on a steel tower that is adjustable from a height of 35 to 80 feet. KXX is expected on 3.5-Mc. c.w. from Lovington soon. DER, ISN, and KCW are sporting three-element 28-Mc. beams and DER is really pulling in the DX with his. DER and HJF attended the West Gulf Division Convention at Oklahoma City. HJF drew a model 101B Electronics Corps multimeter. He spent the night with BHD at Altus, Okla., on the way home, and picked up the BC-348-H receiver BHD and Hardin White had converted for him, which he now is using in the shack. White should have his ticket before this is published. 73. Jake.

**CANADA**

**MARITIME DIVISION**

**MARITIME**—SCM, A. M. Crowell, VE1DQ—Will all stations interested in traffic and schedules please call EY, our RM, who is forming a net? AP is back on 3.5 Mc. with a pair of 807s in top shelf. BD, active on 14-Mc. 'phone, uses S-40 receiver. CO has separate transmitter for 3.5 and 14 Mc. CW is planning new home with a built-in ham shack. FQ, our SEC, would like all interested in emergency work to contact him with a view to membership in AEC. Put your self-powered rig to work. QZ recently organized and donated nice prizes for a successful 56 Mc. Hunt. A fair amount of 56-Mc. rigs are going in Halifax area now and QZ has heard "W" on this band. EP continues to knock off the DX on 14 Mc. with the new v.f.o. ET has taken to the key again. MZ, FQ, HV, and DQ have been holding midnight discussions on antennas, etc. BC/OW continues to work DX on 28 Mc. with the greatest of ease. HI, another DX 'phone man gets out very well, especially on 14 Mc. DQ took a few messages from OX2MJ. LZ has been trying out new rig on 3.8-Mc. 'phone in addition to whacking out on 14-Mc. c.w. NW has been heard on 14 and 28-Mc. c.w. going great guns. PQ has been knocking 'em off on 14-Mc. c.w. OE has been taking the "bugs" out of his new 3.8- and 14-Mc. 'phone rig. Say, gang, please make with the reports. 73. Art.

**ONTARIO DIVISION**

**ONTARIO**—SCM, David S. Hutchinson, VE3DU—OI is too busy with canning factories to bother with ham radio. QK is ORS again. QTH Centre Island. Welcome to another ORS, VE3BDX, ex-2JK, VO6D, with 600 watts to an 810. BDX already made WAC this summer on 14 and 28 Mc. ATR is having trouble moving traffic; he is on 3.5 and 7 Mc. OJ, another old ORS heard from, is in Ottawa with RCAF. SF is on 3775 kc. The Hamilton 50-Mc. gang is quite active, and consists of BKM, AOR, DC, BHX, XZ, AND, BFF, ARM, and KM. In conjunction with Toronto gang they recently moved a message from South America to Toronto via 28 Mc., then 50 Mc. to Hamilton, and return to S.A. in one hour. BHX is a new-comer to 50 Mc. BCS is new ORS in Dundas. BFJ, who has ten watts on 3.5 Mc., says there are ten licensed hams in Peterboro, also that NC of prewar days is in the process of rebuilding and will have p.p. T20s in final with p.p. 6L6 modulator. TM is rubbing the sand out of his eyes and promises to have a new rig by the time this appears in print. BLE has TM's old rig and is on 7 Mc. mostly. HI had an operation on his throat and was forced to go back to c.w. for awhile. AOO is back on the air since he sold car. AJQ is on 3.5 Mc.

(Continued on page 122)

# Amateurs - Sensationally popular "TALKIE" XTAL KIT

Still only \$

1

POSTPAID  
in the U.S.

No advance yet from this remarkably low price!

Engineered for the 40 meter operation. Crystals are approximately 50 to 100 KC below 7000 KC to be ground to a frequency in the 40 meter band. Each kit contains 3 crystal blanks; 2 holders complete with electrodes, spring and gasket; 2 additional sets of electrodes; bag of abrasive and instructions for grinding. Ideal for the amateur to grind and adjust his own frequencies. TYPE 41-A.



## FLASH!

**While They Last  
SURPLUS HOLDERS**

\$1.79  
DOZEN  
6 for \$1

Either octal or 5 prong mounting (as supplied in the "Talkie Kit") complete with springs, gaskets and electrodes, everything except the crystal plate. Prepaid within U. S. A. with cash order. Sorry, but we can't accept orders for fewer than 6 at this give-away price.

**Also get our low prices on additional blanks to your specifications.**

## 20 METER THIRD HARMONIC

A 20 meter crystal operating on a third harmonic fundamental. Mounted in compact holder  $1\frac{1}{8}'' \times \frac{3}{4}'' \times \frac{3}{8}''$  for octal socket. Crystal blank is guaranteed to be within .01% of marked frequency. Frequency furnished to within 10 KC of your specification.

TYPE 209 TH Popularly priced for the amateur's budget ..... \$400



**ALL CRYSTALS ARE PRE-AGED**

**Crystal**  
**PRODUCTS COMPANY**

MAIN OFFICE 1519 MCGEE STREET

Phone Victor 9203  
KANSAS CITY 8, MISSOURI

Canadian Distributors  
**MEASUREMENT ENGINEERING**

61 Duke Street  
Toronto 1, Canada

in BUTLER

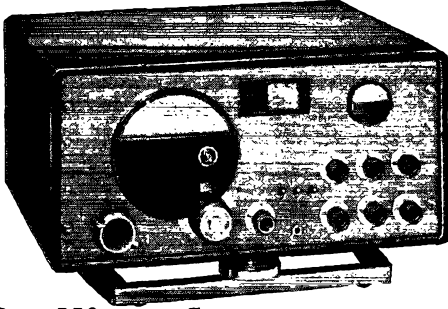

hallicrafters sx-42

\$25000 AMATEUR NET | ADJUSTABLE BASE MODEL B-42 \$7.50

HENRY RADIO STORES

Butler, Missouri

"World's Largest Distributor of Short Wave Receivers"

in LOS ANGELES

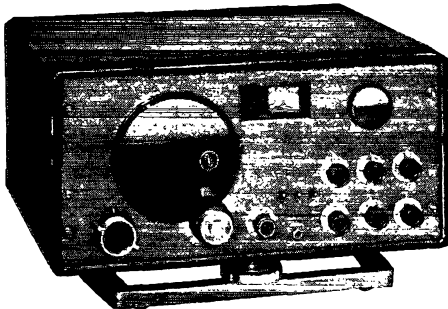

hallicrafters sx-42

\$25000 AMATEUR NET | ADJUSTABLE BASE MODEL B-42 \$7.50

HENRY RADIO STORES

Los Angeles, California

"World's Largest Distributor of Short Wave Receivers"

(Continued from page 120)

with an 807. AJP was heard on 14 Mc. with his 813 e.c.o. GB still is waiting for that Signal Squirter. DU will be heard on 7, 14, and possibly 28 Mc. ADB is active on 3.8-Mc. 'phone, also GV. New-comers to the air in London are BJR, BJT, BMU, and APG. Old pal AJE threatens to increase power so he can get through QRM on 14 Mc. WX will be forced to work on frequencies from 7 Mc. up because of lack of antenna space. Sorry the radio clubs did not see fit to answer my letter, as so far only one club has come through with any information. I would like to hear from more of the gang in Northern and Eastern Ontario. How about it, boys? Traffic: VE3BDX 16, ATR 4. (Aug.): ATR 8. (Aug. & Sept.): OI 3. Dave.

### QUEBEC DIVISION

QUEBEC — SCM, Gordon F. J. Phelan, VE2SU — Condolences are extended to XI on the loss of his brother. FS is using a v.f.o. Ron and HZ are acting executives for ACF-TSF until the club gets going again. GG, KZ, and AI have been on 14 Mc. II is crowding in some good schedules with UO, WINJM, WINKW, W2LRI, W3JQN, VE3VZ, and VE1HJ. Ossia can put your messages where you want, including ARRL Headquarters direct. He recently entertained OK1QQ, who spoke at the September MARC meeting. DR has renewed his ORS. SU is trying out AFARS. More stations are needed in Montreal district. SA, QB, XD, and DX are among AFARS 'phone members. UO says fast relays are the secret to successful traffic work. TM sends in the following with his ORS application: One look at the layout at NK produces a Sinatra-type swoon. Five separate transmitters for 3.5, 7, 14, 28, and 50 Mc. are set in the wall, controlled from one operating desk. IW is on 3.5 Mc. with indoor antenna. TN is house-hunting for his new XYL. VB solved advance reservations with TM via amateur radio. DL, Montreal, worked HL, in Quebec, with 15 watts on 4 Mc. LA helped NK get going. TM has new SX-25. The following news reporters are helping your SCM: Quebec — TM, Sherbrooke — UO, Hull — SD. Others are needed for other districts. *The Skywire Bulletin*, II editor, published monthly by MARC, is getting better and better. More new calls around Montreal are VE, VH, PQ, KR, UU, TC, JB, KF, NG, DV, IP, GK, GT, RD, WF, BG, TY, and UH. LT is on Rock Island. Ex-20B now is VE3ASX on 3541 kc. BY does well with his 7-watt 'phone, including a good QSO with VO1A on 4 Mc. Are you ORS or OPS? Traffic: VE2II 51, SU 5, DR 4, UO 2.

### VANALTA DIVISION

ALBERTA — SCM, W. W. Butchart, VE6LQ — 6AO is a new RM. 6WG is ORS. 6HJ is moving to farm outside Camrose. EA has 150-watt rig with 813 final on the air. KK has wound modulation transformer for 300-watt modulator. FH, ex-5TR, ex-7TR, will be on 7, 14 and 28 Mc. with half-kw. soon. 6IJ is new call of Howard Crowle in Edmonton. 3QE lives in Edmonton now and will have rig on the air as soon as he finds QTH. 6LG was up on Alaska Highway on Operation North. 6SZ worked 8AO, 1KK, 2AI, 3DE, 3AES, 4AC, 5CM, and 7OT on Canada-wide round table QSO one night and he notes all stations were able to hear each other 100 per cent. 6JK, ex-4ABZ, of Calgary, spent a few days in Edmonton learning to handle new Electro-buses. 6MJ is new OPS and OBS appointee in Edmonton. 6HM works FB DX on 14 Mc. 6EY has rotary beam working on 28 Mc. with FB results. W8 has four-element beam down on 28 Mc. giving him S9-plus reports. 6AE gets out nicely on 3.9 Mc. with poor antenna. 6CE blasts 3.9 Mc. with all of his 11 watts to get S9 reports. He is talking new rig now, and has line-up pretty well figured out. His problem is to use line-up which is economical on storage batteries! LQ is looking for nominees for AEC work in Alberta. How about it, boys, get in on this interesting work! Traffic: VE6AO 17, 6LQ 15.

BRITISH COLUMBIA — SCM, W. W. Storey, VE7WS — RCARA reports 7FY is going all out on 50 Mc. He just finished a 50-Mc. converter to feed into his Sky Champion. 7HA has his exciter finished. 7ABQ finds time to snag the odd East Coast station on 50 Mc. 7ACS is heard frequently in the United States and Eastern Canada. With the addition of an 813 p.a. the boys in the URC are sharpening their pencils for DX. The club is starting Morse Code classes and theory lectures, and professors are being signed up to speak on pertinent radio topics. The club is eager to contact

(Continued on page 124)

# HARVEY *has the latest!*

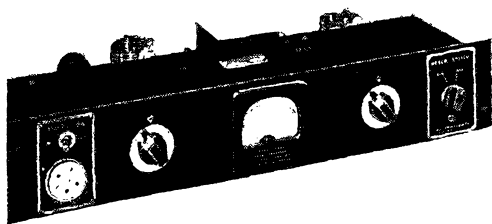

**MILLEN EXCITER — POWER SUPPLY — R.F. AMPLIFIER**  
**Millen 90800 50-watt Transmitter/Exciter**  
 Popular unit uses Tri-Tet circuit, xtal or v.f.o. excitation, 807 final, working straight or as doubler. Ideal for use with 90281 power amplifier. The 90881 power supply is particularly suited for use with this rig. Complete with set of coils for 10 and 11 meters. Less Tubes.....**\$37.50**  
 Extra coils, per set of three..... **\$3.40**  
 Kit of tubes..... **\$3.75**

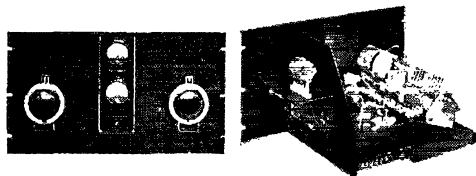

**Millen 90881 500-watt Amplifier**—A universal power amplifier for use with a pair of tubes such as 35T's, T40's, T55, HK154, RK35, etc. Wired for use with 812 tubes, instructions for conversion to other tubes included. Individual plate and grid meters of 100 and 500 ma. range mounted on panel. Terminal strip for connections with insulated standoff for high voltage.....**\$89.50** Less Tubes

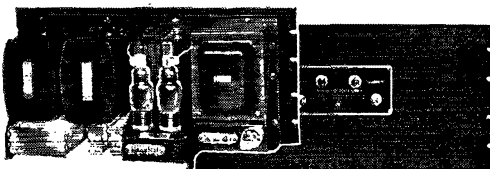

**Millen 90281 High Voltage Power Supply** — This new Millen Power Supply provides an ideal power source for transmitters such as the Millen 90800 Exciter/Transmitter, etc. It has a d.c. output of 700 volts with maximum current of 235 ma. A.C. filament power of 6.3 volts at 4 amps is also available. Uses two 816 rectifier tubes, has two section pi filter and 1000 volt pyranol condensers. Filament and plate switches on panel.....**\$84.50** Less Tubes

## HARVEY'S HITS OF THE MONTH

Harvey has 20 meter crystals for a buck!! Mounted in holder with 1/2" pin spacing. Also 40 and 80 meter and 6 and 13 mc. bands at the same low price.....**\$1.00** plus 10c postage  
 Special 8 mc. xtals for 2 meter xtal control only....**\$1.50** plus 10c postage  
 Still a few left... those 3 mc. precision xtals in dustproof holders with neoprene gaskets. Harvey Special Price. ....**\$1.95**

## HARVEY'S HAMFESTIVAL OF VALUES

**Army Signal Corps LS7 Speaker**, in steel case with weatherproof louvre. Complete with self-contained 4000 ohm to voice coil transformer. Speaker unit 4" p.m. With PL55 plug and 5 feet heavy duty cable. Mounting clamp may be removed if desired. This speaker is an exact match for 312, 342, 348, SCR284 and other Signal Corps receivers.



**HARVEY  
 SPECIAL  
 PRICE  
 \$3.95**

All receivers in stock for immediate delivery.

(Quantities limited on a few items, send your order at once.)

**Thermador Filter Reactor, C513810**. Inductance 6 Henries at maximum current of 350 ma. D. C. resistance 82 ohms. Electrostatic shield brought out to external terminal. Special at.....**\$3.95**

**Hytron HY-Q75 1 1/4 and 2 meter kit**. All "plumbing" done for you; all RF parts silver plated; completely assembled, wired and tested.....**\$11.95**  
 HY75 tube..... **\$3.95**

**Cardwell V.H.F. Oscillator**—complete with coils for 141-151 mc., 215-230 mc., 415-455 mc. Uses 6F4 tube .....**\$10.80**  
 6F4tube ..... **\$5.55**

Telephone: **3-10rc** Longacre 3-1800

**HARVEY  
 RADIO COMPANY INC.**

103 West 43rd St., New York 18, N. Y.

NOTE: All prices quoted are Net, F.O.B. New York City

## GON-SET CONVERTERS

Now available for 20, 10-11,  
or 6 Meters

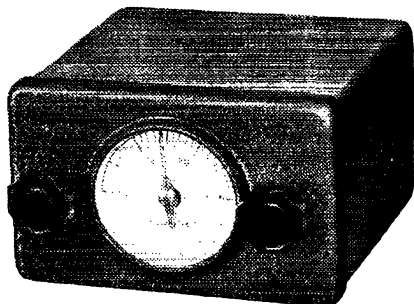

Immediate Delivery

Price Complete, \$39.95—Special Noise Silencer, \$8.25—High Frequency Antenna Lead Cable, 8 Cents Foot

O.P.A. Approved • W6VR

See Your Dealer

Manufactured by

**WATERPROOF ELECTRIC CO.**  
BURBANK, CALIFORNIA

in **ST. LOUIS**

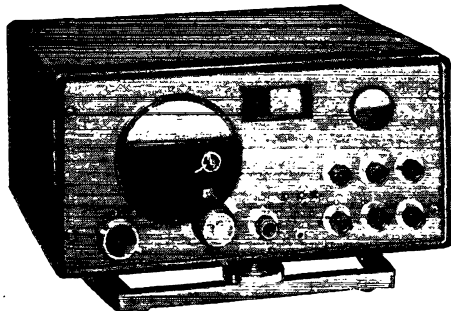

**hallicrafters sx-42**

**\$250<sup>00</sup>** AMATEUR  
NET

ADJUSTABLE BASE  
MODEL B-42 \$7.50

**VAN SICKLE RADIO COMPANY**

1113 Pine St. • St. Louis 1, Mo.  
Chestnut 1814

(Continued from page 100)

other universities sporting ham transmitters. All interested are requested to write Mr. B. Cooper, secretary, 2325 West 1st, Vancouver, B.C., Canada. The Collingwood Amateur Radio Club reports all YLs and OMs are invited to attend meetings held the first and third Tuesdays at 8 P.M. at 5755 McKinnon. A code practice unit has been set up and special instruction will be given to beginners and old-timers. 7BE manages to make a few c.w. contacts despite other activities. AJR has a new HQ-120 receiver and can be heard on 28-Mc. 'phone. 7AK is open for contacts on 3.9-Mc. 'phone and 3.5-Mc. c.w. 7AZ is busy on a home-brew receiver. 7OJ reports a QSL card from KL7. 7ADV hooked a couple of ZLs on 28 Mc. with flea power. 7AKK still is completing the round of all W7 hams. 7ADV can be heard on 28-Mc. 'phone and 3.5- and 7-Mc. c.w. 7AK worked a ZL on 7-Mc. c.w. late one night. 7AZ logged VK4DO, VK4ES, K46ET, K6PLZ, ZL2BS, ZL3AB, J6AAC, and VE8AW on 14 Mc. Sept. 11th. 7UU logged 20CW, ZL3GU, ZLACK, ZL1AU, CO2JJ, F8KW, LU7AZ, and VP9F.

### PRAIRIE DIVISION

**MANITOBA** — SCM, A. W. Morley, VE4AM — Many thanks to CC, who has taken over the QSL Bureau for the VE4 District. Cam needs your cooperation so get your envelopes in. 14 Mc. becomes more active every day. BG couldn't wait till he got his high-voltage transformers wound so got on with 6L6. AT runs T21s on 'phone/c.w. KU, OU, LH, KI, AE, and NZ are on 14-Mc. c.w. NI got power supply for 805. EI, NT, FU, and LF are on 14-Mc. 'phone. SH, HI, and WF are having fun grinding crystals. XO has new NC-100X. NO has S-20R. WF has a new FB7X. CC runs 500 watts to p.p. T55s. AFY and 5QG are back in the Air Force. HV has a pair of 813s on 'phone/c.w. and AR88 and is active on all bands. BN went on 7 Mc., having become disgusted with 3.5-Mc. He likes it so much he pulled the 80-meter coils apart. FR, CB, and DX are busy on 7 Mc. JY is new on 3.5 Mc. KD cracked half a dozen crystals trying to get PP807s to work and finally settled for single one. 3AFH, MJ, LS, KN, and 5QG were visitors in Winnipeg. WF visited the SCM, made a few remarks about the rig, and ended up rebuilding entire job. The result is a swell-looking job at AM/JM. FB7 also is a new addition. 73. Art.

**SASKATCHEWAN** — SCM, Arthur Chesworth, VE5SY — 5MW reports he has schedules with 4FR and 5JP and is trying to get a net started. There is a strong possibility that he will be the new RM for this section. Former 4AE now is 7ABO and his QTH is at the Privateer Gold Mine, Zebaloo, B.C. 5PK, at Hamton, Sask., would like to hear from someone who has a "bug" for sale. He also is having trouble putting up his sky wires because he lives right on top of a hill. 5LY is on 3.9-Mc. 'phone with about 85 watts. 5JV has a new RME-45 and it sure sounds very FB Traffic: VE5MW 1. 73. Ches.



# W9RRX



## W9RXX Small, but Potent!

W9RXX—Bob Adair, of Midlothian, Illinois. Listen for him on 10 meters.

## Communications Equipment

for earliest delivery order from **ALLIED**  
Time Payments Available  
Trade-Ins Accepted

**NEW! HALLCRAFTERS SX-42 \$250.00. Order yours now!**

Hallcrafters S-38 . . . . . \$39.50	RME DB-20 Presselector \$ 88.20
Hallcrafters S-40 . . . . . 79.50	Hammarlund HQ-129X . . 173.25
National NC-46 . . . . . 97.50	RME-45 . . . . . 198.70
NC-46 Speaker . . . . . 9.80	National HRO . . . . . 274.35
RME-84 . . . . . 98.70	National NC-240D . . . . 225.00
RME VHF-162 Converter 88.80	Hammarlund SPC-400X . 342.00

Net F.O.B. Chicago. Prices subject to possible change.

### • • ALLIED HAM "SCOOP"!



**MECK  
T60-1 60-WATT  
TRANSMITTER  
IMMEDIATE  
DELIVERY!**

A great performer on any band, 10 to 80 meters, phone or C. W. Compact, single unit design, only 15" x 11" x 9". Features: Plug-in coils for band selection; Combined plate and screen modulation; Two complete built-in 60-cycle power supplies, 1 for final RF, 1 for Modulator, Speech Amplifier and Oscillator; built-in antenna change-over relay; meter switching to final amplifier grid or plate circuits for tuning; crystal socket on front panel. Complete with set of coils covering 10 and 11 meter bands (other band coils available at \$5.50 per band); includes 5-6L6, 2-6SN7 GT/G, and 2-5U4G tubes. Only **\$15000**

Bob Adair, a pre-war and post-war "permanent" resident on ten meters, believes his 250 watts to a 100-TH is the equal of any Kilowatt—and his amazingly high number of "short-skip" and "ground-wave" contacts as well as foreign DX QSO's supports that statement.

Says Bob, with no prompting at all: "I like to build my own transmitters, and I've found that ALLIED'S fast service gets me the parts I want, when I want them most."

Well, Bob—that's the kind of testimonial we like. We get lots of them. We like getting them because they prove we're delivering the goods.

Whether you're an amateur just beginning, rebuilding, or newly licensed—you can count on fast, preferred service from ALLIED'S licensed hams, each of whom shares your interest in Amateur radio.

### Send for Allied's 1946 Radio Catalog



Here's the Buying Guide that lists everything for the Ham . . . communication receivers, xmitters, Ham gear, code apparatus, parts, kits, tubes, test instruments, etc. Send for your FREE copy.

**ALLIED RADIO CORP., D. L. Warner, W9IBC**  
833 W. Jackson Blvd., Dept. 27-MM-6  
Chicago 7, Illinois

- Enter order for . . . . . Model . . . . .  
 Enclosed \$ . . . . .  Full Payment  Part Payment  
 (Balance C. O. D.)  
 Send Literature on Receivers and Time Payment Plan.  
 Send FREE 1946 Catalog.  
 Send special bulletins on Surplus Equipment.

Name . . . . .  
Address . . . . .  
City . . . . . Zone . . . . . State . . . . .

# ALLIED RADIO

*Everything for the HAM*

## BIRNBACH'S QUALITY PRODUCTS

Since 1923

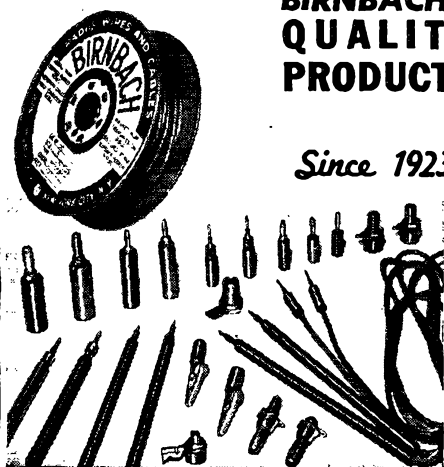

A Complete Line of

WIRES, CABLES, HOOK-UP  
WIRES, RADIO HARDWARE,  
SHIELDED MICROPHONE CABLE  
AND S. J. CABLE

Complete Stock at Your Dealer



**BIRNBACH RADIO CO., Inc.**  
145 HUDSON ST. NEW YORK 13, N. Y.

in. **LOS ANGELES**

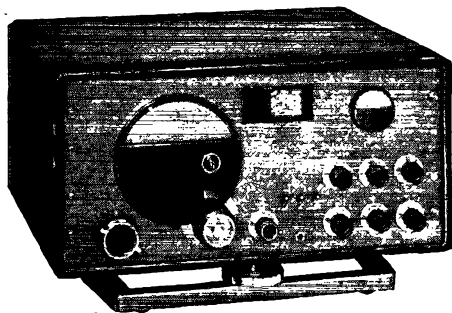

**hallicrafters sx-42**

**\$250.00** AMATEUR  
NET

ADJUSTABLE BASE  
MODEL B-42 \$7.50

**Leo J. Meyber & Company**

2027 So. Figueroa St. • Los Angeles 7, Cal.

## A Broad-Band Exciter

(Continued from page 25)

ing condenser so that the connecting lead is less than an inch long. Because of the extremely-small contact capacitance of this relay, there is no noticeable frequency shift when keying. The 300-ohm relay coil is used as the cathode resistor of the 6L6 so that that circuit is keyed simultaneously with the oscillator. Although not done in the unit shown, it would no doubt be desirable to mount the keying relay on a piece of sponge rubber or some such material to absorb the operating shock.

One drawback in most VFO designs has been lack of real bandwidth. No one could be expected to trust the things when an entire 'phone band occupied perhaps a 1/4-inch spread on the dial. Plug-in coils did not seem to be the solution because the main object in building this transmitter was to eliminate them. On the other hand, separate switched coils would take a lot of chassis room and a rather long ganged switch.

The answer seemed to be to use a single coil, tapping down on it with the main tuning condenser, and at the same time compensating for the resulting loss in total capacity. This was tried and it worked perfectly. A coil and condenser combination was found that, with the condenser across the entire coil, made the 3.4-4.0-Mc. range occupy the entire dial scale. The 3.4-Mc. frequency was chosen for the low end because it gives coverage of part of the new eleven-meter band.

To spread the other bands the main tuning condenser is tapped down on the coil by means of the bandswitch, while at the same time another wafer on this switch connects a fixed capacity consisting of a zero-temperature-coefficient condenser of a capacity equal in value to that lost by the tapping-down process. Thus, by the use of the coil taps and compensating capacitors listed in Fig. 2, each of the bands is spread over the complete dial. A new-type Erie zero-temperature-coefficient trimmer that is very compact and easily mounted is used for the initial setting up of the band edges on the dial. The 100-kc. oscillator, if used, will take care of the calibration of those points. If would be desirable, however, to calibrate all scales against a standard having smaller frequency intervals.

All the components of the 6SJ7 oscillator and 1853 isolating tube are mounted in the compartment in the bottom center of the VFO chassis. A substantial aluminum plate screws on to complete the shielding.

No vibration troubles have been experienced because reasonable care was taken to locate parts so that leads would be short. Where leads of appreciable length were required intermediate tie-points were provided.

A slug-tuned plate tank coil is used for the 6L6 in the VFO so that crystal control can be used. If the use of crystals is not planned an r.f. choke can be substituted for this coil but at some sacrifice of output.

(Continued on page 128)



# HARRISON HAS IT!

Good-bye to  
Battery Expense!

- Portable for Receivers
- Transmitters
- Walkie Talkies
- Remote Controls
- Test Equipment

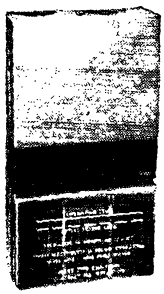

Complete Vibrator Pack, less only battery (use it on four flashlight cells or your car battery, etc.) **\$3.95**

● **KW MODULATION TRANSFORMER**  
Here's an FB HSS value in a hard-to-get item! RCA commercial quality construction. Conservatively rated at 550 Watts of audio, will modulate up to a kilowatt final.  
Primary matches any Class B modulators up to 10,000 ohm plate to plate. Impedance ratio 1:1. Secondary carries 450 ma. Tertiary winding to modulate screens or suppressors carries 80 ma.  
Mycalox terminal board with three adjustable protective flash-over gaps insures against breakdowns. Open frame mounting. Actual weight 3 3/4 lbs. 9 1/2" x 7 1/2" x 7 1/2" high. **\$24.75**

● **ANTENNA TUNING UNIT**  
Signal Corps BC-939-A (Hallierafter AT-3)  
Will efficiently couple up to KW transmitter to any short or long wire antenna working against ground. Full range of 1.5 to 18 Mc.  
You've seen these sold as *surplus* at \$79.50. Harrison sells them NOW, brand new, complete with RF meter, cabinet, and both plug-in vacuum condensers, for only **\$29.95**

● **COAXIAL CABLE**  
Save money! See our previous ads for all types!  
RG-58/U. 55 ohms. An efficient, light-weight transmission line (.195" OD) for Amateur, FM, and Television antennae. Also use as high quality, inexpensive crystal mike or pick-up cable. List price. . . . . **\$18.50**  
HSS SPECIAL — 100 feet for **\$3.95**

● **OIL FILLED CONDENSERS**  
Standard makes, new, guaranteed, all at prices that will save you money. HSS 2 Mfd, 1000 Volt. Round, upright case mounts in 1/4" hole. FOUR **\$2.34**

Rectangular, upright cases, with ceramic terminal insulators:  
4 Mfd, 600 Volt. Three for **\$1.98**  
10 Mfd, 600 Volt. TWO for **\$2.47**  
8 Mfd, 1000 Volt. TWO for **\$3.88**  
4 Mfd, 1500 Volt. TWO for **\$3.98**  
1 Mfd, 5000 Volt. **\$2.45**

● **24G TUBES** (3C24/VT204) An FB triode for VHF. 90 Watt rated Class C output, 6.3 Volt, 3 amp filament. Small bulb. Made by H & K, Gov't, inspected, fully guaranteed! Regular amateur net price was \$9.00, reduced to **\$6.00**, Harrison sells them for only **\$1.49**

● The last time we offered these popular tubes, orders and reorders came in so heavy, we had to ration them. But this time, we think we have plenty — so order as many as you want — spares — presents, etc.!

# HARRISON HAS IT!

## COMPACT POWER PACK

For little more than the cost of one set of regular dry batteries, you can obtain a new, modern, vibrator pack that will save you space, weight, and money! Ruggedly made for Navy radio equipment, this pack gives excellent service under the roughest field conditions.

- Only 1 1/2" x 3 1/2" x 4" high (6 1/2" high with battery)!
- Weighs 3 lb. 10 oz., complete!
- Delivers: 135 volts at 20 ma. in continuous Military duty or 30 ma., or more, in intermittent Amateur service; 1.5 filament or 6.3 heater, bias, and microphone voltages.

This efficient pack works on any 6 Volt DC source, and has such desirable design features as neon voltage regulator, complete filtering, remote load start relay, etc. Brand new in sealed Navy inspected cartons, fully guaranteed. *One of the most sensational HSS values ever offered!*

Complete Power Pack including clip-in Willard storage battery. Unbreakable plastic Non-Spill Case (even if turned upside-down). Shipped bone-dry, fully charged, ready to put into immediate service, or to store for years. Can give several hours of continuous operation at full rated load and then be Recharged for only a few pennies by any 1/2 ampere charger or our special charger. . . . . **\$5.50**  
Spare Storage Battery **\$2.75**

If recharging facilities are unavailable we can supply these packs with clip-in Willard 6 volt lead-zinc Primary batteries. 25 watt hour capacity. Unlimited shelf life. (Can store for years!) Excellent for export.) 1 1/2" x 3 1/2" x 2 1/2", only 2 1/2 ounces! Complete pack with TWO **\$5.75** Primary batteries.

REPLACEMENT PRIMARY BATTERIES. These batteries are also a fine source of 6 Volts DC for many other applications. Each . . . . . **95¢**  
Export packed case of twenty **\$14.75**

## COLLINS ART-13 AUTOTUNE TRANSMITTER Price **\$124.50**

Brand new, latest production 47A. With instructions for conversion to FB ham xmitter. Less tubes. (With tubes, \$144.50)

● **TRANSMITTERS**  
Still the best buy in a modern, post-war rig! *Conservative* output rating of 75 Watts Phone, 100 Watts CW. The price of \$495 brings you a FB *stable* VFO, full coverage of 10, 15, 20, 40, and 80 bands, one dial tuning, band-switching, and everything to go on the air but key, microphone, and antenna. Add it up yourself and you'll see why the Temco 74-GA is gaining such popularity! And to step up your power later, just slip it into the 500-GA Amplifier and you will have a complete, well engineered 500 Watt output transmitter.  
Order your 75-GA from Harrison, to-day!

● **BC-406 15 TUBE UHF RECEIVER \$19.95**  
(BC-406-A 16 Tubes, with motor — \$29.75)  
These are the good ones! Complete with tubes and conversion instructions. Ask the ham who got one from us! See our previous ads.

● **XTALS**  
40-80 meters. Good oscillators, mounted, sealed, **90¢** guaranteed. (Three or more postpaid.) Each . . . . .

● **MAIL ORDERS?** Certainly! Just list everything you want (items in this ad, or any ad, magazine, or catalog) and include deposit.  
Vy 73 de

*Bill Harrison, W2AVA*

**HAM HEADQUARTERS**  
Since 1925!



# HARRISON RADIO CORPORATION

12 WEST BROADWAY • NEW YORK CITY 7

BARCLAY 7-9854

JAMAICA BRANCH — 172-31 Hillside Ave. — REPUBLIC 9-4102

**Sylvania Modulation Meter X-7018.** Now in Stock. Accuracy is within 5% from 300 Kc. to 144 Mc. No plate or filament supply needed. Order yours now.

**\$29.50 net**

\*\*\*

**PREMAX Rotary Beam Kit RB-6109.** Extremely light assembled weight, one man can erect it. Small mounting space required. Adjustable for use on 6-10-11 meter bands.

**\$30.00 net**

\*\*\*

**125-Watt Multi-match Thordarson Modulation Transformer. Type 11M76.....\$19.15 net**

ALL OF THE ABOVE F.O.B. OAKLAND, CALIF.

Mail orders given careful attention

**W. D. BRILL CO.**  
198 TENTH ST. • OAKLAND 7, CALIFORNIA  
**WGKLO W6SSN W6FJX**

*in* **BELLEVILLE**

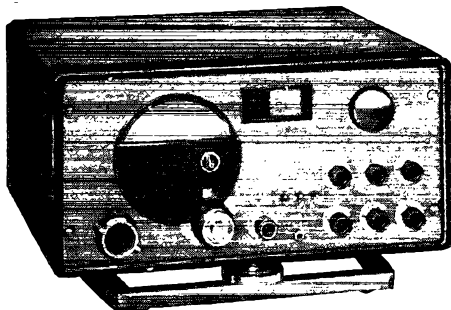

**hallicrafters sx-42**

**THE BIG A COMPANY**  
179 Pinnacle St. LIMITED BELLEVILLE, ONT. Tels. 849-850

## A Broad-Band Exciter

(Continued from page 126)

Since the output of this VFO is in the 3.5-Mc. band, a pair of wires from its output terminals is run to the VFO terminals in the cathode circuit of the 3.5-Mc. 6L6 in the transmitter unit.

When the VFO is first connected to the transmitter unit, the slug in the VFO 6L6 plate circuit should be adjusted for maximum grid current to the 807 at the center of the band and then locked. For setting up on any given band, set the frequency at about the center of the band and tune the 807 plate tank to resonance. From then on all tuning is done with the VFO dial only. After midband settings of the 807 plate condenser have been determined for each band, this dial can be set at the same time the band-switches are operated.

Many stations have been worked on all bands with the complete unit, including numerous foreign contacts on 14- and 28-Mc. c.w. All reports have been T9X.

The author wishes to express his thanks to William Cowperthwait, W3FKK, for his many excellent suggestions in the design of a unit of this type.

## A 10-Meter Plan

(Continued from page 27)

Narrow-band f.m. 'phone will occupy no more spectrum space than a.m. of the same audio range, will be receivable on our ordinary receivers, and has the tremendous advantage of overcoming most cases of BCI. Speaking strictly of the narrow-band method, it may be regarded as merely another means of modulating, and it therefore should have the same allocations as we ordinarily think of for A3 or a.m. 'phone — and because of what it does to BCI it deserves this encouragement.

The purpose of the 28,100-28,250 proposal for tone-modulated telegraphy and frequency-shift keying is to encourage code operation in the 28-Mc. band for other purposes than DX work, something that needs to be done to relieve code congestion elsewhere. Pure c.w. of course will remain best for DX. The right to use tone modulation in this band would appeal to some c.w. men. Frequency-shift keying offers a way to circumvent BCI and its authorization here would probably attract some experimenters who would uncover its general advantages to us. You will note that this allocation for special telegraphy partially overlaps one of the 'phone allocations. There are two reasons for this. The chief one is to provide a test region in which we can determine whether either of these telegraphy methods can be used successfully in the same territory occupied by 'phone. 'Phone normally knocks the spots off of c.w. communication, much more than the converse, and you can see how enormously important it could be to us in our other bands if we could successfully duplex 'phone and c.w. in the same assignments. Such telegraph activity,

(Concluded on page 130)

*in* KANSAS CITY



# hallicrafters SX-42

**\$250<sup>00</sup>** AMATEUR  
NET

ADJUSTABLE BASE,  
MODEL B-42 \$7.50



**BURSTEIN-APPLEBEE**  
1012-14 MCGEE ST. *Company*  
KANSAS CITY, MO.

# LINE SPACER

- Low Loss
- Easily Attached
- No Metal Contact

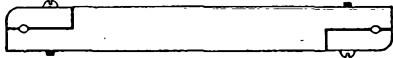

PATENT APPLIED FOR

Type LX-2 (2 in.)      Type LX-4 (4 in.)  
 Type LX-6 (6 in.)

- Fabricated from Amphenol 912-B (low moisture absorption—low power factor—low loss factor).
- Easily attached to line wires without threading wire through holes.
- No metal contact between line wires and spacer to cause noise or changes in line characteristic.

**FREE**—Ask your jobber or write for pamphlet, "Some Methods of Feeding Half-wave Antennae with Open-wire Lines," by A. L. Munzig, W6BY.

**SEE THEM AT YOUR SUPPLY HOUSE!**

FACTORY: Laurelwood and Tippecanoe Avenue  
 Loma Linda, California

**THE** *Arthur L. Munzig*  
**MANUFACTURING COMPANY**

*in* **FORT WORTH**

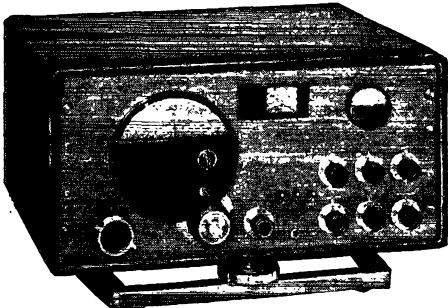

**hallicrafters sx-42**

**\$25000** AMATEUR  
 NET

ADJUSTABLE BASE  
 MODEL B-42 \$7.50

*The Electronic* EQUIPMENT COMPANY  
 Ledger Building · 301 East 5th Street  
 Fort Worth Texas

(Continued from page 128)

by its very nature, would offer much less QRM to 'phone work than would the activity of another 'phone station. The secondary reason is that, while it is not anticipated that much code operation would take place normally between 28,150 and 28,250, the overlap facilitates intercommunication between 'phone and telegraphy, something that is desirable but normally out of reach because 'phone receivers don't have their b.f.o.s turned on for c.w.

When all kinds of operation tend to concentrate in the same small segment of a band, interference becomes difficult for everybody. We need to spread out more. We need to keep the lower portions of this band for the longer distances but there is no reason why, if we go up a bit in the band, we could not afford duplex 'phone operation for local work. The plan therefore provides for duplex 'phone (AØ) on all the frequencies above 28,800. The incentive to move up to get the right to duplex will relieve the low end of some of its interference.

Until our 10-meter population grows a whole lot more we shall have no congestion above 29 Mc. In that portion there is no reason to restrict communication to the modes that take the least spectrum space. It is therefore proposed that above 29,000 the band be open to *all* types of emission that have been mentioned, plus wide-band f.m. That is our "reserve," which some day may rate similar whacking up to fill new needs that we develop — but that time is not yet.

It is believed that the foregoing plan gives 'phone operators all they are asking for, provides ample space for c.w. operation in the absence of foreign 'phone interference, and offers the best arrangement that has been thought up to deal with that interference — the chance that it will be trapped in one c.w. segment or the other. It is also felt that having narrow-band f.m. on the same frequency basis as a.m. will help a great deal in solving the broadcast-interference problem as well as provide an opportunity for determining the merits of the system in amateur DX communication generally. The proposal seems to yield the maximum possible communication facilities, making a place for almost every type of telegraph and 'phone emission, taking numerous technical considerations into account and looking ahead to the development of the art. It seems to make adequate place for the differing kinds of operation that we know we'll have in that band as its performance characteristics vary through the cycle. Throughout it has been planned to be of maximum usefulness after the remainders of our other bands have been returned and we have shaken down into a stable occupancy pattern.

The question now is on what *you* think of it. Study it, talk it over, and then write your comments and suggestions to your division director. And, if convenient, send Headquarters a carbon copy of your letter.

— K. B. W.

# Meet "BUCK" STRETCHER

W9HEI WINS SUPER-PRO! He's loaded with XMAS SPECIALS!



The happiest ham in the world today is Maurice Kraay, W9HEI, of Hammond, Indiana, whose shack is the home of a brand new Super-Pro. Here's Maurice's own story:

"I received my new license and call letters on October 8, just a week before your contest closed. I had been off the air for 10 years which can be attributed largely to marriage and a couple of "harmonics". My old call was W9MFW.

"While building my new kilowatt phone rig, I have been on the air daily on 80, 40, 20, and 10 meter CW.

"Thanks to Sun Radio and best of luck to 'Buck' Stretcher."

Lots of luck to you too, 9HEI.

"Buck" will bring luck to ALL hams. Take a look at the money-saving specials on this page. Send Sun Radio your order today. Quantities are limited.

"Buck" Stretcher's new Ham Catalog is coming out soon. Get on his mailing list.



Real 'BUCK STRETCHERS' for XMAS!

EXCLUSIVE!

RF PROBE  
Operates up to  
1500 Megacycles



Handy and reliable RF field strength indicator. Quickly detects standing waves, shielding and RF choke leaks. Checks neutralization and relative transmitter output. Does not effect operation of circuit.

Only 11" long, 13 oz., comfortable hand grip and convenient probe for small openings. Insulated against high voltages. Uses Weston 506

\$26.50

meter.

Only

Marion 0-200 Microamp (scaled) 3" meter	\$3.95
JAN 832A UHF Xmitting tube	4.95
4 mfd 1500V Sprague oil filled condenser	2.20
Kenyon fil. xformer 115V pri, 2.5V-10 amp. C.T. sec; 10,000 V breakdown	4.95
Kenyon miniature mike-to-grid xformer; ±1 db, 60-15,000 cycles; 1¼"x1¼", 2½ oz.	1.08
6AK5 tube	1.90
Plate xformer, Hallicrafters, 115-125V Pri, 870V C.T. at 250 Ma Sec, Fully cased	4.25
Electro-Voice Push-to-talk dynamic mike	9.50
Kenyon swinging choke 4/24 hys, 400 ma, 60 ohm DC res, 10,000V breakdown	11.00
Kenyon Driver xformer, Pri PP-45's to Sec 4-46's	1.80
Kenyon Output xformer, Class B PP 25L6's, 2000 ohms P to F, to 4, 18, 15, 200; 500 ohm line	1.95
Kenyon Fil. xformer. Pri 115V, Sec. 6.3V C.T.-16 amp.	5.95
You can always use a better receiver!	
HQ 129-X	173.25
SPC 400-X Super Pro	347.25
NC 2-40 D	240.00
HRO 5TA1	303.00
RME 45	198.70
Sonar FM Exciter	39.45
RME DB-20 Preselector	68.20

Filament Transformer

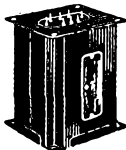

Kenyon fully cased 816 Bridge Rectifier transformer

er. 115V Pri, 2.5V-2 amp., 2.5V-2 amp., 2.5V-4 amp. 2500 V insulation. A real "buck stretcher" at.....

\$2.50

816 HV mercury vapor rectifier tube.....

\$1.25

Shure Model 30 Xtal Mike



With non-breakable plastic stand and 7 ft. cord. Easily removable base.

\$5.95

U. S. Army Type J-36 Bug



Brand new! Sturdily built, bright nickel finish, with heavy black crackle base.....

\$6.75

Mail orders promptly filled — Please enclose 25% Deposit

## SUN RADIO

& ELECTRONICS CO., Inc.

ESTABLISHED 1922

122-124 DUANE ST. · NEW YORK 7, N. Y. · BARclay 7-1840

*in* **NEW ORLEANS**

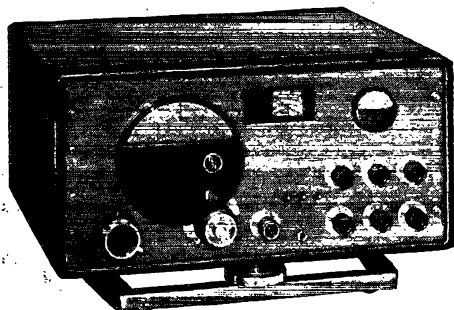

**hallicrafters sx-42**

**\$2500** AMATEUR  
NET

ADJUSTABLE BASE  
MODEL B-42 \$7.50

*Radio  
Parts*  
INC.

807 Howard Ave. • New Orleans 13, La.  
Telephone Magnolia 5121-5122

## Not On The Air

(Continued from page 28)

a flashing neon sign on the corner drug store. I decided to ignore the situation, but I wondered what would happen when I really went on the air.

"Another letter came from Washington. This noted that I hadn't included my operator license with my request for a call, so I figured that the Commission had gone through all the previous applications and would shortly come upon my final, complete and correct application. My ticket was imminent.

"So far, no one has cut down my antenna. Summer school takes up a good deal of my time. A red-headed YL has become a pretty permanent part of my scheme of things, and excursions to night clubs around town with her keep me on the edge of being penniless. I lower my head and walk quickly past the neighbors when I meet them in the hall. I put red dots on the volume control/power switch and main tuning dial of the Ultra-Obnoxious. Every evening for a half hour, while I'm at school, my dad finds the red knobs, and twelve tubes of communication receiver work like mad to bring in results of the day's ball games. The modulator makes a swell phonograph amplifier for which I have infrequent use, and the rest of the transmitter is a pile of parts in a box. I have a swell idea for remote control of the rig, which is copied after the sets I used in the Army. I'm on the lookout for a gear train which will rotate a beam. The station license will come any day, I hope. No, I'm not on the air!"

### About the Author

• FLASH! We have just learned that the FCC has relented and Author Jablin is now the proud possessor of W2QPQ. He plans an active campaign on 2 meters, YLs and BCI permitting. W2QPQ spent 4 years in the Army in the ETO, as a radio operator, working mostly from a Jeep. He is now working for his degree at N.Y.U.

### ~~Strays~~

When Californian Tom Nikirk, W6KA, strayed into the domain of *Jupiter Pluvius* last summer he found time to do a spell of operating at W1CCZ. He learned from W3LPY, over the air, that a good way to cure wet-weather troubles with 300-ohm line was to give the surface a generous Simonizing job — in fact one manufacturer had suggested it. It must work because W1MJH/W3JDA, another native, recommends the application of two coats of floor wax to Twin-Lead to eliminate the impedance change during rainy weather.

*in* **RALEIGH**



**hallicrafters sx-42**

**\$2500** AMATEUR NET | ADJUSTABLE BASE MODEL B-42 \$7.50

**RADIO AMATEUR CENTER**

Cameras — EQUIPMENT — SUPPLIES — Radio  
11 E. Hargett St., Raleigh, N. C. • Tel. 2-1461  
HEADQUARTERS FOR THE AMATEUR

*in* **SANTA ANA**  
*in* **LONG BEACH**

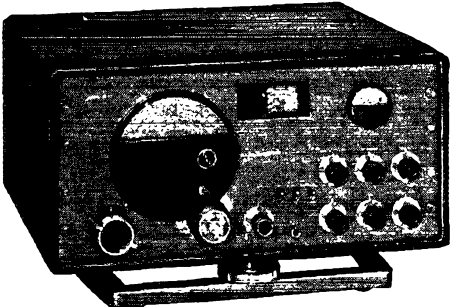

**hallicrafters sx-42**

**\$2500** AMATEUR NET | ADJUSTABLE BASE MODEL B-42 \$7.50

**RADIO & TELEVISION EQUIPMENT CO.**

207 Oak Street • Santa Ana, California  
709 Cherry Avenue — Long Beach, California

*in* **CHICAGO**

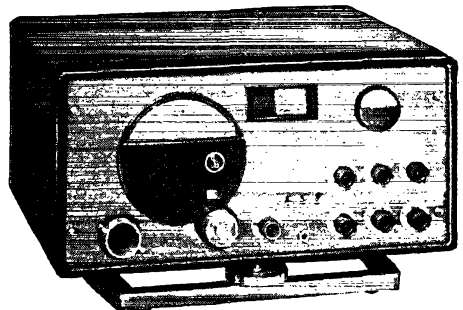

**hallicrafters sx-42**

**\$2500** AMATEUR NET | ADJUSTABLE BASE MODEL B-42 \$7.50

**THE LUKKO SALES CORP.**

5024 Irving Park Blvd.  
Chicago 41, Illinois  
Tel. AVENue 4800

in **TWIN CITIES**

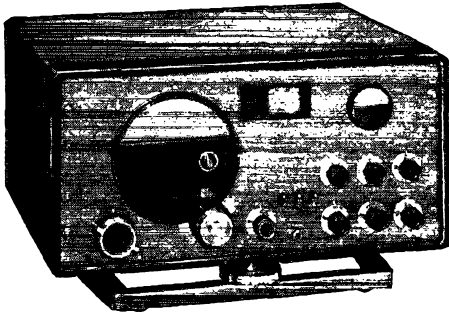

**hallicrafters SX-42**

**\$25000** AMATEUR  
NET

ADJUSTABLE BASE  
MODEL 8-42 \$7.50

**NORTHWEST**

**RADIO & ELECTRONIC SUPPLY CO.**

204 So. Tenth St.  
Minneapolis 2, Minn.  
BRidgeport 5173

194 W. 4th St.  
St. Paul 2, Minn.  
GARfield 6377

**RADIO**

RADIO Technician and Radio Communications courses.  
Register now for new classes starting first Monday of each  
month. Day and Evening Classes.

AMERICAN RADIO INSTITUTE

101 West 63d St. New York 23, N. Y.  
Approved under GI Bill of Rights

• • • **THE WONDER KEY** • • •

Genuine Easy-Working

SEMI-AUTOMATIC  
RADIO KEY

**VIBROPLEX**

Reg. Trade Marks: Vibroplex, Lightning Bug, Bug

"Original" Deluxe  
Model

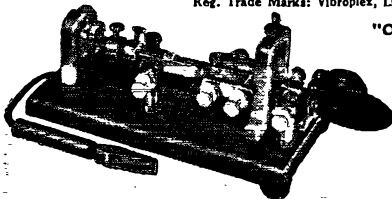

WITH  
PATENTED  
JEWEL  
MOVEMENT

**\$19.50**

The only key equipped with amazing JEWEL-  
ELED movement.

Vibroplex keys are the same as those placed in the  
finest made watches and precision instruments.  
Actually cuts sending effort in half, prevents 'glass'  
arm and develops the highest degree of sending skill  
attainable. Adjustable to speed and personal touch.  
Easy to learn. Striking design. Polished chromium  
base and machine parts. Colorful red switch knob,  
finger and thumb piece. DIE CUT contacts and main  
spring. 3/16th contacts. Circuit closer, cord and  
wedge. Deluxe finish also available in "Blue Racer"  
and "Lightning Bug" models. Specify model when  
ordering. Remit by money order or registered mail.  
FREE catalog.



The "BUG"  
Trade Mark  
identifies the  
Genuine  
Vibroplex.  
Accept No  
Substitute

**THE VIBROPLEX CO., Inc.**

833 Broadway

New York 3, N. Y.

**5 Band Antenna**

(Continued from page 31)

operation is practicable. The resonant line permits full input clear across all the bands, its one chief drawback being that the line itself has fairly high Q so that any wide excursions in frequency necessitate retuning the antenna-matching tank. This problem has been solved by using a large knob at the operating position linked by a Selsyn motor to the antenna tuning condenser. By the use of an exaggerated scale on the condenser, visible from the operating position, a very convenient method of resonating the antenna-matching tank circuit has resulted. One interesting point of this particular installation is the fact that because of a 48-foot long transmission line, a voltage peak appears very near the end for 10, 15, 20 and 40-meter operation. A parallel-resonant circuit provides a convenient impedance-matching method between line and transmitter.

The 20-meter rotary under any circumstances is a fairly substantial structure and requires a reasonably good support. The tower used is made by the Bethlehem Steel Company at South San Francisco, California. It is steel, and 50 feet high, being only 7 inches square at the top and 27 inches at the base. It was designed originally to support an additional 40 feet of 4-inch pipe, the whole structure being a lightning rod for use around open oil-storage tanks. The price was quite reasonable. Because of the small section, a very substantial concrete base is required. The concrete slab is 4 feet square and 5 feet deep, and weighs more than five tons!

With such a nice slender steel tower, we immediately had visions of a vertical radiator on 80. The next question was logical. Why not use all of the loose radiators as top-loading capacity for this band? To accomplish this result, two things were necessary — first, a method of tying the elements together and, second, a method of insulating the base. The first problem was solved by tying the center of the fifteen-meter shorting bar on each stub to the center bearing, which is connected electrically to the top of the tower. The radiator itself is not connected to the tower and therefore is not part of the loading capacitance. Insulating the base was accomplished by mounting the tower on 8 by 8-inch timbers. The wood should be completely dry and impregnated to keep out the moisture. Otherwise, wood is not too good an insulator. It was decided to insulate the base, rather than to shunt excite the tower, because of the possibility of operating the structure at slightly more than a half-wave vertical on forty meters. Actually, however, forty-meter operation has been so good using only the radiator section of the beam loaded to forty by the resonant transmission line that the characteristics of the tower radiator on 7 Mc. have not been determined.

**Adjustment**

The elements were adjusted at housetop level before raising the beam to the top of the mast. An

(Concluded on page 156)



*in* **SAN  
BERNARDINO**

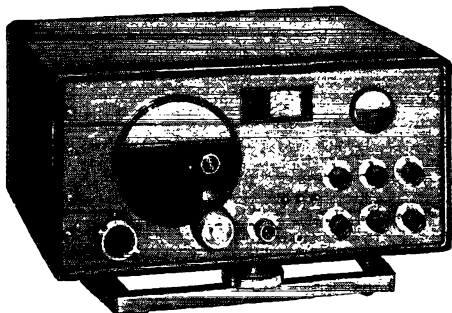

**hallicrafters sx-42**

**\$250<sup>00</sup>**

AMATEUR  
NET

ADJUSTABLE BASE  
MODEL B-42 \$7.50

**ARROWHEAD RADIO  
& TELEVISION SUPPLY CO.**

1216 "D" St. • San Bernardino, Calif. • Phone 225-81

*in* **WINNIPEG**



**hallicrafters sx-42**

**ELECTRICAL SUPPLIES  
LIMITED.**

TELEPHONE 26 366 WINNIPEG 306 ROSS AVENUE

*in* **PITTSBURGH**

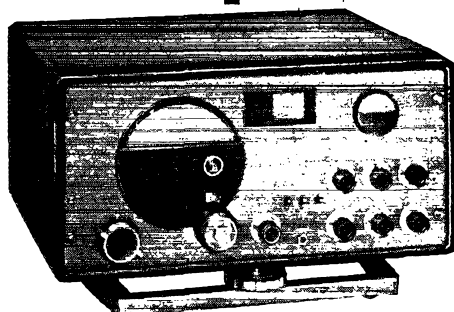

**hallicrafters sx-42**

**\$250<sup>00</sup>**

AMATEUR  
NET

ADJUSTABLE BASE  
MODEL B-42 \$7.50

**CAMERADIO**

963 LIBERTY AVE.  
PITTSBURGH - PA.

*in* **LOS ANGELES**



## hallicrafters sx-42

**\$2500** AMATEUR  
NET

ADJUSTABLE BASE  
MODEL B-42 \$7.50



**RADIO PRODUCTS SALES, INC.**

DISTRIBUTORS OF ELECTRONIC EQUIPMENT

238 WEST 15TH STREET LOS ANGELES 15, CALIF.

PROSPECT 7471

(Continued from page 134)

HRO receiver was used as an indicator, while a generator about a block away provided the signal. The elements were adjusted for minimum signal. First the 20-meter relays were closed and the elements were trimmed for maximum rejection on that band. This determined the physical length of the elements. Next, the 10-meter relays were closed and with the 20-meter relays open, the stubs were slid back and forth at the relay terminals until the position of best rejection for 10-meter signals was found. The approximate position for the relays can be located by making a "short" from a piece of wire and a couple of clips and sliding this back and forth until the dip in signal is found. After the 10-meter position was found, the final short for 21 Mc. was found with all relays open. Very little final readjustment was found necessary. Because of the capacitive effects of the relays, the actual stub length turned out to be considerably shorter than the theoretical length.

Results with the antenna have been extremely gratifying. The front-to-back ratio on both ten and twenty is all that is claimed by the good book. The ten-meter front-to-back ratio is slightly better than that at twenty meters, although evidence of a few minor lobes is apparent. The forward gain is anybody's guess, since no accurate method of comparison with a half-wave dipole was available. The DX capabilities are comparable to the best arrays found in this area. One novel feature of the antenna is the ability to turn on or off the gain or rejection afforded by the parasitic elements simply by actuating the proper relays. This feature is very convenient because a rough approximation of the direction of a received signal can be made quickly in this manner. If the signal decreases in strength when the elements are switched out, the beam is pointing close to the proper direction. If the signal strength increases, the station is behind the beam, and if there is little change, the station must be off the ends.

The antenna system works well on forty and eighty meters, but comparatively little time has been spent operating these bands. Most of the time devoted to operating has taken place on ten and twenty where the DX has been so good, or else it seems that way after such a long layoff. WAC has been worked many times on both 'phone and c.w. on ten as well as twenty. The beam wasn't completed until after the peak of 10-meter DX last winter, so we have high hopes for this fall.

### Better Than Three

(Continued from page 32)

the wind, the weight of the ladder and other assorted things). The ladder started slipping and this guy (still the same one) started backtracking down the ladder, but fast. Quite a balancing act it was. The ladder fell, but by that time this fellow

(Concluded on page 138)



Air and moisture cannot penetrate this transformer case. That's why climatic extremes do not affect the unfailing performance of Peerless hermetically-sealed transformers.

# PEERLESS

**ELECTRICAL PRODUCTS CO.**

6920 MCKINLEY AVENUE, LOS ANGELES 1, CALIFORNIA

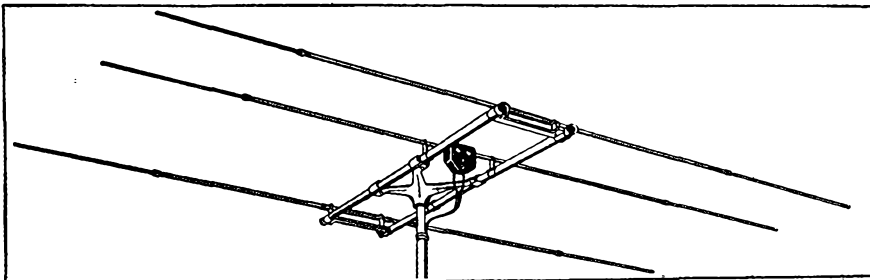

## S/C LABS ADJUSTABLE ROTARY BEAM KITS 702A, 702B, 702C

- Type 702A 27 mc to 29.7 mc (10 and 11 meter band).....\$44.95
- Type 702B 50 mc to 54 mc ( 6 meter band)..... 29.95
- Type 702C 144 mc to 148 mc ( 2 meter band)..... 24.50

The new S/C LABS THREE ELEMENT BEAM presents a distinct high-gain directive antenna designed for 2, 6, and 10 meter amateur bands, adjustable in every respect and sound in mechanical design. Electrically and mechanically engineered to give the best in efficiency. The antenna is constructed of the finest grade aluminum, weight of entire beam is less than 15 lbs.

**PRECISION AND ADJUSTABLE ANTENNA**  
 Type 701A (28-44 mc) 10-meter amateur.....\$6.50  
 Type 701B (44-88 mc) Television 5 meter amateur..... 5.85  
 Type 701C (88-148 mc) FM 2 meter amateur..... 5.75  
 In stock, all types of coaxial cables, transmission lines and hookup wire.  
**SEE YOUR LOCAL DEALER.**

**S/C LABORATORIES, Inc., Dept. Q, 20-22 Van Wagenen St., Newark 4, N. J.**

*in* WINNIPEG

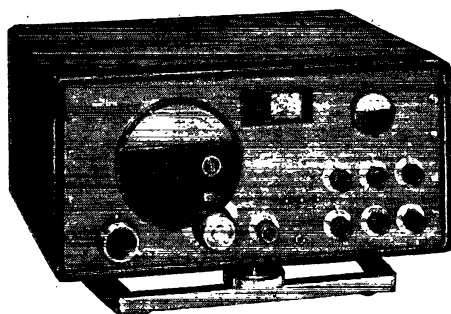

hallicrafters sx-42

**SPARLING SALES, LTD.**

Winnipeg, Manitoba

(Continued from page 138)

had made a two-point (both feet) landing on terror firmer with not an element bent, no worse off except for an empty feeling in the bottom of his stomach.

The ole nerves were finally calmed down a bit and the second expedition started (these mountain climbers have a cinch). Yeah, the beam was tied down so it wouldn't rotate come hail or high water. This guy (same one) finally got to the top of the ladder and found another one of those lil' problems waiting — how to hold this hunk of aluminum and wood up with one hand and nail it onto the front of the beam with the other. Finally a compromise was reached by mutual agreement — one-and-a-half hands were used to hold the contraption, the other one-half (hand) to do the nailing. (Figger it out for yourself, wise guy.) Well, with all this extra conglomeration hanging on the front end of the beam, it was just a slight bit overbalanced. About forty pounds of lead weight on the back end did the job, though the first tall guy that comes by may get smacked on the bean with a bunch of lead (it's hanging down) if he's not careful.

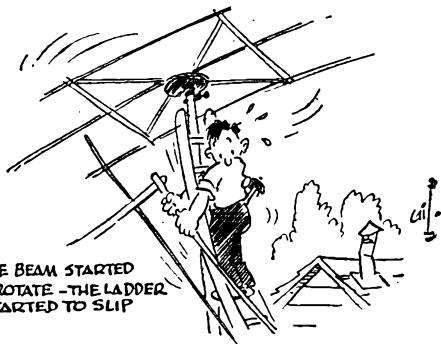

This completed the hard work except for a few slight adjustments to the elements and delta match, to compensate for all this extra aluminum. This guy never would tell how he made those "few slight adjustments" except to say that the ladder fell down twice more and he busted several neon bulbs. He says it's surprising how you can tune up a beam with neon bulbs.

He says, too, that the whole idea in this harem-scarem bunch of aluminum and wood is that the two elements, one above and one below the first director, will lower the angle of radiation drastically and the reports he gets seem to bear out his contention. This fellow says he gets S8 and 9 reports from the VKs, Japan, the Gs, Africa and the Pacific Islands without the complaints of QRM he used to get with the three-element beam, the power being about 120 watts 'phone on ten meters.

Now the dope tells me he's got another bee buzzing around in his bonnet, an *eight*-element beam built on the same principle, and he hopes the ladder doesn't fall down more than three times. So do I.

*in* **CHARLESTON**  
*in* **KNOXVILLE**

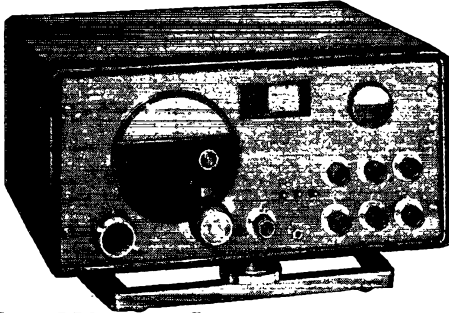

**hallicrafters sx-42**

**\$250<sup>00</sup>** AMATEUR  
NET

ADJUSTABLE BASE  
MODEL B-42 \$7.50

**Chemcity RADIO & ELECTRIC CO.**  
Charleston, West Virginia • Knoxville, Tenn.

*in* **DALLAS**

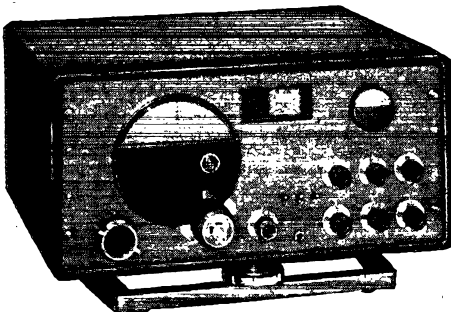

**hallicrafters sx-42**

**\$250<sup>00</sup>** AMATEUR  
NET

ADJUSTABLE BASE  
MODEL B-42 \$7.50

**WILKINSON BROTHERS**  
P. O. Box 1169  
2406-2408 Ross Ave. • Dallas 1, Texas  
Phone R-6339

*in* **MINNEAPOLIS**  
*in* **ST. PAUL**  
*in* **DULUTH**

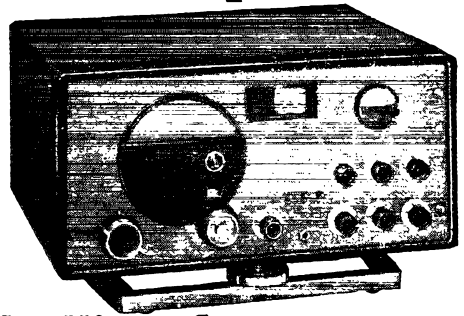

**hallicrafters sx-42**

**\$250<sup>00</sup>** AMATEUR  
NET

ADJUSTABLE BASE  
MODEL B-42 \$7.50

**THE LEW BONN CO.**

67 South 12th Street • MINNEAPOLIS 4  
141 West 7th Street • ST. PAUL 2  
228 East Superior Street • DULUTH 2

# Announcing

## HANDY-TALKY HT-144

A 1947 engineered transceiver for the 2 meter band.

● Attractive grey hammered baked-on enamel or wrinkle finishes.

● Completely telescoping antenna actuates on-off switch.

● Press-to-talk single hand control.

● Economy with efficiency; B battery lasts 75 hrs. reception 45 hrs. trans. A battery 10 hrs. Rapid change thru snap bottom. 6C4 and 1S4 tubes.

● 10 3/4 x 2 3/4 x 2 3/4" wgt. 4 lbs. with batts.

HT-144—less tubes & batts. **\$31.50**

A batts. . . . . \$ .50, set

B batt. . . . . 1.75, set

2 tubes . . . . . 2.49, set

Immediate Delivery!

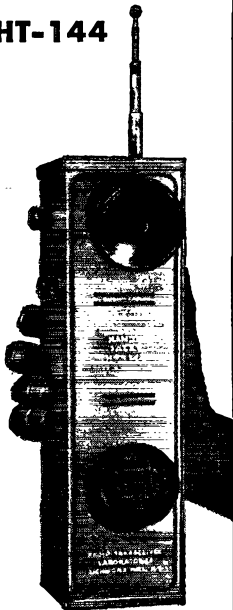

**RADIO TRANSCEIVER LABORATORIES**

116-23 Jamaica Avenue Richmond Hill 18, N. Y.

# in LOS ANGELES

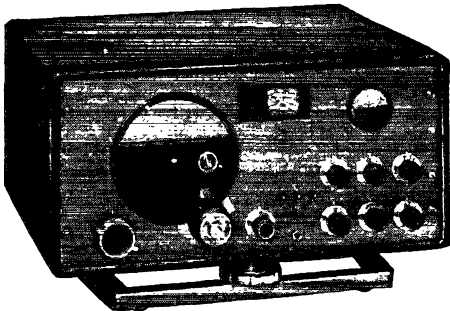

## hallicrafters sx-42

**\$25000** AMATEUR NET

ADJUSTABLE BASE MODEL B-42 \$7.50

### RADIO SPECIALTIES COMPANY

1956 South Figueroa Street  
Los Angeles 7, California

W6FEX W6WFG W6SB W6JBC W6RYU W6EJF W6WMC  
W6TGW W6FQV W6IYI W6JVK W6QFO W6JBO

## Happenings

(Continued from page 37)

license has been reinstated and extended to expire with your operator license, and your operator license expires on the next anniversary of its date of issuance. (Operator licenses dated December 1st to 7th, inclusive, do not expire until the corresponding date in 1947.) Know your expiration date! Within 120 days of that date, write the FCC engineer-in-charge of your district for an amateur application form, fill it out, *attach your current licenses*, and mail direct to FCC at Washington 25.

You may not operate after your expiration date, even though you have a renewal application pending, so it is important that you remember to file in time.

### ELECTION NOTICE

#### To All Members of the American Radio Relay League Residing in the Dominion of Canada:

You are hereby notified that, in accordance with a resolution of the ARRL Board of Directors, a special election is about to be held in the Dominion of Canada to elect both a member of the ARRL Board of Directors (in the office of Canadian General Manager) and an alternate thereto, for the unexpired remainder of the 1946-1947 term and for the following 1948-1949 term of two years. Your attention is invited to §1 of Article IV of the Constitution, providing for the government of ARRL by a board of directors; §2 of Article IV, and By-Law 12, defining their eligibility; By-Laws 13 to 24, outlining the process for the nomination and election of directors and their alternates; and By-Laws 28 to 30, dealing particularly with Canada. Copy of the Constitution & By-Laws will be mailed any member upon request.

Voting will take place between January 1st and February 20, 1947, on ballots that will be mailed from the Headquarters office in the first week of January. The ballots will list, in one column, the names of all eligible candidates nominated for Canadian General Manager and, in another column, all those similarly named for the office of alternate thereto. Each member will indicate his choice for each office.

Nomination is by petition. Nominating petitions are hereby solicited. Ten or more Canadian members of the League may join in nominating any eligible Canadian member as a candidate for Canadian General Manager or as a candidate for alternate thereto. No person may simultaneously be a candidate for both offices. Inasmuch as all the powers of the director are transferred to the alternate in the event of the director's death or inability to perform his duties, it is of as great importance to name a candidate for alternate as it is for director. The following form is suggested:

*Executive Committee,*

*The American Radio Relay League*

*West Hartford 7, Conn.*

*We, the undersigned Canadian members of the ARRL, hereby nominate . . . . . of . . . . . as a candidate for Canadian General Manager; and we also nominate . . . . . of . . . . .*

*as a candidate for Alternate Canadian General Manager; for the remainder of the 1946-1947 term and for the full 1948-1949 term.*

(Signatures and addresses)

The signers must be League members in good standing. The nominee must have been both a member of the League and a licensed radio amateur operator for a continuous term of at least four years immediately preceding receipt by the Secretary of his petition of nomination, except that a lapse of not to exceed ninety days in the renewal of the operator's license and a lapse of not to exceed thirty days in the renewal of membership in the League, at any expiration of either during the four-year period, will not disqualify the candidate; *provided*, that if a candidate's membership has been interrupted by reason of service in the armed forces of

(Continued on page 142)

*in* **NEW YORK**



# hallicrafters **SX-42**

**\$250<sup>00</sup>** AMATEUR  
NET

ADJUSTABLE BASE,  
MODEL B-42 \$7.50

Telephone:

LO. 3-1800

**HARVEY**  
RADIO COMPANY, INC.  
103 West 43rd St., New York 18, N. Y.

# Prepare NOW for a Better Job in RADIO ENGINEERING



Don't Delay—  
Write Today!

## ADD TECHNICAL TRAINING TO YOUR PRACTICAL EXPERIENCE

Cleveland Institute offers these three outstanding courses—

1. Advanced Radio and Communication Engineering. 2. Master Course in Radio Communication. 3. Specialized Television Engineering.

### All Courses Include

The Remarkable Workbooks of Instructional Aids, prepared by the instructing staff of Cleveland Institute

Write for descriptive literature

### CLEVELAND INSTITUTE OF RADIO ELECTRONICS

Successor to NILSON RADIO SCHOOL, Founded 1939  
SMITH PRACTICAL RADIO INSTITUTE, Founded 1934

QT-12 Terminal Tower Cleveland 13, Ohio  
Approved for Veteran Training under G-1 Bill of Rights

Cleveland Institute of Radio Electronics  
QT-12, Terminal Tower, Cleveland 13, Ohio

Gentlemen: Please send information about your home study courses in Radio Electronics.

Name.....Address.....

City.....State.....

Check here, if a Veteran

# in DAYTON

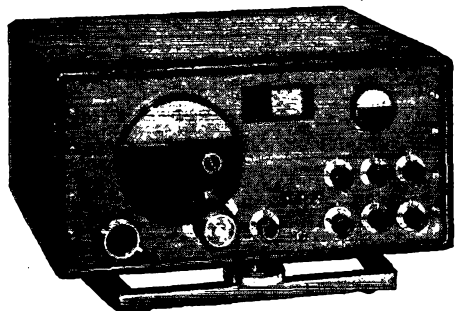

## hallicrafters SX-42

\$25000 AMATEUR NET

ADJUSTABLE BASE MODEL B-42 \$7.50

# SREPCO

STANDARD RADIO & ELECTRONIC PRODUCTS CO.

135 East Second Street, Dayton 2, Ohio

142

(Continued from page 140)

Canada or the United States, he shall not be deemed to be disqualified so far as concerns continuity of membership if he has, since May 7, 1943, renewed his ARRL membership within ninety days of discharge from the military service. He must be without commercial radio connections; he may not be commercially engaged in the manufacture, selling or renting of radio apparatus normally capable of being used in radio communication or experimentation, nor commercially engaged in the publication of radio literature intended, in whole or part, for consumption by licensed radio amateurs. Further details concerning eligibility are given in By-Law 12. His complete name and address should be stated. The same requirements obtain for alternate as for director. All such petitions must be filed at the headquarters office of the League in West Hartford, Conn., by noon EST of the 20th day of December, 1946. There is no limit to the number of petitions that may be filed on behalf of a given candidate but no member shall append his signature to more than one petition for the office of director and one petition for the office of alternate. To be valid, a petition must have the signature of at least ten members in good standing; that is to say, ten or more members must join in executing a single document; a candidate is not nominated by one petition bearing six valid signatures and another bearing four. Petitioners are urged to have an ample number of signatures, since nominators are frequently found not to be members in good standing. It is not necessary that a petition name candidates both for director and for alternate but members are urged to interest themselves equally in the two offices.

Classification of Canadian members into Full Members and Associates is still in process, occurring at time of renewal throughout the coming year. Members possessing certificates of Full Membership, and members not yet classified and holding valid old-style membership certificates, may nominate candidates, or may stand as candidates if otherwise eligible. But members holding certificates of Associate Membership are not eligible to either function.

The present Canadian General Manager is Alexander Reid, VE2BE; the Alternate Canadian General Manager is Leonard W. Mitchell, VE3AZ.

This election constitutes an important part of the machinery of self-government of ARRL, providing the constitutional opportunity for Canadian members to put the management of their affairs in the hands of representatives of their own choosing. Canadian members are urged to take the initiative and file nominating petitions immediately.

For the Board of Directors:

K. B. WARNER,  
Secretary

October 1, 1946

## ARE YOU LICENSED?

- When joining the League or renewing your membership, it is important that you show whether you have an amateur license, either station or operator. Please state your call and/or the class of operator license held, that we may verify your classification.



## 25 Years Ago

this month

THE Second Transatlantics are in full swing as we read our December 1921 QST. We hope our trusty spark and infant c.w. are hurdling the bleak Atlantic. They must . . . this time! There is a reassuring note in QST's word that ARRL-sponsored Paul Forman Godley, fortified with the finest American-made receiving equipment avail-

(Continued on page 144)



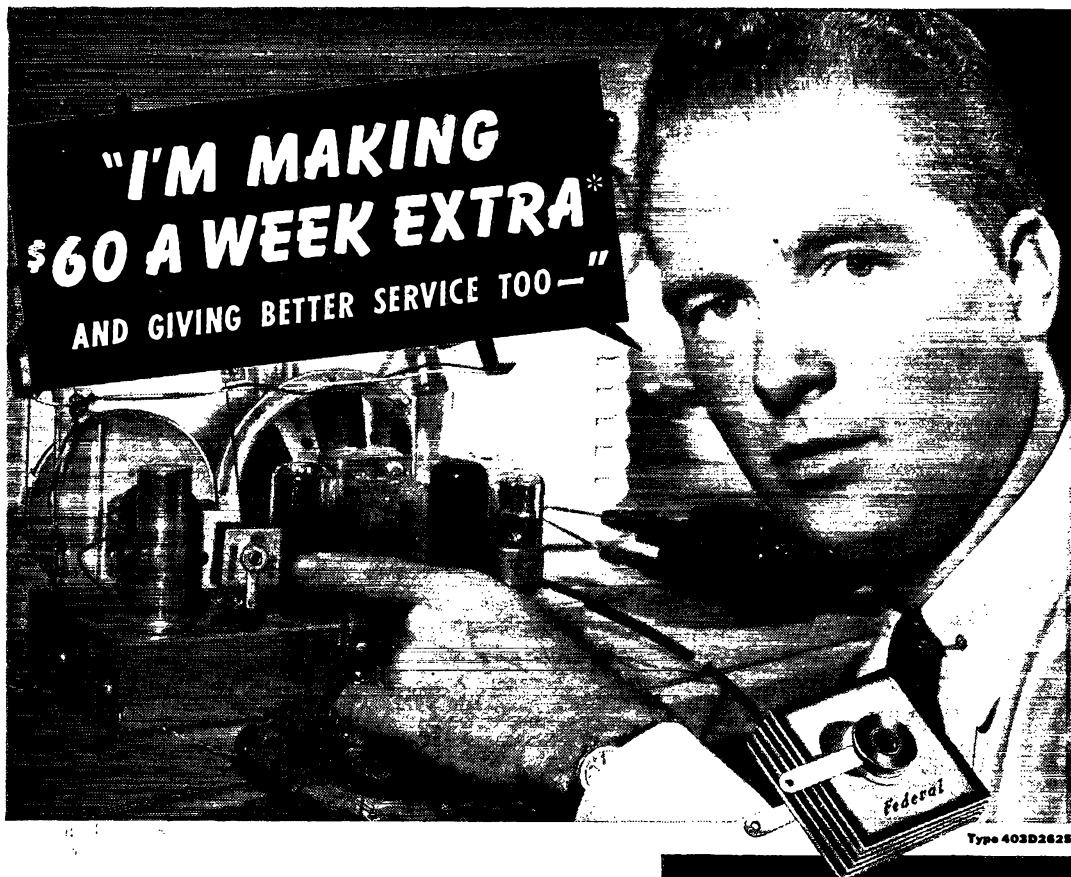

Type 403D2625

**by Installing Federal's Miniature Selenium Rectifier—in AC-DC home radio receivers to replace rectifier tubes**

HERE'S A REAL OPPORTUNITY for the progressive service man—a chance to make extra money and do a better job. For Federal's new, miniature Selenium Rectifier is more than just a substitute for a tube. It's the modern way to give old sets new performance—gives them instant starting without warmup, makes them run cooler, last longer—replaces 29 different rectifier tube types.

Only 1¼ x 1½ x ¾ inches, it fits anywhere, with just a few simple soldered connections and minimum circuit changes. Once installed, it's in for the life of the set. It withstands overloads from defective electrolytic condensers, and is practically unbreakable.

This miniature Selenium Rectifier gives the same performance that has made Federal "Center-Contact" Selenium Rectifiers the standard of the industry.

**\* HERE'S HOW YOU CAN DO THE SAME**

By installing Federal's Miniature Rectifier in place of a tube, you earn from \$1 to \$2 extra per set serviced. Ten sets a day gives you \$60 a week (or more) added profit.

**Replaces these 29 different rectifier tubes:**

5T4	5Y3	6Y5	25Z6	50Y6
5U4	5Y4	6Z5	35W4	50Z7
5V4	5Z4	12Z5	35Z3	117Z3
5Z3	6X5	7X4	35Z4	117Z6
5W4	0Z4	12Z3	35Z5	0Y4
5X4	80	25Z5	35Z6	

**FREE**—eight page service bulletin telling how to install this rectifier in AC-DC radio sets. Miniature Selenium Rectifiers now available in standard packages of 12, with window poster and mailing pieces. Send check or money order for \$12.00\* for 12 rectifiers in display carton and complete sales accessories. Write to Dept. F857.

\*excludes State and City use and sales taxes



# Federal Telephone and Radio Corporation

In Canada:—Federal Electric Manufacturing Company, Ltd., Montreal.  
Export Distributors:—International Standard Electric Corp. 67 Broad St., N.Y.C.



Newark 1,  
New Jersey

# LEARN WIRELESS and TELEGRAPHY!

A BOOK EVERY AMATEUR  
SHOULD HAVE —

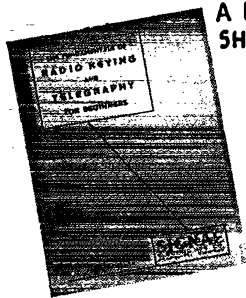

Hundreds of amateurs have  
learned from this book,  
so can you.

Send Now!

15¢  
POSTPAID  
COIN, OR  
STAMPS

This book gives you the fundamentals of wireless and telegraphy. It contains the codes and how to learn them. Mail your order now to:

**SIGNAL ELECTRIC MFG. CO., Menominee, Mich.**

ESTABLISHED  
1892



in **PASADENA**

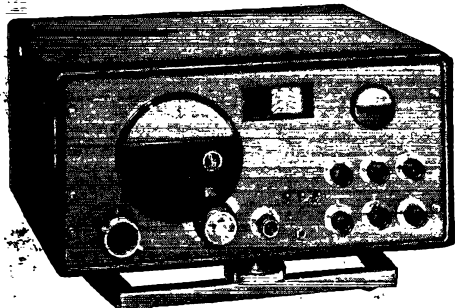

**hallicrafters sx-42**

\$250.00 AMATEUR NET | ADJUSTABLE BASE MODEL B-42 \$7.50

**DOW Radio Supply Co.**  
1759 E. Colorado Street • Pasadena 4, Calif.

## 25 Years Ago

(Continued from page 148)

able, sailed for England on schedule aboard the *S.S. Aquitania*. Mr. P. R. Coursey at the English end, and Traffic Manager Schnell here at home, both report everything in readiness. Not only "Paragon Paul" but over 300 English amateurs, plus a sizeable number of French and Dutch stations, are expected to monitor 200 meters during our "Test" transmissions. Lend an eager ear nightly to MUU, 14,200 meters, for possible good tidings.

It was a confident, enthusiastic little band of radio men that saw Mr. Godley off. A testimonial dinner, attended by Messrs. Maxim, Schnell, Hebert, Camp, Stewart, Service, Goette, Armstrong, White, Bourcheron, W. S. Smith and Warner, was held on the eve of sailing. "I'll stake my scientific reputation on Paul Godley," declared E. H. Armstrong in his speech of well-wishing. And *QST's* editor writes, "We believe we have done a good job of the arrangements and we are confident that, barring rottenly unfavorable atmospheric conditions the entire ten days, American amateur signals will be heard in Europe on schedule." H. H. Beverage, 2BML, RCA receiving engineer and authority on antennas, was a chance companion of Mr. Godley on the crossing, the two never having met until sailing time.

The Chicago Convention paper of Cyril M. Jansky, jr., on "A High Efficiency C.W. Transmitter," heads the technical section this month. Four Signal Corps VT-2 electron tubes, in a circuit developed by Prof. Jansky in 1918, are operated at near 50% efficiency. The unit features a constant output over its complete wavelength range and couples to all types of antennas with ease. Third prize in *QST's* article contest goes to Sumner B. Young, 1AE, for his pointers on "Improving the Relay Spark Transmitter." The battery-operated loop-modulated 'phone outfit at 5ZX is described, along with Carlos S. Mundt's (6AJ) cabinet arrangement for sending sets. "The Design of Loop Antennae" can become extremely involved, we discover, after digging through this mathematical discussion by David S. Brown on the theory of spiral and solenoid types.

*QST's* campaign for better radio-frequency amplification is bearing fruit! The JM-3 amplifier, consisting of three r.f. stages, soft detector and audio amplifier, merits the attention of the "New Apparatus" department. Plug-in iron-core transformers are used between stages.

A new feature headed "With The Radiophone Folks" has been inaugurated. Schedules and program reviews of KDKA, WBZ, WJZ, 1XE, 6XC, 6XG and 6XAK are listed therein. An editorial, entitled "The Radiophone," takes up the pros and cons of this new voice in our bands. Radiophones, and wireless exhibitionism in particular, are objects of the Old Man's latest tirade, "Rotten Bunk."

The Central Division leads the country in traffic handling, followed in turn by the Atlantic

(Continued on page 146)

*Important advantages  
are yours with  
JOHNSON condensers*

Many evidences of superiority in JOHNSON condensers reflect the twenty-three years of experience that has gone into them. Each type is carefully designed by electronic engineers for maximum circuit efficiency. A primary design objective at JOHNSON'S has been the accomodation of a greater number of specific requirements with a standard condenser or minor modification of a standard. JOHNSON'S search for better design and methods is continuous and employs first class engineering talent and equipment. Many developments, such as the new plate design mentioned below, not only bring increased efficiency but a saving in cost.

JOHNSON offers many standard types from which to choose with capacities to 10,000 mmf, voltage ratings to 30,000. See your distributor or write to Dept. M today.

Plates for types A and B condensers are of the new heavy rounded edge design recently developed by JOHNSON engineers. Their higher breakdown voltage permits closer spacing, a shorter condenser, lower minimum, and less inductance at UHF. These features combined with new end frame design reduce weight to minimum, yet cost no more, in most cases less because of the saving in material.

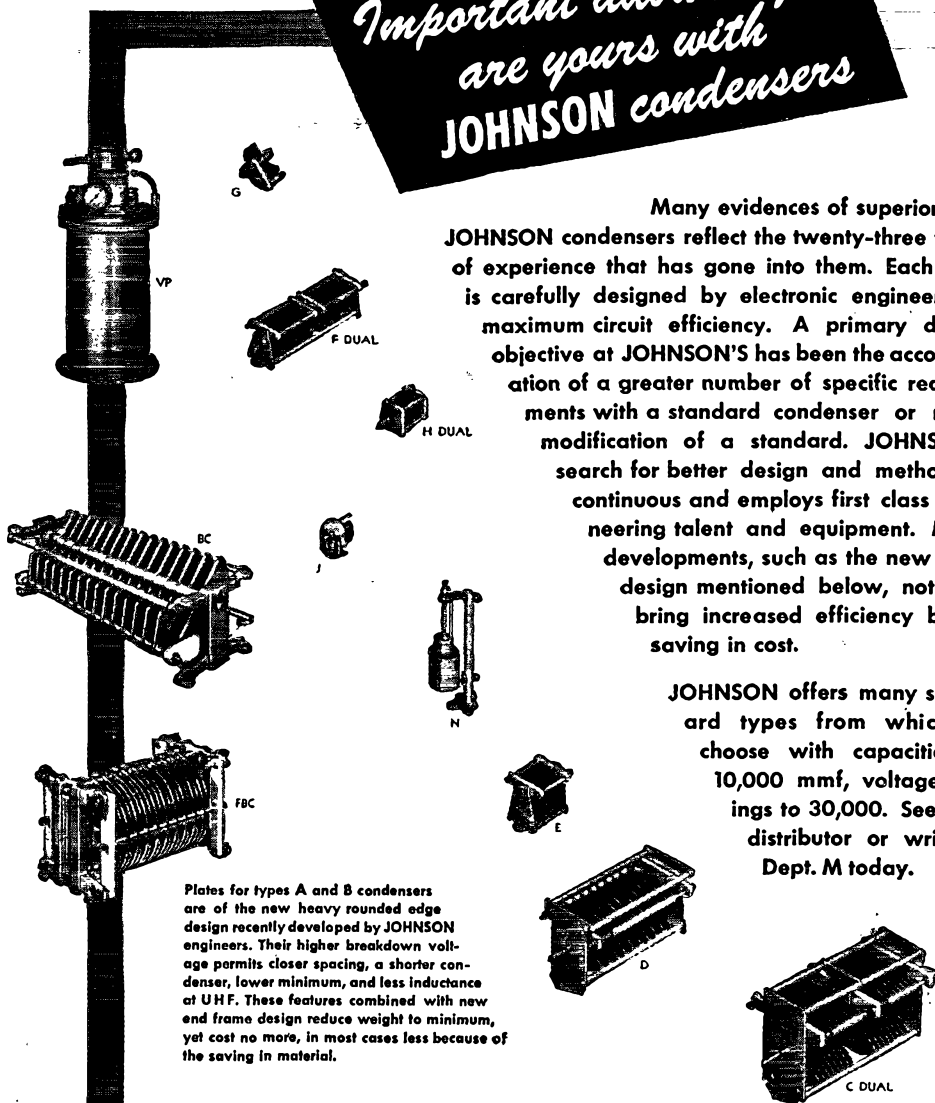

*Johnson products include*

- |                               |                      |            |
|-------------------------------|----------------------|------------|
| Condensers                    | Inductors            | Sockets    |
| R. F. Chokes                  | Q Antennas           | Insulators |
| Connectors                    | Plugs & Jacks        | Hardware   |
| Pilot and Dial Lights         | Broadcast Components |            |
| Directional Antenna Equipment |                      |            |

**E. F. JOHNSON CO., WASECA, MINNESOTA**



**NARROW FM BAND**

Watch for "SONAR'S" new Exciters and Transmitters to be announced shortly

- \*POSITIVELY ELIMINATES BCI
- \*GREATER OUTPUT AND MORE DX
- \*ANY AM RECEIVER CAN BE USED



See Your  
Local Dealer,  
or Write Us!

"SONAR"  
makes a new  
transmitter  
"MODERN"

**SONAR RADIO CORP.**  
P. O. Box 445      Brooklyn 1, New York

*in* **COLUMBUS**  
and **DAYTON**

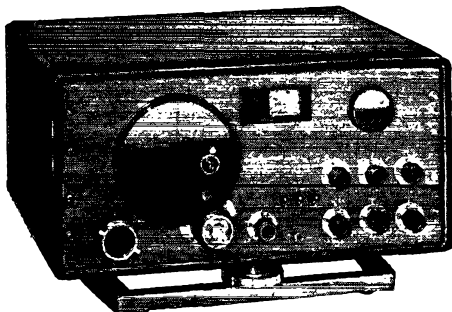

**hallicrafters sx-42**

**\$250<sup>00</sup>** AMATEUR  
NET

ADJUSTABLE BASE  
MODEL B-42 \$7.50

**HUGHES-PETERS, INC.**

117-117 E. Long St. • Columbus, Ohio  
Ma-4356

(Continued from page 144)

and New England Divisions. Ostman, 20M, is still top man, handling 512 messages. Spark stations relayed 83% of our October total, c.w. 17%.

The self-rectified c.w. transmitters at 6ALE and 8IB, the spark at 9YK, and the receiving station of ARRL Member Agusty, in Puerto Rico, highlight the station-description section . . .

Strays report that Clarence Adams, a Chicago amateur, was electrocuted when the iron-pipe mast he was erecting came in contact with an 18,000-volt line. . . . Someone is bootlegging 3ZL's call and he has a total of 57 cards and letters of verification to prove it. . . . Battery chargers are to be relegated to the junk heap, says the prospectus on a new "miracle" charging fluid, known as "liquid electricity," which will rejuvenate any battery electricly by adding the solution to dead cells. . . . New records are being established daily on c.w. — 6KA has heard 2FP, 6BF reports 8BOX.

**BC 375 E**

(Continued from page 42)

preamplifier and the makeshift coupling method described, was entirely adequate for ham use. The over-all response was good for voice frequencies, cutting off at about 100 cycles, and having a fairly flat response to 3000 cycles, dropping off noticeably above that. This restricted range is far from what the 'phone brethren are moved to call "broadcast quality," but why anyone should want to have an audio system that is flat to 10,000 cycles in a ham band has always been a mystery to us. It is wasteful, and causes unnecessary side-band QRM. Most of the range restriction in the BC-375-E seems to be in the audio transformers, making them seem like a pretty good bet for use in our bands.

If you are considering the possibility of boosting the output of the BC-375-E, the power-supply requirements should be kept in mind. Like any other contemplated power increase, it is apt to prove costly unless you have the supply needed to do the job. With the modifications discussed above, the final amplifier runs with 1000 volts on its plate at 150 to 200 ma. depending upon the band in use at the time. The "converted" oscillator tube draws 90 to 100 ma. — more when doubling than when operating straight through — and the modulator tubes draw 230 ma. when delivering full output. The total drain, therefore, of between 470 to 530 ma. makes the use of a heavy-duty power supply imperative if decent regulation is to be obtained. It should also be borne in mind that a huskier driver tube is needed for 14-Mc. operation at higher output than the simple 6L6 required if low-power operation is desired.

No attempt was made to modify the antenna tuning system, which is designed to permit almost any length of wire to be tuned up. In some instances this may prove to be more of a disadvantage than a favorable feature, because no provision has been made for working into a

(Concluded on page 148)

# B & W "BABIES" are back!

A ham friend took us to task recently. "Sure we're interested in your Co-Ax Cable Connector and all the other new B & W developments — but what about those 25-watt B & W Baby Air Inductors? Do you still make them?"

Sure we do! But only lately has production reached a point where "Babies" were again generally available through B & W distributors. Look 'em over — or write for our Baby Air Inductor Data Sheet X100.

These husky little coils are the finest, best-looking 25-watters ever made. 5 types cover from 10 to 160 meters. 5-prong bases permit easy band changing. Windings are perfectly spaced and B & W, Air-Wound design puts an absolute minimum of insulating material in the coil field.

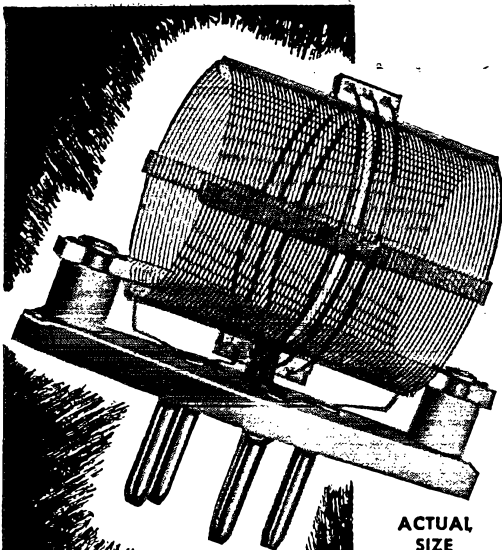

ACTUAL  
SIZE  
1 1/2" long x  
1 1/4" diameter

## B & W

**BARKER & WILLIAMSON**  
237 Fairfield Ave., Upper Darby, Pa.

*in* **LONG BEACH**

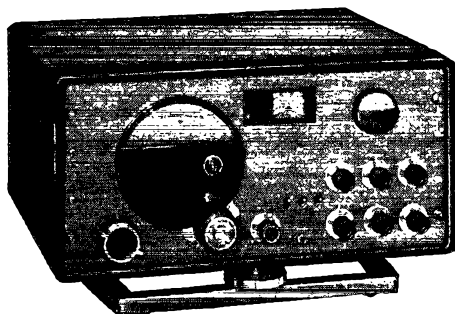

**hallicrafters sx-42**

**\$2500** AMATEUR  
NET

ADJUSTABLE BASE  
MODEL B-42 \$7.50

**SCOTT RADIO SUPPLY**

266 Alamitos Ave.  
Long Beach 2, California

*in* **DALLAS**



**hallicrafters sx-42**

**\$2500** AMATEUR  
NET

ADJUSTABLE BASE  
MODEL B-42 \$7.50

JOBBERS AND DISTRIBUTORS OF ELECTRONIC EQUIPMENT

**CRABTREE'S**  
WHOLESALE RADIO

2608 Ross Ave • Dallas 1, Tex. • Tel. R-3059

Our High Forward Gain, Wide-Spaced, 4-Element,  
All-Aluminum

## 10 METER BEAM

and High Forward Gain, Wide-Spaced,  
3-Element, All-Aluminum

## 20 METER BEAM

Are both now available with

### A PERFECT MATCH, NO STANDING WAVES

Do not fail to send for literature

We have now shipped out several hundred beams and the following are typical of letters sent in. "Recently purchased one of your wide-spaced beams and I want you to know that I have had excellent results with it. I have worked such DX as VS9AB in Eden Arabia, SM7QC in Sweden, OQ5BH in Belgian Congo, ZP8CN in Paraguay, and numerous others. I have also been heard in Rangoon, Burma. The beam sure does all you say it will, and you may use the enclosed picture in any way you desire. Respectfully, Roland Bragg, W1HRI."

"Received the beam in good condition yesterday and at 6:30 P.M. had it up and ready to go. First station heard was W8WHW/KG6 on Guam, and on the third call worked J2AAP in Japan with R7 to R8 reports. Beam is only 17 ft. off ground at present. 73, G. W. Morrow, W8BKP."

All our beams are completely guaranteed to work as stated, are made by amateurs for amateurs, Elements are all of 24St Duralumin, so the entire beam is also guaranteed to withstand any wind and ice. Read folder on structural strength.

### U.H.F. RESONATOR CO.

W. F. Hoisington, 2 BAV

GUION ROAD, RYE, N. Y. • Telephone Rye 2030

(Continued from page 146)

balanced system. It does do a good job of loading the final, however, and probably would work satisfactorily with balanced systems if a coupling unit such as is described in the ARRL *Handbook* is used.

### A Few Conclusions

By now you've probably reached the same conclusion that we did about the BC-375-E. It isn't satisfactory as it stands, but it can be fixed up. The modifications needed are extensive and difficult, especially time-consuming because of the rugged construction used, and are costly, especially if you have to start from scratch on the power-supply question. Whether or not it is worth the price being asked for it depends largely on the individual. The components in it are of excellent construction, and quite a few of them are useful in almost any ham shack. Along with these, however, there are quite a few that are not usable in ordinary ham work. They might be of use in occasional experimental work, but for everyday operating they are not. There are several good transmitting-type variable condensers, ceramic coil forms, and a set of audio transformers. Two of the three meters seem useful, but the range of the r.f. ammeter (0 to 8 amps.) is too large for most ham applications.

Dismantling the BC-375-E and using as many of its parts as possible to build a new rig appeals to us as the most practical thing to do. The suggestions of a few who have purchased the unit are worth passing along. Some like the idea of retaining the plug-in r.f.-unit idea, and are planning to rebuild in the same framework. This is a possibility, but it is certainly not the easy way. A few fellows plan to use the tuning units, each of which has a useful aluminum case, as the source of parts and cabinets for monitors, frequency meters, low-drift VFO units, etc. This last sounds like a good idea, because low-drift and temperature-compensated components are plentiful in the tuning units. Just how to use them is a problem we're not able to answer right now, as our efforts were confined to the attempt to make the rig work and to appraise its desirability as a piece of operating equipment, not particularly with the idea of utilizing all of its parts to best advantage.

Thus, the answer to the question asked by the title of this article depends entirely upon the guy who asks it. The BC-375-E is a tough baby to work on if you want to modify it, and modify it you must if you plan to put it on the air! It's also a tough customer to dismantle. Whether it would be more economical, from the standpoint of time and energy expended, to modify or to rebuild depends on the individual. It's pretty much of a toss-up in our minds.

—R.M.S.

in PROVIDENCE



## hallicrafters sx-42

\$25000 AMATEUR  
NET

ADJUSTABLE BASE  
MODEL B-42 \$7.50

### W. H. EDWARDS CO.

92-94 Broadway • Providence 3, R. I.

20 Years Distributing Amateur Equipment

Tels. GAspee 6158-6159

## SWITCH TO SAFETY!



*in* **NORFOLK**

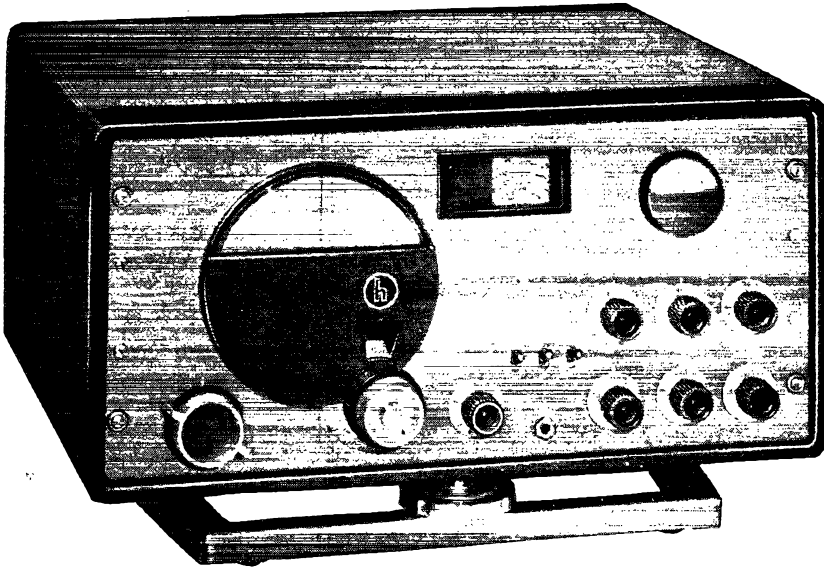

# hallicrafters **SX-42**

**\$250<sup>00</sup>** AMATEUR  
NET

ADJUSTABLE BASE,  
MODEL B-42 \$7.50

**RADIO PARTS DISTRIBUTING CO.**

128 West Olney Road - Norfolk 10, Va.  
Phone 25711

# AMATEUR GEAR

## 8 CONNECTICUT AND MASSACHUSETTS HAM STORES

Quick as you can say "Ham," you'll find the first-choice makes, the elect in electronics, at Hatry & Young. Eight conveniently located stores . . . dozens of lines . . . and the best names, such as . . .

**Amphenol • Bud • Cardwell • G.E. Hallcrafters • Hammarlund • Mal-lory • Millen • National • Ohmite Panoramic • Par-Metal • Petersen RCA • R.M.E. • Silver • Shure • Stan-cor • Taylor • Turner • Valpey and many others**

### CONNECTICUT:

Hartford, New Haven, Bridgeport, New London, Stamford, Waterbury. MASSACHUSETTS: Boston and Lawrence

**HATRY & YOUNG**  
**The Elect in Electronics**

**CODE SENDING SPEED**  
**CODE RECEIVING SPEED**

**Have Skill, Accuracy**

Be a "key" man. Learn how to send and receive messages in code by telegraph and radio. Commerce needs thousands of men. Expansion of air commerce and freight after war should create an even bigger peacetime demand for operators. The famous Candler System, maker of world's champions, teaches you the "knack" of sound sense and sound consciousness that is the secret of speedy sending and receiving. Good pay, adventure. Learn at home quickly.

**FREE 52-PAGE BOOK** explains extra course of training. Rush name for it today. It's absolutely free.

**CANDLER SYSTEM CO.**  
Dept. 4-O, P. O. Box 928, Denver 1, Colo., U. S. A.  
and at 121 Kingsway, London, W.C. 2, England

## World Above 50 Mc.

(Continued from page 44)

W4IUJ, West Palm Beach, Florida, worked W1LSN, Exeter, N. H., on the night of October 12th, and on the 23rd he had contacts with W9UNS, W9CZD, and W9ZHL, all in Indiana. Your conductor was pleasantly surprised to hear W4GJO, Orlando, Fla., break through on the 24th for a brief period.

One of the best aurora sessions yet experienced produced c.w. contacts on 6 for W1s PFJ, LLL, AEP and HDQ, W2s IDZ and BYM, W3s RUE and KXI, W8s SFG and SLU, W9PK and WØNFM, that we know of, on the night of the 26th. This was different from most of our post-war experiences with aurora, in that it was a pure example of reflection from the north. All signals so reflected had the extremely-broad and fuzzy characteristics which were reminiscent of our prewar sessions on 5. The associated magnetic storm was relatively mild, for the lower-frequency bands were not completely wiped out. Few observers were able to see any aurora in the northern sky, the display being of insufficient brilliance to compete with city lights in most locations.

—♦♦♦—

The boys who do the outstanding work on 50 Mc. are an enthusiastic lot. They see, in their particular phase of amateur radio, a field where the surface has been little more than scratched. The WACA was the first objective, and many have already made it. The current urge is to be the first to make a DX contact via  $F_2$  propagation, and there is every reason to believe that this (and the first international DX beyond 2500 miles) will be accomplished within the next few months. After that, a 50-Mc. WAS looms. If the battle of the kilowatts now raging on the lower frequencies has you down, why not try 6? A good clean signal and effective antenna system, a sensitive receiver, and (the most important consideration) wide-awake operation are all that are needed.

Some idea of the enthusiasm of 50-Mc. men may be gained from a perusal of the home addresses of the 6-meter representatives at the recent Midwest Division Convention at Topeka, Kansas. If there had been prizes for the hams from the greatest distances, they would have been a pushover for the 50-Mc. gang — they came from Douglas and Tucson, Arizona, Washington, D. C., West Hartford, and from all parts of the Middle West, to get together personally at Topeka, each making the trip especially for that meeting. The v.h.f. meeting drew a large crowd, and there was every evidence that coming months will see large increases in the v.h.f. population of that area. The Eager Beavers were out in force, and they lost no opportunities for propagandizing in favor of 6.

### International Notes

By the time this appears in print we will be riding the peak of the  $F_2$  season. The maximum usable frequency for  $F_2$  reflections has already

(Continued on page 152)



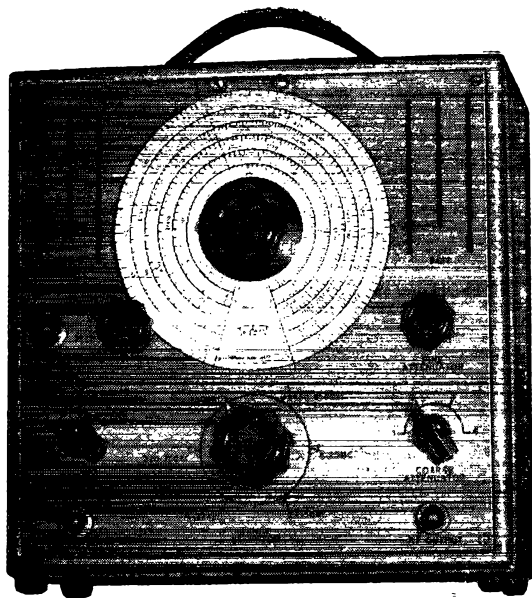

## For the Man Who Takes Pride in His Work

**FM and Television Band Coverage on  
Strong Harmonics. Strong Fundamentals to 50 MC.**

Another member of the Triplet Square Line of matched units this signal generator has features normally found only in "custom priced" laboratory models. **FREQUENCY COVERAGE** — Continuous and overlapping 75 KC to 50 MC. Six bands. All Fundamentals. **TURRETTYPE COIL ASSEMBLY** — Six-position turret type coil switching with complete shielding. Coil assembly rotates inside a copper-plated steel shield. **ATTENUATION** — Individually shielded and adjustable, by fine and coarse controls, to zero for all practical purposes. **STABILITY** — Greatly increased by use of air trimmer capacitors, electron coupled oscillator circuit and permeability adjusted coils. **INTERNAL MODULATION** — Approximately 30% at 400 cycles. **POWER SUPPLY** — 115 volts, 50-60 cycles A.C. Voltage regulated for increased oscillator stability. **CASE** — Heavy metal with tan and brown hammered enamel finish.

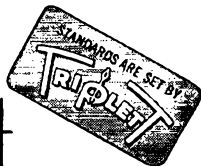

**MODEL 2432  
SIGNAL GENERATOR**

# Triplet

**ELECTRICAL INSTRUMENT CO., BLUFFTON, OHIO**

*in* **PUEBLO**

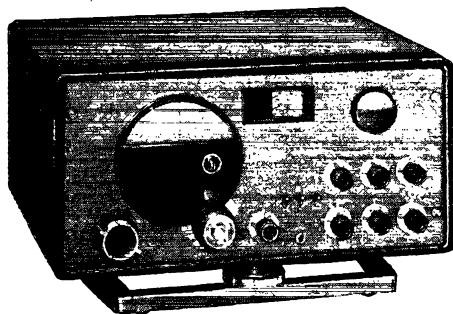

**hallicrafters sx-42**

**\$25000** AMATEUR  
NET

ADJUSTABLE BASE  
MODEL B-42 \$7.50

**L. B. WALKER RADIO CO.**

218 West 8th Street • Pueblo, Colorado  
Tel. 357

*in* **PITTSBURGH**

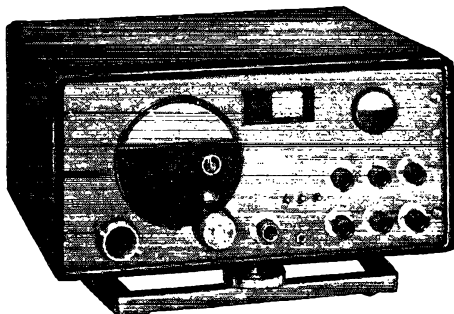

**hallicrafters sx-42**

**\$25000** AMATEUR  
NET

ADJUSTABLE BASE  
MODEL B-42 \$7.50

**TYDINGS** *Company*  
DISTRIBUTORS

Radio and Electronic Equipment  
632 Grant Street • Pittsburgh 19, Pa.  
Phones Atlantic 9260-9261-9262

## ↔ LEARN CODE ↔

**Speed Up Your Receiving  
and Sending with**

## G-C AUTOMATIC SENDERS



**TYPE S**—Housed in aluminum case—black instrument finished—Small—Compact—Quiet

**\$20.00 Postpaid**

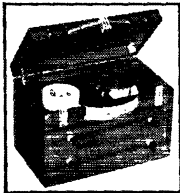

**DE LUXE CABINET**—Matched grain walnut. Enclosed retracting contacts.

**\$30.00 Postpaid**

Each unit equipped with silent induction type motor 110 Volts AC—Adjustable speed control—Maintains constant speed at all settings—Complete with ten rolls

of double perforated tape. A wide variety of other practice tapes available at 50¢ per roll.

*If your dealer cannot supply you write us*

**GARDINER & COMPANY**  
STRATFORD, N. J., U. S. A.

*in* **WICHITA**

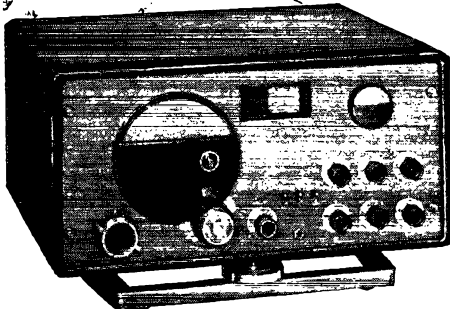

**hallicrafters sx-42**

**\$250.00** AMATEUR NET | ADJUSTABLE BASE MODEL B-42 \$7.50

WRITE FOR FREE CATALOG

**INTERSTATE**  
DISTRIBUTORS INC.

1236 E. Douglas • Wichita 7, Kansas

(Continued from page 150)

passed 50 Mc. in some parts of the world, as we write in late October, but that long-awaited  $F_2$  DX contact has yet to be made. The 28-Mc. band is opening earlier and staying open later than ever before in history, and working foreign stations on that band has reached the "shooting fish in a barrel" stage. The 10-meter skip has shortened up to as little as 1000 miles recently, indicating that 50-Mc. openings are certainly not far off. The main thing is to get stations on in the most favorable localities, and prospects here are improving.

While in New Zealand recently W6WNI talked with ZL1AO, who is determined to make the first ZL-W QSO on 50 Mc. He is on 50.88 or 51.6, with a beam aimed at the States, and will be in there trying at every opportunity. The ZLs have a good chance for 50-Mc. DX, especially if more interest can be aroused in Hawaii and other Pacific Islands, for it is in this part of the world that the highest m.u.f. is expected. ZK1AA, on Raratonga in the Cook Islands, a fine DX prize on any band, is reported to be scheduled to break forth on 6 in November, and W6TZB/KH6 has plenty of power ready to go on the extreme low edge of the band. KH6AR is doing some listening at Waialua, Oahu, and KA1CB reports hearing unidentified signals in the 50-Mc. band in the Philippine Islands, another likely spot.

The 4-letter N-calls reported heard near 50.7 Mc. by G5BY have been identified as emanating from American naval vessels which were at Plymouth, England, at the time. While this is hardly DX, the fact that G5BY was able to hear high-order harmonics over a 15-mile distance speaks well for the sensitivity of his receiver! KYL, heard by G5BY on 52.5 Mc., is identified by W4IPI as the call of a commercial aircraft on an international flight, which probably takes care of the DX possibilities of that report. The reception of KOE, also recently reported, has yet to be tracked down.

Now that  $F_2$  skip offers the principal opportunity for transatlantic work, the automatic transmission schedule (see July QST, page 51) of G5BY will be altered to run from 1430 to 1850 GCT. He will be making calls "to all 6-meter men" on the low end of 10 for five minutes preceding each automatic transmission on 58,632 kc. He is on 10 and 5 at random times on other days, and will be glad to make cross-band tests with interested v.h.f. workers.

From the *Associazione Radiotecnica Italiana* comes an announcement of a 5-meter DX contest for members of the Association. The contest period will run from September 15, 1946 to July 31, 1947, the winner to be the Italian amateur whose 5-meter signals are heard at the greatest distance. The Association requires that authentic QSL cards be supplied as evidence, and requests that any DX station hearing an Italian amateur make his report in that form.

One of the most likely parts of the United

(Continued on page 154)

# 2 METER DX

Can be really heard and worked with the **ULTRAPHONE** model UHP-2 144-148 Mc. receiver and transmitter, using a 6AK5 electron-coupled highly sensitive super regenerative detector. Transmitter consists of Taylor TUF-20 stabilized ultra-audion oscillator audio from 7A4 or 7B4 and 7C5 class AB modulator and output tube. Specially designed antenna kit for high performance on 2 meters available @ \$8.50 amateur net. Includes mast and supports, antenna and 75 ft. 300 ohm twin lead.

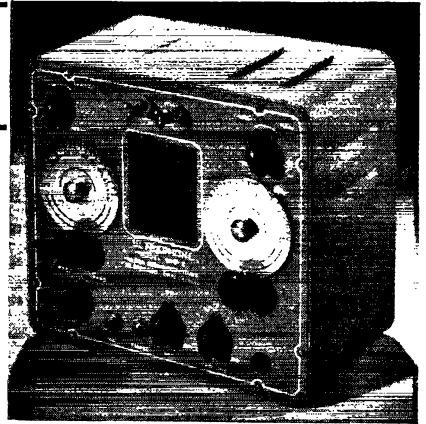

**\$75 Net** WITH TUBES  
FACTORY CALIBRATED

FOR SALE AT LEADING JOBBERS

## GROSS COMMUNICATIONS, INC.

1865-71 Prospect Avenue, Cleveland 15, Ohio

PRospect 0782

Export Agent: ROYAL NATIONAL CO., N.Y.C., N.Y.

*in* **MINNEAPOLIS-  
DULUTH - LA CROSSE**

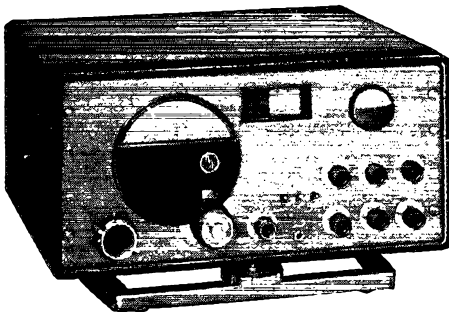

**hallicrafters sx-42**

**\$250<sup>00</sup>** AMATEUR NET | ADJUSTABLE BASE  
MODEL B-42 \$7.50

**STARK RADIO SUPPLY CO.**

71 So. 12th Street • Minneapolis  
22 E. Superior • Duluth  
131 So. 6th Street • La Crosse, Wis.

*in* **WILMINGTON**

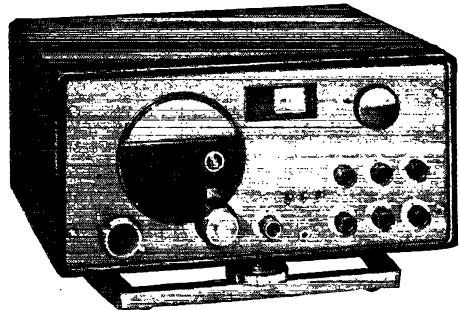

**hallicrafters sx-42**

**\$250<sup>00</sup>** AMATEUR NET | ADJUSTABLE BASE  
MODEL B-42 \$7.50

**WILLARD S. WILSON**

W3DQ  
(DELAWARE RADIO SALES CO.)  
405 Delaware Ave. • Wilmington, Delaware



Keep Up With New Developments!  
**CHECK RESCO'S LIST OF  
 RADIO'S BEST SELLERS!**



Measurements in Radio Engineering, Terman **\$4.50**

Fundamentals of Radio, Terman **4.00**

Radio Engineering, Terman **7.00**

Principles of Radio, Henney **3.75**

Principles of Television Engineering, Fink **5.50**

Ultra High Frequency Techniques, Woodruff **5.00**

Frequency Modulation, Hund **4.50**

Communication Engineering, Everitt **5.50**

Principles of Radio Engineering, Glasgow **4.50**

Radar, What it is, Rider, Rowe **1.00**

Instrument Rectifiers, Onant **.25**

Electronic Physics, Hector, Hein Scouten **3.75**

Television Simplified, Kiver **4.75**

The Electric Eye, Eby **.50**

Radiotron Designers Handbook, RCA **1.00**

Radio Primer, **.25**

RCA Receiving Tube Manual, **.25**

Radio Code Manual, Nelson **2.75**

Mathematics for Electricians and Radiomen, Cooke **4.50**

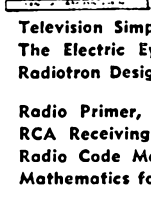
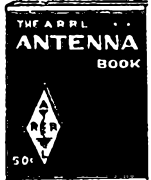

**FOR IMMEDIATE DELIVERY!**

**HYTRON HY-Q TRANSMITTER KITS**  
 for 2 Meter and 1 1/4 Meter Bands  
 Assembled **11.95** — Unassembled **9.95**  
 Requires HY 75 Tube **3.95**

**GENUINE VIBROPLEX BUGS**

CHAMPION MODEL	.....	<b>9.95</b>
ZEPHYR MODEL	.....	<b>12.50</b>
LIGHTNING BUG	.....	<b>13.95</b>
BLUE RACER	.....	<b>15.95</b>



**NEW MODEL RECEIVERS  
 WRITE FOR DETAILS!**

Special Bulletin of Values on Radio Parts and Equipment Now Available! Send for one today!

**Radio Electric**  
 SERVICE CO. OF PENNA., INC.

7TH AND ARCH STREETS, PHILA. 6, PENNA.  
 Branches: 5133 Market St. and 3145 N. Broad St. in Phila.  
 Also in Wilmington, Del., Easton, Pa., Allentown, Pa., Camden, N. J.

(Continued from page 152)

States for prospective DX contacts on 50 Mc. is the Southwest. In Tucson and Douglas, Arizona, W7QAP and W7KAD are hearing occasional carriers which have the "DX sound." The signals peak with their beams aimed west, and they have been heard at the middle of the period when 10 is best. W6YBP, Isleton, Cal., has heard Radio Moscow on 36 Mc., and he and W7QAP have heard commercial harmonics and f.m. signals as high as 47 Mc. That m.u.f. is hanging very close to 50 Mc. these days, and constant vigilance (and plenty of transmitting) should make that first  $F_2$  contact possible.

**More DX on 144 Mc.**

The tremendous splurge which occurred in late September is rather old stuff by now, but, as the distances covered were beyond anything ever worked before or since, the contacts made deserve more reporting than we were able to give them last month. It all started on the night of September 27th. Returning home at 11:45 that night, W3HWN, Mechanicsburg, Pa., found the 2-meter band alive with signals from the New York area and beyond. Several W2s were worked, and then W1MNF, East Orleans, Mass. was heard. After nearly two hours of frantic calling, during which W1MNF was working various W2s (which looked like pretty good DX, from Cape Cod!) Paul finally raised him, and the previous record of 310 miles was broken by an 80-mile margin. The following evening was good as early as 7:30 p.m. In addition to numerous W2s, all about 200 miles distant, Paul worked W1OSQ, Milford, Conn., 220 miles, W1PBG, Litchfield, Conn., 235 miles, W1BJE, Westport Harbor, Mass., 335 miles, W1OGS, Bridgeport, Conn., 215 miles, W1JFF, Newport, R. I., 320 miles, W1IZY, East Freetown, Mass., 345 miles and W1MNF again!

During September your conductor operated his mobile rig from Mt. Cadillac, the highest peak on the Atlantic Coast, on Mt. Desert Island, in Maine. We worked exactly no one, but W1JCT had better luck on October 10th and 11th. Starting at 10:40 p.m., and continuing until about 2:45 the following morning, Johnnie gladdened the hearts of 34 W1s in Maine, Massachusetts, Rhode Island, and Connecticut. Practically all the contacts made were beyond 200 miles, as Mt. Cadillac is a long way up that Maine Coast. The best DX was W1SF, Branford, Conn., more than 330 miles distant. Another nice one was W1JMJ, Martha's Vineyard Island, 265 miles! A nice bit of low-power DX: one of the stations worked by W1JCT/1 was W1KB, Haverhill, Mass., who was running less than 3 watts to a 2C44. His signal was S6 over the 200-mile path! That Mt. Cadillac is a good spot for Maine vacationists to remember. It rises abruptly from the ocean, in Acadia National Park, near Bar Harbor, 1562 feet of solid rock. There is a fine road to the top, and the view is well worth the

(Continued on page 156)

# PERFORMANCE PLUS

## THE TURNER MODEL 211 DYNAMIC

A high fidelity unit combining accurate pickup, distortion-free reproduction, and utmost dependability under difficult operating conditions. Its dynamic circuit utilizes an improved magnet structure and acoustic network to extend the high frequencies and raise the extreme lows 2 to 4 decibels. A specially designed diaphragm results in unusually low harmonic and phase distortion without sacrifice of high output level. Ruggedly Turner built to perform indoors or out regardless of climate or temperature. Finished in rich brushed chrome. Level: -54db at high impedance (1 volt/dyne. sq. cm.) Response: within  $\pm 5$ db from 30-10,000 cycles. Equipped with 90° tilting head, balanced line output connections, and 20 ft. heavy duty removable cable set. In all standard impedances.

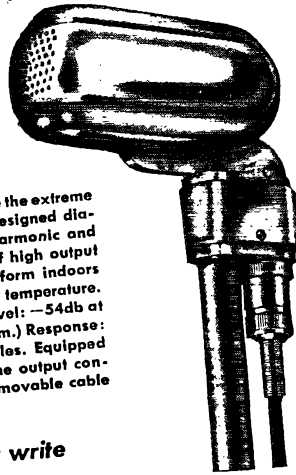

Licensed under U. S. Patents of the American Telephone and Telegraph Company, and Western Electric Company, Inc.

Ask your dealer or write



TURNER

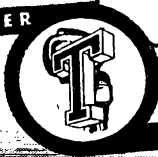

# TURNER

Pioneers

in the communications field

## Microphones

THE TURNER COMPANY  
917 17th Street N.E.  
CEDAR RAPIDS, IOWA

Complete Microphone Catalog  
Write for Your Free Copy

Crystals licensed under patents of the Brush Development Co.

## in CHEYENNE

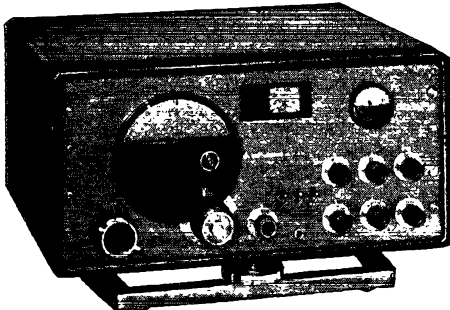

### hallicrafters SX-42

\$250.00

AMATEUR  
NET

ADJUSTABLE BASE  
MODEL B-42 \$7.50

HOUGE RADIO & SUPPLY CO.

2008 Carey Avenue • Cheyenne, Wyo.

Phone 6398

## in DES MOINES



### hallicrafters SX-42

\$250.00

AMATEUR  
NET

ADJUSTABLE BASE  
MODEL B-42 \$7.50

IOWA RADIO CORPORATION

1212 Grand Avenue • Des Moines 9, Iowa

Wholesale Distributors

Parts—Accessories—Supplies



**Get on the  
Beam to M & H  
for SPECIALS in  
HAM EQUIPMENT!**

**SURPLUS TUBES**

UHF, 15E, 15R . . . . . \$3.95  
Klystrons, 723 A/B . . . . . \$2.50

**CATHODE RAY TUBES**

5 CP1, 5 BP1 . . \$6.95 5 BP4 . . \$7.95  
Scope Transformers, 3750 V. 2 MA, \$4.95

**SURPLUS TRANSFORMERS**

For 866 A's. 2.5 V. 10 A . . . . . \$3.50  
With Isolantite Sockets and pr. of 866A  
Rectifiers . . . . . \$7.50

**SOCKETS**

Type 813 . . . . . 59c  
7 Pin Button Shielded, 45c

**SUB-MINIATURE TUBES**

Types 2E31, 2E32, 2E42, 2G22 . . \$1.92

**SURPLUS METERS**

Bendix Tuning Meters, 2" 0-300 MA, \$3.95  
General Electric Meters  
2" 0-25 Amps. . . . . \$3.95

Thordarson T19M14 Modulation  
Transformer 30W . . . . . \$7.49  
HY-Q-75 Transmitter Kit . . . . . \$9.95  
Assembled . . . . . \$11.95  
XTAL Mike, Turner "BX" . . . . . \$6.51

**EIMAC**

4-125A . . \$25.00 4-250A . . \$36.00

**GAMMATRONS**

24G . . . \$6.00 354 . . . \$24.50  
54 . . . \$8.00 454 . . . \$27.50  
Abbott TR4B . . . . . \$52.00

Distributors for Amateur Equipment by  
National, Millen, Hammalund, B & W, Halli-  
crafters, Triplett, Simpson, Weston, Thordarson

**M & H**

**SPORTING GOODS CO.**

512 Market St., Philadelphia 6, Pa.

(Continued from page 154)

trip, even if you don't happen to hit a good night for v.h.f. DX.

Other contacts with Maine are being provided by an increasing number of stations operating on 144 Mc. in the vicinity of Portland, according to W1OKU. Massachusetts and Rhode Island stations were worked for the first time on Sept. 27th, and this provided the impetus the gang needed to get them started on high-gain antennas and better gear. The boys get on nightly at about 8:30, and the list includes W1FBJ, who has a 16-element array; W1AWT, crystal control and 3-element array; W1OHY, W1LNI, W1CPL, W1OIS and W1EWN.

How about that suggestion advanced by W6OVK, that crystal-controlled stations operate

**V.H.F. MARATHON**

Call	Contacts through September		States Worked	
	50 Mc. 144 Mc.	235 Mc. Score	50 Mc. 144 Mc.	
W1BCT*		199	2	4
W1CGY	37			302 15
W1DXL		46		216 5
W1EH <sup>1</sup>		43		205 4
W1HDD <sup>1</sup>	102	117		1789 25 7
W1KLR		74		426 3
W1LL	97			1056 27
W1LMU		147		572 3
W1MBS*		131		432 2
W1PFJ	121			1029 25
W2AMJ	95			863 24
W2AUF*		160		453 3
W2BQK	64			580 17
W2BYM	117			1017 24
W2COT	18	31		140 3
W2DZA		202	8	904 8
W2JWO		174		1088 9
W2LXO		224		960 5
W2QVH		274		1235 8
W2RPO	6	55		439 3 2
W3BKB		74		498 5
W3BTP*		78		467 4
W3CGV	36	55		553 8 5
W3GKP*		126		941 6
W3HWN <sup>2</sup>		165		1644 8
W3KIE		81		399 3
W3LN*		118		652 5
W3RUE	26	18		426 13 1
W4CDG/ <sup>3</sup> *	9	141		1026 6 6
W4HVV	32			574 15
W6BWG	37			120 2
W6IBS		60	1	294 1
W6NJJ*		247		1186 1
W6OVK	9	62		451 6 1
W6QG	49			465 8
W6RYL*	125	173		873 5 1
W6TGY*		51		148 1
W6WNN	38			224 3
W7KAD	60			1262 19
W7QAP	32			587 11
W8NKKJ	18	6		106 7 1
W9AB		14		87 5
W9ACU	8			84 2
W9ALU	15			152 6
W9PK	62			737 19
W9ZHB				25
W0YUQ	63			874 20
W0ZJB	99			1229 26

\* Includes portable or mobile work.  
1 Not eligible for award.  
2 September winner: W3HWN, with 600 points, all made on 144 Mc.

in the first megacycle of the band, and in the top 200 kc., with modulated-oscillator and MOPA jobs staying between 145 and 147.8 Mc.? So far, our presentation of it here has brought just two

(Continued on page 158)

**TRY IT...**



**then**

**TRY TO DO WITHOUT IT!**



Prove it to yourself. Try operating the PANADAPTOR for just ten or fifteen minutes. See all the band activity at once on the Panoramic screen. Learn what it means to pull in sig after sig on your receiver when tuning the Panoramic way... then... cover the screen with your hand and try to do without it. You'll think twice before sliding back to the old way. Only with Panoramic Reception can you see what is going on... why miss anything?

The longer you use Panoramic Reception, the more it will grow on you, and the more you will WANT TO DO WITH IT. Many of the things you can do are clearly shown in a Handbook which you will find at your dealer's when you go in for a demonstration.

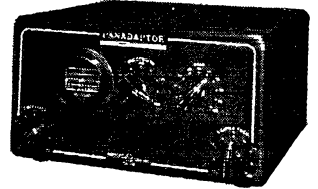

PANADAPTOR... the seeing eye of radio. Buy it—then try to do without it!

**PANORAMIC**

MAIL ADDRESS:  
PANORAMIC NEW YORK



**RADIO CORPORATION**

242 250 WEST 55<sup>th</sup> ST New York 19, N.Y.

Exclusive Canadian Representative: Canadian Marconi, Ltd.

The Panadaptor Model PCA-2 is a 10 tube electronically tuned superheterodyne with a self contained scope, complete with accessories and full instructions for 115V, 50-60 cycle operation at only \$99.75 net. One Year Guarantee.

*in* **SALT LAKE CITY**

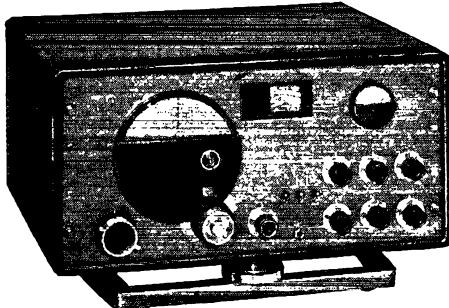

**hallicrafters sx-42**

**\$25000** AMATEUR NET

ADJUSTABLE BASE  
MODEL B-42 \$7.50

**STANDARD SUPPLY CO.**

531 So. State Street • Salt Lake City 1, Utah  
Tel. 4-7727

*in* **MANCHESTER-  
BANGOR - PORTLAND**



**hallicrafters sx-42**

**\$25000** AMATEUR NET

ADJUSTABLE BASE  
MODEL B-42 \$7.50

**RADIO SERVICE LABORATORY**

1191 Elm Street • Manchester, N. H.  
45 Haymarket Sq. • Bangor, Maine  
45A Free Street • Portland 3, Maine

*in* **TORONTO**

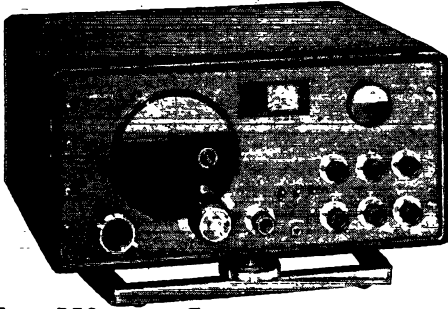

**hallicrafters sx-42**

**WHOLESALE RADIO CO. LTD.**

1133 Bay Street • Toronto, Ontario

*in* **TACOMA**

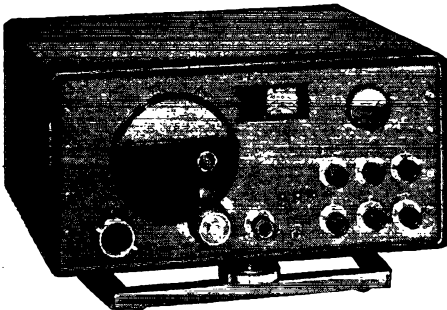

**hallicrafters sx-42**

**\$250<sup>00</sup>** AMATEUR  
NET

ADJUSTABLE BASE  
MODEL B-42 \$7.50

**C. & G. RADIO SUPPLY CO.**

714 St. Helens Avenue • Tel. Main 2139

W7DAI Tacoma 2, Wash. W7EHQ

(Continued from page 166)

responses. One takes us to task for not advocating 100-per-cent stabilization by legislative action, another says that modulated oscillators are OK if operated within reason. Both comments avoid the issue, which is that, if we are to realize the full value of our assignment in this range, we must use stable rigs and selective receivers, and yet the band is a good place for low-powered rigs of simplest possible design. In the last month or so we've noted, with considerable satisfaction, the great increase in the number of crystal-controlled rigs on 144 Mc. In Eastern New England, and in the New York area, the trend is really taking hold; and we know that stabilization is gaining ground in the Middle West and along the California Coast also. We suggest that anyone planning a crystal-controlled rig keep the above frequency segregation in mind in selecting his operating frequency.

**Another New Record for 420 Mc.!**

The mountains of Northern and Southern California have been the scene of considerable 420-Mc. work in recent weeks. The record for that band is now up to 170 miles, as the result of a contact between W6FZA/6, operating from Mt. Hamilton, and W6UID/6 at Blue Ridge Lookout, 17 miles east of Exeter, Cal., on Sept. 28th. Contact was established at 12:50 P.M., and after antennas were orientated correctly the signals were S9. The shape of things to come may be seen from their report that their respective receivers could be heard S6! Antennas and rigs were nearly identical, the transmitters using a 446A lighthouse and the receivers a 955 super-regenerative detector. The antennas each consisted of 8 half waves in phase with a copper-screen reflector.

Operating from Point Loma, San Diego, W6IBS/6 has worked W6WSQ/6 and W6BOB/6 on Mt. Wilson, approximately 120 miles, and

**More 80-Mc. Frequencies**

W1DEO	Portland, Maine	52.48 Mc.
W1EIO	Berwick, Maine	51.15
W1IUI	Kingston, N. H.	50.58
W1LJ	Lowell, Mass.	51.0
W1OFT	Sanbornville, N. H.	51.0
W3OMY	Pittsburgh, Pa.	50.04
W6BWG	San Gabriel, Cal.	52.4, 52.7
W6FPV	San Nuy, Cal.	51.57
W6YBP	Isleton, Cal.	50.78
W8ALZ	Pleasant Hill, O.	51.9
W8CYE	W. Carrollton, O.	51.3
W8VSY	W. Milton, O.	51.9
W6WPN/8	Wilmington, O.	50.6
W7IYW/8	Dayton, O.	51.2
W9HOG	De Soto, Ind.	52.5
W9MBL	New Castle, Ind.	51.15
W6TZB/KH6	Honolulu, T. H.	50.002
ZLIAO	Auckland, N. Z.	50.88, 51.6

W6RJS/6 at Palos Verdes, approximately 100 miles. Signals were S9 in each case. W6IBS operates from his home location each Tuesday and Thursday evening between 8 and 9 P.M., using 60 watts input to a pair of 15Es feeding a beam aimed at Los Angeles. He would appreciate reports from that area.

(Continued on page 160)



**TERMINAL IS YOUR BEST BET FOR BETTER BUYS!**

**HEADQUARTERS  
FOR AMATEUR  
EQUIPMENT**

**RECEIVERS & TRANSMITTERS — NOW!**

**We Specialize in High Quality Equipment!**

For speediest delivery, mail your orders to TERMINAL! We ship orders same day they are received. If near New York, shop at our store for everything in radio. Visit our "Specials Dept." for choice buys!

**National**  
HRO-5TA1, complete ..... **\$306.71**  
NC-240D, with speaker ..... **241.44**  
1-10A, less spkr and pwr supply,  
with National selected tubes..... **67.50**  
1-10 power supply No. 5886.... **19.10**

**RME**  
RME-45, complete..... **\$198.70**  
RME-84, complete..... **98.70**  
DB-20 preselector..... **68.20**  
UHF 1.52 (2, 6 and 10 meter conv.) **86.60**

**Hammarlund**  
HQ-129X, complete..... **\$173.25**  
SP-400-X, complete..... **342.00**

**Hallcrafters**  
S-38, complete..... **\$39.50**  
S-40, complete..... **79.50**  
SX-42 receiver..... **250.00**  
R-42 speaker for SX-42..... **25.00**  
HT-9 Transmitter, 100 Watts on  
Phone and CW. Complete with  
tubes, less crystals and coils.... **250.00**  
TEMCO 75-WATT XMTR..... **495.00**  
Waterman Pocketscope..... **55.00**  
Sonar FM Exciter..... **39.45**  
Hytron HY-Q UHF Kit..... **9.95**  
Hytron HY-Q UHF, Assembled..... **11.95**  
Cardwell UHF Oscillator Kit..... **10.20**  
Millen 90800 50 Watt Exciter..... **37.50**  
DuMont 274 5" Oscilloscope..... **99.50**



**National NC-46**  
Ten-tube communications receiver, complete with separate speaker in matching cabinet. Immediate delivery..... **\$107.40 net**

Send 25% with order, balance COD; or remit in full

**TERMINAL Radio Corporation**

85 CORTLANDT STREET • NEW YORK 7, N. Y. • WOrth 2-4415

*in* **TRI-CITIES**

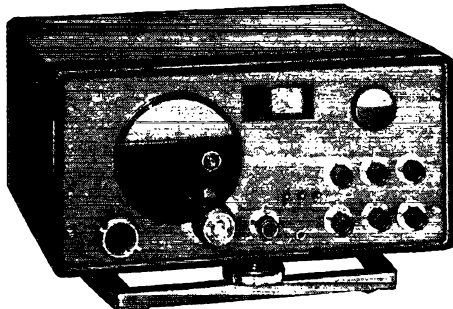

**hallicrafters sx-42**

**\$250<sup>00</sup>** AMATEUR NET

ADJUSTABLE BASE MODEL B-42 \$7.50

*in* **SALT LAKE CITY**

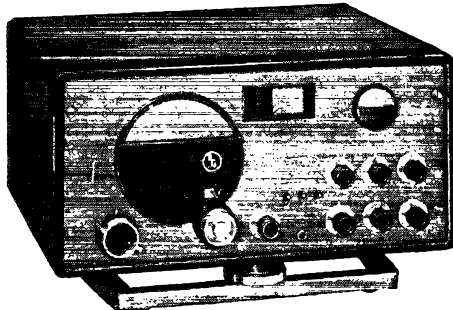

**hallicrafters sx-42**

**\$250<sup>00</sup>** AMATEUR NET

ADJUSTABLE BASE MODEL B-42 \$7.50



**RADIO SUPPLY**

Rock Island, Illinois  
Electronics for Davenport,  
Rock Island and Moline

**RADIO SUPPLY CO.**

45 East Fourth South • Salt Lake City 1, Utah  
Tel. 5-2817

*in* **ANCHORAGE**

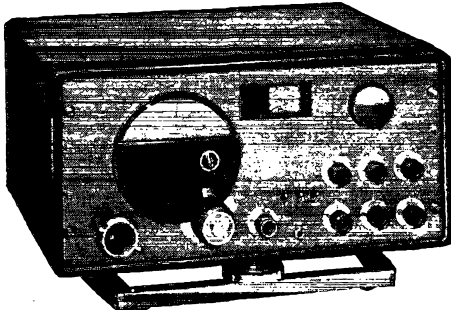

**hallicrafters sx-42**

**\$25000** AMATEUR NET | ADJUSTABLE BASE MODEL B-42 \$7.50



*in* **BUFFALO**

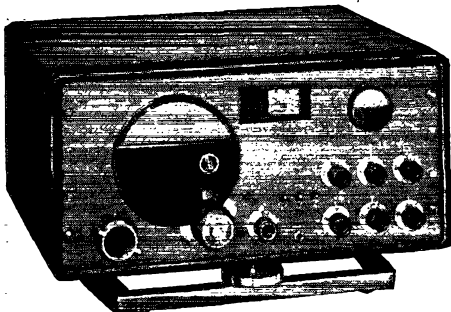

**hallicrafters sx-42**

**\$25000** AMATEUR NET | ADJUSTABLE BASE MODEL B-42 \$7.50

**RADIO EQUIPMENT CORPORATION**  
147-151 Genesee Street • Buffalo 3, New York

(Continued from page 158)

**S.S.L.C.W.S. — Join Now!**

One of the most abominable operating practices now current on the v.h.f. bands is the long call without signatures by the calling station. It is questionable whether this type of calling is justified on any band, but certainly there is no basis whatever for its use in v.h.f. work. Anyone who has ever been in the enviable position of being a sought-after station (a mountain-top portable on a good night; a station in Vermont; the southern end of a temperature-inversion session along the Atlantic Seaboard) knows well the exasperation of hearing an over-eager DX aspirant call "W1XXX — W1XXX — W1XXX — W1XXX —" endlessly, on and on, even complete with phonetic words, for as many as 40 or 50 repetitions of the call, without a single mention of his own call until he is ready to stand by. When conditions are hot, one station fortunately situated may be in a position to provide DX contacts for scores of others, by using snappy operating technique, if the callers will cooperate and sign frequently, with identifying words.

A few charter memberships in the S.S.L.C.W.S. (Society for the Suppression of Long Calls without Signatures) are still open. Join now! All you have to do to qualify for membership is to pass up *any* caller who gives your call more than five times without signing his. The "long call" is used only because its users get results. Stop answering such calls, and the practice will soon disappear — and all of us will be able to make more contacts when things are hot!

**Cathode Ray Tube Circuits**

(Continued from page 50)

layouts neat, firmly anchored, and with plenty of space between high-voltage points.

The cathode-ray tube is one of the most useful indicators ever devised. The author hopes to describe in a subsequent article the constructional details of a c.r.t. indicator which can form the basic unit for a modulation monitor, panoramic indicator, high-impedance voltmeter, or, in conjunction with an amplifier and sweep circuit, as a general-purpose oscilloscope or oscillograph.

**About the Author**

• Walt Knoop, ex-W9KHG, was first licensed in 1932, the net result of being afflicted with the ham radio bug in 1929. He is now patiently awaiting FCC issuance of a new amateur station license to add to his collection of amateur Class A, radiotelephone-first and radiotelegraph-second operator licenses. A graduate of RPI in 1941 with a B.E.E. degree, the author has been an operator at W8XYR, Whiteface Mountain Weather Observatory station, and WABD, DuMont tv. station in N. Y. C. At present he is a sales engineer for his own firm, Gawler-Knoop, Newark, N. J.

**Christmas  
Delivery  
Insured by**



**Walter Ashe**  
... PLACE YOUR ORDER NOW!

We offer Christmas delivery because we're getting the stocks to back it up! Be certain of Christmas delivery by ordering from Walter Ashe! Get the radio equipment dear to your heart, and get it now, when you order it! Barring strikes or other unforeseen circumstances, we pledge to deliver every gift item before Christmas or else notify you at the time you order!

**RECEIVERS—For Certain Christmas Delivery!**

**HAMMARLUND HQ 129-X**—The receiver with the noise silencer everyone is talking about. **\$173.25**  
A pre-war value.....

**NATIONAL HRO 57A**—'Nuf said! One of the recognized leaders in the field. Less speaker and power supply..... **\$274.35**

**NATIONAL NC 240-D**—Outstanding stability and built-in quality known to all. Excellent audio quality..... **\$241.44**

**RME-45**—One of the first entirely redesigned Ham receivers of the Post-War era. A real value..... **\$198.70**



**THINK OF IT!**... in this day of uncertain deliveries and shortages, any of the above can be had for Christmas **IF YOU ORDER NOW!** Liberal trade-in allowances, too!

**EARLIEST DELIVERY**

Hammarlund SPC 400-X with speaker..... **\$342.00**  
National NC-46 complete..... **\$107.40**  
Collins 75A complete (January delivery)..... **\$350.00**

**A Generous Trade-In!**

**in ST. LOUIS**

**WALTER ASHE IS HALLICRAFTERS HEADQUARTERS!**

SX-42, with speaker..... **\$275.00**  
S-38, complete..... **\$39.50**  
S-40, complete..... **\$79.50**



**BARGAIN SPECIALS—GRAND TO GIVE OR RECEIVE!**

**ARMY-NAVY HEADPHONES**

Highly sensitive, 8000 ohms impedance, bi-polar magnets. With short cord and plug..... **\$1.96**  
*Long Cord, 30c Extra*

Talkie Crystal Kits to grind your own 40-meter crystals..... **98c**

**Surplus Filament Transformers**

110 V AC primary, sec. 5 V @ 25 Amps..... **\$6.15**  
110 V AC primary, sec. 6.3 V @ 3.6 Amps, 6.3 V @ .6 Amps..... **\$1.18**  
110 V AC primary, sec. 6.3 V @ 3 Amps..... **\$1.08**

Antenna Changeover Knife Switch, army surplus, DPDT, 8" x 3 1/2" x 3"..... **98c**

Ham Type Surplus Condensers, 110 Mmfd. max., 15 Mmfd. min., 2500 volt peak, reg. \$3.69..... **\$1.95**

4 Mfd. 2500 V Condensers, GE Pyranol..... **\$3.75**

2 Mfd. 4000 V Condensers, GE Pyranol..... **\$5.75**

SONAR F-M EXCITER, narrow band, for use with any CW or Phone Transmitter, less crystal..... **\$39.45**

**AMERTRAN PRIMARY CONTROLS**  
—to adjust your input voltage

Pri. 95 to 130 V @ 9 1/2 Amps. Type 32415..... **\$14.95**  
Pri. 102 to 128 V @ 16 Amps. Type 31970..... **\$17.95**

**Sincere Holiday Greetings to Our Customers and Friends**

*Season's Greetings to our Friends and Customers*

WØGTF WØULH WØIYD WØPGI WØZIP WØLDO

Write for Our Catalog

**Walter Ashe**

**RADIO CO.**

**1125 PINE ST. \* ST. LOUIS, MO.**

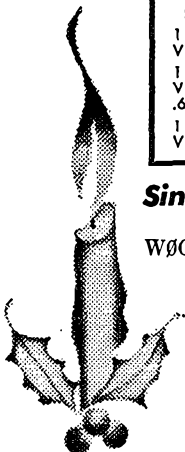

*in* **BOISE**

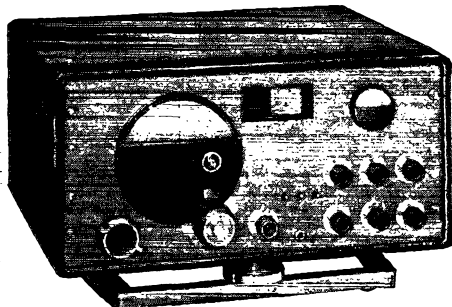

**hallicrafters SX-42**

**\$250<sup>00</sup>** AMATEUR  
NET

ADJUSTABLE BASE  
MODEL B-42 \$7.50

Don Oberbillig, W7AVP, Owner  
**ELECTRONIC ASSOCIATES, Inc.**  
Ham Store: 111 S. Ninth • Boise, Idaho

*in* **LOUISVILLE**

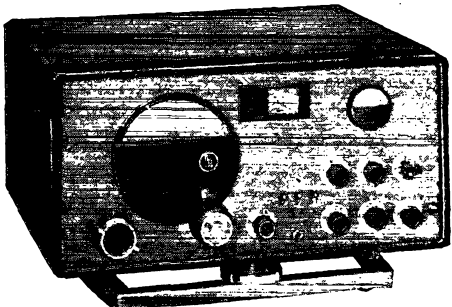

**hallicrafters SX-42**

**\$250<sup>00</sup>** AMATEUR  
NET

ADJUSTABLE BASE  
MODEL B-42 \$7.50

**UNIVERSAL RADIO SUPPLY CO.**  
715 So. 7th Street • Louisville 3, Kentucky

## Foreign Notes

(Continued from page 61)

were convinced, the idea was rapidly adopted by regular broadcasters.

We echo the sentiment of R.S.G.B.: "May he live long to enjoy the honor which the present Council has bestowed upon him."

### DENMARK

OZ amateurs now have 3505-3630, 3690-3795, 7150-7200, 14,000-14,300, 28,100-29,700 and 58,700-59,800 kc., with the former power limit of 5 watts now raised to 50. Prewar licenses were renewed on payment of the annual fee; new applicants must pass a technical examination. Portable and mobile operation are permitted normally only in the 5-meter band, although exemption is granted for hidden-transmitter hunts, a highly-popular radio sport in Denmark.

### A.R.R.L. QSL BUREAU

FOR the convenience of American and Canadian amateurs, the League maintains a QSL-card distributing system which operates through volunteer "District QSL Managers" in each call area. To secure such foreign cards as may be received for you, send your district manager a standard No. 10 stamped self-addressed envelope. If you have reason to expect a considerable number of cards, put on an extra stamp so that it has a total of six cents postage. Your own name and address go in the customary place on the face, and your station call should be printed prominently in the upper left-hand corner. If you have held other calls in previous years, submit an envelope for each such call to the proper manager — there are many thousands of uncalled-for cards in the files. All incoming cards are routed by Hq. to the home district of the call shown in the address. Therefore, cards for portable operation in other districts should be obtained from the home-district manager.

- W1 — Jules T. Steiger, W1BGY, 231 Meadow St., Wilimansett, Mass.
- W2 — Henry W. Yahnel, W2SN, Lake Ave., Helmetta, N. J.
- W3 — Maurice W. Downs, W3WU, 1311 Sheridan St., N. W., Washington 11, D. C.
- W4 — Edward J. Collins, W4MS, 1215 North 12th Ave., Pensacola, Fla.
- W5 — L. W. May, jr., W5AJG, 9428 Hobart St., Dallas 18, Texas.
- W6 — Horace R. Greer, W6TI, 414 Fairmount Ave., Oakland, Calif.
- W7 — Frank E. Pratt, W7DXZ, 5023 S. Ferry St., Tacoma, Wash.
- W8 — Fred W. Allen, W8AER, 1959 Riverside Drive, Dayton 5, Ohio.
- W9 — F. Claude Moore, W9HLF, 1024 Henrietta St., Pekin, Ill.
- W0 — Alva A. Smith, W9DMA, 238 East Main St., Caledonia, Minn.
- VE1 — L. J. Fader, VE1FQ, 125 Henry St., Halifax, N. S.
- VE2 — C. W. Skarstedt, VE2DR, 3821 Girouard Ave., Montreal 28, P. Q.
- VE3 — W. Bert Knowles, VE3QB, Lanark, Ont.
- VE4 — C. J. Campbell, VE4CC, 276 Ash St., Winnipeg, Manitoba.
- VE5 — Fred Ward, VE5OP, 899 Connaught Ave., Moose Jaw, Sask.
- VE6 — W. R. Savage, VE6EO, 329 15th St. North, Lethbridge, Alta.
- VE7 — H. R. Hough, VE7HR, 1785 Emerson St., Victoria, B. C.
- VE8 — Yukon A. R. C., P. O. Box 268, Whitehorse, Y. T.
- K4, KP4 — E. W. Mayer, KP4KD, P. O. Box 1061, San Juan, P. R.
- K5, KZ5 — Signal Officer, KZ5AA, Quarry Heights, Canal Zone.
- K6, KH6 — Andy H. Fuchikami, KH6BA, 2543 Namaau Dr., Honolulu, T. H.
- K7, KL7 — J. W. McKinley, KL7CK, Box 1533, Juneau, Alaska.

W6FEF W6WFG W65B W6JBC W6RYU W6EJF W6WMG W8TGW W6FQV W5IY W9JVK W9QFO W6JBO

# Wish You A Merry Christmas and A Happy, Prosperous New Year

## BELL AIR: 35-A AMPLIFIER

Up to 35 watts of undistorted output (measured). Excellent response in the range from 40 to 18000 cycles. 4 mike inputs and 2 phono inputs. There is a bass boost and treble boost circuit incorporated, as well as separate tone control. Individual gain controls. 4, 8, 16 and 500 ohm output. Perfect for low power modulator or driver for class "B" stage.  
Complete \$90.60

## BELL AIR: 14-A AMPLIFIER

A high quality medium power amplifier, suitable for use as speech, modulation, etc. 14 watts measured output. Input—1 mike and 1 phono. 1—6SJ7 mike input. 1—6SN7 mixer, 1—6SN7 phase inverter. 2—6V6 P.P. power output. 1—5U4G rectifier. Output 4, 8, 16, 500 ohms.  
Complete \$39.00

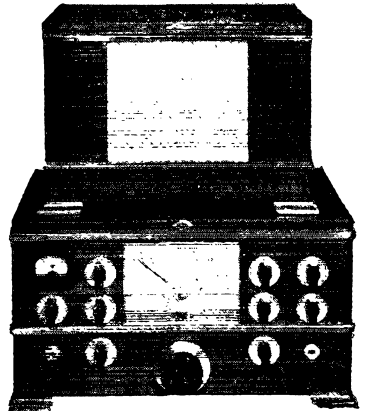

## NC-240-D RECEIVER

National's newest in modern receiver design. Expanded coil ranges for the 10, 20, 40, 80, meter bands also general coverage on the frequencies from 490 kc to 30 mc. On broadcast as well as amateur reception, the tone quality is brilliantly reproduced. Complete with speaker \$241.44 Net

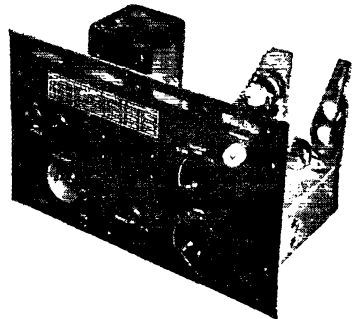

## LORAN TEST OSCILLATOR

Multivibrator type. Uses 6 tubes and 1.181 kc xtal. Used for checking out Lorán equipment on the ground. Built-in power supply for 6X5 tube. Many useful parts, also good foundation unit for speech amplifier, etc.  
New, less tubes and Xtal \$6.95

## RADIO SPECIALTIES COMPANY

(Dept. 73) 1956 So. Figueroa Street — Los Angeles 7, Calif.

Please ship..... Cash \$..... C.O.D.

- |  |  |  |   |
|--|--|--|---|
| <input type="checkbox"/> NC-240-D Receiver         | <input type="checkbox"/> Bell Air 35A Amplifier    | <input type="checkbox"/> Bell Insulator            | <input type="checkbox"/> Cecelia Twinax Cable |
| <input type="checkbox"/> 14A                       | <input type="checkbox"/> Lord Mounts A, B, C, D, E | <input type="checkbox"/> Micro Condenser           | <input type="checkbox"/> RG 58/U              |
| <input type="checkbox"/> Lorán Test Oscillator     | <input type="checkbox"/> Galvin Transformer        | <input type="checkbox"/> Lord Mounts A, B, C, D, E | <input type="checkbox"/> RG 6/U               |
| <input type="checkbox"/> Ripple Wound Loop Antenna |  | <input type="checkbox"/> Butterfly Tank Circuits   | <input type="checkbox"/> RG 57/U              |

### Butterfly Tank Circuits

- TN20  
 TN2A  
 TN30  
 TN3A

### Mounted Xtals

- 5000  
 5040  
 2100  
 2200

Name.....

Address.....

City..... Zone..... State.....

## RIPPLE WOUND LOOP ANTENNA

Replacement part for built-in antenna. 7 3/4 "x10 1/2" oval. New, \$4.85

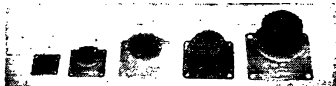

## LORD MOUNTS

Vibration control for any and all equipments.

New, A-100P2—25c, B-100PA3—49c  
C-153PH45—79c, D-150PH12—89c  
E-200PH75—\$1.15



## MICRO CONDENSER

50 mmf S.W. and Ultra S.W. trimmer, etc. Type APC 50.

New, 39c



## BUTTERFLY TANK CIRCUITS

Here's the answer to that microwave transmitter. Four different ranges.

TN20 - 76 to 300 Mc.  
TN2A - 106 to 330 Mc.  
TN30 - 135 to 485 Mc.  
TN3A - 300 to 1000 Mc.

New, \$7.95

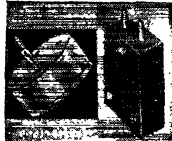

## MOUNTED XTALS

A.T. Cut-Xtals in 43 type holder. 2040, 2100, 2200 kc, a nice start if you grind your own.

New, 39c, 3 for \$1.00

Type CF5 xtal in round holder, 5000 kc. .02% accuracy. New, \$2.29

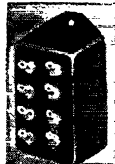

## GALVIN (input and output) Trans.

2 windings Carbon mike to grid, also 5000 ohm plate to voice coil in one transformer. Small size adapts it nicely to small amplifier, transmitter, etc. New, 49c

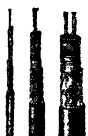

## COAXIAL AND WINAX CABLE

polyethylene insulation. Black vinyl covered braided braid shielding.

G 58/U—50 ohm—25' lengths with amphenol connectors. New, \$1.49

## G 8/U—50 ohm with connectors

ew, 51', \$4.95  
ew, 25', \$2.45

## G 57/U—Large size 95 ohm Twinax.

New, 15c ft.

The West's Largest Radio Parts Distributor. Established 1932

# RADIO SPECIALTIES COMPANY

1956 S. FIGUEROA ST. • PROSPECT 7271 • LOS ANGELES 7, CALIF.

in PHILADELPHIA

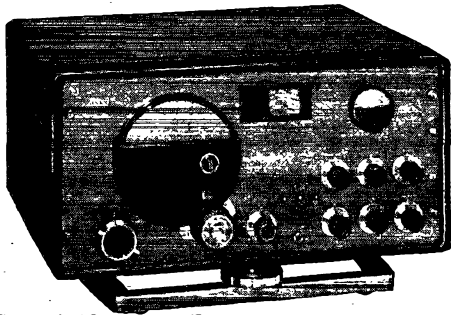

hallicrafters SX-42

\$25000 AMATEUR NET | ADJUSTABLE BASE MODEL B-42 \$7.50

MAIL ORDERS FILLED PROMPTLY		Lombard 3-0513
509 ARCH STREET • PHILADELPHIA 6, PA.		

in MONTREAL  
in TORONTO



hallicrafters SX-42

CANADIAN ELECTRICAL SUPPLY CO., Ltd.

WHOLESALE DISTRIBUTORS

Montreal 1, Que.

Toronto 1 Ont.

285 Craig Street West

387 Yonge Street

## Technical Topics

(Continued from page 57)

is that much actual variation with different tuning adjustments. A good way to match any two different impedances is the quarter-wave transformer or "Q" section shown in Fig. 3, if it is physically possible to use it. Since the terminating impedance is low, a low-impedance transformer is needed. Line material having an impedance of the order of 70 ohms is available — one, for example, being 75-ohm transmitting-type Twin-Lead.

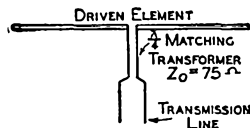

Fig. 3 — Quarter-wave matching transformer between the driven element of a parasitic array and a parallel-wire transmission line.

A quarter wavelength of this line at 28 Mc. will be a little over 6 feet long. Terminated in 8 ohms, the standing-wave ratio on the transformer will be 9.4 to 1, and in 12 ohms it will be 6.25 to 1. On the basis of the rated loss, matched, of 1.4 db. per 100 feet, the loss in the transformer will be 0.43 db. for the 9.4 ratio and 0.3 db. for the 6.25 ratio. In the first case the transformer output impedance will be 705 ohms and in the second case 470 ohms. The main feeder evidently should be a 600-ohm line in this case. If the antenna impedance is 8 ohms, the transformer will give a rather close match with a 600-ohm line; the standing-wave ratio will be less than 1.2 and the losses will be negligible as compared with an ideal match. If the antenna impedance is 12 ohms the standing-wave ratio on the line will be less than 1.3 — approximately the same as with an 8-ohm load. With any intermediate load value the standing-wave ratio will be still smaller.

However, the use of 300-ohm line is not out of the question with the same transformer. With a 300-ohm line the standing-wave ratio will be under 2.5 to 1 if the antenna impedance is as low as 8 ohms, and will be under 1.6 with the 12-ohm load. Even on the 100-foot line (Curve A) the increase in loss as compared to a perfect match is only about 0.35 db., with the worst mismatch. Adding the transformer loss of 0.43 db. gives a total increase of 0.78 db. as compared to a perfect match with the same line and a loss-free matching system. Since the loss in the latter case is 0.84 db., the total loss between the transmitter and antenna is 1.6 db. This is not an ideal situation, it is true, but most of the loss is there already if this particular type of line is used; the difference between this system — which requires no adjustment beyond cutting the transformer to the proper length — and the arduous business of trying to eliminate standing waves completely

(Continued on page 168)

# "Say, 'MERRY CHRISTMAS' to Your Favorite Ham with One of These Items"

Since, you, as an XYL will be scratching your head to think what to give your OM or answering questions from the family as what to give the OM for XMAS 1946, we have jotted down some gift suggestions to aid you. If in ordering, you will note on your order — "FROM XMAS SUGGESTIONS," special care and speed will be used to rush these items to you.

(MAYBE YOUR FAVORITE HAM IS YOURSELF — WHY NOT?)

## FOR THE HAM SHACK:

### Liven Up His Rig With A Name and Call Desk Plate

Engraved Name plate with vivid white call letters and operator's name on jet black bakelite set on sparkling lucite will be an appreciated gift for the OM. The size, 8 inches high by 2 inches wide, make it ideal to sit on his desk or rig.

In ordering give all initials, last name and call and allow two weeks for delivery . . . . . \$3.50

### Let Him Say "Merry Xmas" Through A New TURNER Mike

The Turner 22X or 22D will make Xmas 1946 a happy one for your OM. These mikes give clean, clear, and sharp reproduction.

These chrome type finish mikes with tilting heads and seven foot removable cord sell for only:

22X (Xtal) . . . . . \$12.00\*  
22D (Dynamic) . . . . . \$14.10\*

\* Add \$1.20 for Built-in Switch

### Give A Bruno Hole Cutter Kit To The "Building" OM

The Hole Cutter Kit comes in an attractive Red and Black Plastic Case. Kit contains two bits for cutting holes 3/4" to 2 1/4". Xmas is a fine time to add this kit to your OM's working tools. . . . . \$7.85

### Help Your Beginning OM Learn His Code With ICA's Signa Tone Code Practice Oscillator

This ICA Signa Tone will be an excellent present for either an individual or a Club as it will enable 25 people to use keys or phones in sending or receiving code. Also Signa Tone may be used as a Keying Monitor and a Signal Tracer in Audio Circuits. Finished in smooth gray crackle finish. Headphone Model. \$9.00

## FOR THE TRANSMITTER:

### Xmas Will Be Brighter For Your OM With A McElroy FU-40 Exciter Unit Kit

This McElroy FU-40 exciter kit can be constructed into an efficient low powered transmitter or an exciter. Kit contains a foundation, all hardware with all holes punched and three tuning units: TU-49, 52, and 53, designed to cover the Amateur Bands.

Features Crystal Control and ECO. . . . . \$25.75

### Give Your OM A HY-Q Transmitter Kit

Every Amateur likes to "roll his own," therefore no better present could be given than the new HYTRON HY-Q 1 1/2 and 2 Meter Transmitter Kits. Long hours of engineering have ironed out the "bugs" to give maximum efficiency on VHF.

Kit complete, less tubes . . . . . \$9.95  
Kit completely assembled and wired, less tubes . . . \$11.95  
HY-75 tube . . . . . \$3.95

## RECEIVERS AND TRANSMITTERS

Deliveries Can Be Made On These Receivers And Transmitters In November and December

Hallicrafters		National	
S-38 . . . . .	\$ 39.50	NC-2-40-D (Speaker \$16.44) . . . . .	\$225.00
S-40 . . . . .	\$ 79.50	NC-46 (Speaker \$9.90) . . . . .	\$ 97.50
S-42 (Speaker \$25.00) . . . . .	\$250.00	HRO-STA-1 (1700 KC to 30 MC) . . . . .	\$274.35
HT-9 Transmitter . . . . .	\$250.00	Speaker . . . . .	\$12.00
		Power Supply . . . . .	\$ 20.36
Hammarlund		RME	
HQ-129-X — with speaker . . . . .	\$173.25	RME-45, complete . . . . .	\$198.70
Super Pro — SPC-400-X — with speaker . . . . .	\$342.00	RME-84, complete . . . . .	\$ 98.70
		VHF-152 (2, 6, and 10 Meter Converter) . . . . .	\$ 86.60

(State Tax Not Included)



R. C. (Dick) Hall  
WSEIB

## R. C. & L. F. HALL, INC.

### "The Ham Shack"

HOUSTON: 1306 Clay Avenue — Tel. C-9731

BEAUMONT: 961 Pearl Street — Tel. 4740

DALLAS: 2123 Cedar Springs Ave. — Tel. R-8689

GALVESTON: 1803 Tremont Street — Tel. 24807



L. F. (Lillian) Hall  
WSEUG

All prices quoted subject to change without notice

*in* SEATTLE  
*in* PORTLAND  
*in* SPOKANE

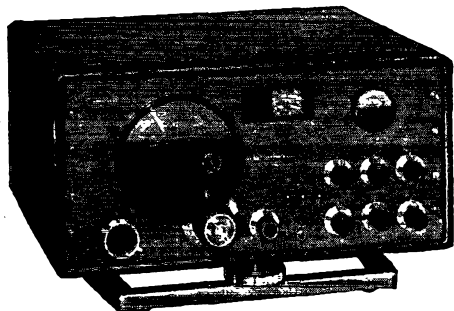

**hallicrafters sx-42**

**\$250<sup>00</sup>** AMATEUR  
NET

ADJUSTABLE BASE  
MODEL B-42 \$7.50

*HARPER-MEGGEE Inc.*  
 SEATTLE • PORTLAND • SPOKANE

(Continued from page 164)

does not add up to a detectable improvement in signal strength.

Some other things — which will have to be left for later discussion — come into the picture, but in general it seems quite obvious that standing waves are not necessarily disastrous, especially on frequencies below the v.h.f. region. Unless the line is overly long it is possible to dispense with tedious adjustment of matching sections — work that often results in no better actual performance because of the real difficulty of making reliable measurements on transmission lines.

— G. G.

### How's DX?

(Continued from page 61)

Cpl. Vandongen, Coenenlaan 17, Macassar, Celebes . . . . . From W3KNT: EK1AA, c/o RCA Comm., British P.O. Box 57, Tangier, Morocco . . . . . W2KPV and W2ENZ send in the address of one we queried: TIMR, Mario Rodriguez, Quepos, Costa Rica. We know now, however, why he uses the call. He likes the swing of it! . . . . . From W2HZY: XU1YR, Dr. J. H. Dooley, Lt.(jg) MC USNR, 1st Bn. 7th Reg., 1st Marine Div., c/o FPO, San Francisco, Calif. . . . . From W6VFR: HI8X, Box 1045, Ciudad Trujillo, Dominican Republic.

### WHO:

EP1A was W3EPR and you can reach him now at 1301 St. Paul St., Baltimore, Md. Camille worked 38 countries from Iran in November and December, and while he was there he met YI6JS and EP5SO, ex-G5UG . . . . . W9ERU writes to say that the FCC is picking up the boys for key clicks, as Gene can testify. Well, a listen across the band shows they have plenty of fine ticket material any time they want to be tough . . . . . W5ADZ has been picking up countries on 10 with a fixed 3-element beam in his attic. The radiator is No. 12 wire and the parasitic elements are 3/4-inch tubing, and the whole thing is hung from the rafters by string. He has 72 countries . . . . . W6CIS worked PAØXG, G4JJ, VK3NM and VK5FM on 10 c.w., with an 807 doubler and an indoor half-wave antenna 12 feet off the actual ground. Jeeves, cut the antenna down and bring it down to the basement, we're going to work DX! . . . . . And to show how easy it is, W7KEK in Idaho worked G5BM on 10 'phone while running 7½ watts input. What was the half watt for? . . . . . W1KKS says G6WY is moving to Toronto in the near future, which won't make it any easier on the North American DX chasers . . . . . From PY1DH via W1ME we learn that Stephen Liebermann, the prewar undercover QSL Bureau for YU, was killed during the war in a German prison camp . . . . . In the district shuffle, W9FS came up with W4FU, which will no doubt soon be as well known as his old call . . . . . W5CX worked LU5WB who is down close to the tip of South America. How-

(Continued on page 168)



# NEW!

## MODULATION MONITOR

MODEL AMM-1

**PRINCIPLES OF THE BROADCAST STATION MONITOR NOW AVAILABLE TO THE HAMS**

**INDICATES**—Modulation Percentage, Carrier Shift, Over-modulation and unequal positive and negative modulation peaks.

**FLASHING LIGHT**—Can be set to flash at any desired percentage of modulation up to 100% by means of calibrated front panel control.

**CARRIER LEVEL**—Set by means of precision micrometer carrier level indicator circuit.

**FREQUENCY RANGE**—10, 20 and 80 meter fone bands.

**SIMPLE TO INSTALL**—Only connection to transmitter is loosely coupled link to final amplifier through coaxial cable.

**TUBES USED**—(1) 1V, (1) 6SL7, (1) 6J7, (1) 884, (2) 6E5 and (1) 5Y3GT.

PRICE — \$44.50

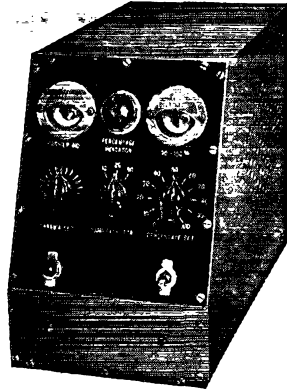

DESIGNED BY HAMS—FOR HAMS

BY THE MANUFACTURING DIVISION OF

### THE HAM CENTER

HERBACH & RADEMAN, DEPT. Q-1  
522 MARKET ST. PHILA. 6, PA.

*in* TULSA

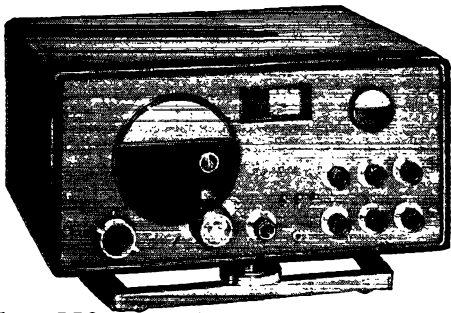

### hallicrafters sx-42

\$250<sup>00</sup> AMATEUR NET | ADJUSTABLE BASE MODEL B-42 \$7.50

## Radio, Inc.

WHOLESALE ONLY

Equipment • Parts • Apparatus

1000 South Main Street • Tulsa 3, Oklahoma

*in* JERSEY CITY • TRENTON  
CLIFFSIDE • PASSAIC



### hallicrafters sx-42

\$250<sup>00</sup> AMATEUR NET | ADJUSTABLE BASE MODEL B-42 \$7.50

## NIDISCO

713 Newark Ave., Jersey City, N. J.  
147 N. Warren Street, Trenton, N. J.  
658 Anderson Ave., Cliffside, N. J.  
205 Madison Street, Passaic, N. J.

# in SHREVEPORT

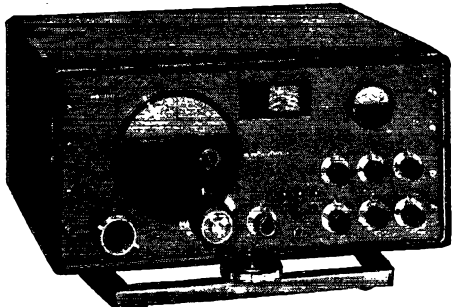

## hallicrafters sx-42

**\$250<sup>00</sup>** AMATEUR NET | ADJUSTABLE BASE MODEL B-42 \$7.50

### KOELEMAY SALES COMPANY

Pa - Ma - James - Lawrence  
(Formerly K-D Sales)  
WHOLESALE RADIO SUPPLIES  
Phone 5789

325-327 Market Street • Shreveport 24, La.

# in OAKLAND



## hallicrafters sx-42

**\$250<sup>00</sup>** AMATEUR NET | ADJUSTABLE BASE MODEL B-42 \$7.50



W6TT W6DUB  
W6GIZ W6TFY

Tel. Hlgate 7011

149 12th St. at Madison • Oakland, California

# in KNOXVILLE

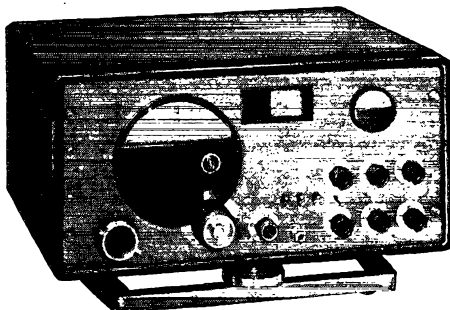

## hallicrafters sx-42

**\$250<sup>00</sup>** AMATEUR NET | ADJUSTABLE BASE MODEL B-42 \$7.50

### RODEN ELECTRICAL SUPPLY CO.

Dial 3-0491 • 808 N. Central Ave.

Knoxville, Tennessee

(Continued from page 166)

ever, he isn't as far south as CE7AA was — or should it be "is"? . . . . . VE8MJ points out the importance of accurate reporting of signals to some of the isolated DX stations. In his case, for example, he has no monitoring equipment and must rely on outsiders to tell him how good — or how bad! — his signal is. His transmitter is vibrator-pack powered, and some of the T9 and T9x reports he got when first on the air "were absurd." A few honest fellows eventually took some time and helped him get straightened out a little. He adds that the mail only gets through to the VE8 boys in the N.W.T. once or twice a year, so bear with them on QSLs . . . . . The district shuffle is giving the DX an occasional thrill because now they can work W7s. W7JHB in Arizona has been knocking off quite a few on 10 'phone, and many tell him he's the first W7 ever heard or worked. Cream there includes VQ4ERR, VQ2PL, YN1RZ and a flock of Pacific stuff . . . . . The VO1G who was on during July and August was a bootlegger, the real VO1G writes. Apparently some not-too-well-meaning guys in Newfoundland or vicinity have been borrowing calls without regard for the licensee, a wonderful way to cement international relations — six feet under! . . . . . AC3SS writes that he is running 100 watts on and about 14,180, 'phone and c.w., and he has an SX28 and an AR88 for receiving. A rotary beam is planned for the near

(Concluded on page 170)

# SUN RADIO — The Home Of Nationally Known Radio Parts

## WAR SURPLUS EQUIPMENT--

At A Fraction of Their Original Government Cost!

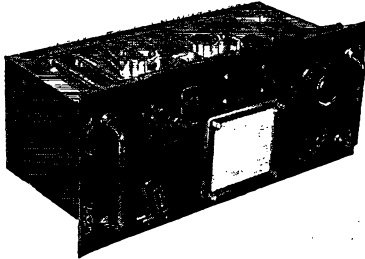

**TUNING UNIT** This "RF" tuning unit designed and manufactured for the United States Army to their rigid specifications is offered at a fraction of its original cost... Guaranteed in excellent condition... less **\$3.89**

- No. TU5B, 1500 to 3000 KC
- No. TU6B, 3000 to 4500 KC
- No. TU7B, 4500 to 6200 KC
- No. TU8B, 6200 to 7700 KC
- No. TU10B, 10,000 to 12,500 KC

Please specify model

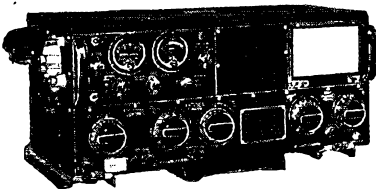

### NEW COLLINS AIRCRAFT TRANSMITTER

(The Popular Transmitter of Today.) Channels .2 to 18.1 MC up to 90 Watts output. Furnished with two antenna loading units, one control box, one antenna shunt, and dynamotor with tubes. Write today for our special price and conversion data.

### RHOMBIC RECEIVING ANTENNAE

Complete with all accessories including 2200 feet of No. 14 copper weld wire, 50 feet of heavy twin X lead 720 ohm good up to 2 KW, dozens of insulators, pulleys, neon lightning arrestors, ground rod... less poles **\$24.95** —only.....



### COMPLETE 4 TUBE INTERPHONE AMPLIFIER

Comes in an aluminum cabinet 9 3/4 x 4 3/4 x 5 1/2 inches with two 12J5GT and two 12A6 tubes; also General Electric Dynamotor 28DC Volt input and 250 V DC output at 60 MA. Complete instructions and diagram for high fidelity phonograph or speech for 110 Volt operation. This is the greatest offering ever made in War Surplus Electronics. **\$8.95** Yours for only

### NAVY ANEMOMETER

Beautiful precision designed instrument that will enable you to determine the Wind Velocity in miles per hour. Complete instructions. 6-volt battery operated. Brand new. Less **\$14.95** Battery.....\$6.00

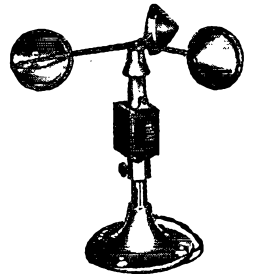

### NAVY V.H.F. RADIO TRANSMITTER

Battery operated (67 1/2 V.B. and 1 1/2 V.A.). Frequency 80 to 105 M.C. Complete with 2-1G4 tubes and full instruction manual. Brand new. Less Batteries..... **\$14.95**

Battery.....\$2.45

### ATTENTION

Amateurs, Service Men and Experimenters in the Washington, D. C. Area!!!

It will pay you to visit our new enlarged Parts Section where you'll find hundreds of bargains in radio surplus which we cannot advertise because the quantities are too small. Stop by!... it will be worth your while!!!

- All items F.O.B., Washington, D. C. All orders \$30.00 or less cash with order. Above \$30.00, 25 percent with order balance C.O.D. Foreign orders cash with all orders plus exchange rate.

### J. B. T. VIBRATING REED FREQUENCY METER

Range 56 to 64 C.P.S. with eleven reeds. Regular net price \$24.75. **\$9.95** Your cost only.....



# SUN RADIO

OF WASHINGTON, D. C.

938 F STREET, N. W. WASH. 4, D. C.

in OMAHA

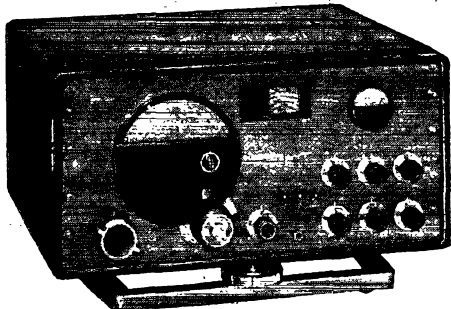

hallicrafters sx-42

\$25000 AMATEUR NET | ADJUSTABLE BASE MODEL B-42 \$7.50



Distributing Co.

2855-57 Farnam Street  
Omaha 2, Nebraska

in SEATTLE

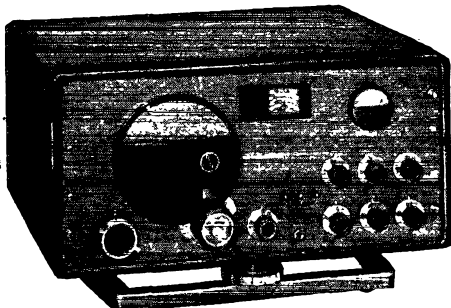

hallicrafters sx-42

\$25000 AMATEUR NET | ADJUSTABLE BASE MODEL B-42 \$7.50

SEATTLE RADIO SUPPLY  
INCORPORATED

2117 Second Avenue • Seattle 1, Washington  
Tel. SEneca 2345

(Continued from page 168)

future, at his location at Gangtok 5500 feet above sea level. . . . . Harry Pasquaye, chief operator at F7AE, is now at 141 Sanford Avenue, Lyndhurst, N. J. and has a duplicate log with him. Get the idea, hm-m-m? . . . . . And Ken Bay, W4GSJ, who operated FO8FN, is at West Lodge, Ypsilanti, Mich. He says it will be some time before he can acknowledge SWL cards, but he is handling the "worked" ones in a hurry. . . . . Some fellows just don't have the luck. W0NCS, W0YXO and W0JRI had a DX expedition all cooked up, a trip to a cabin in Northern Minnesota where they could put up super antennas and work the world with a UV-199. Oh, they made the trip all right, but picked those bum weeks in September when the ionosphere was on a bender! . . . . . W9JVP wants it known that when you worked him in /K6 and /J9 he had no APO number and couldn't QSL, but he can now, so write to Fred Wells, Fire Department, Fargo, N. Dak., for your pasteboard. . . . . W2PLR has one of those antennas that never find their way into antenna handbooks because no one can explain them, but it seems to do a job for him. In his attic he has a single square loop, 16 feet on a side, but it apparently works well on 10 and 20 and in all directions. With 50 watts input to the ubiquitous 807, he has everything but Asia. . . . . From a very reliable source whom we choose to protect, we learn that the citizens of Orangeburg, S. C., for several weeks were reporting strange lights in the sky but they couldn't come to any definite conclusion as to what they were. The newspapers carried the story — some figured it was St. Elmo's lights (whatever they are), a few Negroes had the cause as an *ignis fatuus*, and the smart money was on meteors or a new kind of aurora. The lights were always seen late in the evening, and one day W4BPD checked the times of his radio transmissions against the reported observation times of the phenomena. He then telephoned the *Times and Democrat* to tell them that he had solved the mystery. His antenna was shorting high up on the pole!

— W1DX

### Strays

It took a mere 35 milliseconds for SU1AX's signals to get across to W2KEZ when they were QSO on August 15, 1939. However, getting written confirmation is another story. Postmarks on SU1AX's QSL, recently received at W2KEZ, show that the cherished pasteboard was 7 years and 2 months in transit!

-----

W8UPS/3 found this one in October 1946 *Electronics*: "Wanted — Sound-Powered Engineer." Now you know, Henry, what keeps 'em going!

# RECORD - SMASHING DX AHEAD

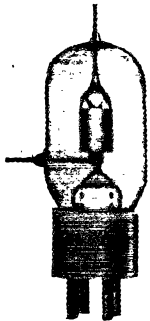

3C24

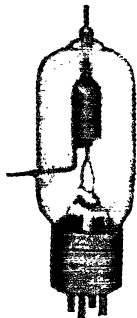

35TG

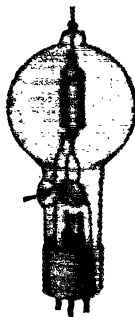

75T

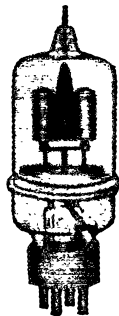

152T

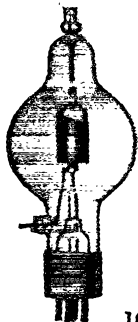

100T

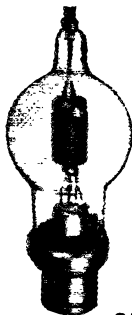

250T

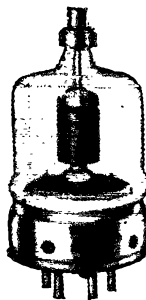

4-125A

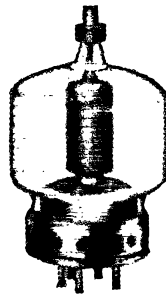

4-250A

## These are the Tubes for Champions

Look at the record of DX champions over the past ten years, and you'll find Eimac tubes the predominant favorite. And why not? . . . It's natural, after all, that in seeking top performance you're just bound to end up with Eimac tubes, whether for a new rig or rebuilding an old one. You can't pass by Eimac tubes, because their outstanding performance capabilities, their dependability, and long life make them vastly superior for DX work . . . truly the tubes for champions. Today Eimac tubes, incorporating many new features, are better than ever. Get back on the air with Eimac tubes for the record-

smashing DX ahead. Write now for latest information. Eitel-McCullough, Inc., 1292M San Mateo Ave., San Bruno, California. Export Agents: Frazar and Hansen, 301 Clay St., San Francisco 11, California.

Follow the leaders to

**Eimac**  
REG. U. S. PAT. OFF.  
**TUBES**

THE COUNTERSIGN OF  
DEPENDABILITY IN ANY ELECTRONIC EQUIPMENT

*in* **RICHMOND**

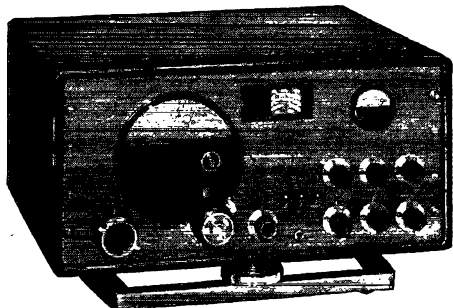

**hallicrafters sx-42**

**\$250<sup>00</sup>** AMATEUR  
NET

ADJUSTABLE BASE  
MODEL B-42 \$7.50

**D. R. JOHNSTON CO.**

1315 East Cary St. • Richmond, Va.

Phone 73617

*in* **DETROIT**

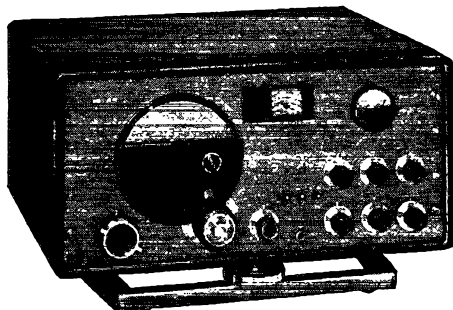

**hallicrafters sx-42**

**\$250<sup>00</sup>** AMATEUR  
NET

ADJUSTABLE BASE  
MODEL B-42 \$7.50

**M. N. DUFFY & COMPANY**

2040 Grand River Ave. • Detroit 26, Mich.

Tel. Cherry 2270

## Correspondence

(Continued from page 63)

peared stronger for a moment on the westward bearing from here. The final stunt indicated fairly clearly there wasn't much reverse English on our beams. While I transmitted north, he swung his beam due south and could not hear me at all.

Noteworthy is the fact that Australian QRM, continuously around him while my beam was a bit west of north, or the Great Circle route, almost entirely disappeared when we both were on the long course over the South Pole, distance approximately 13,675 miles. Other approx. distances: 11,440 miles via North Pole and 11,300 miles via Great Circle.

Moral: Shortly after completing the 40-minute QSO I began to feel very cold and soon was sneezing unmercifully. Take it easy, fellers, with these polar transmissions unless you have a germ trap in your receiving antenna.

— John M. Murray, W8AMD/1

### “COMPLEXITY”

Box 875, Jefferson City, Mo.

Editor, *QST*:

Your editorial in October *QST* entitled “Complexity” expresses indirectly the need for a master plan on the part of the League.

Progress in radio, as in any business, is a function of economic necessity. When it's needed badly, additional investment has always paid off. And the advances made have caused our hobby to spread out. To me, the League has always been a guide. It has furnished the basic plan and know-how. It made *QST* the best publication for beginners or students, and a very good one for engineers. I would like to see it stay that way. In other words, why not stick to the fundamentals, and let the others, such as IRE and AIEE, take care of the branches?

I would like to see you adopt a plan whereby the feature articles of *QST* are based on learning (which means construction). Restrict this to simple forms of receivers, transmitters, and test equipment. The League library could take care of the rest. And don't worry about the man who forsakes “home-brew” for manufactured equipment. It's a temporary condition due to lack of curiosity and too much cash. A ham (as we know him) *must* be curious and want to learn by doing. The cash always helps but isn't a prerequisite.

In the meantime, the combination of advertising gusto and war surplus will keep the ham on his toes. The stuff he buys will work but not without use of soldering iron, pliers, and a lot of that unknown quantity called ingenuity. What won't work, he will trade for something that will. The net result is: a good ham — a guy you can chin with hours on end, and who gets a kick out of radio.

— J. R. Tracy, W8KNQ

P. O. Drawer 701, Commerce, Texas

Editor, *QST*:

Right you are! There is too much to radio for most of us to understand, much less try to keep up with. In its simplest form, radio is too complex for the average ham.

I am one who would shout for joy if *QST* would publish circuits for xmtrs that were simple enough for me to understand. I would like to know what I was doing as I put it together. I find that those technically trained in radio make some very big mistakes on their rigs, too.

Troubles! I've had plenty with my xmtr. I cannot get the thing to work. Furthermore, I do not know what to do next. Checking and double-checking, times two, has not given me any results. I've been trying to get on the air for months. I'm not there yet. These complicated circuits are too discouraging for me. If you can, go ahead and publish some of the gear circuits of the 30s. Do not tell how old it is, to see how many of the old timers complain about it. Many new hams will find it a relief to be able to make something they can understand, and that it works after they are finished. It is the simple things that give us the most joy in life. . . .

— Helen M. Douglas, W6LGY

(Continued on page 174)

*in* OKLAHOMA  
CITY

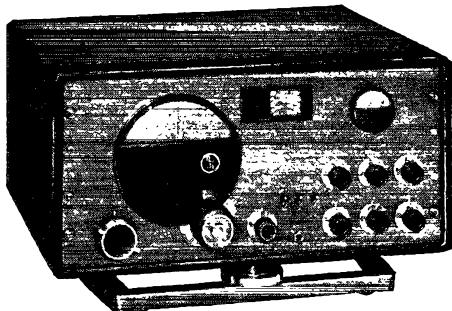

**hallicrafters sx-42**

**\$2500** AMATEUR NET | ADJUSTABLE BASE  
MODEL B-42 \$7.50



*Radio Supply, Inc.*

724 N. Hudson • Oklahoma City, Okla.  
Tels. 3-3409 — 3-3400

*in* FORT SMITH

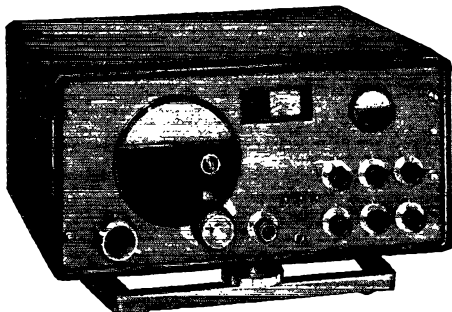

**hallicrafters sx-42**

**\$2500** AMATEUR NET | ADJUSTABLE BASE  
MODEL B-42 \$7.50

**WISE RADIO SUPPLY**

Wholesale Distributors

Radios • Parts • Equipment

1001 Towson Avenue • Ft. Smith, Ark.

*in* CANADA

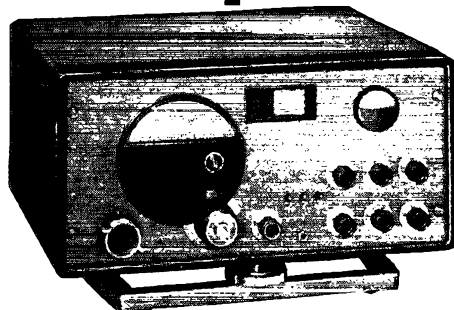

**hallicrafters sx-42**

**ROGERS MAJESTIC LIMITED**

11-19 Brentcliffe Road

Leaside (Toronto 12) Ontario, Canada

# in PORTLAND



## hallicrafters sx-42

**\$250<sup>00</sup>** AMATEUR NET | ADJUSTABLE BASE MODEL B-42 \$7.50

### UNITED RADIO SUPPLY, INC.

Eugene Branch  
179 W. Eighth St.  
Tel. 4988

203 S. W. Ninth Ave.  
Portland, Oregon  
Tel. BEacon 6323

### RADIO INSTRUCTORS ●

Receiver servicing experience. College degree preferred. \$3600 a year to start. \$4200 after four months. Work in the heart of the Radio Industry. We will teach you practical television. Write Raleigh G. Dougherty, 158 Market Street, Newark 2, New Jersey, c/o New York Technical Institute of New Jersey. America's foremost Television school.

### CONNECTICUT HAM HEADQUARTERS

Complete stocks of nationally known amateur gear — radio electronic parts — tubes — sets and equipment.

Wholesale Only

### R. G. SCALI & CO.

317 Asylum St., Hartford 3, Conn.  
Tel. 2-1144

84 Elm St., Bridgeport 3, Conn.  
Tel. 6-1811

ASK FOR OUR BARGAIN BULLETIN

(Continued from page 178)

Williamsport, Pa.

Editor, *QST*:

In view of your recent editorial concerning lack of home-built equipment, would suggest *QST* constructional articles would be amended to follow more modern engineering practices and more material of a constructional nature than a rehash of conventional circuits. Suggest also that articles appear utilizing surplus parts rather than expensive and hard-to-get parts. . . .

— J. H. Heim, *W3UFP*

### INSURANCE

230 Park Pl., Brooklyn, N. Y.

Editor, *QST*:

I have come across some interesting facts which might be very helpful to any of the boys who have big antenna systems in the large cities. A few months ago I contacted my insurance broker regarding a liability policy for my equipment. I live in a large 100-family apartment house, and have a 20-foot tower with a ten-meter beam on top in addition to a Premax 20-meter vertical — all of which are a constant threat to the well-being of the house rooftop and the other families who frequent the roof.

My broker offered me a comprehensive personal liability policy which covers me up to \$25,000 for any damage caused to the building due to any of my radio equipment. This policy also covers anyone who might be injured while helping me put up an antenna or other equipment up to \$250 out-of-court settlement, or up to \$25,000 otherwise. The policy has a broad coverage in the respect that it protects you against any personal injury accidentally inflicted upon anyone, such as hitting some person with a baseball while playing.

I was also advised that my household insurance would be no good in case of fire due to the fact that the radio equipment was under the same roof and was not mentioned in the fire insurance policy. So, if any of the boys have failed

(Continued on page 178)

# in TOPEKA

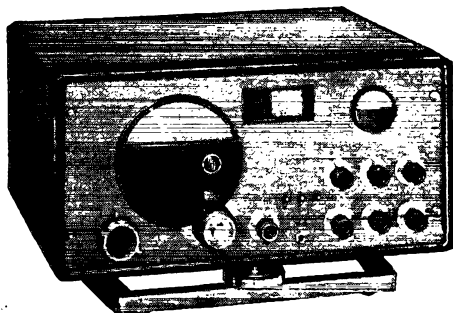

## hallicrafters sx-42

**\$250<sup>00</sup>** AMATEUR NET | ADJUSTABLE BASE MODEL B-42 \$7.50

### ACME RADIO SUPPLY

516 Quincy Street • Topeka, Kansas  
Tel. 3-3702



# HAM SPECIALS

From Ham Headquarters

Order	Net Price
Panoramic Adapter PCA-2	\$99.75 Each
Cabinet: 24 1/2" Wide, 29 1/2" Deep, 7 1/2" High, Gray Crackle Finish, Ideal for Transmitter	90.00 Each
Choke: 300 MA Swing 9-19 Henry	7.50 Pair
Code Oscillator: Complete with Speaker, Telegraph Operated, MS-700	9.95 Each
Coil Assembly: R.F. from Army Receiver BC-224M	.75 Each
Condenser: 1x.1x.1 Mfd. 600-Volt Tobe Metal Case, Bathub	.49 Each
Condenser: 100 MMF. Midget Variable	.50 Each
Condenser: 2 Mfd. 1000-Volt, Oil Filled, Round Can, C.D.	1.50 Each
Condenser: 10 Mfd. 1400-Volt, Oil Filled, Rectangular Type	6.75 Each
Condenser: 10 Mfd. 1000-Volt, Oil Filled, Rectangular Type	6.75 Each
Condenser: 3 Mfd. 2000-Volt, Oil Filled, Rectangular Type	3.25 Each
Condenser: 50 MMF. Variable	.50 Each
Condenser: 3x3 Mfd. 600-Volt Oil Filled, Rectangular Type	.99 Each
Condenser: 4 Mfd. 600-Volt C.D. Aluminum Can, Oil Filled	1.50 Each
Converter: Gonsett New 10-11 Meter, 20 Meters or 6 Meters	39.95 Each
Crystals: IN 27	.50 Each
Handy Talkie: Complete with Batteries, 3835 K.C. Frequency	49.50 Each
Chassis: for Handy Talkie 611F	10.00 Each

Order	Net Price
Meter: Westinghouse 2" D.C. M.A. 0-10-25-50-100-150-200-250-300-400-500	\$3.50 Each
Meter: Burlington, 2" A.C. 0-150 2" Round	2.25 Each
Meter; Time Hour 110-Volt 60-Cycle	3.50 Each

### MANY OTHER METERS UPON REQUEST

Mike: T17B Carbon Hand Mike	2.50 Each
Receiver: BC 342 Frequency 200 to 500 KC. — 1500 KC — 20 MC AS 15	60.00 Each
Relay: D.P.D.T. 6-Volt D.C. Coil, Leach 1/2" Silver Contact	1.75 Each
Transformer: G.E. Modulation — 200 Watts, 811 to 813	6.00 Each
Transformer: Filament, 6.3 Volt at 1 3/5 Amps, Small Round	Each

### IMMEDIATE DELIVERY ON SOME COMMUNICATION RECEIVERS

National HRO STA-1	\$306.71 Each
National 240 DT	241.44 Each

### MAIL ORDERS PROMPTLY FILLED

Amateurs to Serve You

(20% Must Accompany All C. O. D. Orders)

Write to Dept. QST

W6SCQ • W6UXN • W6NAT • W6VHZ • W6UIW  
WRITE FOR FREE BULLETIN NO. 29

## Radio Products Sales Company

238 WEST 15TH STREET

LOS ANGELES 15, CALIFORNIA

PRospect 7471

### IRON CORE TUNERS

For Broadcast Band Superhets. Replace 2-gang condenser and oscillator. One compact tracked unit. Includes hookup diagrams and instructions.

Only \$4 Postpaid

Send for FREE price list of Standard radio coils

**MAGNA-METAL PRODUCTS CO.**

Room 1048, 70 E. 45 St., New York 17, N. Y.

### COMPLETE RADIO TRAINING!

Prepare now to accept a responsible position in Commercial Radio. New developments will demand technicians with thorough basic training, plus a knowledge of new techniques discovered during the war. Training open to high school graduates or those with high school equivalency. Courses 6 to 18 months' duration in RADIO AND ELECTRONICS. Approved Veteran training in Radio. Write for Particulars.

VALPARAISO TECHNICAL INSTITUTE

Dept. TN

Valparaiso, Ind.

## ELECTRICITY

FOR RADIO AND ELECTRONIC APPLICATIONS

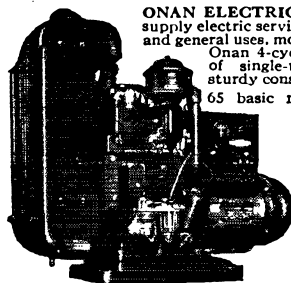

ONAN ELECTRIC GENERATING PLANTS supply electric service for electronics applications and general uses, mobile or stationary. Driven by Onan 4-cycle gasoline engines, they are of single-unit, compact design and sturdy construction.

65 basic models ranging in capacity from 350 to 35,000 watts. Standard A.C. models, 115-volt, 60-cycle, single-phase. Standard D.C. models, 32 to 115 volts. Special voltages to 660 A.C., and 6 to 4000 volts D.C. 5 KW to 35 KW units available in 3-phase. High frequencies to 800 cycles. Combination A.C.-D.C. types. Write for detailed literature or engineering assistance.

**D. W. ONAN & SONS** 4653 Royalton Ave. Minneapolis 5, Minn.

## Electronic Volt-Ohmmeter, Model 406

IMMEDIATE DELIVERY!



We invite comparison of this instrument with any at any price for appearance, ruggedness, accuracy, stability. 0-1 to 1,000 volts U.H.F., A.C., D.C. 0-1,000 megohms. Pen-type dual-diode A.C. probe. No extras to buy. Send for details or order today.

\$89<sup>50</sup>  
NET

from jobber or  
F.O.B. Cincinnati

**Clippard**

INSTRUMENT  
LABORATORY, INC.

Dept. 2, 1127 Bank Street, Cincinnati 14, Ohio



*in* **WICHITA**



**hallicrafters sx-42**

**\$2500** AMATEUR NET | ADJUSTABLE BASE MODEL B-42 \$7.50

**RADIO SUPPLY COMPANY**

1125 East Douglas • Wichita 7, Kansas  
Tel. 3-9738

**W8CFK**

**Aluminum Call Plates**

Your call cast in aluminum with black background panel mounting, L for car license and D for desk use. \$1.75 each, postpaid.

P & H SALES CO.

619 Jasper St.

Kalamazoo 31, Michigan



Founded in 1909

**RADIO TELEPHONY  
RADIO TELEGRAPHY**

Courses ranging in length from 7 to 12 months. Dormitory accommodations on campus. Advanced students eligible for practical training at KPAC, 1 KW broadcast station owned and operated by Port Arthur College. New students accepted monthly. If interested in radio training necessary to pass F.C.C. examinations for first-class telephone and second-class telegraph licenses, write for details.

**PORT ARTHUR COLLEGE** PORT ARTHUR TEXAS

Approved for G.I. training

(Continued from page 174)

to realize this point, they should get in touch with their insurance broker and have a rider attached to the policy; otherwise they may find out when it is too late.

At any rate, I took out a \$2,000 policy on the transmitter and the antennas on the roof, which are also covered for destruction by wind as well as fire. The most interesting part of the entire deal, is that it only runs \$30 for the liability policy for three years and \$14.15 for the fire insurance for three years. This not only protects you, but the landlord is more apt to be agreeable to letting you erect antennas on the roof, when he realizes that it won't cost him money for any damage to the roof due to ham gear. It also eliminates the constant worry of the wind taking down that prize beam.

— R. Clark, W2OMM

**TECHNICAL INFORMATION SERVICE**

448 Riverside Dr., New York, N. Y.

Editor, QST:

I'm sending you this letter to thank you all, and in particular, W1FWH. I have quite often written to QST for information. Some of the questions I asked might have seemed quite simple to some; however, I always received a prompt—and, if need be, a detailed answer. I don't know how you can answer everyone's questions but it seems that you do.

Everyone on the QST staff seems to be a typical ham. Whenever someone like myself asks a question, he gets a friendly answer. As they would say in the Navy, "Well done, QST!" and keep up the swell work.

— Justin C. Barton

**BLIND ZLs**

New Zealand Institute for the Blind, 545 Parnell Rd., Auckland, L.E.1., Auckland, N. Z.

Editor, QST:

... Could you furnish me with particulars as to any blind hams in the States, or in any other country? There are six blind hams here in New Zealand: Tom Taylor, ZL2GP; George Harvey, ZL1DO; Terrance Small, ZL1MA; Lyall Laurent, ZL1LB; Tuma Tarewa, ZL1AP; and myself, ZL1LD. Our rigs were built for us and are being maintained by ZL1JQ, ZL1KJ, ZL1MC, ZL2IY. We get a great deal of pleasure out of the hobby, and would like to be able to contact some blind hams overseas on the higher frequencies. At present we all operate on 80 meters, but overseas contacts on this band are not easily made, so some of us hope to be in a position to operate on the higher frequencies in the near future. . . .

— Joseph H. E. Papesch, ZL1LD

**IRAQ**

c/o Postmaster, New York, N. Y.

Editor, QST:

... Here's the story on YI5KG as it was told to us, as nearly as can be remembered.

The Iraqi government did not have an organization to perform the functions of our Federal Communications Commission, at least as far as amateur radio was concerned. Regardless, a Mr. Talib Rifaat proceeded to operate his "two-valve wireless" under a call of his own invention. I'm sorry not to remember what it was; however, I think it had a YI prefix.

The late ruler of Iraq, King Ghazi I, heard of this Mr. Rifaat, who enjoyed a very unique hobby, and asked to have him presented in court and to demonstrate his equipment. The King was intensely interested from the very first and would not be satisfied with anything else but to have Mr. Rifaat install his station there. Thus, the call ending in KG, in honor of King Ghazi I. Mr. Rifaat told us that the King spent most of his spare time in the shack and developed into a regular ham himself.

After a period of time, the King decided to send Mr. Rifaat to Marconi College (London) in order that he learn more in radio engineering and therefore qualify him to build successfully a higher-power rig. I believe Mr. Rifaat attended Marconi College upon two different occasions.

(Continued on page 178)

*in* **SAN JOSE**

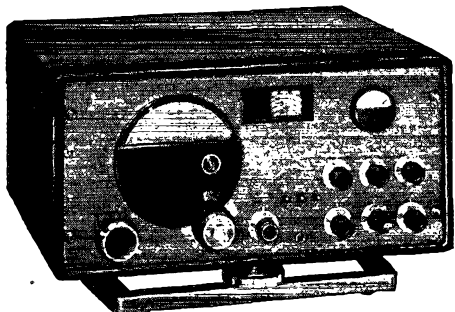

**hallicrafters sx-42**

**\$250<sup>00</sup>** AMATEUR NET | ADJUSTABLE BASE MODEL B-42 \$7.50

**FRANK QUEMENT**

156 W. San Fernando St. • San Jose, Calif.  
Since 1933 • Phone Ballard 1824

*in* **ITHACA**

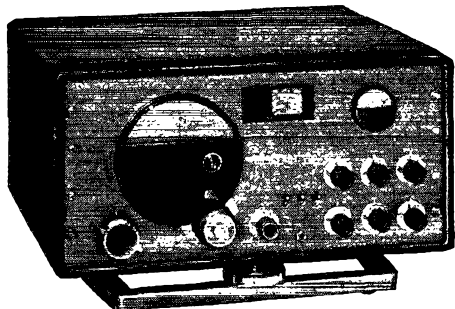

**hallicrafters sx-42**

**\$250<sup>00</sup>** AMATEUR NET | ADJUSTABLE BASE MODEL B-42 \$7.50

Phone 2297

**STALLMAN OF ITHACA**

210-212 N. Tioga St. • Ithaca, New York

*in* **HARTFORD**

*in* **NEW HAVEN**

*in* **BRIDGEPORT**

*in* **WATERBURY**

*in* **STAMFORD**

*in* **NEW LONDON**

*in* **BOSTON**

*in* **LAWRENCE**

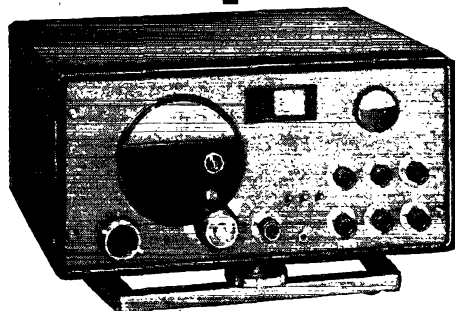

**hallicrafters sx-42**

**\$250<sup>00</sup>** AMATEUR NET | ADJUSTABLE BASE MODEL B-42 \$7.50

Hatry & Young, Inc.  
203 Ann Street  
Hartford 3, Conn.

Hatry & Young, Inc.  
77 Broadway  
New Haven, Conn.

Hatry & Young, Inc.  
544 East Main Street  
Bridgeport, Conn.

Hatry & Young, Inc.  
89 Cherry Street  
Waterbury, Conn.

Hatry & Young, Inc.  
525 Main Street  
Stamford, Conn.

Hatry & Young of New  
London, Inc.  
428 Bank Street  
New London, Conn.

Hatry & Young of Mass.,  
Inc.  
42-44 Cornhill  
Boston, Mass.

Hatry & Young of Mass.,  
Inc.  
639 Essex Street  
Lawrence, Mass.

**HATRY & YOUNG**

**The Elect in Electronics**

# in TORONTO

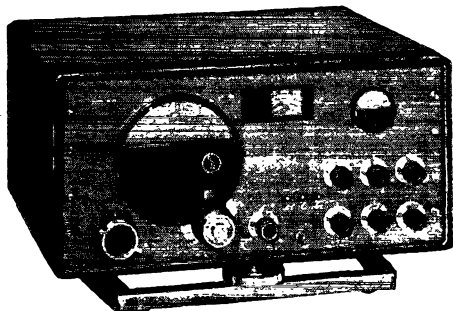

## hallicrafters sx-42

### ALPHA ARACON

*Radio Company Limited*

29 Adelaide St. W. • Toronto 1, Ontario

### TEST INSTRUMENTS

NOW IN STOCK!

TRIPLETT 666-H.....\$20.00	SIMPSON 215 v.o.m.....\$32.50
TRIPLETT 625-N.....45.00	SIMPSON 260 v.o.m.....38.95
TRIPLETT 2405.....68.50	SUPREME 542-B v.o.m. 23.65
TRIPLETT 2432.....88.50	SUPREME 576 osc.....68.95
SILVER "Vomax".....59.85	SILVER "Sparx".....39.90

25% deposit with order. Many others in stock. Catalog  
SCENIC RADIO • 53 Park Place • Dept. T • New York 7

**RADIO FLIGHT OFFICERS** wanted by international carrier for overseas assignments. Draft exempt. Applicant must hold radiotelegraph license — 2nd Class or better. Radiotelephone license — 2nd Class or better. Age 21 to 25. Ability to copy code 20 to 25 words per minute. Must have proof of citizenship for passport procurement. Pass flight physical. (Glasses permitted).

Address inquiries to: Personnel Relations Dept., Trans World Airlines, AAF Annex No. 1 Bldg., T-7 Room 1534, National Airport, Gravelly Point, Washington, D. C.

### RADIO COURSES

SERVICING  
BROADCAST ENGINEERING  
COMMERCIAL OPERATING  
TELEVISION

*Individual Laboratory Work Learn by Doing!*  
Day and Evening Classes

Approved by the Maryland State Department of Education and the Veteran's Administration.

FREE TO VETS — Textbooks, Tools, Test Set

Write for Bulletin

### Baltimore Technical Institute

1425 EUTAW PLACE • Dept. S  
BALTIMORE 17, MARYLAND

(Continued from page 176)

While he was in England, the King would order the parts for the new rig, and upon his return from college, they would both go to work rebuilding. The station didn't run over a kw., contrary to our expectations. The King insisted that Mr. Rifaat have full knowledge of his equipment before venturing into larger fields. Mr. Rifaat is sorry never to have worked a W; however, his DX record sounded pretty good.

Mr. Rifaat now owns and operates his own radio shop, dealing in U.S.-made sets as well as other foreign makes, and is interested in getting back on the air again as soon as conditions permit. Mr. Rifaat seemed to be a real ham. His story was quite interesting to me, and surely makes one realize the difficulty under which foreign hams have to operate.

— H. A. Christensen, ex-W9MBR

### SURPLUS NOTES

8214 Fairview Rd., Elkins Park, Pa.

Editor, *QST*:

Working 80 meters tonight and am I burned up! I have worked 80-meter c.w. for 12 years and have never heard so many sloppy notes on the air due to surplus transmitters (Army and Navy jobs). I think you ought to mention something in *QST* about keeping notes clean. There are thousands of these surplus rigs being sold that have chirpy notes and should be fixed up before being operated on the amateur bands.

— H. Kenneth Richter, W3ETM

### HOME STUDY

1210 No. Brazos St., San Antonio 7, Texas

Editor, *QST*:

With reference to your editorial entitled "Complexity," I wish to put in my two cents worth. What you say is 100 per cent true and as I see it one way to get around this increasing dilemma would be for more fellows to enroll in home-study courses. A home-study course on servicing would be practically worthless for our purpose, but an engineering course in communications — that's something else. I for one am taking a course such as this. . . .

Certainly *QST* is an excellent example of home study for all of us for from it we learn of new circuits, equipment, etc., which we otherwise would not hear or know about.

— Edward Antonio Gariel, W6HZJ

### WANTS EXPERIMENTERS

Kannimangalam, Nemmara.  
Cochin State, Madras, India

Editor, *QST*:

I have applied for patent rights for a new "short-wave generator," in the United Kingdom No. 10662/44, and in the U. S. A. Serial No. 595,211.

Present systems of broadcasting are either amplitude-modulated or frequency-modulated. I have yet another method which eliminates the defects of both the systems and retains the good points. . . . It will be interesting to test the system over long distances and your country is the farthest from India (either way). For this purpose, I shall be obliged if you can put me in touch with a few of your enthusiastic members.

— E. S. V. Pattamaly

### UNIVERSAL RECEIVER?

P.O. Box 398, El Cajon, Calif.

Editor, *QST*:

Your "Midsummer Daydreams" and Byron Goodman's discussion of an amateur receiver in August *QST* started the wheels turning out here with the following thoughts resulting. Why not a universal receiver consisting of replacement units or sections? The receiver might consist of the following or more units: r.f., i.f., b.f.o., noise silencer, detector and 1st audio, audio amplifier, speaker, and power supply. An r.f. section could be supplied for each type of service such as: maritime, police, amateur, broadcast, and commercial. Thus considerable improvement could be made in the efficiency of the receiver, and also the user would only pay for the frequency coverage desired. The buyer would purchase only those units which would be necessary to meet his operating

(Continued on page 180)

in **TOPEKA**

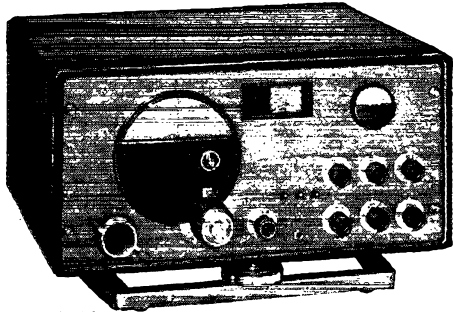

**hallicrafters sx-42**

**\$250<sup>00</sup>** AMATEUR NET | ADJUSTABLE BASE MODEL B-42 \$7.50

SERVING RADIO STATIONS IN THE MIDDLE WEST

**JOHN A. COSTELOW COMPANY**  
DISTRIBUTORS

125 Kansas Avenue • Topeka, Kansas

in **NEW YORK**



**hallicrafters sx-42**

**\$250<sup>00</sup>** AMATEUR NET | ADJUSTABLE BASE MODEL B-42 \$7.50

**SUN RADIO**  
& ELECTRONICS CO., Inc.

122-124 DUANE ST.

NEW YORK 7, N. Y.  
BARCLAY 7-1840



A. A. Ghirardi's RADIO PHYSICS COURSE book has been more widely used for home study, for Army-Navy training and by more civilian schools than any other of its kind.

**KNOW WHAT YOU'RE DOING . . . and why!**

**Ghirardi's COMPLETE COURSE IN BASIC RADIO-ELECTRONICS (including Basic Electricity)**

You'll understand ham circuits and problems better! You'll know every component, its function and purpose! You'll be better equipped for FCC examinations — and you'll have the proper basic training for a clear understanding of helpful ham manuals such as the ARRL Handbook!

Ghirardi's 972-page RADIO PHYSICS COURSE starts at the very beginning. Nothing is omitted. Nothing condensed. You'll understand every word — even without previous training. To the beginner, it is

ideal basic training — at only \$5 complete. To the "old timer" it offers a splendid way of brushing up on specific problems or forgotten fundamentals.

Over 300 pages cover Basic Electricity. From here this big, 3½ lb. book carries you through components, tubes, circuits and radio and audio amplification to every factor on which modern Radio-Electronics is based. 508 illustrations, 356 self-check review questions. Read it for 5 full days on our Money-Back Guarantee offer!



**Only \$5. Complete**

**36 Courses in one — Easily Worth \$50 if Sent to You in Monthly Lesson Form.**

**LEARN TO SERVICE ALL TYPES OF EQUIPMENT PROFESSIONALLY . . . at home . . . without an instructor**

Ghirardi's MODERN RADIO SERVICING is the only complete 1-vol. course in Radio-Electronic servicing by modern, scientific methods. Invaluable "background" training for Hams, it can also fit you for a profitable Radio-Electronic professional

future. Explains Test Instruments — how used and why — even how to build your own. Covers Troubleshooting Procedure; Circuit Analysis; Component Test and Repair; Installations; Adjustments, etc., etc. 1300 pages. 706 illus. Only \$5 complete.

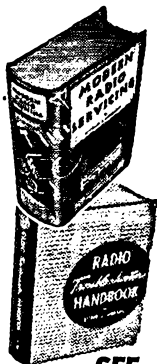

**SEE SPECIAL OFFER IN COUPON**

**Learn Exactly How to REPAIR OVER 4800 RADIO MODELS without costly test equipment**

4 out of 5 common radio troubles can be repaired simply by referring to Ghirardi's RADIO TROUBLESHOOTER'S HANDBOOK! Bothered with fading? Poor volume? Noise? Just look up the make and model. Covers practically every radio in use — over 4800 of them. Tells what to do, how to do it. Leading servicemen repair two sets in the time normally required for one. Beginners overcome obstacles that would take hours of study and tedious testing. Over 300 additional pages contain tube charts, graphs, service data compilations, etc. Weighs over 4 lbs. 744 pages. \$5. 5-Day Money-Back Guarantee.

**5-DAY MONEY-BACK GUARANTEE**

Dept. Q126, MURRAY HILL BOOKS, INC.  
232 Madison Ave., New York 16, N. Y.

Enclosed find \$\_\_\_\_\_ for books checked; or  send C.O.D. (U.S.A. only) plus postage. If not fully satisfied, I may return books within 5 days and get my money back.

MODERN RADIO SERVICING \$5 (\$5.50 foreign)

RADIO TROUBLESHOOTER'S HANDBOOK \$5 (\$5.50 foreign)

RADIO PHYSICS COURSE \$5 (\$5.50 foreign)

MONEY-SAVING OFFER Modern Radio Servicing and Troubleshooter's Handbook, \$9.50 for the two. (\$10.50 foreign)

Name \_\_\_\_\_  
Address \_\_\_\_\_  
City and Dist. No. \_\_\_\_\_ State \_\_\_\_\_  
(Please write or print plainly)

in **TUSCALOOSA**

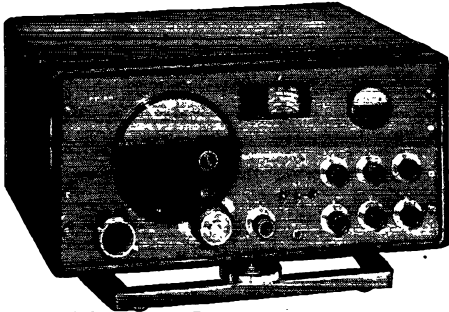

**hallicrafters SX-42**

**\$250<sup>00</sup>**

AMATEUR  
NET

ADJUSTABLE BASE  
MODEL B-42 \$7.50

**ALLEN & JEMISON CO.**

Tuscaloosa, Alabama  
Telephone 2781

in **CEDAR RAPIDS**



**hallicrafters SX-42**

**\$250<sup>00</sup>**

AMATEUR  
NET

ADJUSTABLE BASE  
MODEL B-42 \$7.50

**GIFFORD-BROWN, INC.**

• Radio Parts and Supplies •

106-108 1st Street, S. W. • Cedar Rapids, Iowa  
Phone 2-1106

(Continued from page 178)

requirements. An original purchase might consist of only the following units: r.f., i.f., detector and 1st audio, and power supply. Other units could be added as desired. Also, as improvement was made in design only the unit affected would need be replaced and not the entire receiver. . . .

— R. B. Heckert, W9SYC

### CLASS D

c/o Bureau of Ships, Navy Dept., Washington, D. C.  
Editor, *QST*:

. . . The arguments presented in favor of the Class D proposal are as old and worn as can be, and are almost the same as were presented about twenty years ago when the League was working to get 14 and 28 megacycles opened up. Only the frequencies were different. Even in the days of the 10 w.p.m. requirement there were those who campaigned for a no-code license, being led by a certain group I would rather not name. To lift the code requirement would result in throwing the band open to a number of people who would, in effect, trade on their so-called amateur rights. If these same people who would come in under the no-code provision really want to experiment, there are plenty of frequencies available outside of the amateur bands for this purpose, and I am sure that FCC would make them available to experimenters.

The broadcasting industry is now witnessing what happens when the license requirements are lowered. During the war, when the number of first-class radiotelephone operators was reduced, FCC permitted holders of restricted telephone permits to operate at broadcast stations, with the result that in many stations even the stenographers were holders of licenses and could operate the station, only one radiotelephone first being necessary in order to do any required tuning. This spring, with a number of first-class telephone operators returning from the armed forces, FCC proposed to terminate the use of restricted operators' licenses at broadcast stations. Immediately they were deluged with a pressure campaign to let the stations keep them, even though there was a large number of first-class license holders looking for jobs. (Did you ever read the story in *Arabian Nights* about the camel putting his nose in the tent on a cold winter night?)

This can also happen in amateur radio circles. If we let in the so-called experimenters instead of making them stay in experimental channels, we will open up something that we can not close off later on. Most of these fellows who cannot qualify under the existing requirements could not pass the test if they dropped it to one word per minute. Knowing something firsthand of the requirements of a person conducting experiments at those frequencies above 200 megacycles, if they have the mental capacity to do some real experimental work, they can easily pass any amateur exam. I think it is the tinkerers who are raising the fuss. . . .

— Lester Harlow, W5CVO/4

84 Shellbank Pl., Rockville Center, N. Y.

Editor, *QST*:

It is my opinion that the Class D license proposal should not be considered dead. September *QST* hardly does this important question justice. The only reason set forth for the Board's decision is a ". . . feeling gradually crystallizing that the best interests of amateur radio would be served by abandoning the whole proposal." This sounds pretty but does not let one in on your line of reasoning that leads to the "feeling."

The Board meeting report on page 24 of July *QST* set forth clearly the valid reasons for the Class D proposal and the general tone of the report leads one to believe that you are all in favor of the proposal. Page 38 of August *QST* further strengthened the hope of myself and many others that desire to see this type of license granted for operation above either 200 Mc. or 1215 Mc. To lightly pass the whole matter off with a statement such as mentioned in my first paragraph is to my way of thinking ridiculous and the manner in which it was presented constitutes a real blow to those who thought that something was really going to be done about the proposal.

To go into the reasons for the issuance of a Class D license would only be repeating what has already been mentioned in the July and August issues of *QST*. All I can add is that knowledge of the code proves nothing. Those that

(Continued on page 182)

*in* CLEVELAND

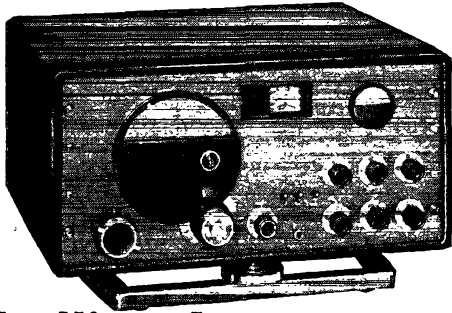

**hallicrafters sx-42**

**\$250<sup>00</sup>** AMATEUR  
NET

ADJUSTABLE BASE  
MODEL B-42 \$7.50

**THE PROGRESS RADIO  
SUPPLY COMPANY**

413-415 Huron Road • Cleveland, Ohio

*in* BELLINGHAM

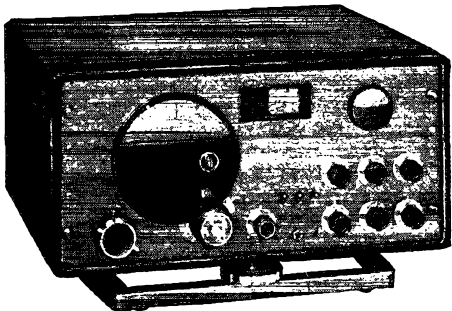

**hallicrafters sx-42**

**\$250<sup>00</sup>** AMATEUR  
NET

ADJUSTABLE BASE  
MODEL B-42 \$7.50

**WAITKUS SUPPLY COMPANY**

110 Grand Avenue • Bellingham, Washington

*in* BALTIMORE

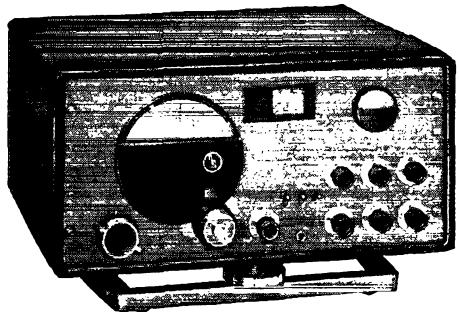

**hallicrafters sx-42**

**\$250<sup>00</sup>** AMATEUR  
NET

ADJUSTABLE BASE  
MODEL B-42 \$7.50

**"F.Y.I." (For Your Information)**

That's the title of our 4-page monthly brochure—planned to keep our customer friends informed on what's available and what's new in radio. It's FREE! A penny post card will bring YOUR copy each month. Write for F.Y.I. Today!

**WHOLESALE RADIO PARTS CO., Inc.**

311 W. BALTIMORE STREET  
BALTIMORE 1, MARYLAND

Phone, Mulberry 2134 2135

# in PETERSBURG



## hallicrafters sx-42

**\$2500** AMATEUR  
NET

ADJUSTABLE BASE  
MODEL B-42 \$7.50

## Va. Battery & Ignition

Radio Parts Distributors

35 E. Bank Street • Petersburg, Virginia



## STAND-OFF INSULATOR FOR 300 OHM LINE

Keeps both conductors rigid and parallel... eliminates unbalance and loss of efficiency caused by proximity effects. Molded polystyrene. Available at better dealers everywhere.

**THE WORKSHOP ASSOCIATES, INC.**  
66 Needham Street - Newton Highlands 61, Mass.

## DYNAMOTORS

to Power Your Mobile Rig!

Get lightweight, efficient, dependable rotary power for your mobile rig. Choose from a wide range of Carter Dynamotors, Magmotors, DC to AC Converters and Generators to meet every receiving and transmitting need. Used by leading State and City Police networks. Write for Free Bulletin.

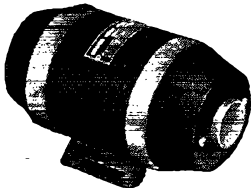

**Carter Motor Co.** (A Well Known Name In Radio for Over 20 Years)  
2645 N. Maplewood Avenue • Chicago 47, Illinois

(Continued from page 180)

are going to operate on 'phone generally forget the code soon after they are on the air. The time consumed learning the code might well have been spent learning more radio law and theory. In my opinion the scope of the radio-theory section of a Class D examination should be such as to include questions pertaining to microwave techniques, circuits and tubes. An examination of this nature would preclude the possibility of "letting in the butcher boys," as you so aptly put it.

During the last six years I have been associated with a company which has pioneered in the microwave field. I have daily contact with physicists, engineers, and laboratory technicians. Generally speaking they are all in favor of the Class D license proposal. They desire to get on the air to conduct experimental work on such things as propagation studies, a.m., f.m., fax., television and pulse-time modulation work. To deny the privilege of operating in the microwave region of the amateur bands to men of such caliber as to be able to pass more comprehensive theoretical examinations is akin to cutting the throat of the radio amateur body. By denying this privilege to them you may keep them out of the radio amateur ranks. Allow them to enter and I feel sure that they can do nothing less than enhance the status of the radio amateur group.

— Robert H. Hatch, W2A9V

2541 South Edsel, Detroit 25, Mich.

Editor, QST:

I reread my code-proficiency certificate, particularly that portion which reads, "who has this date demonstrated skill in the basic art of the true amateur." I call your attention to that portion as ARRL's own conception of the true amateur. What are we going to call this Class D person? What amateur will he be?

My livelihood is obtained as chief radio engineer for a station in the emergency services. The operating is exclusively radiophone, and many times requires fast and accurate thinking. During the war period, turnover in personnel was rapid. Experience taught me that a good c.w. man invariably made the best operator. Why? I don't know, unless it's because the process of learning c.w. develops the mind enabling a quicker and clearer response. . . .

— Harold E. Campau, W8JD

## Strays

Hum in a.c.-operated BC-221-D frequency meters can be cured by disconnecting the cathode of the 76 tube from the negative side of the heater circuit and grounding it through a 1000-ohm biasing resistor. — W2BAI via W2IXH

— . . . —

"Have just read George Grammer's September article on revamping the BC-342-N. It may interest the gang to know that the BC-342-D is much better suited for amateur purposes than the 'N' model. It has a jack in the first audio stage, no backlash in gears, and is of good peace-time workmanship. I found one for a song and after 2 hours of work I had it perking beautifully, calibration out only 400 cycles at 10 Mc." — W2PUF

## COMMERCIAL RADIO INSTITUTE

A RADIO TRAINING CENTER FOR 26 YEARS

Resident Courses Only • Broadcast, Service, Aeronautical, Television, U.H.F., Frequency Modulation and Marine telegraphy classes now forming for term February 1st. Entrance examination January 13.

Literature upon request. Veteran training

Dept. B, 38 West Biddle Street, Baltimore 1, Maryland



*in* **ROCKFORD**



**hallicrafters sx-42**

**\$25000** AMATEUR NET | ADJUSTABLE BASE MODEL B-42 \$7.50

**MID-WEST ASSOCIATED**

506 Walnut Street • Rockford, Illinois

*in* **JEFFERSON CITY**

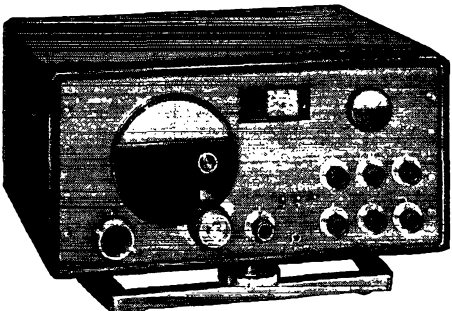

**hallicrafters sx-42**

**\$25000** AMATEUR NET | ADJUSTABLE BASE MODEL B-42 \$7.50

**CENTRAL MISSOURI DISTRIBUTING CO.**

409 W. McCarty • Jefferson City, Mo.  
Tel. 2855

*in* **PHOENIX**



**hallicrafters sx-42**

**\$25000** AMATEUR NET | ADJUSTABLE BASE MODEL B-42 \$7.50

*Radio Specialties & Appliance Corp.*

401 West Jackson Street • Phoenix, Arizona  
Phone 4-7184

# HAM-ADS

(1) Advertising shall pertain to radio and shall be of nature of interest to radio amateurs or experimenters in their pursuit of the art.

(2) No display of any character will be accepted, nor can any special typographical arrangement, such as all or part capital letters be used which would tend to make one advertisement stand out from the others.

(3) The Ham-Ad rate is 30c per word, except as noted in paragraph (6) below.

(4) Remittance in full must accompany copy. No cash or contract discount or agency commission will be allowed.

(5) Closing date for Ham-Ads is the 25th of the second month preceding publication date.

(6) A special rate of 7c per word will apply to advertising which, in our judgment, is obviously non-commercial in nature and is placed and signed by a member of the American Radio Relay League. Thus, advertising of bona fide surplus equipment owned, used and for sale by an individual or apparatus offered for exchange or advertising inquiring for special equipment, if by a member of the American Radio Relay League takes the 7c rate. An attempt to deal in apparatus in quantity for profit, even if by an individual, is commercial and all advertising by him takes the 30c rate. Provisions of paragraphs (1), (2), (4) and (5), apply to all advertising in this column regardless of which rate may apply.

(7) Because error is more easily avoided, it is requested signature and address be printed plainly.

(8) No advertiser may use more than 75 words in any one issue.

*Having made no investigation of the advertisers in the classified columns, the publishers of QST are unable to vouch for their integrity or for the grade or character of the products or services advertised.*

**QUARTZ**—Direct importers from Brazil of best quality pure quartz suitable for making piezo-electric crystals. Diamond Drill Carbon Co., 719 World Bldg., New York City.

**CRYSTALS:** Precision low drift units. Type 100A in 80, 40, and 20 meter bands. Two pins plug in one octal socket. One dollar each. Rex. Bassett, Inc., Ft. Lauderdale, Fla.

**QSLs** in colors. Stamp for samples. Glenn Griffith, W3FSW, 1042 Pine Heights Ave., Baltimore 29, Md.

**W2PTS** is former W8CJJ.

**OLD amateur, commercial radio sets, parts, catalogs, wanted.** Will trade new gear or pay cash. McMurdo Silver, Simsbury, Conn.

**AMATEUR radio licenses.** Complete code and theory preparation for passing amateur radio examinations. Home study course. American Radio Institute, Inc., 101 West 63rd St., New York City.

**SELL:** Spare meters, transformers, tubes, relays and miscellaneous parts priced right. Send for list. Cerny, WOSUG, 1020 W 22nd, Kearney, Neb.

**COMMERCIAL radio operators examination questions and answers.** One dollar per element. G. C. Waller, WSATV, 6540 E. Washington Blvd., Tulsa 15, Okla.

**WRL Transmitting kits**—15, 35, 70, and 150-watt units—low priced. All makes of receivers, both new and reconditioned. One offers best trade-in deal, and easy time payment plan. One of the country's largest parts supply houses. Write today for free catalog, special radio map offer, tube-base calculator offer, and other items. Leo, at World Radio Labs, Dept. HA, Council Bluffs, Iowa.

**RADIO tubes, parts, condensers, free bargain lists.** Potter, 1314 McGee, Kansas City 6, Mo.

**NATURAL color bakelite tubing;** 3 ft. lengths, 3/4" and also 3/8". Heavy 7/8" OD. Impervious to moisture. Ideal for long insulators, spacers, coil forms and insulation. Any three lengths, \$1.00 postpaid. Bud Slocum, W8JO, Roscomon, Mich.

**SELL or swap for shop equipment.** TBV2 walkie-talkie with carrying pack, two mikes, two headpieces, antennae, spare tubes and trunk \$35.00; Collins MBF transmitter-receiver 110 A.C. or D.C., 60 to 80 Mc. contains 28 tubes, new, \$45. SCR handie talkies \$30; BC348Q converted to A.C. and souped up \$75; SCR284 80-meter 35-watt phone transmitter and superheterodyne mike speaker dynamos, \$85. Dassen, Box 69, Claremont, Calif.

**SURPLUS parts and ham equipment at fractional prices.** Complete and varied stock of recognized manufacture. All components new and guaranteed. Send for free illustrated catalog of 1001 different items. Surplus Radio, Inc., 2-54 148th St., Whitestone, N. Y.

**AMATEURS, experimenters, industrialists and export accounts write for catalog and monthly bulletins.** Buy the "TB" guaranteed way and save. TAB, Dept. Z, 6 Church St., New York 6, N. Y.

**DON'T "rush order"** Kernz quality QSLs! Rotation, dispatch handling given; they're worth waiting for! Kernz, W2RUT, Fulton, N. Y.

**RADIOTELEPHONE first class sample tests, \$10.** We correct. New correspondence course. Box 1298, Hollywood, Calif.

**PANEL engraving.** Gilpin, Box 638R4, Mount Clemens, Mich.

**W2SFT** is former W3GNU.

**SELL:** choke, 450 mil, 16 henries, 6000 volt insulation, \$6.50. William J. Ziner, W2MAY, 834 Penfield St., Bronx 66, N. Y.

**SELLING out:** 300-watt fone/c.w. xmtr. Best offer. Bill McKnight, Brookville, Pa.

**BRAND new:** 150-watt xmtr. General Electric BC-191E cw or fone. 80 and 40 meter bands, slight change for 20 and 10. Complete with new tubes, 7 tuning units, antenna tuning, unit, power supply 1000 volt 350 mil dynamotor. 327 lbs. in original packing case. All for \$59. Phillips Radio, 701 56th, Kenosha, Wis.

**HEADPHONES** at a real bargain. Army type ANB-H-1 complete with adjustable headband and rubber ear cushions. New condition. \$1.25 postpaid. Van Lyon, W5LMH, Rt. 11, Box 161, San Antonio, Texas.

**COMPLETE QSL printing outfit wanted.** Send particulars to P.O. Box 4682, Washington 20, D.C.

**FOR Sale:** Meissner signal shifter surplus, new. Coils for 160 to 270 meters. Best offer. Clyde Keeler, Seward Ave., Port Jervis, N. Y.

**SELL:** 90-watt c.w. transmitter and 100-watt modulator, both \$140. Write Don McNamara, Loras College, Dubuque, Iowa.

**SELL:** new heavy duty deluxe plate supply 1000 or 750 volts, pure d.c. @ 300 mils. On 19" x 13" x 3" chassis, \$65. Good used plate transformer 1000 volts after filter 250 mils. \$9.75. Will ship c.o.d., f.o.b. W3HIG.

**SELL basic parts to 300-watt xmtr.** New 1RC resistor, 25000 ohm 200 watt, \$2.31; Cardwell var. condenser MF 100 GD, 7.05; MR 260 BD 5.25; UTC modulation xfmr. 250 watt 19.95; UTC choke 20 h 550 Ma., 11.40; 5/25 550 Ma., 11.40; Thordarson fila. xfmr.s, 2.5 v-10 a, 2.55; 6.3 v-10 a, 2.98. Take all for \$60. Also Stancor 100 watt xmtr \$60, coils, xtals, and meters. C. Hines, W4HCJ, 409 N. Reed, Wilson, N.C.

**WANTED:** QSTs for 1940. W3KVS, 700 Allison Ave., Washington, Pa.

**TRANSMITTERS, new BC-375Es converted 110 VAC, 100-plus watts output, fone/c.w.** 20-160 meters. \$150 complete for operation, including 4 tuning units, tubes, A.C. power supply, mike, key, cables, etc. Arnold Resnik, W9SDF/6, 177 Broadway, San Mateo, Calif.

**BC-221 frequency meter, power supplies with mixer tube built-in for modulating R.F. output, \$23.50.** Send for our price list now. Television Specialties Co., 315 Madison Street, Oak Park, Ill.

**SELL or trade:** 2000 volt power supply; 1500 watt a.c. engine generator; 5000 watt alternator; 1500 watt alternator; 2KUA pole xfmr; new Vibroplex; Underwood typewriter; 1000 volt d.c. generator; motors 1/4 to 2 h.p. Need communications rcvr. W0EWM, Purdy, Mo.

**ONE Sherman tank xmtr, complete with spare parts in 3 sealed export boxes, \$65.** f.o.b. Keene, N.H. J. Lee, W10EH, 1035 Shrader, San Francisco.

**NEW:** gasoline-driven generators, 110/220 volts, 60 cycles, 300 and 10,000 watts. United Sales Corp., 700 Murphy Ave., SW, Atlanta, Ga.

**SCOPE transformers, Westinghouse, Sealed, 2790V, 8 Ma.; 2.5V, 3A; two 6.3V, 6A, \$4.75, 3 for \$12.** Allow transportation. D. Duncan, 4077 Garden, Western Springs, Ill.

**SELL Meissner deluxe signal shifter with 10, 20, 40, 80 meter coils good condition, \$55.** W2BZB/W3KNN. Doersam, Palisade, N.J.

**FOR sale:** National FBXA with power supply, HRO xtal filter, coils thru 30 Mc., pre-selector, silencer. Best offer takes it. Wm. A. Baker, 2919 23rd Ave., San Francisco, Calif. W6LW.

**SX-28A:** latest model like new with speaker, \$225. Set of 3 Mims 10 meter elements and insulators, Gordon KW relay, make offer. W2RRN, 422 Palisade Ave., Bogota, N.J.

**SELL:** National NC-101-X rcvr, perfect condition, complete tubes, crystal speaker, make offer. W1IAP, 75 Simonds Road, Lexington, Mass.

**DELUXE QSLs, Samples, 10¢.** Refunded. Vern Slagle, W9VVS, 1704 Hale Avenue, Ft. Wayne 6, Ind.

**SELL Hallcrafters S-41W, used 2 1/2 months.** Best offer. 551 So. Columbus Ave., Mt. Vernon, N.Y.

**SELLING new K.W. final with new 100T1s, KW Ant. tuner; Bud streamline 6-ft. rack; 1250 volt, 500 Mil supply; 750, 500 volt dual supply at 300 mils, total; Mounted components for 300 watt modulator without Mod. Xfmr; pair new 805 1/2; all top quality. Write for details. W5LHZ, 214 So. Jeff., Enid, Okla.**

**COLLINS monitoring amplifier, 7R-9 in original carton.** Never used. Individual response chart. Grey rack panel mounting. Replacement cost \$150. Quick sale, \$100. Tubes included. C. W. Boegel, Jr., P.O. Box 224, Cedar Rapids, Iowa.

**TRANSFORMERS:** 115V primaries, unshielded; 2.5V, 10A, 10,000 V. insulation, \$4; 5.0V, 10A, \$4.50; 10.0V, 10A, for 813s, \$6; 250/300 watt step-down autoformer, 220V/110V., \$10. Others built to order. W2CRB, 1523 41st St., Brooklyn, NY

**SELL National NC-100 ASD, brooklyncv condition, \$110.** Frederick Evans, 33 Jayson Ave., Great Neck, N. Y.

**SELL:** extremely versatile 10-w Class B amplifier mounted in rugged portable case. 2 channels electronically mixed. Operates from 6v to 117 v. D.C. or 117 v. to 240 v. A.C. Used under 20 hours. \$40. Dean Borden, 52 Salter Place, Maplewood, N. J.

**BEAMS, elements, drives 14 to 450 Mc. 10 meter 1 1/4" tunable dural elements, \$5.** Beam complete, \$33. W9KOA/2, 375 Oak Place, Mineola, N. Y.

**PLACE an automatic fire extinguisher in your rig for protection.** Write for details. Shur-Ex, 1836 Crenshaw, Los Angeles, Calif.

**KILOWATT phone rig for sale.** Pair 250Th driven by 813, 807, 6L6 oscillator-modulated by pair 810s. Separate power supplies for each stage. Varic controls, final high voltage. Built-in send/receive relay. Contained in steel mounting racks. Well metered. High quality parts. Highest offer. Mervin Swing, W2OWM, R.D. 4, Penn Yan, N. Y.

**WANT Thordarson xfmr.s 19P66, 1750/1500V, 19F99 6.3V 10A (or Kenyon); P-P2A3 speech amplifier peak limiting (Thordarson or equivalent) rack panels 834" masonite (Bud or equivalent), 110VAC relays, ceramic insulation. New or in excellent condition. W5ACL, 4010 River Drive, Houston 12, Texas.**

**WANTED:** surplus tubes, new or used ham gear. R. M. Jones, L601 13th Court North, Birmingham 4, Ala.

**SELL:** transmitter never used. BC375E, 6 plug-in units, VFO phone /c.w. Ideal for 80 and 40 meter bands, better than 75-watt output. Complete with dynamotor, antenna unit, spare parts, \$160. Donald E. Freidel, Box 76, Yankton, S. D.

**D4ATE** now in states, all stations who contacted me in Germany and have not received QSL card write W20J, 40-12 44th St., Sunnyside, L. I., N. Y.

**CON-SET converters** for improved reception, mobile or fixed stations. Voltage regulator, 6A5 pre-selection, without mags. Instructions and schematic, complete, \$39.95. Shipped same day. Murray Black, W6UVF, 839 N. June, Hollywood 38, Calif.

CATHODE ray tubes SCPIs brand-new, \$7.95 (plus 6-lb. shipping socket with tube 45¢, otherwise, 90¢. SCPI steel shields, 85¢ (3 lbs). Brand-new 954, 955, 956, 957 ACorn tubes, not rejects, 89¢ ea., postpaid. 100' spaghetti, \$1.00 (2 lbs); ¼ wave midject selenium rectifiers, 5 for \$1; RG-34/U 72 ohm 50-90' 6 ½ ft. Free electronic bargain list. Ohmeyer Engineering Labs, Dept. A, Fairview Blvd., Hempstead, N. Y.

FOR Sale, 250 watt input transmitter, complete with tubes, power supply and key. Ready for operation on 20 meter band. Mrs. Grace Black, 1820 5th St., Perry, Iowa.

TRADE for TR4 for set for \$50. TBY, complete, 14 spare tubes, 5-10 meters. Barr, 37-177 5th St. Jackson Heights, L. I., N. Y.

CRYSTALS: Where quality and not price is the primary consideration. Demand Eidson crystals. Fine commercial units for aircraft, police, marine, geophysical and other services. Highly accurate, fully dependable and strong in output. Well over a decade of satisfaction and fast service! Newest Hallicrafters receivers, best delivery, order from "Eidson's", Temple, Texas.

4 µfd 610 V oil-filled condensers, 75¢ ea., postpaid. WIHXT, 45 May Ave., Brockton 38, Mass.

SELL several new unused 829B tubes. Bargain. Hoefle, Box 22, Parkersburg, Kans.

QSLs the way you want them. Vern, WOOMC, Hutchinson, Minn.

SALE: SW3, 20 and 40 m band spread coils, tubes, less power supply, \$15. 2-meter xmt-rvcr, Q ant., all tubes and power supplies, \$25. M. Reznik, 1036 Manor Ave., Bronx 59, N. Y.

SOMEWHERE some place somebody must have Mims indicator for sale. Notify W2LHO, 944 East 24th St., Brooklyn, N. Y.

FOR Sale: KW/CW xmt, complete, B & W coils for all bands; RME-67 rcvr, all in first class operating condition. Many other items in connection with ham shack included. Make an offer for quick sale. WDIR, Portage, Wis.

FOR Sale: old timers, commercials, souvenir hunters! Pre-World War I Navy SE143 receiver with external detector. 250-3000 meters. Condition excellent. \$15. W1BB.

SELL transmitter T47/ART13 Collins Autotune, new unused, with tubes, plugs and remote box, \$176. A. W. Bateman, W6WYW, 1249 South Rosemead Blvd., El Monte, Calif.

FOR Sale: Meissner Model 150-B transmitter. Operates on 80, 40, 20 all that is necessary for ten is to double. Best offer takes it. W2NQV.

ART-13 transmitter complete with generator. See article P 75, Sept. QST. \$175. f.o.b. David L. Goldberg, 410 Asylum St., Hartford.

WANTED: Meissner signal booster in perfect condition. W3JMA, 533 South Longwood St., Baltimore 23, Md.

METERS repaired, rebuilt, and calibrated. Factory accuracies. Springfield Testing Laboratory, 2931 East Enos, Springfield, Ill.

WANTED: Hallicrafters SX-25, used, reasonable. Hoffhaus, 612 State, Salina, Kans.

PLATE transformers, 1 ½ k.w., 2000 volts, 500 Ma., d.c. conservative. Secondary center tapped, primary 115 volts 60 cycles. New Kenyon in original cartons, weight 87½, \$35 each. Art Wearth, 6006 El Monte, Mission, Kans.

FOR Sale: National NC-100A receiver, best offer. Write or call Thomas Anglos, 201 Elder Avenue, Millbrae, Calif. Tel. 2868.

SPECIALIZING in Hallicrafters receivers, transmitters and other equipment. Pioneer Radio, T. Tappan, Waverly, N. Y. W2AVD.

QSLs-SWLa. Meade, W0KXL, 1507 Central Ave., Kansas City, Kan.

WANTED: A, B, C coils for National HRO rcvr. L. Krumlind, 55 Pignin Ave., San Francisco, Calif.

SACRIFICE equipment, closing shack. Panadaptor PCA-2 used 150 tubes. Like new. \$75. Hallicrafters BC-610 xmt, 500-watt fone, 750 cv, 20-40-80 coils and xtals, fb shape. First offer \$350. Robert Lewin, W2PIE, 336 West End Ave., New York 23, N. Y.

NEED new parts? Send 10¢ for details of the Radio Amateurs Swapper's Club, 13B Cooper St., Greenwood, Mass.

TOWERS for your rotary beam. Full latticework, spruce construction. Priced for the amateur. Write for Bulletin T-101. Sky-lane Products, Ironwood, Mich.

FOR Sale: Thirty watts for thirty dollars. Complete. Forty and eighty meters cw. Detailed ltr from W7JPW, Box 420, Lovelock, Nev.

2-METER receiver, phones, with external speaker in cabinet, pre-paid \$30. New code practice oscillator, paid \$8. Will take \$5. Will entertain bids for my Super-Pro, heavy-duty external power supply, 10' FM speaker. Tubes 1250 Kc. to 40 Mc, like new. 20-watt bread-board xmt with tubes, coil, three 80 meter xtals, bug and key, \$30. Hauck, 172 Manchester, Battle Creek, Mich.

SELSYNS, Govt. surplus, 115 volts, 60 cycles, size 3 ½ x 5 in. Matched pair, \$9.85 f.o.b. J. A. Weber, 150C Maple, Hershey, Penna.

QSLs? QSLs? America's finest! What's your desire? 20¢ for samples. RME-45, DB20 for sale. Sakkers, Printery, (Sakkers, W8DED) Holland, Mich. (Veteran)

SELSYN motors, new G-E Beam direction indicators, operate on 60 cycle a.c. \$5 pair. W8QPH, George Toma, 835 Starkweather Ave., Cleveland, Ohio

SELL General Electric d.c. dynamotor, 28 volts input, 1000 volts at 350 Ma. output. \$10. Write for details. WINWM, 27 Pearl Hill, Milford, Conn.

WANTED: All-wave receiver with separate speaker and all-wave converter. State condition and price. E. R. Pearl, 736 Buena, Chicago, Ill.

SALE or trade for test or photographic equipment, 5 Kw. oil transformer, 10,000, 5000, 2500, 1250 volt with 110-220 Volt primary, new, 805 tube, new. Other items. W9CQW.

FOR Sale: AN/CRT-1B Sono-bouy portable FM transmitter. Consult May 1967 "FM & Television" for details. Make offer. R. Englehardt, Larchmont Hills, Larchmont, N. Y.

GIFORD-Brown Bargains: RCA 3E29 (829B) with socket, \$4.75; 2 µfd, 1500 volt filter condenser, \$1.25; Thordarson 550 Ma. chokes, swinging and smoothing, \$6.95 each; many more bargains like above in our Bulletin, Gon-set converter, \$39.95; Sonar FM exciter, \$39.45; Millen x-mitter exciter, \$37.50; HQ-129-X with speaker, \$173.50. Limited quantities of these items in stock. Write for W9YCF's New Call Area Map and Bargain Bulletin. Gifford-Brown, Inc. Cedar Rapids, Iowa.

NEW motor generator, 1500 watts, 115 v.a.c. Army type, \$275. f.o.b. or signal generator, condenser checker or? Also have meters and tubes. W2MAV: 622 Boulevard East, Weehawkin, N. J.

FOR Sale: RME-69 rcvr, excellent condition. Meissner Deluxe signal shifter, less coils. W6JAS, Oswego, Kans.

SELL National ACSWJ, power supply and five coils. Best offer. WLSE, 222 Wickham Ave., Middletown, N. Y.

RECEIVER for sale. RCA AR-88 perfect condition. Best offer over \$250. W8VBZ/6, 6896 Krause Ave., Oakland, Calif.

TRADE Busca Pressman camera with accessories for medium power xmt fone. Will answer. C. W. Hale, W6EXG, 1929 Fairview Wichita, Kans.

FOR Sale: SX-28 in excellent condition, \$165. Also 60-watt phone/c-w transmitter, \$60. S. Kulpa, W8THI, 29 Crescent Road, Poughkeepsie, N. Y.

BC610 or other transmitter wanted. Please give all details including condition and price. R. W. Yeager, 4423 Sheridan Rd., Chicago, Ill.

ACORN tubes, new, 955 with Isolantite socket, \$1.25; pre-selectors 70 to 20 meters, self-contained power supply, new with tubes, \$19.95. Constant Electric, 112 Cornelia St., B'klyn 21, N. Y.

SELL NC100 receiver, 150W-c.w. xmt, complete. 2-meter rcvr and 2-meter 40-watt xmt, complete, \$325. W2HFM, Merrick, N. Y.

WILL pay fifty dollars for complete 10-meter fone xmt. W6VDR, Box 511, Colfax, Calif.

QSLs, samples, Albertson, W4HUD, 705 So. Hamilton, High Point, N. C.

20,000 ohm 25W Resistors, \$5 per 100; RK-60 Rectifier tubes, full wave, 5V 3A, regular 4-pin base, 250 mil 750V max., \$2.75 regular net, 36¢, \$24 hundred, 1 mid 5000 V oil, \$1.54. Selenium rectifiers, Sylvania germanium xtals, write for Bargain Bulletin. Electronic Research, 5832 Hagerman, Phila., Penna.

826 triode, at 250 megs; 100-watts input as oscillator; 75 watts input as plate modulated r.f. amplifier, \$7.10 postpaid from 164 Beechwood Ave., Bogota, New Jersey. L. Gillingham.

SELL for best offer. Candler highspeed and auxiliary code course. Ten lessons complete. W6DKK, 1727 Athens St., Boulder, Colo.

SELL Thordarson xfrmer, 1450 v. CT, 550 Ma., unused, \$10. Updike, Thornton Hall, University of Va., Charlottesville, Va.

WESTERN Electric 18A radio xmt, 6 volt mobile, ten fone, \$40. Original Vibron 100, 1 mid 5000 V oil, \$1.54. Selenium rectifiers, WJCO, 1408 Laramie St., Manhattan, Kans.

CIRCUIT for BC-348-P wanted. Buy or borrow. Larky, 444 W. 3rd, Bethlehem, Penna.

PHOTOS for your QSLs printed from your any size negative. See X, X, 72 for \$1. Negative returned. Leo Comeau, 2910 Elgin Ave., Baltimore, Md.

SELL custom-built regenerative TRF communications rcvr. New condition. Special VR power supply. Want portable typewriter. W1QOM, Humboldt, Tenn.

FOR Sale: National 100 ASD 10-tube rcvr and speaker. Brand new. In perfect shape. Freq. range 200 to 400 and 1300 to 30,000 Kc. Will include kit and instructions for conversion to broadcast band. \$100. H. E. Moore, 13 So. Dubuque, Iowa City, Iowa.

TRADE: "Radio" magazines for olden day ham gear. G. Starry, R. D. Box 487, Latrobe, Penna.

LUCY S. W. portable, compact, receiver (kit form) 2-12 Mc. 2-band, complete with 6 min. tubes, \$19.95. 2 µfd, 2000 v. oil condensers, 2 chokes, 70, 000 Mill, 2 ½ square meters, \$2.95; 805s, sealed cartons, \$4.95. 2-5V 10 amp. C. T. Kenyon 10,000 V. test 115 V.A.C. \$4.89. Deposit with order. Kelvin Electronics, 74 Cortlandt, N. Y. 7, N. Y.

TELEVISION components; deflection yokes 55° tubes, \$14.75, 40° tubes, \$15.75. Focus coils, \$4.50. Blocking oscillator transformers, \$1.75 each. At many jobs. If not at yours, order direct. Teletron, 1988 East 59th St. Cleveland 3, Ohio.

TRANSMITTING tube 304T1, \$7; 250T1 & R, \$7; 807, \$1; 836, \$3.50; 832, \$4; VT127A, \$2.25. Also large assortment of resistors, condensers, pilot bulbs, neon bulbs, fuse holders, potentiometers, code keys, knobs, meters all types; transmitters; receivers; relays; speakers, sockets, switches, terminal strips, variacs, receiving tubes, cathode ray tubes. This material being sold at rock-bottom prices. Send for flyer on items interested in. Abell Distributing Co., 5 E. Biddle St., Baltimore 2, Md.

WAR Surplus: extra special this month: Sylvania crystal, type IN21 high frequency (make a fine meter rectifier) 98¢; Sprague metal-encased, oil impregnated, tubular condensers, 600 VDC, 0.1 µfd, 10 for \$1.39; Signal Corps type JK34A short phone jacks, 10 for \$1.49; Micampoid condensers, 0.01 µfd, 400 volt, molded-in-base, 10 for 79¢; 25 for \$1.79, write for spec. circular, shipping extra. Special prices on quantities. Eric Supply Co., 88 Exchange St., Rochester, N. Y.

CRYSTALS: low drift mounted units, within 80 and 40-meter bands. Two fit in one octal socket. Phenolic case, stainless electrodes and neoprene gasket, \$1 each. Treatise on quartz crystals included. Breen Laboratories, Williamsport, Penna.

KENTUCKY Values! 2 µfd, 4000 V Pyranols, \$5. 4520V C. T. 700 Ma. Kenyon, \$49.95. Transmitting variables: 70-70, 50-50, 0.07 in. spacing at \$3.75. Stancor 6L6 driver transformers, \$2.75. Taylor Tubes, B & W, Vibroplex, Most merchandise previous QST ads in stock. Inquiries answered. Kentucky Radio Supply, Lexington, Ky.

SELL: BC-348Q receiver, 8" Jensen unmounted speaker, all perfect condition appearance, AC operated. W4IE, 429 So. Pineapple, Sarasota, Fla.

WANTED: Thordarson platter chokes T-15C30, T-15C32. Sell SX28A, speaker, Meissner Signal Shifter, coils. Make offer. A. U. Haugen, Canton, S. Dakota

BC610E, complete with many extras, 0 to 900 watts input. Also AT-3 antenna tuning unit, BC-342 receiver, RME DM36 converter, BGA 2-band xmt, BC-221 rfr, write for precision E200 signal generator. Triplett 1-56 circuit analyzer. Best offer. W3KAX/3, Box 3276, Tulsa, Okla.

SEASON'S Greetings from Fritz, printer of distinctive QST!el 1213 Briargate, Joliet, Illinois.

# Designed for



# Application

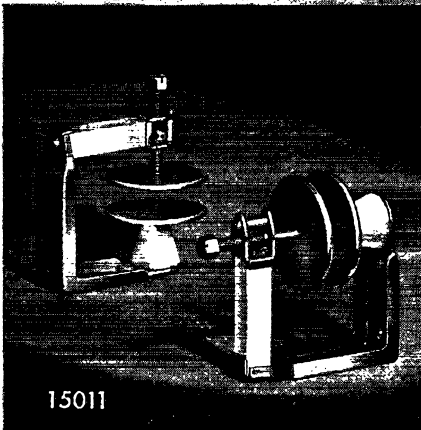

15011

## Disc Type Neutralizing Capacitor

Designed originally for use in our own No. 90881 Power Amplifier, the No. 15011 disc neutralizing capacitor has such unique features as rigid channel frame, horizontal or vertical mounting, fine thread over-size lead screw with stop to prevent shoring and rotor lock. Heavy rounded-edged polished aluminum plates are 2" diameter. Glazed Stealite insulation.

## JAMES MILLEN MFG. CO., INC.

MAIN OFFICE AND FACTORY

**MALDEN  
MASSACHUSETTS**



## Index to Advertisers

Acme Radio Supply.....	174	Millen Mfg. Co., Inc., Jas.....	186
Advance Electric & Relay.....	82	Munzig Mfg. Co., Arthur L.....	130
Alaska Radio Supply.....	160	Murray-Hill Book Co.....	179
Allen & Jenison Co.....	180	National Co., Inc.....	71, Cov. III
Allied Radio Corporation.....	125	Newark Electric Co.....	106, 108, 109
Almo.....	164	New York Tech. Institute.....	174
Alpha Aragon Rad. Co., Ltd.....	178	Nidico.....	167
American Phenolic Corporation.....	7, 90	Northern Ohio Labs.....	98
American Radio Institute.....	134	Northwest Radio & Elec. Supply Co.....	134
Arrowhead Radio & Telev. Sup- ply Co.....	115	Ohmite Mfg. Co.....	77
Ash Radio Co., Walter.....	161	Onan & Sons, D. W.....	175
Astatic Corp., The.....	107	Panoramic Radio Corp.....	157
Baltimore Technical Institute.....	178	Peerless Elec. Products Co.....	137
Barker & Williamson.....	147	P & H Sales Co.....	176
Bell Telephone Laboratories.....	83	Petersen Radio Co.....	85
Big A Co., The.....	128	Port Arthur College.....	176
Birnback Radio Company.....	126	Progress Radio Supply Co.....	181
Bliley Electric Co.....	81	Quement, Frank.....	177
Brill Co., W. D.....	90, 128	Radio, Inc.....	167
Burgess Battery Co.....	86	Radio Amateur Center.....	133
Burlington Instrument Co.....	120	Radio Elec. Service Co. of Penna. .....	100, 154
Burstein-Applebee Co.....	106, 129	Radio Equip. Corp.....	160
Cameradio Company.....	110, 135	Radio Manufacturing Engineers.....	187
Canadian Elec. Supply Co.....	164	Radio Parts, Inc.....	132
Candler System Co.....	150	Radio Parts Distributing Co.....	149
Capitol Radio Eng. Institute.....	76	Radio Prod. Sales Co.....	104
Cardwell Mfg. Co., Allen D.....	78	Radio Prod. Sales Co.....	136, 175
Carter Motor Co.....	182	Radio Service Lab.....	157
Central Missouri Dist. Co.....	183	Radio Shack Corp.....	116, 117
C. & G. Radio Supply Co.....	158	Radio Specialties Co.....	140, 163
Chem. City Radio & Elec. Co.....	158	Radio Spec. & Appliance.....	183
Chicago Radio Apparatus Co.....	92	Radio Supply, Inc.....	173
Cleveland Inst. of Radio Elec- tronics.....	104, 142	Radio Supply Co.....	154
Clippard Instrument Labora- tories.....	175	Radio Supply Co.....	176
Collins Radio Company.....	91	Radio & Television Equip. Co.....	133
Commercial Radio Institute.....	182	Radio Transceiver Labs.....	140
Condenser Products Co.....	113	RCA Mfg.....	Cov. IV
Consolidated Radio Co.....	120	Roden Electrical Supply Co.....	168
Continental Sales Co.....	114	Rogers Majestic, Ltd.....	173
Costelow Co., John A.....	179	Satterfield Radio Supply.....	100
Crabtree's Wholesale Radio.....	147	S-C Laboratories.....	137
Crystal Products Co.....	121	Seattle Radio Supply.....	170
Dow Radio Supply Co.....	144	Seel & Co., R. G.....	102, 174
Drake Electric Company.....	80	Seenic Radio Co.....	178
Duffy & Co., M. N.....	172	Scott Radio Supply.....	147
Edwards, W. H.....	148	Shure Brothers.....	88
Eitel-McCullough, Inc.....	167	Signal Elec. Mfg. Co.....	144
Electric Supply Co.....	168	Silver Co., McMurdo.....	119
Electrical Supplies, Ltd.....	135	Solar Capacitor Sales Co.....	188
Electronic Associates, Inc.....	162	Sonar Radio Corp.....	146
Electronic Equipment Co.....	130	Sparling Sales, Ltd.....	138
Electro-Voice Corp.....	97	Sprague Products Co.....	79
Federal Tele. & Radio Corp.....	143	Stallman of Ithaca.....	177
Gardiner & Co.....	152	Std. Radio & Elec. Products Co. .....	142
Gates Radio Co.....	89	Standard Supply Co.....	157
General Electric Company.....	1	Stark Radio Supply Co.....	153
Gifford-Brown, Inc.....	180	Sun Radio & Elec. Co.....	131, 179
Gross Communications.....	153	Sun Radio of Washington.....	95, 169
Hall, R. C. & L. F.....	112, 165	Supreme Transmitter Co.....	101
Hallcrafters Co.....	8-15	Sylvania Elec. Products Co.....	4
Hammarlund Mfg. Co., Inc.....	73	Terminal Radio Co.....	84, 159
Harper-Meggee, Inc.....	166	Transmitter Equip. Mfg. Co.....	2
Harrison Radio Co.....	105, 127	Trans-World Airways.....	178
Harvey Radio Co.....	123, 141	Tri City Radio Supply.....	159
Hatry & Young.....	150, 177	Triplet Elec. Instrument Co.....	151
Henry Radio Stores.....	111, 167	Turner Co., The.....	155
Herbach & Rademan Co.....	135	Tydings & Co.....	151
Houge Radio & Supply.....	155	U.H.F. Resonator.....	148
Hughes Peters, Inc.....	114, 146	United Electronics.....	87
Hytron Radio & Electronics Corp.....	93	United Radio Supply.....	174
International Resistance Co.....	74	United Transformer Corp.....	Cov. II
Interstate Distributors.....	152	Universal Radio Supply Co.....	162
Inter-State Radio & Supply Co.....	98	Valparaiso Tech. Institute.....	175
Iowa Radio Corp.....	155	Van Sickle Radio Co.....	124
J & B Distributing Co.....	170	Vibroplex Co., The.....	134
Jensen Manufacturing Co.....	99	Virginia Battery & Ignition Co.....	182
Johnson Co., E. F.....	145	Waitkus Supply Co.....	181
Johnson Co., D. R.....	172	Walker Radio Co., L. B.....	151
Ken-Rad.....	103	Ward Leonard Elec. Co.....	94
Koelmay Sales Co.....	168	Waterproof Electric Co.....	124
Law Bonn Co.....	139	Wenger Co., E. C.....	94
Lukko Sales Corp.....	133	Western Electric Co.....	75
M & H Sporting Goods Co.....	156	Wholesale Radio Co., Ltd.....	158
Magna-Metal Products Co.....	175	Wholesale Radio Parts Co.....	181
Maguire Industries.....	115	Wilcox Electric Co.....	5
Mallory & Co., P. R.....	72	Wilkinson Brothers.....	139
Mass. Radio & Tele.....	82	Willard S. Wilson.....	153
Meyberg, Leo J.....	126	Wise Radio Supply.....	173
Mid-West Associates.....	183	Workshop Associates.....	182
		World Radio Laboratories.....	96, 118
		Zack Radio Supply Co.....	102

*Now Available - the new . . .*

# VHF-152 converter

FOR 2, 6 and 10 METERS

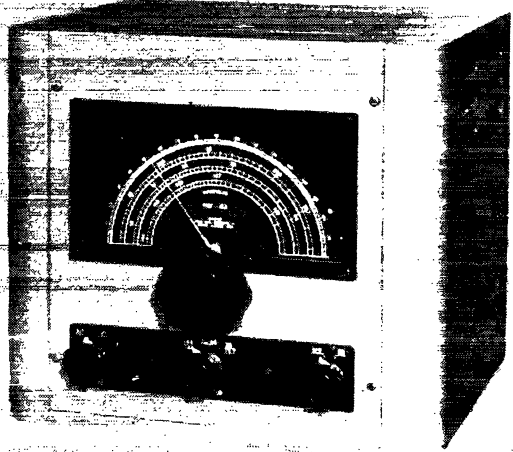

THE NEW VHF-152, used with any communications receiver, will give you peak performance on the 28 to 29.7, 50 to 54 and 144 to 148 mc. bands, utilizing the extremely efficient double detection system. Not only can you enjoy reception on these frequencies economically, but you'll do so more efficiently and effectively than is possible with any higher priced, specifically designed VHF receiver.

## *Features*

### TUNING MECHANISM

*An all-gear, planetary drive. The three bands are calibrated to cover the full sweep of a seven-inch diameter scale, calibrated in mc.*

### MINIATURE TUBES

*New miniature tubes are used for sensitivity, stability and extremely low VHF circuit noises. A Built in power supply includes voltage regulator tube.*

### SENSITIVITY AND IMAGE REJECTION

*Order of two microvolts on all bands. Image rejection ratio of approximately 54 db eliminates images.*

### ANTENNA CONNECTIONS

*Provision made for use of four separate antenna connections.*

### OTHER FEATURES INCLUDE

*Shielded output cable, sturdy construction, antenna change-over switch, band selector, tuning control, line switch.*

Illustrated  
Folder  
On Request



# RME

FINE COMMUNICATIONS EQUIPMENT

## RADIO MFG. ENGINEERS, INC.

*Provia 6, Illinois U. S. A.*

**CHECK**

## the features in these Capacitor Analyzers

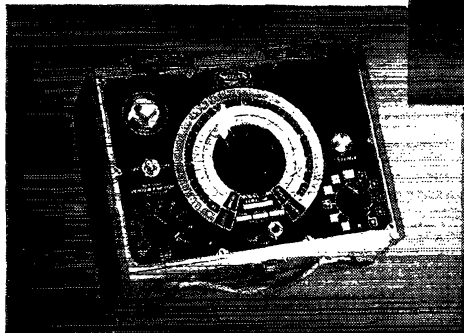

Model CBB CAPACITOR ANALYZER

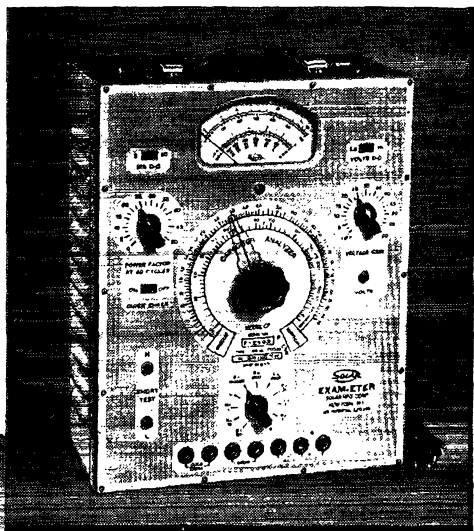

Model CF EXAM-ETER

### MODEL CF

Most comprehensive of all capacitor analyzers, this sturdy, reliable instrument is designed to simplify electronic servicing.

- Has exclusive, patented "Quick-Check" circuit for qualitative tests and intermittent checks without unsoldering capacitor leads
- Capacitance range—10 mmf to 2000 mf
- Power Factor range—0 to 55 percent
- Insulation Resistance range—3 to 10,000 meg-ohms
- Leakage Current—Reads electrolytic leakage current directly on large 4 1/2" meter

### PLUS

- ✦ Continuously Adjustable 0-550 volt D-C power supply for electrolytic tests
- ✦ 0-550 volt, 3-range D-C VTVM
- ✦ 10-50 volt, A-C VTVM
- ✦ 100 ohm to 7.5 megohm A-C resistance bridge
- ✦ JAN Quality Components for Long Troublefree Service

### MODEL CBB

An up-to-the-minute version of the famous Solar Model CB, long-time standard analyzer of the radio service industry.

- Capacitance range—10 mmf to 800 mf
- Power Factor range—0 to 55 percent
- "Magic-Eye" Tube for bridge balance indication
- Simplified Neon-Lamp circuit for visual check of insulation resistance and electrolytic leakage
- Resistance Bridge—50 ohm to 2 megohm range

### PLUS

- ✦ Color-coded easy-to-read scales
- ✦ Portability—small size and light weight
- ✦ Reliable components for operation in humid climates

Solar Capacitor Analyzers are fully described in Catalog IN-2, available at your distributors or directly from Solar Capacitor Sales Corp., 285 Madison Avenue, New York 17, N. Y.

# SOLAR CAPACITORS

"Quality Above All"



## Index to Volume XXX—1946

### ANTENNAS

Cliff-Dweller's Antenna, A (Peterson) . . . . .	64, May
Feeding Parasitic Arrays with Coaxial Line (H & K) . . . . .	148, Apr.
Five Are Better Than Three (Basden) . . . . .	32, Dec.
Flexible Coaxial Cable (Krueger) . . . . .	51, Apr.
Folded Doublet for 3.9 Mc. (H & K) . . . . .	47, Oct.
Half-Rhombic Antenna, The (Mullaney) . . . . .	28, Jan.
High-Gain Microwave Antennas (Tuller) . . . . .	34, Mar.
High-Gain Two-Meter Rotary Beam, A (Kmosko) . . . . .	45, Nov.
Impedance Matching with an Antenna Tuner . . . . .	38, Oct.
Inexpensive 3-Element Beam for 28 Mc., An (Nichols) . . . . .	27, Aug.
Long Wire Antennas (Roberts) . . . . .	36, June
New Kind of Skyhook, A (Ferrier, Baird) . . . . .	24, Oct.
New Six-Element 144-Mc. Beam . . . . .	65, Aug.
Plan Position Indicator . . . . .	79, Mar.
RG-22U Cable as Matching Transformer (H & K) . . . . .	68, July
Rotary Beam Antenna for 2-Meter Work (H & K) . . . . .	58, Dec.
Solving Feeder Problems Graphically (Kelley) . . . . .	25, Sept.
Standing Waves on Transmission Lines . . . . .	54, Dec.
Umbrella-Type Antenna, An (Robinson) . . . . .	70, May
Unique 5-Band Antenna System, A (McCulough) . . . . .	29, Dec.
Weather-Proofing 300-Ohm Twin Lead (H & K) . . . . .	47, Oct.

### AUDIO-FREQUENCY EQUIPMENT AND DESIGN

Audio-Modulated Detection (Griffin, Waller) . . . . .	13, July
Direct-Coupled Audio Amplifier (H & K) . . . . .	66, June
Let's Not Overmodulate (Smith, Hale) . . . . .	23, Nov.
Link-Coupled Modulator (H & K) . . . . .	51, Jan.
Pre-Modulation Speech Clipping and Filtering (Smith) . . . . .	46, Feb.
Simple "Wien-Bridge" Audio Oscillator (Sterling) . . . . .	29, Oct.
V.H.F. Modulator with A-2 and A-3 (H & K) . . . . .	51, Jan.

### COMMUNICATIONS DEPARTMENT

A-1 Operator Club . . . . .	78, July
Addition to C.D. Staff . . . . .	81, Mar.
Affiliated Club Honor Roll . . . . .	74, July
Club Instruction in Code and Theory . . . . .	75, June
Code Proficiency Program . . . . .	79, May; 53, June; 76, July
DXCC Certificate Awards . . . . .	74, June
Meet the SCMs . . . . .	W5JC, 73, Jan.; W8NCJ, 74, Feb.; W2KDC, 82, Mar.; W6PSQ, 82, May; W4HYW, 80, June; W9SWH, 80, Aug.; VE3DU, 78, Sept.; W9EVP, 72, Nov.
MRAC Achievement Award . . . . .	75, July
Official Experimental Station . . . . .	66, Mar.
Old Timers Club . . . . .	78, June; 62, Oct.
Press Schedules . . . . .	73, Jan.
Rag Chewer's Club . . . . .	81, Apr.; 73, Nov.
SCM Elections . . . . .	75, Feb.; 83, Mar.; 80, Apr.; 80, June; 82, Aug.; 63, Oct.; 71, Dec.
Traffic Plans . . . . .	61, Oct.

### CONTESTS AND OPERATING ACTIVITIES

ARRL Band-Warming Party . . . . .	57, Feb.; 81, May; 39, July
ARRL Get-Acquainted Party . . . . .	51, Sept.
Canadian 28-Mc. Contest . . . . .	83, Mar.
C.D. QSO Party . . . . .	59, Oct.
Dreamboat Flight, The . . . . .	66, Dec.
Most States Above 50-Mc. . . . .	80, May
North Carolina Field Day . . . . .	63, Oct.
Simulated Emergency Test . . . . .	77, June
Sweepstakes, Thirteenth Annual . . . . .	30, Nov.
Tenth ARRL Field Day . . . . .	22, June; 79, Sept.
1946 V.H.F. Marathon . . . . .	51, May

### CONVENTIONS

Maritime Division . . . . .	18, Aug.; 116, Nov.
Midwest Division . . . . .	42, Oct.
New England Division . . . . .	12, Apr.
New Hampshire State . . . . .	42, Oct.
Rocky Mountain Division . . . . .	18, Aug.
Vermont State . . . . .	42, Oct.

### CONTROL CIRCUITS

Bias Supply Time-Delay Circuits (H & K) . . . . .	67, June
Inexpensive Relay for Push-to-Talk Circuits (H & K) . . . . .	75, Apr.
Power Control Circuits in Amateur Transmitters (Lawson) . . . . .	43, May
Quiet Break-In Operation (H & K) . . . . .	65, Mar.
Relay Coil Transient Reduction (H & K) . . . . .	61, May
Remote Control Using V.H.F. . . . .	68, Feb.
Simple Time Delay Circuit (H & K) . . . . .	76, Apr.
W8VGV Control Circuits (H & K) . . . . .	61, Jan.

### CRYSTAL BALL

Built-In Safety at W3JOP . . . . .	128, Feb.
Compactness and Flexibility . . . . .	63, Jan.
Conversion Exciter . . . . .	62, Jan.
Postwar Shop and Shack Layout . . . . .	64, Jan.
Safety in the Ham Shack . . . . .	67, Feb.
Small but Mighty . . . . .	63, Jan.
Station Planning . . . . .	77, Mar.
Unique General Coverage Receiver . . . . .	64, Jan.

### EDITORIALS

Bad Signals . . . . .	11, Nov.
Bum Superhets . . . . .	11, Oct.
Complexity . . . . .	11, Oct.
DX QSLs . . . . .	11, May
Eleven Meters . . . . .	11, May
Forty . . . . .	17, Dec.
How About F.M. . . . .	12, Oct.
Idea and a Proposal, An . . . . .	11, June
Look Behind and Ahead, A . . . . .	11, Sept.
Licensing Resumes . . . . .	11, Mar.
Midsummer Daydreaming . . . . .	11, Aug.
More of 80 . . . . .	11, May
On Reporting . . . . .	11, Nov.
Our Good Frequencies . . . . .	12, Mar.
Rebirth Pains . . . . .	11, Jan.
Ten Meter Observations . . . . .	11, Nov.
These Bands . . . . .	11, Feb.
War Surplus . . . . .	11, Feb.
Who's on 11? . . . . .	11, June
160-Meter Band, The . . . . .	11, July
3700-40001 . . . . .	11, Apr.

### EMERGENCIES AND EXPEDITIONS

AEC in Kings County . . . . .	74, July
Alaskan Earthquakes . . . . .	79, Aug.
Belgian Plane Crash . . . . .	69, Dec.
MacMillan Arctic Expedition . . . . .	75, Sept.
Ohio Emergency Corps Net . . . . .	79, Aug.
Operating Practices in AEC Networks . . . . .	80, Sept.
Susquehanna Emergency Net Operation . . . . .	78, Aug.

### FEATURES AND FICTION

Amateurs on "Crossroads" Electronics Ship . . . . .	37, Aug.
Christmas 1944 (Newkirk) . . . . .	25, Jan.
Circular-Band Theory, The (Rapp) . . . . .	65, Apr.
Color (Sourdough) . . . . .	56, Sept.
Dixie Jones Owl Juice . . . . .	26, Feb.
DX Record: To the Moon and Back (Kauffman) . . . . .	65, May
Ex-DX Hound . . . . .	41, Nov.
For Beginners Only (Fraser) . . . . .	53, Aug.

Hamming in North China.....	76, June
How to Catchum DXCC (Jessup).....	24, Sept.
It's Fascinating Work (Williams).....	32, Aug.
Listening Post in the Philippines (Visintainer).....	70, Apr.
Military Television Cameras — and the Amateur (Middleton).....	41, Mar.
"No, I'm Not on the Air" (Jablin).....	28, Dec.
On or Off.....	66, Feb.
Opening of the Band, The (Bourne).....	28, Mar.
Postwar DX — Where is Thy Ring? (Jacoby).....	42, Nov.
Postwar Naval Reserve, The (Cowan).....	54, Apr.
WICPI, WINKW, W6TT, KP4AU (Ham Shacks).....	52, Dec.
W6MBA/Tinian.....	59, May
W9USA — Milwaukee Centurama.....	60, Oct.
XACA/XADK.....	69, Nov.

### FOREIGN NEWS

Argentina.....	71, Feb.; 68, June; 47, Aug.; 32, Nov.
Australia.....	66, Apr.; 69, May
Austria.....	69, May
Belgium.....	47, Jan.; 68, June; 46, July
Brazil.....	71, Feb.
Colombia.....	47, Jan.; 52, Sept.
Cuba.....	69, May; 68, June; 47, Aug.
Czechoslovakia.....	47, Jan.; 46, Mar.; 46, July
Denmark.....	46, Mar.; 68, June; 51, Dec.
Far East.....	32, Nov.
Finland.....	71, Feb.; 52, Sept.
France.....	47, Jan.; 66, Apr.; 68, June; 47, Aug.; 37, Oct.
Great Britain.....	46, Mar.; 52, Sept.; 51, Dec.
Hands Across the Sea.....	37, Sept.
Italy.....	130, Mar.; 68, June
June Calendar.....	52, Sept.
Luxembourg.....	130, Mar.
Mexico.....	47, Jan.
Netherlands.....	47, Jan.; 69, May; 51, Dec.
Newfoundland.....	47, Jan.; 66, Apr.
New Zealand.....	130, Mar.; 66, Apr.; 51, Dec.
Norway.....	138, May; 146, Sept.
Portugal.....	37, Oct.
QSL Bureaus.....	138, May; 37, Oct.
South Africa.....	120, Feb.
Sweden.....	120, Feb.; 138, May
Switzerland.....	108, Jan.
U.S.S.R.....	37, Oct.
Venezuela.....	68, June
WAC Certificates.....	32, Nov.

### FREQUENCY MODULATION

Amateur FM.....	40, Oct.
Narrow-Band FM with Crystal Control (Shuart).....	27, Nov.
New Approach to FM Reception.....	73, Sept.
New FM Detector Circuit, A. (Grammer).....	26, Jan.
4.3-Mc. FM/AM I.F. and Audio Amplifier (Bran- nin).....	51, Mar.

### HAPPENINGS OF THE MONTH

AACS Needs Hams.....	28, June
Allocation Proposals.....	36, Sept.
Army Signal Association.....	39, Sept.
Bands Open.....	36, Dec.
Board Meeting (Announcement).....	36, May
(Summary).....	23, July
(Minutes).....	27, July
(Matters).....	36, Aug.
Canadian Memberships.....	45, Mar.
Canadian Notes.....	45, Mar.; 27, July
Class D Proposal Withdrawn.....	36, Sept.
Election Notices Canada, 39, Nov.; 37, Dec.; Delta, 43, Feb.; 45, Mar.; Pacific 26, July; 40, Aug.; 1946, 32, Aug.; 40, Sept.	
Election Results Atlantic, Dakota, Midwest, 41, Jan.; Delta, 27, July; Central, New England, Midwest, Southwestern, 38, Nov.; Midwest, 43, Feb.; Pacific, 37, Dec.	
Engineers and Technicians Wanted.....	27, July
Executive Committee Minutes.....	40, Aug.
Further Glossary.....	42, Jan.
Georges.....	39, Sept.
GI Operation.....	45, Mar.

Handprinting Code.....	39, Sept.
Hudson Directorship.....	38, Nov.
If Your QST Is Late.....	42, Jan.
International Conferences.....	38, Nov.
Kudos to Budlong.....	114, Jan.
Licensing and Renewals.....	26, Oct.
Licensing Matters.....	41, Apr.
Long Zero, The.....	38, Sept.
Midwest Directorship.....	37, Dec.
Miles Joins FCC.....	42, Jan.
New Frequencies.....	44, Mar.
New Licensing Plan.....	38, Sept.
Norwine Heads Committees.....	42, Feb.
Outlook, The.....	42, Feb.
Police Permits.....	39, Aug.
Prospects.....	36, May
QSL Cards.....	36, Dec.
Renewal Applications.....	27, May; 38, Nov.
Staff Notes.....	29, June; 38, Aug.
U. S. Radio Districts.....	27, June
Ten-Meter Plan, The.....	26, Dec.
VWOA Honors Amateurs.....	41, Apr.

### KEYING

Advanced Type of Keyer.....	78, Mar.
Audio Oscillator in the Receiver, An (H & K).....	148, Apr.
Automatic Break-In Circuit (H & K).....	64, Nov.
DeLuxe Electronic Key, A (DeHart).....	17, Sept.
Electrostatic Key, An (H & K).....	75, Apr.
Frequency Shift Keying.....	46, June
Postwar Signals.....	56, Dec.
Speed Key Adjustment (Smith).....	76, Aug.

### MEASUREMENTS AND TEST EQUIPMENT

Automatic High-Low Meter Switching (H & K).....	59, Feb.
Combination Test Meter, A (Dellar).....	61, Sept.
Design for Cathode-Ray Tube Circuits (Knoop).....	45, Dec.
Field-Intensity Meter for V.H.F. (Summerford).....	40, June
Field-Strength Meter with Adjustable Antenna (H & K).....	67, July
How Much Inductance? (Floyd).....	69, June
I.F. Xtal for Calibration Points.....	128, Feb.
Improved Condenser Checker (H & K).....	66, June
"Little Gem II, The" (Goodman).....	48, Jan.
Measuring Galvanometer Resistance (H & K).....	68, July
Panoramic Reception, 1946 (Clurman, Schlessel).....	22, Mar.
Remote-Indicating Field-Strength Meter, A (Til- ton).....	21, May
Simple Capacitance and Inductance Measure- ments (Gadwa).....	71, Mar.
Soup-Can Wavemeter for the 24-Cm. Band, A (Jenks).....	33, Oct.
Wide-Range Test Oscillator, A (Lober).....	40, May

### MICROWAVE TECHNIQUES

CQ — 2400 Megacycles (Koch, Floyd).....	32, July
Duplex 'Phone on 5300 Mc. (Merchant, Harri- son).....	19, Jan.
High-Gain Microwave Antennas (Tuller).....	34, Mar.
Oscillators and Amplifiers at 1000 Mc. (Rand).....	34, Apr.
QRM — The Electronic Life Saver (Robbiano).....	12, Jan.; 27, Feb.
Selective Pulse Communication System, A (Knight, Storck).....	74, May
Soup-Can Wavemeter for the 24-Cm. Band, A (Jenks).....	33, Oct.
Wave Guides (Part III).....	61, Mar.

### MISCELLANEOUS

Book Reviews Electronic Dictionary.....	120, Feb.
Principles of Radio for Operators; Two- Way Radio; Inside the Vacuum Tube.....	146, June
Canadians Organize AFARS.....	83, May
Claim Your Old QSL Cards Now or Never.....	31, July
Listening in on the Stars (Villard).....	59, Jan.
Loran — The Latest in Navigational Aids (Mc- Kenzie).....	54, Jan.; 62, Feb.
New Apparatus (Tuned Plug-In Coil Forms).....	35, Feb.
RMA Color Code for Multiwire Cables (H & K).....	75, Apr.



Standardized Component Values.....	46, June
Wanted — Hams for Overseas.....	52, Aug.

## OBITUARY

W5ERV.....	44, Mar.
W6GG.....	42, Feb.
W9CAA.....	41, Jan.

## OPERATING PRACTICES

(See also, "Operating News" section in each issue.)

Bad Signals (Editorial).....	11, Nov.
Building Friendships on the Air.....	70, Nov.
Good Operating Pays Off! (Huntoon).....	31, Apr.
How to Deliver a Message.....	78, July
Idea and a Proposal, An (Editorial).....	11, June
On Good 'Phone Operating.....	74, Aug.
On Reporting (Editorial).....	11, Nov.
Operating Practices in AEC Networks.....	80, Sept.
'Phone Roundtables.....	77, Sept.
Speed Key Adjustment (Smith).....	76, Aug.
Tolerance and Courtesy.....	79, July
VFO Technique.....	80, Aug.

## POWER SUPPLIES

Bias-Supply Time-Delay Circuits (H&K).....	67, June
Filament Transformers for Bias Supply (H&K).....	69, Sept.
How Much Inductance? (Floyd).....	69, June
Simple Bias Isolator (H&K).....	65, Mar.
Sure-Fire Safety Precaution (H&K).....	65, Nov.
Unusual Rectifier Circuit, An (Comstock).....	56, Nov.

## PROPAGATION

Bright New World — of Sunspots, The (Conklin).....	43, Jan.
Bustans 10-Meter Studies.....	56, Mar.; 35, May; 17, June; 11, Nov.
Forecasting Long Distance Transmissions (Foley).....	36, Feb.
Listening in on the Stars (Villard).....	59, Jan.
NBS-ARRL Radio Observing Projects (Gautier).....	18, Apr.
Need There Be Line-of-Sight? (Tilton).....	47, Mar.
Propagation Predictions Now Available.....	46, Aug.
Radio Propagation Work at the National Bureau of Standards (Smith, Silberstein).....	45, May

## RECEIVING

Applying AMD to the Communications Receiver (Griffin, Waller).....	56, Aug.
Audio-Modulated Detection (Griffin, Waller).....	13, July
Coupling 500-Ohm 'Phones to the Receiver (H&K).....	65, Nov.
New Tuning System for the Amateur Receiver (Halligan, Foot).....	18, May
Noise Limiting in C.W. Reception (Grammer).....	13, May
Noise Silencer Using Germanium Crystals (H&K).....	61, May
Quiet Break-In Operation (H&K).....	65, Mar.
Revamping the BC-342.....	42, Sept.
S.S. C.W. Reception and Crystal Filters.....	59, Mar.
Untuned Preselector, An (H&K).....	140, Aug.

## RECEIVERS

Amateur Band 8-Tube Receiver, An (Goodman).....	13, Aug.
Band-Pass 28-Mc. Converter, A (Goodman)....	44, Apr.
Looking Over the Postwar Receivers.....	
Hammarlund HQ 129X.....	24, June
Hallicrafters S-40.....	69, July
RME-45.....	48, Oct.
4.3-Mc. FM/AM I.F. and Audio Amplifier (Brannin).....	51, Mar.
28-Mc. Receiver-Converter, An (Goodman)....	17, Feb.

## REGULATIONS

Activity Waived Until December.....	39, Aug.
Attach Your Current License.....	38, May
Call Letter Phonetics.....	27, Oct.

Canadian Assignments.....	38, May
Canadian Regulations.....	44, Feb.
Changing Operating Address.....	39, Aug.
Citizenship Proof Abandoned.....	44, Mar.
Fingerprints Eliminated.....	39, Aug.
Half of 40 and 20 Returned.....	36, Aug.
Handprinting Code.....	28, Oct.
High Seas Mobile.....	27, Oct.
Microwave Changes.....	36, Sept.; 38, Nov.
More of 80.....	11, May
More Operator Licenses Extended.....	41, Jan.
Naval Bases Stations.....	45, Feb.
New Frequencies.....	44, Mar.
New Portable Status Rules.....	26, June
Non-Continental Prefixes.....	43, Apr.
Recent Assignments.....	37, May
Registration Eliminated.....	41, Jan.
State Guard WERS.....	42, Jan.; 39, Aug.
Station Licenses Extended.....	26, June
Two-Letter Calls.....	27, Oct.
U. S. Radio Districts.....	27, June
We Have New Regulations (Warner).....	23, May
What Bands Available?.....	44, Mar.; 42, Apr.; 29, June; 37, Sept.
1200-Mc. Band Relocated.....	42, Jan.
5-Meter Band Becomes 6 Meters.....	42, Apr.
75 and 10 'Phone Changed.....	36, Aug.

## STATION CONSTRUCTION AND WORKSHOP PRACTICE

(See also, "Crystal Ball.")

Convenient Tie-Point Substitute (H&K).....	58, Dec.
Crystal Grinding Compound (H&K).....	76, Apr.
Crystal Grinding Without Tears (Cowles).....	48, Apr.
Crystal Holder Sockets (H&K).....	76, Apr.
Ham-Made Cable Lead Markers (H&K).....	70, Sept.
Ham-Made Solder Flux (H&K).....	76, Apr.
Making the Most of It (Hubbell).....	49, June
New Decalcomanias for Panel Marking.....	65, Aug.
Notes on Cleaning Crystals (H&K).....	67, July
Operating Console for the Amateur Station (H&K).....	60, May
Perforated Metal Sheetting (H&K).....	76, Apr.
Soldering Hints (H&K).....	59, Feb.
Unique Coupling, A (H&K).....	144, Apr.

## TELEVISION

Extended-Range Television Reception (Part II) (Wilder).....	35, Jan.
I.F. Amplifiers in Television Receivers (Kronenberg).....	62, June
Military Television Cameras — and the Amateur (Middleton).....	41, Mar.

## TRANSMITTING

BCI.....	54, Sept.
Cathode-Coupled Oscillator, A (H&K).....	69, Sept.
Conductor for Twin Lead (H&K).....	64, Nov.
Eliminating Stand-By Drift in a VFO (H&K).....	71, Aug.
Frequency-Meters as Master Oscillators (Conklin).....	34, Aug.
Keeping Your Harmonics at Home (Grammer).....	13, Nov.
Long Leads Aren't Necessary (Shuart).....	55, June
Midsummer Daydreaming (Editorial).....	11, Aug.
New Linear Amplifier Circuit (Fisher).....	21, Feb.
No Neutralization Required.....	48, June
Operating the 807 (Mix).....	53, May
Permeability-Tuned Oscillators (Hunter).....	42, Aug.
Preventing Self-Oscillation in Tetrode Amplifiers (Frelich).....	22, Oct.
Radio-Frequency Auto Resonator, A (Clemens).....	65, Jan.
Remote Control Using V.H.F.....	68, Feb.
Simple VFO-Amplifier Coupling.....	59, Sept.
Simplified Transmitter Frequency Changing... ..	53, Sept.
Six Oscillator Input Circuits in One Socket (H&K).....	71, Aug.
Those 14-Mc. Signals.....	67, Apr.
Uni-Frequency Transmission and Reception (H&K).....	68, July
Unstable Signals (Mix).....	23, Aug.

## TRANSMITTERS

Band-Switching VFO Exciter Unit, A (Bradley)	29, Mar.
Beginner's Two-Stage Transmitter, A (Middletown)	16, July
Conservative Kilowatt, A (Mix)	54, July
High-Power in Two Stages (Mix)	13, June
Low-Power 28-Mc. Phone-C.W. Transmitter, A (Mix)	13, Mar.
Medium-Powered Bandswitching Transmitter, A (Smith)	13, Sept.
Most Inexpensive Transmitter, The (Goodman)	33, Dec.
Self-Contained 60-Watt C.W. Transmitter, A (Mix)	13, Apr.
Simple VFO Crystal Substitute, A (Mix)	13, Sept.
Single Control in the Bandswitching Transmitter (Harms)	19, Dec.
Ten-Dollar Wonder, The (H&K)	66, June
Three-Band Utility Transmitter, A (DuBois)	20, Nov.
What About the BC-375E? (Smith)	38, Dec.

## TUBES

RK-4D32, 2E25	73, Mar.
HD59, TB-35, 3D23, 4E27, TUF-20	74, Mar.
3C28, 4C34, 4C32, GL-592	140, Mar.
2C39, 2C43	142, Mar.
117Z3	146, Mar.
VT-127A	33, Nov.

## VERY HIGH FREQUENCIES — APPARATUS

Converting Your Converter (Smith)	47, July
Crystal Control on 144 Mc. (King)	46, Sept.

Getting Started on 420 Mc. (Hoisington)	43, June
Miniature Tubes in a Six-Meter Converter (Houghton)	18, June
Mobile Receiving Equipment for 2, 6 and 10 Meters (Tilton)	28, Sept.
Mobile Rig for 50 and 28 Mc., A (Tilton)	31, June
More Stations Per Megacycle at Two Meters (Hadlock, Hawkins)	61, July
New Ground-Plane Antenna	136, May
Non-Radiating Superregenerative Receiver for 2 Meters (Tilton)	53, Feb.
One-Tube V.H.F. Receiver (H&K)	140, Apr.
Stabilizing the 144-Mc. Transmitter (Grammer)	24, Apr.
"Tiny Tim" Handie-Talkie, The (Haist)	58, Apr.
Two-Meter Crystal-Controlled Converter, A (Hadlock)	31, May
V.H.F. Amplifier Using the 829, A	55, Mar.
V.H.F. Modulator with A-2 and A-3 (H&K)	51, Jan.
4.3-Mc. FM/AM I.F. and Audio Amplifier (Brannin)	51, Mar.

## VERY HIGH FREQUENCIES — GENERAL

Harmonics in the V.H.F. Range	68, Apr.
More on the HY-75 (H&K)	70, Aug.
Need There Be Line-of-Sight? (Tilton)	47, Mar.
Our Best DX — 800 Feet (Sharbaugh, Watters)	19, Aug.
Raising the Efficiency of the V.H.F. Linear Oscillator (Perkins, Burnett)	48, Aug.
Remote Control Utilizing V.H.F.	68, Feb.
Tuned-Circuit Design for the Ultra-High Frequencies (Apstein, Joffe)	13, Feb.
Two V.H.F. Adjustment Hints (H&K)	70, Sept.
VT-127-A in Amateur Transmitters, The (Davies)	33, Nov.

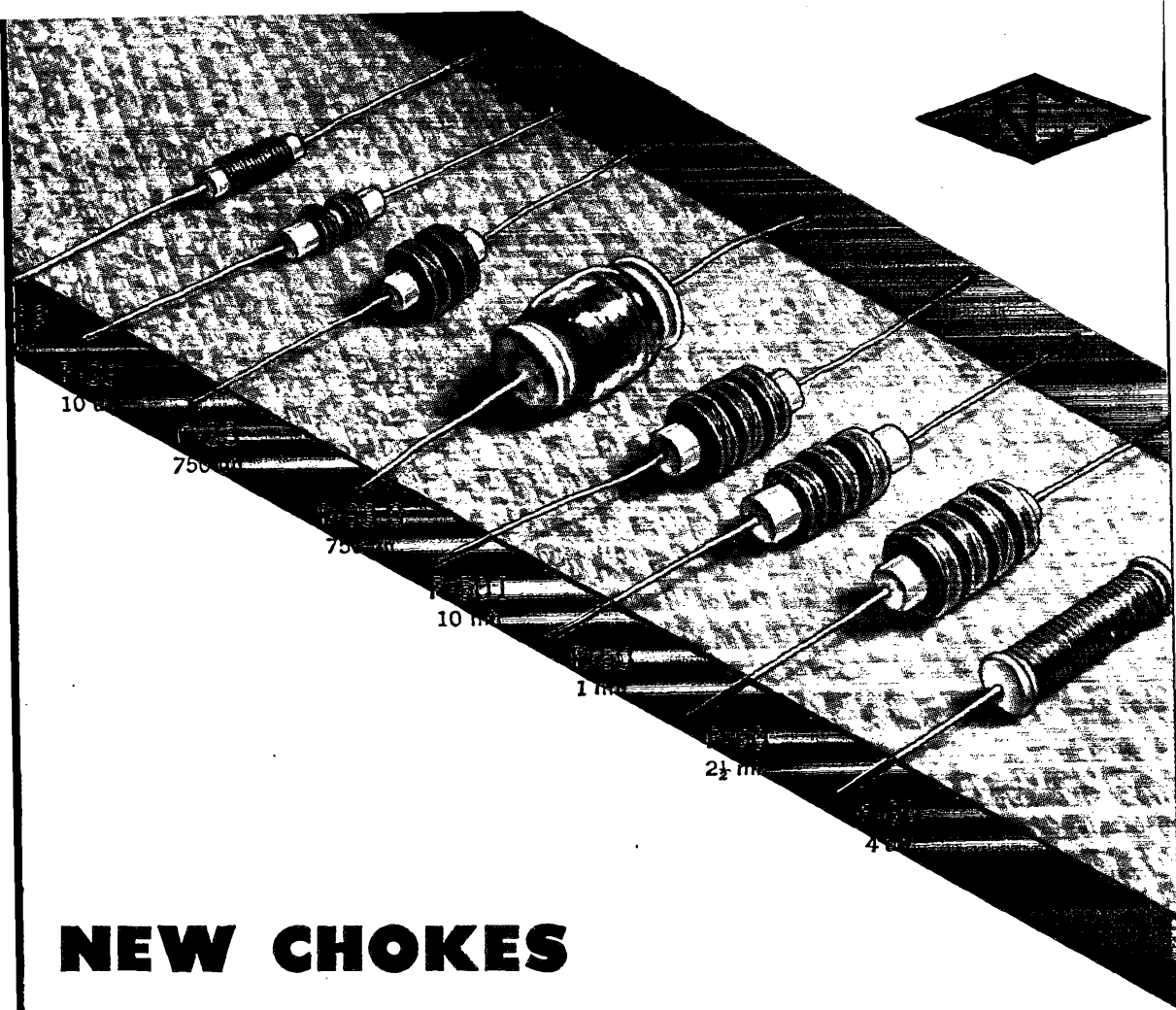

# NEW CHOKES

The enlarged line of chokes now offered by National includes many new sizes and types and provides units suited to specialized as well as standard applications. Many popular new chokes are illustrated above, including the R-33G which is hermetically sealed in glass. Other models cover current ratings from 33 to 800 milliamperes in a variety of mountings carefully planned for your convenience. These as well as old favorites like the R-100 are listed in the latest National Catalogue.

**NATIONAL COMPANY, INC., MALDEN, MASS.**



**Now-**  
**NEW PEAKS OF  
PERFORMANCE  
AT LESS COST**



**POWER INPUT**

~~620 WATTS\*~~

**750 WATTS\***

\*Class C telegraphy,  
ICAS

**PRICE:**

~~\$12.50~~

**\$12.50**

## **Why the RCA-810 is now the outstanding triode for high-power cw and phone transmitters**

**1. Power Input:** A single RCA-810 at its new ICAS ratings will take 300 ma. at 2500 volts in class C telegraphy, or 250 ma. at 2000 volts in class C telephony.

**2. RF Power Output:** 575 watts tube output in class C telegraphy, or 380 watts tube output in class C telephony is possible with one RCA-810.

**3. Push-Pull Operation:** A pair of RCA-810's will take 1000 watts on phone for that high-power final. A pair in class B at reduced ratings will plate-modulate an input of 1.0 kw.

**4. Low Driving Power:** Its high perveance allows the RCA-810 to deliver 575 watts output in class C telegraphy with a grid-driving power of only 19 watts, or 380 watts output in class C telephony with a grid-driving power of only 35 watts.

**5. High-Frequency Operation:** RCA-810's will operate at full plate input at frequencies up to 30 Mc.

**6. Features:** The filament of the RCA-810 is shielded at both ends to eliminate losses resulting from bulb bombardment and stray electrons.

The large, graphite anode provides high thermal radiation and a minimum of gas. Plate and grid leads are brought out to rugged terminals at the top and side of bulb, respectively, providing low lead inductance and permitting compact circuit layouts. The ceramic washers provide a superior bond to the glass, and eliminate strain. The plate washer minimizes corona discharge.

For further details, see your local RCA Tube Distributor or write RCA, Commercial Engineering, Section A-21L, Harrison, N. J.

Have you seen **HAM TIPS?**

Get a copy from your local RCA Tube Distributor

**THE FOUNTAINHEAD OF MODERN  
TUBE DEVELOPMENT IS RCA**



**TUBE DEPARTMENT**

**RADIO CORPORATION of AMERICA**

**HARRISON, N. J.**