

March, 1947

35 Cents

QST

devoted entirely to

amateur radio



FOR COMPACT HIGH FIDELITY EQUIPMENT

Ultra compact, lightweight, these UTC audio units are ideal for remote control amplifier and similar small equipment. New design methods provide high fidelity in all individual units, the frequency response being ± 2 DB from 30 to 20,000 cycles. There is no need to resonate one unit in an amplifier to compensate for the drop of another unit. All units, except those carrying DC in Primary, employ a true hum balancing coil structure which, combined with a high conductivity outer case, effects good inductive shielding. Maximum operating level ± 10 DB. Weight—5 1/2 ounces. Dimensions—1 1/2" wide x 1 1/2" deep x 2" high.

6V6 tube shown for comparison size only.

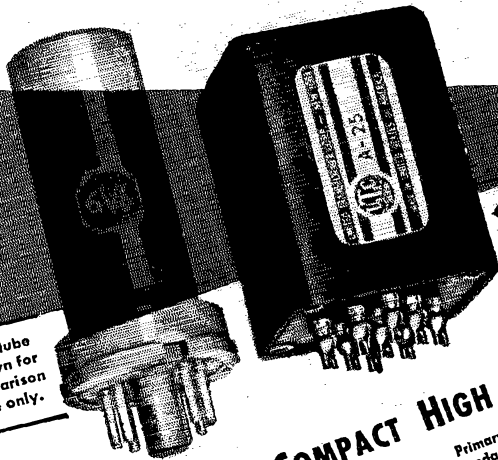

FOR IMMEDIATE DELIVERY
From Your Distributor

ULTRA COMPACT HIGH FIDELITY AUDIO UNITS

Type No.	Application	Primary Impedance	Secondary Impedance	± 2 DB from	List Price
A-10	Low impedance mike, pickup, or multiple line to grid	50, 125, 200, 250, 333, 500 ohms	50,000 ohms	30-20,000	\$15.00
A-11	Low impedance mike, pickup, or line to 1 or 2 grids	50, 200, 500 ohms	50,000 ohms	50-10,000 multiple alloy shield for extremely low hum pickup 30-20,000	16 00
A-12	Low impedance mike, pickup, or multiple line to push pull grids	50, 125, 200, 250, 333, 500 ohms	80,000 ohms overall in two sections	30-20,000	14.00
A-18	Single plate to two grids	8,000 to 15,000 ohms	80,000 ohms overall, 2:3:1 turn ratio overall	30-20,000	15.00
A-24	Single plate to multiple line	8,000 to 15,000 ohms	50, 125, 200, 250, 333, 500 ohms	50-12,000	14.00
A-25	Single plate to multiple line 8 MA unbalanced D.C.	8,000 to 15,000 ohms	50, 125, 200, 250, 333, 500 ohms	30-20,000	15.00
A-26	Push pull low level plates to multiple line	8,000 to 15,000 ohms each side	50, 125, 200, 250, 333, 500 ohms		10.00
A-30	Audio choke, 300 henrys with no D.C. 450 henrys @ 2 MA 6000 ohms D.C., 75 henrys @ 4 MA 1500 ohms D.C., inductance				

The above listing includes only a few of the many Ultra Compact Audio Units available . . . write for more details.

United Transformer Corp.
NEW YORK 13, N. Y.
130 VARICK STREET
EXPORT DIVISION: 13 EAST 40th STREET, NEW YORK 16, N. Y.
CABLES: "ARLAN"

GL-4D21/4-125A

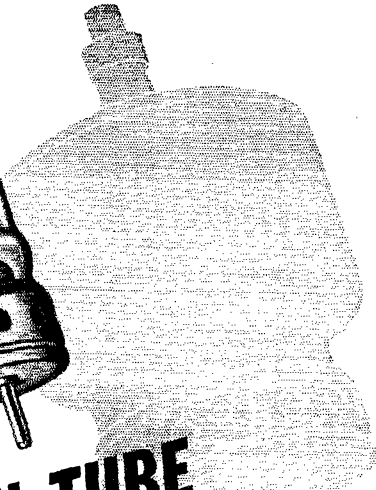
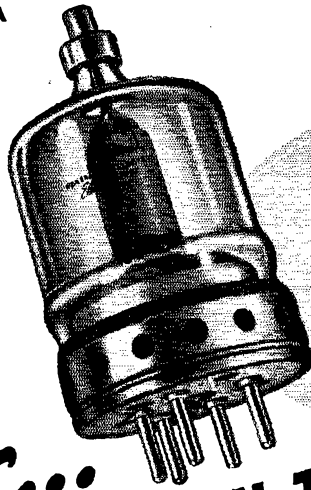

And now... A SMALLER COMPANION TUBE TO THE HIGH-EFFICIENCY GL-5D24

Negligible driving power requirements . . . this advantage underscores Type GL-4D21/4-125A's desirability for your rig. At 500 w max CW input, only 2.5 w driving power is required. At 380 w max phone input, only 3.3 w.

No neutralization at most frequencies . . . a feature typical of tetrodes, that greatly simplifies your circuit design! (Grid-plate capacitance in this case is only .05 mmfd.)

Modern . . . compact . . . efficient! . . . these qualities reveal themselves in the tube's up-to-the-minute appearance, its structural sturdiness, and in electrical performance that matches your highest expectations.

An ideal tube for your final . . . alone, or in push-pull. A pair of GL-4D21/4-125A's in push-pull will take 1 kw input CW, or 760 w input phone.

Because of ultra-compact construction, this tetrode needs a very limited amount of forced-air cooling for the base, and if operated at higher ratings, the bulb also requires some forced air. However, a small household fan will "do the trick" in both respects.

Ask your G-E tube distributor for further details. He will be glad to discuss with you this outstanding modern addition to the G-E tube line. Or write to *Electronics Department, General Electric Company, Schenectady 5, New York.*

**GL-4D21/4-125A
TETRODE**

500 W MAX CW INPUT. 120 MC
FREQUENCY AT MAX RATINGS

ELECTRICAL CHARACTERISTICS

Filament voltage	5 v
current	6.5 amp
Avg interelectrode capacitances:	
grid-plate	.05 mmfd
filament-grid	10.8 mmfd
filament-plate	3.1 mmfd
MAXIMUM RATINGS, CLASS C TELEGRAPHY	
Plate voltage	3,000 v
Screen voltage	400 v
Plate current	225 ma
dissipation	125 w

● Have you obtained your BINDER for G.E.'s "Ham News"? If not, your G-E tube distributor will be glad to give you one. It's a handy, permanent way to assemble your copies of "Ham News" for ready reference.



ELECTRONIC TUBES OF ALL TYPES FOR THE RADIO AMATEUR

GENERAL ELECTRIC

161-P6-6650

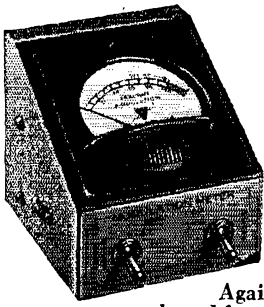

HERE ARE THE MARCH WINNERS OF NEW SYLVANIA MODMETERS!

Again, this month, three winners were selected for our crystal diodes contest. They will receive—free—a new Sylvania Modmeter. For details on this handy instrument see your September, 1946 issue of QST.

—THE MONTH'S WINNING CRYSTAL KINKS—

1 Contributed by: Charles T. Brasefield, Jr.
Alabama Power Company
Birmingham 2, Alabama

Compact Series—Gate Noise Limiter. Install this highly-efficient, hum-free noise limiter in your present receiver in less than two hours, and enjoy relatively noise-free operation. Contributor suggests building limiter in small, shielded plug-in can.

- $R_1, R_2 =$
270,000 ohms.
- $R_3 =$
820,000 ohms.
- $R_4 =$
1,000,000 ohms.
- $SW_1 =$ S.P.D.T.
toggle switch.
- $C_1 =$.0001 μ fd mica condenser, 400 V.
- $C_2 =$.01 μ fd paper condenser, 400 V.
- $C_3 =$.1 μ fd paper condenser, 400 V.

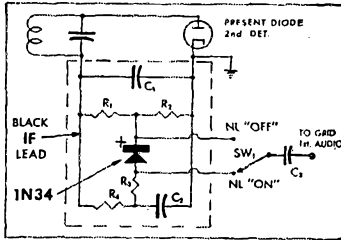

Our hearty congratulations to the winners this month and our thanks to the many other contributors from all over the world who sent us their ideas. The tremendous interest and response to this contest prove one thing conclusively . . . that Crystal Diodes 1N34 and 1N35 have many varied uses, some of which are still to be found.

Remember that Sylvania can not assume responsibility concerning any use made of the entries or the ideas expressed therein. Remember, too, that you can find complete details about the handy new Sylvania Modmeter in your September, 1946, issue of QST.

Watch for our ad in the May issue of this magazine naming the final three winners of the contest!

3 Original idea submitted by:

Francis G. Southworth, W5JJ
7006 Coronado Avenue
Dallas 14, Texas

(Circuit simplified by Sylvania Engineering Dept.)

Try this simple voice-operated transmitter switch for rapid "phone" break-in operation. Requires no external power supply. Shunt primary (E_1) of T across 500 ohms output of speech amplifier and parallel contact terminals (E_2) of relay RY with present transmit-receiver switch. Adjust potentiometer R so that relay RY is actuated only when microphone is addressed. Adjust receiver gain and R so that loudspeaker will not trigger RY.

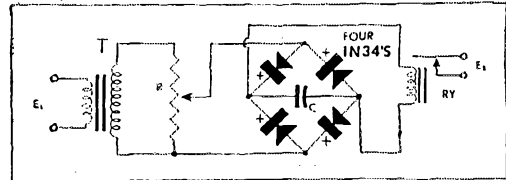

- T = standard audio interstage transformer.
- R = 100,000 ohm potentiometer.
- C = .5 μ fd paper condenser (increase, if longer "hold" time is preferred).
- RY = Sigma Type 5F1600S relay, or equivalent.

2 Contributed by: G. Franklin Montgomery, W3FQB
4557 South Chelsea Lane
Bethesda, Maryland

Bias Supply for Class A Audio Stage from 6.3 Volt Heater Supply. Uses Voltage-Doubling Circuit with two 1N34 Crystals.

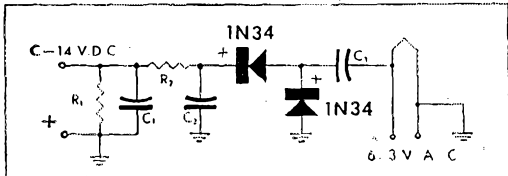

- $R_1 =$ 500,000 ohms. $R_2 =$ 100,000 ohms.
- $C_1 =$ 30 μ fd, 25 Volt Electrolytic Condenser.
- $C_2, C_3 =$.1 μ fd, 25 Volt Paper Condenser.

SYLVANIA ELECTRIC

Electronics Division . . . 500 Fifth Avenue, New York 18, N. Y.

MAKERS OF ELECTRONIC DEVICES; RADIO TUBES; CATHODE RAY TUBES; FLUORESCENT LAMPS, FIXTURES, WIRING DEVICES; ELECTRIC LIGHT BULBS

PUBLISHED, MONTHLY, AS ITS OFFICIAL ORGAN, BY THE AMERICAN RADIO RELAY LEAGUE, INC., AT WEST HARTFORD, CONN., U. S. A.; OFFICIAL ORGAN OF THE INTERNATIONAL AMATEUR RADIO UNION

STAFF

Editorial

KENNETH B. WARNER, W1EH
(Managing Secretary, ARRL)
Editor

HAROLD M. MCKEAN, W1CEG
Assistant to the Editor

GEORGE GRAMMER, W1DF
(Technical Director, ARRL)
Technical Editor

DONALD H. MIX, W1TS
BYRON GOODMAN, W1DX
Assistant Technical Editors

EDWARD P. TILTON, W1HDQ
V.H.F. Editor

RICHARD M. SMITH, W1FTX
C. VERNON CHAMBERS, W1JEQ
JOHN W. PADDON, VE3BLZ

Technical Assistants

JOSEPH E. GRAHN, W1CH
Contributing Editor, "How's DX?"

WALTER E. BRADLEY, W1FWH
Technical Information Service

Production

RALPH T. BEAUDIN, W1BAW
Superintendent

NANCY P. PORTEUS
Assistant

Advertising

F. CHEYNEY BEEKLEY, W1GS
LORENTZ A. MORROW, W1VG
EDGAR D. COLLINS

Circulation

DAVID H. HOUGHTON
Circulation Manager

RALPH T. BEAUDIN, W1BAW
Assistant Circulation Manager

OFFICES

38 La Salle Road
West Hartford 7, Connecticut

Subscription rate in United States and Possessions, \$2.50 per year, postpaid; \$3.00 in the Dominion of Canada, \$4.00 in all other countries. Single copies, 35 cents. Foreign remittances should be by international postal or express money order or bank draft negotiable in the U. S. and for an equivalent amount in U. S. funds.

Entered as second-class matter May 29, 1919, at the post office at Hartford, Connecticut, under the Act of March 3, 1879. Acceptance for mailing at special rate of postage provided for in section 1103, Act of October 3, 1917, authorized September 9, 1922. Additional entry at Concord, N. H., authorized February 21, 1929, under the Act of February 28, 1925.

Copyright 1947 by the American Radio Relay League, Inc. Title registered at U. S. Patent Office.

CONTENTS

"It Seems to Us . . ."	11
Low-Cost Six-Meter 'Phone <i>C. Vernon Chambers, W1JEQ</i>	13
Our Cover	17
More on Speech Clipping . . . <i>W. W. Smith, W6BCX</i>	18
Fundamental Beam Patterns <i>David C. Cleckner, W8YBF</i>	23
Clean-Cut Break-In Keying . . <i>Harry G. Burnett, W1LZ</i>	27
Technical Topics	
N.F.M. Reception	30
Bonus for 28-Mc. Observers	32
ARRL QSL Bureau	33
Navy Day — 1946	34
An Improved Receiver for Two Meters <i>Calvin F. Hadlock, W1CTW</i>	38
Silent Keys	40
Happenings of the Month.	41
The BC-221 Frequency Meter as a VFO <i>Howard W. Johnson, W7NU</i>	43
Rotten 'Phones. <i>William R. Marks, W1DEF</i>	48
How's DX?	50
In QST 25 Years Ago This Month	52
Foreign Notes	53
Finding the Inductance of R.F. Coils <i>Robert M. Crotinger, W0GUY</i>	54
The World Above 50 Mc.	57
The Balloon Antenna Rides Again! <i>George Bonadio, ex-W8OMM</i>	60
Hints and Kinks	61
Correspondence from Members	62
How to Cook a Ham <i>C. L. Stong, W2PFM</i>	64
Lament for the Past. <i>Mrs. Doris C. Grautoff</i>	64
Feed-back	64
Operating News	65
Station Activities	74

Going places (again)

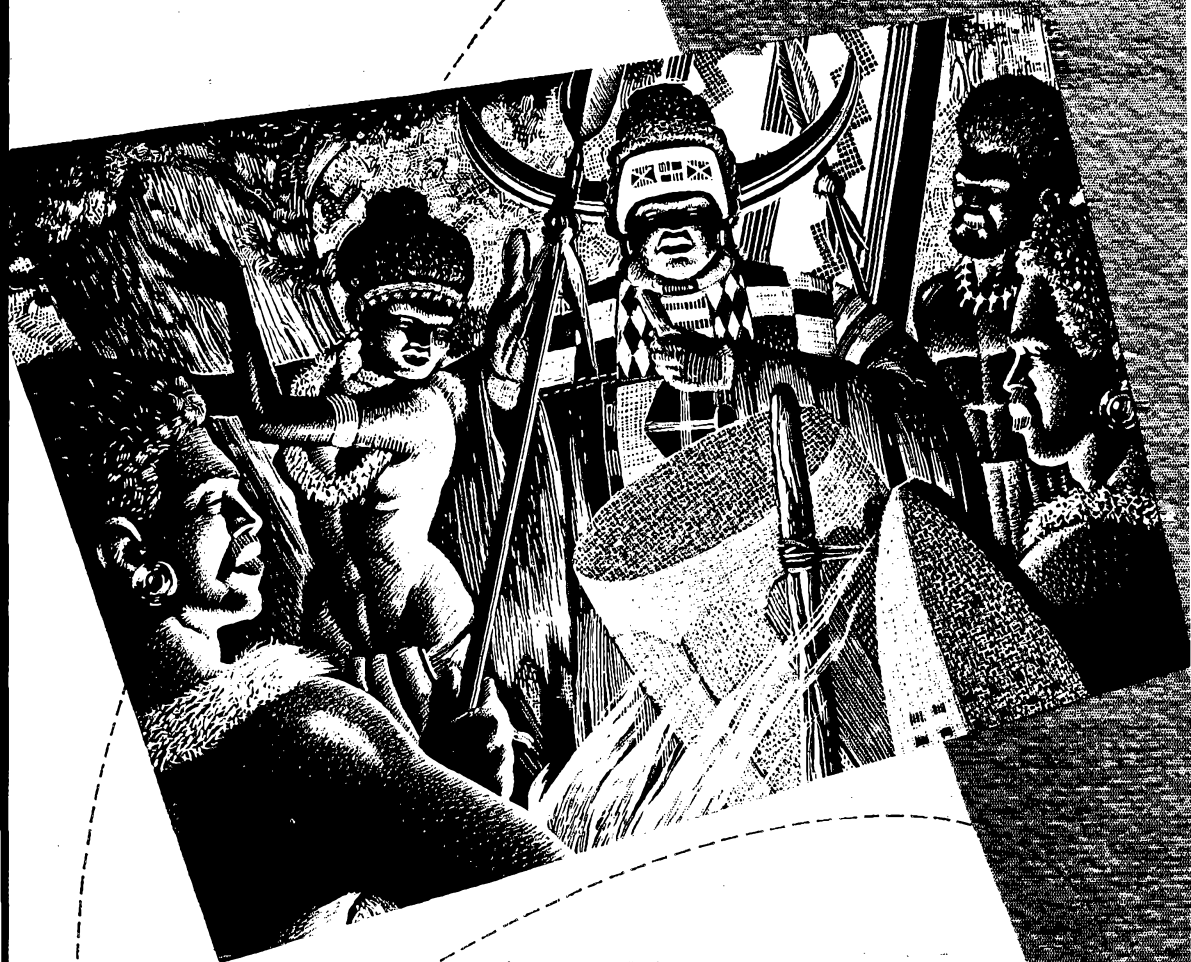

hallicrafters



Hallicrafters famous radio equipment, sold and distributed around the world before the war and used with superb effectiveness in every theater during the war is once again on the move. Watch for latest details of the Gatti-Hallicrafters mobile radio equipped expedition to the Mountains of the Moon in deepest Africa—a new and exciting test for the ingenuity of hams and the performance of Hallicrafters equipment.



GREAT RECEIVERS

designed and priced for hams
who are going places, too

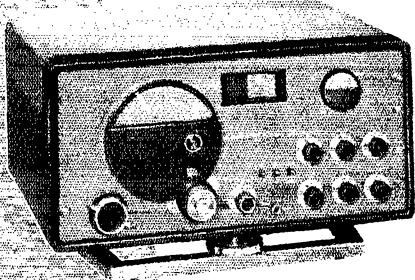

Model SX-42 Described by hams who have operated it as "the first real postwar receiver." One of the finest CW receivers yet developed. Greatest continuous frequency coverage of any communications receiver—from 540 kc to 110 Mc, in six bands. FM-AM-CW. 15 tubes. Matching speakers are available. **\$27500**

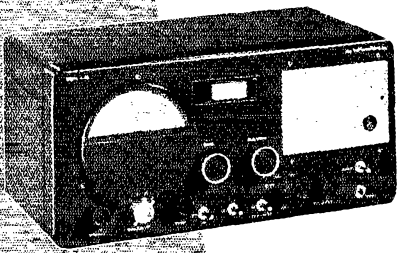

Model S-40A Function, beauty, unusual radio performance and reasonable price are all combined in this fine receiver. Overall frequency range from 540 kc to 43 Mc, in four bands. Nine tubes. Built-in dynamic speaker. Many circuit refinements never before available in medium price class. **\$8950**

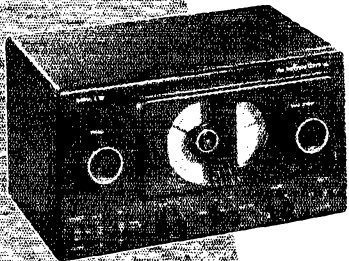

Model S-38 Overall frequency range from 540 kc to 32 Mc, in four bands. Self contained speaker. Compact and rugged, high performance at a low price. Makes an ideal standby receiver for hams. CW pitch control is adjustable from front panel. Automatic noise limiter. **\$4750**

BUILDERS OF *Skycrafters* AVIATION RADIODIAPHRAGM
©1947

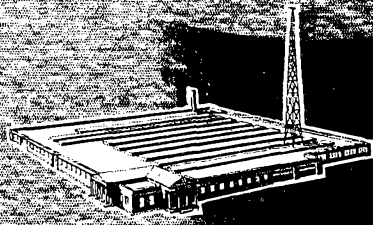

hallicrafters RADIO

THE HALLICRAFTERS CO., MANUFACTURERS OF RADIO AND ELECTRONIC EQUIPMENT, CHICAGO 16, U. S. A.
Sole Hallicrafters Representatives in Canada:
Rogers Majestic Limited, Toronto-Montreal

Section Communications Managers of the ARRL Communications Department

Reports Invited. All amateurs, especially League members, are invited to report station activities on the first of each month (for preceding month) direct to the SCM, the administrative ARRL official elected by members in each Section. Radio Club reports are also desired by SCMs for inclusion in QST. All ARRL Field Organization appointments are now available to League members. These include ORS, OES, OPS, OO, and OBS. Also, where vacancies exist SCMs desire applications for SEC, EC, RM, and PAM. In addition to station and leadership appointments for Members, all amateurs are invited to join the ARRL Emergency Corps (ask for Form 7).

ATLANTIC DIVISION				
Eastern Pennsylvania Maryland-Delaware-D. C.* Southern New Jersey Western New York Western Pennsylvania	W3RES W3BWT W2GCU W2UPH W3NCJ	Jerry Mathia Eppa W. Darne Ray Tomlinson Charles I. Otero R. R. Rosenberg	623 Crescent Ave. 132 Tennessee Ave., N.E. 623 E. Brown St. 4158 Ridge Road, West 927 East 23rd St.	Glenside Gardens Washington 2, D. C. Trenton 10 Spencerport Erie
CENTRAL DIVISION				
Illinois Indiana Wisconsin*	W9AND W9SWH W9DKH	Wesley E. Marriner Ted K. Clifton Ralph Klein	624 College Ave. 550 Eden St. 1106 Manitow St., R.F.D. 3	Dixon New Haven Manitowoc
DAKOTA DIVISION				
North Dakota South Dakota Minnesota*	W0EVP W0QVY W0EPJ	Raymond V. Barnett P. H. Schultz Norman Beck	406 17th St. 118 N. Yankton Ave.	Bismarck Pierre Mound
DELTA DIVISION				
Arkansas Louisiana Mississippi Tennessee	W5JIC W5VT W5IGW W4FLS	Marshall Riggs W. J. Wilkinson, jr. Harold Day James W. Watkins	4405 Howell Ave. Room 313, Jefferson Hotel Route 1, Box 111 220 North Howell St.	Fort Smith Shreveport Greenville Chattanooga 4
GREAT LAKES DIVISION				
Kentucky Michigan Ohio	W5IEZ/4 W8DPE W8PNQ	Joseph P. Colvin Harold C. Bird William D. Montgomery	1653 Beechwood Ave. R.F.D. 2, Box 228 1290 Coolidge Ave.	Louisville 4 Pontiac 2 Cincinnati 30
HUDSON DIVISION				
Eastern New York N. Y. C. & Long Island Northern New Jersey	W2HZL W2KDC W2IIN	Ernest E. George Charles Ham, jr. John J. Vitale	2044 Lexington Parkway 151-06 84th Drive 57 Sayre St.	Schenectady 8 Jamaica, L. I., 2 Elizabeth 3
MIDWEST DIVISION				
Iowa Kansas Missouri Nebraska	W0PIR W0AWP W0QUD W0POB	Leslie B. Vennard Alvin B. Unruh Mrs. Letha A. Dangerfield Roy E. Olmsted	2712 Washington St. 842 N. Terrace Drive 411 Moffett Ave. 101 Arikari Ave.	Hurlington Wichita 6 Colin Wauneta
NEW ENGLAND DIVISION				
Connecticut Maine Eastern Massachusetts Western Massachusetts New Hampshire Rhode Island Vermont	W1KQV W1AOL W1ALP W1AZW W1AXL W1HRC W1NDL	Edmund R. Fraser G. C. Brown Frank L. Baker, jr. Prentiss M. Bailey John H. Stoughton Clayton C. Gordon Gerald Benedict	90 Atwater St. 379 No. Main St. 91 Atlantic St. 62 Dexter St. RFD 2 70 Columbia Ave., Gaspee 23 Foster St.	West Haven Brewer North Quincy 71 Pittsfield Claremont Providence 5 Montpelier
NORTHWESTERN DIVISION				
Alaska Idaho Montana Oregon Washington*	K7CBF W7IWU W7EQM W7HAZ W7EHQ	August G. Hiebert Alan K. Ross Albert Beck Raleigh A. Munkres Lloyd Norberg	c/o KFAK 1017 East Jefferson St. 2326 Amherst Ave. Box 744 P. O. Box 281	Fairbanks Boise Butte Baker Stellacoom
PACIFIC DIVISION				
Hawaii* Nevada Santa Clara Valley East Bay San Francisco Sacramento Valley Philippines* San Joaquin Valley	KH6EL W7CX W6BPT W6TI W6NLC W6MGC KA1CB W6PSQ	John Souza N. Arthur Sowie Roy E. Pinkham Horace R. Greer Samuel C. Van Liew John R. Kinney Craig B. Kennedy James F. Wakefield	Box 2025 1061 Fremont St. 414 Fairmount Ave. 215 Knowles Ave. 3240 Jay St. 25 Roosevelt Road 2940 Adoline Ave.	Waikuku, Maui Reno Santa Clara Oakland 11 Daly City Sacramento 16 San Francisco Del Monte Quezon Fresno
ROANOKE DIVISION				
North Carolina South Carolina Virginia West Virginia	W4CYB W4BOE/ANG W4JHK W8JFM	W. J. Wortman Ted Ferguson Walter R. Bullington Donald B. Morris	c/o Duke Power Co. 3422 Rosewood Drive 1203 E. Brookland Pk. Blvd. 303 Home St.	Charlotte 1 Columbia 25 Richmond 22 Fairmont
ROCKY MOUNTAIN DIVISION				
Colorado Utah-Wyoming	W0QVT W7LLH	Glen Bond Victor Drabble	2550 Kendall 1024 Oak St.	Denver 14 Ogden, Utah
SOUTHEASTERN DIVISION				
Alabama Eastern Florida Western Florida Georgia West Indies* (Cuba-P.R.-V.I.)	W4GBV W4IP W4MS W4HYW KP4KD	Lawrence J. Smyth Robert B. Murphy Lt. Comdr. Edward J. Collins Thomas M. Moss Everett Mayer	808 Winona Ave. 3612 Palmarita St. 1003 East Blount St. 570 Oak Drive P. O. Box 1061	Montgomery Coral Gables Pensacola Hessville San Juan 5, P. R.
SOUTHWESTERN DIVISION				
Los Angeles Arizona San Diego	W6OWZ W7MLL W6GC	Ben W. Onstent Cladden C. Elliott Irvin L. Emig	9631 3rd Ave. 1408 West Fresno St. 4852 Marlborough Drive	Inglewood Tucson San Diego
WEST GULF DIVISION				
Northern Texas Oklahoma Southern Texas New Mexico	W5DAS W5HXI W5JC W5HJF	N. C. Settle Bert Weidner James B. Rives J. G. Hancock	2911 Elm St. Box 14 1721 Kentucky Ave. 110 S. E. Nevada St.	Dallas Creasant San Antonio 1 Portales
MARITIME DIVISION				
Maritime (Nfld. & Labr. att.)	VE1DQ	A. M. Crowell	69 Dublin St.	Halifax, N. S.
ONTARIO DIVISION				
Ontario	VE3DU	David S. Hutchinson	827 Lovett St.	London, Ont.
QUEBEC DIVISION				
Quebec	VE2SU	Gordon F. J. Phelan	4829 Isabella Ave.	Montreal, Que.
VANALTA DIVISION				
Alberta British Columbia Yukon*	VE6LQ VE7WS VE8AK	W. W. Butchart W. W. Storey W. R. Williamson	10740-107 St. 3915 W. 32nd Ave. P. O. Box 137	Edmonton, Alta. Vancouver Whitehorse, Y. T.
PRAIRIE DIVISION				
Manitoba Saskatchewan	VE4AM VE5CO	A. W. Morley Norman Thompson	26 Lennox St. 1120 7th Ave., N. W.	St. Vital Moose Jaw

*Officials appointed to act temporarily in the absence of a regular official.

✓ Check up on

PR



✓ STABILITY

Stay put with PRs! They're really **LOW DRIFT** ... without sacrificing high output characteristics. X-ray orientation guarantees uniform cut for maximum low-drift performance ... drift limited to less than 2 cycles per MC per degree.

✓ ACCURACY

Guaranteed accurate within .01 per cent of specified frequency or better. When doubling and quadrupling accuracy is absolutely necessary. You **KNOW** where you are with PRs.

✓ POWER OUTPUT

PRs are designed to give maximum power output from the exciter stage. They will stand up under the high voltages and currents common in amateur operation. PRs can "take it" and like it.

✓ ACTIVITY

PRs give you high activity. They "come in" instantly on phone ... key without chirps, even at high bug speeds, without excessive "backing off."

✓ Unconditional Guarantee

Every PR Precision CRYSTAL is guaranteed unconditionally by the makers of fine crystals since 1934.

✓ EXACT FREQUENCY at NO EXTRA COST

You pay no premium for the exact frequency you want (integral kilocycle). PR makes a special effort to keep its jobbers supplied with **EVERY FREQUENCY** available to amateurs. The factory maintains 24-hour airmail service to its jobbers. If your jobber doesn't have the exact frequency, he can get it at once from the factory **AT NO EXTRA COST.**



SINCE 1934

PR Precision CRYSTALS

10 METERS
PR Type Z-5.

Harmonic oscillator. Ideal for "straight through" mobile operation. High activity. Heavy drive without damage in our special circuit\$5.00

20 METERS
PR Type Z-3.

Harmonic oscillator. Low drift. High activity. Can be keyed in most circuits. High power output. Just as stable as fundamental oscillators\$3.50

40 & 80 METERS
PR Type Z-2.

Rugged, low drift fundamental oscillators. High activity and power output with maximum crystal currents. Accurate calibration \$2.65

MAKING TUBES IS EASY...

If **YOU KNOW HOW!**

AND THEY SAY...
WATCHMAKING IS FINE WORK!

A fine watch—delicate Italian lace—these are synonymous with superb craftsmanship. But imagine such hand-to-eye co-ordination at mass production speeds. The mount operator who assembles with a small spot welder the tiny internal parts of your Hytron tubes displays just such craftsmanship. Despite painstaking engineering and intricate machinery, it is finally her accuracy, speed, perseverance, and appreciation of fine tolerances which build Hytron quality. Assembly mistakes once sealed within a tube cannot be corrected.

That is why Hytron is so fussy about selecting and training its mount operators. Each applicant must pass exacting tests for eyesight and for finger and tweezer dexterity. Then begins a long training cycle: two months to master a single constructional step; up to two years to

develop the versatility of the expert mounter.

Every possible aid is given to the Hytron mount operator. Work simplification helps her co-ordinate smoothly and efficiently motions of eyes, hands, and feet. Parts design is simplified; supporting micras serve as templates. Welding is automatically timed. Tight spacing tolerances (.003") and frequent engineering changes prohibit widespread use of jigs and fixtures. Magnification is impracticable, because of width and depth of field. Major effort must always be to train the mounter's keen eyes and nimble fingers to assemble delicate parts to fine tolerances, despite varying materials and machine set-ups.

Yet the Hytron mounter works so effortlessly that it all looks easy. It is easy only because she has the know-how. Next time you pick up a Hytron tube, examine her handiwork.



SPECIALISTS IN RADIO RECEIVING TUBES SINCE 1921

HYTRON

RADIO AND ELECTRONICS CORP.

MAIN OFFICE: SALEM, MASSACHUSETTS



GET YOUR SIGNAL INTO THE ANTENNA WITH

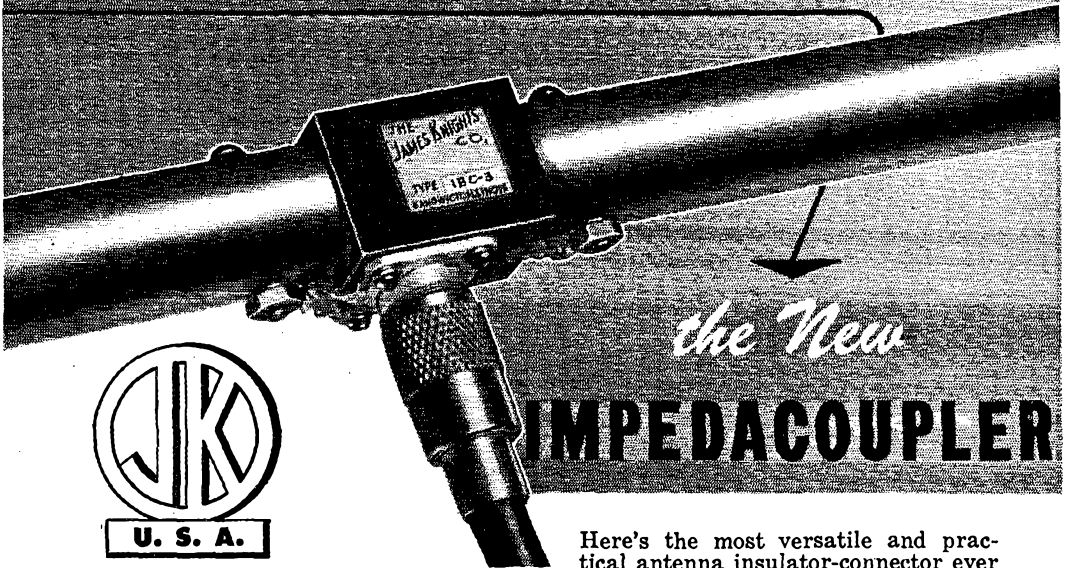

the New
IMPEDACOUPLER

Here's the most versatile and practical antenna insulator-connector ever offered the radio amateur or the professional operator. The IMPEDACOUPLER makes a secure and weatherproof junction between Amphenol coaxial line and any current fed antenna or array. It also can be used in many other ways: for connection to flat lines, to an open wire line and to serve as a center insulator of a ½ wave doublet. Equipped with an Amphenol type 1R receptacle, the IMPEDACOUPLER provides quick, positive connection without fanning and without disrupting terminal impedance of the line.

INSULATION PLUS STRENGTH

A genuine MYKROY center insulator block provides optimum dielectric properties, has ample strength to withstand the pull of the antenna and to support the weight of the coaxial line. The insulator is drilled at both ends for bolt or rivet for holding tubing and connections, or for looping wire if latter is to be used. The insulator ends are machined to fit the inside diameter of standard aluminum or dural tubing having 1" outside diameter, commonly used for rotary beams. However, the user can easily turn down the insulator ends to fit his particular needs. With the IMPEDACOUPLER, losses from moisture, deterioration at antenna end of the line and resultant insulation breakdown are eliminated.

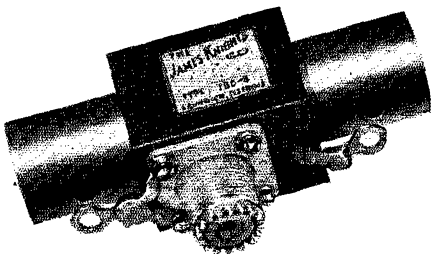

Write for IMPEDACOUPLER folder illustrating fifteen practical applications, or see the IMPEDACOUPLER at your dealer's.

Weight Only 6 oz.
Net Price Less Amphenol
1SP Connector

\$3.50

Other J-K Products Include Quartz Crystals, Crystal Ovens, Frequency Standards.

The **JAMES KNIGHTS** *Company*
Sandwich, Illinois

THE AMERICAN RADIO RELAY LEAGUE, INC.,

is a noncommercial association of radio amateurs, bonded for the promotion of interest in amateur radio communication and experimentation, for the relaying of messages by radio, for the advancement of the radio art and of the public welfare, for the representation of the radio amateur in legislative matters, and for the maintenance of fraternalism and a high standard of conduct.

It is an incorporated association without capital stock, chartered under the laws of Connecticut. Its affairs are governed by a Board of Directors, elected every two years by the general membership. The officers are elected or appointed by the Directors. The League is noncommercial and no one commercially engaged in the manufacture, sale or rental of radio apparatus is eligible to membership on its board.

"Of, by and for the amateur," it numbers within its ranks practically every worth-while amateur in the nation and has a history of glorious achievement as the standard-bearer in amateur affairs.

Inquiries regarding membership are solicited. A bona fide interest in amateur radio is the only essential qualification; ownership of a transmitting station and knowledge of the code are not prerequisite, although full voting membership is granted only to licensed amateurs.

All general correspondence should be addressed to the Secretary at the administrative headquarters at West Hartford, Connecticut.



Past Presidents

HIRAM PERCY MAXIM, W1AW, 1914-1936
EUGENE C. WOODRUFF, W8CMP, 1936-1940

Officers

President GEORGE W. BAILEY, W2KH
Washington, D. C.
Vice-President J. LINCOLN MCCARGAR, W6EY
Oakland, California
Secretary KENNETH B. WARNER, W1EH
West Hartford, Connecticut
Communications Manager F. E. HANDY, W1BDI
West Hartford, Connecticut
Treasurer DAVID H. HOUGHTON
West Hartford, Connecticut
General Counsel PAUL M. SEGAL
1026 Woodward Building, Washington 5, D. C.

DIRECTORS

President
GEORGE W. BAILEY W2KH
921 19th St., N.W., Washington, D. C.

Vice-President
J. LINCOLN MCCARGAR W6EY
86 Hamilton Place, Oakland 12, Calif.

Canadian General Manager
ALEX. REID VE2BE
240 Logan Ave., St. Lambert, P. Q.
Alternate: Leonard W. Mitchell VE3AZ
78 Raglan Ave., Toronto, Ont.

Atlantic Division
EDWARD G. RASER W2ZI
315 Beechwood Ave., Trenton 8, N. J.
Alternate: J. Victor Brotherson W8BHN
1743 Ottawa Drive, Erie, Pa.

Central Division
CLYDE C. RICHELLEU W9ARE
4901 So. 30th St., Milwaukee 14, Wisc.
Alternate: Harold H. Jansen W9DJG
3519 California Ave., Alton, Ill.

Dakota Division
TOM E. DAVIS W6SW, ex-W9VVA
915 W. Becker Ave., Willmar, Minn.
Alternate: Harold B. Love W9ZRT
Box 426, Mandan, N. D.

Delta Division
GEORGE S. ACTON W5BMM
Plain Dealing, La.
Alternate: Eugene H. Treadway W5DKR
P. O. Box 44, La Place, La.

Great Lakes Division
HAROLD C. BIRD W8DPE
114 Hlekyor Dr., R.F.D. 2, Pontiac 2, Mich.
Alternate: John H. Brabb W8SFP
1321 Berkshire Rd., Grosse Point Park 30, Mich.

Hudson Division
JOSEPH M. JOHNSTON W2SOX
427 Lincoln Ave., Avon-by-the-Sea, N. J.
Alternate: Robert A. Kirkman W2DSY
1910 Oak Drive, West Belmar, N. J.

Midwest Division
G. A. COLVIN W 01HR
c/o Omaha & Council Bluffs St. Railway Co.,
Omaha 2, Nebr.
Alternate:

New England Division
PERCY C. NOBLE W1BWR
37 Broad St., Westfield, Mass.
Alternate:

Northwestern Division
HAROLD W. JOHNSTON W7DXF
3727 Belvidere Ave., Seattle 6, Wash.
Alternate: R. Rex Roberts W7CPY
110 W. Brennan St., Glendive, Mont.

Pacific Division
WILLIAM A. LADLEY W6RBQ
300 Naylor St., San Francisco 12, Calif.
Alternate: Elbert J. Amarantes W6FBW
1675 Dale Ave., San Jose, Calif.

Roanoke Division
H. L. CAVENESS W4DW
2607 Vanderbilt Ave., Raleigh, N. C.
Alternate: J. Frank Key W3ZA
Box 707, Buena Vista, Va.

Rocky Mountain Division
FRANKLIN K. MATEJKA W6DD
P. O. Box 212, Estes Park, Colo.
Alternate: P. Arthur Smoll W6KVD
529 No. Nevada Ave., Colorado Springs, Colo.

Southeastern Division
WILLIAM C. SHELTON W4ABR
527 Revilo Blvd., Daytona Beach, Fla.
Alternate: William P. Sides W4AUP
Fleming Road, Montgomery, Ala.

Southwestern Division
HANS R. JEPSEN W6KEI
6837 Ethel Ave., No. Hollywood, Calif.
Alternate: Arthur E. Schifferman, sr. W6RBI
1445 Raymond Ave., Glendale 1, Calif.

West Gulf Division
WAYLAND M. GROVES W5NW
Mail Box 586, Station Humble Pipe Line Camp,
Oceasa, Texas
Alternate: Jack T. Moore W5ALA
4529 Fairway, Dallas 4, Texas

"It Seems to Us..."

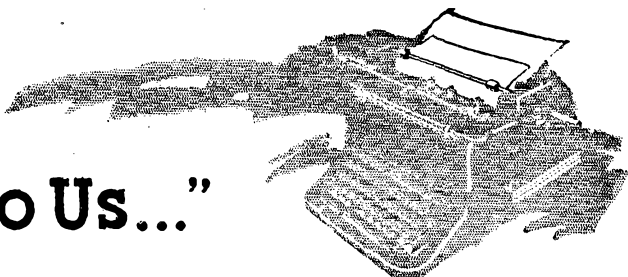

SHOULD WE HAVE A CLASS D LICENSE?

This article appears at the direction of the ARRL Board of Directors to inform you that the Board will again have under consideration at this May's meeting the question of whether amateur radio would be benefited by having a no-code license available exclusively for the microwaves; to explain the proposition precisely; and to solicit your opinion on it, pro or con, for the information of the Board.

This proposal first took form in ARRL circles about a year ago, as a recommendation to the Board from its Regulations Committee, a committee made up of directors and having the duty of proposing desirable changes in amateur regulations. The report reached directors only a few days before their departure for their annual meeting, with insufficient time to sound out division sentiment on the proposal, and too late for mention in *QST* before the meeting. While the Board considered the proposal to be in the interests of amateur radio and adopted it as a request to FCC, it was later withdrawn when considerable membership objection to it was expressed. It was apparent that it needed a fuller discussion in our circles. It is believed that the objection stemmed more from lack of understanding of the proposition, and from the feeling of surprise at not having heard of it previously, than it did from the honest belief that the scheme was contrary to our best interests. This year the Board wants to reconsider it in the light of collected amateur opinion, believing that that will permit final disposition of the matter one way or the other on the basis of a fair examination of its merits, or lacks, by amateurs generally. You are asked to avail yourself of the opportunity to express your views.

In preparing this article the Headquarters has endeavored to be a neutral and impartial reporter. If it seems to lean in favor of the proposal it is perhaps only because what it reports is that the Board last year favored it and believed that it had worked out detailed safeguards that made it a desirable thing. To the best of our Hq. ability we are presenting all the pros and cons that have been men-

Poll of Amateur Opinion

• The continuation of this article on page 32-A contains a post card which you are invited to detach and return to the League to express your opinion on this subject. Don't overlook it.

tioned or that occur to us. We have no viewpoint to sell. Our purpose is solely to present the facts so that you can appraise them.

The Argument

The proposal is that the League ask FCC to make available an additional class of amateur license without examination in the telegraph code, the license to be good only on the microwaves, the arrangement to incorporate various safeguards to prevent abuses or unwholesome conditions as hereinafter described in detail. For want of a better term the proposed new ticket is being called a Class D license. Here is the argument that gives rise to the proposal:

"Regular" amateurs, particularly the great body of older prewar amateurs, so far are making relatively little use of amateur allocations above 200 Mc. and very little use of those above 1000 Mc. We have numerous allocations there, fought for by the League so that we could have our share of the new part of the spectrum in which so many people believe much of the future of the art to lie. Commercial and Government services are actively working in that part of the spectrum. We aren't. Already there is allocation pressure and some of our unoccupied bands have been kicked around a bit. In any long-range planning it is important that we retain our fair share of this new world. So we need occupancy. The ordinary amateur of the older school is, generally speaking, simply not interested at all — yet. It is a different world and it requires different techniques. It is the world of special tubes and magnetrons and klystrons, of cavity resonators and wave-guides, of dish and horn and slot antennas, of pulse and television techniques and automatic relaying, and of construction techniques built around lathe-

work and silver plating and the brazing of "plumber's nightmares." It is, in short, the world of the skilled experimenter of laboratory leanings, of men who will get as much of a boot out of working crosstown on thousands of megacycles as the rest of us do from handling traffic in a hot net or working Timbuctoo and Patagonia. Most of us, it seems, are not equipped for this new work or not interested. It doesn't have much appeal to the "communicator," which is what most of us are. Almost no apparatus exists for amateur communication on these bands.

Yet just outside the doors of amateur radio, it is said, there is a considerable body of trained men awaiting admittance to this branch of our game. They are, for example, the war-trained radar technicians and microwave maintenance men and, in particular, the laboratory workers who have acquired experience through development work on these projects. They move in this other world we have just described. Our lower frequencies have never interested them; they aren't, let's say, the communicator type. But they are experimenters, and they are interested in applying to the amateur type of communication the microwave techniques in which they do possess skill, and they would approach it as amateurs — that is, as persons with a personal and non-pecuniary interest in the technique. They do want to be amateurs on microwaves. Their trouble is that, being more of the scientific type and less of the operator or communicator type, they don't know the code. Nor is code used on the frequencies that interest them. Of course it *could* be, and if you and we were moving into the 10,000-Mc. band we'd very possibly rig up for A2 and a key. But it is a fact that in all our experience there has never been any appreciable amount of telegraphy above 30 Mc. It's 99.99% voice operation. On behalf of these microwave technical aspirants it is argued that they would have no use whatever for the code, that their development work would be greatly facilitated by voice communication, and that their entry into amateur radio is being prevented by the requirement to spend weeks to get up a code speed of 13 words a minute which they will never use in that work. Such people never will qualify under our present examination, just to be able to work on microwaves. Yet we need them. We need them to develop these bands for which the more numerous type of amateur doesn't yet have enough skill or knowledge or present interest. We need them as a new or purely technical type of amateur to occupy the bands and to make advancement in the technique there in the name of amateur radio. It therefore practically suggested itself that there ought to be some arrangement whereunder persons of this type could do amateur work without having to learn the code, provided they confined their activities to such frequencies without in any wise hurting the rest of amateur radio. The purpose of

the proposal, then, may be said to be to attract into amateur radio a certain type of technically-qualified people, so that what they do may be credited to amateur radio and so that they may assist in the pioneering of two-way communication techniques for these bands.

On the contrary side it is argued that the distinguishing sign of the amateur has always been his knowledge of the code and that nobody should be allowed to call himself an amateur unless he masters the code the same as the rest of us did, whether he will have use for it or not. Since we possess that knowledge ourselves, we shouldn't let anybody else in who doesn't. The rebuttal to this, as expressed to Headquarters by numerous *licensed amateurs* professionally engaged in the microwave field, is that it is unjust of us to require code knowledge in bands where it wouldn't be used, even though we do know code ourselves, and that those of us who have no interest in the microwave bands shouldn't oppose a plan that will add very valuable men to the amateur ranks and do much for amateur radio generally.

On the objectors' side it is suggested that there are plenty of people who would like the right to operate 'phone on lower frequencies without a code requirement, and if we're to waive it on microwaves why isn't it just as sensible to do it in the case of, say, 75-meter 'phone? There are several answers. The international treaty regulations clearly require amateurs to have code knowledge for the use of frequencies of international effect, although this isn't true in the microwave field where the treaty doesn't apply. On our lower frequencies we use c.w. and 'phone more or less interchangeably, whereas our present practice is almost exclusively voice above 50 Mc. On frequencies of longer range it is logical that we should be prepared to use code, to be able to deal with c.w. distress messages or to understand other imperative messages from code stations. The two ranges are, it is thought, quite different worlds, and different standards could be regarded as logical.

There are also, on the contrary side, several objections more nearly based on fear or mistrust of the way the scheme would work out. Just what they are, and the safeguards against them which the Board has in mind, will be more apparent in an examination of the pros and cons of each feature of the pending proposal.

The Proposal

Let us therefore put down just what would be contemplated by the plan the Board has under consideration, and look at the whys and wherefores of each item.

I. The proposed Class D license would authorize operation only on frequencies above 1215 Mc. (wavelengths below $\frac{1}{4}$ meter).

II. The examination for it would be the same

(Continued on insert after page 38)

Low-Cost Six-Meter 'Phone

Receiving-Type Tubes in a Complete One-Chassis Transmitter

BY C. VERNON CHAMBERS,* WJIEQ

THANKS to the crystal manufacturers, it is no longer necessary to employ a mile-long string of frequency doublers to secure v.h.f. output. For example, output in the six-meter band can be obtained by using nothing more complicated than an ordinary Tri-Tet oscillator with its plate circuit tuned to the second harmonic of a 25-Mc. crystal. As a matter of fact, crystals of lower fundamental frequency can be used to obtain the same result if a higher order of frequency multiplication is used in the oscillator circuit. But it must be admitted that a Tri-Tet delivers considerably more output at the second harmonic than it does at higher multiples and this allows a low-power amplifier to be driven directly by the oscillator-tube output.

The transmitter to be described takes advantage of this type of operation. It not only gets to "six" with the minimum number of stages but does so at low cost — less than fifty dollars — including a high-frequency crystal, the tubes, and every other component from bias battery to chassis.

Circuit Details

As shown in the wiring diagram, Fig. 1, the oscillator is a 6V6GT tube in the Tri-Tet oscillator arrangement. A Valpey Type CB5 25-Mc. crystal is used so that the second harmonic (the one to which the oscillator plate circuit is tuned) will fall within the 50-54-Mc. range. The tuned plate circuit includes a fixed condenser, C_6 , so that the tuning condenser frame can be grounded, which simplifies the mounting job. A dropping resistor, R_2 , reduces the power-supply output voltage to a value suitable for the screen grid.

* Technical Assistant, QST.

• Haven't tried "six"? If it's cost or unwillingness to revamp your present transmitter that has held you back, here's a little job that's inexpensive and complete in itself. Low power, naturally, but the 50-Mc. band is still open enough for a 15-watt transmitter to show results.

Considerable care was given to the determination of the constants of the cathode circuit, C_2L_1 , and the recommended capacity and inductance should be duplicated as closely as possible. In the event that the values are altered, the resonant frequency of the combination should be approximately 31 Mc., because this frequency gives maximum oscillator efficiency along with minimum crystal current. The crystal current in the oscillator shown is too low to light a 60-ma. dial lamp to full brilliancy.

A closed-circuit jack, J_1 , is connected in series with the cathode of the 6V6GT for checking the plate-and-screen current. Reading combined plate and screen current is not the most desirable method because the plate current alone cannot be determined without auxiliary voltage measurements and calculation, but it is even more desirable to have the metering-jack frame grounded so that the operator is protected against accidental contact with a high-potential point. Fortunately, the screen current of this oscillator is only 3 to 4 ma. and it is a simple matter to subtract this small amount from the total cathode current indicated by the milliammeter. A by-pass condenser, C_4 , is connected between the cathode coil and ground so that r.f. current need not flow through the meter.

A front view of the complete six-meter transmitter. The components and controls along the front wall of the chassis, from left to right, are as follows: microphone jack and pilot-light assembly, audio gain control, stand-by switch, phone-c.w. switch, oscillator tuning knob, jacks J_1 through J_4 , and amplifier plate-circuit tuning control.

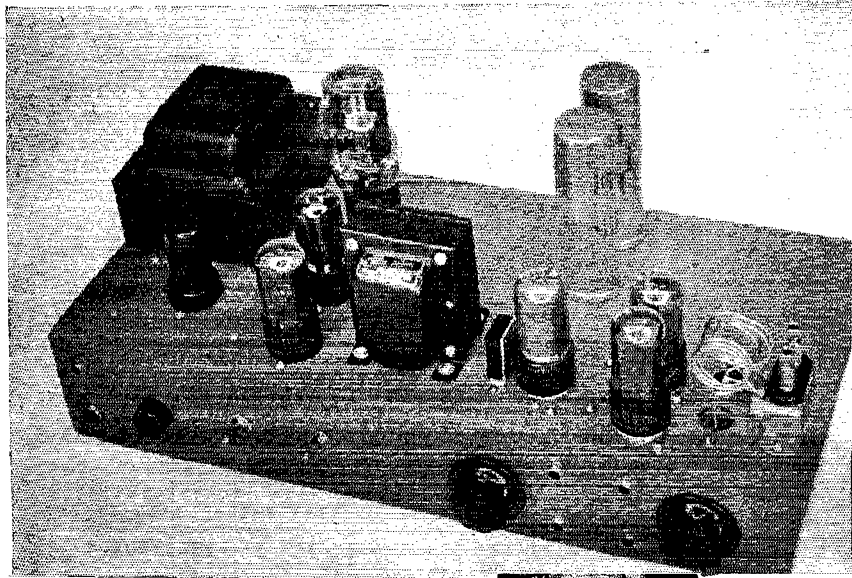

March 1947

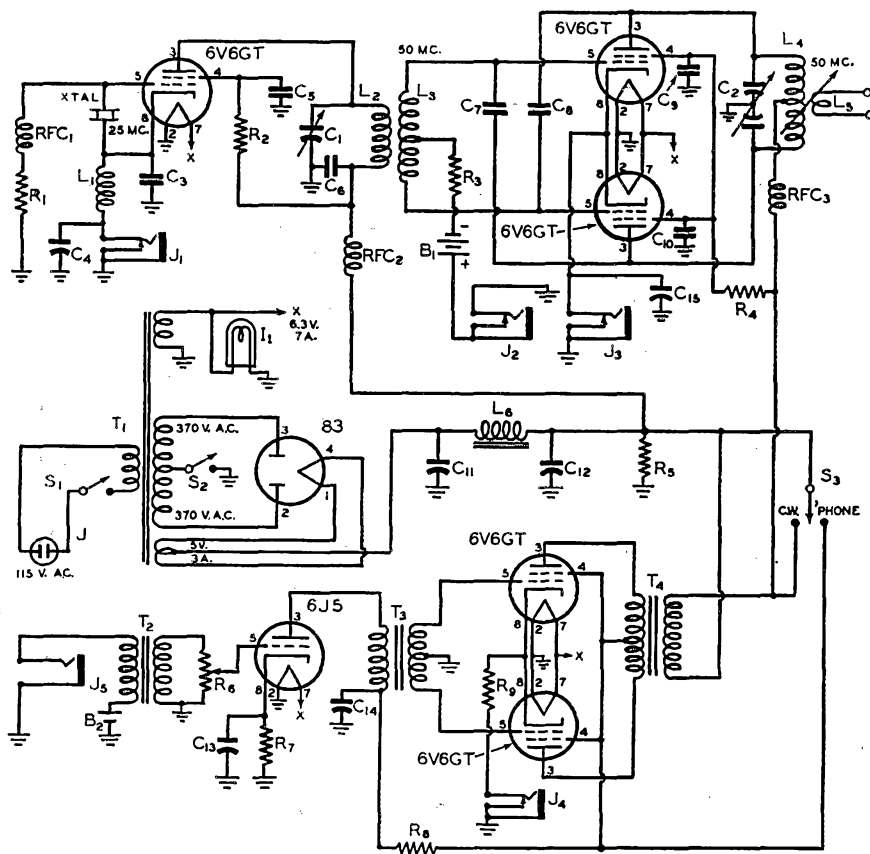

Fig. 1 — Circuit diagram of the six-meter transmitter.

- C₁ — 35- μ fd. variable (Cardwell ZR-35-AS).
- C₂ — 15- μ fd.-per-section split stator (Hammarlund HFD-15-X).
- C₃ — 100- μ fd. mica.
- C₄, C₁₅ — 0.01- μ fd. paper.
- C₅ — 0.0068- μ fd. mica.
- C₆, C₉, C₁₀ — 470- μ fd. mica.
- C₇, C₈ — Neutralizing condensers; see text.
- C₁₁, C₁₂ — 8- μ fd. 600-volt electrolytic.
- C₁₃ — 50- μ fd. 25-volt electrolytic.
- C₁₄ — 8- μ fd. 450-volt electrolytic.
- R₁ — 0.1 megohm, $\frac{1}{2}$ watt.
- R₂ — 12,000 ohms, 1 watt.
- R₃ — 10,000 ohms, $\frac{1}{2}$ watt.
- R₄ — 4700 ohms, 2 watts.
- R₅ — 15,000 ohms, 10 watts.
- R₆ — 0.5-megohm potentiometer.
- R₇ — 1000 ohms, $\frac{1}{2}$ watt.
- R₈ — 10,000 ohms, 2 watts.
- R₉ — 300 ohms, 10 watts.
- L₁ — 3 turns No. 18 enameled, close-wound, $\frac{1}{2}$ -inch diam.
- L₂ — 3 turns No. 14 tinned, $1\frac{1}{2}$ -inch diam., $\frac{7}{8}$ inch long.
- L₃ — 9 turns No. 14 tinned, $\frac{3}{4}$ -inch diam., 1 inch long.
- L₄ — 6 turns No. 14 tinned, $1\frac{1}{2}$ -inch diam., wound in two sections with half the total number of turns each side of center; turns spaced wire

- diam.; a space of $\frac{1}{2}$ inch is left between sections.
- L₅ — 2 turns No. 14 tinned, $1\frac{1}{2}$ -inch diam., turns spaced wire diam.
- L₆ — Filter choke, 4 by., 250 ma., 60-ohm d.c. resistance (Stancor C-1703).
- B₁ — 45-volt bias battery.
- B₂ — 1.5- or 3-volt microphone battery.
- I₁ — 6.3-volt a.c. pilot-lamp-and-socket assembly.
- J — Panel-mounting a.c. male socket (Ampheno 61-M1).
- J₁, J₂, J₃, J₄ — Closed-circuit jack.
- J₅ — Open-circuit jack.
- RFC₁ — 2.5-mh. r.f. choke.
- RFC₂, RFC₃ — V.h.f. r.f. choke (Ohmite Z-1).
- S₁ — S.p.s.t. switch; mounted on potentiometer R₆.
- S₂ — S.p.s.t. toggle switch.
- S₃ — S.p.d.t. toggle switch.
- T₁ — Power transformer, 370 volts a.c. each side of center-tap, 275-ma. rating. Filament windings: 6.3 volts, 7 amp.; 5 volts, 3 amp. (Stancor P-6315).
- T₂ — Microphone transformer, s.b.-to-single-grid type (Stancor A-4705).
- T₃ — Interstage coupling transformer, single plate to push-pull grids (Stancor A-62-C).
- T₄ — Modulation transformer, primary 10,000 ohms, secondary 5000 ohms (Stancor A-3845).

The push-pull amplifier is inductively-coupled to the oscillator stage, the amplifier grid coil, L_3 , being placed inside the oscillator plate coil. Inductive coupling between a single-ended circuit and a self-resonant push-pull circuit has a certain amount of capacity unbalance because one end of the amplifier coil is near the plate end of the driver coil while the other end is nearer the grounded end of the driver coil. Such unbalance may cause one of the amplifier grids to receive more excitation than the other and the amplifier tubes will not function with equal efficiency. The unbalance can be corrected to an acceptable degree by proper orientation of the grid coil with respect to the plate coil, a point which will be covered more thoroughly later. Bias for the amplifier tubes is obtained from a 45-volt "B" battery, plus the voltage drop across the grid leak, R_3 .

Because of the low plate-grid capacitance of the 6V6GT, it is not practical to employ standard condensers to neutralize the amplifier — and, unfortunately, neutralization is necessary. Complete neutralization is realized by making use of the capacity that exists between the wires of low-impedance Twin-Lead. The material used for the neutralizing condensers, C_7 and C_8 , is the 75-ohm type, but 150-ohm line, or even insulated wires twisted together, can be used with equal success. The plate circuit of the amplifier is perfectly standard and is of the type that permits grounding the condenser frame.

The screen-dropping resistor is R_4 , while C_9 and C_{10} are the screen by-pass condensers. Jacks J_2 and J_3 are provided for grid and cathode metering. The screen current will be 14 ma. when the amplifier is properly excited, and this value plus the grid current can be subtracted from the total reading to obtain the plate current. Coupling to the antenna load is adjusted by means of a swinging link, L_5 . The amplifier may be used for c.w. operation by plugging keying leads into the cathode jack, J_3 .

The audio system uses a single-button carbon-microphone transformer coupled to a 6J5 which drives 6V6GT push-pull modulators. Voltage for the microphone can be obtained from any small flashlight or bias battery that will deliver from 1.5 to 3 volts. The gain can be varied by adjustment of potentiometer R_6 . The tube is biased by the voltage drop across resistor R_7 , which is bypassed for audio by C_{13} . Resistor R_8 drops the power-supply voltage to 250 for the speech-amplifier tube. A decoupling condenser, C_{14} , is connected between the "B"-plus side of the transformer and ground.

Transformer coupling, through T_3 , transfers the driver-tube output to the 6V6GT modulator-tube grids. These tubes operate with the full supply voltage applied to both the plate and screen. Cathode bias is developed across resistor R_9 and cathode metering is employed. The plate-

to-plate load impedance required by the tubes is 10,000 ohms, and the output transformer used is one which provides a match between this impedance and the 5000-ohm (approximately) load presented by the r.f. amplifier. The modulator operates as a Class AB₁ amplifier and is capable of delivering approximately 15 watts of audio output.

The power-supply circuit uses a condenser-input filter consisting of condensers C_{11} , C_{12} and filter choke L_6 . The output voltage is 320 when loaded by the entire transmitter, and rises to 350 when only the r.f. system is in use. A snap switch, S_1 , mounted on the audio gain-control potentiometer serves as the a.c. on-off control, and a s.p.s.t. toggle switch, S_2 , connected in the high-voltage center-tap lead, allows the transmitter plate voltage to be removed during "stand-by" periods. A third switch, S_3 , removes plate voltage from the audio system and at the same time shorts out the modulation-transformer secondary winding, when thrown to the c.w. position. The power-supply bleeder, R_5 , is a 10-watt resistor which may have any value between 10,000 and 50,000 ohms.

Construction

The photographs show how the components are laid out on the 3 × 8 × 17-inch chassis. The audio driver tube is well toward the left end of the base, with the modulator tubes and output transformer to the right. Several inches of clear space are left on either side of the driver tube so that the microphone and interstage transformers can be mounted "below deck" during the last stages of construction.

The r.f. section starts to the right of the modulation transformer with the crystal socket, oscillator-tube socket, and sockets for the amplifier tubes in line. The leads from the plate coil to the condenser go through two holes, $\frac{3}{4}$ inch in diameter, to the right of the amplifier tubes. A feed-through insulator, used to complete the "B"-plus lead to the center-tap of the plate coil, and the antenna terminals are at the right end of the chassis. The output link, L_5 , is soldered to the lugs with which the strip is provided.

The power transformer, T_1 , is at the rear left-hand corner of the chassis. The rectifier tube is to the rear of the modulator tubes, and the filter condensers, C_{11} and C_{12} , are directly to the rear of the oscillator tube.

The audio-system layout and wiring are non-critical because the chances of feed-back or similar audio difficulties are slight since there are no high-gain stages. Spare tube prongs are used as tie-points and for resistor mounting. In the bottom view, the microphone transformer is to the left of the 6J5 tube and the interstage coupling transformer is between the driver and modulator tube sockets. A small microphone battery can be wedged in between the power trans-

former and the rolled-over edges at the bottom of the chassis.

A two-terminal connector strip is located at the front center of the chassis; these terminals are used as tie-points for the plate-voltage leads and as the support for the hot end of the bleeder resistor, R_6 . The coiled-up leads to the left of the bleeder resistor are the three spare output leads from the modulation transformer.

The r.f. section is at the top right in the bottom-view photograph. The oscillator tuning condenser, C_1 , mounted on the front chassis wall, is located midway between the crystal and oscillator-tube sockets. L_1 , the cathode coil, is mounted between the grid-prong end of the crystal socket and an insulated tie-point; the lead to the cathode jack and the ungrounded lead from the cathode by-pass condenser both connect to this terminal. The grid r.f. choke is mounted on a stand-off insulator to the rear of the tube socket and the grid-leak resistor is self-supported between the choke and ground. A small stand-off insulator is mounted at the front of the chassis just to the right of the tuning condenser and is used as a connection point for the plate by-pass condenser, plate r.f. choke, screen resistor, and the cold end of L_2 . The power-supply end of the r.f. choke and the positive-voltage input lead are brought to an insulated tie-point mounted by means of the nut and screw that hold the variable-condenser stator terminals in place. The plate end of the tank coil is returned to the plate prong of the tube socket.

Two small stand-off insulators, separated $1\frac{1}{2}$ inches, are mounted between the oscillator and amplifier tube sockets and are used as mounting posts for the amplifier grid coil, L_3 . Before the grid coil is mounted, the oscillator plate inductance, L_2 , should be wound and wired in place with its axis in line with and above the tops of the two stand-off insulators, and a center-tap lead should be soldered to the grid coil. The grid coil may then be slipped through the plate coil and soldered in place. Pin 6 of the amplifier tube socket, located toward the center of the chassis, is used as the connection point between the coil

center-tap and the grid resistor, R_3 . The grid circuit is completed by connecting the battery end of R_3 to a tie-point mounted at the rear of the tube socket and by installing a lead between the resistor and the bias battery. The positive side of the battery is connected to the metering jack, J_2 . Incidentally, this jack must be insulated from the chassis and connected as shown in the circuit diagram if a single meter is to be used for making both grid and cathode readings; if the frame of J_2 is grounded the meter leads will have to be reversed when the meter is shifted from one circuit to the other.

The plate tuning condenser requires slight modification before being mounted. The screws holding the stator-plate assemblies in place should be removed and husky soldering lugs slipped under the screw heads. After the condenser has been reassembled, the soldering lugs are used as terminals for the plate-coil leads that come down through the $\frac{3}{4}$ -inch holes in the chassis. Leads of No. 14 wire are connected between the condenser terminals and the plate prongs of the tube sockets. The r.f. choke is supported by its own leads between the feed-through insulator at the right of the condenser and the tie-strip at the rear of the tube socket. The screen resistor, R_4 , and the positive high-voltage lead for the final also join at the tie-strip terminal. However, do not solder this connection until after the amplifier has been neutralized, because the plate and screen voltages must be removed while neutralizing.

The neutralizing condensers are connected in crisscross fashion, between the plate-condenser stator terminals and the grid prongs of the tube sockets. The approximate lengths of the strips required will be three inches of 75-ohm line or five inches of 150-ohm line. If twisted wires are used, it is suggested that the lengths be five inches, also.

Testing

If a voltmeter is available it is well to test the power-supply section before attempting to operate the rest of the transmitter. With all tubes

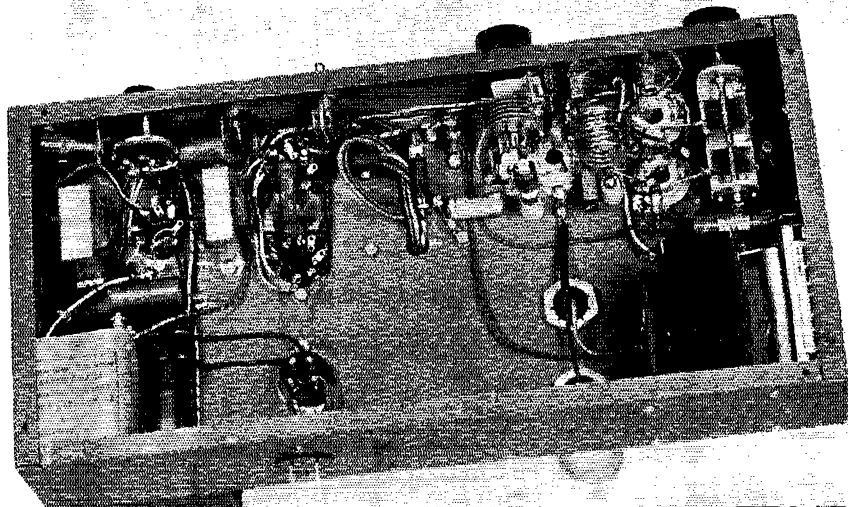

A bottom view of the six-meter transmitter. The r.f.-section components are grouped at the upper right-hand end of the chassis and the audio stages are located at the left end. The filter choke is mounted on the rear wall of the chassis along with a male connector for 115-volt a.c. input.

QST for

except the rectifier removed, apply 115 volts a.c. and close S_1 , leaving S_2 open. After the rectifier filament warms up, close S_2 and check the voltage across R_5 . The voltmeter should indicate well in excess of 400 volts.

Next, S_2 should be opened and the audio tubes should be inserted in their sockets. A 0-100 milliammeter, equipped with a 'phone plug and leads, should be plugged in J_4 and, after setting S_2 at the 'phone position, S_2 may be closed. The modulator cathode current should approximate 70 ma. The operation of the driver stage can be checked by plugging a microphone into J_5 and talking into the microphone. Driver output is indicated by an upward fluctuation of the modulator plate current. These audio tests should occupy the shortest possible period of time because the output stage is operating without load.

To test the r.f. stages, disconnect the high voltage by opening S_2 , set S_3 for 'phone operation, and plug the crystal and r.f. tubes in their sockets. Disconnect the h.v. lead to the amplifier plate and screen at the junction point previously mentioned. Voltage may now be applied to the oscillator and C_1 tuned for maximum output, as indicated by amplifier grid current. This current should be 8 to 10 ma. The oscillator cathode current should be approximately 45 ma.

The next step is neutralizing the amplifier. With the milliammeter connected in the amplifier grid circuit, rotate C_2 until there is a flicker in the grid current. The lengths of the neutralizing capacity strips should then be reduced by clipping off a fraction of an inch at a time until the plate condenser can be rotated through resonance without affecting the grid current. It is advisable to open S_2 each time a condenser is pruned because the r.f. and battery-bias voltages are present at the grid side of the circuit and, although not dangerous, are not especially pleasant on accidental contact. It is also important to prevent the ends of the wires in the condensers from short-circuiting, a thing that may happen when 75-ohm line is clipped.

To test the amplifier grid circuit for any capacity unbalance, touch the socket grid prongs with a pencil and observe the effect on the grid current. Unbalance is made evident by unequal dips in grid current when the pencil is moved from one grid to the other. It can be corrected by forcing the entire grid coil farther toward the cold end of the oscillator plate coil. Changing the position of the grid coil may change the tuning range of the oscillator plate circuit, and if this happens the turns of both coils should be spread or squeezed together until the oscillator tunes to resonance with C_1 set at half capacity.

After the amplifier is neutralized and balanced, a dummy load should be connected to the output terminals and the milliammeter plugged into the cathode jack, J_3 . Voltage can then be applied to the plates and screens of the amplifier and the

plate circuit tuned to resonance, as indicated by minimum cathode current. It must be remembered that the meter reads the combined plate, screen and grid currents. The screen current cannot be assumed to be 14 ma. (the correct value) until the excitation has been adjusted. The best method of excitation adjustment requires a voltmeter connected between the screen and ground; the oscillator tuning should be adjusted to make the meter read 250 volts. Since this reading will vary as the amplifier loading is changed, the oscillator tuning must be reset as the loading is adjusted. Proper operation and loading of the amplifier is indicated by the following readings: amplifier grid, 2.5 to 3 ma.; screen potential, 250 volts; cathode current, 90 ma. (73 ma. plate current, 3 ma. grid current, and 14 ma. for the screens). A 15-watt lamp used as a dummy load should show practically full brilliancy. Actual measurement of the power output under the conditions described shows it to be 14 watts.

As a final check, under full load the voltage at all points connected directly to the high-voltage supply should be 320. The oscillator screen voltage should be 250 to 260 volts, as should also the voltage at the plate of the speech-amplifier tube. The cathode pin of the 6J5 should be 8 volts positive with respect to chassis, and the bias developed across the modulator cathode resistor should be approximately 20 volts when the plate current is at the static value. All voltages will increase somewhat when the transmitter is switched to c.w. operation because of the decreased drain on the power supply when the audio system is inoperative.

The output link allows the transmitter to be coupled either to a flat line, to a link-coupled antenna tuner, or to a higher-power amplifier.

With voice modulation, the modulator cathode current should be 90 to 100 ma. on peaks. And incidentally, it is wise to remember that the audio system is capable of overmodulating the final — so don't let the amplifier plate current take any upward excursions while working 'phone!

OUR COVER

It's a far cry from guided missiles to amateur 6-meter transmitters, but ex-Sergeant Chambers, AAF, has happily negotiated the transition. Our cover shows Technical Assistant WIJEQ back at his old spot in the ARRL lab, putting his latest creation through its final tests. You'll find Vern's low-cost receiving-tube rig described in this issue, starting on page 13.

**SWITCH
TO SAFETY!**



More on Speech Clipping

Practical Design Data and Circuit Information

BY W. W. SMITH,* W6BCX

THE author's first *QST* article on speech clipping¹ was intended primarily as an introduction to the basic principles of pre-modulation speech clipping and the considerations involved. It must be admitted that the low-level clipper-filter circuit that was shown as a prototype in order to facilitate explanation of the basic system is somewhat more elaborate than necessary for practical application to typical amateur transmitters. While it could be used to advantage in a transmitter boasting a modulator with virtually zero distortion and a modulated Class C stage with virtually perfect linearity, the residual splatter resulting from the harmonic and intermodulation distortion generated after a low-level clipper-filter is, in practical amateur transmitters, far from zero. Therefore there is no point in trying to achieve absolute perfection in the clipper-filter.

A much simpler low-level circuit which gives very good results was shown in November *QST*,² and one of still different persuasion and intermediate complexity is shown in Figs. 1 and 2. Fig. 1 shows the basic series clipper circuit, and Fig. 2 shows the complete clipper-filter incorporated in a speech amplifier suitable for amateur work.

As was stated in the author's original article, there are many types of series limiters and many

* 215 West Cook St., Santa Maria, Calif.

¹ W. W. Smith, "Pre-modulation Speech Clipping and Filtering," *QST*, February, 1946.

² J. W. Smith and N. H. Hale, "Let's Not Overmodulate — It Isn't Necessary!," *QST*, November, 1946.

• Speech clipping and filtering can greatly increase the effectiveness of a 'phone transmitter. It can also make that transmitter take up less room on the air than an unfiltered job that isn't properly operated. But it also requires great care and attention to design and operating details that, unfortunately, are only too frequently neglected in the average 'phone. This article emphasizes those points in addition to introducing some new circuits.

types of shunt limiters which can be made to work satisfactorily, but the many limiters in either class differ only as to detail. When one analyzes them carefully it becomes apparent that all shunt limiters are basically the same and all series limiters are basically the same, even though there are many ways of obtaining delay bias and feeding the signal in and out. The similarity between speech-clipper circuits and conventional receiver noise-limiter or "chopper" circuits also becomes apparent.

A Practical Speech-Amplifier Front End

Fig. 2 is intended as the front end of a speech amplifier for an amateur 'phone transmitter. It has sufficient gain for any of the common p.a.-type diaphragm crystal or high-impedance dynamic microphones for moderately close talking. It is not designed for the ham who likes to sit

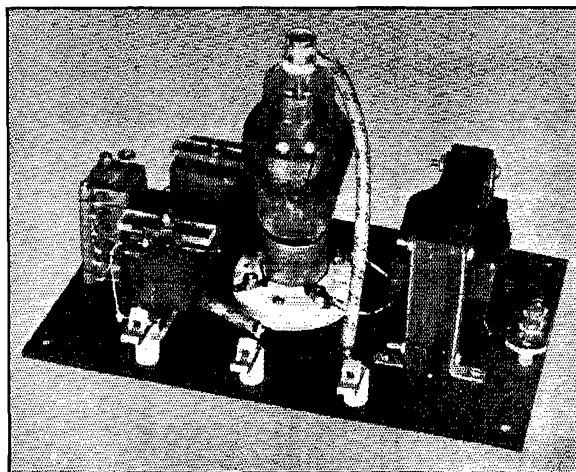

This high-level clipper and filter employs inexpensive components and can be used at inputs up to 500 watts (ideal for use with a BC-610 transmitter). Starting from the left may be seen the stack of 5000-volt mica capacitors; the two improvised air-core chokes which are clamped and mounted by means of Lucite strips; the 866 clipper tube; and finally the rectifier filament transformer. Because of the high peak voltages involved, and also to simplify construction, the entire unit is mounted on a sheet of Masonite, which in turn can be supported above a metal chassis if desired.

across the room from the microphone and whisper at it. The amplifier incorporates a moderate amount of bass suppression ahead of the clipper-filter, a highly desirable feature for communications work at any time and a virtual necessity when a low-level clipper-filter is employed in a transmitter using anything other than "broadcast-quality" transformers following the clipper-filter. The suppression is obtained by proportioning the RC values in the grid coupling circuits of the first two stages to give a cut-off frequency that is about as high as can be tolerated without the quality becoming quite thin and unnatural.

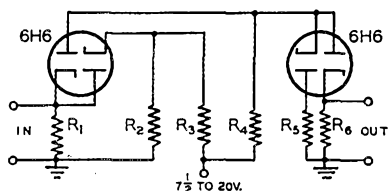

Fig. 1 — Full-wave series clipper which maintains constant load on an RC driving circuit, thus preventing axis shift. At low clipping levels a series clipper gives cleaner chopping than a shunt clipper, although the difference is not great at levels of 2 volts or more. The values of resistors R_2, R_3, R_4, R_5 and R_6 should be equal to each other and to twice the value of R_1 . The clipping level is one-fourth the positive bias voltage.

The positive bias source should have low impedance. There should be no external path for d.c. across either the input or output terminals.

The values shown are recommended as a good compromise between voice "naturalness" and "get-through" ability, but if the reader insists upon slightly more bass the values of C_1 and C_2 can be increased to $0.002 \mu\text{fd}$.

Mica condensers are specified at these points to avoid possible leakage and consequent short life of the bias cell, and to prevent the possibility of application of positive voltage on the grid of the next stage. When a high value of grid resistance is employed, many paper capacitors have or eventually develop enough leakage to put a volt or two of positive voltage on the grid of the next tube. There is no excuse for using anything but mica when $0.006 \mu\text{fd}$. or less is required, but when larger capacities are indicated the writer has found it wise to use only top-quality paper capacitors rated at 1000 working volts and to make the capacity as small as can be tolerated from the standpoint of frequency response or phase shift.

The resistors R_8, R_{11} , and R_{13} are very critical if symmetrical clipping is to be accomplished. R_9, R_{10} and R_{12} are also fairly critical. The exact values are not so important as their uniformity and ratio. $R_9, R_{10}, R_{11}, R_{12}$ and R_{13} should all be equal in value and R_8 should be equal to exactly half this value. The best way to get a perfect match is to persuade the clerk to let you get into the resistor bin with an ohmmeter and measure

"220,000-ohm" resistors until five are found which are within 1 or 2 per cent, then tie two in parallel and look for a "110,000-ohm" resistor which is exactly equal to the parallel combination. When this procedure is used, the absolute accuracy of the ohmmeter is unimportant. Good quality resistors should be used at these points to ensure that they retain their characteristics with age.

A 6F5 is used in the first socket because the tube is relatively nonmicrophonic (which is more than can be said of some 6SJ7s), and because it provides good gain with low noise and hum. Also, the writer prefers a double-ended tube for the input stage in any amplifier, as it makes for less grief with hum and feed-back. R_2 serves in conjunction with the input capacity of the tube to prevent excessive r.f. from getting on the first grid, a common trouble around high-power rigs when a high-impedance microphone with a long cable is employed.

It is recommended that the 6F5 be mounted so that the grid cap is close to the microphone connector, and that C_1, R_1, R_2 and B_1 be placed in a shield can which also shields the grid end of the tube and the back side of the microphone connector. Sometimes this saves trouble later on, and it is more easily done in the first place.

The filter uses two standard 125-mh. powdered-iron core "r.f." chokes, such as are made by Meissner or Bud. When a wire-wound potentiometer is used at R_{15} to set the output level it need not be touched after once being set, regardless of changes in the weather, provided that the modulated stage is run at the same input. A slight change in the characteristics of a composition- or carbon-type potentiometer will not be noticed when the potentiometer is used as a volume control, but even a slight change can cause trouble if it is used to set the modulation "ceiling," and initially is advanced as far as is possible without producing splatter.

The maximum peak voltage available across R_{15} is about 8 volts. The rest of the speech system should be so designed or altered that between 2 and 8 volts peak input produces approximately 95-per-cent modulation. If less than 2 volts is required, proper adjustment of R_{15} becomes difficult, because wire-wound potentiometers ordinarily are not available with tapered windings. If less than 2 volts is needed, the situation can be saved by using two resistors as a voltage divider at R_{16} , proportioning them to give the desired voltage with R_{15} at about half scale. If between 10 and 25 volts is required at the next grid, the primary of a 1-to-3 ratio interstage transformer can be connected from the pot arm to "B" plus, eliminating C_{13} and R_{16} — but be sure the transformer is not of the bargain-counter variety.

The correct adjustment of R_{15} is the one that gives the highest percentage modulation that can be used without splatter *even when screaming into*

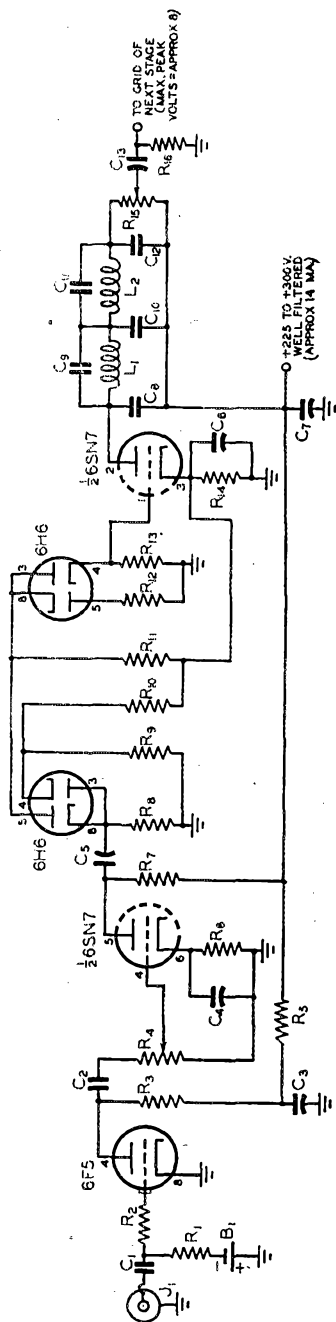

Fig. 2 — Speech-amplifier front end for amateur work, incorporating bass suppression and speech clipping and filtering, utilizing the series clipper of Fig. 1.

- C₁, C₂ — 0.001- μ fd. mica.
- C₃ — 8- μ fd. 450-w.v. electrolytic.
- C₄ — 25- μ fd. 50-w.v. electrolytic.
- C₅ — 0.05- μ fd. tubular paper, 1000 w.v., best quality.
- C₆ — 50- μ fd. 50-w.v. electrolytic.
- C₇ — 16- μ fd. 450-w.v. electrolytic.
- C₈, C₉ — 0.008- μ fd. mica.
- C₁₀, C₁₁ — 0.007- μ fd. mica.
- C₁₂ — 0.016- μ fd. mica.
- C₁₃ — 0.56 megohm, tubular paper, 1000 w.v., best quality.
- R₁ — 0.56 megohm, $\frac{1}{2}$ watt.
- R₂ — 27,000 ohms, $\frac{1}{2}$ watt.
- R₃ — 0.27 megohm, 1 watt.
- R₄ — 1000 ohms, $\frac{1}{2}$ watt.
- R₅ — 0.11 megohm, $\frac{1}{2}$ watt (see text).
- R₆, R₁₀, R₁₁, R₁₂, R₁₃ — 0.22 megohm, $\frac{1}{2}$ watt (see text).
- R₇ — 1500 ohms, $\frac{1}{2}$ watt.
- R₈ — 47,000 ohms, 1 watt.
- R₉ — 66,000 ohms, 1 watt.
- R₁₄ — 0.5 megohm potentiometer, a.f. taper.
- R₁₅ — 1500 ohms, $\frac{1}{2}$ watt.
- L₁, L₂ — 0.47 megohm, $\frac{1}{2}$ watt.
- L₃, L₄ — 125-mh. powdered-iron core "r.f." choke.
- B₁ — Bias cell, 1.1 or 1.25 volts.
- J₁ — Microphone connector.

the microphone with the gain control full on. If the following stages have very good low-end phase-shift characteristics, R₁₅ can be advanced somewhat more than would otherwise be the case. Phase shift tends to cant the flat-topped waves after they leave the clipper-filter.

Actually, phase shift can be tolerated if it is linear with respect to frequency, but when phase shift is due to inadequate capacity in coupling condensers or inadequate transformer inductance, the resulting phase shift is not linear with respect to frequency and the waveform is distorted.

Modulation Distortion

If a 'scope check should indicate that the clipped waves are substantially flat-topped into the modulator but no longer so when the rectified carrier envelope is viewed on the 'scope, the Class B modulation transformer is guilty. This condition is most common with a combination of cheap modulation transformer, high plate-to-plate load on the modulators, and Class C plate current flowing in the transformer secondary. If the condition is not cured when the d.c. is eliminated from the secondary by resorting to shunt feed, a bigger and better modulation transformer is in order.

With a low-level clipper-filter the modulator distortion either must be kept low at full modulation, or else the high-order components must be removed from the modulator output by filtering. The latter can be done fairly well, simply by shunting both primary and secondary of the Class B output transformer with as much capacity as can be employed without excessive attenuation at 3500 cycles. These capacitors act in conjunction with the leakage inductance of the transformer to constitute a pi-section filter. If this does not do the trick — and it may not if the transformer is of very good quality and has low leakage reactance — then the solution is to augment the leakage inductance with a filter

choke designed for the purpose, such as a Thor-darson-"splatter choke."

Linearity of Modulated Amplifier

With any type of speech clipper, linearity in the modulated Class C stage is of vital importance. Distortion generated here can produce

Fig. 3 — High-level half-wave clipper-filter system for use with 8000- to 10,000-ohm loads and plate voltages up to 2000. If the same power supply is used for both the modulator and Class C amplifier, the latter should be decoupled by means of a suitable choke and capacitor.

- C₁, C₂, C₄, C₅ — 0.002- μ fd. 5000-volt-test mica.
- C₃ — 0.004- μ fd. 5000-volt-test mica.
- L₁, L₂ — Approximately 0.4 hr., capable of carrying 250 ma. without overheating; high-voltage insulation. See text.
- T₁ — Class B modulation transformer.
- T₂ — 866 filament transformer, 7500-volt insulation.

NOTE: If plate blocking condenser is 0.001 μ fd. or larger, refer to text regarding value of C_s.

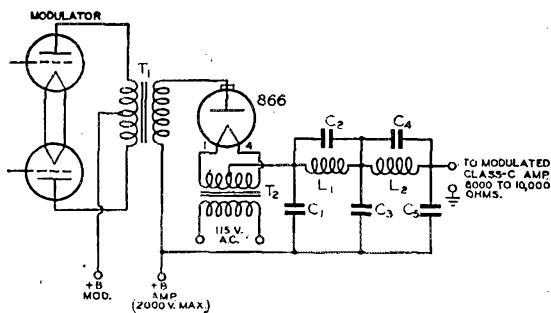

splatter just as well as anywhere else in the rig, and it is too late to filter it out. One cure for a stubborn Class C modulated amplifier is to modulate the r.f. driver stage along with the final stage. (This is not so wasteful of audio power as it might seem, particularly if a high-voltage low-current tube is used as an r.f. driver.) The reason is that excitation of a value that ordinarily would be used for c.w. operation will suffice, because on a modulation up-peak the excitation power will increase to four times the unmodulated carrier excitation if the r.f. driver is fully modulated along with the final r.f. stage. Also, on a down-peak the driver power decreases with the final plate voltage, and to avoid modulation distortion caused by a discontinuous characteristic caused by insufficient excitation — which would occur if fixed bias were used on the final amplifier — the final must have all-grid-leak bias and a very small grid by-pass or coupling condenser.

The plate voltage for the r.f. driver in such an arrangement is best obtained from a series dropping resistor, in the same manner as screen voltage commonly is obtained for modulated tetrodes and pentodes. The same precautions apply with regard to keeping the modulation voltages in phase. The plate by-pass condenser in the driver stage should be small, or detrimental phase shift will result at the higher voice frequencies. The same applies to the grid coupling or by-pass condenser in the final. Shunt plate feed to the driver permits use of a much smaller plate blocking condenser, and is recommended when the arrangement is otherwise acceptable.

Clipping Symmetry

When a speech clipper is built into any speech system, all single-ended stages ahead of the clipper should have fairly low distortion even under conditions of maximum clipping. Bad overloading of any single-ended stage ahead of the clipper will cause an asymmetrical wave to be fed to the clipper because of shifting of the axis, and will prevent maximum realization of the clipper benefits. In other words, for best performance the clipping should be confined to the clipper.

The series clipper shown in Figs. 1 and 2 utilizes two diodes and three resistors whose only purpose

is to maintain a constant load on the RC driving circuit over a complete cycle regardless of the amount of clipping. This provides a slight improvement in the performance of the clipper proper by keeping the axis where it belongs. Although the improvement is slight it is not negligible, and it certainly is worth the cost of one 6H6 and three carbon resistors.

High-Level Clipper

Illustrated in Fig. 3 is a practical high-level clipper-filter system for use at Class C inputs up to 2000 volts at 250 ma. The particular filter constants shown are for a load impedance of 8000 to 10,000 ohms, and the filter is designed to use some of the thousands of surplus 0.002- μ fd. 5000-volt-test mica condensers that are reposing on bargain counters around the country.

Because inexpensive filament transformers with high-voltage insulation are more readily available in 2.5-volt rating, an 866 is shown as a clipper tube instead of a 5R4GY or other high-vacuum rectifier. The use of an 866 is perfectly feasible so long as it is run at reduced rating, as is done here, and careful checks indicate that the performance is as good as with a high-vacuum rectifier.

The two air-core "splatter chokes" for the high-level filter are obtained by removing the iron cores from ordinary filter chokes of suitable current rating, and then removing turns or adding a few laminations to trim up the inductance to the desired value. The nonlinear characteristic of conventional laminated iron-core chokes makes them inferior to air-core chokes for use in splatter filters which must carry lots of d.c. and handle high a.c. voltages within the pass-band, as is the case when the filter is placed after the modulator. The slightly-greater d.c. drop in an air-core choke, because of the greater number of turns required, is not of serious consequence.

Inexpensive uncased filter chokes having comparatively low-voltage insulation can be doctored up to make excellent air-core splatter chokes if the current rating is adequate. With the core removed it cannot "talk back," and it is an easy matter to insulate the whole coil from a metal chassis. The greater number of turns reduces the voltage between turns and between windings, and

the only possible vulnerable point is the termination for the inner end of the winding. If the choke originally was designed for low-voltage use, this wire probably crosses over one end of the coil and is anchored to a lug or pigtail lead taped to the outside of the coil and not too well insulated from it. This is easily remedied by snipping the wire and fixing it up with its own tie-point or lug, well spaced from the outside end of the coil.

Some very useful information would be a list of all the popular filter chokes of commercial manufacture by type number, with exact inductance with the core removed. Unfortunately the author is not in a position to supply such information at the present time, but it is hoped that such information can be made available at a later date. The two chokes used in the filter shown in Fig. 3 were obtained by removing the cores from two old homemade filter chokes, vintage 1927, which were found in the junk box. The inductance with no d.c. superimposed was measured at 17 henries before removal of the core, and 0.32 henry with core removed. Just to get some idea of what could be expected of typical chokes of recent commercial manufacture, a choke rated at 8 henries at 150 ma. was measured with no d.c. in the winding and the inductance found to be 21 henries. With the core removed the inductance was measured at 0.43 henry. A 250-ma. factory-made choke rated at from 6 to 10 henries with rated d.c. in the winding probably would give just about the right inductance for the filter of Fig. 3, without removing any turns or replacing any laminations.

Naturally it is desirable to hit the inductance value on the button (or nearly so) with all of the core removed and no alteration of the winding. However, removing a few layers of the winding is not a very big job should this be necessary. If the inductance is too low, it can be raised by sticking a few of the *straight* laminations (not the "E" pieces) through the coil, separating them with tape and wedging them in tightly to prevent "talking" once the right number of laminations has been determined. This is a little more messy than removing turns, but still is not a formidable job. Even if enough iron is inserted to double the inductance, the total reluctance still is so high that the characteristics of the choke still will be substantially those of an air-core choke.

When checking the inductance it is best to make the measurement at approximately the cut-off frequency of the filter. Because of the comparatively high distributed capacity of an air-core choke of this type, and the tendency for it to increase the mutual inductive coupling between different portions of the coil at the higher frequencies, the inductance as measured at or near the cut-off frequency of the filter will be appreciably higher than that measured at 60 cycles. If one does not have access to equipment suitable for direct measurement, the inductance can be determined with fair accuracy using an audio

oscillator and diode peak voltmeter, making reference to a reactance-frequency chart to determine the reactance of a capacitor of known value which resonates the choke at a known frequency.

If the plate blocking condenser in the modulated stage is 0.001 μ fd. or larger, the value of C_5 should be reduced by approximately the same amount. Obviously the blocking condenser should never be much larger than 0.002 μ fd. The filter constants are not extremely critical, and some leeway can be tolerated. But for best performance the values should not deviate too much from those specified.

When using a high-level clipper-filter it is important that there not be appreciable "lopsided" overloading of any stage ahead of the modulator at maximum clipping level. It is recommended that a Class A₁ push-pull a.f. driver stage be used ahead of the modulator, and that a 250,000-ohm resistor be placed in series with the grid of each driver tube, right at the grid. If the driver stage uses fixed bias, then the resistance value should be as high as is permitted for fixed-bias operation, usually 50,000 ohms. The stage ahead of the a.f. driver also should use 250,000-ohm series resistors at each grid, and preferably be push-pull, although this is not absolutely necessary if the stage is capable of delivering without serious distortion several times the peak output voltage required for 95-per-cent modulation.

It is true that the high-level clipper-filter system is more expensive than the low-level system, but it has the advantage of being self-adjusting, removes splatter components generated in the modulator stage, and renders harmless any phase shift in the modulation transformer. Also, if a husky modulator is employed in conjunction with plenty of r.f. excitation to the Class C stage and a comparatively low plate-to-plate load on the modulator, the signal will have noticeably more "punch" for the same resting carrier power.

Strays

ARRL President George W. Bailey, W2KII, has been elected a director of Army Signal Association Post No. 1, in his dual capacity as a League official and executive secretary of IRE.

— — — —

No, Hobart, Q fever isn't an occupational malady prevalent among efficiency-minded radio design engineers — it's a form of virus pneumonia sometimes mistaken for influenza, according to *Science News Letter*.

SWITCH TO SAFETY!



Fundamental Beam Patterns

Simplified Plotting of Antenna Characteristics

BY DAVID C. CLECKNER,* W5YBF

• Here is a story designed to take a little of the black magic out of how antenna patterns are obtained. By following the principles set forth, anyone can see how some of our common types of arrays "get that way" and what can be expected from them in the way of directivity, and you don't have to be a super-mathematician or slide-rule pusher to figure them out.

AMATEURS are becoming increasingly aware of the importance of taking advantage of the directional characteristics of even a simple half-wave antenna, particularly at the higher frequencies, but many may feel that the plotting of directional patterns of common combinations of half-wave elements is too complicated for the average operator. It is the purpose of this story to show that the technique is well within the reach of any interested ham with some paper and a pencil.

Basic Patterns

A short review of first principles is in order, for background purposes. It will be recalled that the free-space pattern of a half-wave antenna is a figure-8 pattern revolved about the antenna, and that this pattern is modified by the orientation (horizontal or vertical) of the antenna and its height above ground. Thus the pattern of any half-wave antenna is obtained by multiplying the figure-8 pattern by the ground-reflection factor for the particular height above ground. This subject is elaborated in Chapter Three of *The ARRL Antenna Book*.¹ The maximum lobe (or lobes) may be at any vertical angle, depending on how many wavelengths or fractions thereof that the antenna is mounted above ground, and it should be kept in mind that all of the patterns to be described are modified in exactly the same manner.

Studying the patterns obtained for a half-wave antenna immediately shows that at some heights above ground there is considerable radiation upward at undesired angles, undesirable because low-angle radiation is the most useful at the

higher frequencies. The radiation at undesired angles represents lost power, or at least power that could be utilized to improve the signal strength in a desired direction. This power can be directed to some extent by selecting the proper height above ground, and to a greater extent by combining antenna elements in an "array" and feeding them with currents of correct phasing and amplitude so that the radiation from the individual elements adds in the desired direction and cancels in the undesired directions. In a parasitic array this is done by choosing an optimum spacing, usually between 0.1 and 0.2 wavelength, and tuning the parasitic elements until the correct induced currents flow on the reflectors and directors. The elements are combined in such a way that the radiation from the driven element and the reradiations from the parasitic elements add in the desired direction.

In arrays where all of the elements are driven, there are three basic arrangements that are normally used: collinear, broadside and end-fire, as shown in Fig. 1. The elements can of course be grouped in more complex designs than those shown, to obtain more gain and sharper patterns, but these arrays can always be broken down into a combination of the basic types; e.g., one might have an array of two broadside sections arranged and excited to give end-fire operation through the two broadside sections, and so on. Also, one could consider a broadside array of four elements as a broadside arrangement of two broadside arrays or a collinear array of four elements as a collinear arrangement of two collinear arrays.



Fig. 1 — The three basic types of driven arrays.

The collinear (A) has the axis of each element in the same line and the elements are excited in phase. The maximum radiation is at right angles to the common axis.

The broadside array (B) uses elements in the same plane, spaced from $\frac{1}{4}$ to 1 wavelength, and the elements are excited in phase. The maximum radiation is perpendicular to the plane of the elements.

The end-fire array (C) uses elements in the same plane, spaced from $\frac{1}{10}$ to $\frac{1}{2}$ wavelength, and the elements are excited out of phase. The maximum radiation is in the plane of the elements and at right angles to them.

* 1376 Aberdeen Ave., Columbus 3, Ohio.

¹ And, in greater detail, Grammer, "The All-Around Radiation Characteristics of Horizontal Antennas," *QST*, November, 1936, and Grammer, "More on the Directivity of Horizontal Antennas," *QST*, March, 1937.

Combining the Patterns

In order to compute the beam patterns of arrays that are composed of vertical or horizontal half-wave elements, it is only necessary to multiply the fundamental pattern of the horizontal or vertical element of which the array is composed by the pattern of the group. Table I gives the group patterns for vertical elements for the following popular conditions: (A) in phase, half-wave spacing (broadside), (B) 180° out of phase, half-wave spacing (end-fire), (C) 180° out of phase, close spacing (end-fire), and (D) 90° out of phase, spaced quarter wavelength (unidirectional end-fire). The table also gives the necessary values for patterns of the basic horizontal (E) and vertical (F) elements. These patterns are plotted in Figs. 2, 3, 4, 5 and 6. In converting the patterns of A, B, C or D for horizontal elements, it is necessary to multiply them by the values in E. For example, the horizontal pattern of the popular W8JK horizontal end-fire array can be obtained by multiplying E by C. The multiplication is simply that of multiplying the value given in Table I for 5° for E by the value given for 5° for the group pattern, C. This is then repeated for 10°, 15° and so on until the complete pattern is obtained, after which it can be plotted on polar-coördinate paper.

To find the pattern of two horizontal half-wave elements strung end to end and fed in phase (collinear), the fundamental pattern of the horizontal half-wave element (E) is multiplied in 5° steps by the group pattern of two vertical antennas fed in

Table I — Pattern Values of Simple Antennas and Arrays

θ	A	B	C	D	E	F	θ
	2 vert. ant. spaced half-wave-length. Fed in phase	2 vert. ant. spaced half-wave-length. Fed 180° out of phase	2 vert. ant. Very small spacing, fed 180° out of phase	2 vert. ant. spaced quarter wave-length, Fed 90° out of phase	Horizontal half-wave antenna	Vertical half-wave antenna	
0	150	111	124.5	146	131.5	89	360
5	148	110	123	145	131		355
10	145	109	122.5	144.5	131		350
15	140	108.5	120	143.5	128		345
20	129	108	117	141	122		340
25	120	107.5	112.5	138.5	117		335
30	108	107	107.5	135	111		330
35	92	107	101	132	103.5		325
40	79	105	95	130	94.5		320
45	64.5	101	87.5	124.5	84		315
50	53	91	80	120	75		310
55	41.5	85	71	115	66		305
60	33	75	62	109	55		300
65	24	65	51	103.5	40		295
70	15	57.5	41	98	26.5		290
75	7.5	44	30	91.5	18.5		285
80	3.7	25	20	86	8.8		280
85	2.2	5.5	10	79	4.4		275
90	0	0	0	72	0		270
95	2.2	5.5	10	67	4.4		265
100	3.7	25	20	60	8.8		260
105	7.5	44	30	53	18.5		255
110	15	57.5	41	46.5	26.5		250
115	24	65	51	40	40		245
120	33	75	62	35	55		240
125	41.5	85	71	31	66		235
130	53	94	80	26.5	75		230
135	64.5	101	87.5	22	84		225
140	79	105	95	17.5	94.5		220
145	92	107	101	13	103.5		215
150	108	107	107.5	11.5	111		210
155	129	107.5	112.5	6.5	117		205
160	145	108	117	3.3	122		200
165	140	108.5	120	4.5	128		195
170	145	109	122.5	3.5	131		190
175	148	110	123	1.7	134		185
180	150	111	124.5	0	134.5	89	180

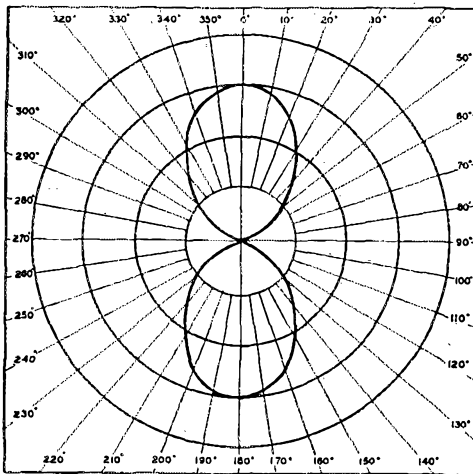

Fig. 2 — A plot of A in Table I — the horizontal pattern of two vertical radiators spaced one-half wavelength and excited in phase.

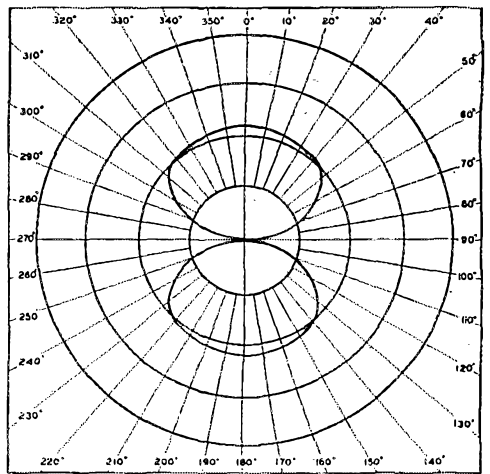

Fig. 3 — The horizontal pattern of two vertical radiators spaced one-half wavelength and excited 180° out of phase — B in Table I.

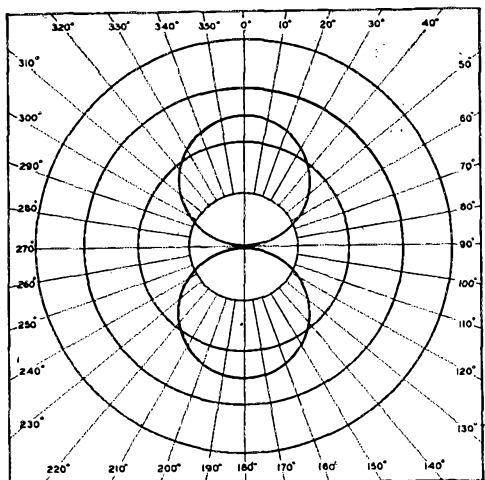

Fig. 4 — A plot of C in Table I — the horizontal pattern of two close-spaced vertical radiators excited 180° out of phase.

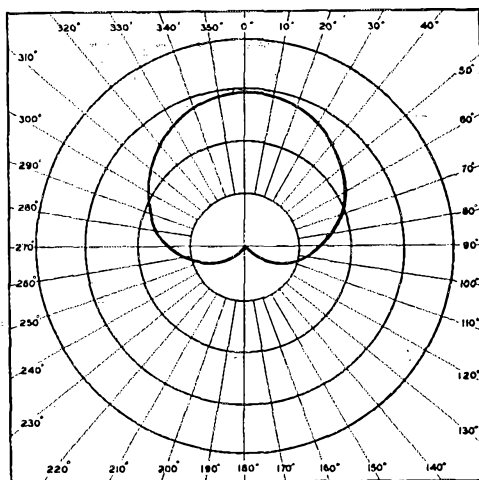

Fig. 5 — The horizontal pattern of two vertical radiators spaced one-quarter wavelength and excited 90° out of phase — D in Table I.

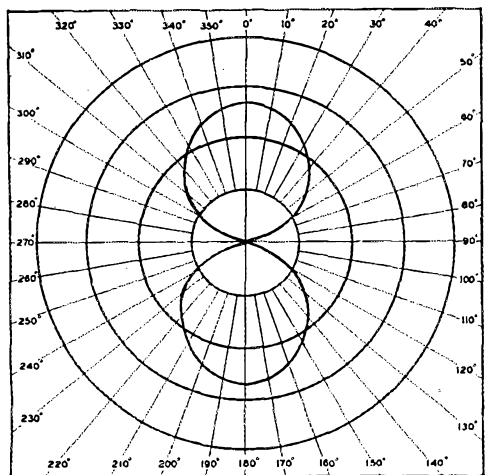

Fig. 6 — One of the most fundamental configurations — the horizontal pattern of a horizontal half-wave antenna — E in Table I.

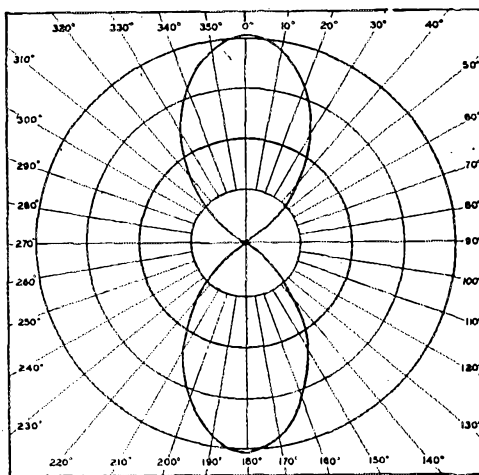

Fig. 7 — A plot of the result of Table II, the horizontal pattern of two collinear horizontal antennas spaced one-half wavelength.

phase and spaced one-half wavelength (A), as shown by the sample calculations in Table II. The resultant pattern is shown in Fig. 7. Note that in this and other combinations, it is only necessary to consider the centers of individual elements, their orientation and their spacing in order to use the basic group patterns of A, B, C and D in Table I.

In order to determine more closely in which vertical and horizontal directions the energy is being radiated, it is necessary to multiply in the same manner the horizontal pattern you have just obtained by the ground-reflection factor given in *The ARRL Antenna Book* (pages 16 through 19)

for the particular height at which your array is located. The ground-reflection factor then shows you at what vertical angle the lobe of maximum radiation is directed.

By using combinations of group patterns, particularly the cardioid pattern of Fig. 5 (D in Table I), many more complicated arrays can be computed. Also binomial arrays — arrays in which lesser currents are fed to the outer elements, for minor-lobe reduction — can be computed. For example, the pattern of a binomial array in which three horizontal elements in line are fed with unit current in the outer elements and twice this current in the center element (all

Table II — Sample Calculation for Collinear Elements

θ	A	\times	$\frac{E}{100}$	Pattern of 2 half-wave-length antennas fed in phase and placed end to end	θ
0	150		1.345	202	360
5	148		1.34	198	355
10	145		1.31	190	350
15	140		1.28	179	345
20	129		1.22	157	340
25	120		1.17	140	335
30	108		1.11	120	330
35	92		1.035	96.2	325
40	79		.945	74.7	320
45	64.5		.84	54.2	315
50	53		.75	39.8	310
55	41.5		.66	27.4	305
60	33		.55	18.2	300
65	24		.40	9.60	295
70	15		.265	3.98	290
75	7.5		.185	1.39	285
80	3.7		.088	.326	280
85	2.2		.044	.0968	275
90	0	0		0	270
95	2.2		.044	.0968	265
100	3.7		.088	.326	260
105	7.5		.185	1.39	255
110	15		.265	3.98	250
115	24		.40	9.60	245
120	33		.55	18.2	240
125	41.5		.66	27.4	235
130	53		.75	39.8	230
135	64.5		.84	54.2	225
140	79		.945	74.7	220
145	92		1.035	96.2	215
150	108		1.11	120	210
155	120		1.17	140	205
160	129		1.22	157	200
165	140		1.28	179	195
170	145		1.31	190	190
175	148		1.34	198	185
180	150		1.345	202	180

in phase and spaced one-half wavelength) can be obtained by multiplying by itself the pattern of two vertical elements spaced one-half wavelength, fed in phase, and then multiplying the result (approximately a figure 8 squared) by the fundamental pattern of a horizontal half-wave antenna. This is possible because the center element with its twofold current can be considered as two superimposed elements with unit current in each element. This antenna might then be made unidirectional by adding another three half-waves spaced a quarter wavelength from the first set, feeding them in phase with each other but 90° out of phase with the initial set and with unit currents in the outer elements and twice unit current in the center element. This pattern could be computed by multiplying the pattern of the initial three-element section by the pattern for two vertical elements spaced one-quarter wavelength and fed 90° out of phase (D in Table I).

Other Arrangements

The patterns of a good number of arrays can be calculated by the above method, and a little paper work in one's spare time will be found interesting and educational. However, it must be remembered that gain comparisons cannot be readily made with these patterns unless something is known about the impedances of the

various elements making up an array, since the only way the patterns can be compared directly to give relative gains is to reduce them to a common basis with equal currents flowing in the elements of the arrays under consideration. If this can be done, by a knowledge of the impedances present, and assuming unit power delivered to each system, a direct graphical comparison can be made. However, some idea of the relative gains can be obtained by visualizing the amplitude of the major lobes if the two antenna patterns under comparison were drawn on such a scale as to have equal total areas.

Strays

Who said Smith? While thumbing the *Call Book* W3KEW ran across this consecutive outpouring of FCC's Doctor of Humor:

- K6UJO—J. Davis, Honolulu
- W6UJP—C. Davis, San Diego
- W6UJQ—C. Davis, Salt Lake City

The last time KL7AD at Tanacross opened his mail box (the postman doesn't get around very often in some parts of Alaska) he found 81 QSLs, confirming contacts with 7 countries, 48 states plus the District of Columbia, and all VE districts!

Alternate Director Roberts, W7CPY, reports that at the recent hamfest at Glendive, Montana — the land of wide-open spaces — the closest visiting ham lived 80 miles away, the farthest 340 miles!



You just can't believe in signs, OMs! The s.y.t. is Mrs. Rosemary Robin, W6PJF, of 80-meter c.w. fame, and the comely smile and road-sign sentiments are directed exclusively at the cameraman, lucky OM, who happens to be Art Robin, W6INF.

Clean-Cut Break-In Keying

Primary Keying and a T9 Note

BY HARRY G. BURNETT,* W1LZ

TEN years ago, if someone had said that he could key his whole transmitter in the primary and produce sharp break-in keying with a T9 note, we probably would have said that it just could not be done. Believe it or not, it can be done. Here is the story of such a system of primary keying.

From 1932 until 1937, W1LZ was keyed conventionally in the primary of the final power supply (Fig. 1). The power-supply filter nicely eliminated all clicks but, because of the keying lag, the filter was of necessity only a small input choke and a 1- μ fd. condenser. In 1937, the FCC began to bear down hard on near-d.c. notes, and we were politely informed that our signal would comply with the law only if the power supply were more adequately filtered. Necessity then became the mother of invention; a long series of experiments was begun which led finally to the primary-keying system to be described.

Keying only in the primary of the driver power supply was first tried. The keying characteristic was none too good, and the note still could not be made really pure without introducing a bad keying lag. Keying in the primaries of both the driver and final power supplies proved to be no

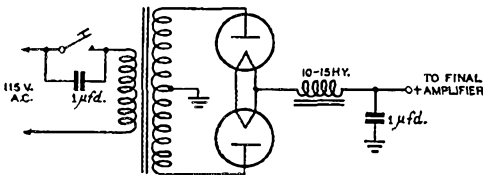

Fig. 1—Primary keying first used at W1LZ. It is impossible to obtain crisp keying and a T9 signal when only the final-amplifier supply is keyed.

better. A resonant filter on the final supply gave better keying, but resulted in pronounced tone modulation, in addition to ruining the mercury-vapor rectifier tubes.

T9 Primary Keying

Then a faint glimmer of inspiration began to flicker. If there were only some way to keep the filter condensers of the final power supply charged all the time the transmitter was in operation, there would be no bad lag as the filter charged and discharged with primary keying. Automatic grid-leak bias was being used on the final amplifier, but a bias pack with higher than cut-off

* % Hytron Radio & Electronics Corp., 76 Lafayette St., Salem, Mass.

• Much break-in keying is chirpy and full of clicks, and much primary keying isn't T9 and won't handle bug sending. Here is a keying system which retains the acknowledged advantages of good primary keying and break-in operation with none of the disadvantages. Since primary keying is recognized as the "keying least likely to cause BCI," this article merits the attention of every c.w. man.

potential was connected across this grid leak. Things began to happen fast. We had stumbled on the secret of clean primary keying with a pure d.c. note!

First, by keying simultaneously the respective primaries of the driver and final power supplies — second, by using the fixed more-than-cut-off bias on the final amplifier — and third, by not connecting a bleeder across the final power supply, when the key was lifted, excitation was immediately removed from the final amplifier, the fixed-bias pack sharply cut off the plate current of the final, and the final filter condensers remained charged. True, the first time the key was pressed the transmitter acted as it would under normal primary keying; the filter condensers and chokes storing up energy drew heavy current from the line. But from that time on, the output voltage of the filter remained practically constant, because there was no drain from the supply with the key up.

When the fixed-bias pack was used and the final power supply only was keyed, the continuing excitation from the driver prevented cut-off of the final amplifier's plate current and permitted the final amplifier to drain the filter of the final power supply as soon as the key was raised, thus producing a keying lag. If the fixed-bias pack was eliminated, but the driver and final power supplies were keyed simultaneously, plate current of the final amplifier did not cut off when the key was opened, and consequently the final filter discharged through the tube and caused a keying lag. Of course, connecting a high-current bleeder across the final power pack would also drain the final filter when the key was raised. With no final bleeder, however, and with simultaneous removal of excitation and application of cut-off bias to the final amplifier, we had what we had been seeking — lagless primary keying.

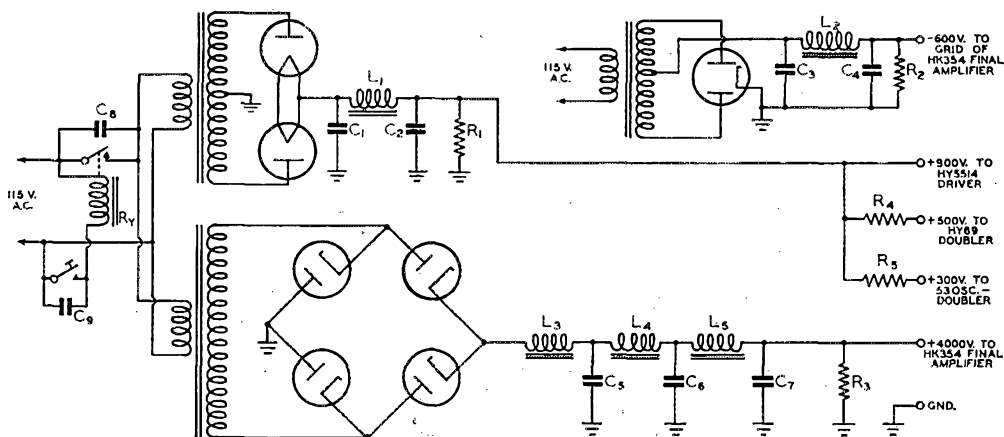

Fig. 2 — The break-in primary keying used at WILZ which gives lag-free T9 keying. The large amount of filter in the final amplifier supply is not necessary — it was included only to prove that any amount can be used without introducing lag.

C₁, C₂, C₃, C₄ — 2 μ d.
 C₅, C₈ — 1 μ d.
 C₆, C₇ — 4 μ d.
 C₉ — 0.1 μ d.
 R₁ — 17,000 ohms.

R₂ — 20,000 ohms.
 R₃ — 10 megohms. See text.
 R₄ — 10,000 ohms.
 R₅ — 30,000 ohms.

L₁, L₂ — 15 henries.
 L₃ — 5 henries.
 L₄, L₅ — 8 henries.
 R_y — Keying relay. See text.

The clean-cut "make" and "break" of the keying thrilled us. Now to try some real filter in the final power pack. We piled the chokes and condensers on until the note was unquestionably T9. We were keying in the primary with no lag and with a truly p.d.c. note!

This new system was so effective that several local amateurs were persuaded to experiment with it. They had no difficulty in obtaining the same results. *Radio* published two articles we wrote on the system in their March and April, 1937, issues. Incidentally, remember that old saying about great minds running in the same channel? W6CUH described a similar system in an article appearing simultaneously in the March, 1937, issue of *QST*. Hi!

Break-In Operation

When WILZ was put back on the air after the war, this plate-current cut-off form of primary keying was again used. The ability to work break-in had always seemed desirable. Perhaps it could be used with primary keying, by applying the plate cut-off principle already discussed. Well, there's nothing like trying.

Our present 14-Mc. rig consists of a Type 53 twin-triode crystal oscillator/doubler, an HY-69 beam-pentode doubler, an HY-5514 triode driver, and an HK-354 triode final. It was decided to use the 900-volt pack which fed the HY-5514 alone to power also the 53 and HY-69. A suitable dropping resistor was connected between the positive terminal of the 900-volt pack and the plates of the 53; and another resistor, with less voltage drop, between the positive terminal and

the plate of the HY-69. (Power wasted in these dropping resistors is negligible, because the plate current for the 53 is only 20 ma. and plate-and-screen current for the HY-69 only 40 ma.) Simultaneous primary keying of the 900-volt and the final plate supplies now keyed all stages of the transmitter (Fig. 2). Darned if it didn't work! When the key was pressed, we had clean-cut primary keying of a T9 note, and complete break-in.

Considerable tinkering disclosed that the best filter for the 900-volt oscillator/doubler/driver pack is a condenser-input set-up consisting of 2 μ d., 15 henries, and 2 μ d. Choke input is not recommended, because it will introduce an undesirable lag. If two 866A tubes are used for rectifiers in this supply, the peak current will be below the maximum permissible value (250 ma.), even with condenser input. If you prefer high-vacuum rectifier tubes with condenser input, the 1616, 5R4GY, 5Z3, or 80 (dependent on voltage and current) would be suitable. A 45-volt B battery in addition to resistor bias is employed on the HY-69 and HY-5514 stages, and combination cathode and resistor bias on the 53 stage — for protection only.

By experimentally keying the 53 oscillator/doubler stage alone, it was found that a 17,000-ohm bleeder across the 900-volt pack quickly drains energy from its filter when the key is opened, and thus removes traces of keying lag or chirp. Since a bleeder is required across this supply, you may prefer to use it also as a voltage divider, and thereby eliminate the dropping resistors. Or you may need no dropping resistors,

because your oscillator, doubler, and driver stages may all operate at the same potential. We preferred separate dropping resistors for flexibility in adjusting our various voltages and the bleeder current. No special treatment of the crystal stage is necessary, except that it must be one that is reasonably free from chirps.

Yes, the keying will follow a bug easily at high speeds. The keying relay used is a d.p.s.t. 115-volt a.c. Model 1177-BF Leach relay with the two poles connected in parallel and the $\frac{1}{4}$ -inch contacts adjusted to close simultaneously. To reduce sparking, a 0.1- μ fd. condenser is connected across the key contacts and a 1- μ fd. condenser across the relay contacts. If you can find a suitable relay with a 12-volt a.c. solenoid, sparking at the key contacts and shock hazard will be lessened. Adjustment of the dot lever of the bug is made until the plate current of the final amplifier hovers around 50 per cent of the normal value when the dot lever is held over.

This system of keying does not even sound like primary keying. Most amateurs guess it to be blocked-grid or tube keying. Needless to say, there is not a click to be heard by local hams or by BCLs, even with a kilowatt input to the final amplifier. You can make the tone as pure as you wish simply by adding filter to the final power supply.¹ At 4000 volts, we have 5 henries, 1 μ fd., 18 henries, 4 μ fd., 18 henries and 4 μ fd. — which at that potential is certainly an adequate filter. Actually this large filter is not necessary, and was employed only to prove that it is feasible to use a husky filter. The filter has been increased successfully to as much as 17 μ fd. at 4000 volts.

There are some additional ideas in which you will be interested, if you decide to test this system. For safety's sake, you may wish to have a high-resistance bleeder across the output of the final power supply. A one-watt one-megohm resistor for each 400 volts of power-supply potential will

be satisfactory. In practice, however, you may omit this bleeder, if your bias pack is switched on and off simultaneously with your plate supplies. When the bias pack is switched off, the energy in the filter condensers is dissipated instantaneously through the static d.c. plate resistance of the final-amplifier tube.²

If your final amplifier is running well into the Class C region under saturated grid conditions, the filter for the oscillator/doubler/driver power pack need not be large. A small percentage of a.c. ripple in the grid excitation will not introduce serious hum into the output of the final amplifier, because under such Class C conditions, your final amplifier is insensitive to grid-bias modulation. Remember, however, that too little filter on this pack gives very sharp keying, but tends to modulate the note undesirably. Let your monitor be your guide.

No input choke should be included in the final grid-bias pack. Filter condensers for this pack should be capable of withstanding the full operating grid voltage, but their capacitance may be small, because current flows in this pack only when the key is up. With the key down, current flows through the grid leak in the reverse direction, and no current is supplied from the pack.³

Since the potential across the final power-supply filter remains constant (filter is always fully charged) and at the normal key-down operating value, you can readily understand why clicks and thumps are washed out better than they would be with other forms of keying. This is particularly true if the voltage regulation of the final power supply is not well-nigh perfect with other keying methods. Then, too, with this system, the power-supply filters themselves serve as excellent key-click filters.

In a nutshell, this simple plate cut-off primary keying system requires only that you: (1) key the final power supply and the combined oscillator/doubler/driver supply simultaneously in the primary, (2) connect a simple bias pack with more than cut-off potential across the grid-leak resistor of the final amplifier, (3) use no high-current bleeder for the final power supply, but (4) use a bleeder across the oscillator/doubler/driver pack which should have condenser input and an adequate but not excessively-large filter. The final power supply may have as much filter as you desire. Output voltage of the final grid-bias pack should be approximately twice the cut-off potential (for a triode, cut-off potential is the plate voltage divided by the amplification factor).

Principal advantage of the break-in system of plate cut-off primary keying described is that it is sure-fire. There is no exasperating cut-and-try of chokes, condensers and resistors for a special keying filter. Other advantages are: no clicks on broadcast or amateur bands; clean-cut fast

(Continued on page 118)

¹ This is true provided certain conditions are maintained. It is imperative that the output stage be adequately excited, so that it will be operating Class C at all times and hence not amplify any amplitude modulation from the driver stage. Further, no frequency modulation can be introduced at the oscillator stage, but this condition is met by an oscillator which doesn't chirp with keying. — Ed.

² Do not be alarmed by the high surge current and plate dissipation which occur during this momentary discharge cycle. Actual time of the several time constants required by the R-C combination of d.c. plate resistance and filter condensers to bring the filter potential by degrees to zero is measured in a few milliseconds. As was learned from radar applications, under such brief pulsing conditions a tube will withstand many times the peak load it would in continuous duty. At WILZ, the plate milliammeter flips up to less than normal current during this brief surge and causes no damage to the meter, but it is well to check the meter when first trying the system.

³ Another type of bias supply that is useful in such applications is one making use of VR tubes. See Fig. 810, *The Radio Amateur's Handbook*, 1947 edition. Also, McCullough, "Another Approach to High Power," *QST*, February, 1940. — Ed.

• Technical Topics —

N.F.M. Reception

FROM the beginning of its commercialization, frequency modulation has been promoted as a noise-reducing system, permitting higher fidelity in broadcasting and a better signal-to-noise ratio in emergency services operating with mobile equipment. The latter point is of considerable interest to us amateurs; anything that will enable us to hear weaker signals through the noise level is all to the good. Practical information on how to build and adjust amateur f.m. equipment and the kind of results it will produce has appeared in *QST* from time to time over a period of several years. Nevertheless, except for a few more or less isolated experimenters, amateurs have made practically no use of f.m. for the purpose of obtaining a better signal-to-noise ratio in reception.

The over-all situation — a rather curious one — is this: F.m. receivers are used to some extent on v.h.f., particularly 144 Mc., as a means for obtaining better-sounding speech from modulated oscillators than can be secured with straight a.m. reception; and f.m. transmitters are used to some extent on the 28-Mc. band as a means for operating 'phone without causing interference to broadcast reception. So in the one case we have a group of receivers without any transmitters and in the other a group of transmitters without f.m. receivers. And in neither case is f.m. used because of its outstanding feature, noise reduction, but because some peculiarity of the system happens to meet an amateur need better than a.m. methods.

We wonder whether this doesn't indicate that the amateur perspective on f.m. shouldn't have a different orientation than the commercial. Our problems are different, certainly. Below 30 Mc. our principal problem is QRM, not noise. In fact, a.m. noise-reducing systems have been developed to the point where man-made noise can be eliminated practically as well in a.m. reception as it can by an f.m. receiver, when the channel utilized is kept down to the width of an a.m. transmission. And on frequencies below 30 Mc. wide-band f.m. is out of the question.

So far, reception of narrow-band f.m. on the 28-Mc. band has been by the rather makeshift method of detuning the incoming signal so that it falls on one side of the selectivity curve and its frequency modulation is thereby converted to amplitude modulation, for later detection in the ordinary way. This has some disadvantages: the signal appears in two places, one on each slope of the selectivity curve; full use cannot be made of the receiver's a.v.c. because detuning causes the gain to rise and thus makes the receiver much

more vulnerable to a signal on a nearby frequency, as well as causing the noise to increase; the conversion from f.m. to a.m. is likely to be nonlinear, causing distortion. The frequency-modulated signal is under a handicap in such reception, as compared with an a.m. signal of the same power.

F.M. Receiver Defects

But is a true f.m. receiver a real solution to the reception problem? We have our doubts, at least for frequencies below 30 Mc. Besides increased complexity, there are two features of a conventional f.m. receiver that appear to us to be distinctly undesirable in amateur work. These are the suppression of a weaker carrier by a stronger one when the two are close to each other in frequency, and the inherent spurious responses in an f.m. receiver. The first is all right when you happen to want the stronger signal, but the usual problem is to pull the weaker fellow out from under. The phenomenon is not something that is peculiar to f.m. reception as such, incidentally; it is characteristic of any device having amplitude limiting. It just so happens that such limiting, in one form or another, is essential to f.m. reception if amplitude noise is to be suppressed.

There seems to be no way to circumvent spurious or "side" responses in an f.m. receiver. Besides the tuning that gives the main response, an additional spot can be found on each side of the main tuning where the signal will be heard again. The receiver, therefore, makes each signal appear to be three — hardly conducive to reducing interference in an amateur band! If the receiver's selectivity curve has very steep sides the tuning width of these spurious signals will be small, but the responses are there, nevertheless. Just how serious the side responses may be depends upon a number of factors, including the signal strength, shape of the selectivity curve, the shape of the discriminator curve and its relation to the selectivity curve, and so on.¹ Some of the newer f.m. detectors such as the ratio detector have less side response than the discriminator type. It appears to be physically impossible, however, to design an f.m. detector that will be wholly free from such responses, for the simple reason that there is of necessity always a threshold signal amplitude below which any f.m. detector, no matter how good, ceases to be responsive only to frequency modulation and not to amplitude changes. After all, any detector has to have a signal before it can do any detecting — and there is always a signal

¹ For a discussion of some of these factors, see "Some Thoughts on Amateur F.M. Reception," *QST*, March, 1941.

smaller than the one it *does* detect. When the receiver is detuned sufficiently from an incoming carrier the signal level eventually will drop to the threshold level, and when that happens the frequency modulation on the carrier will be converted to amplitude output, creating a new response point. The fact that the output is usually distorted does not help matters particularly.

As it looks to us at the moment, these two "features" of f.m. reception are more likely to be appreciated in the absence than in the presence. They need not be introduced if we forget about noise suppression, limiters, discriminators, and the like. On the other hand, we need a better method of receiving f.m. than just detuning an a.m. receiver. For one thing, the value of "single-signal" reception has been established too long in c.w. reception — a truly comparable case — for us to tolerate two-spot tuning in 'phone work. For another, the f.m. signal doesn't get a fair break.

Crystal-Filter Detection

The fact is that once the intriguing objective of obtaining a small improvement in signal-to-noise ratio is replaced by the simple one of getting good f.m. detection, the means is to be found right in every good a.m. communications receiver. Crosby has pointed out² that an off-neutralized crystal filter converts phase modulation to amplitude modulation, and the practical difference between phase and frequency modulation is simply the audio-response characteristic. When the phasing condenser in a crystal filter is set to neutralize the crystal-holder capacitance exactly, the crystal has an essentially symmetrical resonance curve just like any tuned circuit. However, if the phasing capacitance is slightly too small or too large, the resonance curves take the form shown in Fig. 1. The well-known rejection notch appears, either above or below the resonant point depending on whether the phasing capacitance is too small or too large, and the response on the side on which the notch is placed is reduced in comparison to the response on the other side. The point to note about these curves (which are for the crystal filter alone, without any other i.f. selectivity) is that the response drops rapidly at first as the frequency is moved away from resonance, but then flattens off. Over a moderate frequency range the energy transfer off resonance will be substantially constant, assuming that the output circuit (that is, the circuit into which the crystal filter works) is not in itself highly selective. Insofar as the crystal filter itself is concerned, this characteristic results in substantially uniform transmission of sidebands in a modulated signal when the carrier is tuned to the crystal peak. There is no progressive cutting of sidebands as the modulation frequencies become

higher provided the filter is adjusted to be as *sharp* as possible. With a broad filter the lower frequencies are allowed to get through with greater amplitude and hence are accentuated in the final audio response. Inasmuch as the response is greater on the side of resonance opposite to that on which the phasing notch is placed, a form of single-sideband reception results. This characteristic, useful in a.m. reception through interference, also is helpful in converting f.m. to a.m.

However, an off-neutralized filter is responsible for another effect. Off the resonance peak the filter acts as a reactance, while at resonance it

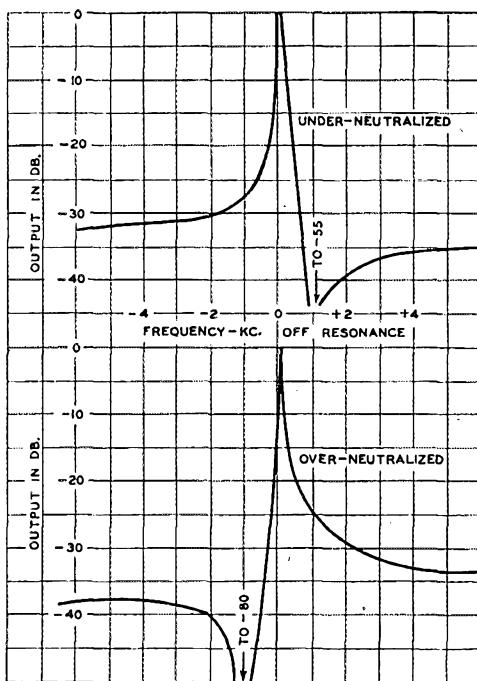

Fig. 1 — Typical frequency-response curves of an off-neutralized crystal filter with rejection notch set 1 kc. above resonance (upper curve) and below resonance (lower curve). (From M. G. Crosby, *Proc. IRE*, February, 1939.)

looks like a comparatively low series resistance. The consequence is that if the carrier is tuned to the peak, the phase of the sidebands (which are off the peak) is shifted with respect to the carrier by 90 degrees. This 90-degree phase shift will convert phase modulation into amplitude modulation. It will also convert frequency modulation into amplitude modulation, but because of the difference between phase and frequency modulation with respect to the a.f. characteristic, frequency modulation comes out with the lower frequencies accentuated while a phase-modulated signal comes out with the audio frequencies in their proper proportions.

² M. G. Crosby, "Communication by Phase Modulation," *Proc. IRE*, Vol. 27, No. 2, February, 1939.

There is nothing makeshift about this method of converting f.m. or p.m. into a.m. Since every good a.m. communications receiver has a crystal filter, no special equipment is required for n.f.m. reception. What is required is the development of an operating technique. In the first place, the filter should be set to the sharpest position and the carrier should be tuned in on the crystal peak, not set off to one side. The phasing condenser should be set not for exact neutralization but to give a rejection notch at some convenient side frequency such as 1000 cycles off resonance. There is considerable attenuation of the sidebands with such tuning, but it is not *selective* attenuation except for the added selectivity of the i.f. amplifier, and it can readily be overcome by using additional audio gain.

The fact that a crystal filter so used is inherently a phase-modulation detector rather than an f.m. detector brings up the question of p.m. *versus* a.m. at the frequencies at which this type of detection will be used. The argument that the means of reception is already at hand, without modification, in every good a.m. communications receiver strikes us as being a potent one for p.m. rather than f.m. There are at least two others on the side of p.m.: If the carrier frequency is to be stabilized — which is certainly essential in low-

frequency operation — phase modulation is the natural method, and is simpler than any of the stabilized reactance-modulator methods we have seen. (It is questionable whether reactance modulation applied to a crystal oscillator actually results in frequency modulation. The "stiffness" of the crystal and the easily-demonstrated fact that sufficiently large frequency changes cannot be obtained on a static basis by varying reactances in the oscillator circuit indicate that phase modulation rather than frequency modulation is actually what takes place.) The other argument in favor of phase modulation is that, as demonstrated by Crosby in the same paper,² it is less affected by selective fading in long-distance transmission than is frequency modulation. Changing from one system to the other involves nothing more serious than proper shaping of the audio-frequency characteristic, but it so happens that no special shaping is necessary in the transmitter's speech amplifier if phase-modulated output is desired from a phase-modulation system, nor is any a.f. compensation required in a crystal-filter receiver if the incoming signal is phase-modulated. Phase modulation thus represents fewer complications in low-frequency work, in addition to promising better long-distance communication than f.m. — G. G.

Bonus for 28-Mc. Observers

THE participants in the NBS-ARRL 28-Mc. Band Observing Project³ recently received, and will continue to receive, a very worth-while bonus for their efforts in the form of simplified prediction charts for 28-Mc. F_2 propagation throughout the world. Since part of the purpose of the project is to observe propagation on the band when it is not normally expected via the regular ionosphere layers and at times near the expected beginning and ending of regular layer transmission, these prediction charts are useful to the observers in determining these times. However, they also serve as very useful devices for judging the best time for communication over long distances, and in this respect they comprise a "bonus" for the participants in the program.

Starting in January, the Bureau of Standards is furnishing each month to its observers, in addition to the regular report forms, a set of simplified 28-Mc. prediction charts for the W, I and E zones, a CRPL base map of the world, a great-circle chart drawn to the same scale as the world map, and a sheet of transparent tracing cloth on which the transmission paths can be drawn.

³ "Ten-Meter Observations," *QST*, June, 1946.

⁴ Foley, "Forecasting Long-Distance Transmissions," *QST*, Feb., 1946. "Propagation Predictions Now Available," *QST*, Aug., 1946.

Simple instructions are also furnished which enable the operator to use the charts for determining when any path of over 4000 km. (2500 miles) is predicted to be open. The simplified charts are much easier to use than the usual D series,⁴ although a sample copy of the D series is also supplied. The D-series charts can of course be used for the prediction of paths at any useful frequency.

If you haven't already registered for the program, write to 28-Mc. Band Observing Project, Radio Section, National Bureau of Standards, Washington 25, D. C. — B. G.

Strays

The Delaware Valley Radio Assn., Trenton, N. J., will sponsor its Third Annual Old Timers Nite & Banquet, Saturday, March 22nd, at the Stacy-Trent Hotel. Turkey dinner, prizes, old-timer guest speakers and W2ZI's display of radio gear of yesteryear are on the program. Tickets \$4 (otherwise \$5) per person for reservations made before March 15th through Edward G. Raser, Secy., 315 Beechwood Ave., Trenton 8, N. J.

"taking control" of amateur affairs would be eliminated.

There may remain the worry as to whether, having set up Class D and then denied such people a vote in our affairs, they would want to set up a competing society of microwave amateurs and buck us, to our damage. They'd claim they didn't have representation, it is said, and they'd want their own magazine, and so on. We have heard it feared that there might become as many of them as there are amateurs knowing code, particularly if manufacturers bring out ready-made apparatus for them. Well, the writer of this article of course doesn't know. It has seemed to our Board that there is no room to worry on such scores. We all have at least speculative interest in the microwaves and QST proposes to look after our needs for adequate information in that field. The Board, in making recommendations to FCC for changes in technical regulations, of course will always be willing to listen to the suggestions of those most active with the frequencies; the League, in short, will expect to continue to represent microwave men. The outlook is that u.h.f. and s.h.f. work will always remain relatively expensive and difficult, with rather unattractive returns in miles per dollar or hour of work. That is enough to interest a particular class of person but it is not believed that it will ever have the widespread appeal that will result in numbers that could be dangerous to our other interests.

That describes the proposal and the question now is on what you think of it. Every licensed amateur in the United States, League member or not, is invited to respond by means of the detachable card* in this article. You are requested to consider the pros and cons and decide whether you think it advantageous to amateur radio to request such a Class D license. You will wish to study whether you think the reasons are sound, whether or not it is in our long-term interest to have such an arrangement, whether or not you consider the various safeguarding provisions adequately protect us from possibilities of harm while giving us the benefits of the plan. Your responses will constitute an advisory, informative poll of amateur opinion to help guide the Board in its decision on this matter this spring. The Board wants to know how you regard it, and the subject is presented to you for expression at the Board's order. R.s.v.p.!

Asbury

* At the Board's instruction this card provides for simple yes or no expressions on the pending plan as described, to be sent to ARRL Headquarters for tabulation and report to the directors. If you have further comments or suggestions they should be sent direct to your division director, whose name and address you will find listed in the front of this issue.

ARRL QSL BUREAU

FOR the convenience of American and Canadian amateurs, the League maintains a QSL-card distributing system which operates through volunteer "District QSL Managers" in each call area. To secure such foreign cards as may be received for you, send your district manager a standard No. 10 stamped self-addressed envelope. If you have reason to expect a considerable number of cards, put on an extra stamp so that it has a total of six cents postage. Your own name and address go in the customary place on the face, and your station call should be printed prominently in the upper left-hand corner. If you have held other calls in previous years, submit an envelope for each such call to the proper manager — there are many thousands of uncalled-for cards in the files. All incoming cards are routed by Hq. to the home district of the call shown in the address. Therefore, cards for portable operation in other districts should be obtained from the home-district manager.

- W1 — Charles Mellen, W1FH, 320 Cornell St., Boston, Mass.
- W2 — Henry W. Yahnel, W2SN, Lake Ave., Helmetta, N. J.
- W3 — Maurice W. Downs, W3WU, 1311 Sheridan St., N. W., Washington 11, D. C.
- W4 — Edward J. Collins, W4MS, 1003 E. Blount St., Pensacola, Fla.
- W5 — L. W. May, jr., W5AJG, 9428 Hobart St., Dallas 18, Texas.
- W6 — Horace R. Greer, W6TI, 414 Fairmount Ave., Oakland, Calif.
- W7 — Frank E. Pratt, W7DXZ, 5023 S. Ferry St., Tacoma, Wash.
- W8 — Fred W. Allen, W8GER, 1959 Riverside Drive, Dayton 5, Ohio.
- W9 — F. Claude Moore, W9HLF, 1024 Henrietta St., Pekin, Ill.
- W9 — Alva A. Smith, W9DMA, 238 East Main St., Caledonia, Minn.
- VE1 — L. J. Fader, VE1FQ, 125 Henry St., Halifax, N. S.
- VE2 — C. W. Skarstedt, VE2DR, 3821 Girouard Ave., Montreal 28, P. Q.
- VE3 — W. Bert Knowles, VE3QB, Lanark, Ont.
- VE4 — C. J. Campbell, VE4CC, 276 Ash St., Winnipeg, Manitoba.
- VE5 — Fred Ward, VE5OP, 899 Connaught Ave., Moose Jaw, Sask.
- VE6 — W. R. Savage, VE6EO, 329 15th St. North, Lethbridge, Alta.
- VE7 — H. R. Hough, VE7HR, 1785 Emerson St., Victoria, B. C.
- VE8 — Yukon A. R. C., P. O. Box 268, Whitehorse, Y. T.
- K4, KP4 — E. W. Mayer, KP4KD, P. O. Box 1061, San Juan, P. R.
- K5, KZ5 — Signal Officer, KZ5AA, Quarry Heights, Canal Zone.
- K6, KH6 — Andy H. Fuchikami, KH6BA, 2543 Namaau Dr., Honolulu, T.H.
- K7, KL7 — J. W. McKinley, KL7CK, Box 1533, Juneau, Alaska.

SWITCH

TO SAFETY!



Navy Day - 1946

THE eighteenth Navy Day Receiving Competition, conducted jointly by ARRL and the Navy Department, was held on October 27, 1946. A message to radio amateurs from the Secretary of the Navy was transmitted on pre-announced schedule from stations NSS, Washington, and NPG, San Francisco. Transmission was at approximately 25 words per minute.

Special letters of appreciation from the Secretary of the Navy were offered to those amateurs making perfect copy of either station. Fifty-eight such letters have been awarded. Copy was submitted by a total of 202 operators, 47 of whom copied both NSS and NPG. A total of 74 participants were present or former members of the Naval Service.

All contestants are listed on the Honor Roll. Many made the mistake of attempting to correct transmission errors when submitting copy. A tip for future competitions — *do not recopy; submit your original copy!* Congratulations to the letter winners! — E. L. B.

1946 Navy Day Honor Roll Letter Winners

First Naval District: W1BFT, W1FSV, W1KYK, W1LYX, W1MZE, W1OCX, W1OOD. *Third Naval District:* W1BDI, W1LV, W1LZE, W2ANM, W2CHA, W2CNC, W2DOD, W2GVZ, W2HAZ, W2LYH, W2MRH, W2NAZ, W2NKD, W2PQS, W2SEI, W2SJR, W2SZK. *Fourth Naval District:* W3ADE. *Fifth Naval District:* W3FFN, W3GJY, W3IGX, W4KHK, W4KMG, W5CYO-4, W8BTV, W8CSF. *Seventh Naval District:* W4GEE. *Eighth Naval District:* W4JNN, W5CX, W5DTJ, W5GJG, W5JYF, W5NW, W5RH. *Ninth Naval District:* W1LXB, W8SLH, W8TSF, W8VUK, W8WVL, W9BWZ, W9HUJ, W9RLB, Robert I. Braatz, Jr. *Tenth Naval District:* KP4BJ, KP4KD. *Eleventh Naval District:* W6AOA,

Letter of Commendation

THE SECRETARY OF THE NAVY
WASHINGTON

Dear

With the recent war brought to a successful conclusion, it is gratifying to note the resumption of interest and participation in the art of radiotelegraphy displayed by the American Radio Amateurs. Many of you have served with the United States Navy during the war and your self-imposed training prior to the emergency served to promptly fit you for active duty manning the radio circuits which were so vital to conduct all types of naval operations. We are gratefully appreciative of the continued interest in naval affairs. *

In your own case we have been notified by the American Radio Relay League, without whose cooperation the renewal of this annual event would not be possible, that you have submitted a perfect copy of the Navy Day Broadcast.

I extend to you my personal congratulations on your ability and my appreciation of your interest in copying this broadcast.

Sincerely,
James Forrestal

W6NKM, W6PAQ. *Twelfth Naval District:* W6PBV. *Thirteenth Naval District:* W7CZY. *Canada:* VE7GS.

Other Participants

First Naval District: W1AHP, W1APK, W1BB, W1BDV, W1BMS, W1HFJ, W1INU, W1JAH, W1KJV, W1KHA, W1KWU, W1LML, W1MEG, W1MJP, W1MQB, W1MRQ, W1ONO, W1OPU, W1QR, W2QKC, Ray Dewing, Herman C. Grugin. *Third Naval District:* W1KKS, W1MDF, W1RY, W2ALD, W2AWG, W2KPU, W2LA, W2LFR, W2MZB, W2OXL, W2PJV, W2PRI, W2QB, W2R JL, W2RUK, W2SHQ, W2SKV, W2SOU, W2SWC, W2WH, Gregory S. Philactos. *Fourth Naval District:* W2RG, W3ARK, W3EU, W3GKO, W3GKT/3, W3JAF, W3JIR, W3LGT, W3NCJ, W3UX, W3VN, W3WNN, Harry Hood, Jr., Beth Rosenberg. *Fifth Naval District:* W1NWW, W2KHA/3-W9SAG, W2MRL/3, W3AJZ, W3JVY, W3KFN, W3KRE, W3VT, W8BWK. *Sixth Naval District:* W4BIN. *Seventh Naval District:* W4AAR, W4EHZ, W4IP, W4KQD. *Eighth Naval District:* W4CSZ, W5BVF, W5DQW, W5HLE, W5IGO, W5JKD, W5KOT, W5OJ. *Ninth Naval District:* W7HUK, W8BKE, W8BKM, W8DAE, W8GFB, W8HS, W8MTC, W8QC, W8RN, W8SNU, W8TYE, W8UTC, W8YBC, W8ZAU, W9BDP, W9BEA, W9DHJ, W9FIN, W9FKI, W9FNU, W9GMT, W9IZQ, W9JNV, W9JTX, W9NVJ, W9ORP, W9PVA, W0AIR, W0ARH, W0EVP, W0FKS, W0FSR, W0FWN, W0KZL, W0QVA, W0RJF, W0SQT, W0TDH. *Eleventh Naval District:* W6HII, W6ISR, W6LM, W6MKW, W6VCV, E. F. Faktor. *Twelfth Naval District:* W6BZU, W6CWR, W6JQX, W6QXN, W6SAN, W6VJK, W6WQU, W6WUE, W6WXZ, W8ERZ/7, W0DRB, W0IQZ. *Thirteenth Naval District:* W7AJ, W7EBQ, W7ETO, W7GDE, W7JMJ. *Fourteenth Naval District:* KH6EZ. *Canada:* VE5DW, VE7AEU, VE7AGM.

1946 NAVY DAY MESSAGE

During the recent war it was found that the Armed Forces received a great benefit in communications from the large number of qualified radio operators who were prepared to step from their civilian roles into the military radio circuits and take over the watches. These individuals were the so-called ham operators who had spent so many hours on this chosen hobby or avocation building sets and perfecting themselves in the techniques of operating to the extent that they were ready to go. On this Navy Day, it is my pleasure to extend my greetings and those of the nation to these little-publicized individuals who have spent so many hours punching their keys and maintaining their sets to carry the word in the successful prosecution of a vast war against our enemies. Naval communications has found such an enormous bulwark in the ranks of the amateurs and the reserves that the entire Naval Service and the nation are happy to express their gratitude and appreciation on this occasion of renewing the Navy Day Broadcast to the radio operators of the United States and insular possessions. Should the occasion arise which might require your mobilization again, we are confident of your response and your capability whereby we could promptly restore our Navy to its high operating standards which existed during hostilities.

The Secretary of the Navy

Text of the Message Transmitted from NSS

An Improved Receiver for Two Meters

Increased Selectivity and Sensitivity to Cope with Today's Conditions

BY CALVIN F. HADLOCK,* W1CTW

ANYONE around Boston who has operated on 144 Mc. when a temperature inversion was dumping S9 signals into his lap from distances of 100 miles and over does not need to be convinced that the straight superregenerative receiver is far from adequate. At such times, the band sounds not unlike 75-meter 'phone from the point of view of occupancy and QRM.

Although the receiver described in the May, 1946, issue of *QST* had given the writer good service, it was felt that a still better receiver could be built and used to advantage, since the quality of many signals has improved to the point where a sharper receiver is both desirable and practical. Four objectives were to be kept in mind: first, better selectivity; second, improved sensitivity; third, no radiation within the band limits; and fourth, a design that the average amateur with a minimum of equipment and experience could build and make work.

Design Considerations

Selectivity should be in the order of 75 kc. bandwidth at 20 db. (10 times) down. The bandwidth should remain reasonably sharp when signals of local intensity are received, in contrast to the ordinary superregenerative receiver which broadens out very rapidly with increases in signal level. A sensitivity better than 0.5 microvolt was desired and it was hoped to get down to 0.1 microvolt. Radiation within the two-meter band limits, even without an r.f. stage, would be eliminated through the use of a superheterodyne circuit with an i.f. of at least 4 Mc.

Three versions of this circuit were taken under consideration; first, a straight superheterodyne in which the i.f. stages were all on one frequency, using a conventional a.m. detector; second, a double-conversion circuit; and third, a superheterodyne using a superregenerative second detector. Since one cannot expect much gain from the r.f. section of a 2-meter receiver, it becomes

• Almost as soon as the 2-meter band becomes occupied in a given locality, the limitations of the superregenerative receiver become obvious. With activity on this band rocketing toward an all-time high the necessity for something better in the receiver line cannot be overlooked. Now is not too soon to get started on a receiver which will permit the interesting potentialities of the 144-Mc. band to be realized. This receiver is not costly or difficult to build and its performance is vastly better than that of the simple straight superregen.

necessary to get practically all the gain from the i.f. and audio amplifiers. Hum and motor-boating limit the amount of audio gain that can be used, so it is up to the i.f. amplifier to provide the rest. It was felt that the i.f. sensitivity alone should get down to at least one microvolt.

A half-hearted attempt was made to build an i.f. amplifier using three stages tuned to 10.7 Mc. but it soon became apparent that to reach our desired sensitivity level, and still have the receiver remain stable, would require shielding, by-passing and care in location of parts that might be beyond the ability or desire of the average ham.

A double-conversion circuit was next considered. This circuit would be easier to stabilize, as only part of the i.f. gain would be on 10.7 Mc. while the rest would be on a different frequency, say 1.6 Mc. However, a second conversion oscillator is required and this must be chosen to avoid "birdies" from oscillator harmonics in the 2-meter band. This, too, was somewhat involved.

Ed Tilton's article in the September issue of *QST* started us thinking along the lines of the superregenerative second detector. With only one i.f. stage, it should not be difficult to keep the system stable, and the superregenerative

*Engineering Dept., The National Co., Malden, Mass.

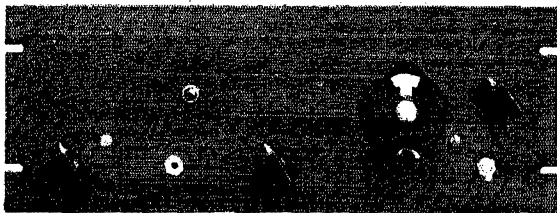

Panel view of the 2-meter superhet. The knob at the left is the audio gain control, the one in the center is the regeneration control. At the right is the r.f. input trimmer. Other items are pilot light, 'phone jack, B+ switch and the tuning dial.

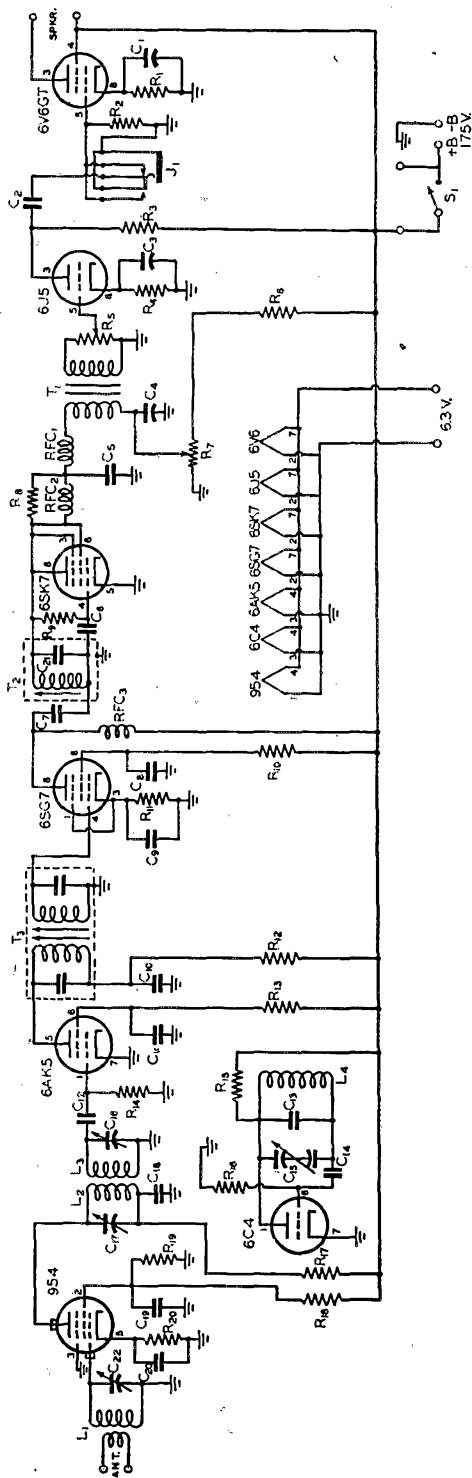

Fig. 1 — Schematic diagram of the 144-Mc. superhet.

- C₁, C₂ — 25- μ fd. 50-volt electrolytic.
- C₃ — 0.01- μ fd. paper.
- C₄ — 0.5- μ fd. paper.
- C₅ — 0.006- to 0.01- μ fd. mica.
- C₆, C₇ — 75- μ fd. ceramic.
- C₈ — 470- μ fd. mica.
- C₉, C₁₀ — 0.002- μ fd. mica.
- C₁₁, C₁₂ — 35- μ fd. ceramic.
- C₁₃ — 10- μ fd. ceramic, 0.0007 negative temperature coefficient.
- C₁₄ — 47- μ fd. ceramic.
- C₁₅ — Small double-stator variable — see text.
- C₁₆, C₁₇ — National Type PSR-25 reduced to 2 rotors and 2 stators.
- C₁₈ — 47- μ fd. ceramic.
- C₁₉, C₂₀ — 47- μ fd. special enclosed ceramic — National XLA-C.
- C₂₁ — 20- μ fd. ceramic.
- C₂₂ — National Type UM-10D.
- R₁ — 470 ohms, 2 watts.
- R₂ — 0.47 megohm, $\frac{1}{2}$ watt.
- R₃ — 0.1 megohm, $\frac{1}{2}$ watt.
- R₄ — 4700 ohms, $\frac{1}{2}$ watt.
- R₅ — 0.5-megohm potentiometer.
- R₆, R₁₄ — 0.27 megohm, $\frac{1}{2}$ watt.
- R₇ — 50,000-ohm potentiometer.
- R₈ — 4700 ohms, $\frac{1}{2}$ watt.
- R₉ — 10 megohms, $\frac{1}{2}$ watt.
- R₁₀, R₁₈, R₁₉ — 47,000 ohms, $\frac{1}{2}$ watt.
- R₁₁ — 270 ohms, $\frac{1}{2}$ watt.
- R₁₂, R₁₇ — 2000 ohms, $\frac{1}{2}$ watt.
- R₁₃ — 1 megohm, $\frac{1}{2}$ watt.
- R₁₅ — 20,000 ohms, 2 watts.
- R₁₆ — 33,000 ohms, $\frac{1}{2}$ watt.
- R₂₀ — 420 ohms, $\frac{1}{2}$ watt.
- L₁ — 1 $\frac{3}{4}$ turns No. 14 solid wire, about $\frac{5}{8}$ -inch diam.
- L₂, L₃ — 1 $\frac{3}{4}$ turns No. 14 solid wire, about $\frac{1}{2}$ -inch diam.
- L₄ — 2 $\frac{1}{2}$ turns No. 14 solid wire, about $\frac{3}{16}$ -inch diam.
- J₁ — Multicircuit jack.
- RFC₁ — 250-mh. choke (National Type SA:52-N).
- RFC₂ — 750- μ h. choke (National Type R-33 or two pies of a National R-100 choke).
- RFC₃ — National Type R-100 choke.
- S₁ — S.p.s.t. switch.
- T₁ — 4:1 interstage audio transformer (National Type SA:696).
- T₂ — National Type 1FN revised — see text.
- T₃ — 10.7-Mc. i.f. transformer (National Type 1FN).

detector is well known for its sensitivity, a.v.c., noise-limiting action and simplicity. With the aid of a double-tuned intermediate-frequency transformer operated at a low frequency, the selectivity might be acceptable. Although being somewhat prematurely cold to superregeneration and knowing that it becomes increasingly difficult to get smooth action without squealing as the frequency is decreased, it was decided to give it a try.

Circuit Details

The receiver (Fig. 1) was built backward, starting from the 'speaker and working toward the antenna. The audio amplifier uses a Type 6J5 triode resistance-coupled to a Type 6V6GT output tube. A 'phone jack is provided which cuts out the 'speaker output when the 'phones are plugged in, and an audio gain control is inserted at the grid of the 6J5. Crystal-controlled signals give comfortable volume with the audio gain control turned up about halfway.

The i.f. amplifier uses a 6SG7 tube in a conventional amplifier circuit. The heart of the receiver is the superregenerative second detector. Several types of tubes were tried here. The 6C4 and 6J5 oscillate very well and go into oscillation at less than 10 volts, but they are prone to squeal too easily and too soon after the regeneration control is turned past the point at which superregeneration begins. A 6C5 was much better in this respect but it is an antiquated type, having been replaced commercially by the 6J5, and it may be difficult to obtain. It was found that a 6SJ7, triode-connected, with the plate, suppressor and screen grids tied together, worked equally well. A Type 6SK7, also triode-connected, was found to work best of all, going into superregeneration very smoothly and slowly, and it did not squeal badly at the higher voltages. Metal tubes were used in the circuits mentioned so far, as there were no electrical advantages to be gained by using the more expensive miniature tubes and no attempt was being made to save space.

It will be noticed that the fundamental superregenerative circuit is very similar to that in the previously-mentioned article by WIHDQ. Since a ready-made i.f. transformer was used between the mixer and first i.f. amplifier, it was thought that a similar transformer might be used for the superregenerative tank circuit by merely removing the upper winding from the coil form, leaving a single coil resonated by a 100- μ fd. fixed condenser and tuned by an iron slug. This tank did not oscillate well, however, and it was necessary to rewind it to provide a higher L/C ratio. The winding was removed and rewound, starting at the same point on the form and using the same size (No. 26) enameled wire, following the grooves as far as they went and then merely close-winding until there was a total of thirty turns. The condenser which resonated the coil was replaced by a small 20- μ fd. ceramic condenser and the coil is tuned with the iron plug as before. If the iron plug tunes too far out of the coil to provide leeway, it may be necessary to remove two or three turns until the coil can be tuned easily to 10.7 Mc., which is the nominal frequency for which the transformer is designed.

A 10-megohm resistor is connected directly to the grid and plate of the 6SK7. The 6SG7 amplifier is impedance-coupled to the *grid* side of the superregeneration tank through 50 to 75 μ fd. The values of this condenser and the 6SK7 grid

condenser are fairly critical. The plate voltage is fed to the superregenerative detector through a 750- μ h. r.f. choke. This choke is also critical but two pies of an R-100 choke should work quite well. It will be noticed that this choke is shunted by a resistor, the value of which can be adjusted to suppress the squeal which may appear when the regeneration control is advanced beyond the threshold of superregeneration.

The condenser C_5 produces the quench action. The required value may vary and should be adjusted for best superregeneration, the optimum value lying between 0.006 and 0.01 μ fd. It will also affect the audio fidelity, cutting highs quite strongly, thereby reducing the hiss produced by superregeneration action and producing a low ratio of hiss to audio output. The choke RFC_1 should be a real husky one as on this choke falls most of the work of keeping the quench frequency from getting into the audio amplifier. The audio transformer is a 4:1 interstage unit. Transformer coupling is not used for the second audio stage as this results in too much audio gain and is apt to produce a high hum level. High hum level may come from pick-up in the audio transformer if the receiver is located too close to the power supply, the chief reason why a built-in power supply was not used. If the amount of hiss or highs in the audio system still seems to be more than is desirable, a 100- or 250- μ fd. condenser could be tried as a by-pass across the *secondary* of the audio transformer or from plate to ground on the 6J5 first-audio tube. Experimentation with the various components pertaining to the superregenerative detector is worth while to get smooth operation, but the final adjustment should be made after *both* the first i.f. and superregeneration transformers have been tuned to 10.7 Mc.

The screen by-pass condenser on the 6SG7 i.f. amplifier can be laid across the middle of the socket to provide additional screening between the grid and plate circuits. The cathode by-pass must be fairly large, at least 0.002 μ fd.

The mixer circuit that is used is identical with the one which was worked out for the converter described by the writer in the May, 1946, issue of *QST*, except that the primary of the i.f. transformer is connected into the plate circuit in the conventional manner. It will be noticed that the screen voltage of the mixer is quite low, as a result of the use of a one-megohm resistor. This had been adjusted for optimum conversion gain.

The 954 r.f. tube and socket are at the right. The condensers and coils of the double-tuned system are between the 954 and the 6AK5 sockets. The 250-millihenry choke, RFC_1 , is just beside the power-supply socket. The 750-microhenry r.f. choke, RFC_2 , is mounted with one end on RFC_1 and the other end on the detector socket in parallel with the resistor R_4 .

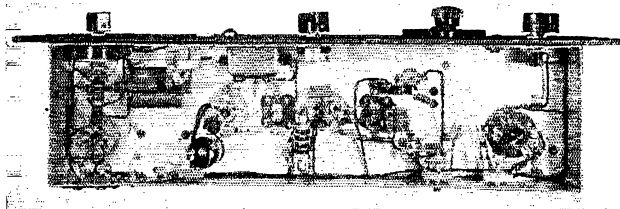

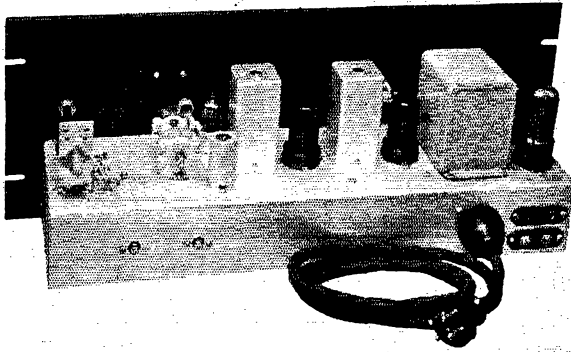

Back view of the 2-meter receiver. The shielded miniature tube in front farthest from the panel is the 6AK5 mixer. The one near the panel is the 6C4 oscillator. The 6J5 first audio is nearly hidden behind the 6V6GT output tube on the right. The grid of the 954 r.f. tube can be seen sticking up through a hole in the chassis under the r.f. coil on the left. The two adjustments at the back of the chassis are the PSR condensers in the double-tuned r.f. tanks. The antenna is coupled to the r.f. input by inserting a one- or two-turn pick-up coil into the r.f. coil.

The high-frequency oscillator uses a 6C4 tube. A Type 9002 could be used but the 6C4 is a husky tube and a good oscillator at this frequency, and it was felt that the oscillator frequency drift might be kept down if the larger tube were used. A split-stator condenser is used with the rotor floating, to prevent noise resulting from variable or poor contact. This rotor is driven through a flexible coupling and a bakelite shaft. The oscillator coil is mounted above the condenser from stator to stator and a small 10- μ mf. ceramic condenser is also connected between the stators, making the circuit relatively high-*C* and reducing the tuning range of the variable condenser. The ceramic condenser should have a high negative temperature coefficient and it can be pushed toward the tube a bit to produce some temperature compensation, although the leads should be kept short.

By squeezing the coil and pulling plates off the condenser, the receiver described was made to tune from 15 to 90 on the 100-division dial scale. With this spread it was found that S9 *stable* signals occupied about two divisions on the dial, providing very comfortable tuning with the vernier dial. The coupling between the oscillator and mixer is very loose. Stray coupling alone might be sufficient, but a short piece of wire was used just to be sure, one end being connected to an unused contact on the 6C4 tube socket, while the other was wrapped around the 6AK5 grid condenser. At this point, the addition of a tuned circuit connected to the mixer grid completes the receiver in its simplest form and very good performance will be obtained by connecting the antenna coupling coil closely to this input tank coil.

Adjustments

If the receiver is built at home where a signal generator is not available, a signal at approximately 10.7 Mc. can be obtained by using the high-frequency oscillator of a short-wave communications receiver. Practically all receivers run the oscillator on the high-frequency side of

the signal and can be set approximately to 10.7 Mc. by tuning the receiver dial to a frequency which is lower than 10.7 Mc. by the frequency of the i.f. amplifier used in that receiver. For example, if the intermediate frequency of the receiver is 456 kc., set the dial to 10.25 Mc. The oscillator will then be at 10.7 Mc. and its radiation can be picked up by connecting a wire to the grid of the mixer and bringing this wire near enough to the oscillator tank of the communications receiver to pick up a suitable amount of voltage from it. The signal thus obtained will be unmodulated and the i.f. amplifier and super-regenerative detector can be trimmed up for maximum quieting of the superregeneration hiss.

About the only satisfactory manner of checking sensitivity when using a superregenerative receiver is to use the quieting action of an unmodulated carrier input as a criterion. In all sensitivity checks made on this receiver, the input was read when a quieting action equivalent to an S5 signal was obtained. A Measurements signal generator was used with a 50-ohm coaxial output cable, and a sensitivity of one microvolt was reached when the generator was connected directly to either the grid of the 6SG7 or the 6AK5 mixer. This would seem to indicate no gain through the mixer tube but we are not interested in this but rather in the conversion gain obtained at 144-148 Mc.

With the signal generator coupled by means of a two-turn pick-up coil soldered to the end of the generator cable and with the high-frequency oscillator in operation, a sensitivity of 0.25 to 0.3 microvolt was obtained at 2 meters.

There is a slight interlocking effect between the oscillator and the mixer input tank. The latter can be tuned up in the middle of the band and left alone unless the antenna or antenna coupling is changed. When tuning it up in the middle of the band, the two controls should be rocked until a setting of the mixer condenser is found which produces the maximum quieting action. A weak signal should be used for this adjustment. If the antenna is coupled directly to the mixer grid coil, care must be taken to keep 10.7-Mc. signals

from getting into the mixer grid by capacity coupling from the antenna system. The grid coupling condenser C_{12} and grid resistor R_{14} should be connected directly to the grid contact, the tube may require a shield, the feeders should be kept away from the tube and its socket wiring, and the mixer input tank should be grounded with as short a connection as possible. With a grounded antenna system such as a coaxial feeder type, no trouble should be experienced but with a two-wire feeder type where the entire system is floating, a ground of some sort such as a quarter-wave grounded stub will undoubtedly be necessary.

The receiver as described so far should not be difficult for the average ham to construct and adjust. One warning should be given, however. Some of the parts are quite critical. A good single-peaked intermediate-frequency transformer should be used; if a double-peaked or broad transformer designed for use in f.m. broadcast receivers is used, a loss in selectivity and possibly sensitivity will result. If the circuit diagram and parts list are followed carefully the receiver should work efficiently and smoothly but if the constructor makes changes or substitutions he should do so with care and — well, "You're on your own."

After using the receiver for some time, the writer felt that the addition of an r.f. stage would be interesting and useful. A band-pass r.f. stage appeared to offer an out from the necessity of ganging and tracking several tuned circuits. It would eliminate any trouble from 10.7-Mc. pick-up by the mixer, and it would provide some improvement in image rejection and sensitivity. That 0.1-microvolt limit on the signal-generator attenuator looked inviting, so, although we got into a number of arguments as to "how much is 0.1 microvolt?" it was decided to try to get the sensitivity down to that point. Alignment of the band-pass r.f. stage may be beyond the capabilities of some inexperienced amateurs, but the time and effort required are well worth while if the constructor feels equal to the task.

The first consideration, of course, was the tube to be used. Although the 6AK5, 6J4 and other recent tubes are reputed to give more gain than the lowly 954, it was believed that the difference in practice is not so great as is often expected. The G_m of the 954 is considerably less than that of the newer tubes; and, at lower frequencies, where the gain of a pentode is proportional to G_m , there would be no question as to the best choice of tubes. At 150 Mc., however, another factor demands consideration. This is the input conductance. A "figure of merit" at this frequency should take into consideration both the G_m and the input conductance and in this second respect the 954 is much better than the high- G_m tubes. Moreover, the construction of the acorn provides an easy means of isolating the input and output tanks by putting one above and the other below

the chassis. The Type XLA acorn socket is mounted below the chassis so that the grid end of the tube extends upward through a hole to be connected to the antenna input circuit above. This tank is tuned from the front panel, though the control is seldom used.

The acorn socket has seven contacts, two of which will not be used and are removed. The nut was removed from one heater contact and the suppressor grid contact, and the grounding block put in its place. The screws and nuts from the cathode and screen-grid contacts were removed and were replaced by the Type XLA-C ceramic by-pass condensers which are supplied especially for use with these sockets. They are completely enclosed in the socket itself and have two tabs which, after the Type XLA-S grounding shield is put in place, are soldered to this shield to provide a ground.

The only difficult part of this arrangement was the alignment of the circuits coupling the r.f. plate to the mixer grid. These use National PSR-25 condensers with all but two rotor and two stator plates removed. The coils have to be trimmed so that they will tune up with reasonable leeway and the coupling is adjusted to produce a certain amount of over-coupling. When they were finally adjusted, two peaks were obtained, occurring at approximately 144.7 and 147.3 Mc. The dip in the middle was down about 3 db. but this dip is filled in by the antenna tank which is tuned to 146 Mc. and, of course, has a single peak. The over-all band-pass characteristic is, therefore, essentially flat.

To line up the over-coupled tanks, it is necessary to eliminate the selectivity of the intermediate-frequency amplifier and the antenna tank. This is done by connecting the coaxial cable of the generator directly to the 954 grid and removing the 6SK7 detector tube. Modulation is applied to the generator and the 6AK5 mixer is operated as an ordinary detector. The audio voltage developed in the plate circuit across the decoupling resistor R_{12} is fed by means of a large condenser into the primary of the audio transformer and thence through the audio amplifier. Headphones had to be used as the audio amplifier howled if the loudspeaker were used. The input signal was run up to a level at which the modulation could be heard. Then the coupling and tuning of the two circuits were adjusted to give the band-pass characteristic just described. This is quite difficult, as anyone knows who has worked with over-coupled circuits, but eventually, after considerable effort, the desired condition can be met.

Performance with R.F. Stage

After the band-pass circuits were aligned, the sensitivity was checked and it was found that the desired 0.1-microvolt level was reached, but with no leeway. This showed a gain of $2\frac{1}{2}$ to 3 times or

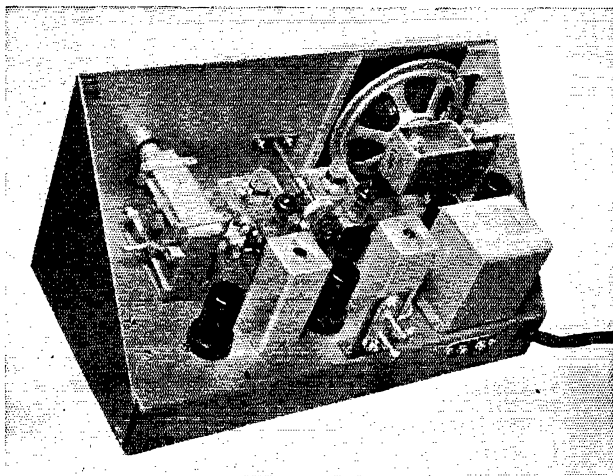

General-coverage receiver for 27-250 Mc. The audio tubes are on the right. The mixer is the miniature (6AK5) next to the 'speaker. The oscillator (9002) is next to the PW dial drive. The tuning condensers are handmade double-stator units with floating rotors. The second detector is the metal tube behind the dial drive and the i.f. tube is between the two transformers. A 5-inch p.m. 'speaker is used. The shaft in the center is for the r.f. input trimmer. The leads from tuning condenser to tube sockets are extremely short, resulting in excellent performance on 1 $\frac{1}{4}$ meters.

about 8 db. in the r.f. stage which is equivalent to that of a very respectable beam antenna. The image ratio had increased from 22 db. to over 60 db. The selectivity was as follows: 2 times down (6 db.) — 40 kc.; 10 times down (20 db.) — 70 kc.; 100 times down (60 db.) — 125 kc.; 100,000 times down (100 db.) — 600 kc. On the air the receiver performed very well. After the wind pulled the feeders off my 16-element beam and I went back to using a dipole, I found that I was hearing signals with the dipole as well as I used to hear them with the old receiver with the 16-element beam! The 2-meter band covers 75 dial divisions and S9+ signals occupy two divisions. The boys who operate mobile just behind me on the hill now occupy less than three divisions and a mobile rig operating about thirty-five feet from the antenna occupies 6 divisions. Although the receiver places a premium on stable signals, it is possible to work the majority of the modulated oscillators if they will reduce their modulation level to a point where they are sure I can't hear a thing. Many Boston stations can be copied with the detector completely out of superregeneration. This method of operation gives noticeably better quality.

The receiver described so far was meant for 2-meter reception only. However, James Ornets, who is hoping to be licensed soon, has built up a general-coverage receiver using ganged condensers and plug-in coils, which has a continuous range from 27 to 250 Mc. It has no r.f. stage but the performance duplicates the previously-described receiver at 2 meters without that stage. It is equally sensitive at 1 $\frac{1}{4}$ meters and is still better at 6 and 10 meters. At 50 Mc. it looks particularly good. It is enough broader than the usual communications receiver to make it easier to handle, yet its selectivity is adequate in view of the occupancy of this band. Credit should be

given to Jimmy for several ideas that he contributed, especially in regard to the performance of the superregenerative circuit.

It is hoped that the material described here will help other amateurs to get more out of their operation on 2 meters. Many hams think that any piece of junk is good enough for 144 Mc., but the writer believes that with a good transmitter, receiver and antenna, you will get a lot more out of the band at any location.

Silent Keys

IT is with deep regret that we record the passing of these amateurs:

W1HGV, Ralph W. Fiske, Milford, N. H.
W2WIF, Roy W. Woollacott, Rochester, N. Y.

W3DVH, John H. Duane, Lancaster, Pa.
W4FAO, George H. Pinney, Orange City, Florida

W5KHR, George A. Williams, jr., Provençal, La.

W6NRC, Harold B. Savage, jr., San Diego, Calif.

W81FQ, Thorvald Petersen, Ludington, Mich.

W9FNH/Ø, Grover H. Helmer, Minneapolis, Minn.

W91IU, David Rayfiel, Chicago, Ill.
W9KVB, Elmer O. Calder, Council Bluffs, Iowa

W9LPB, John W. Steller, Jeffersonville, Ind.

WØJVL, Max H. Lohse, Omaha, Neb.

G2VG, Col. F. E. Wenger, Newcastle, Staffs.

Ex-VE7KN, Harry Meek, Vernon, B. C.

Happenings of the Month

CONFERENCE PREPARATIONS

The major nations are now hard at work preparing their proposals for this year's world telecommunications conference. Although the place and date are still not entirely settled, the outlook as we write is that the portion of the conference concerned with revising the regulations will open at Atlantic City, N. J., on May 15th.

We wish that every amateur would read A. L. Budlong's report of the Moscow five-power preparatory meeting which we published on page 25 of our January issue. He was ARRL's representative at that conference. Since December 2nd he has also sat daily in Washington as a member of the Department of State's government-industry committee which, against the Moscow background, is making the final revisions of the United States proposals for the world conference. At this writing that work isn't finished and a detailed report of it must await a later issue; but up to this writing the U.S. plans maintain all our existing bands above 3.5 Mc. and continue the proposal of a new band at 21-21.5 Mc.

It is apparent that 1947 will be a very busy year for us. Although we may expect the unrelenting protection of the United States delegation, it is to be expected that the divergent viewpoints of various foreign nations will produce the usual severe fight over the preservation of our rights. For several years back, the League has participated actively in the formulation of U.S. postwar radio plans and of course it will be constantly represented at the world conference, where these plans meet their final test. Watch *QST* for news of further conference developments.

MORE LICENSE EXTENSIONS

Because of the confusion in determining the expiration dates of amateur licenses, as we have mentioned in these pages, FCC made a clean sweep and replaced its four previous extension orders with a new one, Order No. 115-C, on January 3rd, which should clarify the matter forever. As a result of this further extension, there will now be *no expiration of licenses in 1947. Every amateur operator license originally issued for a term of three years, anywhere in the period from three years before Pearl Harbor up to the end of 1945 (and not since surrendered or suspended or renewed) will now expire on the 1948 anniversary of its date of issuance. Station licenses expire*

concurrently with the operator licenses. This should make the matter clear to everybody. Below is the complete text of the order:

At a meeting of the Federal Communications Commission held at its offices in Washington, D. C., on the 3rd day of January, 1947;

WHEREAS, The Commission has, by Orders 115, 115-A, 115-B, and 130-F, adopted between May 25, 1943, and April 7, 1946, reinstated and extended certain amateur operator licenses issued on or between December 7, 1938, and December 7, 1943, so that the expiration dates of those amateur operator licenses fall within the period December 7, 1946, and December 7, 1947, and validated certain amateur station licenses for the term, as extended, of the amateur operator licenses held by the licensee of the station; and

WHEREAS, It is now desirable to establish a clear and uniform understanding of the status of all amateur operator and station licenses and to eliminate the effects of certain misunderstandings that have occurred in connection with the application of the above-mentioned orders and to provide for the orderly processing of applications for new, renewed, or modified amateur licenses;

IT IS ORDERED, That all amateur operator licenses issued on or between December 7, 1938, and December 31, 1944, except amateur operator licenses heretofore at any time or hereafter suspended or voluntarily surrendered, are hereby extended, and if expired on or since December 7, 1946, are hereby reinstated and extended, until 1948, at 3 A.M., Eastern Standard Time, the same day and month as the date of issuance.

IT IS FURTHER ORDERED, That all amateur station licenses held by operators whose operator licenses are extended, or reinstated and extended, by this Order, except amateur station licenses heretofore at any time or hereafter revoked or voluntarily surrendered, are hereby validated, and if expired on or since December 7, 1946, are hereby reinstated and validated, for the term, as extended, of the operator license held by the licensee of the station;

IT IS FURTHER FOUND AND ORDERED, That, WHEREAS, Authority for this Order is contained in Sections 303(l) and (r) of the Communications Act of 1934, as amended, and the effect of the Order is to extend for an additional period after December 7, 1946, the relief from certain restrictions as has been or now is afforded by Commission Orders 115, 115-A, 115-B and 130-F, and is non-controversial, and it is in the public interest that this Order be made effective immediately, notice and public procedure required by Section 4 of the Administrative Procedure Act are, hereby, Found Unnecessary, and this Order SHOULD BE, AND IS HEREBY, MADE EFFECTIVE IMMEDIATELY.

There's another way of putting this, if yours is the ordinary case of an active amateur whose licenses have not been surrendered, revoked or suspended. FCC began issuing five-year licenses the first of 1946. These of course will normally run their stated term. Up to the first of 1946 all amateur licenses were issued for a term of three years. If yours is still one of these licenses originally issued for three years, it now expires on its date in 1948. It's on the basis of calendar years now, too — no more worrying about December 7th instead of December 31st.

80 IN HAWAII & WEST

In compliance with permission given by the military services, and subject to some restrictions originating with them, FCC on January 3rd issued its Order No. 130-L which restored the missing part of our 80 meter band in Hawaii and then extended the use of the whole 3500-4000 band to all United States possessions west of Hawaii as far as 170 degrees west longitude, but at the same time imposed an input power limitation of 500 watts for the whole band throughout this whole region.

The power reduction was dictated by the Army theater commander and did not originate with FCC, which was necessarily bound by it. The League immediately protested the power limitation, pointing out that it was without practical effect except as a nuisance to amateurs. The War Department is asking the theater commander to remove the restriction and we hope that it will be one of those forgotten things by the time you read these lines.

STAFF NOTES

Starting this month, "How's DX?" is being written by Joseph Grahn, W1CH, who becomes *QST's* DX editor, handling the job from his home in Worcester, Mass. In Worcester Mr. Grahn is supervisor of engineers at WAAB but in *QST* he will need no introduction, at least to the DX gang, since his 25 years of hamming have been taken up with chasing the elusive stuff with notable success. The change gives By Goodman a much-needed opportunity to devote his full time to his assigned job of assistant technical editor.

Lorentz A. Morrow has joined our staff as assistant advertising manager of the ARRL publications. Widely known both in the trade and in amateur circles under the nickname of Pete, he has been an active amateur since before War I, starting in his home town of Springfield, Ohio, in 1913 with a spark coil and the call W1. He has a list of ex calls as long as your arm, the latest and best-known being W9VKF, which he enjoyed in Peoria while serving as sales manager of RME. He is now W1VG; his operating specialty is ARRL contests. He is an MIT graduate. During War II he served as a naval communications officer in the South Pacific, emerging with the rank of lieutenant-commander.

Latest addition to the Technical Department staff is John W. Paddon, VE3BLZ, whose particular field of work will be some investigations into amateur antenna design and performance. Jack has done engineering work in a dozen countries. Although a Canadian, his base for a few years before the war was G2IS, from where he was particularly well known in the 10-meter band. He came to this country early in the war to serve as radar liaison officer with the

ARE YOU LICENSED?

• When joining the League or renewing your membership, it is important that you show whether you have an amateur license, either station or operator. Please state your call and/or the class of operator license held, that we may verify your classification.

Canadian Department of Munitions & Supply at Washington, removing after the war to Toronto. He is an ardent ham and has been for many years a contributor to *QST*.

"A PLAN FOR THE 10-METER BAND"

Under the above title we had an article on page 26 of *QST* for December, presenting for your inspection a plan for an improved subdivision of the 10-meter band which the ARRL Board of Directors has under study and which it intends to consider finally at its meeting in May. Members were requested to write their directors their opinion of the plan, pro or con, with any suggestions that occur for its improvement. We hear from several of the directors that the response has been very small and that little interest seems to be shown in the subject. This is your opportunity to express yourself and your director wants to know what you think of the proposal. Dig out December *QST*, refresh yourself, and drop him a card.

RESIGNATION OF BAKER

At the very beginning of his term of office, Frank L. Baker, W1ALP, the popular alternate director of the New England Division, developed a business connection as a radio salesman which made him ineligible to continue in that office and under the necessity of offering his resignation. The League has accepted it with regret. The office remains vacant.

NOTICE TO MEMBERS DISCHARGED FROM THE MILITARY SERVICES

The requirement of continuous membership in the League for eligibility to ARRL offices has been waived for members serving in the uniform of the United States or Canada. See particulars on page 27 of *QST* for July last. Those desirous of taking advantage of this arrangement are required to claim the right when renewing membership, stating the beginning and ending dates of their military service.

**SWITCH
TO SAFETY!**



QST for

The BC-221 Frequency Meter as a VFO

A Combination Crystal and Variable-Frequency Exciter for Transmitter Control

BY HOWARD W. JOHNSON, * W7NU

• In an earlier issue of *QST*¹ the use of surplus military frequency meters as frequency-control units in transmitters was suggested. This article shows how one of these meters may be made to serve as a calibrated highly-stable VFO exciter without impairing its use as a frequency meter. Not the least attractive feature of this unit is that the oscillator is sufficiently well-shielded so that it need not be keyed for break-in work, thereby minimizing the problem of good keying.

THE already crowded conditions on the amateur bands plus the rapid influx of new operators have made variable-frequency exciters a necessity rather than a luxury. The subject of spot-frequency operation has been well-enough covered recently so that no amateur has to be sold on its merit. It can almost be said that if two or more stations would use the same frequency during contacts, there would be twice as much effective space in the bands as there is now. This is not quite true, because many amateurs are following this practice at the present time. Obviously we can't zero-beat stations operating outside the American bands!

It is desirable that the VFO be variable only at the will of the operator; too many of those built without proper care have ideas of their own

* 5201 Beach Drive, Seattle 6, Wash.

¹ Conklin, "Frequency Meters as Master Oscillators," *QST*, August, 1946, p. 34.

The BC-221 frequency meter mounted to serve as the VFO in a transmitter exciter. Controls to the right are for the added stages which boost the power output to about 3 watts. The entire assembly is mounted in a cabinet fitted with shock-absorbing rubber feet.

on the subject and seem to want to be constantly variable. Let's take a look at the desirable features which should be incorporated in a variable-frequency exciter for amateur use.

1) *Stability*: This is the primary consideration and should mean stability under vibration, temperature variation, and load variation.

2) *Calibration*: The combination of stability and accurate calibration are the two things which help to insure operation within the band limits.

3) *Keying*: The exciter should be capable of being keyed for break-in operation without being heard in the receiver with the key open, and should be free from transients or chirps.

4) *Output*: This will vary with transmitter requirements, but in general the output should be from two to five watts and preferably at low impedance to allow the exciter to be located at the operating position.

5) *Crystals*: It is desirable but not necessary to have one crystal on each band for use in band-edge operation.

Most of the commercially-available VFO exciters satisfy the first fairly well. As for the second, very few of them have calibration accurate enough for dependable operation adjacent to band edges. The third requirement is seldom met in commercial models, since it is necessary to key the oscillator for spot-frequency break-in work and this cannot be done without chirps or clicks to a greater or lesser degree.

The power output mentioned in the fourth consideration is more than ample in some of the models available. It is the opinion of the author

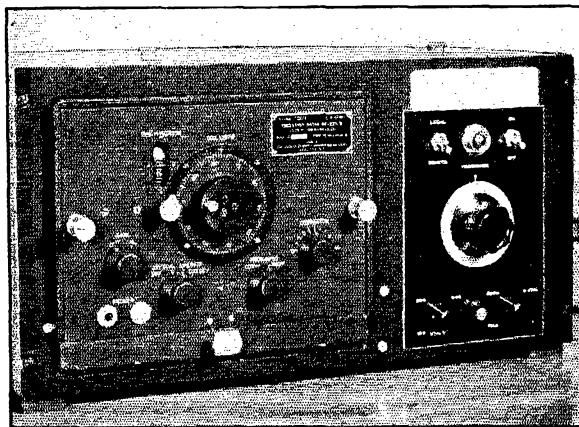

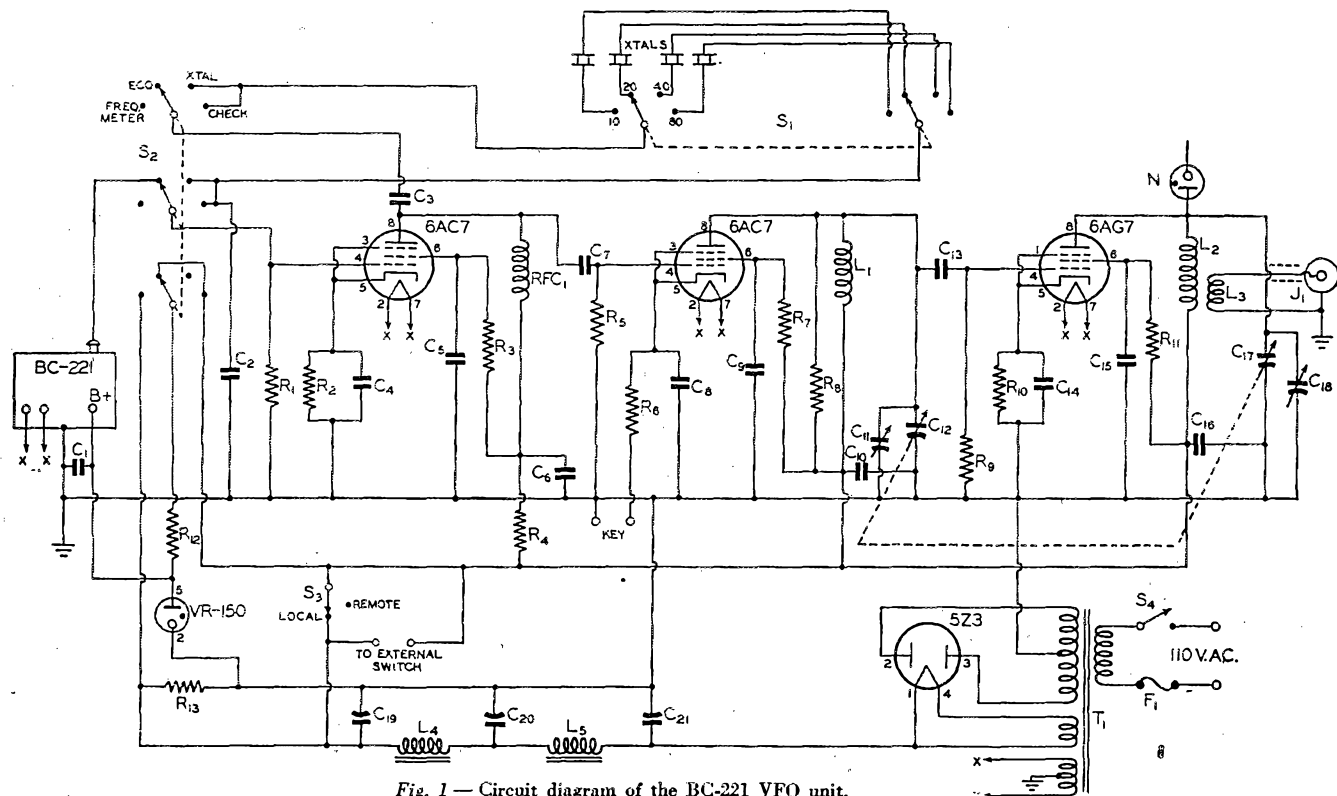

Fig. 1 — Circuit diagram of the BC-221 VFO unit.

- C₁, C₃, C₄, C₅, C₆, C₇, C₈, C₉, C₁₀, C₁₄, C₁₅, C₁₆ — 0.006-μfd. mica.
- C₂, C₇, C₁₈ — 100-μfd. mica.
- C₁₁, C₁₈ — 50-μfd. variable.
- C₁₂, C₁₇ — 75-μfd. variable.
- C₁₉, C₂₀, C₂₁ — 8-μfd. 450-volt electrolytic.
- R₁, R₅ — 0.47 megohm, 1 watt.
- R₂, R₆ — 150 ohms, 1 watt.
- R₃, R₇ — 68,000 ohms, 1 watt.
- R₄ — 4700 ohms, 2 watts.

- R₈, R₁₁ — 22,000 ohms, 1 watt.
- R₉ — 0.22 megohm, 1 watt.
- R₁₀ — 220 ohms, 1 watt.
- R₁₂ — 5000 ohms, 10 watts.
- R₁₃ — 20,000 ohms, 10 watts.
- L₁, L₂ — 30 turns No. 18, 1½ inches diameter, 2 inches long, 20 μh.
- L₃ — 2 turns coupled to cold end of L₂.
- L₄, L₅ — 30-hy. 85-ma. filter choke.

- F₁ — 1-amp. panel fuse.
- J₁ — Coax-cable connector.
- N — ¼-watt neon bulb.
- RFC₁ — 2.5-mh. r.f. choke.
- S₁ — 2-pole 4-position rotary switch.
- S₂ — 3-pole 4-position rotary switch.
- S₃, S₄ — S.p.s.t. toggle switch.
- T₁ — Power transformer: 700 volts c.t., 85 ma.; 5 volts, 3 amp.; 6.3 volts, 3 amp.

that therein lies perhaps the greatest weakness of these units. It is impossible to achieve real stability and still develop seven to ten watts in only two stages. The control oscillator should not be a power-generating device. Stability is dependent on circuit-merit factor, and high Q cannot be obtained with heavy power demand.

Very few if any commercially-built exciters have the band-edge crystals mentioned in (5) above but supplementary units are available which serve the purpose very nicely.

The above comments on commercially-built units may seem to be too critical. The fact is that all of these units are good and unless you are prepared to put some real time and care into the construction of a VFO, then by all means buy one, or stick by crystals.

Features

The exciter described here is built around the BC-221 frequency meter which is now available at most parts houses or through surplus dealers. This unit is admirably adaptable to use as the oscillator unit of a VFO exciter for ham transmitters. The oscillator tube in the unit is a 6SJ7-Y (special nonmicrophonic type) which is operated at very low input. The shielding of the unit is excellent, so that the leakage with the oscillator running continuously is below the noise level of a good receiver. Therefore oscillator keying is not necessary for break-in work and advantage may be taken of the superiority of amplifier keying.

The frequency stability of the oscillator is exceptional. The circuit is electron-coupled and the grid of the tube is connected to the tuned circuit through a resistor which limits the feedback to the minimum required to maintain oscillation. The unit is provided with a calibrated dial which may be read accurately to 50 cycles over the range of 2000 to 4000 kc. There is no mechanical back-lash and return to logged settings is dependable.

Extremely good isolation at the output terminal is achieved so that connecting a capacitive or inductive load or even short-circuiting it to ground causes no noticeable frequency deviation. Because load conditions do not affect the frequency, keying is as clean as with any crystal—cleaner than many. The rugged construction satisfies the requirements of stability under vibration. Striking the unit with the fist during operation causes practically no instantaneous frequency change and absolutely no permanent change.

The FCC requires that some means other than the dial reading of the frequency-control oscillator shall be provided for frequency checking. The crystal calibration which is an integral part of the unit should satisfy this condition. It is a separate oscillator and may be set on WWV. The crystal frequency is 1 megacycle.

Circuit

The modification to adapt the unit to VFO use consists of adding amplifier stages and a power supply to bring the output level up to 3 watts or so. The circuit diagram appears in Fig. 1. The output of the BC-221 is capacitance-coupled to an untuned stage in which a 6AC7 is used. This stage operates as a Class A amplifier, since it draws no grid current. Another 6AC7 is used in the following stage which is tuned. A 6AG7 is used in the output stage, and its tuning condenser is ganged with that of the preceding stage and the low-impedance output is fed through a link to a coaxial-cable outlet connector.

Some eyebrows may be raised at the use of resistor R_2 across the plate coil of the second 6AC7, but because of the extremely high-gain characteristics of the 6AG7 it showed some tendency to operate as a t.g.t.p. oscillator under key-up conditions in spite of careful shielding. More output was obtained by loading the tuned circuit than by running the second stage untuned, undoubtedly because this stage operates Class B or BC. The value of this resistor may have to be altered slightly depending upon output loading and other factors.

The untuned 6AC7 doubles in brass as a Pierce oscillator when the switch, S_2 , is in the "xtal" position. Four crystals are provided for band-edge operation on 10, 20, 40 and 80 meters. S_3 is the "on-off" switch. A pair of terminals is connected in parallel with S_3 for remote control when desired.

High values of grid-leak resistance are used in the first two stages to compensate for the difference in drive between crystal and ECO operation. The first stage operates strictly Class A on ECO but as a Pierce oscillator a high bias is developed which keeps the output low and improves stability. The high-resistance grid leak in the second stage (R_5) performs a like function and the output is substantially the same with either crystal or ECO. The output 6AG7 stage has extremely-high power gain and runs well into the Class C range. The cathode bias is approximately 6 volts and a grid bias of about 8 volts is developed for a total of approximately 14.

The power supply is standard. With condenser input it delivers about 300 volts under load. The high voltage to the BC-221 is regulated by a VR-150; the voltage to the external stages is not regulated.

Construction

The illustrations and the schematic contain most of the necessary constructional information and moderate deviation should not affect the operation of the finished unit.

The lower battery compartment of the BC-221 was sawed off on a contour saw and the face of the cabinet was cut off flush with the panel of the

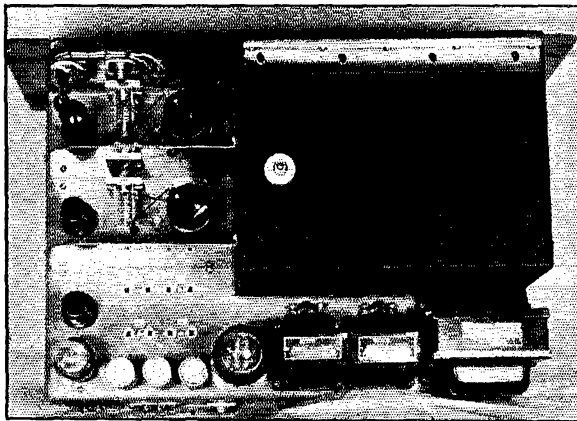

Top view of the BC-221 exciter designed to drive a crystal stage. The chassis is fitted around the BC-221 cabinet with the power supply at the rear and the additional r.f. amplifiers at the left.

oscillator unit. After smoothing with a file, the unit was refinished and mounted through a cut-out in a $9\frac{1}{2} \times 19$ -inch panel. This is not a standard panel width but it fits the only cabinet we had. It is fastened to the panel with aluminum angle strips. The cut-out in the panel is made large enough to accommodate the calibration book underneath the oscillator. The book holder is provided with a knob and slides in and out like a drawer on two runners of aluminum angle. The chassis is made of $\frac{1}{8}$ -inch aluminum with welded corners and is built to fit around the BC-221 cabinet. It is 3 inches deep and 17 inches long at the rear. The depth will be determined by the amount of space required behind the frequency meter for the power transformer.

In the top-view photograph, the power supply components are lined up along the rear edge of the chassis with the additional r.f. stages to the left. The first untuned 6AC7 stage is to the rear with the second 6AC7 stage in the middle and the 6AG7 output stage toward the front. Baffle shields between stages are provided both above and below the chassis. Four crystal sockets are provided although there is space for additional

sockets if they are found desirable. The two padder condensers, C_{11} and C_{13} , are mounted vertically beneath the chassis with their shafts protruding above so that they may be adjusted with a screwdriver. The resonance-indicator neon bulb is mounted on the front panel with a single lead connecting its center terminal with the top end of L_2 .

In the underneath view, the crystal switch, S_1 , is to the left and the function switch, S_2 , to the right near the rear. They are fitted with shafts extending to the front panel. R.f. ground returns in each stage are tied to a common point within the stage.

The output lead from the frequency meter is run down inside the inside corner of the cabinet through a feed-through insulator at the bottom of the cabinet to the wafer switch. This keeps it shielded from the output stage and prevents any tendency for feed-back. Some of the BC-221 meters have the antenna post on the other side of the cabinet, and in this case it might be well to mount the unit on the right side of the panel to shorten this important lead. No attempt has been

Bottom view of the VFO unit built around the BC-221 frequency meter. The amplifier stages are shielded both above and below the chassis.

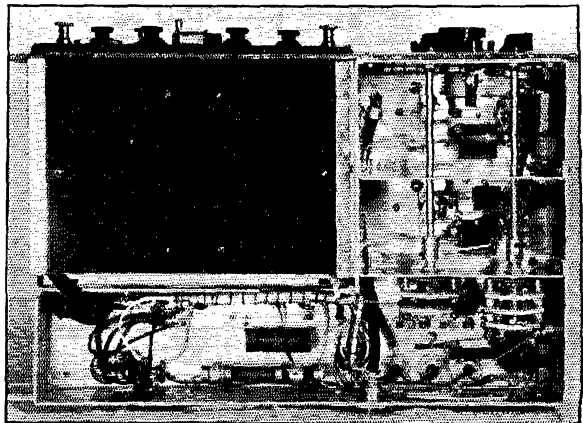

made to specify manufacturers' names on transformers or other components, since it is the experience of the author that the average ham usually comes up with a pretty good substitute out of the junk box. If desired, an equivalent arrangement can be made up by combining a $3 \times 4 \times 17$ -inch chassis across the back and a 7×7 -inch chassis to the left.

Operation

The switch S_2 performs four functions. In the "Freq. meter" position plate voltage is applied to the BC-221 directly from the power supply without the necessity for closing the "local-remote" switch. The frequency meter then performs in the normal manner and the amplifiers are inoperative. The antenna post may be used for coupling to receivers, oscillators, etc. In the "ECO" position the output of the BC-221 is connected to the grid of the first 6AC7 and, when the "local" switch is thrown to the "on" position, plate voltage is applied to the oscillator and the amplifiers. The tuning control for the two tuned amplifiers may be rotated until the neon light indicates maximum output. With the switch in the "ECO" position the trimmer condensers, C_{11} and C_{13} , may be set so that maximum output occurs when the output tuning control is at mid-scale and the frequency meter is set at 3750 kc. The range from 3500 kc. to 4000 kc. is used since this range covers all of the amateur bands in use at the present time. The output is always in the 80-meter band and any frequency multiplying should take place in stages external to the unit. Quick frequency readings of received signals may also be taken in this position by logging the dial setting being used for transmitting and then zero-beating the received signal for a check, after which the dial is returned to the former setting.

In the "xtal" position the first amplifier functions as a Pierce oscillator and plate voltage is removed from the BC-221. In the "check" position the crystal oscillator functions and plate voltage also is applied to the frequency meter so that the crystal frequency may be checked. This makes a convenient method for a quick check on any crystal by simply plugging it into one of the crystal sockets.

A small calibration chart is mounted on the front panel which contains the following information for each band:

- 1) Upper and lower settings for total band
- 2) Upper and lower settings for 'phone band
- 3) Check-point for either range

This makes it unnecessary to refer to the book for anything but exact frequency checks.

If the coaxial cable between the exciter and the transmitter exceeds 6 or 8 feet it should be terminated at approximately its surge impedance or reflections will cause detuning of the output stage. In most cases a 75- or 100-ohm resistor across the line will still give ample voltage to

drive a former crystal-oscillator stage nicely. If more drive is required a small tuned circuit with a link will give good voltage step-up and serve to terminate the line. The transmitter at W7NU is remotely controlled from the floor above and the coaxial line is about 30 feet long.

Let us have more variable-frequency oscillators, but let us have good ones. *But*, of course, the best VFO in the world will be no better than the nut on the dial.

About the Author

● Howard W. Johnson, W7NU since 1927, was first licensed in 1923 as 7JJ. This long-time two-letterer is currently handling radiotelephone, teletype and carrier-shift equipment for the Army Signal Corps. He is in charge of the construction and maintenance shops of the SCs Alaska Communication System. The Seattle Radio Club named W7NU its president in 1940.

Strays

Brooklyn's Metropolitan Amateur Radio Society is holding its first postwar hamfest on March 13th at the Livingston, 301 Schermerhorn Street. Prizes, dancing and refreshments are scheduled. Admission: OMs \$1.50; YLs and YFs, 75 cents.

United Airlines is now using spun-glass lacing cord instead of the familiar linen type in applications affected by heat and humidity.

"Lecturing at N.Y.U. the other night, one of our radio advertising professors — no doubt a fugitive from Radio City's gilded halls — gave us this one. He claims that on the b.c. band, stations on the 550-kc. end get out better than those on the high end. The reason: The ground waves vibrating at 550,000 c.p.s. are not so quickly exhausted of energy as those vibrating at 1,600,000 c.p.s. or so. Well, now I know why my 144-Mc. sigs get so tired going from the Bronx to Brooklyn!" — W2QPQ.

"New Electronic Terms" Department: *Evening Tribune*, Lawrence, Mass., via L. G. Wilde: ". . . a live wire carrying 110 colts." *Boston Record*, tnx to W1ATJ: ". . . amplifier . . . maintains two watts of *undisturbed* output." *The C-D Capacitor* for September, courtesy W3DRH: "R-1 is 500 kilowatts or higher in value."

Radio News for November, spotted by W6ITH: "This set designed for . . . locating grounds, shorts, crosses, split pears."

(Italics ours.)



Rotten 'Phones

(With Apologies to the Spirit of The Old Man)

WHETHER you're an old-timer with a two-letter call and recollections of decoherers — and maybe a past customer of Wm. B. Duck! — or whether your ticket is of the post-World War II era, you should be cognizant of the preponderance of rotten 'phones in our ham bands. And, more to the point, the length of your ham career is not a yardstick for measuring the quality of your 'phone signal. If some of us only could hear our own signals we might be reluctant to mention over the air how long a ham life is behind such a rotten 'phone. The 'phone bands never seem large enough, but with so many broad and raspy QRM contrivances in our midst it must be time to get out the broom. Let's look into the situation.



All of us who have worked the most commonly-used amateur 'phone bands have many times been on the losing end of a QSO ruined by an interloping signal of broad and rough characteristics, a signal whose center frequency often was fifteen or more kilocycles removed from the station we tried to copy. We all deplore such conditions, especially when it's the other fellow causing the trouble. Such signals have no legal or ethical basis for existing, but we must accept the fact that they are with us and attempt to clean house. It has been my observation that while any one of us might be guilty occasionally of radiating an offensive signal (from a strictly technical point of view, of course) the most common offender of this sort is of a habitual nature; his signal never is good and no amount of suggestion from other hams seems to convince him of the unnecessary QRM he inflicts on fellow amateurs. Admittedly,

* %WTIC, Hartford, Conn.

there are a few hams who just don't care about the other fellow so long as they themselves can blast through, but fortunately such fellows are few and far between. So it is to the fellows interested in operating in a legal and ethical manner that these remarks are addressed.

First, we all know the radio-frequency end of the transmitter generates and radiates a signal on the operating frequency. Also, we know that the audio equipment is arranged to superimpose on the radio frequency another signal whose alternations vary at the frequency rate of the sound going into the microphone at a given moment. In plate modulation, probably the most common method, we are told that the audio system should provide power equal to 50 per cent of the input power to the modulated radio-frequency amplifier to give 100-per-cent modulation of the radiated signal. Of course we don't modulate the r.f. signal 100 per cent all of the time, but only on occasional speech peaks. Now all of this appears relatively simple and would seem to be easily achieved; however, practice proves there must be some pitfalls along this seemingly smooth path.

It should be obvious to even the least informed of the ham brethren that such things as improperly-neutralized amplifiers, stages infested with parasites and other conditions indicative of instability, economy-minded low-*C* plate tanks, and finals with too-low drive or improper grid bias should not be modulated and used for communication until the trouble is corrected. It might be mentioned that low filament voltage and overloaded Class C tubes are contributing factors in otherwise acceptable amplifiers that give unacceptable results. The filament emission is insufficient for the modulation peaks. Of course r.f. getting back into the speech amplifier and modulated r.f. getting into a VFO are basic causes for trouble and should not be tolerated. Also, with filter condensers so cheap there is no excuse for so much hum on so many carriers today.

Let us now assume we have a stable r.f. amplifier to which is coupled a modulator with a speech amplifier whose audio characteristics seem to meet good ham standards. We now contact another ham who, in his best diplomatic manner,

tells us we have a slightly broad signal. He says, also diplomatically, it won't bother him too much because he uses the lower half of the band most of the time and we occupy only the upper half, anyway. Now, how does he get that way telling us our signal takes up such a wide channel; didn't we closely observe the data sheet furnished with our Class B tubes and isn't our speech amplifier "high-fidelity"? Our case may be one of over-modulation and a slight backward twist on the audio gain control will work wonders — if only we have the courage and the will to do it. But how can we be overmodulating? The Class B plate



meter doesn't go over to the tube manufacturer's rated peak very often. Well, sad as the revelation may be, the answer *can* be over-modulation!

Most of our 'phone transmitters have far more potential audio power than we oftentimes realize. The Class B ratings provided by the tube manufacturer are based on sine-wave conditions which don't correspond with the complex waveform of human speech, and the power peaks of speech may be far greater than a sine-wave peak for a given Class B plate-current reading. So at best the Class B plate meter is a poor device to indicate audio power and should not be relied upon too much. If you don't now have separate means for determining your percentage of modulation, obtain such a device and not only comply with the law but expect a revelation. It may irk you to find your audio gain should be turned down. But hold on, there may be a silver lining in an otherwise slightly dark cloud — you may find you can run a little more r.f. input and still modulate fully without sentencing the modulator tubes to too short a life. Let me hasten to say that the tube manufacturer is not trying to delude you with his ratings on the data sheet; also, you are not getting something for nothing because Class B amplifiers are no exception to the basic physical laws. The reason for the apparent discrepancy is that the average power in speech waveforms may be low while the peak power, which does the damage in cases of overmodulation, can be quite high.

It is unfortunate, but many of us hams give indication of being naïve enough to suppose a pair of Class B tubes rated at 100 watts of audio

power must stop generating any additional power beyond their ratings once the top of 100 watts has been reached. If this were true you would not be able to modulate fully even a 200-watt r.f. amplifier with the 100-watt modulator because the Class B output transformer, being an imperfect device, consumes some of the power itself before the audio reaches the Class C stage. While the loss in the output transformer is small, the fact that the loss is seldom considered in ham circles proves we have some excess audio power in most cases. These points, which have been discussed at length in many technical articles, are no invitation for you to run more power with no change in the audio system but are intended for your consideration next time you are sure your signal "just can't be overmodulated." If you want proof of Class B plate-current readings in relation to actual developed audio power, visit a broadcast station using high-level Class B modulation and observe the modulator plate meter and the percentage-of-modulation indicator during transmission of speech. Music will not make such a striking difference, but hams are legally banned from music transmission so we have no reason to consider it unless some of us who delight in whistling for testing purposes feel that our efforts have something in common with music.

There is another common cause for a broad signal, and although this cause is common it does not seem to be apparent to many operators even when their signals cut a wide swath in the 'phone bands. The culprit is audio distortion. Anything that alters the waveshape causes distortion, and distortion may be represented as an output waveshape that is an unfaithful reproduction of the input signal. Most audio amplifiers are guilty of some distortion but the better ones are less guilty. If the distortion reaches the point of greatly changing the waveshape so that a high order of audio harmonics is developed, then our modulated signal will be at least as broad as twice the frequency of the highest-frequency audio harmonic. While these high-order harmonics may be cut off after being generated by use of by-pass condensers, the over-all quality will still suffer if the harmonic-distortion percentage was high in the first place. The average ham can minimize distortion in his speech amplifier by careful adherence to good design practice as outlined in the ARRL *Handbook* and in many *QST* articles; so, with a good speech amplifier and an r.f. section working properly, where else may he look for distortion troubles? The only thing left is the Class B modulator.

A listen across any ham 'phone band might indicate a common notion that about the only thing that can be wrong in the seemingly simple circuit of a Class B stage is the "match" or the relation of the Class C load reflected back on the plates of the modulators. While this point is of

(Continued on page 180)



How's DX?

CONDUCTED BY JOSEPH E. GRAHN, * WICH

How:

The mail bag continues to spill forth letters from the DX gentry griping over the operating practices. This column for the past several months has made many worth-while suggestions, but no one seems to have put them into use, with the possible exception of a few of the rare DX stations (more power to them!). Jeeves suggests that the W gang try calling the DX 5 to 10 kc. off his frequency, so that when the DX does come back (maybe not to you) he can be heard, regardless of how many are calling him. I've tried this procedure for the past couple of months or so, with not-too-good results, for the simple reason that upon finishing the call and listening the DX was buried under — mind you — not by newcomers, but "old-timers."

To the DX: Not answering any W calls on your own frequency makes the chances of your being heard much greater — you have at your fingertips the power to control DX QSOs. A QSY to your frequency, at your request, tends to make the best use of the frequencies available.

There really is strong agitation for running a "Pig Pen" to list the violators of good ethics, the worst stinker of all, the "off-frequency bird," plus the "hanger-on-till-the-DX-fades," although the last-mentioned is now beginning to be a rare specimen.

W6VBY is all riled up because the Ws pay no

* 53 Quinapoxet Lane, Worcester, Mass.

attention to QLM, etc., to which I add "old-timers" again. The above-mentioned list is growing daily, both via mail and personal contacts. Stop a moment and think how your call would look in a box, set aside in this column and marked "Pig Pen" in bold type. Not nice, eh? Okay — be a gentleman and it won't appear.

All right, Jeeves, you can come out from under the table now — I feel a little better.

What:

The 80-meter boys are doing themselves proud and showing some of the 14- and 28-Mc. gang how to do it. W3WJF starts the ball for 80, having worked PAØNG (3505), G1SUR (3513), HB9EO (3528), G16TK (3535), G5HH (3537), G8QZ (3538), G5LI (3538), ON4WR (3540), G2HFO (3540) and HB9AJ (3549) W4IWT with a No. 18 wire in the trees hidden from BCLs snagged W8QEN/CT2, FN4PB (French airplane over Marseille) and a flock of stuff on 40. What kind of trees are they? W2PWU worked G5JU (3550), G5RI (3515), G6ZO (3509), G8DZ (3519), PAØDC (3543) and G8BM (3527) W2AIS tagged onto 36 pieces of 3.5-Mc. DX in 10 countries VE1EP hooked G5LI (3548), HB9OD (3525), OK1CX (3530), OK1FF (3525), G2DOW (3515), PAØSS (3520), ON4HC (3525) and G6RB (3510) W6LHN snagged G6ZO (3510) which isn't bad.

Seven Mc. is one of our pets, and is still holding its own W3KCI worked ZL3FP (7130), HH2FE (7050), ZL2MM (7120), UB5KAE (7040), LA7Y (7120), OK2NR (7030), HB9BX (7035), ON4AU (7062), EI9Q (7180), KL7CR/KL7 (7035) and EI9Q (7180), for a total of 29 countries W8WSL kept busy knocking off 41 DX stations but gives no frequencies. He lists just about everything except Asia W2PUD sez 40 is better than 20 during rush hours, and his proof is YN1GJ (7180), PAØYN (7085), ZL2MM (7120), OK2NR, (7030), GW3VB (7025), G13AXI (7020), LA2H (7040) and SM4WZ (7180). Sez EP1AL will be on 7050 soon W1MDF with 25 watts lists 28 foreigners worked Part of the worked list at W1KXB: W7HOM/KH6 (7090), UB5AL (7187), VK2RA (7226), ZL2PM (7241), ZL2BH (7241), TI4MAR (7222), OX1AA (7235), KH6AO (7094), IIRZ (7046), PY2AFA (7040), HB1CE (7146) and I1US (7088).

Roaring 20 is always good, VFOs and all W6SN snagged 34 real nice hunks for

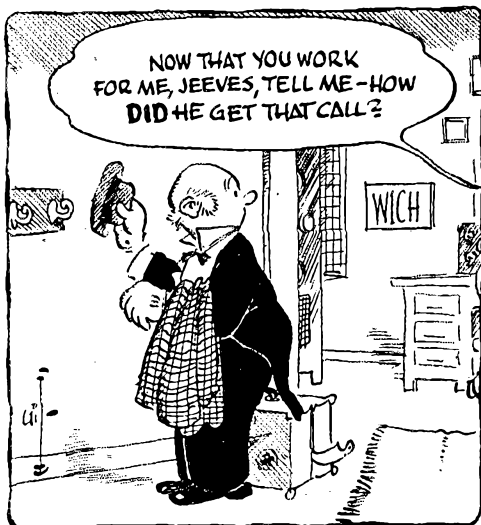

himself, the best of which are **UB5KAE** (14,050), **UA4HB** (14,075), **VP9K** (14,050), **W6VKV/I6** (14,090), **UN1AO** (14,000), **ET1JJ** (14,040), **VS9AU** (14,000), **ZB1AD** (14,085), **OX5JJ** (14,040), **CR7VAL** (14,040), **VQ8AD** (14,015), **TF3A** (14,125) and **VQ5JTW** (14,065) **KP4KD** has been keeping busy with **EK1AZ** (14,100), **VS1BU** (14,140), **W3EKK/J2** (14,130), **ZD4AB** (14,130), **ZA2D** (14,140), **VQ2HC** (14,130), **KL7AD** (14,005), **OX5JJ** (14,160) and **W6BWS/KG6** (14,080) **W1NWO** and **W2OOL** invite any of the 20-meter 'phone gang to get into a QSO they have been having with **W2CDJ/J** on 14,350, about 5:00 P.M. EST. These contacts have been the long way around, over the South Polar regions **W4BRB** lost sleep working **VQ8AB** (14,115), **ZK1AB** (14,105), **J9CRP** (14,120), **UA9CA** (14,120), **UA0KAU** (14,120), **UI8AA** (14,100), **PK4KS** (14,035), **UQ2AB** (14,100), **UA0KTU** (14,120) and **UA1AT** (14,100) **W2ALO**, **W3BKZ**, **W2HHF**, **W3MLN**, **W3GHD**, **W1JYH**, all sent in nice worked lists. Thanks.

The 28-Mc. boys are really in there grabbing the rare ones On 'phone **W5KUC** grabbed **J2GHQ** (28,475), **ZL3JO** (28,160), **VK3ABA** (28,460), **W6VRF/KG6** (28,520), **PY7VB** (28,150), **J9ACS** (28,420), **J9AAR** (28,380), **HR1MB** (28,480), **W4BOW/Iwo Jima** (28,500) and **W8OK/KG6** (28,500) **W8UUS**: **W7JIT/KL7** (29,620), **G2YH** (28,215), **J9AAI** (28,325), c.w. **ZS6H** (28,210), **GM4FK** (28,185), **OZ7UU** (28,125) and several Gs and ONs **W9KOK** managed **CR9AG** (28,085), **CN8BK** (28,165), **CR7AD** (28,035) and **OE1AX** (28,040) **W8NOH** worked **G15ZY** (28,460), **OZ6SQ** (28,400), **LX1BO** (28,375), **D4ACV** (28,115), **ZL3BV** (28,405), **J9AAI** (28,500), **XU6GRL** (28,435), **LA7Y** (28,502), **KG6AB** (28,710), **PZ1G** (28,460), **I1SM** (28,120), **LU4EB** (28,340) and **OQ5BL** (28,485). **WAC** on Jan. 20th in 11 hours At **W9TWC** it was **CR9AG** (28,180), **VQ2GW** (28,150), **CN8MZ** (28,250) and **W6VDG/KW6** (29,200), with a

• Close observers of this column will notice that it is now being run by one DX man instead of by WIDX. The reason behind the change is, of course, pretty obvious — By Goodman just couldn't take the boobing he was getting about his new call, and at present he is hiding in a corner of the laboratory, trying to confirm Ohm's Law. The change is all for the good — QST gains a real DX editor, WICH, who will handle the job from his home in Worcester, Mass.

nice bunch on 20 **W1OS** made it four-band trans-Atlantic with **G5LI** on Dec. 14th. This may be a record, as to the best of my knowledge it's never been done in such a short time.

Where:

From **W1TW**: **J3AAD**, Capt. F. O. Stevens, APO 301, c/o PM, S. F., Cal.; **J4AAC**, Major J. Dridge/Coates, Brindiv Signals, Japan; **PK6EE**, Peters Arends, Merdekajaweg, 59 PTT, Macasser, Celebes, N.E. Indies From **W2HHF**: **ZC1AN**, c/o Arab Lgn., Es Salt, Transjordan; **J9CRP**, NAB Navy No. 824, Box 22, care FPO, S. F.; **PK2AA**, c/o P.O. Djokja, Java; **PZIAL**, Box 226, Paramaribo, Surinam; **CR4BQ**, British Sea Cables Station, Porto Grande, Cape Verde Islands; **W0MCF/C1**, Box 401, Shanghai, China **W6GAL** sends along **VP8AI**, Alan Betts, Pebble Island, Falkland Islands; **VU2WS**, 12 Balbedie Terrace, Lochore, Fifeshire, Scotland; **XU6GRL**, Dr. Stuart, c/o International Dept. Ministry of Information, Nanking, China; **KV4AD**, Box 136, Frederickstad, St. Croix, Virgin Islands From **W6GHG**: **VQ2GW**, Box 74, Luanshya, N. Rhodesia; **J3GNX**, 126th Signal Service Co., APO 713, c/o PM, San Francisco, Cal.; **OA4BE**, The National Club, Lima, Peru; **VS7MB**, Ceylon West Receiving Station, c/o BMFO, Colombo, Ceylon.

◆ The photo last month of **CR9AN** showed only one-half of his shack. Here is the other side with the rig that is now doing the business. The transmitter is a 6L6 driving an 813, and crystal switching is used when quick QSY is required to get out from underneath the DX hogs. The receiver is an NC-100A and the antenna is a single-section **W8JK**. Those cards on the wall are all a result of the QRP work, however.

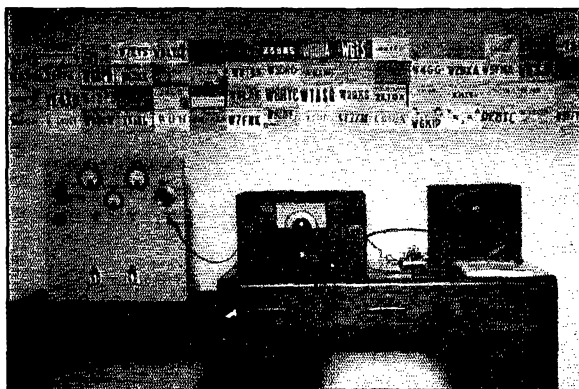

Tidbits:

VP3JM has 10,000 cards printed and all contacts will receive one in due time. W9KXN/CT2 will QSL to anyone not having received his card upon receipt of one. His QTH is Ray Lane, 918 E. Macon, Clinton, Ill. W2ITD wants more c.w. activity from Venezuela. HZ1AB comes through with the info that the station is run by J. P. Anderson, 1130 Leighton Ave., Anniston, Ala., who is W4JMQ, and A. M. Buta, 418 Great Falls Street, Falls Church, Va., W3JEG. QSLs for HZ1AB should go to 1432 AAFBU, APO 816, c/o PM, N. Y. C. From W6BCX, re W1DX's call: "It don't mean a thing even if it has got that swing!". W6VBY is looking for some way to pry QSLs loose from the DX stations, and suggests the "shotgun" routine. If it works let us know, Herb — we'll furnish the gun and shells. To all stations: did you check yourselves on the "DX Personality" chart given in February's DX column? No? We did, and found ourselves to be an "optimistic stupe"! With that, 73 till next month.

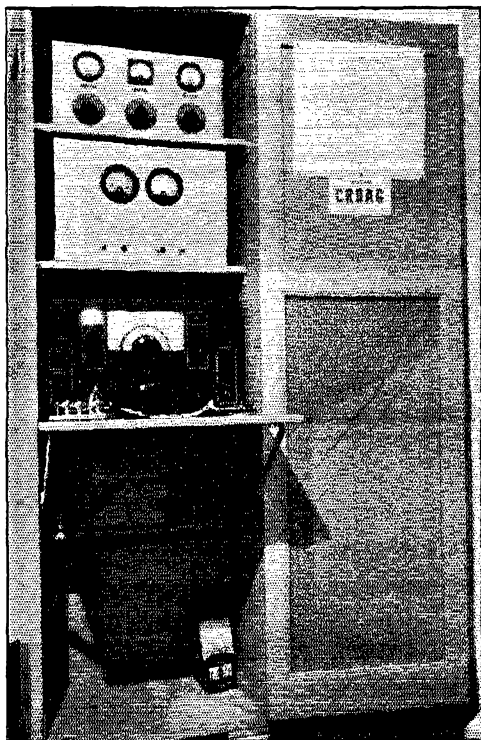

To round out the description of amateur radio in Macau, here is the rig of CR9AG, ex-VS6AG. John Alvares has always had neat stations and this one is no exception. The transmitter on the top shelf uses a 6L6-807-811, and the power supply rests below it. The receiver is an NC-100A, and a two-element rotary beam is used for transmitting and receiving.



MARCH 1922 *QST*'s hottest story — appetizingly served up by Clyde Darr's Hawaiian beach-scene cover of grass-skirted hula maids, a sailor, the moon and a wireless receiver — tells the startling news of the reception of two dozen of our stations by Clifford J. Dow, 6ZAC, now living in the Island Paradise. American amateurs as far inland as Wisconsin were heard on Mr. Dow's detector and one, sometimes two, stages of audio. Traffic already has been handled, and now that we have one leg secured in the hurdle of the Pacific, we read predictions of a Honolulu-Pekin-The Hague relay!

Reports are still arriving on the Transatlantics. We were heard by eight British amateurs, as well as stations in France and Holland. Only c.w. stations — including the new rig at 1ZE — were copied by the British. "The Successful Transatlantic Stations," by Robert C. Higgy, replete with pictures and diagrams, describes these noteworthy performers. There are many lessons to be drawn about antennas, adjustments and operating techniques. The record of IBDT's 5-watter alongside the kilowatters has thrown the power consideration wide open.

Destined to enjoy wide readership is "The Improved Reinartz Tuner," this month's leading technical paper. Fixed, tapped spider-web coils have replaced the movable coils used in the original. To expedite wide frequency coverage, provision has been made for changeable exterior coils. In another receiver article, Charles T. Jacobs details a method for receiver condenser switching using the new antiparallel switches. "A Spark-Coil C.W. Transmitter," by Francis L. J. Duffy, 9DDY, gives the plan for a popular new 5-watt c.w. transmitter with a spark-coil plate supply.

The advent of the radiophone has disturbed the tranquillity of our amateur radio world. With 14,000 of us — sparks, c.w. and 'phones — strongly crowding the upper limit of our 200-meters-and-down assignment, operation has been none too pleasant. S. Kruse's "The Radiophone and the Code Station" argues convincingly for cooperation between these two factions in our ranks. New commercial radiophones have been making their appearance in the wavelengths above us, and in line with their regulation, our voice stations have been temporarily prohibited from broadcasting programs of information and entertainment. Editorially, *QST* points to the seriousness of the situation and calls for local discussion. There are policy-making days ahead, new laws to be written, and a rapidly-growing

(Continued on page 188)

Foreign Notes

R.C.A. 25TH ANNIVERSARY

The Argentine amateur society recently celebrated the 25th anniversary of its founding, commemorating the date with a banquet attended by more than 200 persons, including telecommunications officials of the government and representatives of the amateur societies in Brazil, Uruguay, Paraguay, Bolivia, Peru and Puerto Rico.

President Osvaldo Risso Peuser, in addressing the group, recounted many memories of the early days and briefly described the society's history. Perhaps the keynote of the speech, however, was contained in his final words, "This is America . . . in its own modest sphere the *Radio Club Argentino*, now celebrating its 25th anniversary, tries to contribute to a better understanding and mutual friendship among all the peoples of the world . . . I propose a toast to the brotherhood of the ether . . . *Salud!*"

QSL PROCEDURE

There seem to be some amateurs who still are not fully aware of the required methods of preparing and dispatching QSL cards distributed through the various member-societies of the International Amateur Radio Union.

A list of QSL bureaus of the world appears in the "Foreign Notes" section of each May and October *QST*. Each address is that of an individual (or group) who has volunteered to arrange the local distribution of cards intended for amateurs in his country. American and Canadian

hams should send their foreign cards direct to the proper QSL bureau and *not* via ARRL Hq. If you have cards for countries not listed, and the individual addresses have not been published in "How's DX?," they may be sent via ARRL.

Do *not* affix postage to cards. They are sent in bulk via the bureau system. U. S. postage is not valid in foreign countries! (But you can sometimes make a hit with the QSL manager, in case he is also a stamp collector, by using U. S. commemorative issues on the outer envelope.) There is no need to include international reply coupons with cards sent via the bureau system.

Please take note that the QSL bureau address in a foreign country may be different than that of the headquarters office. R.S.G.B. is a case in point; British cards should be sent to the October *QST* address and not to that shown, in error, in current editions of the *Call Book*. It is also well to keep in mind that foreign amateur societies in most cases will not handle cards for GIs temporarily operating in their countries; such cards should be sent direct.

Specific instructions on how American and Canadian amateurs can obtain *incoming* cards appear in another part of this issue and will continue to appear in every other issue hereafter.

POPULATION SUMMARY

Simply as one of the factors complicating the attempts at solution of international operating and suballocation problems by informal agreement between the member-societies of I.A.R.U., it is interesting to note the following tabulation of amateur population in several countries selected at random. If nothing else, it is mute evidence why amateurs outside the United States do not look with favor on agreements limiting their 'phone operation to the same channels available for A3 in America.

Argentina	1040	Mexico	545
Australia	1700	Netherlands	407
Belgium	300	Newfoundland	52
Colombia	87	Norway	150
Cuba	250	South Africa	365
Czechoslovakia	150	Sweden	540
Denmark	300	Switzerland	145
Eire	60	U.K.	4500
Luxemburg	45	U.S.A.	75,000

R.S.G.B. PROGRESS

Exceeding all expectations, the membership of the British society increased by nearly 3000 in the past year to bring the total to 12,570. This compares with 9600 and 7700 as of the end of

(Continued on page 188)



Ernst Krenkel, chairman of the Central Radio Club of Moscow. In the amateur bands he uses the call RAEM, originally assigned to the 1938 Russian Polar Expedition, of which he was chief operator. For his communications work Krenkel holds the government citation, "Hero of the Soviet Union."

Finding the Inductance of R.F. Coils

The Grid-Dip Oscillator for Convenient Measurement

BY ROBERT M. CROTINGER,* W0GUY

HIGH-SCHOOL algebra teaches that if we know two of the unknowns in a formula containing three, we can find the third by transposing the formula. This principle is the basis of many present-day test instruments.

The resonant frequency of a circuit is determined by two factors, the inductance and the capacitance constituting the circuit, and can be found from the formula

$$f = \frac{1}{2\pi\sqrt{LC}}$$

The solution of the equation frequently is expressed in various forms that require little or no arithmetical work: for example, nomographs such as the one in the ARRL *Handbook*, slide rules and calculators of various types, tables of *LC* products at different frequencies, and so on. The principle, either with or without the aids to calculation, offers a simple way to determine the one quantity, inductance, that is generally known to a lesser degree of accuracy than the other two quantities.

In laboratories, inductance is generally measured on a *Q*-meter or on an r.f. bridge. These instruments are quite costly and cannot be made in the low-priced field. Therefore, the amateur must turn to some other method. A generally accepted device is the grid-dip oscillator.

The principle of the grid-dip oscillator is based on the fact that an *LC* circuit tuned to resonance

* Asst. Chief Engineer, KANS, Wichita, Kansas.

† See chapter on Measurements in *The Radio Amateur's Handbook*.

• Among the collection of gadgets that is to be found in every ham station that has got beyond the bare transmitter-receiver stage there certainly ought to be a grid-dip meter. Like a voltohmmeter and a "Little Gem," it's so useful that once you have one you'll consider it indispensable. Measuring inductance values is just one of its applications.

with a self-excited oscillator and coupled to the oscillator inductance draws power from the oscillator. Because the oscillator is then supplying power to a load, less power is fed back from the plate to the grid to sustain oscillations. This results in a decrease in the grid current of the oscillator.

With this method of measurement it is necessary to know the oscillator frequency and the capacitance required to resonate the unknown coil to that frequency. An oscillator easily can be calibrated for frequency by methods that are well known to most amateurs.¹ The condenser is a little harder to calibrate, but a sufficiently-good calibration can be obtained by methods to be described later.

The instrument pictured offers a convenient and quite accurate means for measuring r.f. inductance values. It consists basically of an electron-coupled oscillator variable from 2000 kc. to 16 Mc., and a standard condenser with a group of shunts to extend its range.

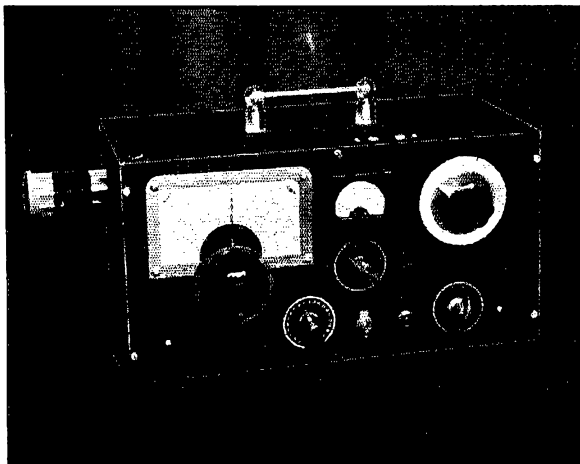

W0GUY's grid-dip meter, complete with power supply in cabinet, with oscillator coils plugging in from the outside. The pin jacks for connecting the coil to be measured are on top at the front edge, between the meter and the control for the calibrated variable condenser.

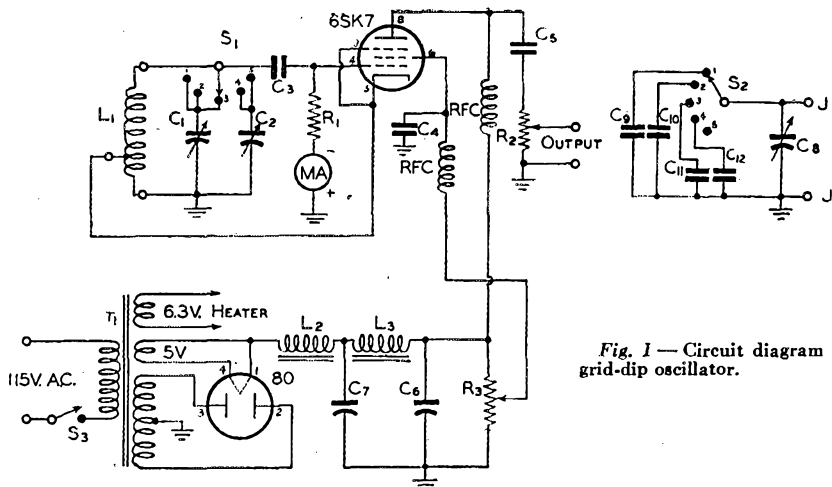

Fig. 1—Circuit diagram of the grid-dip oscillator.

C_1 —140- μ fd. variable (Hammarlund MC-140-M).

C_2 —35- μ fd. variable (Hammarlund MC-35-2).

C_3 —100- μ fd. mica.

C_4, C_5 —0.005- μ fd. mica.

C_6 —16- μ fd. electrolytic, 450 volts.

C_7 —8- μ fd. electrolytic, 450 volts.

C_8 —140- μ fd. variable, s.l.c.

C_9 —50- μ fd. mica.

C_{10} —75- μ fd. mica.

C_{11} —100- μ fd. mica.

C_{12} —200- μ fd. mica.

R_1 —75,000 ohms, $\frac{1}{2}$ watt.

R_2 —1000-ohm wire-wound potentiometer.

R_3 —25,000 ohms, 10 watts, adjustable (set screen voltage at approximately 100 volts).

J—Tip jack.

MA—0-1 ma. d.c. milliammeter.

RFC—2.5-mh. r.f. choke.

S_1, S_2 —Ceramic wafer switch, 1 pole, 5 positions.

S_3 —S.p.s.t. toggle.

T_1 —Receiver-type power transformer, 250 v. each side c.t. at 50 ma., approx.

L_1 —No. 1—43 turns No. 22 s.c.c. on $1\frac{1}{4}$ -inch diam. form, tapped at 10th turn from ground.
No. 2—18 turns No. 14 enameled, on $1\frac{1}{2}$ -inch diam. form, tapped at 8th turn from ground.
No. 3—8 turns No. 18 d.c.c. on $1\frac{1}{4}$ -inch diam. form, tapped $2\frac{3}{4}$ turns from ground.

Frequency Ranges

S_1 Position	Coil No.	Frequency Range
1	1	2000 to 4400 kc.
2	2	3900 to 8100 kc.
3	3	7.1 to 15.25 Mc.
4	3	11.25 to 15.6 Mc.
5	2	6.1 to 8.3 Mc.

L_2, L_3 —16 henrys, 50 ma.

4 and 5, Coils 3 and 2 (L_1) respectively, are tuned by a 35- μ fd. variable. This was done to expand these parts of the range which include the 7- and 14-Mc. bands.

The coils plug into a ceramic socket on the side of the unit. In this position they radiate appreciably when not shielded, and the signal can be picked up on a receiver with no connection to the oscillator, permitting accurate measurement of the oscillator frequency with a multivibrator-type frequency standard if available. This would be desirable for accurate measurements.

The standard condenser (C_8) should be a straight-line-capacity unit; the one used is a Cardwell ZU-140-AS. Shunts permit increasing the standard capacity to resonate coils over a wide range. The ideal method of calibration would be to use an r.f. bridge, but the ham seldom has access to this instrument. However, he can generally obtain a serviceman's capacity bridge. To obtain a reasonably accurate calibration from this instrument it is best to measure the condenser capacitance along several parts of the bridge scale. This is done by first measuring the capacitance for different dial settings with the condenser connected directly across the bridge. A graph is then drawn for this measurement. Then a capaci-

The oscillator circuit, Fig. 1, employs the usual Hartley-type frequency-determining tank, which permits the condenser rotor to be placed at ground potential with consequent elimination of hand-capacity effects in tuning. Provision is made for obtaining r.f. output from the oscillator plate circuit, with the 1000-ohm potentiometer, R_2 , offering a means for adjusting the output voltage. This is useful for lining up receivers. When using the unit for this purpose a metal shield is placed over the oscillator coil and electrically connected to the cabinet to avoid pick-up from the coil.

The oscillator and its power supply are built on a $13\frac{1}{2} \times 5\frac{1}{2} \times 2$ -inch chassis and are enclosed in a $7 \times 15 \times 7\frac{1}{2}$ -inch cabinet. The parts layout shown in the photographs was selected chiefly from the standpoint of convenience in operating. The number of holes to be drilled is not large. Two of them, one carrying the lead from the standard condenser to the shunt switch and the other the grid lead from the tuned circuit to the 6SK7, should be insulated with ceramic grommets.

It will be noticed that on bandswitch Positions

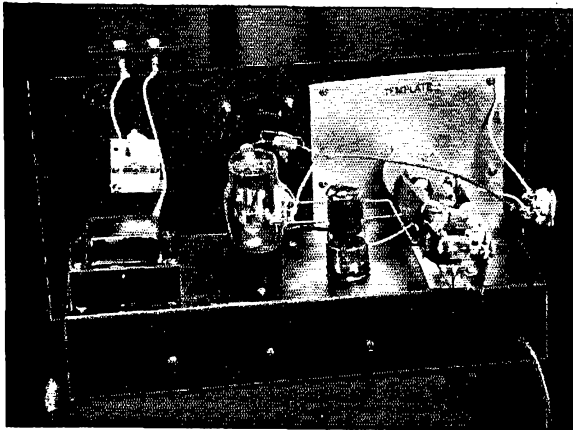

A view of the chassis arrangement. It was necessary to dismount the pin jacks and coil socket from the cabinet to take this picture.

small values of inductance, remember to keep the leads to the standard condensers as short as possible, since the lead inductance adds to the coil inductance and thus makes the measured value slightly high.

Other Applications

Many other uses for the instrument will be apparent. The calibrated condensers can be substituted quickly when servicing, in place of one thought bad. The oscillator can be used as a signal generator, provided a shield is placed over the coil on the unit.

Another practical use of the instrument is the determining of the resonant points of radio-frequency chokes. Each r.f. choke has distributed capacitance which resonates with its inductance at certain points, and both series and parallel resonance can occur. The choke may burn up if used at the parallel-resonant frequencies in a transmitter because of the high circulating current. At series resonance the choke presents no appreciable impedance and consequently completely fails its purpose.

The parallel resonance points can be determined by placing the choke in close proximity to the oscillator coil and varying the oscillator frequency until a pronounced dip occurs in the grid current. It must be remembered when varying the oscillator frequency over one of its ranges that the grid current also will vary across the range, but this variation is easily distinguished from the resonance dip. To determine the series resonance points it will be necessary to short the choke leads so the choke can absorb power from the oscillator with the parallel-resonant circuit shorted. The choke to be measured should not be held in the hand because body-capacity effects will change the resonant points.

The unit also provides a very quick and convenient method of checking the resonant frequencies of antennas. For example, the fundamental frequency of a half-wave center-fed antenna can be measured by lowering the antenna and tying it together at the center with a small shorting loop loosely coupled to the oscillator coil on the instrument. The oscillator frequency is varied until a dip is obtained. The frequency of the oscillator can then be measured by any of the usual means. Harmonic resonance can be similarly checked.

tance of known value is connected in parallel with the condenser to be calibrated and the capacitance values measured again. Another graph is drawn subtracting the known capacitance value from each reading. Although the serviceman's bridge may be off a little as to direct scale reading, it is generally correct in its variation along the scale. The graphs will show the condition of the bridge calibration and thus permit a better calibration of the standard condenser to be made.

Measuring Inductance

In making measurements, the coil of unknown inductance is connected to the two pin jacks indicated at *J* in Fig. 1. The coil is then placed in close-enough proximity to the oscillator coil to give a pronounced dip in grid current when C_2 is tuned to the frequency to which the oscillator is set. An oscillator frequency must be chosen at which the coil can be expected to resonate with the standard condensers in the unit; this is not hard to do because of the rather large capacitance range. The instrument will give a good dip with high-*Q* coils at distances of several feet.

With the unknown connected and the oscillator frequency chosen and set, the standard condenser is varied until the grid-current reading dips. This indicates that the tank formed by the unknown coil and standard condenser are in resonance at the frequency of the oscillator. Knowing the frequency and the resonating capacity, it is a simple matter to transpose the resonant frequency formula and find the inductance, or it can be found from *LC* tables or an ARRL Lightning Calculator. Actually, the value so found is the "effective" inductance at the oscillator frequency and includes the padding effect of the distributed capacitance of the coil. However, the true inductance usually differs from the measured inductance by such a small amount that the discrepancy is well within the normal errors in measurement.

When measuring coils, particularly those with



The World Above 50 Mc.

CONDUCTED BY E. P. TILTON,* W1HDD

AMATEUR RADIO being the medium it is for the dissemination of news, it is highly improbable that anyone needs to be told that we have a new 50-Mc. DX record. It was 10 P.M. EST on January 25th when Capt. Bob Mitchell, KH6DD, Ewa, Oahu, worked J9AAK on Okinawa, but by 7:30 the following morning most of us had heard about it — and good news it was!

For some time it had been believed that the maximum usable frequency for F_2 work hits its highest peaks over the vast reaches of the Pacific Ocean, but we had no positive proof, as there was little interest in 50-Mc. work in this whole great area. There were plenty of hams on the various islands, to be sure; but they were far from home, and no one could blame them if they were interested in using ham radio principally as a means of keeping in touch with their families and friends. There wasn't much encouragement for the few who were interested in the possibility of v.h.f. DX, but KH6DD (ex-W6TZB) kept on trying.

His first success came at 1:16 P.M., Hawaiian Time, on Jan. 25th, when contact was established with W6VDG/KW6 on Wake Island, who was replying on 28 Mc. The signal of J9AAK was first heard by KH6DD at 3:07 P.M. and the first contact was made at 3:13, when J9AAK answered his CQ. Signals were S7 at peak during this QSO, which lasted until 3:40. A second QSO took place at 4:33, with signals over S9. At 4:48, W7ACS/KH6 at Pearl Harbor took over, the contact lasting until 5:07, when signals began to fade out. It is said that W7ACS/KH6, who had access to m.u.f. information, was responsible for getting things started at the right time.

The rig at J9AAK runs 68 watts to an 829, feeding a 5-element close-spaced array. KH6DD used 500 watts to VT-127-As, and a single-section "Twin-Three" rotary array. W6VDG/KW6 is expected to be on 8 soon for 2-way work, with a converted BC-522. Crossband contacts with Wake were made by KH6DD on the 26th (1:50 to 2:45) and on the 27th (1:12 to 1:35), and schedules are being kept daily.

Schedules have been arranged for daily tries with Okinawa, and interest is at fever pitch. With the ball now rolling, it is probable that many more contacts will be made throughout the Pacific islands, and there is a likelihood that work with VK, ZL, KA and even W6 is not far off.

RECORDS

Two-Way Work

- 50 Mc.: KH6DD — J9AAK
4600 Miles — January 25, 1947
- 144 Mc.: W3HWN — W1MNF
390 Miles — September 29, 1946
- 235 Mc.: W9OAW/6 — W6WQN/6
110 Miles — December 15, 1946
- 420 Mc.: W6FZA/6 — W6UID/6
170 Miles — September 28, 1946
- 2300 Mc.: W1JSM/1 — W1LIS/1
1.6 Miles — June 23, 1946
- 5250 Mc.: W2LGF/2 — W7FQF/2
31 Miles — December 2, 1945
- 10,000 Mc.: W4HPJ/3 — W6IFE/3
7.65 Miles — July 11, 1946
- 21,000 Mc.: W1NVL/2 — W9SAD/2
800 Feet — May 18, 1946

As is often the case, the excitement of the occasion gave rise to countless versions of the story. Such work has historic significance and is of considerable scientific interest, so it is important that details be recorded accurately. Our thanks to KH6AR and W1PFJ for their help in getting the story straight, and our hearty congratulations to KH6DD and J9AAK for an outstanding achievement.

January proved to be slightly better than December in respect to the maximum usable frequency for the North Atlantic path, but the m.u.f. never went quite high enough to permit 50-Mc. work with Europe. Beginning about Jan. 14th the observed m.u.f. was high enough to make observations interesting, but there was little hope of any trans-Atlantic work. For several days the European television signals on 45 and 46 Mc. came through well in W1, and on the 16th, 18th and 19th, harmonics were heard up to 48 Mc. They were in and out for brief periods, however, indicating that the m.u.f. was barely up to 48 Mc. Our European observers, G6DH, PAØUN, and PAØUM, were more optimistic. They were hearing signals from the east and southeast up to 50 Mc., and they were sure that reception of amateur 50-Mc. signals would have been possible from Rumania, southern Russia, and southwestern Asia, had there been anyone active in that direction. G6DH reported reception of a Rumanian broadcast harmonic on 49.2, and a harmonic of ODD (Lebanon) near 50 Mc. From the predictions available it would appear

* V. H. F. Editor, QST.

that there is a possibility of trans-Atlantic work in February and March, and the picture for Europe, Africa, Asia, and the Pacific Ocean areas is very good indeed. The path from southern Europe, western Asia, and northern Africa to South Africa should be open high enough to permit DX work even on 56 or 58 Mc., and east-west paths in the vicinity of Latitude 20, north or south, should be open up to as high as 60 Mc. during peak periods.

In the Netherlands at least three special licenses for 50-Mc. work have been issued by the very cooperative licensing authority of that country. PAØUN and PAØUM are already on the air, and PAØWJ is nearly ready. Our one hope in Asia, YI2CA, has disappeared without trace from the 28-Mc. band. He was a regular in keeping skeds, and was to have been ready, by now, with a 50-Mc. rig and automatic transmissions, but at this writing he is on the list of missing signals, on 28 as well as 50 Mc. Here's hoping he just took time out to get that 50-Mc. rig finished. In Tanganyika, on the west coast of Africa, VQ3TOM is getting set to transmit on 50,160. He does not, as yet, have a receiver for 50 Mc., but will make crossband tests with interested parties. A signal will be provided by a station in Palestine (call not being published) during the m.u.f. peaks in February, March and April. Watch for this signal, identification of which will be obvious from the transmission content, and report reception of it at once. Tests with the station may be arranged through SU1CX on 28 Mc. — if you ever hear SU1CX!

V.h.f. DX interest is developing in the Pacific Ocean areas, with stations on for two-way or crossband work in the Hawaiian Islands, the Marshalls, the Marianas, on Wake, and Okinawa, all of them near that magic Latitude 20, where the m.u.f. is supposed to be above 50 Mc. for hours daily. KH6DD is on regularly from 2330 to 0100 GCT, aiming at W6, and from 0200 to 0300 for VK and ZL tests. He has 500 watts or more and plenty of good antennas. He is keeping skeds with J9LG on Kwajalein, W6VDG/KW6 on Wake, KG6AC on Guam, and several VK and ZL stations, as well as with the boys on Okinawa. The inter-island (Hawaiian) 'phone (scrambled speech) on 49.2 Mc. provides a good check for possible DX work, and W6VDG/KW6 has heard it on several occasions.

The 28-Mc. band is just one great international grapevine for 50-Mc. news these days. Your conductor got his first inkling of the Pacific DX by listening to ZS6DW, and over a relay route which included W7EYS, ZS1T and W1PFJ, we have dope on the gang in Okinawa, also sent in by J9ABX/W6EFH. The J9s have an island network on 50 Mc., which includes J9s AAR, AAL, AAK, ABX, ANA and AAW, with more to come. These fellows transmit at 1930 PST for 10 minutes, and for alternate 10-minute periods there-

More 50-Mc. Frequencies

W1ATP Holliston, Mass.	50.48 Mc.
W1CGY Enfield, Conn. (n.f.m.)	52.51
W1NSS Bristol, Conn.	50.25
W1OOG Providence, R. I.	50.78
W2COT Maplewood, N. J.	50.7
W2GYV Schenectady, N. Y.	51.45
W4CYW Richmond, Va.	50.38
W4FJ Richmond, Va.	50.26
W7ACS/KH6 Pearl Harbor, T. H.	50.03
W8TOB Lorain, Ohio	50.19
J9AAK Okinawa	50.08
J9AAL Okinawa	50.64
J9AAR Okinawa	51.9
J9ABX Okinawa	51.0
KH6DD Ewa, Oahu	50.001
PAØUM Rotterdam, Holland	50.00
PAØWJ Leusen, Holland	50.58
VE4FU Winnipeg, Manitoba	51.96
VQ3TOM Tanganyika	50.16
XE1GE Mexico City	50.4
YI2CA Habianiya, Iraq	50.2

after. They are interested in DX skeds with other Pacific islands, and with the Asiatic mainland.

We have persistent reports that there is activity on 50 Mc. in the Philippines, but we wonder if anyone has done much actual transmitting or listening out there, since the m.u.f. between KA and KH6 should be up around 60 Mc. these days. Through PAØUM we have the report that KA1ABA has a high-powered rig and a receiver for 50 Mc., and also that PK1AW has promised to get on.

December and January in Australia, which are like our June and July, have made sporadic-E work almost commonplace to the VKs, according to VK2NO, who has worked three states, Victoria, Queensland and South Australia, and has been heard by VK7CW in Tasmania. On the evening of Jan. 8th, VK4s worked VK5s, for what is believed to be the first work between these two areas. The stations are separated by approximately 1000 miles. One of those grapevine reports says that VK5KO has heard W signals on 50 Mc., but no details have yet been obtained.

In Mexico, XE1KE and XE1GE are now active on 50 Mc., the latter being a recent convert who now has a 4-element array. Both stations work regularly on 28 Mc. and they are looking for schedules with the boys who work both 10 and 6. Situated as they are, 600 miles from Ft. Worth, 1000 miles from Douglas, and 1400 from San Diego, these fellows should be able to get in some sporadic-E work with W stations, even if the F_2 m.u.f. doesn't go high enough this spring to do them any good. It will be interesting to see how E-layer work turns out that far south.

There was a smattering of sporadic-E skip during January, just to keep the record clear. On the 4th the band was open for work between the Middle West and South. W9PK reports contacts with W4EQR, Pensacola, Fla., W5HHT, New Orleans, and W5FRD, Ft. Worth. WØZJB worked W4EQM, Langdale, Ala., W5AOK, Ingleside, Texas, and W5WX at Amarillo.

The ionospheric disturbances of Jan. 24th and Jan. 25th produced some aurora effect in the Middle West, reports WØZJB. He tells us that WØDZM, Anoka, Minn., worked W9QUV, W9PK, WØNFM, and WØIFB. WØQIN and WØDWU were also in on the Minnesota end of this party. The aurora condition was a mild one, as is customary in the midwinter period. More violent disturbances can be expected to follow the m.u.f. peaks in February and March. Watch for some good aurora sessions during the third weeks in both these months.

What About N.F.M.?

In prewar years a few hardy souls used f.m. on the 5-meter band, but it was wide-band f.m. and there were very few receivers capable of doing it justice. Those who had suitable receivers enjoyed good reception of the f.m. rigs, but it was far from a sensation. F.m. was wonderful for broadcast reception, but did it really pay off in amateur circles? The answer was open to considerable doubt.

Now we have a somewhat different picture. Narrow-band f.m. with crystal control has brought reception of f.m. within the capabilities of the receivers we already have. Phase-modulated crystal rigs bear little resemblance to the old reactance-modulated VFO jobs, the signal from which sounded like a bad case of a.c. hum and overmodulation troubles on any selective receiver. N.f.m. can just about hold its own in competition with a.m., when received on the conventional receivers, and when equipment especially designed for it is available it outshines all other forms of modulation in providing high intelligibility under difficult conditions, as has been demonstrated in actual tests. Use of n.f.m. in crowded city areas has shown that it is the long-sought-for cure for the broadcast-interference problem, thus opening up the use of the 50-Mc. band to many apartment-house dwellers who have not dared to operate on the band with a.m.

The chief deterrent to the use of n.f.m. has been the segregation of f.m. transmissions to the frequencies above 52.5 Mc. The few who have tried f.m. on 6 have ample proof that it is practically impossible to get contacts while operating in that range. In this day of beam antennas and sharp receivers it simply is not possible to cover both ends of the band, so everyone tunes the end where the stations are operating, and the f.m. user is left out on a very long limb. The result has been the receipt of numerous letters and petitions asking that the entire 50-Mc. band be opened to n.f.m. operation.

This is, of course, a matter for the next ARRL Board meeting, to be held in May. Now is the time to make up our minds as to what we want in this connection, and *inform our directors of our wishes*. Looking at the matter from the technical

considerations only, there is no logical reason why n.f.m. should not operate alongside a.m. in the entire band, since it has been demonstrated that properly-controlled n.f.m. need occupy no more territory than a properly-operated a.m. station of the same power. It may, actually, use less.

There are other considerations, however. It occurs to the writer that n.f.m. might be used as a lever to encourage use of more of the band, and the suggestion is advanced that n.f.m. be extended to 51 Mc., and that all other forms of emission be permitted above 52.5 Mc. The use of n.f.m. between 51 and 52 Mc. would impose no hardship on the experimenter, and it would tend to populate that portion of the band, since many potential users of n.f.m. are holding back at present. Duplex operation should be permitted, and encouraged, in the high end of the band, since this would provide a good opportunity for crossband work with 11-meter stations, where duplex is also legal. Let's think it over, in any event, and don't forget — your ARRL director wants to know how you feel about it!

Here and There on 6

Our published reports of commercial harmonics heard on 50 Mc. have never failed to bring a response from someone who was able to give us more information. In this category is WEDI, reported heard during the trans-Atlantic opening on November 24th by G5BY. O. L. Rairdon and W3KZS came forward with the fact that WEDI is the S. S. America, formerly the troop transport *West Point*. All we need to know now is where the *America* was at 10:17 A.M. EST on the morning of November 24th. Some months back we reported reception by G5BY of KOE, which is now identified as the call of an aircraft on an international flight. Actually, the call is KHDOE, the HD in which is dropped by international agreement. This would seem to rule out this reception as a DX possibility, as the signal heard was apparently an 8th harmonic, and the plane was probably over or near the English coast at the time of reception. Our thanks to W2OLU for this information.

How many states will we work on 50 Mc. this year? The 1946 record of 27, made by W1LLL and WØZJB, should be topped by a wide margin in 1947, but there are still states in which no activity has yet been reported on 50 Mc. These include South Carolina, Mississippi, Tennessee, Arkansas, Nebraska, Colorado, New Mexico, Wyoming, Montana, Utah and Nevada; a total of 11. There have been promises from several of these, but what we want are active stations! Who will get going in these and other hard-to-get states? Several which were missing last year are now taken care of: Alabama is represented by W4EQM and W4HVD, Oklahoma by W5HLD,

(Continued on page 184)

The Balloon Antenna Rides Again!

More Practical Dope on Gas-Filled Skyhooks

BY GEORGE BONADIO,* EX-WBOMM

HERE is good news for the ham with the condensed backyard but expanded antenna ideas. Hydrogen and helium gases are *not* required! Further, they are both too expensive and too cumbersome for the average enthusiast to use in putting up "Kytoons,"¹ or just plain round balloons.

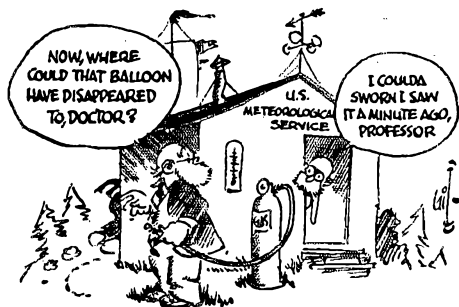

In spite of its low pressure, ordinary house gas brought out of the cellar with the garden hose will inflate any prewar-style meteorological balloon to bursting. Coal gas averages a specific gravity of 0.5. This means that a given balloon must be inflated about 20 per cent greater in diameter by coal gas to equal the lift of hydrogen. The surface of a balloon increases as the square of the diameter while the gas volume increases by the cube of the diameter. Hence, a natural gas of only 0.75 specific gravity could still be used for balloons with some compromise.

During the summer of 1941 I set out three vertical full-wave antennas on 160 meters. Somehow there is an immense thrill to letting a balloon up eighteen times as high as the house. It provokes a peculiar type of elation much like the first overseas contact. In each case the support was a D & A Co. balloon filled with house gas through the garden hose. The distinctive odor of house gas is lost through latex, so that the sense of smell cannot be used as a safety check on releasing the gas at disassembly times.

The first two balloons were only about 3 feet in diameter, and supported just one strand of No. 26 wire in the safety of the night. Because of the nearby airport I lighted the third by two auto bulbs internally mounted through the neck gas seal and fed by two enameled wires. The wires were fed from the ground through r.f. chokes.

The third balloon was about eleven feet in

diameter. It took 3 hours to inflate it with a half-million cubic inches of gas at a cost of about 85 cents. Two hundred feet of light 3-ply house twine were used in a triangular-shaped balloon net to support the wire, because the neck of the balloon was listed by the manufacturer to be safe only up to 5 pounds lift. A car battery was used for an anchor, since it was soon apparent to me that our muscles are not built for holding down the ten pounds lift which a spring scale indicated. I experienced some difficulty in getting the top of the balloon to expand under the pressure it exerted on the net. Perhaps talcum on the string would have helped. The extra stretching on the bottom might have shorted its life to eight hours in the air. With even expansion it was not rated for over 9 feet in diameter, but I went the whole hog. This was in daylight.

The effect was astounding. Crowds swarmed the neighborhood. No parking places were left on either side of the road. Mother almost fainted when she saw little children running across the road while Sunday drivers drove their cars with their heads out of the windows to look at the balloon. One carload drove in from fifteen miles away, having determined to track down this new planetoid.

Transmission and reception were equally spectacular. To start with, the HQ-120X would no longer take care of the two local broadcast stations — 450 kc. apart, i.f. of receiver 455 kc. — without wavetraps. Whole states usually unheard in the daytime were heard and worked on 160

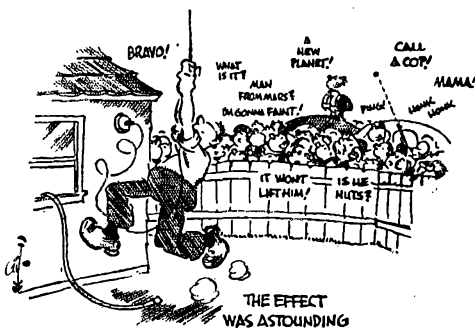

meters, with good reports both ways. Thirty watts of 'phone was used. It seemed to be a little better in all directions than my horizontal full wave was in its very best direction. The full-wave vertical seems to be a great low-frequency antenna.

*325 Winslow Street, Watertown, N. Y.
¹Ferrier and Baird, "A New Kind of Skyhook," *QST*, Oct., 1946.



Hints and Kinks

For the Experimenter



UNTUNED KEYING MONITOR

To eliminate the need for retuning the keying monitor every time transmitter frequency is changed, the gadget shown in Fig. 1 was designed. The entire set-up is simple, noncritical, and can be built compactly, permitting its use inside the receiver cabinet. There, out of the way, it does a nice job without readjustment no matter how often you QSY.

A 1N34 crystal detector is used to provide a small rectified voltage from the r.f. signal picked up on a short antenna placed near the transmitter. This voltage is then used to overcome an initial blocking bias on an oscillator tuned to the i.f. frequency of the receiver. The signal thus created appears in the rest of the receiver the same as any other c.w. signal, beating with the b.f.o. and producing any tone or volume that the operator may desire. The r.f. stages of the receiver are killed by rewiring the stand-by switch, so that it removes B+ from them but permits the i.f. and audio stages to function normally.

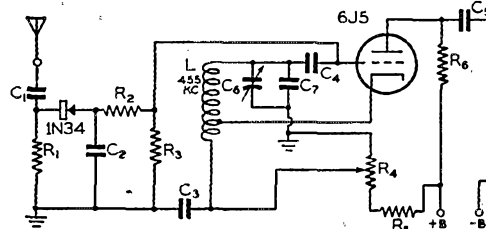

Fig. 1 — An untuned keying monitor that may be installed inside the receiver cabinet.

- C₁ — 0.0002- μ fd. mica.
- C₂ — 0.001- μ fd. mica.
- C₃ — 0.01- μ fd. paper.
- C₄ — 0.0001- μ fd. mica.
- C₅ — 5- μ fd. mica.
- C₆, C₇ — As required to tune inductance to i.f. frequency of receiver.
- R₁ — 1000 ohms, $\frac{1}{2}$ watt.
- R₂ — 0.47 megohm, $\frac{1}{2}$ watt.
- R₃ — 1 megohm, $\frac{1}{2}$ watt.
- R₄ — 20,000-ohm potentiometer.
- R₅ — 0.1 megohm, $\frac{1}{2}$ watt.
- R₆ — 47,000 ohms, $\frac{1}{2}$ watt.
- L — 455-kc. i.f.-transformer coil, modified. (See text.)

In adjusting the unit for operation, the bias on the 6J5 must be set so that the oscillation is just triggered with each keyed character and is killed between characters. This is controlled by potentiometer R₄. The output condenser is merely clipped onto the grid of the first i.f. tube. Over-

coupling to the i.f. grid will produce a signal rich in harmonics that is less tiring to the ear, but may detune the i.f. stage. The location of the cathode tap on the 455-kc. i.f. coil used as the oscillator inductance should be determined experimentally. Somewhat more than the usual "one-third up from ground" will give best results, assuring sufficient feed-back to permit the oscillator to follow fast keying. A fairly high-C circuit should be used here to obtain the degree of stability desired. Some experimentation may also be required to get the correct value for R₁. Too much resistance here will result in lack of rectified voltage, too little in excessive crystal current. — Rowland C. Medler, W4ANN

INEXPENSIVE BCI CURE

HAVING about 75 midget a.c.-d.c. "cracker-box" sets in the immediate vicinity of my 250-watt 10- and 20-meter 'phone rig, I had to do something about the resulting BCI. It had to be inexpensive, yet effective. I found that by-passing one side of the heater of the combination detector/first-audio tube (usually a 12SQ7 or its equivalent) with a 0.001- μ fd. mica condenser cured about 95 per cent of all cases when the trouble was caused by power-line pickup. — Ted Wilds, W4GVD/9

MORE ON BCI

AFTER spending much time and effort, two very simple methods have been found to be effective in eliminating interference to the broadcast receivers in this neighborhood. The type of interference was the common garden variety where the listener picks up the local ham all over the dial of his receiver, and at almost any setting of the volume control. The r.f. in this case is apparently entering via the power lines, and getting into the audio circuit at the grid of the first audio tube.

In the conventional a.c. transformer sets, and in all a.c.-d.c. midgets, it was found necessary to by-pass the 110-volt a.c. leads to the chassis, and in addition to lower the value of the grid leak on the first audio tube, by-passing it at the same time with a 0.00025- μ fd. condenser. By-passing the grid without first reducing the grid-to-ground resistance simply put a lot of hum into the set which was more objectionable than the gabbing

(Continued on page 138)



Correspondence From Members -

The Publishers of *QST* assume no responsibility for statements made herein by correspondents

WANTS SALARIED DIRECTORS

412 E. 17th St., Los Angeles 15, Calif.

Editor, *QST*:

... I'll be darned if I can discern the slightest justification in any ham's argument against becoming a member of the League or in any action taken by groups of hams direct with Governmental agencies instead of through ARRL. . . . The comments about ARRL being a one-man organization (particularly here on the West Coast) and the reluctance of some fellows about joining are attributable to three things: ignorance, laziness, and the organization of the League as it exists today. My experience in amateur affairs discloses that the majority of the "bickerers" are those who attend club meetings for the express purpose of being entertained; seldom will they accept and discharge responsibilities with any degree of tenacity. Consequently, clubs are carried solely by the perseverance of a few individuals. Similarly with ARRL: Through the Headquarters gang and the directors, ARRL has survived and functioned, decisions being arrived at by common sense and the contact you have with the minority of fellows who have the enthusiasm and energy to express their opinions in writing to their elected representatives.

I must admit, however, that our directors are not as much in contact with their constituents as they should be. This situation largely is due to the economic problem of having to earn a living while trying to occupy the office of director. . .

Common sense tells you which function suffers. A director has three strikes on him before he gets up to bat, regardless of how enthusiastic he may be. The end result is that he infrequently if ever covers all the clubs in his division and is guided to a great extent by the dictation of his own common sense and by the discussions which take place at the Board meetings. It is a natural reaction that follows then, when many fellows feel that they have no voice in the actual decisions being made. What's to be done to correct this situation?

The answer which first occurs to me is that of making our directors paid full-time employees of the League with the establishment of a branch office of ARRL in each division. You kill two birds with one stone by this move. First, you have available a full-time full-coverage representative. Secondly, the branch offices bring ARRL closer to the home fronts and eliminate the prevalent feeling that "Hartford" is too far away. How to pay for the program? Assess the amateur a yearly fee! Smacks of unionism you say — but, so what? No matter what the price, organization is the only answer to achieving the demands which we may make and combatting the perils of encroachment which other interests may present. . . .

— Ken Kiernan, W6BPM

FROM "PARAGON PAUL"

P.O. Box J, Upper Montclair, N. J.

Editor, *QST*:

My January *QST* arrived today and I found myself very much impressed both by your editorial, "Accomplishments Old and New," and by the well-done spread under "Twenty-Five Years Ago This Month." Both are fine examples, it seems to me, of first-class writing; and I shall have to break down and admit that, as I read the stories, all the old 1921 thrills came alive again. Please thank all the boys who participated in this work. Your gang there shows a performance record and spirit of which they should be deeply proud.

— Paul F. Godley

TAKING STOCK

1605 Lincoln Pl., Brooklyn 33, N. Y.

Editor, *QST*:

I note with interest the question raised in the October issue: "Anybody any idea what we can do about it?"

It seems to me that the real problem of the Headquarters gang is one of re-examination of our basic ingredient, the ham.

When a new member of the fraternity opens his first *QST*, some of the impressions he gains are not very much to boast about. Our first principle of making a minimum do the same or better job as a maximum is conspicuously lacking. Instead he finds a gruesome collection of 100- to 1000-watt rigs complete with beam tetrodes, bandswitching, VFO, etc. On the other hand, if he wants to find something to parallel his technical knowledge and billfold, he is faced with some utterly ridiculous article featuring a rig for about \$2.79 complete with doorbell wire, a tube stolen from his receiver and embodying construction principles which are much less seen than talked about. In the receiver section, the one article of note for the entire year featured an 8-tube job which by now has passed into obscurity with many more of its class. The newcomer's other slant is obtained by looking at pictures of "model stations." He is always certain of finding an 18-tube "Sky-Skunker" sitting on top of a handsome desk. So, as far as his means go, receivers of less than six tubes don't exist any longer, and are antiques which went out with honeycomb coils and the '01-A.

Well then, let's take stock. Where are we headed? At our present rate and direction I'd say it isn't where some of the old-timers would like to see the gang.

If we are to judge by trends, it wouldn't be hard to predict that the commercial houses will move into the transmitter field within the next five years as they have the receiver field. Since our mainstays are the receiver and transmitter, the expression "resplendent with boughten gear" should be applicable to most of the gang. This points immediately to a miserable state of affairs, since if we buy and don't build, people would have a right to question the term "amateur." In short, this wonderful hobby called amateur radio will be knocked for a loop unless it follows along the principles created on home-built, home-experimented and home-proved equipment. I've no respect for the character that displays a wallful of QSL cards obtained the easy way.

It's not too late to swing our beam in the right direction. Let's go back to squeezing our 25-100 watts all over the globe, concentrating on antenna design and transmitter efficiency rather than clumsy kilowatts. We know that a 15-tube receiver can pull 'em in but with a galaxy of new and better tubes developed in the last five years, let's see what the two-to-five-tube job can do. And finally, let us 100,000 experimenters go back to our old job of feeding the manufacturers the latest developments in high-efficiency versatile gear and circuits.

Only when we've found ourselves will we have re-exchanged inertia and dollar bills for ingenuity and resourcefulness. I, as an amateur, look to *QST* and the League to lead the way. The sooner the better!

— Raymond Goldstein, W2QGC

"CALLING AND RETURNING"

75 Minaville St., Amsterdam, N. Y.

Editor, *QST*:

Your reference to the use of the word "handle" in radio-telephone conversations brings to mind another inane expression which many ham 'phone ops use these days. That is the

expression "calling and returning." If a guy is calling how can he be returning? If he is returning how can he be calling?

However, after all is said and done, the hams will always use the expressions they like and time and tradition will keep the ones that are best.

— Jack Nelson, W2FW

THEORIES

100 Adams St., Dorchester 22, Mass.

Editor, QST:

The exact nature of electricity, what it is, or whence it comes, has never been understood. The modern explanation, as we all have read, is supposed to be the electron theory. The definition of theory is as follows: "A proposed explanation designed to account for any phenomenon." It is my firm belief that the electric current as we know it is really a magnetic current.

The ancient Greeks discovered that when a piece of amber (which has mineral properties) was rubbed on a piece of fur it acquired attraction. Is this electricity? I say no. An electric current, as we know it, has a starting point to which it returns to complete the circuit. We have a South and North Pole.

I purposely have avoided a deeper explanation in order to make this brief. I would like to hear from several brother members who are serious in their hobby and have definite ideas on this subject.

— John J. Marshall

SPOT FREQUENCIES?

Ironwood, Mich.

Editor, QST:

Would it be worth trying, in order to lessen QRM on the 'phone bands, to suggest that amateurs grind their crystals to any one of an experimentally-determined number of channels an equal distance apart? Suppose we channel from 3850 to 3900 kc., suggesting that crystals be ground for 3852, 3854, 3856, etc. Maybe that would be found to be too close, and 3-ke. separation would be better. You would know that better than I. The ECO boys could mark their dials and choose their channels. . . .

— L. W. VanSlyck, W3BY

STIGMA

Woods Hole Oceanographic Institution,
Woods Hole, Mass.

Editor, QST:

Heard on 23-Mc. 'phone Saturday morning, November 2nd: "W5KMD, The Ladies Delight Station, calling CQ, CQ, CQ, W5KMD, W5-Kiss-Me-Deer calling CQ" (a long, low wolf-call whistle then followed). But no, this wasn't enough of a blow to serious-minded amateurs — this was just the beginning. We then heard that W5 call more stations, more CQs, etc., signing with "W5KMD — W5-Kiss-My-Dimple," followed by a lot more long, low wolf-calls. By this time I could stand it no longer so I promptly resurrected the old stamp album and settled back to paste stamps, without the radio on. See what I mean?

— Robert G. Walden, W1LVN

CONTESTS

c/o Radio Station WHOT, South Bend, Ind.

Editor, QST:

. . . The Sweepstakes Contest was on this afternoon and it seems that every amateur in the country entered. I don't know where the fellows were that didn't care to get into the contest (probably gave up in disgust the same as I), but I couldn't get a QSO of any kind. I would like to enter these contests myself but it is impossible for me to do so because of the hours that it is necessary for me to work. . . .

I would like to suggest that a part of each band be set aside where fellows who can't or don't care to enter a contest could get together for enjoyable QSOs while the contest is going on.

— Jack C. Andrews, W9YWE, W9EPA

"HAM"

618 E. Mitchell St., Petoskey, Mich.

Editor, QST:

I note that in one of the recent issues of QST some of the radio amateurs are taking exception to being called "hams" and I believe they have a valid kick coming. In railroad parlance "ham" means an operator who has a receiving quotient of practically nothing-minus and by the same token a radio ham would not be at all proficient in the art.

I have been doing a little cramming on radio theory now and then for over ten years and was just about set to take a little run over to Detroit for an examination in hope of getting a ticket when alas! — complications arose. After getting a copy of the study guide issued by the FCC, and borrowing a copy of *Radio Operating Questions and Answers* pertaining thereto, I decided with little hesitation that an amateur should not be called a ham, but a radiotrician or electrical engineer.

Radio is my hobby and I enjoy reading QST and other radio publications very much as well as constructing a receiver or transmitter to the extent that my meager knowledge of the subject will permit. I am no kid any more, either, and the brain-assimilation department does not function as well as it did in the old high school days. Rather tough at that to have to heave the *Handbook, How to Become, etc.*, as well as many other radio publications into one corner of the basement and listen to the engineers carry on. Radio, even amateur radio, is their field, so more power to them.

In conclusion I want to mention that congratulations are in order for the ARRL for the fine work they are doing for the radio amateurs, not only at present but in the past. As the boys on the air say, "Fine business."

— Horace C. Dolph

W6USN

Mare Island Naval Shipyard, Vallejo, Calif.

Editor, QST:

We, the amateur radio operators of the Mare Island Amateur Club and of the electronics facility at Mare Island, wish to express in this open letter our wholehearted thanks and deep appreciation for the services rendered in the handling of the amateur radio traffic of station W6USN during the Navy Day program at Mare Island Naval Shipyard.

Much credit is to be given to the Pioneer Network, W6REB, of Yreka, Calif., control; the Gem Network, W7JMH, of Boise, Idaho, control; the Canadian networks in particular; station W6IOX of Santa Barbara, Calif. Credit is also to be given to all other networks and individuals who handled or relayed the traffic. We are very grateful for the time and energy they gave so freely for helping along this Navy Day program.

— L. O. Shovalter, W6KITW, J. W. Clark, W6CAN

NOTE TO MR. RAPP

179 Harris Ave., Needham, Mass.

Editor, QST:

Upon reading L. E. Rapp's "The Circular Band Theorem," W2SGJ, W4GZT and I constructed receivers and transmitters to operate in the 10-meter circular band. . . . Circular-band equipment is very expensive. The VFO, for example, cannot use a straightforward tuning condenser of, say 150 μ fd., but must have one of complex capacity; i.e., 150 + j150 μ fd. This, of course, is because the tuning characteristic has to be circular instead of linear.

Secondly, wide-band f.m. is impossible on a small circular band. The frequency shift due to modulation may pull the carrier all the way around the band until it's on the other side of the center frequency.

The final blow, though, was when I ruined a \$79.45 transmitter by quickly changing frequency while on the air. It would have been OK to QSY on a linear band, but when I hurriedly moved my frequency halfway around the circular band one night, centrifugal force pulled the carrier right off the band, and no one has been able to hear my signal since.

— Lindsay Russell, W1PCJ

(Continued on page 138)

How to Cook a Ham

A Tested Recipe

BY C. L. STONG,* W2PFM

A CASUAL glance at the panel showed all meter readings at zero. Only two of the pilot lamps showed any color and those were green; any ham would know the rig was dead.

It seemed rather silly to install interlocks. Anyone with half a brain, even without twenty-five years of "hamming" behind him, knows that high voltage kills. Perhaps interlocks make sense to a youngster just starting in the game. But, speaking personally, a full quarter century of experience certainly has placed me above the need for automatic safety gadgets. Indeed, why not interlocks on flashlights?

So, certain that everything was "off," I slid down behind the rack. Grasping one of the angle braces for support, I gingerly reached with the other hand for a tiny resistor buried deep in the wiring of the buffer stage.

Instantly, it struck! A horrible agony ripped through my body. Something was tearing the flesh from every bone. Yet, I could see a little. I watched the tendons in my wrists grow stiff like slender bars of steel. My fingernails doubled under as they dug into the metal.

I could even think — a little. Shake loose! Get loose . . . pull . . . pull! You fool! You hopeless idiot! Get loose! You're stuck fast and *now you are going to DIE!*

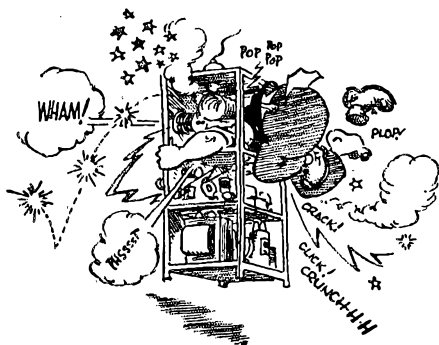

As suddenly, it ended. I dropped free.

My fifteen-year-old son had heard a low groan had yanked the main switch — just in time. Brother! That was a close one!

For a few seconds more thin blue smoke curled up from three black holes in my left hand. It was stinking smoke and it slowly drifted through the whole house.

Later, my kid remarked, "Gee, pop, I didn't know you could get that kind of a burn off low

voltage . . . you were across only 350 volts! What would a thousand do?"

"There is no such thing as *low* voltage," I shakily replied. "Say, where in heck did we put those interlocks I brought home last year?"

Lament for the Past

My love was fair as the summer breeze
Kissing a night-stained sea.

My love was free as a soaring gull
Blithe in his artistry.

My love was brilliant as northern lights
Shimmering over the vast
And mystic void of the northern nights
Entombing the infinite past.

I lost my love when the moon was new,
Gleaming with golden sheen
Over mountain edges that melt from view
Into time and the great unseen.

I lost my love to an errant witch
Riding a Hertzian broom
(The FCC says "witch" rhymes with "which")
She hovers about his room.

I lost my love to a carrier wave
Bred of a 6L6,
Who turned him into a puling slave
With her sneaky seductive tricks.
My love was a being of flesh and blood
In the sunny idyllic past,
A structure of bone and cartilage;
And as such was unsurpassed.

But now a transformer pumps his blood,
That steady electron stream,
Through veins of wire that guide the flood
Into an aerial beam.

And as I watch in my bitter grief,
His pulse keeps pounding anew,
As it throbs for the witch its beat of love —
"Calling CQ, CQ . . ."

— Mrs. Doris C. Grautoff, XYL of W3KNU

FEED-BACK

Dana W. Atchley, jr., W1HKK, coauthor of the February *QST* article, "Direct-Reading Modulation Meter," has regretfully notified us of the following errors in his manuscript: in the parts list of Fig. 1, R_1 should be 1100 ohms, R_2 16,000 ohms. Both resistors should be rated at 1 watt.

* 27 Barry Road, Scarsdale, N. Y.



Operating News



F. E. HANDY, WIBDL, Communications Manager

E. L. BATTEY, WIUE, Asst. Comm. Mgr.

GEORGE HART, WINJM, Communications Asst.

J. A. MOSKEY, WIJMY, Communications Asst.

LILLIAN M. SALTER, Communications Asst.

About DX. Practically all amateurs have at least a speaking acquaintance with DX. Who hasn't worked some at one time or another? Those yellow survey cards that you are still sending back indicate that many of us take DX as it comes, one interesting part of a great institution, Amateur Radio. While the rag-chewer group outnumbers the strictly-DX group, the radio columnists have in DX something with natural glamour. While some take their DX thrills in intermittent doses and in stride, others go crazy over DX and make it their all in amateur radio. The ARRL Countries List was presented in *QST* last month. It serves for day-to-day reference of casual DXers and DX hounds alike. The DX urge is a "natural" with amateurs. Enumeration of DX by countries, likewise.

DXCC Announcement. Everyone working any DX likes to keep track of his progress. To facilitate that and provide recognition for the top specialists in the DX field we have the new DXCC Award. The Award rules are explained in detail elsewhere in this *QST*. ARRL is now ready to open the business of card checking for 100-countries-worked-postwar certification.

The Countries List first, DXCC Award second, and finally the DX Competition going on currently to help you work some this month! New to the gang will be the recognition available for those who keep plugging after they have achieved the basic Award for their initial 100 countries worked. For each block of ten additional countries for which written proof-of-QSO can be submitted there will be added ARRL endorsements to attach to each large postwar DXCC certificate.

On Getting 100. One hundred will remain the big basic achievement for the DX-minded to work toward. Of course most hams are nowhere near 100 countries worked postwar. We're for the chap just started on the road, and for making the DX available to help him have fun in getting his 100. (It's partly because, believe it or not, some DXers are almost at the century mark that ARRL had to provide immediate additional goals "beyond 100.") The tips on DX, "How's DX?" will try to give you. It will take you a lot of listening and patience. We think this DX pursuit should be a sporting proposition, operating skill and good will combined, just as it was in the days when 100 meters was the prime DX spot and

countries available were numbered at only a dozen. While amateurs in certain new spots have been in much demand, leading to some regrettable ECO-pouncing and shoving around on the part of a few, it is increasingly apparent that orderly awaiting one's turn and decent courtesy in operating will pay off. The Golden Rule, when followed, will insure each operator of keeping his self-respect. Operate to inspire the good will of the foreign DX operator. He can set the pace and he should insist on rewarding those who operate with common sense and courtesy, if he will.

A DX-minded friend indicated to us not long ago his opinion that there was no special magic formula for raising DX. Required are a good rig, operating proficiency, and the expenditure of lots and lots of time listening and following up all the possibilities as they develop. Improving antennas and rigs and employing calling-working judgment as we go along, will pay off for all of us.

FMT. Like every other activity, the Frequency-Measuring Test went over the top. Hundreds more measurements than expected were made and reported. Our homework for the next fortnight will be FMT accuracy calculations. Your patience please. Each participant will get an individual report on his results. By next month we hope to have figured out who gets the Clock Awards. Of course we're glad the world has been so good to Official Observers and Members. The many, many new and surplus BC221- and LM-type frequency meters and low-frequency bars in the hands of amateurs, the high interest in practicing to reduce personal and instrument error, all augur well for an expanding ARRL OO organization.

SECs-ECs-AEC & Preparedness. A disastrous December fire in Alaska placed a burden of communications responsibility squarely on the hams of a community. Sudden similar emergency may wreck vital facilities in your city or town. Winter's last gasp may mean blizzards, wires down, spring floods and communications emergency . . . public calls may be expected on the amateur radio service.

ARRL requests every active licensed amateur who has not already done so to get an ARRL Emergency Corps blank and fill it out for his EC, SEC or SCM. Emergency Coördinators have been asked to work out community organization

in line with a set plan, adapted to amateur service facilities and the needs of their city or territory.

In any city where AEC radio drills are not being held, you as an individual amateur should talk up plans for a local net and outside contacts for possible emergency. Make it your business to see that the SCM has a recommendation for any needed Coördinator activity — and if plans are not being developed properly suggest to any locally-responsible ARRL officials what you think could be done, and offer your personal assistance. *QST* will continue to tabulate time, date, frequency, and number of members in AEC groups dedicating drills or tests to the cause of constant preparedness of amateur communication facilities, for such possible emergencies as described above.

Wanted: Official Experimental Station Applications. Some interesting new projects are coming up. If your station works at 50 Mc. or any frequency above and you are a consistent and sincere experimenter, there's a place for you in this group. Write your SCM for an application form. See the *Operating an Amateur Radio Station* booklet, or page 66, March 1946 *QST*, for complete details on OES.

FCC Active in Necessary Amateur Monitoring. We hear that a good friend is off the air with a ticket for a "drifting" signal. Now he'll have to fix it up! Reports from many sources reach us indicating consistent FCC activity in checking bad notes, unstable or creeping signals, BCI, and key thumps and chirps within our bands. In addition FCC follows up illegal or unlicensed stations, and those hams with harmonics, parasites or off-frequency effects. Next month we'll try to run some short items covering actual use of mobile FCC gear in nabbing offenders. Suffice it to say this month that "a word to the wise" is enough. To avoid citations, blue (and other color) tickets, advisory notices and what have you, *monitor your own signal*. Check carefully after every operating change! Even doing this we can go wrong unless our check covers a lot of territory and conditions. It's a good idea to get acquainted with the ARRL Official Observer in your city or Section. Local tests with two or three other amateurs sometimes pick up things not as surely discernable in station monitoring gear. ARRL OO reports as well as known FCC observations covering the DX Competition period will be used as a basis for the Contest Committee to use in disqualifying entries in line with standing policy. Amateur Radio must utilize such checks to maintain high operating standards. We want no complaints against the amateur radio service at the coming International Telecommunications Conference.

— F. E. H.

ATLANTA HOTEL FIRE

Upon learning of the disastrous Wineoff Hotel fire on last December 7th, W4KV, of Atlanta, Net Control Station, alerted the Cracker Emergency Net (3995 kc.). Many messages concerning the welfare of victims were handled. Active stations included W4ZD, W4JLB, W4BIW, W4AAY, W4BTI, W4BOL, W4DBM, W4GUN, W4QT, W4BA, W4FUO, W4GLX, W4VF, W4FSW, W4BYV and W0MSF. The net remained active until midnight. W4BIW operated portable gear from the Atlanta Red Cross Headquarters, furnishing replies to inquiries. W4HKA at Albany, Georgia, handled traffic concerning the Albany high-school girls caught in the fire. W4KV's XYL did yeoman service handling land-line communications. W4BPT, in Hapeville, served as alternate NCS.

SCM Moss, W4HYW, writes, "The Cracker Emergency Net proved its value as a section net in emergencies. The Georgia Section has been complimented by the National and Southeastern Red Cross Headquarters for its efficient organization, and is the first to complete its organization with the Red Cross."

NORTHERN CALIFORNIA DX CLUB

Dan L. O'Brien, W6PB, Oakland, is first president of the Northern California DX Club. The purposes for which this club is organized are "to bring together radio amateurs interested in DX; to secure closer cooperation and coordination in their effort to achieve DX; to elevate the standards of practice and ethics in the use of amateur radio communication; to participate in the exchange of knowledge, methods, or any other expedient that would be mutually beneficial to the members in achieving DX accomplishments."

All members must have confirmations of two-way communication with a minimum of 25 countries, based on the ARRL Countries List. Each member must be a member of ARRL. Any person desiring to join the Northern California DX Club should apply for application through a member or the secretary. There are twelve charter members. Vice-president is Phil Caldera, W6IKQ; secretary-treasurer is Charles Henry, W6EJA, 125 Glenn Ave., Point Richmond, Calif.

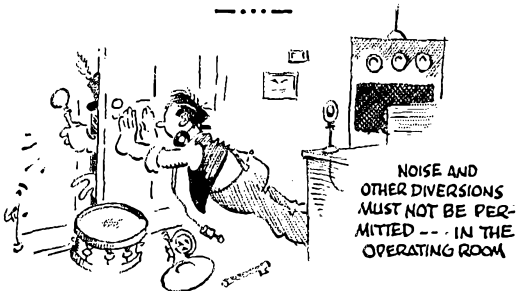

CODE-PROFICIENCY AWARDS

ARRL's Code-Proficiency Program provides certificate awards for those proving ability to copy code at any of five speeds, 15 through 35 w.p.m. Endorsement stickers for the certificates are awarded later, if first qualification is at less than 35 w.p.m.

The next opportunity to qualify for a certificate or endorsement sticker is on March 17th. At 10:00 P.M. EST that date, W1AW transmits the monthly qualifying run at speeds of 15, 20, 25, 30, and 35 words per minute. Frequencies: 3555, 7145, 14,150, 28,060, and 52,000 kc., simultaneously.

The text copied, received successfully by ear at the highest speed you can copy, should be sent to ARRL for checking. To avoid errors in recopying, send your original copy. *Attach a statement certifying over your signature that the copy submitted is direct copy, made from reception of W1AW by ear, without any kind of assistance, personal or mechanical.* If you qualify, you will receive your certificate or appropriate endorsement sticker for certificate you already hold. Those who qualified in the past should submit copy only if speed is higher than indicated on certificate or endorsement sticker.

Each night, Monday through Friday, at 10:00 P.M. EST, on the frequencies mentioned above, W1AW transmits practice material. References to text to be used on several of the practice runs appear below. This makes it possible to check your own copy. It also provides a means of obtaining sending practice since it permits direct comparison of one's fist and tape sending. To get sending help hook up your own key and buzzer and attempt to send right in step with the tape transmissions. Adjust your spacing in the manner indicated as necessary for self-improvement.

Subject of Practice Text from January QST

- Date
Mar. 3rd: *A New Phase-Modulation Circuit . . .*, p. 11
Mar. 6th: *Converting the BC-348-Q*, p. 19
Mar. 11th: *A Simple Rotatable Antenna . . .*, p. 22
Mar. 14th: *A 15-Watt Modulator . . .*, p. 28
Mar. 17th: Qualifying Run, 10:00 P.M. EST
Mar. 19th: *Technical Topics*, p. 34
Mar. 25th: *A Tuned-Line Matching Transformer*, p. 36
Mar. 27th: *Put 'Em Push-Push!*, p. 39
Mar. 31st: *A World-Time Slide Rule*, p. 47

BRIEFS

Here's a nice bit of amateur radio service. A Covington, Kentucky girl was leaving for Shanghai, China, to get married. It was necessary to start within two days to catch a ship out of Seattle, but the final necessary word from Shanghai had not arrived. Cables had gone unanswered. Enter W4FU (ex-W9FS) of Covington. It was known that he scheduled W8URU/C7, Peiping. Could he get a message through to Shanghai? Well, he went to work, and W8URU went to work. The next evening the answer came back,

and the young lady is Shanghai-bound. The routing was W4FU to W8URU to W6JIM/C7 at Nanking via ham radio, and long distance telephone from Nanking to Shanghai. Reply was via the reverse route. This was routine business for W4FU: during December alone he handled 704 messages from W8URU/C7.

W9RCJ, Joliet, Illinois, advises that all former members of OSS are invited to participate in a rag-chew session on 3540 kc. Monday evenings at 7:00 P.M. CST.



C. W. DeRemer, W7FST, Sandy City, Utah, for five consecutive months has handled more traffic than any other amateur, according to reports to SCMs. He rates the No. 1 BPL position. Practically all operation is by voice, although all bands are used, both c.w. and 'phone. Overseas traffic handling and personal radiophone contacts between GIs and relatives in the States are W7FST's specialties. Up to thirty-eight daily schedules are maintained, propagation conditions and traffic load permitting. Ten of these schedules are domestic, U. S. and Canada, seventeen with the South Pacific and South America, one each with China, South Africa and Australia, two each with the Philippines and Japan, four with Europe. If conditions make voice impractical, c.w. is used. OM DeRemer has no trouble with the code, having been a Signal Corps operator on the WAR net.

W7FST is an active member of the Utah-Wyoming Section, holding appointments as PAM, ORS, OBS and OES. He is prime organizer and manager of a network of 60 stations on 3935 kc., known as the Inter-Mountain Missions Net. The tag "Missions" comes from the fact that DeRemer believes amateur radio has very definite "public-service" missions and to those the net is dedicated. W7DTB, Lewiston, Utah, is NCS, W7JHH, Ogden, Utah, NCS-2. Net members are located in Utah, Wyoming, Montana, Idaho, Nevada, New Mexico, Arizona and Colorado. Meeting time is 7:15 P.M. MST, Monday through Friday, and 8:30 A.M. MST, Sundays and holidays. Connections are maintained with many c.w. and 'phone nets throughout the country, permitting speedy and efficient traffic routing. On top of his many other activities, W7FST transmits code practice on 28 Mc.

The OM is shown at his operating position. The large certificate above the SX-28 is an early ORS appointment when he was PIICW in Corregidor, P. I. (1922-25). Left to right are seen a BC-221-M frequency meter, receiver, two speech amplifiers, and a BC-610-E transmitter, above which is a pi-network for matching each of thirteen (!) antennas to the output.

W7FST's operating efforts merit the respect of all amateurs, but become even more praiseworthy when one realizes that the operator is blind!

BRIEFS

Outstanding DX traffic relaying is reported by W2KY. In 14-Mc. 'phone contact with ZS2CI, East London, South Africa, he was asked to handle a message addressed to ZS1T, Capetown. The message had originated at W1PFJ. ZS2CI, unable to get into Capetown, suggested that W2KY watch for ZS1DJ there. W2KY took the message and started some serious listening. Within ten minutes he had logged ZS1DJ signing with another station. With the beam square on Capetown and the kw. rig backing it up, W2KY was in contact with ZS1DJ in short order. The message was delivered to ZS1T fourteen minutes after it left ZS2CI!



The cigars are on Jeter! "It's a boy!" November 6, 1946 was a red-letter day in the life of Marine Corps Lieutenant Manning T. Jeter, jr., XUIYA, Tientsin, China. On that date he received word, by amateur radio, that he was the father of an eight-pound 11-ounce junior operator. "Boys," he said as he passed the cigars, "you can quote me as saying that radio is here to stay and that not only is this the biggest moment in my amateur radio career, but it's the biggest moment in my life."

Anxious over failure of word to reach him regarding the expected October 25th arrival, Jeter decided to try amateur radio. Unable to reach the States with his 18-watt rig, he raised J9AAB on Okinawa and requested him to try to get a message to his wife's home in Montgomery, Alabama. J9AAB made contact with W8HG W, Cleveland, Ohio, and asked him to telephone Montgomery for information. It was only 6 A.M. in Cleveland but 8 P.M. in China and 10 P.M. on Okinawa. There was to be little sleep for Jeter that night! Within 20 minutes of the initial contact with J9AAB, the message came through: "Jeter's mother-in-law says his wife and baby doing fine. It's a boy. Weighed 8 pounds, 11 ounces. Looks like his father."

Add code-practice schedules: W7FST, C. W. DeRemer, R.F.D. 1, Box 533, Sandy City, Utah, 29,000 kc., daily except Sundays and holidays, 9:00 to 10:00 A.M. MST.

A.R.R.L. TRAINING AIDS AVAILABLE

There is now available for free loan to affiliated clubs a total of seven motion-picture films and nine film strips, forming the embryo of the ARRL Film Library. Clubs conducting training programs will find them particularly useful and are urged to take advantage of them.

All motion picture films are 16 mm. sound; all film strips are 35 mm. silent, the latter accompanied by a complete lecture outline. Reviews of these films and film strips, written by the ARRL staff, are available upon request to the ARRL Communications Department. Additions to the ARRL Film Library will depend on how much use is made of the films now available and how much demand there is for additional subjects. A list of films and film strips follows:

Motion Picture Films:

- 1) "The Electron — an Introduction," U. S. Office of Education, 16 minutes.
- 2) "Radio Antennas: Creation and Behavior of Radio Waves," U. S. Army Air Forces, 12 minutes.
- 3) "The Triode: Amplification," U. S. Office of Education, 14 minutes.
- 4) "Radio Technician Training: Capacitance," U. S. Navy. In two parts, both on same reel; 30 minutes.
- 5) "Radio Receivers: Principles of Radio Receivers," U. S. Army Air Forces, 17 minutes.
- 6) "Wire Sizes and Voltage Drop," U. S. Office of Education, 13 minutes.
- 7) "Vacuum Tubes: Electron Theory and the Diode Tube," U. S. Army Air Forces, 16 minutes.

Film Strips:

- 1) "Measuring Electrical Units: Part I," U. S. Navy, 54 frames.
- 2) "Measuring Electrical Units: Part II," U. S. Navy, 38 frames.
- 3) "Inductive Reactance," U. S. Navy, 32 frames.
- 4) "Capacitive Reactance," U. S. Navy, 29 frames.
- 5) "Alternating Currents," U. S. Army Air Forces, 63 frames.
- 6) "Vacuum Tubes," U. S. Navy, 37 frames.
- 7) "Radio-Frequency Amplification," U. S. Navy, 18 frames.
- 8) "Audio-Frequency Amplification," U. S. Navy, 25 frames.
- 9) "Reproducers," U. S. Navy, 29 frames.

Three commercial free-loan films have also been reviewed by the ARRL staff, and copies of these reviews are available upon request. They are *not* available in the ARRL Film Library and must be obtained from the producer, owner or local distributor:

- 1) "On the Air," Westinghouse, 28 minutes.
- 2) "Electrons on Parade," William J. Ganz, 20 minutes.
- 3) "Radio at War," William J. Ganz, 23 minutes.

Additional films will be reviewed from time to time and reviews sent free of charge to anyone requesting them. Films and film strips from the ARRL Film Library are available *only* to ARRL-affiliated clubs. See club bulletins for further details.

NEW DX-CENTURY-CLUB AWARD

Certificate for Amateurs Who Prove Postwar Contact with 100 Countries

We present below the rules under which the DX Century Club Award will be issued to amateurs who have worked and confirmed contact with 100 countries in the postwar period. They are effective for contacts made since November 15, 1945.

Please note that the new award does not wash out your prewar DX work. If you worked fewer than 100 countries before the war and have since worked and confirmed a sufficient number to make the 100 mark, the DXCC is still available to you. See page 74 of June 1946 *QST*, for complete details on how to apply for such certification.

The new award is available to any amateur who works 100 countries from November 15, 1945, and who submits satisfactory confirmations to ARRL. Prewar holders of the DXCC award and those who may have received certificates for work based on combined prewar and postwar work also may apply upon proper presentation of 100 postwar confirmations. The new certificate will be marked to differentiate it from awards previously made. Note, too, that you may now work for endorsements to certify, in steps of 10, your countries confirmed above 100. These will take the form of attractive stickers or coupons to be attached to your postwar certificate.

The Countries List to be used in connection with the new DXCC was published in February *QST*. Please refer to it and the rules published herewith to determine how you stand in working for the Postwar DXCC Award.

1) The Century Club Award Certificate for confirmed contacts with 100 or more countries is available to all amateurs everywhere in the world.

2) Confirmations must be submitted direct to ARRL headquarters for all countries claimed. Claims for a total of 100 countries must be included with first application. Confirmation from foreign contest logs may be requested in the case of the ARRL International DX Competitions only, subject to the following conditions:

a) Sufficient confirmations of other types must be submitted so that these, plus the DX Contest confirmations, will total 100. In every case, Contest confirmations must not be requested for any countries from which the applicant has regular confirmations. That is, Contest confirmations will be granted only in the case of countries from which applicants have no regular confirmations.

b) Look up the Contest results as published in *QST* to see if your man is listed in the foreign scores. If he isn't, he did not send in a log and no confirmation is possible.

c) Give year of Contest, date and time of QSO.

d) In future DX Contests, do not request confirmations until after the final results have been published, usually in one of the early fall issues. Requests before this time must be ignored.

3) The ARRL Countries List, printed periodically in *QST*, will be used in determining what constitutes a "country." (February 1947 *QST* contains the postwar ARRL list.)

4) Confirmations must be accompanied by a list of claimed countries and stations to aid in checking and for future reference.

5) Confirmations from additional countries may be submitted for credit each time ten additional confirmations are available. Endorsements for affixing to certificates and

showing the new confirmed total (110, 120, 130, etc.) will be awarded as additional credits are granted. ARRL DX Competition logs from foreign stations may be utilized for these endorsements, subject to conditions stated under (2).

6) All contacts must be made with amateur stations working in the authorized amateur bands or with other stations licensed to work amateurs.

7) In cases of countries where amateurs are licensed in the normal manner, credit may be claimed only for stations using regular government-assigned call letters. No credit may be claimed for contacts with stations in any countries in which amateurs have been temporarily closed down by special government edict where amateur licenses were formerly issued in the normal manner.

8) All stations contacted must be "land stations" . . . contacts with ships, anchored or otherwise, and aircraft, cannot be counted.

9) All stations must be contacted from the same call area, where such areas exist, or from the same country in cases where there are no call areas. One exception is allowed to this rule: where a station is moved from one call area to another, or from one country to another, all contacts must be made from within a radius of 150 miles of the initial location.

10) Contacts may be made over any period of years from November 15, 1945, provided only that all contacts be made under the provisions of Rule 9, and by the same station licensee; contacts may have been made under different call letters in the same area (or country), if the licensee for all was the same.

11) All confirmations must be submitted exactly as received from the stations worked. Any altered or forged confirmations submitted for CC credit will result in disqualification of the applicant. The eligibility of any DXCC applicant who was ever barred from DXCC to reapply, and the conditions for such application, shall be determined by the Awards Committee. Any holder of the Century Club Award submitting forged or altered confirmations must forfeit his right to be considered for further endorsements.

12) OPERATING ETHICS: Fair play and good sportsmanship in operating are required of all amateurs working toward the DX Century Club Award. In the event of specific objections relative to continued poor operating ethics an individual may be disqualified from the DXCC by action of the ARRL Awards Committee.

13) Sufficient postage for the return of confirmations must be forwarded with the application. In order to insure the safe return of large batches of confirmations, it is suggested that enough postage be sent to make possible their return by *first-class mail, registered*.

14) Decisions of the ARRL Awards Committee regarding interpretation of the rules as here printed or later amended shall be final.

15) Address all applications and confirmations to the Communications Department, ARRL, 38 La Salle Road West Hartford 7, Conn.

BRIEF

KL7AD is a busy man when he comes on the air. The lads are standing in line to work Alaska. Such was the case on the afternoon of October 13, 1946, but one of the callers had something on his mind besides a DX contact. Ted Carnes, W9GMV, was repeating the word "urgent" at frequent intervals. KL7AD answered with a simple "K Ted." It developed that GMV had been asked by KL7AD's brother in Chicago to attempt contact and advise AD to come home at once because of a death in the family. Information was relayed back and forth, arrangements for plane reservations were made, and on the morning of the 14th AD was en route to Chicago. He was met at the airport by W9GMV and W9DO (Joliet) and their families, and spent an evening with the Joliet gang.

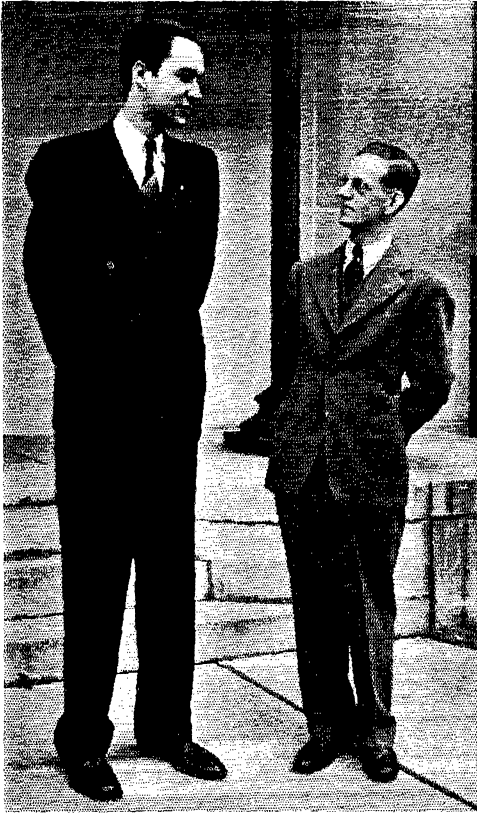

No, the chap on the right is not the world's "shortest ham." However, that other lad surely must be one of the "tallest." He is Albert E. "Doc" Hayes, W3LVY, and he rises 6 feet, 9 inches in size 15 shoes! The fellow tipping slightly backward to look "Doc" in the eye is Bob Merryman, W3FBB, a gentleman of normal height. W3LVY (ex-W1IIN), now in Baltimore, Md., is ARRL Emergency Coördinator, ORS, OBS, member of the A-1 Operator and Rag Chewers clubs, and holder of a Code Proficiency Certificate. "Doc" is 25 years old and has been licensed since 1934. It is rumored that in emergencies one end of W3LVY's skywire is supported by an upraised arm!

BRIEFS

Lieut. Colonel Frank J. Shannon, USAAF, communications officer on the Honolulu-to-Cairo *Pacusan Dreamboat* flight, is now on the air as W3QR/4, mostly on 14-Mc. c.w. His address is Wing Communications Officer, Hq. 311th Reconnaissance Wing, Tampa, Florida.

— . . . —

Communication from blizzard-isolated Greenville, Mississippi, was furnished on January 2nd by SCM W5IGW. EC W5BYX, Waco, Texas, and EC W5KTE, W5JPJ and W5KUG, New Orleans, were among those who maintained watches for two days in readiness to handle traffic from the isolated city.

QUEBEC AMATEURS AID ICE-FLOE RESCUE

On the morning of December 23, 1946, a Quebec Airways plane left the hamlet of Godbout on the north shore of the St. Lawrence en route to the Mont Joli airport with pilot and six passengers. Almost to its destination, a Mayday call was transmitted: "Over the river. Engine trouble. Turning back to Godbout." And then silence. For the next 24 hours it was assumed the plane had nose-dived into the river. The RCAF dispatched an air-sea flying boat in search. Before noon on the 24th the pilot and five passengers were sighted on an ice floe. There was no sign of the plane or the sixth passenger. Supplies were dropped, including rubber dinghies. The pilot and two companions set the dinghies in the water while the rescue ship attempted to land nearby. It was late afternoon of that day before the three men were picked up. The other three survivors meanwhile were dangerously drifting toward the Gulf of St. Lawrence at a rate of about three miles per hour.

At 4 P.M. on December 24th, VE2RO at Petit Mechin on the Gaspé Coast sighted the three survivors. An emergency call on 75-meter 'phone raised VE2NL, Rivière du Loup, who called the Mont Joli airport by long-distance telephone with the news. After alerting amateurs, VE2RO arranged to go on the river with a rescue party. After a few hours of trying, the party was forced to return because of darkness. On Christmas Day at 4 P.M. the party, consisting of VE2RO and five other men, again set out, driving fifty miles by truck east along the Gaspé Coast to the small settlement of Rivière a la Marte. At daybreak the three survivors were again sighted on a floe a mile and a half from shore. The party could not drag a more rugged boat across the treacherous floes so they set out in canoes. They returned 18 hours later with one survivor. The others were rescued later.

The frequencies 3800 to 3820 kc. were kept clear for handling emergency traffic. Messages were handled for the many Canadian and United States planes engaged in the search and rescue operations, for Marconi station VCC in Quebec, for the air dispatcher at Mont Joli airport, and for the *S.S. Colabee*, which aided in the search. Traffic was concerned with availability of aircraft, weather, landing conditions, location of the rescue parties, call for an icebreaker to rush to the scene, and incidental safety reports. Special credit is due the wife of VE2RO, who operated the station for over 24 hours, as well as the following, most of whom were on the air more than 20 hours: VE2AW, VE2NE (36 hours), VE2LA, VE2HB (50 hours), VE2DD, VE2AG, VE2DZ, VE2DV, VE2IC, VE2NL, VE2GU, VE2VX, VE2AB, VE2HL, VE2AI, and VE3GM.

RONNE ANTARCTIC RESEARCH EXPEDITION

The motor vessel *Port of Beaumont, Texas*, of the Ronne Antarctic Research Expedition, is authorized to communicate with radio amateurs "on frequencies above 4000 kc. on a secondary basis, when using A1 and A2 emission only . . . provided no pecuniary interest is involved and no interference is caused to commercial communications." The expedition, which will conduct scientific work and geographical explorations, is under the auspices of the American Antarctic Association, Inc., and is led by Commander Finn Ronne, USNR. Radio operator is Lawrence DeWolfe Kelsey, W3LYK. The expedition will be of approximately 18 months' duration, with base on Palmer Island, approximately 1000 miles south of Cape Horn. It is expected that amateur communications will be used extensively in enabling staff members to keep in touch with their families. The cooperation of all amateurs is requested.

The *Port of Beaumont, Texas* is assigned the call AYZH. Amateurs wishing to communicate with the party should listen on the 36-meter ship frequencies immediately after W1AW's 10 P.M. EST code-practice transmissions (about 11 P.M. EST, Monday through Friday), and at 11 P.M. EST Saturday and Sunday. The ship frequencies are 8240, 8250, 8260, 8300, and 8330 kc. The operator will use the channel found to have the least interference on each night's schedule. Amateurs should reply on the 7-Mc. band. Un-scheduled contacts with amateurs also will be made frequently on the 10- and 11-meter amateur bands, using the call W3LYK/MM, followed by the name of the vessel and its approximate position. Two transmitters are available for use on the marine frequencies, one capable of 200 watts output with A1 emission, the other with 100 watts, A2.

W1AW is maintaining schedule with the expedition. Operator Kelsey requests that amateurs keep posted on frequency changes and possible revision in operating schedules by following the regularly-scheduled W1AW bulletin transmissions.

EXPEDITION KON-TIKI

In early March the ethnological expedition Kon-Tiki is scheduled to leave on a 4000-mile trip by raft across the Pacific Ocean. The party will be under the leadership of Thor Heyerdahl, noted Norwegian explorer. The origin and civilization of the Polynesian islands of the mid-Pacific will be studied. The raft on which Mr. Heyerdahl and five other Norwegians will make the trip from Ilo, Peru to Polynesia will be fashioned of balsa-wood logs and lashed together with native-made hemp rope. Steerage control will consist only of a small oar. Although the raft

will carry radio and the most modern type of Army Air Forces protective clothing and life-saving equipment, the mode of transportation itself will not vary from that of the ancient settlers of the Americas. "The object of the trip," according to Mr. Heyerdahl, "is to prove the feasibility of the voyage itself, not to prove that we are pre-Incas. The modern equipment which we will carry will be for research and emergency purposes and will not affect the basic aim of the expedition." The name given the expedition is explained as follows: "There are preserved in Inca legend accounts of a race of white folk, bearded and blue-eyed. These whites, whose chief was traditionally known as Kon-Tiki, meaning 'Tiki the Sun God,' were defeated in a terrible battle by the forebears of the Incas at about the time of the fall of Rome. The legend records their migration to the western part of Peru from their native Andes and their eventual disappearance into the Western Ocean."

Plans for radio operations include communication with amateurs on the 14-, 28- and 50-Mc. bands. A Norwegian experimental license with call letters LI2B has been authorized. The raft transmitter will use approximately 15 watts. Beam antennas will be used in the 28- and 50-Mc. bands. Because of the physical dimensions of the raft and low power available, frequencies below 14 Mc. will not be used.

Predictions of the Central Radio Propagation Laboratory indicate that 28 Mc. may be the best frequency for contacting the United States during the trip. Antennas will be suspended from masts located approximately in the corners of the raft, which is approximately 25 to 30 feet by 15 feet in size. Final arrangements regarding communications with possible schedule for a regular listening watch by amateurs will be announced in *QST* and via W1AW bulletins.

BRASS POUNDERS' LEAGUE

(December Traffic)

Call	Orig.	Del.	Rel.	Extra Del. Credits	Total
W7FST	—	—	1329	—	1329
W4FU	22	65	780	65	932
W8SCW	30	100	478	78	686
W8TQD	5	8	662	—	675
W4PL	39	80	414	56	589
W5IGW	66	8	472	3	549
W2LTP	143	390	—	—	533
W9RCB	23	24	463	17	527
W3ECP	26	83	339	74	522
W3LVY	55	64	365	35	519

The following make the BPL with over 100 "deliveries plus extra delivery credits":

W1UE	170	W9DXL	107	VE3HP	102
W6IOX	130	W6QXN	102	W9JTX	100

A message total of 500 or more, or 100 "deliveries plus extra delivery credits," will put you in line for a place in the BPL. The Brass Pounders' League listing is open to all operators who qualify for this monthly "honor roll."

WIAW OPERATING SCHEDULE

Operating-Visiting Hours

Monday through Friday, 8:30 A.M.-1:00 A.M.
 Saturday, 7:00 P.M.-2:30 A.M.
 Sunday, 3:00 P.M.-9:00 P.M.

Official ARRL Bulletins containing latest FCC information relating to amateur operation and reactivation, and other bulletins on matters of general amateur interest, are transmitted on regular schedules, as follows:

Frequencies: 3555, 7145, 14,150, 28,060, and 52,000 kc. (Voice — 3950, 14,280, 52,000 kc.)

Times: Monday through Friday, 8:00 and 11:30 P.M. EST. (0100 and 0430 GCT, Tuesday through Saturday)

Sunday, 1:00 A.M. and 8:00 P.M. EST (0600 Sun. and 0100 Mon., GCT)

Starting at the times indicated, bulletins are transmitted by telegraph simultaneously on all frequencies. Bulletins are sent at 25 w.p.m. and repeated at 15 w.p.m. on the early schedule to facilitate code practice. Telegraph bulletins are followed in turn, by voice transmissions on 3950 kc. and 52,000 kc. simultaneously, and then on 14,280 kc. Changes from this schedule will be announced by the operator.

Code-Proficiency Program: Practice transmissions at five speeds, 15 through 35 w.p.m., are made Monday through Friday on the above-listed frequencies, starting at 10:00 P.M. EST (0300 GCT, Tuesday through Saturday). Approximately ten minutes practice is given at each speed. Next certificate qualification run is scheduled for Thursday, February 13th.

General Operation: WIAW engages in two-way work with amateurs as follows:

Monday through Friday, all times EST —

11:00 A.M.-11:30 A.M.	28,060-kc. c.w.
11:30 A.M.-12 noon	29,150-kc. voice
3:00 P.M.-3:30 P.M.	14,280-kc. voice
3:30 P.M.-4:00 P.M.	14,150-kc. c.w.
4:30 P.M.-5:00 P.M.	3950-kc. voice
6:00 P.M.-7:00 P.M.	7250-kc. c.w.
7:00 P.M.-8:00 P.M.	3555-kc. c.w.
9:30 P.M.-10:00 P.M.	3555-kc. c.w.
12:15 A.M.-1:00 A.M. (Tues. through Sat.)	7250-kc. c.w.

Saturday and Sunday (excepting dates of official ARRL activities)

Saturday: Midnight-1:00 A.M. (Sun.)	3555-kc. c.w.
Sunday: 1:45 A.M.-2:30 A.M.	7250-kc. c.w.
6:00 P.M.-7:00 P.M.	3950-kc. voice
7:00 P.M.-8:00 P.M.	7250-kc. c.w.

The station staff:

John T. Rameika, W1JJR, "JR"
 Wm. H. Matchett, W1KKS, "BM"
 James E. White, W1PHW, "JE"

BRIEF

On New Year's Day W8AQ's first QSOs were with the following, in the order mentioned: W1AQ, W2PNA, W3MBZ, W4JCI, W5GHK, W6QMQ, W7MLL, W8MPW, W9AMI, and W9VHD. Try it sometime!

F.C.C. APPREHENDS ILLEGAL OPERATORS

"A word to the wise is sufficient," but somebody usually fails to get or heed the word! Close to 200 illegal operators have been apprehended by the FCC since V-J Day. Minor violations result in warnings and confiscation of equipment, but the law provides for a \$10,000 fine, or jail for two years, or both. In addition to the FCC's extensive monitoring system, each licensed radio operator, including nearly 80,000 amateurs, should be on the alert to report any transmissions believed to originate from an unlicensed source. There is no reason for tolerance toward those who "steal" the use of our precious frequencies. Amateurs are invited to report all cases of illegal operation to the nearest FCC office.

BRIEFS

W5BYX reports the designation of 3520, 7040, 14,080, and 28,160 kc. as "get-together" frequencies for amateurs employed by the Civil Aeronautics Administration. "CQ CAA" is suggested when looking for other CAA hams. In signing your call, add "CAA" to identify yourself as a CAA employee. Bill Edens, W5BYX, 2608 Alexander, Waco, Texas, requests a postal or QSL card from all interested amateurs, with information on QTH, place of employment, and other data of interest. He plans to prepare a reference list to be mailed to each CAA amateur sending a stamped self-addressed envelope.

W0JHN working W1NBG mentioned that his name was "Smitty." W1NBG thought it quite a coincidence when his next contact, W6DYW, also turned out to be "Smitty." But the unusual became more so when W6DYW advised that W0JHN was his twin brother!

A.R.R.L. ACTIVITIES CALENDAR

Mar. 5th: Frequency-Measuring Test
 Mar. 7th: Frequency-Measuring Test
 Mar. 14th-17th: DX Competition (c.w.)
 Mar. 17th: CP Qualifying Run
 Mar. 21st-24th: DX Competition ('phone)
 Apr. 4th-6th: VE/W Contest
 Apr. 18th: CP Qualifying Run
 Apr. 26th-27th: CD QSO Party
 May 14th: CP Qualifying Run
 May 17th: V.H.F. Relay and QSO Party

Jan. 16th-Dec. 15th: 1947 V.H.F. Marathon
 Jan. 1st-Dec. 31st: Most-States V.H.F. Contest
 First Saturday night each month:
 A.R.R.L. OFFICIALS NITE (Get-together for SCMs, RMs, SECs, ECs, PAMs, Hq. staff, Directors, Alt. and Asst. Dirs.)

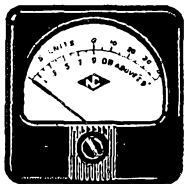

WE OFTEN receive letters suggesting changes in our receivers. These are extremely useful to us because they serve as field reports, telling us how our equipment can be made more useful to you. We study all such comments carefully and do our best to give you what you want.

Unfortunately, all amateurs are not in agreement on the ideal receiver. The S-meter, for instance, has been a subject for lively discussion ever since it was first introduced, the main argument being "How big is an 'S'?"

We have worked out an S-meter calibration which has become standard in our receivers. Listening tests indicate that there is about 40 db difference between an S-1 and an S-9 signal as defined by the ARRL. Specifically, S-1 is about 0.5 microvolt and S-9 is about 50 microvolts. Our S-meter scales are made accordingly, with 5 db per S unit starting at 0.5 microvolt for S-1.

Actual tests on the air have shown that 5000 microvolts is about the maximum that is encountered. This is 40 db above S-9 as defined above, so we have made the whole range of the S-meter about 80 db.

There are some interesting technical problems in providing such a range for an S-meter. This is because of AVC action. In general, the better the AVC action the harder it is to make an "active" spread-out scale on the meter. The reason for this is pretty obvious. The whole purpose of the AVC is to keep the signal strength constant at the second detector, and if the signal strength is constant there is no change with which to operate a meter.

As a practical matter, the AVC action is so good on National receivers that we have to use some rather tricky circuits for the S-meter, involving the use of vacuum tube bridge circuits. With these we are able to get the desired scale with good calibration stability.

Bear in mind that the S-meter is not a precision field-strength meter. You should not attempt to use one for any such purpose as calibrating the output level of a test oscillator. They can be used for measuring the front-to-back ratio of a beam antenna or for any purpose where approximate signal strength ratios are needed. For their intended purpose — reporting signal strength — they are amply accurate.

WILLIAM A. READY



• All operating amateurs are invited to report to the SCM on the first of each month, covering station activities for the preceding month. Radio Club news is also desired by SCMs for inclusion in these columns. The addresses of all SCMs will be found on page 6.

ATLANTIC DIVISION

EASTERN PENNSYLVANIA — SCM, Jerry Mathis, W3BES — DWA's family found it impossible to get passage from England until Don contacted G2AMG, who arranged everything via Pan-American Airways. RCQ and 3WDQ are interested in starting a net on 7 Mc. for Coast Guard radiomen who attended Groton, Curtis Bay, and Atlantic City schools. If interested contact RCQ, 623 Delaware Ave., Wilson, Penna. New officers of the Schuylkill Amateur Radio Club are: OML, pres.; LXV, vice-pres.; VMF, secy.; MCX, treas.; KIJ, act. mgr. AQN has his new 150-watt rig on all bands. BXE, Section EC, states that he is open to suggestions for an EC to handle Wayne, Pike, and Monroe Counties, and another for Carbon, Lehigh, and Northampton. MAL's XYL purchased an 8-38 Hallcrafters for his Christmas present. ITZ operates on narrow-band f.m. on 28 Mc. The West Philadelphia Radio Association has the call MKA. GMK is getting set for the DX Contest. EU is looking for a Philadelphia schedule on 3.5 Mc. KZ is on 14 Mc. MJB is DXing on 7 Mc. with 20 watts. MDK is ex-2HWS. PFC says the Night Owl Net has met every morning for eleven months straight. Frequency is 28,746 kc. and any hardy soul is invited to join them after 12:30 a.m. The Chester Radio Club meets every other week at the Chester YMCA. BXE finally received his WAC. LGZ operates 3.9- and 14-Mc. 'phone with 300 watts to a BC-810. IKQ is on 14- and 7-Mc. c.w. from Egypt, Pa. EHD has 20 watts and a five-element beam on 144 Mc. New officers of the York Road Radio Club are: HIO, pres.; ALB, vice-pres.; BWQ, treas.; JPP, rec. secy.; ETM, corr. secy. The Frankford Radio Club held its annual holiday party recently in Delanco, N. J. QEW is traffic-handling with the "Traffic Outlet Net" on 3705 kc. KMW is organizing a 7-Mc. traffic system. While home from the Navy LHI operated a little over twenty-one hours contacting forty-eight stations in seventeen states and four in Canada on 3730 kc. with 35 watts to an 807. QV is working Europe on 3.5 Mc. in the wee small hours. GHD's new three-element 14-Mc. rotary is netting him some rare DX such as VQ5JTW and UI8AA. BES has a new HQ-129X and is putting the finishing touches on a ten/twenty rotary beam. QSLs for members of the Frankford Radio Club may be sent to P. O. Box 34, Philadelphia. FUF put up a 14-Mc. rotary on the penthouse of the Hotel St. Francis. GQS has over 300 contacts on 144 Mc. GNA worked a J9 and a KA on 28-Mc. 'phone. Traffic: W3EU 57, QEW 54, AQN 30, MJB 13, BES 7, BXE 7, ID 7, HFD 5, QLW 4, PFC 2.

MARYLAND-DELAWARE-DISTRICT OF COLUMBIA — Acting SCM, Eppa Darne, W3BWT — The Washington Radio Club's Christmas Party of December 21st was very successful. Contests, games, music, and a contest answering the FCC questions for broadcast radiotelephone license was conducted, the first prize being five dollars. At a recent meeting EYX exhibited movies of the club group on Field Day. At the same meeting Bob Werner told of his experiences at Operation Crossroads. PA9JX has been "adopted" by the club. MNA now is on 144 Mc. AB is back in the game after many years' absence; look for him on 7004 kc. JYS has a new addition to the family. CDQ visited 2FKA during YLRL Contest. EEB is on 3.5-Mc. c.w. when he has any spare time. MJQ has a rig on the three most popular bands which gets out nicely. ADO, the Naval Academy Club at Annapolis, is holding code and theory classes. The club held an informal hamfest in Ban-

croft Hall at the annual Christmas Dinner. MAI is on 3.5-Mc. c.w. with a ten-watt rig. 4JVJ/3, our 15-year-old member, is on 7-Mc. c.w. with 25 watts from his new Baltimore QTH. Despite heavy school work, ISF has a new five-band rig going nicely and is getting into traffic work. HUM is on TL AP, along with ECP. CZJ is doing nicely after his recent operation. Two of our section stations, ECP and LVY, made BPL this month. The section net meets Sunday 10:00 a.m. on 3705 kc., with LVY as NCS. Any section member desiring to join should contact LVY. Traffic: W3ECP 522, LVY 519, HUM 92, ISF 16, BWT 10, AKB 2.

SOUTHERN NEW JERSEY — SCM, Ray Tomlinson, W2GCU — Section EC: BAQ, ECs: SAK, PSZ, ASQ. The S.N.J. ORS net was reactivated Dec. 17th with eight ORS reporting in to ZQ, net control for the opening meet. The net meets Tues., Thurs., and Sat. at 8 p.m. EST on 3700 kc. Credit for its success should go to OXX, QCL, TNN, RG, ZQ, CFB, SPN, FXN, BEI, QUH, and ZI. JAG takes most of the operating time at the DVRA station. ZQ. ORS has 6SJ7/6L6G e.c.o. on 7 Mc. QCL erected 3.5-Mc. skywire and overhauled the rigid 14-Mc. dipole. ZI snagged G5LI on 3.5 Mc. RYB has two-element rotary with folded dipole radiator. RSP is changing rig over into an RCA deluxe streamlined cabinet. RYB will use BC221 frequency meter as basic e.c.o. unit. ZI works into the "TO" net daily. QCM is using e.c.o. on 3.5, 7, and 14 Mc. BEI has resumed his Class I OO activities with a brand-new 100-kc. unit. QCM hit SS score of 83,350. ZI heard ON4HC and HB9CX on 3.5 Mc. BEI maintains daily schedule with G6BY. The third annual "Old Timers' Nite," sponsored by the DVRA, will be held Mar. 22nd. IJC is heard on 50 Mc. with the four-element parasitic beam. At the December meeting of the SJRA a complete AEC unit was won by 2EQ. BEI has resumed schedules with G8MN. FXN worked 66 stations in SS. SDP has 829 on 7 and 14 Mc. OQN has TR-4 on 50 Mc. mobile in his new car. SHM has 500-watt rig perking on 14 Mc. QOK is constructing 1-kw. rig. Traffic: W2QUH 83, RG 48, FXN 25, OXX 22, ZI 18, ZQ 18, CFB 7, ORS 7, QCM 6, BEI 3. Ray.

WESTERN NEW YORK — SCM, Charles I. Otero, W2UPH — A team of four members of the Rochester Amateur Radio Association met a team of four members of the Kenmore-Buffalo-Tonawanda Club at the "Quiz of Two Cities" broadcast by WHAM at Rochester and WBEN at Buffalo. It was fine publicity for both organizations and also for amateur radio. The Rochester gang won the contest. QHH, ex-8JWJ, with 11 watts input on 3.5 Mc., has worked three Gs and an ON4; with 20 watts on 14 Mc. he has worked FF8FP, VP8AM, EL5B, VP4TR, VP9K, several LU's, Gs, a GM, GW, KL7, three OXs, YR, EI, VO, HI, KP4, XE, CM, NY4. PJF worked Hawaii on 3.9-Mc. 'phone. QCP is hunting for unusual and interesting places all around the globe with a two-element beam for 14-Mc. 'phone. FBA is a DX man on 14-Mc. 'phone. VTR has regular schedules with CO7CX on 14-Mc. 'phone in the morning. USF and VLN, of the Rochester area, are newcomers on 3.9-Mc. 'phone. TTQ gave a talk on audio at the last meeting of the RARA. TTQ just got his Class B ticket. RUK is active on 28.1 and 28.6 Mc. with a new four-element beam and 38 watts input to an 807. He is control board operator at WMBO, of Auburn. ROQ is the new vice-president of RAWNY. The Lackawanna Amateur Radio Club visited RAWNY. VQM is instructing radio classes. RPO has a class in f.m. Inspector Ryan, of the Buffalo Police Department, gave a talk on "Police Activities" at the last RAWNY meeting. The KBT put on its annual Carnival Night. QWG has an HT-9 on 3.9 Mc. RXM has an HRO. SJV has an HT-9. CGU is located at Niagara Falls. PJF and SYV compete for DX on 3.9 Mc. RVH is on 3.9 Mc. PE puts in a good signal with his revamped 610-E. 8BHK was changed to 2PWS and now is 2FE which is not too far from 8FC, which he got back in 1928. He is on 14- and 28-Mc. 'phone and 7-Mc. c.w. working DX. He is putting up a proper aerial to work 3.5-Mc. c.w. and 3.9-Mc. 'phone. 8FAL, now 2FAL, is very active

(Continued on page 78)

Be sure you're right

with the

HAMMARLUND

FS-135-C

FREQUENCY STANDARD

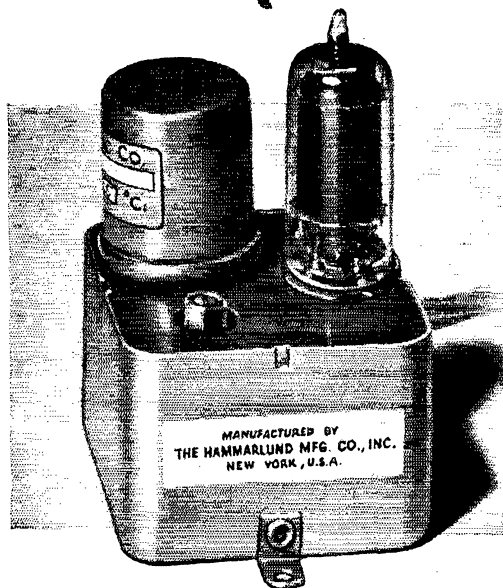

Connect up the FS-135-C in your receiver and you have a first-class frequency meter all set to go. You will have the satisfaction of knowing you are obeying F.C.C. rules and you'll get accurate signals every 100 KC's to mark the band edges or make any other checks you want.

You will find the FS-135-C is a cinch to connect and it's so small it fits in any receiver. The ingenious circuit and a special crystal permit variation of the crystal frequency for zero beating with WWV. Once this adjustment is made you practically have a WWV junior built right in your receiver.

See
the FS-135-C
at your dealer's

HAMMARLUND

THE HAMMARLUND MFG. CO., INC., 460 W. 34TH ST., NEW YORK 1, N. Y.
MANUFACTURERS OF PRECISION COMMUNICATIONS EQUIPMENT



on 28 Mc. with 100 watts and four-element rotary, and is working all kinds of DX. FAL is building higher power stuff. 8NYA, of Rochester, now is 2SKA. 8WGC, now 2WGC of Avoca, is building speech equipment for 'phone and 28 Mc. Meanwhile he is active on c.w. CO7CX, of Florida, Cuba, is now on 3.9-Mc. 'phone and wants to get up to Western New York. Look for him in the morning. 73. *Charlie.*

WESTERN PENNSYLVANIA — SCM, R. R. Rosenberg, W3NCJ — Section EC: AVY. New ORS: UVD. MLN lists new members of 3YA's staff at Pennsylvania State College: KCI, LTC, KBO, LMS, MHA, JZF, MAG, LFG, PIM, LZS, KZO, LRD, LRD, GNV, 4FWO. YA has contacted eleven countries and is trying for WAS. Call changes: 9EXW/3MOM, 9YDJ/3YDJ, 8IYI/3LEJ, 8GEJ/3MEF, 8KGB/3MED, 2WKE/3MLN. New Erie amateurs: MMH, MMI, MMJ. Erie County AEC conducts net drills each Monday evening on 144 Mc. with WBM, NCS, LJF, LPA, KQB, UTQ, and QN are heard on 28-Mc. 'phone. SER and VHP are on 14 Mc. and NMP is on 3.9 Mc. CB uses 807 final on 7 Mc. Active Meadville amateurs include: KEW, CB, UVM, QWD, MIE, KYT, and TKU. TWI has 813 final on 3.5, 7 and 14 Mc. running 350 watts input. TVA occasionally works OUH's transmitter on 3.5 Mc. BWP maintains daily 14-Mc. 'phone schedules with 4GVC, 9OTM, and 2ENX/4. OFO worked forty countries on 14 Mc. with T-200 final. NDG is on 14 Mc. NUG has surplus 1200-volt, 200-ma. power supply and new speaker for BC-312 receiver. USM and NUG have built c.w./break-in monitors. LYC is on 14-Mc. 'phone. AAQ is working 14- and 28-Mc. 'phone from Phoenix, Ariz. KWL pushes traffic on 3.5 Mc. RM1c/WRK, USCG, at Chesterland, Ohio, desires to hear from RAE members. NCJ contacted 7KIY in Glenrock, Wyo. KWA is building new exciter/ED rig, and worked G2CYU on 3.5 Mc. TTN works 7 Mc. with 809 final and has new 8-20 receiver. VNE has resumed operating on 28-Mc. 'phone. UVD has worked forty states toward WAS. BOZ has new NC-100A receiver and reports that MOJ is located at Warren. Other active Warren amateurs include: VNW, PMY, TOJ, RMM, and 8JSQ. RM TOJ submits Western Pennsylvania ORS Net report for December: 15 net sessions and 120 messages handled with following participating stations: KWL, LQQ, LOD, MJK, NCJ, TWI, SMPG, OQR, YA, SZK, and TOJ. QEM has 144-Mc. mobile rig in his car. LTN, 8NBV, and QKI are constructing high-gain beam antennas. QKI makes nightly contacts with 8UKS, at Cleveland. Traffic: (Nov.) W3TWI 29, (Dec.) W3TOJ 128, KWA 91, TWI 30, MJK 20, YA 20, MOM 15, BWP 7, LOD 7, LQQ 3, NCJ 3, OFO 3. 73. *Ray.*

CENTRAL DIVISION

ILLINOIS — SCM, Wesley E. Marriner, W9AND — RMs: Northern, EVJ; Central, SXL; Southern, JTX. New at Vermont is CPI, on 3.5-Mc. c.w. and 28-Mc. 'phone. ACU now operates on ILN 3765 Net. KQL also is new to the net. EVJ worked G5VB on 7 Mc. KMN works DX every night on 7 Mc. and schedules 7IWU and 5CDU. NIU has had his hands full with police and taxi radio installations. JTX has 200 watts now and schedules RCB and QMW. SXL built "HO" gauge railroad for his boys and himself. YBY, on 27- and 28-Mc. 'phone and 3.5-Mc. c.w., is anxious to contact Vienna, Austria, where his son-in-law is located. HON is ex-7HAL and is on all bands with 300 watts. A number of the fellows have sent your SCM envelopes asking if he has any DX cards for them. Please send your envelopes to the QSL Manager, F. Claude Moore, W9HLF, 1024 Henrietta St., Pekin, Ill. Activity at BRX was at a complete standstill during December. SCH reports the Austin Radio Club, Chicago, held an election. Following are new officers: ENC, pres.; CSC, vice-pres.; IYD, secy. ENC operates on 3.9-Mc. 'phone. NFK is on 144 Mc. He is editor of VHF, the activity paper in the Chicago area. MBI has moved from Chicago back to Coleta. JMG added e.o. unit and long-wire antenna for 14 Mc. Christmas shopping and illness kept KA's activity at a low ebb. The Chicago Area Radio Club Council met and elected officials as follows: HXE, chairman; HXW, vice-chairman; HPG, secy.; KA, treas. EVJ threw a swell turkey dinner for the ILN gang at his home. AND, CZB, FKI, JVC, MRQ, QLZ, JMG, and SXL were present. Mrs. EVJ not only knows the code but also knows how to cook. AND spent a pleasant evening with Mr. & Mrs. CZB. FUR visited AND. Those stations you hear in Illinois, Indiana, and Wisconsin using

prefix K9 are licensed by FCC and are OK. MUX reports Europe coming through on 3.5 Mc. Sunday mornings, 0530 to 0730, 3505 to 3525 kc. DXL has new BC-348Q receiver and had as visitor Diana Tuck, ZS6GH. The Cahokia Amateur Radio Club now has forty members and would like to contact any ham living in St. Clair, Madison, and Monroe Counties who at present is not a member of any club. Call or write EBX for information. SYZ is new ORS. UPW now is on 3.5- and 7-Mc. c.w. FKV is moving to Springfield; he likes the new 28-Mc. band plan. JEA is assistant fire chief at Freeport. ERU is wherever the DX is. CKM and EQJ rag-chew for hours on 3680 kc. Both have second-harmonic trouble. AWA is torn between 3.9-Mc. 'phone and 14-Mc. c.w. DX. GNU built a 28-Mc. rotary (?) beam in the attic. New Starved Rock Radio Club officers are: QLZ, pres.; YBY, vice-pres.; ATA, secy.-treas. FID is on 14 Mc. from Mendota. A few still report on the 16th of the month. This is too late, OMs! New postwar reporting date is the 1st of each month and anything received after the sixth is too late. 8HRH would like to hear from 9GGW, wherever he is. Maybe OMA will go on 'phone now that he has competition in polo. Traffic: W9JTX 358, DXL 275, EVJ 172, YTV 43, EBX 36, FKI 36, MRQ 33, JMG 31, SXL 28, ACU 13, MKS 12, KMN 9, MUX 6, AND 2, SYZ 2, YBY 2, 73. *Wes.*

INDIANA — SCM, Ted K. Clifton, W9SWH — AB is back on 3.5 Mc. 8IU is a new-comer to Fort Wayne. JMS and ANH are on 50 Mc. A new radio club at Evansville College is sponsored by DFD, physics professor, and EHU, president. FJT acted as fireman when building at air base burnt. FMJ is back on QIN after an operation. JYD is new Fort Wayne call. TBM tried to short out one of the power lines. SBF and PMT received Class A licenses. ENB is working for GOX and has new Panoramic. DUU has 9 watts on 3.9 Mc. PRO is new call assigned to Harold Norton. NZZ has e.o.o. on 14, 7, and 3.5 Mc. SNQ, of Portland, has 150 watts to 813 using a Meissner Signal Shifter for exciter; his receiver is HQ-129X. TZD, also of Portland, is on 28-Mc. 'phone with a pair of T55s with 330 watts input and uses an HRO. PHV, New Castle, has 50-Mc. rig going. MBL's work is interfering with the QIN although he can still make the 50-Mc. net. UTU now has call CYB and is on 3.5 Mc. with ten watts to 816 at Liberty. UIA has worked his 50th country on 28 Mc. EGQ has 250 watts on 3.5-Mc. c.w. GOE has new beam on 28 Mc.; also a new e.o.o. SFA recently married and the first thing to be moved in the house was the 14-Mc. 'phone rig. YLE, formerly from Vincennes, is 6WVU at Napa, Calif., with an e.o.o. pushing a couple of 807s to 100 watts on 14-, 7-, and 3.5-Mc. c.w., where he is looking for Indiana contacts. A group of sixteen of the Delaware Amateur Radio Assn., of Muncie, toured Cincinnati and Mason, Ohio, on Dec. 7th and spent the day visiting WLW studios, transmitters, and antennas. They had as special guides 8JVD, 8JRM, and 8TJM, engineers at WLW. IU has new rig using Eimac 4-250A with 200 watts to 800 into a three-element beam. BKJ, one of our old SCMs, is back handling traffic after being off c.w. for seven years. He is on 3800 kc. and is dividing time between 3.9 and 3.5 Mc. UKT, our OO, has logged over 300 harmonics to date. Tom will check you upon request. He is doing a job of which we of Indiana should be proud. KYM gave a talk at the Michiana Amateur Radio Club of South Bend. Traffic: W9RCB 527, ENB 33, ENH 26, DHJ 13, QLW 12, BKJ 11, SWH 9, HUV 6, FMJ 5, PMT 4. 73. *Ted.*

WISCONSIN — Acting SCM, R. G. Klein, W9DKH — LFK, SZL, NWM, QIX, SIZ, IQW, KCY, and HUJ, are regular reporters into Wisconsin State Net, 3775 kc., 6 p.m. Monday through Friday. Ex-DSF now is KIZ at De Pere and is on 3.5-Mc. c.w. Manitowoc County Radio Amateurs have organized a club to be known as the MANCORAD Club. BZU is chief operator; GI, 2nd operator; TVA, keeper of the log; DKH, operations manager. Meetings are held the 2nd Tuesday of each month at Lincoln Field House. Visiting hams are welcomed. ARE had the last word over Van Johnson at the Strand Theater in Manitowoc recently while passing through and working 28-Mc. mobile. JAW and OVE are on 3.5-Mc. c.w. with KQB on 7 Mc. EWC is raving about beams. 9QZO is on 28-Mc. 'phone along with DDG, HNX, NVJ, and OJL. MUM is active on 3.5-Mc. c.w. at Eau Claire. CCI is on 28-Mc. 'phone at Oshkosh and keeps regular schedules with 9FAV/6, at San Jose, in sunny California. Which reminds us to ask how our recent Wisconsin sleet storm treated you? An emergency rig or set-up should be number one on our New Year's resolutions

(Continued on page 78)

AMATEURS!

WHAT ARE YOU GOING TO BUILD?

Fill Out the **SPRAGUE** Questionnaire

~~WE'LL GIVE YOU THIS HANDY TESTER~~

for only 25¢ to cover cost of packing and mailing.



Here's how you can help us: Sprague Capacitors and Koolohm Resistors have never been matters of guesswork. Now, to tie them in even more closely with amateur requirements, we are conducting an extensive research.

Questionnaires have already been mailed to several thousand amateurs. In them, we are asking about future building plans and needs for their rigs. If you have not already received a questionnaire, write for one today. You'll enjoy filling it out — it will be mighty helpful to us — and to repay you, we'll send a Sprague Handy Tester for only 25c cash or stamps to defray cost of packing and mailing.

The Handy Tester tests ac-dc voltages up to 500v; indicates r-f and parasitic oscillations; checks charge on high-voltage capacitors, distinguishes a.c. from d.c. and is a tool of dozens of other uses.

Sorry, but of course we've got to limit this offer — and the questionnaires — only to licensed amateurs.

Write today to Dept.

TRADING POST USERS ATTENTION!

Due to the necessity for devoting our space to the accompanying message this month, The SPRAGUE TRADING POST feature has been omitted from this publication. It will appear again next month.

SPRAGUE

PRODUCTS COMPANY

NORTH ADAMS, MASS.

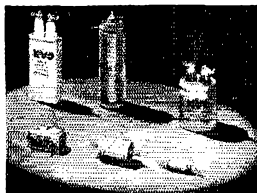

PAPER DIELECTRIC



MICA CAPACITORS

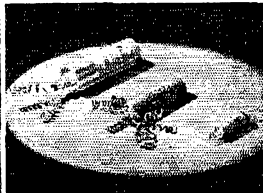

DRY ELECTROLYTICS



KOOLOHM RESISTORS

Trademark Reg. U. S. Pat. Off.

list. Ex-Kenoshian E2P is announcing at WOMT and is active on 3.5-Mc. c.w. BZU is interested in 144 Mc. work and v.h.f./u.h.f. appointment. AOF and NRJ are on 14-Mc. 'phone. Route Manager LFK is regular reporter into general coverage net QMW on 3565 kc. From Madison YPP reports KML and TMB are new additions to the "20ers" of the Four Lakes Amateur Radio Club. FUS has three-element resonator on 14 Mc. to go with his BC-610. RNX has new secondary frequency standard and can give checks on 14 and 28 Mc. within 500 cycles. Ex-7EYD/9 now is KBU at Appleton and is active on 3.9-, 14-, and 28-Mc. 'phone. RQM was QRL with holiday rush. Traffic: W9DKH 336, LFK 201, SZL 41, HUJ 30, NWM 26.

DAKOTA DIVISION

NORTH DAKOTA — SCM, Raymond V. Barnett, WØEVP — Two more members of the North Dakota Net have moved out of the State; LHB to Pontiac, Mich., and PIT to Duluth, Minn. We welcome AFK, of Minot, to the net. ABP is engineer at KGCU and is building a rig. EOZ is active on 3.5 Mc. and reports new club at Jamestown becoming affiliated with ARRL. Ivar Nelson, chief engineer of KFYZ, gives interesting and helpful lectures on technical topics at each meeting of Cendak Club. PDN has been appointed Route Manager. Two PE103 dynamos have been ordered for emergency use in this area. No reports, no news. Traffic: WØPDN 25, SSW 14, EVP 13. 73. Ray.

SOUTH DAKOTA — SCM, P. H. Schultz, WØQVY — Please get your reports to me before the fifth of each month. QVY visited ILL at Huron and ZAL at Ravinia during the Christmas holidays. TI, of Milbank, is heard quite well in Watertown on 145 Mc. PRZ, TXK, MNI, and KQO form the Conde Club. YMB has his Class A ticket. OLB and BLK are interested in starting a South Dakota net. I will act as a clearing house for your ideas and appoint a controller for the net. Let me hear from all interested. What about a hamfest this spring? GCP sent in his ORS certificate for endorsement. YQR has a new shack and is working all bands. ZBU has a new v.f.o. unit. BLK is working in a traffic net. OEO, of New Underwood, has joined the Rapid Club. SZR is a part-time engineer with KOTA. IWE is with CAA at Rapid. The BHARC is looking for a good location for a club house. TZJ is with an oil company in Texas and APT is with an electric company in California. 73. Phil.

MINNESOTA — Acting SCM, Vernon G. Pribyl, WØOMC — Congrats to BBL on the arrival of a new YL at his house! UWG reports that the Winona Amateur Radio Club was recently organized with PPZ, pres.; DIH, vice-pres.; ZSA, secy.; IIK, treas.; and UWG, program director. LID is operating regularly on 7120 kc. but has ground a few 7-Mc. blanks and now is able to QSY with ease. He is using a new Gonsett 28-Mc. converter with his BC-348Q. GRJ is operating on 27 Mc. OEP is again on the air wrestling with the QRM on 14 Mc. GRJ reports there are five amateurs active in Excelsior: WQF, YBD, OEP, KDZ, and GRJ. That's a good number for a town of 1100! JNC sends an interesting report this month. Conditions permitting, he holds schedules with OX3GE and LA3GA. He has forty-four countries now and is building a modulator using a pair of 811s to modulate his half-kw. RJF has boosted his power to a kw. and is gunning for good DX. RCT got in a little operating on 3.5- and 7-Mc. c.w. during his vacation from college. He is planning on building a 100-watt rig. DNY is really doing FB work in traffic-handling. GBZ is having trouble getting parts for his big transmitter. JSS is back on the air again. GKC is trying to get a rig on 28 Mc. and work some of that good DX but doesn't have much time on week ends only. He is attending Worthington Junior College. While GBZ was in Heron Lake he inquired where ØBNN lived, only to learn he had joined the list of Silent Keys about a year and a half ago. Thanks for sending in the nice reports, gang. Traffic: WØDNY 23, BBL 12, HKF 12, RJF 12, JNC 9, GRJ 7. 73. Vern.

DELTA DIVISION

LOUISIANA — SCM, W. J. Wilkinson, jr., W5VT — We can use more dope from all of you. So, on the first of each month drop a line and let us all know what you have been doing. A new net ('phone) has begun operation under the administration of CEW, our PAM. If interested, drop him a line and arrange schedules. The Pelican Net (LSN),

a c.w. traffic set-up, operates nightly at 8 P.M. on 3550 kc. KTE, our RM, wants more stations in the Net, especially in Baton Rouge and Monroe. The Shreveport Club (CARG) will apply for ARRL affiliation. Meetings are held on the second and fourth Fridays of each month and all are cordially invited to attend. CNG had antenna trouble during recent ice storm. BSR, EC for Lake Charles and vicinity, has storm net in operation. EKY, ANP, BV, KZM, FDC, and others are in the set-up. JET has been QRL work and missed ISN schedules. LSZ has a new Meck transmitter. FPX expects a Naval Reserve ham call soon. The Southwest Louisiana Institute Ham Club, KB, is getting under way. KUG is in the CAA net on Sundays and the LSN during the week. LQO is trying to get a new crystal oscillator going since burning up his power supply. The following were active in the emergency net during the severe ice storm of January 1-2: CEW, HJK, JPI, FMO, KTE, CNG, IVF, BLQ, and VT. Thanks to all who assisted. FYS, LQV, and ABA are on 7 Mc. QH, GHF, HBY, and BSR are active in the State 'phone net on 3905 kc. Traffic: W5KTE 129, VT 111, KUG 101, IYL 64, JPI 51, BSR 26, FPX 12, JET 1. 73. Dub.

MISSISSIPPI — SCM, Harold Day, W5IGW — LN works 3.9- and some 14-Mc. 'phone. HKJ was of great help during the recent communications emergency. The Delta 75 'Phone Net, covering Arkansas, Mississippi, and Louisiana, has been reorganized. HBY is NCS; LN and HKJ are alternates. LYD uses "fish cane" antenna and ten watts. JTL is on the air. LNU, a new Class A ham, works on 28 Mc. AGZ is active on 7-Mc. c.w. HYV is active on 7-Mc. c.w. LAK is feeding the Rebel Net plenty of traffic. CQJ is back on with a brand-new job. LXT is on 7- and 3.5-Mc. c.w. WZ, alternate NCS for Rebel Net, has finished bandswitching exciter and is working on bandswitching final. DEJ built an e.c.o. DNV is running 999 watts on 3.9- and 14-Mc. 'phone. CUU is courting 14-Mc. 'phone. HZP has new S-40 receiver. HGL is active on 28- and 14-Mc. c.w. with three-element beam for each. His best DX is UA9DP. Traffic: W5IGW 549, WZ 209, LAK 183, EGE 56, DNS 9, DEJ 4. 73. Hal.

TENNESSEE — SCM, James W. Watkins, W4FLS — BYN reports the following from Memphis: The Mid-South Amateur Radio Assn. elected new officers. IBG, EIS, VT, BWI, and GPV have a local 144-Mc. net. AQR and DQH are active on 14-Mc. 'phone. FWX is at new QTH with three-element 28-Mc. beam. PV is building a 14-Mc. 'phone rig after over twenty years of c.w. BDK is on 7 and 3.5 Mc. with 200 watts and has plans for cathode modulation. 5HHA, at Air Base, is doing a good job on 28 Mc. FEB has a four-element beam and a DX look in his eyes. SW has a new three-element beam. BYN installed a new peak clipper and got an R5-SØ report from Alabama the first day in use. EYO and BYN are on 3.9 Mc. HQM reports from Humboldt that ITF is on 14-Mc. c.w. with an 807. JMW is destined to become a top-notch traffic hound on 3.5 and 7 Mc. HXC has new 14-Mc. rotary. HQM is on the high end of 7 Mc. with 100 watts to a TZ40. TM is on 14- and 3.9-Mc. 'phone. ZZ says he is knocking himself out on 3.9, 14, and 28-Mc. 'phone and 7-Mc. c.w. on week ends from his Greenville QTH. He is c.c. on 50.18 and 50.04 Mc. and is looking for the Tennessee 50-Mc. gang. The Nashville Club has been reactivated and meetings are held at the Hume-Fogg High School at 8:00 P.M. the first Thursday in each month. MP and ERJ are active on 144 Mc. QT is new OPS. MP is new OBS in Nashville and ERJ is new OPS in Watertown. PL again is RM and ORS. FUW is active at Friendsville, but because of transmitter trouble, present power is only 18 watts. Traffic: W4PL 589, HQM 8, FLS 3, JMW 1. 73. Jim.

GREAT LAKES DIVISION

KENTUCKY — SCM, Joseph P. Colvin, W5IEZ/4 — The Corncrackers Net with 4CMP, IYV, KUY, TFK, and TXC (NCS) is active on 3955 kc. at 7 A.M. Tues. and Sat. 4NQQ is working 14-Mc. 'phone. 9JWW and 9KUY are on 3.5-Mc. c.w. 4KLP, ITB, JXM, RBV, KQU, IUP, and KKG are on 14-Mc. 'phone. 4NEP is on 3.5-Mc. 'phone. 4LNU has made recordings of some rag-chews on 28-Mc. 'phone. 4KMX is working narrow-band f.m. on 28 Mc. 4PN has a beautiful 14-Mc. c.w. signal. 4JXX/4, KUP, KNX, KFE, MN, KZJ, FKX, KFI, JPC, JEL, KLL, and JEB are on 28-Mc. 'phone. 4KMJ works 28-Mc. 'phone and 3.5-Mc. c.w. 4ELL is working NFM on 28 Mc. 4ITR and TLZ are working 14-Mc. c.w. 4YPR, JTC, and MRF are

(Continued on page 80)

4-750A



ANOTHER EIMAC TETRODE

Designed for

- Industrial Heating**
- Communications**
 - Airline**
 - Police**
 - Emergency Broadcast**
- Medical**
 - Diathermy**
- Experimental r-f**

Here's a new Eimac tetrode—the power step-up you have been asking to have added to the Eimac line.

Capable of 2-kw power output at 4000 plate volts, with less than 15 watts of grid drive, the 4-750A opens a new field of possibilities to designers of electronic equipment. A pair of these tetrodes, driven by low cost, low-power tubes, will supply more than 4-kw output.

A potential workhorse for communications and industrial use, the 4-750A has the ability to deliver its maximum power over a wide range of frequencies. Inherent characteristics include the familiar attributes of Eimac tetrodes—stability, economy, and dependability.

Complete technical data and performance characteristics will soon be available. Write now for your copy.

**EITEL-McCULLOUGH, INC., 1407 San Mateo Avenue
San Bruno, California**

EIMAC 4-750A POWER TETRODE Electrical Characteristics

Filament: Thoriated tungsten	
Voltage	7.5 volt
Current	20 amp
Direct Interelectrode capacitances (av.)	
Grid-plate	24 μf
Input	26.85 μf
Output	7.78 μf
Maximum Ratings	
D-C Plate Voltage	6000 max. volts
D-C Plate Current	700 max. ma.
Plate Dissipation	750 max. watts

Follow the Leaders to

Eimac
REG. U.S. PAT. OFF.
TUBES

EXPORT AGENTS: FRAZAR AND HANSEN, 301 CLAY STREET
SAN FRANCISCO 11, CALIFORNIA, U. S. A.

on 3.5-Mc. c.w. 4ZLF is on 144 and 540 Mc. 4FU, with daily schedules to China, Baffin Island, etc., set a new record for himself this month with a message total of 932. The day 4ZUZ put up a new 40-foot tower topped with a four-element beam a storm took it down. He is active on 3.9 and 28 Mc. with 600 watts to a pair of 813s. 4KKG is putting up a beam. 4KLP is building new shack; he has new BC-342N receiver. 4FR is on 3.9-Mc. 'phone with pair of 810s; also mobile 28-Mc. 'phone. 4OEE works South Africa, Northern Rhodesia, Germany, and England with a new ground-plane antenna. 4PN/ITR have 91 countries in 4½ months. 4MO wants all 28-Mc. 'phone men to look for D4ARN, ex-W4RBN, Frankfurt, Germany, on 28.02 to 28.4 Mc. at 10:45 a.m. CST daily. JML has VHF-152 working into SX-28A. Traffic: W4FU 932, PN/ITR 81, TXC 24, BAZ 32. 73. Jos.

MICHIGAN — SCM, Harold C. Bird, W8DPE — TRP sends his congratulations. UGR is having harmonic trouble. WYP comes at us with "It couldn't happen here," but in Leroy they lost all their power and land line facilities because of snow and ice. He now is building an emergency rig. FX is busy with club work and reports that BGY is rebuilding. WWL is rebuilding but will send in measurements for the Frequency Measuring Tests. FWU renewed ORS appointment. ONK is working on the QMN Net and TLAP. DED is selling his QSL cards and other equipment and is working on 28 Mc. NOH has been busy on 27 and 28 Mc. He also is coming on 3.5 and 7 Mc. and reports handling two messages from Okinawa. He also worked two Jima and KL7 and is getting a ground-wave DX club organized with Kalamazoo, Muskegon, Three Rivers, Lansing, Centerline, and South Haven amateurs. NXT sends in renewal for membership. URM is working nights but keeps schedules with Colorado. MCV sends in the following: RQF is gathering materials for a new ham shack on the banks of Lake St. Clair. MYP is obtaining crystals for contemplated club net. LXE is attending school nights at Lawrence Tech. and is working WJBK. UMI is attending Michigan State College. KEQ, former member of DMRC, is working for CAA in Everett, Wash. SAY is handling traffic in fine style with a new rig and fine signal. RJC and TBP sent reports by radio. ABH is handling Early Net on QMN and sounds like a veteran. TYE is taking his turn on the Early Net and sounds great. TMN is a regular reporter in the net and handles traffic for Ferndale. SCW is assistant general manager of the QMN Net and is doing a nice job. He also can be heard on TLAP. BIU finally got into the swim and is handling traffic his way. JUQ can be heard plugging away on QMN Net between 6 and 7 p.m. daily except Saturday and Sunday. WET has been snowed in up his way but is doing his share to keep communications open. IJS is having trouble getting on 7 and 3.5 Mc. because of limited space in his yard for antenna. KNP dropped in during the holidays but now is making his home in Cleveland. The Oakland County Radio Club was entertained at its January 13th meeting with a demonstration on the SX-42 and Pandapter through the courtesy of M. N. Duffy, of Detroit. Traffic: W8CW 686, SAY 335, ONK 122, ABH 101, JUQ 58, UGR 41, FX 39, WET 33, TBP 29, TYE 29, DPE 27, DAQ 22, RJC 20, URM 20, TRP 13, QQK 11, TMN 11, NOH 8, BIU 6, FWU 5, XDI 5, NXT 4. 73 to all. Hal.

OHIO — SCM, William D. Montgomery, W8PNQ — All you fellows with ARRL appointments, check the dates on your certificates and send them in for renewal yearly. Recent appointments include MFV as OO, PMJ as ORS, STZ and JFC as OPS. Monthly reports should be mailed on the 3rd or 4th of the month. CBI, who works the Buckeye Net and a couple of Trunk Lines, leads with 131, and MPG, the Buckeye net control station and Assistant RM, who also works two Trunk Lines, runs a second with 118. Stations with a total of over 60 are ZAU, UPB, and RN. RN is trying all the mail order houses for a Meissner 150B. DAE has added Malta and Gibraltar to his country list. Orchids to Paul Hughes, of Hartville, for his help to the marooned motorists in Albuquerque. N. M. WSC reports astonishing results from a 25-watt BC-654A c.w. rig that he is using until he can find a BC-610. AYS is looking for Asia to complete his WAC on 14-Mc. 'phone, and needs three states for WAS on 14-Mc. c.w. WAB is tickled at receiving his old call again, as well as Class A license. WDQ and 3RCQ are forming a c.w. net on 7 Mc. for all present and former Coast Guard radiomen, especially those who attended the Groton, Curtis Bay, and Atlantic City Radio Schools. All interested, please get in touch with WDQ, 2815 Euclid

Hts. Blvd., Cleveland 18. VWX is working into the BN from Ohio State University, Columbus. YPS left our fair State to take a job as operator for the Airways in Florida. MFV reports that SVI is located in his new home on Route 2, Osborn. WRN reports the annual Columbus Amateur Radio Association Christmas Party was a huge success. WRN also reports that ZOE is a newcomer, and is active on 3.5-Mc. c.w. with a Millen exciter. TMA reports as follows: WJD is settled at his new location with a 7-Mc. doublet 175 feet above ground, which makes his temporary 80 watts sound like 800. EFW has decided things are too rough on 'phone with low power, so he is tackling c.w. until he can rake up a kw. From the *DARA Bulletin* we learn that DIU and VIP are active again after long silence, that TQT's transmitter is now perking on 28 Mc. after the services of a couple of high-power consultants were obtained, that Cleveland's 144-Mc. activity is on the upswing and becoming crowded with about thirteen consistently active stations, that ZOK, a new ham, talked to England and Japan before he had been on three weeks, and that the speaker for the Dec. 6th meeting of the DARA was E. A. Blasi, radio engineer of the Army Radio Labs, who gave a swell talk on microwaves, wave guides, etc. NDN is happy over working Hartford, Conn., and Waltham, Mass., on 50 Mc. He heard a few more, but the band folded before he could work them. JFC reports that YFS, a new ham with 25 watts, worked Wake Island, Alaska, Hawaii, and others on 28-Mc. 'phone. YEJ and 4HAV did a swell "super-rush" job of rebuilding the exciter for the QCBEN Outcast Memorial Station, VVL, but it remained for VBG to solve the mystery of the "missing paint spot" and get the exciter cooking. MEU now is 4KZF. TMZ has a new jr. YL. TQS is vacationing in Florida to recover from last year's QCBEN presidency. Traffic: W8CB 131, MPG 118, ZAU 87, RN 80, UPB 63, VWX 39, UZJ 32, WE 30, DAE 23, EQN 23, LCY 21, QIE 20, PNQ 12, ROX 12, PUN 11, JFC 10, EFW 8, AQ 7, TGU 7, MOH 3, GVL 2, TIH 2. 73. Bill.

HUDSON DIVISION

EASTERN NEW YORK — SCM, Ernest E. George, W2HZL — The ENY Traffic Net is really active under the direction of ITX. Active participants are MXR, BVR, OAA, QOM, ITX. Outside contacts are EC, 1EFW, 3KWA, 3MCZ, HXT, QYZ. Interested hams, listen for ENY 8 p.m. Monday through Friday; TLC 8:30 p.m. Monday through Friday. PGE reports from Mid-Hudson Valley. NCR moved to Las Vegas, Nev., and is working the old gang on 28 Mc. PEH finally threw out his gassy 815 and put in a new 829B in the final. PRK will be on with 100 watts on 144 Mc. RML uses a wet clothes line for an antenna on 28 Mc. He found no standing waves but one sitting and one kneeling. PGE suggests the Poughkeepsie gang change to vertical antenna on 28 Mc. so they can work the Ulster gang at night. IKK described to your SCM the new permanent headquarters of the Mid-Hudson Amateur Radio Club, consisting of a freshly decorated room in Lincoln Center in Poughkeepsie. The members are considering the purchase of a club receiver. They also are planning radio coverage of Albany motorboat races and annual intercollegiate crew races. TDT's buffer ignores his crystal oscillator. APT's antenna coupler and CGT's 813 final have given up and now work like it says in the book. NOF's sixteen-element beam and 24 Ga pump out a signal on 144 Mc. solid enough to stand on. GYV hears 1AW on 50 Mc. regularly in Schenectady. The Tri-City Thursday night group includes OPW, CRE, SSV, RTM, MAD, 5CEY/2, GYV, IEC, RDL, and RMA. Some are using narrow band f.m. Traffic: W2ITX 43.

NEW YORK CITY AND LONG ISLAND — SCM, Charles Ham, jr., W2KDC — BGO comes across as usual on time with the AEC report. He probably should be reintroduced to all at this time as the Section EC who leads the other ECs so well. Queens, Brooklyn, and Suffolk are the only counties reporting for December. Emergency Coordinators are sought for Bronx and Manhattan. BSP says Queens membership increases each month and new stations include TRT, QHD, QUK, and JCT. Traffic-handling has become the rule, holiday greetings being exchanged all around. Mondays at 2100 at least eighteen stations represent "the Borough of Homes." KDC visited OHE recently. Press is the sparkplug of the Brooklyn EC gang; he has an FB shack and equipment and reports as follows: "clocklike regularity is the watchword

(Continued on page 88)

Listen . . . IT'S A Jensen SPEAKER!

4 COAXIAL SPEAKERS

8 REPRODUCERS

3 BASS REFLEX* CABINETS

COAXIAL SPEAKERS

REPRODUCERS



MODEL HNP-51 COAXIAL (ST-122). A 15 inch articulated Coaxial with cone-type h-f unit and horn-type h-f unit. Alnico 5 PM design throughout. Dividing network gives two-way performance; Wide-range response and excellent polar pattern. Ideal for FM receivers, high quality phonographs and similar applications, including monitoring. In Bass Reflex cabinet, response ranges from 50 to 15,000 cps. H-F Range Control lowers cut-off in four steps to suit program quality. Input impedance, 500-600 ohms. Maximum power rating in speech and music systems, 25 watts. List Price, \$125.00.

UTILITY DESIGN (Brown Opaque Lacquer)

DELUXE DESIGN (Satin Finish Walnut)

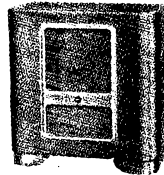

MODEL RA-151. Complete with Model HNP-51 Coaxial and H-F Range Control installed. List Price, \$181.15.

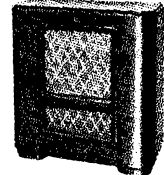

MODEL RD-151. Complete with Model HNP-51 Coaxial and H-F Range Control installed. List Price, \$201.00.

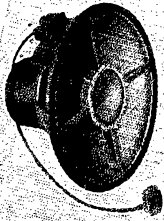

MODEL JAP-60 COAXIAL (ST-600). A 15-inch cone-type Coaxial with FM design. Furnished with H-F Range Control. Nominal input impedance, 500-600 ohms. Maximum power handling capacity in speech and music systems, 20 watts. List Price, \$86.00.

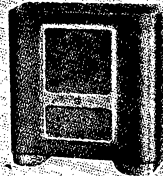

MODEL RA-153. Complete with Model JAP-60 Coaxial and H-F Range Control installed. List Price, \$142.15.

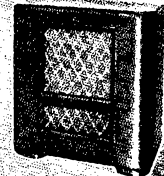

MODEL RD-152. Complete with Model JAP-60 Coaxial and H-F Range Control installed. List Price, \$162.00.

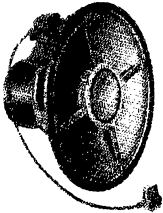

MODEL JHP-52 COAXIAL (ST-601). A 15-inch cone-type Coaxial like Model JAP-60 with efficiency approximately 4 db less. Furnished with H-F Range Control. Input impedance, 500-600 ohms. Power handling capacity in speech and music systems, 15 watts. List Price, \$65.00.

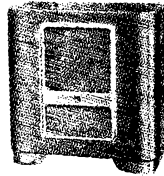

MODEL RA-154. Complete with Model JHP-52 Coaxial and H-F Range Control installed. List Price, \$121.15.

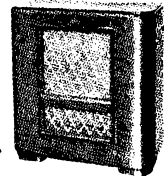

MODEL RD-153. Complete with Model JHP-52 Coaxial and H-F Range Control installed. List Price, \$141.00.

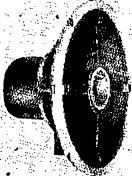

MODEL JCP-40 COAXIAL (ST-603). A 12-inch Coaxial at low cost. Ideal replacement and modernizing unit where 12-inch speaker is required. Simplified low-cost bridging network inbuilt. Terminals provided for addition of ST-606 Level Control. Nominal input impedance, 6-8 ohms. Power rating, 10 watts in speech and music systems. List Price, \$35.

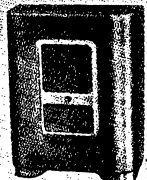

MODEL RA-124. Complete with Model JCP-40 Coaxial installed. List Price, \$94.15.

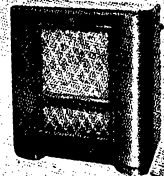

MODEL RD-122. Complete with Model JCP-40 Coaxial installed. List Price, \$114.00.

JENSEN MANUFACTURING COMPANY

6611 S. Laramie Ave., Chicago 38, U. S. A.

In Canada: Copper Wire Products, Ltd.,
11 King St., W., Toronto, Ont.

*TRADE MARK REGISTERED



Jensen

SPEAKERS WITH ALNICO 5

Designers and Manufacturers
of Fine Acoustic Equipment.

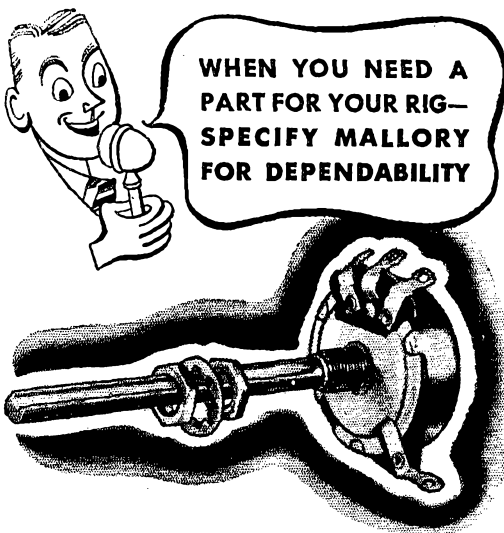

In the Mahory line you can find *exactly* the control you want—and you can get it at a conveniently located Mallory distributor. That's because Mallory makes the *complete* line—33 stock types of correctly tapered wire wound controls, 61 stock types of correctly tapered carbon-element controls, 31 stock types in single tapped controls, 10 stock types in double tapped controls, 12 stock types in clutch type controls, 10 stock types in Universal Dual Controls, 92 Popular Special Controls.

But when you buy a Mallory control, you get more than just a replacement. Mallory is mighty fussy about quietness, tapers, resistance values. You get extra quality, closer tolerances, extra dependability.

It's easy to select the correct replacement. Recommendations will be found in the Mallory Radio Service Encyclopedia.

P. R. MALLORY & CO., Inc.
INDIANAPOLIS 6 INDIANA

P. R. MALLORY & CO. Inc.
MALLORY

(Continued from page 80)

of Monday night operation, twelve stations being the minimum guarantee!" The Metropolitan Amateur Radio Society enrolled sixty new members but they still solicit more. PFA now is 6HYF. MWA is trying narrow-band f.m. on 28 Mc. PRL is BCL happy. HY hangs the clothes on new four-element beam. LXD kept in touch with the XYL while she vacationed in Oklahoma. NZR deserted 144 Mc. for the low frequencies. Congratulations to DUS on a new third harmonic. OHE solicits reports from other than EC members for forwarding to the SCM. In Suffolk OQI arranged a ham-fest on Dec. 29th at Sunrise Inn, Eastport. Thirty hams attended and talks were given by ADW, AA, OQI, and OOG. The latter has been forced to resign as EC. The SCM and all others give him our sincere thanks for a job well done. OQI will work in as EC and all are asked to report and cooperate with Van in Center Moriches. OE, in Florida for the cold months, wants 7-Mc. contacts with the home gang. BSR has new BC-221 frequency meter. NMZ has nice clean 3.9-Mc. 'phone signal. PDU is on 3.5-Mc. c.w. and is joining the AEC gang; he also is on 144 Mc. ADW is local Field Day chairman of 1947 Field Day. JFP, now in Connecticut, is trying to work home on 144 Mc. DOG has new BC-348 receiver. SKV protests 'phone on 7 and 14 Mc. in c.w. bands. TEO is ex-1KZJ and is on 3.5-Mc. c.w. using HRO and 807 and half-wave end-fed antenna. VLJ, ex-8VLJ, helps operate. GUR has thirty-one countries on 14 Mc. but 'phones bother him. A kilowatt is coming up. LGK is busy on NYC-LI Net and on 144 Mc. Joe gets the dope direct from KDC; both work in Sperry's mile-square plant in Lake Success. RQG is ex-1CVL. Ray uses 13 watts to a 8L8 on 3540 and 3585 kc. AOD deserted Flushing for a month in Southern California and is using a 958 transceiver on 144 Mc. CKQ is building for television, GGN and GXC are rebuilding for 14-Mc. c.w. KCH dreams of a new rig while flying for Pan-American. KPA is active on 7 Mc. KXG is in new QTH at New Hyde Park. LGS has new jr. operator. LPJ is rebuilding 14-, 7-, and 3.5-Mc. rig. LRI is building p.p. 811s final for 28 Mc. LUX completed two-element beam on 28 Mc. The Queens Radio Amateurs now meets at the home of LRI, reports LUX, secretary. PF has new receiver and a borrowed transmitter from BN on 7200 kc. OUT is on 7-Mc. c.w. and made fourteen contacts using low power. George was with WERS in Akron, Ohio. PZE worked a little DX but did lots of calling. AYJ temporarily is at east end of Long Island operating on 28- and 14-Mc. c.w. EC was very busy handling Christmas messages, several hundred starting in China. HMJ has thirty-four countries on 14-Mc. c.w. using 200 watts to 813. BO schedules Palmyra Islands daily. PRE worked forty-three states and KP4 and KH6. QYZ was very busy with Christmas messages. OBU was asked to join Trunk Line G. Traffic: W2BO 172, EC 156, OBU 127, QYZ 126, LR 85, AYJ/2 12, PRE 10, BGO 7, KDC 7, LGK 4, RQJ 3, RQG 2.

MIDWEST DIVISION

KANSAS — SCM, Alvin B. Unruh, W9AWP — The big news is the reactivation of the Kansas Section Traffic Net. NJS is NCS-RM. The net meets Monday, Wednesday, Friday at 8:45 p.m. We need stations in Emporia, Salina, and Parsons. Get on 3610 kc. and join the fun. Write SCM for dope. Following are new ORS: EPX, NJS, KPJ, VBQ, VEL, KSY, ZUA, TVU, OZN. New OPS: EPX. VWU is working into TL A. BPL (OO) suggests a 8.7-Mc. daytime band for Class B-C 'phones. BSX has his 852s on 3.5 Mc. and handled traffic. MAE has daily schedule with Minnesota. OTV has Laxy H with reflector on 28 Mc. JCH has a four-element 28-Mc. beam. JCQ has crystal-controlled 144-Mc. rig, and reaches Manhattan 89. OZA ordered 3610-ke. crystal to join QKS net. KSY reports ex-9FLG is 5LSN in Dallas. KSY has p.p. 813s. EPX is building 28-Mc. mobile. The Radio Communication Club, UTI, has been formed at Haskell Indian Institute, Lawrence. HKV has 100-watt rig in Keokuk Hall; MOD has 40-watter in Haskell radio shop; KING is building 50-watt 28-Mc. job. NYE, KJS, and NMB are working to complete rigs for Haskell's DX contest. OWT has pair 812s. NBB, the instructor, is working on 200-watt 14-Mc. rig for his XYL. JUV. UTI has 28- and 14-Mc. beams, and two Collins rigs. The club has 144-Mc. Field Day each Friday. QQT and FER joined QKS net on opening night. GLV is building 28-Mc. mobile. Traffic: W6MAE 18, OZA 9, DWC 6, NJS 6, BSX 4, EPX 4, KSY 4, OZN 4, AWP 4, MSO 4, BPL 3.

(Continued on page 84)

TRANS-WORLD DX

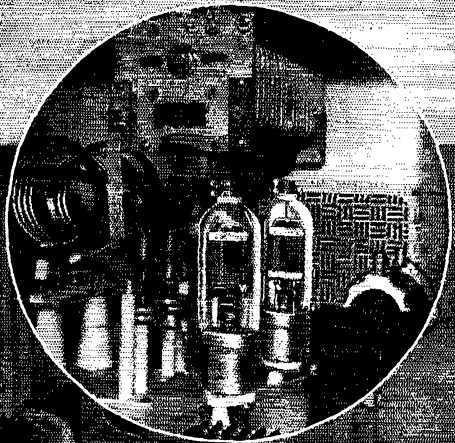

John A. Callanan
AMATEUR RADIO W9HOB

December 11, 1946

WAS
WAC

When after the amateur bands reopened, I substituted a pair of UNITED V-70-D tubes for the type previously used and found that the final stage power output was increased about 50%. Moreover, this increased output was obtained with approximately 25% less driver power than required by the original tubes.

With the pair of tubes operating somewhat less than 1/2 KW output, I have contacted some 40 odd countries since the war on 14 continents and have been active in handling traffic for O.I.'s overseas.

Some of the unusual activities have been to transfer an army officer's wife and family from the states to North Africa; the radio and telephone contact to bring a G.I. stationed in far-off Germany to his wife's bedside in a hospital in Indiana; to announce the arrival of a bouncing baby boy to a G.I. stationed in far-off Japan (needless to say it is understandable that many dramatic incidents such as the time that a G.I.'s mother fainted when she opened in that celebration). There have also been many dramatic incidents such as the time that a G.I.'s mother fainted when she heard her son say "Hello Mom" from Okinawa or the time that a G.I. spoke from his hospital bed in the Philippines to his wife and mother.

Considering that the brunt of this work is carried by the pair of V-70-D's in the final stage and they are often subjected to considerable abuse, such as no warm-up period, etc., I could not help but write you and offer my commendation. Needless to say, I am completely sold on these tubes and look forward to many more enjoyable hours of amateur operation with them.

Best of 73's
John A. Callanan
John A. Callanan, W9HOB

UNITED V-70-D graphite anode triodes fire powerful sigs from the final of W9HOB. Following are a few of the rare DX QSO's that have elated the O. M. pictured above.

- | | | | | | | |
|-----------|-------|-------|-------|-------|-------|-------|
| V59AR | PK5AR | VR2JI | F7AE | CO7CX | T14AC | VP3LF |
| OX1AS | VO6G | E13J | XU144 | HH2ME | XE1JS | J9LG |
| W1LQ/TF | EA1D | GM2UU | J2AAP | XZ2AA | YV4AM | PZ1G |
| VQ2PL | LA7R | G6BY | KA1CB | J9AAB | HK3BJ | 1U4EC |
| VQ4EE | OZ5AA | F7AA | ZS1CN | KG6AA | UE8NA | VP3AC |
| W9BND/KL7 | ZB1L | XACP | XADW | CE3AB | FG3FP | OA4R |
| WBSTR/VP9 | VU2WS | E15B | D4AOT | KH6FT | VK4JP | HC2CC |

Type V-70-D and similar type 812-H are briefly described below. See your electronic parts distributor or write us for further data.

Type	Filament		Max. Plate Dissipation	Max. Input per tube	Max. Plate	
	Volts	Amps			Volts	Mils
V-70-D	7.5	3.25	85 Watts	300 Watts	1750	200
812-H	6.3	4.0	85 Watts	300 Watts	1750	200

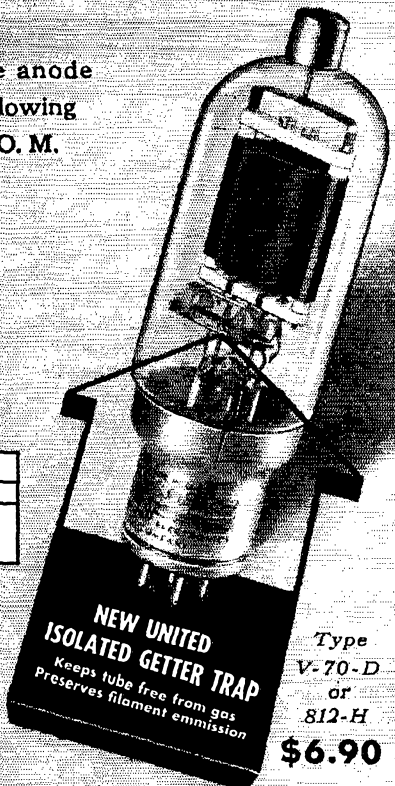

Type
V-70-D
or
812-H

\$6.90

UNITED
ELECTRONICS COMPANY
NEWARK, 2 NEW JERSEY

Transmitting Tubes EXCLUSIVELY Since 1934

FIRST

FOR THE
GREATEST NAMES
IN
HAM RADIO



C
A
M
E
R
A
D
I
O

Est.  1914

FAMOUS NATIONAL PARTS

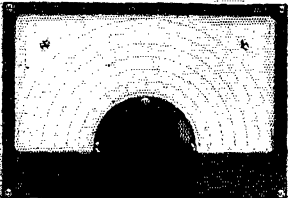

NATIONAL ACN DIAL

For experimenters who "build their own" and desire direct calibration. Fine for Freq. Monitors and VFO'S. Dial bezel size 5" x 7 1/4". Five blank ranges for direct calibration. Employs Velvet Vernier Drive... 5 to 1 ratio... amateur net, \$3.00.



NATIONAL OSCILLOSCOPE CRU WITH CRU-P PANEL

This 2" scope is an indispensable item of equipment for amateurs and electronic experimenters. Connects to any phone transmitter. Measures percentage modulation. Easy to interpret. Rack model, amateur net, \$42.75; table model, \$39.90.

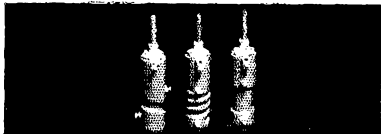

NATIONAL COILS AR-2, AR-5, XR-50

The AR-2 and AR-5 coils are high Q permeability tuned RF coils. The XR-50 coil forms may be wound as desired to provide a permeability tuned coil. AR-2, amateur net, \$1.71; AR-5, \$1.46; XR-50, \$1.01.

Ham Radio Suppliers since 1919

CAMERADIO CO.

963 LIBERTY AVE., PITTSBURGH 22, PA.

(Continued from page 87)

VWU 2, ZUA 2, YOS 2, KPJ 2, QQT 2, TVU 2, FER 2, 73. *Abie.*

MISSOURI — SCM, Mrs. Letha A. Dangerfield, W9UD — ZOA, Poplar Bluff, has applied for Official Observer appointment. That will make two OOs for Missouri. The other is YHZ, of St. Louis. ZZW is back from the Army; he is in Jamison and has ten watts on 7 Mc. and needs traffic outlet there. He suggests a net at noon. CRM worked 236 stations on 7 Mc. in December and says hamming is a blessing for a shut-in like himself. ZVS now is working days so has opportunity for net schedules and is doing an FB job on MON. KIK worked over power supply, now has thirty watts, and is another MON regular. ZIS made a very fine SS score, including contacts with VP5HN, ZK1AB, and GBJ, in Springfield, on 14 Mc. QCK, of b.c. station WIL, has his new call and plans 50 watts on 7-Mc. c.w. and 28-Mc. 'phone. GCL has his buffer working on 7 and 14 Mc. EYM reports traffic only. VKY/8 works Kansas City from his car. GBJ is on 28 Mc. suffering from SS hang-over. ARH has new Meissner working on 3.5, 7, and 14 Mc. and has schedule with Iowa Net. ZKY's new 28-Mc. beam works K6s but needs elements pruned. QXO topped traffic list again and manages MON between work periods. OUD is a regular on MON. FSI and PUV, of pre-war gang, are back on the net and PKB is a new-comer. We need more stations and more traffic. Thanks for the reports, gang. Keep them coming. Traffic: W6QXO 77, OUD 17, CRM 11, KIK 7, EYM 3, GBJ 3, ARH 2, ZZW 1, 73.

NEBRASKA — SCM, Roy E. Olmsted, W8POB — Santa brought a mate for the BC-610 — named NC-240D. EKP is on 3.9 Mc. with 1/2 kw. COU is active on 28-, 14-, and 3.9-Mc. 'phone with Meissner rig. EDY is putting 500 watts 'phone through a pair of 812s. HHB is working 3.5- and 7-Mc. c.w. YMU has new RME-43. FQB is active on 7-Mc. c.w. and DX on 28-Mc. 'phone. PLK, age 82, got a ticket so he could visit with his son, ex-WGL, now 2SGX. Ex-ZGA, now D4APN at Frankfort, is on 28,103 kc. and wants Nebraska QSOs spotted above 29 Mc. Sorry to report the death of 9KVB, at Council Bluffs, on December 28th. PLO is operating 7-Mc. c.w. JED is having fun with 14-Mc. DX. HLX is on 3.9-Mc. 'phone in GI. TQD reports DX QSOs with G5LI, G6Z0, and ON4HC on 3.5-Mc. c.w. FAM is on 3.5-Mc. c.w. with his old 852. KPA divides time between income tax clients and building a new rig. UHT is erecting a new home on a windy hill — for antenna reasons. YOP, with CAA, has been transferred from Hayes Center to Pierre, S. D. YOD, instructor at Millford Trade School, is assembling the school 1/2-kw. rig; the jug was empty when GTG called recently but the dirt flew just the same. If your ham news isn't printed here, who is to blame? More reports are wanted. The State net frequency is 3555 kc. Report on this spot at 7:30 p.m. CST for Atlantic-Southern-Pacific traffic to TQD and at 8:30 p.m. CST for Northeast-Northern-Northwest traffic to FAM, Monday through Friday. Both have fine TL connections. Traffic: W8TQD 675, FQB 6. Regards. Pop.

NEW ENGLAND DIVISION

CONNECTICUT — SCM, Edmund R. Fraser, W1KQY — Club News: NARA — MGX reports LRT on 7 Mc. MGX is building 1/2-kw. rig for all bands. PEA completed 85-foot tower. OOT is on 28 Mc. NXB has new Millen exciter. BARA — All prewar members desiring to continue as members are requested to contact OPG, treasurer, 320 North Ave., Bridgeport. GRU is using p.p. 813s on 28-Mc. 'phone. BRAC — RY has been elected president. JBK is conducting code classes and OHI and ETC theory classes. BRAC would like to swap club news with other clubs. Write LIG, 1862 North Avenue, Bridgeport 4. SARC — Dietz reports ASO, KUO, OGQ, and PLI are instructing code classes. CARA — IQE reports club net frequency, 28,712 kc., is very active after 9 p.m. C.w. men use 3589 kc. Meetings are held the second Monday of each month in Masonic Hall, Bethel. LZE is working DX on 14 Mc. with 8JK. CQF has three-element Mims beam atop his house. PEP has new HQ-129X. WR has 28-Mc. 'phone rig in car. QI is using four-element beam and p.p. 813s. KKG is on 28-Mc. 'phone. OGR is using 807 final. IQE handled traffic for D4AMX using p.p. T55s 450 watts to three-element beam. NEARA — ATH reports FMV appointed to transmitter committee with AMM and IGT. OCH is on 28 Mc. narrow-band f.m. with new kw. rig. AMM is conducting code and theory classes. JQK is active on 144 Mc. NWC has final

(Continued on page 88)

E. H. Rietzke, President of CREI, Invites You to Write for this

Free Significant Analysis of Job Opportunities in Radio-Electronics

EVERY RADIOMAN
Who Wants to Hold His Job
or Advance to a Better Job
**WILL WANT TO READ
THIS LETTER!**

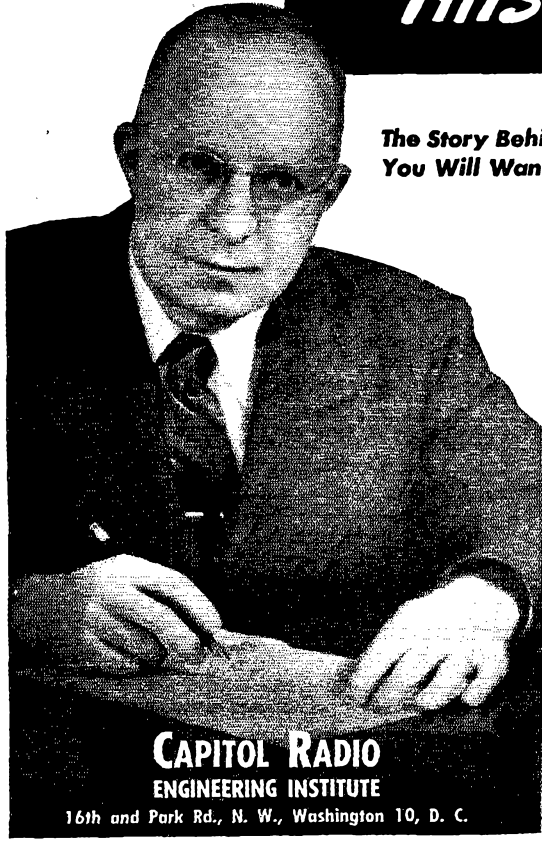

The Story Behind This Interesting Letter You Will Want to Read . . .

Our advertising agents, realizing that vital changes are taking place in the radio industry, asked me to give them a factual report of the unprecedented job opportunities created by the almost unbelievable expansion of the radio industry.

My letter to them contains some pertinent viewpoints on the subjects of **COMPETITION—INDUSTRY EXPANSION—OPPORTUNITIES**. These are first-hand observations based on my own experiences . . . a great deal of time spent in the field and constant contact with leaders in the radio industry.

The immediate reaction of our agency upon reading this letter was that it contained so much inspiration and information that it should be reproduced for thousands of radiomen to read. Therefore, this unusual advertisement to invite you to send for, and read, this letter.

It is doubtful if many radiomen realize the actual things that are happening. That is why I think you will want to read this letter. You are invited to send for your personal copy today.

E. H. Rietzke
President, CREI

**CAPITOL RADIO
ENGINEERING INSTITUTE**

16th and Park Rd., N. W., Washington 10, D. C.

MAIL COUPON FOR FREE COPY • NO OBLIGATION

Capitol Radio Engineering Institute
16th and Park Road, N. W., Dept. Q3
Washington 10, D. C.
Gentlemen: Please send me FREE, Mr. E. H. Rietzke's
Analysis of Job Opportunities in Radio-Electronics.
NAME.....
POSITION..... AGE.....
ADDRESS.....
CITY..... ZONE..... STATE.....

designed for

modern amateur **MEISSNER** *Signal Shifter*

Designed to meet the most exacting requirements of the modern amateur, the new Meissner Signal Shifter has built-in band-switching. No coils to change . . . six position switch. Normally equipped with five sets of coils for 10, 15, 20, 40 and 80 meter bands plus a blank strip for any additional new band. All controls placed on front panel. Reduced warm-up time. Minimum power output six watts on all bands.

Choice of built-in or separate power supply.



For complete specifications . . .
write to the address below today.

EXPORT SALES DIVISION
SCHEEL
INTERNATIONAL
INCORPORATED
4237-39 N. LINCOLN AVENUE
CHICAGO 18, ILLINOIS, U. S. A.
CABLE ADDRESS
HARSHEEL

MAGUIRE

936 N. MICHIGAN AVENUE,

requirements!

THORDARSON

Transformers

Power your new rig with Thordarson . . .
the transformer that has been helping to
make and break DX records since radio
began. New Thordarson designs now
available to match the newest tubes.

Ask for them at your dealers today.

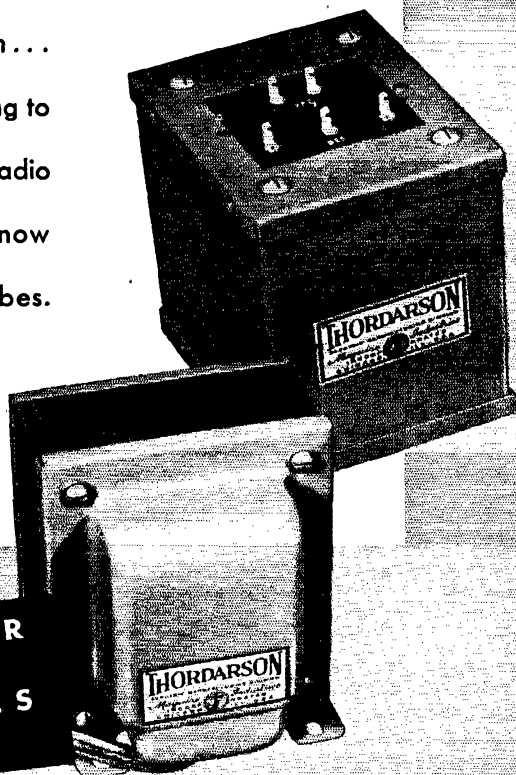

**ELECTRONIC DISTRIBUTOR
AND
INDUSTRIAL SALES
DEPARTMENT**

INDUSTRIES, INCORPORATED

CHICAGO 11, ILLINOIS

STATION TESTED*

... an added
proof of Quality!



*Pres. W. A. Kuehl is shown at his amateur radio station W9EZN. With the war over, Walt is again pursuing his favorite hobby.

DRAKE RADIO SOLDERING IRONS

Yes, Drake irons are right for radio. And these sturdy irons have proved their dependability and worth in use on countless other jobs, too, for over 25 years. That's why we say—whatever your needs, you are certain to find a Drake iron that fills the bill. exactly!



600-10—the Drake No. 600-10 is ideal for those all important connections when rewiring your rig. Get back on the air fast. Make good dependable connections with this 100 watt $\frac{3}{8}$ " tip.



400—the Drake No. 400 is the perfect iron for work in small places. Only 9 inches long, it is especially designed for tight corners and delicate connections. 60 watt, $\frac{1}{4}$ " tip.



Ask your nearest supplier or write for the name of the distributor nearest you . . . and give yourself the advantages of these superior irons.

DRAKE ELECTRIC WORKS, INC.

3656 LINCOLN AVE.

CHICAGO 13, ILL.

(Continued from page 84)

p.p. 812a working on 3.5 and 7 Mc. GC has new three-element 28-Mc. beam. MVH leads in DX with twenty-seven countries confirmed. IC and JQD are active in Nutmeg Net. CUX is using narrow-band f.m. EUG keeps morning schedule with IIGX in Rome on 28 Mc. General News: NJM has new shack. APA is using HRO and 250 watts to T55. BDI is on 144 Mc. with HY-75 and recently bought LM-14 frequency meter and converter. FSH reports Meissner 150-B working fine. TK is active on 14-Mc. 'phone with 8JK. BIH is handling traffic with XU1YR and 8URU/C7. KXB completed new 900-watt 4-250-A rig bandswitching and driven from a 4-watt v.f.o. KNM is working plenty DX on 28 Mc. Traffic: WIUE 368, VB 340, DAV 154, EFW 139, IC 87, AFB 81, ORP 80, AW 72, BIH 66, KQY 53, LOP 40, NJM 34, ZL 25, ITT 19, AMQ 16, OS 15, BDI 12, APA 6, IQE 2. 73. Ed.

MAINE—SCM, G. C. Brown, WIAQL—TO reports that he spends about 85 per cent of his time DXing but wants his OPS and ORS tickets renewed. LKP handled a little traffic this month. OIL doesn't think much of the idea of giving up part of the c.w. band for 'phone. A nice letter, in which he gives an outline of his traffic activities as 4HRN during the Miami hurricane was received from ex-LHA. His call now is HH2CW and he is on 7030/7272 and 14060/14345 kc.; also he will be looking for the gang on the Pine Tree Net on 7 and 14 Mc. FQ recently moved from Bangor to Portland, where he expects to get his rig on the air. QH was on the job for WTVL at the inaugural ceremonies for Governor Horace Hildreth at Augusta. At the last regular meeting of the Eastern Maine Amateur Radio Club the following officers were elected: AQL, pres.; BPX, DBC, EBJ, BGG, and DAS, vice-pres.; OLQ, secy.; and 4HGF, treas. CBV, DLC, and KOB were appointed to serve on the instruction committee. Major Brophy, communications officer from the U. of M., will be the next guest speaker. Traffic: WILKP 2. 73. "GC."

EASTERN MASSACHUSETTS—SCM, Frank L. Baker, jr., WIALP—Following are leaders of various activities: Section EC: FVL, PAMs: IN, 50 Mc.; HIL, 28 Mc.; LMB, 14 Mc.; KTE, 3.9 Mc. RMs: BDU, 3.5 Mc.; OUD, 7 Mc. KCT is Regional EC for New England Power Net, which is active on 3.5-Mc. c.w. The following have renewed appointments: OPS—LXQ, HUV, MRQ, LMB, DJ, PZ, HUP, IX, HKK, MPP, COX, GDY, ORS—AGX, LBV, TY, HX, OJM, EC—IBF, LBV, COX, JXZ, HUV. OBS—COX, GDY, HUV. OO—HUV, OGP. New OES: COX, KB. KOF is getting out well on 14-Mc. c.w. ILZ has new Sonar f.m. exciter. OBJ has new S-40. OIM has a new RME-45. Ex-HUG now is IG. Ex-AEPU now is PAY. Ex-7GIL now is PPI. Ex-5DQD is PBB. Ex-INVI/9ULR is 5KWI in Tulsa, Okla. JNX has new VHF152. Ex-2FLN is PPZ in Lynn. 6QMY is in Boston. PBN, in Medford, is on 28 Mc. The Shoreline Amateur Radio Assn. is putting out a monthly paper called *Shore-Line*. GN and PH are on 14-Mc. c.w. More on 144 Mc.: AHB, IIB, IGA, IGD, 5LCF, and PNK. HHW and FAX are on 3.9-Mc. 'phone. The Brockton, South Shore, and Eastern Mass. Clubs all held auctions in the same week. The T-9 Club held a meeting at IPK and also a dance in Beverly. NXM gave a talk on f.m. at South Shore Club meeting. Mr. Rowland, of Workshop Associates, gave a talk on beams before the Eastern Mass. Club. Ben Geyer and Pete spoke at M. I. T. Radio Society meeting. Ex-IKK now is 3MDQ in Pennsylvania. GOU WACed on 28 Mc. one week end. OEK has rig on 144 Mc. in car. JXU/PQA has new HQ-129X. HIL QSOed 6QER on 3.9-Mc. 'phone. LVV worked VK3GM on 14-Mc. 'phone. MEG has new 150-watt job on 3.5 Mc. PKW has schedule with 4JLV in Virginia. FHW is on 14-Mc. 'phone. PAN will have a kw. on the air. SI has his 28-Mc. beam up again. BIA has new Workshop 28-Mc. beam. OLV is on 144-Mc. mobile. PIN is on 28 Mc. MGP is back on the air. LML is on 28-Mc. narrow band on week ends. OUD is getting a net going on 7 Mc. AGX has schedules on 7, 3.5, and 28 Mc. AAL has new vertical folded doublet on and is on all bands. CST is on in Brookline. KBN is on 14-Mc. 'phone with a kw. LQQ, secretary of Yankee Radio Club, writes the club is affiliated with ARRL and holds two meetings a month. NLU lost his beam. JNE has new receiver. AKS is back on 28-Mc. 'phone. PZ has new 14-Mc. three-element beam. NVB has new e.o.o. DPG and CDG are back on 7 Mc. AYD has new beam on 28 Mc. IVU is on 14-Mc. 'phone. The Yankee Radio Club is running a raffle to aid invalid hams on North Shore. OUP has

(Continued on page 90)

3 Basic Ways TO IMPROVE THE EFFICIENCY AND STABILITY OF YOUR RIG

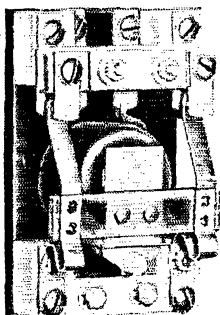

1 WARD LEONARD RELAYS

Proper relays have many practical uses in amateur rigs. They provide convenient circuit control and greater operating efficiency. They help reduce the length of connecting leads, prevent unnecessary transfer of stray or transient currents to critical parts of the transmitter circuit. Designed and built for rugged service, WARD LEONARD Amateur Relays are available from stock in the following types: Antenna Change-Over — Antenna Grounding — Band Switching — RF Break-In — Keying — Overload — Underload — Latch-In — Remote Control — Safety — Sensitive — Time Delay.

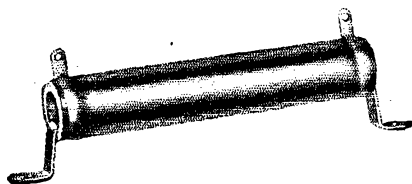

2 WARD LEONARD RESISTORS

The installation of VITROHM wire-wound resistors insures that *extra* performance you want in critical circuits. With exclusive features developed in the WARD LEONARD laboratories . . . these resistors meet the most rigid specifications. Fixed resistors are available in 8 stock sizes from 5 watts to 200 watts. Adjustable resistors, in 7 stock sizes from 10 watts to 200 watts. Wide range of resistance values. Stripohm, Discoh, and Plaque resistors are also available.

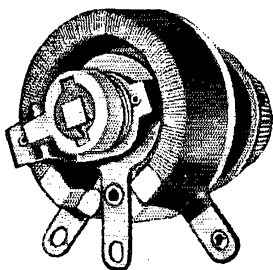

3 WARD LEONARD RHEOSTATS

These Vitrohm Ring-Type units are widely used as potentiometers or rheostats, for fixed or variable close control, in commercial as well as amateur equipment. Made of highest grade ceramic materials. Resistance wire is held in place and protected by special WARD LEONARD vitreous enamel. Many other features. Available from stock in 25 watt, 50 watt, 100 watt and 150 watt sizes, in wide range of resistance values.

SEND FOR FREE CATALOGS

For helpful data and information, write for Relay Catalog No. D-111 and for Resistor-Rheostat Catalog No. D-2.

AUTHORIZED DISTRIBUTORS EVERYWHERE

WARD LEONARD

RELAYS • RESISTORS • RHEOSTATS

Electric control  devices since 1892

WARD LEONARD ELECTRIC CO., Radio and Electronic Distributor Division, 538 West Jackson Blvd., Chicago 4, U. S. A.

DO YOU INSIST ON THESE ESSENTIAL CHARACTERISTICS ?



CHECK THIS LIST
NOW!

- (1) Low operating temperature
- (2) Low noise level
- (3) Well anchored, easily soldered leads
- (4) Positive contact between resistance element and wire leads
- (5) Excellent wattage dissipation
- (6) Fully insulated
- (7) Maximum protection against humidity
- (8) Sturdy construction
- (9) Light weight
- (10) Compact size

When buying resistors for your rig, ask for and be sure to get IRC BT or BW Resistors ... with proven excellence in all 10 of these important characteristics.

FREE



Big 8-page catalog bulletin with complete technical data on all 10 characteristics plus other valuable information about IRC BT Insulated Composition Resistors and Type BW Insulated Wire Wound Resistors. Write for Bulletin 27C now.

IRC

INTERNATIONAL RESISTANCE COMPANY

401 N. BROAD STREET
PHILADELPHIA 8, PENNSYLVANIA

In Canada: International Resistance Co., Ltd., Toronto, Licensee

Wherever the Circuit Says Ω

(Continued from page 88)

QSOed 300 hams on 144 Mc. The Suburban Net now is the Suburban Radio Club. KCP has new HQ-129X. ALP is building new rig for 3.5-Mc. c.w. HUV is going strong on 50 Mc. JJE has new RME-45. AHP writes that the Fall River Radio Club's new QTH is 233 South Main St., and they have call ACT back. New officers are: JYR, pres.; DHX, vice-pres.; AHP, trustee. The Shoreline Radio Club, MDE, will be on 28 Mc. NRS has Class A license. Traffic: WIBDU 162, LML 123, OUD 80, EMG 42, AAL 34, JDP 32, BB 28, MD 24, LM 20, KTU 17, OEK 16, PKW 13, TY 12, AAR 11, NXY 8, AGX 6, HWE 6, MEG 6, MDU 5, OKB 5, LMB 3, MGP 3, CST 2, PJG 2, MRQ 1.

WESTERN MASSACHUSETTS — SCM, Prentiss M. Bailey, W1AZW — RM: BVR. SEC: UD. The call W1BSJ was buried with all appropriate ceremonies by the Springfield gang when Ike received his new call, W1UD, recently. MIV is a new member of the Western Massachusetts Net and has applied for ORS. BIV has acquired a scope to see what goes on when he modulates. NKN is trying to keep New Year's resolution of more activity and better monthly reports. He proves it by getting the rig on 14 Mc. and working some DX. EOB is frigidly dreaming of a new rig. Hil HFO, of Southbridge, reports he has 50 watts on 7 and 14 Mc. Harold hails from Manchester, N. H. COI built up a field strength and modulation meter using crystal rectifier. Holly is looking forward to next CD Party. JGY is fixing up the rig so he can move from basement to dining room. BVR is pleased with good attendance and growing traffic on Western Massachusetts Net. JAH received new camera for Christmas. MZC, of Holden, recently dismantled a 40-foot-windmill tower and moved it to his QTH. Now to get the darned thing up again when WX permits. The Pittsfield Radio Club recently had the honor of hearing Mr. A. R. Koch, Vacuum Tube Division, General Electric Co., on the subject of "Getting Started on 2400 Mc." JLT now has fifty-three countries postwar. You just can't keep up with him. Bob handled some nice traffic from OX3GE. KZS is rebuilding his big rig into rack and panel job. BKG is having good luck with his cathode modulated 812s on all 'phone bands. Many of the boys are getting set for the DX Contest, which promises to be a big event this year — the first since the war. See you on 3760 kc., Mon., Wed., and Fri. at 7 p.m. Traffic: W1BVR 56, NY 28, BIV 23, AZW 21, IHI 21, JAH 20, MIV 17, EOB 13, JGY 8, COI 4. *Prent.*

NEW HAMPSHIRE — SCM, John H. Stoughton, W1AXL — We don't hear many of the New Hampshire gang on 3.5-Mc. c.w. Those who are active seem to be operating on the higher frequencies. We have had no response as yet in regard to a c.w. traffic net. Will any of you who are interested, please contact WIATJ, Airport, Claremont? You also can find him on 3530 kc. every noon and evening. How about dropping us a card giving your operating frequencies and schedules on 3.5-Mc. c.w.? MUW attended the National Crafts and Science Show in New York. Her escort, of course, was JMY, the OM. She expects to be with Joe at West Hartford soon. CFG, of Reed's Ferry, now is out of the Navy and is back at WFEA. MOI now is BT. 3MY now is MZ. Both are in Manchester. 2KDN, ex-1BFY, is back on 3.5 Mc. and expects to be on 3.85-Mc. 'phone soon. OMO, of Charlestown, now is with the merchant marine as radio operator. OCY, of Charlestown, is on 3.85-Mc. 'phone. GTY, of Lebanon, is trying out the 28.5-Mc. 'phone band. AXL has a new beam on 28.7 Mc. HC has gone to Florida. He now is 4IFU. Traffic: WIATJ 15, MUW 9, AXL 4, 30, #4.

RHODE ISLAND — SCM, Clayton C. Gordon, W1HRC — HXS has his crystal-controlled 144-Mc. job running nicely, in addition to having done some demonstration work for the "phone" company on 10,000 Mc. The P.R.A. enjoyed one of those demonstrations recently, followed by doorprize drawings in which yours truly walked home with a 144-Mc. antenna kit. EZW and HRC are feudin' for the most different stations on 144 Mc. LYE says he wants to make it a three-cornered fight. LWA reports the Rhode Island Net is progressing nicely on 3540 kc. DWO is grinding crystals and also is checking the Bendix frequency meter to see if it will do for the ARRL frequency runs. INU has automatic keying unit and tape puller. He has commenced construction of Wheatstone Perforator and plans Boehme type auto keying head, hoping to start some contest transmissions and also handle Official Broadcasts. QR has moved shack to "new doghouse quarters" in the basement where he hopes everything will be peaceful and quiet. LYE has

(Continued on page 88)

GET YOURS NOW!

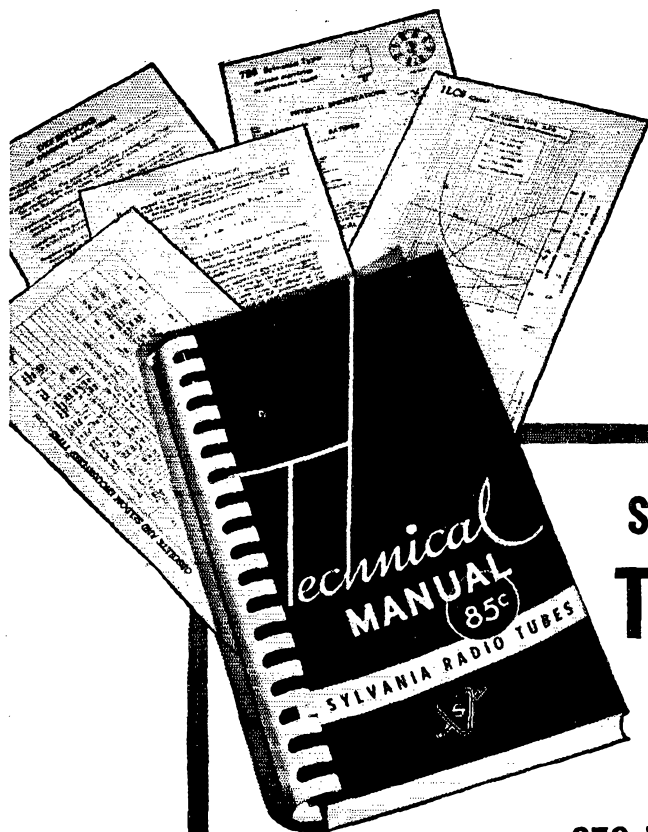

SYLVANIA'S NEW TECHNICAL MANUAL

DESCRIBING
378 RADIO RECEIVING TUBES

Bigger, better-than-ever—the new Sylvania Technical Manual is available now.

The large number of tube types listed (old and new) — almost four hundred — has been made available as a result of the solution of extensive and elaborate tube engineering problems.

Contents of this descriptive manual

include: Fundamental Properties of Vacuum Tubes; The Characteristic Curves; General Tube and Circuit Information; Typical Radio Receiver and Amplifier Circuits; Interchangeable Tube Chart — and many more.

We urge you to get a copy right away — because we know you'll find this volume chock-full of invaluable information.

Available from your Sylvania Tube Distributor or direct from Radio Tube Division, Emporium, Pa.

SYLVANIA ELECTRIC

MAKERS OF RADIO TUBES; CATHODE RAY TUBES; ELECTRONIC DEVICES; FLUORESCENT LAMPS, FIXTURES, WIRING DEVICES; ELECTRIC LIGHT BULBS

SILVER

NOW Available!

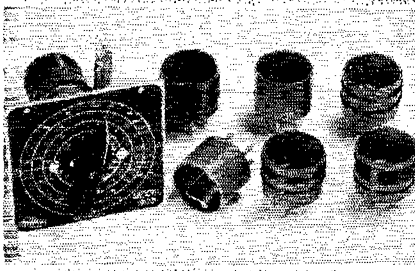

You've waited a long time for the neat little instrument pictured above. We are deeply appreciative of your understanding consideration in waiting for us to finally get material to manufacture it. That day is here. Your favorite jobber has received substantial allotments. He ought to have one for you right now. But we're not positive about that, for orders seem to come in just a bit faster than we can satisfy our increasing material needs. . . . but not for much longer, we hope. We don't need to point out the worth of an absorption wavemeter to you in neutralizing, chasing parasitics, etc., etc. . . . in finding r.f. and its approximate frequency in any tank circuit. It's one of amateur radio's most useful tools. We can, however, point out the neatness, small size to get into tight places, and wider frequency coverage of Model 903.

Model 903 Wavemeter \$3.30
Plug-in Inductors .65 each

Specify #100 for 1.6-3.7 mcs.; #101 for 3.5-8 mcs.; #102 for 8-19 mcs.; #103 for 17-40 mcs.; #104 for 40-100 mcs.; #105 for 100-300 mcs.; #106 for 400-500 mcs.

We hope next month to be able to announce that "ATOM-X" transmitters and receivers are in production, too.

Send postcard for catalog of new measuring equipment, communication receivers, transmitters, kits, parts. See them at your favorite jobber.

OVER 36 YEARS OF RADIO ENGINEERING ACHIEVEMENT

McMurdo Silver Co., Inc.

1249 MAIN ST., HARTFORD 3, CONNECTICUT

(Continued from page 80)

BC-406 on 144 Mc. KFT is a new-comer to 144 Mc. Traffic: WILWA 57, QR 36, INU 29, DWO 14.

VERMONT — SCM, Gerald Benedict, WINDL — MCQ has kept daily schedule on 28 Mc. with G6AY for three weeks. KJG, MMV, CCF, and 2PGF visited MCQ. EZ now is located in Pownal, has new 14-Mc. beam, and puts about 300 watts to an 813 final. Ex-KTB, now 9PHP, is located at Leavenworth, Kansas, and is on 14 and 7 Mc. JRU is located in Suffield, Conn. LYD is back home in Wolcott and is on 3.5-Mc. c.w. OAB divides his time on the air between WJOY and 28-Mc. 'phone. MEP has HY75 and six-element beam on 144 Mc.; also 20 watts and three-element beam on 14 Mc. EWF is located at South Londonderry and has tank rig on 3.5 and 7 Mc. He has an HRO receiver and BC-211 frequency meter. He operates a wood-working plant. Traffic: W1MCQ 3, OAB 2, EFW 1, 73. Jerry.

NORTHWESTERN DIVISION

ALASKA — SCM, August G. Hiebert, K7CBF — New officers of the Arctic Amateur Radio Club are AO, pres.; FU, vice-pres.; and CF, secy-treas. The club received high commendation from city officials when its members provided emergency communication following the fire that wiped out the telephone exchange. AN, ex-president of AARC, organized the network. DM, Adak, reports 7-Mc. c.w. traffic schedules with FY and CQ, Shemya and Anchorage, respectively. GT has been called back into the Army Airways Communications System. Members of the 3940-ke. Coastwise 'Phone Net are watching woo-pitching developments between FC and a peachy YL stenographer, courtesy DB and GM, whose stations she visited. DY has a new rig using a pair of VT-127As cathode modulated. EB flies a DC-3 out of Anchorage; he also has a new 200-watt rig on the air in between times. New appointments: DB, OBS, and CF, ORS. Traffic: K17CF 22, DM 4, 73. Augie.

IDAHO — SCM, Alan K. Ross, W71WU — The following appointments are in effect: Prewar OBS: IEY. Postwar OBS: IYG. ORS: JMH. RM: JMH. EC: KJO. OO: EMT. The Gem Net on 3743 kc. now meets at 8 p.m. MST Mon., Wed., Fri. Those meeting are IEE, Seattle; BAA, Firth; AMU, Casper; EMT, Kuna; GKA, Eugene; JMH, Boise, RM and NCS. IWU relieves JMH at times. Stations in North and Southeast Idaho are needed so please advise if interested. IY/7 still is on 7 Mc. only. FDH, Moscow, sends in nice report of Moscow gang as follows: U. of I. Radio Club officers are UQ, pres.; JHX, vice-pres.; FDH, secy-treas.; and IVR, act. mgr. Other Moscow stations are: ELH on 28-Mc. mobile and 4 Mc.; HIR on 28 Mc. with BC-610; BVK on 28, 7, and 3.5 Mc.; GGH on 28 and 4 Mc.; IJX with BC-610 on 28 and 14 Mc. FDH heard HXN, Coeur d'Alene, on 7-Mc. c.w. HST, Rupert, has BC-610 on all bands. Traffic: W7JMH 151, EMT 24, IWU 10, IY/7 2, 73. Alan.

MONTANA — SCM, Albert Beck, W7EQM — Section EC: BWH. The Helena gang organized the Capital City Radio Club, promoted by HIZ with IVY, pres.; JOT, secy-treas. EWR moved to Great Falls. Most of the Helena gang on 28-Mc. 'phone plan 144 Mc. activity. The Butte Amateur Radio Club held its annual inauguration banquet and dance at Rainbow Inn Jan. 4th with seventeen present. JFR is pres.; KKB, vice-pres.; FLB, secy-treas. CT is building e.c.o. with power supply. The Glendive Hamfest was a big success. FMV had high score. CBY was luckiest there. FIN is working ZLs on 28-Mc. 'phone with a pair of 807s. EQC is stationed at Fort Dix. BOZ and EO1 are active on 14-Mc. 'phone. DQG has 841 on 7 Mc. GBI is starting airport at Stanford. CC expects to be on 144 Mc. soon. BUJ received his old call. CRD reports a club at M.S.C. FL has new rotary beam on 28 Mc. EQM is permanently out of the dog house; the XYL hung long winter underwear over the transmitter to dry and blew out new 0-300 millimeter. Traffic: W7CT 16, 73. Al.

WASHINGTON — Acting SCM, Lloyd Norberg, W7-EHQ — Our new postwar RM is CZY, Rt. 2, Everett. He needs help in operating your trunk lines. Please contact him for further details. He has North-South Trunk going and wants extensions. CZY has 1 kw. on 3.5 Mc. DGN hooks CFK after ten years holding regular traffic schedule with 9BUU/KL7 with 45 watts. JHJ is in Port Townsend on 3951 kc. with 18 watts. HAD reports ARAB still progressing with six new members. EBL is on 14 Mc. with 500 watts. GWL is busy with coming ARAB Hamfest. DYH contacted

(Continued on page 84)

FLAT or RISING RESPONSE

... as you need it!

No need to worry about your microphone, or even to install a filter in your speech amp . . . when your choice is the Electro-Voice CARDAX. With dual frequency response and high output in this one microphone, you can use a flat response for clear channel, or rising response to cut thru QRM. Simply adjust the two-position selector switch on rear of case. When in the "out" position, the frequency response curve is wide and flat. Your voice quality is smooth, rounded and full range. In the "in" position, the curve rises 7 db at 4000 c.p.s., and your signal is sharp, clean, brilliant. Model 950 lists at \$37.00.

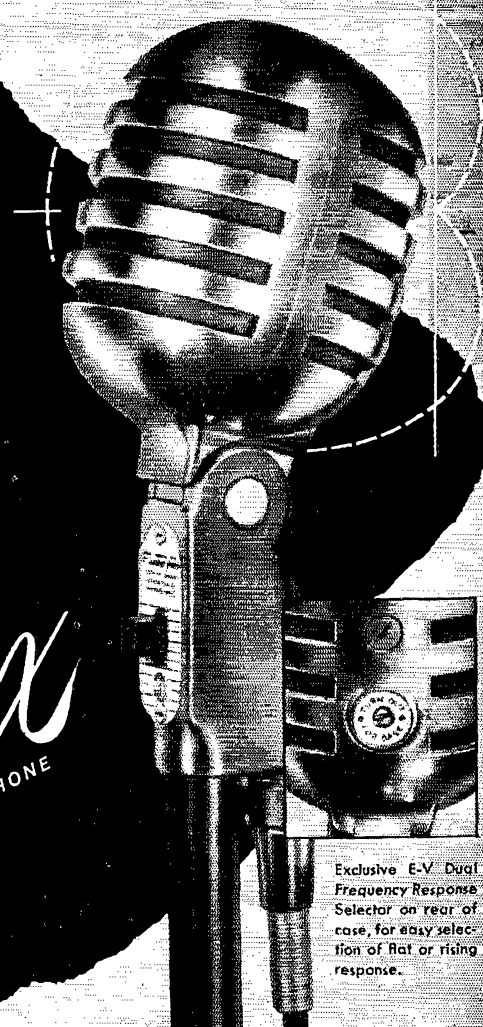

THE
Cardax
CARDIOID CRYSTAL MICROPHONE

Exclusive E-V Dual Frequency Response Selector on rear of case, for easy selection of flat or rising response.

SEND FOR CATALOG No. 101



Authorized Distributors Everywhere

NO FINER CHOICE THAN

Electro-Voice

ELECTRO-VOICE, INC., BUCHANAN, MICHIGAN

Export Division: 13 East 40th Street, New York 16, N. Y., U. S. A. Cables: Arlab

*Electro-Voice Patent Pend.
Licensed under Brush Patents*

In this NEW WORLD OF ELECTRONICS



NEW DEVELOPMENTS
SPELL New Opportunities!

A FEW YEARS AGO broadcasting was born—many of the first radiomen to enter that field have long since arrived at the top of their profession.

TODAY, the techniques of this New World of Electronics, war-developed and now released, offer greater opportunities than ever existed in the early days of broadcasting.

MICRO-WAVE RELAY SYSTEMS, TELEVISION, FM broadcasting, mobile communication systems for trains, automobiles, busses and trucks, many industrial applications—these are only a few of the new developments and new techniques which offer marvelous, exciting opportunities to you who are alert—and are qualified!

YOU HAVE THE OPPORTUNITY to "get in on the ground floor"—where promotion will be rapid—where you can go to the top, IF—you have the foundation of technical knowledge which is so vital to an understanding of the new techniques. Your first step toward success in this new world of electronics is your resolution to acquire a formal, fundamental technical knowledge. CIRE courses of home study training are planned to do that job. **Mail the coupon today!**

CIRE HOME STUDY COURSES COVER THE FIELD OF RADIO-ELECTRONICS—TELEVISION, ULTRA-HIGH FREQUENCY TECHNIQUES, AM AND FM BROADCASTING, COMMUNICATIONS ENGINEERING—from simple treatment of fundamentals, through preparation for FCC commercial radio operators' license examinations, up to and including complete high level quantitative treatment of advanced radio-electronics and communications engineering. **Choose the course best suited to your needs, and start with the section you are qualified to enter. You pay for only the section or sections you need. Use the "Pay-as-you-go plan" patterned after ethical, educational practice.** These features are unique with Cleveland Institute, and represent the best in the modern, post-war concept of home study training.

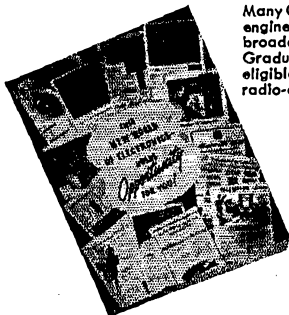

Many CIRE students of advanced engineering courses today are broadcast chief engineers. Graduates of CIRE courses are eligible for the top jobs in radio-electronics.

Write today for free, descriptive booklet—"THIS NEW WORLD OF ELECTRONICS HOLDS OPPORTUNITY FOR YOU." No obligation.

Cleveland Institute of Radio Electronics
Contractors to the Canadian Broadcasting Corporation
QT-3 Terminal Tower Cleveland 13, Ohio

Cleveland Institute of Radio Electronics
QT-3, Terminal Tower, Cleveland 13, Ohio

Gentlemen: Please send information about your home study courses in Radio Electronics.

Name.....

Address.....

City.....State.....

If a veteran, check here

(Continued from page 98)

Capt. Parrott, USNR, and with two radio-equipped jeeps carried communications during the recent White River Valley Flood. Orchids to Capt. Parrott and the hams in USNR. BG works 28 Mc. with HT-9. DP reports DRD is on with BC-610. ERH is on 3.9 and 28 Mc. with new rig. CSN is on 3.5 and 3.9 Mc. EQN has new receiver, new antenna, and new transmitter. His XYL, KCV, is eagerly awaiting her turn at the rig next year. JHP, home from Maine for the holidays, operated on 28 Mc. PDD is on 39. Mc. FDL is on 28 Mc. DP has new 28-Mc. folded dipole. CKZ is on 27 Mc. and has new VHF162 to go on 50 Mc. EYF, in Chehalis, is on with BC-376E looking for traffic. ACF, on 3.5 Mc., yells for traffic every night of the week. JFB contemplates OPS on 3.9 Mc.; 3940 is her schedule frequency. TL A Monday through Friday. APP, 7:30 P.M. 6MDI, daily 8:00 P.M., 3565 and 3550 kc. 9QGJ now is KKV of Seattle. FWD is trying to cure relay troubles in BC-610. FWR is showing Tate how to operate on 28 Mc. CWN is on 3.5 Mc. HGC is working TL A on 3565 kc. KIL is on 3.5, 14, and 28 Mc. with TZ40s at W.S.C. BTV has new antenna location in west end of Tacoma. CXR built new PPTZ40 modulator on his 3.9-Mc. rig. GVL is operating on 28 Mc. LB has new four-element signal quarter; he climbs the roof at night to tune with a neon bulb. IMB bought new modulator meter and found out 100 per cent was half of what he was using. JTF has 800 watts on 7 and 14 Mc. DXZ and DSZ have 304T1s with IKW. IDZ is new chief at KONP. GDW has more BCI with antenna 300 feet long. GRQ finally found his voice on 28 Mc. EHQ schedules J3GNX now and then. Areas not reporting are Spokane, Vancouver, Centralia, Yakima, Port Angeles, Bellingham. Traffic: W7CZY 361, DGN 47, FWR 21, FWD 12, DYH 4, HBC 1, HGC 1. 73. Lloyd.

PACIFIC DIVISION

HAWAII—SCM, John Souza, KH6EL—GP is on 14 Mc. with T40 final. EB is on 28 Mc. with 807. GW is on 7 Mc. using 6L6. AU is busy on 7 Mc. with 807. EJ has new BC-610B and RME-69. EB and EX finally received HQ-129X. AU received new HRO. W9FDK, a member of the Hilo Amateur Radio Club, handles code classes. K6TKA, Kauai High School, handled Christmas messages for the teachers. K6CGK now is KH6IK. BG is rebuilding to TZ40a. DF rotates 28-Mc. beam without the use of crowbar. GM is using BC-312 with converter for receiving. W6WZS/KH6 is modulating 45 watts on 28 Mc. ET is an OBS. EK has 57-foot steel tower. EL is on NB f.m. on 28 Mc. EM is on 50 Mc. with single 829. K6SDM is using NC-101X. GH is on 28 Mc. with BC-610 and four-element fixed beam atop 60-footer. DD made 376 contacts in SS. New officers of the Maui Amateur Radio Club are: DK, pres.; EM, vice-pres.; IH, treas.; Silva, secy. Traffic: K6TKA 92, KH6DF 41, 73. Johnny.

NEVADA—SCM, N. Arthur Sowle, W7CX—Asst. SCM, Carroll Short, jr., 7BVZ. RM: PET. ECs: JU, TJJ. Asst. ECs: OPP, KEV. OBS: JUO. OES: TJJ. JUO is on 3.9 and 14 Mc. JXH is on 7 Mc. with 6L6 oscillator and p.p. 809s in the final. KJQ is on 28-, 14-, and 7-Mc. c.w. PZY operates 200 watts on 7 Mc. JU increased power to 600 watts on 3.5-, 7-, and 14-Mc. c.w. SXD is running his Millen exciter on 7 Mc. RXG is active in the Nevada Sagebrush Net (3898 ko.). BVZ is on the Mission Trail Net for Southern Nevada outlet. PGD found that a loading coil in his antenna increased his signals considerably on 7- and 3.5-Mc. c.w. TFF is on 3.9 Mc. with a VT-127A grid modulated. JVV, PWE, and RPG are on 3.9 Mc. TJJ takes net control on Mission Trail one night a week. TJJ is experimenting on 28 Mc. KLK has 30 watts on 3.9 Mc. 6BIC is using a MacElroy exciter. GC has 900 watts and is active on 3.9 Mc. QYK is on 3.5-Mc. c.w. Traffic: W7CX 82, BVZ 2. 73. Art.

SANTA CLARA VALLEY—SCM, Roy E. Pinkham, W6BPT—Asst. SCM, Geoffrey Almy, 6TBK. PAM: QLP. The San Mateo Club had a pre-Christmas Party at St. Georges Hall, attended by seventy-five. PBV plans to move his station from San Mateo to Pescadero. He reports hearing Europeans coming through very well in the morning on 7 Mc. IC soon will be on with a 1-kw. c.w. and 'phone rig. ZZ has worked fifty countries. He is operating on 28.99 Mc. and is looking for his old friends in and around Boston. The following are on in Los Altos: SYW, TZK, WCT, VGO, HJP, and AEW. HJP has realigned in the AAF as a master sergeant. TBK received a modulation meter for Christmas and

(Continued on page 98)

Everybody and his brother



prefers a **TEMCO**

Meet the three Schweitzer brothers, from left to right... Bill—W2KG... Pete—W2MDQ... and Lou—W1MBJ. Heard over the air on ten, twenty and seventy five meters, their custom-built TEMCO Kilowatts are quickly recognized by their outstanding signals.

Say these three well known and frequently heard radio amateurs, "Our pre-war experience with TEMCO TRANSMITTERS was so extremely gratifying that when the time arrived to equip our new stations... naturally we selected TEMCO. Short skip—long skip—northern lights or what have you, our TEMCOS always get through. And for easy handling they're unsurpassed... everything's at your fingertips and everything's in one cabinet."

Discriminating amateurs, like the Schweitzers prefer TEMCO TRANSMITTERS because of their excellent DX capabilities, operational flexibility and highly efficient circuit designs. If you too want a transmitter that leaves nothing to be desired in both performance and appearance... make yours a TEMCO. Available in a range of power output ratings from 75 watts up. Write for full details and prices stating your requirements.

Work a QSO with a TEMCO KILOWATT at the IRE Show. Booth 65 B March 3rd to 6th inclusive.



TRANSMITTER EQUIPMENT MFG. CO., INC.

445 HUDSON STREET • NEW YORK 14, N. Y.

See these REMARKABLE SAVINGS offered by the RADIO SHACK

BC-348 RECEIVER

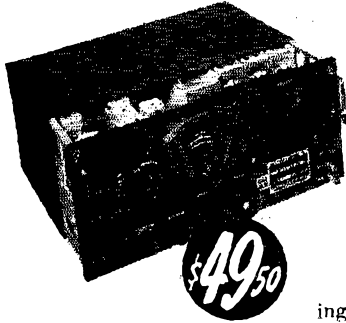

\$49.50

Acclaimed the best military receiver for amateur use, this easy-handling set covers six band-switched ranges from 200 kc to 18 mc (less BC band), with constant sensitivity on all bands. Has Xtal filter, AVC, MVC, BFO, automatic noise compensator, temperature-compensated oscillator; output at 300 or 4000 ohms; vernier tuning on all bands. Furnished with built-in dynamotor, full set of tubes, and details of conversion to 110v. a-c.

Complete a-c conversion kit for BC-348.....\$6.50

***Famous for fair dealing with radio amateurs for more than twenty years.**

Gon-Set 10-11 Meter Converter

Ideal for use with BC-348. Supplied with full set of tubes.

\$39.95

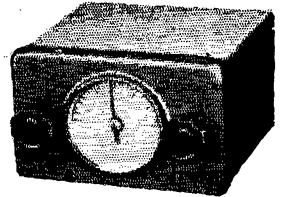

SCR-522 VHF XMTR-RCVR for all-purpose work at 100-156 MC

So good it was standard equipment on all AAF and RAF planes, this set is now yours at but a small fraction of its original cost. Ten-tube crystal-controlled superhet has 3-microvolt sensitivity at 10 mw output. Seven-tube temperature-stabilized xmtr delivers 15 watts. Remote control box gives push-button tuning on four crystal-controlled send-recv channels. Dynamotor (28-volt d-c) powers entire rig. Furnished with all tubes, plugs, and detailed dope on conversion to 110-volt a-c operation. Condition — like new. Weight — about 100 lbs.



\$39.95

AAF XMTR BC-375-E



\$35.00

For a real bargain, you can't beat these used, but in A-1 shape, BC-375's. Furnished complete with five tubes, seven tuning units covering 200 kc to 12 mc (less BC band); antenna tuning unit BC-306-A

with variometer and tap switch, dynamotor PE-73-C with relay, fuses, and filter. For detailed description of this 200-pound bargain, see our Feb. QST adv.

PE-103 DYNAMOTOR New Lot, only \$9.00



Brand new, in original Signal Corps packing; delivers 160 mills at 500 volts; operates from 6 or 12 volts d-c; complete shock-mounted assembly includes breakers, switches, relays, filters, and cables.

STANDARD RECEIVERS

- HALLICRAFTERS**
 S-38 complete\$39.50
 S-40 complete 89.50
 SX-42 250.00
- NATIONAL**
 HRO-5TA-1 complete..306.71
 NC-240D with speaker 241.44
 NC-46 with speaker...107.40
 1-10A with tubes, less speaker and power supply 67.50
- HAMMARLUND**
 HQ-129X complete178.25
 SP-400X complete342.00
- RME**
 RME-45 complete198.70
 RME-84 complete 98.70
- PANADAPTER**
 Complete 99.75

and the entire line of COLLINS EQUIPMENT

Check RADIO SHACK first for RELIABLE SURPLUS Values

*The one and only original RADIO SHACK is located in Boston and has no branches or affiliates elsewhere.



BUYS in TUBES

872A	\$2.25	304-TH Eimac	\$9.95
807 Westhse	1.05	809	1.79
811	1.95	810	2.59
813	6.75	814	4.50
211 GE	4.95	826	2.25
829B	3.94	832A	4.05
829B socket	.69	931A	1.88
		2AP1	2.25

FREQUENCY STANDARD BC-221

This stable, heterodyne frequency meter checks up to 5th harmonic on most receivers and up to the 125th on the better ones. Fundamental ranges are 125-250 and 2000-4000 kc; stability is better than .005%; instrument works on 110 v.a.c., on vibra-pack, or on batteries. You can use it for a signal generator or make it into a VFO that's a hum-dinger. It's complete with tubes, original crystal and calibration charts. Hardly to be told from new, this is one of the finest instruments we've yet been able to bring you from surplus stocks — it's a value you can't afford to miss. Order today!!

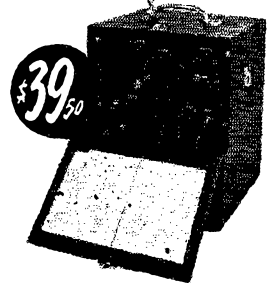

SCR-274-N COMMAND SET

This remarkable assortment of gear — with parts alone worth far more than our entire selling price — gives you

- 3 RCVRs — 190-550 kc; 3-6 and 6-9.1 mc
- 2 XMTS — 3-4 mc; 4-5.3 mc
- 4 DYNAMOTORS — 28-v. d-c input
- 1 MODULATOR — carbon mike input
- 2 TUNING CONTROL BOXES
- 1 ANTENNA COUPLING BOX with r-f ammeter, antenna relay, and 5000-volt, 50 mmfd. WE vacuum condenser
- 29 TUBES — a complete set for each unit

Our extremely low price is possible because the equipment is slightly used — but it's in first class shape ready to give you years of service. DON'T MISS THIS BARGAIN IN USABLE GEAR!

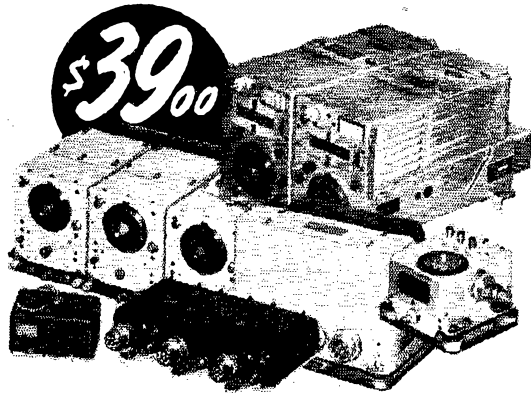

XMTG CAPACITORS

Nationally known, high-voltage, oil xmtg capacitors, all in rectangular cases, with stand-off insulators.

Mfd.	Volts d-c	Net Ea.	Mfd.	Volts d-c	Net Ea.
4	600	\$0.71	2	1500	\$1.20
6	600	.79	4	1500	1.59
8	600	1.19	6	1500	1.79
10	600	1.29	2	2000	2.95
2	1000	.71	8	2000	3.75
4	1000	1.19	2	2500	3.25
8	1000	1.49	2	3000	3.45
10	1000	1.79	4	3000	4.25
			2	4000	4.95

Speed delivery and save C.O.D. charges — send full amount with order; 50% deposit required on all C.O.D. orders.

The RADIO SHACK

★ 167 WASHINGTON ST. ★
BOSTON, MASS., U.S.A.

SEE OUR ADVERTISEMENT IN FEBRUARY QST FOR DETAILED DATA ON ALL THESE AMAZING VALUES



YES EVERYTHING THE MODERN HAM DESIRES

... all in one rack mount unit, or table top use. A VFO that is on constantly, yet signals can be copied plainly in the up-key position. An xtal control that needs no switching in or out, just insert the xtal and tune. Remove the xtal and the unit is automatically in VFO position. A VFX control that rubberises any cut xtal and permits deviation of the xtal frequency as much as 30 kc on 80 mtrs; 60 kc on 40 mtrs; 120 kc on 20 mtrs; 240 kc on 10 mtrs.

YES it has FM phone on all bands*. The same unit that SONAR is famous for in the XE-10 is incorporated in the VFX 680.

YES ... there's more ... it also incorporates a CW MONITOR and PHONE MONITOR, for earphones, as well as a dual tuning eye that employs the upper half for tuning the various stages and the lower half for visual monitoring.

Send for catalog or see your dealer about the VFX 680 and its companion exciter model XE-10.

*NBFM is at present permitted on 11 mtrs. & above 29 megs.

SEE
YOUR
DEALER
OR
WRITE US
DIRECT

SONAR
Radio

SONAR
RADIO
CORP.
Box 445
BKLYN 1
NEW YORK

NARROW BAND FM

(Continued from page 94)

says he is filling his earrier to about thirty per cent. CIS is doing FB with his new 813 rig, having worked G6ZO for a 579 on 7 Mc. DZE reports K6QUD and his XYL, K6TCW, were visitors in San Jose. JSB can be found handling traffic on the Mission Trails Net any evening during the week. Cecil also checks into Trunk AW when he can hear the boys on 3565 kc. He is using NBFM on 29.008 Mc. and says that the BCI on 28 Mc. is a thing of the past. JDC has the first VHF-152 converter in the section and says it's very good. QCB operates at his QTH in Sunnyvale on week ends and attends school in Davis the rest of the week. Some may remember him as ZD4AF, who operated in Africa just after the war. PVV has her new rig completed and can be found on 3.5- or 7-Mc. c.w. Let's keep the reports coming. Traffic: W6JSB 90, ZZ 38, TBK 18, DZE 11, CIS 6, SYW 2, 73. *Pinky.*

EAST BAY — SCM, Horace R. Greer, W6TI — Asst. SCM, C. P. Henry, 6EJA. SEC: OBJ, RM; ZM, OO: ITH, EC: QDE, Asst. EC u.h.f.: OJU. The following officers were elected by the Oakland Radio Club for 1947: EE, pres.; MFZ, vice-pres.; MNG, secy.; OLL, treas.; ZM, director; BF, chief operator. The Mission Trail Net, on 3854-kc. 'phone, is doing a bang-up job throughout California, Oregon, Washington, Utah, and Arizona. The Richmond Radio Club elected the following officers for 1947: CTL, pres.; NJX, vice-pres.; KEK, secy.-treas.; QUL, sgt. at arms. WHG is doing good job as sergeant at arms for ORC. WP blew up his power supply on large rig. BUY is hammering after 14-Mc. c.w. DX. PB is mostly on 14-Mc. c.w. chasing DX. IDY just completed FB e.c.o. JUW is working on new 14-Mc. beam. GPY is working for DX records on 2000 Mc. CZQ is on 14-Mc. c.w. UPV is working out fine on mobile 28-Mc. 'phone. IKQ is on with a complete new 1-kw. rig. AED is working on new 28-14 Mc. four-element beam. The Northern California DX Club, Inc., members are sporting new QSL cards. EJA reports that all Richmond traffic has been handled by PGZ. CRF is building new a.m. and N.B. f.m. rig with p.p. 35Ts in final and reports that the North Bay Radio Club is going along FB. Those interested may contact EUL. KEK is rebuilding 1/2-kw. rig. CDA expects to have narrow-band f.m. rig, three-element premax beam, and higher power. GZH's ticket has been renewed. WVK is getting to be a DX hound. K6RVU/8 has new 14-Mc. four-element beam. QXN is doing a bang-up job on traffic. ITH has permission to operate 'phone from Cocos Island during DX Contest, probably signing T16ITH. SAN reports that he is on the SS J. L. Hanna and works plenty of stations with his Abbott TR4-A on 144-Mc. while in port. The SARO is a fraternal organization and has elected new officers for 1947. Let's all try to keep the e.c.o.s off the DX stations. It is getting to be a bad habit. It is time to think about this when you hear dozens of stations calling a DX station zero beat at the same time. What do you say? Beat of luck and let's remember to keep amateur radio a pleasure. Traffic: (Nov.) W6CRF 6, (Dec.) W6QXN 212, ITH 115, TI 6, CRF 5, LMZ 2. "TI."

SAN FRANCISCO — SCM, Samuel C. Van Liew, W6NL — Phone JU 7-6457, Asst. SCM, Joseph Horvath, 6GPB. RM: RBQ. ECs: KNZ, DOT, KZP, LLJ, SRT, UHN, VCG, QFX. OO: NJW, WB, OBS: FVK, KNH, DJI, OZC, BYS. ORS: RFF, BIP, ATY, RBQ, NL. OPS: OZC, NYQ, STY. EYY reports very fine DX on 28-Mc. 'phone and c.w. VR2AB and CR9AG are samples. He is using one of AHH's all-aluminum plumber's delights. Five lucky hams fabricated five such antennas with the aid of AHH and machine shop facilities. They were all precision-made and adjustable as to length and spacing between elements. The proud possessors are WQO, DEK, RCG, FGP, and EYY. Harold also held daily schedule with NPY/MM, SS Blue Jacket, clear across the Pacific to Japan. VJO is back on the air on 3.9-Mc. 'phone and is handling traffic on the Mission Trail Net. He is attending college in Berkeley and operates 144-Mc. portable from that location. HJF re-listed in the AAF as master sergeant. He is stationed on top of Mt. Tamalpais and sends his regards to all the gang. An old friend is back in our midst; MWK is out of the services as a major of the AAF and intends locating in San Anselmo. The old-timers will remember Lee as active on 28- and 14-Mc. 'phone. He is now to be heard on 28 Mc. with a pair of HF300s and a three-element beam. Les Powell is on 28-Mc. 'phone from his home QTH in Santa Venetia. QIA is on 28-Mc. 'phone from St. Vincent's School for Boys, just north of San Rafael. He is using a pair of 6L6s in the final. ZI, an

(Continued on page 100)

NEW!.. 152-162 Mc fm

Specifically designed for the Urban Mobile Service Band

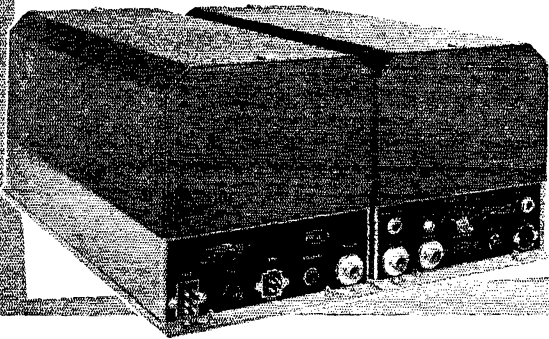

KAAR

Radiotelephones

**INSTANT
HEATING**



POLICE



FIRE



TRANSPORTATION



FOREST & RANGE

- ★ Improved Voice Quality
- ★ Higher Sensitivity
- ★ Greater Noise Rejection
- ★ Lower Battery Drain

Tested and proved equipment specifically designed for the 152-162 Mc band is now brought you by the engineers who made instant-heating FM practical. The new KAAR FM-175X transmitter and FM-40X receiver are thoroughly engineered to do a better job in the urban mobile service band.

You will hear a startling improvement in voice quality. A special circuit boosts the low tones, rounding out the voice quality to a naturalness that actually permits recognition of the speaker's voice! Controls are reduced to a minimum, making operation almost automatic!

Service men will find that this new KAAR equipment requires a minimum of upkeep and repair. For quick checking and servicing dust covers can be removed by a quarter turn of two airlock fasteners. The entire chassis can be released simply by freeing two slide catches.

KAAR instant-heating transmitters with zero standby current eliminate the need for costly special generators or extra batteries. Only about 4% of the current used by conventional equipment is needed.

IMPROVED OVER-ALL FREQUENCY RESPONSE THROUGH KAAR FM TRANSMITTER AND RECEIVER

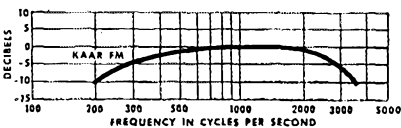

SEND FOR NEW BULLETIN

Write today for illustrated bulletin number 26-47 giving complete details of the FM-175X transmitter and FM-40X receiver. No obligation, of course. KAAR ENGINEERING CO., 605 Emerson St., Palo Alto, California.

READY TO GO... INSTANTLY!



KAAR ENGINEERING CO.
PALO ALTO, CALIFORNIA



SAVE at RESCO!

Send for Big, Free Bulletin TODAY!

ON **GOV'T SURPLUS**

All Brand New!

Standard Brand **TUBE SPECIALS**

CATHODE RAY!



DuMont 3GP1 Reg. Price \$13.00 Resco's Price... **3.95**

Sylvania 5BP1 Reg. Price \$20.50 Resco's Price... **4.95**

RCA 1624 Quick heating beam power amplifier similar to 807 tube. Filament voltage 2.5 at 2 amps. Max. plate volts-600. Max. plate current-90 MA. Standard 5 pr. socket. Reg. \$3.50 **1.49**



811 - New, in original packing. Reg. Price \$3.50 Resco's Price... **2.65**

28D7 Twin beam power amplifier filament—28 volts at 0.4 amps. Plate volts—28. Screen volts—28. Power output—0.1 watts... **2.35**

1616 Half-wave, high vacuum rectifier similar to 866 tube. Filament. 2.5 volts at 5 amps. Peak inverse voltage 5500. Peak plate current 0.8 amp. Socket standard 4 pr. Reg. \$7.50 **1.49**

National 4" 'N' Dial #3 scale, 100-0 in 180° Reg. \$4.50. Resco's Price— **2.75**

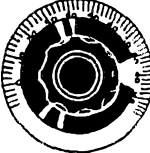

CROWE DIRECT DRIVE TRANSMITTER DIAL 4" metal flange with black fluted knob, 2 1/4" diam. Graduated 100 to 0 in 270°. Reg. Price \$1.47 **79c**

HEAVY DUTY ANTENNA TRANSFER SWITCH—Double pole, double throw, 30 amp. knife switch insulated for high voltage by ceramic pillars 2 1/2" high, mounted on base 4" x 8". Suitable for antenna changeover, antenna grounding, etc. **49c**

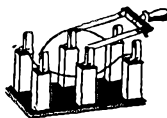

STANDARD KEY Made to Signal Corps specs. Solid coin silver contacts. Silver plated lever, bakelite base. Model J-37. Regularly \$1.80... **49c**

MODEL 200 Built to professional standards. Coin silver contacts, accurately matches bearing screws. Black crackle finish, metal base. Less circuit closing switch. Reg. 1.75 **1.49**



Radio Electric SERVICE CO. OF PENNA., INC.

7TH AND ARCH STREETS, PHILA. 6, PENNA.
Branches: 5133 Market St. and 3145 N. Broad St. in Phila.
Also in Wilmington, Del., Easton, Pa., Allentown, Pa., Camden, N. J.

(Continued from page 98)

old-timer, is back on 14 Mc. YME is a new call on the air from Tamalpais Valley. Bob is an old-timer, however, being an ex-commercial operator and having held several ham calls in the past. He is operating 7- and 14-Mc. c.w. with 60 watts to an HY69 using an NC101X receiver. The Marine Radio Club held its annual Christmas Party on Dec. 14th at the Mill Valley Golf and Country Club. A fine dinner was served and a swell evening was had by all. The club was pleased to have in attendance ARRL vice-president J. L. MacCargar, EY, and family, and our new Pacific Division Director, Bill Ladley, RBQ, and wife. The following new officers were introduced and installed: OZC, pres.; PVC, prize chairman; Frank Barnes, program chairman; RTH, publicity chairman. Thanks for the reports, fellows, and please get them in before the end of the month. My call has been changed to a two-letter call, W6NL. Traffic: W6RVQ 44, BIP 22, EYY 11, VJO 8. Sam.

SACRAMENTO VALLEY — SCM, John R. Kinney, W6MGC — OJW has schedules with KL7CF and wants more SS Contests. DBP put up end-fed Zepp for 7 Mc. and added new country, NY4CM. WTL reports schedules with KL7FL, 9AVX, 2KOW, 4ERS, 4IQQ, 6OY, 6CZB, 6OV, 8YUP, and 80PA and made 2,152 points in SS Contest on 'phone. GVM, on 28- and 14-Mc. 'phone, is glad SS Contest is over so that he may enjoy some DX and rag-chews. AF is new OBS on 7186-kc. c.w. with 810s in his final. HIR, ORS, on 3552.5-kc. c.w., reports schedules with VJN and 7BWD. OJW, ORS and OO, reported eighteen stations with chirpy and poorly-filtered signals. FRP sent a photographic QSL card of his FB station with RK-20 c.w. rig with 100 watts input and Abbott TR-4B that puts out FB signals on 144 Mc. PIV keeps schedules daily with Pioneer Net on 3725 kc. Besides working 3.5, 28, and 144 Mc., he is preparing rigs for 50 and 235 Mc. GZY, OBS, is on 3608-kc. c.w. and 147-Mc. 'phone. He reports that IOB is moving to Alameda. 9MXA now is 6YCA. QKJ is on 28-Mc. 'phone using an 813 in final; he also has a rhombic on 144 Mc. KME has a 28-Mc. rig in his car. YLO is a new ham on 144 Mc. The SARC, Inc., held its first annual Christmas Party on Dec. 18th attended by 125. ZF was guest speaker. EJC offered \$750 to finance the purchase of a lot for a club house for the SARC, Inc. Traffic: (Nov.) W6OJW 5, DBP 1. (Dec.) W6PIV 74, WTL 6, DBP 5, GZY 5, HIR 4, OJW 4, GVM 2, 73. Jack.

SAN JOAQUIN VALLEY — SCM, James F. Wakefield, W6PSQ — UBK is on 28 Mc. and JCB is on 3.9 Mc. with an 829. KUT has sixteen postwar for ninety-one total confirmed. LTO has twenty-two postwar for sixty-five confirmed. SRU has three-element rotary for 14 Mc. MGN is building a pair of handie-talkies for 144 Mc. VLS is on 144 Mc. with a 6C4-6C4 m.o.p.a. OHP is with KFRE and is on the air with 50 watts to an 807. OWL has taken on a wife. TFF is on 28 Mc. PDD has a 522 on 144 Mc. JPU has a sixteen-element beam on 144 Mc. and is working UID in Porterville nightly with S9 both ways. Drop Ralph a line for a schedule on 144 Mc. WYT, ex-8STJ, has installed 152-Mc. gear in a local taxi under the call XOS. MEY is on 3.9 Mc. The Fresno gang meets nightly on 28,700 kc. for rag-chews. From Sonora CQI reports he is active on 144 Mc. with 25 watts c.c. and tests on Sunday afternoons. He also says QJT is on 14 and 3.9 Mc. and RAF has an 807. GJJ has finished his new QTH. GJI runs 200 watts on 3.5-Mc. c.w. with HK-54s and 348Q receiver all off of a gas generator. JQF is on 3.9 Mc. from Angela Camp and WJ is on 3.9 Mc. from Oakdale. FV has moved to Sacramento. The SCM has 100 watts into an 829, all bands 3.9 through 28 Mc., and is in a new shack. HKV is new OBS and applications are in the mail to CQI and QOP for appointments. How about some of the rest of you fellows dropping me a line? Also, reports from your district should be sent by the first of the month. 73. Jimmie.

ROANOKE DIVISION

NORTH CAROLINA — SCM, W. J. Wortman, W4CYB — AVT is busy on 3.5 and 7 Mc. with an 813 final. ANU has the rig working on 28 Mc. PEY is active on 14 and 28 Mc. with 35 watts. FDV, WMI, and HYV hold Sunday morning schedules on 50 Mc. HUW maintains schedule with 8QPO. EBA purchased a BC-375E. ZZ, Elizabethton, Tenn., wants 50-Mc. hams in the western part of North Carolina to contact him for schedules. The Key & Mike Club, Winston, is in full operation. BYA is experimenting with antennas. HUL is working low power on

(Continued on page 108)

COMPLETE STOCKS OF QUALITY SERVICE KIT VALUES!

Yes, **TERMINAL** is your best bet for better buys!
TERMINAL is New York's leading distributor of
 Radio and Electronic Equipment

Complete Stocks of Everything in Radio
 All Standard Lines at Lowest Prices
 Hundreds of Choice Quality Surplus Bargains

FOR PROMPT, COURTEOUS SERVICE — DROP IN, WRITE, WIRE, PHONE!

RECEIVERS & TRANSMITTERS - IN STOCK!



HALLICRAFTERS
 S-38 47.50
 S-40 89.50
 SX-42 275.00

HAMMARLUND
 HQ-129X 173.25
 SP-400-X 342.00

All receivers complete with speakers, except
 SX-42 and I-10-A

NATIONAL
 NC-46 107.40
 NO-240D 241.44
 HRO-STAI 306.71
 I-10 A 67.50

R. M. E.
 RME 84 98.70
 RME 45 198.70



HALLICRAFTERS
 Panoramic Adaptor
 Model SP-44 Simul-
 taneous visual re-
 ception for extra
 efficiency! Complete
 with attachment ac-
 cessories and simple
 instructions. Buy it
 — then try to do
 without it! 99.50

**GON-SET
 CONVERTER**
 Specify 20,
 10-11 or
 6 Meters 39.95
 Special Noise
 Silencer 8.25
 Bliley CCO 69.50
 Millen 90700
 ECO 42.50

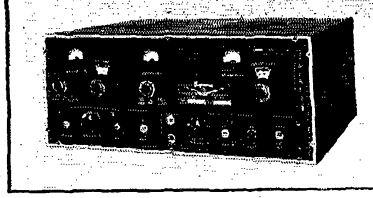

TRANSMITTERS
 SUPREME AF-100,
 complete 450.00
 TEMCO 75-GA,
 complete 495.00
 SONAR FM Exciter,
 XE-10 39.45
 MILLEN 90800,
 50 Watt
 Exciter 37.50

**UHF Complete
 Kits**
 HYTRON HY-Q 75,
 complete with
 fancy plumb-
 ing 9.95

**CARDWELL VHF
 OSC. KIT 10.80**

COMPARE THESE OUTSTANDING TERMINAL VALUES!

**ADVANCE 1 KW.
 ANTENNA
 RELAY**

All-ceramic
 insulation,
 wide spacing,
 self-cleaning
 contacts, DPDT. This is the
 famous relay hams swear by,
 not at 115 V. A.C. Coil. **395**
 Your cost only.....each

**HIGH VOLTAGE
 MICA CAPACITORS**

**BAKELITE
 CASED
 5000 Volts
 D.C. Working
 .0001 Mfd.**

.0002	.0005	.00072	.002
.00025	.0006	.0011	.004

All Brand New,
 Best Quality!
 Your cost.....each **88c**

**OIL FILLED, High
 Voltage Condenser**

10 MFD.
 600 W.V.D.C.
 Our best seller,
 because quality
 is tops and
 price is ridicu-
 lous! Brand new, made by fa-
 mous condenser manufacturer!
 Ruggedly built for long-life,
 hermetically sealed!
 Your cost.....each **98c**

**BLEEDER
 RESISTORS**

50,000 ohms 100 Watts
 IRC type HA..... **69c**
 10,000 ohms 120 Watts
 Sprague Koolohm **39c**

All brand new,
 fully guaranteed!

**THORDARSON
 POWER
 TRANSFORMER**

Type 92R21
 Primary: 115
 volts AC. 50-60
 cycles. Second-
 aries: 389-0-389
 Volts @ 200 Ma.
 6.3 Volts @ 5 Amps. CT
 5 Volts @ 3 Amps. **598**
 Brand new, fully shielded!

KENYON CHOKE

6-19 Hy. -200
 Ma., D.C.
 5,000 volts
 insulation
 test, 140 ohms
 D.C. resist-
 ance. Fully shielded input choke
 Brand new! Type T-509. **289**
 Your cost

**STANCOR FILAMENT
 TRANSFORMERS**

Professional
 series, tops for
 quality. Brand
 new, fully
 shielded, 105-
 115 Volt A.C.
 primaries.

P-8540 - 5 Volts @ 8 Amps.
 C.T. 2,500 volts **295**
 ins. Wt. 4 1/2 lbs.

P-8547 - 10 Volts @ 4 Amps.
 C.T. 5,000 volts **295**
 ins. Wt. 5 lbs.

**UTC VARIMATCH
 MODULATION
 TRANSFORMERS**

VM-0, 15 W.... 4.67
 VM-1, 30 W.... 7.41
 VM-2, 60 W.... 10.94
 VM-3, 125 W.... 15.64
 VM-4, 300 W.... 27.37

Will match any Class B tube or
 tubes to any Class C load.

**TRIPLETT 666-H
 Pocket Multimeter**

3" Red Dot Lifetime
 Guarantee meter
 with long, two-color
 multirange scale for
 accurate readings.
 AC-DC Volts: 0-10-
 50 - 250 - 1,000 - 5,000
 volts at 1000 ohms
 per volt. D.C. Milliamps:
 0-10-100-500 Ma. Resistance:
 0-300-250,000 ohms. With self-
 contained batteries, instructions
 and test leads **1960**
 Wt. 3 lbs.

**G.E. MINIATURE
 0-1 MA. DC METER**

1 7/8" Sq. —
 mounts in 1 1/2"
 hole. Complete
 with faceplate
 and mtg. hard-
 ware. Compact
 and accurate, ideal for in-
 numerable applications. **298**
 Your cost only.....

**POWER TUBES
 JAN
 APPROVED!**

807..... 1.05
 811..... 1.95
 813..... 6.75
 814..... 4.50
 832A 4.05
 3E29 3.00
 Ceramic Socket
 & Base Shield
 for 3E29 75c
 872A 2.95

**TRANSMITTING
 KEY**

for CW and
 Code Practice
 Don't let our
 low price fool
 you! These are
 brand new rugged keys priced
 only so low because we bought
 'em for less! **69c**
 Your cost.....each

WARRANTY — No change in our policy.
 Every item we sell is fully guaranteed,
 regardless of its low price.

If unable to visit our store, send us your mail orders with
 25% deposit. Remit in full all orders under \$5.00. Prices
 are F.O.B., New York.

TERMINAL RADIO CORP.
 85 CORTLANDT STREET, NEW YORK 7, N. Y.
 PHONE WORTH 2-4415

Part One of Our GENERAL CATALOG Is Ready Now! Send for Yours, FREE!



This new 16 page section of our general catalog is jam-packed with real savings for amateurs, experimenters, and servicemen. Send for yours today. Order from WRL, the only "personal service" radio parts mail order house in the nation.
—LEO WOGFQ

ORDER YOUR RECEIVER FROM LEO, TODAY!

We carry all types and models. RME 45, HQ 129X, and all National models in stock for immediate delivery. Collins receivers available soon. Buy on our easy payment plan—lowest terms in the country. Liberal trade-in allowance.

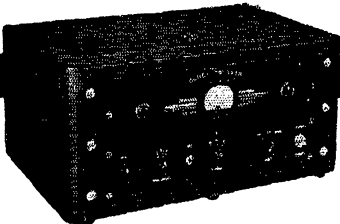

Tops For Performance WRL Globe Trotter KIT

Here's What WOPFB, Chilhowee, Mo. Says about the Globe Trotter:

"I want to thank you for bringing out such a wonderful transmitter as the Globe Trotter. For such small power it really packs a strong signal."

Many other actual field reports of amateurs using the Globe Trotter testify to its excellent performance. It's the hottest ham equipment on the market today. The WRL Globe Trotter is capable of 40 watts input on C.W. and 25 watts input on phone on all bands from 1500 KC through 28 Megacycles. Incorporates the Tritet Oscillator using a 40 meter Xtal; Heising choke modulation; three bands, all pretuned; 10, 20, and 80 meters; two power supplies.

IMMEDIATE DELIVERY—40 Watt
Input. Cat. No. 70-300..... **\$69.95**
Complete including all parts, chassis panel, streamlined cabinets, less tubes, coils, and meter.
No. 70-312 same as above, wired by our engineers **\$79.50**
1. Set Coils, Meter, Tubes..... **\$15.15 Extra**

All prices quoted are domestic. Write for export prices.

Address Dept. QST-3
Council Bluffs, Iowa



(Continued from page 100)

all bands. NI, on 28-Mc. 'phone, is working on kw. final. DGV has a new 28-Mc. beam. IZR is working on new rig with 805 final. KJS is looking for traffic schedules. 2JEB/4 is on 28-Mc. 'phone. DCW is working 14-Mc. c.w. and 28-Mc. 'phone and c.w. FXU is on 3.5 c.w. LAI is working 7-Mc. c.w. and 29-Mc. 'phone. 1GJH/4 is operating 144-Mc. rigs, one in car. KHR and EYE have 1/2 kw. on 3.9 Mc. BCZ and his XYL, KOH, are working 28-Mc. 'phone. 2JRU/4 is on 28 and 144 Mc. HEQ has 813 going. 3BAG/4 is active on 7 Mc. AEH is putting in 304T88 for a kw. HDS is back on 28 Mc. GHY is on 3.9-Mc. 'phone. FLT leads round tables on 28 Mc. on nights off. EYG is building 1/2 kw. for 28 Mc. COC has new 1/2 kw. on 28 Mc. New officers of Greensboro Club, GNF, are: AGD, pres.; HEH, vice-pres.; KYR, secy.; and GG, treas. MR has eighty-eight countries postwar. EL is operating on 3875 kc. HER raised score to thirty-eight states and forty countries with his exciter. Traffic: W4CAY 4, KJS 4, FXU 3, 73. *Buck.*

SOUTH CAROLINA —SCM, Ted Ferguson, W4BQE/ANG — HMG is now 100 percent c.w. IRK, our only YL operator, is pounding 'em out on 3.5-Mc. c.w. ILP works 7 Mc. with 807 final. 8YGG/4 and 5KDW/4 are on 7-Mc. c.w. at Summerville. GCH works 3.5-Mc. c.w. HDO has 19 watts on 3.5-Mc. c.w. and 22 on 28-Mc. 'phone. EXY is active on 28 Mc. FHE is turning to portable mobile gear JEF made contact with England on 28 Mc. concerning the health of the famous Gypsy Smith, sr. BSS has a new converter for 28 and 14 Mc. FMZ revamped his BC-375E. BEN works all bands on c.w. BZX works 3.9-Mc. 'phone and is chief instructor for the Palmetto Amateur Radio Club's radio school. AZT is PAM and is organizing a 3.9-Mc. 'phone net. The 3.5-Mc. c.w. net is coming along nicely under the direction of CZA and FNS. BPD has completed his collection of 100 postwar QSLs for Century Club. CZA is a member of the S.C. Net, Ga. Net, Rebel Net, and TL C, and is looking for traffic. EZF worked 59 sections in the SS. KVL and KWB are new hams. EMT works 3.9-Mc. 'phone. HMG is sporting a new Meck T60-1 rig. CEL is on 3.9-Mc. 'phone. KGX works on 3.5- and 7-Mc. c.w. FNC spends his time on 3.9-Mc. 'phone. FAL was seen loading a BC-375E to move to his QTH. Traffic: W4CZA 108, 73. *Ted.*

VIRGINIA —SCM, Walter R. Bullington, W4JHK — KAO is rebuilding a new bandswitching rig. IOQ is on 3.5, 14, and 28 Mc. and has application in for OPS. At present he is using an HT-9 and has twenty-three countries. IHN is going to town on 7 and 14 Mc. JBY schedules 9YB at Purdue. He has an 807 and is doing fine on all bands. JLV is on again after twenty-seven months in the ETO. AGH demonstrated the effects of directors and reflectors of a three-element beam on 112 Mc. at the last meeting of the Richmond Amateur Radio Club. FJ and CYW are on 112 Mc. and from their reports it must be interesting and lots of fun. DML is back on all bands with a new bandswitching rig after six years' absence. EOP has new home-grown super that's really one. He also has new dipole on 14 Mc. that pours it out especially with that new 500-watt driver. KFC schedules the "TO" net daily on 3705 kc. at 10 p.m. He still needs North Dakota for postwar WAS and Asia for postwar WAC. Let's have the reports, fellows, and make this a real column. Traffic: W4KFC 58, 73. *Monk.*

WEST VIRGINIA —SCM, Donald B. Morris, W8JM — GBF is running a kw. and has worked several English and HB stations on the low end of 3.5 Mc. around midnight. JM has 450 watts input on all bands for c.w. KKG is operating portable from Chattanooga. YCK is attending school in Baltimore. The Kanawha Valley Radio Club is issuing a club bulletin and sending code practice on 3800 kc. Mondays and Fridays at 9 p.m. QHG hooked G2 and XE1 for his first DX on 28-Mc. 'phone. EWM and DFC have their heads together planning a high-powered final. LLI is up to his old tricks of winning prizes, the latest being at the Charleston-Huntington Hamfest. EYV, an old-timer, is on 3.9-Mc. 'phone from Keyser. VPO rebuilt his kw. rig and is on 3.9-Mc. 'phone. AFB, WUE, and YDF attended KVARA meeting. OXO and EZR are active on 3770 kc. Traffic has picked up on the MARA 3770 Net and more stations are reporting in. WSL has worked eighteen countries on 7 Mc. with only 50 watts input and fixed frequency. Get ready, gang, for the Third Annual West Virginia QSO Party to be held in April. Details next month in QST. It will be worth your while to be in this QSO Party. Traffic: W8CSF 23, GBF 22, YCK 15, DFC 11, FMU 6, WSL 5, QHG 3, 73. *Don.*

(Continued on page 106)

Bob Henry says:
MOST MODELS
IN STOCK



**FOR
 IMMEDIATE
 DELIVERY**

Most models listed below are in stock... ready for immediate delivery:

Hallcrafters S38 complete	\$47.50
Hallcrafters S40A	89.50
Hallcrafters SX 42	275.00
Hammarlund HQ-129X and speaker	168.00
Hammarlund SP-400-X and speaker	342.00
National NC-2-40D (complete with speaker)	241.44
National HRO-5TA1 and HRO-5RA1	274.33
National NC-46	97.50
National 1-10A with tubes and coils	67.50
RME-45 complete	198.70
RME-84 complete	98.70
Pierson KP-81 complete	342.00
Panoramic panadaptor complete	99.73
Temco 75GA transmitters	495.00
Meck 60T transmitters	150.00
Millen 90800 ECO	42.50
Millen 90800 exciter	37.50
Millen 90281 power supply	84.50
Millen 90902 scope	42.50

Gordon, Amphenol, other rotary beams
The new Hallicrafters and Collins receivers, transmitters, VFO, etc. as fast as available. Prices subject to change.

The delivery situation is much improved. I can make immediate delivery of most receivers and other apparatus. Take advantage of the extra service and selection you get by dealing with me, based on my reputation as the world's largest distributor of short wave receivers. Send me your order now. Send five dollars and I will ship at once C.O.D. Or order on my 6% terms. I finance the terms myself to give you better service and save you money. Trade-ins accepted. Tell me what you have to trade, and let's make a deal.

Besides having all amateur receivers and transmitters, I also have a complete stock of all other amateur apparatus and parts, also test equipment, etc. I have real bargains in the really good war surplus such as SCR-211's, BC-610, BC-342, BC-348, BC-312, parts, etc. Write, phone, wire or visit either of my stores.

Bob Henry
 WØARA

Butler, Missouri **HENRY RADIO STORES** 11240 W. Olympic Blvd
 Los Angeles 25, Calif.

"WORLD'S LARGEST DISTRIBUTORS OF SHORT WAVE RECEIVERS"

Why this team is *Tops*

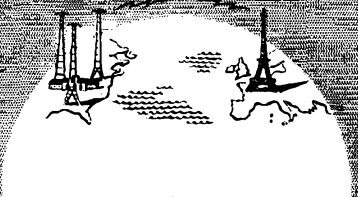

1915

The ocean, long a barrier to spoken communications, was conquered when Bell System engineers designed, built, and operated the transmitter which first sent the human voice across the Atlantic and Pacific.

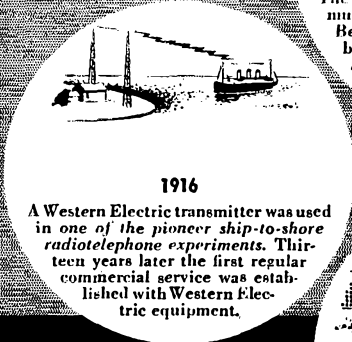

1916

A Western Electric transmitter was used in one of the pioneer ship-to-shore radiotelephone experiments. Thirteen years later the first regular commercial service was established with Western Electric equipment.

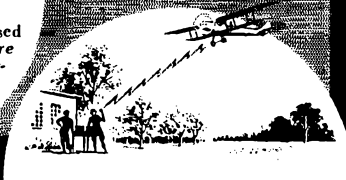

1917

With the first airborne transmitter, Western Electric demonstrated two-way radiotelephone between a plane in flight and the ground. From this earliest experiment came commercial airline equipment in 1930.



1920

Western Electric radio became a part of the nation's telephone system when it was used to connect Catalina Island to the mainland. Seven years later, the Bell System offered commercial radio-telephone service to Europe.



1922

Western Electric manufactured and installed the first "high power" (500 Watt) commercial broadcast transmitter — for the Detroit News Station WWJ.

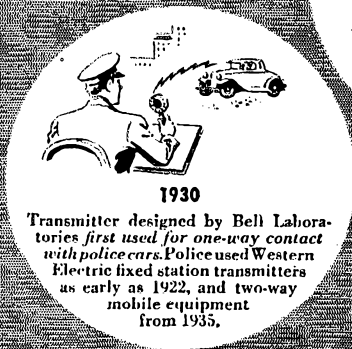

1930

Transmitter designed by Bell Laboratories first used for one-way contact with police cars. Police used Western Electric fixed station transmitters as early as 1922, and two-way mobile equipment from 1935.

From the basic developments pictured at the left, the team of Bell Laboratories and Western Electric continued to set the pace with the best in transmitting equipment. Among the later advances pioneered by this team were:

- 1928. The first 50 kw commercial broadcast transmitter, built by Western Electric, installed at WLW, Cincinnati, Ohio.
- 1935. A 50 kw Western Electric AM transmitter installed at WOR was the first to incorporate the Bell Laboratories-designed stabilized feedback circuit, since accepted as a broadcasting standard.
- 1937. The first single sideband transmitter was introduced for long distance point-to-point communications. The world-wide military communications network used in the war came directly from this development.
- 1938. Flying tests of the first VHF aircraft transmitter showed relatively static-free communication at all times. Modifications of the original Bell Laboratories design were used for basic Army-Navy aircraft radiotelephony in World War II.
- 1940. The first Synchronized FM transmitter installed at WOR enabled broadcasters to put top-quality FM programs on the air and keep them on their assigned frequency.
- 1941. First FM transmitter to use grounded plate amplifier circuit was Western Electric 10 kw installed at WOR.
- 1941. Twelve talking channels adjacent to each other, available for the first time on a single radio frequency band, used to connect telephone lines on either side of Chesapeake Bay. Envelope feedback developed by Bell Telephone Laboratories and applied to the carrier technique in radio telephony made this possible.

—QUALITY COUNTS—

for Radio Transmitters!

The experience gained during the war, when the Bell Laboratories-Western Electric team was the largest supplier of communications equipment, added greatly to the skill and knowledge acquired through 30 years of transmitter development.

This background, plus unequalled research and manufacturing facilities, provides assurance that there are no finer transmitters than those designed by Bell Telephone Laboratories and built by Western Electric—whether for AM or FM broadcasting, point-to-point radiotelephony, or any type of communication or mobile service.

1943. The ARC-1, a crystal controlled ten frequency transceiver, used by the Navy's fighter planes during the war, has been accepted as standard VHF equipment by U.S. airlines. Provides nine plane-to-ground frequencies and one plane-to-plane frequency.

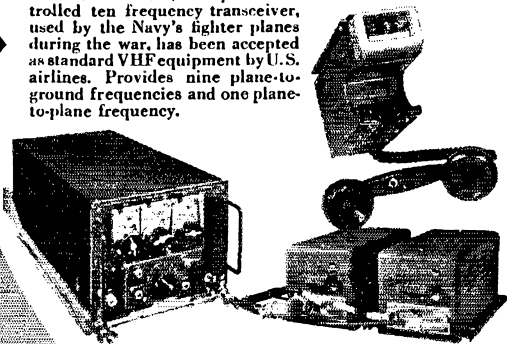

1947. The Western Electric 238-type mobile radiotelephone system is providing dependable Bell System service between vehicles and any wire telephone in a growing number of cities and along trunk highways.

1947. The new TRANSVIEW design FM transmitter, being produced in 1, 3 and 10 kw units, for the first time provides the operator with an unobstructed view of all tubes while in operation. Incorporates Bell Laboratories-developed synchronized frequency control.

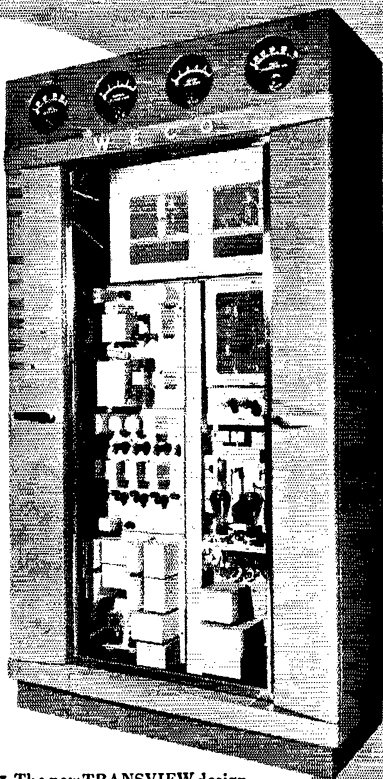

Distributed by
Graybar
OFFICES IN 95 PRINCIPAL CITIES



BELL TELEPHONE LABORATORIES

World's largest organization devoted exclusively to research and development in all phases of electrical communications.

Western Electric

Manufacturing unit of the Bell System and the nation's largest producer of communications equipment.



LIST YOUR NEEDS ON A PENNY POST CARD TONIGHT AND DROP IT IN THE MAIL TO US (DEPT. M. O.) IN THE MORNING.

YOUR ORDER WILL BE FILLED AND BACK IN THE MAIL, ENROUTE TO YOU, WITHIN FIVE HOURS AFTER BEING RECEIVED BY OUR STORE.

A FEW OF OUR LINES ARE LISTED BELOW AND ALL ITEMS ARE AT NATIONALLY ADVERTISED PRICES. YOU MAY SEND CASH OR WE WILL SEND MERCHANDISE C.O.D. VIA PARCEL POST.

- | | |
|--------------|------------------|
| ★ NATIONAL | UTC ★ |
| ★ JOHNSON | B & W ★ |
| ★ MALLORY | BLILEY ★ |
| ★ MILLEN | TURNER ★ |
| ★ SHURE | BUD ★ |
| ★ AMPHENOL | NATIONAL UNION ★ |
| ★ EIMAC | HAMMARLUND ★ |
| ★ HYTRON | SPEED-X ★ |
| ★ THORDARSON | SYLVANIA ★ |
| ★ TRIPLET | RME ★ |
| ★ OHMITE | CARDWELL ★ |

★ MAIL ORDERS OUR SPECIALTY!

**KIERULFF'S
HAM SHACK**
828 W. OLYMPIC BLVD.
LOS ANGELES 15, CALIF.

ROCKY MOUNTAIN DIVISION

COLORADO — SCM, Glen Bond, W8QYT — We hope that the New Year will bring you more pleasure operating your rigs and stations, whether flea power or a kilowatt. 0WO has rebuilt 150 watts to a T55. IQZ and 0WO are having their own DX contest. IQZ heard Greeley on short skip. CND reports a 28-Mc. mobile rig in his car, WILCO transmitter and Gonset converter. The Electron Club Emergency Net held its second drill Jan. 6th at 8:00 p.m. on 28 Mc. with four mobile rigs and six home stations. The net plans to drill each Monday evening on 29,100 to 29,300 kc. Anyone interested in joining, please contact JBI or listen for call at 8:30 p.m. from JBI, net control station. DRB, in Canon City, has dismantled and secured his station. Clay is leaving Colorado for a while but hopes to be back in a year. The WERS gang remembers KFND-5. Chick is now out of the Army and is 6SSA in Oakland, Calif. He has a half-kw. rig on 28 Mc. Give him a call on short skip. We now have a new director and he is anxious to serve you. Write him your views. Let's all mail him a card. MGX, from Grand Junction was a visitor in Denver recently. Herb still misses 160 meters. Traffic: W8WAP 79, DRB 36, JBI 20, IQZ 14, 73. *Glen.*

UTAH-WYOMING — SCM, Victor Drabble, W7LLH — FTE has a new HRO. LE has Meissner 150B transmitter and HQ-120 receiver. JTU has an HQ-129X and a 6L6-807 rig running about 60 watts on 7-Mc. c.w. JOF works at least one station each day on 28-, 14-, or 7-Mc. c.w. JXJ has a new S2OR and has been working 28-Mc. 'phone. IRI has a new HQ-129X receiver. KFV has an 813 on 7-Mc. c.w.; also a crystal-controlled 144-Mc. transmitter and a super-heterodyne 144-Mc. receiver. JQU has a new 8-40 receiver. TAR is putting on a pair of 813s. MAV is modulating a Millen exciter. The OBS schedule for TMK is at 2 p.m. on Mondays and Wednesdays and 1:30 p.m. Fridays, all on 14 Mc. JZC is building a low power rig with 807 in the final. DLR is remodeling his SCR-221-AH frequency-meter for break-in v.f.o. and is building doublers and 807 final as companion unit. FST conducts a code class on 29,000 kc., 9 to 10:30 a.m. daily, except Sundays and holidays. KIY is ORS and EC. MQL is organizing the AEC program in this area. He is experimenting on wave propagation with LLH and 9GZA/7. UPI gets on the 144-Mc. band with crystal control and is running 20 watts into a 832. UOM installed beam rotating unit. Traffic: W7FST 1329, DTB 28, DLR 15, 73. *Vic.*

SOUTHEASTERN DIVISION

ALABAMA — SCM, Lawrence J. Smyth, W4GBV — I am very glad to see Anniston, Birmingham, Sheffield, Mobile, Dothan and Montgomery interested in getting clubs organized. If there is any other club started that is not listed, please drop me a line. Hope the day is not long off when each club will have its own transmitter and will be operating on the Alabama Club Net. A card from EQM states that he and HVD, KPJ, and about five stations in Georgia, have a net of their own on 28 Mc. They are looking for someone interested in working 50 Mc. Let's hear from the gang. *73. Larry.*

EASTERN FLORIDA — SCM, Robert B. Murphy, W4IP — ASR has been down Mexico way. DOO is experimenting with antennas of the long wire type. BXL soon will have a new ORS certificate. He watched DUW work CM2EJ on 7 Mc. with a tank set in his car. 6OQ/4 is begging for traffic on the high end of 7 Mc. He is on almost every evening from 7:30 to 9:30. ACZ, with FWZ as his assistant, is Section EC. If you want to get into emergency work, get in touch with them. We have one of the finest 'phone nets in the country, but definitely need a c.w. net. BYF, BNR, BXL, NB, and 6WOQ/4 are begging for traffic. BNR is lining up all those interested in handling traffic for the Florida Fair in Tampa. DQW has a very unique card for reporting to his SCM. BYF, our OBS, sends official bulletins on 7170 kc. at 2330Z every night except Saturday and Sunday. GXU has arrived in the section with an ORS certificate and is looking for some of you traffic hounds. JYG dates his calls in the third district as BZY-RI back to 1923. He has been in the AARS, a BPLer, an AI operator, and an RCC member, and has a code endorsement of 35 w.p.m. West Palm Beach has a real ham club with ISF as secretary. ACZ uses a BC-610 on 29 Mc. BRB has a Florida kw. with eighty

(Continued on page 108)

HARVEY has COLLINS XMITTRS

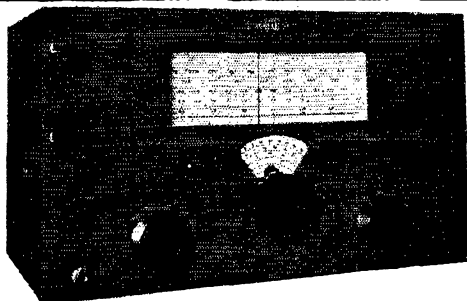
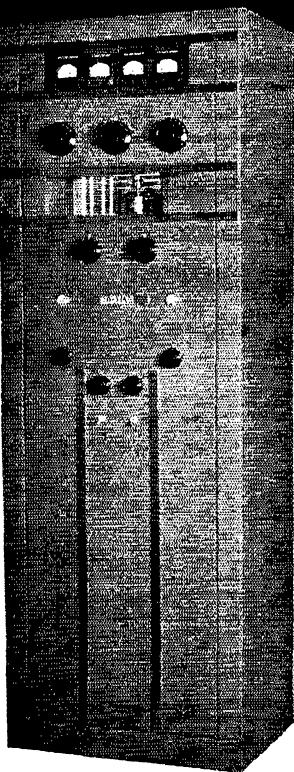

It's here! ... the new Collins ham transmitter! 500 watts input on CW, 375 watts on phone. The 30K combines the desires and dreams of hams with brass in their blood and also those who want only a push-to-talk button. It was designed by engineers to whom CQ is a cherished and friendly sound. Every detail has been worked out carefully to provide efficient economical operation. Select quality components are used throughout to assure long trouble-free life.

Look at these features:

- fully metered
- push-to-talk
- vfo controlled
- band switching
- 80, 40, 20, 15, 11, 10 meters
- speech clipper
- 115 v. a.c. power source
- 3 pairs antenna terminals
- break-in operation
- 100% modulation

The 310A Exciter Unit for the 30K sits right on the operating desk. With vfo control, you can vary frequency several kc. up or down without retuning the final.

Harvey has the 30K with the 310A Exciter.

\$1250

Telephone: **7** **orc** Longacre 3-1800

HARVEY
RADIO COMPANY INC.
103 West 43rd St., New York 18, N. Y.

HARVEY'S HITS OF THE MONTH

Harvey has 20 meter crystals for a buck! Mounted in holder with 1/2" pin spacing. Also 40 and 80 meter and 6 and 13 mc bands at the same low price.....\$1.00

Special 8 mc. xtals for 2 meter xtal control, only.....\$1.50

Also in stock complete line of Billey AX-2 xtals.

Include 10¢ postage with your crystal order.

HARVEY'S HAMFESTIVAL OF VALUES

The best value this month is the 30K Collins xmitter but you'll also like these:

L5-7 Speaker in steel case with weatherproof louvre. Complete with self-contained 4000 ohm to voice coil transformer. With PL55 plug and 5 ft. heavy duty cable. Mounting clamp may be removed if desired. Packed with drying agent... Harvey Special Price.....\$3.95

Shure T-17B Hand Mike with M-367 weatherproof cover, switch in handle, heavy duty cable and PL-68 plug. Ideal for portable use... Harvey Special Price, \$1.45

Sylvania IN21-B Crystal Rectifiers, 3 for \$1.00

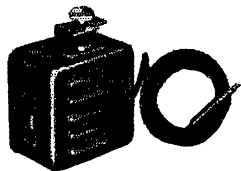

Note: All prices F.O.B. New York and subject to change without notice.

SAVE 30%!

SAVINGS PASSED ON TO YOU

Through Our Big-Lot Purchase!

TYPE A

ENGLOSED RELAY RACK

\$19.95 NET, F. O. B. LOUISVILLE

Regular List \$47.50

CABINET
16½ x 22 x 42"

PANEL SPACE
19 x 36¾"

FRONT INSIDE
Width: 17¾"

REAR INSIDE
Width: 19"

CLEAR INSIDE
Depth: 14¼"

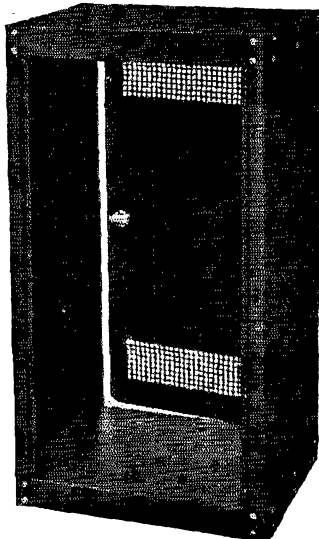

Ideal for your next Transmitter or P. A.

Attractive in price and appearance, the ER-213 Relay Rack is fabricated from sturdy rolled steel. Panel mounting angles of 1/8" steel are accurately drilled and tapped for 10/32 machine screws. Panels fit into recess, with edges concealed. Side and screen section louvers provide ample ventilation. Rear door offers dependable loose-joint hinges, with flush snap catch. Shipped knocked-down, the money-saving ER-213 is easily assembled. The supply is limited, so —

- ORDER TODAY!

UNIVERSAL
RADIO SUPPLY COMPANY, Inc.,
715 S. 7th St., Louisville 3, Kentucky

(Continued from page 106)

foreigners to his credit. ISF has 300 watts. IUJ, vice-president of the club, QSOed 6PPV and it looks like a record for 50 Mc. BRB is president of the club and ran away with the SS Contest. The club transmitter is HAW and is on all bands. ITI is having fun on 29-Mc. 'phone. FNR commutes via WPB for A.T.&T. Co. LTS is visiting us for the winter. KGJ is having trouble getting his 807 perking. The WPB Club is planning a hamfest for June. Your SCM's new address is listed on page 6 of QST. I am trying to stay on the high end of the 7-Mc. band. Give me a call. Traffic: W4-DW 117, DTW 59, BYF 30, GHP 30, BNR 26, IP 10, ACZ 8, BXL 5, 73. *Merf.*

WESTERN FLORIDA — SCM, Lt. Comdr. Edward J. Collins, W4MS — EQR has been giving 50 Mc. a whirl. EQR and MS had their first 144-Mc. QSO. EGN has new three-element beam. BCC has his new ART-13 war surplus transmitter perking. DAO is the proud possessor of a VHF-152. AXP is active on the Rebel Net. APJ is active on 7 Mc. HIZ is on 144 Mc. crystal-controlled with vertical polarization. KFP also is on 144 Mc. JJZ is the proud owner of an RME-84X. KIK has three-element beam all set to go. DZX is building more power with a pair of 810s in the final. HJA has a new 60-ft. steel tower set to go up with his four-element beam on top. JV has been experimenting with 28-Mc. beams. FHQ has a new steel tower. ACB is working on his 28-Mc. mobile job. GAA has been pushing his HT-9 5KXM/4 is keeping 4 Mc. hot with 500 watts. KAS is heard on 28 and 14 Mc. and has new SX-28. ILY, 6KV, and 5DAS gave the boys a 28-Mc. mobile demonstration. 73.

GEORGIA — SCM, Thomas M. Moss, W4HYW — We can now report organization of our first postwar section traffic net. The Cracker Waves Net is in operation on 3802-ke. c.w. at 2100 EST on Fridays. JBM is NCS and BIW is ANCS. Present net members are: MA, EYK, BOL, GGD, AAY, CZA, and IAO. All are ORS. Prewar ORS are urged to renew appointments and take part in net activities. In addition to this net, present ORS are: VX, AQL, HWS, HYW, DXI, FLI, YC, FKE, KV, and TO. Our OPS are: AQL, DXI, FDX, ERS, YC, and TO, with FWD as PAM. OBS are as follows: BIW, BQU, EEE, EWY, FWD, HYW YC, and TO. Listen for their transmissions. Club and school stations are urged to participate in these section traffic activities. Additions to the Cracker Emergency Net are: AJ, CEL, CBR, GZF, RM, VF, AIS, AZT, and FLS. BOL is the net's PAM. BOL, KV, and OK are members of the Rebel Net on 3625-ke. c.w. at 2030 EST nightly. 5IGW is NCS and 5HGG and AXP are ANCS. The net covers the Gulf Coast States. JRQ is our second section member to become an Old Timers Club member. Ultra-high interest is increasing, and you on the ultra highs are urged to inquire as to OES appointment. New officers of Atlanta Radio Club are: EFS, pres.; HZG, vice-pres.; IEO, secy.; FKN, treas.; HDC, act. mgr. Thanks for all the cooperation during my first year as SCM. Traffic: W4KV 107, BOL 50, HYW 46, JBM 37, AAY 15, FKE 12, GGD 8, MA 1, 73. *Tom.*

WEST INDIES — Acting SCM, E. W. Mayer, KP4KD — AM annexed a Sola standard voltage transformer. BE holds daily schedule with CE on 28-Mc. 'phone with 15 watts. AS worked eleven countries on 28-Mc. 'phone for WAC with PKIAW best DX. NY4CM schedules FF8FP daily. BY, AQ, AW, and CD are active on 28-Mc. 'phone. CC, CA, CU, CG, and KD are round-tabling on 7-Mc. e.w. on Sunday a.m.s. KV4AD is active on 7, 14, and 28 Mc. He commutes between KP4BC and KV4AD. JA and CU have new HROs. JA erected 60-foot tower for his two-element 14/28-Mc. beam. CM and CN are active on 28-Mc. 'phone with CM working home-state W6s regularly. KD works W2QHH regularly on 14-Mc. c.w. CE is active on 14-, 28-, and 3.9-Mc. 'phone. AU contacts WFB regularly. BK is on 7 and 3.5 Mc. and handles traffic. AJ put up a four-element close-spaced non-rotatable beam for the test. He has QSL from XZ2YT. Traffic: NY4CM 39, KP4BE 4, AM 3, BK 2, KD 2, 73. *Er.*

SOUTHWESTERN DIVISION

LOS ANGELES — SCM, Ben W. Onstenk, W6QWZ — The meeting of the Southwestern Division Council of Radio Clubs, held January 6, 1947, was attended by our new Director, Rudy Jensen, W6KEI. Delegations were present from the Inglewood Amateur Radio Club, the Los Angeles Section, the Metropolitan Radio Club, the Santa Ana Radio Club, the Tri-County Radio Club, the Foothill Radio Club, the Pasadena Short Wave Club, the Southeast

(Continued on page 110)

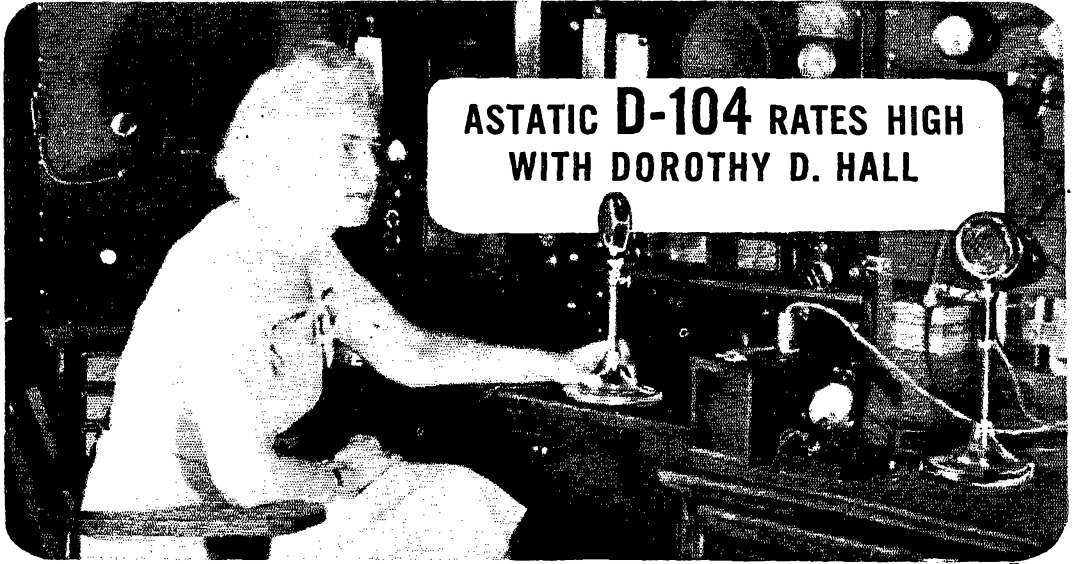

**ASTATIC D-104 RATES HIGH
WITH DOROTHY D. HALL**

Outstanding Performance . . .

PRAISED BY AMERICA'S FOREMOST YL

● Dorothy D. Hall, W2IXY, of Springfield, N. Y., who began her amateur radio career in 1934, today holds the distinction of being the most outstanding lady OP in "Hamdom." Her Shack boasts of four transmitters, eleven receivers, four recorders, and other modern installations . . . and is, of course, a veritable amateur's paradise.

"My D-104's," says Dorothy, "are my pride and joy. Their high output level and ideal voice characteristics get me through the most severe QRM. Personally, the D-104 is my favorite." Amateurs the world over are loud in their praise of Astatic Microphones. Such praise must be justified.



**Astatic Crystal
Microphone
Model D-104**

For Astatic's complete line of electronic products, see your Radio Parts Jobber or write for Catalog.

THE
Astatic
ASTATIC CORPORATION
CONNEAUT, OHIO
IN CANADA CANADIAN ASTATIC LTD, TORONTO, ONTARIO

Astatic Crystal Devices Manufactured
under Brush Development Co. patents.

New! Munger ELECTRO-BEAM ROTATOR

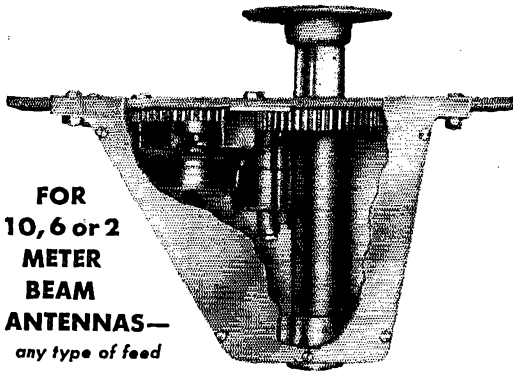

FOR
10, 6 or 2
METER
BEAM
ANTENNAS—
any type of feed

PRICED AT ONLY

\$69.50
COMPLETE

F.O.B. Chicago, Illinois

● Price Includes Reversible Electro-Beam Rotator and Direction Indicator.

● Foolproof Potentiometer and Meter Circuit. Calibrations in Both Degrees and Directions.



A BIG VALUE— Immediate Delivery if You Order Now!

When you see the many fine features of my new Electro-Beam Rotator, you'll be as pleased as I am. And you'll feel good too, because it's such an honest value—priced low because we kept you in mind constantly through all the stages of design, engineering and testing. Now that it's ready for delivery, you can take my word that it's a real honey. About the specs: 1 R.P.M.—115 volts, 60 cycle operation. Powerful reversible motor drives main shaft through heavy steel gears. Lifetime Oilite bearings. Mechanism is completely weatherproofed—housed in sturdy non-rusting duraluminum case. All parts accessible for easy inspection. Rotator mechanism weighing only 10½ lbs. makes it easy to mount. Top mounting plate 10" x 12".

10 Day Free Trial Offer

Send your check for \$69.50 for one Electro-Beam Rotator complete with Direction Indicator. You pay small express charge upon arrival. Try it at my risk for 10 days. If you are not completely satisfied in every way, return the units undamaged in their original carton and your money will be immediately refunded in full. You take no chances. Order your Munger Electro-Beam Rotator today!



W9LIP

Illustrated Bulletin on Request

MANUFACTURED AND SOLD
EXCLUSIVELY BY

Rex L. Munger Company

4701 Sheridan Rd., Chicago 40, Illinois

(Continued from page 108)

Radio Club, the Midcities Radio Club, the Associated Radio Amateurs, the United Radio Amateurs, the San Fernando Valley Radio Club, the Glendale Amateur Radio Club, the Valley Radio Society, the Liemert Park Radio Society, the Santa Monica Mike and Key Club, and the Santa Barbara Radio Club. The president of the Council, ANN, extends an invitation to all clubs in the Southwestern Division to send two delegates to the next meeting which will be held at the San Marino City Hall, April 7th, 8:00 p.m. Please bring a certified count of ARRL members in your club and be prepared to vote on matters of importance to the amateur. The AEC now has a majority of its nets on 50 Mc. Among them are Long Beach, Inglewood, Santa Monica, Santa Barbara, and Los Angeles. Glendale, Inglewood, and Covina are on 144 Mc. The AEC net in San Fernando Valley is to be called the Golden State Net and is operating on 3965 kc. HOE is net control with LUG, DJN, VIG, LZV, PIB, JYP, SRJ, AIT, UYE, HHJ, PDW, and KEI sitting in. OLO is their 50-Mc. tie-in. SQO and RIU are in the Naval Reserve at Santa Monica, setting up a station for ham use in the new Armory. Any of you ex-Navy hams who would like more information on the Naval Reserve, write to Naval Reserve Armory, 850 Lilac Terrace, Los Angeles, or Lt. Watson, Naval Reserve Armory, Santa Barbara. The Mike and Key Club will hold meetings at the Frank Dyne Plant, 33rd and Pico, in Santa Monica, every other Thursday beginning March 13th. JQB is new Asst. SCM for Owens Valley area and reports the following: CUY is getting ready to return to the air, as is KMC. COQ is running a big rig on 3.9- and 14-Mc. 'phone. LHY, in Independence, has been heard several times working some pretty nice 7-Mc. DX. The City of Los Angeles Bureau of Power and Light Net meetings are held every Saturday at 9:00 a.m. on 7172 kc. with regular turnouts. NS moved into Lone Pine. 28Y is waiting for a 6 call. M and K news: ASW is on 28-Mc. 'phone with p.p. 250TH. BEA is back on 3.9 Mc. 'phone. DIO is the MK Club's photographer. ESR has 5- and 10-meter converter in his car. JFY is on 28-Mc. c.w. with all directional rhombics on the desert at Yermo. NSC is trustee for the MK station, VB. NSM reports FB DX in Arizona. QWL worked a ZL with 7 watts on a Signal Shifter with an antenna 8 ft. high. SQO is building 350-watt all-band rig. TVK is on 28 Mc. FCO now is KH8AK. AOA is 7-Mc. RM. The Mission Trail Net is going strong on 3.9-Mc. 'phone. BKY now is NY. Members of the Inglewood 50-Mc. net are VES, SJF, QXB, QWZ, MSO, RNN, NAW, QIR, EKM, REE, RZK, VST, UXN, and SEZ. Traffic: W6IOX 303, CMN 181, AOA 141, OGM 89, EMJ 34, TZD 13, ERT 9, MTO 7, NY 7, ASW 8, MEP 6, AM 4, IWU 2, BUK 2, AAE 2. 73. Ben.

ARIZONA—SCM, Gladden C. Elliott, W7MLL—KOL visited Tucson hams; he now is 3LIY in Philadelphia. QJL has a new XYL. Ruby LaRue has Class A ticket. OIF and MDD are increasing power on 3.9-Mc. 'phone. DFE, GYK, and RU are sporting new bugs on 3515 kc. DFE is promoting a fishing trip for hams to Mexico. MAE and NEL are working regularly on 3515 kc. MLL won the first round of the Arizona QSO Contest and SBN was second. The Phoenix Club meets twice a month. New officers of the 25 Club are: SMZ, pres.; JFG, vice-pres.; MLL, secy. UPY has a new YL. The Phoenix Club has challenged the Tucson clubs to a donkey baseball game. UAF has an 80-40-20 bandswitch rig. PNJ is going on 3.9 Mc. to save phone bills. JDZ has a new 8X-42 receiver. 9WKC/7 bought RNB's BC-810 and a new 8X-42 so as to be the high power man in Tucson on 28 Mc. JVK formerly was 9MIJ. Carl Clemente now is KLZ. JYT is working 28 Mc. in Tucson. KKH is moving to Japan. JEC works 7 and 144 Mc. at chloride. JSL is Dick Smith at Yuma. JHB has fifty-one countries on 28 Mc. JGX operates from a trailer in Phoenix. RXP is getting a degree in E.E. PEY reports working OK1FF and LA7Y. KAE has a 60-foot tower. JMQ is mobile on 28 Mc. See you in the state QSO contest. 73. Gladden.

SAN DIEGO—SCM, Ralph H. Culbertson, W6CHV—MKW reports that YDK is new station of Signal Battalion at Camp Pendleton active on 14 and 28 Mc. VXJ has been operating portable with MBF rig on 50 Mc. at Balboa. In Orange ADT has rig going on 14 Mc. and NVX is on 3.9 Mc. CTP is on 3.9 Mc. at Fullerton, where 7JJY occasionally shows on 3.9 Mc. IZ is on 3.9 Mc. at Balboa and CQ gets on 3.9 Mc. as fixed portable from Yacht Marquesa. YEW is new call in Santa Ana. URU is on with 35Ts using othodde modulation with good results, mainly on 3.9 Mc. New officers

(Continued on page 119)

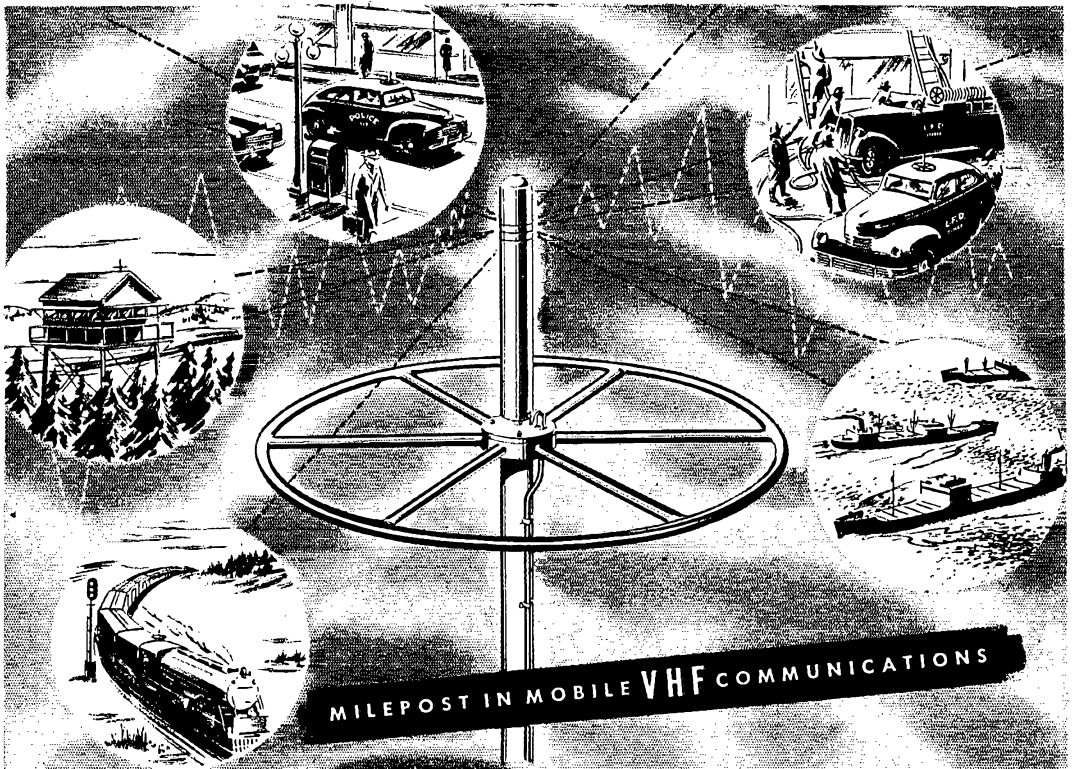

THE NEW

AMPHENOL

GROUND PLANE ANTENNA

Efficient VHF radio communications is a must in modern railroading. Used to expedite freight and express service, it is cutting hours from schedules, and eliminating waste time and money in switching operations.

Designed principally for use in the 152-162 mc band by railroads for "train-to-fixed-station" and "end-to-end" communications, the new Ground Plane Antenna illustrated is foremost among many new VHF radio components and accessories perfected by Amphenol engineers.

Providing maximum power radiation at low initial cost, this extremely rugged antenna consistently out-performs other antennas under normal and extreme conditions. It is easily and quickly installed, and has been thoroughly tested in main-line railroad installations.

Danger from lightning or contact with power lines is eliminated, as this antenna is at ground potential. The nature of its radiation pattern insures uninterrupted service during sharp "U" or "S" turns.

The Amphenol Ground Plane Antenna is also widely used by police and fire departments, by forestry, geophysical, power and petroleum field crews, for mobile marine installations, and many others. It is available with Ground Plane Skirt, as shown, for installations where a large metallic mounting surface is not available.

Write today for complete technical data on the Ground Plane Antenna, or for engineering aid in solving your VHF radio communications problems.



AMERICAN PHENOLIC CORPORATION
CHICAGO 50, ILLINOIS

COAXIAL CABLES AND CONNECTORS - INDUSTRIAL CONNECTORS, FITTINGS AND CONDUIT - ANTENNAS - RADIO COMPONENTS - PLASTICS FOR ELECTRONICS

SPACED ANTENNA RELAYS

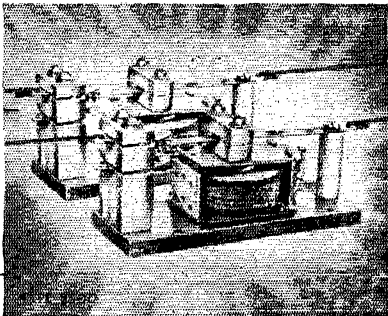

Any spacing
down to 2"

THE NEWEST wrinkle in transmission line switching . . . spaced twin relays. Enables you to preserve accurate line spacing from tank to radiating element. No bends or discontinuities . . . no radical impedance changes.

Built for QRO. Type 2300 has $\frac{1}{4}$ " pure silver SPDT contacts, $\frac{1}{8}$ " air gap, low loss white Ceramic Steatite insulation. Standard model wound for 110 V. AC, 50-60 cycle . . . can be supplied for any AC or DC voltage on request. Write for free catalog.

Amateurs net price at jobbers

\$4.35 each



Advance Relays

ADVANCE ELECTRIC & RELAY CO.
1260 West 2nd Street, Los Angeles 26, Calif.
Phone Michigan 9331

ELECTRICITY

FOR RADIO AND ELECTRONIC APPLICATIONS

ONAN ELECTRIC GENERATING PLANTS supply electric service for electronics applications and general uses, mobile or stationary. Driven by Onan 4-cycle gasoline engines, they are of single-unit, compact design and sturdy construction.

ONAN Electric Plants are available in many sizes and models. ALTERNATING CURRENT: 350 to 35,000 watts in all standard voltages and frequencies. DIRECT CURRENT: 600 to 10,000 watts, 115 and 230 volts. BATTERY CHARGERS: 500 to 3,500 watts; 6, 12, 24 and 32 volts. Write for detailed literature or engineering assistance.

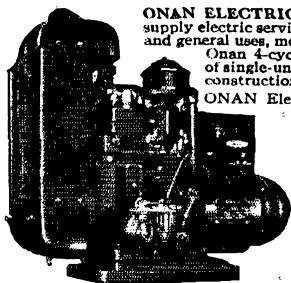

D. W. ONAN & SONS 4657 Royalston Ave. Minneapolis 5, Minn.

112

(Continued from page 110)

of the Orange County Amateur Radio Club are: ALO, pres.; LDJ, vice-pres.; FCT, secy.; MKW, act. mgr. VNN claims possession of the best fist in Trabuco Canyon; YDM, the other station, is on 'phone. HAA is on 28 Mc. MQF is getting good results on 14-Mc. 'phone with folded dipole. BWO has gone to higher power with 35Ts on 3.9 Mc. ØBDU, a new-comer to Santa Ana, is getting rig on 28 Mc. LDJ is active on 7 Mc. PHJ is active on 144 Mc. HWJ finished 50-Mc. rig but had to measure grid drive with microammeter. RKL is trying to get a pair of VT-127As to behave on 28 Mc. BEY, of El Centro, participated in the search for Western Air DC-3 that crashed east of San Diego on Christmas Eve. QUS, UQI, and YES are active on 3.9 Mc. at El Centro. LCL is on 3.9 Mc. at Escondido. VJQ reports FB round table on 28 Mc. with ØKNX, of Kansas City, and 2PHB and PRW of Orange, N.J. GC has converted an ARC-5 for v.f.o. operation and found 6AG7 best oscillator tube. MHL has FB new rig on 14-Mc. 'phone. The Palomar Radio Club elected new officers as follows: VTV, pres.; MI, vice-pres.; Mable Fields, secy.; LKC, treas. EZM has completed a new FB four-element rotary beam for 28 Mc. APG reports FB contact with a D4 in Germany with a forty-minute contact and an R9 report using 'phone. Traffic: W6VJQ 57, LDJ 17, CHV 7, APG 6. 73. Ralph.

WEST GULF DIVISION

NORTHERN TEXAS — SCM, N. C. Settle, W5DAS — Asst. SCM. Joe Bonnett, W5IIL Section EC: 5QA. PAM: ECE. RM: CDU. New officers of Ft. Worth Club are: GVZ, pres.; EYU, vice-pres.; CHU, treas.; JOU, secy.; LTY, act. mgr., 1704 Washington, phone 9-5827. FRD and CDA are on 50 Mc. KXC is on with 40 watts. JOL and FVF are back on. Active hams in Waco are KAU, LOU, KVI, IPO, CQQ, UF, ATW, BIN, DZ, JLU, KLC, KXR, KYV, LXE, KOE, ILE, LTZ, KLN, LLD. On 144 Mc.: ATW, KVI, LOU, LXE, and BYX. The Central Texas Club includes thirteen towns around Waco. The next West Gulf Division Convention will be at Taxarkana, Aug. 16-17, 1947. ASA wants a c.w. net on 3657.5 kc. QN, KVL, LUM, LUD, ATG, GML, and LDQ are active in Fannin County. QN has an HRO with 300 watts on 14-Mc. c.w. and has worked thirty countries. KVL has HQ-129X with 75 watts on 14- and 7-Mc. c.w. LUM is QN's son. LUD has a Millen exciter on 14-Mc. c.w. and has worked forty-one states and three countries. ATG has NC-200, FB-7, and BC-348. LDG is GML's father-in-law. LVM has four watts on 28 Mc. CMS, DXR, and KUY are on 3.9-Mc. 'phone. KBU is doing a nice job. In December your SCM took a motor trip to Florida, worked 28-Mc. mobile, went by Port Arthur and met BUZ and DEW. We would like to hear from El Paso. The Waco 144-Mc. boys are on from 8 to 9 P.M. Contact BYX, Waco, for 144-Mc. schedules. FOY, GZH, and JQY are mobile. CQO is back on 28 Mc. The Dallas Amateur Radio Club's call is W5IME. Don't forget the Convention. Traffic: W5HCH 121, BYX 11, ASA 7, KQW 1. *Skippy*.

SOUTHERN TEXAS — SCM, James B. Rives, W5JC — GDH has moved to Benjamin, Tex. EVK is recuperating from a recent operation. HGU is working in the Air Communication Office at Kelly Field. LZI is a new station at Baytown and is using a Meissner 150-B and a new bug he received for Christmas. LFM is OO for San Antonio. LCU is a new ORS at Harlingen. MN is handling a lot of traffic with his new rig on 7165 and 3628 kc. KTL received OBS appointment. LVD, LFM, KZG, and LUY are active on a 7-Mc. net. LZA is a control tower operator at Biggs Field and is on the air with a Meek transmitter. LZP is active on several bands and is trying to beat his OM, ESZ, for WAS. LYT, age 14, is the youngest ham in El Paso. ESZ built a 144-Mc. transceiver to take on a trip to Chicago. MCT has requested appointment as ORS. EHM is now traveling for the CAA. EUK is using his 35-watt portable rig. IYS is constructing a new rig and is stationed in the Canal Zone. A new amateur radio club has been organized at Kelly Field with an elaborate station set-up using the call 5AAF for on-the-job training of military and civilian personnel. AQN announces the arrival of a second harmonic; it's a boy. JC is busy building that new rig and will have kw. transmitters on at least four bands shortly. Traffic: W5MN 58, LVD 30. 73. *Jim*.

NEW MEXICO — SCM, J. G. Hancock, W5HJF — LGS, ex-9BEZ, is going to town on 14 and 28 Mc. with an "HK" rotary antenna. He worked eleven European coun-

(Continued on page 114)

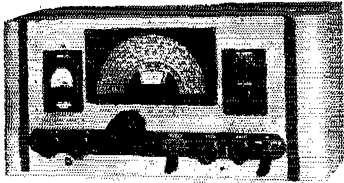

IMMEDIATE DELIVERY! **THE RME-45**
Net, with Speaker... \$198.70

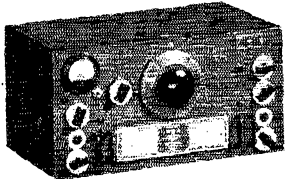

IMMEDIATE DELIVERY! **NATIONAL HRO**
Net, less Speaker... \$274.35

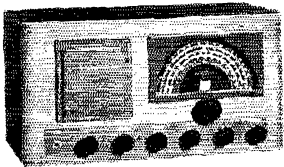

IMMEDIATE DELIVERY! **THE RME-84**
Net, with Speaker... \$98.70

Order Your Communications Receiver from ALLIED!

IMMEDIATE DELIVERY

on most models

Time Payments

Trade-Ins Accepted

Hallicrafters SX-42.....	\$275.00
Hallicrafters S-38.....	47.50
Hallicrafters S-40A.....	89.50
Hallicrafters S-41G.....	36.75
National NC-46 & Speaker.....	107.40
National NC-2-40D.....	225.00
Hammarlund SPC-400X.....	342.00
Hammarlund HQ-129X.....	173.25
Collins 75A-1 Receiver.....	375.00
Collins 32V-1 Transmitter.....	475.00
Collins 30K Transmitter.....	1250.00
Collins 70E8 VFO Unit.....	40.00
RME VHF-152 Converter.....	86.60
RME DB-20 Preselector.....	68.20

Net FOB Chicago. Prices subject to possible change.

RELAY RACK SPECIAL

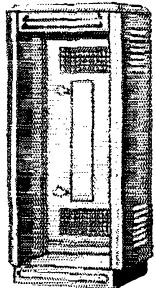

Standard ParMetal Type ER-213 heavy-duty enclosed type cabinet. 42" high, with 36 3/4" panel space. Has full-length door in rear. Handsome, all-steel construction, in rich, black wrinkle finish. Brand-new; in overseas packing case. Shpg. wt., 100 lbs. Regular selling price, \$29.95.

ALLIED SPECIAL, ONLY...\$1995

SPECIAL! NEW 2-METER TRANSCEIVER KIT!

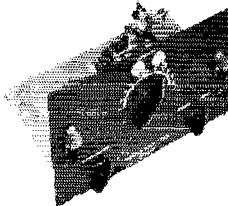

Uses 6N4 as mod.-osc. for transmitting, and as super-regen. det. for receiving; 7C5 as mod. in transmitting, and as power audio in receiving. Supplies current for carbon mike; with output transformer for coupling to speaker or phones. Requires 250 v. at 75 ma., 6.3 v. at .65 amp. Kit includes all necessary parts and tubes (less mike, speaker and power supply). No. 83-220. **NET.....\$18.95**
Power Supply Kit. Includes all parts necessary to build power supply for transceiver. No. 83-371. **NET..\$10.25**

ONLY \$1895

ALLIED RADIO

Everything for the HAM

ALLIED RADIO CORP., D. L. Warner, W9IBC
833 W. Jackson Blvd., Dept. 27-C-7
Chicago 7, Illinois

- Enter order for.....
 Enclosed \$..... Full Payment Part Payment
 (Balance C.O.D.)
 Send Literature on Receivers and Time Payment Plan.
 Send FREE Catalog.

Name.....

Address.....

City..... Zone..... State.....

AMATEUR GEAR

8 CONNECTICUT AND MASSACHUSETTS HAM STORES

H & Y has an eye

for Government Releases that are double-checked for usefulness and value. Look to your nearest Hatry & Young store for the latest and best Government surplus buys.

CONNECTICUT: Hartford, New Haven, Bridgeport, New London, Stamford, Waterbury. **MASSACHUSETTS:** Boston and Lawrence

HATRY & YOUNG
The Elect in Electronics



RECEIVING SENDING
CODES Speed *without strain*

CHAMPIONS ENDORSE CANDLER WAY

Get skill, accuracy, speed with the highly endorsed Candler System. Learn to send and receive by telegraph or radio code. Government service and commerce need thousands of better trained operators. Air commerce, mail, freight, etc., demand expert, reliable operators. Good pay. Get the Candler System, the maker of champions. It teaches you the "knack" of sound sense, alertness, speedy sending and receiving without strain. Adventure—good pay. Learn at home or wherever you are. Rush name today for free book.

FREE!

CANDLER SYSTEM CO.

Dept. 4-C, Box 928, Denver 1, Colorado, U.S.A. and at 121 Kingsway, London, W.C. 2, England

(Continued from page 118)

tries Armistice Day. Bill also is active on 3.9-Mc. 'phone GXL has his Old Timers Club certificate; he got his first ticket in 1922. Dell is rapidly winning a reputation as "the only New Mexico station on 75" since his swing shift puts him on that band from midnight until daybreak! 9NGL is building a 28-Mc. three-element beam driven by a gun mount of a B-29; he expects delivery on a Collins ART-13. LKS is attending California U. MEW is new ham in Clovis on 28-Mc. 'phone. ZU is on 29.1 Mc. narrow-band f.m. from Arlington, Va. The New Mexico Military Institute Radio Club has been reactivated under the trusteeship of Capt. Louis Falconi, ZA, and will resume operation under its old call, W5ZM. Officers are: LKP, pres.; W. P. Brown, vice-pres.; and E. Sullivan, secy.-treas. Brown and Sullivan hope to have their ham tickets before the end of the school year. KYL is attending Hardin-Simmons at Abilene, Tex. HJF is having trouble with his main rig. Traffic: W5HJF 11, LGS 2. 73. Jake.

CANADA

MARITIME DIVISION

MARITIME—SCM, A. M. Crowell, VE1DQ—RM: EY, EC: FQ. While on a special mission for CBC, HJ and a companion were stranded in the snowy wilderness of Labrador when their dog-team broke away. A fortunate rescue by snowmobile brought the boys back to Goose Bay where they reported to their office via VO6H and DQ. NA has been putting the new HQ-129 through its paces. FQ has been keeping schedules on 14 Mc. for 'phone traffic. QM is on 14 Mc. with nice 'phone signal. OM handles traffic on 3682 and 14,024 kc. OL is in Labrador as VO6N. SO is doing well on 3.5 Mc. with 50 watts. HC just received his ticket and is on 3.5-Mc. c.w. BD is active on 14- and 28-Mc. 'phone. CO is going strong on c.w. on these same bands. AP may be found on 3.5-Mc. c.w. CW is active on 14 and 28 Mc. QT reports for Lakeburn Radio Club. RE has new Meissner receiver. BF counts twenty-nine countries since Sept. 15th. QT is working FB DX on 3.5 Mc. SF is building modern 50-Mc. equipment. QZ has 50-Mc. converter with 11-Mc. i.f. and three-element steel tubing beam. LT sports AR88 and returns to air with p.p. 813s. FB bought Super-Pro. TH, doing FB on 3.5- and 28-Mc. c.w., uses 807. GY is active on 28-Mc. c.w. Traffic: VE1HJ 36, QT 38, OM 8, EK 6.

ONTARIO DIVISION

ONTARIO—SCM, David S. Hutchinson, VE3DU— The following qualified in the November code run of W1AW: AML, 25 w.p.m.; and ATR, 35 w.p.m. CP has Ontario 'Phone Net working with ten stations each in A and B nets. BME is active on 3815 kc. MT is getting out well with a pair of 813s. Since getting a new NC-46 WB has knocked off EK, ZD2, UA8, J2, ZS, and OH2. TM is back on 3.5 Mc. BCN has new call, 4AA, for use in Churchill with the Army. VD is active on 7 Mc. The Peterboro Club station, AEA, now is in operation. ALO made 370 contacts in SS. The West Side Club of Toronto had club station JJ, operated by AYE and AHV, in the SS. Other club members taking part were ADR, AEM, AIB, HB, AHX, UT, MI, AWX, AD, ASX, and AFY. AWX took honors on c.w. and AIB on 'phone. AIB and UT now have R1155 receivers. AUR received 28-Mc. converter for Christmas. BKL's rotary beam came down in a windstorm. AAQ has a pair of 807s. OX has a pair of 813s. BJG has two-element beam on 28 Mc. AY is on 7-Mc. c.w. BBH made WAC on 'phone in 8 hours 17 minutes with YI, ZS, G, VP8, W5, and VK. BKL and TW also WACed on 28-Mc. 'phone. AUQ's pole snapped in a sleet storm. The North Shore Club now has thirty-nine licensed hams in its membership of sixty-six. QU worked F8 on 3.5-Mc. c.w. with 30 watts to an 807; also HB on 7 Mc. JY is on 28- and 3.9-Mc. 'phone. BIE is on 50, 28, and 14 Mc. AGT, AKB, AFI, AXM, QO, ADD, AHJ, ATS, and ATT are active in Oshawa district. BAJ schedules BG. HP schedules BCS, BME, 2II, and 3GN. MB helped out in emergency work when men were marooned on ice in the St. Lawrence River. WM, HI, GV, ADD, WX, BJI, AJQ, BLD, GB, WF, JN, YJ, AOO, BEV, BBI, ADB, and AGY are active in London area. Traffic: VE3HP 216, WX 132, SF 111, ATR 64, CP 34, TM 27, OI 25, GV 22, AIV 15, APM 14, QB 10, BCS 9, AHP 8, AQP 4, KM 3, YI 2, AXQ 1.

(Continued on page 118)

COMPLETE-COMPACT and INEXPENSIVE!

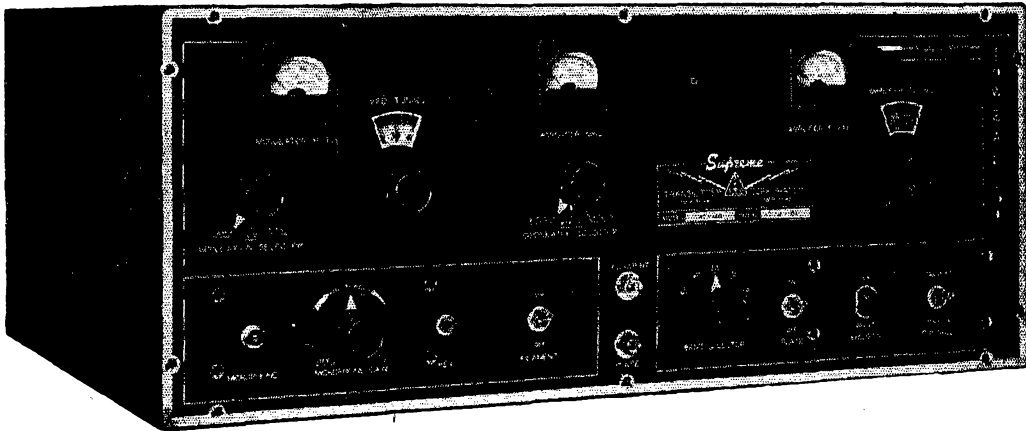

SUPREME TRANSMITTER Model AF-100, 6-Band, 100 Watt (output) Desk Type Transmitter. Embodies ALL the features most desired by the majority of the amateurs. Designed to cover the amateur bands most frequently used: 10, 11, 15, 20, 40 and 80 meters for CW, ICW, AM and FM Phone transmission. This is the very first transmitter offered to the amateur which has the new feature of Frequency Modulation in the band of frequencies assigned for this purpose, namely 27.185 to 27.455 and 29 to 29.7 megacycles. Model AF-100 is continuously tunable throughout the range of each of the amateur bands. A highly stable variable oscillator followed by slug-tuned buffer and doubler stages which are ganged to the oscillator dial simplifies the problem of working through

severe QRM and further enhances the pleasures of easily establishing and retaining QSOs. Band changing is easily accomplished in the exciter by a band selector switch and in the final by the plugging in of a coil for the particular band selected. This unit is one of the simplest to operate—and highly efficient on all bands, for all types of emission.

Front Panel Controls: Oscillator Dial; Final Amplifier Dial; Oscillator Selector Dial; Modulation Selector Dial; Microphone Gain Control; Band Selector Switch; Filament Power Switch; Plate Power Switch; Emission Selector Switch; Standby Control.

Metering: PA Plate Current; PA Grid Current; Modulator Plate Current.

TUBE COMPLEMENT

Type	Function
1—6AC7	Reactance Tube Modulator
1—6J5	Variable Frequency Oscillator
1—6AC7	Class "A" Amplifier or Crystal Oscillator
1—6L6	80 meter Buffer or 40 meter Doubler, or 30 meter Tripler
1—6L6	20 meter Doubler
1—6L6	15 meter Doubler
1—6L6	10 meter Doubler
1—3D23	Final Amplifier
2—807	Class AB ₂ Modulators
1—6J5	Modulator Driver
1—6SJ7	Speech Amplifier
2—866A	High Voltage Rectifiers
1—5R4GY	Low Voltage Rectifier
1—5R4GY	Modulator Rectifier
1—80	Speech Rectifier
1—6X5GT	Bias Rectifier
1—VR 150	Voltage Regulator
1—6SN7GT	Audio Oscillator

ELECTRICAL CHARACTERISTICS

Frequency Range:	Amateur Bands—10, 11, 15, 20, 40, 80 meters
Output Power:	100 watts on CW, ICW and Frequency Modulation 100 watts Amplitude Modulation
Method of Modulation:	AM—High Level Class AB ₂ FM—Reactance Tube Modulation
Modulation Capabilities:	AM—100% FM—100% = ±75 kilocycles (variable from 0 to 75 kc)
Input Audio Source:	High Impedance Crystal or Dynamic Microphone. Level 60 DB down
Audio Frequency Response:	AM—±2DB, 200 to 6000 cps FM—±1DB, 100 to 7500 cps
Noise Level:	AM—Minus 45DB below 100% modulation FM—Minus 60DB below 100% modulation (±75 kilocycles)
Audio Frequency Distortion:	AM—5% at 85% modulation for 100 watt output FM—1.5% at 100% modulation
Frequency Control Elements:	Stabilized Variable Frequency Oscillator or two (2) crystal controlled positions

COMPACT: 29 3/4" long, 11 1/4" wide, 18 3/4" deep.

Economical — Power Consumption: 325 watts.

Power Source: 110-117 volts 50/60 cycles AC.

Approximate Weight: 125 lbs.

COMPLETE: The only items needed to get "on the air" are a key, a mike and two crystals.

INEXPENSIVE: A WONDERFUL VALUE!



Write for detailed information and catalog
DESIGNERS AND BUILDERS OF BROADCAST STATION EQUIPMENT,
250 WATTS to 50 KW — AM and FM

SUPREME TRANSMITTER CORPORATION
280 NINTH AVENUE, NEW YORK 1, N. Y.

Going Places?

Keeping posted away from home?
 Attending hamfests?
 Tuning a beam or a television antenna?
 Talking back from that vacation spot just right for v.h.f.?

HANDY-TALKY HT-144

- Completely telescoping antenna actuates on-off switch.
- Press-to-talk single hand control.
- Economy with efficiency; B battery lasts 75 hrs. reception 45 hrs. trans. A battery 10 hrs. Rapid change thru snap bottom. 6C4 and 1S4 tubes.
- 10 $\frac{3}{4}$ x 2 $\frac{3}{4}$ x 2 $\frac{3}{4}$ " wgt. 4 lbs. with batts. HT-144 — less \$34.50 tubes and batts. Slightly higher in west.

Immediate Delivery!

RADIO TRANSCIVER LABORATORIES
 116-23 Jamaica Avenue Richmond Hill 18, N. Y.

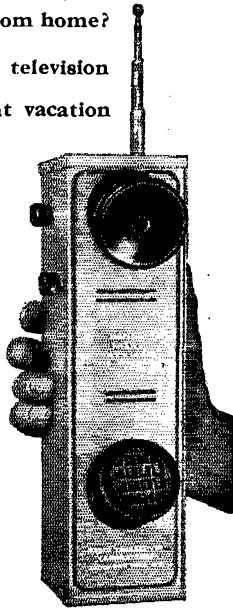

(Continued from page 114)

VANALTA DIVISION

ALBERTA — SCM, W. W. Butchart, VE6LQ — LX is AFARS outlet in Calgary, and exchanges traffic with Alberta Net. The Calgary gang is divided in opinion over appearance of typewritten sheet in GD's Gyp-Joint deriding local hams for over-modulation, key-clicks, etc. GD had his rig sold over his head! SB is on 3.5 and 28 Mc. GR has new HT-9. AC tries a spot of DX but AO says Frank's too good a rag-chewer! BR and DK are new Calgary calls. IA, of Calgary, attends U. of A. in Edmonton. BU needs only one more continent for WAC on 28-Mc. 'phone. DF, CARA's YL secretary, up and got married at Christmas. JK got FB newspaper write-up in Calgary daily paper. HM works consistent DX on 14 Mc. NR got cranked up on 14-Mc. 'phone. MJ hasn't told his neighbors that his new rig runs 180 wattel! EL sold his old heap and is busy building a new one. LL keeps Camrose on the map as far as 28-Mc. 'phone is concerned. EA built low-power stand-by rig. EY moves up to 3.5-Mc. 'phone every once in a while to enjoy the QRM. WS got new motor to turn his four-element array. The NARC has possession of its new clubhouse and 300-watt rig. LG and SZ have worked hard to get the rig on the air. Traffic: VE6AO 87, LQ 36, AC 14, ZL 11, MJ 10.

BRITISH COLUMBIA — SCM, W. W. Storey, VE7WS — We have just started a 5 p.m. net on 3850 kc. with the following: PO, CB, AAZ, DY, DF, DE, ND, LK, AAJ, ADL, DB, TA, ADI, AEU, SO, ALJ, FB, BY, BJ, and HY. AC, net control, says his net is working fine. Collingwood: New members are YS, LF, K. Wright, and Art Lelong. YS is open for contacts on 28-Mc. c.w. AKK is on 3.5-Mc. c.w. MH is putting up 135-ft. antenna for his e.c.o. AK was heard testing on 28-Mc. 'phone. ADV is heard on 28-Mc. 'phone with 125 watts. UU runs 150 watts on 14-Mc. c.w. LF is open for contacts on 7-Mc. c.w. and is building a regenerative receiver. OJ heard LF calling him so he must be on the air. AKK worked a KL7 with a beat oscillator. Collingwood Radio Club meetings are held the first and third Tuesdays, 8 p.m., 5755 McKinnon Street. For information call Harold Olsen, BE, Dex. 0515L. GE reports for the Dawson Creek A.R.C. and says the 28-Mc. band is improving rapidly. PR is back on the air. HIN reached out into New York recently on 3.5-Mc. c.w. GQ is on 3.9-Mc. 'phone. DG expects to get on 3.5-Mc. c.w. soon. LU is active on 3.5 Mc. c.w. W2CPT is with LORAN station in Dawson Creek. GE has been spending spare time building bandswitching exciter in ARRL Handbook and intends to follow this with single 813. OT and AEY are sporting the new 28-Mc. Gonset converter which is giving them fine results. AJO is on the air with his rig at Radio Range at Carmi, four thousand feet up in the air. Ex-5AIM also is up there. Please send in your activity reports.

YUKON — Acting SCM, W. R. Williamson, VE8AK — Semi-monthly meeting of the YARC was held at the home of 8BB on Jan. 7th. Present were 8AG, 8AY, 8BB, 8AS, 8AJ, 8AK, and 8AN. 8AK was nominated as SCM. New hams are 8BH and 8BL, both in Whitehorse. 8AS has Sunday schedules with Toronto boys, using 250TL and 8JK beam, and claims hasn't missed more than once in two months. 8AG and his XYL, plus 8AK and 7AP, drove fifty miles to 8AO's shack to spend Christmas with Ed and his wife. 8AJ QSOs his dad, 6HQ, on 14 and 28 Mc. 8NG is on 14 Mc. with about 150 watts to a 83-ft. dipole antenna and has had good results, with thirty-one countries on five continents worked. He advises that all QSL cards are now in the mails, but if you haven't received yours you should send an envelope to your QSL Bureau, as that's where he had to send most of them. All VE8s, please write in and help make this report from the Yukon really something.

PRAIRIE DIVISION

MANITOBA — SCM, A. W. Morley, VE4AM — Flin Flon has been doing a lot of rebuilding. EQ came up with a new rig and receiver. EO has a new rig with p.p. 807. AN, at Portage, has had to QRT on 7 Mc. He cracked all his crystals. XP, at Dauphin, has his 813 going fine. XC, of Dominion City, is active on 'phone and c.w. on 3.5 Mc. KY is using p.p. 802. CL, ex-ACL, is on 3.5-Mc. c.w. after ironing out the kinks. RN is on 7 Mc. and has cleared up his note. SS is new call in St. Vital. KX is hauling in the DX on 28 Mc. They say no news is good news, so I guess every one is happy this month. If you want to see this column grow,

(Continued on page 118)

★ YOUR FUTURE
 IN
 ★ RADIO . . .

May depend on the integrity and ability of your School's Administration.

At MELVILLE no effort is spared to provide the best in facilities and service for the serious student of RADIO, TELEVISION, FREQUENCY MODULATION, TELEGRAPHY, SLIP TRANSCRIPTION, RADIO MATHEMATICS, etc.

Approved for Veterans
 Licensed by the State of N. Y.
 Write or call today for FREE Bulletin B

**MELVILLE
 RADIO INSTITUTE**
 45 W. 45th St., New York 19, N. Y.
 BRyant 9-5080
 "Managed by Radio Men"

PLASTICON* ASG Silicone-Filled GLASSMIKES



1-3/8 x 3-1/2

FOR HIGHER VOLTAGES

*Extreme Temperature Range
from Minus 60° C to Plus 125° C*

From 600 to over
30,000 Volts

Modern functionally designed capacitors. Metal ferrules are soldered to silver bands fused to each end of heavy-walled glass tubes. This vacuum tight assembly is fungus-proof and passes Signal Corps, Air Corps and Navy thermal cycle and immersion tests

Announcing an illustrated technical booklet on uses of Plasticon* Glassmikes.

Contains the following subjects: —

- Glassmike characteristics and design data
- Comparison of Glassmikes and Mica Capacitors
- Uses of Glassmikes for improved RF and Audio bypassing
- Use in Audio and RF coupling
- Glassmikes in television power supplies
- Video coupling
- Vibrator buffer applications
- Geiger Counter Capacitors
- Instrument capacitors
- and many other applications

Write for above free
booklet on your firm
letterhead or give your
call letters

* PLASTICONS: Plastic-Film Dielectric Capacitors

Order from your jobber: If he cannot supply you, order direct



Condenser Products Company

1375 NORTH BRANCH STREET • CHICAGO 22, ILLINOIS

DEKA XTAL

**COMBINED
ROTABLE
XTAL HOLDER
AND SWITCH**

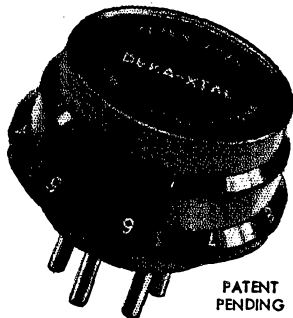

Ten Crystal Frequencies Controlled Faster than Counting

Plug into a standard 5-prong tube socket on the front of your Xmitter. By rotating the Deka-Xtal any one of the ten crystals is switched into the circuit.

Write for folder and prices on the Deka-Xtal and other precision crystal products by SCIENTIFIC . . . or see your distributor.

SCIENTIFIC RADIO PRODUCTS COMPANY

738½ W. Broadway • Telephone 3-1412

COUNCIL BLUFFS, IOWA

Manufacturers of Piezo Electric Crystals
and Associated Products

(Continued from page 116)

please let me hear from you the first of every month Traffic: VE4AM 133. 73. Arf.

SASKATCHEWAN — SCM, Norman Thompson, VE 5CO — New officers of the MJARC are: OM, pres.; CO, vice-pres.; HB, secy.-treas.; AV, act. mgr. New members include RA, GH, BE, ED, DF, J. Waruk, at present a VE8 in Whitehorse, and T. Bisch, now signing BD in Maple Creek. Meetings are held on the first Friday of the month and all hams are welcome. CZ, the Canadian Vocational Training School for Vets in Mooee Jaw, has 50 watts on 3.5 and 7 Mc., 500 watts to a pair of 813s on 14 Mc., and 150 watts to a T55 'phone on 28 Mc.; with AR88s for receiving. RA is active on 14 Mc. and worked an LZ for his first DX. OM works KH6s regularly with R9 reports on 14-Mc. 'phone. HB has pair of 807s in final, JS gets out FB with 15 watts on 3.9-Mc. 'phone. AV is working on a 50- and 144-Mc. transceiver. AI gets out a lusty signal from low power. MW, ORS, is active on 7 and 3.5 Mc. and would like schedules for traffic net. JP is handling traffic in Regina. OP is doing a good job as QSL Manager. Please send in envelopes if you want your DX cards. The Saskatchewan gang thanks SY for his FB job as SCM. Yours truly is scrapping a handswitching exciter in favor of a slug tuned effort. Look for me on the low end of 7 Mc. around 9 P.M. 73. Norm.

Break-In Keying

(Continued from page 29)

break-in keying; a T9 note; no backwave; only two plate supplies required; absence of troubles with hash from the mercury-vapor rectifier tubes; no peak-voltage strains on the insulating materials of filter condensers and chokes; no need for a wasteful high-current bleeder on the final power supply.

Although VFO has not been tried with this keying system, it should be satisfactory if your VFO keys well with combined plate-and-screen keying. We do know that it gives crisp, chirpless keying with X-, Y- or AT-cut crystals in holders with fixed or variable gaps.

Did we hear someone say, "It sounds FB, but what about blinking the house lights?"? Yes, primary keying or any other method of keying a kilowatt rig will blink the lights, if an ordinary electric-light line is the a.c. source. If you run a kilowatt, however, you should have a special, heavy 230-volt three-wire a.c. line, to reduce blinking and to keep your tube filaments within plus or minus 5 per cent of their rated voltages. With a heavy line suitable for operating an electric stove, you will not be troubled by blinking lights. And with this keying system, you will have keying which sounds as sweet as it is simple.

~~W4~~ Strays

W4IFW/3, Lieut. Cmdr. Roy H. Tabeling, USN, who does pretty well for himself chasing the rare ones on 28 Mc., took time out to assist in setting new aeronautical DX records as a crew member of the Navy's *Truculent Turtle*.

— W4GPW/3

With the recent death of Mr. Frank C. Spoon, K7GLD, Pilot Point, Alaska, the amateur radio world is believed to have lost its only Eskimo member. — KL7AV

NOW
The TOWER
You've Been
WANTING!

For Directional
Beam Antenna
and dozens of
other uses.

RUGGED
Aluminum alloy throughout. Guaranteed to support 200 lbs. with an area of 5 sq. ft. in 70 mile wind!

SIMPLE
Triangular, tapered, self-supporting, light weight. 30 ft. tower can be assembled anywhere, using only wrenches, erected by hand.

SIZE
Triangular Base 3 ft. 4 inches on a side; top 1 ft. 4 inches. Ladder rungs 15 inches apart.

ECONOMICAL
Buy the height you need, 10, 20 or 30 feet. All fastenings and metal parts of footing finished. Reasonably priced.

Write immediately for Brochure **FREE!**

FABRICATED LIGHTMETALS CO.
42 West 15th St. New York City 11, N. Y.

HIGH SENSITIVITY Model 3256 ABSORPTION FREQUENCY METER

Know What Band You're In... Avoid "Pink Ticket" Trouble

Brand New!—A band switching, tuned absorption type frequency meter covering five amateur bands. Incorporates the new germanian crystal and a DC Milliammeter indicator for greater sensitivity. Direct calibration on panel—no coils to change. Switching permits instantaneous band change. Audio jack, another new feature, provides for monitoring of phone signals. Calibration is in megacycles in the following bands: 3.5-4; 7-7.3; 14-14.4; 21.5-20; 28-30..By removing plug-in coil other frequencies may be covered.

Use This New Unit for Checking:

1. Fundamental frequency of oscillating circuits.
2. Presence, order and amplitude of harmonics.
3. For parasitic oscillations.
4. The neutralization of R. F. amplifiers.
5. Standing wave ratio on transmission lines.
6. The presence of undesirable R. F.
7. For small quantities of R.F.
8. Monitoring of phone signals.

Model 3256 is fully shielded, highly sensitive, compact—invaluable for use in restricted spaces.

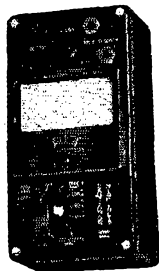
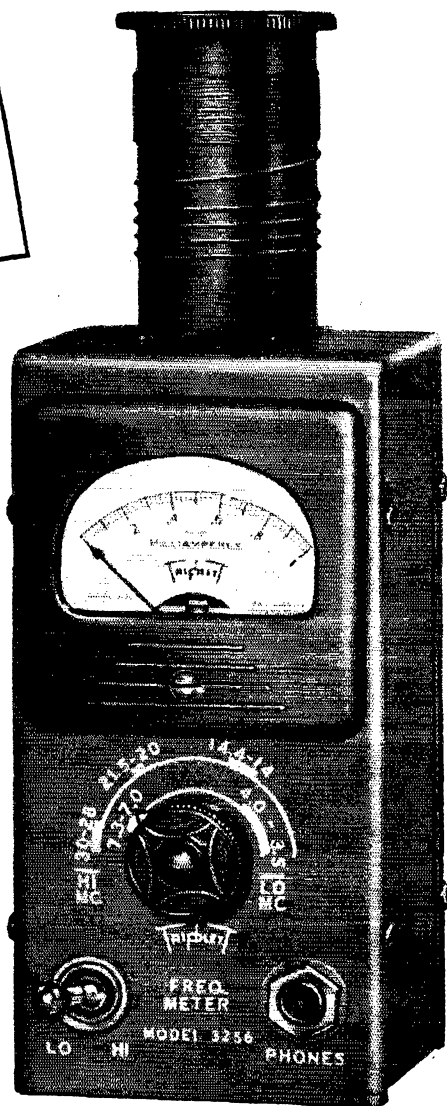

MODEL 666H Volt-Ohm-Milliammeter

The handiest tester of all. A.C. and D.C. Volts at 1000 Ohms per Volt 0-10-50-250-1000-5000 (compensated copper-oxide rectifier provides for A.C. measurements); D.C. Milliamperes 0-10-100-500; Resistance 0-300 Ohms; 10 Ohms reading at center scale; 0-250,000 Ohms.

Triplett

ELECTRICAL INSTRUMENT CO. BLUFFTON, OHIO

U.H.F. RESONATOR CO.

**3 ELEMENT
4 ELEMENT
AND
5 ELEMENT
TEN METER BEAMS
3 ELEMENT 20 METER BEAM**

Having delivered nearly one hundred of our 20 meter beams, many reports of users are in, as follows: "Having my 20 meter beam up and working. I want to take this opportunity to tell you it is 'terrific.' In the past two weeks I have worked everything I can hear. This includes innumerable ZS, VO, EI., CN, D, G, F, H, IC, PZ, LU, PV, HK, VP, CE, K1K, etc. The percentage of come-backs to calls made has been excellent and all of my reports have been very good also. Sincerely, W3MCH, Frederick Hamburger, 1207 Eutaw Place, Balt., Md."

The strength of our 20 meter beam is attested to by the following. "Dear Bill, . . . on the night of Dec. 28th a real blizzard hit Winnipeg and tore the beam off the pole. I thought that was the end of my 20 meter beam but believe it or not nothing was broken. If anyone wants to know about the strength of the Beam let them write to me — that beam will stand any storm if it is securely fastened. Sincerely, John Gordon, VE4ZK."

Amateur net prices. 10-meter beams: 3 el. beam, length 12 ft., weight 5 1/4 lbs., \$38. 4 el. beam, length 20 ft., weight 13 1/4 lbs., \$50. 5 el. beam, length 29 ft., weight 25 lbs., \$65. 3 el. 20-meter beam, 23 ft. long, 39 lbs., \$100. For shipping prepaid anywhere in U.S.A. or Canada add \$10 deposit on strong wood box. Refund on return of box, less outgoing shipping chgs. Beams available for all amateur bands from 14 m.c. up, including 16 and 32 element beams for 2 meters. Send for literature A, 10 and 20; B, 50 m.c. and up; R, Rotator and masts. Our beam mount, rotating mast, fixed mast, rotator with indicator, are now available, making a complete installation.

U.H.F. RESONATOR CO.

W. F. Hoisington, 2 BAV

GUION ROAD, RYE, N. Y. Telephone Rye 2030
Factory at Portchester, N. Y.

Rotten 'Phones

(Continued from page 49)

considerable importance it alone is not the only cause of trouble; in fact, in many cases a fair-sized departure from specifications may not be as harmful as supposed. This latter point is mentioned only to relieve the poor old "match" from being blamed for nearly all Class B ailments. Now about the only place left for trouble is the grid circuit, and it is here that many difficulties exist. As good audio regulation as possible should be provided in the plate circuit of the driver tubes; this may be easily obtained by using Class A low- μ power triodes working into a properly-designed Class B driver transformer. Since this transformer is a power device and therefore subject to regulation difficulties, don't use a "bargain" and remember the manufacturer didn't just guess at the recommended step-down ratio. Zero-bias Class B tubes are to be preferred over low- μ triodes that require relatively high grid bias, because the zero-bias tubes start to draw grid current with the first application of signal voltage and thereby reflect a more constant load on the driver tubes; this contributes to better driver regulation. The bias required on some tubes is the source of trouble for many an unsuspecting ham because ordinary batteries are generally unsuited for long-time operation and many home-designed bias supplies are of far too great internal resistance for the degree of regulation necessary. Connect a voltmeter across your Class B bias supply and observe its operation during transmission.

PEERLESS POWER PACKS

HARD-TO-FIND AND SPECIAL PURPOSE TUBES

59c 954	98c 807 6X4 6Y6	\$1.79 6AK5 801A	\$4.45 829B/3E29*
69c 3A4 955 9002 1625 1629 6C4	\$1.19 6L6 6AG5	\$1.95 2C26A EF50	\$4.95 2C40 2C43 826 5BP1* 5CP1*
79c 9005 9006 9006Y 5R4GY VR105 VR150	\$1.29 884 885	\$2.95 802 836	\$5.95 805 5BP4
89c 6AL5	\$1.39 866A	\$3.95 3BP1* 715B*	\$8.95 100TH 813
		\$9.95 8012 803	

All tubes individually boxed

Prices FOB New York City. State tax not included. Send 25% with order. Write Dept. QS

*Complete with socket and mounting ring.

Peerless R A D I O D I S T R I B U T O R S
92-32 Merrick Road, Jamaica 3, New York
Republic 9-6080
BRANCH: 71 MURRAY ST., N. Y. 7 • BA 7-6377

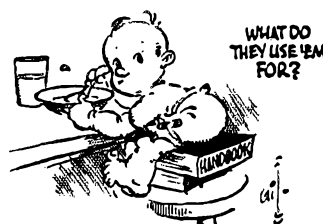

There are many other causes of improper ham 'phone operation and they, as well as the few mentioned here, are well covered in detail in most radio handbooks. But judging by the bandwidth required by many of our ham 'phones some of us must use the books for door stops or to raise Junior to table level in his high chair.

About the Author

• William R. Marks, W1DEF, is a 'phone man around the clock. During working hours he's master control operator in the studios of the BCL 50-kw. WTIC, and on his own time he operates W1DEF a la voice. But Bill's not so one-sided as to neglect the c.w. art — he has a second-class radiotelegraph ticket to go with his amateur Class A and first-class radiotelephone licenses. W1DEF has been on the air since 1931 "without distinction — not even an FCC citation," he complains!

The West's Largest Radio Parts Distributor—Established 1932

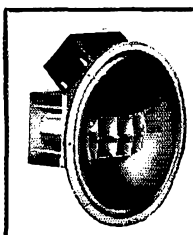

STEPHENS TRU-SONIC COAXIAL SPEAKERS

New series 52 TRU-SONIC Coaxial Speakers. Combines Low Frequency cone

type unit and High Frequency multicellular type unit in single assembly with complimentary 2-channel Dividing Network. Ideal for AM-FM reception, broadcast station monitoring and sound motion picture reproduction. Specifications: power input—20 watts; input impedance—16 ohms; frequency response—5 db. + or - from 50 to 10,000 CPS. O.D. 1 1/2". Weight 30 lbs.

STEPHENS MODEL P-52A TRU-SONIC P.M. SPEAKER, COMPLETE \$123.00



HANDY-TALKY HT-144

The versatile 144 Mc. transceiver. Telescoping antenna actuates On-Off switch. Press-to-talk single hand control. Gray wrinkle finish. With tubes and batteries.

COMPLETE \$36.24

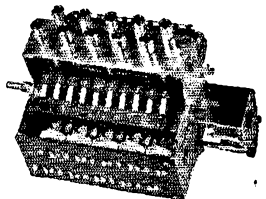

PUSH BUTTON TUNER

Shaft can rotate to 10 preset positions; any variable condenser rotates with shaft. Two groups of 10 SPST switches (each button closes 2 switches) and 10 APC type silver plated variable condensers connected to one group of switches. A real Surplus bargain!

EACH \$3.50

G.E. POWER TRANSFORMER



New surplus G.E. 68G684 transformer. Fully shielded. 4" x 4" x 5". Wt. 9 lbs. 115 V. primary. Secondary 450-0-450 @ 250 Ma. 5 V. @ 3 Amp. 6.3 V. @ 5 Amp.

SPECIAL \$5.95

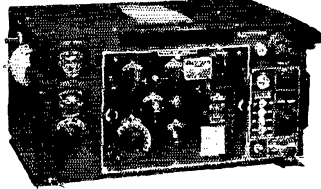

GP-7 TRANSMITTER

USED, Navy type. 400 cycle A.C. operated. 125 watt CW & MCW, 40 watt phone. Tubes 801, 803, 843, 5Z3, (2) 1616's. Contains wealth of usable Amateur parts. Wt. 65 lbs. Less A.C. Alternator but with tubes and one tuning unit. F.O.B. Los Angeles.

EACH \$17.50



SONAR F-M EXCITER

Narrow band (2-3 Kc. deviation). Use with any CW or phone transmitter. Eliminates BCI. Penetrates QRM. Greater signal to noise ratio. Use any AM receiver. More output from your final amplifier. Self contained power supply, 110 V, 60 cycle.

MODEL XE-10 \$39.45

BC-306B TUNING UNIT

Antenna tuning unit used in BC-375 Liaison Transmitter. Contains Antenna variometer, heavy duty variometer switch, high voltage mica condenser, insulators, etc. Black crackled finish metal cabinet.

COMPLETE \$3.45

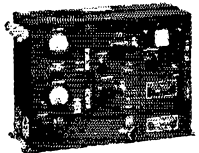
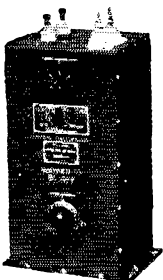

BC 223A TRANSMITTER

SPECIAL \$9.95

Easily converted; ideal as a basic unit for a lower powered amateur rig. 10 to 30 watts output self-contained antenna tuning unit. Frequency 2,000 to 3,000 Kc. Less tubes, cables, crystals and genemotor.

Write for our Surplus Bargain Flyer!

We carry in stock all standard brands. Regular shipments are being received of communications receivers:

- | | |
|---------------|--------------|
| MILLEN | PIERSON |
| CARDWELL | RME NATIONAL |
| HALLICRAFTERS | HAMMARLUND |

—and all other major lines. Orders filled promptly.

Broadcasters: We carry a full line of Cannon "X," "XL," and "P" Plugs and Receptacles.



TU-52 TUNING UNIT

6.35 to 8 Mc. E.C.O. or Xtal. Used in Hallicrafters HT-4 (BC-610E) transmitters and in the new McElroy Exciter Kits.

EACH \$2.50

K-7 GUN MOUNT

Excellent geared rotary beam mount. Tach shaft drive. 40 to 1 ratio. Adaptable for either manual or motor drive.

SPECIAL \$6.95



VIBRATOR POWER SUPPLY

Dual Unit. 540 Volts D.C. @ 150 Ma. 6 V. D.C. input. Contains two vibrators, two power transformers, two OZ4A tubes. Complete with filters, wired, ready to operate.

LIMITED QUANTITY \$16.95

RADIO SPECIALTIES COMPANY
 (Dept. 73) 1956 So. Figueroa Street, Los Angeles 7, Calif.

Please Ship Cash \$ C.O.D.

- | | |
|---|---|
| <input type="checkbox"/> Stephens Tru-Sonic Speaker | <input type="checkbox"/> HT-144 Handy Talky |
| <input type="checkbox"/> Sonar FM Exciter | <input type="checkbox"/> BC-223A Transmitter |
| <input type="checkbox"/> GP-7 Transmitter | <input type="checkbox"/> GE Power Transformer |
| <input type="checkbox"/> Vibrator Power Supply | <input type="checkbox"/> TU-52 Tuning Unit |
| <input type="checkbox"/> BC-306B Tuning Unit | <input type="checkbox"/> Push Button Tuner |
| <input type="checkbox"/> K-7 Gun Mount | |

NAME.....
 ADDRESS.....
 CITY.....ZONE.....STATE.....

RADIO SPECIALTIES COMPANY

1956 S. FIGUEROA ST. • PROSPECT 7271 • LOS ANGELES 7, CALIF.

COMPLETE EXPORT FACILITIES. CABLE "RASPEC"

**THE CLARKSTAN REMACO
4 Element — T Match**

BEAM-ANTENNA

**TUNABLE
6 to 10 meters**

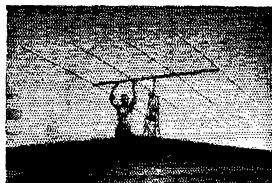

A 15-LB., easily assembled all metal directional antenna incorporating the best in electrical and mechanical design. Has popular "T Match" feed system for convenient impedance match to any standard feed line. Has four elements with .1 wave length spacing. Can be tuned and accurately adjusted before erecting. Fits any rotating mechanism. Assembly instructions and tuning charts furnished plus all parts — supporting cross-arm, T Match assembly and hardware.

Order your Clarkstan Remaco Antenna today, through your local distributor or send check for 20%, balance C.O.D.

Model 4-6-10, 4 element, 6 to 10 meters, complete with "T Match" assembly. List price \$87.50. Write for complete catalog on antennas for all amateur bands.

**Amateur Net Price
\$52.50**

CLARKSTAN CORPORATION
11927 W. Pico Blvd.
Los Angeles 34, Cal.

**RADIO CHASSIS
PUNCH**



Saves hours of work cutting clean, accurate holes in radio chassis — for connectors and other receptacles. Simply insert cap screw in hole to be enlarged (drill small hole if necessary), turn with ordinary wrench to force punch through the metal. No reaming or filing — hole is smooth and clean. No distortion — die supports metal. Ten sizes from $\frac{3}{4}$ " to $2\frac{1}{4}$ "; also up to $3\frac{1}{2}$ " for meters. Write for free catalog 33E to Greenlee Tool Co., 1863 Columbia Ave., Rockford, Ill.



25 Years Ago

(Continued from page 68)

broadcast-listener element with which to contend. Already there has been talk of restricting our early-evening operation. Let the Board of Direction know your club's thoughts!

Boyd Phelps, 9ZT, writes farsightedly of "Radio Below 200 Meters" as the answer to this pile-up. The low-wavelength performance of antennas, vacuum tubes and receivers is discussed optimistically by "Beep." He envisions 100 meters as a practical ham frequency! Streaming bold-face type rallies our traffic handlers to the cause of the Governors'-President's Relay, scheduled for this month. "We must make a strong impression on our President. . . ."

S.P.W.'s "And It Came to Pass," a parable of a c. w. ham and his landlord, contributes much to the lighter side of this issue. Station descriptions take us behind the scenes at 8LF, the phenomenal c.w. performer at Crafton, Pa., and 9MC, the prominent spark at Roodhouse, Ill. Strays report notable transcontinental reception in both directions. . . . Edwin C. Adams, *QST's* advertising manager, has turned benedict. . . . The optimists at Headquarters have dusted off the world globe in a search for new conquests — 12,000 miles shapes up as a potential maximum for our DX efforts!

Foreign Notes

(Continued from page 65)

each of the previous two years, respectively, and nearly parallels the U. S. situation of doubling membership in the full year since V-J Day.

British amateurs are now back on all Cairo bands plus several new microwave assignments, and need only channels in the 60-500-Mc. region to complete the basic principle of "sample" portions of all parts of the radio spectrum available for amateur use. Several important operating privileges were obtained, including the elimination of "guard" or "buffer" bands, permission to use CQ as a call of inquiry (instead of TEST), and the elimination of most restrictions on the length and height of antenna structures. Portable operation privileges were granted with the use of the identification suffix /P, and operation from an alternate address with the identification suffix /A. Perhaps most important of all is the fact that licenses are now issued on an amateur, instead of an experimental, basis.

Although plans to increase the size of the *Bulletin* have been hampered by paper restrictions, the society has been able to publish a "how-to-become" booklet entitled, *The Transmitting Licence*, designed to indoctrinate the beginner with the fundamentals of amateur radio.

MISCELLANY

South Africa is issuing new licenses, "temporary" until after the next world conference. For new operators, the first year must be spent on

(Continued on page 184)

SHOP NEWARK FIRST!

GREAT VALUES

GREAT STOCKS

3 GREAT STORES

GREAT SERVICE

Look at These Buys!

G.E. O-1 Ma. DC Meter
A standard, fine 3 1/2" meter with scale reading 0-2, 0-40 Ma. DC, with internal multiplier of 100 ohms. Round bakelite case. High sensitivity. Regular \$10 value. Limited quantity - Buy Now! Only



\$3.95



\$3.95

Westinghouse Rectifier Type AC

VOLTMETER. What a buy! Model NC-35, standard, sturdy 3 1/2" 0-2 Voltmeter, 2000 ohms per volt, 3 scale readings. Rnd. bakelite case. Made to sell for \$17.00. A steal at this price!

A Great Value!

Cardwell Xmitting Condenser

\$5.00 Value! Brand new type NUV 150-VS. 35 plates, .078 gap. 150 mmfd. Mycalex insulation. While quantities last, only

\$1.49

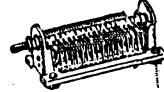

They Hit the Spot!

NEWARK CRYSTALS

6-11-20-40-80 Meters
Sensational Value! Precision-cut low drift crystals, accurately calibrated, fully guaranteed. Orders filled from stock to nearest specified frequency. Order Now!

88¢ EACH

3 Ass'd for only \$2.40

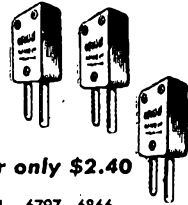

80 Meter Type X1-3500-4000
40 Meter Type X2-7000-7300
6 Meter Type X3-6250-6750

11 Meter Type X4- 6797- 6866
6 Meter Type X5- 8335- 9000 KC
20 Meter Type X6-14100-14300

WAR SURPLUS TRANSMITTING and SPECIAL PURPOSE TUBES

2AP1	Cathode Ray	\$ 2.25
2C40	Receiving UHF Triode	2.63
2X2/879	Diode Rectifier	.90
3E29	Trans. twin pentode amplifier	2.99
100TH	Trans. triode modulator amplifier	4.13
211	Trans. triode amplifier oscillator	1.13
250TH	Trans. triode amplifier oscillator	9.00
304TH	Trans. triode power amplifier	12.00
800	Trans. triode amplifier	2.25
801A	Trans. triode amplifier	1.73
803	Trans. pentode amplifier	9.00
807	Trans. Beam Power Tetraode	1.05
810	Trans. triode amplifier	2.63
811	Trans. triode	1.95
813	Trans. Beam Power Tetraode	6.75
814	Trans. triode amplifier	4.50

815	Trans. HF twin pentode	\$ 2.25
826	Trans. UHF triode	2.25
829B	Trans. UHF twin pentode amplifier oscillator	5.25
830B	Trans. triode amplifier	5.25
832A	Trans. twin pentode amplifier	6.00
838	Trans. triode amplifier	3.75
860	Trans. triode amplifier	3.00
861	Trans. tetraode amplifier	90.00
865	Trans. tetraode amplifier	1.50
872A	Trans. diode gas rectifier	2.25
931A	Vacuum multiplier phototube	1.88
2050	Grid-controlled gas rect. (tetraode)	.90
2051	Grid-controlled gas rect. (tetraode)	.90
EF-50	UHF Pentode	.69
E-1148	HY 615 Replacement	.99

SONAR VFX-680 EXCITER

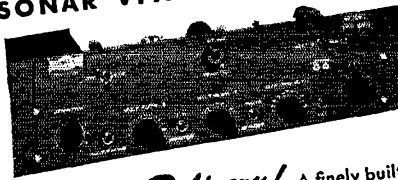

Immediate Delivery! A finely built rig. Functions as Variable Frequency Crystal-Controlled (or straight ECO) Oscillator. Oscillator Range: 1,565 to 2000 KC; 30 KC on 80, 60 KC on 40, 120 KC on 20, 240 KC on 10, 480 KC on 6 meters. Output: 4 to 6 watts overall. Frequency shift keying provisions self contained. Works CW or Break-In operation on same frequency when oscillator is on. (For additional data see mfr's ad in this issue.) Your cost.....

\$87.45

ALL BRAND NEW GUARANTEED AT FRACTION OF ORIGINAL COST

Mail orders filled promptly FOB New York or Chicago. Send 20% deposit with order. Prices subject to change.

STANDARD RECEIVERS NOW AVAILABLE!

HALLICRAFTERS
S-38 complete \$ 47.50
S-40A complete 89.50
SX-42 275.00

NATIONAL
HRO-Stal complete \$306.71
NC-240D with speaker 241.44
NC-46 with speaker... 107.40
1-10A, less speaker and power supply... 67.50

HAMMARLUND
HQ-129X complete \$173.25
SP-400X complete 342.00
RME-45 complete 198.70
RME-84 complete 98.70
Panadaptor 99.50
Tenco 75 GA XMTR... 495.00
Meck Transmitters 150.00
Supreme Transmitter Model AF-100 (for complete specs see mfr's ad in this issue) 450.00

MAIL ORDERS FILLED FROM EITHER NEW YORK OR CHICAGO

NEW YORK
Offices & Warehouse
242 W. 55th St., N.Y. 19

NEWARK
ELECTRIC COMPANY, INC.

CHICAGO
323 W. Madison St.
Chicago 6, Ill.

New York City Stores: 115-17 W. 75th St. & 212 Fulton St.

NEW YORK
CHICAGO

(Continued from page 188)



First WITH DISCRIMINATING AMATEURS

ON STANCOR'S PROGRAM
Transformers and Reactors of all types
... Versatile Line of Transmitter Kits,
Audio Amplifier Kits, and other
Electronic Devices to serve the
Discriminating Amateur.

STANCOR STANDARD TRANSFORMER CORP.
ELSTON - KEDZIE AND ADDISON, CHICAGO, ILL.

c.w., and 10 or 20 meters must not be used until after six months of experience. . . . The Italian society has inaugurated a five-meter DX contest, running from last September until July of this year. The object is to obtain a QSL card reporting reception of 5-meter Italian signals at the greatest possible distance. . . . The *Radio Club de Cuba* held its second national convention at Matanzas in October. The club station was in operation, and a special QSL card was sent to all stations contacted during the convention. . . . Add countries issuing licenses to U. S. citizens: Netherlands (PA0AO to W2KTJ) and Newfoundland (numerous VO calls to American servicemen).

50 Mc.

(Continued from page 69)

Louisiana by W5HHT, Idaho by W7ACD, and possibilities are reported for most of the rest. Our 1947 winner should have at least 35 states under his belt, perhaps more.

The whole of W5 was hard for some of us last year, a condition which is to be remedied, according to W5LIU, who reports that W5s JDL, EYZ, CVW, GVZ, and LIU will be helping W5FRD to keep things going around Fort Worth. These fellows have only W5AJG in Dallas to work, and would like skeds with others within a 200-mile radius. How about it, W5AOK, W5LOW, and others?

There are many who still feel that paths of 100 miles or so cannot be negotiated on a regular schedule unless the path in question is over fairly open country. True, signals are much lower during the winter months, but a 100-mile hop over rough country can be made, even under the difficult conditions imposed by a New England winter. Proof of this is being furnished by W2GYV, Schenectady, N. Y., who has been working W2AMJ, Bergenfield, N. J., 140 miles, and W1LLL and your conductor, 100 miles, regularly. Signals are plenty weak at times and c.w. is often necessary, but he makes it right along. Examination of the contour maps for the intervening country will show that this is something for the book. Jeff has copied W1AW on 52 Mc. almost nightly for months. A 4-element array and 450 watts started things rolling for W2GYV. Watch for him on 51.45 when things are good.

Another long haul that is being covered regularly is the Richmond-Washington, D. C. path. W4CYW and W4FJ in Richmond almost nightly, and they hear W2BYM, Lakehurst, N. J. occasionally.

Final Results, 1946 Marathon

The scores listed in the Marathon box in this issue are the final results for the 1946 Contest, which ran from May through December of last

(Continued on page 188)



BARGAIN SPECIAL

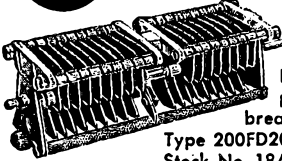

JOHNSON VARIABLE
Dual section, 200 mmfd per section, 2000 volt breakdown. Spacing .045".
Type 200FD20. List \$10.
Stock No. 18A510. Each **\$2.95**

Johnson variable, dual section, 304 mmfd per section. Spacing .045". Type 300ED20.
List \$9.95. Stock No. 18A509. Each **\$3.45**

OIL FILLED HIGH VOLTAGE CONDENSERS

10 mfd 1000 volts C.D. Dykanol
TJU List \$12.00. Stock No. 17A268.
Each **\$2.95**

5 mfd 600 volts Sprague CR list
\$7.00. Stock No. 18A366. Each **95c**

KEN-RAD 829B. Brand new in original packing. Signal corps inspected.
Reg. \$14.75. No. 20A660. Ea. **\$4.95**

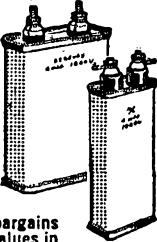

HAM VALUES AT BA
Order now from this ad while these hot bargains are available. Many more outstanding values in big BA catalog. Write if you do not receive it.

BURSTEIN-APPLEBEE CO.
1012 McGEE, KANSAS CITY 6, MO.



Nobody, But NOBODY can beat BUCK'S BUYS FOR HAM GUYS



READY FOR OPERATION!



GET ON THE AIR NOW With This SUPREME 100 WATT TRANSMITTER

Designed and built by the same company that makes commercial broadcast equipment, so you know it can't be beat. It's continuously tunable throughout the range of each of the ham bands. Simple band changing. Complete, compact, and moderately priced. 29% "x 11%" x 18%. Immediate delivery.

\$45000

Complete.....

- 100W output on 6 bands: 10, 15, 20, 40, 80.
- Modulation either AM or FM.
- FM deviation adjusted from zero ± 75 kc.
- Stabilized VFO or xtal controlled position.
- Provides for break-in operation.
- Completely AC operated from 115V source.

Send for complete descriptive literature.

NARROW BAND FM FROM 6 TO 80 METERS!



SONAR EXCITER VFX-680

Variable frequency xtal controlled (or ECO) voltage regulated oscillator on 160 meters. Osc. range: 1565 to 2000 kc, of which multiples fall into all bands. With 160 meter xtal, frequency variation is 15 kc; 30 kc on 80; 60 kc on 40; 120 kc on 20; 240 kc on 10; 480 kc on 6 meters. 4W to 6W output; 6, 10, 11, 20, 40, & 80 meters. CW and NBFM monitors. Tuning deviation indicator. 5 1/4" x 19", rack or table mtg. "Buck" really recommends it for all hams. Complete

\$8745

BUCK'S FEATURE LINE OF THE MONTH

Kenyon Transformer Co.
**HERE'S ANOTHER GREAT BUCK STRETCHIN'
COLLECTION OF TRANSFORMER VALUES!**

PLATE TRANSFORMERS



Type	Sec. Voltage	DC Volts	DCMA	Weight lbs., ozs.	Cost
T-668	1000/750-0-750/1000 1460/1180-0 1180/1460	500/750	300	12, 6	9.12
T-669	2360/2080/1760-0-1760/2080/2360	1000/1250 1500/1750/2000	300	19, 2	14.67
T-670	1460/1180-0-1180/1460	1000/1250	500	31, 9	20.19
T-671	1460/1180-0-1180/1460	1000/1250	500	31, 9	20.19

FILTER CHOKES

Type	Induc. Henries	Max. MA	DC Resis.	Insul.	Weight lbs., ozs.	Cost
T-154	15	165	210	1000V	3, 2	3.57
T-151	10	250	100	1000V	5, 10	5.58
T-152	10	200	100	1000V	2, 13	3.99
T-166	11	300	125	1500V	10, 1	7.77
T-159	12	500	77	1500V	15, 9	9.57
T-168	13	250	125	3000V	10, 10	7.77
T-160	11	300	120	3000V	10, 1	8.55
T-167	11	400	80	3000V	15, 9	10.17
T-176	10	300	110	5000V	10, 11	7.77
T-178	10	400	90	5000V	15, 2	10.77
T-177	12	500	95	5000V	21, 1	16.56
T-161	10	600	50	5000V	21, 4	16.56

PRICE COAXIAL ANTENNA TRANSFER RELAY



"Buck" Stretch-er brings you something new in relays. It's a low-loss method of electrically switching a low impedance coaxial line from xmtr to rcvr and vice-versa.

Handles up to 750W RF. Coil operating voltage 115V AC. Internal relay contacts SPDT.

Your cost **\$750**
With auxiliary contacts: one normally open, one normally closed.

\$850

FREE

PLEASE PRINT PLAINLY

SUN RADIO & ELECTRONICS CO., Inc.
122-124 DUANE STREET
NEW YORK 7, N. Y.

Dear Buck:

Please send me your flyer as soon as it is printed.

Name

Call

Address

City

Zone State

SUN RADIO

& ELECTRONICS CO., Inc.

ESTABLISHED 1922

122-124 DUANE ST. · NEW YORK 7, N. Y. · BARclay 7-1840

GORDON'S

NEW ROTO-BEAM ANTENNA ROTATOR



**Immediate
Delivery**

\$225.00 NET
Complete with
**SYNCHRO ANTEN-A-CATOR
STATION CONTROL**

Precision built to rigid specifications for year in and year out service in all climates. For dependable and accurate performance use the ROTO-BEAM ROTATOR to direct your R.F. energy where you want it, when you want it. 110 volt 60 cycle operation. Weight approx. 60 lb. For complete details write for descriptive folder.

SREPCO

STANDARD RADIO & ELECTRONIC PRODUCTS CO.
135 East Second Street, Dayton 7, Ohio

V.H.F. Marathon

Call	Contacts Through December 50 Mc. 144 Mc. 235 Mc. Score 50 Mc. 144 Mc.	States Worked
W1BCT	40 266 2 1197	6
W1CGY		374 15
W1EHL	82	278
W1HDQ ¹	122 130	2277 25
W1KLR*	127	775 7
W1LLI*	113	1316 27
W1LMU	176	738 25
W1PFJ*	137	1383 4
W2AMJ*	104	1109 24
W2AUF	202	708
W2BQK	66	632 18
W2BYM	123	1182 25
W2COT	37 77	365 7
W2DZA	235	1044 2
W2QVE*	23 327	1615 8
W2RPO*	6 71	591 3 3
W3GKP	128	952 6
W3HWN ²	211	2192 9
W3KIE	145	931 6
W3RUE*	36 32	668 16 1
W4CDG/3*	9 175	1255 6 7
W6BWG	76	276 2
W6HZ*	150 194	1099 5 1
W6JJ*	303	1506 1
W6VK*	12 119	828 6 1
W6QG*	61	641 9
W6TGY	54	159 1
W6WNN	38	249 3
W7KAD	65	1322 19
W7QAP	37	643 11
W9AB	16	111 6
W9ALU	17	155 7
W9PK*	83	1057 21
W0YUQ	78 1	1274 22 1
W0ZJB	113	1625 27 1

Incomplete reports were received from: W1AEP*, W1BDI/1, W1DXL, W1JNX, W1MBS, W2JWO*, W2LXO, W2OQI, W2PWP, W3BKB, W3BTP, W3CGV, W3GEJ, W3LN, W4HVV*, W5VV, W6SLO/5, W6ANN, W6IBS, W8NKJ, W8WKE, W9ACU, W9ALU, W9NCS, W9UNS, W9ZHB, W9PKD.

*Certificate award — highest in his ARRL Section.
¹Ineligible for award.
²December winner: W3HWN with 152 points.

LOOK

AT THESE TUBE PRICES!

805.....	\$3.75	866A/866....	\$.90
807.....	1.05	HK-24G.....	1.20
809.....	1.50	HK-54.....	1.90
810.....	2.65	100TH.....	4.15
811.....	1.90	250TH.....	9.00
812.....	1.90	VT-127A.....	3.45
813.....	6.75	954.....	.90
816.....	.60	900290
1N28 Germanium Crystal.....			.20
1N34 Germanium Crystal.....			.20

All brand-new **JAN** inspected

Write for latest bulletin. We distribute leading brands of Ham and Equipment.

Steinberg's

633 WALNUT STREET • CINCINNATI 2, OHIO

year, the delayed release date of the 50-Mc. band preventing the usual year-long contest. For the first time in the history of the Marathon, the national high score was made on 144 Mc., W3HWN, Mechanicsburg, Pa., piling up the impressive total of 2192 points, winning the Section award for Eastern Pennsylvania and the medallion award for the high scorer on his band for the entire country. Never, in the years since the Marathon became a v.h.f. institution, has an award been more richly deserved. With all that is representative of the best in v.h.f. techniques, a 16-element electrically-driven rotary beam, a crystal-controlled 250-watt transmitter, a beautifully-performing superhet receiver, and a consistent record of alert activity on the band, Paul H. Hertzler, W3HWN, certainly rates his position at the top of the list! For those who think of 144 Mc. as backyard stuff, let it be noted that Paul worked six different stations more than 250 miles distant and no less than 19 beyond the 200-mile mark.

Top man in the 50-Mc. competition was Vinceo

(Continued on page 128)

Save On Brand New RADIO TUBES!

ALL STANDARD
BRAND TUBES
IN CARTONS...

UP TO
80%
OFF!

Number	Price	Number	Price	Number	Price
0Z4	1.45	6F7	1.50	12S17GT	1.10
1A7	1.80	6F8	1.10	12SK7GT	1.10
1B4	.80	6G6	1.00	12SL7GT	1.20
1B7	.80	6H6	.75	12SN7GT	.95
1C5GT	1.00	6J5	.80	12SQ7GT	1.10
1D5	.80	6L7	1.15	12SR7	1.00
1D8GT	1.10	6L8	1.30	14A7	1.50
1E4	.80	6K6	.85	14B6	1.40
1E5	.90	6K7	.85	14B8	1.60
1E7	1.00	6K8	1.30	14CS	1.60
1F4	.80	6L5	1.10	14C7	1.60
1F5	.80	6L6G	1.50	14D7	1.60
1F7	.90	6L7	1.40	14H7	1.60
1G4	1.30	6N7	1.40	14J7	1.60
1G6	1.20	6P5	.80	14N7	1.60
1H4	.70	6P7	1.40	14Q7	1.20
1H5	1.50	6Q7	1.30	14R7	1.60
1I5	.75	6R7	1.40	14W7	1.85
1I6	.80	6S7	1.20	14V4	1.60
1LA4	1.95	6SA7	1.00	18	1.25
1LB4	1.95	6SF5	.70	19	1.00
1LC6	2.70	6S17GT	.70	20	1.75
1LD5	1.25	6SK7GT	1.00	22	1.00
1LH1	1.95	6SL7GT	1.00	24A	.90
1LN5	1.95	6SN7GT	.85	25L6GT	1.10
1N5	1.30	6SQ7GT	1.00	26	.75
1R5	1.25	6T7	1.00	27	.70
1S4	1.25	6G5	.95	30	1.00
1S5	1.25	6U6GT	1.50	31	1.00
1T4	1.25	6U7	1.00	32L7GT	1.95
1T5	1.50	6V6	1.10	33	1.00
1V	1.00	6V7	1.00	34	.80
2A6	.75	6W7	1.20	35W4	1.08
2B7	.75	6X5GT	1.00	35Z3	1.30
2B5	.65	6Y6G	1.00	36	1.00
2X2/879	.90	7A4	1.00	37	.75
2Z2/G84	.45	7A5	1.00	38	.85
3A8	1.95	7A6	1.00	39/44	.80
3G5	1.95	7A7	1.00	41	.85
3L3	1.25	7B5	1.00	42	.85
3U4	.80	7B5	1.00	45	.80
5V4	1.60	7B6	1.00	46	1.00
5X4	1.10	7B8	1.30	49	.95
5Y3GT	.70	7C5	1.00	50	1.75
5Y4	.75	7C6	1.30	50L6	1.24
5Z3	.95	7C7	1.00	55	.50
6A5	1.70	7E6	1.00	56	.80
6A6	.80	7E7	1.30	57	.75
6A8	1.00	7E7	1.30	59	.80
6A5G	1.70	7H7	1.50	76	.75
6AC5GT	1.00	7J7	1.50	77	.75
6AF5	1.00	7L7	1.50	78	.75
6AF6	1.60	7N7	1.50	79	.85
6B4	1.50	7Q7	1.00	80	.60
6B7	.95	7R7	1.30	81	1.50
6B8	1.00	7S7	1.50	82	.85
6C5	.95	7V7	1.80	83V	1.30
6C6	1.00	7Y4	1.30	84/624	1.10
6C7	.45	7Z4	1.30	89	.40
6C8	1.25	12BE6	1.44	99	1.50
6D6	.75	12F5GT	1.00	117L7GT	2.35
6D7	1.00	12J5GT	1.00	117Z6GT	1.60
6F5	1.00	12SA7GT	1.30	XXB	1.50
6F6	.95	12SF5GT	1.00	XXFM	1.50
				XXL	1.50

* 10% discount on orders for 100 tubes or more

CHECK THESE SUN RADIO SAVINGS

WAR SURPLUS EQUIPMENT

AT A
FRACTION
OF
ORIGINAL
GOV'T.
COST

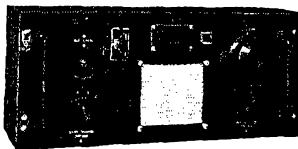

R. F. TUNING UNIT

Comes in a beautiful black crackled aluminum cabinet with two Variable Transmitting Condensers and two Vernier dials, one heavy duty ceramic four position wafer switch, two or more mica condensers 2,500 Working Volts and coils wound on porcelain ribbed forms.

\$3.89

Yours for only.....

No. TU5B	1500 to 3000 KC
No. TU6B	3000 to 4500 KC
No. TU7B	4500 to 6200 KC
No. TU8B	6200 to 7700 KC
No. TU10B	10,000 to 12,500 KC

Please specify model

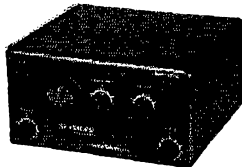

HALLICRAFTER SP4 PANORAMIC ADAPTER

For immediate delivery. Easily installed in any set. Shipping charges prepaid in full to your home.....

\$99.50

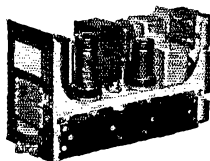

SPERRY AMPLIFIER

Contains four tubes, 2 mica condensers, dozens of 1/2W resistors, 3 bathub condensers, 2 dual, and 1-4 section, 3 sealed transformers, 2 wafer switches, 1 volume control, 4 octal sockets, new, with tubes.....

\$3.95



SCR 536 B2 HANDIE TALKIE CHASSIS

Comes completely wired with 1-1R5, 1-1T4, 1-1S5, 2-3S4 Tubes and two 455 KC iron core I.F. transformers less antenna output coil and crystals.

\$9.95

RHOMBIC

Receiving Antennae

Complete with all accessories including 2200 feet of No. 14 copper weld wire, 50 feet of heavy twin X lead 72 ohm good up to 2 KW, dozens of insulators, pulleys, neon lightning arrestors, ground rod, less poles, only....

\$24.95

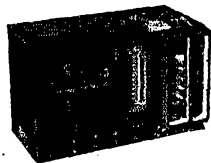

F. M. TRANSMITTER

BC-684. The BC-684 Transmitter provides 35-watt output, 10 channel push button, crystal control, employing NONLENIER MODULATING COIL, complete with 8 tubes. Frequency 27 to 38.9 mc. Complete with tubes less power supplies and crystals. Excellent 10 meter band for "Ham" and police. Your Cost.....

\$24.95



J. B. T. VIBRATING REED FREQUENCY METER

Range 56 to 64 C.P.S. with eleven reeds. Regular net price \$24.75. Your Cost Only:

\$9.95

SUN RADIO

OF WASHINGTON, D. C.

938 F STREET, N. W. WASH. 4, D. C.

● All items F.O.B., Washington, D. C. All orders \$30.00 or less cash with order. Above \$30.00, 25 percent with order, balance C.O.D. Foreign orders cash with all orders plus exchange rate.

Your best move
IS BIRNBACH'S

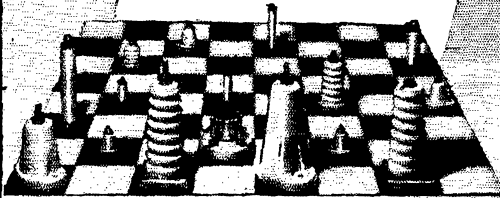

CERAMIC—
PORCELAIN & STEATITE
INSULATORS

for every
purpose

Since 1923



BIRNBACH RADIO CO., Inc.

145 HUDSON ST. NEW YORK 13, N. Y.

Ham Post!

HAMS — 10 meter mobile 30 watt F.M.
Xmitters in stock. Also new Sonar VFO-VFX
\$87.50 net. Place your orders now.

Distributors of National, Hammarlund,
Hallicrafter, Millen and Gen-Set.



CONTINENTAL
SALES COMPANY

195-197 CENTRAL AVENUE, NEWARK 4, N. J.

Mass. Radio School

271 Huntington Ave., Boston 15, Mass.

For over 27 years the educational radio center of New England. Prepares for all U. S. Government Radio Operators' Licenses. Also gives Radio Technician Training. Approved courses for Veteran Training under G.I. Bill.

Licensed by Commonwealth of Mass.
Department of Education

Dawson, W0ZJB, Cashland, Missouri. Vince could work in all directions from his "Heart-of-America" location, but the most distant stations were still inside the 10-point limit. No 1500-mile 50-point contacts for W0ZJB, but by riding the band for all it was worth he managed QSOs with 113 different 50-Mc. stations, for a total score of 1625, second only to W3HWN. Vince also was tied for the lead in number of states worked on 50 Mc. His only competition was from WILLL, who ran up the impressive total of 27 different states on 50 Mc. in the nine months competition. Not bad for a fellow in an ordinary city location on the East Coast.

Leader on 235 Mc. was Alex Knights, W2DZA, of Teaneck, N. J., who worked 9 stations for a total of 90 points. The states-worked award for 235 Mc. was declared "no competition" since only one state was worked by any contestant reporting operation on that band.

The states-worked award for 144 Mc. was won by Edward F. Schwinge, W2JWO, who corralled 10 different states on the 2-meter band during the year. Ed also employed crystal control, a superhet receiver, and a beam antenna, to work every state on the Atlantic Seaboard from New Hampshire to Virginia. He beat out W3HWN by the scant margin of his New Hampshire contact.

High scorers for each month, each awarded a certificate, were as follows: May — W6NJJ, 314 points; June — W0ZJB, 706 points; July — W7KAD (then W5JGV/7), 822 points; August — W2JWO, 298 points; September — W3HWN, 600 points; October — W0YUQ, 295 points; November — W3KIE, 532 points; December — W3HWN, 152 points.

Winners of the certificate awards for the highest score in each ARRL section are indicated with an asterisk in the Marathon score summary.

2-Meter News

A reader (one of our leading 144-Mc. workers) writes that he looks in vain to this department for information he thinks many 2-meter men would like to have. He says that DX work via inversions and other abnormal conditions is very interesting, but what does John Ham do when the band is *not* open? What is his normal working range? How many nights a week can he work an associate 60 miles away? What does he do to start working 100 miles consistently instead of 50? How does he organize his DX efforts to keep his reliable range moving farther out? What results, in working-range extension, does he get when he raises his power from 60 watts to 600? Good questions, all — but you know where the answers must come from. What appears in this department is what you, the serious 144-Mc. workers of the country send in, and if what you see here is not what you want, be sure to tell us, just as did Sam Harris, W8UKS, in the questions raised above. Here are some of his answers:

(Continued on page 130)

AND SO ONE HAM TELLS ANOTHER . . .

"Top Trade-Ins at Walter Ashe"

EARLIEST DELIVERY! ORDER NOW!

NATIONAL HRO	\$274.35
NATIONAL NC 240D	225.00
NATIONAL NC 46	97.50
RME-45	198.70
RME-84	98.70
HAMMARLUND HQ-129X	172.25
HAMMARLUND SPC 400X	342.00
COLLINS 75A-1	375.00
HALLICRAFTERS SX-42	275.00
HALLICRAFTERS S-40	89.50
HALLICRAFTERS S-38	47.50

Prices subject to possible change

Top trade-in allowances? Right, OM! In the well-over-20-years of our business history, allowances have never been so big, nor the eager takers so many! No wonder the hams are talking about it!

MODEL 905
TRANS-METER

\$49.50 With Batteries

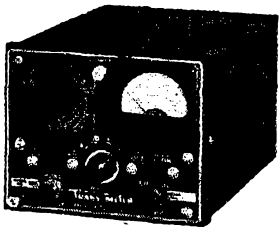

Functions as: 1. Field Strength Meter. 2. Wave Meter. 3. % Modulation Meter-Transmitter. 4 and 5. "S" Meter and % Modulation received signal—in connection with receiver. 6. AC VTVM. 7. DC VTVM. 8. Phone Monitor. 9. Neutralizing Indicator.

GON-SET CONVERTER

20, 10-11 METERS \$39.95

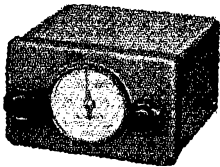

For fixed and mobile use. Built-in pre-selection. Well-constructed, complete with connecting cables.

Special Noise Silencer \$8.25

TRANSFORMER AND CHOKE SPECIALS

Thordarson Heavy Duty Broadcast Type Plate Transformer, 115 or 230 V pri. 1510-0-1510 V @ .5 A sec. tapped at

1330 and 1230 V, easily worth 3 times our low price of..... **\$39.50**

Thordarson Heavy Duty Swinging Choke, 500 mill, 5-16 Hy 7500 V RMS, rated at 500 mills continuous. Intermittent (Ham) use should be much higher. Ideal companion to 2 KVA Amertran, listed at bottom..... **\$11.85**

Surplus Filament Transformer—110 V AC pri., sec. 6.3 V @ 3.6 A, 6.3 V @ .6 A..... **\$1.18**

Surplus Filament Transformer—110 V AC pri., sec. 6.3 V @ 3 A..... **\$1.08**

Thordarson Smoothing Choke, 200 Mills, 12 Hy..... **\$3.50**

Midget Transceiver Transformer, Mike to Grid, Plate to Voice Coil..... **74¢**

Sonar FM Exciter, model XE-10, price less crystal..... **\$39.45**

Astatic R-3 Microphone—economy type for Pa and home recording. Our special bargain price..... **\$4.95**

Type FT Crystal Holder with new 1/2" pin spacing. **25¢**

POWERHOUSE VALUE!

807's

\$1.05



Army-navy surplus! Brand new 807's at this smash price!

Talkie Crystal Kits to grind your own 40 meter crystals..... **98¢**

Ham Type Surplus Condensers, 110 mmfd. max., 15 mmfd. min., 2500 V peak, reg. \$3.69..... **\$1.95**

REVERSIBLE MOTOR

1/2 to 2 RPM, with conversion instructions for rotary beam drive. Has 50 in. lbs. torque..... **\$4.95**

AMERTRAN PLATE TRANSFORMER \$39.95

Rated at 2 KVA, Pri. 105-110-115, 60 cycle, Sec. 3100-0-3100, full voltage across sec. 6200 V @ 700 Ma. Free delivery anywhere in Continental U. S. A.

WRITE FOR BIG FREE CATALOG

RADIO CO.

WØIYD WØLDO
WØPGI WØGTF
WØZIP WØULH

1125 PINE ST. ST. LOUIS, MO.

IN STOCK
For Immediate Delivery!

THE ULTRAPHONE
144-148 MC Xmitter-Receiver

Designed for portable, mobile or fixed station use

Look at These Features:

- Newly designed 6AK5 detector circuit.
- Expanded band spread and increased sensitivity.
- Transmitter will handle 30 watts of input.
- Operating capabilities up to 250 mc.
- Transmitter uses the Taylor TUF-20.

Comes complete with matched set of tubes, but less power supply. Will operate from 6 volt vibrator pack or AC power supply.

\$75 NET

F.O.B. OAKLAND, CALIFORNIA

W. D. BRILL CO.
198 TENTH ST - OAKLAND 7, CALIFORNIA
W6KLO W6SSN W6FJX

COMMERCIAL RADIO INSTITUTE

A RADIO TRAINING CENTER FOR 26 YEARS

Resident Courses Only • Broadcast, Service, Aeronautical, Television, U.H.F., Preparatory Course, Frequency Modulation and Marine telegraphy classes now forming for July 1. Entrance Exam. June 16.

Literature upon request. Veteran training

Dept. B, 38 West Biddle Street, Baltimore 1, Maryland

Sending Made Easier!

Genuine Easy-Working

SEMI-AUTOMATIC
RADIO KEY

VIBROPLEX

Reg. Trade Marks: Vibroplex, Lightning Bug, Bug

"Original" DeLuxe Model

WITH
PATENTED
JEWEL
MOVEMENT

\$19.50

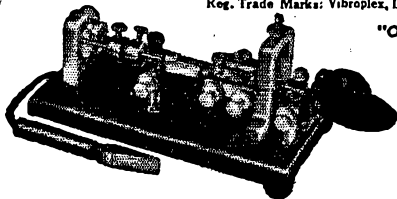

The "BUG" Trade Mark identifies the Genuine Vibroplex. Accept No Substitute

PATENTED JEWEL MOVEMENT is an exclusive DeLuxe Vibroplex feature — a feature that has so completely eliminated tiring sending effort that sending is no longer a task but astonishingly easy. No special skill required. Polished chromium base and parts. DIE CUT contacts and main spring. Colorful red switch knob, finger and thumb piece. 3/16th contacts. Circuit closer, cord and wedge. DeLuxe finish also available in "BLUE RACER" and "LIGHTNING BUG" models. Get a DeLuxe JEWELLED movement Vibroplex NOW! Money order or registered mail. FREE catalog.

THE VIBROPLEX CO., Inc.

833 Broadway

New York 3, N. Y.

(Continued from page 128)

The rig at W8UKS runs 600 watts to a pair of VT-127-As, crystal-controlled. Two corner-reflector arrays are used, one backing up an extended double-Zepp with directors, and the other employing two half-waves in phase for the radiating portion. A four-bay turnstile is used for general coverage. The receiver is a converted SCR-624, with a two-stage grounded-grid pre-selector. The front end feeds into sharp or broad i.f. amplifiers.

The best DX yet worked was W2RPO, Buffalo, nearly 200 miles, when conditions were favorable. Consistent work is done with W3QKI, Erie, Pa., 100 miles distant. W8LIO, Andover, Ohio, is worked at 75 miles, though W8LIO has only 6 watts. He has a square-corner array 70 feet up. W8UB, Port Clinton, 65 miles away, is another regular contact, with power running at 10 watts and his antenna a 3-element array up about 40 feet.

Sam finds that running 600 watts has its good points when the going is rough, but ordinarily 50 watts seems all that is worth while. He raised his antennas until he could see no improvement in signals from beyond the horizon, and his three arrays are at 65, 75, and 90 feet respectively. He has worked extensively with both vertical and horizontal arrays, but has standardized on horizontal because of the improved signal-to-noise ratio. With vertical systems, the signal from W3QKI would be buried in noise most evenings, whereas with horizontal it is consistently readable. He believes that work with the Pittsburgh area will be feasible just as soon as someone gets on there with crystal control and horizontal polarization. Surely this is good dope — how about more of the same from the rest of the 2-meter gang?

We have similar information from W3QKI, who passes along all the dope on the gang around Erie. This group includes: W3GV, who has a 250-watt crystal rig in the works; W3KKJ, who is listening with a converter feeding a communications receiver, and will be on with a 522 transmitter soon; W3LTN, with a 522 transmitter and receiver, and 4 half-waves in phase with reflectors, which can be used either vertical or horizontal; W3NBV, with 50 watts to an 815 (described in QST some time back), and a super-array (24 elements, horizontal) soon to go up; W3WBM, with 50 watts to an 815, a home-built superhet receiver, and a 4-element vertical array; and W3QKI, with 50 watts to an 829B. The array at W3QKI satisfies the addicts in both polarization camps. It has four driven elements, one set vertical and the other horizontal, on either side of a flat screen reflector. Gain of this array is estimated at about 12 db. over a dipole. Consistent work is done with W8UKS and W8WJC, both an even 100 miles distant. There are plenty of stations, but the trouble is (and this is a universal complaint among the serious workers in every area) that "there are too many

(Continued on page 128)

LET THESE WAA DISTRIBUTORS HELP YOU

Save with surplus

The War Assets Administration has appointed a representative group of competent well established distributors to help dispose of war-surplus electronic tubes and equipment. We suggest that you get in touch with the distributor nearest you. He will know the items available and how they can aid in solving your electronic problems.

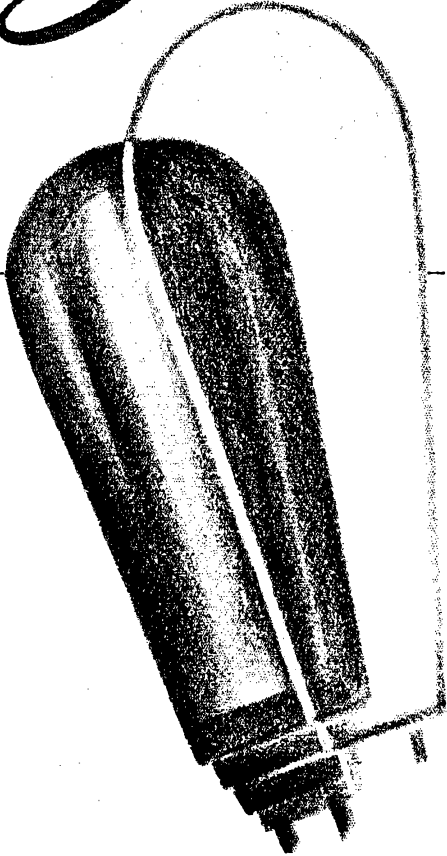

**Here is an up-to-date list of
WAA approved distributors.**

BOSTON, MASS. Automatic Radio Mfg. Co., Inc. Technical Apparatus Co.	122 Brookline Ave. 165 Washington St.
BUCHANAN, MICH. Electro-Voice, Inc.	Carroll & Cecil Sis.
CANTON, MASS. Tobe Deutschmann Corp.	863 Washington St.
CHICAGO, ILL. American Condenser Co. Majestic Radio & Television Corp.	4410 Ravenswood Ave. 125 W. Ohio St.
EMPORIUM, PENN. Sylvania Electric Products, Inc.	
FORT WAYNE, IND. Essex Wire Corp.	1601 Wall St.
LOS ANGELES, CALIF. Cole Instrument Co. Hoffman Radio Corp.	1320 S. Grand Ave. 3761 S. Hill St.
NEWARK, N. J. Standard Arcturus Corp. Tung-Sol Lamp Works, Inc.	99 Sussex Ave. 95—8th Ave.
NEW YORK, N. Y. Communication Measurements Laboratory Electronic Corp. of America Emerson Radio & Phonograph Corp. Hammarlund Mfg. Co., Inc. Newark Electric Co., Inc. Raytheon Mfg. Co. Smith-Meeker Engineering Co.	120 Greenwich St. 353 W. 48th St. 76—9th Ave. 460 W. 34th St. 242 W. 55th St. 60 E. 42nd St. 125 Barclay St.
SALEM, MASS. Hytron Radio & Electronics Corp.	76 LaFayette St.
SCHENECTADY, N. Y. General Electric Co.	Bldg. 267, 1 River Rd.
WASECA, MINN. E. F. Johnson Co.	206—2nd Ave., S. W.

ELECTRONICS DIVISION
OFFICE OF AIRCRAFT DISPOSAL

WAR ASSETS ADMINISTRATION

425 Second St., N.W.



Washington 25, D. C.

Here Today ... And Here TOMORROW!

Are you an Electronic Equipment Manufacturer looking for a highly satisfactory —and, above all else, stable source of transformers?

Kenyon, for over 20 years, has served and pleased people just like you. And will continue to serve and please indefinitely. So if you are having "here today and gone tomorrow" trouble on transformer supply—come to Kenyon!

THE MARK OF  EXCELLENCE

KENYON

TRANSFORMER CO., Inc.

840 BARRY ST., NEW YORK, N. Y.

W8CFK

Aluminum Call Plates

Your call cast in aluminum with black background panel mounting. L for car license and D for desk use. \$1.75 each, postpaid.

and polished 1 1/4" letters. Plate size 2" by 6 1/4". 3 styles: P for panel mounting, L for car license and D for desk use. \$1.75 each, postpaid.

P & H SALES CO.

619 Jasper St.

Kalamazoo 31, Michigan



Founded in 1909

RADIO TELEPHONY RADIO TELEGRAPHY

Courses ranging in length from 7 to 12 months. Dormitory accommodations on campus. Advanced students eligible for practical training at KPAC, 1 KW broadcast station owned and operated by Port Arthur College. New students accepted monthly. If interested in radio training necessary to pass F.C.C. examinations for first-class telephone and second-class telegraph licenses, write for details.

PORT ARTHUR COLLEGE PORT ARTHUR
TEXAS

Approved for G.I. training

unstable oscillators and blooper receivers, fed by dipoles hanging on the wall. If these fellows would spend half the time and money on 2 that they do on 75, if they would replace their antiquated gear with a crystal rig and a superhet and put up a good antenna system, they'd be amazed to find that 2 is like 75, but without the continual QRM!"

Herb feels that there is at least some possibility of work with East Coast stations under favorable conditions, if the more progressive stations can get lined up on some sort of schedule. He suggests that 75 might be used for liaison to get the thing rolling. Erie stations operate above 145 Mc., to keep the low end clear for the reception of crystal-controlled DX stations. Some frequencies: W3NBV — 145,030; W3KQI — 145,085; W3LTN — 145,100; W3WBM — 146,300.

The Boston area is going for stabilization in a big way. More and more crystal-controlled and MOPA signals are appearing, until now the use of a fairly-sharp receiver is practical. Occupancy of the band demands the employment of advanced techniques, if operation on 2 is to amount to anything more than a medium for exchange of backyard gossip. W1OJT takes issue with those who still believe that crystal control is difficult. He got on with three tubes, using the 6L6-807 exciter described in November, 1940, QST, driving an 829 tripler. An 8-Mc. crystal, and the necessary plug-in coil changes are all that are required. At 60 watts input the 829 tripler produces a very respectable signal on 144 Mc. W1IPE and W1LJT are also using similar arrangements with good results. Several of the gang in this area are getting improved receiver performance using coaxial tank circuits in r.f. stages and superregenerative detector circuits. W1CTW reports working 15 crystal-controlled and 9 MOPA stations during December.

Work over long paths in California has been principally a matter of mobile and portable work, but the boys are finding that good antennas and improved gear are making possible some mighty interesting DX from seemingly poor home locations. Work between W6OVK, Redwood City, and W6BVK and W6YLO at Sacramento continues with solid signals and practically no fading. W6OVK has also worked W6CZB at Grizzly Flats, east of Sacramento. The Sacramento stations are hearing W6JPU at Fresno, a hop of 160 miles, and are being heard by W6UID at Porterville, a distance of more than 220 miles. Dr. Jeffers, W6SX, is at Mt. Hamilton, a 4000-foot elevation, and is working over a wide area.

420 Mc. and Higher

Belief that gear for 420 Mc. is either costly or difficult to build is refuted by W6ULE, Glendale, Cal. He and W6UXC are having a lot of fun with a couple of transceivers using 955 acorn tubes. The tuned circuit is a 1/2-inch coil tuned with a round tuning vane of aluminum. Chokes are 25

(Continued on page 136)

The 1947 HANDBOOK

THE LATEST EDITION of THE RADIO AMATEUR'S HANDBOOK is postwar in content, containing the kind of information which has made the HANDBOOK world-famous. To maintain the high standard of practical usefulness set by previous editions, a new treatment of the constructional sections of the HANDBOOK has been accomplished. The theory and design sections cover every subject encountered in practical radio communication. Completely sectionalized by topics with abundant cross-referencing, and fully indexed. The HANDBOOK continues to be the world's most valuable and widely-used radio book.

POSTPAID IN
U. S. A. PROPER

\$1²⁵

\$2.00 ELSEWHERE
BUCKRAM BOUND
\$2.50 in U. S. A.
\$3.00 Elsewhere

AMERICAN RADIO RELAY LEAGUE

» » » » » » »

**WEST HARTFORD 7
CONNECTICUT**

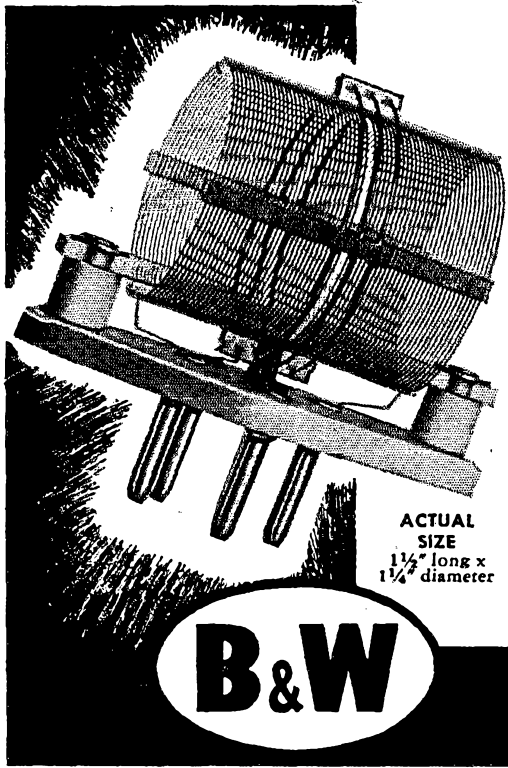

B & W "BABIES" are back!

A ham friend took us to task recently. "Sure we're interested in your Co-Ax Cable Connector and all the other new B & W developments — but what about those 25-watt B & W Baby Air Inductors? Do you still make them?"

Sure we do! But only lately has production reached a point where "Babies" were again generally available through B & W distributors. Look 'em over — or write for our Baby Air Inductor Data Sheet X100.

These husky little coils are the finest, best-looking 25-watters ever made. 7 types cover from 10 to 160 meters. 5-prong bases permit easy band changing. Windings are perfectly spaced and B & W Air-Wound design puts an absolute minimum of insulating material in the coil field.



BARKER & WILLIAMSON
237 Fairfield Ave., Upper Darby, Pa.

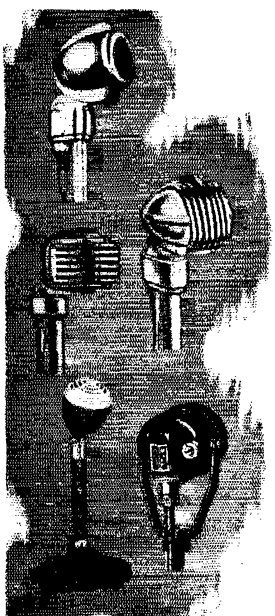

A WORLD WIDE FAVORITE FOR QUALITY REPORTS

The Turner VT-73 Crystal Desk Microphone

Praised by thousands of amateurs for its crisp, clear results, the Turner VT-73 is an efficient precision unit. Engineered especially for quality speech recording, public address, and amateur work. *Rising curvature of response between 300-4000 c.p.s.* increases intelligibility at effective voice frequencies without over-modulation. Crystal circuit utilizes corrosive resistant diaphragm and high quality moisture sealed crystal. Output: 52db below 1 volt/dyne/sq. cm. Response: 50-7000 c.p.s. Attractively finished in black crinkle and chrome. Complete with ball swivel head, stand, and 7 ft. cable. *Ask your dealer or write:*

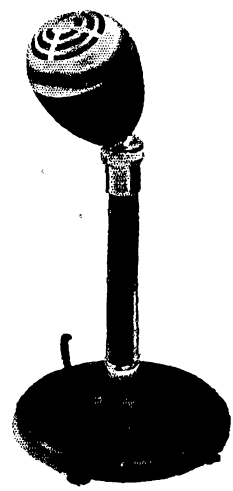

THE TURNER COMPANY

917 17th STREET, N. E. • • • CEDAR RAPIDS, IOWA



Microphones BY TURNER

Microphones licensed under U. S. patents of the American Telephone and Telegraph Company, and Western Electric Company, Incorporated. Crystals licensed under patents of the Brush Development Company.

HARRISON HAS IT!

HARRISON HAS IT!

ALL STANDARD LINES . . .

We are Factory Authorized Distributors for the top quality manufacturers and we now have in stock lots more new, latest improved production Ham gear! Visit our stores today, for everything you need. We promise you fresh, clean material—quicker—at the lowest current prices—and, above all, our sincere desire to be of friendly, helpful service.

As one of the world's largest distributors of Communications Equipment, we are delivering plenty—right now! ALL MAKES—practically all models. If you want yours in the quickest possible time send your order to HARRISON!

Send in your parts orders, too—if it's new, if it's good, if it's made by a leading manufacturer—

Harrison Has It!

RECEIVERS

COLLINS 75A-1	\$375.00	SPC-400X , new "Super-Pro" .55 to 30 mc, with pack, and speaker in cabinet . . .	\$347.25
HALLICRAFTERS			
SX-42 new FM-AM, 54-110 mc, less speaker	\$275.00	NATIONAL	
S-36A , FM-AM-CW 27.8- 143 mc.	307.50	NC-240-D with speaker . . .	\$241.44
S-37 , FM-AM 130-210 mc. . .	591.75	NC-46 , with speaker	97.50
S-40	89.50	HRO-5TA1 , with pack and speaker	306.71
S-38	47.50	1-10A , with tubes	67.50
HAMMARLUND			
HQ-129X , with speaker in cabinet	\$173.25	RME-4 , with speaker	198.70
		RME-84 , with speaker	98.70

TRANSMITTERS

COLLINS		500GA	\$1800.00
32V-1	\$475.00	ABBOTT TR-4B , new 2-meter transmitter-receiver, with tubes	
30K-1 , complete with 310A-1 exciter	1250.00		59.80
MECK 60T	150.00	Hallcrafters Panoramic Adaptor	
TEMCO			99.50
75GA	\$495.99		

[Other models and makes will be carried in stock as they become available.]

Complete stock—quicker deliveries—lowest prices—top trade-in allowances—easy 6% Budget Plan, if desired—and my personal attention to your wishes, all insure your complete and lasting satisfaction with every transaction. I guarantee you'll like doing business with me!

Send me your order, today. A small deposit (you name it) will bring you your new equipment. Balance C.O.D., or tell me what Budget Plan terms you want.

Twenty-two years of experience serving Amateurs in all parts of the world is at your command.

Vy 73 de

Bil Harrison, W2AVA

HARRISON SELECT SURPLUS

Read our ads — past and future — for real values in selected surplus material. Reasonably priced — honestly described — guaranteed perfect! You don't "take a chance" when you buy Harrison Select Surplus!

HAM HEADQUARTERS

Since 1925!



HARRISON RADIO CORPORATION

12 WEST BROADWAY • NEW YORK CITY 7

PHONE—BArdoy 7-9854 • EXPORT DEPT.—CABEE—"HARRISONRAD"

[JAMAICA BRANCH—172-31 Hillside Ave.—REpublic 9-4102]



ESTABLISHED 1906

ANTENNA SYSTEMS for USERS of PRIVATE BRANDS

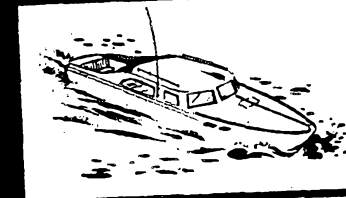
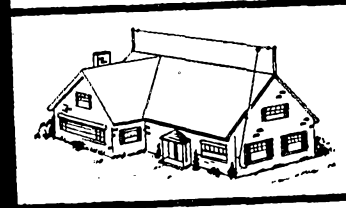
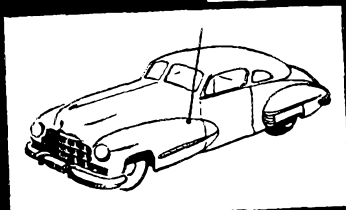

We manufacture the following, under private labels and trademarks:

AUTOMOBILE ANTENNAS . . . every variety, including types that can be raised and lowered from inside the car.

RESIDENTIAL ANTENNAS . . . AM and FM, for homes, stores and multi-family buildings. Complete lines of noise-reducing systems incorporating latest patented developments of coupling transformers.

FM, AM and TELEVISION . . . Dipoles with or without reflectors, folded dipoles, turnstile, radiating types and other combinations for roof, sidewall and other mountings.

MARINE ANTENNAS . . . Collapsible and transmitting types for every purpose.

For **POLICE and other mobile units** . . . roof-top antennas for ultra-high frequencies.

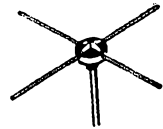
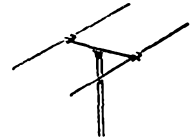
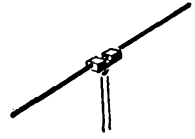

WE INVITE INQUIRIES AND CONSULTATIONS.

L. S. BRACH MFG. CORP.

200 CENTRAL AVENUE NEWARK, 4 N. J.



WORLD'S OLDEST AND LARGEST MANUFACTURERS OF RADIO ANTENNAS AND ACCESSORIES

EASY TO LEARN CODE

It is easy and pleasant to learn or increase speed the modern way — with an Instructograph Code Teacher. Excellent for the beginner or advanced student. A quick, practical and dependable method. Available tapes from beginner's alphabet to typical messages on all subjects. Speed range 3 to 40 WPM. Always ready, no QRM, beats having someone send to you.

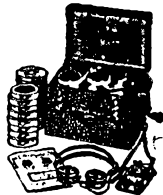

ENDORSED BY THOUSANDS!

The Instructograph Code Teacher literally takes the place of an operator-instructor and enables anyone to learn and master code without further assistance. Thousands of successful operators have "acquired the code" with the Instructograph System. Write today for full particulars and convenient rental plans.

INSTRUCTOGRAPH COMPANY

4709 SHERIDAN ROAD, CHICAGO 40, ILLINOIS

AMATEURS EXPERIMENTERS SUPPLIES & EQUIPMENT

Leading Brands

Headquarters for

HALLCRAFTERS NATIONAL HAMMARLUND

RADIO PARTS DISTRIBUTING CO.
128 W. Olney Road NORFOLK, VA.

The RADIO AMATEUR'S LIBRARY

THESE are the publications which every amateur needs. They form a complete reference library for the amateur radio field; are authoritative, accurate and up to date.

Title	Price
QST.....	\$2.50 per year*
Operating an Amateur Radio Station— Free to members; to others....	10c
The Radio Amateur's Handbook,	\$1.25**
The Log.....	35c each
How to Become a Radio Amateur..	25c
The Radio Amateur's License Manual.....	25c
Hints & Kinks for the Radio Amateur.....	50c
Lightning Calculators:	
a. Radio (Type A).....	\$1.00
b. Ohm's Law (Type B).....	\$1.00
A.R.R.L. Antenna Book.....	50c
The Minilog.....	25c
Learning the Radiotelegraph Code	25c
A Course in Radio Fundamentals..	50c

*Subscription rate in United States and Possessions, \$2.50 per year, postpaid; \$3.00 in the Dominion of Canada, \$4.00 in all other countries. Single copies, 35 cents.

**Postpaid in U.S.A. Proper—\$2.00, postpaid, elsewhere. (No stamps, please.)

**THE AMERICAN
RADIO RELAY LEAGUE**
Incorporated
WEST HARTFORD 7, CONNECTICUT

Correspondence

(Continued from page 68)

INSURANCE

24 Grove St., Bangor, Me.

Editor, QST:

Was pleased to note W2OMM's letter in the December issue stressing the advantages of adequate liability and fire insurance coverages for amateur equipment, as I am in that type of business. However, what holds true "insurance-wise" in New York state may not always be the case in other states, as each is governed by its own insurance regulations. For instance, we feel that in Maine the form covering household and personal property against fire and attached to the policy is broad enough to cover amateur equipment without specific mention. As W2OMM says, it is an excellent idea to check this point, for in those states that require specific mention, the agent or broker may not always have been aware that radio transmitting equipment was involved.

Protection against windstorm is not afforded by a fire policy alone. Specific windstorm insurance or extended coverage endorsement to fire policy is required.

— Al Lancaster, W1OLQ

AIN'T SCIENCE WONDERFUL?

2121 Santa Clara Ave., Alameda, Calif.

Editor, QST:

Regarding contrapolar frequencies, there is one application of interest to the radio amateur who is also interested in photography. In my experiments with contrapolar frequencies to darken my kitchen so it could be used as a dark room during the daytime, I found that if it took just 250 negative watts to balance the daylight when I increased the negative illumination to 500 watts, instead of my films developing as negatives they came out as positive transparencies.

My next experiments were with color photography. I found that if I process Kodacolor film in this negative illumination, instead of producing a negative in complimentary colors I got a color transparency. I found also that if I process Kodachrome film I get as a result the same complimentary-colored negative that would result from processing Kodacolor film by the orthodox method. I expect that this will revolutionize color photography. There will be no need to have two kinds of color film. The color photographer needs only to buy Kodacolor film and process it normally if he wants colored photographs, and under properly balanced negative light if he wants color transparencies. . . .

— J. A. Young, W8AQN

Strays

Surplus savings:

W7NRI says there's lots of salvage in surplus 1625s and 1626s (12-volt equivalents of the 807 and 6J5), especially if you have a power transformer in the junk box that did duty back in the days of Type '10 and '50 tubes. These transformers have filament windings of 7.5, 5 and 2.5 volts, together with a high-voltage winding which will deliver from 500 to 600 volts after filtering. Art ties the 7.5- and 5-volt windings in series for the 12-volt heaters, and uses the 2.5-volt winding for the filaments of a pair of 816 or 866 Jr. rectifiers.

RADIO

RADIO Technician and Radio Communications courses. Register now for new classes starting first Monday of each month. Day and Evening Classes.

AMERICAN RADIO INSTITUTE

101 West 63d St.

New York 23, N. Y.

Approved under GI Bill of Rights

PREMAX

Mobile Antennas

*Police, Emergency Vehicle
and Portable Unit Equipment*

Tested and tried under the most exacting war and peacetime conditions, Premax Mobile Antennas and Mountings have proven themselves outstanding for endurance, ability to withstand shock and uniformly excellent radio reception. If your problem is a suitable mobile antenna, your Premax jobber can supply you.

Premax Products

Division Chisholm-Ryder Co., Inc.
4715 Highland Ave. Niagara Falls, N. Y.



At
Your
Jobber

WATERMAN DOES IT AGAIN!

**A NEW PORTABLE INDUSTRIAL AND TELEVISION
POCKETSCOPE** AN OSCILLOSCOPE
of UNUSUAL VERSA-
TILITY AND UTILITY
MODEL S-11-A



**LIGHT... COMPACT
EFFICIENT**

A 3-inch oscilloscope for measuring AC and DC... Amplifiers for vertical and horizontal deflection as well as intensity... Linear time sweep from 4 cycles to 50 kc with blanking of return trace... Sensitivity up to 100 mv/in... Fidelity up to 350 kc through amplifiers... Attenuators for AC as well as for DC... Push-pull amplifiers... Anti-stigmatic centering controls... Trace expansion for detail observations.

Direct connections to deflecting plates and intensity grids accessible from rear... Retractable light shield... Detachable graph screen... Handle... Functional layout of controls.

Light weight: 8 3/4 lbs. \$99
... Portable size: 11" x 7" x 5" ... F. O. B. PHILA.

...and the GENERAL PURPOSE

POCKETSCOPE
MODEL S-10-A

Widely known, widely used by engineers, industry, amateurs and laboratories for convenient, efficient and accurate testing and measuring requirements... an instrument of versatile application and dependable performance.

\$66 F. O. B. PHILA.

WATERMAN PRODUCTS COMPANY
INCORPORATED
PHILADELPHIA 25, PENNSYLVANIA

HAM-ADS

- (1) Advertising shall pertain to radio and shall be of nature of interest to radio amateurs or experimenters in their pursuit of the art.
- (2) No display of any character will be accepted, nor any special typographical arrangement, such as all or part capital letters be used which would tend to make one advertisement stand out from the others.
- (3) The Ham-Ad rate is 30¢ per word, except as noted in paragraph (6) below.
- (4) Remittance in full must accompany copy. No cash or contract discount or agency commission will be allowed.
- (5) Closing date for Ham-Ads is the 25th of the second month preceding publication date.
- (6) A special rate of 7¢ per word will apply to advertising which, in our judgment, is obviously non-commercial in nature and is placed and signed by a member of the American Radio Relay League. Thus, advertising of bona fide surplus equipment owned, used and for sale by an individual or apparatus offered for exchange or advertising inquiring for special equipment, if by a member of the American Radio Relay League takes the 7¢ rate. An attempt to deal in apparatus in quantity for profit, even if by an individual, is commercial and all advertising by him takes the 30¢ rate. Provisions of paragraphs (1), (2), (4) and (5), apply to all advertising in this column regardless of which rate may apply.
- (7) Because error is more easily avoided, it is requested signature and address be printed plainly.
- (8) No advertiser may use more than 75 words in any one issue.

Having made no investigation of the advertisers in the classified columns, the publishers of QST are unable to vouch for their integrity or for the grade or character of the products or services advertised

QUARTZ—Direct importers from Brazil of best quality pure quartz suitable for making piezo-electric crystals. Diamond Drill Carbon Co., 719 World Bldg., New York City.

CRYSTALS: Precision low drift units. Type 100A in 80, 40, and 20 meter bands. Two units plug in one octal socket. One dollar each. Rex Bassett, Inc., Ft. Lauderdale, Fla.

QSLs in colors. Stamp for samples. Glenn Griffith, W3FSW, 1042 Pine Heights Ave., Baltimore 29, Md.

COMMERCIAL radio operators examination, questions-and-answers. One dollar per element. G. C. Walter, W5ATV, 6540 E. Washington Blvd., Tulsa 15, Okla.

METERS paired and converted. Correspondence included. Haledon Electrical Instrument Co., 319 Belmont Ave., Haledon, N. J.

CALL letters, very attractive white letters on blue desk stand. All "Lucite." \$2.50 postpaid. Bernard Hartz, W. Pine, Frackville, Pa.

WANTED: "Wireless" apparatus prior 1925; early books, catalogs magazines, etc. Franklin Wingard, Rock Island, Ill.

AMATEURS, experimenters, industrials and export accounts write for catalog and monthly bulletin. Buy the "TB" guaranteed way and save. TAB, Dept. Z, 6 Church St., New York 6, N. Y.

DEKA-XAL. New compact 10-crystal unit for standard 5-prong socket. Looks and operates like a dial-koob. Just plug it in and turn to any of 10 frequencies, your selection. Ask your dealer or write us. Also other low T-hz crystals in FT cases to fit octal sockets, 80 and 40 at \$2.65; 20 at \$4.00. Scientific Radio Products Co., 738 1/2 W. Broadway, Council Bluffs, Iowa.

AMATEUR radio licenses. Complete code or theory preparation for passing amateur radio examinations. Home study and resident courses. American Radio Institute, 101 West 63rd Street, New York City.

BEAM antenna, all aluminum. High efficiency with minimum weight and torque. 2 to 20-meters. Write for information. Housekeeper, W2KMQ, 956 Paulding, Peekskill, N. Y.

QSLs. Samples for stamp. Peersvaai, W9GIL, Lincoln Printing Co., 305 W. Wells St., Milwaukee 3, Wis.

SELL: tubes, meters, xfrms, power supplies, electric drills, hundreds other parts. Free list. Marks, 97 South 8, Brooklyn, N. Y.

WANTED: Back copies of Proceedings of IRE, Electronics, RCA Review and QST; also binders and textbooks. State price and condition. Box 349, Forrest City, Ark.

IN Stock; new and used Hallicrafters, Hammarlund, National, Pierson, RME, Collins, Temco, other rcvrs and xmtrs. All other amateur tubes. Trade-in accepted. Terms financed by me. Write: Henry Radio, Butler, Mo. and Los Angeles 25, Calif.

SELL SX-28A, like new, with spkr, \$225. Lyle Dunlap, 806 No. Main St., Abington, Ill.

2,000 government surplus condensers by Cardwell 15 different types. While they last: 27 mmf/section, 15 plates per section, 0.070 airgap 90 cents each or two for \$1.58; 35 mmf/section, 13 plates/section, 0.030 airgap, 75 cents each or two for \$1.29; 150 mmf single sec, 35 plates, 0.030 airgap 90 cents each or two for \$1.80. Post card brings list of other bargains. Hieronymus Radio, W2GWS, 100-35 201st Street, Hollis 7, N. Y.

WIRE Recorder head: records, reproduces, erases. Highest quality laboratory instrument. Brush made for govt. Value, \$12.50. Our price, \$2.50 with order. Radioco, 1110T, Marshall Bldg., Cleveland, Ohio.

SELL: gray metal speaker cabinet for 10" speaker, matches Hallicrafters rcvrs; \$4. less spkr, 32 volt vibrator filtered B supply, \$6; 110 volt 60 cycle 65 watt Delco blower, \$16. All f.o.b. Ellsworth, Phillip Bircher, Ellsworth, Kans.

HAVE you seen Trading News? It's the meeting-place for buyers, sellers and traders of ham gear. Advertising rate 4¢ per word. Subscription free. Trading News, P. O. Box 7012, Lafayette Sta., Norfolk, Va.

"BT" mounted crystals within 80 and 40 meter bands. Two units fit in one octal socket, \$1 each. Crystal treatise included. Breon Labs, Williamsport, Pa.

SIGNAL shifter coils. Write for information. Rodgers & Harris Laboratories, 727 Main St., Mt. Carmel, Ill.

SELL Hallicrafters Model S-15, 5 band 9 tube superhet, one r.f. stage; best offer takes it. Also Vibroplex Champion, \$10. Never used. W2EC, 52 Buckingham Rd., Hempstead, L. I., N. Y.

1 1/2 RPM beam drive. Motor, gear, reversing relays in weather proof housing, \$7.50. Also HQ-120, \$125. E. Harris, 6748 No. Ashland, Chicago, Ill.

NAVY sound power telephones, ideal for checking continuity of multi-conductor cables. Requires no power. Cheat mike and headset set, three 900 ohm dynamic units, \$5. For further information, drop card to Alan F. Swenson, P. O. Box 1276, Worcester, Mass.

R-100 rcvr, 8 tubes, r.f. stage, 560 1500 Kc., 3.5, 8.6 Mc. 8.6, 19.9 Mc. AC/DC/Battery. Self-contained spkr. Modern black wrinkle steel cabinet. Sell or trade for RME VHF 152 converter or BC 224-F aircraft rcvr. S. E. Lucia, 328 Oaklawn Ave., Roanoke 12, Va.

SELL QST's, complete from Jan. 1933 through Sept. 1938, \$27.50. Also Qth through 14th Editions Handbook, \$1 ea. W9VXF, 3839 So. 14th St., Milwaukee, Wis.

CATHODE ray scope, 3" radar indicator ID-93/A PG-13A, 115 volt, 400 cps, light compact, main chassis will make fine scope, new, \$25. BC 1068A radar rcvr, 150-210 megacycles, permeability tuned, individual tuning dials for r.f. stages, 115 volt, 60 cps, compact, new, \$35. Rubin Radio, Shrewsbury, N. J.

FOR sale: new frequency meter BC-221. Crystal, tubes, spare parts, chart and carrying case, \$65. Wilcox, 3834 W. 59th St., Los Angeles, Calif.

TRADE Bausch and Lomb Aero-Tessar F6.0 24 in. for HQ-129X or Aerostigmat F5.0, 12 in. for BC-344 or S-40. Chas. Conrad, Box 127, Racine, Wis.

WANTED: National NTN-30 transmitter and NSM modulator. Thorpe, W8JDC, St. Clair Ave., Detroit 14, Mich.

SELL 60 watt airline power amplifier, Electro Voice cardak mike and stand, four metal projectors with 2 Jensen and 2 RCA 127 spkrs, cables, connectors, etc. Sky Rider, Jr., S-41W Hallicrafters, National SW-3, RCA 203As, Weston 0-1.5, r.f. ammeter, Model 425. Want Utah wirerecorder and high grade disc recorder. William A. Rlaiki, Guthrie Center, Iowa.

SELL QST's, July 1932 thru 1945. Interested in enlarger. W3EKZ, 7702 Chestnut Ave., Parkville 14, Md.

SELL HRO rcvr, power supply, 4 bandspread coils, loudspeaker. Highest offer. Sacrifice kilowatt phone cw xmtr, pair 100th final, 10 individual meters, crystal mike, modernistic wood cabinet, \$175. A. Lukach, 13 East 84th St., New York City 28.

WANTED: Cash for BC-610E, modified for ten. WIPFO, Capt. Harold Hicks, 101AAF, Presque Isle, Me.

WANTED: Old issues of Modern Electrics, Popular Electricity, QST 1919 and 1920. Cash or will swap other old issues. Lipani, 157 Leverett St., Boston 14, Mass.

SUPER PRO Model 400, \$300, f.o.b. James Fernane, WIJOP, 3648 Wyandotte, Kansas City, Mo.

WANT 500 ml filter choke from BC610. Sell Universal modulation transformer 300 watts, \$23. Thordarson 400 ml swinging and smoothing chokes, \$7. Weston 0-200 microammeter, \$8. Double choke, 15 henries 600 ml per section conservative, \$19.50. Write for list xmtz tubes, chokes, xfrms, meters. W4KTZ, Eupedon Farm, Clarksville, Tenn.

FOR sale: 450 watt phone or CW xmtr, used one month, also 100 watt phone or CW xmtr, brand new, both plate modulated. W5LEP, Box 146, Mansfield, La.

CRYSTALS: Where quality and not price is the main consideration, demand Eldon crystals. Fine commercial units for Aircraft, Police, Marine, Geophysical and other services. Highly accurate, fully guaranteed and strong in output. Over a decade of satisfaction and fast service. Send for our new L-6 catalog. Eideon Electronics Company, Temple, Texas.

SELL complete Superhet 10, 20, 40, 80, \$35; 50 Ma, DC, 200 Ma, DC, 1.5 Amp, r.f., 15 volt AC panel meters, ea. \$3; Bullet mike, \$5; two 2 mfd 1000 volt, twelve 2 mfd 2000 volt, \$1 ea., also xfrms, tubes, chokes, tubes, etc. Moxey, W3BFL, 325 Wadsworth St., Phila 19, Penna.

TCS transmitters and receivers, less power supplies, \$149, both units (new). 3DPI tube, new, \$12.50; T-17-B mikes, \$1.95 @; Mallory 12 volt Vibrapak No. G329, \$7.95 @; 27-volt in 300 at 120 Ma. out, dynamotors, \$6.95 new. Vibrator power supp 12-24 volt in, 500 volt at 160 Ma. out, new, \$12.95. TS-251-UP Loran test set, new. Make offer. Joe's Radio Shop, Bridgeton, N. J.

SELL Super Pro, 550 Kc. to 20 Mc. Good condition, \$160; Bendix 522 xmtr and rcvr combination with tubes 100-150, \$20; 400 watt CW rig, cabinet rack, \$450. W4AIS, c/o WMRC, Greenville, So. Carolina.

FOR sale: 35 watt amplifier with built-in radio and phonograph; 2 Shure dynamic microphones with floor stands; 2 Chaudograph spkrs. For further information, write R. Ramsen, 211 Hudson St., Hoboken, N. J.

CRYSTAL microphone: prewar Shure 730A with 8' cable and desk stand, all in good condition. Best offer. W9LTR, C. J. Evans, La Grange, Ind.

\$100 or best offer: Large assortment pre-war ham equipment including 250 watt Thordarson multimatch modulation xfrmr, 811s, 822s, 866s, chokes, hi-voltage xfrms, filament xfrms, etc. Phone Fitzroy 6229, Los Angeles, Calif. Eze-W6FQK is now W9KWL.

FOR sale: Stancor 20-P, 30 watt phone-CW xmtr complete; also V-101, portable xmtr-rcvr, 25 watt, complete. Best offer takes both or either. W4GQH.

BEST offer takes: Hallicrafters SX-28, only two weeks use! Perfect condition. Guaranteed A-1. Also 350 W xmtr for parts, and new tubes: 830B, 250TH, 3API, 813, 811, 807, 866-866A, 829, many others. Rollin Yorty, RD 4, Lebanon, Pa.

10,000 volt 2 mfd, \$6.95. All lines of new equipment, everything for the amateur. Send for large list. Mytronic Co., 121 W. Central Pkwy, Cincy 2, Ohio.

BLILEY xtrs. half price. Write for details. W8KJ.

BC-375E xmt, 7 tuning units, 2vt. tuner, 1000 v. MG, tubes, instruction book and AC conversion data, \$50; Meissner 14 tube rcvr, 12" spkr, \$60; Mass. Public Defense Comm. 2-meter xmt/rcvr (similar to TR4) tubes and 110 VAC — 6 VDC supply, \$55; HY75 xmt with tube, \$10; BC-683 10-tube FM rcvr, 27-40 Mc, manual tuning, plus 10 push buttons, needs 80 Ma. AC supply, \$30; H. P. 73 C dynamotor, 28 dcv to 1000 dcv @ 350 Ma, \$25.00; WIMRIS, 57 Hancock St., Auburndale, Mass.

SALE: New SX-28A, \$200; pair new 85's, \$7.50; master Teleplex tape sender and puncher, with 14 factory punched tapes \$50; 600 power supply of 1200 volts @ 300 ma ea. on 17" chassis, \$100; Hi-speed photoflash, complete with Kodak bulb, \$150; Precision 844(P) tester with damaged meter; Philco push-button test oscillator, 125 to 35,000 Kc, \$25. W31BT, 2905 Stanton Ave., Silver Spring, Md.

WANTED: Ecophone or similar rcvr. W. Folkins, VE2US, Hotel St. Malo, Quebec City, Canada.

RME LF-90 for sale. Range 90-550 Kc. Converter output on 1570 Kc. Used two months. Complete with new tubes and RME manual. Will not work with HRO account output frequency too low. Reason for selling: Have new HRO. All inquiries amsd. You name price. W7EVS, Box 221, Bellingham, Wash.

MEISSNER De Luxe signal shifter four sets of coils. Factory modified for phone. Never used. In original carton. Wanted: 500 watt modulation xmr. Arthur Dailey, 1431-35th Ave., Seattle, Wash.

SELL: One volume containing Oct. 1916, March through Aug. 1917; June, 1919, September 1919 through July 1920; another containing August through November 1921, January 1922, April through July 1922, best offer; Panadapter with 3' crt perfect, \$75; Hickok 133B, 20,000 ohm/volt voltohmmillimeter, new, \$45; Lavoie 105S microwave frequency meter, 375-725 megacycles, new, \$75; 500 v. megger in leather case, perfect, \$45; BC 251, \$45; W2XR, 71 Crosshill St., Staten Island, N. Y.

WANTED: Instructions books for BC 348L and Q. W9GHR, Omro, Wis.

CARTOON QSLs. 10¢. Chas. Merchant, Box 1592, Rapid City, So. Dakota.

QSL's, SWLs. Large variety of designs and colors. Estimates also given on your own designs. Samples, W2DEE, Box 103, Maple Shade, N. J.

BC-348 rcvrs converted 110 volt, \$20, with stage audio added, \$22.50. One day service. Ship to H. C. Ford, jr., W5CHE, Granite, Okla.

DXers: Did you work W2OAA/J8 (AK1MO-JO1MO) when I was in Korea? If so and have not yet received a QSL card, send your card to me for one. Please check with your QSL bureau first. W2OAA, 226 Coligni Ave., New Rochelle, N. Y.

SELL: NC100 rcvr and spkr, excellent condition, \$75. W2HFM, Merrick, N. Y.

SELL: 125 watt class B modulator, complete with power supply and built-in phone/CW relay. Uses 811a, and 816s. Thordarson multistage CHT xmr in mod. section. 500 ohm imp. input. Minimum bid, \$55. A. J. Seltzer, 7812 45 Ave., Jackson Heights, N. Y.

SIGNAL generator, heterodyne, 8-15, 150-230 Mc, laboratory quality, xtal calibration, new \$44.20; dual 10 μ d aluminum can electrolytic 29¢; electronic photo-flash parts. Write for bargain bulletins. Lectronic Research, 5832 Hegerman, Phila., Pa.

SEND 3¢ stamp for sample QSLs to Harrison, 8001 Piney Branch Road, Silver Spring, Md.

SALE: Hallicrafters SX-9, top condition, D.C. Mast, W6SW, 423 East E St., Ontario, Calif.

FOR sale: xmt, new condition. 400 watts CW, 325 fone. Coils for all bands to ten. \$370. C. C. Reed, jr., Allen Junction, W. Va.

WANTED: 10-meter Biley crystals, type HF2, Any freq., ea. \$2; \$1 for holder without crystal HRO with push button on signal strength meter without tubes, coils, power supply or speaker, \$35. Nations S.R.R. rcvr, without power supply, tubes or coils, \$10. W. H. Martin, Box 30, Leesburg, Va.

(60 ea.) General Electric Transformers, plate: Model K2424, form WFP, cycle 50/60, filament phase rating, 155-115, 115, 115, 115, 5.2, Cont. 55c rise. Filament: model K2424, Form CP, Cycles 50/60, single phase, voltage rating 100-5, KVA .065, Cont. 55c rise, priced for immediate sale. M. Matlow & Sons, Inc., 200 Vine St., Syracuse 1, N. Y.

WANTED: QST for March, April, 1940; April 1942; August, September 1945. Major M. M. Kovacevich, Box 743, March Field, Calif.

WOULD like to buy good amateur communications rcvr. 550 Kc to 20 Mc. Can pay around \$80. Send details to Jack Foster W6JVQ, 2201 East Evans, Denver 10, Colo.

SELL: NC100XA rcvr and spkr. Excellent condition. New noise limiter. Best offer. I. Werlin, W1JPT, 77 Bartlett St., Somerville, Mass.

QSL's? SWL's? No cheap trash! America's finest! Samples 25¢. RME-457, RME-847, VHF-1527 Sakkers, Printery, W8DED, Holland, Mich. (Veteran).

QSLs, samples, Albertson, WAHUD, 705 So. Hamilton, High Point, N. C.

QSLs, highest quality, samples free. VYS Print, 1704 Hale Avenue, Ft. Wayne 6, Ind.

CUSTOM-built 325 watt fone/CW xmt. SX-28A rcvr with matching spkr. Many other ham shack items. All under one year old. Write for picture and details. All inquiries amsd. Ken R. Lundy, W4IRJ, 8 1/2 Toulin Ave., Mobile 17, Ala.

SALE: New HQ-129-X with spkr, \$150. Hallicrafters S-38, \$40. Theodore Ferus, 48 Hawthorne St., Lowell, Mass.

LOCAL Hams: speech amp. P2A3s, self-contained power supply Modulator, PPT240s, 250-watts output. Will easily modulate half Kw or more. Two separate units, rack and panel construction. Will not be sold separately. \$55. Harold J. Carr, W3JFI, Hillcrest Ave., Crofton Manor, Pa.

ELECTRONICALLY regulated power supply. 200 to 400 volts 0 to 150 ma. Uses four tubes, \$40. Jacobs, 48 Bellevue Place, Chicago 11, Ill.

FIRST \$185 takes my Super Pro; Japanese 5-10 meter zero plane xmt and rcvr, both xtal controlled, complete, less control box. Uses 4 xtal and 3 standard 6-prong tubes. Japanese tubes included in excellent condition. First \$100. Victor Sive, 284 Loomis St., Little Falls, N. Y.

MOBILE and custom built radio equipment. 10-meter excitation plug-in unit for Meissner 150B, \$75. Crandell-May, Inc., 356A Longwood Ave., Boston 15, Mass.

QSLs-SWLs postpaid. Quality plus Stamp for samples. W1HJ1, P. O. Box 1023, Manchester, N. H.

FOR sale: Instructograph Code instructor. Electric model complete with 10 tapes, oscillator unit, tube, xmr, key, headphones, battery and book of instructions. Used less than a week. Like new. Cost \$39.50. Will take \$35. Also have model 99 Turner dynamic mike, like new, on table stand, \$20, or best offer. Billy Gant, 5916 Charlotte Pike, Nashville 9, Tenn.

FOR sale: 10-meter converter with power supply, 1852 preselection, 6AK5 mixer, 955 osc. vernier dial, \$20. Want to buy 35-watt mod. or 35-watt P.A. Al Ubben, Madison, Minn.

WANTED: Howard "490." Swaim, 1902 Hawthorne, Waterloo, Iowa.

SACRIFICE: Beautiful kilowatt phone, new. No expense spared in construction. You must see foto to appreciate. Over 1600 parts alone. Stamped envelope for details. \$800 cash steals it. W6PZL, 10425 Lanark, Roscoe, Calif.

RADIO, electrical books for sale. Over 500 magazines covering ten years. Write for list. Hillery, W2GNK/9, Elmwood, Ill.

WANTED: Thordarson T19P57 plate transformer. Also T19P58. C. H. Robinson, E. T. Patuxent River, Md.

FOR sale: NC-200 in good condition, \$150. W1OER, 9 Peters St., Cambridge 39, Mass.

WANTED: 32 volt DC to 110 volt, 60 cycle AC rotary converter, 150 to 250 watts. F. C. Beardsley, P. O. Box 335, Winter Park, Fla.

ERECO Beam rotator. High torque output 1-3 Rpm, Selsyn indicators. Attractive control panel. Reversing switch. Watertight. 120 VAC operated. Models from \$37.50 to \$50. Build your own kits from \$17.50 to \$25. Write for photos, literature. Dealers' inquiries invited. Manufacturer Eresco, 1006 Hewitt, Everett, Washington.

RADIO engineering library, as advertised in January 1947 QST, P. 112, \$20. Electronics (1943-1946 inclusive), \$12. Max Van Horne, 5474 Philloret Dr., Cincinnati 24, Ohio.

FOR sale or trade: HT-9 xmt, complete with tubes, coils, mike and crystals for 10 and 11 meter bands, used about 14 hours. Like new. F.o.b. \$235. Bound volumes of QST, 1933-1946. \$1, volume, prepaid. Want a good camera. Will give a good trade for good camera and accessories. Frank Ridgway, W9KXJ, 516 West 6th, Peru, Ind.

QSLs. Quick service. Samples, 25¢. Refunded first order. Sunland Print, Box 662, Hi Leah, Fla.

MUST sell: Transferring to New York City. HQ-120X rcvr, with brand new 11" PM Jensen spkr, in matching cabinet, perfect, \$115. Also xmt, 100TH final, T240s mod. complete with pwr supplies. Constructed in four metal cabinets. \$145. Harry W. Crawford, 3433 Piedmont Ave., Baltimore 16, Md.

SELL Complete station, 100 watts fone xmt for 10 and 11, SX-25 rcvr with spkr, converter for 10 and 11, vacuum tube, voltmeter. W2FBK, 164-11 97th St., Howard Beach 14, L. I., N. Y.

FOR sale: S-39 Sky Ranger, good condition, used less than six months, \$85. F.o.b. Elkhart, Ind. W9SVH.

KENTUCKY value! Believe it or not! We really have new, guaranteed, factory cartoned tubes as follows: 211, \$1.95; 801A, \$1.95; 805, \$4.00; 807, 28¢; 810, \$2.95; 811, \$1.95; 813, \$7.95; 830B, \$1.95; 872A, \$1.95; 3500 cycle clipper filter kit, \$2.63; 8V, 8.5A filament xmr, \$2.40; 20H, 200 Ma choke, \$2.85; 4520V CT 700 Ma. Pyranol, \$49.95; kw modulation xmr, \$24.75 2 μ d, 4000V Pyranola, \$5. Inquiries answered. Kentucky Radio Supply Co., Lexington, Ky.

SELL RME-45 rcvr, complete. Perfect condition. Reason: dislike bandspeed. First \$145 takes it. W2JWK, Pine Island, N. Y.

CASH for 25 or 50-watt transmitter. Must cover 10 meter phone. HT9 or HT6 preferred. Woody, W5LTG, 108 So. Broadway St., Oklahoma City, Okla.

TRADE new Army surplus BC-375-E xmt for small complete cw-phone xmt. H. E. Pywell, 44 Channing St., NW, Washington 1, D. C.

QSLs. Made the way you want them. New ham gear, too. Write Dossett, W9BHV, 857 Burlington, Frankfort, Ind.

FIRST \$70 or best offer gets new BC-348Q. Modified for 115V. AC operation. Tom Anderson, 39-C Oak Grove Drive, Baltimore 20, Md.

MEISSNER 150-B. Brand new, complete with signal shifter, spars. 150 watts fone C.W. \$300 or best offer. Harold Green WIKO, West Hanover, Mass.

SELL: HRO STAI, practically brand new, used less than 6 hours, including four sets of coils, PS, spkr, \$269. With 9 sets coils \$325. New Panadapter, \$69. Weston 772 tester, \$46. George Kravitz, 7919 20th Ave., Brooklyn, N. Y.

FOR sale: PR-16 communications receiver. P. O. Box 53, Cincinnati 13, Ohio.

WANTED: Power supply, 110 volt A.C. input, 12 volt 12 amps. D.C. output. Richard Bruce, 1171 Union, Manchester, N. H.

HAMMARLUND Comet Pro, 10-550 coils, \$35; Practical Radio Engineering Course, \$75. Box 58, West Norwood, N. J.

TOWERS for your rotary beam. Full latticework, spruce construction. Priced for the amateur. Write for Bulletin T-101. Sky Lane Products, Ironwood, Mich.

WRITES & G Instrument Co. for sheet metal work engraving, machining for fine equipment to your specifications. Box 1461, Tulsa, Okla.

Designed for

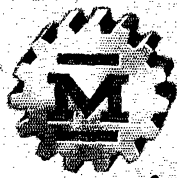

Application

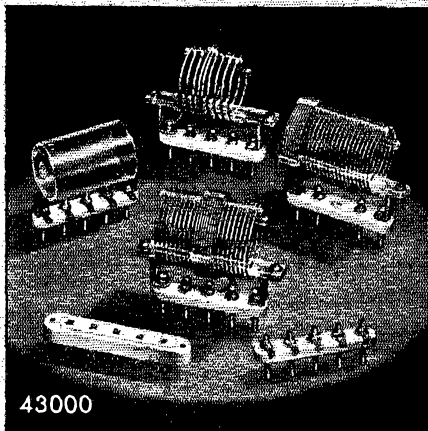

43000

**The No. 43000
AIR WOUND INDUCTORS
and ACCESSORIES**

Plug-in air wound inductors, coil forms, jack bars and sockets that have been "Designed for Application." The sockets are of the "straight line," type, facilitating symmetrical circuit arrangements and avoiding the undesirable bunching of leads, as when standard tube base socket-plug arrangements are used. Illustrated herewith are units from the small 75 watt or 43000 series. Two larger groups, the 44000 rated at 150 watts and the 42000 rated at 500 watts are also regularly available from your distributor of Millen radio products.

**JAMES MILLEN
MFG. CO., INC.**

MAIN OFFICE AND FACTORY
**MALDEN
MASSACHUSETTS**



Index to Advertisers

	Page
Advance Electric Relay Co.	112
Allied Radio Corporation	113
American Phenolic Corporation	111
American Radio Institute	138
Ashe Radio Co., Walter	129
Astatic Corporation, The	109
Barker & Williamson	134
Birnbach Radio Co.	128
Brach Manufacturing Co.	137
Brill Co., W. D.	130
Burstein-Applebee Co.	124
Cameradio Co.	84
Candler System Company	114
Capitol Radio Engineering Institute	85
Clarkstan Corporation	122
Cleveland Inst. of Radio Electronics	94
Collins Radio Co.	144
Commercial Radio Institute	130
Condenser Products Co.	117
Continental Sales Co.	128
Drake Electric Co.	88
Eitel-McCullough, Inc.	79
Electro-Voice	93
Fabricated Lightmetals Co.	118
General Electric Co.	1
Greenlee Tool Co.	122
Hallcrafters Co., The	4, 5
Hammarlund Mfg. Co., Inc., The	75
Harrison Radio Co.	135
Harvey Radio Co.	107
Hatry & Young	114
Henry Radio Stores	103
Hytron Radio & Electronic Corp.	8
Instructograph Co.	137
International Resistance Co.	90
Jensen Mfg. Co.	81
Kaar Engineering Co.	99
Kenyon Transformer Co.	132
Kjerulf & Co.	106
Knights Co., James	9
Maguire Industries	86, 87
Malloy & Co., P. R.	82
Mass. Radio & Television	128
Melville Radio Institute	116
Millen Mfg. Co., Inc., Jas.	142
Munger Co., Rex	110
National Co., Inc.	73, Cov. III
Newark Electric Co.	123
Onan & Sons, D. W.	112
P & H Sales Co.	132
Peerless Radio Distributors	120
Petersen Radio Co.	7
Port Arthur College	132
Premax Products Co.	139
Radio Electric Ser. Co. of Penna.	100
Radio Manufacturing Engineers	143
Radio Parts Distrib. Co.	137
Radio Shack Corp.	96, 97
Radio Specialties Co.	121
Radio Transceiver Labs.	116
RCA Institute, Inc.	136
RCA Mfg. Co.	Cov. IV
Richardson Labs., Kenneth	136
Scientific Radio Products	118
Silver Co., McMurdo	92
Sonar Radio Corporation	98
Sprague Products Co.	77
Standard Rad. & Elec. Products Co.	126
Standard Transformer Corp.	124
Steinberg's, Inc.	126
Sun Radio & Electronics Co.	125
Sun Radio Co. of Washington	127
Supreme Transmitter Co.	115
Sylvania Electric Products Co.	2, 91
Terminal Radio Co.	101
Transmitter Equip. Mfg. Co.	95
Triplett Elec. Inst. Co.	119
Turner Co., The	134
U.H.F. Resonator	120
United Electronics	83
United Transformer Corp.	Cov. II
Universal Radio Supply Co.	108
Valparaiso Tech. Institute	136
Vibroplex, Co. The	130
War Assets Administration	131
Ward Leonard Elec. Co.	89
Waterman Products Co.	139
Western Electric Co.	104, 105
Wile, Eugene, G.	136
World Radio Labs.	102

the RME 84 excels in all three

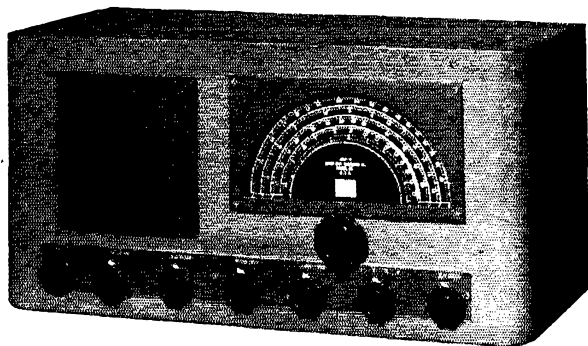
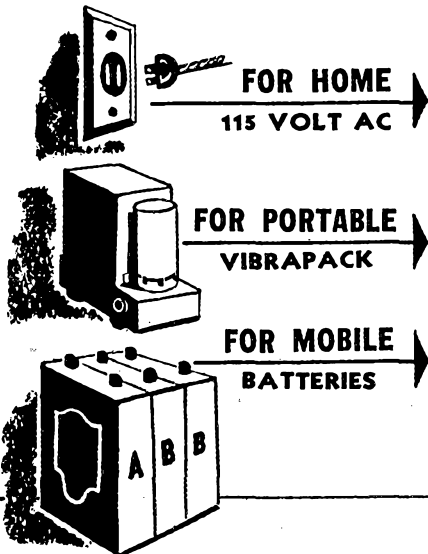

BEING a ham, you've often wished for a portable receiver. The RME 84 was engineered with this in mind and is equipped with a special socket connection on the rear of the chassis apron making possible connections to either a B battery and an A battery supply or a similar source of power such as an external vibrapack.

Because of its modern loctal tubes, the RME 84 will operate at full power on 135 volts of B and 6 volts of A battery. Drain on the B battery is only 22 milliamperes at 135 volts and the 6 volt A battery provides 1.5 amps, including the two dial lights. Disconnecting the dial lights reduces the A battery drain to but 1.2 amps.

For those many field days, for mobile use or for home use, this modestly priced, 8-tube communications receiver is an outstanding value because of its high quality, precision construction.

• • •

Write for Illustrated Folder

Features

- Self Contained Shock Mounted 5" PM Speaker
- Four tuning ranges .54 to 44 MC
- One Preselector Stage
- Smooth Vernier Tuning Control
- Bandspread, positively geared to main tuning control for accurate logging—no backlash!
- Automatic Noise Limiter
- Beat Frequency Oscillator—continuously variable by panel control
- Headphone Jack
- Antenna Input Terminals, provision for doublet or single wire
- Eight tube superheterodyne circuit



RME

FINE COMMUNICATIONS EQUIPMENT

RADIO MFG. ENGINEERS, INC.

Provia 6, Illinois U. S. A.

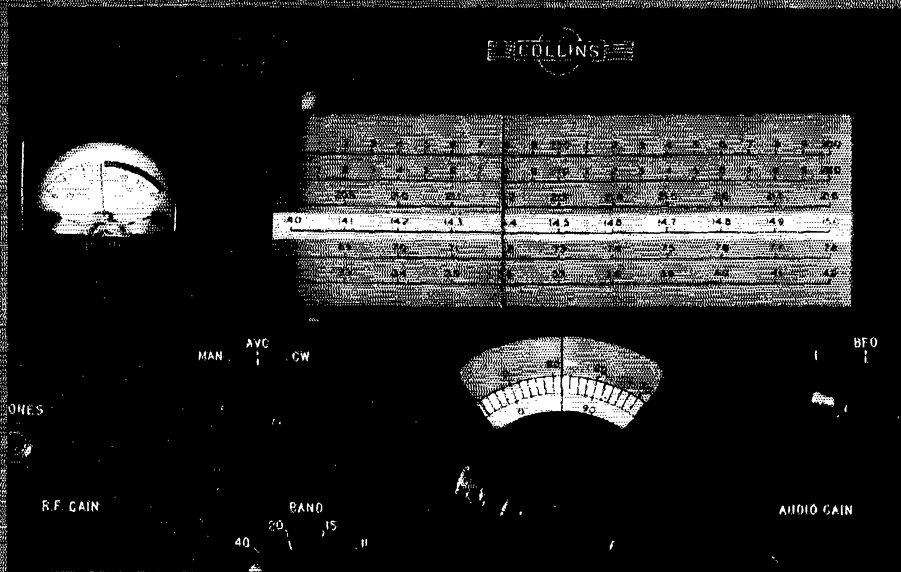

The Collins Band-Lighted Dial Gives You *Added Pleasure*

Wherever the Collins 75A receiver is shown—ham-fests, fairs, club meetings—the band-lighted dial wins enthusiastic endorsement from all who can crowd close enough to see it. And no wonder! It's so easy to use, both visually and mechanically, that once you've used it you'll see why it ranks high among the many new features of this receiver.

Here's how it works. The dial amply covers six amateur bands—80, 40, 20, 15, 11 and 10 meters. When you turn on the filament supply, the dial lights are turned on. *But only the band selected for use is lighted!* There's no band pointer to get out of adjustment, no feeling for the detent action, and no scanning the dial to see where the frequency indicator is! With only one band lighted at a time you just naturally read the correct figures at first glance.

The vernier dial, which gives you directly the exact frequency to within 1 kc (2 kc on 11 and 10

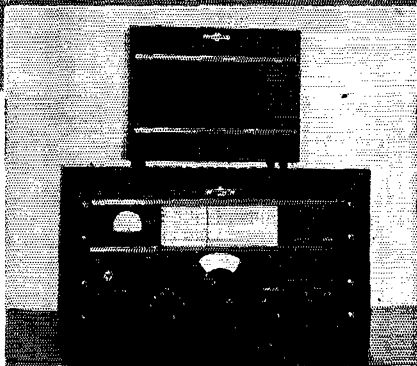

meters), works the same way. Only the band you're listening to is lighted. The frequency shown in the photograph is 14,394 kc.

The band-lighted dial is further proof of Collins interest in amateurs. In every equipment designed and built for amateurs by Collins, you'll find engineering that advances the art of amateur radio.

FOR RESULTS IN AMATEUR RADIO, IT'S . . .

COLLINS RADIO COMPANY, CEDAR RAPIDS, IOWA

11 W. 42nd St., New York 18, N. Y.

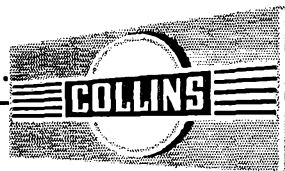

458 S. Spring St., Los Angeles 13, Calif.

NEW

SOON... THE

The NC-173 is the wholly new product of months of post-war research, prompted by war-time advances in radio technique.

The new "Double Diode" noise limiter and the new AVC system are effective on both phone and CW. The voltage-regulated oscillator circuits are extremely stable. The frequency range includes the 6-meter amateur band. (0.54 to 31 and 48 to 56 MC.)

The NC-173 offers all the features you expect in a fine receiver. A glance at the illustration below will suggest the versatility of its adjustments and the handiness of its controls, but only a trial will prove its thoroughbred qualities. Study the advanced design of its 13-tube circuit, appraise its modern styling and challenge its performance with the toughest conditions that crowded amateur bands can offer.

Here is a receiver a man can be proud to own. See it at your dealer's within the next 30 days.

NATIONAL NC-173

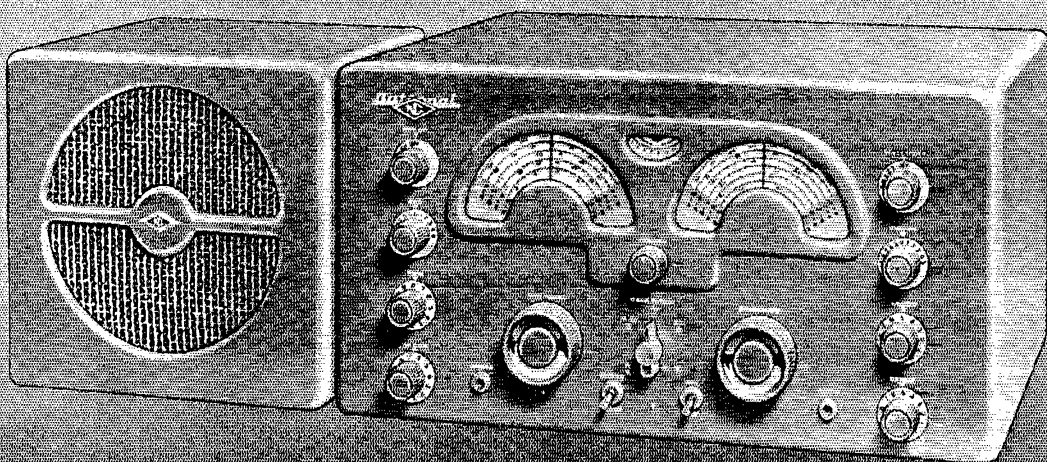

NATIONAL

COMPANY, INCORPORATED

MALDEN, MASS

THE MOST DISTINCTIVE NAME IN RADIO COMMUNICATIONS

Now— THE LOW-COST VHF BEAM POWER TUBE YOU'VE BEEN WAITING FOR

Here's why you'll want to use the new RCA-2E26 for 6 and 2 meters...

RCA gave you a *very-high-power* version of the 6L6—the justly popular 807. Now RCA brings you the 2E26—a *very-high-frequency* version of the 6L6. It's destined to become the hottest VHF final in the field for these reasons:

1. Economy: Because of its small size, high power sensitivity, and high efficiency, the RCA-2E26 makes an excellent final amplifier for a compact, inexpensive VHF transmitter operated from a simple low-voltage power supply.

2. High Power: A single RCA-2E26 operated at its ICAS ratings will take an input of 33 watts at 500 plate volts in class C telegraphy at frequencies as high as 150 Mc., and 40 watts at 600 volts at 54 Mc. It will take an input of 22.5 watts at 415 plate volts in class C telephony at frequencies as high as 150 Mc., and 27 watts at 500 volts at 54 Mc.

3. Low Drive: At 144 Mc., about 2 watts of RF must be delivered to the grid circuit. A 6V6-GT is a satisfactory driver tube.

4. Features: The 2E26 has short internal leads, a rugged button stem fitted to an octal base having a low-loss micanol insert and metal sleeve, excellent internal shielding, and double-ended construction for isolation of grid and plate circuits.

5. Application: The 2E26 is an excellent medium-power final amplifier for 6 and 2 meters. As a doubler, it will supply more than adequate power to drive an 829-B or 815. It will deliver 15 watts of 2-meter RF as a TPTG oscillator.

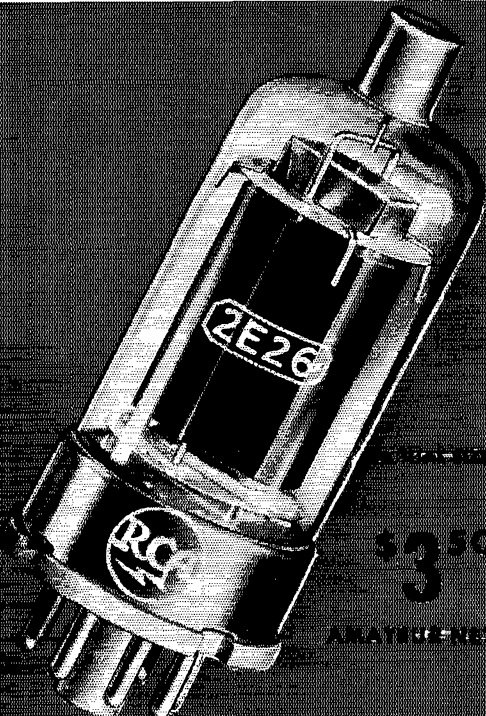

\$3.50
3
ANALYZED

RATINGS AND CHARACTERISTICS

Heater Volts	6.3
Heater Amps.	0.8
Direct Interelectrode Capacitances, mmf	
Grid to Plate (maximum)	0.20
Input	13.0
Output	7.0

CLASS C TELEGRAPHY Max. Ratings (ICAS)

	Frequencies up to 125 Mc.	At 160 Mc.
DC Plate Volts	600	450
Plate Input, Watts	40	30
Grid No. 2 Input, Watts	3.5	2.7
Plate Dissipation, Watts	13.5	13.5

TYPICAL OPERATION

DC Plate Volts	600	350
DC Grid No. 2 Volts	185	200
DC Grid No. 1 Volts	-43	-90
Peak RF Grid No. 1 Volts	57	105
DC Plate Current, ma.	66	85
DC Grid No. 2 Current, ma.	10	7
DC Grid No. 1 Current, ma. (Approx.)	3	3
Power Output, Watts (Approx.)	27	16.5

For further information, see your local RCA Tube Distributor or write RCA, Commercial Engineering, Section M-54C, Harrison, N. J.

Have you seen HAM TIPS ?
Get a copy from your local RCA Tube Distributor

THE FOUNTAINHEAD OF MODERN TUBE DEVELOPMENT IS RCA

TUBE DEPARTMENT

RADIO CORPORATION of AMERICA

HARRISON, N. J.



Should We Have a Class D License?

(Continued from page 18)

as the present Class B or C license except for the omission of the code test.

III. Stations of Class D licensees would have a distinctive type of call.

IV. Class D licensees would not be entitled to voting membership or the holding of elective office in the League.

I — The Frequencies

Below our 2-meter band we have assignments near 200 and 400 Mc. to which the same general techniques are applicable as we use on lower frequencies. We don't need help there. Then we have a long gap, a big jump up to 1215 Mc. Here the new world begins, where conventional equipment will not work and where new techniques must be employed. The field of the Class D licensee would begin here and would be confined to these wavelengths of 25 cm. and shorter. It is therefore not a popular field and it offers no present opportunity for dabblers, WERS permit-holders, dilettantes with handie-talkies, popularized "Citizen's Radio Service," or anything else of large dimensions. It is confined to the frequencies where genuine scientific knowledge is required to accomplish communication, and where development work must be done before the frequencies are useful to the average amateur.

There is, of course, the danger that the s.h.f. techniques won't always remain so difficult and expensive. There could be some smart technicians, say radio servicemen, for example, who could build such apparatus, and who would avail themselves of this opportunity to get into hamming without being subjected to the code requirement — the kind of people who have wanted noncode examinations for 'phone on our lower frequencies. Also it might not be too long before some smart manufacturer found it possible to bring out a ready-made set, say for the 1215-Mc.

band, at a price that some dilettantes could afford. We should examine whether we think we could afford to have some such butcher-boys for the sake of the larger gain of serious technical workers, or even whether a few such occupants wouldn't be affirmatively worth while. We should also consider whether we could protect ourselves if we did run into such troubles as the years rolled on by raising the lower frequency limit of the Class D field, keeping it confined to the bands on which original developmental work was still required.

II — The Examination

Chief reason for proposing that the examination be the same as for Class B except minus the code test is the FCC already has that mechanism set up and the Class B exam has the good feature of requiring knowledge of laws and treaties and regulations governing amateurs. Such an arrangement would also permit a Class D holder to get an endorsement for Class B privileges whenever he subsequently got interested in the lower frequencies and passed the code test. It has been suggested, as an alternative, that Class D be available only upon passing a comprehensive technical examination on microwave techniques. The Board thinks that the considerations earlier outlined outweigh any possible advantages of this alternative; and it is also doubtful whether the present administrative streamlining of the workload at FCC would make it desirable for us to propose a special examination for this purpose. No person is going to attack the difficulties of the microwaves unless he has at least rudimentary skill in that field. And rudimentary skill is all that any amateur test should require: the amateur learns by doing and the beginning requirement should be just enough to insure that he can conduct himself properly. All things considered, it has seemed best to the Board to rely on the present amateur examination. Even though it does not treat of the microwaves at all, it is basic to the business of becoming an amateur.

Please
Detach
and
Mail
This
Card
Now

PLACE
POSTAGE
STAMP
HERE

American Radio Relay League,
West Hartford,
Conn.,
U. S. A.

While a special microwave technical exam would keep out the butcher-boys we've mentioned, wouldn't it also seem to have the objection of setting up a class too much apart from the rest of us? To be sure, we want highly qualified people but we don't want to bestow a sort of special rank on them that would ever permit them to complain that the rest of us weren't well enough qualified to use our own bands. We would be wanting them only as amateurs, and it has seemed to the Board that having the one basic examination would be conducive to that and to the avoiding of unwholesome jealousies.

It should be well understood that in any event the Class A, B and C licenses authorize amateur operation on all such frequencies, without the need to pass any other test of any description.

III — The Call

The fear has been expressed that some Class D microwave men, once licensed, would unlawfully invade our lower-frequency 'phone assignments and so get in by the back door, so to speak, to operate DX 'phone without qualifying for code as every other 'phone man has had to do. He'd have a call, it is said, and nobody would spot him as unauthorized. To help offset this the Board proposes that Class D stations have a distinctive form of call, one immediately recognizable as such. It is also proposed that the call structure be such that it could be converted to a "regular" amateur call when and if the holder qualifies for Class B. Such a call, for example, might have an extra letter in the prefix, that could later be deleted by FCC.

Of course this doesn't entirely eliminate such dangers. Nothing can. There would be nothing to prevent a Class D man from dropping the significant part of his call himself — except the vigilance of the local gang. But only that and FCC monitoring (and the ordinary honor of most people) prevent Class B men from working in Class A bands now, so it would be no different. The Class D licensee would be authorized only microwaves; for lower frequencies he would be an

unlicensed person. There's no difference from what now prevents phonics from trying to operate without any license whatever — fear of the law and amateur vigilance are the biggest deterrents. But if a Class D man did go overboard and changed his call, he'd be guilty of both unlicensed operation and signing a false call, so the proposed provision seems helpful. There seems to be no room to feel that a Class D invader of lower bands would find it any easier to get away with anything because of his possession of a D ticket.

IV — Voting

The fear has also been expressed that Class D men would be so numerous that they would dominate the affairs of the League and, not being c.w. men themselves, would succeed in shaping ARRL policies to the eventual elimination of the code requirement everywhere, the gradual liquidation of c.w., and the opening of the lower-frequency 'phone bands to persons without code knowledge, thus ruining amateur radio. The opposing point of view is that there is no likelihood of Class D attaining appreciable numbers, that the number of people of microwave skills is so relatively limited that we would be fortunate if we ever got as many as two or three thousand of them. Nevertheless, the Board is considering Class D strictly as a mechanism for getting desirable people into this branch of amateur radio, it believes utterly that code is basic to every other part of amateur radio, and it intends to surround the matter with adequate safeguards. It is therefore part of the whole approach to this matter that the League would regard a Class D man as only partly licensed and would deny him full (voting) membership. If the amateurs of the country want to see Class D established and the Board so undertakes, the Board will simultaneously amend the League's by-laws so that the right to vote will unmistakably be confined to those who have passed the code examination. It will also follow from that that Class D men will not be eligible to elective office in the League. Thus any possible hazard of noncode persons ever

General Amateur Poll No. 2

Should the League seek a Class D license without code test, to be valid only above 1215 Mc., licensees of such stations to use distinctive station calls and to be denied voting membership in the League?

YES

NO

Your name

Call

City and state

Are you a member of ARRL? _____

ARRL Division in which you live: _____

(See list on page 6.)