

August, 1947

35 Cents

# QST

entirely to

# amateur radio

HAMFEST AND  
TRANSMITTER HUNT

TOWN HALL  
1851



# Positive Voice Recognition!

Your signal is clear and distinct, your voice retains its individuality, you get quick recognition and more QSO's—when you call with the CARDAX. Ideal for DX or rag-due radio.

## THE Cardax

CARDIOID  
CRYSTAL  
MICROPHONE

The only high level cardioid crystal microphone with Dual Frequency Response. Gives you high fidelity for clear channel; or rising characteristic for extra crisp speech signals that cut thru QRM. Also overcomes room background noise. Outstanding in every way. Thousands in use today. Model 950 lists at \$37.

# Electro-Voice

ELECTRO-VOICE, INC., BUCHANAN, MICH.

Export Division: 13 East 40th St., New York 16, N. Y., U. S. A.  
Cables: Arlab

AUTHORIZED  
DISTRIBUTORS  
EVERYWHERE



"Cardyne" Cardioid Dynamic  
Models 731 and 726



Crystal—Model 910  
Dynamic—Model 610



High Fidelity Dynamic  
Model 630



"Comet" Crystal Model 902  
Dynamic—Model 601

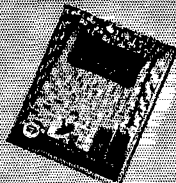

Send for Catalog 101  
Get valuable data on  
today's most complete  
microphone line.

**DO  
AWAY  
WITH...**

**C BATTERIES  
VOLTAGE-REGULATED  
BIAS PACKS**

**—BY CHOOSING ONE OF THESE  
FINE ZERO-BIAS TUBES FOR  
YOUR CLASS B MODULATOR!**



**S**URE ENOUGH . . . tubes with negative grid-bias requirements will do a first-class modulator job IF you want to invest in C batteries or a bias pack with good voltage regulation!

That's one option you have, though not the most saving in money, time, or circuit layout. And to operate tubes of that sort *without* providing bias voltage—though it's done all too commonly—is inefficient, shortening tube life and reducing your signal quality.

*Better do the smart thing and select zero-bias tubes!* Triodes GL-811 and GL-805 are stand-outs in this and other respects for Class B modulator service, for which they were designed.

Two GL-811's, operating zero-bias at 1,250 v, have an output of 175 w, ample to voice-

modulate low-to-medium-power rigs. Type GL-805 in push-pull, operating zero-bias at the same voltage, will put out 300 w—more than enough power to voice-modulate a 1-kw transmitter.

Check the value-giving prices of these tubes at your G-E tube distributor's. Then figure in the extra economy and simplicity that come from operating your modulator circuit with zero bias! No question about it, the GL-811 and GL-805 are bargain "buys". *Electronics Department, General Electric Company, Schenectady 5, N. Y.*

● Reading Ham News regularly? Ask your G-E tube distributor for the latest edition. By missing an issue, you may pass up valuable suggestions that will help keep your rig up-to-the-minute. Get Ham News; it's FREE.

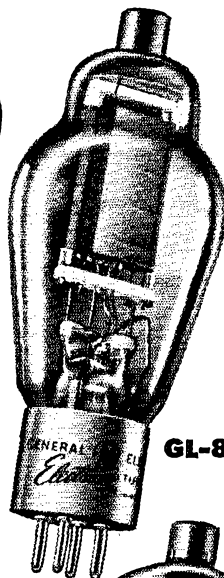

**GL-811**

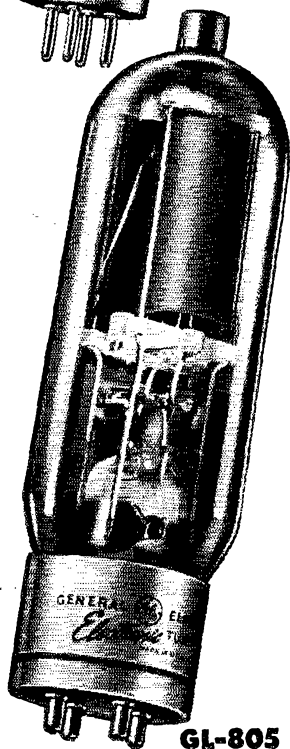

**GL-805**

**RATINGS FOR TYPICAL OPERATION, CLASS B  
MODULATOR SERVICE (2 TUBES)**

	<b>GL-811</b>	<b>GL-805</b>
Filament voltage	6.3 v	10 v
Filament current (per tube)	4 amp	3.25 amp
Plate voltage	1,250 v	1,250 v
Signal plate current (max)	200 ma	400 ma
D-c grid voltage	0 v	0 v
Driving power	3.8 w	6 w
Plate power output	175 w	300 w
Load impedance, plate-to-plate	15,000 ohms	6,700 ohms

**ELECTRONIC TUBES OF ALL TYPES FOR THE RADIO AMATEUR**

**GENERAL  ELECTRIC**

161-F16-8890

# Radiomen!



## HERE ARE 1947's MOST NEEDED REPLACEMENT CAPACITORS

It's a lot easier to service both post-war and pre-war radios when you use Solar Capacitors. Following a thorough survey of the dry electrolytics actually used in post-war set production, Solar has pioneered in making available to the radio serviceman the capacitors needed for repairing today's compact receivers—quickly, neatly, and with a minimum of puzzling over what to do.

You'll find the needed listings of high capacitance and multiple-section capacitors in the three new Solar leaflets shown here.

Form ES-100A describes the newly introduced Solar DSB plastic-film internal wrap cardboard tubulars; Form ES-101A covers the famous metal-clad "MINICAP" units; and Form ES-102A describes the greatly expanded listing of twist-prong mounting Solar Type DY capacitors.

All three leaflets are available from your Solar distributor or directly from

**SOLAR CAPACITOR SALES CORP.**  
1445 Hudson Boulevard • North Bergen, N. J.

**SOLAR CAPACITORS**  
*"Quality Above All"*



PUBLISHED, MONTHLY, AS ITS OFFICIAL ORGAN, BY THE AMERICAN RADIO RELAY LEAGUE, INC., AT WEST HARTFORD, CONN., U. S. A.; OFFICIAL ORGAN OF THE INTERNATIONAL AMATEUR RADIO UNION

### STAFF

#### Editorial

KENNETH B. WARNER, W1EH  
*(Managing Secretary, ARRL)*  
Editor

HAROLD M. MCKEAN, W1CEG  
*Assistant Editor*

GEORGE GRAMMER, W1DF  
*(Technical Director, ARRL)*  
Technical Editor

DONALD H. MIX, W1TS  
BYRON GOODMAN, W1DX  
*Assistant Technical Editors*

EDWARD P. TILTON, W1HDQ  
*V.H.F. Editor*

RICHARD M. SMITH, W1FTX  
C. VERNON CHAMBERS, W1JEQ  
JOHN W. PADDON, VE3BLZ  
*Technical Assistants*

JOSEPH E. GRAHN, W1CH  
*Contributing Editor, "How's DX?"*  
WALTER E. BRADLEY, W1FWH  
*Technical Information Service*

#### Production

RALPH T. BEAUDIN, W1BAW  
*Superintendent*

NANCY A. PRICE  
*Assistant*

#### Advertising

F. CHEYNEY BEEKLEY, W1GS  
LORENTZ A. MORROW, W1VG  
EDGAR D. COLLINS

#### Circulation

DAVID H. HOUGHTON  
*Circulation Manager*

RALPH T. BEAUDIN, W1BAW  
*Assistant Circulation Manager*

### OFFICES

38 La Salle Road  
West Hartford 7, Connecticut

Subscription rate in United States and Possessions, \$3.00 per year, postpaid; \$3.50 in the Dominion of Canada, \$4.00 in all other countries. Single copies, 35 cents. Foreign remittances should be by international postal or express money order or bank draft negotiable in the U. S. and for an equivalent amount in U. S. funds.

Entered as second-class matter May 29, 1919, at the post office at Hartford, Connecticut, under the Act of March 3, 1879. Acceptance for mailing at special rate of postage provided for in section 1103, Act of October 3, 1917, authorized September 9, 1922. Additional entry at Concord, N. H., authorized February 21, 1929, under the Act of February 28, 1925.

Copyright 1947 by the American Radio Relay League, Inc. Title registered at U. S. Patent Office.

## — CONTENTS —

"It Seems to Us . . ."	11
ARRL QSL Bureau . . . . .	12
A 120-Watt Modulator and Speech Amplifier <i>C. Vernon Chambers, W1JEQ</i>	13
Curing Interference to Television Reception <i>Mack Seybold, W2RYI</i>	19
The "Last-Ditcher" . . . . . <i>John Paddon, VE3BLZ</i>	24
Coupling to Flat Lines . . . . . <i>Byron Goodman, W1DX</i>	26
Silent Keys . . . . .	27
Atlantic City Report . . . . .	28
In QST 25 Years Ago This Month . . . . .	31
Happenings of the Month . . . . .	32
An Electronic Multicircuit Breaker <i>G. D. Hanchett, jr., W2YM</i>	34
Cathode-Coupled Converters for Surplus Receivers <i>John H. Bender, W2EVI</i>	37
Delta Division and West Gulf Division Convention . . . . .	42
Technical Topics	
Horizontal vs. Vertical — 80 Meters . . . . .	43
N.F.M. Reception . . . . .	45
Shorthand Circuit Symbols . . . . .	46
How's DX? . . . . .	48
I.A.R.U. News . . . . .	51
An Inexpensive Rig for Local Duplex Operation <i>Donald D. Ralston, W8SFI</i>	52
The World Above 50 Mc. . . . .	54
Correspondence from Members . . . . .	57
Hints and Kinks . . . . .	58
'Phone-Band Phunnies	
Little Sir Echo . . . . . <i>John T. Frye, W9EGV</i>	60
Convention Calendar . . . . .	60
Hamfest Calendar . . . . .	60
A Position Indicator for Directional Arrays <i>Joseph S. Tomczak</i>	61
Operating News . . . . .	62
Station Activities . . . . .	70

# Presenting the **NEW MODEL SX-43**



**...to give amateurs:**

## **Built in the Hallicrafters Classic Tradition**

The new SX-43 is built in the Hallicrafters classic tradition: providing custom quality, precision engineering, excellent performance and wide frequency range at a medium price. The SX-43 offers continuous coverage from 540 kc. to 55 Mc. and has an additional band from 88 to 108 Mc. AM reception all bands. CW on four lower bands and FM on frequencies above 44 Mc. In the band 44 to 55 Mc., wide band FM or narrow band AM, just right for narrow band FM reception is provided. This is a big-league, versatile, all-around receiver with the hottest ham performance ever offered at this price.

Added technical details on all these models in Hallicrafters New Catalog, No. 38. Ask your local distributor for a copy.

**MORE  
VALUE**

Never before all these features at this price

**GREATER  
PERFORMANCE**

AM-FM-CW . . . all essential amateur frequencies from 540 kc. to 108 Mc.

**LOWER PRICE**

**\$169<sup>50</sup>**

Sets available after August 1947

*New*

**BETTER QUALITY** **AM**  
**WITH NARROW BAND** **FM**

**Exclusively designed**  
**VARIABLE**  
**MASTER OSCILLATOR**  
**only \$110.00** (amateur net)

Here is the hottest transmitter item available today. Packed with outstanding features never before available in one low-priced unit. Add to the HT-18 one or two amplifier stages and you have a complete, high quality transmitter permitting operation on phone or CW up to 1 KW. Low frequency drift, low FM distortion, low hum and noise level, dual voltage regulators and low impedance output circuit all contribute to superior performance that only Hallicrafters can provide at this price.

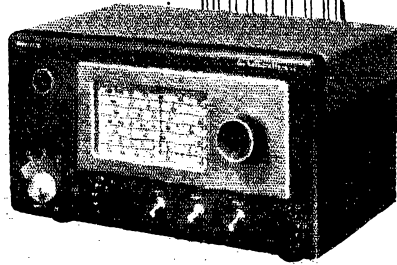
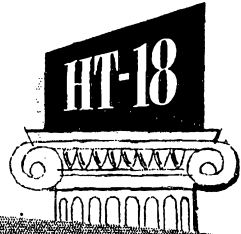

*Narrow band FM . . . direct frequency calibration . . . finger-tip control of entire station . . . full frequency deviation on all ham bands to 29.7 Mc. . . only 1/10 the distortion of comparable units . . . excellent stability . . . clean keying . . .*

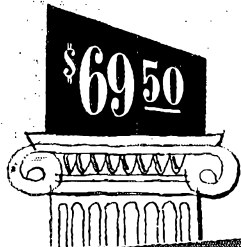

**New** **LOW PRICE** **Transmitter**  
**MODEL HT-17**

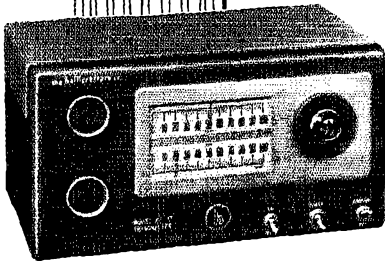

- Ham bands from 3.5 to 30 Mc.
- 15 watts power output on low frequency bands.

Here's real Hallicrafters transmitter performance with maximum convenience and economy. This compact and smartly engineered unit provides an honest 15 watts of crystal-controlled CW output on the amateur bands of 3.5 and 7 Mc. and 10 watts on 14, 21 and 28 Mc. A pi-section matching network, as well as a link, provides coupling to any type of antenna or permits the HT-17 to be used as an exciter for a high power final amplifier. Oscillator stage uses a type 6V6-GT tube and is automatically switched to a Tritet circuit when coils for the 3 higher bands are plugged in. Coil sets extra.

BUILDERS OF *Skyphone* AVIATION RADIOTELEPHONE

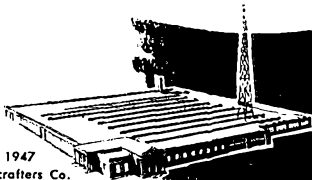

**hallicrafters RADIO**

THE HALLICTRAFTERS CO., MANUFACTURERS OF RADIO AND ELECTRONIC EQUIPMENT, CHICAGO 16, U. S. A.

Sole Hallicrafters Representatives in Canada: Rogers Majestic Limited, Toronto-Montreal

Copyright 1947  
The Hallicrafters Co.

## Section Communications Managers of the ARRL Communications Department

**Reports Invited.** All amateurs, especially League members, are invited to report station activities on the first of each month (for preceding month) direct to the SCM, the administrative ARRL official elected by members in each Section. Radio Club reports are also desired by SCMs for inclusion in QST. All ARRL Field Organization appointments are now available to League members. These include ORS, OES, OPS, OO, and OBS. Also, where vacancies exist SCMs desire applications for SEC, EC, RM, and PAM. In addition to station and leadership appointments for Members, all amateurs are invited to join the ARRL Emergency Corps (ask for Form 7).

ATLANTIC DIVISION				
Eastern Pennsylvania Maryland-Delaware-D.C. Southern New Jersey Western New York Western Pennsylvania	W3RES W3BWT W2GCU W2UPH W3KWL	Jerry Mathis Eppa W. Darne Ray Lomlinson Charles I. Otero Ernest J. Hlinsky	623 Crescent Ave. 132 Tennessee Ave., N.E. 623 E. Brown St. 4159 Ridge Road, West 509 Beechwood Ave.	Glenside Gardens Washington 2, D. C. Trenton 10 Spencerport Parrell
CENTRAL DIVISION				
Illinois Indiana Wisconsin	W9AND W9SWH W9QKM	Wesley E. Marriner Ted K. Clifton Reno W. Goetsch	624 College Ave. 550 Eben St. 929 S. 7th Ave.	Dixon New Haven Wassau
DAKOTA DIVISION				
North Dakota South Dakota Minnesota	W8EVP W8QVY W8CWB	Raymond V. Barnett P. H. Schultz Walter G. Hasskamp	406 17th St. 118 N. Yankton Ave. 116 3rd Ave., S.W.	Bismarck Pierre Crosby
DELTA DIVISION				
Arkansas Louisiana Mississippi Tennessee	W5JIC W5VT W5IGW W4FLS	Marshall Riggs W. J. Wilkinson, jr. Harold Day James W. Watkins	4405 Howell Ave. Room 313, Jefferson Hotel Route 1, Box 111 220 North Howell St.	Fort Smith Shreveport Greenville Chattanooga 4
GREAT LAKES DIVISION				
Kentucky Michigan Ohio	W5IEZ/4 W8SCW W8PNQ	Joseph P. Colvin Joseph R. Belian jr. William D. Montgomery	1653 Beechwood Ave. 13959 Tuller Ave. 1290 Coolidge Ave.	Louisville 4 Detroit Cincinnati 30
HUDSON DIVISION				
Eastern New York N. Y. C. & Long Island Northern New Jersey	W2HZL W2KDC W2IIN	Ernest E. George Charles Ham, jr. John J. Vitale	2044 Lexington Parkway 200 Harvard St. 57 Sayre St.	Schenectady 8 Westbury Elizabeth 3
MIDWEST DIVISION				
Iowa Kansas Missouri Nebraska	W8PPP W8AWP W8OUD W8RQK	William G. Davis Alvin B. Unruh Mrs. Letha L. Dangerfield William T. Gemmer	3rd St. 842 N. Terrace Drive 411 Motier Ave. 1708 West 6th St.	Mitchellville Wichita 6 Joplin North Platte
NEW ENGLAND DIVISION				
Connecticut Maine Eastern Massachusetts Western Massachusetts New Hampshire Rhode Island Vermont	W1KOY W1GKJ W1ALP W1AZW W1AXL W1HRC W1NDL	Edmund R. Fraser F. Norman Davis Frank L. Baker, jr. Prentiss M. Bailey John H. Stoughton Clayton C. Gordon Gerald Benedict	90 Atwater St. RFD 1 91 Atlantic St. 62 Dexter St. RFD 2 70 Columbia Ave., Gaspee 23 Foster St.	West Haven Old Orchard Beach North Quincy 71 Pittsfield Claremont Plateau, Providence 5 Montpelier
NORTHWESTERN DIVISION				
Alaska Idaho Montana Oregon Washington*	K7CBF W7IWU W7EQM W7HAZ W7EHQ	August G. Hiebert Alan K. Ross Albert Beck Raleigh A. Munkres Lloyd Norberg	% KFAR 1017 East Jefferson St. 2326 Amherst Ave. Box 744 P. O. Box 281	Fairbanks Boise Butte Baker Steilacoom
PACIFIC DIVISION				
Hawaii Nevada Santa Clara Valley East Bay San Francisco Sacramento Valley Philippines*	KH6EL W7CX W6BPT W6TI W6NL W6MGC KAICB	John Souza N. Arthur Sowle Roy E. Pinkham Horace R. Greer Samuel C. Van Liew John R. Kinney Craig B. Kennedy	Box 2025 1061 Fremont St. 414 Fairmont Ave. 215 Knowles Ave. 5240 Jay St. 25 Roosevelt Road	Wailuku, Maui Reno Santa Clara Oakland 11 Daly City Sacramento 16 San Francisco Del Monte, Quexon Fresno
San Joaquin Valley	W6PSQ	James F. Wakefield	2940 Adoline Ave.	
ROANOKE DIVISION				
North Carolina South Carolina Virginia West Virginia	W4CVB W4BQE/ANG W4HKK W8JM	W. J. Wortman Ted J. Veroson Walter R. Bullington Donald B. Morris	% Duke Power Co. 3322 Rosewood Drive 1710 Oak Hill Lane, Rt. 1 303 Home St.	Charlotte 1 Columbia 25 Richmond 23 Fairmont
ROCKY MOUNTAIN DIVISION				
Colorado Utah-Wyoming	W8QYT W7NPU	Glen Bond Alvin M. Phillips	2550 Kendall 3887 Quincy Ave.	Denver 14 Ogden, Utah
SOUTHEASTERN DIVISION				
Alabama Eastern Florida* Western Florida Georgia West Indies* (Cuba-P.R.-V.I.)	W4GBV W4BYF W4DAO W4HYW KP4KD	Lawrence J. Smyth W. E. MacArthur Luther M. Holt Thomas M. Moss Everett Mayer	808 Winona Ave. 899 N.E. 92nd St. 223 W. Romana St. 570 Oak Drive P. O. Box 1061	Montgomery Miami Pensacola Hapeville San Juan S, P. R.
SOUTHWESTERN DIVISION				
Los Angeles Arizona San Diego	W6QWZ W7MLL W6GC	Ben W. Onstenk Gladden C. Elliott Irvin L. Emig	9631 3rd Ave. 1408 West Fresno St. 4852 Marlborough Drive	Inglewood Tucson San Diego
WEST GULF DIVISION				
Northern Texas Oklahoma Southern Texas New Mexico	W5DAS W5HXI W5HIF W5HJF	N. C. Settle Bert Weidner Ted Chastain J. G. Hancock	2911 Elm St. Box 14 3037 So. Staples St. 110 S. E. Nevada St.	Dallas Crescent Corpus Christi Portales
MARITIME DIVISION				
Maritime (Nfld. & Labr. att.)	VE1DQ	A. M. Crowell	69 Dublin St.	Halifax, N. S.
ONTARIO DIVISION				
Ontario	VE3DU	David S. Hutchinson	827 Lovett St.	London, Ont.
QUEBEC DIVISION				
Quebec	VE2SU	Gordon F. J. Phelan	4829 Isabella Ave.	Montreal, Que.
VANALTA DIVISION				
Alberta British Columbia Yukon	VE6LQ VE7WS VE8AK	W. W. Butchart W. W. Storey W. R. Williamson	10740-107 St. 3915 W. 32nd Ave. P. O. Box 137	Edmonton, Alta. Vancouver Whitehorse, Y. T.
PRAIRIE DIVISION				
Manitoba Saskatchewan	VE4AM VE5CO	A. W. Morley Norman Thompson	26 Lennox St. 1120 7th Ave., N. W.	St. Vital Moose Jaw

\* Officials appointed to act temporarily in the absence of a regular official.



# *Crystal and Dynamic* **MICROPHONES**

**FOR  
THE  
AMATEUR  
FIELD**



Model D-104, Old  
Favorite, Crystal  
Microphone

Model DN-HZ-S  
Dynamic  
Microphone



The Conneaut  
Model 600-S Crystal  
Microphone

The dependable performance of Astatic Microphones over a long period of time has earned the confidence of thousands of Radio Amateurs. It is natural to assume, therefore, that for replacement, modernization of existing equipment or new installations, first preference will be given to Astatic Microphones. New and old favorites with ideal voice range characteristics are now available.

*See your Radio Parts Jobber  
or write for Catalog*

**THE**  
*Astatic*  
**ASTATIC CORPORATION**  
CONNEAUT, OHIO  
IN CANADA CANADIAN ASTATIC LTD. TORONTO, ONTARIO

Astatic Crystal Devices Manufactured  
under Brush Development Co. patents.

# Jensen

## Bass Reflex CABINETS

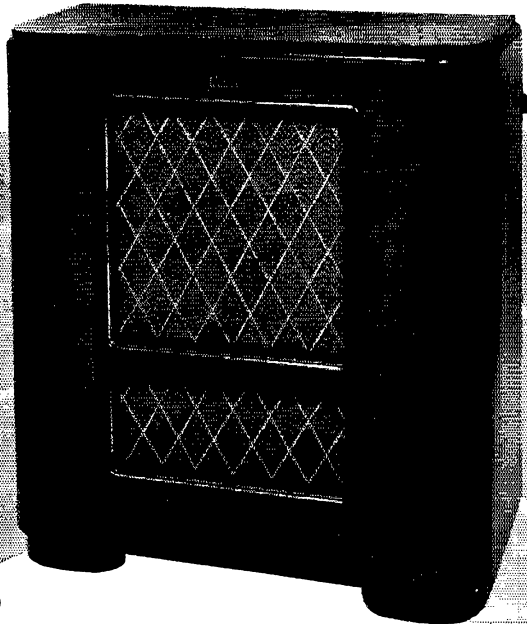

Three types—six models to accommodate 6", 8", 12" and 15" speakers

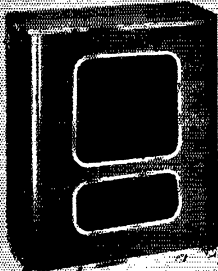

TYPE B Bass Reflex Cabinets are manufactured in sizes for 6", 12" and 15" speakers. A superior new wood composition in outer walls and panels assures distinguished appearance at a modest price. Finish is an attractive, bakeloid laminaroid, trim is of chromium and aluminum.

**BASS REFLEX PRINCIPLE:** Through exact acoustical proportioning of the completely enclosed cabinet, and the use of an auxiliary port, the port is made an auxiliary radiator at low frequencies; this controlled use of what otherwise would be waste energy increases efficiency.

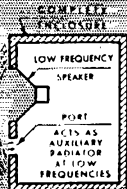

TYPE J PERIDYNAMIC (Model J-51) CABINET is a wall-mounting style which takes any standard six inch speaker. Handsomely styled of a textured composition material, it is complete with mounting bracket. A five-lug terminal board facilitates installation.

Meeting the high engineering and appearance standards which for years have been a Jensen hallmark, these new Bass Reflex cabinets provide acoustically correct enclosures for Jensen speakers. They are particularly suitable for Jensen Coaxials.

All of them (except the J-61) employ the widely heralded Jensen Bass Reflex principle. This, together with special acoustical treatment, assures maximum extension of low frequency response, and freedom from objectionable "boom" or resonance.

See these new cabinets today at your dealers—or write for full information and prices.

ABOVE RIGHT: New Type D Deluxe Bass Reflex Cabinets are available for either 12" or 15" speakers. Exterior styling is by a noted designer; construction by one of the nation's foremost furniture manufacturers. All hard woods are of selected striped walnut. Finish is natural walnut rubbed to a satiny smoothness.

**JENSEN MANUFACTURING COMPANY**

6625 SOUTH LARAMIE AVENUE • CHICAGO 38, ILLINOIS

In Canada: Copper Wire Products, Ltd.,  
137 Oxford St., Guelph, Ontario



# Jensen

*Designers and Manufacturers of Fine Acoustic Equipment*



CUSTOM MADE

TECHNICAL CERAMICS

FOR ELECTRONIC AND ELECTRICAL USES (SOLD ONLY TO MANUFACTURERS)

**ALSIMAG**

TRADE

**AMERICAN LAVA CORPORATION**

46TH YEAR OF CERAMIC LEADERSHIP  
CHATTANOOGA 5, TENNESSEE

# THE AMERICAN RADIO RELAY LEAGUE, INC.,

is a noncommercial association of radio amateurs, bonded for the promotion of interest in amateur radio communication and experimentation, for the relaying of messages by radio, for the advancement of the radio art and of the public welfare, for the representation of the radio amateur in legislative matters, and for the maintenance of fraternalism and a high standard of conduct.

It is an incorporated association without capital stock, chartered under the laws of Connecticut. Its affairs are governed by a Board of Directors, elected every two years by the general membership. The officers are elected or appointed by the Directors. The League is noncommercial and no one commercially engaged in the manufacture, sale or rental of radio apparatus is eligible to membership on its board.

"Of, by and for the amateur," it numbers within its ranks practically every worth-while amateur in the nation and has a history of glorious achievement as the standard-bearer in amateur affairs.

Inquiries regarding membership are solicited. A bona fide interest in amateur radio is the only essential qualification; ownership of a transmitting station and knowledge of the code are not prerequisite, although full voting membership is granted only to licensed amateurs.

All general correspondence should be addressed to the Secretary at the administrative headquarters at West Hartford, Connecticut.



## Past Presidents

HIRAM PERCY MAXIM, W1AW, 1914-1936  
EUGENE C. WOODRUFF, W8CMP, 1936-1940

## Officers

President . . . . . GEORGE W. BAILEY, W2KH  
Washington, D. C.  
Vice-President . . . . . J. LINCOLN MCCARGAR, W6EY  
Oakland, California  
Secretary . . . . . KENNETH B. WARNER, W1EH  
West Hartford, Connecticut  
Communications Manager . . . . . FRANCIS E. HANDY, W1BDI  
West Hartford, Connecticut  
Treasurer . . . . . DAVID H. HOUGHTON  
West Hartford, Connecticut

. . . . .

General Counsel . . . . . PAUL M. SEGAL  
816 Connecticut Ave., Washington 6, D. C.  
Assistant Secretaries . . . . . ARTHUR L. BUDLONG, W1BUD  
JOHN HUNTON, W1LVG, LEROY T. WAGGONER, W1PEK  
West Hartford, Connecticut

## DIRECTORS

**President**  
GEORGE W. BAILEY . . . . . W2KH  
921 19th St., N.W., Washington, D. C.

**Vice-President**  
J. LINCOLN MCCARGAR . . . . . W6EY  
66 Hamilton Place, Oakland 12, Calif.

**Canadian General Manager**  
ALEX REID . . . . . VE2BE  
240 Logan Ave., St. Lambert, P. Q.  
Alternate: Leonard W. Mitchell . . . . . VE3AZ  
78 Raglan Ave., Toronto, Ont.

**Atlantic Division**  
EDWARD G. RASER . . . . . W2ZI  
315 Beechwood Ave., Trenton 8, N. J.  
Alternate: J. Victor Brotherson . . . . . W8BHN  
1743 Ottawa Drive, Erie, Pa.

**Central Division**  
CLYDE C. RICHELIEU . . . . . W9ARE  
4901 So. 30th St., Milwaukee 14, Wisc.  
Alternate: Harold H. Jansen . . . . . W9DJG  
3519 California Ave., Alton, Ill.

**Dakota Division**  
TOM E. DAVIS . . . . . W68W, ex-W9VVA  
915 W. Becker Ave., Willmar, Minn.  
Alternate: Harold B. Love . . . . . W0ZRT  
Box 446, Mandan, N. D.

**Delta Division**  
GEORGE S. ACTON . . . . . W5BMM  
Plain Dealing, La.  
Alternate: Eugene H. Treadaway . . . . . W5DKR  
P. O. Box 44, La Place, La.

**Great Lakes Division**  
HAROLD C. BIRD . . . . . W8DPE  
114 Hickory Dr., R.F.D. 2, Pontiac 2, Mich.  
Alternate: John H. Brabb . . . . . W8SPT  
1321 Berkshire Rd., Grosse Point Park 30, Mich.

**Hudson Division**  
JOSEPH M. JOHNSTON . . . . . W2SOX  
427 Lincoln Ave., Avon-by-the-Sea, N. J.  
Alternate: Robert A. Kirkman . . . . . W2DSY  
1910 Oak Drive, West Belmar, N. J.

**Midwest Division**  
C. A. COLVIN . . . . . W0VHR  
c/o Omaha & Council Bluffs St. Railway Co.,  
Omaha 2, Nebr.  
Alternate:

**New England Division**  
PERCY C. NOBLE . . . . . W1BVR  
37 Broad St., Westfield, Mass.  
Alternate:

**Northwestern Division**  
HAROLD W. JOHNSTON . . . . . W7DXF  
2727 Belvidere Ave., Seattle 6, Wash.  
Alternate: R. Rex Roberts . . . . . W7CFY  
110 W. Brennan St., Glendive, Mont.

**Pacific Division**  
WILLIAM A. LADLEY . . . . . W6RBQ  
200 Naylor St., San Francisco 12, Calif.  
Alternate: Elbert J. Amarantes . . . . . W6FBW  
1675 Dale Ave., San Jose, Calif.

**Roanoke Division**  
H. L. CAVENESS . . . . . W4DW  
2607 Vanderbilt Ave., Raleigh, N. C.  
Alternate: J. Frank Key . . . . . W3ZA  
Box 707, Buena Vista, Va.

**Rocky Mountain Division**  
FRANKLIN K. MATEJKA . . . . . W6DD  
P. O. Box 212, Estes Park, Colo.  
Alternate: P. Arthur Smoll . . . . . W6KVD  
529 No. Nevada Ave., Colorado Springs, Colo.

**Southeastern Division**  
WILLIAM C. SHELTON . . . . . W4ABR  
527 Revilo Blvd., Daytona Beach, Fla.  
Alternate: William P. Sides . . . . . W4AUP  
Fleming Road, Montgomery, Ala.

**Southwestern Division**  
HANS R. JEPSSEN . . . . . W6KEI  
6837 Ethel Ave., No. Hollywood, Calif.  
Alternate: Arthur E. Schifferman, sr. . . . . W6CGI  
1445 Raymond Ave., Glendale 1, Calif.

**West Gulf Division**  
WAYLAND M. GROVES . . . . . W5NW  
P. O. Box 586, Odessa, Texas  
W5NW at Humble Pipe Line Camp, Odessa  
Alternate: Jack T. Moore . . . . . W5ALA  
4531 Fairway Ave., Dallas 4, Texas

# "It Seems to Us..."

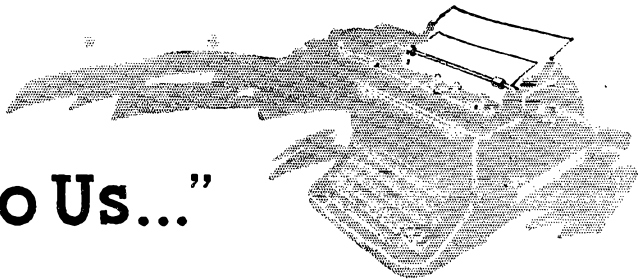

## PUBLIC RELATIONS CONSCIOUSNESS

Through a combination of favorable circumstances and the usual amateur alertness to take advantage of opportunities, the avocation of amateur radio is presently receiving some of its best publicity in many years. Against the background of a notable record of war-service participation, amateur activities have come strikingly to the public attention through outstanding performances in the recent disasters in the Central South, in providing two-way communication between servicemen overseas and family and friends in this country, in setting new distance records for the v.h.f. regions, and through the new UN-IARU liaison.

Amateur radio needs your continuing help in a steady program of favorable publicity. The success of any such program depends to a large extent on the efforts of individual amateurs and clubs. ARRL Hq. has the responsibility for stories via the press associations, and in magazines and other national media, but the attitude of Main Street, U.S.A., toward amateur radio is determined by the activities of its local hams and how thoroughly their accomplishments are brought to public notice. You personally may never have the opportunity to perform a feat of national news and good-will value, but your individual activities as part of the huge group of amateur enthusiasts who do function in the public service can be newsworthy to the people in your community.

The local newspaper editor is interested in names and stories about home-town folks. Few weeklies subscribe to the press wire services; the metropolitan dailies and the radio are pretty stiff competition for national and world-wide news. That makes small-town media, daily or weekly, all the more appropriate for news of individual amateur doings.

There are a good many amateur interests and accomplishments that seem routine to us but which may be considered newsworthy by editors. Maybe you're putting up a new rotatable or fixed beam to work Afghanistan — it has the makings of a story plus a picture. Perhaps you have a pretty good DX record, or

contact a famous foreign ham, or receive an appointment as emergency coordinator for your area; these things are just as much of interest to your local paper as the doings of the ladies aid or an item that Mr. and Mrs. Snerd and son Mortimer visited Yellowstone Park on their vacation. The ability of a ham to contact distant places using equipment constructed with his own hands has in itself a romantic appeal to the average reader. When that ability is called on to provide communication with a soldier overseas for parents in your city, or to relay a message to isolated areas in time of emergency, it's front-page stuff.

In relations with news media the amateur has one priceless advantage — that his activity is principally a hobby, indulged in for the love of the game and the pleasure it returns. He has nothing to sell. He has no press agents engaging in ballyhoo about his public service. The story he can tell to editors is plain and straightforward — the editor himself will find the glamour and news appeal to put the story over.

So drop the home-town editor a note when you've done something with your ham station that you think might be interesting to your neighbors. Give him the facts briefly. If he likes the angle, he'll probably telephone you for more information. If the idea doesn't strike him that particular day, there's no harm done — and you can try again on some later occasion. It should be a part of the make-up of every ham to have an awareness of the value of good public relations and see that material about himself or his club group is given appropriate public mention.

Sometimes your story will so strike the editor's imagination that he'll want to run a special feature on it. And don't overlook the possibilities in local broadcast stations. Most of them are on the lookout for good feature material concerning the activities of home-town individuals and groups; here you may have a better *entrée* by reason of one or more hams on the technical staff of the b.c. station.

To assist individual amateurs and clubs in any major publicity undertaking, ARRL has

available, on request, several mimeographed pieces of literature:

1) *Your Interview on Amateur Radio*, a question-and-answer presentation of background information, aimed principally at writers contemplating a feature story on amateur radio.

2) A sample broadcast script, giving basic ideas on how the local b.c. station, with the aid of several hams and an announcer-interviewer, may present a round-table discussion of amateur radio.

3) A sample speech, containing the fundamentals of a talk which might be made before any community group such as the Rotary Club.

They're yours for the asking. But they are principally background and reference information — they won't automatically build up your press clippings. In the local paper or station approach we have been talking about, the news is still *you*.

Now we're not trying to convert you into a publicity hound, which we despise as much as you do. We don't mean that you should dress up an insignificant event and attempt to make it look important. We mean simply that certain activities which we have come to regard as routine *are* actually newsworthy and would be considered favorably by editors. There is no reason for any ham to be publicity shy, thinking his friends "might get the impression he is seeking notoriety." It is his duty, to further the cause of amateur radio, to see that his genuine part in unusual and notable events is brought before the general public as a further illustration of the many services that amateurs perform.

Don't plague your editor. He knows what is news and what isn't — or he wouldn't get paid for his work. The fact that the Podunk Radio Club "met last night" might get a few lines, but it isn't news. Now if at the meeting your club appropriates some money for a gasoline generator supply or decides to set up a show station at the annual chamber of commerce exhibit, that becomes news copy. But no matter what you think, let the editor be the judge and respect his decision. As we said, you can always try later on another angle.

Remember, OM, the attitude of the general public toward amateur radio depends a lot on how well you as an individual sell your community on it.

— J. H.

## Strays

Item from the Atlanta Radio Club's publication, *The Atlanta Ham*: "In case you get across the high voltage in your transmitter, we suggest Patterson's at Spring Hill. They are kind enough to loan us additional chairs for our meetings."

## A.R.R.L. QSL BUREAU

FOR the convenience of American and Canadian amateurs, the League maintains a QSL-card distributing system which operates through volunteer District QSL Managers in each call area. To secure such foreign cards as may be received for you, send your district manager a stationer's size No. 10 stamped self-addressed envelope. If you have reason to expect a considerable number of cards, put on an extra stamp so that it has a total of six cents postage. Your own name and address go in the customary place on the face, and your station call should be printed prominently in the upper left-hand corner. If you have held other calls in previous years, submit an envelope for each such call to the proper manager — there are many thousands of uncalled-for cards in the files.

W1, K1 — Charles Mellen, W1FH, 320 Cornell St., Boston, Mass.

W2, K2 — Henry W. Yahnel, W28N, Lake Ave., Helmetta, N. J.

W3, K3 — Maurice W. Downs, W3WU, 1311 Sheridan St., N. W., Washington 11, D. C.

W4, K4 — Edward J. Collins, W4MS, 1003 E. Blount St., Pensacola, Fla.

W5, K5 — L. W. May, jr., W5AJG, 9428 Hobart St., Dallas 18, Texas.

W6, K6 — Horace R. Greer, W6TI, 414 Fairmount Ave., Oakland, Calif.

W7, K7 — Frank E. Pratt, W7DXZ, 5023 S. Ferry St., Tacoma, Wash.

W8, K8 — Fred W. Allen, W8GER, 1959 Riverside Drive, Dayton 5, Ohio.

W9, K9 — F. Claude Moore, W9HLF, 1024 Henrietta St., Pekin, Ill.

W0, K0 — Alva A. Smith, W0DMA, 238 East Main St., Caledonia, Minn.

VE1 — L. J. Fader, VE1FQ, 125 Henry St., Halifax, N. S.

VE2 — Austin A. W. Smith, VE2UW, 6164 Jeanne Mance, Montreal 8, Que.

VE3 — W. Bert Knowles, VE3QB, Lanark, Ont.

VE4 —

VE5 — Fred Ward, VE5OP, 899 Connaught Ave., Moose Jaw, Sask.

VE6 — W. R. Savage, VE6EO, 329 15th St. North, Lethbridge, Alta.

VE7 — H. R. Hough, VE7HR, 1785 Emerson St., Victoria, B. C.

VE8 — Yukon A. R. C., P. O. Box 268, Whitehorse, Y. T.

KP4 — E. W. Mayer, KP4KD, P. O. Box 1061, San Juan, P. R.

KZ5 — Signal Officer, KZ5AA, Quarry Heights, Canal Zone.

KH6 — Andy H. Fuchikami, KH6BA, 2543 Namaau Dr., Honolulu, T.H.

KL7 — J. W. McKinley, KL7CK, Box 1533, Juneau, Alaska.

# A 120-Watt Modulator and Speech Amplifier

*Restricted Frequency Response for Reduced-Sideband Operation*

BY C. VERNON CHAMBERS,\* WIJEQ

WITH the exception of audio combinations ending up with 6L6s, it is almost always customary to think in terms of several chassis whenever the audio-output requirements exceed twenty or thirty watts. Even a medium-power layout will ordinarily require separate chassis for the speech amplifier and the modulator and, in many cases, will include separate chassis for the driver and modulator power supplies. Unfortunately, problems such as placing the gain control within convenient reach of the operator, installing equipment without a million interunit connections, and conserving space, increase at a rate just about equal to the increase in the number of units being employed.

The unit described in the following pages is one capable of power output up to and including 120 watts. It is simple and inexpensive in design and, with the exception of the power supply for the output tubes, is self-contained on a single chassis of dimensions suited to operating-table space accommodations. And last — but not least — it includes a frequency-limiting system that is simple to understand and install.

## Circuit Details

The main reason why it is possible to get this much audio power from a relatively compact unit is that the output tubes are 807s. These tubes give full output as audio amplifiers with almost negligible driving power, and this means that the driver can be a small tube (in this case, a double tube) that, unlike the power triodes ordinarily used for driving a Class B stage, also can give a worth-while voltage gain. As a result, the speech amplifier is simplified.

As shown in Fig. 1, the speech amplifier em-

\*Technical Assistant, QST.

• Here's a modulator for the transmitter running 200 watts or less on the plates. The versatile 807s make it a compact job that can be built at low cost. By restricting the audio band to that required by speech only, the effective output is increased and the channel width is reduced, so both the user and the listener benefit.

loys a 6J7 tube in the input circuit. This type was selected in preference to the 6SJ7 so the input circuit could be completely shielded up to and including the first grid. A crystal microphone must be used with this circuit. A gain of 100 can be expected from this first stage.

A 6SN7GT is used in the second stage of the amplifier, with one section serving as a straight triode voltage amplifier and the second section as a phase inverter of the self-balancing type. The gain control for the complete system is connected in the grid circuit of the first half of the tube. Bias for both triode sections is developed across the cathode resistor,  $R_7$ . The phase inverter can be eliminated if an appropriate transformer is available to couple the triode amplifier to the push-pull grids of the third stage.

The third stage employs a 6SN7GT tube with the two grids capacity-coupled to the triode amplifier and the phase inverter. Cathode bias, developed across  $R_{13}$ , is used and the circuit is transformer-coupled to the grids of the Class AB<sub>2</sub> modulator. The voltage gain of this third stage is about equal to that of the second — approximately 20.

The three driver stages are equipped with a

◆  
The speech amplifier and modulator. The microphone jack and the gain control are at the left end of the chassis. The audio components and tubes occupy the front section and the power supply for the driver tubes is laid out along the rear edge.

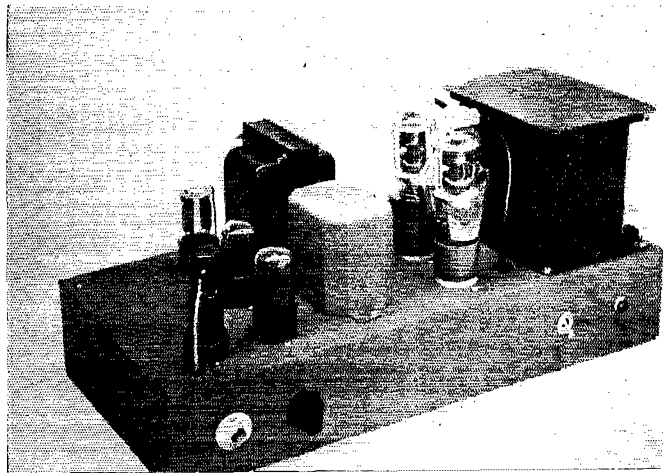

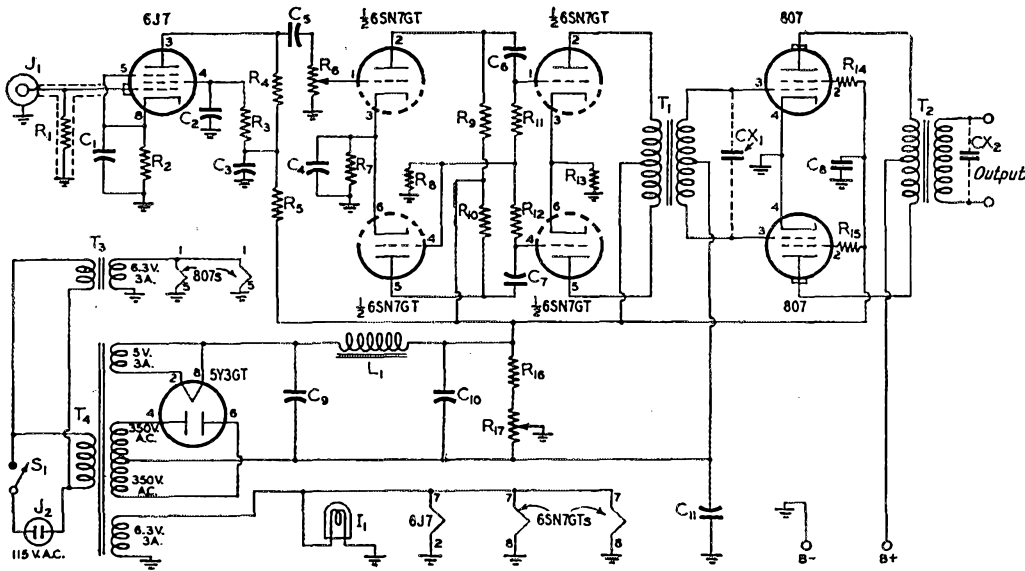

Fig. 1 — Circuit diagram of the 120-watt speech amplifier-modulator.

- C<sub>1</sub> — 10- $\mu$ fd. 50-volt electrolytic.
- C<sub>2</sub> — 0.1- $\mu$ fd. 400-volt paper.
- C<sub>3</sub>, C<sub>9</sub>, C<sub>10</sub> — 8- $\mu$ fd. 450-volt electrolytic.
- C<sub>4</sub>, C<sub>11</sub> — 50- $\mu$ fd. 50-volt electrolytic.
- C<sub>5</sub>, C<sub>6</sub>, C<sub>7</sub> — 0.01- $\mu$ fd. 400-volt paper.
- C<sub>8</sub> — 0.0068- $\mu$ fd. mica.
- CX<sub>1</sub> — 0.001- $\mu$ fd. mica (see text).
- CX<sub>2</sub> — 0.02- $\mu$ fd. mica (see text).
- R<sub>1</sub> — 1 megohm.
- R<sub>2</sub>, R<sub>7</sub> — 1500 ohms.
- R<sub>3</sub> — 1.5 megohms.
- R<sub>4</sub>, R<sub>8</sub>, R<sub>11</sub>, R<sub>12</sub> — 0.22 megohm.
- R<sub>5</sub> — 47,000 ohms.
- R<sub>6</sub> — 1-megohm volume control.
- R<sub>9</sub>, R<sub>10</sub> — 0.1 megohm.
- R<sub>13</sub> — 470 ohms.
- R<sub>14</sub>, R<sub>15</sub> — 100 ohms.
- R<sub>16</sub> — 15,000 ohms, 10 watts.

- R<sub>17</sub> — 1000-ohm wire-wound potentiometer  
(All resistors  $\frac{1}{2}$  watt unless otherwise noted.)
- L<sub>1</sub> — Smoothing choke, 30 hy., 75 ma., 340-ohm d.c. resistance (Utah 4002).
- I<sub>1</sub> — 6.3-volt a.c. pilot-lamp-and-socket assembly.
- J<sub>1</sub> — Shielded microphone jack.
- J<sub>2</sub> — Panel-mounting a.c. plug (Amphenol 61-M1).
- S<sub>1</sub> — S.p.a.t. switch.
- T<sub>1</sub> — Push-pull plates to push-pull grids (UTC S-9).
- T<sub>2</sub> — Output transformer, type depending on requirements. A multitap transformer (UTC VM-3) is shown in photos.
- T<sub>3</sub> — Filament transformer, 6.3 volts, 3 amp. (Thordarson T-21F10).
- T<sub>4</sub> — Power transformer, 350 volts a.c. each side of center-tap, 70-ma. rating. Filament windings: 5 v., 3 amp.; 6.3 v., 3 amp. (Stancor P-4078).

power supply built on the speech amplifier-modulator chassis. The supply circuit is slightly unusual only in that it does not have the negative side returned directly to the common ground. Instead, the return to the chassis is made through the center arm of potentiometer *R*<sub>17</sub>, which is in turn connected in series with the bleeder resistor, *R*<sub>16</sub>. The current flow through the lower section of *R*<sub>17</sub> causes a negative voltage (with respect to chassis) to be developed and this voltage is used as the bias for the modulator circuit. A filament transformer for the modulator stage is included with the other power-supply components, and the primary of the filament transformer can be wired in parallel with the primary of the amplifier plate-supply transformer. Many manuals do not include the Class AB<sub>2</sub> data for the type 807 so the typical operation conditions for 600- and 750-volt plate supplies are listed in the adjoining column:

	CCS	ICAS
D.C. Plate Voltage.....	600	750 volts
D.C. Screen Voltage.....	300	300 volts
D.C. Grid Voltage (Fixed Bias).....	-30	-32 volts
Peak A.F. Grid-to-Grid Voltage.....	78	92 volts
Zero-Sig. D.C. Plate Current.....	60	60 ma.
Max.-Sig. D.C. Plate Current.....	200	240 ma.
Zero-Sig. D.C. Screen Current.....	5	5 ma.
Max.-Sig. D.C. Screen Current.....	10	10 ma.
Load Resistance (per tube).....	1600	1740 ohms
Effective Load Resistance (Plate-to-Plate).....	6400	6950 ohms
Approx. Peak Grid Input Power.....	0.1	0.2 watt
Approx. Max.-Sig. Power Output.....	80	120 watts

Biasing voltage for the modulator is stabilized by the high-capacity filter condenser, *C*<sub>11</sub>, and any tendency for parasitic oscillations to occur is discouraged by the 100-ohm resistors, *R*<sub>14</sub> and *R*<sub>15</sub>, and the mica condenser, *C*<sub>8</sub>. Although in many cases this extra precaution against parasitics will not be necessary, depending upon the 807s and the circuit arrangement, it is cheap protection to incorporate these suppressors right at the start.



### Limiting the Speech Band

Limiting the frequency response of the modulator to hold down the channel width is probably the most interesting subject in connection with the circuit. In accordance with previous recommendations, the response here is limited to an approximate audio-frequency range of 200 to 2500 cycles.<sup>1</sup> A restricted frequency range is not hard to get. A cut-off at the high end can be achieved quite easily by connecting suitable values of capacity across one or more of the audio transformers, a process often referred to as "building out" the transformers. While it is not to be expected that the cut-off characteristics will be as good as with a well-designed low-pass filter, "building out" is decidedly effective for amateur applications — and it is about the least expensive system that can be employed.

It is possible, therefore, to build a simple low-pass filter by connecting a condenser of the proper value across a transformer winding. In a practical transformer a small part of the magnetic

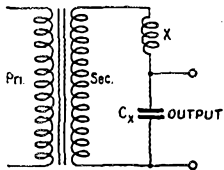

Fig. 2 — The transformer leakage inductance, in conjunction with a "building-out" condenser, forms a simple low-pass filter.

flux set up by one winding fails to link with the other winding, resulting in a small amount of self-inductance. As shown in Fig. 2, this "leakage" inductance,  $X$ , acts in series with the transformer winding, and if a condenser,  $C_x$ , is connected across the transformer terminals it forms, with the leakage inductance, a low-pass filter. The effectiveness of the filter will depend on the amount of leakage inductance, the cut-off frequency desired, and the load resistance (that is, the resistance represented by the Class C stage if the transformer is feeding that stage). Whether or not a good cut-off characteristic is obtained therefore depends on the particular transformer used and the resistance of the load into which it works, assuming that the cut-off frequency is chosen beforehand.

However, it does not matter too much whether or not building out gives a "good" filter. It is possible to attenuate the high-frequency response anyway, even though a sharp cut-off may not be obtained. A condenser connected across the transformer winding will have a definite tone-control effect if its capacitance is made large enough in relation to the load resistance, simply because the internal resistance of any vacuum-tube amplifier is high enough to provide the

necessary resistance part of the common  $RC$  tone-control circuit.

On either basis, it is necessary to determine the proper value of capacitance by trial. It is possible to apply the same tactics to the driver transformer as well as the modulation transformer, and in many cases a more desirable response curve can be obtained by doing so. Incidentally, it must be remembered that the voltage ratings of the condensers should be at least as high as the d.c. plate voltage applied to the tubes with which the transformer is associated.

The low-frequency cut-off of the audio equipment can be handled by the selection of coupling condensers for the first stages of the amplifier. Condensers having a capacity of  $0.01\text{-}\mu\text{fd.}$  offer sufficient reactance at 200 cycles to do an acceptable job of reducing the frequency response at this point of the audio spectrum and below. The reactance decreases as the input frequency is increased and, as a result, the condensers will not affect the high-frequency end of the range.

A family of response curves applying to the amplifier-modulator described here is shown in Fig. 3. Curve No. 1 shows the attenuation obtained with a  $0.01\text{-}\mu\text{fd.}$  condenser connected across the modulation-transformer secondary when working into a load of 3000 ohms. It also shows that the output voltage holds up fairly well — in fact, too well — out past the 2500-cycle point. Curve No. 2 was obtained with a  $0.02\text{-}\mu\text{fd.}$  condenser across the secondary; with this order of capacitance the cut-off is too tapered, as shown by the drop of nearly 4 db. between the maximum-output point (approximately 500 cycles) and 2500 cycles. Curve No. 3, obtained by building out the secondary windings of both the driver and modulation transformers, comes as close to the desired characteristic as can be expected from an attenuation system of such simplicity. Note that the output remains at a reasonable level out into the vicinity of 2500 cycles and that the attenuation thereafter is more rapid than that obtained without the condenser across the driver transformer.

The building-out condensers are referred to in the circuit diagram and in the parts list with the symbols  $CX_1$  and  $CX_2$ . The values suggested will allow a response curve similar to the one shown as No. 3 in Fig. 3 only when they are used with the transformers specified in the parts list. Different transformers will require different capacity values and the manner in which these values are selected will be described later.

### Construction

The photographs of the unit show how the components are laid out on a metal chassis measuring  $3 \times 8 \times 17$  inches. In the front view, the 6J7 and the phase-inverter tube are in line at the left end of the chassis. The driver tube and the 5Y3GT rectifier tube are to the rear of the

<sup>1</sup> G. Grammer, "House Cleaning the Low-Frequency 'Phone Bands,'" *QST*, May, 1947.

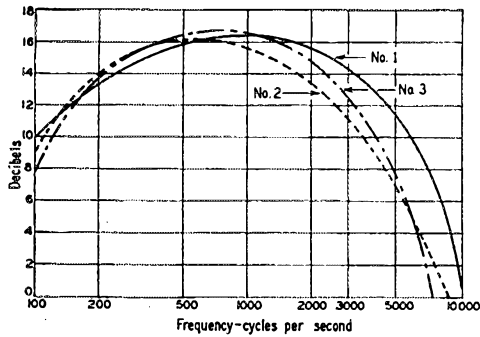

Fig. 3—These curves show how the frequency response of the amplifier shown in the photographs is affected when capacitance is connected across the secondary windings of the driver and modulation transformers. The three curves and associated condenser values are discussed in the text.

6SN7GT phase inverter. The driver transformer,  $T_1$ , at the front and the power transformer,  $T_4$ , at the rear, are next in line. The 807s are located to the left of the modulation transformer, which is at the extreme right end of the chassis. Plate leads for the 807s run through rubber grommets in the chassis; the 6J7 shielded grid lead is handled in the same manner.

The bottom view of the unit shows that the by-pass condensers and the resistors are grouped around the sockets to which they connect. Tube-socket prongs are used as tie-points where possible. The electrolytic condensers,  $C_9$ ,  $C_{10}$  and  $C_{11}$ , can be seen at the bottom of the photograph at a point just above the 115-volt input connector. The bleeder resistor,  $R_{16}$ , is mounted between the bias control,  $R_{17}$ , and a tie-point strip located to the right of the a.c. plug. The microphone jack is shielded with a National JS-1 jack shield.  $R_1$ , the 6J7 grid-leak resistor, is mounted inside this shield.

If the UTC S-9 driver transformer is used, it should be wired with the No. 1 terminals connected to the grids of the 807s. If a different transformer is used, it will be necessary to select a set

of taps that will allow the correct peak-to-peak voltage (the actual voltage required will depend upon the manner in which the 807s are operated — CCS or ICAS) to be supplied to the modulator tubes. The wiring of the modulator-transformer connections will depend upon the type of operation selected for the output tubes, and also upon the impedance of the r.f. load to which the modulator is to be coupled. Transformer manufacturers usually supply data sheets with their transformers which give the connections for various combinations of plate-to-plate and r.f. loads.

### Testing

The power-supply section of the unit should be tested before the audio tubes are placed in their sockets. A voltmeter connected across the output of the supply should show approximately 380 volts when the supply is operated without load.

The speech-amplifier tubes can now be plugged in their sockets and, with the gain control rotated to the *off* position, the voltages at the tube prongs should be measured. (The 807s should not be installed at this time.) The 6J7 plate, screen and cathode potentials should be in the order of 150, 35 and 1.3 volts, respectively. Approximately 130 volts should be indicated at the plates of the first 6SN7GT and 6 to 7 volts should be developed across the cathode resistor,  $R_7$ . The second 6SN-7GT plate potentials will be in the vicinity of 300 volts, and the bias potential, measured at the cathode pin, should be around 9 volts.

A resistive load, equal to the impedance that will be presented by the r.f. amplifier with which the modulator is to operate, should be connected across the modulator output terminals. With the 807s in place, and with the plate connections completed, the speech-amplifier power supply is turned on. The high-voltage supply for the 807s should not be connected to the tubes at this time. The bias control,  $R_{17}$ , should be adjusted to deliver -30 volts to the grids of the modulator tubes. This test must be made as quickly as possible because the screen currents of the 807s will be excessive since the tubes are being operated without plate voltage.

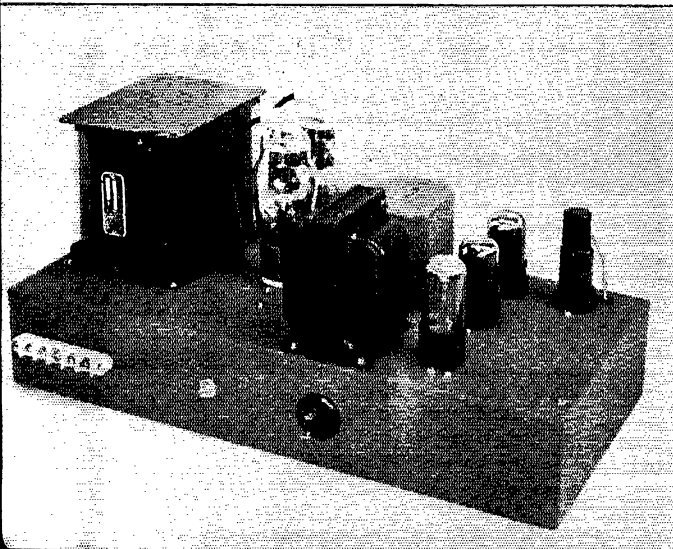

This rear view shows the 115-volt receptacle mounted on the rear wall of the chassis. Plate voltage and output connections for the output stage are made to the terminal strip mounted at the left end. The bias-control shaft, slotted for screwdriver adjustment, is to the right of the terminal strip.

**QST** for

After the bias is set the modulator plate supply may be connected. The supply must deliver 600 volts at 200 ma. if the unit is to be set up for a power output of 80 watts, or 750 volts at 240 ma. for 120 watts output. With the Class C load connected, power may be applied to the complete tube line-up, and the bias control should be reset to cause the modulator tubes to draw a plate current of 60 ma. (this is the total current for both tubes). While talking normally into a microphone connected to the input jack,  $J_1$ , the gain control should be advanced until the modulator plate-current peaks jump to 200 or 240 ma., depending upon the applied plate voltage. This method of testing is not to be considered as a thorough test of the over-all performance of the system, but it will allow a quick check of the equipment.

A few pieces of test equipment are needed for determining the frequency-response characteristics of this or any other amplifier. A calibrated audio oscillator and an output meter are the two most desirable instruments to have available. The output meter must be capable of furnishing accurate readings over the audio-frequency range. The average multirange test meter is not reliable because the accuracy decreases as the test signal is increased in frequency. An oscilloscope makes the best output meter, and will also be very useful in checking individual stages for overloading and distortion.

The amplifier characteristics and the correct condenser values for attenuation of high frequencies can be found in the following manner: With the Class C r.f.-amplifier load replaced by a resistor of the same value, the meter or oscilloscope should be connected across the secondary winding of the modulation transformer and the audio oscillator should be connected in place of the microphone. During the testing procedure the audio-frequency input voltage should be kept low so that the 'scope or meter range will not be exceeded (an alternative method is to connect the measuring device across a small portion of the total load). If the oscillator output is too high for the first tube to handle, the oscillator can be cut in at a later stage. The amplifier response curve can be obtained by applying constant input voltage at various frequencies throughout the audio range and by making note of the output-meter readings as the input frequency is varied.

The selection of condenser values for high-frequency attenuation requires a test set-up

similar to the one outlined above. The difference in the test procedure is that various values of capacity are connected across the transformer secondary winding, or secondary windings as the case may be, until values are found that result in a pronounced drop in output at the desired frequency.

The amount of capacitance required does not depend on the transformer alone; in the usual case, in fact, it will depend mostly on the value of load resistance into which the amplifier works. (The type of tube used in the modulator also can be expected to have some effect on the value of capacitance.) The lower the load resistance the greater the capacitance required.

### A Test Oscillator

Usually, it is possible to borrow an oscilloscope or output meter for any measurements that must be made. However, an audio oscillator is not the type of instrument that is ordinarily found around a ham shack and so the following information may be of interest.

The circuit shown in Fig. 4 is that of a two-terminal oscillator, known as a *cathode-coupled oscillator*.<sup>2</sup> It is easy to construct, simple to adjust, and the circuit will deliver a good waveform throughout the audio-frequency range. The frequency of the oscillator is controlled by the values of  $C$  and  $L$  inserted between terminals  $A$  and  $B$  of Fig. 4. The potentiometer,  $R_3$ , serves as an output attenuator, and output connections are made to terminals  $B$  and  $C$ . The power supply for the oscillator should be capable of delivering 200 to 250 volts at 12 ma.

It would be difficult to construct an oscillator having continuously-variable frequency over the entire audio spectrum and, as a matter of fact, such an oscillator is not required for the type of work for which this oscillator is intended. We have therefore selected standard values of capacitance to be used with a commercial inductance for the purpose of obtaining oscillator output at ten of the more useful frequencies. The condensers can be wired into a switching circuit so that they may be cut into the oscillator circuit at will. The  $LC$  combinations, and the resultant output frequencies, are listed under Fig. 4.

It is not possible to secure oscillator output below a frequency of 1100 cycles (with the 125-mh. coil) when the  $C$  of the resonant circuit ex-

<sup>2</sup> Lt. (jg) F. C. Alexander, jr., "A Cathode-Coupled Oscillator," *QST*, September, 1946.

◆  
The shielded microphone jack is in the upper left-hand corner. The filter choke is mounted in the lower left-hand corner and the 807 filament transformer is to the rear and slightly to the right of the 807 tube sockets. The condenser for attenuating the high audio frequencies, shown at the right-hand end of the chassis, is supported by No. 12 wire leads.

August 1947

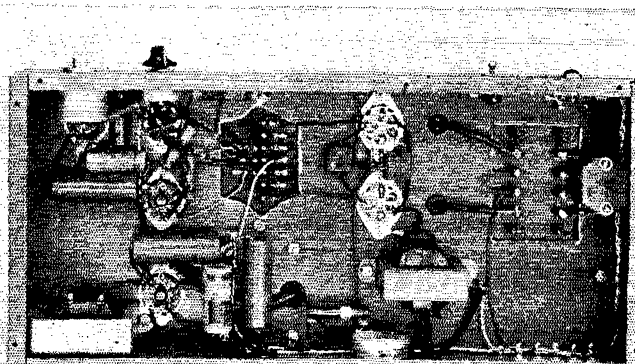

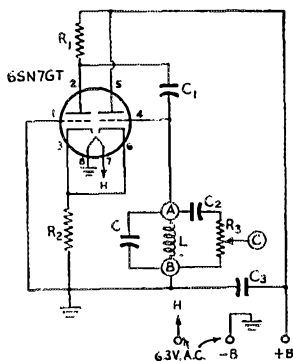

Fig. 4 — Circuit diagram of the test oscillator.

$C_1, C_2$  — 0.1- $\mu$ fd. paper, 400 volts.

$C_3$  — 0.01- $\mu$ fd. paper, 400 volts.

$R_1$  — 68,000 ohms, 1 watt.

$R_2$  — 1500 ohms, 1 watt.

$R_3$  — 50,000-ohm potentiometer.

The following combinations of  $C$  and  $L$  are used for frequencies between 1300 and 10,000 cycles.  $L$ , in each case, is a 125-mh. coil (Meissner 19-6848).

Frequency (cycles)	Capacitance ( $\mu$ fd.)	Frequency (cycles)	Capacitance ( $\mu$ fd.)
1300	0.1	3300	0.015
1800	0.05	4000	0.01
2000	0.04	5200	0.0068
2300	0.03	6250	0.005
2800	0.02	10,000	0.002

ceeds 0.2  $\mu$ fd. It is therefore necessary to increase the value of  $L$  if low-frequency audio output is to be generated. For frequencies below 1100 cycles, it is suggested that the  $LC$  values be as follows:

Frequency (cycles)	Inductance (hy.)	Capacity ( $\mu$ fd.)
1000	1.2	0.02
600	1.2	0.06
400	1.2	0.15
200	1.2	0.5

The value of inductance recommended above can be obtained by removing the iron core from a Thordarson T-14C61 choke. With some tubes, it may be impossible to get the circuit to oscillate at 200 cycles using the specified inductance.

The output of the oscillator will decrease as the resonant-circuit capacity is increased and it is therefore necessary to measure the oscillator output voltage as the frequency of operation is either raised or lowered. This can be done with the aid of an oscilloscope or a low-range output meter having flat frequency response. If the meter does not have a low range (under one volt) it is possible to monitor the oscillator output by measuring the voltage at the grids of the modulator tubes. However, the 'scope should be used to check the voltage waveform at the grids so that overloading of the input or driver stages can be prevented. In the absence of an oscilloscope, it is possible to detect overloading of the first stages by observing the cathode and plate voltages of the three speech-amplifier tubes. Overloading is indicated when the plate voltage decreases, or the cathode-bias voltage increases, because of larger

plate current. When these conditions occur, the tube — or tubes — will no longer operate straight Class A and the output will be distorted. Naturally, the output of the oscillator should be kept below the point at which this distortion begins.

Cutting down the high-frequency response of the modulating system will do much toward relieving interference in the 'phone bands, and the methods outlined above can be used with any audio system. It must be remembered, though, that this only limits the high-frequency response of the audio system. Unnecessary sidebands can still be radiated — regardless of restricted audio response — if the transmitter is overmodulated or improperly adjusted.<sup>1</sup> Equal attention has to be paid to that aspect of 'phone operation!

## WWV Schedules

STANDARD-FREQUENCY transmissions are made available by the National Bureau of Standards over its standard-frequency station, WWV, on the following schedules and frequencies:

Mc.	EST	Power Output (kw.)	Audio Freq. (cycles)
2.5	7:00 P.M.-9:00 A.M.	1.0	440
5.0	7:00 P.M.-7:00 A.M.	10.0	440
5.0	7:00 A.M.-7:00 P.M.	10.0	440 and 4000
10.0	continuously	10.0	440 and 4000
15.0	continuously	10.0	440 and 4000
20.0	continuously	0.1	440 and 4000
25.0	continuously	0.1	440 and 4000
30.0	continuously	0.1	440
35.0	continuously	0.1	440

A 0.005-second pulse may be heard as a faint tick every second, except the 59th second.

The audio frequencies are interrupted precisely on the hour and each five minutes thereafter, resuming after an interval of precisely one minute. This one-minute interval is provided to give Eastern Standard Time in telegraphic code and to afford an interval for the checking of radio-frequency measurements free from the presence of the audio frequencies. Ionospheric-disturbance warnings applicable to the North Atlantic path are given at 20 and 50 minutes past each hour. If a disturbance is in progress or is anticipated within 24 hours, the time announcement is followed by 6 Ws; if conditions are quiet or normal, the time announcement is followed by 8 Ns. The announcement of the station's services and of the station's call (WWV) is given by voice at the hour and half hour.

The accuracy of all the frequencies, radio and audio, is better than a part in 50,000,000. Transmission effects in the medium may result in slight fluctuations in the audio frequencies as received at a particular place; the average frequency received, however, is as accurate as that transmitted. The time interval marked by the pulse is accurate to 0.000001 second. The beginnings of the periods when the audio frequencies are off are synchronized with the basic time service of the U. S. Naval Observatory.

# Curing Interference to Television Reception

## Harmonic Suppression in a 14-Mc. Transmitter

BY MACK SEYBOLD,\* W2RYI

• If you live in an area where television broadcasting is getting under way, it's probably only a matter of time until you come up against the same situation that faced W2RYI. This article tells how one case was cleaned up to the entire satisfaction of the "looker-in" — with no restrictions on W2RYI's operating.

**I**N the sixteen years that I have been an active amateur on half-a-dozen bands in five different homes strung out through three call areas, I have never had any complaints of BCI. Normal precautions taken with the usual ham rigs have been the basis of our good-neighbor policy. Having lived in a variety of places with all kinds of broadcast receivers in nearby locations, there has been ample opportunity to find out if my transmitters, which are normally in a constant state of flux and consequently haywire, were interfering with other radio services. A little common sense and the application of ARRL precepts have paid dividends.

Progress, however, has a habit of catching up with conservatism. The next-door neighbors bought a television set. Until then, the neighbors were not aware that I was conversing nightly with the brotherhood by key and microphone, but when it was made known that an order had been placed for a 7-inch television set, I suggested that the service company installing the equipment might place the receiving antenna at the end of the house farthest from my transmitting antenna. I explained that there might be some interference on Channel No. 2, which is in even-harmonic relationship to most of the amateur bands.

That was extreme optimism! When the dipole with reflector was accommodatingly placed 75 feet away at the far end of the roof, and the television set finally turned on, all hell broke loose. Not only did we interfere with Channel 2, but also with Channels 4 and 5. The pictures wouldn't sync, my voice came in all over the place, and if I keyed the transmitter, the screen flickered like a firefly in the middle of June.

Thus began a series of investigations that took

nearly six weeks to complete. There were two major questions to be answered: What frequencies were causing the interference? What could be done to the transmitter and to the receiver that would restore the good-neighbor policy?

### Initial Tests

The transmitter at W2RYI is a typical 20-meter ham rig. It is unshielded, spread out in two racks several feet apart, link-coupled directly to the 52-ohm co-ax feeding a half-wave antenna, and possesses normal modulation and key-click control. The supply line has an r. f. filter, and the high-voltage power supply, of necessity, has good regulation because the Class B modulator and Class C final operate from the same pack. A 6L6 crystal oscillator operates at the 3.5-Mc. level, followed by two 6L6 stages, each doubling, and the final amplifier is a single RCA-813 adequately isolated so that neutralization is unnecessary. The final input power is 250 watts at a plate potential of 1500 volts.

The first tests, made with the coöperation of the neighbors, were to determine how much power we could use without causing interference. Step by step we cut the power and excitation until we had about 20 watts input. At 20 watts we were still causing interference, so that method of approach was eliminated immediately. With the final plate and screen supply voltages at zero, no interference was reported, meaning that the doublers by themselves were not radiating sufficiently to cause trouble. From that point, all tests were run with 250 watts input.

When the 300-ohm receiving-antenna line was disconnected from the television set, no incoming radiation of any sort was detected, so it was evident that we wouldn't have to work on additional r.f. filters for the power line. This showed that the interference was coming in on the receiving antenna.

The television receiver could be partially responsible for the difficulty by poor image rejection, cross modulation, or by spurious radiation from the transmitter getting through to the i.f. amplifier. The transmitter could be at fault by producing spurious radiation and regular integral harmonics. Measurement of the frequency and magnitude of radiations from the transmitter was the next step.

\* % Tube Dept., RCA, Harrison, N. J.

A Hallicrafters S-27 receiver was borrowed for taking the necessary data. Its range is from 28 Mc. through 144 Mc.; the S-meter was calibrated against two different Ferris signal generators. Below 28 Mc. we used an ACR-111 receiver which was checked against the S-27 at 28 Mc. It took hours of work to take the radiation data as we progressed from filter to filter and trap to trap. Throughout the tests I was helped immeasurably by Morton Aronson, a patient worker and potential ham.

The receivers were conveniently set up 200 feet from the transmitter in the Aronson attic. Two antennas, a 6-foot and a 16-foot folded dipole, were used, one at a time, on the receiver. Each time the harmonics were analyzed, two sets of data were obtained. The signal level reported in this article for each frequency in each test is the higher of the two obtained. The actual difference between the readings from the two antennas at the higher harmonics was very much less than the magnitude of signal intensity reduction necessary to stop television interference.

While making the initial harmonic measurements, we were amazed at the W2RYI spectrum. The integral harmonics of the fundamental frequency, 14.25 Mc., were all present. There were also some intermediate signals which were harmonics of 7.12 Mc., indicating that the driver-doubler was furnishing some excitation to the final at lower frequencies. Table I, Column A, shows the data compiled from the initial test.

Insasmuch as we were handling such a wide range of signal amplitudes and were interested more in relative strengths than absolute values, the data were recorded in decibels. *QST* has published articles<sup>1</sup> dealing with such notations. Briefly, to simplify the interpretation of our tables, the following relationships are derived from the definition of the decibel:

- 1) Each time voltage on the antenna is doubled, add 6 db.
- 2) Each time voltage on the antenna is halved, subtract 6 db.
- 3) Each time power on the antenna is doubled, add 3 db.
- 4) Each time power on the antenna is halved, subtract 3 db.

Similarly, if voltage is changed by a factor of 4 or  $\frac{1}{4}$ , the resulting decibel change is +12 db. or -12 db. respectively; if power is changed by a factor of 4 or  $\frac{1}{4}$ , the resulting decibel change is +6 db. or -6 db. respectively. The figure to which you add the plus or minus db. change is the reference level representing some arbitrarily selected standard which can be reproduced when needed for comparison of signal levels. Our particular problem was to stop interference to television signals; therefore, the television signals were measured to establish the reference level.

<sup>1</sup> *QST*, January, 1947, p. 55.

Our location is in a valley some 15 miles from New York City. The signals from the three television stations are adequate, but not exactly needle-benders. The strongest unmodulated sound carrier of the three reads S9 on the S-27 meter. With the present state of alignment of this receiver, S9 represents an input signal of 600 microvolts as calibrated by the Ferris generators. So there we have our convenient reference level: 600 microvolts, equivalent to S9 on the receiver, called 0 db. in our data.

Referring to Table I, it can be seen that the W2RYI harmonics falling within the three television bands were equivalent in strength to the television signals. In addition, there were strong harmonics in adjacent channels and also at frequencies where receiver image response might cause trouble. Obviously, the first thing to be done was to reduce harmonic radiation, particularly radiation in the 50- to 90-Mc. range.

### Traps & Filters

A trap tuned to 57 Mc. was placed in the plate circuit of the 813. Immediate improvement of the Channel 2 picture was seen — at least the picture would sync! Channels 4 and 5 were still very bad. Table I, Column B, shows the effect of this trap; the great attenuation, 46 db., produced by the circuit at 57 Mc. gave impetus to our work and much encouragement.

The next step was to see if we could get some over-all attenuation at the high frequencies by reducing the high-frequency components in the driver output. A 0.5- $\mu$ h. choke was placed in series with the control-grid lead of the 813, as a result of our theorizing that the 813 input capacitance would offer low impedance to the high frequencies, and the series choke would offer high impedance. Measurements showed that a general attenuation of about 5 db. was produced — not great, but still in the right direction. With the grid choke in the circuit the driving current increased, so we backed the excitation off a little to keep the transmitter running exactly the same for all tests. The grid coil stayed in.

With two circuits in the final amplifier now presenting several high-impedance points for certain frequencies, we wanted to make sure that the transmitter wouldn't take off as a self-excited oscillator. Excitation was cut off, the grid bias was reduced to zero, and the plate and screen voltages were raised until the plate was dissipating 100 watts. No r.f. was produced under these conditions, and we couldn't shock it into oscillation by keying the supply line. It appeared that the grid and plate traps were not reducing the stability of the circuit, so we could proceed with further attenuation experiments.

The next harmonic that needed attention was 71.25 Mc. This one breaks out in Channel 4 near the television sound carrier, and mixes the voice of W2RYI and that of WNBT with fine quality

**TABLE I**

*Analysis of Radiation from W2RYI and Progressive Suppression of Harmonics*

W2RYI		New York Television	Relative Strength Shown in Decibels						% of Radiated Power (G <sub>2</sub> )	
Harmonic	Mc.		Initial Transmitter Radiation (A)	57-Mc. Plate Trap (B)	Grid Choke, 57-Mc. Trap, **Mc. Trap (C)	Choke, 57-Mc. Trap, 71-Mc. Trap (D)	Choke, 2 traps, 1-section filter (E)	Choke, 2 traps, 3-section filter (F)		Choke, 2 traps, 5-section filter (G <sub>1</sub> )
Fund.	14.25	—	+40	+40	+40	+40	+40	+40	+40	99.9
1.5#	21.4	—	*	*	*	*	*	*	— 4	0.003
2	28.5	—	+ 8	— 3	+ 3	— 2	— 2	— 8	— 4	0.003
3	42.7	—	—14	—13	— 8	—15	—18	—23	—15	0.0005
4	54 } 57 } 60 }	Channel 2 WCBS-T	{ — 4 — 4 — 4	{ — 50 — 50 — 50	{ — 45 — 45 — 45	{ — 50 — 50 — 50	{ — 50 — 50 — 50	{ — 50 — 50 — 50	{ — 50 — 50 — 50	0.000001
4.5#	64.1	—	—13	*	—26	—22	—28	—22	—29	0.00001
5	66 } 71.2 } 72 }	Channel 4 WNBT	{ + 7 — —	{ 0 — —	{ —15 — —	{ —31 — —	{ —32 — —	{ —31 — —	{ —40 — —	0.000001
5.5#	76 } 78.5 } 81.7 }	Channel 5 WABD	{ — — —	{ —16 — —	{ —32 — —	{ —34 — —	{ —38 — —	{ —34 — —	{ —38 — —	0.000002
6	85.5	—	0	0	— 8	— 8	—13	— 9	—12	0.0008
7	100	—	0	—12	—13	—12	—15	—14	—12	0.0008
8	114	—	—34	—25	—25	—25	—23	—24	—45	0.0000005
9	128	—	*	—20	—36	—18	—24	—18	—20	0.0001
*10	142.5	—	—27	—25	—40	—30	—34	—28	—28	0.00003

# Spurious radiation attributable to excitation from driver-doubler. \*\* 71-Mc. trap before final adjustment was made.  
\* Not measured. \*\*\* Reference signal level, WABD unmodulated sound carrier.

reproduction of both. Unfortunately, the neighbors wanted to hear only WNBT. A trap was made and tuned to resonance at 71.25 Mc. by the absorption method, using a Boonton Q-meter as the indicator. After installing the new trap in series with the previously mentioned 57-Mc. trap in the plate circuit, and again being pleased and surprised that the transmitter didn't take off through the roof when the power was applied, we went on the air and immediately received a telephone call. Channel 4's picture was a little better — not good, but better — but the unwanted voice was still too loud in the loudspeaker.

Again we set up the receivers 200 feet from the transmitter, and began to plot our spectrum. The result was reasonable, as shown in Column C. Attenuation was present in the vicinity of 71.25 Mc., but not sufficient to take us clear out of WNBT. Wiring capacitance in the plate line had evidently taken the trap to a lower resonant frequency.

The S-27 receiver was brought back and set up about ten feet from the transmitter. A foot of wire was connected to the receiver antenna terminal and progressively cut down until, at a length of six inches, the 71.25-Mc. harmonic from the transmitter gave a reading of S9. By carefully varying the capacitance of the trap condenser with a bakelite rod while the transmitter was operating, we could swing the output at 71.25 Mc. up 25 db. and back below the reference level. The minimum point was S2, which was the level

of signal from the driver stage by itself. The 71.25-Mc. trap was left at maximum attenuation, and we resumed taking data at the 200-foot location. Column D shows the measurement results, and the voice level in Channel 4's sound had dropped to faint audibility.

**Cleaning Up the Receiver**

At this point in our investigations the television pictures showed improvement. All three channels had about the same moderate amount of fine-mesh crosshatching<sup>2</sup> superimposed on the television picture. This defect was strong enough so that, at a normal viewing distance, one was conscious of the pattern. In addition, each channel had streaks passing horizontally through the picture, caused by modulation peaks from 'phone operation of W2RYI. The oscilloscope on the transmitter showed 100% modulation, and reports from distant and local amateurs indicated that our modulation was good, we did not splash, and the transmitter was under control.

Now was the time, evidently, to see what could be done at the receiver. The biggest signal at the

<sup>2</sup> There are two main classifications of interference patterns on a synchronized picture. One type has a herringbone configuration caused by an interfering signal that is frequency-modulated. The other type has a crosshatched or uniformly meshed appearance, and looks very much like the scene one sees while watching a baseball game through a fine-mesh backstop. The crosshatch variety is created by a stable r.f. carrier producing beat notes with the picture carrier.

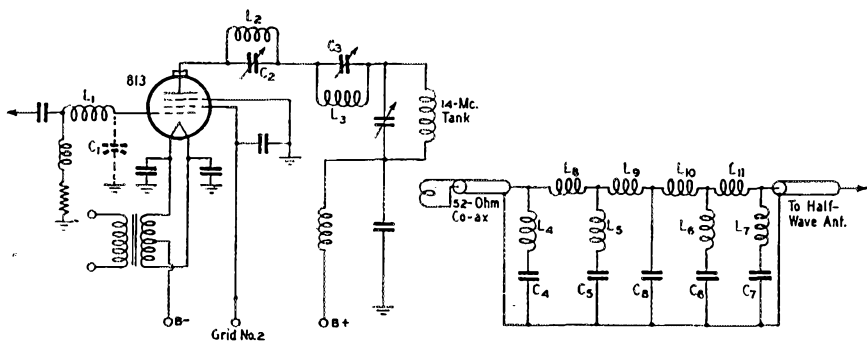

Fig. 1 — 14-Mc. amplifier circuit with harmonic traps and line filter. Each coil is mounted for minimum coupling to all other coils.  $L_1$  to  $L_{11}$ , inc., are  $\frac{1}{2}$ -in. diam. self-supported, No. 12 copper.

- $C_1$  — Input capacitance of 813.
- $C_2$  — 5-30- $\mu$ fd. ceramic variable. Set to resonate with  $L_2$  at 57 Mc.
- $C_3$  — 5-30- $\mu$ fd. ceramic variable. Set to resonate with  $L_3$  at 71.2 Mc.
- $C_4$  — 54- $\mu$ fd. fixed mica (selected from stock for closest value).
- $C_5$  — 144- $\mu$ fd. fixed mica (selected from stock for closest value).
- $C_6$  — 158- $\mu$ fd. fixed mica (selected from stock for closest value).
- $C_7$  — 54- $\mu$ fd. fixed mica (selected from stock for closest value).
- $C_8$  — 180- $\mu$ fd. fixed mica (selected from stock for closest value).

*Coil Specifications*

Coil	Inductance $\mu$ h.	Turns	Length Inches
$L_1$	0.5	10	$1\frac{3}{8}$
$L_2$	0.24	5	1
$L_3$	0.38	6	1
$L_4$	0.26	6	$1\frac{1}{2}$
$L_5$	0.055	2	$\frac{3}{4}$
$L_6$	0.032	1	—
$L_7$	0.26	6	$1\frac{1}{2}$
$L_8$	0.34	9	$2\frac{1}{2}$
$L_9$	0.44	10	$2\frac{1}{4}$
$L_{10}$	0.46	10	2
$L_{11}$	0.36	9	$2\frac{1}{2}$

receiver would be our fundamental, and cross talk from it could be the thing appearing uniformly in all channels. Two traps were made, each with a 68- $\mu$ fd. mica condenser and coils with turns adjusted to resonate at 14.2 Mc. One was put in each leg of the 300-ohm transmission line at the terminals of the receiver. The effect on the passbands of the television set was negligible — picture and sound were at a normal level — but there was a marked improvement in the interference condition. Our cross-talk modulation streaks had disappeared, and the cross-hatching had become less noticeable. Later tests showed that this design of trap in a 300-ohm line will attenuate at least 20 db. within  $\pm 100$  kc. of the resonant frequency.

**Transmission-Line Filtering**

All that remained to the solution of the problem was to remove the last vestiges of sound in the Channel 4 audio system, and to minimize or completely eliminate the remaining crosshatch. Throughout all the trap tests, I had been getting as many signal-strength reports as possible to check my measurements of the fundamental-frequency radiation. The transmitter always seemed to be getting out all right, so I hadn't worried too much about the matter. The next step in the proceedings, however, involved filters

in the co-ax feeder, and I wanted to be sure that the "old sock" didn't get hung up on the wrong end of the line. Inadvertently, we parked on the frequency of W2MJ one evening, struck up a conversation, and our QSO ended up by his volunteering to keep track of my signal strength on his HQ-129X during filter tests. The ground wave comes in on W2MJ's antenna at a convenient level to observe changes in my carrier strength. If I should drop 2 or 3 db. somewhere along the line, I certainly wanted to know about it. If the loss were lumped in a filter, 50 to 75 watts dissipation would soon show up as heat; but it was reassuring to know that a double-check reading was available.

Three separate units were designed for the 52-ohm line using the standard formulas for  $m$ -derived low-pass filters.<sup>3</sup> The first was simply a

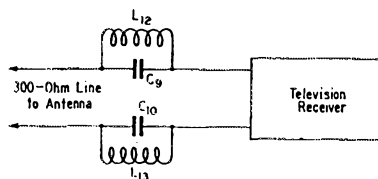

Fig. 2 — Traps for preventing receiver pick-up of fundamental component.

- $C_9, C_{10}$  — 68- $\mu$ fd. fixed mica (not critical).
- $L_{12}, L_{13}$  — 17 turns, 1.8  $\mu$ h., adjusted to 14.2 Mc.
- $L_{12}$  and  $L_{13}$  are No. 18 d.c.c. on  $\frac{1}{2}$ -inch diameter rods.

<sup>3</sup> Radio Engineers' Handbook, F. E. Terman, p. 228 (1943).



**TABLE II**  
Major Television Interference Points  
(Receiver with an i.f. of 21 to 27 Mc.)

Frequency Mc.	Service	Type of Amateur Interference	Correct at:
3.5, 7, 14, 28, etc.	Amateur	Cross talk from fundamental	Rev'r
21-27	Television I.F.	Cross talk from harmonics	Rev'r, Xmtr
44-50	Channel 1	Direct harmonic pick-up	Xmtr
54-60	Channel 2	Direct harmonic pick-up	Xmtr
60-66	Channel 3	Direct harmonic pick-up	Xmtr
66-72	Channel 4	Direct harmonic pick-up	Xmtr
76-82	Channel 5	Direct harmonic pick-up	Xmtr
82-88	Channel 6	Direct harmonic pick-up	Xmtr
92-98	Channel 1 image	Harmonic in receiver image	Rev'r, Xmtr
102-108	Channel 2 image	Harmonic in receiver image	Rev'r, Xmtr
108-114	Channel 3 image	Harmonic in receiver image	Rev'r, Xmtr
114-120	Channel 4 image	Harmonic in receiver image	Rev'r, Xmtr
124-130	Channel 5 image	Harmonic in receiver image	Rev'r, Xmtr
130-136	Channel 6 image	Harmonic in receiver image	Rev'r, Xmtr
174-267	Channels 8 to 13 and images	(Same as above for direct pick-up or image)	

single-section "T" supposedly starting to attenuate at 35 Mc. and increasing in attenuation to an infinite frequency. There were no end-matching sections in this filter, and the mismatch to the line should have been appreciable, but the transmitter loaded well to our standard conditions, the report from W2MJ was normal, nothing got hot, the data taken with the S-27 showed some attenuation (Column E), and the television picture improved one step further.

The next filter tried was like the original one, but it had three sections and was supposed to cut off at 28 Mc. Nothing startling happened with this one (Column F) except that it wasn't any better than the first although I thought it should have shown some additional attenuation other than the few db. we got at 28.5 Mc. Antenna loading was still normal and signal reports were satisfactory.

The next design was to be the perfect match affair with a 34-Mc. cut-off. It had end sections to match the line exactly and to attenuate at 42 Mc. It also had three intermediate "Ts" to attenuate at 57,  $\infty$ , and 71 Mc., in that order of arrangement. The calculated attenuation curve of this 5-section gimmick should have placed our harmonics in the subbasement of a Mexican copper mine. But it didn't. See Column G<sub>1</sub>. With external shielding and complete isolation between the sections, etc., perhaps this type of filter would behave according to theory and take out all the harmonics in one operation all by itself. At any rate, the main reason that low-pass filters are mentioned in this article is that this last filter did show some improvement in the recorded spectrum, and, most important of all, it finished the job so far as television interference was concerned.

With the 14.2-Mc. traps at the receiver, the grid choke and two plate traps at the transmitter,

and the low-pass filter in the 52-ohm transmission line, television reception at the neighbor's proceeds uninterrupted by my activities. Only by careful examination of the picture at a few inches from the kinescope can one see the faint, close weave of a pattern produced by W2RYI. At normal viewing distances there is no visible evidence of my transmissions, either 'phone or c.w. No sound emanates from the loudspeaker to indicate that I am on the air.

Television is a rapidly expanding service. Eventually, many set owners and amateur operators who live within shouting distance of each other will face an interference problem of the type described here. When the problem does arise, the details of Figs. 1 and 2 may help to get the solution well under way. Table II lists the main frequencies at which interference may be caused in a television receiver with an i.f. of 21 to 27 Mc. One should not become discouraged at the length of the table; the problem can be solved.

It may also be well to remember that other wires beside the transmitting antenna can radiate. We found that there was a 6-db. rise in the radiation of all harmonics when a 10-meter antenna feeder was brought in near the 20-meter transmission line. An extreme case of this nature might be the difference between success and failure.

Table I, Column G<sub>1</sub>, giving radiation values, shows the operation of our present transmitter incorporating all the modifications discussed in this article. In the final column (G<sub>2</sub>) of the same table, the relative power now radiated at each of the harmonics is listed. The percentages are based on total radiated power. At 250 watts input, with 70% efficiency, W2RYI puts 175 watts into the antenna system. At the fourth harmonic, 57 Mc., our calculated radiation is

*(Continued on page 110)*

# The "Last-Ditcher"

## A Dry-Battery C.W. Transmitter for Portable or Emergency

BY JOHN PADDON,\* VE3BLZ

**I**N most emergencies the amateur stations carrying the load of traffic have been powered by car batteries, storage batteries or gasoline-driven generators. The world knows the value of their service.

But suppose an emergency appeared under conditions such that it was utterly impossible to reach the scene except on foot and that all gear had to be back-packed. An example might be a plane crash on a mountain in broken country or a spot in a flood that could only be reached by wading.

The little set described in this article was designed to meet "last-ditch" conditions. It can be powered entirely from dry batteries. It was tried out on a Saturday afternoon and evening at the busy low end of the 80-meter band. From a station near Hartford the operator made contact with stations from Old Orchard Beach, Maine, south to Pittsburgh and west to Racine, Wisconsin, and Toronto, Ont. — all with the rock-crushing input of 135 volts at 17 ma.!

The circuit is a simple push-pull crystal oscillator. The tube is the 1J6G, which is the modern equivalent of the old reliable Type '19.

The set is housed in a steel card-index file box. The dimensions are 4 inches by 4½ inches by 6 inches; it fits nicely — see photograph — in the palm of the hand. The total weight of transmitter and cables is 2 pounds 10 ounces.

Filament power is supplied by two ordinary doorbell dry cells in series.  $R_2$  drops the 3-volt

\* Technical Asst., QST.

potential down to the 2-volt value demanded by the tube.

High voltage can be obtained from "B" batteries; four 45-volt blocks in series give "high power." The set will oscillate freely on less than 22½ volts plate supply.

When a storage battery and Vibrapack or dynamotor are available,  $R_2$  can be shorted out and the filament supply taken directly from one cell of the storage battery. The Vibrapack or dynamotor will furnish plate potential which should not exceed a maximum of 200 volts.

The circuit was designed to work against a prefabricated dipole fed with 72-ohm receiving-type "flat" line. A good lightweight wire for the antenna itself is the copper trolling line (solid) available in most sporting goods stores. The same store will supply a couple of 50-foot reels of nylon bait-casting line to act as both halyards and insulators. Even on 80 meters a precut dipole-and-feeder system can be rolled up on a light wooden reel or frame of no great bulk.

### The Layout

Let's look at the front panel in the photograph.

The left-hand knob in the bottom row actuates a Mallory ceramic switch. There are four positions running from left to right: "off," "receive," "send," and "test."

The right-hand knob is the tuning control on the plate tank condenser.

Just above and centered between the two knobs there is a round aperture in the panel; it is there to permit the operator to see the tuning lamp. A glass bull's-eye was not fitted since in strong daylight it is hard to determine whether one is seeing the lamp or a reflection.

The right-hand pair of binding posts take the feeders from the dipole. The left-hand pair carry a short feeder to the receiver input. The dipole is switched through to the receiver on "receive." This does away with the need for two antennas and also gives the advantages of using the dipole for receiving.

The 0-50 milliammeter in the plate circuit is, admittedly, a refinement that is not absolutely essential, as the set can be tuned up on the flash lamp only.



The "Last-Ditcher," built in a metal file-card case, works on either 80 or 40 meters with appropriate crystals and uses dry batteries for power.

QST for



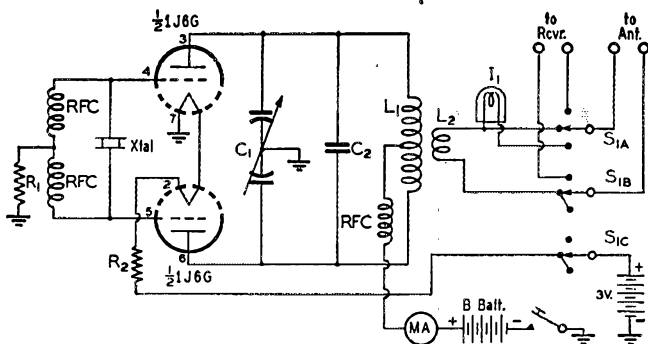

Fig. 1 -- Schematic diagram of the "Last-Ditcher."

- C<sub>1</sub> — 100- $\mu$ fd. per-section variable.
- C<sub>2</sub> — 22- $\mu$ fd. silvered mica.
- R<sub>1</sub> — 1800 ohms, 1 watt; carbon.
- R<sub>2</sub> — 4.17 ohms of resistance wire, wound on a one-watt resistor of 100 ohms or larger.
- L<sub>1</sub> — Two sections,  $\frac{1}{4}$ -inch space between sections, wound on 1-inch 5-prong forms (Millen 45005). The inner ends of the windings are connected together to form the center-tap.
  - 3.5 Mc.: Each section 22 turns of No. 22 enamel wire, close-wound.
  - 7 Mc.: Each section 12 turns of No. 18 enamel wire, close-wound.
- L<sub>2</sub> — Wound in the space between the two sections of L<sub>1</sub>.
  - 3.5 Mc.: 4 turns No. 18.
  - 7 Mc.: 3 turns No. 18.
- I<sub>1</sub> — 2.5-volt 0.06-ampere screw-base pilot lamp.
- MA — 0-50 ma. d.c.
- RFC — 2.5-mh. r.f. choke.
- S<sub>1</sub> — 3-section ceramic wafer switch (4 positions needed, including "off").

The flash lamp (2.5-volt 0.06-ampere screw-base type) is connected in one leg of the feeder. In the "send" position it is shorted out of the circuit by one of the switch elements. In the "test" position it is in series with one leg of the transmission line to the antenna. By switching to the "test" position and shorting the antenna posts the flash lamp is thrown across the pick-up coil. It will light brightly and can be observed through the aperture below the meter when the circuit oscillates. Having thus determined that the set is oscillating the short is removed and the 72-ohm feeder substituted for it. The condenser is then tuned for maximum radiation as shown by the brightness of the flash lamp. The fact that the antenna is taking load properly being thus determined, the switch is thrown to "send" and we're in business.

The flash lamp also acts as a rough-and-ready test instrument. By setting the switch to "test" and connecting the filament batteries, one at a



An inside view of the transmitter. The tube is a 1J6G, used as a push-pull crystal oscillator.

August 1947

time, across the antenna terminals the brilliance of the lamp will give a useful indication of the condition of the battery. In the reverse sense: if it is suspected that the lamp is blown it can be checked in the same fashion.

Construction is so simple as to require little description beyond a study of the photographs and the wiring diagram, Fig. 1.

An aluminum front panel is cut to fill the opening in the card-index box. A shelf just deep enough to clear the bottom of the box is fitted to the front panel. In our case the panel size was  $3\frac{3}{4}$  by  $6\frac{1}{4}$  inches and the shelf  $3\frac{3}{4}$  by  $3\frac{3}{8}$  inches. The front panel is supported by short lengths of aluminum angle fastened to the ends of the box.

The shelf carries the crystal holder, tank coil and tube. It would seem more logical to place the tube next to the crystal holder but that would have placed the tank coil right beside the metal wall of the box.

The tuning flash-lamp holder is mounted on a small block of mica-filled bakelite and the assembly fastened to the front panel opposite the aperture and just below the plate milliammeter.

All leads taken through the shield are carried by soft rubber bushings.

Wiring requires care and patience. The quarters are cramped, but by using a good clean iron with a small tip and carefully pretinning wire ends, the job can be done with little difficulty.

### Power Supply & Tuning

Battery supply is brought in through a small four-pin Jones plug fastened to the side wall of the box. Sufficient lead length is allowed so that the unit can be withdrawn from the box for servicing without disconnecting.

The key is connected externally between B+ and set or between B- and ground.

If the set is built without the milliammeter, or uses a 1 or  $1\frac{1}{2}$ -inch instrument, there will be

(Continued on page 110)

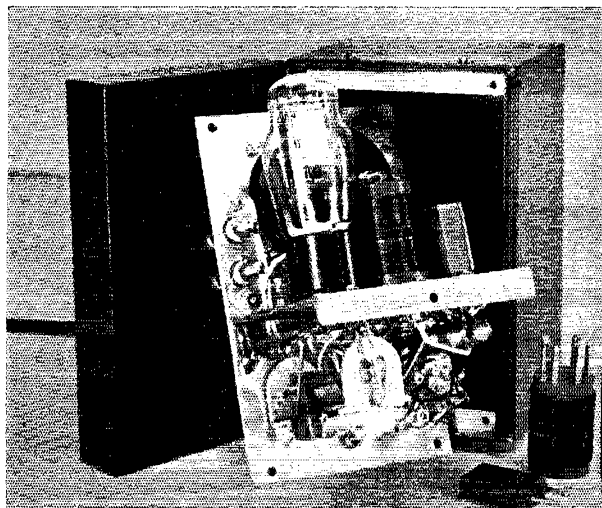

# Coupling to Flat Lines

## Circuit Considerations for Matched-Line Coupling

BY BYRON GOODMAN,\* WIDX

• Here is a story full of useful information for the operator who has been having trouble coupling to a "flat" line. It explains why some lines seem to require very tight coupling and why some don't, and it tells how to insure that you will have no coupling difficulties.

THE widespread use of 50- and 75-ohm coaxial lines for feeding amateur-band antennas has introduced the amateur to some problems that he was unprepared for through his experience with higher-impedance tuned lines. The following discussion will cover only the coupling of transmitters to a pure resistive load, such as is presented by a properly-matched coaxial or parallel-wire transmission line. It must be remembered that whether or not the line is matched — and hence presents a resistive load at the transmitter end — is dependent entirely upon the load at the antenna end, and no amount of adjustment at the transmitter end will correct for an unmatched condition. The condition of match at the antenna end results in no standing waves on the line, and the line is called a "flat" or untuned line. It is perfectly possible to put power into a line that isn't "flat," as is done with any tuned line, but there seem to be some misconceptions about coupling into untuned lines.

In the past, many amateurs have acquired a "flat" line and then blithely connected the transmitter end of the line to a few turns jammed into the transmitter tank coil. Sometimes it "loaded" and more often it didn't. The poor results were usually blamed on the flat line, but so were the good results, and it may be difficult to reconcile the different results. A little discussion of coupled circuits may clear up some of the questions.

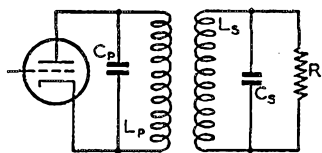

Fig. 1 — A load  $R$  is coupled to a tube through circuits  $L_p C_p$  and  $L_s C_s$ .  $R$  can be connected in parallel as shown, or in series.

Normally we couple two resonant circuits, as in Fig. 1, at the value of coupling called "optimum," which is the amount of coupling obtained just before the tuning starts to broaden out and interlock. The coupling is a factor depending on

the mechanical relation of the coils in the two circuits under consideration, and approaches a maximum value of 1. In practice, however, a value of 0.1 is readily obtainable and anything above about 0.3 becomes difficult with adjacent coils. With overwound or interwound coils, values up to 0.7 can be obtained. The value of optimum coupling is given by the relation

$$k_o = \frac{1}{\sqrt{Q_p Q_s}} \quad (1)$$

where  $Q_p$  and  $Q_s$  are the primary- and secondary-circuit  $Q$ s, respectively. Since we normally design our plate tank circuits with a  $Q$  of about 12 (see ARRL Handbook), Equation 1 above shows that, for  $k_o = 0.1$  (a practical value, remember) an antenna-circuit  $Q$  of over 8 is required. If the antenna-circuit  $Q$  becomes too low, it will require

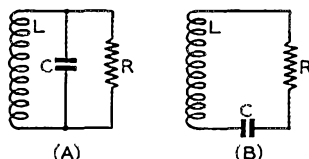

Fig. 2 — A parallel circuit, A, and a series circuit, B. The series and parallel notations are derived from the connection of the resistance.

a higher value of  $k$  to reach  $k_o$ , and this may be a physical impossibility. This is the condition generally described as "it won't load up!"

The  $Q$  of the parallel-tuned circuit in Fig. 2-A at resonance is given by

$$Q = 2\pi fCR \quad (2)$$

where  $R$  is the resistance in parallel with the tuned circuit.

When the resistance  $R$  is in series with the tuned circuit, as in Fig. 2-B, the equation becomes

$$Q = \frac{1}{2\pi fCR} \quad (3)$$

If a value of  $Q = 10$  is assumed, and values of  $C$  calculated from Equations 2 and 3 for various frequencies and values of resistances, a family of curves is obtained as in Fig. 3. Inspection of these curves will show the best way to couple one's flat line to the transmitter. Suppose, for example, one is using a 75-ohm line to feed a beam on 29 Mc., and the line is flat. The 75-ohm lines in Fig. 3 intersect the 29-Mc. line at 740  $\mu\text{fd.}$  for parallel tuning and at 7.4  $\mu\text{fd.}$  for series tuning. Thus if one is to couple his 75-ohm line to the final tank he can connect the line as in Fig. 2-A (the re-

\* Assistant Technical Editor, QST.

Fig. 3 — The capacity necessary for a tank  $Q$  of 10 with 50-, 75- or 300-ohm loads, connected in series or in parallel.

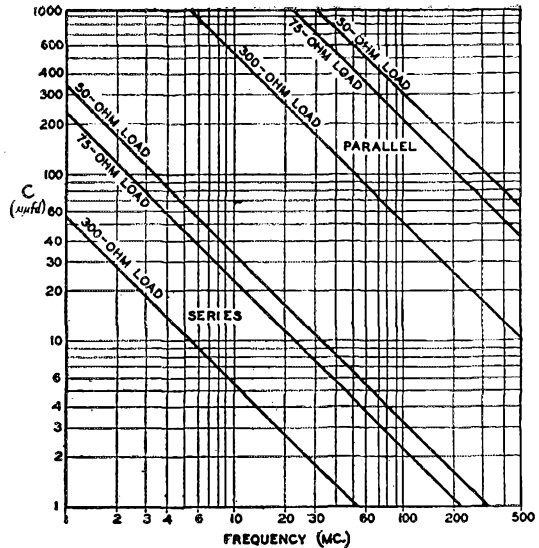

sistance  $R$  represents the line) and use a capacity of 740  $\mu\text{fd.}$  and the small coil necessary to resonate at 29 Mc. (a very small coil, in this case!), or he can use the series circuit of Fig. 2-B and a capacity of 7.4  $\mu\text{fd.}$ , with the correspondingly larger coil required to resonate to 29 Mc. with 7.4  $\mu\text{fd.}$

The curves of Fig. 3 are for an antenna-tank  $Q$  of 10, which is the correct value for a plate tank-circuit  $Q$  of 12 and a coupling factor of 0.09. Tighter coupling will allow the antenna-circuit  $Q$  to be reduced, and less  $C$  will be required for the parallel circuit and more for the series circuit. An antenna — it should be "line" — that "won't load" is the result of not having adequate  $Q$  in the antenna coupling circuit, and the curves of Fig. 3 can be used as a starting point for determining the proper circuit and the approximate  $L$ -to- $C$  ratio when coupling to flat lines. To use the graph, find the intersection of the resistance-load line with the operating frequency for both series and parallel tuning. This will give two values of capacity. Select the more reasonable value of capacity of the two, and build a coil that will resonate with this capacity to the operating frequency. Then connect them to the line and you will have no trouble "loading" the transmitter. If the condenser for series tuning is selected, then the antenna line must be connected in series, of course.

A glance at Fig. 3 will also show that if you are using, for example, a "flat" 75-ohm coaxial line on 144 Mc. but the system loads nicely when you put a 20- $\mu\text{fd.}$  tuning condenser across the antenna coil, you don't have a flat line! If the line were flat, about 150  $\mu\text{fd.}$  would be required for parallel tuning, and your results would indicate that your line is presenting a much higher load than 75 ohms to the antenna coupling circuit or that the coupling factor is high.

The chart also shows that at 50 Mc. a 300-ohm line requires about 1.0  $\mu\text{fd.}$  for series tuning or 100  $\mu\text{fd.}$  for parallel tuning. Since the normal reaction is not to use a coil large enough to resonate to 50 Mc. with 1  $\mu\text{fd.}$  for series tuning, or to use as much as 100  $\mu\text{fd.}$  for parallel tuning, it is easy to see why 300-ohm lines "won't take the soup" at 50 Mc., and one usually ends up by jamming a large coupling coil in the final amplifier tank when this type of line is used. A small copper-tubing coil of 1 or 2 turns and a larger

condenser for parallel tuning would make the line "load" as it should.

It is hoped that, with the aid of the chart, more amateurs will realize that series tuning, with the proper  $L$ -to- $C$  ratio, is generally necessary for coupling to low-impedance lines. When using a series-tuned circuit with coaxial line, it is advisable to connect the rotor of the condenser to the outer conductor of the coaxial line. This junction can then be grounded, if any hand-capacity effects are observed.

### Silent Keys

It is with deep regret that we record the passing of these amateurs:

W1BCF, Vernon R. Brien, Attleboro, Mass.

W2EPU, Morris W. Stormer, Jamestown, N. Y.

W2JWH, Frank Altman, jr., Cliffside, N. J.

W4BNX, L. T. Campbell, Hapeville, Ga.

W4DCC, Henry H. Fincher, Atlanta, Ga.

W5ELS, Henry C. Gotcher, Clarksdale, Miss.

W6BL, ex-W6HZL and 8AX, Harry E. Corey, Los Angeles, Calif.

W6PZK, Leroy M. Lechner, San Luis Obispo, Calif.

W8JO, W8VC, Orson B. Slocum, Roscommon, Mich.

W9TSJ, Paul F. McDonald, Omaha, Neb.

PZ1AB, Otto Groman, Paramaribo, Surinam.



# Atlantic City Report

## JUNE IN REVIEW

Our first report in this column a month ago described the preliminary phase of the radio administrative conference at Atlantic City, the process of organizing and shaking down into a working machine. The weeks of June have constituted the second or working phase of the conference, a steady schedule of grueling committee meetings. In some of the less controversial portions of the work, steady progress has been made and some of the committees report themselves about halfway through their tasks. In the more difficult fields, such as allocations and the creation of an international frequency registration board and the revamping of the CCIR, the work is much less advanced and the month has pretty much gone to the cautious development and putting forward of views to be kicked around by the other countries. Real progress is perhaps scarcely to be expected until the third or semi-desperate phase, which is now only beginning as the plenary conference (to revise the Madrid Convention) opens on July 1st.

This situation has been particularly true of the allocation work. There has been great value in the maneuvers and partial agreements of the past few weeks, because they have brought points of view out into the open and have resulted in the elimination of many extreme proposals and in many cases have narrowed the fields of disagreement. But, generally speaking, it has to be said that the allocations group has spent the month of June chasing its tail in circles in four languages without getting very far forward. Broadcasting, of course, has been the outstanding difficulty — broadcasting and its particularly thorny relative, tropical broadcasting. The divergent philosophies of the maritime and the nonmaritime nations make another major difficulty. While these differing views have been thoroughly debated and some adjustments made, no over-all allocation plan has yet emerged.

With conference documents approaching the 500 figure and formal proposals numbering well

over 2500, we might as well put on the record a few more proposals affecting amateurs. *Egypt* proposes that there be no 80-meter amateur band, 100 kc. at 40 meters, 250 kc. at 20, 500 kc. at 15 meters. *Italy* requests the elimination of the code test for 'phone amateurs. *The Netherlands* apparently favors the maintenance of the 160-meter band in Europe, at a power of 10 watts, and proposes exclusive allocations for amateurs at 3.5-3.7, 7-7.15, 14-14.4, 21.25-21.45 and 28-29.7 Mc. *Netherlands Indies* mention that they want 7.2-7.3 for tropical broadcasting. *U.S.A.* has amended its proposals to take account of the new ISM provisions announced by FCC in May, modifying our 5-kMc. band.

But preliminary proposals have meant very little in the face of such widespread divergence of views, and it is the negotiation in committees that has counted. The main allocations committee, under Sir Stanley Angwin, has had four subcommittees at work for a month. One has dealt with the low-frequency end of the spectrum up to 2.85 Mc., with subsubs of its own to work out compromises on the troublesome question of navigational aids, and another has tackled the main problem of 2.85 to 25 Mc., again with the aid of subsubs. Both of these subcommittees have now reported the extent of their agreements and have been discharged. A third subcommittee, of quite different complexion, is still working on tropical broadcasting and has been going 'round and 'round for weeks. While most of the conference seems to regard its ideas as fanciful in the extreme, with visions of many hundreds of kilocycles exclusively for tropical broadcasting in addition to the regular assignments of h.f. broadcasting, the report isn't in and the issue is by no means settled yet. Then a fourth subcommittee is defining the regions of the world in which allocations may differ for frequencies of shorter range. The American Region has been satisfactorily defined as containing Hawaii.

The June work of greatest interest to amateurs has occurred in the subcommittee studying 2.85

Some of the delegates at the Atlantic City radio administrative conference pose for a picture before the conference hotel. This is only a small part of the total number of persons engaged in the conference.



A typical committee meeting at the Atlantic City conference.

to 25 Mc. Originally consisting of but nine countries, its membership was gradually expanded until it embraced Argentina (speaking for the South & Central American countries except Chile), Australia, Canada, Chile, China, France, India, the Netherlands, Sweden (for the Scandinavian countries), United Kingdom, U.S.A. and U.S.S.R. — and sometimes Belgium and Mexico. We mentioned last month that the work of this group was taking the form of examining spectrum segments of a width of about 2 Mc. and making an initial determination of the requirements for each of the five main services (aero mobile, amateur, broadcasting, fixed and maritime mobile) in each segment. Since these determinations were to be made independently for each service in each segment, it was then intended to "pick up the pieces" for a given segment and see what could be done toward sandpapering them to fit into the available kilocycles. It proved impossible to get the agreements to accomplish this second part of the job but the requirement figures were gone over a second time and "refined," the process also serving to give some ideas of the amount of each assignment that would have to be on a world-wide exclusive basis and the amount that could be shared with some other service. There were many serious disagreements throughout this effort. Although unanimous agreement was found for an occasional proposed allocation for a particular service, the "requirements" of tropical broadcasting were not yet available and in no event did the results approach anything that could be put together to make an allocation ladder. However, inconclusive as the results are of the 22 three-hour meetings of this subcommittee, it did go over the amateur bands on two occasions, and in most respects with considerably greater unanimity than in the cases of the other services. There is therefore a certain validity to the findings it passed along to its parent committee in its final report:

*3.5 Mc.:* No agreement was possible. Europe talked about 100 or 200 kc. and other regions talked 200 or 300 kc., while the American group of nations said 500 kc. Regional agreements, differing in the several regions, were considered the only possible solution — the same thoughts applying to other services as well. The United States took the opportunity to say that while she would not object to diverse regional agreements, she would insist that 3500-4000 be amateur on this side.



*7 Mc.:* The 6-8 Mc. segment was about the most difficult in the spectrum. Agreement was had on 325 kc. for maritime mobile, and near-agreement on 240 kc. for aeronautical mobile. The requirements for the fixed service varied from 820 to 1000 and averaged about 950, the U.S. figure. Because of the interest of the countries outside the American region in an exclusive broadcasting band in this segment, many were unwilling to agree to the maintenance of our assignment. It was impossible to come to any compromise figure. France, India and the U.S.S.R. put themselves down for 150 kc. only. Australia, the Netherlands, Sweden and the United Kingdom voted for 200 kc., although Australia and U.K. said they were willing to consider an additional allocation on a shared basis. Chile, Argentina for the other Latin countries, Canada, China and U.S.A. all insisted on 300. At this point Mexico repudiated the spokespersonship of Argentina and proposed that the amateur allocation be made 150 kc., alleging that the 7-Mc. band is not much used by amateurs in Mexico (!) and that until she saw what provisions were going to be made for tropical broadcasting she wanted to retain some rubber in her commitments. So Mexico was added to those plumping for 150 kc., in a 13-country comment on 6-8 Mc., and in that form it went to the main allocations committee.

*14 Mc.:* On this band there never was disagreement in the subcommittee. Mexico put in her independent one only as concerns broadcasting (although she refused to put down as affirmatively supporting us) and a figure of 400 kc. for amateur radio was unanimously reported.

*21 Mc.:* When this band was first considered, the U.S.A. proposed a new amateur assignment of 500 kc., U.K. proposed that it be 200 kc., and the other powers suggested figures lying within this range. No country questioned the desirability of setting up a new ham band. Eventually a compromise figure of 400 kc. was agreed upon, being prevented from going any higher by adamant U.K. opposition. On the second examination, a couple of weeks later, it was found that the proposed target figures for the five services in this

spectrum segment did not total as much as the available space, and the United States consequently proposed that the amateur figure be upped to 450 kc., which would bring it up to 21.45 Mc. where a broadcast band currently begins. U.K. readily agreed but it was temporarily blocked by France, the Netherlands and Sweden (for the Scandinavian bloc). However, a short while later U.S. agreed to increase a broadcasting band in this segment, and it then became possible — with some adroit help from Canada — to get the objections removed. Thus the 12 nations unanimously joined in proposing a new band of 450-kc. width for amateurs.

In the other subcommittee, dealing with the low end of the spectrum, the portion around 1715–2000 kc. has been found exceedingly difficult because of problems associated with loran, and the possibilities of an amateur provision in this vicinity are still unclear as we write. There seems to be some possibility of a permissive sharing by amateurs in Europe at a power of 10 watts. For the rest of the world the tentative proposal is that 1800–1900 and 1900–2000 kc. be two regional loran bands, and that amateurs, fixed and mobile, be permitted, on regional arrangements, to share whichever 100 kc. is not used for loran in that region. Both bands are used for loran in North America, so that no facilities for W or VE amateurs are implied by the proposal.

At this stage, in the closing days of June, the chairman of the allocations committee has begun a series of meetings of the full committee. With the raw material of agreements, disagreements and partial agreements generated by the subcommittees before him as working data, he has prepared suggested draft allocation tables as targets for discussion. And are they that! With almost all of the 71 registered nations participat-

ing, the full-dress allocations debate is beginning as we bring this part of our report to a close for this month. Progress promises to be more laborious from here on in, with heated battles looming, but next month there should be definite news.

#### Other Matters

*Regulations:* Often postponed for more urgent matters, the question of the amateur regulations (Article 8 in your copy of Cairo) has not yet been reached. There are about 30 proposals for changes, coming from eight nations. We expect this question to be disposed of soon.

*Definitions:* The difficulty with U.K. we mentioned last month was happily resolved by a slight change in wording, after many conferences and several cablegrams with London. In a technical subcommittee the following definition has now been adopted: "Amateur Service: A service of self-training, intercommunication and technical investigations carried on by amateurs, that is, by duly authorized persons interested in radio technique solely with a personal aim and without pecuniary interest." Then the amateur definitions are to be completed soon by the adoption of one defining an amateur station simply as "A station in the amateur service." This outcome being the U.S. proposal, it is of course quite satisfactory.

*Miscellaneous:* It has been decided that the figures 1 and 0 may continue to be used in amateur calls. (The argument was over the possibility of confusion, when written, with the letters I and O.) . . . There is a shortage of prefix letters for calls. An unsatisfactory but ingenious proposal to solve this by the Republic of the Philippines, and having the backing of many small countries, would give each country a two-letter prefix chosen from its own name, resulting in our case in such calls as US1AAAA. . . . A proposal by



Hamfesting on an international scale — 14 countries are represented in this Atlantic City get-together.



U.K. to require licenses for receivers was quickly defeated. . . . A subcommittee is going over the Q code. . . . It is not at all true, as rumored on the air, that the U.S.S.R. is all out to get the amateur. See the Soviet proposals in last *QST*. Although their frequency ideas are rather grim in our lower bands, one of the best speeches in defense of amateur radio at this conference was made by the U.S.S.R. allocations spokesman. . . . A new subcommittee is expected to begin study soon of the spectrum above 25 Mc., which no one has had time to look at yet.

The backing the U.S. delegation is giving the amateur at this conference, particularly through the spokespersonship of Capt. Paul D. Miles on allocation matters, leaves nothing whatever to be desired. It is superb.

### *International Hamfest*

The amateurs of Atlantic City and vicinity are extending their hospitality to the amateurs on visiting delegations to the international conference. With Larry Norcross, W2PXXZ, as liaison, numerous delegates have visited numerous local stations and have had many contacts with home. There are a number of particularly hot stations in the vicinity and some of the QSOs have been beautiful demonstrations of amateur prowess.

On the night of June 7th the local gang held an informal amateur meeting in the recreation room of St. Paul's Methodist Church, with Rev. J. Stanley Wagg, W2JBF, pastor of the church, as M.C. Fourteen countries were represented by the 75-or-so amateurs attending and a most interesting time was had in getting acquainted with each other. Short talks, reporting the status of amateur radio and bringing greetings from the respective countries, were made by representatives of Argentina, China, Cuba, Ecuador, Great Britain, Mexico, the Netherlands, New Zealand, Norway, Panama, Switzerland, Uruguay, Venezuela and the U.S.A. An unusual feature was the presence of the government administrators of amateur radio in five countries — Cuba, New Zealand, Panama, Switzerland and Venezuela — with good-natured ribbing back and forth with the hams present. In addition to officials of RSGB and ARRL, the attendants included K. T. Chu, CIKT, acting president of the China Amateur Radio League, from whom the meeting learned with great interest of the progress of the amateur movement in that land. The speakers also included Capt. Bjorn Arnold Rorholt, LA1GA, representing amateurs of the Scandinavian countries, one of the few non-British holders of the Distinguished Service Order, awarded for his sterling communication accomplishments in the Norwegian underground in liaison with the British in the late war. W2JBF entertained with amateur magic, including eating a dozen flashlight bulbs and "reappearing" them neatly wired in parallel, while the XYLs conjured up coffee and cake to

stimulate the rag-chews and the making of schedules. A pleasant evening, thanks to the locals, and a foretaste of the international conventions to which we shall some day grow.

The names of Mr. Chu and Capt. Rorholt, by the way, have recently been added to the IARU representation at the conference.



**T**HE weatherman's pronouncements of torrid doings for August, 1922, were not his exclusive privilege. *QST* for this same month reported equally hot developments in the amateur radio field: the workings of superregeneration; Senatore Marconi visits Dr. Steinmetz of GE; facts on the new gaseous-type S-tube rectifiers; and c.w. bests spark in traffic totals for the first time.

We're given the ground-floor approach to E. H. Armstrong's new invention in the month's leading technical article, "More on Superregeneration," by K. B. Warner and Boyd Phelps. A number of vague points have been cleared up for hams, particularly as concerns expected performance in the reception of 'phone and c.w. At this experimental stage loop antennas are recommended, to cut down on radiation. The search for additional practical information goes on, however, stimulated by this *QST* which announces a competition among superregenerator constructors.

"The S-Tube Rectifier" — its characteristics, circuits and features — is discussed in learned detail by Howard J. Tyzzer's paper. Articles further adding to the fund of knowledge of the rapidly-growing c.w. clan are "Operation of the Low-Power C.W. Transmitter," by A. M. Young, 3BEC, "Coils for C.W. Reception," by the well-known authority, A. L. Groves, 3BID, "A Single-Circuit Receiver," by L. W. Austin, and "Wave Traps," by Assistant Editor Boyd Phelps. A comparison of the operation of hot-wire and thermocouple indicating devices is presented in "The Application of Measuring Instruments to Radio," an enlightening article by John H. Miller. New apparatus announced this month includes Giblin low-distributed-capacity honeycombs, Jewell meters that read filament current in up to three stages, the Queens Radio Company variocoupler, and the Adapt-O-Phone loud-speaker.

Not all interference to radiophone listeners is from amateurs. The commercials and poorly operated radiophones contribute their share, as is convincingly proved by 2FZ's article, "Amateur Interference." An insight to WSB, Atlanta, Georgia, is provided in this issue by the radiophone section.

(Continued on page 118)

# Happenings of the Month



## ELECTION NOTICE

To All Full Members of the American Radio Relay League residing in the Atlantic, Dakota, Delta, Great Lakes, Midwest, Pacific and Southeastern Divisions:

You are hereby notified that, in accordance with the Constitution, an election is about to be held in each of the above-mentioned divisions to elect both a member of the ARRL Board of Directors and an alternate thereto for the 1948-1949 term. Your attention is invited to §1 of Article IV of the Constitution, providing for the government of ARRL by a board of directors; §2 of Article IV, and By-Law 12, defining their eligibility; and By-Laws 13 to 24, providing for the nomination and election of division directors and their alternates. Copy of the Constitution & By-Laws will be mailed to any member upon request.

Voting will take place between October 1 and November 20, 1947, on ballots that will be mailed from the headquarters office during the first week of October. The ballots for each election will list, in one column, the names of all eligible candidates nominated for the office of director by Full Members of ARRL residing in that division; and, in another column, all those similarly named for the office of alternate. Each Full Member will indicate his choice for each office.

Nomination is by petition. Nominating petitions are hereby solicited. Ten or more Full Members of the League residing in any one of the above-named divisions may join in nominating any eligible Full Member residing in that division as a candidate for director therefrom, or as a candidate for alternate director therefrom. No person may simultaneously be a candidate for both offices. Inasmuch as all the powers of the director are transferred to the alternate in the event of the director's death or inability to perform his duties, *it is of as great importance to name a candidate for alternate as it is for director.* The following form for nomination is suggested:

*Executive Committee*  
*The American Radio Relay League*  
*West Hartford 7, Conn.*

*We, the undersigned Full Members of the ARRL residing in the . . . . . Division, hereby nominate . . . . . of . . . . . as a candidate for director; and we also nominate . . . . . of . . . . . as a candidate for alternate director; from this division for the 1948-1949 term.*

*(Signatures and addresses)*

The signers must be Full Members in good standing. The nominee must be a Full Member and must have been both a member of the League and a licensed radio amateur operator for a continuous term of at least four years immediately preceding receipt by the Secretary of his petition of nomination, except that a lapse of not to exceed ninety days in the renewal of the operator's license and a lapse of not to exceed thirty days in the renewal of membership in the League, at any expiration of either during the four-year period, will not disqualify the candidate; provided that if a candidate's membership was interrupted by reason of service in the armed forces of the United States or Canada between September 1, 1939, and May 3, 1947, he shall not be deemed to be disqualified so far as concerns continuity of membership if within those dates he resumed his League membership within the 90 days following his release from active military duty. He must be without commercial radio connections; he may not be commercially engaged in the manufacture, selling or renting of radio apparatus normally capable of being used in radio communication or experimentation, nor commercially engaged in the publication of radio literature intended, in whole or part, for consumption by licensed radio amateurs. Further details concerning eligibility are given in By-Law 12. His complete name and address should be stated. The same requirements obtain for alternate as for director. All such petitions must be filed at the headquarters office of the League in West Hartford, Conn., by noon EDST of the 20th day of September, 1947. There is no limit to the number of petitions that may be filed on behalf of a given candidate but no member shall append his signature to more than one petition for the office of director and one petition for the office of alternate. To be valid, a petition must have the signature of at least ten Full Members in good standing; that is to say, ten or more Full Members must join in executing a single document; a candidate is not nominated by one petition bearing six valid signatures and another bearing four. Petitioners are urged to have an ample number of signatures, since nominators are frequently found not to be Full Members in good standing. It is not necessary that a petition name candidates both for director and for alternate but members are urged to interest themselves equally in the two offices.

League members are classified as Full Members and Associate Members. Only those possessing Full Membership may nominate candidates or stand as candidates; members holding Associate

Membership are not eligible to either function.

Present directors and alternates for these divisions are as follows: Atlantic Division: director, Edward G. Raser, W2ZI; alternate, J. Victor Brotherson, W8BHN. Dakota Division: director, Tom E. Davis, W0SW; alternate, Harold B. Love, W0ZRT. Delta Division: director, George S. Acton, W5BMM; alternate, Eugene H. Treadaway, W5DKR. Great Lakes Division: director, Harold C. Bird, W8DPE; alternate, John H. Brabb, W8SPF. Midwest Division: director, C. A. Colvin, W0VHR; alternate, none. Pacific Division: director, William A. Ladley, W6RBQ; alternate, Elbert J. Amarantes, W6FBW. South-eastern Division: director, William C. Shelton, W4ASR; alternate, William P. Sides, W4AUP.

These elections constitute an important part of the machinery of self-government of ARRL. They provide the constitutional opportunity for members to put the direction of their association in the hands of representatives of their own choosing. Full Members are urged to take the initiative and to file nomination petitions immediately.

For the Board of Directors:

K. B. WARNER,  
*Secretary*

July 1, 1947

#### 420-MC. BAND WIDENED

FCC Order 130-O of June 11th made immediately available to amateurs the entire band 420-450 Mc., of course still subject to the limitation of 50 watts peak antenna power to protect the altimeter service still operating in that region.

Consider for a moment that a half-wave at 420 Mc. is slightly more than 13 inches — what possibilities for beams! The band is reachable with generally-available tubes and equipment, and with fairly standard techniques. The lowest-frequency amateur band sufficient to support emissions requiring a very large bandwidth, 420 Mc. is consequently the first, as we go up the scale of frequency, in which television is permitted. In its new width, the band provides not only plenty of room for u.h.f. enthusiasts but also a happy hunting ground for television experimenters.

#### CHANGES IN CANADIAN REGS

Canada changes its regulations but once a year, generally speaking, printing the new rules on the back of licenses issued April 1st. This year finds numerous changes of practical import to VE hams.

'Phone may no longer be used on ten meters below 28,200 kc., the lower 200 kc. now being reserved for A1. Similarly, 27,185 to 27,245 kc. is restricted for c.w. — and also i.c.w. Stability requirements have been extended through 54 Mc., so that modulated oscillators will disappear from 6 meters. Frequency-modulation techniques are now permitted on 27.395-27.455, 29.5-29.7, 52.5-

#### INCREASE IN DUES

• Effective July 1st, ARRL membership dues in both the United States and Canada were increased fifty cents a year, by action of the Board of Directors, and apply to both full and associate memberships. Dues, including subscriptions to *QST*, are now as follows: In the United States & Possessions, \$3 a year. In the Dominion of Canada, \$3.50 a year. In all other countries, \$4 a year. In the special case of "family memberships" in the United States and Canada, without *QST*, as limited by By-Law 4, \$1 a year.

54 Mc. and all higher-frequency bands.

But perhaps most interesting is the new procedure concerning privileges available to new licensees. A new amateur may not use 'phone on any band below 30 Mc. until after six months of experience with c.w. below 30 Mc., at which time he may use 'phone on the assigned portions of 10 and 11 meters. After one year of license tenure, the amateur may take the advanced 'phone examination, plus a 15-w.p.m. code test, to obtain permission to use the 75- and 20-meter 'phone bands. Of course, a new amateur may use any permitted type of emission above 50 Mc., but he may not use 'phone below 30 Mc. without complying with the low-frequency c.w. experience or examination requirements, regardless of the amount of time he may have spent above 30 Mc.

#### TELEVISION INTERFERENCE

In an attempt to solve some of the problems of interference being caused television broadcasting by the fixed and mobile services, and amateurs, FCC held an informal engineering conference in Washington on June 10th and 11th. Practically all users of the frequencies between 42 and 88 Mc. had representatives in attendance, and Technical Director George Grammer and Robert Morris, W2LV, appeared on behalf of the League and the amateur service.

Data presented at the meeting both by the Commission's staff and by industry representatives indicated that it was impossible to continue successfully shared use of television channels by fixed and mobile services; the adjacent-channel interference is simply too great and, because of the very nature of television receivers, practically impossible of solution.

The League's statement was simple but forceful: that it is a mistake to assign any kind of broadcast service to channels which are harmonics of amateur bands — because there are so many amateurs interference in metropolitan areas is bound to result, and in the present state of the art no amount of engineering can completely elimi-

(Continued on page 118)

# An Electronic Multicircuit Breaker

Simple Overload Protection for Transmitting Gear

BY G. D. HANCHETT, JR.,\* W2YM

• Amateurs in general seldom give even slight consideration to automatic overload protection for their transmitting equipment. And yet it would be expected that such devices should pay dividends to hams most of all, because it is their well-known habit to run equipment at maximum ratings as a minimum, in contrast to the more conservative practices in commercial installations. The system described here by W2YM is simple and easily understood and yet not so expensive and difficult to build as to offset the protection it provides. Furthermore, it ought to be an interesting departure from the usual type of constructional job — an ideal summer project.

THE problem of protecting ham transmitting gear has confronted amateurs for many years. The failure of a circuit component may result in costly damage to tubes or equipment, to say nothing of valuable time lost in checking, trouble-shooting and repair work. The problem becomes more important the larger the transmitter and the more efficiently it performs.

There are several well-known methods available for protecting transmitting tubes and equipment, but they have certain disadvantages. Fuses, for instance, are not very reliable and, for high-voltage protection, are relatively expensive. Magnetic circuit breakers, while ordinarily superior to fuses, are quite expensive when a number of circuits have to be protected.

This article describes a method of using electron tubes to accomplish circuit protection. Besides being reliable, easy to operate, and relatively inexpensive, an important advantage of the electronic circuit breaker is that many inde-

pendent circuits can be protected simultaneously by the same breaker. In addition, resetting the breaker is accomplished by merely opening a conveniently-located switch. If for any reason the circuit fault has not cleared, the breaker will immediately throw out again when the power to the transmitter is reapplied. An additional feature which may save considerable trouble-shooting time is the fact that panel lamps are used to indicate which circuit caused the breaker to operate.

The "brain" of the electronic multicircuit breaker is the 2D21 or 2050 thyratron. These tubes, designed for relay applications, are useful because for any specific shield-grid voltage and positive anode voltage, there is a critical value of control-grid voltage that determines whether the tube stays cut off or whether it is triggered and conducts with d.c. voltage on the anode. Once the tube is triggered, it continues to conduct independently of subsequent normal values of control-grid voltage. It is a property of thyratrons that once the gas content is ionized, conduction may be stopped by removing the anode voltage.

## Circuit Discussion

The circuit of the complete electronic multicircuit breaker is given in Fig. 1. In this circuit, the trigger voltage for the thyratron is obtained from the cathode-return circuit of the stage to be protected. A resistor combination,  $R_5$  and  $R_6$ , is inserted in the circuit so that if the current increases, the voltage drop across  $R_5$  and the control-grid voltage of the thyratron will also increase. By proper adjustment of  $R_5$  and by proper selection of shield-grid and anode potentials, any increase in current through  $R_5$  that exceeds a preset value will trigger the thyratron and cause it to conduct. When the tube draws current, relay  $Ry$  operates and opens the circuit to the primaries of the high-voltage transformers of the transmitter.

To insure fast action, the initial relay current is augmented by about 50 per cent through the

\*c/o Application Eng. Lab., Tube Department, RCA-Victor Div., Radio Corporation of America, Harrison, N. J.

◆  
Front view of the completed circuit breaker.  
◆

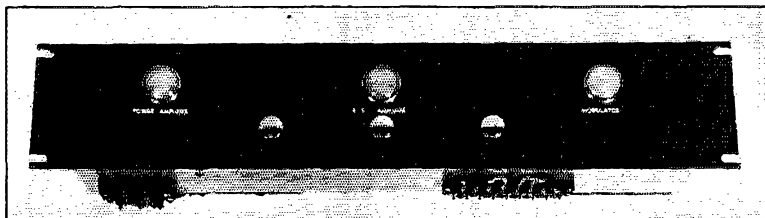

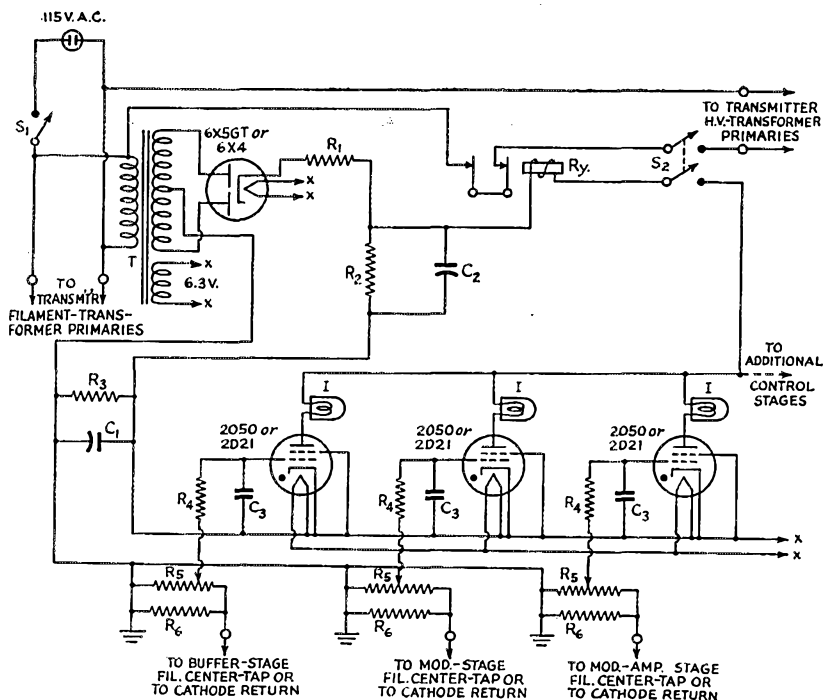

Fig. 1 — A schematic diagram of an electronic multi circuit breaker. The dash line indicates the point to which additional tubes are connected when additional circuits are required.

$C_1$  — 50- $\mu$ fd. 50-volt electrolytic.  
 $C_2$  — 20- $\mu$ fd. 450-volt electrolytic.  
 $C_3$  — 100- $\mu$ fd. 300-volt mica.  
 $R_1$  — 2500 ohms, 10 watts.  
 $R_2$  — 10,000 ohms, 25 watts.  
 $R_3$  — 200 ohms, 2 watts.  
 $R_4$  — 0.1-megohm,  $\frac{1}{2}$  watt.  
 $R_5$  — 50-ohm potentiometer, 1 watt.

$R_6$  — 10 ohms, 10 watts.  
 $R_y$  — Double-break normally-closed relay, 30-amp. contacts.  
 $I$  — 115-volt 6-watt Mazda lamp.  
 $S_1$  — S.p.s.t., 12 amp.  
 $S_2$  — Plate-power switch, d.p.s.t., 12 amp.  
 $T$  — 600 volts c.t., 50 ma.; 6.3 v., 2.5 a.

use of a capacitor,  $C_2$ , charged through a resistor,  $R_1$ , in series with the plate supply. Upon the ionization of the thyatron, the energy in this capacitor is discharged through the relay coil, augmenting the plate supply and thereby causing faster action. After this initial charge has subsided, however, only normal relay current will flow, because it is limited by the resistance of  $R_1$  and the panel lamp in series. Tests show that the breaker action is fast enough in most cases so that the pointer of a meter connected in the plate circuit of the stage to be protected will not reach the full-scale deflection stop even on a dead short-circuit.

The electronic circuit breaker diagrammed in Fig. 1 is designed for the protection of three stages and, in the particular transmitter used, these are the buffer, modulated amplifier, and modulator stages. The triggering voltage for each thyatron is obtained from the drop across  $R_5$  in combination with the potentiometer  $R_6$ .  $R_6$  should be large enough in resistance to produce a drop of about two volts at the minimum current desired for relay drop-out. The circuit can be

adjusted for heavier currents than this value by means of potentiometer  $R_5$ . In Fig. 1 the value of  $R_6$  is ten ohms. This value allows a minimum drop-out current of approximately 200 milliamperes.

In the electronic multicircuit breaker, the switch,  $S_2$ , serves two purposes. One pole of this double-pole switch is used for a power control; the other pole is connected in series with the anodes of the thyratrons. If any one of the thyratrons conducts, the relay coil will be energized, opening the primary circuits to all plate transformers and therefore removing plate voltage from the transmitter. In order to reset the breaker, the plate-power control switch  $S_2$  is turned to the "off" position. In this position the anode circuit of the thyratrons is open, allowing the triggered tube to deionize. Throwing the plate power-control switch,  $S_2$ , back to "on" position reconnects the d.c. voltage to the thyratrons and the supply voltage to the transmitter high-voltage transformer primaries. If the trouble in the transmitter has not been remedied, the circuit breaker will again immediately remove

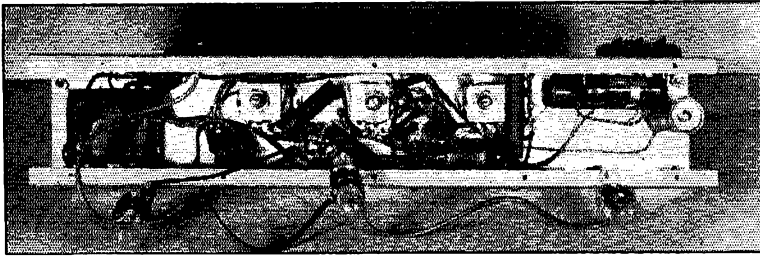

◆  
 Inside view of chassis with panel removed. Note how the drop-out controls ( $R_5$ ) are mounted on small metal brackets.  
 ◆

the supply voltage to the high-voltage transformers of the transmitter.

Each thyatron has a six-watt panel lamp in series with its anode circuit. This lamp acts as an indicator to locate the circuit that caused the breaker to open. The operator, therefore, can immediately determine the circuit in which the allowable current was exceeded and in this way greatly expedite troubleshooting.

### Construction

The three-circuit multibreaker built by the writer for protection of his transmitter is mounted on a  $3\frac{1}{2}$ -inch standard steel relay-rack panel as shown in the photographs. The chassis is formed from a piece of aluminum and is bolted to the front panel. The drop-out current controls,  $R_5$ , are located behind the panel and are adjusted with a screwdriver through a hole in the panel. When not in use, these holes are closed by small nickel-plated snap buttons. Placing the controls behind the panel has the definite advantage of being out of reach of dial twiddlers. Connection of the transmitter multicircuit breaker is accomplished through the use of a terminal strip at the rear of the chassis.

The construction of the electronic circuit breaker is comparatively simple. Since the operation of the circuit breaker is intermittent, the components may have low ratings. The power transformer supplying the d.c. anode voltage may be of the conventional receiver replacement type. It should have a rating of approximately 300 volts r.m.s. each side of center-tap at a current rating of about 50 ma. It should also have a

6.3-volt winding sufficient to handle the heaters of the thyatron tubes and the rectifier. Each tube in this circuit breaker requires a heater current of 0.6 ampere. The relay should be of the heavy-duty type with a coil rating of about 100 to 120 volts d.c. (50 ma. or less). Most 115-volt d.c. relays meet this requirement. Lower coil voltages can be used provided a proper resistor is connected in series. The contacts should be as large as possible and, for protection of transmitters with an input up to one kilowatt, contact ratings of 30 amperes a.c. are satisfactory.

Bias for the thyatrons is obtained from a voltage divider across the plate supply. Since the electronic breaker is usually operated near strong r.f. fields, it is desirable to incorporate some method of r.f. filtering in the grid circuit of each thyatron. In the circuit of Fig. 1, filtering is accomplished by a resistance-capacitance filter,  $R_4$  and  $C_3$ .  $C_3$  is a mica capacitor connected as closely as possible to the tube socket.

With the addition of an electronic multicircuit breaker to his transmitter an amateur can adjust the breaker circuits to operate just above normal currents and, thus he can positively and reliably protect his equipment against excessive currents. In the event that a modulation peak or a transient should operate the breaker, it is a very simple matter to resume operation again — just snap the switch off and on. Should one desire to protect more than three circuits, all that is required is an additional thyatron, indicating lamp, and grid-circuit components, connected as indicated by the dashed lines in Fig. 1., for each additional circuit to be protected.

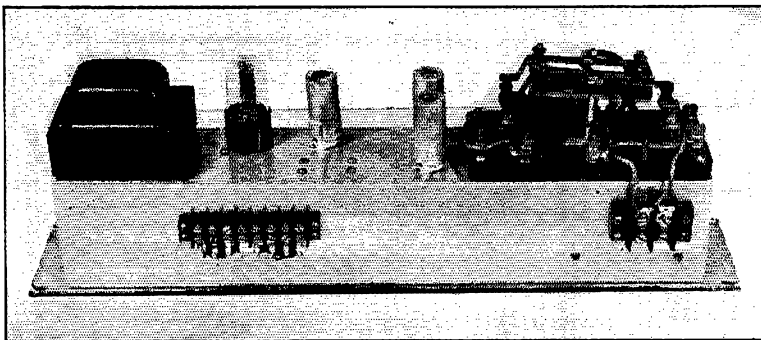

◆  
 Rear view of chassis showing placement of parts. The relay shown is of 30-ampere capacity allowing protection up to the maximum legal input.  
 ◆

# Cathode-Coupled Converters for Surplus Receivers

*A Single-Tube Crystal-Controlled Adapter for 28 Mc.*

BY JOHN H. BENDER,\* W2EVI

• The fact that most surplus communications-type receivers do not cover the amateur 10- and 11-meter bands accounts, of course, for the current surge of interest in converters. In the one described here by W2EVI high-frequency stability is obtained through the use of a crystal-controlled fixed-tuned oscillator, while cathode coupling between converter and receiver is used as a means of simplification without sacrifice in performance. It requires no tuning control and only a single tube. Included also are suggestions for extending the principle to higher frequencies.

HAVING been so fortunate as to acquire at a bargain price a surplus Army receiver of the BC-779 (Super-Pro) variety, which tunes only as high as 20 Mc., I found myself face-to-face with the dire necessity of building a converter so that I could use the thing on ten meters. Thinking in terms of the orthodox type of converter, it occurred to me that it was a shame to have all that handsome conglomeration of radio parts, including two tuning dials, which comprised the BC-779, and then have to spend more time and money assembling more parts and dials, just to hear ten-meter signals.

\* P.O. Box 66, Upper Montclair, N. J.

In order to take full advantage of the performance capabilities of the Super-Pro and not spoil the appearance of the operating position where it would be used, it would be necessary, if conventional design procedure were followed, to build a nice solid unit in a cabinet, with a good, expensive tuning dial. There is nothing I hate worse in a receiver than back-lash unless it is oscillator instability.

A bit of cogitation along these lines brought forth the not-entirely-novel idea of crystal controlling the converter oscillator and using the receiver as a tunable i.f. amplifier. This, it seemed, should eliminate the necessity for a fancy tuning dial on the converter, since only the relatively broad mixer grid circuit need be tuned from the front panel, and such an arrangement should provide the utmost in stability with the minimum of parts and constructional effort.

## *Design Considerations*

The fundamental aim in designing this unit was, as indicated above, to provide as simple and compact a converter as possible, without sacrificing performance. It was recognized that the converter need contribute no gain, since the Super-Pro already had plenty, but that it should contribute a minimum of noise and spurious signals. Also, it had to work efficiently with the low-impedance receiver input as a load.

A conventional triode mixer circuit, as shown

The cathode-coupled converter for 10 and 11 meters installed above the receiver in a standard mounting rack.



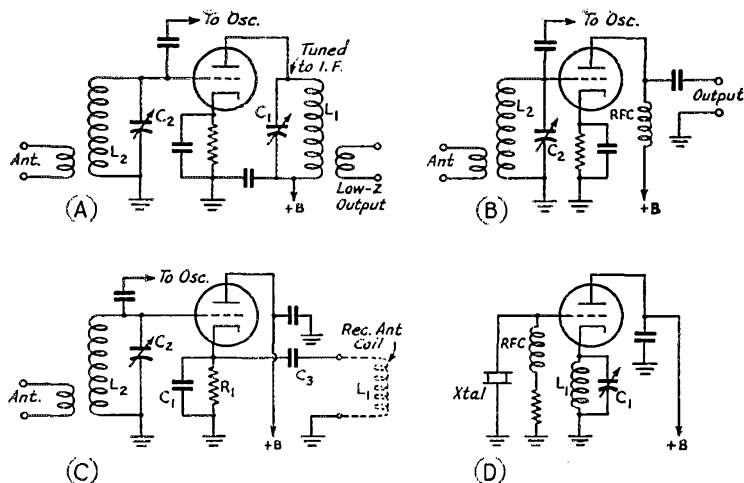

Fig. 1 — (A) — Conventional triode mixer circuit. (B) — Same as (A) with untuned output circuit. (C) — Cathode-coupled mixer circuit. (D) — Grid-plate crystal oscillator circuit.

in Fig. 1A, can give good performance, but it has the serious disadvantage that the plate circuit,  $L_1C_1$ , must be kept tuned to the same frequency as the variable i.f. amplifier. Substituting an r.f. choke for  $L_1C_1$  as in Fig. 1B, also would work but the plate resistance of even a triode mixer would be so much higher than the load impedance which would result with this arrangement that it was feared a net loss in signal would result. A pentode mixer was not considered, by the way, because its greater gain was not needed, its signal-to-noise ratio is not so good as that of a triode, its higher plate resistance increases the difficulties mentioned in the preceding paragraph, and its additional elements would merely complicate the circuit.

The circuit which on paper looked to be the most promising, and certainly the most interesting, was the cathode-follower arrangement shown in Fig. 1C. To the best of my knowledge a cathode follower has not been used in this application before. According to the information available on cathode followers, this circuit should have the advantages of high input impedance, resulting in improved signal-to-image ratio, and some gain attributable to transformer action in the input circuit, because the circuit is not loaded. Also, it provides a low-impedance output circuit without the need for the transformer shown in the plate circuit of Fig. 1A. Actually, these advantages are obtained, but the situation is more complicated than it appears because of the presence of reactance in the cathode load circuit.

If we redraw Fig. 1C with a crystal in place of the grid coil-condenser circuit, and a condenser  $C_1$  in parallel with the receiver antenna coil,  $L_1$ , as in Fig. 1D, we recognize a simplified version of our old friend the grid-plate crystal oscillator.<sup>1</sup> The tube doesn't care whether the resonant cir-

cuit between its grid and plate (remember, the plate is by-passed to ground) is a crystal or a coil and condenser and, of course, it is impossible not to have some capacitance across  $L_1$ . If the combination of the capacitance and inductance at  $L_1C_1$  happens to present a capacitive reactance of the proper value to the cathode, or in other words if  $L_1$  and  $C_1$  in parallel tune to a frequency somewhat lower than  $L_2$  and  $C_2$ , the circuit will oscillate.<sup>2</sup> In most practical cases this is exactly what happens.

Let us not despair, however. Remember the "if" —  $L_1C_1$  must tune to a lower frequency than  $L_2C_2$  in order to promote oscillation. But, as shown graphically in Fig. 2, if we tune  $L_1C_1$  low enough the circuit stops oscillating and becomes merely regenerative. It is also apparent from Fig. 2 that oscillation can be prevented by tuning  $L_1C_1$  to the same frequency or to a higher frequency than  $L_2C_2$ , but in most cases this will be difficult or impossible. Furthermore, if  $L_1C_1$  looks inductive at the frequency of  $L_2C_2$ , degeneration results, with consequent loss of performance.

By deliberately adding capacitance to whatever stray capacitance may exist at  $C_1$ , we are able not only to stop oscillation but also to control the amount of regeneration present. The more regeneration, short of oscillation, the more gain and selectivity (and noise). Fortunately the value of  $C_1$  is not critical.

### The Converter

The unit shown in the photographs was, of course, built to suit my own particular requirements. Certain specific features of it, such as its physical dimensions and the use of single-ended input and output circuits, may not suit the needs

<sup>2</sup> Schlesinger, "Cathode-Follower Circuits," *Proc. I.R.E.*, Dec., 1945, p. 849.

<sup>1</sup> *Radio Amateur's Handbook*, ed. 23, p. 98.



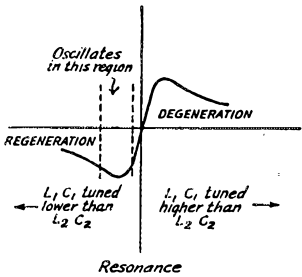

Fig. 2 — Curve showing effect of tuning cathode tank circuit above and below frequency of grid circuit.

of all hams, but the circuit shown in Fig. 3 should work with any receiver and, in fact, it has been tested with several different types.

As shown in the photographs, the converter is mounted on a 1¾-inch panel which, in turn, mounts between the receiver and its power supply in a small table rack. On the front are two controls — the mixer grid tuning and a three-position rotary switch whose purpose is explained later. On the back are the coaxial-connector socket for the antenna input and the adjusting nut for the oscillator tuning condenser,  $C_3$ . On the left side is a feed-through insulator used for connecting a spare indoor antenna to the receiver in case break-in is desired, or for reception on the low-frequency bands. The crystal and tube are on the right side where they are convenient for replacement and are properly ventilated.

It was obvious from the start that shielding would be an important problem with this arrangement, and experience with an experimental model emphasized the point. Therefore the entire unit was enclosed within an aluminum box which was battered into the desired size and shape with the aid of tin snips, hammers, files, etc. The aluminum partition through the center is intended to prevent undesired signals at the i.f. from being coupled to the converter circuit from the various input circuits. A 1½-inch hole was cut in this partition with a socket punch, and a small Faraday screen mounted across the hole on a strip of polystyrene. The grounded end of  $L_2$  butts against one side of the screen, and the antenna coil,  $L_1$ , is mounted on terminal lugs on the other side. The Faraday screen, of course, is intended to pre-

vent capacitive coupling of stray signals to the mixer circuit, without affecting the inductive coupling between  $L_1$  and  $L_2$ .

It was feared originally that shielding of the crystal holder and perhaps the adjusting nut on  $C_3$  would be necessary, since both are connected to the antenna post of the i.f. receiver, but this was found to be unnecessary when using an i.f. of 3 to 4.7 Mc. With an antenna tuned to ten meters coupled to the converter, and the converter oscillator disabled, it is possible to tune the i.f. receiver from 3850 kc. to 4000 kc. in the evening without hearing the faintest suggestion of a signal. However, touching a finger to the ungrounded antenna terminal on the i.f. receiver produces S9 signals anywhere in that range. With an antenna tuned to 75 meters connected to the converter, weak signals can be heard in this range. After some experimentation I concluded that this was not an indication of poor shielding, but simply proof of the fact that the skirts of the response curve of  $L_2C_2$  are not down to zero response even at 25 Mc. from resonance.

As the i.f. receiver is tuned higher in frequency, more signals are heard "leaking" through the converter, which is one reason I chose to use the 3-4.7-Mc. range. Experimentation indicates that this "leakage" is caused by both insufficient shielding and insufficient selectivity of  $L_2C_2$ . Since I didn't intend to use these higher intermediate frequencies, I made no attempt to improve the situation, but I mention the point to emphasize the need of great care in shielding. Still further, I found that touching the metal shaft on  $C_2$  would sometimes increase the strength of the signal "leaking" through. This means that at high frequencies the condenser shaft is not adequately grounded, even though the lead grounding it is not over an inch long. If considerably higher intermediate frequencies were used with this unit it might be necessary to mount  $C_2$  completely within the shielding and use an insulated shaft extension to prevent the shaft from acting as an unwanted antenna. The leads from  $S_{1A}$  to the antenna-input connector, and from  $S_{1B}$  to the 6J6 cathode, are shielded to prevent undesired signals from taking a short-cut from the antenna lead right into the i.f. receiver.

As shown in the circuit diagram of Fig. 3,  $S_1$

Top view of the crystal-controlled 28-Mc. converter. The antenna-input section is to the left, separated from the mixer grid and oscillator circuits by the shielding partition.

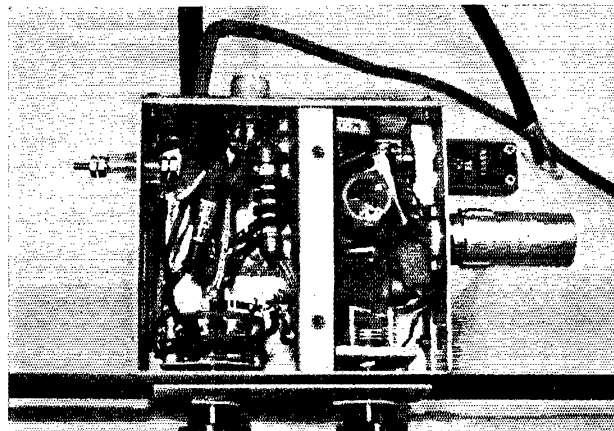

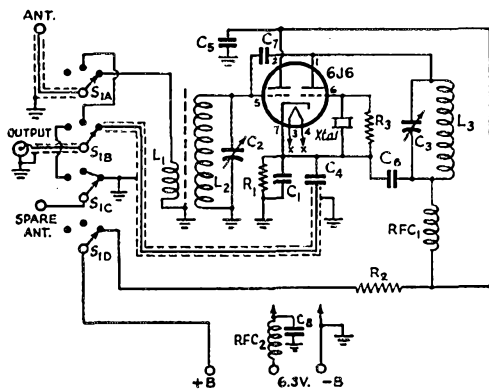

Fig. 3—Circuit diagram of the single-tube cathode-coupled converter for 28 Mc.

- $C_1$  — 100- $\mu$ fd. mica.
- $C_2$  — 15- $\mu$ fd. variable (Millen 20015).
- $C_3$  — 25- $\mu$ fd. variable (Hammarlund APC-25).
- $C_4, C_5$  — 0.001- $\mu$ fd. mica.
- $C_6, C_6$  — 470- $\mu$ fd. mica.
- $C_7$  — Coupling condenser, see text.
- $R_1$  — 4700 ohms,  $\frac{1}{2}$  watt.
- $R_2$  — 0.1 megohm, 1 watt.
- $R_3$  — 0.1 megohm,  $\frac{1}{2}$  watt.
- $L_1$  — 2 turns No. 18,  $\frac{3}{4}$ -inch diameter.
- $L_2$  — 14 turns No. 24,  $\frac{3}{4}$ -inch diameter, 1 inch long.
- $L_3$  — 10 turns No. 24,  $\frac{3}{4}$ -inch diameter,  $\frac{3}{4}$  inch long.
- $RFC_1$  — 2.5-mh. r.f. choke.
- $RFC_2$  — Ohmite Z-1 r.f. choke.
- $S_1$  — Poles of four-section 3-position rotary switch.

is a three-position four-pole rotary switch. In the clockwise position of  $S_1$ , the center conductor of the antenna-input connector is connected to  $L_1$ , the center conductor of the short length of coaxial cable which is used for the output cable to the i.f. receiver is connected to the cathode of the 6J6 through condenser  $C_4$ , while B+ is connected to the converter plates. In the middle position the center conductor of the antenna connector is connected to the center conductor of the output cable, and B+ is removed from the converter. This position is used for normal operation of the Super-Pro without the converter. In the counterclockwise position the center conductor of the output cable is connected to the spare antenna feed-through terminal which, by the way, is grounded in the other two positions of  $S_1$  to remove another possible source of our old enemy, the undesired signal. This last may be an unnecessary refinement, but the switch I found in my junk box had four poles, so I figured I might as well use the extra pole for something. This switch need not have ceramic insulation because it switches only low-impedance r.f. circuits.

The counterclockwise position of  $S_1$  is provided because an indoor antenna works better on the broadcast band than my transmitting antennas, but this switch position also could be used for break-in or duplex operation, or any other occasion when an extra antenna is desired. And

before some BC-779 owner has a hemorrhage from this discussion of broadcast-band reception, let me explain that my particular receiver has been promoted to the rank of BC-1004, first class. In other words, I obtained from the Hammarlund Company a set of coils, dials, knobs, etc., with which I altered the original 100-400-kc. tuning range to the more useful one of 540 to 2500 kc. This also explains, in case anyone wonders, how I am able to receive the 11-meter band with a 25-Mc. crystal frequency in the converter, which requires tuning the receiver from 2160 to 2450 kc.

The tuning range of the coil and condenser shown,  $L_2$  and  $C_2$ , is approximately from 21 to 30 Mc., taking in all of the 10-, 11- and 15-meter bands. Even with this large coverage, adjustment of  $C_2$  is easy, provided that the amount of regeneration in the mixer is kept within reason. The value of condenser shown at  $C_1$  gives a degree of regeneration which results in an apparent signal gain of 8 or 10 db. with reasonably uncritical tuning of  $C_2$  when the converter is feeding into a Super-Pro receiver tuned to 3 Mc. If some other receiver is used for the i.f. it will probably be necessary to experiment with different values of  $C_1$  to obtain optimum results, since the receiver antenna-coil inductance will be different. Some military receivers, such as the BC-342, have a variable condenser in series with the antenna coil which must be adjusted for optimum results when using this converter.

To tune from 21 to 21.5 Mc., the i.f. receiver is tuned from 4 to 3.5 Mc. Putting the oscillator frequency between the major bands to be covered in this manner has the advantage of keeping the i.f. low, thereby reducing "spurious-signal" trouble and also makes the operation of changing bands quite simple. But it has the disadvantage of causing images of the ten-meter band to fall in the 15-meter band, and vice versa, and means that one must tune the i.f. receiver higher in frequency to receive a signal lower in frequency in the 15-meter band, which may prove confusing. The relative importance of these advantages and disadvantages can best be determined when and if we get a fifteen-meter band. Under present conditions the 25-Mc. oscillator frequency works out very well.

$RFC_2$  and  $C_8$  are intended to reduce a weak spurious signal that results from a beat between the converter oscillator and a harmonic of the receiver oscillator. The two frequencies are coupled together through the heater supply in my case, but this condition might not arise at all with other makes of receivers.

The crystal oscillator is the conventional tuned-plate crystal-grid circuit, using the second half of the 6J6. The grid and plate circuits are returned directly to the cathode, and  $RFC_1$  prevents  $C_5$  from shunting  $C_1$ . The value of  $R_2$  was determined by reducing the plate voltage while listening to a very weak signal. As  $R_2$  was

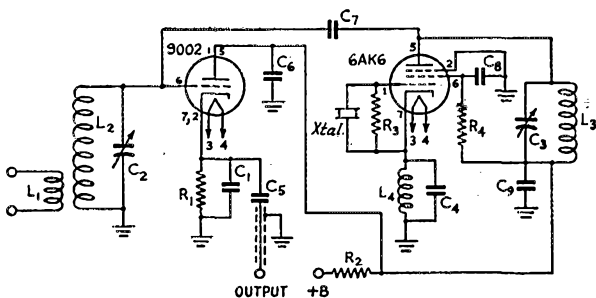

Fig. 4 — Suggested circuit for cathode-coupled crystal-controlled converter for higher frequencies.

C<sub>5</sub>, C<sub>8</sub>, C<sub>9</sub> — 0.001- $\mu$ f. mica.

C<sub>6</sub> — 470- $\mu$ f. mica.

R<sub>1</sub> — 10,000 ohms.

R<sub>2</sub> — 22,000 ohms.

R<sub>3</sub> — 0.47 megohm.

R<sub>4</sub> — 4700 ohms.

Other values will depend upon frequency.

increas and the plate voltage went down, the noise level went down while the signal stayed the same as became more readable. Strong signals became noticeably less strong as the voltage was reduced but that did not seem disadvantageous. The value shown for R<sub>2</sub> is about the practical limit with a 250-volt supply. Further increase in resistance reduces weak-signal strength with no further improvement in signal-to-noise ratio.

The oscillator coupling condenser, C<sub>7</sub>, is a "gimmie" — a short length of insulated wire from the oscillator plate wrapped once around the mixer grid lead.

### Notes & Comments

Before building a converter of this type, it would be wise to tune the receiver with which you intend to use it over the i.f. range you intend to use at a time when strong signals are present in that range, and with no antenna on the receiver. If you hear signals give up the whole idea, because the receiver is not sufficiently well shielded. Probably most communications receivers will pass this test, however.

The choice of an oscillator crystal frequency depends on a wide variety of factors, not the least important of which is what is available. One reason for my choice of 25 Mc. was that a number of crystal manufacturers advertised crystals in that range for doubling to the 6-meter band. After writing to one after another of these manufacturers, and having them all reply that they did not manufacture such an item (apparently they don't read their own ads) I was ready to give up when finally the Valpey Company ran a similar ad, and I decided to try once more. Much to my astonishment, I got a crystal for 25,008 kc., which is close enough.

An oscillator frequency which is an even multiple of 1000 kc. is convenient, because it is then easy mentally to add the oscillator frequency to

the i.f. indicated on the receiver dial and come out with the frequency being received. For instance, when my Super-Pro dial reads 3.6 Mc., I automatically translate that to 23.6 Mc. This works only when the oscillator is lower than the signal frequency, of course; on 15 meters it will be necessary to subtract which is not so convenient.

Other considerations in choosing an oscillator frequency are: (1) fundamental and harmonics of the oscillator should not fall within the bands to

be covered by the converter nor within the range to be covered by the i.f. receiver; (2) resulting intermediate frequencies should not contain extremely-strong local signals (this rules out the broadcast band in some locations), but should preferably be fairly low since this simplifies shielding and associated "spurious-signal" problems; (3) resulting intermediate frequencies for any one band should all fall in one tuning range of the i.f. receiver. It would be annoying to have to switch coils to cover both ends of the ten-meter band, for example.

So far as I am able to tell without elaborate test equipment, the sensitivity and signal-to-noise ratio resulting from this receiver-converter combination are as good as is normally obtained with a good communications receiver on ten meters.

With the i.f. in the 3-5-Mc. range, attenuation of i.f. "spurious signals" is apparently (no test equipment again) better than 70 db., and attenuation of images is around 35 db. As mentioned previously, the antenna used for receiving can contribute a surprising amount of useful selectivity. The above attenuation figures are based on observations made on ten meters with a 75-meter half-wave center-fed doublet, with feeders tuned to resonate in the ten-meter band. Using a center-fed ten-meter half-wave antenna, much better attenuation figures have been obtained. In any

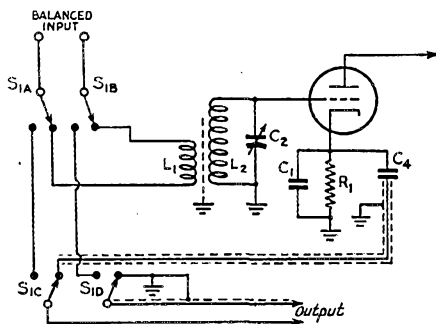
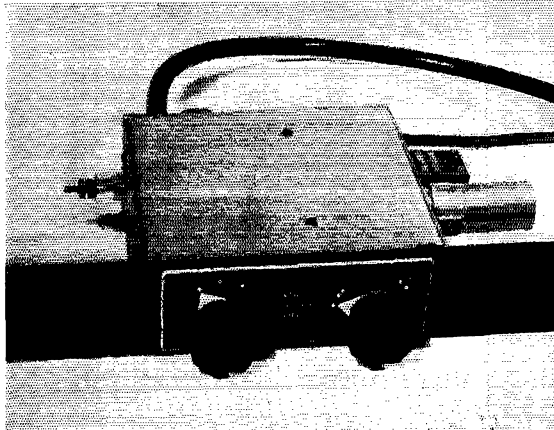

Fig. 5 — Suggested circuit for balanced input to converter. S<sub>1A-D</sub> are poles of a four-pole double-throw rotary switch. Other designations are similar to those of Fig. 3.

Panel view of the cathode-coupled converter with top cover in place.



case, the figures given compare favorably with image-rejection ratios of standard communications receivers on ten meters.

Theoretically, a better signal-to-noise ratio could be obtained with a tube having separate cathode terminals for the two triode sections, because the oscillator plate current would then not have to flow through the cathode load resistor,  $R_1$ , thus contributing to the noise, but not to the signal. A new miniature type, the 12AU7, has just been announced which should be ideal for the purpose.

The addition of a 6AK5 tuned r.f. stage ahead of the mixer in this unit should result in a receiving combination with very superior performance at 10, 11 and 15 meters. While this would not be entirely in keeping with my original objective of extreme simplicity, it should not complicate the tuning-control problem, since the additional gain would make it possible to reduce the regeneration in the mixer thus, in turn, reducing the sharpness of the mixer tuning. The net sharpness of tuning near resonance then should be about the same as without the r.f. stage, but the rejection of signals far removed from resonance would be greatly increased, resulting in complete solution of the image and "spurious-signal" problems. At the same time the best signal-to-noise ratio theoretically possible should be obtained. I do not intend to add an r.f. stage to my unit because I feel that its present performance is quite adequate, but I mention the point for the benefit of those who seek perfection.

#### *Variations on the Theme*

During the many months when I was searching for a 25-Mc. crystal, I used an experimental converter the circuit of which is shown in Fig. 4. The principle feature of this circuit is the Tri-tet crystal oscillator which permits the use of a lower-frequency crystal. In my case the crystal frequency was 5.5 Mc., and the plate of the Tri-tet was tuned to the fourth harmonic, or 22 Mc. This circuit should be particularly useful in extending the range of existing ham receivers to include the 6-meter band, or even the 2-meter band. The choice of a crystal frequency for this circuit is affected by all the previously-mentioned factors, plus the fact that spurious responses can result from beats between undesired signals and harmonics of the crystal frequency other than the

one you are intending to use. If, for example, you are trying to use the tenth harmonic of a 4-Mc. crystal to give an i.f. range of 10 to 14 Mc. for the 6-meter band, you will very likely find that there is enough 44-Mc. (11th harmonic) energy in the Tri-tet plate tank to give you a whopping big signal in the middle of the band from your local television station operating in the 56-60-Mc. channel. This effect can be minimized by using a low  $L/C$  ratio in the Tri-tet plate tank, but the best solution is not to go above the fourth or fifth harmonic of the crystal. This still permits 2-meter operation using crystals at 25-30 Mc.

If the single-ended input and output circuits shown do not fit in with your favorite antenna-feeder system, it should be possible to use a balanced input system with little difficulty. One possible circuit is shown in Fig. 5. Note that one side of the receiver input is grounded when the converter is in use, since the converter output must be single-ended, but that the antenna input circuit remains balanced at all times.

### **DELTA DIVISION AND WEST GULF DIVISION CONVENTION**

**Texarkana, Texas, August 16th-17th**

The Delta and West Gulf Divisions are this year holding a joint convention in the borderline city of Texarkana, August 16th and 17th. "The biggest convention south of the Mason-Dixon Line" is promised by the sponsoring groups, East Texas Radio Club and Texarkana Radio Amateurs Club.

Technical talks, code contest, representatives from ARRL and FCC, Saturday night dance, Wouff-Hong initiation, gala banquet — these are the highlights of a big week-end of fraternal activities. Headquarters will be the Grimm Hotel. Send your registration fee of \$5.00 now to Chairman Joe Hargis, W5AQF, Okay, Arkansas. See you there!

# • Technical Topics —

## Horizontal vs. Vertical — 80 Meters

ONE of the questions always a subject of lively discussion on 75-meter 'phone is the difference in performance between horizontal and vertical antennas. So far as we can tell, the antennas themselves seem to be doing just what is to be expected — if you know what to expect. A lot of fellows evidently don't.

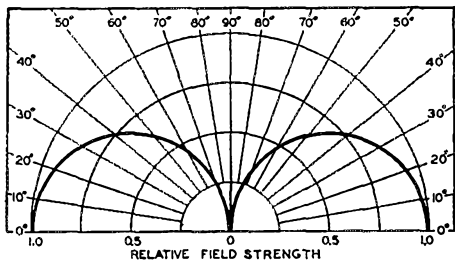

Fig. 1 — The theoretical vertical pattern of a vertical antenna less than  $\frac{1}{4}$  wavelength high, with base end at ground level.

This has been said many times before, but bears repeating: Antenna characteristics *must* be considered in conjunction with the propagation characteristics of the frequency used if a reasonably accurate forecast of antenna performance is to be made. The directional characteristic of the antenna itself is only one of several factors that enter into the picture.

However, of them all it is undoubtedly the best known and the easiest to visualize, so let's take the antenna itself first. If it is vertical, it will seldom be more than a quarter wave tall — that is, about 66 feet high — and often will be shorter. If it stands on ground of good conductivity, its vertical-plane radiation pattern will be about as shown in Fig. 1. Maximum radiation will be along the ground, or very close to it, and there will be substantially no purely vertical radiation. So far as compass directions are concerned, the radiation intensity will be the same in all directions if there are no nearby obstructions to modify the pattern. (Such obstructions always exist in a practicable location, so it is impossible to make any general observations about the horizontal directional pattern aside from noting that it would be an exceptional location in which the pattern was perfectly circular.)

The vertical-plane radiation pattern of a horizontal antenna will vary with the height of the antenna above ground and with the characteristics of the ground. At 3.5–4.0 Mc. it is generally safe to assume that the ground acts as a fairly

good conductor, in which case there will be very little radiation in the vertical plane at small angles but very considerable radiation at high angles. The theoretical vertical-plane radiation patterns for horizontal half-wave antennas at heights of one-eighth and one-quarter wavelength (approximately 35 and 70 feet, respectively) are shown in Fig. 2, for the horizontal direction at right angles to the antenna wire. In the direction of the wire, the vertical-plane patterns have the shapes shown in Fig. 3. Thus the vertical-plane pattern is dependent upon the compass direction, in the case of a horizontal antenna, whereas the vertical antenna is nondirectional in this sense.

### Ground Waves vs. Skywaves

In themselves, these patterns give utterly no clue to the performance differences between horizontal and vertical antennas at 80 meters. Before any comparison can be made it is necessary to know what vertical angles are useful, and useful for what purpose. To get that information we have to take a look at the ionosphere.

However, before doing so let's stay on earth for a moment and dispose of the ground wave. The distance that can be covered by the ground wave depends upon the amount of power radiated along the ground and the intensity of the noise at the receiving location, as well as upon the re-

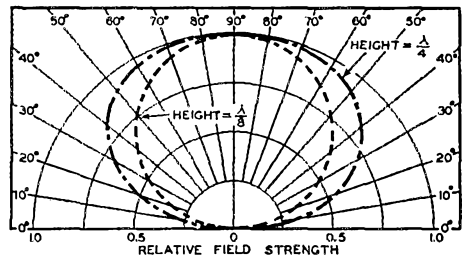

Fig. 2 — Vertical patterns of a horizontal half-wave antenna at two different heights, taken at right angles to the wire.

quency. From Figs. 1 to 3 it is quite clear that a vertical antenna will have a much stronger ground wave than a horizontal antenna, because only the power radiated at zero vertical angle is useful in producing the ground wave. The ground-wave range varies with location, time of day, and the season, since atmospheric noise varies with those factors, and can be expected to be smaller the farther south we go because Q<sub>RN</sub> is worse. It is also dependent upon the kind of ground over

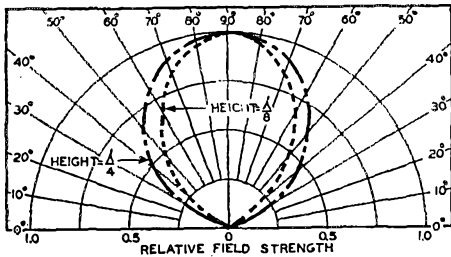

Fig. 3 — Vertical patterns of horizontal half-wave antennas in the direction of the wire, for two different antenna heights.

which the wave must travel, because absorption of power from the wave depends upon the ground characteristics. In the average case, if there is such a thing, the limit of the 80-meter ground-wave range over flat land is probably in the neighborhood of 50 miles for a transmitter running a kilowatt input with a vertical antenna. With a horizontal antenna the ground wave is negligible a few miles away.

Most communication is by way of the ionosphere. At night, the skywave is bent back to earth by the *F* layer, which is around 175 to 200 miles above the earth. During a sunspot maximum the *F*-layer ionization is sufficiently high so that 80-meter waves going straight up from the antenna to the layer (radiation at 90 degrees to the earth) are returned back to earth practically all night long at any time of the year. Consequently waves that strike the layer at smaller angles also are returned; in other words, there is no skip zone. This simplifies things somewhat because the directional patterns of Figs. 1 to 3 do not have to be modified to take account of skip.

Considering the single-hop transmission, where the wave makes only one contact with the layer in its travel between the transmitting and receiving stations, the radiation angle required for each distance up to the maximum possible for a single hop is shown in the graph of Fig. 4,<sup>1</sup> assuming a layer height close to 200 miles. In Fig. 5, the vertical-plane directional patterns (the broad-

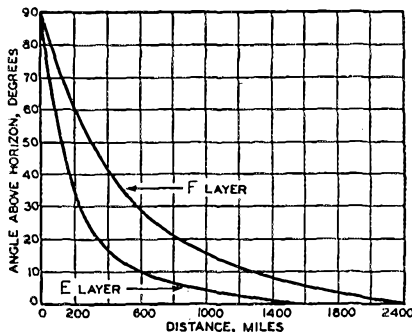

Fig. 4 — Distance plotted against vertical angle of radiation for average heights of the *E* and *F* layers of the ionosphere.

side patterns only, in the case of the horizontal antennas) have been replotted so that they are roughly comparable in scale, assuming the same power in each antenna. By using this figure in conjunction with Fig. 4, it can be seen that a vertical antenna should be better than a horizontal at all distances beyond about 350 miles. However, this assumes *single-hop* transmission. It is somewhat questionable whether the vertical's presumed advantage at distances over 350 miles is realized fully, because the high-angle signals from the horizontal can get to the same point by two or more hops. Nevertheless, since multi-hop transmission is accompanied by additional energy loss at each hop, the odds favor the vertical for the longer distances, particularly over land. At all *shorter* distances the horizontal antennas should be better, insofar as *sky-wave* transmission is concerned. Very frequently the horizontal antenna is better than the vertical

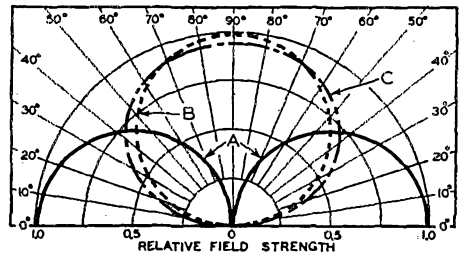

Fig. 5 — This drawing gives an approximate comparison of the relative effectiveness of horizontal and vertical antennas with respect to vertical angle. A — vertical; B — horizontal antenna  $\frac{1}{2}$  wavelength high; C — horizontal antenna  $\frac{1}{4}$  wavelength high.

even within "ground-wave" range — say beyond ten miles or so from the transmitter — because the skywave loses relatively little energy as compared to the true ground or surface wave and is stronger at a nearby receiving point even though it has had to travel some 400 miles to reach it.

That is the nighttime picture. In daylight things are different. So long as the sun is up such skywave transmission as occurs takes place by means of the *E* layer, which is about 70 miles above the earth. (At night this layer practically disappears; that is, it becomes transparent to high-frequency waves and plays no part in long-distance transmission. Sporadic-*E* is an exception.) Because the *E* layer is lower than the *F* layer, the same vertical radiation angles result in shorter distances, as shown in the curve in Fig. 4. Comparing again with Fig. 5, the vertical antenna should be better for distances beyond about 150 miles. Unfortunately, however, the *E* layer does not get much of an opportunity to reflect 80-meter waves in the daytime; there is a still lower ionized region, the *D* layer, in which the ionization is so intense that waves of this fre-

<sup>1</sup> Rockey, "Distance vs. Angle of Radiation," *QST*, October, 1940.

quency are almost completely absorbed. Since ionization in the *D* layer is proportional to the height of the sun, it is greatest at noon; consequently transmission is poorest around midday. Toward sundown it disappears and there is some chance of *E*-layer transmission in a short period before nighttime conditions with the *F*-layer operative set in. However, for most of the daylight period there is little if any transmission with any type of antenna over distances beyond a few hundred miles, and then only with relatively weak signals. The shorter distances are best because they are achieved by high-angle radiation, which means that the wave spends less time in going through the *D* layer than it would if the angle were low; consequently the signal does not lose quite so much energy.

In daytime, then, the vertical antenna should not be expected to be really good for anything except the ground wave. For distances within that range it ought to give better signals than a horizontal antenna because the "local" signal from the latter loses power in its up-and-down journey through the *D* layer.

In a sunspot minimum the *F* layer is not sufficiently ionized to reflect 80-meter waves that strike it vertically except for a short period after sunset in the winter. Consequently there is a night skip zone on this band and the horizontal antenna becomes useless for short-distance work at night. Since the ground-wave range of the vertical antenna is unaffected by the ionosphere, the vertical is better for distances up to the ground-wave limit. In the daytime the story is much the same as it is at a sunspot maximum.

Anyone who has read this far must have guessed that there isn't any yes-or-no answer to the ques-

tion as to which is best, horizontal or vertical. It depends on the height of the horizontal antenna, the direction it points, the distance you have in mind, the time of day, whether the year is 1944, 1947, or 1949, and whether it's summer or winter. Right now, as we approach a sunspot maximum, we'd guess that there is relatively little difference between the two types except for extreme distances at night; for ordinary work over the distances customary on 80 meters the horizontal probably has the edge. For true ground-wave work the vertical will be better in daytime and will give a strong signal with little fading at night within a few miles of the transmitter.

If there is any really definite conclusion to be drawn, it is this: the fact that you may get good reports at distances up to several hundred miles with a horizontal antenna close to the ground is nothing to brag about or marvel at. It's simply the natural combination of the antenna pattern and the ionosphere. When the antenna is really low — say 20 or 25 feet — it is the equivalent of a close-spaced array shooting at just the right area in the layer to put down a good signal anywhere within a radius of two or three hundred miles, no matter what the direction in which the wire runs. It is only off the ends of horizontal antennas that any directive effects show, and then only for distances beyond 300 miles or so, regardless of height. It is more important to get a horizontal antenna clear of buildings and other obstructions than it is to get it really high. Incidentally, it is also necessary to keep the vertical antenna clear of obstructions if its low-angle properties are to be utilized. Last, but perhaps not least, a vertically-polarized signal will cause far more rumpus in nearby broadcast receivers than the same power in a horizontal antenna. — G. G.

---

## N.F.M. Reception

A COMMON question these days is "When is someone going to bring out a receiver with a discriminator in it for n.f.m. reception?" And a common criticism of n.f.m. on 29 Mc. is that "it takes up too much room on my receiver!" The subjects are closely related and can stand a little discussion at this time.

A receiver with a narrow-band discriminator will give excellent n.f.m. reception, since it allows the receiving operator to enjoy the noise-reducing characteristics of true f.m. detection. However, it is possible to tune in the signal at *three* points on the tuning dial. The center spot is the correct one, and it gives minimum noise and maximum audio recovery. The other two spots give fair but noisier audio output. The reason, of course, is that a discriminator characteristic (the familiar

lazy-S shape) has three slopes where detection can take place, and there just isn't any way to get around this. Superior selectivity ahead of the discriminator isn't the answer, although it will tend to make the two false points less understandable. With three spots showing up on the tuning dial, it makes the signal *look* broad, because *it takes up more room on the receiver!*

Reception of n.f.m. signals with a normal a.m. receiver gives two-spot tuning, since there are two slopes to the i.f. characteristic where detection can take place. This is a slight improvement, selectivitywise, over the discriminator, although the actual dial space isn't too much less. It is the same problem we had with c.w. reception before the invention of single-signal reception: every c.w. signal repeated on the tuning dial

on the other side of zero beat. No one complained particularly about c.w. signals taking up too much room because we didn't know any better, but a c.w. receiver certainly sounds crowded nowadays if it doesn't have the single-signal feature. Unfortunately the c.w. solution doesn't solve the n.f.m. problem, although a crystal filter used for p.m. reception does give the most selective form of p.m. reception known thus far.<sup>1</sup>

What is needed, of course, is a *one-spot* detection system for f.m. and p.m. — we already have them for c.w. and a.m. 'phone. An n.f.m. or p.m. signal occupies no more spectrum space than does an a.m. signal<sup>2</sup> — it only seems that way. The fault lies in our receiving methods, and only the further development of receiving techniques will remedy the situation. In the meantime, we can

all demonstrate our technical acumen if in our QSOs we discuss the problem for what it is and not get taken in by how our receivers seem to act. If you don't mind the three-spot tuning, an out-rigger f.m. adapter for your receiver will give you good n.f.m. reception, with the added feature of noise reduction. Otherwise, you will have two-spot tuning on your regular a.m. receiver when you listen to n.f.m.

Incidentally, if a good n.f.m. signal doesn't sound the same at the two spots on your a.m. receiver, it indicates that the receiver i.f. is out of alignment. If the i.f. is realigned so that the n.f.m. signal sounds the same on either side, it will indicate a symmetrical passband and give best a.m. reception. The n.f.m. modulation will come close to disappearing when the carrier is peaked on the a.m. receiver, but probably will not disappear entirely except with pure sine-wave modulation.

— B.G.

<sup>1</sup> Grammer, "N.F.M. Reception," *QST*, March, 1947.

<sup>2</sup> Goodman, "Low-Frequency N.F.M.," *QST*, July, 1947.

## Shorthand Circuit Symbols

THE March, 1947, issue of Britain's *Wireless World* carries a story entitled "Shorthand Circuit Symbols," by A. W. Keen, that presents enough new ideas in representing radio circuits to be of interest to all who deal with the beasts.

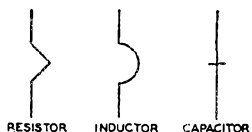

Fig. 1 — Simplified symbols for "shorthand" circuit representation.

reducing the present symbols to a bare minimum, as shown in Fig. 1. That this "shorthand" presentation lacks nothing in flexibility can be seen in Fig. 2, where various special forms of the basic components are represented. Further, when these symbols are combined, they still suffer nothing in clarity and certainly gain in simplicity, as is obvious from Fig. 3.

Although Mr. Keen points out that his "shorthand" method was developed only as a faster technique for circuit representation and not as a replacement, there is much to recommend it for general use. You can be the judge.

As Mr. Keen points out, there are four common components that must be represented in radio circuits: resistance, inductance, capacity and vacuum tubes. These are the ones, therefore, that should be simplified, since they occur so frequently. The first three basic circuit elements are simplified by

Mr. Keen's symbol for a vacuum tube is quite ingenious. He points out that following the various grids in multigrid tubes is an unpleasant process prone to error, and that one must count the grids carefully before deciding what type of tube is being represented. To eliminate all this, he represents a triode by a triangle, a tetrode by a square, a pentode by a pentagon, and so on, as in Fig. 4. The side of the polygon representing the cathode is made distinctive by superimposing a small heater (resistance). The other elements of

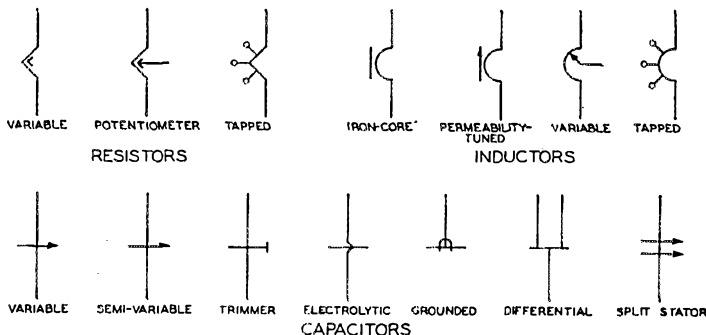
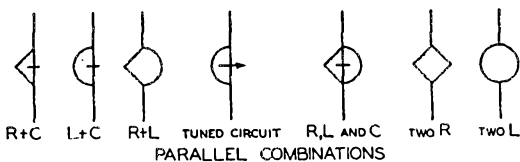

Fig. 2 — Special forms are easily derived from the basic symbols of Fig. 1.



Fig. 3 — Combinations of the basic components are a simple matter, and they take less time to draw than the more conventional representations.



the tube then follow logically in a clockwise direction around the figure, each element being represented by a side of the polygon.

Tubes like triode-pentodes and the like are represented by surrounding the triode with the pentode and using the common cathode as the common side of the figure.

Several other interesting points were de-

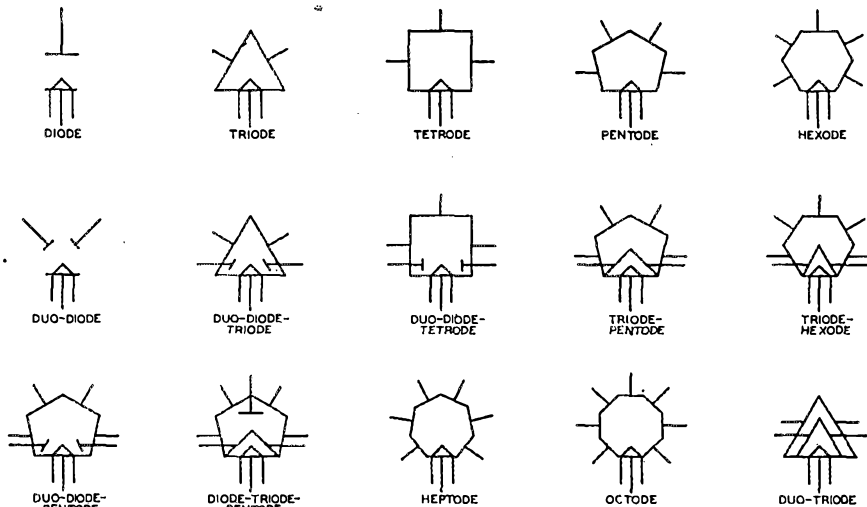
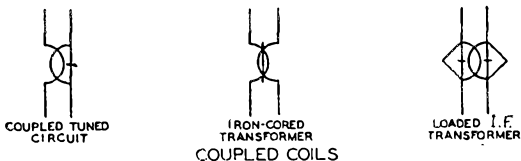
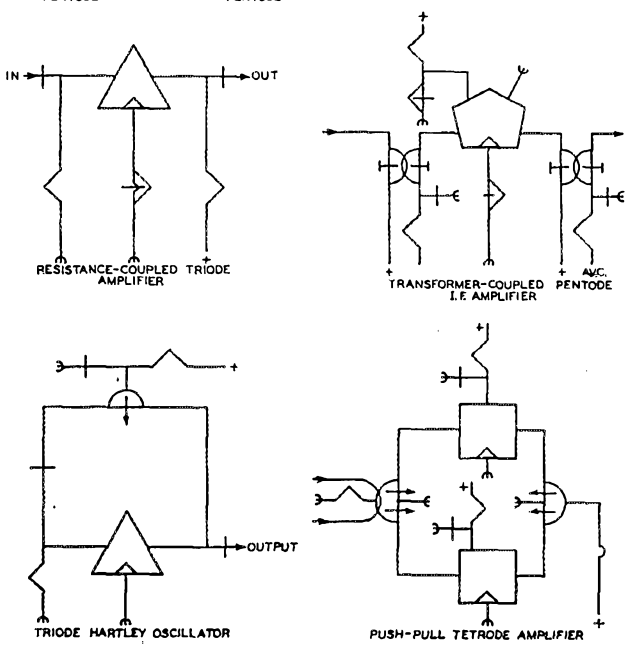

Fig. 4 — The "shorthand" vacuum-tube symbols are based on the use of polygons whose sides equal the number of elements in the tube. Combination tubes with common cathodes are easily represented.



veloped in the "shorthand" system. Because the symbols are small, the average wiring diagram is opened out and there are not many "crossover" points. To avoid the "loop" used in *QST* diagrams, or the dot-no-dot system adopted during the war — which often leads to confusion and error — the "shorthand" method separates a four-wire junction into two separate junctions, and hence any normal crossover of lines represents no connection. This makes for very simple construction and considerably less chance of error. Chassis grounds, the usual common return, are represented by a small "C" superimposed on the end of the wire, resulting in what looks like a bird's claw, or the letter "E" (for "earth").

A few sample diagrams are shown in Fig. 5. — *B. G.*

Fig. 5 — Familiar circuits represented by the "shorthand" method.



# How's DX?



CONDUCTED BY JOSEPH E. GRAHN,\* WICH

## How:

Last month the postwar DXCC listings were presented for the first time, minus the call of a certain W who had also submitted 100 cards. This DXpert undoubtedly thought he had himself a foolproof racket, because not a single one of the submitted cards was a forgery or unusual in any way. As a matter of fact, they were all cards received directly from the foreign stations. Why then, you ask, did we toss the guy out? Well, maybe we were a little hasty and narrow-minded, but this great DX man had been sending plenty of cards to stations claiming contacts that never took place!

Apparently a number of foreign operators, trying to be good Joes and figuring they had slipped up on their logging, sent the guy enough cards to make up his 100. But our pal didn't reckon with the many careful foreign stations who smelled a rat and tipped off the gang at Hq. Reports from VS1, VS7, CR9, EP, JS, ZC1, ZC4, ZC6, VQ3, VP9, GC and VS4 really nailed the guy, and the DXCC Dept. was just waiting for the great man to send in his cards.

The \$64 question is, of course, what kind of a guy does it take to pull a trick like that? We just hope he cuts out this column and tacks it on the wall where he thought his DXCC certificate would go! Any suggestions as to what he can do with the cards?

## What:

The DX pickings the past month or so have been on the slim side, which is to be expected at this time of year, with vacations, rebuilding, etc. going on. However, some good stuff is still being reported: W5ASG grabbed himself UO5AC, ZC6DD, EP2BU, UB5BC, VR6AA, TA3SO, EK1AF, EK1AS and VQ4ERR. . . . WØVEE helped himself to UR2KAA, HZ1AB, KH6DE, KH6JQ, UA3KAK, VR5PL, GW3ZV, OK1DW, UA1AB, CE3DZ, VO2M, OH4NF, VP3JM and IIVV. . . . The best at W8MFB include EP1AL (14,055), J2VFW (14,090), J2AAO (14,055), J3AAD (14,080), J2AIA (14,150), UA9CC (14,110), UAØKQA (14,050) and UQ2AB (14,085). . . . W6OBD sweated out W2WMV/C9 (14,080), VP8AD (14,115), KA6FA (14,110), SM4WZ (14,080), UAØSF (14,120), J4AAK (14,040), J9ANJ (14,110), ZS5BW (14,090), W2OUB/C1 (14,040), PK1TC (14,050), K6SCJ/KP6 (14,130), MX3KG (14,110), ZS6KF

(14,050), G5UB (14,100) and KL7IY (14,080), which Lec says isn't so hot, but he was. . . . With a pair of 6L6s and an 80-meter Hertz, W9BRD got FT4AN, KS4AC, KV4AA, VQ3HJP, HI8MAF, ZB2B and CN8BK, which isn't bad at all. . . . In what spare time he had, W4BRB worked UG6WD (14,115), ZD4AH (14,115), ZB1AH (14,110) and EA1D (14,020), for a postwar total of 131. . . . W2ITD replaced his 8JK with a folded dipole and immediately knocked off seven new countries, including ET1IR, KG6AV/VK9, VP7NK, ZE1JN, VP6YB, CR6AI, OE9AN and TR1P, giving him an even 100 postwar. . . . W5LVD complains after working KH6KL/KP6, ZS6CH, LU7CE, SM5UN, RAEM, VS4VRA, OZ9U, VP5AL, UAØAK and EL5B! . . . In the past few weeks W8YIN has managed to collect 58 countries, the latest of which are UA3AF, CT1JS, HI3L, G15TK, EA9AI, CN8EE and HZ2TG, and mentions that he at one time operated at W9QMD/KE6 and those who worked this station may get a confirmation by sending a card to W9QMD. . . . W6ZZ sends in a hatfull, the best being G5AX, UAØKFA, G3BTA, G5MF, G3SR, PY1HX, VK4CZ, GW4CX, PAØJQ, VK2MT, VK2NJ and KL7IB, plus a nice batch on 28-Mc. 'phone. . . . W1JYH collected PK6HA (14,050), UC2AC (14,110), UA9CB (14,000), CT1DD, UD6BM, UI8AR, CR7AD and ZB1AF, for 108 postwar. . . . Finally being driven to a VFO, W2BRV is proud to have snagged OH2SB,



\* 53 Quinapoxet Lane, Worcester, Mass.

ZL1JR, EI9P, TF3EA, VS7ES, J9CRP, ZS6CT, HP4Q, UA9AB, I6USA, VK4HC and FT4AN, making 96 postwar . . . . . W6HJP/WØ, in the YMCA at Minneapolis, tagged onto ZS6DW, XU6GRL, VK2TI, VK5KO and PY5QJ. Between sailing on Lake Michigan and the heat, W9NRB swelled his postwar pile to 130 with VK9WF, PK6NG, ZD1KR, LI2JC, F9BT, YV5ACX, ZD3B and ZD6DT . . . . . New ones at W8NBK are HS1SS (14,098), HS1LN (14,060), VK4BI (14,050), UAØKFC (14,010), VS7IT (14,065), VR5IP (14,018) and UA9CB (14,000), for 114 postwar . . . . . WØCMH snared UB5KAE, CM2SW, OZ3FL, W6VDG/KW6, KL7IN and UK4ZL, plus a 19-minute WAC during the DX contest . . . . . OM (thirteen years old) W2UFT is mighty tickled with 1AHC/16 (14,000), OH2RL (14,000), W6NQG/KM6, GC4LI (14,035), KZ5EE (14,005), W6RWQ/VR6 (14,050) and CX4CZ (14,050), giving him 5 times his age as a postwar total . . . . . W6JKH/2 states it's nice to be able to work Europeans more often from W2 than at W6, but knocking over Asia is another thing. He did manage to grab a few, such as UAØKQA, YR5AH, HA1KK, OH2NQ, HK5PA, FA8RA and UC2AD . . . . . CM2AZ kept real busy swapping sigs with ZS2AG, VK5JS, LU8AK, HZ2YY, SM4QU, CN8MZ, OH2PK, J2EAR, VK6AP, VK6SA, ZL2FA, PAØBX, VK3KB, GM2AV, G2HCP, VK3VR and GW2HIR . . . . . W2IXY, of VR6AY fame, was the first W contact for VR6AA, on June 10th. How about letting us in on the VR6 secret? . . . . . The pick of a swell pot of DX at W6WLY is VR2AC (14,100), I1KN (14,000), FA8BG (14,060), PK6VR (14,035), VR2AO (14,160), VP3JM (14,110), AYZH (12,480), CIAN, C1DK, D2KW, OK1WF, LA2B, OX3BD, SM7YE, SM7VI, UA1KAD, UAØKAA, OK1RW, OK1LM, MX2AG, KA1ABU and FU8AA (28,000) . . . . . It's 111 postwar at W5CPI, the latest being VS4VR, CR7VAL, CR6AI, OI2KAB, GC4LI and HZ1AB . . . . . W6CIS went and "do-ed it," grabbing AC4YN and FK8NQ for 86 postwar. Nice going, mister! . . . . . With microphone in hand and a few yodels, W9WCE ran his postwar total to 103, the best new ones being GC4LI, ZB2A, ZB1AD, LX1BO, YR5G, ES1TU, OX1Z, CN8EA, OQ5AR, EL2A, SUIRC, ZE1JM, VQ2PL, EK1AA, VP5RS, HI6O, KV4AD, VS9AB, YI2CA, VU2CQ, YN1RA and ZC6FP . . . . . The pick of a long list at W2MPA include CR1OCB (14,160), D4AUD (14,300), VR2AP (14,240), W4BOW/Iwo Jima (14,250), XAMC (14,360), YS3PL (14,150), ZB1AE (14,180), ZS1DM (14,160), YN1HB (14,190), YV5ABY (14,100), ZS1DU (14,140), VK6HT (14,120), VK6WG (14,150), W7IMW/C6 (14,300) and W6OG/KG6 (14,200), for 113 postwar on two-way 'phone . . . . . W1DDO, sticking with 80, grabbed OK1VW who was using 5 watts at

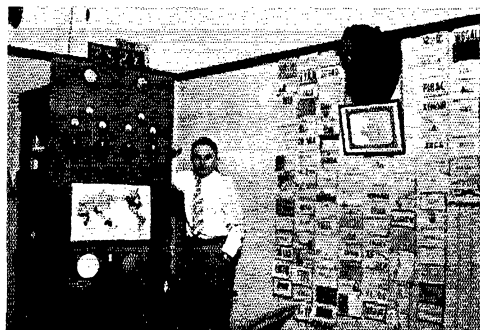

ZS2X, of Port Elizabeth, South Africa, is a familiar call to all DX men — be they of prewar or postwar vintage. The rig consists of a Franklin oscillator, 6SK7 isolating stage, 6V6 doubler, 802-807, and 50-T final. The audio end makes use of a crystal microphone, 6J7, 6C5, p.p. 6C5s and 6L6s. Antennas are three half-wave doublets switchable from the operating position. Rex says the object immediately above the DXCC certificate on the wall is not a relative of his; instead it's a baboon, prize of a hunting trip when he was a youngster.

the time . . . . . The 25 watts at W2EQS worked nine countries on 80 and 36 on 40. His all-time total with low power stands at 71 . . . . . W3HH had fun giving 40 a try, with all the gee being prompted by KZ5CB (7104), GI3AOB (7075), KH6GP (7090), G3AYL (7065), CO6ZE (7077), UB5AL (7058), SM5GW (7055), KP4EN (7050), KV4AA (7095) and PAØBQ . . . . . As we all know, ten has cooled off plenty; however, W4KXV stuck around and swapped stories with UA9CF, VQSAD, UA3DS, UA3AG, PK1MF, CP5EA and LI2B, the Kon-Tiki Expedition . . . . . W4ITP/4, increasing power to 50 watts, burned into CX4GS, ZE1JX, ZS1DJ, ZS5Q, ON4MS, F3KW, W1LTQ/TF, OK4IDT, LU7-DB, ZB2A, XADW, XAAN, OZ7PH, PAØDR, D4AQW and numerous Gs.

#### Where:

QTHs being a very important part of DX-chasing, the gang have come through with some nice ones we can appreciate . . . . . W5JPC contributes: KL7GT, Box 2386, Anchorage, Alaska; VE8AY, George Siteman, Box 324, White Horse, Yukon, Canada. From W3BXE: EK1TF, Box 57, B.P.O., Tangier Zone, N. A., and W4IKC/KP4, Box 14, USN Air Station, San Juan, P.R. . . . . VP9E informs us that his full QTH is: Charles Holmes, P.O. Box 11, Mangrove Bay, Bermuda . . . . . XABU, now MD5BU, says anyone QSO XABU will receive a confirmation by dropping a card to Major I. McAnsh, C/o Communications Board, G.H.Q., M.E.L.F. . . . . From ON4TA we get: W6WCN/Saipan, Utility Squadron 3, Marianas Islands, C/o FPO, San Francisco, Calif. . . . . W3DZ drops us: KH6LF, C. H. McInnis, jr., 614th A.C. & W. Sqdn., APO 953, C/o PM, San Francisco, Calif. . . . . KP6AB tells us QSLs

will reach him promptly if sent: CAA, Palmyra Island, C/o PM, Honolulu, T. H. . . . . In answer to many requests we give you: SU1US, Clifford A. Bruce, Farouk Airport, C/o Trans World Airlines, Cairo, Egypt . . . . . W9KMN sends along: YV5ADA, Box 1247, Caracas, Venezuela, OH4NF, Paul Meisala, Piekamake, Finland, W0SXC/KG6, 20 Fighter Wing, APO 182, C/o PM, San Francisco, Calif., and VP4TU, 155th AACs Sqdn., APO 869, C/o PM, Miami, Fla. . . . . W6VOE hands us: W6NQG/KM6, C/o PAA, Midway Island, C2KT, Box 73, Hankow, China, and HK1BZ, Box 190, Cartagena, Colombia . . . . . VK5RX suggests the following bureaus used to expedite QSLs for Australia: VK2 — J. B. Corbin (VK2YC), 78 Maloney Street, Eastlakes, Mascot, New South Wales; VK3 — T. G. Roper (VK3ZB), 26 Leicas Street, Caulfield, S.E.8, Victoria; VK4 — E. Neale (VK4EN), 38 Felix Street, Woolloovin, N.3, Brisbane, Queensland; VK5 — G. W. Luxon (VK5RX), 8 Brook Street, West Mitcham, South Australia; VK6 — J. E. Rumble (VK6RU), Box F319, GPO, Perth, Western Australia; VK7 — T. Allen (VK7AL), 6 Thirsa Street, New Town, Tasmania . . . . . Cards for CR6AI go to Box 131, Lubango, Port. West Africa; for KP4EN to James C. Pirtle, 7503 Signal, APO 846, C/o PM, Miami, Florida . . . . . QSLs for TA3SO (who turned out to be legit) should go to: Phil Morrell, C/o TWA, Kansas City, Kansas.

Word from ZS4T informs us that there are only two stations in Basutoland, these two being ZS4P and ZS4AW. All other ZS4 stations fall under the Union of South Africa . . . . . Cards for VP2AA should be sent to Paul E. Kepner, AACs Det., APO 855, C/o PM, Miami, Florida . . . . . W2TXB contributes: VP2LA, Steve Kravchuck, St. Lucia, B.W.I., APO 867, C/o PM, Miami, Florida; HK1DZ, P.O. Box 59, Barranquilla, Colombia; EA7A, Pedro Franco, Box 101, Cabo Yubi, Rio de Oro, West Africa . . . . . QSLs and correspondence for XZ2AA should go to Sgt. R. Braithwaite, Transmitting Area, 3rd Squadron, Burma Command Signal Regt., C/o GPO, Rangoon, Burma.

#### Tidbits:

W4CYY received the following short note from LX1AS: "Since Nov. '46 I have received 328 QSL

cards which do not concern me. Today I send you back your card telling you how sorry I am that you worked a pirate." So-o-o-o . . . . . KS4AC has 2000 cards on the way and plans to QSL 100%, in case anybody has been getting anxious . . . . . On May 29th what seems to be the first Tonga-Europe QSO was pulled off by VR5PL and G5LI, with the help of W7BE . . . . . To the gang who know old W1IE: he is now signing OA4BR and wants his old pals to listen for him . . . . . In the June column we reported J7ELS as the only active station on Hokkaido. W9CIH tells us that J7AAA has been active there for a year, so in all fairness to J7AAA, we hope the above will make all concerned happy . . . . . If you have been hearing DX stations with the prefix MB, they are legit. The letters are assigned to Austria, according to info received from OE9AA, via W2BRV . . . . . MX2AG is strictly under cover and not in Manchuria, but when the time comes will undoubtedly be a new country for many of us . . . . . If you have QSOed EL5B and need his QSL card, drop your card to W2LTP, Hank Greenberg, 401 Rahway Ave., Elizabeth, New Jersey . . . . . W1KKS tells us that G3LU will be operating VR6WA on Pitcairn Island on 14,330 and 14,371, where he is with the British Airways . . . . . Yes, gang, HZ2TG is definitely legit; QSLs for him should go via W0ZRA . . . . . W1BBN is really riled because some guy said he was a candidate for the Pig Pen for his zero-beat calling of DX. Why feel bad? You have plenty of company! . . . . . From W4GUY/6 we learn that ZL1KN is hearing plenty of 75-meter 'phones from all over the U. S. A. and wants the gang to listen for him on 3932 kc. . . . . KP4KD requests in a gentlemanly way that the W gang refrain from calling him on his CQ DX. He mentions that the going has been good, because of two things: QRO to 450 watts and ignoring the Ws answering his DX CQs . . . . . Both FF8FP and FF8WN have closed. Anyone not receiving cards due from FF8WN may obtain them by writing to W4FHJ; FF8FP is W2LEL.

By the time this is in print, Gordon Chalwin (VS1BU) will have returned to England, but the station will still be in operation signing VS1BA

(Continued on page 114)



W6VK got a gang of the hams at Nandi Airbase in the Fijis to stand still long enough for this picture. In the front row, from l. to r.: W6VDY (visiting), VR2AT, VR2AP and VR2AO. Standing: a native police officer, VR2AK/ZL2QB, ZL2TF, VR2AN, Don Logan (license pending) and VR2AQ. Most of the fellows are New Zealanders serving at the base in their equivalent of our CAA. The greatest part of their hamming is on 20 right now, but they can also be found on 10 and 40.

**QST** for

# I.A.R.U. News



## JUNE CALENDAR

The June issue of the I.A.R.U. Calendar reports the progress of the International Telecommunications Conference now in session at Atlantic City. First describing the opening ceremonies, the election of a chairman and a vice-chairman and the appointment of important committees, the Calendar lists the representatives of the various member-societies in attendance, who also constitute the Union's delegation, as follows:

*American Radio Relay League* — George W. Bailey, Kenneth B. Warner, A. L. Budlong;

*Canadian Section*, Alex Reid

*Chinese Amateur Radio League* — K. T. Chu  
*Liga Mexicana de Radio Experimentadores* — Lt. Comdr. J. H. Cerdan

*Norwegian Radio Relay League* (also for the societies in Denmark, Finland, Sweden) — Capt. Bjorn A. Rorholt

*Radio Club Uruguayo* — Alfredo Guimaraes Balparda

*Radio Club Venezuelo* — Cornelio Nouel

*Radio Society of Great Britain* — Stanley Lewer, John Clarricoats

The recent agreement between the United Nations and I.A.R.U. is recounted and support of the program by the various member-societies is solicited. The two major objectives of the agreement — to disseminate news of the actions, decisions and activities of the U.N. by making them subjects of conversations in contacts with foreign amateurs, and to enroll as monitors and critics of the broadcasts of the United Nations Department of Public Information, both as concerns programming and the technical aspects of propagation and reception — are detailed and member-societies urged to enlist the aid of their members to realize these objectives.

The adoption is reported of a proposal by V.E.R.O.N. that a combined DX contest be held on behalf of all European societies, rather than a number of individual smaller contests. The honor of sponsoring the first such contest has been extended to the Netherlands society.

◆  
Soviet Union radio amateur V. Palagin at his station. Chief news from Russia is that the Central Radio Club has indicated interest in becoming a member of the I.A.R.U.

Membership in the Union was proposed with full endorsement of Headquarters, for the following societies: *Chinese Amateur Radio League*, China; *Radio Club de Chile*, Chile; and *Radio Club Paraguayo*, Paraguay.

The Headquarters was pleased to chronicle the admission of *The Union Belge des Amateurs-Emetteurs* into membership in I.A.R.U. as member-society for Belgium, replacing F.E.B.

## JAPAN

Allied military personnel have formed the *Far East Amateur Radio League*, with Major C. Q. Wadsworth, J2BRX, as president. F.E.A.R.L. has established a headquarters station, J2USA, in the Dai Ichi Auditorium at Tokyo and proposes to publish a monthly bulletin.

## FRANCE

*Reseau des Emetteurs Français* announces that from August 4-25, 1947, the International Scout Jamboree will be held in France. R.E.F. will organize trials of radio control of model planes and boats and set up an amateur station at the camp for the use of visitors from all over the world. R.E.F. members who attend the Jamboree will form into small groups to welcome foreign radio amateur visitors.

(Continued on page 114)



# An Inexpensive Rig for Local Duplex Operation

*A QRM-Eliminator for Use on 11 Meters*

BY DONALD D. RALSTON,\* W8SFI

THE rig to be described was built with one purpose in mind — to provide a simple and inexpensive means of communication for local rag-chewing. In this particular case there are three of us in the immediate vicinity and we wanted simultaneous communication. Duplex or triplex operation was a must. This type of emission (AØ) necessitated using either the 11- or 2-meter bands and it was decided to give the 11-meter band a tryout.

The first line-up that was tried consisted of an 89 Tri-tet oscillator driving another 89 amplifier which was suppressor grid-modulated. A one-tube modulator with a carbon microphone was tried, but the quality was far from satisfactory. A crystal microphone was tried next, but to approach 100-per-cent modulation required two additional stages of speech and the tube line-up began to take on ponderous proportions for what had started out to be a simple rig.

The accompanying photographs and diagram show the final results. The r.f. section is simply a 7C5 Tri-tet oscillator quadrupling to 27,340 from a 6835-kc. crystal. The speech equipment consists of a crystal microphone, 6SJ7 preamplifier and a 6F6 modulator. Personally, the convenience of not having to bother with microphone batteries offsets any objections to the use of a stage of speech amplification; otherwise the 6SJ7 could have been eliminated and a carbon microphone substituted for the crystal job.

The top-front view shows placement of parts clearly. From left to right through the center of the chassis are the crystal, 7C5, 6F6 and 6SJ7. Along the front edge of the top are the cathode

condenser, plate tuning condenser and output transformer. The closed-circuit plate-and-screen meter jack is on the front. The crystal-current indicating lamp and output terminals from the link are at the left and right sides of the chassis respectively. The bottom view shows the placement of parts underneath the chassis. The cathode coil is directly below the cathode condenser. The plate coil and tuning condenser are at the top center. The microphone jack can be seen on the lower right side next to the output terminals. Power is brought into the rig through the 4-prong socket in the lower left-hand corner. The gain control is on the lower edge.

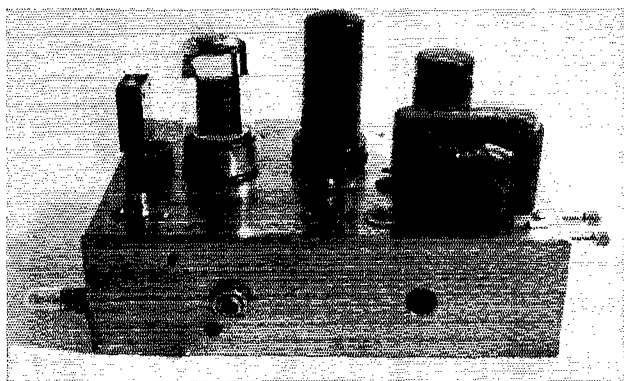

The 27-Mc. duplex rig is mounted on a chassis only 5 × 7 inches in size. From left to right are the crystal, oscillator tube, modulator, and speech amplifier. The two tuning condensers have screwdriver-adjustment shafts protruding above the chassis.

Perhaps some will shy at the thought of modulating the crystal oscillator. It is agreed that this would be bad practice in a rig used for general communication work on other ham bands, but for this particular job and frequency it worked out quite well. With the carrier tuned in on a communications receiver and the r.f. gain control backed off to obtain a low beat note with the beat oscillator on, negligible carrier shift is noted when the carrier is modulated. This stability can be attributed to the buffering action of the Tri-tet oscillator and the fact that the audio power is insufficient for 100-per-cent modulation.

The chassis measures 5 × 7 × 2 inches. No panel is used and the tuning condensers are of the screwdriver-adjusted type. The only metering provided for is in the plate-screen circuit of the 7C5, plus a 60-ma. dial light to indicate crystal current. This arrangement makes for simplicity and a minimum of parts. The gain control could be left out since experience has shown that this control is always run full on.

\*137 Madison Ave., Mingo Junction, Ohio.

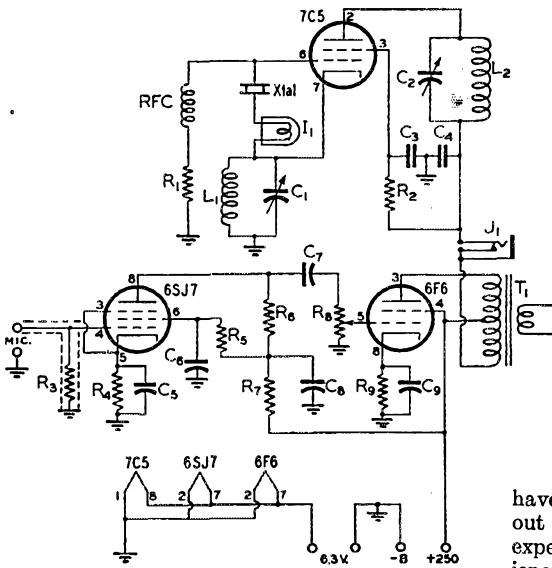

Fig. 1 -- Schematic diagram of the 11-meter duplex transmitter.

- C<sub>1</sub>, C<sub>2</sub> — 50- $\mu$ fd. Hammarlund APC type.
- C<sub>3</sub>, C<sub>4</sub> — 0.002- $\mu$ fd. 600-volt mica.
- C<sub>5</sub>, C<sub>6</sub> — 10- $\mu$ fd. 50-volt electrolytic.
- C<sub>7</sub> — 0.1- $\mu$ fd. 600-volt paper.
- C<sub>8</sub> — 2- $\mu$ fd. 450-volt electrolytic.
- C<sub>9</sub> — 0.01- $\mu$ fd. 600-volt paper.
- R<sub>1</sub> — 0.1 meg., 1 watt.
- R<sub>2</sub> — 22,000 ohms, 1 watt.
- R<sub>3</sub> — 4.7 meg.,  $\frac{1}{2}$  watt.
- R<sub>4</sub> — 1500 ohms, 1 watt.
- R<sub>5</sub> — 2.2 meg., 1 watt.
- R<sub>6</sub> — 0.47 meg., 1 watt.
- R<sub>7</sub> — 47,000 ohms, 1 watt.
- R<sub>8</sub> — 0.5-meg. volume control.
- R<sub>9</sub> — 400 ohms, 2 watts.
- L<sub>1</sub> — 15 turns No. 16 enamel,  $\frac{7}{8}$ -inch dia., 1 inch long (close-wound).
- L<sub>2</sub> — 7 turns No. 16 enamel,  $\frac{1}{8}$ -inch dia.,  $\frac{3}{4}$  inch long.
- I<sub>1</sub> — 60-ma. dial lamp.
- J<sub>1</sub> — Closed-circuit jack.
- RFC — 2.5-mh. choke.
- T<sub>1</sub> — Output transformer.

One other circuit detail worth mentioning is the high order of tank inductance in the cathode circuit of the oscillator. Take it from one who sweat for a week trying to get sufficient fourth-harmonic output: this cathode inductance works best! The combined plate and screen current of the 7C5, with 250 volts on the plate, runs 30-35 ma. loaded. The crystal-current indicator lamp shows a little more than half-brilliance when the plate circuit is loaded, showing the crystal is running well below rated r.f. current.

A word about duplex operation is in order at this point: The input to the transmitter must be kept to a minimum to avoid blanketing the receiver and the other fellow's signal. With full input to this rig, a signal 30 kc. away can be received with little interference from the transmitter.

Excellent signal strength and quality reports

have been received from up to a mile away without the use of special antennas. If you wish to experience the maximum in operating convenience with a minimum of outlay in parts and cash, this little rig is the answer to your problem. If everyone used such rigs for crosstown QSOs the reduction in QRM would make the effort involved in their construction well worth while.

• We all talk about the good that would accrue if more fellows would use the lowest possible power for local contacts, instead of employing the "big rig" for such work, but few of us carry the idea through. W8SFI describes here a little job he and two other fellows built especially for duplex (or triplex) operation with one another. It serves the purpose admirably, and does not make enough noise to bother anyone any distance away — a QRM-eliminator for ten bucks or less!

Under-chassis view of the 11-meter transmitter.

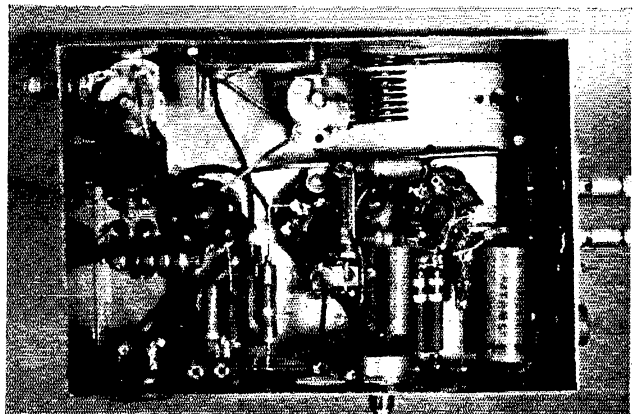



# The World Above 50 Mc.

CONDUCTED BY E. P. TILTON,\* W1HDQ

**F**OR those who like advance predictions, here is one that is infallible: the big event in any given month will come immediately after the QST deadline. It never fails!

The copy for this department in the July issue was completed on May 29th — and on June 1st the first major double-hop 50-Mc. opening broke. A last-minute insertion took care of the principal details. Four weeks later the August copy was ready for the printer — containing a line which read, "Only one major 50-Mc. path remains unbridged: no W1 has yet heard or worked a Pacific Northwest W7." And on Friday night, June 27th, in the midst of what appeared to be a normal W1-WØ opening, W7FDJ, St. Helens, Oregon, broke through with a "CQ East Coast" which netted him contacts with W1LLL, Hartford, and W1HDF, Elmwood, Conn., W1AEP, Springfield, Mass., and possibly others; the first such contacts in v.h.f. history.

A few minutes later, W7BQX, Port Angeles, Washington came through, working W2RC/1, Fairfield Beach, Conn., and (of course) W1LLL. It is believed that both W7s worked other East Coast stations, but there is not time, at this writing, to get their end of the story. Other DX reported included contacts with W7ACD, Shelley, Idaho (15 watts input!), by W1CLS, Waltham, Mass., and W3CIR/1, Boston. W1CLS also worked W6YX, the station of the Stanford University Radio Club, whose signal was reported heard with good strength by numerous Eastern stations. This evening's activities raised the states-worked totals of W1CLS and W3CIR/1 to 40 and 39 apiece, tops for the eastern part of the country.

Several W9s and WØs have passed the 40 mark, and some have worked practically every available state, but with double-hop openings occurring every few days during June there are stations in all parts of the country that are only a few states behind the "Heart-of-America" gang. Competition for new states remains keen, as West Virginia, Tennessee, Arkansas, Oklahoma, Montana, Idaho, Wyoming and Nevada are still in the one-station category, or nearly so.

Only three states remain without at least some resident activity: Mississippi, South Carolina and Vermont. Of these, the latter two have ap-

## Okinawa and Iwo Work Japan on 50 Mc.!

• According to a message received from J2AAO, Toyko, Japan, he worked J9AAK, Okinawa, on June 22nd, following a CQ at 10:30. Contact was maintained until 12:30, and resumed at 13:30, the second QSO lasting for twenty-five minutes. Signals were S9 throughout. J9ACS was heard in Tokyo on the same date, from 10:00 to 16:00.

On June 28th W2KDJ/J2, Yokohama, worked W5DIV/Iwo, also believed to be the first 50-Mc. contact between these locations.

Thanks to J2AAO, W5ACL, W2KEL, W4ZX and W1BIH for their efforts in getting this information through.

peared on a few 50-Mc. logs as the result of expeditions by mobile enthusiasts bent on doing the brethren a good turn, but as far as is known, nobody has ever heard or worked a 50-Mc. station located in Mississippi, portable or otherwise.

In all our active years since the middle '30s there have been a couple of nights each summer when country-wide ionization has produced contacts of a double-hop nature, when a few fortunate (and alert) operators have made history. With the change to 50 Mc. last year, double-hop was more often in evidence, and contacts beyond 2000 miles were made on six different dates in June and July of '46. Activity was just getting under way on the new frequency, however, and there may have been opportunities lost through lack of stations in the right places.

The record thus far in 1947 seems to bear this out. Now that stations are working on 50 Mc. in practically all parts of the country, and most of them using good equipment and high-gain antennas, not many openings are being missed. Sporadic-E skip has been worked almost every day since the middle of May, and double-hop contacts, literally hundreds of them, have been reported on 14 different dates since May 26th. Stations in all call areas have made WACA, and several Middle Western operators have worked them all in a single day.

The first contacts between the northeastern part of the country and the Pacific Northwest

\* V. H. F. Editor, QST



were made on June 1st, when W2QVH, Bernardsville, N. J., worked W7JPA, Yakima, and W7CTY, Grandview, Wash.; W2AMJ, Bergenfield, N. J., worked W7FDJ, St. Helens, Ore.; W2IDZ, Westfield, N. J., worked W7HEA, Toppenish, Wash.; W2BQK, Bergenfield, N. J., worked W7FFE, Houlton, Oregon; and W2MGF, Metuchen, N. J., running 20 watts input, worked W7FDJ. This same night was extraordinarily good for W1-W6 work. W6ANN, San Pedro, Calif., worked W1s CLS, LLL, KHL, HDQ, GJZ, PJC, W3CIR/1, VE3BFF, VE3KM and several W5s and W0s. The following morning W6ANN also worked W9ZHB and W8QYD, both contacts being made before leaving for work at 6:40 A.M. PST!

June 16th was another hot one, with the double-hop covering even more territory. From the western tip of Texas, W5AOT and W5ESZ, El Paso, worked W3CIR/1, W1GJZ, W1LLL and others. W2AMJ had a partial contact with W6PUZ, and heard W7ACD and W7SP, Idaho and Utah, respectively. W2BQK worked W6GGM. W1CLS worked W7KAD, W6PUZ, W6FMH and W6ANN, and heard W6OVK, W6GGM, W5AOT and W5ESZ. W1CGY heard all the above-mentioned stations. W6OVK worked W9HGE, W9ZHB, W9PK, and heard W8VIB, W1CLS and W1LLL. W7QAP worked W1HDQ and heard W1LSN, W1CLS and W1GJZ.

The afternoon of the 20th provided an opening to W1 for W6AMD, Santa Barbara, Calif., who worked W1JLK, W3CIR/1 and your conductor, and was heard by other W1s who turned their receivers on immediately upon arriving home from work. W4WMI, Raleigh, N. C., worked W7QAP and W6QUK on this one, and W3CIR/1 worked W6AMD, and W6OB, Compton, Calif., who was running only 20 watts input. New Mexico (W5MLE and W5ELL), Western Texas and Arizona were working into W1 and W2 on the 23rd, and minor double-hop openings were reported on the 3rd, 6th, 7th, 8th, 15th, 19th and 25th, in addition to the dates reported in detail above.

June also provided the shortest skip on record. The evening of the 24th started out as an ordinary opening between the East and Middle West, when suddenly signals began to appear from dis-

tances as short as 275 miles. Throughout the East skip contacts were made over distances normally covered only by tropospheric bending or aurora. The violent fading, and the short duration of their appearance, labeled these definitely as of *E*-layer origin. As is always the case during June and July, there was a considerable amount of short skip worked elsewhere in the country as well, probably as a result of increased ionization density. There was evidence of considerable sharp-angle reflection at times, with signals being received seemingly off the sides or back of the beam, in a manner similar to aurora reflection. And there was aurora in June, too, contacts on c.w., with beams aimed north, being made in the East and Middle West on the 7th and 13th.

Ordinary *E*-layer contacts were so frequent as to become almost commonplace, but this made them nonetheless enjoyable. After the first flurry of hit-and-run contacts early in the season, many of the regulars had relaxed into leisurely QSOs over 800-1400-mile paths. For this sort of stuff 6 was fine — the signals were as strong as on 10, and there was but a fraction of the QRM. And in the process of trying to work the DX, more and more of the newcomers were discovering that 6 was the best band now available for making friendly contacts over local and extended-local distances as well. The experiences of June will, we hope, serve to generate activity for the months to come, when the skip-DX is no longer with us so frequently.

### Beyond Our Borders

Canadian activity is coming along nicely. As a result of the fine work of VE1QY and VE1QZ, there is a growing interest in 6 on the part of other VE1s. Already active are VE1SF, 50.44 Mc., VE1PQ, 51.0 Mc., and VE1QG, 53.4 and 50.036 Mc., and several more stations are in prospect. Since their initial success on May 23rd VE1QY and VE1QZ have worked 53 and 63 stations respectively. The first VE1-VE3 contact was made on May 27th, when VE1QY had a brief exchange with VE3AZV. Over in St. John, N.B., VE1FJ, has been hearing plenty of Ws and will have a rig on to work them before this appears in print. In Valois, Quebec, VE2GT and VE2KH have stimulated interest in 50-Mc. operation through their numerous DX contacts. They

Oscar Sandoz, VE1QZ, Halifax, Nova Scotia, who, with VE1QY at Yarmouth, provided the first VE1 contacts on 50 Mc.

August 1947

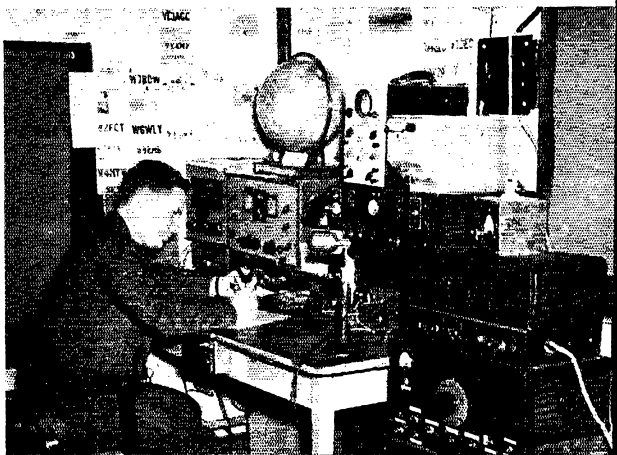

report reception of W6UXN during the night of June 1st.

A summary of DX results received from VE3ANY, who conducts the v.h.f. department in XTAL, shows that the VEs have been keeping step with the Ws when it comes to consistent DX results. From May 22nd to June 18th, there were only three days when sporadic-E skip was not worked by Canadian 50-Mc. stations in the Winnipeg, Toronto and Halifax areas. VE3BQL lists VE3s BFF, AND, KM, NH and BQL as among the more successful of the stations in the Hamilton, Ontario area. Along with VE3DC of Dundee, they have worked W4, 5, 6, 9 and Ø.

Last month we wondered, in print, what had happened to the VE4s in the vicinity of Winnipeg. They're on deck, and contacts with W8, 9 and Ø have been made by VE4GQ. VE4DG sends in a long list of W calls heard on 6. Only VE5, 6 and 8 are not represented this month in reports in hand.

The VE7s have been having good luck on 6, and there has been quite a bit of 50-Mc. interest out there ever since the opening of the band. The Totem Amateur Radio Club, Vancouver, B.C., is conducting extensive tests during the weekends of Aug. 9th and 16th. Beginning at noon on Saturday, VE7BQ will make 10-minute transmissions on 50.8 Mc. every alternate 10 minutes, until midnight on Sunday. In between these transmission periods they will listen on 20, 10, 6 and 2 for replies. Verification of authentic reception reports will be sent on request.

South of the border there is activity, too. The first success of XE1KE was reported briefly last month, when three W5s were worked on May 29th. This was followed, on the 31st, by a series of contacts with W5s FSC, EEX, VY, IOP, LBG, LCZ and ML. Four W5s were heard on June 1st. The signals of XE1KE have been reported heard in W6, W9 and WØ, but so far as is known the only XE contacts to date have been made by W5s. From Monterrey, Mexico, comes a report from Gilberto Quintanilla, formerly XE2C, who heard W9LF, W9VZM, W9HSB, W8QYD and W9ZHB, between 9:30 and 10:45 (Monterrey time) on the morning of June 2nd. Both ends of a QSO between W9ZHB and W9HSB were heard from 10:50 to 11:05. Many other stations were heard, including two WØs, but identification was not possible. Our reporter says he will be on 6 before long.

Interest in 50-Mc. work on the part of fellows who work maritime-mobile is increasing. WØTKX/MM, mentioned last month, has been working out on 6. On a trip down the Atlantic Seaboard, he has been in contact with numerous Middle Western stations. On the 16th, while the *Fort Winnebago* was in the Delaware River, he worked VE1QY, Yarmouth, N.S. His rig runs 10 watts input to a doubler — but you can't beat the location! Another prospect is W8QOH/MM,



### Standings as of June 30th

W1CLS	40	W4HVV	23	W9UNS	30
W3CIR/1	39	W4AVT	16	W9ALU	28
W1LLL	37			W9HSB	26
W1HDQ	36	W5FSC	32	W9CZD	11
W1HMS	30	W5JLY	29	W9AB	9
W1AEP	30	W5ESZ	22		
W1CGY	27				
		W6ANN	28	WØTQK	42
W2BYM	33	W6WNN	21	WØZJB	42
W2RLV	30	W6OVK	16	WØDZM	41
W2PWP	29	W6HZ	14	WØUSI	41
W2AMJ	27	W6BWG	7	WØYUQ	39
W2QVH	27			WØQIN	37
		W7BQX	26	WØCJF	36
W3RUE	27	W7QAP	22	WØDKS	36
W3CGV	25	W7ACD	19	WØYKX	36
W1KMZ/3	19	W7JPN	12	WØBJV	35
W3LEF	10	W7CJN	7	WØJHS	34
				WØDYG	33
W4DRZ	35	W8QQS	16	WØKYF	32
W4GJO	32	W8TDJ	14	WØSV	37
W4EID	30	W8RFV	11	WØDNW	26
W4GY	30			WØINI	20
W4QN	29	W9ZHB	41	WØVIK	15
W4WMI	27	W9DWU	40		
W4FLH	26	W9ZHL	34		
W4FBH	25	W9PK	33	VE1QY	19
W4FJ	24	W9JMS	31	VE1QZ	14

aboard the freighter S. S. *Del Mundo*. He has more power than many of the shipborne fraternity, running 75 watts to a pair of 807s, on 50.33 Mc. His ship is on a regular run between New Orleans and the Virgin Islands, Trinidad, Brazil, Uruguay and Argentina. He will be on the lookout for high m.u.f. this fall, as well as checking between 10 and 6 for sporadic-E prospects this summer.

On his return trip from Genoa, W5BSY/MM, aboard the S.S. *Crest-of-the-Waves*, made a flock of contacts with European 5-meter stations on June 13th and 14th, while in the Mediterranean off the coast of Spain. His list includes PAØUN, G6DH, G5BD, G5BY, G2MV, G2XC, ON5G, I1PB, I1XW, I1IRA, I1AY, F8AQ, F3HL and F3JB. W5BSY/MM is back in American waters at this writing, but will be off for another European trip later in the summer.

There has been sporadic-E DX almost daily in Europe, according to news from G6DH, G5BY, PAØUM and I1AY, all of whom we wish to thank for sending along the latest information. The situation there is similar to ours in years gone by: they have evidence that the band is open (in the form of commercial and 10-meter harmonics) but often there is no one to work for hours at a stretch. G6DH worked FA8IH on June 4th, 12th and 13th; F9BG, F9BN and W5BSY/MM on the 13th; and heard HB9BZ working GW5YB

(Continued on page 116)



# Correspondence From Members -

The Publishers of *QST* assume no responsibility for statements made herein by correspondents

## GOLD IN THEM THAR *QST*'s

4422 Silsby Road, University Heights.  
Cleveland, Ohio

Editor, *QST*:

Looking over old *QST*'s is an enjoyable habit of mine. As a result I now find items of interest that I had passed by at the time the magazine appeared. I would like to point out several items that have proved most helpful with the hope that more of the gang will look for similar items of interest in past issues.

In the November, 1936, issue I found the "Heterotone" and built it up just before the war. I will never have a ham receiver without this useful device. I can pull S2 signals out of the soup and, together with my xtal filter, make them actually sound S9. That i.c.w. tone is ever so much easier on the ears, too! Why manufacturers have never incorporated this circuit into the better communication receivers is a mystery to me.

Recently, after a year of trying to get out on ten meters with something less than a beam (they're out, here) I dug up an article I remembered about a skywire that had a variable-angle feature. I found it in February, 1935, *QST*. It was by our old friend, John Reinartz, and entitled "A New Antenna System for Operating Control of Radiation." It uses a three-wire feed system and is giving me more signal on all bands than any antenna I've ever had. I don't know too much about its variable-angle operation, but I just load it up and boy, does it work, both DX and local, 10 to 80 meters! You see, not many of us worried much about angle radiation back in 1935, but we certainly know its value today!

More recently, in an experimental mood, I went back to the June, 1946, issue and tried that little audio amplifier in "Hints and Kinks." Now there is really something! That thing has less parts and more sock and fidelity than anything I've heard in a long time. Every ham friend that has seen and heard it marvels at it!

So please tell the gang not to forget all those valuable bits of information in old *QST*'s. A lot of them can make a much more interesting ham radio for us all.

— Paul M. Cornell, W3EFW

## POSTWAR B.C. SETS

Deep River, Ontario, Canada

Editor, *QST*:

The trend in amateur radio has always been for continued technical progress. Present-day transmitters are becoming much more efficient, flexible, difficult to construct and, last but not least, represent a considerable outlay to the average ham.

The opposite is true of commercial b.c.-receiver manufacture. The tendency would seem to consist of wiring approximately four tubes in an a.c.-d.c. arrangement, with no preselection, most inadequate shielding, on a two-by-four tinpan, and then carefully camouflaging it by means of a shiny, veneer cabinet and a full-vision dial. Price: by no means cheap!

These bloopers are being turned out in large numbers and just as quickly picked up by an unsuspecting public. The joker is that 90 per cent of the complaints of BCI originate with owners of these sets who know nothing about their internal workings but only that they paid what they thought a high enough price to ensure good b.c. reception.

In a couple of years the number of these "receivers" in

use will have been increased many times — also the headaches of the average ham in proportion — and amateur radio thereby will have lost much of the good will accumulated through the years.

I think it would be to the advantage of everyone concerned if every manufactured b.c. receiver was required to pass certain standards of performance, i.e. selectivity, radiation, sensitivity, etc. However, until such legislation is passed I think it is in the best interests of every amateur that he advise any acquaintance who is considering purchasing one of the "new postwar receivers" of the numerous limitations which the average model possesses; and if he already has a prewar receiver, to defer purchase until the quality of the present models has improved.

— H. H. Wood, VE3ABF

Pineview Apartment 205  
501 N.E. Ocean Avenue,  
Norfolk 3, Virginia

Editor, *QST*:

I am writing to tell of a case which I think might be of interest to other amateurs living in apartment houses under the same conditions as I enjoy (?).

... This a.c.-d.c. receiver had strong harmonics from the local oscillator — as high as my HQ-129 will tune! For many months I have heard a narrow-band f.m. station on 29.52 Mc. with fair signal strength, but this station never gave its call sign and would broadcast the local a.m. station for hours at a time. I could hear people in the background, but never a station call. This bothered me, as I couldn't see a self-respecting ham leaving his f.m. carrier on the 10-meter band broadcasting the local a.m. station without being concerned about it.

Last night I got the answer. While working on this receiver I tuned in the harmonics of the local oscillator on the HQ-129 and was surprised to hear the f.m. signal again only this time much stronger. To make a long story short, my little case of BCI is radiating on 10 meters, the 'speaker rattles the chassis, vibrates the local oscillator and mixer tube, and gives me that narrow-band f.m. signal! No kidding, I checked and double-checked; you can even talk at the 12SA7 mixer, or hit it and hear the signal come through the HQ-129!

— H. Paul Bohlander, W4LBP

## CALL YOUR SHOTS

47 Keeney Ave., W. Hartford, Conn.

Editor, *QST*:

Here's Suggestion 653.5 to lessen useless QRM. Custom — or an ARRL procedure regulation — should make it mandatory for lads with beam antenna to "call their shots."

At present, Dodsworth Inkefoot, at Spook, Ill., with his full k.w. and 4-element rotary, may call "CQ twenty" with the big birdcage pointed southwest. He plans to listen only on his own frequency. Erratic skip conditions lay his signal down S9 in West Hartford. But to the SW he is burning the leaves off the trees. Being rusty on my crystal gazing, I have no way of knowing that. So I go on with my block-buster about 10 kc. north of him, at least turning the lethal eye of my birdcage on Spook, Ill. I may be crystal-controlled — or don't take time to QSY. Perhaps 25 charming QSOs

(Continued on page 130)



# Hints and Kinks

## For the Experimenter



### GRID-DIP OSCILLATOR

ONE piece of equipment which does not seem to have attained its deserved popularity among amateurs is the grid-dip oscillator. Among the uses of this instrument are checking the resonant frequencies of tuned circuits (without the necessity of applying power to the circuit), measuring inductance and capacity, and finding the resonant frequencies of antenna systems. A simple version of the grid-dip oscillator which will be found very useful around the average ham shack is shown in Fig. 1. A 6E5 "magic-eye" tuning indicator has

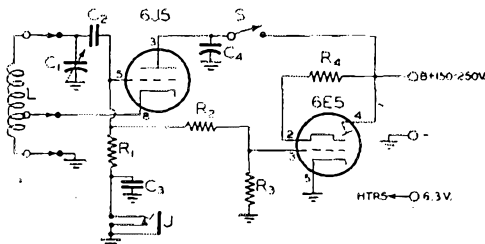

Fig. 1 — A grid-dip oscillator for general utility in the ham shack.

- C<sub>1</sub> — 150- $\mu$ fd. midget variable.
- C<sub>2</sub> — 220- $\mu$ fd. mica.
- C<sub>3</sub> — 0.001- $\mu$ d. mica.
- C<sub>4</sub> — 0.01- $\mu$ d. paper.
- R<sub>1</sub> — 0.1 megohm,  $\frac{1}{2}$ -watt carbon.
- R<sub>2</sub> — 4.7 megohms,  $\frac{1}{2}$ -watt carbon.
- R<sub>3</sub>, R<sub>4</sub> — 1 megohm,  $\frac{1}{2}$ -watt carbon.
- L — (2.5-7 Mc.) 29 turns, tapped at 1 turn,  $1\frac{1}{4}$ -inch diam.
- (6-14 Mc.) 12 turns, tapped at 1 turn,  $1\frac{1}{4}$ -inch diam.
- (12-35 Mc.) 5 turns, tapped at  $\frac{3}{4}$  turn,  $1\frac{1}{4}$ -inch diam.
- (30-60 Mc.) 3 turns, tapped at  $\frac{1}{2}$  turn,  $\frac{1}{2}$ -inch diam.
- J — Closed-circuit 'phone jack.
- S — S.p.s.t. toggle switch.

been substituted for the usual milliammeter to indicate change in grid current. Besides being cheaper, it is extremely sensitive, and is immune to damage from overload. A 6J5 is used as an ordinary Hartley oscillator, with the 6E5 connected to indicate oscillator grid voltage. When power is absorbed from the tank circuit by another circuit tuned to the same frequency, a sharp indication is obtained on the tuning eye. With its help, a new transmitter can be closely tuned up before applying any power at all.

The unit becomes a sensitive absorption wavemeter when switch S is opened, giving a much more accurate indication than can be obtained

with the usual pilot bulb, and yet without fear of damaging an expensive meter. By plugging a pair of 'phones into the closed-circuit jack, the unit can be used as a diode monitor or oscillating detector (with the plate switch off and on, respectively.) For checking the natural frequency of an antenna, it will be found convenient to couple the coil to the antenna by means of a link line, as described in the *Handbook*. The method of measuring C and L is also adequately described therein. Calibration curves for each coil range can be made with sufficient accuracy for most normal work, but in any case, the oscillator frequency can be measured with fair accuracy by tuning it in on the station receiver. A standard 3 X 4 X 5 metal box makes a convenient housing for all parts, with the coil plugged into a socket on one end, and the tuning-eye screen visible through a hole in the top.

— R. V. McGraw, W2LYII

### DRILLING GLASS PANES

A SIMPLE way to drill a hole in a pane of glass is to use an old drill (that you have no further use for) and a high-speed electric drill. Place the glass on an absolutely flat surface, and turn on the drill, applying moderate pressure. After a time, the drill will become red hot, and then almost white hot. Suddenly it will fall right through as it melts the glass. Do not try to take the drill out while it is still turning, but turn it off, removing it from the hole before the glass has had a chance to cool. The drill will be no good for drilling metal, or even wood, after use in this fashion, but it may be used on glass again. There will be a slight burr around the edges of the hole when it hardens, but this is usually of small consequence, and can be covered by a beehive, or other feed-through insulator.

— J. A. Felthouse, KL7ED

### SELENIUM RECTIFIER HINTS

THE following will be helpful in prolonging the life of the new midget selenium rectifiers: the rectifiers should be mounted with their "fins" vertical to prevent heat from the lower sections causing destruction of the upper section.

The use of a current-limiting resistor of 50 ohms or so immediately after the rectifier will limit the initial surge into the large input capacitor usually used with such gadgets.

— Laurence Geis, W6OKF

## ALIGNMENT AID FOR V.H.F.

A SIMPLE, effective alignment indicator for receivers using superregenerative second detectors, such as those described recently in *QST*,<sup>1</sup> consists of a 0-100 microamp. meter in series with a 0.1-megohm resistor, connected as shown in Fig. 2.

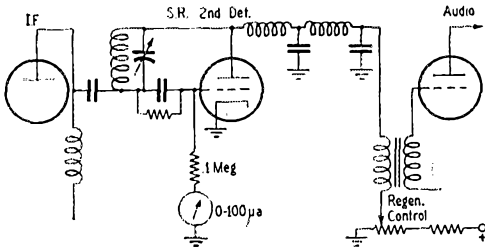

Fig. 2—A simple alignment indicating circuit for use with superregenerative second detectors. By changing the values as described in the text, the same set-up may be used for field-strength measurements.

With this set-up, with the regeneration control turned fully off, the detector tube acts as a diode rectifier. It is not necessary to by-pass the plate to ground, because at the frequencies where these detectors are usually operated (10 Mc. or higher) the stray circuit-and-tube capacitance is usually sufficient.

With this device, and very loose coupling of the mixer grid to a signal generator, a reading of 50 to 100 microamperes is easily obtained. The i.f. and mixer stages can then be trimmed to obtain top performance.

If desired, the circuit may be used for field-strength measurements by increasing its sensitivity. In this use, the resistor should be 0.5 megohm, and the meter 0-30 microamperes.

— *Erich Kohout, HB9AT*

## SERVICING XTAL FILTERS IN THE BC-348

LACK of ventilation in BC-348 receivers that have been converted for a.c. operation with built-in power supply sometimes leads to failure of the crystal-filter section. Excessive heat from the power supply melts the gummy substance covering the three-section crystal holder, causing it to seep into the holder and deposit on the crystal and the electrodes.

The remedy was found to be quite simple and easily performed. The crystal and its holder, which are directly behind the crystal switch, should be removed and taken apart. Clean the crystal, and all parts of the holder, by scrubbing with warm

<sup>1</sup> "Mobile Receiving Equipment for Two, Six and Ten Meters," Tilton, *QST*, September, 1946, p. 28. "An Improved Receiver for Two Meters," Hadlock, *QST*, March, 1947, p. 35.

water and soap. Rinse and dry thoroughly, being careful to avoid touching the crystal with anything that will leave dirt or grease on it. Reassemble the crystal in the holder, seal all seams with Duco household cement, and wire it back into the circuit. Results are surprisingly good.

— *Herbert K. Armistead, W4WAI*

## NEON-BULB PROTECTOR

DOZENS of neon bulbs are tossed into the ash can because they rolled off the bench and smashed on the floor. A simple way to avoid this is to wind a piece of insulated hook-up wire around the base once or twice, give it a twist, and cut off the ends, leaving about an inch of each end of the wire sticking out. These short tabs will prevent the bulb from rolling, and will keep it on the bench where it belongs.

— *H. A. Fanckboner, W9BPS*

## BALANCING PHASE-INVERTER CIRCUITS

THE arrangement shown in Fig. 3 provides a simple yet effective means of balancing phase-inverter circuits. It requires little equipment, and is perhaps more accurate than other more involved methods.

The primary of a plate transformer is temporarily connected in the B+ lead to the center-tap of the output transformer. Headphones are

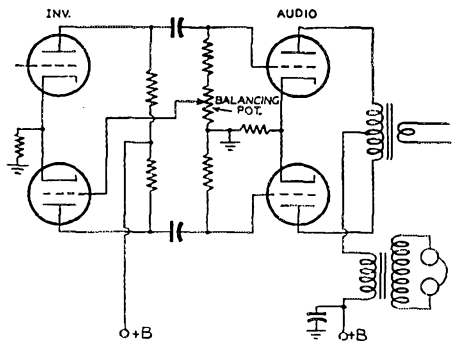
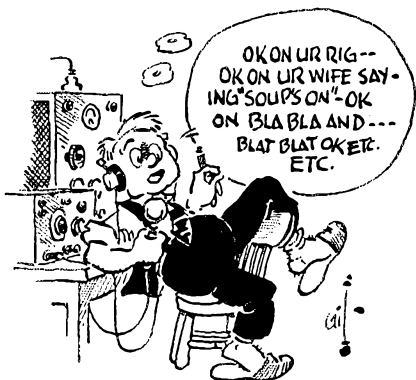

Fig. 3—Arrangement used for balancing phase-inverter circuits without the use of elaborate test equipment.

connected across the secondary as shown. Signal input is then applied to the phase inverter, and the balancing potentiometer is adjusted until minimum signal, mostly distortion products, is heard in the 'phones. This point is very critical, and indicates balance of the inverter circuit. Slight variations introduced when replacing tubes can be offset by readjustment using the same method. — *H. G. Brower, ex-W2FQP*

# Phone-Band Phunnies

## Little Sir Echo



THIS specimen's mother was undoubtedly frightened by a parrot, and he himself must have been vaccinated with a phonograph needle, for he "plays back" to you everything you say.

"R all okay," he will say. "Okay on your rig there being a pair of 1T4s with three kilowatts input; okay on your handle being Egbert and on your receiver being a converted Treasure-Finder; okay on your having in-growing toenails," etc., etc., *ad infinitum, ad nauseam.*

He goes right on down the list repeating each and everything you said in even greater detail than you used in the telling of it. Three-quarters of every transmission he makes is devoted to this meticulous and exasperating repetition.

Psychologists who have studied this tautological terror are more or less baffled, but the author has a theory as to the cause of it all. For his money, the guy is really a congenital liar and knows that he is. Out of this knowledge has arisen a form of inferiority complex that expresses itself in a compulsion to *prove* every statement that he makes, no matter how trivial. Having committed himself with that first "R all okay," he simply is forced to go ahead with the redundant rigamarole to show that he *did* receive everything.

In the cynical language of the bobby-soxers, this guy is all right in his place, but it has not been dug yet. — *John T. Frye, W9EGV*

(AUTHOR'S NOTE: The writer has always been delighted with the wide variety of personalities displayed to such good advantage on the amateur 'phone bands. In this new QST series he has attempted to sketch, as a light-hearted hobby, some of the more interesting types.

Before you smile your best Pharisee smile upon reading them, ask yourself these two questions: (a) Am I sure there is not a little bit of me in this sketch? (b) What kind of a dull, drab band would this be without colorful characters such as these? — *J. T. F.*)

## Strays

The ad writer for the Mueller Electric Co. is suffering from a bad case of overreading of his wife's *Mademoiselle* and *Ladies' Home Journal*, as witness his latest effort on behalf of the Company's new alligator clip (reprinted from the *Mueller Clipper*):

"The new No. 85 is deftly designed for sheer charm with every dimension just so. The long-toothed jaws gaily ignore tradition in that they do not meet face to face but one snuggles securely inside its sheathing mate. . . . But the pay-off is the new plastic insulator — as supple as your own skin. It follows the classic lines of the clip as closely as the flute follows the soprano in a cadenza. . . . The insulator comes in two colors, Satan Red and Siren Black."

All this, and a test clip to boot, for ten cents!

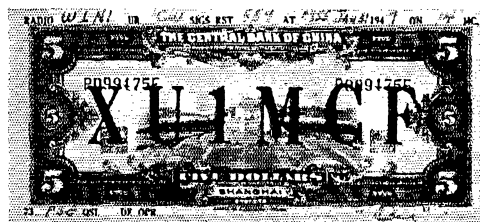

Work this Asian and it'll be no lie when you tell the other guy that your shack is wallpapered with five-dollar bills — Chinese dollars, that is. W1NI and a number of others were the recent recipients of XUIMCF's unusual QSL, a "card" printed on crisp greenbacks issued by The Central Bank of China. Capt. Howard J. Olson, operator of the station, is serving in China where rampant inflation has greatly depreciated currency values.

### COMING CONVENTIONS

Delta-West Gulf Divisions, Texarkana, Arkansas, August 16th-17th.

Connecticut State, Bridgeport, September 27th-28th.

Hudson Division, Asbury Park, N. J., September 26th-28th.

Southwestern Division, Phoenix, Arizona, October 18th-19th.

New England Division, Boston, October 18th.

### HAMFEST CALENDAR

GEORGIA — The Rome Radio Club invites all amateurs to a hamfest to be held at Rome, Georgia, on Sunday, August 10th. An all-around good time is promised. Reservations may be made through Secy. Gordon L. Hight, 106 Second Ave., Rome, Ga.

OHIO — Sunday, August 10th, is the date of the 8th Miami Valley Ham Picnic, sponsored by the Piqua Radio Club, Piqua, Ohio. The affair starts at 1:00 P.M., with plenty of eats, soft drinks and swimming scheduled. Tickets are \$1.00 per person — children under 12 free. Advance registration may be made through Secy. John R. Mollman, 325 East Main St., Piqua, Ohio.

# A Position Indicator for Directional Arrays

BY JOSEPH S. TOMCZAK \*

WITH beam antennas becoming more popular day by day, the author decided to install one, and with it a simple and inexpensive electrical means of determining beam direction. Many types of indicating device are available for this purpose, but only one appears satisfactory from both practical and financial standpoints. This consists of a pair of Selsyns, which may be purchased from war-surplus outlets at low cost.

The operating-position indicator unit described, housing one of them, requires only the altering of a meter case, cutting a new Lucite front, and making a bakelite support block, to which the Selsyn is mounted. Details are shown in the accompanying sketch. The procedure in making the unit was as follows:

First a Triplet Model 321 shallow 3-inch meter case, a pair of small Selsyns, a bakelite block, and miscellaneous other small parts were procured. Any other type of meter case may be used provided it is cut down to a suitable depth. The glass was removed by prying out the inner band with a small screwdriver. Next the "zero-set" screw lip was cut out, and the surface left was

\* % Naval Research Laboratory, Washington 20, D. C.

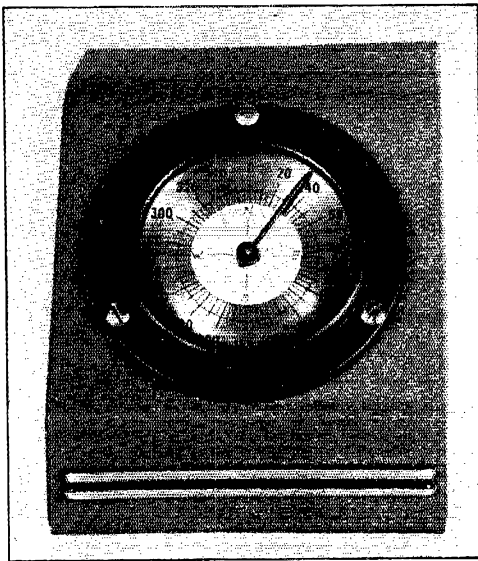

The Selsyn indicator unit for directional antenna systems is built into a revamped meter case. It may be rack mounted, or housed in a small cabinet, as shown, for use at the operating position.

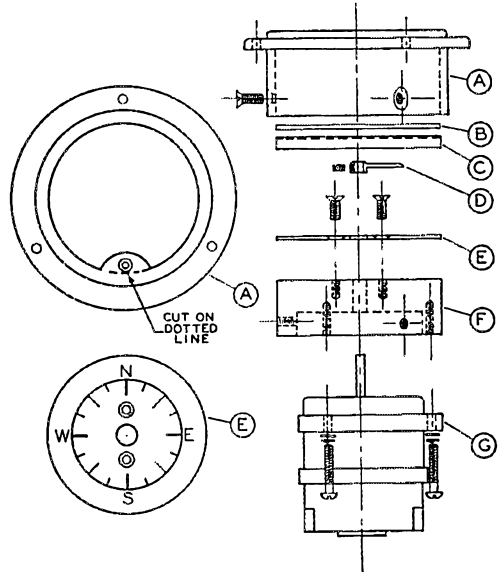

Fig. 1 — Details of the meter-case beam indicator unit.

- A — Meter case, with changes.
- B — Lucite window,  $\frac{1}{16}$  inch thick, cut to fit inside of meter case.
- C — Inner hand.
- D — Pointer, with  $\frac{1}{40}$  Allen setscrew in collar.
- E — Calibrated scale.
- F — Bakelite block,  $\frac{3}{8}$  inch thick, machined to fit inside meter case.
- G — Indicator Selsyn.

filed smooth to match the rest of the beaded contour.

A piece of  $\frac{1}{16}$ -inch-thick Lucite was cut to size to provide a new crystal for the meter front. However, before cutting, the inside diameter of the meter case should be measured accurately, and the Lucite dimensioned to provide a snug fit. The inner retaining ring is then pressed in against it.

The bakelite block for mounting the indicator Selsyn in the case was turned out on a lathe, a recess being cut in the block to accommodate the top of the synchro, as shown in the sketch. No dimensions are given, since these will vary with the parts obtainable. The Selsyn is mounted with its shaft protruding through the front side of the block.

A hub for the indicating pointer was made by drilling a small piece of  $\frac{1}{4}$ -inch brass rod to the diameter of the synchro shaft. A  $\frac{3}{40}$ -tapped hole

(Continued on page 158)



# Operating News



F. E. HANDY, WIBDI, Communications Mgr.  
J. A. MOSKEY, WJMY, Asst. Comm. Mgr.

GEORGE HART, WINJM, Communications Asst.  
LILLIAN M. SALTER, Communications Asst.

**Field Day Recapitulation.** The emergency-testing of low-power amateur stations, self-powered, in this year's ARRL FD exceeded all previous records for events of this type, taking early reports as a barometer.

There's a thrill in having successfully proved one's communication ability in a Field Day, regardless of the quantitative individual result. FDs demonstrate the value of good operating procedures; necessary modifications or improvements in equipment and FD organization readily suggest themselves. Like the Army, Field Day groups have a "morale factor" depending on the effectiveness of the culinary department! Then too, the techniques of handling equipment and using procedures to get best results take on increased significance to operators, once they are exposed to FD communication and accuracy requirements. The desirability of holding club meetings or pre-Field Day seminars on formulation of messages, notations of handling data, and need for correct word-count and calling procedure are emphasized by the FD. We heard one chap, nev to c.w. no doubt, *spell out* "CQ Field Day" painfully at the start, for example . . . but he'll have more operating savvy by another year. Technical lessons too are learned from the necessity to subdue generator hash, key clicks and splatter from different installations in the confines of one location! The methods of handling and packaging equipment for safe transportation to field locations also rate mention here -- plus the requirements for ruggedness as well as for flexibility of control, adaptability for "push-to-talk" and break-in! In our personal case this year's Test, in an open spot, exposed all equipment (for 10 hours until conditions cleared) to about the worst that nature and altitude could offer in the way of extreme moisture, humidity, condensation on apparatus, absorption into control cords, etc. . . . the first time of working FD in a rain cloud and our lessons were all in the "control" department.

The importance of moisture-proofing all leads and containers of equipment, and of having replacement keys and microphones on hand for prompt substitution where bushings or other parts fail is emphasized. This vacation season is a good time to complete and test equipment modifications in your portable gear.

In future FDs it is likely that the several op-

tions and choices available to contestants under the rules will be continued. The tremendous growth in participation during recent years is a testimonial to the happy combination of objectives and possibilities. The choice of bands and equipment, we believe, should be left to participants, but emphasis placed on construction of gear for easy transportability.

**Should Battery Work Be Credited Separately?** Gas-electric powered stations are ideal for clubs to develop as dependable community-center stations for emergency. The more such, the better! Opinions are solicited from readers as to whether, in future years, a special department of Field Day listings should be set up for work accomplished exclusively with genemotors, Vibrapacks and storage cells or dry batteries -- or should some additional multiplier be accorded for those contacts obtained when so equipped? If so, what multiplier? Should there be weight limits or entries by ampere-hour classes? The power handicap will continue to bring the contest to the level where any individual can enter with low-level self-powered gear.

Surveys show that even now we do not have enough truly self-powered sets generally distributed within the fraternity. However, the very wide availability of the automobile battery lends itself particularly well to the development of additional 6- and 12-volt emergency gear. With the possibility that FCC sanction will be given a wider use of amateur station equipment in automobiles, a decision on one of the above options will probably be necessary prior to next year's announcement. In the purchase of receivers, it is believed that amateurs should give preference to units that are convertible to run from 6 volts in the event of unexpected need!

The more such stations we create the less likely the possibility of isolation for any community or section following any type of disaster, and the greater our ability to render a public-service contribution in emergency.

It is suggested that over the next year clubs conduct private competitions and field outings dedicated to *preparedness*. Get the SCM to appoint an EC and support the ARRL Emergency Corps by having a meeting devoted to AEC enrollments and community planning. Emergency coordinator groups should plan for the most effective disposition of facilities in each commu-



nity, after consultation with the Red Cross and other agencies. Then arrange a local radio test.

**On Checking Messages.** A cursory examination of the first thirty "FD" messages reaching Hq. indicates a lack of knowledge by some ham groups on the subject of checking messages. Reference to pages 12 and 13 of *Operating an Amateur Radio Station* (free on request of Members, ten cents to others) or review of the 1947 *ARRL Handbook*, pages 464-465, should make it easy for any ham to start traffic with a correct check.

ARRL message checks are based on text-only count. Every "dictionary" word in the text counts *one* . . . that's fundamental, and simple enough! Groups of letters that are *not* dictionary words are counted at the rate of 5 letters or fraction thereof to a word. As explained by examples in the booklet, radio call signals *sent as one group* count as one word under ARRL count. Initials and grouped characters *sent separately* count as separate words. Letter groups such as USS, USCG, ARRL and the like count as one word each. Each group of five digits or less counts as a word. The decimal indicator (R) may constitute one of the digits. A group of six to and including ten letters or digits (not dictionary words) counts *two* in the check. *Mixed* letters and figures, *except radio calls*, take a count of one word for *each letter and figure*. Suffixes like "th," "nd" and "st" are not transmitted since they contribute unnecessarily to possible errors.

A preliminary look at the file of received FD messages indicates that perhaps 25 per cent of those received have careless errors in the check, or errors in word-count in transmission. Deduction of 10 credits will not be necessary of course if confirmation copies filed with reports prove that the check was OK at both ends of the first relay. Fifty per cent of the errors noted could have been avoided easily by consulting reference material!

**Speed vs. Rate of Sending.** Some new hams, it is reported, say they think much c.w. work seems to be at too high speeds. But they would like to take advantage of c.w.'s ability to get out well with low or modest power. Contrary to this "speed" impression every good operator customarily modifies his sending speed to meet that of the chap who calls him. Here are two additional facts: Practically all amateurs are *very* desirous of working *new* amateurs. Every c.w. amateur of our acquaintance is willing to send at *any speed desired* by the amateurs with whom he is in contact.

What about the *rate of sending* and the *speed* of communication? In our opinion, except when two fast operators familiar with each other's practices work together, rates of sending in excess of 18 or 20 words a minute often *slow down* instead of *speed up* the transmission of intelligence between two stations! More time-consuming repeats are necessary. The slow, steady

style has been found best for DX men, traffic men, and for a good deal of the general rag-chewing. In air-ground work and many other fields it is specifically stressed over and over that a *solid* 12 w.p.m. is preferable! A flashy response may be misunderstood or require repeats. This reminds us of the old saying "More haste, less speed." Amateur radio is with few exceptions a thoroughly democratic institution. A hint at the comfortable speed at which one can copy to cope with particular atmospheric or interference conditions, and 98% of our brother hams will accommodate! In a majority of instances the rate at which you call and send will govern the rate of

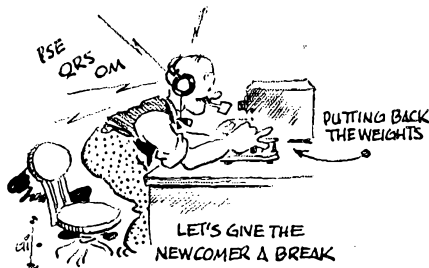

sending on replies to your transmissions. For more specific instruction use the following:

- QRQ? Shall I send faster?  
 QRQ Send faster ( . . . . . words per min.)
- QRS? Shall I send more slowly?  
 QRS Send more slowly ( . . . . . w.p.m.)

**United Nations WIAW Schedule.** In mid-June the ARRL Headquarters station initiated a new program of transmissions dedicated to cooperation with the United Nations. (See UN agreement, pages 46-47, June 1947 *QST*.) Simultaneous transmissions on all WIAW frequencies of the latest UN information now are being made as follows:

Wednesday	9:00 A.M. EST and 6:30 P.M. EST
Sunday	1:00 A.M. EST and 8:30 P.M. EST

Sent at 18 w.p.m. (automatic tape transmission), the UN data are repeated by voice on 3950 kc. and then 14,280 kc. This permits copying down the tape-sent information accurately for retransmission; also reception by voice is available where a bulletin is not being written down for record purposes. It will be appreciated if amateurs will report either reception or retransmission to authorized amateurs of the information sent on these WIAW schedules. W2BSP relays the information to us on 3.6 Mc. for transmission by WIAW. Reports to UN should be sent to Chief Communications Engineer, United Nations Headquarters, Dept. of Public Information, Lake Success, N. Y.

— P. E. H.



Members of the Palo Alto Senior High School Radio Club tune up their rig. Licensed under the call W6PII, with W6UCE as trustee, the club station works in the 3.5-, 7- and 14-Mc. bands using a BC-610E transmitter and RME-69 receiver. Traffic handling, code and theory instruction, servicing their school's electronic equipment and cooperation in the Bureau of Standards 28-Mc. propagation studies are included in the activity program. The club would like to make schedules with similar high school groups.

## RADIO CHESS

Chess matches between the San Juan, Puerto Rico Chess Club and the Chicago Chess Federation were held via amateur radio in March and April. The first match was run on March 31st, with KP4CM and W9JDE providing the communications. Six boards were played and the radio contact involved lasted about 7 hours. W9JDE used 850 watts input and a beam antenna on 29.5-Mc. narrow-band f.m.; KP4CM ran 25 watts input on a.m. and employed a rotatable half-wave antenna. A second match, the same two stations providing the radio facilities, was played on April 13th and lasted 9½ hours. Contact during both matches was practically perfect and very few repeats were required. All participants, amateurs and players, were enthusiastic about results.

Amateurs in Washington, D. C. have formed an informal chess club. Games are played almost every evening on the 28-Mc. band, but the regular meeting nights are Tuesday, Thursday, Saturday and Sunday. The calling time is 9:00 p.m. and the calling frequency 29.4 Mc. W3NL acts as control station and makes assignments of games and frequencies. Games are not scheduled in advance but are assigned at the time of roll call.

The Washington amateur chess group use a coordinate system of transmitting moves in lieu of the regular chess terminology. The experience of the club has been that while the regular system works perfectly for the dyed-in-the-wool chess fan, the occasional player cannot use it without much difficulty, the game generally ending in the middle by virtue of each player having the men on different squares. The files (from black's viewpoint) are numbered from 1 to 8 from left to right and the ranks from 1 to 8 from top to bottom. The squares thus run from 11 to 88 (less all 9 and 0 digits). Moves are thus given: "Bishop 22 removes pawn 66." White always sets up on the low-numbered squares. The advantage of the coordinate system, according to the Washington club members, is that it identifies the specific man moved, where from and where to, without the necessity of interpretation.

## CODE PROFICIENCY CERTIFICATES

ARRL's Code Proficiency Program provides certificate awards for those proving ability to copy code at any of five speeds, 15 through 35 w.p.m. Endorsement stickers for the certificates are awarded later, if first qualification is at less than 35 w.p.m.

The next opportunity to qualify for a certificate or endorsement sticker is on August 19th. At 10:00 p.m. EST that date, WIAW transmits the monthly qualifying run at speeds of 15, 20, 25, 30 and 35 words per minute. Frequencies: 3555, 7145, 14,150, 28,060 and 52,000 kc., simultaneously.

The text, received successfully by ear at the highest speed you can copy, should be sent to ARRL for checking. To avoid errors in transcribing, send your original copy. *Attach a statement certifying over your signature that the text submitted is direct copy made from reception of WIAW by ear, without any kind of assistance, personal or mechanical.* If you qualify, you will receive a certificate or appropriate endorsement sticker for certificate you already hold. Those who qualified in the past should submit copy only if speed is higher than previously certified.

Each night, Monday through Friday, at 10:00 p.m. EST, on the frequencies mentioned above, WIAW transmits practice material. References to text to be used on several of the practice runs appear below. This makes it possible to check your own copy. It also provides a means of obtaining sending practice since it permits direct comparison of one's fist and tape sending. To get sending help hook up your own key and buzzer and attempt to send right in step with the tape transmissions. Adjust your spacing in the manner indicated as necessary for self-improvement.

Date	Subject of Practice Text from June QST
August 5th:	Overmodulation Splatter Suppression, p. 13
August 8th:	A New Noise-Reducing System for C. W. Reception, p. 21
August 11th:	The Dialless Converter, p. 34
August 14th:	Choosing a Transmission Line, p. 39
August 19th:	Qualifying Run, 10:00 p.m. EST
August 20th:	Amateurs and the United Nations, p. 46
August 22nd:	F. M. on Two Meters, p. 48
August 25th:	The "Barracks Bag VFO," p. 54
August 28th:	Adapting the Car Radio to a Converter, p. 60

## RESULTS—1947 VE/W CONTEST

The first postwar VE/W Contest furnished thrills for over a thousand operators. The receipt of three hundred and seventy-four logs was indicative of the good will and popularity fostered by international competition.

Leading the thundering pack with 40,900 points for a new high was Sam Trainer, VE3GT, whose 208 contacts with 50 sections represent a remarkable achievement. The old Contest King again gave us a sterling example of what can be attained with low power and a VFO in the hands of a fine operator! W2IOP retained supremacy in the United States by making 138 contacts with all eight VE sections for a score of 24,864 points and wins the Montreal Amateur Radio Club Trophy. He was closely followed by W3BES with 22,624. VE7HP, who worked 309 stations in 60 sections, can be consoled by the fact that he and VE7HC with 266 in 51 led the field from the standpoint of QSOs and sections worked. VE3GT's power multiplier gave him the lead.

Certificates of Merit are being awarded the leader in each ARRL section. Special trophies go to the highest scoring of all participants in Canada and the U.S. The ten highest scorers in each country follow:

Canada	
VE3GT.....	40,900
VE7HP.....	37,080
VE7HC.....	26,316
VE2FG.....	25,785
VE3QD.....	20,374
VE3SF.....	19,856
VE3AGX.....	18,925
VE3IR.....	17,226
VE6EO.....	16,896
VE3JT.....	16,520
United States	
W2IOP.....	24,864
W3BES.....	22,624
W8PQK.....	20,064
W2SSC.....	19,776
W2WC.....	19,776
W1BFT.....	19,488
W0CMH.....	17,856
W9BRD.....	17,280
W2KHT.....	16,912
W6EYH.....	16,704
W0YCR.....	15,264
W9NII.....	15,264

Section Leaders			
E. Pa.	W3BES 22,624	R. I.	W1CSH 10,080
Md.-Del.-D. C.	W3LVJ 10,080	Mont.	W7EWR 5728
So. N. J.	W2LHZ 4032	Wash.	W7KEM 8704
W. N. Y.	W2SCJ 19,776	Nev.	W7ONG 11,524
W. Pa.	W3GJY 5760	S. C. V.	W6MLY 6144
Ill.	W9BRD 17,280	East Bay	W6LMZ 640
Ind.	W9NZZ 15,036	San. Fran.	W6MHF 5184
Wis.	W9HVM 9600	S. J. V.	W6SRU 3192
No. Dak.	W9LHX 800	N. C.	W4EXB 4800
So. Dak.	W0WUU 1008	S. C.	W4FNS 8640
Minn.	W0YCR 15,864	Va.	W4JUQ 4080
Ark.	W5LSH 1216	W. Va.	W3JJA 5248
La.	W5KC 1536	Colo.	W9CDD 3648
Miss.	W5MMT 128	Utah-Wyo.	W7BED 160
Tenn.	W4IQY 9108	E. Fla.	W4BRB 10,360
Ky.	W4OMW 1088	Los Ang.	W6EYH 16,704
Mich.	W8SAY 5952	Aris.	W7RFE 3872
Ohio.	W8PQK 20,064	San Diego	W6MI 8736
N. Y. C. & L. I.	W2IOP 24,864	S. Tex.	W5VPC 6336
No. N. J.	W2EQS 15,568	Okla.	W5AQE 4704
Kans.	W0BQJ 14,440	New Mex.	W5HOY 32
Mo.	W0CMH 17,856	Mar.	VE1TR 16,441
Nebr.	W0DMY 816	Ont.	VE3GT 40,900
Conn.	W1RY 11,640	Que.	VE2FG 25,785
Maine	W1GKJ 7080	Alta.	VE6EO 16,896
E. Mass.	W1OJM 4900	B. C.	VE7HP 37,080
W. Mass.	W1EJO 7980	Yukon	VE8NQ 12
N. H.	W1BFT 19,488	Man.	VE4DG 4992
Sask.	VE5BB 3344		

## BRIEFS

SS corrections: The '47 Sweepstakes Contest results (page 51, June QST) incorrectly listed W4AQR as the 'phone winner for the Tennessee section; recipient of the award is W4FLS, who worked 265 stations in 56 sections for a score of 29,512 points. . . . The West Indies c.w. award goes to NY4CM (49,840 points, 64 sections, 312 QSOs). The announced score of KP4KD was made by two operators. SS rules permit only the highest one-operator score of a participating station to be submitted for competition. KP4KD's official score should have been listed at 26,220. . . . The 'phone winners for Arizona and Vermont were inadvertently omitted: W7JHB placed high in Arizona with 17,786 points, 51 sections, 143 contacts, and W1KNC (683 points, 14 sections, 21 QSOs) won the Vermont award. . . . The winner of the 'phone award in the Merrimack Valley Amateur Radio Club is W1NNG, not W1PKV as announced. Belated congratulations are in order to these SS winners and we extend our apologies for the errors and omissions in listing.

Patients at the Veterans Administration Hospital, Oakland, Calif., are communicating with their families and friends through a system initiated by W6RBQ, ARRL Pacific Division director. Personal messages are written on Vet-O-Gram forms furnished by American Legion Post No. 5, Oakland, turned in to a Special Services staff and then routed to local amateurs for transmission. W6QXN has been very active in assisting with this service. We recommend the idea to traffic handlers who are looking for sources of traffic origination. You can do a good turn for the boys in the VA hospitals and, incidentally, give your traffic total a worthwhile boost.

### A.R.R.L. ACTIVITIES CALENDAR

Aug. 19th: CP Qualifying Run  
 Sept. 18th: CP Qualifying Run  
 Sept. 19th: Frequency-Measuring Test  
 Oct. 17th: CP Qualifying Run  
 Oct. 18th-19th: Emergency Corps Test  
 Oct. 25th-26th: CD QSO Party  
 Nov. 12th: CP Qualifying Run  
 Nov. 14th-16th and 21st-23rd: Sweepstakes Contest  
 Dec. 16th: CP Qualifying Run

Jan. 16th-Dec. 15th: 1947 V.H.F. Marathon  
 Jan. 1st-Dec. 31st: Most-States V.H.F. Contest  
 First Saturday night each month: ARRL Officials Nite (Get-together for SCMs, RMs, SECs, ECs, PAMs, Hq. Staff, Directors, Alt. and Asst. Dirs.)

## BRASS POUNDERS LEAGUE

(May Traffic)

Call	Orig.	Del.	Rel.	Extra Del. Credit	Total
W2CPX	1365	—	—	—	1365
W7WJ	—	—	—	—	717
W2TYU	10	10	620	10	650
W9RCB	8	43	310	35	596
W2LFR	175	40	303	19	537
W9LFR	22	75	347	67	511

The following make the BPL with over 100 "deliveries plus extra delivery credits":

W8SCW 154	W2OEC 112	W5KUG 111
W2PGT 129	W8SKA 112	W6CMN 111

A message total of 500 or more, or 100 "deliveries plus extra delivery credits," will put you in line for a place in the BPL. The Brass Pounders League listing is open to all operators who qualify for this monthly "honor roll."

## MACMILLAN ARCTIC EXPEDITION

Commander Donald B. MacMillan's schooner *Bowdoin* sailed in June for Labrador, Baffin Island and other points in the North. The purpose of the expedition is to collect scientific data. As in past years, the schooner will carry two-way high-frequency radio equipment and will work under the call KLPO. The radio operator is Mr. Barney Turner. Powered from a 28-volt section of the ship's batteries, the station consists of a Collins ART-13 transmitter and a BC-348 receiver. The *Bowdoin* does not expect to handle as much personal traffic as last year, but the assistance of amateurs may be required. On occasions when amateur cooperation is desired, KLPO will use the frequencies 12,480, 8250 and 4150 kc. for contacts with stations working the 14-, 7- and 3.5-Mc. bands.

## KH6BV — U. S. MARINES AT PEARL HARBOR

The U. S. Marines at Headquarters, Fleet Marine Force, Pacific, Pearl Harbor, have placed KH6BV in operation. Thus far, the station has been able to reach 50 per cent of the states on the mainland and has worked Guam, Japan, China, Canada, Alaska and South America.

KH6BV is operated by the Camp Catlin Amateur Radio Club for the benefit of club members and Marines in the Pacific. Typical of the benefits possible are the long conversations between Marines and their families and the handling of third-party messages.

Equipment consists of two 500-watt h.f. transmitters, a 100-watt v.h.f. rig, and four receivers. The gear was all issued by the Marine quartermaster from surplus stocks.

Colonel Lee H. Brown, Commanding Officer of Force, Headquarters and Service Battalion, is the trustee for KH6BV. The commanding general, Fleet Marine Force, Pacific, originally authorized installation of the station.

## RIVER DATA FLOW VIA AMATEUR RADIO

Floodwaters in the Upper Mississippi and Red River of the North, occurring at the same time as the national telephone emergency, placed the U. S. Corps of Engineers of the St. Paul district in the position of really needing the communications services provided them by stations of the Minnesota State Net. Numerous other stations not regularly members of the Net and stations in St. Louis and Betendorf, Iowa, furnished valuable assistance. Every reading of river stages and dam levels normally handled by long-distance telephone in the states of Minnesota, Iowa, Wisconsin and North Dakota was handled by amateur radio for 29 days.

In anticipation of the requirement for some emergency service, the Washington offices of the Corps of Engineers suggested that each district arrange for using the amateur service several days prior to the actual strike. At the request of the St. Paul office of the C of E and with the assistance of the FCC office in St. Paul, W0JIE arranged for mailing questionnaires to amateurs in every community where communication was desired, asking for their cooperation should the emergency actually arise. Response was almost 100 per cent and a practice session was held a few days prior to the date of the strike threat. With the advent of the actual emergency, data from 16 dams on the Mississippi and six control points on the Red River began to move exclusively via the amateur service.

The complete routine involved collection of the data from each source station, consolidation of all the data at the central control station and transmission of a summary message to Rock Island and St. Louis. On the practice session and for the first two evenings, the procedure required about three hours and was approximately equal to the time normally required to achieve the same results by land line. This time was improved almost daily until on the final evening of the emergency the entire procedure occupied only 63 minutes.

The St. Paul Corps of Engineers sent their office records and personnel to the amateur stations, and as the data were read by the transmitting station, these men copied the reports directly into their permanent records. This arrangement permitted the amateurs collaborating to operate using a streamlining of normal procedure. Engineers present at the receiving station plotted the various readings on graphs and charts so that within fifteen minutes after the last information had been received a consolidated summary including a prediction of river flow rates for three days was ready for transmission to amateur stations for delivery into the St. Louis and Rock Island Division Engineer offices.

One of the largest factors contributing to the improved speed of transmission of this data via

the amateur service was that in many cases the lockmaster or dam-tender originating the message actually came in person to the nearest amateur station and remained present during the transmission to answer any questions and to receive instructions for the control of water levels for the next 24 hours.

Several interesting incidents occurred that illustrate the resourcefulness of amateurs in an emergency. One station, unable to make contact on 3.5 Mc., dropped down to 28 Mc. and relayed his message through a W6. Another, unable to get the data for his transmission, drove 60 miles to pick it up and get it into St. Paul on time. Still another, hampered by a freak band condition, anticipated the impossibility of making contact and mailed the data via special delivery in time for it to be received and used. Innumerable times stations listening volunteered their services when the going was tough. In every case, without exception, amateurs whose signals interfered with the river traffic were exceedingly cooperative in either changing frequency or standing by until the session was completed.

Final statistics on the 29 days of operation indicate that over 800 messages were handled, that 65 different amateurs participated, and that approximately 1500 station operating hours were involved. The telephone personnel of course had made arrangements for emergency traffic, but the amount of traffic handled would have taxed the restricted facilities and therefore represents a real public service by the amateur.

All of the amateurs participating in the emergency received a letter of thanks for their help from Col. Wilson, U. S. Corps of Engineers, St. Paul, Minn.

— *Aaron Swanberg, W0BHY, and  
John L. Hill, W0ZWW*

### KON-TIKI

Expedition Kon-Tiki (see page 71, March QST) left Peru in April on its trip to the Polynesian Islands. Adrift on the Pacific with nothing but wind and ocean currents to push it in the desired direction, the raft with its six-man crew has reached the halfway mark of its voyage. In mid-June, position was reported as 2300 miles west of Peru.

Under the call LI2B, the Expedition has worked numerous amateurs. The first station worked was W6EVM. The Expedition radio operator has advised that excellent cooperation has been received from amateurs in relaying traffic from the raft to points in the United States. The assistance of W6AOA, W6EVM, KZ5AW and W3YA has been notable in this respect. To avoid interference, it is requested that amateurs who wish to call wait until LI2B is clear of traffic. The expedition CQs at 0200 GCT on 27,980 kc. for general contacts with 28-Mc. stations and on 14,142 kc. at 1600 GCT for 14-Mc. contacts.

### WEST PALM BEACH RADIO CLUB INTERNATIONAL V.H.F. TROPHY

Now that two-way work with each of the six continental areas of the world on frequencies between 50 and 60 Mc. appears well within the realm of possibility, the West Palm Beach Radio Club offers an attractive trophy for the first WAC



on v.h.f. The award will go to the first amateur who qualifies in accordance with the following requirements:

#### RULES

- 1) The trophy shall be awarded to the first licensed amateur establishing two-way communication from the same location \* in any country with each of the six recognized continents on amateur frequencies of 50 Mc. or higher.
- 2) Confirmation of communication shall be in the form of documentary evidence, submitted by the claimant directly to the ARRL, and satisfactory to ARRL and the West Palm Beach Radio Club. Evidence may consist of QSL cards from each continent claimed, logbooks, sworn evidence or letters of proof, as may be required by an Award Committee.
- 3) IARU rules defining "location" and governing the determination of continental boundaries (as for WAC Certificate awards) shall apply.
- 4) In the event of simultaneous claim, duplicate awards will be made subject to the approval of ARRL and the West Palm Beach Radio Club. Decisions and interpretations of a designated award committee shall be final.
- 5) The WPBRC and ARRL reserve the right to modify the above rules at a future time, should changes in international regulations so require.

\* The IARU rules permit locations within a 25-mile area.

#### BRIEFS

'Phone stations we can do without working: Fellows who end a transmission by saying "Dah-de-dah."

## MEET THE SCMs

Joseph R. Beljan, W8SCW, our versatile Michigan SCM, was born on September 14, 1917, in Calumet, Michigan. He attended Electronics Institute in Detroit and is at present employed by Meli-Dy Enterprises as a technician.

In 1937 he was bitten by the radio bug and his first license, with the call W8SCW, was issued to him shortly after. Receiving speed is 35 w.p.m., for which he was awarded a Code Proficiency Certificate in 1940. A WAS Certificate also was won the same year.



For more than four years, until his discharge in September 1945, Joe served in the Army as a master sergeant in charge of communications for the 413th Bomb Squadron (H), part of the 8th Air Force in ETO. His fine work in communications and in the development of a special project for heavy-bombardment technique

gained recognition for him and he was honored with the Bronze Star and Legion of Merit.

SCM Beljan is an active participant in ARRL QSO Parties, in which he led Michigan this year, Field Days, CD Parties and Sweepstakes. He also holds ORS appointment and is present director of the Detroit Amateur Radio Association and assistant manager of the Michigan QMN Net.

The layout in use at W8SCW is as follows: Transmitting equipment — 6SK7 ECO-6V6-807-p.p. 8I2s; an SCR-522 is on hand for 144-Mc. work. Receiving equipment — Skyriider SX-23 and 144-Mc. superhet. A Zepp antenna is in regular use. Bands covered are 3.5-, 7-, 14- and 28-Mc. c.w., and 144-Mc. 'phone. A new rig with the following line-up is under construction: 6J5 VFO-1853-1852-6SG7-6L6s-807-p.p: 35-Ts.

His devotion to amateur radio leaves little time for his secondary interests of photography, baseball, skating, ice hockey and football.

An industrious and alert SCM, Joe is primarily interested in c.w. work, but is planning some 'phone operation in the near future. His good work in traffic-handling nets (he is NCS of the Michigan QMN Net and a member of TO Net) is attested to by the fact that W8SCW is often to be found in the BPL.

## BRIEFS

W9QCK, publicity director of WIL, St. Louis, recently received his season press pass for all home baseball games of the St. Louis Cardinals. His official pass number is 73, but no one can say whether this ham flavor injection will have any effect on the Cards' final league standing for 1947.

## TRAINING AIDS

With the summer recession set in, the use of films, film strips and slide collections by affiliated clubs has dropped off considerably. This is to be expected, of course, and gives us a chance to take stock of the program in general.

If your club is one of the unfortunate ones that were unable to obtain what they wanted from the Film Library during the past busy season, now is the time for you to start lining things up for the fall season, which is bound to be a very busy one. Careful study of the rules as outlined in club bulletins will indicate how best to make your requests to save everybody concerned the most correspondence time.

Considerable damage has been inflicted on some of the motion picture films used by affiliated clubs. A certain amount of attrition is inevitable, but we feel that it has been excessive to date, and at the present damage rate the films will not last long. This, then, is simply to implore you to please be careful in handling and running the films!

We regret that because of a very limited supply of Training Aids it has been impossible so far to make them available to any but affiliated clubs, and many requests have been turned down for this reason. Affiliation doesn't cost you a thing, and there are many mutual benefits. Why not consider it? It is very likely that it will be a very long time before our stock of films and other Training Aids will be such that we can make them available to others.

The following two films are the most recent additions to the ARRL Film Library (reviews upon request):

*F21: Periodic Functions* — 16-mm. sound, U. S. Navy, 17 minutes.

*F22: Radio Shop Techniques* — 16-mm. sound, U. S. Navy, 38 minutes.

The following films, not available in the Film Library, have also been reviewed by the ARRL staff. Written reviews, along with complete information on how to obtain, will be supplied on request:

*Sound Recording and Reproduction* — 16-mm. sound, *Encyclopaedia Britannica*, 10 minutes.

*Sources of Electricity* — 16-mm. sound, Edited Pictures, 10 minutes.

*Principles of Electrostatics* — DeVry, 16-mm. sound, 22 minutes.

*What is Electricity?* — 16-mm. sound, Westinghouse, 20 minutes.

*Commutation of D. C. Machines* — 16-mm. sound, Westinghouse, 24 minutes.

*The Vacuum Tube in Radio* — 16-mm. sound, *Encyclopaedia Britannica*, 10 minutes.

*The Electron* — 16-mm. sound, *Encyclopaedia Britannica*, 10 minutes.

*Electrochemistry* — 16-mm. sound, *Encyclopaedia Britannica*, 10 minutes.

*Electrodynamics* — 16-mm. sound, *Encyclopaedia Britannica*, 10 minutes.

*Ham! Well Done!* — 16-mm. silent, color, Oklahoma City Amateur Radio Club, 15 minutes.

## BRIEFS

Add summer traffic net schedules: The Pioneer Net, covering Calif., Ore., Wash., Idaho, Colo., Alberta, S. Dak., No. Dak., B. C. and Pacific points, continues active during the summer months with no change in its regular schedule. The net meets Monday through Friday at 7:00 P.M. PST on 3725 kc. In addition, a free-lance session is held at 10:00 P.M. each evening during which any stations with traffic are invited to call in. The Illinois Net likewise is maintaining its regular schedule on 3765 kc. Monday through Friday at 6:00 P.M. CDT.

W2ADP thought his 1947 DX Contest score of 216 points somehow looked familiar. Looking through his old station records he found that his 1930 DX score was exactly 216 points. Lee says, "Seems like I'm not getting anywhere."

On May 14th at 3:00 P.M. W6TDO, Puente, California, worked W6BQI, Los Angeles. At 6:00 P.M. the same day a lusty CQ from a locomotive whistle blasted its way into TDO's shack. Grabbing a QSL card, he dashed to the railroad crossing one block away. The CQer was none other than W6BQI, engineer of the iron horse! TDO boarded the engine and had a fine personal QSO with BQI, riding with him to Pomona, where he debarked and caught a bus home. During the trip the boys filled out and swapped QSL cards confirming their earlier on-the-air rag-chew.

### GENERAL TRAFFIC PERIOD

6:30-8:30 P.M., Your Local Time

### GENERAL TRAFFIC CHANNELS

3575 to 3600 kc. 7150 to 7175 kc.

ARRL recommends the above-mentioned hours and frequencies for use by those amateurs who have an occasional message to send but are unable to keep regular schedules or participate in organized networks. ORS and other active traffic handlers will monitor the General Traffic Channels, particularly during the General Traffic Period. They will be watching for your directional CQ to the state your message is addressed (for example: CQ Illinois, CQ Oregon, etc.). If you wish to break into message handling, it should be possible for you to use the general period and channels to pick up traffic from fellows like yourself for relay or delivery. No ARRL nets will be registered in the General Traffic Channels. Those frequencies have been purposely kept free to aid the casual message handler. Use the facilities provided and let us hear of your results.

## ELECTION NOTICE

(To all ARRL Members residing in the Sections listed below:)

You are hereby notified that an election for Section Communications Manager is about to be held in your respective Sections. This notice supersedes previous notices.

Nominating petitions are solicited. The signatures of five or more ARRL full members of the Section concerned, in good standing, are required on each petition. No member shall sign more than one petition.

Each candidate for Section Communications Manager must have been a licensed amateur for at least two years and similarly a full member of the League for at least one continuous year immediately prior to his nomination.

Petitions must be in West Hartford, Conn., on or before noon on the closing dates specified. In cases where no valid nominating petitions were received in response to previous notices, the closing dates are set ahead to the dates given herewith. The complete name, address, and station call of the candidate should be included with the petition. It is advisable that eight or ten full-member signatures be obtained, since on checking names against Headquarters files, with no time to return invalid petitions for additions, a petition may be found invalid by reason of expiring memberships, individual signers uncertain or ignorant of their membership status, etc.

The following nomination form is suggested:

Communications Manager, ARRL (Place and date)  
38 La Salle Road, West Hartford, Conn.

We, the undersigned full members of the . . . . .  
. . . . . ARRL Section of the . . . . .  
Division hereby nominate . . . . .  
as candidate for Section Communications Manager for this  
Section for the next two-year term of office.

Elections will take place immediately after the closing dates specified for receipt of nominating petitions. The ballots mailed from Headquarters to full members will list in alphabetical sequence the names of all eligible candidates.

You are urged to take the initiative and file nominating petitions immediately. This is your opportunity to put the man of your choice in office.

— F. E. Handy, Communications Manager

Section	Closing Date	SCM	Present Term Ends
Maritime *	Aug. 15, 1947	Arthur M. Crowell	.....
West Indies	Aug. 15, 1947	Mario de la Torre	Deceased
Philippines	Aug. 15, 1947	George L. Rickard	Oct. 15, 1938
Western N. Y.	Sept. 1, 1947	Charles Otero	Sept. 14, 1947
Eastern Pa.	Sept. 15, 1947	Jerry Mathis	Sept. 23, 1947
New Mexico	Oct. 1, 1947	Junius G. Hancock	Oct. 15, 1947

\* In Canadian Sections nominating petitions for Section Managers must be addressed to Canadian General Manager Alex Reid, 169 Logan Ave., St. Lambert, Quebec. To be valid such petitions must be filed with him on or before the closing dates named.

## ELECTION RESULTS

Valid petitions nominating a single candidate as Section Manager were filed in a number of Sections, as provided in our Constitution and By-Laws, electing the following officials, the term of office starting on the date given.

Utah-Wyoming Alvin M. Phillips, W7NPU May 1, 1947

In the Wisconsin Section of the Central Division, Mr. Reno W. Goetsch, W9RQM, Mr. Ross Hansch, W9RBI, and Mr. Wilfred T. Simonsen, W9PFH, were nominated. Mr. Goetsch received 126 votes, Mr. Hansch received 110 votes, and Mr. Simonsen received 66 votes. Mr. Goetsch's term of office began May 12, 1947.

## BRIEF

Amateurs who do their "wooting" over the air can shorten the customary "73" and "88" by sending "161" instead, according to G6CL, who says, "It's simple: 73 plus 88 equals 161!"

• All operating amateurs are invited to report to the SCM on the first of each month, covering station activities for the preceding month. Radio Club news is also desired by SCMs for inclusion in these columns. The addresses of all SCMs will be found on page 6.

## ATLANTIC DIVISION

**EASTERN PENNSYLVANIA** — SCM, Jerry Mathis, W3BES — EKK is home for a while after being on the air from J, VK9, VR4, VR5, and FO8. He made over 4000 QSOs from overseas. Old 8ASW now is 3JPM/D4ASL. He operates on 14 Mc. and is open for E. Pa. schedules. While they are not allowed on 3.5 Mc. in Germany he will listen for us on that band if requested. His QTH is Karlsruhe and has an 807 on with 40 watts and a BC-342 revamped as per article in QST. The Susquehanna Valley Club was active in Field Day. BFH is on 3.85-Mc. 'phone now. MGL built a 20-watter with a 1614 in the final. UWQ has a pair of TZ4Os on 28 Mc. The following stations handled the traffic for the Penn State open house exhibit at YA: AVK, ELI, HCT, OML, QEW, QV, and VMF. The Eastern Penna. Net is on its summer schedule of one day a week, Thursdays. The following is from OY, secretary of the Lancaster Radio Transmitting Society: Work has been completed on a club 144-Mc. rig using 829 final with 100 watts input. The rotary beam has 168 square feet of surface. This equipment will be used as an Emergency Control Center. 144 Mc. activity is very strong in the Lancaster area with some fellows working W1s, W2s, and W4s. The hidden transmitter hunts are well attended. LN found the hidden transmitter near Marietta on May 25th. LDV is on 7 Mc. with an ARC-5 VFO. He tried f.m. on 28 Mc. but no luck. He managed to secure a 2nd-class radiotelegraph ticket, however. BXE worked ZC6AA for his 100th country with his 100 watts and wash-line antenna. He is going to rebuild. AKF does considerable operating from Delano Summit, 12 miles north of Tamaqua, on 146.5 Mc. KT has 70 countries confirmed. ELI handled some fine traffic from the stamp show. The Civil Air Patrol has an interesting program for radio operators. If interested contact Lt. Col. Chas. B. Rich, 501 1414 S. Penn Square, Philadelphia 2, Pa. All the local clubs were active on Field Day. Traffic: W3QEW 130, ELI 115, GMK 35, EU 27, HCT 15, OK 13, LDV 12, BXE 6, KT 6, ADE 4, AQN 4.

**MARYLAND-DELAWARE-DISTRICT OF COLUMBIA** — SCM, Eppa W. Darne, W3BWT — The Argument Radio Club has voted to affiliate with ARRL; new members are NIH and 2CUT/3. The Washington Radio Club held another auction of ham parts at its May 10th meeting, affording an evening of fun and enabling many to get certain long-sought articles. At the May 24th meeting MSK lectured on the grinding of crystals, methods, and apparatus. The Potomac Valley Emergency Net continues its operations and is increasing in membership. It now meets at 8:00 A.M. Sundays for regular drill. Those participating to date are as follows: FPC, AHQ, AQV, CIQ, HAL, KBX, KJF, PA, PV, WN, 4BCT, 4BJG, 4KUC, 8UDJ, and 8YIE. The Capital Suburban Radio Club meets the 1st and 3rd Fridays of each month at the Berwyn School, Berwyn, Md. It has been declared a duly affiliated society by ARRL and has received its charter. BDY is vice-president, erroneously listed in prior report as BDN. The Club publishes a bi-monthly bulletin called *NUZLTR* which is very swell. DK is building a new rig for 14- and 7-Mc. c.w. ISF has intercom. 'phone between shack and rest of house, has been getting QSLs from Europe on 7 Mc., and recently increased power to 120 watts. IQZ has worked Europe on his new bandswitching VFO rig with 807 final. NHA, formerly IJYW, is a new-comer to the section. KTR is being transferred to Norfolk Navy Yard. KKH has new three-element

rotary beam on 28 Mc. GKP is installing a new beam antenna with 64 half-waves. LUE and JVI have new four element wide-spaced beams. KHJ has a brand-new 1st-class radiotelephone ticket. CDQ has a new end-fed Zepp for 14 Mc. DRD has worked 121 countries and is putting up a rotary beam for 28 and 14 Mc. He also handled Red Cross emergency traffic to Texas. LVY has new Super-Pro and is Baltimore member of the Susquehanna Emergency Net. CAB recently celebrated his 25th anniversary on the air with the same call. MNA is newly-appointed OBS and has new sixteen-element beam. QL is newly-appointed ORS. KUX worked 1MNF on Cape Cod with new sixteen-element beam to capture 144-Mc. DX record. EZV and DKT are active on 14 Mc. PK and PM have their old calls back. DTO, a commercial operator, shoved off from Texas City just prior to the fireworks. FEG is active again. MCD is on 3.5 and 7 Mc. using 15 watts. MJQ has a new jr. operator and has worked 46 states and 20 countries. AKR is on 7-Mc. c.w. and 14-Mc. 'phone. KJF has a new jr. operator and a full-wave 3.5-Mc. antenna. MGM, EYX, LTR, MHW, PV, GCK, FSO, and MNA are heard operating portable-mobile on 144 Mc. AWS lost his beam antenna in windstorm. ENZ schedules 4FJ in Richmond, Va., nightly on 144 Mc. LVY has new rig with swell VFO arrangement on 3.5 Mc. 2QDW/3 has a new jr. operator. FNG has a new antenna and half-kw. rig. DF is now chief engineer for the FCC and is active on 28 Mc. NFC is building a 28-Mc. rig. CKI has a Class A ticket. HXN is on 28 Mc. KBX has 46 states worked, and has made 1875 QSOs on c.w. and 132 QSOs on 'phone in two weeks. FYB has a new rotary beam with relay controls. CIZ will be on 3.5- and 7-Mc. c.w. in the fall. LYA schedules Joliet, Ill., where his oldest daughter goes to school. Traffic: W3LVY 245, ECP 157, BKZ 61, FPQ 48, AKB 45, BWT 21, ISF 12, KBY 12, KBX 5, MJQ 4, AKR 2, EQK 1, DRD 1.

**SOUTHERN NEW JERSEY** — SCM, Ray Tomlinson, W2GCU — The big annual outdoor hamfest and outing of the Delaware Valley Radio Association will be held on Aug. 10. Information may be had by writing QOK or listening to ZQ on 3900 kc. For many months the 4th Coast Guard District has held simulated emergency communications drills in various areas on 2676 and 2696 kc. Anyone who owns a ham station or a boat is eligible for membership in the C. G. Auxiliary and may obtain information from OUN. Activity on the SNJ ORS Net will be resumed Sept. 8th at 7:00 P.M. local standard time on 3700 kc. QCM has erected 14-Mc. rotary and has worked 64 countries. PSZ made WAC and needs Vermont and South Dakota for WAS. He maintains schedules with 3IU on 28,700 kc. each Tuesday and Friday at 0830. The Lakelands Amateur Radio Association was affiliated with ARRL at the Board Meeting. The efficient Susquehanna Emergency Net meets at 8:00 A.M. EST Sunday mornings on 3910 kc. VJI is new ham in Trenton. 147.3 Mc. is one of SAK's regular operating frequencies. SXX is dragging in the DX on his new HQ-129X. HEH has new Collins VFO exciter. SAI is working out super with the new 28-Mc. mobile rig in that 1947 Buick Super! RDK has boosted his DXCC total to 102 countries. VIS is new ham. RG maintains schedule with 2ORS at 7 P.M. Mondays and with 3BFH at 8 P.M. Mondays. We would appreciate news from Sussex, Warren, and Morris County organizations. Traffic: W2RG 38, SXX 26, QUH 24, ZI 16, BEI 8, RDK 8, ORS 7, BAY 5, CFB 5, QCM 3, HX 2.

**WESTERN NEW YORK** — SCM, Charles I. Otero, W2UPH — The Rochester DX Association has been formed. The purpose is to further the interests of its members in the pursuit and enjoyment of DX. The organization is formed by, and for, DX men exclusively. Prospective members must show proof of working at least 25 countries postwar, or 50 countries prewar. Chairman is PUD; vice-chairman is DOD; secretary-treasurer is PYW. The executive committee is made up of these officers, plus QCP and TXB. At the last meeting of the Rochester Amateur Radio Association the following new officers were elected: OWF, pres.; SEN, vice-pres.; NESS, re-elected treas.; SNF, secy. The greatest handicap was not big enough to stop SCI from getting her ticket. She can't see but is doing wonderfully

(Continued on page 7E)



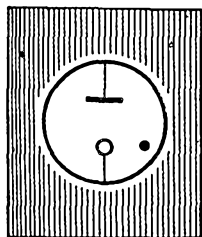

WHILE riding on a farm wagon during our vacation we were forcefully reminded of the importance of both a smooth road and a round wheel for a smooth ride. The road and wheel situation is somewhat paralleled when we think of receiver frequency stability as affected by changes in line voltage. More and more receivers are being built which include a voltage regulator in order to more perfectly "round the wheel" of receiver design to provide less frequency drift during reception. At first glance one might think that the voltage regulator is a "cure-all" for frequency drift

problems. This is not strictly true so it might be well to review the situation.

There are several major causes of drift in a receiver and usually one of the first to be encountered is changing line voltage. When the line voltage changes, both the plate and heater voltage of the high frequency oscillator change thereby causing receiver tuning drift. Careful oscillator design will minimize this drift as the oscillator can be adjusted so that these two causes of drift will counter-balance each other over a relatively wide range of line voltage. As it turns out with these two causes adjusted to cancel each other, changes in plate voltage have only a small effect on oscillator frequency as changes in heater voltage inherently have only a small effect. The voltage output of a VR tube changes slightly with applied voltage so the addition of the VR tube can often result in minimized drift over a wider range of line voltage change than could be obtained without a VR tube.

A somewhat similar situation occurs with changes in R.F. gain control setting. Typical R.F. gain control arrangements act to change the amount of current drawn by the R.F. and I.F. tubes which in turn changes the voltage applied to the high frequency oscillator. In this case heater voltage change is not involved so the VR tube is very effective in minimizing frequency drift. However, with the oscillator designed to be relatively insensitive to line and plate voltage variations, changes in R.F. gain control setting will inherently have a small effect on oscillator frequency. The addition of a VR tube can often reduce this drift even further.

Warm up drift involves mainly heating of various portions of the receiver which will cause oscillator frequency drift. Compensation for warm up drift usually involves a negative temperature coefficient capacitor of the proper size appropriately located. The addition of a VR tube will usually reduce this type of drift as the VR tube will aid in stabilizing the oscillator plate voltage during the warm up period. It should be remembered, however, that the VR tube has a warm up voltage drift characteristic of its own which may be appreciable if the VR tube is subjected to a high starting current.

Similarly frequency drift is encountered when the receiver has been left at the standby position for an appreciable length of time and turned on again. This type of drift is usually reduced by the addition of a VR tube due to stabilization of the oscillator plate voltage even though a large part of the drift is caused by heating of oscillator circuit elements.

To summarize the situation, it appears that neither oscillator design nor the addition of a VR tube can compensate perfectly for all causes of frequency drift in a receiver. Receivers with entirely acceptable frequency stability can be built without the use of a VR tube, but the addition of a VR tube can improve the frequency stability when all of the causes of instability are considered.

RAY CAULK



well on 28 Mc. 2TTQ and 3TTQ called HR1MB on the same frequency at the same time; 2TTQ is from Rochester, N. Y., and 3TTQ is from Rochester, Pa. Corning and Painted Post amateur radio operators met with representatives of the Corning Chapter of the American Red Cross to discuss the possibility of offering their services during emergency and disaster periods in the area. RZP is EC for Delaware County. RAWNY had an auction of ham parts at the last meeting. QGC is a papa. KBT had a round-table discussion on solving troubles of members in attendance. UHI has a 312-N receiver. He is on 144 Mc. with horizontal polarization beamed towards Cleveland, Detroit, and Chicago. On 7 Mc. are QOS, UAC, UEB, and EWT. RYJ is on 3.5 Mc. PRI is on 28 Mc. with a 610-E n.f.m. RPO visited hams in the Central West while on vacation. A bigger and better RAWNY Hamfest will be held in Buffalo, N. Y., on October 18th at the Hotel Statler. Every amateur should belong to the AEC. Emergency Coördinators are needed in various areas. Contact SJV for appointment. FBA is on 50 Mc. AFQLifted his 3-20, 6-10 beam up 60 feet. Many thanks to QOM, LRW, RUF, and ITX for splendid service rendered Mrs. Albert Ashline while her husband was in New Rochelle Hospital. Traffic: W2PGT 478, RF7 172, AOR 35, PZC 31.

WESTERN PENNSYLVANIA — SCM, Ernest J. Hlinsky, W3KWL — New OBS is LGM, new OPS are PJJ, VNE, LGM, and new ORS is RAP. YA reports new kw. rig on 28- and 14-Mc. c.w. 8NBV now is 3AU. QKI's XYL is now NIX. Erie 144-Mc. boys QKI, LTN, and NFR journeyed to Smethport to demonstrate 144-Mc. gear on VHF Field Day, working 8WJC near Akron. NCJ, our former SCM, reports Erie Radio Assn. set up club station, LTK/3, at Erie Home Show, Waldameer Park, May 21st, handling several hundred messages, using 144 Mc. and 28 Mc. RAT complains of receiver troubles. RAP rebuilt his chimney to accommodate his new antenna. LFM is using 813 final on 28-Mc. 'phone. BWP now has AER, his old call of 1919. RIS can be heard on 28 and 14 Mc. KQD is proud possessor of WAC; XU6GRL did the trick. Altoona Club Field Day call was QZF/3. The Horsehoe Radio Club of Altoona did a beautiful job in honoring ROA in club publication. Your SCM appreciates your swell *Hamateur News*. Club frequency is 6805 kc. Following are HRC members: KKK, WPA, NDI, ROA, RBH, KQD, KXN, RYN, MBB, TXQ, KUQ, VRM, LQD, MJC, KFD, MLU, MYN, LJS, FER, BWL, LQJ, VPF, WJR, RFM, LIV, WBD, ex-8ASE, and ex-8KRO. TXQ dreams p.p. 813a. LQD is back at Sylvania. LWN is trying out 14-Mc. QRM. YA reports State College held open house and originated 150 messages. DX totaled 26 countries. AER and RAT are doing excellent job as PAM. The Mercer County Radio Assn., together with Youngstown and Warren, Ohio, Radio Clubs held a club banquet in Youngstown recently. KQA and KWL managed to work Akron, Chagrin Falls, and Andover, all in Ohio, on 144 Mc. and also heard Cleveland. KQA holds local DX record on 144 Mc. with 103-mile QSO. LNA reports Greenville actually had three stations operating one evening. KXI and 8SPG are working West Coast on 50 Mc. MCRA operated 30AJ/8 on Field Day on all bands. Remember the South Hills Brass Pounders and Modulators Annual Hamfest, South Park, Sunday Aug. 3rd in Pittsburgh. Your SCM would like to hear from all of you. Traffic: (April) W3YA 53. (April/May) W3CKO 65. (May) W3YA 249, KWA 160, PY 21, RAT 20, AER 19, NCJ 14, LWN 2.

## CENTRAL DIVISION

ILLINOIS — SCM, Wesley E. Marriner, W9AND — SIY will soon crank up his pair of 813s. HAB has been building 28-Mc. mobile rig. NDA has been rebuilding operating room. New reporter is OOE, active on all bands and interested in traffic nets and appointments. VOQ has new VX-101-jr. VFO. GBT purchased new HQ-129X and a 2-kw. plate transformer. VJN has new National-173 receiver and is constructing 14-Mc. beam and 57-ft. windmill tower. AWA has new R-9er. TZQ has a new 7-Mc. folded dipole. D4AON/W9QKJ says the boys in Germany plan a traffic net on 7 Mc. Listen for Ken on 14,080 kc. CES is on 7- and 14-Mc. c.w. with 616-807-811, 125 watts input, and S-20R and BC-348Q receivers. ZHB is working states right and left on 50 Mc. AND broke down and purchased new VHF-152 so he can listen in on 144 and 50 Mc. NON is on 3517 kc. IBU is on 7, 14, and 28 Mc. OXB is on 14-Mc. c.w. with Millen exciter. NON reports that on May 25th Herbert E. Cremer, W9FCW, Kankakee, passed away from pneumonia. He was a member of ARRL and an RCC member. TUI

reported he is in favor of 28-Mc. plan. JVC and IQC are working on a radio club for LaSalle. TAY's vacation ended two days before Field Day. BIN likes his new receiver so much he could sleep with it under his pillow but the XYL would object. ATA and YBY had two-element beam ready for Field Day. ARRL Frequency Measuring Test Results in Ill: Class 1 — SGL, KA, HV, GMV, NUF, BON, ERU, BWZ, DET, IJ, NUX, GFF, and GY. Class 2 — BRX, BBZ, ADN, and ZYL. Ill. DX. List: W9ERU 116, AWA 71, GNU 71, AND 70. Send in your postwar DX country total and keep it up to date each month. KQL is working in Decatur on airport construction and dicker for half-kw. Navy rig. HSB, on 50 Mc. every night, worked 16 states in two months. While awaiting parts for r.f. amplifier, LNI uses 17-watt oscillator section to stay on the air. His frequency is 3650 kc. DBO, who is the brother of LNI, says there will be a new ham in Wenona soon. EBX says spring fever and summer slump are a bad combination. SXL is fixing up SCR-522 for some 144-Mc. work. The Kickapoo Radio Operators' Club is going strong with about 38 members and had a big get-together at PRV's place at Randolph. YLs, XYLs and harmonics attended. HAB has Mark II tank rig on 7-Mc. c.w. SYZ says VQS is new call in Chicago on 144 Mc. with BC-522. The KA and York Club were out on Field Day. YTV has nice traffic total despite plenty of other activities. BRX has acquired an SCR-522 for 144 Mc. He is troubled with BCI interference to local television receiver. EVJ was with Starved Rock gang on Field Day. ZPC has 807 final, perking OK now. FDF is swinging a bug on 3.5-Mc. c.w. NDA had his beams blown down so now is on 3.9-Mc. 'phone. He is putting up 60-ft. steel tower. The ICN-ILH team now is on 14-Mc. 'phone. HAB and QJL are having fun with their mobile 28-Mc. rigs. HNL is working on one. QHM has new Meissner 250-watt job on 28-Mc. 'phone. VZM and OLN are on 50 Mc. QEQ has 807 final on 7 Mc. CYP is active on 7- and 3.5-Mc. c.w. CHQ was on the shack list for two months. PCI is on 14 Mc. DXing with 250 watts. QKF is dreaming up new all-band rig. BKF is on 3.85-Mc. 'phone. D4AON sent report via radio from Weisbaden, Germany, on the 3rd and the SCM received it on the 5th. 6ZLE, former Dixon ham, reports from California. 7MWQ and 7NGD visited Dixon hams. FUR has VFO finished. UPW, new ORS, now on 7 Mc., has new relay. The Kickapoo Club's station call is AML. Traffic: (April) D4AON 4. (May) W9EJV 229, JTX 173, SYZ 88, YTV 38, JMG 16, KQL 15, NDA 13, SXL 12, AND 11, D4AON 11, W9DBO 7, TZQ 5, EBX 2, NIU 1. INDIANA — SCM, Ted K. Clifton, W9SWH — Arnold K. Dickmeyer, W9JPX, president of the Indianapolis Radio Club, turned in his call on May 13th and applied for one in the Great Beyond. He assisted in the planning of the Hoosier Ham Picnic, which was later held on June 8th at Mounds State Park. John Brand won the BC-221 attendance prize at the picnic, which was sponsored by the Indianapolis, Muncie, and Ft. Wayne clubs. RE has moved from Peru to South Bend. The directors of the new Tri-State Amateur Radio Society are: Illinois, KBA; At Large, UIA; Kentucky, ZHX. DPI spoke at a recent meeting of the new club. BKH, president of the Atomic Club, gave a talk on "Modulation Indicators" before the Ft. Wayne Radio Club. AET is chief engineer of new Westinghouse station in Carolina. YDA, Bloomington, is our newest ORS and is doing a bang-up job on the QIN. SRN now is Class I OO. RAU, SNF, WJV, and CWO have 28-Mc. mobile rigs. INL, of Mineral, went on the air Sept. 24th and has worked 45 states, several VEs, two CMs, and one PY using the 1947 *Handbook* VFO, which Bob says works better than his crystals. TT, of Indianapolis, has reapplied for ORS after a span of 25 years. EDU, of Selma, a member of the DARA, has a brother, Wayne E. Humbert, at Rose Polytechnic Institute, Terre Haute, who just received the call, ZPX. ERN is vacationing from Notre Dame and will work for Philco in Philadelphia during the summer. LQE is putting a pair of 813s on 7 Mc. EHU got married and along with the XYL will attend I.U. QLW added two-element 14-Mc. rotary to his "V" beam. MBL, at New Castle, is working on radio-controlled model airplanes. QLW and TKH, along with GFO who is chief engineer, work at WEOA. The Indiana Radio Council held its first meeting at 1 p.m. on July 12th at Indianapolis. NZZ put up a folded dipole for 14 Mc. and worked 38 countries the first five weeks using 70 watts. MOK is chairman of emergency committee of Tri-State Amateur Radio Society. Traffic: W9RCB 596, NH 336, DHJ 39, ENB 25, TT 18, EDU 16, YDA 6, QLW 2, TBM 2, SWH 1.

(Continued on page 74)

# NOW—For The FIRST TIME You Can Have The Transmitter YOU Want

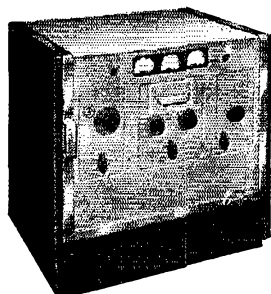

**The new Temco Series RA Transmitters are the answer to every Amateur requirement**

Up to now no manufacturer has ever produced all the different type transmitters which your dealer would have to stock in order to fill every Amateur requirement. Because of production problems and costs the manufacturer has had to limit his output to a few types. Likewise, your dealer, for reasons of good merchandising has faced comparable problems. Hence, in choosing equipment Amateurs were compelled to buy from a limited selection, frequently paying for features that were of no interest to them. Others whose budgets did not permit this luxury had to build their own.

We at Temco, who have been Radio Amateurs all our lives, have been wrestling with this problem for over ten years. Spurred by the desire to build Temco Transmitters that would fill every Amateur requirement at prices within easy reach of all, yet represent a sound, practical merchandising plan for the dealer, we enlisted our wartime experience with sectionalized units and plug-in construction to solve this long standing problem.

By sectionalizing a transmitter circuit into basic functions, then engineering them into indi-

vidual plug-in units and combining them into a cabinet of standard internal design WE HAVE FINALLY SUCCEEDED! From 12 different Temco Chassis Units your dealer now provides you with a selection of 16 different type transmitters. The first of this series are already in his store. He can now supply the following 4 Temco Transmitters: (1) 150 Watt CW (2) 150 Watt CW & AM Phone (3) 150 Watt CW & FM Phone (4) 150 Watt CW, AM & FM Phone . . . AND YOUR ORDER WILL BE FILLED WHILE YOU WAIT!

Furthermore, with each new development in radio communication Temco will produce additional chassis units to enable you to bring your Temco Transmitter up-to-date at all times with a minimum investment. For the first time in the history of Amateur Radio you can start with a 150 Watt CW unit and later, if you wish, increase power, add NBFM or AM Phone or a VHF unit and be assured of obtaining all the necessary units from one manufacturer who has designed them to operate in unison as a highly efficient and completely integrated transmitter.

Your equipment will never grow obsolete and your investment in a Temco will be protected forever.

All Temco Basic Chassis Units can be purchased individually to augment your present equipment. See your dealer now and have him explain this latest and greatest advancement in communication engineering. He has a special Temco Series RA Catalog waiting for you.

◀ SERIES RA TRANSMITTER CABINET (Rear View) showing universal wiring and plug-in arrangement with chassis units in position. Cabinets are wired for all combinations in 150 and 250 Watt input ratings.

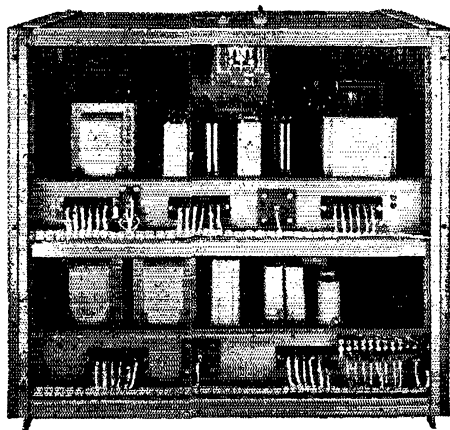

**TRANSMITTER EQUIPMENT MFG. CO., Inc. 345 HUDSON STREET  
NEW YORK 14, N. Y.**

WISCONSIN — SCM, Reno W. Goetsch, W9RQM — Our thanks and best wishes are certainly in order to DKH for a swell job while at the wheel as SCM. I wish to thank you for your support and assure you that every effort will be made to keep Wisconsin on the map. Your reports on the first of each month are hereby solicited. YCV is acting NCS of Wisconsin traffic net, 3775 kc., Mon. through Fri. at 6 p.m. YCV worked G3, KL7, and VK2 on first call with new 14-Mc. antenna. LFK makes BPL. IDG has fired up 35 watts on 7- and 3.5-Mc. c.w. IQW is rebuilding to work 14 and 28 Mc. DTE reports via Wisconsin net. ARE, as director, has an itinerary that really keeps him busy. HEE, activities manager of Wausau club, sends an FB report. FZC and VHA attended Cedar Rapids Hamfest, with 28-Mc. mobile in operation all the way. WMK is back on the air. JBF is attending summer school at Menomonie. CFT is on 28-Mc. 'phone after more than 20 years on c.w. CIH, our OO at Ashland, has high order of accuracy on frequency measurements. CTD is seriously ill at Wisconsin General Hospital in Madison. FTG and MRY are moving to Sauk City. PYE has been working locals on 28 Mc. with no antenna. EAE makes his appearance on 28 Mc. in Madison. SGU is active on 3.85 Mc. RBL won first place in Madison club WAS Contest with all 48 worked, followed by LNM, 47; HVN 41; MRY, 29. The Racine Megacycle Club will hold its annual picnic at Johnson's Park, Racine, Aug. 24th. Write KZU for information. IZL and WWM are on 144 Mc. AJL and ACQ are new calls at Racine. GDD is active on 50 Mc. RTR, PNW, and SZL are rebuilding. PQY and DXI are on 7-Mc. c.w. Your SCM will be on 3.5-Mc. c.w. and 3.9-Mc. 'phone regularly the first week of each month for the express purpose of collecting activity reports. Traffic: W9LFK 511, YCV 69, IQW 50, CFT 25, DTE 8, RQM 7.

### DAKOTA DIVISION

SOUTH DAKOTA — SCM, P. H. Schultz, W0QVY — The hamfest was a complete success and the Huron Club is to be congratulated on the manner in which it was handled. DIY and HON, of Sioux Falls, used 420-Mc. rigs en route to Huron from Sioux Falls. BLK and NGM helped in organizing the c.w. and 'phone nets respectively. GCF is net control for c.w. Please get in touch with him on 3720 kc. The 'phone net is in charge of NGM and is on 3935 kc. OLB, SDE, BLK, and YEZ are in the c.w. net. There are plenty of openings left. AOM is the call of 14-year-old Bob Himmerich at Aberdeen. ZIQ operates an electrical shop at Tyndall and PAP runs one at Miller. ZRA, of Sioux Falls, set up first contact with Ottumwa, Iowa, during the flood and with the Sioux Falls Club handled traffic. While on vacation 6AQJ/B contacted WVY on 28-Mc. 'phone and had a personal call when he arrived in Pierre.

MINNESOTA — SCM, Walter G. Hasskamp, W0CWB — IRM has 50-watt mobile! YYG also has nice mobile. St. Paul and Minneapolis radio clubs have applied for club station calls. TPN has a new Temco transmitter. HQW has new Signal Shifter and is building an 813 final. KYE is getting his 144-Mc. portable-mobile rig going. A Duluth church gave a hobby show at which LNV exhibited his handie-talkies. KYE also showed some of his works. NRV has been QRL because of telephone strike. CZY picked up a surplus transmitter. BOL has gone "surplus nuts." RJF, as OO, monitors 7 Mc. during traffic periods. ZSA is building new ham shack. 6HJP, now in Minneapolis, has been assigned to the Military Department at the U. of Minnesota as an instructor in Air Communications. BGY has a tough BCI problem. There are 150 h.c. receivers in the same building with him! MRX is putting his rig in a new rack and moving his shack into the den. RPT, JDO, QCR, TLE, and others attended the Tall Corn Hamfest at Cedar Rapids, Iowa. MOW's new QTH is Mason City, Iowa. QCR and JDO are spending the summer on 14 Mc. UWG has a new 7-foot rack and still can't get the rig in it. 6ZBX, ex-90SR, visited KQA. EPJ moved to Spring Park. ØSW has two complete 'phone-c.w. finals running a kw. each. TUO is new station at Willmar. Ex-2MNI now is ØBFV, active with BC-610. RHT put his 7-watt mobile rig on 3.85 Mc. and had Q5 reports 140 miles away! The St. Paul Club elected the following officials: YCR, pres.; JRL, secv.-treas.; DYH, vice-pres.; ONB, TOZ, UCA, JIE, and EYK, advisory board. A committee headed by LAE arranged for the sending of a complete transmitter and receiver to PAØ ham. CWB worked his first K9 on 7 Mc. More stations are desired for the MSN c.w. net. Contact RPT, our new RM. ZZK, Bemidji, is northernmost station reporting into the 'phone net. All stations, please report all traffic no matter

how small your total. Traffic: WØDNY 85, PPZ 50, EPJ 35, BBL 32, CWB 32, ITQ 31, RHF 22, BHY 21, NQD 20, VJH 18, RPT 17, UWG 12, EHO 8, SW 7, ORJ 2.

### DELTA DIVISION

ARKANSAS — SCM, Marshall Riggs, W5JIC — 5GKP got his old call back and now is 5SQ. MWI is new ham on 28-Mc. 'phone. MJC is building new three-element beam. LVT took the rig away from the OM, so LGH is dreaming again. KVN has 250THs in final. MNJ is putting up new beam. KKM is active on 14- and 28-Mc. 'phone. AQF and EGY are in a whirl over the convention. LMO expects to hit 14 Mc. soon. LLO is back on with CM812 and needs good exterminator for parasitics. LQN has new and better QTH. LVB has mobile rig working fine. DYT has been heard on c.w. 6CUV/5 took a YF recently. LSH put up towers again. The wind took one down. LCZ is on 50 Mc. and getting results. LUX is new AEC member. JKO is new Class A licensee and will have 500 watts on 3.85-Mc. soon. DSW is new OBS on 3885 kc. at 7:15 p.m. CST. Mon., Wed., and Fri. BQA is OBS on 7012 kc. at 8:30 p.m. CST. Tues., Thurs., Fri., and Sun. LQG is organizing a c.w. net on 3.5 Mc. EA and gang are going to town. The 75 'Phone Net meets at 6:00 a.m. Mondays. Anyone interested? HMI is new call of old ham, IWL. GTS, GWT, and GQG are new Class A licensees. The Ft. Smith Club has new 2½-kw. a.c. generator. Traffic: W5LSH 261, EA 57, LVB 55, ICS 18, LQN 15, LMO 5, JIC 4.

LOUISIANA — SCM, W. J. Wilkinson, jr., W5VT — SEC: KTE. RM: KUG. PAM: CEW. KUG makes BPL by working hard on the summer Rebel Net, 7100 kc. CGC is showing some activity on 7 Mc. IOP had a 13-minute QSO with XEIKE on 50 Mc. Both used 50 watts. CEW is working DX on 14 Mc. MPK has new e.c.o. KMD, LET, BZR, and GCM report 28-Mc. activity. NBK is new local ham. Cancellation of some appointments will be necessary unless reports are received each month. Also all OBS who haven't as yet done so should furnish copy of schedules to the SCM. Let's hear from all ORS, OPS, and OBS next month. KJE had QSO with LDH on 28 Mc., about 285 miles air line. LXX, the home station of LDH, has about 25 watts on 3.85 Mc. FVR has portable going on 28 Mc. MXH, MXJ, and MXP are all new on 28 Mc. KTB says he is getting all his power into the new four-element beam. KXU listens daily on 50 Mc. FSA is on 14-Mc. 'phone. KYK got Class A. IXL is working DX with portable-mobile rig. ZV is helping his daughter to get her ticket. LUR has new rig. HQE is working New Orleans regularly on 28-Mc. ground wave. HRD is experimenting with antennas. HHT works VK and ZL nightly on 14-Mc. 'phone. LVG is getting lots of QSOs on 28 Mc. AVO is working out on portable. BUK is working on 28-, 14-, and 3.85-Mc. 'phone. GHP runs 800 watts. GHF says DX is good on 14 Mc. DHE is a rag-chewer. JFR aids BSR with EC work. AXS is on 3.85 Mc. with 800-watt. EKY is working 3.85-Mc. DX with BC-610E. Traffic: W5KUG 192, VT 6.

MISSISSIPPI — SCM, Harold Day, W5IGW — PAM: VJ. A well-deserved appointment as Route Manager goes to WZ. HAV recently changed over from cathode to plate modulation, and substituted a pair 8005s for 812s. From the Coast gang: IOK, ANP, and HAV are on 3.85-Mc. 'phone. IBO and DLA are on 28-Mc. 'phone. JHS and JSH are active on 14- and 28-Mc. 'phone. AHA, just out of the Army Air Forces where he was communications officer, is running 250 watts on 28 Mc. with three-element beam. He also is working on 14-Mc. c.w. KUT, at Vicksburg, is new ORS appointee. GRJ, on 7 Mc., is using a VFO. KYC, LYD, DZG, and W4BZ/5 are operating 28-Mc. 'phone. FGE is working DX on 14-Mc. c.w. FO is working on 7 Mc. running 12 watts and Sky Champion receiver. AGZ is on 7 Mc. Thanks to LAK and HAV for the dope this month. Fellows, you see what is happening all around us. There are plenty of EC appointments available. What about it?

TENNESSEE — SCM, James W. Watkins, W4FLS — AAW is building a new 813 driver. AFR is on 3.85 Mc. with an ARC5. EBQ keeps schedule on 7 Mc. with his brother in Pennsylvania. FLY has a new 809 rig under construction. FEI is on 3.85 Mc. with low power. GYE has a new receiver. KFK is on 14-Mc. c.w. FWH has a new 8JK beam and a new rig on 50,360 kc. JSM has a new 14-Mc. antenna. DKX is building a new kw. rig using VT127As and a BC-610 exciter. HPA is on 3.5-Mc. c.w. KH is on 7 and 14 Mc. EAL is on 14-Mc. LVR is Mrs. HRL and is active on 28 Mc. HRL is working out FB with his 28-Mc. mobile. HOJ is

(Continued on page 76)

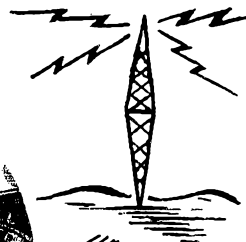
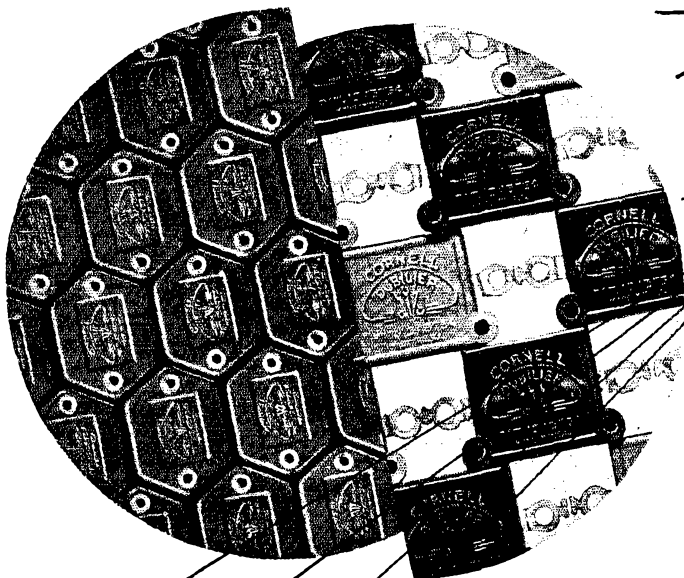

Wherever the schematic  
calls for  a C-D will do the job Best

A FEW OF THE MANY C-D TRANSMITTING CAPACITORS



**TYPES 4 AND 9**—C-D Mica Capacitors Types 4 and 9 are designed especially for grid- and plate-blocking and r-f by-pass functions in low-power transmitters. High stability under the most gruelling conditions.



**TYPE T**—C-D's Type T Dykanol Capacitors feature small size, light weight, low dielectric stress and long life at high operating temperatures. They are the finest and most dependable transmitter capacitors obtainable.



**TYPE TLA**—C-D Dykanol Capacitors Type TLA are ideal for compact high-voltage filter applications in h-f portable transmitters and transceivers. They are built to "take it."



**TYPE TQ**—C-D's Type TQ Dykanol Capacitors are designed primarily for filter circuits. They provide extreme mounting flexibility, with insulated terminals and universal mounting rings for placing the unit in any position, either above or below panel assembly.

**CORNELL-DUBILIER**  
world's largest manufacturer of  
**CAPACITORS**

1910



1947

SEND FOR FREE CATALOG NO. 195A—A complete display of the world's most widely used capacitors. Write to: Cornell-Dubilier Electric Corporation, Dept. JA8, South Plainfield, New Jersey.

MICA — DYKANOL — PAPER — ELECTROLYTIC

looking for Nashville traffic. Anyone desiring a traffic outlet with Smyrna, look for RTU on 7 Mc. between 0700 and 1700. LCA is active on 7 Mc. with a BC-375. GLW is active on 3.85 Mc. with 500-1000 watts. He recently put up an eighty-foot "Block Diamond" for his sky hook. CVM is active on 14-Mc. c.w. using about 150 watts input and an inside antenna, a folded-dipole. QT finally got his card from Japan for his WAC. HHU is active on 14-Mc. 'phone. ENL, our OO, occasionally gets on 28-Mc. 'phone. ESQ is doing FB with a 28-Mc. mobile. EHO has new e.c.o., so look for him on 3.85 Mc. DIJ spends most of his time on 28-Mc. 'phone. The Chattanooga Club was active in Field Day. BAZ, manager of Trunk Line J, is interested in securing a member station in Tennessee. This net operates on 3780 kc. at 8:30 P.M. CST Mon., Wed., and Fri. If interested, drop me a card.

## GREAT LAKES DIVISION

**K**ENTUCKY — SCM, Joseph P. Colvin, W5IEZ/4 — The following report was written by 4BAZ. JBU is recovering from a serious operation. JXB is in Tennessee. KIV is running 100 watts on 50 Mc. JXM has new 14-Mc. beam. LQI has beam on 28 Mc. ELL moved across the road from BAZ. KLK has new mobile rig on 29 Mc. JXX put up beam for 28 Mc. MDB has 25 watts on all bands c.w. and 120 watts on 28-Mc. 'phone. IUP has p.p. 810 on 28 Mc. KZJ says his long wire is very directional on 28 Mc. OEE is trying mobile 28 Mc. and TXC has f.m. rig mobile on 28 Mc. MRF sticks up fancy rotating beam for 28 Mc. KQI is working 28-Mc. local net with 3 watts. ITB has improved his audio quality. WZU is trying for 14 Mc. YNQ relieved TXC on KYP. CNE is on 14-Mc. c.w. MQ has husky key clicks. MO gets on 14 Mc. nowadays. KLP has nice(?) harmonics on 28 Mc. PN and JXM have over 130 countries each post-war. IEZ/4 is operating on 14-Mc. 'phone from Shawnee High. CIC wants 144-Mc. contacts. CMP is alternate NCS on KYP. IXN was seen in Louisville. JHU does beautiful sign-painting for hams. KUP has regular Ft. Knox outlet on KYP. KUY keeps KWO's ART-13 going. Working on 3.85-Mc. 'phone: CDK and KGS. Working on 14-Mc. 'phone: JTZ, NQQ, and PXF. Working on 28-Mc. 'phone: KFE, KFI, JVF, JXF, and BAZ. YPR is most regular on KYN, LTU and MMY alternating. If you can push a key, get on 3810 kc. with the KYN boys. NDY works on KYP at times. (KYP is Kentucky 'Phone Net, on 3955 kc. at 7 A.M. CST.)

**M**ICHIGAN — SCM, Joseph R. Beljan, W8SCW — SEC: SAY. New appointments: PAM — QBO and WWL. RM — NOH. ORS — NOH, UFR, and KZO. OBS — QQN. OO Class I — WWL. Section Net Certificates have gone to DNM, KZO, QBO, WWL, UKV, and YDZ. RMH is back from Manila and in civvies once again. FJL worked 124 countries in three months. UAS finally logged his 100th country and LSR is crowding the century mark with 97. ZBU sold his rig and is starting on a new one with a BC-221 for VFO. YBU and YDR are cousins but haven't QSOed as yet. ZEX, one of our younger hams, is just 15 and is running a pair of 807s on 3.5 Mc. HAN reports thirty active members from Saginaw and Bay City in the club. IV sends in his first monthly report since he has been on the air. The West Quad Radio Club, ZSQ, U. of Michigan, is on the air with a half-kw. Licensed operators include VWK, WYC, YEN, and ZRY. SWF reports possible tie-in with Tampa, Fla., net on QMT frequency. NXB is building mobile rig. CUP is sporting a new surplus receiver. AZZ is working nice DX on 50 Mc. and has QSIs to prove it. EMP is putting up television antennas. SOE is planning on three one-kw. rigs. ILP is doing swell job as secretary of the Edison Club and reports the club's activities each month. UGR and YCJ are pleased with new HQ-129X receivers. CLL converted BC-454 receiver for emergency work and is building companion transmitter. FX is kept QRL with work as secretary for DARA and QMN but finds time to do some surplus converting. DYH is about set to surprise the gang and get back on the air. UKV reports that the 5 P.M. QMN Net will continue during the summer months. The QMN 6 and 7 P.M. Nets have QRXed for the summer but will have a directed net on Tuesdays and Fridays at 6 P.M. WWL is working on new beam and plans to operate the rig remote control. AKI and SKY are new reporters in the Grand Rapids Emergency Net with VTG as new mobile unit. SAY reports the emergency set-up for the State is shaping up nicely and would like to hear from those who have not as yet contacted him. Traffic: (April) W8ONK 295, DAQ 30, EGI 18. (May)

W8SCW 303, NOH 193, UKY 85, SAY 81, DNM 61, DPE 43, VPE 38, IV 35, ABH 19, UGR 15, CLL 14, KZO 11, WET 11, TBP 9, FX 6, QF 6, HAN 5, WWL 5, YDR 5, URM 4, MGQ 2, HEX 1.

**O**HIO — SCM, William D. Montgomery, W8PNQ — New appointments include: ROX, ZEI, BEW, and SJF as ORS; QBF and DZO as OPS; and RJD as OES. Coming dates to remember: Sept. 7, 1947 — Findlay Radio Club Ham Picnic. Sept. 14, 1947 — GCARA (Cincinnati) Annual Stag Hamfest. New Dog House Net officers are: TRX, pres.; PUN, vice-pres.; DZO, treas.; EQN, secy. Further dope from QV indicates that there were over 400 in attendance at the Cuyahoga Radio Association's hamfest on April 26th. BCI complaints in Cleveland are being ably handled by JNF and QV. From the *CRA Bulletin* we learn that COX now is AF, which was his call in 1919; that LZE's antenna is under his living room rug; and that WV now has his kw. working on 14 Mc. From SGF and the *Cambridge ARC Bulletin* we note that RVU has a new jr. operator; NBM now believes in ghosts 100 per cent; and the new meeting time for the Cambridge club is 7:00 P.M. the last Thursday of each month. The Buckeye Net (BN) has cut operations to Tuesday and Friday evenings for the summer, according to RN. OGK reports that he will be off the air for a month or two because of a Middletown cloudburst which flooded his basement and ruined all his radio equipment. RDZ reports that the Case Institute of Technology now has a net on 3552 kc. WRN reports from Columbus that YBF has cards from 51 countries on 28 Mc. during the last 9 months of operation; and that 144-Mc. activity still is on the increase. ZQB is on 50 Mc. at Chillicothe, and is looking for some Central Ohio boys. WYN says that PMD and JWT are engineers at the new f.m. station, WATG, at Ashland; that ZET, ZES, and KUW now have BC-610s; and that NQD has a VHF-152 being used on 50 and 144 Mc. WDQ reports that the Northeast Amateur Radio Club has a new location at the Mermaid Club, 8803 Euclid Avenue, Cleveland, with separate meeting room and radio room. Meetings are held every Friday night. Officers are NGW, CCO, OQI, and ZMH. WDQ goes on to say that HGW has 170 countries, 125 of which are confirmed; that WDQ has two new 8JK beams, one on 28 and one on 14 Mc.; and that YOS received the annual "BOBER" medal for working a G on 28 Mc. and then trying to continue the QSO with his modulator turned off. Our little spyglass receiver tells us that QBF is carrying on QSOs in Spanish where necessary; that UW is "going to sea" for the summer; that EFW has a new Supreme AF-100 transmitter; that AQ likes his 14-Mc. folded doublet so well that he has been converted to a temporary "DX hound"; and that PMJ has worked Detroit, Erie, Sharon, Mansfield, Akron, Cleveland, etc., on 144 Mc. using five-element horizontal beam with 90 watts. The winners of the May 11th QCBN Hidden Transmitter Hunt in Cincinnati (144 Mc.) were Paul and Hod Luhn. These new-comers to transmitter hunting really showed up the old-timers. We close this month's report with a plea to you fellows to check the date on your ARRL appointment certificates. If dated over a year ago the certificate is no good, and should be sent to me at once for endorsement. Traffic: W8PZA 137, CBI 117, UPB 57, RN 47, MPG 32, QBF 30, PMJ 24, PUN 24, WAB 21, EQ 20, EBJ 18, WE 17, DAE 13, LCY 11, ROX 10, BEW 9, TIH 7, AYS 6, QIE 6, BUM 5, UW 5, EFW 3, AQ 2, PSE 2.

## HUDSON DIVISION

**E**ASTERN NEW YORK — SCM, Ernest E. George, W2HZZL — FEN reports on the fine work done by the Albany gang at the Albany-New York outboard races on May 25th. AWF, PXY, and VDO were instrumental in making the affair a success at the Albany end. Others participating were AUV, SUL, VB, and KNQ, from Albany to Peekskill. All the club members pitched in and a successful Sunday of operations resulted. BLU reports that he is receiving help from NQW in working out his emergency set-up around Maybrook. ITX reports the NYS Net is going on vacation with informal net traffic on Tuesdays and Thursdays, 7 P.M. EDST. Full schedules will be announced later. LRW is to be congratulated on the first harmonic at his shack. He is now starting a construction program on his antennas while the net is closed for the summer. HZL and KLM handled the communications on 144 Mc. at the outboard motor races at Schenectady. RMM, GYV, KLM, and HZL constitute the 50-Mc. boys in the tri-city. On his

(Continued on page 78)

# NOW - A SIXTY-FIVE WATT

## EIMAC TETRODE

TYPE

# 4-65A



- **Hard Glass**
  - **Non-Emitting Grids**
  - **Instant Heating Filament**
  - **Low Drive**
  - **Low Voltage**
  - **Low Feed-Thru Capacitance**
  - **Low Cost**
- \$14.50**

### THE ANSWER TO THE TRANSMITTER-MAN'S PRAYER

Available now, type 4-65A is a small radiation cooled, instant heating tetrode. Devoid of internal insulating hardware, the 4-65A was designed as a transmitting tube . . . not a blown-up receiving tube. This rugged new Eimac tetrode really performs at low voltage, and its instant heating thoriated tungsten filament makes it ideally suited for mobile installations. The 4-65A operates well into the VHF, beyond the 160-Mc. band, and is capable of delivering relatively high-power with a plate voltage range from 400 to 3000 volts. As do other Eimac tetrodes, type 4-65A embodies the inherent characteristics of low grid drive, low feed-thru capacitance, and general stability of operation.

Type 4-65A's versatility of operation is demonstrated in the adjacent data showing typical operation at 400, 1000, and 2000 volts. Additional data on the 4-65A are now available, write direct.

**EITEL-McCULLOUGH, Inc.**  
 1771 San Mateo Ave., San Bruno, California

TYPE 4-65A	
ELECTRICAL CHARACTERISTICS	
Filament: Thoriated tungsten	
Voltage	4.0 v
Current	3.5 amp
Grid-Screen Amp. Factor (Av.)	5
Direct Inter-Electrode Capacitances (average)	
Grid-Plate	0.08 $\mu$ f
Input	8.0 $\mu$ f
Output	2.1 $\mu$ f
TYPICAL OPERATION	
Class C Telegraphy or FM Telephony (Key Down Conditions, 1 Tube)	
D-C Plate voltage	400 1000 2000 v
D-C Screen voltage	250 250 250 v
D-C Grid voltage	-40 -50 -70 v
D-C Plate current	100 125 125 ma
D-C Screen current	40 37 35 ma
D-C Grid current	13 16 16 ma
Peak R-F grid input voltage	135 155 180 v
Driving power (approx)	1.8 2.5 2.9 w
Screen dissipation	10.0 9.2 8.8 w
Plate power input	40 125 250 w
Plate dissipation	12 30 50 w
Plate power output	28 95 200 w

Follow the Leaders to **Eimac** TUBES The Power of R-F

EXPORT AGENTS: FRAZAR AND HANSEN, 301 CLAY STREET  
 SAN FRANCISCO 11, CALIFORNIA, U.S.A.

retirement J. Keane received congrats on his fine job of editing the *Schenectady Amateur Radio Assn. News* for so many years. NJF has been temporarily issued the call K2NRH with authority to use it on all bands. Upon completion of the Naval Reserve Armory, Yonkers, the call will be transferred to the station set up there. Traffic: W2ITX 263, LRW 234.

**NEW YORK CITY AND LONG ISLAND — 8CM.** Charles Ham, jr. W2KDC — The SCM is trying to get his report in early each month. All are requested to get reports in the mail as near the last day of the month as possible. Thank you. Reliable BGO, the SEC reports a slight lull in Queens, although CIQ, EK, JTV, OIE, SYW, TRT, TWJ, LGK, and TZT are doing business as usual on 144 Mc. Less active, but still very important to the emergency set-up, are NZJ, MXJ, CDS, TJA, LRI, BYH, ATI, PQG, and KMA. Mobile activity is expected to reach a peak shortly and will help the EC Net. CIQ, BSP, UZX, and UGV are most active on 3.5-Mc. c.w. while BDN settles in a new home. In Brooklyn, OHE, the EC, reports the unofficial and very desirable swing to crystal-control has curtailed activity during the rebuilding process. Press has been working Boston and Washington consistently on 144 Mc. QHZ has acquired crystal-control on the band, while KU and HG, the father and son team, can be heard on 235 Mc. Tuesday evenings portable-mobile. DIO is on 144 Mc. using an ARC-5 plus five-element beam. NQQ is rebuilding completely for 30-144 Mc. NXT has what could be called a crystal e.c.o.; he has over 50 crystals which hit the 144-Mc. band. QYS and EPF are welcomed to the EC net and IXJ does very well on 144-Mc. mobile. In Suffolk, BAV gave an interesting lecture on v.h.f. antenna problems at a meeting of the SCRC. IOL is welcomed at Speonk; he uses an SCR-522 and also operates at QXY. JWO is back on 144 Mc. Mobile activity is increasing here with EBT, LUD, PDU, and OQI going strong. Ditto for CRZ at Amagansett. ADW finally got that 60-footer up with four half-waves and really pushes out a signal with an 829. BFA, PTQ, and FCH all sport new BC-312s. PTQ is active on 144 Mc. TLE, of Valley Stream, is a Motor Vehicle Inspector in Suffolk. On 3.5-Mc. c.w. the June first message showed the need of using a "Standard Operating Practice." The words "June One" became garbled to "June 15." Numerals are never used in the text by NYC-LI and our EC nets. TSA is anxious to arrange schedules on 420 Mc. SJC, although living in the Bronx, is a member of Queens EC because of inactivity in his home borough. TVE squeezes some 3.5-Mc. c.w. operating into his high school schedule. He is president of school radio club. ESO built up to a pair of 813s gradually. ELN is back on using a Signal Corps transmitter SSTR-4-53 with 100 watts c.w. Brad also uses an H.F.M. mobile rig (built by BSL) and a Sky Challenger with his own pet crystal filter circuit. He believes the old Flatbush Transmitting Club has folded for good, but would like to hear from some of the old-time members. PWJ is QRL but always remembers the good old monthly report. HMJ has 86 countries since Jan. 1. QYZ was active in Field Day with NYC-LI net gang at Amityville. BO keeps good schedules and handled much traffic from CPX at the Philatelic Exhibition. RTZ is a new member of the NYC-LI net. We finally got one in Manhattan! SHE reports that NOD is back on the air as club transmitter of Pratt Institute, where HPC is faculty adviser and trustee. VHS, new Brooklyn ham, is on 7 and 14 Mc. with Meck transmitter and 2 super-pros. CPX handled 1200 messages in 9 days using 25 operators with rigs on 3.5, 7, 14, and 28 Mc. LFR, LR, NJF, JZX, QUJ, PL, NQC, and NKD deserve much credit. All operators please note KDC's new QTH, 200 Harvard St., Westbury. TYU has Millen VFO modified to cover 3.5-4 Mc., etc. 807 buffer-doubler neutralized 813 running 300-350 watts. Traffic: W2CPX 1365, TYU 650, BO 267, QYZ 90, OBU 75, SJC 65, RTZ 6, AYJ 4, HMJ 2.

**NORTHERN NEW JERSEY — 8CM.** John J. Vitale W2IIN — Asst. SCM, T. J. Ryan, 2NKD. SEC: GMN. N.N.J. Net, 3630 kc. daily 7 p.m. except Sun., LFR NCS. N.J. 'Phone Net, 9 a.m. Sun., 3900 kc., QEM NCS. JKH is finishing up his 235-Mc. remote control link for 3.85-Mc. operation. NIY suggests that some N.N.J. club sponsor a N.N.J. QSO Party. RDO is anxious to contact some stations in Sea Isle City on 3.5 or 7 Mc. LV gave a talk on "Television Interference by Amateurs" at UCARA and Watchung Valley Radio Club joint meeting. APL, Jersey City EC, reports LQP is Assistant EC and NXS, OJC, and QVA are new AEC members. SCQ has new four-element beam, 813 final on 28 Mc. LZM has 750 watts on 4 Mc. and is playing

with home television. REY works his brother at Glen Gardener every night. UZQ is on 3.5 Mc. with 25 watts. RJM and IQQ are on 38.5 Mc. PLH is on 38.5 and 14 Mc. with a Meissner 150B and XX-420 and praised the Oklahoma Net for the services rendered during Texas City disaster. Fort Monmouth Radio Club's new officers are 4WE, pres., QEM, vice-pres., QDU, secy-treas. Club call is OEC. The Ramapo Valley Chapter of the American Red Cross has requested an EC to serve on the Disaster Committee. Write to Mr. C. F. Tibbals, jr., chairman, and the SCM for appointments. The NNJRA meets the 2nd and 4th Mondays. The Club held its first annual Social Field Day June 7th. JT was elected vice-president. OEC keeps schedules with LU3DO, KZ5AA, KP4DD, PY1BIC, and D4ARA, handling much G. I. traffic. New Jersey 'Phone Net held its first outdoor meeting at EGM's. BZJ is organizing a volunteer electronic warfare platoon in the Naval Reserve. TZY handles traffic on 3.5 and 7 Mc. and holds a Code Proficiency Certificate for 25 w.p.m. PQS has NC-200 and is getting high scores in QSLs. DED has BC-348. UNA has 807 on 3.5 Mc. with 25 watts and HQ-129X. KXX is working much DX on 28 Mc. BYK, on 14 Mc. with 813 'phone, BC-348, is doing well with doublet. NZC has new five-element beam. NUI has new 1-kw. rig. RFE engineered the rig. GVZ reports that 2IIN is one of the signs in the railroad tunnel in Jersey City. The UCARA furnished communications for the judges of the Soap Box Derby in Elizabeth on July 4th. PIY has a 522 on 144 Mc. OSQ has three-element beam on 28 Mc. running 850 watts and works 144-Mc. mobile. NPJ has gone c.w. on 14 Mc. JSARA and MCARA expect to see you at the Hudson Division Convention in Asbury Park Sept. 26-7-8. The N.N.J. Net was kept very busy with traffic from the International Stamp Show. EWL is putting up a 50-foot tower in his back yard with several beams on it. LCR, with his two-element beam, certainly works the DX on low power. EUI is mobile on 50 Mc. TH is on 28-Mc. 'phone. LUJ has 28- and 144-Mc. beams on same mast above 50-foot tower. LAG is rebuilding his 38.5-Mc. 'phone rig. FNT and LCO are heard mobiling on 144 Mc. Traffic: W2LFR 537, ANW 348, CGJ 348, OEC 344, NKD 194, NCV 68, QEM 42, ANR 32, CXX 22, IIN 22, OXL 22, APL 16, LTP 12, BRC 8, LQP 6, PQS 2, GVZ 1, NIY 1.

## MIDWEST DIVISION

**IOWA — 8CM.** Leslie B. Vennard, W9PJR — W8YBV, who has been attending law school for the past year, is ready to give radio a good workout. AAL is a new ham at Rembrandt. HMM has been pretty busy with traffic the past month. HKN got Class A license. He is in TLCN and wants more operators in Jr. Operator Net. ZXG and ARN are new licensees in Burlington. A good time was had by all at Cedar Rapids Convention. NMA has only 8 hours work per day and then radio. Water was 12 feet deep in South Ottumwa during the recent severe floods in Southeast Iowa. Most of the members of the Iowa 75 Net did noble work in handling emergency traffic. CVU and WIJ are new ECs. We need 50 more in Iowa. How about it, boys, won't you volunteer? Traffic: W8HMM 173, QVA 22, TIU 14, HKN 6.

**KANSAS — 8CM.** Alvin B. Urnher, W8AWP — ZJY is new call in Wichita. ESL will summer in Sabetha. He is rebuilding two SCR-522s for 144 Mc. BQJ has been working DX and is building 8JK antenna. OAQ has schedules with CE4AD and KL7AD. He is building 813 crystal oscillator for 3610-kc. net work. IJK is attending school in Kansas City. AMT is new call in Leavenworth. BDU reports traffic from Newton. He will be in Oklahoma during the summer. CKV was Wichita visitor. Several Kansas clubs, including Wichita and Topeka, were out on Field Day. OKD is building new final for more power. The Field Kindley High School Radio Club, Coffeyville, has an emergency station powered by 2.5 kva. alternator. NJS has schedule with ex-9FLG and ex-9IOL, now both W5s. 7UTM, near Salt Lake City, sends 73 to the Kansas gang. He is ex-netter, 9SID. 5HIV also sends regards; he is ex-9TFR of Wichita. RMJ, formerly of KANS and Boeing-Wichita, is civilian radioman at Smokey Hill Air Base. The Garden City Amateur Radio Club was granted a charter as an ARRL affiliated club at last Board of Directors meeting. Congratulations! W-R-I-T-E-I Traffic: W8OAAQ 15, BDU 7, AWP 2.



**MISSOURI — 8CM.** Mrs. Letha A. Dangerfield, W8OUD — The summer slump in reporting seems to have hit already. QRN, on 3.5 Mc., made it seem advisable to

(Continued on page 80)

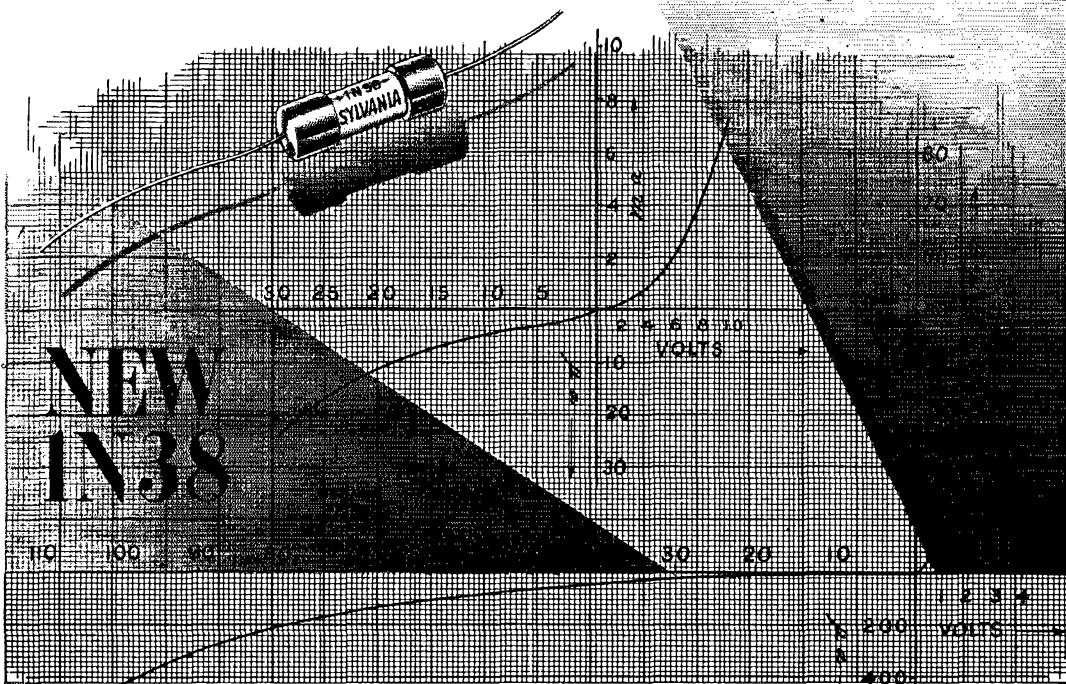

# HIGH VOLTAGE FREQUENCY TEMPERATURE CRYSTAL



-  **HIGH VOLTAGE.** The new Sylvania 1N38 Crystal is designed for a back voltage of 100 volts maximum.
-  **HIGH FREQUENCY.** With its shunt capacitance of only 0.8 to 1.1  $\mu\text{f}$ , the 1N38 is ideal for high frequency use.
-  **HIGH TEMPERATURE.** Rectification efficiency decreases only .0007% per degree temperature rise from 27° to 75° C.

Newest addition to the Sylvania family of Germanium Crystals, the 1N38 is of compact, space-saving design. Pigtail leads permit easy soldering into position.

Back resistance is as high as 2½ megohms.

Minimum life is 5,000 hours at 22.5 ma DC.

*Write for full details*

*Electronics Division, 500 Fifth Avenue, New York 18, N. Y.*

# SYLVANIA ELECTRIC

**WHEN YOU NEED  
CAPACITORS FOR YOUR  
RIG . . . SPECIFY  
MALLORY FOR  
DEPENDABILITY!**

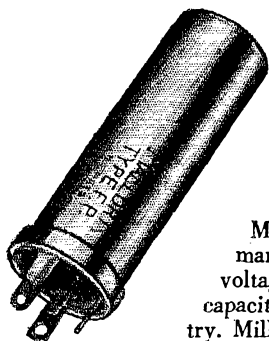

Mallory is the *oldest* manufacturer of high voltage dry electrolytic capacitors in the country. Millions of capacitors with the Mallory trade mark have been sold in the past 16 years. Mallory experience, including its experience in building for military requirements, is available to you in product and in application information.

You can benefit, too, from the wide variety of Mallory stock items. This means that you can usually get the exact type needed and avoid the necessity of awkward substitution.

For complete capacitor replacement data on pre-war receivers, consult the Mallory Radio Service Encyclopedia. Special application information for specific problems may be obtained from the factory by addressing the Engineering Application Section. Take advantage of these services. Remember, too, that you can get Mallory electrolytic capacitors from a *conveniently* located authorized distributor.

**P. R. MALLORY & CO., Inc.**  
INDIANAPOLIS 6 INDIANA

**P. R. MALLORY & CO. Inc.**  
**MALLORY**

(Continued from page 78)

move the traffic net to 7 Mc., but difficulties arose. Some of the gang dropped out. OUD's rig became eccentric and would not double. ARH started overhauling his transmitter. NNH was swamped by QRN and QRM. QXO and CKS made 7-Mc. schedules with 4PL and SKA. KIK is still available for traffic on either 3.5 or 7 Mc. DRM says his QSOs are piling up on 7 Mc. FNN has worked 20 countries on that band and 6 on 14 Mc. since the first of the year and has a new YL operator. Ditto on the YL operator for WGT. ZIS is much pleased with his Collins 70E-8 oscillator. He says activity on 50 and 146 Mc. is picking up and suggests we ask car manufacturers to try to eliminate ignition hash from new models. YHZ is still collecting parts for his 400- to 1200-Mc. outfit. ZZW is building a new power supply. GCL's antenna built of tin cans fell down while he was on vacation. IKI's first night on 50 Mc. netted four contacts; he had good luck also on 144 Mc. and still works 28 and 3.85 Mc. WVS has moved rig to Kansas City, where he is attending radio school. He has worked 27 states on 28 Mc. since getting his ticket in March. ZFL, ex-Army operator licensed two months, works both coasts on 7 Mc. with a single 6L6. DEA is building a new shack and putting up two 60-foot masts and a 75-foot tower for a beam. Check up on your official appointments, and if they need endorsing, send them along. Traffic: W8SKA 140, CKS 132, CMH 37, KIK 18, VEE 8, ZZW 6.

NEBRASKA — SCM, William T. Gemmer, W6RQK — The following has been received from Marvin Olson, W6MLB, SEC: We who saw the damage done by the flash flood at Cambridge, Nebraska, June 22nd, realize the need for an organized Emergency Communication Corps. Railroads were torn up with their ties standing on end looking like picket fences. Bridges were washed out. Parts of houses and furniture were scattered all over the roads and fields. Homes were destroyed. Stores were flooded and merchandise ruined from water and mud. Basements were full of water. Homeless people were looking for food and shelter. Others were combing treetops and low spots looking for the bodies of their missing loved ones. There were no lights, no gas, no railroad service, no telegraph or telephone; nothing but sorrow and trouble. People in other towns and states with loved ones in the flooded area had no way of contacting them. In the midst of this dark picture there was one bright spot. A group of amateur radio operators in an upstairs room of the school house, with a portable light plant and battery-operated generator, operated all day and all night after driving miles through high water and deep mud. These hams sent more than a hundred messages from and to loved ones who were worried about each other's welfare. Let us all prepare for emergency communication. Let us prepare BEFORE the disaster strikes us. NEBRASKANS: Send in YOUR application NOW for membership in the AEC.

#### NEW ENGLAND DIVISION

CONNECTICUT — SCM, Edmund R. Fraser, W1KQY — Club News: BRAC — LIG reports JW, JRV, FT, MC, and DWK are deserting 144 Mc. for operation on 425 Mc. MZZ is on 28-Mc. n.f.m. Sixty-eight hams attended Horse-trader's affair at Saybrook, with 2AMJ demonstrating new 144-, 50-, and 28-Mc. converter. NHARA — KG6AS, ex-WI0KN, writes from Guam that he will be on the air soon with BC-610, HQ-120, AR-88, and SX-28. NRR sent sea letter from *Park Benjamin* en route from Genoa. BHM, our OO, reports improvement noted in signals. Carmine Polo Club's most active ham supplies a 10-kw. generator for Field Day, courtesy of Benzoline Co. WARA — MXZ reports two c.c. and six modulated oscillators being operated in Wallingford on 144 Mc. GZG is building a c.c. rig for the same band. A coaxial antenna has been erected for the club atop the Town Hall. Code and theory classes are being held to prepare members for September exams at Hartford. BARA — HBL had his 28-Mc. elements welded at OPG's Spring Shop. GVK won a year's subscription to QST donated by the club to the highest scorer in DX Contest. Another subscription is being offered for first postwar WAS. FC, not satisfied with kw. rig, is operating three 50-kw. rigs — WCBX-WCBN-WCRC. APW is back with the ham itch. IBY now is with P.A.A. NARL — DXT reports the club purchased a BC-654 for Field Day and AEC use. FWH is a new member. SARA — BRL, Field Day chairman, did a swell job on advance preparations. OQG, the section's most active EC, plans Red Cross disaster tests complete (Continued on page 82)

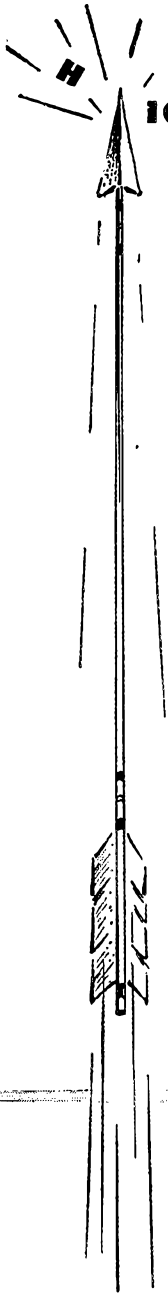

**HIGH SCORER**

# HQ-129-X

In any contest, Sweepstakes or DX, you will find HQ owners way up among the High Scorers. Why? Because the HQ-129-X has what it takes—plenty of selectivity to dig out those “down under” stations that you have to work if you want to be **HIGH SCORER**.

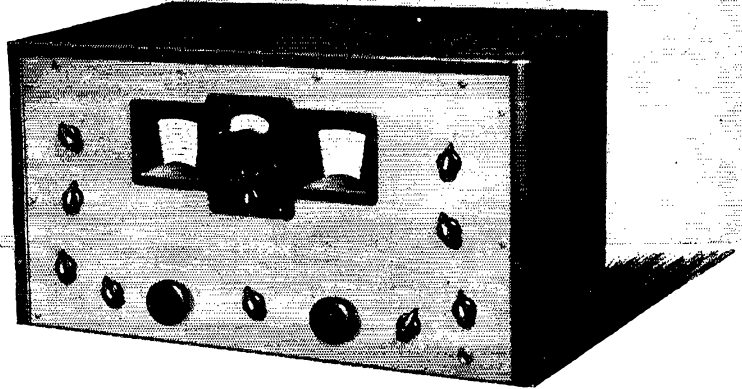

# HAMMARLUND

THE HAMMARLUND MFG. CO., INC., 460 W. 34<sup>TH</sup> ST., NEW YORK 1, N.Y.  
MANUFACTURERS OF PRECISION COMMUNICATIONS EQUIPMENT

**36  
TYPES  
OF...**

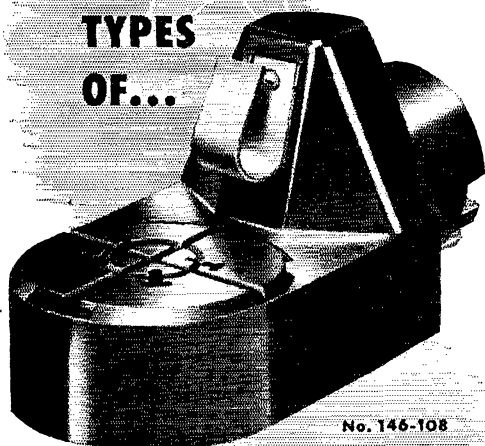

No. 146-108

**...INDUSTRIAL ELECTRON  
TUBE SOCKETS**

by



To insure top performance and long uninterrupted tube life, leading manufacturers of electron tubes cooperated with Amphenol engineers in designing these new Industrial Sockets. With 36 types currently available, and more to come, Amphenol Sockets today are available for practically all electron tubes now in use.

Amphenol Industrial Electron Tube Sockets combine the best of design in terminals, contacts and insulation. Quick-connect screw type terminals simplify testing in original equipment and the replacement of sockets in older equipment. Cloverleaf contacts, an exclusive Amphenol feature, provide four full lines of contact to the tube pins and assure against loss of conductivity under the heavy current loads of industrial applications. Insulation materials have been chosen to provide maximum physical strength, high arc-resistance and reduced carbon tracking. Barriers provide extra safety factors.

See your parts jobber, or write today, for full technical and cost data on Amphenol Industrial Electron Tube Sockets.

**AMERICAN PHENOLIC CORPORATION**  
1830 South 54th Avenue, Chicago 50, Illinois

COAXIAL CABLES AND CONNECTORS • INDUSTRIAL  
CONNECTORS, FITTINGS AND CONDUIT • ANTENNAS  
RADIO COMPONENTS • PLASTICS FOR ELECTRONICS

(Continued from page 80)

with messages, etc., with all Red Cross officials present. News in general: AMQ handled plenty traffic from Stamp Exhibit. BKO received his old call, WW. EFW will cover Connecticut Net and TLC Tuesdays during the summer. KKS increased Philatelic Exhibition's traffic flow. IKE transferred his OO appointment back to this section from Maine. While visiting in Easthampton the SCM had a pleasant time with CKQ, EAP, JOS, and TK. FMV, using 3.85-Mc. 'phone rig at GB, had first QSO on that band in 5 years with 2QXS. Both were new to each other and operated only c.w. prior to this QSO. A USNR Electronic Warfare Company is being formed in Hartford. Radiomen, radar-men, technicians, and sonarman of all rates are needed. Former Navy officers and men are invited to meet with the Company on the LST 722 at the old steamboat wharf in Hartford Mondays at 2100. Traffic: W1AW 288, KKS 274, NJM 145, EFW 120, AMQ 63, ORP 39, HYF 17, BHM 8, BDI 7.

MAINE — SCM, F. Norman Davis, WIGKJ — SEC: LNI, PAM; FBJ, ECs: OHY and JRS. CPL has rigs on 50 and 144 Mc. and would like to have some activity on 420-Mc. band. FAX and FXA are on 3.85- and 28.5-Mc. 'phone. FAX has 829B in final. PP is on 3.5- and 28-Mc. c.w., also 144-Mc. 'phone. MFK and DEO are on 50 Mc. JRS runs 90 watts to a pair of 1625s on c.w. 5KUD now is QDO. JOC, KEZ, MAW, MXT, NHT, OHT, and OHY, recently received their Class A tickets. MTR has been visiting MGP in Massachusetts and has new Super-Pro. IKE has finished college and moved back to Connecticut. EFR, MJS, and OGZ are on 144 Mc. almost every night at 9:30 and wish for more activity at that time. OHY runs 300 watts c.w. and 200 watts 'phone to pair of 812s. The Sea Gull Net on 3961 kc. has new members coming in all the time and plans are being made to handle traffic and hold emergency drills. Anyone interested in appointment as EC for his community should drop a line to the SEC at 28 Dennet St., Portland. A few prewar ORS and OPS appointments have been renewed, but many still need postwar endorsement. Please check yours if you hold either of these appointments. Anyone interested in an appointment, please write and I will send application. The Pine Tree Net will need better coverage of the State this fall when activity increases, so those who would like to handle traffic will be welcome on 3550 kc. at 7 P.M. Monday through Friday. Traffic: WINXX 22, IKE 2, OHY 2, GKJ 1.

EASTERN MASSACHUSETTS — SCM, Frank I. Baker, jr. W1ALP — New ECs: HJ for Wellesley, BAQ for Arlington, OJT for Abington. 5GNV/1 is new ORS and OBS. LVN, CBY, MIH, and BBL renewed EC appointments. LMU renewed OES and OBS appointments; JCK and BDU ORS appointments. The last Sunday of each month has been set aside for emergency tests. 3745 kc. is the frequency of the Eastern Mass. Emergency Net. NK, commander, USNR, reserve communication officer, sends calls of the Naval Reserve Armories in this section: K1NRA, Lynn; K1NRB, Boston; K1NRS, Squantum; K1NRV, Hingham; K1NRW, Fall River; K1NRX, New Bedford. SH is on 144 Mc. with a TR-4. LXL moved to Dedham. HNV is on 3.5-Mc. 'phone. 3VUA/1 is living in Boston. QCA is on 3.5-Mc. c.w. PFL worked 5 states on 144 Mc. Ex-NMK is in Germany using call D4AUJ and is on 14050-kc. c.w. Anyone know where LGH is living now? The T-9 club held a meeting at MNK's QTH. LVN, EC for Falmouth, has the following hams lined up in the AEC: OTS, JNM, TQ, HQH, DVS, NFE, and 2MIW. They are forming a radio club which will meet the last Thursday of each month. AVY has a Meissner 150-B and is on 144 Mc. HXK has new beam for 144 Mc. QFI is call of new Coast Guard Auxiliary club station in Winthrop. PXH has new beam for 28 Mc. EL is going on 1250 Mc. NBV is on 28-Mc. marine mobile. HSF has new 144-Mc. superhet. KLV has 144-Mc. rig on his bike. AYG says there are about 20 active hams in Hingham. NXY has 32-ft. mast on the roof with 144-Mc. "J" beam. The Brockton club held a swap nite. BAQ has 75 watts on 144 Mc. 5GNV will have a 600-watt job on using a pair of 813s. NBS, Dedham EC, had the following on in May 25th test: JNX, OUM, OUZ, PMM, OEJ, and SH. OBN is using the shifter on 7 Mc. IPZ is on 3.5-Mc. 'phone and also 144 Mc. SM is on 7 Mc. with pair of 809s. OBU is on 28-Mc. 'phone. JXM has 43 countries on 28-Mc. 'phone and has WAC. HJ's postwar DX is 27 countries on indoor antenna. MEG has mobile transceiver on 144 Mc. ONZ, one of our OBS had a rebroadcast to short skip area via

(Continued on page 86)

# New 5514

## ECONOMICAL TUBE TO GROW WITH!

### STANDARDIZED FOR ECONOMY

The 5514 supplants the HY30Z, HY40, HY40Z, HY51A, HY51B, and HY51Z. Concentration on this one 65-watt triode gives you a better tube for much less — only \$3.95. Two 5514's take 525 watts input in class C; deliver 400 watts output in class B audio—at CCS (continuous commercial service) ratings.

### EFFICIENT AT ALL PLATE POTENTIALS

Low internal tube drop of the 5514 permits excellent efficiency over a wide range of plate potentials. In class C, two 5514's give plate power outputs of 60 watts at 400 volts, 400 watts at 1500 volts. Furthermore, associated components are economical and still usable as power is increased. Truly the 5514 is a tube to grow with.

### READILY INTERCHANGEABLE

The 5514 has a standard 4-pin medium base, conventional overall dimensions, a 7.5-volt filament, and a high mu (145). Dependent upon the triode it replaces, the 5514 may require slight readjustment of filament voltage and/or grid voltage and driving power. Chances are you will need no new parts.

### ALL-PURPOSE ZERO-BIAS TYPE

In either modulator or r-f amplifier, performance of the 5514 is exceptional. One HY69 or 807 can overdrive at maximum input two 5514's in class C. You need no costly fixed bias for protection. Economical, efficient, interchangeable, versatile — the 5514 was designed for you. See it at your jobber's.

### 5514 FEATURES

- Zirconium-coated Speer graphite anode
- Grid leads to both pins two and three
- Plate cap has ceramic insulating bushing
- Dual low-resistance plate connections
- Low-loss synthetic lava insulators
- Convenient low-loss 4-pin medium base
- Elements firmly supported by dome micas
- Efficient at low or high plate potentials
- Only 13 w drive for 262 w input class C



**\$3.95**  
AMATEUR  
NET PRICE

### HYTRON TYPE 5514

High-Mu All-Purpose Transmitting Power Triode  
GENERAL CHARACTERISTICS

Filament . . . . .	thoriated tungsten
Potential . . . . .	7.5 ± 5% volts
Current . . . . .	3. amperes
Grid-plate capacitance . . . . .	7.9 μmf
Grid-filament capacitance . . . . .	7.8 μmf
Plate-filament capacitance . . . . .	1. μmf
Max overall length . . . . .	6-9/16 inches
Max diameter . . . . .	2-7/16 inches
Bulb . . . . .	ST-19
Base . . . . .	low-loss 4-pin medium

### ABSOLUTE MAXIMUM CCS RATINGS—CLASS C

Characteristic	Mod. †	Unmod.
D-c plate potential . . . . .	1250	1500 v
D-c plate current . . . . .	175	175 ma
D-c plate power input . . . . .	175	262 w
D-c grid potential . . . . .	-200	-200 v
D-c grid current . . . . .	60	60 ma
Plate dissipation . . . . .	43	65 w
Frequency (max ratings)	60	60 mc

### PLATE POWER OUTPUT (CCS) TYPICAL OPERATION\*

Service	Plate Potential			
	400	750	1250	1500
Class B audio #	50	150	330	400 w
Class C unmod.	30	70	165	200 w
Class C mod.	30	70	135	--- w

† Carrier condition with a max modulation percentage of 100. \*To determine useful power output to load, subtract circuit and direct radiation losses from plate power output. #For 2 tubes.

SPECIALISTS IN RADIO RECEIVING TUBES SINCE 1921

# HYTRON

RADIO AND ELECTRONICS CORP.



MAIN OFFICE: SALEM, MASSACHUSETTS

# The New MEISSNER

## ...the outstanding variable

With more amateurs going on the air almost daily, the ability to dodge QRM has become of utmost importance. As the ham bands become increasingly crowded, amateur operators all over the world have come to regard the Meissner Signal Shifter as their most useful single piece of equipment. Built-in band switching, all controls on front panel, crystal control on all bands plus many more new, exclusive features all combine to make this new instrument the finest variable frequency exciter ever offered. At your dealers or write to the address below for full information.

**Meissner Signal Shifter (Model EX), less all coils and less power supply but with aluminum strips attached to turret.**

Amateur Net . . . . . \$66.50

**Power Supply Only (Model PX),**

Amateur Net . . . . . 13.00

**Coils, per set**

Amateur Net . . . . . 4.00

# Meissner

ELECTRONIC DISTRIBUTOR AND  
INDUSTRIAL SALES DEPARTMENT

**MAGUIRE INDUSTRIES, INCORPORATED**  
936 NORTH MICHIGAN AVENUE, CHICAGO 11, ILLINOIS

### CHECK THESE FEATURES:

**BAND-SWITCHING** is accomplished by a six position shielded turret.

**CRYSTAL CONTROL.** Not only does the Shifter function as a variable frequency oscillator, but by plugging in a suitable crystal it may be converted into an excellent crystal controlled exciter for any band (especially desirable for net operations).

**TUNING.** Only two controls select any operating frequency; the band selector switch to move coil strip into position and the precision vernier control to rotate the ganged condensers. Illuminated dials for 0-500 calibration. Exceptionally stable.

**KEYING.** Two jacks for CW or phone. May be keyed in oscillator or amplifier circuits. Tuning eye checks keying.

**POWER.** Input 110V 60 cyc. AC. Output in excess of six watts.

**TUBES.** 6V6GT/G oscillator doubler, 807 amplifier-doubler, 2-5Y3 high voltage, 0D3/VR150 osc. voltage reg., 6U5/6G5 tuning eye.

**COUPLING.** Output impedance 300 ohms. Coupling possible into grid circuit of single-ended or push-pull stage of transmitter; into crystal stage with crystal removed; into plate tank of crystal oscillator with tube removed.

**CABINET.** Gray-wrinkle metal, 13 13/16 by 13 1/4 by 8 3/4.

# SIGNAL SHIFTER

frequency exciter

## Plays Important Role In Texas City Disaster



Meissner Industries, Inc.  
936 North Michigan Ave.  
Chicago 11, Ill.

c/o CAA Box 779  
Galveston Texas  
April 20, 1947  
WSKVM

Gentlemen:

I know you will be interested to learn what an important role your Meissner Signal Shifter has played in the recent Texas City disaster:

Three days ago I got delivery on my new Meissner Signal Shifter, #3007, Series 712. I had just about gotten it out of the box and was temporarily checking it into the xtal stage of the xmitter for 75 meter fone work when the shack was rocked by the explosion from the first blast of the Texas City disaster. At first we did not know what had happened except that we could see high flames and black smoke mushrooming like an atomic cloud over Texas City, nine miles away.

Another terrific explosion followed on the heels of the first and we immediately listened in on the EC band. In a few minutes our local radio station here in Galveston advised us that a ship had blown up in Texas City. We immediately got on 75 fone and inquiries started to pour in from Houston Texas, 50 miles away. W5FQQ started out for Texas City and was soon set up over there on 75 fone. At that time I was the only "out" known on 75 fone and 5FQQ the only means of communication into Texas City. Thus, in those first few hours, our two stations were the only means of communication between the stricken city and Galveston.

To make a long story short, your Signal Shifter stayed in operation, in my station W5KVM, for two solid days of continuous operation without "missing a beat". In that time we handled close to 1000 messages and utilized three radio operators, 2 clerks, 1 shorthand operator and two others on the special lines that the telephone company ran into W5KVM for us. I don't know what we would have done without the Shifter since, previous to purchasing it, I had always operated xtal control and thus would never have been able to have operated the clear channel of 3860 Kcs assigned to us by the FCC.

Very truly yours,

Julius J. Bamberg W5KVM

EXPORT ADDRESS—SCHEEL INTERNATIONAL INCORPORATED  
4237 NORTH LINCOLN AVENUE, CHICAGO 18, ILLINOIS—CABLE HARSHEEL



**BURGESS BRINGS THEM IN BETTER**

FIRST CHOICE  
OF HAMS  
EVERYWHERE

# BURGESS BATTERIES

RECOGNIZED BY THEIR  
STRIPES • REMEMBERED  
BY THEIR SERVICE

(Continued from page 82)

XAGG in Italy. AAR has new beam for 144 Mc. and worked 6ZZ, ex-1WV, recently. IIM and KVH are on 14-Mc. phone. KTE has five-element beam on 144 Mc. PYE handled a message from J9AAW via 7FST, in Utah, to Providence. R. I. OGJ was on 27 and 28 Mc. with new Supreme AF-100. CTR has been helping out on the Framingham Club's paper, *III-MU*. NVB has the rig at his camp in Hampstead, N. H. JNE has 53 countries on 28 Mc. OMM has a 28-Mc. rotary dipole. PZ has a new rig with an 814 final. LQQ wants QTH of FAS: H in Algeria. LVZ has new low-power rig on 28 Mc. QEU is on 3.5-Mc. c.w. The 10th Annual Boston Hamfest committee has started work on the affair which will be held Oct. 18th at Mechanics Building. HNN is chairman; NXM, vice-chairman; OLP's XYL, secy. ALP has charge of tickets. 3VUA/1 is Assistant SEC. Traffic: (April) W1AAL 48. (May) W1LML 86, BDU 77, AAL 54, EMG 30, TY 25, BB 12, JDP 11, RCQ 10, ONZ 8, KTE 7, HJ 6, MDU 6, LM 4, AAR 2, AGX 2, JBY 2, MEG 1, NBS 1.

**WESTERN MASSACHUSETTS** — SCM, Prentiss M. Bailey, W1AZW — RM: BVR. SEC: UD. BIV has 811 modulators with 200 watts plus. BVR leads the section in traffic and plans to keep the West. Mass. net going during the summer as long as members report. JGY has rig rebuilt with bandswitching features. IHI is faithfully handling traffic but never has much to say. HFO has 144-Mc. mobile rig for summer fun. COI built ground plane antenna to go with his converted (?) 522 rig. UD reports for the 144 Club in Springfield. Seems like the gang has been working a little DX along with traffic-handling and rag-chewing. PRT and PEN in Conn., and QCC and JRA in Florence and Amherst report in to make the DX. KUE has mobile rig with ground plane antenna. OBQ has remounted his sixteen-element beam. OLS and his XYL have twins. NH is back on 144 Mc. LDE is building an addition to the house for his shack. Europe is no longer DX for FQX. MBT is a proud papa. The Springfield hams were active during Field Day with rigs on all bands. GZL sends Official Broadcasts on 28,712 daily at 10 p.m., except Saturdays. MBL has been made full EC for Fitchburg. QEY is a new call in Fitchburg. 6YEM, ex-1KYI, will be on 50 and 27 Mc. from Sacramento soon. MVF recently graduated from business college. IBZ took the fatal step. OOOY is living in Fitchburg. MIM is Fitchburg's representative in the West. Mass. Net. The Pittsfield Radio Club station, OSA, was active during Field Day. Rigs on all bands were operated from Skyline, Windsor, Mass. JLT received that last card which makes him eligible for DXCC. Bob now has 94 countries postwar. PXN, of Dalton, now has his old call, TR. HNE has been working DX on 14 Mc. IE now is O44BR and is looking for the Worcester hams on 14 Mc. AZW made WAC with his 50 watts. Traffic: W1BVR 107, NY 48, IHI 22, MIM 13, AZW 10, BIV 1.

**NEW HAMPSHIRE** — SCM, John H. Stoughton, W1AXL — Well, gang, here we are again. Sorry we were unable to send in an activity report for the last two months. We are back home again after an extended visit at the hospital and hope to have things straightened out soon. 50-Mc. activity seems to be gaining interest throughout the State. AUW has been working some FB DX. KPL reports very good 50-Mc. receiving conditions. CNX has been experimenting with 144 Mc. from an airplane at 7000 ft. The Concord Brasspounders have received and are using the call W1OC. Let's have a few more reports on the first of each month. KPL and AXL, in the New Hampshire section, were on the air about 14 hours assisting in the Rutland, Vt., flash flood emergency.

**RHODE ISLAND** — ACM, Clayton C. Gordon, W1HRC — Commander Horace Young, W1CAB, entertained the PRA again June 6th with more 16 mm. movies by courtesy of the USN. This time both pictures were in technicolor: one was "Operations Crossroads," the other "Fighting Lady." The PRA meets only once per month now but Commander Young hopes to be able to bring more movies for future meetings. He also went into much greater detail regarding the Electronic Warfare Component, which is the modern successor to the NCR, and Commander Young presents a pretty strong case in favor of becoming affiliated with this effort. The proper place to get further information, or to make application for joining, is the District Reserve Electronics Officer, 495 Summer Street, Boston, Mass. DWO has acquired a BC-654A and DWC also has one. AJQ, HLK, and PLY visited the PRA recently but failed to meet the SCM,

(Continued on page 88)



# New OHMITE

## Direction Indicator Potentiometer

MODEL  
RB-2

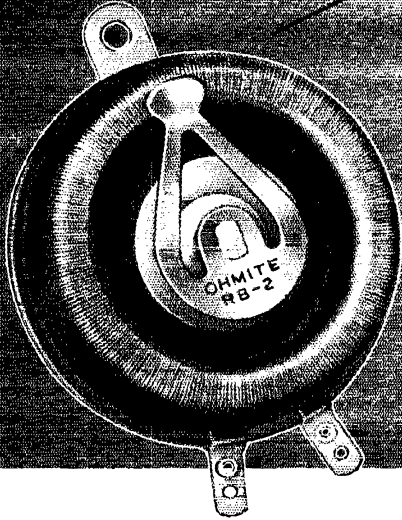

... for rotary-beam  
*Antennas*

• Now you can make a simple, accurate direction indicator for your rotary-beam antenna, at an amazingly low cost. Simply couple the shaft of the new Ohmite RB-2 potentiometer to your rotary-beam antenna so it rotates with the antenna. Then connect the potentiometer to a 6-volt bat-

tery and an ordinary d-c, 0-1 millimeter with specially marked scale. The meter will indicate the position of the antenna. It's simple, accurate, and inexpensive. Write for Bulletin 128.

**OHMITE MANUFACTURING CO.**  
4864 Flounoy Street, Chicago 44, Ill.

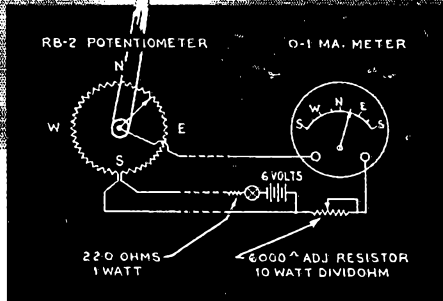

### NEW R. F. PLATE CHOKES

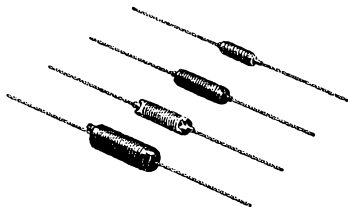

• These tiny, new high-frequency chokes are single-layer wound on low-power factor bakelite cores, covered with a moistureproof coating. Four new stock sizes for all frequencies from 50 to 460 mc. Rated 1000 ma or more.



*Be Right with*

# OHMITE

RHEOSTATS • RESISTORS • TAP SWITCHES

# FOUR-11 MODULATOR



The Four-11 Modulator attenuates unwanted frequencies below 200 cycles and undesirable highs above 3000 cycles. The desirable frequencies between these limits are amplified by the modulator to produce clear crisp speech.

With the Four-11 Modulator your signal will cut through the QRM on a crowded band and you'll have more of those 100% QSO's.

The Four-11 is available with an 8000 ohm output to modulate the Four-20 Transmitter, or with a 600 ohm output for use as a speech amplifier.

## HAMMARLUND

THE HAMMARLUND MFG. CO., INC., 460 W. 34<sup>TH</sup> ST., NEW YORK 1, N.Y.  
MANUFACTURERS OF PRECISION COMMUNICATIONS EQUIPMENT

WRITE FOR DESCRIPTIVE BOOKLET

(Continued from page 86)

which they claim was a disappointment. Almost all of the 144-Mc. gang heard 2ER when 144 Mc. opened up recently. Everybody called him; a few worked him. We suggest that when conditions like this occur, the sporting thing is for everybody to cut out local QSOs and tuning-up operations and give the DX a chance. Traffic: W1DW0 13.

VERMONT—SCM, Gerald Benedict, W1NDL—OKH is working Trunk Line C and has new atom rig on 28-Mc. 'phone, 20 watts. AD now is on 3.85-Mc. 'phone. AVP is building 50-Mc. rig. GQJ has BC-312 receiver. NDJ has new four-element wide-spaced 28-Mc. beam. Traffic: W1OKH 25, AVP 7.

### NORTHWESTERN DIVISION

ALASKA—SCM, August G. Hiebert, K7CBF—RD, at Moses Point, is setting some new DX records in the North, where DX is noted for its inconsistency. He has daily schedules with VK2VC, which he keeps almost 100 per cent, and will start traffic as soon as the VKs are permitted to handle it. DM has a new 200-watt final on the air and schedules 7RT every Friday in connection with the 2SLW/KL7 144-Mc. experiments. The Adak Radio Club lost 7ELJ and BP, who transferred Stateside, but gained 7KHH and 2QDO, now on 14- and 28-Mc. 'phone. Other newcomers at Adak are 9YU7 and KD, the latter being radio operator aboard DM's airplane. AI, who runs the AFRS station at Barrow, visited Fairbanks, and plans to have his XYL join him. CF just took his Class A exam and is sweating out the returns. Traffic: KL7BD 19, CF 1.

IDAHO—SCM, Alan K. Ross, W7IWU—Shelley: ACD reports hearing 18 different W6s on 50 Mc. on Apr. 30th. He has worked Washington, Oregon, California, Illinois, and Iowa. Firth: BAA is enjoying the short skip on 29 Mc. and is a real rag-chewer. Mountain Home: IY-7 is trying to get on 14 Mc. now. Kuna: EMT has new BC-221 frequency meter and is waiting for the fall FMT. Boise: The annual boat races at Lake Lowell called for communication between the judges' stand, docks, headquarters, and gate entrances. The Gem State Radio Club furnished IGK, JMH, FIJ, HPH, LEB, and IWU from Boise, and IZZ and ETU from Nampa, with KJO in charge. Frequencies used were 3.9, 50, and 144 Mc. New hams in town are LEB and LFS. Pocatello: KEA reports operating on 3.8 Mc. with a BC-654A and says BDL and BNJ are active there. Traffic: W7EMT 9, BAA 7, IWU 7, ACD 6.

MONTANA—SCM, Albert Beck, W7EQM—SEC: BWH, CPY reports BCE is back at Miles City working portable. KPR is new ham in Glendive. DXQ is building new garage and radio work shop. LEK is a new call in Lewistown. He plans an 807 crystal oscillator on 7 Mc. soon. 5IRC is installing KXLO. His XYL is with him. They have 28-Mc. mobile rig in their car. HBM is putting up new sticks. BYX is improving ham shack. FTO is working on kw. rig. 6UDY is stationed in Butte with KXLF. BOZ recently added twin jr. operators, a boy and a girl, to his family. BUJ and DSS work on 144 Mc. with good results. The ECRC has been using ARRL film strips and slides with lectures at club meetings. CJN made first outside contact on 50 Mc. in Butte. He worked seven states on this frequency in three days, and also boasts good DX. The BARC had a camp site on top of the mountain on Beef Trail Road on Field Day. JFR is working all bands. EQM is about finished with new 28- and 50-Mc. rig and is ready to raise new 28-Mc. rotary beam. KNH, KHC, and JEQ, from Havre, stopped for a visit in Butte on their way to Army Air Corps at San Antonio, Tex. Thanks for all the reports, gang.

OREGON—SCM, Raleigh A. Munkres, W7HAZ—The Corvallis Amateur Radio Club has reorganized. Officers are BWD, pres.; EPI, vice-pres.; KAU, secy.; and JMW, treas. Meetings are held the second Wednesday and fourth Thursday of each month. JGC, Portland, has signed up at Lewis and Clark College for the fall term, and will take pre-engineering. BEE, Pendleton, is struggling to get the last bit of ignition noise out of his FB mobile job. There seems to be quite a bit of activity around Pendleton but no reports. Reports also have been missing from Klamath Falls since GLF moved to Salem. KVG has had quite a few visitors to his mountain retreat near Starkey to view the 272-foot antenna he has on the side of the mountain. The remarkable thing is he is feeding with a 250-foot open line—without spreaders! Speaking of mountains, the SCM is thinking of joining the Crag Rats after innumerable climbs

(Continued on page 90)

# 100,000 VOLT

.01 Microfarads

## Filter CAPACITOR Unit

for the Princeton University

# CYCLOTRON

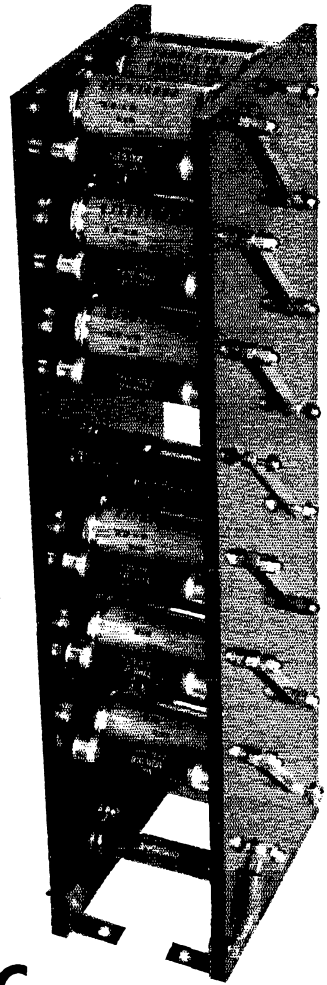

Built with  
**PLASTICON\* ASG**  
**Silicone-Filled GLASSMIKES**

Part of oil-filled power supply built by Beta Electronics Co.

**NOW AVAILABLE!**

New illustrated technical booklet on uses of PLASTICON\* GLASSMIKES

Obtain from your local distributor or enclose ten cents for handling and mailing when ordering direct

\*PLASTICONS — Plastic Film Dielectric Capacitors

Order PLASTICONS\* from your jobber. If he cannot supply you, order direct

**CP** **Condenser Products Company**

1375 NORTH BRANCH STREET • CHICAGO 22, ILLINOIS

# Browning Instruments

## New HAM FREQUENCY METER

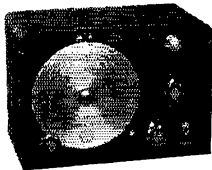

Checks all your operating frequencies with a .05% accuracy. Has direct, frequency-reading dial on seven ham bands. Audio detection of zero beat. Also an accurate ECO with an output comparable to a crystal for driving an exciter. The MJ-9 meter is an essential for your shack.

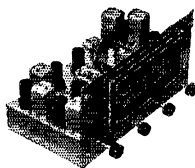

## New BROWNING TUNER FOR FM-AM

Hi-sensitivity unit with Armstrong circuit. Provides distortion-free reception on FM and quality reception on AM. Separate RF and IF systems on both bands. One antenna serves both FM and AM. Tuning eye shows correct tuning.

WRITE FOR DESCRIPTIVE LITERATURE

## OTHER BROWNING INSTRUMENTS

Model RH-10 Frequency Calibrator for full, accurate use of WWV. Model OL-15 Oscilloscope for laboratory work, production testing or research. Model S-4 Frequency Meter for mobile transmitters.



**BROWNING**  
LABORATORIES, INC.  
WINCHESTER, MASS.

(Continued from page 88)

to the site of the new CAA VHF range which is being constructed at Baker. Groups from Portland, Corvallis, Medford, Ashland, LaGrande, and Baker were perched on various mountain peaks throughout the State for the Eleventh ARRL Field Day. Traffic: W7WJ 717.

## PACIFIC DIVISION

**HAWAII** — SCM, John Souza, KH6EL — New calls at Schofield are: KH6LP, ex-W9WLD, with 40 watts on 7 Mc. and new three-element 28-Mc. beam; MI, ex-W4KKJ, using BC-610; SC, ex-W4IIT/W1QDS, using ART-13. GH is looking for 3.85-Mc. contacts at 1730 HST. AS has reliable contacts with FD on 28 Mc. K6UOX is on 3.85-Mc. phone with TCS. DU also is using TCS. W7EVX/MM, on SS *Ben Chew*, has modified TCS for 28 Mc. with 50 watts input to 1625. BX is on 14 Mc. with new aluminum beam. GQ is on 28 Mc. BH is on 14 Mc. AS is modifying 829 for mobile on 28 Mc. AW has brand-new rotar for 14-Mc. beam. AZ and CT are rebuilding. BD QSOs ZK1AA on 3.85-Mc. 'phone. BW has 1200-volt power pack ready for 813 on 7 Mc. JL is awaiting completion of new rig. ET is back from mainland vacation. IL completed single 811 modulated with p.p. 807s and is looking for Delaware, Rhode Island, and West Virginia for WAS on 28 Mc. Traffic: KH6DF 66, IL 8.

**NEVADA** — SCM, N. Arthur Sowle, W7CX — Asst. SCM, Carroll Short, jr., 7BVZ. SEC: JU. ECs: OPP, TJJ, KEV, QYK, and JLV. RM: PST. PAM: KHU. OBS: JUO. OES: TJI. JU has signed up MSG for AEC. BVZ has been on 14-Mc. 'phone working DX and good local QSOs on the short skip. JXH is on 7 Mc. regularly with T55 final into an end-fed antenna. CDM works his e.o. on 7 and 3.5 Mc. to good advantage. JUO is knocking out unusual DX with his Nevada kw. KJQ had a QSO with IIZZ. TFF is on 7- and 14-Mc. c.w. ONG has a trick antenna that works as well on 7 as it does on 14 Mc. TZZ is on 7 Mc. doing a swell job with an 807. GC is DXing on 14 Mc. with his new three-element beam. New officers of the Nevada Amateur Radio Assn. are: BNK, pres.; KLK, secy.-treas.; PST, vice-pres.; and GC, who swings the Wouff Hong. Club call now is W7YN. BTJ puts out a beautiful signal with three 35Ts — one is the e.o. Traffic: W7KHU 158, CX 13.

**SANTA CLARA VALLEY** — SCM, Roy E. Pinkham, W6BPT — Asst. SCM, Geoffrey Almy, 6TBK. RM: CIS. PAM: QLP. LCF has been appointed vice-president of SCCARA to fill the vacancy left by the resignation of MUR, and NKP has been appointed to the board of directors of the club, filling the vacancy left by YPM's resignation. NYS and 90FS/6 have formed Pierce Electronic Corp. WNM, VHE, and TJJ are working for the company building low-power rigs for amateurs. KMM is new ORS. Marvin was 7KMM before moving to the West Coast. WNI has been confined to the hospital for the past few months. He has been on 7 Mc. from his bed. The rig and receiver was obtained through the courtesy of OCQ, QPM, and SUZ. TBK has worked G5BY and CX1DB on 28-Mc. 'phone. Jeff was in Los Angeles during the early part of June. PBV reports hearing 1HDQ on 50 Mc. on the first of June. RFF tried 14-Mc. 'phone but gave up because of QRM and returned to 14-Mc. c.w. JSB still is keeping traffic schedules with Saipan and KAIHR. DZE has 53-foot tower with two-element beam for 14 Mc. Bryon says that it makes a big difference. CIS had a schedule with LI2B, the Kontiki Expedition, until the *New York Times* station, WHD, grabbed him. SYW is back on 3.5-Mc. c.w. checking into the Mission Trails Net. YMA has three-element beam on 28 Mc. ZZ has worked Nevada on 28-Mc. 'phone for his WAS on that band from the West Coast. Traffic: W6JSB 36, RFF 30, VZE 24, CIS 15, DZE 14, ZZ 12.

**EAST BAY** — SCM, Horace R. Greer, W6TI — Asst. SCM, C. P. Henry, 6EJA. SEC: OBJ. RM: ZM, EC: QDE. Asst. EC u.h.f.: OJU. The Oakland Radio Club had a bang-up set-up at the Oakland Boys' Club Hobby Show. A Winsby-Fleming #200A transmitter made by SSN and a National NC-173 receiver made up one unit and a Hallcrafters HT-9 transmitter and a Hammarlund HQ-129X receiver made up the second unit. A Gordon Rotator three-element beam was used on an especially constructed tower in the center of the booth for 28 Mc. and several outside conventional antennas were used for other bands. Many messages were handled. We believe the hundreds of visitors better understand amateur radio. UPV was chairman with

(Continued on page 94)

# WEEKENDS ARE RUGGED!

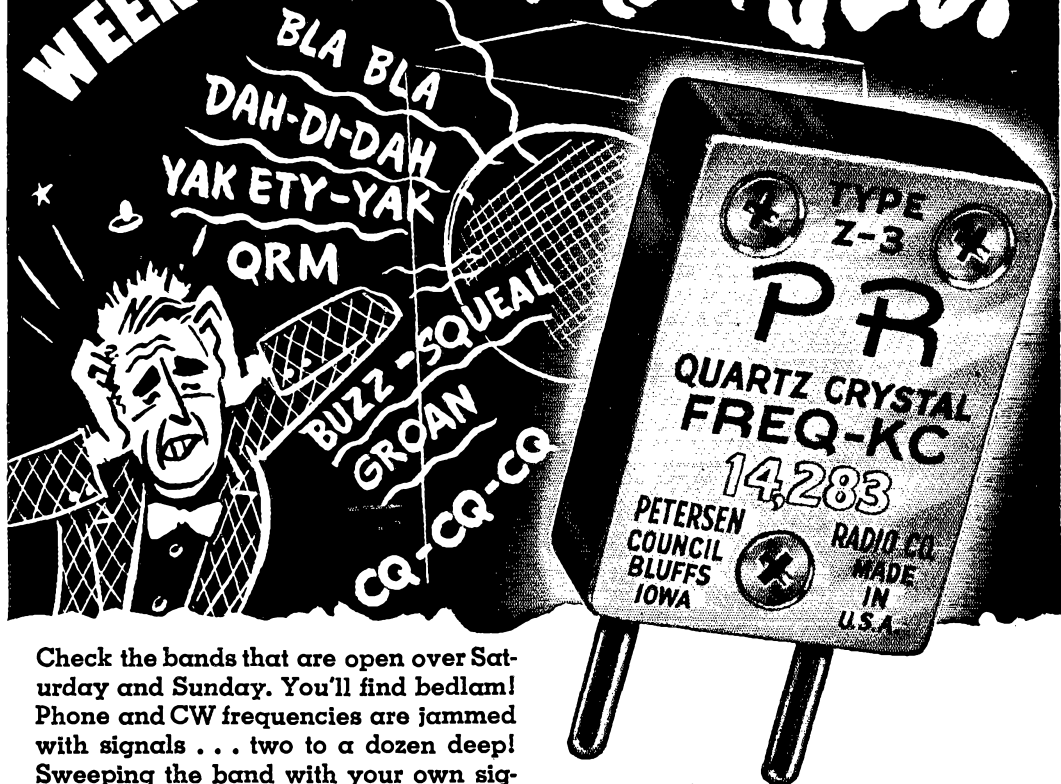

Check the bands that are open over Saturday and Sunday. You'll find bedlam! Phone and CW frequencies are jammed with signals . . . two to a dozen deep! Sweeping the band with your own signal only adds to the confusion, particularly on DX bands. If you want more solid QSO's... if you want band friendships . . . if you want to be something more than just another call signal . . . pick your spots and stick to them! You'll get more real ham enjoyment. Crystal control with PRs gives you *stability, high output, low drift, economical oper-*

*ation.* PR Precision CRYSTALS are unconditionally guaranteed. You get your EXACT FREQUENCY (integral kilocycle) WITHIN AMATEUR BANDS, AT NO EXTRA COST. Order from your Jobber. — PETERSEN RADIO COMPANY, INC., 2800 WEST BROADWAY, COUNCIL BLUFFS, IOWA. (Telephone 2760)

  
 SINCE 1934

# PR

Precision

# CRYSTALS

<b>10 METERS</b> PR Type Z-5.	Harmonic oscillator. Ideal for "straight through" mobile operation. High activity. Heavy drive without damage in our special circuit. . . . . \$5.00
<b>20 METERS</b> PR Type Z-3.	Harmonic oscillator. Low drift. High activity. Can be keyed in most circuits. High power output. Just as stable as fundamental oscillators . . . . . \$3.50
<b>40 &amp; 80 METERS</b> PR Type Z-2.	Rugged, low drift fundamental oscillators. High activity and power output with maximum crystal currents. Accurate calibration \$2.65

The RADIO SHACK brings you POPULAR VALUES  
at Sensationally Lower Prices!

\*The one and only original RADIO SHACK is located in Boston and has no branches or affiliates elsewhere.

**SCR-522 VHF XMTR-RCVR**  
for 100-156 MC work

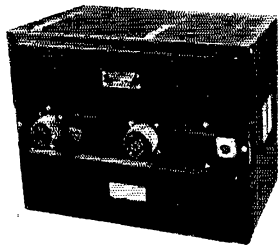

**\$14.95 NEW LOW PRICE**

An amazing value at a new low price. Sensitive receiver combined with 15-watt xmtr as used in AAF and RAF planes. Used, but in good condition, these popular rigs, complete with tubes are yours at only \$14.95.

When you're in Boston, be sure to visit our surplus section — it's terrific; crammed with bargains we haven't room for here.

**AAF XMTR BC-375-E**

A special buy brings you this favorite at a greatly reduced price. Basic xmtr unit and tubes, plus one hand-calibrated tuning unit and detailed data on easy modification to 110-volt a-c operation. Made by G.E.; used but in good condition.

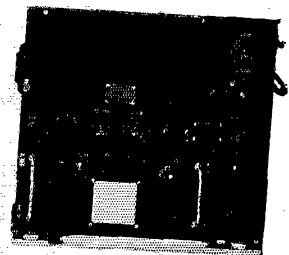

**\$17.50 NEW LOW PRICE**

**COLLINS AN-ART-13 XMTR \$89.50**

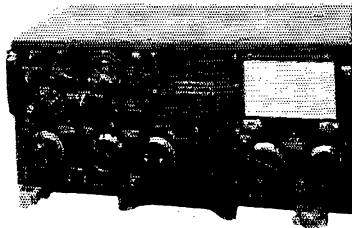

A real bargain — famous Collins quality in a transmitter covering 1500 KC to 18 MC — in A-1 used condition — complete with tubes. Shipping weight, 90 pounds.

**SUPER SPECIAL BRAND NEW 807's**  
Westinghouse  
JAN-inspected  
**70¢ each**  
3 for \$1.95  
6 for 3.75  
**THE BUY OF A LIFETIME**



**GOVERNMENT SURPLUS TUBES**

Type	Net	Type	Net	Type	Net
2AP1A	\$5.25	801	1.72	957	.75
2C34	1.12	803	9.00	958	.75
2C40	2.62	809	1.79	959	.75
2D21	.60	811	1.95	954	.75
VR75	.90	813	6.75	955	.75
VR90	.75	814	4.50	9001	1.05
VR105	.75	836	1.50	9002	.90
VR150	.75	840	2.70	9003	1.05
3B24	3.00	866A	.75	9004	.90
3C24	1.20	872A	2.25	9005	1.05
5CP1	6.00	874	1.95	9006	.60
5CP7	9.00	914	5.62	3B24	3.00
5CP1	3.37	860	3.00	832	2.25
5CP7	5.25	923	.45	(VT118)	
3BP1	3.00	931A	1.87	3C24	1.20
5PB1	3.37	1619	.75	807	1.05
5BP4	3.37	1624	.90	826	2.25
6AK5	.90	1625	.75	(VT222)	
6C21	13.50	1626	.60	2X2A	.90
250TH	9.00	1651	.75	815	2.25
304TH	\$9.95	8005	\$3.15	(VT287)	
		8000	6.00	3E29	3.00

**RADIOPHON HANDSET TS- only \$3.45**



Bakelite case, 2 ohm mike, 2000-ohm phone, push-to-talk switch, heavy rubber cord, separate microphone and phone plugs.

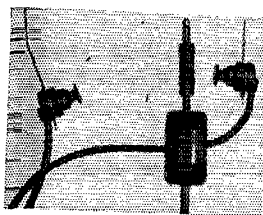

**HS-30 HEADPHONES**  
only **79¢**

"Ear-plug" style phones, complete with head-band, cord, plug, and impedance matching transformer (2000-8000 ohms). Used, excellent condition.

Speed delivery and save C. O. D. charges — send full amount with order. 50% deposit required on all C. O. D. orders.

**CO-AX CABLE SETS**

Fifty-foot RG-8/U co-ax cable with PL-259 connectors **\$1.95** attached each end

One hundred-foot RG-8/U cable comprising two 50-foot cables coupled with CPH-4919 **\$3.90**

**SHURE SW-HAND MIK**



Brand new single button carbon mike with push-to-talk switch, cord and plug. A rare chance to get a fine hand mike under a dollar.

only **98¢**

**XMTG CAPACITORS**

Nationally known, high-voltage, oil xmtg capacitors, all in rectangular cases, with stand-off insulators.

Mfd.	Volts d-c	Net Ea.	Mfd.	Volts d-c	Net Ea.
4	600	\$0.71	2	1500	\$1.20
6	600	.79	4	1500	1.59
8	600	1.19	6	1500	1.79
10	600	1.29	2	2000	2.95
2	1000	.71	8	2000	3.75
4	1000	1.19	2	2500	3.25
8	1000	1.49	2	3000	3.45
10	1000	1.79	4	3000	4.25

THE BEST SURPLUS COMMUNICATIONS RECEIVER  
*Value in the World!*



**BRAND NEW**

**SIX BANDS**

*New BC-348*

**2 TECHNICAL MANUALS**

**NEVER USED**

**NEVER OPENED**

*Only \$69.50*

F. O. B. BOSTON

**COMPLETE WITH TUBES — CRYSTAL — DYNAMOTOR and TECHNICAL MANUALS**

NOW . . . your first opportunity — and, we believe, your last — to get a **BRAND NEW BC-348** and to have the thrill of knowing you are the first to use it. Remember — these splendid receivers are *absolutely new* — not merely “like new”

— guaranteed to be unused receivers shipped to you in the original, unopened wood cases in which the AAF received them.

You know all the features of these superlative receivers: calibrated 200-500 KC, 1.5-3.5; 3.5-6.0; 6.0-9.5; 9.5-13.5; 13.5-18.0 MC; built-in dynamotor; constant sensitivity all bands; crystal filter; two complete technical manuals; etc., etc., It's a **VALUE** you won't match in years.

**DON'T WAIT . . . ORDER YOUR BRAND NEW BC-348 N O W !**

Shipping weight 61 lbs., size, packed, 3.00 cu. ft.

Easily converted to 110 v. a-c; kit and detailed instructions.

**only \$6.50**

Transformer for 220 volt use; step-down 220-110 60 cycles.

**only \$6.50**

**The RADIO SHACK Corp.**

CABLE ADDRESS · RADIOSHACK  
 167 WASHINGTON ST., BOSTON, MASS., U.S.A.

**SILVER****75 WATTS CW  
30 WATTS AM  
PHONE**

**A LETTER** from W2RNB tells the story of Model 701 Transmitter: "I work for Electronic Marketers, Inc., and when the 701s came in I immediately took one home to test. The results were as follows: With a 40-meter Zepp antenna I worked F85F, 559; ON4SU, 589; UA3AF, 579; PZ1AL, 599X. Power input was approximately 45w with 500v on the 807. Freq. 14138."  
Only 5" x 5 1/4" x 10", MODEL 701 covers 80, 40, 20, 16, 11, 10 and 6 meter bands. . . . hardly drops output at all even when quadrupling xtal frequency. 6AQ5 Tritet oscillator drives one 807 at anything up to 75 watts CW input. Push-pull 14-watt 6AQ5 modulator gives 100% phone modulation of 28 to 30 watts phone input. Ideal for your main station, literally perfect for portable, mobile and emergency work, price of this little demon is only \$36.95 less power supply, tubes, . . . with plug-in coils only 50c each. We know its DX will thrill you, too, exactly as it does hundreds of users every day.

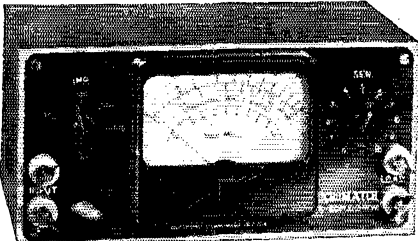
**"MICROMATCH"**

**APRIL, 1946 QST** told the story of MICRO-MATCH in two words — "simply astonishing." It's a new meter which, connected in your feeders . . . in any link coupling line . . . measures standing-wave ratio directly. At long last MICROMATCH lets you determine what happens to the power your transmitter generates. It will surprise you by proving how little really gets into your antenna. With MICROMATCH you can probably double, triple, possibly quadruple the power going into your antenna . . . where it alone does you good. In "ATOM-X" construction, same size as 701 Transmitter, with big 4 5/8" meter, fully tested, range 1 through 1,000 watts, 3 through 30 mc., 50 through 300 ohms impedance, it's the biggest insurance of transmitter efficiency money can buy. Only \$29.90 net.

Mail penny postcard for NEW, 16-page catalog of amateur and measuring equipments.

OVER 36 YEARS OF RADIO ENGINEERING ACHIEVEMENT

*McMurdo Silver Co., Inc.*

1249 MAIN ST., HARTFORD 3, CONNECTICUT

(Continued from page 90)

SSN, TI, DUB, SS, OBJ, KZN, EE, MFZ, ZM, ZLX, NTU, UGO, MQR, FXX, and ELW assisting. YDI is new ORS. QDE is playing with new 14-Mc. beam. KEK got chirps out of transmitter. TYF says his pal just received the call ZOZ and both are using the same rig. QXN is busy on Pioneer Net. RMM has completed his new high-power modulator with p.p. 805s. CDA has new RME receiver and has been on air for 20 years. EJA says his DX has fallen off. ZM is having his rig rebuilt. CWR reports new club known as the Humboldt Amateur Radio Club has been formed in Eureka. KZN is working some DX on 14-Mc. 'phone with 100 watts. IKQ claims keeping up a 1-kw. rig is rather expensive. J2EAR reports he has two transmitters going, a BC-610 and a BC-447, on 14 Mc. He wishes the ARRL lots of success at the Atlantic City meeting. The SARO gang was active in Field Day. The Mission Trail Net had a big get-together over the week end of May 31st. Many of the gang have bought and are using those little Navy aircraft jobs, according to BUY, who is taking his along on his summer vacation. Postwar countries worked are: TT, 120; PB, 103; TI, 102. The Northern California DX Club claims the East Coast boys sure are having all the breaks this year on DX; they seem to work around the clock when we are having dead band periods. ITH has been QRL. The Mare Island and the Vallejo Radio Clubs are having a big hamfest which might be turned into a convention over Navy Day in October. The boys will have the Navy behind them so it should be a gala event. Let's have those traffic and news reports by the fifth of each month. Traffic: W6QXN 177, OT 150, TYF 15, EJA 14, RMM 12, ZM 10, TI 7, BIL 6, QDE 4, YDI 3, KEK 2.

**SAN FRANCISCO**—SCM, Samuel C. Van Liew, W6NL — Phone JU 7-6457. Few reports were received this month as everyone was preparing for Field Day. HJP writes that he is operating fixed portable W8 from downtown YMCA, Minneapolis, Minn., on 28-Mc. 'phone using 100-watt input. He is on the lookout for San Francisco stations. WN has been working regular schedules with 1DX, who has talked Art into sending in regular traffic reports. Wish 1DX could schedule all the fellows in this section. YZP is the proud owner of a relay rack for his equipment. He says it makes a big improvement in looks and accessibility. He intends to work on 14-Mc. c.w. now that 28 Mc. is having its summer slump. OZC finally made WAS on 28 Mc. before he left his Sausalito address for his new location at Portland. The last on the list was Nevada; the contact was 7KEV at Las Vegas. Henry Alvernaz now has new call, ZQK. He is located at Tamalpais Junction and is on 7-Mc. c.w. MWK is packing up to move on to his boat with a South Sea voyage in prospect. MWH now is a Quartermaster with the American President Lines. He married a Russian girl in Shanghai on his last trip to the Orient. The turnout for Field Day was excellent with many clubs and individual set-ups. Many good scores were made in spite of the prevailing conditions. The SARO again made a very fine showing with the usual fine score. The San Francisco Naval Radio Club, a new-comer to Field Day competition, made a grand showing with many humorous experiences. Its emergency equipment was actually brought into emergency use when the 144-Mc. equipment was used to report in to a fire department. A grass fire had started in the hills near by. Prompt action by all concerned minimized any hazard. Traffic: W6JWF 113, WN 50, NI, 5, YZP 1.

**SACRAMENTO VALLEY**—SCM, John R. Kinney, W6MGC — Asst. SCM, R. G. Martin, 6ZF. EC: KME. RM: REB. The SARC Inc., will have exhibit booth in the Educational Bldg., at the California State Fair, Aug. 28th to Sept. 7th. REB is handling a vets hospital deal, whereby disabled vets may send messages home. The Pioneer Net is handling the traffic and the messages will be known as "Vet-O-Grams." REB reports that the Pioneer Net is now split into two controls with REB as the northern and FDR as the southern control. PIV is handling Vet-O-Gram traffic on the Sacramento outlet. RAQ and WYX announced the Chico gang held a hamfest on June 22nd in Bidwell Park with an Army SCR-545 radar unit in operation, and a hidden 144-Mc. hunt. GUV won an O-1 MA. meter at Golden Empire RC meeting in Willows and tells us he has a 35T with 125 watts on 3.5 and 7 Mc. He reports that GHG is attending telephone school in Redding and that WYX has lots of bugs in his new e.c.o. OJW has bugs in his 'phone rig so is back on c.w. with DX worked as follows: MX3KG, CM2CT, KG6AM, ZL1MR, J2AAK, W8LXN/KG6, and

(Continued on page 96)



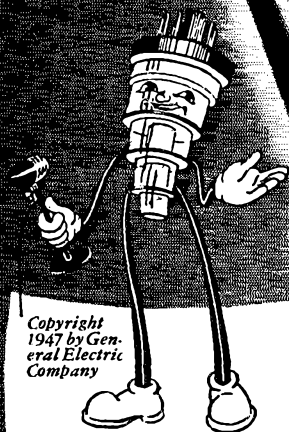

Copyright  
1947 by Gen-  
eral Electric  
Company



METAL TUBES

## KEN-RAD Radiogram

### Lighthouse Larry Comments:

**I**N OUR LAST CHAT about choosing the right metal tube for a given ham application, we compared pentagrid converter tubes used as self-excited oscillators.

Admittedly it's convenient, combining mixer and oscillator functions in one tube. However . . . the stability and sensitivity of your receiver or converter improve when a separate tube is employed as a local oscillator.

Which metal type, then, makes the best local-oscillator tube? Choice lies pretty much between four well-known tubes—6J5, 6SJ7, 6AC7, and 6SH7. Of these, the 6J5 is a triode, the others pentodes; however, the latter group for our purposes will be regarded as triode-connected.

This time the decision between types isn't going to be easy! In fact, it's almost a case of "You pays yo' money an' takes yo' choice". Any one of the four metal tubes named will do a good job. Here's how and why:

Stability, we know, is desirable. The tube should have a low input capacitance so that temperature variations will not greatly affect frequency, and also in order to permit a high input impedance. Too, oscillator transconductance must be considered, since this ties in with the ability to maintain oscillation when load impedances have to be low. Such low load impedances may occur when band-switching is employed, particularly at the higher frequencies.

The difficulty is, each of the above qualities affects the rest to some extent. Design emphasis on one characteristic often means sacrificing another equally important. Should you want good stability, your choice naturally would trend toward a tube with low input capacitance. But . . . low input capacitance also generally means low oscillator transconductance! Thus, while each of the four tubes is outstanding in some particular characteristic, none is better in *all respects* to a point where one may say with assurance, "This is it!"

If you give first place to stability, best select a 6J5 or 6SJ7 with low input capacitance. Should high oscillator transconductance be a prime factor, use a 6AC7 (9,000 micromhos). If general performance up through the 6-meter band is your yardstick, choose any of the four metal tubes, for all are sufficiently balanced in their qualities to serve as good all-around local oscillators. (Very-high-frequency work, of course, calls for Ken-Rad miniatures and other types made specially for h-f operation.)

That's the story on local-oscillator tubes! No single outstanding choice—instead, four reliable Ken-Rad metal types, any one of which will do a first-class job. Your Ken-Rad distributor or dealer will be glad to give you prices and ratings. And if you need further data or application advice, I'll be happy to hear from you!

*Lighthouse Larry*

178-F8-8850

# KEN-RAD *Radio Tubes*

PRODUCT OF GENERAL ELECTRIC COMPANY

Schenectady 5, New York

Make the nearest Ken-Rad distributor or dealer your preferred source for amateur tubes

# New! Munger ELECTRO-BEAM ROTATOR

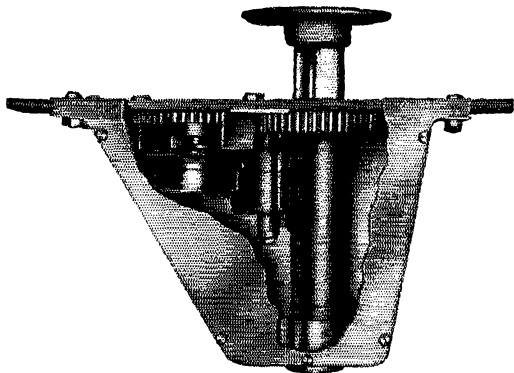

PRICED AT ONLY

**\$69.50**  
COMPLETE

F.O.B. Chicago, Illinois

- Price Includes Reversible Electro-Beam Rotator and Direction Indicator.

- Foolproof Potentiometer and Meter Circuit. Calibrations in Both Degrees and Directions.

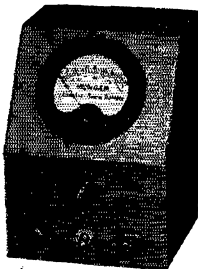

## A BIG VALUE—

### Immediate Delivery if You Order Now!

When you see the many fine features of my new Electro-Beam Rotator, you'll be as pleased as I am. And you'll feel good too, because it's such an honest value—priced low because we kept you in mind constantly through all the stages of design, engineering and testing. Now that it's ready for delivery, you can take my word that it's a real honey. About the specs: 1 R.P.M.—115 volts, 60 cycle operation. Powerful reversible motor drives main shaft through heavy steel gears. Lifetime Oilite bearings. Mechanism is completely weatherproofed—housed in sturdy non-rusting duraluminum case. All parts accessible for easy inspection. Rotator mechanism weighing only 10½ lbs. makes it easy to mount. Top mounting plate 10" x 12".

### 10 Day Free Trial Offer

Send your check for \$69.50 for one Electro-Beam Rotator complete with Direction Indicator. You pay small express charge upon arrival.

Try it at my risk for 10 days. If you are not completely satisfied in every way, return the units undamaged in their original carton and your money will be immediately refunded in full. You take no chances. Order your Munger Electro-Beam Rotator today!



W9UP

Illustrated Bulletin on Request

MANUFACTURED AND SOLD  
EXCLUSIVELY BY

## Rex L. Munger Company

4701 Sheridan Rd., Chicago 40, Illinois

(Continued from page 94)

XE2CW. ZF rebuilt his T-350-XM with B. & W. kw. coils in final with the p.p. 813s pushing a kw. He also has new BC-342-N receiver. DBP with Temco 75-GA is operating on all bands but likes 7-Mc. c.w. best. VDR has a motorola rig on 3.85-Mc. 'phone with 807 final and 35 watts on the Mission Trail Net. HIR reports schedules with 6VJN and 7BWD. Traffic: (April) W6VDR 28, HIR 3. (May) W6REB 368, VDR 99, PIV 12, ZF 4.

### ROANOKE DIVISION

**N**ORTH CAROLINA — SCM, W. J. Wortman, W4CYB — NI has learned the old Southern method of getting things done via the "corn-shucking" route. He recently had an antenna-mast-raising with all "hands" being fed for their help in getting it up. BYA is working short skip on 50 Mc. BCS has an electrically-rotated selayn indicated beam. IZR is hearing more DX with a new preselector. HVL keeps adding the DX. LPY keeps 28 Mc. hot, and DGV is a 14-Mc. man for the time being. KJS and KDI are rebuilding. DCW is proud papa of a new jr. operator. IMH, at Plumtree, is interested in the traffic net. Some of you traffic guys, please contact Friel. DSO is working on 28 Mc. and is planning a "plumbers delight." LDJ is active on 3.5 and 7 Mc. and asks us to listen for him on 235 Mc. GIF, whose activity has been on 28 Mc. has moved to 7 and 3.5 Mc. EYF, Charlotte-Mecklenburg County EC, had an emergency test in which HJY, HGC, LEI, GKG, EYF, FO, IOY, DLX, and KYL took part. The emergency transmitter went to town with good contacts. EC has contact with Red Cross and is on Red Cross disaster committee. How about more of you guys getting in the Emergency Corps. Thanks to the Raleigh gang for the swell hamfest. We broke a fifteen-year record and won a prize. Wonders will never cease! A hamfest was held in Asheville July 6th. What are you doing gang? Drop us a card with dope on your activities.

**SOUTH CAROLINA** — SCM, Ted Ferguson, W4BQE/ANG — LJJ is now on 7-Mc. c.w. and 28-Mc. 'phone. HMG reports a liking for n.f.m. GKD now possesses a BC-522, so look for him on 144 Mc. GB reports good DX on 28-Mc. 'phone. IW is in the surplus radio game with much equipment. New hams at Columbia are MAO, MAP, MAQ, MAR, and MAS. Welcome, fellows. These boys were members of the class taught by Palmetto Amateur Radio Club. BSS reports that the railroad for which he works is interfering with his radio. HJR uses the time available from studies for rag-chewing. ILP is still snagging the good DX.

**VIRGINIA** — SCM, Walter R. Bullington, W4JHK — KYD has a new VFO-21 and is trying to get a traffic net started on 3560 kc. for next fall. Look for him on 3.5 Mc. IYC schedules D4ASM weekly for local traffic and will give accurate frequency checks on request. WO is building rig with a pair of 807s but still is cramped in apartment. ISQ has 45 watts on 7216 kc. to an 807. KEH is on 3607 and 3721 kc. and wants traffic net. BZE is on 3790 kc. Tuesday and Thursday nights with local bulletins and code practice. EOP went to town in the last DC Party. The Roanoke Radio Club has sent in 12 applications for Emergency Corps membership. Nice going, fellows. JXE has an HY-69 on 7 Mc. JXQ has a pair of 813s on all bands. JFY is on all bands with 300 watts to a pair of 812s. JDT uses a pair of 03As on 7 Mc. and a pair of 800Ss on 14-Mc. 'phone. KPZ has an 807 on 7 and 14 Mc. KQC runs an 807 on 7 Mc. and ARC-5 on 144 Mc. QKB has an 807 on 14 Mc. EPK ends up with an 810 on all bands. MAD has an 812 on 3.5, 7, and 14 Mc. and an 807 on 28-Mc. 'phone. Traffic: W4BZE 26.

**WEST VIRGINIA** — SCM, Donald B. Morris, W8JM — AGH is new station call of the Huntington Radio Club. ZBK, with low power, worked 38 countries and made WAC on 28-Mc. 'phone. MOP and FMU have new e.c.o.s. for all-band operation. PQQ made WAC several times in one day and worked two stations in Mongolia. JF, formerly KGT, has returned to Clarksburg. EP, one of our oldest hams, is the proud father of a new baby boy. The MARA 3770-kc. Net closed on June 1st and will reopen Oct. 1st with GBF as NCS. VAB, ESQ, KWL, QG, and FMU have 28-Mc. mobile rigs in their cars. SHU visited GBF and JM. As a result of winning a contest, a picture was carried in the Charleston papers showing HI shaking hands with the Governor. YIF won the UHF Design Contest sponsored by the KVARA. The MARA received excellent publicity in the Monongahela Valley newspapers on its Field Day

(Continued on page 88)

**XLA**  
 A low-loss socket for the dF4 and 950 series acorn tubes for frequencies as high as 600 mc. By-pass condensers may be compactly mounted between contact terminals and chassis. Low contact resistance, short and direct leads, and low and constant inductance are features. Net Price.....\$ .99

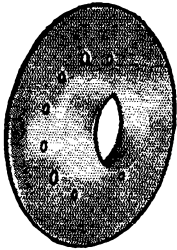
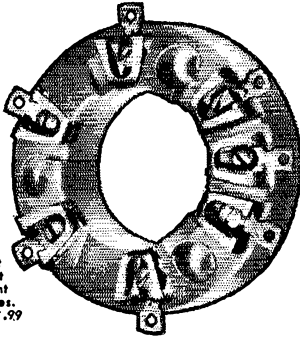

**XLA-S**  
 An internal shield fitting the XLA socket and suitable for tubes such as the 956. Net Price.....\$ .36

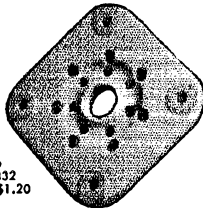

**HX-29**  
 A low-loss wafer socket with steatite insulation for the popular 829 and 832 tubes. Net Price.....\$1.20

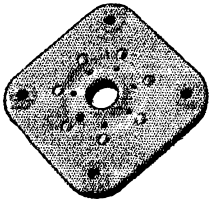

**JX-51**  
 A low-loss wafer socket for the 813 and other tubes having the Giant 7-pin base. Net Price.....\$ .81

**HX-100S**  
 A low-loss wafer socket suitable for the type 4-125-A, 4-250-A and other tubes using the Giant 5-pin base. Shield grounding clips are supplied. Air holes are provided for forced air cooling.

**HX-100S** (with standoff insulators). Net Price.....\$2.55

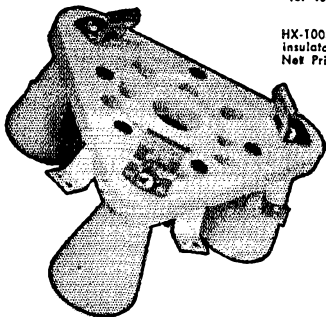

**HX-100** (without standoff insulators). Net Price \$1.98

**National**  
  
 EST. 1914

**A TUBE IS NO BETTER THAN  
 THE SOCKET IT FITS IN**

The most expensive tube available will fail to function properly if the socket it fits in is not made correctly.

That's why National sockets have come to be so widely used by hams, engineers and manufacturers in constructing new equipment.

When you use a National socket, you know from experience that it will grip the tube perfectly and will stand up under heavy duty.

Send today for your copy of the 1947 National catalog, containing over 600 parts.

**National  
 Company, Inc.**  
 Dept. No. 8  
 Malden, Mass.

**Type AR-16 (Air-Spaced)  
 Exciter Coils and Forms**

These air-spaced coils are suitable for use in stages where the plate input does not exceed 50 watts and are available for the 6, 10, 20, 40 and 80 meter bands. All have separate link coupling coils and all include the PB-16 Plug, which fits the XB-16 Socket.

AR-16, Coils, End Link, Center Link or Swinging Link. Net Price...\$1.15 (Include PB-16 Plug)

PB-16, Plug-in Base Only. Net Price.....\$ .27

XB-16, Plug-in Socket Only. Net Price.....\$ .33

**Type TMK Transmitting Condenser**

—An ideal condenser for exciters and low power transmitters. Available in single and double stator models. For panels or stand-off mounting. Steatite insulation. Net Price.....From \$2.30 to \$5.11

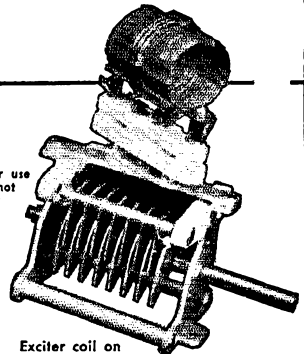

Exciter coil on TMK condenser

**MAKERS OF LIFETIME RADIO EQUIPMENT**

# Handy CONVERTERS

10-11 or 6 METER BANDS

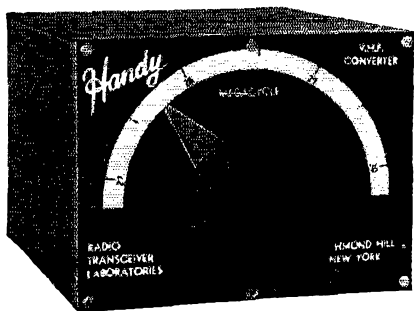

The smallest converters made (3½ x 4½ x 5") with the largest, most easily tuned velvet vernier dials. Designed for mobile operation. Pack a wallop when used with any standard broadcast receivers, especially car sets. I.F. frequency adjustable 1500-1600 Kc.

**IMMEDIATE DELIVERY** either 10/11 or 6 meters **\$29.95** less tubes. Require 6AK5 \$0.90 and 6C4 \$1.09.

**ULTRA-SENSITIVE**

## Handy

**D. B. FIELD STRENGTH  
METER**

**EIGHT BANDS**, panel switched, 3.5-4; 7-7.3; 14-14.4; 21-21.5; 27-28; 28-30; 50-54; 144-148 Mc. Amplification is several times that of crystal or diode types. Employs 1T4 miniature r.f. pentode and 22½ v.

*Checks the following:*

1. Beam antenna patterns at several hundred feet; other antennas too.
2. Standing waves on lines.
3. Presence of harmonics on calibrated dial.
4. Fundamental frequencies on calib. dial.
5. D.B. gain or loss on calib. meter.
6. Neutralization of amplifiers.
7. Presence of extremely small r.f. voltages.
8. Quality and degree of modulation of phone.

The HANDY is fully shielded and the collapsible antenna actuates the on-off switch. Size 10¾ x 2¾ x 2¾".

**IMMEDIATE DELIVERY** complete with 3 section telescopic antenna and tube **\$29.95**; batteries \$1.45 per set.

## RADIO TRANSCIVER LABORATORIES

116-23 Jamaica Avenue - Richmond Hill 18, N. Y.



(Continued from page 96)

activity. YPC, the only active station in Summers County, may be found on 3609 kc. JM leads in counties worked with 30, followed by GBF with 18. MIS is on 3.85 Mc. and was heard in New Zealand. There is need for a River Center Coordinator in the Parkersburg area for the U. S. Weather Net. Please write, if interested. Traffic: W8GBF 42, OXO 37, CSF 17, DFC 16, MOL 10, JM 10, FMU 2

### ROCKY MOUNTAIN DIVISION

**COLORADO**—SCM, Glen Bond, W0QYT—WAP is radio officer on the S.S. *Franklin P. Mall*, U. S. Lines, 200 East Main, Norfolk, Va. Mac is planning to put his rig on 23-Mc. mobile marine. IZY, in Colorado Springs, says the gang there was active on Field Day with some very good operators and equipment. 7JMQ, ex-9UPT, in Bisbee, Ariz., just received his Class A ticket and will be on 3.85-Mc. 'phone looking for contacts with his Colorado friends. The Colorado Springs Emergency Net handled a nice bit of traffic from Texas City during the disaster. Good work, fellows, you are doing yourselves a lot of good. 50 Mc. has been open here most every evening in May. VK worked the following: Arizona, 1 station; California, 18; Colorado, 4; Illinois, 5; Indiana, 3; Iowa, 3; Louisiana, 1; Michigan, 1; Minnesota, 5; Missouri, 3; Ohio, 1; Oregon, 3; Texas, 6; Washington, 10; and Wisconsin 3. WYX, with 12-watt input doubling in the final working mobile, made 19 contacts in 7 states and 5 districts. The Western Slope Radio Club meets the first Sunday of each month. The June meeting was attended by 61. Nathan Bales is president. The club is going in for high-frequency emergency testing and drills. The San Isabel Amateur Radio Assn. held a special meeting at the Whitman Hotel, at which your SCM was present. After dinner speakers were Director Matejka and Alternate Director Smoll. Traffic: W0IQZ 30, LZ Y 2.

**UTAH-WYOMING**—SCM, Alvin Phillips, W7NPU—Well, fellows, as the new SCM, I solicit the cooperation of the gang in carrying on the activities of this section. As we say 73 to Vic let's give him our thanks for a job well done! JPN reports that the UAROC is busy working on the centennial transmitter. JPN has worked 12 states on 50 Mc. and 80 miles on 144 Mc. 1 BED has new 7- and 14-Mc. vertical. DAD is working good stuff on 23-Mc. 'phone. 6WIK/7 now is 7WIK. MAJ, ACG, and IJW are the new officers of the reactivated Casper Club. Chief project is building emergency gear. JVU works Europe and Asia S-9 but is not satisfied with his 14-Mc. rotatable beam! RIZ, OKF, JHH, and NPU work at KLO, Ogdén. BLE, using 813s with a pi tank, can load up anything from bed springs to the a.c. house wiring (also any antennas). DLR still is experimenting with 144-Mc. equipment. Ogden area BCI complaints have reached the SCM. Let's watch it, fellows, and cooperate. 144-Mc. activity in Ogden is spasmodic. Main gripe: Plenty of equipment, but little activity. BED reports all his schedules cancelled until September. UOM is still DXing on 14-Mc. c.w./'phone.

### SOUTHEASTERN DIVISION

**ALABAMA**—SCM, Lawrence J. Smyth, W4GBV—The Ben Lane Radio Club of Dothan held its annual hamfest May 25th. It was a big success, and everyone had a bang-up good time. There were 78 hams present and the XYs brought the total to almost one hundred. Everyone attending won a prize. GSO came away with a BC-221 frequency meter. Six mobile rigs tried out for DX prizes but conditions on 28 Mc. were poor. Feature speaker was GQM, of Tallahassee. Master of Ceremonies was DMV. JYB has received his WAS certificate. He has been operating portable airborne with converted SCR-274N receiver and transmitter on 28 Mc. He is using a C45 Beechcraft for his mobile job and used a BC-654A for Field Day operation. The Montgomery Club was active on Field Day. The Club has the rig in the club room all set up, and soon will have a club license. JLB is leaving Montgomery June 10th. We sure hate to see you leave, Fred. DGS now is 1PZG. EBZ contacts 1PZG Mon., Wed., and Fri., at 7:30 p.m. The Anniston Club held its annual hamfest on Cheaha Mountain on Field Day. Give us a report on this, BCU. Traffic: W4ATF 30, JYB 10.

**EASTERN FLORIDA**—Acting SCM, W. E. MacArthur, W4BYF—SEC: ACZ. Asst. SEC: FWZ. RM: BNR. PAM: ACZ. FWZ keeps busy with Trunk Line C and the Gator Net. He says that the Lake Worth Radio

(Continued on page 100)

Stay away from "over modulation"

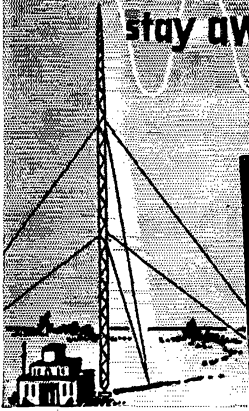

**MODEL  
3296**  
MODULATION MONITOR

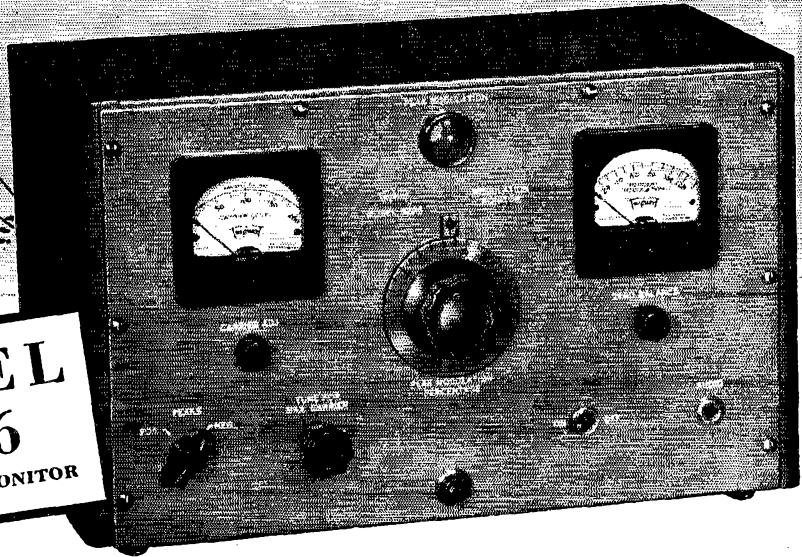

MAKE THE MOST OF YOUR *Station Power*

Every time your modulation exceeds 100 percent, harmonic distortion is introduced which causes interference with other stations, and violation of FCC Regulations. With this Modulation Monitor you can modulate to the fullest for top power-output, yet you know instantly when you are over-modulating. Model 3296 provides four separate circuits for measuring amplitude modulation—(1) percent modulation, average; (2) peak flash percent modulation; (3) carrier shift; and (4) audio output for headphones. These methods may be used separately, all at once, or in any combination. The peak indicator can be pre-set for any percent of modulation from 20 to 120, and will flash when pre-determined modulation is reached. You can figuratively "see" the signal received by your listener!

*A handsome, precision-built instrument, Model 3296 blends with any standard amateur equipment, enhances the appearance of your station, and will greatly step up your operating efficiency.*

### ✓ Check these "SPECS"

**FREQUENCY**—R. F. Police Band; 1550-2950 KC; 3.5 MC to 7.3 MC and 14 MC to 30 MC Audio; 60 to 10,000 CPS.

**INPUT**—Variable inductance and capacity tuned coil.

**SWITCHING**—Front panel switch is provided for checking the positive and negative peaks of the RF signal.

**CARRIER METER**—Provides indication of adjustment of Carrier Level.

**PERCENTAGE MODULATION METER**—Provides indication of average modulation percentage.

**PEAK MODULATION**—A dial calibrated in peak percentage is provided for adjustment of the peak flash indicator.

**PEAK INDICATOR**—The peak indicator flashes when RF modulation reaches percentage set on peak modulation dial.

**AUDIO OUTPUT**—A phone jack is provided for monitoring the audio component of the modulated wave.

**POWER SUPPLY**—Voltage regulated—115 Volt, 60 cycles AC.

**TUBES**—1-6X5; 1-VR105; 1-VR150; 2-6H6; 1-6SJ7; 1-2050; 1-6SN7.

**PANEL**—Metal enamel, gray with white screened markings and black control knobs.

**CASE**—Metal with dark gray hammered enamel finish; overall dimensions 15¼" x 9" x 8", nickel plated hardware.

**WEIGHT**—20 pounds.

SEE YOUR DISTRIBUTOR FOR DETAILS OR WRITE TODAY. Address Dept. J87

**Triplet** ELECTRICAL INSTRUMENT CO. BLUFFTON, OHIO



**M & H HAS THE  
FAMOUS MAKE  
Ham Equipment  
YOU'RE LOOKING FOR**

**SPECIALS**

2-866 A  
2-SOCKETS  
2-PLATE CAPS  
1-FIL. TRANS. } \$ **695** COMPLETE

2-816  
2-SOCKETS  
2-PLATE CAPS  
1-FIL. TRANS. } \$ **495** COMPLETE

STAND OFF INSULATOR, 4 1/4" high 29c  
813 SOCKET . . . . . 45c  
W.E. 310 B TUBE . . . . . 98c

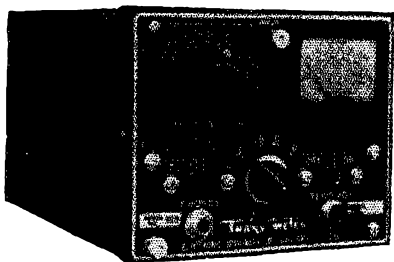

**RANGER TRANS-METER \$ 49.50**  
MODEL 905

**RECEIVERS IN STOCK**

Hammarlund Super-Pro . . . . \$347.25  
Hammarlund HQ-129-X . . . . \$173.25  
RME-45 . . . . . \$198.70  
RME-84 . . . . . \$98.70  
RME VHF-152 . . . . . \$86.60

Wholesale  
Radio Parts Division

**M & H**

**SPORTING GOODS COMPANY**  
512 MARKET ST., PHILADELPHIA 6, PA.

(Continued from page 98)

Club, with LJS as president, has been reactivated. AGL has BC-654 transmitter and receiver for hurricane emergency. The Dade Radio Club annual election resulted in IKI, pres.; BTM, vice-pres.; KPW, secy.; IJM, treas. ECV-ITE, East Coast Vagabond and Son, cleared the bugs out of that 28Mc. transmitter but now are expecting chirps. A pair of swallows have built their nest on the doubler plate tank and the eggs should hatch any day. With the rig on the air daily; anything can happen. BT's DX is cutting in on his sleep. If he doesn't begin to receive some cards very soon he will be applying for a passport. IKI moved for the summer but that has not interfered with his regular OBS schedule. AAR has Rebel Net summer schedule and also schedules IQV Tuesdays and Thursdays and SARA, Atlanta, on Mondays. BYF hopes his health will soon permit increased activity. Traffic: W4BT 72, FWZ 38, AAR 38, IKI 19.

WESTERN FLORIDA — SCM, Lt. Comdr. Edward J. Collins, W4MS — EQR worked all call areas and 25 states on 50 Mc. CNK is pushing him on 50 Mc. and is new president of Pensy Radio Club. DAO is on 14-Mc. 'phone. JPA has new mobile rig and 50-Mc. beam. KVG has FB installation of Gon-Set in his Chevy clock space. BCC has 28- and 14-Mc. beam on one mast. BKQ has swell new four-element beam. LRC is working on R-9er. IVY is building beam. QK has new beam. HJA is heard on all bands. HIZ attended Dothan Hamfest. ASV is on 7 Mc. EQZ-GWY have new 28-Mc. converter perking FB. MAM is our newest ham. JNP was heard on 28-Mc. 'phone. DZX is installing splatter suppressor. FHQ is talking modulation for his rig. EGN has added 14-Mc. beam. AXP works Rebel Net in FB style. MS is working on the 28- and 14-Mc. beam. JV has rotary beam and is the big DX man. KIK has new final. LT has a W. Fla. kw. going. JBH works plenty of DX.

GEORGIA — SCM, Thomas M. Moss, W4HYW — The Skyways Amateur Radio Club at LaGrange has received its ARRL charter. LNG is having lots of luck on 144 Mc. WMMP now is 4MMP. JZV made his first ZL with 30 watts on 28-Mc. 'phone. FKE participated in Texas City traffic. FFC is in Powder Springs. FCW finally got back on 28-Mc. 'phone. JDR is new ORS. We have several requests for the formation of emergency nets, and hope to announce details next month. Cooperation of government agencies, including Army and Navy, has been assured. We hear that 9BMC is en route to J2. We regret to announce as a Silent Key Lawrence T. Campbell, jr. Larry was well known to Georgia hams in the thirties when he was active as BNK in Hapeville. He was superintendent of communications for Delta Air Lines in Atlanta for several years. Although not active in late years he had maintained an interest in ham radio. Larry's friends all over the section will be sorry to learn of his passing in the crash of an aircraft at Columbus, and our deepest sympathies are extended to his family. The U. S. Naval Reserve has announced plans for organization of communications outfits. Full information is available from the SCM or from Sixth Naval District Headquarters at Navy Yard, S. C. Plans for amateur nets with no military and naval ties will be complete and announced very soon. Best of luck. Traffic: W4GZF 54, FKE 5.

WEST INDIES — Acting SCM, Everett Mayer, KP4KD — NY4CM reported by radio direct from home station, W8LZK. AM is going on 28- and 27-Mc. 'phone and has added BC348R to his FB station equipment. He had a contact with his mother through W7UPX. BE rag-chews over the noon hours and also handles traffic. DV has 600/800-watt rig on 14 Mc. c.w. and has 7-3.5-3.85-Mc. 'phone-c.w. rig coming up next. EN and DT are working nice DX. AN, AO, CC, and CD are active on 14-Mc. c.w. W2KMY/KP4 was transferred to Roosevelt Roads and will get on there with Meissner 150-B. He schedules his brother, W2PTV. W4ETE/KP4 is knocking them off on 28-Mc. 'phone. BJ is warming up for the take-off with half kw. KD's 450/625 watts are doing nice job for him with WAC two days running and a VK QSO every day during May. Bad conditions on 28 Mc. have AU's circuit with W0FFB tied up in knots. Traffic: NY4CM 18, KP4KD 6, BE 3, AM 1.

**SOUTHWESTERN DIVISION**

LOS ANGELES — SCM, Ben W. Onstenk, W6QWZ — L JQB, Assistant SCM, reports that things are shaping up on the 3.5-Mc. nets. He has RMs IOX and CMN helping him. They need a little more assistance from around the Los Angeles area, so any of you fellows that would like to help

(Continued on page 102)



# “Particular People--

those folk at Sangamo! They know that top-notch rigs need precise, stable capacitors to stay on the air—and they have been making just such dependable capacitors for a quarter of a century.”

Old-time hams recognize Sangamo Quality . . . Get acquainted with the Sangamo line today. Your jobber can supply you.

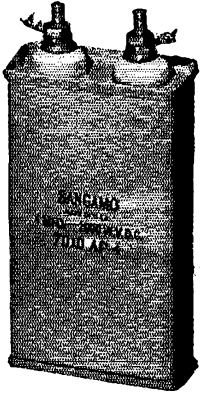

**Type 71  
Diacior  
Impregnated  
Capacitors**  
600 to 6000 W. V. D. C.

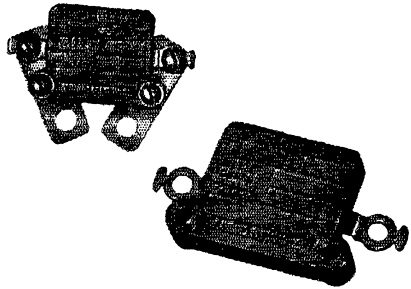

**Type H Mica Capacitors**  
600 to 2500 W. V. D. C.

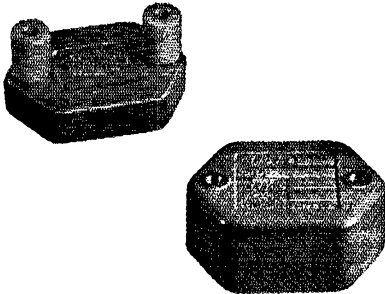

**Type A Mica Capacitors**  
600 to 2500 W. V. D. C.

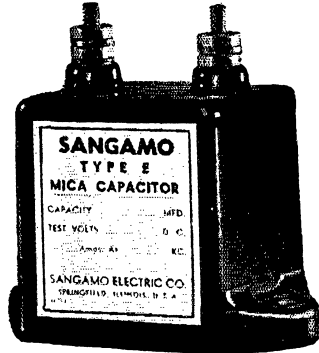

**Type E Mica Capacitors**  
Specifically Designed for Hams



**CAPACITORS  
MICA  
PAPER  
SILVER**

**SANGAMO**  
ELECTRIC COMPANY  
SPRINGFIELD • ILLINOIS

# SUMMER SURPLUS SPECIALS!

FROM COMPLETE STOCKS

## TRANSFORMERS

- ★ Stancor 52CO46 Plate Transformer as used in BC 610 Transmitter. Primary: 117v, 50-60 cyc. Secondary: 2500v or 2000v each side of center adjusted by primary taps. Rated output from single section filter 2500v D.C. at 350 ma. or 2000v D.C. at 500 ma. These ratings are for continuous operation. Size 14" x 10½" x 9". Shipping weight approx. 125 lbs. Each.....\$29.95
- ★ Filament Transformer. Primary: 115v, 60 cyc. Secondary: 2.5v at 10 amps. 9000v insulation. Shipping weight approx. 6 lbs. Each.....\$2.95

## CONDENSERS

- ★ Johnson Variable Dual Transmitting Condenser 150DD70. 151 mmf. per section. Spacing .175 in. Each.....\$5.40
- ★ Variable Dual Transmitting Condenser. 100 mmf. per section. Spacing .030 in. Each.....\$1.62

## MILLIAMMETER

- ★ General Electric Milliammeter 0-200 mils. Bakelite case. Round flush mounting. 3½" dia. Each...\$2.95

## COAXIAL CABLE

- ★ RG8/U Cable. 52 ohm. Less than 100' \$.05 per ft. 100' or more, \$.04¾ per ft.
- ★ RG11/U Cable. 75 ohm. Less than 100' \$.10 per ft. 100' or more, \$.08½ per ft.

## TRANSMITTING TUBES

No.	Each	No.	Each
HY 75	\$2.05	6AG7	\$1.05
RK 34	.75	6AK5	.90
TZ 40	1.85	807	1.05
2X2	.90	813	6.75
3C24/24G	1.20	872A	2.25
5R4GY	.95	884	.75

TERMS: 20% cash with order. Balance C.O.D.  
All items are subject to prior sale.

## ARMY SURPLUS RADIO GEAR

Write or call for Bulletin "Q" which lists exceptional bargains in Army and Navy surplus equipment including Transmitters, Receivers, Laboratory Instruments, Test Equipment, Frequency Meters, Radio and Radar Components, etc. All in good operating condition. Remarkable values.



# ELECTRONIC MARKETERS, Inc.

190 VARICK ST. • NEW YORK 14, N. Y.

CAnal 6-6931

(Continued from page 100)

out on traffic-handling, give these fellows a call. They are using 3615 kc. Some of the OOs are doing all right on the Frequency Measurement Test. Among them are IWU, DFO, SUD, and QIL. Here's some dope on the Mike and I Key Club: BHA is on 3.85 Mc. MK Club members are getting ties with their calls embroidered on them. Didn't know they wore ties in Santa Monica. QJG is on 3.5-Mc. c.w. OKL is working 14- and 7-Mc. mobile aircraft trans-Pacific. AEC, area 4, has moved from 51.84 to 53.84 Mc. COQ is on 14-Mc. 'phone. RFX is on 14 and 3.85 Mc. from Bishop. NBT is on 28 Mc. CUY is on 3.85- and 14-Mc. 'phone with 250 watts and has a nice signal. 50 Mc. really opened up here with plenty of DX coming through. Here are some of the scores on states: UXN, 1 kw., 33 states; NAW, 100 watts, 25 states; AMD, 100 watts, 17 states; QWZ, 5 watts, 12 states; YES, 5 watts, 5 states; URN, 20 watts, 6 states. For some real exciting DX try 50 Mc.; only keep your kws. out of my back yard. Present officers of the Southeast Radio Club of Southern California are: CFC, pres.; TLO, vice-pres.; WWU, secy.; Fred L. Wolfard, treas. The club meets at 10022 California St., South Gate, on the 1st and 3rd Fridays of each month and would like to see more amateurs take an interest in their local amateur radio clubs. Thanks to RIU, JQB, CMN, MU, AAE, SMI, OGM, ANN, and NDZ for the dope they sent in. Traffic: W6JQB 327, IOX 197, CMN 145, OGM 20, MU 4.

ARIZONA — SCM, Gladden C. Elliott, W7MLL — We regret the passing of KTA, who became a ham only three months ago. PBD reports 97 daily consecutive contacts with ZL2FY, the chain being broken by poor conditions on May 23rd. SAV has 375 watts on 28-Mc. 'phone at St. David. MAE, UPF, and MLL have their Class A tickets and are working the A 'phone bands. KXB is handling Boy Scout traffic from Mt. Lemon. KMM says to remind the Arizona gang he is not a prune picker. The following are on 50 Mc.: KRH, QNC, QAP, UPF, TXM, OWX, and QLZ. QAP reports all districts but the 2nd and 23 states in May. JXL is working 7-Mc. c.w. at Douglas. OMH has a new XYL. RLC has increased power by putting in a pair of 803s in the final. JGU worked a W2 and W8 with a two-foot antenna on 7 Mc. KUJ has 200 watts on 28 Mc. at Ajo. KOU is on 7-Mc. c.w. at Ajo. PDA is on 7-Mc. c.w. in Wickenburg. LJN, SQN, SNI, and RLC are doing a lot of mobile 14-Mc. work with distances of 25 miles being covered in mountainous areas. 3HEC/7 is on 28-Mc. 'phone in Benson. LFE and LFF are new Tucson calls. TCQ is working 14-Mc. c.w. DX. NHW is a new Phoenix ham. IIG is reported in the Army in Georgia. Make your plans to attend the hamfest in Phoenix in October.

SAN DIEGO — SCM, Irvin L. Emig, W6GC — Asst. SCM and SEC, Gordon Brown, 6APG, MI now boasts 73 countries and 31 zones. BAM spends 100 per cent of his time on DX. YYW has new NC-173 and works 14 and 7 Mc. still picking off those hard-to-get prefixes. MHL is high man on traffic, probably as a result of a new three-element 14-Mc. beam. He also is providing an excellent communication system for service men overseas by connecting them via amateur radio through the telephone line to their families. BGF sends in nice traffic total. LUJ had a visit from W6YOT/C7 while he was on emergency leave in the States. FMJ is active on Mission Trail Net. HWJ, MKW, and DEY participated in recent VHF QSO Party, with HWJ reporting a nice score. VEP has old 7th district call, HLV, back. YDM moved to Santa Ana and has 813 on 28 Mc. NGN is mobile on 144 Mc. ADT is on the way to Central America as operator of a small freighter. 5LPZ/6 moved to reduce BCI. VIH and UEF have new Supreme AF-100 transmitters. YBI is too busy with technician job at KVOE to get on ham bands. The 3.85-Mc. picnic at San Dimas on May 4th was well attended. VKA is active at Newport Beach on 144 Mc. YJH is new call heard on 3.85 Mc. QG worked W6s and W5s during recent 50-Mc. opening. Lt. LVB, Coast Guard, was communications officer aboard ice breaker *Northwind* during recent Navy Antarctic Expedition and gave an interesting talk on his polar experiences at Orange County Club meeting. 3LKB/6 now is 6LKB while SZZ is SI. JYV will be on with pair of HK54s in final. MWL is building the last word in all-band double super. JNE is busy building a new home while NCS is impatiently awaiting the stork. CHV worked two new countries. Traffic: W6MHL 96, LUJ 39, MI 39, BGF 37, YYW 21, CHV 15, OBD 7, DEY 4, FMJ 3, GC 2, WNN 2.

(Continued on page 104)



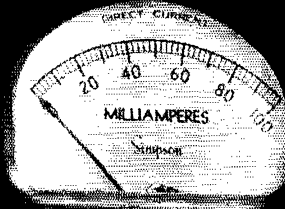

**Here's a new way  
to read meters  
...in the dark!**

How often have you wished for a meter you could see *clearly*—the whole scale of it, wherever you were using it—in the dark, under low lights, or even in the kind of glare that causes reflections on the glass—a really illuminated meter for your transmitter? Well, here it is—the result of a new Simpson patented method of illumination.

On these new Simpson Illuminated Meters (A.C. and D.C. voltmeters; D.C. milliammeters; and Radio Frequency ammeters), every fraction of the dial face is flooded with a full and even radiance—there isn't a spot of shadow.

An ingeniously shaped Lucite cone carries the light from a recessed bulb in the back of the instrument through the front edge that surrounds the entire dial. This makes possible the use of the standard Simpson metal dial. Unlike translucent dials, it cannot fade or discolor so that reading becomes difficult. It cannot warp or buckle, causing the pointer to stick, or distort readings. The bulb recess is neoprene sealed.

Behind this refinement to the basic reason for preferring Simpson instruments—their in-built accuracy. That high quality which is the indispensable component of every Simpson instrument makes sure that the accuracy will *stay* there, year after year.

**ASK YOUR JOBBER**

3" Rectangular Case. Width, 3"; height, 3-1/8". Mounts in round hole. Body diam. 2 3/4".

2" Rectangular Case. 2-3/8" square. Mounts in round hole. Body diameter, 2-3/16".

**SIMPSON ELECTRIC COMPANY**  
5200-5218 West Kinzie St., Chicago 44, Ill.  
In Canada, Bach-Simpson Ltd., London, Ont.

**Simpson**

**INSTRUMENTS THAT STAY ACCURATE**



**THE NEW SIMPSON  
MODEL 240  
"HAMMETER"**

1946 version of the first self-contained pocket portable instrument built expressly to check high voltage and component parts of transmitters and receivers.

Ranges: 0-15, 150, 750, 3000 A.C. volts; 0-15, 75, 300, 750, 3000 D.C. volts; 0-15, 75, 300, 750 D.C. milliamperes; 0-3000 ohms (center scale 30). 0-300,000 ohms (center scale 3000); 1000 ohms per volt A.C. and D.C.

# Don't Muff Your Chances in RADIO ELECTRONICS

NEW DEVELOPMENTS  
SPELL

*New Opportunities!*



## YOU MUST ADD TECHNICAL TRAINING TO YOUR PRACTICAL EXPERIENCE

Old jobs as well as new ones in radio require new knowledge. To forge ahead you must "Know the WHY, as well as the HOW." FM, Television, Micro-Wave Relay Systems, Mobile Communication Systems for trains, buses, automobiles, trucks, —all these new techniques and many more mean new, better jobs for you who are qualified. Start your training NOW for one of those better, more exciting jobs in this New World of Electronics!

LET CLEVELAND INSTITUTE TAKE OVER YOUR PERSONAL UPGRADING PROBLEM! Qualified, competent instructors, ample, personalized instructional aids, orderly, progressively arranged study assignments in recognized, approved technical texts—these are only a few of the many superior advantages of CIRE's plan of personalized spare-time home study training for professional self-improvement.

### Cleveland Institute Courses Offer Complete Technical Training Ranging from Low-Level to College-Level

- A. Master Course in Radio Communication.**  
Covers complete Preparation for broadcast station employment including preparation for FCC Commercial Operator License Examinations.
- B. Advanced Course in Radio Communication Engineering.**  
A college-level Radio Engineering course.
- C. Specialized Television Engineering.**  
Including post-war Television Techniques.

**All Courses include the Remarkable Workbooks of Instructional Aids, prepared by the instructing staff of Cleveland Institute.**

Choose the course best suited to your needs—Start with the section you are qualified to enter—Use the economical CIRE "Pay-As-You-Go Plan."

You may enroll for individual sections for highly specialized training. Study any one or more of the following sections if you do not require a complete course—

1. Mathematics of Radio.
2. Fundamentals of DC and AC Theory.
3. Essentials of Radio Communication.
4. Communication Networks.
5. Advanced Radio Telephony for the Broadcast Operator.
6. Audio and Radio Components and Systems (Design of Receiver and Transmitter Equipment).

WRITE FOR DESCRIPTIVE FOLDER

## Cleveland Institute of Radio Electronics

Contractors to the Canadian Broadcasting Corporation  
QT-8, Terminal Tower Cleveland 13, Ohio

Cleveland Institute of Radio Electronics  
QT-8, Terminal Tower, Cleveland 13, Ohio

Gentlemen: Please send information about your home study courses in Radio Electronics.

If a veteran, check here

Name.....

Address.....

City.....State.....

Check Training Desired A  B  C

(Continued from page 102)

## WEST GULF DIVISION

**NORTHERN TEXAS** — SCM, N. C. Settle, W5DAS/MNL — Asst. SCM, Joe Bennett, 5III. SEC: QA. PAM: ECE. RM: CDU. DXR is NCS for emergency net which meets Sundays at 0930 on 3910 kc. with EVI, FFX, GJU, GSZ, ICH, IRZ, IXJ, JUY, MAW, LVR, and CZZ. DXR and CZZ maintain daily schedule on 144 Mc. between Dallas and Terrell. OL is head technician in an x-ray laboratory. MUF, ex-4DAP, has a 250TL on c.w. GZH, JQY, and ILZ are now Class A license holders. The Dallas Radio Club will soon have an emergency rig ready for operation. JOU says the Fort Worth Club is building an emergency unit. R. O. Dietrick won the National 173 receiver given by the DARC. EZP won the Millen e.c.o., and Kane, a soon-to-be ham, won the pair of 8128. NCI is a brand-new call in Dallas. LSN, ex-9FLG, would be very happy with a traffic schedule into South Texas. Spet works NTX, Rebel, and TLAP Nets. NTX traffic and emergency net is maintaining activity on 3657.5 kc. with ASA, BBH, CDU, FMY, GYW, GZU, ILZ, ISD, LDN, LOS, LSN, LVR, LPO, JDZ, HCH, and MJN. NTX meets on Monday and Thursday at 2000. If you are interested in net participation, please contact DXR or CDU. Mr. McKean, ICEG, of Headquarters, recently visited Texas. We should like to see more interest displayed by officials on LO Nite, the first Saturday of each month. Members of NTX and the Oklahoma Net joined in a get-acquainted party. Thanks to Skippy for this opportunity as guest reporter and 73 to all from your RM, CDU. Traffic: W5LSN 82, CDU 28, ASA 9.

**OKLAHOMA** — SCM, Bert Weidner, W5HXI — Asst. SCM, George Bird, 5HGC. SEC: AHT. This is the second month that few activity reports have reached your SCM. If you want to be in the news, drop me a card early in the month. Another tornado disaster struck in this section at Leady. ATJ was there with the utility company but had no time to handle traffic. At his request, FMB moved in a portable transmitter with WQ as second operator. No traffic was handled and the second day they returned to their homes. The social event of the month was the annual picnic of the Pole-Cat gang at the home of EAK. About 75 persons attended. The following hams and their families were present: 5EZK, 0TKF, 0EBE, 0FUM, 0HUI, 0TGN, 0DEA, 0BRN, 0IFR, 0LYF, 0BPL, 0MNE, 0EGN, 0JAS, 0ZYF, 5JNG, 5AEK, 5AHT, 9DKY, 0NSD, 0HEC, 5WI, 5FDQ, JBX, 5HXC, 0CSK, and 5EAK. At least ten different groups operated in this section during Field Day. Traffic: (April) W5AHT 601, YJ 284, IGO 212. EGA 116, JKS 59, HXU 44, ADC 25, FMF 25, GZU 20, IOW 14, JFY 9, AAJ 2. (May) W5IGO 74, GVS 40, AHT 17, JFY 13, FMF 11, ADC 10, IOW 8, GZU 6.

**SOUTHERN TEXAS** — SCM, Ted Chastain, W5HIP — SEC: BVU. PAM: EYV. The Rio Grande Valley International Radio Club now is affiliated with the ARRL. BAJ is EC for that area. LWV is OO III and reports new hams in El Paso are MSW, MWX, and QB. The El Paso Amateur Radio Club is also affiliated with ARRL. ON, secy. of Houston Amateur Radio Club, reports regular meetings and that JMI is pres.; JIY, vice-pres.; FJA, treas. GLS is EC for Houston area as well as OPS. BHO is OBS. ACL has p.p. V70DS 500 watts on 28-, 14-, and 7-Mc. c.w.; he has 70 countries postwar. The Corpus Christi Radio Club operated a 500-watt c.w. rig during "Buccaneer Days," and handled messages for visitors. HUV has NC-173 and VHF-152. LXO has NE-173 and R-9er. GKI took LGG and HLK to Texas City disaster. FND is completing kw. phone. CX has been transferred to San Francisco. LRD has BC-610E; receiving equipment is SX-28, S-40, and a BC-683. MKL has new Super-Pro. KZG has p.p. 811s 250-watt c.w. final. AQN is on 7-Mc. c.w. in Galveston. LLA, new ORS, has HT-9 Supreme 281 'scope and wants traffic on 7-Mc. c.w. MCN has new rotary on 14 Mc. LOW is very active on 50 Mc. MN schedules 4PL, 2CGG, 1BDU, 3MJK, 61OX, and KL7BD, and wants more traffic. EWZ worked TINS. JPC, Kilgore, reports new beam under construction. MVD is new call in that area. VEIJO reports from Houston that he is now 5MPE, using a BC-348Q and BC-459A on 7-Mc. c.w. CCD reports p.p. V70Ds in new final and 38 countries postwar. JLY has worked 15 states on 50 Mc. The annual business meeting of the South Texas Emergency Net was held in Cuero. The following officers were elected: Zone 1 — GMT; Zone 2 — BCG; Zone 3 — IVU, FNY, net control officer; CIX, alternate net control officer; FNI, secy.-treas.

(Continued on page 106)

THE ORIGINATORS OF NBFM EQUIPMENT FOR THE AMATEUR

# THE NEW NBFM

# MOBILE XMITTER

PLANE • BOAT • SHIP • CAR  
SUMMER CAMP • EMERGENCY  
OR STAND-BY IN THE SHACK



AMATEUR NET

**\$72.45**

LESS XTAL AND POWER SUP.

**POWER SUPPLY REQUIRED**—Between 250 to 600 volts at 100 mills—vibrator, dynamotor or A.C. Supply.

**FREQUENCY OUTPUT**—The MB-611 is supplied with 10 and 11 meter output. 6 meter output may be had by specifying when ordering.

**FREQUENCY DEVIATION**—Adjustable 2-3 K.C.

**POWER**—40 WATT INPUT  
30 WATT OUTPUT

**ANTENNA**—Will match any type of antenna or transmission line.

**MOUNTING**—A mounting plate is furnished suitable for any type vehicle.

**OSCILLATOR**—40 meter xtal—6000 K.C. to 8000 K.C.

**DUAL INDICATOR**—For R.F. tuning and deviation.

**SIZE**—10 $\frac{1}{8}$ " x 7" x 5" overall.

NBFM of present permitted on 11 meters and above 29 MEGS. In Canada on 27.395 to 27.455 and 29.5 to 29.7 MEGS.

## ANOTHER GREAT

THE NEW **C**ALIBRATED **F**REQUENCY **C**ONTROL

- 1—Direct, all-band, calibrated dial, equipped with finger-tip control vernier.
- 2—Provisions for spot frequency xtal control and/or VFO from selector switch.
- 3—Built-in 1000 k.c. frequency standard calibrated against WWV standard.
- 4—Band-switching 80 and 40 meter 5 watt output.
- 5—CW keying and built-in CW monitor.
- 6—Built-in provision for remote control.



AMATEUR  
NET

**\$59.75**

Furnished complete with tubes, regulated power supply and a 1000 k.c. crystal.

**COMING SOON!!!!**

SONAR Representatives in Canada — FRANK'S AGENCIES, CALGARY — MEASUREMENTS LTD., TORONTO

**XE-10**  
AMATEUR NET  
**\$39.45**  
LESS XTAL

SEE  
YOUR  
DEALER  
OR  
WRITE US  
DIRECT

**SONAR**  
*Radio*  
NARROW BAND FM

SONAR  
RADIO  
CORP.  
Box 445  
BKLYN 1,  
NEW YORK

**VFX 680**  
AMATEUR NET  
**\$87.45**  
LESS XTAL

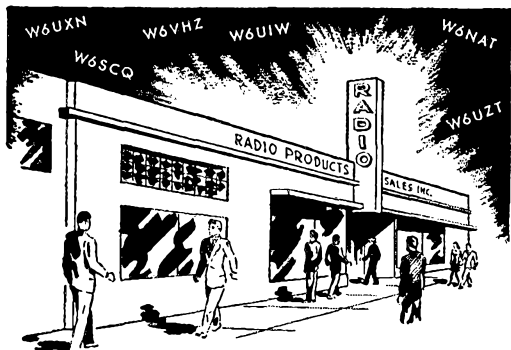

## Stretch Those Dollars

### SENSATIONAL VALUES DURING OUR August Sale of "Ham" Equipment

100 ft. rolls of No. 12 gauge, soft drawn enameled wire. Each .....	<b>85c</b>
Surplus Hammarlund "S" meters, 100 U A movement. Each .....	<b>\$1.95</b>
New 0-150 volt A.C. meters, 2" standard brand (round). Each .....	<b>\$1.95</b>
B.A. 38 battery, 105 volts, for use with Handy Talkie. Each .....	<b>95c</b>
No. 20 tinned copper bus bar wire, 1/4 lb. spool. Each .....	<b>18c</b>
35mm fd. Midget (variable). Each .....	<b>35c</b>
300 ohm. Line (Belden). Your cost per 100 ft.....	<b>\$2.86</b>
150 ohm. Line (Belden). Your cost per 100 ft.....	<b>\$2.32</b>
Sig. Corps, HS 23 head phones (new). Special, per pair .....	<b>\$1.45</b>
D.P.D.T. 6 volt, heavy duty, silver contact relay (Leach) .....	<b>\$1.79</b>
3 mfd.—2000 volt oil filled condenser, C.D., (Rect. case) .....	<b>\$2.95</b>

### NOTE!

You may wish to order Standard Brand Merchandise, that in many cases is hard to get.

Some of the Famous Brands to be found in our stock of "Ham" Equipment are:

Hammarlund, Bud, National, Barker & Williamson, Advance, Eimac, United, Taylor, Heintz & Kaufman, Johnson, Cardwell, Millen, Amphenol, Cornell Dubilier, U.T.C., Thordarson, General Electric, and numerous other famous makes that we are unable to mention, due to the lack of space.

Feel free to call upon us at any time, no matter how small your needs may be, and be assured that we will exert every effort to comply with your every wish.

Thousands of "Ham" items to be had from our vast "Ham" stock, so order now.

Prices subject to change

All prices F.O.B. Los Angeles (California purchasers add 2 1/2% sales tax). Include 25% with order — balance on delivery. Foreign orders cash

Get YOUR NAME on our mailing list. We'll keep you posted on merchandise available, new equipment and special bargains. Address correspondence to Dept. C-2.

IN RADIO SINCE 1926

**RADIO PRODUCTS SALES INC.**

1501 South Hill Street • Los Angeles 15, Calif  
Phone: PR. 7471 • Cable Address: RAPRODCO

(Continued from page 10A)

XE2BN of Ojinaha, Chihuahua, Mexico, was a guest. Traffic: W5MN 139, GEL 47, KZG 18, MKL 18, GLS 16, CCD 13, JPC 10, HQR 3, LLA 2.

NEW MEXICO — SCM, J. G. Hancock, W5HJF — DER is active on 50 Mc. with his new VHF-152 converter and four-element beam which is stacked atop his three-element 2S-Mc. beam. HJF is having trouble with his 80-meter Zepp and will not be on that band until a supply of electronic DDT kills the bugs. Although there are no official reports, most of the New Mexico gang seem to be operating on 14-Mc. 'phone with a few heard on 7-Mc. c.w. I have had some good luck working KA1, J2, J3, and J9s since my Zepp failure "forced" me on 14-Mc. 'phone and c.w.

## CANADA

### MARITIME DIVISION

MARITIME — SCM, A. M. Crowell, VE1DQ — R.M.: EY, EC, FQ. The HARC had three separate rigs in action on Field Day. ES schedules GT and SV and has raised power to 46 watts. DB handles a few and spends most of the time rag-chewing. WL was a recent guest of SP. QL was a visitor to Halifax. The new Radio Club of Sydney got off to a nice start with 21 members. CR is putting out very well with the new rig, a pair of 810s in the final. CI had some trouble with lightning. Add these to the ranks of the new "beam users": BC, DQ, ET, QZ, FQ, and VV. The following dope on the St. John gang was received via RQ: IE does a bit of rag-chewing on 3.8-Mc. 'phone in addition to his activities in the Airforce Net. GP keeps regular schedules with a couple of Gs on 14 Mc. IW, one of the newer members, was formerly on 7 Mc. under the call MM, FL and the XYL, AYL, are working wonders on 14-Mc. 'phone with 15 watts and a piece of wire. Some of the gang demonstrated ham radio at the Lion's Club Hobby Show. Connected with the show were FU, JO, TS, FC, and IW. Four new calls in the Loyalist City Amateur Radio Club are IW, HQ, DL, and FU. Traffic: VE1ES 5. DB 2.

### ONTARIO DIVISION

ONTARIO — SCM, David S. Hutchinson, VE3DU — The London Radio Club members, along with fellow hams from Ingersoll and Stratford, paid a visit to the Clinton Radar and Communications School (RCAF) the evening of May 29th. The Canadian National Carbon Co. donated a beautiful trophy for the club in Canada making the highest Field Day score. The Hamilton ARA, the West Side RC, and the TARA competed for the trophy. The Beaver Net still is functioning on 3535 kc. although traffic is rather scarce. AXQ is busy with the AFARS nets and reports from Peterboro that the boys were active in Field Day. BRC is a new ham. OJ reports from Ottawa that he has new RME VHF152 converter and is trying to stir up interest in 50 Mc. in that city. VD kept schedule with W2NFR to the Philatelic Exhibition in New York, on 7 Mc. He says he is getting the bugs out of his rig and expects to have the 813 perking very soon. HP reports that activities are dropping off in the traffic line and he is planning on rebuilding and doing some DX during the summer months. BMG is our latest addition to the ranks of ORS appointees. WY is looking for a new QTH so as to get away from interference troubles. WK schedules BAJ up in Pagwa River. BAJ reports very bad earth current troubles lately. AJP is running 400 watts to 813 on 7 and 14 Mc. HI has his pair of 810s perking now. BLD has his new car so will be able to try out his 28-Mc. mobile rig. ARA is new licensee in London. ACO is active on 14-Mc. 'phone. AWJ and AWH got Code Proficiency Certificates on the last run and ACB and AWQ received 25 w.p.m. and 30 w.p.m. stickers respectively. The West Side Club now is affiliated with ARRL. ACB, BCS, ATR, QU, OI, and WX are keeping BN going. Traffic: (April) VE3WY 20, (May) VE3HP 54, WX 35, OI 24, VD 24, ATR 15, BCS 9, AWJ 7, QU 7, BMG 6, ACB 5, AXQ 3.

### VANALTA DIVISION

ALBERTA — SCM, W. W. Butchart, VE6LQ — New calls in Calgary: JI and JX. P.O. Box proves popular with Calgary gang. LQ spotted 28-Mc. beam on 16th Ave., N.W., while driving through Calgary recently. CARA

(Continued on page 10B)

# Now Available! HEINTZ AND KAUFMAN FREQUENCY SHIFT TERMINAL EQUIPMENT

## FS offers vastly improved signal-to-noise ratio . . . faster keying—greater selectivity

The rapid trend toward Heintz and Kaufman frequency shift transmission for communication circuits has been prompted by the superior signal-to-noise ratio obtained as compared with "make-break" keying systems.

Properly designed FS terminal equipment improves the signal-to-noise ratio by 11 DB by virtue of frequency shift alone. Further gains are obtained under circuit conditions where noise and atmospherics are high. The gain of the Heintz and Kaufman dual diversity carrier shift system over a single channel "make-break" system approximates 22 DB.

The selectivity obtained with this equipment cannot be approached in constant frequency systems except at very slow keying speeds. Key clicks, transients, and keying sidebands are either eliminated by frequency shift or effectively kept within the pass band of the system. High speed keying with no loss of selectivity is a marked advantage of this new equipment.

### General Description:

The H&K A-4601 dual diversity frequency shift terminal is the heart of the FS system. This unit accepts a frequency shifted signal from two communication receivers, and converts it either to tone, neutral, or polar d.c., keyed in accordance with telegraphic intelligence. The recording device may be Radiotype, teletype, or hi-speed telegraph tape recorder.

The terminal consists of a crystal oscillator and BFO, input filters, three stage limiter amplifiers, discriminator filters, discriminator amplifier-rectifier, mixer, and tone keyer or d.c. keyer.

Power Requirements: 110-125 volts, 60 cycle, approximately 150 watts.

### Write for detailed information

Descriptive literature describing operation of sub-units is now available. Our engineering department will be glad to correspond with you about your requirements.

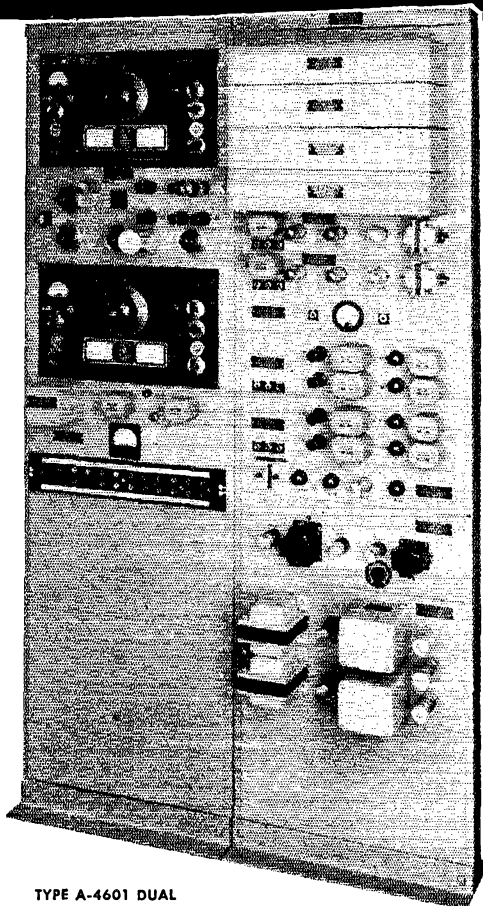

TYPE A-4601 DUAL  
DIVERSITY RECEIVER TERMINAL,  
including receivers, is mounted on two  
6' x 19" racks. Cabinet mounting can also be provided.

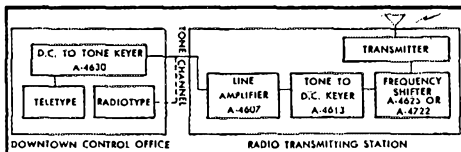

FREQUENCY SHIFT TRANSMITTING SYSTEM

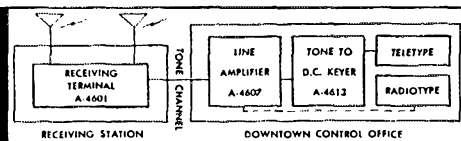

FREQUENCY SHIFT RECEIVING SYSTEM



## HEINTZ AND KAUFMAN LTD.

Communications Equipment Division

50 DRUMM STREET • SAN FRANCISCO • CALIF.

Gammatron Tube Division • South San Francisco • Calif.

# LEEDS The house you have known for 25 years

## RADIO TRANSMITTER & RECEIVER APS 13

Tunes 410/420 megacycles; light weight airborne Radar. 17 tubes, including 5/6J6; 9/6AG5; 2/2D21; 1/VR-105 and 30 megacycle 1F. strip. Schematic diagram. All for.....\$11.95

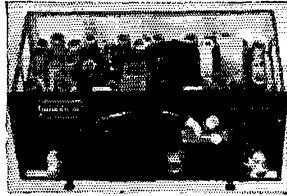

### METERS

0-1 MA	DC	3"	G.E.	\$3.50
0-1 AMP	RF	2"	G.E.	2.45
500-0-500 microamps		4"	W.E.	3.75

**HEINEMANN MAGNETIC TYPE CIRCUIT BREAKERS** in 5-20-35-65 amp. sizes. Only.....95c each

### STANDARD BRAND OIL FILLED CONDENSERS

2 Mfd 1000 vDC	\$ .79	16 Mfd 400 vDC	\$ .98
8 Mfd 1500 vDC	3.25	3X.2 Mfd 4000 vDC	.98
2 Mfd 2000 vDC	1.75	2X.1 Mfd 600 vDC	.25
0.1 Mfd 7500 vDC	1.50	2 Mfd 600 vDC	.49
.02 Mfd 8000 vDC	.98	10 Mfd 1500 vDC	3.50
2 Mfd 10000 vDC	17.50	7 Mfd 330 vAC	1.25

300 Ohm Twin Lead Cable, Indoor, or outdoor, per 100 ft....\$2.95  
52 Ohm Coaxial Cable RG/8, outdoor, per 100 ft.....\$4.50

**BC 645A TRANSRECEIVER:** 420-450 Mc; complete with 15 tubes including W.E. 316A doorknob and conversion diagram. Brand new in original packing. Special.....\$14.95

**SCHWEIN** Free and rate Cynoscope; operates from 24 vDC; complete in metal case. Special.....\$5.00

**BC 406 RECEIVER:** 15 tubes; tunes 195-207 Mc; 110 vAC, 60 cycle, suitable for conversion to 2 meters or television. Special..\$13.95

**1N23. CRYSTAL DIODES**.....17c each, 3 for \$ .51  
**1N21-B. CRYSTAL DIODES**.....35c each, 3 for \$1.00  
Suitable for use in field strength meters; as meter rectifiers, or even crystal sets.

## LOUDSPEAKER

### LS-6-C

Consisting of Microphone, P.M. Speaker and trumpet, with triggered gun grip handle and connecting cable. Brand New. Now..\$3.95

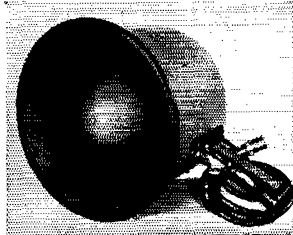

Wire Wound **POTENTIOMETER**, 100,000 Ohm precision made, General Radio type; 25 watts, 6" diameter. Brand New. Special for.....\$1.95

**SELSYNS:** Type 5 Syncro transmitter, used in pairs as transmitter and follower: 110 vAC 60 cycle. Per pair.....\$3.00

**SELSYNS:** Type 11-1 indicator type in armored cases; 110 vAC 60 cycle. Per pair.....\$9.00

### TRANSMITTING TUBES

Type 805.....\$2.95	Type 837.....\$2.95
813.....5.45	866A......75

Limited Quantity, First Come, First Served

**TRANSFORMER**—2.5V @ 10 amps. 9000V insulation, completely shielded; perfect for 866's. Special at.....\$1.95

Complete stock of National and G. R. Parts

If not rated 25% with order, balance C.O.D. All prices F.O.B. our warehouse New York. No order under \$2.00. We ship to any part of the globe

# LEEDS RADIO CO.

75 Vesey Street,  
Cortlandt 7-2612

Dept. Q58  
New York City 7

108

(Continued from page 106)

membership extends to rural centers. GD, TM, AY, FK, and their XYLs went to visit TA and Ellen at Hussar. NF, AY, and TK are active on v.h.f. work. NQ, CARA station, was active in Field Day. The club was winner in SS Contest. AO was top man in WIA Contest as far as Canada was concerned. GD ran 99,999 watts to get best out of low-power multiplier in the Contest! FK has gone Class B with T-40s. BU has 304TL, 8AL and 8AJ were Calgary visitors, as well as 4EK of Winnipeg. 6OT, SR, IX, JJ, and MI. BW moved QTH and finds UT only block away! BD has trouble getting good note. MJ works VKs easily. EA was elected president of local Cine Club. ZW sports HQ-129. HM bought exciter unit from BC-610, and has been trying to figure out circuit ever since. EF inhabits 75 frequently. EO, of Lethbridge, organized and helped produce fifteen-minute SARC broadcast on the occasion of CJOC's power boost to 5 kw. He was assisted by OG. Traffic: VE8AO 23, MJ 14, LQ 7.

**BRITISH COLUMBIA** — W. W. Storey, VE7WS — News from Collingwood Club, DJ: OJ is looking over noise suppression circuits. While working ZLs he copped NY4 through bus QRM with about 40 watts input. ABP, on 7-Mc. c.w., broke through QRM on 7097 kc. to W6 and K17 Land. LF is off to the Caribou to become a dude ranch cowhand. Transmitter is going along as well and probably will be run by horsepower. MH is busy handling QSP from VQ2AL on 14-Mc. c.w. Gordie went home with a fist full of Sweden cards from the QSL Manual last meeting. (It was Russians the time before). AZ sports new close space three-element beam (muscle work done by UU, JS, and DH). UU overheard phone dropping off the elements while Jack was working XE1JE. XT sadly watches 14-Mc. beam sagging and wonders if starch would help. UU is revamping shack and building a console layout. Sex modulation indicator using 1N21 Bes O-lma works FB for field strength meter, also terrific absorption from guy wires, wire fence, etc., from 28-Mc. beam has him contemplating doing away with all metal around the place. KK will be on 7- and 14-Mc. c.w. soon with 75 watts to a pair of T20s and 840 for ears. W6YAZ, ex-VE5HU of Haney and N. W., is looking for VE7 contacts. New QTH is Los Angeles, Calif. AJR on 28-Mc. with more power now is collecting more ZL cards. AKK has rack and panel now running 100 watts input on 7-Mc. c.w. Geo. Huhn is a new member looking forward to his ham ticket. Listen for VE7DJ on 3.5-Mc. c.w. for a good rag-chew.

## PRAIRIE DIVISION

**MANITOBA** — SCM, A. W. Morley, VE4AM — GQ worked 8 Ws on 50 Mc. on June 1st. The Ws have been coming in good lately and all districts except the sixth have been heard by DG. VK is on 14 Mc. with an 813 to a folded dipole and an AR77. TJ is series-cathode-modulating an 810. CD is running 190 watts to an 813. JF has given us his usual "farewell to ham radio forever" line. KF has new operating table and uses 4 receiving antennas. NI took such a razzing on 'phone about going to bed with his hat on that he has been trying c.w. for a change. DN is new at Shilo and uses an 807 on 28 Mc. and reports that EI, DE, QD, and CT, of Brandon, are on 28 Mc. and have some nice round tables. FU and KX are experimenting on 12 centimeters when not busy on 144 Mc. MP, BV, OU, BG, YZ, and JJ are heard on 14-Mc. c.w. WL left for Regina and AC for Edmonton. QV has had his beam in the back yard for a couple of months. Volunteers are requested to put it up. It's a boy at MW's. 3BKC now is located in Dauphin and will be signing VE4 soon. JM is transmitting ARRL Official Bulletins on 3816.5 kc. Mon., Wed., and Fri. at 8 P.M. CST. If favorable comments are received this will become a permanent feature.

**SASKATCHEWAN** — SCM, Norman Thompson, VE5CO — Well, gang, the big news this month is the ham-fest held at Saskatoon on the 24th of May. A swell time was had by all attending. About one hundred OMs and XYLs were present at the do. Things were very well organized even though the Sask. Radio Club had such short notice in which to complete arrangements. Les Tickner, Moose Jaw, is on the air signing DP. BB worked an HP4 and a KH6 with 20 watts power. EV and VA have daily schedules at noon on 3.8-Mc. 'phone. Joe McLellan, CW, a new ham in Moose Jaw, is running about 25 watts to a 6L6, 807, on 3.5 Mc. Sorry there is not much news this month, boys, but I received nary a report. How about sending in your dope before the 7th of the month, fellows? Traffic: VE5HR 5.

**CAPITOL RADIO ENGINEERING INSTITUTE**  
*Where Professional Radiomen Study*

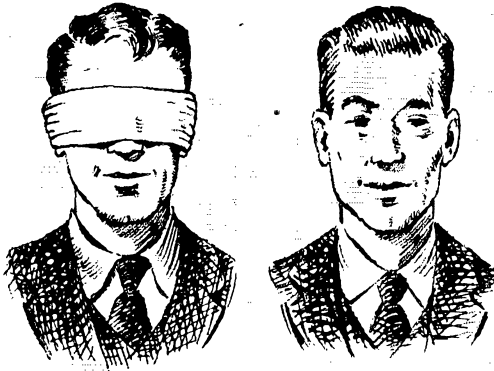

# Which Will Get the Better Job?

## The Radioman Who Looks Ahead Will Get Ahead

Don't play blind man's bluff with your future! Are you, like many other professional radiomen, so wrapped up in your present routine work that you are losing sight of where you will be tomorrow? Look at the successful radioman. You'll find that he's the fellow who looked and *planned* ahead.

The radio industry is expanding so fast, that it is doubtful any radioman can truthfully say he has kept pace with all the major developments. Thousands of new men have joined the ranks of the radio industry creating new competition for you. New developments create demands for more advanced technical ability. You can't afford to be a "pre-war

model." You must "re-tool" your technical knowledge in order to keep pace.

Look ahead and start now to increase your technical ability with the thorough, practical technical training for which thousands of professional radiomen have enrolled with CREI since 1927. In our proved method of instruction, you learn not only "how," but "why." This is real, honest-to-goodness practical engineering training that leads to better jobs and security in the knowledge that you are capable of coping with tough problems of communications and industrial electronic equipment.

It costs you nothing to read the interesting facts. Please write today.

### Mail Coupon for FREE BOOKLET

*If you have had professional or amateur radio experience and want to make more money, let us prove to you we have the training you need to qualify for a radio job. To help us intelligently answer your inquiry — PLEASE STATE BRIEFLY YOUR BACKGROUND OF EXPERIENCE, EDUCATION AND PRESENT POSITION.*



**CAPITOL RADIO ENGINEERING INSTITUTE**  
 16th & Park Rd., N. W., Dept. Q-8,  
 Washington 10, D. C.

Gentlemen: Please send me your free booklet, "CREI Training for Your Better Job in RADIO-ELECTRONICS," together with full details of your home study training. I am attaching a brief resume of my experience, education and present position.

Check  Practical Radio Engineering  
 Course  Practical Television Engineering

Name.....

Street.....

City.....Zone.....State.....

I am entitled to training under the G.I. Bill.

**VETERANS! CREI TRAINING AVAILABLE UNDER THE "G. I." BILL!**

## Capitol Radio Engineering Institute

*An Accredited Technical Institute*

**DEPT. Q-8 16TH AND PARK ROAD, N. W., WASHINGTON 10, D. C.**

Branch Offices: New York (7): 170 Broadway • San Francisco (2): 760 Marek St.

# "The ELECT In Electronics" For Industry • Schools And The Amateur

**NOW THERE ARE 9!  
Hatry & Young Adds  
SPRINGFIELD, MASS.**

In baseball language, Hatry & Young now has a complete team of 9, with the addition of a new wholesale branch in Springfield, Mass. The Hatry & Young line will be followed in Springfield, as elsewhere:

- 1) Electronics, exclusively.
- 2) Radios, Radio Parts and Accessories for the Dealer and Repair Man.
- 3) Internationally known as a Radio Amateur Supply House.
- 4) An excellent Industrial clientele.
- 5) Wholesale only—no retail compromises.

*H & Y goes to bat for you — with  
the ELECT in Electronics*



CONNECTICUT

HARTFORD  
203 ANN STREET  
BRIDGEPORT  
544 E. MAIN STREET  
NEW HAVEN  
7 BROADWAY

NEW LONDON  
428 BANK STREET  
WATERBURY  
? CHERRY STREET  
STAMFORD  
97 MAIN STREET

MASSACHUSETTS

BOSTON  
42-44 CORNHILL  
LAWRENCE  
639 ESSEX STREET  
AND NOW  
SPRINGFIELD  
169 SPRING STREET

## ELECTRICITY

FOR RADIO AND ELECTRONIC APPLICATIONS

ONAN ELECTRIC GENERATING PLANTS supply electric service for electronics applications and general uses, mobile or stationary. Driven by

Onan 4-cycle gasoline engines, they are of single-unit, compact design and sturdy construction.

ONAN Electric Plants are available in many sizes and models. ALTERNATING CURRENT: 350 to 35,000 watts in all standard voltages and frequencies. DIRECT CURRENT: 600 to 10,000 watts, 115 and 230 volts. BATTERY CHARGES: 500 to 6,000 watts; 6, 12, 24 and 32 volts. Write for detailed literature or engineering assistance.

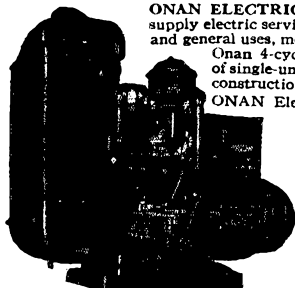

**D. W. ONAN & SONS** 4662 Royalston Ave.  
Minneapolis 5, Minn.

110

## Television Reception

(Continued from page 23)

0.0000001%, which would be a power output of 0.000000175 watt, or 0.175 microwatt. At 75 feet, this radiation does not impair reception of Channel 2 programs, but at shorter distances such as those that are sometimes involved on an apartment-house roof, a few tenths of a microwatt might cause considerable trouble.

The future program of W2RYI includes work on the 10- and 75-meter bands. Investigation of the behavior of other types of antenna systems will involve 300- and 600-ohm transmission lines. An attempt will be made to approach theoretical attenuation from low-pass filters. In spite of our normal ham apathy toward such devices, we might even have to resort to isolated antenna tuners and Faraday shields. Transmission-line stubs are a possibility, as well as plate-circuit filters of the bandpass type.<sup>4</sup>

No matter what the outcome of this work may be, it is certain that a good many hams will soon be working on similar problems. It is also certain that television will flourish, and the amateur radio art will grow with it.

<sup>4</sup> *Electrical Engineers' Handbook*, Pender and Mellwain, Sec. 7, p. 104.

## The "Last-Ditcher"

(Continued from page 25)

room available to mount the Jones plug on the front panel. It should be emphasized that the plug on the end of the battery cables is the one with socket connectors. The pin connector goes on the set.

In setting up, just connect the batteries and antenna, and run a feeder to the receiver. Put the switch on "receive" and have a listen. It will probably be immediately clear whether the antenna is okay or not. Then switch to "test" and follow the procedure outlined above. If a milliammeter is used it will be found that with 135 volts of battery the set, loaded, will demand about 20 milliamperes. With 180 volts on the plate as much as 40 milliamperes can be crammed into the oscillator although such heavy loading will soon wear out lightweight batteries.

With the "Last-Ditcher" on the shelf you are ready to go should any emergency arise. Let it be hoped there never will be a call for it. When there is no emergency a surprising amount of fun can be had — if you have a yen to operate from a mountain top or a bush camp it is a lot easier to shove this little box in with the lunch. You won't have to run leads into your car, unload storage batteries or drag out the gas putt-putt.

**SWITCH  
TO SAFETY!**





# \$175 AND 25 MONOSETS GIVEN

## To Winners of This

# EASY CONTEST!

### RADIO AMATEURS

*Just write 50 words or less telling us why you like the TELEX MONOSET better than old style earphones.*



WIN:

**\$100**

and a MonoSet

**\$50**

and a MonoSet

**\$25**

and a MonoSet

PLUS

TELEX MONOSETS  
to 22 Runner-ups!

### HERE'S ALL YOU DO:

1. Go to your *parts jobber* and ask him to let you try out the revolutionary under-the-chin TELEX MONOSET.
2. In 5 minutes you'll get at least half a dozen good, WINNING ideas. Be sure to get *all* the facts and an OFFICIAL ENTRY BLANK.
3. Then write 50 words or less telling us "Why the TELEX MONOSET is

Better than Old-Style Earphones." Clearness and sincerity will count most.

4. Print or type your answer on the OFFICIAL ENTRY BLANK your jobber will give you.

Mail direct to: TELEX, INC., Telex Park, Minneapolis 1, Minnesota, before Midnight October 15, 1947.

FIRST PRIZE: \$100.00 cash and a TELEX MONOSET

SECOND PRIZE: \$ 50.00 cash and a TELEX MONOSET

THIRD PRIZE: \$ 25.00 cash and a TELEX MONOSET

TELEX MONOSETS to the 22 next best opinions. In case of a tie, *duplicate* prizes will be awarded.

Employees of Telex, Inc. and their advertising agency not eligible to enter this contest.

NO BOX TOPS!  
NO JINGLES!  
Get Entry Blank  
From Your Parts  
Jobber

## CONTEST CLOSES MIDNIGHT OCTOBER 15, 1947!

### TIPS TO GET STARTED WITH:

1. TELEX MONOSET is quickly replacing old-style, cumbersome headsets because you wear it under-the-chin instead of over-the-head.
2. Featherweight: Only 1.2 oz. No ear fatigue.
3. Excellent fidelity. Clear, natural reception of sound.
4. Reliable performance assured by TELEX precision engineering.
5. Exclusive, TELEX designed, volume control—permits individual adjustment of volume.

*Decision of impartial judges will be final. All entries become property of Telex, Inc. Winners will be notified by mail approximately November 1, 1947. Contest subject to all state and federal regulations.*

*Remember, wherever a headset is used—TELEX MONOSET will do the job better.*



HEARING AT ITS BEST

**TELEX INC.**

ELECTRO-ACOUSTIC DIVISION

TELEX PARK  
Minneapolis, Minn.

*First*  
**WITH DISCRIMINATING  
 AMATEURS**



**ON STANCOR'S PROGRAM**  
 Transformers and Reactors of all types  
 . . . Versatile Line of Transmitter Kits,  
 Audio Amplifier Kits, and other  
 Electronic Devices to serve the  
 Discriminating Amateur.

**STANCOR** STANDARD  
 TRANSFORMER CORP.  
 ELSTON - KEDZIE AND ADDISON, CHICAGO, ILL.

# COAXIAL CABLE RELAYS

for high frequency switching

Two sizes: 50 watt and 250 watt capacity —  
 standard coil operating voltages AC or DC

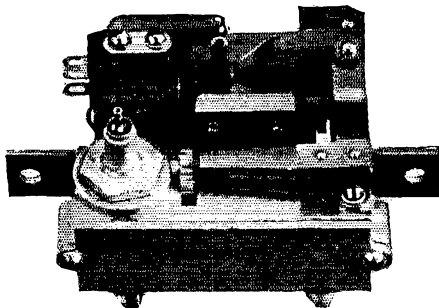

Write for  
 Descriptive Literature C35

2/3rds Actual Size

**SIGNAL**  
 ENGINEERING & MFG. CO.  
 154 WEST 14<sup>TH</sup> STREET, NEW YORK

## 25 Years Ago

(Continued from page 31)

Summer QRM is no longer the nemesis of traffic totals that it used to be. Traffic Manager Schnell's Operating Department gives the June traffic breakdown as 55% for c.w., 45% for spark, the first reversal of form ever experienced. However top individual station honors go to W. E. Heckman's spark, 1AA, with 302 messages handled!

Clyde Darr, 8ZZ, *QST*'s cover artist, and ARRL Director Harvey Mitchell Anthony are presented in "Who's Who." "Book Reviews" give us favorable reports on the most recent works of Stuart Ballantine and Austin C. Lescarboura.

Strays report the good news that Charles A. Service, jr., has returned to Hq. as assistant secretary; also that the power-factor debaters, M. B. West and Ellery W. "A-P" Stone, have taken up new positions in the commercial field.

## Happenings

(Continued from page 33)

nate it. Since this meeting was an informal one no decisions were forthcoming, but among other things the conference discussed the possibility of moving amateurs back to 56-60 Mc. and reassigning Television Channel 2 to 50-56; and then moving the 11-meter "QRM band" to 29.7-30 Mc. so that we would again have the entire band 28-30, the top 300 kc. still being shared with industrial, scientific and medical devices — thus permitting amateur harmonics to fall again within one of our own bands instead of in a television channel. If such a proposal takes tangible form, we shall of course report it promptly.

We think you will find of interest the results of a survey made by RCA employees having television receivers in their homes in the New York area, showing the relative positions of various services causing television interference compared to ISM (principally diathermy) rated as 100. As more television receivers are marketed, we shall soon be running a poor fourth.

- |   |     |
|---|-----|
| 1) ISM . . . . .  | 100 |
| 2) Images, f. m. broadcasting . . . . .                           | 70  |
| 3) Oscillator radiation from other television receivers . . . . . | 50  |
| 4) Amateurs . . . . .   | 50  |
| 5) I.f. from s.w. broadcasting . . . . .                          | 20  |
| 6) All others (ignition, etc.) . . . . .                          | 11  |

## EXECUTIVE COMMITTEE MEETINGS

The following is an abstract of the minutes of the Executive Committee of the League during the past year between Board meetings, as ratified by the Board at its recent meeting, here published for your information by order of the Board.

(Continued on page 114)

• ALWAYS FIRST WITH THE FINEST •

# Newark PRESENTS 4 GREAT NEW RIGS BY HALLICRAFTERS

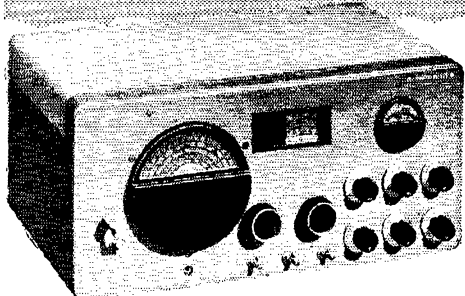

**IMMEDIATE DELIVERY  
ONE YEAR TO PAY**  
20% Down—12 Monthly Payments  
on Our Convenient Easy-Pay-Plan

**SX-43 • 6 Band AM-FM RECEIVER**  
**\$169.50 Amateur Net**  
**\$33.90 Down—\$11.98 Per Month\***

## SX-43

Never before so many features at such a low price! All essential amateur frequencies 540 kc to 108 mc. AM reception all bands. CW on four lower bands, FM above 44 mc. In band 44 to 55 mc, wide band FM or narrow band AM, just right for narrow band FM reception is provided. A big-league, versatile, all-around receiver with hottest ham performance ever offered at this price!



**Hallicrafters**  
**HT-17**  
**Transmitter**  
•  
**Amateur Net**  
**\$69.50**  
**\$13.90 Down—\$4.91 Per Month\***

**Ham Bands from 3.5 to 30 Mc 15 Watts power output on low frequency bands—**  
A Low Power, High Quality, Low Price Compact, smartly engineered unit provides honest 15 watts crystal-controlled CW output on 3.5 and 7 mc bands, and 10 watts on 14, 21, and 28 mc. Coil Sets extra.



**Hallicrafters**  
**HT-18**  
**Variable Master Oscillator**  
•  
**Amateur Net**  
**\$110.00**  
**\$22 Down—\$7.77 Per Month\***

**Modernize Your Old Transmitter—**Here is the hottest Transmitter item available today! Add to the HT-18 one or two amplifier stages and you have a complete high quality 1 Kw transmitter on phone or CW. Narrow band FM. Better quality AM. Excellent stability, clean keying. Directly calibrated.



**Hallicrafters**  
**S-47**  
•  
**Amateur Net**  
**\$189.50**  
**\$37.90 Down—\$13.39 Per Month\***

## 15 Tube AM-FM Receiver

A superb radio chassis for Specialized Installations, with push-button tuning. 535 Kc to 108 Mc in 3 bands with 5 band switch positions. Separate AM and FM controls. This is a high precision fine quality receiver for homes, schools, institutions requiring utmost in reception and ease of operation. Can be used with any speaker having 500/600 ohm input.

**COMPLETE HALLICRAFTERS LINE ALWAYS IN STOCK FOR IMMEDIATE DELIVERY**  
**Use Your Credit—Take One Year To Pay for Receivers, Transmitters, or Group of Parts Totalling \$75 or more. Write for any or all your requirements.**

Ask for our Liberal **TRADE-IN-ALLOWANCE** on Your Old Equipment

Prices Subject to Change

\*Includes 6% carrying charge.

**20% DEPOSIT  
REQUIRED WITH ALL  
C.O.D. ORDERS**  
Shipments FOB N.Y. or Chicago  
**SEND FULL AMOUNT  
SAVE C.O.D. CHARGES**

**NEW YORK**  
Offices & Warehouse  
242 W. 55th St., N.Y. 19

**NEWARK**  
**ELECTRIC COMPANY, INC.**

**CHICAGO**  
323 W. Madison St.  
Chicago 6, Ill.

**SEND ORDERS TO**  
242 W. 55th STREET  
NEW YORK 19, N. Y.  
OR  
323 W. MADISON ST.  
CHICAGO 6, ILL.

New York City Stores: 115-17 W. 45th St. & 212 Fulton St

## Crystals for the Critical

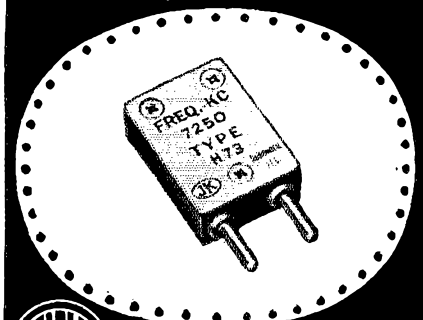

### "STABILIZED"

### H 73 HAS HIGHER Q

Because JK crystals are stabilized, contact with the electrodes is so perfect that the Q is materially increased. This process absolutely prevents frequency shifts due to age in use or on the shelf. Available in any amateur frequency between 3,000 and 3,000 K.C. Pin spacing is  $\frac{1}{8}$ ".

Write for Illustrated Folder

**The JAMES KNIGHTS CO.**  
SANDWICH, ILLINOIS

## Feather Light MINIATURE Test Meter

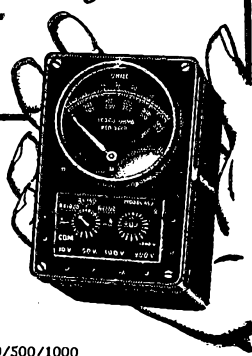

Dependable accuracy plus convenient pocket size make these little instruments most useful and popular aids to better amateur station performance. Self contained standard size batteries supply current for resistance readings. Three models are available in this small size: 3 15/16" x 2 3/4" x 1 1/4".

- Model 450A Volt-Ohm-Milliammeter**  
The outstanding value in the test equipment field. D'Arsonval movement. Zero adjustment. Rotary range switch. 1000 Ohms per volt.  
Volts DC: 0-5/10/50/500/1000  
Mils DC: 0-1  
Ohms full scale: 5000/50,000/500,000  
Ohms center scale: 30/300/3000  
Shipping weight 2 lbs. Price only \$10.90 net
- Model 451A AC-DC Volt-Ohmmeter with Output Ranges**  
Volts DC: 0-10/50/100/500/1000  
Volts AC and Output: 0-10/50/100/500/1000  
Ohms center scale: 7200 Price only \$14.90
- Model 452A High Sensitivity Volt-Ohmmeter**  
10,000 Ohms per Volt  
Volts DC: 0-10/50/100/500/1000  
Ohms full scale: 2000/20,000/200,000/2,000,000  
Ohms center scale: 30/300/3000/30,000 Price \$14.90  
Ask your Jobber or write direct for circular

America's Pioneer Makers of Pocket Test Equipment

**CHICAGO INDUSTRIAL INSTRUMENT CO.**  
536 West Elm Street - Chicago 10, Illinois

Meeting No. 191, May 20, 1946. Opened and counted ballots in special election for alternate director of Delta Division, certifying winning candidate.

Meeting No. 192, Aug. 21, 1946. Examined nominations in special election for director of Pacific Division, determined eligibility of candidates, ordered ballots sent division membership. Authorized John Huntoon, an assistant secretary, to sign checks on behalf of the Secretary, under bond. Affiliated 14 clubs.

Meeting No. 193, Oct. 2, 1946. Examined nominations in regular autumn elections, determined eligibility of candidates. In cases where there was only one eligible candidate, declared him elected without balloting. Ordered ballots sent on others. Affiliated 4 clubs.

Meeting No. 194, Oct. 21, 1946. Opened and counted ballots in special Pacific Division election for director, certifying winning candidate. Directed Secretary to call attention of directors to their jurisdiction over management, program and financial plans of division conventions and responsibility for investigating same.

Meeting No. 195, Nov. 20, 1946. Opened and counted ballots in regular autumn elections, certifying winning candidates. Authorized Secretary to execute agreement waiving ownership rights on lot near Headquarters office where League mows grass. Affiliated 6 clubs.

Meeting No. 196, Jan. 8, 1947. Examined nominations in special election in Canada, determined eligibility of candidates, ordered ballots to members. Accepted resignation of New England Division Alternate Director Frank L. Baker. Affiliated 11 clubs.

Meeting No. 197, Feb. 20, 1947. Opened and counted ballots in special Canadian elections, certifying winning candidates. Affiliated 14 clubs.

### W PORTABLES IN CANADA

If you're one of those planning a vacation in Canada with a mobile installation, you'll have to forego the radio angles this year. According to Canadian customs, any vehicle equipped with a mobile two-way radio will be permitted entry only after a customs seal is affixed "in such a manner as to prevent operation in Canada." Upon return to the U. S., the customs officer will remove the seal.

Meanwhile, consideration is being given to an agreement between the U. S. and Canada providing reciprocal privileges for mobile operation, both by amateurs and by other services, in each other's country.

### How's DX?

(Continued from page 60)

and cards may be sent to: Korean Camp, G.H.Q., Signal Regt., S.E.A.L.F., GPO, Singapore  
A fine letter from XZ2AA informs us that license regulations there are very strict and that they are allowed only 150 watts on 20 and 50 watts on 10. His operating frequency is usually 14,320 kc., and he is on daily looking for W contacts. His full QTH is given elsewhere in this column. The signal we have been hearing, signing W6RWQ/MM, emanates from the 56-foot ketch *Karleris* and is as "legal as a dollar bill," as W6EYB puts it. The gear aboard consists of a t.r.f. receiver and a crystal-controlled 70-

(Continued on page 116)

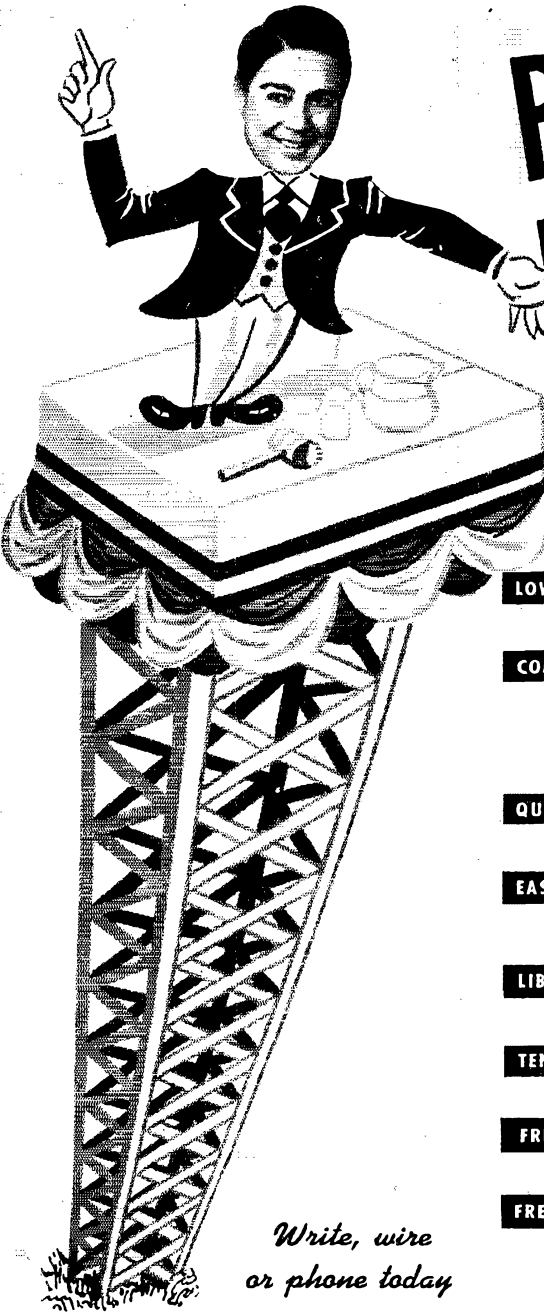

# BOB HENRY'S PLATFORM

## LOW PRICES

I guarantee to sell to you as cheap as you can buy anywhere.

## COMPLETE STOCKS

Hallicrafters, National, Hammarlund, Collins, Millen, RME, Pierson, Temco, Meissner, Supreme Transmitters, Meck, Gordon, Amphel-Mims, RCA, Vibroplex, Sonar, all other amateur receivers, transmitters, beams, parts, etc. If it is amateur or communications equipment—I can supply it.

## QUICK DELIVERY

Mail, phone, or wire your order. *Shipment within four hours.*

## EASY TERMS

I have the world's best time sale plan because I finance the terms myself. I save you time and money. I cooperate with you. Write for details.

## LIBERAL TRADE-IN ALLOWANCE

Other jobbers say I allow too much. Tell me what you have to trade and what you want.

## TEN DAY FREE TRIAL

Try any receiver ten days, return it for full refund if not satisfied.

## FREE NINETY DAY SERVICE

I service everything I sell free for 90 days. At a reasonable price after 90 days.

## FREE TECHNICAL ADVICE

and personal attention and help on your inquiries and problems.

*Write, wire  
or phone today*

*Hallicrafters products slightly higher  
when shipped from Los Angeles Store.*

Butler, Missouri

# HENRY RADIO STORES

Los Angeles 25, Calif.

"WORLD'S LARGEST DISTRIBUTORS OF SHORT WAVE RECEIVERS"



**Ruf-Koat  
Ne-O-Lite Tester  
Electronic Chemical Lab.**

**G-C RUF-KOAT AIR DRY  
WRINKLE VARNISH**

Only wrinkle finish that will air dry. Baking not required. Easy to use. Gives wrinkle finish. No. 60-2 — ¼ pt. List 45c



**G-C ELECTRONIC  
CHEMICAL LABORATORY**

Ideal for "hams," servicemen, experimenters, etc. 19 different bottles of chemicals in heavy steel rack (FREE RACK). No. 998. List. . . . . \$11.12



**G-C NE-O-LITE  
TESTER**

Handy, inexpensive, for countless ham uses. For 60 V. A.C. and 90 volts A.C.-D.C. Up to 500 Volts A.C. or D.C. No. 5100, on card. List. . . . . 50c

G-C Products are available at leading distributors

Write for the new G-C 147 and Hardware Catalog of over 4000 items

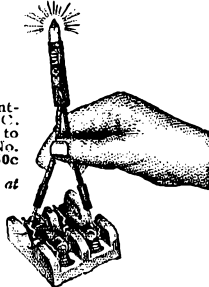

RADIO DIVISION DEPT. C

**GENERAL CEMENT Mfg. Co., Rockford, Ill., U. S. A.**

Manufacturers of over 3,000 products • Sales offices in principal cities

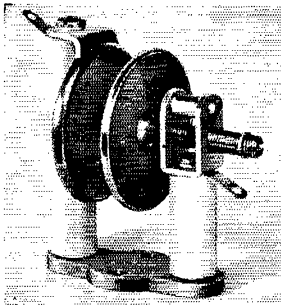

**NEW**

**NZ-10 NEUTRALIZING  
CONDENSER**

The improved design of the NZ-10 features smooth micrometer capacity adjustment and positive locking. Suitable for either single ended or push pull stages the NZ-10 has particular application in high frequency circuits where very fine capacity adjustment is required.

**HAMMARLUND**

THE HAMMARLUND MFG. CO., INC., 460 W. 34TH ST., NEW YORK 1, N. Y.  
MANUFACTURERS OF PRECISION COMMUNICATIONS EQUIPMENT

(Continued from page 114)

watt c.w. transmitter, plus distorted 'phone (??). The itinerary is Lima, Peru, Easter Island, Pitcairn Island, Mangreva, Fiji, Samoa, Palmyra, Hawaii, and Santa Monica, California. Gordon M. Curtis and William E. Olson (W6RWQ), and their wives, make up the crew. General contacts are made every night except Monday, using frequencies of 14,005 and 14,113, for c.w., and 14,220 for 'phone . . . . . Jeeves hopes you all have a pleasant vacation — he is wearing a grin a mile wide, because his boss is taking one also . . . . . 73.

**I.A.R.U.**

(Continued from page 51)

I.A.R.U. headquarters has been advised that there were approximately 1200 F amateurs before the war. The growing amateur population now numbers about 700 and is expected to reach 2000 in another year.

**QSL BUREAUS**

Changes and additions; complete list will be published, as usual, in the May and October issues of QST.

*Fiji:* D. A. Leslie, P & T Dept., Suva.

*Eire:* R. Mooney, "Eyrefield," Killiney, Co. Dublin.

*Germany:* (D4 calls only) Radio Branch, Communications Division, OCSigo, Hq. EUCOM, APO 757, c/o Postmaster, New York, N. Y.

*Hungary:* A. Sass, Dohany-u 1/c, Budapest.

*Mauritius:* V. de Robillard, Box 155, Port Louis.

*Nicaragua:* L. B. Satres, Bolivar Ave. 106, Managua.

*Roumania:* Nestor, Box 326, Bucharest.

*Yugoslavia:* H. Oton, Ljubljana-Provsetova nr. 1.

**50 Mc.**

(Continued from page 56)

on the 7th. Italian and French stations were heard on several other days, and on June 4th, WIK/WLL2/WRA13 was heard on 41.6 Mc., and WRG5/WRH5 was heard on 40.3 Mc. Can any reader furnish the location of these stations? This is important, as it may give us some idea whether there is a possibility of sporadic-E transmission across the Atlantic. Bursts of tone modulation on 47 Mc., believed to be a New York f.m. station, were heard on June 13th at 2015 GCT.

There is considerable interest in 5-meter work developing in Belgium and the Netherlands, and contacts are being made across the North Sea by tropospheric bending. G6DH has worked ON-4KN, PAØPN, PAØUN (117 miles) and PAØUM (203 miles). Quite a bit of work is being done around 0600 GCT, a point which should be of interest to our 2-meter men who are working on the early-morning schedule mentioned later on.

Harmonics from 28-Mc. D4 stations, commercial harmonics from Austria, and HB9CD and

(Continued on page 118)

# Leo Offers You The FIRST LOW PRICED 250 WATT XMTR KIT WITH 6 METERS—AT NO EXTRA COST

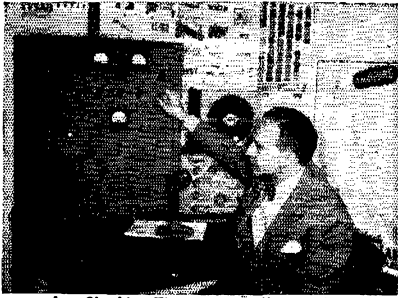

Leo Checking The New 250 Watt XMTR

We're making delivery now on our new 250 Watt Xmitter! In keeping with the times, we have designed for the first time a Xmitter Kit that meets the tremendous demand for a low cost, high quality unit — with 6 meters at no extra cost.

Comes in streamlined, gray crackle finish steel cabinet, 28 3/16" high x 22" wide x 14 3/4" deep. Here is a compact, versatile unit that will sell for approximately \$350, completely wired. Place your order now for fast delivery.

## LOWEST TIME PAYMENTS—LIBERAL TRADE-INS

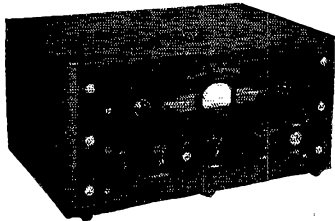

### W.R.L. Globe Trotter XMTR Kits

Giving 'round the world performance for amateurs 'round the world!

Hams everywhere say it's the hottest transmitter kit on the market. You will, too, once you've used it. It's a 40 watt input kit including all parts, chassis, panel and stream lined cabinet. Write for export prices.

- Caf. No. 70-300 Less tubes . . . . . **\$69.95**
- Caf. No. 70-312 Same as above, wired . . . . . **\$79.50**
- 1 set coils, meters, tubes, extra . . . . . **17.15**

### SCOOP! Receivers, Xmtrs for Ham Bands

Leo has waited until now to stock those few good surplus items that hams can use with minor changes. Some new, some used—available at lowest prices yet offered.

### BRAND NEW BC-348 RECEIVERS! in original wooden boxes

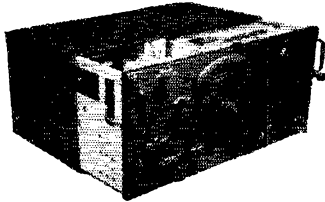

The most popular Surplus receiver on the market. They're New! — not used.

Complete with tubes and dynamotor only

**\$54.50**

Converted to 110 volt AC operation by our engineers . . . . . **\$69.50**

Complete A.C. Conversion kit . . . . . **6.50**

- ARN-5A 11-tube Superhet Will operate 6 meter band **\$13.95**
- BC-645 1 F.F. Xmtr-Receiver **\$14.95**
- BC-654 Xmtr-Receiver 25 Watts output. Fine for 80 **\$12.95**
- SCR-522 Xmtr-Receiver Fine for 2 meter operation **\$19.95**
- SCR-274-N Xmtr-Receiver \$600 value — at Leo's for only **\$34.95**

Write for detailed descriptions on above



### HAM GEAR — we have it!

**GET FAST DELIVERY FROM LEO!**

Item	Cash Price	Down Payment
Hallcrafters S38 . . . . .	\$ 47.50	\$ 9.50
Hallcrafters S40 . . . . .	89.50	17.90
Hallcrafters SP44 . . . . .	99.50	19.90
Hallcrafters SX42 . . . . .	275.00	55.00
Hallcrafters HT-9 . . . . .	350.00	70.00
RME VH-F-152 . . . . .	86.60	17.32
RME-84 . . . . .	96.70	19.74
RME-45 . . . . .	198.70	39.74
Hammarlund HQ 129X . . . . .	161.40	32.28
Hammarlund SPC400X . . . . .	334.05	66.81
National NC46 . . . . .	97.50	19.50
National 1-10A . . . . .	67.50	13.50
National NC173 . . . . .	179.50	35.90
National NC240DT or NC240D R . . . . .	225.00	45.00
National HRO-STAL or HRO-SRA . . . . .	245.00	49.00
Piercon KP-81 . . . . .	367.65	73.53
Gon-Set Converters . . . . .	39.95	7.99
Collins 70E-8 . . . . .	40.00	8.00
Bud VFO-21 . . . . .	52.50	10.50
Melrose Signal Shifter . . . . .	120.00	24.00
Abbott TR-4B Special . . . . .	45.00	9.00
New Micro-Match Unit . . . . .	29.50	5.90
Millen R-9er . . . . .	24.75	4.95
BB-27 10 meter converter F.B. for 348 . . . . .	27.50	5.50
Sonar Mobile MB-611 transmitter . . . . .	72.45	14.49
MB-611 with power supply . . . . .	31.45	16.29
WRL exciter unit wired . . . . .	23.95	4.79
Millen 90800 exciter . . . . .	42.50	7.50
Sonar XE-10 transmitter . . . . .	87.45	17.49
Workshop 28 megacycle beam 3 element . . . . .	39.50	7.90
Workshop 6 element 28 megacycle type . . . . .	100.00	20.00
Workshop 20 meter beam 3 element . . . . .	120.00	24.00
Gordon Rotary Beam . . . . .	225.00	45.00
Direct-O-Beam . . . . .	117.00	23.40
New Beach ECO . . . . .	32.50	7.50

★ 4 Mfd 1500 Volt DC Condenser \$1.29  
0-500 D.C. Mills G.E. 2 3/4" Round Meter 2.95  
0-1 D.C. Mills — 3 3/4" " " 3.95 ★

FOR THE BEST DEAL, WRITE TO LEO, W6GFQ

**World Radio Laboratories**  
Department G-8  
Council Bluffs, Iowa

FREE

Send latest Free Flyer

Send data on WRL 250 Watt XMTR

Send more data on the Globe Trotter

Send data on your Good Surplus

Send more data on . . . . .

.....

Name . . . . .

Address . . . . .

City . . . . .

..... Call letters

..... Zone . . . . . State . . . . .

# DRAKE RADIO SOLDERING IRONS



**600-10**—the Drake No. 600-10 is ideal for those all important connections when rewiring your rig. Get back on the air fast. Make good dependable connections with this 100 watt  $\frac{3}{8}$ " tip.



**400**—the Drake No. 400 is the perfect iron for work in small places. Only 9 inches long, it is especially designed for tight corners and delicate connections. 60 watt,  $\frac{1}{4}$ " tip.



Ask your nearest supplier or write for the name of the distributor nearest you . . . and give yourself the advantages of these superior irons.

**DRAKE ELECTRIC WORKS, INC.**  
3656 LINCOLN AVE. CHICAGO 13, ILL.

## Micro Match

AN INSTRUMENT FOR MEASURING  
STANDING WAVE RATIO AND RF POWER

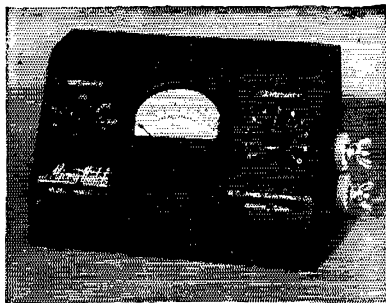

FEATURED IN APRIL QST  
Amateur net \$29.50  
Contact your local distributor

Manufactured by

**M. C. JONES ELECTRONICS COMPANY**  
BRISTOL, CONNECTICUT

Distributed Outside of Continental U. S. A. by  
RCA International Division, Radio Corporation of America  
745 Fifth Avenue, New York 22, N. Y., U. S. A.

(Continued from page 116)

### RECORDS

#### Two-Way Work

50 Mc.: KH6DD — J9AAK  
4600 Miles — January 25, 1947  
144 Mc.: W3KUX — W1MNF  
425 Miles — May 16, 1947  
235 Mc.: W6OVK — W90AW/6  
186 Miles — March 2, 1947  
420 Mc.: W6FZA/6 — W6UID/6  
170 Miles — September 28, 1946  
1215 Mc.: W1BBM — W1ARC  
3 Miles — April 7, 1947  
2300 Mc.: W6IFE — W6IFE/6  
24.6 Miles — May 24, 1947  
3300 Mc.: W6IFE — W6IFE/6  
20.2 Miles — June 5, 1947  
5250 Mc.: W2LGF/2 — W7FQF/2  
31 Miles — December 2, 1945  
10,000 Mc.: W4HPJ/3 — W6IFE/3  
7.65 Miles — July 11, 1946  
21,000 Mc.: W1NVL/2 — W9SAD/2  
800 Feet — May 18, 1946

I1DA, were heard on June 7th by G5BY, and Hilton's signals were reported heard by OK2MV and OK1GA on this date. F3JB was heard on June 10th. On the 13th, FA8IH, I1IRA, F9BG, F9AQ and W5BSY/MM were worked, the maritime-mobile station being worked again the following day. FA8BG and FA8II were worked, with very strong signals, on the 17th. On June 1st, a new inter-G record was set by G5BY and G5GX, of Hull, a distance of 285 miles. In a message relayed by W9FKC, I1AY tells us of working several Gs on June 7th, and W5BSY/MM on the 14th.

#### New 50-Mc. DX Record?

A message from Mr. Clyne, federal secretary of the WIA, tells of a contact between VK3BD and a station signing LU2CP on May 31st at 0615 GCT. VK3BD used m.c.w., while the LU used 'phone, in Spanish. Since this is a distance of more than 7000 miles, it is a new world's record by a wide margin, and mighty important news, if true. Unfortunately, LU2CP is not listed in the *Call Book*. Can anyone shed any light on this report?

The report of reception of the signals of VK2NO by VE7AEZ, detailed last month, appears to have been false. A check by VK2NO reveals that the information available does not agree with his log, either as to time or frequency. Another report, arriving by relays, says that J9AAK, current holder of the far end of the recognized DX record, has worked a station in Japan on 6. No confirmation has yet been received from Tex on this one.

#### Fall DX Prospects

While we are on the subject of international DX, here is an interesting prospect: XZ2AA,

(Continued on page 120)



# NEWARK—HEADQUARTERS FOR VALUE

Amazing 7"  
TELEVISION  
KIT  
\$7750  
LESS TUBES

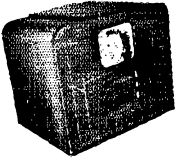

Again Newark shows the way! This fine 7" Telekit, at our amazing price, is easy to assemble from complete kit of parts, with simple instructions. Thousands in use. Guaranteed Performance! 17 tubes, including 7" picture tube. Sound reception is high fidelity FM. Less tubes and cabinet. **Only \$15.50 Down—\$5.48 Per Month**  
Walnut Cabinet for above.....\$29.50  
Front Panel Only.....\$10.00

0-150

## DC MICROAMMETER

Precision — Made by leading mfrs. 2 1/2" Bakelite case. All BRAND NEW and Perfect! No. S-437 **\$345**



## WEBSTER WIRE RECORDER

Foundation Unit Thrilling new Wire Recorder—Reproducer Unit

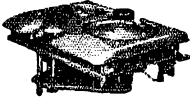

around which you can build a complete instrument. Consists of wire-moving mechanism, recording head that records, erases and plays back, self-starting motor for 110 v., 50-60 cycles, 1-15 minute spool of wire, Osc. coil, instructions. Inexpensive, simple, **\$5292**

## Smashing Reductions! TRANSMITTING AND SPECIAL PURPOSE TUBES

Hams, Experimenters! Save NOW on these Great Surplus Tube Buys! All JAN Approved — All NEW and GUARANTEED. Many thousands in stock! Order NOW!

Hy69	\$1.65	809	1.50
Hy615	1.13	811	1.95
2AP1	2.25	813	6.75
2AP1A	5.25	814	4.50
2C26A	.75	826	1.50
2C40	2.63	832A/832	2.25
2C44	1.50	836	1.13
2K25/723AB	12.00	837	2.25
2X2/879	.90	838	3.75
3AP1	3.00	845W	3.75
3BP1	3.00	865	1.50
3C24/24G	1.20	872A/872	2.25
3CP1	6.00	874	1.95
3DP1	4.50	884	.75
3EP1	3.00	931A	1.88
3E29	3.00	954	.75
3FP7	3.00	955	.75
3GP1	3.75	956	.75
5AP1	4.50	957	.75
5BP1	3.75	958A	.75
5BP4	3.75	959	.75
5CP1	3.75	1616	3.00
5LP1	9.00	1619	.75
6AC7W	.68	1624	.90
6AK5	.90	1625	.53
9IP1	6.00	1626	.60
9CP7/9MP7	12.00	1629	.27
10Y	.75	1851	.95
12D7	6.00	2051	.53
75TL	2.25	7193	.45
OC3/UR105	.75	8005	3.15
OD3/VR150	.75	9001	1.05
304TL	3.75	9002	.90
316A	.75	9003	1.05
801A/801	1.13	9004	.90
807	.95	9006	.68

## 440 mmfd. CONDENSER

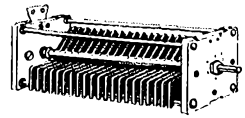

Super Quality! 87 Plates, .070 air gap. Ceramic end plates. Silver Contacts. One piece constr., nickel-plated brass. 2" x 2" x 7", 1/4" shaft. Many uses. **Wonderful Buy, only 69¢**

## Scoop!

### HS-30 Phones

NEW Signal Corps Phones. 250 ohm impeded with matching transformer to 8000 ohms. PL-540 Plug, 8 ft. cord. Soft rubber ear plugs. Light adj. headband..... **\$195**

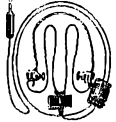

### HS-23 Phones

Brand New! 8000 ohms impeded. Bakelite cap and shell, rubber cushions, adj. band. No. S-144..... **\$195**  
HS-33, same as above, but low impeded. No. S-333..... **\$189**



Attention Hams! The well known and popular Robert W. Gunderson W2JIO, Ham extraordinary, will be available at our New York Stores EVERY SATURDAY. Old Hams and new will appreciate his guidance and enjoy his company.

Choose any Receiver, Transmitter or Group of Parts Totalling \$75 or Over  
**TAKE ONE YEAR TO PAY! 20% DOWN — 12 MONTHLY PAYMENTS**

## HALLICRAFTERS

Famous  
**HT-9**  
XMITTER

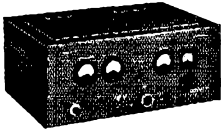

Ideal 100 Watt Transmitter for maximum flexibility and convenience on phone and CW. A streamlined rig to enhance any shack. Wonderful Performance! Complete with tubes, less coils and crystals..... **\$350**

Only \$70 Down—\$24.73 Per Month  
10 meter coils for above.....\$16.50 per set  
20 meter coils for above.....\$15.50 per set  
40 meter coils for above.....\$11.75 per set  
80 meter coils for above.....\$10.85 per set

## Now Available! RECEIVERS & TRANSMITTERS

	Cash Price	Down Pay't	Per* Mo.
<b>HALLICRAFTERS</b>			
S-38 Complete.....	\$ 47.50		
S-40A Complete.....	89.50	\$17.90	\$ 6.32
SX-42 .....	275.00	55.00	19.43
<b>NATIONAL</b>			
NC-173 W/Speaker ...	189.50	37.94	13.39
NC-240D W/Speaker ...	241.44	48.36	17.06
NC-46 W/Speaker ....	107.40	21.48	7.59
<b>HAMMARLUND</b>			
HQ-129X Complete .....	173.25	34.65	12.24
SP-400X Complete .....	342.00	68.40	24.17
<b>R M E</b>			
RME-45 Complete.....	198.70	39.70	14.04
RME-84 Complete.....	98.70	19.74	6.97

\*Includes 6% per yr. Interest.



**MILLEN**  
**50 WATT EXCITER**  
Model 90800 — 50 Watt Xmitter/Exciter, uses 807 final straight or as doubler. With 10-11 meter coils. **\$4250**

**McMURDO SILVER**  
**702 — VFO EXCITER — AM & NFM.** Crystal-Controlled. Another fine "Atom" 5" H x 10" x 5 1/4" D. Complete with crystal, cord and plug. Less Tubes. 10 lbs..... **\$4990**  
Kit of 10 Tubes (4-6C4, 1-6BE6, 1-25L6, 2-25Z6, 1-6AU6, 1-0B2)..... **\$10.55**  
**703 — FREQUENCY MULTIPLIER.** 3-54 MC, 10 watts output. Switches bands with pre-tuned accuracy. 6" x 6" x 10 7/8" D. Less tubes, cabinet and Power Supply. 10 lbs..... **\$4990**  
Kit of 5 tubes (4-6AG7, 1-2E25) **\$11.95**

Prices Subject to Change

**NEW YORK**  
Offices & Warehouse  
242 W. 55th St., N.Y. 19

**NEWARK** CHICAGO  
ELECTRIC COMPANY, INC.  
323 W. Madison St.  
Chicago 6, Ill.

SEND ORDERS TO  
242 W. 55th STREET  
NEW YORK 19, N. Y.  
OR  
323 W. MADISON ST.  
CHICAGO 6, ILL.

New York City Stores: 115-17 W. 45th St. & 212 Fulton St.

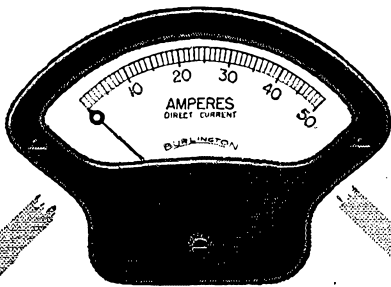

RUGGED . . . DEPENDABLE . . . ACCURATE



## PANEL INSTRUMENTS

For utmost reliability—specify and depend upon Burlington Panel Instruments. They are designed, engineered and built to give satisfactory service even under most severe applications—and are fully guaranteed for one year against defects in material or workmanship. Write today for full details.

**BURLINGTON INSTRUMENT COMPANY**  
816 Fourth Street  
BURLINGTON • IOWA

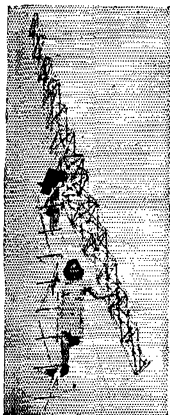

## TRYLON ROTARY BEAM ANTENNA SUPPORT

for 4-element 20-meter array

Quick, easy to install on any tower. Stainless steel, spot-welded construction. 19' 2" long, yet weighs only 30 lbs. Adaptable to either manual or motor drive. Ball bearing design provides full 360° traverse. Support can be tilted in either direction for easy accessibility. Has ample safety margin to withstand severe wind and icing conditions. Write for descriptive circular.

### RADIO TOWERS

Standard and special types for amateur and commercial requirements.

**TRYLON TOWER AND ANTENNA DIVISION**  
Wind Turbine Co., West Chester, Pa.

Rangoon, Burma, is all set to go on 50.4 Mc. He would like to arrange schedules with stations in the Philippine Islands and elsewhere in the high-m.u.f. belts. His address: Sgt. R. Braithwaite, Transmitting Area, 3 Sqdn., Burma Command Signal Regt., c/o G.P.O., Rangoon, Burma.

The LUs are now on 50 Mc., and several of them are interested in the possibility of working into the United States on 6. LU5AQ and LU2AR, attending the Atlantic City Conference, report that our f.m. stations, 42-48 Mc., have been heard quite well. A message relayed by W111A says that LU9AX is on 50.15 Mc. every Saturday, from 1600 to 1900 GCT, and on Sundays from 1200 to 1500 GCT. He has 250 watts input and a vertical array pointed at this country. LU5CK will be listening at the same times.

The CRPL predictions for the fall season are now available, and they look promising. North-south paths, particularly, are up over last year. The OA-W4 path should be open this fall in fine style, and contacts with other South American countries may be possible. In Chuquicamata, Chile, CE1AH is getting ready. Ida and Larry hoped to be on before now, but the parts and receiving equipment were slow in arriving, but they should be all set before September. They have two frequencies, one close to the low edge, and another just above 50.5 Mc. They will have an 829 in the final, for which the exciter is already in working order.

The path from Hawaii to Australia looks promising for this fall, too. W7ACS/KH6, visiting here recently, was quite enthused over the appearance of the September charts. He feels sure that he will be able to make some good contacts with VK4HR at Brisbane, with whom he had several fragmentary exchanges on 50 Mc. last spring. Gene will be back in the Islands by the time this appears in print, and can be counted upon to ride the 50-Mc. band for all it's worth. KH6DD, unfortunately, has orders to return to the States, so Bob will not be out there to help this fall.

Here's another good one: SU1HF (W6IAQ) will be on from Cairo this fall. He should be in an excellent spot for 50-Mc. DX, and if his signal on 10 is any indication, he's the man to do it.

### Here and There on 6

"Why don't more of you guys use c.w.?" This question appears frequently in the reports sent in by stations in W6 and W7. The log provides the best answer: scores of CQs on c.w., with practically no answers; results on voice are much better. This proves nothing, of course, except that if you'd like to have fellows use c.w. you should use it yourself. More use of c.w. for calling, at least, would certainly raise all of our percentages — if there were more use of the b.f.o. in receiving! Since DX openings are often a matter of a few priceless minutes in which to grab off a new



# With a Modern Communications Receiver!

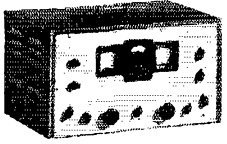

Hammarlund HQ-129X

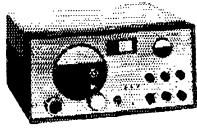

Hallicrafters SX-42

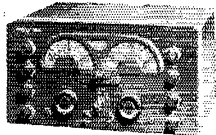

National NC-173

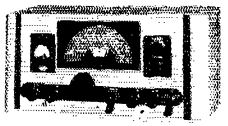

RME-45

## ALLIED has them all — available for immediate delivery

- National NC-173, with speaker.....\$189.50
- National NC-2-40D, less speaker..... 225.00
- National NC-46, with speaker..... 107.40
- National HRO, less speaker..... 274.35
- Hallicrafters SX-42, less speaker..... 275.00
- Hallicrafters S-38..... 47.50
- Hallicrafters S-40A..... 89.50

- Hammarlund SPC-400X, with speaker. \$347.25
- Hammarlund HQ-129X, with speaker. 173.25
- RME-84..... 98.70
- RME-45, with speaker..... 198.70
- RME VHF-52 Converter..... 86.60
- RME DB-22 Preselector..... 60.00
- Collins 75A-1 Receiver..... 375.00

**Time Payments Available**  
Trade-Ins Accepted

You can't work 'em if you can't hear 'em. Making WAC is no accident. It's the result of operating skill—and the *quality of the equipment you use*. Stations "equipped by ALLIED" are FB. ALLIED offers you the world's largest stocks of fine receivers and station equipment, available for immediate delivery at lowest prevailing prices. Get everything you need from ALLIED'S latest catalog—the largest and most complete in the field. Try us for personal service, speedy action and the kind of help you want when you want it.

**ALLIED SCOOP! SPECIAL CASE VALUE**

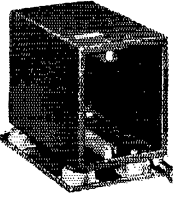

Mobile transmitter or receiver case. Sturdy steel cabinet, 10 1/2" deep, 7 1/2" high, 6 1/4" wide; black wrinkle finish. Rubber shock-mounted base. Ideal for constructing mobile equipment, power packs, UHF gear, etc. Brand-new; offered at less than manufacturer's cost. Shpg. wt. 8 lbs. No. 86-399. NET, F.O.B. Chicago. **95c ONLY**.....

Keep This Buying Guide Handy...



**ALLIED RADIO**

*Everything for the HAM*

ALLIED RADIO CORP., D. L. Warner, W9IBC  
833 W. Jackson Blvd., Dept. 27-H-7  
Chicago 7, Illinois

- Send FREE 1947 ALLIED Catalog.
- Enter order for.....
- Enclosed \$..... Full Payment     Part Payment (Balance C.O.D.)
- Send Literature on Receivers and Time Payment Plan

Name.....  
Address.....  
City..... Zone..... State.....

(Continued from page 120)

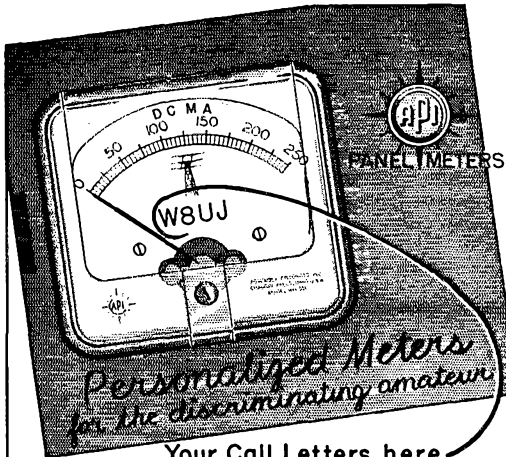

**Your Call Letters here**

- Crystal clear plastic
- One piece front
- Full view
- Rear illumination
- 3 3/8" high 3 3/4" wide
- Voltmeters
- Milliammeters
- Ammeters
- AC-DC-RF

See these at your jobber or write for circular

**ELECTRICAL INSTRUMENTS**  
 ASSEMBLY PRODUCTS INC.  
 Chagrin Falls, Ohio, U.S.A.

OTHER API PANEL METERS  
 2 1/2" & 3 1/2" Sizes  
 Round - square  
 AC - DC

**W8CFK** **Aluminum Call Plates**

Your call cast in aluminum with black background and polished 1 1/4" letters. Plate size 2" by 6 1/2". 3 styles: P for panel mounting, L for car license and D for desk use. \$1.75 each, postpaid.

P & H SALES CO.  
 619 Jasper St. Kalamazoo 31, Michigan

**Founded in 1909**

**RADIO TELEPHONY**  
**RADIO TELEGRAPHY**

Courses ranging in length from 7 to 12 months. Dormitory accommodations on campus. The college owns KPAC, 5 KW broadcast station with studios located on campus. New students accepted monthly. If interested in radio training necessary to pass F. C. C. examinations for first-class telephone and second-class telegraph licenses, write for details.

**PORT ARTHUR COLLEGE** PORT ARTHUR TEXAS  
 Approved for G.I. training

state, or work some new locality, the contacts so made usually last only long enough to carry out an exchange of calls and signal reports. Such exchanges could be handled in half the time on c.w. How about it, gang?

Which brings up the suggestion recently received from several quarters that the first 100 kc. of the band be set aside for c.w. only. The congestion at the low edge has become almost intolerable for voice operation. Since band-edge work is logical for DX chasing, and c.w. is the best medium, why not set aside that first 100 kc.? There is plenty of room elsewhere in the band for voice work, and it's just about as easy to work out on voice from at least 51 Mc. as it is on 50.0 — if only more of the gang will tune above the low edge when working on 'phone. Here at WIHQD we've been working on 51.1 Mc. a good deal recently as an experiment, and we find that our QSOs are far more solid than when we use our low-edge DX rock. With u.f.m. about to be authorized above 51 Mc., there will be more boys in that 51-52 range. Let's tune up there, and above 52, too, and give the fellows who are trying to promote use of more of the band a break.

The fellows who are in the sought-after class, particularly, have a chance to help in this use-the-whole-band movement. There is little point in these fellows working in the low edge of the band, where they are constantly being lost in the welter of stations who are calling them. If you are in a sparsely-populated state, how about moving up in the band? And let it be known, as you call CQ or stand by, that you tunc above 50.1 occasionally, too! Another point for the DX stations: announce the frequency you are tuning — it will save a lot of useless calling on the part of hopefuls who are far away from your receiver setting.

Once upon a time we considered any night a hot one when two or more DX stations were heard. Times have changed — WØZIS, St. Louis, Mo., logged an even 100 stations, in all call areas, one night recently!

**490 Miles on 144 Mc.!**

No, it's not a new two-way record, as yet, but it can happen here. Early in the morning of June 11th, W2ADW, East Quogue, Long Island, worked W4CLY, Cape Henry Lighthouse, Va., a distance of about 370 miles. During this QSO, the signals of W4CLY were heard by W1SF, Branford, Conn., 380 miles, W1JFF, Newport, R. I., 430 miles, and W1MNF, East Orleans, Mass., 490 miles. With the exception of W1SF, who must cross Long Island, the path from each of these stations to Cape Henry, at the southern end of Chesapeake Bay, not far from the North Carolina border, is entirely over water. It is apparent that W4CLY has the ideal location for setting a new 144-Mc. record during the summer and fall months.

That long stretch of Atlantic Seaboard, with

(Continued on page 124)

# HARRISON HAS IT!

# HARRISON HAS IT!

## I offer you —

### ● COMPLETE STOCKS

Everything for the Shack, Shop, or Lab! All good makes all models

### ● LOWEST PRICES

I guarantee our prices to be the lowest in the country. I don't expect you to pay one penny extra for our better service and friendly cooperation!

### ● TOP TRADE-IN ALLOWANCE

Our reputation for fair dealing gives us a tremendous steady market for reconditioned equipment. We pass this advantage on to you by giving you 5% more than the best allowance offered for your present gear.

There you are, fellows! There's plenty of good reasons for doing business with me. Let's get together — I promise you'll be well satisfied. Drop in, or write to me — now!

### ● QUICKER DELIVERY

Being an active Ham, I know the eagerness with which you await the thrill of putting a new receiver or transmitter through its paces! That is the reason why every single person in my organization really sees to it that your orders (for a small part or a complete station) are shipped quickly, with no mistakes, carefully packed to arrive in perfect condition.

### ● TIME PAYMENTS

As usual, I bring you the best deal! With the Harrison Easy Pay Plan you can enjoy the use of your new equipment right away with a total down payment of as little as 20%. Entire charge is only 6% on the balance, with a full year to pay. Tell me the items you want, and the approximate terms you desire (you need send only \$5 with your order).

Tnx es 73 *Bil Harrison*, W2AVA

### ALTEC — LANSING SPEAKERS

Model 604 Duplex Speaker. "The finest loudspeaker on the market." Unexcelled for FM and other wide range applications. 15 inch low frequency cone with 3-inch voice coil, 2000 cycle crossover, concentric high frequency driver with multi-cellular diffuser horn. Alnico V fields, 30 watt rating. The best speaker \$157.50 (In model 605A finely finished Mahogany floor cabinet 31" X 17" X 36", Complete. . . . . \$322.50)

Model 603 Multicell Diacone. Metal high frequency diaphragm and 15 inch low frequency cone coupled to mechanical dividing network driven by single 3-inch 10 ohm voice coil. Multi-cellular horn. \$63.00 Rated 25 watts. . . . .

Model 600. 12inch Diacone, similar to 603 but does not have multi-cellular horn. Rated power 20 watts. \$45.00 A superior speaker at a reasonable price . . . . .

Harrison can furnish all Altec — Lansing "Voice of the Theatre" Speaker Systems, Amplifiers, Cabinets, etc. Ask for Literature

### See the new TEMCO "RA"

Transmitter Units FIRST at *Harrisons* Premier Exhibit of these versatile transmitter "building blocks" that eliminate obsolescence. Come in, or write for "RA" Catalog!

### TELEX MONOSET \$7.50

Entry blanks available for the TELEX PRIZE CONTEST (we refund to prize winning customers)

### TELEVISION KITS

Build your own television receiver — for fun, or profitable sale. Complete, detailed instructions and factory wired and tuned RF section make construction simple and sure. Ten meter horns can probably (not guaranteed) get invaluable first-hand experience with TVI. Kits contain punched chassis, speaker and all parts for complete video and FM audio reception.

7" Telekh. . . . . \$77.50 10" Telekit. . . . . \$124.50  
Kit of 17 tubes. . . . . \$39.97 Kit of 19 tubes. . . . . \$64.94

Folded dipole Antenna, with reflector . . . . . \$11.40  
300 ohm Ribbon lead, 100 feet. . . . . \$2.85

### WIRE RECORDERS

Coming soon! Place order now for earliest delivery when available.

RCA. Complete recorder, with microphone and half hour wire cartridge pack \$139.50

WEBSTER-CHICAGO. Foundation unit — to be used with present amplifier. \$52.92

BRUSH. Professional Model. 80 to 8000 cycles. Up to 3 hour continuous recording. Complete \$795.00

### — HARRISON SELECT SURPLUS —

#### SCR 522-A

The one they're all raving about! An FB Xtal controlled transmitter and super-het receiver for 2 meters. See articles July '52, etc. Slightly used, in perfect condition (we were careful to get the good ones!), complete with 17 tubes, dynamotor, remote control, plugs, crystals, and conversion data. . . . . \$34.95  
Less accessories, but with complete set of tubes and data. . . . . \$14.95

#### Ideal E-Z Automatic WIRE STRIPPER

Model 01. Cleanly strips all wire 16 to 22. Jaws remain open, not crushing wire. Regular Net \$6.45. HSS \$3.49

#### BC 406 UHF RECEIVERS

We managed to secure a few more of these popular Signal Corps receivers — and look at the price! Like new, complete with 15 tubes, case, and data. 115 volt, 60 cycle operated. KB for conversion to a *het* 2, 6, or 10 meter super-het, or television receiver. \$14.98  
See our previous ads. A HSS Special! . . . . .

**HAM HEADQUARTERS**  
Since 1925!



## HARRISON RADIO CORPORATION

12 WEST BROADWAY • NEW YORK CITY 7

PHONE — BArlay 7-9854 • EXPORT DEPT. — CABLE — "HARRISORAD"

[JAMAICA BRANCH — 172-31 Hillside Ave. — REpublic 9-4102]

# ELINCOR ALL ALUMINUM BEAMS

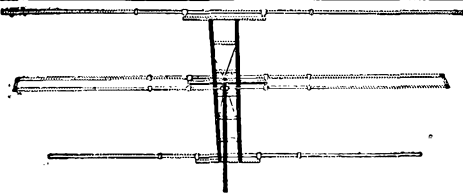

Model 400-EA

Model 400-EA. 3-ELEMENT FOLDED DI-POLE 10 METER BEAM KIT. Feed with RG8/U coaxial cable. Amateur net price. **\$31.20**

Model 400-RA. 3-ELEMENT 10 METER BEAM KIT. Feed with 300 ohm twinax line. Amateur net price. **\$27.00**

Model 400-BA. 2-ELEMENT 10 METER BEAM KIT. Feed with RG8/U coaxial cable. Amateur net price. **\$20.40**

All of the above antennas are furnished complete with all aluminum supporting ladder, 2 1/2" steatite standoff insulators, hardware and instructions. The elements are 3/4" aluminum tubing telescoping to 3/8" and are adjustable over a range of several feet.

Model 200-EA. 5-ELEMENT 2 METER BEAM KIT. Folded di-pole driven element. All aluminum construction. Feed with low impedance coaxial cable. Amateur net price. **\$8.40**

We also manufacture a complete line of FM, Television, Broadcast and shortwave antennas. Send for literature.

Sold through Dealers  
Only



Prices slightly higher  
on West Coast

## ELECTRONIC INDICATOR CORP.

35-44 61st STREET

WOODSIDE, L. I., N. Y.

★ YOUR FUTURE  
IN  
★ RADIO . . .

May depend on the integrity and ability of your School's Administration. At MELVILLE no effort is spared to provide the best in facilities and service for the serious student of RADIO, TELEVISION, FREQUENCY MODULATION, TELEGRAPHY, SLIP TRANSCRIPTION, RADIO MATHEMATICS, etc.

Approved for Veterans  
Licensed by the State of N. Y.  
Write or call today for FREE  
Bulletin B

MELVILLE  
RADIO INSTITUTE  
MELVILLE BUILDING  
15 W. 46th St., N. Y. 19, N. Y.  
Bryant 9-5080  
"Managed by Radio Men"

(Continued from page 122)

## V. H. F. MARATHON

Contacts Through June 15th  
(Incomplete)

Call	50 144 235			Score	States Worked in 1947	
	Mc.	Mc.	Mc.		50 Mc.	144 Mc.
W1AF	111			690	19	
W1BCT		154	5	717		6
W1CGY	95			923	27	
W1CLS	173			1615	34	
W1EH*		31		136		3
W1FRK		26		142		2
W1HDQ*	160	45		1705	29	5
W1HMS	45	8		420	19	
W1KLR		102		495		4
W1LLL	157			1590	31	
W1LMU		72		302		2
W1MPO		24		134		4
W1PEN		81		668		4
W1PLQ		78		285		1
W1PYM		43		154		1
W3CIR/1	202			1807	35	
W2AMJ	175			1428	27	
W2BYM	190			1657	30	
W2CBB		121		468		5
W2COT	59	116		590	9	3
W2DZA/2		134	11	635	5	5
W2NLY		220		1344	6	6
W2PWP	121			942	27	
W2QVH	162	83		1434	37	3
W2RLV	82			1116	30	
W2RSO		102		1022	6	
W2ZD		247		1313		4
W3AWS/8		29		138		3
W3CGV	106	30		989	25	5
W3GFP	8	64		557	2	6
W3HWN/3		150		1255		6
W3MHW		173		956		5
W3MNA		83		536		5
W3RUE	75	50		1367	26	2
W4AVT	43			440	16	
W4FJ	50	21		856	24	5
W4HVV	101	4		1264	23	2
W4LNG	8	27		203	3	1
W4WMI	104	2		1144	27	1
W5LIU	9			49	3	
W5ESZ	49			561	22	
W5FSC	69			1375	28	
W6BWG	114			614	7	
W6BZ	126	142		1240	13	1
W6VOK	60	121		1721	17	1
W6WNN	105	5		1618	21	1
W7ACS/KH6	6			123	0	
W7QAP	78			1028	19	
W8QQS	51			639	16	
W8RFW	37			227	11	
W8TDJ	23	1		323	14	1
W8UKS		61		628		4
W9AB	43	6		466	17	1
W9AGV		29		113		2
W9ALU	55	8		768	27	1
W9CZD	32			337	11	
W9JMS	125	2		1926	31	1
W9MBL	17			218	5	
W9PK	152	34		2248	31	2
W9ZHL**	172	4		2571	34	1
W0DNW	124			1294	26	
W0QIN	148			1907	37	
W0VIK	63			624	15	

\* Not eligible for award.

\*\* Fifth-period winner: W9ZHL, Terre Haute, Ind., 1785 points — the highest one-month score in Marathon history!

its favorable propagation characteristics during the summer months, may look just too good to the fellow who is not so fortunately situated, but

(Continued on page 126)

# BENDIX 100 WATT TRANSMITTER

## FOUR SEPARATE ELECTRONIC COUPLED OSCILLATORS:

These can be easily converted to 20-40-80 meters. Crystal required for 10 meters. Each electronic coupled oscillator dial has 3000 divisions enabling quick precision shifting. This transmitter was constructed of the highest quality of precision parts, with laboratory precision. Four separate output tanks; one 4-position selector channel switch having seven sections which changes the ECO, PA and output tanks simultaneously. All the controls are mounted on the front panel. The housing is cast aluminum; shields and case are sheet aluminum. Dimensions 11 x 12 x 15 inches, weighing 35½ lbs. Complete, simple instructions for conversion furnished. Uses three 807, four 12SK7 tubes; one 2-inch 5 amp. R.F. meter.

A complete coverage transmitter, for the new or experienced amateur. Double Size... A TRUE HAM VALUE—BRAND NEW, complete with tubes... \$49.95

\$**49.95**

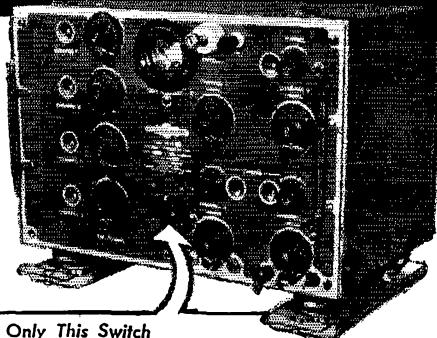

Only This Switch  
Used to Change 10-20-40-80  
Meter Bands

# Hot RADIO VALUES

AT SUN RADIO

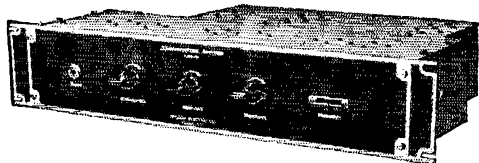

## 110 VOLT AC SUPERHETRODYNE RECEIVER

This crystal fixed frequency receiver comes with full conversion instructions for variable tuning of all ham bands and broadcast. A highly selective superheterodyne receiver, 110 V. A.C. power supply built in. Uses the following tubes; 6K7 RF Amplifier; 6K8 Mixer and Oscillator; 6K7 I.F. Amplifier; 6F7 Detector and A.V.C.; 6C8 Output and Noise Suppressor; 80 Rectifier. Dimensions: 3½ x 19 x 11½ inches. Comes complete, brand new, with one set of coils and two sets of tubes. . . . . \$16.95

Extra set of coils. . . . . \$2.95

● All items F.O.B. Washington, D. C. Orders \$30.00 or less cash with order. Above \$30.00, 25 percent with order, balance C.O.D.

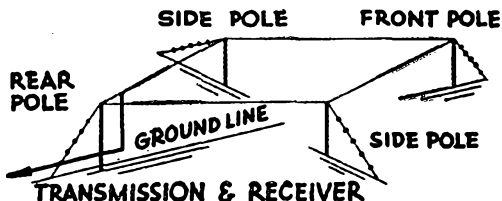

## RHOMBIC ANTENNA KIT

Consisting of:

- 2200 ft. wire, No. 14, AWG. Copperweld
- 9 spacer insulators
- 10 strain insulators
- 1 lightning arrester protector (Viso Glow)
- 50 ft. 2 wire cable, 200 ohm transmission line
- 12 wire rope clips
- 3 sheave pulleys
- 24 ft. flexible wire, tiller rope
- 50 ft. wire, 5/16" messenger, G.S.

Plus many other items, including steel thimbles; ground rod wire, guy clamps, thimbleye nuts, curved washers, anchors, anchor rods, bent eye bolt, staples, machine bolts, round washers, line support turn block, porcelain tube, line support insulator, galvanized iron shield, lag screws, screw eye insulator.

THE PRESENT MARKET COST OF THIS AERIAL  
EXCEEDS \$150.00

OUR PRICE COMPLETE **\$24.95**  
(less poles)

**SUN RADIO**  
OF WASHINGTON, D. C.  
938 F STREET, N. W. WASH. 4, D. C.



# Scoops Again!

## 52 OHM COAX CABLE

**BRAND NEW 60 Foot COILS COMPLETE WITH CONNECTORS..... \$1.25**

It's genuine Amphenol RG-5/U—use it in place of RG-8/U. Has smaller diameter (.332), less capacity between center conductor and shield, less weight, easier to handle than RG-8/U. Rated at 1100 watts at 30 Mc. Supplied complete with standard Amphenol 83-1SP-(PL 259) connectors attached at each end.

No. 4A496—60 ft. coil with connectors ..... **\$1.25**

Any number coils connect together with 83-1J connectors (below)



**Extra Connectors**  
For use with above Choice Each. **35c**

## 10 Hy. - 200 Ma.

### Thordarson Filter Choke

200 ohm D.C. resistance, 2000 V. RMS. Size 3 3/4" sq. x 4 3/4" high. Wt. 5 1/2 lbs. Has 12" leads at side.

No. 13A266 Special Each... **\$1.88**

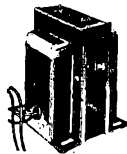

ORDER NOW, from this ad. Add Postage



**BURSTEIN-APPLEBEE** Company  
1012-14 MCGEE STREET,  
KANSAS CITY 6, MISSOURI

## COMPLETE RADIO TRAINING!

Prepare now to accept a responsible position in Commercial Radio. New developments will demand technicians with thorough basic training, plus a knowledge of new techniques discovered during the war. Training open to high school graduates or those with high school equivalency. Courses 6 to 18 months' duration in RADIO AND ELECTRONICS. Approved Veteran training in Radio. Write for Particulars.

VALPARAISO TECHNICAL INSTITUTE Valparaiso, Ind.  
Dept. TN

# THE Mytronic COMPANY

**AMATEUR RADIO HEADQUARTERS FOR SOUTHERN OHIO**

W  
8  
A  
N  
T

W  
8  
C  
N  
V

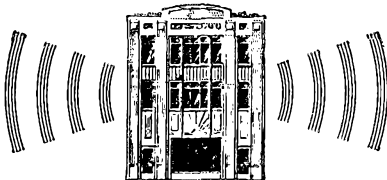

**CINCINNATI'S ONLY AMATEUR OWNED AMATEUR BUSINESS**  
SEND FOR LIST

**THE MYTRONIC COMPANY**  
121 West Central Parkway  
Cincinnati 2, Ohio

there are other possibilities for long-haul work on 144 Mc. The early-morning schedule mentioned last month may be one of these. Sponsored by W2DOG, as the result of commercial investigations in this field, the idea of keeping an early-morning schedule during the summer months has taken hold throughout the East. To help things along, the Erie, Penna., 2-meter group, lead by Herb Johnson, W3QKI, have mailed out about 100 letters to various prospects in the East and Middle West, asking for volunteers to keep the sunrise schedule, starting at 6:45 A.M. EDST daily. In the original group lined up by W2DOG are W1CTW, Arlington, Mass., W1SF, Branford, Conn., W2QAG, Buffalo, N. Y., W3HWN, Mechanicsburg, Penna., W3QKI, Erie, and W8WXV, Shiloh, Ohio. The propaganda efforts of the Erie group have added dozens of calls to the list, and quite a few early-morning contacts have been made. So join in, gang, any of you who have stabilized transmitters and hot receivers. Be on the job, particularly, on clear calm mornings, when the barometer is high — and let's hear how you make out!

Out in California there is interest in linking the entire length of the state with a 2-meter network. Some time back we reported that the mountainous path between Bakersfield and Los Angeles was one of the few remaining barriers. This has now been closed by W6DYJ, Bakersfield, who worked W6YTU, Los Angeles, and W6UFH, Burbank, on June 4th. The following night contact was made with W6TZX at Wilmington, a distance of nearly 120 miles, over very mountainous terrain. W6DYJ uses a crystal-controlled rig with an 829 in the final, running 75 watts input. The antenna is a 16-element array, and the receiver a superhet with coaxial lines in the r.f. and mixer stages. The signals of W6YTU and W6TZX faded out completely at times, but W6UFH was in solidly. W6RJE, also located in Bakersfield, has been heard in Burbank. Contacts such as these serve to demonstrate that there is practically no such thing as an "impossible" path for 144-Mc. signals, when tropospheric conditions are favorable.

Another path over high mountains, that between Sacramento and the San Francisco area, has been bridged regularly for more than a year. W6BVK of Sacramento has had nearly 500 QSOs on 2 since June 1st of last year. Up to June 1st of this year, 214 contacts had been made beyond 50 miles, 89 of them being with W6OVK at Redwood City, a path directly over the coast range at an altitude of 4000 feet. With the aid of high-gain beams, sensitive receivers and stable transmitters, signals over this route have been raised to a consistent S9 or better. Numerous other stations the length of the San Francisco Peninsula have been worked also.

At Baldwin Park, Calif., the mountains cause some peculiar directional effects, according to W6EBK, who says that he has to use two beams,



# HARVEY FOR VARIETY

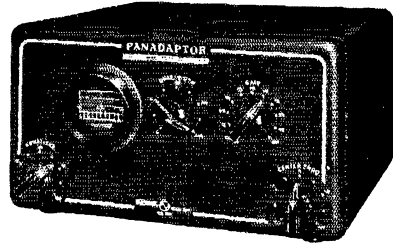

**PANADAPTOR**

Fits any receiver with 456 kc IF; shows 200 kc of band, or spreads one signal out to permit study of characteristics. Many uses in traffic, experimentation, etc.....\$99.50

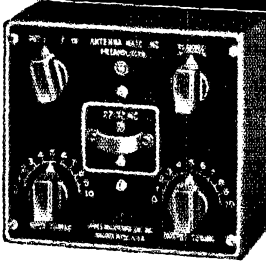

**MILLEN R-NINER**  
Millen 92101 is an Antenna Matching Pre-amplifier, combining an electronic impedance matching device and broad-band preamplifier. Designed primarily for use on 6 and 10, coils are also available for 20. Uses 6AK5, has power plug for connection to receiver. With 10 meter coils, less tube.....\$24.75

6AK5 tube .....\$ 1.90  
Coils in stock for 6 or 20 meters, each.....\$ 3.15



**1616 TUBE**

Half wave, high vacuum rectifier. Filament 2.5 volts, 5 amps; peak inverse 5500 volts; peak current .8 amps; surge current 2.5 amps; average plate current .130 amps. List price \$7.50, Harvey special price, while they last.....\$.95¢

## HARVEY'S HITS OF THE MONTH

Harvey has 20 meter crystals for a buck! Mounted in holder with 1/2" pin spacing. Also 40 and 80 meter and 6 and 13 mc. bands at the same low price.....\$1.00  
Special 8 mc. xtals for 2 meter xtal control, only.....\$1.50

Also in stock complete line of Bliley AX-2 xtals.  
Include 10¢ postage with your crystal order.

## HARVEY'S HAMFESTIVAL OF VALUES

**Jones MICROMATCH** measures standing wave ratio, RF power.....\$29.50

**SONAR PORTABLE/MOBILE** xmitter for 6 or 10 meters, NB, FM, 40 meter xtal, new 2E26 in final, 22.5 watts into antenna.....\$72.45

**Shure T17B** Hand Mike, ptt switch, plug.....\$1.49

**Abbott TR4B** Completely redesigned.....\$52.00  
Kit of tubes, HY75, 6L6, 955..... 9.39

**Handy Talky HT-144** 2 meter band, batteries self contained, one hand control.....\$34.50  
Set of tubes.....\$2.49 Batteries.....\$ 2.25

**Supreme AF-100** transmitter. 100 watts output on CV or phone, 10 to 80 meters, VFO and 2 xtal positions. \$450.00

**Broad Band Converters, C.M.L.** BB-27 for 10-11, BB-50 for 6, BB-144 for 2 meters. Takes power from receiver. \$27.50

Power supply for above.....\$19.50

**W20DL Rotary Support** and drive, built to stand the gaff. Takes up to 4 element 20 meter beam, selsyn indicator .....\$240.00

### In stock for immediate delivery

Collins 75A .....\$530.00  
Hallicrafters S38 complete .....\$47.50  
Hallicrafters SX 42.....\$275.00  
Hallicrafters S40A .....\$89.50  
Hammarlund HQ129X and speaker .....\$173.25  
Hammarlund SP-400-X and speaker .....\$347.25  
National NC-173 .....\$189.50  
National NC-2-40D (complete with speaker).....\$241.45  
National HRO-5TA1 .....\$306.71  
National NC-46 complete .....\$107.40  
National J-10A with tubes and coils .....\$67.50

RME-45 complete .....\$198.70  
Hallicrafter panadaptor.....\$99.50  
Meck 60T transmitter.....\$150.00  
Millen 90700 ECO.....\$42.50  
Millen 90800 exciter.....\$42.50  
Millen 90281 power supply .....\$84.50  
Millen 90902 scope.....\$42.50  
Collins 30K-1 xmitter \$1825.00  
Collins 32V xmitter.....\$590.00  
Collins 70-8 PTO.....\$45.00  
Meissner signal shifter.....\$120.00  
Bud VFO-21 .....\$52.50  
Sonar XE10 FM exciter.....\$39.45  
Sonar VFX680 FM exciter .....\$87.45

Note: All prices are Net, F.O.B. NYC and are subject to change without notice.

Telephone: **7** Longacre 3-1800

**HARVEY**  
RADIO COMPANY, INC.  
103 West 43rd St., New York 18, N. Y.

# LOOK

**RECORD THAT DX QSO!**  
 With a General Industries  
 Recording and Playback Assembly



Deluxe, dual speed, weighted table, operates from any receiver or 3-watt audio amplifier.

Model R90L.....\$28.95  
 Single Speed Model R70L.....\$24.51

We distribute all leading brands of ham gear, write for latest bulletin. Send 20% with COD orders

73, Jule Burnett W8WHE

## Steinberg

633 WALNUT STREET • CINCINNATI 2, OHIO



### RCA INSTITUTES, INC.

Offer thorough training courses in all technical phases of

**RADIO and TELEVISION**

WEEKLY RATES

DAYS—EVENINGS

**VETERANS:** RCA Institutes is approved under G. I. Bill of Rights

For Free Catalog write Dept. ST-47

**RCA INSTITUTES, INC.**

A Service of Radio Corporation of America  
 75 Varick Street, New York 13, N. Y.

## Send the Easier Way.....

WITH THE GENUINE EASY-WORKING

### VIBROPLEX

Saves the Arm  
 and

Improves Sending

Reg. Trade Marks: Vibroplex, Lightning Bug, Bug

SEMI-AUTOMATIC  
 RADIO KEY

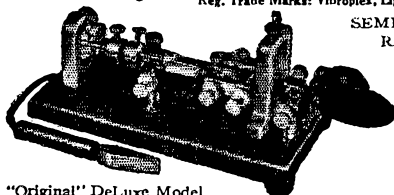

With  
 Patented  
 Jewel  
 Movement  
**\$19.50**

"Original" DeLuxe Model

Eliminate forever the nerve-trying and tiresome pounding on the ordinary key. No arm strain. No special skill required. Simply press lever... Vibroplex does the rest. Striking design. Polished chromium base and parts. DIE CUT contacts and main spring. Colorful red switch knob, finger and thumb piece. 3/16th contacts. Complete with circuit closer, cord and wedge. DeLuxe finish also available in "Blue Racer" and "Lightning Bug" models. Place your order to-day! Immediate shipment. FREE folder.



The "BUG"  
 Trade Mark  
 identifies the  
 Genuine  
 Vibroplex.  
 Accept no  
 substitute

**THE VIBROPLEX CO., Inc.**

833 Broadway NEW YORK 3, N. Y.

(Continued from page 126)

one for transmitting and another for receiving, often pointing them in different directions for best results. To work W6WGT at Riverside, who is slightly south of east, he points his receiving beam straight north, and the transmitting beam northeast. Working W6YTU at Wilmington, who is to the southwest, he transmits in that direction, but receives best from the northeast. If he uses the northeast beam for transmitting, his signal is received in Wilmington with very bad fading and audio distortion. Looks like these boys have plenty of natural reflectors in the mountains above Los Angeles!

Here's a report from Indianapolis, where, according to W9THL, there are more than 20 stations active, most of them with converted 522s and ARC-3s, but with a few home-built rigs, too. The gang would be glad to hear of others in the surrounding territory. They hope to dig out more of the fellows who used to be on 160, as 2 is just as good for those evening rag-chews.

Now here's a fellow who has real DX ambitions: W2SLW/KL7, Adak, Alaska, is running tests on 144 Mc., using 300 watts and a 16-element array aimed at Seattle! Who knows — he might make it. There have been quite a few instances of sporadic-E skip reported in the new f.m. band, which raises the known limit for such reflections to more than 100 Mc. On June 1st, during the double-hop opening reported in the 50-Mc. section, W6PJR, Santa Barbara, Calif., heard KYFM, San Antonio, Texas, for about an hour. The signal was readable throughout, though subject to slow fading at intervals, occasionally peaking strong enough to operate the limiters in his SX-42. The frequency of KYFM is 101.5 Mc.!

### Try for New 235-Mc. Record

Sometime during the first week in August, depending on weather conditions, an organized onslaught on the existing 235-Mc. record of 186 miles, held jointly by W6OVK and W9OAW/6, will be made by the Maspeth U.H.F. Club. One station, W2ER/1, will be in operation from Mt. Washington, highest point in the northeastern part of the country. Another, W2HG/2, will be set up at High Point Park, in Northern New Jersey. A third, W2DIO, will be airborne. The club station W2AUF (or perhaps the new club call, now in the works), will act as clearing house. Any other stations who have efficient gear for 235 Mc. are invited to participate. Horizontal polarization will be used by all stations.

### More Microwave Records

Not being content with setting a 10,000-Mc. record last July (see records box), W6IFE, Reedley, Calif., has now set up records in two other microwave bands, 2300 and 3300 Mc. Finding no one else interested in building equipment for the microwave bands, he built two complete units for 3300 Mc., one to serve as a fixed

(Continued on page 130)

Ready for you...

**SURPRISE**

**TRADE-IN ALLOWANCES**  
BY  
*Walter Ashe*



Trade in your used Receiver or Test Equipment. Take advantage of the extra-liberal allowances offered

by Walter Ashe. All the big-name brands in stock ready for your selection. Phone, wire or write today!

**SURPLUS CHOKES, TRANSFORMERS AND CONDENSERS**

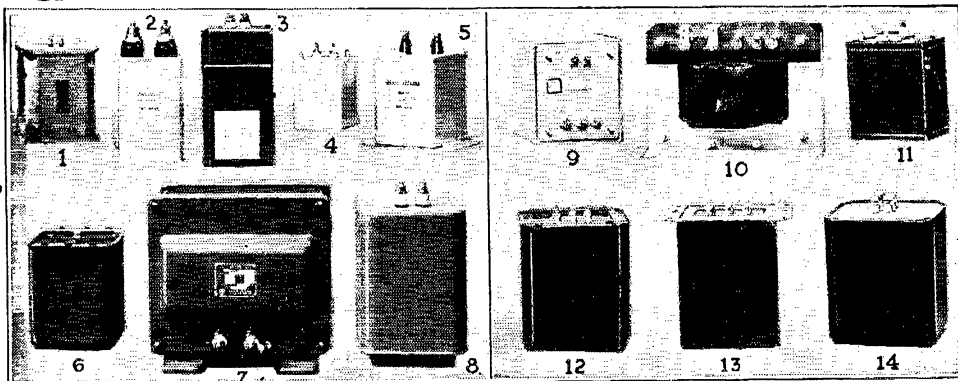

**1 FILTER CHOKE**  
12 HY @ 200 MA. 200 ohms DC Res. Steel Case..... **\$3.50**

**2 TRANSMITTING FILTER CONDENSER**  
2 Mfd. 5000 VDC, 'Dykanol, regular net price \$29.63. Our low bargain price..... **\$7.51**

**3 DUAL CHOKE**  
12 HY @ 200 MA. per section. 55 Ohms DC res. Steel case with stand-off insulators. No. 2785..... **\$4.95**

**4 FILTER CHOKE**  
4 1/2 Hy. 150 MA. 70 ohms Res. DC. Hermetically sealed in case. Stand-off insulators No. 5209..... **\$1.29**

**5 TRANSMITTING FILTER CONDENSER**  
2 Mfd. 4000 VDC. oil filled regular net price \$25.44. Our give away bargain price..... **\$4.50**

**6 FILTER CHOKE**  
4 Hy. 300 MA. 40 ohms DC resistance. Hermetically sealed in case, screw terminals. No. 6317..... **\$4.95**

**7 HIGH VOLTAGE FILTER CHOKE**  
6 Hy. at 1.2 Amps., 27 ohms. DC resistance, 12500 volt breakdown insulation. Shielded case and standoffs. No. 6813. A super buy at..... **\$17.95**

**8 FILTER CHOKE**  
8 Hy. at 500 MA. 55 Ohms DC res. Very high quality. Hermetically sealed. No. 8056. Net..... **\$11.85**

**9 PLATE TRANSFORMER**  
2500 VCT., 150 MA. Pri. 115 VAC. 60 CY Steel case with standoff insulators. No. 161919..... **\$9.95**

**10 RCA 1 KW MODULATION TRANSFORMER**  
Primary will match class "B" tubes up to 10000 ohms plate to plate. Secondary No. 1, 450 MA or beam tube plate. Secondary No. 2, 80 MA for screen grid.... **\$14.95**

**11 SCOPE TELEVISION TRANSFORMER**  
2100 volts at 10 MA. Pri. 115 VAC, 60 CY. Steel case with standoff insulator. No. ST. 1..... **\$4.25**

**12 PLATE TRANSFORMER**  
2010 VCT 200 MA. Pri. 105-125 VAC 60 Cy. Steel case screw terminals. No. 8275..... **\$9.95**

**13 PLATE TRANSFORMER**  
1400/1200 VCT at 200 MA. Pri. 115 VAC 60 CY. Steel case, screw terminals. No. 4891-N..... **\$7.45**

**14 PLATE TRANSFORMER**  
1400/1200 VCT at 260 MA. Pri. 115 VAC 60 CY. Hermetically sealed steel case, screw terminals. No. 8931..... **\$7.95**

**"MICROMATCH"**  
Jones MM-1..... **\$29.50**  
McMurdo Silver..... **\$29.90**

**SELSYN MOTORS**  
115 VAC 60 CY. Navy Surplus Selsyn Motors. Heavy Brass Case. Large continuous duty type. No. 806, per pair..... **\$12.50**



**YOUR ORDER FILLED AND SHIPPED THE DAY IT IS RECEIVED!**

**IS YOUR NAME ON OUR MAILING LIST?**  
W8JWD W8WTA W8PGJ  
W8BULH W8NRF W8QDF  
W8IYD

*Walter Ashe* **RADIO CO.**  
1125 PINE ST. • ST. LOUIS, MO.



# Amateur Gear

**INSPECTED and TESTED  
BEFORE DELIVERY**

## RME RECEIVERS

Model 45 — 6 bands — 550 to 33000 KC.....\$198.70

Model 84 — 4 bands — 550 to 44000 KC.....\$98.70

This remarkable receiver is portable — use it on 110 AC — 6 V. power pack or dry cells.

**MODEL VHF 152 CONVERTER** — 2, 6, 10 and 11 meters. It's hot — a fine piece of equipment — 50 DB image ratio.....\$86.60

**V2-6 VOLT POWER PACK for RME 84**.....\$28.00

**GM1 — S METER for RME 84**.....\$14.00

**TEMCO TRANSMITTERS** — Provide the amateur advanced engineering in separate units of the highest quality — can be purchased as desired — any combination from 150 watt CW rig to complete AM or FM — phone transmitter power 150-250 watts to 1 K.W.

**ALUMINUM TUBING** — tempered — light weight — no bending —

1/2" — 12 ft. lengths.....\$1.44

5/8" — 12 ft. lengths.....\$1.68

Other sizes, 1/4" to 2" — also angles

**SONAR VFX680 EXCITER**.....\$87.45

**SONAR-MB611** — Portable Transmitter — 30 W. output.....\$72.45

## SURPLUS RECEIVERS & TRANSMITTERS

TERMS • Mail Orders Given Prompt Attention • TRADE

# ART A. JOHNSON SALES

Art Johnson, W9HGQ

1117 Charles St.

Rockford, Ill.

## CLIPPER CHOKES and FILTERS

Triple speech power on carrier without over-modulation, as suggested in QST Nov. 1946, page 23.

**SHIELDED CHOKE**, 3.75 hy. 5%, hi-alloy laminations high efficiency. Model C-375 \$4.75

**COMPLETE FILTER ASSEMBLY**, including laboratory selected choke C-375, capacitors C3, C4, C5 and terminating resistor R5, sealed in 1 5/8" x 1 3/4" x 2 1/4" shield can.

Model LP-3000, cut-off freq. 5000 cy. \$5.95

Model LP-3500, cut-off freq. 3500 cy. \$5.95

IMMEDIATE DELIVERY, postpaid in U. S.

Special Chokes, Transformers and Magnetics to Order

**Kenneth Richardson Laboratories**

254 Vincent Avenue, Lynbrook, L. I., N. Y.

# Mass. Radio School

271 Huntington Ave., Boston 15, Mass.

For over 28 years the educational radio center of New England. Prepares for all U.S. Government Radio Operators' Licenses. Also gives Radio Technician Training. Approved courses for Veteran Training under G.I. Bill.

Send for Catalog

Licensed by Commonwealth of Mass.

Department of Education

(Continued from page 128)

station, and another to be mounted in a panel truck. In a fashion similar to that employed in the 10,000-Mc. gear, the communications system consisted of two oscillators 30 Mc. apart, serving as local oscillators for receiving, and for wave-mitting oscillators as well. The fixed station used a 707B, modulated by varying the repeller voltage. The i.f. strip has a conventional a.m. detector. The oscillator was fed into a section of wave-guide made from tin cans, soldered to a 20-inch funnel serving as an electromagnetic horn. The mobile unit used a 446B lighthouse oscillator modulated by a 6AG7. The receiver used an f.m. discriminator for detection. The antenna system used more tin-can wave-guide, feeding an 18-inch "dish" mounted on the top of the truck.

With W6IMZ operating the fixed station, W6IFE/6 departed for a 5000-foot elevation on the road to Grant Park. At a distance of 20.2 miles from the home station, contact was established, with signals running about S8.

Encouraged by this success, W6IFE decided to try for a new record for the 2300-Mc. band also. The equipment described above was converted to the lower frequency, except that a 42-inch parabola was used at the fixed station. Again, with W6IMZ operating the home station, contact was established at about 21 miles, continuing on to another point 24.6 miles distant. Now W6IFE is looking for others who are interested in micro-wave work.

## Correspondence

(Continued from page 57)

(see Fig. 26) are smeared into oblivion by my vast signal. I call him and I call him. Then I stand by and find he has been chatting with Percy Pottle in Graceleg, N. M., for the past several moments. How silly and futile. If Dodsworth had announced his beam was pointed SW and where he planned to listen, I certainly would not have called him, perhaps would not have opened up at all.

So let's consider the following plan. It can do no harm, might help enormously. When approaching the world with a CQ, the originator should always:

- 1) Give his location.
- 2) Announce as precisely as possible the direction in which his beam is pointing.
- 3) Indicate approximate or exact frequencies he will cover when listening for a reply, specifying whether DX or local contact desired.

The above should be shortened to: "W9 — at Spook, Illinois, calling CQ southwest. . . . My frequency, etc."

During certain hours of the day and night, when DX is heard in our 'phone band and is desired, inclusion of the word DX would eliminate much futile gum-beating, resultant hair-tearing and an unholy amount of QRM.

Let's give it a try.

— John M. Murray, W1BNN

## CQ ARTISTS

201 Pavilion Ave., Riverside, N. J.

Editor, QST:

I suggest that QST start a new department called, "The CQ Artists Club." We could note and submit a list of offenders. I'll wager that in a very short length of time, this practice of long CQs would be greatly reduced. After a fellow once had his call listed in the department he would take

(Continued on page 128)

# TERMINAL IS YOUR BEST BET for Everything in Television!

**TELEKITS**, manufactured by Electro-Technical Industries, were designed by Television Training Institute—America's foremost television specialists. Instructions furnished with each kit are complete in every detail—schematics, pictorial wiring diagrams, photographs and step-by-step instructions made easy by top-flight television experts!

### PERFECT PERFORMANCE GUARANTEED

Providing instructions are followed correctly! FREE guarantee service available coast-to-coast! Telekit Service Labs in all principal cities!

**IN STOCK FOR IMMEDIATE DELIVERY!  
NO WAITING! SAME DAY SHIPMENT!**

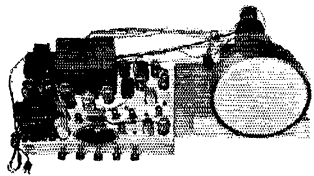
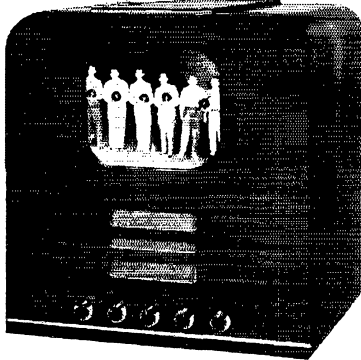

You get the same detailed instructions followed successfully by thousands of students in the leading television schools who include these kits in their regular television training courses!

It's fun learning television by building your own — and you save **PLENTY** at Terminal!

## 7" Electro-Tech TELEKIT

New advanced television receiving circuit uses only five control knobs for perfect picture and high fidelity F.M. sound. Comes complete with high quality parts (famous brand names!) pre-tuned I.F. coils, punched chassis, wire, hardware and easy-to-follow instructions. Three fixed-tuned bands. Tubes required: 1—6J6, 1—5U4G, 1—2X2/879, 1—6V6, 1—XXFM, 6—6SN7, 5—6AC7/1852, 1—7GP4. Follow the clear, easy instructions — with guaranteed results assured!

#7 TELEKIT, complete, but less tubes and cabinet .....

Complete kit of matched tubes, including RCA 7GP4 7" picture tube..

Cabinet for above kit, walnut finish..

Front Panel only (not required if cabinet is ordered) .....

**77<sup>50</sup>**

**39<sup>95</sup>**

**2250**

**1000**

## 10" Electro-Tech TELEKIT

The 10" Telekit incorporates the new TTI interlock circuit for horizontal and vertical sync control. Features include 5 bands, electro-magnetic scanning and focusing, pre-tuned I.F. coils, 9500 volt power supply for 10" tube, two separate low voltage power supplies, high fidelity F.M. sound. Only five control knobs used. Tubes required: 1—6J6, 1—XXFM, 1—6V6, 1—6AC7/1852, 4—6AG5, 5—6SN7, 1—6BG6 or 807, 1—5V4G, 1—1B3GT/8016, 2—5U4G, 1—10BP4. Complete with all parts, punched chassis, wire, hardware and easy-to-follow instructions.

#10 TELEKIT, complete, but less tubes and cabinet .....

Complete kit of matched tubes, including RCA 10BP4 10" Bright Picture tube .....

Cabinet for above kit, walnut finish..

**124<sup>50</sup>**

**65<sup>35</sup>**

**2950**

## RCA TELEVISION COMPONENTS — IN STOCK!

For television engineers, experimenters and servicemen, Terminal maintains a complete, up-to-the-minute stock of television parts! Of course, we have Everything in Radio!

Width control, type 201R1 .....	.76
Projection size control, type 201R2 .....	1.29
Horiz. Linearity control, type 201R3 .....	.82
I.F. & Video coil kit, type 204X1 .....	19.40
Filament choke, type 204L1 .....	.17
Horiz. sync-discriminator, type 208T8 .....	2.79
Deflection yoke (direct view), 201D1 .....	8.08
Deflection yoke (projection), 201D2 .....	8.76
Yoke mounting hood, type 201X1 .....	1.62
Focus coil, type 202D1 .....	5.34
Ion trap magnet, type 203D1 .....	3.82
Horiz. output transformer, 204T1 .....	13.52
Horiz. output transformer, 204T3 .....	8.56
Horiz. output transformer, 211T1 .....	9.90

### TELEVISION TUBES

RCA 58P4 .....	<b>27.50</b>
RCA 7DP4 .....	<b>27.00</b>
DuMont 7EP4 .....	<b>23.25</b>
RCA 7GP4 .....	<b>24.25</b>
RCA 5TP4 .....	<b>67.50</b>
RCA 9AP4 .....	<b>62.50</b>
RCA 10BP4 .....	<b>49.50</b>
Rauland 10FP4 .....	<b>42.20</b>
RCA 12AP4 .....	<b>75.00</b>
DuMont 20BP4 .....	<b>275.00</b>

Horiz. output transformer, 211T2 .....	13.38
Vertical output transformer, 204T2 .....	5.29
Horiz. bl.-osc. transformer, 208T1 .....	3.53
Vertical bl.-osc. transformer, 208T2 .....	3.35
Horiz. bl.-osc. transformer, 208T3 .....	2.67

### RCA Bright Picture Antennas for Clear All-Channel Reception

Dipole kit, type 226 .....	5.88
Dipole/reflector kit, 225 .....	8.82
Universal mtg. brackets for above kits, type 227, per pair .....	4.41
RCA Bright Picture Transmission line, per 100 ft. ....	2.79

**WARRANTY** — No change in our policy. Every item we sell is fully guaranteed, regardless of its low price.

If unable to visit our store, send us your mail orders with 25% deposit. Remit in full all orders under \$5.00. Prices are F.O.B. New York.

# TERMINAL RADIO CORP.

85 CORTLANDT STREET • NEW YORK 7, N. Y.

Phone: WOrth 2-4415

Cable Address: TERMRADIO

## MODULATION & DRIVER TRANSFORMERS

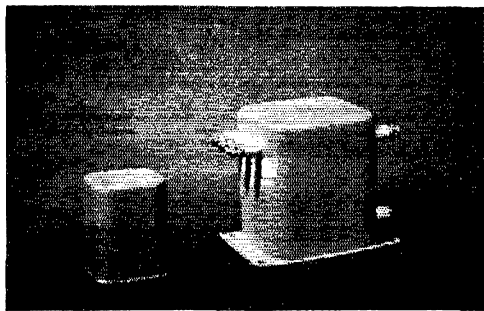

These transformers are suitable for use with type 811, 809, TZ40, TZ20, etc. to modulate either triode or beam tube RF amplifiers. Two secondaries are provided. Impedance ratio primary to secondary number one, 2 to 1. Primary to secondary number two, 16 to 1. Will modulate up to 300 watts input. Modulation transformer, driver transformer, circuit diagrams and other information all for . . . . . \$6.90 Please include 50 cents for postage and handling. Write for latest bargain bulletin listing bargains in filter condensers, chokes, transformers, vacuum condensers, switches and many other items.

**ELECTRONIC NAVIGATION, INC.**

Box 735, Church Street Station  
New York 8, New York

## ROTATORS SO-1 Radar Type

Plenty husky for any beam antenna a ham can dream up. Built to last a lifetime.

Powerful gear train and motor housed in rugged aluminum pedestal. Speed 2 RPM. Instantaneous reversing. Automatic lock-in prevents drift in strong winds. This is a he-man rotator and not a toy! Ask any navy communicator or radarman about the SO-1.

Price brand new—complete with 110-  
volt 60-cycle power supply, **\$89.00**  
f.o.b. Tuckahoe . . . . .

See our advertisement on page 122 in the June issue of "QST"  
Also available—slip ring assemblies and selsyn indicator control units for the SO-1 Rotator. Write for details.

**ELECTRONICRAFT, Inc.**

5 Waverly Place • Tuckahoe, N. Y.

## AMATEURS EXPERIMENTERS SUPPLIES & EQUIPMENT

Leading Brands

Headquarters for

**HALLICRAFTERS  
NATIONAL HAMMARLUND**

**RADIO PARTS DISTRIBUTING CO.**

Agents for War Assets Administration

128 W. Olney Road NORFOLK, VA.

(Continued from page 130)

steps to make sure his call would not be listed again. And he would be pleased and satisfied that his operating technique had been improved.

— Chas. B. Roop, W2ORS, ex-W3DNU

## LISTEN FIRST

459 K St., Columbia, Mo.

Editor, QST:

During the times when amateurs in the [Texas-Oklahoma] disaster areas were trying to get important traffic through, their efforts were impeded by the large number of hams who would operate on the disaster frequencies, utterly without reason. A lid would call a long-winded CQ; some fellow trying to get a message through would have to call him and ask him to please QSY because emergency traffic was being handled on the frequency, to which the lid would reply, "Sorry, old man, I didn't know about it, etc., etc.," for about five minutes before signing and clearing out.

Surely the standards of amateur radio can be raised to a point where hams attempting to render a vital public service can do so without being hampered by poor operators. The answer to the problem is really very simple — just listen. When any ham finds out that a disaster has occurred, he should immediately ask himself, "What frequencies are being used for emergency traffic? Is it important that I clutter up the air with my signal until I find out?" Then he should spend a few minutes finding out what is happening on the band.

— John R. Somerville, jr., W6ZZW

## POLLS

P. O. Box 533, Sackville, N. B., Can.

Editor, QST:

I have a word or two in reply to W8PXH whose letter appeared in QST for June. His letter seems to rave on and on, calling people names and presenting no arguments of consequence. He makes only one statement to back up his stream of meaningless adjectives (totalitarian, lopsided, etc.) and that statement itself tends to show that he misinterpreted at least one section of the editorial in question. From his letter I quote, "You claim that the knowledge of a code is a nonessential part of amateur radio." From the editorial I find, "It (the Board) believes utterly that code is basic to every other part of amateur radio." For his information I wish to point out that the Board inferred that code is a nonessential part of the microwave region only! Is he working c.w. on 1215 Mc.? Of course not — nor is anyone else!

He states that the editorial shows only one side of the question. Can he present an argument for the opposing side? I can't think of a good one myself. In my opinion the editorial seemed one-sided because the question itself has only one major side.

He speaks of doubtful experimenters. Isn't he an experimenter? Every amateur who ever built his own rig is an experimenter. And if any OM didn't build his own first rig, he should have!

— P. R. Munro, VE1IX

U.S. Naval Hospital, St. Albans, N. Y.

Editor, QST:

May I take this opportunity of thanking the ARRL for its method of polling the members individually by postcard as has been done on two recent occasions. In my opinion, this offers a much better method than the gathering of membership opinion by the somewhat haphazard procedure of depending on the individuals to contact their section managers, etc. It has been my contention that the Eastern part of the membership is badly out of touch with the Western portion on League matters. I believe the individual postcard ballot will do much to give the members the feeling that they have a very direct voice in League matters and satisfy those of us who have criticized in this respect. Having formerly been a West Coast member (W7JNF), I believe I speak more or less accurately. . . .

— Jesse F. Adams, W8UJT, Lieut. (MC) USN

(Continued on page 134)

# MR. RADIO RETAILER

A MUST for NOISE-FREE STORE DEMONSTRATION

## BRACH PURATONE\* SIGNAL BOOSTER

CARRIES AM, FM and TV ANTENNAS ALL ON THE SAME MAST

Increase your radio sales by bringing home-like reception to any AM, FM and TV set in your showroom... eliminating all interference and bothersome noises.

**HERE'S HOW:** The Puratone Signal Booster System is easily installed on the roof of your building. A shielded coaxial cable runs directly from the mast to the concealed amplifier on the display floor.

From the amplifier a radiating wire is placed inconspicuously around the display space. No direct wire connection to radio sets required. One system serves any number of floor models. Dual wave traps in the video-type AM-FM amplifier bring in all stations at an average tone-level. 30-40 DB gain on FM; 40-60 DB gain on AM. Effective for any radio department layout.

Write for illustrated circular.

**L.S. BRACH MFG. CORP.**  
200 CENTRAL AVE., NEWARK 4, N. J.

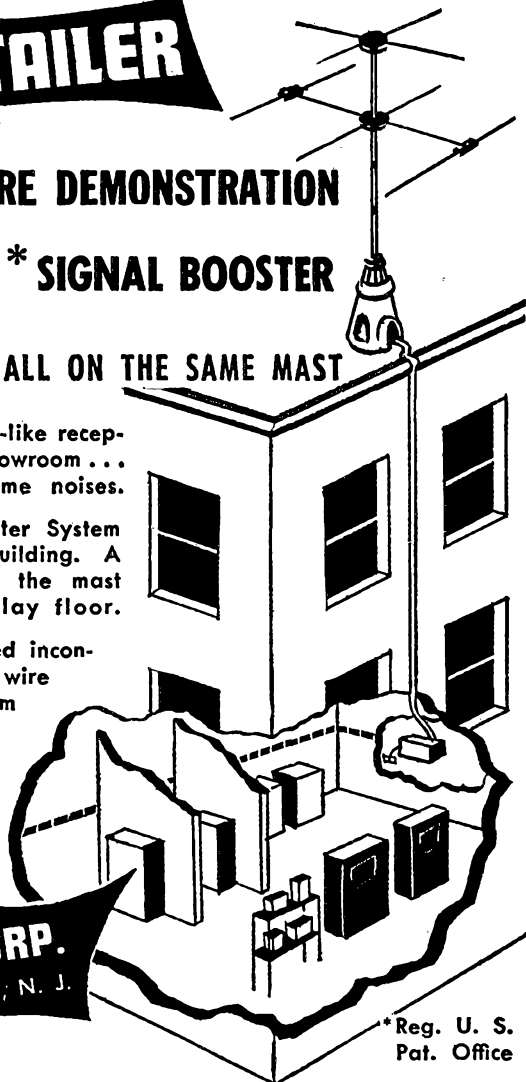

\*Reg. U. S. Pat. Office

WORLD'S OLDEST AND LARGEST MANUFACTURERS OF RADIO ANTENNAS AND ACCESSORIES

## Electronic Volt-Ohmmeter, Model 406

Accurately Tests All F. M. Circuits



We invite comparison of this instrument with any at any price for appearance, ruggedness, accuracy, stability. 0-1 to 1,000 volts U.H.F., A.C., D.C., 0-1,000 megohms. Pen-type dual-diode A.C. probe. No extras to buy. Send for details or order today.

**\$89<sup>50</sup>** NET

from jobber or F.O.B. Cincinnati

**Clippard**

**INSTRUMENT  
LABORATORY, INC.**

Dept. 5, 1127 Bank Street,

Cincinnati 14, Ohio



# The A.R.R.L. WORLD MAP

Although the world situation has not settled sufficiently to permit a postwar revision of the ARRL Map of the World, this reprint has been produced to make again available another of the League's operating aids and working tools so necessary to the practicing amateur.

THE A.R.R.L. Amateur Radio Map of the World is a special type of projection made by Rand, McNally to A.R.R.L. specifications. It gives great circle distance measurements in miles or kilometers within an accuracy of 2%. Shows all principal cities of the world; local time zones and Greenwich; WAC divisions; 230 countries, indexed; 180 prefixes, districts and subdivisions, where used; and U. S. examining points. Large enough to be usable, printed in six colors on heavy map paper, 30 x 40 inches.

**\$1.25**

POSTPAID ANYWHERE

**AMERICAN  
RADIO RELAY LEAGUE  
WEST HARTFORD, CONNECTICUT**

(Continued from page 138)

1836 E. 16 St., Tulsa 4, Okla.

Editor, *QST*:

The most interesting thing about this "poll" [Class D] is that you appear to be taking some interest in what the amateur might think of the use of the bands. So far as this matter is concerned, it is a far cry from the deal you put over requiring c.w. operation for renewal of license. I have not voted the ballot, since you have already decided what would be best for the amateur.

— G. E. Harris

## STAGGERED BANDS?

Blue Bell Post Office, Ambler, Pa.

Editor, *QST*:

With all due regard for the humor in Brother Rapp's article, "The Staggering Band Theorem," in April *QST*, why isn't that the solution of the problem? I don't know how seriously anybody will take his suggestions, but if any such move does develop, please count me in on the hands raised in favor. I can't think of any plan that could do more for our hobby by way of increased satisfaction for all, and final relief from the eternal 'phone-c.w. fist-fights. Everybody would have an equal chance to use the bands in toto and perhaps even the Class A 'phone requirement could be done away with.

I hope someone will pick up this ball and carry it over the line some day.

— John B. Morgan, W3QP

## 'PHONE PROCEDURES

67 Sheridan St., Chicopee Falls, Mass.

Editor, *QST*:

Just finished 'Rotten 'Phones,' and does it do my heart good! I've just never had the time to expound as Brother Marks has done — but he certainly hit the offenders. I'm strictly 'phone and I like a good QSO. . . .

— Bernie Beaudoin, W1MYZ

## LIKES *QST*

R.F.D. 1, Hutchinson, Minn.

Editor, *QST*:

There are lots of ARRL members that will take time to write about gripes, mistakes and shortcomings of ARRL, FCC, *QST*, etc., but not many will write about good points. So here goes: I like *QST* so much I read it from cover to cover. I believe ARRL is trying to do what the most of its members want it to. If not why don't more members write their directors and SCMs?

— Francis L. Ahrens, W0ANU

## SWL CARDS

Fertile, Minnesota

Editor, *QST*:

'Tain't so about U. S. and foreign amateur stations being careless about answering reports. My SWL log shows 85 per cent of U. S. stations answer within 10 days — the foreign stations average the same, but naturally take longer for a reply. Not a bad average at all — so tnx, OMs.

— O. C. Vidden

## GHOST SIGNALS

Box 302, La Tijera Sta., Los Angeles 43, Cal.

Editor, *QST*:

. . . Once in a while shades of the past flicker out of the air for a time in unbelievable style. Continental code comes over a nonexistent receiver, through windows in a clear, readable, high-pitched tone. For some time I chose to resist the actuality of this phenomenon. Recently, however, when in the middle of the night I was awakened, a Navy news-

(Continued on page 136)



# Condensers for BROADCAST-COMMUNICATION ELECTRONIC AND AMATEUR EQUIPMENT

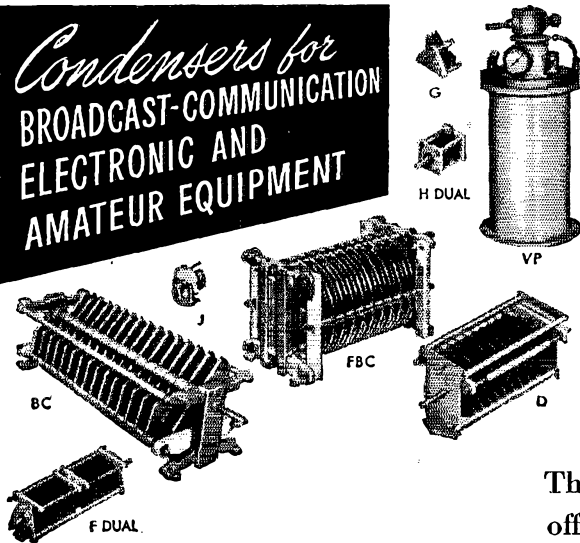

## New Catalog No. 969

(JH) Free on Request. Specific Data furnished separately on larger types.

The big JOHNSON condenser line offers an unequalled choice of types and sizes beginning with miniatures with .015" plate spacing, and extending through the pressurized types which offer RMS voltage ratings to 30,000 V. and capacities to 10,000 mmf. Each type is carefully designed by electronic engineers for maximum circuit efficiency. Many exclusive JOHNSON developments such as the heavy, beaded edge plates on commercial types not only increase electrical efficiency, but reduce mounting space, and through the savings in material, lower your costs.

### Johnson Products Include

Transmitting Condensers, Inductors, Tube Sockets, R.F. Chokes, Q Antennas, Insulators, Connectors, Plugs and Jacks, Hardware Pilot and Dial Lights, Broadcast Components, Directional Antenna Equipment.



**JOHNSON** ... a famous name in Radio  
E. F. JOHNSON CO. WASECA, MINNESOTA

## NEWS ABOUT

THE LATEST IN RADIO PARTS—EQUIPMENT—ELECTRICAL DEVICES—brought to you in our monthly bulletins. **ABSOLUTELY FREE!** No obligation.

WRITE TO  
MANUFACTURING DIVISION  
**HERBACH & RADEMAN, INC.**  
ELECTRONICS SPECIALISTS  
522 MARKET ST., PHILA. 6, PA. • DEPT. A

## EASY TO LEARN CODE

It is easy and pleasant to learn or increase speed the modern way—with an Instructograph Code Teacher. Excellent for the beginner or advanced student. A quick, practical and dependable method. Available tapes from beginner's alphabet to typical messages on all subjects. Speed range 5 to 40 W.P.M. Always ready, no QRM, beats having someone send to you.



### ENDORSED BY THOUSANDS!

The Instructograph Code Teacher literally takes the place of an operator-instructor and enables anyone to learn and master code without further assistance. Thousands of successful operators have "acquired the code" with the Instructograph System. Write today for full particulars and convenient rental plans.

## INSTRUCTOGRAPH COMPANY

4769 SHERIDAN ROAD, CHICAGO 46, ILLINOIS

IT'S

*New*

**VALPEY  
XTALECTOR**

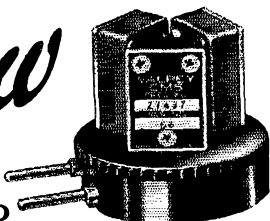

Facilitate rapid QSY from one frequency to another by mounting two or three crystals in a new VALPEY XTALECTOR. Instant QSY from one crystal to the next by a simple turn of the knurled rim. Simplicity of contact design does not add capacity or loading to the crystal. Unused crystals are completely out of the circuit.

Ruggedly constructed of glossy molded Bakelite, it is the handiest little gadget that you can have in your shack. Designed to hold Valpey type CM5 crystals having 1/2" spacing and .094 diameter pins.

Supplied in two types — "X 2" with 1/2" spacing and "X 3" with 3/4" spacing. Your local dealer can supply you with an XTALECTOR from stock.

XTALECTOR to fit 1/2" or 3/4" sockets — ONLY.

**\$1.35 each**

Valpey type CM5 crystals for 80 and 40 meters net \$2.80  
— 20 meters \$3.50  
— 10 meters \$4.50



**VALPEY CRYSTAL CORP., Holliston, Mass.**

Craftsmanship in Crystals Since 1931

WIATP WIHVP WIBZJ WIPLX WIONF

**QST YEARLY BINDERS**

**ARE WE RIGHT?** You should have at least two of them—one for your complete 1946 file of copies, and one for each 1947 issue as published. Price \$2.00 each, postpaid. Available Only in United States and Possessions.

**THE AMERICAN RADIO RELAY LEAGUE**  
West Hartford 7, Connecticut

**COMMERCIAL RADIO INSTITUTE**

A RADIO TRAINING CENTER FOR 27 YEARS

Resident Courses Only • Broadcast, Service, Aeronautical, Television, U.H.F., Preparatory Course, Frequency Modulation and Marine telegraphy classes forming for Fall Term Oct. 1. Entrance examination Sept. 15.

Literature upon request. Veteran training

Dept. B, 38 West Biddle Street, Baltimore 1, Maryland

*Ham Post!*

Millen R-9ER. Less Tubes.	\$24.75	R.M.E. 45.	\$198.70
6AK5 Tubes. Hammarlund FS-135C — 100K C Standard	3.15	Hammarlund 129 X.	173.25
Sonar VFX 680 with Tubes	14.25	Halicrafters SX-42.	275.00
	87.45	National NC 2-40-D.	240.00

Delivery from Stock — Cash with Orders or C.O.D.



**CONTINENTAL  
SALES COMPANY**

195-197 CENTRAL AVENUE, NEWARK 4, N. J.

(Continued from page 134)

broadcast followed by figure code messages pierced the quiet in readable cipher. This time I was sufficiently alert to ask my wife and 17-year-old son if they too heard the signals. They did.

Therefore would you mind asking your readers to assist in compiling a dossier of similar receptions? Would your readers experiencing similar receptions write the circumstances of such uncanny receivings? Tell the hour of the day, the condition of the weather, the apparent source, the approximate pitch in cycles, the identity of the sending station, the power and distance away of the sender, the duration of the messages and all other data with the approximate date of each reception. Note whether there was a nearby window or door screen. And finally: a possible theory of the reason for the receiverless reception.

I have talked to several old-time amateurs who have had this experience and I know there must be others. A complete survey will include not only readers of QST but their friends. Would you mind reaching as many as you can thru your pages? Have them address the writer at Box 302, La Tijera Station, Los Angeles 43, Calif.

— F. S. Stewart, ex-WGTT

**GHOST WRITING**

Box 626, Riverhead, L. I., N. Y.

Editor, QST:

As if it weren't bad enough having two governors in a certain state, we now have two writers contending for the title of authorship of one and the same book. At the head of the Book Review on page 152 of February QST, Mr. Colebrook is mentioned as the author of *Basic Mathematics for Radio Students*. However, in the review proper, it develops that Mr. Colebrook had nothing to do with writing the book. Mr. Cosgrove did it. That's what the man says! Since Colebrook is mentioned only once, and Cosgrove twice, it might seem that the decision should go to the latter. However, I'm rooting for Colebrook. . . .

— Arthur M. Braaten, W8BSR

[EDITOR'S NOTE: The book is indeed by Mr. Colebrook. We regret the error.]

**LAST STRAW**

4170 Malaya Ave., Miami, Fla.

Editor, QST:

I'm always ready to help a fellow ham. I've found a runaway son for a W2, bought an xfmr for a Key-Wester and xtals for a CM2. But when a W5 asks for a hotel room in Miami on 6-hr. notice in February I had to pass!

— Dick Canfield, W4BXL

**HAMS IN THE ARCTIC**

Pangnirtung, Baffin Land, N.W.T., Canada

Editor, QST:

. . . You probably never receive any reports from up this way so I'll try to give you an idea of amateur radio in the Eastern Arctic. To the best of my knowledge there were until recently, seven VE8s and one VE2 in the area. The VE2 is at Port Harrison, P. Q., while all the VE8s are in the Northwest Territory. Northern Quebec is just as much Arctic as the N.W.T. VE8MO is located at Nottingham Island, MR at Resolution Island (both in Hudson Straits), MK, MM, MQ and MT are all at Clyde River, Baffin Island, and MJ (myself) at Pangnirtung, Baffin Island. MJ and MT are Hudson Bay Company men, the others are all professional radio men with the Department of Transport.

The Department of Transport boys arrived in the country last year and most of them are returning south this fall. They were fortunate in that they had been able to secure some radio gear before arriving so they were fairly well set when the bands opened up during the winter. Both MT and myself have been in since 1943 (both of us are getting into the "old-timer" class with 20 years in the Arctic!) and just didn't have any radio gear to speak of. I know all of us had a few headaches before we finally got on the air. MM, and MK were the first to break the silence on 28 Mc. with something fancy with 100 watts input. With the

(Continued on page 138)

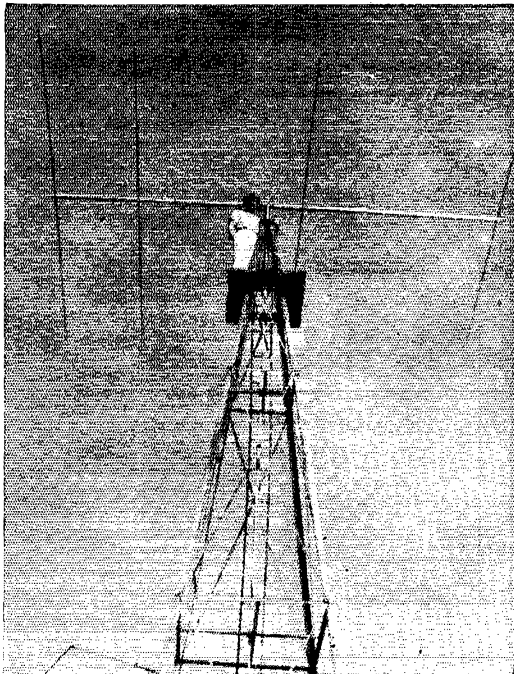

## U.H.F. RESONATOR CO.

Pre-Tuned — Pre-Spaced — Prematched  
 High-Power Beams Use  
 Wide Maximized Spacing

*Illustrated is typical installation of our 4-element 10-meter beam on windmill tower.*

*Also Available Now*

U.H.F. Resonator Co. "Ten-Over-20"  
 \$189 and up Including 18-ft. Vertical  
 Dural Mast

### POWER GAIN OF OUR BEAMS OVER A FOLDED DIPOLE

Three El. ....	9.9
[10 or 20 meter beams]	
Four El. ....	11.5
Five El. ....	15.0

These gains are guaranteed to be obtained no matter where installed, under normal conditions (Don't put it up 3 ft. from tin roof) as beams are pre-tuned, pre-spaced and pre-matched.

Amateur net prices, 10-meter beams: 3 el. beam, length 12 ft., weight, 8½ lbs., \$35. 4 el. beam, length 20 ft., weight 13½ lbs., \$50. 5 el. beam, length 29 ft., weight 25 lbs., \$65. 3 el. 20-meter beam, 23 ft. long, 39 lbs., \$100. For shipping prepaid anywhere in U.S.A. or Canada add \$10 deposit on strong wood box. Refund on return of box, less outgoing shipping charges. Send for literature "10-20".

Beams for 50, 144, 235, 425, and parabolas, including 32 el. on 2 meters, 32 el. on 425 MC. Send for literature "50 UP."

GUION ROAD, RYE, N. Y.  
 Telephone Rye 2030

U. H. F. RESONATOR CO.  
 W. F. Hoisington, W28AV

Factory at Portchester, N. Y.  
 Telephone P. C. 959

## FOR LOW HUM . . . HIGH FIDELITY

SPECIFY KENYON TELESCOPIC SHIELDED HUMBUCKING TRANSFORMERS



### ✓ CHECK THESE ADVANTAGES

- ✓ **LOW HUM PICK-UP . . .** Assures high gain with minimum hum in high fidelity systems.
- ✓ **HIGH FIDELITY . . .** Frequency response flat within  $\pm 1$  db from 30 to 20,000 cycles.
- ✓ **DIFFERENT HUM RATIOS . . .** Degrees of hum reduction with P-200 series ranges from 50 db to 90 db below input level . . . made possible by unique humbuckling coil construction plus multiple high efficiency electromagnetic shields.
- ✓ **QUALITY DESIGN . . .** Electrostatic shielding between windings.
- ✓ **WIDE INPUT IMPEDENCE MATCHING RANGE.**
- ✓ **EXCELLENT OVERALL PERFORMANCE . . .** Rugged construction, lightweight-mounts on either end.
- ✓ **SAVES TIME . . .** In design . . . in trouble shooting . . . in production.

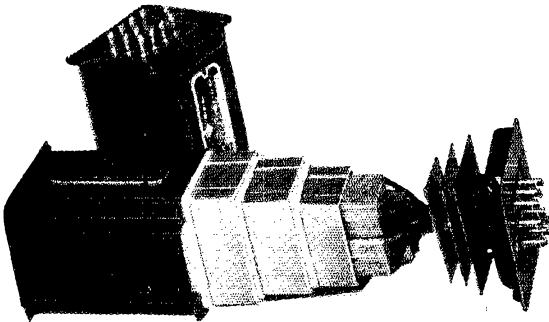

Send for our catalog for complete technical data.

# KENYON TRANSFORMER CO., Inc.

840 BARRY STREET  
 NEW YORK, U. S. A.



**No. 89**  
**1/2" ELECTRIC DRILL**  
**\$29.95**

**No. 209**  
**Drill Stand**  
 (less drill)  
**\$12.95**

Light in weight, convenient and handy, this improved drill has a special aligning grip that makes straight drilling natural. Backed by 35 years of electric drill manufacturing, produced in great quantities by modern methods, this is today's best drill buy. For every day farm, garage, construction and maintenance use, you can't get a better drill at any price. Specially wound, long life, high torque, fan-cooled motor. Cut steel gears, self-lubricating bearings, sturdy die cast case and a full sized snap action chuck (no key to lose).

With a No. 209 Drill Stand, the 89 Drill makes a capable lever operated drill press. Order from your local Speedway Dealer.

**SPEEDWAY MANUFACTURING CO.**  
**1826 S. 52nd Ave., Cicero, Ill.**

## RADIO

**TECHNICIAN and RADIO SERVICE COURSES**  
**FM and TELEVISION**

Approved under G. I. Bill of Rights

**AMERICAN RADIO INSTITUTE**

101 West 63rd St., New York 23, New York

TEACHING RADIO SINCE 1935



### Have Skill, Accuracy

Be a "key" man. Learn how to send and receive messages in code by telegraph and radio. Commerce needs thousands of men. Expansion of air commerce and freight after war should create an even bigger peacetime demand for operators. The famous Candler System, maker of world's champions, teaches you the "knack" of sound sense and sound consciousness that is the secret of speedy sending and receiving. Good pay, adventure. Learn at home quickly.

**FREE 52-PAGE BOOK** explains extra course of training. Rush name for it today. It's absolutely free.

**CANDLER SYSTEM CO.**

Dept. 4-J, P. O. Box 928, Denver 1, Colo., U. S. A.  
 and at 121, Kingsway, London, W.C. 2, England

(Continued from page 136)

exception of myself the others were silent until the 75-meter band opened. I won't bore you with the painful details of what I went through before I finally managed to stretch my few bits of junk, homemade chokes, coils, remade condensers, etc., into a rig which more or less (rather less than more!) worked on 28 Mc. . . . I maintain fairly regular skeds with G6CL, London, and he QSPs for me, which is very FB especially to my folks who live in East Africa. . . .

— George Anderson, VE8MJ

### QSLs

Suite 507, 111 W. 7th St., Los Angeles 14, Calif.

Editor, QST:

. . . Recently while working a VK2 I asked him for his QSL. He replied quite honestly that he didn't have any, so not to expect one. My salute goes to that fellow. The incident got me thinking about the honesty angle in this business of sending, or rather not sending, QSL cards. When a promise to send a card is not kept, the other fellow experiences a letdown. Isn't it just a matter of plain fraternal courtesy to tell the fellow not to expect a card, if you know pretty well he isn't going to get one anyway?

— Maurice J. Hindin, W6EUV

### A Position Indicator

(Continued from page 61)

in the side of this collar receives a small setscrew. The pointer itself was made by flattening a piece of brass wire to the desired shape, and then soldering this pointer to the hub.

There are several possibilities for the indicator scale. A circle could be drawn on a white file card, with points for north, south, east and west, and eight or more midpoints inked in. I found a dial plate that was marked from 0 to 360 degrees; by orientating this correctly with the antenna I can thereby aim the array to an accuracy well within practical limits. The completed indicator unit may be panel-mounted, or it may be installed in a sloping-face meter case, as shown in the photo, for use at the operating position.

The antenna Selsyn must, of course, be tied to the antenna shaft through a one-to-one coupling arrangement, such as a pair of like gears or a shaft coupling. If 60-cycle synchros can be found, their use simplifies the installation, but 400-cycle units may be used on 60 cycles if the voltage is dropped to about one-fourth of the rated value.

### Strays

"New Electronic Terms" Department:

*Rapid City Daily Journal*: ". . . a 200-volt steel tower has been erected for the station." — W0IWT

QST for March, Steinberg's ad, page 126: "We distribute leading brands of ham and equipment." — W3MHE, W3TUC, K. D. Hopper (*Italics ours.*)

**PROFESSIONAL TRAINING**  
**IN A MINIMUM OF TIME**

# RADIO-ELECTRONICS TELEVISION • BROADCAST ENGINEERING

An Accredited Technical Institute nationally recognized for high calibre training. Prepares high school graduates for technical careers. Classes start every Monday. Comprehensive courses in Radio-Electronics Engineering, Broadcast and Television Engineering, Broadcast and Television Servicing; 2,100 hours classroom and laboratory study. Write today for free informative booklet. "RADIO ENGINEERING AS A CAREER."

**CAPITOL RADIO ENGINEERING INSTITUTE**

DEPT. QS-8, 16th STREET & PARK ROAD N. W. • WASHINGTON 10 D. C.



# IDEAL FOR AMATEUR RIGS

## The New Turner Model 20X

Here's a new, light weight hand microphone that is high in performance yet low in cost. Convenient to use, natural to hold. Hangs on a hook when not in use. Metalseal crystal withstands moisture conditions not tolerated by the ordinary crystal. Circuit design results in exceptionally fine response for a low priced unit. Range is 50-7000 c.p.s. Level: 54db below 1 volt/dyne/sq. cm. Finished in rich baked brown enamel. Available with slide-lock switch at slight additional cost.

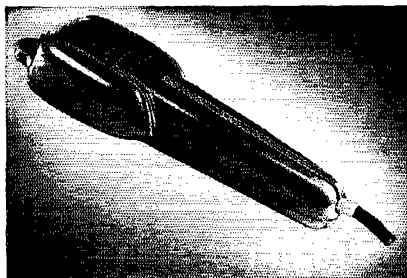

At your dealer's or write for Bulletin

### THE TURNER COMPANY

917 17th STREET, N. E. • • • CEDAR RAPIDS, IOWA



## Microphones BY TURNER

Microphones licensed under U. S. patents of the American Telephone and Telegraph Company, and Western Electric Company, Incorporated. Crystals licensed under patents of the Brush Development Company.

# The Radio Amateur's Library

These are the publications which every amateur needs. They form a complete reference library for the amateur radio field; are authoritative, accurate and up to date

<i>Title</i>	<i>Price</i>	<i>Title</i>	<i>Price</i>
QST.....	\$3.00 per year*	Hints & Kinks for the Radio Amateur.....	50c
Operating an Amateur Radio Station — Free to members; to others....	10c	Lightning Calculators:	
The Radio Amateur's Handbook,	\$1.25**	a. Radio (Type A).....	\$1.00
The Log.....	50c each	b. Ohm's Law (Type B).....	\$1.00
How to Become a Radio Amateur..	25c	A.R.R.L. Antenna Book.....	50c
The Radio Amateur's License Manual.....	25c	The Minilog.....	25c
		Learning the Radiotelegraph Code.	25c
		A Course in Radio Fundamentals...	50c

\*Subscription rate in United States and Possessions, \$3.00 per year, postpaid; \$3.50 in the Dominion of Canada, \$4.00 in all other countries. Single copies, 35 cents.

\*\*Postpaid in U.S.A. Proper — \$2.00, postpaid, elsewhere. (No stamps, please.)

THE AMERICAN RADIO RELAY LEAGUE, Incorporated  
WEST HARTFORD 7, CONNECTICUT

# HAM-ADS

(1) Advertising shall pertain to radio and shall be of nature of interest to radio amateurs or experimenters in their pursuit of the art.

(2) No display of any character will be accepted, nor can any special typographical arrangement, such as all or part capital letters be used which would tend to make one advertisement stand out from the others.

(3) The Ham-Ad rate is 30¢ per word, except as noted in paragraph (6) below.

(4) Remittance in full must accompany copy. No cash or contract discount or agency commission will be allowed.

(5) Closing date for Ham-Ads is the 25th of the second month preceding publication date.

(6) A special rate of 7¢ per word will apply to advertising which, in our judgment, is obviously non-commercial in nature and is placed and signed by a member of the American Radio Relay League. Thus, advertising of bona fide surplus equipment owned, used and for sale by an individual or apparatus offered for exchange or advertising inquiring for special equipment, if by a member of the American Radio Relay League takes the 7¢ rate. An attempt to deal in apparatus in quantity for profit, even if by an individual, is commercial and all advertising by him takes the 30¢ rate. Provisions of paragraphs (1), (2), (4) and (5), apply to all advertising in this column regardless of which rate may apply.

(7) Because error is more easily avoided, it is requested signature and address be printed plainly.

(8) No advertiser may use more than 75 words in any one issue.

*Having made no investigation of the advertisers in the classified columns, the publishers of QST are unable to vouch for their integrity or for the grade or character of the products or services advertised*

**QUARTZ** — Direct importers from Brazil of best quality pure quartz suitable for making piezo-electric crystals. Diamond Drill Carbon Co., 719 World Bldg., New York City.

**QSLs** in colors. Stamp for samples. Glenn Griffith, W3FSW, 1042 Pine Heights Ave., Baltimore 29, Md.

**DEKA-XTAL**. New compact 10-crystal unit for standard 5-prong socket. Looks and operates like a dial-knob. Just plug it in and turn to any of 10 frequencies, your selection. Ask your dealer or write us. Also other low TC ham crystals in FT cases to fit octal sockets. 80 and 40  $\pm$  1 kc. \$2.65; 20  $\pm$  4 kc. \$3.50. Scientific Radio Products Co., 738 1/2 W. Broadway, Council Bluffs, Iowa.

**SURPLUS** bargain catalog. Send for the bargain ham catalog everyone is talking about. Surplus Radio, Inc., 30 Munson St., Fort Washington, N. Y.

**QSLs**, samples, Albertson, W4HUD, P.O. Box 322 High Point, N. C.

**CHASSIS**: all sizes. Write for price list. John Heim, 713 W. Third, Williamsport, Penn.

**AMATEURS**, experimenters, industrials and export accounts. Write for catalog and monthly bulletins. Buy the "TR" guaranteed way and save. TAB, Dept. Z, 6 Church St., New York 6, N. Y.

**AMATEUR** radio licenses. Complete code or theory preparations for passing amateur radio examinations. Home study and resident courses. American Radio Institute, 101 West 63rd Street, New York City.

**COMMERCIAL** radio operators examination, questions-and-answers. One dollar per element. G. C. Waller, WSATV, 6540 E. Washington Blvd., Tulsa 15, Okla.

**LATE** radio-television courses, \$50, commercial radio ops sample questions, 10 sets, \$10. Corrected. Used radio, math books, reasonable. W6VTC, Box 1298, Hollywood, Calif.

**QSLs** on kromekote cards. Dauphinee, WKMP, P.O. Box 219, Cambridge, Mass.

**BEAM** control cable 8 conductors, weatherproof, shielded 10 ft. Associated Industries, 6639 S. Aberdeen, Chi., Ill.

**QSLs**, highest quality, samples free. VVS Print, 1704 Hale Avenue, Ft. Wayne 6, Ind.

**INSTRUMENTS** and meters repaired, cores. invited. Universal Electronics, Dept. N, Box 7754, Kansas City 3, Mo.

**METER** repair. Braden Engineering, 3317 Kenmore, Dayton, O.

**HAVE** brand new Govt. surplus sender/rcvr Set No. 16, SG3673 complete all parts, plus spare set of tubes, and will swap for Hallcrafters S-38 receiver or what have you. T. O. Britt, Box 206, Bladenboro, N. C.

**BOOKS** for hams supplied by mail. Operating, math, UHF, television. All latest titles. Postcard brings free illus. catalog. Nephews Pub. Co., Dept. Q7, 300 Pacific St., Brooklyn 2, N. Y.

**SELL**: BC-1068-A ultra high frequency receiver with all tubes, tuning eye and carrying case. Best offer takes it. W2JBL, George M. Clark, Jr., 222 Hicks St., Brooklyn 2, N. Y.

**SELL**: one kilowatt C.W., 800 watt fone xmt. comp. in 6 ft. rack, PP T200 final, 350 watts audio. Turner 22X mike, Stancor 415 speech amp., all tubes, coils, 11 Tripletta, band-switching 3.5 to 30 Mc. VFO (Mar. '46 QST), fone monitor, No junk. First \$900 or best offer f.o.b. Lincoln, 25¢ for fotos and particulars. John H. Deal, W9HLR, 319 Lincoln Ave., Lincoln, Ill.

**BUY** or borrow: BC-342-N instruction book TM 11-850. WIMPY, 3208 W. Lapham, Milwaukee 4, Wisc.

**BC-342** rcvr. A.C. Perfect, xtal, comp. \$27.50. BC-312 A.C. converted. Excellent. \$22.50 or trade either plus cash for small xmt. W6UCL, 2691 Ringgold St., Sacramento, Calif.

**HALLICRAFTERS** xmt. HT-6. Coils for 80, 40, 20, 11, 10. \$125 Dr. D. F. Grant, 10374 Lanark Ave., Detroit 24, Mich.

**SELL** new Navy RAK-7 low freq. rcvr. pwr supply, tubes, orig. packing case. \$57. RCP multitester Model 414, perfect. \$30. Prepaid. WIPNR, Chestnut Hill, Mass.

**SELL**: Rcvr, Howard 460 and spkr, excellent condition, 55-43 mega, xtal filter, noise limiter, freq. monitor, Bargain at \$90. A. Greenberg, W2CYK, 211 Willis Ave., New York 54, N. Y.

**IN STOCK**: New and used Hallcrafters Hammarlund, National, RME, Pierson, Collins, Millen, Temco, Supreme, Harvey receivers and transmitters and parts. Reconditioned receivers: S-38, \$35; S-40, \$69; SX-42, \$199; SX17, \$89; SX-2, \$139; Panadaptor, \$59; HQ-129X, \$129; RME-45, \$89; S-39 SX-28A, RME 69; NC-240D, HRO, SPC 400SX, SPC 400X, etc. Terms available. Shipped on approval. Send \$5.00. Pay rest COD. Write, Henry Radio, Butler, Mo.

**QSLs**, SWLs. Quick service. Samples for stamp. McQuade, W8WRL, 1071 E. Fulton, Columbus 5, Ohio.

**FOR Sale**: Harvey Radio Labs 700R 1 Kw xmt. final converted to push pull 810s for CW only. 6L2 xtal osc. RK20A hf-dblr. VR bias supplies. 4 spare 810s and 866AS. Coils 10, 20, 40, 80 bands including 1 Kw collins type antenna network. Work into any antenna. Will deliver, install and put on air anywhere L, I, or metropolitan NY area. Any other point add cost packing, crating. Sacrifice \$350. W2KEZ, Press Wireless, 1475 Broadway, NYC 18.

**NEW BC-312** receivers \$44.50; GR No. 200-CMH 500-watt Variac, \$15.75; Thordarson T-10P57 xfmrs 2150 v CT @ 125 Ma and 1015v CT @ 150 Ma, \$5.95; Code practice oscillator, bakelite case with key, tubes, speaker, CW power supply, \$6.95; BC-654 xmt-rcvr new, \$29.50; PE103 dynamometers, new, \$12.75; BC223 75-80 meter phone-CW xmt. new, \$16.95. Supreme 542 voltohmmeter, \$14.75. Write for bulletin. Keep, W5EAL, 1110 Winbern, Houston, Texas.

**QSLs/SWLs**. Meade, W0KXL, 1507 Central Ave., Kansas City, Kansas.

**NEW RME-45** rcvr for sale. Hospital expense forces sale. Best cash offer takes it. A. R. Meier, 828 Manitou Blvd., Colorado Springs, Colo.

**FOR Sale**: 80-watt ECO fone or CW xmt. speech amp., condnr mike, 500 watt power supply. Teleplex code machine, cuts tape 6 ft. a.c. No reasonable offer refused. W2CIA, Sole, 235 Crawford Terr., Union, N. J.

A 600-watt p.p. 813 fone cw rig, constructed of only highest quality components. On the air for only \$389.50 f.o.b. Denver. Welley, 1549 Boston, Aurora, Colo.

**RUSH QSLs**, SWLs! \$1.35 hundred; stamp, samples. Cushing, W1HJL, P.O. Box 32, Manchester, N. H.

**PORTABLE Recorder**: Webster-Kauland W1207, complete. Flat fidelity; cutting and 4 playback heads, 4-rotatable speaker, crystal microphone, in leather luggage case. Excellent. First \$50. 2-METER TR-4 xmt-rcvr complete with tubes, 110 volt a.c. and 6 volt d.c. power supply and microphone. Perfect. Best offer. W4CJO, Box 2867, Orlando, Fla.

**ATTENTION**: KL7FO needs Hallcrafters HT-6 xmt. Cash ready. Describe condition and state price in letter to Cyril Hoyer, W2VM, 45 Harold Avenue, Princeton, N. J.

**BEST** offer takes DM36 5-10 meter. Good condition. L. E. Huggins, W5GBS, Morton, Texas.

**SELL**: SX-28 with matching floor model base reflex speaker. Perfect condition. W. J. Friderici, Port Clinton, Ohio.

**WANTED**: Audio amplifier. 7 to 14 watts, low distortion. Harry Gingrich, 4613 Derry St., Harrisburg, Pa.

**CLEANING** out. 60-watt cw rack xmt. comp. Best offer over \$60. RCA record player, \$10. McElroy key, \$2.00. Many other parts at give-away prices. W2JAQ.

**SALE**: Pr 250TH, \$20 each; plate xfmr, 3100v. @ 700 Ma., \$50. RCA modulation transf. 550 watts audio, \$35; all new. Also Howard model, 430 rcvr. \$20. Butterfield, 518 Forest Ave., Mansfield, Ohio.

**WANTED**: 12-volt D.C. input dual unit dynamotor for Collins TCS xmt rcvr. Howard, 48 Chestnut Boston 8, Mass.

**150-Watt** cw/fone commercial xmt. comp. \$150. John Tate, 3214 41st St., Astoria, La. I.

**QSLs**. Personal stationery, colors, quality printing. 24 hr. service. W2SWL Reber Print, R.D. 1, Sewell, N. J.

**WANTED**: Battery portable. W2PNN.

**NEW** 350-watt bandswitching xmt. vfo freq. controlled. Covers 3000 to 18000 kc. frequency; react. tolerance of 0.02 o/o. Includes antenna matching network, seven meters, control panel, antenna and keying relays, instruction manuals, etc. No modifications required. Final is an 803 straight amplifier. Connects to regular power supplies. Navy aircraft type Go-9. Aluminum construction. Weight 137 lbs. Price \$136. C.o.d. Tube kit \$13. Addtl. info on request. Ryan, 16 Birka Pl., Newark, N. J.

**SELL** RME-45, complete, A-1 cond. Best offer. W9OLO, 112 Clayton, St. Louis 17, Mo.

**25-28 watt** xmt. to operate surplus equipment from 115 V.a.c. or convert ART-13, 200 watts, \$12.50, 35 volts, 300 watts, \$16.50. J. Reidel, W2CRB, 1523 41st St., Brooklyn 18, N. Y.

TRANSFORMERS: 1875V-1560V, each side centertap, 500 Ma., \$19, 300 Ma. \$14. Spear Engineering, 3003 121st, Toledo, Ohio.

HQ-129-X for sale. New condx. \$145. Cash f.o.b. W2ESP, Packanack Lake, N. J.

QSLs: Good service. Free samples. Central Printing Co., Box 345, Huntington, Ind.

SELL complete 300 watt fone/cw rig, \$250 OR power supplies, modulator and speech racks separate; write for prices and data on same. RF: 6V6, 807, pair 812s. Speech: 6S17, 6NJ, PP 6A3s, 807s. Bill Snyder, W4WG, Clarksville, Va.

SELL used National NTE exciter. New precision 856P VOM. Best offer for each. Werlin, 77 Bartlett, Somerville, Mass.

SURPLUS, items new with tubes, BC-654-A, rcvr/xmtr, \$21; PE-103-A dynamotor, \$9.95; PE-104-A Vibrapak, \$4.95; Cable, \$1.95; complete unit above, \$34.50; BC-474-A xmtr-rcvr, \$37.50; GN-44-A Hand generator, \$5.95; BC-221 frequency meters, \$37.50; BC-1068-A hi-frequency rcvr, \$14.95; RAK-7 rcvr, \$39; RBL-3 rcvr, \$44; Mark II xmtr-rcvr comp., \$39; BC-348-L (reconditioned), \$44.95; photoflash, capacitors, tubes. Write your needs. Pasadena Electronic Sales, 1062 No. Allen St., Pasadena 7, Calif.

CRYSTALS: Where quality and not price is the main consideration, demand Eidson crystals. Fine commercial units for Aircraft, Police, Marine, Geophysical and other services; crystal regrinding. Also broadcast station monitor service. Over a decade of satisfaction and get the best Try us first. Eidson Electronic Co., Temple, Texas.

QSL'S SWL'S Super-glossy stock! No cheap trash! Samples, 20¢. WOOD Sakers Printery, Holland, Mich. (RME equipment, Biley crystals).

FOR Sale: Ten surplus JK FS-344 frequency standards, complete, \$34 each postpaid. Paul Jahn, 637 Benton St., Aurora, Ill.

BC-610-E All bands, HRO 5TA1, DM36, VX101 jr. ECO. All like new. Complete for \$1165. Local buyer preferred. Used RME-45, \$150. Few new 304T1s, \$4 ea. W8VJD, Bob Lora, Findlay, Ohio, R. 6.

TRANSMITTER: McElroy all band MT-35 fone/cw 50-watts, pretuned bandswitching. This rig never used. In orig. carton. Just right for that low power rig or as bandswitching exciter. In cabinet but can be rack mounted. Self-contained power supplies. First \$125 gets it prepared. Complete with 10-meter coils, crystal and tubes. Beautiful job. W1EJD, 12 May St., Worcester, Mass.

WANTED: Meissner signal shifter as used with Meissner 150B xmtr. Must be reasonable. W4HLO, P.O. Box 3404, Orlando, Fla.

SX-18 receiver: 0.55 - 38.0 Mc. 6AC7 RF stage, noise limiter, completely aligned in good operating condition. With spkr, \$40. W9KWU, 7712 Jeffery Ave., Chicago 49, Ill.

COLLINS Model 30J xmtr. 300-watts. \$775. Dr. Paul Kincaid, 912 Rhode Island, Lawrence, Kansas.

QSLs. Samples free. Quick service. Sunland Print, Box 662, Hialeah, Fla.

FOR Sale: One BC-38R converted to 115 v 60 r, \$53.00, one reconditioned SX-25 \$66. W11BY, Sunnyside Ave., Wellesley 81, Mass.

FOR Sale: HRO coils. JA, JB, JC, JD, G, H, J, brand new; Kopp, 1295 Brentwood Road, Washington, D. C.

TRANSFORMERS: Kenyon type T-389, 2.5 volts, 10 amps. 9000 volt insulation, \$3.50; Kenyon T.5 volts 12 amps, \$3.50, 110 v. 60 c. W8TH, 545 Aberdeen Ave., Dayton 9, Ohio.

BEAM elements, 5/8" dia. durul tubing 10-1/2" meter elements, cut to specified frequency. 3-element set \$5.00 1 1/2" dia. durul adjustable elements, extra rigid \$5 per element. W2SYG, 375 Oak Place, Mineola, N. Y.

SELL SX-28A, like new, \$200. G. Baborsky, 6128 S. Wood St., Chi. Ill.

BARGAINS in new items! Jefferson 1800 v ct plate xfrmr. @ 500 M. \$12.85. A.R. JAX antenna rotator, \$9. Stancorp dynamos A-3898 300-watt modulator xfrmr @ \$33. All f.o.b. Boston, Mass. W1KZD, "Pat" Nicholas, 85 Surrey St., Brighton, Mass.

SELL: S-38 receiver. Excellent condition. W8ZKO, R.F.D. #3, Chagrin Falls, Ohio.

MICRO-match builders. Those hard-to-get 10-ohm, 2-watt resistors - 10 for \$1.00 postpaid in eastern US. Highest quality, Lloyd Chapel, WINYC, Niantic, Conn., P.O. Box 151.

FOR Sale: new equipment not used: pair Eimac 4-125As and associated final amplifier chassis near completion, \$40. Precision E200 freq. meter, \$45, Millen VFO, \$35. RCA 155 C 3" scope, \$80; RK 20, \$5. Pair RK 31s, \$6; W2s only. WZGFV, 86-10-34 Avenue, Jackson Heights, N. Y. Tel. Havemeyer 4-1646.

KENTUCKY VALUES! 6AK5s, 3 for \$2.95; New, fully guaranteed factory cartoned tubes, 211, \$19.5 805, \$4.90; 807, 95¢; 810, \$2.65; 811 \$1.95; 813, \$6.95. Any other type tubes at comparable prices. 3995 KC xtals, FT holder, 4¢; 3500 cycle clipper filter kit, \$2; 6AL5 A, filament transformer, \$2.40; 12 H, 500 Ma, filter choke, \$7.95; 432W 700 Ma Kenyon transformer, \$49.95; Standard shape 115 µfd, 3800 v. peak, or 156 µfd, 3500 V. peak, transmitting variables, \$1. 20 H, 200 Ma choke, \$2.85. Inquiries answered. Kentucky Radio Supply Co., Lexington, Ky.

QSLs "by hams for hams" quality at a surprising price, quick service, stamp for samples. W1JXP, Firman, 3739 S.W. 98th St., Seattle, Wash.

All-band rack mounted 500 watt fone or c.w. Hammarlund band-switching exciter, xtal or ECO. Thordarson peak-clipping speech, separate Class B supply, HK 254 final, flexible antenna tuner. Write for photo and details. W0HAA, 401 Hamline, Grand Forks, N. D.

SELL: Meissner 14 tube "Trafficmaster" with speaker, cabinet, \$50. Gon-Set 6 meter converter, brand new, \$33. W6VDX, 1820 Oak Knoll Rd., Glendale, Cal. CI 3-4953.

HAVE fun last year? Remember those prizes? 10th Annual Boston Hamfest, October 18th, Mechanics Building.

QSLs! Samples for stamp. Pearce Press, Danbury, Conn.

NEW HQ-129-X and HT9 mike and 4 set coils, used less than 10 hours, \$400.00. Sold complete only and pick up here or furnish crate for HT-9, Snyder, W8CQI, 1636 Broadway, Springfield, Ohio.

SELL RME-45 and speaker in excellent condition for best offer over \$100. W5JXP, 434 Louisiana, Corpus Christi, Texas.

SELL S-40, 5 months old. Perfect condition. \$75. J. Burroughs, 123 S. Appleton St., Appleton, Wisconsin.

SELL: QSTs, 1932-1946 inclusive, in QST binders, \$5 per year. Proceedings of the IRE, 1939-1946 inc. in IRE Binders, \$7 per year. W8KLP, 1273 Andrews Ave., Lakewood 7, Ohio.

FOR Sale: new BC-610E, comp. with speech amplifier, modified for 10 meters. \$720. W71VH, Box 383, Kirkland, Wash.

SELL or trade: TG10-H automatic keyer. Reproduces code from inked paper tape, and uses eight tubes with pushpull 6L6 output 110V. 60 c. inout. Use as keyer, audio oscillator or amplifier. Need receiver, scope, freq. meter or? Boland, 223 14th Ave. SE, Rochester, Minn.

WANT HT-6 complete with mike and coils for all bands including ten. Write airmail giving details and price. Sacks, KL7JL, Nenana, Alaska.

PANADAPTOR-Model PCA-2, Type T-200, used only few hours. Complete with instructions, \$75. Phil McCrum, W1CRP, 286 Woodford St., Portland, Me.

SELL: 75-watt 5-band CW rig. Complete. W0CUP, 656 Marshall Ave., Webster Grove, Mo.

SELL National 240-D receiver and matching speaker. C. Horn, 325 East 163rd St., New York 56, N. Y.

NATIONAL HRO complete with all coils, \$250. W6WRD, 2930 F Street, Sacramento, Calif.

QSLs, new designs. Samples 10¢. QSL Printers, Box 974, Ft. Wayne, Ind.

SELL small quantity of new and used parts. Write for list. W2WV, 4 Prospect Pl., Morristown, N. J.

TRANSMITTER ART 13 T/47A. Good condition, less dynamotor, \$100 or best offer. Hugh Ware, W1PYD, 11 Hillside St., Milton, Mass.

WANTED: Thordarson plate xfrmr, T-19P70 and filament xfrmr T-19F77. Bertal P. Neal, P.O. Box N, Trotwood, Ohio.

FOR Sale: Meissner 150-B transmitter, ECO, 300 watt, 80-40-20 phone CW xtal mike input complete A-1 used only few hours. Too much power, \$325. F.o.b. Wayne Hilmer, Dayton 3, Ohio.

SELL: Modulation transformer Thordarson 11M77 300 W with matched components for 811s, all new. Bud BPA-500 final. Power supplies. HRO-W. Many other parts. Send stamp for big list. W5ACL, 4010 River Drive, Houston 12, Texas.

FOR Sale: BC-610 E transmitter with BC-614E speech amplifier and 1870A junction box. Also key and 600 DL microphone. Like new. Best offer takes it. P.O. Box 441, So. Houston, Texas. W5MHC.

WANTED: Patterson PR16 comm. rcvr, in good condition. Write W6YAV, Box 175, Newhall, Cal.

QSLs. SWLA. Neat, businesslike. Fast service. Dossett, W9BHV, 857 Burlington, Frankfurt, Ind.

THORDARSON "Multi-band" 100-watt transmitter, three bands panel switched, indirectly lighted meters, fifteen Thordarson xfrms and chokes, "multi-match" Class B, 6L6-6L6-TZ-40, cabinet, tubes, 10 and 20 B&W coils, two 14 m/c xtals, bug, instruction book. Ready to go except for microphone, excellent condx. bargain, best offer \$175 or over. F.o.b. Tulsa. N. W. Smith, W5EYK, 3210 So. Cincinnati, Ohio.

SELL or swap for 8 mm movie equipment - 150 watt fone transmitter complete; Abbott MRT-3. Evan Boden, Bucknell Village, Lewisburg, Pa.

NEW or used; all popular brands in stock. Hallcrafters, National, Hammarlund, Collins, RME, Gonset, Millen, Meissner, others. Send deposit for new gear or write for list of used or surplus. Van Sickle Radio Supply, Indianapolis 6, Ind.

FOR Sale: National HRO 5TA1, practically new, \$250; complete with power supply, speaker, and general coverage and bandspeed coils from 1.7 to 30 Mc. Trevor L. Jones, jr, Havana, Ill.

FOR Sale: Meissner B-150. Transmitter, signal shifter, spare parts, data for conversion to 10-20 meters. Local buyers preferred. \$325.00 or best offer, John J. Gillen, (W3NFG), 2329 St. Albans St., Phila., Pa.

WANTED: BC-610 transmitter. Must be new or in good working condition. Will pay cash. Ralph V. Scoyk, jr., W8VVC, 27 Carlands Dr., Dayton 9, Ohio.

CRYSTAL Kit: includes 4 low drift, highly active crystals, 2 holders, abrasive, instructions, treatise. Special preferred freq. band in range from 3500 to 8500 kilocycles. \$1.00. Mounted crystals, your exact freq. \$1. Breon Laboratories, Williamsport, Pa.

SELL Temco 500GA. Perfect, \$1500. 200 hrs on tubes. Reason: marriage. Write W3LJD, 4912 Quebec St., NW, Washington 16, DC or Ione Emerson 34341.

FOR Sale: low drain battery ham rcvr. 1.5-16 mc, 9 x 6 x 5 cabinet, \$15. 20-watt cw rig complete in 9 x 6 x 5 cabinet, \$20. BC-455-B rcvr with built-in 110VAC supply. RF & AF controls, switch, excellent for 40 meters, \$20. WSJYW, Box QQ, Hobbs, New Mexico.

FOR Sale: ARR7 (Airborne SX28A) New, \$125. W3MOD, 720 No. Atherton St., State College, Pa.

FOR Sale: HT-9 xmtr, comp., with tubes and coils for 40-20-10 meters. This xmtr just a few months old. New condx. Best offer. F.o.b. Canton, Ill. Barton Matthews.

SOLID silver 16 gauge buss wire for uhf, jewelry, \$1.25 roll. Guaranteed. R. J. Cartwright, 69 Mountfort St., Boston, Mass.

SX-28, \$160, S-40 \$75. Both used but in excellent condx. Pick them up at W2GUR.

FOR Sale: Kw. amp. and 5 1/2 ft. aluminum rack \$15. Paul Graves, 65 Adam St., Hartford, Conn.

SELL: Meissner 150-B, modified. High gain speech stage; push-to-talk dynamic mike, oversize modulation keyer, break-in cw, 150 watts output, fone or cw, 80, 40 and 20. \$300 f.o.b. Bob Simmons, 810 E. Orchard, Kirkeville, Mo.

SELL Hammarlund SP-400X rcvr, complete with pwr supp. and cabinet spkr. Perfect, only 3 mos. old. Cost \$347. Sell \$275. Reason, leaving radio. New 221AK freq. meter with tone. Check point chart but no calibration book, \$35. Also LM type freq. meter with calibration book, \$35. Harms, W2JME, Morris Plains, N. J.

SELL HT-9 xmtr. Perfect condx. Used 4 mos. 10 meter coils extra. \$14. First certified check takes it. \$280. W5LGC, Box 57, Pyote Tex.

Designed for



Application

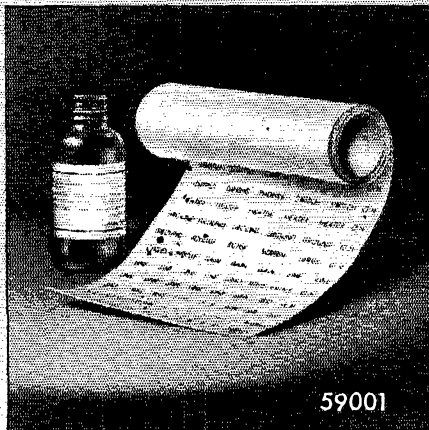

59001

**The No. 59001  
PANEL MARKING  
TRANSFERS**

The panel marking transfers have 1/8" white block letters. Special solution furnished. Must not be used with water. Equally satisfactory on smooth or wrinkle finished panels or chassis. Ample supply of every conceivable word or marking required for amateur or commercial equipment.

**JAMES MILLEN  
MFG. CO., INC.**

MAIN OFFICE AND FACTORY  
**MALDEN  
MASSACHUSETTS**



**Index to Advertisers**

	Page
Allied Radio Corp.	121
American Lava Corp.	9
American Phenolic Corp.	82
American Radio Institute	138
Asite Radio Co., Walter	129
Assembly Products, Inc.	122
Astatic Corp., The	7
Brach Manufacturing Co., L. S.	133
Browning Laboratories	90
Burgess Battery Co.	86
Burlington Instrument Co.	120
Burstein-Applebee Co.	126
Candler System Co.	138
Capitol Radio Eng. Inst.	109, 138
Chicago Industrial Instrument Co.	114
Cleveland Inst. of Radio Elec.	104
Clippard Instrument Lab.	133
Collins Radio Co.	144
Commercial Radio Inst.	136
Condenser Products Co.	89
Continental Sales Co.	136
Cornell-Dubilier Elec. Corp.	75
Drake Electric Co.	118
Fitel-McCullough, Inc.	77
Electro-Voice, Inc.	Cov. 11
Electronic Indicator	124
Electronic Marketers	102
Electronic Navigation, Inc.	132
Electroncraft, Inc.	132
General Cement Mfg. Co.	116
General Electric Co.	1
Hallcrafters Co., Inc.	4, 5
Hammilund Mfg. Co., Inc.	81, 88, 116
Harrison Radio Company	123
Harvey Radio Company	127
Hatry & Young	110
Heintz & Kaufman, Ltd.	107
Henry Radio Stores	115
Herbach & Rademan	135
Hytron Radio & Elec. Corp.	83
Instructograph Co., The	135
Jensen Mfg. Co.	8
Johnson Sales, Art A.	130
Johnson Co., E. F.	135
Jones Electronics Co., M. C.	118
Ken-Rad	95
Kenyon Transformer Co.	137
Knights Co., James	114
Leeds Radio Co.	108
M & H Sporting Goods Co.	100
Maguire Industries	84, 85
Mallory & Co., P. R.	80
Mass. Radio & Television	130
Melville Radio Inst.	134
Millen Mfg. Co., Inc., James	142
Munger Co., Rex L.	96
Mytronic Co., The	126
National Company, Inc.	71, 97, Cov. III
Newark Electric Co.	113, 119
Ohmite Manufacturing Co.	87
Onan & Sons, D. W.	110
P & H Sales Co.	122
Petersen Radio Co.	91
Port Arthur College	122
Radio Mfg. Engineers	143
Radio Parts Distributing Co.	132
Radio Products Sales Co.	106
Radio Shack Corp.	92, 93
Radio Transceiver Labs.	98
RCA Institutes	128
RCA Manufacturing Co., Inc.	Cov. IV
Richardson Labs, Kenneth	130
Sangamo Electric Co.	101
Signal Eng. & Mfg. Co.	112
Silver Co., McMurdo	94
Simpson Electric Co.	103
Solar Capacitor Sales Co.	2
Sonar Radio Co.	105
Speedway Mfg. Co.	138
Standard Transformer Corp.	112
Steinberg's	128
Sun Radio of Washington	125
Sylvania Elec. Prod. Co.	79
Telex, Inc.	111
Terminal Radio Co.	131
Transmitter Equip. Mfg. Co.	73
Triplet Electrical Instr. Co.	99
Turner Co., The	139
UHF Resonator Co.	137
Valparaiso Tech. Inst.	126
Valpey Crystal Corp.	136
Vibroplex Co., The	128
Wind Turbine Co.	120
World Radio Labs	117



ADD **11** MORE **EVEN METERS**  
 TO YOUR **EXISTING** SCHEDULE

the **VHF 152**  
 FOR 2, 6, 10 and 11 METERS

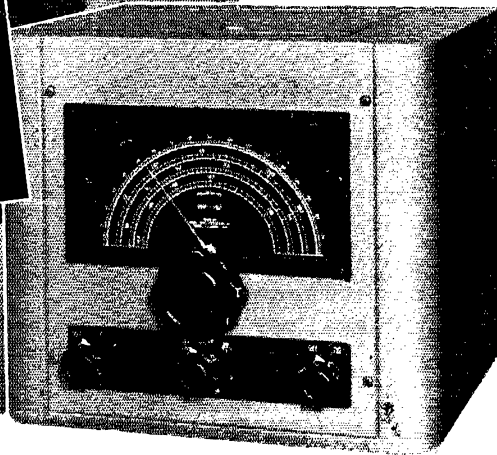

**BE PREPARED FOR THE INCREASED  
 ACTIVITY ON TWO AND SIX METERS**

**SPRING** and **SUMMER** will provide a new high in VHF interest and activity—and a VHF 152 Converter will enable you to get on these bands efficiently and economically. Six meters will be good for "Sporadic E" this Summer. In the Fall F2, long distance skip, will also prevail.

Because many are going to crystal control on 144 mc., the VHF 152 is a must. It employs the extremely efficient double detection system when used with any communications receiver—at a low price and with high efficiency.

What's more, amateurs are discovering that two and six meter bands are best for local rag chews—eliminating QRM on the crowded bands when they are open for DX.

In order that imageless operation on the eleven meter band can also be enjoyed, the VHF 152 has now been redesigned to include this band also. Features include a regulated power supply and provision for four separate antennas.

Yes, the VHF 152 will greatly improve reception on the high frequencies, and it's an especially vital adjunct to those receivers that tune only to 18 MC.

ILLUSTRATED  
 FOLDER  
 ON REQUEST



**RME**

FINE COMMUNICATIONS EQUIPMENT  
**RADIO MFG. ENGINEERS, INC.**  
*Provia 6, Illinois U. S. A.*

# two grand exciters

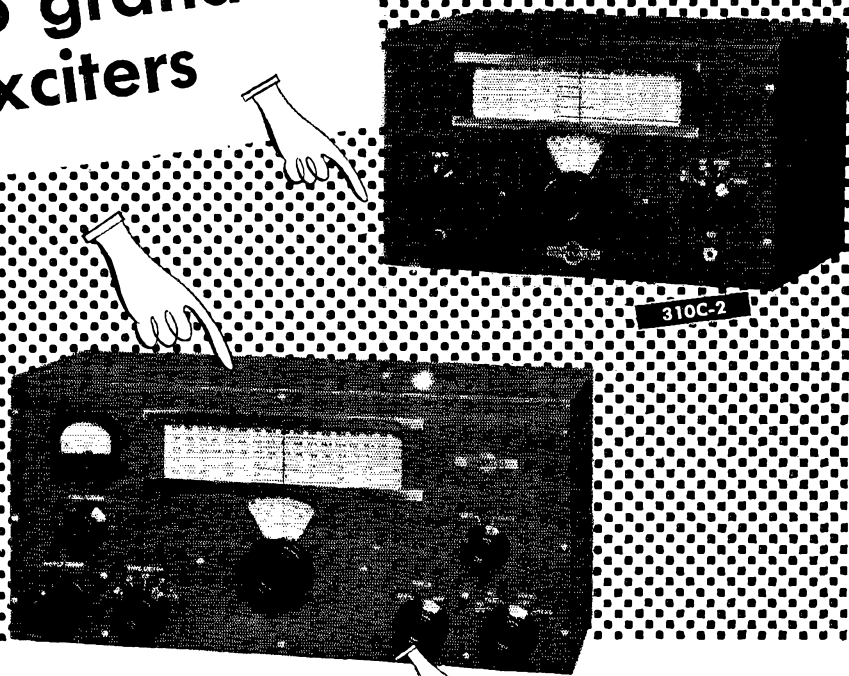

● The Collins 310B-1 and 310C-2 exciters provide not only the flexibility and convenience of variable frequency, but also the accurate calibration and high stability inherent in the Collins 70E-8 permeability tuned oscillator. They give you a precision frequency control usually found only in laboratory instruments. Yet they are built for continuous service under all normal fluctuations in operating conditions.

Frequency is read directly from the dial. There are no reference charts or curves to interpolate. Accuracy is within 0.015% under normal conditions. Thus you can read your actual operating frequency to within 150 cycles per megacycle—to within one dial division on all bands.

Both of these exciters have self-contained power supplies. A third, the 310C-1, is similar to the 310C-2, minus power supply. All three are fully described and illustrated in a new Collins bulletin, just off the press. Write for your copy.

**THE 310B-1** is a versatile band-switching exciter unit, conservatively rated at fifteen watts output on all amateur bands under 32 megacycles, and can be used as a complete low power cw transmitter. It has ample drive for a kilowatt final utilizing the new pentode tubes available. With additional multiplication it makes an excellent frequency control for amateur bands in the VHF and UHF regions.

**THE 310C-2** consists of a 70E-8 PTO and a multiplier, with an r-f output of approximately 80 volts rms across 40,000 ohms. Its frequency range is from 3.2 mc to 4.0 mc. Its output can be plugged into the crystal socket, or applied to the grid of an 807 buffer stage, thus providing a versatility far greater than any number of crystals, while at the same time maintaining crystal accuracy and stability.

FOR BEST RESULTS IN AMATEUR RADIO, IT'S . . .

**COLLINS RADIO COMPANY, Cedar Rapids, Iowa**

11 West 42nd Street, New York 18, N. Y.

458 South Spring Street, Los Angeles 13, California

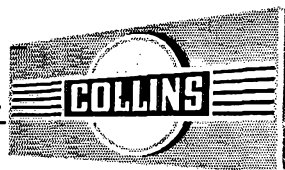



**THE NATIONAL COMPANY**

*Proudly Presents*

**THE NEW HRO-7**

Known and used by hams the world over for 13 years, the old HRO now has a new successor — the HRO-7 — incorporating every one of its strong points and adding a number of modern refinements.

To begin with, the HRO-7 is housed in a streamlined grey cabinet that will enable you to meet the XYL's former objections to bringing your rig into the main part of the house. The whole family can listen when you pick up a French OP talking about the latest UN news.

Two new miniature tubes have been added to further stabilize the receiver. This will enable you to turn the rig off and on again with an absolute minimum of retuning.

As you turn the RF gain control, there'll be no appreciable change in the pitch of code signals and the HRO-7 remains unaffected by normal fluctuations in the voltage sent in by the power company.

We could go on endlessly like this — but why not go down to your nearest National dealer today and ask to see and hear the new National HRO-7 for yourself.

- 11 tube (plus voltage regulator) superheterodyne.
- Frequency Range of 50 to 430 and 480 to 30,000 KC.
- AM phone and code reception.
- Accessory Connector Socket makes possible use of wide variety of accessories, such as narrow band FM discriminator, crystal calibrator, etc.
- New double action noise limiter effectively reduces interference caused by external noise pulses.
- A 6 position switch for crystal filter operation.
- Maximum bandspreading of the Amateur bands.
- Streamlined cabinet with attractive grey finish.

**National  
Company, Inc.**

**Dept. No. 8  
Malden, Mass.**

**MAKERS OF LIFETIME RADIO EQUIPMENT**

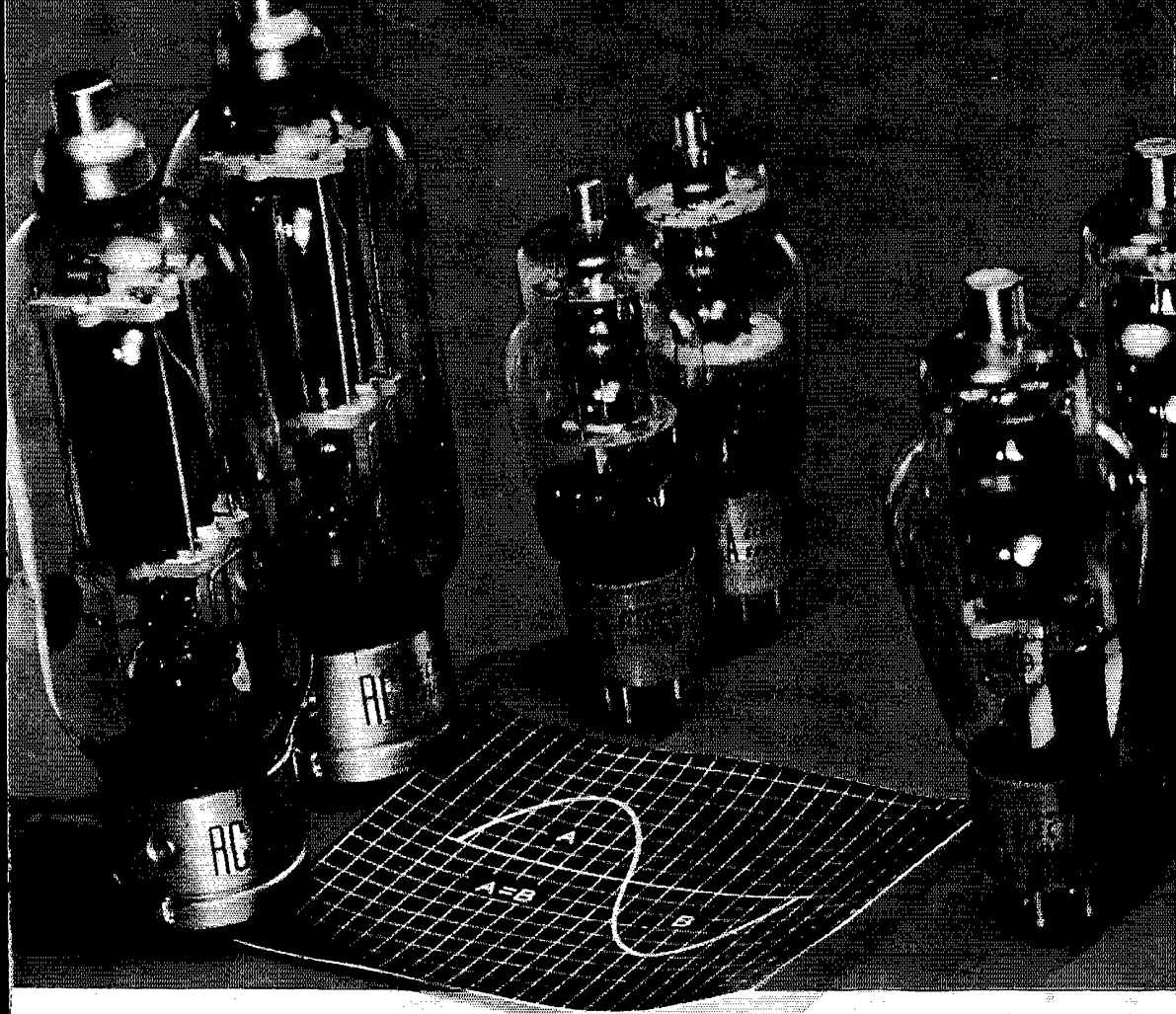

**In modulator service, uniformity counts . . .  
 . . . and you can count on RCA tubes to have it**

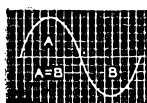

To make A equal B...to keep a-f distortion low and power output high, the plate currents of a push-pull modulator must be alike. In short, tubes must have dependable uniformity.

RCA power tubes have that uniformity, because they're built to exacting tolerances . . . and held there by modern production methods and thorough quality control.

Your local RCA tube distributor can supply you with modulator tubes...uniform tubes...for every transmitter power. For information, see him or write RCA, Commercial Engineering, Section M54H, Harrison, N. J.

**Have you seen HEADLINERS FOR HAMs?**  
 Get this latest data on amateur tubes from your local RCA Tube Distributor.

TYPICAL RCA HIGH-MU TUBES FOR MODULATOR SERVICE				
Tube	max. d-c plate volts	max. signal		Amateur net price per tube
		driving watts	output watts	
2 RCA-807's	750	5.5	120	\$2.30
2 RCA-810's	2750	13	725	12.50
2 RCA-811's	1500	3	220	3.50

Note: Values shown are for ICAS operation.

The Fountainhead of Modern Tube Development is RCA



**TUBE DEPARTMENT**

**RADIO CORPORATION of AMERICA**  
 HARRISON, N. J.