

January, 1949

40 Cents

QST

devoted entirely to

amateur radio



In This Issue... USING PROGRAMMER TUBES ON 400 MC.

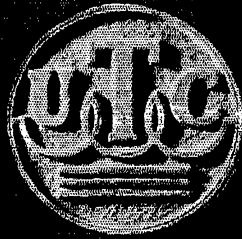

Since its inception, the designs of the UTC Engineering Department have set the standard for the transformer field.



Hum Balanced Coil Structure: Used by UTC in practically all high fidelity designs. . . . Hum balanced transformers are now accepted as standard practice in the transformer field.

1
9
3
3

1
9
4
1

Hermetic Seal Pioneering: Realizing the essentiality of hermetic sealing for many applications, UTC pioneered a large number of the terminals and structures for hermetic transformers . . . now available for commercial use.



Linear Standard Audio Units: Flat from 20 to 20,000 cycles. . . . A goal no others have met.

1
9
3
4

1
9
4
2

Toroidal Wound High Q Coils: UTC type HQ permalloy dust coils afford a maximum in Q, stability and dependability with a minimum of hum pickup. Standardized types for all requirements from 200 cycles to 500 KC.



Ultra-Compact Audio Units: A complete series of light weight audio and power components for aircraft and portable applications. Ultra-Compact Audio units are hum balanced . . . weigh approximately six ounces . . . high fidelity response.

1
9
3
5

1
9
4
3

Variable Inductors: The type VIC high Q variable inductor revolutionizes the approach to tuned audio circuits. Variation of +90% to -30% of mean inductance permits tuning any type of filter or equalizer to precise frequency characteristic.

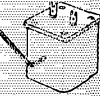

Tri-Alloy Shielding: The combination of Linear Standard frequency response and internal tri-alloy magnetic shielding is a difficult one to approach. Used by G.E., RCA, Western Electric, Westinghouse, Raytheon, Collins, Gates, etc.

1
9
3
6

1
9
4
4

Standardized Filters: UTC type HPI, Lri, and BPI (low pass, high pass, and band pass) Filters are standardized to effect minimum cost and good delivery time. Available for frequencies throughout the entire audio range.



Ounce Audio Units: Extremely compact audio units for portable application were a problem until the development of the UTC Ounce series. Fifteen types for practically all applications . . . range 40 to 15,000 cycles.

1
9
3
7

1
9
4
5

Sub-Audio and Supersonic Transformers: Embody new design and constructional principles, for special frequency ranges. 1/2 to 60 cycles for geophysical, brain wave applications . . . 8 to 50,000 cycles for laboratory services, 200 to 200,000 cycles for supersonic applications.



Universal Equalizers: The UTC Universal Equalizers, Attenuators, and Sound Effects Filters fill a specific need of the broadcast and recording field. Almost any type of audio equipment can be equalized to high fidelity standards.

1
9
3
8

1
9
4
7

Stabilized Low Frequency High Q Coils: Temperature stabilized units for frequencies from 1 to 300 cycles with minimal variation in I for wide range in exciting voltage.



Sub-Ounce Units: A series of 1/2 ounce miniature units with non-corrosive-long life construction for hearing aid, miniature radio, and similar applications. Five types cover practically all miniature requirements.

1
9
4
0

1
9
4
8

Transformers for Power Control and Amplification Purposes Employing Nickel Steels: These saturable reactors are available for frequencies from 25 cycles to 250 KC.



1
9
4
9

New Items: The UTC Research Laboratory is developing new items and improving standard designs in 1949. While some of these developments will be described in our advertisements, many are applied to customers' problems.

Write for new catalogue



For only a few cents more,
get a tube that's

R-F-TESTED!

While a 6L6 in design and basic characteristics, the GL-1614 is factory-approved for radio-frequency work. Play safe by plugging-in this sure-fire performer for oscillator, doubler, other r-f applications.



**TYPE
GL-1614**



THAT little extra you pay for a GL-1614—it will come back to you many times over in performance hours, in assurance that you've installed a tube fully able to do an r-f job.

Maybe the 6L6 you were thinking about would have perked along... for a time... but why gamble? The 6L6 is tested only for audio-frequency service. To employ it at radio frequencies is like using your pen-knife to tighten screws. Maybe the blade won't buckle in service for which it wasn't intended!

Rated up to 80 mc at full input, and 120 mc at somewhat reduced input, a GL-1614 will loaf along with the plate taking 30 w CW or 23 w phone. Here's a low-cost beam power dependable, with plenty of jobs waiting for it in your rig. Install it with confidence!

Your nearby G-E tube distributor will be glad to tell you more. Or write *Electronics Department, General Electric Company, Schenectady 5, New York.*

Series 1 in a listing, by areas, of tube distributors who can supply you with Ham News, G. E.'s bi-monthly magazine:

- Auburn, Maine: Radio Supply Co.
 - Bangor, Maine: Radio Service Laboratory.
 - Boston, Mass.: Louis M. Hurman Co.; Demambro Radio Supply; Hatry & Young, Inc.; Radio Shack Corp.; Radio Wire & Television, Inc.; Wholesale Radio Laboratories.
 - Bridgeport, Conn.: Hatry & Young, Inc.
 - Concord, N. H.: Evans Radio Co.
 - Dover, N. H.: American Radio Corp.,
 - Fall River, Mass.: Flint Radio.
 - Hartford, Conn.: Hatry & Young, Inc.; R. G. Scell & Co.
 - Holyoke, Mass.: Springfield Radio Co.
 - Manchester, N. H.: Demambro Radio Supply; Radio Service Laboratory.
 - New Haven, Conn.: Hatry & Young, Inc.
 - New London, Conn.: Hatry & Young, Inc.
 - Portland, Maine: Maine Electronic Supply Corp.; Radio Service Laboratory.
 - Providence, R. I.: William Dandreta & Co.; Demambro Radio Supply; W. H. Edwards Co.
 - Roxbury, Mass.: Gorber Radio Supply.
 - Springfield, Mass.: T. F. Cushing; Hatry & Young, Inc.; Springfield Radio Co.; Springfield Sound Co.
 - Stamford, Conn.: Hatry & Young, Inc.
 - Waterbury, Conn.: Bond Radio Supply; Hatry & Young, Inc.
 - Worcester, Mass.: Demambro Radio Supply; Radio Electronic Sales Co.; Radio Maintenance Supply Co.
- (List as of Oct. 25, 1948.)

6E-2224	6E-2226	6E-4021/4-125A	6E-5D24	6E-351	6E-1001N	6E-202-A	6E-211	6E-592
6E-802	6E-803	6E-805	6E-806	6E-807	6E-810	6E-811	6E-812-A	6E-813
6E-814	6E-815	6E-816-B	6E-817-A	6E-817	6E-818	6E-819	6E-820	6E-821
ELECTRONIC TUBES OF ALL TYPES FOR THE RADIO AMATEUR								
6E-1024	6E-1025	6E-2000	6E-2005	6E-2012-A	6E-2025-A	6E-2041	6E-210	6E-200-A
6E-212-A	6E-2005	6E-1132	6E-1121	6E-1136	6E-1136	6E-1137	6E-1131	6E-1125
6E-1122	6E-1123	6E-1124	6E-2040	6E-2043	6E-2E24	6E-2E26	6E-3D21/4-125A	6E-3D24

GENERAL  ELECTRIC

100-HA1-8850



Left to right: Collins 75A-1 receiver, 310A-3 exciter with speaker above, 30K-1 transmitter

Sitting Pretty

● The owner of a group like this has the best performing half-kilowatt outfit money can buy.

Operating in the 80, 40, 20, 15, 11 or 10 meter bands, he can run 500 watts of stable c-w, or 375 watts of clean, intelligible phone into his PA amplifier. He has bandswitching in all transmitting circuits except the antenna tuning network, where one plug-in coil covers 80 and 40 meters, and another covers 20, 15, 11 and 10. He has very accurate Collins PTO control right on his desk, in the 310A-3 exciter.

It is often said that you can spot a Collins 30K-1 transmitter on phone as soon

as you hear it, and that it seems to have more sock than its rated power. One reason is well engineered speech clipping, which permits running the audio gain at high level, with 100% modulation. Another reason is found in good audio design and fine components, providing remarkable clarity of voice transmission.

Add the sensitivity, stability and tuning accuracy of the 75A-1 receiver, and you have the ideal combination, whether for DX or maintaining schedules.

Get in touch with your Collins dealer. If you do not know him, we will be glad to give you his name and address.

FOR SUCCESS IN AMATEUR RADIO, IT'S . . .

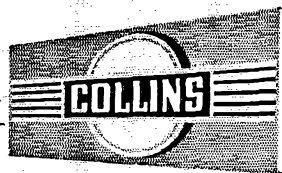

COLLINS RADIO COMPANY, Cedar Rapids, Iowa

11 West 42nd Street, New York 18, New York

458 South Spring Street, Los Angeles 13, California



PUBLISHED, MONTHLY, AS ITS OFFICIAL ORGAN, BY THE AMERICAN RADIO RELAY LEAGUE, INC., AT WEST HARTFORD, CONN., U. S. A.; OFFICIAL ORGAN OF THE INTERNATIONAL AMATEUR RADIO UNION

STAFF

Editorial

A. L. BUDLONG, W1BUD
(Acting Secretary, ARRL)
Editor

HAROLD M. McKEAN, W1CEG
Assistant Editor

GEORGE GRAMMER, W1DF
(Technical Director, ARRL)
Technical Editor

DONALD H. MIX, W1TS
BYRON GOODMAN, W1DX
Assistant Technical Editors

EDWARD P. TILTON, W1HDQ
V.H.F. Editor

RICHARD M. SMITH, W1FTX
C. VERNON CHAMBERS, W1EQ
Technical Assistants

ROD NEWKIRK, W9BRD
DX Editor

WALTER E. BRADLEY, W1FWH
Technical Information Service

Production

RALPH T. BEAUDIN, W1BAW
Superintendent

NANCY A. PRICE
Assistant

Advertising

F. CHEYNEY BEEKLEY, W1GS
LORENTZ A. MORROW, W1VG
EDGAR D. COLLINS

Circulation

DAVID H. HOUGHTON
Circulation Manager

RALPH T. BEAUDIN, W1BAW
Assistant Circulation Manager

OFFICES

38 La Salle Road
West Hartford 7, Connecticut

Subscription rate in United States and Possessions, \$4.00 per year, postpaid; \$4.50 in the Dominion of Canada, \$5.00 in all other countries. Single copies, 40 cents. Foreign remittances should be by international postal or express money order or bank draft negotiable in the U. S. and for an equivalent amount in U. S. funds.

Entered as second-class matter May 29, 1919, at the post office at Hartford, Connecticut, under the Act of March 3, 1879. Acceptance for mailing at special rate of postage provided for in section 1103, Act of October 3, 1917, authorized September 9, 1922. Additional entry at Concord, N. H., authorized February 21, 1929, under the Act of February 28, 1925.

Copyright 1949 by the American Radio Relay League, Inc. Title registered at U. S. Patent Office.

INDEXED BY

INDUSTRIAL ARTS INDEX

-CONTENTS-

"It Seems to Us . . ." 9
Our Cover 10
Feed-Back 10
The "Basic" 'Phone Exciter. . . Byron Goodman, W1DX 11
80 and 40 on Wheels . . . Richard M. Smith, W1FTX 18
Propagation and Antennas Above 50 Mc.
Plotting V.H.F. Station Performance Graphically
M. R. Ludwig, W0QHC 24
Making the Higher Frequencies Pay Off
Calvin F. Hadlock, W1CTW 25
A Doorknob Oscillator for 420 Mc.
Edward P. Tilton, W1HDQ 29
Happenings of the Month 32
How's DX? 35
A Versatile Low-Power 'Phone-C.W. Transmitter
G. A. Baker, W6CWQ 38
Silent Keys 41
15th ARRL International DX Competition 42
The Governors-to-President Relay 44
Some Notes on the Clapp Oscillator
Richard G. Talpey, W2PUD 48
I Will Do It in '49! Herbert S. Brier, W9EGQ 46
The Black Box. Albert E. Hayes, jr., W1IIN 48
The World Above 50 Mc. 51
In QST 25 Years Ago This Month 55
I.A.R.U. News 56
WWV Schedule 57
2nd V.H.F. Sweepstakes, Jan. 15th-16th
F. E. Handy, W1BDI 58
On the Air with Single Sideband 60
United States Naval Reserve 61
Hints and Kinks 62
Correspondence from Members 63
Operating News 64
Station Activities 72

ACCEPTED



An Eimac 4-65A in the versatile Hallicrafters HT-19 medium-power amateur transmitter. The unit is completely self-contained, 20 x 10 x 18 inches in size and operates both narrow-band FM and CW, plus provisions for AM . . . to give maximum flexibility on five popular bands.

HT-19
hallicrafters
 AND
 the **Eimac**
REG. U. S. PAT. OFF.
4-65A

GENERAL CHARACTERISTICS	
ELECTRICAL	
Filament: Thoriated tungsten	
Voltage	6.0 volts
Current	3.5 amperes
Grid-Screen Amplification Factor (Average)	5
Direct Interelectrode Capacitances (Average)	
Grid-Plate	0.08 μuf.
Input	8.0 μuf.
Output	2.1 μuf.
TYPICAL OPERATION	
RADIO FREQUENCY POWER AMPLIFIER AND OSCILLATOR	
Class-C Telephony or FM Telephony	
D-C Plate Voltage	600 1500 3000 Volts
D-C Screen Voltage	250 250 250 Volts
D-C Grid Voltage	-50 -75 -90 Volts
D-C Plate Current	100 150 115 Ma.
D-C Screen Current	40 35 20 Ma.
D-C Grid Current	13 14 10 Ma.
Peak R-F Grid Input Voltage (approx.)	145 180 170 Volts
Driving Power (approx.)	1.9 2.3 1.7 Watts
Screen Dissipation	10 9 5 Watts
Plate Power Input	84 225 345 Watts
Plate Dissipation	30 55 65 Watts
Plate Power Output	54 170 280 Watts

Universally accepted as the dependable tetrode to supply ample power with extremely high stability, the Eimac 4-65A is appearing in ever increasing numbers in the most modern of amateur and commercially built transmitters.

As an example of the trend, in the above illustration the Eimac 4-65A is pictured in the final amplifier of the new Hallicrafters HT-19. This compact transmitter gives maximum flexibility on five popular bands. The 4-65A runs at an input of 185 watts and delivers 125 watts output.

Complete technical data on the 4-65A, including its use as a Class-B linear amplifier in SSSC operation, may be found in a new 4-65A data sheet which is yours for the asking, write direct.

E I T E L - M C C U L L O U G H I N C .

208 SAN MATEO AVE., SAN BRUNO, CALIFORNIA

Export Agents: Frazier & Hansen, 301 Clay St., San Francisco, California

**NBFM or CW
VFO or CRYSTAL!**

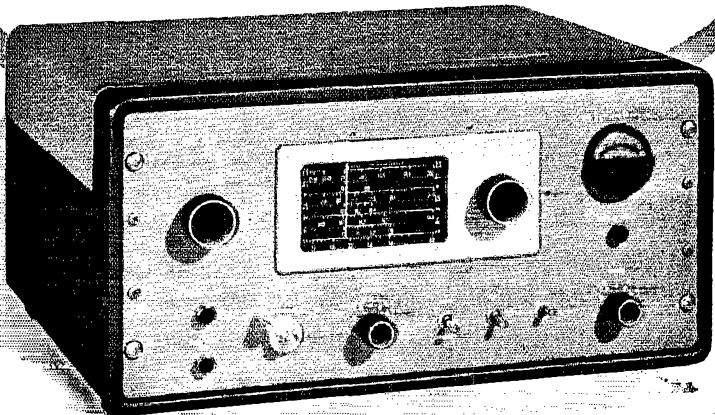

\$359.50

Slightly Higher
West of Rockies

...the New HT-19 transmitter

● Designed for the modern-minded Ham. Maximum flexibility on 5 Bands — 3.5, 7, 14, 21, and 28 MC. High stability, low FM distortion (measured at less than 5%). Provisions for applying AM from external modulator. 125 watts output.

Oscillator—reactance modulator with speech amplifier—buffer—and final. The 4-65A in/output stage is air-cooled by a 1000-rpm fan! 5 Tubes plus 2 Voltage Regulators and 3 Rectifiers.

See it at your Hallicrafters Dealers!

the hallicrafters co.

4401 W. Fifth Ave., Chicago 24, Ill.

World leading manufacturers of precision radio and television equipment

Section Communications Managers of the ARRL Communications Department

Reports Invited. All amateurs, especially League members, are invited to report station activities on the first of each month (for preceding month) direct to the SCM, the administrative ARRL official elected by members in each Section. Radio Club reports are also desired by SCMs for inclusion in *QST*. All **ARRL Field Organization appointments** are now available to League members. These include ORS, OES, OPS, OO and OBS. Also, where vacancies exist SCMs desire applications for SEC, EC, RM, and PAM. In addition to station and leadership appointments for Members, *all amateurs* are invited to join the ARRL Emergency Corps (ask for Form 7).

ATLANTIC DIVISION				
Eastern Pennsylvania	WBES	Jerry Mathis	103 Crescent Ave.	Glenside Gardens
Maryland-Delaware-D.C.	W3BWT	Eppa W. Darne	132 Tennesse Ave., N.E.	Washington 2, D. C.
Southern New Jersey	W2OXX	G. W. (Bill) Tunnell	22 Wyoming Ave.	Audubon
Western New York	W2PGT	Harding A. Clark	753 Westmoreland Ave.	Syracuse 10
Western Pennsylvania	W3KWL	Ernest J. Hlinsky	509 Beechwood Ave.	Farrell
CENTRAL DIVISION				
Illinois	W9EVJ	Lloyd E. Hopkins	27 Lynch St.	Elgin
Indiana	W9SFG	Charles H. Conway	3345 College Ave.	Indianapolis 5
Wisconsin	W9RQM	Reno W. Goetsch	929 S. 7th Ave.	Wausau
DAKOTA DIVISION				
North Dakota	W8GZD	Paul M. Bossoletti	204 Polk St.	Grand Forks
South Dakota	W8NGM	J. S. Foasberg	509 Idaho Ave., S.E.	Huron
Minnesota	W9CWB	Walter G. Hasskamp	116 3rd Ave., S.W.	Crosby
DELTA DIVISION				
Arkansas	W5JIC	Marshall Riggs		Danville
Louisiana	W5VT	W. J. Wilkinson, jr.	Room 313, Jefferson Hotel	Shreveport
Mississippi	W5IGW	Harold Day	Route 2, Box 333	Shreveport
Tennessee	W4QT	Ward Buhrman	1000 Overlook Ave.	Chattanooga
GREAT LAKES DIVISION				
Kentucky	W4CDA	W. C. Alcock	135 St. Mildred's Court	Danville
Michigan	W8SCW	Joseph R. Beljan, jr.	13959 Tuller Ave.	Detroit
Ohio	W8RWZ	Dr. Harold E. Stricker	RFD 5	Marysville
HUDSON DIVISION				
Eastern New York	W2EQD	Fred Skinner	500 Wolfs Lane	Pelham 65
N. Y. C. & Long Island	W2KDC	Charles Ham, jr.	200 Harvard St.	Westbury
Northern New Jersey	W2ANW	Thomas J. Lydon	190 Mortimer	Rutherford
MIDWEST DIVISION				
Iowa	W8PP	William G. Davis	3rd St.	Mitchellville
Kansas	W8ICV	Earl N. Johnston	624 Roosevelt	Topeka
Missouri	W8ICD	Ben H. Wendt	RFD 10	North Kansas City
Nebraska	W8RQK	William T. Gemmer	1708 West 6th St.	North Platte
NEW ENGLAND DIVISION				
Connecticut	W1VB	Walter L. Glover	Glover Ave.	Newtown
Maine	W1GKJ	F. Norman Davis	RFD 1	Old Orchard Beach
Eastern Massachusetts	W1ALP	Frank L. Baker, jr.	91 Atlantic St.	North Quincy 71
Western Massachusetts	W1AZW	Frentiss M. Bailey	62 Dexter St.	Pittsfield
New Hampshire	W1AFO	Gilman C. Crowell	15 Academy St.	Concord
Rhode Island	W1CIH	Roy B. Fuller	17 Ledge Road	East Greenwich
Vermont	W1NLO	Burtia W. Dean	P. O. Box 81	Burlington
NORTHWESTERN DIVISION				
Alaska	KL7IG	Charles M. Gray	Box 1237	Douglas
Idaho	W7IWU	Alan K. Ross	2105 Irene St.	Boise
Montana	W7EGN	Fred B. Tintinger	328 Central	Whitefish
Oregon	W7HAZ	Ralph A. Munras	Box 744	Baker
Washington	W7ACF	Clifford Cavanaugh	Route 1	Auburn
PACIFIC DIVISION				
Hawaii	KH6EL	John Souza		Wailuku, Maui
Nevada	W7CX	N. Arthur Sowle	Box 2025	Reno
Santa Clara Valley	W6BPT	Roy E. Pinkham	1061 Fremont St.	Santa Clara
East Bay	W6T1	Horace R. Greer	414 Fairmount Ave.	Oakland 11
San Francisco	W6NL	Samuel C. Van Liew	215 Knowles Ave.	Daly City
Sacramento Valley	W6ZF	Ronald C. Martin	264 13th St.	Sacramento 14
Philippines*	KA1CB	Craig B. Kennedy	25 Roosevelt Road	San Francisco Del Monte
San Joaquin Valley	W6FKL	Ted R. Souza	3515 Home Ave.	Quezon City, Rizal Fresno 4
ROANOKE DIVISION				
North Carolina	W4CYB	W. J. Wortman	c/o Duke Power Co.	Charlotte 1
South Carolina	W4BQE/ANG	Ted Ferguson	3422 Rosewood Drive	Columbia 25
Virginia	W4KFC	Victor C. Clark	Box 73	Annapdale
West Virginia	W8JM	Donald B. Morris	303 Home St.	Fairmont
ROCKY MOUNTAIN DIVISION				
Colorado	W8IQZ	M. W. Mitchell	1955 Uinta St.	Denver 7
Utah-Wyoming	W7NPU	Alvin M. Phillips	RFD 2	Ogden, Utah
SOUTHEASTERN DIVISION				
Alabama	W4GJW	Dr. Arthur W. Woods	411 Woodward Bldg.	Birmingham
Eastern Florida	W4FWZ	John W. Hollister	3809 Springfield Blvd.	Jacksonville 8
Western Florida	W4DAO	Luther M. Holt	223 W. Romana St.	Pensacola
Georgia	W4DX1	Clay Griffin	1557 Athens Ave., S.W.	Atlanta
West Indies (Cuba-P.R.-V.I.)	KP4KD	Everett Mayer	P. O. Box 1061	San Juan 5, P. R.
Cand. Zone	KZ5AW	Everett K. Kimmel	Box 264	Gambou, C. Z.
SOUTHWESTERN DIVISION				
Los Angeles	W6IOX	Vincent J. Haggerty	1017 Indio Muerto St.	Santa Barbara
Arizona	W7MLL	Glauden C. Elliott	39 North Melwood	Tucson
San Diego	W6GC	Irvin L. Emig	4852 Marlborough Drive	San Diego
WEST GULF DIVISION				
Northern Texas	W5CDU	Joe G. Buch	5231 Vickery Boulevard	Dallas
Oklahoma	W5HX1	Bert Weidner	Box 14	Crescent
Southern Texas	W5HIP	Ted Chastain	3037 So. Staples St.	Corpus Christi
New Mexico	W5SMA	Lawrence R. Walsh	P. O. Box 1663	Los Alamos
MARITIME DIVISION				
Maritime (Nfld. & Labr. att.)	VE1DQ	A. M. Crowell	69 Dublin St.	Halifax, N. S.
ONTARIO DIVISION				
Ontario	VE3CP	Thomas Hunter, jr.	1774 Westcott Road	Windsor, Ont.
QUEBEC DIVISION				
Quebec	VE2GL	Gordon A. Lynn	c/o Radio Division Montreal Airport	Montreal, P. Q.
VANALTA DIVISION				
Alberta	VE6MJ	Sydney T. Jones	P. O. Box 373	Edmonton, Alta.
British Columbia	VE7HP	J. T. Hepburn	1149 Cortell Rd.	North Vancouver
Yukon	VE8AK	W. R. Williamson	Radio Range Sta., D.O.T.	Testin, Y. T.
PRAIRIE DIVISION				
Manitoba	VE4AM	A. W. Morley	26 Lennox Ave.	St. Vital
Saskatchewan	VE5CO	Norman Thompson	1120 7th Ave., N. W.	Moose Jaw

* Officials appointed to act temporarily in the absence of a regular official.

Two Reasons Why the SX-43 Is Extra-Hot on 6 Meters --

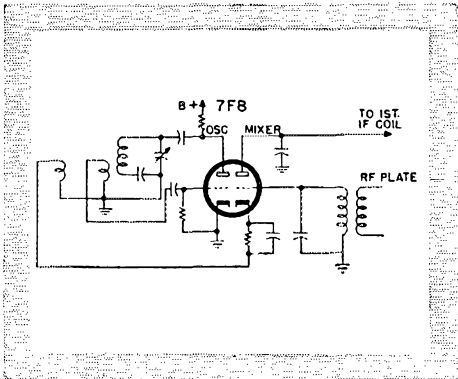

TRIODE MIXING . . . in the first detector. This quieter method of conversion greatly boosts the signal-to-noise ratio because there's almost no first detector "hiss." Inductive coupling (rather than electronic) of the oscillator signal avoids multi-grid noise in the sensitive 50-Mc range.

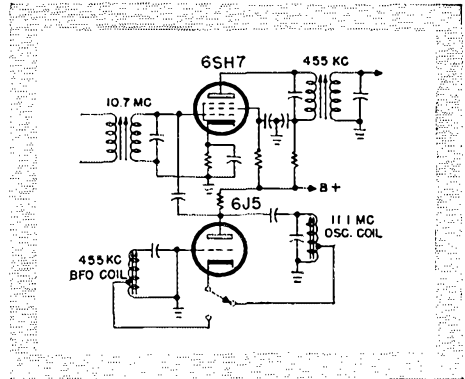

DOUBLE SUPERHET . . . After two stages of IF at 10.7 Mc, this 6SH7 makes a second conversion down to 455 kc for ample selectivity, plus complete absence of images. The 6J5, which is used as BFO on other bands and otherwise idle on this band, acts as local oscillator. No extra tubes, yet plenty of extra performance!



SX-43 \$189.50

Before you buy, see and try the SX-43. Compare its features . . . learn the thrill of its superior performance. At its price, it's the hottest thing available—by far.

Range 540 kc to 55 Mc plus FM Band 88 — 108 Mc; other features include calibrated bandspread, one stage tuned RF, temperature compensated oscillator, crystal filter, two stages IF, tuning meter, two stages audio; 10 tubes plus rectifier.

the hallicrafters co.

4401 W. Fifth Ave., Chicago 24, Ill.

Manufacturers of precision radio and television equipment.

THE AMERICAN RADIO RELAY LEAGUE, INC.,

is a noncommercial association of radio amateurs, bonded for the promotion of interest in amateur radio communication and experimentation, for the relaying of messages by radio, for the advancement of the radio art and of the public welfare, for the representation of the radio amateur in legislative matters, and for the maintenance of fraternalism and a high standard of conduct.

It is an incorporated association without capital stock, chartered under the laws of Connecticut. Its affairs are governed by a Board of Directors, elected every two years by the general membership. The officers are elected or appointed by the Directors. The League is noncommercial and no one commercially engaged in the manufacture, sale or rental of radio apparatus is eligible to membership on its board.

"Of, by and for the amateur," it numbers within its ranks practically every worth-while amateur in the nation and has a history of glorious achievement as the standard-bearer in amateur affairs.

Inquiries regarding membership are solicited. A bona fide interest in amateur radio is the only essential qualification; ownership of a transmitting station and knowledge of the code are not prerequisite, although full voting membership is granted only to licensed amateurs.

All general correspondence should be addressed to the Secretary at the administrative headquarters at West Hartford, Connecticut.



Past Presidents

HIRAM PERRY MAXIM, W1AW, 1914-1936
EUGENE C. WOODRUFF, W8CMP, 1936-1940

Officers

President GEORGE W. BAILEY, W2KH
New York, N. Y.
Vice-President J. LINCOLN MCCARGAR, W6EY
Oakland, California
Acting Secretary A. L. BUDLONG, W1BUD
West Hartford, Connecticut
Communications Manager FRANCIS E. HANDY, W1BDI
West Hartford, Connecticut
Treasurer DAVID H. HOUGHTON
West Hartford, Connecticut

General Counsel PAUL M. SEGAL
816 Connecticut Ave., Washington 6, D. C.

Assistant Secretaries JOHN HUNTOON, W1LVQ
LEROY T. WAGGONER, W1PEK, RICHARD L. BALDWIN, W1KE
West Hartford, Connecticut

DIRECTORS

President

GEORGE W. BAILEY, W2KH
1 East 79th St., New York 21, N. Y.

Vice-President

J. LINCOLN MCCARGAR, W6EY
66 Hamilton Place, Oakland 12, Calif.

Canadian General Manager

ALEX REID, VE3BE
240 Logan Ave., St. Lambert, P. Q.
Alternate: Leonard W. Mitchell, VE3AZ
78 Raglan Ave., Toronto, Ont.

Atlantic Division

WALTER BRADLEY MARTIN, W3QV
1033 Arbutha Rd., Abington, Pa.
Alternate: Henry W. Wickenhiser, Jr., W3KWA
1112 State Ave., Coraopolis, Pa.

Central Division

JOHN G. DOYLE, W9GPI
4331 N. Wildwood Ave., Milwaukee 11, Wis.
Alternate: Wesley E. Martner, W9AND
624 College Ave., Dixon, Ill.

Dakota Division

GOODWIN L. DOSLAND, W0TSN
Moorhead, Minnesota
Alternate: Robert A. Kimber, W0BLK
Canyon Lake Rd., Rapid City, S. D.

Delta Division

VICTOR CANFIELD, W5BSR
P. O. Box 965, Lake Charles, La.
Alternate: James W. Watkins, W4FLS
220 N. Howell St., Chattanooga, Tenn.

Great Lakes Division

HAROLD C. BIRD, W8DPE
114 Hickory Dr., Crescent Lake, Pontiac, Mich.
Alternate: John H. Brabb, W8SPF
1321 Berkshire Rd., Grosse Pointe Park 30, Mich.

Hudson Division

JOSEPH M. JOHNSTON, W2SOX
Avalon-by-the-Sea, N. J.
Alternate: Gay E. Millus, Jr., W2NJP
170 Broadway, New York 7, N. Y.

Midwest Division

LEONARD COLLETT, W0DEA
Civil Aeronautics Administration
Box 776, Joplin, Mo.
Alternate: Alvin G. Keyes, W0KQT
1201 Merchants Nat'l Bank Bldg., Cedar Rapids, Ia.

New England Division

PERCY C. NOBLE, W1BVR
37 Broad St., Westfield, Mass.
Alternate: Clayton C. Gordon, W1HRC
70 Columbia Ave., Providence 5, R. I.

Northwestern Division

R. REX ROBERTS, W7CPY
110 W. Brennan St., Glendale, Mont.
Alternate: Allan D. Gunston, W7GP
7209 Wright Ave., Seattle 6, Wash.

Pacific Division

WILLIAM A. LADLEY, W6RBQ
200 Taylor St., San Francisco 12, Calif.
Alternate: Kenneth E. Hughes, W6CIS
810 W. Orange Ave., So. San Francisco, Calif.

Roanoke Division

EVERETT L. BATTEY, W4IA
2008 N. Cleveland St., Arlington, Va.
Alternate: J. Frank Key, W4ZA
Box 707, Buena Vista, Va.

Rocky Mountain Division

FRANKLIN K. MATEJKA, W0DD
P. O. Box 212, Estes Park, Colo.
Alternate: William R. White, W0PDA
1263 Pearl St., Denver 3, Colo.

Southeastern Division

WILLIAM C. SHELTON, W4ASR
527 Revillo Blvd., Daytona Beach, Fla.
Alternate: William P. Sides, W4AUP
Fleming Road, Montgomery, Ala.

Southwestern Division

JOHN R. GRIGGS, W6KWV
3212 Grape St., San Diego 2, Calif.
Alternate: John E. Riekel, W6NY
1834 Whittier Blvd., Whittier, Calif.

West Gulf Division

WAYLAND M. GROVES, W5NW
P. O. Box 586, Odessa, Texas
W5NW at Humble Pipe Line Camp, Odessa
Alternate: David H. Calk, W5BHO
7730 Joplin St., Houston 17, Texas

"It Seems to Us..."

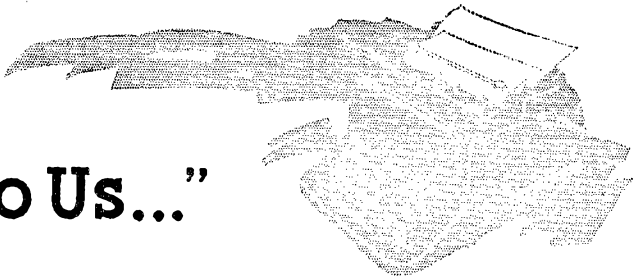

THE 21-MC. BAND

When do we get the 21-Mc. band?

That's a question we've been asked more than any other in recent months, and particularly since it is common knowledge that the Atlantic City regulations go into effect January 1, 1949, as chronicled in "Happenings" this same issue. The same item also contains the clue to the answer; it is true the Atlantic City regulations and allocation table go into effect the first of the year, *but only that part of the new allocation table above 27.5 Mc.* The allocation table *below 27.5 Mc.* will stay as it is for the time being, and the Atlantic City table won't go into effect for some time to come in that portion of the spectrum. What we propose to do this month is explain this somewhat curious state of affairs — curious, that is, until you know the reason.

First, some background. After every international radio conference, such as Atlantic City, the world emerges with new radio regulations, a vital feature of which is a new allocation table for all the services in the spectrum. The nations at the conference sign the documents, and except for the formality of ratification, the world then has a new set of regulations and a new table of allocations. But these don't go into effect right away; such procedure would be impracticable. It takes time, for instance, to make equipment changes that might be required by new technical regulations for ship installations, or to print and distribute new callbooks and Q signals, just to take a few simple examples. From the allocations standpoint, it obviously is impossible to make the required shifts in services without considerable preparation; new crystals and sometimes new transmitters have to be obtained, perhaps even whole new antenna layouts. Circuits have to be shifted, and that can't be done overnight. So from every standpoint, it is desirable and customary to put an effective date on the new regulations sufficiently far in the future to enable everyone to meet the obligations imposed by the new requirements. The provisions of the Washington conference of 1927 didn't become effective until 1929; the Madrid regulations, arrived at in 1932, didn't become effective

until 1934; the Cairo regulations were written in early 1938, but they didn't take effect until the latter part of 1939.

All we've said so far explains the reason for an effective date some time after the conference but it doesn't explain why this January first couldn't be effective for the whole allocation table instead of, as is the case, only part of it. Why not the whole table?

The answer to that is the extensive nature of the changes being made in allocations in the region below 27.5 Mc. We amateurs may not think Atlantic City changed the allocation table very much; it's another story for the other services! Virtually wholesale changes are in the works for them, to an extent that amateurs unfamiliar with the details of the allocation table can scarcely appreciate. These complications arise from the inevitable increase of space for h.f. broadcasting — because the majority of the nations wanted it — and the necessity for carving out of the spectrum sufficient operating frequencies for what is almost a brand-new service, from the standpoint of the international allocations table: aviation. Between the two of them, they made it necessary to find hundreds of kilocycles in the spectrum between 2 and 27.5 Mc. Those channels had to come out of a spectrum in which there are no unassigned frequencies.

Well, they came. But what it means to the radio world is the biggest readjustment for other services that the radio world has faced since the Washington conference of 1927 first created assignments on the high frequencies. Entire bands of frequencies heretofore assigned to the maritime-mobile service have disappeared; not only must the ship stations operating there shift to new frequencies, but the shore stations with which the ships communicated must also shift. Fixed circuits established in bands now to be assigned to aviation or broadcasting (or now in the 21-Mc. amateur band) must move. Move, yes — but where? The Berne list of frequency registrations has stations assigned on every available channel from top to bottom; more than that, there is usually more than one assignment for the same channel, and any subsequent registrations after the

"first" must accept a lower priority, operating only if no interference is caused to the earlier registrant or registrants. Some of the circuits that must be shifted, however, are in themselves "priority" circuits, whose operation is vital; somehow a way must be found to continue them in spite of the fact they have no chance of assuring themselves of continuing rights if they move in on presently-registered assignments.

The radio world, confronted with this apparently insurmountable problem, took the plunge — it decided to wash out all the old system of registrations under the Berne procedure, to throw the whole thing overboard bag and baggage, and to make a completely new start on an "engineered" allocation of every single one of the existing fixed and coastal and broadcast and ground stations in the world. They decided to do this by assembling at Geneva, Switzerland, the experts of the world on these circuits and their requirements, armed with circuit-by-circuit lists of their operating requirements and assisted by propagation experts to help them engineer precisely the right frequencies required — but only those actually required — for their operation. They would employ to the fullest extent, as indeed they are forced to, such technical expedients as geographical and time sharing of frequencies, low-power relays to permit more operation simultaneously on the same frequency in widely-separated regions, and such operating expedients as multiplexing, forked circuits, etc.

And they decided that when they got the job done, but only when, they would have another administrative conference to approve it, and fix a date when the new table and the new set-up would go into effect.

When will that be? Well, the job started just a year ago. The United States, as did other nations, sent a sizable group of Government and industry people to Geneva, where they have been living and working daily ever since. In Washington, a "home team" meets frequently and long to keep them supplied with essential data. Much work has been done, but much still remains to be done. As of this writing, announcement has been made that a "target date" of May 17, 1949, has been set for completion of the new list, so that the special conference to approve it can be called next October 17th. Whether the schedule can be kept is open to question. But if no complications develop, if both these take place on schedule, and if the conference in October approves the job now being done in Geneva, it would be reasonable to expect that the Atlantic City table below 27.5 Mc. could be made effective almost immediately thereafter.

At that time, but not before, two things will

happen simultaneously as concerns us amateurs in this below-27 Mc. region: we lose the top 50 kc. of the 14-Mc. band, and we gain the 450-kc. band at 21 Mc.

— A. L. B.



OUR COVER

The boys who like to collect surplus bargains were quick to snap up "doorknob" tubes at the super-bargain prices recently quoted, but using them turned out to be another matter. This month our V.H.F. Editor describes a simple 420-Mc. oscillator, which should help to get some of these neat little bottles into service.

In our cover picture, LeRoy Waggoner (now known around La Salle Road as "The Hands") checks the transmitter frequency at 440 Mc. Four pilot lamps glowing brightly indicate an output close to 10 watts.

FEED-BACK

F. A. Bartlett, W6OWP, contributor of "Further Advances in Electronic-Keyer Design," October, 1948, *QST*, advises that the values of R_8 and R_{11} in Fig. 2 should be transposed. Correction of the circuit along this line will make possible proper keying action of R_{v2} .

A note from Cal Hadlock, W1CTW, coauthor of "Improving F.M. Transmission Techniques," November, 1948, *QST*, regretfully informs us that his manuscript was in error in specifying 0.47 megohm as the value for R_{18} , Fig. 1. This resistor should be 470 ohms.

**SWITCH
TO SAFETY!**



The "Basic" 'Phone Exciter

Single or Double Sideband or P.M. from One Transmitter

BY BYRON GOODMAN,* WIDX

• While the gadget described in these pages is called a "basic" 'phone exciter, it is actually a single-sideband exciter, with p.m. and double-sideband a.m. thrown in at no extra cost. Also included is adjustable carrier injection, a necessary adjunct to the a.m. and p.m. and a big help in raising operators who don't recognize a carrierless single-sideband signal for what it is or whose receivers suffer from atrophy of the b.f.o.

The output of this unit is on 5.2 Mc., so that a subsequent mixer and a 9-Mc. oscillator will heterodyne the signal to either the 75- or 20-meter 'phone band without complication and with a minimum of adjustment.

If you have been waiting for a "how-many-turns" article on the phasing system of single-sideband generation, here it is.

THE principles described by W2KUJ earlier this year¹ make it possible to build a single-sideband exciter unit that has just about everything in it. One three-position switch gives a choice of double-sideband a.m., p.m., or single-sideband. Another switch flips the unit to one sideband or the other, when you are using single sideband. A third control governs the amount of carrier radiated, which can run anywhere from enough to avoid overmodulation on a.m. to something like 25 or 30 db. down from this value. Lacking only f.m. (but substituting p.m.), it can truly be called a "basic" 'phone exciter. This article will tell how to build and adjust such a device — the theory of operation was covered in the original disclosure.

* Assistant Technical Editor, *QST*.

¹ Norgaard, "A New Approach to Single Sideband," *QST*, June, 1948.

² Norgaard, "Practical Single-Sideband Reception," *QST*, July, 1948.

³ "Single-Sideband Reception," *GE Ham News*, November, 1948.

You might wonder why we even bother with the other modes if they are so inferior to single sideband. There are two reasons, and they are both good ones. First off, the other modes are easily obtainable from the single-sideband exciter circuit, requiring the addition of only one switch to make them available, so you get them "for free." Second, they come in handy when you are testing the device, or comparing the various systems. Actually, you don't need the double-sideband position, but it's convenient if you want to prove to yourself (and others) that the "quality" doesn't suffer with single-sideband operation. The p.m. comes in handy if you have sporadic BCI trouble. The adjustable-carrier feature is a "must" until most operators recognize and know how to tune in a suppressed-carrier signal. With this exciter, all you have to do is to put in enough carrier to give a single-sideband-full-carrier signal and call in the usual manner. Then, after you raise the unsuspecting victim, you can explain to him that you have single sideband and how he can tune it in, if he doesn't already know. Then you reduce your carrier and hop up your single-sideband output (to make full use of your output stage), and you're in business. So, until such time as a large number of operators recognize single-sideband signals or use receivers that don't distinguish between single-sideband-reduced-carrier and normal a.m. signals,^{2,3} adjustable carrier injection is a very desirable feature.

The basic unit uses receiving-type tubes throughout, and generates a 5.2-Mc. signal, at a low level. Having once generated the signal at this frequency, it is a simple matter to heterodyne to either 3.9 or 14 Mc. with a 9-Mc. oscillator. Hence following this exciter with a mixer and a 9-Mc. oscillator provides for 75- or 20-meter operation merely by using the proper coils in the output of the mixer and in the following amplifier stages. With the basic signal generated at 5.2 Mc., all you do to change bands is to change coils, and all you do to change frequency within a band

◆

A "basic" 'phone exciter unit. The controls along the front, from left to right, are audio gain control, double-sideband / phase modulation / single-sideband selector switch, sideband selector switch, and carrier-amplitude control.

◆

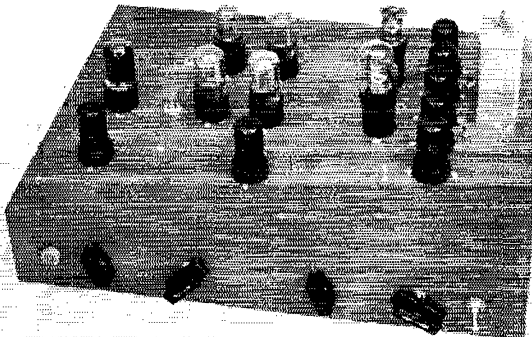

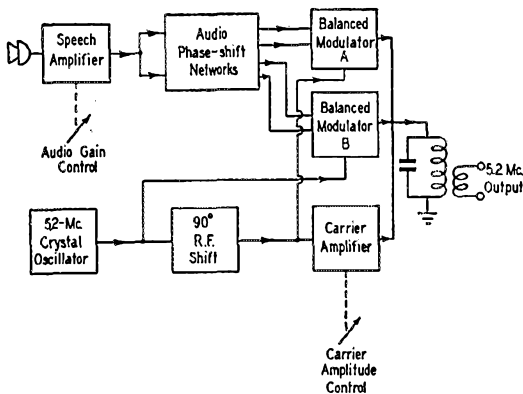

Fig. 1 — A block diagram of the basic exciter. As shown, a single-sideband signal is generated, and any amount of carrier can be added through the "Carrier Amplifier." Reversing the push-pull audio input to either of the balanced modulators shifts to the other sideband. Disabling "Balanced Modulator A" and injecting sufficient carrier results in a double-sideband (a.m.) signal. With "Balanced Modulator A" operating, "B" disabled, and carrier inserted, a phase-modulated signal is obtained in the output.

is to shift the 9-Mc. oscillator to some other frequency. VFO operation is a cinch. While the exciter to be described could be built for direct 3.9- or 14-Mc. output, it would be capable of covering only a small frequency range without some readjustment. This other system seems much more attractive.

The Circuit

Basically, the circuit is as outlined by W2KUJ. It is shown in block diagram in Fig. 1. A speech amplifier builds up the crystal-microphone input to a usable level. The output of the speech amplifier is then passed through the phase-shift networks described by W2KUJ, which offer two sources of push-pull audio, with a 90-degree phase difference between these two sources. Each of these sources feeds a balanced modulator. The r.f. drive for the balanced modulators is obtained from a crystal oscillator, and there is a 90-degree difference in the r.f. to the two balanced modulators. There appears in the combined output of the balanced modulators only a single-sideband signal, with substantially no carrier. To reintroduce the carrier, a "Carrier Amplifier" with adjustable gain feeds the desired amount of r.f. to the common output circuit.

In the single-sideband condition, the upper or lower sideband is selected by reversing the push-pull audio into one of the balanced modulators. (It doesn't matter which one.) For double-sideband operation, disabling Modulator B and introducing sufficient carrier provides the signal, because the r.f. is returned in the same phase that it had before removal in the balanced modulator. For p.m. output, Modulator A is disabled, and the

carrier is combined with a pair of sidebands originally related to a carrier different by 90 degrees.

The audio phase-shift networks and the balanced modulators used in this exciter were described by W2KUJ, and you can refer to the earlier article for explanations of them. The r.f. circuit in this unit was devised by W2KUJ but not described, so a few of the salient points will be mentioned. The circuit is shown in Fig. 2. Two similar tanks are link-coupled and both tuned to resonance, resulting in a 90-degree difference in r.f. at the two circuits. Low-impedance push-pull output to drive the balanced modulators is obtained across the 680- μ fd. condensers. Equal-amplitude r.f. at A and B is obtained by adjusting the link coupling between L_1 and L_2 , and the over-all magnitude of the r.f. is controlled by the plate and screen voltage on the 6SJ7. Phase and amplitude adjustments are provided at the grids of the balanced modulators, so that the carrier can be balanced out easily.

The detailed audio circuit is shown in Fig. 3. If you don't want to include the 3000-cycle low-pass filter you don't have to, of course, but it's easy to incorporate and doesn't add much to the cost. However, you should have something in your audio amplifier to attenuate frequencies above 5000 cycles, because the audio phase-shift network used in this unit begins to fall down above 5500 or 6000 cycles. If you already have a speech amplifier capable of a few volts output, you can use it instead of the one shown in the diagram. But notice that, in this exciter, the speech amplifier plus the audio phase-shift networks represent *all* of the speech equipment. You can

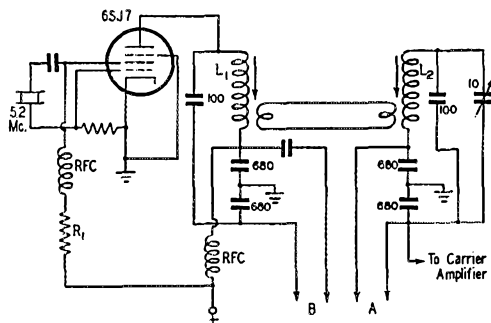

Fig. 2 — Basic circuit of the crystal oscillator and 90-degree r.f. phase-shift circuit. The plate circuit of the 6SJ7 is tuned to resonance by adjusting the slug in L_1 , and low-impedance push-pull r.f. is obtained at point A. The other tuned circuit is tuned close to resonance with the slug in L_2 and tuned carefully with the 10- μ fd. trimmer. When this circuit is tuned to resonance, push-pull r.f. appears at B that is different by 90 degrees to that at A. The amplitudes of the r.f. at A and B are made equal by adjustment of the coupling link between L_1 and L_2 , and the over-all amplitude is controlled by the value of R_1 .

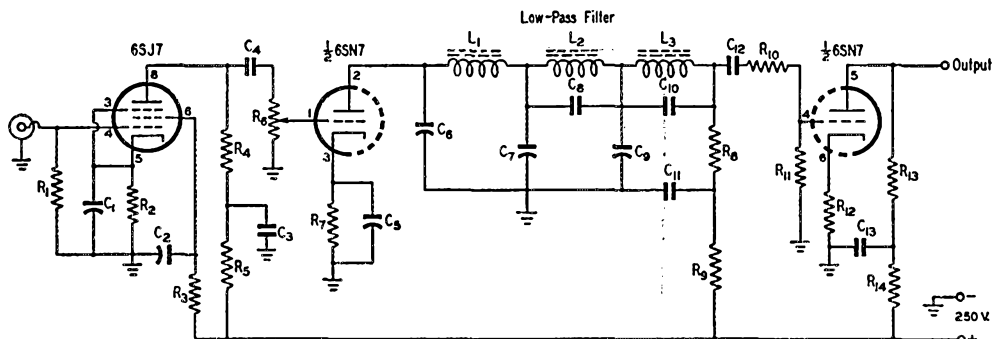

Fig. 3 — Wiring diagram of the audio amplifier used in the basic exciter; The low-pass filter is not necessary for the proper generation of a single-sideband signal, but its use is recommended in *all* 'phone transmitters.

C_1, C_5 — 10- μ fd. 25-volt electrolytic.
 C_2, C_3 — 0.5- μ fd. 400-volt paper.
 C_4 — 0.0022 μ fd.
 C_6 — 0.05- μ fd. paper.
 C_7 — 0.045- μ fd. (0.025 + 0.02) paper.
 C_8 — 0.005- μ fd. paper.
 C_9 — 0.035- μ fd. (0.03 + 0.005) paper.
 C_{10} — 0.03- μ fd. paper.
 C_{11}, C_{13} — 1.0- μ fd. 400-volt paper.
 C_{12} — 0.0068 μ fd.
 R_1, R_2 — 1.0 megohm.
 R_2 — 820 ohms.

R_4 — 0.27 megohm.
 R_5, R_{10} — 68,000 ohms.
 R_8 — 0.25-megohm volume control.
 R_7 — 1000 ohms.
 R_3 — 2200 ohms.
 R_9, R_{14} — 47,000 ohms.
 R_{11} — 22,000 ohms.
 R_{12} — 5600 ohms.
 R_{13} — 0.22 megohm.
 L_1 — 0.25 hy. (Millen 34400-250).
 L_2 — 0.20 hy. (Millen 34400-200).
 L_3 — 0.075-hy. (Millen 34400-75).

go from a watt to a kilowatt and only add r.f. amplifiers — you already have all of the audio gear you need!

The rest of the circuit is shown in Fig. 4. All of the components in this exciter are standard over-the-counter parts, with the possible exception of the low-tolerance resistors in the phase-shift networks. High-grade resistors are used here because of their greater stability over long periods of time, but they probably aren't an absolute "must." We know of several rigs that have been built with standard units, but here we stuck to the recommendation of W2KUJ and used precision units. The condensers in the phase-shift networks are mica units shunted by adjustable mica compression trimmers, since you will want to adjust the networks for best results. Here again you might cut corners, if you have access to a capacitance bridge (W6YX and W6DHG built their rigs without the adjustable feature), but being able to "tune" the networks is highly convenient.

How much trouble you take with the networks depends entirely on how good you want to make your rig. For example, you might use the network configuration described by W6DHG⁴ and W6QYT⁵ and, by carefully measuring the components beforehand, get a minimum attenuation of the undesired sideband of from 20 to 25 db., over a modulation-frequency range of 130 to 3600 cycles. Using the network in this unit and adjust-

ing it carefully, you can get a minimum attenuation of around 30 db., from 70 to 5000 cycles. The latest network constants³ with careful adjustment will give close to 40 db. minimum attenuation over the same range. One big advantage of the latter two networks is that they can be adjusted after wiring into the set — that used by the W6s cannot. The simpler network, while it cannot be adjusted, saves four tubes. This might be a factor in some cases, even though the tubes are only receiving types.

The values of the network components are shown in Table I. Each pair of plate and cathode resistors (e.g., R_{17}, R_{18}) should be matched as closely as possible to each other, but they can depart from the "book" value by 1 per cent or so with no ill effects. Since they should stay matched over a long period of time, precision resistors of the types mentioned in the table are strongly recommended.

The resistance and capacity value for each stage (e.g., R_{15} and C_{15}) are adjusted so that the resistance is equal to the reactance of the condenser at the "check" frequency. This is done in this unit by making the capacity adjustable. This is no trick with the smaller values of capacity, but the larger ones may require some experimental paralleling of smaller condensers. The values in the table are the "book" values, and variations from the exact resistance are made up by adjusting the capacity value to match. The resistors dissipate no power, and it might be possible to get along with regular types, but the precision units are usually better protected against temperature and humidity effects.

⁴ Dawley, "An S.S.S.C. Transmitter Adapter," *QST*, July, 1948.

⁵ Villard, "A Simple Single-Sideband Transmitter," *QST*, November, 1948.

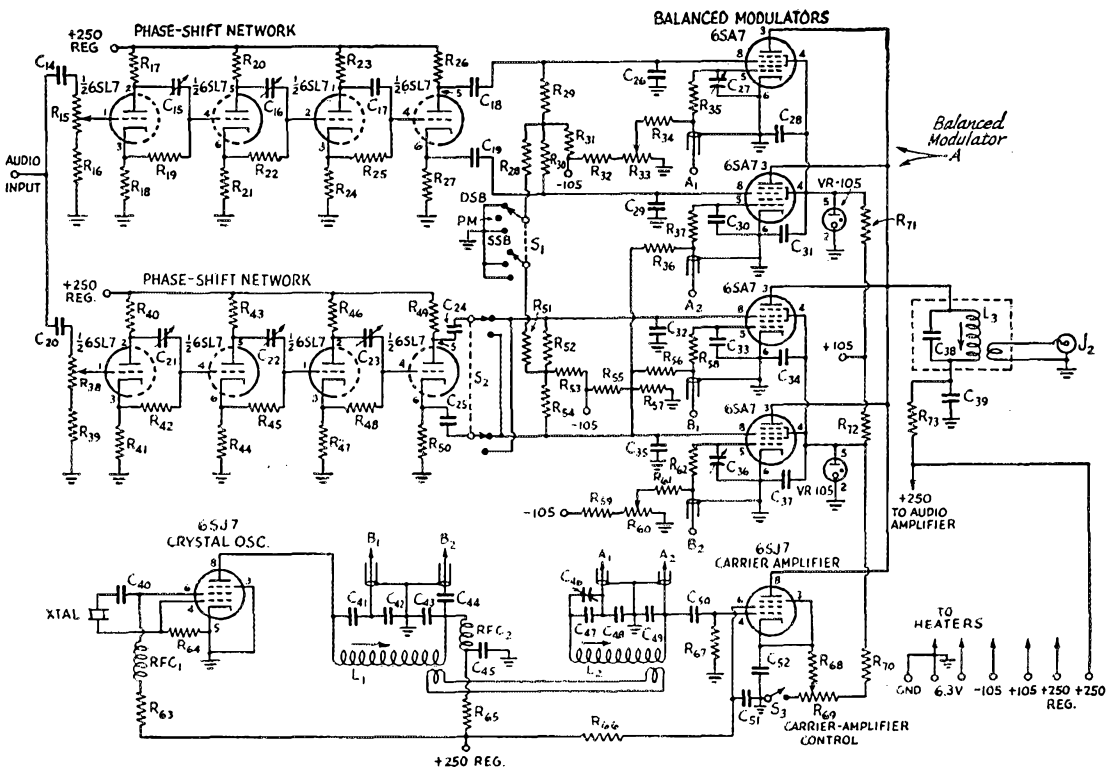

Fig. 4 — Circuit diagram of the single-sideband exciter.

- C14, C20 — 0.1- μ fd. 400-volt paper.
 C15, C16, C17, C21, C22, C23 — See Table I.
 C18, C19, C24, C25 — 0.05- μ fd. 400-volt paper.
 C26, C28, C32, C35, C38 — 47- μ fd. mica.
 C27, C35 — 15- μ fd. midget variable (Johnson 160-107).
 C28, C31, C34, C37, C38, C42, C43, C48, C49 — 0.0068- μ fd. mica.
 C30, C33 — 10- μ fd. ceramic.
 C40, C44 — 470- μ fd. mica.
 C41, C47, C50 — 100- μ fd. mica.
 C45, C51, C52 — 0.0022- μ fd. mica.
 C46 — 9- μ fd. midget variable (Johnson 160-104).
 R15, R38 — 50,000-ohm volume control.
 R16, R29 — 0.47 megohm.
 R17 through R27, R40 through R50 — See Table I.
 R28, R51, R57 — 4700 ohms.
 R29, R30, R31, R32, R34, R36, R52, R53, R54, R55, R56, R59, R61, R64, R67 — 0.1 megohm.
 R35, R60 — 10,000-ohm wire-wound potentiometer.
 R35, R37, R58, R62 — 470 ohms.

- R62 — 0.56 megohm. See text.
 R65 — 47,000 ohms.
 R66 — 68,000 ohms.
 R68 — 270 ohms.
 R69 — 5000-ohm wire-wound potentiometer.
 R70 — 12,000 ohms, 1 watt.
 R71, R72 — 330 ohms, 1 watt.
 R73 — 390 ohms, 1 watt.
 L1, L2 — 34 turns No. 26 d.s.c. close-wound on National XR-50 form. Two-turn coupling loop on L1, one-turn coupling loop on L2. See text.
 L3 — 27 turns No. 24 d.s.c. close-wound on National XR-50 form; 3-turn coupling loop wound over "cold" end.
 RFC1, RFC2 — 0.5-mh. r.f. choke (National R-50).
 S1 — Two-pole three-position rotary switch.
 S2 — D.p.d.t. rotary switch, shorting type (Mallory 3122J).
 S3 — S.p.s.t. toggle.
 J2 — Cable connector (Jones S-101).
 Xtal — 5.2 Mc. (James Knight Co.).

Construction

The photographs show how the unit was built on a 13 × 17 × 3-inch chassis. We allowed plenty of room, and there is no doubt that the thing could be made smaller. However, the extra space makes working on the unit a simple matter. Usual practice was followed throughout, and there isn't anything tricky about the construction. The output circuit is mounted on a shield can above decks, but this is just a National XR-50 form wound with the proper coil and shunted by a

fixed condenser. The tuning is done with the iron slug in the coil. The link coupling between L1 and L2 will require adjusting, so it should be left free to slide up and down until the adjustment is complete, after which it is made secure with a few drops of Duco cement. The trimmer condenser C46 is insulated from the chassis with a pair of fiber washers.

The wiring in the audio end of things is conventional, and no great pains need be taken, although you do want to keep the hum level down

as low as possible. The main point to watch in wiring the audio phase-shift networks is to provide for ready access to the cathodes involved, because these are used as test points when aligning the set. In the r.f. end of things, make R_{63} easy to get to, because you may want to change it during the tune-up process. The "hot" r.f. leads from C_{42} , C_{43} , C_{48} and C_{49} to their respective modulator tubes are shielded wires, as indicated in Fig. 4.

Audio Alignment

It is possible that in the future means may be devised for aligning a unit of this type without an oscilloscope, an audio oscillator and a vacuum-tube voltmeter. For example, if 90-degree audio phase-shift networks were for sale "over the counter," you could do a fair job of checking the unit with just a receiver and a multimeter. But until such things are available (enterprising dealers please note!), it is best to rely on the instruments named above. You don't have to own them — you just have to know people who do.

The first step in getting the exciter working is to check the shift through the audio networks. This requires an oscilloscope and an audio oscillator. The audio from the oscillator is fed in at the point marked "Audio Input" in Fig. 4, because one of the check frequencies wouldn't be passed by the audio filter. Connect the vertical and horizontal amplifiers of the 'scope across R_{18} , and set the audio frequency to 2710 cycles, the first "check" frequency. Adjust the gain of the 'scope amplifiers until you get a line that slants at an angle of 45 degrees. If it is a thin straight

line, you have 'scope amplifiers with equal phase shifts, but if the best you can get is a thin ellipse, you will have to compensate one of the amplifiers. This generally means simply putting a resistor in series with one of the leads, and adjusting the resistor value until you get the single straight line. Or, it may be necessary to shunt a condenser across the amplifier input, in some cases. In any event when you have the straight line, you are ready to go ahead. Remove the lead from one of the amplifiers and connect it across R_{21} . If C_{15} is set properly, you will get a circular pattern on the 'scope, or rather an ellipse with one axis horizontal and the other vertical. If the ellipse is canted, a slight adjustment of C_{15} should bring it into line. If it is found impossible to correct the pattern, it indicates that the resistor is too far from the correct value and the condenser cannot be adjusted through the correct capacity. If the ellipse is not smooth all around, the audio level is too high and something is overloaded.

With both 'scope leads on R_{21} , recheck the 'scope amplifiers at 382 cycles for the single straight line canted 45 degrees. If a thin ellipse is obtained, correct one of the amplifiers as described above. Then transfer one lead to R_{24} , and adjust C_{16} for the correct ellipse.

With both 'scope leads on R_{24} , check the amplifiers at 35 cycles, transfer one lead to R_{27} and check the ellipse. Since C_{17} is a large condenser, it is best to bring it to the right value by adding additional mica units across it, or by making minor corrections in R_{25} .

The same alignment procedure is repeated in the other phase-shift channel, starting at R_{41} and a frequency of 10,840 cycles. Once you find your way around in these networks, the actual alignment procedure takes very little time, unless one of your values is in error quite a bit and you have to scurry around to correct it.

If you are using a 'scope in which the amplifiers have similar phase shifts regardless of the gain-control settings, another way to align the networks is to connect one amplifier across R_{18} (for example) and, at the check frequency of 2710 cycles, adjust for a deflection of, say, 10 divisions. Then disconnect this amplifier and connect the other amplifier across R_{21} and set it for the 10-division deflection. Then when you reconnect the first amplifier across R_{18} you can adjust C_{15} for a perfectly circular pattern. And so on down the line. This is a more accurate alignment method, but it does require good 'scope amplifiers.

When you are finished, confirm the action of the two networks over the range by connecting one amplifier across R_{27} and the other across R_{50} , after first setting the amplifiers to equal gains. Then, over a range from 70 to 5000 cycles, you should get a pattern that deviates very little from a true circle. If you find a point where it does, check the phase shift of the 'scope amplifiers, and you will probably find the trouble is in

TABLE I
Audio-Network Components and Check Frequencies

Component	Check Freq. (cycles)
C_{15} — 588 $\mu\text{fd.}$ (680 adjustable)	2710
R_{19} — 0.10 megohm	
C_{16} — 745 $\mu\text{fd.}$ (470 + 580 adjustable)	382
R_{22} — 0.56 megohm	
C_{17} — 8140 $\mu\text{fd.}$ (8200 \pm 5%) *	35
R_{25} — 0.56 megohm.	
C_{21} — 288 $\mu\text{fd.}$ (380 adjustable)	10,840
R_{42} — 51,000 ohms.	
C_{22} — 1600 $\mu\text{fd.}$ (1200 + 680 adjustable)	997
R_{45} — 0.10 megohm	
C_{23} — 2040 $\mu\text{fd.}$ (1800 + 680 adjustable)	140
R_{48} — 0.56 megohm.	
R_{17}, R_{18} — 1000 ohms.	R_{40}, R_{41} — 1000 ohms.
R_{20}, R_{21} — 2000 ohms.	R_{43}, R_{44} — 2000 ohms.
R_{23}, R_{24} — 3000 ohms.	R_{46}, R_{47} — 3000 ohms.
R_{26}, R_{27} — 4000 ohms.	R_{49}, R_{50} — 4000 ohms.

Resistors are $\pm 2\%$ values, $\frac{1}{2}$ -watt rating (Continental Carbon "Nobleloy" or IRC BTS).
Fixed condensers are mica ± 5 or $\pm 10\%$ values. Adjustable mica padders are El-Menco Type 46 trimmer condensers.
* May require several smaller mica condensers in parallel.

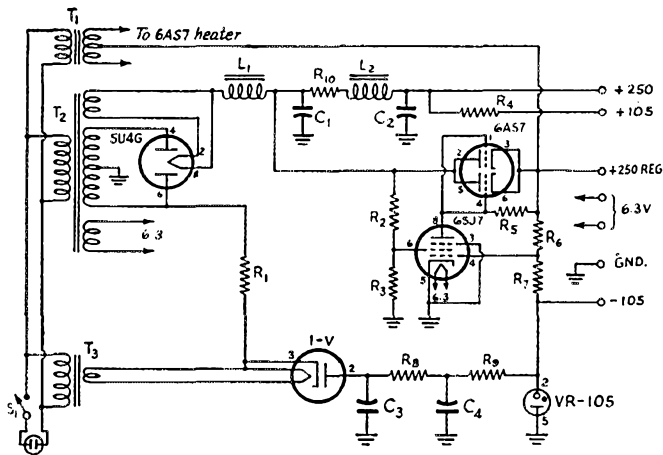

Fig. 5—Wiring diagram of the regulated power supply.

C_1, C_2, C_3, C_4 —16- $\mu\text{fd.}$ 450-volt electrolytic.

R_1, R_4, R_8, R_9 —2500 ohms, 10 watts.

R_2 —47,000 ohms, 2 watts.

R_3 —22,000 ohms, 1 watt.

R_5 —0.47 megohm, $\frac{1}{2}$ watt.

R_6 —0.27 megohm, $\frac{1}{2}$ watt.

R_7 —0.1 megohm, $\frac{1}{2}$ watt.

R_{10} —1000-ohm wirewound, 10 watts.

L_1 —8/30-hy. 150-ma. choke (Stancor C-1718).

L_2 —30-hy. 100-ma. choke (Stancor C-1001).

T_1 —6.3 volts, 3 amp. (Stancor P-5014).

T_2 —375-0-375 volts, 150 ma.; 5 volts, 3 amp.; 6.3 volts, 5 amp. (Stancor P-6014).

T_3 —6.3 volts, 1.2 amp. (Stancor P-6134).

the 'scope amplifiers and not in your network, if you have been careful in your procedure.

The R.F. Alignment

Most of the hard work is done now. The first step in the r.f. alignment is to adjust the output of the crystal-oscillator stage and the other tuned circuit to give about 1-volt r.f. signals at the grids of the 6SA7s. You can check that the oscillator stage is working by tuning in the signal on a receiver. Then adjust the slug in L_1 until a maximum r.f. voltage appears at the grids of Balanced Modulator B. If this voltage is too high above 1 volt, increase the value of R_{63} . You can measure the voltage with a vacuum-tube voltmeter, or by temporarily biasing the modulator tubes to 1.5 volts (with a dry cell) and checking to see if there is any grid current through R_{56} and R_{61} . (You are using the tube as a slide-back voltmeter.) Make the same check at R_{34} and R_{36} , with L_2 tuned for maximum signal at the grids. If the r.f. voltage at the grids of Balanced Modulator A is not within 5 per cent of that at B, move the links on L_1 and L_2 until you get what you want. Start out with too little coupling, to avoid any double-hump tuning. You won't be able to get all of the r.f. voltages to exactly the same value without trimming C_{42} , C_{43} , C_{48} and C_{49} , but don't worry about it if they are all within 5 per cent of each other.

Pull out the "Carrier Amplifier" tube, and connect the output at J_2 to your receiver. Set the receiver on a.v.c. and tune in the 5.2-Mc. signal that is coming through. Then tune the slug in L_3 to peak the signal. If you knock your S-meter off scale at this point, short your antenna input with a small resistor until you can get back on scale. With S_1 set for "SSB," adjust C_{27} , C_{36} , R_{33} and R_{60} for minimum signal in the receiver. You are now "balancing" the balanced modulators, and you will find that this works just like the book says. With no trouble at all,

and in less time than it takes to read about it, you should find the setting where very little signal gets through to the receiver.

The next step can be done on a 'scope or on the receiver. Assuming you are using a receiver, leave it connected as described, with the a.v.c. on. Feed in the audio oscillator at a low level through the microphone circuit, at 1000 cycles or so. Your S-meter will go off scale as you increase the level, so short out the receiver input with 10 or 20 ohms and put a resistor in series to the "hot" side of J_2 until you get back on the S-meter scale. The audio output from the receiver will be an audio tone. Adjust C_{46} for minimum audio output from the receiver, and do the same for either R_{15} or R_{38} . (One of these is generally enough.) Now run the audio oscillator up and down the scale. You should hear little or no modulation on the signal, at any frequency.

The equivalent check on the 'scope requires that the output at J_2 be link-coupled to a tuned circuit connected directly to the vertical plates of the 'scope. With the 1000-cycle audio signal at the microphone jack, a pattern vaguely similar to an a.m. envelope should appear on the 'scope. As you adjust C_{46} and R_{16} (or R_{38}), the modulation should decrease, and you should minimize it for the correct adjustment. The correct pattern for a single-sideband signal (no carrier and a single modulation frequency) is what you are used to thinking of as an unmodulated carrier. If everything is perfect, no trace of modulation will appear, but everything won't be perfect, rest assured of that! However, over the entire audio range (limited by your audio filter, of course), the ripple should be small. Since this ripple can be introduced by harmonics generated in the audio amplifier, harmonics present in your audio signal generator, carrier leaking through or past the balanced modulators, and incorrect audio and r.f. phase and amplitude, you can see why we aren't too afraid that it will all be perfect.

The pattern should be the same for either position of S_2 . If it isn't, it indicates that your audio network isn't perfect, but you know that the network isn't *exactly* right except at a few frequencies. If the ripple has the same order of magnitude at either setting of S_2 , you are doing quite well.

All that is left to do now is to plug in the "Carrier Amplifier" tube and retune L_3 , to compensate for the output capacity of the added 6SJ7. The tube was left out during the alignment procedure to avoid the chance of some carrier leaking through the tube. Even with S_3 open you may get a little more carrier leaking through than you do with the tube out of the socket, but it isn't enough to bother anyone on the air. On p.m. and double sideband, you have to insert carrier sufficient to prevent distortion and over-modulation, and your 'scope will help you to determine these levels.

Power Supply

We haven't mentioned the power supply up to this point, but it is an important part of the system. The B+ side of the phase-shift network has to be "stiff," and the best way to keep it this way is with an electronically-regulated supply.⁶ The supply we used furnishes 250 volts regulated, 250 volts unregulated, -105 regulated (for the various biases), and a lead to the two VR-105s across the screens of the balanced modulators. The diagram is shown in Fig. 5.

General

While the description of this unit may seem long and involved, it is only the result of trying to make the description as complete as possible. Naturally, questions will crop up that have been

⁶ The audio phase-shift network described in footnote 3 is a later development and does not require quite such a "stiff" power supply. — Ed.

left unanswered, but we feel that anyone with a little familiarity with the use of a 'scope and an understanding of what he is trying to do will have no trouble with his single-sideband exciter. As mentioned earlier, if prealigned audio networks were available the exciter could be set up using only a receiver and perhaps a vacuum-tube voltmeter. Using the later type of network, one could dispense with the electronically-regulated power supply.

On single-sideband with single-tone modulation, the output at J_2 is about 0.1 volt across 300 ohms, and working into a tuned circuit will give about 20 volts. This is more than enough, of course, to drive any small mixer tube. The combination used at W1DX consists of a pair of 6K8s in a balanced mixer circuit, followed by a neutralized Class A 6AG7 driving a Class B 829-B. On a.m. the 829-B will comfortably handle a carrier output of about 20 watts, and on p.m. the carrier output can run close to 80 watts. In single-sideband operation, the 829-B will *loaf* along at a peak sideband output of 80 watts, but this gives a signal equivalent to an a.m. 'phone with 160 watts carrier output (about 225 watts to the modulated stage). As an amplifier for a single-sideband signal, the 829-B is the equivalent of a quarter-kilowatt a.m. 'phone.

Because of space limitations (and the fact that this article is plenty to chew over at one sitting), nothing has been said about the design and adjustment of the converter and output stages. But it is in the works and will be presented in the near future. The important thing to know is any and all converters and amplifiers following this exciter unit should be linear, which means using Class A or Class B amplifiers. The general practice seems to be to use Class A amplifiers at low levels (receiving tubes) and Class B when running powers above 10 or 20 watts.

The 3000-cycle low-pass filter, at the lower left, is made from standard components mounted on a small resistor board. The components for the audio phase-shift networks are mounted on the tube sockets just to the left of center. The crystal-oscillator components are grouped around the tube socket, and the crystal socket is mounted on an aluminum bracket.

The two balancing potentiometers, R_{3a} and R_{60} , are at the lower right.

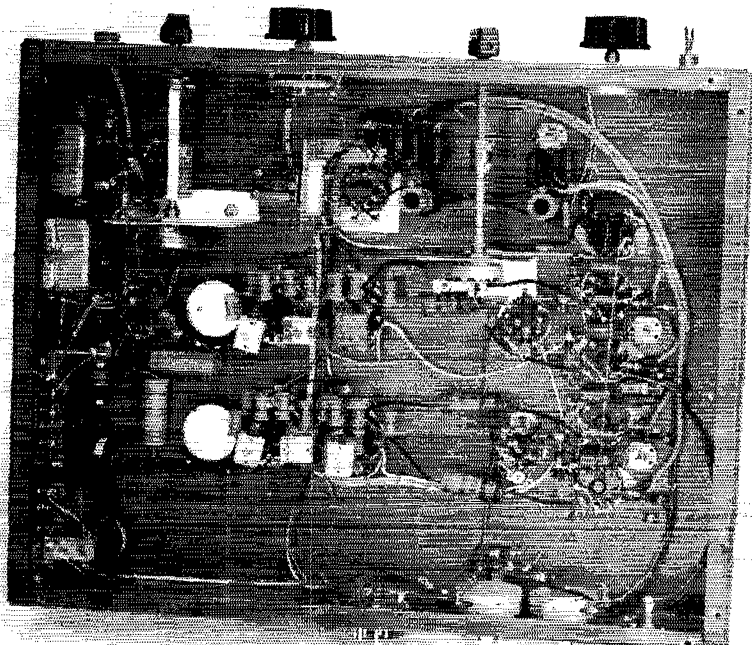

80 and 40 on Wheels

A 20-Watt 'Phone-C.W. Rig for Mobile, Portable-Emergency and Fixed-Station Use

BY RICHARD M. SMITH,* W1FTX

ME go mobile! Are you nuts? — it ain't worth the bother!" Well, that's not an uncommon attitude, and it was to combat the objections voiced by our imaginary friend that the 20-watt rig described here was built. Used with a versatile power supply that permits operation from either the car battery or from regular 115-volt a.c. lines, it fills the bill nicely for that long-desired mobile rig for the buggy, serves as a fun-producing QRP rig for home use, and is ever-available for instant use should disaster strike. Thus, you kill three birds with one stone, taking care of mobile, fixed-station and portable-emergency rigs.

The Circuits

The r.f. end of the rig is handled capably by a 6AK6 crystal oscillator that drives a 2E26 amplifier. The oscillator uses a crystal in the 3.5-Mc. range, and will deliver output either at the fundamental or at the second harmonic of the crystal. The plate coil of the oscillator covers both bands, 3.5 Mc. with the condenser set near maximum capacity, and 7 Mc. near minimum, thus eliminating the need for plug-in coils. Capacity coupling is used to series-feed the grid of the 2E26. The parallel-fed plate circuit of the 2E26 is a pi-section affair with a tap switch to adjust the circuit to optimum conditions for loading into random lengths of antenna wire on either band. A small r.f. choke in the plate lead eliminates v.h.f. parasitics.

In the audio department, a 6N7 Class B modulator, self-biased to restrict current drain, is driven by a Class A triode, half of a 12AU7. (This tube includes two separate triodes, each of which has the same characteristics as a single 6C4.) The other triode section is used as a voltage amplifier to step up the output of a T-17 single-

* Technical Assistant, QST.

• Here's a pint-size 'phone-c.w. rig that is designed to be tucked under the dashboard of your car, or hidden in a corner of the kitchen cabinet. Its compactness and versatility make it a natural for portable and emergency work, in two of our most popular bands.

button carbon microphone. This particular mike has very low voltage output, and a miniature transformer is used to boost it to the required level. With microphones having higher output, the transformer may be unnecessary. The modulation transformer is connected to match the 8000-ohm plate-to-plate load impedance of the 6N7 to a 4000-ohm load, which is close enough for the nominal 4300-ohm impedance of the 2E26 plate and screen. *C*₇ is connected across the primary of the modulation transformer to eliminate a parasitic that showed up in the Class B stage; otherwise the circuit is standard.

A three-section three-position switch is used as the 'phone-c.w. switch. It is connected so that voltage is applied to both the audio and r.f. units when 'phone operation is desired, and to the r.f. unit alone in c.w. operation. The cathode returns of both tubes in the r.f. unit are brought out together; this lead is used with the switch in the microphone to provide "push-to-talk" control for 'phone operation. It is also the break-in keying lead in c.w. operation.

The microphone and key plug into a small control box designed to be mounted on the steering post of the car. The microphone battery and a series resistor to limit microphone current are mounted in the control box.

The power supply uses one of the *Handbook* circuits, slightly modified to provide the charac-

A compact 20-watt mobile transmitter for the 3.5- and 7-Mc. bands. Designed for mounting under the dashboard of the car, the transmitter and its power supply occupy standard 5 × 6 × 9-inch utility boxes, and the control box, which clamps to the steering post, is in a 4 × 4 × 2-inch box.

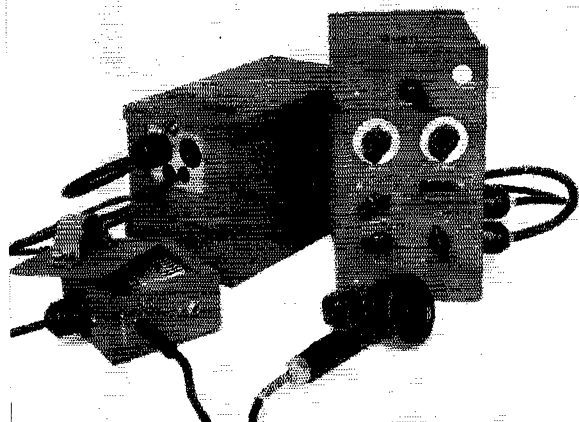

QST for

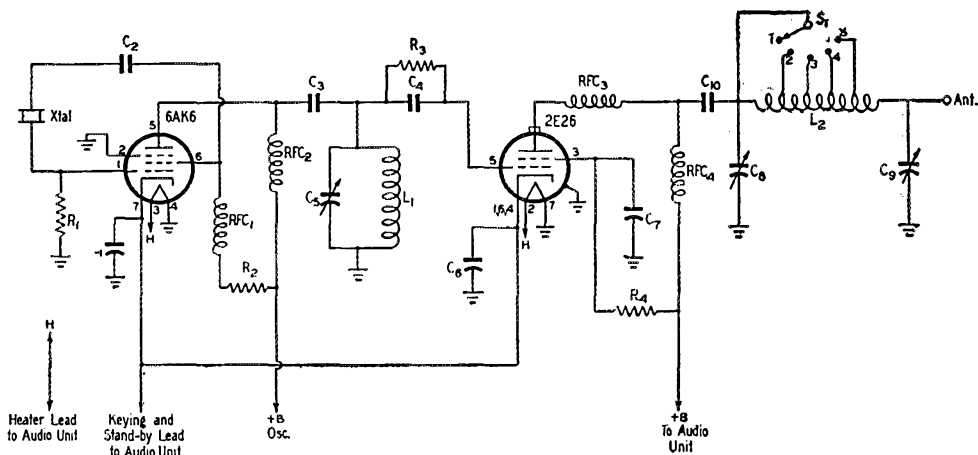

Fig. 1 — Schematic diagram of the r.f. unit.

- C₁, C₈ — 0.01- μ fd. paper, 600 volts.
- C₂, C₁₀ — 0.001- μ fd. mica, 500 volts.
- C₃ — 0.0047- μ fd. mica, 500 volts.
- C₄ — 47- μ fd. mica, 500 volts.
- C₅ — 250- μ fd. variable (National STH-250).
- C₇ — 0.0068- μ fd. mica, 500 volts.
- C₈, C₉ — 335- μ fd. variable (National STH-335).
- R₁ — 47,000 ohms, $\frac{1}{2}$ watt.
- R₂ — 56,000 ohms, 1 watt.
- R₃ — 22,000 ohms, 1 watt.
- R₄ — 15,000 ohms, 10 watts.

- L₁ — 32 turns No. 22 enam. close-wound on $\frac{1}{4}$ -inch diam. form.
- L₂ — 48 turns No. 20 tinned, $3\frac{1}{8}$ inches long, 1-inch diam., taps at 12, 22, 32 and 40 turns from plate end (B & W Miniductor No. 3015).
- RFC₁, RFC₂, RFC₄ — 2.5-mh. 100-ma. r.f. choke (National R-100-S).
- RFC₃ — 25 turns No. 26 enam. close-wound on $\frac{1}{8}$ -inch diam. form (National R-33, 1 μ h.).
- S₁ — Single-pole 5-position ceramic switch.

teristics needed by this particular rig. Any supply capable of providing 300 volts at 100 ma. or more will suffice, whether it be from a vibrator, dynamotor, or batteries.

Construction

Mechanically, the transmitter proper is made up of two separable units housed in a standard 9 x 5 x 6-inch steel utility box. The r.f. unit is on a small chassis folded from sheet aluminum, and on a portion of one cover of the box — which also serves as the "panel." The aluminum chassis is 6 inches long, 4 $\frac{1}{4}$ inches wide, and 1 inch deep, small enough to be made with tools no more elaborate than a vise, a ball-peen hammer, and a couple of extra sheets of aluminum to serve as stiffening material while the bends are folded. All parts in the r.f. unit with the exception of the plate coil and tap switch are mounted on the chassis as shown in the photograph. The switch, however, is mounted on the cover of the box, and the coil is mounted directly behind it, supported at one end by a 2-inch ceramic stand-off insulator and at the other by a short length of No. 14 solid copper wire that extends from the feed-through insulator used as the antenna post to the tuning condenser below it. Additional support is provided by the tap wires that run from the coil to the switch.

Parts placement underneath the r.f. chassis is a very important consideration, from the mechanical end, because there must be enough clearance

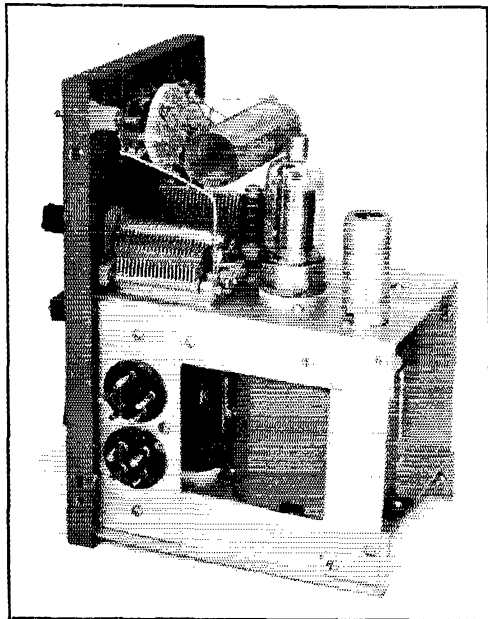

General view of the complete transmitter assembly. The r.f. circuits occupy the upper deck, and are held above the audio section by simple tab brackets. Power and control cables enter through connectors mounted on one of these tabs. The construction of the choke circuit of the 2E26 stage is shown, with the r.f. choke just visible between the two tuning condensers.

between these parts and the components mounted on the top of the audio chassis. The arrangement shown in the photograph provides sufficient clearance, with the oscillator plate coil and tuning condenser mounted along one edge where they extend down into the space just above the driver transformer and the 12AU7 on the audio chassis. The smaller parts in the r.f. unit are mounted near the other edge, as close to the chassis as possible to insure adequate clearance for the modulation transformer and the 6N7 on the left-hand side of the audio unit. A little care in parts placement and wiring will do the job so that nothing gets shorted to the high voltage when the two units are bolted together.

The audio unit is built on a similar small chassis having the same surface dimensions and depth as that used for the r.f. unit, but with $\frac{1}{4}$ -inch lips bent into the vertical sides of the chassis to provide "rails" on which the assembly rides when it is being slipped into the utility box. Included in the audio unit are the 'phone-c.w. switch and the audio gain control, which mount with their shafts extending through the cover of the box. The parts mounted beneath the audio chassis are visible in the bottom view. As in the case of the

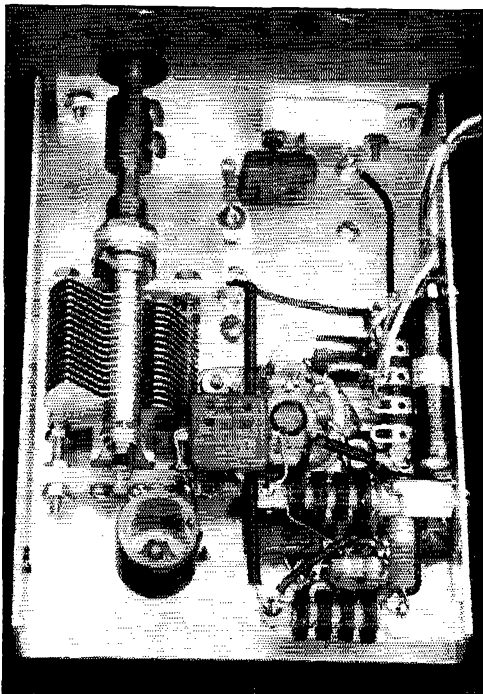

Bottom view of the r.f. chassis. The oscillator socket is partly hidden from view by the two r.f. chokes that are mounted on the right-hand chassis edge. Directly to the left of the oscillator socket is the oscillator plate coil. The socket for the 2E26 is mounted a little to the right of center of the chassis, close to both the oscillator socket and the tuning condenser.

r.f. unit, all parts are mounted as close to the chassis as possible.

The two chassis are fastened to the cover of the box by 6-32 screws which pass through the front apron of the chassis. Aluminum strips $4\frac{1}{2}$ inches long by 1 inch wide serve as braces between the two chassis at the rear. A similar strip $1\frac{5}{8}$ inches wide, at the front on the right side, provides a mounting strip for the two Amphenol connectors used to bring the supply voltage and the control circuits into the unit. A cut-out is made in the edge of the utility box to clear the prongs of these connectors when the assembly is slipped into its housing.

Power Supply

The power-supply circuits are shown in Fig. 3. A combination transformer is used to permit operation from either the 115-volt a.c. line or the 6-volt car battery. Two 6X5 tubes are used in parallel to carry the total current drain of about 110 to 120 ma., which exceeds by far the 75-ma. rating of a single tube. An extra-large capacity, 32 μ d., is used as the output condenser (C_5) to improve the regulation on modulation peaks. Hash filtering is accomplished by chokes and by-pass condensers. Separate output connectors are used for 6-volt and 115-volt power sources. When operating from a 6-volt d.c. source, d.c. is applied to the heaters direct from the battery. When 115-volt a.c. input is used, the other connector applies 6.3 volts a.c. to all heaters from the transformer secondary. A single-pole double-throw switch, S_2 , is used to switch the heaters of the 6X5 tubes from the battery to the transformer when changing from d.c. to a.c. operation.

All parts in the power supply are mounted on a home-built aluminum chassis measuring $4\frac{1}{4} \times 8\frac{3}{4} \times 1$ inches. A bracket is mounted at one end of the chassis to hold the output connectors and the on-off switch. The input cables pass through grommet-lined holes just below the connectors. The entire supply may be enclosed in a steel utility box the same size as that used for the transmitter unit as shown in the photograph. An opening is cut through one end of the box to permit access to the bracket on which the connectors and the toggle switch are mounted.

Control Circuits

The control circuits have been simplified as much as possible without sacrificing operating convenience. The control box is a standard $4 \times 4 \times 2$ -inch utility box with a mounting bracket made of sheet aluminum bolted to one of the covers to permit it to be clamped to the steering post of the car. Jacks for both the microphone and the key are mounted on the box, which also contains a small $4\frac{1}{2}$ -volt battery to supply microphone voltage as well as the series limiting resistor. A 5-terminal receptacle is mounted on

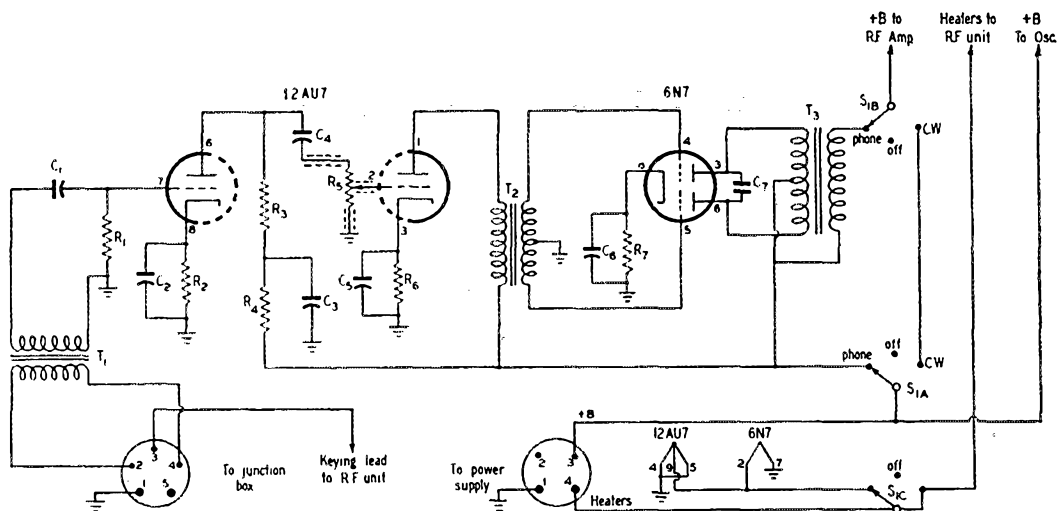

Fig. 2—Schematic diagram of the audio unit.

- C₁—0.1- μ fd. paper.
- C₂, C₅—10- μ fd. 25-volt electrolytic.
- C₃—8- μ fd. 450-volt electrolytic.
- C₄—0.01- μ fd. paper.
- C₆—50- μ fd. 50-volt electrolytic.
- C₇—0.0068- μ fd. mica, 500 volts.
- R₁—470,000 ohms, $\frac{1}{2}$ watt.
- R₂—2200 ohms, $\frac{1}{2}$ watt.
- R₃—0.1 megohm, $\frac{1}{2}$ watt.
- R₄—4700 ohms, 1 watt.

- R₅—0.5 megohm potentiometer, audio taper.
- R₆—560 ohms, $\frac{1}{2}$ watt.
- R₇—220 ohms, 2 watts.
- S₁—3-pole 3-position rotary switch.
- T₁—Midget microphone transformer, s.b. mic. to grid (Inca F-65).
- T₂—Driver transformer, single plate to Class B grids (Thordarson T-20D76).
- T₃—Multitap modulation transformer (UTC S-18, connected to match 8000 ohms primary to 4000 ohms secondary).

the bottom of the box to bring the control cable into the box from the transmitter unit.

Only two interunit cables are required. One is a three-wire shielded cable that runs from the control box to the transmitter. The other requires three conductors, one for high voltage, one for the heater voltage, and the third for ground. The ground lead and the lead that carries heater voltage should be made of as heavy wire as possible to minimize voltage drop. In our unit we used a seven-conductor cable, using the shield braid for the ground lead, and a single wire for high voltage. The other conductors were tied in parallel.

The control circuits are arranged so that push-to-talk operation is possible, controlled by the switch on the microphone, once the main power switch has been turned on. Likewise, break-in keying is also possible. In 'phone operation, the switch in the microphone closes the cathode circuits of the two tubes in the r.f. portion of the transmitter. In the "stand-by" position the cathode circuits are opened, taking the signal off the air. Plate voltage is still applied to all tubes in the audio circuits but the microphone circuit is opened, so there is no signal input to the grid of the first audio tube. In c.w. operation, the key performs the function of closing and opening the cathode circuits, and plate voltage is

removed from the audio tubes by the 'phone-c.w. switch. A more elaborate system can be used if desired to incorporate an antenna-changeover relay and to open the primary circuit of the power transformer, thus removing all plate voltage during stand-by periods. These refinements are not

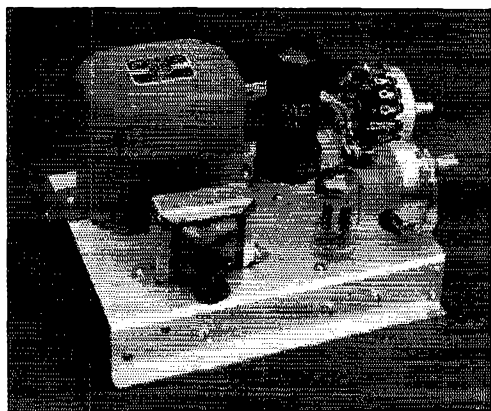

Top view of the audio unit. At the right-hand edge are the gain control and the 'phone-c.w. switch. The 12AU7 and the 6N7 are mounted in line behind the two controls. The transformers occupy the rear of the chassis, located in such position that they clear all parts in the r.f. unit, which mounts above them.

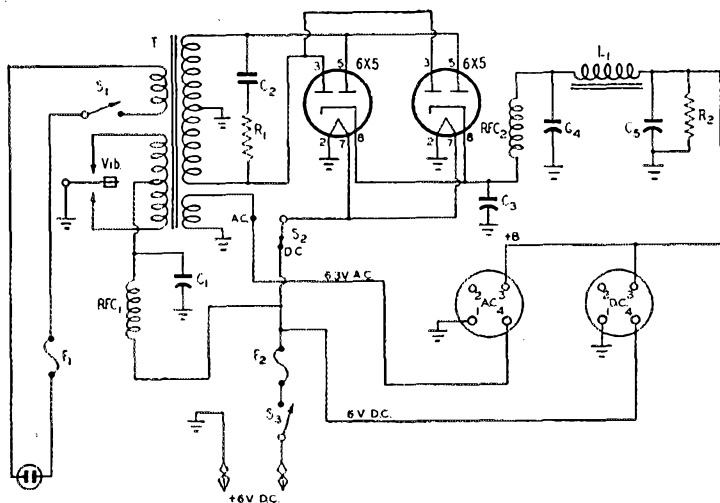

Fig. 3 — Circuit diagram of the power supply used with the 20-watt mobile rig. Provisions are made for operation from either the 115-volt a.c. line or from a 6-volt storage battery.

- C₁ — 0.5- μ fd. paper, 50 volts or more.
- C₂ — 0.005 μ fd., 1600 volts.
- C₃ — 0.01- μ fd., 600 volts.
- C₄ — 8 μ fd. 450 volts, electrolytic.
- C₅ — 32- μ fd., 450 volts, electrolytic (dual 16- μ fd. condenser with sections in parallel).
- R₁ — 4700 ohms, 1-watt carbon.
- R₂ — 25,000 ohms, 20 watts, wire-wound.
- L₁ — 2.5 hy., 100 ma. filter choke, 100 ohms d.c. resistance (Stancor C-2303).

- T — 6-volt vibrator transformer, with separate 115-volt primary. 350-350 v. r.m.s., 125 ma. and 6.3 v. a.c. at 2.25 amp. (Stancor P-6166).
- F₁ — 2-amp. fuse.
- F₂ — 15-amp. fuse.
- RFC₁ — $\frac{1}{4}$ turns No. 14 enameled, $\frac{1}{2}$ -inch diam., 2 $\frac{1}{2}$ inches long.
- RFC₂ — 2.5 mh., 300 ma. (National R-300).
- S₁ — S.p.s.t. toggle switch.
- S₂ — S.p.d.t. toggle switch.
- S₃ — Heavy-duty s.p.s.t. toggle switch.

essential and were omitted in the interest of simplicity.

Adjustment and Operation

The r.f. portion of the transmitter should be tested before the audio unit is bolted in place, otherwise some of the points that should be checked will be inaccessible. Separate meters may be inserted in the various supply leads during these initial checks. For 80-meter output, insert an 80-meter crystal in the crystal socket. Disconnect the plate and screen voltage from the 2E26 stage. Apply power, and tune the oscillator condenser, starting at maximum capacity, tuning slowly toward minimum. A sharp dip in current, indicating resonance, should be reached before the capacity has been reduced much from maximum setting. Continue on and look for another dip indicating resonance at the second harmonic of the crystal near minimum capacitance. If it is not possible to go through a complete dip at the second harmonic, remove a couple of turns from the oscillator plate coil and check again to make sure that two points of resonance can be found. Once this is achieved, check the grid current developed in the 2E26 stage. It should be possible

to obtain at least 2.5 ma. through the grid leak specified, at both the crystal fundamental and the second harmonic.

After the oscillator circuit is working properly, connect the plate and screen voltages to the 2E26 stage, apply grid drive, and tune the plate circuit to resonance. The dip in current at resonance should be quite pronounced, and plate current should be no more than a few milliamperes. Do not keep the key closed for more than a few seconds, because when operated without load the screen current in the 2E26 stage may be excessive. Connect a 15- or 20-watt lamp between the antenna terminal and ground. Close the key in current at resonance, and plate current should be no more than a few milliamperes. Do not keep the key closed for more than a few seconds, because when operated without load the screen current in the 2E26 stage may be excessive. Connect a 15- or 20-watt lamp between the antenna terminal and ground. Close the key again, retune the amplifier tuning condenser for resonance, and then tune the antenna condenser until the lamp starts to glow. It will be necessary to retune the amplifier plate circuit each time the antenna condenser is readjusted. The extent to which the lamp will load the amplifier stage can be controlled by back-and-forth adjustment of the

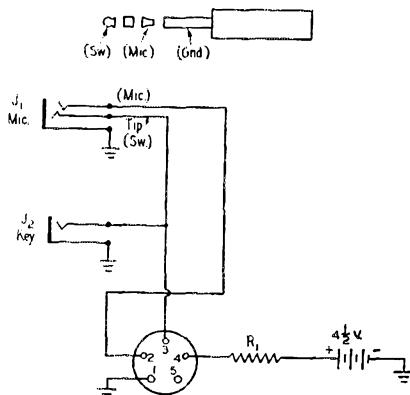

Fig. 4 — Schematic diagram of the control box. Connections of the 2-circuit plug used with the T-17-B microphone are shown in the sketch at the top.

- J₁ — 2-circuit microphone jack.
- J₂ — Open-circuit key jack.
- R₁ — 200 ohms, 1 watt.

antenna condenser and the plate tuning condenser. It should be possible to load the 2E26 to 75 or 85 ma. in this manner. When this point is reached, measure the screen voltage. It should be close to 200 volts. If it is much below this, it is possible that the tube is being overdriven, and excitation should be reduced. If it is much over 200 volts, excitation may be insufficient. With the circuit values shown, operation should be close to the figures mentioned above, for both 80- and 40-meter output. A chart of typical operating currents and voltage is shown.

To tune the transmitter for output in the 40-meter band, set the oscillator tuning condenser at the second harmonic first and then tune the 2E26 stage for a dip, as before. Resonance will be found near the low-capacity end of the tuning range of this condenser. Depending upon the antenna, it may be necessary to turn the loading switch S_1 to short out some of the turns of the output coil. Operating conditions for 40-meter output are also shown in the table. If there is any doubt that output is actually on 40 meters, check with an absorption wavemeter.

After the r.f. unit is functioning properly, connect the audio unit into the circuit and, with the amplifier loaded as described above, close the microphone circuit and check for modulation. The brilliance of the lamp should increase per-



Bottom view of the audio chassis. The small microphone transformer is in the upper left-hand corner. The terminal strip on the right-hand edge serves as a convenient tie-point on which several of the smaller resistors are mounted. The leads from the driver transformer and the modulation transformer pass through grommet-lined holes.

Typical Operating Data

Conditions: c.w.; loaded to 110 ma. total cathode current; supply voltage (under load) 390 volts; 80-meter crystal used.

	80-meter output		40-meter output	
	volts	ma.	volts	ma.
6AK6 plate screen	390	19	390	21
	200	3	210	3.5
2E26 plate screen grid *	390	78	390	78
	200	6	210	5
	-100	4	-90	3

* Grid current and voltage will vary widely from these figures depending on tuning. Optimum obtainable values are shown.

ceptibly under modulation. If an oscilloscope is available, the percentage of modulation can be checked in the normal manner. In the absence of an oscilloscope, check for carrier shift with an indicating wavemeter. It should be possible to reach 100 per cent modulation on voice peaks with the gain control at about three-fourths maximum.

A record of the operating voltages and currents should be kept for future reference. In addition, the setting of the oscillator condenser for coverage of 80 and 40 meters should be noted. Data on the settings of the amplifier tuning condenser and the antenna condenser can only be obtained with the transmitter operating with its antenna connected, because the settings of these condensers will depend largely upon what sort of antenna is connected to the transmitter.

After the transmitter and its audio system have been checked on the test bench, assemble them and place the completed unit in its cabinet. In actual operation, all tuning is done with a 0-200 ma. meter plugged into the key jack. At this point the meter will read the total cathode current of both tubes in the r.f. portion of the transmitter. Once the individual operating currents have been measured on the test bench, as described above, all tuning adjustments can be made with only the meter in the common cathode lead. If the transmitter is to be operated from a 6-volt d.c. supply, plug the power cable into the d.c. output connector on the power supply, and turn the heater switch in the power supply to the d.c. position. For operation from the 115-volt lines, this switch must be turned to the a.c. position, and the power cable must be transferred to the a.c. output connector.

It should be remembered that the rating of the vibrator used in the supply will not permit sustained loads of much over 100 ma. if maximum

(Continued on page 114)

Propagation and Antennas Above 50 Mc.

Plotting V.H.F. Station Performance Graphically

BY M. R. LUDWIG,* W6QHC

THOUGH many of us who work on the v.h.f. bands were attracted to them originally by the lure of the extended ranges that may be worked when unusual ionospheric or tropospheric conditions are present, sooner or later we are bound to be concerned with the minimum ranges which are workable on these bands as well. In addition, some operators are not interested in a band unless it is useful to them at all times, regardless of conditions. Our years of v.h.f. experience have given us much information on the sky-wave possibilities of 50 Mc., and recently we have had numerous examples of the phenomenal distances which can be covered on 144 Mc. when tropospheric conditions are favorable. The purpose of this paper is to examine the possibilities of these two bands under conditions when no aiding factors are present.

Formulas and graphs will be presented which will permit comparison of 6- and 2-meter operation. They also serve to show the improvement in reliable working range which can be expected as a result of increasing the transmitter power, raising the antenna height, or improving the receiver performance. From these charts it is also

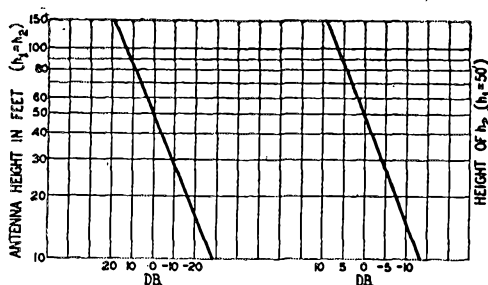

Fig. 1 — Graph showing increase in signal level resulting from increases in antenna height. At the left is the improvement obtained by raising both antennas a similar amount. At the right is the curve for one antenna being varied and the other fixed at a height of 50 feet.

possible to determine the amount of power required to transmit a given distance on either band.

Many factors must be taken into account in determining reliable v.h.f. working range, but if standard levels are established for each, and all variations from these levels handled in decibels, it becomes relatively simple mathematically. In

• We all know that world-wide DX is workable on 50 Mc. at certain times, and we know that the right tropospheric conditions can bring in strong signals from distances up to 500 miles or more on 144 Mc., but what can we expect from these bands on a day-and-night basis, 365 days in the year? Since v.h.f. activity is largely a matter of local work for most of us, we would do well to know something of our operating range under adverse, as well as favorable, conditions. Here are two papers which tell us what to expect under normal conditions, the first concerned with 50 and 144 Mc., and the second applying to these and still higher frequencies. An understanding of the simple principles they set forth will help you in getting more out of your v.h.f. and u.h.f. work.

the discussion to follow, one-watt output from the transmitter and antenna heights of 50 feet are taken as zero levels for these two factors. As seen in Fig. 1, if one of the antennas is raised to 100 feet a 6-db. increase in received signal should be obtained. Raising both antennas to 100 feet increases the signal by 12 db. over the level obtained with 50-foot antennas. A similar situation applies when the antennas are lowered to 25 feet, except that a transmission loss is incurred.

Determining Working Ranges

The curves of Fig. 2 are based on one watt radiated by half-wave dipoles at 50-foot height,¹ and show the working range under normal conditions on 50 and 150 Mc. over a plane earth (curve A) and for the two frequencies with the earth's radius increased to 4/3. If we know the capabilities of our receiver, our transmitter power output, and the gain of our antenna systems, we can use these curves to plot our reliable working range on 6 and 2 meters with reasonable accuracy.

The weakest signal which we will be able to recognize is computed by the following formula: $Power \text{ (minimum receivable)} = 4 \times 10^{-18} \times \text{receiver bandwidth in kc.} \times \text{receiver noise figure based on power.}$

¹ Proc. of I.R.E. October, 1947; Bullington, "Radio Propagation Above 30 Mc."

*315 E. 24th St., Minneapolis, Minn.

If we assume a bandwidth of 4 kc. a perfect receiver would give some indication of a signal which is 168 db. below one watt, though it would be far from readable if voice-modulated. Since receiver noise figures vary widely it is difficult to determine the minimum detectable signal. Properly-designed circuits permit a noise figure of about 3, and will be able to reveal a signal which is 5 db. stronger than that which could be detected by a perfect receiver. It frequently happens that a receiver will have a high noise figure, because of serious regeneration in the r.f. stage. Such a receiver will appear to be very sensitive because of high internal noise level and sharpness in the r.f. tuning. Because a 15-db. noise figure can be attained by careful workers this value will be employed in the sample calculations. If we allow 10 db. for a passable signal-to-noise ratio and 3 db. for transmission-line losses to the receiver the minimum observable signal input to our receiver would then be 140 db. below one watt.

Since we can receive a signal of 140 db. below one watt, our maximum reliable range is that distance at which the propagation loss is equal to -140 db. (receiver input level) -20 db. (for use of beam antennas having a gain of 10 db. at each end of the path) -5 db. for transmitter power (the rated output level of an SCR-522), or a total of -165 db. Consulting the curves of Fig. 2, we find that this represents a distance of 65 miles on the 6-meter curve and 54 miles on the 2-meter curve.

Let us now investigate the improvement which can be attained with increases in power. Increasing the transmitter power output 10 times (10 db.) permits a maximum propagation loss of -175 db., conforming to 83 miles on 50 Mc. and 67 miles on 150 Mc. This increase in range is comparable to that obtainable with a receiver having a very low noise figure, with no increase in transmitter power. Obviously weak-signal reception is helped considerably by significant reductions in receiver noise figure. Up to line-of-sight distances a power output increase of

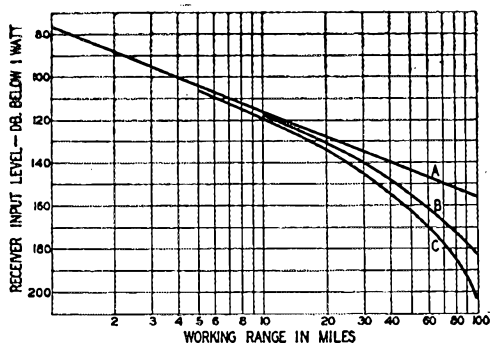

Fig. 2 — Curves showing the working ranges to be expected with one watt of power radiated on 50 and 150 Mc. from half-wave dipoles 50 feet high. Curve A is for a plane earth; B and C are for 50 and 150 Mc., with earth radius increased to 4/3 the actual value, to account for normal refraction.

16 times is required to double the distance with the same signal level. Beyond line-of-sight this figure increases rapidly, and soon becomes prohibitive.

Since trees and buildings produce a certain amount of scattering and absorption of the transmitted signal, these results apply only to open terrain. The curves are based on an increase of the earth's radius to 4/3 its normal value, this being considered normal for refraction over open areas. It should be emphasized that these figures are acceptable as distances which could be worked in such terrain day and night throughout the year, regardless of conditions. Actually, weather variations will cause considerable increases during a fairly high percentage of the time, but the fact that two stations using SCR-522 transmitters and relatively small beams can work each other consistently over distances in excess of 50 miles on 2 and 60 miles on 6 meters is still too little appreciated in many quarters.

For greater distances they can make the improvements suggested, or wait for more favorable tropospheric or ionospheric conditions, which may multiply these distance figures many times.

Making the Higher Frequencies Pay Off

BY CALVIN F. HADLOCK,* W1CTW

WHEN a ham decides to give v.h.f. a try, he usually starts out on two or six meters with a simple transmitter and receiver and a dipole antenna. If he likes the newly-chosen band, he will probably try to extend his working range by improving his equipment. He may increase his transmitter power or take steps to improve the efficiency of his present gear. The receiver may be redesigned or r.f. stages added to give the best possible sensitivity. The antenna will be given consideration to see what can be

done there to send and receive stronger signals. Here, in the antenna, is where the greatest improvement for the least cost can be made. What can be expected of the antenna and what should be done to improve it?

The material to follow is intended to be a simple discussion of antenna characteristics, particularly adapted to v.h.f. (or higher) bands. It will be concerned with line-of-sight or extended ground-wave propagation normally encountered at these frequencies, thereby limiting the discussion to transmission in a plane parallel to the

*41 Bellington St., Arlington, Mass.

earth's surface and excluding higher-angle radiation such as is common in the ionospheric transmission of the lower frequencies. In the interest of restricting the discussion to antennas alone, differences in efficiency and sensitivity of the transmitters, receivers and antenna feedlines will be ignored, and we will assume that these are maintained constant if a change in frequency is made, although we know that this is not necessarily true in practice.

Let us start with the dipole which is the simplest form of practical antenna and consists of a single wire or element one-half wavelength long connected to the receiver (or transmitter) by a feeder system which should be adjusted to match the receiver impedance to the antenna by one method or another. We will often hear the remark that a "J" antenna is better than a folded doublet or a "Y"-matched antenna, or vice versa. This is not a comparison of one dipole to another but rather is connected with the degree and ease (or luck) with which each feedline is matched to its antenna. A dipole is a dipole and will intercept the same amount of energy from space regardless of what feeder system is used with it. Whether the maximum amount of this energy gets to the receiver depends on the quality of the feedline and how perfectly this feedline matches the antenna and receiver impedances. If the match is perfect, the antenna and receiver impedances are equal and the maximum energy transfer occurs. Under this condition, half of the energy developed in the antenna is dissipated in the antenna and the other half is delivered to the receiver, minus some unavoidable loss in the feeder. For further discussion, we will ignore feeder loss.

If a transmitter is connected to an antenna so as to deliver power to it, that power is radiated into space in the form of an electromagnetic wave. The strength, or intensity, of this wave decreases as it gets farther from the transmitting source but its intensity can be measured, or calculated, at any point in free space. This free-space field intensity is given by:

$$E_o = \frac{\sqrt{30G_t P_t}}{d} \text{ volts/meter.} \quad (1)$$

where:

P_t = antenna radiated power in watts,
 d = distance from antenna in meters,
 G_t = power gain of the antenna.

If we assume that the antenna is a point which radiates equally well in all directions, the antenna gain $G_t = 1$. Such a theoretical antenna, called an isotropic antenna (Fig. 1-A), obviously does not exist. If a dipole is used, more power is radiated broadside to the antenna (Fig. 1-B) than off the ends so that, in a direction broadside to the antenna, the dipole has a gain of 1.64 times, or 2.14 db. over the isotropic antenna. It may be a source of satisfaction to the simple-antenna users to find that a dipole has a gain over some-

thing! For a dipole antenna, the above formula can be rewritten:

$$E_o = \frac{7.03 \sqrt{P_t}}{d} \text{ volts/meter} \quad (2)$$

Notice that frequency is not a factor in the above formula. This means that a given amount of power radiated from a dipole will produce the same field strength at a given point in free space, regardless of the frequency used. In other words, a dipole for 2300 Mc. or 420 Mc. is as good for transmitting as a dipole on 144 or 50 Mc.

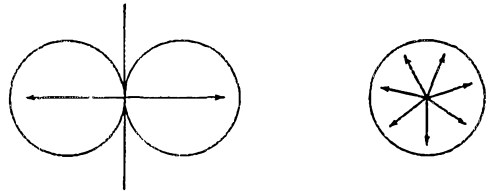

Fig. 1 — Comparison of the field patterns of the theoretical point (isotropic) antenna and the dipole. In the case of the former, radiation is uniform in all directions, while the dipole is bidirectional.

This is not the whole story, however. We are interested in field intensity E_o only so far as it is capable of inducing a voltage in an antenna for receiving purposes. Now, let us suppose that we have a given field strength, E_o , developed by a magnetic field traveling outward from a transmitting antenna and we place a dipole antenna broadside to this magnetic field. Let us assume that the dipole is perfectly matched to a receiver. The field strength E_o will now induce a voltage in the dipole which will develop an amount of power available to the receiver given by:

$$P_r = \left(\frac{E_o \lambda}{2\pi} \right)^2 \frac{G_r}{120} \quad (3)$$

where:

P_r = watts input to the receiver,
 E_o = field intensity in volts/meter,
 G_r = power gain of receiving antenna
 (1.64 for a dipole).

$$\lambda = \text{wavelength in meters} = \frac{300}{\text{Freq. (Mc.)}}$$

This formula shows us that the power developed in a receiving antenna in free space is directly proportional to the square of the wavelength or inversely proportional to the square of the frequency. Since E_o is directly proportional to the transmitted power, it follows that as the frequency is doubled, the signal in the receiver will be reduced to one-quarter. This would indicate that a six-meter dipole would be nine times as effective as a two-meter dipole for receiving. This is not surprising since a six-meter dipole is three times as long as a two-meter dipole and therefore intercepts three times as much voltage.

Since E_0 is merely a means to an end, we can get rid of it by dividing equation (3) by equation (1) after first transposing equation (1). This gives a formula which shows directly the ratio of received power P_r in free space to transmitted power P_t as follows:

$$\frac{P_r}{P_t} = \left(\frac{\lambda}{4 \pi d} \right)^2 G_t G_r \quad (4)$$

for two dipoles $G_t = G_r = 1.64$ giving:

$$\frac{P_r}{P_t} = \left(\frac{1.64 \lambda}{4 \pi d} \right)^2 = \left(\frac{0.13 \lambda}{d} \right)^2 = \left[\frac{1525}{F^2 d^2} \right]. \quad (5)$$

As before, this formula indicates that, in free space, the received power varies inversely as the square of the frequency. This would indicate that if one contemplates going to higher frequencies, he must use either higher power or more antenna gain to keep the received signal strength from going down. The cheapest way to do this is to use beam antennas which, fortunately, are capable of higher gains in a given space as the frequency is increased. The use of high-gain antennas (i.e. — a power gain of 200 at 2300 Mc. in a four- or five-foot parabola) is therefore not a case of building a "dream beam" to produce a Utopian signal but merely a necessity for holding your own with the lower frequencies. It is apparent that in order to extract a lot of power from a transmitted wave, it is necessary for the antenna to occupy as much space as possible. If you reduce the over-all size of the antenna system as you increase frequency, the received power will go down in spite of the fact that the antenna gain (with respect to a dipole of the same frequency) may have gone up. For example, in the case of parabolic or broadside arrays whose area is maintained constant (by adding elements as needed), the received power remains essentially constant for a given field intensity. This is a result of the fact that the gain of a parabolic or broadside array whose area is held constant is approximately proportional to the square of the frequency while the received power in a dipole to which this gain is referred is inversely proportional to the square of the frequency. These two factors balance out so that the received power is essentially independent of frequency if the beam area is held constant.

So much for the receiver. Suppose we turn now to the transmitting antenna. Since we are now holding our own at the receiver by keeping the area of the antenna constant as we increase frequency, what will happen if we maintain the same condition at the transmitter? As in the case of the receiving array, if the area of the transmitting array is held constant as the frequency is changed the apparent transmitting power P_t varies directly as the square of the frequency. Thus, if both transmitting and receiving arrays are maintained at the same over-all size, the net receiver power increases as the square of the frequency. This points the way toward making the higher-frequency bands pay off.

Another advantage is gained by using a beam antenna. If the noise received by the antenna is coming from all directions with equal strength, the noise level is approximately constant regardless of antenna gain. The strength of the received signal, on the contrary, is proportional to the antenna gain. Therefore, it can be said that the signal-to-noise ratio of a received signal is directly proportional to the antenna gain. A high-gain beam can produce a decided improvement in signal-to-noise ratio in almost any location. This is *not* true of the addition of a preselector if the receiver to which it is connected already has ample gain.

The above discussion has been carried on with regard to antennas in free space. This assumption is reasonable for local signals with antennas not too far apart and reasonably high and clear. As the stations get farther apart, the ground starts to get into the argument to a greater degree until finally it cuts off reception completely. The stations that most hams are particularly interested in receiving are those weak ones beyond the horizon that are considered DX or near-DX on the v.h.f. bands. Here the ground *really* gets into the argument. We also find that the higher frequencies are penalized less than they are in free space and the use of high gain beams is a real advantage.

Let us take the special case of two stations located near the horizon almost out of sight of each other with antennas located as shown in Fig. 2. Above 50 Mc., over ground paths of this sort, we have two signal waves to consider. First there is the direct or free space wave AB which

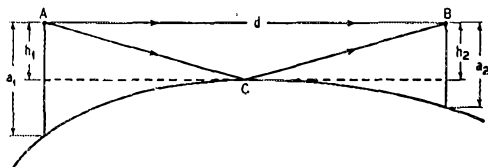

Fig. 2 — Diagram showing the two wave paths involved in v.h.f. communication, the direct path, AB , and the ground-reflection path, ACB . The radius of the earth's curvature is increased by one-third, taking normal refraction into account.

is the same free-space signal that we have been discussing. In addition, there is a reflected wave ACB which combines with the free space or direct wave to produce the net received signal. To further define our conditions, let us make the following stipulations which, at these frequencies, are valid.

- 1) The coefficient of reflection is 100 per cent. This means that the earth is a perfect or near-perfect reflector. This is true for horizontal polarization but is only true for vertical polarization for angles of reflection less than about one degree.

2) A shift of 180 degrees in phase occurs at the point of reflection. This means that the reflected wave will arrive nearly out of phase with the direct path and will therefore tend to cancel it.

3) The difference in phase from 180 degrees of the two waves is less than $\frac{1}{6}$ wavelength. This is true if:

$$\frac{h_1 h_2 F}{d} < 433,000 \quad (6)$$

where:

$h_1 =$ feet, $h_2 =$ feet, $F =$ Mc., $d =$ miles.

4) The antennas are more than two wavelengths above ground. At two meters this is about thirteen feet.

5) The actual radius of the earth's curvature is increased 33 per cent to produce an apparently flatter earth. This takes into account the normal refraction of the signal around the earth.

It can now be shown that:

$$\frac{P_r}{P_t} = \frac{h_1^2 h_2^2}{2.97 d^4} \times 10^{-14} \quad (7)$$

Let's see what is going on here. Suppose h_1 and h_2 were zero. Then, the length of the direct path is equal in length to that of the reflected path. Since they are 180 degrees out of phase because of the phase reversal of the reflected wave, they cancel each other and the signal strength is zero. As the antennas are raised above the line (dotted) which is tangent to the earth at the point of reflection, the length of the reflected path becomes longer than the direct path so that the relative phase of the two signals is now less than 180 degrees and a signal strength equal to this difference results. As the signal frequency is raised, the phase difference for a given height and difference in path length increases more rapidly; therefore a higher-frequency signal will grow strong faster than a lower-frequency signal. This effect nullifies the loss in strength from the increase in frequency over the direct path as indicated in equation (5). For this reason, equation (7) does not contain a frequency term and the signal strength is independent of frequency. Thus, under the above conditions, two dipoles would be as effective at 220 Mc. as at 144 or 420. Of course, between the two extremes of free-space and horizon conditions, there will be a transmission effect attributable to the reflected ground wave of greater or less degree. These intermediate conditions are still subject to calculation, but the equations become somewhat formidable. However, we are not particularly interested in actual values of signal strength but rather in what to expect when we try a new v.h.f. or u.h.f. band. I believe that it is apparent that beams are a "must" for the u.h.f. and s.h.f. bands and that the size of the array is what counts rather than its actual-power gain.

Beyond the horizon, we have to depend on diffraction and unusual weather conditions for our

DX. It is being realized that most of these v.h.f. contacts on two meters and above are made by way of ducts or waveguide effects. These ducts are waveguides usually formed between the earth and a discontinuity in the air above the earth caused by a change in density at a certain level. The width of a duct determines the lowest frequency that will be passed by it. Also, the frequency of lowest attenuation is usually quite close to the cut-off frequency. And, incidentally, it makes no difference whether the signal is vertically- or horizontally-polarized. A duct that will pass 144 Mc. would be about a half mile high, a condition that occurs quite frequently. If the duct becomes narrower, it may cut off the 144-Mc. signals while still passing higher frequency signals and these with less attenuation. Good examples of this occurred last fall (1947) when the writer was scheduling with W2HWX in Little Silver, N. J., on 235 Mc. One Sunday night the two-meter band was fairly open, and stations in the Boston area were working some W2s around New York City and Long Island; but with generally weak signals. The six-meter boys were working W2s easily. W2HWX was S2 on 235 Mc. On Monday night, six meters was normal but two meters was wide open with the locals working W2 and W3 stations with strong signals. W2HWX was S5 on 235 Mc. On Tuesday night, the two-meter band was absolutely dead both in Boston and in New Jersey. But the duct was still there, apparently too narrow for two meters, and W2HWX was rolling through S9! Wonder what was doing on 420 Mc.? There were several nights when W2HWX was heard with good signal strength on 235 Mc. when two meters was dead at both ends of this 210-mile path.

It is hoped that this material has helped to clarify the picture of antenna performance at v.h.f. and higher. We hope that we have impressed the reader with the idea that the dipole is the world's worst antenna and that beams are "good business." Realizing that the space an antenna occupies is the prime factor in producing strong signals, the writer wishes to express the opinion that 220 Mc. is perhaps the optimum v.h.f. band, as at this frequency we have a practical compromise between size and complexity in the antenna array. However, there is a lot to be learned on still higher frequency bands and some of the results obtained are apt to be quite surprising. Let's explore them!

**SWITCH
TO SAFETY!**



A Doorknob Oscillator for 420 Mc.

A Simple Rig for Inputs up to 50 Watts

BY EDWARD P. TILTON,* W1HDD

• Most of the activity currently on 420 Mc. is conducted with gear obtained on the surplus market. It is true that there are several transmitters and receivers available at very low cost, which can be converted to amateur use with a minimum of difficulty, but we feel that the fellow who gets started that way is missing at least half of the fun. For those who prefer to build their own, here is a simple rig which will outperform most of the surplus jobs—and since the components are almost entirely handmade or from surplus stock, the cost is pleasantly low.

THE AMATEUR who wants to build gear for 420 Mc. has a limited choice of tubes for his transmitting equipment. The 6J6 performs quite well at this frequency,¹ but the amount of power it will take is usually too low for anything but short-range work. The 832 may be made to function as a push-pull tripler with fair efficiency,² if the necessary 144-Mc. excitation is available, but this approach may be somewhat beyond the inexperienced worker. There are the various lighthouse types, which do a fine job, but their design makes for mechanical problems which are difficult for the fellow who is not well-equipped with tools.

This leaves the "doorknob" as about the only other possibility. These types are far from new (as far back as 1936, *QST* and the *Handbook* were running descriptions of u.h.f. gear using the 316-A) but their design makes them well adapted to 420-Mc. work. They were originally

* V.H.F. Editor, *QST*.

¹ "Four-Twenty Is Fun," Nov., 1947, *QST*, p. 13.

² "Tripling to 420," Brannin, June, 1948, *QST*, p. 52.

quite costly, and consequently received little amateur attention, but recently both the 316-A and the 703-A have been available on the surplus market at attractive prices, and hundreds are taking on dust in the shacks of amateur surplus collectors. The 316-A (also sold as VT-191) is the better-known and the cheaper of the two. It has a 2-volt filament, and a top frequency rating of about 700 Mc. The 703-A used in the rig described herewith has a 1.15-volt filament, and is capable of operating at frequencies as high as 1200 Mc.

The chief problem in using these tubes is the difficulty involved in making satisfactory contact to the pins. At the frequencies for which they are designed there cannot be anything like a socket or leads in the ordinary sense; the tube pins must make direct contact with the circuit elements, in order to permit operation higher than about 300 Mc. or so. They require considerable filament current, so the connection to the filament pins must be solid. The net effect of these requirements is that, so far as the amateur constructor is concerned, at least, the transmitter must be built around the tubes. If he resigns himself to some arrangement which makes it impossible to change tubes at will he can achieve excellent performance with either of these tubes in the 420-Mc. band.

Two 703-As are used in this oscillator, with a half-wave line in the plate circuit acting as the frequency-controlling element. The grids are tied together and connected to ground through the bias resistor, R_1 . Small self-supporting r.f. chokes are used in each filament lead, directly at the tube pins. Plate voltage is fed into the lines at their approximate midpoint through a center-tapped r.f. choke, the exact position of which is determined by experiment. At the opposite end of the line from the tubes a small split-stator tuning condenser is used for frequency adjustment.

◆
Front view of the doorknob oscillator for 420 Mc. Note the four filament chokes connected at the pins of the 703-A tubes. Plate voltage is fed through an insulated bushing near the middle of the chassis to the center-tapped r.f. choke. The variable condenser at the end of the plate line provides frequency adjustment.
◆

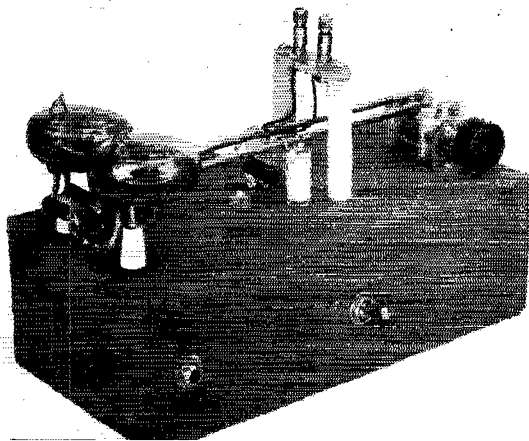

With 703-As and the line dimensions shown, the oscillator just hits 450 Mc. with C_1 at the minimum position. The low end of the band is reached with the plates three-quarters meshed. Output is fed to the antenna by means of a hairpin coupling loop at the midpoint of the line.

Mechanical Details

The plate lines are made of $\frac{3}{16}$ -inch soft copper tubing 8 inches long and spaced $\frac{3}{4}$ inch center to center for the first $6\frac{1}{2}$ inches of the line, at which point the line is fanned out at an angle of about 60 degrees to the tube plate pins, as shown in Fig. 2-A. The two tubes are mounted $2\frac{1}{4}$ inches apart, center to center. If 316-As are to be used the line will have slightly different dimensions, as

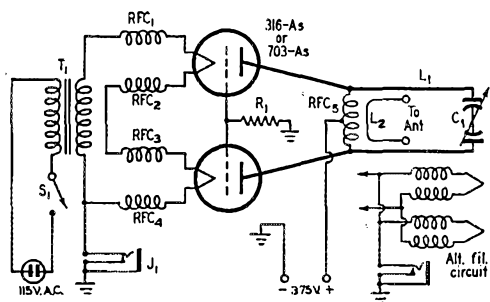

Fig. 1—Schematic diagram of the 420-Mc. door-knob oscillator. The insert at the lower right shows an alternate filament connection.

C_1 —Miniature split-stator variable, about $4 \mu\text{fd.}$ per section. (Millen 21906D, with one stator plate removed from each section).

R_1 —3300 ohms, 1 watt.

L_1 —Plate lines; see text and photographs.

L_2 —Antenna coupling loop, No. 14 enameled wire. Coupling portion about one inch long and $\frac{3}{4}$ inch wide.

J_1 —Cathode meter jack, closed-circuit type.

RFC_1 —9 turns No. 18 enameled wire, $\frac{1}{4}$ -inch diameter, $\frac{3}{8}$ inch long.

RFC_5 —16 turns No. 18 enameled wire, $\frac{1}{4}$ -inch diameter, $15/16$ inch long, center-tapped.

S_1 —S.p.s.t. toggle switch.

T_1 —2.5-volt 6-amp. filament transformer; Stancor P-4083.

these tubes are a trifle larger in diameter. Contact to the tube pins is made much more easily, however, as the pins on the 316-A are $\frac{1}{16}$ inch long, as compared with $\frac{1}{4}$ inch for the 703-A. Larger-diameter tubing may be used for the plate lines with the 316-As, but $\frac{3}{16}$ inch is the limit with the 703-As.

Connection to the filament pins is made by means of specially-made clips. Pieces of $\frac{1}{8}$ -inch diameter brass rod are sawed lengthwise to a depth of about a quarter of an inch and then drilled, parallel to the axis of the rod, with a No. 54 drill, which is just smaller than the tube pins. These clips (Fig. 2-B and C) are forced onto the filament pins. They should not be removed un-

necessarily as a tight fit is not usually possible after one or two insertions. The grid connection (Fig. 2-D) is made in the same manner, except that a single piece of brass rod, bent up at each end, is used. Here, again, larger diameter rod stock may be used with the 316-A, because of the wider pin spacing. Two of the filament clips are threaded at the bottom end, in order to screw them into small cone stand-offs which provide the supports for the tubes.

The split-stator tuning condenser, C_1 , is mounted at the right-hand end of the chassis, with the ends of the plate rods soldered directly to the stator rods. The condenser is a Millen 21906D with one stator plate removed from each section. It may be used in its original form, but the removal of the two plates makes for greater ease of adjustment. The rotor of the condenser is not grounded, though this is probably not important, one way or the other.

Connection to the plate line is made with clips cut from soft sheet copper, mounted on one-inch stand-offs. The antenna-coupling loop is connected to a National FWG terminal assembly, which is mounted atop two $2\frac{1}{2}$ -inch stand-off insulators. These high posts are used so that the feeder will be well above the plate line, preventing coupling to the antenna other than that provided by the loop itself.

The chassis used is a standard 3 by 5 by 10-inch size. Actually the last operation in the assembling of the unit is the drilling of the chassis, reversing the usual procedure, as the exact position of the various parts will be known only when assembling of the components has been completed. This work should be done with care, as the final assembling should place no strain on any of the tube pins; thus it is best to assemble the unit and then lay out the chassis holes accordingly. The filament transformer is mounted on the rear wall of the chassis, and the cathode jack and filament switch on the front wall.

The filament circuit will depend on which type of tube is to be used, and what type of transformer is available. The 703-As were operated with the series filament connection shown, and also with the filaments in parallel, as shown in the insert in Fig. 1, without any noticeable difference in operation. The transformer employed is a 2.5-volt 6-ampere type, but the heavy drain of the 703-As brings this down to just about the 1.15 volts required, at the tube pins, with the series connection. With 316-As the same transformer could be used with a parallel connection, or a 5-volt transformer could be used with the filaments in series. Whatever arrangement is used, the filament voltage should be checked at the tube pins. If it is higher than 1.15 volts for the 703-A or 2.0 volts for the 316-A, a heavy-duty variable resistor or a Variac may be connected in series with the filament transformer primary to drop the voltage to the required value.

Adjustments

Initial tests should be made with a plate voltage not exceeding 250. The clips on the plate lines should be set at approximately the midpoint of the lines, and the plate voltage applied. A meter plugged into J_1 will read about 65 to 70 ma. if the tubes are oscillating, increasing about 10 ma. when a lamp load is connected across L_2 and the

necessary to move the point of connection the frequency should be checked again after the change.

The plate voltage may now be increased, if desired. At 300 volts the tubes will draw around 100 ma., and the output will be 7 to 8 watts. More pilot lamps should be added to the load at this point. At 375 volts the tubes draw about 120 ma. and deliver about 10 watts output, as measured on a u.h.f. wattmeter.

The visual indication, with four blue-bead pilot lamps in parallel, checks fairly closely, but at high output levels the bulbs tend to go gassy. The same is true of other lamp loads, and 15-watt incandescent lamps are completely unreliable.

Adjustment of the antenna coupling may be quite different with an antenna than with a lamp load, tending to be looser with the former. It cannot be stressed too strongly that the coupling should be adjusted while checking the power in the antenna, rather than by meter indications, as it is very easy to overcouple.

The coupling should be as loose as possible, as increasing beyond the optimum point detunes the oscillator and may cause a considerable reduction in output and an increase in the tubes' plate dissipation.

Since minor variations in power will have a negligible effect on the signal strength at the receiving point, there is little point in pushing the tubes to the point where the plates show color. At about 45 watts input the 703-As run along nicely, and the 10 watts or so that they deliver at this level, while not high efficiency as we think of it on lower frequencies, is plenty good at 450 Mc., and it will be enough stuff to provide a lot of fun for the experimenter who wants to investigate the possibilities of this intriguing territory.

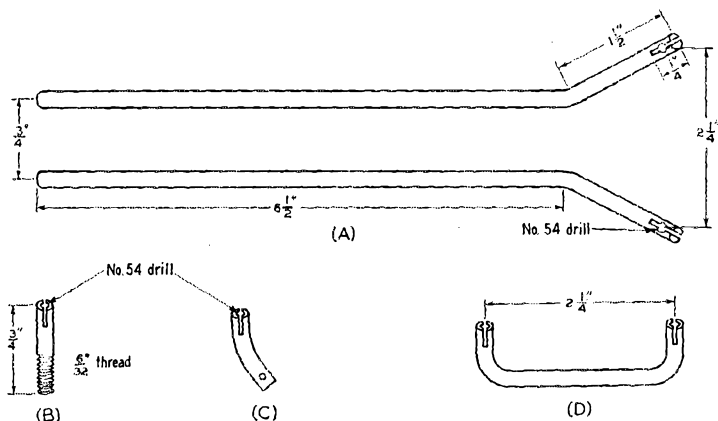
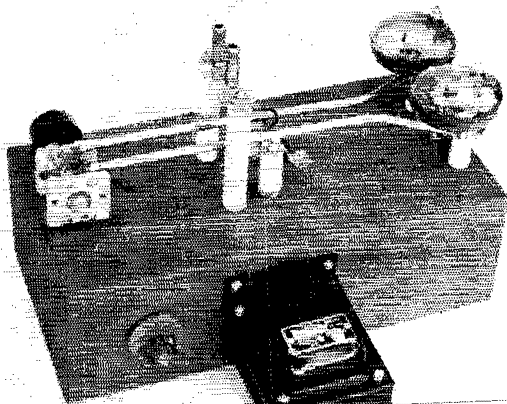

Fig. 2—Detail drawing of the plate lines (A), the filament connection pins (B and C), and the grid-connecting rod (D). In each case, the rods are slotted with a fine hack-saw blade, and then drilled out with a No. 54 drill. Pressing the rod onto the tube pin makes a tight fit, and does away with the necessity for any connecting leads. The threaded filament pins (B) are mounted on small cone stand-offs to provide support for the tubes.

position of the loop adjusted for maximum output. Two 6-8-volt 250-ma. pilot lamps (blue bead) connected in parallel make a good load for this test, and they should light to approximately full brilliance, indicating an output of 4 watts or so. Set C_1 near minimum capacitance, and check the frequency, which should be toward the high end of the band.

Next, the proper point of attachment for the plate-voltage connection should be determined. Touch a pencil to the plate line at various points and note the effect on the output. It will be found that at some spot near the middle of the line the pencil will have little or no effect on the output, this being the point of lowest r.f. voltage. The plate voltage should be fed in at this point. If it is

Rear view of the push-pull 703-A oscillator.



Happenings of the Month

ELECTION RESULTS

As a result of the balloting which has just occurred in six ARRL divisions, four new directors and two new alternates have been elected for the 1949-50 term, and two incumbent directors and one incumbent alternate have been returned to office. Here are the details:

In the Central Division, John G. Doyle, W9GPI, was elected in close balloting:

John G. Doyle, W9GPI.....	701 votes
George E. Keith, W9QLZ.....	657 votes
Carl A. McKay, W9IDZ.....	296 votes

Jack Doyle is president of the North Shore Motor Company of Milwaukee. He is a director and an honorary life member of the Milwaukee Radio Amateurs' Club, and was general chairman of last year's ARRL National Convention. He is an active amateur of many years' standing, and has held PAM and OBS appointments.

Wesley E. Marriner, W9AND, is the Central's new alternate director, the voting having been:

Wesley E. Marriner, W9AND.....	1044 votes
Raymond L. Hupp, W9CLF.....	596 votes

Wes Marriner is an assistant to the research engineer of the Illinois State Highway and Engineering Office. He was active in the affairs of the Ogle County Traffic Association and is a former RM. During the war, Wes was an instructor in radio-operating procedure at the Officer's Candidate School of Yale University. He is currently SCM of Illinois, active in the Rock River Amateur Radio Club, and holds appointments as ORS, OPS and OBS.

In the New England Division, the incumbent, Percy C. Noble, W1BVR, was returned to office by a thumping majority. The voting:

Percy C. Noble, W1BVR.....	998 votes
Frank L. Baker, jr., W1ALP.....	332 votes
David F. Erickson, W1NLU.....	271 votes
Arthur A. Stockellburg, W1SS.....	200 votes
Lawrence R. Mitchell, W1HIL.....	93 votes

Clayton C. Gordon, W1HRC, won the alternate post handily by receiving 1358 votes to 487 for Carroll O. Peacor, W1GAG. Thus Clayt Gordon resumes the alternate post he held for three terms, 1941-1946.

In the Northwestern Division R. Rex Roberts, W7CPY, the current alternate, was elected the new director, the voting having been:

R. Rex Roberts, W7CPY.....	470 votes
Harold W. Johnston, W7DXF.....	330 votes
Raleigh A. Munkres, W7HAZ.....	232 votes

Rex Roberts is manager of the Glendive and Wibaux, Mont., exchanges of the Mountain State Telephone and Telegraph Co. He has served four terms as alternate director of his division, as well as several terms as SCM of Montana. He holds appointments as PAM and OPS.

As previously reported, Allen D. Gunston, W7GP, has been elected alternate director of the Northwestern Division without membership balloting.

In the Roanoke Division balloting, Everett L. Battey, W4IA, was elected the new director when he received 520 votes to 254 for the incumbent, Hugh L. Caveness, W4DW. Ev Battey has the long title of "administrative assistant for elec-



With nearly 10,000 votes cast, the annual ballot-counting operation occupies a full day at Hq. In this corner are, l. to r. around table, Treas. Houghton, Comm. Mgr. Handy, Asst. Secy. Huntoon, Mr. Soule (certified public accountant who triple-checks the tallies), Acting Secretary Budlong, President Bailey, Asst. Secy. Baldwin.

tronics and special schools, officer training section, field administration division, training activity, Navy Department." He has taken particular interest in organization matters, starting perhaps with his term as SCM of Eastern Massachusetts from 1927 to 1929; he then became assistant communications manager on the Headquarters staff where he served until March, 1947, when he resigned to take up his present work. He is a commander, USNR, and was on active duty for five years during the war.

In the race for alternate the incumbent, J. Frank Key, W4ZA, was reelected when he received 449 votes to 319 for his opponent, William H. Jacobs, W4CVQ.

In the Southwestern Division, the new director is John R. Griggs, W6KW, who received 831 votes to 520 for the incumbent, Hans R. Jepsen, W6KEI. John Griggs is research laboratory analyst for the Consolidated Vultee Aircraft Corporation of San Diego. He has been licensed since 1922, and is especially active in affairs of the San Diego Amateur Radio Club and the San Diego County Council of Amateur Radio Clubs, being respectively president and chairman of those associations at present. He served overseas during the war as a radar field engineer.

As previously reported, John E. Bickel, W6NY, was elected alternate director without membership balloting.

In the West Gulf Division the incumbent, Wayland M. Groves, W5NW, was returned to office by receiving 685 votes to 265 votes for his opponent, Richard W. White, W5EY. As previously reported, the new alternate in the West Gulf Division is David H. Calk, W5BHO.

— . . . —

Almost exactly 50% of the eligible voters returned ballots in the six divisions where balloting took place, but individual divisions varied well above and below that figure, as can be seen:

Division	% of Membership Voting
Central	43.4
New England	58.4
Northwestern	52.9
Roanoke	56.4
Southwestern	47.9
West Gulf	47.6

ATLANTIC CITY REGULATIONS

The Atlantic City regulations, with the exception of the allocation table below 27.5 Mc., become effective January 1, 1949, and it is incumbent on the ratifying countries, of whom the United States is one, to alter their service regulations to comply with the new international provisions. For some services this is going to mean some substantial changes, but amateurs — especially we in the United States — will hardly notice the difference between the old and the new. The allocation table above 27.5 Mc. under Atlantic City is what we have here now, with the

exception of a slight shift in the 11-meter band; other changes in the international regulations applicable to amateurs are mostly editorial clarification, although one or two Q signals change somewhat and there will eventually be some new call allocations for some countries.

Our 11-meter band, now 27.160–27.430 Mc., will be shifted to 26.960–27.230 Mc. This shift is now in process at FCC but has not yet been made; it shouldn't be long, however, so keep an ear out for WIAW if you're one of the boys on "11." While on this subject of allocations, bear in mind that only that portion of Atlantic City allocations above 27.5 Mc. is effective January 1st; as further explained in this month's editorial, the new table below 27.5 Mc. is not yet effective. This means both that we do not yet acquire operating rights to our new 21-Mc. band, and that the 50-ke. cut at the high end of the 14-Mc. band doesn't take place. Don't look for them soon, either; it will probably be the end of the year, at the earliest, before these changes occur.

Apart from allocations, there will eventually be a change in the system for indicating types of emission, but we'll go into those when the FCC acts to put them into effect here. A desirable addition to the international regs is that the amateur service is now recognized and defined as "A service of self-training, intercommunication and technical investigations carried on by amateurs, that is, by duly authorized persons interested in radio technique solely with a personal aim and without pecuniary interests." The definition of an amateur station is simply a station in the amateur service. Both these are in accord with our wishes.

Changes in existing Q signals are for the most part merely editorial, except for QRI and QRX, where the exact meaning will now be slightly different although still treating of the same subject matter as before; these will be discussed next month in Operating News, as will the merits of some of the new Q signals that have been created under Atlantic City which may have amateur application. In connection with call allocation blocks, the United States inherits the AAA-ALZ series, but it is not anticipated that amateur calls will be assigned from it; some foreign allocations have been changed and will be reported in these pages when actual changes in amateur calls are made.

Under the old Cairo regulations, there was an Article 8 which gave general treatment to certain aspects of amateur stations and private experimental stations. Under Atlantic City, this article becomes Article 42, and — again as we wished — is devoted solely to us amateurs; experimental stations are given a separate article. Aside from editorial changes for purposes of clarification, this article duplicates old Article 8 except for one new provision appearing as the last sentence of paragraph (1) of § 3, where it is now provided that the code requirement may, if desired, be waived in

the case of stations making use exclusively of frequencies above 1000 Mc.; this, again, was a U. S. proposal. This whole article on amateur stations, incidentally, is something with which amateurs should be familiar, so we quote it herewith:

ARTICLE 42
Amateur Stations

§ 1. Radiocommunications between amateur stations of different countries shall be forbidden if the administration of one of the countries concerned has notified that it objects to such radiocommunications.

§ 2. (1) When transmissions between amateur stations of different countries are permitted they must be made in plain language and must be limited to messages of a technical nature relating to tests and to remarks of a personal character for which, by reason of their unimportance, recourse to the public telecommunications service is not justified. It is absolutely forbidden for amateur stations to be used for transmitting international communications on behalf of third parties.

(2) The preceding provisions may be modified by special arrangements between the countries concerned.

§ 3. (1) Any person operating the apparatus in an amateur station must have proved that he is able to transmit, and to receive by ear, texts in Morse code signals. Administrations concerned may, however, waive this requirement in the case of stations making use exclusively of frequencies above 1000 (one thousand) Mc/s.

(2) Administrations shall take such measures as they judge necessary to verify the qualifications, from a technical point of view, of any person operating the apparatus of an amateur station.

§ 4. The maximum power of amateur stations shall be fixed by the administrations concerned, having regard to the technical qualifications of the operators and to the conditions under which these stations work.

§ 5. (1) All the general rules of the Convention and of the present Regulations shall apply to amateur stations. In particular, the transmitting frequency must be as constant and as free from harmonics as the state of technical development for stations of this nature permits.

(2) During the course of their transmissions amateur stations must transmit their call sign at short intervals

CIVIL DEFENSE

The long-awaited report of the Office of Civil Defense Planning has finally been issued. It is a formidable job, comprising some 300 pages, put together during the past nine months by the planning group of 43 persons at Washington, assisted by 133 consultants, among them Acting Secretary Budlong and Communications Manager Handy, of ARRL.

The report outlines the requirements for civil defense planning, suggests the structure for local, state and national civil defense organizations, discusses the many specialized requirements of these groups in civil defense planning, outlines the means at their disposal in the solution of defense problems and lays the groundwork for suitable legislation to implement the plan at national, state and local levels.

About the only way to comprehend the full scope and nature of this tremendous job for those interested is to study the report itself. Titled "Civil Defense for National Security" it is available for \$1.00 from the Superintendent of Documents, U. S. Government Printing Office, Washington 24, D. C.

It should be stressed that this is a report on *all* phases of civil defense — medical and radiological control problems, chemical and special weapons, defense, fire, police, warden, rescue and transportation services, communications, plant protection, mutual aid, evacuation considerations, air-raid warning systems, etc. Communications, therefore, represent only a part of the picture; but, as the report itself points out within the first few pages, they are essential to any defense system. The general nature of communications necessary to civil defense are then treated in subsequent sections.

Primary reliance is, understandably, placed on wire communications but it is gratifying to report that the place of the amateur is recognized and commented upon. First treatment is in connection with a chapter on local organization in the defense program, where local communications aspects are discussed as follows:

"Communications: Should embrace all forms of communications, namely telephone, telegraph, radio, emergency messenger service and all other emergency means. Existing telephone, telegraph and radio facilities and services should be used insofar as possible, but provisions should be made for emergency communication services and alternate means of transmitting messages when regular facilities are put out of working order. Such emergency means would include mobile radiotelephones, the use of amateur radio services, and any other possible means that could be developed . . ."

Later in the report we are again included in a general discussion of communications as a special service where, under the heading of fundamental requirements, it is stated:

"Studies and surveys will be required of the availability and for the proper utilization of various systems of communications. These should embrace common carrier telephone, telegraph, typewriter and radiotelephone services, municipal communications systems, radio broadcasting stations and amateur radio services."

Finally, in separate paragraphs devoted to each of the above classifications there appears the following:

"Amateur Radio: Emergency service is a tradition in amateur radio operations. The amateurs' record during peacetime disaster indicates they are resourceful, adept at improvisation and possess a high sense of community service. They are licensed radio operators owning their own portable radiotelephone and telegraph equipment, thus providing for maximum flexibility. Under a carefully organized plan they are capable of making an important contribution to civil defense in providing supplementary emergency communications channels, especially during a post-raid period. The Office of Civil Defense should initiate study with a view to integrating the civil defense program with the Army and Air Force for the utilization of the amateurs' services."

The fundamental unit in the whole plan is the municipality; everything stems from this concept. The basic philosophy is self-help within communities, with mutual aid between communities being the second line of civil defense, state aid being the third line and finally a fourth stage of military aid to the civil government where and when required. As a result, the greatest organiza-

(Continued on page 118)

How's DX?

CONDUCTED BY ROD NEWKIRK,* W9BRD

How:

Don't fall over, guys, but we're off the soapbox this month. Since you'll all be busy lining up your own 1949 resolutions, anyway, there should be no need for kibitzing on our part. So we have turned up a more congenial subject to hash over.

The real granddaddy of this little corner (we won't name him but he is at present busily suppressing his carrier all over the place) took time out recently to remind us of the good old days. By the same token he wondered out loud what had become of the on-the-air DXCC Roundups that were so popular just before the

Although the Roundup won't be intended as a knock-down-drag-out contest it will be interesting to see who swaps pleasantries with the most members in the most countries and continents. The leaders in these respects won't win fur-lined bathtubs or the like but we think they'll meet a lot of nice guys. Naturally, those who made DXCC under different previous calls could also join the fun and there won't be any distinction between prewar, postwar and all-time sheepskin holders.

Since awardees now number in the hundreds, an interesting few hours should be had by all. You'll probably bump into a lot of buddies you haven't heard for years as real DX men supposedly listen 90 per cent of their operating time!

Well, the above details are tentative and depend upon what comments turn up in our mailbag. If the "ayes" have it, we'll surely set an early date — perhaps in May — for such a shindig.

Now let's get down to business. . . .

What:

W2CKN has been making hay on *eighty* between 8:30 P.M. and 1:30 A.M. local time, scoring with GD3UB (3520 t8), FA8IH (3518), HB9AW (3525 t8), GI6TK (3515), OZ4FT (3520), ON4FG (3523) and various Fs and Gs HH2BL has been haunting 3705 kc. during thrice-weekly skeds with W1IIN. Doc also accounts for KV4AA (3505) ZL1CI (3507), ZL2MP (3524), FA8BG (3502), CM2SW (3520), ON4QF (3516) and a collection of Gs occupy space in the log at W2EQS VE1EA's list includes HP1BR, KZ5AX, GW3ZV and PAØRE The following Gs have been reported working Ws on 80: G2DOW; G3EKH; G5LI; G6s FO and GM; G8s JR, RL, TK and VB. French stations getting through: F3MS; F8s EO, PK and TM A lone report from west of the Mississippi has KL7KB (3517) being worked by WØCFB. Gerald has his 3.5-Mc. WAC salted down but needs a card from FA8BG.

On *forty*, W2KIR and VE1EA captured ZC1CL (7030). The former also snagged VP6SJ, HA1KK, OX3BC, TI2KP, HC1JB, CE4AD and KM6AK, all countries of 14-Mc. quality WØCFB collared KG6DI, KP6AE, OX2MR, OX3J, VP2GE, VP5AX, CN8AN, TG8MO, TI2RZ, GI6TK/A, GM3BST, GW3DXP, 10 Gs, 13 VKs and 8 ZLs Four hundred watts raised HE1CE (7100), TI2EXO (7087), VP9CC (7093) and GI4NU (7003) for WØVDC W1QMJ lost shuteye for YV5AL, D5BG (7010),



Big Fracas. Of course, he might have been mildly insinuating that we're holding out on such doings until we break into the Select Circle ourselves [If we ever do, I'll DDT.¹ — *Jeeves*] in order to participate, but we'll accept his comments in better faith.

As the old-timers know, DXCC Roundups were cozy little affairs held during some otherwise quiet week end in which holders of the hallowed certificates took part. Now, seeing as how you've all been at each others' throats without a break for the past few years, isn't it about time everybody got together and shook hands for the next round?

* DX Editor, QST. Please mail reports of DX activity to W9BRD's home QTH: 1517 Fargo Ave., Chicago 26, Ill.
¹ Drop Dead Twice.

OZ8M (7005), **YR5I** (7020) and **IIBRO** (7015) The rig at **W4MDV/5** blows up every time he calls **VK2SH!** So Bert resorted to a chat with **VR2AM** **VE3OY** has a lot of Oceania catches as well as **CN8MZ**, **T14MAR**, **VP6EG** and some **Cs** **VR2AM/ZK2** (7030) adorns the log of **W2PUD**, as well as **OX2MR** (7050), **FM3AD** (7000) and **VP2AG** (7035) **W7LAN** is awaiting cards from **PY7DN**, **PY7WS**, **KJ6AB** (7075) and **PK2AB** The **BC-458** of **W5ONL** cooked up **KL7HI** (7080), **VK3QH**, **VK2RA** and **KH6LQ** Here's one that will make the 14-Mc. 200-country gang perk up and take note: **FY8AC** (7150), worked by **W2SUO**. Bob also hooked **HB9HQ** (7022), **OK3RF** (7020) and **HR1AT** (7197) **W7JM** built the **W9AEH** receiver that appeared in August *QST* and quickly knocked off **W7LHF/KX6** and **W0MCF/C1** Nailed down by **W2YDG** were **CT1AZ**, **PJ0X**, **LA4R** (7028), **FA9IO** (7009) and **CT3AB** (7040).

As far as *twenty* is concerned, **W5ACL** "wasn't on much" and accumulated **VQ5JTW** (14,010), **M13FG** (14,015), **VR2BD** (14,085), **KM6AJ** (14,040), **ST2GH** (14,095) and **HA1KK** (14,105) **W9IHN** recommends **PJ0X** (14,090), **CR9AN** (14,100), **J9ADE** (14,078), **HA4EA** (14,055), **UB5BK** (14,112) and **VE8MR** Some of the cagier individuals swiped by **W2ITD**'s newly-engineered anti-TVI layout include, on 'phone, **Js** **2AAL**, **2HYS**, **2ROC**, **2NZI**, **2AAA**, **9ACN**, **9AKG**, **KG6DW**, **KA1AP**, **KA1ABX**, **C3ZZ**, **HL1AB**, **HL1CC**, **CR9AG**, **KX6AF**, **OQ5CF**, **ZC6UN**, **HZ1AB**, **YS1PB** and **PJ5KO**. All this and no spots on the neighbors' Kinescopes! **W2GUR** associated with **VQ8AD** (14,055), **VQ4SGC** (14,050), **VQ2GW** (14,080), **UA0FL** (14,100), **UA0SI** (14,030), **W0MCF/C1** (14,080), **I6DD** (14,100), **UN1AB** (14,090), **ZC6UNJ** (14,080), **IS1FIC** (14,045), **W1EEC/KW6** (14,020), **C1JH** (14,110), **VP2GT** (14,000) and several **Js** Slipping through the **W/VE** gauntlet, **CM2AZ** grabbed **ZD1PW** (14,090), **UD6BM**, **ZD2RGY**, **KG6DY**, **PZ1OY**, **CE7AA**, **LB8FA**, **YR5I**, **HA4EA** and **KW6AG** **W2QHH** reeled in **ZC8PM** (14,010), **VP8AK** (14,100), **VP8AP**, **VP8AM**, **VS6AE** (14,039), **VS6BA** (14,013), **ZS3D** (14,070), **ZS3B** (14,119), **W7KMY/Iwo** (14,080), **UC2CB** (14,113) and **C7AT** (14,039) which helped make up two more 24-hour **WACs** for **Howy's** 35 watts Some nice 'phone confirmations have already

reached **W8BF** from **ET3AF**, **M13ZJ**, **AR1PC**, **ZK1AA**, **CR9AG**, **D4AVL/MD7**, **TA3FAS** and **VR4AA** **W2TXB** had little trouble with **CZ2AC** (14,040 t7), **UI8AE** (14,045), **VP2GJ**, **VP8AO** (14,095), **ZD9AA** (14,070), **ZC1CL** (14,064), **MP4BAB** (14,025-075 t7) and the aforementioned **ZC8PM**, who is in Arab Palestine A line from **W6BIL** lists as worked **C4BC**, **VS1CT**, **RV2/FO8**, **FO8AA**, **VR2AP**, **W4DGW/KJ6**, **CE4AD**, **VP1IM**, **YN1FTB** plus a truckload of **Us** and **Js** **Texan** **W5JPC** dented the wall for **OH2PG** (14,042), **VP5MU** (14,029), **UA3AF** (14,060), **UA3DC** (14,062) and **VO6Z** (14,130) A long-distance report from **VK9CV** specifies **UBSKAF** (14,100), **ZB1Q** (14,100), **OH2NB** (14,100), **FK8AB** (14,095) and **GM3BZ** (14,110) which shows that a rare **DX** station *can* work something else when the **Ws** are napping. **VK9GW** has been using 40 watts and a doublet with one crystal Relaxing after an **AC4YN QSO**, **W6MX** trapped **VQ8CB** (14,110), **GC4LI** (14,140), **EPIAW** (14,070), **UF6KAB** (14,160), **C3EA** (14,080), **UO5AC** (14,140), **VP8AJ** in **Grahamsland** (14,030), **ZC1AZ** (14,065), **U8KAA** (14,090) and **UL7BS** (14,070) **KH6PM** warmed up the new **VFO** with **CR7AP** (14,055 t8), **CR7BC** (14,080 t8), **CR7VAL** (14,025), **HK3FF** (14,005), **HP1BR** (14,045), **KX6BA** (14,035), **PZ1FM** (14,060), **VP1AA** (14,035), **VP3JM** (14,110), **VP5AX** (14,070), **VS1CV** (14,050), **VS6AZ** (14,105), **XZ2KM** (14,000 t8), **ZD8B** (14,020), **ZE2JS** (14,035), **ZK2AA** (14,130) and **CX4CZ** (14,025). Not bad for a single cool 807! An extensive 'phone summary from **W4BA**: **AP4B** (14,290), **KP6AA** (14,250), **KX6BA** (14,190), **TR1P** (14,350), **VP6SD** (14,155), **CT2AB** (14,350), **ZD1BD** (14,399), **ET3AB** (14,395), **ZE1JX** (14,350), **CT3MN** (14,370), **PZ1FM** (14,390), **CN8EN**, **EL5s A** and **B**, **W7MV/Iwo** and **ZD3A** **W4IUO's** mike work featured **AR8AB** (14,395), **EA1FO** (14,303), **FA9OW** (14,347), **PJ5KO** (14,335), **VK7AZ** (14,315) and **GD6IA** (14,398). On c.w. he derived **HZ1A** (14,060), **M13AB** (14,013), **UG6AB** (14,070) and the popular **ZC1CL**.

With *ten* getting a big workout, the mail sack is taking a beating. **W2QHH** found **J2AAL** (28,020), **J2HYS** (28,002), **ZE1JJ** (28,080), **ZD4AB** (28,090), **CR7VAL** (28,070), **SP8XA**, **VQ4FCA** (28,000), **VP2GJ** (28,000) and **VP8AD** (29,020) **W5OJH's** list has **ZD4AH**, **OQ5BQ**, **HH2ME**, **HL1BK**, **HC1KU**, **HR1MB**,



A modest array of gear does not necessarily make for modest results. Here we have Jack H. Hill of Cessnock, N.S.W., at the controls of his station, **VK2ADT**. There are p.p. 807s in the final at 50 watts, modulated by p.p. 809s. A newly-completed double-conversion superhet is not shown, as well as several beam antennae. **VK2ADT** has been high **VK** 'phone scorer in **ARRL DX Tests** for two successive years.

QST for

VP6LD and some ZS-men Samples at W2KZE are KP6AA, UA3AC, UA3BU, LB8R, ZL4GA, OE7FR, OH2OP, CN8BK, OK2SO and OZ1W ZS8A (28,200), OA1C (28,220), EL7A (28,245), VP9DD (28,315) and HH1SW (28,245) were nice A3 contacts for W5FUE W2RUK chatted with GM8MJ and then raised GW8WJ — nope, it wasn't GM8MJ sending upside down! From W8CCJ we hear of C7HY, CE4AD, CX6AF, LA4K, TG9BA, VP8AD and an armful of VKs, Gs and PYs, all c.w. W1EKU contrived conversation with IS1AYN, IS1AEX, KA1AC, AP2R and KX6BB, all nice ones on 'phone. On the West Coast, W6ZGY gathered up GM3AWW (28,055), CE3AX (28,080), OK3SP (28,065) and last, but not least, FASBG (28,035). Long time no hear from W6ZZ. Miles now has 10 countries on *eleven*, TI2FG, KH6KA, KX6BC and KZ5EL being the latest additions, and needs just three more cards for DXCC.

Where:

We have a few items of general interest to propound. Further data from Spain dwell upon details concerning a new unofficial-status QSL bureau, as follows: EA1 — P.O. Box 12, Gijon; EA2 — P.O. Box 113, San Sebastian; EA3 and EA6 — P.O. Box 1312, Barcelona; EA4 and EA5 — P.O. Box 12354, Madrid; EA7 — P.O. Box 228, Cadiz. These are in Spain proper and then we have EA8 — P.O. Box 346, Las Palmas de Gran Canarias, Canary Islands, plus EA9 — via EA9AI. ZD9AA claims that cards for him must be sent via Box 4887, Johannesburg, only AP5A or AP5B will act as a bureau for AP2, AP4 and AP5 areas. The OE QSL situation is pretty weird, each station devising its own route of entry. Better check all lists you have available pertaining to OE before you uncork that card.

- | | |
|-----------|--|
| C700 | Box 52, Peiping, North China |
| CN8AN | E. R. Foud, Tafilalet, French Morocco |
| D2CH | % R. E. C. Collings, 33 Cromwell Road, Colchester, England |
| D4AQH | (to W9AQH) |
| EA5BS | P.O. Box 98, Cartagena, Spain |
| EA5JM | Jose Maylin, Gandia, Valencia, Spain |
| ex-F8NE/C | Rue Marechal Reille, Antibes, A. M., France |
| HH2BL | (via W1LIN) |
| ex-HS1LA | (via W6RRG) |

ZL1MB, one of the more widely-heard New Zealand fellows, operated by "Slim" Herbert in Auckland. This station was high ZL c.w. scorer in the last ARRL DX Competition.

- | | |
|------------|--|
| IS1FIC | San Giovanni 208, Cagliari, Sardinia, Italy |
| J2AAD | Capt. C. B. Kindred, Box 194, APO 328, % PM, San Francisco, Calif. |
| KM6AJ | % CAA, Midway Island, Pacific |
| MD5PS | % P. C. Swann, Largham Road, Bowdon, Cheshire, England |
| MP4BAB | RAF Station, Sharjah, Persian Gulf |
| MP4BPC | Post Office, Hargeisa, British Somaliland |
| OE1RR | (via W6AVM) |
| OE6WX | (via W6AVM) |
| PY4ZI | L. Drumond, Casilla Correo No. 3, Itauna, Minas Gerais, Brazil |
| PY4ZV | A. de Paula, R. Cel., Portugal 398, Caturbas Sul do Minas Gerais, Brazil |
| PY6CO | P.O. Box 1101, Salvador, Brazil |
| TA3AA | (via ARRL) |
| TG8MO | Radio Nacional, Puerto Barrigs, Guatemala |
| TI2DL | (via TI2FG) |
| VE8MC | (to W4WV) |
| VE8PN | % Eastern Arctic Patrol, RMS, Ottawa, Canada |
| VO2CP | Navy 103, F.P.O., New York City |
| VP3TW | Cecil Wiltshire, 25 Upper Norton St., Wortmanville, Georgetown, B. G. |
| VP6SD | Box 252, Barbados, B. W. I. |
| VP7NG | (new license) P.O. Box 874, Nassau, Bahamas |
| VP7NH | P.O. Box 874, Nassau, Bahamas |
| VQ4RF | R. F. B. Featherstone, Box 264, Nakuru, Kenya Colony |
| VS7BJ | RAF Station, Koggala, Ceylon |
| W3MPM/C7 | (via ARRL) |
| W4DGW/EKJ6 | (to W4DGW) |
| W6DLX/KW6 | (to W6DLX) |
| W8TDP/KL7 | Box 115, N.O.F., Adak Island, Alaska |
| YN1RO | 153rd AACs Sqdn., APO 755, % PM, Miami, Florida |
| ZC8PM | (via W2AIS) |
| ZD1PW | G.P.O., Waterloo, Sierra Leone, West Africa |
| ZK2AA | P.O., Niue Island, South Pacific |
| ZS3B | Box 404, Windhoek, Southwest Africa |

These were snaffled from the mail of W1s GOU, IKE, PRR; W2s CJX, HAZ; W3SNA/2; W4s BA, CYY, IUO, MR; W5JPC; W6s CYI, MX; W9s IBC, JJD; W0CFB; KH6PM; LU8BF; VK9GW.

Tidbits:

We hasten to announce glad news to the effect that CZ2AC cards are now being widely distributed. G8PL reports that QSLs were delayed because of red tape which was not the fault of the Monsinis. Rosetta, by the way, will soon become the Mrs. of a lucky HB9 [You sound like Winchell.— *Jeeves*] G8PL desires no direct cards and considers himself as being under-

(Continued on page 118)



A Versatile Low-Power 'Phone-C.W. Transmitter

A 6AG7-2E26 Rig for 3.5 to 50 Mc.

BY G. A. BAKER,* W6CWQ

SOME of the arguments usually advanced for a small transmitter are that it is ideal for the beginner, while the old timer should have it around as an auxiliary or emergency transmitter. It is also supposed to be good for portable operation, for use as a stand-by while rebuilding the big rig, or as an exciter for driving a high-power stage to be added later. The transmitter described in this article seems to meet the above requirements. It was designed with the idea that it would be used primarily for "fixed-station" operation and perhaps occasionally installed in a car to take advantage of the new regulations concerning mobile operation.

Before proceeding with the circuit or construction data let's see what this little rig has to offer. Complete coverage from 80 to 6 meters, 'phone and c.w., is possible using crystals in the 3.5 to 9

• Here's a neat little transmitter that covers a lot of bands on both 'phone and c.w. Only two stages, and it can be run from a receiver-type power pack.

The circuits used have appeared in several publications, but the combination provided results which were even better than anticipated. A 6AG7 harmonic oscillator delivers enough output up to the fourth harmonic of the crystal to drive the 2E26 amplifier, which can be operated either straight through or as a doubler. The 2E26 seems to be an excellent frequency multiplier and delivers a moderate amount of power when operated as a doubler; the output on ten meters when using 80-meter crystals will compare favorably with that obtained when using higher-frequency crystals and driving the final straight through. Normally, 40-meter crystals are used for ten-meter operation and the 6AG7 is tuned to their fourth harmonic. The same is true for 11 meters, using 6-megacycle crystals.

If you have purchased any surplus crystals outside the regular amateur frequencies, here is where you can possibly put them to work. Those between 4667 and 4800 kc. will triple into the 20-meter band. Just plug a 20-meter coil into the oscillator and you will find it delivers ample grid drive to the 2E26. You can also double in the amplifier stage to 10 meters, in which case crystals up to 4950 kc. can be used. Operation on 15 meters can be accomplished by tuning the oscillator to the third harmonic of a 40-meter crystal. For operation on 6 meters the 2E26 is always used as a doubler. Crystals from 8337 to 9000 kc. should be used with the oscillator tuned to the third harmonic. Six-meter operation is also possible using crystals from 6250 kc. to 6750 kc. and tuning the oscillator to the fourth harmonic.

Circuit and Construction Data

The complete transmitter, less power supply, is mounted on a 7 × 9-inch chassis with a front panel of the same dimensions. The oscillator and amplifier are located at the front of the chassis and the modulator portion at the rear. The front-panel controls are as follows: oscillator and amplifier tuning on the left and right respectively, stand-by switch, meter switch and two jacks for

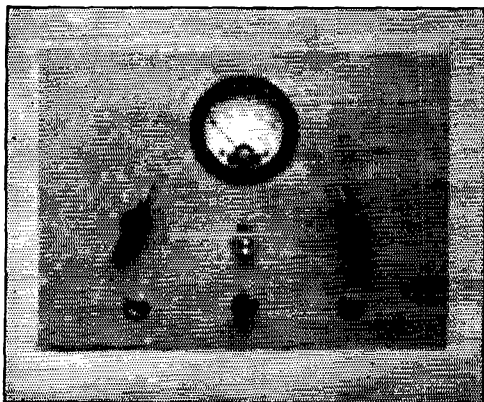

A compact low-power rig that can be used on all bands from 3.5 to 50 Mc. It is adaptable to portable or mobile work as well as fixed-station operation. Tuning controls, meter and stand-by switches, and microphone and key jacks are mounted on the panel.

megacycles range. That is seven bands, if you count 11 meters and the projected 15 meter band. Only three tubes are used, which makes compactness and simplicity possible. The tube filaments require a total of 2.35 amperes, a rather high value for mobile work; however, it is doubtful if any other combination of tubes would give the same flexibility and power output with much less filament current.

*431 Encina Avenue, Menlo Park, California.

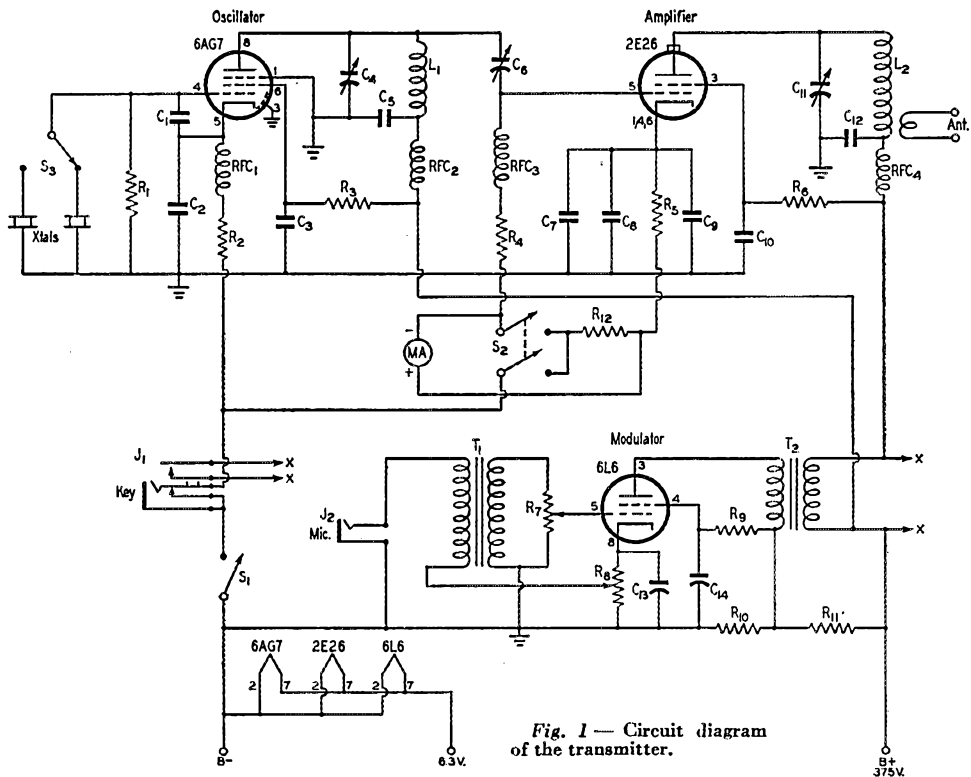

Fig. 1 — Circuit diagram of the transmitter.

- C₁ — 15- μ fd. mica.
- C₂ — 50- μ fd. mica.
- C₃ — 0.002- μ fd. mica.
- C₄ — 100- μ fd. variable.
- C₅, C₇, C₈, C₉ — 500- μ fd. mica.
- C₆ — 25- μ fd. variable.
- C₁₀ — 0.003- μ fd. mica.
- C₁₁ — 50- μ fd. variable.
- C₁₂ — 0.001- μ fd. mica.
- C₁₃ — 10- μ fd. 50-volt electrolytic.
- C₁₄ — 0.1- μ fd. 600-volt paper.
- R₁ — 68,000 ohms, $\frac{1}{2}$ watt.
- R₂ — 500 ohms, 1 watt.
- R₃ — 47,000 ohms, 1 watt.
- R₄ — 20,000 ohms, $\frac{1}{2}$ watt.
- R₅ — 300 ohms, 1 watt.
- R₆ — 30,000 ohms, 5 watts.
- R₇ — $\frac{1}{2}$ -megohm potentiometer.

- R₈ — 300 ohms, 10 watts (with slider).
- R₉ — 25,000 ohms, 1 watt.
- R₁₀ — 50,000 ohms, 5 watts.
- R₁₁ — 1500 ohms, 10 watts.
- R₁₂ — Meter shunt; see text.
- L₁, L₂ — See text.
- J₁ — 2-circuit jack, one normally closed and one normally open.
- J₂ — Open-circuit jack.
- MA — 0-10 ma.
- RFC₁-RFC₄ — 2.5-mh. choke.
- S₁ — S.p.s.t. toggle switch.
- S₂ — D.p.s.t. jack switch.
- S₃ — S.p.d.t. snap switch.
- T₁ — Microphone transformer, single button to single grid (Stancor A-4706).
- T₂ — Modulation transformer, single 6L6 Class A₁ to 8500 ohms, 60 ma. d.c. (Stancor A-3871).

key and microphone. Three controls are located behind the panel. They are the gain control, crystal switch and variable coupling condenser.

The crystal holder plus oscillator coils and coil socket were taken from a surplus BCR-746-A tuning unit. Since the crystal holder would accommodate two crystals a s.p.d.t. switch was added for crystal switching. The oscillator circuit is not tricky, and none of the faults common to some oscillators was encountered. There was no heating of the crystal and keying seemed quite satisfactory. The crystal oscillates at all times regardless of whether the plate circuit is in resonance. A very pronounced plate-current dip

occurs when the oscillator is tuned to the fundamental frequency, but the dip becomes progressively less as the higher harmonics are used. With 400 volts on the plate the current did not exceed 20 ma. and no particular precautions are necessary, since this is within the plate-dissipation rating of the tube.

In the original design a meter was provided for measuring oscillator plate current, but the amplifier grid current proved to be a much more accurate indication of resonance. In tuning the oscillator stage care must be exercised at the higher frequencies to select the proper harmonic. Some grid drive can be detected up to the eighth or

tenth harmonic with low-frequency crystals, and as many as five harmonics may appear when using the ten-meter coil.

The coupling condenser, C_6 , is a 25- μ fd. air variable, mounted underneath the chassis between the 2E26 and the shield. It is adjustable from the top with a screwdriver. For operation on the lower frequencies adequate grid drive will be secured with this condenser almost open. For operation where the oscillator is tuned to the third or fourth harmonic all the capacity may be required.

The 2E26 tube has three cathode socket terminals, and the manufacturer recommends that each be by-passed through individual mica bypass condensers. The high power gain of this tube necessitates complete isolation of the grid and plate circuits. For that reason the amplifier plate tank circuit was mounted on top of the chassis and a small shield installed between the two stages. This shield is rather difficult to see in the photograph, but it is nothing more than a piece of aluminum approximately four inches square. It is fastened to both the front panel and chassis and extends to the rear of the 6AG7. The amplifier tank coil was elevated slightly above the chassis by using an Amphenol (23-IS) socket mounting, but the socket could be supported with two short spacers or stand-off insulators. This procedure keeps the tank circuit above the chassis, and makes possible a shorter lead to the amplifier-tube plate cap. No trouble with feedback or instability was encountered, and a tube shield for the 2E26 proved unnecessary.

The final amplifier has a combination of grid leak and cathode bias. R_4 is the grid resistor and

R_5 the cathode resistor. The cathode bias provides partial protection for the 2E26 should excitation be lost by detuning or interrupting the crystal oscillator. As an additional precaution, the meter switch keeps the negative "B" lead to the amplifier circuit open until the meter is switched to read the amplifier cathode current.

The meter used should have a 0-10 ma. range in order to read the amplifier grid current ac-

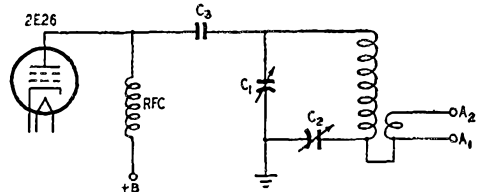

Fig. 2 — Alternative output circuit for coupling to random-length antennas.

C_1 — 100- μ fd. variable.
 C_2 — 140- μ fd. variable.
 C_3 — 0.002- μ fd. mica.
 RFC — 2.5-mh. r.f. choke.

curately. The meter switch is double-pole single-throw, and when it is open the meter reads grid current. With the switch closed the meter reads amplifier cathode current, and the meter shunt, R_{12} , is connected across the meter to extend the range to 100 ma. The shunt was made of No. 32 copper wire wound on a small form. No value is given since the exact resistance required will depend on the type meter selected for use.

The 6L6 modulator stage seems to be adequate, and reports received from contacts on the air ranged from "very good" to "all that could be expected when using a carbon mike." The gain control appears on the right rear corner of the chassis. Mounting it on the front panel seemed unnecessary, because once set it requires no further adjustment. The microphone current is obtained from a tap on the 6L6 cathode resistor, R_8 . Microphone current can be adjusted to the required value by sliding the tap.

For c.w. work, both the oscillator and amplifier cathodes are keyed. An extra set of contacts on the key jack shorts out the secondary of the modulation transformer when the key plug is inserted for c.w. operation.

The oscillator coils were wound on small surplus coil forms measuring $\frac{3}{4}$ inch outside diameter. For 80 meters a total of 60 turns was required, using No. 30 wire close-wound. The 40-meter coil has 24 turns close-wound, and for 20 meters 14 turns are spaced over a length of $1\frac{1}{4}$ inches. No form is required for the 10-meter oscillator coil since it consists of 4 turns of No. 12 wire, which is self-supporting. The 6AG7 tube was used as a winding form. This same coil is used for 6-meter operation since the oscillator is tuned between 25 and 27 megacycles.

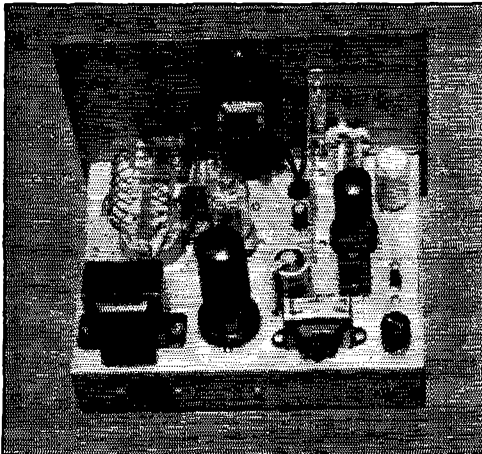

The oscillator section is at the right and the 2E26 amplifier at the left. The oscillator coil is just to the right of the 6AG7 and nearer the panel. The crystal-switch lever protrudes through the chassis alongside the crystals. Along the rear edge of the chassis, left to right, are the modulation transformer, 6L6 modulator, microphone transformer, and gain control.

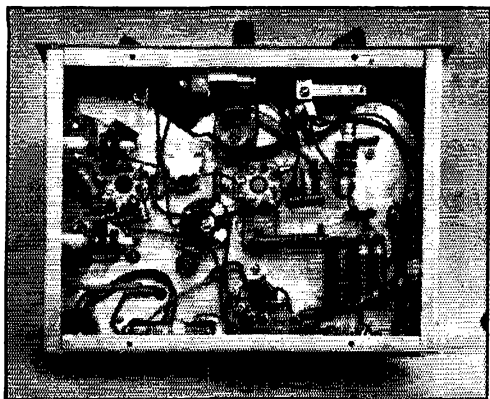

In this bottom view, the variable coupling condenser is visible just to the right at the 6AG7 socket. The form seen end-on just below the meter switch at the top center is the one on which the meter shunt is wound. The circular object just below the coupling condenser is the r.f. choke in the grid circuit of the 2E26. Other parts are easily identified.

The amplifier uses B & W "junior" size plug-in coils. None was available for 6 meters, so it was constructed by winding 3 turns of No. 12 wire around the metal 6L6, using the tube as a temporary winding form.

Power Supply

Any power supply delivering 300 or more volts at 125 ma. is adequate. For c.w. operation a maximum of 600 volts at 66 ma. can be applied to the 2E26, but 500 volts is the maximum tube rating for 'phone. In this rig the limitation on 'phone input is the power output of the 6L6 modulator. With cathode bias as shown in Fig. 1 the rated audio output is 6.5 watts, which will modulate 13 watts input. The modulation transformer is rated to work from a 6L6 into an 8500-ohm load and to carry a primary current of 60 ma. For all-band operation a 375-volt plate supply is suggested. With this voltage an amplifier plate current of 44 ma. will provide the proper load for the modulator and will permit about 90 per cent maximum modulation. The dropping resistor, R_{11} , is calculated for a power supply delivering 375 volts.

It is possible to increase the amplifier input and modulate 100 per cent if 18 volts of fixed bias is substituted for the cathode bias on the 6L6 as shown in the diagram and the 6L6 plate voltage is increased to 350. In this case a 425-volt plate supply can be used and R_{11} changed accordingly. (Also, a dropping resistor should be provided to lower the oscillator voltage.) The amplifier plate current under these conditions should be 50 ma. for an impedance match. However, the inconvenience of having to supply fixed bias outweighed the small increase in power output, in the writer's opinion. Also, on 10 and, particularly, 6 meters there may not be quite enough grid

drive available for the higher input. Six-meter 'phone operation is not optimum in any event, since the 2E26 is used as a doubler, but it works out quite satisfactorily as evidenced by local contacts on that band.

With 375 volts on both the oscillator and amplifier, the following readings were obtained: On 80, 40 and 20 meters the 2E26 unloaded plate current was 15 ma. when operating straight through, and about 20 ma. on 10 meters. When doubling in the final to 10 meters, the current is about 25 ma. and on 6 meters it is near 30 ma.

The circuit values shown in the parts list may not be optimum, but some experimentation indicated the rig was performing about as well as could be expected. In operation on all bands from 80 to 6 meters, using both 'phone and c.w., many favorable reports were received in actual contacts on the air.

Mobile Operation

Although, as stated in the beginning, some thought of mobile operation was in mind in designing the set, actual operation in a car has not yet been tried. However, since building the transmitter we have experimented a bit with feeding a whip antenna, and have found that the revised amplifier plate circuit shown in Fig. 2 will load a 12-foot whip or any random length of wire on all bands. This is the customary pi-network output circuit when the antenna is connected to terminal A_1 , the loading being adjusted by the setting of C_2 and resonance maintained with C_1 . For working into the output link with a full-sized antenna, condenser C_2 should be shorted out. This restores the circuit to the original, with the exception of the substitution of parallel feed.

Silent Keys

It is with deep regret that we record the passing of these amateurs:

W2GCD, Fr. Henry P. Curley, O.F.M., Paterson, N. J.

W2MRO, R. Kenneth Ruether, East Syracuse, N. Y.

W3AEG, George F. Jackson, Baltimore, Md.

W3EZV, J. Parsons, Baltimore, Md.

W3NLT, William H. Brosious, III, Rebuck, Penna.

W4EP, Rufus O. Hardin, Knoxville, Tenn.

W5MIH, Claude A. Maund, Dallas, Texas

W8KIM, Glen Johnson, Crestline, Ohio

Ex-W9GBH, Gordon Blee, Negaunee, Mich.

W9WUM, Peter Riepl, Wauwatosa, Wis.

VE1GR, Harold J. Ward, Armdale, Halifax, N. S.

VK3KU, H. K. Love, Victoria

15th ARRL International DX Competition

*C.W.: Feb. 11th-13th and March 11th-13th;
'Phone: Feb. 18th-20th and March 18th-20th*

It's time again to ready your station for the ARRL International DX Competition, to be held in February and March of this year. This contest, the fifteenth of its kind, gives an opportunity for all W and VE operators to add new countries to their DX totals, other stations to fill in for their WAS and WAVE awards, and everyone to match DX operating skill with other

shows that this pays off *very seldom*. On c.w., Ws and VEs have quotas but this doesn't apply to 'phone. Keep your log carefully, and send a copy of it, in the form shown, to ARRL. Free contest forms are available from ARRL Headquarters, West Hartford, Conn., upon request. Get your station working at top efficiency, make no social commitments for the important week ends, read the rules to acquaint yourself with the pattern, and then get set for more DX per kilocycle per hour than your poor crystal filter and "Q5-er" have ever had to cope with before.

Explanation of DX Contest Exchanges		
Exchanges	RST report of station worked	Self-assigned number, same throughout contest
Sample (c.w.)	579	864
Sample ('phone)	57	612

Rules

- 1) **Eligibility:** Amateurs operating fixed amateur stations in any and all parts of the world are invited to participate.
- 2) **Object:** Amateurs in the continental U.S. and Canada will try to work as many amateur stations in other parts of the world as possible under the rules and during the contest periods.
- 3) **Conditions of Entry:** Each entrant agrees to be bound by the provisions of this announcement, the regulations of his licensing authority, and the decisions of the ARRL Award Committee.
- 4) **Entry Classifications:** Entry may be made in either or both the 'phone or c.w. sections; c.w. scores are independent of voice scores. Entries will be further classified as single- or multiple-operator stations. Single-operator stations are those at which one person performs all the operating functions. Multiple-operator stations are those obtaining assistance, such as from "spotting" or relief operators, or in keeping the station log and records.

operators in his country or ARRL section. But, whether you have 9 or 9 hundred watts, whether you work 2 or 2 thousand stations, whether you have a wire out the window or a 7-element antenna, you can have a whale of a lot of fun in this annual event.

As in the past, two week ends are devoted to c.w. operation and two to 'phone operation, giving everyone an opportunity to participate in four week ends of hot activity. The rules are practically identical to those of last year, except that the c.w. quota for VE stations is raised to 5. Past contests have shown that the sparse amateur population of some VE call areas has penalized foreign stations working for a maximum multiplier, and the increased quota should help.

Entries by multiple-operator stations are encouraged and will be listed, but only single-operator stations will be eligible for the special bronze medallions offered to the top 'phone and c.w. scorer in each country and ARRL section. Multiple-operator scores can be grouped with single-operator scores in club competition, however, and a handsome gavel is offered to the club with the highest aggregate score. Within a club, single-operator entries can compete for the "club-certificate" awards given to the highest c.w. and 'phone scorers.

If you're new to the DX Contest, it won't take you long to catch on. During the contest period, stations outside of the U.S. and Canada will call "CQ W/VE" or "CQ TEST" and will exchange numbers as shown in the sample elsewhere on these pages. You can try a "CQ DX" or "CQ TEST" if you're a W or VE, but past experience

CONTEST TIMETABLE

C.W. Contest:

Time	Starts	Ends
GCT	Feb. 11th 2400	Feb. 13th 2400
AST	Feb. 11th 8:00 P.M.	Feb. 13th 8:00 P.M.
EST	Feb. 11th 7:00 P.M.	Feb. 13th 7:00 P.M.
CST	Feb. 11th 6:00 P.M.	Feb. 13th 6:00 P.M.
MST	Feb. 11th 5:00 P.M.	Feb. 13th 5:00 P.M.
PST	Feb. 11th 4:00 P.M.	Feb. 13th 4:00 P.M.

The second period of this contest starts at these same hours Mar. 11th.

The second period of this contest ends at these same hours Mar. 13th.

'Phone Contest:

GCT	Feb. 18th 2400	Feb. 20th 2400
AST	Feb. 18th 8:00 P.M.	Feb. 20th 8:00 P.M.
EST	Feb. 18th 7:00 P.M.	Feb. 20th 7:00 P.M.
CST	Feb. 18th 6:00 P.M.	Feb. 20th 6:00 P.M.
MST	Feb. 18th 5:00 P.M.	Feb. 20th 5:00 P.M.
PST	Feb. 18th 4:00 P.M.	Feb. 20th 4:00 P.M.

The second period of this contest starts at these same hours Mar. 18th.

The second period of this contest ends at these same hours Mar. 20th.

LOG, 15th A.R.R.L. INTERNATIONAL DX COMPETITION

C.W. Entry

(Logs from W or VE show, for each band)

Call

Name

Address

Antenna(s)

Transmitter Tubes

Plate Watts (input last stage)

No. Hours Station Operation

ARRL Section (for continental U.S. and Canada)

Bands	3.5 Mc.	7 Mc.	14 Mc.	27 Mc.	28 Mc.	Total	Different Countries Worked
No. DX Stations QSOed		3	5		1	9	
No. Countries QSOed		2	4		1	7	

(Logs from remote points indicate, for each band, in the above part of the log: "Number U.S.A.-Canada stations QSOed" and "Number U.S.A.-Canada licensing areas worked.")

Date & Time	Station Worked	Country	Worked Record of New Countries for Each Freq. Band						Numbers Exchanged		Points
			3.5	7	14	27	28	50	Sent	Received	
Feb. 11th 4:02 P.M. PST	VP9E	Bermuda			1				568543	478001	3
Feb. 12th 8:15 P.M.	G2MI	England			2				488543	578988	2
9:40 P.M.	PA0AZ	Netherlands			3				488543	488111	3
Mar. 12th 9:38 P.M.	ZL1MR	N.Z.		1					579543	579287	3
10:50 P.M.	VK2TI	Aust.		2					487543	398657	3
11:50 P.M.	VP9X	Bermuda			3				349543	588984	3
Mar. 13th 12:05 A.M.	VK2RA	Aust.		2					588543	579000	3
3:10 P.M.	VK2TI	Aust.					1		499543		1
3:20 P.M.	PY2AC	Brazil			4				487543	489852	3
										24	

Multiplier: 2 + 4 + 1 = 7

Assisting person(s): name(s) or call(s) 24 (points) × 7 (multiplier) = 168 Final Score

I certify, on my honor, that I have observed all competition rules as well as all regulations established for amateur radio in my country, and that my report is correct and true to the best of my belief. I agree to be bound by the decisions of the ARRL Award Committee.

Operator's Signature

5) **Contest Periods:** There are four week ends, each 48 hours long: two for 'phone work and two for c.w. The c.w. section starts at 2400 GCT, Friday, February 11th and Friday, March 11th, ends 2400 GCT, Sunday, February 13th and Sunday, March 13th. 'Phone section starts at 2400 GCT, Friday, February 18th and Friday, March 18th, ends 2400 GCT, Sunday, February 20th and Sunday, March 20th.

6) **Valid Contacts:** In the 'phone section, all claimed credits must be made voice-to-voice. In the telegraph section, only c.w.-c.w. contacts count.

7) **Exchanges:** Each participating operator will choose three figures as a self-assigned number. C.w. contestants will exchange six-figure numbers, each consisting of an RST report plus the three self-assigned numbers. (Examples are given in the sample log). 'Phone contestants will exchange five-figure numbers, each consisting of a Readability-Strength report plus the three self-assigned numbers.

8) **Scoring:**

a) **Points:** 1 point is earned by a W (K) or VE station upon receiving acknowledgment of a number sent, and 2 points upon acknowledging a number received. Two points are earned by any other station upon receiving acknowledgment of a number sent, and 1 point upon acknowledging a number received.

b) **Final Score:** W (K) and VE stations multiply total points earned under Rule 8(a) by the number of countries worked on one band plus the number of countries worked on each other band. All other stations multiply total points earned under Rule 8(a) by the sum of the number of W (K) and VE licensing areas worked on one band plus the number of W (K) and VE licensing areas worked on each other band.

Countries will be those on the ARRL Countries List. There are 18 licensing areas: 10 in the United States, 8 in Canada.

9) *Repeat Contacts*: The same station may be worked again for additional points if the contact is made on a different frequency band. The same station may be worked again on the same band if the complete exchange for a total of three points was not made during the original contact on that band.

10) *Quotas*: The maximum number of points per country per band which may be earned by W (K) stations in the c.w. section is 9, and contacts made on the same band with the same country after the quota is filled will not count. Thus complete exchanges with 3 stations in one country on one band fill the band quota for that country. The maximum number of points per country per band which may be earned by VE stations in the c.w. section is 15, and contacts made on the same band with the same country after the quota is filled will not count. Exchanges with 5 stations in one country on one band are thus permitted VE participants. There is no quota for stations in the c.w. section outside of W (K) and VE. There is no quota for any station in the 'phone section.

11) *Reporting*: Contest work must be reported as shown in the sample form. Each entry must include the signed statement as shown in that example. Contest reports must be mailed no later than April 20, 1949, to be eligible for QST listing and awards.

12) *Awards*: To document the performance of participants in the Fifteenth ARRL International DX Competition, a full report will be carried in QST. In addition, special recognition will be made as follows:

a) Engraved medallions will be awarded to the 'phone and to the c.w. winners in each country (as shown in the ARRL Countries List) and in each of the 72 U.S. and Canadian ARRL sections (see page 6 of this issue) from which valid entries are received. Only single-operator stations will be eligible for these awards.

b) A suitable certificate will be awarded to the operator making the highest single-operator 'phone score in each ARRL-affiliated club, provided the club secretary submits a listing of a minimum of three 'phone entries by bona fide resident members of such club, and provided further that these scores are confirmed by receipt at ARRL headquarters of the individual contest logs from such members. The highest single-operator c.w. scorer in each club will be awarded a certificate under the same conditions.

c) ARRL will award a gavel to the affiliated club submitting the greatest aggregate 'phone and c.w. score by bona fide resident club members, whether single- or multiple-operator entries, provided such scores are confirmed by receipt at ARRL headquarters of the individual contest logs from such members.

13) *Judges*: All entries will be passed upon by the ARRL Award Committee, whose decisions will be final. The Committee will void or adjust entries as its interpretation of these rules may require.

14) *Disqualifications*: Off-frequency operation (as confirmed by a single FCC citation or advisory notice or two accredited official observer measurements) will disqualify. Low tone reports in logs will also be considered by the ARRL Award Committee as grounds for disqualification.

Strays

From a recent AACCS bulletin:

"S/Sgt. Wm. ('Pappy') Henderson was making an AACCS installation on the Island of Cyprus, and found he was lacking supplies. He fired up his ham rig, called Wiesbaden, and raised D4AFE. 'Pappy' asked D4AFE to copy a list of needed supplies, and to pass it on to AACCS headquarters. D4AFE did even better -- he saw to it that the supplies were on a Cyprus-bound plane the next day.

"D4AFE, incidentally, is the call of Lt.-Gen. Curtis LeMay."

THE GOVERNORS-TO-PRESIDENT RELAY

Jan. 19th (5 P.M. EST) to Jan. 20th (5 P.M. EST)

The President of the United States will be inaugurated on January 20, 1949. On that occasion radio amateurs will participate in a sixth Governors-to-President Relay. Each ARRL section communications manager in whose territory there is a state capital is designating an amateur to approach and secure a message for President Truman from his Governor. The Washington Radio Club, in cooperation with area clubs, is sponsor of this activity and has requested that the National Emergency Net and WIAW be alerted to funnel messages into Washington.

Every active U. S. amateur with a station on the air will be interested in helping in the relay. Messages will all start from designated amateur stations at 5 P.M. EST (4 P.M. CST, 3 P.M. MST, 2 P.M. PST) January 19th. The relay will continue until the same hour January 20th. Some of the governors' messages will be long ones. Handle messages whenever you can, but be ready to QRX and assist in copying as well as relaying, if QRM or other difficulties turn up.

Information for Operation in the Relay:

(1) Listen on 3550, 3650, 3875, 7100, and 14,150 kc., or call near these frequencies. Washington-area stations will monitor these frequencies (those italicized are the National Emergency Net frequencies). (2) Stations with GPR traffic will call "CQ Wash. . . . GPR." (3) Washington stations may call "CQ GPR." (4) W3AKB/W3BWT will maintain a tabular chart by states of messages received. Area stations will telephone Randolph 9407 and report receipt of each message, state from which received, and their own call. (5) Short calls with break-in will be most effective. (6) After the relay is completed, messages will be collected at a central point to be designated to area stations.

Reporting: Send ARRL complete copies of the message(s) you handle in connection with this relay. Show time received, time forwarded, and both or all stations with whom handled. A file of traffic showing the consecutive handling of the message of each state is desired so that QST can fully credit each routing in this demonstration of amateur capabilities.

— F. E. H.

Some Notes on the Clapp Oscillator

BY RICHARD G. TALPEY,* W2PUD

THE following notes on the Clapp series-tuned oscillator are a result of the author's experience in building a VFO using this circuit. It is hoped that they will be useful to others.

The circuit used is shown in Fig. 1. Values are conventional, but only high-quality components were used.

Greatly-improved isolation between the oscillator and succeeding buffers may be accomplished with the circuit as shown. One half of a double triode (12AU7 or 6SN7) is used as the oscillator and the other section operates as a cathode follower. The low output impedance of the cathode follower makes the voltage and frequency less sensitive to load changes. W2FBA has used a cathode follower to isolate other VFOs, but the Clapp oscillator lends itself very simply to this circuit. If the oscillator is not keyed, the follower grid may be directly coupled to the oscillator cathode, since little or no d.c. voltage exists at this point. If the oscillator is keyed in the cathode circuit, capacity coupling should be used to prevent the open-circuit cathode voltage from appearing on the follower grid.

It was found that an r.f. choke in the cathode circuit of the follower improved the output. The output is somewhat less than that from the oscillator alone, although neither is very large. In this installation about 3 volts output was obtained, enough to drive a 6AC7 Class A. The 6AC7 was found to be superior to the 6AG7 in cases where the grid drive is small. This is to be expected from the high perveance of the 6AC7. In addition, it was desired to keep power dissipation to a minimum, and the 6AC7 gives more output at lower current. A 2E26 may be driven to full output with the 6AC7 operating Class A from the cathode follower.

The mechanical construction used with this type of oscillator must be considerably more rugged than with the usual high-*C* VFO. The junction between the tuning capacitor and the coil is very hot and any change in stray capacitance at this point will spoil the stability. The coil and condenser should be mounted so that no relative motion can occur between these components or between them and the shield.

Available ceramic coil forms did not give *Q*s which came up to expectations. An air-wound coil similar to the B&W type having a length about equal to its diameter was selected as having the best *Q*. The coil was clamped on one side in a polystyrene bracket. The *Q* of this coil with-

out a shield was measured as 275 at 3.5 Mc. It should be realized that placing a shield around a coil will reduce its *Q*. The coil should be spaced from all sides of the shield by a distance at least equal to the coil diameter to lessen the reduction in *Q* by the shield.

The usual precautions as to condenser bearings should be observed. The small amount of tuning capacitance used in this circuit makes the frequency more dependent upon strays and minimum capacitance of the condenser. Condensers in which spacing can be changed with longitudi-

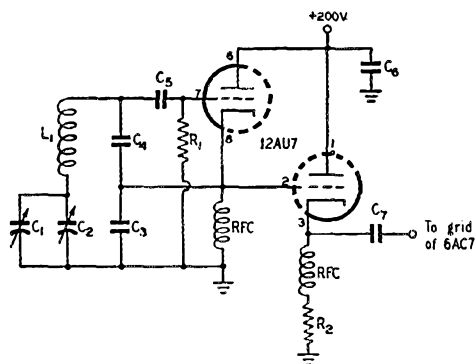

Fig. 1 — Series-tuned oscillator with cathode follower.

- C₁ — 50- μ fd. variable.
- C₂ — 15- μ fd. variable.
- C₃, C₄ — 0.001- μ fd. silver mica.
- C₅, C₇ — 100- μ fd. mica.
- C₆ — 0.01- μ fd. mica.
- R₁ — 0.1 megohm, $\frac{1}{2}$ watt.
- R₂ — 15,000 ohms, $\frac{1}{2}$ watt.
- L₁ — 45 turns No. 18, $2\frac{1}{4}$ -inch diam., $2\frac{1}{4}$ inches long.
(See text.)
- RFC — 2.5-mh. choke.

nal pressure on the shaft should be avoided, since they can cause errors in setting the frequency.

The keying properties of the circuit were investigated only as a matter of academic interest. A barely-discernible chirp seems to be present with the usual filter arrangements. Previous experience with the critical tastes of the FCC in the matter of key clicks made it desirable to eliminate them from this unit. In any keyed oscillator the frequency will change as the applied voltage builds up; the Clapp oscillator is no exception, although it is considerably better than others. If the rise in the keyed voltage is sharp the chirp will appear as a click, and many cases of clicks may be traced to this effect. Wishing to

(Continued on page 118)

* 59 Orland Road, Rochester 9, N. Y.

I Will Do It in '49!

BY HERBERT S. BRIER,* W9EGQ

If you have ever felt the thrill of raising, on the first attempt, a DX station that the other locals have been calling for hours, you know all about the annual ARRL DX Competition. If you do not, all I can say is that to a DX man it combines the thrills of a big-game hunt, the World Series, and the Rose Bowl Game.

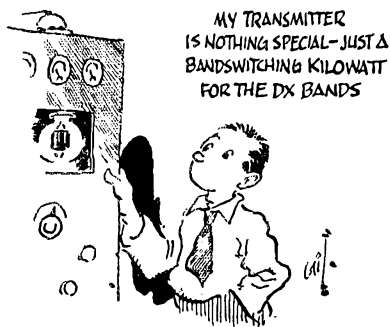

In 1947 my score was among the first ten, which wasn't bad for a location with room for only a dual ten-twenty four-element rotary and a 40-meter doublet bent in a "Z." But I resolved to do better in 1948 — I raised the rotary another twenty feet, and . . .

. . . Who am I? Well, I was christened Thomas Kenneth Wilson, but since I have been a ham even my mother calls me "TK." I started out on forty meters with fifty watts input, and my one ambition was to WAS until I dropped to twenty and worked a G. From that moment I have been a DX man!

Before continuing, I want to make a few things plain. First, my wife Betty can never say she is a radio widow, because I hardly ever spend more than four hours a day on the air, week ends and holidays excepted, of course. Secondly, if you have heard that my initials stand for "Three-Kilowatt Willie," forget it. My transmitter is nothing special; just a bandswitching kilowatt for the DX bands, with everything big enough to run coolly at full input.

To get back to the contest. On New Year's Day of 1948 I hung a calendar in the parlor with the all-important week ends circled. Betty and the kids did not have to be told what that meant. Skipping ahead to the first Friday of the contest, I came out of the shack at 2300 GCT (5:00 P.M. CST) and ate a light lunch. Then I kissed the family good-by, and carried the thermos jug of

coffee and two cartons of cigarettes into the shack. Closing the door, I deliberately locked it behind me.

At 0001 GCT, plus fifty seconds, I called XF1A. Juan went back to Hammerhead Nelder, three blocks away. This set the pattern. Every station I called seemed to hear Hammerhead first. And he has only a pair of prewar T40s! Otherwise things went pretty smoothly. I was really pepped up to work FM8AD for No. 199 postwar.

XF1A was tough, and I was calling him for the eighth time when there was a timid knock at the shack door and Susan said, "Daddy, Mr. Smith is here. He says you're interfering with both his radio and television set."

"Tell him I'm not home."

"We did, but he can see the light in your shack. And besides, the street light is blinking like it always does when you're working DX."

Meanwhile I was trying to copy XF1A's number through Hammerhead's key clicks. I asked for a repeat as Smith started pounding on the door. Seeing that I was trapped, I barked, "Just a minute," receipted Juan's number, and started to send my own.

In spite of all my warnings, Betty picked that moment to plug in her electric iron, and every light in the house went out! My anguish then was nothing compared to when I discovered that there wasn't another fuse in the house. The next thing I remember is finding myself sitting in a chair, staring aimlessly into the darkness.

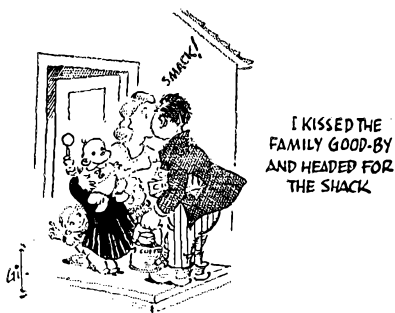

It would take some doing to get back on the air. All the stores were closed, and there was no use appealing to the neighbors. Even if they had 50-amp. fuses, they would never help me get back on the air. Pennies were out, too, after what the electrical inspector said after our little fire last fall. Suddenly I recalled the drugstore.

*385 Johnson St., Gary, Ind.

They had two 15-amp. fuses left. I knew that such small ones would hardly carry the filament load with the final connected. But if I coupled the antenna to the 304TL drivers . . .

The first dot after the change blew the new fuse. Slipping the other one into the box so the family could see to go to bed, I tortured myself by listening to the juicy stuff coming through. Then I grabbed a pencil to figure how much power I could squeeze through a 15-amp. fuse.

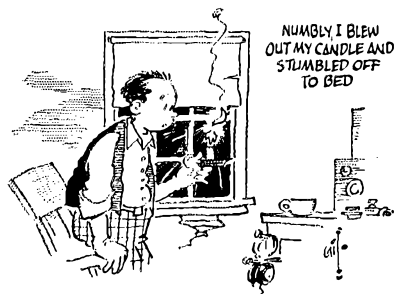

The power consumed by the receiver (in stand-by), the transmitter tube filaments (without the final), the exciter power supply, and the beam motor totaled about eight hundred watts. This, divided by 115 volts, equaled seven amperes, leaving eight amperes. I brightened up a little, figuring that I could work a few stations with 920 watts input. But I had forgotten two things: the driver power supply was not more than 75 per cent efficient, and its bleeder drew sixty milliamperes at three thousand volts. Subtracting these additional losses left me with only 510 watts! Suddenly I remembered that I did not have to rotate the beam while transmitting. I had another hundred watts! Disconnecting the refrigerator and shutting off all the lights, I tuned up by the light of a candle. Being conservative, I only ran the autotransformer up to six hundred watts, leaving ten watts to spare.

Working VK3EO, PY2BA, KH6IJ and G2LR in quick succession reassured me that low power would get out; therefore I started listening under the top layer. CR9AG came back on my first call, and gave me 589000. I answered, "R GE JOHN. HR NR —"

I got no further. Betty's brother Fred (who lived with us then) came in from a date and turned on a light. The last fuse quietly collapsed. Numbly, I blew out my candle and stumbled off to bed to dream of hundreds of fuses picketing my transmitter.

Without power the electric alarm failed to ring, and it was late when I awakened. Bounding out of bed, I hurried to the receiver; the Europeans would be pounding through on ten. My hand was on the switch when I remembered. . . .

The first electric shop had no 50-amp. fuses, nor

did the second, nor the third. "I don't know why," a clerk told me, "but we've had a terrific demand for heavy-duty fuses the past week." It was no mystery to me — mine aren't the only 750Ts in town!

I grabbed the telephone to call some of the other DX men, only to be told that none of them was home. I should have known; they all were in the contest, and had given their families the usual instructions. I would have to visit one in person, but which one? W9BUNK was out. He hasn't spoken to me since I called that CM on top of that CR4 he thought he had raised. And a little thought made me realize that my chances of success would improve the farther from my own shack I went seeking help.

W9OGEE, across town, seemed my best bet. We have never had a run-in, except the time . . . but I hoped he would not remember that. I do not think he did, because he parted with three fuses in exchange for a 4- μ f. 5000-volt filter condenser and a promise to help him erect his new ninety-footer.

My score for the first period was fifty-eight contacts and a multiplier of twenty-five.

Getting ready for the second week end, my first move was to install a new three-wire line of No. 4 wire for 220-volt service for the transmitter. Next, I replaced the fuses with circuit breakers. In some way I was so busy that I forgot about the radio club meeting, which saved me a lot of explaining.

The day before the second period began, I put blackout curtains on the shack windows and instructed the telephone company to disconnect the telephone until Monday morning. And it was a stroke of genius to pack the family off to Grandma's for the week end.

My work paid off. By the time ten had faded out I had forty-one contacts! Results on twenty and forty were equally good; operating continuously, I worked everything I heard, and much of it stuff I had never heard before. As a result, I knew that I had done my best as I fell asleep in my chair after the last contact at 2359 GCT, Sunday.

By Tuesday my ears had stopped ringing enough for me to get on the air to compare scores. My smile got bigger and bigger. It looked as though I had done it so I went to the radio club to gloat a bit.

"Hi, 'TK,' what do you think of Jim's score," greeted me at the door.

There was no use kidding myself. Jim would be hard to beat, but I managed to reply casually, "I haven't heard. What was it?"

I almost laughed aloud on hearing that he had worked eighteen fewer stations and five fewer countries than I did. Then the sky fell on me! Jim had worked twenty countries on eighty, and his multiplier was fifteen greater than mine!

(Continued on page 110)

The Black Box

3.5- and 7-Mc. VFO Transmitter for Fixed, Portable or Mobile Operation

BY ALBERT E. HAYES, JR.,* W1IIN

THE acquisition of a PE-103A dynamotor was the spark that got us thinking of the possibilities of portable/mobile/emergency operations. Visions of checking into a traffic net while breezing merrily down U. S. route 6, plus a consideration of the writer's location — back in the Connecticut hills twenty-five miles from Hartford, where the power line goes out every time one of the neighbors' cows sneezes — finally proved too much to resist, and the project was begun. The ratings of the PE-103A, 500 volts output at 160 ma., continuous duty, and a consideration of the needs of W1IIN/portable/mobile/emergency 3.5-Mc. and 7-Mc. traffic circuits, virtually dictated the final-amplifier stage if maximum performance was to be attained: a single 807. Allowing 100 ma. for the plate of the final, and 10 ma. for bleeder currents and the like, left 50 ma. for the exciter.

Crystal control or VFO operation? There was the question. With crystals at a couple of bucks apiece and the recent introduction of the series-tuned Colpitts oscillator circuit giving VFO operation a "new look," it was determined to try a 6L6 "Clapp-circuit" oscillator driving the 807 final. A 7 × 7½ × 14-inch black crackle-finished cabinet happened to be available, so we convinced ourselves that here, indeed, was the optimum size for housing the brain child. An antenna tuner was a "must" since such items are usually difficult to haywire together in time of emergency.

A look at the circuit diagram will show that the circuit arrangement is along conventional lines. The 6L6 oscillator operates without benefit of a tuned circuit in its plate. In the usual set-up where a 6L6 drives an 807, there is an excess of drive available — in our case, with the untuned 6L6 plate circuit, we need every available bit of drive. Hence the unusually large coupling condenser to the 807 grid. Untuned coupling is not a

* National Emergency Coordinator, ARRL.

• With surplus vibropacks and dynamotors still readily available, there is no reason why every amateur should not provide himself with a transmitter which can serve his community when the wires go down in time of emergency. The little rig described in this article was tailored specifically for a popular surplus dynamotor, but readily adapts itself to almost any portable supply you may have available. Give it a try — you'll find it a lot of fun to build and use, and you will be preparing yourself to be of public service when your neighbors need you most.

shortcoming, however, since the 807 is driven sufficiently hard to double with good efficiency, and the untuned circuit in the 6L6 plate contributes materially to the stability of the unit when the oscillator is keyed.

The switch S_1 lives a double life; purists may call it a "key-either-oscillator-or-final switch," but the traffic man calls it a "nonswisher." By pushing S_1 to the side that connects the cathode of the 6L6 directly to ground it is possible to set the oscillator on top of your quarry unbeknownst to the general public. When the switch is in its other position, the oscillator is keyed along with the 807. In addition, leaving the switch in the "nonswish" position provides amplifier keying, with a continuously-running oscillator, thus yielding the best possible keying characteristics when break-in keying is not needed. The other switch is not there just for appearance's sake, but operates the starting relay in the PE-103A when Terminal 2 is connected to the appropriate pin on the dynamotor plug.

The 200-ma. meter is wired permanently into the plate circuit of the 807 since we can't see any

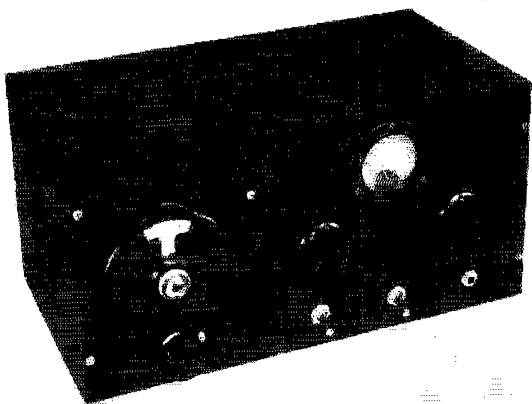

The variable-ratio dial satisfies both those who must hop madly around the band during contests and the more conservative operators who seek to set themselves exactly on a net frequency. The two knobs are (l. to r.) 807 plate tuning and antenna tuning. Two bat-handle toggle switches and a key jack round out things on the appearance side.

QST for

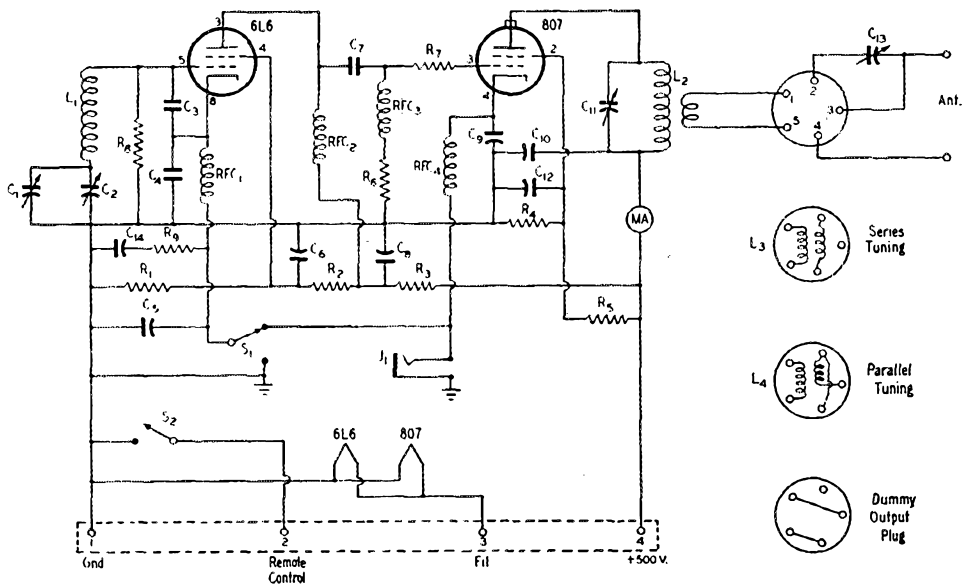

Fig. 1 — Schematic diagram of the transmitter.

- C₁ — National ST-35 with all but one stator plate removed.
- C₂ — 35- μ fd. air trimmer.
- C₃ — 500- μ fd. silver mica.
- C₄ — 750- μ fd. silver mica.
- C₅, C₆, C₈, C₉, C₁₀, C₁₂ — 0.01- μ fd. 600-volt paper.
- C₇ — 220- μ fd. mica.
- C₁₁, C₁₃ — 100- μ fd. variable (National ST-100).
- C₁₄ — 8- μ fd. 150-volt electrolytic.
- R₁, R₂, R₅ — 25,000 ohms, 10 watts.
- R₃ — 3000 ohms, 10 watts.
- R₄ — 50,000 ohms, 10 watts.
- R₆ — 15,000 ohms, 1 watt.
- R₇ — 220 ohms, $\frac{1}{2}$ watt.
- R₈ — 0.1 megohm, $\frac{1}{2}$ watt.

- R₉ — 10 ohms, 1 watt.
- L₁ — National AR 16-80E with link removed.
- L₂ — 3.5 Mc. — 27 turns No. 16 enameled, close-wound. — 7 Mc. — 14 turns No. 16 enameled, close-wound. Both coils 1 $\frac{1}{2}$ -inch diameter; six-turn link at cold end of each coil.
- L₃ — 3.5 Mc. — B & W 80 JCL with base connections rewired as shown.
- L₄ — 7 Mc. — B & W 40 JCL with base connections rewired as shown.
- J₁ — Open-circuit jack.
- MA — 0-200 d.c. meter.
- RFC₁, RFC₂, RFC₃, RFC₄ — 2.5 mh. r.f. choke.
- S₁ — S.p.d.t. toggle switch.
- S₂ — S.p.s.t. toggle switch.

reason to measure any of the other currents — no adjustments are provided to do anything about them.

The antenna tuner is ideally suited for coupling to a 135-foot wire fed at the center with 50 feet of 300-ohm Twin-Lead, providing series tuning on 80 and parallel tuning on 40. Such an antenna, if the flat top is made of reasonably limp wire, is an excellent two-band portable antenna since it can

be coiled up and stuffed under the back seat of the car, or under the bed, until needed. For mobile operation, the dummy plug indicated can be used to provide link-coupled output to the antenna loading coils or what-have-you which will adorn the family chariot as soon as the mobile disease takes hold.

Most of the constructional details will be apparent from the photographs. The 807 is sub-

The area above the 6 $\frac{1}{2}$ × 11 × 2-inch chassis is divided by aluminum partitions into (l. to r.) the antenna tuner, 807 amplifier and its associated tank circuit, and the entire oscillator. The Millen terminal strip used for power-supply connections is preferred to the use of a plug since the transmitter can be hooked to a "strange" power supply more conveniently during emergency.

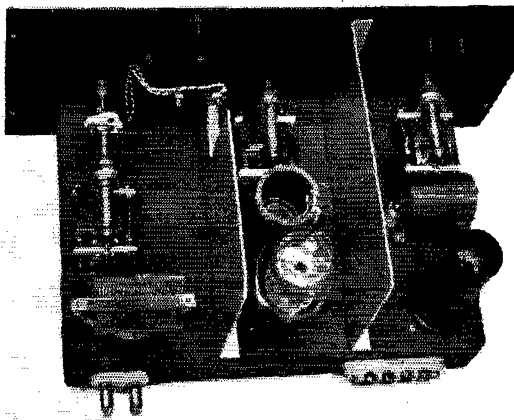

mounted about an inch to provide adequate clearance between the plate cap and the lid of the cabinet. If a slightly larger cabinet is used this submounting will not be necessary.

It is in the physical construction of the oscillator itself that the greatest care should be used, since mechanical instability of any kind will result in unsatisfactory performance. Tighten down every mounting screw, and see that all joints are well soldered, and there should be little trouble with oscillator instability.

The antenna tuning condenser and the 807 tank tuning condenser are insulated from the chassis by virtue of their being mounted on small polystyrene buttons. In order to keep all tuning shafts lined up the oscillator tuning condenser is similarly mounted, but well grounded both at the point of mounting and to the common ground bus which connects the common grounding points of the two stages.

The shield between the oscillator and amplifier is bent from a sheet of aluminum, and is firmly fastened to both the chassis and the front panel. It not only provides shielding between the adjacent oscillator and amplifier tank circuits, but contributes to the rigidity of the assembly -- a factor to be considered in the search for oscillator stability. The shield between the amplifier and the antenna tuner is not especially needed for its shielding properties, but is provided as an additional strengthening member.

In operation, with the 3.5-Mc. coils in the appropriate sockets, 6.3 volts applied to the filament circuit, and 500 volts for the plates, and the key depressed, a minimum unloaded plate current to the 807 of about 15 ma. should be obtained. With an antenna or transmission line connected to the output terminals, rotation of the antenna tuning condenser should increase the current to well over 100 ma. Don't leave the current at that setting, but retune the amplifier tuning condenser for minimum plate current, which should now be considerably higher than 15 ma. Repeat these operations until the minimum 807 plate current is between 90 and 100 ma. If it is impossible to

load her up to this extent it is probable that adjustment of the number of turns on the link which is coupled to the antenna tank circuit will straighten things out.

The 3.5-4 Mc. band should cover most of the 100 divisions on the oscillator dial. If not, adjustment of the trimmer C_2 will correct the matter. Bandspread is entirely adequate for any purpose, since 3500 kc. appears at 5 on the dial while 4000 kc. falls at 95. Could anyone ask more bandspread than this?

Operating on 40 simply requires that the appropriate coils be plugged into the amplifier and antenna circuits. The output is about 60 per cent of the 80-meter output when doubling in this fashion.

With 500 volts applied from the dynamotor, the output is about 30 watts on 3.5 Mc. When operated at the home station from a 750-volt supply, the output is about 50 watts, and the keying is every bit as good as when 500 volts is used. We even tried the gadget with 100 volts applied to the "high-voltage" terminals, and it still works FB.

The voltage-frequency characteristic of this unit is well above average. Changing the applied high voltage from 750 to 250 volts produces a frequency shift of about 100 cycles. Temperature-wise, we have no problems either since after a ten-minute warm-up period (during which the drift is about 100 cycles) no appreciable drift has been detected.

Although parasitics were not a problem in the construction of the particular unit illustrated, they should be watched for carefully in the first tests before the Black Box is put on the air. The damping resistor in the grid circuit seems to kill all signs of instability, but additional damping resistors or chokes in the screen or plate circuits may be found necessary in the event that unwanted frequencies are found.

Don't be surprised if our little monster gets out as well as your high-powered rig. The effectiveness of 30 to 50 watts in the antenna has been proved by a weekly schedule with HH2BL on the low end of the 3.5-Mc. band.

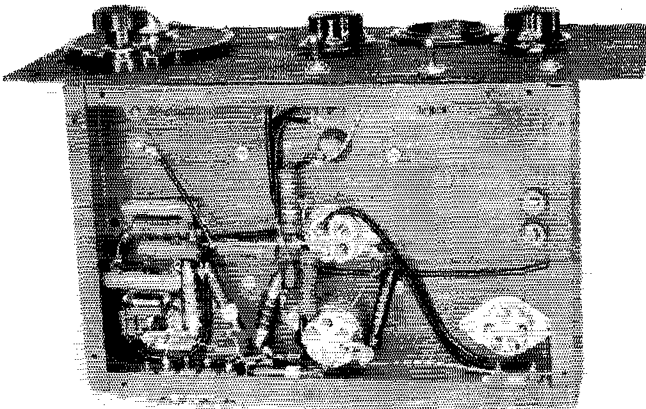

The works, illustrating the compact and rugged wiring of the oscillator circuit and the relative simplicity of the amplifier portion. The several tubular paper condensers are separated from the wire-wound resistors in the bleeder string, otherwise wax would flow. A bottom plate is in order, even though the unit is mounted in a metal cabinet, since it contributes materially to the rigidity of the structure.

QST for



The World Above 50 Mc.

CONDUCTED BY E. P. TILTON,* WIHDO

THE fall of 1948 may have been several months past the peak of the sunspot curve, but that did not keep the sharper operators from getting in a few 50-Mc. F_2 DX contacts during November. Most of the openings were of short duration, and relatively few of the gang were on deck at the right time (that F_2 stuff *will* break out at 10 in the morning!) but transcontinental openings occurred on several days, and a few fellows added South America to their 6-meter logs. The North Atlantic path was being watched closely, both in this country and in Europe, but though the m.u.f. crept up close to 50 Mc. on several occasions, as far as is known there were no actual contacts over that route this year.

Generally speaking, the m.u.f. on north-south paths was higher than on the east-west ones. As early as Nov. 1st 50 Mc. was open between England and South Africa, G5BY and ZS1P making several two-way 6-meter contacts between 1404 and 1509 GCT on that date. There were indications that 50 Mc. was open between the United States and South America on several days, but the only contacts thus far reported from the southern end were made by HC2OT, Guayaquil, Ecuador. Steve, ex-W5DNN, worked W5ZZF, Big Spring, Texas, on the 20th, at 11:05 EST, after having heard W5JTI, Jackson, Miss., and W5JLY, San Antonio, Texas, just previously. On the morning of the 21st, HC2OT worked W8MVG, Clio, Mich., W5AJG, Dallas, Texas, W8CMS, Newton Falls, Ohio, W8NQD, Ashland, Ohio, W5JTI, W5VY, San Antonio, and W4LNG, Atlanta, Ga., in rapid succession between 9:50 and 10:50. W1CLS, Waltham, Mass., was heard at 10:28 A.M. calling CQ on c.w. The band opened to Mexico City at 8:20 P.M., at which time HC2OT had a 90-minute 3-way QSO with XE1KE and XE1GE, interspersed with frequent looks across the band for other stations.

Contact with XE1GE and XE1KE seems to be possible almost nightly in the period between about 7:30 and 9 P.M. EST. Schedules have been kept consistently during the latter part of November on this 2000-mile path. The band was open in other directions during the evening of the 22nd, and PZ1A and PY7YA were worked in addition to the two Mexico City stations. HC2OT had another big day on Nov. 27th. The first 50-Mc. signal heard was W1AEP, Spring-

field, Mass., calling CQ on c.w. at 9:44 A.M. Beginning at 10:07 Steve worked W5s EEX, FSC, AJG, JLY, ZZF, VY and LBG, and XE1KE in a 2-hour opening.

November provided a number of transcontinental openings, which, though not up to last year in either duration or signal strength, came as a welcome surprise. Predictions had indicated an m.u.f. between our two coasts of about 40 Mc. for the month, but the W1, W2-W7, VE7 route was open several days, and there were brief flashes of W6s on a couple of occasions. On the 13th W7DYD, Bothell, Wash., worked W2BYM, Lakehurst, N. J., at 11:35 A.M. PST, having heard him first about a half hour earlier. W7DYD heard W2BYM again the following day at 10:15 A.M., and worked VE1QY, Yarmouth, N. S., and heard W1CLS, in about 2 hours of intermittent band-edge openings. On the 15th W1CLS was worked at 9:55 A.M. PST, followed by W1FMH, Cochituate, and W1ATP, Holliston, Mass.

Apparently Nov. 14th and 15th were about the best days. W1CLS noticed that the skip on 28 Mc. was getting down under 1000 miles at 2:45 P.M. EST on the 14th and W7s started to break through on 50 Mc. just before 3 P.M. W7DF, Everett, Wash., and VE7BQ, Vancouver, B. C., were worked, and various commercial harmonics were heard up to about 51 Mc. around 3:30. W7BQX, Sequim, Wash., worked VE1QY and heard W1CLS. The band opened for sporadic-E skip to W4, W5 and W6 during the evening. The 15th was good in the early afternoon, and W1CLS worked VE7CN, W7DYD, W7ERA, VE7AEZ and VE7NM. On the 17th a brief opening to California permitted an exchange with W6QG, Santa Ana, around 1 P.M.

During the week of the 14th the North Atlantic path was showing brief flashes up to about 50 Mc. The frequencies between the 10- and 6-meter bands were opening with a rush each morning, the m.u.f. shooting up to about 47 Mc. almost daily, and a careful listener would hear occasional bursts up to 50 Mc. or higher, but the openings, if such they may be called, were of such short duration that no contacts had been made, up to this writing.

The m.u.f. was high to South America during this week, too. Commercial harmonics were reported up to 50 Mc. by several listeners on dates other than those for which the reports of HC2OT

* V.H.F. Editor, QST.

show the band to have been open. An unusual feature was the evidence of actual openings between northeastern U. S. A. and South and Central America. No W1 has yet worked two-way with Latin America, but reception by HC2OT of W1CLS and W1AEP demonstrates the possibility. Your conductor heard a Spanish-transmitting c.w. signal on 50.2 Mc. on the 16th, and HPE, Panama, was S9 on 47.8 Mc. for more than an hour the same morning. HKO, Colombia, and various other commercial sigs, were heard with good strength between 46 and 50 Mc. on several dates. The 16th must have been good in some direction, for, though no DX contacts have been reported for that date, W8MVG heard W1CLS and W1HDQ, apparently by the rebound method, around 1 P.M. EST, indicating an m.u.f. well above 50 Mc. somewhere. The beam at W8MVG brought in these signals best when aimed in the direction of South Africa.

There was repeated evidence of band openings during November, but only a very small number of contacts were made. Why? To be sure, these openings tend to come at times when many fellows are unable to be on the air, but there is no lack of 10-meter activity at the same hours. If even a small part of the time and effort now being devoted to 10-meter operation were diverted to 50 Mc., it seems certain that the possibilities of the higher band would be shown to be much better than the above meager reports would indicate.

Wanted: More Regular V.H.F. Activity

Almost without exception, the letters received from 50-Mc. men recently bear the same comment. They report DX heard or worked, and then add: "This was my first activity on the band since last summer. Activity here is at a very low ebb." Though v.h.f. activity always sags at this season of the year, this time it seems to have dropped more than ever. Yet there are plenty of fellows scattered around the country who would like to see things rolling. Can't we get together on some program to this end? This need applies to other v.h.f. bands as well, for the same complaint is heard from 2-meter workers.

First of all, we would do well to remember that v.h.f. interest and activity cannot live by DX alone. We all like to work the DX, of course, and much of the good that has come from amateur v.h.f. operation is directly or indirectly the result of our urge to expand our horizons. But the fair-weather v.h.f. enthusiasts — those who put in an appearance on a band only when DX starts to break — miss the best part of it all. Almost all of us, by now, recognize that the v.h.f. bands are without equal for reliable night-and-day local coverage. When we want local contacts let's shift to the v.h.f. bands to make them. If every contact which is possible on 6 and 2 meters were made there, these two bands would never lack for oc-

2-Meter Standings

	States	Call Areas
W8UKS.....	14	7
W8WJC.....	14	6
W8WXV.....	13	--
W8CYE.....	12	6
W0NFM.....	12	6
W3KUX.....	12	5
W4FBJ.....	11	5
W3PCV.....	11	5
W3RUE.....	11	5
W9JMS.....	10	5
W2WLS.....	10	4
W3GV.....	9	6
W0IFB.....	9	6
W3BLF.....	9	5
W3HB.....	9	5
W9AB.....	9	--
W8WRN.....	9	5
W2PJA.....	9	4
W1HDQ.....	9	3
W1CTW.....	9	3
W1OOP.....	8	3
W0HAQ.....	8	--
W1QXE.....	8	2
W0WGZ.....	6	4
W0BZE.....	6	3
W0GOK.....	6	--
W8RDZ.....	6	4
W4KKG.....	5	--
VE3AIB.....	4	3
W0HXY.....	4	2
W0JHS.....	3	2
W0KPK.....	3	2

Send in claims for most-states worked awards before Jan. 10, 1949. See Jan. 1948 QST, page 150, for details.

cupancy. How many contacts are now being made over distances under 100 miles on 10, 20, 40 and 80? Diverting even a small part such work to 6 and 2 would certainly help. How about it?

Many would-be v.h.f. operators are discouraged over their prospects when they listen on 6 and 2 and discover nothing but silence or auto ignition. If they heard a dozen stations talking amongst themselves they'd rush to join them — but silence breeds more of the same. Now it is not always possible to keep things rolling every night in the week, but getting on is easy, and we can help matters along by getting together on an operating schedule for a night or two a week. Not a night or two when we'll listen in and see if there's anything doing, but a night when we guarantee actually to get on the air and generate some activity.

Such a program requires some promotion. Talk it up with your local gang. Keep the subject alive at radio club meetings. Send the dope on your local schedules in to us and we'll run it in QST. And get on, not just when it's convenient, but every schedule period. It pays off.

In the region around Akron, Ohio, W8LBH is attempting to promote a local 6-meter net. W3KPH writes, from Sunbury, Penna., that he would like to hear from others in eastern and central Pennsylvania who would be interested in

6-meter schedules. W7BQX, Sequim, Wash., says that he works W7DF at Everett nightly on 6, but otherwise there is almost nothing doing, except for the band openings. W7EYS, Bellingham, Wash., says he's heard only two signals since last summer. W8NQG, Ashland, Ohio, finds the picking lean. On almost any night but Tuesday 6 seems rather quiet in New England, but with the Horsetraders and the New England Net functioning that evening at least 20 stations may be heard, and efforts are underway to promote similar activity on other nights.

The boys around Erie, Penna., have been doing something about the winter slump in 2-meter activity. This group has been mailing out letters to the 2-meter regulars within a radius of 50 miles or so of Erie, suggesting Monday and Thursday nights for concentrating on keeping activity going. They will be on between 9 and 11 on these evenings for a starter, but will change the schedule if a consensus indicates the desirability of a different time or date.

Activity on 144 Mc. is being maintained on the Minneapolis-Champlin-St. Cloud circuit by a uniform operating technique which involves calling and listening on the hour and half hour, nightly, starting at 7:30 P.M., according to W9QHC.

Two-Meter News

Pittsburgh, Penna. — Readers of Bill McNatt's popular V.H.F. News know well, by now, that statements of a controversial nature regarding v.h.f. propagation are sure to bring a response from Lew Gilmer, W3HZF. The moon-reflection proposition of W2RH, offered last month in these pages, produced the expected (and desired) result. With characteristic thoroughness and humor, Lew makes the point that the system proposed by W2RH is 21 db. below that employed by DeWitt in the 1946 experiment at Belmar. Says Lew, "The idea of an amateur having a self-checking half-million mile circuit, over which he could hear his own signals banging around in space, and talk to himself if no one else was on, is just a pleasant pipe dream." With the difference in performance he claims the circuit of W2RH would be 1 to 11 db. below the noise level.

Submitting this comment to W2RH brought the reply that Lew's analysis and mathematics are acceptable to him, but that there are factors of possible difference in approach which add up to a difference of some 17 db. between the two. These include the figure for actual power radiated, the antenna gain, the receiver bandwidth, and possible reflections from the earth. Lew included a 4-db. line loss applied to 500 watts transmitter output; Ken believes that proper design should permit actual radiation of 500 watts of power. Lew assumed a receiver bandwidth of 50 cycles; Ken hopes to narrow this to 10 cycles — a stiff design problem, but not insurmountable — add-



Standings as of Nov. 30th

	All-Time 1948		All-Time 1948		All-Time 1948
W9ZHB	48	W5AJG	43	W9DWU	46
W8ZJB	48	W5ML	42	W9QUV	44
		W5VY	40	W9PK	43
W1CLS	44	W5HLD	40	W9ZHL	43
W3CIR/1	42	W5JLY	39	W9JMS	43
W1LLL	40	W5FRD	38	W9ALU	42
W1HDQ	39	W5FSC	37	W9QKM	40
W1CGY	38	W5DXB	35	W9UIA	36
W1HMS	36	W5ZZF	34	W9AB	26
W1JLK	35	W5GNQ	32		
W1NF	35	W5IOP	30	W9USI	47
W1KHL	34	W5LIU	24	W9NFM	46
W1LSN	33	W5LWG	19	W9QIN	45
W1CLH	32			W9BJV	45
W1CJL	30	W6UXN	47	W9CJS	45
W1AF	27	W6OVK	40	W9KYF	44
W1EIO	24	W6ANN	38	W9DZM	43
W1EIL	21	W6LWS	37	W9KFP	42
		W6BPT	35	W9TQK	42
W2BYM	39	W6AMD	35	W9SV	42
W2AMJ	38	W6FPV	31	W9INI	42
W2IDZ	38	W6BWG	18	W9HXY	41
W2QVH	37			W9YUQ	39
W2RLV	37	W7BQX	45	W9JHS	38
W2RGV	26	W7ERA	43	W9PKD	36
		W7DYD	41	W9GSW	29
W3OJU	38	W7HEA	40		
W3OR	35	W7FDJ	36	VE1QY	28
W3RUE	34	W7FFE	35	VE3ANY	27
W3MKL	33	W7KAD	35	VE1QZ	26
W3MQU	25	W7JPA	34	G5BY	24
		W7QAP	32	XE1KE	23
W4GJO	46	W7ACD	28	VE4GQ	20
W4EQM	41	W7JRG	27	VE2KH	19
W4QN	40	W7JPN	19	G6LK	16
W4GIY	40	W7OWX	15	XE2C	14
W4EID	40			VE2GT	14
W4DRZ	38	W8QYD	44	XE1QE	10
W4FBH	34	W8NQD	31		
W4GMP	34	W8RFW	25		
W4WMI	33	W8TDJ	22		
W4FNR	33	W8LBH	21		
W4HVV	29				
W4MS	26				
W4FJ	26				
W4LNG	23				

Last call for 1948 States-Worked reports! Remember that medalion awards are offered to the amateurs working the most states on 50, 144 and 220 Mc. and up. Send in claims before Jan. 10, 1949.

ing 7 db. Lew's assumption of a power gain of 50 for a 32-element array can be improved upon, according to Ken, raising this figure to at least 100, and gaining 6 db. for the system on the two-way basis. The figure for gain resulting from earth reflections, set at 8 db. by W3HZF, can be boosted to approximately 12 db. by installation of a reflecting mat or counterpoise, according to W2RH. We suspect that the end has not yet been heard of this discussion, and more will be

run in these pages as developments come along.

Two-meter signals cross the Atlantic? Not yet, despite last month's report of 144-Mc. reception of W3EKK in the Netherlands. A check with PA0JQ brings the response that report is false. Somebody having fun (?) again, it would appear. But there is plenty of activity on the other side of the Atlantic. With the 5-meter band about to be denied to most of Europe's amateurs, they have turned to 2 meters in droves. Results have been most gratifying, particularly in Great Britain, Belgium, France and the Netherlands.

Conditions between England and the Continent provide almost daily extended ranges on the higher band, and distances now being covered far exceed the range formerly attained on 58 Mc., as far as tropospheric coverage is concerned. As more stations come on in the continental countries, the European DX record is being expanded every few days. Numerous Gs have been working the ONs, PA0s and Fs, at distances up to more than 400 miles, and inter-G work is possible over many paths which were seldom, if ever, workable on 58 Mc. G5BY and G6DH, some 250 miles apart, have had numerous solid 2-meter QSOs, whereas 5-meter contact between the two was a rare occurrence. Located in the southwestern tip of England, G5BY has nevertheless been able to work the stations on the Continent on several of the better nights. The Gs are now hoping for 2-meter activity in D2 and HB9, as the current DX is already limited by the extent of activity on the Continent.

Lancaster, Penna. — A Spanish-speaking voice was heard on 149 Mc. by W3AKC on the night of October 29th, around 7:30 p.m. The signal had considerable fading, fairly rapid and even, peaking about S3. W3AKC would like to know if others have heard this signal, and if information is available as to its source.

Greenfield, Mass. — A chance for v.h.f. hams with portable or mobile gear to do some interesting work in connection with timing of sled-dog races is mentioned by W1JHK. He has been discussing the possibilities with K. C. Saxton, president of the New England Sled Dog Club, which sponsors a series of races in various Maine, New Hampshire and Vermont locations in January and February. Race dates are as follows: Jan. 1st, Tamworth, N. H.; Jan. 8th and 9th, Fitzwilliam, N. H.; Jan. 15th and 16th, Pittsfield, N. H.; Feb. 5th and 6th, Lyndonville, Vt. (N. E. Championship); Feb. 12th and 13th, Colebrook, N. H.; Feb. 19th and 20th, Bridgton, Maine; and Feb. 26th and 27th, Newport, Vt. Anyone who would like to work with the Club in providing radio facilities for timing any or all of these races is invited to get in touch with Mr. Saxton, 217 Chapman St., Greenfield, or L. G. Massey, W1JHK, 272 Silver St., Greenfield.

Baltimore, Md. — Not all the stuff is being worked on 2 meters with high power and big

beams. W3LMC started in this fall with a 15-watt rig and a folded-dipole antenna, yet he has had many contacts in Pennsylvania and New Jersey, and during the evening of Nov. 8th he worked W1JKC of Stratford, Conn. The attractions of the 2-meter band looked good, and high power and beams are on the agenda.

Newport, R. I. — That night of the 8th was pretty good for late fall, all along the Atlantic Seaboard. W1JFF raised W3GGR, Pleasant Hill, Md., on a CQ, and worked three other W3s in Eastern Pennsylvania. This was one of those nights that caught many of the gang napping, and there were not too many W1s active, but those who were, including the Cape Cod DX twins, MNF and BCN, were knocking off the W3s in fine style.

Helpful Hints Department:

Reducing F.M. Interference in 50-Mc. Receivers

As more and more broadcasters move into the high f.m. band, 88 to 108 Mc., the interference problems of 50-Mc. operators multiply. As anyone who has attempted work on 6 in the vicinity of these high-band stations knows, the second harmonic of the receiver or converter oscillator beats with f.m. signals, producing strong and very annoying spurious responses in the 50-Mc. band. Of course some of the signals are *not* spurious — we know of at least one instance where an f.m. station is actually radiating an S9-plus subharmonic — but most of the signals are in the spurious category, and can be gotten rid of easily.

The selectivity of tuned r.f. circuits at 50 Mc. is not sufficient to reject strong 100-Mc. signals completely, even when two r.f. stages are used; and when broad-band stages are employed, or in receivers having one or no r.f. stage, the interference can be very bad, indeed. This trouble can be corrected in two ways, though in the case of very strong interference both methods may be necessary. Usually just a simple trap circuit inserted in series with the antenna pick-up coil at the antenna terminals will suffice. Such a trap, which will have an attenuation of about 40 db., may consist of about 7 turns of No. 14 wire, $\frac{1}{8}$ -inch diameter, across a 3-30 μ fd. mica trimmer. This, when tuned to the frequency of the interfering signal, will knock it out completely, or at least drop it below troublesome level in most cases. It will tune quite sharply, so it should be adjusted on the most troublesome signal, if more than one are in evidence. Normally it will have no effect whatever on the 50-Mc. operation of the receiver. If several interfering signals are present the selectivity of this arrangement may be too great, in which case more inductance and a lower setting of the trimmer should be used, for broader tuning.

Many converters use more oscillator injection than is necessary. Ordinarily this is not harmful, but it may increase the interference pick-up of

the converter considerably. If the trap method does not completely cure spurious responses, try reducing the oscillator plate voltage. It may be found that considerably less oscillator power can be used, without reducing the converter's sensitivity, and in some instances such reduction may even improve the signal-to-noise ratio. It certainly will not harm the converter's stability, in any case.

The 6J6 as a Doubler

The use of an 832 as a tripler seems to be a more-or-less standard way of getting excitation for a 144-Mc. amplifier, but there are other ways which may do fully as well. The various dual triodes (6J6, 12AT7, 7F8, etc.) all operate as triplers, but the output is usually too low to drive an 832 amplifier satisfactorily, unless the tripler itself is driven very hard. The 6J6 makes a fine doubler to 144 Mc., however, according to W6PIV. Running the 6J6 either as a push-push or parallel doubler requires lower drive than for tripling in push-pull, and the over-all complexity of the rig may not be greater in the end. A 6J6 doubler provides more than adequate drive for an 832 amplifier, at 200 to 250 volts on the 6J6. The amplifier grid circuit may be made to resonate on about 180 Mc., and still pick up enough drive for the 832. No neutralization is required in such an arrangement.

A Simple System for 2-Meter N.F.M.

Wishing to try n.f.m. on 144 Mc., W1CTW put in a 6J5 alongside the crystal oscillator in his 2-meter rig (described in *QST* for July, 1946, and in the 1947 ARRL *Handbook*). The 6J5 is resistance-coupled to the crystal-oscillator screens, and driven from the regular speech amplifier. About 15 to 20 volts of a.m. produces sufficient phase modulation for true narrow-band operation. A screen by-pass of about 0.0015 μ f. cuts the highs enough to balance the audio quality, the low tones being somewhat weak with this arrangement otherwise. The fellows with the communications receivers report good speech quality but those with 522s have a difficult time of it, with that amount of deviation.

The World Above 420 Mc.

After months of testing, with the one-way results previously reported, W1IYO, Milford, Conn., has worked W2HWX two-way on 420 Mc., the first contact taking place on Oct. 30th. W1IYO had been hearing W2HWX, W2ASL and W2UCD, all about 75 miles distant, in cross-band tests with W1IYO listening on 420 and transmitting on 144 Mc., but had not been able to get back to them on 420 until the above date, when the first Connecticut-New Jersey 420-Mc. QSO finally came off. Signals were about S5 in both directions.

(Continued on page 118)



JANUARY, 1924, *QST* gives full listing to the \$4000 in prizes awaiting U. S. and Canadian amateurs who turn in creditable performances during the fourth — and it is hoped, last — Transatlantic Test. Among the prominent manufacturers contributing apparatus prizes are the Grebe, Howard, Tuska, Zenith, Nathaniel Baldwin and Adams-Morgan companies. Now that two-way transatlantic and transpacific work is an accomplished fact (see "Twenty-Five Years Ago," Dec., 1948, *QST*. — *Ed.*), hopes are running high in our ranks. Further encouragement is gained from early reports that during the current Transpacifics Yankee signals are a bedlam in New Zealand, and from the news that 14 American amateurs have been heard in Japan.

The new year 1924 should see many improvements in amateur receiving and transmitting techniques, if the technical offerings in this issue are any criterion. John L. Reinartz's Hartley transmitter, used with great success in the two-way spanning of the Atlantic, comes in for full description. Another transmitter article, "A Constant Frequency Set with a Record," by Capt. Tom C. Rives, Signal Corps, features an MOPA transmitter that has been heard in Holland. Touching on the receiving field, J. C. Warner of the GE Research Lab answers pertinent questions on the construction, design and applications of receiving tubes.

Meet the Headquarters crew — all 19 of them! This *QST* is replete with photos of the rapidly-growing ARRL staff and offices at 1045 Main Street, Hartford. The entire League staff is introduced pictorially, starting with President Maxim and continuing with Secretary-Editor Warner, Assistant Secretary Service, Traffic Manager Schnell, Treasurer Hebert, Circulation Manager Houghton, Technical Editor Kruse, Department Editor Mason, Assistant Editor Beekley, Advertising Manager Adams and others.

Intimate glimpses into the shacks of a number of outstanding stations are provided this month. Included are Don Parsley's 4FT, Wilmington, N. C., George Sturley's 7BJ, Vancouver, Wash., John McCaa's 5GP, Anniston, Ala., and Robert Kraus's 2CEI, New York City.

Good news! The Bureau of Standards, co-operating with the League, has agreed to continue standard-frequency broadcasts on schedule.

**SWITCH
TO SAFETY!**



I.A.R.U. News

QSL BUREAUS

Changes and additions. Complete lists will be published as usual in the May and October issues of *QST*.

Germany (D2 only): E. G. Styles (D2GU), PW/DP Branch, 120 HQ CCG (BE), Brunswick Baor 11

Philippine Islands: Elpidio DeCastro, Philippine Amateur Radio Assn., 931 R Hidalgo St., Quiapo, Manila

Southern Rhodesia: S. E. B. Anderson (ZE2JN), 3388 Queens Park, Bulawayo, Southern Rhodesia

Virgin Islands: Richard Spenceley (KV4AA), Box 403, St. Thomas

CHILE

The *Radio Club of Chile* is seeking from its sister societies in South America an expression of opinion as to how the 14- and 28-Mc. bands should be subdivided for phone and c.w. operation. The Chile society suggests that c.w. be restricted to the frequencies 14,000-14,100 and 28,000-28,100 kc.

SOUTH AFRICA

The *South African Radio League* extends to all amateurs an invitation to participate in its first postwar DX Contest, to be held on the week ends of January 22 and 30, 1949.

General

1) The contest is open to licensed amateurs throughout the world, and will be on c.w. only.

2) Contacts with ships or unlicensed stations located in countries where licenses are obtainable will not count for points. The decisions as to whether a station is to be classed as unlicensed will rest with the S.A.R.L. DX committee.

3) Only one person is allowed to operate a specific station for the duration of the contest.

4) Certificates will be awarded to the first three DX stations, and to the first three Southern Africa stations who are members of the S.A.R.L. Certificates also to the leading station in each prefix zone provided at least three entries received from that zone.

5) All entry forms should be posted so as to reach Port Elizabeth not later than April 30, 1949, and should be addressed to S.A.R.L. DX Contest, P.O. Box 462, Port Elizabeth, Union of South Africa.

6) The decision of the DX Contest Committee is final.

Rules

1) The contest will extend from 0001 GCT Saturday, January 22 to 2400 GCT Sunday, January 23, and from 0001 GCT Saturday, January 29 to 2400 GCT Sunday, January 30, 1949.

2) Stations in the Southern Africa zone must exchange six-figure groups with stations in the rest of the world. The first three figures must be the signal report and the last three the self-assigned serial; e.g., 569333, 559807, etc.

3) (a) Southern Africa is divided into the following prefix zones: (1) ZS1; (2) ZS2; (3) ZS4, ZS7, ZS8; (4) ZS5; (5) ZS6, ZS9; (6) ZS3, ZE1, ZE2, VQ2, VQ3, CR7.

(b) The rest of the world will be divided into zones according to the official country prefix list, except in the case of (a) U. S. A. and Canada, where each call district will be a separate zone, e.g., W1, W2, VE1, VE2, etc., and (b) Australia, where the zones will be: (1) VK2, (2) VK3, (3) VK4 and 7, (4) VK5 and 8, (5) VK6 and 9.

4) *Bands:* The 80-, 40-, 20- and 10-meter amateur bands may be used.

5) *Scoring:* 20 points for the first contact, 19 for the second, 18 for the 3rd and so on down to 1 point for the 20th contact, and 1 point for each contact thereafter, in each zone. The same method applies to each band used.

6) Only one contact with a specific station may be made on each band during each week end of the contest; stations worked during the first week end may be contacted again during the second week end.

7) Band-monitoring stations under the auspices of the S.A.R.L. will be active and any station reported off frequency will be disqualified.

8) *Logs* should show the following: (a) date, (b) time (GCT), (c) band, (d) serial in, (e) serial out, (f) station worked, (g) points claimed. An analysis sheet for each band should accompany entries: (a) prefix zone, (b) contacts (number), (c) points.

ARGENTINA

The first convention of Argentine radio amateurs was held earlier this year at the Savoy Hotel, Tucuman. As a result of this meeting various suggestions were made to the Argentine government, and are briefly outlined below.

Adoption of a call-letter assignment system of suffixes was advocated whereby certain letters would indicate the particular territory of location,

Recent guests of the El-Ray Radio Club, Waltham, Mass., were D. R. Austin, ZS6JC (center), a member of the Council of the South Africa Radio League, and R. G. Michell, ZS6OU (right). Extending greetings on behalf of the club is President W. R. Burrows, WIPAW (left).

QST for

such as "Z" for island possessions and the numeral "0" for mobile stations.

The government was offered the facilities of amateur stations for propagation studies.

It was recommended that dummy antennas be required for testing and that authorization to handle third-party traffic within the country be granted on the basis of no remuneration.

A proposal to recommend the issuance of licenses to foreigners was turned down.

It was resolved to recommend to the government the following subdivisions of the amateur bands:

- 7,000- 7,050 exclusively c.w.
- 7,050- 7,300 exclusively 'phone
- 14,000-14,100 exclusively c.w.
- 14,100-14,150 shared between c.w. and 'phone
- 14,150-14,400 exclusively 'phone
- 28,000-28,100 exclusively c.w.
- 28,100-30,000 exclusively 'phone

FIRST EUROPEAN DX CONTEST RESULTS

V.E.R.O.N. lists the following winners of the First European DX Contest, held the week ends of November 28 and December 12, 1947.

C.W. — OK1FF, OZ5SN, EI9N, G8KP, OY3IGO, OH3NB, F8EO, D2JH, TF3EA, G13BKG, I1AY, ZB1E, GD2DF, PA8RE, LA3CA, GM8CH, SM5PA, HB9AW, GW3ZV, KL7UM, VK2EO, VE1HG, VE2DR, VE3AFY, VE4RO, CE3AG, KH6IJ, VS6AE, G2FDF/YI, J2AHI, MD1D, KM6AB, ZL3BJ, CX1FY, W1RY, W2ALB, W3BES, W4HKJ, W5EXR, W6AY, W7CJB, W8DAE, W9AEH, WØPIH.

'Phone — OK3ID, OZ7G, G8JQ, OH1OD, F3WV, HA4AB, I1RM, LX1SI, PA8OO, CT1NT, GM2UU, GW3QN, LU5AD, VK6RU, VE3AFY, CN8BV, J9AAI, W2IUV.

JAPAN

The *FEARL* (Far Eastern Amateur Radio League) *Bulletin* of November, 1948, carries an announcement that effective January 1, 1949, amateur stations operated by civilian and military personnel of the occupying nations will use the prefix JA, instead of J as formerly. This announcement does not carry with it any implication that Japanese nationals are soon to be licensed.

The new JA calls, a list of which is available at IARU headquarters, bear no relationship to the J calls, insofar as numerals and the letters following the numerals are concerned.

The QSL bureau address remains the same.

MISCELLANY

Liga Panamena de Radio Aficionados has proposed to its government a set of regulations to govern amateur radio in Panama. Action on the recommendations has not yet been taken by the civil authorities.

The Headquarters has been unofficially advised that the sister society in the Netherlands Indies (N.I.V.I.R.A.) may soon be dissolved because of lack of sufficient activity.

Amateur radio activity in Spain continues to

increase. An amateur society has been formed whose organizers hope the Spanish authorities will soon grant official sanction to amateurs.

The Headquarters continues to receive regularly the official organs of the various sister societies. These publications all evidence a high order of workmanship and enthusiasm. Our congratulations are extended to all.

WWV Schedule

STANDARD-FREQUENCY transmissions are made continuously, day and night, as a public service by the National Bureau of Standards over its standard-frequency station, WWV, on the following frequencies:

Mc.	Power (kw.)	Audio Freq. (cycles)
2.5	0.7	1 and 440
5.0	8.0	1 and 440
10.0	9.0	1, 440 and 4000
15.0	9.0	1, 440 and 4000
20.0	8.5	1, 440 and 4000
25.0	0.1	1, 440 and 4000
30.0	0.1	1 and 440
35.0	0.1	1

A 0.005-second pulse may be heard as a faint tick every second, except the 59th second of each minute. These pulses may be used for accurate time signals, and their one-second spacing provides an accurate time interval for physical measurements.

The audio frequencies are interrupted at precisely one minute *before* each hour and each five minutes thereafter (59th minute; 4 minutes past hour, 9 minutes past hour, etc.), resuming after an interval of precisely one minute. This one-minute interval is provided to give Eastern Standard Time in telegraphic code and to afford an interval for the checking of radio-frequency measurements free from the presence of the audio frequencies. Ionospheric-disturbance warnings applicable to the North Atlantic path are given at 19 and 49 minutes past each hour. If a disturbance is in progress or is anticipated within 12 hours, the time announcement is followed by 6 Ws; if conditions are quiet or normal, the time announcement is followed by 8 Ns. The announcements of the station's services and call are given by voice at the hour and half hour.

The accuracy of all the frequencies, radio and audio, as transmitted, is now better than a part in 50,000,000. Transmission effects in the medium may result in slight fluctuations in the audio frequencies as received at a particular place; the average frequency received, however, is as accurate as that transmitted. The time interval marked by the pulse every second is accurate to 0.000001 second. The beginnings of the periods when the audio frequencies are resumed are synchronized with the basic time service of the U. S. Naval Observatory.

2nd V.H.F. Sweepstakes, Jan. 15th-16th

Certificate Awards to Section¹ and Club Leaders, 50 Mc. and Above—Gavel to Winning Club

BY F. E. HANDY,* WIBDI

TEST your v.h.f. station coverage on January 15th and 16th. The Second Annual V.H.F. Sweepstakes will start at 2:00 P.M. your local time, Saturday, January 15th, ending at midnight Sunday. 'Phone, m.c.w. or c.w. may be used, with results all contributing to one score. The aim of the contest will be to work as many v.h.f. stations as possible in one week end. All points from such work will be multiplied by the number of *different* ARRL sections worked. Here's a chance to advance your WAS standing. "CQ Sweepstakes, this is W. . . , over" will identify stations desiring to make contest exchanges. On c.w. this becomes simply "CQ SS de W. . . K."

To "prove" a QSO customary SS exchanges (for the report sent Hq.) will be required. Exchanged information is in the form of a message preamble, with the ARRL section¹ substituted for the city and state, and the RST report for "check." Any station you work is good for *one* point in the score, if you get the other operator's acknowledgment of "message" whether he is in the contest for score or not. If an exchange of SS data is completed in both directions *two* points may be claimed. To make it easy to record exchanges they should be sent in the order of information shown.

Contest reporting forms for your convenience will be sent gratis to anyone who requests them by radiogram or card. Neither advance entry nor

* Communications Manager, ARRL.

¹ See list of sections in the ARRL field organization, page 6. Awards include Puerto Rico, Hawaii, Alaska, P. I. In operating use section name abbreviations such as E. Mass., R. I., W. N. Y., Neb., N. Y. C.-L. I.

forms is *required*. You can follow the log arrangement shown. All lists are welcomed by ARRL even if they show only a small score, to help support claims and make complete results in *QST* possible. Report as soon as the test is over.

Awards—Individual and Club

Distinctive certificates will go to V.H.F. Sweepstakes winners in *each* ARRL section¹ and to leading operators of clubs where three or more submissions are received under our rules. Also, a *club gavel* goes to the club with top aggregate score. Get set for a v.h.f. operating week end and see what you can do!

Rules

1) *Eligibility*: Amateur operators in any field-organization section¹ operating fixed, mobile or portable *under one call* on or above 50 Mc. are invited to take part.

2) *Object*: Amateurs in U. S. and Canadian sections of the ARRL field organization will attempt to contact as many other stations in as many of the 72 sections as possible during the contest period.

3) *Contest Periods*: The contest starts at 2:00 P.M. your local time Saturday, Jan. 15, 1949 and ends at midnight Sunday, Jan. 16, 1949.

4) *Exchanges*: Contest exchanges including all data shown in the sample must be transmitted and receipted for as a basis for each scored point.

5) *Scoring*: (a) Contacts count *one point* when the required exchange information has been received and acknowledged, a *second point* when exchange has been completed similarly in both directions.

EXPLAINING V.H.F. SS CONTEST EXCHANGES

<i>Send Like Standard Msg. Preamble</i>	<i>NR</i>	<i>Call</i>	<i>CK</i>	<i>Place</i>	<i>Time</i>	<i>Date</i>
Exchanges	Contest numbers 1, 2, 3, etc., a new NR for each station worked	Send your own call	CK (Readability . . . Strength . . . or RST ² of station worked)	Your ARRL section ¹	Send time of transmitting this NR	Send date of QSO
Purpose (example)	QSO NR tells how you are doing. (NR 1)	Identification (WIAW)	All exchange reports (589)	Section ¹ vital contest data. (E. Mass.)	Time and date must fall in contest period. (6R55 P.M. Jan. 15)	

STATION W. . . . — SUMMARY OF V.H.F. SWEEPSTAKES EXCHANGES

Freq. Band (Mc.)	SENT (1 point)				Time ST	Date (Jan.)	RECEIVED (1 point)				Time	Date (Jan.)	Number of Each Different New Section as Worked	Points
	NR	Stn.	CK- RST	Section			NR	Stn.	CK- RST	Section				
50	1	W1AW	57	Conn.	4:15 P.M.	15	3	W1QLX	47	Conn.	4:18 P.M.	15	1	2
50	2		43		4:35 P.M.	15	7	W1HDQ	59	Conn.	4:40 P.M.	15	..	2
50	3		58		9:09 P.M.	15	6	W1EIO	359	Maine	9:11 P.M.	15	2	2
144	4		49		9:30 P.M.	15	32	W1CLS	58	E. Mass.	9:36 P.M.	15	3	2
144	5		57		9:50 P.M.	15	15	W1SF	58	Conn.	9:46 P.M.	15	..	2
50	6		54		11:30 P.M.	15	11	W2OHE	48	N. Y. C.-L. I.	11:32 P.M.	15	4	2
144	7		58		11:35 P.M.	15	30	W1QLX	57	Conn.	11:35 P.M.	15	..	2
144	8		57		11:45 P.M.	15	21	W3MKL	59	Md.-Del.-D. C.	11:56 P.M.	15	5	2
144	18	W4FNR ^b	59	E. Fla.	12:24 A.M.	15	6	1
144	9	W1AW	34	...	8:50 A.M.	16	27	W1NY	59	W. Mass.	8:47 A.M.	16	7	2
50	10		479		9:18 P.M.	16	12	W5AJG	379x	N. Tex.	8:20 P.M.	16	8	2
50	11		589		10:40 P.M.	16	20	VE1QY	569	Maritime	11:35 P.M.	16	9	2

No. Bands Used: 2 9 Sec., 23 Pts.

Number and names of operators having a share in above work:

Claimed score: 23 points X 9 sections = 207.

I hereby state that score and points set forth in the above summary are correct and true.

Equipment:

Signature:

Tubeline-up:

Address:

Number different stations worked:

(b) Final score is obtained by multiplying totaled points by the number of *different* ARRL sections¹ worked, that is, the number in which at least one SS point or exchange has been credited.

6) *Conditions for Valid Contact Credit:* (a) Repeat contacts in other bands confirmed by completed exchanges of *up to two points per band* may be counted for *each different station* worked. (Example: W1XXX works W3MQU on 50 and 144 Mc. for complete exchanges, 2 points each on each band. 2 + 2 gives 4 points but only *one* section multiplier.)

(b) Crossband work shall not count for any points or sections.

(c) All work submitted as one entry must be accomplished from points within a given ARRL section.

7) *Awards:* Entries will be classified as single-operator or multioperator, a single-operator station being defined as one manned by an individual amateur who neither receives assistance nor gives assistance to any person in the contest period. Certificates will be granted based on the leading work in the single-operator classification in each ARRL section. Multioperator work will be grouped separately in the *QST* report of results.

¹ In 'phone RST exchanges only two numerals need be used. Say *Readability* . . . *Strength* . . . On c.w. contacts full 3-number RST reports should be logged.

² Where only one point is made on a contact you can add a point by working this station again for exchange in the opposite direction later. Leave right or left report column blank so that other pairs of exchanges completed in one contact are side by side in your report.

When three or more individual club members compete and submit logs naming the club with which they are identified, an ARRL certificate will be issued through such club to the leading individual in the local competition. When less than three individual logs are received there will be no club award or club mention.

A gavel with engraved sterling-silver band is also offered to the club whose secretary submits the greatest aggregate score, which is the tabulation of all individual V.H.F. Sweepstakes score claims successfully confirmed by individual amateur reports which mention the club.

8) *Conditions of Entry:* Each entrant agrees to be bound by the provisions of this announcement, the regulations of his licensing authority, and the decisions of the Award Committee.

9) Reports from all entrants must be post-marked no later than February 1, 1949, to be considered for awards.

Strays

A 4-page mimeograph, "Bibliography of Articles Concerning Conversion of War Surplus Equipment for Civilian and School Use," may be obtained without charge by writing to the Office of Education, Federal Security Agency, Washington 25, D. C. Sixty-nine information sources and articles are indexed in this handy reference, including twenty-four titles from postwar *QSTs*. The bibliography was compiled by Willis C. Brown, W3HB, an assistant specialist for aviation of the agency.

On the Air *with* **SINGLE SIDE BAND**



One of the questions asked most frequently about the single-sideband stations is, "When are they on the air? I want to hear what the stuff sounds like." This column will report schedules and operating times of active single-sideband stations, describe operating experiences and sometimes the gear in use, and possibly discuss some of the practical operating problems and suggested solutions. Contributions from active single-sideband stations will be welcomed.

THE dog team finally got through the drifts with a letter from W7IKY in Seattle, with full details on his rig and recent experiences. Dick built his own filter, and first got on 75 with a Class A 807 running about 10 watts peak output. With this power, his best DX was W7JCU in Montana. Adding Class B 811s, he has worked KH6FQ, W5QH and W4CPG. "W5QH . . . had his r.f. gain turned down so low that, when he also turned off his b.f.o., he couldn't tell I was there," and "On some local contacts, when I was running low power, selective fading was quite bad on a.m. signals, but not on mine!" are quotes from Dick's letter that bear out the theory nicely. Of course it hasn't all been smooth sailing. At first he landed close to a "net" frequency, and his 10 watts was smearing some 150-watt signals that then reacted in the traditional manner. But rewinding a few coils, so that the other sideband could be used, put his signal away from the injured parties, and all is serene.

Another newcomer to the ranks is W2VVC in Rochester, N. Y., who runs about 400 watts peak input to a pair of 813s, driven by the W6DHG exciter described in July, 1948, *QST*. No startling DX so far, but lots of interesting contacts and some duplex work with W3ASW.

But it isn't the duplex work that is the big news this month. It is the QRM tests made by W3ASW and W2VVC. They made them with the help of W2STK, who was receiving both of their single-sideband signals at about equal strength on an NC-100-A. Both were using the same sideband and, with a (suppressed) carrier separation of about 250 cycles, all W2STK had to do to copy one or the other, when they were both transmitting, was to shift his b.f.o. back and forth! The two signals were close enough to enable W2STK to set his b.f.o. halfway between the two and copy one when the other wasn't talking. Do you blame them for being enthusiastic?

This W3ASW is really getting into the fine points in his rig. He made a few refinements in his filter, but most of his efforts have been directed toward complete elimination of the car-

rier, with an eye to better duplex work. He has the carrier down to a point where it is lost in the tube noise. But the tube noise is amplified, of course, and sets a limit to the duplexing. Here is a point that hasn't been mentioned before, but it is going to be a problem if we're going to have good duplex operation. When you have a string of high-gain r.f. amplifiers, as one does in a single-sideband rig, the tube noise in the low-level stages is amplified to a level sufficient to be heard in the receiver. Any suggestions as to how to get around the thing will be gratefully received. Dick has an "unbalance" control on his modulator that will throw in enough pilot carrier for locking in on receivers using the W2KUJ single-sideband adapter, and reports complete success with the system. But duplex and pilot carriers aren't going to live together unless someone comes up with one or two smart angles.

Work on filters at W0MNN has resulted in some refinements of design that show considerable promise. By using a first carrier frequency of 20 kc. he is able to simplify the subsequent stages in the rig.

The filter rig that W3MBY uses on 14 Mc. will be described in an early issue of *QST*, with full dope on how to build and check the sideband filter. Since this filter uses inductances that are not too difficult to obtain, its construction is within the reach of practically everyone.

The hams beat the mobile-marine service to single sideband, but not by very much. A recent announcement of the radio equipment on the new 34,000-ton Cunard White Star liner *Caronia* contains the following interesting paragraphs:

"Greatly-improved radiotelephone service over long distances is provided by means of single-sideband transmission and reception, with equipment operating in the frequency band 4 to 22 Mc. The *Caronia* will therefore have the distinction of being the first passenger ship to be fitted for single-sideband telephony. The radiotelephone installation will consist of a single-channel single-sideband transmitter with associated drive equipment and one double-channel single-sideband receiver. The double-channel feature on the receiver will permit reception of either channel of a double-channel single-sideband circuit as offered by a shore station. The second channel may also be usefully employed as an order wire while the main channel is busy on subscriber calls.

"The single-sideband transmitter has been so designed that a further single-sideband channel may be readily added, thus providing two separate channels on a single frequency in one direction during peak traffic periods.

"In addition to the single-sideband equipment a high-power double-sideband radiotelephone-radiotelegraph transmitter is installed. This may be used either for supplementary telephone duties to countries where single sideband is not yet available or for intership calls." — B. G.



United States Naval Reserve



THE first of a series of two-day courses in Combat Information Center indoctrination was held recently at the Kenosha (Wis.) Naval Reserve Training Center. The new school, a project of the Electronics Warfare Program of the Ninth ND, is directed by Lt. A. C. Canepa, USNR, district CIC training officer. Twenty-five officers and men from a dozen cities attended the initial course which was geared for Reserve officers and men who will be concerned with CIC training in their respective training centers. It is planned to hold similar courses on the last Thursday and Friday of each month during the year. It is expected that by July, 1949, future instructors from all 96 Naval Reserve training centers in the Ninth will have attended this indoctrination course. The Kenosha CIC installation was designed as a model for other training centers. To date, fifty Naval Reserve training centers in the Ninth Naval District have equipment installed for CIC work. All of these installations are to be fully operative by next July.

In addition to the above, plans are being formulated for a number of major CIC installations in various parts of the country, for advanced training of officers and men in this important phase of Naval operations. At a number of these projected installations advanced training in antisubmarine warfare will be integrated with the CIC training. A pilot model of such an installation is now in operation at the Naval Gun Factory, Washington, D. C.

Naval Reservists on active duty at Eighth Naval District headquarters supervising the Reserve Electronic Warfare Program include W5OM, W5HKP, W5BUK, ex-W5DPT, W5LNU and W5JKT.

Plans for Naval Reserve radioteletype nets are well underway. It is expected that the first link of a network that will eventually connect all district headquarters will be activated in the near future between Washington, D. C., and Chicago using f.s.k.

Cmdr. Walter Rogers, USNR, W1DFS, is in command of Electronic Warfare Company 1-5, with a splendid radio station installed in the Police Station at Somerville, Mass.

Results of the Receiving Competition and of the QSO Party held on Navy Day-1948 are scheduled for February QST. Early reports indicate the success of both activities.

The Federal Communications Commission recently licensed the following amateur stations at Naval Reserve activities:

K1NRP	Pawtucket, R. I.	K6NAL	Fillmore, Calif.
K4NRP	Perry, Fla.	K6NAM	San Luis Obispo, Calif.
K5NAS	Tyler, Tex.	K8NRC	East Liverpool, Ohio
K5NAT	San Angelo, Tex.	K9NRD	Moline, Ill.
K5NAU	Waco, Tex.	K9NRG	Decatur, Ill.
K5NAV	Van Horn, Tex.	K0NAR	Denver, Colo.

"Skunk bearing 090, range 6000!" Ninth ND personnel get the latest dope on CIC operation at the new CIC indoctrination course held two days each month in Kenosha, Wis. *L. to r.:* Lt. A. C. Canepa, USNR, in charge of Reserve CIC training in the Ninth ND and organizer of the course; S. J. Green, SR; J. M. McDonnell, RM2c; R. E. Spoor, ET2c; W. C. Hoffmann, RM3c.





Hints and Kinks

For the Experimenter



RECEIVER B.F.O. AS KEYING MONITOR

It may not have occurred to some of those who have added a "Q5-er" to their communications receivers that the idle b.f.o. in the receiver may be used as a convenient keying monitor.

If oscillator cathode keying is used in the transmitter, the b.f.o. can be keyed simultaneously simply by tying the two cathodes in parallel, as shown in Fig. 1. Otherwise, the b.f.o. can be keyed with a relay.

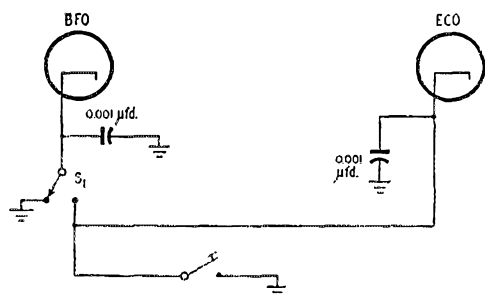

Fig. 1 — Keying the idle b.f.o. in a receiver that is used with a "Q5-er," to provide a keying monitor. In some receivers, it is merely necessary to tie the two cathodes in parallel, and install a switch to return the b.f.o. to its normal use when desired.

If desired, the usual b.f.o. switch can be replaced with a s.p.d.t. switch, as shown at S_1 , so that the b.f.o. can be switched from normal use to use as a monitor.

If the electron-coupled circuit is used in the b.f.o., as shown in Fig. 2-A, the circuit may be keyed by parallel-feeding the cathode as shown at B.

Usually the b.f.o. is operated at low voltage

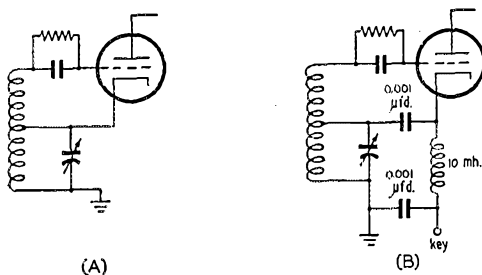

Fig. 2 — If the receiver b.f.o. uses the electron-coupled circuit as shown at A, it may be keyed by parallel-feeding the cathode as shown at B.

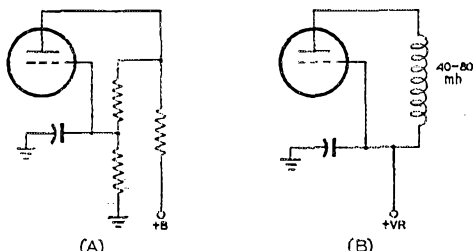

Fig. 3 — In cases where dropping resistors in the b.f.o. circuit result in a chirpy note when it is keyed, voltage regulation may be added as shown at B.

through dropping resistors, as indicated in Fig. 3-A. These resistors may be responsible for a chirpy monitor signal. If this is the case, the chirp can be eliminated by operating the b.f.o. from a VR tube working from the receiver power supply as shown in Fig. 3-B. The b.f.o. voltage should be checked first and an appropriate VR tube selected. A VR-75 will serve in most cases.

— WITS

TWO USES FOR BLOWN FUSES

The life of small glass cartridge-type fuses does not need to end when the fuse element blows. They make excellent forms for small v.h.f. chokes, and when pigtail leads are soldered to the ends, they can be mounted firmly the same as a resistor or condenser. — Jack Nelson, W2FW

The need for an insulated coupling device to tune small condensers in v.h.f. gear can sometimes be filled by using a small glass-cartridge fuse. The diameter of many of these fuses is $\frac{1}{4}$ inch, making them a "natural" for use with the usual tuning condenser. The fuse can be attached to the shaft by soldering the metal tip to the end of the condenser shaft. This method is ideal for use with the many screwdriver-adjusted padder condensers that are so plentiful in surplus gear, but which are often unusable because of the lack of suitable means of tuning by knob or dial. — Harold Held, W9OCK

DE LUXE CALL-LETTER PLATES

A new type of sign material called "Scotchlite" is now available, and is widely used on highway signs. This material reflects light and makes an excellent call-letter plate for a ham's car.

(Continued on page 120)



Correspondence From Members -

The Publishers of *QST* assume no responsibility for statements made herein by correspondents.

"QUADS"

Casilla 691, Quito, Ecuador

Editor, *QST*:

I wish to take this opportunity to thank you for your interesting article on the "Quad" antenna, which appeared in the November issue of *QST*.

Measurements or tests we have made seem to agree with everything you say. This type of antenna has been used here at HCJB for some time, because of limited space for antennas. Therefore, we're able to use no other type, except the dipole.

For your information, we made a test at one time with RCA between this antenna and the dipole and they reported a gain of 3 to 6 db. However, the "Quad" antenna was at a height of nearly a wavelength and the dipole at a height of about a half-wavelength; and the location of the dipole was such that it did have some obstructions in front of it during this test.

Again, let me thank you for your article and I trust that you have cleared up a good number of questions that have been in the minds of many people in regard to this antenna.

— P. K. Myhre, HC1JB

EKGI

906 Franklin Street, Columbus, Ind.

Editor, *QST*:

I have run into a new and novel problem. Have you ever heard of EKGI? Well, EKGI, or electrocardiograph interference, caused the ending of a QSO very abruptly. My father, a doctor, has his office next door and I got a 'phone call asking if I was transmitting at that moment. I finished the transmission and found that I had been interfering with his taking of an electrocardiogram. The dots and dashes were appearing on the graph, mixed with the heart beats. The machine uses high-amplification factor tubes to amplify the minute electric current produced by the heart beat. A ground into the earth outside the office is used. That is the only type of wire, except the line cord, which could be picking up the signal. I am running 25 watts at present and hope to go to 150 very soon. I am on 40 or 80 when the interference occurs. It is definitely from my transmitter, I have established to my sorrow. Now, what I want to know is if someone has had the same trouble and can suggest a solution. I am baffled as to where to install a wavetrap or if that would help. I certainly hope someone can help me with the EKGI problem.

— Richard Scott Fisher, W9FJL

QST

4081 Manayunk Ave., Philadelphia 28, Pa.

Editor, *QST*:

It seems to me that you people are missing up on a good thing when you sidestep television in your mag. Next to the pursuit of the hobby of "ham" radio, it is running a close second in many a ham shack. But it is your business and if you don't think it is worth thinking about, I say you are wrong.

There are a lot of us who really can't afford subscriptions to more than one mag — or think we can't. So maybe it will be a good thing to think it over. You may or may not know it but there has been a lot of adverse criticism about the way you handled war surplus, or rather the way you didn't handle it. Especially the neglect shown toward the SCR-522.

But I realize that you have been criticized for a lot of things — and have survived — and grown. Also I know that a lot of institutions have grown — gotten a little smug and careless — and collapsed. Even empires.

I'm sure that in monitoring the 75-meter band, as an example, the faces of ARRL must occasionally grow very red. However, as I have said, this is your business.

— Edward P. Ellison, W3IBU

5010 Walsh Ave., East Chicago, Ind.

Editor, *QST*:

I'm just a guy who wants a ticket more than anything else in this world. Learning the "ropes" in preparation for the great event, I eagerly shell out four shining dimes every month for the privilege of perusing the academic pages of *QST* which stimulate a desire to rush to the nearest seat of higher learning in search of a course on higher electronics and radio engineering. Doggone it, I'm not inferring that you cater to Einstein minds. It appears, rather, that your material is strictly for the advanced professional or old-timer who has forgotten more than I ever hope to learn — me, with my rickety code-practice key and buzzer and anemic skeletal structure that is gradually shaping up into a transmitter.

Like a vast number of would-be hams, I'm interested in the activities and gear of those who haven't been in the game too long — who have started humbly and who are still having a sweet time. Neither does my heart flutter at the sight of a thousand-dollar layout topped by a collection of distant QSLs. Shouldn't I be at a loss when my eye wanders across such gems as "low vertical angles of radiation, azimuthal resolution or discrimination — with wide coverage when rotated"? This seems to be the general tone of most of your stuff. I'm not slapping scallions at the boys who are familiar with it, who have the necessary where-withal and time to make it a reality — they are all a highly-developed form of amiability, courtesy and — good gosh, they're OK.

Consider my plea, good sir. Give the lowly ham a break — or, can you recommend a good publication for amateurs?

— W. A. Furman

114 West Front St., Oil City, Pa.

Editor, *QST*:

You stress building your own rigs, receivers and what have you, and still devote a large number of pages to single sideband or v./u.h.f. using the latest tubes and sometimes items that are just out of our reach. How about a few items for an old 27 tube or even some of the 6- or 12-volt tubes that are pirated from b.c. sets — things the ham can get his hands on quicker than folding money?

Realizing that these old bottles won't handle the higher frequencies, we may be restricted to the lower bands. At least we are getting on the air and still have some home-built equipment, and are enjoying our hobby — having fun.

Or have you gotten away from the oversimple rigs that appeal to some of us casuals — not casualties?

— Laurence A. Shafer, W300F

Bayfield, Wis.

Editor, *QST*:

This business "About Antennas for 80-Meter Mobile" is very interesting to me, being connected with marine applications. Around this corner of Lake Superior, we have radiotelephones on our boats. One of the goals constantly

(Continued on page 120)



Operating News



F. E. HANDY, WIBDI, Communications Mgr.
J. A. MOSKEY, WIJMY, Asst. Comm. Mgr.
ALBERT HAYES, WIIIN, Natl. Emerg. Coördinator

GEORGE HART, WINJM, Communications Asst.
A. F. HILL, JR., WIQMI, Communications Asst.
LILLIAN M. SALTER, Communications Asst.

Participation in ARRL Week. ARRL Week (Jan. 16th-23rd) is not a contest but instead is a time set down for observance and thoughtful dedication to some League betterment or personal steps toward taking a *more active part* in ARRL organization. It is hoped that all operating members will for *each* of the seven days of this week accomplish some act that will strengthen or broaden or perfect one's own part in his ARRL organization or contribute to future strength of the amateur service. Practical plans to make the week mean all it can for you might include such things as: (1) applying to your SCM for station appointment along lines of qualification, experience and interest; (2) building an emergency transmitter to work off your car battery; (3) reporting into your section net to originate messages over the air through your own station, asking replies from old radio friends or from director or SCM with whom you should be personally acquainted. Our December *QST* announcement gave further suggestions. There is also one "operating angle" to ARRL Week. Six sets of ARRL President certifications will be arranged for the pairs of written confirmations confirming the *greatest DX worked between any two ARRL members* in each of six designated frequency ranges. A special recognition or written citation by Mr. Bailey will also be sent for the most constructive report of projects started or furthered in the given week, in the direction of *better or fuller ARRL organization*. As we see it, this might mean anything from submission of a *QST* article to individual suggestion letters pointed at key problems of ARRL and the amateur service. A best report on what you or a group under inspired leadership did or planned or suggested *in the given week* will meet the requirements for consideration.

January Activities. The first month of the New Year will be filled with opportunities for operating and technical accomplishment. For details on the Member QSO Party of Jan. 22nd-23rd, a separate activity but rating a top listing in ARRL Week, see December *QST*. Members outside the U.S.A. and Canada will have the good word this year, so without turning this into a DX contest, we shall see DX QSOs on some bands. All frequencies open to amateurs can be used. In this 7th annual event Member Party scores will be welcomed from *all* appointees and members. A generous credit is given in the Member

Party score for copying President Bailey's ARRL Week message, as sent by radio from WIAW and 500 OBS appointees Jan. 16th to 23rd, and attaching the message with call, date and time of transmission of the station you copied to your report on the January 22nd-23rd QSO Party.

Other January activities are so numerous as to be handled best by tabulation:

- Code-Proficiency Certification*, Jan. 13th (Thurs. 10 P.M. EST) See announcement, page 70. Correct copy attached to score or statement of highest code speed in an earlier ARRL certification counts for points in the Member QSO Party.
- V.H.F. Sweepstakes* Jan. 15th-16th Report QSOs on 50 Mc. and above. See rules elsewhere in this issue.
- Governors-to-President Relay* Jan. 19th-20th A demonstration of traditional radio-traffic forwarding from SCM-appointed stations at state capitols to WRC-PVRC receiving points at Washington, D. C., on the occasion of the inauguration.
- Frequency-Measuring Test* Jan. 21st Prizes to leading OO and non-OO. See full announcement elsewhere in these columns. Open to amateurs with individual equipment.

New BPL Recognition. The Brass Pounders League has long provided a monthly mention in *QST* constituting editorial credit for the leading traffic handlers. Over the years the actual requirements have been changed upward or downward to follow seasonal and long-term trends in originations and interest. At present handle 500 messages (ARRL count per *Handbook*) in a calendar month and you are in. Or handle 100 messages made up of deliveries and extra delivery credits and you're there.

The American Radio Relay League, Inc.

MEMBER MATTERS - CONT.

This certificate is issued in recognition of the fact that

by virtue of having achieved a traffic total equal to or above the required standard, has attained membership in the

Brass Pounders' League

and is due the honors of this achievement, including the use of the letters BPL in connection with the station call.

Month _____

Traffic total: _____

Station Communications Manager

Now it is quite some accomplishment and takes consistent application and effort as well as a good station and know-how to handle 500 messages in a 30-day period. Delivery records are

equally hard to make for most amateurs. . . . The BPL position is an "earned recognition." However, not since an international test many years ago in which we filed 500-word messages with all entrants have we actually backed *QST* credits with a real citation or token award to the hard-working traffic operator! In an era in which we give out some certificates just for being many years in the game we think that situation should be changed. Therefore, effective Jan. 1, 1949, ARRL is pleased to announce the availability of a new BPL citation. This is in the form of a certificate-card that will be distributed to section communications managers, and issued over their signatures on receipt of traffic reports, backed up by message files, attesting and confirming that the monthly operations qualify for the Brass Pounders League. A handsome certification printed in color, we trust it will soon be displayed in many ham shacks.

Traffic Originations. There are quite a number of ways to tap interesting sources of traffic. Message boxes in hospitals, veterans' recreation facilities and other places from which convenient daily collections can be made, standing invitations to file (with appropriate explanation giving points covered by net for fastest service) in church and club papers, and exhibit stations all provide opportunities to the alert operator, not to mention families, friends and radio acquaintances. W2OUT writes to suggest convention bureaus and hotel staffs, with the caution that all such traffic must be limited, accepting only that where fast service is assured. He also reports, "Amateur service was given the delegates of the American Institute of Chemical Engineers on Nov. 7th to 10th at their N. Y. C. meeting at the Hotel Pennsylvania, and some 104 filings were originated. Traffic was 'phoned to W2RTZ and W2VNJ, who moved it promptly via nets and trunks."

14-Mc. Conditions. "Speaking of key clicks, listen on twenty each night; it's horrible. FCC could well assign more monitoring to this band to clean it up." — W6RBQ "If we can get the DX boys to specify frequencies well off their own we will go a long way in eliminating the cause of the present mess. The excellent article on the 'Monitone' should be the answer for DX amateurs to

use. For days at a time I did not find one station that could use break-in. Another thing: right when there's fairly good DX, some W comes on *testing* to get out parasites or some such. Please remind the gang that dummy antennas [lamp-bulb load, etc. — Ed.] are simple to apply, and why not use them! One more thing — remind the fellows that 14 Mc. is a prime DX band. Listen on your frequency as on other bands before transmitting — and before improperly starting to talk to some guy just across your city or state!" — W2HMJ

Building Operating Ability. To the scores of new amateurs interested in this subject we want to say that the surest way to learn to copy faster is to practise copying transmissions sent several words a minute above your normal receiving speed limit. Write down those characters and words you can get even though you can't get them all. Make a habit of copying WIAW or fast commercial tape stations for practice. Just listening to "automatic" transmissions improves one's ability to send with rhythm as well as to receive faster. Copying ability is what you are out to develop; a few words noted orally proves but little and is no builder of accuracy, so write down what you hear to develop coördination and accuracy. ARRL sometimes receives complaints concerning interference on WIAW code-practice runs. "Interference" may be painful and disconcerting but it is that additional practice in consciously reading through QRM that can be regarded as desirable in that it has given the experienced American amateur the reputation of being the "best in the world!" An S2 signal of differing pitch from a loud one is often capable of giving 100% copy. There are little tricks to this business such as cutting down the receiver volume to keep the ear from overloading when picking out the wanted signal. Make proficiency your aim, even when copying through QRM. Those skilled in making hand copy can gain new prowess by practice in copying on a "mill." To one and all, may we say that it will give us great pleasure to extend ARRL certification (and endorsement at increasing speeds) if you will accept our invitation to participate in ARRL's Code Proficiency Program this season and let us check your qualifying-run copy. — F. E. H.

Major General S. B. Akin, chief signal officer of the Army, opens K4USA at the Pentagon. Alton R. "Al" Hart, W5FB, does the honors. K4USA will operate daily on 3.5-, 7-, 14- and 28-Mc. c.w. and 'phone. For 14- and 28-Mc. operation, the BC-610E transmitter shown is used with a three-element dual 10-20 close-spaced rotary mounted atop the Pentagon. Transmitters for 3.5 and 7 Mc. are located at the transmitting stations of WAR at Battery Cove and Fort Myer, Virginia, and are operated from K4USA by remote control.

January 1949



OCTOBER CD QSO PARTY

Any Communications Department appointee who missed the October CD Party lost out on what was undoubtedly the biggest such activity yet held. The gang was out in large numbers and at times the affair took on the aspect of an SS contest. For the second consecutive contest, W6WNI brought top scoring honors to the West Coast, this time to the tune of 907,630 points. W4KFC trailed close behind with 878,970 points and a record-breaking QSO total of 491 to keep the East Coast in the top bracket, and the Midwest was ably represented by W9RQM in third place.

The next opportunity for the CD appointee group to get together will be during the ARRL Member QSO Party, January 22nd-23rd. It should be an even busier week end than that of the October Party. Plan now to be on hand for the fun!

Claimed Scores (C.W.)

Station	Score	Contacts	Different Stations	Sections
W6WNI	907,630	355	223	38
W4KFC	878,970	491	296	57
W9RQM	685,850	424	262	57
W4IA	679,250	411	270	55
W6BRD/9	642,130	402	258	58
W8ROX	552,975	358	248	55
W1EOB	506,940	350	229	55
W9VES	481,380	332	229	55
W6RBQ	477,750	212	198	52
W6ISQ	428,610	224	158	52
W8GBF	407,880	302	211	53
W1IKE	400,920	305	209	48
W2GFG	383,160	302	199	49
W3LIW	356,250	289	201	49
W6FKL	351,000	100	100	39
W4LRI	340,580	264	210	48
W3NF/2	330,000	270	192	48
W7KWC	327,888	184	151	47
W1LHE	321,300	264	189	49
W1JYH	314,875	271	183	46
W8TAQ	310,800	233	211	48
W2IOP	304,470	299	155	44
W6VAQ	304,200	185	129	51
W1BIH	300,375	260	178	47
W1CRW	297,570	273	168	50
W4FBJ	296,250	250	192	45
W2CWK	292,500	255	177	48
W2ESO	290,700	248	182	46
W6IUW	282,720	222	198	50
W8DAE	278,845	250	166	51
W8VTF	273,280	240	178	46
W7QAP	263,160	170	124	48

W2PGT	255,335	224	180	43
W9NH	353,080	222	169	53
W7CZY	250,834	163	121	46
W4KVM	249,310	228	161	53
W7BSU	247,404	174	109	50
W1QMJ	247,320	223	171	45
W8YDR	246,340	226	169	49
W1FTX	245,300	215	173	50
W1AQE	242,320	233	163	45
VE3WY	238,260	225	165	44
W4MPF	233,260	218	174	40
W6CMN	229,068	156	117	45
W2KYS	225,720	218	173	36
W2PZE	222,610	223	157	40
W2RPH	221,450	210	162	44
W1LVQ	221,340	210	158	48
W4DXI	215,130	218	154	48
VE3AWE	204,015	201	161	42

Others with scores above 150,000: W9QLW 194,820, W9TAL 193,060, W2WPU 191,580, W8HOX 189,000, W4LAP 188,110, W8ZAU 178,875, W1OS 175,630, W9WFS 174,355, VE7SW 174,096, W4AYV 169,235, W3EIS 166,430, W6CIS 164,593, W7LPA 164,284, W4FCF 163,160, W1NJM 159,030, W9NZZ 152,280, W8LIT 152,100.

FREQUENCY-MEASURING TEST

W1AW will transmit signals for the purpose of frequency measurement starting at 9:30 P.M. EST (6:30 P.M. PST), Tuesday evening, January 18th. The signals will consist of dashes interspersed with station identification. They will follow a general message sent to enable listeners to locate the signals before the measurement transmission starts. The approximate frequencies used will be 3510, 7195, 14,110, and 28,370 kc. About 4½ minutes will be allowed for measuring each frequency, with long dashes for measurement starting about 9:36 P.M. It is suggested that frequencies be measured in the order listed. Transmissions will be found within 5 or 10 kc. of the suggested frequencies.

At 12:30 A.M. EST January 19th (9:30 P.M. PST January 18th), W1AW will transmit a second series of signals for the Frequency-Measuring Test. Approximate frequencies used will be 3660, 7125, 14,145 and 28,150 kc.

Individual reports on results will be sent ARRL members who take part. Copies of this report are sent SCMs so eligibility for OO appointments is known. When the average accuracy reported shows error less than 71.43 parts per million, or falls between limits of 71.43 and 357.15 parts



Hams all! Amateur radio is a family affair with the Zellingers of Oklahoma City, Okla. Mary, the XYL, used to sit and crochet while Fred, sr., W5HXJ, was on the air. In January, 1948, she, daughter Margie, aged 14, and son Fred, jr., 12, were bitten by the radio bug. The inevitable result: three shiny new calls. Mary is now W5PCH, Margie W5PAD and Freddie W5PBO. A room in the Zellingler home has been converted into a ham's paradise with several receivers, transmitters and other pieces of gear. So far as is known the Zellingers hold the record for the largest all-ham family. Can any other 100% amateur family top them in numbers?

QST for

per million, the participants will become eligible for appointment by SCMs as Class I or Class II official observers, respectively. It is only necessary that the individual amateurs have the interest and other qualifications for carrying forward in such League-organization posts.

This ARRL Frequency-Measuring Test will be used to aid qualification of Class I and Class II observers. Observers not demonstrating the requisite average accuracy will be reclassified appropriately until they demonstrate the above-stated minimum required accuracy for these classes of appointment. It is required that all Class I and Class II OOs participate in at least two Frequency-Measuring Tests each year.

Awards

All League members (and only members) who take part and who are not connected with the Official Observing System will compete for an electric-clock award by submitting their best measurements on the FMT. It will be presented to the member whose readings show the highest accuracy. A second electric-clock award will be presented to the leading Class I official observer. To be considered for the clock award it is necessary to attach a statement that you, alone, as operator, handled your equipment in making the readings submitted to the Communications Department of the League.

All participants may submit frequency measurements on one or all frequencies listed above. However, no entry consisting of a single measurement will be considered eligible in the prize competitions; at least two readings must be submitted. Awards will be based on the over-all accuracy, as compared with readings submitted by an independent professional frequency-measuring organization. An award committee will examine results to insure fairness to all, and its decisions shall be final.

FMT RESULTS

The Second 1948 Frequency Measuring Test, open to both ARRL official observers and other amateurs, was held on September 17th. Entries were received from 134 participants, 58 of whom were OOs and 76 non-observers. The leader in each category has received as an award an electric clock capable of controlling automatically the on and off switching of 115-volt a.c.-operated equipment.

Each participant received an individual report comparing the accuracy of his measurements of the WIAW FMT transmissions with those made by a commercial frequency-measuring laboratory. Frequencies used in the September FMT were as follows:

3599.066	3741.828
7170.494	7258.640
14,079.780	14,150.040

Prize winner in the OO group was Robert S. Palmer, W9CIH. Among the non-OOs, the prize-winning entry was submitted by Joseph F. Eckert, jr., W3GEX. The standings of leaders in the test are given below. In accordance with the announced rules, no entry covering a single measurement was considered eligible in the prize competition, Except where indicated, entries consisted of two or more measurements.

LEADERS

Observers	Parts/ Million	Non-Observers	Parts/ Million
W9CIH.....	1.4	W3GEX.....	1.1
W2OUT.....	2.6	W2CVV.....	1.8
W1BHW.....	2.7	W8HB.....	4.3
W1VW.....	2.7	W1ETC/2.....	4.6
W2ESO.....	2.9	W4AXU.....	4.9
W3JDM.....	3.5	W2DOP.....	6.9
W2AIQ.....	6.7	W3MCG.....	7.8
W3VNE.....	6.9	W2WOQ.....	8.4
W1MUN.....	7.1	VE2RD.....	9.5
W4IQV.....	9.3	W3IGX.....	9.8
W6IWU.....	10.2	GM6IS.....	10.8
W1ON.....	11.8	W4NGB.....	11.3
W9LFK.....	12.1	KP4AM.....	11.4
W5ARV.....	12.8	W9WJH.....	11.9
W9UKT.....	13.1	W9BOR.....	12.7
W2ZT.....	16.9	W9BQM.....	12.9
W1BKG.....	17.0	W6DFO.....	15.6
W1BGW.....	17.2	W4LOI.....	15.7
W2WI.....	19.4	W3GEG.....	15.9
W6GC.....	19.7	W2AFQ.....	16.0
W2BEL.....	21.8	W8LCA.....	16.2
W9ERU.....	23.5	W6UWR.....	18.5
W6GTE.....	24.9	W9WGM.....	18.6
W1BB.....	25.7	W2VMK.....	18.7
		W3ADE.....	19.3

The following ratings are based on a single measurement: OOs—W7GP 1.2. Non-OOs—D. E. Roberts 0.277, W2PIU 6.4.

A.R.R.L. ACTIVITIES CALENDAR

Jan. 13th: CP Qualifying Run
 Jan. 15th: V.H.F. Sweepstakes
 Jan. 22nd-23rd: ARRL Member Party
 Feb. 11th-14th: DX Competition (c.w.)
 Feb. 15th: CP Qualifying Run
 Feb. 18th-21st: DX Competition (phone)
 Mar. 11th-14th: DX Competition (c.w.)
 Mar. 16th: CP Qualifying Run
 Mar. 18th-21st: DX Competition (phone)
 Apr. 18th: CP Qualifying Run
 Apr. 23rd-24th: CD QSO Party
 May 20th: CP Qualifying Run
 June 4th-5th: V.H.F. Contest
 June 15th: CP Qualifying Run
 June 18th-19th: ARRL Field Day
 July 19th: CP Qualifying Run
 July 23rd-24th: CD QSO Party

— —
 Jan. 1st-Dec. 31st: Most-States V.H.F. Contest
 First Saturday night each month: ARRL Officials Nite (get-together for SCMs, RMs, SECs, ECs, PAMs, Hq. Staff, Directors, Alt. and Asst. Dirs.)

BRASS POUNDERS LEAGUE

(October Traffic)

Call	Orig.	Del.	Rel.	Extra Del. Credit	Total
W7CKT	6	35	1585	30	1656
W0HMM	10	25	860	9	904
W1QMI	60	315	89	314	778
W8FFK	43	76	454	67	640
W6FDR	31	48	476	46	601
W1ILN	17	274	28	270	589
W6REB	10	8	506	6	530
W0TQD	3	2	523	0	523
W9LFK	24	40	427	32	523

The following made the BPL with over 100 "deliveries plus extra delivery credits":

W1AW 414	W8UUS 184	W5KTE 129
W3ECP 259	W1FTX 138	W8TRN* 117
W9DUA 246	E3NRW 137	W2WFU 112
W1NJM 232	W1AQE 133	W3NHI 100
	W6DDE 130	

A message total of 500 or more or 100 "deliveries plus extra delivery credits" will put you in line for a place in the BPL. The Brass Pounders League listing is open to all operators who qualify for this monthly "honor roll."

* August traffic.

TRAFFIC TOPICS

The subject of shifting two or more stations five or ten kc. each side of the net frequency is again brought up for discussion. As a result of this practice, several nets are experiencing much undue QRM from nets operating on adjacent channels. If you wish to use this system of operation, your NCS should check the adjacent frequencies during net operation to determine if those spots are clear.

The Teenager Net (TAN) has been formed and will meet on 7150 kc. each Wednesday at 3:45 P.M. EST, and each Saturday at 11:00 A.M. EST. Amateurs in their teens are cordially invited to join the net and are requested to contact W2VXI either by mail or on the air.

The Jersey Net is going great guns, and has made up a complete routing chart to facilitate fast service. The net is operating on 3630 kc. at 9:00 P.M. EST, Monday through Friday. All "Traffic Hounds" are invited to check in to clear with them.

The Buckeye Net of Ohio is proud to have as members four doctors, physicians W8PNY, W8AVB, W8WZ, and oculist W8EBJ. All that is needed now is a dentist!

The ILN Net of Illinois has published a map showing the location and call of each member station. This should prove invaluable to all net members for information, and in particular to the various net control stations for use in routing traffic. It also gives a very nice picture of just what coverage the net enjoys.

A net has been formed on 29,400 kc. called the Marine Corps Net. Operating each day, Monday through Friday, at 2200 GCT, it covers Marine Corps bases throughout the United States and in the Pacific Area. Member stations will monitor the frequency before the net meets to accept traffic for handling via MCN. Call "CQ any Marine Corps Net Station" and you will be cleared. It is requested that you clear prior to 2200 GCT. Additional Marine Corps bases are requested to check into the net for greater coverage.

The Alabama Section now boasts three full-fledged emergency nets: AENB, 3715 kc., operates at 7:00 P.M. CST daily; AENP, 3955 kc., Monday through Friday, 6:00 P.M.; AENZ, 7220 kc., 7:00 P.M., Monday through Friday. Good work, Alabama!

The Ontario Section now sports a 40-meter net called QON, which operates daily on 7267 kc. at 7:30 P.M. EST. Other 40-meter nets are invited to contact VE3ATR to arrange schedules for the exchange of traffic.

Reports from the nets are coming in slowly. Please pass along any information regarding your net for inclusion in this column.

SUPPLEMENT TO DIRECTORY OF ACTIVE NETS

This listing is to be added to the directory as published in November, 1948, *QST*, page 72. Supplements will be published at intervals to keep the directory up to date on all net listings and changes.

AENB (Ala.)	3715	7:00 P.M. CST Daily
AENP (Ala.)	3955	6:00 P.M. CST Mon.-Fri.
AENZ (Ala.)	7220	7:00 P.M. CST Mon.-Fri.
Alberta Net	3730	7:00 P.M. MST Mon.-Fri.
Arkansas Emergency Net	3885	6:00 A.M. CST Mon.
Badger Emergency Net (Wis.)	3950	6:00 P.M. CST Daily
Conn. Emergency Net	3640	7:00 P.M. EST Sat., Sun.
Conn. River Net	3580	8:00 P.M. EST Mon.-Fri.
Conn. Valley Net	29250	9:00 P.M. EST Thurs.
Cracker Emergency Net	3995	8:30 A.M. EST Sun.
Diablo Net (Calif.)	3885	8:00 P.M. PST Daily
Eastern Pa. Traffic Net*	3785	6:30 P.M. EST Mon.-Sat.
Eastern Shuttle Net	7120	10:30 A.M. EST Sun.-Sat.
		7:30 P.M. EST Mon., Wed., Fri.
Eastern Traffic Net (Mar.)	3545	7:00 P.M. EST Mon.-Fri.
Florida Emerg. Fone Net	3910	6:15 P.M. EST Tues.
Illinois Emergency Net	3940	7:00 P.M. CST Tues., Thurs.
		9:00 A.M. CST Sun.
Jersey Net*	3630	9:00 P.M. EST Mon.-Fri.
KYN (Kentucky)*	3800	7:00 P.M. CST Mon.-Sat.
		9:00 A.M. CST Sun.
Minn. State 'Phone Net*	3892	6:15 P.M. CST Mon.-Sat.
Missouri Emerg. Net*	3905	10:00 A.M. CST Sun.
		7:30 P.M. CST Mon., Wed., Fri.
North Dakota Net*	3525	8:30 P.M. CST Mon., Wed., Fri.
NYB Net*	3720	7:00 P.M. EST Mon.-Sat.
Ohio Emerg. Corps Net	3725	8:30 P.M. EST Mon.
Ohio Emergency Net	3860	6:30 P.M. EST Thurs.
Ohio River Emerg. Net	3860	8:00 A.M. EST Sun.
Ontario 40 Net*	7267	7:30 P.M. EST Daily
Ozark C.W. Net (Ark.)	3695	7:00 P.M. CST Mon.-Fri.

Palmetto Net (Fla.)*	3675	7:30 P.M. EST Mon.-Fri.
	7290	7:00 P.M. EST Mon.-Fri.
Pine Tree Net (Maine)*	3550	7:00 P.M. EST Mon.-Fri.
QPO (Police Net)	7260-3715	
Rhode Island Net	3540	7:00 P.M. EST Mon.-Fri.
Sea Gull Net (Maine)*	3961	5:15 P.M. EST Mon.-Fri.
South Texas Emerg. Net	3840	6:30 P.M. CST Mon.
	3860	6:30 P.M. CST Mon.
Southern Border Net ¹ *	3550	8:00 P.M. PST Daily
Susquehanna Emerg. Net	3910	9:00 A.M. EST Alt. Sun.
Swing-Shift Net ² *	7280	12:30 P.M. EST Mon.-Sat.
		7:00 P.M. EST Mon.-Fri.
Teenager Net (TAN)	7150	3:45 P.M. EST Wed.
		11:00 A.M. EST Sat.
Tri-State Net	3870	6:00 A.M. CST Mon.
		8:00 P.M. CST Wed.
TLM*	3570	10:00 P.M. EST Mon., Wed., Fri.
TLN*	3590	8:00 P.M. MST Mon., Wed., Fri.
Vermont C.W. Net	3740	7:00 P.M. EST Mon.-Sat.
Virginia Fone Net	3880	7:30 P.M. EST Mon.-Fri.
West North Dakota Net*	3670	8:30 P.M. CST Mon., Wed., Fri.

* Change in listing.

¹ Calif., Ariz., New Mex., Okla.

² New England, N. Y., N. J., Pa., Md., D. C., Ohio, Ont., Que.

³ D. C., Va., W. Va., Ky., Mo., Kans., Colo., Utah, Nev., Calif.

⁴ Tex., New Mex., Utah, Idaho, Ore., Wash.

RED CROSS TRAFFIC ROUTING

The Disaster Communications Unit of the American National Red Cross is circulating a pamphlet to all Red Cross chapters in which a definite plan for the handling of disaster communications in cooperation with amateur radio is set forth. The plan is built around the three amateur stations which have been provided with teletype connections with the Red Cross coast-to-coast teletype system, K3NRW in Washington, D. C., W9DUA in Evanston, Ill., and W6CXO in San Francisco, and instructs local Red Cross personnel to ask amateurs in time of emergency to route Red Cross traffic via those three stations. The frequencies monitored by K3NRW, W9DUA and W6CXO — 3550, 7100 and 14,050 kc. — are set forth in the pamphlet, and it is believed that most Red Cross chapters will be able to obtain suitable stand-by facilities in accordance therewith by working through the ARRL emergency coordinator for their community.

In the event that it is impossible for an amateur to work directly into either K3NRW, W9DUA or W6CXO, the National Emergency Net, which is alerted during time of communications emergency, and which monitors the frequencies 3550, 3875, and 7100 kc., will be prepared to handle emergency traffic of all types. The National Emergency Net is dedicated to the routing of third-party traffic between emergency nets operating in a disaster area and the normal

traffic-routing facilities of the amateur service. They will, as well, provide a sure route into either K3NRW, W9DUA or W6CXO.

The following is quoted from the Red Cross pamphlet for your information:

Advance planning is vital if your chapter and the community it serves is to be provided with an emergency radio communications service capable of functioning rapidly and effectively when disaster strikes. The fundamental problem involved is one of coordinating communications personnel and facilities with the permanent chapter disaster preparedness setup. In order to do so, contact the American Radio Relay League emergency coordinator, and through him arrange a meeting with local amateur radio operators. Discussions with this group should include the development of the following essential points:

1. Develop a step-by-step disaster plan covering the use of all available radio facilities that could possibly serve your chapter — with particular emphasis on those stations having emergency power sources.
2. Make certain that all concerned have a clear and complete understanding of the above plan of operation. In other words local radio operators must understand the nationwide radio and teletype communications system described herein and how best to tie in with it locally. At the same time, disaster committee members must be fully acquainted with the communications facilities, both local and national, which are to be used in the event of an emergency.
3. Finally, see that the local radio group have permanent representation on the chapter disaster committee. This integration is best achieved by appointing the emergency coordinator, if he lives within the chapter's jurisdiction, or in any event, a qualified local radio amateur to serve as a liaison member of the disaster committee.

During this meeting, there should be distributed to all participating amateurs copies of Form which shows the standby frequencies of the three principal radio stations which are permanently connected to strategically located terminals of the American National Red Cross Teletype System (Amcross TC System).

Dick Bischoff, W9QVA, is operator of this business-like station in Burlington, Iowa. Holder of ORS and OO appointments, W9QVA is active in traffic as alternate NCS for the Iowa Tall Corn Net. The rig consists of BC-696 and BC-459-A units used as VFOs driving a Stancor ST-202-A at 100 watts input. Reception is provided by an HQ-129X working into a "Lazy Man's Q5-er" for added selectivity.



THE RST SYSTEM

Headquarters has become increasingly aware of late that our RST system of signal reporting, as correctly detailed on CD Operating Aid Number 3, is being shamefully misused. Considerable research on the part of our Midwest secret operative, W9BRD, enables us to present the following interpretation of the RST system as employed nowadays by the majority of hams:

- R5 — Got everything, somehow.
- R4 — QRM chopping you up, got a little.
- R3 — Got practically nothing but squeaks.
- R2 — (This is an insult — never use it.)
- R1 — I am trying to be funny.
- S9 — Strong as heck (or "pse QSL").
- S8 — Above-average signal.
- S7 — Average signal (also is the only correct report for use during contests).
- S6 — Below-average signal.
- S5 — Weak as the devil — don't want your QSL anyhow.
- S4 — I think that's you in the mud.
- S3 — (Never use this report — no receiver can be this punk.)
- S2 — (Obsolete term -- has not been used since 1938.)
- S1 — (Given to S9 locals as a joke.)
- T9 — Your signal sounds as though you have a d.c. plate supply.
- T8 — Your note is very rough.
- T7 — Your note is terrible. Better QRT before FCC catches you.
- T6 — (Insult, never use this report.)
- T5 — " " " " "
- T4 — " " " " "
- T3 — " " " " "
- T2 — " " " " "
- T1 — (Given to locals as a joke.)

CODE-PROFICIENCY CERTIFICATES

The next Code Proficiency Qualifying Run will be made on January 13th at 10:00 P.M. EST. Identical texts will be transmitted simultaneously from W1AW, W6OWP and WØTQD. Frequencies of transmission from W6OWP will be 3590 and 7248 kc., from WØTQD 3534 kc. W1AW will use the frequencies listed in the schedule elsewhere in this section. Mail your copies of the qualifying run to Headquarters no later than January 23rd. Please indicate the call of the station whose transmissions you copied. If you qualify at one of the five speeds transmitted, 15 through 35 w.p.m., you will receive a certificate. If your initial qualification is for a speed below 35 w.p.m., you may try later for endorsements indicating progress above the first certified speed.

Code-practice transmissions are made from W1AW each evening, Monday through Friday, at 10:00 P.M. EST. References to texts used on several of the transmissions are given below.

These make it possible to check your copy. To get sending practice hook up your own key and buzzer and attempt to send in step with W1AW.

Date	Subject of Practice Text from November QST.
Jan. 4th:	<i>A Simple Single-Sideband Transmitter</i> , p. 14
Jan. 7th:	<i>A Lightweight 14-Mc. Four-Element Beam</i> , p. 18
Jan. 10th:	<i>Improving F. M. Transmission Techniques</i> , p. 21
Jan. 12th:	<i>The "Co-ax Twin-Lamp"</i> , p. 25
Jan. 13th:	Qualifying Run, 10:00 P.M. EST
Jan. 18th:	<i>A VFO/Crystal Exciter</i> , p. 36
Jan. 20th:	<i>The "Quad" Antenna</i> , p. 40
Jan. 26th:	<i>About Antennas for 80-Meter Mobile</i> , p. 42
Jan. 28th:	<i>So It's Hard to Get on V.H.F.I.</i> , p. 44
Jan. 31st:	<i>A Rack-Top Operating Table</i> , p. 58

NO REST FOR THE WEARY

Not one, but two major hurricanes traversed the Florida "hurricane belt" during the past few months. The first, that of September 20-22, found the Florida gang well prepared, with their three emergency nets alerted well ahead of time by SEC Lowery, W4DQW. Key West was the only community of major importance which was not provided with amateur radio for communications when the wires went down. In the potentially-dangerous Okeechobee area, W4ISR of Clewiston, marooned in his shack by high water, provided the sole source of information concerning the status of the dike surrounding Lake Okeechobee. At one stage of the proceedings the Weather Bureau "misplaced" the center of the storm momentarily, and W4GZY of Homestead set them straight on that point.

Torrential rains which accompanied the September 20th-21st storm created high water conditions throughout most of southern Florida, and it is fortunate that a second hurricane, on October 5th, which traversed nearly the same territory, was almost "dry." Coincidentally, W4GZY was once again responsible for "finding" this hurricane after the Miami Weather Bureau had "misplaced" it. The two storms did comparatively little damage, so the Florida AEC members confined their operations mostly to the handling of weather data and the guarding of the three frequencies used.

As W4JQ of West Palm Beach was heard to say: Two hurricanes in a row "is just too darn much radio — rather play golf."

WITH THE A.E.C.

Members of the LaCrescenta (Calif.) Amateur Emergency Corps assisted the local sheriff's office in seeking an airplane which crashed into a near-by mountain on October 19th. Mobile units in cars and 144-Mc. pack rigs which were carried into the hills successfully maintained communications between the searchers and their base of operations. Among the members of the group which assisted in this effort were W6s HMC, VRK, BTX, YGT, YKB, RTR, UBY, BTA.

— . . . —

Clay Griffin, W4DXI, has been appointed regional emergency coordinator for the South-

eastern Area of the American Red Cross. The RC Southeastern Area includes the states of Alabama, Florida, Georgia, Louisiana, Mississippi, North Carolina, South Carolina and Tennessee. Acting as liaison man between that RC office and the amateur service, Clay occupies one of the hottest of the EC seats.

The Nutmeg Net, the Connecticut traffic facility, has expanded its operations to a 7-day-a-week schedule. The new Saturday and Sunday evening runs are under the banner "Connecticut Emergency Net," and are slow-speed sessions. The Connecticut gang have shown that many casual operators who either have insufficient time to get into the week-night operations of the regular section net, or who do not feel themselves sufficiently experienced to operate in a traffic net, welcome the opportunity to train themselves for emergency work. How about some other sections trying this?

The Eastern Mass. gang have declared the last Sunday of each month to be "Emergency Test Day." Operating on the section emergency frequencies of 3745 kc. and 144 Mc., all local AEC groups will be tied into a section drill. This is one way to keep the gang from letting their batteries go dead between emergencies!

WIAW OPERATING SCHEDULE

(All times given are Eastern Standard Time)

Operating-Visiting Hours:

Monday through Friday: 1130-0600 (next day).
Saturday: 1900-0230 (Sunday).
Sunday: 1600-2200

A mimeographed local map showing how to get from main state highways (or from Hq. office) to WIAW will be sent to amateurs advising their intention to visit the station.

General Operation: Refer to page 71, November, 1948, *QST*, for a chart showing WIAW general operation. This schedule is still in effect and is not reproduced here for space considerations. Mimeographed complete master schedules of all WIAW operation in EST, CST, MST or PST are available upon request.

Official Bulletin Schedule: Bulletins containing the latest information on matters of general interest to amateurs are transmitted on regular schedules:

Frequencies:

C.W. — 3555, 7215, 14,100, 28,060, 52,000, 146,000 kc.
Phone — 3950, 14,280, 29,000, 52,000, 146,000 kc.

Times:

Sunday through Friday, 2000 by c.w., 2100 by 'phone.
Monday through Saturday, 2330 by 'phone, 2400 by c.w.

Code Proficiency Program: Practice transmissions at 15, 20, 25, 30 and 35 w.p.m. are made on Tuesdays and Thursdays on the above-listed frequencies starting at 2200, and on Monday, Wednesday and Friday at 9, 12, 18, 25 and 35 w.p.m. Approximately ten minutes of practice

is given at each speed. Next certificate qualifying run is scheduled for Thursday, January 13th.

Only two comments have been received concerning the use of 24-hour time: one for and one against. Drop the ARRL CD a line if you have any opinion on this.

W1AW will be closed from 1800 December 24th and December 31st until 1600 December 26th and January 2nd respectively, and from midnight February 21st to midnight February 22nd. The station participates in all official ARRL operating activities, omitting some week-end general operating periods for this purpose (see Activities Calendar).

DX CENTURY CLUB AWARDS

HONOR ROLL

W1FH.....	209	W8HW.....	189
W3BES.....	195	W4BPD.....	187
W6VFR.....	194	W2AOW.....	181
W2BXA.....	191	W3GAU.....	180
G2PL.....	191	W6SAI.....	180

NEW MEMBERS

G6RH.....	168	VK2ACX.....	104
PY1DH.....	139	W3EIV.....	103
CX1FY.....	119	W8AVB.....	102
W9VND.....	112	W2DKF.....	101
W0SBE.....	111	GW4CX.....	101
ZS6CZ.....	110	G2FSR.....	101
SMBLL.....	110	W2KXK.....	101
W2IMU.....	110	W6UZX.....	101
G6LX.....	108	W6DZZ.....	101
W4TM.....	108	W3KZQ.....	100
W2DPS.....	106		

ENDORSEMENTS

W30JV.....	178	CE3AG.....	141
W2QKX.....	174	W2LJR.....	141
W3DPA.....	171	W8FJN.....	140
W3KT.....	171	G8KP.....	140
W3GHD.....	170	W1FYH.....	140
W3CPV.....	166	W8FJL.....	140
ZS2X.....	163	W3FGB.....	140
W6DI.....	163	W6OMC.....	136
W2CYS.....	160	W6BPD.....	135
W5KC.....	160	W3DKT.....	131
W6TT.....	160	W4OM.....	130
W3EJV.....	160	W4JXM.....	130
W2IOP.....	156	KP4KD.....	130
W3JTC.....	156	VE7HC.....	130
W3KQF.....	154	W2HMJ.....	130
W8LEC.....	152	ON4OF.....	127
W3DRD.....	152	W2BLS.....	125
W2COK.....	151	W1AB.....	122
W6ZCY.....	151	W8UDR.....	120
W4PN.....	150	W9FJB.....	118
W0NUC.....	150	W2RDK.....	117
VE3QD.....	150	W2RWE.....	113
W6WKU.....	150	W3FUF.....	112
W2CWE.....	150	W6PZ.....	111
W9IU.....	150	W6CIS.....	111
W4MR.....	145	W6BVM.....	110
W5FNA.....	143		

RADIOTELEPHONE

HONOR ROLL

W1FH.....	170	XE1AC.....	136
W6DI.....	150	W2BXA.....	130
W4CYU.....	142	W2AFQ.....	130
W1JCX.....	138	W6VFR.....	130
G2PL.....	137	W1HKK.....	128

NEW MEMBERS

G6RH.....	105	G8AY.....	101
W2DPS.....	103	WIENE.....	100
W2EOH.....	102		

ENDORSEMENTS

W5BF.....	120	W4EWY.....	111
-----------	-----	------------	-----

• All operating amateurs are invited to report to the SCM on the first of each month, covering station activities for the preceding month. Radio Club news is also desired by SCMs for inclusion in these columns. The addresses of all SCMs will be found on page 6.

ATLANTIC DIVISION

EASTERN PENNSYLVANIA—SCM, Jerry Mathis. **W3BES**—HNW and KMH lectured to the Chester Radio Club on T.V.I. and harmonic reduction. New officers of the West Philadelphia Radio Assn. are: COZ, pres.; BXD, vice-pres.; IUD, secy.-treas. West Philly's 300-watt station, MKA, now is on 28 Mc. n.f.m. NNV is new OPS and AEC. He has 7-, 14- and 28-Mc. antennas up and is trying to find room for 3.5 Mc. ADE will try for OQ appointment. He reports into the E. Pa. Net. EU visited 8F7K in Cleveland to QSL in person. AXA enjoyed the CD Party. AQN has been appointed EC for his ninth term. NEH makes the BPL on deliveries. DZ has a new Chevie. KLZ keeps regular schedules with QEW on 144 Mc. OPU is on 28-Mc. 'phone and will be on 144 Mc. along with LCK and NEG. CAU reported three stations off frequency this month. SNZ attended the Boston Hamfest. OP relayed seven messages from Greenland. JPR made his first South American contact. AIW built a new receiver. The Lancaster Club will continue to hold its popular Wednesday night transmitter hunts until the weather gets too cold. CLM is back on 14- and 28-Mc. 'phone and 7-Mc. c.w. after an 8-year layoff. ELI reports dampness in his cellar keeps him busy replacing transformers in his transmitter and receiver. He hopes a small heater will cure the trouble. The Susquehanna Valley ARC has been laboring on the interior of its new club house. The club calls VPJ and the station at present is on 144 Mc. New SVARC activities managers are MXE and MGL. LAK is building a new shack. QJP's super kw. is nearing completion. UWQ took the fatal step in September and hasn't been on the air since. IVM and NES are building 32-element beams for 144 Mc. VYA is a new SVARC member. Eleven vacancies exist in the Electronics Division of the Aircraft maintenance department at Naval Air Station, Willow Grove, Pa. These vacancies are up to and including First Class Petty Officers. Any man with a previous rating may return to extended active duty in his old rating provided a vacancy exists. Duty is for this station only and may be terminated upon request. Full pay and allowances are authorized. For information write or call R. M. Mullins, Lt. (jg.), USNR Maintenance Department, Naval Air Station, Willow Grove, Pa. Traffic: W3NHJ 201, VMF 172, DZ 153, ELI 81, QEW 62, AQN 60, BES 34, CUL 32, OML 22, ADE 14, EAN 14, AXA 10, VR 7, CXE 5, EU 5, CAU 3, CLM 2.

MARYLAND-DELAWARE-DISTRICT OF COLUMBIA—SCM, Eppa W. Darné, W3BWT—At the first October meeting of the Washington Radio Club, Warren Andrew, AM, the Club's vice-president, gave a talk and demonstration on "Interstage Coupling." Mr. Cortwright, of the American Red Cross, spoke on the new Red Cross National Headquarters Station, K3NRW, which will be operated by the membership of the Washington Radio Club and the Potomac Valley Radio Club. The second October Washington Radio Club meeting featured an auction of spare parts and gear by the membership and also an announcement and short talk by the SCM on the coming Governors-President Relay to be held in January. The Potomac-Rappahannock Valley Emergency Net members are holding regular drills on 144 Mc. and are using the 3935-kc. channel about once each six weeks to keep same in readiness. Members of the Washington Mobile Radio Club were on Skyline Drive the week end of October 9th for a get-together and DX spree. About fifteen members participated, plus several 28-Mc. mobile units from Baltimore. Many stations in the Midwest and West, plus Puerto Rico, were successfully contacted. HRZ now is in China. NMU and OBV are very active on 28 Mc. BDY and JE have 28-Mc. mobile units. JVG now is GTX and is building 28- and 144-Mc. gear. KRJ did some nice work in the recent VHF Party on 144 Mc. from Gambrell State Park. Md. CDQ is regularly on 14,020 kc. and worked in the CD Party. "Emzie" also reported at K3NRW during the Simulated Emergency Test. JZY now works on Trunk Line "M." MYM does nice work with 20

watts. John announces the arrival of a jr. operator in October. The SCM regrets to announce the death of EZV on October 21st after a short illness. OQG is on 14 and 7 Mc. and gets out well using an indoor antenna. CDL has new National HFS receiver for 144 Mc. EFZ had an emergency appendectomy while on a recent fishing trip. He is now OK, although activities were curtailed for the past month. NRW and ECP made the B.P.L. this month. NRW was operated by 14 Washington, D. C., Area operators during the October Simulated Emergency Test. IEM works with Swing Shift Net on 7 Mc. LVJ is rebuilding. EQK now has 69 countries on 14-Mc. 'phone, and recently had a two-hour-and-thirty-four-minute QSO with 8UUS in Michigan. Traffic: W3ECP 339, K3NRW 223, W3AKB 180, MJQ 102, QL 38, OQG 37, JHW 14, EQK 8, BWT 5, IEM 5, MYM 4, LVJ 2.

SOUTHERN NEW JERSEY—SCM, G. W. (Bill) Tunnell, W2OXX—The Delaware Valley Radio Association operated QZ/2 at the State Fair in cooperation with the local broadcast station. A message service was offered to the public, day and night, with ten operators participating, headed by JAG. ZI now is a member of Trunk Line "A." ORS is the eastern terminal station of the Transcontinental "TC" Net. RG requests more participation in net functions by those holding ORS appointment. SXK claims a rare disease—"traffic tremors." BEI has had more than 600 contacts with G6BY. BAY is working on a new modulator. HAZ and RPH are busy with house repairs. ZBE handled his first traffic. Six members of the 3.85-Mc. Emergency Net have battery-operated portable rigs for that band. EZM moved to Philadelphia and obtained his old call, 3BYK. UKS is all set for emergency work with mobile gear for 7, 14, 27, 28, and 50 Mc. VUM has new home with a beam. YAO is using n.f.m. YRV moved to W3 Land. Sea Isle City has a new ham, K2AZ. CYI reports the following: "RSF worked TR1P, which resulted in a telephone call to Boston and an emergency furlough for an overseas sergeant to visit his critically ill wife." The Atlantic Radio Club held a dinner gathering for its forty members. Incidentally, the club has applied for a call. Our old neighbor, 3QL, can be found in the 3700-kc. Net. Traffic: W2ZQ 284, SUG 152, ZI 115, ORS 69, RG 35, SXK 30, BEI 20, BAY 10, 3NF/2 10, 3HAZ 5, ZBE 2.

WESTERN NEW YORK—SCM, Harding A. Clark, W2PGT—SEC: 8JV, RM: FCG. It is with deep regret that I report the recent death of Ken Ruether, MRO, after an extended illness. Ken was one of our most active hams and his absence will be apparent to all the gang. The recent Simulated Emergency Test saw many of the gang participating in local emergency problems. From reports received the tests, where conducted, met with loud praise from public officials and Red Cross Chapters for the efficient operation of the various groups. The time is rapidly approaching when our existence will depend on our ability to provide a public service—we are you carrying your share of the load? Congrats to IGI, WFU, and YVH on new harmonics. 80 has new six-element all-band fixed "rotary" beam. WFU is editing an FB monthly bulletin for RARA. EEB postponed a trip to the hospital to participate in the EC Test. QZI is back on the air after an aircraft accident. UPH has new final with 304THs. CXO is having good luck with quad antenna on 28 Mc. QHH still continues to add new countries with QRP and now has 153. SB, RXT, RJH, TBA, SVL, CDX, WTC, SSK, and AWB are all active in the Emergency Corps in Chautauqua County. UZN/2 is attending Syracuse U. and is looking for 420-Mc. activity. WFU has joined the select group in the BPL. Traffic activity is rapidly increasing, with several new members in NYS. Traffic: W2WVF 391, PGT 367, RUF 345, WOE 203, 8JV 133, FCG 76, QHH 44, WZQ 27, BLO 19, AOR 17, VBH 15, RUK 11, USO 10, UZN/2 8, QNA 6, 80 4.

WESTERN PENNSYLVANIA—SCM, Ernest J. Hlinsky, W3KWL—The Horseshoe Radio Club, of Altoona, is looking for a new QTH. During the VHF Contest KJU snagged Mechanicsburg and York on 144 Mc. OQQ managed to hook KBA. RFM and OJX are having their taste of QRM. LJQ did snag his first VK. TXQ is on 14 Mc. Newly-elected officers of the ATA of Pittsburgh are: NUG, pres.; YDJ, vice-pres.; UHN, secy.; UL, treas. Latest Polecat Net drills showed only 2 members reporting. The Port Necessity Amateur Radio Assn. of Uniontown, UUZ, sends in a few notes. BCY worked 57 countries postwar using indoor folded dipole on 14 Mc. LAC is building rig for 28-Mc. 'phone. UUZ has a BC-459 to hunt for DX. The new club house now is completed and has a 1-kw. generator for lighting purposes. New officers of the Wesco ARS are: GRZ, pres.; ORP and KQU, vice-pres.; APH, secy.; OIW, treas. UVD was the SS chairman. KQU's elegant display of his

(Continued on page 74)



(Number one hundred seventy-seven of a series)

Merry Christmas

and

Happy New Year

from NATIONAL COMPANY

- | | |
|------------------------------|----------------------------|
| C. L. Gagnebin.....W1ATD | Donald Poulin.....W1MXC |
| Herman S. Bradley.....W1BAQ | Dexter Atkinson.....W1MYH |
| Lawrence Amann.....W1BG | Milton Kalashian.....W1NXT |
| James Ciarlone.....W1BHW | Martin Oxman.....W1NYU |
| Calvin Hadlock.....W1CTW | Robert Anderson.....W1ODV |
| Harvey Poore.....W1DKM | Ralph Hawkins.....W1OEX |
| Seth Card.....W1DRO | John Prusak.....W1OPT |
| Hollis Peters.....W1EAB | Austin Banks.....W1ORK |
| Albert Porter.....W1ESI | William McNamara...W1OTK |
| J. Francis Bartlett.....W1ED | Harry Harris.....W1PFF |
| William Osborne.....W1EXR | William Bartell.....W1PIJ |
| George R. Ringland....W1EYZ | Charles Coyle.....W1PME |
| Don Hinds.....W1FRZ | Harry Paul.....W1PMS |
| Robert Murray.....W1FSN | Richard Brayley.....W1PRZ |
| Dave Smith.....W1HOH | Hyman Kana.....W1PSJ |
| John Baxter.....W1HRK | George Serzente.....W1PWG |
| Jack Ivers.....W1HSV | Raymond Jordan.....W1QIU |
| Edmund Harrington....W1JEL | Harry Mayo.....W1QPQ |
| Alfred Zerega.....W1JMK | S. W. Bateman.....W1RX |
| Robert Williams.....W1JOX | Clark Rodimon.....W1SZ |
| Frank Lopez.....W1KPB | William S. Doyle.....W1TV |
| Richard L. Gentry.....W1LEN | Edward Braddock....W3BAY |
| John Stanley.....W1LFF | Arthur H. Lynch.....W4DKJ |
| Leo Green.....W1LML | Raymond Lewis.....W4JU |
| Francis Waden.....W1LNV | M. B. Patterson.....W5CI |
| Richard Thurston.....W1MFZ | Herb Becker.....W6QD |
| Victor Penney.....W1MTS | W. Clif McCloud.....WøAZT |
| Clyde Schryver.....WøRPE | |

* The above reproduction of the National Tuberculosis Society Christmas Seal symbolizes our customary contribution to this most worthy cause



QSLs attracted lots of attention at local Family Day. The club gang is going strong for QST's article on the Clapp VFO circuit with ORP, UVD, and GRZ experimenting along those lines. NLU is starting new p-p. 812 rig. VNE, our OO, says the boys seem to be staying within the band limits. NBK now is mobile operating. LIW is doing an FB job as ORS in Johnstown. LSS is building three-element and five-element beams for 14 and 28 Mc. LWN says DX on 7 Mc. is FB with LA, F, G, ON, and PA, and on 3.5 Mc. with F and ON. AER was W. Pa. 'phone winner in DX Contest, while LOE was c.w. winner. PJJ is using n.f.m. with good results. KXU is sporting HRO-7 receiver. LWT and KSI are trying new three-element beam on 28 Mc. Those reporting nightly in the Western Pa. ORS Traffic Net are: LOD, KQD, KKA, LWN, NUG, GEG, LJO, GJY, NCJ, KWL, YA, LQQ, LIW, UVD, NT, and YDJ. If interested in ORS appointment, contact your SCM or one of the net members. In another few months my term of office expires, so let's give the SCM post some thought. Remember, it's the amateurs who make the section and it's the SCM's job to see that the men in his section are kept active. Thanks to all for the generous help you have given me. Traffic: W3GEG 69, KQD 45, KKA 43, YDJ 32, KWL 21, AER 18, LIW 13, LWN 1.

CENTRAL DIVISION

ILLINOIS — SCM, Lloyd E. Hopkins, W9EVJ — Net frequencies: ILN, 3765 kc.; IEN, 3940 kc.; RMs: KQL and SYZ; PAM: UQT. JTX is visiting 51KC in Oklahoma. HON is back in traffic. NN is building 1/2-kw. rig. ERO is getting high power ideas. OAL is new operator at WGN and is on 7 Mc. WEA is busy with OO duties. ZPC worked five new states. RSM is new ORS. LQP is working on mobile job and is new EC. PKF is new ham in Melrose Park. KQL turns in a fine traffic total. YTV has been QRL with home chores. SYZ is having a little B.C.I. trouble. EEK has been having trouble with the rig. JMG is busy dispatching trains in Chicago. ASN is EC for Jefferson County. BRX is busy putting up new tower. CMC is installing mobile job. BUK is EC for Evanston area. EVJ visited clubs in Chicago, Aurora, De Kalb, Evanston, and Springfield during the month. DUA was nearly swamped with traffic during the Simulated Emergency Test. FRP is ORS and OPS. FED is a new ham in Geneva. AEP completed new 807 final. PQH has finally gotten up the tower that blew down last Easter. LIN gets a big kick out of our c.w. net. BNO is on 3.85-Mc. 'phone. BRY is kept busy building his garage. AGV recently married. CZB is the father of a son. RBT is laid up in the hospital after a bad automobile accident. The Weldon Springs Amateur Radio Club was organized at Clinton, with LWZ, chairman; LYE, secretary; and eleven charter members. NIU recently made a trip to Texas. TLC worked a W8 on 144 Mc. QLZ is kept busy traveling around the State. BIN is getting good results with mobile job. The Midwest VHF Club had a Hidden Transmitter Hunt on Oct. 7th and 14 members participated. According to OBW a 144-Mc. QSO was held on Oct. 23 and 24 with good results. The Fox River Radio League of Aurora elected QBL, pres.; KRZ, vice-pres.; and EYL, secy.-treas. TAL is new OO. MRQ is now in Berwyn and active on ILN. ZHB has portable power unit. LHK, with stacked array, is rolling them in while OLM drools over the reports. IQC has new beam on tower. BJA needs help to get his antenna up. JVC is working on new 144-Mc. rig. ACJ sends in news for the Illinois Valley Radio Assn. of La Salle. MRH, DSX, BIK, and BPU are operating mobile. PRV is building a new home. #MIN visited Bloomington to renew old acquaintances. CEO and AIK have new 610Es. APK is getting results with 70 watts on 3.85-Mc. 'phone. EBX is very active in traffic of late. It is rumored that r.f. from LI's rig is killing the trees in his neighborhood. FET had his key stolen while chasing Halloween pranksters. DXL is off the air while rebuilding. WFS has worked G2PN three successive years on almost the same date without a schedule. EBX has new Collins 30K1. DOQ is employed at 5th Army Hq. in Chicago. BON worked nine VKs in one evening. WEA is active on 7 Mc. YBY is getting ready for 144 Mc. MYK reports the Wheaton Community Radio Amateurs Club is eight months old and growing. GNU, GBT, and AND have Collins 32V1 rigs and ZRB hopes to have one soon. AHV has new 275-watt rig. AAH runs 10 watts to a 522 and gets S9 from England. CKM has new VHF-152A. CBZ is sporting new 28-Mc. beam. AWA has 3.85-Mc. 'phone mobile job working. DNX has new HQ-129X and built new rig. VJN has new radio den and is building new operating desk. UNG is building 3.85-Mc. mobile. QBG took time off and got married. Traffic: (Sept.) W9EBX 282, EEK 42, ASN 27, DUA 12, BUK 9, VOA 6, WFS 5, BPU 3. (Oct.) W9DUA 324, KQL 255, EBX 212, DXL 183, EVJ 159, SYZ 89, CMC 57, ASN 54, ZPC 43, CTZ 35, EEK 32, LQP 31, JTX 30, AQH 29, LIN 23, BUK 20, RSM 18, DOQ 13, AND 10, FRP 8, WFS 5, NN 3, HON 2, BON 1, YBY 1.

INDIANA — SCM, Charles H. Conway, W9FSG — The Delaware Amateur Radio Association aided Delaware County authorities in preventing vandalism over Halloween by setting up a fixed station in the Muncie Police Headquarters, two fixed relay points in the county, and furnishing three mobile stations. All work was done on 144 Mc.

The Wabash Valley Amateur Radio Association is presenting a good program for its members this winter. Club activities are written up weekly in the *Terre Haute Tribune Star* by ANH. The Tri States QSL Contest is promoting a great deal of activity. Competition is keen with DGA, last year's winner, leading with QLW, BFB, EVR, and GFS close behind. MBL, New Castle, has 29 states in 9 call areas plus VE1, 3, and 4 on 54 Mc. and 6 states in 4 call areas on 144 Mc. DHJ, Crown Point, has new five-element beam up — on 144 Mc. that is. MYI, South Bend, put up a cubical quad on 28 Mc. BCJ, South Bend, is new OO. Ft. Wayne: UDD is new president of the Fort Wayne Radio Club. MYJ hooked KV4AA and CT3AB on 3.5 Mc. ENB put up new 3.5-Mc. antenna which really worked, only to lose it 3 days later in a wind storm. FNF and FLT are new calls. FTJ has 10 states on 144 Mc. ASZ has folded dipole on 7 Mc. VDB bought a nice new t.v. receiver and found he had a neighbor — FJT. Kokomo: UKT has new QTH with no power leak. Tom reported a list of 25 3.85-Mc. 'phone harmonics. PAP is new OO. IU is hunting new countries, and finding 'em too. KBQ, Knightsville, worked J3, G, and KZ5 with 100 watts on 28 Mc. JMS, Cory, has 10 states and VE3 on 144 Mc. FLB is new call in Terre Haute. Jim has an ARC-5. ET, Terre Haute, received 40 DX QSL cards in one batch from the QSL Manager. The Indianapolis Radio Club bought a generator for emergency work. The Indianapolis Emergency Mobile Net did an excellent job during the Simulated Emergency Test. Traffic: W9RCB 449, NH 244, DKV 108, TT 78, BKJ 64, BCJ 63, CKP 29, MBL 23, DHJ 14, KLF 14, QLW 13, PMT 10, SNQ 10, DGA 9, HUV 4.

WISCONSIN — SCM, Reno W. Goetsch, W9RQM — The Green Bay Mike and Key Club was reorganized and elected the following officers: FWO, pres.; BKD, vice-pres.; WLZ, secy.; KIZ, treas.; WJH and QYH, activities committee. LFK made BPL with 523 messages. The 15-w.p.m. C. W. Net at 6 p.m. is growing. All who are interested in getting started in traffic work are invited to participate. VHA is off to a good start with his OBS schedules. ESJ is newly appointed OBS with a 4-Mc. 'phone schedule. YCV has portable rig on 3775 kc., but has to drag it out of the closet each time to use it! DJV is newly-appointed ORS at Madison. CIH came through the September Frequency Measuring Test with an average accuracy of .00014 per cent! Also participating in this activity were WJH, LFK, BQM, and JNU. FNC, a new call at Wauwatosa, is on 7-Mc. c.w. with 18 watts to a BC-458 and a BC-348 receiver. AH, Chippewa Falls EC, is planning drills for local emergency practice. AFT has 28-Mc. beam and 144-Mc. sixteen-element beam on the same stick now. Reports of participation in the National Emergency Test were received from the following ECs: UFX, Madison; FZC, Wausau; CWZ, Stevens Point; SZL, Racine; MUM, Eau Claire. FLARC operated with WFZ-9 located at Red Cross Headquarters in Madison and put on a splendid demonstration. Operations at Racine included both mobile and fixed stations with full support of local Red Cross officials. Two local nets, 28-Mc. 'phone and 7-Mc. c.w. were used at Wausau, with traffic outlet on 3.5 Mc. LED is kept busy with code practice sessions for prospective hams. On a 25-ft. windcharger tower mounted on top of the building is the new 10-over 20-meter beam of UFX. Study time at U. of W. limits OQY's operating time. BKP, FZC, and RYA have new Class A tickets. Traffic: W9LFW 523, ESJ 205, RQM 113, SZL 68, DND 36, CBE 29, CWZ 28, DKH 22, SIZ 21, IQW 18, DSP 11, VHA 4.

DAKOTA DIVISION

NORTH DAKOTA — SCM, Paul M. Bossoletti, W9GZD — East No. Dak. meets on 3525 kc. and West Net on 3670 kc., both at 8:30 p.m. CST Mon., Wed., and Fri. The 3.85-Mc. 'Phone Net meets on the low end of the band Sundays at 3:00 p.m. CST. K9ND may be the call of a new station in Bismarck if the Cendak Club and the State Historical Society have the power. UNU built the quad but likes three-element beam better. PVS finished rebuilding. JPW is EC in charge of publicity and u.h.f. emergency technique. JVK is a new call in Fargo. FX has new three-element 28-Mc. beam hanging over Jamestown College. CBM is 3.85-Mc. n.f.m. in Fargo. YIZ got on 28 Mc. HJK is on at Jamestown. GEH tried to build Clapp VFO. OEL's final doesn't know 7 from 3.5 Mc. I BJJ is Assistant EC in Fargo. BJZ made Class A. EOZ built an FB portable. ONE and HDD are stickin' to 28-Mc. 'phone. SSW needs YOU in the EMERGENCY CORPS! Traffic: W8SSW 9, GZD 8, ZCM 8, GEH 3, LHB 2, CAQ 1.

SOUTH DAKOTA — SCM, J. S. Foasberg, W9NGM — VT, RQV, DYM, and YJO are on 3.85-Mc. mobile. VT also is on 7- and 14-Mc. mobile. OXC also is on 3.85-Mc. mobile. VT puts out the Official Bulletins on 14 Mc. at 1939 CST Mon., Wed., and Fri. GCP, the RM, wants more stations on the State net, which meets three nights a week on 3720 kc. Mon., Wed., and Fri. at 2000 CST 10-12 w.p.m. Let's give Bill a boost with this work. HDO, the SEC, reports that the Simulated Emergency Tests went off fine although there is room for more stations in this work. There are several reports of news articles from the gang but no clippings. In the future please clip out any article and send it to your SCM no matter how small it may be. RRN is the

(Continued on page 79)

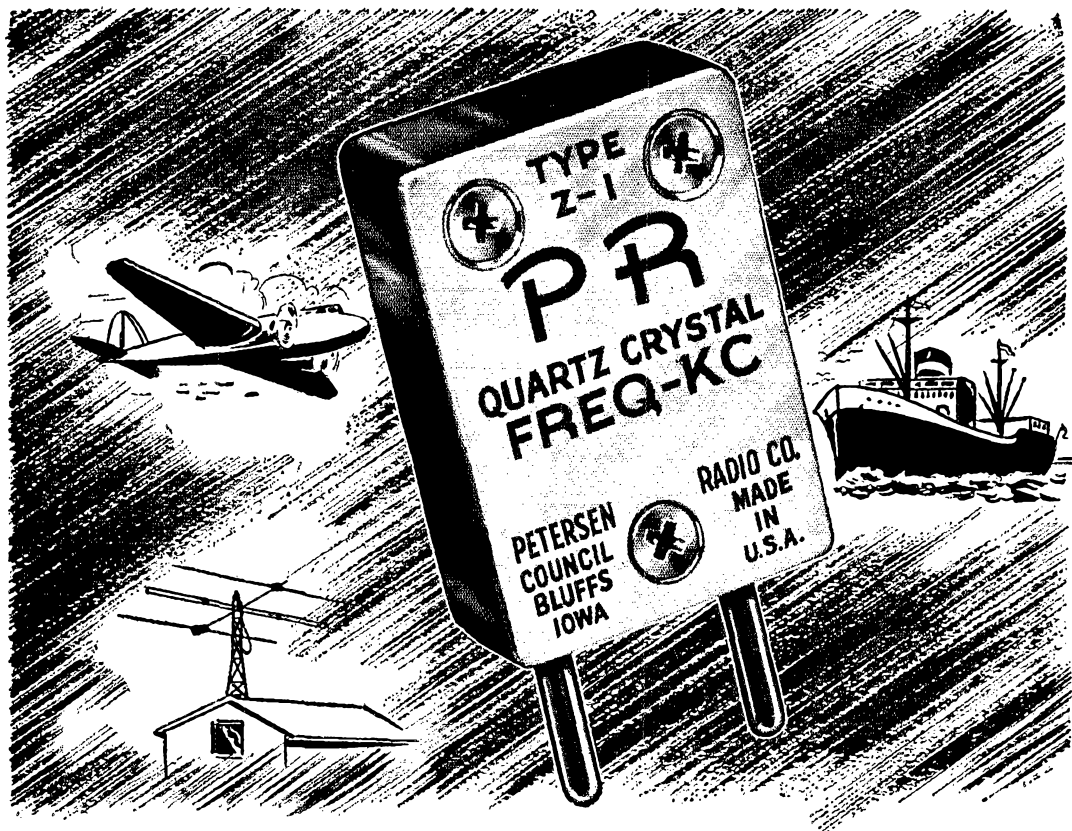

LAND, SEA and AIR

PRs stand the gaff! Wherever you go you find these fine precision crystals doing their jobs with honor . . . meriting the praise of engineers, operators and technicians. Yes — you can depend on PR for perfect frequency control . . . at low cost . . . for all amateur, commercial and industrial services.

10 METERS, Type Z-5, \$5.00 • 20 METERS, Type Z-3, \$3.75 • 40 & 80 METERS, Type Z-2, \$2.75

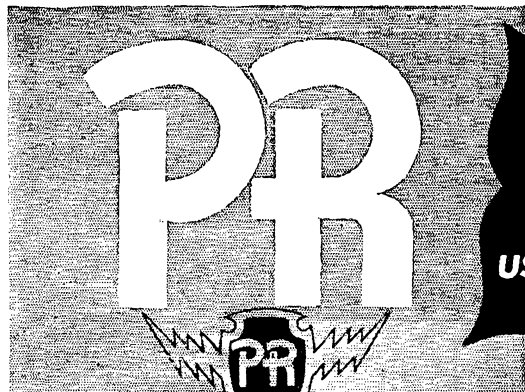

**PRECISION
CRYSTALS**
USE "PR"
and KNOW where You Are!

PETERSEN RADIO COMPANY, INC., 2800 W. BROADWAY, COUNCIL BLUFFS, IOWA

CHOOSE THE RESISTORS SPECIFIED FOR MOST CRITICAL ELECTRONIC CIRCUITS

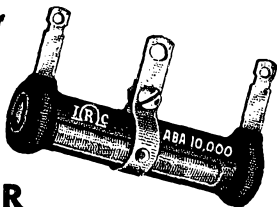

IRC POWER WIRE WOUND RESISTORS

for exacting, heavy-duty applications. Uniformly wound with highest grade alloy wire on tough, ceramic tubes. Coated with climate-proof cement, specially developed to provide rapid heat dissipation and maximum moisture protection. Rugged terminals are securely attached, and heavily tin dipped for easy soldering. Available in fixed or adjustable types in full range of sizes, ratings and terminals—10 to 200 watts.

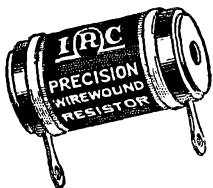

IRC PRECISION WIRE WOUND RESISTORS

for dependable accuracy (standard 1%). Winding forms of non-hygroscopic ceramic with high insulation qualities, mechanical strength and low coefficient of expansion. Non-inductive winding impregnated with special varnish which improves insulation—eliminates breakdowns and shorted turns. Fully protected against high humidity. Low noise level. Minimum temperature coefficient of .002% per degree C. Available in a wide selection of ranges and types.

When you order heavy-duty or close tolerance resistors, ask for IRC Power Wire Wounds or IRC Precisions—the same accurately manufactured resistors specified by electronic engineers.



INTERNATIONAL RESISTANCE CO.

401 N. Broad St., Phila. 8, Pa.

IN CANADA: INTERNATIONAL RESISTANCE COMPANY LTD.,
TORONTO, LICENSEE

new president of the SFARC. We wish Tony success and know that he will do a fine job. EXX is now on with an 813 all bands. Traffic: W9GCP 58, HDO 45, FJS 13.

MINNESOTA—SCM, Walter G. Hasekamp, W9CWB—FTT and FOH, of Albert Lea, have worked the Twin Cities on 28-Mc. ground wave. 3QP, ORS in Eastern Pennsylvania for 20 years and SCM there for 2 terms, now is located in St. Paul and has joined MSN. DOQ is a father for the first time! GKP, Duluth, worked Grand Marais on 144 Mc. using a double extended Zepp antenna. Having been interested in ham radio for many years, the 65-year-old father of QND and RQT took his Class B exam. MSN lost a valuable member when Victor Volz, GPH, joined the Silent Keys. MXC is again conducting regular code practice on 28.2 Mc. on Mon. and Wed. Several of the clubs are reorganizing their emergency organizations. The Minneapolis Club now owns an NC-173 receiver, an HT-6 rig, antenna masts, a portable gasoline-electric power unit, and a large tent. The 144-Mc. gang of Anoka, Robbinsdale, St. Cloud, and the Twin Cities were out in force at a dinner in Anoka. On 144 Mc., HXY has worked 2 districts and 4 states, JHS and KPQ each have 2 districts and 2 states, SV has 1 district and 2 states. BOL now is Class A and is on 3.85 Mc. with MSN. The St. Paul Radio Club has rented P. O. Box 512 for the use of members and the club secretary. HFF is alternate for RJF on TLA, while VJF alternates for QMW. DZM has a nightly go-around with OPA. EA is back in Minnesota for most of the winter. ZOB put up a 35-ft. pole for a sixteen-element beam for 144 Mc. He also acquired a Silver 701. Fergus Falls reports 5 active hams on 3.85-Mc. phone. ORJ is building a new 28-Mc. final. EEP has a pair of 807's now. PSD has a new antenna. VIP has a new three-element beam on 28 Mc. and 9VIL now is there operating fixed portable pending modification. 2VDD now is LLW, not MAL as previously reported. Ask him how he "legally bootlegged" MAL for 28 days. HII HTS reports into the Rebel Net twice a week. YBM has a horizontal quad on 3.85 Mc. It's a quarter wave on each side. BGY acts as Alternate NCS on MSN c.w. He also visited your SCM. MSN c.w. roll call now is 20 or more. Who will be SEC? Traffic: W9JFF 101, BGY 33, VJH 22, JIE 18, CWB 12, RPT 11, BOL 6, K9NAH 3.

DELTA DIVISION

ARKANSAS—SCM, Marshall Riggs, W5JIC—AUG has added a new power control panel to his 813 rig. NBG is doing fine on 14-Mc. phone. OCX is on 28-Mc. phone with 829-B with 75 watts. KYQ is in hibernation at Hendrix. NCM has new QTH for 829-B rig. JIN is making plans for new rig. The Conway Club has been very active and has doubled its membership. OXL is working on rig with p.p. 826s on 28 Mc. OQS has put up new 50-ft. antenna. MRD gradually is licking the problem of supply and demand. The p.p. 810s are taking shape. Don't forget the Hot Springs meeting. W5T is looking for you. Traffic: W5LUX 114, JIC 106, FMF 94, MRD 38, ICS 35, HPL 11, OXL 6.

LOUISIANA—SCM, W. J. Wilkinson, Jr., W5VT—SEC: KTE, PAM; CEW, KTE has a trio of 45-ft. poles for use as antenna poles. NNE's XYL now is PFE. KYK is on 7, 27, and 28 Mc. GMO is on 3.85- and 14-Mc. phone. QH is using a 804TL on all phone bands. LLF is now Class A. GMR is using a pair of 810s in the phone rig. AEN and IOP are latest additions to the Delta 75 and Pelican Nets. CGC sends official bulletins on 3.85 and 14 Mc. FMO has a new antenna and is knocking off plenty on 14 and 3.85 Mc. HHT and QH handled overseas phone patch traffic. IV is on 7 Mc. with FT-102. FPX is on 3.85 Mc. KME is pioneer on 3.85-Mc. mobile operation. CEW received confirmation on his 100th DX contact. DU can be found on 7 Mc. almost any Sunday morning. ACY is on 14-Mc. phone. FDC is active on Delta 75. HBY is on Delta 75 Net Sundays. RX has QSOed KZ5, VE7, KL7, PV7, and ZL2MM with 7 watts on 7 Mc. EAY received his ticket shortly after his 77th birthday. New officers of the Delta Radio Club of New Orleans are KRS, pres.; JUD, vice-pres.; NBY, secy.; UK, treas.; ASE, EC; and KOU, act. mgr. MBY is ORS and OPS. JSG donated a gas-driven light plant to the southwest Louisiana Club of Lake Charles. HW, IYL, FDC, JFR, BSR, JBW, IYG, IHR, KKR, NIXX, NNV, MOQ, and JSG made the Red Cross Relay a big success. EM has 144-Mc. rig going. YT is on 3.5, 7, and 14 Mc. MIU has 200 watts on 28.756 kc. DRF is on 3.85-Mc. phone. Traffic: W5KTE 207, VT 38, GHF 32, JFR 12, MOQ 12, FDC 7, IHR 6, JBW 5, HW 4, IYG 3, KYK 3, BSR 3.

MISSISSIPPI—SCM, Harold Day, W5IGW—SEC: JHS, PAM; LN, RM; WZ, LPL, is new. ORS IHP is new EC. JHS sends in the following: NYV has a nice band-switching job built from surplus parts. VS is busy testing 144-Mc. antennas. ANF was on with emergency rig. HAV was on with big rig on auxiliary power, with IBO, DT, and OBC as operators. MJL checked in with Magnolia Net then called the Shrimp Net to order along the Gulf Coast. Highlight of the 28-Mc. net was the message from 4FZN to JHS, a distance of 90 miles. JHS relayed messages with his 25-watt 6-volt battery rig to LN on the Magnolia Net, who in turn relayed them to the National Emergency Net through liaison stations DEJ and IGW. DEJ also handled

(Continued on page 78)

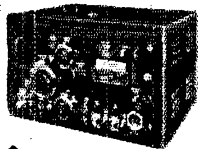

FREQUENCY SHIFT EXCITER
—Provides RF drive and frequency shift keying to transmitter

B&W DISTORTION METER MODEL 400

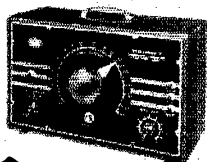
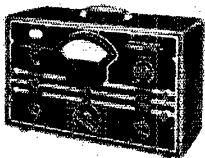

B&W AUDIO OSCILLATOR MODEL 200

B&W AUDIO FREQUENCY METER MODEL 300

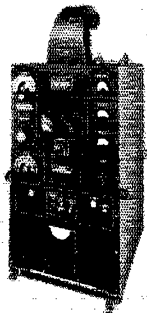
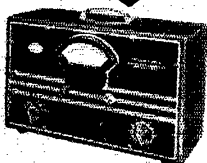

CONTROL UNIT — Operates as an electronic repeater in teletype lines.

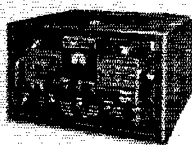

2 KW AMPLIFIER — Class C RF Amplifier. Range: 1-25 Mc's.

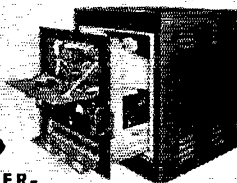

DUAL DIVERSITY CONVERTER — Provides diversity mixing on frequency shift circuits.



RECEIVER ASSEMBLY — Standard Army BC-342 modified for dual diversity reception.



B&W ALL BAND FREQUENCY MULTIPLIER MODEL 504



THE TRADEMARK THAT GREW through service to you!

Today, the Barker and Williamson trademark is backed by three plants, excellent manufacturing facilities, and a competent technical staff—all because amateurs, through the years, have shown a definite preference for quality products and a willingness to try practical ideas that give promise of improved performance. Today, too, this famous trademark appears on many new items of complete equipment—all produced by an organization that grew because it designed and built the kind of products you wanted. With its improved facilities, B&W pledges to continue to build better and better parts and equipment for amateurs, and to develop and offer only those products which the amateur can use with confidence and pride.

NOW IN PRODUCTION AT B&W

Complete Radio Transmitters • Dual Diversity Converters, Control Units and Frequency Shift Exciters for Radio Teletype Transmission • Special Test Equipment • Redesign, Modernization and Modification of Existing Equipment • Machine Work • Metal Stamping • Coils • Condensers • Other Electronic Devices in a Wide Range of Types.

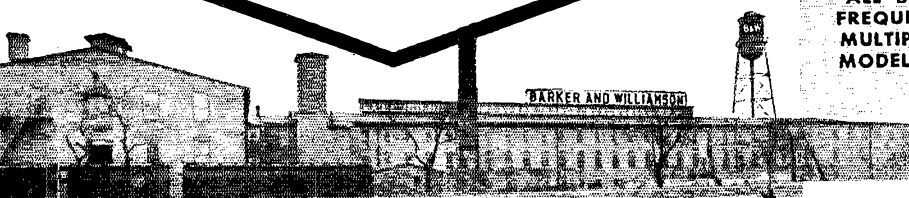

BARKER & WILLIAMSON, INC.

237 FAIRFIELD AVE.

UPPER DARBY, PA.

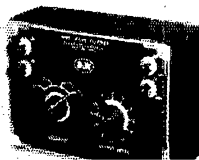

B&W SINE WAVE CLIPPER MODEL 250

JOHNSON

167 Variables ...

CERAMIC SOLDERED
for
STABILITY & STRENGTH

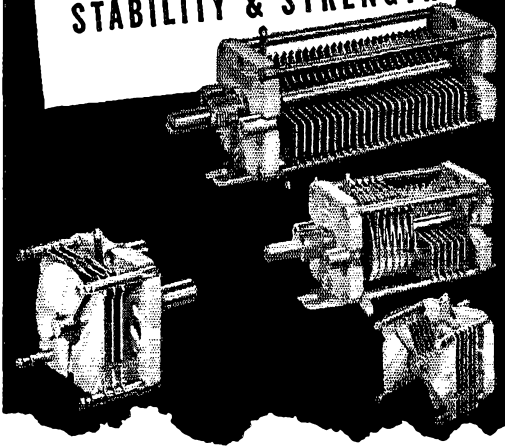

PEAK EFFICIENCY, plus permanent maintenance of capacities—even under severest operating conditions such as portable-mobile operation—is assured in JOHNSON'S new line of 167 Variables. The use of perfected ceramic soldering eliminates the need for eyelets, nuts or screws. There is nothing to work loose, causing stator wobble and fluctuations in capacities!

Available in .030" and .080" spacings for all types of communications equipment having tuned circuits operating as high as 500 mc.

Single Type—Available in six models: 2.8 to 11 mmf, 3.5 to 27 mmf, 4.6 to 51 mmf, 5.7 to 75 mmf, 6.8 to 99 mmf, 11.6 to 202 mmf.

Dual Type—Available in three models: 3.5 to 27 mmf, 4.6 to 51 mmf, 6.8 to 99 mmf.

Differential Type—Available in three models: 2.8 to 11 mmf, 3.5 to 27 mmf, 4.6 to 51 mmf.

Butterfly Type—Available in three models: 2.8 to 10.5 mmf, 4.3 to 26 mmf, 6.5 to 51 mmf.

...

OTHER CAPACITIES and SPACINGS AVAILABLE ON SPECIAL ORDER
Write for new JOHNSON 167 Variable Catalog

JOHNSON
a famous name in Radio
E. F. JOHNSON CO., WASECA, MINN.



all Atlanta Red Cross traffic. OOT finally got his D4 on low power. 7JHS/5 whipped B.C.I. by going to p.f.m. NRM now is a D4. OIX and IBO are now Class A. OMK is working 7-Mc. c.w. Traffic: W5IGW 315, WZ 84, LN 35, DEJ 31, KUT 21.

TENNESSEE—SCM, Ward Buhman, W4QT—The Oak Bridge Club is out in front with 144-Mc. activity. Six operators manned a v.h.f. expedition to Frozenhead Mountain, elevation 3500 ft., and set up equipment in a fire patrol tower, approximately 80 ft. high. Contacts were made with 13 stations in four states. Best DX was W8CYE, 235 miles distant. The rig ran 90 watts; power was supplied by gas engine and generator. Several v.h.f. antennas were tried. A 7-Mc. antenna was supported by a balloon, which broke away from its moorings during the night. Strong winds enabled the substitution of a box kite. AFI is among the 28-Mc. quad experimenters. HHQ visited the Lexington, Ky., Club. DPI and FX have broken the ice on 4-Mc. 'phone. LCB, new Nashville EC, reports his group made a good showing in the Simulated Emergency Test, and a story was carried by local newspaper. FCF supplied clipping from newspaper covering Memphis activity. ILY is new Memphis EC. GQL turned in a nice report of doings in Maryville. BXG and MEU are working 14 Mc. and 28-Mc. 'phone. FHT has a new beam on 28 Mc. GQI is getting fired up for the first time since the war. The Smoky Mountain Amateur Radio Club is constructing a club station. GQL works all popular bands, 'phone and c.w. FWH and FLW have frequent 60-Mc. QSOs. HOJ has new shack. AAW has some 304TLs and a new ten-over-twenty beam. EAL also is contemplating 304TLs. HHC is working c.w. since his audio power supply blew up. Traffic: W4NNJ 99, ETN 77, LNN 69, BAQ 50, CZL 36, CVM 22, FCU 16, BBT 14, HOJ 3, FLW 2.

GREAT LAKES DIVISION

KENTUCKY—SCM, W. C. Alcock, W4CDA—Twenty-seven stations reported to the SCM this month in the biggest month of Kentucky ham activity. FBI Keep those reports coming in. ALR is building automatic c.w. monitor. FKM works KYN-KYP Nets. JCN needs break-in to save ears! MSC put up cobweb beam and has spiders in it already! FQJ is manager of Trunk Line "M." TXC says CMP, EDV, IXN, JDE, JQY, JTT, KUT, KWO, LBW, and TFG are active in 3955-kc. 'phone net. BAZ reports BEW, CDA, FQQ, FR, FBJ, JCN, JQY, JRO, KWO, MSC, MWX, NBY, OGP, YPR, LMN, and CNE in the 3600-kc. net, and FBJ reports Emergency Net (KYE) composed of BPE, KKG, KMX, MKJ, MRI, and FBJ on 145.8 Mc. The 144-Mc. gang is glad that BPE has a different clock. HAV sold BC-610 and got Collins 32V. AHL worked the 'phone net 22 times in September. OEY is new at Murray. OGB is new at Henderson. LQX now is Class A. LXA worked over 40 countries to date. CIS worked Rhodesia. LAK is on 14- and 28-Mc. 'phone and has no room for 3.5-Mc. antenna. BAZ has new Collins exciter. JQV gets a kick-out of watching five-element 30-ft. beam turning at 1/4 r.p.m. MWX wants Western Kentucky in KYN Net. GHJ is on 3955-kc. with kw. JPV runs 350 watts to p.p. 813s on 3810 kc. (How about slow-speed net on 3810 kc? Write BAZ about it.) NBY moved to the basement. FR and PWB are working to get WKLO on the air. Fort Knox is needed by Kentucky nets! Traffic: W4BAZ 204, FQQ 70, MWX 37, JCN 32, MSC 31, ALR 26, FBJ 26, CDA 19, TXC 12, BEW 9, FKM 2, BPE 1.

MICHIGAN—SCM, Joseph R. Bellan, jr., W8SCW—SEC: GJH. RMs: NOH, PVB, and UKV. WXO is new ORS. Section Net Certificates have gone to BVV, CLY, LLD, LME, WXO, and ZSU. The Grand Rapids Amateur Radio Club elected YDJ, pres.; AKI, vice-pres.; ASK, secy-treas.; and FFF, act. mgr. Twin Sault Radio Club elected III, pres.; VE3AFR, vice-pres.; and MEV, secy-treas. The Muskegon Area Amateur Radio Council elected TBP, pres.; CNN, vice-pres.; Israel, secy-treas. and WAK, act. mgr. Congrats to the newly-formed Lake Superior Radio Club and sincere wishes for its every success. We regret to announce the passing of ex-9GBH of Neganuee, ZDE of Laurium, and YFT of Ahmeek. ACW reports a fine turnout in Genesee County for the Simulated Emergency Test. BLR reports the QMT AEC continues to hold drills on Saturday night and membership keeps increasing. DWB is back on the QMN. ZKZ is new-comer to the QMN and has Command transmitters on 3.5 and 7 Mc. EMD is active on 50 and 144 Mc. and is rebuilding to include 3.5- and 7-Mc. operation. FOV is a regular on the 50-Mc. round tables in Flint. CBM finally cleared out all the bugs and has his 27/28-Mc. mobile perking nicely. SWF plans to extend his OBS schedules to include 3.5 and 7 Mc. KRS continues to do a nice job as OO. DPE, our director, covers his division nicely by reporting into the QMN, BN, and KYN. TRN and UKV enjoyed their recent visit from 2OUT. CE3AO and HK5CO dropped in for a visit with NOH. BBK is doing a nice job as editor of the *QMN Bulletin*. YCT is looking for Asia to complete his WAC. PVB is working out nicely with his 28-Mc. mobile rig. MGQ put up a three-element beam for 28 Mc. CJ is back on 28 Mc. YNG reports the MEN and BR Net enjoying fine turnout. NXT has

(Continued on page 80)

MALLORY HAM BULLETIN

Oscillator Switching with the MALLORY 152L 6 Position Switch

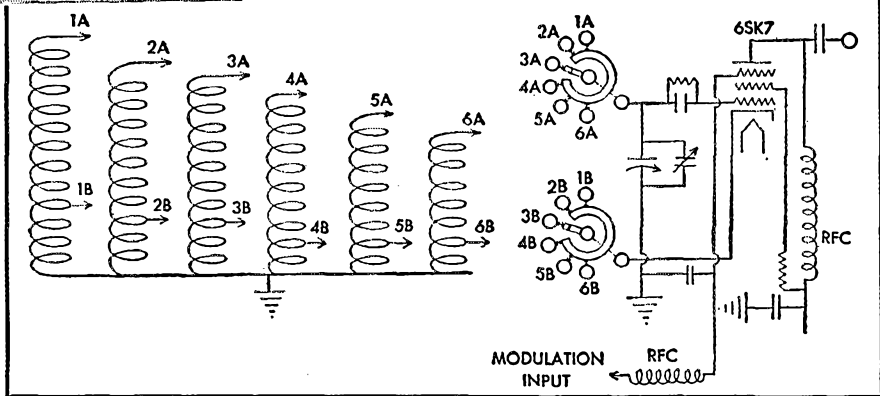
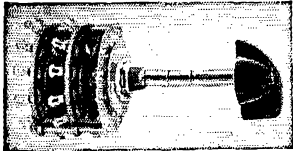

It is surprising how much the sensitivity of the average communication receiver can be improved by the use of a simple variable frequency test oscillator, to "touch up" the I.F. section or to peak the R.F. stages.

An oscillator suitable for most amateur work need not be complicated or difficult to build. It should consist of a reasonably stable circuit similar to the one shown here, and should be roughly calibrated over a range from approximately 400 KC through 30 MC. Some method of modulating its output should be employed, although this is not a necessity if the receiver to be tested is equipped with a carrier level "S" meter.

Bandswitching should be employed for convenience in switching from one range to another. Mallory type 152L is admirably suited for this purpose. It consists of 2 sections and 6 positions. A unique feature of the Mallory 152L switch is its automatic shorting mechanism which shorts out all unused coils, thus eliminating the possibility

of harmonic "suck-out" points. In addition, this switch is equipped with an adjustable "stop" so that any number of positions may be used from 2 through the full 6.

Circuit constants and modulation methods for the suggested oscillator schematic may be found in most of the late Amateur Handbooks. The 152L band switch and other parts may be purchased at your nearest Mallory authorized distributor.

You can rely on Mallory Precision manufacturing to supply you with the most dependable line of: ham band switches, push button switches, controls—rheostats—potentiometers—pads, tubular capacitors, transmitting capacitors, dry electrolytics, dry disc rectifiers, vibrators, and vibrator power supplies—practically every component you need to keep your rig in A-1 condition.

P. R. MALLORY & CO., Inc., INDIANAPOLIS 6, INDIANA

P. R. MALLORY & CO. Inc.
MALLORY

Bliley
CRYSTALS

TYPES
AX2-AX3

The only plated
amateur crystal

Drift less than
0002% /°C

Precision
calibrated

Peak
performance

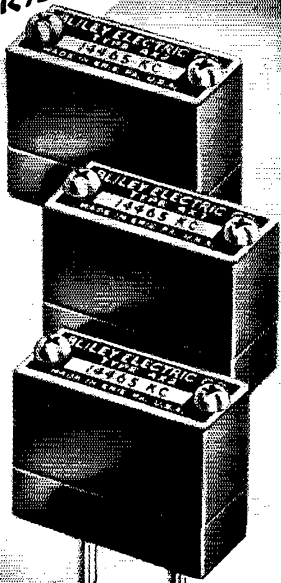

FOR BEST RESULTS
USE THE
RIGHT COMBINATION!

CCO-2A

Packaged crystal
control for
2-6 (10-11) meters

Efficient VHF
performance
with proven
design

Bliley
CRYSTAL
CONTROLLED OSCILLATORS

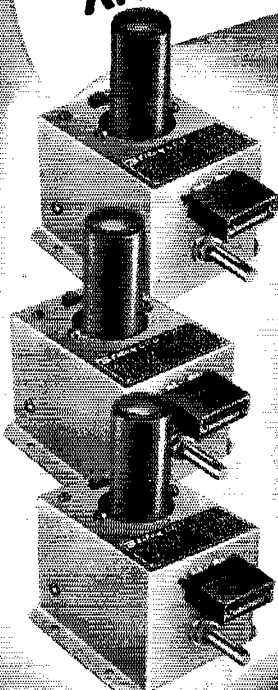

BLILEY ELECTRIC CO. - UNION STATION BLDG. - ERIE, PA.

moved to new QTH. IQS was the lucky ham who won the Motorola mobile rig at the Milwaukee Convention. BGY, GSJ, SCW, TRN, and YDR were active in the CD Party. VV has a new four-element beam. UUS makes BPL on deliveries this month. GLS and SOX have installed 3.85-Mc. phone rigs in their airplanes and both are enjoying fine results. FM is back on the air with a new rig. Many thanks, gang, for the fine cooperation you have shown me in the past year. Keep up the good work. A very Happy New Year to all. Traffic: W8UUS 286, TRN 260, TBP 154, WXO 137, GSJ 132, UKV 101, SCW 87, ACW 42, YNG 37, FVB 29, AQA 28, DPE 28, GJH 21, URM 20, UES 15, YFI 12, BVY 10, IHR 10, NOH 9, TNO 9, FOV 8, JTQ 8, DED 4, BLR 3, INF 3, DWB 1.

OHIO — SCM, Dr. Harold E. Stricker, W8WZ — SEC: UPB, PAM: PUN, RM: RN. The following new appointments have been made: ORS — OUR, PIH, WAB, WYH, OPS — EQN, HOX and VHI received BN Certificates. At the October meeting of the Cleveland Area Council of Radio Clubs the following officers were elected: AJH, pres.; QV, vice-pres.; MXO, secy.; FBK, treas. The meeting was turned over to DS, the EC, who outlined his work in emergency organization from 1937 to the present date. The Springfield Amateur Radio Club Publication, Q-5, reports the following new officers: OKB, pres.; BMC, vice-pres.; VZE, secy.; WAU, treas. The club owns a very good 3KV portable emergency generator set. Excellent code practice transmissions are being made every Tuesday and Thursday night at 8:00 P.M. by WXG on 144 Mc. CDT is working plenty of DX. QWC is back on the air after a six-month layoff. The October meeting of the Central Ohio Radio Club has as the principal speaker our SEC, Dana Cartright, UPB. He brought many pieces of emergency equipment and a complete transmitter and receiver was set up with antenna hanging out the window. Several QSOs were made. He talked about the importance of emergency set-ups and how soon it could be available in case of an emergency. His talk was very interesting and instructive. From the *Carascope* we learn that GL and TO were made honorary life members of the club. GL is confined to bed because of a serious illness but still works 7-Mc. rig built by ZCQ; also ABO, ZCQ, YBF, QQ, HAM, and KMD went out and put up a three-element beam for TO. EYE chalked up country No. 125. BAX is getting good results with a 522 on 144 Mc. HB was tops and LCA second in the September ARRL Frequency Measuring Test; 4.3 and 16.2 respectively. The following Columbus hams took part in the October Simulated Emergency Test: ABO, HAM, IVC, VWX, WAB, WXM, and WYH. PNY is chief recruiting officer for BN. RN is using Meissner Signal Shifter for all contacts. PMJ has new jr. operator. PZA and UJ have moved to Eugene, Ore. VTF is building new bandswitching rig. TZO is rebuilding. PUN has new Meck T60-1 for portable and emergency work. HOX has a new Meissner Signal Shifter. BFB operated 28-Mc. mobile during the entire month of October. AOD still is 18-watting when time permits. GZ has been devoting all his time to Far East traffic. ZAU has been busy with football games; he didn't say in what capacity. ROX has new HR07 and still is having beam trouble. LJH blew coils in the receiver. Watch that r.f. FFK made BPL. CBI is splitting his operating time about evenly between traffic and rag-chewing. KNP has new 7-Mc. Zepp. DAE is active in VK/ZL Contest. TKS reports that the Toledo Radio Club had its annual picnic at Side Cut Park. WRN, OES for Columbus vicinity, reports that 144-Mc. activity is picking up and he has worked 9 states in 5 call areas so far. WE had trouble in the CD Party because of power line leaks. Will all clubs that publish bulletins please send them to me so I can use the information for QST publication? As to ARRL appointments; please send in your report every month with some news. I thank one and all of you for your cooperation. Traffic: W8FFK 640, HOX 270, GZ 233, UPB 159, EBJ 126, RN 119, TKS 99, VHI 77, PIH 49, TAQ 45, OUR 41, CBI 38, PMJ 31, WZ 31, EQN 30, SJF 30, THJ 28, WE 28, WYH 26, VWX 24, PNY 23, WAB 19, ZAU 19, LJH 18, IVC 15, UJ 15, PUN 14, ROX 14, QIE 13, BEW 12, CNY 10, PR 9, TLW 6, WKG 6, AYR 5, UW 5, WXA 5, VTF 4, DAE 3, LBH 3, LCY 3, BUM 2.

HUDSON DIVISION

NEW YORK CITY AND LONG ISLAND — Charles Ham, jr., W2KDC — WFL, Southern Queens, with the assistance of NZJ, is driving for new AEC members. Queens County Red Cross messages during the Simulated Emergency Test went direct to Washington from WFL. In Suffolk County CJZ, Port Jefferson, is installing a tank set at Red Cross Hq. so that any operator can cover this area when necessary. During the Simulated Emergency Test the following kept 3995 kc. very busy: JI, YLF, PDU, SHQ, JWO, and CJZ; CJZ, ADW, and WLS were on 146.24 Mc., while MZB, YPA, ADW, and CJZ were on 3600 kc. The Washington message was sent to 3GV. In Manhattan County, WHB and JXH, with RGP assisting, are scouring for AEC members. NKO promises action on 144 Mc. In Nassau County, DUS and YKM are new ECs, making a total of ten who really cover the county. Monday at 2100 is the regular period for 144 Mc. As many as 38 stations have

(Continued on page 58)

Ample connections
for coils and leads

Steatite frame bars

Right angle drive

Steatite insulated rotor

Rotor grounded
at center

NATIONAL LMT Condenser

new heavy duty condenser gives BETTER CONTROL OF HARMONICS

Now, for the first time, a heavy duty transmitting condenser that completely eliminates troublesome closed loops, vastly simplifying the problem of unwanted harmonics. The rotor shaft is completely insulated from the end plates. Absolutely no extraneous capacity! Rigid and stable construction. Long leakage path (higher safety factor). Plates and parts are extra heavy with highly polished rounded edges to prevent flash-over. Adjustable stator plate mounting and end bearings. Multi-fingered spring contact. Center tap ground makes this condenser ideal for push-pull operation. Available in single-stator, double-stator, or double-stator right angle center drive models. Same capacities as National TML Condenser.

The National LMT Condenser is only one of many National precision components. See your dealer or write for catalog.

national

©

EST.

1914

NATIONAL COMPANY, Inc.

MALDEN, MASSACHUSETTS

For BOTH

MOBILE & FIXED STATION USE

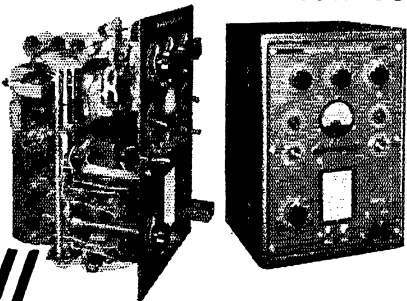

Harvey - WELLS

TBS - 50
TBS - 50A

Now that mobile phone can be used on all amateur bands (except 40 meters) the TBS-50 & TBS-50A become more adaptable than ever before because it is ideal for use in automobiles, trucks, boats, camps, etc.

50 WATTS **8 BANDS**
PHONE OR CW
(Class B. Modulation)
NO PLUG-IN COILS

80, 40, 20, 15, 11, 10, 6 and 2 METERS
(Completely wired and tested — not a kit)

Crystal controlled on all bands, yet requires no oscillator or multiplier tuning. Operates from AC pack or Dynamotor Supply for mobile work. New, beautiful black crackle finish.

TBS-50..Complete with tubes, only **\$99.50**

THE NEW TBS-50A

Incorporates a small three tube preamplifier with sufficient gain so that any high impedance microphone having an output level of approximately -50 db can be used.

TBS-50A, complete with tubes only

\$121.25

Send for catalogue describing Harvey-Wells Transmitters, Power Supplies, Preamplifiers and Rack Panels

Harvey - WELLS
ELECTRONICS, INC.
SOUTHBIDGE,
MASSACHUSETTS



participated, all handling traffic. During the Simulated Emergency Test the Red Cross Hq. in Mineola was the NCS. Over 60 messages were handled, mostly by emergency-powered stations. HJ, of City College, hopes to start an active 14-Mc. c.w. college net on 14,040 kc. at 1200 EST, so advises WLW, chairman. YSF finally is getting on the air on 28-Mc. 'phone n.f.m. and 14-Mc. c.w. and also is working on a second emergency rig. The Staten Island ARA is very much in business but SGO, secretary, is quite busy with a new jr. operator. Meetings are held the first and third Mondays at 2100, preceded by a 90-minute code class. YDG is active in the SS Net and NNJ Net and Jack also is looking for members for a "teen-agers" net. PZE is very QRL with work but did run up a good score in the CD Party. Cal also is interested in emergency work. ESO has new h.v. power supply. HXT was forced to remove his antenna from the roof and hence has been bidding his time with t.v. PFP now is operating /4 at Route 1, Donelson, Tenn. HAE operates at the Huntington Naval Reserve Army using the call K2NRK. ZFK is a new call there. All mobile or portable stations in Manhattan, please contact WHB. VXI is running 7 watts on 7 Mc. LGK is busy as Tuboro RC delegate to the Federation. WK moved from Jersey Shore to Baldwin. URX completed new VFO. QBS is QRL college. RQJ is up to 50 countries. KV4AF/2 finally got up new sky wire. BIV has new Collins receiver and is installing frequency standard. VAF says he urgently needs more stations in the Slow Speed Net, 15 w.p.m. limit. BGO is doing a good job as SEC, but night work keeps Vin pretty busy. DBQ is on 7, 3.5, and 14 Mc. with ART-13. QYZ is active again. VOS has new VFO and expects new receiver shortly. PRE is at Brooklyn Poly with TUK and QBS. This one will really kill you: OBU has t.v. set. George still has not forgotten the NLI. EC says TLAP takes traffic for Western U. S. from 2100 to 2125 on 3630 kc. RTZ attended the Boston Hamfest and visited IJE and IKJF. Hope has a new rig and shortened antenna. TUK maintains NLI schedule only but manages to run up a good traffic score. KDC has recovered from a recent illness. Traffic: W2TUK 201, VNJ 149, RTZ 136, EC 117, OBU 114, PRE 112, BO 103, OUT 92, VOS 91, QYZ 75, DBQ 43, BGO 35, VAF 28, BIV 25, ESO 22, KV4AF/2 16, W2RQS 14, QBS 13, ESO 7, URX 7.

NORTHERN NEW JERSEY—SCM, Thomas J. Lydon, W2ANW — The N.N.J. C.W. Net meets daily, except Sunday, on 3630 kc. at 7 p.m. The 40-Meter Net meets Monday, Wednesday, and Friday on 7070 kc. at 7:30 p.m. The J.N. Net, which meets daily, except Saturday and Sunday, on 3630 kc. at 9:00 p.m., is going full blast. Fifty-one different stations reported during the first month of operation. This is an excellent outlet for TLAP traffic and all are welcome. LFR handled 71 ARC or ARRL emergency messages under tough conditions. QEM, on furlough from OEC, checked into the NNJ Net from ANE. NCY had poor results working 28-Mc. mobile on his recent 3000-mile vacation trip, but he visited plenty of hams, including 9FIN. KUS now is reporting into five traffic nets and handling lots of traffic. GFW has 95 countries confirmed and is looking forward to that DXCC Certificate. He also schedules G6TT weekly. OXL is reporting into all three nets regularly. ANG operated 28-Mc. mobile during the recent Simulated Emergency Test. T.V.I. has kept him off other bands. CWK, with new antenna, hopes to top GFG in the next CD Party. Looks like plenty of competition in the next party, as KUS is also a new high-scorer. NLY finds it more convenient to QNI the 7-Mc. net and finds he can clear traffic just as easy. This net is perfect for those who cannot make NNJ at 7:00 p.m. YJC is on 7 Mc. most of the time. OUS is working plenty of DX with only 20 watts. BRC spent two weeks in Salt Lake City. EWZ operated for the first time in the CD Party. After visiting LFR, JRV and YVP, operating on 28 Mc., say that they will get on 3.5-Mc. c.w. All Monmouth County 144-Mc. stations participated in the Simulated Emergency Test and cleared their traffic through CQB. ZT keeps daily schedule with 0BES. New appointments include ATE as OO, VJN as ORS, KQZ as EC for Short Hills, YZY as EC for Jersey City, LOP as EC for Roselle Park, and ZEE as EC for Linden. Montclair, under the direction of JN, has 20 stations operating on 144 Mc. in the emergency net. Rutherford has an emergency net in operation under the direction of DRA. All licensed amateurs in these towns are requested to get in touch with their EC. DRV has curtailed activities for the present because of ill health. We are all waiting for his return to the air. ZCL is now on 7 Mc. and looking for foreign schedules. He reports for the first time this month. PQC is on 28-Mc. 'phone. QLF has three-element beam on 28 Mc. SLK is attending Rutgers College. Traffic: W2LFR 433, CQB 129, CGG 121, ANW 99, NKD 94, KUS 86, MTV 63, OXL 55, NCY 27, MJC 24, BRC 18, CWK 14, ZCL 14, K2AO 10, W2BZJ 9, CJX 8, NLY 5, OUS 5, ANG 4.

MIDWEST DIVISION

IOWA—SCM, William G. Davis, W0PP — The Iowa fellows did themselves proud on the Simulated Emergency Test. Reports indicate that about 150 hams took part. All the planning was left to the SEC since PP was attending

(Continued on page 84)



**MORE
HOURS
OF
SERVICE
OF
MICROPHONE
CABLES**

Every Type for Every Service

Belden
Radio WIRE

8411

8401

8422

8410

8412

8423

8424

a Pocketful of
PRECISION



Series 40
Compact Wide-Range
Circuit Tester

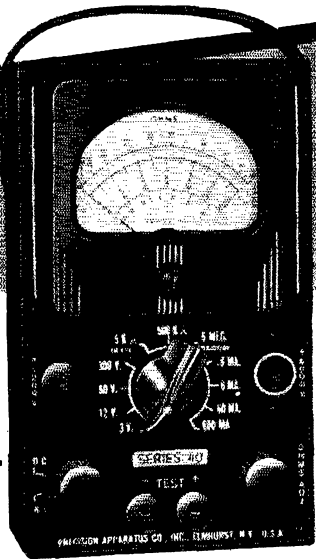

Self-Contained to 6000 V
5 Megs, 600 MA, + 70 DB,
with full size 3" Meter

Complete with bat-
teries and test leads.
Net Price \$24.75

In custom molded carrying case, Series 40 is ideally dimensioned and engineered as a portable, compact test set to withstand the hard usage of amateur radio, servicing, production test, etc.

Series 40 offers features and components as incorporated in "Precision's" larger test sets, including: Rotary Selection — 1% shunts and multipliers — heavy duty insulated pin jacks — large numeralled, easy reading meter.

ALL RANGES are SELF-CONTAINED

RANGE SPECIFICATIONS

- ★ 6 A.C.-D.C. & Output Voltage Ranges:
all at 1000 ohms per volt.
0-3-12-60-300-1200-6000 volts.
- ★ 4 D.C. Current Ranges: 0-6-60-600 MA.
- ★ 3 Resistance Ranges: self-contained batteries.
0-5000-500,000 and 0.5 megohms.
- ★ 5 Decibel Ranges from —22 to +70 DB.
- ★ 1% Wirewound & Metallized Resistors.
- ★ Only 2 Pin Jacks serve all standard functions.
- ★ Recessed 6000 volt safety jack.
- ★ Anodized, etched aluminum panel:
resistant to moisture and wear.

See this new "Precision" Test Set at all leading radio parts and ham equipment distributors. Write for the Precision 1948 catalog describing quality Electronic Test Instruments for all phases of modern radio-electronics — A.M., F.M. and TV.

**PRECISION APPARATUS
COMPANY, Inc.**

92-27 Horace Harding Blvd., Elmhurst 13, N. Y.

Export Division: 458 Broadway, N. Y. City, U.S.A.
Cables: MORHANEX

the Midwest Division Convention. SEF is sporting new power supply. QVA reports a new 28-Mc. vertical. TIU says he's ready for a heavy schedule on TLCN. FP now is a jr. member of TLCN. OM is developing a new habit: he's going to report to the SCM regularly. Fifteen members of the TLCN took an active part in the Simulated Emergency Test. The North Iowa Radio Transmitting Assn. has organized 28-Mc. ground-wave net. Meetings are held each Monday except the first Monday of the month, with roll call at 8 p.m. AEH renewed OBS appointment. NMA is operating portable from Quad City area. WMU has his 167-BY working FB now. UFL sent in a fine report on the activities of the Sioux City gang during the Simulated Emergency Test. AHQ will have a pair of 813s in the final. IHW worked K2UN on 14-Mc. 'phone and has his QSL. HUH is back on 28-Mc. 'phone after several years' layoff. UFL has new sky-hook for his 3.85-Mc. folded dipole. SCV is getting back on the air. The Wichita gang is to be congratulated on the fine work on the Midwest Division Convention. BAL has new three-element beam on 28 Mc. The paper work has the SCM snowed under. Be patient, fellows, and the renewals and appointments will come through. Thanks a lot. Traffic: W0HMM 904, AUL 335, FP 230, SEF 52, QVA 50, PP 40, TIU 20, SQV 18, OSC 11, WMU 10, OM 4.

KANSAS — SCM, Earl N. Johnston, W0ICV — Over 400 attended the Midwest Division Convention. "By" Goodman, IDX, stole the show. 0RHB has new HT-18 and mobile rig. Wichita Emergency Corps members, using 28-Mc. mobiles, assisted Wichita Police on Halloween. MAR is new EC for Zone 16. Topeka Emergency Corps members held a Simulated Emergency Test the night before going to the Midwest Division Convention. NCV was Net Control with 3 mobile and 6 fixed on 29.5 Mc., 1 on 7 Mc., 1 on 3.9 Mc., and 1 on 3.5 Mc. The KVRG held a picnic Oct. 31st. SSB has new Meissner kit going FB. AGC moved shack to basement. HEC is new PAM with 3.85-Mc. 'Phone Net. going full swing. NCV, new RM at Topeka, reports the QKS Net is gaining in numbers. LCZ is new Olathe station. DRB and PHI are active on 3.85 Mc. IYR now is on 7 Mc. PAH, our SEC, asks for full support in the Emergency Corps. LOU and CV have kw. rigs on 3.85 Mc. IFR reports for Chanute. LYF has new 28-Mc. beam. NXJ has new tower for beam. IFR is working on 144-Mc. rig. OAQ is new Asst. EC for Zone 4. GHR has nice EC equipment. KXL, of KCK, reports CLX is rebuilding. TSA is on 3.5 Mc. with antenna in the attic. BC-348, and 50 watts. MOX is using S-40 and 15 watts on 6L8 on 7 Mc. GDH has new final with pair of 304TLs. AHA reports Slow Speed Trunk Line going FB. Traffic: W0NCV 51, AHA 33, IFR 27, WKA 27, WGM 25, BNU 19, MAE 18, JDX 17, KXL 17, ODU 14, ICV 8, VBQ 5, FER 4, HEC 3, OAQ 2, NSD 1, W5TXM 1.

MISSOURI — SCM, Ben H. Wendt, W0ICD — Both of Missouri's active nets, 3905 kc. and 3755 kc., are in full swing. Traffic-handling is the chief order of business. The Missouri Emergency Net, with 59 active members, is in session on Fridays at 10:00 a.m. and on Mondays, Wednesdays, and Fridays at 7:30 p.m., 3905 kc. The HARC is successfully publishing a ham paper which is being circulated throughout the Kansas City territory, serving some 500 hams. The Ozark Amateur Radio Club elected EYU, pres.; and VMI, secy-treas. After an 18-year attempt, ARH finally succeeded in working Asia. Sixteen countries were added to his list in the past month, bringing his total to 71 countries. All continents have been worked with the exception of Africa. OMG has the mobile fever and is working on 28-Mc. gear. KVS is in the A.A.F. Signal Corps. ZAO is the proud owner of a new SX-43. National Simulated Emergency Test stations from Columbia were RMF, CKS, ZLN, GEP, and AFC. On the Trunk Lines JSR, CKS, SKA, and GEP will be happy to handle traffic. KXL is a Kansas City outlet for MON. NMD has a new Collins 32V2 and WAP has a new SX-43. BCD, VOF, EXE, and OOT traveled in a mobile-equipped caravan to and from the Midwest Division Convention held at Wichita. Traffic: W0GEP 152, SKA 62, YSM 58, QXO 39, CKS 38, DEA 19, GKT 18, KTK 14, WAP 14, EEE 11, ICD 8, CGZ 6, QMF 3, ARH 2, IAC 2.

NEBRASKA — SCM, William T. Gemmer, W0RQK — Don't forget the Emergency Corps. "BE PREPARED." Watch for renewal date on your appointments. KON and KJP, two new OBS, both work the Nebraska Net on 3745 kc. Orchids to MUQ, a World War I disabled veteran, who has just received his ticket. HXH has new VHF-152. JPI built new 6L6 modulator and is now working over his e.c.o. ZHJ has a new QTH and a pair of V7ODs at 425 watts input. HZE is on 144 Mc. with a 522. WVE is using new BC-610 on 3.5 and 14 Mc. ILS put up three-element 28-Mc. beam with WWV, BVR, and LJO giving moral support. The HARC has kept its code machine rented out for the past two years. The HARC was out 100 per cent on a Simulated Emergency Test. AGS put up a "comical quad." QXR is erecting steel towers for 144-Mc. beam. ZFC, now a W6, has a new jr. operator. CQD is installing 28-Mc. mobile rig. WIF sold BC-610 and is now using a Utah 5-10-20 rig. AVM is now Class A. FBK has a separate ham shack at his new rural station. RQS moved his rig to the basement

(Continued on page 86)

PUT YOURSELF ON YOUR CARRIER

Reproduce the Individuality of Your Voice..

Transmit Your Own Personality

...with an E-V Microphone

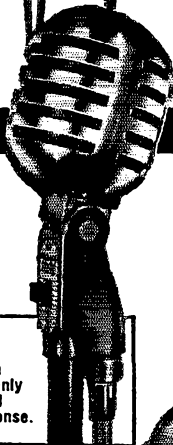

The CARDAX

World's favorite premium crystal microphone. The only high level crystal cardioid with dual frequency response.

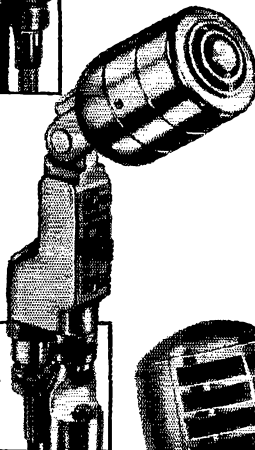

The "630"

Super dynamic. Long proved in service. Ideal frequency response. High output. Acoustalloy diaphragm.

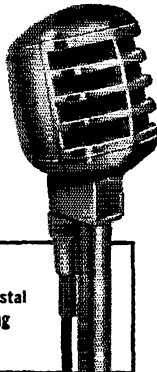

The "910"

Rugged, handsome, crystal microphone. Outstanding performer, at low cost.

With an E-V microphone, you assure *accurate reproduction of your own speaking voice*. The shading and warmth of your speech arrive at the other end of the QSO undistorted and undiminished.

Your carrier is modulated with your exact speech . . . the individuality of your voice is clearly retained . . . your personality is on your carrier.

WRITE FOR HELPFUL BULLETINS

Authorized Distributors Everywhere

ELECTRO-VOICE, INC., BUCHANAN, MICH.

Export: 13 East 40th St., N. Y. 16, U. S. A. Cables: Arlab

NO FINER CHOICE THAN

Electro-Voice

E-V Pat. Pend. Licensed under Brush Patents

QST

YEARLY BINDERS



Are We Right?

You should have at least two of them—one for your complete 1948 file of copies, and one for each 1949 issue as published.

With each Binder is furnished a sheet of gold and black gummed labels for years 1929 through 1949. The proper one can be cut from the sheet and pasted in the space provided for it on the back of the binder.

Price **\$2.50** postpaid

Available only in United States and Possessions

THE AMERICAN RADIO RELAY LEAGUE
West Hartford, Connecticut

86

to overcome a.c. voltage drop. The Ak-Sar-Ben Radio Club (Omaha) meets the second Fri. of each month. The North Platte Amateur Radio Club meets the first and third Fri. of each month. DNVY built electronic key in preparation for SS. RQK built bandswitching exciter with 12A6s and 1625 for the big Sweepstakes brawl. BBS is putting separate 304TLs on each band. FQB is putting out code for beginners on 27,312 kc. Traffic: WJOTQ 528, FAM 40, SAI 40, KJP 25, FQB 21, KON 20, LJO 17, DMY 13, WVE 6.

NEW ENGLAND DIVISION

CONNECTICUT — SCM, Walter L. Glover, W1VB — The fall meeting of the Nutmeg Net was held on Oct. 30th at the clubrooms of the New Haven Club with a good attendance. Plans for the season and the formation of CEN were discussed. This is to be a combination emergency and slow speed net meeting at 7 p.m. on 3640 kc. on Sat. and Sun. nights. All stations in the section are invited to join. New officers of the Manchester Club are: NMP, pres.; MHF, vice-pres.; QUJ, secy.; QIX, treas. LMK is replacing FSH as EC in Manchester, the latter having resigned. In the Simulated Emergency Test on Oct. 17th, HCARA reports the handling of 235 messages with 23 operators participating, and MRC reports 33 messages with a good turnout. MBK, West Hartford EC, also held a fine drill. BVB is back after an absence of 17 years. AW has new kw. rig on 28 Mc. IKE is building a kw. final. AOS is on 3.5-Mc. c.w. CTI is having receiver trouble. Night work still is interfering with TD's hamming. The Mattatuck Amateur Radio Society held its regular meeting Oct. 1st. President OMW presided. Several new members were admitted and the membership now totals 47. Interest in the organization is at a high pitch. Cordial invitations are extended to any clubs or organizations to attend meetings. For particulars contact the secretary, Bill Abrahams, QKI, 222 No. Main, Waterbury. CNV is on 3.85-Mc. phone. RMS has new four-element wide-spaced beam. PGX is operating 28-Mc. mobile. So are QKI, QYQ, and CNV and RFI will be soon. QZI is building a tower to the skies to support some thin metal tubes for some purpose or other. QBF is leaving soon for W6 Land. QKI is going to 3.85-Mc. phone. Traffic: (Sept.) W1DXT 7, (Oct.) W1QMI 778, IIN 589, AW 484, NJM 294, FTX 138, LKP 106, ADW 79, ORP 76, VB 74, LVQ 68, IKE 52, VW 34, HYF 25, EFW 23, DXT 15, KUO 14, CEG 11, CTI 7, TD 4, JTD 1.

MAINE — SCM, F. Norman Davis, W1GKJ — SEC: LNL, PAM; FBJ, RM; NXX. Renewed OPS appointments: APT and LNL, NXX reports fine work is being done on the Pine Tree Net by all the regulars, both in operating the P-T-N, and in representing Maine in other c.w. nets. EFR did a fine job of relaying traffic in the Simulated Emergency Test. ROM now is running 250 watts to V-70Ds on 3.5-Mc. c.w. and 28-Mc. phone. LNI has 6L6-815 phone-c.w. rig for emergency or mobile use on all bands 3.5 to 28 Mc. QIQ reports the rig at YA is running 325 watts to a pair of 812s modulated by 811s. QYB is president of the University of Maine Radio Society. MPP is now XYL of PS. They reside in Lovell, having moved there from Massachusetts. NKM has Signal Shifts driving an 813 final at 300 watts. RSB is new amateur in Saco and has a 200-watt rig with a 5514 in the final modulated by 809s. Season's greetings to all and best wishes for the New Year. Traffic: W1YA 84, LKP 83, NXX 82, OHT 53, OHY 43, EFR 37, KVI 26, JAS/1 13, KYO 8, AFT 6, GJK 3, ROM 1.

EASTERN MASSACHUSETTS — SCM, Frank L. Baker, Jr., W1ALP — OMI is a new ORS. The following OBS have sent in their schedules: MEG, HXK, AAR, GOU, RP, QHC, PZG, and BHD. The following have renewed appointments: ORS — MEG, AQE, HXK, and PYM. OPS — LAO, RP, and HXK. ECs — MAL, FIK, BWH, JYC, MD, BHD, LVN, and MSF. RM — AQE. RQZ is on 7 Mc. HRF and OIZ are on 144 Mc. RRB and SEW are on 3.5 Mc. AIO is on 144-Mc. portable. LAO, CAU, and QHI are on 3.85-Mc. phone. NKZ and RJH are on 28 Mc. MCR has his gang in Dorchester on regular drills. PLQ had a rig on 3.5 and 144 Mc. from the car on the Oct. 16th Test. QJB is in 7-Mc. chess club with 2UUV, VSU, and 1FES. QMJ got Utah and New Mexico for WAS. Another teen-age net is going on 7118 kc. Mon., Wed., and Fri. at 6 p.m. AQE made 242,320 points in the CD Party. OMI made a score of 282,815 in the CD Party. JSM was at the key. KB is on 144 Mc. and can work AQE anytime. RBK is on the Brass Hat Net, on 7114 kc. Wednesday nights. WU is building a new transmitter. MEG has 200 watts on 28-, 14-, 7-, and 3.5-Mc. phone and c.w. MD is on Eastern Shuttle Net on 7120 kc. IIM has a rig in his car on 27 and 28 Mc. and keeps a schedule with G8VB nightly on 3.85-Mc. phone. The Parkway Radio Assn. is looking for new members. BWH has a Navy TCS-9 on the air and is in the Sub Sig Net Mondays at 8 p.m. on 3665 kc. 6HJ, on 7, 14, and 28 Mc., wants to work the Massachusetts gang. The Brockton Radio Club showed movies and Jim Ornet gave a talk and demonstration on the output of audio amplifiers. The T-9 Radio Club held a meeting at ISX's QTH. Ken Larkin and ex-VE2KX gave talks on h.f. receiver and converter design at the Eastern Mass. Assn. meeting. SS is new secretary of the Club. IVI gave a talk and showed slides of WBZ-t.v. and EKG gave a talk

(Continued on page 88)

Introducing —
Another Plasticon Development

HiVOLT POWER SUPPLIES

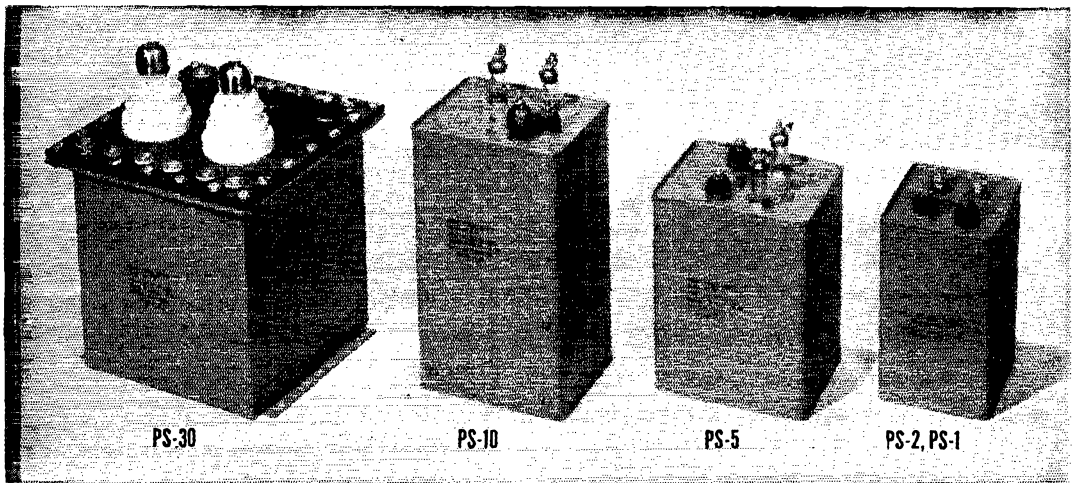

HiVolt Supplies are self-contained in hermetically sealed metal containers. They are designed to transform low voltage AC to high voltage — low current DC.

- PS-30 — 30,000 VDC; 1 Ma.;
dimen. 7" x 7" x 7"
- PS-10 — 10,000 VDC; 2 Ma.;
dimen. $3\frac{3}{4}$ " x $4\frac{9}{16}$ " x 8"
- PS-5 — 5000 VDC; 5 Ma.;
dimen. $3\frac{3}{4}$ " x $4\frac{9}{16}$ " x 6"
- PS-2 — 2400 VDC; 5 Ma.;
dimen. $3\frac{3}{4}$ " x $3\frac{9}{16}$ " x $5\frac{1}{2}$ "
- PS-1 — 2400 VDC — Capacitor
load; dimen. $3\frac{3}{4}$ " x $3\frac{9}{16}$ " x
 $5\frac{1}{2}$ "

High Voltage — Low Current DC
Power Supplies for
Television — Radiation Counters —
Photoflash Devices — Electrostatic
Precipitators — Spectographic Ana-
lyzers — Oscilloscopes, etc.

Write for descriptive literature

Plasticon Capacitors, Pulse Forming Networks
and HiVolt Power Supplies are available at all
leading jobbers.



Condenser Products Company

1375 NORTH BRANCH STREET • CHICAGO 22, ILLINOIS

Heavier Windings

ON NEW

JOHNSON HAM INDUCTORS

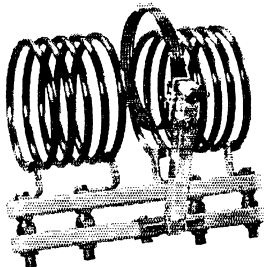

Lower Loss — High Efficiency

If it's efficiency you want, you'll insist on the new JOHNSON Ham Inductors. Coil windings are a wire size larger than on most available inductors — resulting in less heating, lower loss and consequently higher efficiency.

For instance, the 1000 watt twenty meter inductor, pictured above, is wound with .250" diameter copper tubing, not wire. It is intended to match low voltage high current tubes — efficiently! Extra heavy size statite plug and jack bars insulated by clear polystyrene — not conventional plastic — also result in additional efficiency.

Only with JOHNSON Ham Inductors can you match coil to tube. Another exclusive feature is the matching of link to line with the new JOHNSON "plug-in" swinging link assembly. These outstanding inductors are also available in semi-fixed models.

Remember, too, that the new JOHNSON Inductors and Plug-In Link Assemblies fit all conventional inductor assemblies.

LOADED WITH FACTS

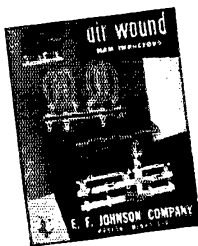

The new JOHNSON "Air Wound Ham Inductor Catalog" contains information and tables which will enable you to select the correct inductor, link or links for your individual application. The booklet is a virtual storehouse of information on Q considerations, tube-inductor matching,

link-line impedance matching, antenna coupling, etc. Get it at your dealer or write JOHNSON for a copy of this important reference manual today. It's yours for the asking.



JOHNSON

a famous name in Radio

E. F. JOHNSON CO. WASECA, MINN.

on antennas and feeders at South Shore Radio Club. VK3NW, HH2BL, and ON4AD attended the Boston Hamfest. The HI-Q Club elected the following: ALG, pres.; BSG, vice-pres.; JYB, secy.; JX, treas.; KAE, act. mgr. Meetings are held the 2nd and 4th Fridays at JYB's QTH. The Club has received the call PG, which belonged to CRM Henry Rand, USN, who lost his life in the war. The Yankee Radio Club elected: NVB, pres.; OLC, vice-pres.; LQQ, secy.-treas.; PZ and KVQ, directors. New hams are RNM, ROL, XYL of OLC, RRA, RRF, and ROQ. The Northeastern Radio Club, KBN, elected the following: ODO, pres.; QCI, treas.; PCB, secy. KNI and DA are on 50 Mc. BWH, Attleboro EC, and his gang were on during the Simulated Emergency Test with a rig at Red Cross Headquarters. KB, Haverhill EC, has CCF, KUA, KQV, OLN, MTS, OAJ, LHT, QZS, QDD, and IWR signed up. HKG has new VFO. HOH has new beam for 28 Mc. QFI, Coast Guard station, held open house on Dec. 5th. The South Shore Club had a rig on 144 Mc. at the Hobby Show in Quincy. AGC is on 3.5-Mc. c.w. OLP and QON have a new antenna which is working out well. Traffic: (Sept.) W1JCK 48, (Oct.) W1AQE 158, QMJ 65, LM 64, JCK 63, EMG 58, TY 38, KB 35, QJB 30, QZS 23, FYM 19, OMI 16, WU 15, QDD 13, MCR 11, BDU 9, LAO 8, MD 8, MEG 6, MRQ 4, RBK 4, PLQ 3, IM 2.

WESTERN MASSACHUSETTS — Prentiss M. Bailey, W1AZW — RM; BVR, SEC; UD. PAM: NY. The first thing this month is to congratulate our entire West. Mass. AEC on the swell job accomplished during our National Simulated Emergency Test. The SEC, the ECs, and all concerned did one bang-up job. Many West. Mass. boys attended the Boston Hamfest, where a good time was had by all. BVR spoke at the ARRL meeting there. IJT is now ORS. JYH took part in the CD Contest. EOB went to town in the CD Contest also. CCH built band pass converter for 144 Mc. and has increased power to 90 watts on 144 Mc. NY is looking for more members for the West. Mass. Phone Net on 3865 kc. Sunday mornings at 9 A.M. DPF has been busy traveling all over the U.S. JE and BVR lead in traffic totals for the month. RPN is new ham in Worcester. PBS is hospitalized as the result of an auto accident. Speedy recovery, OM. EJD has new phone rig. RIQ works plenty of DX on 28-Mc. phone with 25 watts. MUN found many bad notes in the CD Contest. KDE worked many stations on 3.5 Mc. with .6 watt. New officers of the Pittsfield Radio Club are: JGY, pres.; QCA, vice-pres.; DPF, secy.; COI, treas.; AZW, act. mgr. A gala Halloween Party was held by the PRC with YLs and XYLs in attendance. Games, eats, and dancing were all enjoyed. IBZ has new QTH with plenty of space for antennas. George now is on 3.85 Mc. GZ gets plenty of traffic on SSN. GVJ is active on West. Mass. Phone Net. BDV is kept busy with teaching duties and odd jobs around the house. JGY has power supply trouble but got on for AEC Test. HNE attended Rutland Hamfest. MUN schedules CPAAQ weekly. QNI received his Class A license. AZW has worked seven countries on 3.5 Mc. Traffic: W1BVR 109, JE 104, NY 82, GZ 61, AZW 35, IJT 35, INI 20, BDV 17, JGY 12, DPF 10, GVJ 8, RDB 2, RH 2.

NEW HAMPSHIRE — SCM, Gilman K. Crowell, W1AQO — The New Hampshire 28-Mc. Emergency Phone Net, 28.2 Mc., is operating every Thursday evening with CNX as Net control. Many thanks to LSN for the nice job he did as NC on the 50-Mc. emergency net. RMH is now employed at WKXL. ATJ now is equipped for 3.85-Mc. mobile. The Great Bay Radio Club held its last meeting in Portsmouth on November 12th. We all welcome WS and EWF to New Hampshire. QJY has a new QTH and a 410-foot antenna. CRW is sporting a new Collins receiver and has recently been appointed Assistant Net Control for NTL. Now that the nets are in full swing, let's hear a little more activity. Traffic: (Sept.) W1MXP 8, (Oct.) W1CRW 269, CVK 21, MXP 19, QJY 19, PFU 8, QJX 8.

RHODE ISLAND — SCM, Roy B. Fuller, W1CJH — The PRA invited the NAARO members to view movies taken of the joint picnics held this summer. It's amazing how one looks trying to be young again. The program also included technical films, a new method of growing crystals. The professionalist was JO. IQZ placed high in the recent VHF SS Contest. HRC lugged 274N units to Vermont while on vacation and had good results on 7 Mc. with 15 feet of inside antenna. QLD is set up for checking your modulation on a scope so if you want to know look him up on 28-Mc. phone. FB, NCX, QQG, MJL, KNE, HLK, LTH, BEH, and CJH took part in the SS. Looks like a good club score for NAARO. Your SCM has several appointments for qualified hams. Please drop me a line if interested. Traffic: W1BTY 67.

VERMONT — SCM, Burtis W. Dean, W1NLO — The Vermont Hamfest, held Oct. 23rd at the Hotel Bardwell in Rutland, with 150 present, was the largest hamfest ever to be held in Vermont. The members of the GMARC are to be congratulated on the FB program and entertainment. The Vermont Phone Net operates every Sunday morning at 9:30 on 3860 kc., with NCS rotating among the members. The Vermont C.W. Net operates Mon. through Sat. at 7:00 p.m. on 3740 kc. with PBD as RM and GKA as NCS alternate. The Green Mt. Net (28 Mc.) meets every night at 8

(Continued on page 80)



QSO's from OHMITE

NEWS ABOUT AUTO-TRANSFORMER TAP SWITCHING

We have developed a series of Tap Switches that are particularly suited to auto-transformer switching applications. If you now use a tapped auto-transformer for controlling the voltage output of the power supplies in your rig, investigate the possibilities of these tap switches. Illustrated are some typical applications of the Ohmite 10- and 15-ampere switches. Model 111 for 10 amperes and Model 212 for 15 amperes.

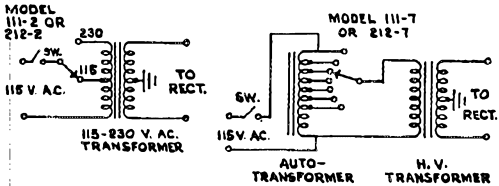

The tapped transformer below is wired so the secondary voltage is 180° out of phase with the line voltage and bucks the line voltage down to as low as 55 volts.

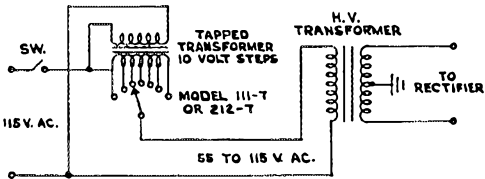

BUILD A LOW-COST ANTENNA DIRECTION INDICATOR

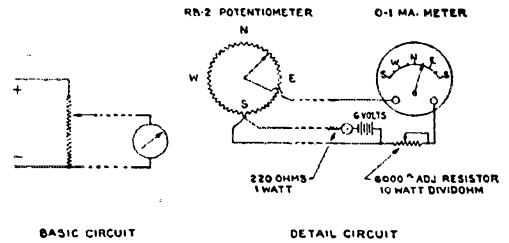

If you are tired of running outside to look at your beam antenna to determine the direction it's pointed, you should investigate the Ohmite RB-2 Direction Indicating Potentiometer. This unit, with a 0-1 ma. meter, two resistors, and 6-volt battery, provides an inexpensive means of direction indication.

The circuit diagram for this unit is shown here; however, for complete details, write for Bulletin No. 128.

NEW DUMMY ANTENNAS ANNOUNCED

All amateurs will be glad to hear about the new line of Dummy Antennas recently announced by Ohmite. They're particularly useful in transmission-line work, and have been improved so the reactance is kept to a low value at frequencies up to 28 megacycles. The higher resistance units can be used to even higher frequencies. And remember to consider one of these Ohmite Dummy Antennas when choosing a terminating resistor for a 14- or 28-megacycle Rhombic. Ohmite Bulletin No. 136 gives the analysis of tests conducted on these new units.

Write for Bulletin 137
"Ohmite Ham Hints"

OHMITE MANUFACTURING CO.
4863 Flournoy St. Chicago 44, Illinois



Be Right with

OHMITE

RHEOSTATS • RESISTORS • TAP SWITCHES

Now — Plan for a Good-Paying Career Job in TELEVISION



New CREI Home-Study Course in Practical

Television

Be in a position to command a "key" job in the growing TELEVISION Industry by preparing now with the type of thorough, practical TELEVISION Engineering training that the industry requires. The new CREI TELEVISION Engineering course is (1) A complete well-coordinated course of study that covers the entire field of practical TELEVISION Engineering, (2) Presented in CREI'S professional and proven home study form, (3) Prepared by CREI'S experienced staff, based on actual experience in our own TELEVISION Studios and Laboratories, plus years of close contact with leaders in television development. Here's your opportunity to be prepared for television well ahead of competition, if you start NOW!



**JUST OFF THE PRESS!
WRITE FOR FREE BOOKLET**

Let us prove to you we have the training you need to qualify for a better radio job. To help us answer intelligently your inquiry — please state briefly your background of experience, education and present position.

VETERANS! CREI TRAINING AVAILABLE Under G. I. Bill

CAPITOL RADIO ENGINEERING INSTITUTE
Dept. 161A, 16th & Park Road, N. W.
Washington 10, D. C.

Mail me your FREE 32 page booklet.

Check field of greatest interest:

- TELEVISION PRACTICAL RADIO-ELECTRONICS
 BROADCASTING AERONAUTICAL RADIO ENGINEERING
 RECEIVER SERVICING

Name.....

Street.....

City..... Zone..... State.....

I am entitled to training under the G.I. Bill.

P.M. The BARC has been reorganized with OHD, pres.; QVS, vice-pres.; and NLO, secy.-treas. FSD is new OBS. MMV has Collins 75-A receiver. OKH has 300-watt Globe King. CUN has worked Montreal on 144.2 Mc. from Richmond. AZV, IQG, and B.W.C. are busy with the CAP. AD is using FM because of F.C.I. Best wishes for a bang-up New Year from all of us at NLO. Traffic: W1PSD 68, GKA 22, BJP 7, AVP 6, FPS 4.

NORTHWESTERN DIVISION

IDAHO — SCM, Alan K. Ross, W7IWU — Mullan: I HAH is active on all bands and has applied for membership in the AEC. Mountain Home: IY has been operating portable from Fall Creek working at Saw Mill. American Falls: DMZ now has separate 28-Mc. final with 810s. Kendrick: KDV has new rack for 350-watt rig. MHR soon will be on 7 Mc. and 28-Mc. mobile. Teaching keeps MGL busy. Twin Falls: The club now is meeting in members' shacks until all are visited. Its Simulated Emergency Tests were successful with JMX, IOA, JPP, and KEK participating. LQN has pulled stakes for New Mexico. LNC bought a new car. Both KEK and HKJ are working on mobile rigs. Boise: MQU is a new ham. 146.25-Mc. members are GTN, HPH, DOH, FOF, and IWU. Emergency tests went off fairly well with GTN, DOH, GQA, LUS, JMH, and IWU participating. Thanks for the nice reports this month. Traffic: W7EMT 25, DMZ 22, IWU 7, JMX 7.

MONTANA — SCM, Fred B. Tintinger, W7EGN — SEC: EMF. PAM: CPY. RM: COH. CPY conducted a successful emergency test at Glendive and AEC members participating were DXQ, BHB, BAR, and FOA. BSU has vertical parasitic beams on 14 and 28 Mc., a ground plane on 7 Mc., and a doublet on 3.5 Mc. CBY and IBG are working 144 Mc. EJC is rebuilding. DPK reports the State is divided into seven CAP emergency communication areas with an amateur in charge of each. Six areas are now operating and they have secured 190 SCR-511 walkie-talkies for distribution to CAP members. The Hellgate Radio Club of Missoula has been formed with 21 members. Officers are: ELY, pres.; Mack Helman, vice-pres.; JOI, secy.; MAK, act. mgr. The Hellgate Radio Club and the Glacier Radio Club motored to Polson for a week-end miniature hamfest and banquet. One highlight was "ship to shore" 144 Mc. on Flathead Lake. LBK and COH visited FTO in Lewiston. CAL and FTO helped HBM plant high antenna poles. HBM is controller for CAP area No. 6. JRM attends college in Billings and spends week ends hamming in Lewistown. KIY is new ORS and EC at Poplar. EWR burned up No. 18 wire in 80 tank with 809. Traffic: W7KGJ 55, CT 16, COH 7, EGN 6, KIY 3.

OREGON — SCM, Raleigh A. Munkres, W7HAZ — LaGrande: The Blue Mountain Radio Club now is an ARRL affiliate. ITN and IYG, of Nampa, Idaho, were visitors in town. KVG and HBO made a four-day trip to Salem and Portland, visiting many shacks. JOD is active on 28 Mc. with 2 wattal BVV, of Salem, hunted in the area using 3.85-Mc. mobile for "outside" contact. Baker: New officers of the Baker Amateur Radio Club are: AMI, pres.; Bill Johnson, vice-pres.; Oscar Nygard, secy.-treas. AOL is going to start building an 813 rig. LQW and HAZ have 28-Mc. beams now turning. IXT is experimenting with a multitude of ways for keying a Command transmitter. Portland: SEC DIS sends FB report on National Emergency Corps Test. Fifty-seven stations in Portland, Salem, Vancouver, and Corvallis participated. The *Oregonian*, Portland's leading newspaper gave front page publicity. Portland phone outlet for traffic, LI, is on American Legion Net. Mission Trail Net, WARTS Net, and Oregon C.W. Net. HVD, of Klamath Falls, reports that the American Legion Net needs outlets in Eugene, Salem, and Rogue River Valley. Emergency drills are being conducted regularly by Pendleton, Klamath Falls, Astland, Portland, Medford, and Grants Pass. ECs are being appointed for Bend, Redmond, and Prineville. HHH reports from Bend that KCI and XYL LKG have moved from Klamath Falls to Hooker, Okla. Their new calls are 5PDC and 5PDC GNJ has new p.p. 250TH final, 600 watts. HLF is using 150 Globe Champion 28-Mc. phone. Traffic: W7APF 268, HVD 80, DIS 70, LT 55, HLF 25.

WASHINGTON — SCM, Clifford Cavanaugh, W7ACF — SEC: GP. RM: CZY. PAM: CKT. Glad to see that CKT, our PAM, has so many of the phone boys reporting this month. FB gang, YH, at Pullman is being manned nightly on the WARTS Net and is handling lots of traffic. CZY worked two ZIs on the low end of 3.5 Mc. EAU moved and is having a tough time getting on again. KWC is laying for the SCM for mixing up his report on the Mt. Baker Radio Club's activities. CWN reports good DX conditions on 14 Mc. as he has no trouble working ZS. JC hears LU7AZ on 3.5 Mc. but lets the VEs work him. Always the gentleman, that's Van. FWD is remodeling his entire station — the whole house for radio and tape mixing. EAU washed. GR WART outlet at Yakima, is busy handling traffic. KNV says college and radio don't mix. IXT reports noise level is getting higher and higher at his QRA. LIL is back on WBSNET again after a long absence. He and DRA handle the bulk of Tacoma traffic. HGC says his family

(Continued on page 68)



MERIT PLATE TRANSFORMERS

MERIT LEADS AGAIN!

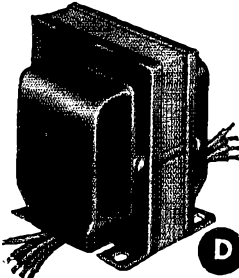

MERIT MODEL D

Now! Merit Plate Transformers, open and sealed types, for small transmitters, amateur, or experimental use, provide you with transformer equipment unequalled. . . . For dependability — for economy. Shown below are four more leaders in the Merit quality line — your best buy, by all odds!

BUY THEM FROM YOUR MERIT DISTRIBUTOR TODAY!

OPEN TYPE MOUNTING "D"

Type No.	Net Price	Sec. Rms.	Sec. DC Volts	Sec. DC MA
P-3157	\$6.90	{ 660-660 550-550 }	{ 500 400 }	250
P-3159	8.10	{ 900-900 800-800 }	{ 750 600 }	225

† Has 40 volt bias tap

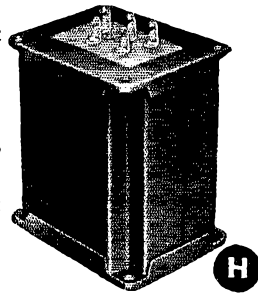

MERIT MODEL H

SEALED-IN TYPE MOUNTING "H"

Type No.	Net Price	Sec. Rms.	Sec. DC Volts	Sec. DC MA
P-4057	\$9.60	{ 660-660 550-550 }	{ 500 400 }	250
P-4059	10.80	{ 900-900 800-800 }	{ 750 600 }	225

** Has 40 volt bias tap

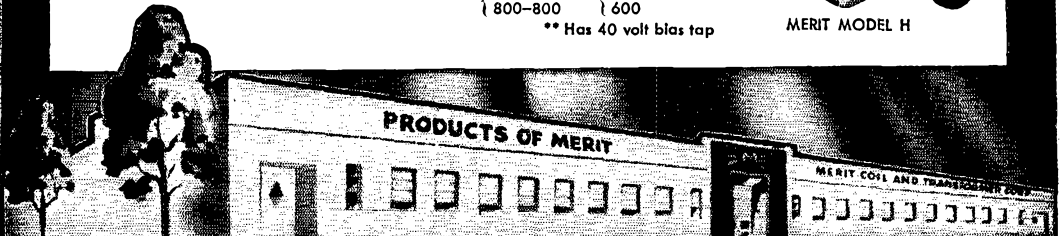

MERIT COIL & TRANSFORMER CORP.

TELEPHONE

4427 North Clark St.

Long Beach 6311

CHICAGO 40 ILL.

Thermal Time Delay Relay

Set for 2 minutes but adjustable over a range of 15 seconds to 2½ minutes. Delay accomplished by a bi-metallic thermal element which automatically compensates for changes in room temperature. 110 V 60 CY coil. SPDT 4 amp 110 V silver contacts. Additional set of contacts disconnects thermal circuit when relay closes.

Stock No. B-904A



Regular Net \$9.00
Only \$2.95

Plate Transformer

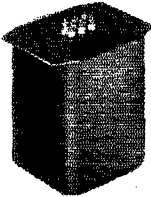

Primary 115 and 230 volt 50/60 cycle. Secondary 550-0-550 volts at 212 ma. Hermetically sealed gray case, 5" x 6" x 7" high. Net wt. 21 lb.

Stock No. B-292A \$6.95

Stock No. C-523A - Same as the B-292 except primary is 210, 220, 230, 240 and 250 volts 50/60 cycle. \$4.95

Power Transformers

- Primary - 115 volt 50/60 cycle.
- Sec. #1 - 420-175-0-175-420 volts at 60 ma.
 - #2 - 6.3 volts 9 amperes (Term. 7, 8)
 - #3 - 6.3 volts 0.6 amperes (Term. 3, 4)
 - #4 - 6.3 volts 0.6 amperes (Term. 5, 6)

Hermetically sealed gray case, 4½" sq. x 5½" high. Four 8-32 mounting studs. Net wt. 10 lb.



Stock No. C-464A \$2.95

- Primary - 220 volt 50/60 cycle.
- Sec. #1 - 340-0-340 volts at 135 ma. with 77V bias tap.
 - #2 - 5 volts, 3 amperes.
 - #3 - 5 volts, 2 amperes.
 - #4 - 6.3 volts, 3 amperes.
 - #5 - 6.3 VCT (2 amp) tapped at 1.25V (5 amp) each side of CT.

Gray case 4½" sq. x 5½" high. Net weight - 10 lb.

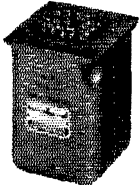

Stock No. C-98A \$1.95

We can still supply these transformers as advertised in June and September QST's.

- C-702A 20 Volt 9 Amp \$1.95
- C-721A 11.5 Volt 11.3 Amp 3.49
- C-787A 24 Volt 4½ Amp 2.49

The above are only a few of the many money saving items in our 1949 Surplus Catalog. Write for your free copy.

SREPCO has been radio parts distributor for over 16 years and carries all the well known lines such as Amphenol, B and W, Johnson, Millen, National, Stancor, etc. Include your standard parts requirements on your orders for surplus. Your orders and inquiries will receive our prompt and personal service.

TERMS - cash with order or 20% deposit, balance C.O.D.

SREPCO INC. ALL PRICES ARE NET, F.O.B. DAYTON, O.
135 E. Second St. - DAYTON 2, OHIO. - Tel. FUKton 2174
STANDARD RADIO & ELECTRONIC PRODUCTS

has got him under the table. KCU is a new ORS in Colfax, FB, Martha. ETO is having e.c.o. trouble — no end. FRU is handling lots of traffic and harvesting a big crop of pumpkins. LVB is busy developing new traffic outlets. ZU is busy collecting various patterns of wallpaper. AMZ keeps Centralia on the map while EAU moves. MCW is doing liaison work between WARTS and WSNET. APS will be TL "N" Seattle outlet. GRM has put up new 28-Mc beam. GHI is laying plans for better Seattle AEC organization. SSQ checks in on WSNET. Long time no see, Stan. LXP operates from U.S.S. Grady in AEC drill. BLP had the most power in AEC drill. MBY, MCT, and KWC put on an FB AEC drill in Bellingham. LLE is building new rig and beam antenna. LNW had the best looking report card received by the SCM. The following 'phone men sent in reports: EHB, EVW, and ELN. DXF is on with his ten-watter. EYS has modulator trouble and no moolah. Everyone in LEC's QRA hopes he gets his new transmitter going as there is no living with the man. NLB is busy as secretary of the Puget Sound Council of Radio Clubs and is doing an FB job. The PAM says the WARTS Net is going to be 100 per cent OPS soon. FB, fellows. Traffic: W7CKT 1656, YH 423, CZY 280, FRU 212, ACF 88, MCW 76, FIX 65, GRM 53, FWD 45, KWC 43, ETO 38, AMZ 34, ZU 32, EAU 30, GR 28, DXF 25, DRA 23, ELN 20, LVB 19, LNW 12, JC 10, EHB 8, EVW 5, KCU 5, APS 4, CWN 4, LIL 1.

PACIFIC DIVISION

SANTA CLARA VALLEY — SCM, Roy E. Pinkham. S W6BPT — KMM is QRL going to school but will be on with 250 watts as soon as he gets new power line run into his QTH. 4LGE wishes schedule on 14-Mc. 'phone with station in San Jose to handle traffic from Washington, D.C. WJM reports that the Monterey Bay Radio Club is using the film from ARRL Headquarters and recommends that the test from ARRL be used by clubs. SYW now has his quad in the air. A nice letter was received from PBV, who is in Dhahran, Saudi Arabia. Bob will be at QTH for about two years as an operator for the Arabian American Oil Co. EOA is a new ham located in San Jose. WOZ is employed by RCA in television in San Francisco. Joek plans to move closer to San Francisco in order to cut down travel time to and from work and to have more time for radio. HC gave nice talks on T.V.I. before the Santa Cruz Radio Club. It is reported that JSF and CCW are taking unto themselves XYLs. ZZ is using long wire on 28 Mc. until he can get the slip rings on his beam back in order. TBK is busy on 144 Mc. in the evenings so is not heard on 28 Mc. WCL now is using n.f.m. YRB built e.c.o. from Meissner Kit. WDF silenced his prop pitch motor according to the dope in Hints and Kinks in November QST and says that it works to perfection. NOE can be heard on 3.85-Mc. mobile 'phone at times. BO will open a theater in Saratoga in the near future. Traffic: W6WJM 155, KMM 8, SYW 2.

EAST BAY — SCM, Horace R. Greer. W6TI — Asst. SCM, C.P. Henry. 6EJA. SEC; OBJ. ECs: AKB, EHS, NNS, IT, IDY, QDE, WGN. Asst. EC u.h.f.: OJU. RMs: ZM, FDR. VDR is installing n.f.m. at home QTH. BF reports that the HK-57s are working FB. YDI is QRL traffic. WII is having B.C.I. trouble. LMZ is QRL Fire Dept. EJA is rebuilding final power supply. FDR is turning in high traffic reports regularly. QXN reports TLAP is in full swing. PB has new monitor. LDD is building new final with p.p. 250Ths. BUC is on 28 Mc. NHU is on 144-Mc. Net. EDG and DUU are on 28 Mc. WXU is trying to work 144 Mc. without tuning the rig. AIM expects to have an XYL before long. YHI returned home at last after installing radio gear for the Air Forces in Montana. WGM is enlarging his shack. AFC is in Nevada installing gear for Naval Reserve. YUJ is trying to get on the air from Mare Island. VEF is home on leave. EUL is teaching television at Vallejo J.C. OT, the Oakland Radio Club station, is putting out a mean signal on 14-Mc. c.w. CTL is getting to be an expert on keying methods. JZ is a busy man these days. KEK is not doing so bad. WP has been out of town most of the year but hopes to stay around now for awhile. AUT returned home after completing a 12-week course at the FBI National Academy in Washington, D. C., according to ZM. RM likes his new European rhombic. UPV is almost rebuilding crazy. IKK is keeping schedules. FXX still is single-ended. GEA is training his two babies to be 2nd and 3rd operators. Write YI for one of his new choice QSL cards. TT, MEK, and MVQ are trying to outdo each other on new countries. DUB is putting up two new rotary beams. 'TI is thinking about one. EE now has his Class A license. EY still is playing with low power. OBJ is getting to be a mountain climber with his portable gear, according to AKB. Would like to have a list of all the new officers of all clubs in the East Bay section. Your SCM would like to take this opportunity to say best wishes and DX for the coming year. We still are looking for a 'phone man who would like to take on the duties of PAM for the section. ELW is home from Texas at last. YMO is sneaking up on DX. Would like to have some 144-Mc. dope. The East Bay Radio Club and the North Bay Amateur Radio Assn. are putting out fine club newspapers. Traffic: W6FDR 601, QXN 275, YDI 34, BF 29, VDR 26, TI 12, EJA 4.

(Continued on page 98)

DEAR FELLOW AMATEUR:—

"A very serious situation has arisen. Unless all of us amateurs act quickly, a law will be passed in Washington which will wipe Amateur Wireless completely out. . . ."

Thus in 1918 a four-year-old ARRL, already the guardian of a struggling amateur radio in legislative and regulatory matters, wrote each amateur in the United States seeking help to prevent the extinction of "amateur wireless."

Wouldn't you be astounded to receive such an urgent call from ARRL today?

Certainly you would, because you know that today amateur radio is a strong, healthy and stable group. You know that ARRL is the organized body of amateur radio, its capable representative in this country and abroad, its experienced champion against attack by foreign government or opposing interests.

You know that such alert representation, coupled with a strong, united membership, alone has kept amateur radio on the air and enabled amateurs to make their maximum contribution to the public interest.



Are you doing *your* part to ensure a continued healthy and bright future for amateur radio? The first step is to take your place in the ranks of organized amateurs. Join the League today!

ARRL, 38 LASALLE ROAD
WEST HARTFORD 7, CONNECTICUT

Enclosed is \$..... (\$4 in the U. S. and possessions; \$4.50 in Canada; \$5 elsewhere) for ARRL membership dues for one year. Start QST with the.....issue. I prefer a membership
 certificate card.

Name.....Call.....

Street and Number.....

City.....State.....

THE RADIO SHACK IS PRIVILEGED TO PRESENT

HALLICRAFTERS HT-17 XMTR
 Complete with 80-40-20-15-10
 Meter Coils



Originally sold for \$60.50 with
 Coils
RADIO SHACK

Sale Price \$39.50

Save \$21 on this famous low power xmtr which provides 10-20 watts of crystal-controlled CW output on the amateur 3.5, 7, 14, 21 and 28 mc. bands! Self-contained power supply for 105-120 volts AC, with 5Y3-GT rectifier. A never-before value you may never see again!

**EXTRA! ACCESSORY KIT
 FOR IMMEDIATE
 HT-17 OPERATION**

Includes: 80 meter crystal, 40 (20, 15 & 10) meter crystal, 100 ft. #14 antenna, quality CW key and 3 ft. zip cord connection, 2 antenna insulators and 1 feed-thru insulator.

COMPLETE KIT ONLY \$7.50

Kit with 40 or 80 meter crystal \$4.75

*A Smashing
 Sale of*

HALLICRAFTERS GEAR
 (JUST DISCONTINUED FROM THEIR LINE)

**HALLICRAFTERS
 "ECHOPHONE" EX-102
 3 BAND - 5 TUBE
 SUPERHET RECEIVER**

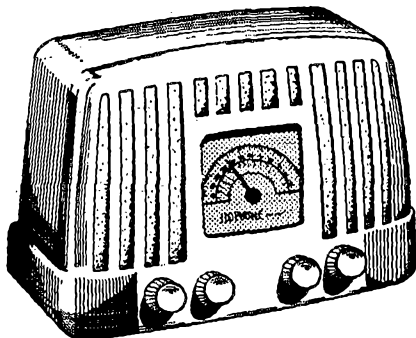

Originally sold for \$50.00
RADIO SHACK

Sale Price \$24.95
 IN WALNUT
 (EX-102 IN IVORY \$26.45)

- Electrical Bandspread Tuning!
- 535-1625, 2200-7100, 6900-22000 KC.
- 4 Controls, Airplane Duplex Dial!
- Vibrationless Rubber-Mount Chassis.

Completely enclosed in smooth plastic, it's a 3-band set you'll be proud to own! Five-inch dynamic speaker; built-in loop antenna; operates on 50-60 cycle AC or DC on either 105/125 or 210/250 volts. Save 25 big dollars!

LUCKY YOU! Hallicrafters is concentrating its 1949 production on other models and has to discontinue these 4 wanted styles. Alert purchasing by **THE RADIO SHACK** saves you (as usual) up to \$80!

OUR MOST SPECTACULAR OFFER IN YEARS...

HALLICRAFTERS

S-55 FM-AM - HIGH FIDELITY RECEIVER

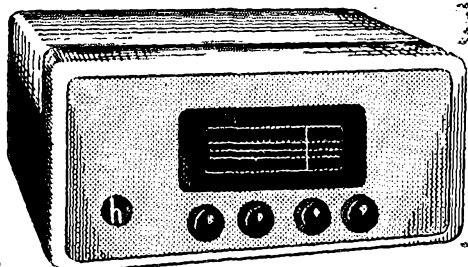

Originally sold for ~~\$129.50~~
RADIO SHACK

Sale Price \$49.50

Exactly as advertised in *December QST* by Hallicrafters for \$129.50, this magnificent receiver is the biggest *new set* value ever offered! Ten tubes plus rectifier, operates on 115 V, 60 cycles AC. Two bands: FM 88-108 mc, AM 540-1700 kc. Complete with all tubes in metal cabinet but less speaker.

**SPECIAL
SPEAKER
PURCHASE**

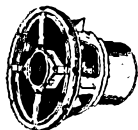

To go with your new S-55 . . . a national famous-name 12-inch coaxial speaker at less than half of its regular list price . . . NOW ONLY \$11.95

A Smashing Sale of

HALLICRAFTERS GEAR

(JUST DISCONTINUED FROM THEIR LINE)

HALLICRAFTERS

S-58 FM-AM RECEIVER

- METAL CABINET!
- INTERNAL SPEAKER!

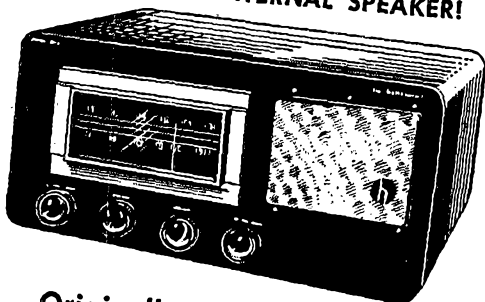

Originally sold for ~~\$59.50~~
RADIO SHACK

Sale Price \$34.95

Save \$24.55! Note these Hallicrafters quality features: 6 tubes plus rectifier . . . 5-inch PM speaker . . . high impedance phono input . . . FM 88-108 mc, AM 540-1600 kc . . . 105-125 volts, DC or 60 cycles AC. Advertised for \$59.50 in *December QST* by Hallicrafters!

The RADIO SHACK Corp.

CABLE ADDRESS · RADIOSHACK
167 WASHINGTON ST., BOSTON, MASS., U.S.A.

RUSH YOUR ORDER! When the "word" gets around, our ample but limited stock of these amazing bargains will go but fast! Immediate delivery guaranteed, on our usual first-come first-served basis!

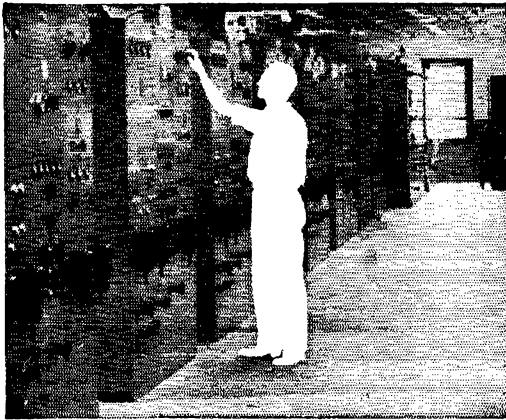

Don't let others put you out of the picture!

CREI Courses for Every Radioman Keep You Ahead of Competition—Earn You More!

Enjoy security and good pay! Step ahead of competition into a better radio job with CREI technical home study training. Protect your future today—keep ahead of the man who is waiting for your job—plan for the better job that can be yours.

You may have "gotten by" up to this point. But, if you are like many other radiomen, many of the recent technical advances have passed you by.

We invite you to see, without obligation, just what CREI home study training can do for you. You can "go all the way with CREI" from introductory basic principles (for the man with limited experience) to advanced training and specialized subjects (for the man with greater experience). No matter what your experience, CREI has a course for you.



JUST OFF THE PRESS!

WRITE FOR FREE BOOKLET

Let us prove to you we have the training you need to qualify for a better radio job. To help us answer intelligently your inquiry—please state briefly your background of experience, education and present position.

VETERANS! CREI TRAINING AVAILABLE Under G. I. Bill

CAPITOL RADIO ENGINEERING INSTITUTE

Dept. 161A, 16th & Park Road, N. W.

Washington 10, D. C.

Mail me your FREE 32 page booklet.

Check field of greatest interest:

- PRACTICAL RADIO-ELECTRONICS TELEVISION
 BROADCASTING AERONAUTICAL RADIO ENGINEERING
 RECEIVER SERVICING

Name.....

Street.....

City.....Zone.....State.....

I am entitled to training under the G.I. Bill.

(Continued from page 98)

SAN FRANCISCO—SCM, Samuel C. Van Liew, W6NL—Phone JU 7-6457. SEC: DOT. CEC: BYS. UDY is back in San Francisco after a year and a half in the Pacific Northwest. His latest fixed portable QTH was Missoula, Mont., from where he worked several San Francisco hams, including YZP. He is now on the air with 28-Mc. mobile, fifteen watts. YZP is back on 7-Mc. c.w. after being off since Feb. '48. He is running 75 watts to a pair of 807s. JWF is looking for a "Teet" order on the ART-13. Frank says the Mission Trail Net expects to try operating twice monthly on emergency power at as many stations as possible to insure that the emergency power and equipment is kept in good shape. We know Frank's emergency equipment is ready to go at any time as we have called on him several times without advance notice. JDSF still is at the University of Minnesota although he is not very active on the air at this time. ZUB and VEJ traded stations the other day. Now they know what we hear when they switch on their carriers. Both have a rebuilding program on now. NLQ and DNY are on the Mission Trail C.W. Net nightly on 3804 kc. ADV again proves the leadership of the West Coast hams by breaking the 28-Mc. DX record. He has just worked Mars on 29 Mc. and is waiting for a QSL card. That shouldn't take too long as Mars, PVC, goes to the same radio club. The National Simulated Emergency Test was held Oct. 17th and the following took an active part: ANY, ZLQ, AQV, DNZ, VYC, RBQ, NL, BYS, DOT, CHP, JWF, CDT, WRM, and WCM. The fellows were representatives from the Golden West Frequency Modulation Club and the San Francisco Naval Shipyard Club. 28-Mc. f.m. and 144-Mc. a.m. were used by the mobile rigs. Three fixed stations aided as controls. By the time this appears in print we will be well along with the installation of both the San Francisco Red Cross Chapter station and the regional Red Cross station. Oct. 31st. was Navy Day at Hunter's Point, S.F., and a wonderful display was given. Of special interest to hams was the display in the new electronics building. The Naval Shipyard Radio Club had an amateur club station installed with transmitters on six amateur bands in operation all day. Greeting messages were handled from the fair throughout the day and any traffic remaining was put on the various traffic nets the following evenings. The bulk of the traffic was handled by BYS and NL. The Marin Radio Club met Oct. 8th at the Engineers' Bldg., College of Marin. The speaker of the evening was O. G. Villard, jr., QYT, Stanford Engineering Dept. His topic was "New Developments in Single Side-Band Transmission and Reception." The usual swell raffle and eats finished off a most enjoyable evening. The San Francisco Radio Club held its meeting Oct. 22nd at the American Legion Hall, 1641 Taraval St., San Francisco. The speaker of the evening was Clayton Bane, WB, who gave an excellent talk on the latest design on loop antennas leading up to the cubical quad and similar types. Hope no one missed this for it was tops. A raffle and the usual coffee finished off a swell meeting. The Naval Shipyard Club held its meeting Nov. 5th in the new quarters at 450 Gough St., San Francisco, at the Red Cross Center. Plans were discussed for the installation of the club station there. DOT was on hand and, with aid of BYS, gave us a few plans for our Emergency Corps work. Traffic: W6BYS 229, NL 187, JWF 126.

SACRAMENTO VALLEY—SCM, Ronald G. Martin, W6ZF—Phone 4-0237. Asst. SCMs: Ray Jensen, 6REB; Northern Area: William Van De Kamp, 6CKV; Central Area: SEC: KME, EC: BVK, RM: REB; OES: PIV; OOs: ZQD and AK. The Sacramento Valley section has been divided into three areas, the Northern, Central, and Southern, to enable a more efficient administrative organization. Northern Area consists of Siskiyou, Modoc, Shasta, Lassen, and Del Norte Counties. Central Area: Tehama, Plumas, Glenn, Butte, Sierra, Colusa, and Yuba Counties. Southern Area: Yolo, Sacramento, Nevada, El Dorado, Amador, and Alpine Counties. Please report your activities to the Asst. SCM in your area, or to the SCM if in the Southern Area. Southern Area: PIV says the 616 as push-pull or parallel triode doubler on 144 Mc. drives 832 very well. AUO erected sixteen-element 144-Mc. beam. GDJ is going on 28 Mc. BLP and MYL vacated at Pyramid Peak with 144-Mc. 1-watt transceiver, worked OVK and GD in the Bay Area. QEO is a new-comer to 144 Mc. with converted 522. YV is very active on 28 Mc. with new beam scheduling VK. MWM is on 14 and 28 Mc. with HK54s. YKZ helps operate MWM. CLV is proving 10 watts on 3.5-Mc. c.w. into quarter-wave antenna with ground can knock 'em over. BVK Sacramento EC, has started 28-Mc. emergency net which drills weekly. KME, our SEC, reports his 144-Mc. emergency net covers a considerable part of the section. BKL is new-comer to 144 Mc. MYL has new 616 pre-selector on 144 Mc. ASI is building new rig with 833s final. Central Area: Those present at the big steak fry at the CKV/FOD home were: VZK, WVR, PJV, ZFJ, TKE, WYX, RAQ, KYO, TID, CLG, GUV, WTN, DHD, GHG, ZNU, RHC, LYQ, and CKV/FOD. The Golden Empire Radio Club met at LYQ's home. Present were BFI, WYX, LYQ, ZNU, WVR, ZFJ, VZK, and GUV. Northern Area: JDN's 813 copied two QSLs from Moscow. CFU is back on with 701 McMurdo rig. The Mt. Shasta Amateur Radio

(Continued on page 98)

Happy New Year from all the gang at



HARVEY

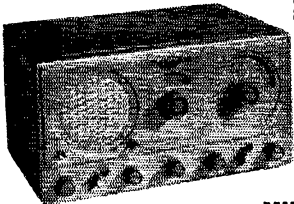

NATIONAL NC-57

540 kc to 55 mc with separate 6SG7 RF amplifier. Bandsread tuning and simple 5-position band switch. Built-in speaker. Shipping Wt. 31 lbs.

\$8950

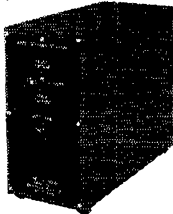

MILLEN 92105 SSSR

Selectable single sideband reception will remove 95% of your QRM difficulties. Use with any rcvr having 455/456 IF. Other IF by changing crystals to your IF. Shpg. Wt. 10 lbs.

\$7500

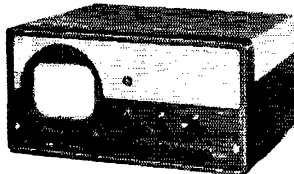

HALLCRAFTERS TV

Push-button tuning covers all 13 channels. Model T-54 in steel cabinet with 7" kine tube. Shpg. Wt. 50 lbs.....

\$18950

Model 61. With 10" kine tube. Shpg. Wt. 65 lbs.....

\$28995

Model T-60, projects 12" x 16" picture. Shpg. Wt. 125 lbs.....

\$59500

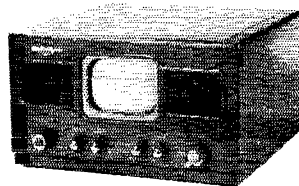

NATIONAL TV

All channels, 2 speakers, automatic gain control. Vernier fine tuning. Model 7-M, steel cabinet. Shpg. Wt. 50 lbs.....

\$18950

Model 7-W, same in fine mahogany cabinet. Shpg. Wt. 50 lbs.....

\$19950

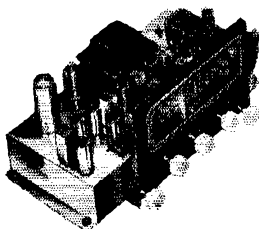

RADIO CRAFTSMEN TUNER

FM and AM with automatic frequency control. T. R. F. Stage on both AM and FM. Model RC-8.

Shpg. Wt. 20 lbs.....

\$11000

Model RC-2 Hi-Fi audio amplifier. Shpg. Wt. 30 lbs.

\$3900

Telephone: **7**

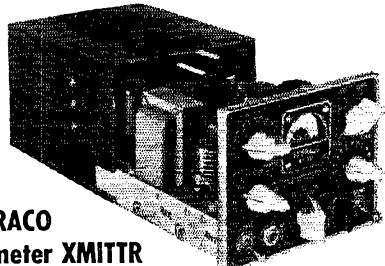

SUBRACO

10 meter XMITTR

Compact mobile xmittr for "dashboard" mounting. Measures only 5 1/2" x 4 1/2" x 6 1/2", weighs only 6 lbs. Designed to operate at 30 wts. input. Uses 6V6 Tritet xtal osc. quadrupling from 7 to 28 mc driving 2E26 Class C mod. amp. High level Class B modulator capable 17 watts audio. Built-in Coax antenna relay; p.t.t. switch. All controls front panel including illuminated meter, xtal jack, etc. Plate requirements: 300-400 volts at 140-180 ma. Shpg. wt. 8 lbs. Less tubes

\$79.95; including complete set tubes.....

\$8750

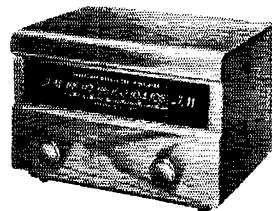

GE FM TUNER

Only a few left of this unusual buy. Covers 88-108 mc range, uses guilotine tuning. Designed for export and tropicalized, has power inputs for 110 to 250 volts 60 cyc. Shpg. Wt. 30 lbs.

HARVEY SPECIAL PRICE

\$4950

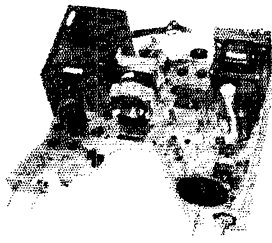

TECHMASTER TV KIT

Exactly the same as the RCA 630TS chassis, complete kit of parts, including pre-wired and aligned RCA front end, condensers, resistors, punched chassis, new and improved, sockets mounted, etc., all tubes including kine, complete manual with service notes, all RCA. (Free circuit and parts list on request). Shpg. Wt. 85 lbs.

\$19850

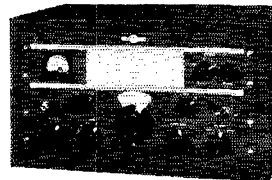

COLLINS 32V-1

Desk xmittr, VFO controlled, band switching, gang tuned. Rated 150 watts input on CW, 120 on phone. Shpg. Wt. 133 lbs. Complete

\$47500

All in stock for immediate delivery.

Luxemburg 2-1500

HARVEY RADIO COMPANY INC.

103 West 43rd St., New York 18, N. Y.

NOTE: All prices are Net, F.O.B. N.Y.C. and are subject to change without notice.

NEW... All Aluminum SELF-SUPPORTING TOWER

The new, roof-mounted, all aluminum RADIODYNE* TV TOWER and top-mast exert less pressure per square inch on your roof than would the weight of a child! This structure of graceful curves and shining beauty accommodates up to 4 arrays... holds antennas high up in the "blue" where signals are stronger and where interference is weaker. Forged steel fastening bolts and two-piece "universal joint" feet are heavily zinc plated to withstand long outdoor service. All angle pieces are made of strong, heat-treated corrosion-resisting aluminum alloys which possess great strength. The RADIODYNE TV TOWER is easy to erect and easy to climb for servicing arrays.

* TRADEMARK REGISTERED

RADIODYNE TV TOWER MODEL 44

(Illustrated)

- Overall Height (To Top of Mast) 44'
- Height (Tower Only) 35'
- Mast Height (Above Tower) 9'
- Mast Length (Inside Tower) 3'
- Mast Outside Diameter 2"
- Number of Tower Sections 3
- Length of Tower Sections 12'
- Base 4'6" x 4'6"
- Top of Framework 8" x 8"

"EIFFEL TOWER" EFFECT GIVES GREATER STRENGTH

The "Eiffel Tower" effect of RADIODYNE "44" is not merely beautiful. It is actually designed this way to give a preload to vital structural members... thus making the whole tower considerably stronger.

WRITE TODAY!

For Complete Information
on
RADIODYNE TV TOWERS
send a card to:

**WESTERN COIL &
ELECTRICAL COMPANY**
(Established 1915)

215 STATE ST.
RACINE,
WIS.

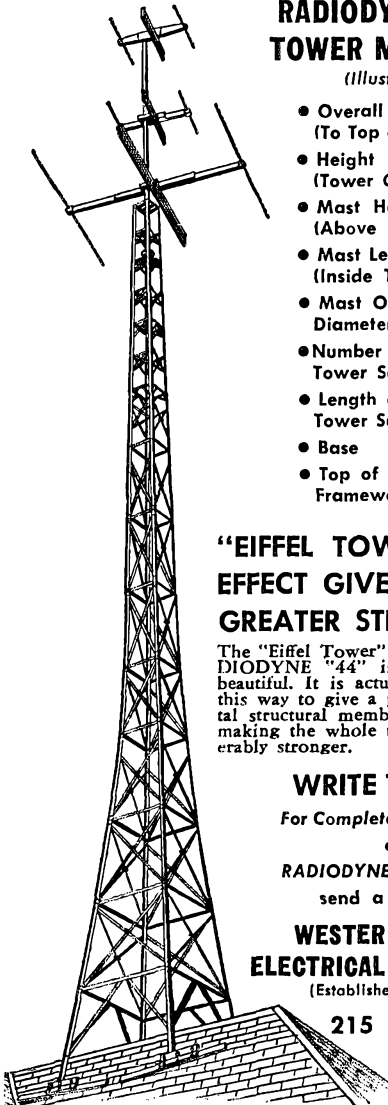

Club meets the 1st Thurs. of each month at the City Hall, Mt. Shasta City. Officers are CAT, pres.; ARR, secy.; NCV, act. mgr. Traffic: W6REB 530, PIV 57.

PHILIPPINES — Petitions for SCM received in the Philippine election named only M/Sgt. Stanley J. Gier, KALAL, and ARRL, in accordance with the provisions of the By-Laws, is awaiting final word from Sgt. Gier before announcing his election. The following has been received in a radiogram from KALABX (Clark Field) where numerous California stations are being heard: REQUEST AMATEURS BE ADVISED 80 METER BAND PHILIPPINE ISLANDS AS FOLLOWS 3500 TO 3540 TYPE A1 3540 TO 3600 TYPE A3.

SAN JOAQUIN VALLEY — SCM, Ted R. Souza, W6FKL — Asst. SCM, James F. Wakefield, 6PSQ. SEC: JPS. ECs: KUT, PHL. EPB is a new call in Fresno, now making it a father-daughter combination with ZKD. MEY is communications officer for one of the local CAP organizations. TFFH is OO, OPS, and OBS. JWK has finally whipped his new rig into shape. ZYR is on 7 Mc. with new 360-watt rig. BHI is busy with several traffic schedules. KUT is easing off DX since he received DXCC and WAZ. SRU is using long wire at new location. LOS has his 28-Mc. antenna troubles whipped. GQZ reports the following: RCL has new ham shack completed. EXH has new 28-Mc. beam and is going to increase power. AJE is chasing the elusive DX on 14 Mc. NGT is revamping his 144-Mc. rig. EKP can be heard on 7 and 144 Mc. DWH goes after DX on 7 Mc. ZNL is active again. VKD is on after summer layoff. INP and PJF are building new 28-Mc. rig. GQZ is out to make WAS-YL on 28 Mc. OYF is all set on 28 Mc. UWY is active on 3.85 Mc. MDQ can be heard on 28- and 144-Mc. mobile. EXH is new OBS. The following is gleaned from the Stockton Amateur Radio Club *Fly Sheet*: DBH and HIP are building Meissner VFOs. UWY acquired HIP's old VFO. MHD has been on 28 Mc. WBZ has a BC-610 on 28-Mc. 'phone. BNW and SAH are going strong on 28 Mc. VPV and WHO are building cubical quad antennas. PHL is planning mobile rig for 3.85 Mc. OHB and PDD are active on 3.85 Mc. PSQ is building video equipment. JCB is mobile on 28 Mc. Traffic: W6BHI 113.

ROANOKE DIVISION

NORTH CAROLINA — SCM, W. J. Wortman, W4CYB — SEC: KJS. The North Carolina State College Radio Club is under way. LJD is faculty advisor and the following are officers: JGA, pres.; ILM, vice-pres.; MSI, secy. treas.; GDF, technician; and JQO, act. mgr. ILM is active on 28-Mc. 'phone and is getting out with a four-element beam. LBV is busy as Acting NCS with the Black Eye Pea Net operating on 28 Mc. NEA and JGA keep 7 Mc. going. JQO is working in the NCN on 3605 kc. DSO works 28-Mc. 'phone nightly, and reports that six and eight state round tables are the order of the day. AIT is proud papa of a new jr. operator. HEH loves his new Collins exciter. ZH is back home in Greensboro. DTE is active on 28-Mc. 'phone. GNF, Greensboro Club, held an auction and raised enough money to add a modulator to the club transmitter. GG, still chasing those elusive boys on 14 Mc., now has 117 confirmations. MR, poking out for DX, snared ZD9AA on 7 Mc. The Kinston Club now possesses the call OIX. The 1330 Club was entertained by Mr. and Mrs. CYN. Among those present were CVQ, CXI, DKG, EYG, FBO, NDO, NEF, IFP, KMO, KYI, MKF, and NYE. KYI was given an "on the air" birthday party during the month. The North Carolina 'Phone Net still is going nightly on 3865 kc. with about 24 active stations. The C.W. Net, on 3605 kc. is doing a grand job with traffic. EYF conducted a drill on the Simulated Emergency Test with net control being from aero-mobile. Traffic: W4CFL 335, IMH 119, JPY 89, KJS 71, JQO 46, CYB 18.

VIRGINIA — SCM, Victor C. Clark, W4KFC — Business is booming on our two section nets: C.w., 3680 kc., 7:00 p.m. 'Phone, 3880 kc., 7:30 p.m. Both nets operate Monday through Friday. BZE, CQW, EFV, FF, II, IQR, JHK, KES, KEH, KSW, KXW, LBP, LBE, NAD, QVL, and QWM have reported into the c.w. net, in addition to those listed in last month's report, making a total of 45 Virginians on deck during October, according to RM IA. Latest word on the 'phone net indicates a comparable turnout. JHK has his "new look" rig on the air. The Red Cross message originated by the Appomattox Chapter during the National Emergency Test was handled by FV, FF, EMJ, LAP, LPP, SU, and IYR are new ORS. IWO now has the 100 cards required for DXCC. KYD, IPC, and IYR are holding down the Virginia position on T.L. "M," while KVM and JDL do the job on T.L. "C." NAD has 35 countries and 47 states with 45 watts on 28-Mc. 'phone. KYD made 85,000 points in the CD Party. KVM acquired a mill for traffic work. FF frequently reports into the National Trunk Line. IQR, of FCC, talked to PVRC about revisions in regulations. NNN put up new beam and promptly forged ahead of KXN in number of countries worked; both have over 160 now. IPC has been using n.f.m. on 3.85 Mc. SU fired up new final with 304TL for 3.5-Mc. DX season. IYR is a student at V.P.I. JFM built a television set. GKY, an apartment dweller, blossomed forth on 3.5 Mc. by the

(Continued on page 100)

±1db

20-20,000 CPS

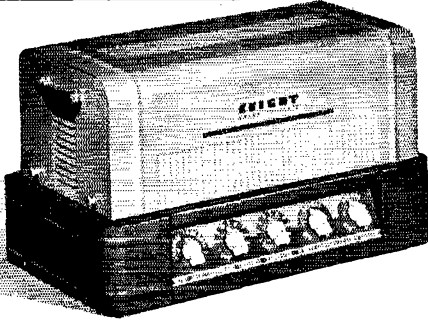

The ALLIED 20 Watt Phono Amplifier An Engineer's Dream—Sensibly Priced

Here's the audio amplifier experts appreciate. It's the *big buy* in high fidelity. *Check the curves:* Note the range of the two tone controls, offering flexible compensation. *Look at the facts:* Less than 2% harmonic distortion at full 20 watts, virtually none at room levels. Up to 10 db adjustable volume expansion independent of volume control setting. 8 db of inverse feedback. Hum is 'way down—80 db below 20 watts. Dual phono input with 78 db gain. Matches anything—output impedances 4, 8, 16, 250 and 500 ohms. For record reproduction or for operation with a radio tuner, there's nothing finer at anywhere near this low price!

93-103. 20 Watt Amplifier complete with tubes. NET, f.o.b. Chicago **\$59.95**

Terms: \$11.99 down, \$5.09 monthly for 10 months

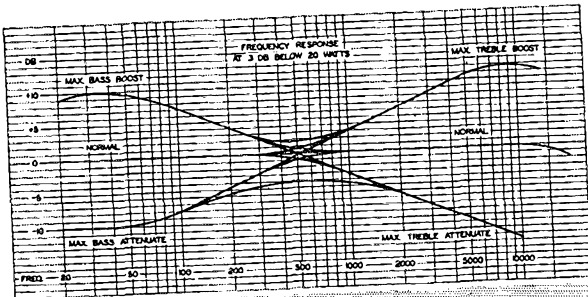

Send for the Leading Amateur Buying Guide

You'll find everything you want in receivers, transmitters, instruments, parts and station equipment in our up-to-the-minute 180-page Catalog. Get it today. And get every buying advantage at ALLIED—fast shipment, money-saving values, top-quality equipment, ideal easy-payment terms, square trade-in deals and down-to-earth help from ALLIED's old-time Hams. For full satisfaction, get and use the ALLIED Catalog!

Have Every Buying Advantage

- World's Largest Stocks
- Top-Quality Gear
- Money-Saving Prices
- Ideal Time Payments
- Square Trade-In Deals
- Speedy Shipment
- Ham-to-Ham Service

Keep Your ALLIED Catalog Handy

ALLIED RADIO

Everything for the Ham

FREE



ALLIED RADIO CORP., D. L. Warner, W91BC
833 W. Jackson Blvd., Chicago 7, Ill., Dept. 15-A-9

- Send FREE 1949 ALLIED Catalog
 Enter order for 20 Watt High-Fidelity Amplifier
 Enclosed \$..... Full Payment
 Part Payment (Bal. C.O.D.)
 Send Time Payment details and order blank.

Name.....

Address.....

City.....Zone.....State.....

CRAZY LOW PRICES ON TOP QUALITY CONDENSERS

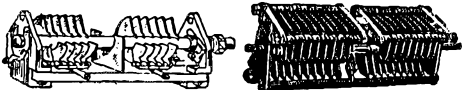

(1) Hammerlund Type "HFD" Micro. Double spaced, 1500 volts, .030" spacing. Screwdriver slot for tuning, with shaft lock. Soldered brass plates, cad. plated. Aluminum end plates mounted on Isolantite base. Has isolating center shield. Silver plated rotor contacts can be shifted to 3 position for shortest possible leads. *Made by Johnson.
*Type HFD15X, 16 max.-3.8 min. mmfd., 11 plates per section. Stock No. 14A680, size 1 1/16 x 1 1/2 x 3". **99c**
SPECIAL EACH

*Type HFD30X, 28.5 max.-5 min. mmfd., 19 plates per section. Stock No. 14A681, size 1 1/16 x 1 1/2 x 3 5/8". **\$1.19**
SPECIAL EACH

(2) Johnson Dual 207 Mmfd. Type 200FD20 .045" spacing, 2000 volts. 207 mmfd. max.-1.3 min. per section.
No. 18A510, size 2 1/8 x 2 1/8 x 8". **\$1.95**
\$10.00 List Value. SPECIAL EACH

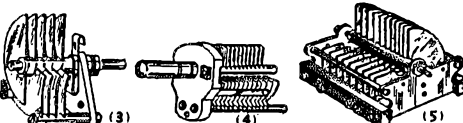

(3) Johnson Type 12G70. 12 max.-6 min. mmfd., 7 plates .225 spacing, 1/4" shaft 1 1/8" long. Has single end plate of steatite, .032" rounded aluminum plates.
No. 14A677, size 2 1/16 x 2 7/64 x 2 5/8". Spec. Ea. **\$1.49**

(4) Johnson Type 50G20. 52 max.-5 min. mmfd., 9 plates .045" spacing, .5/32" long otherwise as above. **99c**
No. 14A679, SPECIAL EACH

(4) 100 Mmfd. ceramic insulated APC type, 1/4" shaft, 7/8" long. Quality make.
No. 18B92, SPECIAL EACH. **40c**
140 Mmfd., as above. No. 18A880, EACH **50c**

(5) Cardwell "Midway", 74 Mmfd., 19 plates air gap .070". Aluminum frame, brass bearings, plates buffed and rounded. Mycalex insulated, 1/4" shaft.
No. 18A853, size 2 3/4 x 3 1/4". SPECIAL EACH. **\$1.45**

80, 75 and 40 Meter CRYSTALS Assortment of TEN only \$3.95

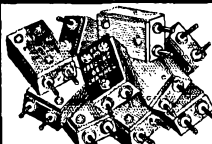

In FT 243 holders, cut from highest quality quartz accurately ground and acid etched. Frequency marked on each within 2 KC. Sorry we must sell them in assortments out of pick of frequencies—but you can't go wrong! There are choice frequencies for 80, 75 and plenty for 40 meters—or for doubling to 20 and 10 meters in each assortment.

Every one guaranteed to be an active oscillator.
No. 21T391. Assortment of TEN. ONLY **\$3.95**

SAVE ON 807 TUBES

Jan inspected, quality make, individually boxed, Clean, Perfect, Guaranteed.
No. 20A668. SPECIAL EACH. **\$1.35**

5B4 CATHODE RAY TUBE \$2.95

Has 5" white screen. Quality make individually boxed in cushioned carton. Brand New, Perfect, Guaranteed.
No. 36T206. SPECIAL EACH. **\$2.95**

RECHARGABLE BATTERIES ONLY 95c



Willard 2 volt, compact rechargable storage battery in Spill-proof Clear Plastic Case only 2 3/8" square and 6" overall height (about the size of the ordinary #6 dry cell) make it ideal for most any need where battery power is desired. Rating 24AH. gangs nicely for other voltages in multiples of 2 volts. Shipped Dry. Uses standard battery electrolyte available everywhere.

No. 5A133. **95c** 6 Lots **75c**
EACH EACH

Order direct from this add—Include Parcel Post Charges. Many More Outstanding Values in the big New 132 page B-A Catalog No. 491—Write us if you did not receive it!



expedient of operating his attic against ground. QY does it by exciting the rainsput. RQR is active from Quantic. EFV is new Quantic member of VN—the first "cootie-key," article on the net. DAF, KWY, DHZ, LAP, KXN, KFC, NNN, and IWO participated in the November DX Contest. Happy New Year, kang! Traffic: (Sept.) W4ITA 6, (Oct.) W4KM 136 IA 78, KYD 56, FV 30, KFC 29, IYR 29, LAP 18, CLD 12, IPC 11, KSW 10, FF 9, ITA 6, BZB 4.

WEST VIRGINIA—SCM, Donald B. Morris, W8JM — A radio club has been formed at W.V.U. with 1PBZ/8, president, and ZOW, secretary. Plans are being made for a club station. QG reports he has a new beam up for 28 Mc. MOP has new HT-18 and DB2A. EZR thinks v.h.f. taxi radios could be used by amateurs effectively in emergency. BKJ, LYG, and YIF have regular schedules to Columbia on 144 Mc. with 100 watts and square corner antenna. GBF has schedules on TL "C," and W. Va. and TLM Nets and made 407,880 points in the CD Party. PQQ snagged ZD9AA and reports DIE new Charleston amateur YDO plans to increase power on his 3.85-Mc. phone rig to keep up with KWI, VAB, and YBQ. ASO has a new rig on 3.85 Mc. W. Va. Phone Net has been organized with HUK, NBS. The net meets nightly on 3890 kc. at 7:30 p.m. with tie-in with C.W. Net on 3770 kc. for traffic interchange to W. Va. cities. FMU, secy. of the M.A.R.A., has revived the club bulletin with news, pictures, and operating hints being featured. HRO is active again from Martinsburg. KWL has new receiver for his shack to match his new 28-Mc. rig. Renner, for W. Va. contacts — r.w., 3770 kc.; phone, 3890 kc. See you there. Traffic: W8GBF 263, DFC 28, AUJ 13, QG 9, JM 5, MOP 3.

ROCKY MOUNTAIN DIVISION

COLORADO—SCM, M. W. Mitchell, W9IQZ—ECN is new ORS and got in time to take part in the CD Party. He was running 800 watts to a pair of 812s and they finally lid down and died on him. OWP is new OPS in Brush. APZ is dispatcher for State Patrol in Pueblo, and he expects to get his HT-9 on 3.85 Mc. soon. PGX, at La Junta, is trying n.f.m. MGJ is moving to Albuquerque and no doubt will be heard as a W5 before too long. SGG is heading the Colorado Net again. The grapevine reports NDM is hating XYL trouble, which accounts for his inactivity. LZY reports he is back on the air and that the Slow Speed Trunk Line would like schedules with Utah and the West. IC will have a pair of p.p.811s going by the time you read this. QYT and CQR flew to Washington, D. C., on CAP business and they were royally entertained by 3VT, of Baltimore, and 3NOL, of Greenbelt, Md., on Oct. 20th and 21st. BJN is new EC for AARD in Denver. AVD, ZUE, QJR, and yours truly, IQZ, received some very nice publicity regarding the United Airlines Net in United Airlines News. The RM appointment for Colorado is open at present. Anyone interested? If so, contact IQZ, Traffic: (Sept.) W9LZY 47, FZ1 25, IC 24. (Oct.) W9ECN 35, OWP 5.

UTAH-WYOMING—SCM, Alvin M. Phillips, WNPU — SEC: UTM, RM: GBB, PAM; EST: Our new SEC is UTM, Floyd Hinshaw, 165 E. 4th No., Bountiful, Utah. This appointment has been accepted by a very capable man. I am sure Floyd will serve us well, fellows, so let's give him all the help and cooperation we can and put our emergency plan on top. BED is EC for St. George area. LCB was appointed ORS. UTM and FYR had lots of fun in the CD Party. SP has been busy making a living but promises more information on v.h.f. soon. TMR has a new ten-over-twenty rotary. Studies and work prevent IQJ from hamming. UTM is planning a modulator for 3.85 Mc. to contact EC phone stations. Our RM, GBB, along with UTM and BED, is organizing a Utah Net. How about it, you traffic hounds? This is what you need, so get in touch with these men and let's go. On the last round table, portable mobiles JVI, MFQ, with SP and MGA as co-pilots, LUP, QDD, UBD, and LKJ, with JHM operating fixed as NCS, set out to see what kind of communications could be maintained between various points in the Salt Lake Valley. Results were surprising in that, with very few exceptions, readability was R5 all the way around. Traffic: W7UTM 182, BED 61, RPX 32, FYR 6.

SOUTHEASTERN DIVISION

ALABAMA—Dr. Arthur W. Woods, W4GJW—SEC: A MAB, PAMS: BA and COU, RMs: DD, LEN, and IMK. New ORS appointments include KVD, KIX, and IMK. CUE, of the Birmingham Amateur Radio Club, operated from State Fair on all bands and has been appointed OPS. Official Bulletins will be released by KIX on 3715 kc. just before net time and the 3.85-Mc. coverage will be taken care of by FZN and CYL just before net time. HA has 100 countries confirmed. New calls in Anniston are OAL, OAO, and OGT. AUP and ECF are on 144 Mc. and want to arrange schedules. JYB makes possible person-to-person schedules with Guam for folks in Montgomery. LRU, in Jasper, schedules GOF at the University. KG6AD and KG6DP are regular customers for DX at JYB. AIY has an
(Continued on page 102)

The Wisest Choice of All is to Choose It at **TERMINAL**

NEW YORK'S LEADING DISTRIBUTOR OF RADIO & ELECTRONIC EQUIPMENT
Where Every Item is Quality-Proven, Fully Guaranteed and Priced the Lowest!

NATIONAL TV-7 IN STOCK!

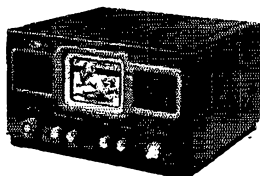

Improved design assures unwavering, brilliantly clear pictures and perfectly synchronized FM sound. 7" video tube plus 18 tubes and 3 rectifiers. Tapped primary autotransformer adjusts line voltages from 105-130 volts, 50-60 cycles. Two 6" PM speakers provide realistic tone qualities to FM sound. Automatic gain control keeps picture and audio at constant level. All-channel coverage, vernier fine tuning. In gray metal cabinet, complete with tubes and instructions....

189.50

Model TV-7W—Same as above, but in gorgeous hand-rubbed mahogany wood cabinet.....

199.50

PHILMORE TV KIT FAMOUS RCA 630TS DESIGN!



10" kit is furnished with 13-channel pre-tuned RF and IF sections already mounted, wired and aligned; even remaining unwired tube sockets are firmly riveted in position on RCA chassis. No instruments needed or alignment required when completed. All parts are individually packaged and clearly labeled for following the complete step-by-step, well-illustrated instruction manual. Kit includes all parts, 30 RCA tubes including 10BP4 picture tube, and instructions. Your cost

205.00

ANOTHER TERMINAL SCOOP! Famous HALLICRAFTERS HT-17 10 WATT All-Band CW TRANSMITTER

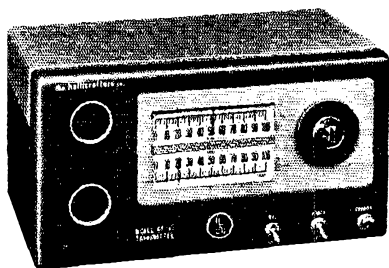

An efficient low-power rig—ideal also as an auxiliary transmitter! This attractive, compact CW transmitter delivers fully 10 watts output on 80, 40, 20 and 10 meters. 6V6 crystal oscillator, 807 power amplifier, 5U4G rectifier. Has matching network for any antenna or for driving a high powered RF amplifier. Panel light tuning indicator can be replaced with meter. Controls: Plate Tuning, Antenna Loading, Standby Meter Switch, Power on-off. Terminals at rear for antenna, ground, key and external modulator. For 105-125 volts, 50-60 cycles AC. Complete with tubes, key and 40 meter coils, less crystal.....

29.95

QUANTITY LIMITED! ORDER TODAY!

EXTRA! WEEKLY STORE SPECIALS SAVE YOU \$\$\$!

Seeing is believing! Hold your breath when you see the many brand-new items we offer each week at practically give-away prices! Don't miss these terrific bargains! Come in at least once a week—what you save will more than make your visit worthwhile!

13-Channel TV ANTENNA—Hi-low folded dipoles and reflectors may be orientated separately for best all-channel reception. Features all-aluminum construction, excellent performance and rapid assembly. Includes 6 ft. mast, insulators, hardware and instructions. Supplied less 300 ohm lead-in. A real Terminal special, only.....

8.45

300 Ohm Twin-Lead—high quality, weather-proof lead-in wire recommended for Television, FM and other high frequency dipole applications. Per 100 ft. roll.....

1.49

TWIN-TRAX RECORDER ASSEMBLY—Build your Own Magnetic Tape Recorder!

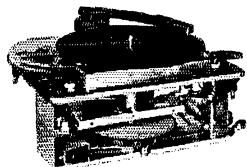

Model 808 — "Twin-Trax" cuts tape costs in half by use of twin recording and erase heads for forward and reverse tape travel. Automatic reverse is fast and smooth, does not interrupt continually. Will also play back single track recordings made on any tape recorder. Flutter and "wow" guaranteed less than 0.1%. No capstan tape slippage, nor can rubber rimmed drive develop "flats". You can use this chassis with any amplifier with minor changes for recording and playback. Optional accessories (at extra cost) include turntable and pickup for mounting as shown above.....

89.50

WIREMASTER RECORDER

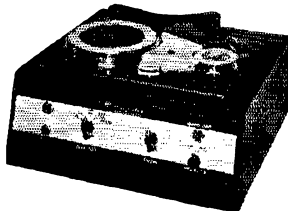

Model H—No other wire recorder offers so much for so little! Professional-type wire recorder, records and plays up to one hour spools. May be played through self-contained speaker; built-in wireless oscillator or direct connection. 7-tube amplifier specially designed for wide-range (50-10,000 cps on wire). Built-in phonograph with lightweight arm plays up to 12" records for listening and "dubbing" on wire. In attractive mahogany or walnut cabinet, complete with microphone, recording wire and phonograph needles. Net.....

142.50

TERMINAL RADIO CORPORATION

85 CORTLANDT ST.—NEW YORK 7, N. Y. • Phone—Worth 4-3311 • Cable—TERMRADIO

LOOK

100 KC FREQUENCY STANDARD

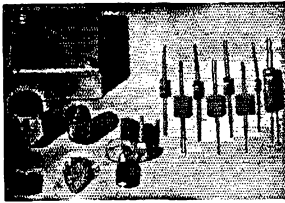

\$6.75

Complete,
crystal, tube
and all parts

CONDENSER SPECIAL

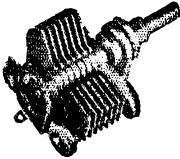

They're going fast! Famous make double-bearing condensers, regularly listing at \$2.70 and \$3.00, isolantite insulation, semi-circular plates (straight-line capacity) .024" air-gap, 100 mmf. or 140

mmf, either size, brand new. ONLY

89¢

BC-221 CRYSTAL

1000 KC crystal, in FT-243 holder, ground to exact frequency to duplicate performance of original crystal in BC-221 Frequency Meter.

\$3.50

2MFD 1000 VOLT



Oil-filled condenser, single mounting hole, negative can, with nut. **59c**

10 for \$5.00

10 HENRY 300 MA. CHOKE



A terrific bargain. Audio Development Co. high-quality 10 Henry 300 MA. filter choke. All black-crackle finish, new, 100 ohms DC resistance, very compact, 4 3/4" x 3 3/4" x 4 3/4", 10 lbs. only. **\$3.50**

STRUTHERS-DUNN RELAY

110 VOLT AC

Control all of your equipment with this one relay. 110 VAC coil, 4-pole, 2 double throw, 2 single throw, 6 Amp. contacts, screw terminals, insulated base, 3" x 3 1/2", a terrific bargain at **\$2.00**



WE DO NOT EXPORT. ALL PRICES NET,
F.O.B. CINCINNATI, OHIO

Steinberg's

633 WALNUT STREET • CINCINNATI 2, OHIO

ART/13 in his car. GBP works 28-Mc. mobile and generally works 3.85 Mc. at home location. GYD has 76 countries confirmed on 14 Mc. Dothan's Ben Lane Amateur Radio Club is reactivated with FYB as president, LUT as vice-president, and OJJ as secretary-treasurer. ECI has moved around the corner on 3rd Ave., Birmingham. New-comers are urged to join the AEC. We'll send slowly enough for you; just request a QRS. Traffic: (Sept. and Oct.) W4JYB 82. (Oct.) W4GJW 52, JAM 14, LZK 14.

EASTERN FLORIDA — SCM, John W. Hollister, W4FWZ — Happy New Year to all, and a thought: Let's all resolve to take a more active interest in ARRL activities, and let's have more applicants for ORS, OPS, and OBS appointment. Clermont: AXX wants 144-Mc. QSOs to try out his five-element vertical beam. Deland: WS reports that 20QI is at Stetson and KOA needs 220 volts to operate his rig. Deland: PEI works four Florida nets plus TLCS and NTL, but bewails the lack of Jacksonville c.w. traffic stations. Jacksonville: B.C.I.? See the *Beam*, or AWE. LZM got LSIABX MB9AD, ZC8XY, MD4JG, ZBIS, FA6IH, H18EC for 80 countries and 31 zones. JCK got AP2R and TA3FAS for 109 countries and 32 zones. CFO is sweating out QSLs for DXCC. PX works KKM at Gainesville nightly on 28-Mc. ground wave. DTV dropped by on the way to K4 Land where he is now stationed. Lake City: IQV wants 144-Mc. QSOs, but plenty. Miami: IYT craved emergency traffic on 14 and 28 Mc. BXL reports his beam is back up. OJN is new in the Gables, and MWJ now is at Hollywood. MKP now is certified Knight of the Kilo-cyc, plus FB, NCS on Gator. New Port Richey: KJ has new exciter for more and better 'phone and c.w. and writes "I have B.C.I. and f.m. troubles." Orlando: The *ORC Bulletin* is the tops in club bags, but who was it that tumbled into the WAS? Work ten Orlando stations and get a swell certificate. The OARC's address is P.O. Box 2067, Palatka: Secretary Crowell reports the officers of ACWC are OBB, OHG, GCD, QR, and PTQ. Address them at 118 S. 2nd St. New calls at Palatka are OBB, ODJ, and OHG. West Palm Beach: JQ finally concedes that an antenna on the ground is as good as one above. LXK is sporting p.p.812s. The IJW beam was another of a long list of storm casualties. TH is vertical on 14 Mc. From Japan comes ISF. Traffic: W4IQV 177, PEI 109, WS 61, AAR 37, MNT 35, DQW 28, HWA 22, MVJ 17, BT 12, IYT 11, KMV 3, AXX 2, BXL 1.

WESTERN FLORIDA — SCM, Luther M. Holt, W4DAO. The Pensacola Amateur Radio Club exhibit at the Interstate Fair created much interest, and the station operating there handled over 400 messages. HIZ works 3.85-Mc. 'phone. BKQ built a quad. MOB is changing over to VFO. LRC is tinkering with 420 Mc. BGI is rebuilding mobile rig. New Pensacola calls include OHJ, OHS, OJJ, OKA, and OKB. MS has been heard in Mobile on 50 Mc. AXP lost a plate transformer. JPD is building 3.5-Mc. rig. NOX/NYZ changed to 14 Mc. NWC did yeoman duty at the club's fair exhibit. FIH has receiver trouble. QK looks at 7 Mc. JJZ moved to 28 Mc. DAO works 7 Mc. with 350 watts. EGN works 14-Mc. DX in the wee small hours. VR works for JNP. CNK moved to 3.5 Mc. to join the traffic nets. MUX schedules FDL each Sunday. DLO joined the PARC. LEX built 28-Mc. 'phone. Traffic: W4NWC 326, CNK 300, AXP 100, HIZ 43, MOB 30, NDB 30, MS 25, NGS 25, EQR 20.

GEORGIA — SCM, Clay Griffin, W4DXI — Thanks to all who helped make the October National Simulated Emergency Test a success. On Sunday of the same week end a Southeastern Simulated Emergency Test, involving eight states, was held. About 60 messages were received and answered from the Atlanta message center at Red Cross Southeastern Area Headquarters. Approximately 20 Atlanta hams assisted in this test, which was the brain-child of HDC, our Atlanta EC. Columbus: CVY, DDQ, and MBZ are now Class A, but still are on 28 Mc. CVY wants to hear from anyone interested in 144 Mc. MBZ has three-element Hy Lite 28-Mc. beam. NRJ is a new ham. ECE and EDI, of Cedartown, are getting back on the air, probably on 28 Mc., for their first postwar activity. Bremen: BTB has been giving 28 Mc. a try. KPQ has a quad on 28 Mc. Cochran: BOL has been working on a new rig. GGD copied Navy Day message. BQU spends a lot of time fishing. Savannah: DEJ is a new member of the Cracker C.W. Net. MMQ has been appointed EC for the Savannah Area. JNL has gear ready for emergencies. MA, of Temple, has rebuilt his final. Atlanta: LNG now works all 'phone bands from 3.85 to 144 Mc. New Georgia 144-Mc. record is KPQ, Bremen, to FQI/4 Petros, Tenn. FQI also worked KIP and LNG. KXX is back on 3.85 Mc. BIW has been on 28 Mc. Traffic: W4BVK 115, KV 82, BOL 63, DXI 45, FKE 41, GGD 21, AAY 17, LNG 4.

WEST INDIES — SCM, Everett Mayer, KP4KD — SEC: AM, ECs: CO, DV, and ES. AM is doing a swell job of organizing an emergency net and still works 3.85-Mc. 'phone with his "clothes line" antenna. He worked GW3, G3, D4, and PA on 28-Mc. 'phone. HR works 3.5-Mc.c.w. in the AEC net and got a four-band card from KD. DV is QRL with new QTH. ID, the PRARC station at Red Cross Headquarters, San Juan, is on with 375 watts and long wire on 3.5-Mc.c.w. ES and FJ work W, G, and OZ on 3.85-Mc. 'phone. HU changed QTH to Caparra Heights. Stickers for

(Continued on page 104)

BOB HENRY HAS IT IN STOCK AND OFFERS YOU A BETTER DEAL!



Henry Radio stores in Butler, Missouri and 11240 West Olympic Blvd., Los Angeles, California have complete stocks of amateur, FM, Television, Short Wave, Communications, Recording, and other radio equipment. I promise you lowest prices, complete stocks, quick delivery, easy terms, generous trade-ins. I promise that you will be satisfied on every detail. Write, wire, phone or visit either store today.

Bob Henry
W9ARA

A FEW OF THE ITEMS I STOCK ARE:

Collins 75A	\$ 375.00
Collins 32V	475.00
Collins 310B-1	190.00
Collins 310B-3	215.00
Collins 30K-1	450.00
National NC-37	89.50
National NC-173	189.50
National NC-183	268.00
National HRO-7T	292.50
National HRO-7C	372.45
National HFS	142.00
National NC240D	236.25
Hallcrafters S38	49.95
Hallcrafters S53	89.50
Hallcrafters S40A	110.00
Hallcrafters SX43	189.50
Hallcrafters SX42	295.00
Hallcrafters SX62	289.50
Hallcrafters S47	229.50
Hallcrafters S51	149.50
Hallcrafters S58	59.50
Hallcrafters S55	129.50
Hallcrafters S56	110.00
Hallcrafters T54	189.50
Hallcrafters HT18	110.00
Hallcrafters HT19	359.50
RME HF-10-20	77.00
RME VHF-152A	86.60
RME DB22A	71.00
Hammarlund HQ129X	177.30
Gon-Set 10-11 converter	39.95
Stancor ST-203-A	44.70
Hunter Cyclomaster	169.50

Millen, Sonar, Bud, Gon-set, Silver, Premax, Workshop, Amphenol-Mims, Jensen, Meissner, Browning; I have everything.

Some prices slightly higher on the west coast.

LOW PRICES

I guarantee to sell to you as cheap as you can buy anywhere.

COMPLETE STOCKS

Hallcrafters, National, Hammarlund, Collins, Millen, RME, Meissner, Meck, Gordon, Amphenol-Mims, RCA, Vibroplex, Sonar, all other amateur receivers, transmitters, beams, parts, etc. If it is amateur or communications equipment—I can supply it.

QUICK DELIVERY

Mail, phone, or wire your order. *Shipment at once.*

EASY TERMS

I have the world's best time sale plan because I finance the terms myself. I save you time and money. I cooperate with you. Write for details.

LIBERAL TRADE-IN ALLOWANCE

Other jobbers say I allow too much. Tell me what you have to trade and what you want.

TEN DAY FREE TRIAL

Try any receiver ten days, return it for full refund if not satisfied.

FREE NINETY DAY SERVICE

I service everything I sell free for 90 days. At a reasonable price after 90 days.

FREE TECHNICAL ADVICE

and personal attention and help on your inquiries and problems.

Butler, Missouri

HENRY RADIO STORES

11240 Olympic Blvd.
LOS ANGELES 25
CALIF.

"WORLD'S LARGEST DISTRIBUTORS OF SHORT WAVE RECEIVERS"

NOW AVAILABLE!

McMurdo Silver ADDS
**REVOLUTIONARY
 NEW SELECTIVITY**

We use "revolutionary" advisedly. You'll agree when you add new "805" 100 kc. I.F. Amplifier to your present receiver that the phone/broadcast selectivity and noise reduction it gives are revolutionary. Less than this improvement has been

described as "like nothing you've ever seen or heard before".

Added to any superhet having i.f. lying between 450 and 500 kc., Model 805 will cut dial-spread on even the strongest local station down by 75% . . . will reduce noise unbelievably. It gives your present set a selectivity curve of 2.4 kc. wide 2X down, falling almost vertically to only 7.2

kc. wide at 10,000X down—an engineering dream come true. 805 gives single-side-band selectivity, the ability to reject noises, heterodyne squeals and all QRM on one side of the signal or the other—yet get clear, crisp speech and music without deleterious side-band cutting.

Add Model 805 to your present set, and you have next year's new receiver today. Its selectivity gain-noise reduction is revolutionary.

Price, less 1 ea. 6BE6, 6BA6, 6C4 tubes **\$24.50**
 Model 805K — kit less tubes **\$20.50**

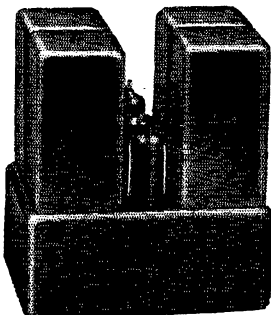

OVER 37 YEARS OF RADIO ENGINEERING ACHIEVEMENT

McMurdo Silver Co., Inc.

EXECUTIVE OFFICES 1240 MAIN ST., HARTFORD 3, CONN.
 FACTORY OFFICE 1249 MAIN ST., HARTFORD 3, CONN.

Mass. Radio School

271 Huntington Ave., Boston 15, MASS.

For over 28 years the educational radio center of New England. Prepares for all U. S. Government Radio Operators' Licenses. Also gives Radio Technician Training. (Pre-Television). Approved courses for Veteran Training under G.I. Bill.

Send for Catalog

Licensed by Commonwealth of Mass.
 Department of Education

each 25 KP4s over the WPR-50 are available for certificates. Congrats to BQ, CI, FJ, and FP on brand-new Class A tickets. All are on 3.85-Mc. 'phone on the net. AQ is working hard with CGA and has net operating on 28-Mc. 'phone. Ex-KP4BJ is now W4OLC in Miami awaiting his gear from KP4. KD's daily schedule with W4RBQ is going strong. HX is working hard at DX. Traffic: KP4KD 10, DV 6.

CANAL ZONE — SCM, Everett R. Kimmel, KZ5AW — AD, GD, the U. S. Air Force, a mobile marine, and KH6 and W6 stations teamed up in a mercy mission to hospitalize an ill tuna boat crewman from Galapagos and to feed progress bulletins to his family. AD commanded the flight mission. GD is SEC, AY is EC of West Bank. CG is PAM. RB replaces SW as vice-president of the CZARA. The CZARA now meets on the SS *Baracuda*, a Sea Scout Ship moored at Diablo, having acquired a private ham shack and a nice cool meeting room. The call KZ5KZ was reserved for use at special public events. New calls are CO, ET, FL, GT, and TM. FL's initial QSO was V0ZGS. PA schedules W3LTW tri-weekly. AX and GD are shooting for OO Class 1 appointments. AK passed a state-side police outfit switching from a.m. to f.m. and acquired a mobile rig for a song. OBS, OPS, and ORS applications are needed from both sides of the Isthmus.

SOUTHWESTERN DIVISION

LOS ANGELES — SCM, Vincent J. Haggerty, W6IOX L — La Crescenta AEC members were standing by within 12 minutes after EC BTA notified them of an aircraft crash on a fog-shrouded mountain at La Crescenta on Oct. 19th. Working in conjunction with sheriff's rescue squads, 144-Mc. AEC pack units entered the search area and established communication with AEC 28- and 144-Mc. mobile units which were standing by to relay instructions. The following AEC members participated: HMC, VRK, BTX, YGT, YKB, RTR, UBY, and BTA. Nice work, fellows! IWU and PJ keep busy as OOs. SCN needs outlets in Riverside and San Bernardino and an additional station in Los Angeles. The net operates on 3765 kc. Contact RAD if interested. QIW is back on the air after six weeks hospitalization. NAZ reports: "Busy doing a t.v. show. If I have to stay off for T.V.I., I might as well be a part of it! Hi." PRB is rebuilding his kw. BYT, GOJ, and CNR are on 7 Mc. CGO has a new frequency meter. The Golden State reports a successful outing, also good AEC drills. ZQV works on Southern Border Net. AM has worked 10 countries and 45 states with the mobile rig in his car. BUK has his rig working well. RPO is working on a signal generator and tracer. YSK is building an auxiliary rig. YVJ has new 200-watt rig. BES hopes for more time for QSO parties. AAE is chasing 3.5-Mc. bugs. Plans for a get-together of the Paso Robles, Santa Maria, and San Luis Obispo Clubs are in the offing. DDE, ZMZ, and CMN reported by radio this month. The section PAM, MVK, is busy recruiting OPS. He has organized a v.h.f. net sponsored by the Two Meter and Down Club of Los Angeles. WKO is NCS and MJ is Alternate Net Control. Stations checking in on the first drill were BWY, CQJ, DMG, EKK, EMM, MJ, WHV, WKO, WWP, WYH, ZGY, and ZUX. This is an ARRL net and all 144-Mc. stations in the Los Angeles area are invited to join. Training in disaster and emergency work is stressed. Net crystals of 8 Mc. to hit into 147.5 Mc. are available at a reduced price by contacting the Two Meter and Down Club in care of ZUX. The Two Meter and Down Club has received its Charter of Affiliation with ARRL. The club call is EMM. TFC is Master Net Control of the Golden State Net and finds time to check in on SCN quite often. LUG also is active in the Golden State Net. HFY is waiting for some QSLs to complete his WAS. Traffic: W6DDE 354, RAD 138, CMN 90, ZMZ 71, NAZ 50, TFC 30, ZOL 18, AEE 17, LUG 14, ZQV 12, IOX 10, QIW 8, AM 8, FMG 4, BUK 2.

ARIZONA — SCM, Gladden C. Elliott, W7MLL — The Tucson Emergency Corps made a fine showing by carrying on communications for the Red Cross and sheriff in a simulated mountain plane crash. Participating were LLO, JPY, KWW, LAD, LHD, MAW, MGM, MPQ, and MPG. 6YNJ is now MVV. LOJ is operating n.f.m. on 28 Mc. LNT is back on 28 Mc. with another Meek T-60. LOC has a Millen exciter on the air. 8DDA is now MUP. KAG is on 3.5 and 3.85 Mc. KQR has a new three-element beam on 28 Mc. MEK is using a Gonset 6-10. MWQ has a five-element beam on 144 Mc. KEC has a VFO on 3.5 and 3.85 Mc. JIY has a cubical quad on 3.85 Mc. 3DDO is now HDO. OZM is operating 3.5-Mc. c.w. and 28-Mc. 'phone at Prescott. VVM is on 3.85 Mc. at Phoenix. MDM reports fair results with an underground antenna on 28 Mc. MQW and QNC had a nice two-way contact on 27 Mc. The Tucson gang regrets the passing of KWF. UPF is on 144 Mc. MDD reports working Colorado at noon on 3.85 Mc. KFS is on 3.85-Mc. mobile. LPA is Acting RM for 3515-kc. net, which meets Mon.—Fri. at 8 p.m. LBN reports 37 countries on 28-Mc. 'phone. LFE has a new Collins receiver. WKC has a Collins 32V transmitter on all bands. MLL is Net Control on 3552-kc. net at 7 p.m. nightly.

SAN DIEGO — SCM, Irvin L. Emig, W6GC — Aest. SCMs, Gordon W. Brown, 6APG, and Shelley E. Trotter, 6BAM. SEC: DUP. RM: BGF, FMZ has been appointed

(Continued on page 106)

Newark Scoop!

SENSATIONAL REDUCTIONS! HALLICRAFTERS RECEIVERS and TRANSMITTER

FAMOUS HALLICRAFTERS HT-17 TRANSMITTER



Regular
\$71.50 Value!
REDUCED TO
\$39.50
WITH ALL COILS

The HT-17 alone was always a grand buy at \$49.50. Now Newark brings you the whole works — Complete Transmitter PLUS a Full Set of Coils for 10, 15, 20, 40 and 80 meters. . . All for the Amazing Low Price of \$39.50. Save \$32.00! The HT-17 is a high quality transmitter or exciter for high power final amplifier. CW operation, with provision for external modulator. Full 10 watts output. 6V6GT crystal oscillator drives 807 final. 5U4G rectifier. This rig is ideal for any beginner . . . a perfect gift! Satin black cabinet 12 3/4 x 7 3/4 x 8 3/4". For 105/125 volts 50/60 cycles AC. Complete with tubes and full set of coils. Less crystal and meter. No. A2056, Shpg. Wgt. 25 lbs. While they last \$39.50

HALLICRAFTERS ECHOPHONE 3-Band AC-DC RECEIVER

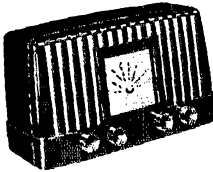

Regularly \$39.50
REDUCED TO
\$24.95

An ideal set for the SW listener . . . at a rack-bottom price! Covers all foreign broadcasts, local and DX domestic ham bands (2200-7100 Kc and 6900-22,000 Kc) PLUS fine broadcast reception (535-1625 Kc). Has electrical bandspread tuning, airplane type dial, sensitive and highly selective superhet circuit, Alnico V PM dynamic speaker, built-in loop. Excellent performance and tone quality. 8 1/2 x 14 x 6 1/2". For 105/125 volts AC or DC. Shpg. Wgt. 15 lbs. Now \$24.95. No. S-967, in walnut plastic cabinet, Now \$26.45. No. S-968, in ivory plastic cabinet, Now \$26.45.

NEW HALLICRAFTERS Model S-58 AM-FM AC-DC RECEIVER

Regular Price
~~—\$59.50—~~
REDUCED TO
\$34.95

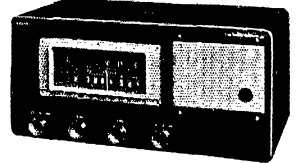

Save \$24.55! We're giving you the benefit of our exceptional buy! Imagine, only \$34.95 for a genuine, brand new, high fidelity AM-FM, AC-DC Hallcrafters broadcast receiver that tunes the full AM and FM bands with a frequency response of 60 to 14,000 cps, ± 3 db. They'll be scooped up fast at this bargain price! Has continuously variable tone control, 6 tubes plus rectifier, built-in power supply and superb construction. Extremely sensitive on AM and FM. Audio output is 4 watts. Loop antenna and phone connection. For 105/125 volts AC or DC. 13 1/4 x 6 x 5 1/2" H. Complete with tubes and speaker in streamlined metal cabinet. No. A2065, Shpg. Wgt. 20 lbs. Limited Quantity at \$34.95

TRANSMITTING and SPECIAL PURPOSE TUBES

E1148	.69	3BP4	3.95	813	7.95	836	1.25
EF50	.49	5CP1*	3.75	814	2.95	838	3.95
HY615	.95	10Y	.59	815	1.69	843	.45
VR105	.89	211	.69	826	.79	1626	.49
VR150	.89	285A*	.75	829B	4.95	1665/2050	1.18
2AP1	2.49	286A*	.69	830B	3.95	2051	.69
2C40	.89	304TH	3.95	832A	2.65	7193	.49
2C43*	4.95	304TL	1.39	845W	3.45	8005	4.95
2C44	1.35	316A	.39	866A*	.98	9001	.49
2D21	1.39	331A/805	4.95	872A	1.75	9002	.69
2E22	1.50	705A	2.95	931A	2.39	9003	.49
2X2A*	.99	801A	1.49	954	.39	9004	.69
2X2/879	.49	803	8.95	955	.49	9006	.49
3AP1	2.39	804	8.95	957	.49		
3CP1	.99	805	4.95	958A	.49	717A	1.65
3CP1S1	.89	807	1.15	959	.49	6AC7	.99
3E29	3.49	809	1.65	1616	2.95	6C4	.29
3E29	3.49	810	6.95	1619	.49	12A6	.29
5BP1†	3.95	811	1.79	1625	.49		

* Available from New York only. † Available from Chicago only.

NEWARK RADIO & TELEVISION

3 GREAT STORES! Uptown: 115 West 45th Street
Downtown at 212 Fulton Street in NEW YORK
323 West Madison Street in heart of CHICAGO

MAIL ORDER DIVISIONS: 242 W. 55th St., N.Y. 19
and 323 West Madison Street, Chicago 6, Illinois

FREE Send for 1949 Catalog
New . . . Just off the Press!

General Electric CRO-3A 3" OSCILLOSCOPE

Regularly \$98.50
REDUCED TO \$59.50

Save \$39.00 on this brand new GE Scope! The CRO-3A was designed to fit into every progressive serviceman's workroom. Its high deflection sensitivity and stability make this scope ideal for visual alignment work with a suitable signal generator. Sweep rate is 20 to 30,000 cps, with vernier control. Uses 3AP1 Cathode Ray, 8B4 Sweep Osc., 6AC7 Vert. Amp., 6AC7 Horiz. Amp., and 2-5Y3GT Rectifiers. Welded steel gray wrinkle case. Size: 8" x 12 1/2" x 13". Shpg. Wgt. 30 lbs. No. S-965 Special \$59.50

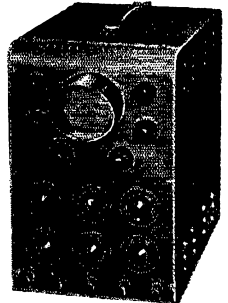

QUANTITIES LIMITED ON
ALL ABOVE ITEMS! F.O.B.
NEW YORK OR CHICAGO

STANDARDIZED METAL EQUIPMENT FOR ELECTRONICS

BUILD BETTER ELECTRONIC EQUIPMENT



with STANDARDIZED

READY-TO-USE CABINETS • CHASSIS • PANELS • RACKS

for ALL P. A. NEEDS Par-Metal Equipment is preferred by Service Men, Amateurs, and Manufacturers because they're adaptable, easy-to-assemble, economical. Beautifully designed, ruggedly constructed by specialists. Famous for quality and economy.

Write for Catalog.

PAR-METAL PRODUCTS CORPORATION

32-62—49th ST., LONG ISLAND CITY 3, N. Y.
Export Dept.: Rocke International Corp.
13 East 40 Street, New York 16

STANDARDIZED METAL EQUIPMENT FOR ELECTRONICS

ORS, while VJQ qualified for Class 2 OO. PG is active on 28-Mc. 'phone after a vacation in Colorado. AD, new OBS, operates on 3.85-, 27-, and 28-Mc. 'phone. FMZ manages to make the Southern Border Net (3550 kc. at 9 P.M.) about four nights each week. BAM says LDJ is now signing portable from Santa Barbara. BKZ did a fine job handling AEC-ARC test traffic. New reporter is DBZ, who is a member of the SBN. BGF runs up a nice traffic total each month from activity with the SBN. This net now has excellent outlets in New Mexico and Arizona with nightly contacts in Oklahoma and Texas. 9VVL, of Ft. Wayne, now is 6ESE. The San Diego YLRL held a Christmas party for YLs and OMs. YXI attended the Southwestern Division Convention. AWW, who sends in the YLRL information, is working 144 Mc. BGF is working 28-Mc. mobile exclusively. SI is building a high-fidelity automatic radio and record player. OBD moved to Point Mugu. LMV has rebuilt his transmitter into a very fancy console cabinet. Visit YTH to see a 30-ft. rotatable tower. VCD rewound his modulation transformer after it burned out. YWR is back at U.C.L.A. getting his master's degree. JYV is a new man who soon will be on 28-Mc. 'phone. The last issue of the *Hamgram*, the voice of the Imperial Valley Amateur Radio Assn., is complete with pasted-in photos! QUS, still working mobile with UQI, soon will have a TBS-50 on the air. LVN and WHW are talking 'phone. CQW is holding out for c.w., while YES is on now and then. New Imperial Valley ham is CAF. DED still is pounding brass. KNL operates on 3.85 Mc. but his night working hours keep him relatively inactive. 5MJZ/6 is another new ham in Imperial Valley. Traffic: W6BKZ 131, BGF 125, K6NMC 84, W6VTS 54, FMZ 18, DBZ 13, BAM 6, WXW 6, AD 3.

WEST GULF DIVISION

NORTHERN TEXAS — SCM, Joe G. Buch, W5CDU — This is my first report as your SCM. The status of organized communications in this section is a good reminder of the accomplishments of the previous SCM. Three EC 'phone nets and one EC traffic net are progressing well under capable leadership. Supporting members of these nets deserve a vote of appreciation by all members of this section. New members are welcome, so choose the net serving your area and join us in our organized operations. AAO, Jim Lee, of Abilene, has accepted appointment as SEC upon the resignation of JDZ. MAW is active on 144 Mc. MQH would like to see a few kcs. cleared on week ends to give the 28-Mc. mobile boys a better chance for QSOs. KWH is given honorable mention by NCS CJJ for his outstanding attendance record in N.E. Texas EC Net. LSN ran overtime with his rebuilding schedule but is back with Rebel and TLAP Nets. FBL reports the NTAC Radio Club, operating EUY, is experimenting with v.h.f. gear and building a new club transmitter for low frequency bands. AAK is working lots of good DX on 28-Mc. c.w. with a 32V rig and long-wire antenna. T.V.I. complaints were very low during the first thirty days operation of the Ft. Worth t.v. transmitter. Activity report cards received for this column total zero. How about some help? — it's your column. Traffic: W5GZU 350, CDU 99, ARK 59, ILZ 34, ASA 18, FMZ 17.

OKLAHOMA — SCM, Bert Weidner, W5HX1 — Asst. SCM. George Bird, 5HGC. SEC: AST. KL7NQ, ex-W5HXU, has returned to the States and is visiting friends. The Comanche, Dewey, Oklahoma, and Pawnee Counties were very active in the Simulated Emergency Test. These were the only groups reporting to either the SEC or the SCM. The OCARC held a fine picnic to stimulate interest in emergency equipment. OWV has joined OIZ. Keith is a former Signal Corps operator and eats traffic. HXG is the Oklahoma terminal for Trunk Line "K." IGO left Trunk Line "L" for "Trunk Line "K." NMM calculates his CD Party score to be 6300 in 10 hours. This is the only station that I have heard of as having operated in this contest. MBV has schedules offering outlets to Colorado, Illinois, Michigan, Minnesota, New York, Nebraska, South Dakota, and Wisconsin. During JKS's absence FMF is checking into the Rebel Net. Traffic: W5MBV 192, AST 119, NMM 119, KDH 67, OWV 38, LHP 22, HXG 14, IOW 13, ADC 11, ADB 9, EHC 9, GCM 8, FRB 6, PA 3.

NEW MEXICO — SCM, Lawrence R. Walsh, W5SMA — SEC: ZU. RM: NXE. PAM: FAG. The Sandia and Albuquerque Radio Clubs were hosts at a joint meeting of the radio clubs in New Mexico on Nov. 6th at the School of Mines in Albuquerque. Your SCM reported on the National Convention, ZU, our SEC, talked about the AEC, and NXE, editor of *CQNM*, discussed plans for the coming year. The outstanding feature of the meeting was a talk on a.s.s.c. by NRP, of Sandia. Ray also discussed the cubical quad antenna. MYI could not attend the joint meeting because of school but reports he has his Class A license. NJX reports that he may be on the air about the first of the year. JYW now is a Class I OO. ZM now is Class A. NJR has a new 3.85-Mc. half-wave antenna, thanks to the assistance of NAS, MPO, and SMA. KAO and FAG and his XYL visited SMA. AZS, Roswell, is Asst. EC on 7 Mc. OCK is busy painting his house and shack. OMR and UFA obtained their Class A tickets. SMA got his rotary beams up on the tower with the assistance of OXC. KAO was host to SMA

(Continued on page 108)

AMAZING NEW Improved

Super De Luxe

VIBROPLEX

Reg. Trade Marks: Vibroplex, Lightning Bug, Bug

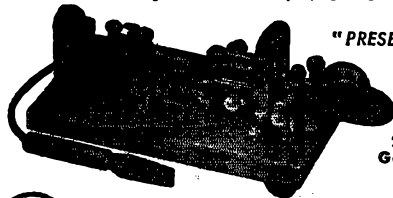

"PRESENTATION" MODEL

24-Karat Gold-Plated Base Top



The "BUG" Trade Mark identifies the Genuine Vibroplex. Accept No Substitute

INTRODUCTORY OFFER! \$25.00 After January 1st \$27.50

Here's the latest word in sending ease and enjoyment. With this amazing New Vibroplex key you can send better, faster and easier. No special skill necessary. No tiring arm effort. Suits any hand or any style of sending. Acclaimed for beauty and operating ease. Super-speed Control Main Spring provides range of speed from 10 wpm to 40 wpm and beyond. Polished chromium machine parts. 24-karat gold-plated base top. Colorful red switch knob, finger and thumb piece. Extra large contacts. Non-slip rubber feet. Order yours to-day! See how easy sending can be! Money order or registered mail. FREE catalog.

THE VIBROPLEX CO., Inc. 833 Broadway NEW YORK 3, N. Y.

• A. R. R. L. • ASTATIC • B & W THORDARSON • NATIONAL • GENERAL ELECTRIC •

ELECTRONIC WHOLESALERS INC.

Exclusive Distributor for

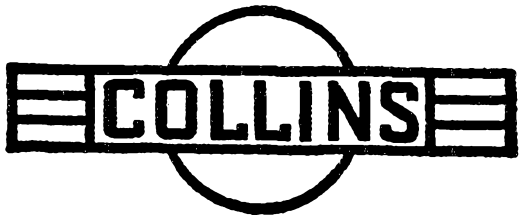

In The Washington Area

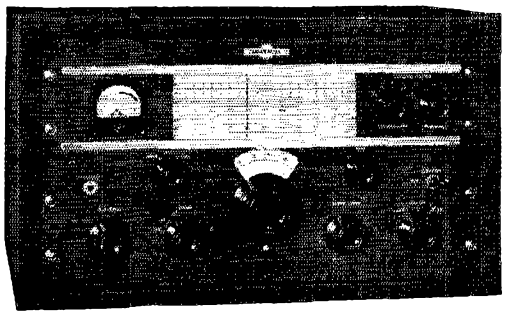

A complete line of Collins transmitters and receivers is always on display in our spacious new showrooms. We invite your inspection of this famous equipment. . . . Just more proof that Electronic Wholesalers has all the greatest names in radio.

- 30K-1 500 WATT TRANSMITTER
- 32V-1 150 WATT TRANSMITTER
- 70E-8A VFO
- 75A-1 RECEIVER
- 310B EXCITER UNITS

Now Ready for Delivery!

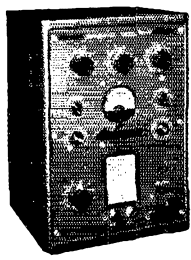

Harvey-Wells
TBS-50 TRANSMITTER

The most versatile small transmitter on the market—only 8" x 13" x 3"—50 WATTS—Phone or CW—8 BANDS with band switch (NO plug-in coils)—Crystal controlled on all bands—For fixed or mobile operation—Supplied complete with tubes. It's today's BEST BUY!

Only **\$9950** ORDER YOURS TODAY

SPECIALS!

4½" Flexible Shaft.	29¢ each
¼" Coupler for above..	35¢ pair
3½" Pillar Insulator.	5 for 89¢
1½" Pillar Insulator.	5 for 69¢
Hand Keys.	49¢ each
Honey Comb Coil A.C. Line Filter.	39¢ each
4 Mfd—600V Oil Filled..	69¢ each

Chassis, Panels, Cabinets in stock!

- Products of all National Manufacturers in stock—25% deposit on C.O.D. orders, F.O.B. Washington, D. C.

Complete Lines of Steel and Aluminum Chassis in Stock

Washington's Big New Radio Parts Distributor Has All the Greatest Names in Radio

Electronic wholesalers, inc.
2010 14th STREET, N. W. • WASHINGTON 9, D. C.
DEatur 9041

LANSING • XCELLITE • KRAUETER • SPRAGUE • BELDEN

J. F. RIDER • WALSCO • LANGEVIN • TRIPLETT • U. T. C. • BILEY • PRECISION • RADIART • R. C. P. • AEROVOX • AMPHENOL

CLARSTAT • HALLGRAFTERS • WORKSHOP • INSULINE • JENSEN • MEISSNER • R. M. E. • RAYTHEON • STEPHENS TRU-SONIC

HAMS SWL'S

- ALL-ALUMINUM
- FULLY ADJUSTABLE
- PERMANENT
- STRONG AND RIGID

HY-LITE
JUNIOR
3 EL. 10-11

\$28⁶⁰
COMP.

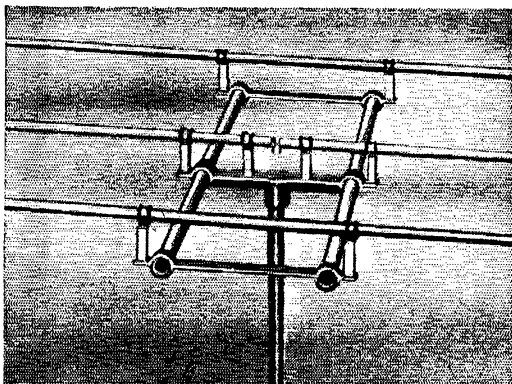

ALSO AVAILABLE in 4 EL. or F.D. WRITE • CAT. 1-9Q

HY-LITE Antennae INC.

Makers of Fine Antennas for AMATEUR • FM • TELEVISION
528 TIFFANY ST., BRONX 59, N.Y.

CUT HOLES FAST IN RADIO CHASSIS

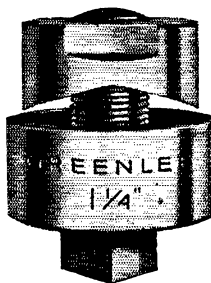

WITH A GREENLEE RADIO CHASSIS PUNCH

Eliminate tedious reaming and filing. Just turn GREENLEE punch with an ordinary wrench and make clean, accurate holes in a hurry. There's a GREENLEE for each of these sizes: $\frac{1}{8}$ " ; $\frac{3}{16}$ " ; $\frac{1}{4}$ " ; $\frac{5}{16}$ " ; $\frac{3}{8}$ " ; $1\frac{1}{8}$ " ; $1\frac{1}{4}$ " ; $1\frac{1}{2}$ " ; $1\frac{3}{4}$ " ; $1\frac{7}{8}$ " ; $1\frac{1}{2}$ " ; $2\frac{1}{4}$ ". Also GREENLEE Knockout Punches and Cutters for conduit and meter holes up to $3\frac{1}{2}$ ". Write for facts, Greenlee Tool Co., 1861 Columbia Avenue, Rockford, Illinois.

TOOLS FOR CRAFTSMEN

GREENLEE



and his XYL on Nov. 6th. NVR now has his a.s.b. receiver in operation. FAG now has his new dual beams in operation. Traffic: W5NXXE 141, ZU 130, SMA 25, NJR 17, ZM 3.

CANADA

MARITIME DIVISION

MARITIME — SCM, A. M. Crowell, VE1DQ — RM: GL. SEC: FQ. It is our sad duty to record the passing of one of our oldest and most popular 3.8-Mc. 'phone men, Hal Ward. GR. Hal will be greatly missed by all his fellow hams. GL sends in a nice traffic total. QU is doing some OO work and now has a new antenna. DB handles a few. MS is now in RCEME. HJ has a 348 receiver now and has the V.T. keyer going. BK has schedules with BO on Sable Island. ES has new NC-173. HT has rebuilt and is on three nights weekly in the net. MK has nice traffic total due to net activity. DB and FB attended the Montreal Convention. QZ made a 28-Mc. WAC recently in 7 hours plus! HG, Yarmouth, has 87 countries with an 807 final. CO, IA, IS, IK, PI, NH, JG, CX, JF, NB, UF, QW, CR, SE, and OY are active on 28 Mc. The Halifax and Dartmouth gangs are resuming their nightly round tables to swap the past day's DX and discuss the ever present topic — n.f.m. vs a.m. HD and TA have increased power and Gerry has the new speech clipper-filter going FB. Many of the gang have acquired ART-55 as extra rigs for portable-mobile on 3.8-Mc. Traffic: VE1GL 161, HJ 58, HT 45, MK 32, DB 7, QU 2.

ONTARIO DIVISION

ONTARIO — SCM, Thomas Hunter, jr., VE3CP — Asst. SCM, M. J. McMonagle, AWJ. SEC: KM. RMs: ATR, AWE, BUR, DU, GI, and TM. PAMs: DD, FQ, and RG. ATR is looking for additional stations for the Ontario 7-Mc. Net, especially stations in the northern and western parts of the Province. OI is back on OBN. BBO is looking for contacts on 144 Mc. The Nortown Club, Toronto, reports RU and BQP are on 28 Mc. BWK is on 7 Mc. and APA is experimenting with quad antennas. The Kirkland Lake gang spent a busy October studying for the R.I.'s visit. ALT has new three-element on 14 Mc. AQN now is operating on 28 Mc. XG now has 70 countries toward DXCC. AZN is the proud possessor of a new shack and an HQ-129. VE8OE has returned to Kirkland Lake. ANH is now a member of the OWLS Club. Former VE7ADT/C77D/VF7B now is located in Timmins and operating under a new call, AZZ. AWE, BND, and GI work both the OBN and the Ontario Eastern Net. Toronto, Hamilton, Kitchener, Chatham, Owen Sound, and Windsor participated in the Simulated Emergency Test. New appointments include FT as ORS, BSG as OPS, and AXK as EC for the Rockcliffe Area. AKR is working both 3.8- and 28-Mc. 'phone. VU reports the Air Force Net is going FB on 3755 kc. at 8:00 p.m. MJ and CP returned from the Montreal Convention as members of the Royal Order of the Wouff Hong. BXM is new in Wingham. QE is using n.f.m. on 14 and 28 Mc. BNQ worked a ZL after two years. BTE and BPE, husband and wife, completed WAS on 7 Mc. within a month of each other. BHU is using 14-Mc. folded dipole. AAN, now 2AIA, can be heard on 3.8-Mc. 'phone. AWJ will welcome queries regarding Ontario nets. Traffic: VE3ATR 106, AWJ 85, CP 78, BUR 75, AWE 71, IA 65, RG 59, GI 57, APS 49, KM 38, AQB 33, NI 27, TM 27, DU 25, VD 24, IL 19, WK 19, YJ 15, BCP 14, FQ 14, DD 9, HK 5, DH 4, ZE 3.

QUEBEC DIVISION

QUEBEC — SCM, Gordon A. Lynn, VE2GL — SEC: 2QQ, ECs: BB, TA, and ZZ. RM: BB. PAM: DX. The Eastern Canada ARRL Convention took place in Montreal Oct. 8th and 9th with an attendance of about 500 from VE1, 2, 3, and 4, and W1, 2, 3, and 8. On Oct. 16th the St. Maurice Valley Amateur Radio Assn. celebrated its 25th anniversary with a banquet at Cap de la Madeleine attended by forty. Interesting talks were given by EK and AT, charter members of the club. Visitors attended from Montreal, Quebec City, and several other points. The Quebec City Club has a new president. EC reports the Quebec 'Phone Net continues active with himself, EV, RM, AEM, OD, ABJ, TR, and ACD. AIM, a new-comer, is very active on 144-Mc. net with ZG and EC. DD had a fire; his induction rotary beam burned out. DR manages to get on the air occasionally and schedules TK twice weekly in Ungava on 7 Mc. BB continues to be very active with traffic and reports success in the Simulated Emergency Test with ER, GM, LO, NR, XB, and XR. GM is ORS and is keeping regular schedules on several nets. He has SC, ACD, XR, AFI, YP, CC, XB, and AIB lined up for formation of Quebec c.w. net and invites any other VE2 interested to drop him a line. WZ is operating from Pointe Claire on 14 and 7 Mc. XB is having trouble with power supply but is on with low power doing a swell job. AGG is very active on 3.5 and 7 Mc. LO continues schedules and handles quite a bit of traffic. What about some reports from Quebec City? Traffic: VE2BB 273, XB 68, EC 48, GM 47, GL 37, LO 26

(Continued on page 110)

HERE COMES LEO!

And he's offering the **MOST COMPLETE HAM CATALOG** ever assembled! Just off the press—write for your **FREE** copy today!

WORLD FAMOUS WRL XMTRS! GLOBE TROTTER

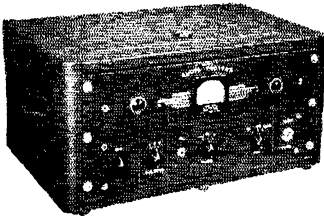

Unconditionally guaranteed 40 watt input kit including all parts, power supply, chassis panel and streamlined cabinet.

Less Tubes **\$69.95**

Wired **\$79.50**

(1 set of Coils, Meters, Tubes, \$17.49 extra)

GLOBE KING

Unconditionally guaranteed 275 Watts phone and CW. An advanced design XMTR giving efficient performance on 10 - 11 - 15 - 20 - 40 and 80 meter bands.

Ready to go— **\$379.45**
Kit form

Wired **\$399.45**

Write for information on NEW 150 Watt Globe Champion.

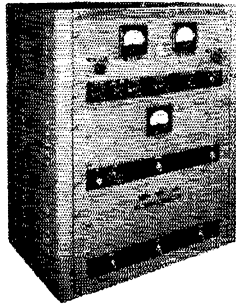

LEO I. MEYERSON
WØGFQ

CU ON 20 - 10 & 75 METERS

E-Z PAYMENTS

WRL offers the lowest E-Z Payment Plan in the country. Any responsible person with a steady job can buy on time from Leo. No red tape—no delays! Financing our own paper saves you money!

LIBERAL TRADE-INS

Leo offers more—use your present equipment as a trade-in. Tell me what equipment you have—what equipment you want—let's trade.

PERSONAL SERVICE

WRL is the World's Most Personalized Radio Supply House for the amateur. Getting acquainted with Leo will help you get on the air faster and for less money.

GIANT RADIO REFERENCE MAP

Just right for your control room wall. Approximately 28" x 42". Contains time zones, amateur zones, leading shortwave stations, monitoring stations. Mail coupon today & **25c**



Save Money On Reconditioned Equipment—Write For Our Big List!

FAST SERVICE ON FOREIGN ORDERS

WRITE—WIRE
PHONE 7795

WORLD RADIO LABORATORIES
744 West Broadway
Council Bluffs, Iowa

Q-1

Please send me:
 Radio Map
 New Catalog

- 40 Watt Globe Trotter Info.
- 150 Watt Globe Champion Info.
- 275 Watt Globe King Info.

Name

Address

City..... State.....



Signal

Wireless and Telegraph Instruments

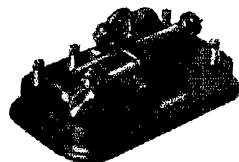
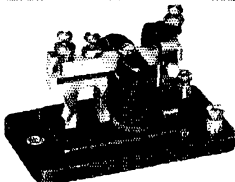

From practice keys for beginners to the very finest commercial equipment, perfect performance calls for Signal. Send for FREE descriptive literature today!

Signal ELECTRIC MANUFACTURING CO.
DEPT. D-1, MENOMINEE, MICHIGAN

MORE SIGNALS PER DOLLAR
From Money Invested in an Antenna

Self-Supporting
STEEL TOWERS
For Rotary Beams, FM, TV

ATTRACTIVE—NO GUY WIRES!

- 4-Post Construction for Greater Strength!
- Galvanized Steel—Will Last A Lifetime!
- SAFE—Ladder to Top Platform
- COMPLETE—Ready to Assemble
- Easy to Erect or Move
- Withstands Heaviest Winds

(We will supply stress diagrams for your building inspector)

EASY MONTHLY PAYMENTS

Up to 12 Months to Pay!

All Vesto Towers are available on a special monthly payment plan which requires only 1/8 down. Write for free details.



Width at
Base Equal

to 1-5 Height
IMMEDIATE DELIVERY
on all 7 popular sizes. Note the low prices for these quality lifetime towers: 22'-\$73.50, 28'-\$92.25, 33'-\$109.75, 39'-\$129.75, 44'-\$149.75, 50'-\$175.00, 61'-\$239.75. Towers

are shipped to your home knocked down, FOB Kansas City, Mo., 4th class freight. Prices subject to change...so order now! Send check or money order...or write for free information.

WRITE TODAY FOR COMPLETE FREE INFORMATION AND PHOTOGRAPHS

The **VESTO** Company
101 Main St., Parkville, Mo.

VANALTA DIVISION

ALBERTA—SCM, Sydney T. Jones, VE6MJ—EE attended the hamfest in Montreal and visited W9ALI on the way. CC is building a converter for 28 Mc. HM visited old friends in Vancouver and Victoria. BN, BW, EA, and LQ joined the AEC in Edmonton. EL has been appointed EC for Camrose. XX worked 3.8-Mc. mobile on trip to Lac La Biche. JP and EO visited MJ. The Alberta Net is active on 3730 kc. Pass your traffic through this net. NA is OBS in Medicine Hat. Listen for him on 3780 kc. Mon. and Fri. at 1930. EL conducted an interesting test on 3.8 Mc. using mobile rig in the car and kept constant contact with his home station during 160-mile trip to Edmonton and return. AE is active on 3.8-Mc. 'phone and announced the arrival of a new jr. operator. LQ and VS have been appointed ORS. BW demonstrated mobile possibilities to NARC at a recent meeting. WG is Alberta representative on T.L. "I." LZ qualified for OO Class I. TK is EC for Calgary and JJ is EC for Medicine Hat. FB visited PJ during a recent trip to Calgary. The NARC is holding series of "at homes," the first of which was held at MJ's shack. Many thanks to those who have joined the C.D. ranks. Contact your local EC for membership in the Emergency Corps. Traffic: VE6MJ 4.

PRAIRIE DIVISION

MANITOBA—SCM, A. W. Morley, VE4AM—BZ, a new ham at Gimli, is using 813s and a Super-Pro receiver and in the first two weeks on worked South America, Europe, and England. Time is spent on 7 and 14 Mc. Rivers has SW active with 813s and an AR77. AR, at Pine Falls, is busy popping tubes. TM is in new QTH and is busy setting things up again. JO was awarded a safe-driving prize. QV and NI are still arguing about antennas. NI is due for overhaul since QV is getting better reports. KX and PD, two 3.8-Mc. 'phone boys, are leaving for VE7 Land. LC had his tower broken while in the process of moving but it's up again. TX is n.f.m. GI ran into some B.C.I. but cleaned it up. AD is pleased with his 14-Mc. vertical which is 72 feet high. GW's rig still is in pieces and is all over the floor. Gerry will have it rebuilt one of these days. JN, at Waskada, is heard on 3.8-Mc. 'phone and 7-Mc. c.w. FU was busy with Stimulated Emergency Test. Remember Emerson? Get in touch with Frank and join the AEC. JM is doing a lot of c.w. practice lately. Thanks for the reports, fellows. How about a few others? Season's Greeting and the best to all in '49. Traffic: VE4AM 52.

SASKATCHEWAN—SCM, Norman Thompson, VE5CO—MK is running 30 watts to his 807 final, while LD is running 5 watts to a 6V8 crystal oscillator. BW is on 28-Mc. 'phone and is looking for Toronto contacts. FG is working on 7-Mc. c.w. EE is on 3.8-, 14-, and 28-Mc. 'phone and c.w. AJ is keeping schedule with ZL3AI on 14-Mc. c.w. EW is working n.f.m. DR, on 28 Mc. using n.f.m. OB is on 3.8 and 28 Mc. GB is on 7-Mc. c.w. FL and RJ are low-power enthusiasts. KQ is rebuilding for 27 and 28 Mc. UZ is pushing out a good signal on 3.8 and 28 Mc. using 125 watts and a speed clipper. FD has a converter for 28 Mc., also 10 over 20 beam, both two-element wire jobs. BF is on 14 and 28 Mc. using n.f.m. and a 458A VFO, also a three-element beam. Saskatchewan hams, please send news for XTAL to BF, Gus Cox, 237—5th Ave., Saskatoon. YF is going strong on 3.5-, 14-, and 7-Mc. c.w. JD has a new Pierce oscillator driving his 807. KB made contact with an SM station. WB is building a grid-dip frequency meter. OP can be found on 14 Mc. in the wee small hours of the morning. OM has a two-element rotary beam for 14 and 28 Mc. HR made 62 QSOs in the CD Party. Traffic: VE5HR 40.

I Will Do It in '49

(Continued from page 47)

"Hello, 'TK,'" Jim shouted from across the room. "How'd ya' do?"

I managed a wry smile, and replied, "Oh, I worked a few, but I wasn't out to win. I understand you had a fair score."

Our new place is only a mile from the bus line, and Betty always did want room enough to put in a garden. And look! Aren't those 80-meter Vees beauties?

It will be different in 1949!

HARRISON HAS IT!



73 FOR YOUR MOST HAPPY AND SUCCESSFUL 1949 AD!

...And we can make you happy by giving you the best service for all your requirements—every standard item that's made and FB bargains in Harrison Select Surplus, too.

Remember — Harrison Has It!



SAVE 50% ON THIS FB HALLICRAFTER XMTR!

Yes, that's right! The famous HT-17 which regularly sold for \$49.50 is yours for only \$24.75 with the purchase of any new receiver selling for \$100.00 or more.

A complete, compact, CW transmitter — 6V6 xtal osc., 807 final, 10 to 20 watts of conservatively rated output on 10 to 80 meters — antenna matching network. An FB rig for the beginner or a 'swell standby.

Complete with tubes and 40 meter coils. Ready to plug into 110 AC line. Quantity limited — send your order today!

HARRISON HAS IT!

HALLICRAFTERS AMAZING HT-19

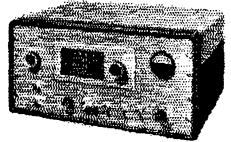

A brand new, high efficiency transmitter — 125 watts, 10 to 80 meters, CW or NBFM phone. VFO built right in! Provision for external AM modulation. Complete with coils for all bands and tubes. All you need is a crystal microphone.

Ready to Operate \$359.50

Harrison Has It — In Stock!!

Crystal mike — Famous Astatic D-104 — favorite of Ham operators for years. **\$14.47**

IS ELECTRONICS YOUR BUSINESS?

Do you purchase or influence the purchase of electronic parts and equipment that are needed in a hurry? Our INDUSTRIAL SALES DEPARTMENT is one of the best in the country, saving time and money for thousands of industrial accounts.

Wire, write or phone the Lucky 7's — Barclay 7-7777

Cordially yours,

BERT SCHREINER, Industrial Sales Manager



DIRECTION INDICATOR KIT

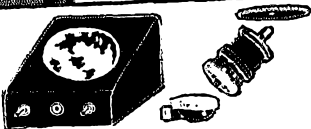

Great circle maps centered on Topeka, N.Y.C., San Francisco or a compass rose for rear illumination — sloping front desk cabinet or rack panel (specify choice) — complete with remote transmitter and one to one coupling gear, specially made for use with prop motors. Operates right off the motor transformer!

Complete \$14.75

Selsyns as used in kit — work on 24-35V, 60 cycle or 115V thru 4 to 8 mfd condenser. New! Per pair \$2.95 Caps for above selsyns (connectors) 24¢ each

TELEVISION?

Sure, HARRISON has them all!

KITS?

- ★ Television Assembly
- ★ Philmore ★ Meissner
- ★ Techmaster

(Ask about the famous type 630TS, completely factory wired)

PARTS? SETS?

- ★ Complete line of RCA TV parts!
- ★ Hallicrafters ★ National

Come in, wire, write or phone for complete information.

HARRISON HAM-A-LOG

Don't miss another issue of the Ham-A-Log. Pages packed with Ham news and hints, Outstanding buys in standard and HSS parts and equipment. Send us your name and call today!

JAMAICA BRANCH

Hillside Avenue at 172nd Street
REpublic 9-4102

OPEN NIGHTS

New York —
Wednesdays
Jamaica —
Fridays

UNTIL 9:00

WE SHIP TO ALL PARTS OF THE WORLD!

Please send ample for postage. We refund every cent not used. Deposit required on all C. O. D. orders unless you are one of my regular customers. Happy to fill any order but please try to make them more than \$3.00.



HARRISON

RADIO CORPORATION

12 WEST BROADWAY,
NEW YORK 7, N. Y.

MM-2 MODULATION MONITOR

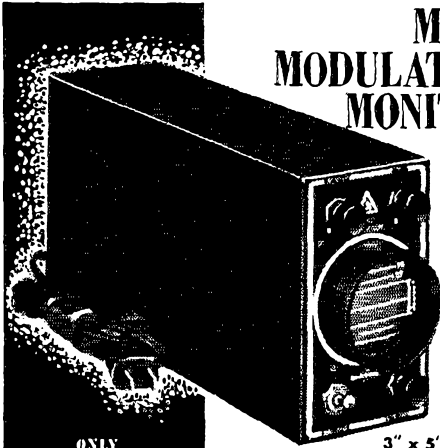

ONLY
\$24.95

COMPLETE WITH CUES
REVERSIBLE PANEL-CALIBRATED
TRACE INTENSIFIER WINDOW
INSTRUCTION BOOK

3" x 5" x 10"

... SEE YOUR SIGNAL
AS OTHERS
HEAR YOUR SIGNAL

with this basic oscilloscope featuring calibrated modulation percentage scale, linear 60 cy sweep with return trace blanking, trace intensifier window, complete controls, reversible panel, rack mounting provisions and many other outstanding features. See the MM-2 at your dealer or write Dept 1-9.



LAMBDA ELECTRONICS CORP.

BOX No. 55

CORONA, N.Y.

**CUSTOM
BUILDERS**

**BUILD YOUR RADIO SALES
AROUND THIS Quality
CHASSIS**

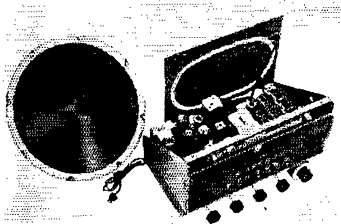

**NEW
ESPEY
MODEL 511
AM-FM
CUSTOM BUILT**

**This Profitable Chassis Replacement Market
means increased sales to you and increased
savings to over 19 million potential customers**

- Here is a fine radio, in chassis form, to please the most discriminating music lovers.
- Easy to install in any console cabinet old or new, the Espey 511 AM-FM radio chassis embodies the latest engineering refinements for lasting high quality at a price that defies competition.
- Features, 12 tubes plus rectifier and tuning indicator; drift compensated circuit for high frequency stability; tuned RF on AM and FM, high fidelity push-pull audio; 13 watts power output; wide range 12" PM speaker; smooth fly-wheel tuning; phono input provision; separate AM and FM antennas.

Makers of fine radios since 1928.

ESPEY

TEL. BUTTERFIELD 8-2300

MANUFACTURING COMPANY, INC.

528 EAST 72nd STREET, NEW YORK 21, N. Y.

Sold through your favorite parts distributor. Write for catalogue, K.D-1 containing complete specifications

Happenings

(Continued from page 34)

tion would take place at municipal levels, with decreasing staffs thereafter at state, regional and national levels. At each of these levels, however, there is to be a group of advisory panels in communications, one for telephone and telegraph companies, a second for radio broadcasting stations and a third for amateur radio groups.

The report admits that certain complications affecting all radio communications are still unsolved problems, namely, radio silence and such restrictions as may be required for security and censorship control. As the report states, the degree of application of one or all of these may impair or even nullify all radio operations. The report makes no attempt to answer the questions posed in this connection, since the responsibility for them will be military rather than civil. It does, however, urge prompt joint studies on these aspects between the armed forces, other government agencies concerned, and the Office of Civil Defense (when that shall be established).

In conclusion, it should be emphasized that the report does not guarantee our participation in civil defense, but it paves the way. When and if it is put into effect and as it begins to go into operation at state and local levels, we will still have need for study and effort of a high order to work out the details of our place in the civil defense structure.

How's DX?

(Continued from page 37)

cover. Landlady trouble, no less! Jules, TA3FAS, now employs the call TA3AA and mail to him still goes via ARRL. The fellow has been banging W ears with a 555-foot longwire tied onto a single 6L6. This via W9AEH. W2GUR and W4CYY bring in some ZD9AA gossip. The latter will be active on Tristan da Cunha for the next year or more and advises the howling mob to keep their shirts on. ZD9AA gets mail once a year and is building a bug. The big news out in Kiloifornia arrives in a telegram from W6TI. AC4YN kicked through with fifty (50) QSLs sent via VU2GB to the eager hands of Horace. VU2GB wonders how come no decent W1 signals come through out there on c.w. (That's easy — BG has them all on single-sideband these days). VR2BC reports that G6BW stopped in at Nadi Airport while on his way to New Zealand. For the record, present frequencies available for VR2 use are 3.5-3.9, 7-7.3, 14-14.4, 28-29.7 and 58.5-60 Mc. Old "V.H.F." Paddon, VE3QV, staggered back to Canada without too much to say after an all-band session under the call VP2GJ. Jack had fun but also confirmed his earlier findings that being DX isn't all it's cracked up to be. We think that VP2GJ did demonstrate that the strategem outlined in our lead for last October can work like a charm if only given a try. This Roch-

(Continued on page 114)

CRYSTALS!

All crystals have Army MC harmonic ratings but Sun encloses directions for deriving the correct fundamental frequency in kilocycles.

CRYSTALS WITH A MILLION USES

Fractions Omitted

kc	kc	kc	kc	kc	kc	kc	kc	kc	kc	kc	kc
412	422	431	441	451	474	487	496	502	507	512	519
413	423	433	442	453	475	488	497	503	508	515	522
414	424	434	443	462	477	490	499	504	509	516	523
415	425	435	444	466	479	491	501	506	511	518	
416	426	436	445	468	481	492					
418	427	437	446	470	483	493					
419	429	438	447	472	484	494					
420	430	440	448	473	485	495					

49¢ each

Crystal Frequency Standards 98.356kc

Easily altered for 100kc Standard. Mounted in low loss 3 prong holder.

\$3.89 each

For Crystal Controlled Signal Generators 525kc

\$26,388	533,333	537,500
\$27,777	534,722	538,888
\$29,166	536,111	
\$30,555		
\$31,944		

99¢ each

I.F. Frequency Standards

kc	kc	99¢ each
450	461,111	
451,388	464,815	
452,777	465,277	

200 KC CRYSTALS

Without holders
2 1/2 x 3 3/2" each **69¢**
3 for **\$2.00**

Assorted Miscellaneous Crystals

Fractions Omitted

370kc	377kc	384kc	387kc
372	379	386	388
374	380		
375	381		
376	383		

For Ham and General Use

Fractions Omitted

390kc	396kc	404kc	408kc
391	397	405	409
392	398	406	411
393	401	407	
394	402		
395	403		

79¢ each

priced at a fraction of the cost of their holders alone.

CRYSTALS FOR SCR 522

5910kc	7480
6370	7580
6450	7810
6610	7930
7350	

\$1.29 Each

Crystals from BC 6 10

3/4" Spacing—2 Banana Plugs

2045	2282	2435	3250	3570
2105	2300	2442	3322	3580
2125	2305	2532	3510	3945
2145	2320	2545	3520	3955
2155	2360	2557	3550	3995
2220	2390	3202		
2258	2415	3215		
2260	2430	3237		

\$1.29 Each

- Payments must accompany order. Enclose 20¢ for postage and handling. Minimum order—\$2.00 plus postage.
- Crystals are shipped packed in cloth bags inasmuch as they are shock mounted. All shipments guaranteed.

Hot Radio Values AT SUN RADIO



SPERRY AMPLIFIER

Brand new servo amplifier containing two beam power output tubes (1632) similar to 25L6, two twin triodes (1633 and 1634) similar to 65C7, two mica condensers, dozens of color coded half watt resistors, two dual and four section bathub condensers, three transformers, two wafers switches, one volume control, four octal sockets. Easily convertible.

\$3.95

RADAR RECEIVER BC1068A

Guaranteed excellent condition. It is a "Hot" receiver for the "Ham" and short wave experimenter covering the 174 to 210 MC Television band. Has individually slug tuned antenna R.F., Detector and oscillator circuits resulting in maximum sensitivity; contains 2 R.F. and 5 I.F. stages detector and video amplifier. Complete with 110 volt AC power supply and 14 tubes..... **\$39.50**



SCR-195 WALKIE-TALKIES

SCR 195 Walkie Talkies, brand new, weight 27 1/2 pounds, including knapsack. Range up to 25 miles in open country. Frequency 52.8 to 65.8 MC. Transmitter and receiver with regular hand set. Complete ready to operate with spare parts.

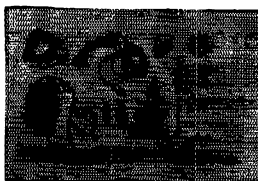

\$59.95

Price per set of 2
\$115



ATTENTION! CLOSEOUT SPECIALS PART KITS!

- KIT 1 Asstd Mica Condensers—Unmarked, 100 for... **\$1.50**
- KIT 2 Asstd Resistors 1/2W-1W, 100 for..... **1.00**
- KIT 3 Asstd Condensers—Tubular Bypass, 25 for... **1.00**
- KIT 4 Asstd Condensers—Electrolytic, 25 for..... **2.00**
- KIT 5 Asstd Potentiometers—with or without switch, 10 for..... **1.00**
- KIT 6 Asstd Ballast Tubes—Line Ballasts, 10 for..... **1.00**
- KIT 7 Octal Sockets—Wafer, 25 for..... **1.00**
- KIT 8 Octal Sockets—Plastic with Flange, 20 for... **1.00**

SPECIAL!! All 8 Kits for \$8.00



MAGNETIC HEADPHONES

Brand new SC 4000 ohm Magnetic phones with 8' cord and standard phone plug. Headphones are adjustable to size A—\$14.50 value..... **\$2.49**



2-6 MC PB RECEIVER

6 tubes (3-1T4, 1-1R5, 1-1S5, 1-3S4). 2-6MC in 4 bands. Easily converted to Broadcast band with instructions furnished by us. Has R.F. stage and audio output stage to drive speaker. As pictured, less case, with speaker... **\$9.95**

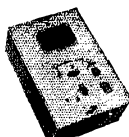

NAVY VHF TRANSMITTER

Battery operated (67 1/2 V "B" and 1 1/2 V "A") 80-105 MC. complete with 2-1G4 tubes, battery box holder and full instruction manual. Brand new. **\$6.95**

ANTENNAS

(A) Small four-section telescopic aerial ideal for portable receivers, transceivers or test equipment. **99¢**

(B) 22" tapered high frequency aerial covering 150 to 200 MC. Ideal for mobile or fixed station use. **\$2.69**



SUN RADIO
OF WASHINGTON, D. C.
938 F STREET, N. W. WASH. 4, D. C.



PANEL METERS

ALL BRAND NEW AND GUARANTEED
West 3" square 0-150 AC-V..... **\$3.49**
Triplet 2" square 0-40 DC-V..... **2.97**
Simpson 2" round 0-15 DC-V..... **2.97**
Sun 2" round 0-300 DC-V..... **2.97**

TERMS All items F.O.B., Washington, D. C. All orders \$30.00 or less, cash with order. Above \$30.00, 25 per cent with order, balance C.O.D. Foreign orders cash with orders, plus exchange rate.

Don't Lose those Good QSO's While Turning Your Beam by Hand

MUNGER

Electro-Beam ROTATOR

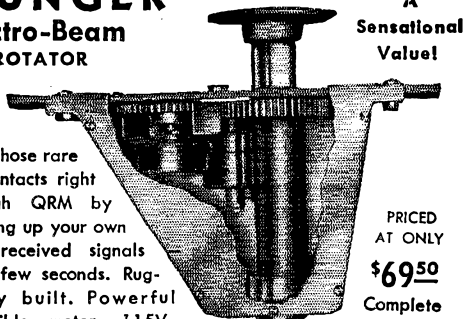

Hold those rare DX contacts right through QRM by peaking up your own and received signals in a few seconds. Ruggedly built. Powerful reversible motor. 115V—60 cycles. Swings your beam at 1 r.p.m.

- Price Includes Reversible Electro-Beam Rotator and Accurate Direction Indicator.

- Foolproof Potentiometer and Meter Circuit. Calibrations in Both Degrees and Directions.

Free Inspection Offer!

Order today. If not satisfied, return rotator within 10 days for refund. (Control-power cable supplied at 10c per ft. in 50' or 100' lengths.)

MANUFACTURED AND SOLD
EXCLUSIVELY BY

REX L. MUNGER COMPANY
4701 Sheridan Road, Chicago 40, Ill.

PRICED
AT ONLY
\$69⁵⁰
Complete

Illustrated Bulletin
on Request

Time Payment Plan

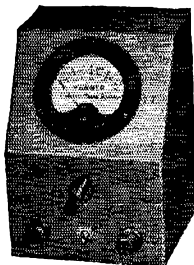

COMPLETE RADIO TRAINING!

Prepare now to accept a responsible position in Commercial Radio. New developments will demand technicians with thorough basic training, plus a knowledge of new techniques discovered during the war. Training open to high school graduates, or those with high school equivalency. Courses 6 to 18 months' duration in RADIO AND ELECTRONICS. Approved Veteran training in Radio. Write for Particulars.

VALPARAISO TECHNICAL INSTITUTE
DEPT. TN Valparaiso, Ind.

EXCELLENT OPPORTUNITY for ADVERTISING ASSISTANT

Must be licensed amateur capable of writing good copy and preparing rough layouts for trade magazine ads, data sheets and catalogs.

Experience with radio jobber or manufacturer highly desirable. Some experience as sales correspondent, copy writer or as author of amateur constructional articles essential.

There will be competent supervision but applicant must be capable of working out details independently. This is not a full time advertising job and applicant will be required to do some sales correspondence.

In reply, state qualifications, experience, salary required and how soon available. Address **FRANK C. MANN, Sales Manager.**

E. F. JOHNSON CO.
Waseca, Minnesota

ester DX Association bunch are gluttons for punishment. W2TXB says they recently ran a month-long DX test of their own and still stayed awake at the following meeting! W3JKO has closed a deal with SP8XA whereby we should be seeing the first influx of Polish QSLs in many a moon W2WMV/C1, lately of C9, should be back in the States by the time you read this. He left C9 while preparing to attempt QSOs with some of the Ws heard leaking through there on 3.5 Mc. Regarding those well-known wallpapers: Notes from EP2B, VS7PH, TA3AA, D4AQH, VR2BC and W6DLX/KW6 pledge these stations to be 100-per-cent in this department Take it on authority from Bob Ford, AC4RF — no station signing AC3GG has ever been on the air in that neck of the woods. That 14-Mc. Laughing Boy can switch to another call.

Jeeves just fathered another unique idea. He figures that maybe you DXCC wheels might be willing to grant us an honorary membership in the organization [I said *dishonorary*. — *Jeeves*] for the week end of the projected Roundup. Then, at an appointed time, everybody will QRX while we try to work CM2SW. Meanwhile, Sergio will be persuaded to add a few more stages of 6AK5 r.f. to his receiver.

80 & 40 on Wheels

(Continued from page 25)

vibrator life is to be obtained. Thus, when operating from a d.c. source, keep the total cathode current in the r.f. unit below 80 ma. for 'phone operation, and below 100 ma. for c.w. Operation at higher currents is permissible for short periods, but will result in shorter life for the vibrator. In a.c. operation, these precautions are not so important, and in practice it has been found permissible to run the cathode current at 110 ma. for normal 'phone operation and up to 135 ma. in c.w. operation without causing the transformer to heat appreciably. The drain of the audio portion of the circuit is appreciable, running as much as 70 to 80 ma. on speech peaks, but most of this is an intermittent drain, because the 12AU7 draws only about 20 ma., and the 6N7, operating with self-bias, draws only 10 ma. with no signal input, swinging up to 40 or 50 ma. on peaks. Thus, plate input for 'phone operation must be restricted somewhat, but for c.w., the full 30-watt capability may be utilized.

About Antennas

The pi-section output circuit used in this transmitter will permit full loading, even when short lengths of wire and whip antennas are used. The effectiveness of the antenna, however, does not depend solely on how well it loads the amplifier! It is a difficult problem to get a short antenna to do much of a job at either 80 or 40 meters, but good results are being obtained in both of these bands with top-loaded whip antennas. The

Our 26th Year



QUALITY - PRICE
DEPENDABILITY

FILAMENT TRANSFORMER

Primary 115-230 volt 60 cycle. Secondary 5 volts at 15 amps. 5000 volt insulation. Swell for 35T, 75T, 100TH, 250TH, HK-54, etc. Completely shielded dimensions 4 1/4 x 5 x 5 1/8. Weight 10 lbs. Special **\$3.95**

PLATE TRANSFORMERS

Primary 115/230 Volt, 25-60 cycle. Secondary 820 volts center tapped at 775 Ma. Hardly any voltage drop at 950 Ma. Completely shielded. Dimensions 6 5/8 x 6 5/8 x 7 1/8. Net weight 36 lbs. Special **\$7.95**

ISOLATION TRANSFORMERS

All 117 Volts to 117 Volts 60 Cy. P-96, 40 watts. \$3.60 P-98, 100 watts \$9.30 P-97, 80 watts. \$5.10 P-99, 250 watts \$17.70

POWERSTAT VARIABLE TRANSFORMERS

Type 20: 115 V. input, O-135 V. output @ 3.0 amps. 0.4 KVA \$12.50
Type 116: mounted; 115 V. input, O-135 V. output @ 7.5 amps. 1.0 KVA \$23.00
Type 116U: unmounted; 115 V. input, O-135 V. output @ 7.5 amps. 1.0 KVA \$19.00
Type 1126: 115 V. input, O-135 V. output @ 15.0 amps. 2.0 KVA \$46.00
Type 1226: 230 V. input, tapped at 115 V. O-270 V. output @ 9.0 amps. 2.4 KVA \$46.00
Type 1156: 115 V. input, O-135 V. output @ 45.0 amps. 6.1 KVA \$118.00

PLATE TRANSFORMERS
For Small Transmitters. DC Voltage Ratings are Approx. Values Obtained at Output of a 2 section Choke input Filter. Using Mercury Vapor Rectifier Tubes Pri. is for 115 V. 60 cy.

Type No.	Sec. Rms. Volts	DC Volts	Dimensions			Price Each		
			MA.	H.	W. D.			
P 57	660-660+	500	250	4 5/8	3 1/2	4 3/8	\$ 6.76	
P 58	550-550	400	125	4 5/8	3 1/2	5	8.23	
	1080-1080	1000*						
P 59	300-300	400	150	225	4 5/8	3 1/2	5 1/8	7.94
	900-900	750						
P 67	800-800	600	300	5 3/4	6 1/8	4	19.84	
	1450-1450	1200						
P 68	1175-1175	1000	300	5 3/4	6 1/8	4 1/4	24.99	
	2100-2100	1750						
	1800-1800	1500						

* For dual operation with simultaneous use of both sec ratings. † Has 40-volt bias tap.

ALUMINUM CHASSIS—

Heavy Duty
7 x 7 x 2 94c
7 x 9 x 2 \$1.06
5 x 10 x 3 \$1.00
7 x 11 x 2 \$1.15
7 x 13 x 2 \$1.23
10 x 17 x 3 \$1.88

ALUMINUM PANELS

1/8" Thick Black Crackle Finish
7" 93c
8 3/4" \$1.17
10 1/2" \$1.32
12 1/4" \$1.62
14" \$1.86

STANDARD STEEL CHASSIS—

Black Crackle
4 x 4 x 2 59c
6 x 14 x 3 \$1.06
10 x 14 x 3 \$1.44
10 x 17 x 3 \$1.44

GREENLEE PUNCHES—

Will cut up to 1/8" thick metal.
1/2" \$2.00
5/8" \$2.00
1" \$2.19
1 1/8" \$2.33
1-3/16" \$2.33
1 1/2" \$2.98
We carry a complete line of all other sizes of punches up to 3 1/2" diameter.

STEEL CASES

Black Crackle
4 x 4 x 2 67c
4 x 5 x 3 79c
6 x 6 x 6 \$1.03
12 x 7 x 6 \$1.91
15 x 9 x 7 \$2.65

RELAYS CS DIFFERENTIAL

Dual coil with armature pivoted normally open. Operates 220-250 Volts. 8000 ohms each coil, contacts S.P.D.T. Controls rated 2 amps. at 110 VAC. Ideally suited for balanced or bridge type circuits where limited current or power is available. **88c**



VARIABLE CONDENSER

6 Gang; 1 section of .00025 Mfd, 4 sections .000035 Mfd, 1 section of .00005 Mfd; with 5 air trimmers of 15 to 25 Mmfd capacity. Silver Plated. Each **95c** only

BIAS TRANSFORMER TYPE KS8779

Completely shielded, Insulator Terminals. Primary: 115 Volts 60 cycle @ 500 Ma. Secondaries
180 V. @ 20 Ma.
300 V. @ 20 Ma. Special
6.3 V. @ 1.2 amps.
5.1 V. @ 7 amps. C.T. **\$1.95**

TUBES

3BP1 3" Cathode Ray Tubes....\$1.45
3C24 Triode. Each 39c, 10 for \$3.50
2 x 2/879 Rectifier 2.5 volts 1.3 amp. 49c

ITEMS YOU MAY BE LOOKING FOR

Multiple Contact Telephone Type Relay No. 882-2 windings 125 ohms, Each 49c. No. 881-Single winding 12,500 ohms, 49c. Heinemann 5 amp. circuit breaker, 95c. Crystal Mike and Stand, \$5.50. Sockets for 813, 832, 829, 73c. 1/4 Watt Neons bayonet base, 20c.

OHMITE

Little Devil Assortment in all-plastic cabinet. Includes 125 selected 1/2 watt Resistors in 40 different values (10 ohms to 10 meg-ohms). Cabinet is 9" long x 4 3/4" high x 5 1/4" deep. These \$10.00 boxes can be stacked. We also carry a complete line of Ohmite rheostats, variable resistors, dummy antennas, etc.

STEP DOWN TRANSFORMERS

Input 220-250 Volts 60 cy. Output 110-125 Volts 60 cy. Primary cord and plug, Secondary, Receptical
80 watts, P-61 \$4.80
150 watts, P-62 \$6.45
250 watts, P-63 \$8.25
500 watts, P-64 \$10.65
1000 watts, P-65 \$20.25

OIL FILLED CONDENSERS

4 Mfd 600 Volt D.C. Sprague..... 49c
8 Mfd 1000 Volt D.C. Tobe..... \$1.69
7.5 Mfd 330 Volt A.C., G.E..... 98c
2 Mfd 10,000 Volt D.C., C.D..... \$13.95
1 Mfd 750 V. Sprague..... 25c
Dual .1 Mfd 600 V. CD Type DYR each 19c, per 100, \$10.00

METERS

100 amp.-6 volt D.C., 3 inch scale, 4 1/2" square, Grey finish, supplied with 100 amp. shunt. Brand New. Each as illustrated \$2.95
0-100 Ma. 2" Rd. McClintock. \$1.95
0-9 amp. R.F. 2" Round \$2.45
5-0-5 amp. ch. & dis. 2" Rd..... 69c



RECTIFIER TRANSFORMER

Dual Primary 110 V. A.C. Each. Secondary 0-35, 34 1/2 Volt at 3 amps. 0-70, 75 Volt at 3 amps. This transformer is completely shielded. Extra Special **\$1.95**

DM-43A DYNAMOTOR

G.E. New. Input 24 V. @ 23 amps. 7500 RPM; output 51.5/1030/2/8 V., @ 215/260 milliamps; filtered. Special. **\$2.95**

CHOKES

SMOOTHING TYPE	Hy	SWINGING TYPE	Hy	PRICE EACH	
				MA	Price
C-80	10	C-87	4-16	150	\$3.09
C-81	10	C-88	4-16	200	\$3.82
C-82	10	C-89	4-16	250	\$5.29
C-83	8	C-90	3-14	300	\$5.59

All above 3000 Volts Insulation

If not rated 25% with order, balance C. O. D. All prices F. O. B. our warehouse New York. No order under \$2.00 We ship to any part of the globe.

LEEDS RADIO CO.

75 Vesey Street
Cortlandt 7-2612

Dept. QS 1
New York City 7

THIS STURDY ROOF-MOUNTED SELF-SUPPORTING TOWER



ONLY
\$37-50

Photo Courtesy
W. S. Egan
Drexel Hill, Pa.

Why struggle with unsightly "plumbing?" Install a neat, sturdy, professional-looking tower that is a credit to your rig and your hobby. Tower illustrated is a TRYLON standard 3-ft. spread utility base, 10-ft. high. It's self-supporting and additional straight 10-ft. sections with guys may be added at any time. Approx. Shipping Wt. 100 lbs. Write to Tower and Antenna Div., Wind Turbine Co., West Chester, Pa. for Complete Details

TRYLON LADDER TOWERS

RADIO COURSES

- RADIO OPERATING
- RADIO SERVICING
- CODE
- FM TELEVISION

• REFRIGERATION SERVICING

Personal Counselling Services for Veterans
Write for Catalog and Picture Brochure

Y. M. C. A. TRADE & TECHNICAL SCHOOLS
15 W. 63rd Street (Near Broadway) New York City

RECEIVERS WANTED

» We want more receivers in trade on new receivers and other equipment. The demand for our good reconditioned receivers at bargain prices is so big that we need more trade-ins. Tell us what you want and how much you want for your receiver. Or ask us how much we will allow. We will bid high. Receivers shipped on ten day trial. Easy terms financed by us. Write.

HENRY RADIO STORES
Butler, Missouri

transmitting range is shortened considerably as compared with the results that would be obtained with a wire a half-wavelength or more long, but entirely adequate local coverage can be obtained with the short antennas. For some suggested antennas, see "Technical Topics" in *QST* for November, 1948.

While primarily designed for use with end-fed antennas, the pi-section output circuit can also be used to feed balanced antenna systems, such as a center-fed half-wave, by connecting a link line between the antenna post and the chassis, and running the link to a separate antenna coupler, such as would be used in any normal home-station installation. As a makeshift means, one feeder of the balanced system can be connected to the antenna post, and the other grounded to the chassis. It will load very well, but it may not give the results that could be obtained if an antenna coupler were used as described above. If it is desired to use coaxial line with the transmitter, the shield braid should be connected to the chassis, and the inner conductor to the antenna post.

Installation

The design of this transmitter is such that it is easy to install in almost any automobile, including some of the "midget" models. By using standard steel angle brackets, the transmitter unit may be supported under the dashboard, against the bulkhead, or any place where it will fit. The control box, as mentioned before, clamps onto the steering post. The power supply should be mounted as close to the car battery as possible, to reduce the voltage drop in the 6-volt input leads. All three units may be mounted in such fashion that they can be removed from the car with ease, to be used in a semipermanent location, or in the home station, without having to rebuild completely! This can be made possible if the angle-bracket idea suggested above is used, with self-tapping screws being used to hold the equipment to the brackets. Then, to remove the set-up from the car, merely back out the screws and lift. If there is enough space left over under the dash to permit it, small plastic or metal handles may be bolted to the tops of the utility boxes used as cabinets, thus making it a lot easier to carry them when you decide to go portable.

The transmitter has had several on-the-air checks at the writer's home QTH, and has performed nobly for its size. With a half-wave antenna, 75-meter 'phone has been used successfully to cover distances up to 150 miles, and listeners' reports indicate that it actually put a signal well beyond that range, too. On 40-meter c.w., contacts have been made with almost any station that could be heard, day or night, and the same held true for 80-meter c.w. It proved a little futile to try operating at night in the 75-meter 'phone band with 20 watts input, but if you are in a location where not more than 5 or 10 miles separates you from the nearest 75-meter 'phone neighbor, you'll probably be able to work him in spite of the congestion and competition from the

(Continued on page 118)

WORKSHOP

10 over 20 Stacked Array with Rotator and Indicator

This combination is the last word in amateur antenna equipment:—

- High Gain
- Light Weight
- Rugged Construction
- Aluminum Alloy Elements
- New Model Rotator with Solenoid Brake
- Matches Directly to 72 Ohm Line

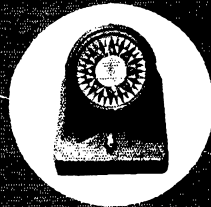

THE WORKSHOP ASSOCIATES, Inc.

Specialists in High-Frequency Antennas

63 NEEDHAM ST., NEWTON HIGHLANDS 61, MASSACHUSETTS

Definitely MORE DX

... less fading

With the DM-430

The Diverse Adaptor, another Decimeter "first", brings diversity reception to the amateur rig at low cost. The DM-430 feeds the signal from either of two antennas through one stage of broad-band amplification, and then to the antenna terminals of any standard communications receiver. It instantaneously switches antennas to follow the strongest signal. Pilot lights indicate the antenna in use. The DM-430 can be used without tuning on any frequency from 3 to 30 MC.

In minimizing the deep fading which often occurs in high frequency communications, the Diverse Adaptor will select the proper antenna on as little as .05 volts of signal at second detector. It is suitable for balanced or unbalanced antennas, and for FM or AM phone signals. Sensitivity is easily adjusted to receiving conditions.

For further information,
write for bulletin 15-B.

- Minimizes fading
- Very low power drain
- Combines best features of two antennas
- Completely automatic electronic action—no relays

DECIMETER

1430 MARKET ST.

INC.

DENVER 2, COLO

ELINCOR ALL ALUMINUM BEAMS

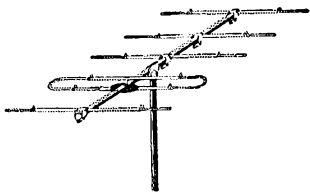

Model 300-EA

- Model 300-EA. 5-ELEMENT FOLDED DI-POLE 6 METER BEAM.** Aluminum tubing construction. Boom 1", elements $\frac{5}{8}$ " telescoping to $\frac{3}{8}$ ". All elements and spacing adjustable. Furnished with 5 ft. mast. Feed with RG8/U coaxial cable. Amateur net price. \$24.90
- Model 300-EA. 5-ELEMENT FOLDED DI-POLE 2 METER BEAM.** Vertical or horizontal polarization. Can be stacked. Feed with RG8/U coaxial cable. Elements $\frac{3}{4}$ " tubing. Amateur net price. \$8.40
- Model 400-EA. 3-ELEMENT FOLDED DI-POLE 10 METER BEAM.** Feed with RG8/U coaxial cable. Amateur net price. \$34.80
- Model 400-RA. 3-ELEMENT 10 METER BEAM.** Feed with 300 ohm twinax line. Amateur net price. \$30.00

10 meter beams furnished with all aluminum supporting ladder and $2\frac{1}{2}$ " statite standoff insulators. Adjustable elements are $\frac{1}{2}$ " aluminum tubing telescoping to $\frac{3}{8}$ ". We also manufacture a complete line of FM. Television, Broadcast and shortwave antennas. Send for new catalog.

Sold through Dealers only.



Prices slightly higher on West Coast

ELECTRONIC INDICATOR CORP.
53 WYCKOFF STREET
BROOKLYN, N. Y.

WANTED •

Teletypewriters complete, components or parts.

Any quantity and condition.

Box 13B, QST



Founded in 1909

RADIO TELEPHONY RADIO TELEGRAPHY

Courses ranging in length from 7 to 12 months. Dormitory accommodations on campus. The college owns KPAC, 5 KW broadcast station with studios located on campus. New students accepted monthly. If interested in radio training necessary to pass F.C.C. examinations for first-class telephone and second-class telegraph licenses, write for details.

PORT ARTHUR COLLEGE PORT ARTHUR TEXAS

Approved for G. I. training

"kilowatt boys." If you have a crystal on your neighbor's frequency, he may even be able to cut you in on the net that he is a part of, and when you have all of the big boys listening for you instead of competing with you, shucks, it's easy! So, get on the air, whether it be from your car, or from your country cabin, or from your home station. You'll be surprised at what you can do with 20 or 30 watts, especially if you've been used to using much more than that. I was, and you'll be, too!

Notes on the Clapp Oscillator

(Continued from page 45)

have none of these difficulties, it was decided to allow the oscillator to run continuously and to take advantage of the mechanical construction to accomplish the necessary shielding. This proved to be a practical solution; no trace of the oscillator can be heard on anything but the fundamental (3.5 Mc.) and this is not objectionable. The unit is keyed in the Class A 6AC7 following the oscillator.

No measurements have been taken on the stability of the VFO. After a warm-up period of 15 to 20 minutes the oscillator will stay in zero beat with a 100-kc. crystal for long periods of time. The main source of drift seems to be the expansion of the inductance. This could be compensated by negative temperature-coefficient capacitance but was not thought worth while for the desired results.

The Clapp oscillator is most certainly superior to previously-used types. It is not a cure-all for VFO troubles, though, and considerable care must be used in construction to realize its capabilities.

50 Mc.

(Continued from page 55)

Up in the Boston area W1OOP and W1PRZ have been working crossband, 144 to 445 Mc., with W1PRZ running an 8012 grounded-grid doubler, driven by his 220-Mc. 829 amplifier. Modulation is applied to both these stages. W1OOP has a revamped BC-645, using a push-pull 6J6 mixer, 955 oscillator and three stages of 7H7 i.f.

Not all the 420-Mc. activity is in metropolitan areas. It takes only two interested hams to make a communications circuit, and there have been that many in Regina, Sask. for more than a year. VE5JK and VE5BL work almost nightly at 7 P.M., with converted BC-645s.

Here's one fellow who is about two bands ahead of most of us. As soon as the 420-Mc. band was released, W1BBM, North Harwich, Mass., was in there, seeing what could be done. Then, almost before others got interested in 420, he was up on 1215 Mc.; then 2400 Mc., and now 3300 Mc. He finds that, with suitable cavities, ordinary lighthouse tubes will operate satisfactorily as high as 3500 Mc., and he would like to hear from other interested workers. He suggests that the i.f. for microwave work be standardized at 30 Mc., making it simpler for all who build for duplex to coordinate their efforts.

distinctive performance

**TURNER
MODEL 33**

Crystal or Dynamic.

Here's a smooth performer you can depend upon for all-around communications, public address, and recording work. The Turner Model 33 combines high output with smooth response over a wide frequency range. Attractively styled with satin chrome finish.

All these performance features

- Moisture sealed crystal or rugged dynamic circuit
- 90° tilting head for semi- or non-directional operation
- 20 ft. removable cable set
- Barometric compensation
- No blasting from close speaking
- Low feedback

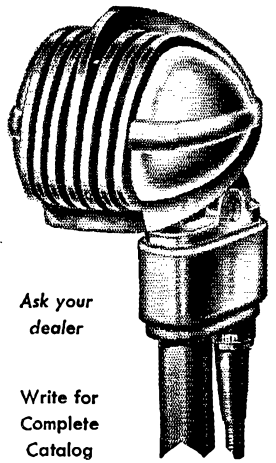

Ask your
dealer

Write for
Complete
Catalog

THE TURNER COMPANY

917 17th STREET, N. E. • • • CEDAR RAPIDS, IOWA



Microphones **BY TURNER**

Microphones licensed under U. S. patents of the American Telephone and Telegraph Company, and Western Electric Company, Incorporated. Crystals licensed under patents of the Brush Development Company



RECEIVING SENDING
CODES *Speed* *without strain*
CHAMPIONS ENDORSE CANDLER WAY

Get skill, accuracy, speed with the highly endorsed Candler System. Learn to send and receive by telegraph or radio code. Government service and commerce need thousands of better trained operators. Air commerce, mail, freight, etc., demand expert, reliable operators. Good pay. Get the Candler System, the maker of champions. It teaches you the "knack" of sound sense, alertness, speedy sending and receiving without strain. Adventure — good pay. Learn at home or wherever you are. Rush name today for free book.

FREE!

CANDLER SYSTEM CO.

Dept. 4-A; Box 928, Denver 1, Colorado, U.S.A. and at 121 Kingsway, London, W. C. 2, England

EXTRA

PLAYING TIME . . .

for half the cost, with a remarkable new **MAGNETIC TAPE RECORDER**. Write today for technical literature.

AMPLIFIER CORP. OF AMERICA
398-11 Broadway, New York 13, N. Y.

EVERYTHING AT YOUR FINGERTIPS
with **SUBRACO MT-15 X**
GO "DASHBOARD" MOBILE-

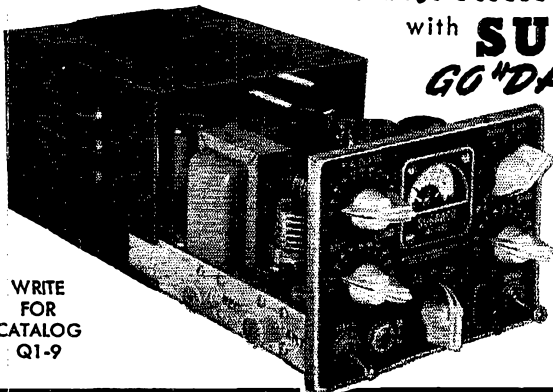

WRITE
FOR
CATALOG
Q1-9

ONLY
79.95
LESS
TUBES

. . . with this completely new, compact, efficiently designed, 30 watt AM phone transmitter, small enough to mount in most glove compartments or under any dash. For complete details write or see the full page ad in August QST.

SUBURBAN RADIO COMPANY
158 CENTRAL AVE. ROCHELLE PARK NEW JERSEY

NOW! PEAK VHF PERFORMANCE

The
NEW
NATIONAL
HFS

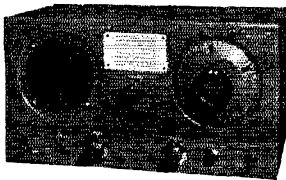

Receiver-Converter

Enjoy amazing reception on the VHF bands with the new NATIONAL HFS Receiver-Converter. There's nothing finer for snagging 6 meter DX!

- ★ **Complete Coverage**—27 to 250 MCS in 6 bands
- ★ **AM—FM—CW**—Optimum signal to noise ratio
- ★ **Mobile—Portable—Fixed**—National 6865 vibrator supply—5886 power supply—or "A" and "B" batteries.
- ★ **Receiver or Converter**—Makes features of connected receiver usable on VHF.

\$142.00 (Power Supply Extra)

Distributors for All National
Parts and Receivers
Write for descriptive literature

CENTRAL RADIO PARTS CO.

1723 W. Fond Du Lac Ave., Milwaukee 5, Wisconsin
Wendell Ciganek • W9SYT

ALUMINUM CHASSIS

Any size or shape, built to order. Angles, brackets, sheet, special assemblies. Two-day service on most orders.

JOHN H. HEIM • W3UFP
MONTGOMERYVILLE R.D. No. 2 PENNSYLVANIA

WANTED . . .

Western Electric Vacuum tubes, types 101F, 102F, 272A, 274A, or B, 310A, or B, 311A, 313C, 323A, 328A, 329A, 348A, 349A, 352A, 373A, 374A, 393A, 394A, 121A, Ballast Lamps.

Box 132 • QST

CALL LETTER PLATES



\$2.95 POSTPAID

Type A-18 - For Your Car
Type A-19 - For Panel Mounting

A large sturdy cast aluminum plate with satin-finished letters and border against a black baked enamel background. Red, green, blue and gray -- 50¢ extra. Size 2-3/4" x 8 1/2" with 1 1/2" letters.

LAPEL BUTTONS

An attractive metal button with highly polished raised letters against a black background. Other colors 50¢ extra.



ACTUAL SIZE \$1.10 POSTPAID

Type A-26L With Screw Backing
Type A-26P With Pin Backing



STANDARD RADIO & ELECTRONIC PRODUCTS
135 E. Second St. DAYTON 7, OHIO - Tel. TULTON 2174

CASH WITH ORDER
Allow 3 weeks for delivery

Hints and Kinks

(Continued from page 82)

"Scotchlite" is a sheet of waterproof flexible material covered with ground glass. The call letters are stenciled on, using thick paint pigment from the bottom of the can so that the paint will not run. Most sign shops now carry this material. If you have a sign made up, be sure to take along a sheet of tin or aluminum to use as the backing plate so that the sign maker can fasten the "Scotchlite" to it with the special waterproof glue that is provided. A variety of colors is available. I use a similar sign (with the name of my town on it) when hitchhiking back from club meetings late at night. — *George C. Robinson, W2RCX/4*

PLUG-IN SHIELD CANS

While building a new exciter, I found it necessary to shield one plug-in coil, but that meant a plug-in shield would be needed. After some thought the solution shown in Fig. 4 presented itself. It is passed along to others who may like to have good-looking gear but who can't afford the commercially-built refinements.

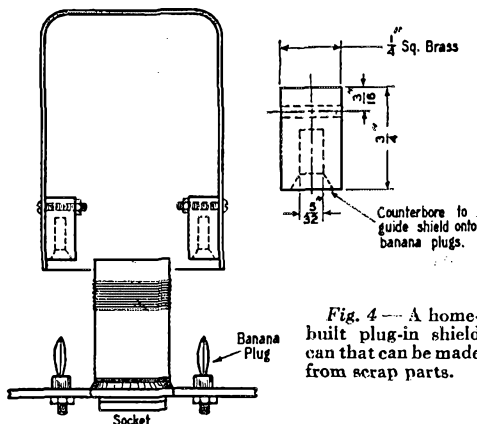

Fig. 4—A home-built plug-in shield can that can be made from scrap parts.

The shield is a square aluminum coil shield from a defunct b.c. set. The two square brass pieces are drilled as shown, mounted inside the can, and the whole works then plugs onto a pair of banana pins mounted on the chassis. — *Bill Wildenhein, W8YFB*

Correspondence

(Continued from page 83)

striven for is an efficient antenna. Most of the boats around here are around 40 feet in length and a quarter-wave antenna would look rather bulky, to say the least. We have been using the customary "whip"-type antenna with lengths approximating 22 feet, with fair success. We have tried the antenna mentioned with the hat and top-loading coil, and found it to work substantially better. It does make an odd-looking arrangement, however, and we have more-or-less discarded the "hat" idea for center- or top-loading only, and have found results to be about the same.

For example, the 19-foot center-loaded antenna shows a 6-db. gain over the customary base-loaded antenna of equal length, at the high end of the marine band (3000 kc.). This is equivalent to quadrupling the transmitter output. Thus, a 10-watt transmitter will produce a signal equal to that of

(Continued on page 122)

Spectacular Bargains

RECORD-BREAKING
SALE OF MOBILE
EQUIPMENT
FOR HAMS!

PREPARE FOR SUMMER OPERATING FUN NOW!

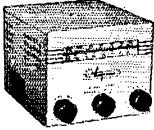

Harvey Wells Receiver AR-3-A
A 5 tube super-het with 1 stage of R. F. designed for Aircraft, but with many Ham applications. Operates from dry batteries. Freq. range, 185 Kc. to 405 Kc. and 550 Kc. to 1500 Kc. in two bands. Has fixed frequency at 278 Kc. for tower reception and 1020 Cy. filter for Range voice reception. Ideal for use with a converter or modified for portable or mobile work. Brand new and at a bargain price. Complete with tubes, battery, connecting cable and instruction manual.

Stock No. 4-F-7 Model AR-3-A. Shpg. Wt. 13½ lbs. Regular price \$79.50. Our Price **ONLY \$24.95 DEL.**

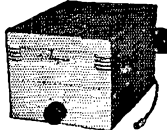

Harvey Wells Transmitter AT-3-B
A crystal controlled transmitter designed for aircraft, but easily adapted to Ham applications with slight modifications. Operates from 8 Volts D. C. 10-12 watts R. F. output. Crystal freq. 3105 Kc. Completely self contained including power supply. Push to talk operation. 7C5 final amp. PP 7C5 Class AB modulator. Brand new and at a price that is right. Complete with tubes, Xtal, 6 Volt D. C. vibrator power supply, connecting cables and instruction manual.

Stock No. 4-F-4 Model AT-3-B. Shpg. Wt. 17 lbs. Regular Price \$74.50. Our Price **ONLY \$24.95 DEL.**



Harvey Wells Transceiver ATR-3
This unit is a combination transmitter and receiver of the same general description as the AT-3-B xmitter and the AR-3-A Rec. except the receiver utilizes 6 volt tubes for use on 6 volts D. C. and vibrator pack operation. Completely self contained. An ideal setup for Ham portable or mobile operation by modifying circuit. Brand new and at a price that can't be passed up. 7C5 R. F. output, PP 7C5's A. F. output and Modulator. Complete with tubes, Xtal, 6 volt D. C. vibrator power supply, connecting cables and instruction manual.

Stock No. 4-F-2 Model ATR-3. Shpg. Wt. 14½ lbs. Regular Price \$159.95. Our Price **ONLY \$49.95 DEL.**

Walter Ashe RADIO CO.

SHIPPED PREPAID ANYWHERE IN CONTINENTAL U. S.
Not Surplus But Brand New, Post-War Design and Manufacture!
THE HOUSE OF "SURPRISE" TRADE-INS
1125 PINE ST. • ST. LOUIS 1, MO.

RADIO

TECHNICIAN and RADIO SERVICE COURSES
FM and TELEVISION

Approved under the G. I. Bill of Rights

AMERICAN RADIO INSTITUTE

101 West 63rd St., New York 23, New York

TEACHING RADIO SINCE 1935

W8CFK

ALUMINUM CALL PLATES

Your call cast in aluminum
with black background

- and polished 1¼" letters. Plate size 2" by 6½". 3 styles: P for panel mounting, L for car license and D for desk use. \$1.75 each postpaid.

P & H SALES CO.

619 Jasper St.

Kalamazoo 31, Michigan

EASY TO LEARN CODE

It is easy and pleasant to learn or increase speed the modern way — with an Instructograph Code Teacher. Excellent for the beginner or advanced student. A quick, practical and dependable method. Available tapes from beginner's alphabet to typical messages on all subjects. Speed range 5 to 40 WPM. Always ready, no QRM, beats having someone send to you.

ENDORSED BY THOUSANDS!

The Instructograph Code Teacher literally takes the place of an operator-instructor and enables anyone to learn and master code without further assistance. Thousands of successful operators have "acquired the code" with the Instructograph System. Write today for full particulars and convenient rental plans.



INSTRUCTOGRAPH COMPANY

4709 SHERIDAN ROAD, CHICAGO 40, ILLINOIS

Quality Products
since 1923

BIRNBACH

pioneers in the design and manufacture of all types of radio hardware, wires, cables, steatite and porcelain ceramics.

Write for new 1948 catalog

BIRNBACH RADIO CO., Inc.

145 HUDSON ST. NEW YORK, 13, N. Y.

EXCLUSIVE DISTRIBUTORS
In The Southern New England Area For

COLLINS

**Southern New England's
Big Radio Parts Distributor**

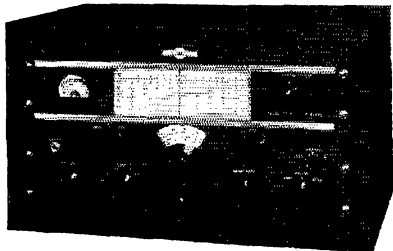

- 30K-1 500 Watt Transmitter
- 32V-1 150 Watt Transmitter
- 70E-8A V.F.O.
- 75A-1 Receiver
- 310B Exciter Units

NOW READY FOR DELIVERY

W. H. EDWARDS COMPANY

94 Broadway, Providence 3, Rhode Island

COMMERCIAL RADIO INSTITUTE

A RADIO TRAINING CENTER FOR 28 YEARS
Resident Courses Only • Broadcast, Service, Aeronautical, Television, U.H.F., Preparatory Course, Frequency Modulation and Marine telegraphy. Classes now forming for mid-year term Feb. 1st. Entrance examination Jan. 17th.

Literature upon request. Veteran training
Dept. B., 38 West Biddle Street, Baltimore 1, Maryland



RADIO and TELEVISION

Thorough Training in All
Technical Phases

APPROVED FOR VETERANS

WEEKLY RATES DAYS—EVENINGS

RCA GRADUATES ARE IN DEMAND

For Free Catalog write Dept. ST-49

RCA INSTITUTES, INC.

A Service of Radio Corporation of America
350 WEST 4th ST., NEW YORK 14, N. Y.

THE RADIO AMATEUR'S LICENSE MANUAL

Before you can operate an amateur transmitter, you must have a government license and an officially assigned call. These cost nothing—but you must be able to pass the examination. The examinations are based on the multiple-choice type of questions. The "License Manual" has been written to make it as easy as possible for the individual to acquire the necessary knowledge to pass the examination with flying colors. Whether you are going up for your Class C, B or your Class A ticket, "The License Manual" will provide the most direct path to getting that ticket. If you are one of the thousands who always want a "License Manual" around the shack for ready reference for amateur regulations, it will please you to know that the regulations are very thoroughly indexed.

25 cents • **POSTPAID ANYWHERE**
(No Stamps, Please)

AMERICAN RADIO RELAY LEAGUE
WEST HARTFORD, CONNECTICUT

a 40-watt transmitter using a base-loaded antenna and tuning system.

Also, the base of this type of antenna presents such a low impedance that less loss is experienced with leaky base insulators during icing and wet weather. The line feeding the base is a low-impedance one and is not as critical as to length and body-capacity effects, as in the case of the base-loaded antenna with the loading coil housed in the transmitter cabinet. By using multiple switching, the operator can switch to different "channels" without retuning the transmitter. I think all of these features are as desirable in a mobile "ham" transmitter as they are in a marine installation.

I would like to see more interest "About Antennas for 80-Meter Mobile" as this would, no doubt, reveal a new field for most amateurs, and—from a selfish viewpoint—it would give us some ideas on how to improve our marine installations for maximum effectiveness.

— *Garner A. Hadland*

510 W. Elm St., Compton, Calif.

Editor, *QST*:

I have been reading *QST* for many years and can say it's the one magazine I always look forward to receiving. . . .

— *Forest Richardson, W6UTG*

"QUICKIES"

Sqdn TN-7, Scott Air Force Base, Belleville, Ill.

Editor, *QST*:

I find a large percentage of fellows making flimsy excuses for terminating QSOs. How about a CQ-plus-something to mean only a report, names, addresses and possibly QSLs are desired? It sounds silly for a fellow, trying to find out just what a new antenna will do, to talk about ten stations that his XYL is calling him for supper.

— *Fred W. Ronnermann, W9YMD*

A VISIT TO HQ.

Shepherd, Tenn.

Editor, *QST*:

Much has been printed about the physical and technical aspects of ARRL headquarters. A recent visit moves me to testify to the entirely human and homelike atmosphere prevailing there as well.

I have been a League member for over two decades. I like traffic and handle it with some measure of success, but I have never held any elective office and I hold no League appointment higher than ORS. What I am getting at is that I was no big shot to make a fuss over. I had anticipated seeing the head of the Communications Department, Mr. Handy, and having a try for the national emergency coordinator, "Doc" Hayes, because we had seen a good deal of each other during the Florida and Gulf Storms of 1947. I estimated that thirty minutes with each would not wear my welcome too thin; I would then be on my way with a half apology for taking up the time of a busy man. This appraisal of Hq. hospitality proved one of the biggest mistakes since the time the Army mule kicked the case of hand grenades. No one seemed to want to hurry me along, I was shown the place from soup to nuts, and everywhere the welcome was cordial with nothing forced or synthetic about it.

As a practicing attorney, I was for many years in and out and behind the scenes of many enterprises, and you can pretty well tell when men of executive ability are in charge of a business. It is my considered opinion that such men are in charge at West Hartford. I hope that as opportunity offers other hams, especially those living in other sections of the country, will visit Headquarters. — *Benton White, W4PL*

**SWITCH
TO SAFETY!**



Owned with Pride
 by the Majority of Amateurs
**ASTATIC
 MICROPHONES**

SENDING AND RECEIVING — and doing it well — never loses its

flavor as one of man's noble ventures. That's why few human experiences are more gratifying than the proud ownership of a fine amateur rig. It is also the reason amateur operators are so discriminating in their choice of equipment. When it comes to microphones, the great majority still choose Astatic. These truly superior instruments have been passing the acid test of actual usage more often, for more years, than any other make. For complete information, please feel free to write.



VELVET VOICE
 CRYSTAL
 DYNAMIC OR
 CERAMIC
 MICROPHONE

● Sparkling beauties in gold-finished case and handle, with dark brown, detachable base for convertibility to desk stand, floor stand, hand use.

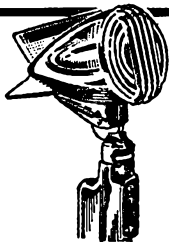

CONNEAUT CRYSTAL
 MICROPHONE

● The ultimate in streamlining, bright chrome finish, shown with Type "S" Off-on Switch.

D-104 CRYSTAL
 MICROPHONE

● First practical crystal microphone developed, with few changes still the top favorite of amateurs.



CARDINAL CRYSTAL DYNAMIC OR
 CERAMIC MICROPHONE

● A major new accomplishment in terms of quality performance at modest cost, has die-cast case in bright gold finish, compact to fit the hand, rests in streamlined CB base (as shown) or lies flat on felt-covered back.



Astatic Crystal Devices manufactured under Brush Development Co. patents



Wanted

... TRC1 equipment, T14 transmitters, R19 receivers, AM and amplifiers, PP13 power units.

Box 141 QST

QSL RUBBER STAMP

As advertised Oct. QST, page 129. We are swamped with orders. Get your name on our list now.

J. V. LOVE & COMPANY

E. E. Joel (W5APP) Owner
 2219 Mechanic Street GALVESTON, TEXAS

LEARN CODE!

SPEED UP Your RECEIVING with G-C Automatic Sender Type S \$24.00 Postpaid in U. S. A.

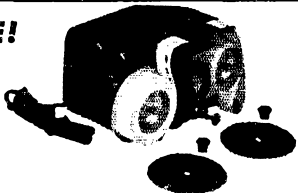

Housed in Aluminum Case, Black Instrument Finished, Small—Compact—Quiet induction type motor. 110 Volts—60 Cycle A.C.

Adjustable speed control, maintains constant speed at any Setting. Complete with ten rolls of double perforated tape. A wide variety of other practice tapes available at 50c per roll.

GARDINER & COMPANY
 STRATFORD NEW JERSEY

THE KEY TO PERFECT CW



Electronic Monitor and Key

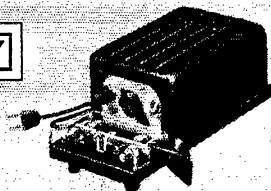

Flawless CW — smooth, rhythmic as a tape — can be quickly achieved by anyone who uses the new MON-KEY.

FEATURES

- Automatic dots and dashes
- Dashes equal to three dots in duration
- Speed approx. 8 to 45 words per minute
- No weights to adjust
- Monitor with volume control
- Operation 115 v AC or DC

ONLY \$29.95
 Amateur Net

If your dealer can't supply you, send check for \$29.95 direct to us. Immediate shipment on Money Back Guarantee.

ELECTRIC EYE EQUIPMENT CO.
 6 West Fairchild Street, Danville, Ill.

EXPORT: Rocke International Corp.,
 13 E. 40th St., New York 16, New York

HAM-ADS

(1) Advertising shall pertain to radio and shall be of nature of interest to radio amateurs or experimenters in their pursuit of the art.

(2) No display of any character will be accepted, nor can any special typographical arrangement, such as all or part capital letters be used which would tend to make one advertisement stand out from the others.

(3) The Ham-Ad rate is 30¢ per word, except as noted in paragraph (6) below.

(4) Remittance in full must accompany copy. No cash or contract discount or agency commission will be allowed.

(5) Closing date for Ham-Ads is the 25th of the second month preceding publication date.

(6) A special rate of 7¢ per word will apply to advertising which, in our judgment, is obviously non-commercial in nature and is placed and signed by a member of the American Radio Relay League. Thus, advertising of bona fide surplus equipment owned, used and for sale by an individual or apparatus offered for exchange or advertising inquiring for special equipment, if by a member of the American Radio Relay League takes the 7¢ rate. An attempt to deal in apparatus in quantity for profit, even if by an individual, is commercial and all advertising by him takes the 30¢ rate. Provisions of paragraphs (1), (2) and (3), apply to all advertising in this column regardless of which rate may apply.

(7) Because error is more easily avoided, it is requested signature and address be printed plainly.

(8) No advertiser may use more than 100 words in any one issue nor more than one ad in one issue.

Having made no investigation of the advertisers in the classified columns, the publishers of QST are unable to vouch for their integrity or for the grade or character of the products or services advertised.

QUARTZ—Direct importers from Brazil of best quality pure quartz suitable for making piezo-electric crystals. Diamond Drill Carbon Co., 719 World Bldg., New York City.

QSL, 100, \$1.50 up. Stamp for samples. Griffith, W3FSW, 1042 Pine Heights Ave., Baltimore 29, Md.

QSLs SWLS? America's Finest! No cheap trash! Samples 10¢. QSL Printer Sakers, W8DED, Holland, Michigan. Made-to-order QSL cards!

BEAMS pre-focused and matched to typical lines. Large diameter duro-aluminum tubing for elements and boom. Peter C. Houskeeper, 956 Paulding St., Peekskill, N. Y.

AMATEUR radio licenses. Complete theory preparation for passing amateur radio examinations. Home study and resident courses. American Radio Institute, 101 West 63rd Street, New York City.

CRYSTALS: Precision low drift units. Type 100A in 80, 40, and 20 meter bands. Two units plug in one octal socket. Plus or minus 5 Kc. One dollar each. Exact frequency. \$1.95 ea. Rex Bassett, Inc., Ft. Lauderdale, Fla.

10-METER Beams, \$19.50. Send card for free information. Riverside Tool Co., Box 87, Riverside, Illinois.

QSLs: Samples. Albertson, W4HUD, Box 322, High Point, N. C.

SURPLUS: Deluxe crystal finishing kits containing holders, quartz blanks, abrasive, etching fluid, complete instructions. \$2.00 each postpaid. Formerly sold \$8.75. Veato Company, Parkville, Missouri.

QSLs! Quality cards priced right. Samples. Ferris, W9UTL, 1708 Fruitdale, Indianapolis, Ind.

SUBSCRIPTIONS: Radio publications a specialty. Earl Mead, Huntley, Mont. W7LCM.

QSLs: Kromkote cards at a fair price. Dauphinee, W1KMP, Box 219, Cambridge, 39, Meade.

WANTED: Teletype 1/40TH HP synchronous motor. W6ITH, Tibbetta, Moraga, Calif.

QSLs, SWLS. For distinctive cards, write to McEachron, 1408 Brentwood, Austin, Texas.

DON'S QSLs. "The finest". Samples. Don Hill Press, 2106 South Sixteenth Ave., Maywood, Illinois.

GIVE Hallcrafters receivers. Lay-away plan. Easy. Atlas Radio Jobbers, Tel. 6-3800, Nashville, Tennessee.

QSLs? SWLS? Distinctive designs, glossy stock, one-day service. Samples. Narvestad, Granite Falls, Minn.

QSLs, SWLS. Finest stock. Fairest prices. Fastest service. Dossett, W9BHV QSL Factory, 857 Burlington, Frankfort, Ind.

LAPEL pins: your ham call letters engraved in white on black plastic, 1 1/4" by 3/4" with white border. 35¢ each, postpaid. G. Lange, W2IYQ, 34 Union Ave., Belleville 9, N. J.

PANELS, dials made to order. Gilpin, Box 638R4, Mt. Clemens, Michigan.

WANTED: QSTs, Dec. 1915 to March 1917; ARRL Handbooks first to eighth Editions. Sell 200 miscellaneous copies QST, from 1920 to 1947. W0MCK, 1022 N. Rockhill Road, Rock Hill 19, Mo.

QSLs: Quality printing. M. Vincek, W2LNT, 111 Center St., Clifton, N. J.

OUR business: Buying and selling amateur radio transmitters. Transmitter Exchange, Wakefield, Rhode Island.

BEAM control cable, new material. Two #16; six #20 rubber insulated, coded, tinned conductors. Weatherproof rubber jacket. Heavy armor shield. 1/4" diameter. Price 10¢ foot. F.o.b. Chicago. Trans-World Radio-Television Corporation, 6639 S. Aberdeen St., Chicago 21, Illinois.

WANTED: Aircraft radios: BC-348, AN/ART-13, RTA-1B, AN/APN-9, R5A/ARN-7, AN-ARC-1, AN/ARC-3, SCR-118, BC-788-C, 1-152, MN-26-C; test sets with TS- or I-prefix. Dynamos, control boxes, others. State quantity, condition, and best price in first letter. HI-Mu Electronics, Box 105, New Haven, Conn.

FOR Sale: HT9, 1947 model, with 10, 20, 40, and 80 m. coils, used less than 30 hours. \$200.00. F.o.b. Bridgeport, Conn. T. H. Craig, Jr., W1KAB, 41 Mountfort St.

SEATTLE and vicinity hams. Rig, in storage in Seattle, must sacrifice, give-away price. 350 watts phone and cw. Standard parts. Barker & Williamson, Triplett, Bud six foot rack. Forty, twenty, ten. Price: \$125. For complete details, write Harland Smith, W8ZLN, 2864 May Street, Cincinnati, Ohio.

DUMONT No. 274, 5" scope. Used only 5 hours. \$90.00. Super-pro complete. \$275.00 Bargain. A. P. Schlachter, 7724 Kelly St., Pittsburgh 21, Pa.

SELL: BC312G in good condition. Has crystal phasing. AC power supply. 12" speaker. \$60.00. Arthur Sterman, W3KFS, 5862 Hobart St., Pittsburgh 17, Penna.

WANTED: A circuit diagram of the NC101X equipped with an "S" meter, noise silencer, and infinite impedance detector. Will pay cash. O. A. Witte, (Ex-W9PDI), 5644 W. Huron St., Chicago 44, Ill.

SELL: BC-348 speaker in case, power supply, \$75.00; RCA 3" scope, \$45.00; Instructograph with 10 tapes, key and phones, \$17.00; BC-684 xmtrr, FM 27 to 39 Mcs., \$24.00. W4NVI, Bill Ferguson, Box 225, Morehead, Ky.

SACRIFICE at \$500.00. Safety kilowatt, bandswitch exciter, 6-20 meters, final RK 65's modulator 805's VM 5, rack panel construction completely metered and relay protected. All chassis checked, only final tuning necessary. All new and complete including tubes, coils, etc. W8CJH, 1121 Delaine Avenue, Dayton, Ohio.

MAGAZINES: radio, electronic, etc., bought and sold. Lipani, 1574 Leverett, Boston 14, Mass.

SUPER-PRO, in good condition, 20-meter band requires slight adjustment. Would keep, but baby needs space. Best offer over \$125.00. Diagram, alignment instructions included. Gerald Oddo, W2VOA, 45 Fleet Walk, Brooklyn, N. Y.

FBXA with AVC, Pre-selector, power supply, general coverage and 10, 20, 40, 80 bandspread. \$25.00. F.o.b. Buffalo. W2WJQ, 144 Deerpur, Buffalo 17, N. Y.

FOR Sale: new National HF receiver and power supply. Make offer. Walter Holzer, W9AVF, 2957 North Second St., Milwaukee, Wisconsin.

BC3480, built-in Q-Ser, 1852 RF stage, noise limiter, external power supply, etc. Make offer. W4MVM, Chickasaw, Ala.

MEISSNER 150-B transmitter modified for 10m. with separate power supply for 807 dblr, many other desirable features added. \$200.00. BC-348A 80m. trans. and rec with rec. var. supply, PE-103 and conn. cable, \$25.00. BC-43 Q-Ser, \$8.00. All inquiries answered. Col. F. L. Moore, W4YJB, Quarters 435, Maxwell Field, Ala.

HQ-129X, complete with matching speaker, packed in original carton. \$135.00. Late model XEC with power supply. Spotless condition. \$65.00. Thordarson T-15P21 CHT plate transformer, 3000 V D.C. 500 Ma, \$75.00. Solar 4 uid, 3000 v. working filters, \$5.00 each. All items F.o.b. W9YFV, 5740 So. Francisco, Chicago 29, Ill.

SALE: RME, 10-20 converter, \$50.00. W. G. Frick, 609 W. Main Street, Norristown, Penna.

WANTED: Meissner analyst or Rider chalanyst; will pay cash or swap. W9AUY, 347 Naperville Road, Westmont, Ill.

WANTED: 7" television receiver. Harry H. Gingrich, 4613 Derry St., Harrisburg, Penna.

N. Y. C. and vicinity, SN-25 speaker, new, \$100.00. H. I. Griffiths 99-82 24th Place, Woodside, L. I., Illinois 7-1549.

WANTED: BC-224A instruction manual or schematic. L. Denison, W4YFE, Rt. 1, Box 495, Aniston, Ala.

100 QSLs, 2 colors, \$1.75. Varney's Printery, Richmond, Mo. Samples 10¢.

FOR Sale: Collins 42-RA bandswitching phone/cw transmitter with coils, instruction book, etc. VLF mc. \$125.00. You pay freight. C. M. Christian, 103 Cedar, Chadron, Nebraska.

QSLs-SWLS. Meade, W0KXJ, 1507 Center Ave., Kansas City, Mo.

FOR Sale: Five 4-125-A tubes. Never been used and personally guaranteed new. \$20.00 each. Reason: no hi voltage to run them. Will pay shipping charges. Check or money order to W. Rashok, W3JLJ, 311 W. Fisher Ave., Philadelphia 20, Penna.

REVOLUTIONARY copyrighted principle. "Rhythmic Sound Sending". Get in tape-sending category. More QSO's, more QSL's from that other "OM". \$1.00 postpaid. Richard D. Thayer, 32 Merrick St., Worcester, Mass.

SELLING out: list. Receivers, transmitters, and other gear. C. R. Funk, 9915 Cavell, Garden City, Mich.

454 (3-6MC) 455 (6-9MC) receivers, used, good condition, with tuning knob, no tubes. Excellent mobile or emergency. Easily converted to 10-20 meter bands. Five dollars each. F.o.b. Tuckerman; weight 7 lbs. No C.O.D.s. C. W. McCollum, W5BAP, Tuckerman, Ark.

WANTED: Post-war Gon-Sel 10-meter mobile. \$25.00. William Murphy, Box 105 West Palm Beach, Fla.

SELL Meissner 150B, 300 watt phone/cw transmitter, W/mode IEX signal shifter. Final amplifier custom rebuilt, using B&W TVL coils. All bands, perfect condition, spares, \$275.00. W8JBI, 598 Wilson Ave., Columbus, Ohio.

NEW NC-183 complete with speaker. Tilt base, NFM-83, Hammarlund FS-135-C 100 Kc standard. All new and in excellent condition. Must sell. First \$225.00 takes all. John R. Doherty, W4NOA, Station WHLF, South Boston, Va.

WANTED: To trade radio parts for overhead cutter. Write description and needs to W3MOD, Box 60, Crenshaw, Penna. J. Poole

FOR Sale: Nearly new NC-240-D, perfect condition. \$200.00; 250 watt fone A.M. 195 final 811 mod. all A-1 parts, new Vibroplex, never used. Accept any reasonable offer. W0REF, Dysart, Iowa.

SELL: Final amplifier with parallel 807's, grid and plate milliammeters, two amplifiers, etc. VXL101 Deluxe. See QST, Dec. 1947, page 113. W1VIG, 69 Bentwood Road, West Hartford 7, Conn.

HALLICRAFTERS S-40A and SM-40, S-meter for sale. Good condition. Both for \$80.00. W8CCJ, 26889 Lyndon, Detroit 23, Michigan.

WANTED: HF 10-20 converter. LL Anthony Borgia, W6EOU, Fort Euata, Va.

SELL: BC-312 receiver, 110 volt operation. Matching speaker \$60.00. W1PWF, 29 Day Ave., Northampton, Mass.

WANTED: Call Book magazines for year 1931, your price. L. Guinn, Lyle-Wrigley, Tennessee.

FOR Sale: QST's January 1928 to date. \$11.00. C. R. Englund, Holmdel, N. J.

FOR Sale: HT-9 transmitter, in excellent condition, coils for 80-20-10 M, spare tubes, instruction book, crystals, \$300.00. Local buyer preferred, L. F. Brown, W21JD, 37-30 81st St., Apt. D-5, Jackson Heights, L. I., N. Y.

SEVERAL BC-348P-H, converted AC, Hammarlund S-meter, \$70 each. W6HCX.

COLORTONE QSL'S! Snappy! Bright! Different! Looking for something new, OM? Then see our beautiful samples! They're free! "No junk". The Colortone Press, Tupelo, Miss.

SELL PE-103 dynamotor, new, complete, sealed in overseas crate, \$14.50. HRO, SR, rack mount receiver and power supply, all coils 1.7 to 30.0 Mc. \$95.00. Millen frequency standard, \$50.00. BC223 with tubes, new unit, \$18.50. Four new 2000 volt 8 μ fd. Oil condensers, \$1.90 each, W6KEG, 1124 Parkway, El Monte, Calif.

FOR Sale: Converted Navy aircraft GF12 transmitter, RU17 receiver, \$40.00. B. J. Parry, Onset, Mass.

BARGAINS: New and used transmitters, receivers, parts. New 150-watt phone, \$199.00; 60 watt phone, \$99.00; Globe Trotter, \$37.50; Abbott TR-9, \$29.50; HT-9, \$295.00; MB-611, \$59.00; Silver 701, 800, 801, 802, \$29.50 each; NC-173, SX-28, \$149.00 ea.; HRO, 129-X, HRO, \$139.00 each; RME-45, SX-25, \$99.50 ea.; RME-9D, \$39.50; SX-24, \$75.00; BC-348, S-40, \$65.00 ea.; S-20R, \$49.00; NC-44, S-38, \$35.00 ea., many others. Large stocks. Trade-ins. Free trial. Terms financed by Leo, W6GFO. Write for Catalog and best deal to World Radio Labs, 740-44 West Broadway, Council Bluffs, Iowa.

MEISSNER Deluxe signal shifter, model 9-1080 (illuminated calibration dial) in excellent condition, complete, with 80, 40, 20 and 10 meter coils, \$35.00. W7FTO.

WANT: HT-6 or Meck 60N. Have Millen exciter, Sonar XE-10, new 17 1/2" rack cabinet S41W. Also cash balance. Samkofsky, 527 Bedford, Brooklyn, N. Y.

FOR Sale: 75-watt c.w. transmitter designed and built by Radio Engineering Laboratories. 6V oscillator, 6L6 doubler, RK20 final. Separate oscillator and doubler power supply, plug-in coils and crystals for 20 meters and. For details write Lionel Bennett, Box 582, Crisfield, Maryland.

ALUMINUM tubing, angles, channels and pipe. Write for list. Willard Radcliff, Fostoria, Ohio.

SELL: 522A complete, perfect, \$25.00; PE103A, new, \$15.00. Los Angeles area only, W6ELX, fone Terminal 4-7674.

QSL'S-SWLS on Kromeoke. Free samples. W1HJJ, Box 32, Manchester, N. H.

SALE: Super-Pro with 100 Kc standard speaker, in good condition, grey 1.25-40 Mcs. \$275.00. Meissner VFO, \$15.00. Moving to UHF. W3KFA, Mechanicsburg, Rd., #1, Penna.

TRADE or sell: T350M xmtrr (Tech-Rad Co. SF) 2-20 Mc, 813's run 800W; 805 hi-level mods. 220 VAC. 5 xtal positions and calibrated osc.; grey steel cabinet. Many special features. OPA said \$1200. First \$375 takes it in original crates. Never used (See Nov. issue p. 173). Also new HQ-129 X. Make offer. Larry Larson, Rt. 3, Box 3249, Edmonds, Wash.

FOR Sale: Sonar VFX 680, coils for 80, 40, 20, 10 meters. Used four months, \$50.00 or best offer. Joseph Nicatira, W1RKG, 176 Water Street, Lawrence, Mass.

SELL 500-watt 115 volt remote start Fairbanks Morse light plant. Use very little. \$200.00. ARCS-ARN7 radio compass, \$20.00. Wette, WHJM, Hingham, Montana.

SELLING out: BC459A with power supply, 10 meter phone/cw 50 watt rig with 2 meters. Also 80-40 meter cw rig with power supply, plug spare parts and tubes. Reason: draft. First \$70.00 takes all. W2VBO, J. Di Pietro, 255 Ainalie St., Brooklyn 11, N. Y.

SELL RME-45 receiver, practically new; Cal-O-Matic tuning and speaker, \$130.00. F.o.b. East Orange, N. J. Joe Ryan, W2W1H, 120 N. 18th St.

TRADE radio courses, ham gear for Riders manuals, test equipment. Karl Stello, 3619-102 St., Inglewood, Calif.

SELL: Triplett volt-ohm-milliammeter model 625 N with leads and instructions, 10,000 and 20,000 ohms per volt. Tests to 5000 volts AC and DC. Costs \$45.00 new. Excellent condition. Ship express collect, \$30.00. W4KCI.

QSL'S-SWLS. Tops in quality. C. Fritz, 1213 Briargate, Joliet, Illinois.

SELL: Meck 60T xmtrr, excellent working condition with coils 10-20 mtrs, 3 xtals, Shure xtal mike with stand, also BC459A with spare set tubes. And good power supply. All \$110.00. Theander, W2WQ, 10-18 116th St., College Point, N. Y., Independence 3-5317.

WANTED: Transmitter-receiver for a boat, marine band, to operate from 6, 12 or 32 watt power source. Prefer Hallicrafters HT-3 or similar outfit. For Sale: Masco MA25P 25-watt speech amplifier, turntable on top, \$40.00 freight collect. W1DBS, John Savonis, 11 Dwight Court, New Britain, Conn.

KILOWATT CW transmitter: Millen exciter drives pair 8000 tubes. Three power supplies, well metered, best parts, in Bud 6 ft. cabinet. Antenna tuner included. Used less than 10 hours. Sacrifice at \$320.00. W3LSS, 3325 Piedmont Ave., Pittsburgh 16, Penna.

QSL'S! Inexpensive! G. L. Taylor, Sumrall, Miss.

CHANGING frequency? Fine commercial units for SCR-522's, police, taxi, aircraft, marine, geophysical, and other services except amateur. Commercial regrinding. Many crystals can be economically reground to new frequencies. Inquire. Over twelve years of satisfaction and fast service! Try us first. Edison Electronic Co., 1802 North Third St., Temple, Texas.

MEISSNER 150-B transmitter modified to operate ECO or xtal, for use with high impedance mike and link output. Ready to operate as is on 20 meters fone or cw 230-watts input. Sacrifice for \$100. Buyer to arrange for transportation. All inquiries answered. Jay Chichon, W2LTU, 160 Vermilyea Ave. New York City 34, N. Y.

FOR Sale: QST 1925 to 1930, inclusive, complete volumes, \$5.00 per year. 1930 to 1946 complete, volumes, \$4.00 per year. All prices plus postage. National SW3 with power supply, \$15.00. Mrs. C. S. Hoffman, Jr. 47 Lynwood Ave., Wheeling, W. Va.

SELL or trade precision laboratory type 638-2 Shalcross Wheatstone-Kelvin bridge. Cost \$130.00, perfect condx. Want complete wire recorder or make offer. Nebel, W2DBQ, 1104 Lincoln Place, Brooklyn 13, N. Y.

FOR Sale: BC348-2 (new when purchased) converted AC with aprk. Shock mounting and 10-11 meter converter. Excellent condition and performance. Best offer takes it. W1QKE, 109 Glenwood St., Lowell, Mass.

FOR Sale: Instructograph: A.C. model, all tapes. Brand new, \$25.00. 2 Sonar CFC exciters, new, \$36.00 each. Gerald Barrone, 3342 Shore Parkway, Brooklyn 29, N. Y.

SELL: BC-344D (A.C.), 150-1500 Kc., \$35.00; McMurdo Silver #802 receiver, all coils, tubes, \$35.00, BC-522 rcvr, converted, \$18.00, or trade for V.H.F. 152. W3EFT, 2174 E. Cumberland St., Philadelphia 25, Penna.

FOR Sale: Collins 32V1 used five months. In perfect condition. National 240-D also in first class condition. Priced for quick sale. All inquiries will be answered. W9CWI, Box 283, Fairfield, Illinois.

SELL: S-38 receiver. In excellent condition, with little usage. Best offer over \$25. H. J. Madden, jr., 166 Buena Vista Road, Bridgeport, Conn.

QST'S badly wanted: 1940 May; all 1941 except May and August; all 1942; all 1943 except October, November and December; all 1944; all 1945 except November and December. James Steffensen, Ehlervej 8, Hellerup, Denmark.

FOR Sale: Triplett modulation monitor 169A-A, 100 watt Variac, 300 V power supply, Meissner receiver, 1-148FS meter, blank HRO cabinet, 16" dual speed playback, surplus antenna tripod, 200 V Vibrapak parts, assortment of tubes, small parts. Wanted: 2 meter equipment, SCR 522, VHF 152A converter (RME), HRO hand-spread coils, volt-ohm-imp, enclosed rack. Will swap for desired items. All inquiries answered. Georg Kravitz, W2OTR, 7919 20th Avenue Brooklyn 14, New York.

NEW: NC-173 receiver, complete, and used only a few hours. Condition perfect. In original carton. \$145.00. W1KCC, 240 Moreland St., Worcester, Mass.

MOTOROLA mobile xmtrr. FMT-30D complete, never used, 10 fone AM-FM special, \$115.00. Meissner 9-1090 shifter, bandswitching, factory wired, \$75.00, or best offer. Both are plus shipping. Stolberg, 1024 E. Knapp, Milwaukee 2, Wis.

MEISSNER 150B coils for 10 and 20 but not converted. Minor changes. Turner 99 dynamic mike, complete set of spare tubes and lots of spare parts. HQ-129 X, Triplett frequency meter, all like new, a little over a year old. Little used and guaranteed. Perfect 300-watt fone/cw rig, ready to go on air, \$195.00. No piecemeal sales. John Jacoby, W3KEQ, 119 Moran St., Oil City, Penna.

INFORMATION wanted: from someone who has successfully converted RT-7/ARN-1 transmitter for 420 Mc. W2PVG, 99 Evergreen Ave., Elmira, N. Y.

FOR Sale: Prewar: 25-watt transmitter, Skybuddy receiver, many parts. Library. War surplus electronic keyer. Write for detailed list. Sold to highest bidder. Robert Butler, Box 147 Sta. A, Ames, Iowa.

SELL KW xmtrr, all bands. 3000 volt, 500 mill supply for final. \$250.00. Three other supplies. RME-69 receiver, XE-10, 3 element beam, mike, key, other items, \$395.00 takes all. W9LVZ, 823 Vine St., Beloit, Wisconsin.

CRYSTALS: Precision, low drift mounted units, 3500 to 9000 kilocycle, ± 5 kilocycles, \$1.00. Exact frequency, \$1.50. Specify mounting. Other frequencies available. Breon Laboratories, Williamsport, Penna.

WANTED: To correspond with amateurs having information concerning operation and maintenance instruction for a BC654 transmitter. Walter Miller, 189 Maple Ave., Blairsville, Penna.

PERSONALIZED book matches. Call letters or name and address. Samples with prices. Miss Amanda Martin, Box 1123, Rochester 3, N. Y.

SELL or Trade: Abbott TR4, Sperti 2-meter 144-148 Mc handie-talkie transmitter with batteries. I need volt-ohm-milliammeter. Make an offer. What have you? J. M. Brown, 5848 Rollins Ave., Washington 19, D. C.

RECORDERS. New wire, disc and tape in stock. Van Sickle Radio, 34 W. Ohio Street, Indianapolis, Indiana.

NEW revolutionary "Automatic Time Indicator" giving comparative times every part of the globe, with modern colored map chart, specially recommended by Popular Mechanics (Feb. 1946, p. 75) to shortwave enthusiasts. Send only one dollar for sample. Box 126, Macleod, Alberta, Canada.

BARGAINS: New and reconditioned receivers, transmitters, VFOs, etc. Reconditioned S-38, \$35.00; S-20R, \$49.00; S-40, \$59.00; SX-43, \$119.00; SX-42, \$199.00; HT-18, \$69.00; NC-46, \$59.00; NC-57, \$69.00; NC-200, \$119.00; NC-240D, \$149.00; NC-173, \$149.00; NC-183, \$219.00; DB-20, \$29.00; DB-22A, \$49.00; HE-10-20, \$59.00; VHF152A, \$69.00; RME-45, \$99.00; HQ-129X, \$129.00; SP-400X, SX-24, SX-25, HRO, HT-9, Meck T60, BC610, Tech-Rad T350XM, Collins 75A receiver, \$295.00; Collins 32V transmitter, \$375.00. Easy terms. Shipped on trial. List free. Henry Radio, Butler Mo.

OSLS, SWLS. Beal, jr., W5OXL, Ft. Smith, Ark.

GET wist to the latest British-European radio-television developments. Follow famous British experts, keep up with "ham" activities, special television features, detailed analysis of newest transmitters and receivers. You'll find them all in "Practical Wireless", Britain's top radio journal. A "must" for every Amateur enthusiast. For one year's subscription (12 issues mailed direct to your address from London) send only \$2.00 to George Newman, Ltd., (PW:29) 342 Madison Avenue, New York City 17, N. Y. Two years: \$3.75.

Designed for



Application

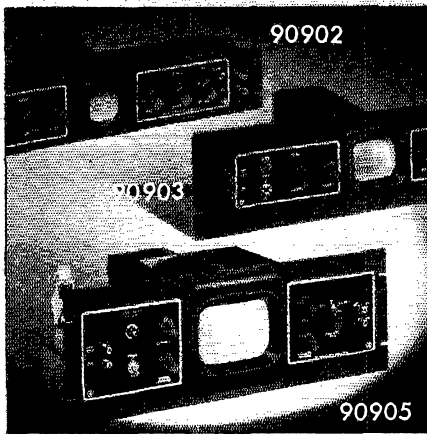

**90900 Series
Cathode Ray Oscilloscopes**

The No. 90902, No. 90903 and No. 90905 Rack Panel Oscilloscopes, for two, three and five inch tubes, respectively, are inexpensive basic units comprising power supply, brilliancy and centering controls, safety features, magnetic shielding, switches, etc. As a transmitter monitor, no additional equipment or accessories are required. The well-known trapezoidal monitoring patterns are secured by feeding modulated carrier voltage from a pickup loop directly to vertical plates of the cathode ray tube and audio modulating voltage to horizontal plates. By the addition of such units as sweeps, pulse generators, amplifiers, servo sweeps, etc., all of which can be conveniently and neatly constructed on companion rack panels, the original basic scope unit may be expanded to serve any conceivable industrial or laboratory application.

**JAMES MILLEN
MFG. CO., INC.**

MAIN OFFICE AND FACTORY
**MALDEN
MASSACHUSETTS**



Index to Advertisers

Allied Radio Corporation	99
American Radio Institute	121
American Radio Relay League, Inc.	86, 93, 122
Amplifier Corporation of America	119
Ashe Radio Company, Walter	121
Astatic Corporation, The	123
Barker & Williamson, Inc.	77
Belden Manufacturing Co.	83
Birnbach Radio, Inc.	121
Bliley Electric Co.	80
Burstein-Applebee Co.	100
Candler System Company	119
Capitol Radio Engineering Inst.	90, 96
Central Radio Parts Co.	120
Cleveland Institute of Radio Elec.	128
Collins Radio Company	2
Commercial Radio Institute	122
Condenser Products Co.	87
Decimeter, Inc.	117
Edwards Company, W. H.	122
Eitel-McCullough, Inc.	4
Electric Eye Equipment Co.	123
Electronic Indicator Corp.	118
Electronic Wholesalers, Inc.	107
Electro-Voice, Inc.	85
Espey Manufacturing Co., Inc.	112
Gardiner & Company	123
General Electric Co.	1
Greenlee Tool Co.	108
Halicrafters Co., The	5, 7
Harrison Radio Corp.	111
Harvey Radio Co., Inc.	97
Harvey-Wells Electronics, Inc.	82
Heim, John H.	120
Henry Radio Stores	103, 116
Hy-Lite Antennae, Inc.	108
Instructograph Co., The	121
International Resistance Co.	76
Jensen Manufacturing Co.	127
Johnson Co., E. F.	78, 88, 114
Lambda Electronics Corp.	112
Leeds Radio Company	115
Love & Co., J. V.	123
Mallory & Co., Inc., P. R.	79
Mass. Radio & Teleg. School	104
Merit Coil & Transf. Corp.	91
Millen Mfg. Co., Inc., The James	126
Munger Co., Rex L.	114
National Company, Inc.	73, 81, Cov. III
New York YMCA Schools	116
Newark Electric Company	105
Ohmite Manufacturing Co.	89
P & H Sales Company	121
Par-Metal Products Company	106
Petersen Radio Company	75
Fort Arthur College	118
Precision Apparatus Co., Inc.	84
RCA Institutes, Inc.	122
Radio Corporation of America	Cov. IV
Radio Shack Corporation	94, 95
Signal Electric Mfg. Co.	110
Silver Co., McMurdo	104
Srepro, Incorporated	92, 120
Steinberg's, Inc.	102
Suburban Radio Company	119
Sun Radio of Washington	113
Terminal Radio Corporation	101
Turner Company, The	119
United Transformer Corp.	Cov. II
Valparaiso Technical Institute	114
Vesto Company, The	110
Vibroplex Co., Inc., The	106
Western Coil & Electrical Co.	98
Wind Turbine Company	116
Workshop Associates, Inc.	117
World Radio Labs, Inc.	109

2. for average "AM" Broadcast

3. for High-quality "AM", "LP" Records, and Transcriptions

for some Phono Records and "SW" Broadcasts

4. for "FM" and Television Sound

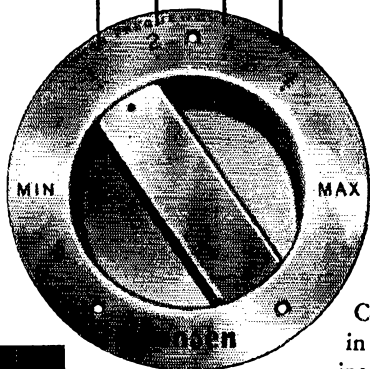

OVERALL LEVEL CONTROL

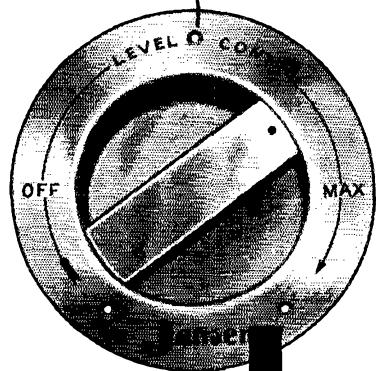

FOR GREATER LISTENING PLEASURE

-MATCH YOUR SPEAKER RESPONSE TO THE PROGRAM

Complete listening enjoyment of the quality inherent in FM broadcasts and high-fidelity phonograph recordings may require loudspeaker response up to 12,000 cycles or more. AM broadcasts may demand response of 5,000 cycles or less, while other program material may call for other high-frequency cut-off points. Matching loudspeaker response to today's wide range of program material is essential for real listening pleasure.

Jensen Coaxial speakers (Models HNP-51, JAP-60 and JHP-52) meet this need simply and positively.

A 4-position high-frequency selector switch adjusts the speaker response to suit listener preference and a level control adjusts the overall volume of the program. These two controls are exclusive JENSEN features.

Jensen

Coaxial SPEAKERS

JENSEN MANUFACTURING COMPANY, 6611 S. LARAMIE AVE., CHICAGO 38, ILL
IN CANADA: COPPER WIRE PRODUCTS, LTD., 11 KING ST., W., TORONTO



Model HNP-51 Coaxial

Without doubt the finest existing 15-inch Coaxial loudspeaker regardless of price. Compression-type h-f unit contributes to an exceptional polar pattern and realistic "presence". Frequency response, in a Bass Reflex enclosure, extends through the entire useful frequency range. Power rating 25 watts maximum speech and music signal input. Input impedance 500-600 ohms.

List price \$125.00



Model JAP-60 Coaxial

A superior quality 15-inch Coaxial loudspeaker with excellent polar pattern. Response, in a Bass Reflex enclosure, extends through the entire useful frequency range. Power rating 20 watts maximum speech and music signal input. Input impedance 500-600 ohms.

List price \$85.00



Model JHP-52 Coaxial

A high-quality 15-inch Coaxial loudspeaker at an economy price. Frequency response, in a Bass Reflex enclosure, extends through the entire useful frequency range. Power rating 16 watts maximum speech and music signal input. Input impedance 500-600 ohms.

List price \$72.00



Model JRP-40 Coaxial

The ultimate in 12-inch Coaxial value. Frequency range, in a Bass Reflex enclosure, from 50 to 12,000 cycles. Power rating 12 watts maximum speech and music signal input. Input impedance 6-8 ohms. "Bridging" type network. H-F range control not included but "shelving" type control (ST-606) may be added by user.

List price \$30.00

Which Do You Want?



Better Pay



A Nice Home



A New Car



Greater Security



Happy Vacations and Travel

Get Your FCC Ticket
Jobs worth
\$3,000 to \$7,500
are opening up
right now for
**FCC Licensed
Radiomen.**

Make Your Hobby Into a Good Paying Job

Get Your FCC COMMERCIAL RADIO OPERATOR LICENSE in a Few Short Weeks



It's EASY if you use CIRE Simplified
Training and Coaching AT HOME
in SPARE TIME

Get your license easily and quickly and be ready for the \$3000 to \$7500 jobs that are open to ticket holders. CIRE training is the only planned course of coaching and training that leads directly to an FCC license.

**YOUR FCC TICKET IS RECOGNIZED
IN ALL RADIO FIELDS AS PROOF
OF YOUR TECHNICAL ABILITY**

**CIRE Graduates Find
FCC License Pays Off**

"I now hold ticket P-10-3787, and holding the license has helped me to obtain the type of job I've always dreamed of having. Yes, thanks to CIRE, I am now working for CAA as Radio Maintenance Technician, at a far better salary than I've ever had before. I am deeply grateful." — Student No. 3319N12

"I was issued License P-2-11188 on November 4. The next day I was signed on board a tanker as Radio Operator-Purser. Besides radio operating, I handle the payrolls, etc., which is all over-time and brings my monthly pay up to between \$500 and \$650." — Student No. 2355N12

CLEVELAND INSTITUTE OF RADIO ELECTRONICS
Desk QT-1 4900 Euclid Bldg. Cleveland 3 Ohio

GET THIS AMAZING NEW BOOKLET

1. Tells of thousands of brand-new, better-paying radio jobs now open to FCC License Holders.
2. Tells how you will benefit by holding an FCC Commercial License.
3. Tells how YOU can get your FCC Commercial Radio Operators' License IN A FEW SHORT WEEKS — EASILY AND QUICKLY, by using CIRE simplified training and coaching AT HOME in your SPARE TIME.
4. Tells of hundreds of our successful students who now have licenses and new, better-paying jobs.
5. Tells how we prepare you to pass the new FCC Commercial License Examinations, which now include FM and Television.
6. Tells how we guarantee to train and coach you until you get your license.
7. Tells how we help you to get a better-paying, licensed job, with our free and exclusive service, which prepares your employment application for mailing to hundreds of employers, including FM, AM and Television Broadcast Stations, Radio Manufacturers, Police Radio Stations, and Radio-Equipped Taxi, Bus and Public Utility Companies.



Get All 3 FREE Send Coupon Now!

CLEVELAND INSTITUTE OF RADIO ELECTRONICS

Desk QT-1 4900 Euclid Bldg., Cleveland 3, Ohio
(Address to Desk No. to avoid delay)

I want to know how I can get my FCC ticket in a few short weeks by training at home in spare time. Send me your FREE booklet, "Money Making FCC License Information," as well as a sample FCC-type exam and free booklet, "How to Pass FCC License Examination" (does not cover exams for Amateur License)

Name.....
Address.....
City.....Zone.....State.....

Veterans check for enrollment information under G.I. Bill
NO OBLIGATION — NO SALESMEN

see inside . . .

then decide . . .

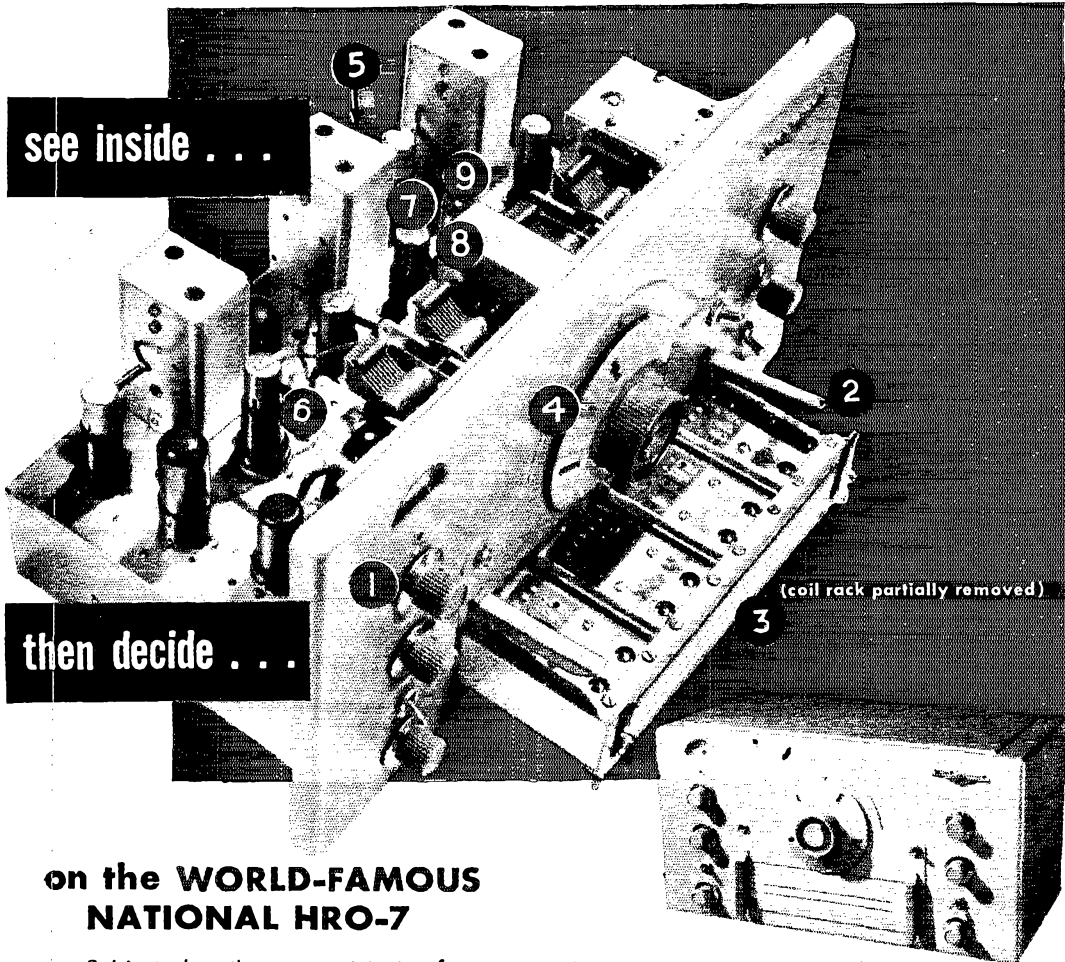

(coil rack partially removed)

on the WORLD-FAMOUS NATIONAL HRO-7

Subjected to the severest tests of government, commercial and amateur use for 14 years, the basic HRO design has set a new high in receiver performance. Now, here it is in its newest, finest form. As always the major components are National designed and made.

RANGE: 1.7 to 30 mcs. (Additional coils available for 50 to 430 kcs, 480 to 2,050 kcs, 30 to 35 mcs.)

SENSITIVITY: 1 microvolt or better.

IMAGE REJECTION: Better than 30 db at 30 mcs.

SIGNAL-TO-NOISE RATIO: Exceeds 16 db with 5 microvolts input.

AVC CHARACTERISTIC: to ± 10 db between 1.0 and 100,000 microvolts input.

- 1 Automatic adjustable-threshold noise limiter.
- 2 Lever handles for coil set changing.
- 3 Slide rule calibration on all coil sets.
- 4 500-degree micrometer dial (effective scale length 12 feet). 400 degrees of bandspread on 80, 40, 20 11-10 meters.
- 5 Accessory socket and switch for NFM adaptor or phonograph.
- 6 Two tuned RF stages.
- 7 Two IF stages.
- 8 Precision gear drive eliminates backlash.
- 9 Voltage-regulated high frequency oscillator for exceptional stability.

\$312.86 (Complete with coils and power supply, less speaker)

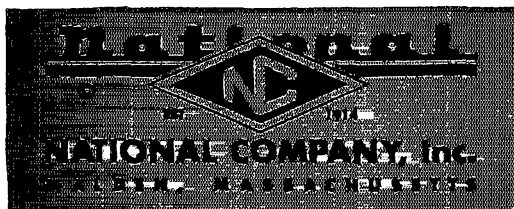

Champions!



807



813

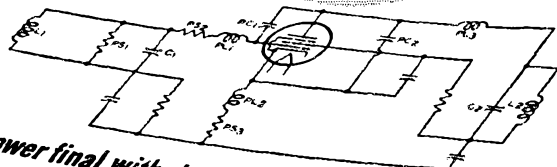

Typical beam power final with degenerative stabilization

THE FOUNTAINHEAD OF MODERN
TUBE DEVELOPMENT IS RCA

Still unmatched . . . in price — power — performance

● No wonder RCA 807 and 813 beam power tubes are today's favorites for finals! These huskies require less drive and deliver more output at lower plate voltage, than any other similar tube types within a comparable price range. You get the *same* results with fewer stages, smaller driver tubes, and a less elaborate power supply.

What's more, RCA 807's and 813's—like all RCA beam power tubes—are excellent for quick-change, multi-band transmitters because they sel-

dom require stabilization in well-designed circuits. Where difficulties may arise, permanent stabilization on all bands is simply achieved by neutralization or degeneration . . . at no sacrifice in efficiency.

To get the most out of *your* beam power tube be sure to read the article on stabilization in the May-June 1947 issue of *Ham Tips*. See your RCA Tube supplier for a copy, or write RCA, Commercial Engineering, Section 48AM, Harrison, N. J.



TUBE DEPARTMENT

RADIO CORPORATION of AMERICA

HARRISON, N. J.