

# QST

November, 1951

40 Cents

45c in Canada

devoted entirely to

# amateur radio

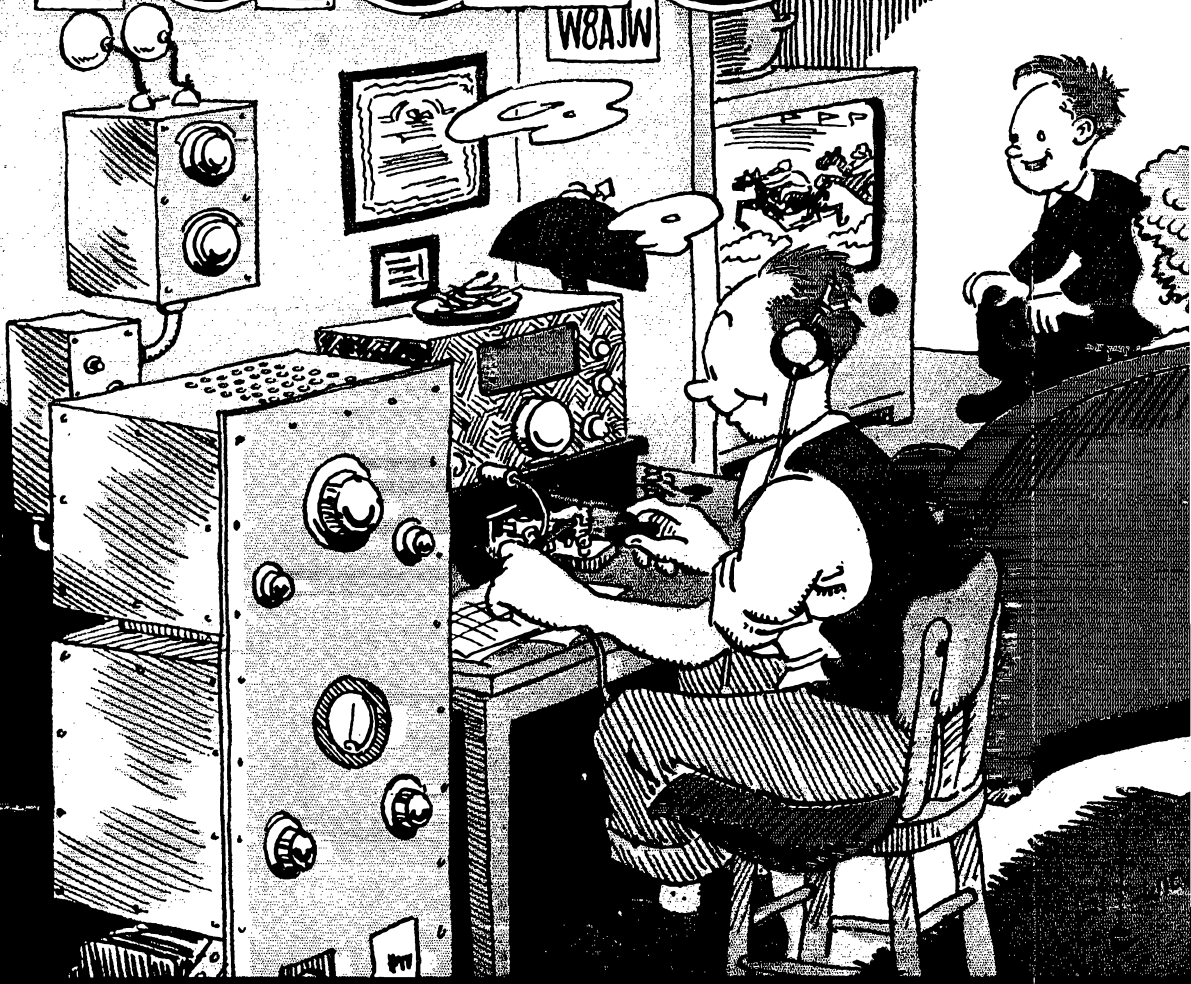

with an E-V microphone

**The CARDAX**

World's favorite premium crystal mike—the first high level crystal cardioid with dual frequency response. List, \$42.50.

**The "630" DYNAMIC**

Popular high-fidelity dynamic. Ideal frequency response. High output. Acoustalloy diaphragm. List, \$45.00.

**The CENTURY**

Low-cost all-purpose crystal and dynamic models. Rugged, dependable. Satin chromium finish. Lists at \$12.50 and up.

**The MERCURY**

Rugged, handsome Crystal or Dynamic. Extra quality features at minimum cost. List prices from \$27.50 to \$39.50.

With an E-V microphone, you assure *accurate reproduction of your own speaking voice*. The shading and warmth of your speech arrive at the other end of the QSO undistorted and undiminished. *Your carrier is modulated with your exact speech . . . the individuality of your voice is clearly retained . . . your personality is on your carrier.*

Write for Illustrated Bulletin

**ELECTRO-VOICE, INC.**

404 CARROLL ST., BUCHANAN, MICH.

Export: 13 East 40th St., N. Y. 16, U.S.A. Cables: Arlab

NO FINER CHOICE THAN

**Electro-Voice**

Authorized Distributors Everywhere

E-V Pat. Pend. Licensed under Brush Patents

**NOW, for civil defense on 2 and 6 meters . . .**

**CASCADE**

**—with one tube,  
bargain-priced!**

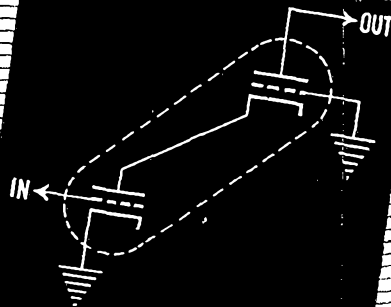

### **6BK7 HIGH-GM TWIN TRIODE**

Typical operating conditions, each section



Plate supply voltage	150 v
Cathode bias resistor	56 ohms
Amplification factor	40
Plate resistance	4,700 ohms
Transconductance	8,500 micromhos
Plate current	18 ma
Noise factor, as a cascode amplifier at 216 mc	7 db

**A LOW-NOISE FRONT END** means clearer signal reception in emergencies—fewer delays from asking the other fellow to repeat, less misunderstanding. Leads between tubes in cascode circuits *were* noise-breeders. Now this problem disappears, for one twin triode does the job and does it well—G. E.'s new 6BK7.

**SPECIALLY DESIGNED FOR CASCODE!** You can apply the 6BK7 with assurance that this well-shielded tube will perform 100-percent. *Precision-built in quantities, so low-priced!* Right now the 6BK7 is serving as a tuner tube in modern TV sets. Production is high and costs are pro-rated over many thousand tubes to achieve real economy for you, the buyer.

**GET THE BARGAIN PRICE** of the new 6BK7 at your nearby G-E tube distributor, to learn how much you'll save by "going cascode" with one tube, developed especially for that field. Less front-end tube circuitry—improved reception—you can chalk these up as additional gains! *Electronics Division, General Electric Company, Schenectady 5, New York.*

#### **JUST WHAT IS NOISE?**

This question was answered for you in Sept.-Oct. Ham News. If you didn't obtain a copy, ask your G-E tube distributor for one, or write Lighthouse Larry Under "Receiver Noise Figures" you'll find clear, simple explanations of what causes noise, what are meant by the terms "noise figure" and "signal-to-noise ratio", etc. Here's a basic discussion of the whole noise problem that will improve your circuit designing. Read Ham News to *stay* posted!

ELECTRONIC TUBES OF ALL TYPES FOR THE RADIO AMATEUR

**GENERAL**



**ELECTRIC**

184-KA11

(At right) Final amplifier assembly with shield removed

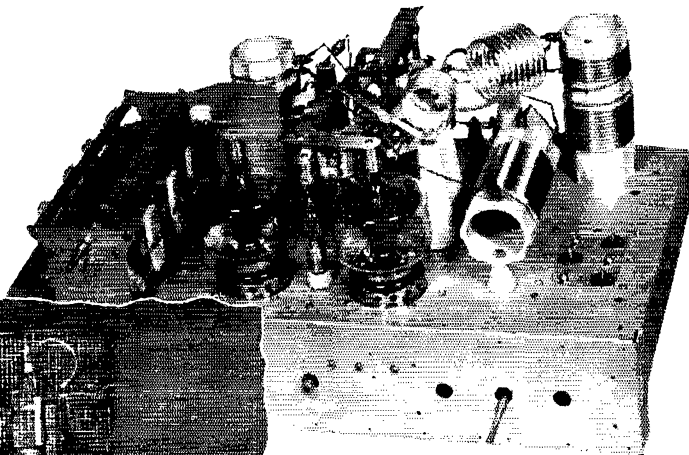

(At left) Showing operator's view of the power tubes through glass and wire mesh

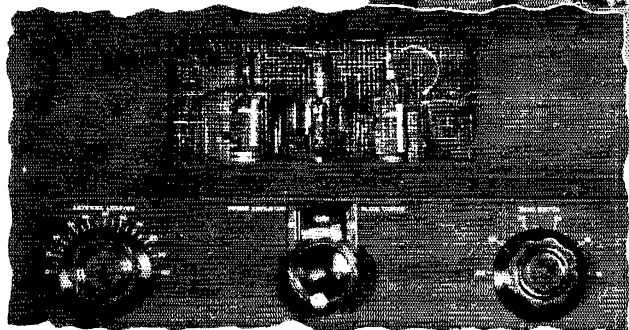

## Features of the KW-1's power amplifier

The final amplifier of the new Collins KW-1 amateur transmitter utilizes two 4-250A tetrodes in parallel, operated well within their ratings at 1000 watts input. The ease of neutralization, stability, and low driving power requirements of these tubes ideally suit them for this high power rig which was designed throughout for maximum TVI reduction.

A pi network is used to match the plate impedance of the 4-250A's to a value of approximately 300 ohms at the input of the L matching section, which in turn transforms the 300 ohms to 50 ohms to feed a standard coaxial line such as RG8/U. Use of the L section in addition to the pi section greatly increases attenuation of the higher harmonics.

A band switch ganged with the band switches of the exciter selects the proper value of inductance in both L and pi sections. Thus bandswitching of the entire transmitter is accomplished simultaneously with a single knob on the front panel.

The power amplifier assembly is completely enclosed in a shield box, a section of which consists of wire mesh. The operator has a clear view of the power tubes through this mesh and a glass window in the front panel of the transmitter.

FOR THE BEST IN AMATEUR RADIO, IT'S . . .

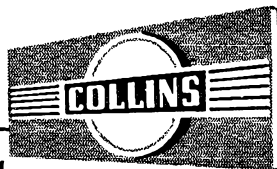

**COLLINS RADIO COMPANY, Cedar Rapids, Iowa**

11 W. 42nd St.  
NEW YORK 18

1937 Irving Blvd.  
DALLAS 2

2700 W. Olive Ave.  
BURBANK

PUBLISHED, MONTHLY, AS ITS OFFICIAL ORGAN, BY THE AMERICAN RADIO RELAY LEAGUE, INC., AT WEST HARTFORD, CONN., U. S. A.; OFFICIAL ORGAN OF THE INTERNATIONAL AMATEUR RADIO UNION

## STAFF

### Editorial

A. L. BUDLONG, W1BUD  
Editor

HAROLD M. MCKEAN, WICEG  
Managing Editor

GEORGE GRAMMER, WIDF  
Technical Editor

DONALD H. MIX, WITS  
BYRON GOODMAN, WIDX  
Assistant Technical Editors

EDWARD P. TILTON, WHDQ  
V.H.F. Editor

RICHARD M. SMITH, WIFTX  
C. VERNON CHAMBERS, W1JEQ  
Technical Assistants

ROD NEWKIRK, W9BRD  
DX Editor

WALTER E. BRADLEY, W1FWH  
Technical Information Service

### Production

RALPH T. BEAUDIN, W1BAW  
Production Manager

NANCY P. McCONNELL  
Assistant

### Advertising

LORENTZ A. MORROW, W1VIG  
Advertising Manager

### Circulation

DAVID H. HOUGHTON  
Circulation Manager

RALPH T. BEAUDIN, W1BAW  
Assistant Circulation Manager

## OFFICES

38 La Salle Road

West Hartford 7, Connecticut

TEL: 3-6268 TWX: HF 88  
Subscription rate in United States and Possessions, \$4.00 per year, postpaid; \$4.25 in the Dominion of Canada, \$5.00 in all other countries. Single copies, 40 cents. Foreign remittances should be by international postal or express money order or bank draft negotiable in the U. S. and for an equivalent amount in U. S. funds.

Entered as second-class matter May 29, 1919, at the post office at Hartford, Connecticut, under the Act of March 3, 1879. Acceptance for mailing at special rate of postage provided for in section 1102, Act of October 3, 1917, authorized September 9, 1922. Additional entry at Concord, N. H., authorized February 21, 1929, under the Act of February 28, 1925.

Copyright 1951 by the American Radio Relay League, Inc. Title registered at U. S. Patent Office. International Copyright secured. All rights reserved. *Quedan reservados todos los derechos.* Printed in U.S.A.

INDEXED BY  
INDUSTRIAL ARTS INDEX

## — CONTENTS —

"It Seems to Us . . ."	9
League Files Call-Sign Comment . . . . .	10
Quist Quiz . . . . .	10
A De Luxe Mobile Transmitter for 14 and 28 Mc. C. Vernon Chambers, W1JEQ	11
High-Level Clipping and Filtering Warren B. Bruene, W0TTK	18
The Novice Conversion of a "Command" Transmitter R. M. Smith, WIFTX, and W. E. Bradley, W1FWH	22
Highlights of the Sixth ARRL National Convention . . .	26
One Db. per Cycle! John Kaye, W6SRY, and Dorothy Kaye, W6YIR	29
Every Mil I Have is Yours, or Beware of Steel Panels George H. Floyd, W2RYT	32
A V.H.F. Receiver for the Novice or Technician Edward P. Tilton, WHDQ	33
Two-Band Antennas with Nonresonant Feed Lines Irving Roberts, W3KQU	38
Silent Keys . . . . .	39
On the Air with Single Sideband . . . . .	40
Technical Topics — Some Aspects of Screen Modulation. . . . .	41
United States Naval Reserve . . . . .	45
Military Amateur Radio System . . . . .	45
Water in the Dust Bowl. . . . . George Hart, WINJM	46
A Civil Defense Control-Station Antenna for 144 Mc. Philip S. Rand, W1DBM	50
ARRL QSL Bureau . . . . .	52
Happenings of the Month . . . . .	53
Announcing the 18th ARRL Sweepstakes . . . . .	54
How's DX? . . . . .	56
Correspondence from Members . . . . .	59
The World Above 50 Mc. . . . .	60
Hints and Kinks . . . . .	61
Operating News . . . . .	62
With the AREC . . . . .	67
Station Activities . . . . .	68
10-Meter WAS Contest Announcement . . . . .	98
In QST 25 Years Ago This Month . . . . .	126

# Hallicrafters

*Precision Performance*

... in Every Price Range!

Your best buy at any price, because Hallicrafters gives you **MORE HAM PERFORMANCE PER DOLLAR.** That is why Hallicrafters sells more communications receivers than all other U. S. manufacturers combined!

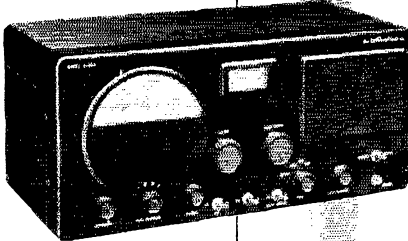

S-40B

#### S-40B—The World's Most Popular Ham Receiver

Latest version of an old favorite, proven through years of dependable service. One r-f, two i-f stages. Temperature compensated oscillator. Series type noise limiter. Micro-set iron core i-f coils. Separate electrical bandspread. Built-in PM speaker. Range 540 kc to 43 Mc in four bands. 7 tubes plus rectifier. **\$99.95**

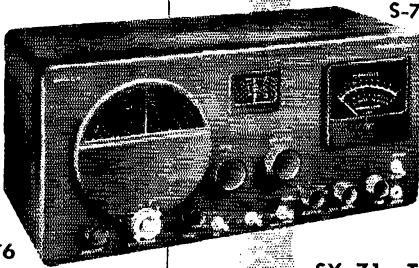

S-76

#### S-76—The Outstanding "Set of the Year—1951"

New double conversion set, with 50 kc 2nd i-f to give more-useable selectivity than the best crystal. 500-cycle selectivity at 6 db down—3 kc selectivity at 60 db down—with selectivity control in sharpest of five positions. 2 microvolt average sensitivity with 1/2 watt output. One r-f, two conversion and two i-f stages. Giant 4-in. "S" meter. Calibrated electrical bandspread. Range 538-1580 kc, 1.72-32 Mc in 4 bands. 9 tubes plus rectifier. **\$169.50**

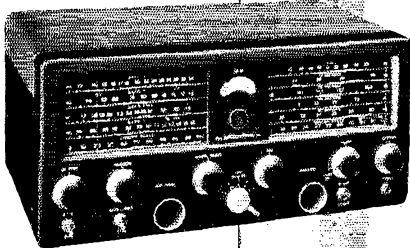

SX-71

#### SX-71—The World's Most Famous Double Super-Het

Value-packed with features specifically asked for by the Hams. Extra sensitivity, selectivity, and stability; double super-heterodyne, plus built-in Narrow-Band FM. Temperature compensated, voltage regulated. One r-f, two conversion, and three i-f stages. Range 538 kc to 35 Mc, 46-55 Mc. Extra-wide dials for main and bandspread tuning. Crystal filter with three positions Selectivity, and Crystal Phasing control. Phono jack. 11 tubes plus regulator and rectifier. **\$199.95**

WORLD'S LEADING MANUFACTURER OF PRECISION  
RADIO AND TELEVISION • CHICAGO 24, ILLINOIS

# hallicrafters

*"The Radio Man's Radio"*

**PR**  
*Stam  
 Put!*



Whether you're "edging the band" or working the middle . . . it's a real satisfaction to know exactly where you are, right down to the kilocycle. That's why DRIFT is the most important characteristic you look for in your crystal controls. Little wonder that tens of thousands of Amateurs—all over the world—prefer PR Precision CRYSTALS. They are truly LOW DRIFT . . . meet commercial drift standards. PRs have

a drift characteristic of less than 2 cycles per MC per degree Centigrade. This LOW DRIFT characteristic does not prevent PRs from giving HIGH ACTIVITY AND OUTPUT, traditionally demanded by amateurs. You can get the EXACT FREQUENCY YOU WANT (Integral kilocycle) WITHIN AMATEUR BANDS, AT NO EXTRA COST. Accept no substitute! Get PRs at your jobbers.

20 METERS, Type Z-3, \$3.75 • 40, 80 AND 160 METERS, Type Z-2, \$2.75

**PR** *Crystals*

Since  1934

USE  AND KNOW WHERE YOU ARE

**PETERSEN RADIO COMPANY, INC.**  
 2800 W. BROADWAY • COUNCIL BLUFFS, IOWA

EXPORT SALES ONLY: Royal National Company, Inc., 75 West Street, New York 6, N. Y., U. S. A.

## Section Communications Managers of the ARRL Communications Department

Reports Invited. All amateurs, especially League members, are invited to report station activities on the first of each month (or preceding month) direct to the SCM, the administrative ARRL official elected by members in each Section. Radio Club reports are also desired by SCMs for inclusion in *O.S.T.* All ARRL Field Organization appointments are now available to League members. These include ORS, OES, OPS, OO and OBS. Also, where vacancies exist SCMs desire applications for SEC, EC, RM, and PAM. In addition to station and leadership appointments for Members, *all amateurs* in the United States and Canada are invited to join the Amateur Radio Emergency Corps (ask for Form 7).

ATLANTIC DIVISION				
Eastern Pennsylvania	W3BES	Jerry Mathis	617 Crescent Ave.	Glenside
Maryland-Delaware-D.C.	W3OMN	James W. John	29 Fawcett St.	Kensington, Md.
Southern New Jersey	W2UCV	Lloyd L. Gaine	Hoffman Ave. & Marlton Pike	Merchantville
Western New York	W2PGT	Harding A. Clark	RTD 2	Manlius
Western Pennsylvania	W3KWL	Ernest J. Hlinsky	509 Beechwood Ave.	Farrill
CENTRAL DIVISION				
Illinois	W9EVJ	Lloyd E. Hopkins	27 Lynch St.	Elgin
Indiana	W9DGA	Clifford C. McGuyer	1321 South Governor St.	Evansville 13
Wisconsin	W9RQM	Reno W. Goetsch	929 S. 7th Ave.	Wausau
DAKOTA DIVISION				
North Dakota	W0JWV	Rev. Lawrence C. Strandenaes	St. Andrew's Church	Weathepo
South Dakota	W0RRN	J. W. Sikorski	1000 South Menlo Ave.	Sioux Falls
Minnesota	W0MXX	Charles M. Hove	1611 1/2 E. Lake St.	Minneapolis 7
DELTA DIVISION				
Arkansas	W5DRW	Dr. John L. Stockton	P. O. Box 302	Siloam Springs
Louisiana	W5GHF	Robert E. Barr	Box 446	Springhill
Mississippi	W5JHS	Norman B. Feehan	P. O. Box 491	Gulfport
Tennessee	W4AFI	D. G. Stewart	McAlice Drive	Fountain City
GREAT LAKES DIVISION				
Kentucky	W4KKG	I. W. Lyle, jr.	R. R. 3	Jeffersonton
Michigan	W8DLZ	Norman C. MacPhail	1340 Giddings, S.E.	Grand Rapids
Ohio	W8AJW	John E. Siringier	2972 Clague Rd.	Cleveland 16
HUDSON DIVISION				
Eastern New York	W2CLL	George W. Sleeper	76 Fuller Road	Albany 3
N. Y. C. & Long Island	W2OBU	George V. Cooke	88-31 239th St.	Bellerose 6, L. I.
Northern New Jersey	W2NKD	Thomas J. Ryan, jr.	1082 Anna St.	Elizabeth 4
MIDWEST DIVISION				
Iowa	W0PP	William G. Davis	3rd St.	Mitchellville
Kansas	W0ICV	Earl N. Johnston	624 Roosevelt	Topeka
Missouri	W0GBT	Clarence L. Arundale	1048 South Jefferson Ave	Springfield 4
Nebraska	W0KJP	Guy R. Bailey	131 North 38 St.	Omaha 5
NEW ENGLAND DIVISION				
Connecticut	W1VB	Walter L. Glover	Glover Ave.	Newtown
Maine	W1PTL	Orestes R. Brackett	Goodrich St.	Bingham
Eastern Massachusetts	W1ALP	Frank L. Baker, jr.	91 Atlantic St.	North Quincy 71
Western Massachusetts	W1EOB	Victor W. Paouloff	26 Denton Circle	Springfield
New Hampshire	W1INC	Norman A. Chapman	98 South St.	Concord
Rhode Island	W1CIH	Ray B. Fuller	17 Ledge Road	East Greenwich
Vermont*	W1FPS	Raymond N. Flood	2 Marlboro Ave.	Brattleboro
NORTHWESTERN DIVISION				
Alaska	KL7MZ	Josiah R. Nichols	213 Manor	Anchorage
Idaho	W71WU	Alan K. Ross	2105 Irene St.	Boise
Montana	W7KGJ	Edward G. Brown	321 Yellowstone Ave.	Billings
Oregon	W7MO	J. E. Roden	519 N.W. Ninth	Pendleton
Washington	W7CZV	Laurence Sebring	Route 2, Box 384	Everett
PACIFIC DIVISION				
Hawaii	KH6RU	John R. Sanders	c/o Mackay Radio & Tele- graph Co. Inc., Box 2993	Honolulu
Nevada	W7BVZ	Carroll W. Short, jr.	1608 Arizona St.	Boulder City
Santa Clara Valley	W7LZL	Roy J. Cozzini	7 Englewood Ave.	Los Gatos
East Bay	W6JZ	Ray H. Cornell	909 Curtis St.	Albany 6
San Francisco	W6ATO	R. F. Czelkowitz	243 Colon Ave.	San Francisco 12
Sacramento Valley*	W6CKV	Willie van de Kamp	RFD 1, Box 492A	Chico
San Joaquin Valley	W6FYM	E. Howard Hale	741 E. Main St.	Turlock
ROANOKE DIVISION				
North Carolina	W4DLX	J. C. Gossett	1832 Logie Ave.	Charlotte
South Carolina	W4AZT	Wade H. Holland	P. O. Box 116	Greenville
Virginia	W4FF	H. Edgar Lindauer	Route 1, Box 431	Annapond
West Virginia	W8JM	Donald B. Morris	303 Home St.	Fairmont
ROCKY MOUNTAIN DIVISION				
Colorado	W0IQZ	M. W. Mitchell	1959 Uinta St.	Denver 7
Utah	W7SP	Leonard F. Zimmerman	House 4	Saltair
Wyoming	W7HNI	A. D. Gaddis	P. O. Box 786	Gillette
SOUTHEASTERN DIVISION				
Alabama	W4LEN	Lewis C. Garrett	818 Maplewood Ave.	Anniston
Eastern Florida	W4FWZ	John W. Hollister	3809 Springfield Blvd.	Jacksonville
Western Florida*	W4MS	Edward J. Collins	1003 E. Blount St.	Pensacola
Georgia	W4ZD	James P. Born, jr.	25 First Ave., N.E.	Atlanta
West Indies (Cuba-P.R.-V.I.)	KP4DJ	William Werner	563 Ramon Llovet	Urb. Truman, Rio Piedras, P. R.
Canal Zone	KZ5AW	Everett R. Kimmel	Box 264	Gambou, C. Z.
SOUTHWESTERN DIVISION				
Los Angeles	W6ESR	Samuel A. Greenlee	1701 Sepulveda Blvd.	Manhattan Beach
Arizona	W7MID	Jim Kennedy	4511 N. 8th St.	Phoenix
San Diego	W6VYM	Mrs. Ellen White	3677 Wightman St.	San Diego
WEST GULF DIVISION				
Northern Texas	W5BKH	William A. Green	1834 University Blvd.	Abilene
Oklahoma	W5AH7/AST	Frank E. Fisher	104 East 11th St.	Pawhuska
Southern Texas	W5FIF	Dr. Charles Fermaglich	618 Medical Arts Bldg.	Houston 2
New Mexico*	W5BIW	Richard J. Matthias	P. O. Box 548	State College
MARITIME DIVISION				
Maritime (Nfld. & Labr. att.)	VE1DQ	A. M. Crowell	69 Dublin St.	Halifax, N. S.
ONTARIO DIVISION				
Ontario	VE3IA	G. Eric Farquhar	16 Emerald Crescent	Burlington, Ont.
QUEBEC DIVISION				
Quebec	VE2GL	Gordon A. Lynn	R.R. No. 1	Ste. Genevieve de Pierrefonds, P. Q.
VANALTA DIVISION				
Alberta	VE6MJ	Sydney T. Jones	P. O. Box 373	Edmonton, Alta.
British Columbia	VE7US	Willf Moorhouse	324 Regina Ave.	Lulu Island
PRAIRIE DIVISION				
Manitoba	VE4AM	A. W. Morley	26 Lennox Ave.	St. Vital
Saskatchewan	VE5HR	Harold R. Horn	1044 King St.	Saskatoon

\* Officials appointed to act temporarily in the absence of a regular official.



# Announcing



Because of a deep-rooted interest in Amateur Radio, and because Hallicrafters makes more short-wave receivers than all other U.S. manufacturers combined, we are offering a Merit Award to Novice-Class Amateurs who make outstanding progress during the coming year.

### Award Given to Everyone Who Qualifies

Hallicrafters Merit Award will be given to every Novice who, during the period beginning 12:01 A.M. September 8, 1951, and ending 12:00 P.M., September 7, 1952, local time, works all states and has obtained by September 7, 1952, a General or Conditional Class Amateur License. Both Novice-Class and "regular" QSOs can be used to make up the total of 48 contacts.

Rules governing contacts and verifications thereof are the same as for ARRL W. A. S. Certificates (see p. 6, "Operating an Amateur Station"). Your package of verifications must be postmarked not later October 7, 1952.

### First Ten Win S-76 Receivers, All Others \$25 Cash

The first ten Novices who complete the above will receive, absolutely FREE, a Hallicrafters S-76 Receiver. All of the other Novices who complete the above will receive \$25 in cash, each. Remember this is not a contest in which only *some* contestants win; *everyone* who completes the course will win either an S-76 receiver or \$25 in cash. No entry blank is required, but we will be glad to have you drop us a line (Attention: WN90EP, Bill Halligan, Jr.) telling us you're going to try for the Award. Best of luck with your QSOs.



S-76. Double Conv., 50 kc 2nd i-f. 9 tubes, Rect., Reg. \$169.50

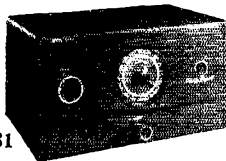

S-81

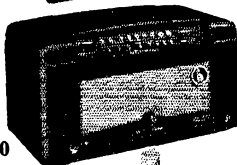

S-80

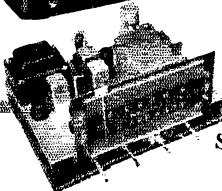

S-78A

**News Flash!**—Three new Hallicrafters are now in production. You'll be seeing soon the . . . S-81 Civic Patrol —Keeps you "in the know" on emergency radio messages! Covers VHF 152-174 Mc. (S-82 covers H/F 30-50 Mc). Either set. . . . . \$49.50

**S-80 Defender**—Super-sensitive, long-life battery radio for remote areas and emergency civil defense. Standard broadcast plus short-wave from 6-18 Mc (aircraft, amateur, international broadcasts) . . . . . \$44.50 (Less batt.)

**S-78A**—Improved FM/AM chassis; radiation-proof; automatic frequency control; standard broadcast plus FM 88-108 Mc.; 8-watt push-pull output. . . . \$89.50



WORLD'S LEADING MANUFACTURER OF PRECISION RADIO & TELEVISION • CHICAGO 24, ILLINOIS

# THE AMERICAN RADIO RELAY LEAGUE, INC.,

is a noncommercial association of radio amateurs, bonded for the promotion of interest in amateur radio communication and experimentation, for the relaying of messages by radio, for the advancement of the radio art and of the public welfare, for the representation of the radio amateur in legislative matters, and for the maintenance of fraternalism and a high standard of conduct.

It is an incorporated association without capital stock, chartered under the laws of Connecticut. Its affairs are governed by a Board of Directors, elected every two years by the general membership. The officers are elected or appointed by the Directors. The League is noncommercial and no one commercially engaged in the manufacture, sale or rental of radio apparatus is eligible to membership on its board.

"Of, by and for the amateur," it numbers within its ranks practically every worth-while amateur in the nation and has a history of glorious achievement as the standard-bearer in amateur affairs.

Inquiries regarding membership are solicited. A bona fide interest in amateur radio is the only essential qualification; ownership of a transmitting station and knowledge of the code are not prerequisite, although full voting membership is granted only to licensed amateurs.

All general correspondence should be addressed to the administrative headquarters at West Hartford, Connecticut.



## Past Presidents

HIRAM PERCY MAXIM, W1AW, 1914-1936  
EUGENE C. WOODRUFF, W8CMP, 1936-1940

• • • • •

## Officers

President . . . . . GEORGE W. BAILEY, W2KH  
1 East 79th St., New York 21, N. Y.  
Vice-President . . . . . WAYLAND M. GROVES, W5NW  
P.O. Box 586, Odessa, Texas  
Vice-President . . . . . FRANCIS E. HANDY, W1BDI  
38 LaSalle Road, West Hartford, Connecticut  
Secretary . . . . . A. L. BUDLONG, W1BUD  
38 LaSalle Road, West Hartford, Connecticut  
Treasurer . . . . . DAVID H. HOUGHTON  
38 LaSalle Road, West Hartford, Connecticut  
• • • • •  
General Counsel . . . . . PAUL M. SEGAL  
816 Connecticut Ave., Washington 6, D.C.  
Assistant Secretaries . . . . . JOHN HUNTOON, W1LVQ  
RICHARD L. BALDWIN, W1IKE . . . . . HARRY PASTON, W1DJV  
38 LaSalle Road, West Hartford, Connecticut

## DIRECTORS

### Canada

ALEX REID . . . . . VE2BDE  
240 Logan Ave., St. Lambert, P. Q.  
Vice-Director: William W. Butchart . . . . . VE6LQ  
10740 107 St., Edmonton, Alta.

### Atlantic Division

WALTER BRADLEY MARTIN . . . . . W3QV  
1033 Arbutha Rd., Abington, Pa.  
Vice-Director: Henry W. Wickensler, Jr. . . . . W3KWA  
1112 State Ave., Coraopolis, Pa.

### Central Division

WESLEY E. MARRINER . . . . . W9AND  
844 N. Galena Ave., Dixon 7, Ill.  
Vice-Director: Charles F. Reberg . . . . . W9MVZ  
3900 W. 10th Ave., Gary, Ind.

### Dakota Division

GOODWIN L. DOSLAND . . . . . W0TSN  
Moorhead, Minn.  
Vice-Director: Alfred M. Gowan . . . . . W0PHR  
325 S. Menlo Ave., Sioux Falls, S. D.

### Delta Division

VICTOR CANFIELD . . . . . W5BSR  
P. O. Box 965, Lake Charles, La.  
Vice-Director: George S. Acton . . . . . W5BMM  
Plain Dealing, La.

### Great Lakes Division

JOHN H. BRABB . . . . . W8SFP  
417 Ford Bldg., Detroit 26, Mich.  
Vice-Director: Harold E. Stricker . . . . . W8WZ  
247 W. 5th St., Marysville, Ohio

### Hudson Division

JOSEPH M. JOHNSTON . . . . . W2SOX  
423 Monmouth Ave., Bradley Beach, N. J.  
Vice-Director: George V. Cooke, Jr. . . . . W2OBU  
58-31 239th St., Bellerose 6, L. I., N. Y.

### Midwest Division

LEONARD COLLETT . . . . . W0DEA  
Box 88, c/o C.A.A., Arana, Guam, M. I.  
Address correspondence to the Acting Director:  
ALVIN G. KEYES . . . . . W0KTQ  
1201 Merchants Nat'l Bank Bldg., Cedar Rapids, Ia.

### New England Division

PERCY C. NOBLE . . . . . W1RVR  
37 Broad St., Westfield, Mass.  
Vice-Director: Frank L. Baker, Jr. . . . . W1ALP  
91 Atlantic St., North Quincy 71, Mass.

### Northwestern Division

R. REX ROBERTS . . . . . W7CPY  
837 Park Hill Drive, Billings, Mont.  
Vice-Director: Karl W. Weingarten . . . . . W7BG  
3219 N. 24th St., Tacoma 7, Wash.

### Pacific Division

KENNETH E. HUGHES . . . . . W6CIS  
810 W. Orange Ave., So. San Francisco, Calif.  
Vice-Director: C. Porter Evans . . . . . W6BF  
134 Dracena Ave., Piedmont 11, Calif.

### Roanoke Division

WILLIAM H. JACORS . . . . . W4CVQ  
Route 6, Raleigh, N. C.  
Vice-Director: Gus M. Browling . . . . . W4BPD  
135 Broughton St., S. E., Orangeburg, S. C.

### Rocky Mountain Division

FRANKLIN K. MATEJKA . . . . . W0DD  
P. O. Box 212, Estes Park, Colo.  
Vice-Director: Ramon S. Walker . . . . . W0OWP  
P. O. Box X, Brush, Colo.

### Southeastern Division

LAMAR HILL . . . . . W4BOL  
104 Myrtle, Cochran, Ga.  
Vice-Director: William P. Slides . . . . . W4AUP  
Fleming Road, Montgomery, Ala.

### Southwestern Division

JOHN R. GRIGGS . . . . . W6KW  
10412 Don Pico Rd., RFD 2, Spring Valley, Calif.  
Vice-Director: Walter R. Joos . . . . . W6EKM  
1315 N. Overhill Drive, Inglewood 3, Calif.

### West Gulf Division

A. DAVID MIDDLETON . . . . . W5CA  
9 Kay Road, Tlheras, N. M.  
Vice-Director: Frank E. Fisher . . . . . W5AHT/AST  
104 E. 11th, Pawhuska, Okla.

# "It Seems to Us..."

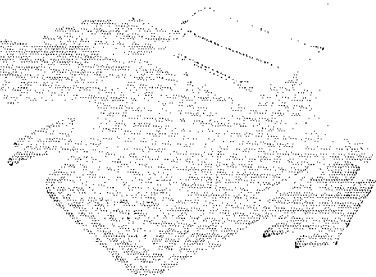

## THE SWEEPSTAKES

How long does it take to become a tradition? We don't know for sure, but we *are* pretty certain that the League's annual Sweepstakes has become a tradition in the fall operating plans of many hams. Yes, the SS is one of those contests in which participation grows by leaps and bounds through the years.

In was in January of 1930 that the first Sweepstakes contest was held, and, brother, it was really a contest. None of this weekend stuff — for fourteen full days the fellows went at it. There was no operating time limit, and it was a test not only of operating ability but also of sheer physical endurance. The winner that year contacted a grand total of 153 stations in 43 sections! The following year's contest also ran 14 days solid (with the winner working 305 stations in 54 sections), but perhaps too many of the boys dropped by the wayside, for in 1932 the SS ran for only nine days — encompassing two full weekends and the intervening weekdays. This same pattern was followed until 1936 when the SS was again shortened, to two weekends and a maximum operating time of 40 hours. This change was apparently made in response to the clamor of a large number of hams and XYLs for relief from the rigors of the longer contest period. As you can see from the present rules (pp. 54-55), that same schedule is still followed, but we might add that some folks *still* think it's too long.

If scores be any judge, then we hams have continually improved our operating ability and our equipment through the years. In 1941 one station made 831 QSOs, and this despite the fact that our VE friends had been forced to leave the air in 1939. From 1942 to 1945 the war forced curtailment of the SS. But in 1946 the contest was on again. Did five years of inactivity cause the masters to lose their touch? Not at all. In fact, the same ham who won in 1941 turned the trick again in 1946, and with a higher score. Since then, scores have consistently been higher, and last year (despite a severe storm on the East Coast) leading contestants worked about 1000 stations in the course of the 40-hour fray.

So far we have mentioned only the "big boys," the fellows whose exceptional skill and experience enables them to rack up astronomical scores. But the attraction of the SS is that

there's fun in it for everybody. (For everyone, that is, except the Headquarters' log checker!) You see, there's special credit for using a power input of less than 100 watts, and so the beginner and the fellow who doesn't own a kw. are not penalized. It's the sort of contest out of which you'll get a great deal of enjoyment and good experience, and what a chance to work those last few states for WAS!

Each year we see if we can't better last year's score — why don't *you* do the same!

## ELECTION TIME

Every day at the office the mail bag pours forth a new pile of ballots arriving from members in those divisions of the League now voting for candidates to the positions of director and vice-director. A lot of ballots are sent out — one to each Full Member in each division participating in the election. You might think that we would get most of those ballots back. But no, unfortunately, that is not true. The piles of ballots waiting for the day of counting may look big, but in some divisions they may represent only 50 per cent of the total votes which could be cast. Apathy? Maybe so. But perhaps it is a lack of understanding of the importance of voting, of the voice each Full Member has in the representative government of the League.

This voice of yours is mighty important. No one understood that better than the late Hiram Percy Maxim, our first president. At the Board meeting in May, the chairman, upon request, read two items from the "President's Box" in early issues of *QST*. It might be well to repeat some of those words of wisdom here, words which apply as well today as they did in years gone by.

"I asked my father once why the Puritans left a perfectly comfortable country to come over to the New World with its savage Indians and hard life. His answer was, 'In order that they might be able to worship God according to the dictates of their own conscience — and prevent others from doing the same.'

"I have thought about that many times in A.R.R.L. affairs. It gets one down to the fundamentals of government. It's a good thing to get down to the fundamentals every once in a while. It keeps one from getting off the road and becoming lost.

"Our A.R.R.L. government is strictly representative. Every two years our members in

each of our fourteen divisions select a man to represent them. These fourteen men are the directors of the A.R.R.L. What the majority of them vote to do is what the majority of the country thinks is best, and it is done.

"These men select a President, a Vice President, a Secretary, a Treasurer and a Communications Manager. They allow the President to vote to break a tie and they allow the Vice President to vote. All the other officers are hired men and they have no vote. The directors may hire or fire them at will. In other words, the directors, representing the entire country, are the rulers of A.R.R.L. It is typically American.

"The President may howl his head off for something. Unless he can convince a majority of the other fifteen directors that it is best for the A.R.R.L. as a whole, he is turned down.

"A director may argue and threaten for something his Division wants. Unless he can convince a majority of the other fifteen directors that it is best for the A.R.R.L. as a whole, he and his Division get turned down.

"In other words, no man nor no local group of men can impose their will upon the whole. Nobody can prevent 'others from doing the same.'

"That's Representative Government. The history of human affairs has shown that it's the kind of government that succeeds."

And *your* vote is the first step in the representative government system. Mark and mail your ballot today!

## LEAGUE FILES CALL-SIGN COMMENT

As reported in the "Happenings" column of October *QST*, the Federal Communications Commission has proposed withdrawal of special call-sign privileges which have been part of our regulations for years. The Executive Committee of the League vigorously opposed the Commission's proposal. At the same time, the Committee agreed that the League would accept *temporary* suspension of these provisions while the present condition of overload exists in the licensing section, caused by heavy flow of renewal applications this year. The League's position is stated in the following document filed with FCC:

### FEDERAL COMMUNICATIONS COMMISSION

In the Matter of  
Amendment of Part 12, "Rules  
Governing Amateur Radio Service." } Docket No. 10040

#### COMMENTS OF THE AMERICAN RADIO RELAY LEAGUE

##### I.

Pursuant to paragraph 4 of the Notice of Proposed Rule Making in Docket No. 10040, released August 27, 1951, the American Radio Relay League, Inc., files these comments.

##### II.

The essence of the proposal is to delete from §12.81 of the amateur rules several provisions, many of considerable years' standing, for the assignment of specific call signs to amateur stations under certain specified conditions. Paragraph (1) of the present text provides that a specific unassigned call sign may be reassigned to the most recent holder thereof; this provision was adopted by the Commission in 1935. Paragraph (2) provides that a specific unassigned call sign may be assigned to a previous holder if not under license during the last five years; this provision was adopted by the Commission in 1938. Paragraph (3) provides that a specific unassigned call sign may be assigned to an amateur organization in memoriam to a deceased member and former holder thereof; this provision was adopted by the Commission in 1938. Paragraph (4) provides that a specific call sign may be temporarily assigned to a station connected with an event, or events, of general public interest; this provision was made formal in 1938, but has been a policy of the Commission for at least twenty years. Paragraph (5) provides that an unassigned two-letter call sign may be assigned to a previous holder of a two-letter call sign; this provision was adopted by the Commission in 1946.

##### III.

It must be assumed that the Commission, at least in the past, has by adoption of these various rules considered the specified conditions to be meritorious and worthy of assignment of special call signs. Their desirability has thereby been established. The League, too, considers these provisions wise and sound, and extremely desirable for the amateur service. They have been Commission policy for periods ranging from five years to the entire length of time the Commission has had jurisdiction over the licensing of amateur stations. As such, they have become, in the minds of amateurs at least, a fixed and permanent part of the amateur rules and the Commission's policy toward the amateur service.

##### IV.

It is a fundamental, unique in the amateur service among all others under the jurisdiction of the Commission, that no pecuniary interest is involved. The amateur's individual enthusiasm is what governs his activity and therefore his ability to perform such public services as are outlined in §12.0 of the amateur rules. The morale of the amateur body is therefore of vital importance in determining the extent of his accomplishments. The several privileges under dis-

(Continued on page 180)

## Quist Quiz

**A** has a 10-meter beam fed with 60 feet of coax line. With a 2-turn coupling loop, it won't load the transmitter to rated plate current without running the coupling loop in all the way. Noticing this, **B** gets **A** to cut off 8 feet of coax line, and now the transmitter loads easily with the loop just barely in. **B** claims he improved the standing-wave ratio and that now the line is flat. **A** says **B** was lucky. Who is right?

(Please turn to page 180 for the answer)

• A *QST* department for YL amateurs will make its initial appearance in January, under the conductorship of Eleanor L. Wilson, W1QON. Anticipating a jam-packed mailbox, W1QON will be pleased to receive newsy items or photographs of interest to the YL fraternity at large. YL Editor Wilson's QTH: 318 Fisher St., Walpole, Mass.

# A De Luxe Mobile Transmitter for 14 and 28 Mc.

*A Thirty-Watt Rig with Solenoid-Type Switching Circuits*

BY C. VERNON CHAMBERS,\* WIJEQ

• This mobile transmitter permits the operator to change frequency — or bands — in less time than it takes to retune a receiver. It's a trunk-mounted job with a driver-compartment control for the frequency-shifting operation.

SEVERAL months ago Stephen S. Friedland, W5PKI,<sup>1</sup> suggested the use of a solenoid-type selector switch in the r.f. section of a trunk-mounted mobile transmitter. The idea met with immediate approval because it held promise of doing away with many of the driver-to-trunk-compartment trips that usually go hand in hand with the frequency-changing adjustments of a trunk-mounted rig. W5PKI also came up with the circuit diagram of a power supply system that permits use of either 6 volts d.c. or 115 volts a.c. as the primary source of power. The 115-volt feature provides relief for the car battery during periods of testing or parking-in-the-driveway operation when an extension cord can be run to a near-by a.c. outlet. These ideas plus the necessary laboratory work have resulted in the transmitting installation to be described.

The transmitter employs a crystal-controlled oscillator-multiplier stage followed by a parallel-tube neutralized amplifier. A solenoid selector unit is wired into the crystal and the r.f. tank circuits and permits remote selection of any one of ten operating frequencies — five frequencies each in the 14- and 28-Mc. bands. With the

original installation it is necessary to go back to the trunk to change the antenna connections before the transmitter is remotely switched from one band to another. However, we plan to eliminate manual antenna switching by the addition of another control switch, and a second coaxial changeover relay. A built-in audio system is used to plate modulate the transmitter.

The 300-volt 200-ma. power supply for the transmitter is designed for 115-volt a.c. input. During mobile operation, this input is supplied by an ATR<sup>2</sup> 6-volt d.c. to 110-volt a.c. inverter. The supply unit includes relays which permit remote control of the system and also includes switches that permit the following modes of operation:

- 1) All power from the car battery. Controls at driver's seat.
- 2) 6 volts d.c. for relays from the car battery. Controls at driver's seat. Supply of 115 volts a.c. for the inverter and the transmitter heaters from a near-by a.c. outlet.
- 3) Standard a.c. supply while removed from the car. Control by 115-volt a.c. relay of the high-voltage circuit.

## *The R.F. and Control Circuits*

Fig. 1 is the schematic diagram of the transmitter. The grid-plate oscillator employs a Type 5763 tube and uses either 3.5- or 7-Mc. crystals when driving the amplifier at 14 Mc. Either 7- or 9-Mc. crystals — preferably the latter — are used for 28-Mc. output. Section *A* of  $S_1$  is the crystal switch, wafer *C* is used as the bandswitch and sections *B* and *D* are used to connect the pretuned tank capacitors,  $C_5$  through  $C_9$  and  $C_{12}$  through  $C_{16}$ , across the 14- and 28-Mc. plate coils,  $L_1$  and

\* Technical Assistant, QST.

<sup>1</sup> Assistant Professor of Physics, University of Connecticut. Author of QST articles dealing with radiological monitoring.

<sup>2</sup> American Television & Radio Co., Saint Paul 1, Minn.

◆  
A control-position view of the mobile installation shows the control box mounted to the right of the converter.  
◆

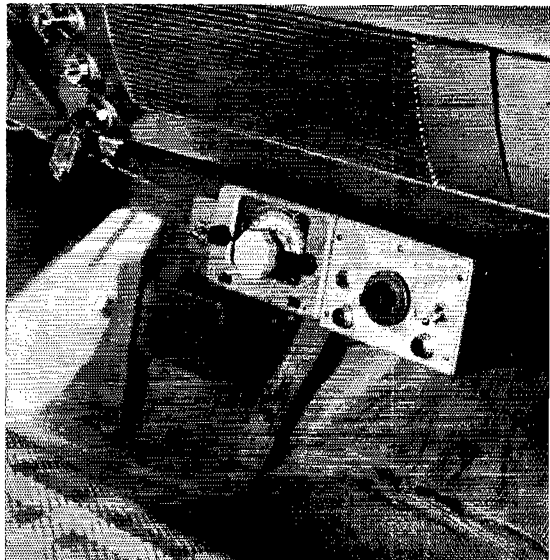

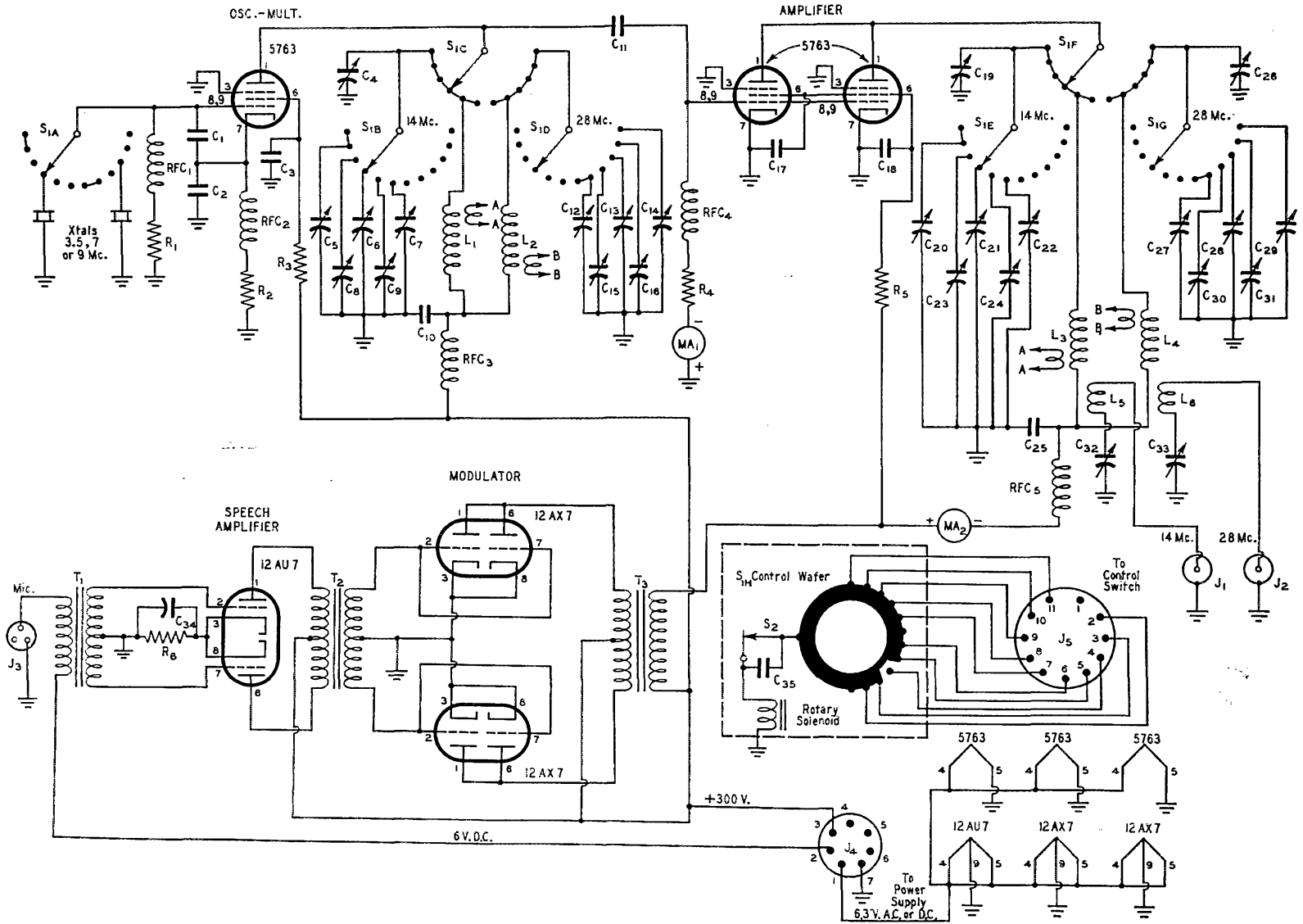

Fig. 1 — Wiring diagram of the mobile transmitter.

- $C_1$  — 15- $\mu$ fd. mica.  
 $C_2$  — 100- $\mu$ fd. mica.  
 $C_3, C_{10}, C_{17}, C_{18}, C_{25}$  — 0.001- $\mu$ fd. disc ceramic.  
 $C_4, C_5, C_6, C_7, C_8, C_9, C_{12}, C_{13}, C_{14}, C_{15}, C_{16}, C_{20}, C_{21}, C_{22}, C_{23}, C_{24}, C_{26}, C_{27}, C_{28}, C_{29}, C_{30}, C_{31}, C_{32}, C_{38}$  — 30- $\mu$ fd. ceramic trimmer (National M30).  
 $C_{11}$  — 100- $\mu$ fd. ceramic.  
 $C_{19}$  — 50- $\mu$ fd. ceramic trimmer (Centralab 822-AN).  
 $C_{34}$  — 10- $\mu$ fd. 50-volt electrolytic.  
 $C_{35}$  — 1- $\mu$ fd. 400-volt paper (Mallory UB-354).  
 $R_1$  — 22,000 ohms,  $\frac{1}{2}$  watt.  
 $R_2$  — 470 ohms,  $\frac{1}{2}$  watt.  
 $R_3$  — 22,000 ohms, 1 watt.  
 $R_4$  — 10,000 ohms, 1 watt.  
 $R_5$  — 4700 ohms, 1 watt.  
 $R_6$  — 680 ohms,  $\frac{1}{2}$  watt.  
 $L_1, L_3$  — 18 $\frac{1}{2}$  turns No. 20 wire, 1 $\frac{1}{8}$  inches long,  $\frac{1}{2}$ -inch diameter.  
 $L_2$  — 7 turns No. 20 wire,  $\frac{3}{16}$  inch long,  $\frac{1}{2}$ -inch diam.  
 $L_4$  — 10 turns No. 20 wire,  $\frac{3}{8}$  inch long,  $\frac{1}{2}$ -inch diam.  
 NOTE:  $L_1, L_2, L_3$  and  $L_4$  made with B&W Miniductor No. 3003.  
 $L_5$  — 16 turns No. 24 wire,  $\frac{1}{2}$  inch long,  $\frac{5}{8}$ -inch diam. (B&W 3008).  
 $L_6$  — 12 turns No. 24 wire,  $\frac{3}{8}$  inch long,  $\frac{1}{2}$ -inch diam. (B&W 3004).  
 $J_1, J_2$  — Coaxial fitting.  
 $J_3$  — Microphone jack.  
 $J_4$  — 7-prong power fitting.  
 $J_5$  — 11-prong cable fitting.  
 $MA_1$  — 0-15 ma. d.c.  
 $MA_2$  — 0-150 ma. d.c.  
 $RFC_1, RFC_4$  — 2.5-mh. 50-ma. r.f. choke (National R-50).  
 $RFC_2, RFC_3, RFC_5$  — 2.5-mh. 250-ma. r.f. choke (Millen 34102).  
 $S_1$  — Rotary solenoid switch (G. H. Leland A 4121-19).

$L_2$ . A padder,  $C_4$ , connected across  $L_1$  provides part of the circuit capacitance at 14 Mc.

Windings  $AA$  and  $BB$  are the oscillator ends of the amplifier neutralizing links. In construction, these links are positioned physically just as they are shown on the diagram — one at the top end of  $L_1$  and one at the bottom of  $L_2$  — for the pure and simple reason that they are less critical to adjust when so mounted.

Output from the oscillator is capacity-coupled to the grids of the Type 5763 amplifier tubes. These tubes are biased by the voltage drop across  $R_4$ , and the plate circuit of the stage is quite similar to that of the oscillator. Capacitors  $C_{20}$  through  $C_{24}$  tune the 14-Mc. plate coil,  $L_3$ , and  $C_{27}$  through  $C_{31}$  are switched across  $L_4$  at 28 Mc. Padders  $C_{19}$  and  $C_{26}$  are permanently connected across the plate inductors.

The amplifier neutralizing windings,  $AA$  and  $BB$ , are connected back to the links at the oscillator by means of twisted pair. Notice that winding  $BB$  is shown coupled to the top end of  $L_4$ .

$C_{32}$  and  $C_{33}$  are the series tuning capacitors for the r.f. output links,  $L_5$  and  $L_6$ .  $J_1$  and  $J_2$  are the output jacks; these are the points to which the second coaxial antenna changeover relay will soon be connected.

In Fig. 1,  $S_{1R}$  is the control wafer,  $S_2$  is an interrupter switch and  $C_{35}$  is a spark-suppression capacitor. Actuating voltage for the solenoid enters the circuit through the control cable jack,  $J_5$ . The control circuit is completed by a cable which runs between  $J_5$  and a selector switch located at the operating position. Other methods of remotely controlling the selector are described in a catalog available from G. H. Leland, Inc., 123 Webster St., Dayton 2, Ohio.

### The Audio Circuit

The audio circuit shown in Fig. 1 uses a s.b. carbon microphone transformer coupled to a 12AU7 push-pull driver stage. Two Type 12AX7s — each tube having similar elements connected in parallel — operate at zero-bias in a Class B modulator circuit which delivers approximately 15 watts output.

### The Power Supply Circuit

Transmitter power requirements of 300 volts at 200 ma. are supplied by the circuit shown in Fig. 2. The plate and the filament transformers,  $T_1$  and  $T_2$ , respectively, receive primary voltage through  $J_2$ . Switches  $S_1$  through  $S_4$  determine the mode of operation for the supply and the setting of the switches for the three modes is listed elsewhere. Relay  $Ry_3$  is in the 6-volt input circuit and is controlled from the operating position by a switch which is connected back to Prong 6 of  $J_4$ .  $Ry_2$ , the plate circuit switch, is controlled by the microphone push-to-talk switch which is in turn cabled back to Prong 7 of  $J_4$ . The  $Ry_2$ - $Ry_3$  relay combination is not used when the supply is removed from the car for straight a.c. input operation and at this time 115-volt a.c. is fed through  $J_1$  to  $Ry_1$  for on-off control of the plate transformer.

The power-output jack,  $J_3$ , is wired with independent 6-volt lines for the heaters of the transmitter and the microphone. This is done to allow a source of d.c. for the microphone and the antenna relay when the heater circuit is switched to a.c. operation.

Rectification in the high-voltage circuit is accomplished by the use of selenium rectifiers, thus doing away with rectifier-filament power con-

The transmitter, power supply and inverter are bolted to a shock-mounted board located in the trunk of the car.

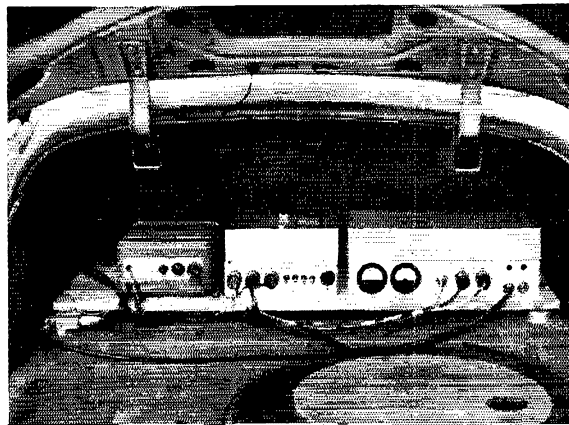

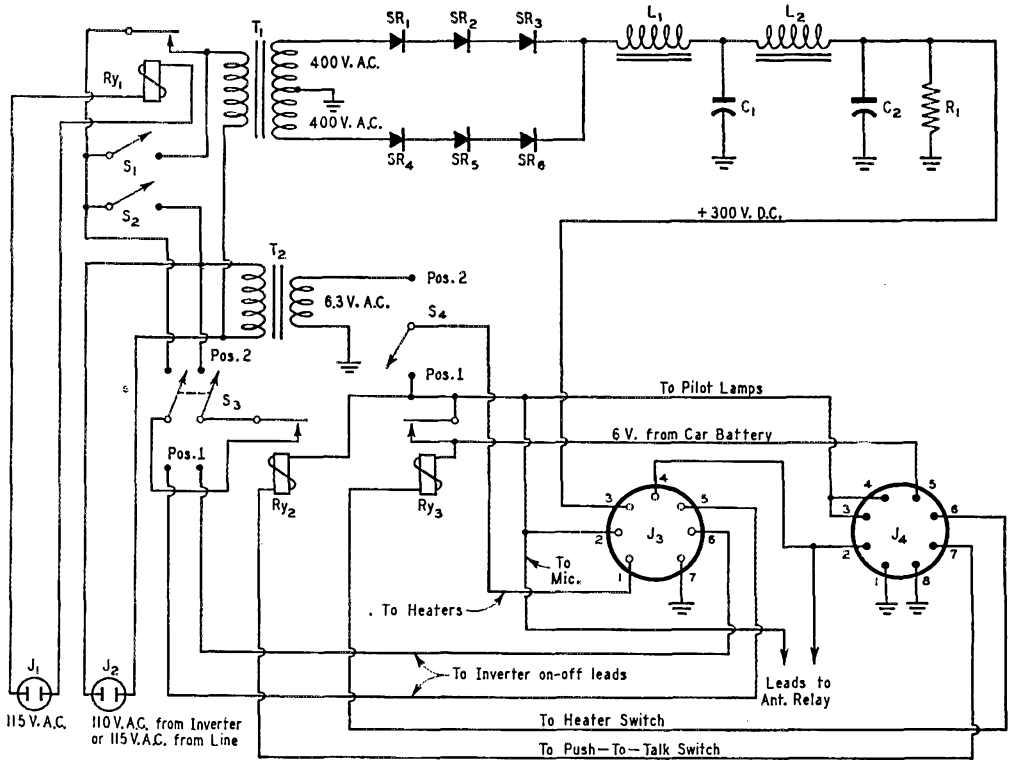

Fig. 2 — Wiring diagram of the triple-purpose power supply.

$C_1, C_2$  — 10- $\mu$ fd. 450-volt electrolytic.

$R_1$  — 0.1 megohm, 2 watts.

$L_1, L_2$  — 1.5-hy. 200-ma. filter choke (Merit C-2994).

$J_1, J_2$  — 115-volt a.c. connector.

$J_3$  — 7-prong female power fitting.

$J_4$  — 8-prong cable fitting.

$Ry_1$  — 115-volt relay.

$Ry_2, Ry_3$  — 6-volt relay.

$S_1, S_2$  — S.p.a.t. toggle switch.

$S_3$  — D.p.d.t. toggle switch.

$S_4$  — S.p.d.t. toggle switch.

$SR_1, SR_2, SR_3, SR_4, SR_5, SR_6$  — 100-ma. selenium rectifier.

$T_1$  — Receiver replacement transformer, 400 volts each side e.t., 200 ma.; filament windings not used (Merit P-2955).

$T_2$  — Filament transformer, 6.3 volts, 6 amp. (Thordarson T-21F11).

sumption. A choke-input filter that uses inexpensive TV replacement chokes is employed and the output from the system is 300 volts at 200 ma. when operated from the inverter output of 110 volts a.c. The output of the plate transformer increases considerably when the primary voltage is raised to 115 volts and for extended operation at this voltage it is recommended that 180-ohm 2-watt limiting resistors be connected in series with the rectifier input leads.

### The Control Circuit

The schematic diagram of the control box is shown in Fig. 3.  $S_1, S_2$  and  $S_3$  are the filament,

push-to-talk and rotary-solenoid control switches, respectively.  $J_4$  is the audio output jack,  $J_1$  is a connector for the 10-wire cable which runs back to  $J_5$  at the transmitter, and  $J_3$  accommodates the control leads which come from  $J_4$  of the power supply. Power for the solenoid circuit is connected to Pin 2 of  $J_3$ . Voltage for the filament and plate pilot lamps,  $I_1$  and  $I_2$ , is cabled from the supply unit to Pins 3 and 4 of  $J_3$  on the control box.

A relay,  $Ry_1$ , is installed in the b.c. receiver used with the original mobile installation. This relay is wired to the control box as shown in Fig. 3 and its purpose is to disable the receiver whenever the transmitter is turned on by the push-to-talk switch.



Front view of the mobile transmitter with the dust cover removed. Meters for the amplifier grid and plate circuits are at the left end of the chassis. Connectors for the microphone, the rotary solenoid and the power input cable are slightly off-center to the left of the coaxial output jacks. Holes drilled at the upper right-hand end of the chassis permit screwdriver adjustment of the antenna tuning capacitors.

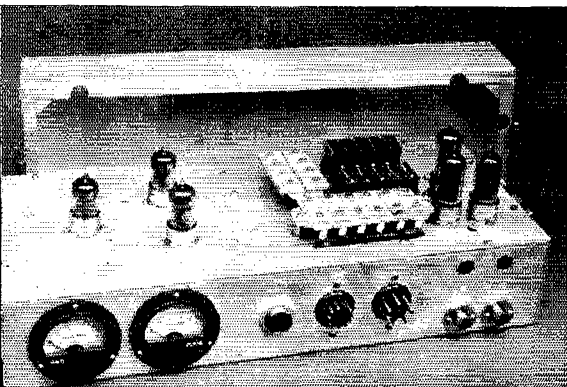



Bottom view of the mobile transmitter. A bottom cover equipped with padder-capacitor adjustment holes has been removed for this view.

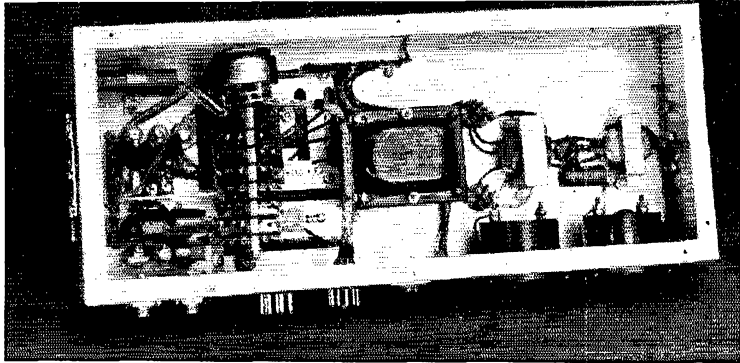

### Construction

A front view of the transmitter shows that two aluminum chassis, each measuring 7 by 17 by 3 inches, are used to enclose the r.f.-audio unit. One of the chassis serves as a dust cover which may be fastened to the main base by the door hinges which may be seen in the photograph. Construction of the transmitter was simplified by mounting most of the components on a flat piece of  $\frac{1}{16}$ -inch aluminum which was bolted to the chassis after the r.f. and audio wiring had been completed. This method of construction requires that a  $6 \times 16\frac{1}{2}$ -inch section be cut from the top of the 17-inch chassis.

POWER-SUPPLY SWITCH CHART

Mode of Operation	$S_1$	Switch Positions		
		$S_2$	$S_3$	$S_4$
1	closed	closed	1	1
2	closed	open	2	2
3	open	closed	1 or 2	2

As shown in the front view of the transmitter, the 12AU7 tube is located at the left end of the chassis to the left of the 12AX7 modulator tubes. The oscillator tube is centered at the right end of the base just to the rear of the r.f. amplifier tubes. A 10-position crystal holder is mounted to the left of the oscillator tube and a bracket holding eight of the padder capacitors is located to the left of the crystal holder. Twelve more of the padders are supported by a bracket mounted toward the front of the chassis. Slots are cut in the mounting plate just below the padder-capacitor terminals to accommodate leads to the selector switch.

A bottom view of the mobile transmitter shows the selector switch centered  $4\frac{1}{2}$  inches in from the left end of the chassis. An aluminum partition, measuring  $2\frac{1}{2}$  by 3 inches, separates the components for the oscillator and the amplifier circuits and is also used as a mounting board for  $RFC_1$ ,  $RFC_4$ ,  $R_1$  and  $R_4$ . A National type TPB bushing is mounted in the partition to permit a short connection between the oscillator plate and amplifier grid circuits.  $C_{35}$ , the spark-suppression condenser, is mounted at the upper left-hand corner of the chassis.

As seen in this view, the solenoid switch is mounted with the control wafer,  $S_{1B}$ , at the top of the photo and with the crystal switch,  $S_{1A}$ , next in line. Going toward the bottom of the photo, the remaining switches are  $B$  through  $G$  in that order.

Padder capacitors  $C_4$  and  $C_{19}$  are to the right of the selector switch and are mounted between the switch wafers and metal grounding posts. The 28-Mc. padder,  $C_{26}$ , is supported by a metal post at the rear of the chassis and by a No. 12 wire lead which runs to  $S_{1G}$ . Antenna trimmers  $C_{32}$  and  $C_{33}$  are bolted to the chassis by means of the mounting hardware for the amplifier tube sockets.

The plate coils for the r.f. circuits are self-supporting and are mounted between the plate r.f. chokes and the switches. The antenna coupling links may be cemented to the plate coils after the loading adjustment has been completed.

Layout of the audio sections starts with the

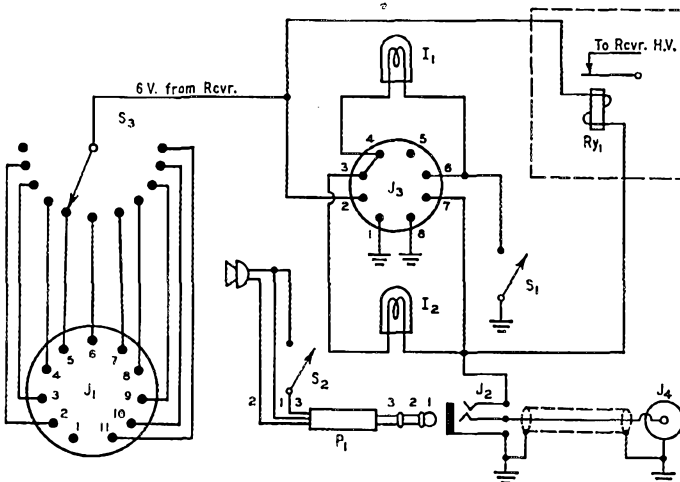

Fig. 3—Wiring diagram of the mobile transmitter control box.

- $I_1, I_2$  — 6-volt pilot-lamp assemblies.
- $J_1$  — 11-prong cable connector.
- $J_2$  — 3-circuit microphone jack.
- $J_3$  — 8-prong cable connector.
- $J_4$  — Coaxial fitting.
- $Ry_1$  — 6-volt relay (located in receiver).
- $S_1$  — S.p.s.t. toggle switch.
- $S_2$  — Microphone switch (included in microphone).
- $S_3$  — Single-pole 11-position selector switch (Centralab 1403).

microphone transformer at the right end of the chassis. The driver tube socket and  $T_2$  are next in line and the modulation transformer is to the left of the 12AX7 sockets. The dimensions of  $T_3$  are such that the transformer must be mounted on its side as shown in the photograph.

### Power Supply Construction

Aluminum chassis measuring 5 by 10 by 3 inches are used as the chassis and the dust cover for the power supply. As shown by the photographs of the unit, the dust cover must have a  $3 \times 3\frac{1}{4}$ -inch cut-out to provide clearance for the power transformer. The cover is fastened in place by means of  $3\frac{1}{2}$ -inch threaded brass rods which extend throughout the chassis to the top side of the cover.

The two filter chokes are mounted at the left end of the chassis and three stacks of selenium rectifiers may be seen at the left of the power transformer. The machine screws used to mount the rectifiers are insulated from the chassis by means of extruded fiber washers. The three rectifiers located closest to the base are connected in series to form one leg of the rectifier circuit and the remaining three are used in the other half of the circuit.

Looking at the bottom view of the power supply, the filament transformer is at the lower left-hand corner and relay  $Ry_3$  is on the rear wall of the chassis to the right of  $Ry_2$ . The a.c. relay,  $Ry_1$ , is mounted on the right-hand wall of the unit and the filter capacitors,  $C_1$  and  $C_2$ , are supported by tie-point strips on the left wall of the base. Several ventilation holes are drilled through unobstructed sections of the chassis.

### The Control Box

The appearance of the control box is made to resemble that of the converter used with the mobile installation. The box measures  $3\frac{7}{16}$  by  $5\frac{3}{16}$  by  $5\frac{1}{4}$  inches and is laid out with the frequency-selector switch flanked by the heater switch,  $S_1$ , and the microphone jack,  $J_2$ . Pilot lamp assemblies are located at the bottom edge of the panel. Jacks  $J_1$ ,  $J_3$  and  $J_4$  are mounted on the rear wall of the box.

### Testing

It is recommended that the gear be given a bench test before it is installed in the car. During this test, the transmitter may be operated from the triple-purpose supply or from any 300-volt 200-ma. unit. Heater power requirements for the transmitter are 6.3 volts — a.c. or d.c. — at 3.15 amp. D.c. voltage for the microphone must be available and a frequency-control switch must be wired to  $J_5$  of the transmitter chassis. Power to actuate the solenoid relay may be obtained from a storage battery or from a fairly stiff source of approximately 20 volts a.c.

If the triple-purpose power supply has been duplicated, this unit should be tested first. During the testing, it is recommended that the 180-ohm limiting resistors be installed and that the supply be loaded with a 1500-ohm resistor capable of dissipating at least 60 watts. With the switches set for a.c. operation (refer to the power-supply switch chart) and with 115-volt a.c. connected to  $J_2$ , the supply should deliver 300 volts when  $Ry_1$  has been closed by the application of 115 volts a.c. to  $J_1$ .

After the power equipment has been checked out and connected to the transmitter, the r.f. section may undergo preliminary adjustment. With voltage for the solenoid connected to the control switch, the selector-switch rotor arms should jump one position — counterclockwise as seen from the bottom of the chassis — each time the control-switch rotor arm is moved ahead one position. However, if the direction of travel for the control switch is reversed, the rotors of the selector switch should continue traveling counterclockwise until the rotors have traveled around to the desired closed-circuit position.

Crystals for the two bands may now be plugged into the holder and the selector switch set to connect capacitors  $C_5$  and  $C_{20}$  across  $L_1$  and  $L_3$ , respectively. Plate and screen voltage should be removed from the amplifier tubes by disconnecting the h.v. lead which runs over to the modulation transformer. With heater voltage applied to all 5763s and with plate voltage fed to the oscillator tube,  $C_4$  and  $C_5$  are adjusted for oscillator resonance as indicated by a flow of grid current through  $MA_1$ . Capacitors  $C_4$  and  $C_5$  should be readjusted so that circuit resonance occurs with the two capacitors having equal spacing between the stator and movable plates.

The remaining oscillator padders may now be individually tuned to resonance as the selector switch is advanced one step at a time. After each

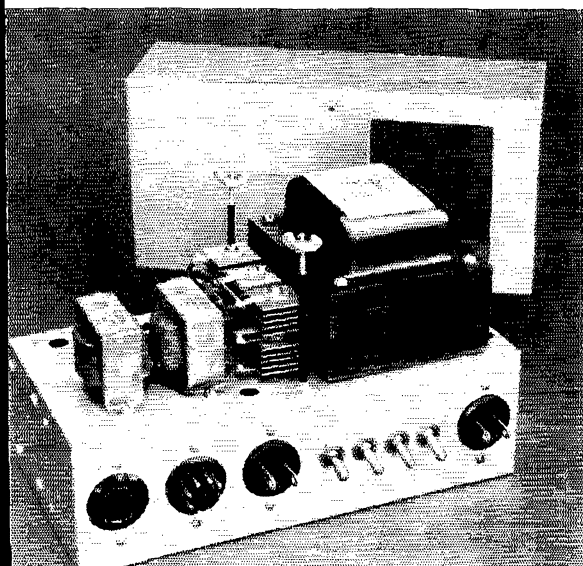

Open view of the triple-purpose power supply. Located from right to left across the front of the chassis are  $J_1$ ,  $S_1$  through  $S_4$ ,  $J_2$ ,  $J_4$  and  $J_3$ .

◆  
 An interior view of the power supply chassis with the hot-bottom tubes removed,  
 ◆

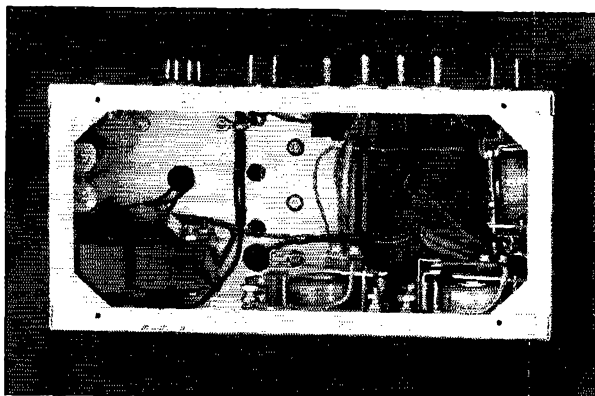

padder has been tuned for maximum current through  $MA_1$ , the amplifier neutralizing links may be adjusted. This operation must be performed at both 14 and 28 Mc. and is carried out without screen and plate voltage applied to the amplifier tubes. While a link is being adjusted, it is preferable that the amplifier be tuned to the center of the band. In any event, excitation is fed to the amplifier and this stage is resonated as indicated by a sudden change in rectified grid current. When resonating the amplifier, remember that part of the plate tuning capacitance is supplied by  $C_{19}$  and  $C_{21}$ . The links must be correctly poled and coupled by the experimental method and, when correctly adjusted, it will be possible to swing the amplifier tuning capacitors through resonance without affecting the grid-current reading.

Plate- and screen-voltage leads may now be reconnected to the amplifier tubes and an r.f. load for the output circuits must be available. It is difficult to duplicate the actual loading conditions that will be encountered in the mobile installation but a 15-watt lamp bulb may be used with reasonable success during the bench tests. With the bulb connected to  $J_1$  of the transmitter and with the amplifier operating at 14 Mc., the antenna coupling circuit,  $C_{32}$  and  $L_5$ , is adjusted for maximum loading as indicated by an amplifier plate current of approximately 75 ma. Amplifier stability may now be checked by removing the crystal and observing the meters. If the amplifier is completely neutralized, the grid current will fall to zero and the plate current will be well above 100 ma. When neutralized and loaded at 14 Mc. the amplifier grid current should be approximately 6 ma. when 3.5-Mc. crystals are used in the oscillator and the current will exceed this value when 7-Mc. crystals are employed. In the latter case, the current should be reduced to 6 ma. by detuning the oscillator tank circuit.

With the load transferred to  $J_2$  and with the transmitter switched to 28 Mc.,  $C_{33}$  and  $L_6$  are adjusted for maximum loading. The lamp bulb will probably load the amplifier more heavily at 28 Mc. than it did at 14 Mc. and it may even be possible to obtain the full-load amplifier current of 100 ma. In any event, the output-coupling ad-

justments are followed by the stability test outlined above. Maximum amplifier grid current will be approximately 4 ma. when 7-Mc. crystals are in use and the current should increase to 6 ma. when 9-Mc. crystals are used.

If a milliammeter is connected in the modulator plate circuit during the audio test, it should show no-signal-input and full-signal-input currents of approximately 30 and 70 ma., respectively.

After the equipment has been installed in the automobile, it is advisable to retune the transmitter with the lamp bulb serving as the dummy load. When retuned, the current readings for the transmitter may not agree exactly with those recorded during the bench test and, in all probability, the discrepancy can be traced to a somewhat lower primary voltage for the power supply.

Just what happens from here on in depends entirely on the antenna system that has been selected. We use a quarter-wave whip for 28-Mc. operation and the same antenna plus a loading coil for 14-Mc. work. The values of  $C$  and  $L$  used to couple the transmitter to the antenna system were worked out by the cut-and-try system and will probably require modification when used with any but the original antenna. The mobile chapter of the ARRL *Handbook* will be of assistance to anyone who should happen to run into antenna-loading problems.

When installed, this mobile transmitter allows frequency changes to be made at a rate of approximately thirty-five steps per second. And because it is so easy to change frequency — nothing more than a flip of the control switch — one must become very familiar with the output frequencies that correspond to the various positions of the control switch. After all, it's mighty embarrassing to be caught calling "CQ ten" — with the rig tuned to twenty.

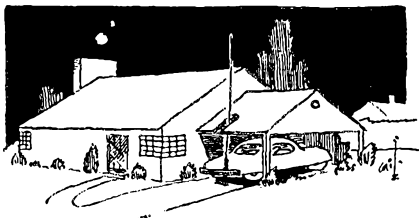

# High-Level Clipping and Filtering

## New Light on Clipper-Filter Behavior

BY WARREN B. BRUENE,\* WØTTK

**H**IGH-LEVEL filtering and "splatter filters" came into use several years ago for the purpose of preventing the radiation of spurious high-frequency sidebands. The high-frequency sidebands generated by overmodulating a plate-modulated amplifier were particularly bad, and the splatter filter<sup>1, 2, 3</sup> resulted from the effort to attain a high modulation level without transmitting the splatter so well-known in amateur circles.

However, the explanations given for the operation of these circuits never quite satisfied the writer. While checking the function of the series-diode negative-peak limiter in the "splatter filter," WØJET found that the transmitted bandwidth was less in his transmitter with the diode removed, and he advanced a theory for the reason why. The writer investigated this theory and studied the general problem of high-level clipping

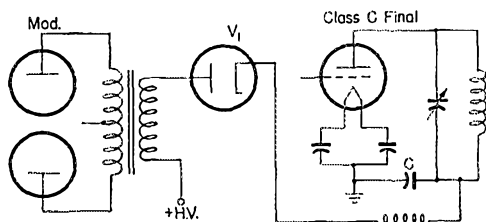

Fig. 1 - Series-diode negative peak limiter or "splatter preventer."

and filtering. It is hoped that the following discussion will clear up much of the misunderstanding regarding the operation of splatter filters<sup>4</sup> and indicate better methods of attaining the desired results.

Now let's get to the heart of our subject and examine Fig. 1. This shows a plate-modulated Class C final with a diode in series with the high-voltage supply to the Class C plate circuit. This is the conventional splatter filter circuit with the filter left out. The Class C final tube looks like a pure resistive load to any positive plate voltage. With  $V_1$  in the circuit the modulated plate voltage cannot swing the plate voltage negative, so for our analysis we can replace the Class C final amplifier with a resistance as shown in Fig. 2. The other important element of the circuit is the capacitance of the Class C final plate feed to

\* Collins Radio Co., Cedar Rapids, Iowa.

<sup>1</sup> W. W. Smith, "An Effective Splatter Suppressor," *Radio*, October, 1940.

<sup>2</sup> Thordarson Splatter Chokes and operating instructions.

<sup>3</sup> Chicago Transformer Splatter Chokes and operating instructions.

<sup>4</sup> Howard W. Johnson, "Self-Filtered Peak Clipping," *QST*, April, 1948.

• This discussion spotlights an inherent defect in the series-diode type of high-level clipper-filter system. The peculiar oscilloscope patterns obtained under certain conditions of modulation are readily explained by the author's analysis, and a better approach to high-level clipping and filtering is described.

ground. Most of this capacitance is contributed by the plate tank-to-ground by-pass condenser.

Now we can inspect Fig. 2 and see how it performs. First let us note that the diode  $V_1$  conducts only when its plate is positive with respect to the cathode and that it appears as an open circuit if its plate gets negative with respect to the cathode. This means that when the voltage at the top end of the modulation transformer secondary, terminal  $P$ , swings higher, the diode  $V_1$  conducts and the voltage across  $R$  (the Class C final) and  $C$  will follow the voltage at terminal  $P$ . It will actually be just a few volts less due to drop across  $V_1$ , but this is not significant.

Now, for the purpose of analysis, let the voltage at  $P$  swing down to zero instantly. Diode  $V_1$  looks like an open circuit because the charge on capacitor  $C$  keeps some positive voltage on the cathode of  $V_1$  although its plate is at zero potential. Capacitor  $C$  discharges through  $R$  and the voltage across  $R$  (the plate voltage on the Class C final) decays in the usual exponential manner as shown in Fig. 3A. The envelope of the r.f. output for this example is shown in Fig. 3B. If the capacitance of  $C$  is increased or the resistance of  $R$  increased, the voltage will drop down at a slower rate. The product  $RC$  is known as the time constant of the circuit and this defines the rate of voltage decay.

### Frequency Effects

With this background let's see what happens with sine-wave audio modulation. When the audio frequency is very low, the voltage across

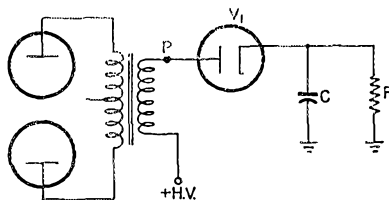

Fig. 2 - Equivalent circuit of Fig. 1, with resistor  $R$  replacing the modulating impedance of the Class C amplifier.

$R$  follows the voltage at point  $P$  over the entire cycle, because the downward voltage swing is so slow that  $C$  can discharge fast enough to keep from affecting the voltage across  $R$ . As the audio frequency is increased, a frequency is reached where the slope of the downward audio swing is steeper than the slope of the first part of the exponential curve shown in Fig. 3A. This shows up as diagonal clipping on the negative peaks, and it can be observed on an oscilloscope displaying the r.f. envelope. As the audio frequency is increased, the voltage at terminal  $P$  and the voltage on the Class C final changes as shown in Fig. 4 at A, B and C for three different audio frequencies. The corresponding 'scope patterns are shown in Fig. 4 at D, E and F.

By examining the diagrams in Fig. 4 we can explain a couple of other things that happen with high audio frequency modulation. In Fig. 4B, for example, it is noted that the average plate voltage is higher than the power-supply voltage. Higher average voltage means higher plate current to the Class C final, and this partly explains why the plate current kicks up with modulation when a splatter filter is used. When a steady sine wave is applied as in Fig. 4B, the actual carrier power is increased by the square of the increase in average plate voltage. Fig. 4B is repeated in Fig. 5 with the dashed line showing the average d.c. plate voltage on the final for this condition of operation. This increased average plate voltage and corresponding carrier power is called "positive carrier shift." The extra carrier power comes from the class B modulator and is rectified by the diode  $V_1$ .

Another thing to notice is that the percentage modulation goes down with increasing audio frequency even though the audio signal on the

modulator grids is maintained at the same level giving 100 per cent modulation if diode  $V_1$  were shorted out. (It should be noted that we have been discussing conditions where the audio input level would normally give 100 per cent modulation.) With lower audio signal levels the above results become less pronounced. This circuit thus

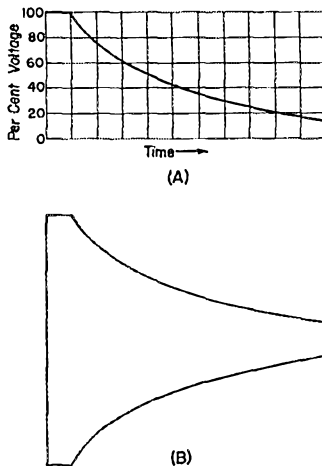

Fig. 3 — (A) Behavior of d.c. plate voltage on Class C amplifier when the plate-supply voltage is suddenly reduced to zero. (B) Corresponding oscilloscope pattern of r.f. envelope.

acts somewhat as a filter in that the high audio frequencies are "attenuated" but this attenuation depends upon amplitude and is less with lower-amplitude audio tones.

Fig. 6 shows this carrier shift due to rectification and the "attenuation" in the form of re-

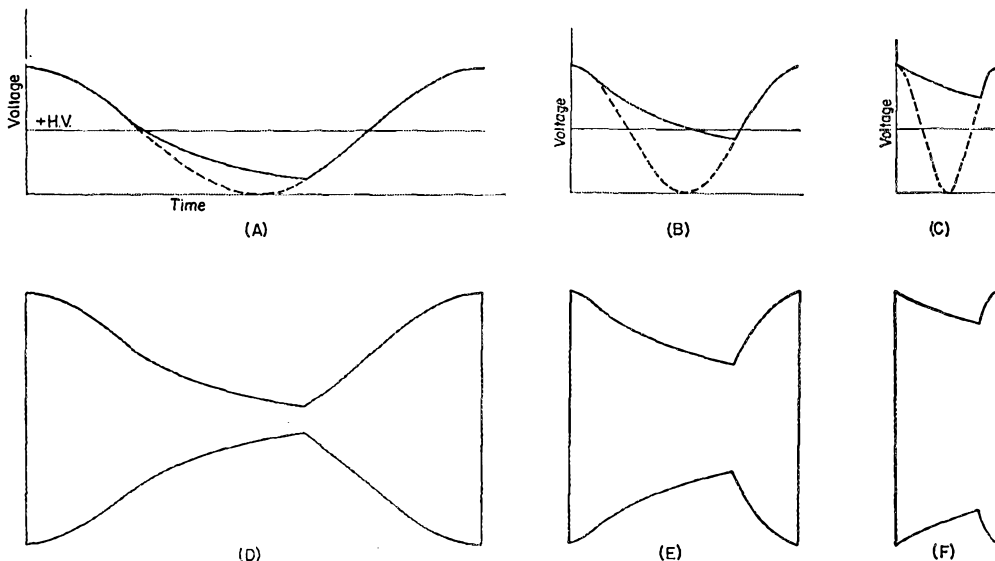

Fig. 4 — Instantaneous voltage, shown by solid curves in A, B, and C, at the plate of the Class C amplifier at various modulation frequencies when the series diode is used. A — moderately low frequency; B — moderately high frequency; C — very high frequency. The corresponding oscilloscope patterns of the r.f. envelope are shown at D, E and F.

duced modulation in an actual test case. The carrier shift and per cent modulation drop will start at correspondingly higher audio frequencies if the 0.007- $\mu$ fd. capacitor is reduced in value or if the Class C load resistance is reduced.

Incidentally, the writer very carefully checked to see if it made any difference when the diode  $V_1$  was placed on the bottom side of the modulation transformer between the Class C final power supply and the modulation transformer secondary.<sup>4</sup> The difference was always less than  $\frac{1}{2}$  db. and did not favor either way consistently.

The other thing to notice is that the modulation is no longer a sine wave and takes on more of a saw-tooth shape. This waveshape contains harmonics of the fundamental audio tone so that the actual bandwidth of the r.f. signal is much greater. The extra sidebands generated might be called splatter, although they will not be found to extend across the band as far as the ordinary splatter does. But even though the higher audio frequencies are "attenuated," high-order harmonics are generated which spread out the signal.

### Where To Clip

In Fig. 7 we have added the low-pass filter to give us the regular splatter filter circuit. Instead of just the simple capacitor  $C$  we have the

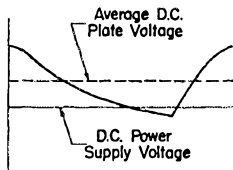

Fig. 5 — Showing how the condition of Fig. 4B results in a change in the average value of d.c. plate voltage, resulting in upward carrier shift.

whole low-pass filter. Figuring the time constant — or more correctly, the transient characteristics — of the filter with the load  $R$  becomes more complex, but the same type of patterns are observed on the 'scope as those shown in Fig. 4. The "time constant" of the filter varies with the value of  $m$  used in the filter design. The writer didn't go very deeply into determining the best value of  $m$ , but a few tests indicated that some value around 0.8 was best.

Now let's try to evaluate the performance of the splatter filter of Fig. 7 compared with the simple high-level filter shown in Fig. 8, which is the same except that the diode is omitted. The splatter filter does reduce splatter to a substantial degree compared with no filter at all, which is attested by its popularity. The writer found in a lab set-up that using the diode did substantially reduce splatter if the modulators were capable of heavy overmodulation. If their power output capability was only enough to overmodulate the Class C final slightly, it made no difference whether the diode was used or not.

High-powered modulators, when using a splatter filter, will deliver more sideband power but this extra-heavy modulation is principally effective on the lower voice frequencies, which produce most of the audio power. However, the original

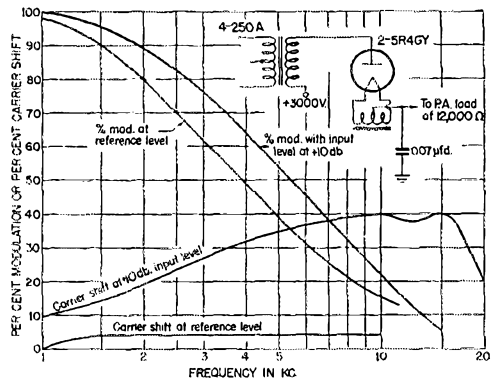

Fig. 6 — Carrier shift and modulation percentage versus modulating frequency in a representative set-up. The curves are referred to the signal-input level, at the grids of the Class B modulators, that gives 100 per cent modulation at 1000 c.p.s. without the series diode.

research on speech clipping showed that much of the intelligibility contained in speech is in the consonant sounds, which are the higher audio frequencies, and that the vowels or lower voice frequencies can be reduced in amplitude several times without impairing intelligibility. Thus, it is better to use a modulator just capable of 100 per cent modulation, along with some form of good speech clipping.

When using the splatter filter the high frequencies, starting from around the cut-off frequency of the filter and going higher, are rectified and cause part of the kicking up of the final plate current meter. However, most of the kicking up is from the heavy modulation of the low-frequency positive peaks, which also cause the average d.c. plate voltage to increase on the final. It may be a thrill to see the modulators blush and the meters kick up, but the value in "getting out" better than a good speech clipper is very doubtful. To "get out" better some form of good speech clipping with modulation limited to just under 100 per cent is a better solution.

One good place to do speech clipping is right in the plates of the Class B modulators.<sup>5</sup> This can be done by raising the plate-to-plate load impedance on the Class B modulators until they are not quite capable of 100 per cent modulation. This can be readily accomplished if a multitap modulation transformer<sup>6</sup> is used. Another way is to lower the d.c. plate voltage on the Class B modulators (but not the Class C final) until they

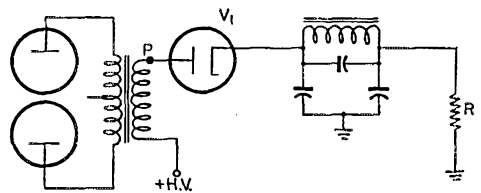

Fig. 7 — Complete splatter filter with series diode and low-pass filter. Resistor  $R$  is the modulating impedance of the Class C amplifier.

are just not quite capable of modulating the final 100 per cent no matter how loudly you yell into the microphone. (Of course, the modulator bias should be reduced also to keep the proper modulator static plate current.) This adjustment should be made with the final loaded in the usual manner or slightly on the light side, because the clipping or plate-overloading level will increase a little in most modulators when the final is loaded more lightly.

Clipping right in the modulator stage reduces the problem of avoiding phase shift of the clipped waves because there is nothing left to shift phase except the modulation transformer and the high-level filter.<sup>7</sup> To avoid unnecessary "tipping" of the top of the clipped wave a modulation transformer with good low-frequency response, along with only one section of filter, is recommended. The filter section should be designed with an  $m$  of 0.8 or, perhaps better yet, may be a constant- $k$  or simple pi-section filter. The straight pi-section filter shown in Fig. 8 doesn't cut off as sharply as the  $m$ -section type but it gives better attenuation farther out, which is more important.

Incidentally, a heavily-clipped wave approaches a square wave in shape and a modulator capable of 100 watts sine-wave output will deliver nearly 200 watts of square-wave output. This helps explain why a transmitter with good speech clipping carries the punch that it does. This isn't hard on the modulator tubes either because their plate efficiency is much higher when passing a clipped wave, so the plate dissipation is nearly the same with either sine-wave or square-wave modulation.

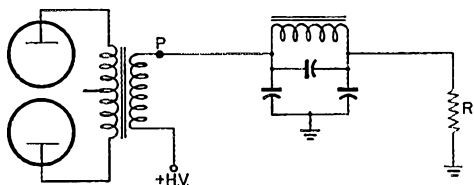

Fig. 8 — Low-pass filter for removing high-frequency components of Class B modulator output and thus preventing splatter. As described in the text, this type of circuit is highly effective when following a Class B modulator adjusted to clip both sides of the wave at or just below the 100 per cent modulation level.

It will be hard on the modulator tubes to run frequency-response tests at 100 per cent sine-wave modulation up beyond the cut-off frequency of the filter because above cut-off they see essentially just the input capacity of the filter, but with voice modulation they can take it. If you want to make life easier for the modulator tubes, put a low-pass filter<sup>8</sup> up in the front end of the speech amplifier and choose the cut-off frequency

<sup>6</sup> Woodrow Smith, "Simplified Speech Clipping," *CQ*, May, 1948.

<sup>8</sup> Adjustable impedance modulation transformers such as the Multi-match, Varimatch, Poly-Pedance modulation transformers.

<sup>7</sup> It is hoped that the effect of phase shift on clipper-filter performance can be discussed in detail in a subsequent article.

<sup>8</sup> Chicago Transformer LPF-1, for example.

of the high-level filter to be a little higher than that of the filter in the front end.

The writer made many tests in the laboratory using all sorts of equipment to test out this theory of high-level clipping and filtering. Also, on-the-air tests at WØJET and WØTTK confirm the theory. Many interesting things were discovered during the tests, but space will only allow the basic discussion which has been presented.

In conclusion, the writer wishes to point out again that some good form of speech clipping that clips both the positive and negative audio peaks, followed by a single-section high-level filter, will give about all that can be practically obtained in

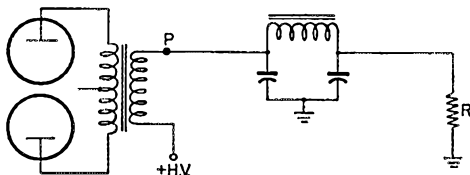

Fig. 9 — Similar to Fig. 8, except that a constant- $k$  filter section replaces the  $m$ -derived section of Fig. 8. Formulas for designing both types of sections may be found in *The Radio Amateur's Handbook*.

the way of heavy modulation without splatter. Careful choice or adjustment of the modulator plate load impedance to limit the modulator power output is well worth while. For example, when using Class B 810s in a 1-kw. transmitter with 2250 to 2500 volts on them, the plate-to-plate impedance should be about 18,000 ohms instead of 12,000 ohms, to limit the sine-wave output to 500 watts. In addition to better performance, this system is more economical since the cost of several parts is saved and the high voltage peaks on the Class C tank circuit are kept down to normal.

## A.R.R.L. ACTIVITIES CALENDAR

- Nov. 5th: CP Qualifying Run — W6OWP
- Nov. 17th-18th, 24th-25th: Sweepstakes Contest
- Nov. 20th: CP Qualifying Run — W1AW, WØTQD
- Dec. 7th: CP Qualifying Run — W6OWP
- Dec. 7th-10th, 14th-16th: 10-Meter WAS Party
- Dec. 19th: CP Qualifying Run — W1AW, WØTQD
- Jan. 5th: CP Qualifying Run — W6OWP
- Jan. 12th-13th: V.H.F. Sweepstakes
- Jan. 17th: CP Qualifying Run — W1AW, WØTQD
- Jan. 19th-20th: CD QSO Party (c.w.)
- Jan. 26th-27th: CD QSO Party ('phone)
- Feb. 1st-3rd: DX Competition ('phone)
- Feb. 5th: Frequency Measuring Test
- Feb. 5th: CP Qualifying Run — W6OWP
- Feb. 8th-10th: DX Competition ('phone)
- Feb. 15th: CP Qualifying Run — W1AW, WØTQD
- Feb. 29th, Mar. 1st-2nd: DX Competition (c.w.)
- Mar. 6th: CP Qualifying Run — W6OWP
- Mar. 7th-9th: DX Competition (c.w.)
- Mar. 17th: CP Qualifying Run — W1AW, WØTQD

# The Novice Conversion of a "Command" Transmitter

*A 75-Watt Low-Cost Rig for 80-Meter C.W. Operation*

BY R. M. SMITH,\* W1FTX, AND W. E. BRADLEY,\*\* W1FWH

IN the years of plentiful surplus gear, it was relatively inexpensive to get a transmitter on the air. Beautifully constructed military gear could be purchased for "a song," and with a little work it could be made into something that approached a ham's dream. Times have changed, and so has the value of the dollar. As a result, the newcomer to amateur radio finds himself faced with a financial obstacle that is apt to be a great deal tougher to pass than the license examination. There remains, however, one unit of surplus gear that fills the bill for the newcomer. It costs only \$5.95 at this writing, and with a little work it can be made into a 75-watt transmitter admirably suited to the requirements of holders of the Novice Class license. It is the 4- to 5.3-Mc. "Command" transmitter, known as either the BC-457A or T-20/ARC-5, depending on whether the Army or the Navy first purchased it.

"Command" series transmitters are designed for operation from a d.c. source not generally practical for amateur use. It is usually preferable, therefore, to modify the heater circuits for 12-volt a.c. operation, and to provide a keying system that does not require the use of the 28-volt d.c. relays supplied with the set. In addition, the original frequency coverage of the unit does not include any of the amateur bands (that is probably why it is still inexpensive), and it uses a variable frequency oscillator. Thus, before it can

\*Technical Assistant, QST.

\*\*Technical Information Service, ARRL.

• The 4- to 5.3-Mc. "Command" transmitters can still be obtained for \$5.95. For a few hours' work and a few dollars worth of parts, the Novice can convert one for use as a 75-watt crystal-controlled rig. When he advances to a higher license rating, he can restore it to use as a VFO. This article tells how it is done.

be used by the Novice licensee, it must be modified to cover 3700 to 3750 kc. and to use a crystal-controlled oscillator. Fortunately, all of these are simple changes, requiring only a few hours' time, and no elaborate tools. The resulting transmitter is a 75-watt rig that can't be equalled for several times the cost.

## Preparing for the Modification

Some of the circuitry of the original transmitter is superfluous so far as this modification is concerned. For example, the calibrating crystal (4400 kc.) and its associated magic-eye tube will be useless because the frequency range must be changed. It is best, therefore, to remove all of the superfluous parts, and to start with a clean slate.

Both "before" and "after" diagrams of the oscillator portion of the circuit are shown in Fig. 1. 1. Remove the bottom plate, and then carefully unsolder and remove each of the small parts found mounted on the three octal sockets at the

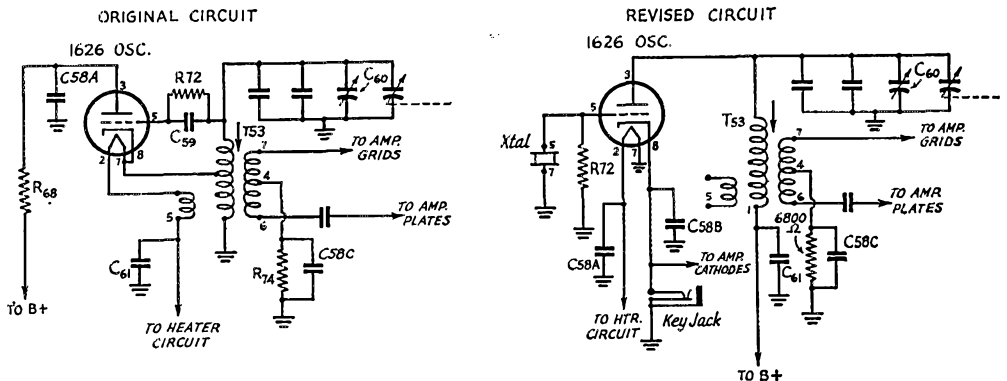

Fig. 1— "Before" and "after" versions of the oscillator circuit. Note that the principal change is the transfer of the tuned circuit from the grid to the plate. A crystal is used in the grid circuit. The diagram has been simplified by the omission of the calibrating circuit, which is removed from the transmitter. Symbol designations are those used in the diagrams of the original equipment, and are used here for reference purposes only. Values, where different from the original, are given in the text.



Rear view of the modified transmitter. The oscillator coil is visible just to the right of the oscillator tube. The new crystal is placed in the center socket, replacing the calibrating crystal.

rear. Also remove the 3-section 0.05- $\mu$ fd. can-type by-pass condenser ( $C_{53}$ ) that is bolted to the rear just over the oscillator socket. This and several other parts are to be used again, so keep them handy. Next, clip all of the leads from the inside of the power socket, and pry it loose so that it can be pushed out from the inside. Now remove all of the bare tinned wires that run between the base terminals of the oscillator coil (visible just "forward" of the oscillator socket) and the octal sockets mounted along the rear. Do *not* remove any of the tinned wires that run from these terminals to other portions of the transmitter. Remove the large wire-wound resistor that is held in spring clips just below the eye-tube socket, and also the wires which connect it to the socket. The two relays can also be removed, as well as the wires which are connected to them.

There will be a number of clipped wires cluttering up the transmitter at this point. The only ones to keep are the B-plus lead to the amplifier stage (red with white tracer), and the screen supply lead (yellow). Remove all the rest, unless they are found to be connected to the heater circuit (Pins 2 and 7 of the oscillator and eye tubes, Pins 1 and 7 of the amplifier tubes).

Install a 5-circuit male connector (Amphenol 87RCP5) in the hole formerly occupied by the power socket. Slip grounding lugs under each of the screws that hold the new connector in place. Connect the plate lead mentioned above to one of the terminals, and the screen lead to another. A third should be grounded to the chassis. It doesn't matter much which terminals you choose, but jot them down so you will know what connections to use when applying power to the unit later.

The decks are now cleared for action, and the remaining job will be much simpler because the unnecessary parts have been removed.

#### **Rewiring Heaters**

As originally wired, the tubes are connected in a series-parallel circuit to permit the 12-volt tubes to be used with a 24-volt supply. For 12-volt operation the heaters *must* be wired in parallel. In step-by-step fashion, perform the following changes: (1) Remove the wire that joins Pins 7 and 8 of the oscillator tube socket. Connect Pin 7 to ground, using one of the ground lugs installed previously. (2) Leave the heater connections of the 1625 nearest the former location of the keying relay unchanged, but unsolder all of the wires that are connected to Pin 3 of the other 1625. Transfer the one wire which runs toward the rear of the chassis to Pin 7 of the same tube. The other wires can be removed, or taped up. Ground Pin 1 of this 1625 by connecting it to Pin 7 of the first 1625. (3) Connect Pin 2 of the magic-eye tube socket to Pin 2 of the oscil-

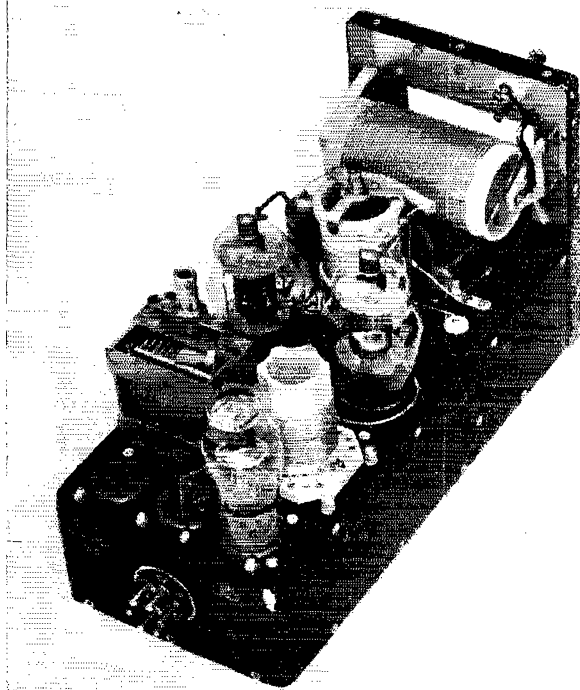

lator tube socket. Ground Pin 7 of the eye tube socket to the chassis. (4) Connect Pin 2 of the oscillator tube socket to an unoccupied terminal of the newly-installed power connector.

These changes result in the heaters being connected in parallel with one side of the circuit grounded so that they can be operated from a 12-volt source. Even though the eye tube is no longer required, its socket is wired for possible later use.

#### **Revising the Oscillator Circuit**

The next part of the conversion changes the oscillator coil from the grid circuit of the 1626 to its plate circuit, so that the tube can function as a triode crystal oscillator. Proceed as follows:

(1) Remove the shield can that covers the oscillator coil and condenser on top of the chassis. (2) Remove the ground connection from the bottom end of the coil. This connection is on the left-hand side of the coil when the transmitter is viewed from the front, and is in the form of a short strap running from one of the three coil-mounting screws to a point a short distance from the actual end of the winding. Merely unsolder the ground strap from the coil, and bend it back out of the way. (3) Looking at the coil from the same side, unsolder the lowest tap connection from the coil, but do not disconnect the other end of the wire, which goes to one of the terminals at the base of the coil. Solder this tap wire onto the bottom turn of the coil. Now turn the transmitter upside down again, and locate the terminals of the coil base. (4) Looking at the transmitter from the side which supports the worm gears, the coil base terminals project through two curved slots just forward of the oscillator tube socket. Number

these terminals in pencil, starting with the terminal nearest the oscillator socket as No. 1 and proceeding around the semicircle in clockwise fashion. Corresponding numbers are shown on the coils in Fig. 1. (5) Remove the wire that connects Pin 5 of the coil base to the smaller of the two mica condensers ( $C_{61}$ ) mounted on the side wall of the chassis. Remove any other wires that may be connected to the ungrounded side of the condenser. (6) Now connect this same condenser to Pin 1 of the base of the coil where it can serve as plate by-pass for the tuned plate circuit. Make sure that the other side of the condenser is grounded to the chassis. (7) Connect the stator plates of the gear-driven condenser to Pin 3 of the oscillator tube socket. (8) Run a wire from the ungrounded side of  $C_{61}$  to one of the unused terminals of the power jack. This provides a connection for the oscillator plate voltage.

The next stage of the conversion is the wiring of the remainder of the crystal oscillator circuit. It is done as follows: (1) Take one of the 51,000-ohm  $\frac{1}{2}$ -watt resistors ( $R_{72}$ ) removed at the start and connect it from Pin 5 of the oscillator tube socket to ground as a grid leak. (2) The new crystal is to be plugged into Pins 5 and 7 of the octal socket that formerly held the calibrating crystal. Run a wire from Pin 5 of the oscillator socket to Pin 5 of the crystal socket. Connect Pin 7 of the crystal socket to ground. Now remount the 3-section 0.05- $\mu$ f by-pass condenser,  $C_{58}$ , in its original position and connect one terminal to Pin 2 of the oscillator tube socket to provide a by-pass for the heater circuit. The remaining sections of this condenser will be used later.

### Revising the Keying Circuit

Cathode keying of both oscillator and amplifier stages is about as simple a system as could be desired in this application. A closed-circuit jack can be mounted on the panel just to the left of the main tuning dial, about  $1\frac{1}{2}$  inches below the locking nut for the antenna coupler. Pry off the small instruction plate, and drill the hole for the jack in its place. Remove the 51,000-ohm  $\frac{1}{2}$ -watt resistor,  $R_{75}$ , from the cathode circuit of the 1625 amplifiers, and connect the cathodes of both 1625s and the oscillator tube to the key jack. Use the second section of  $C_{58}$  as a by-pass condenser for the keying lead, connecting it to Pin 8 of the oscillator socket. Install a 0.005- $\mu$ f. disc ceramic by-pass condenser from Pin 6 to Pin 7 of each of the amplifier tube sockets. The addition of these condensers was found to be needed to kill a parasitic oscillation that showed up as a keying transient. The oscillation was detected only after it was found that each time the key was closed a near-by TV receiver "blinked." Further investigation revealed the parasitic to be at 86 Mc., right in Channel 6! The added by-pass condensers cured all traces of TVI.

The only thing remaining is to change the value of the grid leak of the amplifier stage. The 15,000-ohm resistor originally used is too large for c.w. operation, so a 6800-ohm 1-watt unit is

used instead. Connect it from Pin 4 of the oscillator coil base to chassis ground. The remaining unused section of  $C_{58}$  is also connected to Pin 4 to serve as by-pass for the grid leak.

### Power Supply Requirements

The oscillator plate circuit and the screen grids of the 1625s can be operated from a single supply rated to deliver 250 volts at about 40 or 50 ma. Plate supply for the 1625s can be anything from 400 to 750 volts. Because the transmitter is to be operated at a maximum of 75 watts input, the rating of the plate transformer need be only 100 ma. if a 750-volt supply is used, or about 200 ma. if it is to be 400 volts. The heater requirements are 12.6 volts a.c. at about 1.5 amperes.

A single 0-250-ma. d.c. meter will be adequate for correct tuning of the transmitter. In the simplest case, the power supply terminals can be arranged so that the meter can be transferred from the oscillator plate-supply lead to the high-voltage lead. Normally, the oscillator will be tuned first and then left alone, with further adjustments being confined to resonating and loading the amplifier stage, which calls for the use of the meter in series with the high-voltage lead.

### Adjustment

To change the frequency range of the transmitter to cover the 80-meter band, it is merely necessary to increase the capacity of the padder condensers in the oscillator and the amplifier circuits. With both padders set near maximum capacity the tuning range can be lowered enough to cover from about 3400 kc. to well above 4 Mc. The oscillator padder,  $C_{60}$ , is mounted on top of the chassis, to the right of the oscillator coil. The condenser rotor is locked by a screw passing through an arm attached to the shaft. Remove this screw so that the condenser can be rotated freely. Now set the main tuning dial to read about 4500 kc. Connect the 0-250-ma. d.c. meter in series with the oscillator plate supply lead, apply power (to the oscillator alone), close the key, and turn the oscillator padder condenser until plate current dips sharply. Plate current will be as high as 150 ma. before the circuit starts oscillating, so do not hold the key closed for more than a few seconds until resonance, as evidenced by the sharp dip, is established. Once the circuit starts oscillating, tune in the signal on a receiver, and key the oscillator. If, when the key is closed for the second time, the circuit does not start to oscillate, turn the main tuning control to a somewhat higher frequency until oscillation starts again. Like all triode oscillators, best keying is obtained only when the plate circuit is tuned to the high-frequency side of resonance. With a 250-volt plate supply, best keying and output will be obtained when the circuit is tuned far enough to the high side of resonance to produce about 25 ma. plate current in the oscillator tube. This is the maximum plate current permitted by the tube ratings. Note that the oscillator shield can should be left off, otherwise the circuit will be detuned.

◆  
Bottom view of the transmitter after the changes have been made. Removal of the superfluous wiring makes the modification simple and neat.  
◆

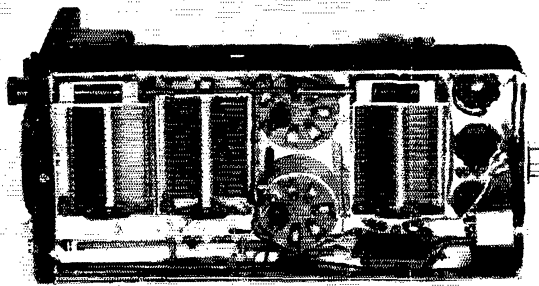

Once satisfactory keying has been established, connect the screen-grid supply lead to the 250-volt source, and anything between 400 and 750 volts to the amplifier plate supply lead. Transfer the milliammeter to the high-voltage supply lead. Apply power to all circuits, close the key, and quickly adjust the amplifier padder condenser, which is located directly below the amplifier plate coil, for a sharp dip, indicating resonance. This adjustment can be made with a screwdriver through the access hole provided on the right-hand side of the transmitter. Even after resonance has been established, the key should not be held closed for more than a few seconds until after the plate circuit has been loaded, otherwise screen current in the amplifier stage will be excessive.

Before the transmitter is put on the air, it should be checked while delivering power into a dummy load. A 60-watt lamp bulb connected between the antenna terminal and the chassis will serve as a suitable load. Before the lamp can be made to take power, however, it is necessary to add a temporary capacitance in parallel with the lamp. A 250- $\mu$ fd. receiving-type variable condenser set near maximum capacity will do the trick. While holding the key closed, and with the antenna coupling knob set at 8, turn the antenna inductance wheel until plate current rises to maximum. Depending on how much plate voltage is used, this should vary between 125 and 200 ma. Recheck the tuning of the amplifier plate circuit to make sure that it is still tuned to resonance. The dip at resonance will not be as pronounced as it was before the amplifier was loaded, but it should be possible to detect a slight dip as the padder is tuned through resonance. If not, reduce the numerical setting of the loading knob and try again, at the same time watching the brilliance of the lamp bulb, to tell when maximum power is being delivered.

Once properly loaded, the transmitter keying should be checked again to be sure that there are no serious key clicks or chirps. Slight readjustment of the oscillator padding condenser is called for if chirp is present. To check for clicks, tune in the signal on a receiver, and then remove the receiving antenna and ground the receiver antenna terminal. Then turn the b.f.o. of the receiver off, a.v.c. off, and set the r.f. gain control as low as possible. This will prevent the receiver from being overloaded by the transmitted signal, and will give a fairly good idea of the true performance of the transmitter. Send a series of slow dashes. If serious clicks are present, they will be easy to distinguish by this system. In the particular transmitter we modified, the keying was good on

"make" (as the key closes), but had a serious click on "break" (as the key opens). In addition to creating unwarranted QRM on the air, such a situation makes the offending signal difficult to copy, so it is doubly worth while to remedy the condition. We found that an 8- $\mu$ fd. 700-volt electrolytic condenser connected across the key (with the negative terminal to the ground side, of course) eliminated the "slurp" that existed on break, and made keying clean.

To put the transmitter on the air, it is merely necessary to remove the dummy load and the auxiliary loading condenser, and to connect the antenna to the output post. The variable antenna inductance in the transmitter will permit almost any length of wire to be used successfully. If a balanced or two-wire feeder system is to be used with a resonant antenna, it will be necessary to use an antenna coupler between the transmitter and the feeders. To do this, connect a link line from the antenna post to a 3- or 4-turn link winding coupled to the resonant circuit in the antenna coupler. The feeders can then be tapped onto the coil of the tuner, the taps being adjusted to give the desired impedance match.

One thing should be remembered. Novice licensees are not permitted to use in excess of 75 watts input to the output stage of their transmitter. With this transmitter it is possible to operate at considerably higher input than that. Loading, therefore, must be adjusted to give only the legal maximum input. This can be done with the antenna coupling knob. Its setting will depend largely on the plate supply voltage and the type of antenna used. The use of a supply voltage between 400 and 500 volts will make it easier to keep plate input within the legal limit. Use of a plate milliammeter is essential. If only a 750-volt supply is available, however, one of the 1625s can be made inoperative by opening one side of its heater circuit. If this is done, plate tuning and loading should be readjusted to produce 100 ma. plate current under load, and a 15,000-ohm grid leak should be used instead of the 6800-ohm unit called for here.

The Novice will find that he can have a lot of fun with this transmitter, and at comparatively low cost. Then, after he has progressed sufficiently to qualify for a General Class license, he can easily reconvert the unit to operate as a VFO transmitter, or as an exciter unit for a higher-power rig. All in all, it is our idea of a real bargain and a swell way to get on the air for the first time.

# Highlights of the Sixth ARRL National Convention

## *Seattle Hams Go All Out To Extend Hospitality of the Great Northwest*

**A**CCLAIMED by many who attended as the best convention ever held, the Sixth ARRL National Convention in Seattle on July 27th-29th is now history. But the fine spirit and the many outstanding events of the program will live on in the memories of those who were fortunate in being able to attend the first "national" held west of the Mississippi.

Seattle began to teem with hams and their friends as the convention week end drew near, and by registration time nearly 2000 conventioners from all parts of the world had assembled in the general vicinity of the headquarters at the Olympic Hotel. They poured in by train, auto, plane and boat. They came equipped with mobiles of every description — the parking areas were a sea of fishpole antennas! All W and VE districts were represented, as well as such distant places as KH6, KL7, XE, ZK2, VP4, KG6, KW6, TI, JA and others.

The Sixth National will be remembered for a number of "firsts" and unique attractions. On display was a complete amateur television station, W6VSV, which transmitted pictures from the convention auditorium to the official hotel. There was a mobile teletype installation, W6RL, which kept in communication with an amateur teletype exhibit in the auditorium. The convention station, W7AA, was in continuous operation on several bands to assist mobilers. A radio-controlled gasoline-powered lawnmower, built by W7JQQ, made short work of its grass-cutting tasks. Broadcast and TV programs, including a coast-to-coast NBC hook-up, stressed various phases of amateur radio and the convention program. The Mayor of Seattle proclaimed Saturday, July 28th, as Amateur Radio Day. It was, indeed, a super week end for the many ham visitors to Seattle.

But we are getting ahead of the story.

Friday morning was registration time at the Olympic Hotel. All day long a crew of over 50 Seattle hams and XYIs were kept busy giving out tickets, booklets, badges and information; another 50 or so acted as ushers, greeters and guides. By evening, several hundred Seattle hams and Convention Committeemen were actively involved with the conclave in some capacity or other. General Chairman W7RT's suite of rooms was a hectic place . . . the operating gang at W7AA were swamped with calls from mobiles and traffic of all descriptions. The Navy had a direct teletype line between the Olympic Hotel and the Civic Auditorium where the exhibits were staged, and soon the crew of Wave operators were deluged with traffic. Within a short while it became apparent to all that this convention was a large affair, and the tempo of plenty of action never did cease during the entire three days.

At 10 a.m. Friday, Art Peterson, W7NL, took the golfers in tow, and a thrilling tournament was held at Seattle's fashionable Sand Point Golf and Country Club. When the smoke of battle cleared away, prizes had been won by Bill Gress, W7MIG, for score of 79, "Bud" Bane, W6WB, for longest drive (250 yards), and "Wink" Wintler, W7KL, for low net of 78.

Numerous tours were started at 1:30 p.m. One of these took several hundred guests to the University of Washington for an inspection of the mammoth cyclotron. A similar-sized group went for a drive to the Government Locks, which connect Puget Sound salt water with the fresh water of Lake Washington. A third caravan drove across the Lake Washington floating bridge, largest pontoon-type structure in the world. Among those acting as leaders of the tours were W7MEU, W7BL, and W7MSI.

Motion pictures were shown during the afternoon in one of the hotel parlors, equipment being operated under the supervision of Bill Cox, W7OZG.

After the various Friday night dinners, the gang gathered at the Olympic for a trip to a radio broadcast originating from the Rainier Brewing Company's beautiful Mountain Room.

The next big event on Friday evening was the Deluxe Gab Session Jamboree in the Spanish Ballroom of the Olympic. A capacity audience

◆  
Partial view of the assemblage during the welcoming ceremonies.  
◆

**QST for**

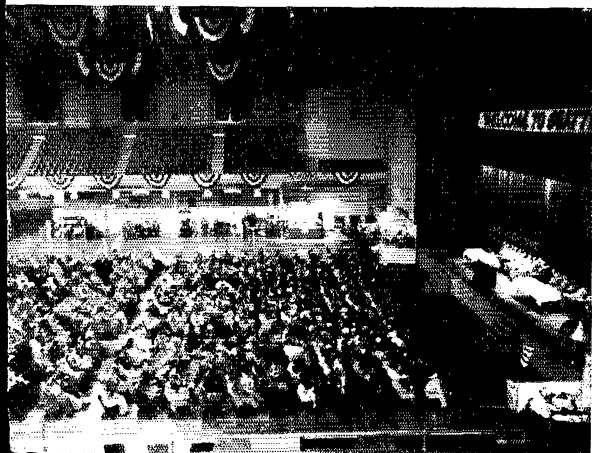

was treated to short skits, vocals, and introductions to prominent guests. It is not certain when the gab session ended, for rag chews lasted far into the night. It was a big day indeed for all good Night Owls!

On Saturday morning activities shifted from the Olympic to the gigantic Civic Auditorium. The Radio Exhibit was opened at 9 o'clock, and at 10:30 the official welcoming ceremonies began. Leo Myerson, W0GFQ, opened the program with a solemn and beautiful rendition of the National Anthem on the Hammond electric organ. Acting as emcee, George Dean, W7EAV, in charge of public relations for Seattle's KOMO, introduced representatives from the Governor's office, the Mayor's office, the armed forces, civil defense, FCC, and ARRL. Vice-Admiral Barbey, speaking as the personal representative of Governor Langlie, tendered a cordial welcome to the guests. At the conclusion of the address of welcome and responses by Northwestern Division Director R. Rex Roberts and ARRL President Bailey, General Chairman Gruble introduced the convention's DX guest of honor, Bill Scarborough, ZK2AA, who had come to the convention after many weeks of travel. Bill's warm remarks fittingly exemplified the friendliness and good



W7JQQ's radio-controlled lawnmower in action.



Convention Chairman W7RT holds leash of "Ham," 3-foot alligator brought to the convention by W4POF (kneeling right), representing Rebel Radio Club.



A "transmitter" blows up during the NBC Scandia Barn Dance program written and staged especially for the convention.

W7CV, winner of the men's code championships, is presented with trophies by ARRL President Bailey.



W3MSU, winner of the YL Quiz, and W3CDQ, YL code champ, receive awards from W2KH.





The panel at the Civil Defense Forum: *l. to r.*: Seattle EC Rex Hess, W7NJ; Sgt. Dwight Johnson, W7GMX, Washington State Patrol; Rear Admiral Barhey, in charge of CD for Washington State; ARRL Communications Manager F. E. Handy, W1BD1; Deputy Chief R. H. McRoberts, ex-8BA-8HII, Attack Warning and Communications Division, Federal Civil Defense Administration; C. Philip Horne, electronics engineer, FCDA.

will that exists among the hams of the world.

The welcoming ceremonies were over by noon, and the gang left for luncheon. Some 125 of the ladies, however, started on a scenic boat ride which took them from Lake Washington out into Puget Sound. This trip was directed by XYLs Ethel Tatro and Jessie Crook. The rest of the women guests, numbering several hundred, were taken to the Olympic Hotel for a luncheon, fashion show, and entertainment.

Meanwhile the OMs settled down for an afternoon of large meetings, the first of which was the ARRL business session, held in the Auditorium and attended by over a thousand amateurs. The meeting was directed by Northwestern Division Director Roberts, W7CPY.

Next came the Civil Defense Forum with Max Bice, W7AEA, acting as moderator and Gene Dodge, W7BTV, as organizer. Significant information was given and discussed by officials of the FCDA, Army, Navy, and ARRL.

After a short intermission, delegates witnessed a broadcast of the regular Seattle NBC program known as the Scandia Barn Dance, with script especially prepared for the National Convention. The entire staff of 50-kw. KOMO, Bill Vandermay, W7DET, chief engineer, assisted.

The National Code Competition was run off Saturday night at 7:30, with entries for both mill and hand copy for the OMs, and a special hand-copy contest for the YLs. Nat Burnett, W7CV (ex-W2GKB), won out in both men's divisions with 36-w.p.m. hand copy and 55-w.p.m. mill copy. Elizabeth Zandonini, W3CDQ, won the women's contest by putting down 32 w.p.m. with a stick.



At 9 P.M. Saturday, in a setting of glittering lights, came the big convention dance. All the women received free corsages. Jackie Souders and his fifteen-piece orchestra provided pleasing melodies as some 2000 hams and friends danced and enjoyed themselves. During intermissions, several entertainment features were presented. A big hit were the "West Seattle Rockettes," a group of hams from the West Seattle Amateur Radio Club. Cleverly done up as chorus gals, and executing delightful dance routines, these fellows had 'em rolling in the aisles. The boys had left their mikes and keys for several weeks of secret rehearsing under direction of Toddy Nye, W7LCS. Margaret Tapping (XYL of W7CBE), who is a dance instructor, presented a colorful Spanish dance number in the Latin style, accompanied by partner Darrell Henline.

At midnight, in an adjoining meeting hall, an ROWH ceremony was presented. The ROWH ritual was capably managed by Cas Arpke, W7LOZ, and was most impressive. Special sound effects were prepared by the staff of radio station KOMO, and the 200 candidates made this one of the largest ROWH rituals on record.

Breakfast on Sunday of necessity started late in the morning. The largest of the morning get-togethers was the DX breakfast, under the direction of Bob Hoffman, W7DL, ably assisted by Herb Becker, W6QD, and Larry LeKashman, W2IOP. The recounting of many anecdotes and spinning of tall tales provided a splendid program. A special DX quiz prepared by W6QD and Andy Elsner, W6ENV, kept the boys scratching. It was won by "Bud" Bane, W6WB. Also, several hundred copies of a delightful souvenir DX booklet, prepared by W6QD and W2IOP, were distributed to guests.

The traffic-minded and emergency gang got together at the SEC-SCM breakfast, with Rex Hess, W7NJ, and Larry Sebring, W7CZY (Washington SCM), in charge . . . another swell get-together!

(Continued on page 100)

A small portion of the more than three score licensed YL amateurs in attendance at the Sixth National. The convention featured a full program for the ladies under the direction of Mrs. Toddy Nye, W7LCS (back row, third from right).

# One Db. per Cycle!

## Real Skirt Selectivity for C.W. Reception

BY JOHN KAYE,\* W6SRV. AND DOROTHY KAYE,\* W6YIR

**D**OES an i.f. amplifier with better than one-db.-per-cycle selectivity sound fantastic? It means that detuning 80 cycles could attenuate the signal 80 db., and that is a mighty fast drop-off! However, such performance is possible, and Fig. 2 shows what can be obtained with the amplifier to be described. With selectivity like this, signals fall in and out of their niches, leaving many "holes" where signals used to be.

The case for selectivity has already been presented in *QST*<sup>1</sup> and need not be repeated here. Suffice to say, selectivity of this type gives much better protection against adjacent interfering signals than does a crystal filter, but the flat top of the curve allows signals to be tuned in more easily than when a crystal filter is used in its

sharpest position. The signal-to-noise ratio is improved because the "noise bandwidth" of the receiver is reduced without attenuating the signal.

### The Circuit

The i.f. amplifier that furnishes this selectivity operates at the relatively low frequency of 20 kc. This requires, of course, that the preceding i.f. amplifier (470 kc., in our case) have fairly good skirt selectivity to avoid images in the 20-kc. amplifier.

The heart of the amplifier is the twelve high-*Q* circuits, inductively coupled and arranged as shown in Fig. 1. The inductances are wound on powdered-iron toroid forms — the fact that toroids have no external field permits close assembly and reduces the shielding problem. The *Q* of each tuned circuit will depend to some extent upon the *Q* of the condenser tuning it. Small

\* 981 North First Street, Banning, Calif.

<sup>1</sup>Githens, "A Super-Selective C.W. Receiver," *QST*, August, 1948; Goodman, "A Variable-Selectivity Sharp I.F. Amplifier," *QST*, May, 1950.

◆

The receiver at W6SRV/W6YIR, of which the 20-kc. sharp i.f. amplifier described in this article is the part hiding under the cover at the bottom of the picture. The receiver tuning control (8-Mc. high-stability oscillator) is located at the operating position — the receiver proper is located downstairs in the basement.

Starting at the top, the 14-Mc. signal passes through two bandpass r.f. stages to a mixer where it is heterodyned to 6 Mc. After passing through a selective 6-Mc. amplifier, the signal is heterodyned to 470 kc. and passed through another sharp amplifier. The signal then goes through the 20-kc. amplifier and an audio amplifier. Except for the tunable 8-Mc. oscillator and the b.f.o., all oscillators are crystal-controlled. The gain throughout the system is held down up to the audio system, to avoid overload and to get the most out of the selectivity.

◆

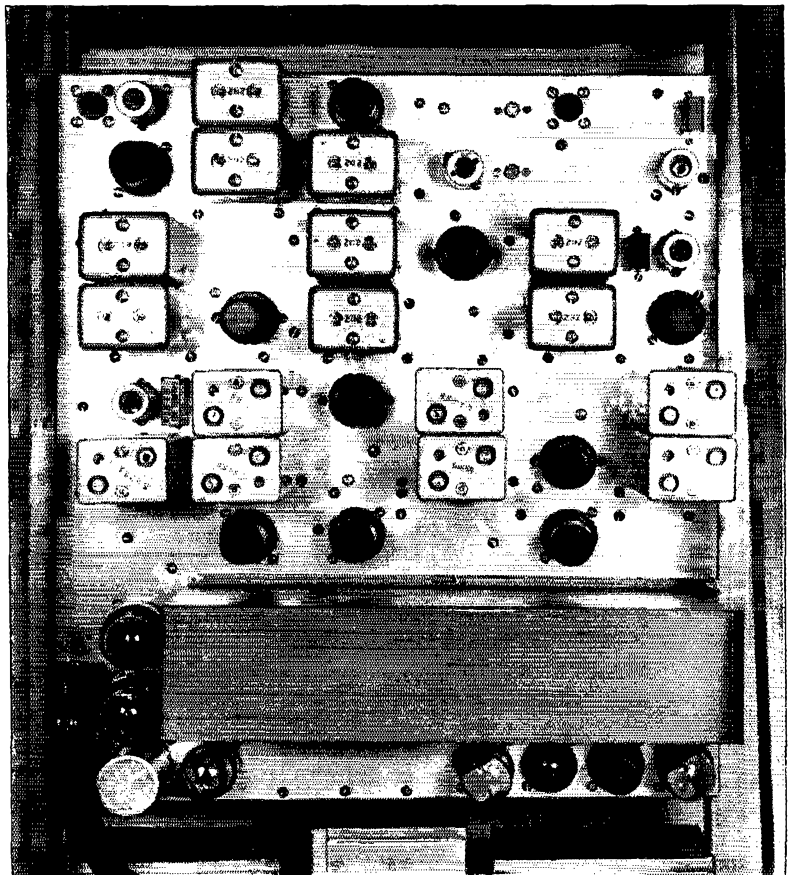

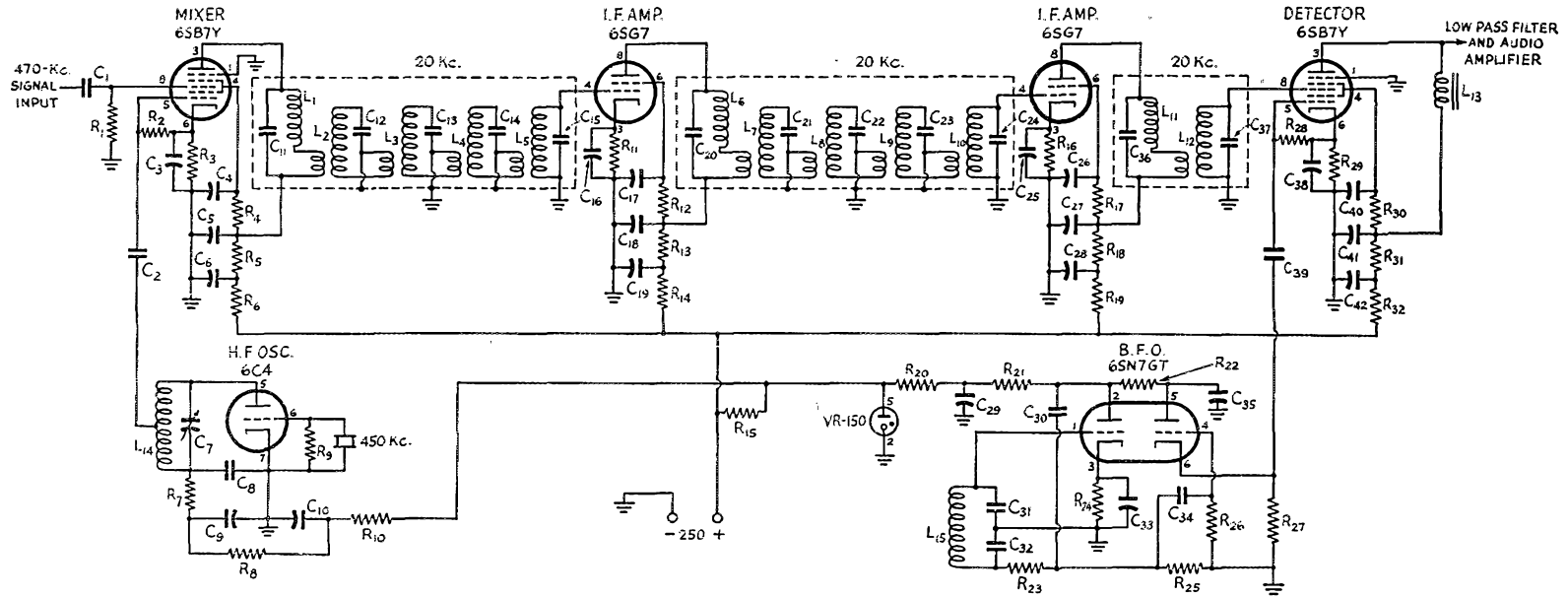

Fig. 1 — Wiring diagram of the 20-kc. i.f. amplifier.

$C_1, C_2$  — 100  $\mu\text{fd}$ .  
 $C_3, C_4, C_5, C_6, C_{16}, C_{17}, C_{18}, C_{19}, C_{25}, C_{26}, C_{27}, C_{28}$  — 0.5  $\mu\text{fd}$ .  
 $C_7$  — Part of 450-kc. b.f.o. tuned circuit.  
 $C_8, C_9, C_{10}, C_{32}$  — 0.1  $\mu\text{fd}$ .  
 $C_{11}, C_{12}, C_{13}, C_{14}, C_{15}, C_{20}, C_{21}, C_{22}, C_{23}, C_{24}, C_{31}, C_{36}, C_{37}$  — 0.01  $\mu\text{fd}$ .  
 $C_{29}, C_{35}, C_{38}, C_{40}, C_{41}, C_{42}$  — 1.0  $\mu\text{fd}$ .  
 $C_{30}, C_{39}$  — 0.006  $\mu\text{fd}$ .  
 $C_{33}$  — 0.3  $\mu\text{fd}$ .  
 $C_{34}$  — 330  $\mu\text{fd}$ .  
 $R_1, R_6$  — 0.15 megohm.

$R_2, R_3$  — 22,000 ohms.  
 $R_8$  — 1500 ohms.  
 $R_4, R_7, R_8, R_{10}, R_{30}$  — 10,000 ohms.  
 $R_5, R_{31}, R_{32}$  — 2700 ohms.  
 $R_6, R_{13}, R_{14}, R_{18}, R_{19}, R_{24}$  — 4700 ohms.  
 $R_{11}, R_{16}, R_{20}, R_{21}$  — 27,000 ohms.  
 $R_{12}, R_{17}, R_{25}$  — 0.56 megohm.  
 $R_{15}$  — 5000 ohms, 10 watts.  
 $R_{22}$  — 51,000 ohms.  
 $R_{23}$  — 91,000 ohms.  
 $R_{26}$  — 0.39 megohm.  
 $R_{27}$  — 15,000 ohms.

$R_{29}$  — 470 ohms.  
 $L_1, L_6, L_{11}$  — Approximately 300 turns No. 24 enam.  
 $L_2, L_5, L_7, L_{10}, L_{12}$  — Same as  $L_1$ , with 3-turn link winding.  
 $L_3, L_4, L_8, L_9$  — Same as  $L_1$ , with 1-turn link winding.  $L_1$ - $L_{12}$  wound on toroid forms. See text for adjustment procedure and suggested sources of supply.  
 $L_{13}$  — High-impedance audio coupling choke, 80 henrys or higher.  
 $L_{14}$  — Part of 450-kc. b.f.o. tuned circuit.  
 $L_{15}$  — 140 turns No. 22 enam. on toroid form.



A close-up view of the 20-ke. amplifier, showing the toroid coils mounted on polystyrene rods and fastened with tape. The shield partitions are to minimize capacitive coupling, as mentioned in the text.

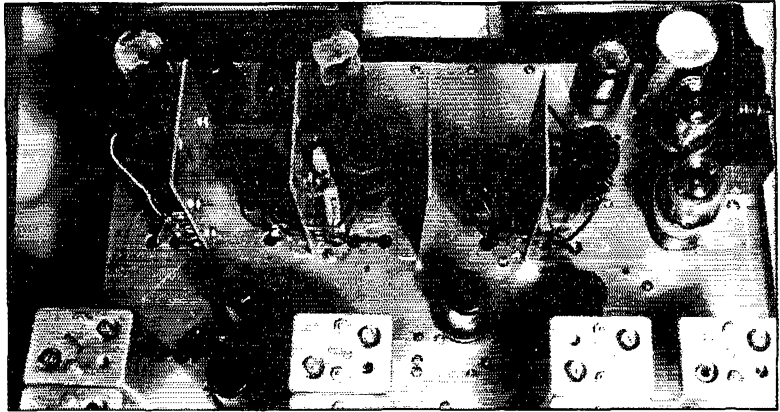

200-volt Sangamo 0.01- $\mu$ fd. mica condensers that came from surplus were used in this amplifier, but any good mica condenser should be satisfactory. Expensive silvered-mica condensers do not give enough advantage in this application to justify their higher cost.

Coils  $L_1$  and  $L_2$ ,  $L_4$  and  $L_5$ ,  $L_6$  and  $L_7$ ,  $L_9$  and  $L_{10}$ , and  $L_{11}$  and  $L_{12}$  constitute overcoupled pairs, while  $L_3$  and  $L_8$  are coupled in below critical, to fill in the overcoupling dip in the middle. The slight ripple across the top of the passband, evident in Fig. 2, is only a decibel or two and is not evident in operation. With all coils undercoupled, the bandwidth at 6 db. down is only 60 cycles, but then the amplifier rings much like a sharp crystal filter, and the arrangement shown is preferable.

The rest of the circuit represents standard technique and will be familiar to anyone with i.f. amplifier experience. At first glance the decoupling in the d.c. leads may seem exorbitant, but a filter is only as good as its decoupling. At least 150 db. around any decoupling loop is mandatory to preserve the better-than-120-db. skirts. The b.f.o. circuit does not have to be duplicated as shown — it was an experiment with resistance stabilization, and any good circuit could be used. The b.f.o. is originally set up and left on frequency — a trimmer could be added to take care of slight frequency variations.

### Construction

The construction is straightforward, and only a moderate amount of shielding is required. Since there is virtually no magnetic field around a toroid, the coils of each section are spaced  $\frac{3}{4}$  to 1 inch apart on a  $\frac{1}{4}$ -inch diameter nonmetallic rod. The b.f.o. coil,  $L_{15}$ , goes on the same rod as  $L_{11}$  and  $L_{12}$ . The unloaded terminal impedance of each tuned circuit is around  $\frac{1}{4}$  megohm, so extreme care must be taken to eliminate capacitive coupling around each section and between sections, and this is the only shielding required.

The coils are wound by chucking six inches or so of No. 12 wire in a hand drill, winding on six or seven layers of No. 24 enameled wire, and then transferring the wire from the hobbin to the powdered-iron toroid form in the same way that

the XYI sews a buttonhole. The wire is wound with the inside parts of each turn tightly butted and the outside parts spaced to accept the next layer in the interstices. Keeping each turn along a radius of the form, with the inner ends butting, will result in a neat-looking coil. With 320 turns as a starter, and the particular condenser that is to be used with the coil, the arrangement shown in Fig. 3 [p. 102] will permit quick adjustment to frequency. One turn on the coil, or 100  $\mu$ fd. in the condenser, is worth about 50 cycles at 20 kc. With a coil adjusted as close as possible to the high-frequency side of the selected center frequency, a small mica will finish the job when tuning up the entire filter.

(Continued on page 102)

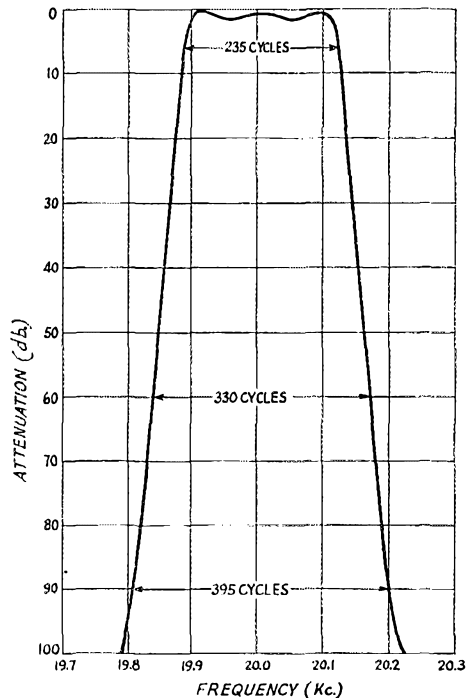

Fig. 2 — Selectivity curve of the "one-db.-per-cycle" i.f. amplifier described in this article.

# Every Mil I Have Is Yours, or Beware of Steel Panels!

BY GEORGE H. FLOYD,\* W2RYT

**I**N the words of an ancient philosopher, the steel panel will get you if you don't watch out. Where does it get you? Right in the pocket-book. Many amateurs are unfamiliar with the fact that the steel panels on their rig cause shortened tube life. Ever burn a hole in the plate of your favorite bottle? Maybe the steel panel on your final is to blame.

It isn't much trouble to demonstrate. Most amateurs use meters to measure the power input to the various tubes in their transmitter. They use milliammeters to measure current and voltmeters to measure voltage (it is rumored that some hams measure voltage by reading the nameplate on the power transformer, but I can't believe this is ever actually done). These meters are normally mounted on panels somewhere in the shack. Further, the odds are good that the meters involved are calibrated to read correctly on *non-magnetic* panels, as are most small instruments that hams beg, buy or borrow.

Is the light beginning to glow feebly? If the ham mounts these nonmagnetic-calibrated meters on his steel panel, he is automatically making things tough for the tubes in his rig, because the meters will all read *lower* than they should. Let's just take a f'r-istance. It is quite possible for the meter to read ten per cent low. Assume our Mr. Average Ham has a pair of 813 tubes in his final, running in Class C telephony with a power input of 800 watts — 2000 volts at 400 mils (being Mr. Average Ham, he's running right up to maximum ICAS ratings).

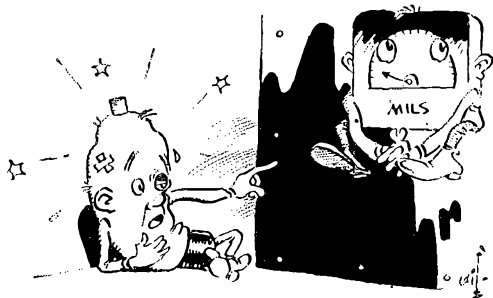

Most hams, with this set-up, would be rather dissatisfied, as who wouldn't. After all, here they have a nice rig, but all they can run is a measly 800 watts, when what they really want is to run a kilowatt. They may not know it, but brother, they are running a kilowatt! How come? Well, assume they measure the current with a meter which is reading ten per cent low. Their 400 mils is actually 445 mils. The voltage? Well, measured

with another ten-per-cent-low meter it is actually 2222 volts. The actual power input is the product of these two figures, which is 989 watts. Our Mr. Average Ham is not only overloading a perfectly good pair of tubes, but he is violating the FCC regulation which states (§12.131): "An amateur



transmitter operating with a power input exceeding 900 watts to the plate circuit shall provide means for accurately measuring the plate power input to the vacuum tube or tubes supplying power to the antenna." You may call our Mr. Average You-Know-What a lawbreaker and a tube-ruiner, but all of it is due to a slight amount of ignorance of the subject of meters. Maybe it's time to dispel this fog of ignorance.

## Types of Instruments

Small panel instruments of the type used generally by amateurs fall into two categories — d'Arsonval movement and moving-iron movement. All except very low-priced d.c. instruments, be they microammeters, milliammeters or voltmeters, fall into the class of d'Arsonval movement instruments. Also in this category is the a.c. instrument which uses an internal rectifier. The less-expensive type of instrument used for a.c. measurement work usually has a moving-iron movement. A look at your meter will quickly tell you which type it is. If the needle is attached to any sort of a moving unit which has a coil on it, it is the d'Arsonval movement (permanent magnet, moving-coil element).

The moving-iron instrument may be placed on any type of panel, and the accuracy will be practically unaffected. This type of meter should not be placed near a permanent magnet, however. This means that a moving-iron instrument should not be jam-packed against a d'Arsonval meter, because the latter type of meter uses a permanent magnet.

\* 1109 S. Country Club Dr., Schenectady 9, N. Y.

(Continued on page 104)

# A V.H.F. Receiver for the Novice or Technician

An Easy-To-Build Receiver for 144 or 220 Mc.

BY EDWARD P. TILTON,\* W1HDO

• The simple receiver pictured here will not be the equal of a well-designed converter working into a communications receiver — let's make that clear at the outset — but the newcomer will find it good enough to permit plenty of interesting work on 145 or 220 Mc. It can be built for a fraction of the cost of a converter-receiver combination, and its construction and adjustment require only the simplest tools.

IF we want a complete receiver for v.h.f. work using only two or three tubes, there is only one way to get it: use a superregenerative detector. In no other way can so much performance be obtained with so little equipment. Unfortunately, we don't get something for nothing in v.h.f. receivers, so the superregen has certain limitations along with its good points. These include broad tuning (a few strong signals fill up the band), high noise level, and the radiation of a strong interfering signal on the receiving frequency. Such failings have caused the superregen in its simplest form to be frowned on in v.h.f. circles in recent years.

These weaknesses can be corrected to a large extent by the use of a high- $Q$  coaxial line for the detector tuned circuit, and the addition of an r.f. amplifier stage. The linear tank circuit makes a marked improvement in the selectivity and smoothness of operation of the detector. The r.f. stage adds some gain, contributes to the selectivity, and, most important, reduces the radiation of interference by the detector. These refinements add to the complexity of the receiver, but the net result is more than worth the extra effort. Construction of such a receiver is still well within the capabilities of the average v.h.f. newcomer. In addition to its regular uses in amateur v.h.f. communication a receiver like this may be very handy in Civil Defense work, particularly for mobile or portable stations.

Three tubes are used: a 6AK5 broadband r.f. stage, another 6AK5 as a superregenerative de-

\* V.H.F. Editor, *QST*.

<sup>1</sup> Santangelo, "Coaxial Line V.H.F. Receivers," *QST*, Mar., 1948.

Front view of the coaxial-line v.h.f. receiver, showing the open end of the detector tank circuit. Tubes are, l. to r., the 6AK5 r.f. amplifier, 6AQ5 audio stage, and 6AK5 superregenerative detector.

tor, and a 6AQ5 audio amplifier stage. Few expensive components are required and the receiver may be built and adjusted with little more effort than would be required for the simplest equipment for lower frequencies. Performance is good enough so that the user should be able to hear anyone he can work with a low-powered transmitter on either of the bands for which the receiver is designed.

## Making the Detector Tank Circuit

Circuitwise the receiver is an adaptation of one described some years ago in *QST* by WINXY.<sup>1</sup> The principal differences are mechanical, the coaxial line assembly having been modified so as to permit its construction with the small hand tools that almost every ham has in his tool kit. Most coaxial lines heretofore used have been made from sections of heavy copper tubing, requiring a blowtorch or a very large soldering iron for the soldering operations. This one is made of flashing copper, which is thin and soft enough to be cut readily with tin shears, and light enough to be soldered with an ordinary 75-watt iron. Drilling and bending are done with ease. The flashing copper can be obtained in any building supply store. It's handy stuff around a ham shack, so the purchase of a few feet of it is a good investment. About 50 cents worth will take care of the job at hand.

The approximate dimensions of the line may be obtained from Fig. 2, which shows all the copper parts before bending and assembling. Dimensions are not critical, electrically or mechanically. If one is good at such things, the holes can be made in the flat sheet stock, but the average kitchen-table mechanic may make out better if the bending is done first and the holes made after the pieces are checked for fit. Don't be alarmed if the thing comes out a little lopsided; it may not be beautiful, but it will work just as well.

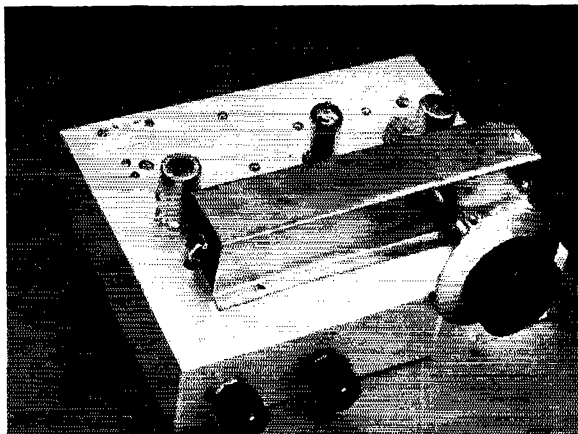

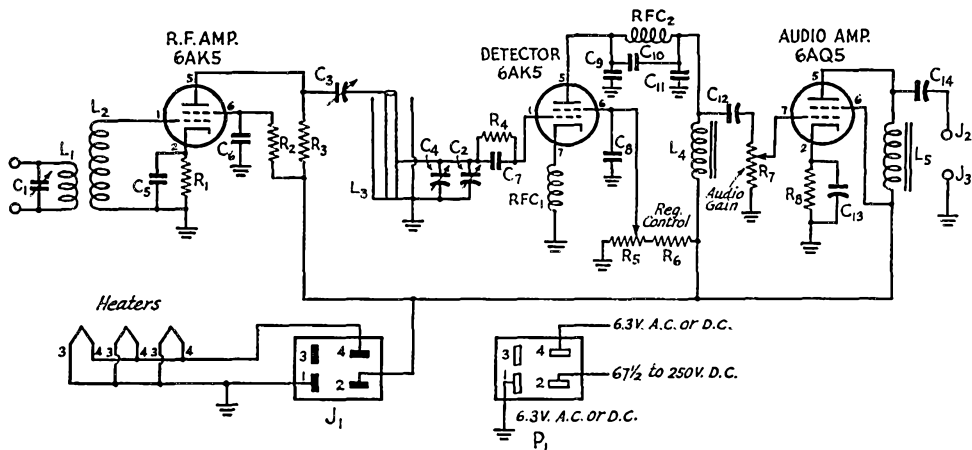

Fig. 1—Schematic diagram and parts list for the Novice-Technician v.h.f. receiver.

C<sub>1</sub>, C<sub>2</sub> — 5–20  $\mu$ fd. ceramic trimmer (Centralab 820B).  
C<sub>2</sub> used only for 144-Mc. line.

C<sub>3</sub> — 3–30  $\mu$ fd. mica trimmer (National M-30).

C<sub>4</sub> — Miniature trimmer mounted inside tank circuit assembly.

— 144 Mc.: 2–12  $\mu$ fd., approx. (Johnson 15M11 with 2 plates removed. See notes in text before removing plates).

— 220 Mc.: 2–8  $\mu$ fd., approx. (Johnson 9M11 with one plate removed. See notes in text before removing plate).

If shaft coupling has  $\frac{1}{4}$ -inch hole, wrap one thickness of flashing copper around condenser shaft for snug fit (coupling Millen 39003).

C<sub>5</sub>, C<sub>6</sub>, C<sub>8</sub>, C<sub>9</sub> — 0.001- $\mu$ fd. disc ceramic.

C<sub>7</sub> — 47- $\mu$ fd. ceramic or mica.

C<sub>10</sub>, C<sub>11</sub> — 0.005- $\mu$ fd. disc ceramic.

C<sub>12</sub>, C<sub>14</sub> — 0.1- $\mu$ fd. paper tubular.

C<sub>13</sub> — 10- $\mu$ fd. 50-volt electrolytic.

R<sub>1</sub> — 220 ohms.

R<sub>2</sub> — 12,000 ohms.

R<sub>3</sub> — 3300 ohms.

R<sub>4</sub> — 2.2 megohms.

R<sub>5</sub> — 0.1-megohm potentiometer.

R<sub>6</sub> — 39,000 ohms, 1 watt.

Good electrical contact is important, however. Drill the end plate to such size that the inner conductor, a  $\frac{3}{8}$ -inch-diameter copper tube, makes a tight fit. If you don't have the right sized drill, make a smaller hole and ream out with a heavy knife or large screwdriver blade. (No objection to a reamer — if you're that well equipped!) Fit the tube into the end plate and solder it in place. Soldering is most readily done with the aid of a vise, but two blocks of wood or metal can be a useful substitute.

Bending of the outer conductor of the line can also be done by using the blocks of wood as a vise. The photograph of the interior of the line shows how it is put together, and the means used to tune it. Originally, the tuning condenser, C<sub>4</sub>, and the padder, C<sub>2</sub>, were both mounted inside the line, but the latter caused some multiple-resonance effects, so it was moved to the exterior position shown in the photographs.

Only minor differences distinguish the 220-Mc. line from the one for 144 Mc. The 220-Mc. line is tapped nearer to its closed end, and no padder capacitance is used. The tuning condenser, C<sub>4</sub>, is mounted with its stator terminals toward the cold end of the 220-Mc. line, whereas in the

R<sub>7</sub> — 0.5-megohm potentiometer.

R<sub>8</sub> — 470 ohms, 1 watt.

All resistors  $\frac{1}{2}$  watt unless otherwise specified. Fixed condenser and resistor values not critical; up to plus or minus 25 per cent variation permissible.

L<sub>1</sub> — 144 Mc.: 2 turns No. 18 enam.,  $\frac{3}{8}$ -inch diam., inserted between first two turns of L<sub>2</sub>.

— 220 Mc.: 1 turn same as for 144 Mc.

L<sub>2</sub> — 144 Mc.: 5 turns No. 18 enam.,  $\frac{3}{8}$ -inch diam.,  $\frac{3}{4}$  inch long.

— 220 Mc.: 2 turns No. 18 enam.,  $\frac{3}{8}$ -inch diam.,  $\frac{1}{16}$ -inch space between turns.

L<sub>3</sub> — Coaxial-line assembly; see drawings and text.

L<sub>4</sub>, L<sub>5</sub> — Midget filter choke, broadcast replacement type.

J<sub>1</sub> — Male chassis fitting for power connections (Jones P-304-AB).

J<sub>2</sub> — Phone tip jack, insulated from chassis.

J<sub>3</sub> — Same as J<sub>2</sub>, but uninsulated.

P<sub>1</sub> — Female plug for power cable (Jones S-304-CCT).

RFC<sub>1</sub> — V.h.f. r.f. choke (Ohmite Z-144). May be made by winding No. 26 enameled wire close spaced on 1-watt resistor,  $\frac{1}{2}$ -inch winding length.

RFC<sub>2</sub> — 85-mh. r.f. choke (Millen 34285).

144-Mc. unit pictured the stator terminals are toward the open end of the line.

The inner conductor is drilled to pass a No. 4 screw, and two soldering lugs are mounted under the screw head, extending in opposite directions. The lugs and screw are soldered to the line if possible, though this is not mandatory. One makes contact to the feed-through bushing, the other to the stator of the tuning condenser. The open end of the line may also be drilled and a screw and soldering lug used to make the connection to the coupling capacitor, C<sub>3</sub>, though in the model pictured the connection was made by soldering a piece of stiff wire to the line directly and running it down through a hole in the chassis, where it serves as a mounting for C<sub>3</sub>.

### Laying Out the Parts

The receiver is built on a 7 × 9 × 2-inch aluminum chassis (Johnson 195-352). This is larger than is required for the job, but the extra space makes assembling and wiring easy. The front edge of the line is about one inch from the edge of the chassis. The tuning condenser is driven from the vernier dial (National type AM) with a single solid shaft coupling (Millen 39003) and a

short length of quarter-inch rod. Arrangement of the rest of the parts is not particularly critical.

The three tube sockets are mounted on a common center line just to the rear of the coaxial line. Looking at the front view, the tube at the left is the r.f. amplifier. At the right is the detector, with the audio amplifier in the middle. In the rear view we see the feed-through bushing (National TPB) and the ceramic padder,  $C_2$ , on the back wall of the tank circuit. At the right, near the back of the chassis, is the antenna terminal, a Millen 33102 crystal socket. Between the terminal and the r.f. tube socket is the hole through which the antenna trimmer,  $C_1$ , is adjusted. On the rear wall of the chassis are the tip jacks for 'phones or 'speaker and the power fitting.

No front panel is used. The vernier dial is mounted on a small plate 2 by  $4\frac{3}{4}$  inches in size, cut for this purpose from sheet aluminum. A soldering lug under one of the dial mounting screws serves as a dial marker. Regeneration and audio volume controls are at the left side of the front chassis wall.

Parts should be arranged for short leads in the r.f. circuits. By-pass condensers  $C_5$ ,  $C_6$ ,  $C_8$  and  $C_9$  should be as close to their respective tube terminals as possible, and the same applies to the grid condenser and grid leak ( $C_7$ ,  $R_4$ ), the detector r.f. choke,  $RFC_1$ , and the r.f. amplifier grid coil,  $L_2$ . Audio components can be mounted to suit the builder's fancy. The r.f. amplifier tube socket is mounted with its Pins 1, 2 and 3 toward the rear of the chassis, while the detector socket has the same pins toward the front. The audio socket may be in any position.

Holes about  $\frac{5}{16}$  inch in diameter are drilled in the chassis to pass the leads from the end of the tank circuit to the r.f. coupling capacitor, and the connection between the line and the detector grid condenser and grid leak. No. 12 tinned wire is used for the feed-through leads, to assure rigidity. The trimmer,  $C_2$ , used only on the 144-Mc. line, is mounted with the rotor connection soldered to the rear wall of the line.

By-passing in the detector and r.f. stages is important. Small disc ceramic condensers are used throughout, and in the detector stage the ground sides are connected to a soldering lug placed on the screw that fastens down the right rear corner of the line assembly. The ground side of the heater, Pin 3, the small cylindrical shield in the center of the socket, and  $RFC_1$  are all returned to this point. Ground connections for the r.f. stage (cold sides of  $L_2$ ,  $C_5$  and  $C_6$  and heater, Pin 3) are made to a lug under one of the tube socket mounting screws.

Looking at the back of the simple receiver for 144 or 220 Mc., showing the closed end of the tuned circuit and the external trimmer,  $C_2$ . The antenna trimmer,  $C_1$ , is tuned through the hole at the right, near the antenna terminals. 'Speaker or 'phone terminals and power fitting are on the rear chassis wall.

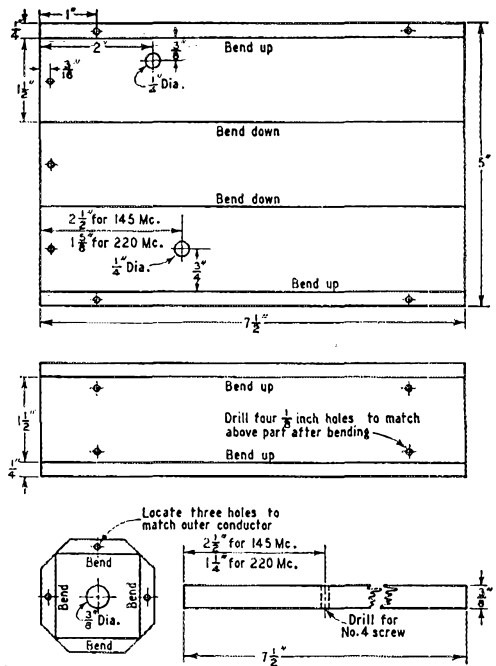
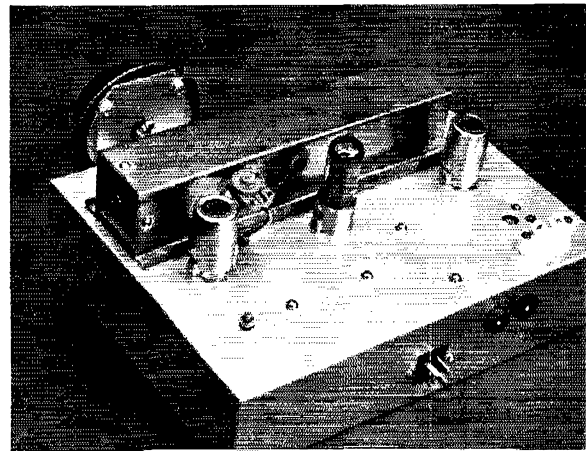

Fig. 2—Detail drawings of copper parts of the coaxial-line tank circuit. The outer conductor (top sketch), the bottom plate (middle) and the end plate (left of lower sketch) are made of flashing copper. The inner conductor is  $\frac{3}{8}$ -inch copper tubing. Note that the hole for the feed-through bushing is in a different position for the 220-Mc. line.

No special precautions are needed in wiring. It is customary to wire the heater circuits first, running the wires close to the chassis. The leads to the regeneration and volume controls make up most of the rest of the wiring, the balance being supplied by the leads on the small components themselves. Tie points should be used to support otherwise free ends of resistors and condensers.

### Testing & Operation

The receiver may be powered in several ways. Perhaps the simplest is merely a 6.3-volt filament transformer and  $67\frac{1}{2}$  or 90 volts of "B" battery. As the total drain at 90 volts is only 15 ma., two medium- or large-sized 45-volt batteries will give a year or more of service. One



addition should be made to the receiver if batteries are used: resistors  $R_5$  and  $R_6$  are connected across the plate supply, causing a continuous small drain even when the heaters are turned off. To eliminate this stand-by drain a switch should be connected between the B-plus and the hot side of  $R_5$ . This can be a toggle switch, or a switch-type potentiometer can be substituted for  $R_5$  or  $R_7$ . If an a.c. supply is used for home-station work it can be anything capable of furnishing 90 to 250 volts d.c. and 6.3 volts a.c. A vibrator or generator supply may be used in portable work. Filtering is extremely important, as any hash in the power supply will have an adverse effect on the sensitivity of the receiver.

If wiring has been done correctly, a loud rushing sound will be heard in the 'speaker or 'phones when the regeneration control is advanced. The rush should develop smoothly, rather than suddenly with a "plop" as the control is turned up. If regeneration control is not smooth try another 6AK5 in the detector socket, and check for poor connections in the line assembly if the trouble persists.

Lining up the receiver is easy if there is activity in your neighborhood on the band you intend to use. The frequency coverage of the receiver is determined by the setting of the main tuning condenser,  $C_4$ , the padder,  $C_2$  (in the 2-meter unit), the position of the tap on the inner conductor, and to a certain extent by the setting of the coupling capacitor,  $C_3$ . The tuning condensers specified will spread the bands in question well across the dial when the other factors are right.

Suppose we want to set up for reception on 144 to 148 Mc. (Don't forget that Novice transmitting is confined to 145 to 147.) A signal at 146 Mc. will be helpful. Set the main tuning at midscale and  $C_3$  about two turns from the tight position. Turn up the regeneration just past the point at which the hiss develops, and turn  $C_2$  until the signal is heard.

There are several ways to do the job if no signals are available. One is to listen for the fifth harmonic of a local 10-meter 'phone station. If you are close by you'll probably hear his fifth harmonic at least weakly. Multiply his frequency

by 5 and you'll have a calibration point. Harmonics of a crystal oscillator or VFO unit can be used similarly, though if they are on a frequency lower than 7 Mc. it may be difficult to tell which harmonic is which at first. The detector frequency may be checked readily with Lecher wires, following instructions outlined in *The Radio Amateur's Handbook*. The Lecher wires may be coupled to the detector by means of a loop of wire inserted in the open end of the line. A drop in the hiss will be heard when the Lecher system is tuned to the receiver frequency. This may be the only satisfactory method of setting the detector frequency on 220 Mc. unless there are stations operating on this band near you.

It is a good idea to check the operation of the detector before removing plates from the tuning condensers, as the full-sized condenser will give a wider tuning range. Once the receiver is made to hit the band, plates can be removed to increase the bandspread to any desired degree. With the plates as specified in the parts list, the bands will cover almost the entire dial. On the 144-Mc. unit, for instance, the calibration works out conveniently as about 20 dial divisions per megacycle: 144 Mc. at 10, 145 at 30, 146 at 50, 147 at 70, and 148 at 90. On 220 the spread per megacycle is about 15 dial divisions.

Setting up the tuning range on 220 is somewhat more critical as no handsetting padder is used. The tuning effect of  $C_3$  is greater, however. Bandspread is determined by the number of plates in the tuning condenser,  $C_4$ , and by the point of connection to the line. Tapping higher on the line will result in more tuning range, but the maximum frequency will be lower. Running the tap down the line increases the spread on the dial (for a given tuning condenser size) and raises the maximum frequency that can be reached. With either band if the tuning range is within a few megacycles of the right value it can be adjusted to the desired spot on the dial by varying  $C_3$ . The value of this trimmer is not critical in the operation of the receiver, so it can be used for band-setting purposes.

Once the band is set up as desired, the antenna trimmer,  $C_1$ , can be adjusted for maximum signal.

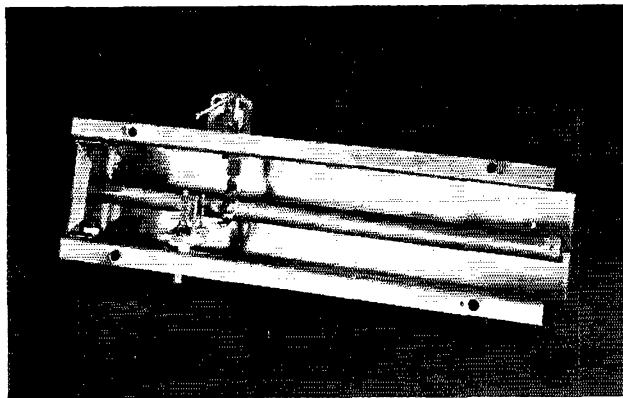

Interior of the 144-Mc. coaxial-line assembly, with the bottom cover removed. Note that the tuning condenser,  $C_4$ , and the feed-through bushing for the detector grid connection tap onto the line at the same point. The assembly for 220 Mc. is similar, but the trimmer is rotated 180 degrees and the feed-through bushing relocated, to permit a lower tap on the line. No external trimmer is used on the 220-Mc. line.

Bottom view of the v.h.f. receiver. At the left are the r.f. amplifier components; at the right the detector parts. Audio chokes and coupling condensers may be mounted in any position. Regeneration and audio gain controls are on the front panel.

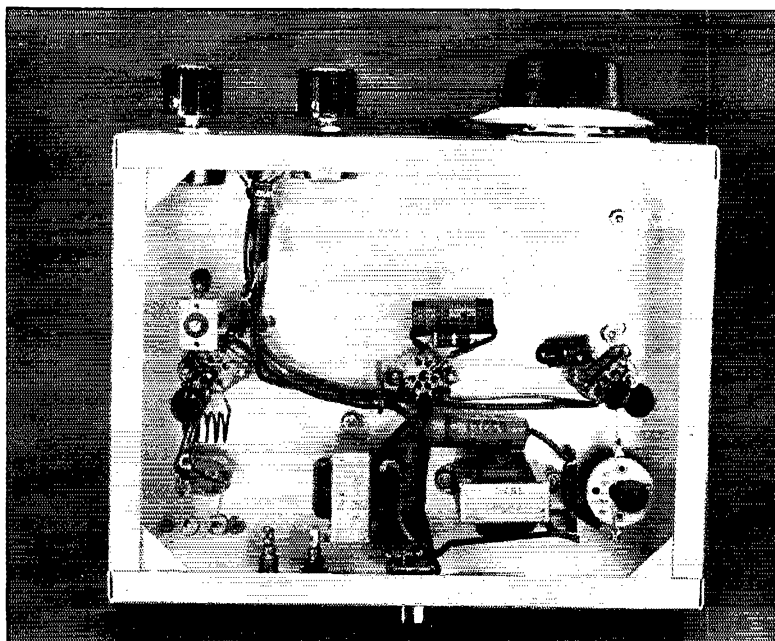

This should be done with the antenna with which the receiver is to be used, as different antenna systems may have some effect on the best setting. A relatively weak signal is best for this purpose, as the effect of adjustment is not so noticeable on strong signals.

#### *What Can We Do with It?*

By now we are ready to do business on 220 or 145 Mc. What is such a receiver capable of picking up, and how will it compare with more complex and expensive equipment? The little job has been given extensive tests, not only in the ARRL Lab, but at W1HDQ, where it has been compared in actual reception of signals with several high-performance v.h.f. receivers. Lab measurements on 146 Mc. show that a modulated signal of one microvolt produces a plainly audible response. At around 3 microvolts there is a good dent in the background noise when the signal is tuned in, and at 10 microvolts the hiss is almost completely quieted. The selectivity is such that about twenty 1000-microvolt signals equally spaced across the band can be received without interference. A superregenerative receiver of the simplest sort cannot handle more than about five or six such signals at a time. On 220 Mc. the sensitivity drops slightly, compared to 144 Mc., this being true of any receiver, however good.

On-the-air checks show that any modulated signal that is solidly readable on the best receivers available can be heard on our little three-tube. The weak-signal readability is not so good, of course, but any signal that is S3 or better on the best receiver we have can be copied on the coax-line job. Control of regeneration is smooth and the stability is good enough so that, with some care in tuning (regeneration must be set

just at the point where the hiss stops), a readable c.w. beat note can be heard.

This receiver won't make you the weak-signal DX champion of your call area, but it will do surprisingly well, considering its simplicity and low cost. In building it you will have gained valuable experience in the way circuits work; experience that will stand you in good stead when you decide to tackle something more complicated later on. Best of all, you will have built a real piece of v.h.f. gear with your own hands—and you will have saved yourself a sizable hunk of cash in the process.

### **Strays**

There are so many husband-and-wife, brother-and-brother, father-and-son, and similar teams in the game these days that we are prompted to mention the Family Membership provisions in the League By-Laws. If one of these persons is a Full Member, the second may also become a Full Member with all privileges except duplicate receipt of *QST*, at the rate of \$1 per year. Both persons must hold amateur licenses, and live at the same address; further, the memberships must be concurrent. So when your Full Membership comes up for renewal, enclose an extra dollar for Full Membership for each other licensed amateur in your family, and we'll put them on the roster.

-----

Followers of radio-controlled model airplane techniques will be interested to know that Howard McEntee, W2SI, has a monthly column on the subject in *Air Trails* magazine. Late news and ideas are presented each month, as well as readers' questions and answers.

# Two-Band Antennas with Nonresonant Feed Lines

## Antennas for "In-a-Hole" Operating

BY IRVING ROBERTS,\* W3KQU

THE rugged terrain of Western Pennsylvania often presents a difficult problem to the amateur, and this is particularly true of the present location of W3KQU. The house is situated on the floor of a valley formed by a U-shaped ridge that effectively blocks the east, south, and

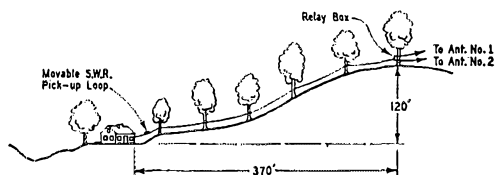

Fig. 1—W3KQU took a page from Mohammed's book and, when the mountain wouldn't go below the antennas, he put the antennas above the mountain. The sketch shows the distances involved.

west. The shack, which is in the rear of the house, faces a wooded slope to the west rising about 120 feet within a horizontal distance of about 370 feet. This is shown approximately to scale in Fig. 1.

After a number of unsatisfactory attempts at operation with antennas placed close to the house, it was decided to install an antenna system at the top of the ridge, even though this involved a feeder length of close to 500 feet. Fortunately, trees were available at frequent intervals up the slope so that no posts had to be erected to support the feeders and, furthermore, enough tall trees were standing at the top of the ridge so that antennas could be strung in almost any direction,

at a height of about 50 feet above ground. Permission to put up the feed line and antennas was easily obtained, since the entire property to the rear of the house is owned by an estate, and apparently no plans for its commercial development are contemplated.

Fairly good general coverage on both 10 and 20 meters is obtained with two fixed antennas oriented at right angles to each other, each antenna being designed for two-band operation. For minimum losses, a nonresonant 600-ohm transmission line is used and, to avoid duplication of the line, the two antennas are switched with a double-pole double-throw antenna relay located near the top of the ridge. The relay is mounted in a weatherproof box containing a vial filled with drying agent (Drierite), and this has given satisfactory service for over two years. The relay is operated by a 115-volt line run up from the shack, and this line is relatively inexpensive since it consists of a continuous length of receiving-type 150-ohm Twin-Lead.

The two types of antennas tested are shown in Fig. 2. Antenna No. 1 is the W5FDQ antenna described on page 104 of the 1942 edition of the *A.R.R.L. Antenna Book*. The antenna operates as a center-fed dipole on 20 meters and as two halfwaves in phase on 10 meters. The 416-ohm stub is made of No. 10 wire spaced  $1\frac{1}{2}$  inches, using Johnson 2-inch ceramic spreaders which fortunately have inside grooves spaced the smaller distance. The design of the matching system was checked by calculation,<sup>1</sup> and assuming a center

\* Spanish Villa, Box 282-A, R.D. 2, Jeannette, Pa.

<sup>1</sup> Marshall, "Antenna Matching with Line Segments," *QST*, September, 1948.

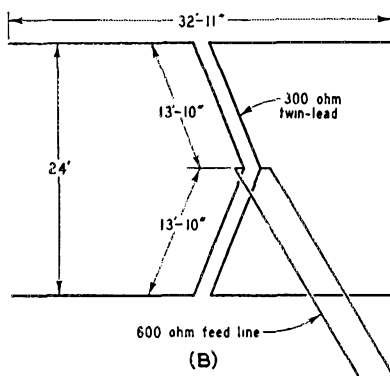
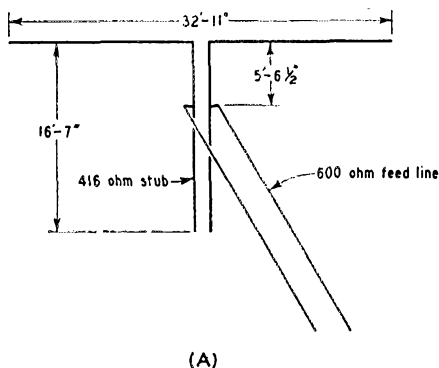

Fig. 2—The two antenna systems that were tested by W3KQU. That at A is simply a 14-Mc. half-wavelength antenna with a two-band feed, and that at B is two 14-Mc. halfwave antennas with  $\frac{3}{8}$ -wavelength spacing, fed in phase.



impedance of 72 ohms on 20 meters and of 2400 ohms on 10 meters, the dimensions and stub impedance of Fig. 2 should give a remarkably good match on both bands.

Antenna No. 2 operates as a pair of horizontal broadside elements on 20 meters, and as a lazy-H antenna on 10. Using the 50-foot height for the upper wire, this antenna should give a gain over antenna No. 1 of about 2.5 db. on 20 meters and about 4.7 db. on 10 meters (6.6 db. gain over a 10-meter dipole). At the same time, the angle of radiation is reduced on both bands, while the horizontal coverage is unaffected. The matching system uses commercial 300-ohm Twin-Lead, and the length of 13 feet 10 inches is based on a velocity factor of 0.84. Assuming a center impedance on 20 meters of 60 ohms for each of the two elements, the use of 300-ohm impedance in the quarter-wave matching sections should give a good match to 600-ohm line. For 10 meters, the closeness of the match cannot be calculated since no data seem to be available on the impedance of the elements in a lazy-H array with three-quarter wave spacing. However, the impedance of each pair of halfwaves should not be very much greater than the 2400 ohms assumed for two halfwaves in phase, and on that basis the match obtained at the junction of the 300-ohm line with the feed line should be fairly good.

Standing-wave measurements were made with a wavemeter indicator similar to that described in the *A.R.R.L. Antenna Book*.<sup>2</sup> The pick-up loop is mounted on a wooden cart fitted with 6-inch axles and Tinker Toy wheels, riding on a section of the transmission line between the shack and the first tree (see Fig. 1). The tuned circuit and crystal diode of the wavemeter are mounted in a steel box also fastened to the wooden cart, and from the box, a length of Twin-Lead runs loosely along the ground to a d.c. microammeter on the operating table in the shack. Fastened to the cart is a length of string which passes through a pulley mounted on the tree and then back into the shack to the operating table. Because of the slope of the feed line, the cart can be made to ride up or down the feeders by pulling or paying out the string. With this arrangement, one person in the operating position can carry out an extensive series of standing-wave measurements, with only an occasional trip outdoors to touch up the tuned circuit in the wavemeter when a large change in frequency is made.

The results are shown in Fig. 3. On 20 meters, both antennas show a reasonably good match over the entire band. On 10 meters, antenna No. 2 shows unexpectedly low standing-wave ratios, with a frequency response broad enough to make it useful on 11 meters as well as on the high end of 10. Antenna No. 1, with fewer elements, gives a broader frequency response, although the standing-wave ratio goes through a maximum at about 28.5 Mc. It is possible that this maximum would be shifted or would disappear entirely with only slight adjustment of the dimensions of the matching stub.

<sup>2</sup> 1949 edition, pp. 127-8.

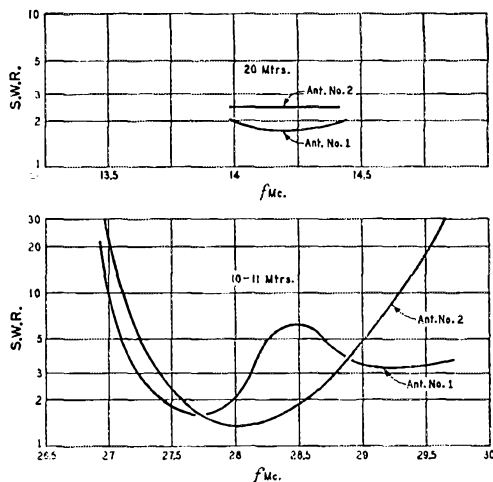

Fig. 3 — The results of the s. w. r. measurements made on the two antennas of Fig. 2.

After installation of the above transmission line and antenna system, it was easy to take advantage of it for 75-meter operation. For this purpose, a 60-foot length of wire is stretched from the shack to a tree in the back yard, and the output link of the transmitter is connected to this wire and to one of the long feeders. The result is a  $2\frac{1}{2}$ -wavelength long-wire antenna, loaded at a current maximum to keep the r.f. out of the shack.

With regard to the on-the-air performance of these antennas, the experience of the writer parallels that of other amateurs in a difficult transmitting location, in that the care and effort expended in developing good antenna systems has produced results far better than would normally have been obtained in an average location. During the two years that the above antenna system has been in operation, the writer has become WAS, WAC and DXCC, and has been sectional phone winner in Sweepstakes and DX contests.

## Silent Keys

IT is with deep regret that we record the passing of these amateurs:

W2ML, Chester B. Adams, Red Bank, N. J.  
 W3SPA, Roland M. Archibald, Hyattsville, Md.  
 W4AYU, Howard G. Cross, Bristol, Tenn.  
 W4JDM, Roscoe E. Pugh, Lake Wales, Fla.  
 W4KGI, William G. Lofstrom, Valdosta, Ga.  
 W4OD, Robert H. Day, Winston-Salem, N. C.  
 W4RLQ, Robert A. Getz, Norfolk, Va.  
 W6LIO, Arnold F. Braun, North Hollywood, Calif.  
 W6PNM, Ralph L. Russell, Stockton, Calif.  
 ex-W8CWY, Robert H. Menegay, Louisville, Ohio  
 W8AY, Porter H. Quinby, Omaha, Nebr.  
 FP8BX, Paul Detchevry, St. Pierre  
 G2SM, Ronald J. Bates, Bury Saint Edmunds, Suffolk  
 G5YR, F. H. Webber, Tiverton, Devon  
 GD5CZ, Robert A. Colby Cubbin, Douglas, Isle of Man  
 VE7AGA, F. R. Tupper, Vancouver, B. C.

# On the Air *with* SINGLE SIDEBAND



The purpose of this column is to report schedules and operating times of active single-sideband stations, describe operating experiences and sometimes the gear in use, and possibly discuss some of the practical operating problems and suggested solutions. Contributions from active single-sideband stations will be welcomed.

G3CU has started a column in the *R.S.G.B Bulletin*, to chronicle the doings of the G s.s.b. gang, and it should do much to increase the activity over there. Anyone looking for tests or schedules with Gs will do well to drop G3CU a note.

G3FHL passes along the information that G3EGB, G8RC and G3BVA are active on 160 s.s.b. The rig at G3BVA sounds interesting for anyone who wants to give s.s.b. a try without too large an investment — he uses a 9002 crystal oscillator, a 6SN7 balanced modulator, and a single-section 2-crystal filter. The filter uses crystals in the FT-241A series: Channel 326 for the oscillator, 327 and 328 for the filter. The attenuation is reported as 28 db. at 1000 cycles. Working directly into the antenna from the filter, he certainly doesn't have to worry about amplifier linearity!

The mobile rig of W6WI, mentioned last month, uses a crystal-lattice filter cooked up by W6KNH and W1JEO/6, followed by a 6J6 balanced mixer, and then a Class A 6BA6, a Class AB<sub>1</sub> 815 and Class B 811s. The final runs around 400 watts on peaks, a right husky mobile rig! Best summer DX was Newport, Ore., to Los Angeles (W6UOC/M), better than 800 miles.

— B. G.



It is a little difficult to tell from this picture if Bill Rust, W2UNJ, of Cortland, N. Y., is considering a change in his present rig or a completely new design, but it is certainly safe to say that he is one of the leaders of s.s.b. in this country. His simplified phasing-type exciter design has been responsible for giving many of the gang their start on s.s.b., via the pages of *QST* and the *Handbook* or by over-the-air advice. (Photo courtesy of W2NJR)



"Hoagy" of W2SHN, Dryden, N. Y., is one of the old-timers on s.s.b., with a phasing rig and p.p. 813s running close to a kilowatt peak.

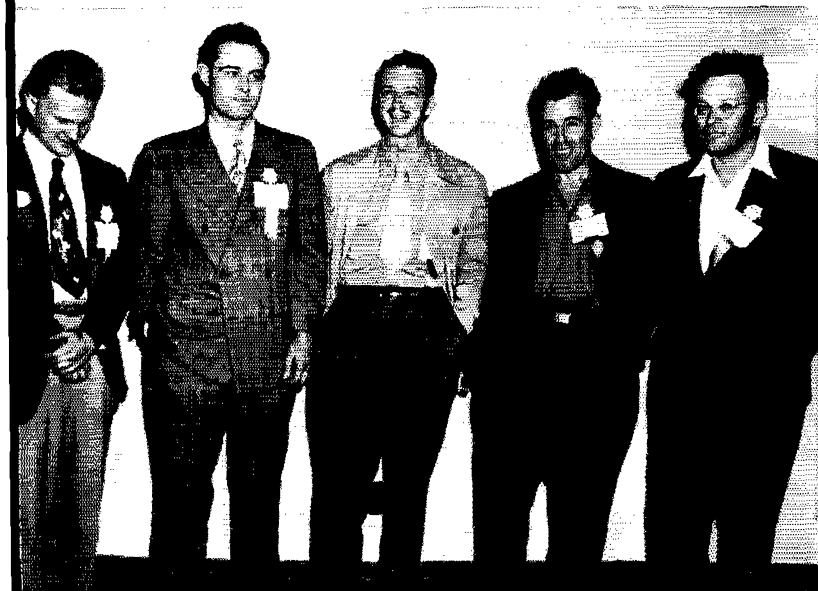

Some of the gang at the Seattle National Convention s.s.b. forum got away before they could be caught by the camera, but here are (l.to.r.) W7IKY, W7EAZ, W6WB, VE7VP, W6WI, apparently considering their answers to the fellow who asked, "How can you transmit voice without a carrier?" (Photo courtesy of W6WI)

**QST** for

# ● Technical Topics —

## Some Aspects of Screen Modulation

MODULATING the screen grid of a beam tetrode is a useful method of radiotelephony, but it is no different, in principle, from modulating any other grid in a tube. It is subject to the same power limitations that apply when, for example, a control grid is modulated.

Every member of the grid-modulation family utilizes what is frequently called "efficiency" modulation. Since the extra power (sideband power) in the modulated signal is not supplied from a separate source — as it is in plate modulation, where the sideband power is supplied by the audio modulator — it has to come from the modulated r.f. stage itself. It cannot do so if that stage is already delivering, at the carrier level, all the power it is capable of delivering. The maximum output of which the tube is capable has to be saved for the modulation peak. And since with 100 per cent modulation the peak power has to be four times the carrier power, the biggest possible carrier that can be used is just one-fourth the maximum power you can get from the tube.

This is a hard fact, but there is no way of getting around it. When a grid is modulated, the modulating voltage causes the plate current and plate efficiency to vary instantaneously. For linear operation — that is, operation without distortion and without the creation of spurious sidebands — the instantaneous plate current and plate efficiency must both reach their maximum values at the same time, and both must be di-

rectly proportional at all times to the instantaneous value of the audio modulating voltage.

Fig. 1 shows an ideal relationship of this sort. At the peak of 100 per cent modulation the plate current is just twice its value at the carrier level. The plate efficiency also is twice its carrier value at this instant. The relationship between either plate efficiency or plate current and the instantaneous modulating voltage is a perfectly straight line. When this is not true, there is distortion in the modulated stage.

### Plate Efficiency

Just what the peak plate efficiency may be depends on the tube and the operating adjustments. It is possible to have a peak efficiency as high as 80 per cent, but under most conditions 70 per cent is as much as can be attained while keeping a satisfactory degree of linearity. Consequently, the efficiency at the carrier level is only about 35 per cent — roughly, the carrier output is equal to one-half the rated plate dissipation of the tube.

The most common mistake in operating a screen-modulated amplifier (or any grid-modulated amplifier) is that of adjusting for too much efficiency at the carrier level. If the carrier efficiency is too high, swinging the screen voltage more positive may increase the plate current, but it cannot cause the plate efficiency to double its carrier value. Result: flattening of the modulation up-peaks — nonlinearity, distortion, spurious sidebands.

On the other hand, if the efficiency at the carrier level is lower than necessary the amplifier often will modulate linearly but the output will be less than it could be. It takes a nice balance between plate loading and grid excitation to hit exactly the right operating conditions for maximum output with good linearity. The only really satisfactory way to arrive at the proper adjustments is with an oscilloscope, using the trapezoidal pattern. The method is described in the *Handbook*, so we won't go into it here. The *Handbook* also describes a cut-and-try method, not requiring a 'scope, that will lead to satisfactory linearity if done carefully and if the plate-supply voltage holds up at twice the carrier value of plate current.

### Linearity with Screen Modulation

The principles discussed briefly above should be thoroughly understood before attempting any kind of grid modulation. Screen modulation has something to offer over modulating a control grid or suppressor grid, but it also has a disadvantage.

Fig. 2 is a typical trapezoid obtained from a

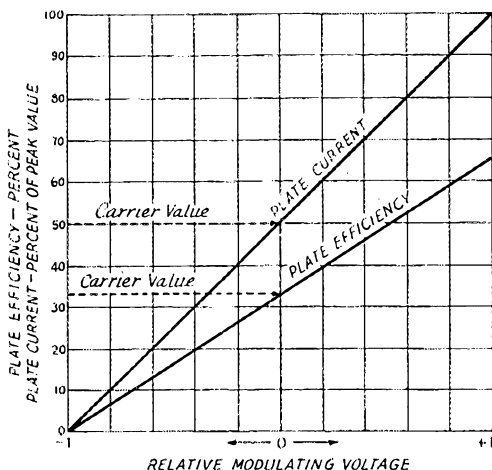

Fig. 1 — How plate current and plate efficiency vary with the instantaneous modulating voltage in an ideal grid-modulation system. Since both the input and plate efficiency double their carrier values at the modulation up-peak, the power output at the peak is four times the carrier output.

properly adjusted screen-modulated amplifier. While this particular pattern was taken on an 813, other beam tubes show similar characteristics. Over most of the pattern the sides are quite straight, indicating good linearity. The sides are considerably straighter than they are with control-grid or suppressor modulation, both of these types having a characteristic concavity that cannot be completely ironed out with any set of adjustments. On the other hand, when either of these grids is modulated the pattern height decreases smoothly toward the point that represents 100 per cent downward modulation, whereas the screen modulation pattern does not, as shown by Fig. 2. The sudden change in the slope of the pattern outline at *A*, near the point of the trapezoid, represents a departure from linearity and, consequently, distortion.

The sudden change of slope coincides with zero voltage on the screen. Zero screen voltage does not cut off the output completely, so it becomes necessary to swing the screen negative in order to reach 100 per cent modulation in the downward direction. Negative screen voltage reduces the output amplitude at a faster rate than positive screen voltage increases it, so the amplifier does not modulate the same way on both sides of zero screen voltage. The location along the trapezoid where this sudden change occurs depends a good deal on the grid excitation, and the linear range can be extended by using the minimum excitation that will just develop the required peak output.

For minimum distortion, the screen should not be swung negative. This limits the modulation percentage that can be used, at least in the downward direction. Assuming a symmetrical modulating voltage such as a sine wave, the carrier should be placed at *B*, Fig. 2, midway between *A* and the large end of the trapezoid. This can be done by adjusting the d.c. screen voltage to the appropriate value. The amplitude of the modulating voltage should of course be

held within the limits represented by *A* on the negative or down swing, and the large end of the trapezoid on the positive or up swing. In the particular case shown in Fig. 2 this limits the modulation percentage to a little over 70 per cent.

### Combined Screen and Control-Grid Modulation

On behalf of users of Eimac tetrodes, John Reinartz, K6BJ, has recently published a circular describing a modulation method having the interesting feature that the modulating voltage is applied to both the screen and control grid. On the thought that this might help correct the nonlinearity described above, a combination of screen and control-grid modulation was tried on the 813, using the circuit arrangement of Fig. 3.

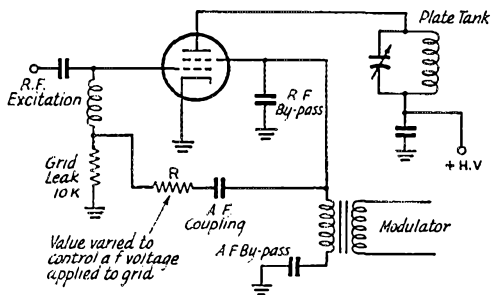

Fig. 3 — Circuit for applying modulation to both screen and control grid. The ratio of control-grid to screen-grid modulation can be varied by changing the value of *R*.

The resulting pattern is shown in Fig. 4. Although the compensation is not complete, the improvement is easily observable. It was found that the shape of the pattern depended critically on the ratio of the a.f. voltages applied to the grid and to the screen, and the optimum result (shown in Fig. 4) was obtained with about  $\frac{1}{3}$  as much voltage on the control grid as on the screen. With a greater percentage of modulating voltage on the control grid the pattern showed the characteristic concavity of control-grid modulation, and at a 1-to-1 ratio of a.f. voltages the pattern was exactly what would be expected from pure control-grid modulation.

One disadvantage of modulating both grids is that considerably more audio power may be required. If the control grid's share of the modulating voltage is applied across the grid leak, which is much the simplest method from a circuit standpoint, more audio power will be used up in the control-grid circuit than in the screen circuit. Inserting the modulating voltage in series with the control-grid d.c. circuit would require a special transformer, because screen and control-grid d.c. voltages must be isolated from each other.

### Audio Power Required for Screen Modulation

Successful screen modulation is not achieved by using any old tube as the modulator. The modulator tube here, as in any method of modu-

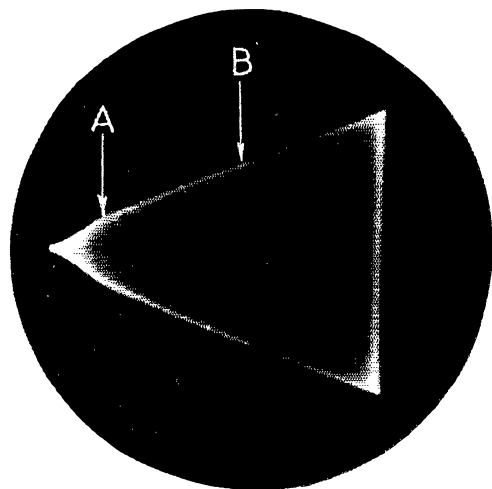

Fig. 2 — Typical pattern obtained with 100 per cent screen modulation.

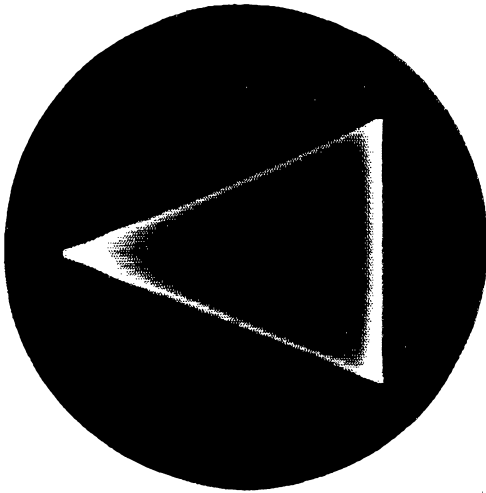

Fig. 4 — Pattern obtained with combined screen and control-grid modulation at the optimum ratio.

lation, has to supply audio power to the element it modulates. The situation is very similar to plate modulation, where it is well known that the modulator must be able to supply sine-wave audio power equal to 50 per cent of the d.c. input to the modulated stage. Exactly the same rule would hold in the case of screen modulation, using the screen input instead of the plate input, if the screen circuit represented a load of as constant resistance as the plate circuit of a Class C amplifier. Unfortunately, it doesn't.

Fig. 5 shows representative screen-voltage *vs.* screen-current curves for the 813 under different conditions of operation. Curves for other beam tubes will be similar in shape, although the actual values will differ. An outstanding feature is the fact that the screen current increases rapidly at the higher values of screen voltage. The situation is in fact quite similar to what happens in the grid circuit of a Class B audio amplifier: the load varies over the audio cycle and a modulator having good voltage regulation is a necessity if distortion is to be avoided. This means, generally, that the modulator should be capable of several times the power output that actually is used in the screen.

The operating point (carrier level of d.c. screen voltage) will be about midway on the voltage scale on these and similar curves for other tubes. The screen current at carrier level is thus much less than at the modulation up-peak.

One way to estimate the audio power required is to multiply the peak screen voltage and current together and divide the result by 8. This gives the power required to modulate a screen having the same peak voltage and current, but representing an assumed constant load resistance. The corresponding modulating impedance is the peak screen voltage divided by the peak screen current. Then a modulator tube having a power capability of three or four times this figure should be chosen, to allow for additional resistance loading to improve the regulation. As an example, at

the 1500-volt condition shown in Fig. 5 the peak voltage and current are 500 volts and 15 ma., respectively. The product, 7500, divided by 8 gives 940 milliwatts, or 0.94 watt, as the required audio power. The approximate modulating impedance is  $500/0.015 = 33,300$  ohms. A modulator tube having an output of 3 or 4 watts would be suitable, the excess power output being dissipated in a resistance of suitable value connected across the output circuit.

A supplement, or even an alternative, to loading is to use as much negative feed-back as possible in the modulator circuit. This reduces the effective plate resistance of the modulator and makes its output voltage relatively insensitive to changes in load resistance. A triode having low plate resistance, such as the 6B4G, is also good.

Tube manufacturers do not publish curves such as those shown in Fig. 5. About the only way to approximate the audio power required is to assume that the peak screen voltage and current will be equal to the rated values for c.w. operation and then figure as above. This method usually will not be far wrong, since the d.c. screen voltage for screen modulation generally turns out to be about half the rated voltage for c.w. operation.

One point should not be overlooked: The lower the excitation, the smaller the peak screen current and the less audio power required. Always adjust the modulated stage to give the required output and linearity with as little grid current as possible. It helps on TVI, too.

#### Coupling the Modulator to the Screen

The only thing simple about a "clamp-tube" modulator is the circuit — and even that may not be so simple when it is properly worked out. Actually, such a modulator circuit presents more design difficulties than almost anything else that might be used. Looking on the clamp tube as some kind of a magical "screen swinger" is merely going back about thirty years to the days before the principles of modulation and audio amplifier operation were really developing. So let's forget about the dark ages and look at the thing on a logical basis.

The function of the modulator is to supply a

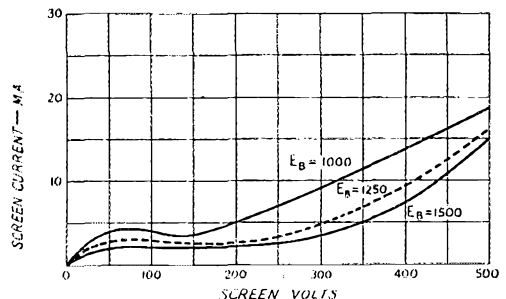

Fig. 5 — Screen current *vs.* screen voltage under conditions representing optimum operation for screen modulation. These curves were taken on an 813. Curves for other tubes have similar shapes although the currents will have different values at a given voltage.

requisite amount of audio power to the screen. A "clamp-tube" modulator is simply a resistance-coupled power amplifier. Part of its output will be used up in the screen-dropping resistor and part in the screen. This is old-fashioned Heising modulation with a resistor substituted for the choke. One of the biggest 'phone problems in the old days before Class B modulators was that of matching the modulator and modulated amplifier. Since the modulated stage had to be matched to the modulator without benefit of transformer, rather odd values of d.c. voltage and plate current in the modulated stage frequently were required. With plate modulation, at least there was some freedom of design in that respect, but with screen modulation there is little or none—the screen voltage and current are fixed by the other operating requirements.

If you have a set of triode plate-family curves of the tube you want to use as a clamp-tube modulator, and have been around long enough to remember how a Heising modulation set-up was calculated for 100 per cent modulation, you may get a nostalgic kick out of working out an optimum design. If not, better copy your operating conditions from someone who has. Better still, forget the clamp tube and do it the simple way—use transformer coupling between the modulator and the screen. The transformer ratio can be figured in essentially the same way as for plate modulation. Additional resistance loading (to improve the regulation) should be allowed for in the calculation. For instance, the 33,000-ohm modulating impedance calculated above actually consumes only about 1 watt. For each additional watt available to be dissipated for improving regulation, 33,000 ohms can be added in parallel. If the output of the tube used as a modulator is 3 watts under rated conditions, the total load will be  $33,000/3 = 11,000$  ohms, 33,000 of it in the screen and  $33,000/2 = 16,500$  in additional loading. If the modulator tube is rated to work into a 5000-ohm load, the impedance ratio is then  $11,000/5000 = 2.2$ , secondary to primary. We won't go into it further here, since the method of calculating the proper transformer ratio is covered in the *Handbook*, except to say that negative feed-back in the modulator will go a long way toward taking care of the variables that are an unavoidable part of screen modulation.

With transformer coupling, almost any beam tetrode can get its screen voltage from the modulator plate supply, thus saving a lot of d.c. power as compared with a dropping resistor. Simply tap off on the modulator plate supply bleeder and by-pass with 8  $\mu\text{f.}$  or more. Fig. 6 is a representative circuit for a pentode or beam-tetrode modulator, complete with feed-back.<sup>1</sup> A small Class B driver transformer, especially if it has a choice of one or two turns ratios, usually will suffice for  $T_1$ . It has to handle only a few watts of audio. The ratio does not have to be exact, especially with feed-back in the modulator.

<sup>1</sup>A similar circuit complete with speech amplifier was described in October, 1951, *QST* ("Screen-Grid Modulation of the Modern-Style 813 Transmitter").

## Waveform Shaping

If you follow the principles and methods outlined above and you have a properly designed audio amplifier, your signal will stand critical comparison with any on the air, whatever the type of modulation. There is nothing wrong with screen modulation that the application of sound principles won't cure.

But don't expect the screen grid to give you any modulation miracles. It hasn't any to offer. There are some things that can be done to squeeze out a few more watts than you would normally expect to get with grid modulation. Controlled carrier is an example; it is not unique to screen modulation but can be applied very conveniently in the screen circuit.<sup>2</sup> Practically all the other schemes now extant, and which promise more output than you normally have a right to expect from screen modulation, are based on plain and simple distortion in the modulated amplifier.

Distortion or "shaping" of speech waveforms to increase the speech power (e.g., clipping) within the confines of 100 per cent modulation is a perfectly legitimate practice for communication work. The catch is that the shaping has to be done *before* modulation, and must be accompanied by some form of audio filtering, if spurious sidebands are to be avoided.<sup>3</sup> Nevertheless, it is

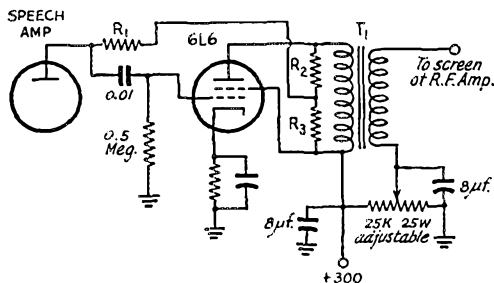

Fig. 6—Transformer-coupled screen-modulator circuit, using negative feed-back to improve regulation and reduce distortion.

invariably stated of systems in which the shaping is done in the modulated stage that the signal is "sharp," as confirmed by reports solicited during casual contacts. This hardly seems possible if distortion in the modulated amplifier generates spurious sidebands, yet it is a fact that some signals of this type do not seem to be unduly broad.

This apparent contradiction is, we believe, fairly easily explained. The spurious sidebands unquestionably are generated. However, the voice components principally responsible for them are the vowels, which have comparatively

(Continued on page 106)

<sup>2</sup>The possibilities and limitations of carrier control as applied to screen modulation have been discussed in Technical Topics, "Design Limits for 'High-Output' Grid Modulation," *QST*, February, 1951, and "Screen Modulation with Limited Carrier Control," *QST*, April, 1951.

<sup>3</sup>Technical Topics, "Some Facts of Modulation," *QST*, March, 1951.



# U. S. N. R.



# M. A. R. S.



### The Midwest Flood

Amateur stations at Naval Reserve activities and the stations of individual Reservists rendered noteworthy emergency communication service during the Midwest flood.

At Topeka, Kans., K0NRZ, Naval Reserve Training Center, maintained a continuous watch from 0800 July 11th until 2200 July 15th on the local emergency net frequency, 29.5 Mc. Control station was W0CET, the Kaw Valley Radio Club. At 2225 July 15th, a long-haul net was started on 7042 kc. This operation accounted for more than 1000 messages handled between July 15th and 20th. K0NRZ extends thanks to the following who served as net control: W3s DVE PRT, W4s EWC MWX, W8s DLF PMJ, W9DUA, W0LOD, and VE3IA.

At Kansas City, Mo., K0NRI, Naval Reserve Training Center, and the following individual amateurs provided both fixed-station and mobile circuits: W0s AHI ATM CFL DPX FIC HIK SSG and ZOS.

At St. Joseph, Mo., K0NRK, Naval Reserve Training Center, maintained watches on the Kansas Amateur Emergency Phone Net (3920 kc.), handling approximately 100 messages. The following amateurs assisted in the operation at K0NRK: W0s BHI CWG HEY IAC, and Royal Osgood and Bernard Jones.

K0NAN, Volunteer Electronics Company 9-198, Junction City, Kans., passed traffic out of the flood area on 3.5-Mc. c.w. from July 13th to 16th, inclusive. Amateurs active at Junction City were W0s ACU BLF BLI CHJ CV and LQW.

K0NBM, Organized Electronics Company 9-12, Parsons, Kans., handled considerable emergency traffic, with the assistance of W0s IEL JDF and ZDQ. . . . K0NAX, Volunteer Electronics Company 9-189, Pittsburg, Kans., guarded the Kansas Emergency Net frequency, 3920 kc. . . . The quarters and equipment of Volunteer Electronics Company 9-193, K0NRM, Manhattan, Kans., were used by the local amateur radio club. . . . W0DJE, Naval Reservist, Hutchinson, Kans., was active in the emergency work. . . . K9NAK, Organized Electronics Company 9-2, Alton, Ill., furnished handie-talkies (3885 kc.) for communication between Army/Air Force trucks and Coast Guard boats engaged in sandbagging the levees.

### Here & There

The first Naval Reserve Electronics Company in the Twelfth Naval District to attain organized status is the unit at San Luis Obispo, Calif. (K6NAM), which is now Organized Electronics Company 12-4. . . . Cmdr. T. C. Pipes (W5PLQ) and Lt. Cmdr. J. P. Foster (W5HNW), both attached to Eighth Naval District Headquarters in New Orleans, represented the Navy at the ARRL Division Convention in Austin, Texas, August 18th and 19th. . . . A group of 200 amateurs participated in a hamfest held in April at the Naval Reserve Training Center, K5NRL, Little Rock, Ark. Active in conducting the program were W0s BUX EEJ and EGX.



Members of Electronics Company 1-5, Somerville, Mass. (K1NRS), display Efficiency Pennant and Trophy won in First Naval District competition.

### Kansas Flood Lessons

MARS chiefs are evaluating the results of the 1951 Kansas Flood disaster with a view to possible future emergency radio requirements.

Information furnished MARS Headquarters indicates that the operator personnel and equipment used by MARS were adequate to establish reliable circuits. However, under continued operation they might have broken down. Take the installation at Camp Funston, Kans., for example. This station went on the air as soon as the need for emergency communications was made known. It operated continuously. On July 12th high water drove the operators from the station, so they moved into a three-quarter ton truck and continued operations using an SCR-264 transmitter with a PE-103 power unit and a long-wire antenna. When this unit burned out, the station stayed on the air using an SCR-506 with 24-volt batteries. This is a fine tribute to the station personnel who had the know-how and the ingenuity to "scrounge" substitute equipment. But it points up the possible need in individual station planning for adequate repair, maintenance and/or replacement.

Training and organization continue to be items of primary importance in the MARS plan. When a command has reliable communications it also has control over a situation. The initial period (amounting almost to a shock period) of a disaster is the most critical time. MARS members are being trained in the use of military procedures and methods; nets are organized to follow military channels of command. This makes for rapid integration and effective liaison between military command circuits and MARS networks.

Frequencies, of course, are the key to reliable communications. A determination is now being made as to what frequencies may be available to MARS in the event training requirements cease and tactical-type operations are needed.

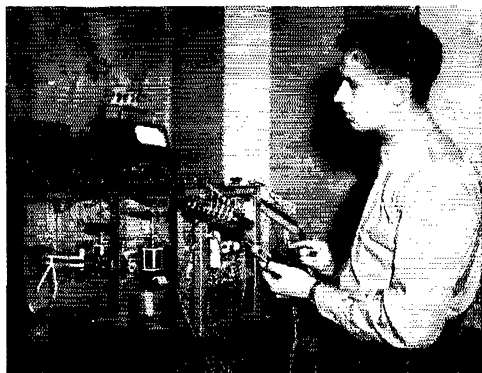

Private First Class Keith Hester has been placed in charge of maintenance for the MARS-Air Force Headquarters station at Washington, D. C.

# Water in the Dust Bowl

## Amateurs Excel in Supplying Emergency Communications During One of the Greatest Floods in the Midwest's History

BY GEORGE HART,\* WINJM

MAY was a wet month in the general vicinity of the State of Kansas, and June was even more so. The ground became saturated, riverbanks filled to overflowing and some communities experienced flooding of their streets even before the big rains really came. Highway and rail traffic slowed down, almost stopped. And then came more heavy rain to produce a record flood and to cause a communications emergency in which the help of amateur radio was needed and was forthcoming. Telephone and telegraph lines fell and became broken in the raging waters, leaving some communities entirely without wire communication, others with only a few wire outlets. What lines did remain were badly overloaded. Into these overtaxed communications facilities came the extra demand for communications in the form of relief and welfare messages, official communications and thousands of "worry" and "agony" messages to and from individuals.

Into this breach stepped many emergency and traffic nets and many public-spirited individual amateurs. The Kansas Emergency Net went on a continuous operation basis. The ARRL Tenth Regional Net instituted 7-day-per-week operation, in order to take care of the great increase in traffic. The

Transcontinental Relay Net operated extra sessions to help out. All over Missouri and Kansas special nets sprang up to meet the demands of the hour, sometimes working into regularly-established nets, at other times serving a temporary need for communications with certain places.

In the affected areas of Kansas and Missouri there was feverish amateur emergency activity. Some AREC organizations were activated in late June, but the real trouble started about July 10th and continued for some 10 days before the waters began to recede. The damage, especially in the Kansas City area, was tremendous —

\* National Emergency Coördinator, ARRL.

and would have been much more so but for the marvelous work of our emergency and traffic nets and our SECs, ECs and AREC members.

It is impossible, from the stack of interconnected reports we have, to establish any kind of continuity of activity over the emergency area as a whole. Rather than try to do so, since most of the work was local in nature, we shall cover the primary areas of activity one by one, then summarize later.

### Lawrence

The first call for amateur assistance in Lawrence

came in late June when community officials called on the AREC to provide mobile stations for patrolling the dikes. Six mobile units made up a network on 29.4 Mc., along with the University of Kansas station W0AHW, K0NAB of the Naval Reserve, and W0SEC. Some of the units were in continuous use for periods of over 24 hours. Two weeks later, on July 10th, the Kansas (Kaw) River rose again and mobiles W0BH and W0FON went to work. W0SEC set up his fixed station at the Chamber of Commerce, and W0AHW again went on continuous duty. W0BH, with PA0CG assisting, flew equipment to Perry.

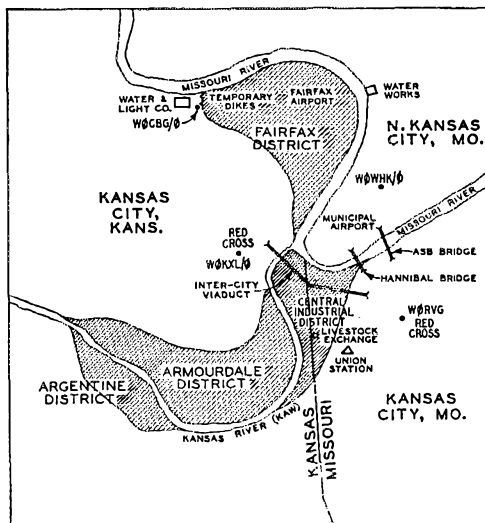

The greatest damage inflicted by the rampaging Kaw took place in Kansas City, where the Kaw flows into the Missouri. This map, submitted by W0KXL, shows the inundated areas and the locations of places referred to in the text.

### Manhattan Area

On July 11th water from the Kansas River began to overflow into Manhattan and city officials had to leave their offices in the downtown area to establish temporary headquarters at Kansas State College. W0DEL and W0PAH installed radio equipment in the temporary headquarters to provide emergency communications for city officials. Using the facilities of the Kansas State College Amateur Radio Club, W0QQQ, this equipment operated under the call W0DEL. The transmitter operated continuously from July 11th to July 17th, using emergency power



• One hardly knows where to begin. The Midwest floods in July caused a flood of reports, each one adding something to the story, each giving a slightly different version of what actually happened. The story is complicated and incredibly long — much too long to reproduce here in any detail. The account which follows is an attempt to reduce some 25 to 30 reports to an all-inclusive narrative — an attempt we know will overlook something or somebody.

part of the time. WØDEL continued to operate from this location on a limited scale until July 20th.

WØQQQ and WØOXE also operated from the campus. The former handled some long-distance traffic on 20 and 75. WØOXE, the Naval Reserve station, was assigned the job of handling welfare messages. WØYUQ maintained contact from his home station at night. Normal communications were off in Manhattan for several days. During this time amateur radio furnished most of the help needed.

WØDEL handled almost nothing but official emergency traffic. Services performed included relay of information to KSAC, the college-owned broadcast station, which went on the air in place of flooded-out WIBW of Topeka. Typical of other traffic handled at WØDEL were calls for typhoid serum, Red Cross calls for food and clothing, weather bureau reports, river information, calls for equipment, death messages, etc. Keeping this station on the air meant using considerable manpower. WØDEL was operated at various times by WØs DEL, PAH, AMG, IYU, and YFE, in addition to necessary nonoperating personnel.

WØQQQ made its first contact on July 12th and handled a great deal of traffic, some of it on the MARS frequency of 14,255 kc. Some of the messages were of an urgent nature, such as instructions to planes dropping needed medical supplies, blankets, and radio equipment. WØQQQ operated for 84 hours, using 14 Mc. during daylight and 7 and 3.5 Mc. at night, with help from W9OOM, WØYFE, WØSQL and W9LPX/Ø.

WØOXE, operating from the Naval Reserve barracks, handled some urgent traffic concerning

gas lines, pipe-line breaks, etc., in addition to the usual welfare traffic. They operated exclusively on 75 meters and moved around the band as required. Operators included WØOXE, WØSQL and WØZGQ. This station was connected by landline teletype to WØDEL, and contact between WØDEL and WØQQQ was maintained with Signal Corps field telephones; thus good liaison was maintained and traffic moved with efficiency.

Radio contact was maintained with Topeka and Ft. Riley at all times, using mostly 75 meters and the assistance of hundreds of amateurs who helped police the bands and who helped by remaining silent. The traffic count for the three stations at Kansas State runs into four figures. Particular praise is due WØZLA who rendered remarkable liaison assistance and WØYFE, who was flooded out of his home and lost his transmitter, but nevertheless volunteered as operator at WØQQQ and WØDEL.

At Ft. Riley, WØAAE, the station of the Ft. Riley Amateur Radio Club, was completely flooded out and operations were started on July 12th from the back end of a small truck. Later the station was moved to the Signal Equipment Pool. Priority and emergency traffic from the post and the Red Cross were cleared first, after which welfare messages were handled to every state in the Union. Some 1217 service and welfare messages, 73 Red Cross messages, 27 telegrams and 122 priority and emergency messages were handled, with only two operators, WØDAF and WØPNQ.

In Junction City, WØBLI handled traffic for Western Union with W9BCY/Ø mobile, and later with WØACU and WØAAE. Other in-state traffic was handled with WØCV and out-of-state traffic by the Traffic Exchange Net on 7230 kc. A few were also handled on 160.

### Topeka

Emergency net drills conducted by the Kaw Valley Radio Club of Topeka, along with some experience in late June when the Kaw River got to pushing at the tops of the dikes at several places, paid off for the Topeka gang on July 10th, when the real test came. The Mayor of Topeka requested three fixed stations and several mobiles. A special meeting was called and preliminary details worked out on setting up the individual stations and staffing them for the first

◆ This, believe it or not, is a broadcast station in operation. KTOP in Topeka was one of three broadcast stations flooded out, but they stayed in operation by using the facilities of WØWIT, with a few slight modifications to make his 14-Mc. transmitter work on 1490 kc. This lash-up operated 18 hours per day for four days in flood service until KTOP got going again. A halfwave doublet cut to the frequency served as an antenna. Shown are (l. to r.) WØWIT, WØNCV and a KTOP engineer waiting for something to let go.

◆

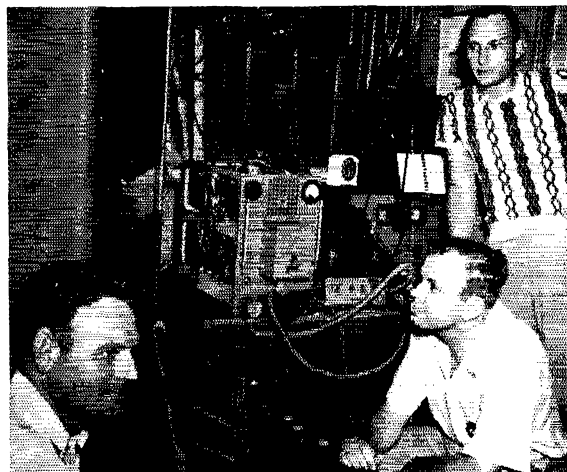

24 hours. Besides the three fixed stations, two emergency-powered portable stations were set up in trucks for continuous duty wherever the need arose. Within 24 hours these facilities were expanded by adding three more fixed stations. Manpower became a very acute problem. Most of the boys put in from 12 to 18 hours per stretch and at one station which became isolated the boys kept the station going for 56 hours before relief arrived.

Stations were set up at National Guard headquarters, the city garage, the fair grounds, at the scene of the flood and at four separate "boat docks" created at several points throughout the city, with mobiles at the city waterworks and others scattered wherever needed and requested by the National Guard or police headquarters.

Most of the traffic handled contained requests for sand, sandbags, trucks, manpower, and boats. This traffic flowed constantly for four days intermingled with requests for food, motorboat repair parts and mercy missions concerning missing persons, pets and livestock.

Three additional stations were set up on 75 meters to handle Red Cross, National Guard and Santa Fe Railroad emergency traffic. All operations were carried out through W0CET, the control station at Police Headquarters. Operation was maintained for five full 24-hour periods, then tapered off for a day and a half before shutting down. The Mayor, National Guard and Chief of Police all voted a hearty "well done" to the members of the Kaw Valley Radio Club and others who assisted.

At Forbes Air Force Base in Topeka, W0TRK was set up and assisted materially in handling hundreds of messages for the Red Cross and city officials.

K0NRZ at the Naval Reserve Training Center maintained a continuous watch from 0800 July 11th until 2200 July 15th on the local net. On July 15th they participated in the Transcontinental Relay Net on 7042 kc.

W0KSY/0 was set up at the Adjutant General's office in Topeka.

### *Salina*

On July 11th, the Chief of Police of Salina contacted EC W0IYR and requested that he immediately organize the Central Kansas Emergency Net and prepare for action. W0TSR moved his equipment to the Police Station and during the afternoon all the mobile units checked in. The Chief of Police assigned a patrolman to each mobile unit to report rising water conditions. W0BGW and W0MVG went to the river gauge south of town. That evening all mobile units were kept busy moving barricades and reporting water levels to the Police Department.

At midnight, W0INW/M and W0MVG were dispatched to the northern part of the city to handle emergency evacuation calls. W0ATS/M and W0ISC were stationed at the Street Department. W0MUY/M was stationed in the southeast part of the city to dispatch boats, maintainers, etc., on evacuation calls. W0BGW and W0IYR

were marooned near their home locations and reported on conditions and helped relay requests for assistance. W0TSR and W0HWE manned the station located in the police building.

From midnight until 6 A.M. July 12th all units remained in service. At 6 A.M., when the Street Department building had to be evacuated, W0ATS and W0ISC were dispatched to the Iron Avenue Bridge to handle emergency calls from the east part of town which was then under water. Thursday afternoon W0IYR escaped the water and relieved W0INW and W0MVG. Late Friday afternoon (July 13th), W0MVG's equipment, manned by W0MUY and W0ISC, was moved to radio station KSAL to provide communications with the Police Department since the landlines were heavily loaded with emergency calls. By midnight Friday evacuations were practically complete and mobiles were taken out of service. During the entire emergency, W0JAF on 75 meters and W0STC on 160 meters handled incoming and outgoing traffic.

On July 14th, W0JFE of Abilene moved his gear to Solomon, near Salina, since they had only one shaky landline operating. Some 80 messages were handled on 160 meters. W0BDK of Abilene moved into Chapman, which was hard hit, to handle emergency traffic until satisfactory wire communications were re-established. W0VDP was on from Abilene, and it is said that fish were swimming around in his shack. W0BGW acted as relay with the aid of W0s TSR, MVG and INW. All in all, a tremendous amount of work was put in by the Salina gang. Several of the boys operated a total of 90 hours with less than six hours of sleep.

### *Kansas City Area*

The swollen Kaw now rolled on toward its junction with the Missouri River and its grand finale in destruction. The dikes and levees in Kansas City were built five feet above the high point of the great 1903 flood and were considered safe. However, it was not until late — almost too late — that engineers discovered the Kaw was carrying 60% more water than in the 1903 flood, and hurried evacuation of low spots was ordered late on July 12th.

The Heart of America Radio Club 10-meter net, with mobiles from all the Greater Kansas City area participating, had been active on the 11th and 12th during the flooding of the Big Blue which cuts through the eastern part of Kansas City, Mo. The mobiles, teamed with Red Cross rescue units, now went into action along the Kaw, aiding and checking on the evacuation work. The Kaw broke through the Argentine dikes on the south bank shortly before midnight. A few hours later the river topped the dikes in Armourdale on the north bank. The Kansas City central industrial district was still considered to be safe, but the amazing Kaw broke through to inundate the rich industrial district, stockyards and railroad yards.

The amateur mobile units went to work under control of W0RVG, permanently set up in the

All operation on 10 meters in and around Topeka was controlled from WØCET, located in the radio room of the Topeka Police Department. This station kept order in the net so that although traffic was heavy, it was handled in an orderly manner. Shown at the controls are WØICV and WØAFN (l. to r.), while WØUPU keeps the records on the dispatch board.



Kansas City, Mo., Red Cross Building. Spotters telephoned or relayed information of marooned and stranded persons and WØRVG contacted the mobile of the nearest rescue team. Many lives were saved this way. Amateur mobiles were also rushed into the industrial district where gas and oil tanks, floating loose from their base, were striking high-voltage lines and exploding into flames. The mobile units remained there for several days providing needed communication for first-aid work, feeding of the fire fighters, etc.

The Kansas City, Mo., Municipal Airport and Kansas City, Kans., Fairfax Airport were both threatened as the Kaw poured its floodwater into the Missouri. Airline activity was shifted to Grandview Airport, 15 miles south of Kansas City, and schedules were disrupted as some airliners left their regular schedules in order to help in the flood work. Johnson County amateurs set up WØEIB/Ø on 75 meters to communicate with Grandview Airport and WØRVG. Later, when 75 proved unsatisfactory, WØEIB/Ø switched to 10 meters where WØUBR/M was already in operation. WØRCU/Ø had earlier been set up as liaison with the Army Engineers and WØKXL/Ø at the Kansas City, Kans., Red Cross Headquarters.

The Kaw's floodwaters now began to tear at the dikes in North Kansas City at the junction of the Kaw and the Missouri. WØWHK/Ø was set up and mobiles WØRDR and WØLKP were rushed in and joined there by WØYPV. WØBQU operated with a fleet of boats on rescue work. But the dikes in North Kansas City held after feverish work and the danger point shifted to the Fairfax District of Kansas City, Kans., where water seepage had developed and later broke through the flood gates. Weakened by water on both sides, the dike was broken by the river at 6 P.M. on the 14th. This precipitated the battle for the Kansas City, Kans., water and light plant in the northern corner of the Fairfax District. Mobiles WØFPH, ODU and UQV were sent into Fairfax. Later as the dramatic inch-by-inch battle between the sandbaggers and the water continued, WØs AHC and KXL moved to 29.6 Mc. for a "point-to-point" radio circuit. The threat of violent explosion should the water hit the 2000-degree-hot boilers brought hundreds of volunteer workers to the scene. WØAHC/M was relieved by other mobiles, then a portable station, WØCBG/Ø, was set up near the plant and remained there until the battle was definitely won and workers hurriedly left, since 53,000,000 gallons of gas and oil stored in the Fairfax District were putting a heavy film on the water and fumes in the air so

that a spark could set off an explosion more disastrous than the flood itself.

The river was not quite finished with its destruction and threats. The Missouri, swollen now by the Kaw, began cutting away at one end of the Truman Bridge, Kansas City's sole remaining rail bridge to the East. WØBGP/M was dispatched to provide communication for the work crews which were rushed there, and operation continued until the morning of July 18th.

Probably 45 to 50 mobiles participated in the communication of the Kansas City area, providing much-needed mobility to the flood communications system and a supplement to greatly-overloaded telephone circuits. The 10-meter net handled messages dealing with rescue work, manpower, equipment, materials, feeding and clothing of workers and flood refugees, evacuation work, and every other type of activity that could be connected with a flood. We cannot reproduce a complete list of amateurs who participated, but we think mention should be made of WØOOT' who, flooded out himself, operated from five different stations during the flood period as well as conducted his own job as operator with the Missouri Highway Patrol. The 75-meter net found its chief use in handling vocal messages for the Red Cross, city and state officials, the military and direct conversations between officials and business executives, to say nothing of a large amount of inquiry and welfare traffic.

#### Miscellany

WØTAW and WØFRK operated in Garnett handling traffic for the Santa Fe Railroad along with Red Cross messages and death notices. Most of the traffic was handled with Ottawa. WØFRK also was instrumental in providing Osawatomie with much-needed contact with the outside world through his 75-meter mobile rig. He handled communications for the Mayor, the telephone company and the state Board of Health, returning to Garnett between times to carry on his work there. Lee put in many long hours of operating both at home and away.

Chanute stations WØLJV and WØIFR were active, the latter operating WØLYF's rig. Traffic was handled with Topeka for the Santa Fe, with flood-stricken Erie, Kans., through WØEQD of Parsons and WØFNS of Neodesha, and with the

(Continued on page 108)

# A Civil Defense Control-Station Antenna for 144 Mc.

## Stacking Coaxial Dipoles for Lowered Radiation Angle

BY PHILIP S. RAND,\* WIDBM

• Widespread use of the 144-Mc. band for Civil Defense communication has demonstrated the need for an antenna system that will give gain over a simple dipole and yet not introduce directivity problems. WIDBM shows here the mechanical and electrical details of a stacked coaxial array that will bring about a marked improvement in control-station coverage.

**A**n antenna system for use at a Civil Defense or Red Cross emergency control station should be vertically polarized, to match the polarization of the mobile units, and nondirectional so that all mobiles in a given area can be heard equally well. It will be very helpful if the antenna has some gain over a simple ground plane. It should be easy to build and erect, weatherproof and neat looking. Preferably, it should be fed with coax cable.

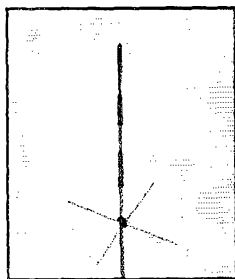

A four-section stacked coaxial array for use in a Civil Defense control station. An array of this sort will give as much as two to three S units increase in signal over that obtained with a single coaxial dipole of equivalent height.

An antenna that meets all the above requirements except that of gain is shown in Fig. 1 and is known as a coaxial dipole. Antennas of this type have not received too much favorable comment in the past, probably because of their high angle of radiation, which wastes power so far as ground-wave work is concerned. This could be explained by examining the standing waves on the mast due to the coupling between the antenna and mast. The skirt or bottom element of the antenna acts like a quarter-wave coaxial transformer and puts a standing wave on the top of the mast in phase with the antenna. This is fine, giving us two halfwaves in the phase at the top; however, the balance of the mast may have up

\*% Laboratory of Advanced Research, Remington Rand, Inc., South Norwalk, Conn.

to 10 halfwaves (if mast is about 30-35 ft. high) all out of phase. What we have, in effect, is a long-wire vertical antenna with the last two halfwaves in phase. Your guess is as good as mine as to the probable angle of radiation.

The answer would seem to be to stack, say, four halfwaves in phase vertically and then try to choke off the r.f. from the mast. Fig. 2A shows the first step in this direction: four halfwaves stacked vertically and phased by three quarter-wave open stubs. This works fine but it is difficult to mount, and a balanced transmission line such as 300-ohm ribbon has to be pulled away at right angles. It meets the gain requirement but none of the others. If we visualize these

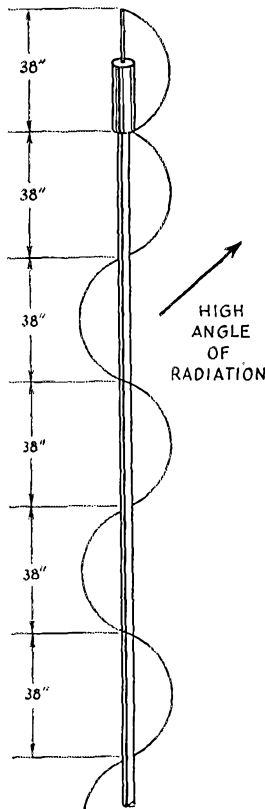

Fig. 1 — The conventional coaxial dipole mounted at the top of a mast made of metal tubing loses much of its effectiveness because standing waves on the mast combine with the radiation from the dipole itself, resulting in radiation at a relatively high angle.

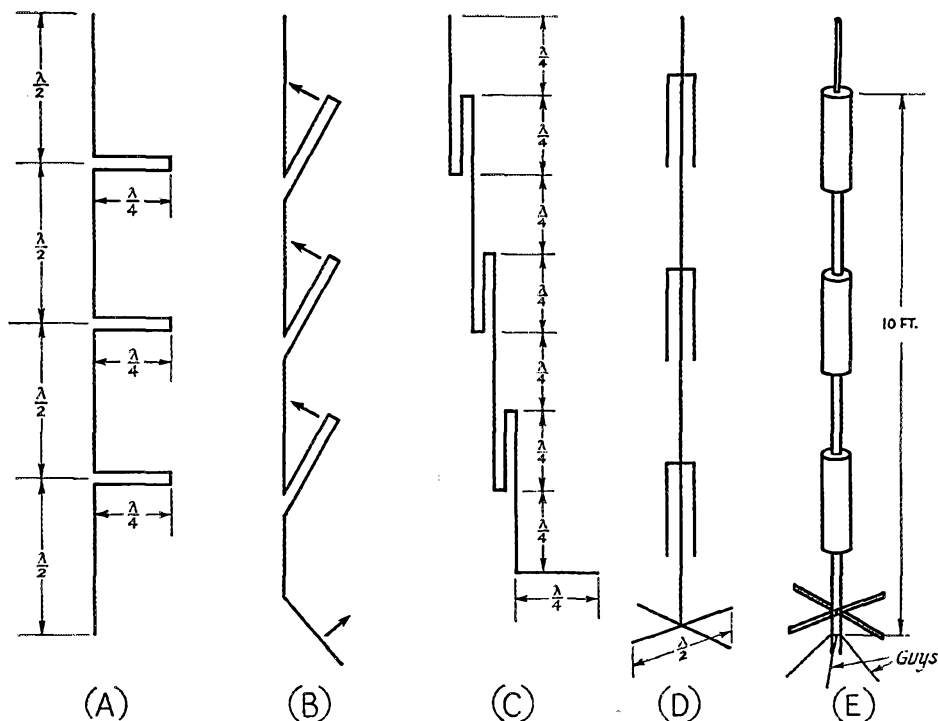

Fig. 2 — Evolution of the stacked coaxial-dipole array. At A we have four halfwaves vertically stacked, with folded halfwave phasing sections between. If these are bent up, as in B and C, we have a comparable arrangement to that of the coaxial-dipole system, shown in cross section at D, and in practical form at E.

three stubs being pulled up into a vertical position as shown in Fig. 2B and 2C and then each one rotated around to form a cylinder, we will then have what is shown in Fig. 2D (in cross section) and in final form in Fig. 2E. Note that the bottom quarter wave was only bent up to right angles and was then extended in four directions to form a ground plane. The center wire in Fig. 2D now becomes a hollow pipe in 2E and our 52-ohm coax can go up the inside.

What we have actually done is to add two additional skirts and a ground plane to the antenna shown in Fig. 1, to give us four half-waves in phase and to attempt to prevent standing waves on the balance of the mast.

The outside of each skirt is the bottom half of each halfwave antenna while the inside of each skirt combined with the mast forms a coaxial quarter-wave transformer to reverse the phase so that the mast immediately below each skirt becomes the top half of the next halfwave antenna. Thus all four halfwaves are in phase. The bottom half of the bottom antenna is bent out at right angles to form a ground plane in an effort to prevent any standing waves on the balance of the mast. Guy wires are attached just below the ground plane to keep the mast from swaying.

The only insulator is at the feed point at the center of the top section. It was thought best to feed the top radiator so that the maximum signal would be radiated from the highest point. As shown in an exploded view in Fig. 3A and an

assembled view in Fig. 3B, each skirt is bolted through a metal ring directly to the mast at its top end and is spaced by a  $\frac{1}{4}$ -inch-thick polystyrene ring at its center. The polystyrene rings are held in place with a couple of layers of Scotch electrical tape above and below on the mast.

The RG/8-U coax cable screws onto a coax chassis fitting attached to the center of a 2-inch-diameter  $\frac{1}{8}$ -inch-thick aluminum washer which is clamped to the top of the top skirt by the formica insulator. This insulator was turned out on a lathe from a piece of 2-inch-diameter formica or canvas-base bakelite rod and was given several coats of liquid polystyrene to seal it. There are several standard insulators that might be adapted for this purpose if lathe facilities are not available. After assembly the insulator and the tops of all skirts were sprayed with plastic and were well wrapped with Scotch electrical tape to prevent the corrosion of the dissimilar metals used (aluminum skirts, brass hardware and steel mast).

### Results

Tests with other 2-meter stations indicate about two S units increase in signal (12 db.) with this antenna over a single coax vertical. This is much too high, of course, but the answer seems to be that the angle of radiation is lower and therefore the receiver at the other end gets more of the signal. Measurements with a standing-wave bridge indicate a low standing-wave ratio

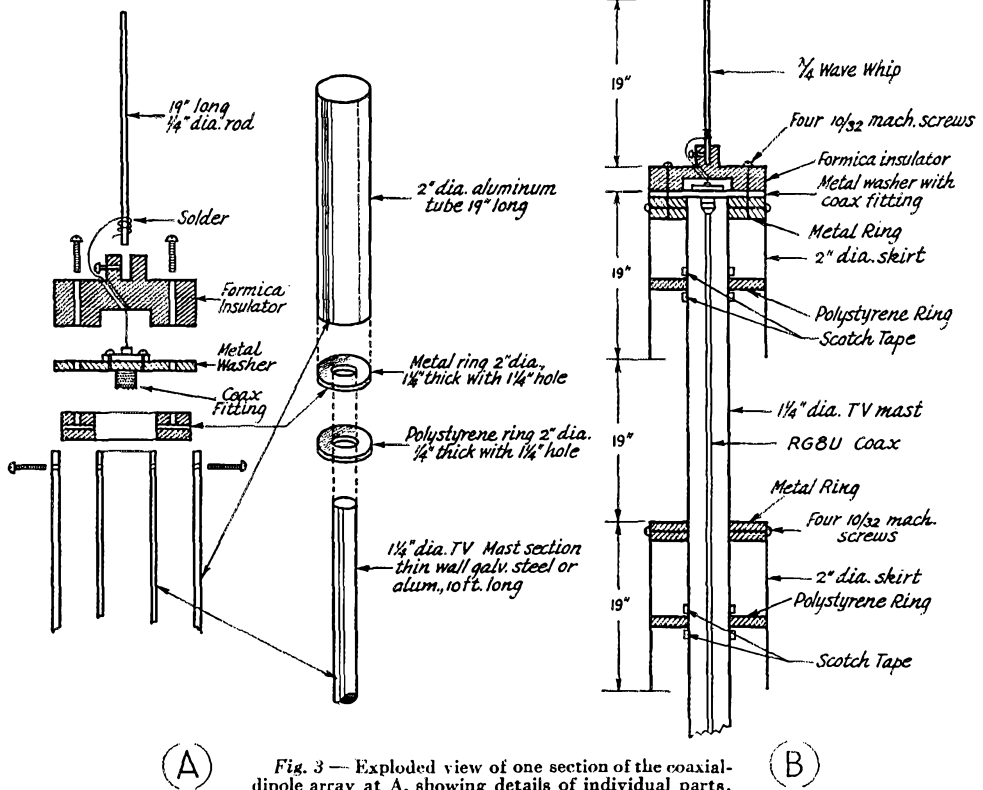

Fig. 3 — Exploded view of one section of the coaxial-dipole array at A, showing details of individual parts. Assembled view, B, shows how the parts go together.

over the entire 2-meter band. Both Eldico 2-meter transmitters and 522s load uniformly on any one of three of these antennas equally well.

Slightly better performance could probably be obtained if the builder took the trouble to adjust the spacing between skirts for maximum field strength. This would insure optimum phasing. The lengths of the elements could also be

changed slightly for a given frequency. The antenna as described gives very satisfactory results, however, and is very simple to build and erect.

An antenna of this type was recently installed at WIRCV, Stratford Red Cross net control station, resulting a gain of 3 S units over their old antenna.

## A.R.R.L. QSL BUREAU

The function of the ARRL QSL Bureau system is to facilitate delivery to amateurs in the United States, its possessions, and Canada of those QSL cards which arrive from amateur stations in other parts of the world. Its operation is made possible by volunteer managers in each W, K and VE call area. All you have to do is send your QSL manager (see list below) a stamped self-addressed envelope about 4 1/4 by 9 1/2 inches in size, with your name and address in the usual place on the front of the envelope and your call printed in capital letters in the upper left-hand corner. For a list of overseas bureaus see p. 62, June '51 QST.

(*Bold-face type indicates recent change of address*)

- W1, K1 — J. R. Baker, jr., W1JOJ, Box 232, Ipswich, Mass.
- W2, K2 — H. W. Yahnel, W2SN, Lake Ave., Helmetta, N. J.
- W3, K3 — Jesse Bieberman, W3KT, Box 34, Philadelphia 5, Penna.
- W4, K4 — Thomas M. Moss, W4HYW, Box 644, Municipal Airport Branch, Atlanta, Ga.
- W5, K5 — L. W. May, jr., W5AJG, 9428 Hobart St., Dallas 18, Texas
- W6, K6 — Horace R. Greer, W6TI, 414 Fairmount St., Oakland, Calif.
- W7, K7 — Mary Ann Tatro, W7FWR, 513 N. Central, Olympia, Wash.

- W8, K8 — Norman W. Aiken, W8LJS, 701 East 240th St., Euclid 23, Ohio.
- W9, K9 — John F. Schneider, W9CFT, 311 W Ross Ave., Wausau, Wis.
- W0, K0 — Alva A. Smith, W0DMA, 238 East Main St., Caledonia, Minn.
- VE1 — L. J. Fader, VE1FQ, 125 Henry St., Halifax, N. S.
- VE2 — Austin A. W. Smith, VE2UW, 6164 Jeanne Mance, Montreal 8, Que.
- VE3 — W. Bert Knowles, VE3QB, Lanark, Ont.
- VE4 — Len Cuff, VE4LC, 286 Rutland St., St. James, Man.
- VE5 — Fred Ward, VE5OP, 899 Connaught Ave., Moose Jaw, Sask.
- VE6 — W. R. Savage, VE6EO, 329 15th St., North Lethbridge, Alta.
- VE7 — H. R. Hough, VE7HR, 1330 Mitchell St., Victoria, B. C.
- VE8 — Roy Walton, VE8CZ, Box 534, Whitehorse, Y. T.
- KP4 — E. W. Mayer, KP4KD, Box 1061, San Juan, P. R.
- KZ5 — P. C. Combs, KZ5PC, Box 407, Balboa, C. Z.
- KH6 — Andy H. Fuchikami, KH6BA, 2543 Namauu Dr., Honolulu, T. H.
- K1.7 — Box 73, Douglas, Alaska.

# Happenings of the Month

## BUDLONG TO SWITZERLAND

In early September Secretary A. L. Budlong, W1BUD, flew to Geneva to join the U. S. delegation, at the request of the Department of State, participating in the current sessions of the Extraordinary Administrative Radio Conference. The problem involves the listing and protection of fixed stations in certain South American countries operating in our 3.5-Mc. band, and arises from the reservations to the 1949 Washington Inter-American agreements<sup>1</sup> taken by Argentina and several other countries in objecting to making the band exclusively amateur for its full width. Nothing specific to report yet; we hope to have some details by our next issue.

## LICENSE RENEWALS

No sooner had we indicated that FCC had pretty well caught up with its backlog of amateur license applications than things went awry again. Continued heavy flow of renewal applications, the new Novice tickets, budget cuts, personnel shortages and inability to get sufficient license forms all combined to set the license-issuance division back on its heels once more. And once more we relay FCC's request: be patient — we're getting the stuff out as fast as we can.

We remind you that FCC permits an amateur who has filed for renewal in ample time, but does not get his ticket back before expiration date due to FCC delays, to continue operating on the basis of his old license until word is forthcoming. We quote from a recent public notice:

Any amateur who files, in accordance with the requirements of Section 12.27 of Part 12, an appropriate and timely application for renewal of amateur radio station or amateur operator license and prior to the normal date of expiration of the license does not receive a new license or notification from the Commission that action has been taken on the application, may continue to operate in exact accordance with the terms of the license to be renewed until such time as a new license or notification of action on the renewal application is received. However, persons who file application for renewal after expiration of license but during the grace period provided by Section 12.27 are governed by that rule and may not operate pending action on the renewal application.

Amateurs are cautioned to make an appropriate notation in the station log at the time the application for renewal of license is filed, to keep a copy of the application, or to keep a copy of the letter transmitting the application with the station records as evidence of the timely filing, in good faith, of an appropriate application for renewal of license.

So get your application for renewal in good and early — right on the dot of 120 days (four months) before expiration date. Remember, too, that the renewal activity requirements are that you affirm ability to send and receive 13 words per minute, and affirm that you have been operating a total of at least 5 hours in the last 12 months

<sup>1</sup> P. 35, QST, September, 1949.

of the license term. Alternatively, you can affirm that you have been operating a total of 2 hours in the last 3 months before expiration, but this will do you no good if you apply on schedule — four months before expiration.

## Porter H. Quinby, W0AY

Amateur radio has lost a true friend in the untimely passing of former Midwest Division Director Porter H. Quinby, W0AY, who succumbed to a heart attack August 29th.

A League Director from 1926 to 1930, Port also held many posts in the Communications Department field organization during his long years of activity in amateur radio. First licensed in 1912 as 9AY, he held the call 9DXY between the two World Wars, obtaining W0AY after World War II.

Active in all phases of amateur radio, Port had devoted the greater part of the past two years to traffic activities, serving as manager of the Nebraska Net and participating in National Traffic System and trunk-line networks. He will indeed be sorely missed by his host of friends and acquaintances. Vale W0AY!

## DIRECTOR ELECTIONS

John H. Brabb, W8SPF, the only nominee, has been declared reelected as director of the Great Lakes Division for the coming 1952-1953 term. Similarly, Kenneth E. Hughes, W6CIS, continues without opposition as director of the Pacific Division.

Five vice-director posts have been filled beginning January 1st, also as a result of no competition: Alfred M. Gowan, W0PHR, continues for the Dakota Division, George S. Acton, W5BMM, for Delta, Harold E. Stricker, W8WZ, for Great Lakes, and William W. Butchart, VE6LQ, for Canada. Richard F. Czeikowitz, W6ATO, as the lone nominee becomes vice-director of the Pacific Division on the first of the new year.

The remaining offices are contested, valid nominating petitions having been filed and balloting now being in progress.

## CALL-LETTER LICENSE PLATES

License-plate legislation for Minnesota was first discussed on the state net, shortly thereafter a committee being appointed to set in motion machinery to secure call-letter license plates. Chairmanned by W0EPJ with W0BGY as secre-

(Continued on page 110)

# Announcing the 18th ARRL Sweepstakes

*Certificates Will Be Awarded to C.W. and 'Phone Winners in Each Section and to Top Scorers in Club Groups*

## CONTEST PERIODS

Time	Start	End
	Nov. 17th & 24th	Nov. 19th & 26th
EST	6:00 P.M.	3:01 A.M.
CST	5:00 P.M.	2:01 A.M.
MST	4:00 P.M.	1:01 A.M.
PST	3:00 P.M.	12:01 A.M.

**I**T'S TIME to get your station in readiness for the 18th Annual ARRL Sweepstakes. This popular contest affords you an opportunity to pit your operating skill against the best men in your ARRL section, or to fill in some of those states that are lacking for WAS. Every licensed amateur in every League section is urged to participate; whether or not you're an ARRL member, you are cordially invited to get into the SS and submit an entry. All scores reported in accordance with the rules will be listed in a QST tabulation of final results.

As usual, the contest will run over two consecutive week ends, with a maximum allowable total operating time of 40 hours out of the possible 66 for each entry ('phone or c.w.). Except for an addition to Rule 7, the rules are the same as last year's. You can operate both 'phone and c.w., but separate logs must be filed for each mode.

Entries by multiple-operator stations are encouraged and will be listed, but only single-operator stations will be eligible for the certificates offered to the top 'phone scorer and the top c.w. scorer in each section. Multiple-operator scores can be grouped with single-operator scores in club competition, however, and a handsome gavel is offered to the club with the highest aggregate score. Within a club, single-operator entries can compete for the "club-certificate" awards given to the top c.w. and 'phone scorers.

The Sweepstakes, like Field Day, puts a premium on operating skill rather than on power, since the 1.25 score multiplier applied to stations operating with 100 watts or less during the contest practically insures that most of the operation will be in this power class. The 807s really go to town in the SS!

If you're new to the SS, it won't take you long to catch on. During the contest period, call "CQ SS" or answer such a call, exchange preambles in the form shown elsewhere in this announcement, and keep your log properly. ARRL will gladly send you contest forms upon request, or you can draft your entry in accordance with the sample. Although it is not mandatory under the rules, more and more operators each year are using the 24-hour time system in their SS ex-

changes. For those unfamiliar with this system, it is based on a 24-hour day starting at midnight. Thus midnight is 0000, 1 A.M. is 0100, 12 noon is 1200, 6:30 P.M. is 1830, and 11:59 P.M. is 2359.

Tune up your gear now, warn the folks that you'll be unavailable the week ends of Nov. 17th and 24th, read the rules to acquaint yourself with the pattern, and then get set for an operating spree that is real fun.

## Rules

1) *Eligibility:* The contest is open to all radio amateurs in the sections listed on page 6 of this issue of QST.

2) *Time:* All contacts must be made during the contest periods indicated elsewhere in this announcement. Time may be divided between week ends as desired, but a total of 40 hours must not be exceeded for each entry. Time spent in listening counts as operating time.

3) *QSOs:* Contacts must include certain information sent in the form of a standard message preamble, as shown in the example. C.w. stations work only c.w. stations and 'phone stations only other 'phones. Valid points can be scored by contacting stations not working in the contest, upon acceptance of your preamble and/or receipt of a proper preamble.

4) *Scoring:* Each preamble sent and acknowledged counts one point. Each preamble received counts one point. Only two points can be earned by contacting any one station, regardless of the frequency band. The total number of ARRL sections (see p. 6) worked during the contest is the "sections multiplier." It is not necessary for preambles to be sent both ways before a contact may count, but one must be received, or sent and acknowledged, before credit is claimed for either point(s) or multiplier. Apply a "power multiplier" of 1.25 if the input power to the transmitter output stage is 100 watts or less at all times during contest operation.

The final score equals the total "points" multiplied by the "sections multiplier" multiplied by the "power multiplier."

5) *Reporting:* Contest work must be reported as shown in the sample form. Mimeographed contest forms will be sent gratis upon receipt of radiogram or postcard request. Indicate starting and ending times for each period on the air. All Sweepstakes reports become the property of ARRL. No contest reports can be returned.

There are no objections to one's obtaining assistance from logging, "spotting" or relief operators, but their use places the entrant in the multiple-operator class, and it must be so reported.

A single-operator station is one manned by an individual

## HOW TO SCORE

Each preamble sent and acknowledged counts one point.

Each preamble received counts one point.

Only two points can be earned by contacting any one station, regardless of the frequency band used.

For final score: Multiply totaled points by the number of *different* ARRL sections worked, that is, the number in which at least one bona fide SS point has been made.

Multiply this by 1.25 if you used 100-watts-or-less transmitter input at all times during the contest.



## EXPLANATION OF "SS" CONTEST EXCHANGES

<i>Send Like a Standard Msg. Preamble, the . . . . NR</i>		<i>Call</i>	<i>CK</i>	<i>Place</i>	<i>Time</i>	<i>Date</i>
<i>Exchanges</i>	Contest info. numbers, 1, 2, 3, etc., for each station worked	Send your own call	CK (RST report of station worked)	Your ARRL section	Send time of transmitting this NR	Send date of QSO
<i>Sample</i>	NR 1	W1AW	589	CONN	1812	NOV 17

amateur who receives no assistance from other persons during the contest periods. He may not have assistance in any manner in keeping the station log and records, or in spotting stations during a contest period. Contest reports must be postmarked no later than December 10, 1951, to be eligible for QST listing and awards.

6) *Awards:* Two certificate awards will be given in each section, one for the highest c.w. score and one for the highest 'phone score. Only single-operator stations are eligible for certificate awards. Multiple-operator scores will receive separate QST listing in the final results.

A gavel will be awarded to the highest club entry. The aggregate scores of 'phone and c.w. reported by club secretaries and confirmed by the receipt at ARRL of contest logs constitute a club entry. Segregate club entries into 'phone

and c.w. totals. Both single- and multiple-operator scores may be counted for club entries. Only the scores of bona fide club members, in a local club territory, may be included in club entries.

The highest single-operator c.w. score and the highest single-operator 'phone score in any club entry will be rewarded with a "club" certificate where at least three single-operator 'phone and/or three single-operator c.w. scores are submitted.

7) *Disqualification:* Failure to comply with the contest rules or FCC regulations or the necessity for avoiding interference with channels handling amateur emergency communication shall constitute grounds for disqualification. In all cases of question, the decisions of the ARRL Contest Committee are final.

Sample of report form that must be used by all contestants.

### STATION W. . . . — SUMMARY OF EXCHANGES, EIGHTEENTH A.R.R.L. ALL-SECTION SWEEPSTAKES

Freq. Band (Mc.)	Time On or Off Air	Sent (1 point)				Time	Date (Nov.)	Received (1 point)				Time	Date (Nov.)	Number of Each Different New Sec- tion as Worked	Points
		NR	Stn	CK-RST	Section			NR	Stn.	CK-RST	Section				
3.5	On 1810	1	W1AW	589	Conn.	1812	17	7	W8JIN	589	Ohio	1814	17	1	2
"	"	2	"	589	"	1815	"	6	W1BFT	599	N. H.	1817	"	2	2
"	"	3	"	579	"	1820	"	6	W1BJP	579	Vt.	1821	"	3	2
7	"	"	"	"	"	"	"	21	W5KIP	479	Ark.	2005	"	4	1
"	"	4	"	479	"	2115	"	38	W5HJF	579	N. Mex.	1915	"	5	2
"	"	5	"	579	"	2128	"	45	W7KEV	479	Nev.	1820	"	6	2
"	"	6	"	589	"	2133	"	59	W8RSP	589	Ohio	2134	"	..	2
"	Off 2135 Time: 3 hrs. 25 min. On 1845	"	"	"	"	"	"	"	"	"	"	"	"	"	"
14	"	7	"	589	"	1915	18	94	KL7AD	569	Alaska	1418	18	7	2
"	"	8	"	569	"	1925	"	127	W7ZN	569	Idaho	1728	"	8	2
"	"	9	"	489	"	1935	"	114	W7HRM	569	Wyo.	1730	"	9	2
3.5	"	10	"	579	"	2110	"	130	W0LHS	579	N. D.	2005	"	10	2
"	"	11	"	589	"	2112	"	"	W5KIP	"	Ark.	"	"	"	1

Total Operating Time: 5 hrs. 55 min.      3.5, 7 and 14 Mc. used.      10 Sec., 22 Pts.  
85 Watts Input Power

Assisting person(s): name(s) or call(s), etc.: .....

Claimed score: 22 points × 10 sections = 220 × 1.25 (85 watts input) = 275

I have observed all competition rules as well as all regulations established for amateur radio in my country. My report is correct and true to the best of my knowledge.

Signature .....

Address .....

Tube Line-Up .....

Number Different Stations Worked .....

# How's DX?

CONDUCTED BY ROD NEWKIRK,\* W9BRD

## How:

"Conditions are good," observed Rattlefist O'Rourke, sipping his black cow daintily and setting same down, "when your first r.f. tube goes dead and you knock off another fast WAC without noticing it."

"I would say that conditions are good for DX when the Northern California DX Club, the Southern California DX Club, the Frankford Radio Club and the Potomac Valley Radio Club all happen to be meeting on the same night," said Parasitics Peterson.

Two-Countries-More Tannenbaum ventured his opinion: "Good conditions are present when I can't copy a thing on twenty meters because of S9-plus nineteen-meter broadcast images."

Solidly copying a roundtable of four or five VQ8s while placidly munching celery, peanut-brittle or popcorn was the definition of good conditions offered by Single-sideband Simpkins.

"Locals always tip me off to good conditions when I'm servicing or rebuilding the rig or receiver," added End-fire Endicott, seeking an eggnog refill.

Visits *en masse* by relatives, enigmatic outbursts of TVI, broken beam rotators, blooming power leaks and shorted coax are other phenomena sworn by our group to be harbingers of wide-open band conditions.

As no two DX men seem to be in agreement on the subject of good conditions, we'd welcome something a little more rigorous in scope and definition if anyone would care to make an offering. Who knows — this could be a research "must" in some future terminology table of DX terms.

## What:

*Twenty* gets the big play, as seems usual these days, and W9HUZ once more hit the jackpot: ET3R (000), F3AT/FF (064), FP8e AG and AH, MP4s BAF (022) BBD (048), MD2JB (008), GD3UB (074), EA8 8BF (096) 8AB (094), ZB8 1GKU (017) 2A (052), 11AHR/M1 (082), PX1AR (072), AP2N (082), VK1BS (015), CR7e AY (019) CI (086), VR2CD (082), HA5BD (060), ZD2JAB (041), ZE4JG (040), ZS7D (009), SV1SP (047), YU1CBI (045), OQ5s AA (078) VN (084), HC9JW (068) and 4X4BN (046). Van's stalk list featured Y13BE8, HV1A, MD5PM, OY3IGO and LB8CH on Jan Mayen which proves he's human; he does miss one now and then! . . . W2QHH's QRP has worked all the FP8e that have been active and Howy's newest include YU1AG (011), SP1JF (003), PX1AR, ZD1SS (129), JA2DS (014), HE1BQ (071), GC3HFE (102), 3A2AD with HB9MA in charge (077) and OE13FN (056). . . . While planning a new Lazy-H, W9IHN traded signals with FG7XA (030), CT3AB (010), YN4CB (018) and ZB2I (090). W9CFT heard from FG7XA and Andre's 10-watter has really been stirring up the QSLs. FG7XA receives with an NC-240. . . . W2JBL received his 100th confirmation for his 45-watt

work using an 8-foot whip antenna; W4IYT married and took a DX vacation, returning in time to be VK9DB's 3rd QSO. . . . VQs 2AB (130) 4CM (125) 4HK (126), VK9MR (120), VR1C (123), VP9OO (020), KB6AK (018) and EA6IF (018) came back to the 48-watt 807W of XE1SA. Manuel then proceeded to raise VS1BX (015) with his 9-watt 2E30. A cute cut-up was logged at XE1SA, one GH0ST (310). . . . In W8BAF's log may be found EAs 6AM (100) 8BD (070), SPIXA (015), YO6VG (080), VR2AS (130), LB5ZC (065), ZC4KN (073) and 9S4AX (020). . . . The very popular FB8BB (075) was worked by PY7WS, and W8BSS encountered one LB2MB who was most probably portable-in-Norway. . . . VK9XK of Papua (110), 3V8AN (015), YU3AC (082) and one LA9US occupied some of the time W5FXN didn't spend on six meters. . . . W3QHP joined the fun for folk like KG6FAA (100), ZB1CH (090), ZB1BS (070), CT2BO (050), HB1JJ/HE (050), HA4SA (040), YU1AD (050) and 9S4AL (050) with his space-restricted folded dipole. . . . W8FID made it 117 by coming up with EK1RR (020), MB9BJ (018) and CP5EK (002). Dick hopes to be DXing from K8AOA while attending college. . . . The West Gulf boys through W5KUC supply us with plenty of food for thought: ZD6DU (050), MP4KAE (040), FR7QA (030), FB8ZZ (040), LZ2DC (050), VR7AA (040), ZD2DCP (040), LB8CH of Jan Mayen (012) and KM6AW/KS6 (140). . . . FKS8AA and F9QV on Corsica entertained W4OEL while W6GEB kept busy with C3AB, VP3TY, VR2CG, OH5NK, ZK1BC, HR1KS and KR6EL. . . . Some of the items lately permeating the Ontario atmosphere and worked by VE3CCK are as follows: JAs 3AF 7AR, VS6s AE BO, KR6HC, 4X4s BD CR DK, MD2s BC RG PW, EA9s AP BA, OQ5RA, FQ8AG, CR4s AH AI, FR7ZA, MI3US, SU1RX, ZB1s AXJ BJ IF, TFs 3NA 3KG 5SV, OE13RL, 8Ps 5AB 6XA, HA5BK, FKS8AL, FQ8AC, KG6s ABE HZ, VK9QK, PK4DA, KB8AT, FY7YB, VP3s YG VN MCB, OA4J, VP2AD, YN1OC, HR2AD and VP5BH. That ain't hay, either. . . . The *DX Bulletin* of the So. Calif. DX Club specifies UJ8KAA (036), UM8KAA (033), OY4T (060) and VR7AA (030) as worth spinning the beam for, as well as AC3PT (090).

On twenty 'phone, XE1SA gets around: FO8AB (330), VK9YT (355), VP1s INW (308) 1DR (180) 3LF (160), HE2S (307) and some PK lads bit the dust. . . . UP1A (265) and UP5A, Lithuania, have been mighty popular with the



\* *New Mailing Address:* Effective immediately, please mail all reports of DX activity to DX Editor Newkirk's new QTH, 5833 North Kenmore Ave., Chicago, Ill.

gang, advises W1JCX and W5KUC. From the latter's West Gulf association we hear also of ZD6HJ (180), HC8GI and KH6PA/KP6 (250) . . . . "YUIAD is QRV for 'phone QSOs every evening on 20 meters and promises 100% QSL," is word received by W1FTX. YUIAD is ex-YU1CAB, by the way . . . . W4NYN got back bounced cards from SP2TH and a no-good OY3IGO, but he has greater faith in PX1AR, VP5BF of the Cacos. GC8MF, YO2BC, ZB2A and KJ6AQ. The latter speaks of no Marshalls activity on 'phone despite nefarious activity of one KX6AE. Jack's late cards came from ZC4XP, FO8AB, ZM6AA, VK9YT, IS1AEX, FG7XA, ZB1ZB, VR5GA and HI6FC, all for A3 contacts . . . . VR3B has the So. Calif. gang alerted around 14,150 kc.



EA3s IIE (left) and FL (right) overcame great obstacles to put this PX1A set-up into operation. In 23 days 1034 QSOs were logged on 40, 20 and 10 meters, 60 per cent of which were on c.w. Good news!—two Andorran citizens have evinced such an interest in amateur radio that future regular QSOs with the small country appear a certainty.

This is about the time that *forty* really comes into its own. An 807 with 50 watts at W3LLD warmed up on HR1DF (020), SV9RP (005), HK5DH (033), YUIAFG (035), KG6FAA (025) and one SHF1 (002). "I live in an 1800-unit apartment here and my antenna is just a 137-foot wire threaded along on the roof under dozens of TV antennas not more than 2 feet away at some points of my wire. Yet, with a de-TVld rig I can work 40 meters with no TVI and 20 meters when Channel 4 is not on." t can be done . . . . W2QHH captured CT2BO (002) while XE1SA was specializing in Down Under contacts, rolling up three dozen VKs . . . . LU2HAH, VK6SA and a CE7 were raised by W9HUZ on a breather from 20 . . . . W5KUC's report mentions SP6XA (010) as a good bet . . . . W9YDP clicked with HC2ME (002) at 2200, VP5BH (002) 2100, KV4AA (002) 2000, VKs 6LU (002) 0500, 6SA (002) 0530 and 7DW (010) 0500, times being CST. Jim finds Oceania quite good with peaks at 0100 and 0600 . . . . Another Hoosier, W9ESQ, combed the pile-ups successfully for FA8RJ, TI8JR, VQs 3KIF 4CM, CE4AD, ZS6GW plus sundry Europeans and South Americans. Lou wants to know how to get a QSL out of Haiti. Guess he'll have to keep using the standard system advocated by Jeeves: First work 'em, then irk 'em!

Our only stalwart holding forth on *ten* this trip is old friend W2ZVS. While on vacation from Lehigh U., Dixie persisted for YVs 1AP 3AU 4AA, EL1BA, OQ5s BI NK, VPs 1BOY 6C1A 6CJ 6FR 6WR, CXs 1GG 1OR 6AW, CEs 1CP 3LA, TI2VMB, ZE2KH, VQ4ERR, HR2JM, ZSs 1DH 1JD, 6CV 6KD, ZP3AW and numerous PY-LU aficionados. These were all oral efforts.

## Where:

One of the most frustrating situations in which to find oneself in the DXing line is to have a nice rare country worked and then have the fellow pull stakes for another QTE, leaving the forwarding address unknown or unavailable. Then, when he is tracked down several gray hairs later, it may be too late to expect him to have retained his old log. So if you run across any rare-DX "ex" calls on QSLs or while on the air you may be performing some of the

gang a great service by tipping them off through this medium. Keep an eye on "Tidbits," too, for clues of this kind.

CN8EB (QSL via W1OUG)  
 FP8AG (QSL to W4RXP)  
 FP8AH (QSL to W1PVF)  
 GW2DHV/A 63 Lewisham Hill, London SE13, U. K.  
 HC9JV Box 2536, Quito, Ecuador  
 JA8WT APO 547, % PM, San Francisco, Calif.  
 ex-KG4AK D. Constantino, USN Radio Station (T), Annapolis, Md.  
 ex-KG6GC (QSL via W0DMA)  
 ex-KM6AB KH6WH, 167 Apoki St., Hilo, Hawaii, T. H.  
 ex-MD2GO ZB1BS, "Eva," School St., Marsa, Malta  
 ex-MP4BAD G3GPE, 100 White Bank Rd., New Lime-side Estate, Oldham, Lancashire, U. K.  
 PX1AR (W8PQQ, F7AR, 3A2AC) Capt. A. Hix, 0-446963, EUCOM COM Z, Signal Section, APO 58, % PM, New York, N. Y.  
 VK9DB "Doug," Port Moresby, Papua Territory  
 W7EDP/KL7 Radio Club, Adak Island, Alaska  
 XU8SR Box 409, Shanghai, China  
 ZB1GKU (QSL via RSGB)  
 ZD2HAH (QSL via RSGB)  
 ZD6RD C. R. Dickenson, P. O. Box 72, Zomba, Nyassaland  
 ZE4JG (QSL via RSGB)  
 Chas of W1AW, W1s NWO ODW, W2JBL, W4s BRB IYT, W5FXN, W6AM, W9s CFT HUZ IHN, and John DeMyer pitched in for this listing.

## Tidbits:

"Regarding my planned trip to Monaco to operate 3A2AC . . . I wish to clear up a matter that has caused several misunderstandings. The call sign 3A2AC was reserved for me when I applied for a license at the first of this year. Due to military conditions beyond my control, I was not able to make the trip at the planned time." This from W6YCW/DL4QH. The call 3A2AC was of course thereafter finally issued to W8PQQ . . . . DL4CX is working hard for a DXCC before returning to his old haunts at W6PME . . . . MP4BAF has been vacationing in India and MP4BBD likewise in California, making Bahrain even more difficult to work than usual, quoting info from W2QHH . . . . W5FNA writes to straighten out a previous squib. PJ5RX, not PJ5FN, married and moved to Venezuela while PJ5FN, still very much in Curacao, has been hitched for two years with one harmonic . . . . Intriguing card from W6AM: "ON4QF told me he is now planning a trip to a country where there never has been any amateur activity. He will go under cover so the name of the country will not be announced ahead of time." We only hope that the deal conforms with DXCC rules so as to make Mick's contacts eligible for QSL qualification. Anyway, this item should help keep the gang on their toes! . . . . The boys at VP4LZ (W1EEC, W6s ABQ AKR HQM and BVU) are toying with the idea of a visit to French Guiana, says W6GEB. This is still a toughie to work and QSL so more power to them . . . . W3GHD brings up a good point. DX stations, rare and otherwise, often send an unsolicited batch of cards to an unsuspecting W station whose operator then proceeds to worry about their delivery. If unable to take the time or cash to do the job, the W should of course relay the cards to his QSL manager who will be glad to take over. There may be many nifty pasteboards pigeonholed in such circumstances when consultation with one's QSL manager would speed them on their way . . . . "Please inform the boys that a QSL card is always sure from me, but with much delay owing to the fact that only a single ship is supposed to reach this place in a year and never a regular air-drop," wrote OX3SF to W9CFT. Same goes for many of our isolated Greenland brethren . . . . Unpleasant information, obtained through the assistance of DL3MO, W6AM and GM6AH, has it that Bob Ford, AC4RF, is doing 20 years at hard labor in Tibet for "attempting revolution." At present it appears impossible to bring him out although we understand efforts will be continued . . . . Having just completed his c.w. WAC, ON4RM has passed his 'phone exam and is going after the award via the more difficult medium. Maurice comments that ON4TT, the Belgian "official station," quickly clamps down on QSOs of a nature any more personal than an exchange of radio technicalities.

An RCC ticket is practically out of the question there . . . . . Our Guam friends are now back on 7 Mc. after a ban of almost a year. KG6FAA intends to operate the band's low edge when conditions are suitable . . . . . During the recent Jamaica storm, W3MLW reports VP5RA as having much trouble drawing attention to his "QRRR" emergency call (although QRR was employed through error). A good spot here to state that we should all be alert for such happenings, even on the higher DX bands, and also that QRR is no longer an emergency signal — it's QRRR . . . . . From W1AW (Chas) we learn that ZM6AK returned to ZLIFT in October and ZM6AA ditto this month. This will leave ZM6AR alone to hold up Western Samoa . . . . . W5s CEW and KTD recently tried a Vee beam so long that a car with 2-way gear was necessary for construction . . . . . W4FNR postals us about some neat 50-Mc. DX accomplishments which we felt more properly due Mr. Tilton. If that band gets any more DXy perhaps we can talk Ed into giving our department another band to chew about. [Over his dead body, Boss — *Jeeves!*] . . . . . Along the line of the "ex" calls mentioned in "Where," we find that G2DHV is secretary of the British "Two-Call" Club for ex-overseas British amateurs. We may get some hot leads from him from time to time . . . . . Here comes some more explicit information on that Helvetia-22 award which appears to be of interest to many W DX men. The Swiss sometimes append an abbreviation after their calls, such as in HB9CI/FR, and the last two letters represent the canton in which they are operating. Here we go: Zurich — ZH, Berne — BE, Lucerne — LU, Uri — UR, Schwyz — SZ, Unterwald — NW, Glaris — GL, Zoug — ZG, Fribourg — FR, Soleure — SO, Bale — BS, Schaffhouse — SH, Appenzell — AR, S. Gall — SG, Grisons — GR, Argovie — AG, Thurgovie — TG, Tessin — TI, Vaud — VD, Valais — VS, Neuchatel — NE and Geneve — GE. When you work 'em all — and it won't be easy — send your 22 cards to the Swiss Test-manager, P. O. Box 1203, S. Gall, Switzerland . . . . . A newly-formed organization with plenty of sock included among its membership is the West Gulf Division DX Club. W5s ADZ ALA ASG BDK HE BGP EGK ENE FFW FNA FXN GEL JC KC KUC LGS LVD and MIS are charter members. "No dues, just lots of cooperation and competition," writes W5FXN. Taking care of their weekly bulletin is W5KUC . . . . . Leaving Guantanamo Bay for Maryland, KG4AK would like to express his appreciation and gratitude to his ham radio contacts the world over, as well as those who handled traffic for him. Those still needing a KG4AK card may write Dominic at the address listed in "Where" . . . . . The SSA (Sweden) has a form letter out to the effect that the SM4BR and SM8BR using 7 and 14 Mc. is a pirate thought to be operating from central Europe. The only legitimate "BR" call is that of SM5BR . . . . . Mr. LeRoy Waite notifies us of ex-ZC6DO's marriage in Philadelphia and VP9TT QRT'd to resume action as G6TT . . . . . W4NQN, who fired up a spark in Boston around 1910, would like a tracer on JA3AA, KM6AN, MF2AA and HA5BC for confirmation purposes. Any help? . . . . . The Cocos-Keeling group may soon become a stop-over for the Australian Air Lines and this development could put a really rare one on the amateur radio map. Tip from W1JCX . . . . . Via W1FH comes word that American nationals in Tangier Zone QTHs may be heard using KT1 prefixes as EK1 labels now become unavailable . . . . . The ZB2L



A consistently-heard 14-Mc. c.w. signal is furnished by ON4RM. A comparative newcomer to DX, Maurice is shown hard at work climbing the countries-total ladder.

everyone has been working has been declared ungood by ZB2I, there being just ZB2A and himself currently licensed. However, Ed says the next call to be issued will be ZB2L and this will cause some confusion. He promises to give us the exact date of the commencement of operation of the legitimate ZB2L, license not yet issued. ZB2I mentions in closing that he would like to see a little more attention paid his directional CQs . . . . . W1BUD gives us a hand re the ET9X problem. ET9X (W6EJ) is now ET3R and has 20 crystals in the 20 c.w. range, which is the only band licensed. The Ethiopian Air Force runs ET3Q and the power maximum there is 50 watts. So if you can break through to ET3R there's still a chance for an ET9X card although the fellow told Bud he had QSL'd everyone 100 per cent . . . . . FP8AH (W1PVF) and FP8AG (W4RXP) returned from St. Pierre after a most enjoyable and interesting DX jaunt. The boys ran into some of the usual trials and tribulations to be expected in locations of poor accessibility but the elixir of being rare DX more than made up for the inconveniences. W1PVF is now back in New Hampshire for college and W4RXP the same in good old Virginia . . . . . The annual joint meeting of the Northern and Southern California DX Clubs is to be held at the Californian Hotel in Fresno on January 19th and 20th. W6AM is meeting chairman and W6FSJ is convention treasurer. The ranks will be swelled by attendance invitations to the San Diego DX Club and the Seattle DX Club . . . . . MP4BAD dropped a line to W4BRB from his back-home QTH (given in "Where") and says he has MP4 QSLs and his Oman log handy should anyone still be shy his card. You may remember that MP4BAD and W4BRB pulled off the first MP4/W 3.5-Mc. contact a short time back. Ken's intention at G3GPE is to stick to 20-watt QRP for DX kicks and his long-wire skyhook has been doing well by him . . . . . VK9YT of New Ireland is a new member of the RCC through the co-operation of W6CPL. Carl's 20-meter 'phone work has accounted for some 50 countries and 41 American states and he is still gunning for his first European QSO. He runs

(Continued on page 110)

Here's a neat rig built and used by CX1GG on 28-Mc. 'phone. An 813 feeds a 3-element rotary beam and the modulator features 807s in Class AB<sub>2</sub>.

**QST** for

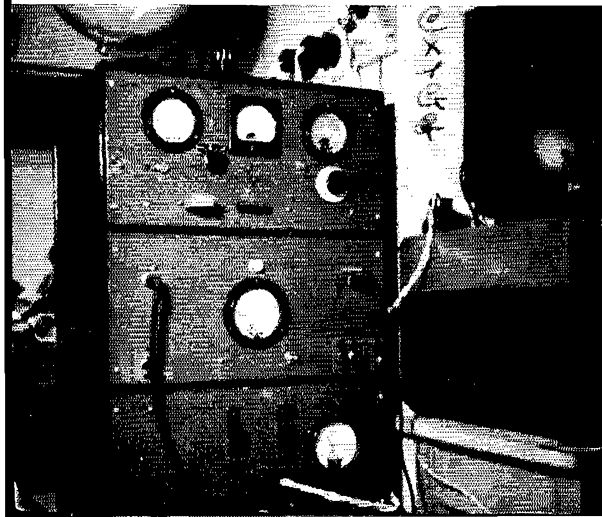



# Correspondence From Members -

The Publishers of *QST* assume no responsibility for statements made herein by correspondents.

## CRUSADE FOR FREEDOM

308 Empire State Bldg.  
New York 1, N. Y.

Editor, *QST*:

I would like to suggest that you inform the members of the American Radio Relay League that all radio amateurs in Czechoslovakia have been instructed by their Communist government to extend their operations abroad to promote Communist political propaganda.

Information that the Czech Ministry of Information has ordered all Czech "hams" to use their contacts abroad to propagandize the achievements of the so-called "people's democracy" and foster Communist "peace" movements has come to me from Radio Free Europe, whose stations in Western Germany are supported by the American people through the Crusade for Freedom. Czech "hams" also have been ordered to acquire, through radio contacts, information about the free world's technical developments and to ask for "gifts" of a technical nature.

Radio Free Europe has learned that such gifts must be reported to the Communist-controlled Central Amateur Office in Prague, where findings will be evaluated by Soviet authorities.

The purpose of this warning is not to discourage people-to-people contact between America and any other nation — but I believe that American amateurs should be aware of the order given by the Red rulers to Czech "hams."

It may also interest you to know that Czech "hams" were told that their contacts abroad are constantly monitored and that if they deviate from instructions action will be taken against them. Maximum penalty for violations is death.

— Harold E. Stassen, Chairman  
1961 Crusade for Freedom Drive

## A QUESTION ANSWERED

Dubois, Ind.

Editor, *QST*:

Bird-lover W4BYA asks in September *QST* (page 54): "Just what would the public gather from that picture?" The picture referred to is the front cover of July *QST*, depicting hams in action on Field Day. The question almost answers itself. *QST* is primarily the radio amateurs' magazine, and the general public does not read it any more than broadcast engineers read *The Woman's Home Companion*. The picture did not appear in *Saturday Evening Post*, for example, nor in *Life*, *Time*, *Look*, nor in any such other publication.

But if it had, who would be so foolish as to deduct from a caricature that a part of Field Day activity is to kill the mother bird and rob her brood? If that follows from the cartoon, then by the same faulty line of reasoning a Democrat candidate for the presidency actually rides a donkey, and a Republican candidate for the office actually rides an elephant, because they are sometimes caricatured that way. My own reaction to that masterpiece of Field Day caricature was a fifteen-minute spell of chucking that was hard to stop.

— Rev. Joseph A. Terstegge, W9LQE

40 Franklin Street  
Rochester 4, N. Y.

Editor, *QST*:

I read with much interest the letter of W4BYA in the September issue of *QST* regarding the cover of the July issue.

I would like to come to the defense of *QST*, and point out to W4BYA that I don't believe that he is very well educated on bird life. I don't believe that anyone would feel badly about the Field Day boys eating a little "crow." Hi!

— Al Keltz, W2TXB

## BOUQUET FOR GIL

Tinker Hill Road  
Pine Plains, N. Y.

Editor, *QST*:

Will you do me a favor?

Please tell "Gil" that I never thought that my little article [Sept. *QST*—Ed.] was very funny, but I laughed most merrily at his wonderful cartoons. Without what Gil gave it, 'twould have been bare!

You may be interested to hear that I've received 11 cards and notes from *QST* readers. Every one of them was from a more or less old-timer, all expressing the thought that "that's exactly the way it was when I took my own examination."

— Fred Myers, WN2IHI

## CALLING FREQUENCY

3632 Jones Street  
Sioux City, Iowa

Editor, *QST*:

A favorite daydream of mine deals with a calling frequency in the 75-meter 'phone band. I like to imagine just how it would work out if most of the stations used a calling frequency. I choose 3900 kc. because it is in the center of the band and it is a good round number and easy to remember.

A person could set the receiver on the frequency and go about his work around the shack. He could have extra speakers or receivers around the place. The family could at times help monitor. And to work someone, one CQ would suffice. If there were a message to be gotten off, a single call such as "CQ traffic west" or "CQ Omaha" would do the trick. It would be a boon to the fellow who has a lot of other interests and wants to do a little hamming with a minimum of time expended. And talk about making an impression on visitors — make a call and send a message in jig time.

Obviously the frequency would be used only for calling except for a very short QSO. Once the contact was established both stations would shift to another frequency — could be to c.w. or to another band. A VFO wouldn't be absolutely necessary but a minimum of two crystals would be required.

When I think of all the possibilities I wonder why it isn't done.

— Elmer E. Hansen, W0AF

## OPERATION CO-OPERATION

Route 4  
Frankfort, Ky.

Editor, *QST*:

I have listened in on the Novice band since it came on the air and am alarmed at the way the "big boys" are trespassing on that band. Two or three or more 100 to 500 watters with bug keys invariably take over and play havoc with the band from dark until late in the night. The Novice with his 10 to 20 watts can hardly get out of his own back yard against such formidable competition. In fact, "competition" is too mild a term. The only competition the big boys have is with each other; with their VFOs they can find an opening while the Novice is stuck with his crystal to one spot. It is obvious that if this situation is allowed to continue the whole Novice idea will be a complete flop.

I assume that the Novices are a full-fledged group in the amateur radio set-up, and as such rate some protection. I hope you will acquaint yourselves with this condition and will register a vigorous protest, until remedial action is taken. It is only through your instrumentality and co-operation that this can be accomplished.

— James Maupin

(Continued on page 112)



# The World Above 50 Mc.



CONDUCTED BY E. P. TILTON,\* W1HDQ

**T**HERE are several ways of participating in a v.h.f. contest. Just as with many ARRL operating activities on lower frequencies, not all the gang try for the country's top score. There's the fellow who just likes to chew the fat; he finds plenty of others willing to do likewise, and even the quick-exchange boys are likely to relax a bit after the first few hours. Then we have the man who has just put up a new beam, or completed a low-noise converter; what better chance than a v.h.f. contest week end to give the new gear a workout? Or take the little fellow with the low-powered rig and an indoor folded dipole; ordinarily he can do little more than listen while the more fortunately equipped high-power-and-beam stations work the DX, but at least three times a year he can count on being "rare" — at least until he's contacted everyone within his working range.

These fellows, just as much as the ones who post the top scores in their sections, have fun. It is for them, just as much as for the ones who work every station they can dig out, that these contests are run. The only trouble is, too few of them bother to report their results. Consequently, the tabulation you'll be seeing soon in *QST* will show probably 100 to 200 calls of reporting stations, whereas if the whole story were told there may have been 1000 or more actually in there making hay.

\* V.H.F. Editor, *QST*.

With the deadline for reporting still ahead as we close our copy for this issue, it is impossible to give any comprehensive report of the September V.H.F. Party, but it can be said that, despite just about average conditions in most quarters, it was a big success. The reports are coming in at a good rate, and scores in general reflect a growth in contest interest — a higher percentage of the stations active seem to be taking advantage of the opportunities a contest affords.

Some results? Well, need we say that the top score thus far received was again submitted by W1FZ/1? As in almost every spring or fall v.h.f. party, this group appears to have swept the field. The calls may be different (the operating job is rotated each time) but the location and equipment are just about the same. Using rigs on 50, 144, 220 and 420 Mc., and operating from a fire tower atop Blue Job Mountain, Farmington, N. H., W1FZ/1 piled up 143 contacts on 4 bands, with a section multiplier of 24 for 4104 points, the highest score received to date by a very wide margin. Another high one is that turned in by W1GJZ, Sherborn, Mass., who worked an even 100 stations with a multiplier of 20, for 2000 points on 6 and 2. K2USA, Ft. Monmouth, N. J., with Al, W8WXV, at the controls, had reached 125 contacts in 10 sections on 144 Mc. early Sunday evening.

Western New York and the VE3s across the Lake were going at their customary busy level. An old friend, W6HZ, shows up for the first time in several contests with his first report from a new home location that appears to have some fine possibilities. Middle West, South, and Far West reports are just accumulating as we write; all we can say of them is that contest interest and activity have developed to a point where it is no longer necessary to have a wide-open band on either 6 or 2 for v.h.f. men in most parts of the country to pile up some impressive totals. Final scores soon.

(Continued on page 114)



The 24-element 144-Mc. array of W4MKJ, Louisville, Ky., has 8 halfwaves in phase with directors and reflectors. The entire vertical member, both guyed and sway-braced, is rotated electrically from its base. The lower array is the 4-over-4 formerly used.

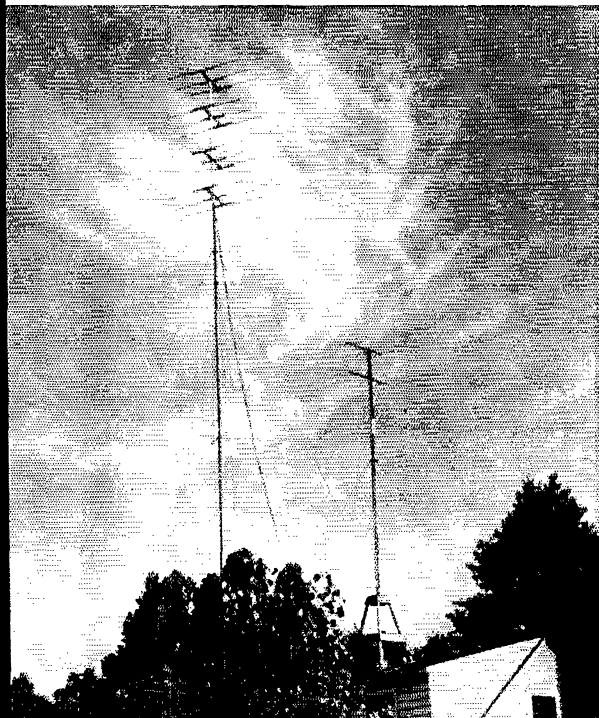

*QST* for



# Hints and Kinks

## For the Experimenter



### HOMEMADE HIGH-VOLTAGE TERMINAL

A very satisfactory high-voltage terminal of the quick-disconnect type can be made from a National XS feed-through bushing, a Type SPP plate connector, and the top cap of a burned-out tube. The method is shown in Fig. 1.

Clean out the top cap. Then insert the threaded bolt from the ceramic bushing, and flow solder in

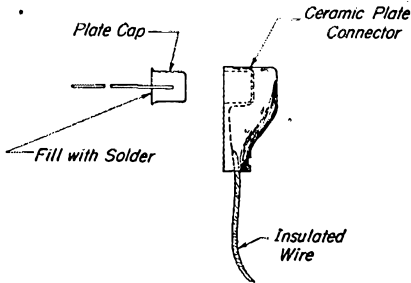

Fig. 1 — Improved high-voltage terminal made from junk box parts.

around it until a firm joint is made. Reassemble the bushing on the chassis. The ceramic plate connector can then be used to attach the lead from the power supply. — Earl F. Hart

### CODE-PRACTICE OSCILLATOR

Shown in Fig. 2 is a simple code-practice oscillator that should be of assistance to anyone studying for the ham examinations. It has sufficient output to drive a small permanent-magnet

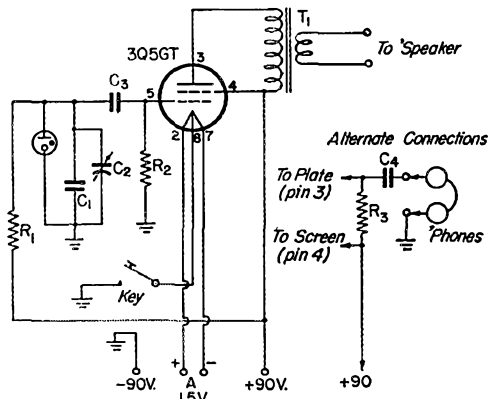

Fig. 2 — Circuit of a simple code-practice oscillator.

- C<sub>1</sub> — 25- $\mu$ fd. mica.
- C<sub>2</sub> — Broadcast-type receiving variable. Approx. 480  $\mu$ fd. max.
- C<sub>3</sub>, C<sub>4</sub> — 0.005- $\mu$ fd. mica.
- R<sub>1</sub>, R<sub>2</sub> — 1 megohm, 1/2 watt.
- R<sub>3</sub> — 5000 ohms, 1 watt.
- T<sub>1</sub> — Output transformer, single plate to voice coil (Stancor A-3877).

speaker, or if desired, it can be used with high-impedance headphones.

The only adjustment required is of C<sub>2</sub>, which can be "salvaged" from an old broadcast set. With power applied, tune C<sub>2</sub> for the desired tone output. The neon tube can be of the midget variety, similar to those found in the ARC-5 receivers. — Harold A. Rogers, W2V1DQ

### ADJUSTABLE CENTER-LOADED MOBILE ANTENNA

Much use has been made of center-loaded whip antennas for 75-meter mobile work, and in several models a shield can is placed around the loading coil. In most instances, satisfactory oper-

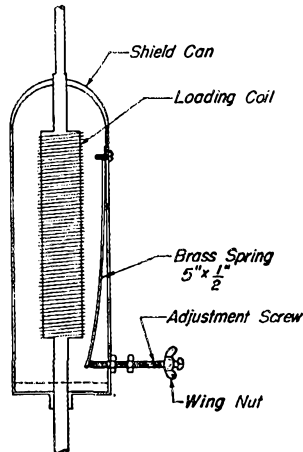

Fig. 3 — Novel method of making a center-loaded whip antenna adjustable.

ation with this arrangement is obtained over only a small frequency range. The gadget shown in Fig. 3 is a simple way to make the antenna system adjustable for peak performance at whatever spot in the band you choose.

An adjustable capacitance is added inside the shield can, with a tuning screw brought out through the side. The "condenser" is made of spring brass, 5 inches long and 1/2 inch wide. It is fastened near the top of the shield can with a 6-32 machine screw. Form it against the can, and then at the lower end use a long 6-32 screw with a wing nut and a lock nut for adjustment. Turning the screw in adds more capacity, thus permitting adjustment over a considerable portion of the band. — Grover Hunsicker, W0BDE

## SWITCH TO SAFETY!





# Operating News



F. E. HANDY, WIBDI, Communications Mgr.  
JOHN E. CANN, W1RWS, Asst. Comm. Mgr., C.W.  
GEORGE HART, WINJM, Natl. Emerg. Coordinator

J. A. MOSKEY, W1JMY, Deputy Comm. Mgr.  
L. G. McCOY, W1ICP, Asst. Comm. Mgr., Phone  
LILLIAN M. SALTER, Administrative Aide

**Novice Aims.** There is very considerable occupancy of 3700-3750 kc. already. Subjects of Novice QSOs: getting the General Class license . . . exchanging QTH, RST . . . if one can get WAS in the 12 months or before taking General Class exam . . . sunset time (during the Army Maneuvers) . . . QSL cards . . . getting around QRM . . . data on the rig . . . planning the "bigger" rig.

WN8HJH sent us the first message to show a WN-call as originator. 'Twas most welcome but couldn't be acknowledged since it arrived with *no place of origin*. Our WN list of addresses cannot be up-to-date for sometime. However, this will cordially invite every new Novice and Technician licensee to send an amateur radiogram to ARRL and to his SCM as soon as on the air to report his call. Be sure the parts of your message are sent in this order: number (consecutive series from the first of each year), station of origin (your call), check (use your count of number of groups in text), place of origin (your city), time filed (local time), date (month and numeral), address (name-street-city) BT Text BT Signature. A set of ARRL Operating Aids cards will be sent gratis to Novices who send requests for those by radiogram and include their name and address in the signature of their message. (The messages should be relayed from your station through amateur stations in your own ARRL section that are familiar with traffic and can forward by radio through established nets.)

**Novices and the SS.** One of the big annual activities that all amateurs use for testing stations, getting QSLs for shack wallpaper, and adding station accomplishment with fun in operating is the *ARRL Sweepstakes*. The natural fun of working in this and all other ARRL contests given general *QST* announcement will be apparent to the Novice — and *this extends cordial invitation* to him to take part. You may think that as a Novice your score will not be comparable to that of those with more frequencies, power, and operating speed. The frequency limit admittedly will cramp your style a bit, but don't let this thought deter you from taking part. No one can take the operating pleasure from you. Other Novice licensees will send in their score and in the results you can compare only with the other WNs. It is the natural operating fun that makes all the radio activities basically appealing. The SS is a good operating experience; it builds operating ability and speed. You can work

many other Novices in the SS we hope! Also other amateurs will be eager to work WNs to get the points and section credits. See the Sweepstakes rules elsewhere in this issue. Try your hand at one of the most popular contests in the ARRL Activities Calendar.

**That First Year!** There's plenty of thrill for Novices in working each other and getting experience. The first effort after getting one's license is just naturally (1) in the making of radio contacts, (2) getting the "feel" of ham radio, (3) getting ready for the test for General Class license, (4) in going out for the 10-w.p.m. ARRL CP Certificate (try W1AW-WØTQD-W6OWP monthly Qualifying Runs) as a milestone on the way to the General Class ticket. About the QRM problem, remember that our W/VE amateurs rate as the *best manual operators in the world* because for the most part they made their way by learning to read through the practical QRM in our bands. We all gripe about QRM, but have to live with it. We can succeed in training ourselves to higher abilities with the aid of it. (Was it Demosthenes who learned to talk effectively by setting a special handicap for himself — a pebble in his mouth? Then let's think of our QRM as just our "pebble" and persist in working in spite of it!)

**7:30-8:30 P.M. Daily for Novice-to-Old-Timer QSOs?** It is certain that radio contact between old- and new-timers is desirable as well as the natural Novice-Novice QSO, to talk out common problems. It seems pretty generally agreed that it would *not* be a good scheme to set up an exercise in which a lot of high-powered stations would invade 3700-3750 kc., even for the desirable purpose of two-way work with Novices. That would congest the band. W1AW announced its own arrangements last month, setting a time right after the early Bulletins to look for Novice licensees, but remaining for transmitting on its 3555-kc. frequency. One old-timer suggests that non-Novices should be encouraged to reduce power when working in the Novice band to get on the same footing. How would it do to set a half-hour or one-hour period each day, say 7:30 P.M. daily, local time, for all Novices to look *outside* 3700-3750 kc. for any calls from non-Novices — and for all old-timers working 80 meters to look *into* this band sector for some two-way "get-acquainted" QSOs! Try it!!!

A calling suggestion: It may help to indicate



the prefix in your calls, when WNs are looking for Ws or VEs or vice versa between 7:30-8:30 P.M. or at other times. The CQ can be made "informative" as described in ARRL publications. But here, instead of indication of direction or city with the CQ, it is possible to send CQ W (or CQ VE) de WN K when a Novice plans to tune his receiver for stations that may be outside his authorized frequency ranges for transmitting. Conversely CQ WN de W K will identify the purposes of any stations between 3.5 and 3.7 Mc. looking for Novice QSOs. Most often, when old-timers are looking for Novice contacts they will move down from the 3.5-Mc. end of the band closer to 3.70-3.75 Mc. when precaution is observed not to move all the way into these frequencies. The principle will always be followed both within and without the Novice-band sector, we hope, of *listening first* on any frequency chosen, before opening up, to avoid the QRM where an existing frequency is already in use.

**One Strong Facility.** More and more amateurs are equipped for *mobile* work these days. Likewise, there are more "sets with handles" for emergency-portability and many more vibrator pack and dynamotor-equipped rigs that can go into action with power source as near as the nearest automobile storage battery. This is all to the good. At this writing the National Emergency Coördinator is making a study of our mobile availabilities and current organization progress as indicated by the annual reports from ECs and the results of the annual SET.

You, as an individual operator, have the best chance to serve in any natural disaster or civil defense emergency if you are lined up with your *Emergency Coördinator* and the AREC in advance. This is the way to be sure that you will have your quota of assignments and messages to be handled. A complete separate self-powered station auxiliary is of course greatly to be desired as an aim for every amateur FCC licensee. But the AREC welcomes you as you are to be fitted in as your equipment and time permit activity. The effectiveness and prestige of ourselves as individual amateurs or our group as an institution depend on our operating together as *one strong facility*. The priority for each assignment depends on the degree of public interest or necessity involved. The AREC is dedicated to public interest through amateur radio emergency operation. Our effectives, after noting the limitations of "supporting" members in other emergency posts (as for the telephone company, public utility, military, etc.) are *not* so numerous as to permit too many to assist *particular* agencies with their radio to the exclusion of everything else in emergency. Make it your aim to be signed up with a current AREC card and to work in the amateur radio group that your Emergency Coördinator organizes with capabilities to serve any and all radio needs come any local disaster. Build on the principle of *one strong facility*; make this *well-organized* through your support and participation.

— F. E. H.

## MEET THE SCMs

Norman C. MacPhail, Michigan's present SCM, became interested in amateur radio in 1935, obtaining his first license with his present call, W8DLZ, in 1948.

SCM MacPhail is a regular participant in ARRL Sweepstakes and Field Day activities; he is a member of the Grand Rapids Amateur Radio Association and a former Official Observer and Emergency Coördinator.

Transmitting equipment in W8DLZ's basement shack includes a BC-696 on 3.5-Mc. c.w., Bendix TA-12B, 807, pair of 807s-parallel on 3.5-, 7-, and 14-Mc. c.w., VFO-



6V6-6V6-6L6-813 main rig, about 200 watts. Receiver is an HRO-7. Antennas are a five-element rotary for 28 Mc., folded dipole on 7 Mc., long wire on 3.8 Mc. MacPhail also has a 28-Mc. mobile in his car and a 75- and 80-meter BC-474A battery-operated transceiver is on hand for emergency use.

During World War II Norm was CO of the 13th Photo Lab Bomb Group, serving in the CBI theater. Football and baseball are his favorite sports and in 1947 he was with the New York Yankees as traveling secretary and personnel manager. Hunting, fishing, and pistol shooting are his other hobbies. He is employed as a life insurance agent for Equitable Life of Iowa.

## CODE-PROFICIENCY AWARDS

Have you received an ARRL Code Proficiency Certificate yet? Twice each month special transmissions are made to enable you to qualify for the award. The next qualifying run from W1AW/WØTQD will be made on November 20th at 2130 EST. Identical texts will be sent simultaneously by automatic transmitters. Frequencies of transmission from W1AW will be 1887, 3555, 7120, 14,100, 28,060, 52,000 and 146,000 kc. WØTQD will transmit on 3534 kc. The next qualifying run from W6OWP only will be transmitted on November 5th at 2100 PST on 3590 and 7248 kc.

Any person may apply; neither ARRL membership nor an amateur license is required. Send copies of *all* qualifying runs to ARRL for grading, stating the call of the station you copied. If you qualify at one of the five speeds transmitted, 10 through 35 w.p.m., you will receive a certificate. If your initial qualification is for a speed below 35 w.p.m., you may try later for endorsement stickers.

Code-practice transmissions are made from W1AW each evening at 2130 EST. References to texts used on several of the transmissions are given below. These make it possible to check your copy. To get sending practice hook up your own key and buzzer and attempt to send in step with W1AW.

Date	Subject of Practice Text from Sept. QST
Nov. 1st:	<i>The Yagi-Dagi</i> , p. 11
Nov. 6th:	<i>QR1? QSD? QRS! de WN2???</i> , p. 14
Nov. 9th:	<i>Receivers for Radio-Controlled Models</i> , p. 22
Nov. 12th:	<i>The Coffee-Can VFO Sr.</i> , p. 26
Nov. 15th:	<i>Curing Industrial TVI</i> , p. 29
Nov. 21st:	<i>The "Rackabinet"</i> , p. 37
Nov. 23rd:	<i>Using the 6BQ7 on 220 and 144 Mc.</i> , p. 41
Nov. 27th:	<i>A Mobile Converter for Civil Defense</i> , p. 46
Nov. 29th:	<i>Amateur Radio in Detroit Civil Defense</i> , p. 52

## NET DIRECTORY

The following nets have been registered with ARRL up to and including Sept. 20, 1951. If your net is not listed below, please send us the registration data requested on page 62, Sept. 1951 *QST*, unless you have already done so. Registration cards are available from ARRL Headquarters on request. The next net list, supplementing and correcting this one, will appear in January *QST*.

Name of Net	Freq.	Time	Days
Alabama Emerg. Mobile Net (AENR)	29,560	1400 CST	Sun.
Alabama Emerg. Net (AENB)	3715	1900 CST	Thurs.
Alabama Emerg. Net (AENP)	3955	1830 CST	Daily
Arizona Emerg. Net (AEN)	3865	1930 MST	Tues.-Thurs.
Arizona Net (AZN)	3515	2000 MST	Mon., Wed., Fri.
Arkansas Emerg. 'Phone Net	3885	0600 CST	Mon.
Arkansas Slow-Speed Net	3700	1830 CST	Mon.-Fri.
Badger Emerg. Net	3950	1800 CST	Daily
Barnyard Net	3924	0800 EST	Mon.-Sat.
Beaver Net (OSN)	3535	1900 EST	Mon.-Fri.
Birmingham Emerg. Mobile Net	29,560	1400 CST	Sun.
Brass Pounders Net (4BPN)	3750	1930 EST	Thurs. Sat.
Broward Emerg. Net (BEN)	7140	0900 EST	Mon., Wed., Fri.
Central Gulf Coast Hurricane Net	3935	1815 CST	Daily
Domestic Overseas Net (DON)	3700	2300 CST	Daily
Eastern Area Net (EAN)	3670	2030 EST	Mon.-Fri.
Eastern Mass. Net (EMN)	3660	1900 EST	Mon.-Fri.
Eastern Mass. Slow-Speed Net (EMNS)	3745	2200 EST	Mon.-Fri.
Fifth Regional Net (RN5)	3645	1945 CST	Mon.-Fri.
First Regional Net (1RN)	3605	2130 CST	Mon.-Fri.
Florida 'Phone Traffic Net	3945	1945 EST	Mon.-Fri.
Gulf Coast Emerg. Net	29,600	0600 EST	Mon.-Sat.
High Plains Emerg. Net	1995	2000 CST	Tues.-Sun.
Hit & Bounce Net (HB)	7150	1830 CST	Mon., Wed., Fri.
Idaho Gem Net	3938	1830 CST	Mon., Wed., Fri.
Iowa 75-Meter 'Phone Net	3970	2100 MST	Mon.-Sat.
Iowa Tall Corn Net	3560	1830 CST	Mon.-Fri.
Kaps. 'Phone Net	3920	1845 CST	Thurs. Sun.
Kentucky Net (KYN)	3600	0800 CST	Tues., Fri.
Md.-Del.-D.C. Net (MDD)	3650	1230 CST	Mon.-Sat.
Mission Trail Net	3704	1900 CST	Mon.-Fri.
Missouri C.W. Net	3854	1800 PST	Daily
Missouri 75-Meter 'Phone Net	3580	1900 CST	Mon.-Fri.
Missouri Valley Emerg. Net	29,850	1230 CST	Tues., Thurs. Mon., Wed., Fri.
Nebraska 75-Meter 'Phone Net	3983	2015 CST	Mon.
New York State Net (NYS)	3615	1230 CST	Mon.-Sat.
New York State Slow-Speed Net (NYSS)	3625	1900 EST	Mon.-Fri.
Ninth Regional Net (9RN)	3565	0900 CST	Mon.-Sat.
North Carolina Net (NCN)	3605	1945 CST	Mon.-Fri.
N. Texas/Oklahoma Traffic Net	3960	1900 EST	Daily
Ozark Net (OZK)	3695	1730 CST	Mon.-Fri.
Pacific Area Net (PAN)	3670	1900 CST	Mon.-Fri.
Pelican Net	3870	2030 PST	Thurs.
Polecat Net (PCN)	3665	1930 CST	Sun.
Puerto Rico Amateur Emerg. Net	3925	1130 EST	Wed.
Rhode Island Net	3540	2000 EST	Mon.-Fri.
San Diego Section Net (SSN)	3560	2030 PST	Daily
Seventh Regional Net (RN7)	3575	1945 PST	Mon.-Sat.
Show Me Net (Mo.)	7272	2130 PST	Sun.
Sixth Regional Net (RN6)	3642	1500 CST	Mon.-Fri.
Southeast Missouri Net	1920	1945 PST	Mon.-Fri.
Southern Calif. Net	3650	2000 CST	Mon., Wed., Fri.
Tennessee Section Net	3635	1930 PST	Mon.-Fri.
Third Regional Net (3RN)	3590	1945 EST	Mon.-Fri.
Thirteenth Regional Net (TRN)	3675	2130 EST	Mon.-Fri.
Traffic Exchange Net (TXN)	7230	1945 EST	Mon.-Fri.
Transcontinental Relay Net (TCRN)	7042	1800 CST	Daily
Trunk Line Atlantic Pacific (TLAP) (East)	3630	2315 CST	Mon.-Fri.
Trunk Line J (TLJ) (West)	3565	2000 PST	Mon.-Fri.
Vermont Net (VTN)	3740	1945 CST	Mon.-Sat.
Wash. Amateur Radio Traffic System (WARTS)	3970	1945 EST	Mon.-Fri.
Western Mass. Net (WMN)	3725	1830 PST	Daily
Western Penna. Emerg. Net (WPEN)	29,425	1900 EST	Mon.-Fri.
Western Penna. ORS Net	3585	2200 EST	Wed. Sat.
Wisconsin C.W. Net (WIN)	3625	2300 EST	Mon.-Fri.

### BRIEF

Mobile units of the Milwaukee Radio Amateurs' Club journeyed to Elkhart Lake, Wis., on August 26th to maintain communications for the annual road race of the Sports Car Club of America. Mobiles stationed along the 6.8-mile dirt track reported on 10 and 75 meters to the club's mobile radio truck at the start-finish line. Under the direction of Charles Kaetel, W9SNK, communications were maintained for more than six hours by W9s BPR, ECV, ESJ, FY, GLA, GIL, GPI, GSP, LCD, LSK, MGT, ONY, PTE and PYM.



Handler of a big chunk of the GI traffic from Japan and Guam is Dave Kennedy, W6KYV, who maintains several nightly schedules with overseas stations for handling of morale traffic. An ORS of the Los Angeles Section, KYV has landed in the BPL for eight consecutive months, often not far from the top. Three transmitters and three receivers keep the station ready to go on any band at a moment's notice, although most operation is on 80, 40 and 20 c.w.

**QST for**



## BRASS POUNDERS LEAGUE

Winners of BPL Certificates for August traffic:

Call	Orig.	Recd.	Rel.	Del.	Total
KG6FAA.....	917	1502	981	521	3921
W3CUL.....	49	1857	1635	189	3730
W6KYY.....	216	1103	415	684	2418
W4PL.....	22	852	715	104	1693
K7FAG.....	354	411	26	382	1173
W6BAM.....	87	384	206	200	877
K8AIR.....	70	348	330	58	806
KG6AAY.....	84	330	288	42	744
W8GYH.....	11	340	254	105	710
W7IOQ.....	71	208	266	100	645
W1CRW.....	19	293	285	4	601
W7CZY.....	13	294	262	22	591
W7KJG.....	3	298	284	2	587
K4WAR.....	246	163	98	65	572
W9ILH.....	3	274	253	22	552
KG6FAB.....	65	232	200	32	529
W2BO.....	23	215	261	28	527
W5QHI.....	42	241	189	52	524
K6WAE.....	10	261	247	6	524
W6SCA.....	14	254	236	16	520
W2COU.....	47	242	184	41	514

### Late Reports

W9ILH (July)....	6	356	335	22	719
W7NSJ (June)...	344	279	0	0	623

The following made the BPL for 100 or more *originations-plus-deliveries*:

W8UTS 390	KG6AAE 132	W8ARO 10
W5GVV 318	W7KGF 121	W6FQE 109
W6BHG 190	W6GEB 109	W8ZJO 109
W7KUH 170		

The BPL is open to all stations with a monthly traffic total of 500 or more or 100 or more *originations-plus-deliveries*.

## TRAFFIC TOPICS

A question noted in the incoming mailbag concerns how to differentiate in counting between amateur and MARS traffic. As far as your amateur traffic total is concerned, no traffic handled outside the amateur bands should be counted. This appears to be straightforward and clear-cut, but since most MARS stations are also amateur stations who operate part time on MARS frequencies and part time on amateur frequencies, the question arises as to how to count traffic received one way and sent another. In the ensuing discussion, we are concerned only with your *amateur traffic count*.

1) Traffic received within the amateur bands and relayed outside the amateur bands can be counted as *received* but not as *relayed*.

2) Traffic received outside the amateur bands and relayed in the amateur bands can be counted as *relayed* but not as *received*.

3) A *delivered* credit can be claimed only if the message was received within the amateur bands.

4) An *originated* credit can be claimed only if the message is originated (i.e., sent) on the amateur bands.

We hope this will help clear up any confusion on that score. Note that the call of the originating station has no bearing on how the message is counted. The only deciding factor is whether the message was handled on amateur or MARS frequency.

- - - - -

From a former operator at JA2ZZ we have some first-hand information on who's who among traffic-handlers in JA-land. Over here in the States we have hundreds of operators willing and eager to handle the fine traffic originated by the very few JA stations engaged in this work. Some of the Stateside operators have been particularly outstanding, and we want to talk about them in a minute. First, let's doff our hats and take a deep bow toward the boys in Japan who are doing the originating.

Probably outstanding among these is one M/Sgt. Fenton A. Martin, of the Marine Corps, operating JA2MB. Sgt. Martin originated somewhere in the neighborhood of 5000 messages during the last Christmas and New Year's holiday season. Others who should be mentioned are Ed

Means at JA2OM, Jim Bailey at JA1KR, Roy and Van at JA2CC, Pat Jordan at JA4AG, Jim Winter at JA8AB.

Among the Stateside amateurs who should be mentioned are Leo Loken, W7IOQ, and an operator known as "Johnnie" at W6HQX, both of whom have spent many long hours behind their keys clearing the GI morale traffic.

Thanks, fellows, for a swell job. And thanks also to ex-lt. John K. O'Neal for sending us this information.

- - - - -

You will find the first installment of the Net Directory somewhere in the vicinity of this column. We have already received a great number of requests for the complete mimeographed cross-indexed Directory. The list elsewhere on these pages is the complete roster of nets registered with us up to and including September 15th.

On August 1st, all nets in our card file were transferred to the "inactive" list. The call for new net registrations was made in September *QST*. The October LO Bulletin and the CD Bulletin both contained net registration cards. By the time these are all entered on our card file and a complete list of nets compiled for the mimeographed Net Directory, the end of the year will be upon us; so those of you who are waiting for a mimeographed Net Directory, please be patient until all nets are registered.

If you have not registered *your* net, better do it now. Even if you miss the cross-indexed Net Directory, supplementary net lists will be carried in January, March and May *QSTs*.

- - - - -

Elsewhere in the pages of this month's *QST* you will find mention of the passing of a former director of ARRL and old-time amateur, Porter Quinby, W8AY. The radio amateur fraternity will feel keenly his loss. We traffic men in particular will miss his strong signal and excellent fist in our NTS traffic lanes. Porter was assistant manager of the Tenth Regional Net and a regular participant in the Nebraska C.W. Net and the Central Area Net. His traffic efforts landed him in the BPL, not far from the top, a good many times.

Enough said. Porter was an honored member of our brotherhood. We will not soon forget him.

- - - - -

*National Traffic System.* As we write in mid-September, things are already looking up. All managership vacancies have been filled and nets which were inactive during the summer months are springing into action. The "Big Picture" of NTS is beginning to make itself felt among the traffic-handling fraternity, and participation is on the increase. This aspect of fall awakening compensates in goodly measure for the hard and sometimes disheartening struggle some of our Regional and Area net managers had trying to maintain activity during August.

Net	Seas-	Traf-	High	Low	Average	Most
	sions	fic				Consistent
EAN (July)...	22	288	42	2	14	2RN
EAN.....	23	345	90	2	15	2RN
PAN.....	22	467	68	3	21	RN6
RN5.....	14	35	15	0	3	Ala.
RN7 (June)...	52	78	17	0	3	Wash.
RN7 (July)...	52	56	5	0	2	Idaho
RN7.....	27	124	50	0	5	Wash.
9RN.....	25	177	17	0	7	Ill., Ind., Ky.
TEN.....	14	411	47	11	29	Minn., Ia., Mo., Kans.
TRN.....	10	12	3	0	1	Ont.

Although schedules must sometimes be altered to fit circumstances, the National Traffic System normally operates on a time schedule, so that if you know a net is part of NTS, you know also the times that it operates. Section nets operate at 1900 and 2200, Regional nets at 1945 and 2130, and Area nets at 2030, all local time. There is now also under way a study of the possibility of NTS nets operating in accordance with a frequency-allocation pattern, designed both to conserve net frequency space and increase the efficiency of NTS nets by introducing frequency sharing as an integral part of the system. W7FLX in his "Pacific Area Net News" has given many NTS traffickers some food for thought by his frequency-allocation proposal. You are urged to let us in on your thoughts concerning the methods and/or feasibility of accomplishing something along this line.

*Eastern Area Net.* (3670 kc.): W2CLL is busily lining up net control and liaison stations for the winter season.

EAN was in full-scale operation all summer and will continue, operating one hour later, on October 1st. Volunteers, especially for PAN liaison, are needed. W2COU has earned an EAN certificate.

**Central Area Net (3670 kc.):** After a summer of frantic searching for a net manager, we have come back to W9CBE for CAN Manager. Hale expects to have CAN running full blast by October 1st.

**Pacific Area Net (3670 kc.):** PAN changed to 3670 from 7207 kc. on October 1st. W9ZJO complains that he can find no one to assist him in the NCS job.

**First Regional Net (3605 kc.):** 1RN has returned to a five-day schedule, operating at both 1945 and 2130 EST.

**Second Regional Net (3690 kc.):** 2RN activity was maintained during the summer months primarily through the efforts of W2RUF and W2COU. W2PRE, net manager, hopes to have the net in full swing in the near future.

**Third Regional Net (3590 kc.):** W3GEG reports that 3RN is "gradually coming to life" after a summer during which activity was not at its greatest.

**Fifth Regional Net (3645 kc.):** W5MRK is to be congratulated for his fine RN5 Bulletin. Forrest wants W5AHT credited for the reproduction and mailing. Look for RN5 to be in there this winter doing its part to make the Central Area a beehive of traffic activity.

**Sixth Regional Net (3642 kc.):** Net Manager W6JZ indicates that the change of frequency is not particularly satisfactory, and additional changes may be necessary. Activity has been high all summer, RN6 being one of the very few Regional nets which maintained full activity in both sessions. Representation from Nevada has fallen off. Former RN6 manager W6CE is active again.

**Seventh Regional Net (3575 kc.):** Idaho, Montana, Washington and Oregon were the only sections represented in June and July. In August, British Columbia also put in an occasional appearance. Representation from Saskatchewan, Alberta, Wyoming and Alaska has been entirely nil. W7NH requires assistance in the NCS job.

**Eighth Regional Net (3530 kc.):** 8RN is back in full operation under the able tutelage of W8SCW.

**Ninth Regional Net (3565 kc.):** Full operation of 9RN is reported for August, with Wisconsin the weakest link. Only one net session, at 1945 CST, was conducted in August.

**Tenth Regional Net (3560 kc.):** All members of TEN are mourning the death of W8AY, their assistant manager. W8ITQ has been designated to replace him by Manager W8SCA. Representation from Manitoba, North and South Dakota has been spotty, but promises to improve with the winter months.

**Thirteenth Regional Net (3675 kc.):** VE3BUR's latest TRN Bulletin was a masterpiece. TRN resumed regular operation on August 1st. Traffic during August was negligible.

### CODE PRACTICE STATIONS

The following station is transmitting code practice in the ARRL Code Practice Program:

W6JZ, Ray Cornell, 909 Curtis Street, Albany 6, California. 3590 kc., Mon., Wed., Fri. at 1845 PST. Speeds are 5, 7½, and 10 w.p.m. on Monday and Friday and 15, 20 and 25 w.p.m. on Wednesday.

Additional volunteers are needed to send code practice by radio. Schedules may be arranged to suit your convenience. Suggestions for conducting code lessons are available from the Communications Department. Drop us a postal card indicating your interest and we'll send the details.

### DXCC NOTES

Applicants for DXCC endorsement credit are asked to submit a sufficient number of cards to insure the issuance of an endorsement sticker. With over 1700 amateurs eligible for endorsement credit in Postwar DXCC, it is essential to the smooth operation of the DXCC desk that each endorsement applicant qualify for at least one sticker, with the exception of those who can qualify for Honor Roll listing. If there's any question as to the validity of one of your cards, it's a good idea to submit an extra QSL or two so you will be sure of earning a sticker. Remember, monthly endorsement listings in QST are based on stickers issued. Endorsement applications that do not include enough cards to qualify for the issuance of stickers waste time, waste postage, and contribute nothing to DXCC listings.

### DX CENTURY CLUB AWARDS

#### HONOR ROLL

W1FH.....241	W6VFR.....234	W2BXA....230
W8HGW....239	W0YXO....233	W3CPV....228
W3BES....235	G2PL.....232	W3GHD....227
	W6ENV.....231	

#### RADIOTELEPHONE

W1FH.....210	XE1AC.....200	W1JCK....184
PY2CK....203	W8GW.....195	W6DI....181
VQ4ERR...203	W9REI....186	W3LTU....181
LU6AJ.....202	W2BXA....186	

From August 15 to September 15, 1951, DXCC certificates and endorsements based on postwar contacts with 100-or-more countries have been issued to the amateurs listed below.

#### NEW MEMBERS

W8BTI.....212	SM5FL.....105	W0TKX....101
W3LMM....132	W0BAF....104	W0AIH....100
CE7AA....124	F8WK.....104	W4CKB....100
DL1CS....112	KP4HU....103	ZS6IH....100
9S4AX....109	YU1CAG...102	ZS3K....100
W6DBP....107	OE1ZZ....102	

#### RADIOTELEPHONE

VE7VO.....122	HB9JZ.....107	W5PFR....100
F9HF.....109	3V8BB....103	W1CUX....100

#### ENDORSEMENTS

W3JNN.....212	W8MPW....151	W5NW....130
VE7VO....180	W9HUZ....150	W6NIG....129
W2DSB....172	W6LV....146	SM5DZ....122
W8EWS....169	W4NNE....146	W6WO....122
I1AY.....169	NY4CM....143	VP5FR....121
W2BJ....165	G0GH....140	IS1FIC....120
I1OJ.....161	W3CGS....140	W4NKQ....114
W4HA....161	W8TJM....136	W2BUY....110
I1AIV....160	W0CU....135	F3RA....110
W1JLT....156	W6KYG....133	

#### RADIOTELEPHONE

W3JNN.....155	W9UUN....131	W8TJM....111
W2AEB....140	W0PUE....130	IIRC....110
I1YJ.....140	W1KJU....124	HB9DY....110
W3GHD....140	W6NIG....123	W3BYL....110



This photo was taken at the annual general meeting of the Beaver Radiotelegraph Club in London, Ontario. Its members constitute Ontario Section's well-known traffic net, the Beaver Net, which operates as a part of the National Traffic System. A great deal of traffic talent is represented in the picture. Standing, l. to r., VE3e ANO, ATR, BBM, BCZ, DU, WX, BUG, BUR, GI. That's VE3WY in the middle of the seated row, along with VE3ATR's harmonic and XYL, VE3ANO's XYL and VE3WY's XYL. Kneeling are two more harmonics of VE3WY.



The recent Civil Defense Conference held at GE's Electronics Park in Syracuse, New York, was a notable success in that it brought together thinking on civil defense communications planning at national, state and local levels. Naturally, as in all such conferences, amateur radio came in for its share of the discussion. One important revelation in particular indicated that regulations for the Radio Amateur Civil Emergency Service are well on their way toward fruition. It may even be that they will have been announced by the time you read this.

One of the features of the Conference was the new film "And a Voice Shall Be Heard," produced by the March of Time for GE. We understand that copies of this film are available on free loan through the various GE distributors. Your local distributor can probably get it for you or tell you where to get it. Using as a theme the development of civil defense communications in Syracuse, the film adequately shows the rôle of the radio amateur, although the popular misconception of the amateur as a teen-aged youngster is carried forward by the youthful exuberance of the actor playing the part of the radio amateur operator.

The place was full of hams, most of them present in other capacities. The opportunity was a rare one for making new civil defense contacts and renewing old ones. Your ARRL representatives made the most of this opportunity.

For some time we have been listing 29,640 kc. as a "National Calling and Emergency Frequency." We do not know how this has been working out, or how it will fit in with civil defense planning throughout the nation and with the proposed Radio Amateur Civil Emergency Service, but it *does* fall within the civil defense earmarked frequencies.

The Washington Mobile Radio Club has recommended that this frequency (29,640 kc.) be designated as a "national mobile calling frequency," on a voluntary basis. As we see it, there are a few questions involved, to wit: (1) Can a channel be spared for this purpose nationally, in view of the many civil defense requirements for channels? (2) Will everybody agree to use the same channel? (3) Will nets now using this channel vacate it? (4) Should we restrict it to mobiles and designate another National Calling and Emergency Frequency elsewhere?

If we want to do something, we have to get together and agree to do it. How do the rest of you fellows feel about this?

SCM Willie Werner, KP4DJ, tells us that back in August when Hurricane "Charlie" was threatening to stir up a ruckus down his way, the Puerto Rico Amateur Emergency Net on 3925 conducted a routine drill in which 32 stations participated. The net was secured within an hour, but most of the stations stood by until midnight, then KP4OE stood guard with four relief operators until the following afternoon when the SCM advised there was no further need for the net. The Red Cross, U. S. Weather Bureau, Civil Air Patrol and Naval Air Station all cooperate in making this network one of the most complete and efficient in existence. They are even trying to arrange to include some of the other Caribbean Islands in their net, to give complete hurricane coverage to as wide an area in the Caribbean as possible.

In recognition of services rendered in the January ice storm, W4s ODK, KFA and MGT receive Public Service Certificates from Western Union. Eli Hall (in dark suit), Western Union assistant manager in Lexington, Ky., made the presentation. W4MGT is SEC for the ARRL Kentucky Section.

## NATIONAL CALLING AND EMERGENCY FREQUENCIES

C. W.	'PHONE
7100 kc. (day)	3875 kc.
3550 kc. (night)	14,225 kc.
14,050 kc.	29,640 kc.
28,100 kc.	

During periods of communications emergency these channels will be monitored by stations of the National Emergency Net for personal-inquiry traffic. At other times, these frequencies can be used as general calling frequencies to expedite general traffic movement between amateur stations. Emergency traffic has precedence. After contact has been made the frequency should be vacated *immediately* to accommodate other callers.

The following are the National Calling and Emergency Frequencies for Canada: c.w. — 3535, 7050, 14,060; 'phone — 3815, 14,160 kc., 28,250 kc.

In late August, the Cuyahoga County Amateur Radio Emergency Corps, in cooperation with the Cleveland Police Department, held a "hidden-transmitter hunt" to determine how long it would take to alert all the amateurs in the county in the event of an emergency which was not publicly known. The hidden transmitter was located on the second floor of a building in an old industrial section of the city. This building was located on a dirt street without street lights. The fixed stations around the county, using their directional antennas, determined the general location of the transmitter. After this general location was determined, the mobiles were dispatched into the area. When the transmitter was located by the mobiles, they relayed the information to the portable station at the radio control room of the Cleveland Police Department and a police cruiser was dispatched to "apprehend" the operator. The transmitter was located within an hour and a half of the time the hunt started. Over 50 mobiles and 25 fixed stations, including about 150 amateur operators, participated in the test. — W8LYD, EC Cuyahoga County, Ohio

Amateurs figured prominently in a public demonstration of aircraft detection last July at North Sydney, Nova Scotia. The problem involved planning the course of an "unfriendly" aircraft on the radar screens of three stations and of a Canadian night fighter which had taken off to intercept the "intruder." Communication between the radar stations was furnished by amateurs in the persons of VE1s AAL PS ZO and CN. Also participating were VE1s AAK ZB CN MK XH and PS. After the demonstration, VE1DS announced that free messages would be accepted to any points in Canada or the United States, and about 100 such messages were originated. The above stations and VE1BC all assisted in clearing the traffic. A large audience, including many Canadian civil defense officials, was greatly impressed with the demonstration of the amateurs' ability to handle military and civil defense communication.



• All operating amateurs are invited to report to the SCM on the first of each month, covering station activities for the preceding month. Radio Club news is also desired by SCMs for inclusion in these columns. The addresses of all SCMs will be found on page 6.

### ATLANTIC DIVISION

**EASTERN PENNSYLVANIA**—SCM, Jerry Mathis, W3BES—PDJ is building a new 813 rig for 3.5 and 7 Mc. for use during the traffic season. 1TPH (ex-3NDZ) and 3QZY were married Aug. 18th. They are making their home in Springfield, Mass. OSE left for college in September. PSH is going to Temple U. this year. OQG is mobile on 28 Mc. ELI, formerly of the NCR, now is in the Army. CAU (OO) sent notices to several 75-meter 'phone hams operating in the 3700- to 3900-kc. band during the time of restricted use. KT fell while repairing his beam and was badly bruised. QV and BES will not be candidates for their respective offices in the ARRL this term. Good luck to the successors. Traffic: W3CUL 3730, HA 14, CAU 6.

**MARYLAND-DELAWARE-DISTRICT OF COLUMBIA**—SCM, James W. John, W3OMN—The annual hamfest-picnic of the Baltimore Amateur Radio Communications Society was held Sunday, August 19th, at Triton Beach. Most of the clubs in the section were recessed during the month of August. However, the Chesapeake Amateur Radio Club meeting of August 21st featured Jim Gordon, LXK, who spoke on "Experimenters' Design Problems." EIS has resigned as Section Emergency Coordinator, and in accepting his resignation I wish to thank him on behalf of the section for the service he has rendered in that position. Emergency Corps organization, as well as appointments for the section, will be listed in this column next month. After ten years silence QGS again is on 7 Mc. with a T-50M transmitter and BC-342 receiver. PXM can be heard on 28 Mc., having acquired QPL's mobile rig. KOA has a new shack in his back yard and is trying to decide how to keep warm this winter. RPQ solved his antenna-support problem by putting steps on a 90-foot oak tree in his yard. CEK moved to California and OUR has a new QTH in Texas. NFW's residence now is Florida. JQN and PB, Londonley, attended the communications sessions of the FODA college at Olney, Md. The Washington Radio Club meets each 2nd and 4th Sat. at 8 p.m. at PZA, ARC, 930 H St., N. W., Washington, D. C. Traffic: W3EQK 8, PRT 6, CQS 5.

**SOUTHERN NEW JERSEY**—SCM, Dr. Luther M. Mkitarian, W2ASG—My congratulations to UCV, who has been elected SCM for this section and will commence the duties of this office next month. Please forward all your reports to him on or before the 1st of the month. The SJRA hamfest and picnic was a success with more than 400 registrations. PFQ certainly is a master of arts as far as hidden transmitters are concerned and the last one was a real tough one to find. It is with great sorrow we record the untimely death of GJV. YRW is a lieutenant in the USNR on active duty. PDV also is on active duty with the Army. HEX is on duty at U. S. Naval Air Station, Atlantic City. VQR heads the Amateur Radio Division of the Department of Defense, Division of Civil Defense, State of New Jersey. YRV has moved to Massachusetts. VX had a real hot vacation in Florida. SPN recently acquired a new boss, a XYL. YPQ had FB contacts with his mobile rig in the car while traveling through the New England States. Well, gang, it has been a real pleasure to serve you as your SCM for the past two years. Wish you all well, 73, and sign off. Traffic: K2BG 62, W2ZI 43, RG 28, ASG 8.

**WESTERN NEW YORK**—SCM, Harding A. Clark, W2PGT—SEC: SJV. RM: RUF. New officers of the Rochester DX Association are SAW, chairman; VTR, asst. chairman; REF, secy. QCF and ICE, board members. WOE acquired an XYL. TGK has a new jr. operator. GXE and JHI are new calls in Oneida. Recently-elected officers of the Binghamton Amateur Radio Association are UJS, pres.; CUK, vice-pres.; VWO, secy.; and PWN, treas. The Schoharie County Amateur Radio Club recently was organized with the following elected as officers: NAI, pres.; BKR, vice-pres.; BLN, secy.-treas. Contact any of these officers for date and meeting place. EMW worked 120 stations with only 15 wats in the July CD party. QHH received "200" endorsement on his DXCC and also "200" endorsement on his KP4 certificate. 3KIQ and 3JEX have

moved to Painted Post and Binghamton, respectively. HVV is a new call in Mount Vernon; GHS is a new call in Attica; GWU is a new call in Hamburg. SCY and FMF have new jr. operators. YVS moved to Connecticut. SJV worked UFI in Syracuse with a temporary "5 over 5" and plans to get it higher in the air and go after the 2-meter DX. A check of the RDXA shows that 14 members hold DXCC, 5 of whom are on 'phone. Five other members have worked more than 100 countries and are working to get the coveted confirmations necessary for DXCC membership. The Rochester Mobile gang put in an active summer with picnics, Field Day, etc., and now are thinking of winter activities to come. YUE, with half-watt to a pair of 958As, works the 2-meter gang around Rochester. The VHF Contest brought out 23 competitors in the Rochester Area. The Northern Chautauqua Amateur Radio Club is planning an active fall and winter program. Contact SB for details regarding meetings. Traffic: (Aug.) W2COU 514, RUF 280, NAI 79, TPN 77, DJF 34, ZHU 29, PGT 28, PYC 10, EUQ 9, QHH 7, (July) W2RUF 366, COU 325, TPN 45, NAI 37, PGT 27, DJF 25, ZHU 22, PYC 12, EUQ 9, BLO 7, EMW 6.

**WESTERN PENNSYLVANIA**—SCM, Ernest J. Hlinsky, W3KWL—KOF's p.p. 811 rig now is running 500 watts. ODU is awaiting his new NC-183 receiver. UHN says LHP, CDU, OFR, OEZ, and UHN participated in the radio link with Donora and the Erie Centennial celebration. A new-comer to W3-Land is 4LDW, who now is working as a research assistant at State College. KYR, at St. Marys, reports schedules with K4USA by 3LKG. DNO reports his new work with Sylvania at Emporium will take place soon. The gang at PIE held a State Gabfest on Sept. 15th. The Annual Hamfest of the Pittsburgh Area Brass Pounders and Modulators, held Aug. 12th, was a swell affair. After attending the Hamfest for many years, your SCM managed to win a nice Heath Kit vacuum tube voltohmmeter. We met NRE and his family, NUG and his new XYL were the center of attraction. GEG and NCD had a family reunion at the Hamfest. Our old friend GJY was in Army uniform and gave a talk on the merits of MARS. The Steel City Amateur Radio Club sent in its monthly bulletin telling us that QES now is a member of that Club. TVB has a new HRO-50. OMY has a nice two-element 20-meter beam. NKM and RUE attended the V.H.F. Hamfest at Turkey Run, Ind. OFL, BGT, NKM, RUE, and KWH really are cutting up the air with their constant chatter on 50 Mc. Congrats to NKM on winning the V.H.F. Contest. NDH has about the smallest mobile rig. Up Erie way the big event was the Centennial celebration which, according to reports from the Radio Association of Erie, was a great success. Those responsible for radio activity for that event were TXZ, KJT, QPD, QMY, QZE, QPD, OIE, POS, VHP, BRC, KSD, and CDU. These boys managed to contact the Donora, Pa., hams, who also were celebrating their Silver Jubilee. TSX is a new-comer to Erie and 28 Mc. RIV was heard on 7-Mc. c.w. QPP continues his swell articles concerning amateur radio in the local papers. NLU is building a 10-meter final. GEG tossed in his hat as Director of the Atlantic Division. Down Jeannette way, HUD reports by his usual nice and interesting letters. VNE is at Memphis Naval Base teaching basic radio transmitter design. Traffic: (Aug.) W3NRE 234, DNO 33, KYR 25, AER 13, KUN 4. (July) W3KRYR 37.

### CENTRAL DIVISION

**ILLINOIS**—SCM, Lloyd E. Hopkins, W9EVJ—Since there was no report from this section last month because of your SCM's vacation, we will attempt to combine news of the past two months. BUK spent his vacation in California. KRH is adding a new antenna tuner. IAX worked at DUA during the Kansas Flood emergency. LNI is taking up flying. IAX's vacation trip took him as far south as Haiti and the Dominican Republic. UQT snagged NC-101X for stand-by receiver. KCW is building a 500-watt 110-volt a.c. power plant. SKR is vacationing in South Dakota. YIX got the mobile job perking, 35 wats to 815 final. NIU spent an enjoyable time at the convention in Miami. JMG returned to ILLN and reports the arrival of a daughter. KJ blew modulation transformer. JJO is sporting new HT-18 and Millen 50-watter. INF took part in the FMT and has his TVI licked. CRD built a pair of 6-meter rigs, as per May, 1951, QST. YTV spent two months in Pennsylvania. ZXR, the Wheaton College Radio Club station, soon will be heard on 7- and 14-Mc. c.w. ICF is one busy man with new appointments as EC, OPS, and OO. GDI has moved to his new QTH in Park Forest. GBT

(Continued on page 78)

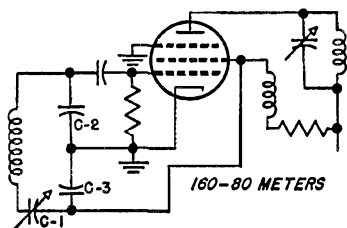

The values for the components in the above circuit are the same as for the conventional Clapp Circuit with the exception that C<sub>2</sub> and C<sub>3</sub> must be reduced to approximately one half the recommended value, or until the feedback is sufficient to support reliable oscillation.

To the dyed-in-the-wool c.w. enthusiast a VFO is a must. Contacts are made these days on or near the other's frequency, and frequency shift may be necessary with every call in an effort to obtain a decent "call to come-back" ratio. There are many of us who will argue that this applies to all types of signals, even extending to mobile operation. However, the circuit we are about to discuss is more applicable to c.w. than phone.

Most everyone is familiar with the Clapp circuit and its well earned reputation. Some are familiar with the fact that when the conventional Clapp circuit is used, a small amount of frequency modulation is noticeable in the form of hum when the frequency is multiplied from 80 or 160 meters to the 10 and 20 meter bands. The amount is small, sometimes noticeable only when a crystal filter is used in the receiver or when the tone is compared with a crystal oscillator's. The only alteration necessary to eliminate the FM is to change the ground point in the circuit to allow grounding in the cathode. In some experimental oscillators tested not only did the FM disappear, but better stability with filament voltage change was obtained.

The circuit shown uses a 6AU6 electron coupled Clapp circuit offering a fair amount of isolation between the tuned circuit and the load. The cathode is grounded and the screen is hot, which unfortunately does not allow the rotor of the tuning condenser to be grounded. The plate can be tuned to the operating frequency or a multiple of it.

In this circuit, the G<sub>m</sub> in use for the oscillating circuit is the G<sub>m</sub> of the screen grid. This is lower than the plate G<sub>m</sub> and does not allow as high a ratio of C<sub>1</sub> to C<sub>2</sub> as is possible with the conventional circuit. Although this would seem to be a disadvantage, tests have shown that the absence of the cathode in the tuned circuit more than compensates for the lower ratio of C<sub>1</sub> to C<sub>2</sub>, resulting in an oscillator of greater stability and free of FM.

As in any oscillator circuit, regardless of type, the long time stability depends upon the quality of the condensers, coil forms and parts that make up the oscillator circuit. The Clapp circuit derives its value by isolating the tube from the tuned circuit, reducing the frequency change with tube change. The frequency of oscillation is still controlled by L and effective C. A change in either the coil or condenser due to temperature variation results in frequency drift exactly the same as in any circuit. With this in mind, it is evident that only quality parts, preferably ceramic, should be used in the oscillator circuit.

Compensation obtained with compensating condensers is necessarily a compromise since all parts concerned do not usually drift at the same rate. Hence, the lower the drift to be compensated, the better the end result. Although deliveries of ceramic parts are slow for civilian use, and we cannot always guarantee their availability, we suggest you compare National's new series of ceramic forms, sockets and condensers when next you shop for VFO parts.

ED HARRINGTON, W1JEL

*Incidentally, our recent page concerning priorities and deliveries of ham items under CMP brought a very nice letter from W4NSP, Don S. Parris, Electronics Division, National Production Authority. Don said that priority assistance for hams was in the NPA mill, with every prospect for a better outlook than we gloomily predicted — and we just learned that M.R.O. priority rating M-85 has now been approved. It appears that good old ARRL is in there pitching for the hams as usual!*



# GET ON THE AIR FAST...

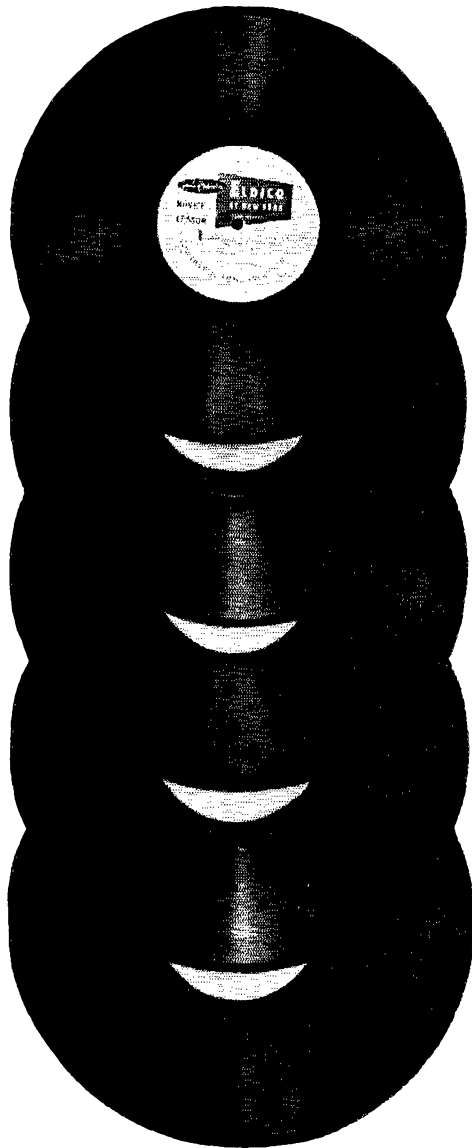

Another Eldico first, the Eldico "Private Tutor" Amateur Radio Course . . . Learning the code made easy by a revolutionary new recorded technique . . . Technical requirements "sugar coated" to guarantee quick, effective results . . . Build your station as you learn.

**What Is It?** Eldico's "Private Tutor" Amateur Radio Course is a unique and tested method for learning the fundamental theory and morse code for all classes of amateur radio licenses in a rapid, thorough, and economical manner. Four courses will be available, leading to the Novice, Regular, Advanced and Extra Class license. The Novice course is now released; other sections will be available shortly.

**Why Is It Unique?** Eldico's "Private Tutor" Amateur Radio Course was created by professional educators, engineers and experienced amateurs. It is not a modification of commercial license courses, it is solely for the radio amateur. Profusely illustrated, the study sections of the course cover theory, rules and regulations, equipment operation, actual on-the-air techniques; included is step-by-step construction which, upon completion, gives the builder practical operating transmitting equipment. By acquiring the material as suggested in the course, every item is useful. Both the code and study sections of each course provide individual instructions, literally your own private tutor every step of the way.

**The Code Course.** The code records are absolutely unique in the educational field. The Novice Code Course consists of five unbreakable long-playing

*Signals of Distinction*

AT YOUR  
DEALERS  
OR DIRECT  
CATALOG 51  
FREE ON REQUEST

**ELDICO**  
OF NEW YORK  
INCORPORATED

44-31 DOUGLASTON PARKWAY • DOUGLASTON, L. I., NEW YORK • BAYside 9-8686



# WITH YOUR OWN **HAM STATION!**

12" records giving a total course of instructions equal to over 20 standard speed records. Code instructions are accompanied by the voice of the instructor. As the code groups are transmitted, the speed is gradually increased. Actual communications-type sequences are interspersed, giving practical code experience under on-the-air conditions. The Novice record series develops speed beyond the requirements of the FCC examination. You are ready for a QSO when your license arrives.

**How Does It Work?** You purchase the Course you want to start with. The complete set of records are sent to you at once. You study the code records whenever you want. Your tutor's instructions are recorded permanently, available as you require them, anytime day or night.

Individual lessons, the study section of the Course, are sent to you *without answer sheets*. As you complete the individual lessons you return the *answer sheet only* to your distributor where you originally purchased the Course. He will correct your lesson, make appropriate comments and answer reasonable questions, and promptly return the corrected answers. At the time you send in your answers you order the materials required for the experiments and construction for the next lesson. The materials list is on the back of each answer sheet. The parts required are available in Eldico kits or may be any other standard brand electronic components.

**Where to Get It?** Eldico's "Private Tutor" Amateur Radio Course is available from any of the outstanding distributors listed. For further information write your nearest distributor or directly to Eldico.

Novice Course, complete with records and study section . . . . . **\$25.00**

**ACK RADIO SUPPLY CO.**  
2205-3rd Ave. No.  
Birmingham 3, Ala.

**ALLIED RADIO CORP.**  
833 W. Jackson Blvd.  
Chicago 7, Ill.

**ALMO RADIO CO.**  
509 Arch St.  
Philadelphia 6, Pa.

**WALTER ASHE RADIO CO.**  
1125 Pine St.  
St. Louis 1, Missouri

**GEORGE D. BARBEY CO.**  
2nd & Penn Sts.  
Reading, Pa.

**BLUFF CITY DISTRIBUTING CO.**  
905 Union St.  
Memphis 3, Tenn.

**C & G RADIO SUPPLY**  
2502 Jefferson Ave.  
Tacoma, Washington

**CONSOLIDATED RADIO CO.**  
612 Arch St.  
Philadelphia 6, Pa.

**THE CRAWFORD RADIO**  
King, Wm. & Hughson  
Hamilton, Ontario, Canada

**DE MAMBRO RADIO SUPPLY CO.**  
90 Broadway  
Providence, R. I.

**M. N. DUFFY & CO.**  
2040 Grand River Ave. West  
Detroit 26, Mich.

**W. H. EDWARDS CO.**  
94 Broadway  
Providence, R. I.

**ELECTRONIC WHOLESALERS**  
2010-14th St. N.W.  
Washington 9, D. C.

**EVANS RADIO**  
P.O. Box 312  
Concord, N. H.

**FEDERATED PURCHASER, INC.**  
911 So. Grand Ave.  
Los Angeles 15, Calif.

**FEDERATED PURCHASER, INC.**  
1115 S. Hamilton St.  
Allentown, Pa.

**FEDERATED PURCHASER CORP.**  
114 Hudson St.  
Newark, N. J.

**FEDERATED PURCHASER, INC.**  
701 No. Hampton St.  
Easton, Pa.

**FORT ORANGE RADIO DISTRIBUTING CO., INC.**  
904 Broadway  
Albany 7, N. Y.

**HARRISON RADIO CORP.**  
225 Greenwich St.  
(10 W. Broadway)  
New York 7, N. Y.

**HARRISON RADIO CORP.**  
Jamaica Branch  
172-31 Hillside Ave.  
Jamaica, L. I., N. Y.

**HARVEY RADIO CO., INC.**  
103 W. 43rd St.  
New York 18, N. Y.

**HATRY & YOUNG OF SPRINGFIELD, INC.**  
169 Spring St.  
Springfield, Mass.

**HATRY & YOUNG OF LAWRENCE, INC.**  
262 Lowell St.  
Lawrence, Mass.

**HENRY RADIO STORES**  
211 No. Main St.  
Butler 1, Mo.

**HENRY RADIO STORES**  
11240 W. Olympic Blvd.  
Los Angeles 25, Calif.

**THE MYTRONIC CO.**  
121 W. Central Parkway  
Cincinnati 2, Ohio

**NEWARK ELECTRIC CO.**  
323 W. Madison St.  
Chicago 6, Ill.

**OFFENBACH & REIMUS CO.**  
1564 Market St.  
San Francisco 2, Calif.

**RADIO AMATEUR CENTER**  
411 Hillsboro St.  
Raleigh, No. Car.

**THE RADIO CENTER**  
62 Craig St. West  
Montreal, Canada

**RADIO ELECTRIC SERVICE CO. OF PENNA., INC.**  
701 Arch St.  
Philadelphia, Pa.

**RADIO ELECTRIC SERVICE CO. OF PENNA., INC.**  
1042 Hamilton St.  
Allentown, Pa.

**RADIO ELECTRIC SERVICE CO. OF PENNA., INC.**  
916 Northampton St.  
Easton, Pa.

**RADIO ELECTRIC SERVICE CO. OF PENNA., INC.**  
3rd & Tatnall Sts.  
Wilmington, Del.

**RADIO ELECTRIC SERVICE CO. OF N. J., INC.**  
513-515 Cooper St.  
Camden, N. J.

**RADIO ELECTRIC SERVICE CO. OF N. J., INC.**  
452 N. Albany Ave.  
Atlantic, N. J.

**RADIO EQUIPMENT CO.**  
821 W. 21st St.  
Norwalk 10, Va.

**RADIO PARTS CO., INC.**  
538 W. State St.  
Milwaukee 3, Wis.

**RADIO PRODUCTS SALES CO.**  
1237-16th St.  
Denver, Colo.

**RADIO PRODUCTS SALES CO.**  
1214-1st Ave.  
Seattle, Wash.

**RADIO SHACK CORP.**  
167 Washington St.  
Boston, Mass.

**SREPCO INC.**  
135 E. 2nd St.  
Dayton 2, Ohio

**WESTERN DISTRIBUTORS**  
227 No. Santa Fe  
Salina, Kansas

**WORLD RADIO LABS, INC.**  
744 Broadway  
Council Bluffs Iowa

(Continued from page 68)

finished a sixteen-element 144-Mc. array to be placed under his sixteen-element 430-Mc. beam. BA sends fine reports on EC activities in his area. TFL reports on the 5th annual hamfest of Illinois, Iowa, and Missouri border hams, held at Hamilton, Ill. Those present were 0AFQ, FNT, PGE, WRM, NLA, GZ, AFI, FKA, VFW, 0JPW, ECZ, ZJD, DYW, ANI, FNE, VGI, and TFL and families. HKA spent some time in Michigan during the Hay Fever season. CTZ resigned as EC for Macon County and EAD is taking his place. Traffic: (Aug.) W9ILH 552, MEM 64, YIX 57, DOQ 47, KRH 38, BUK 29, FRP 28, DOR 8, IAY 8, KJ 7, LCG 6, JMG 3. (July) W9ILH 719, YIX 180, KRH 88, CSW 79, UQT 73, BGN 63, DOQ 51, KCN 21, LAX 14, HOV 13, DOR 10, BUK 7, IAY 7, LIN 2. (June) W9LAX 12.

WISCONSIN — SCM, Reno W. Goetsch, W9RQM — SEC: UFX, PAM; ESJ, RMs: CBE, CWZ, IQW, C.w. net (WIN), 3625 kc., 7 p.m. 'Phone net (BEN), 3950 kc., 6 p.m. The c.w. net begins its operation this season with IQW as Net Manager. George is one of the net's oldest and most consistent members and we look forward to a busy season. JM has the distinction of being the recipient of the first mobile WAS certificate ever issued! The annual groundhog party was held at Watertown Sept. 9th, with QHR in charge, and GVL and GPI as MCs. ONY reported on the status of the Badger Council of Radio Clubs. ANM has two emergency transmitters and receivers ready to operate. LFK has a new QTH with room for outside antennas again. JBF had 50 contacts on 144 Mc. in August after being out of town for summer school in June and July. EC appointments for NRP and RUF were renewed, and IQW was appointed RM. FAN uses f.m. band signals as a guide to conditions on 144 Mc. and possible band openings. UFX reports various communities planning local c.d. nets. NNS has p.p. 1625s on 3.5, 7, and 28 Mc. OOD has an HT-17 on 3-30 Mc., and is interested in OO appointment. Formerly licensed, and back on 3.5-Mc. c.w. with a new call, we find NRA. The annual Sturgeon Bay ham picnic was held at Sunset Park, Aug. 12th. NLH bought a new house. CTH completed an addition to his house for use as a ham shack. KKK is adding to his collection of certificates with such things as DXCC, WAS, WAC, SS, RCC, CP, ROWH, etc. The Blackhawk Club has a new station, NEV. KBT puts out a new letter for the members. PCY soon will be mobile. CBE changed to new QTH. We regret to report as a Silent Key, Dr. R. A. Techan, one of the founders of the MRAC in 1916. RH is mobile on 28 Mc. when not on 14-Mc. c.w. IZE received new Advanced Class ticket. Traffic: (Aug.) W9ESJ 327, IXA 52, ANM 26, LFK 18, RQM 8 GPU 5, NUW 2, OVO 2. (July) W9ESJ 219.

## DAKOTA DIVISION

NORTH DAKOTA — SCM, Rev. Lawrence C. Strandenaes, W6JWY — your SCM was on vacation in August and consequently there was no report last month. FPV reports the arrival of jr. operator No. 1. Communications Manager Handy, 1BDI, made two stop-overs in our section on his way back from the National Convention in Seattle, one in Bismark and one in Fargo. The hams turned out very well for each meeting, got acquainted with our CM, and heard him discuss various topics of timely importance, including ARRL organization structure, recruiting of new hams, civil defense, etc. SSW reports two new calls in Linton: CZX (brother of SSW) and CZZ. Both are on 40 and 160 meters. From KZL come the following items: PJT now is with the CAA in Everett, Wash.; ONM, back from military service, is working as an engineer for KFYR. Our nets are now in operation; join at least one.

SOUTH DAKOTA — SCM, J. W. Sikorski, W6RRN — New appointments: GCP, Mitchell, as OPS; CLS, Mitchell, as ORS and OHS. HDO, Mitchell, has pulled stakes and headed for Portland, Ore., leaving an SEC vacancy for Eastern South Dakota. BQS has his Class A license and is accumulating equipment for a 75-meter mobile rig. CRY has reopened his service shop at a new location. UW0 has been discharged from the Air Force and is back at his old stand at Power City Radio. Please send the SCM your recommendations for a new net frequency outside of the Novice Class band. Not a single report was received by the SCM this month!

MINNESOTA — SCM, Charles M. Bove, W6MXXC — Asst. SCM, Jean Walter 0KYE, SEC: BOL, RM: RPT. UCV now is working mobile regularly on 10 and 75 meters. Fran also lost two fifty-foot masts in the recent wind storms. He now is using a telephone pole. AA sold his 32V-2 to HEO. AA is planning to buy a new Johnson transmitter. HBI moved to a new QTH in Long Beach, Calif. MFC lost his 10- and 20-meter beams in the recent storm. DSF now is Major Art Monsees, squadron commander with the USAF, in the State of Washington. RA is the proud father of a new 8-lb. baby girl. SII now is running a kw. LLW is working out very well with his s.s.b.c. The Minneapolis Radio Club finally won a ball game from the St. Paul Radio Club at their annual picnic. HXG has a new beam and mast. LKM has a new 20-meter Johnson beam. George also is operating mobile on 14 as well as 28 Mc. Here is something for the book. AXJ put up a new antenna that is a mile long, using No. 18 hard drawn wire that is supported at each end

with no supports in the center. One end is 150 feet high and the other end is 80 feet high. The Mobile Amateur Radio Corps station, PZT, is on the air every evening at 1930 CST. This station is prepared to aid the Red Cross and civil defense at a moment's notice. PZT is located at the Hennepin County Sheriff's transmitter building near Minneapolis. Traffic: W0ITQ 174, UCV 25, FTJ 22, MXC 12, FWN 7, RXL 7, BBN 3.

## DELTA DIVISION

ARKANSAS — SCM, Dr. John L. Stockton, W5DRW — A The Catfish Club met at DeValls Bluff October 7th. W5LNU now is EKIPU with 175 watts on 14-Mc. 'phone and has been working some of the Arkansas gang. DYF has moved to West Memphis. ICS visited OUI, NIR, BAB, and DRW. The Tenn. Net is meeting on 3635 kc. at 7 p.m. now. The lack of activity is generally blamed on the hot weather. Traffic: W5EA 8.

MISSISSIPPI — SCM, Norman B. Feehan, W5JHS — NPO is a new EC. MUG, our SEC, is looking for new ECs and Asst. ECs. The Jackson Club reports 11 mobile stations as follows: CQJ, FFF, JIP, PFC, OTD, PNA, RIM, RFA, MZV, RGH, and SRU. CQJ and NPO have new HRO-50s. RFA, PUG, IZS, OYA, QPJ, and PNA attended the West Gulf Convention in Austin, Tex. The Gulf Coast boys gave a picnic at Gulfport for hams far and near. SEP was set up to guide the mobile stations to the picnic grounds. SSB is heard on the Hit and Bounce Net every morning. ROB and ROC have their Advanced Class licenses and are heard on 3.8-Mc. 'phone regularly. The Keesler AFB Club had a Shrimp Boil at the Sportsman Club. The slow-speed net is off to a good start. Check in on MSN on 3635 kc. at 8:30 p.m. Mon., Wed., and Fri. We welcome KL7AEG back to the Coast and Keesler AFB. He will be remembered as W6ABL/5. The Keesler Club is very glad to have PGF back. The Central Gulf Coast Hurricane Net was very busy recently when several hurricanes were brewing. Traffic: (Aug.) K5FBB 71, W5JHS 14. (July) W5SSB 62.

TENNESSEE — SCM, D. G. Stewart, W4AFI — Now that we are in the midst of the fall operating season I would like to take this opportunity to urge all section amateurs to participate in one or both of our nets. The 'phone net still is operating on 3980 kc. but the c.w. net has moved to 3635 kc. Route Manager BAQ is rotating NCS on the c.w. net so everyone gets an opportunity to sit in the driver's seat and gain experience in directing net operations. Check in any evening on 3635 kc. Monday through Friday and 3980 kc. Tuesday and Thursday evenings and Sunday morning. If you are not now registered with AREC, contact your local EC and take an active part in the emergency program. Drop a card or letter to Section Emergency Coordinator AEE for further information. ECs are requested to get their monthly reports to AEE on time and regularly. Let's make Tennessee the foremost section in AREC activities. FLW is collecting weather data daily to be applied to 50-Mc. openings and recently finished a new 36-ft. ladder mast for new six-element 2-meter beam. NNH is active on 14 Mc. and reports hearing extremely short skip stations during the summer months. PMR is chasing DX on 14 Mc. and turned up ZB21 for a nice DX contact. Traffic: (Aug.) W4FL 1693, OUG 68, NNH 8, OOA 6, NDC 5, FLW 2, PMR 1. (July) W4NNH 16.

## GREAT LAKES DIVISION

KENTUCKY — SCM, I. W. Lyle, jr., W4KKG — New! est addition to Kentucky ham ranks is 13-year-old YL TAV, daughter of NEP. She wants to report in on some of the nets and handle traffic. Welcome, and you fellows keep your ears open for Susan RYL has moved to Danville and is putting up a vertical. MGT turned in a nice traffic report for summer time. SKE handles a little traffic and also looks for DX on 7 Mc. MWX fights QRN on 3.5 Mc. and handles a bunch of traffic. MDB has a new Super-Pro and is working on a new transmitter. PRT is getting in gear again. Stir up the gang there in Lexington. Doc. KZF is handling Official Bulletins in good style. K4WBG has a new Johnson Rotomatic and HRO on the way. NZY is active on MARS, the net that is! VP took a vacation and he and his son, SHD, visited ARRL Headquarters. KKG got a new HRO-50T1. This is all, gang. I can't write it if I don't get it! Traffic: W4MGT 190, WBG 160, MWX 119, PRT 14, KKG 12, SKE 4, TAV 1.

MICHIGAN — SCM, Norman C. MacPhail, W8DLZ — Asst. SCM (phone): R. B. Cooper, 8AQA. Asst. SCM (c.w.): J. R. Beljan, 8SCW. SEC: GJH. PAM: JUQ. RMs: UKV and YKC. New appointments: UTH and ZEE as OPS, GJB as EC for Mason, Oceana, and Lake Counties. The Blossomland ARC Hamfest drew an attendance of more than 350, with 150 calls represented. More than 80 mobiles lined the parking lot. The W9s outnumbered the W8s! SCOOP! W8HHM may be the first Net Manager to register a WN traffic net. He, together with W8Ns HIN, HHS, HEH, and HEP, have organized the Michigan Novice Net. It meets Mon. through Fri. at 1800 EST on 3715 kc. Congratulations and good luck! MCV and family now are permanently located in San Francisco, Calif. CPY spent the summer building a new home station; also mobile all

(Continued on page 74)

# AVOID RESISTOR BREAKDOWNS



## OHMITE LITTLE DEVIL RESISTORS

### Provide **EXTRA MARGIN** of SAFETY

Where dependability is of the utmost importance, play safe with Ohmite Little Devil molded composition resistors. While they are tiny in size, these units have exceptional ruggedness, stability, and current-carrying capacity. Little Devils are completely sealed and insulated by molded plastic. Under continuous full load for 1000 hours, their resistance change is less than 5%.

Ohmite Little Devils are available in  $\frac{1}{2}$ , 1, and 2-watt sizes, in  $\pm 5\%$  or  $\pm 10\%$  tolerance. Standard RTMA values, 10 ohms to 22 megohms are furnished. In the 1-watt size,  $\pm 10\%$  tolerance, values as low as 2.7 ohms are provided.

AVAILABLE ONLY FROM YOUR DISTRIBUTOR

**OHMITE MANUFACTURING CO.**

4865 Flournoy Street, Chicago 44, Illinois

- **RATED AT 70C**—Little Devils have a wide margin of safety—being rated at 70C instead of 40C.
- **WITHSTAND TEMPERATURE, HUMIDITY**—Meet all JAN-R-11 requirements, including salt water immersion and humidity tests.
- **RESISTANCE AND WATTAGE CLEARLY MARKED**—In addition to color coding, the resistance value and wattage are marked on every unit.
- **TEMPERED LEADS**—Tinned copper leads are differentially tempered to prevent sharp bends.

Be Right with **OHMITE** RHEOSTATS  
RESISTORS  
TAP SWITCHES

bander. The Muskegon gang came up with another super picnic that won the approval of not only the QMs but the XYLs and jr. operators as well. TBP's "jamoke" was terrific. 2LMB/8 headed home to New Jersey after another summer in the north woods. QBO and ATB, John and Esther, are vacationing in California. UUS is moving plenty of overseas traffic on 14 Mc. The Detroit Whip Club and the Trenton ARC pooled resources to furnish important communications during the National Air Races in Detroit. The Muskegon crew did the same for the National Motorcycle Hill-climbing Championships. The Grand Rapids Club has started a 12-week course in radio theory and code. All club members rotate as instructors and teachers. The MARS net on 4020 kc. continues to grow. Both the BRNet and QAIN are set for the winter traffic season after a relatively quiet summer. SCW is especially busy lining up the 8RN. Joe is the newly-appointed manager. EXZ operated 71 in New Hampshire this summer while on vacation. MGQ is sporting a 75A-2 receiver. EGI toured New York, the New England States, and VE3-Land while vacationing. AYY's new shack is completed and really is a super job. OCC now has Advanced Class license. RFW reports 5 meters has been hotter than a hockshop watch all summer. Traffic: (Aug.) W8UUS 490, RJC 404, NZZ 254, TZD 93, QBO 43, ILP 34, DLZ 31, WVL 24, DAP 22, BVI 14, IV 11, QZ 11, ZEE 4, EXZ 3, (July) W8CYP 45, TBP 32, ILP 30, FLM 26, W2LMB/8 24, W8COW 22, BVI 18, LR 11, TQP 2, (June) W8ILP 57.

OHIO — Acting SCM, Jack Siringier, W8AJW — Asst. SCM, C. D. Hall, 8PUN, SEC: UPB, PAM; PUN, RMs: PMJ and DAE. K8AIR and W8ARO made BPL for August. A new-comer to the amateur ranks is HIF. Tommy is 12 years of age. KZ5BD is vacationing at Heidelberg Beach. SCW is the new 8RN manager, replacing YCP, who has done a swell job in the past. According to LYD, 5th Area Amateur Radio Aide, the Hidden Transmitter Hunt of Aug. 27th was a pronounced success. WXM was home for a few days on leave from the Navy. 8TO/8 was on the air from the civil defense booth at the Ohio State Fair. EZE is back at Kenyon College. New Buckeye Net frequency is 3580 kc., 1900 EST, Monday through Saturday. DMJ has acquired an Advanced Class ticket and a brand-new daughter. WIT is the proud "pappy" of a baby girl. ECJ is going, ten-meter mobile. GCARA staged a Stag Hamfest and Radio Parts Show on Sept. 16th. It's rumored that BXB is going back on c.w. This month has produced a minimum of reports. Apparently the lads still are suffering from the summer heat. Traffic: K8AIR 806, W8ARO 324, FYO 193, DAE 90, IB 73, YCP 29, AL 24, QIE 16, AJW 14, EQN 14, PMJ 14, DMD 13, LCY 12, RLR 9, CBI 8, WAB 7, BEW 2.

#### HUDSON DIVISION

EASTERN NEW YORK — SCM, George W. Sleeper. W2CLL — SEC: ILL. EQD dropped in to say hello the other day. Fred is on his way to White Sands and sends his 73 to the section. BXE writes from Las Cruces, N. M., where he has been assigned since his recall to the Navy. Austin asks to be remembered to the NYSCD phone net. He is on 14-Mc. phone with K5WSP. We probably will be hearing from Fred at that station, also. Best of wishes, fellows. The AARA held its annual clam bake with a good attendance. We would like to know how JQI was abducted from his shack. FZV finally has pulled the big switch and will be QRT for an indefinite time. Good luck to you, Ty, and we want you to know that your efforts have done much to build up the AREC in this section. We hope you will be back very soon. RYT takes over the Schenectady County EC post. The section wishes him the best of success, and is most happy to welcome him to field organization. The scent of traffic is in the air. NYS resumed its regular schedules Sept. 3rd. TYC and his NYSCDCW net is doing well. Your SCM would like to announce that many field appointments still are available. We need spark plugs, so speak up and do your part. Your SCM and SEC visited the Rip Van Winkle Radio Society of Catskill and had an FB time. RYT and the SARA gang had a special meeting to discuss c.d. matters. Welcome to HLU, who has joined the ranks of the traffickers. Appointments: RYT as EC for Schenectady County. Endorsements: ITX as EC for Pleasantville. Traffic: W2BNC 397, LRW 228, PHO 158, TYC 87, CLL 51, WBH 26, FEN 23, BLU 15, BVT 8, BRS 5.

NEW YORK CITY AND LONG ISLAND — SCM, George V. Cooke, jr., W2OBU — Asst. SCM, Harry J. Dannels, TUK, SEC: SYW. RMs: TUK, PRE. Activity was light during the summer months with attendance in all AREC and traffic nets of about 50 per cent but now, with the fall season here, activity is expected to rise to new levels from past seasons. The outstanding group to maintain the highest level of activity during the summer was the Brooklyn AREC nets. With increases of about 7 new members per month and the continuance of drills on all assigned frequencies this group made the outstanding record in the section. Next in line was the Nassau AREC/c.d. growth, showing an average attendance of 33 members and with County Control stations permanently installed on 3.5, 28, and 144 Mc. to work local villages on their nets under the direction of FI, EC for Nassau. In Queens, under the control of JSV, County EC, and the newly-appointed Alternate EC, TJA, an average of 36 mobiles reported during the month at drill

times. Eight test runs were held, conducted by IAG, 23-Mc. EC, on 29,520 Mc. Thursdays at 2030. Four drills were held on 144 Mc. with an average of 18 members QNing. KNA has been appointed Suffolk County EC, and promises increased activity over the average of 50 per cent of members attending during the warm weather. MEF has been designated and appointed as Alternate EC for Richmond, supporting VKF, the full County EC. SYW, our SEC, now is in new QTH in Babylon and hopes to put up better antennas on open land instead of apartment roof as heretofore. For excellent work and attendance in local nets ZPQ, AAG, EPZ, ODS, and IRJ were issued Section Net certificates. WHY now is NCS on 2300 Queens Internet on 29.6 Mc. IAG has gone mobile and is piling up QSOs. The Tu-Boro Net operates Tuesdays at 1900 on 29.52 Mc. and is enjoying increased interest and activity. Your SCM brought as a guest to the New York Radio Club HB9P, from Switzerland, and witnessed a fine demonstration of teletype operation by BFD. Doc Keel was shown the town by club members and was conducted on a number of tours through b.c. and t.v. stations. Cooperation of all stations in the section was appreciated during the recent military maneuvers shift in frequencies. EC, Manager of TLAP, states that the net changed to 3630 kc. at 2130 EST Mondays through Fridays. The NLI traffic net, operating on 3710 kc. at 1930 Mondays through Fridays, has resumed full season activity and is looking for many stations as outlets all over the section. The Mid-Island, Nassau, and Lake Success Radio Clubs teamed up to operate a station at the Mineola Fair. Hundreds of messages were handled and favorable publicity was gained by demonstration on 3.5, 3.8, and 144 Mc. VL is a newly-appointed ORS. PZE, active with c.d. in Smithtown, formed a local club with the call GSW and with JFU as trustee, and has 7 mobiles active in the town. PF's jr. operator now holds the call WN2IVA and plans to join local nets. 9LCS now is residing in Jackson Heights. UNS is teaching code and theory at Camp Cooke, Calif. SMQ and OWP are having loads of fun these days on 75 M/M. Inadvertently, the Amateur Radio Society of Queens, CGK, was not on the list of stations sending in Field Day messages and the addition now is made. Traffic: W2BO 527, OBU 165, EC 73, OJX 66, JHQ/2 64, QUT 48, MQB 47, VL 43, PF 16, EBY 2.

NORTHERN NEW JERSEY — SCM, Thomas J. Ryan, jr., W2NKD — During August and Early September there was some confusion and disappointment that the story of the "hams' part in the work at the Warren (Chemical Co. (Newark) explosion was not printed in September QST. To put everybody at ease, yours truly sent the story to the League in early July and followed up with more information in August. Word was immediately received from the National Emergency Coordinator that those who did such great work in the fire would be recipients of Public Service Certificates. *That still goes!* INJM said the certificates would be mailed as soon as possible following the appearance of the story in this month's QST. Since copy for the magazine must be submitted at least six weeks before the issue is circulated (the same as this column), it was not possible for the story to appear in September QST. Please continue to send in news of your activities, particularly those of you who hold League appointments. Let's take full advantage of our space allotment and submit interesting material. Worthwhile articles will be welcomed with open arms. The percentage of monthly reports is very small. How about taking one minute each month to dash off a postcard? Oct. 13th was a very important day in the short life of the Amateur Radio Division of the N. J. Department of Civil Defense. On that day we were given the splendid opportunity of educating the public on just "what is a ham." A state-wide show of amateur radio was conducted by the four District ECs and the thirteen Area ECs, under the direction of our SEC, VQR. Ham radio gear was installed in the homes of the Governor and the Director of Civil Defense, as well as in the offices of each of the major newspapers throughout the State. The demonstration was conducted on 3995 kc. for the phone net and on 3504 kc. for the c.w. net. Preparations for the show were made at the Sept. 17th meeting in the Municipal c.d. headquarters in Trenton. Next month the list of District and Area ECs will be published here, in case you have not already contacted your local c.d. man, besides the AREC Emergency Coordinator for amateur radio. Dedication of Middlesex County Disaster Control truck found County EC, BAI; Asst. County EC, GPV; and Perth Amboy EC, HIA, manning gear installed on 114 Mc. mobile commercial and p.a. Demonstration provided contacts with County Communications Center at Rutgers Stadium, staffed by LFI, and contacts with UK, VPL, and EKU. NQA, New Brunswick EC, has completed installation of 144-Mc. gear at local City Hall c.d. headquarters. The Irvington Radio Amateur Club officers are: QLF, pres.; VXM, vice-pres.; WFK, treas.; and ZAH, secy. The Club meets the 1st and 3rd Mondays at 8 p.m. at Community Building, corner Clinton and Linden in Irvington. New novice licensees are: JDL, Plainfield; IQP, Newark (XYL of EAO and mother of YGM and YCU); JEO, JZV, and KNI, Mountainside. AYP, of Irvington, is our newest ORS. 2KMF/WN2KMF passed both the Novice and Technician exams at one sitting. Our newest OBS is OUS, of Red Bank. Traffic: W2CCS 207, LMB/8 33, EAS 13, NIT 6, ZEP 5, OUS 4, CJX 2.

(Continued on page 76)

# START RIGHT...

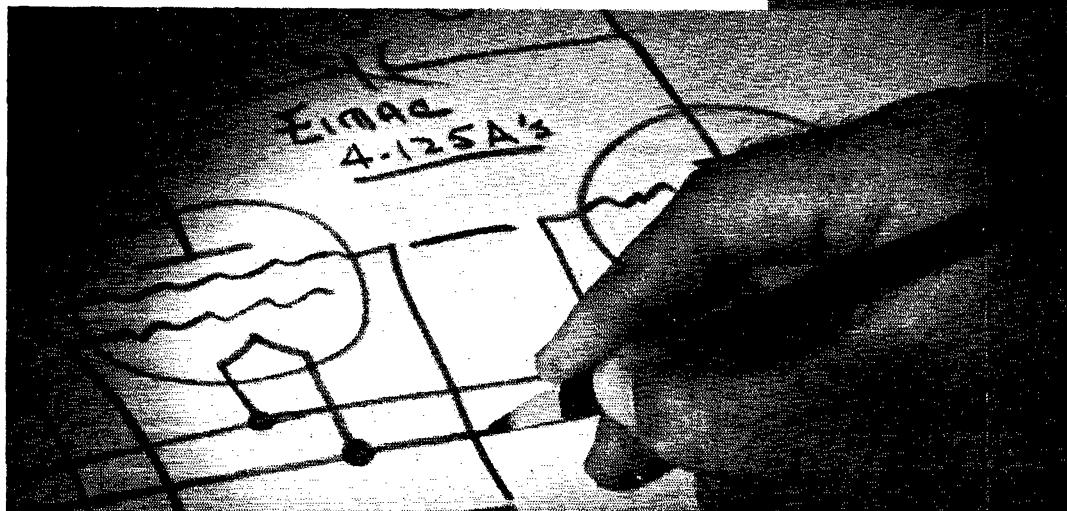

Whether you're going higher power, de-bugging TVI, or building your first rig . . . start right - with Eimac tetrodes. Low driving power, compatibility to modern circuit techniques, and long life will work to your advantage.

A wide selection of input powers is available from the four tube types specially suited to amateur transmitters:

Type	Plate Dissipation (Watts)	Typical Power		
		class C CW (Watts input)	class C Plate Mod. (Watts input)	class B Mod. (Watts output)
4-65A	65	345	270	270
4-125A	125	500	380	350
4-250A	250	1000*	675	1040
4-400A	400	1000*	825	1650

\* Max. input in excess of 1 kw. Capable of conservative 1 kw. operation.

Write today for free complete data on these and other Eimac tubes. Also, remember Eimac offers a personalized engineering service to help amateurs get the most out of Eimac tubes.

*Eimac*  
TUBES

**EITEL-McCULLOUGH, INC.**  
**San Bruno, California**

Export Agents: Frazar & Hansen, 301 Clay St., San Francisco, California

300

## MIDWEST DIVISION

IOWA — SCM, William G. Davis, WØPP — SEC: FP  
ECs: SCA, QVA, HMM. Vacation is over for your SCM  
after a fine trip through Wyoming and Colorado. The  
75-meter mobile was nice to have along. AUL has a 75A-1  
to match his 32V-1. New members of TLCL are BBZ/Ø and  
DFD. SEF enjoyed a 2-week vacation in Glacier National  
Park. UWF now has his Advanced Class ticket. LAC visited  
his brother, 6REI, in Los Angeles; MVE now is at Naval  
Research Lab. in Washington. All the traffic men of Iowa  
mourn the passing of AY, a pioneer ham and past-director  
of ARRL. SCA is back in harness. He comes up with BPL  
again and reports that T.E.N. will be back on full sked Oct.  
1st and will remain on 3560 kc. SCA spent a week visiting  
with hams in Missouri, Kansas, and Nebraska. YTA reports  
new 813 on 3.5-Mc. c.w. The Waterloo Club station now  
has its own call, DVL. The Newton Club had a farewell pot-  
luck dinner for BSQ. Those present were WML, UTP,  
4NNN/Ø, BSY, JDV, YSQ, C. J. Brown, and Ed Green.  
All the XYLs and jr. operators were present. VFM has a  
new license and reports from KSIT. CFX is back in harness,  
in charge of radiation detection lab. at Ames. MRO is re-  
ported to be in Pennsylvania. Traffic: WØSCA 520, YTA 75,  
QVA 62, BDR 45, NYX 7.

KANSAS — SCM, Earl N. Johnston, WØICV --- Wel-  
come to you WNBs we now hear on the band. We sure want  
to urge you to attend local club meetings, hamfests and the  
like and be right in there with us. Join the AREC, too —  
your help and interest is welcomed by all. ISC, reporting  
for CKRC of Salina, says INW, JFE, and ATS all have new  
S-76 receivers. Also ATS has a new Meissner Signal Shifter.  
The CKRC had its annual picnic Sept. 9th with 25 families  
attending. The Kansas-Nebraska Radio Club Hamfest,  
attended by your SCM, found a registration of more than  
100, with lots of eats, more than enough prizes to go around,  
and everybody having a fine time. The Kaw Valley Radio  
Club has four more new mobiles this month and four or  
five Novices have passed the exam and are awaiting tickets.  
DRL just got on 144 Mc. with his neighbor, OBO, scratching  
the bug. WNDVT is building a rig for 420 Mc. SSB  
just completed a TVI-less rig working 3.8 and 14 Mc. KSY  
is having the time of his life with Collins 32V-2 and 75A-1.  
FDJ is RM this season and will be looking for the gang on  
3610 kc. The Kansas 75-meter 'phone net still is on the ball  
with the same skeds Sunday 0800, Tuesday 1230, Thursday  
1845, and Friday 1230 CST on 3920 kc. Traffic: WØFQE  
234, N1Y 95, TDW 79, FDJ 49, KXL 23, BLI 13, ICV 2,  
LIX 2.

MISSOURI — SCM, Clarence L. Arundale, WØGBJ —  
RVG, the Red Cross Center station in Kansas City, erected  
a new antenna extending from Red Cross Building to Court  
House, the latter being 295 feet high. GCL reports the Rolla  
Club is active on 7 Mc. with the call EDA. They also have  
a milk truck which is being converted into a mobile emer-  
gency station. AJD is working in TCRN net daily. JEJ is  
rebuilding. EBE is busy working over mobile rig and paint-  
ing his house. FIR has his car in the repair shop as the result  
of an accident which delays mobile installation. ARH has  
received his DXCC. BAF reports 40-meter mobile operation  
very fine. WAP is on low power waiting for replacement  
power-transformer. Several Joplin amateurs went to Miami,  
Okla., to assist in flood communications. Governor Smith  
signed H. B. 242, therefore all licensed amateurs are urged  
to make application at once for new auto license plates re-  
gardless of when your auto license expires. Make out  
application for new license plate showing call letters printed  
plainly. Indicate your present plate number for identifica-  
tion and enclose check or money order to cover regular fee  
for one year, plus \$1.00, and send to Mr. G. H. Bates,  
Director of Revenue, Jefferson City, Mo. Plans are to issue  
all plates in January, 1952. HUI, assisted by a number of  
other amateurs, played a major part in securing enactment  
of H. B. 242. For a splendid report on the flood emergency  
communications refer to *Midwest Clix*, published by  
WØKXL, August-September issue. Traffic: (Aug.) WØAJD  
51, WAF 48, BAF 40, EBE 7, OUD 7, QMF 4. (July)  
WØUD 21.

NEBRASKA — SCM, Guy R. Bailey, WØKJP — I wish  
to thank Scotty, OED, for his fine cooperation in briefing  
me on my new duties as your SCM. With sadness of heart I  
report the passing of AY, Porter H. Quinby. The Omaha  
Emergency Corps drills every Friday night with twenty  
mobiles reporting. BEW has moved to Columbus. APG  
has a new mobile rig. NKG is on at his new QTH with 600  
watts. HZE is in school in Colorado. Good luck, Bob. IOS  
will be at his new QTH when you read this. The new home  
is equipped for every phase of ham radio. GKL has new  
600-watt rig on 14 Mc. LWJ is on 28 Mc. with 500 watts.  
EHF is teaching math, etc., at Bebetown High School in  
Iowa. The son and daughter of BBX and CSN have passed  
their Novice Class exams. Four hams in one family is a  
record for Nebraska. Congratulations, Doc. Material for-  
warded to the SCM for this report was very meager, because  
of the change in SCMs. In taking over the job which has  
been so ably handled by Scotty, I feel somewhat inadequate.  
However, with the support of the gang I will keep up the  
good work to the best of my poor ability. Your cooperation  
in sending reports promptly on the first of each month will  
help greatly.

## NEW ENGLAND DIVISION

MAINE — SCM, Orestes R. Brackett, W1PTL — SEC:  
IGW. RM: NGV. PTN, 3596 kc., 1900. Correction in  
regards to SWX in Aug. QST: Bob is in the Air Corps not  
the Navy, as we had been informed, and is stationed at  
Keeler AFB, Miss. SSK took the exam one day and got  
new Advanced Class license the next, and is putting out a  
swell signal on 3.8 Mc. Sea Gull certificates go to LBJ, HUL,  
and BTY. If any of the boys in the State of Maine who are  
entitled to one of these net certificates do not have one,  
contact the SCM. LNI has gone mobile. RHA, David  
Nichols, a new ham in the State, is located at Edgecomb.  
About 200 hams got together at BOK's for the fourth year,  
including 23 mobile units. A mobile transmitter hunt was  
held with IGW taking first prize after one hour and thirty-  
eight minutes. Second prize went to SEJ and third to JSY.  
TCS took the prize for coming the greatest distance (300  
miles). OHY wanted to get there so bad that he hitchhiked  
from Portland. Movies were shown and there was plenty of  
Maine dickering at the swap table. On Aug. 19th there was a  
small get-together of about 50 at Spruce Head put on by  
the Knox County Radio Club. Five mobiles were present.  
A prize was drawn and was won by PVY. SCY was winner  
of the WAS Contest for the Maine section. He made 239  
contacts, working approximately 37 states for 9000 points,  
which gives him second place in New England. MFJ demon-  
strated good mobile operation on a recent trip to New  
York. QDO has his new call, 2LBT. Traffic: WILKP 72,  
QQY 54, BTY 27, PTL 16, QIG 3, SUN 1.

EASTERN MASSACHUSETTS — SCM, Frank L.  
Baker, jr., W1ALP. New frequency of our Eastern Mass.  
Net is 3660 kc. To all Novice operators, the slow-speed net  
will be on 3745 kc. If interested in either of these nets, write  
to JCK. Appointments endorsed are: As ECs: CBY,  
Lawrence; KYX, Bedford; AVY, New Bedford; HAQ,  
Arlington. As ORS: NBS, KYV, HWE, AVY. TYR is  
FAA's XYL. CU now is 4CU. JQH is moving to Stoughton.  
TBX, Norwood, is on 7 Mc. NMK is going back South and  
will be on from 4ETP. RHN, Readville, is on 7, 28, and  
144 Mc. 2VZE/MM is on 28 Mc. in Boston. Stations on  
144 Mc.: ALX, PBJ, TUP, GRC, Chatham, is on 3.5 Mc.  
Stations on 28 Mc.: THQ, Billerica; TBC, Winchester;  
SZX, TOG, TAK, TSI, Braintree; RDW, Sharon; QOC,  
OEF mobile, MX, KPX mobile, TSP, Chelsea; OUL, FRZ,  
Stoughton; SMO mobile, SQZ, Newton. KYO's XYL has  
her Novice call, TXD. He is building a new rig for 3.5 Mc.  
AYG is on 3.5-Mc. c.w. and 'phone. BGH is on 144 Mc.  
at Buzzards Bay. VE3AZV called on DJ and OIR when they  
were on Cape Cod on vacation. MVO, Reverse EC,  
reports a net going on 29,480 kc. Monday nights at 7:30.  
THT is Asst. EC. The South Shore Club held a meeting in  
August. 2GFI was a visitor. The Club also went on a Mys-  
tery Trip up to a park in Fitchburg. EMG has a Gonset 3-3  
for car and a BFO for c.w. work. DMS visited Maine and  
called on some hams. AVY installed a TBS-50 and tri-band  
Gonset in AJY's car. WU has new transmitter, his 5th.  
Has anyone seen BB's boat with "73 de BB" on the sail?  
SNW, of Cochituate, will be on 144 Mc. Five members of  
the Framingham Club went to the Portland Hamfest.  
HWE has a TBS-50A but gets on for short periods only.  
NBS has an a.s.b. exciter. The Braintree Radio Club held  
its monthly meeting with a good attendance. PIY is mobile  
on 28 Mc. SIX, JCK, and STA have Class A licenses. OLN  
is going mobile. SNZ is C.O. of Haverhill Flight of C.A.P.  
OLN is communications officer and STA and IWR are his  
assistants. RM spent some time in New Hampshire. EYI  
and his XYL lost their home in a fire up in Maine while on  
vacation. Newton had 7 fixed and mobile stations on for  
alert on Aug. 14th, manned by 15 club members; 22 mem-  
bers were on regular drill. KW, RGY, PIW, and PDN have  
signed up in the Net. NO is feeling FB now. AJY, of Fair-  
haven, has been recalled by the Army Air Force as a major  
in radar. LAZ has 600 watts on 3.8 Mc.; MUM also is on.  
TYP is a new ham in Beverly. JFS has new speech clipper.  
RCA is on 28 Mc. SHV moved to Lynn. ØJBB married one  
of FWS's girls. AWA reports that the 50-Mc. band is start-  
ing to pick up. DJ has 4 watts on. CK, DJ, CTW, and NWL  
worked AWA portable in New Hampshire. LSN and NWL  
have a QSO at noon. AWA is erecting 3-over-3 beam. KTU  
has taken a job as a radio operator on a ship. On Aug. 14th  
a communications test was held in Region 5. The main  
band was 28 Mc., but 144 Mc. was used in several places.  
The State bought a TBS-50 which was set up at Region 5  
headquarters in Milton. TWE is a new Novice ham in  
Squantum. Traffic: (Aug.) W1SS 196, THU 162, JCK 79,  
JFS 64, EMG 55, LM 40, PU 37, TY 33, HWE 10, AVY 8,  
WU 4, BB 2. (July) W1DMS 40, CTR 1.

WESTERN MASSACHUSETTS — SCM, Victor W.  
Paounoff, W1EOB — SEC: JYH. RM: BVR. West. Mass.  
Net meets on 3725 kc. Monday through Friday at 7 p.m.  
and 10 p.m. Your support is needed, gang. Try to spend a  
few minutes a week with the Net. BDV is back tending  
school after a long summer at York Beach. GZ reports  
code and theory classes in session at Region 9 Headquarters.  
MOK is rarin' to go after a slow summer. Along with the  
rest of us, RHU will miss his buddy, RZG, who took off for  
Yale early in September. COI spent much time this sum-  
mer looking for poles for beams. BVR has been busy re-

(Continued on page 78)

Be Sure of Your Installations . . .

Use *Aptitude-Tested* **MULTIPLE CONDUCTOR CABLE**

● You know what you are doing when you use Belden Multiple Conductor Cables—they're aptitude rated. They are designed to provide desirable electrical characteristics, and rigid control assures constant quality.

Specify Belden Radio Wires.  
Belden Manufacturing Co.  
4621 W. Van Buren St.,  
Chicago 44, Ill.

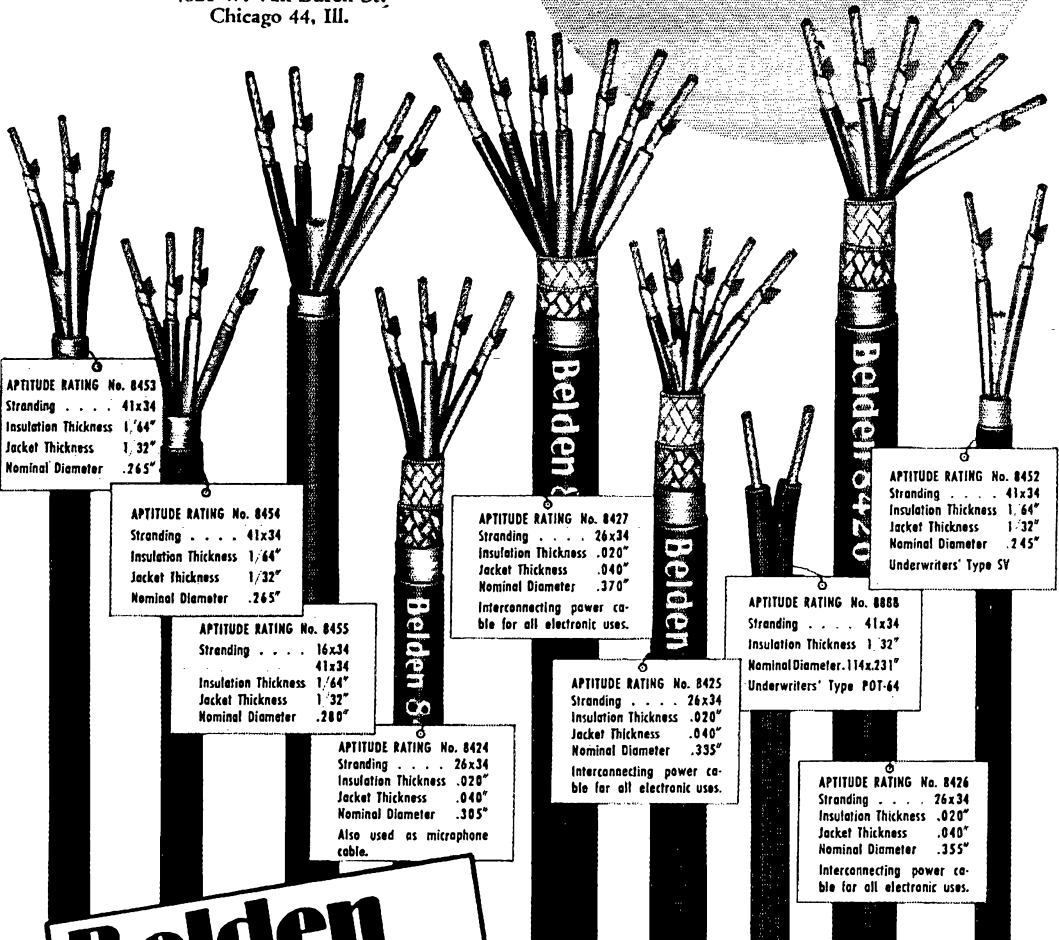

APTITUDE RATING No. 8453  
Stranding . . . . 41x34  
Insulation Thickness 1/64"  
Jacket Thickness 1/32"  
Nominal Diameter .245"

APTITUDE RATING No. 8454  
Stranding . . . . 41x34  
Insulation Thickness 1/64"  
Jacket Thickness 1/32"  
Nominal Diameter .245"

APTITUDE RATING No. 8455  
Stranding . . . . 16x34  
                          41x34  
Insulation Thickness 1/64"  
Jacket Thickness 1/32"  
Nominal Diameter .280"

APTITUDE RATING No. 8424  
Stranding . . . . 26x34  
Insulation Thickness .020"  
Jacket Thickness .040"  
Nominal Diameter .305"  
Also used as microphone cable.

APTITUDE RATING No. 8427  
Stranding . . . . 26x34  
Insulation Thickness .020"  
Jacket Thickness .040"  
Nominal Diameter .370"  
Interconnecting power cable for all electronic uses.

APTITUDE RATING No. 8425  
Stranding . . . . 26x34  
Insulation Thickness .020"  
Jacket Thickness .040"  
Nominal Diameter .335"  
Interconnecting power cable for all electronic uses.

APTITUDE RATING No. 8888  
Stranding . . . . 41x34  
Insulation Thickness 1/32"  
Nominal Diameter .114x.231"  
Underwriters' Type POT-64

APTITUDE RATING No. 8452  
Stranding . . . . 41x34  
Insulation Thickness 1/64"  
Jacket Thickness 1/32"  
Nominal Diameter .245"  
Underwriters' Type 5V

APTITUDE RATING No. 8426  
Stranding . . . . 26x34  
Insulation Thickness .020"  
Jacket Thickness .040"  
Nominal Diameter .355"  
Interconnecting power cable for all electronic uses.

**Belden**  
*Radio WIRE*

The *Aptitude-Tested* **LINE**

organizing WMN and 1RN for the coming season. AGM apparently is having trouble hauling his gear atop the high points that surround his new QTH at Shutesbury. QQQ took a flying vacation with some of the Worcester gang down to HH-Land. MUN did a fine job monitoring 3700-3900 kc. during the military maneuvers. A new lattice tower is being built at RO's. LFI and JWM have new 10-meter mobiles. QWJ now is an instructor at the Great Lakes Naval Station. It's a new 10-lb. daughter for OBU. WNITL is the first Novice I have heard of in our section. Welcome. JYH is coming up with advance alibis for allowing EOB to top him in coming contests—no place to put up an antenna, he says. Traffic: W1BVR 71, RIU 35, GZ 18, AGM 6, MOK 5.

**NEW HAMPSHIRE**—SCM, Norman A. Chapman, W1JNC.—The New Hampshire Net operates regularly Monday through Friday on 3685 kc. at 6:00 p.m. EST. All stations interested in traffic-handling are invited to check in. LDR has moved to Fort Lauderdale, Fla. Don wishes to be remembered to all his New Hampshire friends and the gang on the NEEN. Stations who worked 1P8AC and 1P8AH on the Island of St. Pierre, during the latter part of August, possibly did not know they were New Hampshire boys. PVK, Sandy Cole, Littleton, and ex-ORN, Al Martin, from Whitefield, QHS, NAZ, and QKA are mobile equipped on 28 Mc. CRW made BPL again this month. Attention Novice Class license holders in New England; the first Novice traffic net has been established in New Hampshire. The NNHN operates nightly at 5:00 p.m. EST on 3710 kc. This will afford a fine opportunity for Novices to get their message-handling experience. Those interested may contact TBS or CRW. Your SCM solicits your interest in forwarding monthly reports, especially Club secretaries, to him on the first of each month. Applications for the SEC vacancy are desired. Traffic: (Aug.) W1CRW 601, MCS 44, JNC 30, QJX 5, (July) W1SAL 17.

**RHODE ISLAND**—SCM, Roy B. Fuller, W1CJH.—SEC: M1J. RM: BTY. PAM: BFB. The Rhode Island Net (RIN) meets Monday through Friday on 3540 kc. at 1900. The Newport County Radio Club held its semi-annual election and installed the following: TRX, pres.; SAO, vice-pres.; GQQ, treas. The Club held its picnic this year at Miantonomi Park, with thirty-five members and their families and friends attending. NAARO has resumed its emergency net on 29,080 kc. at 2000 on Mondays. NAARO has formed a bowling team to compete in the local league, but challenges any club to a home-and-home match within an evening's drive. KNE is attending school at Norfolk. BFB is building a new exciter but still is active with the old rig. NCX will appear on c.w. this fall. QBZ is active trying to get 28 Mc. to open in the daytime. OHR has moved to Syracuse.

**VERMONT**—Acting SCM, Raymond N. Flood, W1FPS.—Members of the Tri-County ARC hope you had a bang-up time at the Brattleboro Hamfest and took home a good prize. I note that we have a new club in St. Johnsbury. Maybe next year you will want to put on the State Hamfest. Off to a bad start, new-comer Ralph S. Noyes, TXY, ended up in the hospital at Bellows Falls when an antenna pole he was erecting fell on his leg and broke it in nine places. Watch out it doesn't happen to you. Al Zackey, TYI, is a new ham in the Brattleboro Area. SIO is having YL QRAM. AXN reports VTPN was very active all summer. FB, OMS, AVP must have a still in his shack, judging from all the company he has. He also is MARS A1AVP now. Only five reports were received this month. If it's activity report cards you need just let me know and some will be sent you. Traffic: W1OAK 51, AVP 42, RNA 19, AXN 18, FPS 9, SPK 7.

## NORTHWESTERN DIVISION

**IDAHO**—SCM, Alan K. Ross, W7IWU—Pocatello: I Newly-appointed EC is BDL. Mobile frequency is 29.6 Mc., with BDL, NOG, and KSS active. Hayden Lake: EC FIS is looking for more activity among the gang for fall and winter. Pierce: OXL has applied for AREC membership, having reported a local forest fire on 2207 kc. (CTPA frequency) when phone service failed. Boise: The Gem State Radio Club's annual hamfest had a Hidden Transmitter Hunt on 29 Mc., which was won by DOH. A picnic and auction followed. DX attendance was OQT from Twin Falls. SHN decided renting was on the constitution so he bought a house. IWU worked 1BDI on 7-Mc. c.w. with mobile rig, with the help of GHT. 1BDI was on with his home rig. There was not much news from you fellows for this report, so let's have some. I am interested in what bands you operate so I can try to contact you. Traffic: W7GHT 94, NH 44, LQU 26, JL 12, FIS 6, IWU 4.

**MONTANA**—SCM, Edward G. Brown, W7KGJ—Montana State Net activities started again September 1st with few members checking in. However, we have hopes for a busy season with many new net members. Shut-in LCM was interviewed by program scouts and the interview will be broadcast on the Voice of America program. The time and date of the broadcast is not known. News is lacking this month as we have not received an activities report from anyone for the past two months. Put the fish pole aside for a few moments and drop us a post card with a little news of your doings and plans. The Billings gang had a very in-

teresting display booth at the local fair. Traffic: W7KJG 587, KUH 171, KGF 123, CVQ 2.

**OREGON**—SCM, J. E. Roden, W7MQ—AXJ is expecting a new telephone pole upon which to mount some of his new skyhooks. OVO made a visit to Portland where he had an FB visit with ESJ and AJN. LXR is heard frequently on the OEN 'phone net. NNQ, who was engineer at KWRC, has left Pendleton for Seattle. ESJ finally has broken into the ranks of 'phone, one of the last of the brass-pounding gang to try a little modulating at times. He can be heard on OBN 'phone net, but also is much involved handling traffic via c.w. AJN, the net manager for OSN, the fine Oregon c.w. slow-speed net, is asking for new and old check-ins to start the fall activities and also will welcome any stations wishing to help out as Net Control. GNJ is new statistician for the OEN and will compile monthly data as to the number of daily check-ins, traffic handled, and contacts made. The material as compiled will be published in the *Netter*, official organ of the OEN. This publishing work now is being done by BDN, the OEN manager. Thanks are due BWD for his work in previously doing this publishing. He now is relinquishing it because he is leaving Oregon to reside in California. It would be appreciated if a few more reports as to station activities can be received. Traffic: W7TH 105, HND 101, AJN 91, MUG 65, II 63, GJN 30, AXJ 29, KTG 29, NLJ 29, JKU 26, JRU 26, BDN 21, BWD 17, HJU 17, ESJ 14, OIT 13, OVO 9, NOB 8, NUR 4.

**WASHINGTON**—SCM, Laurence Sabring, W7CZY—SEC: KAA. RM: FIX. PAM: NRB. JZR acquired an SX-28 receiver and says that it works better than his Command receiver. LQX has emergency power available for 150 watts on all bands. ETO spent a vacation in Canada. LVB now is Class A. A new Novice in Sedro-Woolley is WN7PQT. CWN also vacationed in Canada. JPC has mobile on 3.8 and 28 Mc. FWD is giving code practice for Novices on 7218 kc. The Totem Net has been overhauled and is ready for business. NWP revolutionized his station. (Probably jet-powered now). EHQ has worked over his antennas. EAU checks into TC RN and has a 33 1/2-foot vertical ready for long-haul traffic on 7 Mc. The WW Valley Amateur Radio Assn. held a field day and picnic at Pioneer Park Sept. 9th. They demonstrated portable and mobile equipment under simulated emergency conditions. There were 150 hams and families from Oregon, Washington, and Idaho attending. BYK is out of the Navy and back with CAA at KCJ receiver station at Marysville. PHC, at Orting, has been appointed OO. Bill is ex-W2CXL-XBB, at Ft. Monmouth from 1923-26, and was one of the founders of the AARS. The Bremerton gang under HAD and SSQ joined in on the CAP northwest search and rescue tests and provided communications on 28 and 144 Mc. for control tower to planes and as a result won a gold cup for the Bremerton Wing for the best organized and conducted communications unit. The Capitol City Radio Club of Olympia now is an ARRL affiliated club. NJ worked mobile from Sultan to Bremerton, 112 miles. AUS is happy with his new Collins 75A-2, won at the National Convention. P1V and P1Q are new on 28 Mc. OZG is on 3.8-Mc. mobile and likes it fine. MEU is the proud owner of a 75A-2. OHQ has boosted his power to 500 watts. NWI now is Class A. The North Seattle Radio Club honored CV for winning both ends of the code contest at the National Convention. HRC has a new location, which proves to be better for radio. LBI is home from Korea. 9EH visited DND and met KZP, VI, and PGY at BA's. Traffic: (Aug.) W7IOQ 645, CZY 591, TH 188, FRU 184, BA 130, FIX 105, LVB 66, FWD 49, LFA 46, NRB 46, KCU 36, EAU 34, JPC 28, JZR 26, MBY 24, EHH 22, ETO 21, NWP 18, APS 17, OS 15, OEB 14, JWJ 13, CWN 12, GVG 10, FNC 8, GAT 7, HDG 7. (July) W7JZR 22, ETK 18.

## PACIFIC DIVISION

**HAWAII**—SCM, John R. Sanders, KH6RU—The Maui Club held a local DX contest for one week end. Scores: AEX 88, MG 72, PM 48, DK 44, EL 37, AFT 24, AGU 16. The Honnobile Club will hold a big "three ring" transmitter hunt in November. HARC had a talk on Propagation Prediction by AED of CAA. KA is home from Truk Is. ADY won the Mobilers' Treasure Hunt. ADK is building a VFO Mobile Unit. EM has new 32V-2. BA attended West Coast IRE meet. IJ vacationed in Honolulu. ON is struggling with sky-hook problems. RU has joined the 40-or-so mobiles now operating on Oahu. *Far Pacific Area*: KG6WC has departed Koror Is. KG6FAA now skeds Official Bulletins at 0900 GMT, Mon., Wed., Fri. on 14,127-kc. c.w. and invites reports of reception. KG6AAD has closed down, pending transfer to U. S. KG6AAE reports 'phone patching on the increase with 195 handled in two months. KG6AAV had 61 in August. KG6AD has new 65-ft. high rotary. KG6AAV skeds the Far East Emergency 'phone net on 14,250 kc. Traffic: (Aug.) KG6FAA 3921, AA Y 744, PAB 529, AAE 399, AAD 7, KH6ADK 7. (July) KG6AAE 113.

**NEVADA**—SCM, Carroll W. Short, jr., W7BVZ—SEC: JU. ECs: HJ, JLM, JVV, KJO, KOA, MBQ, TJY VO, and ZT. RM: PST. OPS: JJO. Nevada State frequencies: 3660, 7225, and 29,360 kc. QAY, a Reno attorney, still is working with State officials getting the license plate  
(Continued on page 80)



# Here's Centralab's **NEW** Ham Switch

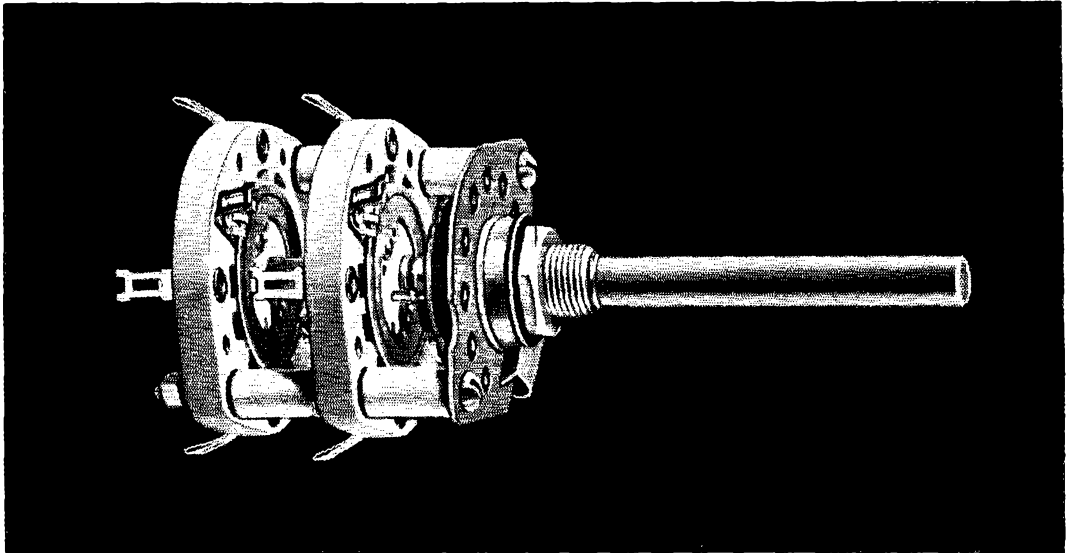

**If you want a rugged low-capacity rotary selector switch  
for rapid band changing during peak traffic ...  
here's the switch for your rig**

## **CHECK THESE FEATURES**

- Use with medium power, transmitter exciter units — up to 1000 Volts. Inputs up to 150 W. Switch can carry 15 W. a.c.
- Use in combinations — up to 5 sections, 5 poles.
- Two to four positions.
- 90° positive indexing adjustable stop.
- Silver plated, spring brass clips and contacts for low loss and low contact resistance.
- Grade L5 Steatite sections and spacers mean higher break-down to ground rating.
- All metal parts — except clips and contacts — cadmium plated.

Today — with more and more rigs built for emergency and civil defense operation—as well as routine traffic — you'll want the high efficiency and durability of this new Centralab Ham Switch on your rig. You'll find you'll get the finest, rapid, band change you've ever experienced — with this new Centralab Ham Switch — built specifically for this job.

And don't forget the other fine Centralab parts — High Voltage Capacitors for TV (10 — 20 — 30 KV), TC & BC Hi Kaps, Printed Electronic Circuits, plus standard and custom controls. See your jobber or write direct for new catalog 27.

# Centralab

Division of Globe-Union Inc.

912 East Keefe Avenue

Milwaukee 1, Wisconsin

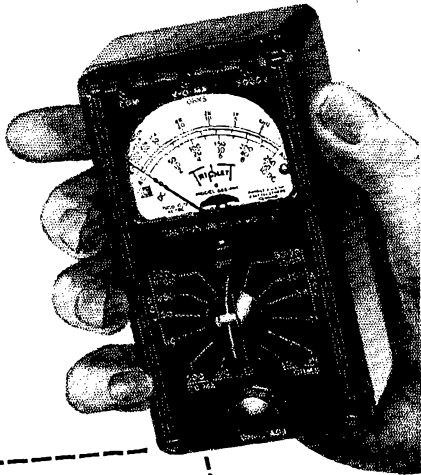

**Mighty  
Midget**

## of the Service World

Mighty Midget of all the V-O-M's! Slips into your pocket for making spot-analyses of D.C. and A.C. Voltage, Current, and Resistance. Has quick-reading scale, only one switch, 50" leads — alligator clips, banana-type jacks, self-contained snap-in type batteries, and plenty of ranges on the one-knob 14-position switch. Remarkable stability on voltage ranges. Completely insulated molded case. Get yours today! Triplet Electrical Instrument Co. • Bluffton, Ohio, U.S.A.

**Model 666-HH Volt-Ohm-Milliammeter**

ONLY \$24.50 AT  
YOUR DISTRIBUTOR  
(Price Subject to Change)

FOR THE MAN WHO TAKES PRIDE IN HIS WORK

# Triplet

TRIPLET ELECTRICAL INSTRUMENT COMPANY • BLUFFTON, OHIO, U.S.A.

deal straightened out. JLN is active again from Boulder on 7 Mc. BJY is planning an 813 final. MRN got his Collins receiver after a 14-month wait. He's on 7225 kc. JU is on 3.5 and 7 Mc. with kw. Collins. PST is active again after antenna trouble. NRU visited JWV on the way back to Ely from Las Vegas. OXX has his 32V-1 on 14-Mc. 'phone. KEV lost both antenna masts in a wind storm. KIO had mobile in his car while on vacation but they took his mike at the Canadian border! OUQ is on 7 Mc. and reports IKA moved to W6-Land. MBQ has Advanced Class ticket now and is on 3842 kc. Bob is building a new rig with a 4-125A final. MJB is on 7 Mc. in PM's. PCH is on 7 and 14 Mc. and says 28 Mc. is dead in Elko. C U on 7225 kc.

**SANTA CLARA VALLEY** — SCM, Roy I. Couzin, W6LZL — AEV, our SEC, reports that general inactivity for the summer vacation period has made organization work slow but an increase in activity on 3.8-Mc. mobile was noted. This means that too many of us are using the Korean situation as a barometer, which does not give the SEC much to go on. An all-out effort must be made by all of us to do the job right. Get something on to check in with. Let your EC know that he has someone to rely on in an emergency of any scope. NW now is running two code transmissions per week, which cuts into traffic work. HC is snowed with business on the MTN Net. QIE received endorsement as EC. VCG received endorsement as OES. The SCCARA appointed committees for participation in the Santa Clara County Fair, which opened Sept. 10th. VCG is getting active again on 2 and 420 Mc. He also is working with the SARO gang on 10,000-Mc. gear. He says he would like to see more activity on the v.h.f.-u.h.f. bands. Lt. Edmonds, of the Naval Electronics School at Monterey, gave a fine talk on mobile antennas at the August SCCARA meeting. Well, fellows, again I will have to say, how about a card on the first of the month to enlighten my efforts in getting this report together. I would like to hear from the club secretaries on future club plans. Traffic: K6WAE 524, W6BPT 166, YHM 160, HC 85, NW 22.

**EAST BAY** — SCM, Ray H. Cornell, W6JZ — Greetings to all members of the East Bay section. As your new SCM, I hope to be able to serve you whenever and wherever possible. You will get as much from ham radio as you are willing to give. With your cooperation it will be possible to build an active, progressive section. I invite your participation in any of the many phases of ham radio in which you may be interested. With civil defense uppermost in the thoughts of many of us, we should build an Emergency Corps second to none. We need an SEC and plenty of ECs. We need a section net — better yet a tri-section net. Why not write for an appointment as ORS, OPS, OO or any of the others, and how about a few volunteers to work on the formation of a net? To you who are already holding an appointment, don't forget to send me your report promptly on the first of the month. CJI is moving to a new hill-top QTH in Richmond Annex with an eye to two-meter possibilities. TI is taking a well-earned rest after 14 years as SCM. He has worked 200 countries! DNX is working on his new 500-watt rack and panel job, recently acquired. PLB is on 28-Mc. 'phone after an 18-month layoff. NGC still is active as OO. CTL enjoyed a vacation on Eel River. QDE has TVI trouble. IVY received his Advanced Class ticket. Congrats, OM. The Central California Radio Council has 10 clubs now on its roster. Meetings are held on the first Wednesday of each month. Purpose of the organization is to correlate and disseminate information pertaining to all problems common to the radio amateur, such as TVI, civil defense, traffic routing and handling, etc. It is hoped to have all clubs in the area actively participating in the near future. EJA reports activity around Richmond limited because of band conditions and summer vacations. FDV got married and moved into a new home. YDI finds little time for ham radio. He's QRL business. WOJ is active on 7 Mc. How about some reports from Solano and Lake Counties? VSV and aides put on a bang-up demonstration of ham TV at Seattle. Traffic: W6JZ 372, NGC 13, EJA 6, TI 4.

**SAN FRANCISCO** — SCM, R. F. Czeikowita, W6ATO — Phone: JU 7-5561. SEC: 6NL. Phone: PL 5-6457. The biggest news of the section comes from the Eureka Area, where EC SLX and a number of the Humboldt County group were very valuable to the Forest Service in handling the bulk of the radio communications during the serious Three Creeks Forest Fire, which devastated 3600 acres of timber. Amateur operators and equipment, in conjunction with Forest Service equipment, did a magnificent job, and credit was given where it was so richly deserved by newspaper articles praising the amateur operators, in the *Humboldt Times* of Aug. 29th and the *Humboldt Standard* of Aug. 31st. Among those assisting were SLX, ZZE, HBI, KAR, ZZK, BME, KXH, JSY, KTV, DQA, and 7MHT. The HARC was host to ZK2AA and W7RT at a banquet. The visit of Bill Scarborough and John Gruble was the subject of a newspaper photo as they were being welcomed by CWR, president of the Club. The Humboldt Amateur Radio Club meets the second and fourth Fridays in the YMCA rooms, Municipal Auditorium, "E" St., Eureka. *Marin Area*: EC: KNZ. Tamalpais Radio Club EC: ZUB. OZC now is located in his new quarters. ZUB and YME handled the radio communications with their mobiles for the V.F.W. Parade in San Anselmo. Ccl. Alan

(Continued on page 82)

# MALLORY HAM BULLETIN

**Simplicity and Rugged Performance  
are featured in the**

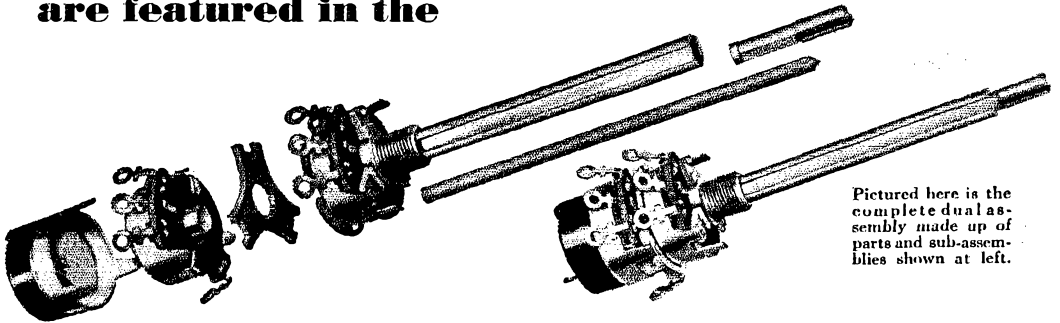

Pictured here is the complete dual assembly made up of parts and sub-assemblies shown at left.

## **... Mallory Dual Midgetrol\* Volume Control**

Every so often Mallory engineers come up with a non-amateur radio component which is so outstanding and useful in its application, that we can't resist the opportunity to do a little justifiable bragging about it in the HAM BULLETIN. *The Mallory Dual Midgetrol Volume Control* for radio, auto radio, television, and electronics replacement is a prime example of just such a component, because this control is truly something new and different in its field.

In one stroke, the Dual Midgetrol has solved one of the most severe problems ever faced by the professional radio-television serviceman . . . that of being able to duplicate quickly and effectively the several hundred different dual controls found in modern radio and television sets, without the expense of maintaining inventories of exact replacement controls.

The Dual Midgetrol does this by introducing a selective assembly style of construction whose front and rear control sections are supplied as separate integral units in a variety of resistances, tapers and taps. The serviceman selects the front and rear sections needed and then spends a few minutes coupling them together to produce a finished unit which looks, feels, and works like a perfect original. A small inventory of just 30 front sections, and 30 rear sections, guarantees duplication of the electrical characteristics of any one of 900 different dual controls at a moment's notice. With associated hardware over 10,000 different dual controls can be made.

Something of the wonderful simplicity of the Dual Midgetrol may be seen in the above illustration. Note in particular how each part has been designed to fit together easily and smoothly without solder or special tools of any kind. Yet, in spite of its utter simplicity, it has demonstrated unusual capability for rugged performance.

Practically any kind of dual control used in radio, television, or other electronic equipment may be duplicated with Midgetrol parts. Concentric shaft duals, single shaft duals, large bushing duals, and wire-wound carbon combinations are a cinch with the Midgetrol. The multitude of resistance values, taps and tapers available in front and rear sections assure matching the electrical characteristics of virtually all original set controls.

The amateur, designer or model shop technician will also find Mallory Midgetrol parts handy and useful for making up those special controls not readily available.

The same Mallory Distributor where you now buy Mallory FP electrolytic and Plascap\*\* plastic capacitors, also has the Dual Midgetrol Volume Control. Ask him to show you one of these controls. You'll see a swell example of proven Mallory craftsmanship.

\*Reg. U.S. Pat. Off.

\*\*Trade Mark

**P. R. MALLORY & CO., Inc.**  
P. O. Box 1558  
**INDIANAPOLIS 6 INDIANA**

**P. R. MALLORY & CO. Inc.**  
**MALLORY**

# for the high-power man!

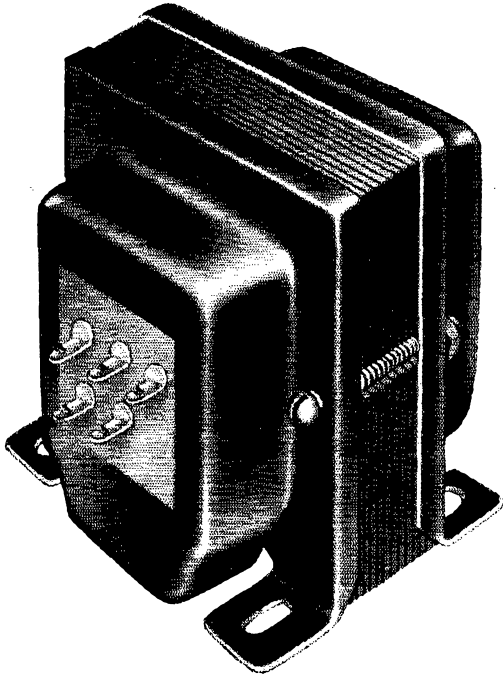

## MERIT HIGHPOWER Filament Transformer P-2943

Designed for highpower use in both Amateur and industrial applications.

Specifications: Sec. Volts, 5—Sec. Amp., 30—Insulation Volts, 3000—Center tapped with primary taps for 110-115-120 volts, 60 cycles—Dimensions, 3 $\frac{3}{8}$  H. x 3-3/16 W. x 4 $\frac{3}{8}$  D.—DL Mounting . . . Will handle a pair of 250 TH's . . . 4—250 A's . . . 4—125 A's . . . 4—400 A's, etc.

Net Price — \$6.60

**Merit Transformer Corporation**  
4427 North Clark Street  
Chicago 40, Illinois



BURTON BROWNE ADVERTISING

Whitaker, 6SG, president of the Marin Radio Amateurs, has been commissioned head of the Civil Air Patrol for the Area. 1YJ is building a new rig with p.p. 813s and 805s Class B. The Marin Radio Amateurs Club meets the second Friday in the Engineering Lecture Room of Marin College, Kentfield. The Tamalpais Radio Club meets at 232 Mirimar, San Rafael, on the third Friday. *Santa Rosa Area:* EC: IEN. The Sonoma County Radio Amateurs now has its own call — W6LJF, the trustee being DTV. PSN now has a half-gallon on 75- and 20-meter 'phone. The SCRA is scheduled to provide the radio communications for the American Legion Armistice Day parade in Cloverdale on Nov. 12th. WOR is putting up a 30-foot steel tower for his 2- and 10-meter beams. The 2-meter emergency net is active on 145.35 Mc. at 8 p.m. Tuesdays with DTV as Net Control. Contact is requested with Bay Area stations at this time. The Sonoma County Radio Amateurs meet the first Wednesday at the Tap Room of the Grace Bros. Brewery, 2nd St., west of the Freeway. *Santa Rosa, San Francisco Area:* EC: BYS. Asst. EC: JWF. EYJ, of the SFRC, took third prize for mobiles at the Seattle Convention. Among the distinguished guests at the August meeting of the SFRC were G. W. Bailey, 2KH, president of the American Radio Relay League; Kenny Hughes, 6CIS, Pacific Division Director; John Gruble, 7RT, Seattle Convention Chairman; ZK2AA, Bill Scarborough, the Postmaster and Radio Supt. of Niue Island, Midway, between the Fijis and Samoa. TVI tips: Shield your final and run the output from the final link THROUGH COAX TO A COAX FITTING MOUNTED ON THE SHIELD. The San Francisco Radio Club meets the fourth Friday at 1641 Taraval St., and the High Frequency Amateur Mobile Society meets the second Friday at the Red Cross Building, 1625 Van Ness Ave., San Francisco. Traffic: W6FYJ 25, SWP 22, ATO 6, BIP 6.

**SACRAMENTO VALLEY** — Acting SCM, Willie Van de Kamp, W6CKV — *Northern Area:* No report was received from YNM. Asst. SCM, *Central Area:* The GERC provided communications for Chico-San Mateo Air Race. GUX obtained Class A and radiotelephone 1st-class licenses and is working in a h.c. station at Fort Bragg. 2EQZ/M bemoaned the lack of activity on 28 Mc. out West, as he passed through Chico. VZKY is going 10-meter mobile. The Gyro Net keeps the high end of 160 meters alive. The annual GERC Barbecue was a big success. *Southern Area:* There was no report from ZYV. Asst. SCM.

**SAN JOAQUIN VALLEY** — SCM, E. Howard Hale, W6FYM — SEC: FYM. RM: JQB, ECs: BCL, CQI, EHN, FIP, GCS, VRF, GJO, HZE, and JPU. ORS: HU, JQB, and LRQ. OBS: GS, EXH, GRA, and OHT. OES: RJE and UWY. OOs: FKL and JQB. GJP has moved from Taft to Los Angeles. Reed did fine work as RM and Manager of SJVN and we are sorry to lose him. JQB, of Leevining, who did an FB job in the organizing of SJVN, has been appointed RM to succeed Reed. New officers of the Turlock ARC, elected at the first meeting of fall season, are: GIW, pres.; EQO, vice-pres.; SQR, secy.-treas.; QER, sgt. at arms. Three stations in the section are working on 420-Mc. TV rigs. They are UWY, CQI, and FYM. QUE, at Stockton, has been acting as NCS of SJVN since the departure of GJP. SJVN still is meeting on 3525 kc. at 1900 Monday through Friday. During August SJVN met 17 times and handled 22 messages with a total attendance of 71 check-ins. No reports were received this month from the Bakersfield, Fresno, or Stockton Areas. Now that fall activity is increasing I would appreciate receiving reports from all areas of the section by the 7th of each month. AXI, in Modesto, now is on 144 Mc. EXH and his XYL, GQZ, got locked in on top of Mt. Diablo during the recent two-meter expedition. Vic reports it got a little chilly about four in the morning. For this feat they won the Stockton Club "Boner" Trophy. Traffic: (Aug.) W6JQB 35. (July) K6FAJ 107, W6GJP 15.

### ROANOKE DIVISION

**NORTH CAROLINA** — SCM, J. C. Geaslen, W4DLX — SEC: ZG. RM: AKC. PAM: NZL. Well, fellows, this is my first report since being elected SCM. Three written reports were received as well as several via air. IFR reports that DCQ is with the Navy at Norfolk. LPE is out of the Navy and is in Charlotte and on 75-meter mobile. SVD has a new Globe Champion on 28-Mc. 'phone. WN4TTF is Technician Class now. OEL, Gary, and RRH, Morganton, are Advanced Class. QDA, Shelby, and DDT, Rutherfordton, have joined the Tar Heel Net. DCG, of Tarboro, sends a very nice report. He has trained, given technical advice, and furnished parts for five new Novices and he is proud of them. Listen for them on 3.5-Mc. c.w.: Cecil Bachelor, WN4TIQ; Mason Fritar, WN4TJU; Jim Arent, WN4TIR; Bucky Fountain, WN4TIV; and Mack Ruffin, no call yet. The XYL of PTM, in Rocky Mount, is awaiting her Novice call. SYG is a new ham in Rocky Mount working 3.5 and 7-Mc. c.w. as well as 28-Mc. 'phone. RRH is very busy working four nets. He is Net Control on the Atlantic Net, 1895 kc., works Great Lakes Net, 1885 kc., MARS Army Net, and MARS Air Force Net. Come on down to 3.5 and 3.8 Mc. and give the Tar Heel 'phone and N.C. c.w. nets a whirl. Riley, OQQ is a new OES. How about  
(Continued on page 84)

# 1

## *always stands out!*

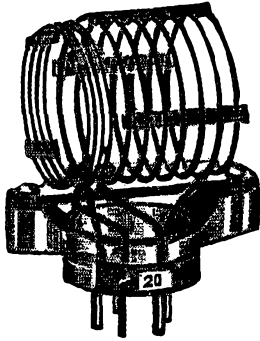

Proved by test, the Bud 75 watt transmitter coil with Polystyrene Base gives you improved performance, better appearance and long lasting quality. Polystyrene has proven superior to porcelain for many reasons, including far greater resistance to breaking or cracking—the Q of the coil is exceptionally high due to the extremely low power factor—pins are moulded in place and always remain perfectly aligned—sharp corners are eliminated, no danger of chipping—transparency adds to smooth, modern appearance.

Bud 75 watt coils are furnished with fixed or adjustable center links and fixed or adjustable end links. They are air wound, mount into 5-prong tube sockets and can be used on bands from 6 meters to 160 meters. Some are designed for use in circuits using Pentode tubes with high output capacity.

See the complete Bud line at your local distributors.

### BUD RADIO INC.



2118 East 55th Street  
Cleveland 3, Ohio

**FREE** This colorful decal of the ARRL safety code which you can mount on your rig. It will be a constant reminder to use care and common sense when working around your transmitter. You can get this decal absolutely free by sending a stamped, self-addressed envelope to Bud Radio, Dept. QST-11, 2118 East 55th Street, Cleveland 3, Ohio. Do it today. It might save you from death or serious injury.

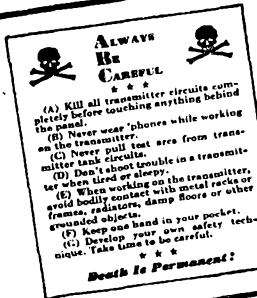

USE THIS HANDY LIST OF  
BUD PRODUCTS

- \*Add-a-Racks
- Aerial Mounting Brackets
- Angles
- Antenna Towers
- Bottom Plates
- Boxes
- Brackets
- Cabinets
- Cases
- Chassis
- Chokes
- \*Code Practice
- Oscillators and Monitors

## coils

\*(Polystyrene Base)

- Coil Links
- Condensers
- Couplings
- \*Dial Lock
- Dials
- Feeder Spreaders
- Frequency Calibrators
- Insulators
- \*Miniboxes
- Meter Case
- Meter Panels
- Panels
- Plugs
- Racks
- Reducers
- Shaft Extensions
- \*Test Prods
- (Vise-Grip)
- Test Leads
- Wave Traps
- Wireless Phone
- Oscillators

\*These items designed and manufactured exclusively by BUD.

Buy THE X'MTR  
you will USE  
FOR YEARS



## Harvey-WELLS BANDMASTER

40 to 50 WATTS

THE WORLD'S MOST VERSATILE X'MTR FOR MOBILE OR FIXED OPERATION, NOVICE OR EXPERT  
For Hams, Business Organizations, Government Dept's, Emergency Services and Civilian Defense.

### BANDMASTER SENIOR . . .

A complete ready-to-go phone transmitter including new crystal-oscillator—vfo switching circuit—Phone or CW—100% break-in-operation—Eight bands: 80, 40, 20, 15, 11, 10, 6 and 2 meters—No plug-in coils—completely wired and tested. Tubes: 6AQ5 Crystal Osc., 6AQ5 Buffer Mult., 807 Final, 2-6L6 class B Modulators. Sturdy Steel Cabinet 12" x \$111.50 8" x 8"

### BANDMASTER DELUXE . . .

The last word in a versatile small transmitter for home or commercial use. Thousands now in use in foreign countries for important applications and now adopted by many of our communities for civilian defense. Has built-in three tube preamplifier for use with crystal mike PLUS all the features \$137.50 of the Bandmaster Sr.

REMEMBER—Your Bandmaster is protected by a continuing Technical Bulletin Service mailed regularly to all registered owners. It provides methods of adding new features as they are developed. No Bandmaster becomes obsolete or outmoded.

Send now for latest catalog

**Harvey-WELLS ELECTRONICS, INC.**

SOUTHBRIDGE, MASSACHUSETTS  
Export Dept. 13 East 40th Street, New York

more of you guys who work v.h.f. reporting in and making OES? There must be some of you working 50, 144, or maybe 420 Mc. Let me know about it. Let's have a big active season this fall and winter, gang. You don't have to be a member of ARRL to send in reports, but you should be an ARRL ham anyway. Traffic: W4RRH 56, DLX 6, REZ 4.

SOUTH CAROLINA—SCM, Wade H. Holland, W4AZT—CPZ has a 450T on 28 Mc. now and that makes him the top high power on that band in S. C. BSS is headed back to Charlotte and the S. C. gang will miss John. N4TGH now is on 144 Mc. and also on 3749 kc. BIZ has graduated his mobile from 7-Mc. c.w. to 3.8-Mc. phone. SXC is a new ham at Congaree Air Base and reports on 75-meter 'phone net. HWZ has added 40 more feet to his tower and has a 10-over-20 combination beam under construction. DCE still carries on his successful daily schedule with JA2KW and any traffic for the Far East can be forwarded to DCE via the 75-meter 'phone net or the 80-meter c.w. net, or any of the gang in Charleston. The September Ham Picnic in Sesqui-Centennial State Park near Columbia was a great success, with a number of Georgia and North Carolina hams present in addition to the South Carolina gang. ADE is back in Smoaks and is on occasionally on 75-meter 'phone. His reason for such little operation is a good one—the NYL recently presented him with daughter No. 2. The SCM would like to hear from the other Novice and Technician Class license holders with a list of bands worked so they can be published to help get the fellows together. Traffic: W4ANK 295, DCE 93, AZT 34, FM 10, CPZ 5.

VIRGINIA—SCM, H. Edgar Lindauer, W4FF—the VFN portion of the Virginia gang got under way for the new season with an initial turnout on the first QNI beginning Sept. 10th when 45 stations checked in. An average QNI of 35 to 40 stations has been maintained since opening night. VN, on the other hand, has consistently tried to crack the VFN attendance record but has only succeeded in wearing out the seat of their individual trousers in the squirming process. HI. Total activities got officially QSO on Monday, Oct. 1st, as follows: VSN, 6:30 P.M. EST.; VN, 7:00 P.M. EST.; and VFN, continuing at 7:30 P.M. EST. VSN and VN operate as usual on 3680 kc., with VFN resuming the official frequency of 3835 kc. after giving way for a short duration for military use of that frequency earlier in the summer. Good news is often shadowed by a little bad. The gang has just learned that Major LAP, USAF, who has been a stalwart RM and a guiding inspiration on how to spark communications in true ham spirit, is leaving for Europe at the persuasion of Uncle Sam. Best of luck "BL," and many thanks for what you have taught us in communication effort and "know now." PXA is a new ORS and will be heard from with RM responsibilities on VSN. QDX expects to be ready with VFO to take over some of the work with EAN, CAN, and 4RN. FF finally thumped through on Sept. 11th following an absence since April 21st. NQV reported to Princeton to take care of that scholarship won over Fairfax High School colleagues. KYD expects to be net active this season. JTG's new QTH is Alexandria, Va., all because his Uncle Sammy needed him at station WAR. Look for him on 3.8-Mc. 'phone a.s.b. Traffic: W4PWX 70, PXA 16, KFG 6, LK 5.

WEST VIRGINIA—SCM, Donald B. Morris, W8JM—ZFI, publicity manager of KVARA Radio Club, reports that the Club now has an emergency station in the ARC Bldg., Charleston. EVR is planning a State Radio Council to be held in Charleston. AUJ devotes all his time to traffic-handling. ALG visited W. Va. amateurs while on vacation. BVK has new VFO and is ready for net operation. DFC continues activity in 8RN. BWD and VCA report good results on 50 Mc. 3VZD visited GBF and attended the Stone-wall Jackson Radio Club picnic. FUS is active on 3.5 and 3.8 Mc. and will give you the only contact available with Gilmer County. Activity still is needed in Morgan, Jefferson, Pleasant, Wirt, and Lincoln Counties. GBF and PZT are rebuilding for the fall season and OO activity. The MARA has concluded a successful code and theory class under the direction of PZT, GBF, SMV, and Ken Parks. JM will be operating portable this season throughout West Virginia on 3770 kc. with low power and will be in rare counties for WACWV (Worked all Counties in West Va). BTV is keeping sked with ZL2AFZ on 14 Mc. ZL2AMY visited BTV for three days while on a trip to U. S. All new licensees in West Virginia, any class of ticket, are requested to report the news to your SCM. Traffic: W8AUJ 88, DFC 27, BTV 22.

### ROCKY MOUNTAIN DIVISION

COLORADO—SCM, M. W. Mitchell, W0IQZ—SEC: C. KHQ. Asst. SEC: PGX. RMs: LZV and ZJO. The summer slump is very noticeable in the receipt of cards this month—two. ZJO makes BPL on deliveries this month. He had bad luck with the power supply gradually blowing piece by piece after putting in higher voltage power transformer on the pole. His power transformer was the first to go but, thanks to IC, another one was rushed to him in time for him to stay in the running. KHQ has blown himself to a '41 Chevy and promises to get around and see the fellows more often. His new rig puts in a much better signal now than ever before. Yours truly has a Conset 3-30 in the car and

(Continued on page 86)

# New 1952 HEATHKITS

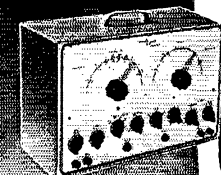

**Heathkit**  
TELEVISION  
GEN. KIT \$39.50



**Heathkit**  
ELECTRONIC  
SWITCH KIT \$19.50



**Heathkit**  
AUDIO GEN.  
KIT \$34.50

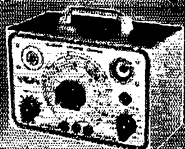

**Heathkit**  
CONDENSER  
CHECKER KIT \$19.50

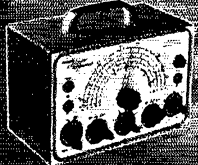

**Heathkit**  
R. F. SIGNAL  
GEN. KIT \$19.50



**Heathkit**  
A. C. VOLTMETER  
KIT \$29.50



**Heathkit**  
SQUARE WAVE  
GEN. KIT \$29.50

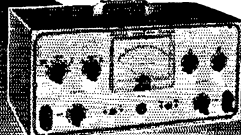

**Heathkit**  
INTERMODULATION  
ANALYZER \$39.50



**Heathkit**  
AUDIO FREQ.  
METER KIT \$34.50

## 5" OSCILLOSCOPE KIT

- New "spot shape" control for spot adjustment — to give really sharp focusing.
- A total of ten tubes including CR tube and five miniatures.
- Cascaded vertical amplifiers followed by phase splitter and balanced push-pull deflection amplifiers.
- Greatly reduced retrace time.
- Step attenuated — frequency compensated — cathode follower vertical input.
- Low impedance vertical gain control for minimum distortion.
- New mounting of phase splitter and deflection amplifier tubes near CR tube base.
- Greatly simplified wiring layout.
- Increased frequency response — useful to 5 MC.
- Tremendous sensitivity .03 RMS per inch Vertical .6V RMS per inch Hor.
- Dual control in vernier sweep frequency circuit — smoother acting.
- Positive or negative peak internal synchronization.
- Multivibrator type Wide Range Sweep Generator.

A brand new 1952 Heathkit Oscilloscope Kit with a multitude of outstanding features and really excellent performance. A scope you'll truly like and certainly want to own.

The kit is complete with all parts including all tubes, power transformer, punched and formed chassis, etc. Detailed instruction manual makes assembly simple and clear — contains step-by-step instructions, pictorials, diagrams, schematic, circuit description and uses of scope. A truly outstanding value.

MODEL 0-7  
SHIPPING WT. 24 LBS.

**\$43.50**

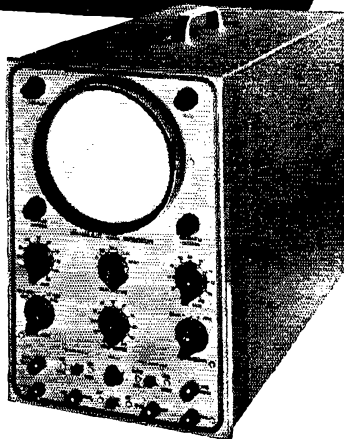

## Heathkit VACUUM TUBE VOLTMETER KIT

- New styling — formd case for beauty.
- New truly compact size — Cabinet 4 1/8" deep x 4-1/16" wide x 7 3/8" high.
- Quality Simpson 200 microamp meter.
- New ohms battery holding clamp and spring clip — assurance of good electrical contact.
- Highest quality precision resistors in multiplier circuit.
- Calibrates on both AC and DC for maximum accuracy.
- Terrific coverage — Reads from 1/2V to 1000V AC, 1/2V to 1000V DC, and .1 to over 1 billion ohms resistance.
- Large, clearly marked meter scales indicate ohms, AC Volts, DC Volts, and DB — has zero set mark for FM alignment.
- New styling presents attractive and professional appearance.

The 1952 Model Heathkit Vacuum Tube Voltmeter! Newly designed cabinet combines style and beauty with compactness. Greatly reduced size to occupy a minimum of space on your work-bench. Covers a tremendous range of measurements and is easy to use. Uses only quality components including 1% precision resistors in multiplier circuit for greatest accuracy. Simpson 200 microamp meter with easy to read scales for fast and sure readings.

All parts come right with kit, and complete instruction manual makes assembly a cinch.

MODEL V-5  
SHIPPING WT. 5 LBS.

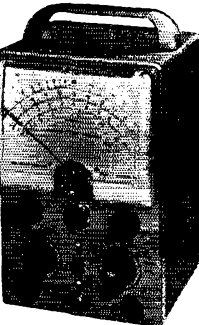

**\$24.50**

YOU SAVE BY ORDERING DIRECT FROM MANUFACTURER

ROCKE INTERNATIONAL CORP.  
138 40th ST.  
NEW YORK CITY 17, N.Y.

**The HEATH COMPANY**

BENTON HARBOR 9, MICHIGAN



**More Safety...Less Guesswork  
When You Use  
—PRECISION—  
TEST EQUIPMENT**

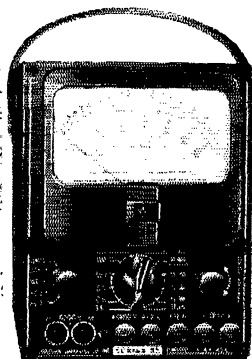

**Stay On The Air  
With "PRECISION"  
SERIES 85  
AC-DC  
Circuit Tester  
(20,000 Ohms per Volt)  
SELF-CONTAINED TO  
6000 volts,  
60 Megohms,  
12 Amperes, + 70DB**

A compact, laboratory type, high sensitivity test set indispensable for test and maintenance of modern amateur communications equipment.

20,000 Ohms per Volt D.C. - 1000 Ohms per Volt A.C.

VOLTAGE RANGES: 0-3-12-60-300-1200-6000 A.C. & D.C.

CURRENT RANGES: 0-120 microamps; 0-1.2-12-120-MA;  
0-1.2-12 Amps D.C.

RESISTANCE RANGES: 0-6000-600K-6 Meg-60 Megohms.

DECIBEL RANGES: From -26 to +70DB.

Complete with batteries and test leads..... **\$3995**

**PLUS superior physical features:**

- ★ 4 5/8", 50 microamps, Easy Reading Meter.
- ★ Heavy duty bakelite case 5 1/2 x 7 1/8 x 3".
- ★ Deep etched, anodized aluminum panel.
- ★ Recessed 6000 volt safety jacks.
- ★ Only two pin jacks for all standard ranges.

LC-1 LEATHER CARRYING CASE—Custom designed, top-grain cowhide case with tool and test lead compartment. \$9.50 See Series 85 and other famous "Precision" instruments, on display at leading radio parts and ham equipment distributors. Write for latest catalog.

**Precision Apparatus Co., Inc.**

92-27 Horace Harding Blvd., Elmhurst 13, N. Y.

the transmitter, a three-band job, will be in by next May. By that time a new car will be in order and will have it all to do over again. Your SCM believes it would be a good thing if every ham in Colorado would appoint himself a committee of one to get more hams to join the ARRL. The Colorado Springs Club is giving memberships as prizes at each meeting and they hope eventually to affiliate with ARRL with a 100 per cent membership. That's all for now, there ain't no more. Traffic: W8ZJO 481.

UTAH—SCM, Leonard F. Zimmerman, W7SP—JPN has discarded the invisible wireless beam for the thumb-tack antenna and is keeping his eye on your signals as an OC. KMR, SBK, LCA, and NMIK are building a TV rig on 420 Mc. so get a converter rigged up for your TV set and see what goes. The UARC Ten-Meter Mobile Net started the fall season with a transmitter hunt and a ham-fest. Official drills are held each Wednesday at 7:00 P.M. on 28.625 Mc. LEB, PGD, and 0BQV are operating from K7FAH, MARS station at Hill Air Force Base. OKZ has new 10- and 20-meter beams on a 50-ft. steel tower. DKA has new HRO and is trying for Advanced Class license. KUX has new 500-watt rig and is set to go on 144 Mc. also. MOQ and OKA are operating mobile. NAU has new 35-ft. tower. NHQ reports he is operating 10- and 20-meter phone now. FYE has built an antenna scope and grid dipper to find out where his signal is going. LQE soon will be on with 800 watts.

WYOMING—SCM, A. D. Gaddis, W7HNI—SEC: I.K.Q. PAM; KFV, Wyoming needs ORS and RM. Apply to the SCM if interested. HDS is active on AF Net. POF is new MARS director at Warren AFB. OWZ reports good results with 2-meter mobile. JRG was heard in McLean, Ill., on 144 Mc. Let's see one of you tie that! HFV is having fun with 75-meter mobile. ABO has new antenna working after a large effort. AEC took HNI for a ride! Nice boat, Hank. Those engaged in smearing eggs on white shirts are in for trouble at the next hamfest.

**SOUTHEASTERN DIVISION**

ALABAMA—SCM, Lewis C. Garrett, W4LEN—SEC: A ISD. The Birmingham Club has 12 mobile units on 28 Mc. and is making application for Alabama Emergency Net. The call AENR has been temporarily assigned. Alabama stations desiring to act as relay points for complete 10-meter State coverage, please contact GJW, MUU and PEK are combining rigs and operating under the last name of Jackson. Best wishes and congratulations, Bob, BFM, NGL, RYY, PWS, EJZ, and KIX are doing a fine job keeping AENR totals up. FGT, Alt. NCS AENP, is the latest member of both c.w. and phone nets. 5RUT is new associate member of AENP. KUX gave a very convincing example of what good equipment can do on 144 Mc., Tuscaloosa and Birmingham from Anniston with less than 10 watts. If you need to be convinced that 144 Mc. is the answer for State coverage, please contact Lou, HCV, GOF, ELX, LRU, KCQ, NJP, and KUX are on 144 Mc. from Tuscaloosa. FSW and FIG are on 144 Mc. from Birmingham. ICI is on 3.8 Mc. from Anniston. OHK handled railroad traffic during the line failure. We need news and reports badly, fellows. Traffic: W4BFM 34, KIX 34, OAO 22, LEN 16, PPK 13, ISD 9, MVM 5.

EASTERN FLORIDA—SCM, John W. Hollister, W4FPWZ—In my opinion this year's preparation for the hurricane season tops, by far, all previous plans and preparations. In particular, the official Weather Bureau extended observation points were a most welcome addition. Based on reports this month (August) special mention goes to SEA, at Madeira Beach, and IM, at Fort Lauderdale, for excellent preparations. Now that we have so many CDC station installations and emergency stations why not get in some additional practice by getting in on the 3675-ke. traffic net each night at 7 p.m. Mon. through Fri. Who was the first Novice licensee in Florida? First reporting is WN4TNR, at Daytona Beach, who is operating 12 watts to a 6F6 on 3730 kc. Clewiston: PNS now is mobile with Command set on 3.8-Mc. phone with 1BD to CL whip. PUN is really into traffic: FEPK on 3910, CGA on 3855, BTU on 3945, Armed Forces Net at 14 255, and 14th AF Net on 3307.5 kc. (H). Daytona Beach: MIP, KFX, and RWM set up the equipment at Red Cross for storm work. Fort Lauderdale: The Broward Emergency Net is on 7140 kc. at 7 p.m. Thursdays (CQ BEN) and at 9 a.m. on Mon., Wed., and Fri. IM reports the net is skippered by JVF up at West Palm Beach. New Port Richey: KJ is back on the job as NCS on MARS 3497.5 and 4020 kc. nets. Oakland: OCG did considerable monitoring of 3.7 to 3.9 Mc. during Army Maneuvers and reports no Florida station was heard in the restricted band. St. Petersburg: The XYL of EYI now is TKD. West Palm Beach: RTX has 56 confirmations from 97 contacts toward DXCC. Norm reports the Rebel Club is pushing up more sky wire and beams. Send me more reports, fellows. Traffic: W4PJU 269, OCG 214, LMT 28, RWM 27, FWZ 20, IM 19, KJ 5, DLL 2.

WESTERN FLORIDA—SCM, Edward J. Collins, W4NIS/RE—SEC: PQW, PTR's XYL passed her exam. NRX is enjoying 75 meters with new ticket. QK is Advanced Class. QU is back on 28 Mc. DAO has been on 7 Mc.

(Continued on page 88)



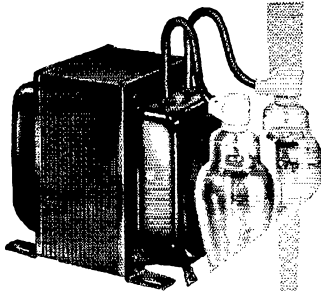

# new STANCOR

## plate transformers

### FUNCTIONAL AMATEUR DESIGN

**PT Mounting.** Provides direct, protected path to anodes\* of rectifier tubes with heavily insulated, HV leads out of top of transformer. Primary brought out bottom for concealed sub-chassis wiring.  
\*Insulated plate caps required.

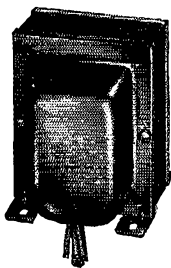

**PC Mounting.** For units requiring single-ended rectifiers where safety, convenience and neatness are achieved with all leads brought out bottom of transformer for concealed sub-chassis wiring.

The new Stancor catalog, listing complete specifications of 441 transformers and related components, including 20 additional plate transformers, is now available. These cataloged transformers are carried in stock by your local Stancor distributor. Ask him for your free catalog and other valuable Stancor references.

Quality built to Stancor standards, with no cost wasted on fancy trimmings. Insulated leads provide protected routing to circuit. No exposed terminals. Simplified design offers ease of mounting and neat, convenient wiring.

Each of these units is "all transformer" taking a minimum of chassis space.

DC output rated at load terminals of single-section, reactor-input filter with full-wave mercury-vapor rectification. Primaries for 117 volts, 60 cycles.

TYPE & PART NO.	SECONDARY AC VOLTS	DC VOLTS	DC MA.		HEIGHT	BASE AREA	SHPO. WT. IN LBS.	AMATEUR NET PRICE
			CCS	ICAS				
PT8311	1200-0-1200	1000	225	280	4 1/4"	4" x 5 1/2"	13.0	\$13.38
PT8312	1200-0-1200	1000	325	405	5 3/8"	4 3/8" x 6 3/8"	22.2	22.14
PT8313	1475-0-1475	1250	250	310	5 3/8"	4 3/8" x 6 1/2"	22.3	21.78
PT8314	1790-0-1790	1500	225	280	6"	4 1/2" x 6 3/4"	24.0	24.90
PT8315	2065-0-2065	1750	200	250	6"	4 1/2" x 6 3/4"	24.5	24.69

DC output rated CCS at load terminals of single-section reactor-input filter, ICAS with single-section capacitor-input filter. Primaries for 117 volts, 60 cycles.

TYPE & PART NO.	SECONDARY AC VOLTS	DC OUTPUT		TYPE FILTER	RECTIFIER	HEIGHT	BASE AREA	SHPO. WT. IN LBS.	AMATEUR NET PRICE
		VOLTS	MA.						
PC8301	415-0-415	300	200	Reactor Input Capacitor Input	SU4G SU4G	4"	3 3/4" x 3 3/4"	4.8	\$ 6.39
		425	160						
PC8302	515-0-515	385	235	Reactor Input Capacitor Input	SU4G SR4GY	4 3/8"	3 3/8" x 4 1/8"	6.8	8.19
		500	200						
PC8303	665-0-665	500	250	Reactor Input Capacitor Input	SR4GY SR4GY	4 3/8"	4" x 4 3/8"	9.6	10.38
		750	200						
PC8304	750-0-750	600	245	Reactor Input Capacitor Input	2-SR4GY SR4GY	4 3/8"	4" x 4 3/8"	11.5	11.61
		850	200						
PC8305	920-0-920	750	250	Reactor Input Capacitor Input	2-SR4GY SR4GY	4 3/8"	4" x 5"	11.9	12.12
		1000	200						
PC8306†	920-0-920	750	150	Reactor Input Capacitor Input	SR4GY SR4GY	4 3/8"	4" x 5"	11.9	12.30
		1100	125						
		500-0-500	380						
		550	125	Reactor Input Capacitor Input	SU4G SU4G				

†Stapped for use with dual rectifier-filter systems to deliver two rated outputs simultaneously.

Stancor builds quality transformers for all industrial and military electronic applications. When you need a quantity of special transformers, Stancor engineers can design a unit that will meet your most exacting specifications.



## STANDARD TRANSFORMER CORPORATION

3580 ELSTON AVE., CHICAGO 18, ILLINOIS

Specify

**AMPHENOL**

for  
**Quality**  
in...

- ★ Low Loss RF Cables
- ★ Remote Control Cables
- ★ Antennas
- ★ Twin Lead Transmission Lines
- ★ AN Connectors
- ★ Submersion—Proof Connectors
- ★ Heavy Duty Power Plugs
- ★ Audio Connectors
- ★ 100 Contact Connectors
- ★ Quick Disconnect Connectors
- ★ Cable Connectors
- ★ Power Plugs
- ★ Rack & Panel Connectors
- ★ Miniature Connectors
- ★ Sealed Relay Plugs
- ★ RF Connectors
- ★ Heavy Duty Radio Connectors

**AMPHENOL**

**AMERICAN PHENOLIC CORPORATION**  
1830 South 54th Avenue, Chicago 50, Ill.

- Send me the 48 page general CATALOG No. 74.
- Add my name to your mailing list for monthly information on currently new products and technical data . . . AMPHENOL ENGINEERING NEWS.

NAME \_\_\_\_\_  
 FIRM NAME \_\_\_\_\_  
 ADDRESS \_\_\_\_\_  
 CITY \_\_\_\_\_ STATE \_\_\_\_\_

SZH has an FB rig on 28 Mc. PAA at last has an all-band antenna. SZZ is the newest call in Pensy. NOX and NYZ have been trying 14-Mc. phone. PQW is working hard on c.d. gear and needs help. PTK is enjoying 75 meters with the HT-9. NJB and MFY have been meeting Alabama Emergency Net. PBE has an active bunch for c.d. at Eglin Field. MS is rebuilding 20-meter beam. VR and MUX keep 7 Mc. hot. Pensacola has emergency mobile units ready for c.d. work at a moment's notice. PLA is doing FB with mobile gear. PLI was in from OX-Land. BMR showed the gang his ART-13 mobile rig. NN still is the Western Florida member of the Knights of the Kilocycles. AGB is the consistent operator. AXP is out of the hospital. RDC is working on v.h.f. gear. BKN is on the Hurricane Net and doing an FB job. FDL is rebuilding the rig. Traffic: W4PQW 12, MS 3.

GEORGIA — SCM, James P. Born, jr., W4ZD — The Georgia Cracker Emergency Net's Annual Hamfest and Barbecue was held Aug. 12th at Dixon's Lodge near Macon. Approximately 125 attended, with 50 net members present. OSE was elected north NCS; FFC resigned because of business. ZD was elected historian of the net. The net formed the Georgia Cracker Amateur Radio Club which will operate the Net. Officers of the Club also will be officers of the Net. KGI has joined Silent Keys as the result of a heart attack. Our sympathies go to YRE, whose wife passed away recently. HKA has a new 14-Mc. four-element beam. ABP now is on 3.8-Mc. phone. KFL has returned to Atlanta after two years in the Army. LXE is the new treasurer of the Macon Amateur Radio Club. PKT resigned because of business. The Club now is in its new permanent location at ORC Training Unit, 1690 Jackson Short Route. Congratulations to the Carrollton Amateur Radio Club on a very successful hamfest and picnic. Mr. C. F. Daugherty, chief engineer for WSB AM-FM-TV, was guest speaker at the September meeting of the Atlanta Radio Club. Mr. Daugherty spoke on the new set-up on Channel 2 TV and answered questions from club members and visitors. EMO has moved to Atlanta from Jersey, Ga. ZS1QP visited OPS and talked to many local hams from there. K4WAR is organizing a traffic net on 7150 kc. which will meet daily at 12:30 P.M. EST to handle traffic anywhere. Traffic: K4WAR 572, W4BOC 49, HKA 35, ZD 26, LYG 23, EJC 20, OSE 15, KXX 12.

WEST INDIES — SCM, William Werner, KP4DJ — SEC: ES. CP has been appointed EC of Guayama District. DJ renewed ORS appointment. UW, DV, DU, and KV4AA are on 160 meters. KD is on 7 Mc. ID, at R.C. Headquarters, has two 400-watt transmitters, a TBS-50 all set up for the hurricane season, plus two emergency power plants. KV4AA skeds W2CTO daily on 14,001 kc. HZ made DXCC. MS is Class A and QSYed to 3925-kc. net, fixed and mobile. PR is on 75-meter mobile. EQ and FB report on 3925 kc. WP4PW, our first Novice, will operate on 3710 and 3745 kc. BV has a stronger signal on the 3559-kc. net because of new antennas. KP4USA, MARS station at Ft. Buchanan, is on 7:30 a.m. to 5 p.m. daily. Hurricane Charlie arrived coincidentally with the regular 3925-kc. net drill and drill routine with all of the 32 registered stations reporting. The R.C. director spoke to all AREC members and R.C. disaster chairmen from ID the same night. The Governor's directive to all agencies advised use of the AREC Net when all other facilities fail. KV4AA and WF6SD report into P.R. Emergency Net on 3925 kc. ES relayed traffic from VP5RA to VP5AA and to U.S.A. after Hurricane Charlie struck Jamaica and was on for ten hours until signals faded, after which W4MTZ took control with HC1KW, CM9AA, and KP4MZ assisting. USWB requested net time in the event regular communications between Ponce and San Juan failed. Traffic: KP4DJ 9, DV 6, ID 2, KD 1.

CANAL ZONE — SCM, Everett R. Kimmel, KZ5AW — MM, delivering technical talks in a style all his own, has become an added attraction of our CZARA meetings. TB arranged another flying visit of FCC examiners for those desiring FCC tickets. AF, AZ, GG, LT, and NP joined up in the weekly Pacific-side AREC drills, making about 25 stations checking into NCS PC. Both sides of the Isthmus check into the MARS nets which meet earlier the same evening. With AU, AW, JB, NM, PC, and TB working on 3910 kc. 75-meter phone is on the upswing. GD and his XYL, DG, returned from Stateside leave. ML is handling lots of traffic during the day while SEC FL, her OM, is at work. Our best wishes to the pair of 13-year-olds now boning up for their ham tickets. CZARA Bulletin editor, BT, is pleading for material and your SCM would like to see a few more reports in the monthly mail, too.

**SOUTHWESTERN DIVISION**

LOS ANGELES — SCM, Samuel A. Greenlee, W6ESR — SEC: K5X. RMs: DDE, FYW, LDR. Another active month. SCN is going great guns under the leadership of LDR, ably assisted by CMN. It's your net — break them with your traffic — for anywhere! Mondays through Fridays, at 2000 hours on 3650 kc. This month's "Pat-On-The-Back" Department features the AREC boys. Dedicated to the cause of aiding humanity in a disaster, the emergency nets operate under simulated emergency conditions, week in and week out, endeavoring insofar as possible to antic-

(Continued on page 90)

*W. Ben Wimberly  
(W9IXD)*

well-known amateur says: "For quick, accurate trouble shooting around my ham shack, the Simpson Model 240 Hammeter is indispensable. I've used Simpson equipment for many years."

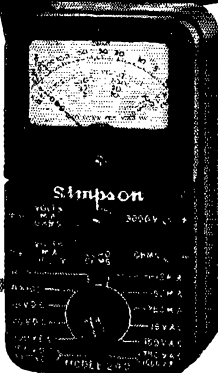

**RANGES: Model 240**

- AC VOLTS:** 0-15, 150, 750, 3000 (1000 ohms per volt)
- DC VOLTS:** 0-15, 75, 300, 750, 3000 (1000 ohms per volt)
- DC MILLIAMPERES:** 0-15, 150, 750
- OHMS:** 0-3000 (center scale 30)  
0-300,000 (center scale 3000)
- ACCURACY:** DC 3%—AC 5%
- SIZE:** 3"x5½"x2½"
- WEIGHT:** 1¼ lbs.
- SHIPPING WEIGHT:** 2½ lbs.
- AMATEUR'S NET PRICE . . .** \$24.60
- Leatherette Case . . . . . 5.00

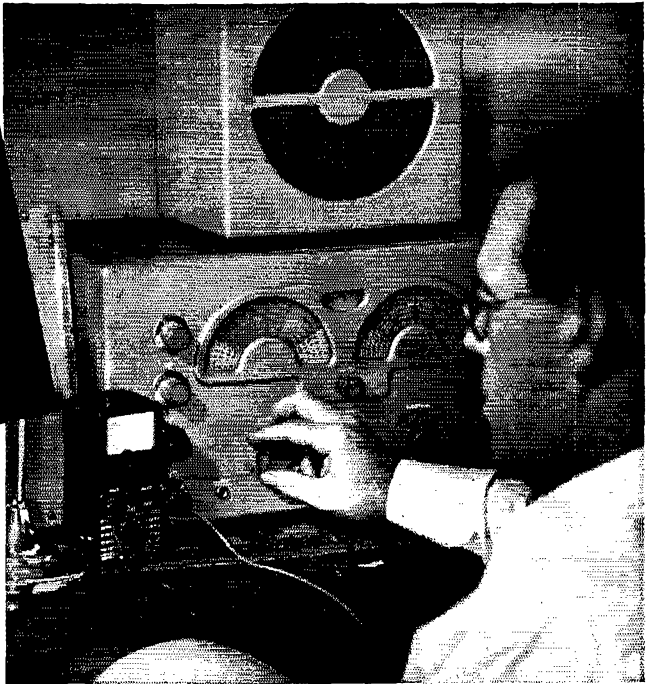

**WORLD FAMOUS SIMPSON HAMMETER IS FIRST WITH RADIO AMATEURS**

The famous 240 Hammeter—named by the radio "ham"—is world renowned for its ruggedness and accuracy. It was designed for the additional voltage and sensitivity required in radio testing.

A favorite with "hams" because of its maximum voltage range of 3000 AC or DC, the 240 was the first self-contained pocket portable built expressly to check high voltage and all component parts of transmitters and receivers.

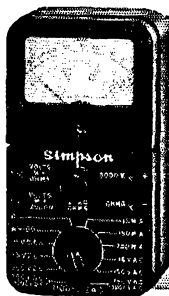

A worthy companion of the Hammeter is the Model 230 volt-ohm-milliammeter, with a maximum voltage of 1000 AC or DC. Its ranges are adequate for most line voltages, for telephone, teletype, and general purpose testing.

**RANGES: Model 230**

- AC VOLTS:** 0-10, 250, 1000 (400 ohms per volt)
- DC VOLTS:** 0-10, 50, 250, 1000 (1000 ohms per volt)
- DC MILLIAMPERES:** 0-10, 50, 250
- OHMS:** 0-1000, 0-100,000
- ACCURACY:** DC 3%—AC 5%
- SIZE:** 3"x5½"x2½"
- WEIGHT:** 1¼ lbs.
- SHIPPING WEIGHT:** 3 lbs.
- AMATEUR'S NET PRICE . . . . .** \$23.40
- Leatherette Case . . . . . 5.00

**Simpson**  
INSTRUMENTS THAT STAY ACCURATE

**SIMPSON ELECTRIC COMPANY**  
5200-18 WEST KINZIE STREET, CHICAGO 44, ILLINOIS  
In Canada: Bach-Simpson Ltd., London, Ontario

# NEW MALLARD HI-Q BASE LOADING COILS

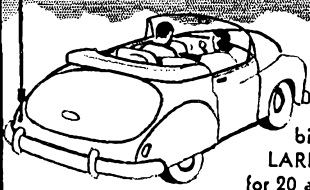

for all 20 & 75 Meter Whips

Here's good news for mobile operators. The new MALLARD HI-Q Base Loading Coils for 20 and 75 meter mobile installations combine all the ruggedness and stability of base loaded type coils with extremely high Q and consequent great efficiency.



The result of extensive research and comprehensive field tests, MALLARD Loading Coils are sturdily built to withstand abuses of mobile operation and are completely weatherproofed to maintain their high Q. They are designed with 3/8-24 threads to fit all standard mounts and whips and supplied with adaptors to take non-standard 1/4" rod types. They are unusually easy to install and adjust.

## MALLARD HI-Q 20 Coil

- Heavily plated 1/8" solid copper wire.
- Heavy flexible copper strap permits exact inductance adjustment.
- Sturdy, weatherproof housing of 1/8" thick plexiglass.
- Removable threaded plastic nylon end-caps.
- All metal parts of brass heavily nickel-plated.

MALLARD HI-Q 20 Loading Coil  
Amateur Net .....\$8.95

## MALLARD HI-Q 75 Coil



- Two pie-wound coils for greatest efficiency.
- Powdered iron-core slug.
- High Q throughout inductance range.
- Easily adjusted to exact inductance.
- Heavy insulated copper wire treated with Insulex to resist moisture and fungus growth and to maintain high Q.
- Completely weather-proof housing of 1/8" thick plexiglass.
- Threaded plastic nylon end-insulators.
- Easy installation—quick adjustment.
- Metal parts of heavily nickel-plated brass.
- Sturdy.

MALLARD HI-Q 75 Loading Coil  
Amateur Net .....\$7.95

See the outstanding MALLARD HI-Q Base Loading Coils at your jobber today. Install one of these efficient coils with YOUR present whip and get the most out of your mobile rig. W95M using one of these loading coils, teamed with a Mallard Converter, worked 93 countries on 20 meter mobile in 19 months.

- Other mallard Products for Better Mobile Operation
- MALLARD 10N, 20N, and 75N Mobile Converters
  - MALLARD 10-20 Two-band Converter
  - MALLARD VFO for 10, 20 and 75 Meters
  - MALLARD ALL Band Mobile Transmitter



**\*REMEMBER,**  
**For Mobile it's MALLARD!**  
**mallard mfg. co.**

pate and be ready for any catastrophe which might occur. Mobile, portable, or operating from their home or c.d. stations, AREC has developed a fast, precise operating procedure that is a pleasure to listen to. They hope they will never be called upon, but if it should happen, they will live up to their motto, "Be Ready." RPL this month was made by W6KYV, GYH, GEB, and BHG. AM worked Andorra for his 222nd confirmed country. KYV held open house honoring Hilliard, JA3AC, on his first Stateside trip in years. DTY erected his masts at new QTH and reports his TV neighbors were very interested. FKO is planning automatic c.w. OBS transmissions. KQS is going high-power mobile. By the way, have you seen RL's new mobile? 400 watts; phone/c.w. all-band; plus teletype, all in a special station wagon. (It took the prize at Seattle.) GTE spent his vacation hiking! Anybody seen NAZ's TV program? The gal's good! FZO moved to Arcadia. EHA/EHB really give out with the OBS. Your SCM attended Radio 50 Club dinner; fine food, fine fellows. GYH still keeps up that killing traffic pace. (How does he do it?) K6EA is visiting 0-Land until December. He will be on mobile. HLZ has new 32V-2. TDW reports: SCQ is on teletype; UBY is on s.s.b.; DJN is back from the East; AGK is about to unveil his top-secret transmitter; VBN is now captain in the Los Angeles Fire Department. Dad-of-the-month: VQN—twins. ('Twas nothing, sezze!) QJW QSOs via pack-set while waiting for the trout to bite. Thanks, Dud. CSS and his boys are doing a grand job manning the AREC station (HGV) at Los Angeles Red Cross Headquarters. BLY reports: WGL and FMQ are in the Service. COZ reports: HYS is leaving for Cal-Poly; IOM for Cal-Tech; they will be on the air. AREC Notes, per KSX, SEC: The Golden State Emergency Net is on 144, 28, and 3.5 Mc. Owens Valley Net is operating mobile on 28 and 3.5 Mc. New ECs: Los Angeles, AOP, GSN, KEI; Owens Valley, WWT. The Crescent Bay, Centinella, and South Bay Nets held a joint drill under difficulties (rain, yet!). OYY acted as Net Control for Crescent Bay Area from his airplane. (Is this another first for that net?) Novice hams: How about some reports on your activities? We are all interested in your progress, too. If you think traffic doesn't move fast on phone, listen to the American Legion Net (3975 kc.) at 1900 hours or Mission Trail Net (3854 kc.) at 2000 hours. Thanks also to BUK, EPL, MU, and YSK for reports. Traffic: W6KYV 2418, GYH 710, DDE 384, GEB 354, BHG 212, LDR 149, HOV 113, MJA 42, GYX 37, K6EA 32, W6HLZ 28, CMN 27, TDW 22, CK 18, YG 16, BLY 11, AM 10, MVF 9, COZ 6, FMQ 4, EBK 2, QIW 2, DBY 1.

ARIZONA—SCM, Jim Kennedy, W7MID—We had a nice visit from MNU, of St. Johns, who tells us that OWL will be at Tempe this winter, operating portable. Bill also reports a visit from KUU, of Ajo, who has been on 3.8-Mc. phone from Greer. UKK is working on his commercial ticket and is building a modulator for 28-Mc. phone. The August c.w. party, sponsored as always by MLL, had the largest turnout yet: 27 stations were heard on 3.5 and 7 Mc. K7FAG, of Davis-Monthan, makes Brasspounders League again. Look at that total! NSJ did all right for himself at Scout Camp, too, running up his total entirely on 144 Mc. KRC has a new NC-183. PKU has a 32V-2 and is going in for traffic-handling in a big way. At a recent meeting of the Tucson gang, MLL was presented with a life membership for his many and varied services for ham radio. OLB is back in town after 3 months duty in Alabama, and is accumulating parts for a "big rig." Despite increased activity on the bands, news is scarce this month, fellows. How about helping out? Traffic: (Aug.) K7FAG 1173, W7JGZ 62, PKU 34 (June) W7NSJ 623.

SAN DIEGO—SCM, Mrs. Ellen White, W6YYM—Asst. SCMs: Shelley E. Trotter, 6HAM; Richard E. Huddleston, 6DLN; Thomas H. Wells, 6EWU, SEC; NBJ. RM: IZG. ECs: DEY and VJQ. The Orange County Amateur Radio Club participated in the Orange County Fair in August handling traffic for GIs overseas and stressing emergency communications, reports DEY. FMZ expects to be operating from New Mexico in December. IZG reports that KIO has been very active on SSN. Again this year FMJ is holding a class at Hoover High in theory and code. APG's new 144-Mc. ground plane is working out nicely into the Los Angeles Area. Dyed-in-the-wool c.w. operator ELQ is starting to use phone for check-in on AREC net Sunday mornings. For the sixth consecutive month BAM makes BPL Local club activity is picking up with summer on the go. The Helix Club of San Diego County held a banquet in September. Latest reports show that the Soledad Club leads the section in Field Day-totals. YYM and YYN are back on 7 Mc. after a busy summer. GMG is handling considerable traffic as chief operator for the Naval Amphibious Base Troop Training Unit of Coronado, BSD. Appointments are available to interested amateurs as OO, ORS, OES, OBS, and PAM. If interested, contact your SCM. Traffic: (Aug.) W6BAM 877, IZG 158, BSD 117, FMZ 6. (July) W6BSD 116.

## WEST GULF DIVISION

NORTHERN TEXAS—SCM, William A. Green, N5BKH—Asst. SCM, Joe G. Buch, 5CDU. SEC: JQD. RMs: GZU, LSN. PAM: IWQ. The appointment of  
(Continued on page 92)

# HERE IT IS!

ALL YOU NEED  
TO  
KNOW!

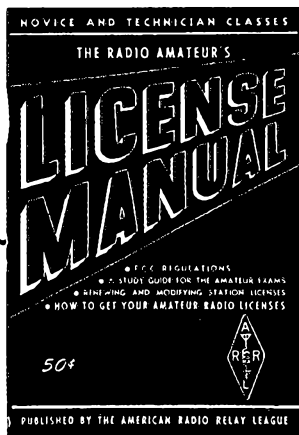

COMPACT! COMPLETE!  
CLEARLY WRITTEN!

## The **KEY** to a Ham Ticket . . .

IF YOU HAVE BEEN WORRYING ABOUT HOW TO PASS THAT  
FCC WRITTEN EXAM, YOU CAN STOP WORRYING NOW

All you need is a copy of the new ARRL License Manual, and a little of the same enthusiasm you had when you first decided to become a ham. A few additional hours looking through this book, and you'll be well on your way to getting that coveted ticket.

Here, in one compact manual, is all the info you will ever need for the written examination. Thoroughly revised, brought up to date, and containing the latest FCC regulations on the new Novice and Technician Class and other licenses, and many other pointers, with complete questions and answers, the ARRL 27th Ed. License Manual is available to help you over the hump.

THIS BOOK WILL BE OF MUCH HELP  
TO YOU IN PREPARING FOR THE  
TESTS, AND MASTERING THE REQUIRED  
KNOWLEDGE.

Revised, enlarged, and printed  
on slick paper

● **50¢** PER COPY — POSTPAID ANYWHERE  
(No Stamps, Please!)



— 38 LA SALLE ROAD —  
**THE AMERICAN RADIO RELAY LEAGUE, INC.**  
— WEST HARTFORD 7, CONNECTICUT —



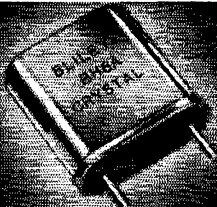

Bliley Type BH6A



Bliley Type TCO-1  
Temperature Control Oven

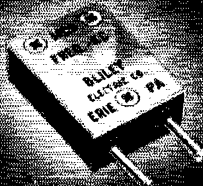

Bliley Type MC9

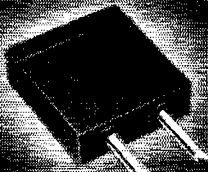

Bliley Type SR5A

## IT'S PRODUCTION

PRODUCTION schedules must be built on a foundation of ability . . . and Bliley is doing an outstanding job of PRODUCTION for the defense program.

Twenty-one years of experience help us to give you a better product . . . when you need it . . . the way you need it.

# Bliley CRYSTALS

**BLILEY ELECTRIC COMPANY  
UNION STATION BUILDING  
ERIE, PENNSYLVANIA**

JQD as SEC, relieving AAO, has been made. Thanks, Jim, for a job well done. Bruce has a big job before him, so let's each assist in all ways possible. He has as his assistants BFA, LEZ, KRZ, ARK, and FQT, each an Area NCS. All hams should have their names registered with their local EC. Look him up and get affiliated with the AREC, which may be our salvation should disaster strike. If you don't know him, contact JQD. All emergency and traffic nets are now in full operation. Congratulations to QHT on making the BPL. Frank is beginning to carry a big load for this section, being active in RN5, CAN, and PAN, as well as section nets. RJM promised considerable fair traffic and we know it will be well handled. 144-Mc. activity in their respective areas is reported by SGR and SQW. The East Texas ARC held an open-air August meeting in Tyler with 30 present. Mobiles were guided to the park by radio contact. We hear that several got lost. Highlights of the meeting were a discussion of the Convention by RHC and OIS and the auctioning off of the surplus of the club transmitting equipment, OIS being high bidder. VIM is busy 'phone-patching. QDF is QRT to enter USAF but will get on the air after boot training. New calls noted were TBX and TES. Traffic: W5QHI 524, KRZ 153, BKH 146, GZU 134, RHC 80, EBW 75, IWQ 47, ARK 38, LEZ 37, RHP 36, AWT 21, IGU 5.

OKLAHOMA — SCM, Frank E. Fisher, W5AHT/AST — SEC: AGM, RM: FOG, PAMs: GZK and ATJ. OXJ has been to California and SLC to Canada, both with mobile gear. MRK has been to the Ozarks. GPD is in Michigan on business. HGC is in Minnesota on business for Uncle Sugar. The annual convention of the West Gulf Division at Austin showed a fine attendance, including a number of us "Okies." Oklahoma County AREC held a Hidden Transmitter Hunt with good success. GGK is building a 28-Mc. converter for his mobile. There is lots of activity on mobile and mobile-to-be these days, most of it on 3.9 Mc. EHC is limbering up his fist on 3.5 Mc. JP has a new jr. operator. EGR is now aircraft mobile on 3.8 Mc. SCX has a new 50-Mc. rig and antenna. SNM is building a new exciter. Ardmore's newest novice, WN5TFP, got his novice ticket, a new home, rig, antenna, and jr. operator all at the same time. OWG says his shack is a converted greenhouse and both too hot and not so hot for summer operation. Hi! QHI is doing a fine relay job working TOTN, OLV, RN5, and PAN with excursions into other nets at times. PHR is building a new shack with all the fixin's. TOTN reports a good two dozen members in Oklahoma and Texas doing a nice job of traffic on 3960-kc. 'phone. Overseas work with the JAs has suffered from poor conditions on 20 meters but the stuff moves along anyway. FOG has been working overtime getting OLV lines up for a big traffic season. He has fine support from all the gang and many new members are expected. Traffic: (Aug.) W5GVV 446, GZK 367, OQD 125, MRK 113, FOG 93, POM 74, AHT 64, LCN 55, JHA 33, WQ 32, MFX 21, PCQ 20, MQI 19, OWG 17, EHC 7, KYG 7, ADB 2. (July) K5NRJ 372, W5WQ 106.

SOUTHERN TEXAS — SCM, Dr. Charles Fermaglich, W5FJF — DEH is a new AREC member. GYM took some swell pictures at the recent STEN Convention. APP is a member of AREC. JRV is on 75-meter mobile. PTV reports good 6-meter activity. AQN, a pharmacist in Navasota, is on 7-Mc. c.w., the same as when he and I were at U. of Tex. 15 years ago. GPQ has a gal on 75 meters. QMF is very active on the high frequencies. SQE is putting up a beam on 10 meters. RAL is doing a nice job working K5USA. PTR is new grandmother. DUK is on 10 through 180 meters. ADZ now is a member of the Radio Society of Great Britain. 20XH and 5SAG are at Randolph Field. GBL has 1 kw. on 14-Mc. 'phone and c.w. GCS is on 75 meters with 32V-1. WN5TFW had his first contact with QME on 2 meters. IRV has 320 watts on 75 meters but he is going back to 10 meters. WN5TIK has many contacts on 80-meter c.w. with 3 watts. IBT is on 3.8, 14 and 28 Mc. SFB is working 3USA, KIO, GZK, and GZS came to the Austin Convention from Oklahoma. IDX, By Goodman, gave an FB talk at the Convention. FXN has 1/2-gallon on 50 Mc. using constant modulation and working DX. QNA, the son of Vice-President Soupy Groves, will be back on the air soon DXing on 7-Mc. c.w. 6BBX, on 14 and 28 Mc., is having a fine time in Austin. UW is working 50 and 144 Mc. MWN is in the State Guard radio net. KC and FXN are working lots of DX. KUC, EFC, AUT, FNA, RS, EGK, FFW, ADZ, and JUF are DX hounds. STP is on 28-Mc. mobile. WN5TFW is on 144 Mc. PTV reports Regional 5 Net went on full schedule Sept. 10th and he is Texas Net Control. KWX, QEM, PBG, PTV, QDX, QJD, and EH alternate as NCS of So. Tex. Traffic Net. NHB reports CERN meets at 8 p.m. Tues. on 146.8 Mc. 10-meter emergency net meets on 29.6 Mc. Wed. at 8 p.m. QGD has mobile receiver and is working on mobile transmitter. RHU is on 75-meter mobile. WN5TEO has SX-71. IPT is working MARS and STEN. AQE reports the local club has resumed regular meetings the 2nd and 4th Mondays of each month. He is new EC for Kermit and has daily sked with his brother, LUK, on 7 Mc. in Borger. ACL is handling traffic direct from Tokyo. NKM is now with G.E. in Washington State and monitors 75, 80 and 40 meters for old friends in the 5th district. K5FAC, W5FKE, BGE, EJT, FNG, FSS, GLP, GTZ, KLV, LVD, MF, OST, PY, QCB, QJB, RAL, RMF, RRS, RSB, RT, SAH, SAM, (Continued on page 84)

# RADIO SHACK 2-IN-1 BARGAIN FOR A HAM'S CHRISTMAS!

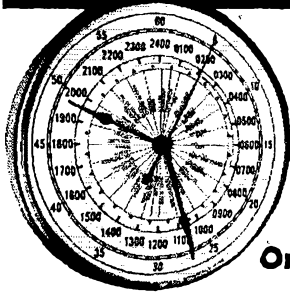

buy him this

## AUTOMATIC, ELECTRIC 2400-HOUR CLOCK WITH HUGE 10" DIAL AND SWEEP SECOND

Only **\$12<sup>50</sup>**

\*Plus \$2.50 U.S. Federal excise tax

AT A SINGLE GLANCE this fabulous clock tells your favorite "ham" the exact time in every time zone of the world. Key cities and countries shown on inner dial, 0100-2400 hours and 1-60 seconds shown in separate bands. Gray metal with chrome plated bezel. Self-starting. Convex crystal. A clock of this quality has never been offered at a price so gift-consciously LOW!

Order by stock number .....32-870

and get this **\$2.00 A.R.R.L. WORLD MAP FREE WITH EVERY CLOCK PURCHASE!**

A MERRY XMAS BONUS at no extra cost (sells everywhere for \$2), the A.R.R.L. map goes with this clock perfectly. It's printed in 6 colors; measures a giant 30" x 40"; heavy paper. Shows time zones, over 265 indexed countries, amateur prefixes. Accurate with 2% in miles and kilometers. Easily read from his operating position. The finest map of its kind, and FREE with each clock!  
Map without clock, 42-803 .....\$2.00

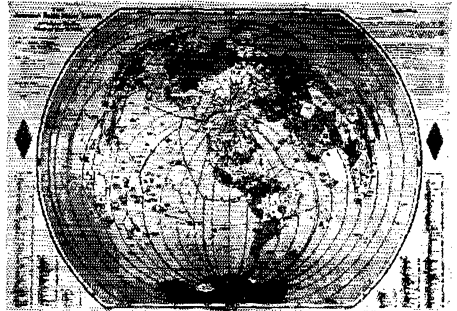

## SENSATIONAL! CLOSE-OUT OF AMPRO TAPE RECORDERS

Order No.	Description	Net
SS-730	Tape recorder .....	<b>\$79.50</b>
34-091	Extra 7" reel .....	.50
34-092	Extra 5" reel .....	.44
34-085	1200 ft. tape (paper)* .....	<b>2.34</b>
34-086	600 ft. tape (paper) .....	<b>1.50</b>
34-088	1200 ft. tape (plastic) .....	<b>3.67</b>
34-089	600 ft. tape (plastic) .....	<b>2.34</b>

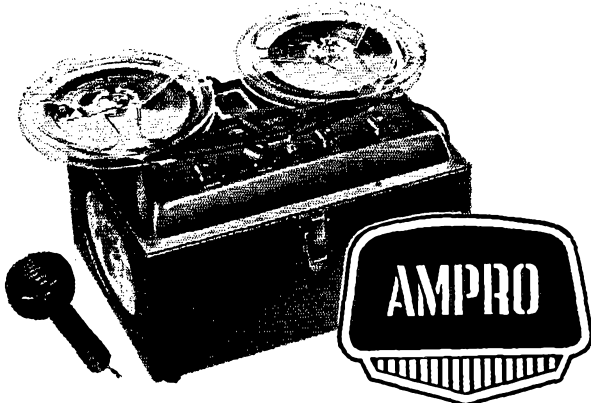

NEVER BEFORE have we seen a nationally advertised tape recorder sold so low! Ampro's fair-trade pre-Korea price on this Model 730 retorder/playback unit was \$94.50. Because this model has recently been superseded by a new, more expensive machine, Radio Shack is privileged to CLOSE OUT the final few at \$79.50. The Ampro 730 offers these special features: TWO-HOUR recording on a 7" reel; LIGHTEST WEIGHT — only 15 lbs.; SMALLEST — only 8½ x 8 x 12"; COMPLETE with microphone, take-up reel, radio-phonó cord, speaker, amplifier. Other features include: dual track recording, monitor system, fast forward skip, fast and manual rewind, timing indicator, level indicator, guarantee.

\*NOTE: Tape comes on plastic reel, 1200 ft. on 7", 600 ft. on 5". Plastic recording tape has higher fidelity and greater strength than paper.

**\$12.95**

Complete as shown, with ¼" AC/DC drill, chuck, lambswool bonnet, 2 sanding discs, PLUS 40" detachable wood handle for using drill as floor waxer, etc. Geared down to 500 rpm with load! Lifetime lubricated. Easily worth TWICE our special price. A deluxe gift at a give-away price!

# RADIO SHACK

CORPORATION

167 Washington St., Boston 8, Mass.

# CIGARETTES and AMATEUR RADIO

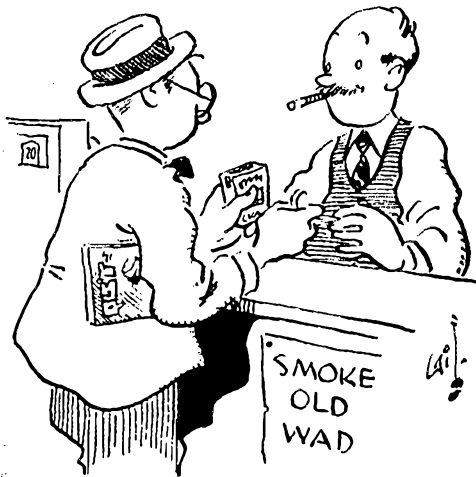

Whether you buy 'em at the counter or vending machine, only one pack a week will cost you more than ARRL membership and QST.

And you can enjoy QST all day every day of every month.

-----

**QST and ARRL Membership**  
**\$4 in U.S.A., \$4.25 in Canada**  
**\$5 elsewhere**

-----

**Is Amateur Radio Worth**  
**8 CENTS A WEEK**  
**to You?**



SOL, STT, TAH, and UB are checking into SAEN, EGK, FRW, BE, MIS, FJF, KC, FNA, GEL, ENE, JC, LYD, LGS, FXN, ASG, BDI, BGP, and ALA are members of West Gulf DX Club. RS worked more than 200 countries with 32-V and 1/2-wave vertical. Traffic: W5PTV 337, MN 272, QFA 62, QJD 52, KWV 48, QDX 48, QEM 22, JRV 19, DSB 5, AQE 4, ACL 3.

**NEW MEXICO** — SCM, Lawrence R. Walsh, W5SMA — Acting SCM, R. J. Matthias, W5BIW, SEC: PLK. PAM: BIW, RM: NKG. PAM v.h.f.: FAG. On his return from the ARRL Convention in Austin, Tex., ZU gave a very interesting account of the convention program to members of the 75-meter emergency 'phone net of New Mexico. On Sept. 27th, the Sunday morning schedule for the net changed back from 7 to 7:30 a.m. for the winter season. On Aug. 11th, a balloon carrying an m.c.w. transmitter on 2 meters was launched about 7:00 p.m., but didn't get much cooperation from the winds and upcurrents. The group who launched the airborne transmitter tracked it as far as possible and followed it about 17 miles west of Albuquerque. We hear that another launching is planned as soon as it can be arranged and publicized. An active group on 2 meters in Santa Fe, together with the 2-meter gang in Albuquerque and MYQ in Los Alamos, has succeeded in establishing a 2-meter link net working from Albuquerque to Santa Fe to the Hill. This link includes stations spread from 144.4 up to 146 Mc. and meets at 7:00 p.m. MST. RMJ now has appointments as OPS and ORS in addition to OO. On Aug. 27th the Sandia Base Radio Club heard a talk by Dr. Howard W. Merideth, PQA, on the subject of "Electronics in Medicine." The El Paso Radio Club members and also amateurs in the southern section of New Mexico heard a very interesting talk on Aug. 15th by Byron Goodman, 1DX, Technical Editor of QST. The open-discussion type of meeting was so thoroughly enjoyed that all were reluctant to have it come to a close. We hope BY will come our way again soon. Traffic: W5ZU 22, DRA 4.

## CANADA

### MARITIME DIVISION

**MARITIME** — SCM, A. M. Crowell, VE1DQ — SEC. FQ reports adding JA2s to his list. WD reports tidings of MZ from VE3-Land. W6GWS was a recent visitor to Lunenburg with motion picture production crew. VE3YR has returned home after a vacation in Dartmouth. Welcome, TA, to the 14-Mc. 'phone fraternity. A new call heard on 14-Mc. c.w. is ACK, VW, of the East Coast Sigs ARC station, sent a fine list of DX worked the past month. DB had his ORS appointment renewed. CR was successful in working FP8 before the boys packed up and returned. VE2WQ/1 has been on 3.8-Mc. 'phone from St. John. KY also has been on from St. John. KR has a nice mobile set-up in his new Mercury. DK had a nice chat with W2CKD, Tex Beneke, during the latter's recent visit to Halifax with his orchestra for a one-night stand. PT has the mobile rig working nicely on 3.8-Mc. 'phone. Old-timers recently QSOed and still going strong on 3.8-Mc. 'phone: RF, JY, AB, AA, HY, and JS. Incidentally, JS will be on from VO1-Land by the time this is read. NO is doing a nice job with AFARS 'phone Halifax Flight. HC is quite active in both c.w. and 'phone nets. Glad to QSO LY, who is back on 14-Mc. c.w. and 'phone. DQ/1 has quit "cramp tube" for Class AB in the Command set portable rig. We are sorry to have to record the passing of a former member of this section, Len Foster, ex-VE1ET. Traffic: VE1FQ 91, VW 15, DB 10, DQ 10.

### ONTARIO DIVISION

**ONTARIO** — SCM, G. Eric Farquhar, VE3IA — IA returned from vacation down Maine way one day before the deadline for writing his report for this column. While at Booth Bay Harbor your SCM, visited the Schooner *Bowdoin*, well known to ham circles. DOS, at Moose Factory, solicits contacts. AHO does a fine job on rebuilding. The Beaver Net, with WY as Manager, takes its stride in traffic-handling. This net enjoyed an FB picnic near London. ATR handled QON very capably during NCS's absence. Welcome EAU and AUU, new-comers in the traffic game, who QNI regularly on QON. AZZ got as far south as Kincairdine on vacation and visited ATR. AVS, EC for Kapuskasing, reports activity is increasing there. BC enjoys his new receiver. The annual stag of Niagara Peninsula ARC, with FZ as host, was a great success. EAM, with new rig, does a good traffic job. With the arrival of autumn, various clubs are resuming monthly meetings. Your reports would be appreciated, fellows. BUR reports increasing interest in TRN, which is back on regular fall session nightly at 1945 and 2130 EST on 3675 kc. AFARS and QON nets likewise report increased activity. Thanks for your reports, gang. Please help your scribe all you can by passing along information early enough to use in the current monthly report. Hope all had as good a vacation as I. Traffic: (Aug.) VE3IA 171, ATR 132, DCZ 91, BUR 70, WY 65, AYW 36, EAM 36, BUY 35, IL 28, YJ 23, DU 18, KM 18, DGA 3, WN 1. (July) VE1L 57, WY 19.

(Continued on page 96)



# Save 60% at ALLIED on famous Norelco DUO-VUE Projection Television!



**3ft. x 4ft.** HOME MOVIE-SIZE television..

from present 10" or 12" TV sets!

**Less than factory cost**  
Brand New • Limited Quantity  
Guaranteed Performance

A great ALLIED purchase now makes it possible for you to own genuine Protelgram projection television at a fraction of the original price! Absolutely brand-new Norelco DUO-VUE units, famous for performance and quality—guaranteed by ALLIED, world's largest and most dependable electronics supply source. Quantities are limited—so order now to take advantage of this once-in-a-lifetime quality Television value.

REGULAR PRICE \$219.50  
ALLIED'S PRICE **\$87.50**  
ONLY... F.O.B. Chicago  
**WHILE THEY LAST**

Now—you can have your TV really BIG and LIFELIKE under home movie conditions. Enjoy a huge, 3 x 4-foot picture right on your wall or home movie screen—sharp and clear, free from reflections, filled with realistic detail you can see even 50 feet away! Connects to almost any present 10" or 12" TV set (either table model placed right on top of the DUO-VUE cabinet—or by conversion of console). You simply tune your old receiver, flip a switch and there's your movie-size TV picture. You can have either your regular small direct-view picture or big screen TV—all in one. Handsome DUO-VUE cabinet is mounted on casters for easy moving. Have the TV thrill of a lifetime—a huge, perfect picture—at a sensational low price!

Use any standard home movie screen for good picture results. For an exceptional image, we recommend our special 37" x 50" portable Aluminized screen, No. 97-995, only \$17.25

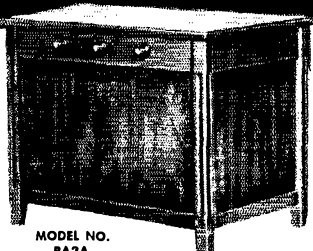

MODEL NO. PAZA

Use with almost any TV set

DUO-VUE connects perfectly to most 10", 12" and 16" TV receivers (fits over 800 models).\* Full instructions are provided for easy connection by anyone familiar with radio equipment. Supplied with complete connecting harness for convenient installation.

\*Not suited for sets wired with filaments in series, and those using electrostatic deflection or cathode-modulated tubes. If in doubt, write us, giving make and model of your TV set.

**Ideal for Clubs, Schools, Churches, Hospitals or Large Group Showings**

**DON'T MISS THIS SENSATIONAL TV BUY OF A LIFETIME**

**PAY LESS THAN THE COST OF THE COMPONENTS ALONE**

DUO-VUE incorporates the genuine Protelgram projection TV system, including precision, highest-quality components. The parts alone—complete optical system, 3" 3NF4 projection tube (worth \$22.00), 25KV high voltage power supply, auxiliary chassis with low voltage power supply and video amplifier, tubes, cables, switches, etc., are actually worth more than our complete selling price!

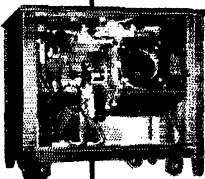

A famous North American Philips product

**QUANTITY LIMITED—ORDER TODAY**

ALLIED RADIO CORP., Dept. 15-1-1  
833 W. Jackson Blvd., Chicago 7, Ill.  
Please ship the following:  
 Norelco DUO-VUE Projection TV Unit at \$87.50  
 Aluminized 37" x 50" Portable Screen at \$17.25  
My TV Set Make and Model No. is .....  
\$..... enclosed  Full Payment  Part Pay. (Bal. C.O.D.)

Name.....

Address.....

City..... Zone..... State.....

**ALLIED RADIO**

833 W. Jackson Blvd. • Chicago 7, Illinois

**IF YOUR GEAR HAS TO FIT  
IN PEANUT SPACE  
BUT DELIVER RESULTS  
COME HELL OR HIGH WATER**

*See what's **NEW**  
— from **SONAR!***

**NEW Sonar  
mobile  
SR-9 Rcvr**

Indispensable when you must hear what's coming through, in mobile or fixed operation, CD, CAP or emergency activity. More than a monitor, more than a converter — it's a 9-tube superhet receiver with over-all sensitivity better than .5 microvolt. Tiny — only 4 9/16" high, 5 3/16" wide, and 5 11/16" deep. Yet SR-9 gives you built-in automatic noise limiter, voltage regulated oscillator, precision slide rule dial.

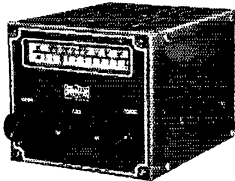

Your choice of 2, 6, 10 meters and commercial frequencies, AM and FM.

**\$72.45**

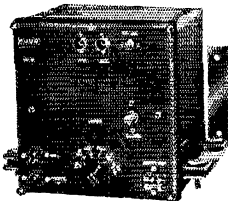

**NEW Sonar  
mobile  
MB-26 Xmtr**

Like SR-9 Rcvr, this crystal-controlled 6-tube Xmtr goes everywhere, fits anywhere, employs latest v.h.f. techniques! Lets you send clear signal, no matter how grueling the going. Output: 6 watts. Power consumption: equivalent to car bright lights. Just 6 1/2" high, 7" wide, 5 7/8" deep. Built-in antenna relay system, power filter network. Low maintenance — standard tubes. Power and antenna co-ax connectors on front panel.

8 or 24 Mc. crystal, over-tone type. Screw-driver adjusted tuning control.

**\$72.45**

PASS THE WORD TO YOUR LOCAL CIVIL DEFENSE AUTHORITIES. SEE SONAR'S SENSATIONAL SR-9 RCVR AND MB-26 XMTR AT YOUR DEALER'S — OR WRITE FOR FREE LITERATURE.

**SONAR**  
RADIO CORPORATION

59 Myrtle Avenue • Brooklyn 1, N. Y.

**QUEBEC DIVISION**

QUEBEC — SCM, Gordon A. Lynn, VE2GL — August 12th saw the third gathering of Quebec Province hams at a picnic at Cap Sainte. This also was the first annual meeting of the recently-formed Radio Amateur du/of Quebec, Inc., with JAM being elected president for the ensuing year. About 75 hams registered together with their families, and a considerable exchange of ideas took place in person. EC has changed QTH to Trois Rivieres and is located in a college on which 40 broadcast antennas are erected. He reports it is not easy to operate his 300-watter but he manages to get the 19-set on. JN has a new car and is installing the mobile gear under the watchful eye of the XYL. He also has new 20-meter open-folded dipole. Phyl, at CA, is keeping her sked with the boys at Nottingham Island for another year. The call up there is VE8SC. AO reports things a bit slow owing to his being away so much during the month, but he still handled a few messages. RZ reports a slow summer with activity being restricted to LEN on Sundays with ADY. AKJ is getting the rig in shape for the fall season. CK reports that he, BK, and IE set up three portable stations at the YMCA camp near Morin Heights. SA was at the camp and it is believed that the demonstration was quite successful. Traffic: (Aug.) VE2CA 49, AO 25, EC 10, GL 7, RZ 1. (July) VE2CK 6.

**VANALTA DIVISION**

ALBERTA — SCM, Sydney T. Jones, VE6MJ — Probably the most successful hamfest ever held in the Province was staged in Edmonton over the Labor Day week end. In spite of inclement weather and very bad roads in many parts, numerous amateurs attended. EO was elected president of the new Alberta Provincial Amateur Radio Association. A total of 162 registered and attended the banquet and 93 attended the swap breakfast on Sunday morning. EA gave a fine demonstration of directional antenna during the afternoon on Saturday. Out-of-town visitors included 5FY, 5YF, 5UC, WDSS, and 6LM, as well as many Alberta amateurs from Calgary, Medicine Hat, and Lethbridge. The Ladies' Auxiliary of the NARC entertained the visiting XYLs with a tour through the new Victoria Composite High School and tea was served later. The banquet on Saturday evening was followed by a dance during which a skit was presented by five of the local XYLs, also a demonstration of folk dancing by EO and KO and their XYLs. A highlight of Sunday afternoon was the return of our good president, EH, who had been weather-bound in British Columbia. Traffic: VE6OD 27, MJ 12.

BRITISH COLUMBIA — SCM, Wilf Moorhouse, VE7US — AQS and his XYL, AQB, are in VE1-Land. AHZ is portable 7 on 28 Mc. AHF is on 28-Mc. 'phone but QF has no r.f. in the antenna. GP is busy with b.c. station. DH is on with .025 kw. The North Vancouver Club had a visit with a Dutch radio operator. The BCARA got reports from PNE committee and SEC. The PNE exhibit was well attended. The SEC will reorganize the AREC plan in British Columbia to bring same up to date. City registrations and activity are lagging, as usual. Civil defense activity is shelved until a Federal plan is forthcoming in which amateurs can participate. The publication of the magazine *Amachever* is on the plans of the BCARA. AEF is playing with movies. The Victoria group is silent except for occasional QSOs. 3755 kc. is established as a "listening-out" frequency for B.C. AREC and other activities. Mobiles will establish a "calling" frequency with a QSY to carry traffic, etc. AOU has hopes for 'phone. ASA hopes for 7-Mc. c.w. for awhile. The AREC is operating on 3755 kc. All amateurs are welcome to check in roll calls at 1800 PST daily. The boys operating all bands are asked to mail in news or reports for publication. Nets are operating on 3755 and 3850 kc. daily. Liaison with Alberta 'phone net via AOQ and OEN is established. Reports are necessary from all stations if we are to have material for this column. Traffic: VE7ZF 23, DH 5.

**PRAIRIE DIVISION**

SASKATCHEWAN — SCM, Harold R. Horn, VE5HR — Saskatchewan amateurs have been invited to participate in the Provincial Civil Defense School during November and there will be a station on the air from Fort Qu'Appelle on Nov. 6th. Be on hand to show the c.d. what we can do in cases of emergency. Proposed frequency is 3780 kc. Time, 7-9 p.m. 'Phone net stations are asked to make an effort to be on hand with other 'phone and c.w. stations welcome to check in. PJ is confined to the hospital. SE has resigned as SEC to take Federal government radio course. GI sports new TBS-50. JW is new PAM. CJ, EE, and JF are working 56 Mc. and going after 420 Mc. VL has new NC-125. AW won the stork derby, sponsored by SARA, with a daughter. 5JK/mobile 6 with 15 watts kept tab on home events from Alberta. UC, LM, HR, and XYLs and YF and FY took in the Alberta Hamfest and thank the VE6 gang for a swell time. FY and XYL, HR, came back with prizes. FY and UC were mobile and it came in handy. FG reports on WARC activities at their Hamfest and Field

(Continued on page 88)

# HARVEY Features the Finest Brands

## CHICAGO

**THE COMPLETE TRANSFORMER LINE THAT MEETS MILITARY SPECIFICATIONS.**

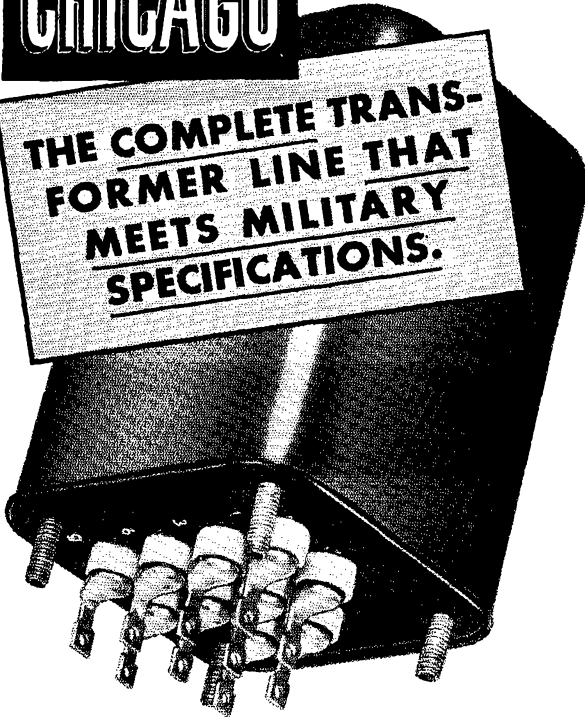

If you want really tough units for rugged applications in your own rig... or if you require fully approved MIL-T-27 Transformers and Filter Reactors for prototype models, pilot runs or special applications — write, wire or phone HARVEY for quick service on these Hermetically-Sealed units. We carry a complete range of CHICAGO's MIL-T-27 Transformers: Power, Bias, Filament, Filter, Audio — and can ship IMMEDIATELY...FROM STOCK!

HARVEY RADIO CO. has been supply headquarters for radio amateurs, broadcasters and industrial organizations for more than 25 years. Six full-time, active amateur operators are an important part of our well-trained technical sales staff. Make HARVEY your one-stop source for anything you may need in radio and electronics.

### SUPERIOR POWERSTATS

Smooth, efficient voltage control, 0-135 volts output from 115 volt AC line. Models also for 230 volt input. Write for free literature. Models for table and panel mounting.

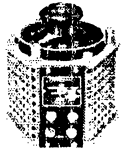

Type 20, 3 amp.....	\$12.50
116, 7.5 amps, table mtg.....	23.00
116U, 7.5 amps, panel mtg...	18.00
1126, 15 amps.....	46.00
1156, 45 amps.....	118.00

### New LYSO Mobile Transmitters

25 watts minimum peak power. Clamp type modulation. Tuning adjustment from front panel. Dimensions 4" wide, 4 1/2" high, 6" deep. Rounded drawn case, black wrinkle finish. Tubes: Model A 3-6AQ5... Model B 3-6V6GT... Model C 3-12A6. 25 watts power minimum. Amateur: 10 meters, 20 meters, 75 meters. Civil Air Patrol: For either 2374 kc or 4585 kc .....less tubes \$29.95 Net



### ELDICO ANTENNASCOPE



Now you can be sure of maximum antenna performance with this Antennascope based on design of W. M. Scherer, W2AEF published in CQ, September. Used with a Grid-Dipper, you can measure radiation resistance, resonant frequency of antenna, line impedance, receiver input impedance, feedline s.w.r. Reduce TVI, increase xmtr efficiency, improve receiver performance, by knowing and measuring your rig. Eldico Antennascope is available in kit form or completely wired and tested. Kit form ..... \$24.95;

Wired and tested ..... \$29.95

**For the MOBILE Ham**  
Harvey carries complete stocks of Gonset and Mallard Converters.

**For your FIXED Station**  
we have the equipment of the outstanding manufacturers — Collins, Hallicrafters, National, RCA...

**PLUS**  
all the products of the country's leading parts manufacturers.

VISIT HARVEY'S AUDIOTORIUM — Come in and visit our new Sound Department... all these items and many more on working display at all times.

Telephone **hrc** LUxemburg 2-1500

# HARVEY

## RADIO COMPANY, INC.

103 West 43rd St., New York 18, N. Y.

NOTE: In view of the rapidly changing price situation in both complete units and components we wish to emphasize that all prices are subject to change without notice, and are Net, F.O.B., N.Y.C.

# NOW a really high-powered RADIO ENGINEERING LIBRARY

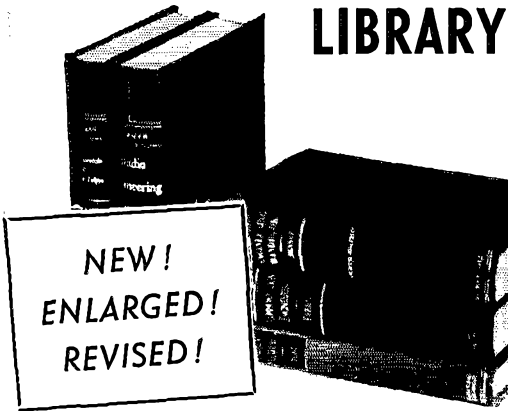

## Special Offer on This Complete Up-to-Date Set

**Save \$5.00!** These fine engineering books would cost a total of \$39.50 at our regular single-copy prices, if you bought them one or two at a time. Under this offer you can have the whole set at once and we'll pass along the saving in handling in a special low Library price of only \$34.50. In addition you may spread this over several installment payments as shown in the coupon below. Take advantage of these convenient terms to add these helpful books to your working library right away.

**5 volumes, 3,921 pages, 2,770 illustrations**

Eastman's FUNDAMENTALS OF VACUUM TUBES, 3rd Ed.  
Terman's RADIO ENGINEERING, 3rd Ed.  
Everitt's COMMUNICATION ENGINEERING, 2nd Ed.  
Hund's HIGH-FREQUENCY MEASUREMENTS, 2nd Ed.  
Henny's RADIO ENGINEERING HANDBOOK, 4th Ed.

### What this library gives you

These books cover circuit phenomena, tube theory, networks, measurements, and other subjects—give specialized treatments of all fields of practical design and application. They are books of recognized position in the literature—you will refer to and be referred to often. If you are a practical designer, researcher, or engineer in any field based on radio, you need these books for the help they give in hundreds of problems throughout the whole field of radio engineering.

### EXAMINE THESE BOOKS 10 DAYS FREE

McGraw-Hill Book Co., 330 W. 42nd St., N. Y. C. 18

Send me RADIO ENGINEERING LIBRARY for 10 days' examination on approval. In 10 days I will send \$4.50, plus few cents for delivery, and \$6.00 monthly until \$34.50 is paid, or return books postpaid. (We pay delivery if first payment accompanies this coupon; same return privilege.)

Name.....

Address.....

City..... Zone..... State.....

Company.....

Position..... QST — 11-51

(This offer applies to U.S. only)

Meet, RB won the transmitter hunt, with UQ and JW next in order. Jean (Mrs. JW) won the ladies' beauty contest with UQ winning the men's beauty event. TE won for traveling the farthest. UQ won the best mobile event. Traffic: VESHR 16, TE 10, YF 8, WH 2.

### 160-METER DX TESTS

The annual 160-meter DX tests which have now become a tradition are again announced and scheduled for December, January and February. These periods have been fixed for the tests: Sundays, 0500-0800 GCT, December 16th and 23rd, January 6th and 20th, February 3rd and 17th.

W/VE stations will call "CQ DX" at 0500-0505, 0510-0515, 0520-0525 and so on. All DX stations will call at 0505-0510, 0515-0520, 0525-0530 and so on. W stations will use authorized frequencies 1800-1825 and 1975-2000 kc. G stations will use 1775-1795 kc. and other DX frequencies as authorized.

Reports from participating W/VE stations should be sent to Stewart S. Perry, WIBB, 36 Pleasant Street, Winthrop, Mass. Log forms for the reports will be supplied by WIBB to those who request them. All DX stations should send their reports to Austin J. Forsythe, G6FO, 49 Victoria Street, London S.W. 1, England.

### Announcing—10-Meter Worked All States Contest

Dec. 7th-8th-9th and 14th-  
15th-16th

How many states and how many stations can you work on ten in two week ends? If you are located anywhere in the League's field-organization territory (see page 6 of *QST*), you are cordially invited to take part in this new operating activity. C.w. to c.w., 'phone to c.w./c.w. to 'phone, or 'phone to 'phone can be used. Certificates will be awarded the highest scorer in each section. The total available operating time will be 96 hours. The week end periods start Friday afternoon (3 P.M. PST or 6 P.M. EST) on the 7th and 14th of December and end on the same times the 9th and 16th.

Scoring is simple. One point is allowed for each contact and 1 multiplier point for each different state worked. The same station may be worked but once during the contest for credit. Total contacts multiplied by the total different states worked gives you your score. Exchange of reports and names of states are all that is necessary for scoring. For contacts that are made with other than the 48 states, for example, KP4 or VE1 through 8, 1 contact point is allowed but no multiplier point.

A complete announcement of the contest, including the rules governing participation, will appear in December *QST*. Contest reporting forms will be sent to all amateurs who request them by mail or radiogram. It is not necessary to make advance entry or to use these forms if the report form described in the next issue of *QST* is followed. Closing date of entries is January 15, 1952.

How many states can you work, OM?

# BOB HENRY, WØARA, OFFERS YOU:



**LOW PRICES:** I sell to you as cheap or cheaper than you can buy anywhere.

**COMPLETE STOCKS:** Collins, Hallicrafters, National, Hammarlund, RME, Millen, Harvey-Wells, Meissner, Gonset, Meck, Johnson, RCA, all other amateur receivers, transmitters, beams, TV, AM-FM, Polic-Alarm and Monitoradio, high fidelity amplifiers and speakers, test equipment, tubes, parts, etc. I can supply nearly any equipment shown in any catalog or advertisement and at lowest prices.

**BEST TRADE-IN ALLOWANCE:** Customers in all parts of the USA trade with me because I allow so much. Tell me what you have to trade and what you want. I also buy equipment.

**TIME PAYMENTS:** You can order anything on terms. I finance the terms myself to save you time and bother. Customers everywhere in the USA find my terms best. Write for details.

**QUICK DELIVERY:** Mail, phone, or wire your order. It will be shipped promptly. I can be reached nearly 24 hours a day, 7 days a week.

**TEN-DAY TRIAL:** Try any communications receiver ten days --- if you return it your only cost is shipping charges.

**PERSONAL ATTENTION:** The Butler store is run by Bob Henry, WØARA, and the Los Angeles store by Ted Henry, W6UOU. We make the deals ourselves. We finance the time payments ourselves. That way we have the lowest overhead and can do more for you. That's why YOU AND I CAN DO BUSINESS. Write, phone, or visit either store. Export orders solicited.

73.

*Bob Henry*  
WØARA

Butler 1, Missouri  
Phone: 395

## HENRY RADIO STORES

11240 Olympic Blvd.  
LOS ANGELES 64  
BRadshaw 2-2917

"LARGEST DISTRIBUTORS OF SHORT WAVE RECEIVERS"

**NO OTHER MICROPHONES  
OFFER YOU SO MUCH  
FOR SO LITTLE!!!**

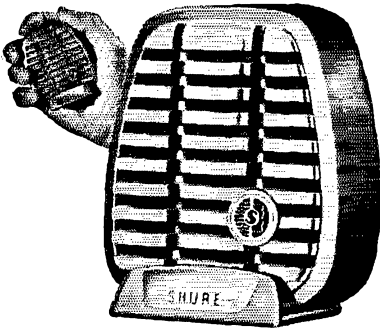

**...The New Shure Controlled Reluctance  
"HERCULES" Only \$15.00 List!**

A revolutionary new hand-held magnetic unit that provides clear reproduction, high speech intelligibility, high output, and ruggedness — at an amazingly low price! A tough microphone that can be used indoors or outdoors — fits snugly in the hand, sits firmly on a desk without tipping over, can be placed on a stand. Metallic Green finish. Complete with stand adapter. Die-cast case. 2 3/8" wide, 3 1/4" high, 1 1/2" thick.

MODEL	CABLE	OUTPUT LEVEL	IM-PEDANCE	SHPG. WEIGHT	CODE	LIST PRICE
510C	7 ft.	52.5 db below 1 volt per microbar	High	1 1/4 lb.	RUTUF	\$15.00
510S (with switch)	7 ft.	52.5 db below 1 volt per microbar	High	1 1/4 lb.	RUTUS	\$17.00

**...The New Shure Crystal  
"REX" Only \$10.95 List!**

A striking-looking low-cost crystal microphone. The "Rex" is a high output, hand-held microphone that fits snugly in the hand, sits firmly on a desk without tipping over, or can be placed on a stand. The "Rex" is recommended where good quality speech reproduction is required, and low cost is an important factor. Burgundy Red metallic finish. Complete with stand adapter. 2 3/8" wide, 3 1/4" high, 1 1/2" thick.

MODEL	CABLE	OUTPUT LEVEL	IM-PEDANCE	SHPG. WEIGHT	CODE	LIST PRICE
710A	7 ft.	50 db below 1 volt per microbar	High	1 1/4 lb.	RUDEL	\$10.95
710S (with switch)	7 ft.	50 db below 1 volt per microbar	High	1 1/4 lb.	RUDET	\$12.95

*Controlled Reluctance Microphones Built Under Shure Patents. Crystal Microphones Licensed Under Patents of Brush Development Company. Shure Patents Pending.*

**SHURE**  
**SHURE BROTHERS, Inc.**  
Microphones and Acoustic Devices  
225 West Huron Street • Chicago 10, Illinois  
Cable Address: SHUREMICRO

**Convention**

(Continued from page 28)

The licensed YL operators — 60 strong — had their own breakfast and a number of interesting discussions. Ethel Smith, W3MSU, won the quiz contest, and was awarded a beautiful loving cup sponsored by the West Seattle Amateur Radio Club. Among other things, each YL received a small totem pole as a gift souvenir.

And the "radio widows" were not to be undone. They had their big breakfast in the Olympic Grill, with Mrs. Monica Zandbergen in charge. Several hundred attended, taxing the facilities of the hotel restaurant.

Late Sunday morning the mobiles vied for prizes, with the officers of the Radio Club of Tacoma acting as judges. Winners in the various mobile divisions included W7DET, W7BAC, and W6RL. During the convention W7KZP, W7CO and W7HRC operated a repair service for visiting mobiles.

The series of boat cruises was resumed Sunday at noon, with a chartered vessel leaving every hour. Guests were taken for a ride on scenic Lake Washington, and were treated to a special performance of the world's fastest speedboat, the *Slo-Moshun IV*, which zipped around the cruise vessel in wide circles at better than 150 m.p.h. as it prepared for the Gold Cup Races a few days later. The Sunday boat cruises were under the direction of Wally Hewitt, W7AJS.

At 1:30 p.m. the United Airlines courtesy flight left the huge Seattle-Tacoma International Airport with Ralph Gibbons, W7KV, as pilot. Fifty-or-more convention delegates got an awe-inspiring view of Mount Rainier, the Puget Sound country and the Northwest.

During Sunday afternoon a technical session was held at the Olympic Hotel. John L. Reinartz, K6BJ (ex-W1QP), gave an interesting talk on methods of combatting TVI, and Assistant Technical Editor Byron Goodman, W1DX, of QST discussed types of modulation.

The culmination of the convention came at 6 p.m. with the huge banquet at the Civic Auditorium. Some 1500 hams and friends sat down to a fine banquet, which was served in double-quick time. The food was excellent, having been chosen only after careful sampling and ordering by the Women's Committee of the convention. Each guest received a special souvenir menu.

ARRL President George W. Bailey, W2KIH, acted as toastmaster, and set the stage for a highly-delightful series of introductions and remarks, including a brief address by Secretary A. L. Budlong of ARRL. The presentation of many awards also took place during this time. The fast-moving and exciting closing minutes of the convention saw hams introduced by each call area in attendance. The W7s were, of course, the most numerous, but over 300 W6s and over 300 VE's vied closely for second place.

When the final gavel fell, closing the Sixth National, it was hours and hours before the gang finally and reluctantly cleared out. Besides the

(Continued on page 102)

# Terminal HAS TEST GEAR IN STOCK!

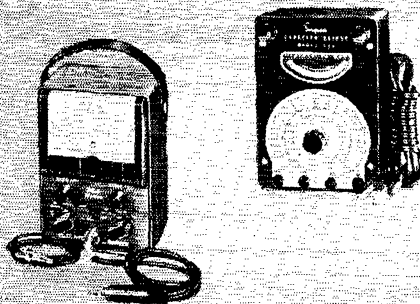
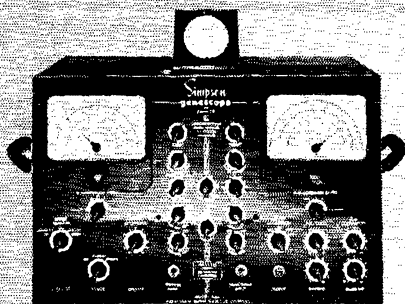
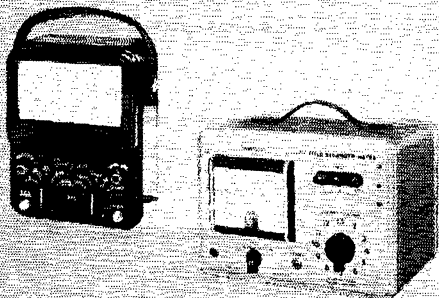

VFO Kit, 10 thru 160 meters. Adequate Output, stable, calibrated, good companion for VIKING-1 XMTR or any other. Less tubes **\$42.75**

**NEW "COUNTER" DIAL**  
Rugged gear drive. Records 99 turns. Vernier 0-100. enables accurate reset. 116-208-1 with dial lock . . . **\$10.00**  
116-208-4 without lock . . . **\$8.82**

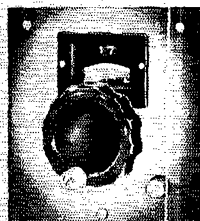

## RCA

WV-77A Junior VTVM **49.50**  
WV-97A Senior VTVM **67.50**

## MILLEN

\*90671—Standing Wave Ratio Bridge **16.80**  
90651—Grid Dip Meter **61.50**  
\*(Special 1" Round 0-1 MA-D.C. meter to use as indicating instrument . . . \$4.61)

## SYLVANIA

132Z-7" Oscilloscope **149.50**  
220—Tube Tester, Portable **114.50**  
219—Tube Tester, Counter Type **114.50**

## SIMPSON

#260—Volt-Ohm-Mil-Ammeter **38.17**  
#303—VTVM **57.57**  
#480—FM-TV Genescope **387.10**  
#488—TV Field Strength Meter **87.81**

## HICKOK

#215—VTVM **67.50**  
#450—Volt-Ohm-Mil-Ammeter **46.50**  
#600—Tube Tester **146.95**  
#610A—TV Alignment generator **219.00**

## PRECISION

#85—Volt-Ohm-Mil-Ammeter **39.15**  
E-200-C—AM-FM-TV Sig. Generator **69.82**  
#612-P—Portable Tube and Battery Tester **71.05**  
ES-500-5" Oscilloscope **156.31**

## TRIPLETT

#625NA—Wide Range Volt-Ohm-Mil-Ammeter. **48.51**  
#630—Volt-Ohm-Mil-Ammeter **38.71**  
#630A—Same with Mirror Scale **48.51**

## JACKSON

CRO-2 Oscilloscope, 5" **193.55**  
TVG-2-TV Sweep & Marker Generator **240.10**  
109-VTVM **58.31**

## ADVANCE

H-1—Audio Generator, Sine and Square Wave **89.50**

## SUPERIOR

#770—Volt-Ohm-Milliammeter **14.50**  
#777—Tube and Set Tester **58.75**

## NEW "JOHNSON" ITEMS

# TERMINAL RADIO CORP.

85 CORTLANDT STREET • NEW YORK 7, N. Y.

Phone: WOrth 4-3311

Cable Address: TERMRADIO

Only

**SPRAGUE**

00000

Makes

**HYPASS CAPACITORS**

for TVI



This exclusive Sprague capacitor design is curing TVI problems all over the country. Unlike ordinary capacitors, it is an effective v-h-f filter and bypass unit... ideal for eliminating harmonics in transmitter circuits and for filtering interference on a-c mains and on control circuits. Developed in cooperation with ARRL HQ. See QST for Feb. and Oct. 1949 and CQ for Sept. 1949 for details on how these capacitors solve tough amateur TV interference problems.

Write for bulletin 432 or see your Sprague jobber today.

Catalog Number	Mfd.	Working Voltage	Size Diam. - Length	List Price
48P9†	.1	250 a-c	11/16 x 1 13/16	\$2.60
46P8	.005	600 d-c	1/4 x 1 5/8	2.15
47P6	.01	600 d-c	7/16 x 1 1/4	2.35
47P12†	.005	1000 d-c	7/16 x 1 1/4	2.40
47P13†	.01	1000 d-c	7/16 x 1 1/2	2.60
47P14†	.005	2500 d-c	1 x 1 9/16	2.90
47P15†	.01	2500 d-c	1 x 1 9/16	3.10
47P16†	.002	5000 d-c	1 x 1 9/16	3.20

\*Recommended for power lines, filaments, and control circuits up to 20 amps line current. Often more effective than a choke-capacitor filter. Has female screw terminals.

†Circulating current to ground at 14 and 28 mc should not exceed 2 amps for 47P15 and 47P16, 3 amps for 47P13 and 47P14, 4 amps for 47P12.

**SPRAGUE PRODUCTS COMPANY**

75 Marshall Street

NORTH ADAMS

MASSACHUSETTS

exhibits of amateur and commercial gear, they had also seen the well-planned Navy and MARS booths, a Coast Guard rescue truck in actual stand-by condition, the ARRL booth with the original 1AW spark transmitter, the W7 QSL bureau manned by W7FWD and W7FWR, and a radio-controlled model yacht doing its stuff through the courtesy of the U. S. Model Racing Yacht Assn.

— . . . —

When the smoke had cleared away, several hundred Seattle hams were tired and happy. The Convention Committee<sup>1</sup> was made up of members from the two sponsoring clubs, the West Seattle Amateur Radio Club, Inc., and the North Seattle Amateur Radio Club, Inc. The Committee itself was incorporated as a non-profit institution, and had worked for over a year on the planning. Over \$13,000 was spent, with a slight deficit when the books were closed. However, the deficit was negligible in view of the size of the undertaking. One thing remains certain — the gang got their money's worth!

<sup>1</sup>The committee for the Sixth National Convention consisted of W7s AA, AAH, BG, BL, BQS, CO, COX, CPY, CV, DET, DL, DXF, EKA, EOP, FD, FIX, FNA, GNY, GRM, GSR, GUV, HUL, IGM, IKY, IOQ, JWC, JWE, JXR, KEU, KGC, KKZ, KV, KZP, LCS, LOZ, MEU, NL, NRB, RT (General Chairman), VI; and Mrs. Monica Zandbergen, XYL of W7KZP.

### One Db. per Cycle!

(Continued from page 81)

The coils in the amplifier are wound on WE P-284395 forms, and the b.f.o. coil is wound on a WE P-285671 temperature-compensated form. The forms were obtained from Fred Berry, WØMNN (who made several helpful suggestions about the design), but they can also be obtained through any Graybar dealer.

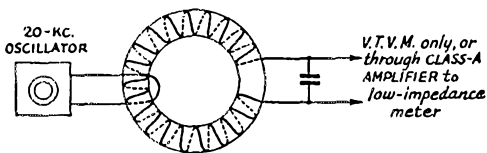

Fig. 3 — The test set-up for adjusting the coil inductance. The 20-kc. oscillator should be calibrated to at least 50-cycle intervals. Each coil is resonated to 20 kc. with its individual condenser. Thus, L<sub>1</sub> would be tuned with C<sub>11</sub>, L<sub>2</sub> with C<sub>12</sub>, etc.

The b.f.o. tuned circuit is placed roughly on the desired side of zero beat and then brought to frequency by padding with small condensers after the amplifier has been finally lined up.

#### Adjustment

The most practical line-up technique was found to be over-all measurement of the passband shape between the 6-db. points. With all circuits

(Continued on page 104)



# THERE IS NOW ONLY ONE NEWARK ELECTRIC CO.

and it is located at 323 W. MADISON ST., CHICAGO, ILL.

Still Supplying the Finest in Radio, TV and Electronics Promptly From Stock . . . At the Lowest Possible Prices!

We Have No Branch Offices or Stores

**Save ON THESE AMATEUR VALUES**

**New! Junior VoltOhmyst**

**Latest by RCA—A Low-Cost, Top Quality VTVM**

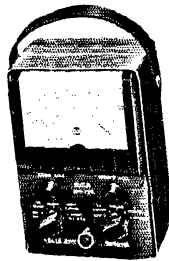

### MODEL WV-77A VOLTOHMYST

Incorporates features found only in more expensive instruments. Measures DC volts from 0.05 to 1200 volts rms in 5 ranges; measures AC volts from 0.1 to 1200 volts rms in 5 ranges; Ohmmeter measures resistance from 0.2 to 1 billion ohms in 5 ranges. Frequency response flat from 30 cps to approximately 3 mc. Has  $\pm 3\%$  over-all accuracy on +DC scales and  $\pm 5\%$  on AC and —DC scales. Zero-center scale for discriminator alignment. Features 200-microampere meter movement. Complete with DC probe, AC direct probe and cable, lead and clip. Size,  $8 \times 5 \frac{1}{2} \times 4 \frac{1}{2}$ ". Shpg. wt., 6 lbs. **\$47.50**  
62G010. NET.....

**RCA's Famous Senior VoltOhmyst**

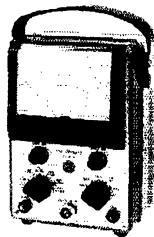

### MODEL WV-97A VOLTOHMYST

Improved version of the famous 195-A. Wide response. 30 cps to 3 mc. Reads DC volts to 1500 in 7 continuous ranges, with an input resistance of 11 megohms. Reads AC rms to 1500 volts; AC peak-to-peak, 4200 volts. Input resistance, .83 megohms and 70 mmf to 1.5 megohms and 60 mmf. Ohmmeter reads 0.2 ohms to 1000 megohms in seven continuous ranges. Overall accuracy: on DC,  $\pm 3\%$ ; on AC,  $\pm 5\%$  of full scale. Size,  $5 \frac{1}{4} \times 7 \frac{3}{4} \times 3 \frac{3}{4}$ ". With probes and leads. Shpg. wt., 10 lbs. **\$67.50**  
62G000. NET.....

PRICES SUBJECT TO CHANGE WITHOUT NOTICE

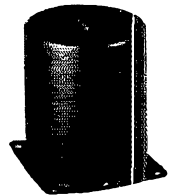
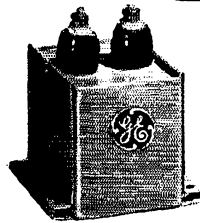

### G. E. TRANSMITTING CAPACITORS

While they last, Newark is offering these top-quality Pyranol-filled transmitting capacitors at less than manufacturer's cost! Conservatively rated at 1 mfd. 5000 volts. Porcelain insulators. Hermetically sealed in metal case,  $3 \frac{3}{4} \times 4 \frac{1}{4} \times 4 \frac{1}{2}$ ". Complete with mounting brackets. All brand new units. Shpg. wt., 7 lbs.

54G004. SPECIAL PRICE.....**\$6.95**

### HI-FI OUTPUT TRANSFORMERS

Save on these 50-watt output transformers — they're terrific values at the sensational low price of \$2.45! Match push-pull parallel or push-pull 6L6, 6V6, 807, and other tubes to 4, 8, 16 ohm voice coil; also 60 and 250 ohm line. Range: 30 to 50,000 cps. For use in high-powered PA amplifiers. 4000 ohms primary, P to P. Case,  $4 \frac{1}{2} \times 3 \frac{3}{4}$ " dia. Shpg. wt., 7 lbs.

54G101. Special Price.....**\$2.45**

Multi-Filament Transformer. Has six CT secondaries: (3) 6.4 V @ 8A; (2) 6 V @ 2.5A; (1) 2.6 V @ 10A. Size,  $4 \frac{1}{4} \times 5 \times 5 \frac{1}{4}$ ". Shpg. wt., 14 lbs.

54G100. Special Price.....**\$3.29**

Filter Choke, 6.5 hy. @ 230 ma. 3000 volts insulation. Size,  $5 \times 7 \frac{1}{2}$ ". Shpg. wt., 23 lbs.

54G102. Special Price.....**\$2.95**

Filter Choke, 4.2 hy @ 300 ma. 78 ohms. 2500 volts insulation. Size,  $4 \frac{1}{2} \times 3 \frac{1}{2}$ " dia. Wt., 9 lbs.

54G103. Special Price.....**\$2.49**

**Send for NEWARK'S 160 PAGE FREE CATALOG**

**The New Electronics Reference Book!**

for  
**AMATEURS INDUSTRIAL USERS**



# NEWARK ELECTRIC COMPANY

323 W. MADISON ST. • CHICAGO 6, ILLINOIS

The COMBINATION of  
**TECH-MASTER**  
**ENGINEERING**  
 and  
**YOUR HAM**  
**EXPERIENCE**

Will give you the finest  
 in TV Reception...

LO-PRICED  
 Universal  
 AC/DC KIT

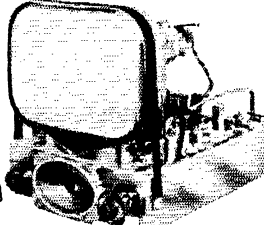

**FOR TUBES UP TO 17" \* RECTANGULAR**

First LOW COST TV Receiver Kit completely engineered exclusively by **TECH-MASTER**. Features 2-knob control and small, lightweight chassis. IF section comes completely wired and pre-aligned.

**MODEL 5116**.....\$89.50

Set of circuit-matched tubes, tested with each individual kit.....\$16.25

\* Up to 14" tube on D.C. current

Advanced  
 630 Type  
 KIT

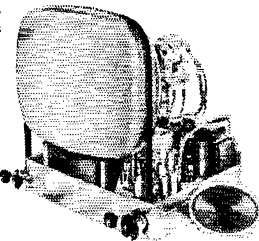

**FOR ALL SIZE PICTURE TUBES, 12" to 24"**

The greatest advance in TV Kits developed by **TECH-MASTER!** Acknowledged by leading engineers as the TOPS in the field!

**MODEL 630D19** (De-Luxe) Principal components assembled—Resale Price...\$159.50

**MODEL 630S19** (Standard) Unassembled. Resale Price.....\$154.50

Above Kits supplied with Tubes, Parts, Speaker and Picture-tube Mounting Brackets (Less Kine, Wire and Solder).

Available at leading Radio Parts and Ham Equip't Distributors. Write to **TECH-MASTER**, Dept. Q-11 for Complete Descriptive Literature.



**TECH-MASTER**  
**PRODUCTS CO.**

443-445 BROADWAY, NEW YORK 13, N. Y.

initially about 50 cycles or so higher than the desired midfrequency, temporary addition of 47- and 100- $\mu$ fd. micas will quickly show what circuits should be lowered permanently to bring the two outside peaks to the same level. Also, 50- $\mu$ fd. variable condensers across  $L_3$  and  $L_4$  will permit placing the center peak exactly in the middle.

The output can be indicated at audio frequencies with the b.f.o. on, but one must be careful to avoid a.f. resonances in the audio amplifier. A more accurate indication can be obtained by switching off the b.f.o., substituting a 47,000-ohm resistor for  $L_{13}$ , and reading the i.f. signal with a v.t.v.m. across this resistor.

Since the shape of the passband top distorts if but one coil is detuned 25 cycles, and the P-284395 toroid form is not temperature-compensated, it is unwise to mount the filter close to a steam radiator or an oven door.

The 470-kc. input to this amplifier should be adjusted so that not more than 0.01 volt appears across the first tuned circuit, if the full discrimination is to be realized, since the coil  $Q$  decreases with strong signals. (It drops from 300 to 250 between 0.01 and 1 volt.) Each 5-coil section introduces about 21 db. loss, and the tube gains should be adjusted to just compensate for this.

The detector is followed by a filter that rejects any 20-kc. components coming through, and the audio is fed to a high-gain audio amplifier (with limiter) that brings the signals up and beyond comfortable headphone level. With this amplifier you get real "super selectivity" for c.w., without a trace of ring even with a Model T turning 2000 r.p.m. under the antenna.

**Every Mil I Have**

(Continued from page 32)

From now on we can forget all about the moving-iron type of meter, and concentrate on the troublemaker — the d'Arsonval type. Regardless of the make of meter concerned, if you walk into a radio store and buy a d'Arsonval meter, the chances are ten to one that you will have a meter which the manufacturer calibrated to read correctly only on nonmagnetic panels. (All bets are off if the meter is a "surplus" buy, because these could be calibrated for practically anything.) In other words, the manufacturer normally supplies meters calibrated for nonmagnetic panel mounting unless specified otherwise.

**What To Do**

Meters of this sort (microammeters, milliammeters, ammeters, voltmeters, r.f. ammeters, etc.) should only be used on aluminum, bakelite, wood, or other material which is nonmagnetic. The minute these meters get close to a steel panel they forget to read correctly. Of course, it does not permanently damage the meter to use it in a steel panel, and this is quite satisfactory if you remember that the meter is reading low. To play safe, figure that the reading is ten per cent lower

(Continued on page 106)

QUALITY — PRICE  
DEPENDABILITY



Our 29th Year

## SPECIALS

2 1/2 watt Argon bulbs .....	19¢ each — 10 for \$1.50
RCA 800 Tube .....	.95
304TL Tube .....	16.50
200 watt 10,000 ohm Ferrule Resistor .....	.30
FT243 Xtals 3245, 3655, 3700, 4110, 4780, 5235 KC. ea. ....	.50

### JOHNSON ALUMINUM CHASSIS WITH REINFORCED CORNERS

350—7 x 5 x 2 .....	\$.82	364—15 x 7 x 3 .....	\$1.76
353—9 1/2 x 5 1/2 x 2 .....	1.00	371—17 x 10 x 3 .....	2.20
354—10 x 5 x 3 .....	1.12	377—17 x 12 x 3 .....	2.67
355—10 x 8 x 2 1/2 .....	1.23	380—17 x 13 x 3 .....	2.82
357—12 x 7 x 3 .....	1.32		

### UNIVERSAL MODULATION TRANSFORMER A-3106

Pri.—2000—20000 @ 220MA P/side	
Sec.—2000—20000 @ 220/440MA P/side	
125 watts .....	<b>\$13.23</b>

### HALF WAVE RECTIFIER TRANSFORMER P-3045

Pri. 115V A.C. Sec. 120V. @ 50 MA with 6.3V.-1.5 amp. filament winding.....	<b>\$ 2.73</b>
--	----------------

### POWER TRANSFORMER

P-2955—115V. pri. Sec. 400-0-400 @ 200 MA. 5V. @ 3 amps.—6.3V. @ 5 amp.....	<b>\$ 8.23</b>
--	----------------

### MERIT HI FIDELITY

OUTPUT TRANSFORMERS .....	<b>\$10.58</b>
---------------------------	----------------

Response 30-20,000 CPS. 20 watts  
A-3100 Pri. imp. 5,000, 3000 C.T. Sec. 4-8-16 ohms  
A-3101 Pri. imp. 10,000, 6600 C.T. Sec. 4-8-16 ohms

### LYSCO MOBILE OR FIXED V.F.O.

Model 381—contains three-6AK5's-Oscillator Doubler-Buffer. 14"-300 ohm lead. Doubler supplies plenty of drive to replace 3.5 Mc. or 7 Mc. crystal. Direct reading illuminated clock dial. Size 4 X 4 3/4 X 5. Operates on 200 to 400V. D.C. @ 25 MA.

Price .....

**\$26.95**

Model 381R—15' coaxial cable with remote tuned circuit to plug into crystal socket; calibrated for 40-20-10 meters. Output 40 meters.

Complete .....

**\$33.95**

### LYSCO TRANSMASTER

35 watt transmitter exciter for 10 to 160 meters. Break in keying illuminated dial, PA plate meter . . . modulation tie in, grid meter jack and built in power supply. 6AG7 OSC, 6AG7 Buffer, 807 P.A., VR150 and 5U4G rectifier. 115V AC, 60 cycles. Output low impedance 50 ohm line. Complete with tubes in black wrinkle finish cabinet. 17"L. X 9"H. X 11"D.

Model 600 TV1 Suppressed .....

Model 500 Standard .....



### LYSCO DIPMASTER

Grid dip meter. Range 3.4 to 160 Mc. Also can be used as absorption wave meter, phone monitor, signal generator, range 3.4 to 300 Mc., and field strength meter. With 5 plug in coils, 955 tube. 115V. AC/DC only. Power requirements 15 watts, 115V. AC/DC. 3" X 9" X 3 1/2". Finished in black wrinkle bar. Model D-11 .....



**\$39.95**

### MERIT FILAMENT TRANSFORMERS 115V. Pri.

P-3042 2.5V. C.T. @ 10 amp.	10,000V. Insul.	\$3.67
P-2943 5V. C.T. @ 20 amp.	2,500V. Insul.	\$6.47
P-3074 6.3V. C.T. @ 1.2 amp.	3,500V. Insul.	\$2.12
P-3146 10V. C.T. @ 10 amp.	3,000V. Insul.	\$5.88
P-2959 12.6V. C.T. @ 2 amp.	2,500V. Insul.	\$2.64
P-2962 25.2V. C.T. @ 1 amp.	2,500V. Insul.	\$2.64
P-2963 12.6V. C.T. @ 7 amp.	2,500V. Insul.	\$5.88
or		
25.2V. C.T. @ 3.5 amp.		

### HIGH VOLTAGE PLATE TRANSFORMER

Merit P-4062 115V. Pri.  
Sec. 2900-0-2900 } @ 300MA  
2385-0-2385 }

Completely shielded .....

**\$47.04**

### SUPERIOR POWERSTATS

Smooth, efficient voltage control. 0 to 135V. output from 115V. AC line.  
Type 20 (illustrated 3 amps) .....

116 for table mtg 7.5 amps .....

116U for panel mtg 7.5 amps .....

1126 15 amps .....

1156 45 amps .....

Also available for 230 volt input. Write for descriptive literature.



### REPLACEMENT POWER TRANSFORMER

for 630 Type TV Chassis. Merit P-3061.....

**\$16.17**

### SCOPE TRANSFORMER. Merit P-3171

Pri. 115V. A.C. Sec. 2500V. @ 5MA with  
2.5V @ 2 amps, 6.3 or 2.5V. @ 3 amps....

**\$ 8.23**

6 VOLT D.C. Input 110V. A.C. Output VIBRATOR Supply  
40 watts. Will fit into any car cigar lighter  
socket .....

**\$ 9.95**

5-WAY BINDING POSTS 5 methods of connection. Complete insulation, 30 amp, current capacity, 1000 v. working voltage. Captive head for convenience. Red or black color. 5 connections: 1. Permanent clamping. 2. Spade Lug. 3. Plug-in for Banana Plug. 4. Looping and Clamping. 5. Clip-Lead.

If not rated 25% with order, balance C.O.D. All prices F.O.B. our warehouse New York. No order under \$2.00 We ship to any part of the globe.

# LEEDS RADIO CO.

75 Vesey Street  
Cortlandt 7-

Dent. QS 11  
New York City 7

- **ELECTRONIC  
DESIGN ENGINEERS**
- **TECHNICAL WRITERS**
- **DESIGN DRAFTSMEN**
- **PHYSICISTS**

# Westinghouse

offers you

## SECURITY AND OPPORTUNITY

EE's and ME's with over 3 years experience . . . a number of excellent positions are now available in our Electronic & X-ray and Air-Arm Divisions for work on:

- Broadcast Transmitters
- Power Line Carrier Communication Equipment
- Railroad Radio
- Radio Frequency Heating
- Medical and Industrial X-ray
- Commercial Radar
- Balancing Equipment
- Military Radar (ship, ground, airborne)
- Military Transmitters
- Specialized Electronic Equipment
- Fire Control Systems
- Automatic Pilots
- Guided Missiles

**Check These Outstanding Benefits:** Top pay, ideal working conditions, advancement on merit, graduate study opportunities, employee scholarships, paid re-location expenses, Baltimore location.

**Send resume of experience and education to:** Manager of Industrial Relations, Westinghouse Electric Corp., 2519 Wilkens Ave., Baltimore 3, Md.

**YOU CAN BE SURE...IF IT'S**  
**Westinghouse**

than it should be. Some meters may only be off as little as five per cent, but you may not have that type of meter.

If you wish to purchase new meters, you may specify the thickness of steel panel you intend to use, and the manufacturer will calibrate the meter to read correctly when used on that thickness panel. For amateur use the standard panels are either one-sixteenth, one-eighth or one-quarter inch thick. Manufacturers will calibrate meters for any thickness, however, such as three-quarter inch steel panels (this latter is in case you are building your transmitter in a surplus battleship turret).

Some of the cannier hams buy meters calibrated for one-eighth or one-quarter inch steel panels, then if they use them in a nonmagnetic panel they put a small square piece of one-eighth or one-quarter inch steel around the meter on the back of the nonmagnetic panel. This works very nicely and is a stunt highly recommended by the author. This piece of steel need not be large. Just make sure that there is some steel all around the meter, which means that you can use a piece of steel which is only an eighth of an inch larger than the required hole for the meter.

Don't let the steel panels get ya! After all, if you want a meter to read incorrectly, it's much easier to drop it on the floor — preferably a cement floor!

### Technical Topics

*(Continued from page 44)*

low frequencies. The spurious side frequencies are harmonics of the distorted modulation frequency, and if that frequency is around 400 cycles harmonics up to the seventh or eighth will fall inside the normal speech channel and thus the distortion may not cause much of a ruckus very far away from the carrier. The higher-frequency components seldom are of high amplitude, do not have a chance to be greatly distorted, and thus do not cause much splatter. The principal over-all effect is simply that the transmitted signal is a distorted one with its important frequency components mostly contained in a normal channel.

In other words, under favorable circumstances the result tends to approximate that obtained with a normally-designed clipper-filter. The fact that these schemes have been used principally in mobile work also helps, since the carbon microphone has relatively little high-frequency response and thus might be said to have a built-in "filter." Also, such splatter as is generated by a mobile transmitter is frequently lost in noise or QRM because of the low power, and thereby passes unnoticed until the mobile is really close. But whether or not all this is true depends pretty largely on how the transmitter is operated. While some are quite passable by reasonable standards, there are plenty that are not only broad but unpleasantly harsh to listen to. To be on the safe

*(Continued on page 108)*

# IT'S HERE!

## NEW, 164-PAGE CATALOG OF RADIO, ELECTRONICS AND TELEVISION

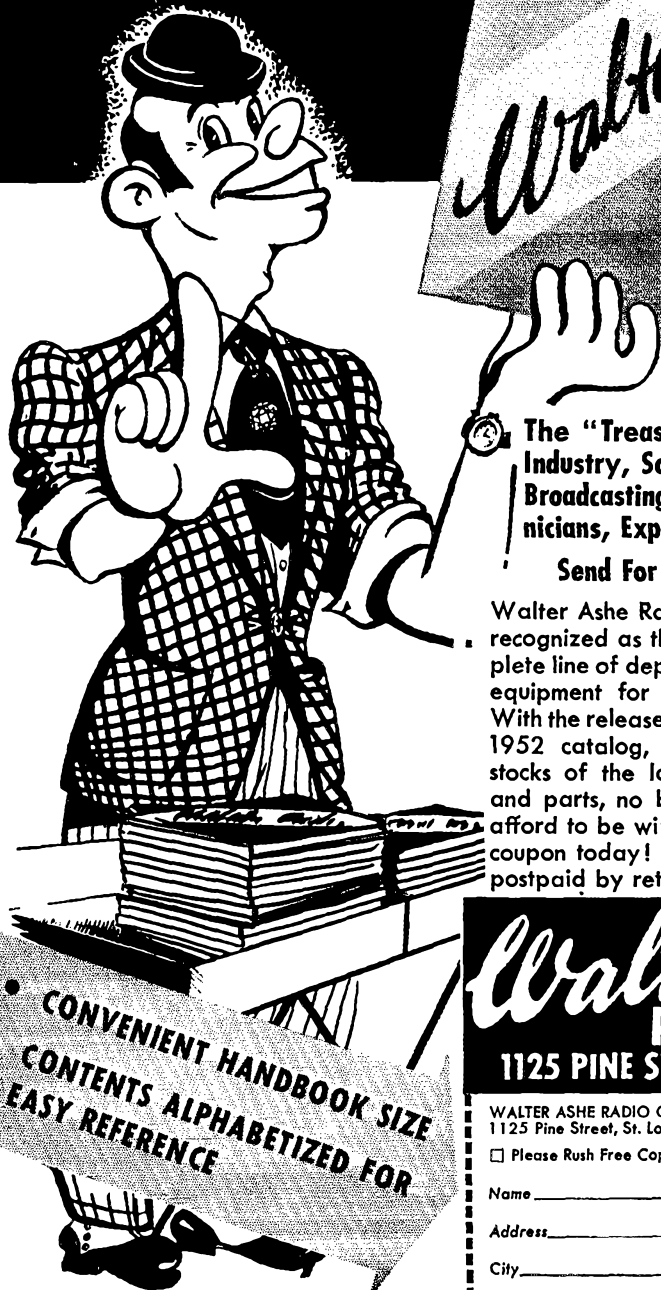

*Walter Ashe*

1952

The "Treasure Chest" of Values For Industry, Schools, Laboratories, Broadcasting Stations, Service Technicians, Experimenters and Amateurs.

Send For Your Free Copy Today!

Walter Ashe Radio Company has long been recognized as the reliable source for a complete line of dependable radio and electronic equipment for every conceivable purpose. With the release of this new, bargain-packed 1952 catalog, featuring bigger-than-ever stocks of the latest equipment, components and parts, no bargain-conscious buyer can afford to be without it. So act now. Mail the coupon today! Your free copy will be sent postpaid by return mail.

• CONVENIENT HANDBOOK SIZE  
• CONTENTS ALPHABETIZED FOR EASY REFERENCE

# Walter Ashe

## RADIO CO.

1125 PINE ST. • ST. LOUIS 1, MO.

WALTER ASHE RADIO CO.  
1125 Pine Street, St. Louis 1, Missouri

Q-11-51

Please Rush Free Copy of your new 1952 Catalog.

Name \_\_\_\_\_

Address \_\_\_\_\_

City \_\_\_\_\_ Zone \_\_\_\_\_ State \_\_\_\_\_

# LOOK

## JACK BOXES

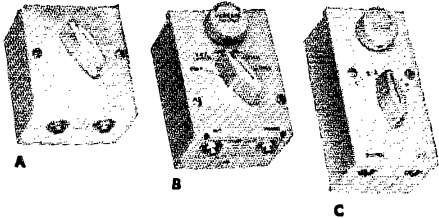

- (A) BC-345. 3½" x 3" x 1¾" aluminum, 2 standard open-circuit jacks, 3-position switch, 6-contact banana plugs and jacks.  
 (B) BC-1366. 4¼" x 3" x 2¼" aluminum, 1 standard open-circuit jack, 1 3-circuit mike jack, 150,000 ohm volume control, 5-position switch, 11-contact banana plugs and jacks.  
 (C) BC-213. 5¼" x 2¾" x 2¼" aluminum, 1 standard open-circuit jack, 1 3-circuit mike jack, 150,000 ohm volume control, 4-position switch, 8-contact banana plugs and jacks.

**YOUR CHOICE 30¢**



### CONDENSER SPECIAL

75 mmf. 4250 peak voltage, ceramic button insulation, adjustable spacing, straight-line capacity, precision construction, 3¼" long, 1¾" wide, shaft ¼" x 1", adjustable tension, **89¢** double-bearing . . . . .

### GRID BIAS CONTROL



2500 ohm, 25 watt Clarostat potentiometer, perfect grid bias control for panel mounting, excellent heavy-duty P.A. speaker volume control, TV focus control, worth \$5.20 list, brand new . . . **69¢**

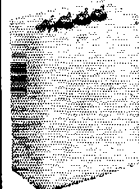

### 8/8/8 MFD. 500 V. D.C.

Triple 8 mfd. 500 working volt D.C. oil-filled condenser, common negative, solder terminals, hermetically sealed, 5" x 3¾" x 2¼". A one-time buy . . . **\$1.95**

### PHOSPHOR BRONZE AERIAL



125 ft. of the finest aerial wire obtainable. 42-strand phosphor-bronze with linen center. Will not stretch, very high tensile strength, diameter approximately same as No. 14 copper, very flexible. Excellent for transmitting or receiving antenna, control cable, guy wire. Regular list \$4.95 . . . . . **90¢**

73, Jule Burnett, W8WHE

# Steinberg

633 WALNUT STREET • CINCINNATI 2, OHIO

side, if you want to take advantage of speech clipping, do your clipping and filtering before the audio reaches the modulated amplifier. Then you can keep the spurious stuff under control.

Any form of grid modulation, and modulating the screen grid is no exception, is harder to adjust, and more critical as to operating conditions, than plate modulation. When you add complications such as controlled carrier and speech clipping, adjustment becomes even more critical and proper operation almost impossible of attainment without a 'scope. Unless you are prepared to accept these facts and be governed accordingly, better stick to plate modulation with its wide tolerances and ease of operation. --- G. G.

### Water in the Dust Bowl

(Continued from page 49)

Kansas Net. WØVRZ was active from Pretty Prairie and WØFLZ from Osage City handled traffic for flooded Council Groves. WØHAU and WØCBK operated from Marion on 160 meters, with the aid of WØGEY and an emergency power supply dug up by WØAFX.

Other places and stations which were active include WØGCJ (Marysville Red Cross), WØJLY/Ø (Quenemo), WØSOE (Wichita Red Cross), WØs JXJ, PYS and FQE (Kansas City area), WØOTN (Paola) assisted by WØUBI and WØOCK, and hundreds of others.

Operating some 50 mobile units, the Heart of America Radio Club reports not a single breakdown during the whole disaster, which lasted better than a week. A pretty good record!

Naval Reserve stations KØNAN at Junction City, Kans., KØNRK at St. Joseph, Mo., KØNBM at Parsons, Kans., and KØNRI at Kansas City, Mo., all took an active part in the emergency work. KØNRM at Manhattan and K9NAK at Alton, Ill., both furnished equipment and facilities for use by local radio clubs and AREC operators.

Long-haul traffic nets on 40 and 80 meters were of material assistance in relaying traffic for distant places, some of it of an official nature. The Tenth Regional Net of NTS was in almost continuous operation during the period of the flood. ARRL Trunk Line J also participated, holding a special Sunday session on July 15th during which much traffic was handled direct with Kansas portable stations in the flood area. The Transcontinental Relay Net, which operates on 7042 kc. and is primarily dedicated to swift overseas and transcontinental relaying, was instrumental in handling considerable quantities of traffic with WØHOC and others in the flooded area.

WØMAE was asked to set up in the Argentine district of Kansas City, Kans., but he preferred to operate from his own home, which was on high ground. Not too much later the place he had been asked to operate from and the Santa Fe Railroad's \$50,000,000 investment in the Argentine were under water.

(Continued on page 110)

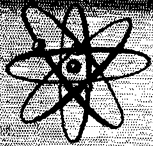

# Ham's Paradise!

OLDTIMER OR NOVICE  
ONE OF AMERICA'S GREAT RADIO STORES

## Introducing W2LLR's Custom Built 75 WATT A.M. MOBILE XMTR.

10 or 75 METERS (choice)

NIAGARA AGAIN PRESENTS FOR YOUR  
MOBILE OPERATING PLEASURE, CUSTOM  
QUALITY AND DESIGN

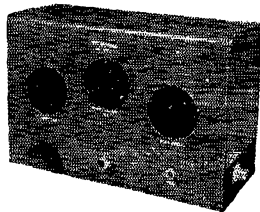

### LOOK AT THESE FEATURES!

- UNCONDITIONAL 90 DAY GUARANTEE.
- 815 (NEUTRALIZED) FINAL.
- SHOCK MOUNTING NOT REQUIRED IN MODERN CARS.
- 100% MODULATION AT 75 WATTS OR LESS.
- DESIGNED FOR PE-103 OR SIMILAR DYNAMOTOR (OR AC POWER SUPPLY).
- METERED FINAL.

#### TUBE LINE-UP

10 METERS  
6AG7.....Xtal Osc. DBLR  
6AG7.....Doubler  
815.....Neut. Final  
6J5.....Audio Amp.  
6N7.....Driver  
815.....Class AB Mod.

75 METERS  
6AG7.....Xtal Osc.  
815.....Neut. Final  
6J5.....Audio Amp.  
6N7.....Driver  
815.....Class AB Mod.

New York **Ham!** — Complete Mobile Transmitter, Antenna, Converter, Pow. Sup. Cables, etc., installed in your car! Write for Details.

\*\*\*\*\*



VIKING  
1 KIT

115 Watts CW, 100 Watts AM Phone Output. Complete details on Page 67 July QST. Transmitter VIKING 1 Kit less tubes, crystals, mike, key, Amateur Net. \$209.49 Only. Wired tested and guaranteed. \$259.50

VIKING VFO KIT  
Complete details on Pages 68-69 Sept. QST. Complete less tubes. Cabinet to match VIKING \$42.74  
Wired tested and guaranteed \$62.75

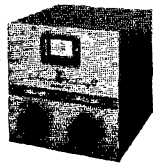

### NOVICE TOOL KIT

Real professional serviceman's tools

- 1—Esico Soldering Iron.
- 1—Hand drill, 1/4" chuck.
- 1—Long nose Pliers.
- 1—Diagonal side cutters.
- 1—1/4" Socket punch.
- 1—5 in one Screwdriver Kit.
- 1—Hand reamer—1/8" to 1/2".
- 1—No. 28 Carbon steel drill. (6-32 clearance.)

If purchased separately would cost over \$20.00. Sold as complete Kit to QST Readers. If not delighted \$12.95 return unused for full refund.

\*\*\*\*\*

#### NOVICE

### 80 MTR Trans- mitting Station

- 1—Transmitter Kit.....\$15.95  
(as described in May QST)
- 2—Power Supply Kit  
(for above)..... 9.95  
(see June QST)
- 3—Antenna Kit  
(80 MTRS)..... 2.95

\$28.85

#### COMBINATION SPECIAL

All three kits are available separately at prices indicated beside each kit. (Complete instructions with each kit)..... \$25.95

#### MODEL AB614

For 10 Meters

#### MODEL AB714

For 75 Meters

Either, with Tubes, less Xtal, Mike or Power Supply

#### YOUR CHOICE

**\$119.95**

#### SONAR

SR-9

2

METER

RCVR

MOBILE

or FIXED



9 Tube Super-Het. Complete details in our Oct. Ad. QST. Immediate delivery..... \$72.45

#### AND NOW

### SONAR MB-26 XMTR

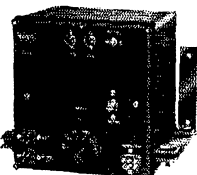

2 MTRS.

6 WATT

OUTPUT

Complete story in our Oct. Ad QST. It's terrific. Immediate delivery..... \$72.45

#### WEBSTER-CHICAGO

100-16



3 Speed AUTOMATIC RECORD CHANGER.....\$24.84



# Niagara Radio Supply Corp.

Phone  
Digby 9-  
1132-3.4

DEPT. Q111

160 Greenwich Street, New York 6, N. Y.

NIAGARA'S  
GUARANTEE  
OF SATISFACTION  
All items ordered  
must meet  
with full approval  
or your  
money back.

how to  
choose a  
high  
fidelity  
loudspeaker

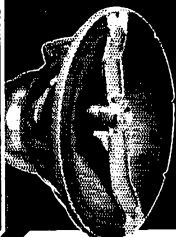

**Genuine**  
**Jensen**  
WIDE RANGE

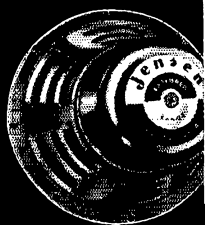

G-610  
TRIAxIAL  
3-WAY

SINGLE-UNIT  
DIRECT RADIATOR  
TYPES (5"-15")

"Genuine Jensen Wide Range" means much more than wide frequency range—it means superior performance all the way—in every attribute that makes for enhanced listening pleasure: 1. Wide Frequency Range . . . 2. Balanced Frequency Response . . . 3. Smooth Response . . . 4. Wide Angle Distribution . . . 5. Low distortion . . . 6. Good Efficiency . . . 7. Adequate Power-Handling Capacity.

Whatever the cost or size, a choice from the Genuine Jensen Wide Range series insures a maximum of performance to today's new high fidelity standards.

Write for free booklet—"Let Music Come to Life"—it includes a listing of Genuine Jensen Wide Range loudspeakers.

**Jensen**  
MANUFACTURING COMPANY  
Division of the Muter Company  
Export Department at the Factory

6601 S. LARAMIE · CHICAGO 38, ILLINOIS

BURTON BROWNE ADVERTISING

As WØVRF, Missouri SEC, says, to write an article adequately covering the good work of amateurs in this emergency would take most of the space in the next twelve issues of *QST*. In the above, we have only scratched the surface in an attempt to cover the salient facts without delving too deeply into details. As a result, it is inevitable that many individuals and even some groups who participated will not have been mentioned. To these we extend our apologies in advance.

No attempt at originality has been made in this factual report. We have leaned heavily on reports of ECs, SECs and SCMs, as well as individual amateurs. Particular acknowledgment is due Merton Meade, WØKXL, from whose monthly bulletin *Midwest Clix* we have borrowed freely, using his exact well-chosen words in some places.

## Happenings

(Continued from page 53)

tary and WØLPT as treasurer, the committee secured the support of Minnesota amateurs in their efforts to obtain successful passage of the bill which was drawn up by WØSW, an attorney. While the bill was under consideration in the legislature a communications emergency occurred in the area of Wheaton, with amateurs supplying emergency radio service. The resultant publicity did much to further the license plate bill. Minnesota amateurs also invited near-by legislators to their amateur stations to discuss the bill with each other via amateur radio. That their efforts were successful is indicated by the almost unanimous passage of the bill.

## How's DX?

(Continued from page 58)

75 watts to a converted Navy rig using an 829B final, with VFO. Extended double-zepp antennae are supported by coconut palms and the shack is just 30 yards from the sea. Power for VK9YT is obtained from a Leland 120-volt 2.5-kw. alternator driven by a Briggs-Stratton engine. . . . . LMRE (Mexico) QSL manager XE18A reports that numerous XE calls are being bootlegged. For instance, he gets cards for XE4 and XE5 stations despite Mexico's having but three call areas. Also for XF stations other than XFIA when the latter is the only Mexican station bearing this prefix. . . . . We have just learned, via W3BXE, VE1AAK and VE1MK, that Paul Detcherry, FP8BX, joined Silent Keys on September 23th. Paul had done a remarkable job of handing out FP8 QSOs and QSLs during the past year, and he will be sorely missed by the DX gang.

Jeeves read this month's lead and scoffed even more vehemently than usual. He says the identification of "good conditions" is simplicity itself: When the W/VEs are all testing with keys down, the Asians all calling "CQ Europe," the Africans calling "CQ VK/ZL" and everybody else calling "CQ no W," then, brother, conditions are good!





**Fellows...**  
**one of the world's best buys is still**  
**a WRL TRANSMITTER...**  
**ask any Globe King Owner**  
 Leo I. Meyerson WØGFQ

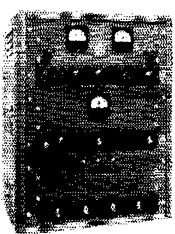

**NEW WRL 400-B GLOBE KING TRANSMITTER**

**HIGH POWER — MORE WATTS PER DOLLAR**  
 Our newest model with increased power — 420 watts Phone, 420 watts CW. Incorporates some of the latest TVI protective features. Efficient performance on all bands — 10 to 160 on phone and CW. Provisions for ECO. Complete with tubes, meters, and one set of coils. Low Down Payments.

**KIT FORM                      WIRE-TESTED**  
**\$475.00                      \$495.00**



**JUST OFF THE PRESS**  
**WRL 1952 CATALOG**

**IT'S NEW! IT'S FREE!**  
**Send For Your Copy — TODAY —**

Contains everything new in radio and television. Jam-packed with bargains.

**LIBERAL TRADE-INS**  
**LOW DOWN PAYMENTS**  
**PERSONALIZED SERVICE**

**WRL 150 WATT GLOBE CHAMPION TRANSMITTER**

**MORE WATTS PER DOLLAR**  
 R. F. Section a complete 150 watt XMTR. Provisions for ECO. Automatic fixed bias on Final and Buffer. Class B Speech Modulator. 150 watt input — 10 thru 160 meter bands. Complete with tubes, meters. Low Down Payments.

**KIT FORM                      and one                      WIRED**  
**\$329.50                      set of coils.                      \$349.50**

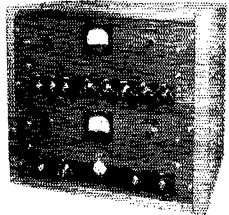

**EXTRA SPECIAL — GOOD CONDITION 100 WATT XMTR's**  
 Collins 32MA. . . . . \$99.50

**GIANT RADIO REFERENCE MAPS**

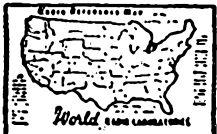

Just right for your control room walls. Approximately 28" x 36". Contains time zones, amateur zones, monitoring stations. Mail coupon today and . . . . . **25¢**

**CU ON 20 - 10 & 75 METERS**

**NEW LOG BOOK**

For mobile or fixed station. Spiral binding — turns up — lies flat. Full column log listing all FCC required info. Log will accommodate 1,525 stations. Front and back covers show "Q" signals, phonetic alphabet, and amateur international prefixes. **25¢**



**GUARANTEED CRYSTALS**

**IN HOLDERS Type FT-243**  
**160 METER**  
 1.8 to 1.825    1.875 to 1.9  
 1.9 to 1.925    1.925 to 2.0  
**\$1.50 ea.**  
**30-40 METER**  
 3.5 to 4.0      7.0 to 7.4  
**\$1.25 ea.**  
 Please state frequency. We will come as close as possible. No refunds or exchanges please.

Write for detailed XMTR specification sheets.

**WRITE - WIRE**

**PHONE 7795**



**World Radio Laboratories, Inc.**  
 744 West Broadway  
 Council Bluffs, Iowa

Q-11

Please send me:

- New Log Book
- New Catalog
- Radio Map
- Globe King Info
- Globe Champion Info
- Used Equipment List

Name \_\_\_\_\_  
 Address \_\_\_\_\_  
 City \_\_\_\_\_ State \_\_\_\_\_

**You asked for it!** It's here  
at last,  
and SREPCO has it . . .

The AC  
Power Line Filter  
that really works . . .  
even thru TV bands!



## Model LN-5 INDUCTUBE

By R. L. Drake Company

FB for keeping RF out of the power line from xmtrs and for keeping power line interference out of TV and Ham rcvrs. and audio equipment.

This unique line filter incorporates a balanced Pi network circuit made up of "INDUCTUBE" elements which have none of the inherent resonant characteristics found in lumped capacitance-inductance type filters. Therefore no resonant frequency exists which would limit the filtering action even in the new UHF TV band. The LN-5 is rated at 115 volts, 5 amps and is enclosed in an enameled, copper clad steel case with UL approved cord and plug attached.

Amateur and Dealer Net . . only

**\$5.82**

Add 25c for postage anywhere in USA

We have complete  
line of R. L. Drake  
Filters in stock.

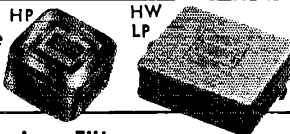

### High Pass TV Receiver Filters

TV-300-50HP for 20 Mc IF—300 ohm	Net \$3.57
TV-300-54HP for 44 Mc IF—300 ohm	Net 4.17
TV-72-50HP for 20 Mc IF— 72 ohm	Net 3.57

Note: On new TV receivers having Add 25c postage  
44 Mc IF, use only TV-300-54HP anywhere in USA

### 1 KW Low Pass Xmtr Antenna Filters

TV-52-40LP 52 ohm coax—10 thru 160 mtrs	Net \$12.95
TV-300LP 300 ohm —10 thru 160 mtrs	Net 12.95
TV-52-20LP 52 ohm coax—15 thru 160 mtrs	Net 12.95

Add 40c for postage anywhere in USA

### 1 KW Half-Wave Xmtr Antenna Filters

TV-300-10HW 300 ohm—10—11 meters	Net \$10.95
TV-300-20HW 300 ohm— 20 meters	Net 10.95

Add 40c for postage anywhere in USA

IMMEDIATE DELIVERY ON ALL  
R. L. DRAKE FILTERS

PRICES ARE  
NET F.O.B.  
DAYTON, O.

**SREPCO**  
Inc.

135 E. Second St. Dayton 2, Ohio MI 3874  
STANDARD RADIO & ELECTRONIC PRODUCTS

TERMS: Cash  
with order, or  
20% deposit,  
balance C.O.D.

112

## Correspondence

(Continued from page 59)

FROM AN XYL

Virginia

Editor, *QST*:

My husband returned from the ARRL National Convention singing the praises of the XYLs who were there "showing interest in their husband's hobby." Nonsense! With the exception of the few strange women who have their license, I bet the XYLs were there only because it was their one chance for a vacation or to keep an eye on the OM. The rest of us have neither the time nor the inclination to do anything except wish we had never heard of ham radio.

[Name withheld — Ed.]

## MOBILE IDENTIFICATION

2819 16th Place South  
Birmingham 9, Ala.

Editor, *QST*:

Having completed some 3000 miles of travel this summer, I have an idea to submit for general discussion. While operating mobile, it is impossible to know whether the car that just passed you bearing a whip antenna was in the amateur service and, if so, what band.

Why not agree to fix to the top of our mobile antennas a triangular metal tag about 3 inches each dimension? Let (for instance) the 10-meter tag be red, 20-meter white, 75-meter blue, or some mutually agreeable color code. Then when the car with the rear-mounted whip passes you, it will be feasible to turn on your transmitter to call him, even working cross-band. I'm sure I've missed several QSOs this summer because of not knowing on what band to listen for a mobile — especially when both cars are going in opposite directions. Let's have some comment from the mobile groups.

— Dr. Arthur W. Woods, W4GJW

## THE AMATEUR'S CODE, II

846 Campbell Avenue, SW, Roanoke, Va.

Editor, *QST*:

It may interest you to know that I have a complete file of *QST* magazines that are all in binders and that include the very first copy that was mailed. I have always kept my membership up and take it from one who has had plenty of experience and found out a lot about this hobby that had it not been for the Headquarters staff and the older men fighting off all comers and coming out successful we would not today have our wonderful hobby as we know it. When I hear some fellow belittle the ARRL I am inclined to commit some real murder in the super-first degree. We old fellows know what an uphill we have had and when we hear those belittle the actions of ARRL as a whole we really get rough. It is up to the rest of the amateurs to band together and join the ARRL one hundred per cent, and never cease to fight for the most wonderful and most democratic hobby this country has or ever will have.

— John F. Wohlford, W4CA

S.S.B.

P. O. Box 202  
Warren, R. I.

Editor, *QST*:

With the increased use of s.s.b. transmitters on the 75-meter 'phone band, it is time that serious thought be given to the QRM they are causing the a.m. transmitters.

For a long time there have been many nets and round

(Continued on page 114)

**SWITCH  
TO SAFETY!**



**Wow!! Look at these bargain Harrison's has!**

Copper is critical - Transformer steel is scarce - prices on quality products are higher - deliveries are uncertain - **BUT...** Harrison comes thru again!

with a sensational offering of the high quality line of one of the larger and better known transformer manufacturers!

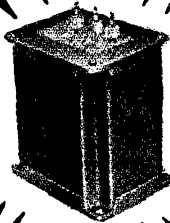

Designed for consistently dependable service in industrial and Amateur applications. Steel cased, compounded, universal mounting.

Every one is brand new - in original boxes - factory rated - guaranteed perfect. We have this tremendous stock here, ready for immediate shipment. But for you better order NOW - low prices it won't be around for long!

**PLATE TRANSFORMERS** DC Voltage Ratings are Values Obtained at Output of a 2 Section Choice Input Filter Using Mercury Vapor Rectifier Tubes. PFI is for 115 V. 60 Cy.

Type No.	Sec. Rms. Volts	Sec. DC Volts	Sec. DC M.A.	List Price	YOUR PRICE!
P-4067	(500-600) (350-550) (200-300)	500 400 300	250	\$ 17.50	6.95
P-4058	(500-600) (350-550) (200-300)	500 400 300	125	30.25	9.95
P-4059	(500-600) (350-550) (200-300)	500 400 300	225	19.75	8.95
P-4067	(1450-1450) (1175-1175)	1200 900	200	49.50	18.95

\* Has 40V. Bias Tap. \* For Dual Operation with Simultaneous Use of Both Sec. Ratings.

**FILAMENT TRANSFORMERS** For Amplifier, Amateur, Industrial Use. 115 Volts, 60 Cycles

Type No.	Sec. Volts	Sec. Amp.	Insulation	List Price	YOUR PRICE!
4849	2.5 e.t.	10	10000	17.75	4.75
P-4849	5 e.t.	20	2500	17.50	3.95

\* Unrated

**DRIVER TRANSFORMERS** To Couple Driver Plates to Amplifier Grids

Type No.	Driver Tube	Output Tube	Turn Ratio (Pr. to 1st Sec.)	Class	In. M.A.	List Price	YOUR PRICE!
A-4020	6CA, 30, 40, 1H4	Single 126, 19, PP20, 40	2.5:1	R	10	6.60	1.45
A-4021	6F6, 42, 2A4	PP20, 6L6	1.75:1, 1.6:1, 1.8:1	B	35	7.25	2.95
A-4022	6AR, 6CA, 6NT, 6Y6, 6X4	Single 6AR, 6NT, PP40	6:1, 4:1, 3:1	B	20	7.70	2.45
A-4023	6F6A, 5Z	PP20, 6AR, 6B	2.5:1	B	16	9.25	3.50
A-4024	6F6A, 6CA, 6NT, 45, 6Y6, 6X4	PP20, 721	2.5:1	B	40	8.75	3.25
A-4025	6F6, 2A5, 4Z	PP20	1.4:1	B	30	12.50	5.75
A-4048	6F6, 2A5, 4Z, 42	Class B Grids 15 watt capacity	1.7:1, 1.85:1, 1:1	B	30	15.50	9.95
A-4047	Line to Grid	Class B Grids 30 watt capacity	1:1, 2.5:1, 1:1, 45:1, 1:1, 7.5:1, 1:1	B	30	17.50	8.95

\* Split Secondary

**VIBRATOR TRANSFORMERS** For Operation from 6 V. Battery and Vibrator

Type No.	Sec. DC Volts to Filter	Sec. M.A.	List Price	YOUR PRICE!
P-4072	260	60	9.00	1.95
P-4073	285	75	10.00	2.95

**FILTER INPUT OR SWINGING CHOKES**

Type No.	Inductance Henries	Current Rating M.A.	DC Res. ohms	Volts Insul.	List Price	YOUR PRICE!
C-4067	4-16	150	210	3000	6.75	2.95
C-4068	4-16	200	140	3000	10.50	3.75
C-4069	4-16	250	125	3000	13.25	4.95
C-4090	2-14	300	90	3000	16.25	5.95
C-4091	2-14	500	75	7000	33.50	7.95

**FILTER SMOOTHING CHOKES**

Type No.	Inductance Henries	Current Rating M.A.	DC Res. ohms	Volts Insul.	List Price	YOUR PRICE!
C-4081	10	200	140	3000	10.50	3.85
C-4082	10	250	125	3000	13.25	4.75

**SAVE!** **UP TO 75% OFF** **HAM HEADQUARTERS Since 1925!** **HARRISON HAS IT!** **SCOOP!**

**SENSATIONAL GENEMOTOR BARGAIN**



**HARRISON SPECIAL \$34.95**

Regular Net Price \$53.55

Brand NEW in original packing. Name plate shows all specifications. Model 4037AS. Ideal for Harvey-Wells TBS-50. Reliability of Carter dynamotors has been proven by over 17 years of Police, Amateur, Marine, and Aircraft Communications use. Your logical choice for mobile, where dependable power is needed.

- Delivers 400 Volts DC at 375 MA rated load
- Input - 6 Volts DC.
- High Efficiency - Easier on battery!
- Ball Bearings - require no lubrication nor maintenance!
- Diamond finished commutators for smooth, long life.
- Compact - 7" x 5" x 3". Fits almost anywhere!
- Good voltage regulation.
- "Instant Power" quick start. Ideal for Push-to-talk.

**HEAVY DUTY OUTPUT TRANSFORMERS** High Level Type to Couple to Line or Sec. Impedance 4-8-15-250-500 Ohms

Type No.	Tube	Class	Pr. Impedance	In. Ms. per Side	Max. Watts	List Price	YOUR PRICE!
A-4027	Single 6L6, 2A5, 6AR, 6Y6	A	2500	80	8	10.00	12.95
A-4028	PP20, 6Y6	AB	8000 C.T.*	50	14	13.25	27.95
A-4029	PP20	AB	4300 C.T.*	95	28	13.25	4.75
A-4030	AB	AB	6000 C.T.*	80	34	14.25	5.00
A-4031	PP20, 6Y6, PP20A	A	8000 C.T.	80	30	12.00	4.05
A-4032	6AR, 6B4, 45, PP20, 45	B	10000 C.T.	40	28	12.50	4.50
A-4033	PP20, 2A5, 7C5	AB	8300 C.T.	60	65	18.25	6.75

\* 10% Feedback Windings.

**MODULATION TRANSFORMERS** Compound Filled Cases - For Specific Applications

Type No.	Output Tube	Ohms Impedance		Max. M.A.		Watts	List Price	YOUR PRICE!
		Pr.	Sec.	Pr.	Sec.			
A-4015	PP20, 6A2, 6B4, 6L6 45, 45, 45	6000 C.T.	5000-3000	80	100	36	12.25	4.40
A-4014	PP20, 6Y6, RK-41, HY66, HY61, HK34	3000 C.T.	10000	175	100	60	19.25	7.95
A-4016	PP20, 6Y6, RK-41, HY66, HY61, HK34	6000 C.T.	4000-5000	175	100	60	22.00	8.95
* P-3110	PP20, 6Y6, RK-41, HY66, HY61, HK34	18000 C.T.	3000-4000	300	300	175	22.25	3.95

\* Upright shielded case with leads

**UNIVERSAL MODULATION TRANSFORMER** Tapped Series-Parallel Cells Provide a Wide Range of Modulation Ratios

Type No.	Pr. Impedance	Pr. M.A. per Side	Sec. Impedance	Max. Sec. M.A.	Watts	List Price	YOUR PRICE!
A-4004	2000-20000	50	2000-20000	50/100	15	\$12.00	4.95
A-4005	2000-20000	150	2000-20000	150/300	60	19.25	4.95
A-4006	2000-20000	220	2000-20000	220/440	126	28.00	12.95
A-4007	2000-20000	250	2000-20000	250/500	300	57.00	22.95

† Series/Parallel.

**HARRISON**  
NEW YORK 7, N.Y.  
225 GREENWICH STREET  
(10 West Broadway, at Barclay St.)  
BARclay 7-7777

**HARRISON HAS IT! And how!!**



\* **HEAT DISSIPATING  
CONNECTORS**

**Vacuum Tube Accessories  
by Eimac —  
Now Available!**

Type HR heat dissipating connectors are designed to provide an efficient method of heat transfer from tube elements and seals to the air. Also facilitate electrical connection to plate or grid leads of most popular transmitting tube types. Machined from solid dural rod, come complete with necessary machine screws for use.

- Write for new Eimac Catalogue Summary showing Eimac tubes and other accessories.



**Eimac**  
SINCE 1912

**EITEL - McCULLOUGH, INC.  
San Bruno, California**

**RADIO ENGINEERS & OPERATORS  
WANTED FOR UNITED STATES  
GOVERNMENT PROJECTS IN ARCTIC**

Government contractor seeks experienced men holding Amateur A or First Telephone license for high priority projects involving the construction and operation of high power VHF transmitting and receiving stations on sites near Air Force Arctic bases. Open positions include Chief Engineers for transmitting and receiving stations with a salary of \$9000 annually and Engineer-Operators at \$6000 annually. In addition to salary there is a generous living expense allowance. Transportation to and from the projects is provided by the government. Estimated term of employment is six to eight months. Please air mail your qualifications and photograph for preliminary review and full information. Do not wire or telephone.

We also have open positions with Radio and TV Broadcast Stations throughout the United States.

BROADCASTERS EXECUTIVE PLACEMENT SERVICE

**HOWARD S. FRAZIER**

Suite 726 Bond Building Washington 5, D. C.

tables in various parts of this band which tend to cut down QRM. The advent of the "Donald Ducks" has posed a serious problem to these operations since one s.s.b. transmitter can and does frequently QRM a whole round table. This is especially so when these transmitters are poorly adjusted. I am sorry to say that there are many of them that splatter over ten kc. either side of their fundamental. It is practically agreed by everyone that the two methods of transmission (s.s.b. and a.m.) are not compatible and cannot efficiently take part in the same round table.

I wish to suggest two logical solutions that would help clear up this situation.

The first one would be to give s.s.b. another spectrum in the band, say from 3800 to 3825 or 3775 to 3800 kc. They boast about how many QSOs they can have in a small space without QRMIing each other. This would give them a good chance to prove it.

The second one would be to allow only those who pass the extra-grade license to use s.s.b. It is quite complicated to build this particular type of transmitter and only those properly qualified should be allowed the privilege.

The League has approved and advocated the use of s.s.b. Now that s.s.b. is becoming a nuisance to a.m. operators in general and mobile in particular, I believe the League should recommend one or both of the above methods of regulation.

— Harold C. Bowen, W1DQ

**WATCH OUT!**

Norwich, Vt.

Editor, QST:

I heard something on the 75-meter phone band that should be commented on, even if briefly. I would hesitate to call it "rotten operating," rather poor taste in operating. A station was giving as a bulletin a "tip-off" that speed traps were set up on the Newburyport Turnpike, and that mobiles and others better keep down to the 60-m.p.h. limit. A lad broke in to say that he thought such junk was poor material to be broadcasting, then left the air without signing. He was challenged to give his call, which he unfortunately did not do. I wish he had, for I would like to second his remarks. As amateurs we do not have the opportunity to mess up the air as a divine right — rather, it is a privilege granted to responsible citizens. The right to have mobile transmitters and receivers is a privilege, contingent on our acting like intelligent citizens. The idea that there are amateurs who would want to act publicly (and the 75' phone band is about as public as one can get) as lookouts for lawbreakers is hard to take, yet it seems to be the case. The idea amateur radio — and especially the nets (who are supposed to show some slight degree of responsibility) — should be used as a means of circumventing law-enforcement agencies is one that should be squelched as soon as possible.

— W. C. Johnson, W1FGO

**50 Mc.**

(Continued from page 60)

**September Doings**

If there was any letdown in v.h.f. activity during September it was not because of any lack of interesting things to do. Already well established as the peak month of the year for tropospheric propagation, the month also provided a touch of sporadic-E activity, and some of the year's best aurora. With a v.h.f. contest thrown in, September, 1951, was a busy month for most v.h.f. men who wanted to be busy.

For the full story, we have to go back to Aug. 30th, for it was on that date that the fall tropospheric season got under way. At 7:47 P.M. MST, W7JRG, Sheridan, Wyo., called CQ on 144.3 Mc., and was amazed to be answered soon after on the telephone by Bill McNatt, W9NFK, who reported that the CQ had been heard and

(Continued on page 118)

*Announcing . . . Uncle Dave is really a PROUD PAPA!!*

## HALLICRAFTERS Newest Receivers

*... and other receivers!*

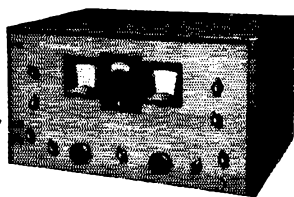

**Hammarlund HQ-129X** . . . . . **\$199.50**  
 Speaker for above unit . . . . . **\$14.50**  
**Collins 75A2** . . . . . **\$440.00**  
 With speaker . . . . .

### TRANSMITTERS

- Harvey-Wells Bandmaster Deluxe **\$137.50**
- Harvey-Wells Bandmaster Senior **\$111.50**
- Harvey-Wells Bandmaster Junior **\$87.50**
- Johnson Viking Kit . . . . . **\$209.50**  
 Wired and Tested . . . . . **\$259.50**
- Lysco A-114 Mobile Transmaster less tubes  
 20 meter . . . . . **\$29.95**
- Lysco A-114T Mobile Transmaster with  
 tubes . . . . . **\$33.55**
- Lysco A-129T Mobile Transmaster with  
 tubes 10-11 meter . . . . . **\$33.55**
- Lysco A-129 Mobile Transmaster less tubes.  
**\$29.95**

### CONVERTERS

- Gonset—two meter . . . . . **\$44.50**
- Gonset—3-30 meter . . . . . **44.75**
- Gonset—Tri-Band . . . . . **47.60**
- Gonset—10-11 meter . . . . . **44.75**
- Gonset—Noise clipper . . . . . **9.24**

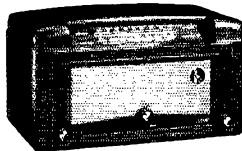

**S-80**—"Defender"—New super-sensitive, battery radio. Uses long-life 1000-hour battery pack 4 tubes. Less battery. 540-1700 kc. and 6-18 Mc in 2 bands. . . **\$44.50**

**S-81**—New, compact, low-cost VHF FM emergency-freq. Ideal for civilian defense. 152-174 Mc in 1 band. Low drift. 2 i-f stages . . . . . **\$49.50**

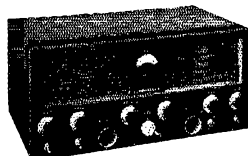
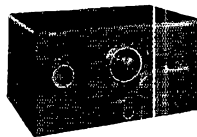

**SX-71**—Double conversion, built-in NBFM limiter stage, 538 kc. to 35 Mc, 46-56 Mc in 5 bands, crystal filter. . . **\$199.50**

Matching speaker for S-76 and SX-71 . . . . . 500-ohm matching transformer . . . . . **\$19.95**

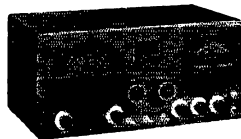
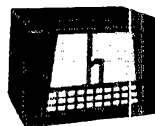

**S-76**—Double conversion with 50 kc, 2nd i-f. Giant 4-in. "S" meter. 540-1580 kc., 1.72-32 Mc in 4 bands, 1 r-f, 2 conversion, 2 i-f stages. . . **\$169.50**

### Uncle Dave's BARGAIN CORNER

USED: Meisner 150B Transmitter—All bands . . . factory converted to 10 meters . . . excellent condition . . . . . **\$375.00**

### WHILE THEY LAST!!

J38 Transmitting Hand Keys. **79¢**  
 Each . . . . .

**FORT ORANGE RADIO DISTRIBUTING COMPANY, INC.**  
**904 BROADWAY . . . . . ALBANY 7, N. Y.**

# ANNOUNCING

## Unusual opportunities in SOUTHERN CALIFORNIA

Senior men with degrees and several years of proven accomplishment may achieve further personal growth by working with some of the nation's outstanding scientists in the West's largest laboratories.

### CHALLENGE AND OPPORTUNITY

for physicists and engineers in the fields of electron tubes, computers, precision electronics, solid state, system analysis, servo-mechanisms, intricate mechanisms, radar, guided missiles, microwaves.

### *Hughes Laboratories*

#### OFFER

✓NEW AIR-CONDITIONED BUILDINGS WITH THE FINEST MODERN LABORATORY FACILITIES AND EQUIPMENT

✓SOLID LONG RANGE PLANS FOR A CONTINUING FUTURE

✓INTRIGUING — VITAL DEFENSE PROJECTS PLUS A STRONG PROGRAM FOR ADVANCED DEVELOPMENT OF NEW PEACETIME PRODUCTS

✓EXCELLENT EMPLOYEE BENEFITS

✓FREQUENT SALARY REVIEWS

✓COMPANY SPONSORED PROGRAM FOR ADVANCED EDUCATION

Ample Good Housing Available

Send resume to

## HUGHES

Research and Development Laboratories

Culver City, California

answered by W9EHX, McLean, Ill.! This is a hop of about 1000 miles, across territory that 2-meter signals have never covered heretofore. It was the first time that W7JRG had been heard anywhere, to his knowledge, except in his nightly work with W7HNI at Gillette, Wyo. There was no evidence of  $E_s$ , so it can be assumed that this was tropospheric in nature.

On the night of Aug. 31st, as reported briefly last month, the 144- and 420-Mc. bands were open in the East. By 7 p.m. EST, VE1QY, Yarmouth, N. S., was working down the Atlantic Seaboard as far as New Jersey. W3GKP, Silver Spring, Md., heard the W2s working Jerry, and got his frequency spotted, but it wasn't until an hour later that VE1QY was first heard by W3GKP. Contact was made at 10:35 p.m., before and after which Bill worked 34 W1s, 2s and 3s, many of them for their first Maryland contacts on 144 Mc. VE1QZ, Dartmouth, N. S., heard VE1QY, W1IZY, W3OWW and several unidentified signals.

Signals on 420 were reaching out to greater distances than ever before, and several "firsts" were made, as mentioned in our October box insert. Notable among these was the 2-way work between W1PBB, Monroe, Conn., and W3AIR, Glenmont, Md. This 260-mile hop comes very close to the recognized record for 420, made by W6ZRN and W6VIX some years ago, working between two mountain locations in California. It surpasses previous home-station marks by many miles, and demonstrates that DX on 420, as on other bands, depends more upon conditions, equipment and operating than it does on location. Elevation helps, of course, but the line-of-sight idea is just as obsolete for 420 as for 144.

The 6-meter gang got a pleasant surprise on Sept. 1st, when the band opened for north-south work over most of the East, the feature of the session being a string of contacts by CO2JF, Havana, Cuba. Steve worked W3BGT, W8CMS, W8NQG, W2BYM, W3MQU, W1HDQ, W2BCR, W3KKN, W3OJU and W9ZHL between 7:15 and 8:50 p.m. EST. The automatic transmissions of W5AJG and W4HHK were also heard, dropping into the noise at around 9:30.

A series of aurora openings on Sept. 11th, 12th and 13th, each of short duration, found some of the sharper operators doing business on both 6 and 2. W3PMG, Dalton, Pa., worked W2SFK, W9UCH, and VE3RM between 8:35 and 9:12 p.m. EST on the 11th, W3NKM and W2AZL at 6:50 and 6:55 p.m. on the 12th, and heard W2YXE, W3NKM and W2AZL on the 13th between 6:00 and 6:30. W1BCN, W1IZY, W2ACY, W2YXE, W3LNA and W8DX were heard on the 11th, and W9UCH on the 12th. W2AZL, Plainfield, N. J., heard W3NKM at 6:45 p.m. and worked W9UCH and W3PMG, signals fading out at 7:12 p.m. On the 13th he caught W3NKM at 5:45 p.m. and heard W3PMG and W1IZY until about 7 p.m. Your conductor was visiting the Cornell Ionosphere Project the

(Continued on page 118)

## Wanted

We need more used receivers and transmitters. Write for our top cash offer for your receiver or transmitter or for our top trade-in offer for it on a new receiver or transmitter.

### HENRY RADIO STORES

Butler  
Missouri

Los Angeles 64  
California

# Lafayette

HOME OF TOP NAMES IN RADIO

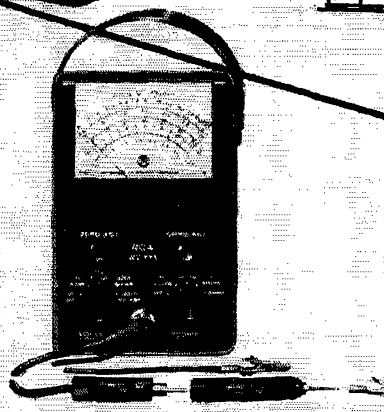

FEATURING  
**RCA**  
LATEST  
TEST  
EQUIPMENT



**NEW WV-77A JUNIOR VOLTOHMYST**  
—Here again . . . at an amazing low price! Includes all the features of previous models, plus greater voltage range, wider frequency response, higher overall accuracy and complete electronic operation. High input resistance on all ranges; 11 megs for DC, 0.2 to 2 megs for AC. Flat frequency response 30 cps to 3 mc (50 kc to 250 mc with WG-264 probe not included). AC & DC volt ranges: 0-3/12/60/300/1200. High impedance vacuum tube diode used as signal rectifier. 5 Ohmmeter ranges from 0-1000 meg with center scale values of 10, 1000, 10,000 ohms; 1 meg and 10 megs. Uses only one 1.5V. battery. Safely measures continuity of filaments of battery-operated receiving tubes. 8" H., 5 3/4" W., 4 1/2" D. Supplied with tubes, battery, probes, cable and instructions. For 105-125V, 50/60 cycles AC. Shpg. wt. 4 lbs.  
RCA Model WV-77A..... **\$47.50**  
RCA Model WG-264 Probe.....\$7.75

Value-wise hams, experimenters, engineers and set builders have come to Lafayette since 1920. Our technical staff is always ready to help. Remember, mail orders receive special attention. Make Lafayette your headquarters for RCA equipment.

**WV-97A SENIOR VOLTOHMYST** — A professional tool for efficient troubleshooting of critical TV service work. Reads peak-to-peak voltages of complex waves directly up to 2000 volts, with frequency response flat to 3 mc. 7 DC volt ranges with readings from 0.02 to 1500. 7 AC volt ranges with readings from 0.2 to 2000 peak-to-peak and 7 RMS ranges with readings from 0.1 to 1500. 7 resistance ranges 0-1000 megs with center scale 10, 100, 1000, 10,000 ohms; .1, 1, 10 megs. Input resistance 11 megs for DC, .83 to 1.5 megs for AC. Accuracy ±3% on DC, ±5% on AC. Push-pull DC amplifier bridge circuit with inverse feedback provides excellent linearity, stability and high input impedance. Reads AC with DC present and vice versa. Blue-gray hammeroid case 7 7/8" H., 5 3/4" W., 4 1/2" D. For 105-125V, 50/60 cycles AC. With tubes, WG-218 direct probe and cable, WG-217 DC probe, ohms lead and probe. Shpg. wt. 10 lbs.  
RCA Model WV-97A..... **\$67.50**

AUTHORIZED  
  
DISTRIBUTOR

# free!

## NEW CATALOG

New! Big! Value-packed with thousands of radio, television and electronic parts. Send for FREE copy today.



COUPON

**RADIO WIRE TELEVISION, INC., Dept. VK**  
*Lafayette Radio* 100 Sixth Ave., New York 13, N. Y.

Please ship the following:  
 WV 97A       WV 77A       WG 264  
 Enclosed \$.....  
 Send FREE Lafayette Catalog

Name.....  
 Address.....  
 City..... Zone..... State.....



## Radio Wire Television Inc.

NEW YORK 13, N. Y.      BOSTON 10, MASS.      NEWARK 2, N. J.      BRONX 58, N. Y.  
 100 SIXTH AVENUE      110 FEDERAL STREET      24 CENTRAL AVENUE      542 E. FORDHAM RD.  
 REctor 2-8600      HUbbard 2-7850      MArket 2-1661      FORDham 7-8813

# RADIO-TV

## Marketing Research

One of the largest Marketing Research firms has several interesting travel positions open in its radio and television department.

Single men, or married men without children can qualify. Age bracket, 25-35.

Radio servicing experience or equivalent training is necessary. Men with 1 year of college or military service training in the fields of radio, radar, electronics, or as *Ham Operators* will receive immediate consideration.

This is not a sales position but *Car is Required*; car allowance and traveling expenses provided.

Good starting salary, excellent opportunity for promotion; salary increases on merit.

Write giving in detail age, education, marital status, work experience, salary expectations, phone number, and address for early interview.

**Box 115 QST**

## 2-Meter Standings

Call			Call		
States	Areas	Miles	States	Areas	Miles
W1HDQ	16	6 650	W5FBT	6	2 500
W1IZY	15	6 750	W5FEK	6	2 500
W1MNF	14	5 570	W5IRP	6	2 410
W1BCN	13	5 500	W5ONS	5	2 950
W1CTW	12	4 500	W5FSC	5	2 500
W1KLC	12	4 500	W5JLY	4	2 650
W2BAV	21	7 1175	W6ZL	2	2 1400
W2NLY	18	6 750	W6WSQ	2	2 1390
W2PAU	16	6 740	W6PJA	2	2 1390
W2AZL	16	6 —	W6ZEM/6	1	1 415
W2DFV	13	5 350	W6GGM	1	1 300
W2CET	12	5 405	W6YYG	1	1 300
W2DPB	12	5 500			
W2QED	12	5 365	W8WJC	21	7 775
W2FHI	12	5 —	W8BFQ	21	7 775
W2QNZ	12	5 —	W8WRN	19	7 670
W2BVU	12	4 260	W8WXY	18	8 1200
W2ORI	8	6 570	W8UKS	18	7 720
			W8EP	17	7 —
W3NKM	19	7 660	W8BAX	15	6 655
W3RUE	17	7 760	W8RWW	14	7 500
W3QKI	16	7 820	W8WSE	14	6 620
W3KWL	15	7 560	W8FQK	13	7 —
W3LNA	14	7 720	W8CYE	12	6 —
W3GKP	14	6 650	W8CPA	12	6 650
W3OWW	13	6 600			
W3KBA	13	6 —	W9FVJ	20	7 790
W3KUX	12	5 575	W9UCH	19	7 750
W3PGV	12	5 —	W9SUV	19	7 —
W3LMC	11	4 400	W9EQC	17	7 820
			W9BOV	15	6 —
W4MKJ	16	7 665	W9WOK	15	5 690
W4HHK	15	6 660	W9AFT	14	7 —
W4JDN	13	6 —	W9NFK	12	7 690
W4JFY	13	5 830	W9UTA	12	7 540
W4IKZ	13	5 650	W9PPE	11	5 800
W4JFU	13	5 720	W9GTA	11	5 540
W4LVA	13	5 400			
W4OXC	13	7 500	W9NFM	14	7 660
W4CLY	12	5 720	W9IHD	14	6 725
W4JHC	12	5 720	W9EMS	13	5 1080
W4OLK	12	5 720	W9ZJB	12	7 1097
W4FJI	12	5 700	W9WZ	11	5 760
			W9HX	9	3 —
W5JTI	14	5 670	W9JHS	7	3 —
W5QNL	10	5 1400			
W5AJG	8	3 1260	V13AIB	12	6 600
W5ML	8	3 725	VE1QY	11	4 900
W5ERD	8	3 570	VE3BOW	8	5 520
W5VX	7	4 —	VE3BQN	7	4 540
W5VY	7	3 1200	VE3BFB	6	4 525
W5CVW	7	2 560	VE3DER	6	4 450
W5ABN	7	2 450	VE3EAH	5	4 380
W5SWV	7	2 —			



**RECEIVING SENDING**  
**CODES** *Speed* *without strain*

**CHAMPIONS ENDORSE CANDLER WAY**

Get skill, accuracy, speed with the highly endorsed Candler System. Learn to send and receive by telegraph or radio code. Government service and commerce need thousands of better trained operators. Air commerce, mail, freight, etc., demand expert, reliable operators. Good pay. Get the Candler System, the maker of champions. It teaches you the "knack" of sound sense, alertness, speedy sending and receiving without strain. Adventure — good pay. Learn at home or wherever you are. Rush name today for free book.

**FREE!**

**CANDLER SYSTEM CO.**  
Dept. 4-M, Box 928, Denver 1, Colorado, U.S.A. and at 52b, Abingdon Road, Kensington High St., London W.8, England

night of the 11th, and thus had a chance to watch W2ZGP, W2TTU and their associates in action.

There were very short bursts of aurora during both evenings of the V.H.F. Party, but little came of them in the way of added points or multipliers. The major aurora workouts of the month came on the 25th and 26th, however. Reports on these are just coming in as we write, and the complete story appears well beyond our space limitations. The session of the 25th began in late afternoon and lasted until nearly midnight, giving almost everyone ample opportunity to get into the fun. As an example of what was going on, we list the 144-Mc. observations of W2AZL, who got on at 5:45 P.M. EST to work W1IZY, W2s KLZ UHHI FBA, W3QKI, W8s BAX DX BFQ WRN,

*Continued on page 180*



# BENDIX RADIO DIVISION



## ELECTRONICS AND RADIO POSITIONS NOW OPEN CAPITALIZE ON YOUR AMATEUR EXPERIENCE

### ● LABORATORY TECHNICIANS

Opportunity to associate with Bendix scientists in laboratory development of high power radar and communication electronic gear. Requirements include working familiarity with electronic components and basic circuits. Salaries from \$3100 to \$3800.

### ● TECHNICAL WRITERS

Knowledge of radar fundamentals required. Work closely with engineers to gather material for instruction and maintenance manuals. Base salaries from \$3400 to \$4300.

### ● ELECTRONICS ENGINEERS — at all salary levels. Research and Production Design.

### ● TEST AND INSPECTION ENGINEERS

Practical knowledge of radio, radar or TV manufacturing processes. Good knowledge of radio fundamentals essential. Base salaries from \$3900 to \$5880.

### ● FIELD ENGINEERS

Supervise installation and maintenance of radio and radar equipment. Factory training will be given. Base salaries from \$4200 to \$6900 per year. 25% bonus for time spent overseas. Traveling and living expenses paid by Bendix. Insurance plan.

**ALL BASE SALARIES QUOTED ABOVE INCREASED UP TO 30% DUE TO SCHEDULED 48 HR. WEEK.**

HOUSING IS NO PROBLEM IN BALTIMORE

EXCELLENT GROUP INSURANCE AND FAMILY HOSPITALIZATION AND SURGICAL BENEFITS

MODERN LABORATORIES—AIR-CONDITIONED PLANT

ATTRACTIVE RETIREMENT PLAN FOR SALARIED PERSONNEL

*Write now stating personal experience record:*

**J. Siena, Engineering Personnel Supervisor  
Bendix Radio Division, Bendix Aviation Corp.  
Baltimore 4, Maryland**



## *For Your Quartz Crystal Requirements*

we can supply for immediate shipment, any frequency, any tolerance, any quantity, to your specific needs. Manufactured to meet all commercial and military specifications. Send us detailed description and quantity for prices.

MICHAEL STAHL, Inc.  
215 Fulton Street  
New York 7, N. Y.

# The Largest Selling LIGHTNING ARRESTER At Any Price!

NO. AT102



APPROVED

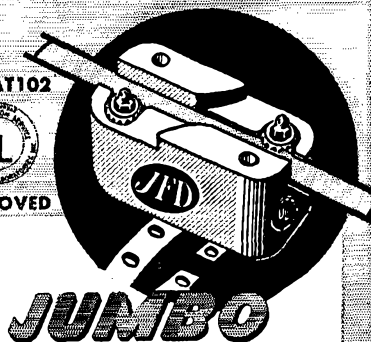

## JUNBO

Protects Home and TV  
Set Against Lightning  
Hazards

**\$225**  
LIST

U.S. Patent No. D-4664

- Installs anywhere
- No wire stripping, cutting or splicing

(Complete with strap and ground wire.)

**OVER 1,000,000 IN USE TODAY!**

See Your Jobber or Write for  
Form No. 84



**MANUFACTURING CO., Inc.**  
6159K 16th AVENUE, BROOKLYN 4, N. Y.  
11227 in Television Antennas and Accessories

VE3s AIB and LU, and heard W1s BCN HDQ DJK, W2s SFK YXE PAU ACY PV OPQ UTH UDD OWF, W3s BLF WBM RUE AIR NKM GKP QIZ, W4MKT, W8s GNN GAB EP, W9UCH, VE1BC and VE3AQQ. Carl's last contact was made at 10:29.

# 50 WAS Mc.

### Standings as of August 25th

W0ZJB.....48	W4IUI.....38	W8BFQ.....39
W0BJV.....48	W4BEN.....35	W8LPD.....37
W0CJS.....48		
W5AJG.....48	W5VY.....47	W9ZHB.....48
W9ZHL.....48	W5GNQ.....46	W9QUV.....48
W9OCA.....48	W5JTI.....44	W9HGE.....47
W6OB.....48	W5ONS.....44	W9PK.....47
W9INI.....48	W5ML.....44	W9VZP.....47
	W5JLY.....43	W9RQM.....47
W1HDQ.....47	W5JME.....43	W9ALU.....47
W1CLS.....46	W5VV.....42	W9QKM.....46
W1CGY.....46	W5FAL.....41	W9UIA.....45
W1LLL.....44	W5NHD.....41	W9UNS.....45
W1KHL.....44	W5FSC.....41	
W1HMS.....43	W5HLD.....40	W9QIN.....47
W1LSN.....42	W5HEZ.....38	W9DZM.....47
W1EIO.....41		W9NFM.....47
	W6WNN.....48	W9TKX.....47
W2RLV.....45	W6UXN.....47	W9KYP.....47
W2BYM.....44	W6TMI.....45	W9JOL.....44
W2IDZ.....43	W6IWS.....41	W9JHS.....43
W2AMJ.....42	W6OVK.....40	W9PKD.....43
W2MEU.....42		W9HVW.....42
W2FHI.....41	W7HEA.....47	W9MVG.....41
W2QYY.....40	W7ERA.....47	W9IPI.....41
W2QVH.....38	W7BQX.....45	
	W7DYD.....45	VE3ANY.....42
W30JU.....45	W7JRG.....44	VE3AET.....35
W3NKM.....41	W7BOC.....42	VE1QZ.....32
W3MQU.....39	W7JPA.....42	VE1QY.....31
W3JVI.....38	W7FIV.....41	XE1GE.....19
	W7CAM.....40	CO2JF.....7
W4FBH.....46	W7ACD.....40	Calls in bold-face are holders of special 50-Mc. WAS certificates listed in order of award numbers. Others are based on unverified reports.
W4EQM.....44		
W4QN.....44	W8NSS.....46	
W4FWH.....42	W8NQD.....45	
W4CPZ.....42	W8UZ.....42	
W4FLW.....42	W8YLS.....41	
W4MS.....40	W8CMS.....41	
W40XC.....40	W8RFW.....41	
W4FNR.....39	W8LBH.....39	



Founded in 1909

## RADIO TELEPHONY RADIO TELEGRAPHY RADAR & LORAN

Courses ranging in length from 7 to 12 months. Dormitory room and board on campus for \$43.00 a month. The college owns KPAC, 5 KW broadcast station with studios located on campus. New students accepted monthly. If interested in radio training necessary to pass F.C.C. examinations for first-class telephone and second-class telegraph licenses, write for details.

**PORT ARTHUR COLLEGE** PORT ARTHUR TEXAS

Approved for G. I. training

The 50-Mc. band opened around 5 P.M., and continued full tilt until 11:30, permitting a phenomenal number of aurora contacts to be made, many of them with fair readability on voice. Reports available at this writing cover only the northeastern quarter of the country and adjoining Canadian Provinces. If the opening extended farther west or south we hope that observers will send as complete information in as possible.

The following night, the 26th, all was quiet until around 10 P.M. EST, but deep fading on the 5-Mc. WWV before sundown (they were sending "W," too) indicated that the disturbance might not yet be over. Shortly after 10 P.M. it

(Continued on page 182)

# the New JOHNSON VIKING VFO KIT

- ✓ Accurate Frequency Calibration (All Bands — 160 thru 10 meters)
- ✓ 5" Calibrated Dial With 6:1 Reduction
- ✓ High Stability — Cleanest Keying
- ✓ Simple Assembly — Build it in an evening

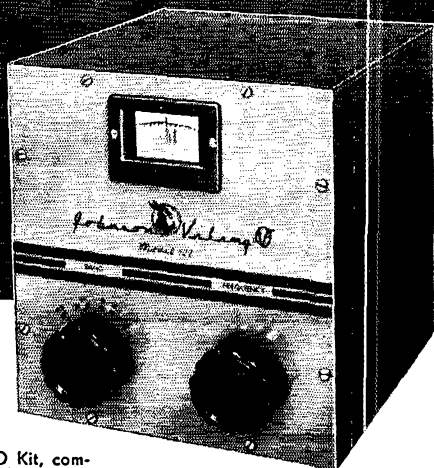

JOHNSON Viking VFO Kit, complete, less tubes in dark maroon finished cabinet to match Viking 1. Size 7" x 6-7/8" x 6-9/16".

**\$4275** Amateur Net

Fundamental output frequencies 1.75–2.0 mcs., 7.0–7.425 mcs. and 6.7–7.0 mcs. Calibrated for all amateur bands from 160 thru 10–11 meters. Ceramic insulation; air dielectric, high and low frequency trimmers assure accurate calibration over long periods of time.

6AU6 electron coupled oscillator, OA2 voltage regulator. Two separate, ruggedly built, tank circuits insure maximum stability and least possible "shock" modulation.

Carefully detailed instructions for easy assembly. Full information supplied for use with the Viking 1 and other transmitters.

See the JOHNSON VFO at your jobbers' now!



## JOHNSON

*a famous name in Radio*

E. F. JOHNSON CO., WASECA, MINNESOTA

## HIGH SENSITIVITY AND SELECTIVITY . . .

with the Ever Popular RME

### CONVERTERS AND PRESELECTORS

Add at least 20 DB gain to your present station receivers with such units as the

VHF 152A Converter, for 2–6–10 and 11 meters

\$97.00 net

DB22A Preselector, for 550 KC to 44 MC, continuous

\$86.00 net

HF10-20 Converter, for 10–11–15 and 20 meters

\$92.00 net

All units have built-in power supplies for 115 volt, 60 cycle current. The finest equipment for any radio station.

And don't forget the RME-84 receiver, covering a range from 550 KC to 44 MC, equipped for 115 volt AC and battery operation. \$110.00 net

Free literature on request

# RME

RADIO MFG. ENGINEERS, INC. PEORIA 6, ILLINOIS

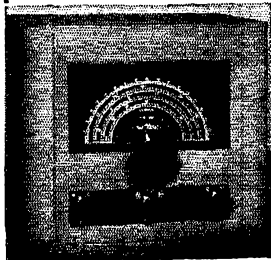

# Unless You are Einstein



... why not let an ARRL Lightning Calculator solve that knotty problem, save hours of operating time, or time you might better be putting in constructing that new rig?

If you're trying to figure out how many turns to wind, you will find the answer by using the Type A Lightning Calculator. No more groping for formulae. Guess-work and doubt are eliminated. Be sure — and be accurate — with one of these dandy time-savers. Know you have a sound piece of equipment, a rig that operates correctly.

## ARRL LIGHTNING CALCULATOR

Type A or Type B

**\$1.00**

POSTPAID ANYWHERE

38 LA SALLE ROAD  
THE AMERICAN RADIO RELAY LEAGUE, INC.  
WEST HARTFORD 7, CONNECTICUT

## COMPLETE RADIO TRAINING!

Prepare now to accept a responsible position in Commercial Radio. New developments will demand technicians with thorough basic training, plus a knowledge of new techniques discovered during the war. Training open to high school graduates, or those with high school equivalency. Courses 6 to 18 months' duration in RADIO AND ELECTRONICS. Approved Veteran training in Radio. Write for Particulars.

VALPARAISO TECHNICAL INSTITUTE  
DEPT. TN Valparaiso, Ind.

## EASY TO LEARN CODE

It is easy and pleasant to learn or increase speed the modern way — with an **Instructograph Code Teacher**. Excellent for the beginner or advanced student. A quick, practical and dependable method. Available tapes from beginner's alphabet to typical messages on all subjects. Speed range 5 to 40 WPM. Always ready, no QRM, beats having someone send to you.

**ENDORSED BY THOUSANDS!**

The **Instructograph Code Teacher** literally takes the place of an operator-instructor and enables anyone to learn and master code without further assistance. Thousands of successful operators have "acquired the code" with the **Instructograph System**. Write today for full particulars and convenient rental plans.



## INSTRUCTOGRAPH COMPANY

4709 SHERIDAN ROAD, CHICAGO 40, ILLINOIS

began to show, as fuzz on the signals of some W2s keeping their nightly 50-Mc. sked, and within a few minutes there was an uproar of S9 signals from the usual aurora distances, up to 500 miles or so. Signals were extraordinarily clear and steady on voice from 10:15 to 10:35, and though they dropped in strength from then on the band remained open until about 11:30 p.m. Results of this one on 144 Mc. are not yet known in any detail.

## OES Notes

To promote interest in the developmental side of v.h.f. hamming, ARRL some years ago inaugurated a new form of appointment, for v.h.f. operators only. Open to any amateur (Novices and Technicians welcome!) operating on the frequencies from 50 Mc. up, the Official Experimental Station appointment aims at a closer-knit v.h.f. family. OES appointees report activity, observations of propagation, experimental projects and progress, antenna and constructional hints, etc. monthly to ARRL through their Section Communication Managers.

They receive the OES Bulletin, a chatty informal mimeograph prepared exclusively for them by ARRL's Communications Department, containing many tidbits of useful information not found in *QST* or elsewhere, much of the material being gleaned from the monthly OES reports. In addition, OES receive any special WIAW Bulletins relating to the v.h.f. field, in postcard form, informing them in advance of interesting propagation conditions in view, special v.h.f. expeditions, and other helpful news.

If you are operating on the v.h.f. bands or higher, we invite you to enroll in the OES Program. Much of the news in "The World Above 50 Mc." each month is contributed by the OES gang. Won't you join them? Application forms are available from your SCM. You'll find his name and address listed on page 6 of every issue of *QST*.

OES W7OWZ reports improved performance when he replaced his 6J6 final in his 2-meter mobile rig with a pair of 6AK5s in the manner described in *QST* for June, 1951, page 60. He now has ample grid drive and the final modulates beautifully. With as little as 3 watts input he has received S9 reports at a distance of 45 miles.

W4FLW checks W4HHK's 50-Mc. automatic daily morning, noon and night. Though it is 130 miles from Dresden to Collierville, Tenn., Harry is almost always able to find some sign of W4HHK's signal. Its variations tie in nicely with weather data collected regularly.

From Columbus, Ohio, W8WRN reports that W8AMR and others have moved up to 145 Mc. or higher, to keep the several WN8s who have appeared on the band in business. Don't forget that provisions of the Novice Class License require that operation on 2 be confined to 145 to 147 Mc. There may be some new stations hanging out above 145 — better tune up there more regularly!

W9JBF, Wausau, Wis., lists the following regular 2-meter skeds, in company with W9LEE: 8 p.m. — W9FAN, Sheboygan; noontime — W9TQ, Milwaukee, and W9LJV, Waukesha. W9s OAC BBN GKP, and W9GDD are also worked quite regularly.

W7JRG, Sheridan, Wyoming, says that his new overtone oscillator rig (6J6 oscillator-doubler, 24 to 48 Mc., using 8-Mc. rock, 832 tripler, 3E29 driver, and p.p. 24G final) is much more stable than the set-up he used before with a high-frequency crystal. He recently added the 24G final, improving results in his nightly skeds with W7ENI at Gillette.

W9TQ, Milwaukee, points out that his score was incorrectly listed in the report of the June V.H.F. Party in August *QST*. Vic made 19 contacts in 4 sections for a total of 76 points. We gave him twice this score, so, regrettably now move him down from second place in the Wisconsin standing to a tie for fourth.

W8FKC, Hudson, Ohio, in his first OES report, mentions tests with a new combination 220-420 array, using a conical dipole with a screen reflector. By using the conical design commonly employed in TV arrays, coverage of both bands is feasible with a single dipole and either a flat sheet or corner reflector. Checking the method of feed is next on the agenda, Ralph says.

(Continued on page 124)

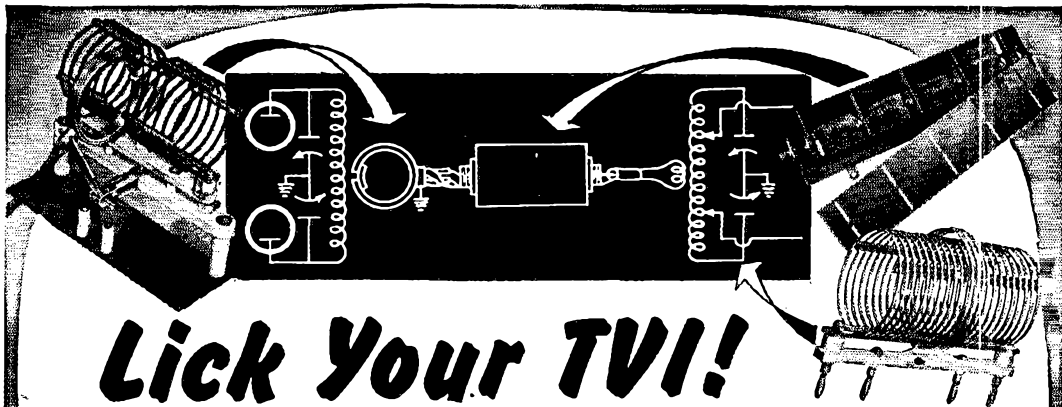

# Lick Your TVI!

Most cases of TVI caused by harmonics and spurious radiations can be reduced to a negligible minimum.

In planning a new rig, the best bet, of course, is to use precision-made B&W components—from oscillator to final including antenna coupler. Filtering and shielding recommendations in our "Filter Facts" booklet show what to do, how to do it.

Should your present rig be

of fairly good design, a few minor changes as outlined in "Filter Facts" plus installation of B&W low-pass filters and Faraday shielded links will effectively throttle TVI. Many hams have proved it!

Send 15c today for a copy of "Filter Facts" giving details on how to lick your TVI and get silent rigs back on the air!

B&W Low-pass Filters, Models 52 and 75 Amateur net \$27.00.

**B&W**

**BARKER & WILLIAMSON, Inc.**

237 Fairfield Ave.

Upper Darby, Pa.

## ATTENTION MOBILE HAMS

Complete mobile package — nothing else to buy. Outstanding mobile signals use motorola equipment — backed by years of communication equipment experience — World's largest producer of 2-way mobile equipment.

A mobile transmitter with a double feature FM or AM at flip of the switch, the MOTOROLA FMT-30-DMS (27-30 MC.). **\$130.00**

P-7253 spring base rear — mount antenna **\$24.75**

New Gon-set Tri-Band Spread Converter **\$47.60**

MOTOROLA P-69-13 or 18-ARS receiver with special noise limiter for use with any converter having 1440-3000 K.C. **\$60.00**

3-30 famous Gon-set converter complete to connect to the P-69-13 or 18-ARS receiver. **\$44.75**

P-327-E Fire wall loud speaker.... **\$5.00**

The above comes complete with all necessary accessories and mounting hardware. Order direct or through the Motorola National Service Organization member in your area.

NOTE: This Receiver and Transmitter is equipment which has been returned from the field, modified and rebuilt for Amateur Service.

For further information write to:

**MOTOROLA INC.**

Amateur Sales Dept. QST — November  
1327 W. Washington Blvd. Chicago 7, Illinois  
Attention: Harry Harrison, W9LLX, Tel. Taylor 9-2200 Ext. 161

CHECK THE FEATURES  
OF ASTATIC MIKES FIRST...

LEARN THE REASONS MOST  
AMATEURS PREFER  
AND USE THEM

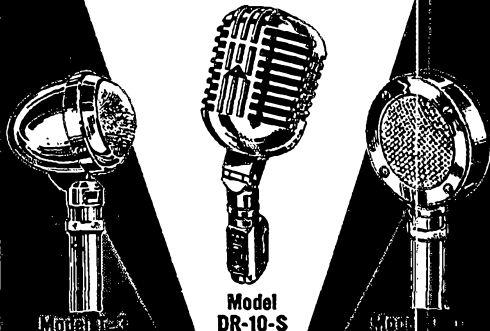

THE  
**Astatic**  
CORPORATION  
CONNEAUT, OHIO  
© CANADA CHAMBER ASTATIC LTD TORONTO ONTARIO

## BUY OF A LIFETIME! TRIED AND PROVEN THE WORLD OVER

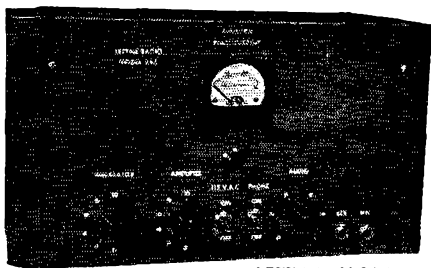

### LETTINE MODEL 240 TRANSMITTER WITH MOBILE CONNECTIONS AND A.C. POWER SUPPLY

This outstanding transmitter has been acclaimed a great performer throughout the world. It is excellent for fixed station, portable or mobile operation. Even if you have a transmitter of your own you can't afford to miss this wonderful buy direct from our factory.

The 240 is a 40 watt Phone-CW rig for 160 to 10 meters, complete with: (3 x 14 x 8) cabinet, self contained A.C. power supply, MOBILE connections, meter, tubes, crystal and coils for 40 meters. Tubes: 6V6 osc., 807 final, 6SJ7 crystal mike amp., 6N7 phase inverter, 2 616's mod., 5U4G rect. Weight 30 lbs. TVI instructions included. 90-day guarantee. Price \$79.95.

\$25 deposit with order — balance C.O.D.

Coils for 80, 20 and 10 meters \$2.91 per set. Coils for 160 meters \$3.69. Equipped for CAP 2374 kc. \$84.95.

### LETTINE RADIO MFG. CO.

62 Berkley St.

Valley Stream, N. Y.

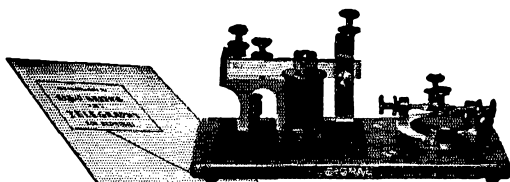

Learner Set  
and Instruction Manual

## Learn Telegraphy & Wireless

## the EASY Signal Way!

**It's fun!** And, you can learn keying fundamentals and codes quickly and easily with Signal's new booklet — "Radio Keying and Telegraphy for Beginners."

Signal's professional-type practice keys and two-way learner sets are also available at student prices. Mail 15c (stamps or coin) today for your instruction manual and equipment catalog.

**Signal** ELECTRIC MANUFACTURING CO.  
MENOMINEE, MICHIGAN

## The World Above 420 Mc.

Now that a real effort is being made in many quarters to extend 420-Mc. coverage, some significant facts are emerging regarding the most effective techniques to be applied. It is being demonstrated, for example, that an easy way to improve receiver performance is to work on the i.f. system first; the front end later.

The value of the best r.f. amplifier is largely lost if the 420-Mc. mixer is followed by a broadband i.f. system of the type generally used in radar or altimeter service. There is little point in straining for the last decibel in improving the noise figure of the front end, if we use an i.f. amplifier that is broader than the minimum necessary to pass a modulated signal.

If no r.f. amplifier (or a poor one) is used, the i.f. system becomes even more important, since its noise figure will contribute greatly to the over-all noise figure of the receiver. We come, then, to the importance of understanding the difference between *noise figure* and *signal-to-noise ratio*.

As ordinarily measured, noise figure is independent of bandwidth. Signal-to-noise ratio (the factor that determines whether a DX signal will be buried in noise) is, however, affected by the receiver bandwidth to a very marked degree — the higher the selectivity the better the receiver performance. Thus it is that a simple mixer-oscillator with, say, 30-Mc. output, followed by a low-noise i.f. amplifier and a second conversion to 455 kc. or lower (for communications-receiver selectivity) may give a better account of itself than a more expensive and complex 420-Mc. converter that is followed by a radar-type i.f. system with a bandwidth of a megacycle or more. And when you take a simple mixer-oscillator and follow it with a high-noise broadband i.f. system in the APS-13 or BC-788 manner, you are doing 420-Mc. progress wrong in that that shouldn't happen to do!

Daily skeds at 7 A.M. have demonstrated that the 435-Mc. signal of W2QED, Seabrook, N. J., is only a matter of some 12 db. below his 145-Mc. one at WHDQ, even with receiver deficiency at the higher frequency included. If the 145-Mc. signal is of good readability and strength, the 435-Mc. signal is usually heard over this 210-mile path. If there is a good opening the 435-Mc. signal is occasionally about equal to the 145-Mc. one, and on at least two occasions the higher frequency has produced the stronger signal. As the early morning inversion dissipates, the 435-Mc. signal fades out first, but by the time it has disappeared completely the 2-meter signal is usually nearly gone as well.

This would seem to show that if we can get some decent receiving equipment going, and if we will make our 420-Mc. antennas equal in size (not number of elements) to our 144-Mc. ones, communication on 420 may soon approach 144 in reliable range. And when things are hot — who can say what our 420-Mc. horizon may turn out to be?

Tripling to 420 with 6J6s? Well, perhaps we've missed a good bet in assuming that they wouldn't work that high. After all, they do about as well as any inexpensive tube in 420-Mc. oscillators, why not as triplers? So reasoned W3-0GL, so he put a 144-Mc. grid circuit in his APS-13 (the oscillator uses push-pull parallel 6J6s, in the manner shown in QST some years ago<sup>1</sup>), and fed in some power from his 2-meter 522. Result, a respectable amount of output on 432 Mc.; at least as much as is usually obtained from an 832 tripler, or from the 6J6s when they are working as an oscillator.

W5AYU, Houston, Texas, mentions *quindupling* to 145 Mc. with a pair of 6J6s, driven by his 10-meter VFO. This quintupler drives an 832 amplifier on 145, followed by an AX-9903 tripler to 435 Mc. He has worked W5e IRP IGL and FON 2-way, and W5HPC crossband to 10. Lee is one of those rare birds who came to 420 Mc. from the lower frequencies, without having first stopped off on 6 or 2. He now works on 2, however, by changing the 9903 tank to run the stage as a straight amplifier.

Reception of signals beyond normal distances on the higher TV channels provides a good indication of 420-Mc. conditions, according to W1PNE, Bristol, Conn. Every time recently that Howard has seen a good picture from Providence, R. I., on Channel 11, or Boston on Channel 7, he has also been able to hear W1CLS, Waltham, Mass. on 432 Mc. On no occasion has the 420-Mc. signal been heard when the high-channel TV signals were weak or missing.

(Continued on page 126)

<sup>1</sup> "Four-Twenty Is Fun," Tilton, QST, Nov., 1947, p. 13.

# CIVIL DEFENSE COMMUNICATIONS

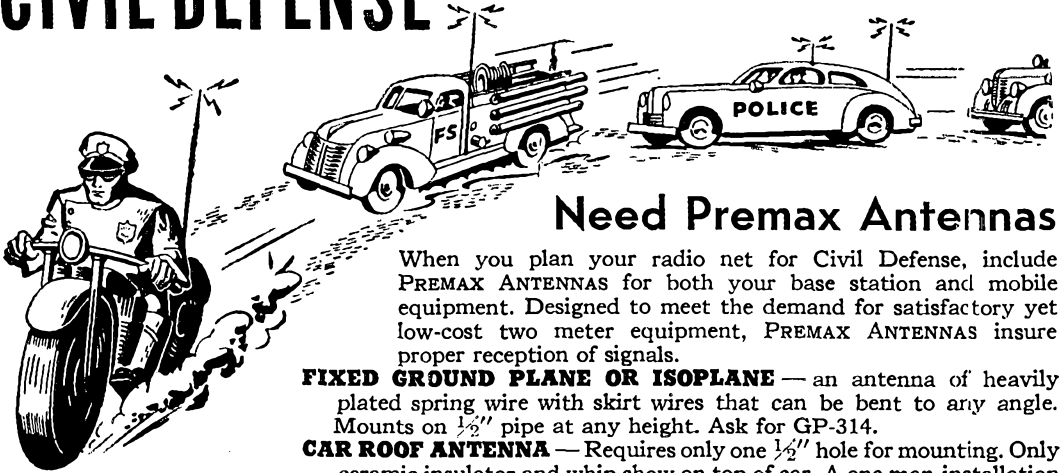

## Need Premax Antennas

When you plan your radio net for Civil Defense, include **PREMAX ANTENNAS** for both your base station and mobile equipment. Designed to meet the demand for satisfactory yet low-cost two meter equipment, **PREMAX ANTENNAS** insure proper reception of signals.

**FIXED GROUND PLANE OR ISOPLANE** — an antenna of heavily plated spring wire with skirt wires that can be bent to any angle. Mounts on  $\frac{1}{2}$ " pipe at any height. Ask for GP-314.

**CAR ROOF ANTENNA** — Requires only one  $\frac{1}{2}$ " hole for mounting. Only ceramic insulator and whip show on top of car. A one man installation job. Ask for CD-114.

**TEMPORARY CAR TOP ANTENNA** — No holes required! Heavy-duty suction cup stays put. Lug at base to attach RG-58 or RG-59A coax which can run in thru window. Ask for CD-214.

**Ask Your Jobber**  
Or Write for Bulletin  
Covering CD Antennas

## PREMAX PRODUCTS

DIVISION CHISHOLM-RYDER CO., INC.

5202 HIGHLAND AVE., NIAGARA FALLS, N. Y.



*Where the Heck  
Did I Put It?*

Stop hunting around for that important QSO entry. Use an **ARRL logbook**. Spiral bound, loose-leaf type, and listing all required data you must enter, it is the answer to "where did I put it?"

ARRL Logbooks..... 50¢  
Minilog..... 30¢

(No Stamps Please)

38 LA SALLE ROAD  
**THE AMERICAN RADIO RELAY LEAGUE, INC.**  
WEST HARTFORD 7, CONNECTICUT

**NOW... Quickly and Easily**  
cut **SQUARE** and **OBLONG**  
openings in radio chassis



**WITH THE GREENLEE No. 731  
SQUARE RADIO CHASSIS PUNCH**

Now, in  $1\frac{1}{2}$  minutes or less you can do hole-cutting jobs that might take an hour or so with old "drilling and filing" methods. Simply insert **GREENLEE Punch** and turn with an ordinary wrench; a "clean" square or oblong opening is quickly cut. An indispensable, timesaving tool that pays for itself in a hurry.



TOOLS FOR CRAFTSMEN  
**GREENLEE**

In sizes  $\frac{1}{4}$ ",  $\frac{3}{8}$ ", and 1"

Write today for facts and prices on this handy Punch.  
**Greenlee Tool Co., 1871 Columbia Ave., Rockford, Illinois.**

**HARRISON HAS**

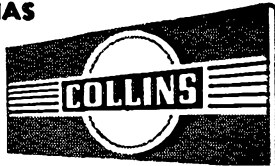

## RECEIVERS

We're making deliveries of the new, improved 75A-2 just as rapidly as they come off the production line to us! And they certainly were worth waiting for!

Proof of Collins superiority of features and performance—the majority of purchasers owned the previous model 75A-1. For fastest delivery, order your new 75A-2 from Harrison. Liberal allowance for your present equipment.

Order now, or write for details. Receiver \$420. Speaker \$20. Plug-in Crystal Calibrator \$25. NBFM unit \$22.50.

★ We have available for

### IMMEDIATE DELIVERY

the excellent Collins receivers taken in trade. Having been given the finest of care by their former owners and being in guaranteed perfect condition, they offer you a wonderful opportunity to enjoy the pleasure and pride of Collins ownership for as little as . . . . . **\$250**

Matching speaker \$15

**MONEY BACK GUARANTEE! ORDER NOW!**



**HARRISON**  
NEW YORK 7, N.Y.  
225 GREENWICH STREET  
BArcley 7-7777

## Learning The Radiotelegraph Code

... is made less difficult by the ARRL publication of the same name.

● Priced at 25¢, it contains all the Novice aspirant needs to know to master those first steps, overcome the mental blocks, and acquire gradual speed and skill. It avoids the usual pitfalls, and it cuts to the heart of the problem. It also contains other helpful data useful to the Novice.

**25¢**

No Stamps Please

38 LA SALLE ROAD  
**THE AMERICAN RADIO RELAY LEAGUE, INC.**  
WEST HARTFORD 7, CONNECTICUT

There is much less correlation between the 50-Mc. and 432-Mc. signals, however, and it has been difficult to guess the nature of u.h.f. conditions by observing the 50-Mc. signals. On the night of Sept. 21st, the 432-Mc. signal of W1CLS was very strong and steady, so W1PNB called your conductor, who was then keeping his nightly sked on 432 Mc. with W1PBB. Turning the beam up to the north-east resulted in the first 432-Mc. communication between W1CLS and W1HDQ, with signals running close to S9 each way. The distance to both W1PNB and W1HDQ is about 100 miles.

The coastal inversion between Santa Barbara and Los Angeles and San Diego, which was responsible for many of our early DX records on 112 Mc., is also effective on 420, according to W6NNN. He has worked W6JBS and W6BYE many times, usually with signals of good strength. At no time has this path of close to 200 miles been found closed. Signals over the 100-mile path from Los Angeles to San Diego are extremely strong.

Ever try to cover a band thirty megacycles wide while using a communications receiver for an i.f.? It's well-nigh impossible, as we have seen from the same problem encountered in trying to cover even four megacycles in the 50- and 144-Mc. bands. The obvious solution, and one now being aimed at by the narrow-band enthusiasts on 420, is to use the third multiple of commonly-used 2-meter frequencies in our 420-Mc. work. The following division of band use is suggested:

420-432 Mc. — Modulated oscillators and wideband f.m.

432-436 Mc. — Crystal-controlled transmitters with a.m., n.f.m. or c.w.

436-460 Mc. — Amateur TV.

This segregation takes care of everyone nicely. The DX enthusiast with the selective receiver can comb his narrow segment with assurance that, if there is anything doing in his department, he'll find it readily. The first 12 Mc. should take care of the simple-rig and wideband-receiver gang — and we need and want them, too. Use of the high end is reserved for TV experimentation, free from QRM that might be caused by the communicators. Will you join the movement on this purely voluntary basis?



November 1926

... The importance of "complete" shielding is stressed in the design of the crystal-controlled exciter built by John M. Clayton, QST's assistant technical editor.

... The intriguing applications of vacuum-tube operated relay circuits are discussed by W. H. Hoffman and F. H. Schnell of the E. F. Burgess Laboratories.

... Don C. Wallace, 9ZT, prominent Midwest ham, has moved to the West Coast.

... A rigging for welding the elements and wires of a homemade Edison battery is described by O. H. Eger, 1CGQ.

... The current "chain letter" craze has crept into domestic amateur circles, with the "good luck" missives being mailed even into foreign countries.

... Recently returned from a trip to Europe, Elizabeth M. Zandonini, 3CDQ, reports on successful 6-meter tests run by Italian station 1ER, Mario Santangeli, operator.

... Suggesting a half-dozen different applications, Raymond B. Roof, 8BTF, recommends a calibrated variable condenser as a worthwhile addition to the ham's test bench.

... M. L. Prescott gives a full report on the GE short wave propagation tests run in cooperation with the ARRL Experimenters' Section.

... Oliver Wright, 6GD-6BKA, has completed a number of experiments using loop antennas and an airborne ham station.

... 1XV-1XAN, the elaborate experimental short-wave station of the Massachusetts Institute of Technology, is described at length.



# NEW TURNER Aristocrat

MODEL 50D DYNAMIC

THE FINEST OF THE FINE

Designed and engineered for television, broadcast, and highest quality recording and public address work. Use the Aristocrat indoors or out—on stand, in hand, suspended, or concealed in stage settings. Flat response guaranteed within 2½ db from 50–15 000 c.p.s. Level: 56 db below 1 volt/dyne/sq. cm. Each unit is individually laboratory calibrated to insure specification standards. List \$150.00.

Write for Literature

In Canada: Canadian Marconi Company, Toronto, Ont. and branches.  
Export: Ad. Auriema, Inc., 89 Broad Street, New York 4, New York

## THE TURNER COMPANY

917 17th Street, N. E.

Cedar Rapids, Iowa

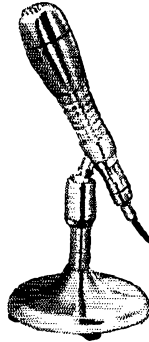
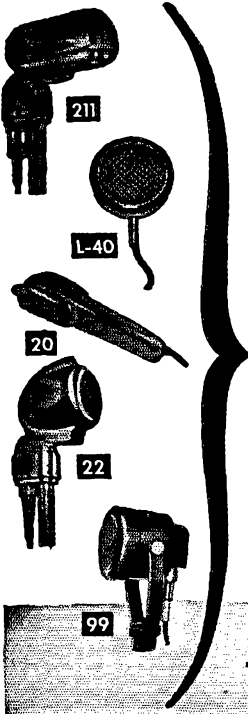

Microphones by **TURNER**



Crystals licensed under patents of Brush Development Co.



### RADIO and TELEVISION ELECTRONICS

in all Technical Phases  
New Classes (Day & Evening) Start  
NOVEMBER 30, 1951

FREE PLACEMENT SERVICE for GRADUATES  
For Free Catalog write Dept. ST-51

**RCA INSTITUTES, INC.**

A Service of Radio Corporation of America  
350 WEST 4th ST., NEW YORK 14, N. Y.

### Send Easier, Faster and Better with a VIBROPLEX Super DeLuxe Key

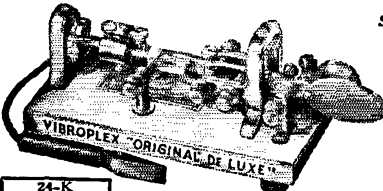

Semi-Automatic

Twice as Easy  
as Hand Sending

Needs no extra  
weights  
for  
slow sending

24-K  
Gold-Plated  
Base Top  
\$29.95

ORIGINAL DELUXE  
model illustrated

A finger-touch on lever button — it's that easy! Transmits SMOOTHLY! EASILY! PERFECTLY! No special skill necessary . . . no arm fatigue . . . no nerve strain. Anyone can use it. The use of patented jewel movement assures a smooth, easy action, easier operation and longer life. Needs no extra weights for slow speed . . . there's no drag . . . no sacrifice of signal quality even at slowest speed. Lets you send from dead slow to a speed beyond the need of the most expert operator. Suits any hand. Order yours today and enjoy keying at its easiest and best! Other models \$12.95 up. Left hand models one dollar more. At dealers or direct. FREE catalog.

Headquarters for NEW portables, all models and styles of type. Also, REBUILT standard and portable typewriters with ALL CAPITAL letters and other styles of type. Immediate delivery. Get our prices before buying.



THE VIBROPLEX CO., INC.

833 Broadway

New York 3, N. Y.

HY-LITE'S NEW

# SKY-LITE

ALL GROUNDED ARRAY FOR 10-11 METERS

4 ELEMENT 6 MTRS. OR  
3 ELEMENT 10-11  
BOTH COMPLETE  
WITH "T" MATCH  
WITH ALL THE ORIGINAL  
HY-LITE QUALITY  
AT THE ORIGINAL  
LOW PRICE

\$ **24**<sup>95</sup>  
WRITE FOR  
CATALOG  
Q-11

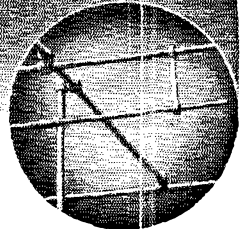

## HY-LITE Antennae INC

Makers of Fine Antennas for AMATEUR · FM · TELEVISION

242 EAST 137TH ST., NEW YORK 51, N. Y.

# ELECTRICAL DRAFTSMEN

There are outstanding opportunities awaiting you *right now* with the large progressive firm that was recently awarded the contract to build the Navy's first *atomic submarine!* Electric Boat Company, Groton, Conn., wants qualified electrical draftsmen at once. Good salaries. Excellent working conditions. Write today, stating qualifications and experience.

**ELECTRIC BOAT COMPANY**  
Groton, Connecticut



# TOPS IN Masts AND Towers

- Amateur radio types
- TV-FM antenna masts
- Vertical radiators
- Micro-wave towers, etc.

From inexpensive TV antenna masts, to 400' guyed vertical radiators for commercial use, the makers of famous Trylon products offer a complete line — including special, built-to-order jobs. Write for details of any type.

Trylon Towers are made only by  
**WIND TURBINE CO.**  
West Chester, Pa.



## Strays

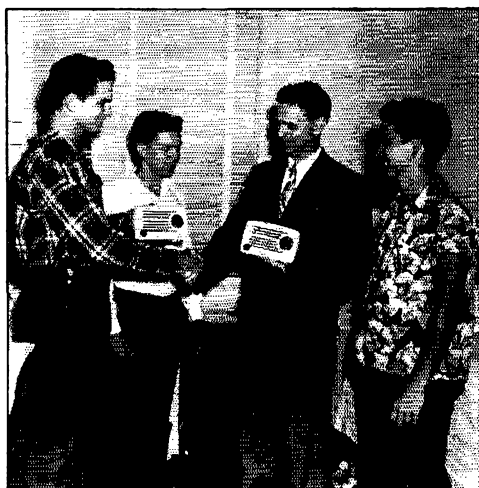

Members of the Pomona (Calif.) High School Radio Club recently presented the Pomona Valley Community Hospital with two table radios for use by patients. Along with the gifts went assurances that the receivers would be kept in working order by the students. Shown at the presentation are, l. to r.: Dave Hartke, W6HYS; Martin Wendruck, W6JMY; B. J. Caldwell, administrator of the hospital; and Larry Hixon, a potential ham. Trustee of the high school club is Heber H. Clewett, W6QE, teacher of physics.

Brig. General Victor A. Conrad, USA, has been elected chairman of the MARS (Military Amateur Radio System) Advisory Committee. General Conrad is chief of the Army Communications Service Division, Office of the Chief Signal Officer. Elected to serve with him was Lieut. Colonel H. H. Moreland, USAF, vice chairman of the committee. The MARS Advisory Committee consists of representatives of the armed services, government agencies, ARRL, and the American Red Cross. Power of the committee is limited to recommending policy to the Chief Signal Officer, Department of the Army, and to the Director of Communications, Department of the Air Force, who are charged with the operation of MARS.



Here lying dead is Stupe Dorrans.  
His XYL is sickly.  
He hunted trouble wearing cans,  
And fried his brains darned quickly.

*the sensational*

# GONSET MOBILE TRI-BAND CONVERTER

*featuring*  
**COMPLETE BANDSPREAD**

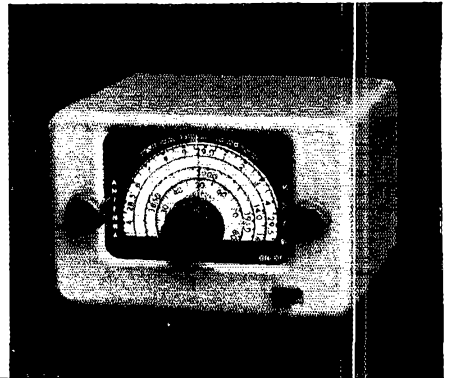

- Covers 10-11, 20, 75 meter phone bands
- 28-29.7 M.C. 8 linear inches bandspread
- 3800-4000 K.C. 6 linear inches bandspread
- 14-14.4 M.C. 2 1/4 linear inches bandspread
- 5 main knob revolutions 28-29.7 M.C.
- Cabinet size 5 1/4 x 5 1/4 x 3 1/2
- Ball bearing planetary
- Four tubes, 6CB6 - R.F. 6C4 - Oscillator  
6AT6 - Mixer 6BH6 - I.F. stage



**\$47.60 net**

**GONSET CO.**

72 E. TUJUNGA AVE.

BURBANK, CALIF

*send for latest bulletin*

## COMMERCIAL RADIO INSTITUTE

**A RADIO TRAINING CENTER FOR 30 YEARS**  
Resident Courses Only • Broadcast, Service, Aeronautical, Television, Radar, Preparatory Mathematics, Frequency Modulation and Marine telegraphy. Classes now forming for mid-year term Feb. 1st 1952. Entrance examination Jan. 21, 1952.

Literature upon request. Veteran training

Dept. B, 38 West Biddle Street, Baltimore 1, Maryland

### Evans Radio

*"Your Friendly Supplier"*

Service to hams by hams. Nationally accepted brands of parts, tubes and equipment. Trade-ins and time payments. Write W1BFT.

10 HILLS AVENUE

CONCORD, N. H.

### LEARN CODE!

SPEED UP Your  
RECEIVING  
with G-C

**Automatic Sender**

Type S

**\$24.00 Postpaid in  
U. S. A.**



Housed in Aluminum Case. Black Instrument Finished. Small—Compact—Quiet induction type motor. 110 Volts—60 Cycle A.C.

Adjustable speed control, maintains constant speed at any Setting. Complete with ten rolls of double perforated tape. A wide variety of other practice tapes available at 50c per roll.

**GARDINER & COMPANY**

STRATFORD

NEW JERSEY

Standard  
Grey  
\$16.75

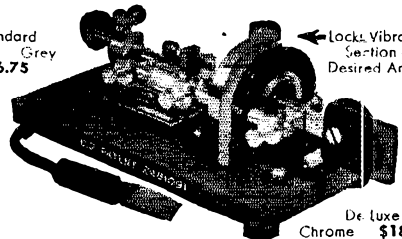

De Luxe  
Chrome \$18.75

Entire **Dow-Key** vibrating section rotatable through 45° clockwise.

*Turn to position which gives you best control — Then see how your sending improves*

- Don't take our word for it, but try a **Dow-Key** on your own rig for 10 days—subject to prompt refund if desired.
- The **Dow-Key** has a patented dot contact assembly that will make firm dots for 12 seconds on one impulse.
- Conventional fixed vibrator type keys as low as \$12.95—send for brochure.

If your distributor has not yet stocked **Dow-Keys** order now direct from factory. Send Cheque, Money Order or will ship C.O.D. Price Net, FOB Warren, Minn., or Winnipeg, Canada.

**THE DOW-KEY COMPANY, INC.**

WARREN, MINNESOTA

Canadian Distributors — Sparling Sales, Ltd.  
120 King St., Winnipeg, Canada



# NATIONAL

- **P**roven
- **D**ePENDABLE
- **Q**uality

MB-40L

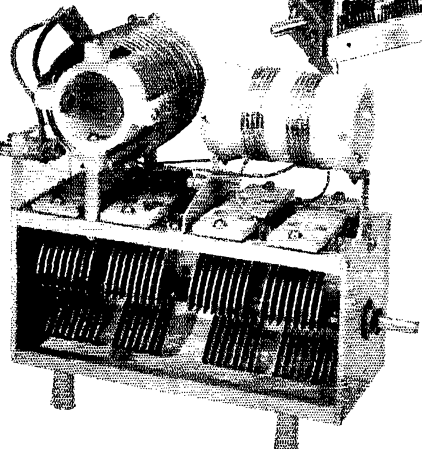
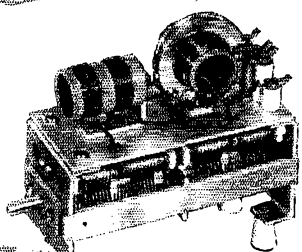

MB-150

## MULTI-BAND TANK ASSEMBLIES

The unique MB-150 high-power and MB-40L low-power multi-band tank assemblies will tune all bands from 80 to 10 meters with a single 180° rotation of the capacitor without changing coils.

The MB-150 is intended for use in plate tank circuits having an input up to 150 watts. It is ideal for a pair of 807's, 809's or a single 829 B.

The MB-40L may be used in the grid circuits of tubes employing the MB-150L in the plate circuit. Will handle 40 watts if link is kept loaded.

# National



NATIONAL COMPANY, Inc.  
MALDEN, MASSACHUSETTS

## Call Signs

(Continued from page 10)

cession are in themselves an especial indication of the Commission's good will and cooperative attitude toward the amateur service. The League believes that the permanent withdrawal of these privileges is bound to have an adverse effect among amateurs.

### V.

The League strongly opposes the permanent deletion of the specified provisions of the amateur rules as proposed by the Commission.

### VI.

The League fully recognizes the difficulty in which the Commission currently finds itself with respect to personnel problems and in particular with respect to the present workload existing in the amateur licensing section of the staff. The present year has seen a sharp upsurge in the filing of renewal applications by amateurs. The Commission's own records will show the exact figures, but certainly it may be said that 1951 represents a peak year in the receipt of renewal applications. This results from the issuance in 1946 of tens of thousands of the new five-year term amateur licenses. The volume of renewal applications cannot be nearly so great in the next few years as it has been this current year. It is also true that the institution of Novice and Technician licenses has added to the problems of the licensing staff — if not the actual number of licenses, at least the difficulty of adjusting a processing system to meet new needs. The present year is an unusual one. It does not seem to the League advisable to make a permanent change in the amateur regulations for reasons which may well be only temporary in nature.

### VII.

Therefore, the League urges the Commission to suspend rather than delete §12.81 and to provide by footnote to §12.81 that paragraphs (1) through (5) are suspended for the period of a year.

Section 12.81 is a statement of Commission policy regarding the assignment of call signs and is procedural in nature. Therefore, compliance with the public notice and procedure for rule making provided for in Section 4 of the Administrative Procedure Act is not required to effectuate the suspension of the rule.

Further, when the now pressure of the administrative work load is relieved, the rule can again be made operative by simple order lifting the freeze upon paragraphs (1) through (5) of §12.81.

Following the procedure herein suggested by the League the Commission could avoid conducting two separate rule-making procedures. Obviously, this will conduce to the public interest and convenience and to a more prompt dispatch of the Commission's business.

AMERICAN RADIO RELAY LEAGUE

October 5, 1951

### Answer to QUIST QUIZ on page 10

It can't be done at the transmitter end of the line. — This must be done at the antenna — and should do some work matching the line and A would be the same regardless of length, coupling would be the same regardless of length, has a bad standing-wave ratio. If it did, the ratio by changing the length of the line. The line will be possible change the standing-wave line-plus-antenna resonant and thus easier to couple. B was lucky in hitting a length that made the

## ATTENTION

### RADIO OPERATORS AND TECHNICIANS

Radiotelephone and radiotelegraph licensees needed by aeronautical communications firm. Domestic and foreign assignments available. Liberal foreign allowances to employees outside the continental U. S. Excellent opportunities for advancement. Send full details to:

BOX 2802, WASHINGTON 13, D.C.

You'll find it

# FASTER in the MASTER

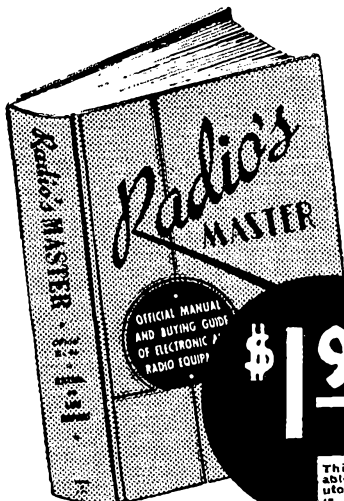

**\$1.95**

This special offer available ONLY thru Distributors (Publisher's price is \$6.50). The Distributors absorb the bulk of the cost for the privilege of printing their ad on the front cover.

The Industry's OFFICIAL Buying Guide of Radio-Electronic-Television parts and equip.

- 1100 Pages
- Hard Cover
- Permanently Bound
- Fully Indexed
- Over 75,000 Items
- Over 7000 illustrations
- Weight—5 lbs.
- Size—8 1/4 x 10 3/4"
- Serving the Industry 16 years

**UNITED CATALOG PUBLISHERS, INC.**  
110 Lafayette Street, New York 13, N. Y.



No More  
Files of  
Small  
Catalogs and  
Loose  
Literature

When you **BUY - - SELL - - SPECIFY**  
you must have the **MASTER**

This single volume replaces other small catalogs

Over 90% of the products manufactured in the Radio-Electronic-Television Parts and Equipment Industry are catalogued in this BIG 1100 page MASTER Buying Guide. Complete descriptions, with specifications and illustrations are written and compiled by each manufacturer covering such products as: tubes, instruments, TV parts, transformers, capacitors, resistors, test equipment, relays, coils and antenna equipment. Also, recording and PA systems, intercoms, tools, hardware, switches and thousands of associated products. IT'S YOUR "RADIO BIBLE"—SAVES YOU TIME AND MONEY.

ONLY available thru Distributors at this special \$1.95 price. GET your copy NOW!!

## RADIO and TELEVISION

Over 30 years N.E. Radio Training Center. Train for all types FCC operators' licenses. Also Radio and Television servicing, FM-AM broadcasting transmitters at school. Send for Catalog Q.

### MASS. RADIO SCHOOL

271 Huntington Avenue Boston 15, Massachusetts  
Lic. by Comm. Mass. Dept. Educ.

**BECOME  
A RADIO  
AMATEUR**

Complete Home Study Course  
For Passing FCC

**Amateur Radio Examinations**

LOW COST • PERSONAL COACHING  
Money Back Guarantee • Write for Details

**FEDERAL ELECTRONICS INSTITUTE**

34 East Putnam Ave. (Dept. C-3), Greenwich, Conn.

### Lysco Grid Dip Meter

Model D-11

955 OSC.

3.4 to 170 Mgs.  
as Dip Meter

3.4 to 340 Mgs.  
as Signal  
Generator

5 Plug-in Coils

Phone Monitor

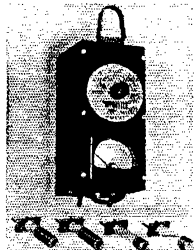

CW Monitor

Harmonic  
Indicator

Absorption  
Wavemeter

Measures Tuned  
Circuits,  
Antennas, etc.

Complete ready to  
operate.....  
\$39.95 Net

Write for Literature and name of Dealer nearest you stocking  
Lysco Ham Equipment.

**LYSCO**

**HOBOKEN, N. J.**

DID YOU GET IT? IF NOT...

**SEND NOW FOR B-A's**

**136 BIG PAGE**

**FREE CATALOG**



**INCLUDING  
21 PAGES OF  
DOLLAR-SAVING  
BARGAINS!**

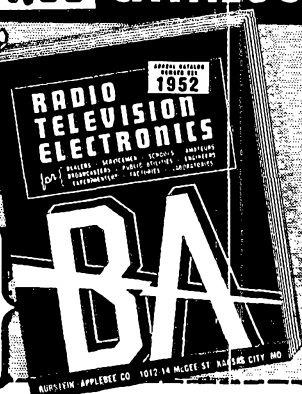

**BURSTEIN-APPLEBEE CO.**  
1012-14 McGee St.  
Kansas City 6, Mo.

**FREE**

Send your 1952 catalog to:

Name .....

Address .....

City .....

State .....

**BURSTEIN-APPLEBEE CO.**

# HAM-ADS

(1) Advertising shall pertain to radio and shall be of nature of interest to radio amateurs or experimenters in their pursuit of the art.

(2) No display of any character will be accepted, nor can any special typographical arrangement, such as all or part capital letters be used which would tend to make one advertisement stand out from the others.

(3) The Ham-Ad rate is 30¢ per word, except as noted in paragraph (6) below.

(4) Remittance in full must accompany copy. No cash or contract discount or agency commission will be allowed.

(5) Closing date for Ham-Ads is the 25th of the second month preceding publication date.

(6) A special rate of 7¢ per word will apply to advertising which, in our judgment, is obviously non-commercial in nature and is placed under a signed by a member of the American Radio Relay League. Thus, advertising of bona fide surplus equipment owned, used and for sale by an individual or apparatus offered for exchange or advertising inquiring for special equipment, if by a member of the American Radio Relay League take the 7¢ rate. An attempt to deal in apparatus in quantity for profit, even if by an individual, is commercial and all advertising by him, takes the 30¢ rate. Provisions of paragraphs (1), (2) and (5), apply to all advertising in this column regardless of which rate may apply.

(7) Because error is more easily avoided, it is requested signature and address be printed plainly.

(8) No advertiser may use more than 100 words in any one issue nor more than one ad in one issue.

Having made no investigation of the advertisers in the classified columns, the publishers of QST are unable to vouch for their integrity or for the grade or character of the products or services advertised.

**QUARTZ**—Direct importers from Brazil of best quality pure quartz suitable for making piezo-electric crystals. Diamond Drill Carbon Co., 719 World Bldg., New York City.

**QSL**, 100, \$1.85 up. Stamp for samples. Griffith, WJFSW, 1042 Fine Heights Ave., Baltimore 29, Md.

**MOTOROLA** used equipment communication equipment bought and sold, W5BCO, Ralph Hicks, 204 E. Fairview, Tulsa, Okla.

**SUBSCRIPTIONS**, Radio publications a specialty. Earl Meade, Huntley, Montana, W7LCM.

**QSL'S-SWL**, Mead, W0KXL, 1507 Central Avenue, Kansas City, Kansas.

**LEARN** Morse Code in just 8 hours! Code-Voice Record method gets you ready for Novice Class license, good Army job in radio. You get 4 sides of code instruction on two 10-in., 78 RPM Vinylite records in handsomely illustrated, completely detailed album. Send only \$4.00. Money-back guarantee. Dept. Q1, The Raybrun Company, Box 66, Orangeburg, N. Y.

**5-Element 2-meter beams**. Riverside Tool Co., Box 87, Riverside, Ill.

**WANTED**: Old radio magazines and catalogs prior to 1921. Send list and prices — or will trade. Vance Phillips, W6GH, Hope Ranch, Santa Barbara, Calif.

**WANTED**: Teletype 1/40th HP synchronous motor W61TH, Moraga, Calif.

**QSL**, SWLS, C. Fritz, 1213 Briargate, Joliet, Illinois.

**WANTED**: March and May 1916 QSTs. 200 copies for sale 1920 to 1951 at 25¢. W0MCC, 1022 N. Rockhill Rd., Rock Hill 19, Mo.

**WANTED**: Your surplus radio receivers, transmitters, ARC-1, ARC-3, ART-13. We buy anything. What have you? Tom Allen, 562 Atlantic Ave., Brooklyn 17, N. Y.

**QSL** Taprint, Little Rock, Mississippi.

**CRYSTALS** Bassett precision Type 100A (FT-243) within 80, 40, 20 bands or MARS channels at \$1.50 each. Specify exact frequency and include postage. Rex Bassett, Inc., Bassett Building, Fort Lauderdale, Florida.

**BALLOONS**: Radiozone, 12' bursting, 3 for \$2.00. Phone patch schematics, practical discussion. \$1.00. C. E. Nichols, W1MRK, 57 Hancock, Auburndale, Mass.

**QSL**: Uncle Fred's QSLs. Three colors and up. Rainbow map QSLs. Special DX QSLs. Bargain QSLs. Samples rushed, 10¢. Uncle Fred, Box 86, Lynn, Penna.

**WANTED**: DeForest Responder, Arc Radiophone, Audion Boxes, Marconi Coherer, Magnetic Detector, Type D, E & Multiple Tuners; other gear prior to 1920. Franklin Wingard, Rock Island, Illinois. FOR SALE: RG-8U in 29 ft. lengths with fittings, \$2.00. New 832A's \$5.00, 829B's, \$6.00 each. C. F. Moretti, W2A1H.

**WANTED**: Indices to QST volumes 6 to 19, both inclusive. Also "Pink sheet" one-page supplement to October, 1919 "QST" announcing lifting of transmission ban, and Apr. 1919 8-page pamphlet entitled "Getting Together Again", mailed to League members before publication of "QST", resumed after World War I. Also complete files, odd lots, or single copies of Southern Edition QST's, Jan. 1936 to Dec. 1939, both inclusive, and Western Edition, years 1936 and 1941. Must have both covers and be in very good condition. Sumner B. Young, W9CO, Route 3, Wayzata, Minn.

**WANTED**: Radio officers for Merchant Marine, \$400 per month or more. Men who hold or who formerly held 1st Cl. 2nd Cl. or IFT radiotelegraph license and 6 months ship radio operating experience. Radio Officers Union, 1440 Broadway, New York, N. Y.

**PLATE** transformers. New. Kenyon secondary 4520 volts ct primary 110 v. 60 cycles, 1450 watts, weight 75 pounds. \$39.50 each, two for \$75. F.o.b. Kansas City, Mo., Art Wearth, 6014 El Monte, Mission, Kans.

**WANTED**: 32V-1 or 32V-2. Cash. W7PMC, Greenough, Montana. **SELL**: Hallcrafters S-72, portable, Late model. \$80. Shipped. James F. Quigley, 645 Polk Blvd., Des Moines, Iowa. **SNOOPERSCOPE**, Infrared. "See-in-Dark", tube, data, \$4.98. IN34, 69¢. Free Tabogram. "TAB", 109 Liberty St., New York 6, N. Y.

**QSL**, Samples for 3¢ stamp. Harrison, 8001 Piney Branch Rd., Silver Spring, Maryland.

**WANTED**: Ham receiver. Sell or trade. Thord. Trans. fully cased, 2000/1500 v. 1000 watts. Tanenbaum, 1535 E. 8th, Brooklyn 30, N. Y.

**WANTED**: Collins 310B3 exciter. W2JIL.

**SELL**: B C-221-M. In new condx. Complete with spare tubes and AC power supply. \$65. W5RWJ, 515 E. Johnson, Jonesboro, Ark.

**FOR SALE**: DB20, HRO prewar. Cash: \$150. In excellent condx. W2LCD.

**FOR SALE**: Collins 310-B-3, new, used only about 20 hours, \$200. VHF152A, \$50. 1 KW xmitter, no junk, standard components. Write for full particulars, \$450. A. L. Rossance, W3NIG, 2409 Livingston St., Allentown, Penna.

**MEISSNER** BC FM receptor. Factory manual. \$35.00 takes it. W9RSR, 511 West Wilson, Madison, Wis.

**FOR SALE**: 1 KW-TVI, \$450. F.o.b. Dr. West, Box 2423, Norfolk, Va.

**NEW** crystals for all commercial services at economical prices; also regrading or replacement crystals for Broadcast, Like, Link, Motorola, G-E and other commercial types. Over 16 years of satisfaction and fast service! Edison Electronic Co., Phone 3-3901, Temple, Texas.

**QSL**, Samples free. Wunder, W2TDV, 135-21 Francis Lewis Blvd., Rosedale 10, N. Y.

**USED** equipment: Gonset 6-15 Converter, \$54.50; RME DB-20, \$29.50; Hallcrafters HT-17 complete, \$40; RME VHF-152A-S, \$69.50; Meck T-60-1, \$89.50; Hammarlund SP-400SX, \$199.50; Sonar AMP-50, \$29.50; others. Write for latest list. Evans, W1BFT, Evans Radio, Concord, N. H.

**ARR8** RCA receiver 14 tubes, 535 Kcs to 32 Mcs continuous. Weight 84 lbs., 1 1/4" x 1 1/4" x 11 high. With LS and CRR74208 freq. meter (as BC221 but mains) perfect condition. Best offer secures America's finest communication RX. Further details SAE Tidmarsh, G3ADD, 108 1/2 Wateman St., Providence, R. I.

**WANTED**: Collins 32V transmitter also 75A receiver. Please advise price and condition. W5BXK, P. O. Box 493, Abilene, Texas.

**WANTED**: DeForest, Wireless Specialty, DeForest, Electro Importing Co. apparatus: Wireless Age, Marconiographs, Electrical Experimenters, Wireless Books before 1919. Catalogs, such as Duck, Meaco, Electro Importing, Louis Rizoli, W1AAT, 100 Bay View, Salem, Mass.

**FOR SALE**: 300 watt modulator in cabinet. Thordarson multi-match transformers. 811's as modulators. \$75. Ester, W9OEV, 149 Harrison, DeKalb, Ill.

**WANTED**: H.V. plate transformer for BC-610 (HT-4) transmitter. Standard Transformer Co. Type 10P43 or similar. J. A. Cheeka, W8RU, P. O. Box 174, Twinburg, Ohio.

**FOR SALE**: Hallcrafters HT-6 transmitter, in very good condx, 25 watts fone and cw, complete with tubes, coils 10 thru 160 inc., ECO on 20 and 75 with Astatic W-30 mike and schematic, \$95 or best offer. Also have: BC-348 converted to AC. Make offer. Will consider mobile equipment in trade. W8UWZ, Arlington, Nebr.

**BC610E** 10 to 80, perfect condx with Drake TVI filter and relay, mike, \$525. Daniels, W9D5W, Box 261, Webster, Wis.

**FOR SALE**: A bargain list of gear. W1CPI, Wakefield, R. I.

**FOR SALE**: Meisner EX signal shifter, all coils \$50; VHF152, \$50; Air King 10" TV rcvr, 630 circuit, \$135. All in A-1 cond. J. B. White, W5LET, c/o Louisiana College, Pineville, La.

**CASH** for well-built 250 to 500 watt xmitter, fone and cw, 80 to 10 meters, rack and panel construx, ready to operate. Shud be VFO controlled. State price, description and condx. Also send foto if available. All letters answered. W2EFP, 138 Cordova St., Syracuse 5, N. Y.

**PERSONALIZE** your QSL card with a Fotostamp; a real photo in stamp-size, gummed. Samples free. 100 glossy Fotostamps only \$2, postpaid anywhere. Send amount and your photo, snapshot, negative or drawing (returned unharmed). Satisfaction guaranteed. Kaufmann, 433 Montvalley, Hotspings, Ark. (quick service by airmail).

**SELLING** out equipment: BC-34 a.c. powered \$65; YRS-1 unused, \$55; BC-221 for \$45; 1.47 Kva H.V. supplies complete, \$60; Johnson Rotator and indicator unused, cost \$236, will sell for \$135; Federal 167-BV less H.V. supply, as is with tubes, \$90; Millen R-9er, \$12. W4ALR, Box 549, Rt. 6, Louisville, Ky.

**SELL**: QST, June 1930 to May 1951 completely. R. McConnell, 151 Center Ave., Pittsburgh 2, Penna.

**CLOSING** shop. Large radio and photo stock, all below cost. For immediate sale. Catalog. Albert Pratt, 1939 N. 18th St., Milwaukee 5, Wisconsin.

**QSL**, SWLS, Kromekote, Crystalon, regular stock. Franzen, W2DEE, Maple Shade, New Jersey.

**SAM'S** Manuals 1-120 for sale. Price \$180. Will ship with inspection privilege. H. Schwartz, W5LMZ, Box 128, Lake Providence, La.

**COLOR** Television patents. Study firsthand information, including Columbia system. Use the comprehensive patent search report. Send \$1.00. Patent Service, 945-Q Pennsylvania Ave., Washington 4, D. C.

**LOOKING** for local ham ops to help me with theory & code. What say, fellas? I'll come down one night per week. David M. Turner, 5202 Haspel St., Elmhurst, L. I., N. Y. Tel. TW.8-3307.

**SELL**: Two tubes never used: 4E27/257B, \$25; 4-125A, \$20; Modernized Delco car radio R663, 6V, dc and 115V a.c., with spkr, \$15; two BC-645a's with connecting plugs, \$10 each (see Feb. '47 QST); 100/1000Kc freq. standard beautifully built, \$15. Will write fully about any item. M. G. Morgan, W1HDA, Thayer School of Engineering, Hanover, N. H.

**QSL'S** SWLS? Modernists? Cartoons? Novices? Photographs? QSL samples, 10¢. Sakers, W8DED, Holland, Michigan. Ham Print Shop.

SELL: TCS equipment, TCS motor generator sets, 115 v.d.c. input, \$35. #804 Federal Sig. Gen., #145; Dumont #164E scope, \$65. Want surplus test equipment, TS or I types. Will trade. T. Clark Howard, 46 Mt. Vernon St., Boston 8, Mass. (W1AFN).

10 and 20 Meter beams, \$23.25 up. Aluminum tubing, etc. Willard Radcliff, Fostoria, Ohio.

WANTED: WRL transmitter, Collins 32V2, Collins VFO, TBS-50, Box 382, Newark 1, N. J.

FOR Sale: Mobile transmitter Motorola FM-T-30D less dynamotor converted for amateur use, \$40. Accessories included. All inquiries answered, Ralph Fries, 66 South Second St., Meriden, Conn.

HQ-129X and 100 Kc. osc., \$130. R. Van Wuyckhuysse, 412 Humboldt St., Rochester 10, N. Y.

FOR Sale: Perfect condx: Collins 32VA, \$495, BC-610, \$495, W4KE, Lloyd Colvin, AFF Board #1, Ft. Bragg, N. C.

FOR Sale: Hallcrafters S40 revr in perfect condx, with spare tubes, only \$60. Best offer takes Hickok tube tester, Mod. 550X, Navy MBF transceiver. Hal Horwitz, W6WSU, 5402 Westhaven, Los Angeles 16, Calif.

SELL: Taylor Western, 1000 Watt, Type 900A transmitter in console, complete with remote control cabinet, dynamic microphone, 10 and 20 meter coils, and spare 4-250As and 1B-35 tubes. In perfect operating condx. \$1000. F.o.b. Tucson. W7LVR, RFD #5, Box 237, Tucson, Ariz.

FOR Sale: HRO50 with speaker, Stancor 203A mobile transmitter, Gonset Triband, Millen 500 watt amplifier. Lawrence H. Lapinske, W9EWM, Box 179, Wausau, Wis.

SALE or trade: AR-11 transceiver, complete. Want: VHF-152A, W9NVU, 39 West Market St., Huntington, Indiana.

FOR Sale: Collins 75-A2 revr, new, unpacked: \$400. Reason: Took up flying. Dr. C. H. Scheiffel, c/o Mayo Clinic, Rochester, Minn. STILL looking for Dec. 1915 and 1916 QST's to complete file. ARRL Handbook 1938, 1947, U.S. Gov't. Prtg. Office Edition Call Books: Commercial Stations, 1922, Amateur Stations, 1926. Any prior 1915. Large sized Call Books any years. Year Book Wireless Telegraphy. Collins Wireless Bulletin, early wireless catalogs prior 1925. Electrical and mechanic, Modern Electrics, have early Call Books, Int'l Rules & Regulations and vintage Electric Wireless Magazine for swap. Rob't. L. Willis, W1PN, 53 Hemenway St., Boston, Mass.

DON'T fail! Send today for a Surecheck Test and answer key. Novice, \$1.50; Conditional and General, \$1.75; Advanced, \$2.00. Amateur Radio Supply, 1013 Seventh Ave., Worthington, Minn.

WANTED: BC-654A, PE-103A, PE-104A, SCR-284A, ARC-1, ART-13, RA-34, RA-62, TCS, BC-610, BC-348, BC-342, BC-312, BC-221, BC-611, BC-721, radar sets, parts, tubes, Sonar, Loran, test equipment with TS or I prefix. Any technical manuals, trade or cash. Arrow Appliance, 525 Union, Lynn, Mass.

3 used self-supporting, fully drilled for panel mounting, standard RCA racks of 7 channels 2 1/2 x 7 5/8, with 1/2" base flange, with 3/32" copper clad steel enclosure and (60" wide rear door) top, all perforated for ventilation, for 2 adjacent racks. Third rack is separate, no enclosure. Make offers f.o.b. Krusel, 928 Curtiss St., Downers Grove, Ill.

WANTED: Copy of "Two Hundred Meters & Down". Must be in good condition. W1DJV, 85 Southwell Rd., Wethersfield, Conn.

BC-312 converted for 110 VAC with spkr and extra crystal filter. A hot ham receiver. \$60. W4ICK, 3200 Circle Hill Rd., Alexandria, Va.

TRADE: Brand new Electro Engineering E-5707 transformer, 3000 DC 650 ma, 115/230 primary. Very small and light. Want: BC-453A, 454A, 946B, and 696 in good condition. J. Murdoch, KL7RS, 811 8th St., Bismarck, North Dakota.

SELL: Instructograph with 10 tapes in good condition, \$20. Bryan Basinger, Findlay, Ohio, R. #6.

FOR SALE OR SWAP: 1 HV xformer, Kenyon Type S, 12941, 500 ma, 2260 VCT; 1 HV xfrm, G-E type WP, 1016 3000 VCT, 750 Ma; 1 UTC Type S34, 5-25 henries, 300 Ma. choke; 4 Eimac 100Th, 2 Westinghouse RX-35MA 0-150 Ma, 2 Hammarlund neutralizing condensers for 100T or equivalent; 2 NJ382A; 1 RCA1625; 2 Heintz & Kaufman 24G H.F. tubes; 1 HY75; 1 RCA8A30B; 2 N.U. C222, A.C. Victor, 1008 N. Spring St., Beaver Dam, Wis.

SELL: 3-band mobile transmitter, 10 and 75 meter converters VFO. L. Jones, W2AEV, 14 Carol Rd., Bethpage, N. Y.

WANTED: GP-7 tuning units D and F, RU-18 coil ranges QM and FG, W1QDQ, Box 177, Swanton, Vermont.

MODERN station for sale: All Collins equipment except Panoramic adapter, 310 B exciter, complete; 75-A revr with plated xtals, 30-J transmitter complete with coils and xtals for 10-20-40-80-160 meter bands; RBU-2 3" tube Panoramic adapter connected to revr. Exciter new, never used, in cabinet to match 75-A. Revr and Panadapter used approx. five hours, adapter new when purchased. Some spare tubes, \$1500.00 for everything, F.O.B. Cedar Rapids, Ia. 3000 cycle filter included. \$200.00. Will sell complete in pieces. There are sales for each unit individually. Everything strictly used condition. W0NLE, 2209 Blake Blvd., Cedar Rapids, Iowa.

SPECIAL: Used S.W. Diathermies. Cost over \$500 new; 500-900 watts input. Tubes, meter, transformers, condensers, etc. worth more than we are asking. Portables, \$25. Consoles, \$35. F.o.b. Chicago. Medical Arts Supply Co., 500 S. Wolcott Ave., Chicago 12, Ill.

WANTED: Enclosed relay cabinet, panel space 60 inches or more. Furnish all pertinent data, condition, price. W2EWT, Wm. Hope, 106 Ullman St., Buffalo, N. Y.

BARGAINS: Extra special Motorola P-69-13 Mobile revrs, \$250; Globe-Ang, \$35; HT19, \$199; H140-7, \$199; Remco 75CA, \$225; Collins 32BA, \$125; Collins 32MA, \$99.50; Collins 75A1, \$295; new 150-watt fone, \$199; HRO-5T, \$175; Hallic, S-47, \$119; RME-45, \$99; SX-17, \$89.50; Meissner EX shifter, NC-46, S-40A, \$69.50; VHF152A \$69; SX-24, \$69; Globe Trotter, \$57.50; new Meissner sig. Calibe, \$24.95; MB611, \$29; 90X00 exciter, \$29.50; XE10, \$14.95 and many others. Large stock trade-ins; free trial. Terms financed by Leo, W6GFG. Write for catalog and best deal to World Radio Labs, Inc., Council Bluffs, Iowa.

BARGAINS: New and reconditioned Collins, National, Hallcrafters, Hammarlund, RME, Millen, Gonset, Harvey-Wells, others. Reconditioned S38, \$229; S40A, \$69; HT18, \$79; SX43, \$119; SX71, \$149; NC57, \$69; NC173, \$139; HRO7, \$189; NC183, \$199; HQ129X, \$139; SP400X, \$259; DB22A, \$49; HF-10-20, \$49; VHF152A, \$59; RME45, \$89; SX25, SX28A, SX42, HRO50T, Collins 75A1, others. Shipped on trial. Terms. List free. Henry Radio, Butler, Mo.

## IMPORTANT!

We believe we can offer more money for select military test equipment and good laboratory test equipment than anyone else. A partial list of our needs follows:

LAE	TS14	TS100	TS239
LAF	TS33	TS111CP	TS263
LAG	TS33A	TS125	TS268
1208	TS34/AP	TS155A/AP	TS270A
1222	TS34A/AP	TS155B/AP	TS323
TS3/AP	TS35	TS173/UR	TSK-45E
TS12	TS36	TS175	TS5-45E
TS13	TS47APR	TS195	TSX-45E

We will also purchase Boonton, Rad-Lab equipment, GR, Ferris, Stoddart, Doolittle—Hewlett-Packard, etc. Prompt replies assured.

### WESTON LABORATORIES

Weston 93, Massachusetts

### AN/APR-4 COMPONENTS WANTED

In any condition. Also top prices for: ARC-1, ARC-3, APR-1, APR-5A, etc., TS-34 and other "TS-" and standard Lab Test equipment, especially for the MICROWAVE REGION; ART-13, BC-348, BC-221, LAE, LAF, LAG, and other quality Surplus equipment; also quantity Spares, tubes, plugs and cable.

### ENGINEERING ASSOCIATES

434 Patterson Road

Dayton 9, Ohio

### HAMMARLUND SALES DEPARTMENT

Wants Ham to handle correspondence, advertising, publicity and literature. Permanent position with good future. Send complete resume indicating salary desired.

HAMMARLUND MANUFACTURING COMPANY, INC.  
460 West 34th Street • New York 1, N. Y.

### • WANTED •

## RADIO COMMUNICATIONS

THE United States Government has openings for radio operator-technicians who are interested in careers in radio communications and general electronics involving extensive overseas assignments.

Applicants should have the following technical qualifications: (A) Two years active radio experience in the design, construction, and maintenance of transmitting and receiving equipment and the ability to copy International code at fifteen words per minute, preferably on a typewriter. (B) Knowledge of radio wave propagation and practical design and construction of antennae.

The required personal qualifications are as follows: (A) Age, over 21 and must be able to pass a thorough physical examination. (B) Indicate a willingness to serve overseas extensively and in any location required.

Current starting salaries for non-supervisory radio operator-technicians range from \$3100 to \$3825 per annum. Salaries, leave, promotions, employee benefits, transportation and baggage allowances, cost of living differential allowances, etc., are in accordance with current government regulations.

Interested personnel are requested to write a brief application letter to Box 5640, Friendship Heights Station, Washington, D. C. Considerable duplication of effort will be avoided if the following outline is adhered to:

1. Experience and training.
  - a. Number of months radio training and type (college, service schools, technical and/or trade schools).
  - b. Number of years radio experience and type (military, merchant marine, commercial, government).
  - c. Amount of this experience in telegraphy and amount in construction or maintenance.
  - d. Present radiotelegraph code speed.
  - e. Present or past radio licenses, including amateur.
2. Marital status.

If your initial application appears promising, you will be sent full application forms upon which detailed information can be entered.

Designed for



Application

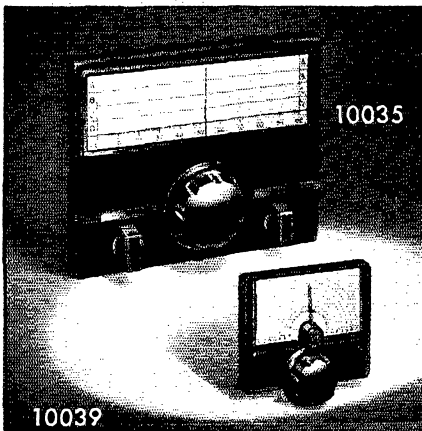

**Nos. 10035 and 10039  
Multi-Scale Dials**

A pair of truly "Designed for Application" controls. Large panel style dial has 12 to 1 ratio; size, 8 1/2" x 6 1/2". Small No. 10039 has 8 to 1 ratio; size, 4" x 3 1/4". Both are of compact mechanical design, easy to mount and have totally self-contained mechanism, thus eliminating back of panel interference. Provision for mounting and marking auxiliary controls, such as switches, potentiometers, etc., provided on the No. 10035. Standard finish, either size, flat black art metal.

**JAMES MILLEN  
MFG. CO., INC.**

MAIN OFFICE AND FACTORY  
**MALDEN**  
MASSACHUSETTS



**Index of Advertisers**

Allied Radio Corporation.....	95
American Phenolic Corporation.....	88
American Radio Relay League, Inc.....	91, 94, 122, 125, 126
Ashe Radio Co., Walter.....	107
Astatic Corporation, The.....	123
Barker & Williamson, Inc.....	123
Belden Manufacturing Co.....	77
Bendix Radio Division.....	119
Bliley Electric Co.....	92
Bud Radio, Inc.....	83
Burstein-Applebec Co.....	131
Candler System Co.....	118
Centralab.....	79
Chicago Transformer Co.....	135
Collins Radio Company.....	2
Commercial Radio Institute.....	129
Dow-Key Company, The.....	129
Etel-McCullough, Inc.....	75, 114
Edico of New York.....	70, 71
Electric Boat Company.....	128
Electro-Voice, Inc.....	Cov. 11
Engineering Associates.....	133
Evans Radio.....	129
Federal Electronics Institute.....	131
Fort Orange Radio Distributing Co.....	115
Frazier, Howard S.....	114
Gardiner & Co.....	129
General Electric Company.....	1
Greenlee Tool Company.....	125
Gonset Co., The.....	129
Hallicrafters Co., The.....	4, 7
Hammarlund Manufacturing Co., Inc.....	133
Harrison Radio Co.....	113, 126
Harvey Radio Co.....	97
Harvey-Weiss Electronics, Inc.....	84
Heath Co., The.....	85
Henry Radio Stores.....	99, 116
Hughes Aircraft Co.....	110
Hy-Lite Antennae, Inc.....	127
Instructograph Co.....	122
Jensen Manufacturing Co.....	110
JFD Manufacturing Company.....	120
Johnson Co., E. F.....	121
Knights Co., The James.....	136
Leeds Radio Company.....	105
Lettine Radio Manufacturing Co.....	124
Lysco Manufacturing Co.....	131
Mallard Manufacturing Co.....	90
Mallory & Co., Inc., P. K.....	81
Mass. Radio & Telegraph School.....	131
McGraw-Hill Book Co.....	98
Merit Transformer Corporation.....	82
Millen Mfg. Co., Inc., The James.....	134
Motorola, Inc.....	123
National Co., Inc.....	69, 130, Cov. 111
Newark Electric Company.....	103
Niagara Radio Supply Corp.....	109
Ohmite Manufacturing Co.....	73
Petersen Radio Company.....	5
Port Arthur College.....	120
Precision Apparatus Co.....	86
Premax Products Co.....	125
RCA Institutes, Inc.....	127
Radio Corporation of America.....	Cov. IV
Radio Manufacturing Engineers.....	121
Radio Shack Corporation, The.....	93
Radio Wire Television, Inc.....	117
Shure Brothers.....	100
Signal Electric Mfg. Co.....	124
Simpson Electric Mfg. Co.....	89
Sonar Radio Corporation.....	96
Sprague Products Co.....	102
Srepeco, Inc.....	112
Stahl, Inc., Michael.....	119
Standard Transformer Corporation.....	87
Steinberg's, Inc.....	108
Tech-Master Products Co.....	104
Terminal Radio Corporation.....	101
Triplett Electrical Instrument Co.....	80
Turner Company, The.....	127
United Catalog Publishers, Inc.....	131
Valparaiso Technical Institute.....	122
Vibroplex Co., The.....	127
Westinghouse Electric Corporation.....	106
Weston Laboratories.....	133
Wind Turbine Company.....	128
World Radio Laboratories, Inc.....	111



# world's toughest transformers

## CHICAGO

### "SEALED-IN-STEEL" New Equipment Transformers

### Preferred!

### the INSIDE STORY tells why!

The proof of toughness is on the *inside*—the actual proof that demonstrates why CHICAGO Transformers are preferred by engineers, why they fully meet the express requirements of today's tubes and circuits. Here are the "inside facts" of CHICAGO "Sealed-in-Steel" design:

- ① Exclusive one-piece drawn-steel case, unsurpassed for strength, moisture-resistance, better electrostatic and magnetic shielding, mounting ease, and streamlined appearance.
- ② Uniformly-wound precise coil structures—cooler operation and better electrostatic shielding in power units—minimum leakage, optimum coupling in audio units.
- ③ Core of high-grade non-aging silicon steel brought to high efficiency by scientific heat-treating in CHICAGO'S own annealing ovens.
- ④ Core and coil vacuum-impregnated with varnish. Final high-temperature baking achieves a perfectly impregnated coil and core locked against vibration.
- ⑤ All internal free space is filled by special, moisture-resistant compound. Prevents corrosion and helps maintain far cooler operation than in conventional air-surrounded mountings.
- ⑥ Checked by quality controls at every stage of manufacture, rigidly inspected, "torture-chamber" tested to insure long, dependable life in actual service.

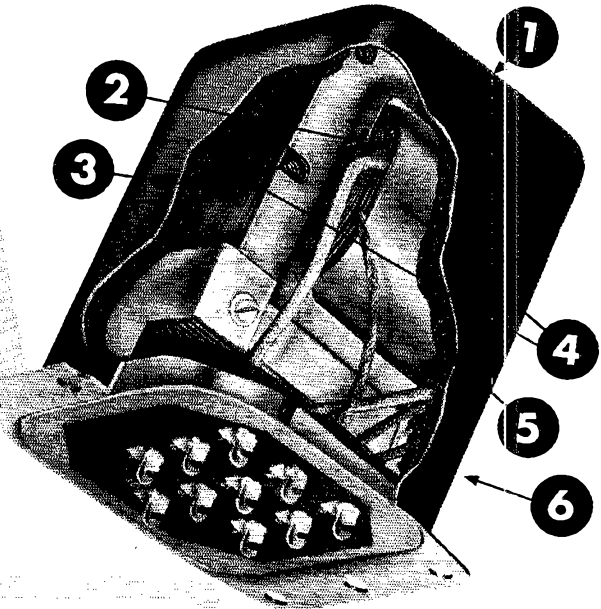

### AVAILABLE IN THREE VERSATILE CONSTRUCTIONS

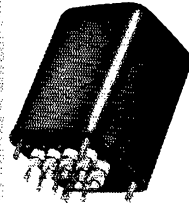

**H-Type.** Steel base cover deep-seal soldered into case. Terminals hermetically sealed. Ceramic bushings. Stud-mounted unit.

MEETS MIL-T-27 SPECS

**S-Type.** Steel base cover fitted with phenolic terminal board. Convenient numbered solder lug terminals. Flange-mounted unit.

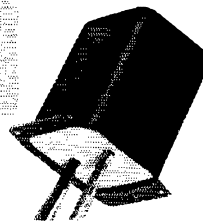
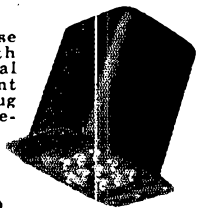

**C-Type.** With 10" color-coded stripped and tinned leads brought out through fibre board base cover. Flange-mounted unit.

### SEND FOR "NEW EQUIPMENT LINE" CATALOG

Get the full details on CHICAGO'S New Equipment Line—the famous Sealed-in-Steel line that offers advanced engineering design to fit today's circuits. Write for your FREE catalog today—or get a copy from your distributor.



Write for  
CHICAGO'S  
"New Equipment"  
Catalog  
Today

## CHICAGO TRANSFORMER

DIVISION OF ESSEX WIRE CORPORATION

3501 ADDISON STREET • CHICAGO 18, ILLINOIS



*Supplying*

**TODAY'S  
NEEDS**

*and*

**DESIGNING  
TOMORROW'S**

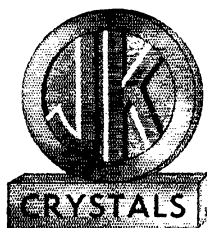

Grand-daddy of this present-day Walkie-Talkie was one of the heroes of World War II. Now in civilian use, too, this pictured Motorola equipment uses James Knights H-17 crystals. Compactly dependable!

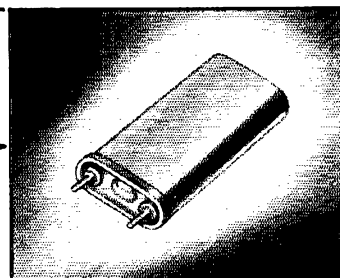

Tomorrow will probably unveil still another use for the refined JK H-17T. Doll-sized yet more precise than a jeweled watch movement, its 20-200 kc frequency range adapts perfectly to small equipment.



**JK H-11**



**JK T-9**



**JK G-9**



**JK H-17**

*The*  
**JAMES  
KNIGHTS  
CO.**

**SANDWICH 6,  
ILLINOIS**

**EVEN NOW JK CRYSTALS ARE GUARDING YOUR FUTURE**

Because James Knights are tooled-up to manufacture every known existing crystal even as they are developing new designs for new uses, JK crystals are preferred in many critical defense projects. This very moment the Navy is putting several JK crystals through their paces in developing new hush-hush equipment. For the James Knights labs have the answer to any question crystal-wise.

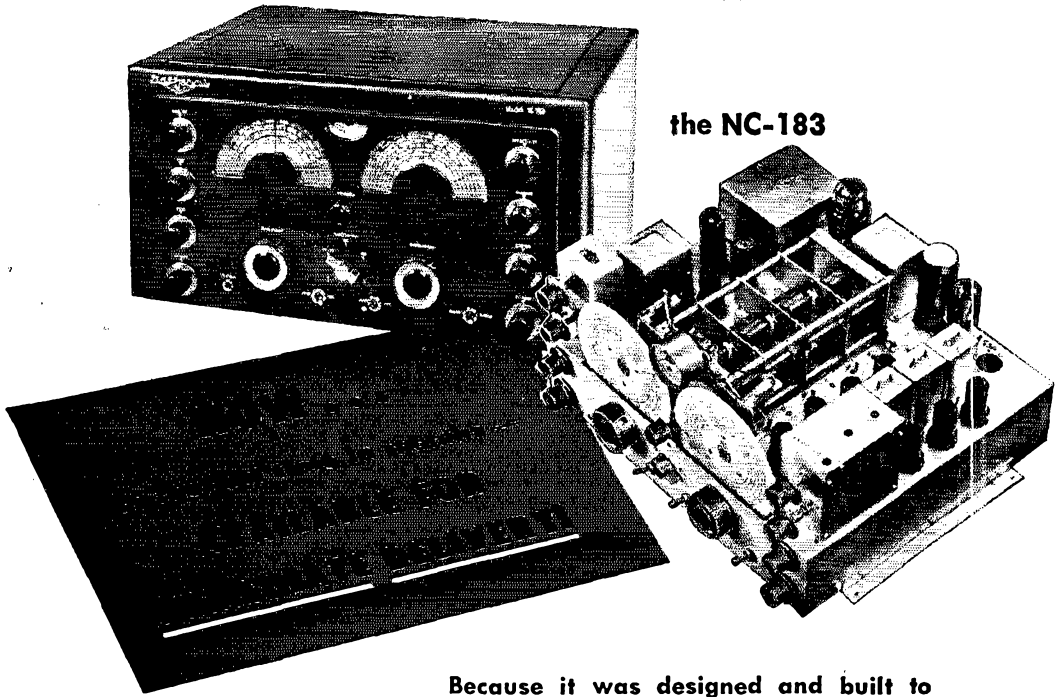

the NC-183

Because it was designed and built to out-perform, the NC-183 has always been a favorite. From 2-stage R.F. to push-pull audio output, the NC-183 incorporates every wanted feature of a fine receiver. Now, for the first time in too long, it is once again available for immediate delivery!

**COVERAGE:** Continuous from 540 kcs. to 31 mcs. plus 48 to 56 mcs. for 6-meter reception.

**FEATURES:** Two tuned R.F. stages. Voltage regulated osc. and BFO. Main tuning dial covers range in five bands. Bandsread dial calibrated for amateur 80,40,20 11-10 and 6-meter bands. Bandsread usable over entire range. Six-position crystal filter. "DOUBLE ACTION PLUS" noise limiter. High fidelity push-pull audio. Accessory socket for NFM adaptor or other unit, such as crystal calibrator.

**CONTROLS:** CWO Switch, CWO pitch, Tone, AF Gain, Main Tuning, Bandsread,

Ant. Trimmer, Bandswitch, Send-Receive, Phono-Radio, Selectivity, Phasing, Limiter, RF Gain.

**TUBE COMPLEMENT:** Uses 2-6SG7 R.F.; 16SA7 1st det.; 1-6J5 osc.; 2-6SG7 I.F.; 1-6H6 2nd det.; 1-6SJ7 B.F.O.; 1-6AC7 A.V.C.; 1-6H6 noise limiter; 1-6SJ7 A.F.; 1-6J5 phase inv.; 2-6V6GT aud. out.; 1-VR-150 volt. reg.; 1-5U4G rect.

**\$279** (less speaker)

*Slightly Higher West of the Rockies*

*Also Available in Professional-looking Rack Model, the NC-183R, at same price.*

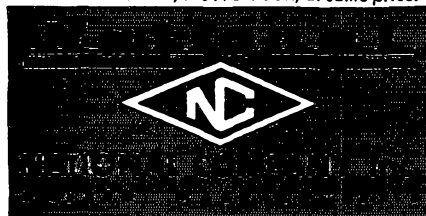

# RCA TUBE LINE-UPS FOR 1951

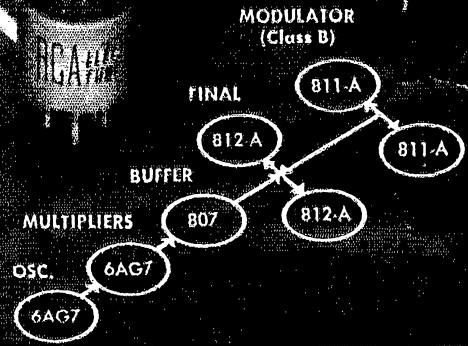
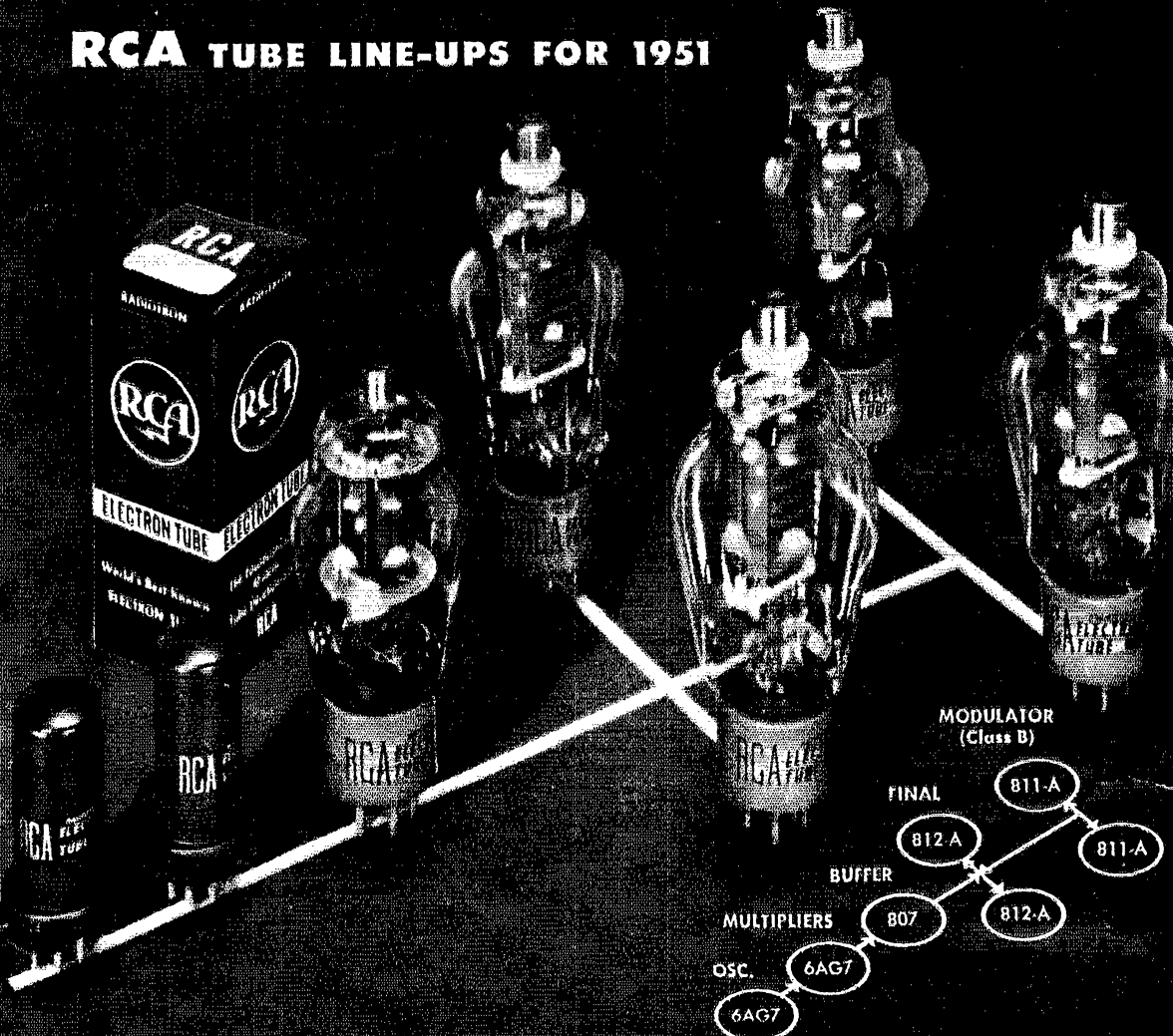

## A full 520 watts input CW...350 watts input phone ...with easy-to-drive RCA-812A triodes

FOR SOLID POWER AND PERFORMANCE—on cw or phone—here's a dependable tube line-up you can follow with confidence.

Designed around the popular RCA-812A high-percentage power triode, this well-balanced line-up offers high power at low cost.

The push-pull RCA-812A's easily handle an input of over 500 watts cw up to 30 Mc, and require only 13 watts driving power to their grids. For phone, the push-pull RCA-811A's . . . operated at zero bias . . . can

deliver an audio output of up to 310 watts...more than enough audio output to 100% modulate the 812-A's

To get all the tube power, performance, and life *you* pay for . . . buy genuine RCA tubes from your local RCA TUBE DISTRIBUTOR.

★ ★ ★

**ARE YOU** getting the new RCA HAM TIPS? There's a copy waiting for you at your RCA Tube Distributor.



**RADIO CORPORATION of AMERICA**  
ELECTRON TUBES  
HARRISON, N. J.