

September, 1952

40 Cents

45c in Canada

QST

devoted entirely to

amateur radio

In This Issue:

- Measuring-Cup Band Spotter
- Mobile Rig for 3.8 and 7 Mc.
- R.F. Voltmeters
- 40-Meter DX Beam
- Exciter for 50, 28 and 21 Mc.

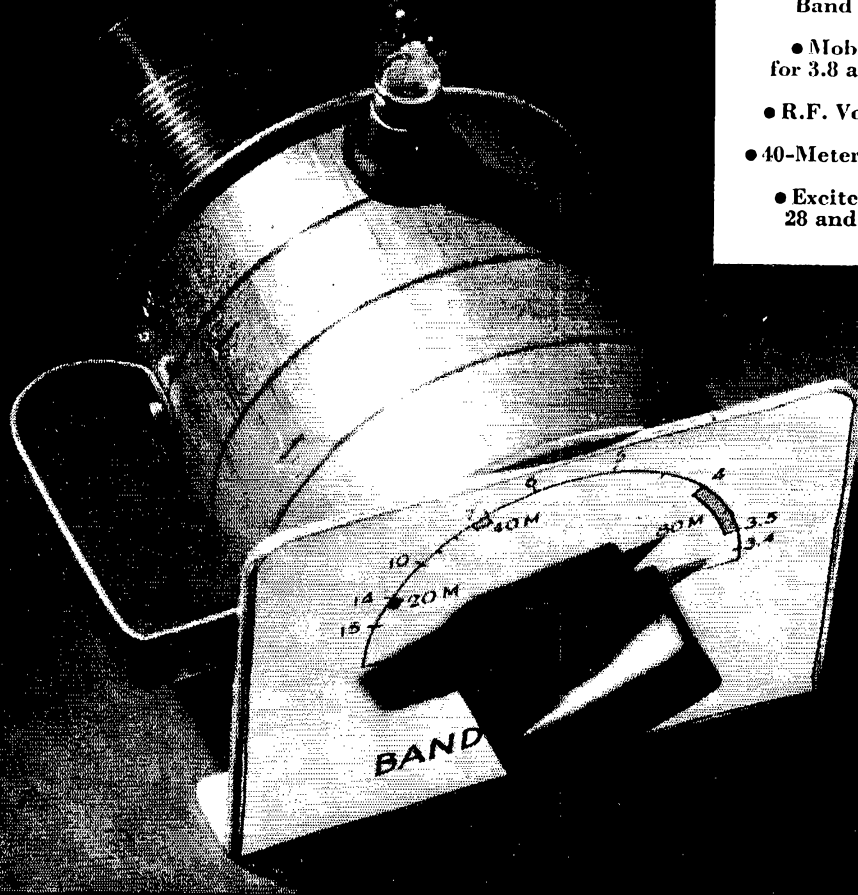

for Stock Hermetically Sealed Components



RCOF CASE

Length 1.25/64
 Width 61/64
 Height 1.13/32
 Mounting 1.1/8
 Screws 4-40 FIL.
 Cutout 7/8 Dia.
 Unit Weight 1.5 oz.

MINIATURE AUDIO UNITS...RCOF CASE

Type No.	Application	MIL Type	Pri. Imp. Ohms	Sec. Imp. Ohms	DC In Pri., MA	Response \pm 2db. (Cyc.)	Max. level dbm	List Price
H-1	Mike, pickup, line to grid	TF1A10YY	50,200 CT, 500 CT*	50,000	0	50-10,000	+5	\$16.50
H-2	Mike to grid	TF1A11YY	82	135,000	50	250-8,000	+21	16.00
H-3	Single plate to single grid	TF1A15YY	15,000	60,000	0	50-10,000	+6	13.50
H-4	Single plate to single grid, DC in Pri.	TF1A15YY	15,000	60,000	4	200-10,000	+14	13.50
H-5	Single plate to P.P. grids	TF1A15YY	15,000	95,000 CT	0	50-10,000	+5	15.50
H-6	Single plate to P.P. grids, DC in Pri.	TF1A15YY	15,000	95,000 split	4	200-10,000	+11	16.00
H-7	Single or P.P. plates to line	TF1A13YY	20,000 CT	150/600	4	200-10,000	+21	16.50
H-8	Mixing and matching	TF1A1GYY	150/600	600 CT	0	50-10,000	+8	15.50
H-9	82/41:1 input to grid	TF1A10YY	150/600	1 meg.	0	200-3,000 (4db.)	+10	16.50
H-10	10:1 single plate to single grid	TF1A15YY	10,000	1 meg.	0	200-3,000 (4db.)	+10	15.00
H-11	Reactor	TF1A20YY	300 Henries-0 DC, 50 Henries-3 Ma. DC, 6,000 Ohms.					12.00

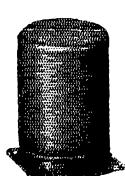

RC-50 CASE

Length 1.5/8
 Width 1.5/8
 Height 2.5/16
 Mounting 1.5/16
 Screws #6-32
 Cutout 1 1/2 Dia.
 Unit Weight 8 oz.

COMPACT AUDIO UNITS...RC-50 CASE

Type No.	Application	MIL Type	Pri. Imp. Ohms	Sec. Imp. Ohms	DC In Pri., MA	Response \pm 2db. (Cyc.)	Max. level dbm	List Price
H-20	Single plate to 2 grids, can also be used for P.P. plates	TF1A15YY	15,000 split	80,000 split	0	30-20,000	+12	\$20.00
H-21	Single plate to P.P. grids, DC in Pri.	TF1A15YY	15,000	80,000 split	8	100-20,000	+23	23.00
H-22	Single plate to multiple line	TF1A13YY	15,000	50/200, 125/500**	8	50-20,000	+23	21.00
H-23	P.P. plates to multiple line	TF1A13YY	30,000 split	50/200, 125/500**	8	30-20,000 BAL.	+19	20.00
H-24	Reactor	TF1A20YY	450 Hys.-0 DC, 250 Hys.-5 Ma. DC, 6000 ohms ... 65 Hys.-10 Ma. DC, 1500 ohms.					15.00



SM CASE

Length 11/16
 Width 1/2
 Height 29/32
 Screw 4-40 FIL.
 Unit Weight 8 oz.

SUBMINIATURE AUDIO UNITS...SM CASE

Type No.	Application	MIL Type	Pri. Imp. Ohms	Sec. Imp. Ohms	DC In Pri., MA	Response \pm 2db. (Cyc.)	Max. level dbm	List Price
H-30	Input to grid	TF1A10YY	50***	62,500	0	150-10,000	+13	\$13.00
H-31	Single plate to single grid, 3:1	TF1A15YY	10,000	90,000	0	300-10,000	+13	13.00
H-32	Single plate to line	TF1A13YY	10,000****	200	3	300-10,000	+13	13.00
H-33	Single plate to low impedance	TF1A13YY	30,000	50	1	300-10,000	+15	13.00
H-34	Single plate to low impedance	TF1A13YY	100,000	60	5	300-10,000	+6	13.00
H-35	Reactor	TF1A20YY	100 Henries-0 DC, 50 Henries-1 Ma. DC, 4,400 ohms.					11.00

The impedance ratings are listed in standard manner. Obviously, a transformer with a 15,000 ohm primary impedance can operate from a tube representing a source impedance of 7700 ohms, etc. In addition, transformers can be used for applications differing considerably from those shown, keeping in mind that impedance ratio is constant. Lower source impedance will improve response and level ratings ... higher source impedance will reduce frequency range and level rating.

- * 200 ohm termination can be used for 150 ohms or 250 ohms, 500 ohm termination can be used for 600 ohms.
- ** 200 ohm termination can be used for 150 ohms or 250 ohms, 125/500 ohm termination can be used for 150/600 ohms.
- *** can be used with higher source impedances, with corresponding reduction in frequency range. With 200 ohm source, secondary impedance becomes 250,000 ohms ... loaded response is -4 db. at 300 cycles.
- **** can be used for 500 ohm load ... 25,000 ohm primary impedance ... 1.5 Ma. DC.

150 VARICK STREET

NEW YORK 13, N. Y.

EXPORT DIVISION: 13 EAST 40th STREET, NEW YORK 16, N. Y.

CABLES: "ARLAB"

Now...

the final link for your
VHF-UHF FRONT END
 G. E.'s new **6AM4 MIXER TRIODE!**



6AJ4
(R-F)



6AF4
(OSC.)



6AM4 heater voltage	6.3 v
Heater current	0.225 amp
Max plate voltage	150 v
Max plate dissipation	2 w
Transconductance	9,000 micromhos

HEAR 420 mc . . . 220 mc . . . 144 mc and below—clearly, cleanly, easily—by rounding out your front-end circuit with G.E.'s brand-new 6AM4! This mixer tube was designed to team up with its 6AJ4 and 6AF4 companions.

The triodes combine to handle frequencies up to 900 mc, and down to the audio range. Their noise level is low, because close spacing and parallel structures minimize random electrons that cause noise disturbance. This is one "why" of the good reception obtained.

Another reason you'll hear well: isolation between tube input and output is excellent, creating a level input impedance over the band width. This means improved reception where grounded-grid circuits are used.

Priced at low receiving-tube levels—all three G-E types! No strain on your pocketbook . . . now . . . to design a front end that will bring in *all* your favorite bands! See your G-E tube distributor for further facts. *Tube Dept., General Electric Co., Schenectady 5, N. Y.*

SUPERHETERODYNE

Basis of modern radio reception!



● In 1923, General Electric announced the superheterodyne circuit, in which the incoming signal was changed to a new intermediate frequency by mixing it with another signal from a local oscillator. This made possible high selectivity and high gain, both of them constant. The "superhet" circuit is almost universally used in today's receivers. G-E research that helped develop it, continues to create new products for better application of the superheterodyne principle. Examples are the v-h-f, u-h-f front-end triodes—in debt for their advanced design to G.E.'s long experience in radio electronics!

ELECTRONIC TUBES OF ALL TYPES FOR THE RADIO AMATEUR

GENERAL  **ELECTRIC**

166-189

Lt. Col. Fred J. Elser
in his ham shack

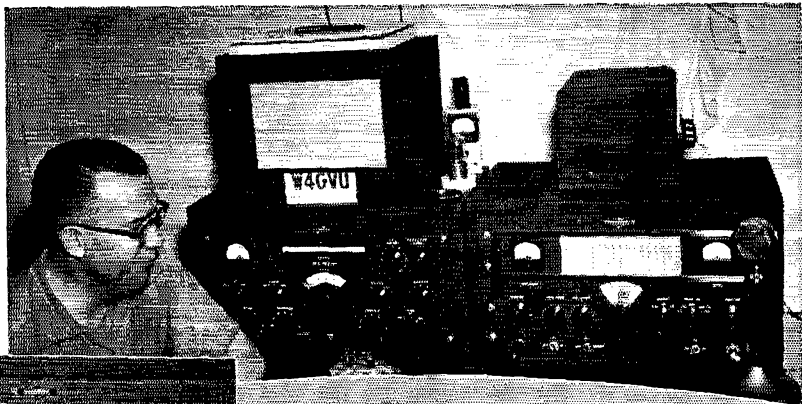

FAN MAIL FOR A STAR PERFORMER COLLINS 32V-3

LT. COL. FRED J. ELSER
820 John's Road, Augusta, Georgia, 21 June, 1952

Mr. R. Bellew
Collins Radio Co.
Cedar Rapids, Ia.

Dear Dick:

I received my 32V-3 on 4 April, 1952 and connected it through my 35C-2 filter with RG8/U coax to the Harrison Antenna coupler bought for use with my old 32V-1 in Turkey. This gives me good loading to my 100' Inverted "L" Marconi Antenna, 30' high, on all bands 10 through 80 meters. Grounding is accomplished by means of 3/8" copper braid to the house copper water pipe system. On Sunday, 6 April, with the assistance of W4EZU, W4HRR, and W4RVE, all also members of the Augusta Radio Club's TVI Committee, tests were performed on my neighbor's TV installation, which is a 4-stack bi-conical rotary beam, 50' from my antenna, feeding thence into the Dumont T.V. Receiver. On no band, including 10 X phone, could my signals be detected while tuning for

WSB-TV on Channel 2, or for WBT-TV on Channel 3. Each of these stations is located approximately 150 airline miles from here, in Atlanta and Charlotte, respectively. A Drake 300 ohm "Hi-pass" filter was placed in the TV antenna lead-in, but was really not necessary. I might mention that while testing on Channel 2, with full gain on the TV receiver and preamp, the WSB-TV signal was so weak that the set would not "lock" on it. A strong TV signal in this locality will only run about 50 UV.

As you know, I had complete success with your 32V-1/75A-1 combination in Turkey, and on being ordered to this location knew my 2 Kilowatt rigs (homemade) would never be satisfactory under prevailing TV conditions here. Your 32V-3 (with 35C-2 filter) and 75A2 allow me to continue my 35 years as an active ham.

Thankfully,
/s/ FRED

For excellence in amateur communications, it's . . .

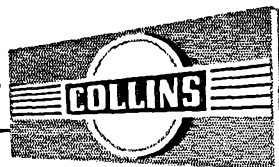

COLLINS RADIO COMPANY, Cedar Rapids, Iowa

11 W. 42nd St., NEW YORK 18

1930 Carpenter Blvd., DALLAS 2

2700 W. Olive Ave., BURBANK

QST

SEPTEMBER 1952

VOLUME XXXVI • NUMBER 9

PUBLISHED, MONTHLY, AS ITS OFFICIAL ORGAN, BY THE AMERICAN RADIO RELAY LEAGUE, INC., AT WEST HARTFORD, CONN., U. S. A.; OFFICIAL ORGAN OF THE INTERNATIONAL AMATEUR RADIO UNION

STAFF

Editorial

A. L. BUDLONG, WIBUD
Editor

HAROLD M. McKEAN, WICEG
Managing Editor

GEORGE GRAMMER, WIDF
Technical Editor

DONALD H. MIX, WITS
BYRON GOODMAN, WIDX
Assistant Technical Editors

EDWARD P. TILTON, WIHQ
V.H.F. Editor

RICHARD M. SMITH, W1FTX
C. VERNON CHAMBERS, WIJEQ
Technical Assistants

ROD NEWKIRK, W1VMW
DX Editor

ELEANOR WILSON, W1QON
YL Editor

DOROTHY A. BUBB
Production Assistant

WALTER E. BRADLEY, W1FWH
Technical Information Service

Advertising

LORENTZ A. MORROW, W1VG
Advertising Manager

EDGAR D. COLLINS
Advertising Assistant

Circulation

DAVID H. HOUGHTON
Circulation Manager

HARRY PASTON, W1DJV
HAROLD K. ISHAM, W1MFA
Assistant Circulation Managers

OFFICES

38 La Salle Road

West Hartford 7, Connecticut

TEL.: 3-6268 TWX: HF 88

Subscription rate in United States and Possessions, \$4.00 per year, postpaid; \$4.25 in the Dominion of Canada, \$5.00 in all other countries. Single copies, 40 cents. Foreign remittances should be by international postal or express money order or bank draft negotiable in the U. S. and for an equivalent amount in U. S. funds.

Entered as second-class matter May 29, 1919, at the post office at Hartford, Connecticut, under the Act of March 3, 1879. Acceptance for mailing at special rate of postage provided for in section 1102, Act of October 3, 1917, authorized September 9, 1922. Additional entry at Concord, N. H., authorized February 21, 1929, under the Act of February 28, 1925.

Copyright 1952 by the American Radio Relay League, Inc. Title registered at U. S. Patent Office. International copyright secured. All rights reserved. *Quedan reservados todos los derechos.* Printed in U. S. A.

INDEXED BY
INDUSTRIAL ARTS INDEX

-CONTENTS-

TECHNICAL —

Ham-Band Transmitting Loops	Richard R. Hay, W4LW	14
Controlled Carrier with a Cathode Follower	Jose A. Vivares, LU1EP	15
Matching Coax Line to the Ground-Plane Antenna	Robert T. DeCamp, W2AFG	18
A Bandswitching Exciter for 50, 28 and 21 Mc.	Edward P. Tilton, WIHQ	20
Identifying Frequency-Meter Harmonics	N. K. Chamberlin	24
7-Mc. Beam for the Small Yard....	A. D. Mayo, WSDF	25
R.F. Voltmeters.....	George Grammer, WIDF	29
Are You U.L. Approved?.....	I. F. Wolk, W6HPV	32
The "Ultimate" C.W. Receiver	Robert R. Pittman, and Gerald Summers, W5FKQ	38
What Price Precision?...	George X. M. Collier, W0EG	42
The Series Balanced Modulator	Fred M. Berry, W0MNN	46

MOBILE —

A Two-Band Miniature Mobile Transmitter	C. Vernon Chambers, WIJEQ	11
---	---------------------------	----

NOVICE —

The Measuring-Cup Band Spotter	Richard M. Smith, W1FTX	16
--------------------------------	-------------------------	----

OPERATING —

VE-W Reciprocal Operation Authorized.....	50
V.H.F. QSO Party.....	54

GENERAL —

"It Seems to Us...."	9	United States Naval Reserve.	54
Hamfest Calendar.....	10	The World Above 30 Mc.....	53
Quist Quiz.....	10	Coming ARRL Conventions...	60
Silent Keys.....	28	In QST 25 Years Ago.....	60
Happenings of the Month....	34	How's DX?.....	61
YL News and Views.....	45	Correspondence from Members	64
On the Air with Single Side-band.....	48	Hints and Kinks.....	66
WWW-WVVH Schedules.....	52	Operating News.....	67
Feed-back.....	52	With the AREC.....	71
On the TVI Front.....	53	Station Activities.....	74
		Military Amateur Radio System.....	132

Military Performance and Dependability

THE SX-73 COMMUNICATIONS RECEIVER

"A Gibraltar of Stability"

It is the ultimate in all-wave receivers . . . this jewel of precision craftsmanship! Refined in even the smallest detail, the SX-73 meets the tough military communications specifications.

Hallicrafters is proud to place its name on the SX-73.

PRECISION

hallicrafters

SX-73

Frequency Range:

540 kc to 54 Mc in six turret-selected bands.

20 tubes, including rectifier, voltage regulation and ballast tubes.

Dual conversion, 455 kc and 6 Mc crystal controlled.

Receiver type: Single superheterodyne in tuning ranges of 540 kc to 7.0 Mc and dual conversion on tuning ranges from 7.0 to 54.0 Mc.

Types of signals: AM, CW, MCW, ICW, and Carrier Shift Tele-typewriter.

Frequency calibration: 2 tenths of one per cent or less at all frequencies.

Image rejection: Not less than 80 db at any frequency.

Front panel controls: R.F. gain, AC on/off; b.f.o. pitch; audio gain; crystal phasing; selectivity; V.F.O./Crystal; crystal vernier; band selector; frequency; receiver/send; CW/modulation; A.G.C./manual; A.N.L./off; antenna adjust.



FRONT VIEW,
SX-73

HALLICRAFTERS • WORLD'S LEADING MANUFACTURER OF PRECISION RADIO & TELEVISION CHICAGO 24, ILL.

hallicrafters presents

Super Fidelity!

A New Precision AM-FM Tuner and Amplifier. A.F.C. Eliminated*

Now you can hear the entire range of audible sound with **ABSOLUTE MINIMUM DRIFT!**

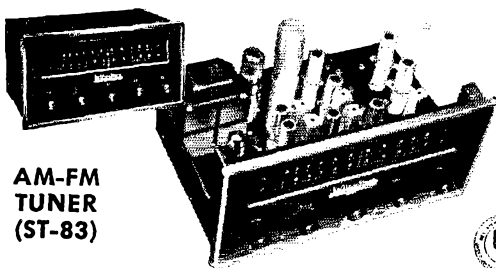

**AM-FM
TUNER
(ST-83)**

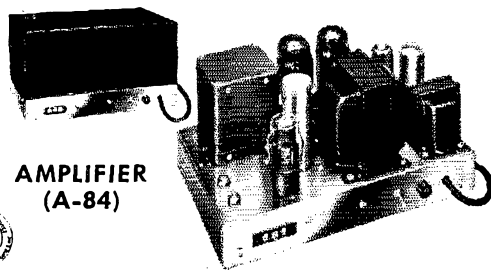

**AMPLIFIER
(A-84)**



*The new Hallicrafters Precision-engineered chassis with temperature-compensated oscillator, eliminating need for A.F.C., is non-frequency discriminating and in conjunction with the ratio detector circuit, makes for accurate, even tuning.

ADVANCED DESIGN: Entirely safe, fully-enclosed case is first to receive Underwriters' Laboratories approval!

NO rf SWITCHING: Individual input for AM and FM eliminates need for rf switching, and increases stability.

PHONOGRAPH, TELEVISION, TAPE RECORDER INPUTS: Including cathode follower output, which permits remote control installations without frequency discrimination.

LOOP ANTENNA: Built-in.

10 Kc FILTER: Built-in.

SEPARATE AUTOMATIC VOLUME CONTROL, for AM.

MILITARY-TYPE FM ANTENNA coupling network, for uniform, increased sensitivity across the band.

STONE CONTROL amplifier for treble and bass, boost or cut.

EXCLUSIVE: New output transformer with widest range ever produced heretofore.

GUARANTEED: Frequency range, 10 to 100,000 cycles per second, at 10 watts. Tests show records high as 3 to 200,000 c.p.s. under same conditions.

HARMONIC DISTORTION: Less than 0.25% at 10 watts level.

COMPLETELY SAFE: U/L Approved; entirely encased for shelf use or ease in custom installation.

POWER OUTPUT: 15 watts, maximum.

DAMPING FACTOR: 32:1, insuring maximum fidelity of square wave response under actual use with various loud speakers.

LOWEST INTERMODULATION DISTORTION: British KT-66 tubes provide 50% or less intermodulation distortion than amplifiers using different tubes!

ADVANCED CONDENSERS: Mineral-oil impregnated coupling condensers; power supply input condenser is oil-filled.

TEMPERATURE COMPENSATED: All components engineered to withstand continuous temperatures of 65°C.

Price \$12995

Price \$9950

Thousands of "Hams" are asked by their friends for advice on high-fidelity systems and equipment. With Hallicrafters new Tuner and Amplifier, they can now recommend a name they can trust for precision craftsmanship, and full value . . . Hallicrafters.

**WORLD'S LEADING MANUFACTURER OF
PRECISION RADIO & TELEVISION—CHICAGO 24**

hallicrafters

Section Communications Managers of the ARRL Communications Department

Reports Invited. All amateurs, especially League members, are invited to report station activities on the first of each month (or preceding month) direct to the SCM, the administrative ARRL official elected by members in each Section. Radio Club reports are also desired by SCMs for inclusion in QST. All ARRL Field Organization appointments are now available to League members. These include ORS, OBS, OPS, OO and OBS. Also, where vacancies exist SCMs desire applications for SEC, EC, RM, and PAM. In addition to station and leadership appointments for Members, *all amateurs* in the United States and Canada are invited to join the Amateur Radio Emergency Corps (ask for Form 7).

ATLANTIC DIVISION			
Eastern Pennsylvania	W3RKE	John H. DuBois	2219 Rhawn St.
Maryland-Delaware-D.C.	W3OMN	James W. John	29 Fawcett St.
Southern New Jersey	W2UCV	Lloyd L. Galney	Hoffman Ave. & Marlton Pike
Western New York	W2SJV	Edward Graf	81 King St.
Western Pennsylvania	W3KWL	Ernest J. Hilinsky	509 Beechwood Ave.
CENTRAL DIVISION			
Illinois	W9RQL	H. F. Lund	3135 S. 5th St.
Indiana	W9DGA	Clifford C. McGuyer	1321 South Governor St.
Wisconsin	W9RQM	Reno W. Goetsch	929 S. 7th Ave.
DAKOTA DIVISION			
North Dakota	W0VKP	Everett E. Hill	1527 Fifth Ave., So.
South Dakota	W0RNR	J. W. Sikorski	1900 South Menlo Ave.
Minnesota	W0MNC	Charles M. Bove	1611 1/2 E. Lake St.
DELTA DIVISION			
Arkansas	W5LUX	Fred Ward	520 South Maple St.
Louisiana	W5GHF	Robert E. Barr	Box 446
Mississippi	W5JHS	Norman B. Feehan	P. O. Box 491
Tennessee	W4CXY	Mark M. Bowelle	109 Dixie Lane
GREAT LAKES DIVISION			
Kentucky	W4KKG	I. W. Lyle, jr.	R. R. 3
Michigan	W8DLZ	Norman C. MacPhail	1340 Giddings, S.E.
Ohio	W8AJW	John E. Siringer	2972 Clague Rd.
HUDSON DIVISION			
Eastern New York	W2LLI	Stephen J. Neason	794 River St.
N. Y. C. & Long Island	W2OBI	George V. Cooke	88-31 239th St.
Northern New Jersey	W2VQR	Lloyd H. Manamon	410 1/2 Fifth Ave.
MIDWEST DIVISION			
Iowa	W0PPP	William G. Davis	3rd St.
Kansas	W0ICV	Earl N. Johnston	624 Roosevelt
Missouri	W0GJB	Clarence L. Arundale	1048 South Jefferson Ave.
Nebraska	W0KJP	Guy R. Balley	133 North 38 St.
NEW ENGLAND DIVISION			
Connecticut	W1HVF	Roger C. Amundsen	RFD 4
Maine	W1PTL	Orestes R. Brackett	Goodrich St.
Eastern Massachusetts	W1ALP	Frank L. Baker, Jr.	91 Atlantic St.
Western Massachusetts	W1EOB	Victor W. Paouloff	702 Rogers Ave.
New Hampshire	W1GMH	Carroll A. Currier	1426 Belmont St.
Rhode Island	W1CJH	Koy B. Fuller	17 Ledge Road
Vermont	W1FPS	Raymond N. Flood	3 Marlboro Ave.
NORTHWESTERN DIVISION			
Alaska	K1LNT	Glen Jefferson	934 1/2 3rd Ave.
Idaho	W7IWD	Han K. Ross	2105 Irene St.
Montana	W7KGJ	Edward G. Brown	421 Yellowstone Ave.
Oregon	W7MQ	J. E. Roden	519 N.W. Ninth
Washington	W7CZY	Laurence Sebring	Route 2, Box 384
PACIFIC DIVISION			
Hawaii	KH6RU	John R. Sanders	c/o Mackay Radio & Tele- graph Co. Inc., Box 2993
Nevada	W7UJ	Ray T. Warner	536 Birch St.
Santa Clara Valley	W6LZL	Roy I. Couzin	16615 Englewood Ave.
East Bay	W6JZ	Ray H. Cornell	909 Curtis St.
San Francisco	W6ATO	R. F. Czelkowitz	243 Colon Ave.
Sacramento Valley*	W6CKV	Willie van de Kamp	RFD 1, Box 492A
San Joaquin Valley	W6PYM	E. Howard Hale	741 E. Main St.
ROANOKE DIVISION			
North Carolina	W4DLX	J. C. Geaslen	1832 Logie Ave.
South Carolina	W4ANK	T. Hunter Wood	1702 North Rhett Ave.
Virginia	W4FF	H. Edgar Lindauer	Route 1, Box 431
West Virginia	W8MCR	John T. Steele	Milburn
ROCKY MOUNTAIN DIVISION			
Colorado	W0IOZ	M. W. Mitchell	1939 Uinta St.
Utah	W7UTM	Floyd L. Hinshaw	165 East 4th, North
Wyoming	W7HNI	A.D. Gaddis	P. O. Box 780
SOUTHEASTERN DIVISION			
Alabama	W4GJW	Dr. Arthur W. Woods	411 Woodward Bldg.
Eastern Florida	W4FWZ	John W. Hollister	3809 Springfield Blvd.
Western Florida	W4MS	Edward J. Collins	1003 E. Blount St.
Georgia	W4ZD	James P. Born, jr.	25 First Ave., N.E.
West Indies (Cuba-P.R.-V.I.)	KP4DJ	William Werner	563 Ramon Lovet
Canal Zone	KZ5AW	Everett R. Kimmel	Box 264
SOUTHWESTERN DIVISION			
Los Angeles	W6ESR	Samuel A. Greenlee	1701 Sepulveda Blvd.
Arizona	W7LVR	Albert Steinbrecher	Maple Road, RFD 5, Box 237
San Diego	W6YVM	Mrs. Ellen White	3677 Wightman St.
WEST GULF DIVISION			
Northern Texas	W5BKH	William A. Green	1814 University Blvd.
Oklahoma	W5GVV	Jesse M. Langford	2045 W. Oklahoma. Ct.
Southern Texas	W5FFI	Dr. Charles Permaglich	618 Medical Arts Bldg.
New Mexico	W5NXE	Robert W. Freyman	2255-46th St.
MARITIME DIVISION			
Maritime	VE1DQ	A. M. Crowell	69 Dublin St.
ONTARIO DIVISION			
Ontario	VE3IA	G. Eric Farquhar	16 Emerald Crescent
QUEBEC DIVISION			
Quebec	VE2GL	Gordon A. Lynn	R.R. No. 1
VANALTA DIVISION			
Alberta	VE6MJ	Sydney T. Jones	10706-57th Ave.
British Columbia	VE7US	Wilf Moorhouse	324 Regina Ave.
Yukon			Lulu Island
PRAIRIE DIVISION			
Manitoba	VE4AM	A. W. Morley	26 Lennox Ave.
Saskatchewan	VESH8	Harold R. Horn	1044 King St.
			St. Vital Saskatoon

* Officials appointed to act temporarily in the absence of a regular official.

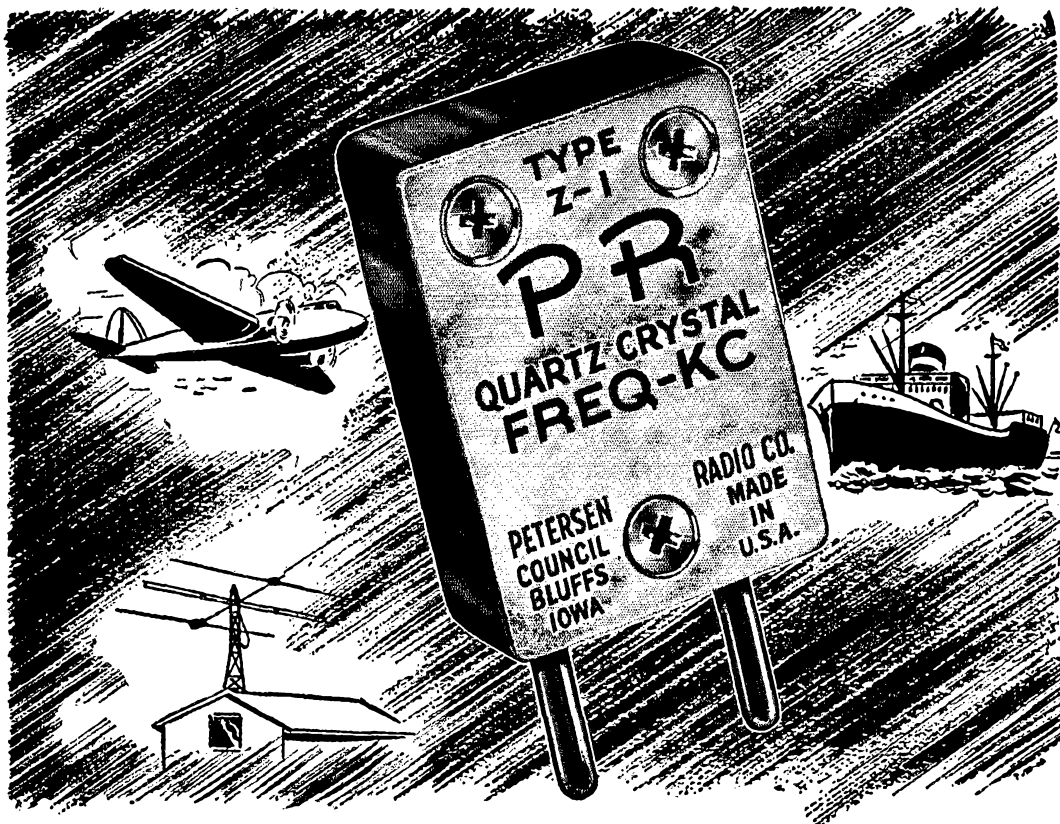

LAND, SEA and AIR

PRs stand the gaff! Wherever you go you find these fine precision crystals doing their jobs with honor . . . meriting the praise of engineers, operators and technicians. Yes — you can depend on PR for perfect frequency control . . . at low cost . . . for all amateur, commercial and industrial services.

20 METERS, Type Z-3, \$3.75 • 40, 80 AND 160 METERS, Type Z-2, \$2.75

PR

Crystals

Since  1934

USE  AND KNOW WHERE YOU ARE

PETERSEN RADIO COMPANY, INC.
2800 W. BROADWAY • COUNCIL BLUFFS, IOWA

EXPORT SALES ONLY: Royal National Company, Inc., 75 West Street, New York 6, N. Y., U. S. A.

THE AMERICAN RADIO RELAY LEAGUE, INC.,

is a noncommercial association of radio amateurs, bonded for the promotion of interest in amateur radio communication and experimentation, for the relaying of messages by radio, for the advancement of the radio art and of the public welfare, for the representation of the radio amateur in legislative matters, and for the maintenance of fraternalism and a high standard of conduct.

It is an incorporated association without capital stock, chartered under the laws of Connecticut. Its affairs are governed by a Board of Directors, elected every two years by the general membership. The officers are elected or appointed by the Directors. The League is noncommercial and no one commercially engaged in the manufacture, sale or rental of radio apparatus is eligible to membership on its board.

"Of, by and for the amateur," it numbers within its ranks practically every worth-while amateur in the nation and has a history of glorious achievement as the standard-bearer in amateur affairs.

Inquiries regarding membership are solicited. A bona fide interest in amateur radio is the only essential qualification; ownership of a transmitting station and knowledge of the code are not prerequisite, although full voting membership is granted only to licensed amateurs.

All general correspondence should be addressed to the administrative headquarters at West Hartford, Connecticut.



Past Presidents

HIRAM PERCY MAXIM, W1AW, 1914-1936
EUGENE C. WOODRUFF, W8CMP, 1936-1940
GEORGE W. BAILEY, W2KH, 1940-1952

Officers

President GOODWIN L. DOSLAND, WØTSN
Moorhead, Minn.
First Vice-President WAYLAND M. GROVES, W5NW
P.O. Box 586, Odessa, Texas
Vice-President FRANCIS E. HANDY, W1BDI
38 LaSalle Road, West Hartford, Connecticut
Secretary A. L. BUDLONG, W1BUD
38 LaSalle Road, West Hartford, Connecticut
Treasurer DAVID H. HOUGHTON
38 LaSalle Road, West Hartford, Connecticut

General Counsel PAUL M. SEGAL
816 Connecticut Ave., Washington 6, D.C.

Assistant Secretaries JOHN HUNTOON, W1LVQ
RICHARD L. BALDWIN, W1IKE JOHN E. CANN, W1RW5
38 LaSalle Road, West Hartford, Connecticut

DIRECTORS

Canada

ALEX REID VE2BE
240 Logan Ave., St. Lambert, P. Q.
Vice-Director: William W. Butchart VE8LQ
10740 107 St., Edmonton, Alta.

Atlantic Division

ALFRED C. HECK W3GEG
515 Cedar Ave., Sharon, Pa.
Vice-Director: Charles O. Badgett W3LVF
725 Garden Road, Glenside, Pa.

Central Division

WESLEY E. MARRINER W9AND
844 N. Galea Ave., Dixon 7, Ill.
Vice-Director: Charles F. Reberg W9MVZ
3900 W. 10th Ave., Gary, Ind.

Dakota Division

ALFRED M. GOWAN WØPHR
325 S. Menlo Ave., Sioux Falls, S. D.
Vice-Director:

Delta Division

JAMES W. WATKINS W4FLS
220 N. Howell Ave., Chattanooga, Tenn.
Vice-Director: George S. Acton W5BMM
Plain Dealing, La.

Great Lakes Division

JOHN H. BRABB W8SPF
417 Ford Bldg., Detroit 26, Mich.
Vice-Director: Harold E. Stricker W8WZ
247 W. 5th St., Marysville, Ohio

Hudson Division

JOSEPH M. JOHNSTON W2SOX
423 Monmouth Ave., Bradley Beach, N. J.
Vice-Director: George V. Cooke, Jr. W2OBU
88-31 239th St., Bellerose 6, L. I., N. Y.

Midwest Division

WILLIAM J. SCHMIDT WØOZN
306 S. Vassar, Wichita, Kansas
Vice-Director: James E. McKim WØMVG
1404 S. Tenth, Salina, Kansas

New England Division

PERCY C. NOBLE W1BVR
37 Broad St., Westfield, Mass.
Vice-Director: Frank L. Baker, Jr. W1ALP
91 Atlantic St., North Quincy 71, Mass.

Northwestern Division

R. REX ROBERTS W7CPY
837 Park Hill Drive, Billings, Mont.
Vice-Director: Karl W. Weingarten W7BG
3219 N. 24th St., Tacoma 7, Wash.

Pacific Division

KENNETH E. HUGHES W6CIS
810 W. Orange Ave., So. San Francisco, Calif.
Vice-Director: Richard F. Czelkowitz W6ATO
243 Colon Ave., San Francisco 12, Calif.

Roonoke Division

WILLIAM H. JACOBS W4CVQ
Route 6, Raleigh, N. C.
Vice-Director: Gus M. Browning W4BPD
135 Broughton St., S. E., Orangeburg, S. C.

Rocky Mountain Division

FRANKLIN K. MATEJKA WØDD
P. O. Box 212, Estes Park, Colo.
Vice-Director: Ramon S. Walker WØOWP
P. O. Box X, Brush, Colo.

Southeastern Division

LAMAR HILL W4BOL
104 Myrtle, Cochran, Ga.
Vice-Director: Ernest W. Barr W4GOR
911 Rosemary Ave., SW, Atlanta, Ga.

Southwestern Division

JOHN R. GRIGGS W8KWV
10412 Don Pico Rd., RFD 2, Spring Valley, Calif.
Vice-Director: Walter R. Jocs W6EKM
1315 N. Overhill Drive, Inglewood 3, Calif.

West Gulf Division

A. DAVID MIDDLETON W8CA
9 Kay Road, Tijeras, N. M.
Vice-Director: Frank E. Fisher W5AHT/AST
104 E. 11th, Pawhuska, Okla.

"It Seems to Us..."

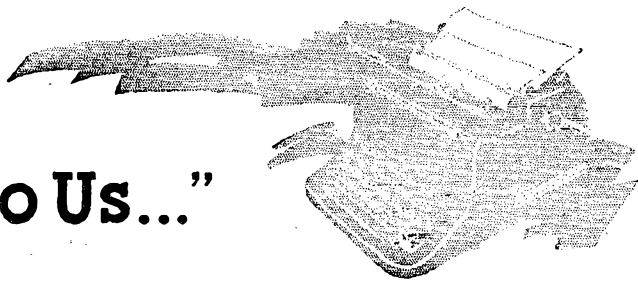

AMATEUR COMMUNICATIONS — A PROPOSED FORMULA

In 1936 and 1937 the amateur body reached some high points of operation in the public interest, convenience and necessity by performing herculean tasks in providing emergency communications during major floods which covered northeastern states. Not content to rest on its laurels, organized amateur radio took a critical look at its own performance, found some phases where increased efficiency appeared possible, and through the League asked FCC for additions to our rules to facilitate emergency communications procedures. In 1938, the Commission adopted the requested modifications. Basically, it was provided that when FCC declared a state of emergency existed in a particular area, within 1000 miles of that area the then 160- and 80-meter bands would be reserved for disaster contacts; small segments of those bands would be available only for initial emergency calls; a 5-minute listening period in those bands was to be observed; certain key stations might be appointed to spread the news of any such FCC declaration and help patrol the bands. These general provisions have remained in our rules ever since, substantially as originally set up.

For some time now it has been apparent that some revision is in order; for example, the present paragraphs in §12.156 speak of frequencies no longer available to amateurs. After studies of its own, FCC has just issued notice of proposed amendment to that rule; the basic concepts are retained, but the general procedure is extended to additional bands. Segments of all our bands (except 21 Mc.) up through 225 Mc. are earmarked to be reserved exclusively for emergency communications if and when FCC declares emergency status. The segments range from 25 or 50 kc. in the lower bands to the entire bands at 220 Mc. (All of the civil defense band for RACES are encompassed in the segments so earmarked.) Additional frequencies might be so reserved, at the Commission's discretion. The text of the proposal appears in this issue beginning on page 37. Comment date is September 19th.

That, however, is not all.

FCC has come up with another idea: a sweeping new concept of how amateurs would conduct their routine communications procedures is also contained in the same document. Without primary relation to emergency

operations, the Commission now proposes to specify other and smaller segments of our bands, also up through 225 Mc., *which would not be available for normal, day-to-day operation*, except for calling and answering purposes. The size of the segments range from 7 kc. in the 1800-kc. bands to 500 kc. in the 220-Mc. band. Refer to the text of the proposal for specific figures on other bands.

How you would make a contact in these restricted segments is all spelled out. For example, you would call CQ not more than four times, and sign your call letters not more than four times; on voice, it would be permissible to use phonetics. In CQs, directional indicators might be employed — e.g., "CQ west." That's all. If you don't get an answer to that CQ, you may not call CQ again for five minutes. If you do get an answer, which similarly is restricted to the sending of your call four times, the "de" (or voice equivalent) and signing of his call four times or less, the *only* thing you may say in acknowledgment is a specification of a channel in an unrestricted part of the band where both of you are going to shift to continue the contact. No signal report, nor anything else, except agreement to a working frequency. (The proposed procedure is almost identical to that used in the commercial maritime mobile service.)

If you choose to listen for a CQ in one of the calling bands, your answering call in that band is limited to the specific four-by-four. If you don't get him on that first blast, you may not call him again for five minutes. Of course, you can always move the rig down into the unrestricted parts of the band and make your contacts in the good, old-fashioned way. In time of disaster, the restricted segments can be used for emergency communications in addition to their primary function as calling channels.

The Commission's proposal is a completely new concept of how regular amateur communications might be conducted. It affects all major amateur bands. It is not merely a suggested procedure; it is a notice of FCC intent to enact provisions into law. It therefore behooves every amateur and club group to give the proposal careful study. Here, too, the comment date to FCC is September 19th.

The League will, of course, submit comment on these proposals; as of this writing studies are in progress, at the direction of the President, to serve as the basis for ARRL comment.

COMING A.R.R.L. CONVENTIONS

See page 60 of this issue for detailed announcements of coming ARRL conventions. Also, don't forget the Roanoke Division Convention at Richmond, Va., on October 11th.

Strays

Paul Reinhardt, first-prize winner in the *Mechanix Illustrated* Old Automobile Contest, is WN2NME. We wonder if Paul contemplates installation of mobile gear in that 1952 Nash Rambler station wagon!

W5UTW, confined in Veterans Administration Hospital, McKinney, Texas, licked a ban on antenna construction by taking advantage of the grounds sprinkler-system network as suggested by W5ICB. Will this result in "hot" cold water?

Use of Tools, Basic Navy Training Courses text, has 258 pages of profusely illustrated information on workshop practices. It is highly recommended to amateurs and should be of great value as a reference work. There are fourteen chapters, each dealing with a specific tool category, plus appended tables and index. It may be procured for 75 cents from the Superintendent of Documents, U. S. Govt. Printing Office, Washington 25, D. C. (Catalog No. N17.25: T61/2-945.)

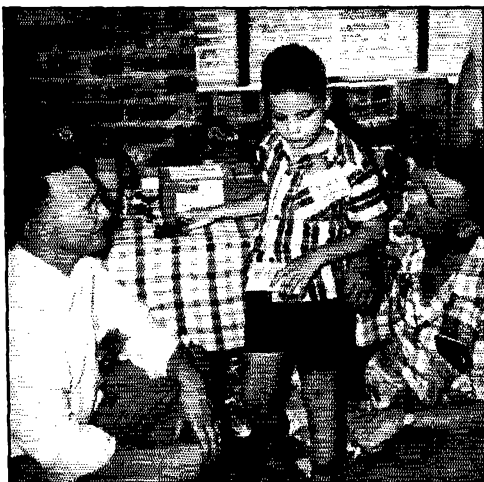

Evidently it isn't quite so difficult to become a ham as the more faint at heart would believe. Johnny Fearon (center) made the grade and is now licensed as WN4WKP. At the age of seven he may not be the youngest Novice in the land but Johnny has had the additional handicap of blindness since birth. Here ARRL Assistant Secretary Dick Baldwin, WIKE (left), and Atlanta Radio Club President Jack Hopton, W4MZO, interview the plucky lad at a recent Atlanta hamfest. (Atlanta Constitution photo)

HAMFEST CALENDAR

INDIANA — Sunday, September 14th, at the Servel Picnic Grounds, southeast of Evansville — the Annual Hamfest of the Tri-State Amateur Radio Society. Refreshments will be available, but each person attending is asked to provide his own lunch. Numerous contests are scheduled, with the c.w.-phone ball game being the main event. Many valuable awards will be distributed. There will be a transmitter on 29.6 Mc. to guide mobiles to the area, and signs will be posted at highway junctions. The registration fee is \$1.00 at the grounds. Further information may be obtained from Fred Sawyer, W9FJI, 627 East Virginia Street, Evansville, Ind.

KANSAS — Sunday, September 7th, at the North Kansas Fair Grounds and National Guard Armory at Belleville, Kansas — the Second Annual Hamfest of the Kansas-Nebraska Radio Club. There will be a full day of activities for everyone, and base stations on 160-, 75-, 10- and 2-meters will be operating to guide mobiles to the park. A communications receiver will be the main award. For further information contact the Kansas SCM.

NEW MEXICO — Sunday, October 5th, at Los Alamos — the New Mexico State Hamfest, sponsored by the Los Alamos Amateur Radio Club. John Reinartz, K6BJ, of Elmac, will be the principal speaker. There will be three classes of mobile contests, a QLF contest, an elementary construction contest, a QSL display, a contest for the best gadget, and a code speed contest open to anyone who has ever held a Novice license. All registrations (\$2.00) and lists of guests must be sent to Bob Freyman, W5NXE, 2255 46th Street, Los Alamos, not later than Sept. 27th, in order to obtain passes into Los Alamos.

NEW YORK — Saturday, September 27th, at Oneida — the Seventh Annual Hamfest and Ladies Night for Oneida and Central New York hams and friends. Registration will be at 5 P.M., with the banquet-dinner at 7 P.M. Admittance is by advance registration only, \$2.50, from Walter L. Babcock, W2RXW, 405 Sayles St., Oneida, N. Y.

NEW YORK — Friday, September 12th, at Lost Battalion Hall, Elmhurst, Queens, Long Island — the Sixteenth Annual Hamfest and Dance sponsored by the Federation of Long Island Radio Clubs, Inc. Special award for the ham attending from the greatest distance, plus favors for the ladies. All the best features of a regular hamfest, and dancing. Tickets purchased in advance are \$2.00 for hams, \$1.25 for the ladies; 50¢ extra if purchased at the door. Tickets and further information may be obtained from Julian N. Jablin, W2QPQ, FLIRC Secretary, 147-14 Charter Road, Jamaica 35, N. Y.

OHIO — Sunday, September 14th, at Ash Grove, Cincinnati — the annual stag hamfest sponsored by the Greater Cincinnati Amateur Radio Association. Eats and drinks are included in the price of \$2.00. For further information write to John Wisenall, W8WWG, 3872 Belmont Avenue, Mariemont, Ohio.

Quist Quiz

After helping **A** to install his new antenna system, **B** is now helping to adjust the tuning system and coupling of the transmitter and antenna coupler. **A** is not satisfied with the final result obtained by **B** because the "pencil test" shows a substantial r.f. arc at the end of the plate tank coil. **A** claims that this indicates there is still quite a bit of "r.f. left in the tank," while **B** says it means nothing. Is **A** right, and will he be smart to tighten the coupling as soon as **B** leaves?

(Please turn to page 138 for the answer)

A Two-Band Miniature Mobile Transmitter

10 Watts in 120 Cubic Inches for 3.8 and 7 Mc.

BY C. VERNON CHAMBERS,* W1JEQ

• Provision for operation on the proposed 7-Mc. 'phone band is one feature that will appeal to anyone interested in a new mobile rig. This transmitter includes that capability along with such attractions as low cost, compactness, simplicity, and low power requirements.

THOSE who favor mobile operation as a secondary means of enjoying ham radio are apt to be extremely cost-conscious while the transmitter selection is being made. It is understandable that these operators do not wish to see a great deal of cash tied up in gear that will be used during the smaller percentage of the total available operating time. This same group is also interested in compactness combined with simplicity because they do not care to devote a great deal of space and constructional time to the in-motion phase of hamming. These three factors — cost, compactness and simplicity — were foremost in mind during the planning of the transmitter to be described.

The cost of the rig is maintained at a reasonable level by designing for low power. A 300-volt 100-ma. power supply, from which the unit is normally operated, is just about the least-expensive job that can be purchased. Keeping the input down also affords a double saving — money and space — at the audio side of the unit where transformers that are compact and inexpensive are used.

Compactness of the transmitter is obtained by employing a carefully planned layout, extremely simple circuits, and small components. Incidentally, the employment of miniature components was not carried to the extreme. We could have cut down on the size of the unit a bit more by using the tiniest variable capacitors made. How-

*Technical Assistant, QST.

Panel view of the 10-watt mobile transmitter. Control knobs for the crystal switch, antenna tuner and the final amplifier are in line from left to right across the panel. Metering jacks for the grid and plate circuits are to the left and the right of the microphone jack, respectively. The ventilation cut-out at the top of the cabinet is covered with window screen that is held in place by a chart frame.

ever, these were the items in the parts list that were not available from our local dealers and we figured that they might be difficult to procure elsewhere.

Simplicity, obtained principally by selecting uncomplicated circuits, shows up in both the constructional chores and the operation of the transmitter. So far as construction goes, the big job, wiring, took less than 7 hours. And as for operation, there is nothing to it. One control allows selection of the crystal frequency and, at the same time, sets up the built-in antenna coupler for either 3.5- or 7-Mc. operation. Variable capacitors for the antenna coupler and the final amplifier are the only other controls. The amplifier covers both bands with a single sweep of tank capacitor, thus eliminating the need for plug-in coils or switches in this circuit.

Circuit

The circuit of the transmitter, as shown in Fig. 1, utilizes a Type 5763 tube in a grid-plate crystal-controlled oscillator. A switch, S_{1A} , permits selection of any one of the five crystals that the circuit will accommodate. When 7-Mc. A3 operation is made legal, we intend to equip the circuit with two 7-Mc. rocks, and three cut for the 3.8-Mc. band. In the meantime, five for the lower of the two frequencies are being used. The plate inductor, L_1 , for the oscillator is self-resonant at approximately 5.5 Mc., a frequency that was determined to be optimum during the adjustments made to balance the oscillator output at 3.5 and 7 Mc.

The Type 5763 in the final amplifier employs grid-leak bias and is capacity-coupled to the oscillator. The amplifier works straight through at both 3.8 and 7 Mc. and is resonated at either of these frequencies by C_7 and L_2 . Resistors R_4 and R_5 are inserted in the grid and the plate leads so an external milliammeter may be connected to circuit.

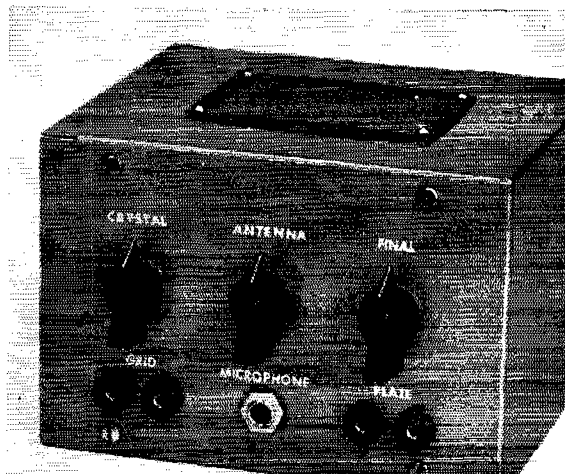

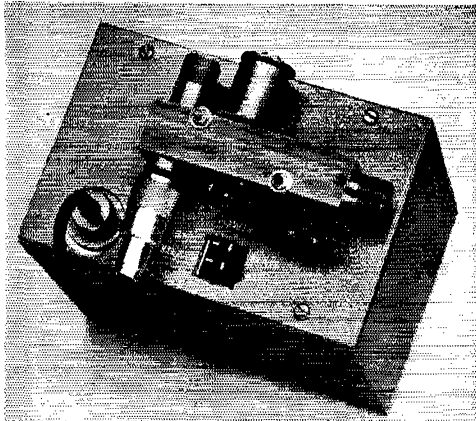

The rear wall of the mobile transmitter provides a convenient mounting surface for the Dow-Key antenna change-over relay.

Output from the final amplifier is coupled to the output jack, J_1 , by a series-tuned coupler consisting of C_9 , C_{10} and L_2 . C_9 and L_2 resonate at 7 Mc. and, when padder C_{10} is switched to the circuit by means of S_{1B} , the tuner will cover the 3.8-Mc. band.

A Type 12AU7 is used in the input-driver section of the audio circuit. D.c. voltage for a single-button carbon microphone is obtained by connecting the microphone in series with the cathodes of the 12AU7. The driver circuit is transformer coupled to a Class B modulator. The 12AX7 modulator tube delivers approximately 6 watts output.

The power plug, J_3 , for the transmitter is wired with prong No. 2 returned to the microphone jack. This connection permits an externally mounted antenna relay (see photograph) to be controlled by the push-to-talk switch of the microphone.

Construction

The transmitter is housed in an ICA No. 29812 utility box. This box has a gray hammer-tone finish and measures 4 by 5 by 6 inches. The homemade aluminum chassis which supports most of the components for the rig is made of $\frac{1}{16}$ -inch stock, measures $4\frac{1}{8}$ inches square, has $1\frac{1}{4}$ -inch fold-over at the rear and a $\frac{5}{8}$ -inch lip at the front. The top surface of the chassis is located $1\frac{1}{4}$ inches up from the bottom of the front panel and these two units are fastened together by means of the jacks for the meter leads and the microphone. Naturally, meter jacks J_5 , J_6 and J_7 must be insulated from the metal.

The interior view of the transmitter shows two mica capacitors (connected in parallel) mounted between S_{2B} and ground. This parallel combination was used as C_{10} only because a single 330- μfd . unit was not available. The interior view also shows that the crystals are closely grouped at the rear of the crystal switch. In order to duplicate the compactness at this point it will be necessary to employ crystal sockets similar to the Cinch-Jones type 2KM.

Under the chassis, the amplifier plate coil is fastened in place by the machine screw which passes through the base to the rear mounting bracket of the amplifier tuning capacitor. The form on which the inductor is wound is a Millen type 45000 which has been cut down to a length of $1\frac{3}{16}$ inches. The B&W Miniductor used as the output link, L_3 , fits inside of the Millen form and may be cemented in place upon completion of the tuning adjustments.

Three tie-point strips are used on the underside of the chassis. A two-terminal job, mounted on the rear wall, supports R_6 and the B+ ends of R_5 and RFC_3 . The single-terminal strip, centered in between the oscillator and the amplifier-tube sockets, holds the grid end of C_4 . RFC_2 and

(Continued on page 116)

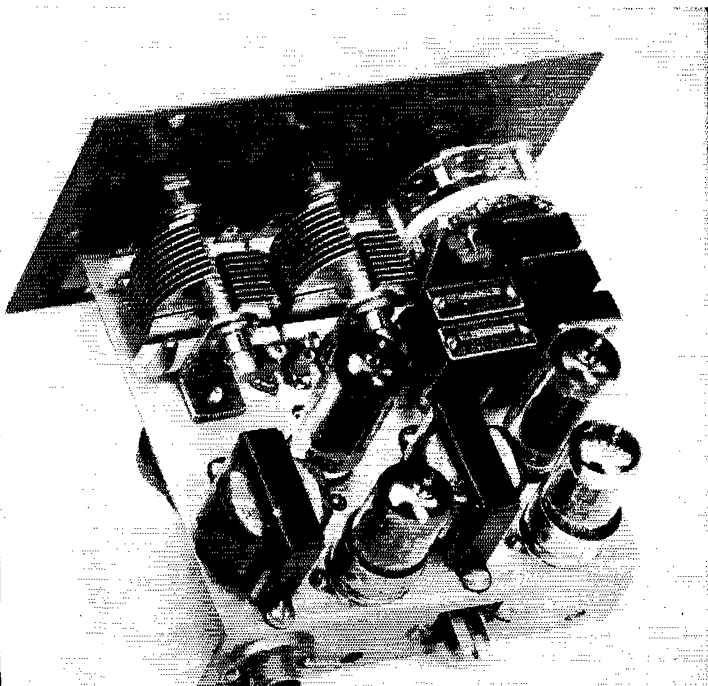

An interior view of the mobile transmitter showing the modulation transformer and the 12AX7 at the rear left-hand corner of the chassis. The oscillator tube is centered between the crystals and the 12AU7 and the power-amplifier tube is to the rear of the variable capacitors. Connectors for the power and the output cabling are mounted on the rear wall of the base.

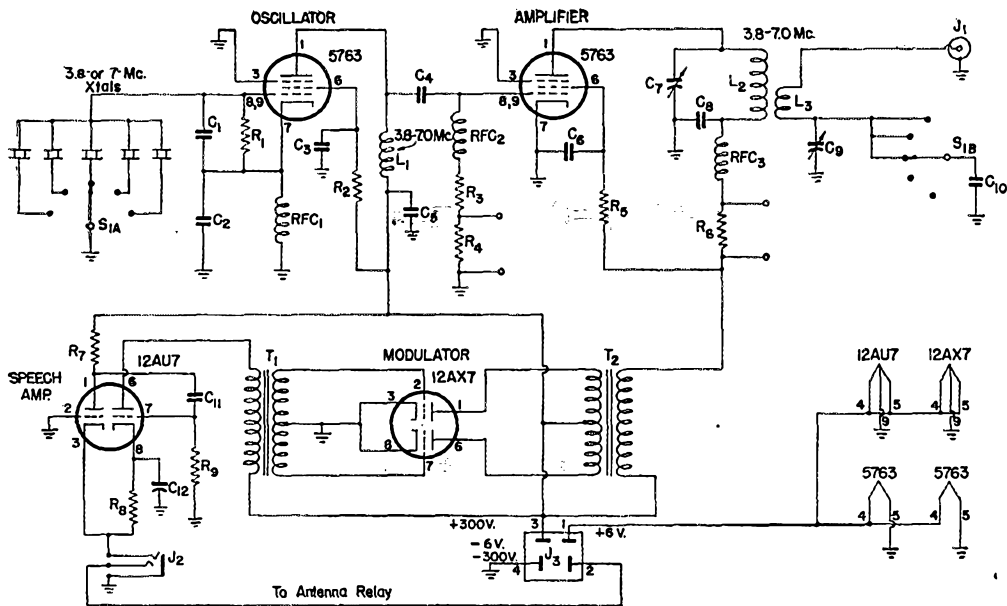
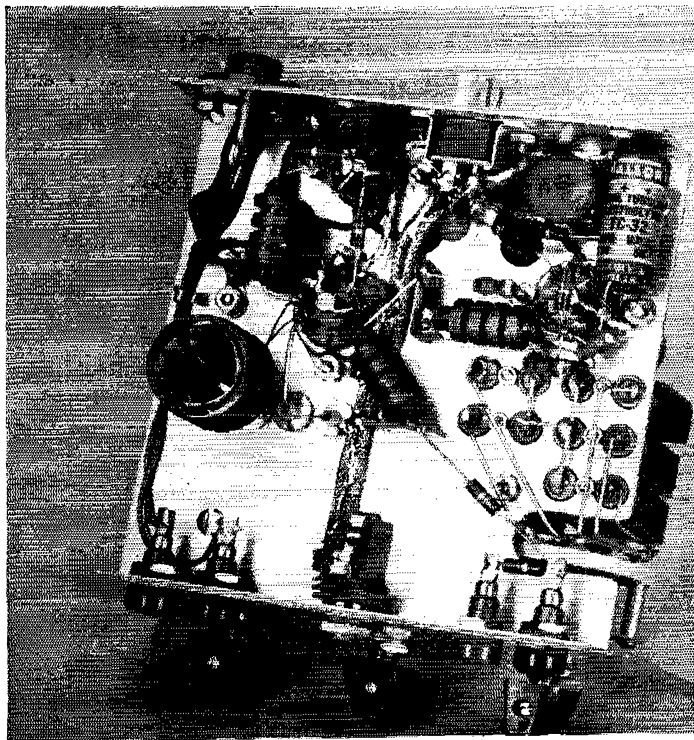

Fig. 1 -- Circuit diagram of the 10-watt mobile transmitter.

- C₁ -- 25- μ fd. ceramic.
- C₂, C₄ -- 120- μ fd. ceramic.
- C₃, C₅, C₆ -- 0.001- μ fd. disc-type ceramic.
- C₇, C₉ -- 140- μ fd. variable (Millen 19140).
- C₈, C₁₁ -- 0.01- μ fd. disc-type ceramic.
- C₁₀ -- 330- μ fd. silvered mica.
- C₁₂ -- 10- μ fd. 50-volt electrolytic.
- R₁ -- 68,000 ohms, $\frac{1}{2}$ watt.
- R₂, R₈, R₉ -- 22,000 ohms, $\frac{1}{2}$ watt.
- R₄, R₆ -- 100 ohms, $\frac{1}{2}$ watt.
- R₇ -- 47,000 ohms, $\frac{1}{2}$ watt.
- R₈ -- 470 ohms, $\frac{1}{2}$ watt.
- R₉ -- 0.47 megohm, $\frac{1}{2}$ watt.
- L₁ -- 39 μ h.; 50- μ h. r.f. choke with 14 turns removed (National R-33).

- L₂ -- 11.3 μ h.; 22 turns No. 22 enam. wire, close-wound, 1-inch diam.
- L₃ -- 4.1 μ h.; 15 turns No. 24 wire, $\frac{1}{2}$ inch long, $\frac{3}{4}$ -inch diam. (B&W 3012).
- J₁ -- Coaxial cable connector.
- J₂ -- Microphone jack, double-button type.
- J₃ -- 4-prong connector (Cinch-Jones P-304-AB).
- J₄, J₅, J₆, J₇ -- 'Phone-tip jack (R₄, R₅ meter shunts).
- RFC₁, RFC₂, RFC₃ -- 2.5-mh. r.f. choke.
- S₁ -- 2-pole 1-section 5-position selector switch (Centralab 2505).
- T₁ -- Driver transformer, s.p. to p.p. grids, 2.66:1, prim. to $\frac{1}{2}$ sec. (Triad A-81X).
- T₂ -- 5-watt modulation transformer, variable ratio, secondary rating 50 ma. (Triad M-1X).

Bottom view of the transmitter. Leads between the crystal holders and S_{1A} pass through a slot at the lower right hand side of the chassis. Bushings to the right of the final tank coil accommodate the through-the-chassis leads to the amplifier and antenna-coupler capacitors.



Ham-Band Transmitting Loops

BY RICHARD R. HAY,* W4LW

• Practical-minded cliff-dwellers as well as hams with an experimental urge will find a welcome suggestion in this short story by W4LW. With a 3-foot loop and an output of 40 watts, he has covered up to 2500 miles on 40 c.w.

THE antenna system to be described in this article probably won't interest proponents of the "long wire — strong signal" theory. However, it should have a definite appeal for apartment dwellers and home owners with small lots. Inspiration for this system came from a description of a similar antenna in *GE Ham News*, July-August, 1950. The idea apparently failed to impress the average ham. However, it seems to have definite advantages where space is at a premium.

Most of the work at W4LW was done in the 40-meter band, and the following data are based on operation in that band. The essential elements for 40-meter operation are shown in Fig. 1. Coil L_1 is provided with two taps — one for varying the total inductance, and one for selecting an input impedance equal to that of the coax line. The coil L_1 , condenser, C_1 , and the loop, all form a circuit which is resonant at the desired frequency. L_1 and C_1 are mounted in a protective box provided with a coax fitting for the transmission line and two feed-through connections for the loop. The loop is mounted in a horizontal plane in order to avoid the null which occurs at right angles to the plane of the loop.

* Capt., USN; 610 No. Buchanan St., Arlington 3, Va.

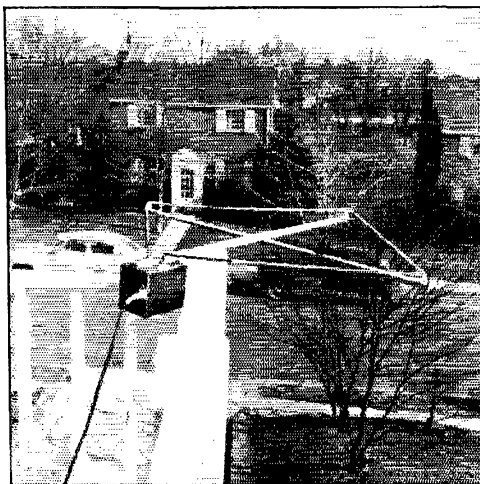

If you live in an apartment house or are having trouble with TVI, this compact horizontal loop for 7 Mc. may be your answer.

Adjustment is as follows:

- Substitute a 52-ohm dummy load for the antenna system and adjust transmitter for proper loading.
- Remove dummy load and replace the loop antenna assembly.
- Set the tap for the coax connection at about 3 turns and tune C_1 to resonance at the transmitter frequency. (If necessary, reduce inductance of L_1 by shorting turns with the second tap.)
- Vary the position of the coax tap (retuning C_1 each time) until proper loading is indicated.

Fig. 1 — The loop is connected in series with a conventional tank circuit. For a 3-foot loop at 7 Mc., L_1 should have an inductance of 2.5 μ h. and C_1 a maximum capacitance of about 150 μ fd.

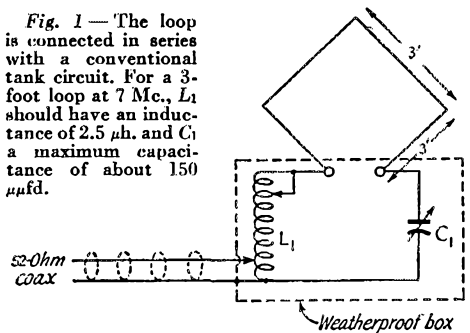

The position of the coax tap is a fairly critical adjustment and must be set to the nearest $\frac{1}{4}$ turn for best results. An s.w.r. indicator would be very helpful, although it can be done by "cut and try."

Once the correct position of the taps on L_1 are determined, it will be desirable to solder the connections. Poor connections will drastically reduce the effectiveness of the antenna. For the same reason, the connections to the loop from L_1 and C_1 should be of low resistance.

Engineers who have been consulted about this antenna system say that its effectiveness will depend upon the ratio between ohmic losses and the radiation resistance. The installation at W4LW uses No. 12 wire for both the loop and for winding L_1 . An improvement could probably be effected by the use of heavier wire or even copper tubing.

While specific values for the W4LW installation have been given, these are not necessarily the optimum values. Considerable variation can be made provided that the circuit composed at C_1 , L_1 , plus the loop, is tuned to resonance with transmitted frequency and that an impedance match is provided for the transmission line.

It would be desirable to make the loop as large as possible, with corresponding reduction in the inductance, L_1 . The ultimate would be to reduce L_1 to just enough to match the coax line impedance. The larger the loop is made, the greater the radiation resistance. Also, a wider band of frequencies can be covered.

(Continued on page 118)

Controlled Carrier with a Cathode Follower

Another Screen-Grid "Constant Modulation" System

BY JOSE A. VIVARES,* LU1EP

THE controlled-carrier system to be described has been in use here for over a year, with excellent results. The idea was born after reading several articles¹ in *QST* that pointed out the advantages of such systems. The ever-prevalent shortage of radio parts here meant dispensing with a crystal rectifier, and the use of a rectifier tube in the more complex Lippert system was not too appealing. I began thinking about using a triode cathode-follower connected in series with the screen supply, with its grid as the rectifying element, and the circuit shown in Fig. 1 was developed. It performed well from the first time it was put to work, and has now been tested long enough to merit passing along to anyone else who might like to try it.

The Circuit

With the constants shown in Fig. 1, the circuit is used to modulate a single 807 amplifier, but other combinations can undoubtedly be worked out for other tubes and power levels. The 6F6 modulator is conventional and transformer-coupled to the 807 screen. The d.c. voltage across C_4 will determine the carrier level of the 807 amplifier—the higher this voltage is, the higher the carrier level will be. The carrier-control 6F6 is a cathode-follower power source for C_4 —driving the grid of this 6F6 in a positive direction will charge C_4 . However, C_4 can discharge only through the screen circuit of the 807 stage being modulated.

When no audio voltage appears across T_1 , the grid of the carrier-control 6F6 is at ground potential, and the voltage across C_4 will be low. Thus the screen voltage on the 807 is low, and only a weak carrier is radiated. When an audio voltage appears across T_1 , it is coupled through C_3 to the grid of the 6F6 carrier-control tube, and each positive peak results in a surge of current into C_4 and a consequent voltage increase. When the audio voltage is removed, C_4 dis-

charges and the carrier level is again reduced. The magnitude of the voltage across C_4 will be determined by the audio voltage, and thus the circuit gives a "constant-modulation" or controlled-carrier system.

There is a highly-distorted audio component in the current passing through the 6F6 carrier-control tube, but it is filtered out by the large capacity at C_4 . This capacity, C_4 , also serves as a low-impedance return path for the modulating voltage that is applied to the 807 screen by the secondary of T_1 .

Operation

In operation, the idling current of the carrier-control tube is practically zero, and the plate current of the 807 is in the neighborhood of 15 ma. Under full modulation by a steady tone, the 807 plate current rises to about 60 ma. Although the carrier increases about 12 db. between no and full modulation, listeners who have no S-meters never seem to notice any dif-

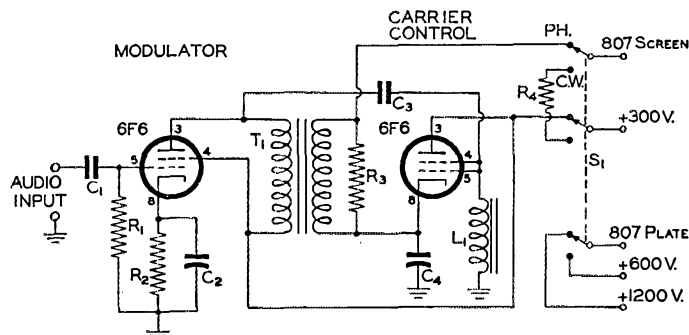

Fig. 1—Circuit diagram of the controlled-carrier system.

- | | |
|---|--|
| C_1, C_3 —0.01- μ fd. 600-volt paper. | R_3 —10,000 ohms, 5 watts. |
| C_2 —10- μ fd. 50-volt electrolytic. | R_4 —7000 ohms, 5 watts. |
| C_4 —1- μ fd. 600-volt paper. | L_1 —Midget choke, 5 hy. or higher. |
| R_1 —0.47 megohm. | T_1 —1-to-1 output transformer (such as Stancor A-4752). |
| R_2 —430 ohms, 2 watts. | |

ference between this signal and normal a.m. signals, and the quality is always reported to be very good.

The transmitter is coupled to the antenna with switch S_1 in the "C.W." position (600 volts on the plate) and loaded to 100 ma. plate current. Then S_1 is thrown to "PH" and that's all there is to it. The percentage of modulation can be checked by inspection of the envelope pattern displayed on an oscilloscope when some of the r.f. output is coupled to the vertical deflection plates.

* Calle 53 No. 1093, La Plata, Buenos Aires, Argentina.
¹ Lippert, "A Constant-Modulation 'Phone System," *QST*, April, 1950; Technical Topics, "Design Limits for High-Output Grid Modulation," *QST*, Feb., 1951; Technical Topics, "Screen Modulation with Limited Carrier Control," *QST*, April, 1951.

The Measuring-Cup Band Spotter

A Wide-Range Absorption Wavemeter for the Novice

BY RICHARD M. SMITH,* W1FTX

• Just because the crystal in your rig is marked 3725 kc. there is no reason to assume the output is at that frequency. Some frequency-measuring means is necessary. Here is a simple, inexpensive gadget that will enable you to tell when output is in the right band.

IT is not necessary to build or buy an elaborate frequency meter for most amateur purposes, especially when the transmitter is crystal-controlled. Much simpler means can serve the purpose just as well. For example, you could hardly want a simpler circuit than that shown in Fig. 1. And as the photographs show, the construction is equally simple. Assembled in a 15-cent measuring cup, this gadget will go a long way toward filling the initial frequency-measuring needs of the Novice licensee. It will also serve the old-timer in many ways when he builds or adjusts transmitters in any ham band from 3.5 to 14 Mc. The cost of the entire unit is less than five dollars, and this figure can be reduced by over fifty per cent if you happen to have a suitable tuning condenser in your junk box.

The measuring-cup wavemeter is nothing more than a tuned circuit covering 3.4 Mc. to 15 Mc. with a flashlight bulb in series with it to serve as a resonance indicator. When the coil in the wavemeter is coupled to a transmitter delivering anything from a few watts of r.f. up to a kilowatt and the condenser is tuned so that the wavemeter is resonant at the frequency of operation, the lamp

* Technical Assistant, QST.

will light. The unit is calibrated so that the frequency at which the power is being generated is read directly from the dial.

Construction of the wavemeter is extremely easy. The measuring cup is used to provide support for the tuning condenser and the calibrated dial, incidentally providing a mounting for the indicator lamp and a handle for the entire unit. The lamp is insulated from the cup by mounting it in a grommet-lined $\frac{1}{2}$ -inch hole drilled at the top where it will not interfere with the rotation of the plates of the tuning condenser. The calibration scale is pasted to the face of an aluminum

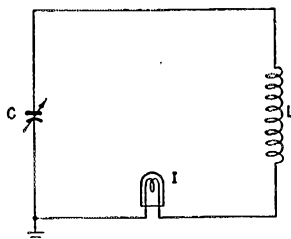

Fig. 1 -- Circuit diagram of an absorption wavemeter covering the 3.4- to 15-Mc. range.

C — 300- μ fd. variable (National ST-300).
L — 22 turns No. 20 wire, 1-inch diam., $1\frac{3}{8}$ inches long (B & W Miniductor No. 3015).
I — 60-ma. dial lamp (pink bead) mounted in bayonet-type bracket (Johnson 147-630).

bracket measuring $3\frac{1}{2}$ inches wide and $2\frac{5}{8}$ inches high, with a $\frac{1}{2}$ -inch lip bent under the cup to form a mounting "foot." This prevents the gadget from rolling off the shelf when stored.

The coil is cemented inside a Quartz-Q coil form $1\frac{1}{8}$ inches in diameter and $1\frac{1}{8}$ inches deep (Millen 46100). Thus the coil is protected from damage and the operator is protected from the high-voltage in the transmitter. The form is mounted $\frac{1}{2}$ inch behind the rear rotor bracket of the tuning condenser by a machine screw and a spacer. The 6-32 screw fits one of the tapped holes that bolt the ceramic spacer bar to the bracket. An insulated tie point is slipped under one of the rear stator connectors of the condenser to serve as the junction point between the tuned circuit and the indicator lamp. One wire from the

One of the handiest "tools" in ham radio is the absorption wavemeter. This unit, built around an aluminum measuring cup, is designed to fit the requirements of the Novice licensee. Construction is simple — the entire assembly is held together with one nut.

QST for

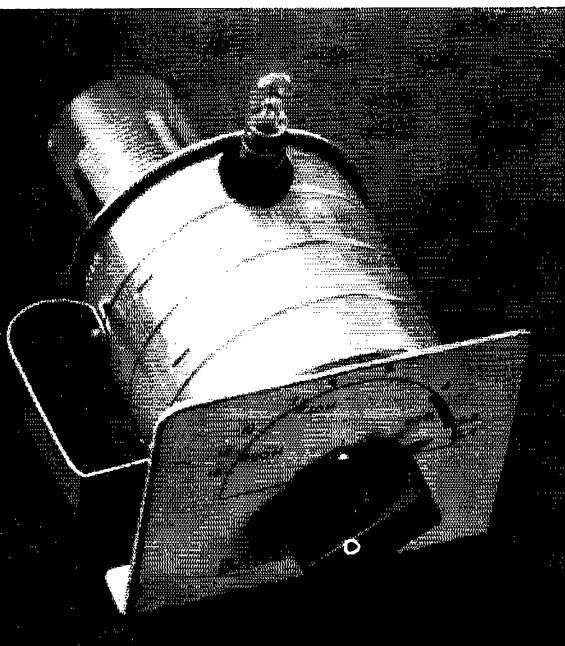

◆
Fig. 2 — Actual calibration of the wavemeter. This drawing may be cut out or traced and pasted to the face of the aluminum bracket provided the parts listed below Fig. 1 are used in the construction.
 ◆

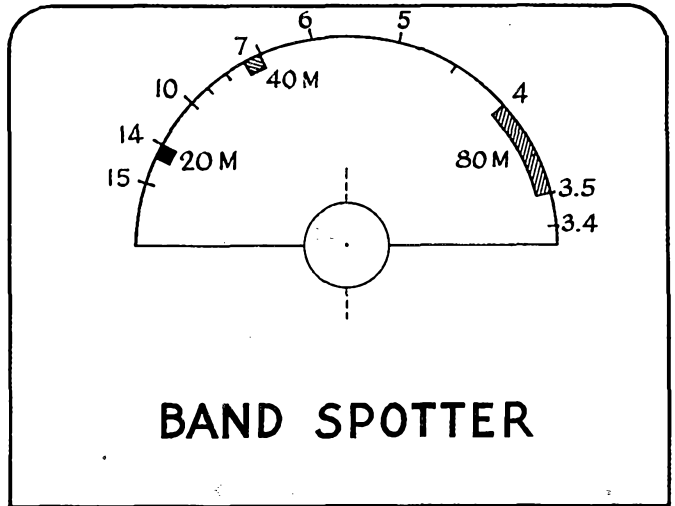

lamp goes directly to the rotor terminal on the rear of the condenser, the other to the insulated tie point. The coil is connected from the stator terminal of the condenser to the lamp at the insulated tie point.

If you use the same parts we specify below Fig. 1, and wire the unit with approximately the same lead lengths shown in the photographs, you will be able to use the calibrated dial scale reproduced in Fig. 2. It can be cut out and pasted on the aluminum bracket, or traced onto another sheet of paper. If other parts are used, the wavemeter can be calibrated by using a grid-dip meter in conjunction with a calibrated receiver.

Using the meter is also easy. Assume for a minute that you have tuned up your transmitter, but are not sure that its output frequency is in the desired band. With the transmitter turned on, hold the wavemeter so that the coil is within a few inches of the plate tank coil of your output stage. Turn the dial until the indicator lamp lights, showing that the wavemeter circuit is tuned to the same frequency as the transmitter output. Don't get too close to the tank circuit or you may burn out the indicator lamp.

The same procedure may be followed for any tuned circuit in which power is flowing. Whenever the wavemeter is tuned to the same frequency as the power in the tuned circuit, it will absorb some of that power and then dissipate it in the form of light in the indicator. If the stage you are checking has a plate meter, you can observe the effect of the wavemeter on the tuned circuit to which it is coupled. As the wavemeter

is resonated, the plate-meter reading will rise slightly as the wavemeter loads the circuit and takes power from it to light the lamp.

This little gadget cannot be expected to be without its limitations. There are some things that it cannot tell you. For example, its calibration is not accurate enough to permit its use as a frequency meter for close-tolerance reading. It will tell you, however, whether your output is in the 3.5-Mc. range, in the 7-Mc. range (as it would be if you happened to tune up on your second harmonic), or somewhere in between (as it might be if the amplifier was unstable and oscillating by itself). It is for this reason that we call it a *band spotter*, rather than a frequency meter. In the case of a crystal-controlled transmitter, you can be reasonably certain of avoiding off-frequency notices if your crystal is actually in the band, provided that you are sure the output is in the band you think it is. This gadget enables you to be sure.

◆
 Rear view of the measuring-cup wavemeter. The coil is mounted on the rear of the tuning condenser inside a protective Quartz-Q form. Also shown is the method of mounting the resonance-indicating lamp in a grommet-lined hole through the side of the cup.
 ◆

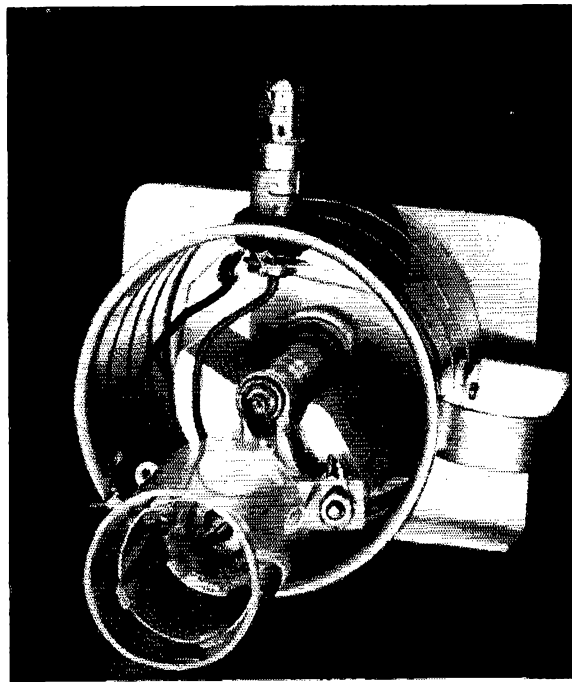

Matching Coax Line to the Ground-Plane Antenna

Design Data and Application

BY ROBERT T. DECAMP,* W2AFG

A GROUND-PLANE antenna is a vertical quarter-wave antenna using an artificial metallic ground, usually consisting of three or more rods perpendicular to the antenna and extending radially from its base. When used on v.h.f., this type of antenna usually is mounted on a mast high enough to clear surrounding objects, and in practice the low-loss metallic ground and low vertical angle of radiation combine to give the ground-plane antenna an actual advantage of the order of 3 db. over a dipole at the same height.

One reason why the ground plane has not had extensive use in amateur circles is that its low driving-point impedance is not a good match for the characteristic impedance of standard coaxial cables. This paper describes a method of adjusting the termination, as viewed by the transmission line, to any desired value higher than the radiation resistance, without appreciably altering the actual radiation resistance of the antenna.

In this method the antenna is first made slightly shorter than the resonant length so it "looks like" a resistance in series with a capacitance. If the length is chosen to make the capacitive reactance the proper value, and the antenna terminals are then shunted by an inductive reactance of proper value, then the impedance at the driving point as viewed by the transmission line will be resistive and of a value that will match the line impedance.

The inductive reactance required can be supplied conveniently in the form of a stub shorted at its far end. It is also convenient to make the stub out of the same type of cable used for the transmission line to the transmitter. The sys-

• This article describes a method for predetermining antenna and matching-stub dimensions for matching any selected transmission line. Although applied particularly to the ground-plane antenna, the curves are useful for half-wave dipoles if allowance is made, when necessary, for the effect of ground on the antenna characteristics.

tem is indicated in Fig. 1, which shows a typical installation using four radial rods.

The various values required for proper matching will depend on the particular type of line used, as well as on the radiation resistance, resonant length, and reactance per unit length of the antenna. These antenna characteristics are dependent on the length/diameter ratio—that is, the ratio of a half wavelength in free space to the diameter of the antenna element—and allowance must be made for this factor. The necessary information for design purposes is given in Figs. 2, 3 and 4.

Procedure

Determining the antenna dimensions can be reduced to a series of steps, as follows:

First determine M , the ratio of a free-space half wavelength to the conductor diameter. The following formula may be used:

$$M = \frac{5906}{FD}, \quad (1)$$

where F = frequency in megacycles,
 D = conductor diameter in inches.

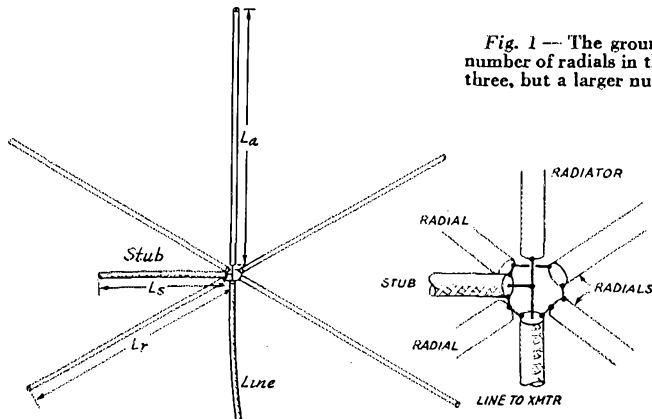

Fig. 1 — The ground-plane antenna in typical form. The number of radials in the ground plane should not be less than three, but a larger number can be used if desired.

The antenna length, L_a , matching stub length, L_s , and radial length, L_r , are determined as described in the text, for matching a transmission line of given characteristic impedance. As shown in the insert, the radials and the outside conductors of the stub and line are all connected together.

* © A. T. & T. Co., 32 Sixth Ave., New York 13, N. Y.

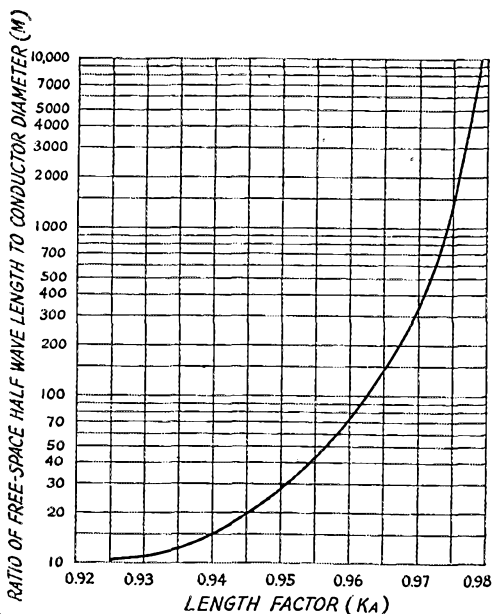

Fig. 2—The antenna-length factor as a function of the ratio of a free-space half wavelength to the conductor diameter. The length factor multiplied by a free-space quarter wavelength is the length of a quarter-wave radiator resonant at the selected frequency.

Using the value of M so found, read the length factor (K_a) from Fig. 2, the reactance change per 1 per cent change in length (K_x) from Fig. 3, and the radiation resistance (R_r) from Fig. 4.

Since the antenna is to be shortened, these values must be modified appropriately. The actual radiation resistance, after the antenna is properly shortened, will be

$$R_o = R_r - \frac{Z_1}{4R_r} \text{ ohms,} \quad (2)$$

where R_o = radiation resistance after shortening,
 Z_1 = characteristic impedance of transmission line to be matched.

The proper value of capacitive reactance in the shortened antenna is given by

$$X_a = SR_o \text{ ohms,} \quad (3)$$

where X_a = capacitive reactance of antenna, and

$$S = \sqrt{\frac{Z_1}{R_o} - 1}. \quad (4)$$

The antenna length that gives the proper capacitive reactance is

$$L_a = \frac{2953K_aK_b}{f} \text{ inches,} \quad (5)$$

where L_a = required antenna length, and

$$K_b = 1 - \frac{X_a}{100K_x}. \quad (6)$$

The only remaining steps are to find the dimensions of the inductive stub and the length

(Continued on page 120)

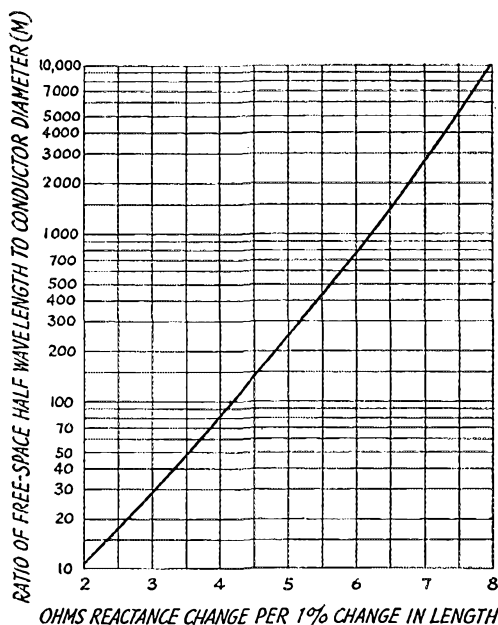

Fig. 3—Reactance change with antenna length as a function of M , for quarter-wave ground-plane (or grounded) antennas. If the antenna is longer than the resonant length the reactance is inductive; if shorter, the reactance is capacitive. The curve is accurate for lengths within 10 per cent of the resonant length. Multiply reactance values by 2 for half-wave antennas.

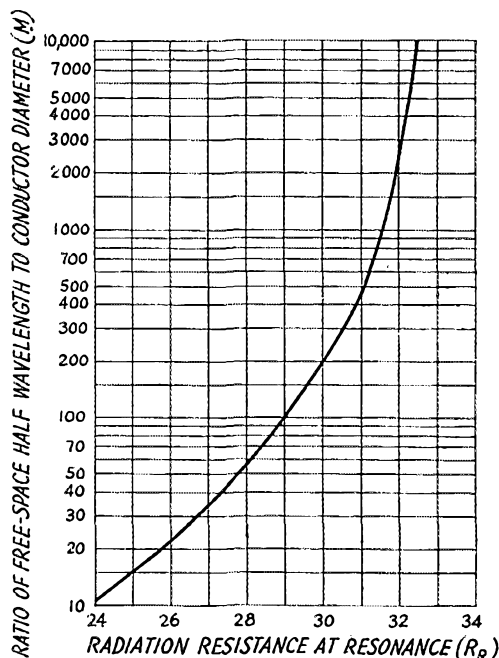

Fig. 4—Radiation resistance of a quarter-wave antenna (with ground plane or grounded) as a function of M . The values apply only when the antenna is of the resonant length. Multiply resistance values by 2 for half-wave antennas.

A Bandswitching Exciter for 50, 28 and 21 Mc.

35 Watts Output on Three Bands in 3½ Inches of Panel Space

BY EDWARD P. TILTON,* WIHDQ

FOR years many 6-meter enthusiasts have also worked on 10. The lower frequency has made a good medium for comparing notes on the higher, and the two bands combine readily in a transmitter design. The 21-Mc. band now looms as a likely substitute for 28 Mc. for DX work, for the next few years at least, and it can be added to a bandswitching exciter without appreciable complication. Crystals or VFO can be in the same general frequency range for all three bands, making the combination a natural for the v.h.f. man who likes a shot of DX now and then.

The primary factor in mind when this exciter was laid out was reduction of TVI potentialities, so provision was made for complete shielding, and all power leads were by-passed where they come out of the chassis. A common cause of TVI in rigs for 50 Mc. and higher is the radiation of unwanted harmonics of the starting frequency in the exciter. Much of this can be eliminated by using a high starting frequency, but such an approach is not practical for multiband applications. Fortunately, the shielding and filtering methods needed to reduce harmonic radiation from 21- and 28-Mc. stages also take care of the high-order harmonics of the oscillator frequency, so no special TVI precautions were required here for the v.h.f. portion of the exciter.

• If a multiband exciter is to be completely shielded, plug-in coils are out — unless you like to take lots of time shifting bands. Building inside the chassis provides the shielding and makes for a neat compact design. The 6146 output stage delivers enough drive for almost any final stage you'll ever want to use on 6, 10 or 15 meters. Output on 48 Mc. is available, too, for tripling to 144.

If we are to have 50-Mc. output we also have, inherently, the means of frequency control for 144 Mc. as well, as customary practice in 2-meter transmitter design involves a stage that triples from 48 to 144 Mc. Bandswitching is easily handled at 21, 28 or 50 Mc., but switched circuits are almost out of the question at 144 Mc., so this band is taken care of at WIHDQ by a tripler stage that is part of the 2-meter portion of the station, described recently in *QST*.¹

Circuit Details

The exciter circuit follows standard practice throughout. The oscillator is a 5763 Tri-tet with provision for 10 crystals and VFO input. Crystals may be in the 3.5-, 6-, 7-, 8-, 14- or 24-Mc. ranges. VFO output should be 7 to 9 Mc. On 21 Mc. the oscillator output is on the signal frequency, and best results are obtained with 7-Mc. crystals, tripling in the plate circuit. For 28 Mc. the oscillator doubles to 14 Mc. with

* V. H. F. Editor, *QST*.

¹ Tilton, "A High-Powered Driver-Amplifier for 144 Mc.," *QST*, June, 1952, p. 11.

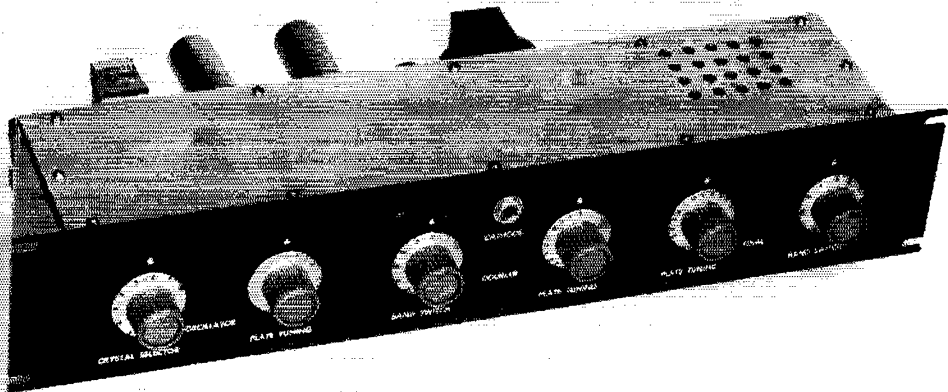

The 4-band exciter occupies less than the full height of a 3½-inch rack panel.

7-Mc. crystals, quadruples from 3.5 Mc., or works straight through with 14-Mc. overtone crystals. For operation on 50 or 144 Mc., the oscillator output is on 24 to 27 Mc., quadrupling, tripling or working straight through, for 6-, 8- or 24-Mc. crystals, respectively. The 100- μ fd. tuning capacitor at C_6 tunes the oscillator plate circuit from 14 to 27 Mc., so no bandswitching is needed in this stage.

Another 5763 follows the oscillator, working straight through on 21 Mc., or doubling to 28 or 48 to 54 Mc. Two coils, L_2 and L_3 , and a 50- μ fd. condenser, C_{10} , cover 21 to 30 Mc., and 48 to 54 Mc., respectively. In case trouble is encountered in making the 5763 run stably as a 21-Mc. amplifier, a third switch position is available for connecting a damping resistor, R_8 , in series with L_2 .

The output stage uses a 6146, with a tapped coil for 21 and 28 Mc., and a second coil for 48 to 54 Mc. Output coupling links in these two coils are also switched. Up to about 40 watts output is available, though for the purpose

intended nothing like that amount of power is required. The characteristics of the 6146 are such that it works nicely over a wide range of plate voltages, so this rig may be used in exciter service with as little as 300 volts on the final, or it may be used as a complete transmitter at up to 500 volts. A 2E26 may be used in the final stage (the two tubes are interchangeable as to socket connections) where its power output is adequate for the job at hand.

Construction

If TVI preventive measures are to be effective in a transmitter operating on frequencies lower than 50 Mc. the r.f. section must be completely shielded. This requirement will be important to v.h.f. men, too, when u.h.f. TV stations come on the air, so now is none too soon to get the habit of shielding and filtering rigs designed for use on 50 Mc. and higher. Shielding, in this case, is taken care of by building the rig inside a standard 3 \times 4 \times 17-inch aluminum chassis. You will note only the crystals, the

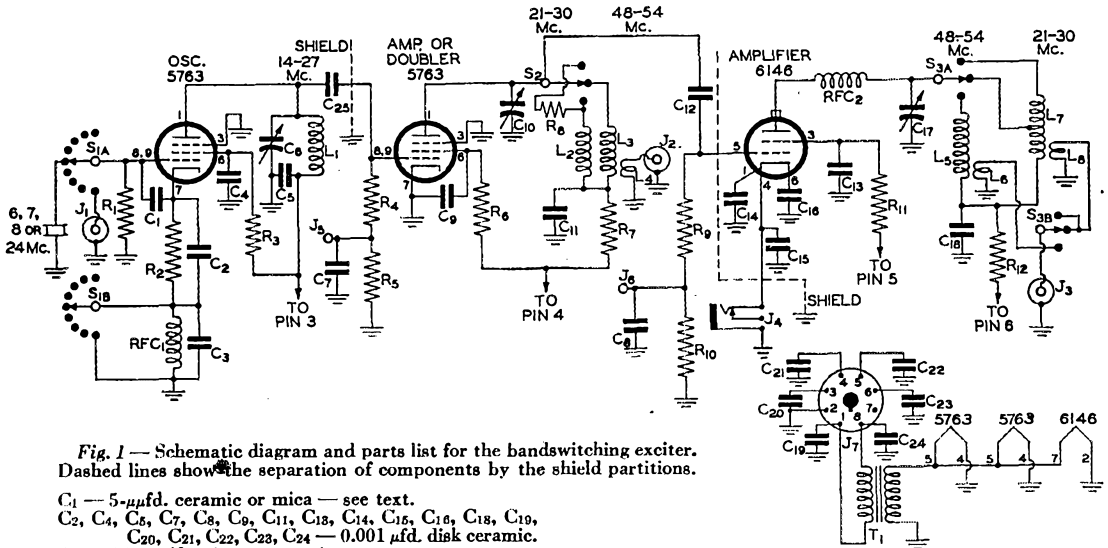
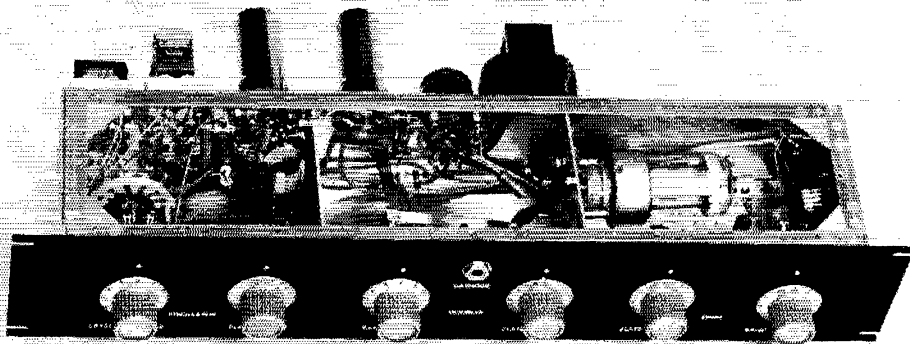

Fig. 1 — Schematic diagram and parts list for the bandswitching exciter. Dashed lines show the separation of components by the shield partitions.

- C_1 — 5- μ fd. ceramic or mica — see text.
- $C_2, C_4, C_6, C_7, C_8, C_9, C_{11}, C_{18}, C_{14}, C_{15}, C_{16}, C_{18}, C_{19}, C_{20}, C_{21}, C_{22}, C_{23}, C_{24}$ — 0.001 μ fd. disk ceramic.
- C_3 — 150- μ fd. mica or ceramic — see text.
- C_5 — 100- μ fd. midget variable, shaft-mounting type.
- C_{10} — 50- μ fd. midget variable, shaft-mounting type.
- C_{12} — 15- μ fd. mica or ceramic.
- C_{17} — 20- μ fd. double-spaced midget variable, shaft-mounting type.
- C_{25} — 50- μ fd. ceramic or mica.
- R_1, R_4 — 0.1 megohm, $\frac{1}{2}$ watt.
- R_2 — 220 ohms, $\frac{1}{2}$ watt.
- R_3, R_8 — 22,000 ohms, 1 watt.
- R_6, R_{10} — 1000 ohms, $\frac{1}{2}$ watt.
- R_7 — 100 ohms, $\frac{1}{2}$ watt.
- R_8 — 7.5 ohms 1 watt (two 15-ohm $\frac{1}{2}$ -watt resistors in parallel).
- R_{11} — 33,000 ohms, 1 watt.
- R_{12} — 20,000 ohms, 10 watts.
- R_{12} — 68 ohms, $\frac{1}{2}$ watt.
- L_1 — 8 $\frac{1}{2}$ turns No. 20 tinned, $\frac{3}{4}$ -inch diam., $\frac{1}{2}$ inch long (B & W Miniductor No. 3011).
- L_2 — 7 turns like L_1 , $\frac{3}{16}$ inch long.
- L_3 — 4 turns No. 20 tinned, $\frac{5}{8}$ -inch diam., $\frac{1}{2}$ inch long (B & W No. 3006).
- L_4 — 2 turns No. 18 push-back, $\frac{5}{8}$ -inch diam., coupled to cold end of L_3 .

- L_5 — 4 turns No. 20 tinned, $\frac{3}{4}$ -inch diam., $\frac{1}{2}$ inch long (B & W No. 3010).
- L_6 — 4 $\frac{1}{2}$ turns No. 20 tinned, $\frac{1}{2}$ -inch diam., $\frac{1}{2}$ inch long, mounted inside cold end of L_5 . (B & W Miniductor No. 3003.)
- L_7 — 11 turns like L_1 , tapped at 7 turns, $\frac{3}{4}$ inch long.
- L_8 — 9 turns B & W No. 3004, $\frac{1}{2}$ -inch diam., $\frac{3}{16}$ inch long, mounted inside cold end of L_7 .
- J_1, J_2, J_3 — Coaxial fitting. J_1 is for VFO input.
- J_4 — Closed-circuit jack.
- J_5, J_6 — Tip jack.
- J_7 — 8-pin male chassis fitting.
- RFC₁ — 100-mh. r.f. choke (National R-100-S).
- RFC₂ — Parasitic choke, 6 turns No. 20 enamel, $\frac{1}{4}$ -inch diam., $\frac{3}{8}$ inch long.
- S_{1A}, S_{1B} — 11-position 2-section ceramic wafer switch. (Made from centralab P-122 index assembly and 2 centralab type Y switch sections. Complete assembly CRL 2513.)
- S₂ — Similar to above, but single section (CRL 2501 on 2503, wafer Type X or Y).
- S_{3A}, S_{3B} — Same but 2-pole 3-position single section (CRL 2505, wafer type RR).



Looking into the handswitching exciter-transmitter from the top front. Oscillator components are in the left compartment, the doubler and power connector in the center, and the output stage at the right. Note that the 6146 socket is mounted inside the output stage compartment.

first two tubes and the filament transformer are outside, these being mounted on the rear wall. This not only provides for the shielding, but it makes possible a very neat and compact unit, the whole affair taking up only $3\frac{1}{2}$ inches of rack space vertically.

Despite the small size, it is not difficult to assemble or wire. Arrangement of parts in the first two stages is not particularly critical, the principal consideration being to mount the second 5763 in such position that the coupling lead from the previous stage is short. The grid circuit should be isolated from the rest of the second-stage components, to reduce the tendency to self-oscillation when the stage is operated straight through on 21 Mc. The tube socket is near the partition that separates the two stages, and the lead from C_{25} to the tube grid is made from a short section of RG-59/U coax, run through a slot filed in the top of the partition.

All power wiring is done with shielded wire, and the inner conductor of each lead is bypassed with a miniature 0.001- μ f. disk ceramic where it comes out to the power plug. Leads from the tube plate to the bandswitch, S_2 , and thence to the tuning condenser, C_{10} , are made with $\frac{1}{4}$ -inch wide copper strap, to hold down lead inductance. A piece of flashing copper $\frac{3}{4}$ by $1\frac{1}{4}$ inches is soldered across the tube socket separating Pins 1 and 9, to isolate the grid and plate leads.

The arrangement of parts in the output stage is important. Note that, contrary to common practice, the 6146 socket is mounted on pillars on the *tube side* of the partition. Cathode, heater and screen pins (1, 3, 4, 6 and 7) are bypassed individually to *separate* points on the partition, with the shortest possible leads; in fact, with virtually no leads at all. Heater voltage and cathode keying leads are brought through the partition with shielded wire, and the control-grid and screen connections are run through on short lengths of stiff wire covered with spaghetti sleeving for insulation.

Two other layouts were tried, both with the

6146 socket mounted in a hole in the partition in the conventional way. No amount of screen and cathode by-passing could stabilize the stage in either case. When the parts arrangement shown was tried the 6146 showed no instability, other than a weak 250-Mc. parasitic that was cured by the insertion of RFC_2 in the plate lead. The value of this mounting arrangement is that it provides a direct plate-to-cathode return, whereas the return circuit with the conventional below-chassis mounting of the socket passes around the edge of the hole to the opposite side of the partition or chassis. This revised approach has proved its worth in previous tetrode amplifiers,² and is well worth a try in extremely tricky stages.

Another important point in the mechanical design of this unit is the use of tuning condensers that are shaft mounted. The rotors of C_6 , C_{10} and C_{17} must be grounded *directly* to the chassis with their mounting nuts. Running the shaft through a clearance hole and then making the ground connection by means of the extension of the rotor star spring leaves the rotor shafts hot for r.f. at harmonic frequencies. They and their knobs (particularly if the latter have metal rims) then act as miniature antennas for radiation of harmonic energy. Two more such "antennas" were provided by the tip jacks, J_5 and J_6 , used for metering the multiplier- and final-stage grid currents. Despite the isolation afforded by resistors R_4 and R_9 , these jacks were hot with harmonics until by-passed individually.

The output coupling links, L_6 and L_8 , are the smallest diameter B & W Miniductor, which makes a close fit inside the larger size used for L_5 and L_7 . They are held in place with household cement. A coupling link is also provided for L_3 , so that a small amount of power can be taken off at 48 Mc. if desired. This is made of self-supporting stiff insulated wire, coupled closely to the cold end of L_3 .

Note that the front-panel appearance is com-

² Grammer, "Practical Application of Pi-Network Tank Circuits for TVI Reduction," *QST*, January, 1952, p. 15.

pletely symmetrical, the controls being spaced at regular intervals horizontally, and in the center of the panel vertically. In addition to providing a pleasing appearance, this has the practical advantage of permitting operation of the unit either side up — at least until the dial index marks and decals are applied. In our case the chassis is bottom up, with the “bottom” cover at the top. This allows ready access to the inside when the unit is in its normal operating position, but nothing prevents its being used the other side up, if the builder so desires. Ventilation of the 6146 is afforded by twenty $\frac{1}{4}$ -inch holes drilled in the top and bottom surfaces over and under the tube.

Testing and Use

For initial tests a power supply delivering 200 to 250 volts is adequate. Each stage has its plate-screen power lead brought out to the plug separately, so that individual metering is possible. Applying voltage through Pin 3, we note that the stage draws low current until oscillation is obtained, because of the cathode bias. Plug a low-range meter into J_5 to read the grid current of the following stage, and tune C_6 for maximum indication, which will be about 0.5 to 1 ma. at normal operating voltage. The oscillator plate-screen current will be around 20 ma.

Should the oscillator refuse to start, try other crystals, and then experiment with the values of C_1 and C_3 . The grid-to-cathode capacitor, C_1 , may not be necessary, particularly if crystals no lower than 6 Mc. are used. Use the lowest value that will permit oscillation with all crystals. The value of C_3 may be critical when overtone-type crystals are used. Improper values at either of these positions may result in intermittent oscillation, or none at all.

Check the output frequency with a calibrated wavemeter, or by listening with a receiver whose calibration can be relied upon, and proceed to the following stage. Plug the grid meter into J_6 , apply power through Pin 4, and check the

output frequency when C_{10} is tuned for maximum grid current. At least 2 ma. should be available. Check for self-oscillation by removing excitation. Should self-oscillation occur on the 21-Mc. range, switch in the damping resistor, R_8 . This should be the lowest value permissible, as the output from the stage drops rapidly as the series resistance is increased above a few ohms.

When around 2 ma. of grid current is obtained the output stage may be checked. This may be done initially with 250 to 300 volts applied through Pins 5 and 6, using a 25-watt lamp plugged into J_3 for a dummy load. Cutting the excitation (do it only briefly — these 6146s draw a tremendous amount of plate current!) should result in zero grid current. If the stage is operating correctly the output should be around 15 watts with 300 volts on the plate.

Increasing to 400 to 450 volts it should be possible to get at least 35 watts output on all frequencies. In an enclosed layout of such small dimensions it is not advisable to go much beyond this level, as the heat dissipation may be high enough to damage the small coils used. Where the exciter is used to drive a high-powered tetrode final stage, as is the case on 21, 28 and 50 Mc. at the writer's station, 300 volts on the 6146 and 200 to 250 volts on the 5763s is plenty. The rig is also used occasionally as a complete transmitter, modulating the output stage on 28 or 50 Mc., at 30 to 50 watts input. The operating conditions in all stages can be adjusted to suit the builder's own requirements by varying the screen resistor values. The exciter is keyed in the 6146 cathode lead for c.w. operation.

Some results of TVI tests may be of interest. Let it be said here that the shielding and bypassing are not, in themselves, TVI “cures” — but they do give us a good start. You can't just hang an antenna on such a rig and blaze away on any frequency, however. The precautions taken in the design of the rig keep the harmonic energy inside the case, except at the

(Continued on page 122)

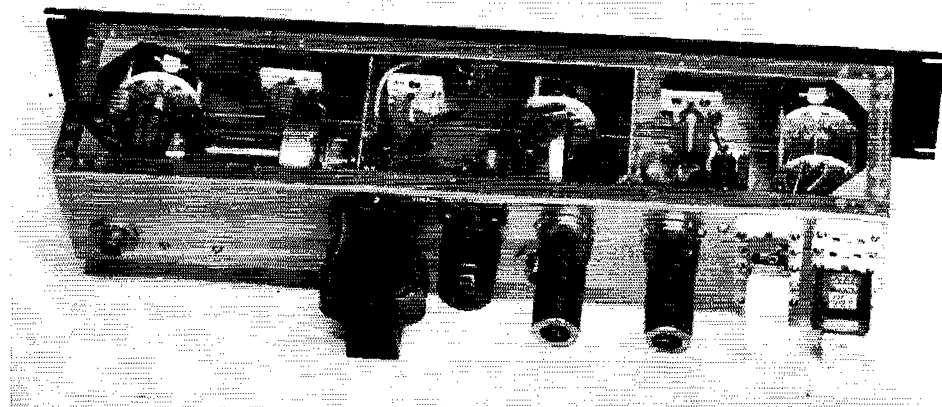

Rear view of the exciter. On the rear wall at the right are 10 crystal sockets of various types. Then come the two 5763s, the power plug, the filament transformer, and the output coaxial fitting. Components on the inside front wall are, in the same order, the crystal switch, oscillator tuning, doubler bandswitch, doubler tuning, and final bandswitch.

Identifying Frequency-Meter Harmonics

A Simple Method of Checking Multiples of the Fundamental

BY N. K. CHAMBERLIN*

• When using the harmonics of the fundamental range of a heterodyne type frequency meter, identification of the number of the harmonic that is beating with the unknown frequency is often puzzling unless the approximate value of the frequency being checked is known beforehand. Here is a simple method that removes most of the guesswork.

IN USING the harmonics of a frequency generator, or heterodyne frequency meter, to check an unknown frequency, it is necessary, of course, to identify the *number* of the harmonic beating with the unknown, as well as the fundamental frequency of the oscillator in the generator. With the number of the harmonic determined, the unknown frequency is then obtained simply by multiplying the fundamental frequency read on the calibration by the number of the harmonic. For instance, if the fundamental calibration of the generator or frequency meter is 3500 kc., and we know that it is the third harmonic that is beating with the unknown frequency, then the unknown frequency is $3500 \times 3 = 10,500$ kc.

This would be a simple process were it not for the difficulty often experienced in identifying the number of the harmonic. A little thought, however, will show that there is a simple way of determining the harmonic number (or determining the frequency without actually knowing the harmonic number) provided that the checks are carefully made.

As a start, let us plot on graph paper, as in Fig. 1, the frequency curves for a fundamental of 2000 to 4000 kc. (this is one of the ranges covered by the BC-221 frequency meter) and several of its harmonics. Now suppose we have an oscillator running at some unknown frequency and we listen on a receiver tuned to the oscillator frequency, or listen on the monitoring portion of the BC-221. We start tuning the frequency meter from the high-frequency end, listening for beats between the frequency meter and the oscillator being checked. Suppose we hear the first beat with the meter tuned to 3600 kc., and the next beat we hear comes at 2400 kc. Since the signal was heard at more than one point on the dial, it is obvious that the unknown frequency does not lie in the fundamental range of the meter. It is obvious, too, therefore, that the unknown frequency must be a harmonic of 3600 kc. and also a harmonic of 2400 kc. In addition, since no other beats were found between 3600 and 2400 kc., we know, regardless of what the actual numbers of these

harmonics may turn out to be, the number of the harmonic in respect to 2400 kc. is one greater than the harmonic number in respect to 3600 kc. (If the unknown is the fourth harmonic of 3600 kc., it must also be the fifth harmonic of 2400 kc., etc.)

Referring to Fig. 1, we draw vertical lines from 3600 and 2400 kc., crossing the harmonic lines. If we have plotted the lines for a sufficient number of harmonics, we will find that there is *one* harmonic frequency, and *only one*, where the 2400- and 3600-kc. lines cross adjacent harmonic lines at the *same* frequency. In Fig. 1, we find that the 2400-kc. line and the third-harmonic line intersect at 7200 kc. Also, the 3600-kc. line and the second-harmonic line intersect at 7200 kc. Therefore the unknown frequency must be 7200 kc.

Any unknown frequency within the usable harmonic range of the frequency meter could be determined graphically in the same manner were it not for the fact that the graph becomes impractically cumbersome and difficult to read with

(Continued on page 124)

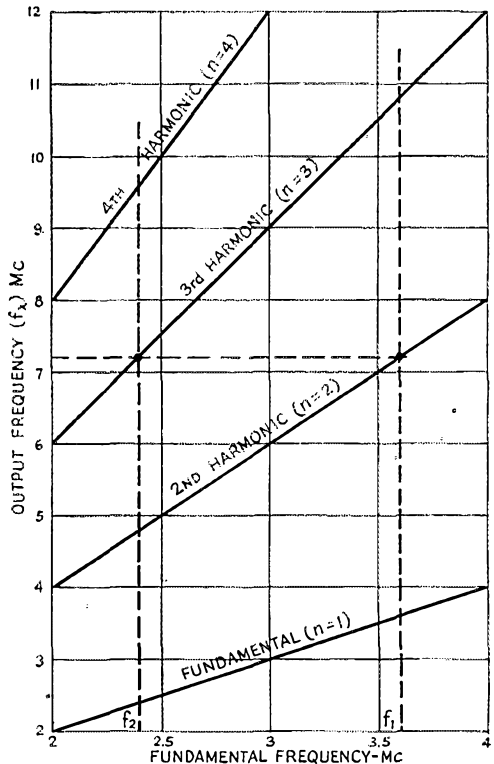

Fig. 1—Frequency-meter curves showing the calibrated fundamental range and its harmonics.

*5810 Greene St., Philadelphia 44, Penna.

7-Mc. Beam for the Small Yard

A 3-Element Parasitic Array with Quarter-Wave Vertical Elements

BY A. D. MAYO,* W5DF

WHEN the first 20-meter beams came into use, hams using dipoles immediately recognized that they were outclassed by more punch, and today it is futile to compete seriously for 20-meter DX without a good beam. However, on the 7-Mc. band beams are extremely rare, the reason being that the common types become too large when a half wavelength is about 66 feet. In terms of developing beams that are practical for small city lots, DX operation on 40 is years behind its counterpart on 20 meters.

The 7-Mc. 3-element beam in use at W5DF will fit into almost any back yard and provides high gain — presumably 7 to 8 db. over a single vertical element, but much more compared with a horizontal dipole at the usual height of thirty to forty feet. This is a DX antenna; at moderate distances of 300 miles or so it may not be as good as a low horizontal dipole since it concentrates the radiation at the low angles desirable for DX work. The writer has proved to his own satisfaction, at least, that it will put a signal into Europe that competes with the East Coast, or into VK and ZL that competes with West Coast stations on practically an equal basis. Almost all of the other stations are using antennas that spray the radiation all over the place instead of in the desired direction and at the desired angle.

The 3-element antenna offers many choices of pattern, and the pattern can be varied by the tuning of the two parasitic elements. Instead of describing all of the possible patterns, perhaps it is best to describe the one which will be obtained when the tuning instructions furnished here are followed. This adjustment can be obtained without a field-strength meter and the only instrument needed is a flashlight bulb with loop. This

*209 Conti St., Jackson, Miss.

• Here's a description of a 7-Mc. beam that has given a good account of itself in competing for 40-meter DX. Inexpensive, easy to build — and it requires so little space that it will fit into almost any backyard.

adjustment will provide slightly less than absolute maximum gain directly forward in the desired direction, but it will provide 60 degrees coverage before the output drops to the half-power points and it will cover 90 degrees in the horizontal plane before the power drops to that provided by a single element. Over the remainder of the 360-degree horizontal plane the radiation drops off rapidly after 45 degrees off the central ray is passed, and in the rear 180 degrees it is generally down 10 to 15 db. A pair of nulls appears in the rear and can be rotated with tuning of the parasitic elements. These measurements were taken on the ground.

Antenna Arrangement

Fig. 1 shows a generalized version of the antenna. It may be visualized as a 20-meter 3-element horizontal beam which has been lengthened to 66 feet, sliced through the center, rotated to bring the elements vertical, and with the ground replacing the missing half of the antenna. To eliminate the necessity for making the elements some exact physical length, tuned circuits are inserted in each one of the antennas. The antenna is therefore very tolerant of physical lengths and spacings. No harm results if the lower ends of the two parasitic elements are folded back and brought into the shack along with the lead-in from the center element. This permits having all

◆

Not a new kind of forest but a "planting" of the W5DF variety of 7-Mc. vertical element. The basic arrangement is a reflector-driven element-director, three elements in line being selected and tuned for a given direction. Unused elements "float," and since disconnecting them makes them nonresonant at the operating frequency they have no effect on the beam formed by the elements in use.

◆



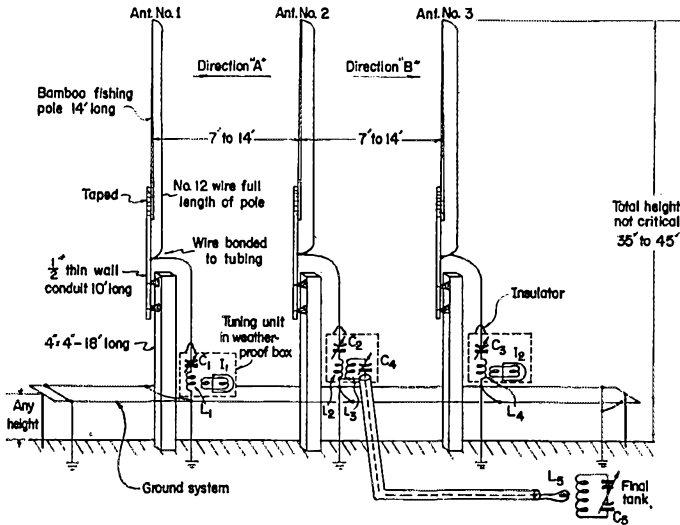

Fig. 1—The 7-Mc. 3-element beam at W5DF. This drawing (not to scale) shows the essential electrical and mechanical features. The same antenna can be used on 14 Mc., but the separation between elements should not exceed 10 feet if that band is to be used. W5DF has also used it on 80 meters to work ZL with a 25-watt transmitter.

three tuning units in the shack for experimental tuning. Ground leads are brought in with these lead-ins, so the current flow will tend to cancel out radiation in the horizontal plane.

L_1 , L_2 , L_3 and L_4 may have any inductance that will tune to 40 meters with condensers C_1 , C_2 , C_4 and C_3 , respectively. The writer used surplus components and the condensers have about 150 or 200 $\mu\text{mfd.}$ full capacity. The condenser should hit resonance at about half capacity to give some leeway in tuning off resonance with various antenna-element lengths. L_2 and L_3 should have ample power rating because they will carry 5 to 10 amperes with high power and close spacing of the elements. Coils wound with No. 12 wire are satisfactory for a kilowatt input. L_1 and L_4 can be smaller—50- or 100-watt size. All of these variables carry high r.f. voltage, but 3000-volt condensers have been used at C_2 and C_4 without breakdown. If the elements are about 33 feet long, from the top to the ground wires, series tuning will resonate the elements. If either the element or its lead-in is lengthened, a point will be reached where parallel tuning is necessary.

The transmission line does not have to be coaxial cable; any type of line can be used to feed the center element. High-impedance lines

may require L_3 and C_4 to be connected in parallel. The center element may be driven by tapping the line on L_2 and eliminating L_3 and C_4 , or with coax it may be driven by connecting the coax in series with L_2 at the ground end. However, these simplified methods of driving this element do not permit much flexibility in matching impedances. All of these methods of feed have been used at W5DF on various antennas.

Impedance Characteristics

The antenna has low radiation resistance and it tunes sharply. It is not for broad-band use, at least in the form shown here. At 7000 kc. it will cover 50 kc. with no noticeable change in tuning, and it will cover 100 kc. if some decrease in loading can be tolerated at the extremes. The radiation resistance is at its lowest value when the two parasitic elements are tuned to resonance, and when closest spacing between elements is used. If broad-band tuning is desired the spacing between elements may be increased to perhaps 20 feet, but the gain of the antenna is reduced. If the spacing is increased to 35 feet there will be practically no gain.

If the antenna is to be used for 20-meter as well as 40-meter operation, which is quite practical, the spacing probably should be kept down to 8 or 10 feet. The spacing should be between 0.1 and 0.15 wavelength for maximum gain. If the spacing exceeds 0.15 wavelength the front-to-back ratio will be reduced. At spacings less than 0.1 wavelength the gain is preserved very well until a spacing of 0.05 wavelength is reached, but the tuning is more critical and the radiation resistance is reduced.

Ground System

Low radiation resistance must be recognized as a hazard that can lead to serious losses unless adequate steps are taken to provide a low-resistance ground system. Ground resistance can be kept at a minimum by having a ground made

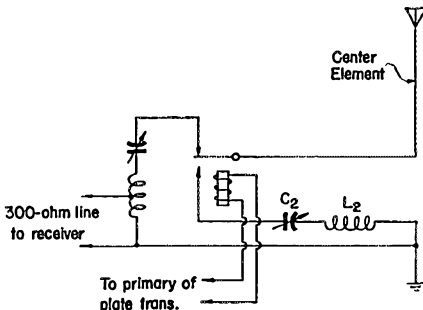

Fig. 2—Relay connections and matching systems for using the antenna for receiving.

of a material with two desirable characteristics, large surface area and high conductivity. The ground itself falls down on the second; its conductivity is low at 7000 kc. One desirable ground might be a metal roof, if the antenna is mounted on it. Another desirable ground plane would be a set of 4 radials, at 90 degrees in the horizontal plane, $\frac{1}{4}$ wavelength long, with the ends insulated.

At W5DF, located on a small city lot, it was convenient to erect a two-wire clothesline for a ground system, thereby killing two birds with one stone and gaining back a wee bit of good-will from the XYL about this entire yard full of antennas, not to mention the house. It has often been said that we moved out here to obtain some room, yet you cannot walk in the yard without tripping over an old wire and breaking a leg, or getting a wire under the chin and breaking the neck.

The clothesline is about 30 feet long and extends in one direction from the center antenna. More wire extends in the other direction. These wires are No. 10 zinc-coated steel. Ground rods are used at each pole and at the end of the clothesline. Connections to these parts are adequately soldered. Various other metallic objects such as the plumbing pipes in the house and the buried coax that runs around the yard are all securely grounded to the place where the clothesline ends. All of these materials act as conductors and effectively lower the ground resistance; however, the clothesline itself is sufficient and may be used alone if other objects do not exist. In the absence of plumbing or buried cables, it might be well to run the ground out in two or more directions, or use a wire fence in the connection if one is available. Long ground wires should not be permitted to float above ground, electrically. The ground wires should be grounded to stakes driven in the ground at intervals. Resonant operation is undesirable because it may cause the ground system to radiate and disturb the beam pattern or it may cause a burn on some passer-by if hot with r.f.

Tuning

Referring to Fig. 1, the simplified tuning procedure is as follows:

1) Decouple or remove L_5 and tune C_5 for resonance in the final tank, as indicated by minimum plate current. Mark this dial point, as the final adjustment should return C_5 to it.

2) Couple L_5 loosely to the final tank. Couple L_3 closely to L_2 . Alternately adjust C_2 for maximum plate current and C_4 for minimum plate current. Do not attempt to tune for maximum antenna current in the center element. Ignore this antenna current, as it can be increased by too many misadjustments in the entire system, some components of which must operate off resonance for proper phasing of the parasitic elements. Several misadjustments can increase the antenna current by lowering the antenna resistance, not by increasing the radiated power.

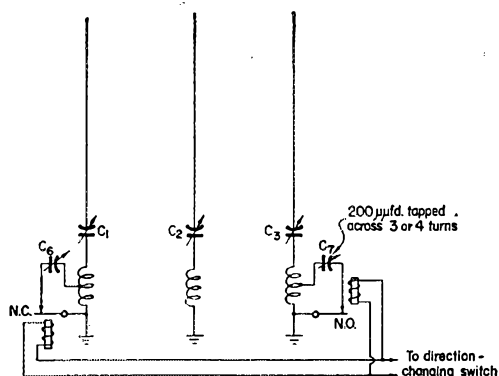

Fig. 3 — Circuit for remote reversal of direction. The two auxiliary condensers add just enough capacitance to the tuned circuit to reverse the direction of fire. To adjust, first adjust C_1 or C_3 with relay contacts open; then bring into tune by adjusting C_6 and C_7 with the corresponding relay closed.

3) Tune C_1 for maximum brilliance of I_1 , coupled to L_1 . Decrease the capacity of C_1 until the bulb is slightly dimmer. (Maximum brilliance is desired, but it is well to go a little on the low-capacity side for safety since if this adjustment gets a little on the high-capacity side it will cause a sharp null to appear in the forward direction.)

4) For maximum radiation in direction "A," tune C_3 for maximum brilliance of I_2 , coupled to L_4 , then increase the capacity of C_3 until I_2 almost goes out. This will increase the brilliance of I_1 slightly. The correct adjustment will result in maximum brilliance of the bulb in the parasitic element toward the direction in which maximum radiation is desired. An antenna-current meter may be used in the parasitic element to find this adjustment, or an indicating-type absorption wavemeter may be coupled to the antenna lead on this parasitic element and used as an indicator. At night the flashlight bulb can be seen plainly.

5) For maximum radiation in direction "B," tune C_3 , then C_1 , for maximum brilliance of I_2 , coupled to L_4 .

6) To complete the tuning, retune C_2 for maximum plate current and retune C_4 for minimum plate current, alternately, until no further tuning of C_2 will increase I_p and no further tuning of C_4 will reduce I_p . Adjust the coupling of L_5 to give the desired plate loading.

As with any antenna coupler, it will be found that the coupling between L_2 and L_3 may be loosened and L_5 coupled more closely to the final tank to get the desired loading. There is a best combination. Adjustment of the coupling between L_2 and L_3 reflects various resistances to the termination of the coaxial feeder and affects the standing-wave ratio on the coax. An s.w.r. bridge will permit exact adjustment. L_3 and C_4 permit tuning the system to exact resonance, removing reactances added by other elements in the coax circuit, and assist in harmonic reduction. Final adjustment of C_5 for minimum I_p should leave it at the same point as in Step 1.

Reversing the direction of radiation should not require any readjustment of C_5 , C_4 or C_2 . If reversal of direction by adjustment of C_1 and C_3 does disturb resonance or loading to any extent, it indicates that it is not symmetrical from an electrical standpoint, and under some conditions the whole thing can appear so snarled up and hopeless as to be beyond possible aid. The tuning procedure outlined above should always lead the adjustments to the correct point if done step by step.

Receiving

For DX work this antenna should by all means be used for receiving. Many hams will say that vertical antennas for receiving will pick up more noise than horizontal antennas, or that vertical antennas increase BCI. This is just another way of saying that vertical antennas will have more low-angle radiation, and that is what we are after. Reject low-angle transmission or reception and you reject DX, because DX signals are not bouncing down from something overhead.

In order to take advantage of the directional effects of this antenna for receiving it is essential that the input to the receiver be matched to the transmission line. The HRO receiver in use at W5DF has an input impedance of several hundred ohms, and it was found that a relay in the coaxial line to the antenna tuner did not work out well. A relay was installed to throw the actual antenna lead to a coil and condenser connected in series, and 300-ohm Twin-Lead was used to the HRO, as shown in Fig. 2. The Twin-Lead was tapped on the coil about four turns from the ground end. With the condenser tuned for maximum signal on the HRO the system is in tune.

When the receiver is matched as described above, the beam may be tuned and nulls brought to bear on any signal. Adjustment of both C_1 and C_3 are required for maximum rejection. The nulls will usually occur at some adjustment other than the two desired ones for transmitting, but this operation suggests interesting possibilities for receiving when the condensers C_1 and C_3 are adjustable from the operating position. When the null is adjusted on a station during reception in a QSO and this adjustment is used for transmitting, on the next transmission the station will usually comment on a 2 or 3 S-point reduction in signal strength. The nulls are sharp and very noticeable in reception, while the maxima are very broad and may not be determined accurately with the receiver.

Changing Direction

Although no drawings are shown for antennas with more than three elements we have used 5-element beams on 20 meters with sharp directivity and high gain. A 33-foot element on 20 meters does not require an extensive ground since practically no current flows in it, this being a half-wave antenna. Likewise it is not necessary to insulate the metal conduit from the pole if it is attached about 16 feet off ground, since the antenna is at ground potential at this point. A

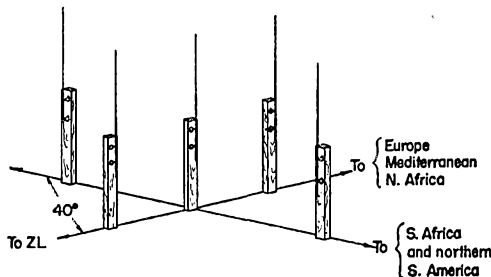

Fig. 4—Two extra elements pivoted on the same driven element will provide two additional directions of optimum radiation. The arrangement shown above has been used at W5DF to cover the compass points indicated. By using a total of seven elements, with the parasitic elements spaced 60 degrees around the driven element, there is a choice of six directions giving complete coverage.

beam tuned to 20 meters in close proximity to the 3-element 40-meter beam did not seem to affect it in any way, and perhaps is comparable to the proximity of a set of 10-meter elements in a rotary beam. This led us to a short cut in devising a second beam for other directions.

The present beam is directed along a bearing of 60 degrees, toward North Africa from here. Europe is covered easily, and in the reverse direction, 240 degrees, ZL is covered well along with most of VK. South Africa is about 40 degrees off the beam and it was found we did not sock into ZS like Europe. Two additional elements were erected along a line 40 degrees south of the European line to bring 100 degrees and 280 degrees along the line of this beam. These elements are also 14 feet from the center element. By means of a d.p.d.t. switch the tuning units can be switched from one set of two parasitic elements to the other set and the beam directed at ZS or the North Pacific. The two elements not in use have no r.f. on them and do not seem to affect the original set in any way. This suggests the possibility of a 7-element arrangement for complete coverage.

Silent Keys

IT is with deep regret that we record the passing of these amateurs:

W2VSW, Clayton E. Ernsberger, Romulus, N. Y.
 W3CIZ, Hermann E. Hobbs, Silver Spring, Md.
 W4RLF, William P. Scott, Fayetteville, Tenn.
 W5IPT, John A. Stippick, Temple, Texas
 W6SVG, Maurice G. Barwick, Burbank, Calif.
 W7CXM, J. A. Haaland, Troy, Mont.
 W8DOJ, Samuel D. Frajick, Cheboygan, Mich.
 W8BEQ, Frank L. Root, St. Louis, Mo.
 G3HP, Capt. W. R. Dainty, Brighton, Sussex
 VE3MB, Miles Whitaker, Morrisburg, Ont.
 VK2TI, W. G. Ryan, Sydney
 VS6AJ, Kenneth Cook, Hong Kong

R.F. Voltmeters

A Lower-Cost Alternative to the Thermocouple Ammeter

BY GEORGE GRAMMER,* W1DF

THERE is no really satisfactory substitute for an r.f. output indicator in a transmitter. Adjusting by plate loading only approximates the proper tuning conditions for maximum output and sometimes, especially with tetrodes, the approximation is not as close as could be desired.

With all the applications that have been thought up for the germanium crystal, it seems to have had little or no use as a rectifier in an r.f. voltmeter for transmitter tuning. Of course, it has been used extensively in s.w.r. bridges, and a very early bridge, the Micro-match, used such a voltmeter for measuring the power delivered to a load. However, it does not seem to be generally realized that a crystal voltmeter is not only an entirely acceptable alternative to an r.f. ammeter for the purposes for which the ammeter is customarily used, but also has a great deal more flexibility and in some cases is more reliable as an indicator. Add to this the fact that the cost is less and you have something worth thinking about.

Representative circuits are given in Fig. 1. Crystals of the general class of the 1N34 have an inverse peak voltage rating in the vicinity of 50 volts, so it is necessary to reduce the actual voltage to a safe value before applying it to the crystal. In the unbalanced (one side grounded) circuit shown at A, this is done by the voltage divider R_1R_2 . The sum of these two resistances should be at least 100 times the impedance of the circuit at the point where the voltmeter is connected, in which case the power consumed by the voltmeter will not exceed 1 per cent of the power level at that point. Small carbon resistors are desirable because they are noninductive and have good r.f. characteristics. The ratio of R_2 to

R_1 should be chosen so that when R_3 is of the order of 10,000 ohms a 0-1 milliammeter will register full scale on the highest r.f. voltage likely to appear across the circuit.

Grounded Circuits

The grounded type of circuit is particularly useful for measuring the voltage into and out of coaxial lines. For flat lines it is sufficient if the sum of R_1 and R_2 is about 7500 ohms, but to take care of standing-wave ratios as high as 4 to 1 this value may be doubled. The d.c. voltage developed across R_3 tends to approach the peak r.f. voltage applied to the rectifier, and since this will be about 10 volts at full scale when R_3 is 10,000 ohms, the ratio of R_2 to R_1 can be based on 10 volts and the probable voltage across the line. With 100 watts of r.f. in a 75-ohm line the peak line voltage is about 120 volts, so R_2 should be about one-twelfth of the total. Near enough, R_1 could be 6800 ohms and R_2 680 ohms, using standard values. The ratios are not critical so long as the inverse peak voltage is well below the maximum rating.

When R_3 is approximately 10,000 ohms (or any higher value) the voltmeter is substantially linear. If it is adjusted for full-scale reading with 100 watts in the line, as in the

example above, a linear voltmeter will read 10 per cent of full scale with only 1 watt in the line. In contrast, a thermoammeter that reads full scale with 100 watts will move only 1 per cent of the scale with 1 watt in the line—a hardly perceptible movement.

Changing the Range

It is obvious that the voltmeter range easily can be changed to fit the voltage level on the line.

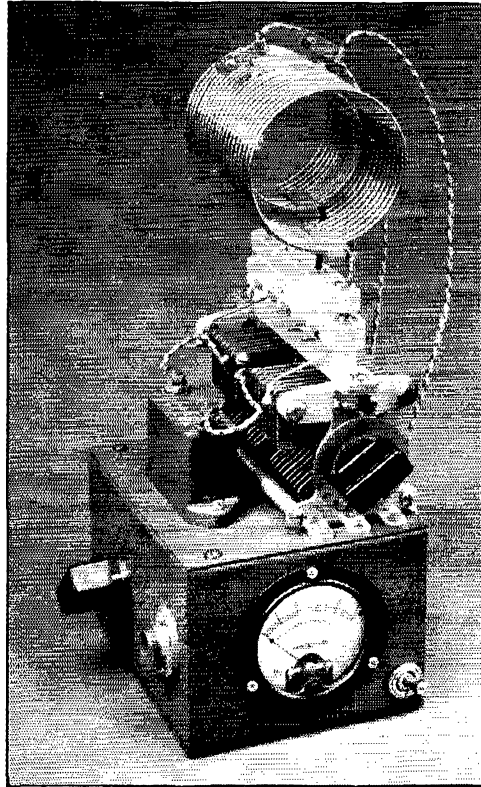

Coaxial-link antenna coupler with r.f. voltmeter. The coupler circuit is the customary parallel-tuned arrangement shown in the *Handbook* (a 325- μ fd. condenser is in series with the link coil) with the addition of the voltmeter circuit shown in Fig. 1A. The switch at the lower right changes the value of R_3 to give two voltage ranges.

*Technical Editor, QST.

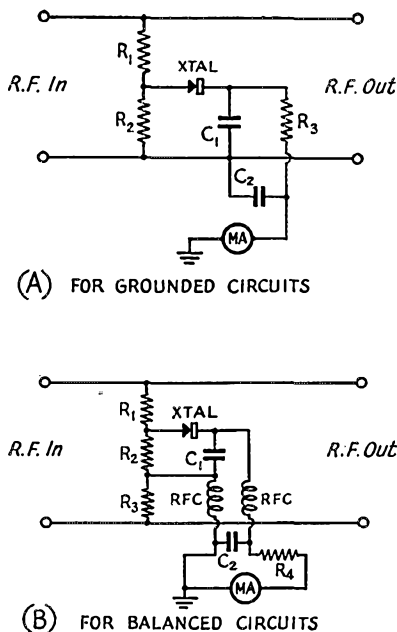

Fig. 1 — R.f. voltmeter circuits. In the upper circuit, A, R_1R_2 is a voltage divider for reducing the peak voltage applied to the crystal; $R_1R_2R_3$ serves the same purpose in the lower circuit. To a first approximation, these dividers can be calculated on a d.c. basis, although the ratios at r.f. are likely to differ considerably, depending on the frequency, the shunt capacitances of the resistors and stray pick-up in the crystal rectifier circuit. C_1 and C_2 are r.f. by-passes; 0.005 μ f. is a satisfactory value. Design considerations are discussed in the text.

Here again it is much more adaptable than the r.f. ammeter. The simplest method is to switch in additional resistance at R_3 , a process that can be continued up to the point where the inverse peak voltage rating of the rectifier is approached. Since R_3 carries only d.c., the r.f. part of the circuit is not affected and any convenient type of switch can be used for the purpose. The maximum resistance that should be used is about 50,000 ohms. The scale factor does not increase directly with the amount of resistance added, somewhat more than 20,000 ohms at R_3 being required for doubling the full-scale range, for example. This is of no great importance for comparative measurements, since the object is primarily to prevent sending the milliammeter off scale.

With 50,000 ohms at R_3 the meter can measure peak voltages up to about 600, which will take care of most coaxial line installations if the line is flat. If there is any doubt about the s.w.r. it would be better to halve the ratio of R_2 to R_1 , keeping R_2 at 680 ohms and increasing R_1 to about 15,000 ohms. The larger resistance at R_1 also is advisable for 'phone, since the peak voltages are doubled with modulation. In this connection, a rectifier-type meter reads average instead of r.m.s. values, so its reading should not change with modulation. In fact, a change in the reading when the transmitter is modulated means that the transmitter is not operating linearly; in

other words, the voltmeter is also a carrier-shift indicator. (This assumes, of course, that ordinary constant-carrier modulation is being used; the meter will kick upward with a controlled-carrier system.)

Balanced Circuits

The lower circuit in Fig. 1 is used with balanced transmission lines. The voltmeter has a definite advantage over ammeters here. For one thing, only one instrument is required. More important, the circuit shown will prevent parallel voltages on the line from operating the meter, a condition that cannot easily be overcome when ammeters are used. The only r.f. voltage acting on the crystal is that developed across R_2 , which is proportional to the voltage difference across the line. Parallel components, assuming the line to be reasonably well balanced to ground, are in phase in the line wires and cannot develop a voltage across R_2 . They could act between each wire and ground through the crystal, but are prevented from doing so by the r.f. chokes. Thus the meter reads only the actual voltage applied to the line by the transmitter.

The same considerations hold in this circuit with respect to the values of R_1 , R_2 and R_3 . R_1 and R_3 should be equal, and the total should be at least 100 times the impedance at that point on the line. A matched 300-ohm line calls for about 15,000 ohms each at R_1 and R_3 . Again using 100 watts as a reference, the peak r.f. voltage is nearly 250, so R_2 should be about $\frac{1}{25}$ of the total if R_4 is 10,000 ohms. A 560-ohm resistor would be close enough. R_4 can be increased to extend the range, as described. For 600-ohm lines R_1 and R_3 should be doubled, leaving the other values the same.

With tuned lines operating at a high s.w.r. some difficulties may arise when "voltage feed" or parallel tuning is required. The line impedance at the feed point may be several thousand ohms in such a case, meaning that R_1 and R_3 must be very high in value. The shunt capacitances of R_1 and R_3 , rather than the resistances, tend to take over the voltage-divider function in such a case, so the method of estimating the required resistance values does not work out too well. Also, for a given resistor combination, the meter reading at a fixed value of voltage will increase as the frequency is raised. It is possible that a capacity divider would be a better solution if the voltmeter is to be used across an impedance of more than a few hundred ohms.

However, there is an even simpler solution for tuned lines. Since there has to be tuning apparatus, the best plan is to use a coax-coupled antenna tuner and measure the voltage across the coax line where it goes into the tuner. When the coax line is properly matched, voltmeter indications at this point mean every bit as much as across the open-wire line itself. The photograph shows such an antenna coupler.

Resistor Ratings

In the grounded circuit, Fig. 1A, substantially all the r.f. power used by the voltmeter is dissi-

pated in R_1 . Assuming that the resistance is 100 times the impedance of the line at the point where the voltmeter is connected, R_1 should have a rating of 1 watt for each 100 watts of r.f. in the line. The necessary dissipation rating can be built up by using identical 1- or 2-watt carbon resistors in series or parallel to make up the required resistance. Although the power output of the transmitter increases with modulation it is probably not too important to make provision for this increase since modulation is intermittent. In any event, increasing the dissipation capacity by 50 per cent will take care of 100 per cent modulation with an adequate safety factor.

In the balanced circuit, Fig. 1B, R_1 and R_3 dissipate the power equally. If the resistors are of identical dissipation rating, the total power that can be handled is 100 times the sum of their ratings. The voltmeter shown in the photograph, for example, is good for 200 watts of r.f., with a matched line, since R_1 and R_3 are 1-watt units.

TVI

Any rectifier will generate harmonics, and it could happen that a voltmeter of the type discussed will be responsible for TVI. The large resistors in series with the r.f. path to the transmission line will help suppress harmonics generated in the rectifier circuit, but on a few occasions, using the antenna coupler shown in the photograph with a dummy load, we have been able to observe faint interference (with a weak TV signal) that disappeared when the d.c. circuit of the voltmeter was opened. So far no effect has been noticed with the same coupler on an actual antenna system, but in a different installation it is possible that TVI might occur.

It is well to keep the possibility in mind. A switch in series with the milliammeter, to break the d.c. path, is all that is necessary to take the rectifier out of operation.

Calibration

Calibration of an r.f. voltmeter is entirely feasible if an r.f. ammeter is available and the power output of the transmitter can be varied over a fairly wide range. Calibration is not needed for the ordinary run of transmitter adjustments since comparative readings are entirely adequate. The principal purpose of calibration is for measuring power output, but it is hardly worth attempting this unless the impedance at the point of measurement is known definitely. For practical purposes, this limits the measurement of power to coaxial systems in which the s.w.r. has been reduced to 1 to 1 by means of a bridge.

To calibrate, the line must first be made flat. Then the r.f. ammeter is inserted in the input lead to the line and voltmeter, taking care to keep the leads short and to keep the ammeter capacitance to ground low. The transmitter power output is then varied, noting the voltmeter readings corresponding to a number of current readings. Knowing the impedance and the current, the power and the r.m.s. voltage can be calculated from Ohm's Law. This also serves as a check on

the linearity of the voltmeter. It is convenient to adjust R_3 , Fig. 1A, so that 1 milliampere d.c. represents, say, 100 volts r.m.s. Then the meter reading at any level is simply multiplied by 100 to give the r.m.s. voltage across the line. The scale can be increased by switching in additional resistance to give any multiplying factor desired, within the voltage limitations mentioned earlier. Beyond determining one point, recalibration on such additional scales is not necessary if the voltmeter is reasonably linear.

The accuracy of measurement with an r.f. voltmeter depends principally on the accuracy of calibration, which in turn depends on the accuracy of the r.f. ammeter used as a standard and the precise value of the load resistance used in calibrating. There is also a frequency error which, in the case of a voltmeter for coaxial circuits using the values suggested earlier, is negligible up to 30 Mc. providing the resistors in the r.f. voltage divider are mounted with very short leads and are kept clear of the chassis and other components. Care also should be taken to prevent r.f. pick-up in the loop formed by R_2 , the crystal, and C_1 , Fig. 1A. This can be checked by disconnecting R_1 , when the meter should show no indication with full power going through the transmission line.

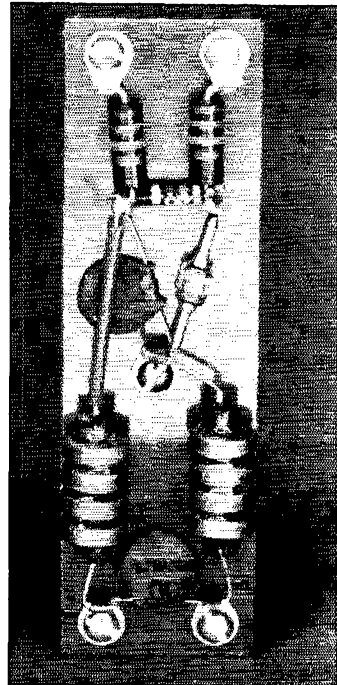

Voltmeter assembly for a balanced circuit. Except for R_4 and the milliammeter, all the parts shown in the lower circuit of Fig. 1 are mounted on a piece of thin bakelite, and arranged so that when the bakelite base is mounted with its flat side at right angles to the direction of the transmission line the coupling between the line and voltmeter circuit will be minimum. The leads to R_4 and the meter may be any length since they carry only a very small direct current.

Are You U.L. Approved?

A Review of Underwriters' Rules Applying to Amateur Installations

BY I. F. WOLK,* W6HPV

THE National Electrical Safety Code, Pamphlet 70, Standard of the National Board of Fire Underwriters, deals with electric wiring and apparatus. The Code was set up to protect persons and buildings from the electrical hazards arising from the use of electricity, radio, etc. Article 810 is entitled "Radio Equipment." The scope of this article, section 8101, says, "The article applies to radio and television receiving equipment and to amateur radio transmitting equipment, but not to the equipment used in carrier-current operation." Without reading further, most amateur stations comply with

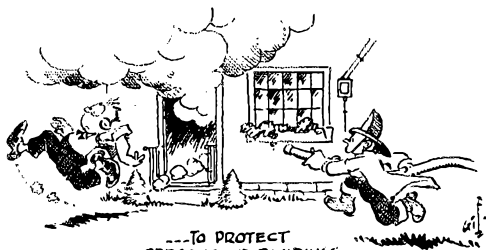

---TO PROTECT PERSONS AND BUILDINGS FROM HAZARDS

these safety rules, not because they are required to do so, but because of the inherent nature of the ham to provide great safety factors in most of his equipment. It is to the one in a hundred, where the safety factor is doubtful, that these articles will be helpful. It will be seen later that not only do these articles satisfy the Underwriters' Code but, when fulfilled, some are measures that one would take to TVI-proof his rig. So it's a matter of killing two birds with one stone.

The Board of Fire Underwriters sets up the code as a minimum standard for good practice. Most cities adopt the code, or parts of it, either entirely or with certain amendments which may apply to that particular city. It is up to the city to enforce these rules. When a violation is reported, periodic checks are made by an inspector until a correction is made and to insure against future recurrence.

Antenna Systems Sections 8111-8115

"Antenna, counter-poise and lead-in conductors shall be of hard copper, bronze, aluminum alloy, copper-clad steel, or other high-strength, corrosion-resistant material. Soft-drawn or medium-drawn copper may be used for lead-in conductors where the maximum span between points of support is less than 35 feet. Outdoor

antenna, counter-poise and lead-in shall not be attached to poles or similar structures carrying electric light or power wires or trolley wires of more than 250 volts. Insulators shall have sufficient mechanical strength to safely support the conductors.

"Outdoor antenna, counter-poise and lead-in shall not cross over electric light or power circuits and shall be kept away from all such circuits so as to avoid the possibility of accidental contact.

"Where the proximity to electric light and power service conductors of less than 250 volts cannot be avoided, the installation shall be such as to provide a clearance of at least two feet. It is recommended that antenna and counter-poise conductors be so installed as not to pass under electric-light or power conductors.

"Splices and joints in antenna and counter-poise spans shall be made with approved splicing devices or by other means as will not appreciably weaken the conductors. Soldering may ordinarily be expected to weaken the conductor; therefore, soldering should be independent of the mechanical support.

"Metal structures supporting antennas shall be permanently and effectively grounded."

Antenna Systems — Receiving Stations Sections 8121-8124

"Outdoor antenna and counter-poise conductors for receiving stations shall be of a size not less than in the following table:

Material	Minimum Size of Conductor When Maximum Span is . . .		
	Less than 35 feet	35-150 feet	Over 150 feet
Aluminum alloy, hard-drawn copper	19	14	12
Copper-clad steel, bronze or other high-strength material	20	17	14

"Lead-in conductors from outside antenna . . . shall be of such size as to have a tensile strength at least as great as that of the antenna conductors (as in the table).

"Lead-in conductors attached to buildings shall be so installed that they cannot swing closer than two feet to the conductors of circuits of over 250 volts, or less; or ten feet to the conductors of circuits of more than 250 volts. . . .



..IT IS UP TO THE CITY TO ENFORCE THESE RULES

* 2323 Vestal Ave., Los Angeles, Calif.

"If an electric supply circuit is used in lieu of an antenna, the device by which the radio receiving set is connected to the supply circuit shall be specially approved for the purpose."

**Antenna Systems — Transmitting Stations
Section 8131 - 8135**

"Antenna and counter-poise conductors for transmitting stations shall be of a size not less than given in the following table:

Material	Maximum Size of Conductors When Maximum Open Span Is . . .	
	Less than 160 feet	Over 160 feet
Hard-drawn copper	14	10
Copper clad steel, bronze or other high-strength material	14	12

Lead-in conductors shall be of a size as specified in the table, for maximum span lengths.

"Antenna and counter-poise conductors for transmitting stations attached to buildings shall be firmly mounted at least three inches clear of the surface of the building on non-absorptive insulating supports such as treated pins or brackets, equipped with insulators having not less than three-inch creepage and air gap distances. . . .

"Entrance to buildings . . . except where protected with a continuous metallic shield which is permanently and effectively grounded, lead-in conductors for transmitting stations shall enter buildings by one of the following methods:

- "a. Through a rigid, non-combustible, non-absorptive tube or bushing.
- "b. Through an opening provided for the purpose in which the entrance conductors are firmly secured so as to provide a clearance of at least two inches.
- "c. Through a drilled windowpane."

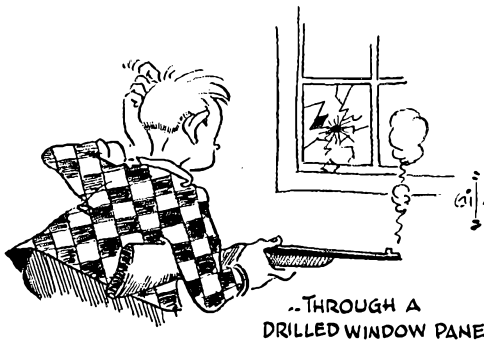

**Transmitting Stations
Section 8192**

"Transmitters shall comply with the following:

"a. Enclosing. The transmitter shall be enclosed in a metal frame or grille, or separated from the operating space by a barrier or other equivalent means, all metallic parts of which are effectively connected to ground.

"b. All external metallic handles and controls accessible to the operating personnel shall be effectually grounded. No circuit in excess of

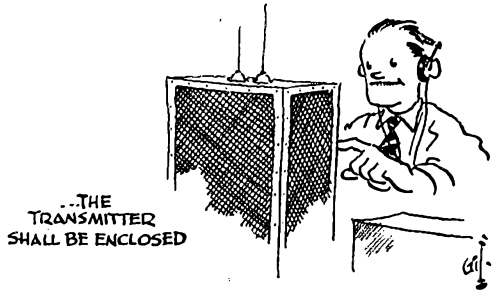

150 volts should have any parts exposed to direct contact. A complete dead-front type of switchboard is preferred.

"c. Interlocks on doors. All access doors shall be provided with interlocks which will disconnect all voltages in excess of 350 volts when any access door is opened.

"d. Audio Amplifiers. Audio amplifiers which are located outside the transmitter housing shall be suitably housed and shall be so located as to be readily accessible and adequately ventilated."

How many hams have transmitters unenclosed or without interlocks or both?

The author has purposely visited over a dozen ham shacks in the last few weeks and there are some who do not comply with various provisions. Of course, no particular station will be shut down because the antenna lead-in is No. 16 instead of No. 14, or because the speech amplifier is not totally enclosed. The National Electric Code is only a minimum standard, and compliance with its rules will assure less operating failures and hazards, and greater safety.

A copy of the pamphlet is available by writing the National Board of Fire Underwriters in your city, or at 85 John Street, New York 38, New York. Ask for pamphlet No. 70.

Other parts of the Underwriters' Code deal with power wiring and, in addition to the requirement of the use of U.L. approved materials and fittings, have the following to say of direct interest to amateurs:

"All switches shall indicate clearly whether they are open or closed.

"All (switch) handles throughout a system . . . shall have uniform open and closed positions.

". . . supply circuits shall not be designed to use the grounds normally as the sole conductor for any part of the circuit."

The latter means that wire conductor should be used for all parts of the power circuit. Dependence should not be placed on water pipes, etc., as one side of a circuit.

SWITCH
TO SAFETY!



Happenings of the Month

ELECTION NOTICE

To All Full Members of the American Radio Relay League Residing in the Central, Hudson, New England, Northwestern, Roanoke, Rocky Mountain, Southwestern and West Gulf Divisions.

An election is about to be held in each of the above-mentioned divisions to choose both a director and a vice-director for the 1953-1954 term. These elections constitute an important part of the machinery of self-government of ARRL. They provide the constitutional opportunity for members to put the direction of their association in the hands of representatives of their own choosing. The election procedures are specified in the By-Laws. A copy of the Charter and By-Laws will be mailed to any member upon request. (The By-Laws will also be found on page 56 of July, 1952, *QST*.)

Nomination is by petition, which must reach the Headquarters by noon of September 20th. Nominating petitions are hereby solicited. Ten or more Full Members of the League residing in any one of the above-named divisions may join in nominating any eligible Full Member residing in that division as a candidate for director therefrom, or as a candidate for vice-director therefrom. No person may simultaneously be a candidate for both offices; if petitions are received naming the same candidate for both offices, his nomination will be deemed for director only and his nomination for vice-director will be void. Inasmuch as all the powers of the director are transferred to the vice-director in the event of the director's resignation or death or inability to perform his duties, it is of as great importance to name a candidate for vice-director as it is for director. The following form for nomination is suggested:

Executive Committee
The American Radio Relay League
West Hartford 7, Conn.

We, the undersigned Full Members of the ARRL residing in the..... Division, hereby nominate..... of..... as a candidate for director; and we also nominate..... of..... as a candidate for vice-director; from this division for the 1953-1954 term.

(Signatures and addresses)

The signers must be Full Members in good standing. The nominee must be a Full Member and the holder of an amateur license, and must have been a member of the League for a continuous term of at least four years immediately preceding receipt by the Secretary of his petition of nomination. No person is eligible who is commercially engaged in the manufacture, sale or rental of radio appara-

tus capable of being used in radio communication, or is commercially engaged in the publication of radio literature intended in whole or in part for consumption by radio amateurs.

All such petitions must be filed at the headquarters office of the League in West Hartford, Conn., by noon EDST of the 20th day of September, 1952. There is no limit to the number of petitions that may be filed on behalf of a given candidate but no member shall append his signature to more than one petition for the office of director and one petition for the office of vice-director. To be valid, a petition must have the signature of at least ten Full Members in good standing; that is to say, ten or more Full Members must join in executing a single document; a candidate is not nominated by one petition bearing six valid signatures and another bearing four. Petitioners are urged to have an ample number of signatures, since nominators are occasionally found not to be Full Members in good standing. It is not necessary that a petition name candidates both for director and for vice-director but members are urged to interest themselves equally in the two offices.

League members are classified as Full Members and Associate Members. Only those possessing Full Membership may nominate candidates or stand as candidates; members holding Associate Membership are not eligible to either function.

Voting by ballots mailed to each Full Member will take place between October 1st and November 20th, except that if on September 20th only one eligible candidate has been nominated, he will be declared elected.

Present directors and vice-directors for these divisions are as follows: *Central:* Wesley E. Marriner, W9AND, and Charles F. Reberg, W9MVZ. *Hudson:* Joseph M. Johnston, W2SOX, and George V. Cooke, jr., W2OBU. *New England:* Percy C. Noble, W1BVR, and Frank L. Baker, W1ALP. *Northwestern:* R. Rex Roberts, W7CPY, and Karl W. Weingarten, W7BG. *Roanoke:* William H. Jacobs, W4CVQ, and Gus M. Browning, W4BPD. *Southwestern:* John R. Griggs, W6KW, and Walter R. Joos, W6EKM. *West Gulf:* A. David Middleton, W5CA, and Frank E. Fisher, W5AHT. Full Members are urged to take the initiative and to file nomination petitions immediately.

For the Board of Directors:

A. L. BUDLONG
Secretary

July 1, 1952

CHANGES IN CANADIAN REGS

In mid-July the Canadian government assigned to its amateurs the privilege of operating 'phone on the frequencies 21.2-21.45 Mc. As you will see elsewhere in this month's "Happenings," this is 50 kc. more than the request which ARRL has made to FCC for U. S. amateurs, thus following the usual pattern of Canadian 'phone suballocations extending a few kilocycles lower than U. S. assignments on each 'phone band. This suballocation is available to Canadians with "unrestricted radiotelephone privileges," a license similar to our Advanced Class.

Canada has also removed some of its mobile restrictions, dropping the requirement that mobile operation for more than one month's duration be reported to the district radio officer and doing away with the restriction that Canadian amateurs could not operate mobile in more than four months during any year.

CHANGES IN U. S. REGS

In mid-July the FCC changed its rules so as to delegate authority to Regional Managers, to the Chief of the Field Operating Division, and to the Chief of the Field Engineering and Monitoring Bureau to declare that a state of general communications emergency exists and to act on behalf of the Commission in accordance with the provisions of Section 12.156 with respect to the operation of amateur stations.

FCC has also amended section 12.21(b) to provide relief for a situation in which amateurs in military service may find themselves as a result of the contemplated discontinuance of Advanced Class licenses after the end of this year. The amended rule provides that any amateur on active duty who normally would be eligible for the Advanced Class exam by December 31, 1952, but who wouldn't be able to take the exam because of the nature of his military assignment, may take the exam prior to the date he would ordinarily become eligible. The results of his examination, however, would be held by FCC until such date as he would normally become eligible. For example, this takes care of the fellow who is going to be eligible for the Advanced Class examination in November but is being shipped off to parts unknown in September. He would be allowed to take the exam in September but FCC would not notify him until November.

A.R.R.L. FILES ON 21-MC. PROPOSAL

For the information of members, we publish herewith the text of filing by the American Radio Relay League of comment on FCC proposals in Docket 10188.

FEDERAL COMMUNICATIONS COMMISSION

In the Matter of
Amendment of Section 12.111
of Part 12, "Rules Governing
Amateur Radio Service"
to specify emissions and other
particulars of operation in
the amateur frequency band
21,000-21,450 kilocycles, and
for other reasons.

DOCKET 10188

COMMENTS OF THE AMERICAN RADIO RELAY LEAGUE, INC.

These comments are filed pursuant to Paragraph 4 of the Notice of Proposed Rule Making in Docket 10188, dated May 1, 1952.

The comments are made pursuant to the instructions of the Board of Directors of the American Radio Relay League, Inc. As the Commission is aware, the ARRL Board of Directors is composed of sixteen amateurs nominated and elected by approximately 35,000 licensed amateurs in the United States and possessions, to represent them in the formation of League policy.

I

As concerns the proposal affecting the amateur band 220-225 Mc. and the alternate band 235-240 Mc.:

As this is merely bringing the amateur rules into line with previous commitments under Part 2 of the Commission's rules, the League offers no comment.

WHAT BANDS AVAILABLE?

Below is a summary of the U. S. amateur bands on which operation is permitted as of August 1st. Readers are cautioned that a number of proposals are now pending before the FCC and that action on those proposals may change this compilation considerably. Changes will, as usual, be announced by WIAW bulletins. Figures are megacycles. AØ means an unmodulated carrier; A1 means c.w. telegraphy; A2 is m.c.w.; A3 is a.m. 'phone; A4 is facsimile; A5 is television; n.f.m. designates narrow-band frequency- or phase-modulated radiotelephony; and f.m. means frequency modulation, 'phone (including n.f.m.) or telegraphy.

3.500-4.000	— A1
3.800-4.000	— A3 and n.f.m. Advanced and Extra Class licensees only
7.000-7.300	— A1
14.000-14.350	— A1
14.200-14.300	— A3 and n.f.m.. Advanced and Extra Class licensees only
21.000-21.450	— A1
26.960-27.230	— AØ, A1, A2, A3, A4, f.m.
28.000-29.700	— A1
28.500-29.700	— A3 and n.f.m.
29.000-29.700	— f.m.
50-54	— A1, A2, A3, A4, n.f.m.
52.5-54	— f.m.
144-148 } 220-225 }	AØ, A1, A2, A3, A4, f.m.
420-450 ¹ } 1215-1300 }	AØ, A1, A2, A3, A4, A5, f.m.
2,300- 2,450 } 3,300- 3,500 } 5,650- 5,925 } 10,000-10,500 } 21,000-22,000 } All above 30,000 }	AØ, A1, A2, A3, A4, A5, f.m., pulse

¹ Peak antenna power must not exceed 50 watts.

In addition, A1 and A3 on portions of 1.800-2.000, as follows:

Area	Band, kc.	Power (watts)	
		Day	Night
Mississippi River to East Coast U.S. (except Florida and states bordering Gulf of Mexico)	1800-1825 kc.	500	200
	1875-1900 kc.		
Mississippi River to West Coast U.S. (except states bordering Gulf of Mexico)	1900-1925 kc.	*500	*200
	1975-2000 kc.		
Florida and states bordering Gulf of Mexico	1800-1825 kc.	200	No operation
	1875-1900 kc.		
Puerto Rico and Virgin Islands	1900-1925 kc.	500	50
	1975-2000 kc.		
Hawaiian Islands	1900-1925 kc.	500	200
	1975-2000 kc.		

* Except in State of Washington where daytime power limited to 200 watts and nighttime power to 50 watts.

Novice licensees may use the following frequencies, transmitters to be crystal-controlled and have a maximum power input of 75 watts.

3.700-3.750	A1
26.960-27.230	A1
145-147	A1, A3

Technician licensees are permitted all amateur privileges in the bands 220 Mc. and above.

II

As concerns the proposal to open a portion or portions of the 21,000-21,450 kc. amateur band for voice operation, A-3 emission and narrow-band frequency or phase modulation:

The League concurs with the principle of authorizing such privileges in this band, and in the proportion suggested by the Commission, but requests that the specific subband for voice operation be, instead, 21,250-21,450 kc.

A. The League's request for 21,250-21,450 kc. is derived from the premise that this band will be used by amateurs primarily for long-distance communication. Propagation conditions over most of the normal sun-spot cycle dictate that this band will have international effect. An appraisal of suballocations questions must therefore take into account the practical operating aspects of long-distance communications.

In this connection it is pertinent to note that 21-Mc. amateur suballocations in a number of other countries are in prospect, based on the expectation that American voice suballocations will, following tradition, be at the high-frequency end of the band. The International Amateur Radio Union, an affiliation of some 45 national amateur societies throughout the world, in May of 1950 held in Paris a Twenty-Fifth Anniversary Congress. Among other problems, suballocations in the 21-Mc. band were discussed at length. Because of the dominance of U. S. voice stations in any subbands to which they are assigned, amateurs throughout the rest of the world have customarily been obliged to accommodate their suballocations and practical operating activities to the basic pattern laid down by U. S. regulations. The recommendation of the IARU meeting in Paris, subsequently concurred in by vote of the Union membership, was based on the assumption that the U.S.A. would traditionally make voice assignments in the high-frequency portion of the band. It also took into account the established practice of amateurs in nations other than the U.S.A. conducting their voice operations in that portion of the amateur band immediately adjacent to whatever frequencies are made available in the U.S.A. for voice operation. The recommendation was that the practical use of the band be as follows:

- 21,000-21,150 kc. — world-wide c.w.
- 21,150-21,250 kc. — world-wide voice,
except U.S.A.
- 21,250-21,450 kc. — voice, U.S.A.

The League is informed that the Canadian Government in mid-July, 1952, presumably upon the basis of the recommendation of the IARU and in consideration of the practical use of the band, provided for a suballocation for voice operation of 21,200 kc. to 21,450 kc.

The maximum effective use of the band by the amateur service requires reasonable uniformity on a world-wide basis. It is largely for this reason that the League requests that 21,250-21,450 kc. be made available for voice operation by U.S. amateurs.

B. On frequencies in the order of 21-Mc. amateurs customarily use multielement parasitic antenna arrays for maximum efficiency in point-to-point communication. It is well established that such directional antenna arrays, properly tuned and adjusted, work effectively only over a very narrow band of frequencies. It would be very difficult to obtain peak performance over the entire 450 kc. amateur band with such a directive antenna array. Therefore the amateur wishing to use voice in this band, under the suballocation proposed by the Commission, would face the choice of tuning his directional antenna to the center of the 450-kc. band and then operating it with considerably reduced efficiency in the band ends, or of tuning his directional antenna to the center of one of the segments proposed for voice and in effect denying himself the practical use of the other segment. On the other hand, a continuous band of 200 kc. as proposed by the League permits reasonably effective employment of a single directional parasitic array to cover the entire subband.

C. It may be argued in behalf of the proposal of the Commission that placing voice assignments at each end of the 21-Mc. amateur band will lessen the potentiality of interference to television receivers utilizing an intermediate-frequency in the 21-Mc. region. In the League's view, this

argument has little validity. Although it is true that several prominent manufacturers chose 21.25 Mc. as the sound i. f. channel for their receivers, the former industry standard permitted a choice anywhere in the range of 21.25 to 21.9 Mc., and a considerable number of models employ intermediate frequency channels higher than 21.25 Mc. Furthermore, in practice the actual operating intermediate frequencies in a production run of television receivers, particularly after installation and a settling-down period, would certainly vary over a considerable number of kilocycles, so that it is improbable any substantial portion of interference would be avoided by shifting the voice subbands anywhere within the 21,000-21,450 kc. range. Moreover, the potential interference to television receivers in this band is primarily the result of inadequacies in receiver design and construction, and the amateur service should in no wise be penalized by suballocations predicated on a condition for which the amateur service is not responsible and for which remedies are easily available from commercial agencies over which the amateur service has no control.

D. It may be argued on behalf of the proposal of the Commission that placing voice assignments at each end of the 21-Mc. amateur band will permit a more equitable distribution of the utility of voice and c.w. amateur assignments at times when the vagaries of the sunspot cycle place the maximum usable frequency in the 21-Mc. range. This reasoning is somewhat more applicable at the more-often-marginal frequencies of the order of 28 Mc., but has comparatively little application at 21 Mc. In practice, for the most part the 21-Mc. band throughout its width would either be "open" or not open for desired communication distances. The maximum usable frequency does not settle down for long periods in the middle of the 21,000-21,450 kc. range, as it does often in the larger and more marginal range 28,000-29,700 kc.

III

As concerns the proposal to authorize Novice operation in the subband 21.15-21.3 Mc.:

The League does not believe it wise to take such action and requests that no assignment for Novices be made in this band.

In the present sunspot minimum, propagation conditions in the 21-Mc. band provide only limited usefulness for long-distance communication, the use of these frequencies otherwise being limited to immediately local contacts. With such restrictions on the range of communication, there is no useful opportunity to beginning Novices to further their radio operating training, as there is on the lower frequency bands of medium distance range.

Moreover, and of greater importance, with the progression of the sunspot cycle these frequencies are of such order that they will shortly become primarily useful for international work over a considerable portion of the day. It is to be expected that as a result, occupancy will be extremely heavy, worldwide. Because of the nature of amateur long-distance communication procedures, this can only result in considerable competitive congestion. Under such conditions the Novice would find it difficult, if not impossible, to establish contacts and accomplish the training objectives inherent in his class of license.

There is also the factor of harmonic interference to television reception. As apprentices, Novices are admittedly not so capable as the permanent amateur in technical matters. As the 3rd and 4th harmonics of 21 Mc. fall in the center of v.h.f. TV channels, there is a potential interference problem.

The same reasoning which prompted the Commission in 1949 to omit 14 and 28 Mc. from consideration for Novice privileges seems still applicable. It should also be noted that in Docket 10073 additional Novice privileges in a more logical band, 7 Mc., are under consideration by the Commission, and have League endorsement.

The League therefore requests the deletion of proposed privileges for Novices in the 21-Mc. amateur band. At the same time the League requests the continuance of present privileges in 26.96-27.23 Mc., a band of much less potential occupancy where Novices can and do engage in successful communication. It should here be noted, also, that the television interference factor is by no means identical to that at 21 Mc., inasmuch as harmonics of 26.96-27.23 Mc. fall — or can be made to fall — at the edges of v.h.f. TV channels rather than near their centers.

IV

As concerns the proposal to open 21.10-21.36 Mc. for F-1 emission:

For the reasons enumerated in our contemporary filing in Docket 10073, and which to save space will not be repeated here, the League does not believe it wise to take such action, and therefore requests withdrawal of the proposal.

THE AMERICAN RADIO RELAY LEAGUE, INC.

By:

PAUL M. SEGAL
Its General Counsel

A. L. BUDLONG, Secretary
July 24, 1952

F.C.C. PROPOSALS

The following release from FCC is discussed on our editorial page.

FEDERAL COMMUNICATIONS COMMISSION
Washington 25, D. C. 77446
FCC 52-753

In the Matter of }
Amendment of Part 12 of the }
Commission's Rules and Regula- }
tions to designate specific ama- }
teur calling, answering and }
emergency communications fre- }
quency bands. }
DOCKET NO. 10237

NOTICE OF PROPOSED RULE MAKING

- Notice is hereby given of proposed rule making in the above-entitled matter.
- The Commission proposes to amend Part 12, Rules Governing Amateur Radio Service, to provide:
 - Specific frequency bands, within the regularly allocated amateur frequency bands, to be used only for calling and answering by amateur stations, except in the case of a communications emergency when they may be used for actual emergency traffic.
 - Specific frequency bands, within the regularly allocated amateur frequency bands, to be cleared of all normal amateur operation in any given area whenever the Commission determines that a state of communications emergency exists in that area.
 - Procedure for the expeditious declaration of a state of communications emergency in any area, whenever the Commission has determined that a state of communications emergency actually exists in that area, and the clearing of normal amateur operation in that area from the designated amateur emergency communications bands as well as any other amateur frequency bands or segments of such bands which appear to be essential for emergency communications purposes.
- The proposed amendments, which are set forth in full in an appendix hereto, are issued under the authority of Sections 4(i) and 303(c) and (r) of the Communications Act of 1934, as amended.
- Any interested party who is of the opinion that the proposed amendments should not be adopted or should not be adopted in the manner proposed herein may file with the Commission on or before September 19, 1952, a statement or brief setting forth his comments. At the same time persons favoring the amendment as proposed may file statements in support thereof. Comments or briefs in reply to

ARE YOU LICENSED?

• When joining the League or renewing your membership, it is important that you show whether you have an amateur license, either station or operator. Please state your call and/or the class of operator license held, that we may verify your classification.

the original comments or briefs may be filed within fifteen days from the last day for filing the said original comments or briefs. The Commission will consider all such comments, briefs, and statements before taking final action. If any comments are received which appear to warrant the Commission in holding an oral argument before final action is taken, notice of the time and place of such oral argument will be given such interested parties.

5. In accordance with the provisions of Section 1.764 of the Commission's Rules, an original and four copies of all statements, briefs or comments shall be furnished the Commission.

FEDERAL COMMUNICATIONS COMMISSION
T. J. SLOWIE
Secretary

Adopted: July 23, 1952
Released: July 29, 1952

APPENDIX

PART 12, RULES GOVERNING AMATEUR RADIO SERVICE, IS PROPOSED TO BE AMENDED IN THE FOLLOWING PARTICULARS:

1. ADD NEW SECTION 12.112 TO READ AS FOLLOWS:
§ 12.112 *Exclusive calling and answering frequencies.* (a) Subject to the limitations and restrictions set forth in this section and in § 12.111 and 12.114, the following segments of the authorized amateur frequency bands shall be reserved for initial calling and answering for the purpose of establishing communications, or for actual emergency message traffic only, and shall not be available for use by amateur stations when transmitting for other authorized purposes except as may be specifically authorized under the provisions of § 12.156:

Authorized Amateur Frequency Bands	Calling and Answering Band Segments
1800-2000 kc	1800-1807 kc 1993-2000 kc
3500-4000 kc	3500-3510 kc 3990-4000 kc
7000-7300 kc	7095-7105 kc 7290-7300 kc
14000-14350 kc	14040-14050 kc 14220-14230 kc
28.0-29.7 Mc	29.63-29.65 Mc
50.0-54.0 Mc	50.35-50.37 Mc
144-148 Mc	145.17-145.19 Mc
220-225 Mc	220.0-220.5 Mc

(b) The following restrictions shall be observed by all stations operating in the segments of the amateur frequency bands specified in paragraph (a) of this section, when making initial calls or answering such calls for the purpose of establishing communications:

(1) An initial call, or an answer to an initial call, shall consist of the call sign of the station being called, transmitted not more than four times, the necessary operating procedure signals or words, and the call sign of the station calling transmitted not more than four times. Such initial call or answer to an initial call shall not be repeated for a period of at least five minutes. An initial call may include a general call, including directional, geographical or special indicators if desired, in lieu of the call sign of a specific station being called. When transmitted by telephony, an initial call or an answer to an initial call may include the use of phonetic spelling of the call sign(s) of the station(s) involved.

(2) When communication is established by means of an initial call and an answer to an initial call, further transmissions by the stations involved, in the specified calling and answering band segments, shall be limited to those necessary to determine the frequency or frequencies on which further communication is to be carried on outside those band segments.

(c) The calling and answering frequency band segments specified in paragraph (a) of this section shall not be utilized for the purpose of establishing communication by means other than telegraphy using the International Morse Code, or radiotelephony where authorized, nor shall they be utilized for communications consisting solely of an exchange of signal strength reports or similar information when further communication on other frequencies between

(Continued on page 128)

The "Ultimate" C.W. Receiver

Super-Selectivity with Simplified Construction and Surplus Components

BY ROBERT R. PITTMAN AND GERALD SUMMERS,* W5FKQ

DURING the past few years several articles have been published that describe "super-selective" devices for c.w. use.¹ The selective devices described previously have varied considerably in design, but have fallen into two general classes: audio filters tacked on at the tail end of a standard communications receiver, and i.f. amplifiers of high selectivity usually tacked on at the end of the standard i.f. channel of a communications receiver. Such devices are invaluable aids when a single station is to be picked out of a number of *equally strong* signals near the same frequency. If, however, a weak DX signal is to be extracted from a mass of W QRM, the situation will be different. Let's be more specific — suppose we have located a 5-microvolt DX signal (S8 on the DX scale) and just as he comes back to us, W9 so-and-so calls "CQ DX" 300 cycles up the band. It so happens that the W9 has a signal of 5 millivolts (S8 local scale). If our i.f. gain is set to read the DX signal, we will have approximately 1 volt at the detector. In ordinary receivers the signal level of the W9 would then be 1000 volts at the detector unless our amplifiers overloaded. Overloading would certainly occur, and we would have our receiver turned off, or blocked, every time the W9 pressed his key. A situation of this type is most distressing, and no degree of filtering at the end of the receiver gain path will do the least bit of good. The solution is to reject the unwanted signal before it is large enough to overdrive any stage (a level of about 1 volt r.m.s. with most pentode amplifiers).

To do this job satisfactorily calls for a complete

* 1447 Fleming Ave., Dallas 16, Texas.

¹ For example: Githens, "The Super-Selective C.W. Receiver," *QST*, August, 1948; Bennett, "Audio Filters for Eliminating QRM," *QST*, July, 1949; Goodman, "A Sharp I.F. Amplifier for 'Phone or C.W.," *QST*, Dec., 1950; Kaye and Kaye, "One Db. Per Cycle," *QST*, Nov., 1951.

receiver design that performs the following essential functions: (1) Channels the signals through very narrow filters with the best possible skirt selectivity consistent with reasonable design considerations. (2) Maintains the signals at a low level until they are operated upon by the above-mentioned filters. This has been done in the receiver to be described, with most gratifying results. From the standpoint of eliminating QRM, it is by far the best receiver we have ever seen or heard.

Before proceeding to the technical details of the receiver, let us clarify one point. Though we believe our receiver to be the best yet built with regard to performance, we do not believe we have yet approached the simplest or the most economical design. By way of illustration, we realize that other coupling schemes would eliminate several of the i.f. tubes. A limited time was available for reducing the number of parts used. We'll leave such worries to hams with smaller junk boxes.

Now that a little groundwork has been laid, let us consider the details from r.f. through to audio.

The R.F. Stage

Many hams of today avoid receiver construction because they are afraid of the r.f. tracking problems. Since our ham bands are so narrow, it is possible, by using a high i.f. for image rejection, to make all tuned circuits in the r.f. stages broad enough to require no tuning over a band, thus averting tracking difficulties and their attendant complications of construction. Remembering that we want to keep the gain as low as possible until we get into the highly selective circuits, we conclude that the r.f. stage will serve only to raise antenna noise level above mixer noise level, so that the weakest possible signals may be received.

◆

This super-selective c.w. receiver doesn't present a formidable maze of controls because they have been reduced to the bare essentials for superlative c.w. reception. The main tuning control is at the left.

◆

QST for

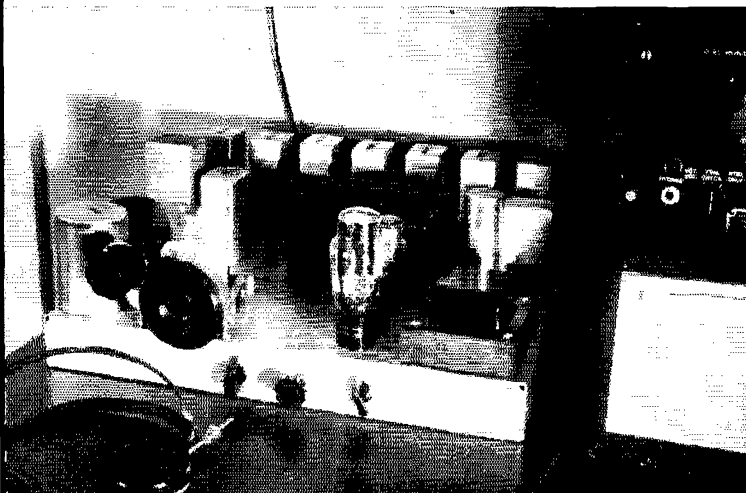

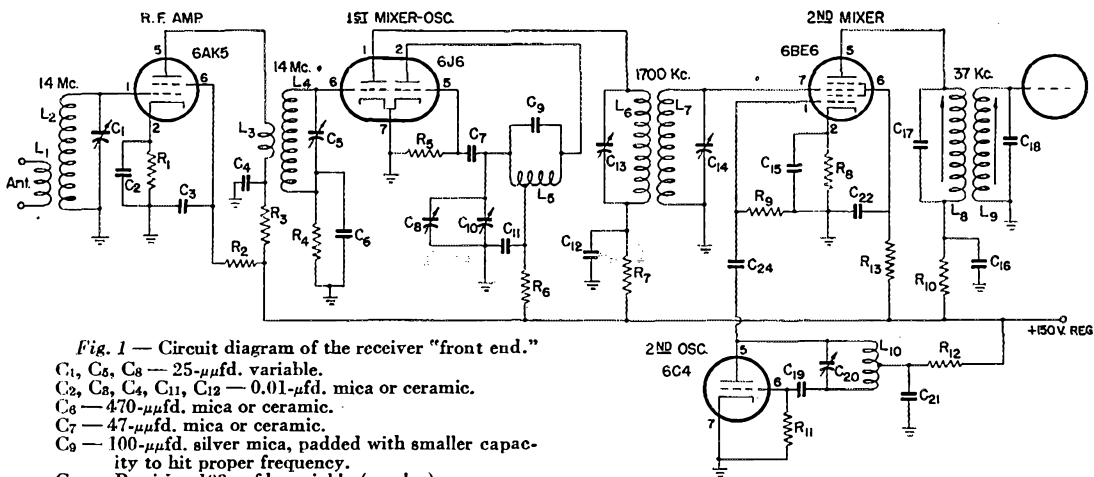

Fig. 1 — Circuit diagram of the receiver "front end."

- C₁, C₅, C₈ — 25- μ fd. variable.
- C₂, C₃, C₄, C₁₁, C₁₂ — 0.01- μ fd. mica or ceramic.
- C₆ — 470- μ fd. mica or ceramic.
- C₇ — 47- μ fd. mica or ceramic.
- C₉ — 100- μ fd. silver mica, padded with smaller capacity to hit proper frequency.
- C₁₀ — Precision 100- μ fd. variable (surplus).
- C₁₃, C₁₆, C₂₁ — 0.1- μ fd. paper.
- C₁₃, C₁₄ — Part of 1600-kc. i.f. transformer.
- C₁₇, C₁₈, C₂₂ — 0.01- μ fd. mica.
- C₁₉ — 100- μ fd. silver mica.
- C₂₀ — Part of 1600-kc. h.f.o. transformer.
- C₂₄ — 5- μ fd. ceramic.
- R₁ — 150 ohms.
- R₂, R₃, R₈ — 270 ohms.
- R₄ — 2.2 megohms.
- R₅, R₁₁, R₁₃ — 47,000 ohms.
- R₆ — 4700 ohms.
- R₇, R₁₀ — 1000 ohms.
- R₉ — 5600 ohms.
- R₁₂ — 18,000 ohms. (NOTE: All resistors $\frac{1}{2}$ watt.)
- L₁, L₃ — 6 turns No. 20 enam. close-wound.
- L₂, L₄ — 8 turns No. 20 enam. on $1\frac{1}{4}$ -inch plug-in form (Amphenol 24-4P), spaced to occupy $1\frac{1}{4}$ inches.
- L₅ — 7 turns No. 20 enam., tapped at third turn, wound on $1\frac{1}{4}$ -inch diam. form (Amphenol 24-5P).
- L₆, L₇ — Coils of good 1600-kc. i.f. transformer (Millen 64161 or equivalent).
- L₈, L₉ — Coils of 37-kc. i.f. transformer. (See text.)
- L₁₀ — 1600-kc. h.f.o. (Millen 63163 or equivalent).

The practical way to design the r.f. coils is to wind them to resonate at the desired ham band with as low *C* as is practical. Make the r.f. and mixer coils identical and as high-*Q* as feasible. Then, when the receiver is completed, load the r.f. and mixer tuned circuits with identical resistors until the receiver gain is down not more than 30 per cent at the high and low ends of the band, with the tuned circuits resonated at the center of the band. If a more scientific approach is desired, a little research in the literature will reveal much on broadband amplifier design.

First and Second Mixer Stages

The diagram of the front end of the receiver is shown in Fig. 1. The first mixer following the 6AK5 r.f. stage is a low-noise triode stage. It also is a low-gain stage, so the r.f. stage gain is actually used to override the noise of the second mixer instead of the first. A 1- μ v. signal at the antenna is amplified to about 50 μ v. at 1700 kc. by the time it reaches the grid of the 6BE6 second mixer, and is only about 200 μ v. at the plate of the 6BE6. The i.f. out of the 6BE6 is 37.4 kc., so there are two image frequencies to be considered in this receiver: one 3400 kc. (2×1700)

removed from the signal frequency, and one 74.8 kc. (2×37.4) from the signal frequency. The rejection of the first image is determined by the selectivity of the r.f. and mixer tuned circuits, and is of the order of 80 db. with the high first i.f. that is used. The rejection of the second image is determined by the selectivity of the 1700-kc. i.f. transformer and is of the order of 50 db. This is a little low and should be improved by using at least one more tuned circuit at 1.7 Mc.

The h.f. oscillator is the only critical part of the receiver — it must be stable. Use of the same circuit principles as in your VFO will give best results. A high quality tuning condenser is required as well as a good reduction drive and dial, since the 20-meter c.w. band, for example, is to be divided into 1000 channels. To be sure, just covering the band will require some time, but your coverage will be complete for the first time in your DX career.

It is well to explain here why a separate oscillator tube is used with the second mixer — it

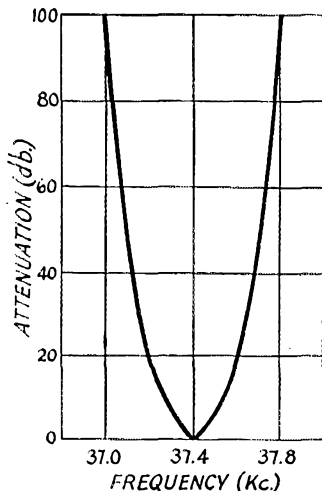

Fig. 2 — Selectivity characteristic of the 37-kc. i.f. amplifier.

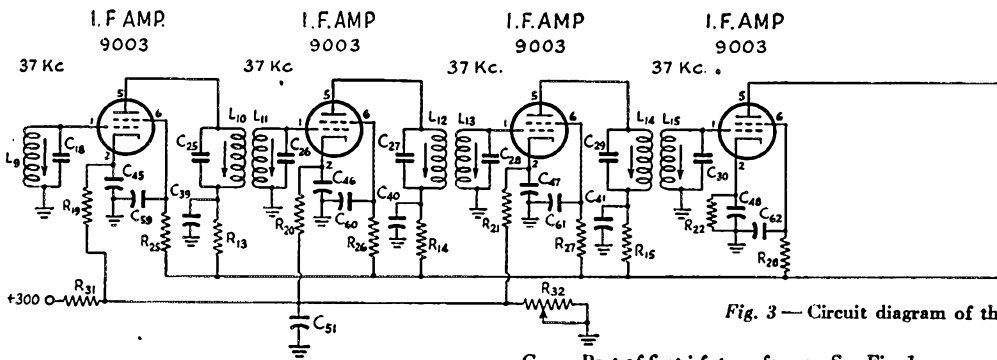

Fig. 3 — Circuit diagram of the

was found that using the 6BE6 as a converter with the 37.4-kc. difference frequency caused the signal grid to be overdriven. This lowered the *Q* of the 1.7-Mc. i.f. transformer and gave extremely low conversion gain. More lengthy research effort might well have allowed use of one tube instead of two.

The 37-Kc. I.F. Amplifier

Much thought went into the design of the i.f. amplifier around circuit components that were available. It was reasoned that a receiver of 40-cycle bandwidth would receive the fastest c.w. encountered in ham operating. It was further concluded that with the questionable frequency stability of ham signals and with the poor notes frequently heard, it would be wise to allow a little safety margin and design a receiver of about 100 cycles bandwidth. This has proven to be a wise decision for, though the receiver is very much easier to tune than a crystal filter receiver, we feel that we have "gone about as far as they can go."

Any receiver of this type must be built around available parts for, unfortunately, the manufacturers of core materials do not deal with individuals. Hams with fortunate company connections may get the "cup cores" from Stackpole, Lenkurt, General Aniline and Film Corp., and others in the business. It so happens, however, that the AN/ARN-7 radio compasses,² once avail-

- C₁₈ — Part of first i.f. transformer. See Fig. 1.
- C₂₅-C₃₇ — 0.01- μ fd. mica.
- C₃₈ — 0.0047- μ fd. mica or ceramic.
- C₃₉-C₄₀, C₅₅-C₆₄ — 0.1- μ fd. paper.
- C₅₁, C₅₆ — 10- μ fd. 50-volt electrolytic.
- C₅₂ — 27- μ fd. mica.
- C₅₃, C₅₄, C₅₅ — 0.001- μ fd. ceramic.
- C₅₇ — 0.002- μ fd. mica.
- R₁₃-R₁₈ — 4700 ohms, $\frac{1}{2}$ watt.

able by the thousands on the surplus market and still offered at a price of \$17.50, include all the coil forms you need. These coil forms are actually better than factory-purchased core materials, since the twenty-odd included in a single receiver are mounted in convenient bakelite holders. A breakdown of one of the forms is shown in the photograph, along with a simple winding jig (mounted in chuck of coil winder) we made from Micarta to hold the little cardboard form from which the old coil was removed and on which the new one is scramble-wound. With 720 turns of No. 35 enameled wire, a *Q* of 95 was obtained at the i.f. Melt a little ceresin wax on each layer or so in order that the wire will not "birdcage" when the jig is removed. The jig ends should be counterbored slightly so that the wire does not go clear to the edge of the form. The coils can be wound with a "egg beater" drill, but a counter is a virtual necessity. There is no magic about the frequency — 37.4 kc. happens to be the only frequency at which all fourteen i.f. circuits would peak with 0.01- μ fd condensers of standard tolerance. It is desirable to use a low-frequency second i.f. in order to obtain narrow bandwidth, while a large number of tuned circuits are necessary to give a steep skirt characteristic. At 37 kc. the *Q* of 95 is so low as not to give an audible ringing effect on signals and just a trace on thermal noise. A slight amount of unintentional regeneration will, however, lengthen the ringing time considerably.

The coils are mounted at opposite ends of Millen No. 80004 shield cans, the grid coils being tuned from the bottom and the plate coils from the top of the chassis. Each coil should be checked

² Or any other of the radio compass receivers may be used. The coils from those made by Bendix are a little better for our purposes than those from the Fairchild receivers.

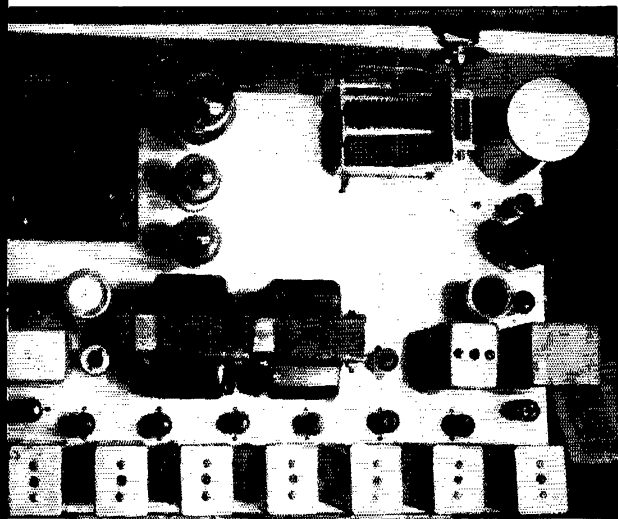

A top view of the receiver shows the precision tuning condenser used for tuning (top right) and the string of 37-kc. tuned circuits (bottom).

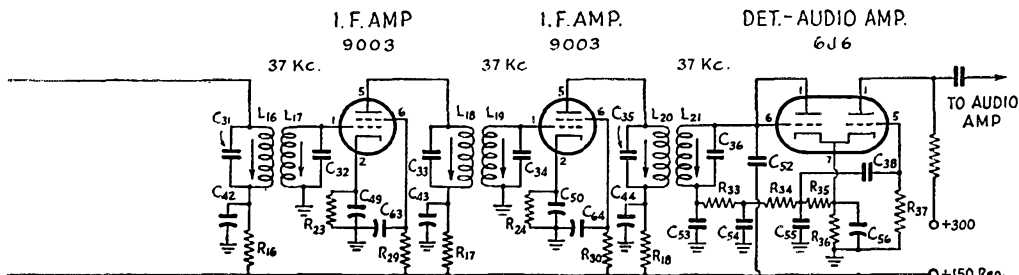

selective 37-kc. i.f. amplifier.

- R10-R24 — 330 ohms, ½ watt.
- R25-R30, R32, R34, R39 — 47,000 ohms, ½ watt.
- R31 — 10,000 ohms, 20 watts.
- R32 — 1000-ohm 3-watt w.w. potentiometer.
- R35 — 0.47 megohm, ½ watt.
- R36 — 2200 ohms, ½ watt.
- R37 — 2.2. megohms, ½ watt.
- R38 — 0.1 megohm, 1 watt.
- L10-L22 — See text.

before installation by paralleling it with a 0.01- μ fd. condenser and measuring the drop across it with a 1-megohm resistor between the circuit and an oscillator of proper frequency. (You must have a reasonable amount of test equipment to construct this receiver — a crude r.f. voltmeter and fair test oscillators are essential.)

Very loose coupling is used between the coils to maintain selectivity and to reduce gain. The gain loss per transformer is about 50, for the stray inductive field of the cup cores is relatively low. Maximum stage gain is about 8 or 9 after taking the transformer loss.

Figure 2 is a plot of the selectivity curve. This curve was obtained by the use of a beat-frequency oscillator with a cycles-increment dial.

A good view of the i.f. transformers can be had in the photograph of the receiver. They are the seven cans in line at the rear of the chassis. Fig. 3 is the wiring diagram of the selective i.f. minus its audio amplifier.

The beat-frequency oscillator was wound on a cup core for the sake of uniformity, though Q is not important here. It uses the same number of turns as the other coils (720), although a tap was made at about 20 per cent from one end.

The b.f.o. should be set for a desirable tone and that tone is about all you'll hear. You won't hear two sidebands or a zero beat, for the band is not wide enough for that. The simplicity of the tuning is beautiful — even a lid can find DX! You may want to keep your old receiver around for quick surveys of the band (we do, since we also operate 'phone), but you'll use it less and less.

Audio

The audio is conventional but need not pass frequencies below those of the beat note you choose. If you misjudge the gain of the i.f. strip, you can make up for it in the audio. Don't worry about missing anything this way — the b.f.o. action makes the third detector linear. Quiet high-gain audio is easy with poor 60- and 120-cycle response.

Conclusions

After several months' use of the above receiver we conclude that 100-cycle bandwidths with steep skirts are practical in ham radio. The slight amount of tracking necessary on occasional drifting signals we accept as a bargain price for the pleasure of relatively QRM-free operation. The low noise accepted by so small a bandwidth allows considerably better than 1- μ v. sensitivity. Having only gain and tuning controls on a communications receiver is a trend reversal, but this receiver so outperforms \$400 commercial receivers for c.w. operation that there is just no comparison — it was built for less than one-tenth that amount, although hams buying all of the parts may spend up to \$100. We believe ours to be the best DX-man's c.w. receiver ever built and have found the narrow bandwidth a limitation in so few cases that no effort at incorporating variable bandwidth is contemplated. Coil data for only the 20-meter band are given since these are the only coils wound to date. Plug-in coils are used.

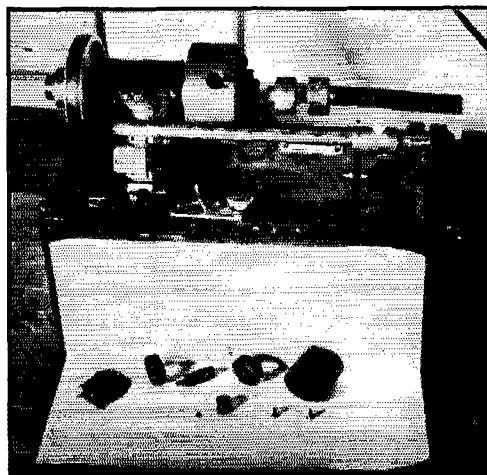

Here one tuned circuit is shown disassembled. From left to right: bakelite case, half shell, tuning slug, coil form, half shell, top of bakelite case. The homemade coil winder was built from an old Dictaphone transcriber.

What Price Precision?

The Economics of Frequency Standards In Two Parts—Part I

BY GEORGE X. M. COLLIER,* WØEG

As the title indicates, this article deals with the cost of generating precise radio frequencies. It also describes the results of experiments conducted on three types of frequency standards, and gives general details of the construction of a 100-kc. unit capable of holding frequency to better than one part in ten million.

As a starter, let's philosophize a bit and look at Webster's definition of the word "precise." It is "sharply or exactly limited, or defined as to meaning; exact, definite, not loose, vague, or equivocal." Now, while the definition standardizes the word, it does not do so with respect to any natural or man-made value, and precise, therefore, may mean most anything. That such is actually the case can be illustrated as follows:

a) In the early days of steam power, a machinist advertised the possession of a boring mill "capable of turning the cylinders of steam engines, accurate to plus or minus the thickness of a shilling"—approximately $\frac{3}{32}$ inch—which at that time was really something. However, when we consider that today's machines easily hold tolerance on the same item to a very few thousandths of an inch, it becomes apparent that what was good precision in the early 1800s is very poor precision in 1952. Precision is, to a large extent, a matter of date.

b) As a second illustration, let's assume one is building a highway. Now, while it would be entirely possible to maintain the straightness of the grade to plus or minus a foot per mile, this would probably be unnecessary because plus or minus a yard or more would, most likely, be entirely adequate. On the other hand, if one were surveying an international boundary, it is probable that a foot per mile would be relatively poor accuracy. We see, therefore, that precision is also a matter of use, and what is precise in one field is coarse in another.

c) As a third and final example, let's consider the stability of the medium composing any standard. When the English system was set up a foot, it is said, was the length of such an extremity attached to a British king, and since said king could easily lose his big toe, thus altering the length of the standard, we see that the foot was really a highly variable item. The example is of course a bit ludicrous, since the length of the good king's foot was no doubt transferred to something more stable than human flesh. It does show, however, that beyond a certain point, the medium determines the stability attained.

* 1816 Third Ave., South, Anoka, Minn.

¹ Schull, "Adjustment of High-Precision Frequency and Time Standards," *Proc. I.R.E.*, January 1950, page 6.

• An ardent exponent of precision frequency measurement for more than twenty years, the author writes with authority on the cost, problems and possibilities of constructing high-accuracy frequency standards. Part I deals with the simpler equipment, and offers suggestions that will give greatly improved precision at very little cost.

Accuracy from WWV

To show how the above examples work, let's examine WWV's transmissions.

Not too many years ago, the WWV transmissions were stated to be accurate to one part in ten million. Today, they publish an accuracy of two parts in one hundred million, a fivefold improvement. While one part in ten million was, and still is, accurate enough for most measurements, recent physical techniques demand time measurements of much greater accuracy.

Although two parts in 100 million is the published accuracy of WWV transmissions, the generated frequency is accurate to a few parts per billion, with received accuracy being reduced by instability of the ionosphere. Further, going another step back, the Naval Observatory and other observatories throughout the world now find that the speed of the earth's rotation, the primary standard, is not constant. So here we have a case where the medium through which the signal passes limits the received accuracy, and where the standard of time itself is becoming inadequate.

From the foregoing, it will be seen that WWV, the best frequency standard generally available, is capable of no better than two parts per one hundred million as received, and this only when propagation is normal and it is high noon mid-way between the receiving station and WWV.¹

Requisites for a Good Standard

When one considers that one part per hundred million is one second in over three years, it becomes apparent that holding such tolerance day in and day out develops into quite a job. Attempting to do so has provided the author with a very interesting twenty years or so of entertainment, from which the following conclusions have been reached:

- 1) That the circuit is as important as the crystal.
- 2) That, unless special components are used, temperature control of the frequency-correcting

components is as important as temperature control for the crystal.

3) That the oscillator should be operated very conservatively, and be well isolated from its load.

4) That operating voltages must be held within small limits.

5) That crystals since World War II are much better than they were before, cost less, are held much closer to frequency, and are much more readily available.

6) That the design of a standard should be approached from one or the other of two angles: use a circuit composed of as few high-quality parts as possible, and temperature control the whole thing; or, if an elaborate circuit is used, develop it in such a manner that a minimum of components affect the output frequency.

7) That any standard, to be worth its salt, should be temperature-stabilized and operated continuously.

Crystal Characteristics

Now to get at the meat of this article. As stated above, the results of experiments with several different standards will be reported. First, however, it will be well to indulge in a short discussion of the various crystal cuts used for frequency standards. The most common are the AT, BT, CT, DT, and GT, with variations of the X cut being used by some manufacturers.

Fig. 1 shows typical temperature-frequency curves for AT, DT, and GT cut plates, these being the only ones used in the experiments. AT-cut crystals, it will be observed, may have either a positive or negative coefficient. If an AT cut were removed from the mother quartz on the exact zero-temperature axis, it might possibly have a zero temperature coefficient. Practically, however, reasonable manufacturing tolerances must be set up plus or minus the zero-temperature axis, and two temperature coefficients result. AT cuts are seldom used for frequency standards below one megacycle.

DT cuts are the most common in the 100-kc. range, and Fig. 1 shows the temperature coefficient of a typical unit. Note that the crest of the parabolic curve is the point of lowest frequency-temperature change. Since it is possible to orient the DT cut, as taken from

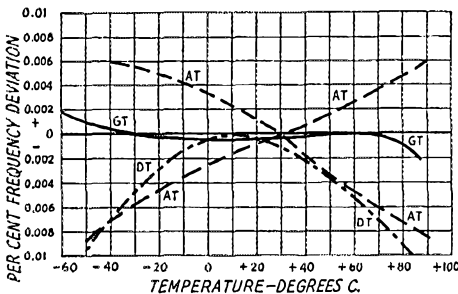

Fig. 1 — Typical frequency-temperature characteristics of three types of crystal cuts used in frequency standards.

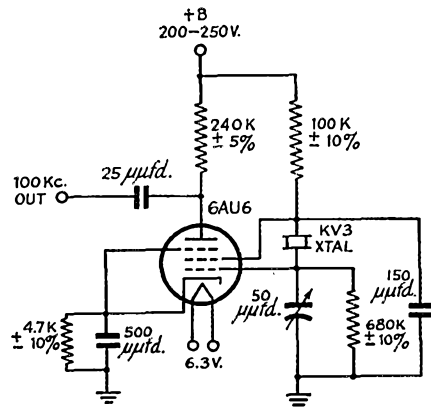

Fig. 2 — Oscillator circuit for a simple 100-kc. crystal standard.

the mother quartz, to put the crest of the parabola at most any reasonable temperature, crystals for operation at say 60 degrees C. are oriented so the crest falls at this temperature, and ground to oscillate at 100 kc. at the same time.

GT-cut crystals are the only units possessed of almost true zero-temperature coefficients. However, good ones are pretty expensive, and cheap ones are no better than good DTs — at least that has been the experience here. Fig. 1 shows a typical GT temperature curve.

Regardless of cut, all crystals age and change frequency in so doing. They never stop completely, but experience shows most of the drift to be gone after the first six months of continuous operation.

The FS135C Standard

Most of you will remember the Hammarlund type FS135C frequency standard, using a 6AU6 or 6AK5 tube in the electron-coupled Pierce circuit, shown in Fig. 2. The crystal furnished with this unit is a Bliley type KV3, 100 kc., DT cut, oriented to put the crest of the parabola at about plus ten degrees C. These standards were advertised as precision units, suitable for mounting in a receiver cabinet. Now, let's see what happens.

Two FS135Cs were purchased, and the crystals and oscillator units labeled Nos. 1 and 2. No. 2 crystal, in No. 2 oscillator, was operated for six months and produced the aging curve labeled A in Fig. 3. No. 2 crystal was then put in No. 1 oscillator, and No. 1 crystal into No. 2 oscillator. Both units were then fired up and operated for about 90 days. No. 1 crystal in No. 2 circuit gave curve B in Fig. 3. No. 2 crystal in No. 1 circuit changed very little, indicating that the crystal, not the circuit, was doing the most aging.

Two more KV3 units were then borrowed from ham friends. These were put to work in oscillators 1 and 2, and both of them drifted low so far that they could no longer be zeroed to 100 kc. Crystals Nos. 1 and 2 were then put back to work, after a 3-week layoff, and low and behold,

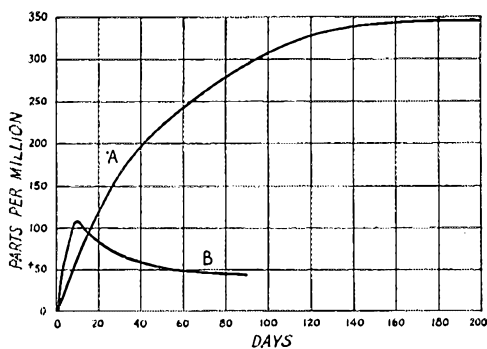

Fig. 3 — Aging curves of Type KV3 crystals in the FS135C 100-kc. oscillator. Curve A, crystal No. 2 in oscillator No. 2; curve B, crystal No. 1 in oscillator No. 2.

they had lost all their aging. No. 1 could not be set to 100 kc. (too low) and No. 2 just barely made it.

In view of the above, a half dozen FS135Cs were rounded up and all of them started off on 24-hour-per-day operation. All of these units drifted low, and beyond control of the zero setter.

A couple of brand-new Bliley KV3 units were then purchased and put to work. These were beautiful, had very low temperature coefficient and aged very little.

Correspondence with Bliley indicated that some of the KV3s furnished with the FS135Cs were of very early vintage, and unproven when Hammarlund got them. So, it's not too hard to see why the FS135Cs were declared surplus, and sold at \$6.95 each. To get a good standard, one has to buy a new rock at \$6.95 again. Those who don't are lucky. However, \$13.90 still isn't too bad for the basic unit of a pretty good standard.

With a good crystal, the frequency of the FS135C was found to vary as follows:

- 1) Short circuit output terminal to case: plus or minus 0.5 part per million.
- 2) Vary plate voltage plus or minus 20 volts: plus or minus 0.5 part per million.
- 3) Temperature rise from 20 to 40 degrees C: minus 20 parts per million but correctable with the zero setter.
- 4) Harmonic output was usable through 10 Mc., and open-circuit output was about 45 volts r.m.s.

To stabilize these units, one should:

- 1) Isolate it by installing a cathode follower between oscillator and load. A 6J5 does very well.
- 2) Operate the unit from a well-regulated power supply of 200 volts or so. The current drain is only 2 to 3 ma. for the oscillator and about 10 ma. for the 6J5.
- 3) Last, but far from least, stabilize the ambient temperature. This means get the unit out of a receiver cabinet, if that's where you now have it. Normal room temperature variations are much less than those in a receiver cabinet, and considerable gain in stability will

be realized. To stabilize the temperature further, build the whole unit, oscillator only, into a wood box about 6 inches on a side. Stand the oscillator on edge and extend the shaft for the zero setter to the front of the box. This, with no heaters or thermostats, will further increase the stability of the unit, provided it is in continuous operation, 24 hours per day, seven days per week, etc., and stability on the order of plus or minus 5 to 10 parts per million, day in and day out, is readily attainable, with short-term stability of one part in 10 million being perfectly practical.

Increased stability may be realized by temperature-controlling the inside of the box. The more stable the temperature, the better the frequency. Temperatures in excess of 40 degrees C. (104 degrees F.) should not be attempted, as it is possible to run off the end of the zero setter, and thus not be able to bring the frequency to a flat 100 kc. Stability of about plus or minus two parts per million can be realized if the temperature is held constant to plus or minus 0.1 degree C., with stability of one part per hundred million being attainable for a few minutes.

Those using the FS135C units have no doubt had difficulty with the relative coarseness of the zero setter. This can be eliminated by paralleling the zero-setting condenser with a small air variable, say 5 μ fd. maximum, driving it with a vernier dial of some sort. Then, coarse settings can be made with the regular zero setter and fine adjustments accomplished with the trimmer. This procedure is almost a necessity if close settings are to be accomplished at 15 Mc.

The FS135C, while not presently available, can be duplicated from the circuit shown in Fig. 2. Bliley type KV3 rocks are a standard item and readily available. These rigs, in my opinion, give the most precision for the least money, and can be completed, including a cathode follower, for about \$25.

The Type 90501 Standard

Standard No. 3 was Millen type 90501 consisting of the following:

- 1) An oscillator using a Bliley type MS433, 1 Mc., AT-cut crystal.
- 2) Two multivibrators, one on 100 kc. and the second arranged for operation on either 25 kc. or 10 kc.
- 3) A harmonic amplifier and tuned circuits, for utilizing the standard frequencies through 54 Mc.
- 4) A mixer-detector, to permit comparison of a transmitter directly with the standard.
- 5) A regulated power supply.
- 6) A 1000-cycle audio modulator.

This unit was used as a station standard from 1947 to 1952, at which time it was superseded by the standard described later. It was in operation for approximately 40,000 hours, and blew nothing but tubes and an electrolytic filter condenser or two. It was advertised as a precision unit, cost

(Continued on page 130)

YL NEWS and VIEWS

CONDUCTED BY
ELEANOR WILSON,* W1QON

WITH the finish of the Sixth Annual Women's Transcontinental Air Race, held July 3rd-11th, it was recognized by the women who flew the race (all members of the famed Ninety-Nines) and by the amateurs who aided them on the ground, that something new would be recorded in both the histories of aviation and amateur radio.

Last December, Marjorie Davis, East Coast chairman of the Air Race, foresaw the possibility and value of aid from amateur stations along the flight route. ARRL turned the project over to Viola Grossman, W2JZX, who organized the amateurs and made the possibility a reality.

Sixteen stops from Santa Ana, California, to Terboro, New Jersey, were scheduled. At each stop amateurs stood by to check off planes as they landed, to report arrivals to CAA, to advise of weather conditions for the next "hop" of the flight, and to relay the departure time of each plane to amateurs at the next "sit-down" point. Most of these contacts were made on 75 'phone. The entire project was a mutual success.

Fifty-six amateurs participated, and they all did a praiseworthy job, but here we are primarily concerned with the rôle played by YLs. Bouquets to W2BTB, W2EEO, W3NXU, W8ZGT, W9LRT, the XYL of W2YBT, and an especially nice one to W2JZX. Again YLs have proved their capabilities and resourcefulness.

Next year we'll look for participation by more YLs. It's something to think about -- an outstanding group of women on the ground operating in an organized network to safeguard and aid an outstanding group of women in the air!

*YL Editor, QST. Please send all contributions to W1QON's home QTH: 318 Fisher St., Walpole, Mass.

Carolyn (Carlie) Hull, W2YCX, of Boonton, New Jersey, is the first YL of whom we have heard who has passed the Extra Class exam! Carlie obtained her first amateur radio license four years ago when she was a college senior. Now a high school science teacher, her interest in science and teaching stimulates her desire to learn all she can about radio theory and to train others to become amateurs. She built her first receiver and transmitter but now uses a 32V-1 and 75A-1, mainly on 10 'phone and 10, 20 and 40 c.w. Particularly interested in circuitry, she has built various pieces of test gear. One of her several other hobbies is the collecting of cats -- but she confesses she has never built a receiver using a "cat's whisker"!

Keeping Up with the Girls

The stork prevented W1RTB from completing the July issue of the *YLRL Harmonics*, Nell's last as editor. But OM WIIPQ took over, and his reward for finishing the issue was little Laura Waterman, born June 14th. . . . Two 75-meter 'phone YL nets functioning regularly invite additional participation. Girls east of the Mississippi meet Wednesday on 3.9 Mc. at 8:00 A.M. EST; girls west of the Rockies on 3.9 Mc. at 3:00 P.M. PST on Monday. . . . W3QPQ, W3QPJ and W3NNS enjoyed the recent visit of KZ5AC and KZ5GQ, Canal Zone mother-and-daughter duo. The girls had previously QSO'd many times. . . . Recently licensed after studying code and theory at school two nights a week for six months, W1VBT, Cecile, is enjoying 40 c.w. . . . Fifteen-year-old Jane Hunt of South Carolina has had the "N" removed from her call -- she's now W4UNO. Another 15-year-old, W2KAE, Lynne, works 20 and 40 c.w. regularly. . . . W8JOK, Helen, of Delton, Michigan, and WN8JCR, Louise, of Findlay, Ohio, are two new YLs in the Eighth call area. . . . W0K0Y has her "MM" certificate. . . . VE2HI, VE3DGT and VE3DEX

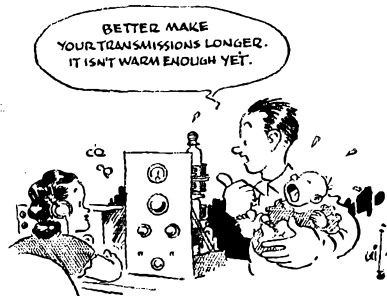

attended a four-day hamfest in North Bay. VE3DGT operated mobile and portable from her trailer while journeying to and from the affair. . . . Canadian YLRL District Chairman VE3BTE is confined to the Hamilton Mountain Sanatorium, but Rose hopes to be soon out and about. . . . YLs noted at the ARRL Pacific Division Convention at San Francisco were W6s ALL CBA FEA FKY GQZ LAD MFW PCN PCR ZTJ, WN6MWW, WN6PIR, and W7QYA. The code-speed contest was won by W7QYA (35½ w.p.m. with a stick). . . . W1s MJE QON RYJ SCS and UQA reported a fine time at the Deep Sea Drag Net picnic held at the home of the NCS, W1PU. . . . In May, seventeen YLs met in Chicago for their second annual get-together. Between discussions of W9 YL affairs, the girls enjoyed a luncheon and banquet, a radio quiz program, the 1952 Audio Fair, a visit to the shacks of W9GME, Grace, and W9DXX, Alice, plus a tour of an amateur equipment manufacturer's plant. W9s AYX BCB FZO GME KQC KXL LOY LRT MYC, WN9s QMA QYG RWV SEZ SSL and SYX declared the entire program a big success.

(Continued on page 134)



The Series Balanced Modulator

A New Circuit for Transmitters and Receivers

BY FRED M. BERRY,* WØMNN

A BALANCED modulator is used in single-sideband work (or in any other application) where it is desirable to prevent one of the modulating or heterodyning frequencies from appearing in the output and obtain only the sidebands or products of heterodyning. The "series" balanced modulator is presented because of its simplicity, good linearity, and excellent carrier suppression. In converting from audio to r.f., no iron-cored transformer is required in the audio portion, which makes it possible to keep the hum down without expensive components.

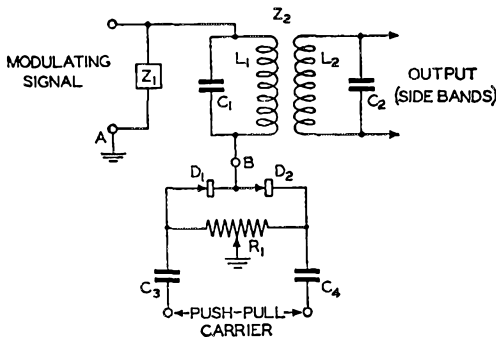

Fig. 1 — The basic series balanced-modulator circuit. L_1C_1 and L_2C_2 resonate at the output frequency, and R_1 is the carrier balance control.

The basic circuit of the series balanced modulator is shown in Fig. 1. The action of the carrier is to switch point B to ground at the carrier rate. A basic requirement of the circuit is that Z_1 (the impedance across which the modulating voltage is developed) have low impedance for the carrier frequency, and that Z_2 (the impedance across which the output is developed) have low impedance for the modulating frequency. In practice, this requirement will be met automatically by using parallel-tuned circuits at Z_1 and Z_2 .

Z_1 and Z_2 should be approximately the same impedance, but exact equality is not necessary unless a very minimum of loss is demanded. Im-

pedance ranges between 500 and 50,000 ohms have been used — the optimum impedance depends upon the carrier power and the bias built up across R_1 and C_2 and C_3 .

Since the diode resistances appear in series as the carrier keys the diodes, the diode resistance must be low for low-loss operation and to prevent mismatch in filter input and output impedances.

Practical Circuits

The series balanced-modulator circuit has been used in a number of different applications throughout a s.s.b. transmitter. Its use in the audio modulator ahead of the sideband filter is shown in Fig. 2. The 6C4 cathode follower eliminates the need for any step-down transformer, and C_2 offers a low-impedance return to ground for the carrier. The coupling coil, L_1 or L_2 , should be sufficient to develop about 6 volts across R_3 . The alternative connection for the coupling coil eliminates R_3 , C_3 , and C_4 and uses R_4 for the balance control. Some improvement in linearity is obtained with this connection, but it requires more oscillator power to develop the proper voltage at the diodes.

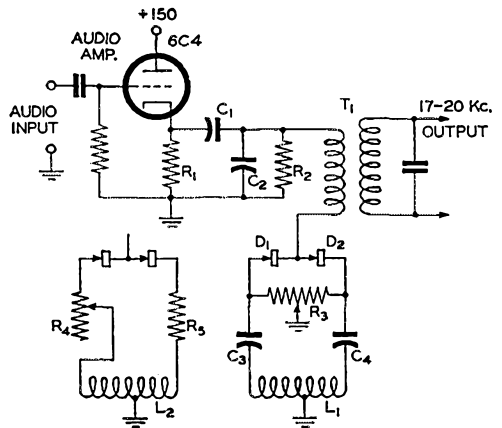

Fig. 2 — The series balanced-modulator circuit for generating double sidebands and suppressed carrier. An alternative oscillator connection is shown at the lower left.

C_1, C_3, C_4 — 0.5 μ fd. 200-volt paper.

C_2 — 0.05 μ fd.

R_1 — 1500 ohms.

R_2 — 2200 ohms.

R_3 — 3000-ohm potentiometer.

R_4 — 200-ohm variable.

R_5 — 100 ohms.

L_1, L_2 — Coupling coil on oscillator coil.

D_1, D_2 — 6AL5, 1N34 or copper-oxide rectifier.

T_1 — 500-ohm-to-sideband-filter coupling transformer (toroid core).

* 1200 East 49th Street, Kansas City, Mo.

• Readers of the *Proceedings of the I.R.E.* will notice a similarity between the series modulator of WØMNN and that described by Mr. A. E. Kerwien in the July, 1952, *Proceedings*. Before any reader accuses WØMNN of larceny, we hasten to point out that he first showed us the circuit in March, 1952, and had been using it for some two years before that.

Fig. 3—The series balanced modulator for heterodyning a 450-kc. s.s.b. signal to the 75-meter band with VFO control.

- C_1, C_4, C_6 — 120 μfd .
- C_2 — 200 μfd .
- C_3 — 300 μfd .
- C_5 — 15 μfd .
- C_7, C_9 — 0.001 μfd .
- C_8 — 45- μfd . variable trimmer.
- C_{10}, C_{11}, C_{12} — 0.01 μfd .
- R_1 — 30,000-ohm potentiometer.
- R_2, R_5 — 0.1 megohm.
- R_3, R_4 — 10,000 ohms.
- L_1, L_2, L_3, L_4 — Slug-tuned coils to resonate as shown.

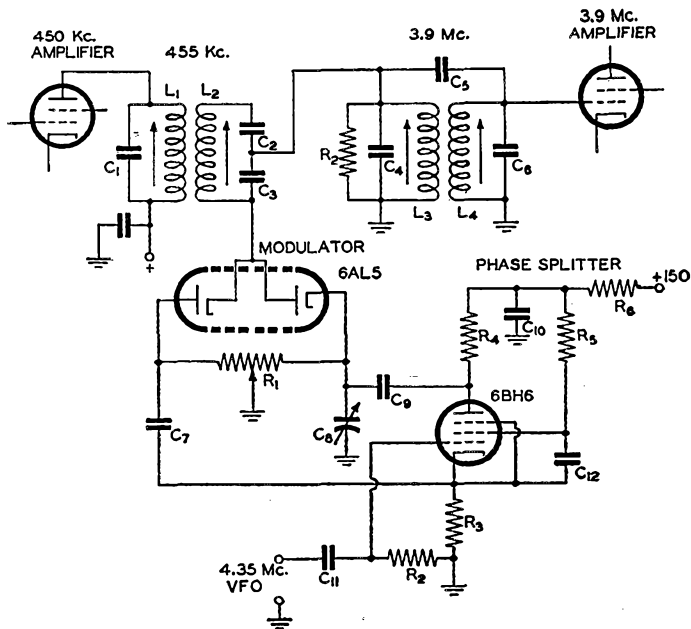

An example of the series circuit used in a 0.5- to 4-Mc. converter is shown in Fig. 3. Here a 6AL5 is shown as the modulator diode, and a 6BH6 phase splitter is used to get push-pull excitation from the VFO. The VFO should deliver enough voltage to furnish approximately 6 volts across R_1 . R_1 and C_8 are adjusted for best carrier balance, as indicated by the absence of VFO-frequency signal in the output of the 3.9-Mc. amplifier. The inductive coupling between L_3 and L_4 is adjusted to give best band-pass characteristics over the 200-kc. 'phone band. This circuit also illustrates the fact that the diodes can be connected between ground and point A or point B of Fig. 1.

Other applications and versions of the circuit will undoubtedly occur to the s.s.b. gang. The modulator circuit of Fig. 2 can, of course, be used at 450 kc. (ahead of a crystal filter) with germanium diodes or a 6AL5 for the modulator and with a 450-kc. tuned circuit at T_1 .

A double-balanced series-modulator circuit can be built for frequency conversion in which neither the signal nor the oscillator frequency appears in the output. In such a circuit, the signal is fed to the center tap of the primary. One side of the push-pull oscillator is fed through resistors and diodes (of opposite polarity) to the ends of the primary, and the other side of the push-pull oscillator is also fed through resistors and reversed diodes to the ends of the primary. A diode anode and a diode cathode connect to each end of the primary. Two of the resistors that run to one end of the primary should be made variable, for adjusting the carrier (oscillator) balance.

General

Referring again to Fig. 1, care should be taken to keep the capacity to ground low at point B (or A, if the modulator is connected on that side). The primary-to-secondary capacity of Z_2 should also be held as low as possible.

The circuit also works well as a demodulator for receiver work where a locally-injected carrier is used (s.s.b. or c.w.). Its main advantage is that no critical balancing or special components are required. In a receiver, the push-pull carrier and its suppression permits the use of high carrier level for maximum linearity without introducing oscillator noise.

Intermodulation products are better than 60 db. down, using a carrier level of 3 volts and a maximum signal level of 0.1 volt.

Strays

Running consecutively in the *Call Book* you'll find W1s UPE, UPF and UPG — son, dad and mom respectively. Grandpop is WITHD.

— W2POC

The latest print-order for those multicolored American Airlines QSLs provided cards for 125 amateurs affiliated with the company.

— W2PXH and W2VQ

Bill Savage, VE6EO, ARRL QSL Bureau Manager for Alberta and widely known on the air, was elected president of the International Municipal Signal Association at its recent Walla Walla, Wash., meeting.

On the Air with SINGLE SIDEBAND



A VERY nice letter from Mr. E. Maurice Walker, ZL1AU, of Auckland, traces the history of s.s.b. in ZL. Apparently, the first on down there was ZL3FV, with a phasing rig and about 10 watts to an 807 on 80. This was about two years ago, and he wasn't on the air too long. Then ZL1AU came on in November, 1951, with no one to work until he finally made it on 7 Mc. with VK3YW a few days before the end of 1951. In February he was joined by ZL1QS and then ZL4AE, and ZL1ADT is the latest arrival. ZL4AE uses a crystal-filter rig at 500 kc., 1ADT uses a phasing rig, and 1AU and 1QS use crystal filters at 5 Mc. Present activity by all hands is on 3.8 Mc., but there are hopes for some 20-meter activity later on.

W9UIT in Milwaukee worked ZL1AU on 80 on July 16th, and he wonders if it is the first s.s.b. ZL/W or only the first ZL/W9. UIT uses a modified Edmunds followed by a 1625 and a 304-TH running about 700-watt peaks.

Arny of W2JJC does a lot of DXing on 20 s.s.b., and the latest one he scared up is VR2CG in the Fijis. No dope on the rig there, however. Other two-way s.s.b. DX includes JA2MB, DL4WC and KP4HF, with G2ALN heard.

Bob of W4INL is another DXer on 20, and recent two-way s.s.b. ones are DL4KA and OE13CC, with new countries EA9AB and EA9-DC added with the s.s.b. rig. Bob wonders if an April 8, 1950, two-way s.s.b. with VK7DH qualifies as the first W/VK.

This column can make no pretense at keeping up with all of the new arrivals on s.s.b., but we can note a few for you. In the East, George Littlefield, W1CRU, at Cape Elizabeth, Maine, has a modified Edmunds exciter with a band-switching 807s-805s driver-amplifier on 15, 20

and 75, with most of the work to date on 20. No need for carrier reinsertion so far, since many of the gang are eager and patient to learn about tuning it in. DX includes ZS6KD, OE13CC, CN8FR and Gs. . . Edgar Seeler, W1BDF, at Cambridge, Mass., is on 75 with an Edmunds driving AB₂ 807s to 75 watts, with best DX the West Coast. . . Two in Kentucky: Fred Lewis, W4LQX in Paducah, on 75 with a phasing job and 800 watts to a pair of Class B 5D21s, and Jack Fulmer, W4HAV, at Fort Thomas, on 75 with a double-lattice voice-controlled exciter ending in a 6AG7 driving a 4-65A, with a "Signal Slicer" (*GE Ham News*, July, 1951) on the HRO. . . Berg Crawford, W6-FMJ, at La Mesa, Calif., has the *Handbook* phasing rig (W2UNJ) and 811-As linear on 75. He doesn't like the way the linear backs down when he reinserts carrier for traffic-net work, and we don't blame him — that's why linears were never popular before the s.s.b. boys started leaving out the carrier. . . Andy Burton, W5-BDX, at Enid, Okla., says he gets more kick out of working s.s.b. with voice break-in than anything else he has done in 20 years of hamming. The rig is an Edmunds with a Good crystal filter (*QST*, October, 1951) to a Class A 807 driving AB₁ 813s. Only 200 watts peak so far, but it gets out better on 75 than the old 600-watt a.m. rig, and no TVI.

Dodging the Linear-Amplifier Problem

The July, 1952, *Proceedings of the I.R.E.* carries an interesting article by Leonard R. Kahn, entitled "Single-Sideband Transmission by Envelope Elimination and Restoration," that is well worth your study. Essentially it is a method for getting around the need for linear amplifiers in a s.s.b. system, which any single-sider will confirm is a worthy objective. This is accomplished by taking a low-level s.s.b. signal and breaking it into two parts, the envelope of the s.s.b. signal and a phase-modulated component with no a.m. present. The p.m. component is then used to excite a Class C amplifier, and the envelope is used to modulate the amplifier. Thus the original s.s.b. signal is duplicated at a higher level without requiring linear amplifiers.

Fort Worth, Texas, is solidly established on the s.s.b. map through the efforts of "Doc" Stanphill, W5OHY. The rig is an Edmunds crystal-filter exciter, modified slightly by adding a grounded-grid 6AG7 following the regular 6AG7, into a Class A 807 that drives a pair of 4-65As to about 400 watts on peaks. The W1FAJ circuit is used to permit voice-controlled break-in with a loud-speaker. Other useful adjuncts in the shack are a "Signal Slicer," Panadaptor, and grid-dip meter. A mobile s.s.b. rig is in the works, using a miniaturized Edmunds exciter to drive a single 4-65A.

"Doc" often checks into the CAA-employees s.s.b. net on 3985 Mondays at 2100 CST, where W4MCL acts as NC and W3BOL, W3QCM, and W2DCF work on plans for making it a transcontinental affair.

QST for

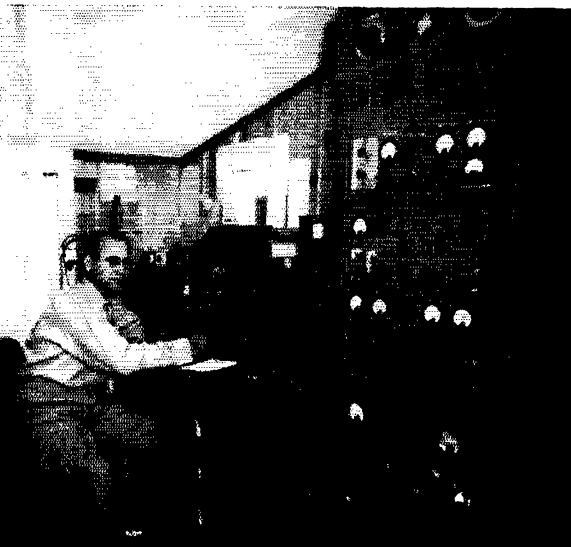

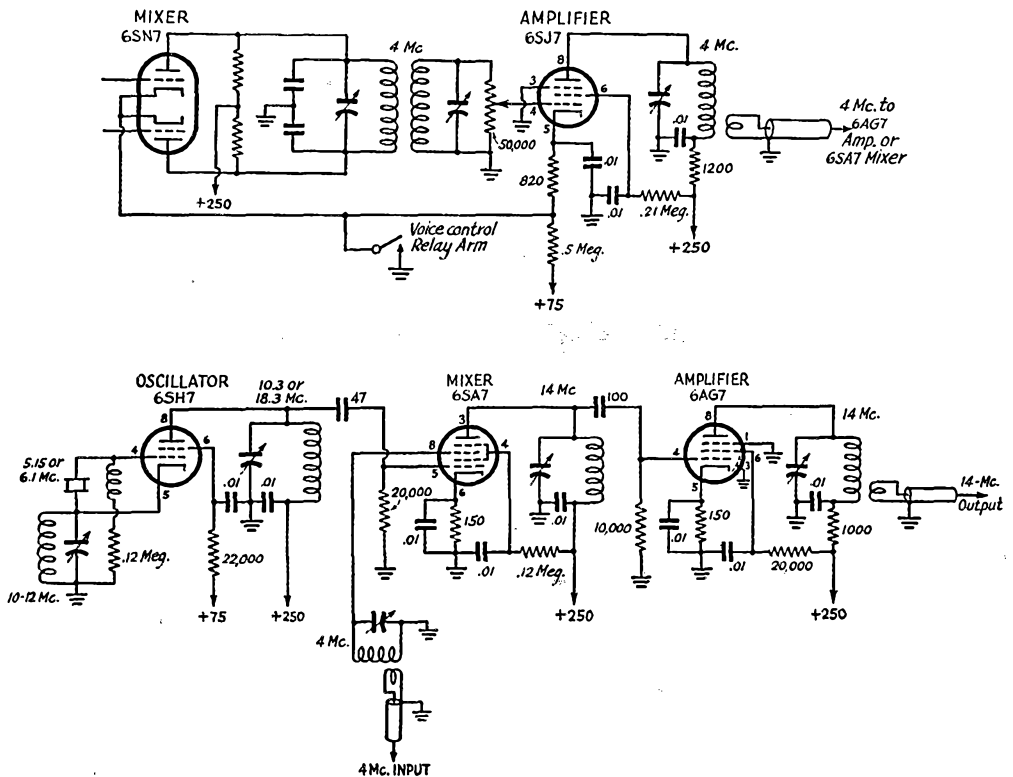

Fig. 1— Here is the way W2FGV converts the 4-Mc. output from his Edmonds (W1JEO) exciter to 14 Mc. The top circuit shows the only modification in the original circuit, the addition of the 6SJ7 amplifier, and the bottom circuit shows the 6SA7 mixer and a 6AG7 amplifier working on 20. John has the whole thing built on a 13 × 17 × 3-inch chassis and uses it to drive a pair of 807s running 125 watts on either 75 or 20.

As briefly described above, the resultant signal would not be of the suppressed-carrier type, but would have a strong carrier when you weren't talking and a minimum carrier on voice peaks. This might be advantageous in amateur work where automatic frequency control is used in the receiver for reinserting the carrier (as is possible with the YRS-1 adapter). It is possible, the article states, to use an "output level control" that will automatically increase and decrease the amplitude of the p.m. component and thus give an output with a suppressed carrier.

In any event, the system bears looking into, because it opens the possibility of a unit that can be applied to a normal a.m. rig to give a s.s.b. signal, without changing the a.m. rig.

S.S.B. Hints and Kinks

John Grubb, W2FGV, thinks many of the fellows with Edmonds exciters may stay off 20 because there have been no descriptions of suitable frequency converters, so he sends along the circuit of the unit he has been using successfully for some time. Shown in Fig. 1, it should require no further details or explanations, since the techniques involved are standard receiver and low-level transmitter practices.

And while we're talking about the very popular Edmonds exciter, Harold Klaiss, W4QN, thinks

it would be well to point out that you don't need the double-channel filter originally described to get a choice of upper or lower sideband. If, for example, your suppressed-carrier frequency starts out at 450 kc., using an oscillator at either 3450 or 4350 kc. will put your (suppressed) carrier at 3900 kc., with upper sideband in one case and lower sideband in the other. It is probably most useful with crystal-controlled oscillators, but worth remembering at any time.

— B. G.

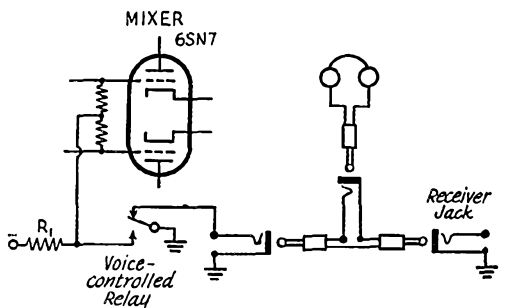

Fig. 2— W5BDX uses this simple circuit with his voice-controlled relay to open the headphone circuit and to bias back the mixer (and other stages) with one arm of the relay. R₁ is a current-limiting resistor, to avoid a dead short on the negative supply.

VE-W Reciprocal Operation Authorized

Details of Regulations and Procedures

JUST in time to catch the end of the vacation season, in mid-July the Governments of Canada and the United States worked out registration procedures for amateurs of one country wishing to operate in the territory of the other, pursuant to treaty brought into effect May 15, 1952. The way is now open for such operation. W1AW carried the essential facts in bulletins immediately the announcement was made. This article will spell out the procedures in detail.

The authority for reciprocal operating privileges comes from a treaty with the extensive title, "Convention Between the United States of America and Canada, Relating to the Operating by Citizens of Either Country of Certain Radio Equipment or Stations in the Other Country." It provides that civilian pilots, properly qualified as radio operators, may work the radio gear in aircraft of the other country's registry. It provides that radiotelephone mobile units (commercial and public—not amateur) in border areas may use their equipment on both sides of the boundary. And it provides that "Amateur wireless operators will be permitted, subject to certain conditions, to use their wireless sets while visiting the other country."

Don't let that "wireless" scare you. It still means amateur radio!

Since Article III of the convention treats the amateur angles, we quote it herewith:

It is agreed that persons holding appropriate amateur licenses issued by either country may operate their amateur stations in the territory of the other country under the following conditions:

- (a) Each visiting amateur may be required to register and receive a permit before operating any amateur station licensed by his government.
- (b) The visiting amateur will identify his station by:
 - (1) Radiotelegraph operation—The amateur call sign issued to him by the licensing country followed by a slant (/) sign and the amateur call sign prefix and call area number of the country he is visiting.
 - (2) Radiotelephone operation—The amateur call sign in English issued to him by the licensing country followed by the words "fixed," "portable" or "mobile," as appropriate, and the amateur call sign prefix and call area number of the country he is visiting.
- (c) Each amateur station shall indicate at least once during each contact with another station its geographical location as nearly as possible by city and state or city and province.
- (d) In other respects the amateur station shall be operated in accordance with the laws and regulations of the country in which the station is temporarily located.

We shall now take up these conditions in order.

Each country has already decided that it wishes amateurs of the other to register and get authorization before engaging in such operation.

U. S. amateurs should write:

Telecommunications Division
Department of Transport
Ottawa, Ontario, Canada

stating their desire to operate in that country, giving their complete name and call letters, and outlining very briefly the nature of the trip and approximate dates. Write several weeks in advance of your contemplated trip. In reply you will receive two copies of an application form. These are to be filled out carefully—preferably with a typewriter—and mailed back to Ottawa. The duplicate is authenticated, if found satisfactory, and returned to you; it becomes, with your FCC ticket, your instrument of authorization to get your gear intact through customs, and for your operation in Canada. Without the signed authority, your transmitter will be sealed at the border and may not be used while you are in Canada.

In addition to name and address, the form calls for a "license number." This refers to other services; amateurs leave this space blank, since we have no such number. It calls for the expiration date—not issuance date—of your ticket. It asks for "authorized communication service and area in Canada where station will be operated." Here you must be brief, as space is limited; you should indicate dates of your trip and area covered, and of course that your service is amateur. A sample entry might be "mobile amateur communications during trip from Niagara Falls, Ont., to Windsor, Ont., September 15-17, 1952." For a summer camp you might say, "portable amateur communications during vacation at Moose Jaw, Sask., September 15-October 20, 1952."

When authenticated and returned to you, the duplicate should be kept with your FCC ticket; the form alone is not your authorization, but only an "endorsement" of your regular license.

VEs headed south should write:

Authorization Analysis Division
Federal Communications Commission
Washington 25, D.C.

in reply receiving similar application forms. The procedure is substantially the same, except that Canadians might allow a little more advance notice.

Items (b) and (c) of the section of the treaty quoted earlier are pretty much self-explanatory. Identification on c.w. includes the usual slant bar (/) after the station call followed by the prefix and the call district numeral. If you are a W operating in Alberta, you'll add /VE6 after your call sign; if a VE operating in Pennsylvania, you'll add /W3. Once during a contact approximate location must be given. On voice, sign your regular call plus "fixed," "portable," or "mobile" as the case may be, and the prefix and call district number. A typical voice signature might be therefore, "This is W1LVQ, Double-You One Lewis Victor Queen, operating mobile VE3, on the Queen Elizabeth Highway north of Hamil-

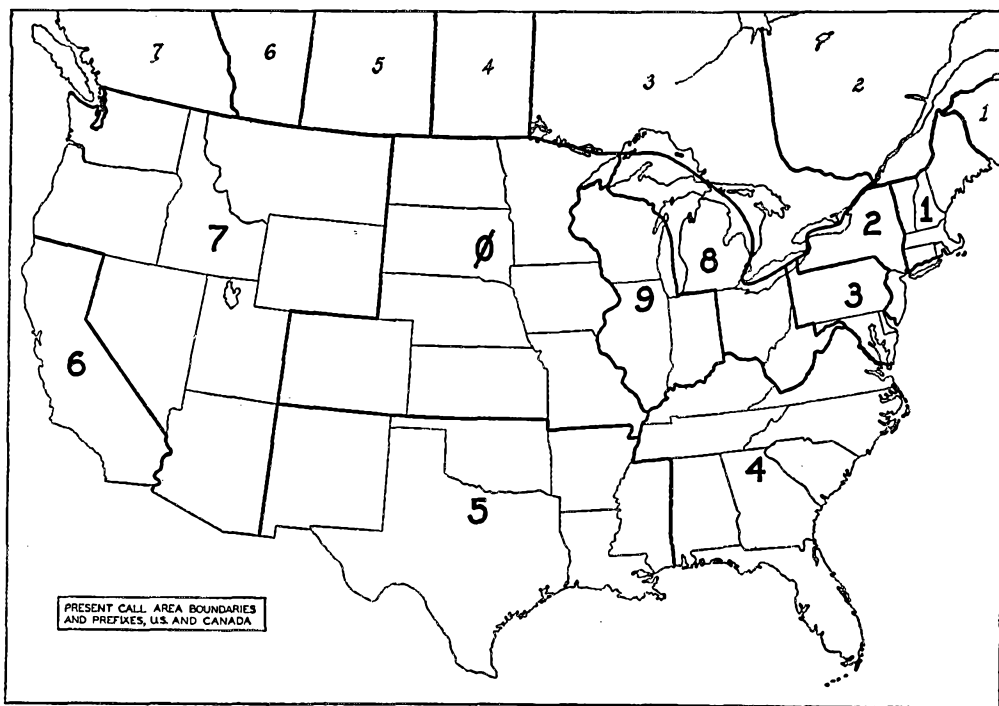

ton, Ontario." Note that the latter geographical identification need be given only once during a contact, but it must be done on c.w. as well as voice.

The map on this page shows call area boundaries in both countries.

FCC licensees are reminded of the present requirement that an amateur operating outside the continental U.S. limits must notify his home district FCC engineer if he is to operate in another country for more than 48 hours; one notification is sufficient for one trip, no matter what the length.

Canadians are reminded of the requirement that monthly notification must be given the U.S. Engineer in Charge of the district in which temporary operation is contemplated. The notice should state the call, name, dates of proposed operation, and portable location or mobile itinerary; it should also make reference to the authorization issued by FCC in Washington. District boundaries and engineer addresses are in the *License Manual*; or see page 43, June, 1951, *QST*.

We come now to the last item, (d), which in effect reiterates the maxim, "When in Rome, do as the Romans do." In other words, you observe the regulations of the country in which you are temporarily operating. An important point to watch is the voice suballocations. As Canadians have generally wider voice bands than Ws, Americans don't have too much of a problem; but VEs crossing the border with a 75-meter mobile rig, for example, ought to remove any crystals lower than 3800 kc.!

Canadians may refer to the item "What

Bands Available" in the "Happenings" column of this issue for a list, accurate as of August 1st, of frequency privileges in the United States. But keep an ear on WIAW or write Hq. for the latest dope before making your trip, as there are a number of proposals pending before the FCC on changes in U.S. bands.

Americans headed for Canada should note the following comparison of frequency privileges, VE and W. In 1800-2000 kc., Ontario and east have 1800-1825 and 1875-1900 kc., 250 watts day and 100 watts night; Manitoba and west, 1900-1925 and 1975-2000 kc., same power limits. Other overall band limits (but not voice suballocations, which we'll mention in a moment) are identical except 11 meters, which is 26,958-27,282 kc.

'Phone suballocations in Canada, in addition to the 1800-2000 kc. segments, are:

- 3725-4000 kc.
- 14,150-14,350 kc.
- 21,200-21,450 kc.
- 28,200-29,700 kc.

To operate voice in their 1800-2000, 3725-4000, 14,150-14,250, and 21,200-21,450 kc. bands, Canadians must have "unrestricted radiotelephone" authorizations; therefore Ws going into Canada intending to operate 'phone in such bands should possess the counterpart Advanced Class (or higher) license. VEs are warned that they should be holders of such unrestricted tickets before operating in U.S. territory in the 3800-4000 and 14,200-14,300 kc. bands.

In Canada, the power limit (except for 1800-2000 kc., specified above) is 500 watts in the antenna, based on a final amplifier efficiency of

(Continued on page 118)

As noted by W4PN in the Manila *Evening News*, the first b.c. station in northern Mindanao, Philippines, has been installed at Cagayan de Oro City. Its call letters — *DXCC!*

Lt. Col. Fred J. Elser, W4GVU, has almost enough WAC-diploma footage to paper his shack. He has earned *eight* under these calls: pi3AA, W2GVU, W1KOM, W3HQW, TA3GVU (phone and c.w.), W6GVU and W4GVU.

An advertising flyer for a new model of a popular tape recorder states the mechanism will rewind at the rate of 1800 feet of tape per *second*. W9LQE figures they really have something — that's a tape speed of over 1227 m.p.h.!

"The trend today is to accept any modern practice as having been just newly thought of by some bright spark. Actually, in many cases, the ideas have been common in the earliest days of amateur radio, although they may have been rather neglected in the intervening years. The recently publicized grid-dip meter is no exception as the following extract from the third edition of the ARRL *Handbook*, which was published on October, 1927, will show:

The best thing to do is to build a good antenna and measure its period by closing the circuit (tying antenna lead to counterpoise lead) and bringing a sensitive oscillator near the lead with a milliammeter in the grid circuit. Varying the oscillator frequency, the reading on the 0-1 or 0-5 meter will drop sharply as the antenna 'tune' is found. The wavelength of the oscillator at this adjustment can now be measured.

"Well! Would you believe it? To think that it was described by Handy in the ARRL *Handbook* just 25 years ago! Why — it's eligible for the Old Timers Club and not such a derved newfangled gadget after all!"

— *ZL2IQ* in *NZART's "Break-in"*

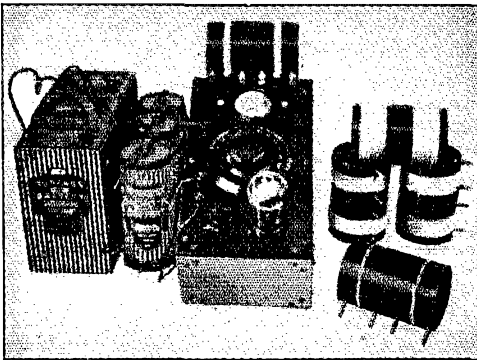

[EDITOR'S NOTE: "A Grid-Meter Driver," by W. A. Hoffman, appeared in August, 1926, *QST*. One of the earlier grid-dip meters, the unit described in that article is shown above. A model has been "on file" at ARRL headquarters for over a quarter of a century.]

WWV-WVVH SCHEDULES

FOR the benefit of amateurs and other interested groups, the National Bureau of Standards maintains a service of technical radio broadcasts over WWV, Beltsville, Md., and WVVH, Maui, Territory of Hawaii.

The services from WWV include (1) standard radio frequencies of 2.5, 5, 10, 15, 20, 25, 30 and 35 Mc., (2) time announcements at 5-minute intervals by voice and International Morse code, (3) standard time intervals of 1 second, and 1, 4 and 5 minutes, (4) standard audio frequencies of 440 cycles (the standard musical pitch A above middle C) and 600 cycles, (5) radio propagation disturbance warnings by International Morse code consisting of the letters W, U or N, together with digits from 1 through 9, indicating present North Atlantic path conditions and conditions to be anticipated. (See June, 1952, *QST*, p. 19, for details on interpretation of forecast symbols.)

The audio frequencies are interrupted at precisely one minute before the hour and are resumed precisely on the hour and each five minutes thereafter. Code announcements are in GCT using the 24-hour system beginning with 0000 at midnight; voice announcements are in EST. The audio frequencies are transmitted alternately: The 600-cycle tone starts precisely on the hour and every 10 minutes thereafter, continuing for 4 minutes; the 440-cycle tone starts precisely five minutes after the hour and every 10 minutes thereafter, continuing for 4 minutes. Each carrier is modulated by a seconds pulse, heard as a faint clock-like tick; the pulse at the beginning of the last second of each minute is omitted.

FEED-BACK

The author of the Sling-Pack portable points out that Fig. 1 on page 34 of the June issue shows the 1N34 noise-limiter diode connected backward — the cathode should connect to the junction of R_3 and R_2 when S_2 is closed. Also, it has been found that a 10- μ fd. 150-volt electrolytic condenser connected from "+90" to chassis will prevent audio regeneration when the B batteries are approaching the end of their life.

In the circuit of the Bandbox frequency-multiplier unit on page 12 of the April issue, the second (40-meter) contact of S_{1B} should not be connected to succeeding contacts on the switch. In other words, there should be no connection between the second and third contacts of this switch.

In the article on the flea-power portable, page 24 of the August issue, it seems that the typesetter ran out of space and cut the caption of Fig. 1 short. The following should be added:

- L4 — 50 turns No. 30, 3/16 inch diam.
- J1 — Open-circuit jack.
- MA1 — 0 to 50 ma.
- RFC1, RFC2 — 2.5-mh. r.f. choke.
- S1, S2, S3, S4 S5 — S.p.s.t. toggle.

• On the TVI Front

TVI QUIZ AVAILABLE TO CLUBS

As part of the League's Training Aids program, a timely quiz has been prepared on the subject of TVI. Consisting of 20 selective-answer type questions, the quiz is designed to liven any club meeting and at the same time impart information on this pertinent topic to the membership. Clubs desiring to make use of this quiz should write ARRL, requesting Training Aid No. 6.

SERVICEMEN ENLIGHTENED ON TVI PROBLEM

Progressive TV receiver manufacturers are leaving no stones unturned in their effort to educate their service agencies in the many causes of TVI and the reasons why. A recent Hallicrafters service bulletin, No. 1952-19, which has been distributed to all members of the Hallicrafters nation-wide service organization along with a copy of Phil Rand's book, *Television Interference*, treats the subject comprehensively. We quote from the bulletin, released by N. J. Cooper, general service manager of Hallicrafters:

... TVI is all too frequently blamed on an amateur radio station — while it is quite possible for the amateur transmitter to be radiating harmonics or for its fundamental frequency to be causing TVI (due to close proximity to a television receiver), actually there is far less to be concerned with in that respect than the average serviceman usually believes. The following are other causes of TVI, some of which are sufficiently prevalent to warrant at least equal if not prior attention to interference that might originate with an amateur station.

- 1) Automobile ignition— spark-plug interference.
- 2) Diathermy radiation.
- 3) Germicidal lamps — mercury-vapor types.
- 4) Airplane flutter.
- 5) Oscillator radiation from a near-by f.m. receiver.
- 6) Oscillator radiation from a near-by TV receiver.
- 7) Oscillator radiation from other near-by short-wave receivers.
- 8) Co-channel interference — two TV stations operating on the same channel and overlapping reception occurs in the deep fringe area of both transmitters.
- 9) Image reception of f.m., police, taxi cab, radiotelegraph and industrial radio service transmitters.
- 10) Superregenerative receivers operating radio-controlled garage doors.
- 11) Harmonics of a TV i.f. amplifier falling in a TV channel.
- 12) Adjacent TV channel being received in part causing sound-bar interference.

♦

At a recent TVI clinic in Washington, D. C., Phil Rand, WIDBM, demonstrates a TVI pattern in one set and compares it to other sets of different circuitry. Co-operating in staging the clinic were the Electric Institute of Washington, the Radio-Television Manufacturers Association, the Washington TVI Committee, and organized ham groups.

♦

13) Cross modulation of high- and low-frequency station signals to produce a beat signal in the TV band.

14) Rectification of signals and reradiation of harmonics (of signals from stations below the TV band) caused by corroded antenna connections or any nonlinear (rectifying) element in proximity to the TV receiving antenna.

15) Overloading of the r.f. stage of the TV receiver due to a very strong signal from a station whose frequency adjoins or is in general proximity to the television channels.

16) Electric motors in household appliances such as vacuum cleaners, fans, sewing machines, shavers, etc.

17) High-frequency heating equipment used for industrial applications.

18) Old-type tungsten-filament lamps.

19) Cracked insulators and defective lightning arrestors on high-voltage power lines.

20) Oscillation of one or more stages of the TV receiver.

21) Neon signs.

22) Oil burners.

23) Belt static.

24) Oscillation in the amplifier stages of a TV booster.

25) Arc welders.

26) Blinker lights or traffic lights.

27) Fluorescent lights.

28) Thermostatically-controlled electrical devices.

29) Poor or unfiltered contact action in devices such as door-bell ringers, dial telephones, demand meters, etc.

The Hallicrafters service bulletin continues with a listing of ten ways in which interference can enter the circuits of a TV receiver:

- 1) Direct signal pick-up or direct feed-thru to the i.f. stages (applies to interfering signals in the i.f. frequency range).
- 2) Combination of the receiver's local-oscillator signal with interfering station signals whose frequencies are below or above the TV band.
- 3) Combination of the second or third harmonic of a TV receiver's oscillator with an interfering station signal.
- 4) Direct reception of oscillator signal radiated by a near-by TV receiver.
- 5) Direct video pick-up of horizontal sweep frequency signal from a near-by TV receiver or the same receiver.
- 6) Direct video pick-up of an interfering signal.
- 7) Harmonics of interfering signal beating with local oscillator in the TV set.
- 8) Rectification of interfering signals in antenna or r.f. stage.
- 9) Overloading or blocking of the r.f. stage in the TV receiver due to strength of interfering signal.
- 10) Rectification of interfering signal in 1st audio stage of the TV receiver.

REMINDER . . .

In case you overlooked it, a bibliography of 72 *QST* titles bearing on TVI was published on page 67 of December, 1951, *QST*.

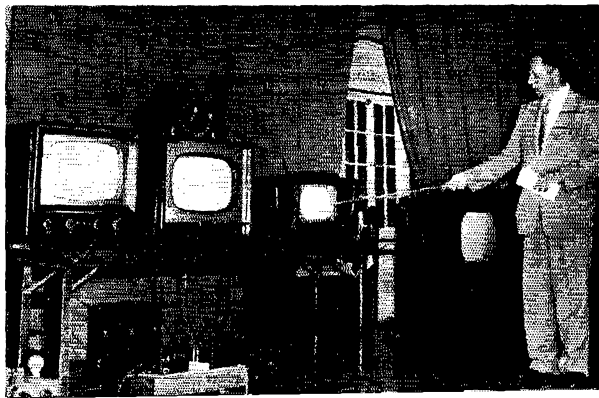



U. S. N. R.



THE Commandant, Eighth Naval District, has announced the following units as winners of their respective type of units in the Eighth Naval District Naval Reserve Program: Organized Electronics Company 8-3, Waco, Texas (K5NAU); Volunteer Electronics Company 8-52, Belleville, Texas (K5NBF); and Volunteer Electronics Platoon 8-8, Mincola, Texas. These units will compete in similar activities with other naval districts, to determine the winning units in the national competition.

Armed Forces Day

During the week preceding Armed Forces Day, K5NRE, Naval Reserve Training Center, El Paso, Texas, set up an SCR-299 communication van at San Jacinto Plaza in downtown El Paso. The unit operated daily from 1000 to 1830 local time and messages to and from armed forces personnel were handled. K5NRE originated 677 messages. W5GCG, Jesse F. Lee, ETRC, and W5SYE, Mario E. Alarcon, RM1 (stationkeepers at the training center), were the operators.

The following Naval Reserve Training Centers in the Ninth Naval District were active during Armed Forces Day: K9NAT, Ft. Wayne; K9NR, Indianapolis; and W9USN, Evansville, Indiana. During open house at the Training Center, Indianapolis, the mobile communication unit was operated in the 7-Mc. band for four hours. Numerous contacts were made on c.w., highlighted by a contact with W9BIL/9 who was operating his car while under way. K9NR also reported into the Indiana amateur radio net to handle traffic.

K8NRT, Naval Reserve Training Center, Toledo, Ohio, operated by R. G. Grob, RM3, USNR, stationkeeper, acted as net control for the Toledo area emergency communications net during their field day held on Armed Forces Day. Between 0900 and 1630 local time, K8NRT worked fifty amateur stations, on 1895 and 29,200 kc. Thirty-one of these were mobile units. Thirty hams from the Toledo area visited the Naval Reserve Training Center's open house.

Here and There . . .

On June 14th and 15th, at Eastern States Exposition Grounds at Springfield, Mass., the Naval Reserve Training Centers at Boston and Springfield, Mass., provided a mobile communications truck and radio jeep to add to the display of Naval Reserve radio equipment at the New England Division Convention. Amateurs were invited to operate the equipment which was on the air during the Saturday morning session.

W5USN, Eighth Naval District Reserve Master Control Station, New Orleans, La., recently received a WAS certificate. Operators are W5s EGX HKP HWN LNU OM LPQ RCZ SPL SPZ TMF TZV UNP, WN5s UEO UEP UTY and UTX.

W4BIH, F. K. Knight, Asst. Reserve Electronics Program Officer, Sixth Naval District, was recently promoted to the rank of Commander, USNR.

W1BCK, Cmdr. E. A. Peavey, USNR, inspector-instructor, Naval Reserve Training Center, Hartford, Conn., and W4ADP, Cmdr. Frank B. Hosdon, USNR, a member of the Naval Reserve at Naval Reserve Training Center, Miami, Fla., recently visited the Naval Reserve section of the Office of the Chief of Naval Operations.

The call sign KR6FL is assigned to Alice Sargent, RMN2, USNR. When in the States, Miss Sargent signs the call W1SSO.

V.H.F. QSO Party

September 20th-21st

Certificates for Leaders

ARRL is pleased to announce another of its popular V.H.F. QSO Parties. All amateurs who can work any band or bands above 50 Mc. are invited to participate in this activity. The Party will be held during a 32-hour period starting at 2:00 P.M. local standard time, Saturday, September 20th, and ending at midnight local standard time, Sunday, September 21st. It will provide opportunities to work new v.h.f. DX and renew old friendships during a week end of concentrated activity on the bands above 50 Mc.

How To Take Part

Call "CQ contest" to get in touch with other contestants. Exchanging signal-strength and readability reports is suggested but not required. When you work another v.h.f. amateur, you must give him the name of your ARRL section. Page 6 of this issue is a register of the League field-organization set-up, and serves as a convenient section check-off list. You compete only with amateurs in your own ARRL section for the certificate award. ARRL staff members are not eligible for awards.

Count 1 point for successfully-confirmed two-way exchanges of section information on 2 or 6 meters. A one-way exchange, confirmed, does not count. When two-way exchanges are accomplished with your transmitter on the 220-, 420-, 1215-Mc. or higher band, you may record 5 points per QSO.

Multiplier

The sum of station points earned is multiplied by a section multiplier. Each time a new section is worked two-way it adds one to the multiplier. *The multiplier grows by one if you rework this same section on another band.* (Scoring differs in this respect from other ARRL competitions to encourage everyone to make use of as many v.h.f. bands as possible.) A simple tabulation with points and section list is all that is required. A card to Headquarters will bring the simple form on which to report; or your own similar tabulation will be accepted.

Rules

- 1) Name-of-section exchanges must be acknowledged by both operators before either may claim the point(s).
- 2) All claimed contacts must fall in the contest period and must be on authorized amateur frequencies above 50 Mc., using permitted modes of operation.
- 3) Fixed-, portable- or mobile-station operation *under one call*, from one location only, is permitted.
- 4) The band your transmitter is on determines whether a QSO counts 1 or 5 points. Cross-band work shall not count.
- 5) A "contestant" is a single operator working without the help of any other person. Results may be presented with names of all participating persons, for listing, but only single-operator scores will be considered for certificates.

(Continued on page 138)



CONDUCTED BY E. P. TILTON,* WHDQ

WELL, here we are, just about through another summer. To date it has not been up to the last few years in a number of respects. Sporadic-*E* skip, particularly, has been down compared to the early-summer periods of 1949, '50 and '51. A natural conclusion to draw is that this is the result of hitting the bottom of the sunspot cycle, but an examination of the record back to 1945 does not bear this out. The summer of 1948, right at the top of the cycle, was very similar to the season now just coming to a close, yet 1947 (on the up side of the cycle) and 1949, '50 and '51 (on the downward slope) were extremely good.

Setting a character figure for sporadic-*E* from amateur observations is difficult, at best. By "good" do we mean frequent openings, long openings, widespread openings, high-density ionization (short skip), or high incidence of multiple hop effects? One thing is sure, however; by almost any of these standards, the summer of 1952 has been no ball of fire. Particularly as to evening openings and double-hop, the season has been disappointing. If you were on 6 in 1948 you can see the similarity between the two years, but if your 6-meter activity dates back only to 1949 you'll be hailing 1952 as the worst ever.

Tropospheric propagation, too, has been less exciting than in recent years. It would take more of a meteorologist than the writer to explain this, but the fact remains that stable and widespread inversions, usually in evidence from May on, have been almost totally lacking thus far this summer. When signals on 144 Mc. and higher bands have been up, it has been largely from stations at distances under 250 miles, and there have been very few indications of duct effects that might make possible communication over distance up to 1000 miles or more. Of course, late summer and early fall are the peak period for that sort of thing, and the best of the year is still ahead as we write.

* V.H.F. Editor, *QST*.

But when this period of good propagation has passed -- then what? Will we pull back into our shells and wait for next May? Hardly! In the past year or so, the value of the v.h.f. bands for local and extended-local communication has been receiving more attention all the time. The particular qualifications of our bands for emergency communication, their relative freedom from TVI, and their adaptability to the needs of the Novice and the experimenter -- all these, and other factors, are working to create a year-round use of the v.h.f. and u.h.f. bands that makes pleasant hamming in them nearly independent of "anomalous" propagation effects.

There'll be a big burst of v.h.f. enthusiasm in evidence over the week end of September 21st and 22nd, when the Fall V.H.F. Party takes place. Let's see to it that the momentum that is developed over this contest week end carries right on through the year!

Here and There on the V.H.F. Bands

One of the best 2-meter openings of the summer season to date is reported by W0JHS, Anoka, Minn. Phil had already retired on the night of July 24th when he was awakened by a 'phone call from W0IFS, who broke the news that the band was open to Illinois. The net result was contacts with W9ALU, Metamore, and W9EQC, Aurora, Ill., at distances around 400 miles.

What was apparently the same weather pattern began to make itself felt in the East late on the night of the 25th. The counter attraction of the Democratic Convention kept activity low, but W2NLY, Oak Tree, N. J., worked W8s SRW GNN BFQ and DX, distances up to

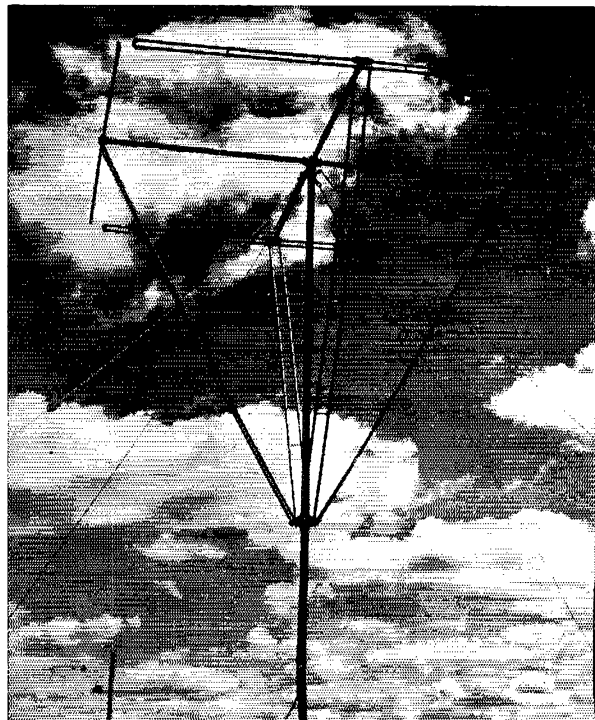

The omnidirectional array used by VE9RA, Halifax, N. S. This station is operated 24 hours a day on 49.99 Mc. by the Defence Research Board of Canada as an aid to those interested in studying v.h.f. propagation phenomena. The slanting supports are half-wave transmission lines to each dipole. Design by VE1QZ.

50 WAS Mc.

W6ZJB.....48	W4IUJ.....38	W8LBH.....39
W8BJV.....48	W4BEN.....35	W8BFQ.....39
W6CJS.....48		W8LPD.....37
W5AJG.....48	W5VY.....48	
W9ZHL.....48	W5GNQ.....46	W9ZHB.....48
W9OCA.....48	W5MJD.....46	W9QUV.....48
W6OB.....48	W5ONS.....45	W9HGE.....47
W9INI.....48	W5JTI.....44	W9PK.....47
WIHDQ.....48	W5ML.....44	W9VZP.....47
	W5JLY.....43	W9QM.....47
W1CLS.....46	W5JME.....43	W9ALU.....47
W1CGY.....46	W5SFW.....43	W9ULA.....45
W1LL.....45	W5VV.....42	W9UNS.....45
W1HMS.....43	W5FAL.....41	
W1LSN.....42	W5FSC.....41	W9QIN.....47
W1DJ.....40	W5ELD.....40	W9DZM.....47
	W5HEZ.....38	W9NFM.....47
W2AMJ.....46		W9TKX.....47
W2RLV.....45	W6WNN.....48	W9EYF.....47
W2MEU.....45	W6UXN.....47	W9HVW.....45
W2IDZ.....45	W6ANN.....45	W9MVG.....44
W2FHL.....41	W6TMI.....45	W9JOL.....44
W2GYV.....40	W6IWS.....41	W9JHS.....43
W2QVE.....38	W6OVK.....40	W9PKD.....43
W2ZJU.....35		W9IPL.....41
	W7HEA.....47	
W30JU.....45	W7ERA.....47	VE3ANY.....42
W3NKM.....41	W7BQX.....47	VE3AET.....38
W3MQJ.....39	W7FDJ.....46	VE1QZ.....34
W3JVI.....38	W7DYD.....45	VE1QY.....31
W3RUE.....37	W7JRG.....44	CO6WW.....21
W30TC.....35	W7BOC.....42	XE1GE.....19
	W7JPA.....42	
W4FBH.....46	W7FIV.....41	Calls in bold-
W4EQM.....44	W7CAM.....40	face are holders
W4QN.....44	W7ACD.....40	of special 50-Mc.
W4FWE.....42		WAS certificates
W4CPZ.....42	W8NSS.....46	listed in order of
W4FLW.....42	W8NQD.....45	award numbers.
W4MS.....40	W8UZ.....15	Others are based
W4OXC.....40	W8YLS.....41	on unverified re-
W4FNR.....39	W8CMS.....41	ports.
	W8RFW.....41	

500 miles. W2AZL, Plainfield, N. J., worked W8WJC, W3RUE and VE3DIR. W2UK, New Brunswick, N. J. caught the first two. The following night saw the first really good Atlantic Seaboard opening of the season, with VE1QY doing business with the W2s, 3s and 4s as far down as Norfolk and Hampton, Va., a distance of around 700 miles.

Hearing someone complaining about lack of activity on 50 Mc. recently set W1DJ, Winthrop, and W1CK, North Scituate, Mass., digging through their 1952 logs. At W1DJ, where there is assistance from W1OIR (Mrs. W1DJ), Art found that he and Martha had worked 128 different Ws on 6 up to the end of July, and there were several others heard but not yet worked. W1CK had managed to find 110 different Ws to work in the same period. How many stations does it take to make activity?

And folks who bemoan the fate of the v.h.f. Novice in finding something to do might well take a look at the record of WNSHOH, Dayton, Ohio. In ten months that he has been on the air, Jim has had over 800 QSOs on 2. He was part of a Dayton delegation attending the Turkey Run v.h.f. hamfest on July 27th. Eight 2-meter hams traveled in three cars equipped with 2-meter gear operated by W8BLN, W8SINQ, and WNSHOH.

Not so many years ago there were those who were sure that v.h.f. bands were no good in the area bordering on the Gulf of Mexico. One Louisiana W5, in fact, insisted that everything had been tried, and they never could work

more than a couple of miles on 144 Mc. Someone must have changed all that in the last few years, however, and now the W6s rank high in v.h.f. enthusiasm. This was well demonstrated at the West Gulf Division ARRL Convention in Corpus Christi, June 28th and 29th, where the v.h.f. meeting brought out an attendance of 135. A feature was the presentation of v.h.f. achievement awards to W5FEK, W5FAG, and W5DFU, as winners for Texas, New Mexico and Oklahoma in the 1951 competition sponsored by West Gulf Director Middleton, W5CA. The competition is being continued in 1952. Big things are being planned for the ARRL National Convention to be held next year in Houston. W5FEK is in charge of the v.h.f. program.

The early morning hours are generally the best of the day for v.h.f. propagation, but too little attention has been paid to this well-known fact in years gone by. The late-evening hours are also often good, and not many of us can burn the candle at both ends and get away with it very long. One thing in favor of the early morning is that it is good the year around, whereas favorable nights are more a warm-weather proposition. For a year now, W2QED, Seabrook, N. J., and your conductor have been maintaining schedules on 144 Mc., daily except Sunday, at 7:00 to 7:30 A.M. and it is seldom that we are unable to make some sort of contact on this 210-mile path, yet tests in the evening hours have been largely unproductive, except during the summer.

Earlier starting times than this would be desirable for those who have the fortitude to roll out for them. VE1QZ, Halifax, N. S., has been testing from 5:30 to 6:30 A.M. EDST recently on 144.65, and has now begun trying the same times in the early evening. W2UK, W2NLY, W2EH, and W2PV often join the morning parade, and others are invited to do so, at their convenience. W3KUQ, Johnstown, Pa., is looking for activity on 2 daily between 6:30 and 7:45 A.M. EDST. There is daily activity in Eastern Texas, starting around 6:30 A.M. Anyone who is keeping regular morning skeds is invited to send information to the writer, so that the times and frequencies can be given publicity.

Been wondering what happened to that Pike's Peak 6- and 2-meter expedition scheduled for the ARRL Field Day? We got the news from W0BXM just too late for inclusion in August QST, so here it is: W0BXM and W0NQW went through with their plans, but unfortunately were not aided by any unusual conditions. They worked several stations in Pueblo on 146 Mc., and in Denver on 50 Mc., but no real DX on either band. Just a few days previously there had been DX all over the place, showing even as high as TV Channels 7 and 9, and on the commercial v.h.f. assignments and the f.m. band, but it was not in the cards for the Field Day week end. They offer a hint for anyone who may be planning high-altitude work with emergency power supplies: their 750-watt a.c. unit would not quite light a 200-watt lamp, when operated at 14,100 feet above sea level!

The flea-powered 50-Mc. portable described by the writer in May, 1951, QST, has proved a popular item. Results obtainable with such gear have been a source of wonder to many. We are so accustomed to thinking of hamming in terms of hundreds of watts input that we tend to forget that even 90 volts of "B" battery on the final stage can do OK in a good location.

There were four of these little rigs at the recent New England Division Convention in Springfield, Mass., built by W1AXA, W1SUZ, W1RO and the writer. W1AXA modified the design by mounting another chassis similar to the one used in the original along with it, to carry larger batteries and more of them. His 135 volts of "B" give him huskier modulation, and he has room for an "A" battery that will allow some rag-chewing. W1AXA is often heard working mobile with this set-up, using the regular car whip antenna. One of the best hops he's made with it was working WIHDQ from Mt. Wachusset, a distance of 70 miles. Even with the little center-loaded whip, W1AXA/1 was a solidly-readable S4 at WIHDQ. Not bad for less than 1/2 watt input to a doubler! Red inserts a dropping resistor between the modulation choke and the final tank, to increase the modulation percentage.

Nebraska has not been well represented on 6 recently, a condition that W9EET tried his best to remedy by spending two weeks in Lincoln during early July, and operating at every opportunity. TVI kept him rather quiet in the evening hours, but frequent daytime openings gave him a chance to work 41 different stations in 14 states, several

being the first Nebraska contacts for the fellows at the other end. Gordon was responsible for station No. 43 for W5SFW, and No. 46 for W5MJD, but ground-wave skeds made with Kansas and Minnesota stations failed to produce the desired result. If things work out well, another attempt will be made next year, with an improved antenna system.

Some Hints on High-Powered 2-Meter Amplifiers

From W2LZD, Scranton, Pa., come some ideas that will be of interest to anyone contemplating high power on 144 Mc. Fred has revamped his 4-125A rig five times in four years, in the interest of increased efficiency and TVI reduction.

In going to coaxial-line feed, he found it desirable to tune out the reactance of the coupling loop at the tank. This resulted in an increase of about 50 watts antenna power at the 600-watt level. Forced-air cooling raised the permissible input to 750 watts on 'phone and a full kilowatt on c.w. Improved tank-circuit efficiency was developed by going to 1½-inch diameter silver-plated tubing. With this tank the coupling loop required is made of only three inches of wire loosely coupled to the tank. The variable condenser for tuning out the reactance is set at about 5 µfd. capacitance.

In his first exciter, Fred started at 8 Mc., with the result that multiples of this frequency appeared all through the spectrum, causing TVI wherever they landed in a TV channel. Replacing capacity-coupled stages with inductive coupling helped some, but was not a complete cure. The early stages ran too much power, too; a 2E26 doubler to 48 Mc., driving an 829B tripler to 144 was really "asking for it." Going to a 24-Mc. starting frequency was a big help, but one of the 24-Mc. multiples still fell in a TV channel used locally, and since many TV sets in the Scranton area run on a signal level around 100 µv., there was still trouble.

Fred's present rig starts out on 48 Mc., using a crystal marked for 28,815 kc., working on its fifth overtone instead of the third (9605 kc. fundamental). Two 6BC5s triple to 144, and this stage and the crystal oscillator are in a separate shielded compartment, with power leads decoupled and the output coming out on coax. Next is an 832 amplifier with shielded parallel-line tank, driving an 829 amplifier similarly constructed. These two stages are in another shielded and filtered assembly, with coax feeding the 4-125As in a third shielded unit.

Even these precautions left some radiation at 96 and 192 Mc., so three-quarter-wave stubs were placed on the outputs of each of the stages. These have no effect at 144 Mc., but they are effectively shorts at the frequencies 48 Mc. on either side. Attenuation of 96 and 192 Mc. is thus so high that they are barely audible in the immediate vicinity of the transmitter, and inaudible at any distance. The end result is no TVI that can be traced to transmitter faults. There is some audio trouble of the midget-receiver variety, but Fred can run a full kilowatt on 144-Mc. c.w. (you hear him doing it regularly during tropospheric and aurora openings) with complete peace of mind.

Doings on 220 and 420

Activity on 220 Mc. has been steadily increasing in the Cleveland area, largely through the efforts of W8IJG, and the following calls are heard quite regularly: W8s IJG BFQ-WJC UKS JWS IY IGP FKC and WM. To provide some DX, W8WM installed 220-Mc. gear aboard the cabin cruiser *Mary Margaret IV*, and has been working the gang from around islands of Lake Erie, about 20 miles north of Sandusky, the home port. From this point, W8WJC-BFQ, 70 miles distant, is worked solidly, and with a freedom from all forms of noise that is a revelation after fixed-station operation in a noisy location. The cruiser's set-up has an 829B amplifier driven by an 832 and a string of 6J6s as oscillator and multipliers. The receiver is a crystal-controlled converter. A 4-section "City Slicker" array is used, with a screen reflector that can be added if weather and wind conditions permit.

W8WM points out that most pleasure craft of 45 feet or larger carry gasoline or Diesel-engine driven generators that are a sure source of emergency power. This points up the desirability of some sort of liaison between ham clubs and yacht clubs, for emergency purposes, where the two kinds of organizations exist in one locality.

On 420 Mc., improvements in receivers, transmitters

2-METER STANDINGS

Call			Call		
States	Areas	Miles	States	Areas	Miles
W1HDQ16	6 650	W5ONS7	2 950
W1LZY15	6 750	W6SWV7	2 —
W1MNF14	5 600	W5FBT6	2 500
W1BCN14	5 580	W5IRP6	2 410
W1DJK13	5 520	W5FSC5	2 500
W1CTW12	4 500	W5DFU5	2 275
W1KLC12	4 500	W5JLY4	2 650
			W5POG4	1 450
W2BAV21	7 1175			
W2NLY18	6 795	W6ZL2	2 1400
W2PAU16	6 740	W6WSQ2	2 1390
W2AZL16	6 —	W6PJA2	2 1390
W2SFK13	6 —	W6GCG2	2 210
W2DFV13	5 350	W6EXH2	2 193
W2CET13	5 405	W6ZEM/61	1 415
W2DPB12	5 500	W6GGM1	1 300
W2QED12	5 500	W6YYG1	1 300
W2FHI12	5 —			
W2QNZ12	5 —	W8WJC21	7 775
W2BVU12	4 260	W8BFQ21	7 775
W2ORI11	6 620	W8WRN19	7 870
W2UTH10	6 —	W8XV18	8 1200
			W8TKS18	7 720
			W8EP17	7 —
W3NKM19	7 660	W8WSE16	7 830
W3RUE18	7 760	W8RWW16	7 500
W3QKI17	7 820	W8BAX15	6 655
W3KWL15	7 550	W8FQK13	7 —
W3LNA14	7 720	W8BLN12	6 680
W3GKP14	6 850	W8CYE12	6 —
W3OWW13	6 600	W8CPA12	- 650
W3KUX12	5 575			
W3PGV12	5 —	W9FVJ20	7 790
W3LMC11	4 400	W9UCH20	7 750
			W9SUU19	7 —
			W9EQC18	7 820
W4MKJ16	7 665	W9BOV15	6 —
W4HHK15	6 660	W9WOK15	5 690
W4OXC13	7 500	W9MBI14	—
W4JDN13	6 —	W9AFT14	—
W4JFV13	5 830	W9ULA12	7 540
W4IKZ13	5 650	W9GTA11	5 540
W4JFU13	5 720			
W4CLY12	5 720	W9EMS15	6 1030
W4JHC12	5 720	W9IHD15	6 725
W4OLK12	5 720	W9NFM14	7 690
W4FJ12	5 700	W9ZJB12	7 1097
W4LRR5	2 900	W9WZ11	5 760
			W9HXY8	3 —
			W9JHS7	3 —
W5JTI14	5 670			
W5QNL10	5 1400	VE3AIB12	6 600
W5CVV10	2 1180	VE1QY11	4 900
W5MWW9	4 570	VE3BOW8	5 520
W5AJG9	3 1280	VE3BQN7	4 540
W5ML9	3 760	VE3TN7	4 480
W5ERD8	3 570	VE3BPB6	4 525
W5VX7	4 —	VE3AQQ6	4 520
W5VY7	3 1200	VE3DER6	4 450
W5FEK7	2 580	VE3EAH5	4 380
W5ABN7	2 450			

and antennas are helping to make many a hop regularly that was formerly considered phenomenal. In the better 420-Mc. installations, there is no longer a large difference between the consistent operating range on 420 and 144 Mc. W2QED, Seabrook, N. J., finds that W3BSV, Salisbury, Md., about 90 miles to the south, is no longer in the DX category. Twice-daily checks between W1CLS, Waltham, Mass., and your conductor in Canton, Conn., have shown that this path of close to 100 miles is open for at least an audible signal on 432 Mc., either morning or evening. The minimum signal is just a trace with the b.f.o. on, but most days show peaks of about 5 db. above the background noise, and when a pronounced inversion is present the 432-Mc. signal may run 15 to 20 db. above the noise level. These contacts are started on 50 Mc., where there is always a

readable signal. When 144-Mc. communication has been tried, that band shows signals only slightly above the 432-Mc. ones. The 50-Mc. signal is considerably better than either, under most conditions.

W2QED's first 435-Mc. DX of the summer to the south was worked on the night of July 26th, two-way contacts having been made with W4NRK and W4ODG, Hampton, Va., 180 miles distant. These fellows are both using APT-5 jammers, but are working on crystal-controlled gear.

In Baltimore, W3KFM and W3JPX are on each Tuesday, Thursday and Saturday, transmitting for 5 minutes each 15-minute interval, starting at 10:15 p.m., beams northeast. They listen after each test transmission, and turn around to the south at 11:15, if nothing has developed in the north-east direction earlier. W3JPX has worked W3BSV, across Chesapeake Bay in Salisbury.

W2UFU, Long Island City, N. Y., is working on amateur TV, and would like to hear from other TV experimenters. He would like to form a club devoted to u.h.f. and TV experimental work, not only for licensed hams, but for others who are experimentally inclined.

W4MS, Pensacola, Fla., is another TV enthusiast. Eddie is working on his camera equipment, and will be in a position to supply prints of the construction to hams who are genuinely interested in this phase of the amateur art.

V.H.F. Net News

To promote interest in year-round v.h.f. operation, we list in these pages at regular intervals the principal details of known active v.h.f. nets. The first such list, published in the June issue of QST, resulted in several groups sending additional information on their activities, and they are added below. The table is far from complete, however; please give us the dope on your regularly-scheduled v.h.f. operations so that they can be added the next time the table appears. And how about those question marks in the table below?

Name or Area Served	Frequency	Control	Date and Time
Minute Men (E. Mass.)	51	W1IN	Sun. A.M.
New England			
50-Mc. Net	50-54	W1CLS	Mon. 2000
Horsetraders (W1, 2)	50-51	W1HDQ	Tues. 1930
Arlington, Mass. CD	53.4	?	?
N. Y. — N. J.	50-54	Rotates	Nightly 2200
N. Y. State CD,			
Zone 9	144 (?)	?	Fri. 2000
N. Y. State CD,			
Zone 10	145.26	W2TBD	Mon. 2200
Phila. High Freq. Club	147.3	?	Thurs. 2000
Intercity (Phila.)	147.3	?	Mon. 2000
York Road Radio Club	146.6	?	Wed. 1930
Oak Ridge Em. Net	50.7	?	Tu., Fri. 1930
RTTY Net (W2, 3, 4)	147.97	?	?
Columbus, Ohio	146.34	?	Mon. 2000
2 Meters & Down Club	144-148	W6IHK	Mon. 2000
Jackson, Mich. CD Net	145.6	W8BBY	Wed. 1930
Muncie, Ind.	145.86	W9GSY	Mon. 2000

OES Notes

W2UTH, Rochester, N. Y., reports that the early part of the summer was not up to previous years in the quality or length of openings on 144 Mc. There have been several short periods when signals have been good for distances up to about 150 miles, mostly during the early evening, but few signs of anything beyond.

W2ZHB, in the same city, notes that DX across the Lake is better on the evenings when the air is cool, after hot days. When the weather began to be consistently hot in the evening (70 to 80 average) the signals from the Canadians were far below the levels experienced when the evening temperatures ran between 55 and 65. Cheer up, boys, that's what we'll be getting again in September; the best period of the year for 2-meter propagation is just coming up.

W3NNV, Colwyn, Pa., needs help with his 2-meter teletype set-up. Any offers?

W5LIU, Ft. Worth, Texas, found the 50-Mc. band open 22 days in June, though the openings were not particularly good, except for June 15th, 18th and 29th.

W7JRG, Billings, Mont., was busy during the early summer providing 50-Mc. contacts for Montana-hungry

state hunters, not the least of them being a certain Connecticut W1, who now can relax, having been pushed into the 48-worked bracket by Ken's move from Wyoming to Montana. W7JRG found 22 openings between May 13th and the end of June.

W8UZ, Columbus, Ohio, found 21 days when the band was open in June, and raised his state total to 45 thereby.

W8FKC, Hudson, Ohio, says that not the least of the advantages of the 220-Mc. band is that you can get antennas ready-made at little cost. Only very minor modifications are required to convert Channel 13 TV Yagis to 220. Ralph's present array is one of those long 8-element jobs. He estimates that it provides around 10 db. gain on 220, and it is noticeably better than a 5-element array of similar design.

W8FKC is also working on 420, and has been experimenting with crystal and vacuum-tube mixers, using a coaxial line made according to the information in June, 1952, QST. A 6A4F triode makes a marked improvement when it is installed in place of a crystal in this tank circuit. One of the new 6AJ4s is used in a coaxial-line r.f. stage, with excellent results and no sign of instability. The transmitter is an AX-9903 tripler, delivering about 10 watts output on 432.36 Mc.

W9CFP reports that the success of the Racine Megacycle Club's 2-meter installation for the ARRL Field Day has started a move in AREC circles to replace the 10- and 75-meter mobile gear in Racine County plans with 144-Mc. equipment.

W9FAN describes a junk-box final stage for higher-powered c.w. operation on 144 Mc., driven by his regular 829B. The new set-up uses a pair of 826s. Example of the junk-box approach: neutralizing capacitance is furnished by short lengths of coax, the adjustment being made by bunching up the outer conductor.

Final Results, June V.H.F. Party

There are 210 calls in the final tabulation of scores in the June V.H.F. Party below, one of the largest turnouts yet seen in a spring or fall v.h.f. contest. Scores were good, too, and activity was at an all-time high in many quarters, particularly in the areas where extensive 2-meter activity concentrations encourage participation by Novices. Generally good tropospheric propagation helped things along, but there was little in the way of sporadic-E skip to bolster the scores of the 50-Mc. men.

As reported last month, the country's high score was posted by Margaret Roberts, W8BFQ, Everett, Ohio, and the NYC-LI Section winner, as often before, was Viola Kapp, W2FHJ. One Novice placed first in his section, WN7RAP of Seattle topping the list of entries in the Washington Section. There were many more reports from the sections bordering on the Great Lakes than we've had in past v.h.f. contests, pointing up the large increases in 2-meter interest in evidence in that part of the country. West Coast reports were generally low, making us wonder what happened to the hundreds of 2-meter operators that are using the 2-meter band in California.

Contest highlights were reported in some detail last month. In the final tabulation to follow, contestants are listed by ARRL Divisions and Sections. Unless otherwise indicated, the first call in each section is the award winner. Columns give the score, the number of contacts, the section multiplier, and the bands used. A is 50 Mc., B 144, C 220, D 420 and E 2400 Mc. Next contest Sept. 20th-21st. See announcement elsewhere in this issue.

ATLANTIC DIVISION

E. Pennsylvania

W3KK/3¹...2709-129-21-B
 W3UKI...2074-122-17-AB
 W3RRA/3...1170-78-15-AB
 W3SAO...462-66-7-B
 W3OXQ...210-30-7-A
 W3NJS¹...156-39-4-B
 WN3RZU...156-26-6-B
 W3IMW...112-28-4-A
 W3TDF...84-21-4-B
 W3PNL...28-14-2-A

W3NH..... 72- 18- 4-B
 W3AHQ..... 60- 15- 4-AB
 W3GKP..... 42- 14- 3-B

S. New Jersey

W2QED.....2086-113-14-ABD
 W2UK.....2015-155-13-B
 W2NYY¹.....1110-111-10-B
 W2HEK.....360-37-8-BD
 W2MEU.....192-24-8-A
 W2ORA.....165-33-5-AB
 W2BAY.....162-27-6-AB
 W2ADA.....126-21-6-AB
 W2DMU.....24- 8- 3-AB

Md.-Del.-D.C.

W3PYW..... 891- 81-11-B
 W3RQK..... 100- 20- 5-BD

W. New York

W2UPT/2... 720-48-15-AB

W2ORI..... 522- 67- 6-BD
W2RUC..... 456- 64- 6-BD
W2FBA..... 330- 55- 6-AB
W2OWF..... 330- 66- 5-B
W2CCR..... 272- 68- 4-B
W2KEC..... 256- 64- 4-B
W2OWQ..... 248- 62- 4-B
KN2AJF..... 220- 55- 4-B
WN2ALR..... 220- 55- 4-B
WN2ISI..... 220- 55- 4-B
WN2LXE..... 208- 52- 4-B
WN2EJO..... 150- 50- 3-B
W2UAD..... 144- 36- 4-B
W2UYS..... 108- 27- 4-B
W2QY..... 78- 26- 3-B
W2SJV..... 72- 36- 2-B
W2CJQ..... 40- 20- 2-B
W2YUE..... 30- 15- 2-B
W2QXE¹..... 8- 8- 1-B
WN2MSF..... 6- 3- 2-B

W. Pennsylvania

W3KXI..... 400- 50- 8-AB
W3FPH..... 297- 33- 9-AB
W3KWH¹..... 162- 27- 6-AB
W3LWA..... 78- 13- 6-B
W3KJM..... 52- 13- 4-A
W3CJF..... 45- 15- 3-B
W3IHF..... 1- 1- 1-B

CENTRAL DIVISION

Illinois

W9FJB..... 414- 69- 6-B
W9JGA..... 248- 62- 4-B
W9QM..... 150- 50- 3-B
W9GRNE 129- 43- 3-B
WN9OKF..... 120- 40- 3-B
W9KDX..... 114- 38- 3-B
W9CT..... 108- 36- 3-B
WN9SEF..... 99- 33- 3-B
W9VNW..... 86- 32- 3-B
WN9RQB..... 84- 21- 4-B
W9PEN..... 46- 23- 2-B
W9ADO..... 42- 21- 2-B
W9PYV..... 25- 25- 1-B

Indiana

W9EWO..... 459- 51- 9-AB
W9GLW..... 130- 26- 5-B
WN9OVL..... 80- 40- 2-B
W9MTV..... 80- 20- 4-B
W9MFH..... 27- 9- 3-A
W9BUM..... 26- 13- 2-B

Wisconsin

W9BTI..... 324- 54- 6-AB
W9AFT..... 305- 61- 5-AB
W9NVK..... 99- 33- 3-B
W9TQ..... 84- 28- 3-B
W9UJM..... 68- 17- 4-B
W9GJE..... 62- 31- 2-B
W9FAN..... 48- 16- 3-B
WN9RXL..... 30- 15- 2-B
W9FEF..... 11- 11- 1-B
WN9RNI..... 8- 8- 1-B
W9GSP..... 6- 3- 2-B

GREAT LAKES

Kentucky

W4PCT..... 300- 50- 6-AB
W4MKJ..... 100- 25- 4-B
W4SMU..... 72- 18- 4-B

Michigan

W8BAN..... 434- 62- 7-B
W8NNE..... 399- 57- 7-B
W8RMH..... 323- 46- 7-AB
W8GYU..... 84- 21- 4-B
W8BGY..... 80- 20- 4-B
WN8HSE..... 72- 24- 3-B
W8DDO..... 69- 23- 3-B

Ohio

W8BFQ 4774-177-22-ABCDE
W8LPD..... 711- 79- 9-AB
W8WRN..... 387- 39- 9-ABC
WN8OH..... 300- 50- 6-B
W8BLN..... 273- 39- 7-AB
W8FKC..... 223- 30- 6-BC
WN8INQ..... 210- 42- 5-B
W8HUX..... 195- 39- 5-B
W8WSE..... 130- 26- 5-B
WN8HQK..... 108- 36- 3-B
W8MFV..... 69- 23- 3-B
W8BMD..... 40- 20- 2-B
WN8JSW..... 30- 15- 2-B
W8IVJ..... 24- 12- 2-B
WN8KJT..... 7- 7- 1-A
W8TCO..... 2- 2- 1-A

HUDSON DIVISION

E. New York

W2PCQ..... 594- 66- 9-B
W2BVU..... 456- 38-12-AB
W2YXE..... 259- 37- 7-B
W2JBQ/2..... 105- 21- 5-B

N.Y.C.-L.I.

W2FHJ..... 2108-124-17-AB
W2BRV..... 1020-102-10-B
W2AOC..... 616- 77- 8-B
W2GLU..... 602- 88- 7-B
W2DHB..... 490- 70- 7-B
W2CET..... 480- 60- 8-B
W2BNX..... 371- 53- 7-B
WN2KDP..... 198- 33- 8-A
WN2IYS..... 92- 23- 4-B
WN2IVN..... 36- 12- 3-B
W2IN..... 15- 5- 3-B

N. New Jersey

W2MLX 2376-104-18-ABCD
W2HUX/2¹ 2301-177-13-AB
W2COT..... 2114-151-14-AB
W2RGV..... 720- 90- 8-B
W2PEV..... 600- 50-12-AB
W2DZA..... 360- 20-10-ABC
W2WKL..... 342- 57- 6-B
WN2ISK..... 275- 55- 5-B
W2RQI..... 225- 45- 5-B
W2MPP..... 175- 35- 5-B
W2IDZ..... 45- 9- 5-A

MIDWEST DIVISION

Missouri

W8IHD..... 33- 11- 3-B

NEW ENGLAND DIVISION

Connecticut

W1HDQ² 4089-141-29-ABCD
W1REZ..... 1274- 98-13-B
W1RMZ..... 1110-110-11-B
W1KYF..... 770- 77-10-B
W1HDF 280- 24- 7-ABCD

W1AW²..... 240- 30- 8-AB
W1PHR..... 224- 32- 7-B
WN1USF..... 132- 22- 6-B
W1IX..... 130- 26- 5-B
W1CEG²..... 85- 17- 5-A
W1RWS²..... 21- 7- 3-A
W1VLK..... 5- 1- 1-D
W1BD²..... 4- 2- 2-B

E. Massachusetts

W1BJN..... 1260-105-12-AB
W1HIL..... 996- 83-12-AB
W1RUU..... 600- 60-10-AB
W1SUR..... 560- 56-10-AB

WN1UNH... 405- 45- 9-B
W1TQG..... 315- 63- 5-B
W1TQF..... 300- 50- 6-A
W1DJ..... 272- 34- 8-A
W1CK..... 135- 27- 5-A
W1JDS..... 130- 26- 5-B
W1CTR..... 39- 13- 3-B
W1MGP/1... 28- 14- 2-A

W. Massachusetts

W1RFU 3475-127-25-ABCD
W1GJO..... 2680-134-20-AB
W1CCH..... 473- 43-11-B
W2ZQA/1... 360- 45- 8-B
W1FKI/1... 133- 19- 7-A
W1CJL..... 48- 12- 4-B
W1PHU..... 30- 10- 3-AB

New Hampshire

W1MHL/11. 3234-147-22-AB
W1KEX/1... 1725- 75-23-AB
W1RMH..... 690- 69-10-AB

Rhode Island

W1KCS..... 1760-110-16-AB
W1SGA..... 1056- 88-12-AB

Vermont

W1CTW/1... 1744-105-16-ABC

NORTHWESTERN DIVISION

Washington

WN7RAP... 48- 24- 2-B
W7MWP..... 23- 23- 1-B
W7KO..... 15- 15- 1-B

PACIFIC DIVISION

Santa Clara Valley

W6CGG/6¹ 2108-124-17-AB
WN6OWQ... 375- 75- 5-B
W6ZBS..... 324- 36- 9-AB
W6ALW..... 290- 58- 5-AB
W6PBV/6... 42- 14- 3-B

East Bay

W6AJF..... 1500-100 15-ABD

Sar Francisco

W6MHF..... 292- 73- 4-B

Sacramento Valley

W6PIV..... 240- 30- 8-AB
W6MCR..... 10- 5- 2-B

San Joaquin Valley

W6LOZ/6... 235- 47- 5-B
W6LRS..... 100- 25- 4-A
WN6OVR..... 84- 28- 3-B
WN6PYY..... 39- 13- 3-A

ROANOKE DIVISION

N. Carolina

W4CVQ..... 14- 7- 2-B

Virginia

W4AO..... 1008- 84-12-B
W4UBY..... 115- 23- 5-B

SOUTHEASTERN DIVISION

W. Florida

W4MS..... 45- 9- 5-B

SOUTHWESTERN DIVISION

Los Angeles

W6NTC..... 215- 43- 5-AB
WN6NJU... 3- 3- 1-B

WEST GULF DIVISION

Northern Texas

W5LIU..... 24- 8- 4-A
W5MJD..... 24- 6- 4-A

Southern Texas

W5AYU..... 164- 41- 4-BD
WN5VDA..... 42- 21- 2-B
WN5UOK..... 2- 2- 1-B

New Mexico

W5RFF/5¹ 42- 14- 3-AB

CANADA

Ontario

VE3BQN 1540-154-10-ABCD
VE3AQE..... 1290-129-10-AB
VE3DIR..... 812-116- 7-B
VE3TW..... 208- 52- 4-B
VE3DKW..... 205- 41- 5-A
VE3BPB..... 190- 38- 5-B
VE3AIB..... 155-131-11-ABD
VE3BMB..... 69- 23- 3-B
VE3KM..... 48- 24- 2-AB

Manitoba

VE4ER..... 1- 1- 1-A

¹ More than one operator — not eligible for award
² Headquarters Staff — not eligible for award.

IS YOURS ON FILE WITH YOUR QSL MGR?

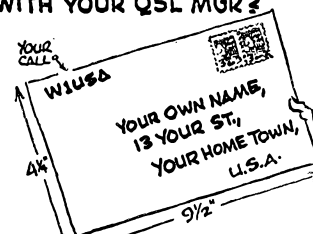

See page 60, August QST, for the address of your QSL manager

Coming ARRL Conventions

HUDSON DIVISION

Albany, N. Y. October 3rd-5th

The ARRL Hudson Division Convention, sponsored by the Albany Amateur Radio Association, will be held at the Ten Eyck Hotel, Albany, on Oct. 3rd-5th. An extensive program is being planned to cover all phases of interest to the amateur fraternity. There will be demonstrations and talks on s.s.b., microwaves, and the transistor. Also to be featured are discussions of interest to the mobile ham and the Novice. An FCC examiner will be on hand to give exams, and there will be the traditional midnight ceremony of the Royal Order of the Wouff Hong. There will be a complete program for the ladies.

Registration prior to September 22nd will be \$5.75; after that date \$6.00. For tickets write to H. L. Schultz, jr., P. O. Box 6073, Albany, N. Y.

VERMONT STATE

Burlington, Vt., September 14th

The annual Vermont State ARRL Convention and Hamfest, sponsored by the Burlington Amateur Radio Club, will be held on Sunday, September 14th, at the Hotel Vermont in Burlington. The program will get underway at 9:30 A.M. with FCC exams, exhibits, 75- and 10-meter hunts, technical talks, ARRL and Civil Defense meetings, and a boat ride on Lake Champlain for YLs and XYLs. There will be a banquet at 2:30, with entertainment and awards.

Registration is \$1.50 until September 12th; \$5.00 after that date. Secure tickets from Burt Dean, W1NLO, P. O. Box 81, Burlington, Vermont.

SOUTHWESTERN DIVISION

San Diego, Calif., October 11th-12th

The ARRL Southwestern Division Convention, sponsored by the San Diego Amateur Radio Emergency Corps, will be held in Balboa Park, San Diego, on Saturday and Sunday, October 11th and 12th. Registration is scheduled to start at 9 A.M. on Saturday. The program will include a mobile rig contest, transmitter hunts, exhibits, a code contest, QLF contest, ROWH ceremony, ARRL open forum, technical talks, v.h.f. round-up, YLRL meeting, and special get-togethers for the DX men, SCMs, and others. The banquet will be held on Saturday evening.

Registrations (\$5.00 each) and information may be obtained from Chairman R. E. Hopper, W6YXU, 4327 Santa Cruz, San Diego 7, Calif.

NEW HAMPSHIRE STATE

Nashua, N. H., September 27th

The annual New Hampshire State ARRL Convention and Hamfest, sponsored by the Nashua Mike and Key Club, will be held Saturday, September 27th, at Pulaski Park, Nashua. Plenty of mobile activity is anticipated, with hunts on 2, 10, and 75 meters. There will be excursions to the famous Benson's Wild Animal Farm, and a special program for the ladies. Lectures, meetings, FCC exams, plenty of cats and refreshments, dancing and awards will round out a full day of activities. There are plenty of indoor facilities, so the weather will be no problem.

Registration prior to September 17th is \$3.00; after that date \$3.50. Write to Nashua Mike and Key Club, P. O. Box 94, Nashua, N. H.



September 1927

... There is every indication of solid backing by our government for exclusive and sufficient amateur-band allocations at the forthcoming International Radiotelegraph Conference in Washington.

... Paul M. Segal, 9EEA, points up the menacing epidemic of local-government "radio-control" ordinances and demonstrates the illegality of such means to deprive radio enthusiasts of constitutional rights.

... Fred J. Elser, op3AA, recounts the saga of xop1ZA, his "radio fivver," which used UX-201-A tubes to put 0.6 ampere into a vertical rod antenna while the author motored across some 3000 miles of Europe.

... A UX-210 ultradion oscillator-transmitter, which QSYs conveniently to any one of four bands — 80, 40, 20 and 5 meters — by way of plug-in coils, is detailed by James T. McCormick, 9BHR.

... Important considerations concerning the functions of the condenser following the rectifier tube in plate power-supply units are presented by James Millen and D. E. Replage in "The First Filter Condenser."

... David Grimes describes "A Harmonic Method of Increasing Selectivity" wherein he employs frequency doubling as a basis for obtaining a greater separation between incoming signals.

... Another 5-Meter CQ Party is announced, scheduled for November, and it is hoped that some of the puzzling reports and phenomena produced by the previous Test will receive clarification.

... John Grinan, of 1BCG transatlantic-tests renown, has his Kingston, Jamaica, station — now a familiar signal on 32 meters — described and illustrated by Clair Foster, 6HM, in an article entitled "nj2PZ."

... Twenty and forty meters are enlivened by the activities of VOQ, Putnam Baffin Island Expedition; WNP, MacMillan Expedition; WOB, ship *Radio* off Labrador; KFVM, yacht *Italia* in the Pacific; and VYG, Canada's *Beothic*.

... Among the many photographs of overseas stations we find ac8GG, Shanghai; amVS1AB, Singapore; en8GA, Netherlands; and KFLF of the yacht *Ripple*, now plying the Pacific with 6BUR at the key.

How's DX?

CONDUCTED BY ROD NEWKIRK,* W1VMW

How:

... They range from 8 to 80; in education, from those who halted in the grammar grades to the erudite holders of doctor's degrees; in social status . . . scions of wealthy families and the son of an ex-president of the United States; in occupations, from coal miners and bellhops to major executives in giant corporations. — DeSoto



AC3PT

Amateur radio never ceases to attract those from every walk of life. Though the late C. B. D. made no reference to Hamdom's royalty in the above excerpt, he was later to chronicle for the pages of *QST* the activities of two prominent DXers of the Thirties — Archduke Anton of Hapsburg, OE3AH, and Vinh San, FR8VX, exiled Prince of Annam — who perhaps took greater pride in their amateur activities than they possibly could have derived from dutiful affairs of state.

One of the most active of ham radio's royal devotees at present is P. T. Namgyal, Maharaj Kumar of Sikkim, who operates a modest station in The Palace, Gangtok. While official duties limit AC3PT's on-the-air time he looks forward to many QSOs with W/VEs and has recently undertaken to act as QSL bureau manager for all incoming AC cards.

GL and DX, OM!

What:

If *twenty* has any of its old form left, the Africans should begin building up this month on both paths. We shall see. W5MPG, who recently entertained visiting firemen W5s

KUC and UCQ, caught up with EA0AM (14,045), FQ8AP (072), KC6DX (114), KS6AA (043), VR4AF (040), VS6s CG (065), CK (070), YI3BZL (097), YU3AT (092), ZC2MAC (023) and 4X4BR (068) CR7AG (070), CR9AF (020), DU1FM (087), FA8DA, FB8ZZ (049), FK8AH, KB6AX (030), KH6MF/KB6, KX6AH, M13ZX, UL7KAA (1), VP7NM, VQ3BM, VQ4DO, VS7s LB, WA, Y810 and YU4BN have been working Truk's KC6QL VS2CN looks for Ws with crystals on 14,013 and 14,077 kc. ZD2DYM, MI3DD, MB9BJ and YU1CAB were appropriated by W2NOY, while W2EEY grabbed FP8AM (W6AIW) CP1BX (009) was raised by W6AIN. Don wants a line on ex-ZC6XY/W9HXF W6EAY has KC6QY (030), KJ6AR (097), VK9GW (052) and VP4LZ in the log Up to 125 goes K2BU because of TA3AA (010), EA0AC (100), EL2R (038), VP2MD (058) and 5A3TA (045) Lack of VQ2AB and VS1DC QSLs plagues K2BU and W2CTO respectively W6NDP landed FO8AR, KM6BD, KW6AZ (091), VR2CJ and other Oceanians TI2s CR (070), TG (030), YV5AQ (070) and LU0AC/MM were welcomed by W6OKK W8NOH reached 110 worked with FP8AN and YU5BN. FY7YB, SV0WB, YS1MS and ZC4RX got away VP8AJ tells W8DAW that VP8AD, now back in LU, doesn't go for QSLing. Russ captured ZD9AA (032), LB6BD on Jan Mayen, JA0IJ and LZ1KAB — a dandy foursome YU1AG (017) and TF3MB (020) worked W4REZ; W2EEY adds CN8FR (115) and VK9XK of Papua Z2ZAA (090 t7), aboard ship in the Indian Ocean, regularly knocks KH6PM's ears off. So does VR7AB (001) W7OEB collected many others in addition to DU1OR, VR1A, OA4DE and KC6QY. Buddy W7OIH adds KG6AAY and two VK9s W9HUZ did well with CP1BK/P (010), DU1s 1FM (078), 6TV (050), EA8BC (055), KX6AI (040), YU1s AD (012), CX (012), VP6UN (020), YS1VJ (095), ZP5AZ (020) and 4X4CW (065). Van is working hard to solve the rapid-QSY system employed by VP2MD W3DKT, an old hand at 14 Mc., recently paid personal visits to YV5AO, VP5s AK, DX, CO2s WY and YW. Charles got back in time to snag FP8AL (W6FNO), a TA3 and some CP1s MF2AG (025), OX3MW, GD3UB, KG6FAB (070) and VP6PV answered W4TVQ; M1B and 3V8AC slipped away W3MFW says he'd like to try RCA's megawatt-output 5831 in a 20-meter dogfight. Anyway, Russ did well on KM6AH/KB6 (116), SU1GG



* DX Editor, *QST*.

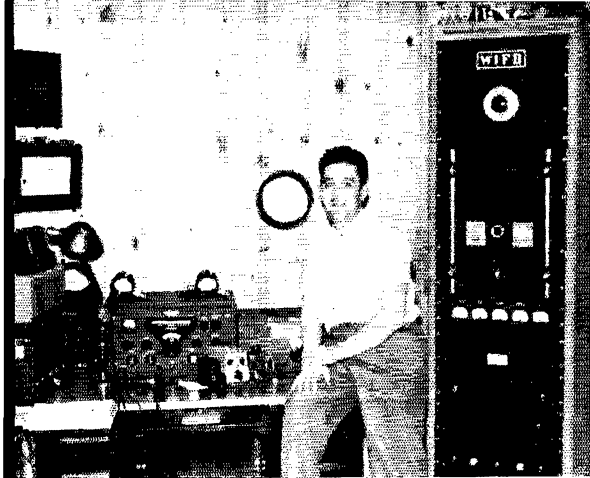

A great many readers have asked for a peek at the shack of W1FH. This is it — nothing unessential to the working of new countries clutters up Charlie's installation. On-the-nose rotary beams for 10 and 20 poke high into the Boston sky nearby.

(060), ZB2A (040), ZC6UNJ (110) and ZP9AH (013). W3MFW ran into W5AGB/F-M — "fixed-maritime" in a floating ice pack — operating from Fletcher's Island, near the North Pole, on 14,040 kc. . . . West Gulf DX Club's *DX Bulletin* has these down in black and white: *Mornings* — CR4AF (083), DU1s CE (078), JI (097), WP (060), FO8AM (040), J3CH (040), KR6JG (070), KX6s AA (045), AR (073), UA6s KFA (088), KKB (050), VK9s DB (050-095), GB (050), YT (305), VO2LM (045), VSs 2CR (045), 6AE (020), 6BE (008), 6CM (015-045), 7TM (080), 7XG (023), VU2JK (065), ZA2AB (001), ZK2AA (012), ZSs 3HX (063), 7BM (071), 7D (080) and 7F (050). *Evenings* — CR8AD (013), CT3s AA (026), AB (021), EA8AD (082), ELs 1DFX (028), 2AFX (065), ET3R (060), FB8BE (110), FK8s AB (016), AE (020), AI (100), FM7s WF (065), WH (164), FN8AD (092-120), FQ8AG (055), FR7ZA (022), GC3WL (067), HA5FA (008), HH3L (020), HI6TC (080), ISPR (046), ISIAHK (070), ITIAGB (057), JY1s AJ (001-063), BB (045), AU (001), OG (018), KX6AE (020), LB6XD (020), MDs 5AP (200), 7AC (025), 7PQ (041), MF2AB (080), MI3SL (058), OQ5RA (021), OY2Z (014), PJ9VDZ (083), PX2QP (020), SL3AU (098), SPs 3FF (007), 6XA (002), STs 1CB (055), 2CB (055), SU1HG (082), ship SV1CFX (030), VP2AD (085), VQs 5AU (015), 8CB (100), VS2YL (070), VUs 2EJ (022), 7FK (077), ZB2H (020), ZC4s RS (040), XP (320), ZDs 1ST (019), 2HAH (075), ZP9TA (015), ZK2AB (050), 4X4s BT (015), BX (001), DK (107), RE (005-085) and 5A2TS (050-198).

On twenty 'phone, this same organization records the activities of AC3PT (205), DU8s 1AL (200), 7SV (194), 9VL (218), EA9DY (260), EL6A (280), FA3DS (250), FF8s CJ (280), CN (280), CS (355), FQ8AI (350), HZ1MY (120), IS1s CUV (260), EH (270), JA8J (270), JY1AJ (043), KB6AO (255), KC6QY (200), KJ6AW (283), KTIWX (120), KW6s BC (210), BD (249), MI3NA (300), OQ5RU (160), SPs 5AG (215), 9KKA (210), SU8s 1AS (350), 1HG (370), 1JY (150), 5EB (200), VQs 3CP (340), 5CY (176-270), 5DQ (180-320), VRs 2CM (118), 3C (040-199), YK1AE (320), ZDs 2TTE (150-180), 4AX (102-200), 4BB (250), 6EF (330), 6RD (250), 9AA (146), ZM6AA (190-257), ZP2CD (270), ZS7F (083) and 5A2TS (250) in the a.m.: CT2FR (140), EA8s AP (308), EF (185), EL9A (312), FA8FA (190), FO8AD (150), HI6TC (337), HZ1TA (150), KTI1s BB (180), WX (120), MI3s CE (336), MK (180), VG (350), OD5s AP (150-325), AD (130), BA (194), TA2EFA (180), VR2s AP (100-130), 2CM (118), VQ2DT (170), UA6KKB (095), YI3BZL (010-210), YUs 1AG (140), 3AC (035-120), ZB2A (170-236), ZC4s NN (037), RX (190), ZK2AA (200), ZM6AC (181), 5A2s TO (340), TW (340) and 3V8BB (185-210) during the p.m. . . . XE1AC adds EA9AI (301), FO8AB (151), FF8GC (320), ISGO (175), KM6BE (214), VS1DS (126) and others previously listed. AI now has three cards for Indo-China but still no soap on F18s for DXCC credit. . . . PJ5FN and ZK1AA made it 132 for GM2DBX. . . . W8NOH tallied GD3UB (310), OX3BF (315) and KTI1D (345). . . . CR6AC, JAZYA (115), KW6AZ (230), FP8AM (155), ZD6HJ, ZP5s CB (155), EQ (155) and 4W1MY (018) bring W4NYN up to 117/108.

Fifteen is gaining converts despite slow conditions. VQ4AQ, FQ8AQ (21,300) and ZD9AA (060) are among the juicy items thereabouts. . . . OQ5RA, HB9FU and ON4VU came back to W3RZL while W4TFD accumulated

PYs 2CK, 6DU, ON4UF and VP9GX. . . . W9NSL worked the band at W9IT/9 on Field Day, coming up with PY2s AQ, HT, KZ5s KZ, TB, KH6RS and VK2ZC. PA8AT was heard. . . . VP9s AB and G hit the band with a will as soon as 15 was made available to Bermudans. . . . ZC6UNJ is on the watch for 15-meter W/VEs and Argentina was authorized 21-Mc. operation on August 1st which should hop up the band a lot in view of present north-south skip conditions. The Dominican Republic, Ecuador, Guatemala, Netherlands Antilles, Denmark and Burma have given 15-meter privileges to their amateurs — the list is growing fast!

The new junior operator's 3 a.m. bottle gives W3MFW a shot at some good stuff on forty: KB6AX (7012), KC6QY (010), VP8AJ (020), ZK1AZ (017) and FP8AN. . . . W6OKK got that ZX1, a bunch of VK/ZLs and one J2GO (012). Pat prefers a ground-plane for 7-Mc. work. . . . PY2AQ, VP5BH, KV4AQ, VKs 6WM and 7KB replied to W3DLI. . . . 4X4DH (039) gave W3RZL a potential WAC on the band and W2AIS/KH6 is hearing all sorts of U.S.S.R. DX — UL7, UH8, et al — working only each other, of course. . . . W3RZL added FA8DA (039), HE9LAA (028), TI2CR (021), VP8s SBN (041), 7NT, YU2AKL (012), YV5EQ (080) and oodles of others.

W6ZAT doesn't let the warm season noises interfere with his DXing on eighty. Del chatted with ZLs 1CI, 1HM, 3GC, 3JT, 3OP, VK2s ADT, TC and CX1FY; he still has test skeds with ZS3K and VS7NG. . . . ZL1HM owes VS7NG a bow for the completion of his 3.5-Mc. WAC and ZL1CI told W6ZAT to keep an eye out for YJ1AB near the low edge.

What ten does this year (as compared to last) may be indicative of the trend conditions will take in '53, so this band will bear watching. At this writing things are still strictly north-south. W9LMC verifies this by reporting 'phones LU5 2QC (28,312), 5DZ (150), 6AB (320), 6MC (145), 8CA (200), 8DAC (235), HC1OX (415), HK4AT (335) and HP1TP (265). . . . W6AIN appends LUs 6AS (400), 7DCO (360) and 7DI (360). . . . W4SCA encountered PJ2CA (490) while W2ZVS bagged PJ5RE, VP8s 5AY, 6HR, 6JB, 6NA, 6SD, 7NT, 9AU, ZL2s BN and JB. . . . At W4RNP we find ZSs 2CY (390), 6TB (370) and YN1WC (450). . . . W1RDV and W2ZVS frequently run into W2ZXMM/MM, who shoves out a weighty signal from *Flying Enterprise II*.

Where:

There are now over 26 CN2s licensed; cards for them may be sent via TARC, French P. O. Box 150, Tangier, Tangier Zone. . . . Legitimate PJ stations are becoming more numerous. We understand that PJ2AA, S. J. Heeringa, Dakota Airport, Aruba, N. W. I., will handle incoming PJ cards. . . . Guam's bureau has had a slight change in address. It's now P. O. Box 145, %CAA, Agaña, Guam, for your KG6-bound pasteboards. . . . FEARL's QSL bureau is holding a stack of cards addressed to former JAs who have left Japan. Forwarding addresses and some postage will ensure immediate dispatch to owners and will help clear the files. Write FEARL, APO 500, % Postmaster, San Francisco. . . . HB1s are Swiss portables — send your QSLs to the corresponding HB9 calls or via USKA.

CE6EB	Abelardo Nunes T., Casilla 608, Valdivia, Chile
CN8FR	Box 28, Casablanca, French Morocco
FA8FA	P. O. Box 321, Oran, Algeria
FP8AK	(QSL to W2BBK)
FP8AL	(QSL to W8FNO)
FP8AM	(QSL to W8AIW)
FP8AN	(QSL to W8UQV)
HB4FE	Post Box 63, Duesbendorf, Switzerland
ex-HC2KJ	E. Feist, 1820 1/2 E. Michigan Ave., Lansing, Mich.
ISGO	% Distrito Postale, Mogadiscio, Italian Somaliland

15PR
JY1XY % Post Office, Balkaia, Italian Somaliland
Leslie Berkeley, RAF Station, Amman, Jordan,
MEAF2

KB6AX % CAA, Canton Island
ex-KG6GU Box 45, Saunderstown, Rhode Island
KH6MF/KB6 % CAA Contractor, Canton Island
KJ6AW Shell, APO 105, % Postmaster, San Francisco, Calif.
KM6BE Box 18, Navy 3080, FPO, San Francisco, Calif.
KX6AR Box 3, Navy 824, FPO, San Francisco, Calif.
PJ2AD J. M. Kelkboom, Box 9, Oranjestad, Aruba, N. W. I.
SU1GG (QSL via RSGB)
TIC2R Instituto Geografico Nacional, San Jose, Costa Rica
VP6JUN (QSL via VP6JR)
VP7NT (QSL via VP7NM)
VP8AH R. M. Pitaluga, San Salvador, Falkland Islands
VQ2KR Mrs. K. C. Ritchie, % PWD Workshops, Lusaka,
No. Rhodesia

VQ3BNU A. Allen, Aeradio Station, Tabona, Tanganyika
VR3C Fanning Coconut Plantation, Fanning Island
VS6CM Lionel, Box 541, Hong Kong
VSTGQ John Griffen, Cable & Wireless Ltd., Negombo,
Ceylon

ex-VU7AH K. S. V. Rajan, VU2RA, Post Box 10, Tumkur, India
YU5BN Box 420, Sarajevo, Yugoslavia
ZE1JY W. Milne, 4 Abercorn St., Bulawayo, So. Rhodesia
ZE2KV G. D. Wall, P. O. Box 2020, Salisbury, So. Rhodesia
ZE3JZ Amateur Radio Club, RAF, Thornhill, Gwe, So.
Rhodesia

ZE4JHQ RSSR Hq. Station, P. O. Box 1068, Bulawayo, So.
Rhodesia

ZM6AA Box 23, Apia, Western Samoa
ZP5AY (QSL via RGP)
ZS8E J. C. du Buisson, P. O. Box 4, Oranjemund, S. W.
Africa

ZS3HX A. G. S. Judd, P. O. Box 81, Keetmanshoop, S. W.
Africa

ZS7A M.E. André, P. O. Box 417, Pietermaritzburg, Natal

The above through the efforts of W1s FTX HA IKE RWS VG, W2s EGG NOY ZVS, W3UGF, W4IYT, W5FNA, W6s NDP OKK YY, W8s DAW NOH, W9s CFT HUZ TRD, CN2AJ, ON4IB, VP9D, OVSF's OEM, VERONA's News, WGDXC's DX Bulletin and SABL.

Tidbits:

According to W6YY, Japanese nationals will be assigned only spot frequencies in the 80- and 40-meter bands but will be able to roam 14,080-14,270, 21,120-21,370 and 28,200-29,500 kc. allocations. 'Phone or c.w. may be used and there are various power maximums specified for different bands ranging from 50 watts input on 10 meters to 500 on 40. Two classes of license are contemplated. . . . W9TRD learns there are now six resident 3A2s licensed. Charlie says each issue of the *Call Book* requires over 5000 modifications in the DX section alone. . . . 3A2AH operates only

Tents, tsetse flies and hand-cranked generators are a far cry from these snappy African consoles. The layouts of VQ4ERR (right), ZS6Z (right, below) and MI3US (below) may show W/VEs a trick or two! (See page 126 for dimensional data on VQ4ERR's set-up.)

'phone on 20 and 10. Henk has been receiving QSLs confirming c.w. QSOs — a neat trick considering he doesn't know the code. Pirates on the prowl W5FNA loaned us a copy of VERONA (Netherlands Antilles) News and the PJ boys, as usual, are right on the ball. Technical articles, DX items, certificate-award information and editorials enhance the effort. By the way, PJ2AA is ex-PJ5RE, PJ2AC is ex-PJ5BX and PJ2AD, ex-PJ5FN KG6ACZ tells WINJM of extremely spotty DX conditions although the path to Stateside appears steadily improving HB9s MQ and KB were to operate HB1MQ/vs in Switzerland's canton Wallis during mid-August. That's a rare one toward the H-22 award. W1HA heard they intended 40- and 20-meter c.w. work Ex-MP4BAD-Y11X, now G3GPE, writes W8DAW to defend rare-DX stations with QSL difficulties. Ken is re-listing in RAF for another 12-year hitch and hopes for further rare-DX assignments. G3GPE currently has 15 watts of c.w. on 40 and 80. W8DAW is considering a DX vacation after he raises his 195-confirmed tally to an even 200 The Radio Society of Bermuda held field days in June and August. VP9D reports them howling successes. VP9AX/P, with VP9s AX, AL and GX operating, rolled up the high score and their log showed QSOs with 26 countries. Trophies were awarded to each member of this winning team. W2KMP, honeymooning in Bermuda, found himself and his XYL right in the middle of the affair. The Garveys rolled up their sleeves and pitched in to assist VP9RC/P, and with the aid of VP9BD, a great time was had by all. VP9D reports the Society's station, VP9BDA, ready to hit the ether on all bands, 'phone and c.w. James will be on the air from G3XL, his British station, during a three-month holiday beginning this month W2QHH was gunning for HB1MQ/vs — Howy needs a very few more to complete his H-22 effort VE3KF mentioned to W5ASG that VQ4RF has ideas of putting ZD8RF on the air soon. . . . Via W1RWS, G6RH would like info on the present whereabouts of W9OZW/KS6, worked in '47. . . . XE1AC took another extensive trip to the U. S. Al reports 3911 QSOs rolled up by EA9DC in Ifni — that's a flock of RSTal OH2NW was looking for visiting amateurs at the Olympic Games ticket office in Helsinki. . . . KC6QL (ex-W3KEV-KH6QL/KB6/KC6) wants to finish his DXCC (Continued on page 136)

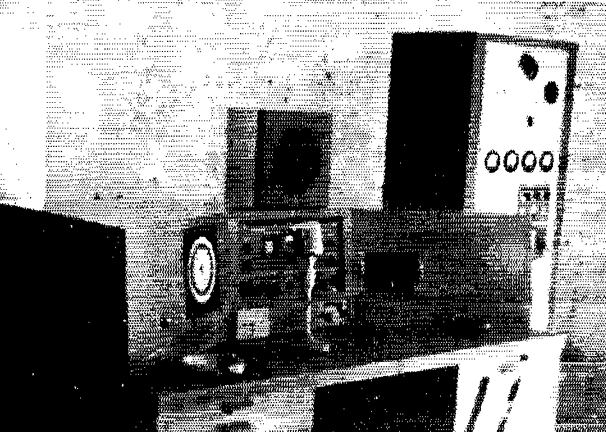
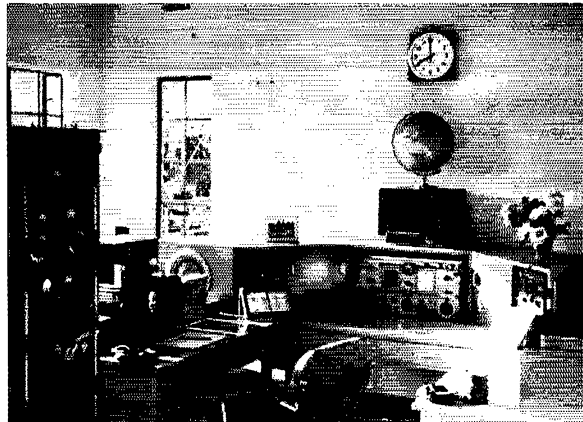



Correspondence From Members -

The Publishers of *QST* assume no responsibility for statements made herein by correspondents.

ANY NURSES?

145 W. 88th St.
New York 24, N. Y.

Editor, *QST*:

I would like to contact radio amateurs who are nurses, male or female, as I want to write an article on the nurses in ham radio.

— Joseph R. Lebo, W2OEU

SWITCH TO SAFETY!

20 Wall Street
Norwalk, Conn.

Editor, *QST*:

For eighteen years I have done maintenance work on broadcast transmitters. And not once have I found a bleeder open-circuited, failing to do its vital job. Until today!

Utilizing a shorting stick for the umpteen thousandth time with nary a display of fireworks over the years, all of a sudden I found my luck had changed. I was startled no end by a loud snap and a flash of fire as the stick shorted out one of WNLK's filter condensers.

All this took place at about six o'clock in the morning. There had been no plate voltage on the transmitter since the night before and, following our usual practice, the filaments had been burned for a few minutes after sign-off. One could assume that this would have bled away any current remaining in the power supply. But there it was, a charge of at least two thousand volts and with enough mills behind it to fry "ham" to a turn.

Broadcast men in particular should be careful about those voltages that can't be there, what with most maintenance being done at late hours when the mind may not be normally alert, but all of us should remember that soon or later, somehow or other, there'll be dangerous voltage where you least expect it. It takes everlasting vigilance to get it before it gets you.

— David W. Jefferies, W1ZA

NOVICE BREAK-IN

14 Elm Street
Valhalla, N. Y.

Editor, *QST*:

One way to lick the QRM problem on the 80 meter Novice band is with break-in. Few Novices realize what a boon to crowded frequencies it is. And for most low-power rigs it's quite inexpensive, too.

The traffic boys have been using it effectively, so why can't we?

— Peter Schorer, KN2ACH

SINGLE-SIDEBAND MODULATION

195 Broadway
New York, N. Y.

Editor, *QST*:

Some years ago when discussing with a friend the so-called "phase" system of generating a single-sideband communication signal, my attention was called to the fact that this system of modulation was invented by R. V. L. Hartley, who also originated the well-known Hartley type of oscillator circuit. The single-sideband modulation system in question is described in Patent 1,666,206, which was applied for January 15, 1925, and was issued April 17, 1928.

The various names given to that system of single-sideband modulation are imperfectly descriptive and an accurately descriptive name would require a good many words. Perhaps the simplest way of designating this system without ambiguity and with brevity would be to call it "the Hartley modulation system."

— Wm. R. Woodward, W2ROY

MOTORBIKE RIGS

Kellogg Route
Oakland, Ore.

Editor, *QST*:

After reading W6JQP's item in a recent *QST* about motorcycle rigs for civil defense, I'm going ahead on my original plan to put an all-band rig on my cycle. The civil defense chain has a weak link in it down here, but if all of you boys who have motorcycles can contribute a little time and effort we can help a lot. The time is coming when they will need us.

— J. R. Barrett, W7PXS

HE'S ABSOLUTELY RIGHT

23 Chelmsford Road
Rochester 18, N. Y.

Editor, *QST*:

Who started this "slant two" business on 'phone for portable operation, on 75 that is!?

It seems to be that FCC specifies that we state whether we are "portable," "fixed portable," "mobile," "maritime or aero mobile" (and not "portable mobile"). In addition we are supposed to state exact location such as "Dripping Lake, N. Y." rather than "slant 2" or "in second call area."

Let's keep it sensible as well as legal and "say it with words."

— E. B. Snow, W2BZN

HEY, RAPP!

Box 633
Goodyear, Arizona

Editor, *QST*:

With regard to the new rules being hashed over at present it looks to me as if someone is forgetting the prime object. I consider this to be "less QRM." Why not allow the boys with Extra Class tickets to operate on any c.w. frequency with + polarized fone, or single sideband, or double sideband reduced carrier?

The polarized fone deal sounded especially good in *QST* a couple of months ago. If some of the boys could be forced to go + and some — we would double our useful frequencies for the mutual benefit of everyone.

I believe the old Class A (unlimited) should be done away with completely and special privileges granted only to Extra Class. Reason — anyone can pass the Extra exam with slight effort and if he doesn't think enough of his hobby to exert that effort Class B privileges are enough for him.

So — let's do something to encourage the latest developments being used and up-grade the whole gang to our mutual gain.

— Arthur E. Luz, W7RTP

"BALLOONTENNA"

Portsmouth, N. H.

Editor, *QST*:

I live in an area where it is hard to find natural things on which to hang an antenna. . . . I went to the local airport and without too much trouble got two weather balloons filled with helium from the man on duty in the weather room. I tied these together and attached a spool of No. 36 enameled wire to them. Then the balloons were let up until the end was reached. I tied the end of the No. 36 wire to a fitting on the roof of my shack and ran a No. 18 rubber-covered wire from the fitting to my transmitter. After adjusting the pi network I was able to load the vertical wire very well. During the next few days I worked a number of stations during daylight which were over 500 miles away. At night I was able to do much better. I am using a rather poor

receiver at present and I feel that the results would have been better if I had been able to hear better. Possibly I had answers from even farther and was unable to hear them.

There are a couple of items I might mention about weather balloons at this point. If they are not tied very tightly or plugged in some manner they will deflate in a few days. In a high wind the No. 36 wire will break so it is a good idea to scotch tape a piece of fishline to the wire leaving the wire slightly slack between the taped areas. Also let the balloons up in a high clear area as they, of course, tend to ride down wind and in a high wind flatten the line out considerably. My first "balloontenna" fouled in the TV antenna causing much QRM from the rest of the family as it did weird things to the picture. Lately I have seen some very large balloons made of plastic advertised in various mechanical magazines. If the weather man's sense of humor still holds out, I intend to try again using heavier wire, and one of these larger balloons.

— Thomas M. Dale, WN1TWP

[EDITOR'S NOTE: Anyone using such an antenna should be careful to keep it away from power lines, to avoid the possibility of bringing umpteen thousand volts into the shack if the wind should shift. Also, don't forget the antenna structure limitations imposed by §12.60 of the regs.]

HELPS ON A.M., TOO

RFD 1, Glen Road
Sparta, N. J.

Editor, QST:

I have heard the gang on 3990 and others complain about s.s.b. QRM. Is it possible that "Class A" amateurs don't know how to use their receivers effectively? I wonder why they don't try using the s.s.b. method of reception for a.m. as well as s.s.b. They are in for a big surprise.

Operation of receivers for s.s.b. should be in every column published on single-sideband as it is simple — a.v.c. off, b.f.o. on, volume on maximum then adjust r.f. gain for audio level as low as possible.

For the beginner or newcomer to single-sideband, do understand this — with no carrier transmitted you have to reinsert the carrier at the receiver. Some strong signals may sound distorted due to overmodulation of your reinserted carrier. This is a modulation percentage problem and calls for stronger injection of the b.f.o., or, if you have a frequency meter, turn off b.f.o. and with frequency meter at fundamental frequency of the received signal couple to receiver and increase coupling until overmodulation distortion stops.

This has a quieting effect on the receiver also, and results are excellent because as injection is increased it increases your selectivity. Fine tuning can then be done on the frequency meter. Try it!

— Mece Kamke, W2ESP

THAT NOVICE RECEIVER

1612 Fairidge Dr.
Kingsport, Tenn.

Editor, QST:

This is just a note to tell you that I appreciate the help and suggestions that your article in August, 1951, QST, has given me. I built that two-tube receiver and I want you to know that it really has been surprising.

I have worked six sections, 16 states, and have 116 contacts on this receiver.

One thing I can say for a regenerative receiver is that it will receive most any signal that's on the air. . . .

— Larry Guenther, WN4UJT

NEW COUNTRIES?

427 Lakeview Way
Redwood City, Calif.

Editor, QST:

I am very curious about those odd signals from out in space, some near ten centimeters, others in all portions of the spectrum. Seems with some fairly good receivers available such as airborne radar surplus we could do more experimental work on u.h.f. and open a new field for discussion.

. . . . If you had a chance to work an off-the-earth or interplanetary contact, would you know if it were legal? Would the State Department, Army or other agency be on your neck?

— John M. Wood, W8WNY

Editor, QST:

In over 25 years of being in the ham game, I ran into my most unusual experience last night. Was on 14-Mc. c.w. about 10 p.m. when the band was out completely except for a couple weak VEs coming through. The weather was very clear and cold. I called CQ several times and after turning on the receiver I could hear my own signals after about a 2-second delay. At first I thought it another station signing off right after me. I then made a series of tests. I could send out a series of dots or the like and then listen on my own frequency and in 2 or 3 seconds I would in each case hear my own signal coming back about S6 or S7.

This condition continued for about 5 minutes and then gradually became weaker until I was no longer able to hear the echo signal.

I was running about 750 watts to p.p. 813s. Antenna was a folded dipole with its broadside aimed just slightly west of due north.

Can you offer a possible explanation for these echo signals?

— Robert A. Lundstrom, W9FUR

[EDITOR'S NOTE: Several possible explanations have been offered — one, for example, is that the signal bounces back and forth for a long time between two layers in the ionosphere.]

MOBILE INSURANCE

354 Linden Avenue
Buffalo 16, N. Y.

Editor, QST:

After talking to my auto insurance man I learned much about the mobile installation in cars — the way they are covered on actual cash value against fire and theft. I suggest that mobile installations be covered by a rider written in the policy or the outfit may not be insured. It costs no more and gives added protection over the actual cash value of the vehicle in which it is installed.

— Charles M. Laloz, W2FSB

HOW'S YOUR RECEIVER?

20 Miles Avenue
Fairport, New York

Editor, QST:

I suggest the following test be conducted by anyone who thinks he has a "sharp" receiver before he condemns single-sideband or double-sideband reduced-carrier operation: Tune in an unmodulated commercial or amateur c.w. signal (in a clear channel) with the a.v.c. on, r.f. gain full on, audio gain up and b.f.o. off, and very carefully rock the tuning dial on both sides of the signal. Note how far the dial has to be tuned in order for the carrier noise to disappear. (It's pretty hard to describe the noise made by an unmodulated carrier, but everyone who tunes a receiver for a while knows by sense when he is approaching a carrier.) Now repeat this test with the a.v.c. off and reduce the r.f. gain to a point where the receiver just begins to block — this is the maximum gain that would ever be used in copying a signal without a.v.c. — and again rock the tuning dial until the keying can no longer be heard. The receiver will appear considerably sharper than before.

An unmodulated keyed carrier occupies a very narrow channel — only a few cycles at moderate keying speeds, yet the average communications receiver with the a.v.c. on will detect the carrier over a bandwidth of at least 15 kc.* So far as the receiver is concerned, a s.s.b. signal is nothing more than several c.w. signals of varying amplitudes (and frequencies) all operating in a band of about 3 kc., and the receiver will respond to them exactly the same as it will to a keyed carrier. If the receiver appears to tune broadly on a c.w. station, which occupies a band of only a few cycles, how can it not be expected to tune broadly when receiving a s.s.b. signal? Turn off the a.v.c. and reduce the r.f. gain — clean up your own receiver before condemning the transmitted signal.

— Fran Sherwood, W2QCF

[* Less if the receiver has decent skirt selectivity but, unfortunately, most receivers leave much to be desired. However, several of the latest ones are featuring improved skirt selectivity — Ed.]



Hints and Kinks

For the Experimenter



ADDING AUDIO SELECTIVITY BY MECHANICAL MEANS

THE gadgets shown in Fig. 1 attack the selectivity problem from an unusual angle, in the sound reproducer itself.

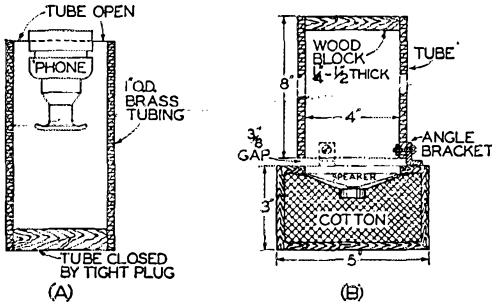

Fig. 1—Two methods of adding further audio selectivity are shown here. Both are extensions of the same principles involved in adding selectivity by means of the Q5-er and other sharp i. f. systems, but attack the problem from the mechanical side.

The arrangement shown in sketch A might be termed "A Soft Speaker," for it utilizes a hearing-aid type receiver found in some varieties of war-surplus headphones. A closed-tube resonator is coupled to the receiver, forming a tiny folded horn. Suitable steps should already be incorporated in the receiver audio circuits to maximize the beat note that is most pleasing to the operator. The length of the tube should then be cut to form a resonant air column at this frequency. The resultant build-up in signal at resonance is sufficient to make copying c.w. possible in a reasonably quiet room. Other signals are attenuated, aiding materially when severe QRM is present.

If you are mathematically inclined, you can compute your own dimensions from simple physical formulae, but a resonator constructed of 1-inch o.d. brass tubing 1 3/4 inches deep has been found generally satisfactory. A simple refinement would be to install a variable plug in the bottom of the tube so that tuning could be varied at will. If a rather low beat note is chosen it is possible to zero-beat out some adjacent channel signals while still retaining the air-amplification of the desired signal. — William Bruce Cameron

Shown in sketch B of Fig. 1 is a simple resonant speaker system which forms an effective tone filter for the reception of c.w. signals under conditions of severe QRM. It consists of a loud-speaker closely coupled to a sealed resonant tube which acts as an attenuator for all except the

frequency at which it is resonant. As a result, the bandwidth of the audio system is greatly reduced.

The construction and method of assembly are shown in the drawing. A 3-inch diameter speaker is mounted as shown in a wooden box in which the only aperture is closed off by the cone of the speaker itself. The interior of the box is packed with cotton to avoid unwanted box resonances. Care should be taken to avoid overpacking or the cone will not vibrate.

A tube, 8 inches long and 4 inches in diameter, is sealed at one end and mounted over the speaker by means of three equally-spaced angle brackets. The open end of the tube should be raised 3/8-inch from the face of the box. The tube itself can be made of stiff cardboard or any other material that will not produce unwanted resonance due to its composition. In operation, the "filter" produces a marked reduction in background noise, and has the property of making most signals sound "pure" in tone. The absence of any ringing effect is useful when weak signals are being copied, since their mark-space characteristics are not altered. — R. Young, G3BTP (R.S.G.B. Bulletin, Feb., 1952)

SOURCE OF SHIELD CANS

LET'S not overlook the corner grocery store as a source of good shielding materials. The 6-ounce cans used for frozen orange juice are just the right size for shielding small coils and tubes. Open them with a wall-type can opener so that the end roll will not be destroyed. Both ends may be removed if desired, and copper screening can be soldered inside one end to provide ventilation where needed. The circular clamps used to mount filter condensers serve as an excellent mounting device for cans of this size. — Jack W. L. Koehne, W9PFW

PLASTIC SPOOLS AS FEEDER SPREADERS

DISCARDED plastic spools from photographic roll film make excellent feeder spreaders for those who desire open-wire transmission lines. Several companies are using this type of spool in most of the popular sizes.

One of the best for this purpose is the spool used with the film required by the Polaroid Land Camera. These spools are already slotted at the ends, and result in a transmission line spaced about 3 1/2 inches. Real estate offices use this film for quick photos of houses, etc., and use a lot of it. Ask them to save the empty spools for you. — Don Langbell, VE6EL



Operating News



J. A. MOSKEY, WIJMY, Deputy Comm. Mgr.
GEORGE HART, WINJM, Natl. Emerg. Coordinator

F. E. HANDY, WIBDI, Communications Mgr.

L. G. McCOY, WIICP, Asst. Comm. Mgr., 'Phone
LILLIAN M. SALTER, Administrative Aide

Expedition. The *Blue Dolphin*, W2BZD/MM, as of July 17th reported 60 QSOs since sailing. W1CH has handled 99 per cent of this traffic with W1CQR, W1CRW, W1NRZ, W2EHV, W2HUG, W2QYT, W3AS, W3WV, W9HO and K4AF taking the rest. Bruce sends greeting to the gang from Hebron, Labrador.

Signing Up in RACES. Since August 15th the Radio Amateur Civil Emergency Service has been a going concern. Every amateur licensee should meet the challenge and invitation implied. It is hoped that in every community operating fun and prestige and serious purpose can be combined for the success of this amateur service. Already-licensed amateurs must apply for an additional authorization from FCC to operate in RACES. The local civil defense communications plans that call for the use of designated amateurs must be approved at state and federal civil defense levels to get a station its authorization from FCC. RACES is amateur in name, and largely in requirements; short of war it operates on a shared basis with the regular amateur service. It is our stake in making a continued wartime amateur operating contribution. To have it then and make it work properly, we should each get into it now. Before this is in print in *QST*, your ARRL Emergency Coordinator will receive a full copy of the RACES rules. Through him or direct it is suggested that, if you hold an amateur license, you at once get lined up to participate in RACES for your community, contacting the Civil Defense Radio Officer, if appointed, to get the proper FCC forms, so the RO can certify these and start them up through channels to get your RACES authorization.

Operating Fun. The July or Summer CD Party was a whale of a success. It was fully enjoyable in the time available to us. Are you readers and new hams in on these things? These radio get-togethers of the whole ARRL appointment family are highlights that come along four times a year. One meets fine operators and QSOs are from *all* over the nation if one's gear permits shifting properly from band to band. Some were fast contacts, but we had long chats with some. Our suggestion to amateurs who would like to engage in station testing like this and the fraternal contact with fellow appointees: Get your SCM to accept your application for appropriate station and leadership appointment along the lines of your natural interest. It is a prime chance for you to belong to groups that count for operating

achievement in amateur radio, to do things in a constructive way. Consistent activity and reports of same in appointment status earn you the right to participate in the "day off" when these quarterly radio activities come along.

DX Problem. The '53 ARRL DX Contest will of course utilize the 21-Mc. band. The new list of countries where amateurs can use 21 Mc. looks *very promising*. Twenty-one different countries are in that list put out in OB No. 356 in July! An informal word now to ask you how you would like the coming DX Test as to band counting and periods. Your frank individual feeling will help our staff committee that examines items or proposals for the next DX Contest rules. Majority sentiment has been closely followed in the past. We need a showing of hands (letter or radio message please) on whether you who plan to take part in the '53 DX test would like (a) to have ten and eleven meters count as one band or two, (b) to limit this year's test to one week end instead of the usual two, risking variable conditions more but making it a shorter run to accumulate a decent DX showing. We'll appreciate whatever you have to offer on this one.

On Correct Signing When Mobile. Just the other day a case was reported to us of a chap using 7-Mc. mobile and improperly signing /M. Very likely he shifted from 'phone on some other band and neglected to examine Section 12.82 for the exact procedure he should follow! A portable or mobile station using radiotelegraphy must transmit immediately after its call sign the fraction-bar character DN followed by the number of the amateur call sign area in which it is operating. It is *not* however necessary for amateurs *answering* this station to use the slant designation with that call. When telephony is used, the call sign identifying the transmissions, sent *last* as always to avoid confusion, should be preceded by the words "this is" or "from" with the call followed by mention of the geographical location in which the portable or mobile is operated. (Example: ". . . operating portable (or mobile) four miles south of Podunk, Fla., over.") /MM is the approved c.w. way to indicate true maritime mobile operation, normally limited by FCC to ten-meter work. It should be noted however that this is *not* the proper way to sign, except out *beyond* the continental limit. The *usual* land-mobile procedure applies when in inland and coastal waters.

By the way, if you hear an amateur call followed by a digit *without any slant sign*, it will

not necessarily be a violation of FCC regulations. It will probably be one of those newly-authorized RACES stations with *several units* operating under the same call signal in mobile work. These are distinguished from other amateur operation by the *omission* of the slant sign when working c.w., as provided in the new FCC rules for Radio Amateur Civil Emergency Service operating.

On Good and Bad Operating Procedures. From time to time members of the fraternity have compiled lists of do's and don'ts; it is valuable to review some of these. The Novice particularly can profit from examining practices considered good and efficient to make his own operating the kind generally admired; he has the advantage of not having to unlearn any habitually poor operating practices! Consideration of the following points is found to contribute to individual operating enjoyment and success in addition to resting on the premise that consideration for others and following of common sense rule-of-thumb will pay dividends in communications results to you and me. Tom, VE3BFK, rates a bouquet for compiling this list for the *Kingston Arc*, presented, as he says, "with malice toward none":

Heard locally—procedures to avoid:

- 1) Excessive tuning and loading of antennae.
- 2) V.f.o. swung over band with h.p. on.
- 3) Excessive strings of dots and other keying to no real purpose; whistles and hellos, no call sign.
- 4) CQ DX, sent on the channel where the DX was calling CQ!
- 5) Failure to identify station properly.
- 6) Tuning up on a frequency where others are in QSO; failure to listen adequately.
- 7) Untruthful reports merely to make distant operator "feel good."
- 8) Improper procedure signs, both c.w. and 'phone, excessive verbiage in sign-offs.
- 9) C.w. signal in 'phone channel ignored with 'phone net controller side references to not answering c.w.

Based on such considerations as the above, it is possible to summarize some general points of good operating and public relations.

Cultivating good listening techniques:

- 1) Learn to recognize open spots, stations you may be interfering with, the stations in QSO, desirable contacts when free.
- 2) Self-criticize your operating time elements: If you transmit excessively (some regard this as more than 10 per cent of the time you listen) you may kill DX or contacts for someone else. Consider also that at the same time you can't listen to it yourself.
- 3) Produce higher results by going after the stuff you *can* satisfactorily copy.

Tuning and loading—high and low power:

- 1) Every rig should have a dummy load—even if just an electric light bulb; be considerate of others, remove the radiating antenna on all preliminary tune-ups.
- 2) Using only the necessary amount of grid drive minimizes harmonic generation and TVI; controlling modulation avoids overmodulation and consequent splatter when using a.m.

— F.E.H.

MEET THE SCMs

Eastern Pennsylvania's SCM, John H. DuBois, W3BXE, has been a licensed amateur since March 1932. During the summers of 1949-50-51 he operated the first licensed station at St. Pierre under the calls FP8AA and FP8AB.

A former Assistant SCM and SEC, he now holds appointment as Official Relay Station and is Assistant Director in the Atlantic Division. SCM DuBois maintains an active interest in many phases of the ham game and is an ardent participant in such ARRL activities as DX Contests, Sweepstakes, Field Days, V.H.F. SS Contests, 160-Meter WAS Contests, LO-Nites, and CD Parties. He is a member of the Frankford Radio Club and has held office as its secretary; in addition he holds membership in the RSGB, DXCC, RCC, ROWH, A-1 Operator's Club, Old Timer's Club, AREC, and possesses WAVE, Code Proficiency (35 w.p.m.), and WAS (3 bands) certificates. Before World War II he was a member of the Atlantic-Pacific Trunk, E. Pa. Net, COP Net, and TL "M."



W3BXE is active on 3.5-, 7- and 14-Mc. c.w. as well as 50-Mc. 'phone but his favorite band is 14 Mc. Regular transmitting equipment consists of a 6AG7 VFO-6AG7 doubler-6AG7 doubler-parallel 807s final running 150 watts on 80, 40, and 20. An SX-71 and DB22A preselector are used for receiving and the antenna is a 66-ft. center-fed. Two 75-watt portable rigs are handy for emergency use.

Previous to his current employment by the RCA Manufacturing Company as product design engineer, Jack was a draftsman and designer. An expert chess player, his favorite sports are football, baseball, tennis, and swimming.

CODE-PROFICIENCY AWARDS

Have you received an ARRL Code Proficiency Certificate yet? Twice each month special transmissions are made to enable you to qualify for the award. The next qualifying run from W1AW will be held on September 16th at 2130 EDST. Transmissions will be made simultaneously on 1887, 3555, 7120, 14,100, 28,060, 52,000 and 146,000 kc. The next qualifying run from W6QWP only will be transmitted on September 5th at 2100 PST on 3590 and 7248 kc.

Any person may apply; neither ARRL membership nor an amateur license is required. Send copies of *all* qualifying runs to ARRL for grading, stating the call of the station you copied. If you qualify at one of the five speeds transmitted, 10 through 35 w.p.m., you will receive a certificate. If your initial qualification is for a speed below 35 w.p.m., you may try later for endorsement stickers.

Code-practice transmissions are made from W1AW each evening at 2130 EDST. References to texts used on several of the transmissions are given below. These make it possible to check your copy. To get sending practice, hook up your own key and buzzer and attempt to send in step with W1AW.

Date	Subject of Practice Text from July QST
Sept. 2nd:	A High-Powered Driver-Amplifier. . . , p. 11
Sept. 4th:	The Siamese Paddle, p. 16
Sept. 19th:	A Phase-Angle Detector. . . , p. 17
Sept. 12th:	Getting the Most Into Your Antenna, p. 21
Sept. 15th:	A Quadriband Mobile Transmitter, p. 24
Sept. 18th:	Two-Element Driver Arrays, p. 28
Sept. 23rd:	Antenna-Mast Loading and Guying, p. 42
Sept. 26th:	A 200-Wattler for 160, p. 48
Sept. 29th:	The World Above 60 Mc., p. 61

W1AW OPERATING SCHEDULE

From September 1st through September 27th W1AW will operate on the same frequencies and at the same times as indicated in the summer schedule announced on page 69 of June QST. The general contact schedule also will remain the same. The fall operating schedule will be announced in October QST.

TRAFFIC TOPICS

On August 1st we moved all card entries in our net registration card file to a new section of the file labeled "inactive," and here they will remain until each net is re-registered by its manager or one of its members or, after one year, discarded. This procedure, which may seem drastic and unnecessary to some netters, especially those who have just recently registered, is absolutely necessary because it is the only way we have of making sure that our net directory card file is current — or at least in no case more than a year old.

If you don't register (or reregister), you don't get in the net directory, thassall.

Net registration cards are available upon request from ARRL Headquarters. The easiest way to register is to get hold of one of them and send it back to us. Alternatively, here is the information that the card asks for: (1) Name of net — and let's make this as short and sweet as possible; and let's avoid names which smack of the facetious (see page 64, January 1952 *QST*). (2) Net call or designation. This applies mostly to c.w. nets which find it convenient to use net abbreviations for roll call purposes. (3) Frequency. (4) Days of operation (including nights). (5) Time of starting and approximate time of ending; we enter this in the record as GCT, but if you prefer to use local time be sure to indicate what brand of time you are using. (6) Direct coverage; this includes only those places which are covered by a station actually reporting into the net, not by nets or stations with whom net members maintain liaison. (7) Starting date of the net (if not continuous). (8) Call letters of the net manager. (9) Call letters of net control stations. (10) Regular net liaison; this includes other nets, not call letters. (11) Name and call of the person submitting the information; this goes on our net registration card so we can trace the source of the information thereon.

Registration is open only to amateur nets on amateur frequencies. We prefer not to register pseudo- or quasi-military nets, or nets which do not handle traffic and have no emergency application. We also would rather not register nets meeting less often than once per week, but will do so if requested.

Net registration information should be labeled as such, otherwise we may never include it in our card file. In the past we have sometimes gotten into trouble by registering nets which, we found out, did not want to be registered. In general, nets are registered only upon specific request and receipt of complete information.

During the summer a good many net control stations are put into long-sleeved jackets and taken away by men in white coats. Some of them are back with us in the fall, and some are not; it all depends on whether or not they completely recover from the horrific experience of trying to conduct a directed net in the midst of the many obstacles with which Old Mother Nature presents us in the summer-time, both biological and meteorological.

These fellows who trifle with their sanity by attempting to keep nets going during the summer deserve a lot of credit. We ought to give them a break. Failing that, we ought at least present them with our salutations and felicitations — and we do herewith!

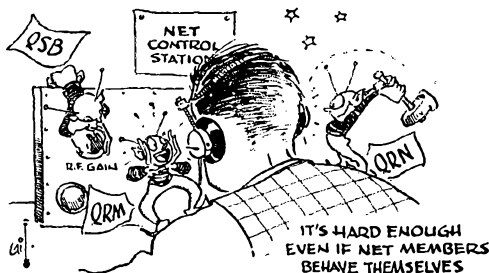

National Traffic System. Now that the long, hard summer is nearing its end, perhaps we can get back in the groove. Particularly needed are some stations to assume a few of the longer-haul TCC schedules, and of these we especially need some from the West Coast, both in regular and alternate capacities. By mid-July, 145 TCC invitations were sent out.

DX CENTURY CLUB AWARDS

HONOR ROLL

W1FH.....248	W6VFR.....240	W6AM.....235
W8HGW.....244	G2PL.....239	W3CPV.....234
W3RES.....243	W6ENV.....238	W8MEK.....234
W0YXO.....240	W3GHD.....236	W3JTC.....233

RADIOTELEPHONE

W1FH.....219	W9RBL.....200	ZS6BW.....185
PY2CK.....216	W1NWO.....196	W3BES.....185
VQ4ERR.....213	W1JXC.....196	W1MCW.....183
XE1AC.....213	W2BXA.....190	W6AM.....183
W8HGW.....201	W3LTU.....189	

From June 15 to July 15, 1952, DXCC certificates and endorsements based on postwar contacts with 100-or-more countries have been issued to the amateurs listed below.

NEW MEMBERS

OH1NK.....108	GM3CFS.....103	W3AS.....100
OH3NY.....106	ZL3CP.....102	W8AL.....100
K2BU.....106	W4GD.....101	G3CUG.....100
W1APU.....105	F81W.....101	G3CSL.....100
KG6GU.....104	F8CW.....101	W8ZYI.....100
OH5NK.....103	G3CHW.....101	HC2KI.....100
SM5HH.....103	W6IDI.....100	W2CWK.....100
ZL3IA.....103	YU3AC.....100	

RADIOTELEPHONE

VP6SD.....136	W2VYH.....108	LX1DC.....100
HK4DF.....119	CX3AA.....101	

ENDORSEMENTS

IU6DJX.....227	W6KYG.....160	W4TP.....128
G4CP.....211	W9ABB.....153	ZL3CQ.....125
W5ENE.....210	W2WC.....152	W6TXL.....121
VK2ACX.....210	SM7MS.....152	F3RA.....121
KV4AA.....201	E1SF.....147	PA0CP.....121
ZS6BW.....192	W3FYS.....146	W6YX.....120
I1KN.....191	W7AH.....144	W1ZW.....120
W6FPZ.....191	W2GNQ.....141	W3MDE.....120
HB9EU.....190	CN8MI.....140	YV5BZ.....120
W4TM.....179	W9RQM.....140	W3MNO.....120
KP4CC.....172	PA0RC.....140	V03X.....117
W5FFW.....171	SM5PA.....135	K6CU.....116
W1FTX.....170	G2BXP.....134	ZS1FD.....116
W2PRN.....170	W8JBI.....130	W5AVT.....115
W7HIA.....166	VE5QZ.....130	W1WG.....114
ZS6A.....165	W3LVE.....130	W9JUV.....110
KH6LG.....164	OZ3Y.....130	

RADIOTELEPHONE

W2AFQ.....180	G4ZU.....142	KH6OR.....118
PK4DA.....175	OZ7TS.....140	W2PRN.....116
W7HIA.....161	W4MKB.....140	W6YX.....115
W3KT.....150	G2BXP.....131	F8XP.....115

DXCC NOTES

From the Radio Club of Chile comes the following information of interest to the DX gang:

All CE7Z stations have been operating from either O'Higgins Base or Gonzalez Videla Base in the Territory off O'Higgins. Our atlas confirms the opinion of the Chilean society that these stations should be counted for Antarctica in DXCC, as both bases are situated on islands just off Palmer Peninsula and do not appear to be attached to the South Shetland Islands group.

FOREIGN TRAFFIC

Traffic of a non-commercial nature may now be handled with the following countries *only*: Canada, Chile, Cuba, Ecuador, Liberia and Peru. Traffic to and from U. S. citizens may be handled with amateur stations operated by U. S. military personnel in *other* countries only if (1) these stations are licensed by an agency of the U. S. Government (*not* by the foreign government) and (2) the licensing authority permits the handling of third party traffic.

BRASS POUNDERS LEAGUE

Winners of BPL Certificates for June traffic:

Call	Orig.	Recd.	Rel.	Del.	Total
W3CUL.....	409	2971	2417	507	4304
KG6FAA.....	674	1223	955	217	3069
W6HK.....	142	1186	1113	71	2512
K4WAR.....	107	924	847	87	1965
W9JUJ.....	22	704	653	25	1404
W2BTB.....	31	629	614	15	1289
W4FJU.....	6	602	535	67	1210
W8ZGT.....	12	608	578	8	1206
W7PMD.....	0	353	420	353	1126
W1CRW.....	19	475	430	37	961
W6GYH.....	22	453	361	51	887
W8SCA.....	3	348	345	6	702
W6QXO.....	18	302	203	97	620
W6KYV.....	103	252	104	148	607
J48AB.....	70	265	226	39	600
W6WPF.....	11	290	278	12	591
W5MNI.....	24	268	111	155	558
W6ELQ.....	5	266	273	2	546
W9TT.....	17	265	240	24	546
Late Report					
KL7AKJ (May)	52	642	612	30	1336

The following made the BPL for 100 or more *originations-plus-deliveries*:

W4RAZ 298	W7BA 109	Late Reports
W9NZZ 258	W2EC 102	JA2KW (May) 311
W6IZG 121		W1QYX (May) 265

A message total of 500 or more or 100 or more *originations-plus-deliveries* will put you in line for a place in the BPL. The Brass Pounders League is open to all operators who qualify for this monthly listing.

Applications were returned fully filled out by 27 stations, resulting in 45 assignments being made to 21 different stations. This means that, up to mid-July at least, the average TCC participant was doing the work of at least two TCC stations; actually, several do more than that.

Here's the complete TCC staff as of mid-July: *Eastern Area* — WIEMG, W2s COU RUF and ZVW, W3s GEG and LZM, W8s DSX UPB YIN, VE3s BUR EAM WY (assistant manager); *Central Area* — W5DRW, W9s JUJ KQL YTV, W6BVE; *Pacific Area* — W6s BPT JZ, W7s FRU PKX. There are openings for TCC stations in every area. With summer weather coming to a close, we hope to hear from a good many of those invitees who are holding their application blanks until time permits their more active participation. How about it?

June reports:

Net	Sessions	Sessions	High	Low	Average	Most
1RN	15*	136	18	0	9.1	Ct., Me., W. Mass.
2EN	42	195	16	0	4.5	JN
3RN	38	196	23	0	5	MDD
4RN	21	96	16	0	4.6	N. C.
RN6	30	1031	98	2	34.2	All
RN7	21	240	32	2	11	Wash.
8RN	13	14	6	0	1	Mich., Ohio
9RN	24	331	25	1	9.6	Ind.
TEN	20	364	52	3	18.3	la., Kans., Minn., Mo.
TRN	21	43	8	0	—	Ont.
EAN	21	545	60	1	26	1RN
CAN	20	597	75	7	29.8	9RN, TEN
QIN	51	527	59	0	10.3	

(Ind.)

* Out of 21 sessions held.

Second Regional Net: W2COU is bowing out of 2RN manership after making 2RN one of the best Regional Nets in the Past. K2BG is expected to take over.

Sixth Regional Net: All that traffic is being handled by a few stations on RN6. Nightly schedules are being kept with W6SCA and W3CUL to dispose of "through" traffic which TCC has not been able to handle.

Seventh Regional Net: RN7 has cut down to one session per day for the summer, at 2000 PST. Assistant Manager

W7PKX has been inactive due to illness in the family.

Thirteenth Regional Net: VE3ATR and VE3BUR are trying to keep things together until fall.

Eastern Area Net: 2RN missed one session in June, its first miss in 1952.

Central Area Net: CAN Manager W9JUJ says "Thanks to TEN and 9RN for 100% liaison."

Pacific Area Net: As of June 30th, no TCC stations had reported in to accept east-bound traffic. W7WJ compliments WIEMG for so valiantly trying to break through with west-bound traffic under trying conditions. Better representation is looked for this fall.

FREQUENCY MEASURING TEST SEPTEMBER 10TH

All amateurs are invited to try their hand at frequency measuring. WIAW will transmit signals for the purpose of frequency measurement starting at 10:30 P.M. EDST (6:30 P.M. PST), Wednesday, September 10th. The signals will consist of dashes interspersed with station identification. These will follow a general message sent to help listeners to locate the signals before the measurement transmission starts. The approximate frequencies used will be 3575, 7136 and 14,138 kc. About 4½ minutes will be allowed for measuring each frequency, with long dashes for measurement starting about 10:36 p.m. It is suggested that frequencies be measured in the order listed. Transmissions will be found within 5 or 10 kc. of the suggested frequencies.

At 1:30 A.M. EDST, September 11th (9:30 P.M. PST September 10th), WIAW will transmit a second series of signals for the Frequency Measuring Test. Approximate frequencies used will be 3594, 7008 and 14,113 kc.

Individual reports on results will be sent to all amateurs who take part and submit results. Copies of this report are sent SCMs also, so eligibility for OO appointments is known. When the average accuracy reported shows error of less than 71.43 parts per million, or falls between limits of 71.43 and 357.15 parts per million, the participants will become eligible for appointment by SCMs as Class I or Class II official observers, respectively.

This ARRL Frequency Measuring Test will be used to aid qualification of ARRL members as Class I and Class II observers. Present observers *not* demonstrating the requisite average accuracy will be reclassified appropriately until they demonstrate the above-stated minimum required accuracy for these classes of appointment. Class I and Class II OOs must participate in at least two Frequency Measuring Tests each year to hold such appointments. SCMs (see address, page 6) are open for initial applications for Class III and IV observer posts, good receiving equipment for 'phone and c.w. bands being the main requirement. All observers must make use of the cooperative notice (mail) forms provided by ARRL, reporting activity monthly through SCMs, to warrant continued holding of official observer appointment.

Any amateur may submit frequency measurements on one or all frequencies listed above. No entry consisting of a single measurement will be considered eligible for the QST listing of the *top results* in this FMT; at least *two* readings and preferably more should be submitted to warrant QST mention. Order of listing will be based on the over-all *average* accuracy, as compared with readings submitted by an independent professional frequency-measuring organization.

A.R.R.L. ACTIVITIES CALENDAR

Sept. 5th: CP Qualifying Run — W6OWP

Sept. 10th: Frequency Measuring Test

Sept. 16th: CP Qualifying Run — WIAW

Sept. 20th-21st: V.H.F. Contest

Oct. 4th: CP Qualifying Run — W6OWP

Oct. 11th-12th: Simulated Emergency Test

Oct. 15th: CP Qualifying Run — WIAW

Oct. 18th-19th: CD QSO Party (c.w.)

Oct. 25th-26th: CD QSO Party ('phone)

Nov. 9th: CP Qualifying Run — W6OWP

Nov. 13th: CP Qualifying Run — WIAW

Nov. 15th-16th, 22nd-23rd: Sweepstakes

Dec. 5th: CP Qualifying Run — W6OWP

Dec. 5th-7th, 12th-14th: 10-Meter WAS Party

Dec. 19th: CP Qualifying Run — WIAW

With the AREC



The new Radio Amateur Civil Emergency Service will go into effect approximately two months prior to the annual ARRL Simulated Emergency Test, which is scheduled this year, as many of you may have noticed, on October 11th-12th. More about the SET next month, before which time ECs should have received a copy of the complete RACES regulations as amended and as finalized by FCC, and an accompanying bulletin which contains an attempt by this office to boil down the regulations to their bare bones for simplification and a better understanding than might be available from casual study of the intricate legal language necessary in formal regulations. The annual SET bulletin should be reaching ECs also about the middle of September, as usual.

The finalized RACES regulations are changed but little in effect, although in a good many places the wording has been rearranged with clarification in mind. The only change made affected the types of emission authorized, and this only to a minor extent. Narrow-band f.m. (6 F3) is authorized on 3990-4000 kc. instead of facsimile (6 A4). Also, on RACES frequencies above 50 megacycles, audio frequency-shift keying is now permitted by both a.m. and f.m. (6 A2 and 6 F2 respectively, but 6 F2 not permitted in the segment 50.35-50.75 Mc.). Other changes in the wording, although in some cases quite extensive, were for the purpose of clarification only and do not affect the intent.

By the time this appears in print, RACES will have been implemented, and no doubt there will be RACES applications before FCC; at least, we hope so. The forthcoming Simulated Emergency Test need not be a RACES function, but this year we are closer to the necessity for civil defense than we were a year ago, and once again civil defense will play a major rôle in our Test. Most civil defense officials manage to restrain their enthusiasm concerning an "amateur show" as such. Be this as it might, the SET is an amateur show. The extent to which RACES figures in the SET will reflect the extent to which we amateurs figure in RACES — and that, after all, is up to us.

Less than 24 hours after the close of the 1952 Field Day, the Edmonton AREC was called out to furnish radio communication for the Engineer's Department of the city. SCM VE6MJ was alerted by the c.d. authorities and advised the Saskatchewan River was rising rapidly. Information from points upstream indicated the river would reach flood

An impressive turnout of some 200-odd amateurs attended a Civil Defense-AREC dinner sponsored by the Briggs Manufacturing Co. of Detroit in May. Each of these amateurs received his credentials as a member of Detroit Area Civil Defense, and with them a Form 7 AREC registration to fill out and submit to his EC. Among those at the speakers' table were W8CYL (Asst. EC, Detroit Area), Emery Lee (FCC Regional Manager), W8WFA (Detroit Area EC), W8QXK, John M. Sullivan (Red Cross), W8WA (m.c.), W8DZT (for Briggs), W8SPF (ARRL director), E. C. Denstaedt (Civil Defense) and W8GJH (SEC). See anybody you know?

proportions endangering the lives and property of those residing in the low-lying areas. In less than two hours, VE6MJ had his portable rig installed in the City Engineer's office and was in communication with VE6EA and VE6HM. They were soon joined by VE6EH and VE6WS. Operations were suspended at 2330 June 23rd after six hours, but the AREC net was again called at 1730 on June 24th, with seven mobiles and two fixed stations reporting in. During the night the mobiles patrolled the four areas concerned, assisting the welfare, police and first-aid workers by passing information to flood headquarters where speedy action was taken.

The city officials were prolific in their praise of amateur radio and the cooperation shown by Edmonton's amateurs in this emergency. The following amateurs participated: VE6s EA EH DZ HM HI FB GW MJ PE WO WS and VK.
— VE6MJ, SCM Alberta

At the request of W5DVI, the calls of all amateurs who participated in the Arkansas-Tennessee tornadoes last March are printed herewith: W1EPE; W3s BIP BFF CVE NRE; W4s AEE AFI AGC AKJ APC ATF ATW BAO BAQ BP BQK CDA CVM CXY EDC FK FLW FWX FX GCH GEH HCZ HPO HXC IGV JRD JU JWO KH KMH KX LC LOJ LUH MGT MVS MPM MWX NNH ODR OFX OIW OMN PUP PWX RHO RKN RMJ RPO SBF SBI SJ SON SQB STX SUC SUD SZI TAV TM TRQ VBA; W5s AKB APW AQF ARH AUU BBX BCZ BDR B.HI RM DI DRW DVI EA EB EEF EET EGY EM FDP FRV FYZ GHI HAA HHT HPL HUF HUS ICS IGM JFT JHL JIC JTR KBH KBO KKM KYV LCO LOK MFO MHS MIG MPG MRD MRK MSH NBT NLO NVO OCP ODX OFX OPD OWW PHP PYH PX QIP QKJ RII RWJ SMU STU STV SUB THY THZ TIC TIE TIE TIQ TIZ TJJ TNY TOE UAA UHD UTW; W6GQY; W8s ACW DLZ EKU ELW IV HZG KJ TBP URM WXO YIN; W9s QBD CTZ DKA EPZ FYM JBQ LZI NTW NWU OCH QLW TG TT UID WT; W0s ANB AUG AUH CEX CXF DMY EBE ESG GBJ KSY NIY NWF OTQ PTG RMX QJL.

Part of the Midwestern flood story which appeared in August QST still remains to be told. The amateurs in St. Joseph, Missouri, set up a station at the City Hall under the call of W0AWH. Mobiles were used on 75 and 10 and went as far south as Rushville. Communication was established with W0LBM/0 at Jefferson City for official state traffic. Both the Kansas Phone Net and QKS were on the job, but no appreciable amount of medium-distance traffic developed. W0RVG, the amateur station permanently set up at the Red Cross building at Kansas City, was active for about a two-week period, mainly on an "alert" basis. There was flooding and damage in the lowlands around Kansas City, but the Missouri's raging lacked



NATIONAL CALLING AND EMERGENCY FREQUENCIES

C. W.	'PHONE
7100 kc. (day)	3875 kc.
3550 kc. (night)	14,225 kc.
14,050 kc.	29,640 kc.
28,100 kc.	

During periods of communications emergency these channels will be monitored by stations of the National Emergency Net for personal-inquiry traffic. At other times, these frequencies can be used as general calling frequencies to expedite general traffic movement between amateur stations. Emergency traffic has precedence. After contact has been made the frequency should be vacated immediately to accommodate other callers.

The following are the National Calling and Emergency Frequencies for Canada: c.w. — 3535, 7050, 14,060; 'phone — 3815, 14,160 kc., 28,250 kc.

the concentrated fury of last year's Kaw flood. The following were known to have been active in one capacity or the other: W6s ATA AZL BGP BIA CBS CJS CXM DNF FHI HS HU IAC IAR ILF ITX JED KSS KSY NDS NH NMD NNU PB PCY POY QCG RDR UBR UFL UQJ VRF WHK WPN ZGK and K6FAY.

— . . . —

We welcome the SECs of Iowa and New York City-Long Island to the list of those who have submitted monthly reports in 1952, making the total 25. For the month of May, 18 SECs reported on behalf of 3718 AREC members. So our reporting progress continues, albeit slowly.

— . . . —

HIGH CLAIMED SCORES— 1952 FIELD DAY

Listed below are high claimed scores reported for the Fifteenth ARRL Field Day, June 21st-22nd. These are subject to checking and grouping according to the number of transmitters in simultaneous use at each station. Complete FD results will be published in a later issue.

Class A

(Listings show call used in FD, claimed score, and number of simultaneously-operated transmitters.)

Frankford Radio Club.....	W3FRY/3	21,078-10
Garden State Amateur Radio Assn..	W2GSA/2	12,789-9
(non-club group).....	W6UF/6	10,638-11
Lakeland Amateur Radio Assn.....	W2VDJ/2	10,494-6
North Suburban Radio Club.....	W9AP/9	10,251-6
North West Amateur Radio Club.....	W9IT/9	10,071-9
Ohio Valley Amateur Radio Assn.....	W4FU/8	10,017-5
Concord Brasspounders.....	W1OC/1	9900-9
York Radio Club.....	W9PCS/9	9225-6
Potomac Valley Radio Club.....	W4KFC/4	8766-2
Somerset Hills Radio Club.....	W2ARL/2	8226-5
Beaver Valley Amateur Radio Club.....	W3VRZ/3	8046-5
Hamilton Amateur Radio Club.....	VE3DC/3	7803-10
Northeast Radio Club.....	W3PKV/3	7587-2
West Side Radio Club.....	VE3JJ/3	7164-7
Chicago Suburban Radio Assn.....	W9SW/9	6858-6
Raritan Valley Radio Club.....	W2QW/2	6516-4
Four Lakes Amateur Radio Club.....	W9SWQ/9	6489-5
West Seattle Amateur Radio Club.....	W7AW/7	6471-5
Helix Amateur Radio Club.....	W6MGJ/6	6183-4
South Jersey Radio Assn.....	K2AA/2	6093-3
San Diego Amateur Radio Club.....	W6GGK/6	6057-5
Soledad Amateur Radio Club.....	W8GER/6	6039-7
Royal Order of Sods Club.....	W6CG/6	6009-3
Electric City Amateur Radio Club.....	W3KX/3	5796-7
Palo Alto Amateur Radio Assn.....	W6OTX/6	5735-8

Cleveland Brasspounders Assn.....	W8BWA/8	5679-2
Penn Jersey Amateur Radio Club.....	W2KFR/2	5661-4
Nortown Amateur Radio Club.....	VE3BR/3	5598-5
Bridgport Radio Amateur Club.....	W1QQA/1	5463-2
Motor City Radio Club.....	W8MRM/8	5430-3
Santa Clara County Amateur Radio Assn.....	W6UW/6	5397-10
Narragansett Assn. of Amateur Radio Operators.....	W1SKT/1	5265-2
El-Ray Radio Club.....	W1OMI/1	5085-5
Grand Rapids Amateur Radio Assn.....	W8DC/8	5085-4
Sandia Base Radio Club.....	W5MPZ/5	5031-3
Los Alamos Amateur Radio Club.....	W5PDO/5	5031-4
Capital Key and Mike Club.....	W3DIM/3	4873-3
Military Amateur Radio System.....	K4AF/4	4848-6
Jersey City Amateur Radio Assn.....	W2NGX/2	4765-5
Twin City Contest Club.....	W0TKX/0	4743-1
Niagara Radio Club.....	W2QYV/2	4717-3
Michiana Amateur Radio Club.....	W9AB/9	4662-5
Milwaukee Amateur Radio Emergency Corps.....	W9ESJ/9	4659-5
Delaware Valley Radio Assn.....	W2ZQ/2	4608-4
Radio Club of Tacoma.....	W7DK/7	4563-4
Morris Radio Club.....	W2FUS/2	4518-4
Utica Amateur Radio Club.....	W2WUX/2	4482-3
Huntington Amateur Radio Club.....	W2DPQ/2	4437-7
Hamfesters Radio Club.....	W9GPS/9	4410-3
Albany Amateur Radio Assn.....	W2GM/2	4356-4
Sacramento Amateur Radio Club.....	W6JN/6	4350-6
(non-club group).....	W8II/8	4347-1
Kenmore Buffalo Tonawanda Radio Club.....	W2EWT/2	4329-2
Oak Ridge Radio Operators Club.....	W4SKH/4	4328-7
Sioux City Amateur Radio Club.....	W0ERG/0	4298-4
Connecticut Wireless Assn.....	W1TX/1	4296-1
Lake County Amateur Radio Club.....	W9JZA/9	4194-3
South Lyme Beer, Chowder & Propagation Society.....	W1EH/1	4176-1
West Valley Radio Club.....	W6ARD/6	4146-7
Mid-Island Radio Club.....	W2UBW/2	4023-3

Class B

(Listings show calls of operators at each station, call used and score.)

W6s LDR RW.....	W6RW/6	5954
W3s EIS VES.....	W3EIS/3	5252
W2s FBA JBQ.....	W2JBQ/2	4495
W9s EWC QYH.....	W9EWC/9	3426
W2WZQ.....	W2WZQ/2	3065
W6s ICN QZQ.....	W6QZQ/6	2952
W7s GUV RT.....	W7RT/7	2133
W9s ERU HOA.....	W9ERU/9	2070
W2s CCR FTY.....	W2CCR/2	2012

Class C

W6MBA/6.....	3645	W3FMG/3.....	986
W6NSX/6.....	2065	W9FMH/9.....	783
W21QQ/2.....	1904	VE3IR/3.....	783
W3CHU/3.....	1807	W3NEY/3.....	743
W5DAH/5.....	1215	VE3WY/3.....	581
W3NXX/3.....	1175	W3OLG/3.....	540
W3FDJ/3.....	1067	W1MGF/1.....	527
W2YTH/2.....	986	WN1TTG.....	527

Class D

K7NRM.....	537	W2FCT.....	68
W1TLA.....	340	W2KEL.....	28
W6OKK.....	164		

Class E

W3QOR.....	176	W2APH.....	97
W3ISE.....	124	W5CA.....	97
W3QLZ.....	123	W6VAQ.....	97
W1BJP.....	120	W4TFX.....	61
W4TRA.....	120	W1LIC.....	57
W6DKB.....	119	W2CVW.....	57
W2GCA.....	118	W8DAE.....	56
W2GRH.....	104	W8KFU.....	52

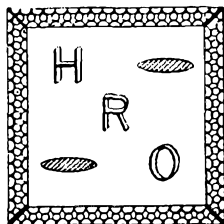

Herewith, another in our series of letters from "Hams" for whom the letters "HRO" have a special meaning.

June 27, 1952

THE NATIONAL COMPANY
MALDEN, MASSACHUSETTS

Gentlemen:

I've been enjoying the recent stories concerning the exploits of ancient vintage National equipment and think the following may be of interest to you.

More years ago than I care to contemplate, when I received my high school diploma, my father gave me \$100.00. Approximately 2 hours later I owned an HRO Jr., had fifty cents change, and the Cameradio Co. of Pittsburgh, Pa. (a swell outfit incidentally) had the hundred bucks. The receiver is serial No. 26 or 28 — it's not quite legible now.

The biography of this patriarch among receivers appears below: Prewar, it enabled me to work 126 countries, (no bandsread of course). It was then stored for eighteen months in an old warehouse where no particular precautions were observed, and later shipped to Miami, Florida, where it was kept in a garage and used only intermittently. During the war it made a trip to S. America and back to Miami. My W4 call was issued there and postwar operation began on 28 mc. In 1946 it rattled around in the back of a Plymouth coupe to N. Carolina. Since 1947 it has been in steady service. Between '47 and '49 it made possible QSOs with 189 countries (still no bandsread). Standard HRO coils for 14 mc. were purchased in '49, and the present country total is 209.

The first tube failure occurred around 1941. The 58's and 57's used originally were removed and replaced with 6D6's and 6C6's etc., and no changes were made other than the filament voltage. These tubes are still in use. The receiver now operated in conjunction with a homemade SSSC adapter and Select-O-Ject and a 1 KW SSSC transmitter. There is no indication that this old receiver has any intention of providing anything but excellent service for many more years, a tribute, I think, to its extraordinarily high quality.

Best regards,

R. E. MORAN, W4INL



• All operating amateurs are invited to report to the SCM on the first of each month, covering station activities for the preceding month. Radio Club news is also desired by SCMs for inclusion in these columns. The addresses of all SCMs will be found on page 6.

ATLANTIC DIVISION

EASTERN PENNSYLVANIA—SCM, John H. duBois, W3BXE—SEC: ISE. RMs: AXA, BIP, E. Pa. Net: 3610 kc. During Field Day the York AREC gained some fine publicity for amateur radio when they invited the public to visit their set-up. A well-equipped communications truck was manned by local amateurs, c.d., and Red Cross officials. AQN, York and Adams Counties EC of Ion standing, spark-plugged the activities. The York Red Cross group regularly operates on 29.492 Mc. On June 22nd during a Red Alert in Philadelphia, communications were aptly handled by members of the Philadelphia Area Council of Radio Clubs on 29.493 Mc. Unfortunately, space here does not permit individual credit to all those who helped make this a successful demonstration. UKI took advantage of some band openings to roll up an impressive list of 50- and 144-Mc. contacts. Despite summer schedules on the traffic lanes, the newly-formed Anthracite Net (AN) keeps things moving on 3610 kc. CUL makes BPL— as usual. The Phil-Mont Mobile Club was visited by KZ5s AC, GQ, and PC. FPC is TVI-proofing a Viking 1. NNV now is on 10-, 20-, and 75-meter mobile. QQH and PXY are moving. HYU now has 14-tube, 23-Mc. mobile receiver. SLF is putting up a three-element 10-meter beam and QFY is building on 75 and 2 meters. Traffic: (June) W3CUL 6304, BIP 110, AD 92, RCG 28, QZL 14, AQN 11, PUY 11, DUI 7, CAU 5, BES 3. (May) W3BIP 280, AQN 2.

MARYLAND-DELAWARE-DISTRICT OF COLUMBIA—SCM, James W. John, W3OMN—Field Day and preparations for it kept most of us occupied in June. All the clubs in the section reported a good time regardless of the scores. Maryland Emergency Phone Net held its first annual picnic June 8th at Gambrill State Park. One hundred of the section's amateurs attended to make the event a most successful one. The auction held for the Net's benefit netted the treasury more than \$140.00. MEPN, which was organized in January of this year, now has 75 active members on its roster. The Washington TVI Committee, co-operating with the RTMA and Electric Institute of Washington, conducted a practical two-night clinic on TVI problems on June 11th and 12th and 17th and 18th. Phil Rand was the guest speaker on TVI. 3RCN/3 was used to create TVI for the demonstration. The Baltimore Amateur Radio Club elected the following officers at its June 16th meeting: PRL, pres.; EF, vice-pres.; PSP, secy.; and RLR, treas. The Rock Creek Amateur Radio Assn. held a Field Day post-mortem at its June 27th meeting. ASE, operator at HZIAB, sends his best wishes to his friends in this area and advises he is on the lookout for W3s operating on 20 meters but hasn't worked any as yet. JHW is losing his antenna supports to a lumber company which is cutting the pine trees behind his QTH. KDP is active again on 75 meters. PTZ now has an outside antenna and reports his TVI is finally licked. CVE reports TCRN now has two daily sessions, 0015 and 0615 (GMT); also TCRN is set up as national emergency net as well as a traffic net. QZC attended the convention at Springfield on June 14th before leaving for two months as camp councillor in the Poconos Mountains. GRF, MFJ, RJS, and FQB helped the W4s of PVRC (4KFC/4) make 950 contacts with two transmitters on Field Day. QCB reports the heat has cost him 5 pounds and an 807. BSV, HL, and AFM have been appointed ECs in the State of Maryland. Traffic: W3CVE 193, QZC 68, LZM 52, COK 32, HC 23, JE 20, ONB 20, CQS 14, FQB 6, NNX 6, PTZ 6.

SOUTHERN NEW JERSEY—SCM, Lloyd L. Gainey, W2UCV—The Delaware Valley Radio Assn. recently acquired the facilities of the old Naval Radio Station at Mercer Airport with three 70-ft. masts and intends establishing a county civil defense control center which will house the new club station, W2ZQ. TNI is active on the low-frequency bands running 100 watts to a pair of 807s. 1RBT/2 now is mobile on 2 meters in this area, a welcome addition to the 2-meter emergency group. Ex-3ABW, formerly of Haddonfield and ex-member of the SJRA, was

elected to Fellow Grade by the I.R.E. BDI is installing a 50-watt all-band VFO transmitter in his new Studebaker. Ed anticipates considerable mobile operation this fall. LSS dropped the N from his call by acquiring a General Class license. WQA recently returned from a cruise to South America. RNO is building a Brownie twin-5 and intends putting out a potent signal on 2 meters. ASQ and UNT have been calling in on 2-meter mobile during Mercer emergency net drills. RIV now is chief operator aboard the S.S. *Longview Victory*. The June meeting of the SJRA featured a very interesting talk by our friend, Bill Gundersen, on the problems and activities of the blind members of our fraternity. Traffic: K2BG 119, W2RG 80, ZI 9.

WESTERN NEW YORK—SCM, Edward G. Graf, W2SJV—SEC: UTH. RMs: RUF, COU. PAM: GSS. NYS: 3615 kc., 7 p.m.; 3980 kc., 6:30 p.m. NYSS: 3595 kc., 3 p.m. NYS CD: 3509.5 and 3970 kc., 9 a.m., Sun. New officers of the Rochester DX Assn. are REF, chairman; PUN, asst. chairman; BJH, secy.-treas. 3CT, ex-8CL, is on vacation and is 75-meter mobile in the Buffalo Area. Advanced Class licensees now are M5F, ALK, and JHL. New RARA officers are VBH, pres.; TEX, vice-pres.; CZT, secy.; YUE, treas. QHH worked South America with single 616 on 160 meters. ARK is EC for Livingston County. The Cattaraugus County Amateur Radio Society (CARS) has been formed with VEP, pres.; FVW, vice-pres. and act. mgr.; ABC, secy.-treas. ZOO has sixteen-element beam on 2 meters. SYM is home from the hospital. Rochester DX Assn. is sponsoring an "Old Timer Nite" to be held Oct. 9th at the Elks Club. Everyone is welcome. Contact ICE for details. Niagara County AREC Net is progressing with fixed antennas being installed at various locations throughout the county. CZP has new Super-Pro. FRL and YLE are on 2 meters with 5225. FBA has a two-element on 2 meters. Rochester DX Assn. held its annual DX-Fest at BZN's cottage. The Genesee Valley Radio Club meets at the State Armory in Genesee each 1st and 3rd Tue. of the month. The LARARA is very active and welcomes the WNs to its meetings. Call Glen 5925-A1 for time and dates. GSS vacationed in Michigan. On the evening of May 20th the Lockport AREC furnished emergency communications for a c.d. test, with 10 mobiles and 8 portable stations being alerted. New calls in Lockport are K2ACQ and KN2AJF. On May 23th Rochester AREC furnished emergency communications for a c.d. test. RARA emergency truck, 6 mobiles, and various fixed stations were used on 10, 6, and 2 meters. BTB makes BPL this month. PGL is active on 80 meters in NYSS. VE3ANY visited v.h.f. friends in the Buffalo Area. ROL is vacationing in VEE-Land. EFU has been appointed Zone 4 c.d. coordinator by the N. Y. office of c.d. UHI is operating mobile on 2 meters. A new ham in Oneida is KN2APT. The Seventh Annual Ladies Nite and Hamfest of the Oneida Amateur Radio Club will be held Sept. 27th by reservation only. Contact RXW for details. The New York State Fair to be held at Syracuse Aug. 30th to Sept. 6th will have an amateur display located in the center of the State Bldg. at the Fair grounds incorporated in the NYS c.d. exhibit. BTB is chairman, assisted by CYD, EC for Onondaga Co. Traffic: (June) W2BTB 1289, ZOL 439, RUF 406, COU 118, TPN 99, GSS 72, VEP 72, OE 54, SJV 45, WZQ 25, ENW 24, KEL 16, RJJ 10, QHH 6, YGW 3, ZHU 3. (May) W2VEP 40.

WESTERN PENNSYLVANIA—SCM, Ernest J. Hlinsky, W3KWL—Your Division Director, GEG, your SCM, and CJF, Mercer County EC, motored to Uniontown to attend the Fort Necessity Radio Club Gabfest. Field Day radiograms were received from KYR/3, St. Marys, with four operators. 3AAX/3 operating mobile, and 2 operators for a total of 28 contacts and 477 points. The Amateur Transmitters Assn. of Pittsburgh had 23 operators and 4 rigs. The McKean Radio Club had 12 operators and 3 transmitters. The Beaver Falls gang, with 3VRZ/3, had 12 operators and 5 rigs. The Erie gang had 30 operators and 5 rigs under 3LTK/3 and the Mercer County Radio Assn. had 6 operators with 1 rig. The boys from Johnstown, 3QYK/3, had 12 operators and 2 transmitters. The Western Pennsylvania Emergency Net meets twice weekly at 2130 Wed. and 2300 Sat. The Weather Net, under the direction of RXT, shows quite a gain in stations reporting in each Wed. night on 144 Mc. Time is 2000-2200 EDST. The team of UUG and MPO are doing a bang-up job in helping Novices with code instruction. UUG is new editor of *YLRL Harmonics*, the official organ of the YLRL. OUA is the proud owner of a Viking, OMY, RUE, and NKM missed out on a good 2-meter opening during the June V.H.F. Contest as they were attending the Uniontown Gabfest while the 2-meter band was hot. RUE has slipped to 10-meter mobile. Down Jeanette, way, UVD tells us the local 80 Net is QRT for the summer. AER will operate a portable station on his

(Continued on page 84)

Signals of Distinction

ELDICO
OF NEW YORK
INCORPORATED

Catalog '52 - '53

ELDICO'S AMATEUR PRODUCTS AVAILABLE AT THESE LEADING DISTRIBUTORS NOW

ACK RADIO SUPPLY CO.
Birmingham 3, Alabama

ALLEN & HURLEY
Trenton, New Jersey

ALLIED RADIO CORP.
Chicago 7, Illinois

ALMO RADIO CO.
Philadelphia 6, Penna.

ALMO RADIO CO.
Atlantic City, N. J.

ALMO RADIO CO.
Wilmington, Delaware

ARROW ELECTRONICS INC.
New York 7, New York

WALTER ASHE RADIO CO.
St. Louis 1, Missouri

GEORGE D. BARBEY CO.
Reading, Pa.

BLUFF CITY DIST. CO.
Memphis 3, Tenn.

CAMERADIO CO.
Pittsburgh 22, Penna.

CONSOLIDATED RADIO CO.
Philadelphia 6, Penna.

CRAWFORD RADIO
Hamilton, Ont., Canada

DE MEMBRO RADIO
Providence, R. I.

DOW RADIO, INC.
Pasadena 4, Calif.

M. N. DUFFY & CO.
Detroit 26, Michigan

W. H. EDWARDS CO.
Providence 3, R. I.

ELECTRIC SUPPLY CO.
Oakland 7, Calif.

THE ELECTRONIC EQUIPMENT CO.
Fort Worth 3, Texas

ELECTRONICA WHOLESALERS INC.
Washington 1, D. C.

EVANS RADIO
Concord, New Hampshire

FEDERATED PURCHASER, INC.
New York 7, N. Y.

FEDERATED PURCHASER, INC.
Allentown, Pa.

FEDERATED PURCHASER, INC.
Newark, New Jersey

FEDERATED PURCHASER, INC.
Easton, Pa.

FEDERATED PURCHASER, INC.
Los Angeles 15, Calif.

FORT ORANGE RADIO DIST. CO.
Albany 7, New York

GRAHAM ELECTRONICS SUPPLY
Indianapolis 4, Indiana

R. C. & L. F. HALL, INC.
Houston 2, Texas

R. C. & L. F. HALL, INC.
Beaumont, Texas

R. C. & L. F. HALL, INC.
Galveston, Texas

HARRISON RADIO CORP.
New York 7, N. Y.

HARRISON RADIO CORP.
Jamaica 3, L. I., N. Y.

HARVEY RADIO CO. INC.
New York 18, N. Y.

HENRY RADIO STORES
Los Angeles 25, Calif.

HENRY RADIO STORES
Butler 1, Missouri

HUDSON RADIO
New York 19, N. Y.

HUDSON RADIO
New York 7, N. Y.

KIERULFF & CO.
Los Angeles 15, Calif.

MYTRONIC CORP.
Cincinnati 2, Ohio

NEWARK ELECTRIC CO.
Chicago 6, Illinois

OFFENBACH & REIMUS CO.
San Francisco 2, Calif.

OLSON RADIO WAREHOUSE
Akron 8, Ohio

PURCHASE RADIO & CAMERA SHOP
Ann Arbor, Michigan

RADIO, INC.
Tulsa, Oklahoma

RADIO AMATEUR CENTER
Raleigh, N. Carolina

RADIO ELECT. SERV. CO. OF PENNA. INC.
Philadelphia 6, Pa.

RADIO ELECT. SERV. CO. OF PENNA. INC.
Allentown, Pa.

RADIO ELECT. SERV. CO. OF PENNA. INC.
Easton, Pa.

RADIO ELECT. SERV. CO. OF PENNA. INC.
Wilmington 22, Delaware

RADIO ELEC. SERV. CO. OF N. J.
Atlantic City, N. J.

RADIO ELEC. SERV. CO. OF N. J.
Camden, New Jersey

RADIO EQUIPMENT CO.
Lexington, Kentucky

RADIO EQUIPMENT CO.
Norfolk 10, Virginia

RADIO PARTS, INC.
New Orleans 12, La.

RADIO PARTS CO. INC.
Milwaukee 3, Wisconsin

RADIO PRODUCTS SALES
Los Angeles 15, Calif.

RADIO PRODUCTS SALES. CO.
Seattle, Washington

RADIO PRODUCTS SALES. CO.
Denver 2, Colorado

RADIO SHACK CORP.
Boston 8, Mass.

RADIO TELEVISION RAYTEL S.A.
Mexico, D. F.

RADIO WIRE TELEVISION INC.
New York 13, N. Y.

RADIO WIRE TELEVISION INC.
Boston 10, Mass.

RADIO WIRE TELEVISION INC.
Newark 2, New Jersey

RADIO WHOLESALE & SUPPLY CO.
Honolulu 11, Hawaii

THE RADIO CENTRE
Montreal, Quebec, Canada

SREPCO INC.
Dayton 2, Ohio

SAN FRANCISCO RADIO & SUPPLY
San Francisco 2, Calif.

SCOTT RADIO SUPPLY
Long Beach 2, Calif.

UNITED RADIO SUPPLY INC.
Portland 9, Oregon

VALLEY ELECTRONIC SUPPLY
Burbank, Calif.

VALLEY RADIO DIST.
Appleton, Wisconsin

WESTERN DISTRIBUTORS
Salina, Kansas

WESTERN RADIO & TELEVISION
San Diego 1, Calif.

WIRELESS RADIO & TELEVISION
Canton, Ohio

WORLD RADIO LABS INC.
Council Bluffs, Iowa



44-31 DOUGLASTON PARKWAY • DOUGLASTON, LONG ISLAND, NEW YORK

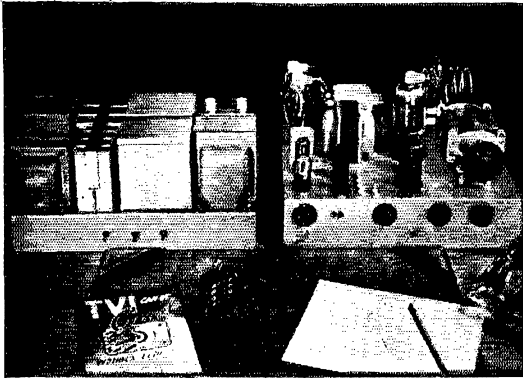

TR-1 TRANSMITTER

All-Band Amateur Transmitter Kit. 300 watts CW. 250 watts AM Phone. Covers 80, 40, 20, 15 and 11-10 meters. Band-switching in all stages except final—has broadband, slug-tuned exciter stages. Includes transformers, capacitors, carbon and wire-wound resistors, meter, coils, all tubes, wire, all hardware. Furnished complete with EV-915 crystal microphone and two punched chassis bases—RF, 17 x 13 x 4"; power supply 17 x 13 x 3". Uses 6V6 crystal oscillator, 6V6 and 6L6 doublers; 813 final, 100% modulated by Class B 811's; 6SL7GT and 6V6 speech amplifiers. Has 6L6 keyer tube. Rectifiers: 5U4G and 2-866A's. With complete instruction manual. For operation from 110-120 volts 50-60 cycles AC.

TR-1: Kit complete with instructions..... \$259.95

TR-1: Factory wired and tested 379.95

TR-1 TV TRANSMITTER

The answer to the "TVI" problem. Eldico's now famous "TR-1" 300 watt CW 250 watt phone all band transmitter, now TVI'd by the experts. Suppression of all harmonics, sub-harmonics or superious responses by 60 db or greater. Completely shielded RF chassis (crystal oscillator-doubler-813 final), all leads by-pass and filter, built in brute force AC line filter and low pass transmission line filter (72 ohm output). Complete kit including tubes, chassis, shield, filter, components, coils and etc.

TR-1 TV: Kit complete with instructions \$379.95

TR-1 TV: Factory wired and tested 499.95

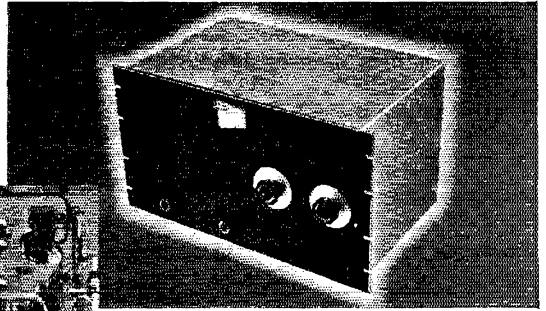

TR-75TV TRANSMITTER

60 watt CW transmitter. Kit includes anti-TVl features—special shielding and bypassing to reduce harmonics. An easily built beginner's transmitter. Covers all bands 80, 40, 20, 15 and 11-10 meters. Pi-network output permits easy matching to any single-wire antenna. Uses 6AG7 crystal oscillator and 1625 final. Husky power supply with 5U4G rectifier delivers 550 volts. Complete with every part, including all tubes, coil forms, coil wire, capacitors, meters, resistors, hardware, chassis, shield cover and TVI-proofing provisions. For operation from 110-120 volts. 50-60 cycles AC, with complete simple instruction manual.

TR-75TV: Kit complete with instructions.....\$64.95

TR-75TV: Factory wired and tested..... 94.95

Extra coil set for additional bands, \$4.50 each set

SINGLE SIDEBAND TRANSMITTER-EXCITER

The Eldico SSB Jr., patterned after the revolutionary unit developed by GE engineers is available in either kit form or completely wired and tested. Eldico's SSB Jr. is a complete 7-tube 5-watt single sideband transmitter. Tube complement consists of 12AU7 combination speech amplifier-oscillator; 12AT7 twin-channel amplifier; 6AG7 final; 12AT7 speech pre-amplifier; 6H6 bias; 5Y3-GT rectifier. Each kit comes with all parts, punched chassis, cabinet, tubes, power supply and full instructions for assembly and operation. No more difficult to construct and adjust than any simple transmitter, because the audio phase-shift network is laboratory assembled and adjusted. Practical SSB at amazingly low cost is now a reality. The Eldico SSB Jr. may be used as a transmitter, as a driver for a high-power linear amplifier, or in conjunction with a v.f.o. The transmitter provides 40 db. sideband suppression by using a simplified phasing method which requires only standard components and no special technical skills.

SSB Jr.: Complete kit with instructions.....\$79.95

SSB Jr.: Wired and tested. 129.95

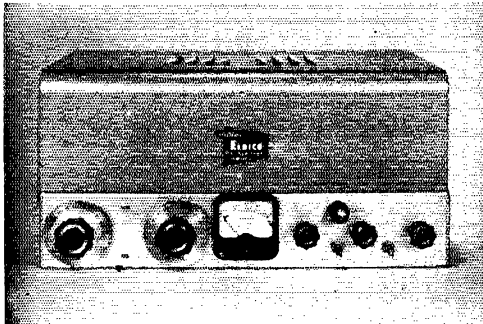

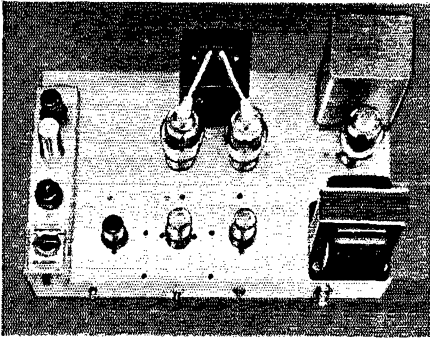

MD-100 MEDIUM POWER MODULATOR

Compact speech amplifier and modulator capable of delivering 100 to 120 watts maximum of AM audio for 100% plate modulation of any CW transmitter up to 250 watts input. 6SJ7 resistance coupled to 6SN7 dual-voltage amplifier and phase inverter, driving a 6SN7 transformer coupled to a pair of modulators in class AB2. Modulation transformer is matched to a class C r.f. plate load of 3000 ohms. This complete package includes everything from a carefully punched and drilled chassis to an Electro-Voice 915 crystal microphone. Plate voltage to the low-power speech stages and screen voltage for the modulator is supplied from an integral power supply. The Modulator plate voltage must be obtained from external supply.

- MD-100: Kit complete with Instruction Manual \$69.95
- MD-100: Factory wired and tested 99.95

MD-40P LOW POWER MODULATOR/SPEECH AMPLIFIER

40 watts of audio; 6SJ7 drives 2 6SN7 amplifier/phase inverter which in turn drives a 6SN7 driving a pair of 6L6G modulator tubes in Class AB2. The output transformer is matched from 6L6's to a Class C r.f. plate load of 6000 ohms. Complete with punched chassis, components parts, and the Electro-Voice 915 High Level Crystal Microphone, less stand. AC Power Supply delivering 350V at 200 ma.

- MD-40P: Kit complete with Instruction Manual..... \$59.95
- MD-40P: Factory wired and tested..... 79.95

MD-40 LOW POWER MODULATOR/SPEECH AMPLIFIER

Same as above with exception that it is less internal power supply.

- MD-40: Kit complete with Instruction Manual..... \$49.95
- MD-40: Factory wired and tested 64.95

EE-1 ELECTRONIC KEY

Self-completing type of automatic keying device incorporating all the latest improvements in automatic keying known to the art. Features self-completing characters that automatically insure perfectly formed sending; continuous variable speed control for any rate of sending from 8 to 50 w.p.m.; separate control for weight of characters and ratio of dashes-to-dot length, allowing individual tailoring to your own fist; self contained with built-in power supply in an attractive hammetone case complete with automatic key.

- EE-1: Kit complete with Instruction Manual..... \$29.95
- EE-1: Factory wired and tested..... 39.95

EE-2 ELECTRONIC KEY

Unit similar to above but with built in tone oscillator and speaker for monitor keying—pitch and speed control on front panel.

- EE-2: Kit complete with Instruction Manual..... \$34.95
- EE-2: Factory wired and tested 49.95

ANTENNASCOPE

The instrument to give you Positive antenna performance and efficiency! The Antennascope is an impedance measuring meter used in conjunction with the Grid Dipper. With the Antennascope you can measure radiation resistance of your antenna; resonant frequency of your antenna; impedance of your transmission line; input impedance of your receiver; standing wave ratio of your feedline. Each kit is absolutely complete and includes detailed instructions.

- AT-1: Kit complete with Instruction Manual \$29.95
- AT-1: Factory wired and tested..... 34.95

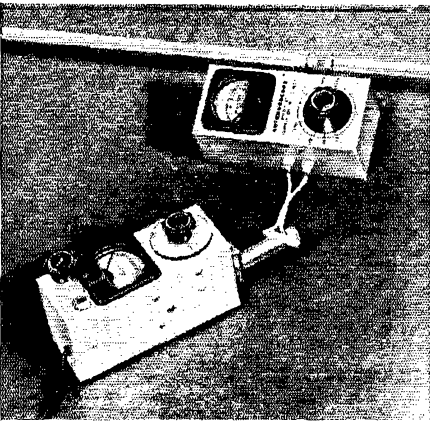

GDO-GRID DIP OSCILLATOR

Based on the original W2AEF grid-dipper the new model incorporates all the improvements. High-sensitivity regeneration circuit is now standard part of kit. 2" square O-1 ma meter improves readability of instrument. Special straight-line frequency capacitor is fully assembled with all mounting brackets and coil socket. Grid Dipper kit includes everything required, special case designed to facilitate one-hand operation, tube, internal power supply, meter and detailed Instruction book covering assembly and operation. Range 3 mc to 250 mc, covered in six steps. Operation from 105-125 volts AC/DC.

- GDO: Kit complete with Instructions and Application Manual \$34.95
- GDO: Factory wired and tested with Application Manual 47.95

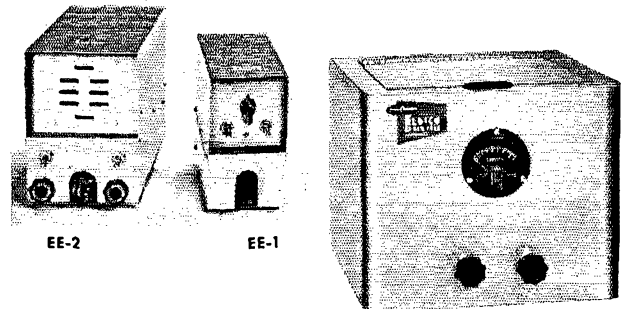

A-300 ALL BAND ANTENNA TUNER

300 watt Universal antenna coupler designed to couple any conventional antenna feedline, regardless of impedance, to any conventional tank circuit. Tuner kit includes split stator capacitor, swinging link, shielded case, 3" round ammeter, coax connector from transmitter, coax and open line connectors and output. Complete with shielded cabinet, R.F. Ammeter, swinging link, dual variable condenser, coaxial plugs, hardware.

- ANTENNA TUNER: Kit complete with Instruction Manual..... \$29.95
- ANTENNA TUNER: Factory wired and tested 39.95

CIVIL DEFENSE

AMATEUR

CIVIL AIR PATROL

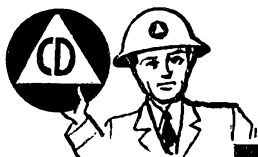

ELDICO'S receiving and transmitting equipment especially designed for TRIPLE SERVICE—

1. For civilian defense (RACES);
2. For Civil Air Patrol;
3. For amateur communication—Mobile or Fixed

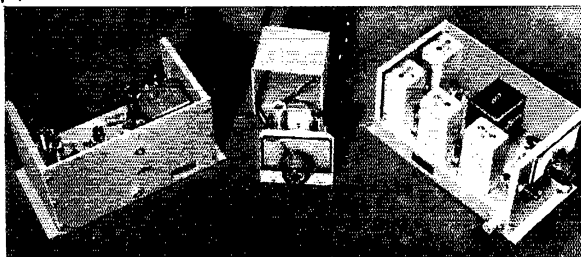

MT-2 2 METER TRANSMITTER

Crystal controlled transmitter designed for operation in the 144-148 mc band; 6AQ5 crystal, 6AQ5 doublers; driving 2E26 final up to 22 watts input. 6C4 speech amplifier for carbon microphone input, driving pair 6V6 modulators. A modified pi-network is provided for ease of coupling to any type 2-meter antenna. Low power plate drain is only 300 v., 100 to 200 ma depending upon plate loading. Coax output and integral antenna switching included. All tuning controls are screwdriver adjusted with positive locking to prevent detuning when used in mobile installations. Parts are conservatively rated to provide trouble-free performance. Layout and circuit design insures stable operation equal to standard low-frequency equipment. Cabinet size 5 1/2 x 9 1/2 x 5 1/2" designed for universal mounting and finished in hammertone baked enamel. Jones plug and coax connectors make installation rapid and positive. Any power supply may be used capable of providing 300 volts at 200 ma. May be operated from dual vibrator supply also supplying receiver.

- MT-2 TRANSMITTER: Kit complete with instructions\$59.95
- MT-2 TRANSMITTER: Factory wired and tested 79.95

MRT-2AC POWER SUPPLY

AC Power Supply for MR-2 Receiver and MT-2 Transmitter. 115V-50-60 cycles AC input for 300 volts DC at 200 ma. Complete with plugs and cables for direct connection to both units. Built in 6V DC selenium supply for operating control relays. 5U4G rectifier furnished.

- Kit complete with Instruction Manual.....\$29.95
- Factory wired and tested..... 39.95

MR-2 REMOTE TUNING KIT

Local oscillator can be removed from receiver and installed at driver's position allowing receiver and transmitter to be mounted remotely. Adapter kit consists of special custom housing, new receiver front panel, brackets, hardware, instructions and etc.

- MR-2 REMOTE TUNING KIT: With instructions. \$12.95

ANT-2 ANTENNA

2-Meter fixed station-non-directional "VXer" antenna. The ideal antenna for CAP, Civilian Defense or Amateur Communication. Can be used for vertical or horizontal polarization; perfect match for 72 ohm coax. Complete antenna ready for easy assembly with instructions.....\$14.50

MR-2 2 METER RECEIVER

Designed for mobile or fixed station operation, this kit is a complete 2-meter superhet tuning 144-148 mc with a sensitivity of better than 1 uv for 6 db signal-to-noise ratio. Using the Walman front end circuit and 9-mc i.f.'s the a.v.c. and a.n.l. contribute to rock-steady stability and unmatched selectivity. The 10 tube circuit has a total battery drain of only 22 watts. 6AK5 r.f. stage; 6C4 cathode followers; 3 stages of 6BA6 i.f.; 6AL5 noise limited; 6V6 audio output of 1 watt into 4 ohms; OA2 voltage regulator. For ease of tuning a geared vernier provides a velvet touch. The local oscillator is designed as an integral assembly. At a slight additional cost it can be purchased in a small external box for mounting in confined areas or where the feature of separate receiver tuning is wanted. Cabinet size is 5 1/2 x 9 1/2 x 5 1/2". Designed for universal mounting and finished in handsome hammertone baked enamel. Jones plug and coax connectors make installation rapid and positive. Standard components are used throughout should replacement of parts be necessary.

- MR-2 RECEIVER: Kit with Instruction Manual.....\$69.95
- MR-2 RECEIVER: Factory wired and tested..... 99.95

ELDICO also custom builds communication equipment for all special purposes—various State, City and Municipal Agencies are now using Eldico mobile and fixed civil defense equipment. See your distributor or write direct to Eldico for your CIVILIAN DEFENSE PLANNING SHEET.

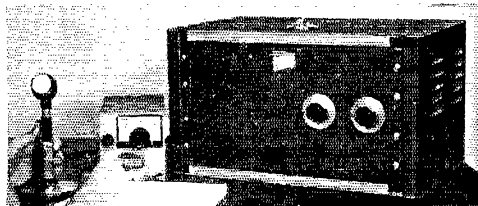

ELDICO'S FT-30 transmitter motor-selected 4 channel crystal controlled fixed station civil defense transmitter; 30 watts AM phone with Eldico's MR-2 receiver; also available with 100 watts AM phone. Price and specifications upon request.

LOW PASS FILTERS

Eldico's TVD-62 is a two-section M-serviced low-pass filter completely self-contained in a special case measuring 9 1/2 x 4 3/4 x 2 1/4" supplied with coaxial connectors for the input and output. Attenuation of harmonics radiated by the antenna, the source of most TVI, is in excess of 60 db. Cut-off frequency of 40 mc insures maximum performance to 10 meters. Each filter includes six 50 uuf ceramic condensers; pre-wound and formed coils, shielded case and all necessary fittings. The TVD-62 is installed directly between the link output of the final and the antenna or tuner. For stubborn cases of TVI in high-powered rigs an additional filter should be installed between driver and final grids. Filter will handle up to 1 kw AM. Insertion loss negligible. For 52 or 72 ohm coaxial feedlines or coaxial feed to antenna tuner.

- TVD-62: Kit complete with Instruction Manual...\$15.95
- TVD-62: Factory wired and tested..... 18.95

DIAXIAL LOW PASS FILTERS

To fill the requirements of amateurs using parallel 52 ohm or 72 ohm coaxial feedlines the Diaxial Low-Pass Filter is a modification of the TVD-62. Consists of two TVD-62 filters paralleled in a single case with a nominal impedance of 100 ohms. All parts and instructions included. Supplied with four standard coaxial connectors for input and output and shielded case.

- TVD-104: Kit complete with Instruction Manual...\$22.95
- TVD-104: Factory wired and tested..... 29.95

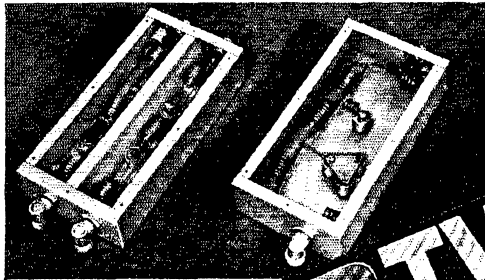

HIGH PASS FILTERS

For television interference reduction. Essential filters to be installed directly at the antenna coil of the television receiver. Greatly reduces or completely eliminates r-f interference from amateur or commercial transmitters, industrial equipment, diathermy, oscillator radiation and other sources. Negligible insertion loss. Efficient on any television receiver. 40-mc cut-off, no attenuation to signals above 40 mc, consequently does not affect picture strength or quality. Available for coaxial or 300 ohm twin-lead transmission line. Can be assembled from kit in a few minutes.

- TVR-300: 300 ohm High Pass Filter
- TVR-62: Coaxial High Pass Filter for 52 or 72 ohms—either model\$1.98
Wired and tested. High Pass receiver filter ready to install with complete instructions for connecting.
- TVR-300: 300 ohm High Pass Filter
- TVR-62: Coaxial High Pass Filter for 52 or 72 ohms—either model 3.98



TVI CAN BE Cured

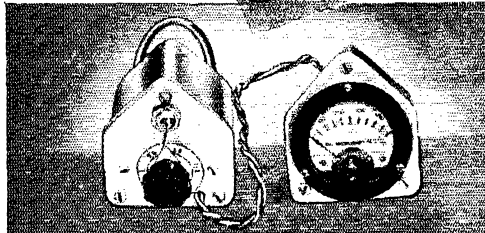

HARMONIC CHASER

Modified absorption type wave-meter for locating, measuring and identifying transmitter harmonics in any of the 12 television channels. Designed to eliminate swamping by the transmitter fundamental when the unit is tuned to the harmonic. Complete with all parts except indicating meter. Requires a sensitive external current indicator. Can be used with most volt-ohmmeters or with the 500 microampere meter listed below.

- TVH: Kit complete with Instruction Manual.....\$10.95
- TVH: Factory wired and tested..... 16.95
- TVH-500: Microampere meter in case to match harmonic chaser 10.95

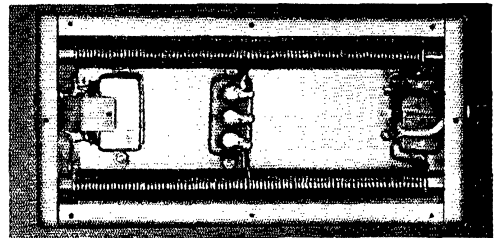

BRUTE FORCE LINE FILTER

R.F. Feeding back through power lines is a serious source of TVI and BCI, Eldico's two-section Brute Force Line Filter will completely eliminate r.f. feed through in an AC line, required only minimum installation. Patterned after the recommendation model in the 1949 ARRL Handbook each filter consists of two special coils (3/16" Sq. Copper in TVL-2.5KW) pre-formed and wound, 5 oil filled capacitors and 3 mica capacitors; all rated at 400 v.d.c. Metal case measures 4 3/4 x 9 1/2 x 2 1/8" TVL-1KW supplied with heavy duty line cord and plug and female AC outlet receptacle. TVL 2.5KW equipped with BX clamps for securing AC lines. Complete with instructions.

- TVL-1KW: For total maximum line drain of 1KW.Kit complete with instructions \$11.95
- TVL-1KW: Factory wired and tested..... 15.95
- TVL-2.5KW: For total maximum line drain of 2.5KW Kit complete with inst..... 18.95
- TVL-2.5KW: Factory wired and tested..... 24.95

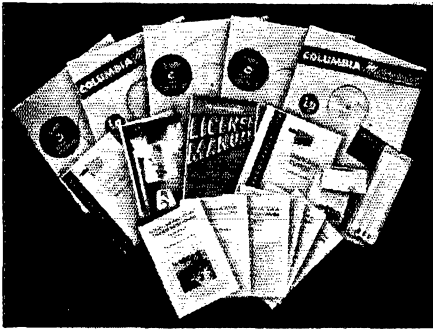

"PRIVATE TUTOR" NOVICE AMATEUR RADIO COURSE

An amateur Radio Course tailor-made for the novice—created by professional educators, engineers and experienced amateurs. All material has been especially selected; profusely illustrated; and arranged in easy step by step sequence to provide individual instruction—literally your own "Private Tutor" every step. The course consists of five Columbia long playing micro-groove recordings; for code instructions, six novice theory lessons and examinations, an ARRL License Manual and various supplementary aids. The unbreakable microgroove 12" records give a total course of instructions equal to almost five hours or the equivalent of fifty (50) standard records. Code instructions are accompanied by the voice of the instructor. As the code groups are transmitted the speed is gradually increased. Speed is developed beyond that necessary for the FCC examination requirements and when your license arrives you are ready for your first QSO.

- Complete course (code and theory)..... \$25.00
- Records only (code course)..... 17.00
- Theory Course only 10.00

"PRIVATE TUTOR" ADVANCED CODE RECORDS

Another Eldico First. Three code speeds on a single record—five long playing Columbia microgroove recordings are available ranging in speed from eight words a minute, up to and including 30 words a minute. Each recording can be played at three record speeds, giving three different code speeds. Records available for speeds of 8, 9, 10, 12 and 15 words per minute at 33½ r.p.m., giving code speeds of 12, 14, 16, 18 and 21 at 45 r.p.m. and 16, 18, 20, 24 and 30 at the higher 78 r.p.m. Straight text, numbers, coded group and cryptograms are included in the practice. Each record at the slower r.p.m. has approximately 30 minutes of practice time. Available as individual records at \$3.95 per record, specify the speed desired.

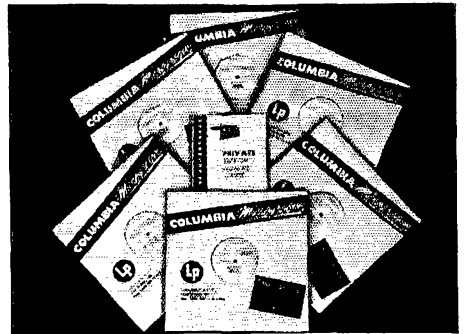

HIGH VOLTAGE POWER SUPPLY KITS

These kits use all standard brand new components and are conservatively rated to give dependable high voltage under continuous duty service. Because high-voltage supplies generally require little modification upon completion, these units are engineered to give trouble-free performance without attention from the day you solder the last connection. Each kit includes plate transformer, separate filter transformer, smoothing chokes, oil filled condensers, rectifier sockets, HV-1500' also includes line cord, pilot light, fuse, fuse post switch and etc. Each kit is supplied with instructions—less chassis and rectifier tubes. All Eldico High Voltage Power Supply Kits are for 110-120v 50 to 60 cycles AC. Total cost of each kit is comparable to what you would expect to pay for the plate transformer alone. 1500 volt supplied uses 866's, all others use 872's.

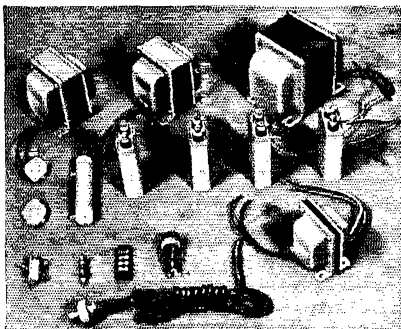

			Weight	Kit	Transformer Only
HV-1500	1500 v.d.c.	350 ma	55 lbs.	\$55.95	\$29.95
HV-2000	2000 v.d.c.	500 ma	100 lbs.	99.95	65.95
HV-2000SP	2000 v.d.c.	700 ma	100 lbs.	129.95	89.95
HV-2000	2500 v.d.c.	500 ma	100 lbs.	159.95	119.95

ELDICO has always given first thought to the Ham . . . to his well being as an individual, the full enjoyment of his hobby, the advancement of his amateur radio knowledge, and to general good fellowship of one Ham for another all over the world. No little thought has also been given to supplying him with finer, more dependable equipment at prices he can afford. This catalog of the ELDICO line reflects that forethought on behalf of the Ham, as well as the foresight of leading distributors throughout the nation who feature ELDICO.

W2UOL

to the **E. E. or PHYSICS GRADUATE**

with experience in

RADAR OR ELECTRONICS

Hughes Research and Development Laboratories, one of the nation's large electronics organizations, is now creating a number of new openings in an important phase of its operation.

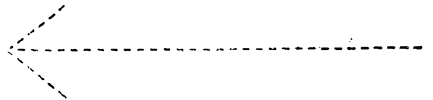

Here is what one of these positions offers you:

1. THE COMPANY

Hughes Research and Development Laboratories is located in Southern California. We are presently engaged in the development of advanced radar devices, electronic computers and guided missiles.

2. NEW OPENINGS

The positions are for men who will serve as technical advisors to the companies and government agencies purchasing Hughes equipment. Your specific job would be to help insure the successful operation of our equipment in the field.

3. THE TRAINING

Upon joining our organiza-

tion, you will work in our Laboratories for several months until you are thoroughly familiar with the equipment you will later help the Services to understand and properly employ.

4. WHERE YOU WORK

After your period of training (at full pay), you may (1) remain with the company Laboratories in Southern California in an instruction or administrative capacity, (2) become the Hughes representative at a company where our equipment is being installed, or (3) be the Hughes representative at a military base in this country—or

overseas (single men only). Compensation is made for traveling and for moving household effects, and married men keep their families with them at all times.

5. YOUR FUTURE

You will gain all-around experience that will increase your value to the company as it further expands in the field of electronics. The next few years are certain to see a large-scale commercial employment of electronic systems—and your training in the most advanced electronic techniques now will qualify you for even more important positions then.

HOW TO APPLY

If you are under thirty-five years of age, and if you have an E. E. or Physics degree, with some experience in radar or electronics,

write to:

HUGHES

RESEARCH AND DEVELOPMENT LABORATORIES

Engineering Personnel Department

CULVER CITY, LOS ANGELES COUNTY, CALIFORNIA

Assurance is required that relocation of the applicant will not cause disruption of an urgent military project.

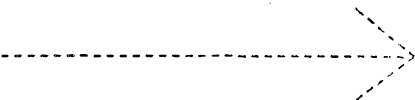

THE NEW JOHNSON

Picture this
in your shack!



Viking II

TRANSMITTER KIT

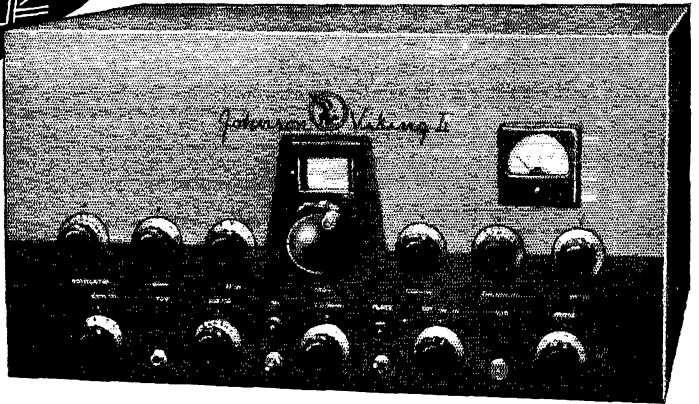

- ★ TVI SUPPRESSED
- ★ BANDSWITCHING
- ★ 180 WATTS CW INPUT
- ★ 135 WATTS FONE INPUT
- ★ 100% AM MODULATION

\$279⁵⁰

* The JOHNSON 250-20 Low Pass Filter is available as a separate accessory and when used, can provide an additional 75 db harmonic attenuation in the antenna circuit.

AMATEUR NET ...

240-102 VIKING II TRANSMITTER KIT, COMPLETE WITH TUBES, LESS CRYSTALS, KEY AND MIKE

These Cooperating JOHNSON Dealers

ALABAMA

BIRMINGHAM
Ack Radio Supply Co.
2205 Third Avenue

CALIFORNIA

GLENDALE
Hagerly Radio Supply
6826 San Fernando Road

LONG BEACH
Larry Lynde Electronics
1526 East 4th Street

LOS ANGELES
Henry Radio Stores
11240 West Olympic Boulevard

WEST LOS ANGELES
California Electronics Supply, Inc.
11801-03 West Pico Boulevard

OAKLAND
W. D. Brill Co.
198 10th Street

PASADENA
Empire Electronic Distributors, Inc.
37 East Union Street

SAN DIEGO
Western Radio & Television
Supply Co.
1415 India Street

SAN FRANCISCO
Offenbach & Reimus Co.
1564 Market Street

SAN FRANCISCO
San Francisco Radio & Supply Co.
1284 Market Street

SAN FRANCISCO
Zack Radio Supply Co.
1424 Market Street

SAN JOSE
Frank Quement, Inc.
161 West San Fernando Street

DISTRICT OF COLUMBIA

WASHINGTON
Capitol Radio Wholesalers, Inc.
2120-22 14th Street N.W.

FLORIDA

MIAMI
Herman Radio Supply Co.
1365 N.W. 23rd Street

TAMPA
Kinkade Radio Supply Inc.
402-04 West Fortune Street

GEORGIA

ATLANTA
Specialty Distributing Co., Inc.
425 Peachtree Street N.E.

ILLINOIS

CHICAGO
Allied Radio Corp.
833 West Jackson Boulevard
Newark Electric Co.
223 West Madison Street

INDIANA

INDIANAPOLIS
Graham Electronics Supply, Inc.
102 South Pennsylvania Street

IOWA

COUNCIL BLUFFS
World Radio Laboratories
744 West Broadway

DES MOINES
Radio Trade Supply Co.
1224 Grand Ave.

KANSAS

WICHITA
Amateur Radio Equipment Co.
1203 East Douglas

KENTUCKY

LOUISVILLE
Universal Radio Supply
533 South 7th Street

LOUISIANA

NEW ORLEANS
Radio Parts, Inc.
807 Howard Avenue

MARYLAND

BALTIMORE
Kann-Ellert Electronics Inc.
9 South Howard Street

MASSACHUSETTS

BOSTON
Haley & Young
811 Boylston Street
Radio Shack Corp.
167 Washington Street
Radio Wire Television Inc.
110 Federal St.

MICHIGAN

ANN ARBOR
Purchase Radio Supply
605 Church Street

BATTLE CREEK
Electronic Supply Corp.
94 Hamblin Avenue

DETROIT
M. N. Duffy & Co.
2040 Grand River

MINNESOTA

DULUTH
Northwest Radio
123 East First Street

MINNEAPOLIS
Low Bonn Co.
67 South 12th Street
Northwest Radio & Electronic
Supply Co.
52 South 12th Street

ST. PAUL

Low Bonn Co.
141 West 7th Street
Northwest Radio & Electronic
Supply Co.
194 West 4th Street

Superb performance on amateur bands 160, 80, 40, 20, 15 and 10-11 meters; 130 watts CW output, 100 watts phone output.

6AU6 oscillator, 6AQ5 buffer/doubler, parallel 6146 output amplifier. Continuous tuning pi-network amplifier matches a wide range of antenna impedances; provides up to 30 db harmonic attenuation before filtering. More than ample excitation at all operating frequencies.

Modulator, pp 807s with 6AU6 speech amplifier, 6AU6 driver. Frequency response limited for effective voice communication.

Power supplies designed for economy, for utmost operating convenience. High vacuum parallel 5R4GY HV rectifiers, 5V-4G low voltage rectifier, 6AL5 fixed bias rectifier.

Crystal selector accommodates 10 crystals. Power and RF input provisions for the Viking VFO. All stages metered, excitation control for output amplifier. CW input may be reduced to 75 watts for novice operation.

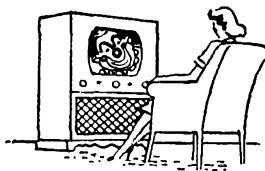

TVI SUPPRESSION MEASURES...

Completely enclosed copper plated steel cabinet. Lid bonded with phosphor bronze contact fingers. Special shields for meter, dial window, and VFO socket. Filters consisting of low inductance chokes and ceramic disc capacitors located as follows: keying jack, microphone connector, VFO power receptacle, power cord and antenna relay connector. Additional filters are used to suppress spurious frequencies at their sources.

OUTSTANDING CHARACTERISTICS OF JOHNSON KITS ARE:

their economy, easy assembly, careful design and completeness. The Viking II kit contains all necessary parts, hardware, tubes, wiring harness and cabinet with heavy rubber feet. Instructions are clear and concise, a novice can assemble the Viking II with excellent results.

The Viking II is available wired and tested by factory authorized wiremen. The cost is nominal, see your JOHNSON distributor. Write for literature describing the Viking II in detail, ask for catalog 714.



E. F. JOHNSON CO., WASECA, MINN.

JOHNSON

CAPACITORS, INDUCTORS, SOCKETS, INSULATORS, PLUGS AND JACKS, KNOBS AND DIALS, AND PILOT LIGHTS.

Solicit Your VIKING II Order

MISSOURI

BUTLER

Henry Radio Stores

KANSAS CITY

Burstein Applebee Co.
1012-14 McGee Street

ST. LOUIS

Walter Ashe Radio Co.
1125 Pine Street

NEW HAMPSHIRE

CONCORD

Evans Radio
10 Hills Avenue

NEW JERSEY

NEWARK

Radio Wire Television Inc.
24 Central Avenue

NEW YORK

ALBANY

Fort Orange Radio Dist. Co., Inc.
904 Broadway

JAMAICA, L. I.

Harrison Radio Co.
Hillside Avenue at 172 Street

NEW YORK

Arrow Electronics Inc.
82 Corlandt Street
Concord Radio Corp.
55 Vesey Street
Harrison Radio Co.
225 Greenwich Street
Hudson Radio & Television
48 West 48th Street
Radio Wire Television Inc.
100 Sixth Avenue
Terminal Radio Corp.
85 Corlandt Street

NORTH CAROLINA

RALEIGH

Radio Amateur Center
411 Hillsboro Street

NORTH DAKOTA

FARGO

Fargo Radio Service Co.
515 Third Avenue North

OHIO

CINCINNATI

The Mytronic Co.
121 West Central Parkway

CLEVELAND

The Progress Radio Supply Co.
413-15 Huron Road

COLUMBUS

Thompson Radio Supply Co.
182 East Long Street

DAYTON

Srepcu, Inc.
135 East Second Street

TOLEDO

Selaelectronic Supplies, Inc.
1013 Jefferson Avenue

OKLAHOMA

OKLAHOMA CITY

Radio Supply, Inc.
724 North Hudson

OREGON

EUGENE

United Radio Supply Inc.
179 West 8th Avenue

PORTLAND

Pacific Stationery
414 S.W. 2nd Avenue
United Radio Supply, Inc.
22 N.W. 9th Avenue

PENNSYLVANIA

PHILADELPHIA

Radio Electric Service Co.
7th & Arch Streets

PITTSBURGH

Cameradio Co.
963 Liberty Avenue

SOUTH DAKOTA

ABERDEEN

Burghardt Radio Supply
P. O. Box 342

WATERTOWN

Burghardt Radio Supply
P. O. Box 41

TENNESSEE

MEMPHIS

Bluff City Distributing Co.
905-907 Union Avenue

TEXAS

DALLAS

Wilkinson Bros.
2406-08 Ross Avenue

FORT WORTH

The Electronic Equipment Co.
917-19 Florence Street

HOUSTON

R. C. and L. F. Hall
1301 Polk Street

SAN ANTONIO

Amateur Headquarters & Supply
P. O. Box 5086, Beacon Hill Sta.

VIRGINIA

NORFOLK

Radio Equipment Co.
821 West 21st Street

RICHMOND

Radio Supply Co., Inc.
3302 West Broad Street

WASHINGTON

SEATTLE

Western Electronic Supply Co.
717 Dexter Avenue

TACOMA

C & G Radio Supply Co.
2502-6 Jefferson Avenue

WISCONSIN

MADISON

Satterfield Radio Supply Inc.
326-28 West Gorham Street

MILWAUKEE

Radio Paris Co., Inc.
536-538 West State St.

(Continued from page 74)

trek around the country during his vacation, using 30-watt c.w. and 18-watt 'phone in the W8, W9, and W7 Areas. Up Erie way, QN sends in his fine reports by paper clippings, and we see that QPP does a wonderful job in keeping the gang up that way posted on all of the League's items of interest. New club officers are LKJ, pres.; OIH, vice-pres.; RLJ, treas.; KLD and ODP, directors. TFX is en route to Anchorage, Alaska. 50-Mc. activity has increased in Erie, with MED, POS, KJM, MMI, and LKJ doing the honors. Around the Mercer County Area, CJF still is carrying on his Penna.-Ohio 2-meter net each night and EC' drills each Sunday night. KWL finally is getting the bugs out of his p.p. 4-125A final for 144 Mc. LNA is heard in the late hours on 2 meters. KXJ and 8SFG keep things humming around the area on 2 meters. Traffic: (June) W3UIIN 27, AER 14, KWL 13, KUN 10. (May) W3NCD 160, AER 16.

CENTRAL DIVISION

INDIANA — SCM, Clifford C. McGuyer, W9DGA — SAR has 147.5-Mc. net going in Tippecanoe County. OFW, FYC, DOK, TE, and W9RBU put on an amateur radio program on WHHS. DARA put on a ham show for the Boy Scout circus. OFW fell off a ladder and broke both wrists. OAC reports Jay County has a 5-kw. emergency power unit. UB reports St. Joseph County had a simulated bomb attack and the AREC proved to be the back-bone of the activity. DPL and OVF work 21 Mc. RKE has new 10-meter mobile rig. APG is rebuilding. MARC held a family night. TCS and MEU received Advanced Class license. The MARC mobile group provided communications for the Armed Forces Day Parade. UKT has 75-meter mobile. HRH resigned as president of TARS to become communications director for c.d. of Vanderburgh County. JBJ was elected the new president and NJR the new treasurer. SAR has 500-watt 2-meter f.m. rig. GRN has the ultimate in kw. rigs. BKJ and PMT handled traffic from Boy Scout Jamboree held at Portland. Highlight of this Jamboree was the appearance of Gov. Schricker, who was introduced to amateur radio by BKJ. ARP was chairman of the FWRC picnic. NYK was elected secy.-treas. of FWRC because of the resignation of NUL, who is leaving Fort Wayne. VGD is new Blackford County EC. MUR is building 2-meter gear for c.d. work. In addition to handling traffic, TT puts in time as OO. DUD is taking summer course at the Case Institute. NTA finds retuning his beam improved his 10-meter operation. The Martinsville Club will hold a Novice Contest. HUV received his first ORS appointment in 1933. YWE is new ORS. LXW, NZZ, and DPL have new Collins rigs. JUJ is a member of TCC. WN9TKO has new receiver. DPL rounded out 25 years with the same call. VNV is building 10-meter mobile. GSY worked EQC on 2 meters. BKJ reports 1F'N traffic for June as 176. KLR installed all-band transmitter in his car. LOZ moved to Michigan City. YWE is radio engineer at WISH. JUJ reports QIN traffic for June as 527. LZJ, the SEC, plans the establishment of an AREC organization in each county. If your county does not have an EC, please make recommendations to LZJ. Traffic: W9JUU 1404, TT 516, NZZ 388, PMT 154, BKJ 147, YWE 144, DGA 75, KDV 63, PZW 51, JBQ 49, VNV 27, JZB 17, DOK 11, CMT 8, GSY 6, YVS 2, QLW 1.

WISCONSIN — SCM, Reno W. Goetsch, W9RQM — SEC: OVO. PAM: ESJ. RM: IQW. 'Phone Net (BEN) 3950 kc., 6 p.m., C.W. Net (WIN) 7 p.m. 3625 kc. State-wide mobile emergency and c.d. frequency: 29,620 kc. Reports of Field Day activity were received from Madison. 8WQ/9; Beaver Dam, TCH/9; Green Bay, ART/9; Chipewewa Falls, DSP/9; LaCrosse, SFL/9; Wausau, NUW/9; Antigo, IZE/9; Mancorad, FMH/9; Racine, UDU/9; Hilbert, EWC/9; Sturgeon Bay, NRA/9; Milwaukee, ESJ/9; HRM/9; ODD/9; St. Pt.-Waupaca, NIT/9; Baraboo, TCR/9. IZE still is busy with 4-Mc. center-loaded mobile whip. HVL is back on 75 meters. BKD's mobile contact on 75 meters from Ohio to Green Bay is a pretty long haul. FDX is recuperating from Field Day operations. Congrats to NLE, now at Little Chute, on a new jr. operator. IFS is on with a new Viking transmitter. ERW also announces a new jr. operator. CSU's frequency measurements in the May test were within .00007 per cent. New appointments: MQV as EC for Buffalo, Trempealeau, and Jackson Counties; KPG as EC for Waupaca County; SGG as OO, ORS, and OPS. Renewals: ESJ as PAM and OPS; MUM as EC and ORS; ANM as ORS and OPS. KXK is polishing up a new kw. rig with p.p. 813 final in readiness for a full DX season. JQP has gone mobile. HQJ has a new Viking transmitter. MRAC's mobile station, HRM/9, received a nice write-up in *International Trail* for July. On 144 Mc.: LEE worked 8HUX for his first Ohio QSO, and also worked 2 in Indiana and 4 in Illinois. DSP and EYN also worked into Ohio, while JBF couldn't get through that hill to the east! FAN reports as new on 144 Mc. WN9SDH is new in Sheboygan. OVO and the DCARC were hosts for the BEN picnic at Sturgeon Bay, July 20th. Is your county or community represented by an Emergency Coördinator? If not, write OVO, the SEC. Appointments are available as OO, OBS, ORS, OPS, and OES. I will be glad to send further information and details upon request. Traffic: W9IZE 13,

IQW 10, RQM 9, ZCL9, HDV 6, NUW 6, FDX 5, CFP 4, NLE 4, IFS 2.

DAKOTA DIVISION

NORTH DAKOTA — SCM, Everett E. Hill, W0VKP — Information on your radio activities for this month's report in QST is solicited from all North Dakota amateurs. This month note the following special announcement of a North Dakota activity!

The Jamestown Amateur Radio Club is sponsoring on September 26th to 28th a North Dakota week end during which time every effort will be made to give a North Dakota QSO for WAS. Clubs in North Dakota have been urged to arrange local contests and outside stations desiring contacts are urged to call within 20 kc. but not on the following frequencies: 1.985 Mc., 3.850 Mc., 3.950 Mc., 7.150 Mc., 14.050 Mc., 21.250 Mc., 37.050 Mc., 29.150 Mc., 28.750 Mc., 50.050 Mc. The week end will start at 1800 CST September 26th and end at 1800 CST September 28th. All stations wishing North Dakota QSL are urged to be on the air at these times.

SOUTH DAKOTA — SCM, J. W. Sikorski, W0RRN — SEC: GCP. RM: OLB. Unofficial reports indicate more South Dakota clubs participated in Field Day than in any previous contest. The Sioux Falls Club accepted a one-transmitter contest challenge with Sioux City ARC, the contest to become an annual affair. JLI is making a movie of SFARC activities and ham shacks. I have received only three requests for renewal of appointments in reply to a request in the *SCM Bulletin*. A majority of appointments expired in July. My apologies to those of you who may have sent in activities reports this month — this is vacation time with activities written in hot and humid Illinois. Will catch up next month.

MINNESOTA — SCM, Charles M. Bove, W8MXC — Report this month is from Jack Morgan, RA, St. Paul, Minn., Acting SCM. The Minnesota gang is greatly concerned to learn that Chuck, our SCM, is again hospitalized. All join in hoping most sincerely for his full and early return to health. It is suggested that active Minnesota hams look on the section net frequencies, c.w. 3795 kc., 'phone 3960 kc., as last registered at ARRL, for any bulletins or information as to whether MXC can receive cards, letters, or messages from well wishers. The June traffic reports follow and activity in the nets will be on the upgrade from now on. Traffic: W0UCV 79, EQV 78, TJA 33, RXL 15, RA 7, BRA 3.

DELTA DIVISION

ARKANSAS — SCM, Fred Ward, W5LUX — The main interest this past month was Field Day, and from the reports it was a very good one. The club at Fort Smith operated 4 transmitters under the call HOT/5 and did a fine job. PZC has a pair of 803s on 75 meters running 250 watts and a new job carrying the mail. K5WBA had a large Armed Forces Day and has a new VFO. STU now is on 75 meters with 125 watts. RDT is mobile with a Lysox rig and a Conset converter. WEE and VUD are new hams in Harrison. OXU, who had been off because of illness, is building a modulator and soon will be back with us. UJW and BAB set up at the Silver Strike Jubilee and handled a nice lot of traffic. I appreciated the nomination as SCM and will do the best I can. Hope I do half as well as DRW. Sure will need your reports to get the news. Fellows, please check the expiration dates of your appointments and let's get things ready for the fall season. We need more ECs and ORS, so if you are qualified and interested just write to your SEC, EA, or to LUX for an application blank. Traffic: W5EA 16, LUX 5.

LOUISIANA — SCM, Robert E. Barr, W5GHP — HEJ has been reappointed as EC to take care of the West Monroe Area, and MWE received EC appointment covering the Monroe or east side of the Ouachita River. 1VF, EB, 4FLD/5, MRT, UDX, JRD, MAV, JEY, HEK, and PZL are Assistant ECs in the Ouachita Valley. MOG and CNG are operating mobile on 27 Mc. EB now has 155 confirmed DX contacts on c.w., and 108 on 'phone. MAV is the newly-elected president of the Ouachita Valley Amateur Radio Club. EGK has 199 confirmed countries, all by c.w. The SCM had nice visits with 0ARA, 0JXJ, 0HTU, and with the Missouri SCM, 0GBJ, while on a vacation trip through Missouri into Kansas City, and also had a personal chat with LQN in Hot Springs. TRQ, not satisfied with Conditional ticket, passed his General Class exam in Dallas. FMO is NCS of the Delta 'Phone Net, 3905 kc., with CNG as Alternate. NVS has moved his QTH from Ruston to Jonesboro, La. The Monroe gang landed 334 contacts from their Field Day set-up. Thanks to PZL, secy.-treas. of the OVARC, for the excellent report on Monroe activity. NG

(Continued on page 86)

where the world's toughest transformers
are a "must" for the toughest installations . . .

you'll find

CHICAGO

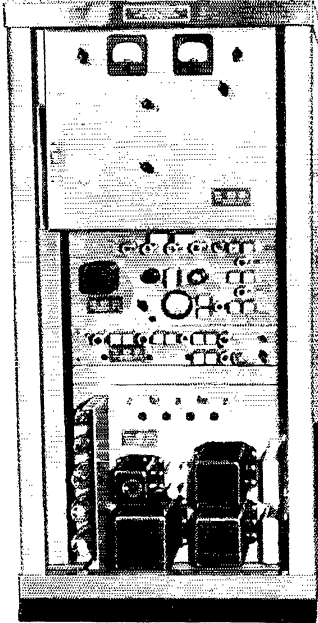

REL specifies and uses CHICAGO

You'll find CHICAGO "Sealed-in-Steel" transformers used throughout REL's FM Transmitting and Relay Equipment. Absolute dependability is a prime requirement in all REL equipment—and CHICAGO transformers contribute significantly to quality, superior performance and long time stability.

COLLINS specifies CHICAGO

This COLLINS MHF Single Frequency Communications Receiver utilizes CHICAGO "Sealed-in-Steel" transformers for trouble-free, continuous service under the most rugged operating conditions.

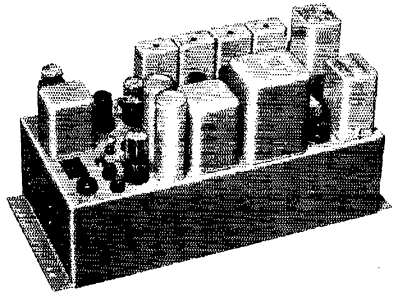

where the going's tough—specify CHICAGO "Sealed-in-Steel"
NEW EQUIPMENT TRANSFORMERS

CHICAGO "New Equipment" transformers (available in 3 mountings) feature one-piece drawn-steel cases—the strongest, toughest, best-looking units you can buy. The one-piece seamless design, enclosing an electronically perfect construction, provides the best possible electrostatic and magnetic shielding, with complete protection against adverse atmospheric conditions. For every application: Power, Bias, Filament, Filter Reactor, Audio, MIL-T-27, Stepdown—ask your electronic parts distributor for CHICAGO "Sealed-in-Steel" transformers.

Free "New Equipment" Catalog

Get the details on CHICAGO's full *New Equipment Line*—covering "Sealed-in-Steel" transformers for every modern circuit application. Write for your Free copy of this valuable catalog today, or get it from your distributor.

H-TYPE

Hermetic sealing meets all MIL-T-27 specs. Steel base cover is deep-seal soldered into case. Terminals hermetically sealed. Ceramic bushings. Stud-mounted unit.



S-TYPE

Steel base cover fitted with phenolic terminal board. Convenient numbered solder lug terminals. Flange-mounted unit.



C-TYPE

With 10" color-coded leads brought out through fibre board base cover. Lead ends are stripped and tinned for easy soldering. Flange-mounted unit.

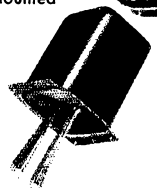

FREE



CHICAGO TRANSFORMER

DIVISION OF ESSEX WIRE CORPORATION

3501 ADDISON STREET • CHICAGO 18, ILLINOIS



TRADE MARK REG.

Why all this Junk?

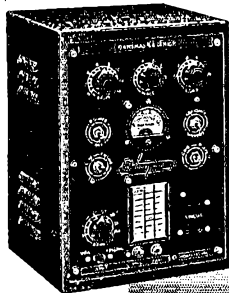
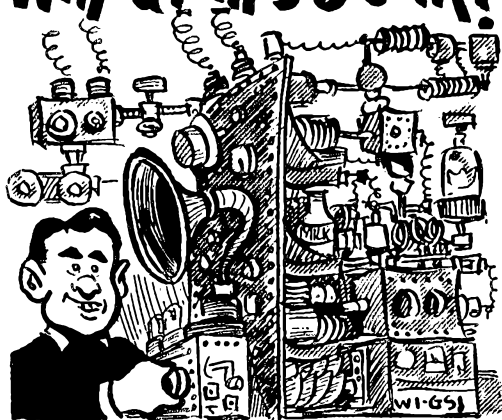

**WHEN
YOU CAN
HAVE**

**A
Harvey-Wells**

BANDMASTER

40 TO 50 WATTS

THE WORLD'S MOST VERSATILE X'MTR FOR MOBILE OR FIXED OPERATION, NOVICE OR EXPERT BANDMASTER SENIOR . . .

A complete ready-to-go phone transmitter including new crystal-oscillator — vfo switching circuit — Phone or CW — 100% break-in operation — Eight bands: 80, 40, 20, 15, 11, 10, 6 and 2 meters — No plug-in coils — completely wired and tested. Tubes: 6AQ5 Crystal Qsc, 6AQ5 Buffer Mult., 807 Final, \$111.50
2-6L6 class B Modulators. Sturdy Steel Cabinet 12" x 8" x 8".

BANDMASTER DELUXE . . .

The last word in a versatile small transmitter for amateur, civilian defense and commercial use. Has built-in three tube preamplifier for use with crystal mike PLUS all the features of the Bandmaster Sr. \$137.50

Your Bandmaster is protected by a continuing Technical Service. It provides methods of adding new features as they are developed. No Bandmaster becomes obsolete or outmoded.

SEND NOW FOR LATEST CATALOG

Harvey-Wells ELECTRONICS, INC.
SOUTHBRIDGE, MASSACHUSETTS
Export Dept. 13 East 40th Street, New York
Canadian Distributor: Canadian Marconi Co.
861 Bay St., Toronto, Ontario

(Continued from page 86)

has several graduates now from his Novice training class. DHE operated portable and mobile on a vacation trip through the Smokies. LVG is a consistent Louisiana outlet on the Central Gulf Hurricane Net. CCD works in with the various Texas traffic nets. ONM and KHC handle CAA traffic. FYZ and HBJ, through their untiring efforts, were responsible for 100 per cent participation for the Louisiana MARS during the last two months. Traffic: W5NG 213, MWE 208, CEW 58, AEN 36, GHF 18.

MISSISSIPPI — SCM, Norman B. Feehan, W5JHS — On Field Day Meridian ARC operated portable 3 miles outside of Meridian with two transmitters and six operators. Jackson operated portable with four transmitters and ten operators on four bands. Keesler ARC operated portable 15 miles northwest of Biloxi with five transmitters, twenty-two operators, and eleven AREC members. JHS, TVI, LWQ, and others of the Mississippi gang report a very good time at the Pensacola, Fla., hamfest. The Central Gulf Coast Hurricane Net boasts a membership of 54 with a big percentage checking in every evening at 6:15 p.m. on 3935 kc. Traffic: W5JHS 23.

TENNESSEE — SCM, Mark M. Bowelle, W4CXY — SEC: AEE, RM; AGC, Pam K. Bowelle, PFP. We were all saddened by the passing of RLF. We are going to miss Billy's cheery voice and fine operating more than words can express. PFP is the new PAM and will carry on the fine work started by KMH, who is having a mild attack of TVI. OGO is not going overseas after all and will be back in the home diggings of Memphis with a new rig. WN4WAX is a new Henderson ham who will give AGC some much-needed help on 80 meters as soon as he gets his (Gen. Cl. ticket. The CW Net is meeting through the summer on his 3635 kc. at 0500 CST with a few sleepy souls QNI. The 3980-ke. "Phone Net is continuing on regular sked of 1900 CST Tue. and Thurs. and 0800 CST Sun. with an average of 20 stations QNI. UFT (Memphis) recently took emergency traffic from Air Force personnel in Florida, being alerted by SWL Dave Henry, who was monitoring with his S38B. This points up the fine service that the unsung SWL often adds to the public service offered by the ham. Traffic: W4FP 239, AGC 82, ODR 68, CXY 40, IIB 39, OCG 29, JWO 21, PMR 2.

GRAND LAKES DIVISION

KENTUCKY — SCM, I. W. Lyle, jr., W4KKG — WN4-KTYP says that to his knowledge he is the first amateur license-holder in Adair County. Since then VIH and VKB have sprung up FB and welcome, fellows. RRU of KYB and TAV of KYN win SCM plaque awards for the most consistent and outstanding operators of these nets. Many other fine operators of these nets deserve honorable mention. FR and JUI scored high in the ARRL Frequency Measuring Test of May 23rd. CDA, the old reliable, reports that the shack was pretty hot this month but he made the net sometimes. June set heat records all over the State. The temperature was below 90 only one day and many days was over 100! ALR/4 writes he will be on in Arlington, Va., soon. We'll be looking for you, Paul. VP moves to a new QTH, his son, SHD, gets married, and the antenna still is on the ground so he says no activity! HI, MDB reports in via Air Mail from Lisbon! Guess he's signing MDB/CT1. KZF is spending the summer building a de luxe shack. Don't forget the air conditioning, Len! OYG makes WAC again the hard way — mobile. Traffic: W4-CDA 13, FR 10, KKG 7.

MICHIGAN — SCM, Norman C. MacPhail, W8DLZ — Asst. SCMs: R. B. Cooper, 8AQA; J. R. Beljan, 8SCW; M. C. Ulls, 8CPB. SEC: GJH, RMs: YKC, UKV, ELW. PAM: With. New appointments: ORS to FFG and ZGT. WNSIUT reports the following new officers of the Motor City Radio Club: AJQ, pres.; GWA, vice-pres.; WNSIUT, secy.; BYB, treas. TAU is back on 75 meters with a Bandmaster from Ypsi. RNJ is building a 432-Mc. TV transmitter. YIN now is heard on all bands with a new rig. DQL is building a new 807 VFO. DYH is back on QMN after several years' absence. Ken sends a big bouquet of orchids to the gang. IMA is gunning for the birdie on his signal. EXZ is on a summer job away from home and will not be heard until September, when he will be /8 from college in Ohio. HKT now is "shotgunning" the bands with a Millen VFO. Mac has a new "antenna farm" lined up and will move there soon. ZLK reports the Cherryland Radio Club has its own call now — W8KTV. THG is experimenting with a "V" antenna. GTM has worked 15 states and Eastern Canada with 6 watts on 160-meter 'phone. CPB reports FYX is off the air because of lending his rig to III so the latter could go mobile. Michigan traffic men, both 'phone and c.w., urge more careful censorship of fair and hobby show traffic at the source. The acceptance and transmission of the 100 per cent useless or silly messages is no feather in our cap. Let's maintain the high standards we have established over the years. AXP now is communications officer for the Kent County CAP. IV still is knocking off DX on 20 meters with 100 watts. Traffic: (June) W8ZGT 1206, NZT 353, FBV 143, JYJ 135, RTN 89, EXZ 88, ILP 70, IV 57, SPF 44, AXP 40, QBO 35, IKX

(Continued on page 88)

MALLOBY HAM BULLETIN

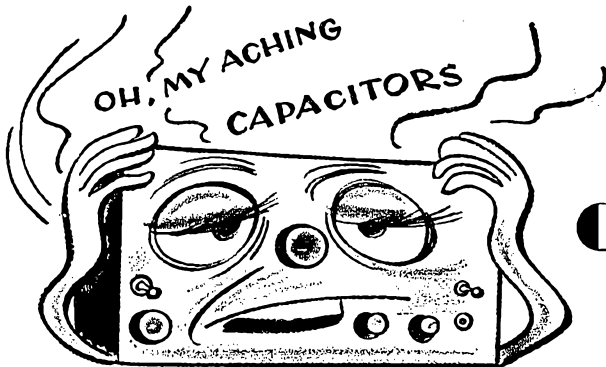

There's a **MALLOBY** **CAPACITOR** For Every Need

Did it ever occur to you that more capacitors are used in an amateur transmitter or receiver than any other single component? As a result, the chance of a capacitor failing and putting you off the air, or permitting your transmitter to emit spurious, illegal signals to land in your neighbor's radio or TV set, is more likely to occur because of a poorly made or defective capacitor, than any other component in your set.

For that reason, every amateur should be especially critical of the capacitors he selects for use in his equipment. Nothing less than top-grade, first line capacitors should ever be tolerated in by-pass, coupling and filter circuits in his equipment.

For a long time Mallory capacitor engineers have recognized the importance of designing and building good capacitors for use in radio and electronic circuits. They have recognized that a truly good capacitor must have low DC leakage and low operating impedance in addition to the usual requirements of full capacity and voltage ratings.

For example, more than 10 years ago Mallory engineers recognized the need for electrolytic capacitors of lower and more uniform impedance. The result: they did something about this need by designing the exclusive Fabricated Plate (FP) anode construction to assure the production of a capacitor with a consistently lower impedance.

Mallory capacitor engineers anticipated the trend toward increased amateur activity in the VHF range above 50 megacycles. The result: ultra small, Mallory tubular and disc type ceramic capacitors were made available for efficient by-passing and coupling at those frequencies.

A number of years ago Mallory vibrator engineers first stressed the importance of proper buffer and timing capacitors to assure long, trouble-free vibrator life in your portable-mobile rigs. But there were no suitable vibrator capacitors available. The result: Mallory capacitor engineers attacked the problem and designed capacitors especially suited for vibrator service.

Mallory engineers have seen to it that almost every conceivable size, shape, and type of fixed capacitor the amateur might need, is included in the Mallory list. And they have seen to it that each Mallory capacitor has had individual, painstaking design effort to make it the finest of its type made.

The next time you have need for a capacitor for use in your station, see your Mallory Distributor, and specify Mallory. With the Mallory label on that capacitor, you'll know without question that you're getting a top-grade, first line capacitor of excellent operating characteristics.

And see your Mallory Distributor for the other Mallory parts designed for amateur service . . . including resistors, ham band switches, rheostats, potentiometers, pads, dry disc rectifiers, vibrators and vibrator power supplies.

P. R. MALLORY & CO., Inc.
INDIANAPOLIS 6 INDIANA

P. R. MALLORY & CO. Inc.
MALLOBY



**More Safety...Less Guesswork
When You Use
—PRECISION—
TEST EQUIPMENT**

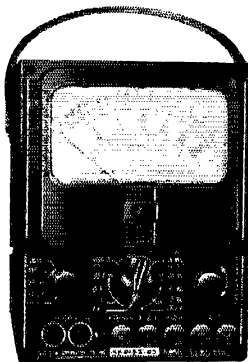

**Stay On The Air
With "PRECISION"
SERIES 85
AC-DC
Circuit Tester
(20,000 Ohms per Volt)
SELF-CONTAINED TO
6000 volts,
60 Megohms,
12 Amperes, + 70DB**

A compact, laboratory type, *high sensitivity* test set indispensable for test and maintenance of modern amateur communications equipment.

20,000 Ohms per Volt D.C. — 1000 Ohms per Volt A.C.

VOLTAGE RANGES: 0-3-12-60-300-1200-6000 A.C. & D.C.

CURRENT RANGES: 0-120 microamps; 0-1.2-12-120-MA;
0-1.2-12 Amps D.C.

RESISTANCE RANGES: 0-6000—600K—6 Meg—60 Megohms.

DECIBEL RANGES: From —26 to +70DB.

Complete with batteries and test leads..... **\$39.95**

PLUS superior physical features:

- ★ 4 5/8", 50 microamps, Easy Reading Meter.
- ★ Heavy duty bakelite case 5 1/2 x 7 1/8 x 3".
- ★ Deep etched, anodized aluminum panel.
- ★ Recessed 6000 volt safety jacks.
- ★ Only two pin jacks for all standard ranges.

LC-1 LEATHER CARRYING CASE—Custom designed, top-grain cowhide case with tool and test lead compartment. **\$9.50**
See Series 85 and other famous "Precision" instruments, on display at leading radio parts and ham equipment distributors. Write for latest catalog.

Precision Apparatus Co., Inc.

92-27 Horace Harding Blvd., Elmhurst 13, N. Y.

32, AQA 30, DLZ 26, DAP 23, HKT 23, COW 16, ZLK 16, CPB 15, LR 14, GJB 7, ACW 2, (May) W8YKC 196, UKV 38, YIN 35, HKT 29, CPB 20, DQL 16, DYH 14, FFG 13, ENX 6, EXZ 4, IKX 2, NQ 2, (Apr.) W8IKX 9.
OHIO — SCM, John E. Siringe, W8AJW — Asst. SCMs: C. D. Hall, 8PUN, and J. Erickson, 8DAE, SEC; UPB, PAM; PUN, RMs: DAE and PMJ. The hot weather really has gotten the lads and lassies this month. Save for Field Day, activity was comparatively light. There were no BPLs or new appointments. Approximately 40 Field Day messages were received here. DAE and LBH were vacationing in northern W8- and W5-Land, respectively. FYO is fishing in Northern Michigan. YGR has been burning a bit of gasoline to deliver messages from servicemen. HOX is donating vibrator supplies to amateurs in Clinton County to promote EC work. PUN still is trying to get the house painted. It is suggested that he hire a few painters or it'll probably carry over to next summer. We understand the TV-viewers have chased DZO out into the country. Toledo *Shack Gossip* didn't show up this month. Wonder if the gals ran out of recipes? Cincy's *Mike and Ken* states that RY and HW have new 32V-3s, and that the GCARA is finding it difficult to get its members to turn in scores for ARRL contests. You fellows shouldn't feel alone in this because the West Park Radior of Cleveland have the same difficulty. The A Bomb Test in Cleveland on June 30th brought out more than 30 mobiles. The Q5 of Springfield relates that PYL and JNK are new members. BLN is burning up 6 meters with his new rig, and the Club purchased a new (second-hand) tent. The *Caracape* out of Columbus tells us that TO/S Field Day station, made 558 contacts; the Tuesday night drills on 29,640 kc. are well attended; and that the recent simulated emergency included 29 Columbus stations. Oh, yes, BN still seeks a Columbus outlet. As we have run out of interesting (?) information, this column is being terminated for this month. Let's attempt to now and then use up our allotment in each issue of QST by getting a bit more dope to your struggling SCM. Traffic: (June) W8ARO 452, FYO 283, DAE 96, AL 47, YGR 43, AJW 27, QIE 21, CTZ 18, HIOX 13, PUN 10, GZ 8, BEW 6, EMO 4, DZO 3, WAV 3, BUM 2, EZT 2, ET 1, (May) W8BEW 7, HNY 6.

HUDSON DIVISION

EASTERN NEW YORK — SCM, Stephen J. Neason, E, W2ILI — RMs: TYC, KBT, PAMs: JGG, JQI, K2CA. VDX is overseas with the Army. TYE is home from college for the summer. Charlie is on 3.8 Mc. and expects to go on 1.8 Mc. soon. FQL is mobile on 144 Mc. NOC expects to be on 14 and 28 Mc. soon, courtesy of HUB. FED is General Class. ITK and his XYL were recent visitors at NOC while on vacation. New officers of the Rip Van Winkle Club are WGE, pres.; ESL, vice-pres.; EYG, treas.; EWO, secy.; IJZ, activities chairman. YXE is mobile on 144 Mc. AWF is operating portable from campsite in Northern New York with WIK and your SCM as his guest. On the same campsite I find BKW, GTC, GAZ, and CAZ. NYS operates on 3615 kc. at 8 p.m.; NYSS on 3595 kc. at 9 p.m.; NYS 'Phone Net on 3980 kc. Mon. through Sat. at 6:30 p.m. EDT, also Sun. at 8:30 a.m. This is an emergency traffic net and all counties in the State should be represented. GSS is the Net Manager. PHO still is QRL. AAO is portable at Lake St. Catherine in Vermont. AAO and GM are Extra Class licensees. ITQ is Advanced Class and will be heard on 3.8 Mc. soon. New Novices are KN2AFZ and KN2ALT. If you are a Novice and interested in our section net, please write UKA, the Net Manager, or your SCM and you will receive full information, also the new directory. Many appointments are now available. Why not investigate? NRD and JKJ kept the RVWARS on the air during the night on Field Day. AARA reports a big turnout on Field Day with plenty of help from the XYLS, who had charge of the kitchen. MHE was active from Dutchess. Appointment: MHE was OO. Endorsements: HUM, FQL, and JJO as EC. Traffic: W2BNC 356, LRW 172, TYL 117, ILI 44, PHO 26, BLU 10, HEI 2, APH 1.

NEW YORK CITY AND LONG ISLAND — SCM, George V. Cooke, jr., W2OBU — Asst. SCM, Harry J. Dannels, 2TUK. SEC: KTF. RM: TUK. PAM: YBT. JZX was the headquarters station here for the Womens International Air Race from Santa Ana, Calif., to Teterboro, N. J., and with the assistance locally by YBT, CLG, VOU, and others numbering about 50 across the country, beat all wire services in reporting the race progress and maintained open-wire contact with the race headquarters in N.Y.C. during the entire race, keeping them informed of the positions nightly of the participants. Field Day was the best yet held in this section, with more stations, clubs, and operators taking part. Higher scores were made despite the inclement weather, and many thanks go to the Mid-Island, Amateur Radio Society of Queens, Lake Success, Brooklyn, Poly, Huntington, Levittown, Tu-Boro, Nassau, Wantagh, and Sunrise Clubs for their messages to the SCM informing him of the number of AREC members in their groups. TUK has taken over as EC for the Bethpage/Levittown Area and QBR replaces Harry as EC for the Hempstead sector. The Tu-Boro Club offers an appropriate certificate to any

(Continued on page 90)

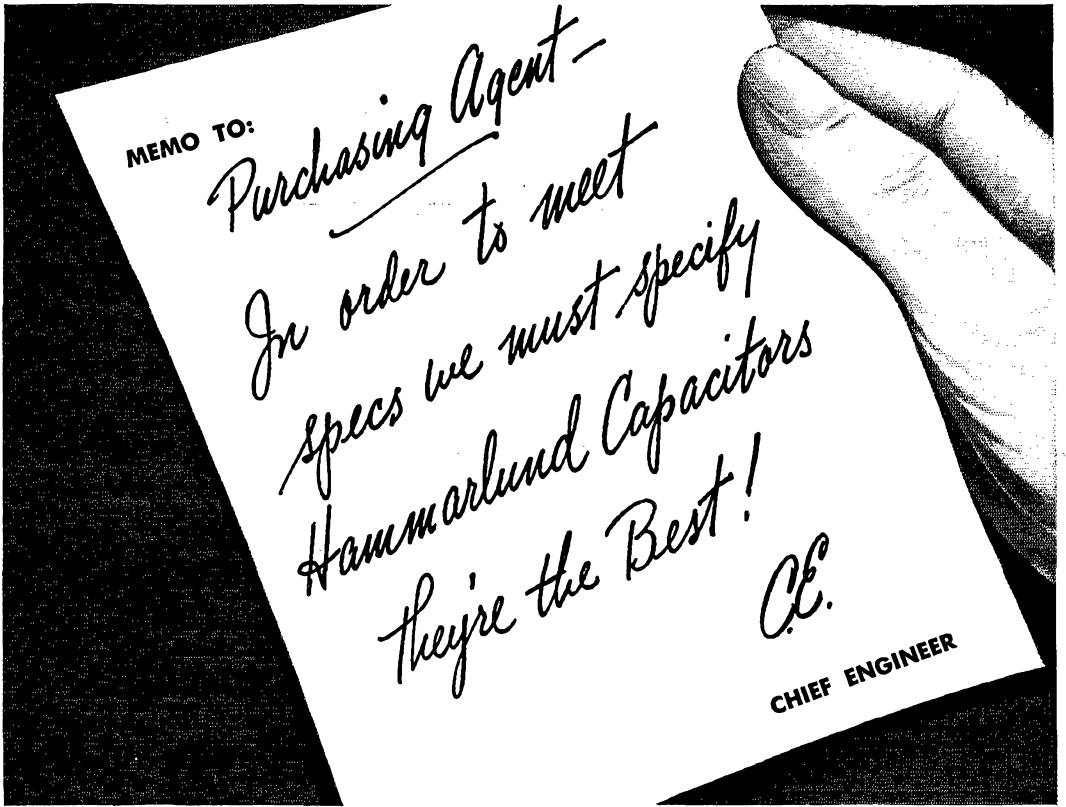

Known for highest quality
VARIABLE CAPACITORS

Hammarlund Capacitors, backed by 42 years of design, engineering and production experience, are today recognized by the military services, electronic manufacturers and research engineers, as the finest quality capacitors available. Millions of them are in use by almost every important manufacturer of electronic equipment.

See for yourself. Write today for the 1952 CAPACITOR CATALOG. It has the complete story.

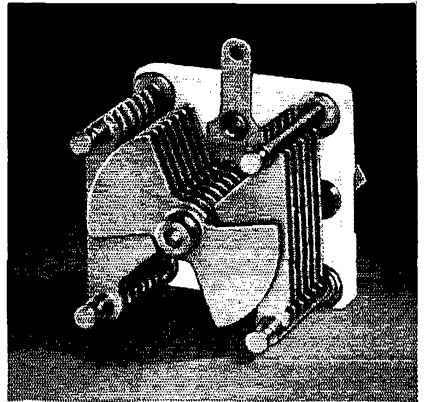

HAMMARLUND

MORE THAN 40 YEARS EXPERIENCE COUNTS!

THE HAMMARLUND MANUFACTURING CO., INC.

460 WEST 34th STREET • NEW YORK 1, N. Y.

ELIMINATE YOUR TROUBLES!

"DX with TELREX"

Increase your
CONTACT TO CALLS RATIO

-with *telrex* CUSTOM-BUILT, PRODUCTION PRICED COMMUNICATION ARRAYS

NOW! the originators and manufacturers of the famous "Conical-V-Beam" TV Antennas offer outstanding performance and ease-of-mind operating. Precision tuned, field tested arrays for 2, 6, 10, 15, 20, 40, 80, 160 meters.

ILLUSTRATED BELOW — 3 ARRAYS
FOR TOP 2-METER PERFORMANCE

"QUAD-X", 8-element Conical Quadrature stacking provides low vertical angle, narrow horizontal beam; Broadband and hi-gain; 11.6 db Gain; 23.0 db Front to back ratio; 23° Beam-width.

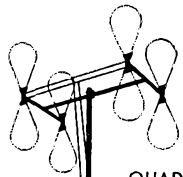

QUAD-X
\$16.50 net
Weight 9 lbs.
V or H
polarization

2-Meter "FISHBONE"
Twin-driven broadband, hi-gain can be stacked up to 40 elements; 11.6 db Gain; 21.0 db Front to back ratio; 18° Beam-width.

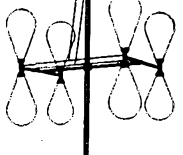
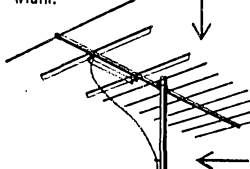

2-Meter "FISHBONE"
\$16.50 net, Wt. 8 lbs.

"TWIN-FIVE". Stacked Side-by-Side for added gain and narrower beamwidth; 9.6 db Gain; 18.0 db Front to back ratio; 16° Beamwidth; V or H polarization.

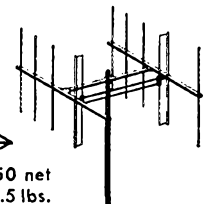

TWIN-FIVE \$16.50 net
Weight 5.5 lbs.

WRITE for
specifications, data
and other information

telrex INC.

AMERICA'S
STANDARD OF
COMPARISON

ASBURY PARK 38, NEW JERSEY

station contacting any five members of the Club on any band or frequency excepting the Club net, Tues. 29.520 Mc. at 1900 local time. The next Tu-Boro Club shindig will be held Sept. 27th at Raschers Hall, East New York. For tickets contact L.G.K., I.A.G. or J.S.V. The Nassau Club bettered its '51 Field Day score by more than 100 points, and were aided by QBS who returned to action after a long lay-off. LDO has shifted QTH from Nassau to Suffolk. KFV is the newest addition to the Nassau Mobile Net on 144 Mc. EC finally has done it — RPL after many years of traffic-handling. Congrats. BGO announces JVG as New York State C.D. Headquarters station, with a kw. on 'phone and c.w. IVS/3, from W. Pa., now is at Washington Square and received ORS appointment. IN was in W6-Land and worked Field Day in Hollywood. Joyce Nantz, ex-W2OKS, now is K2ANH at Melville, and this YL holds plenty of commercial tickets. In the Huntington Area the following are new calls: KN2ARC, ADL, and ANX. WLQ is manufacturing new hams at a fast rate. The NLI Traffic Net resumes full schedule on Sept. 8th at 1930 local time on 3630 kc., and invites new stations to report in and build up needed coverage in the section. Contact the SCM for particulars. GDJ now is out of the Novice class. BRW, in Ridgewood, has gone mobile on 2, 6, and 10 meters. YTR and MYR, mobiles, found themselves upstate via the air, to be close at summer QTH. MVR is sporting new HRO and thrashing 10 watts into a vertical. BNT graduated from Novice grade and now is on all bands. The Annual FLIRC Hamfest will be held in the Lost Battalion Hall, Fri., Sept. 12th. PF spent vacation operating in Maine and put in a spell of operating at K2USA, Fort Monmouth, during military duty encampment. WL received Extra Class ticket, having been active 40 years. OGX joined the Empire State Club and does some operating at GTE, Red Cross station in Manhattan. In the last CD Party this section topped all others in the country for participation. Let's keep the lead by having more appointees get in on the fun in the fall and winter parties. Let's hear more stations in the 75-, 20-, and 10-meter bands during these CD Contests. You can't beat them for fun. Traffic: W2EC 186, GXC 80, OBU 74, WL 30, OJX 23, PF 23, BGO 22, IN 18, L.G.K. 18, BHJ 12, IVS 12, BIV 10, BQM 10, DZK 5.

NORTHERN NEW JERSEY — SCM, Thomas J. Ryan, jr., W2NKD — SEC: VQR. RM: GGG. PAM: CCS. C.D. RACES activity is picking up in this section, the big reason being that the FCC has finalized the c.d. RACES docket. The chairman of the state c.d. advisory committee, VQR, has sent to the thirteen Area Coordinators special identification cards for mobile equipment and zone maps for use in their respective areas. Plans are being made for c.d. test of mobile emergency gear to transmit a test message from the lower New York State border to the tip of Cape May, N. J., by relay using emergency mobile amateur radio gear located along various highways from one end of the State to the other. All New Jersey hams interested in participating are requested to contact their area c.d. coordinator. CCS has just obtained a new SP-400X receiver. LMB, secretary of the GSARA for the past 14 years, has resigned because he is moving to Ohio where he will become director at a private school. He was instrumental in forming the transcontinental 'phone net and has been very active in all local Jersey nets. At a farewell party given him and his XYL the GSARA presented him with a new portable electric drill with case and attachments. He also was presented with a scroll by K2BX, president. Lots of luck, Herm. QND is new GSARA secretary. LUL has just been authorized Hawthorne c.d. headquarters and has 100 per cent attendance during Sunday morning drills. ENM has been appointed area 9 c.d. coordinator. K2BX's new QTH is Arizona for the next two months; look for him on 20 meters. Jersey City hams are doing an excellent job for c.d. in that area with FB installation located in control center at Roosevelt Stadium. NUI is doing his usual FB job for the city of Bayonne. Traffic: W2CCB 248, MTV 192, DXD 161, LMB 145, EAS 74, CFB 4

MIDWEST DIVISION

IOWA — SCM, William G. Davis, W8PP — Because of Field Day the reports this month were overwhelming. It's a great experience. Perhaps justice will not be done because your SCM returned from vacation on the day the report was to have been mailed. Field Day was a huge success, judging from the telegrams received. RV now is in the Philippines. LKK has completed his E. E. course at Ames. HEX has returned to Des Moines. HQA and NUD are vacationing in Des Moines. FQO and his XYL, FVK, are on vacation. DFH and FJV are building new band-switching transmitters. OPK is putting out Official Bulletins regularly on 3850 and 7060 kc. NXW has written a fine story of her experience as an operator during the Missouri River Flood. BVE reports that putting up hay and getting the corn laid by interferes with his hamming. QVA got his Extra Class license the hard way. BDR reports from a nice rocking chair that he's practicing for the "grandpappy" ticket. He missed BPL this month, incidentally. SCA has made BPL 11 times in the past 12 months. New Novices in Urbandale are WN3s KCR, KCX, KCY, KDA, and KDF. Urbandale's Scout Club station call is 1KT. The Waterloo

(Continued on page 98)

*Long Life—Low Maintenance
No Comebacks with the*

New **300 OHM
TRANSMISSION CABLE**
by **BELDEN**

FOR 50 YEARS
*Wiremaker for
Industry*

To You,
Belden's Golden Anniversary
Means

—product performance that
can come only from a "know-
how" that has grown through
actual service since the
inception of Radio.

—an ability to co-oper-
ate in pioneering new
wires to meet or antici-
pate industry's grow-
ing needs.

In the years that
follow

This Belden
Program Is—

— TO BE
CONTINUED

No. 8230

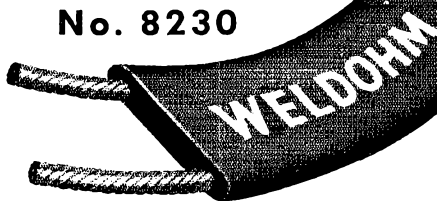

**COPPER-
SHEATHED
20-GAUGE
STRANDED STEEL WIRE**

Brown Polyethylene—Resists Weather and Oxidation

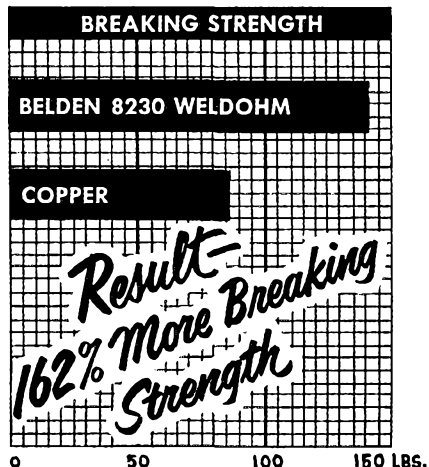

The new Belden Weldohm, 300-ohm Transmission Cable is the
greatest advancement in television installation since television began.

Reducing TV lead-in conductor breakage to a minimum is easy.
The new Belden Weldohm Cable has overcome the breakage point by
162%, that's 1½ times the strength of pure copper wire.

In actual test, Belden Weldohm Cable will withstand 254% more
whipping or severe flexing than the average installation of 300-ohm
copper lead-in wire.

There is no difference in the electrical characteristics between an
all-copper conductor and the Belden Weldohm copper-coated steel
wire. The web is 72 mils of 100% virgin polyethylene.

Replace with Belden Weldohm or make your next new installation
with Weldohm and avoid expensive loss of time and labor.

Specify Belden—Weldohm Transmission Cable.

Belden Manufacturing Co., 4621 W. Van Buren St.
Chicago 44, Illinois

Belden
Automotive **WIRE**



You headphone users have always known just what you want—flat response, high sensitivity, low distortion, rugged construction, lightweight, comfortable design. Now for the first time, all of these features are combined in a single headphone designed around the exclusive **BIMORPH CRYSTAL*** drive element. These outstanding, new headphones result from Brush pioneering and experience in acoustics and electronics.

- Exceptionally flat frequency response
- Exceptional bass response
- Low distortion
- Lightweight—designed for comfortable wear
- Sensitivity is approximately 6.3 dynes/cm²/volt at 1000 cps.
- Exclusive METALSEAL CRYSTAL* for protection against high humidity
- Impedance of 100,000 ohms at 1000 cps.
- No transformer required
- Multiple installations are readily made

Available from your local radio parts jobber in three styles: Double headset, Single headset and Lorgnette style.



Brush Microphones—Superior Brush crystal microphones are available in five models. See them at your dealer.

*Trade Mark Registered



THE
Brush
DEVELOPMENT COMPANY
 3405 Perkins Avenue • Cleveland 14, Ohio

PIEZOELECTRIC CRYSTALS & CERAMICS
 MAGNETIC RECORDING EQUIPMENT
 ACOUSTIC DEVICES
 ULTRASONICS
 INDUSTRIAL & RESEARCH INSTRUMENTS

Club furnished communications July 2nd, 3rd, and 4th at the Cedar Falls Centennial. Fourteen mobiles took part. PWE was instrumental in forming the program. Thanks, fellows, for your wonderful cooperation. Traffic: W6SA 702, BDR 336, QVA 44, BVE 42, BBZ 17, DIB 14, NYX 9.

KANSAS — SCM, Earl N. Johnston, W0ICV — SEC: PAH, PAM; HEC, RM; FDI, Field Day operations were the major activities in June. The JARS of Kansas City, using only one station, made 398 contacts in spite of a bad electrical and wind storm. The CKRC of Salina operated from Coronado Heights with one rig with ten AREC members participating. AZK, of Wichita, broke in his new Viking on Field Day. The KYRC of Topeka manned four stations and the only incident was that of emergency plants throwing a rod. The Kansas Nebraska Radio Club held its annual election of officers June 30th and elected IND, of Belleville, pres.; and GYK, of Linn, secy-treas. The Club's second annual hamfest will be held Sept. 7th on the North Kansas Fair grounds at Belleville. A communications receiver will be the main prize. New Novices in the Club are IOZ, of Washington; KFR and KFS, of Greenleaf; and BUD, of Belleville. CKRC's c.d. set-up in Salina now is working in the city hall. SOE, the Red Cross station in Wichita, is well equipped for emergency duty with 750-watt generator, HQ-129X, and Viking all packed in easy-to-lug portable boxes especially designed for emergency work. ATS and ISC, of Salina, have new Vikings on the air. WN6HAW now has 12 states with his 6V65-watter, but soon is going to 75 watts. EZT is going to attend college in W6-Land this fall. YFE is on 40 meters this summer. BNU is enjoying his new country QTH near Chanute. Traffic: W6NIY 120, BET 22, LIX 10, YFE 8, ICV 5.

MISSOURI — SCM, Clarence L. Arundale, W0GBJ — SEC: VRF. The Missouri Emergency Phone Net held its annual picnic at Kaiser State Park on June 15th. Bill Schmidt, Midwest Division Director, gave an interesting talk to the more-than-180 present. TGG did a swell job of taking care of the gang. The Rolla Amateur Radio Association made approximately 300 contacts during Field Day activities. CPI personally delivered a message, in Benton, Ill., from JA2 to the parents of a son in Japan and received nice publicity in the *Benton Evening News*. IHD, ZEV, and PLY are working 2 meters. BAF works out well on 40-meter mobile rig. IQY made a nice rating in the recent FMT. KIK has been issued on OTC certificate for 20 years licensed activity. FIR has been on 15 meters with 310 exciter. SMARC made 322 contacts on Field Day operations. New AREC members: ETW, CXE, and LNE. We extend our sympathy to GCL, whose father recently passed away. QXO makes BPL again and still retains the loving cup. ESX and EBF passed the Extra Class exams recently. WN6JHY is a new ham in Springfield. We recently enjoyed a visit with Louisiana SCM 5GHF and his family when they passed through town. Most reports complain of the summer heat affecting traffic activities. Your loyalty in mailing your monthly reports is appreciated. Traffic: W0QXO 620, K0FAY 135, W0CPI 51, K0WBD 35, W0UOD 25, KIK 23, HUI 19, GAR 12, BAF 8, EBE 8, GBJ 7, CXE 6, CKQ 3, BVL 2, GCL 2, NNH 1.

NEBRASKA — SCM, Guy R. Bailey, W0KJP — The big news this month is, of course, Field Day activities. However, only a few clubs reported to the SCM. AFZ provided the location for the Ak-Sar-Ben Radio Club of Omaha, about 11 miles northwest of the city. PIHW, QHG, CQX, YMU, and CSN took care of the eats, and plenty of the gang were on hand to operate the three transmitters, all of which were 30 watts or less. SENRC was located near Brock, Nebr., and used three transmitters and five operators under the call NWC. YHN reported for the gang at Crete, located at the Boy Scout Camp with five operators on duty. FNN reported that three non-club members had their own Field Day location somewhere north of Omaha and had a swell time. The 75-meter net is continuing activities through the summer. WZR, a new member from Alliance, now is reporting. Sure glad to have you, Dick. The SCM received a nice letter from FRN, in Omaha, who is joining AREC. FB, Byron. IAJ has suggested that the Nebraska and North and South Dakota c.w. nets consolidate to form a single net. This is a fine idea as all of these nets are small. Maybe we can work this out for our next season. The SCM wishes to thank the gang for the summer reports. Traffic: W0QHG 24, QOU 5.

NEW ENGLAND DIVISION

CONNECTICUT — SCM, Roger C. Amundsen, W1HYF — SEC: LKF. RM: KYQ, CN-3640 kc., CPN-3880 kc., CEN-29,680 kc. STU has found it necessary to relinquish the PAM job. Our thanks to STU for his efforts and we hope to secure an able replacement by next month. Net certificates were distributed and section bulletin was discussed during the section meeting at the FB Convention in Springfield. LHE, AOS, BM, ASJ, SJO, STU, BDI, NJM, LVQ, FTX, IOP, QVF, RWS, GVK, NZM, APA, IQE, LZE, RMZ, KYQ, SRE, LV, ODW, NOM, NEQ, JMI, AFB, DBM, HDQ, JJ, UBM, and many others from Connecticut were there. Big doings on Field Day in Connecticut included QI, QOA, RVF, HA, ORS, TEKA, and RBF, with

(Continued on page 84)

BABY your rig
with the **BEST...**

USE **OHMITE**

WHERE DEPENDABILITY COUNTS!

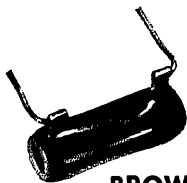
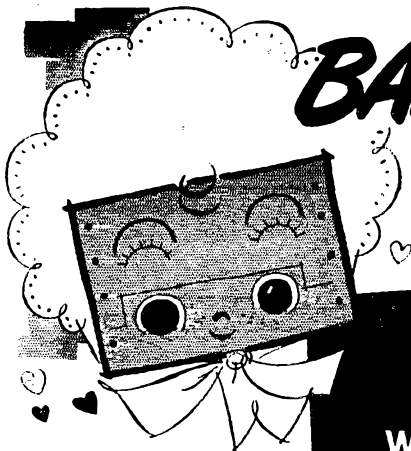

BROWN DEVIL RESISTORS

These wire-wound, vitreous-enameled units provide utmost dependability in a size small enough to fit most installations. Easily mounted by 1½" tinned wire leads. Three sizes: 5, 10, and 20 watts. Tolerance ±10%.



R. F. CHOKES

Single-layer-wound on low power-factor steatite or bakelite cores, with moistureproof coating. Seven stock sizes for all frequencies, 3 to 520 mc. Two units rated 600 ma, others rated 1000 ma. Used in plate circuits of many types of electronic equipment.



Write for
Stock Catalog

RHEOSTATS

Available in 10 sizes from 25 to 1000 watts, Ohmite rheostats can be relied upon for close control and long life. Ceramic and metal construction. Windings are locked in place by vitreous enamel, and the metal-graphite brush provides smooth gliding action.

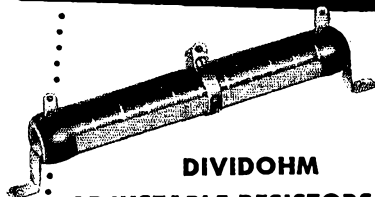
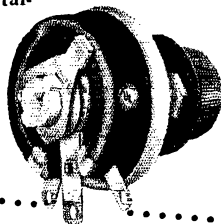

DIVIDOHM ADJUSTABLE RESISTORS

These wire-wound vitreous-enameled resistors, with one or more adjustable lugs, provide a convenient means of obtaining odd resistance values. Stock units made in 10, 25, 50, 75, 100, 160, and 200-watt sizes, in many resistance values.

DUMMY ANTENNA RESISTORS

For loading transmitters or other r.f. sources. New, rugged, vitreous-enameled units are practically non-reactive within their recommended frequency range.

Available in 100 and 250-watt sizes, 52 to 600 ohms, ±5%.

LITTLE DEVIL COMPOSITION RESISTORS

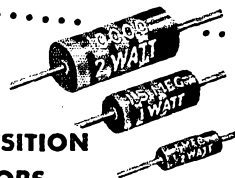

For quick, easy identification, resistance and wattage are clearly marked on every one of these tiny, rugged, insulated composition units. Three sizes: ½, 1, and 2-watts—in all RTMA resistances. Tolerances ±5% and ±10%.

OHMITE MANUFACTURING CO.

4863 Flournoy Street, Chicago 44, Illinois

Be Right with **OHMITE** RHEOSTATS RESISTORS TAP SWITCHES

A new addition

TV-300-15HW

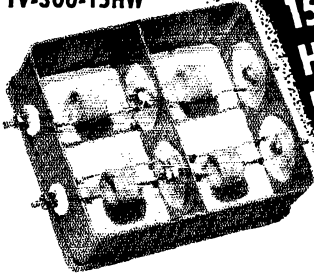

R. L. DRAKE'S

15 Meter
Half-Wave
Filter

\$10.95

Amateur Net

We are proud to announce this third member of our Half-Wave line.

Like its sisters, our new filter is a half-wave "Harmoniker" type, attenuating all harmonics outside its band, including the second harmonic which falls in the IF Channel of the new TV Receivers.

Balanced construction permits its use in 300 ohm twin-lead or in open wire lines 200 to 600 ohms. Rated to handle a modulated 1 KW transmitter in transmission lines with a low standing wave ratio.

Our complete line of TVI Filters

Amateur Xmtr Antenna Filters

1 KW Low Pass	Net
TV-52-40LP 52 ohm coax—10-160 mtrs.	\$12.95
TV-300LP 300 ohm —10-160 mtrs.	12.95
TV-52-20LP 52 ohm coax—15-160 mtrs.	12.95

1 KW Half-Wave		
TV-300-10HW 300 ohm—10-11 meters	\$10.95	LP
TV-300-15HW 300 ohm — 15 meters	10.95	HW
TV-300-20HW 300 ohm — 20 meters	10.95	

High Pass TV Receiver Filters

TV-300-50HP for 20 Mc IF—300 ohm	\$3.57
TV-300-54HP for 44 Mc IF—300 ohm	4.17
TV-72-50HP for 20 Mt IF—72 ohm	3.57

AC Power Line Filter

FB for keeping RF out of the power line from xmtrs and for keeping power line interference out of TV and ham receivers.

LN-5 "Inductube"	Net \$3.82
------------------------	------------



THE R. L. DRAKE CO.
11 Longworth St., Dayton 2, Ohio

Drake Filters are precision engineered, completely assembled and adjusted. See them at your distributors or write for complete data.

QOA highest making 580 contacts. IQE and LZE both have sons that have passed Novice Class exams. RMW is new EC for Norwalk. WN1VNI is a new operator in Willimantic. MHF and his brother, TSI, are both mobile, as is NJM. COB still is using crutches as a result of both legs being broken two years ago. Look for him on 40 meters. DEP is moving to Willimantic. NBP, in Niantic, also is WBO at his gas station. Sorry to hear that MYE is a Silent Key. SJO is trying 20 meters. ODW now is RCC and OTC. RBT is having fun in Southern Jersey during the summer. June CN: KYQ-20. LV-15, RRE, HYF-14. SBU is building a new rig. VK and IMP both are active in Bristol and KYQ asks any Bristol stations to report into CN anytime. LKF is busy getting ECs to have appointments endorsed. Congrats to RWS on his promotion. ODW is asking for a list of all Novices in Connecticut for bulletin use. Does anyone have such a list? Many thanks for much better news reports this month. Keep it up and 73. Traffic: (June) WISJO 343, EMF 160, NJM 75, AW 61, ODW 57, NBP 40, LV 33, HYF 28, RRE 25, KV 21, RWS 14, NEK 8. (May) WISTU 50, KV 15.

MAINE—SCM, Orestes R. Brackett, W1PTL—SEC: BYK, RM: LKP. The Pine Tree Net is operating on 3596 kc. at 1900 EDST Mon. through Fri. VSN, Mary Thurston of Greenville, the XYL of MJR, has her new ticket and puts out a very nice signal with that new 32V-3. Heard EFR on 75 meters the other day for the first time and was quite surprised as he is an old c.w. man. Another fine hamfest at Kezar has come and gone and what a time! About two hundred were there from all parts of New England and the newest in mobile hunts was held. PS operated the hidden transmitter, which was mobile contraband, in motion, and it created a lot of discussion and a lot of fun. If those of you who did not see PS in his get-up, which to me resembled Martha Washington, you certainly missed something. The steaks were as advertised, thick and tender. Unfortunately, it rained during the day but that helped to keep the gang together and to get better acquainted. IUM, from Cape Elizabeth, sure is putting out an FB signal on 75 meters. BAD now is on 75 meters with his new Elmac. PGZ and family made a very successful trip to the northern part of Maine, and from all reports the boys and gals up there sure gave Roger and family a royal welcome. Traffic: WILKP 55, SUK 28, EFR 22, BX 9, FRS/1 5, PTL 4.

EASTERN MASSACHUSETTS—SCM, Frank L. Baker, jr., W1ALP—New ECs this month: OLP Walpole, LJJ Plymouth, UBB Buxford. Appointments endorsed: HUP as EC for Dover, BBL as EC for Manchester, BL as SEC for Eastern Mass., HUP as OPS, PXH as OO, LMU as OBS and OES, AAL as RM. 4CU, ex-1CU, was visiting Quincy and has mobile rig on 28 Mc. in the car. VAN, Norwood, is on 28 Mc. THO has Class A and is on 3.9 and 50 Mc.; he is looking for KR on the air. GCN is on 7 Mc. LQQ is out of the Navy and home again. JCC is on 28-Mc. mobile. 9DGP, ex-1LAQ and ex-1LYC, visited FVD and ALP. He has a rig on 144 Mc. in his car. AMO won a new receiver at Springfield. The South Shore Radio Club, IA, went down to Hull again on Field Day. New officers of the Eastern Mass. Club: SZQ, pres.; HOL, vice-pres.; WN1UPZ, secy.-treas.; QKF, TOG, NBL and AMO, board of directors. 8MV, Cohasset EC, sent in his appointment for endorsement. UOH-KZ5LP writes that he is coming home on a vacation. DWO and TUD are on 1.8 Mc. WN1VGE/1 was on Field Day at So. Sutton, N. H. MGP/1 was on Field Day on 28 and 50 Mc. RLF now is at Transducer. NXW is in the Navy. Congrats to BHD, who was on "Voice of America." BGH is busy with C.A.P. TVZ went out on Field Day with the Framingham Club. SS received a hand-painted plate from 2BTB and 2ZOL at Springfield. AAL is very active on 144 Mc. WU is on 3.9-Mc. phone. UTH is getting a Millen VFO for his TBS-50C. The Old Colony Radio Club, Eastern Mass. Club, Waltham Radio Club, and El Ray Radio Club were all out on Field Day. TNK has Class A and is on all bands and mobile on 28 Mc. WN1VRL is a new ham in Hull. Sorry to hear that QVP is leaving these parts and we all wish him the best of luck. STA, Haverhill EC, reports that their net is on each week. ODQ, RUU, and SUR are on 50 Mc. SUR is on 28 Mc. MTI is mobile on 144 Mc. BB/1 was on Field Day from Harrington, Me. TOY is working on mobile rig. The Gypsy Radio Club was well represented at the Springfield Convention by 8NZ, HP, SIX, DOX, RYJ, QUY, PIY, KUA, HQO, KVT, TQU, UBB, KZZ, UIL, W. I. Tift, George Saunders, and many XYLs. HPH is out of the Navy. The Southeastern Mass. Radio club held its final meeting and a steak dinner attended by AVY, LAZ, FXB, CTZ, QUE, PWL, KHV, WU, MHN, and his XYL WN1UID. AVY is president and LAZ secretary-treasurer of the Club. AVY, CTZ, SSS, and AER worked NSS WAR on Armed Forces Day and have QSL cards. TQS/1 is down in Provincetown for the summer. UG has a 265' flat top. LVN has new QTH in Pal mouth. LMU and PIW have mobile rig on 50 Mc. 8XD will have 829 on 144 Mc. JOW is building Q5-er. FFB lost his beams. QMU is rebuilding. NBS is building VFO and converter for 144 Mc. UXK is on at Fort Devens on 3.5 Mc. and is MARS and has an S-41 and BC-654. WN1VID is going to Japan. Sorry to have to report the death of QYA, of Danvers. BGH and WN1TWG are on 144 Mc. TQP has a beam going up for 144 Mc. The Eastern Mass.

(Continued on page 96)

PUSH-PULL

POWER

with REDUCED CAPACITANCES



250 mc. 85 watts output

500 mc. 45 watts output

New! AMPEREX 5894 / AX - 9903

UHF and VHF Twin Tetrode for **W-I-D-E** Band Operation RF Amplifier, Modulator, Frequency Doubler, Tripler

5894 / AX-9903 CHARACTERISTICS

Filament Voltage

Series 12.6v.
Parallel 6.3v.

Filament Current

Series 0.9a.
Parallel 1.8a.

Maximum

d.c. Plate Voltage 600
d.c. Grid #2 Voltage 250
d.c. Grid #1 Voltage -175
Plate Dissipation (w.)..... 2 x 20
d.c. Plate Current (ma.).. 2 x 100

PER UNIT

Grid to Plate..... <0.08 mmfd.
Input 10.5 mmfd.
Output 3.2 mmfd.

COMPARE CAPACITANCES of
this tube with its nearest
equivalent type.

PER UNIT

<0.12 mmfd.
14.5 mmfd.
7.0 mmfd.

MOUNTING POSITION: Base up or down. Horizontal with anode leads in horizontal plane.

Fits 829B Type Socket.



re-tube with **AMPEREX**

● The AMPEREX 5894/AX-9903 is an improved version of the 829B. The design of this tube incorporates features which produce considerably smaller output capacitances and which, therefore, result in higher resonant frequencies (above 500mc. instead of 250mc.) In addition, because of the low inductances of the connections between the cathode and screen-grid, more stable operation of high frequencies is effected.

● A most desirable design characteristic, also, is the incorporation of internal neutralizing condensers which are connected directly to the control-grids, making impossible self-oscillation in a tuned-plate, tuned-grid transmitter.

● Of importance in this new design are such features as:

1. Direct and short connection between the pins and the anode, causing lower inductance and resistance.
2. No insulating parts (mica or ceramics) between anodes, causing losses at high frequencies.
3. "Screened" micas, thereby preventing possible losses due to contaminated mica.
4. Zirconium-coated moly anodes, giving a higher degree of vacuum than possible with nickel anodes and barium getters.

● For full data on the AMPEREX 5894/9903 AX- see your local radio distributor.

● **IMMEDIATE DELIVERY** Order from your local radio distributor.

AMPEREX ELECTRONIC CORP.

230 DUFFY AVENUE, HICKSVILLE, LONG ISLAND, N. Y.
In Canada and Newfoundland: Rogers Majestic Limited
11-19 Brentcliffe Road, Leaside, Toronto, Ontario, Canada
Cable: AMPRONICS.

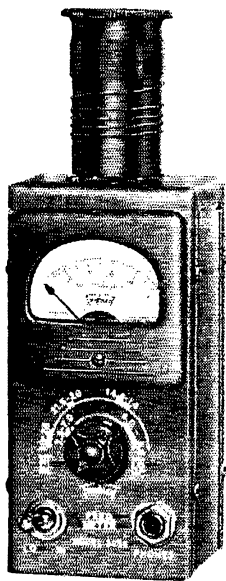

**KNOW
WHAT
BAND
YOU'RE
IN!**
with
Triplet 3256

**High Sensitivity
Absorption Frequency Meter**

Brand New! — A band switching, tuned absorption type frequency meter covering five amateur bands. Incorporates the new germanium crystal and a DC Milliammeter indicator for greater sensitivity. Direct calibration on panel — no coils to change. Switching permits instantaneous band change. Audio jack, another new feature, provides for monitoring of phone signals. Calibration is in megacycles in the following bands: 3.5-4; 7-7.3; 14-14.4; 21.5-20; 28-30. By removing plug-in coil other frequencies may be covered.

Use This New Unit for Checking:

1. Fundamental frequency of oscillating circuits.
2. Presence, order and amplitude of harmonics.
3. For parasitic oscillations.
4. The neutralization of R. F. amplifiers.
5. Standing wave ratio on transmission lines.
6. The presence of undesirable R. F.
7. For small quantities of R.F.
8. Monitoring of phone signals.

Model 3256 is fully shielded, highly sensitive, compact— invaluable for use in restricted spaces.

**ONLY \$17.50 AT
YOUR DISTRIBUTOR**

Price Subject to Change

FOR THE MAN WHO TAKES PRIDE IN HIS WORK

Triplet

TRIPLET ELECTRICAL INSTRUMENT COMPANY - BLUFFTON, OHIO, U S A

Club is going to hold a session from 7 to 8 on meeting nights to help hams-to-be to get their licenses. Traffic (June) WIEMG 259, SS 101, UE 96, MME 95, AVY 19, AAL 18, TY 13, BY 9, WU 7, UTH 4. (May) WIDMS 11.

NEW HAMPSHIRE — SCM, Norman A. Chapman, W1NC — RM: CRW. This will be the last report from yours truly. My sincerest thanks to each of you who has helped to make this an interesting column during the past two years. GMH will take over the reins as SCM. Let's give Cal our full support by getting those reports to him each month. I especially want to extend my thanks to CRW, our Route Manager. With the least number of stations, Cliff has rolled up the largest traffic total of any other section. TNO now is an Advanced Class licensee. WN1VAU is operating W1VAU under his new General Class ticket. AIJ received his Certificate of Merit, awarded to him for making perfect copy of the Secretary of Defense's Armed Forces Day message. POK is rebuilding again. FZ, KEX, TBS, UON, and OUT operated portable on Blue Job Mountain on Field Day, reporting a score of 2860. The Great Bay Radio Assn., with 6 transmitters and 9 operators, worked Field Day from Mt. Agenticus. The Concord Brasspounders worked OC/1 from Oak Hill, Loudon, with 9 transmitters, 18 operators. Congrats to the newly-formed Port City Radio Club, Portsmouth. UEB is acting secretary. CRW keeps regular skeds with 2BZD/MM, the schooner *Blue Dolphin*. Will be seeing you at the New Hampshire ARRL Convention at Nashua. Traffic: (June) W1CRW 961, JNC 22, GMH 20, FZ 3. (May) W1GMH 28, FZ 14.

RHODE ISLAND — SCM, Roy B. Fuller, W1CJH — SEC: MIJ. RM: BTV. PAM: BFB. Summer schedule for RIN is Mon., Wed., and Fri. at 1900 on 3540 kc. This was Rhode Island's most active Field Day. Five clubs reported participation in this annual event: ARASNE (AQ), Newport County Club (SYE), Providence Radio Assn. (INM), Cranston Radio Assn., NAARO (SKT). Those active as reported by their clubs were: PRA — BGM, MIJ, IQZ, and KCS. Newport — JBB, TXF, VBN, MIM, TRX, BBN, ONZ, OMC, JFF, TXL, ULG, and ULS. NAARO — BFB, TEX, TKX, LFE, KHZ, OGT, UEF, ICE, RVQ, NCX, MJL, LWA, THG, and CJH. Newport will start a new series of instructive movies dealing in electronics and narrated by JFF. High-frequency receivers and transmitters will be demonstrated by ULG. The newest ham reported this month is WRE. TFX has new TBS on 10 meters, a sure-fire groundwave contact any evening on 29,080 kc. LVA has moved to a new home in Lakewood and will be active this coming fall. QYX made HPL for the month of May. Traffic: (June) W1OIK 19, TRX 12. (May) W1QYX 292, OIK 20, TRX 17.

VERMONT — SCM, Raymond N. Flood, W1FPS — SEC: JEN. PAM: AXN. RM: OAK. AVP has purchased a 2 1/2-kw. generator for emergency use. SPK is busy working DX and giving c.w. practice. We were sorry to learn that RLS lost his XYL. Our sympathy. Art. TQD is trying for DXCC from all reports. Good luck, OM. Field Day was enjoyed by the Tri-County ARC. A good score (for them) was made in spite of the fact that two of their best operators were unable to participate. BARC members also enjoyed themselves at South Hero, Vt., with four transmitters. Traffic: W1AVP 103, OAK 55, RNA 39, FPS 7.

NORTHWESTERN DIVISION

ALASKA — SCM, Glen Jefferson, KL7NT — KL7BK, A on a hurried trip to Fairbanks, was about to throw his mobile transmitter into the Tanana River when he discovered that no excitation was due to his carrying the 3892-kc. crystal in his pocket! NT is ready to raise a 60-foot vertical. UM is busy keeping Division of Forestry communications on the air and operating during the fire weather season. Call-letter license plates are a sure thing for KL7 operators and if specifications are followed the plates will be of the reflector variety — glass beads and everything but a center-loaded whip. A few of the gang are dusting off their rigs hoping for a good fall and winter communications season. Traffic: (May) KL7AKJ 1336.

IDAHO — SCM, Alan K. Rose, W7IWU — Kendrick: MHR writes a nice letter from Cheney, Wash. He is with the N. P. Railroad and travels around quite a bit. His father, MGL, is active on the Inland Empire Net, 1995 kc. Grandview: IY was all set for a little trip but broke a connecting rod. A week later he contracted summer flu. Boise: KJO vacationed through Yellowstone. The Gem State Radio Club scheduled a picnic at Lowman, some 70 miles north. Among those present were NPO, NPI, ORJ, FOF, GHT, NVO, BBS, PKA, AHS, CDR, GUQ, GQA, and DTF, with their families and fishing poles. IWU now is on 20-meter mobile, phone or c.w. I'm afraid the Idaho QSO Party held last June 8th will have to be "no contest." Only one report was received. We'll try another one in the winter time when there will be better conditions and more interest. No traffic reports were received this month.

MONTANA — SCM, Edward G. Brown, W7KGJ — The Capital City Radio Club has a new call, TCK. OIQ now is in KH6-Land and is looking for the Gallatin gang on 14,280 kc. at KH6AHQ. JDZ has TBS-50 and Gonset (Continued on page 98)

IDEAS for modern STATION DESIGN

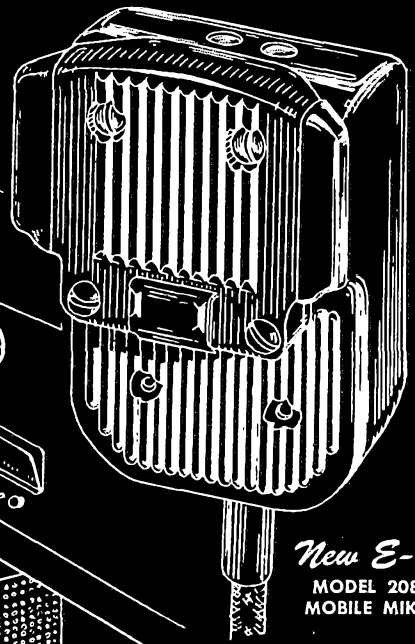

One of
a series

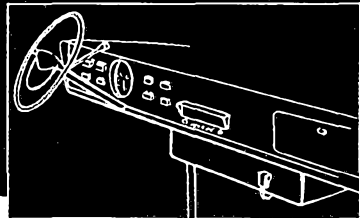

Reconciling ham radio with the symbol of the American highway is a difficult problem since modern automobiles are seldom designed with amateur radio installations in mind. Here is a unique, universal installation that should prove acceptable to critical XYL's across the land. The receiver and transmitter are mounted in an oblong box that pivots from a point under the dash. The equipment housing is reinforced with angle stock for rigidity. Dimensions are limited only by your own requirements. The pivot mechanism is a simple pipe stand held on top and bottom. The pipe should be threaded by a local plumber to permit nuts and washers to snugly hold the equipment case, yet permit it to pivot 90°. When not in use, the entire station is simply pushed under the dashboard. And, unlike the inconsiderate

automotive designer, Electro-Voice has designed, specifically for mobile operation, the new Model 208, a handheld, light-weight carbon microphone. This remarkable unit is a single button, high output, carbon microphone designed for maximum intelligibility. A panel mounting bracket included with the microphone holds it face in on dashboard or side of transmitter . . . thus, when it is removed it is instantly ready for use. A differential noise-cancelling design (the first ever engineered at a popular price), to be operated close to your mouth, it has a high impact gray styrene case which is shock resistant and water proof. Press-to-talk switch actuates button and relay simultaneously. Amazingly enough, the amateur net is only \$9.90. See your E-V distributor today!

W8HCW

Send for Bulletin on
Model 208 Mobile Mike

Electro-Voice

404 CARROLL STREET • BUCHANAN, MICHIGAN.
Export: 13 E. 40th St., New York 16, U.S.A. Cables: Arlab

MICROPHONES • HI-FI-SPEAKERS • PHONO PICKUPS • TV BOOSTERS • TV DISTRIBUTION SYSTEMS

- **ELECTRONIC
DESIGN ENGINEERS**
- **TECHNICAL WRITERS**
- **DESIGN DRAFTSMEN**
- **PHYSICISTS**

Westinghouse

offers you

SECURITY AND OPPORTUNITY

EE's and ME's with over 3 years experience . . . a number of excellent positions are now available in our Electronic & X-ray and Air-Arm Divisions for work on:

- Broadcast Transmitters
- Power Line Carrier
Communication Equipment
- Railroad Radio
- Radio Frequency Heating
- Medical and Industrial X-ray
- Commercial Radar
- Balancing Equipment
- Military Radar (ship, ground,
airborne)
- Military Transmitters
- Specialized Electronic
Equipment
- Fire Control Systems
- Automatic Pilots
- Guided Missiles

Check These Outstanding Benefits: Top pay, ideal working conditions, advancement on merit, graduate study opportunities, employee scholarships, paid re-location expenses, Baltimore location.

Send resume of experience and education to: Manager of Industrial Relations, Westinghouse Electric Corp., 2519 Wilkens Ave., Baltimore 3, Maryland.

If you are using your greatest skill
in a defense industry, do not apply

YOU CAN BE SURE...IF IT'S

Westinghouse

Tri-Band on 75, 20, and 10 meters in his car. Ben has returned from a trip along the FARM Net route. EOJ and NPV are active in the FARM Net. The Gallatin Amateur Radio Club has a new call, ROX, and has just made 100 per cent ARRL membership. Both Montana nets, 'phone and c.w., need some energetic support from the Montana gang. Please write your SCM and offer suggestions in regard to possible frequency changes, change in days or times, who you would like for NCS, or if you would like to rotate the net control job, or anything you may have that might spark more interest and activity in the nets. Don't forget to mail your activities reports. Traffic: (June) W7KJG 42, JDZ 10. (May) W7JDZ 65.

OREGON — SCM, J. E. Roden, W7MQ — RWM is a new Novice located at Merrill. JRU has been very busy shaping up the civil defense communications in Klamath County, being director of communications. BDN is busy rebuilding his rig and revamping his ham shack once more. GNJ is plenty busy since taking over the OEN manager-ship, but is doing one swell job, ably assisted by HHH, his XYL, and SY. Publishing the monthly edition of the *OEN NETTER* is one of duties he also has assumed. HDN, our SEC, is planning a round-the-State tour, visiting different ECs and local AREC groups. AJN and ESJ want more MARS check-ins. Traffic: W7OJG 346, GDV 75, MQ 52, GNJ 51, HDN 33, MLJ 27, FY 23, HJU 22, EDU 8, BXU 5, EUG 5.

WASHINGTON — SCM, Laurence M. Sebring, W7CZY — SEC: BTV, RM: FIX, PAM: NRB. OE is back on the air working 80-, 40-, and 20-meter c.w. and 10-meter 'phone. Clark County Radio Club made a fine score in the Field Day test. KCU wants a YL. MARS net on c.w. JWE is on the air from new QTH. He is using a new BAYMOBILE antenna on 3970 kc. with good results. ZU found some of his old electronic keyer trouble cured by use of crocus cloth on contacts. ETO could use some of the same. He reports a fair Field Day score, from 5000-foot birch mountain. GVC reports an active Field Day from McIntire Point with 2-meter ground wave to Ephrata, and Toppenish, also heard in Wenatchee. FIX and his XYL returned from a three-week vacation trip. The North Seattle Club had 19 operators turn out for Field Day using the call CO. NSI, KWC, and the Bellingham gang operated from Neptune Beach on Field Day. NSI says, it's 10 feet below sea level. RMD, RNF, and QMM would like to start a Novice traffic net. HNQ is having trouble with his converter on 10 meters. PFZ received "greetings" from Uncle Sam. OEB and NDO worked 20 meters during Field Day and worked VRIA, ZS6AFA, ZS2BC, VK9XK, DUJOR, and KC6QY. PHP is in the Air Force in California. GJU is working in Olympia. MTX is servicing TV sets. MPH is home from the U. and working at the experimental station. JJK is on the air from W6. IVJ returned from Korea and sold his gear, then packed up the XYL and left for Tokyo for two years. KHL is operating from a ship on the Far East run. NNQ moved to Aberdeen. NKB built a new workshop and operating position. JVE is working at KTAC; he has a new Merc and a 75-meter mobile rig. OZG keeps in touch with his wife in Seattle via his mobile rig on his sales trips. BA has 'phone asked with his son in Hilo through KH6EJ. PGY and JPH went camping in the rain on Hoods Canal and ended up with one dead battery and three cars stuck in the mud. The North Seattle Radio Club's new officers are HRC, pres.; IHD, vice-pres.; FTR, secy.; CO, sgt. at arms. CO and his wife are flower experts; they won prizes at the Rose Show. MEU got married. EBK now is a Silent Key. Traffic: W7BA 365, CZX 132, ETK 133, EWI 133, FRU 97, KCU 66, TH 49, MSI 44, AQN 34, FWD 34, APS 33, OEB 28, ZU 27, PGY 21, AIB 19, ETO 16, FIX 13, MBY 13, JWE 10, NTU 6, EVW 4, GVC 4, NRB 2.

PACIFIC DIVISION

HAWAII — SCM, John R. Sanders, KH6RU — The Maui Club operated RS near Hokiapa Park using one transmitter on Field Day. The Kauai High School Club had fifteen operators and one transmitter near Lihue. The Honolulu Club had one transmitter set up at a fine camp on Bellows Field with twenty-five operators. NEZ now is schooling at RCA Institute. N. Y. C. W2AIS has joined the local FCC. CH is departing for duty in the Far East. CJ is working toward Extra Class license. Fifteen certificates have been issued so far by the local FCC office. Ex-PY visited Honolulu briefly en route to Guam. JO is rebuilding to a pair of 813s. RU has been appointed Assistant Director for this section of the Pacific Division. Your consideration is requested, fellows, in the selection of a candidate to replace me as SCM. I do not deem it proper to hold both offices. *Far Pacific Area:* KB6AO is remaining at Canton after all. JA6IJ is active on Iwo Jima now. KG6FAA makes BPL again. Traffic: (June) KG6FAA 3069, JA8AB 600. (May) JA2KW 455.

NEVADA — SCM, Ray T. Warner, W7JU — SEC: HJ, ECs: JLM, JVW, KOA, MBQ, OXX, TJY, VO, LGS, and ZT. RM: PST. OPS: JUO. OO: LGS. Nevada state frequencies are 3660, 7225, and 29,360 kc. JUO is enjoying his new 75A-2 receiver and now is working on a new mobile job. OXX, MBQ, and DVJ were active during Field Day in

(Continued on page 100)

NOW AVAILABLE

ROTHMAN MODULATION

*Broadcast Quality • No Over-Modulation
High Efficiency • Less Equipment*



MARMAX 50 WATT MOBILE TRANSMITTER

Model MT-52. Net.....\$79.50

With One Set of Plug-In Coils

- 50 Watt Peak Power.
- 400-600 V.D.C. @ 100-150 M.A.
- Input.
- Controlled Carrier.
- Low Battery Drain.
- All Band Operation 10 through 75 Meters.
- Extremely Compact.
- Dash Mounting.

The heart of the MARMAX MOBILE is the MARMAX MOBILE PLUG-IN MODULATOR MO-52. Also obtainable separately for your present Mobile Transmitter.

MARMAX MOBILE MODULATOR

Model MO-52. Net.....\$12.50

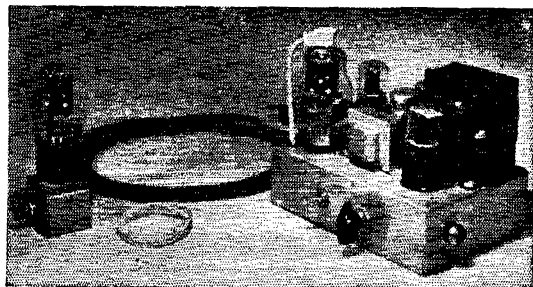

1 KW MARMAX MODULATOR

Model KW-52. Net..... \$54.00

All Units Complete With Tubes — Wired, Tested and Guaranteed

High Fidelity Modulation for powers from 50 watts to 1 KW with built-in speech amplifier for high impedance microphones.

IMMEDIATELY AVAILABLE

If your favorite dealer cannot supply, write direct to factory.

Marmax Electronics

716 NEW YORK AVENUE

ALAMOGORDO, NEW MEXICO

WORLD'S LEADING MAKES

Always
in Stock at **HUDSON**
RADIO & TELEVISION CORP.

Prompt Delivery on All Types

SYLVANIA Germanium Crystal DIODES



DUO-DIODES VARISTORS

Sylvania Germanium diodes are available in Ceramic or Sealed-In-Glass construction. Designed for efficient dependable service for every type of application in Radio, Television, and Electronics.

They're Compact • Lightweight • Rugged • They have Low Shunt Capacity • No Contact Potential • Require No Heater Supply • No Mounting Hardware • Estimated Life more than 10,000 hours •

Write us your requirements . . . get your copy of the New Hudson Catalog . . .

FREE NEW 1953 HUDSON CATALOG

Everything in electronics at your fingertips in this greatest of all 1953 HUDSON CATALOG! Over 196 pages of everything in Radio, TV, and Industrial Electronics. The World's Finest High Fidelity and Audio Equipment, and the latest in Ham Gear, etc. The most complete buying guide of its kind INCLUDES the latest JAN CROSS-REFERENCE GUIDE and all types of fully approved JAN type components with interchangeability charts.



Save Time! Save Money! Select from the largest stocks of all standard makes at LOWEST PRICES!

Send for your FREE Catalog today! *One Call for All!*

HUDSON RADIO & TELEVISION CORP.
48 WEST 48th ST. NEW YORK 36, N. Y.
212 FULTON ST. NEW YORK 7, N. Y.

Hudson Radio & TV Corp. Dept. Q9
48 West 48th St., New York 36, N. Y.

Please send FREE, your NEW 1953 Catalog.

Name.....

Address.....Zone.....

City.....State.....

the Charleston Mountains near Las Vegas. #DKT, #WTV, #RXX, and #CHP are all sojourning hams at Stead AFB near Reno, and all soon will be W7s. BVZ is having trouble with power leaks on 40 meters. NWU now is on 10 meters. MMK left Boulder City to retire in Oregon. Good luck, Al. NRU, PST, KHU, HJ, and JU enjoyed the Pacific Division Convention in San Francisco. Eastern stations having difficulty in working Nevada for WAS may write JU for skeds and same will be arranged. Traffic W7JU 18.

SANTA CLARA VALLEY—SCM, Roy L. Cozlin, W6LZL—It was gratifying to note the number of clubs and the number of operators who participated in the Field Day activities. At the SCCARA meeting Mr. R. H. Miller spoke on P. G. & E. Co. radio system. The Monterey Bay Radio Club, as well as NPEC and PAARA with San Mateo and SCCARA, made extensive and complete plans for a successful Field Day at their meetings. FYK reports he is making 6-meter tests. SYW is QRL studying TV. RFF is preparing to open a radio-TV sales and service in San Carlos. HC reports the SCCARA made 713 contacts on Field Day. YHM reports he had lots of fun on Field Day with the gang from San Jose on Mt. Hamilton. MAFG reports the NPEC held Field Day in the Burlingame hills near Skyline Blvd. OUX now is mobile on 141 Mc. UKM, ALL, N6NEE, and N6ISWV will be mobile on 141 Mc., all operating in South San Francisco. YHC, in Menlo Park, is getting ready for 75-meter mobile. MXO now is living in Shelter Cove near Rockaway Beach. The Palo Alto Amateur Radio Assn. reports 660 Field Day contacts with a total of 5735 points. Your SCM wishes to thank the many friends in all parts of the section who sent cards, phoned, and visited while your SCM was in the hospital and while recuperating at home after the operation. The illness hit very suddenly and the May activity report was not prepared, so my hearty thanks go to CLF and his XYL who, knowing I was worried about it, took up the task and did a swell job. Traffic: W6YHM 107, IIC 74, MMG 19, FYK 6, RFF 4, SYW 4.

EAST BAY—SCM, Ray H. Cornell, W6JZ—Asst. SCMs: Guy Black, 6RLB, and Julio Amaro, 6WGM, SEC: RVC, RMs: IPW, JOH, PAM; KZF. The Pacific Division Convention turned out to be a huge success. It was amazing to see hams who had traveled several hundred miles spend their time keying an audio oscillator and listening to their fists. Apparently c.w. is here to stay. The RN6 boys held their first meeting in years at a convention breakfast. Attending were ELQ, HC, IPW, JOH, UTW, YHM, EXH, HOR, and JZ. TI, TT, RLB, and JZ attended a pre-convention dinner for ARRL Secretary Budlong, together with CIS, ATO, and RBQ. Field Day found all of the clubs out as usual. The Mt. Diablo Club separated the c.w. and 'phone men and used separate power supplies for each. In this manner no difficulty was encountered from key clicks or splatter. In recognition of FB work on BAN, Bob Weber, JOH, has received an RM appointment. With Gene, IPW, and Bob concentrating on improving BAN we can be assured of its continued growth. Gene says that YHM is spending more and more time on BAN. I hope we can get the rest of the fellows who report into RN6 from this area to realize their responsibility to the section net. BAN welcomes EFD, of Richmond, and AQR, of San Mateo, newcomers to the net and invites others anywhere in the Bay Area to participate. CTL reports as follows for the Northern California DX Club: New officers are DZZ, pres.; NIG, vice-pres.; KFK, secy.-treas.; RRG, board of directors. PYIADX was a recent visitor. OMC gave a very FB lecture on tetraodes and why they act as they do. Newest member is CZQ. Bill says, "The boys still are in there knocking off such DX as crops up from time to time. Some of 'em still are fighting TVI as who isn't (except W6JZ of course)?" HFK has received his BS in E.E. He submitted the only report from the section in the last Frequency Measuring Test. One reading was as close as 1.1 p.p.m. Carl Scott is WN6QEF of Richmond. WN6IBF wants to start a Novice traffic net on 3714 kc. Interested parties, please write to me. NGC is constructing a new tower for 10-meter beam. KNY is new AREC member. WGM acts as EC for all of Solano County. CHI took over as chairman of the NBARA exhibit at Solano County Fair because of the illness of BPC. WHA is enjoying vacation. LGW worked AIL on 2 meters and suggests that band for the Sunday Morning Staff Net. LIL is moving to new QTH. YHQ is constructing new mobile receiver. Contra Costa County is providing 28.86 Mc. crystals for the emergency net in the W. C. Martinez Area and the Net will move there from 29.6 Mc. Traffic: W6JOH 190, JZ 44, IPW 36.

SAN FRANCISCO—SCM, R. F. Czeikowitz, W6ATO—Phone JU 7-5561. SEC: NL, Phone PL 5-6457. With the Pacific Division Convention now history, a special word of commendation should be extended to JZ, SCM of the East Bay section; to BYS, EC for San Francisco; and to VSV for their very excellent and interesting operating displays. Ray and Bill were responsible for the code recorders and playbacks and the code contests, as well as for the U. S. Navy displays. Bob operated his amateur TV camera into monitor TV receivers. These exhibits, as well as all the others, were well attended and most interesting. It is impossible to go into detail as to the fine work of many mem-

(Continued on page 102)

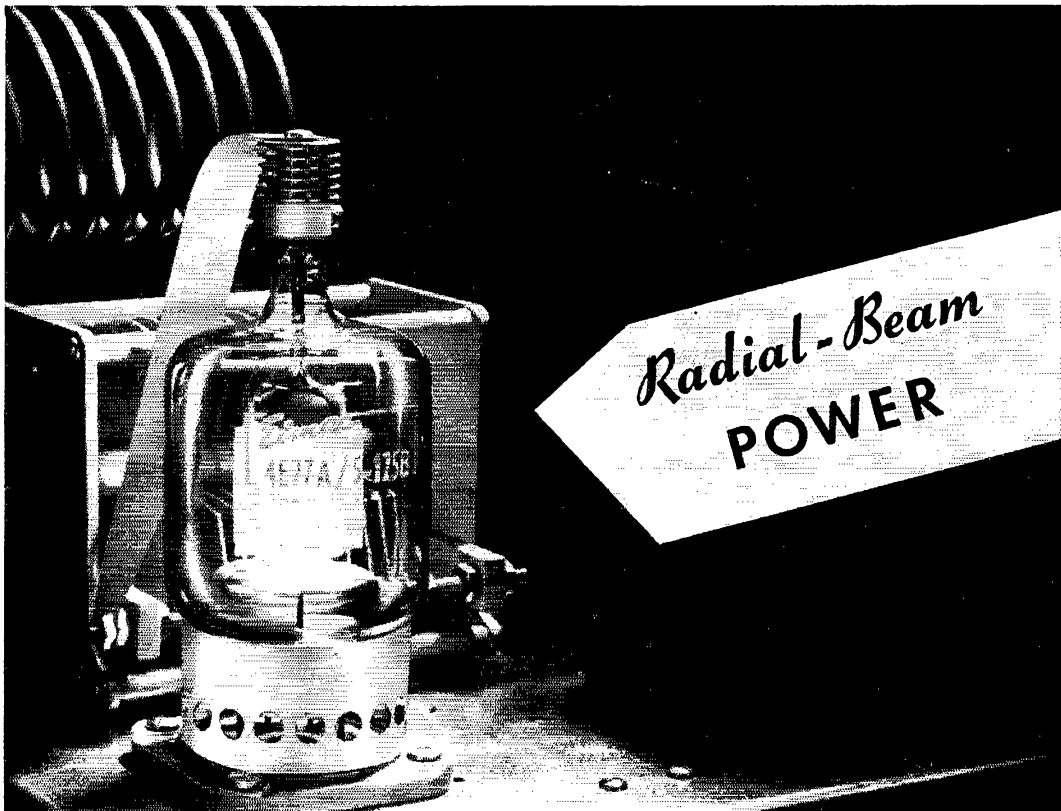

... with the Eimac 4E27A pentode

*Low grid-plate
capacitances*

Ventilated Base

*Adaptable to
suppressor grid
modulation*

Write Eimac's amateur service
bureau for full information
about the 4E27A.

Amateur radio operators get top performance with real economy when they use the Eimac 4E27A radial-beam power pentode. It takes only simple circuits and less than two watts driving power to give dependable operation with high output. Rated at 125 watts plate dissipation the 4E27A is capable of an easy half-kilowatt input in class-C service—or when suppressor modulated will deliver 75 watts power output at carrier conditions. Amateurs with mobile rigs are finding the 4E27A a natural, due to its many features including simple audio modulation requirements—an ordinary receiving tube will do the job—and low driving power. Through exclusive Eimac features and radial-beam controlled electron flow the 4E27A has proved dependable in amateur and commercial applications.

Eimac
TUBES

EITEL-McCULLOUGH, INC.
SAN BRUNO, CALIFORNIA

Export Agents: Frazar & Hansen, 301 Clay St., San Francisco, California

325

How far ahead can
you be next year . . .

IN TV AND ELECTRONICS?



Send for this Free CREI book and find out!

THIS booklet can mean the difference between w-i-d-e-l-y s-p-a-c-e-d salary increases — and rapid advancement.

An exciting new world has opened up. Think of the 1500 TV stations within the next 5 years, and the 2500 stations within 10 years, as predicted by the chairman of the FCC. Think of the 14,496,000 TV sets and the 100,000,000 radios now in operation. Think of the tremendous defense orders for electronics installations — the thousands of transportation, aviation and marine installations.

Countless positions must be filled. Who will get them? You — if you prepare today — if you advance your knowledge — if you take 2 minutes to send for a free copy of "Your Future in the New World of Electronics."

This helpful book shows you how CREI Home Study leads to greater earnings through the opportunities described above.

An accredited technical school, CREI does not promise you a "bed-of-roses." You have to translate your willingness to learn into knowledge — via study. Since its founding in 1927, CREI has provided thousands of professional radiomen with technical educations. Leading firms choose CREI courses for group training in electronics at company expense. (Examples: United Air Lines and RCA-Victor Division). CREI alumni hold top positions in American electronics.

CREI courses, prepared by recognized experts, are practical and easily understood. You get the benefit of personal supervision by a CREI Staff Instructor. At your service is the CREI Placement Bureau, which finds positions for students and graduates. Although CREI does not guarantee jobs, requests for personnel currently exceed supply by far.

Determine for yourself right now that your earnings are going to rise — that you will enjoy your rightful place in the Age of Electronics. All this CREI can promise you — provided you sincerely want to learn. Fill out the coupon and mail it today. We'll promptly send you your free copy of "Your Future in the New World of Electronics." The rest — the future — is up to you!

MAIL COUPON FOR FREE BOOKLET

CAPITOL RADIO ENGINEERING INSTITUTE

Dept. 169D, 16th & Park Rd., N.W., Washington 10, D.C.

Send booklet "Your Future in the New World of Electronics" and course outline.

CHECK FIELD OF GREATEST INTEREST

- TV, FM & Advanced AM Servicing
 Aeronautical Radio Engineering
 Practical Television Engineering
 Broadcast Radio Engineering (AM, FM, TV)
 Practical Radio Engineering

Name.....

Street.....

City..... Zone..... State.....

If residence school in Wash., D.C. preferred, check here

bers of the committee, except to say "well done." Unfortunately, none of the clubs in this section had an outstanding score in Field Day, most being dogged by bad luck of one kind or another — but they all say, "Wait 'til next year." The SFRC used its new club call, QGJ, for the first time. The new meeting place of the SFRC is 51 Lakeshore Plaza, opposite the intersection of 34th Ave. and Sloat Blvd., and the temporary meeting night is the 3rd Friday. JCG spent three weeks operating /KL7 at Nome with 35 watts but with not much success because of heavy QRN, he says. HJP is busy with electronics work in Western Germany, leaving little time for amateur radio. His call — DL4HM. KAH now is mobile and JCG is back on the nets for SFO. Clubs known to have been active on Field Day were the Tamalpais Club, YME/6; the SFRC, QGJ/6 the HAMS, MLK/8; and HQN/6 at Healdsburg. Novices active in San Francisco are WN6PIH and WN6PHT, Melvin and Cynthia DeLauney. Mel worked 51 stations and operated 37 hours during May, working Alaska and Hawaii and handling some traffic on 3725 kc. Reports from all WN6s are welcomed. News from Eureka shows that Betty Wilson, 7P7C/AW6, and D. K. Cable, 6IME, are new members of the Humboldt Amateur Radio Club, swelling the membership to more than 60. The HARC meets the second and fourth Fridays in the YMCA rooms, Municipal Auditorium, entrance on "E" St. The ten-meter net meets each Tuesday night at 1900 PST on 29,160 kc. Don Hitt now is the proud holder of WN6PKJ. Sign up with SLX, Emergency Coordinator, for Emergency Corps work. His address is 3236 "S" St., Eureka. Television interference committees now are active in San Francisco, Marin, and Sonoma Counties — so before your TVI problems get to the shotgun stage, look them up. The Sonoma County Radio Amateurs meets in the Tap Room of the Grace Bros. Brewery, 2nd St., west of the Freeway, on the first Wednesday. The Tamalpais Club meets at the home of OZC in Tiburon on the third Friday. The Marin Radio Amateurs meets at the American Legion Hall, Larkspur, on the second Friday. The HAMS meet on the second Friday at the Red Cross Building, 1625 Van Ness Ave., San Francisco. Traffic: WN6PIH 6, W6ATO 5, WN6PHT 5. SACRAMENTO VALLEY — Acting SCM, Willie van de Kamp, W6CKV — New additions to the Chico gang include WN6QIV and WN6QJD. CTC, KME, and OFY provided radio communications for the boat races on the Sacramento River. KPV is active again from Carmichael. DRG claims to be the most northerly station in California. JDN is busy with traffic. CLG uses city gas for filling balloons to raise antenna. Traffic: W6JDN 180, PIV 47. SAN JOAQUIN VALLEY — SCM, E. Howard Hale, W6PYM — PIQ, at Edwards AFB, is a new ORS and OPS appointee. Very few reports were received this month, gang, probably because of summer vacations, etc. SJVN is operating all summer on 3525 kc. If you are interested in traffic handling check in at 1900 any Monday through Friday. Many clubs in the section were active during Field Day; among them were Bakersfield, Taft, Delano, Fresno, Turlock, Modesto, and Stockton. Traffic: K6FAJ 424, W6PIQ 217, LDI 110, GIW 18, NDP 18, PYM 3.

ROANOKE DIVISION

NORTH CAROLINA — SCM, John C. Geaslen, 4DLX — Well, fellows, it seems that quite a few of the clubs were active in Field Day. VG reports from Asheville that the club here had a big outing. Two gas-generators powered all the rigs on the c.w. and 'phone bands. M took club honors on c.w. and MZS on 'phone. New (general) Class tickets there were WCR, WCM, and TBT, also Novice TYQ. JCS and his XYL, JCR, ex-W8s from Ohio, are on at a new mountain-top QTH. MIQ and DHN are active on 10-meter mobile. Hams visiting Asheville stop at the Information Booth in Pack Square for local ham information. VG is sporting a new tower with 10-20 beams. Both Charlotte Clubs headed for the mountains. The Charlotte Amateur Radio Club was on Mt. Mitchell with five rigs on all bands. The Mecklenburg Amateur Radio Society was on the Blue Ridge Pkwy. at Doughton Park. The Lexington Club enjoyed a nice Field Day week end at Walnut Cove. The club at Greensboro was out for Field Day and was the only one to report a score, 2376 points. BBZ, of Wilmington, has been doing some high-pressure selling for ARRL and got about a dozen new members. SWR has new five-element 10-meter beam. Novice ULY, Franklin, has 22 states on 10 watts and keeps weekly sked with New Orleans at 3:00 A.M. PXE, Wilson, reports 4RN running throughout the summer if anyone is looking for a traffic outlet. Traffic: K4FBY 453, W4RAZ 299, RRH 162, PXE 19, DLX 9, BBZ 2. SOUTH CAROLINA — SCM, T. Hunter Wood, W4-ANK — SSG is on 75-meter 'phone with 120 watts and reports that the Rock Club operated from the Airport on Field Day. UNO now is General Class on 40-meter c.w. and is looking for a 10-meter rig. CPZ has worked his 43rd state on 6 meters. SOD is Class A and is back in Dillon. RXO has a 40- and 80-meter vertical and is Class I Official Observer. FM reports that a new transformer has improved his modulator. All ECs are requested to examine their certificates and, if they have not been endorsed within the last

(Continued on page 104)

HARVEY WHERE COMPLETE STOCKS MEAN BETTER SERVICE

NATIONAL HRO-60 RECEIVER

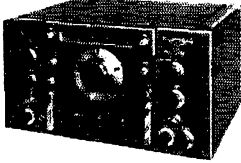

All the features of the famous HRO-50T1 plus 12 permeability-tuned circuits in the 456 kc stages, and dual conversion on all frequencies above 7 mcs. Current regulated heaters in hi-frequency oscillator and 6BE6 mixer, and voltage regulation in hi-frequency oscillator and 5-meter amplifier.

Complete with Built-in power Supply and Coils (A through D).....\$483.00
Speaker in Matching Cabinet..... 16.00
National SW-54 Receiver..... 49.95

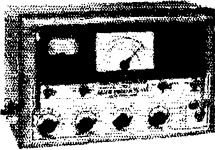

ELMAC-A54 Under-dash Mobile Xmtr.

Measures: 7 1/2" x 7 1/2" x 12"
Weights: 14 1/2 lbs.

For Carbon Mike Input..... \$139.00
For Dynamic or Crystal Mike, 149.00
Power Supply, 110 volts AC, 39.50

JOHNSON VIKING Mobile Transmitter Kit

A low cost, efficient rig in kit form, ready for quick and easy assembly. 30 watts input at 300 volts... up to 60 watts, at 600 volts. 100% modulated...three stages, 807 output...75, 20, and 10 meters with provision for additional band... crystal control. Other features include: band-switching, gang-tuning, RF fixed bias supply, and metered stages.....\$99.50

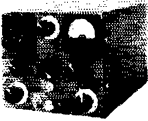

HARVEY Carries a Complete line of all Makes and Types of MOBILE ANTENNAS for Immediate Delivery — Bay, Master Mount, Pre-Max, Ward, etc.

B & W DIP METER MODEL 600

A versatile and compact, quality instrument. Covers 1.75 to 260 mcs. in 5 bands. Handy wedge shape makes for easy access in hard-to-get-places. Has rust-proof chassis and aluminum case... monitoring jack and plate voltage switch... built-in power supply for 110 volts AC. Weighs only 2 lbs. and measures 3 x 3 x 7 inches.



Complete with 5 Color-coded Plug-in Coils\$48.00

HALLICRAFTER

"CIVIL PATROL" S-81 AND S-82

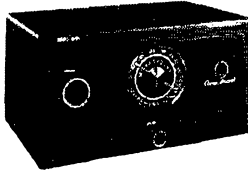

A compact, low-cost, FM receiver covering police, fire, taxi, telephone, railroad, and other industrial frequencies. Ideal for civilian defense and emergency communications. Has built-in FM speaker and phone tip jacks. Operate on 105/125 volts 50/60 cycle AC or DC.

Supplied complete with tubes.
S-81 VHF FM 152-173 mcs.....\$49.50
S-82 HF FM 30-50 mcs..... 49.50

THE NEW NATIONAL NC-183D RECEIVER

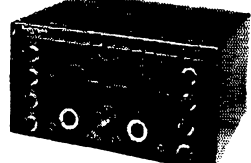

Has everything you want: 3 stages of IF... 15 meter band spread... 6 meter band... dual conversion... 2 stages of RF... broadcast band... push-pull audio output... sharper, narrower IF... sensitivity better than 1.5 microvolts... exclusive full adjustable automatic noise limiter... and many other exclusive features. Finished in smooth gray enamel. Supplied complete with all tubes.

NC-183DT Table Model (with speaker).....\$385.50
NC-183DR Rack Model (with speaker)..... 385.50
NFM-83 Narrow Band FM Adaptor 17.95

MORROW CONVERTER

The latest in Mobile Converter... Easy to operate... Sturdy construction for long, trouble-free service.

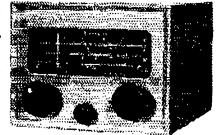

Model 3BR for 10-20-75 meters, net \$64.95

SUPERIOR POWERSTATS

Smooth, efficient voltage control, 0-135 volts output from 115 volt AC line. Models also for 230 volt input. Write for free literature. Models for table and panel mounting.

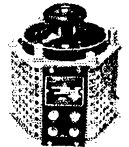

Type 20, 3 amp.....\$12.50
116, 7.5 amps, table mtg.... 23.00
116U, 7.5 amps, panel mtg... 18.00
1126, 15 amps..... 46.00
1156, 45 amps.....118.00

The MODEL 10 is a new, compact unit measuring only 3" in diameter and 2 1/16" deep. It is rated at 1.25 amps. (150 watts/165VA), and is continuously variable to deliver 0-132 volts with 120 volt 60 cycle input.....\$8.50

Complets Stock Always On Hand For Immediate Delivery

QUANTITY LIMITED

HALLICRAFTER Model S-51 All Purpose Marine Receiver SPECIAL \$79.50

Specially constructed for sea and air use. Resists corrosion due to salt water and elements. Frequency range is 132 kc to 12 mc. Has 3 pre-tuned channels for fixed frequency operation... one RF and two IF stages. Power requirements: 105/125 AC or DC, can also operate from vibropack available separately.

BRAND NEW — NON-SURPLUS
Raytheon RK 4D32
IN STOCK
IMMEDIATE DELIVERY **\$22.40**

VISIT THE AUDIOTORIUM. Come in and visit our new sound department... all these items and many more on working display at all times.

Telephone **(hrc)** LUzomborg 2-1580

HARVEY

RADIO COMPANY, INC.

103 West 43rd St., New York 18, N. Y.

NOTE: In view of the rapidly changing market conditions, all prices shown are subject to change without notice and are Net, F.O.B., New York City.

Want a Better Job?

ELECTRONIC

ENGINEERS & TECHNICIANS

investigate

HASTINGS INSTRUMENT CO.

HAMPTON, VIRGINIA

Designers & Manufacturers
of

☆ **Raydist** — Most precise of all radio positioning and tracking systems for land, marine and aviation work — accurate to 1 foot in a mile.

☆ **PRECISION** — Velocity, pressure, flow and vacuum measuring and recording equipment.



• Hastings offers interesting opportunities for engineering and technical personnel in a long term development and production program — Excellent salary — Pleasant working and living conditions — Ideal climate — Investigate this aggressive, medium sized, pioneering, company today — Work with a select group of exceptionally qualified young men. Your inquiry will receive prompt reply.

WORK FOR A GROWING COMPANY IN THE HEART OF VIRGINIA'S FAMOUS RESORT AREA

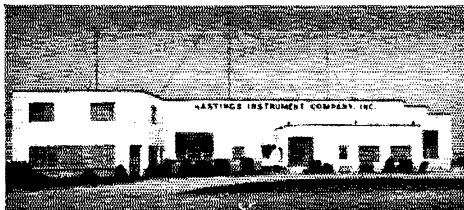

Write Today

HASTINGS INSTRUMENT COMPANY, INC.



HAMPTON 23, VIRGINIA

year, forward them to the SCM for endorsement. DX, the Section Emergency Coordinator, would like to have more reports from the Emergency Coordinators. He needs Emergency Coordinators in more counties. If you are available to act as such and are a member of the ARRL, please submit application to DX. Traffic: W4FFH 15, FM 7, SOD 7, ANK 5.

VIRGINIA — SCM, H. Edgar Lindauer, W4FF — The Potomac Valley Radio Club took its chances on Field Day operations at the same location in Leesburg making 950 QSOs in the two-transmitter class. Among those present for the FH ordeal were CC, FF, KFC, NTZ, NQV, KFT, PNK, and ESK. A surprise personal appearance of ANK, of 4RN fame and recently-elected SCM of South Carolina, added zest to the Field Day efforts as well as additional contacts via mobile en route. Final arrangements for applying for license plates of the full-size version have been announced. Send \$4.00 by money order or certified check to NV, made payable to the Division of Motor Vehicles. To date applications have been received from 200 mobile installations. These tags will be issued only to those licensees who have mobile installations in operation at the time of attachment to their autos. Evidence of installation will be accomplished by certification of designated deputies after an actual QSO. No exceptions here. Applications may be obtained from NV. Under no circumstances should you write the Division of Motor Vehicles. Monitor 3835 kc. for current information. 2KJE/4 assures that PYN will be reactivated at William and Mary by appointment of a new trustee and renewal of membership affiliation with ARRL. FF latched on to UHG sans Novice call. Jack says look for him on the nets this fall. Richmond Convention date draws near. Don't forget to register early. See you there Oct. 11th. KFC and FF visited HQN for a glimpse of that fabulous 40-meter beam and came away with mouths wide open at the achievement of sturdy construction that withstood recent 90-mile winds. HQN proudly invites others to drool in person. MWH and IYI are sporting amateur Extra Class tickets. CC is proxy of PVRC. Traffic: W4SLIJ 21, PWX 19, KFC 8, FF 7.

WEST VIRGINIA — SCM, John T. Steele, W8MCR — Sponsored by the Parkersburg Radio Club and members of the West Virginia Phone Net, a picnic was held in Parkersburg City Park, Sun., June 8th. Fifty hams and their XYLs and YLs attended and all had a grand time. The highlight of the affair was AEN's wash tub. Another picnic is planned for the last Sunday in August at Jackson Mills, W. Va. All hams and others interested in amateur radio are invited. Come and bring your own grub. New appointments: EMC, as EC, FUS as OBS, PQQ is back with us and says he will be on 75 meters soon. Jim Short, of Huntington, tells us the name of the club there is the Tri-State Amateur Radio Association. It meets every Tues. at 7 p.m. Daylight Time. The members are very active on 29.080 Mc. with mobile rigs. Jim has a full gallon gathering cobwebs awaiting his ticket. New ham in Hinton is W8BKJY. GEP is teaching summer radio school near Lewisburg and can be heard on 75 meters with a Johnson Viking.

ROCKY MOUNTAIN DIVISION

UTAH — SCM, Floyd L. Hinshaw, W7UTM — The Ogden Club secretary, UTB, advises that civil defense activities in the Ogden Area are under the supervision of GPN, assisted by MVD and NAY. Ogden Field Day saw twenty operators enjoying the outing in South Fork Canyon, reported by LQE. There is apparently too much interest in outdoor activities to expect much traffic business, but any and all reports are welcomed. Traffic: W7LMH 13, UTM 8.

SOUTHEASTERN DIVISION

ALABAMA — SCM, Dr. Arthur W. Woods, W4GJW — President FOG announces the newly-organized club at Huntsville meets Friday nights at WFUN and participated with great activity in the Field Day. The members are nearly ready to enter 2-meter activities with the rest of the section, and emergency M-G sets are available. PPK will return to the bands Sept. 1st. EJZ announces the formation of a club in the Opp Area. BFM regularly meets four nets, including Tennessee and MARS. DID's entire family shared Field Day fun with him. FBB runs 500 watts at Flat Top. DXB soon will air out with p.p. 833s in Class B final. AENB is ailing for lack of originating traffic destined for out of the section. KIX would welcome assistance in overcoming this situation. Mobile activities in Birmingham are at a high level, both on 10 and 75 meters. Traffic: W4KIX 83, PPK 41, EJZ 38, HFP 19, BFM 14, GJW 14, DXB 4.

EASTERN FLORIDA — SCM, John W. Hollister, Jr., W4FWZ — Field Day in Florida went over big and many reports were received. FWZ, on business up North, dropped in for Field Day with 1BUD and five of the Headquarters gang known as the South Lyme B. C. & P. Society. From reports reviewed it appears that St. Petersburg got the biggest news spreads. Thanks, EYI, for the information. Clewiston: PJIU is up in the Middlewest for a spell but sent in a traffic total of 1210 for June. Deland: RVU is using a

(Continued on page 108)

NEW! 1953 ALLIED CATALOG



COMPLETE, UP-TO-DATE
236-PAGE
BUYING GUIDE

FREE!
SEND
FOR IT

**EVERYTHING
IN
STATION GEAR**

Your Buying Guide for Everything in Radio, TV and Industrial Electronics

Get it—keep it handy—the latest complete ALLIED Catalog that helps fill all your station needs—that brings you everything in electronic supplies—always at lowest prevailing prices. Your ALLIED Catalog features largest stocks of receivers, transmitters, electron tubes, parts, test instruments, audio equipment, recorders, radio and TV components, industrial electronic supplies. And ALLIED gives you the advantages of speedy delivery, expert personal help, lowest prices and the easiest terms in radio. Fill all your electronic supply needs from your ALLIED 1953 Catalog!

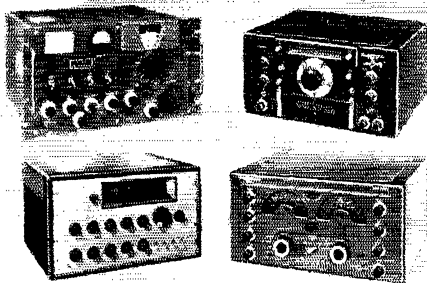

ALLIED gives you every
buying advantage:

- Largest Amateur Stocks
- A Real Break on Time Payments
- A Square Deal on Trade-Ins
- Fastest Service on All Orders
- Ham-to-Ham Personal Help

Everything for the Ham . . .

ALLIED RADIO

Dept. 15-J-2, 833 W. Jackson Blvd., Chicago 7, Illinois

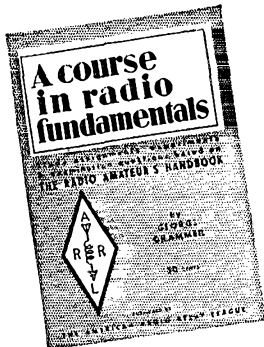

A concise, clearly written text for use with the Radio Amateur's Handbook, *A Course in Radio Fundamentals* is ideal for the beginner but just as useful for the more advanced amateur who wants to brush up on his radio knowledge. For radio theory classes it is one of the most practical books available.

Complete with study assignments, experiments and examination questions based on the Radio Amateur's Handbook.

50¢ POSTPAID

(no stamps, please)

"You get more fun out of radio if you know how and why it works"

The American Radio Relay League

West Hartford 7, Connecticut

two-element beam on 7 Mc. and is working into KX6- and VK-Land. Phil also is working with 7-Mc. verticals. WS maintains 4 net skeds, including local 144 Mc. Fort Myers: SMK reports that CQZ has Elmac on mobile, LNE is working MM, HRA, an OT, is looking for QSOs with the gang on 7 and 28 Mc., WK is in Long Island, RHX is in Clewiston, KE'T is at the U. of F. for a summer brush-up, SFX is using 4-65A in final, and SMK has Eldico TR75. Jacksonville: 3QXU, operator at A4USA, is back home. The MARS gang will miss Gene. The JARS is running code school. Its *Beam* paid a nice tribute to PJU. Miami: TRA reports the Novice Net trials worked out fine. Here is opportunity for WNs to break in on traffic. UJX is using 3.5-Mc. Command set as VFO on 7 Mc. in case you want the conversion information from him. QLC, in charge of Miami Field Day, says more power will be used next time. Dade Club officers are UHM, GHP, QLC, SAT, and BTM. SAT has a new mill to speed up his operations. New Port Richey: KJ is up in New England for a spell. Hal has his Viking transmitter and VFO going now. West Palm Beach: CKB reported in from Mexico for June! Bev is conquering DX over a different path for the diversion. Traffic: W4PJU 1210, DRD 146, FPC 105, KJ 90, FJC 88, PZT 88, HWA 52, RWM 41, WS 34, TKD 21, IYT 13, LMT 13, TRA 12, FWZ 10, RVU 4, IM 1.

WESTERN FLORIDA — SCM, Edward J. Collins, W4MS/RE — SEC: PQW, EC: PLE. The Pensacola Hamfest was a great success. BOL gave the opening address on ARRL activity. 9CGO/4 is keeping 6 meters hot in these parts. VCB is new PARC secretary; HIZ is president. HJA has the HT-9 perking again, as has PTK. MS is rebuilding the beam to add 2-meter antennas. DAO is on 28 Mc. again. NJB has high power on 75 meters. SZH still is battling cyclops. ART hits 2 meters. KWM has FB 14-Mc. rig at Ft. Walton. The EARS gang has a constant round of activity over at Eglin. SRX was heard doing an FB job on Field Day. JA3AH now is in our midst. QK is mobile again. FHQ has been trying 6 meters. BFD and WN4UYS are interested in 2 meters. PLI has returned from the Army. UCY is the 10-meter DX man. TTM is getting ready for the Advanced Class exam. RVZ keeps 75 hot. ODO is busy engineering for the Navy. LCK walked off with the Gonset transmitter at the hamfest. EQZ has been getting the rig ready again. NN, AGB, and ACB attended the hamfest. UTB is going mobile. WN4UUF has cyclops in his area. ISW works 14-Mc. 'phone. VR is having VFO problems. OWN has been in SV-land. PQW was the guiding light behind the hamfest. MUX is adding power to 7-Mc. rig. JM is on 2 meters.

GEORGIA — SCM, James P. Born, jr., W4DZ — New appointments are as follows: GDW as EC for Carroll County; ACH as OBS; NS, POI, EYQ, and EJC as OPS. The following have been endorsed: HBE as EC for Coweta County; OSE as EC for Hall County; AAY as EC for Richmond County; LXE as EC for Bibb County; MTS as OBS; FBH and ZD as OBS; LXE as PAM. SIO has his Extra Class license and is rebuilding. The Confederate Signal Corps Rag Chewers Net meets Thurs. at 2100 EST on 29.200 kc. TJS is the Net Control Station. PVW is moving to Chattanooga, Tenn. SCU now has his Advanced Class license. WN4WKP is Johnny Fearon, 7 years old, who has been blind since birth. Johnny is mascot of the Georgia Cracker Emergency Net, and honorary member of the Atlanta Radio Club and the Confederate Signal Corps. EJC has completed his 7-Mc. 1-kw. rig and is building new kw. 3.85-Mc. rig. PFF has a new mobile rig on 3.85-Mc. 'phone. UR is vacationing in Pennsylvania. BOC is vacationing in Florida. OPS has a new 14-Mc. three-element beam. *The Bugle*, a monthly paper published by the Confederate Signal Corps, does a fine job covering items of club interest and local activities. Please watch the expiration date on your appointments and send certificates in for endorsement. Reports for this column must be received no later than the seventh of each month. FBH still is looking for Utah and Montana, on 50 Mc. to get his WAS. KL now has 99 countries confirmed for DXCC. Traffic: KAWAR 1985, W4POI 62, OSE 49, EJC 38, ZD 37, FBH 21, MTS 13.

WEST INDIES — SCM, William Werner, KP4DJ — SEC: ES, MC, MO, and PR are new AREC members. OD left for the States July 15th and turned over TRCN duties to AK. QR is building a small emergency station operating off vibrator supply. JG is on Stateside vacation. Fifteen PRARC/AREC members participated in Field Day activities using five transmitters and six receivers in three separate tents with one 3-kw. power plant. ID, at Red Cross, is able to work 'phone/c.w. now. DV/LB, using CW3 crystal receiver, monitor the 3925-kc. net frequency. SK blew modulation transformer. BS uses emergency power when reporting to the AREC net. HI6TC is expected to report in to the 3925-kc. net. TV reception is interesting many KP4s. HZ blew plate transformer. ID, at Red Cross, needs reserve operators for the hurricane season. Contact HZ or DJ if you can assist. Traffic: KP4OD 58, DJ 25, DV 9, ID 3.

CANAL ZONE — SCM, Everett R. Kimmel, KZ5AW — SEC: FL Acting PAM; RV, RM; CG. Congratulations to the Crossroads Radio Club for sparkplugging the fine 1952 Field Day. The location was ideal and the food was good and everyone had a swell time even though the bands were

(Continued on page 108)

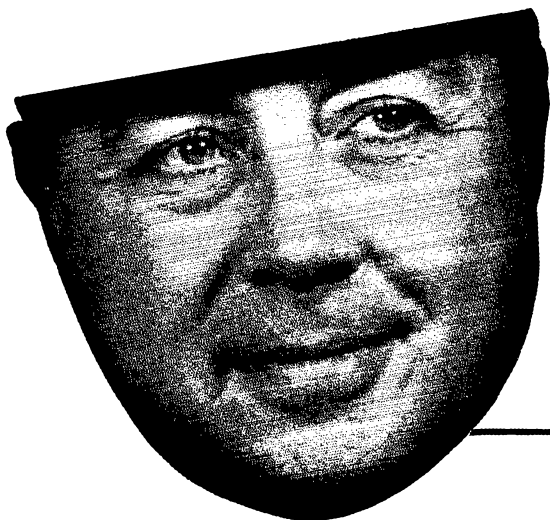

HENRY RADIO offers YOU:

LOW PRICES: You can't beat my wholesale prices.

FAST SERVICE: You get fast service. I have big stocks of Collins, National Hallicrafters, Hammarlund, RME, Johnson, Harvey-Wells, Lysco, Gonset, Morrow, Mallard, Eldico, Master Mobile, Hy-Lite, all other receivers, transmitters, parts at lowest prices.

BIG TRADES: I want trade-ins. I trade big. Tell me what you want—what you have to trade. Get my offer. I pay cash for receivers and transmitters too.

TIME PAYMENTS: Get what you want and pay by the month. I give you better terms because I finance all terms myself. Write for details.

SATISFACTION: Try any communications receiver ten days—if you return it your only cost is shipping charges. I want you to be satisfied. Ask any ham about Henry Radio.

PERSONAL ATTENTION: You get personal attention. Bob Henry, WØARA, runs the Butler store. Ted Henry, W6UOU, runs the Los Angeles store. Bob Henry can be reached nearly 24 hours a day, 7 days a week. Write, phone, wire or visit either store. Send us your orders and inquiries. Export inquiries solicited too.

Bob Henry
WØARA

Butler 1, Missouri
Phone: 395

HENRY RADIO STORES

"LARGEST DISTRIBUTORS OF SHORT WAVE RECEIVERS"

11240 Olympic Blvd.
LOS ANGELES 64
BRadshow 2-2917

CHECK YOUR ANTENNA NEEDS!

WARD'S MOBILE COMMUNICATION ANTENNAS & ACCESSORIES . . . THE COMPLETE LINE

NEW 10 METER TRANSMITTING ANTENNA — Model SPP-143

NEW POLICE TRANSMITTING ANTENNA — Model SPPB-71

MOTORCYCLE MOUNT Model SPP-6 (Ring Top) Model SPP-6A (Ball Top)

ROOF TOP MOUNT Model SPP-26

ROOF TOP ANTENNA Model SPP-18

SINGLE ROD Model SPP-3B

ADAPTABLE 2-SECTION ROD Model SPP-12

SWIVEL BASE Model SPP-3

SHOCK MOUNTING SPRING Model SPP-3A

AND NEARLY 100 OTHER MODELS!

FREE BOOKLET

WARD has a new helpful booklet for you. It is entitled: "How to Specify Mobile Antennas". See your distributor or write for this free booklet now.

WARD'S SPP-143 XMTR-RECEIVER ANTENNA NEEDS BUT ONE HOLE

The WARD SPP-143 Transmitter Antenna designed for the 10-meter band, can now be installed on any passenger car cowl, fender or rear deck . . . without marring the beauty of the car . . . actually increases resale value. It requires but one 15/16" hole which can be used for any standard broadcast antenna later on.

The WARD SPP-143 eliminates damage caused by the longer whip antennas; it's only 55 1/2" long. Easily installed, easily replaced.



THE WARD PRODUCTS CORP.

Division of The Gabriel Co.

1523 East 45th Street • Cleveland 3, Ohio

poor and contacts hard to make. The fish fry thrown for the gang by the QRMarys drew an attendance of 125 hams and friends and everyone hopes it will become an annual affair. Doc Lea, LL, wowed the gang as M.C. WA and the PC family are Stateside with mobiles. PC and family are having a fabulous time lifting all the ham conventions. The code machines at the MARS station at Fort Amador are available all day, every day except license exam day. DG is the first gal to pass the Advanced Class exam. Congrats, Grace. Her OM, GD, is boning for the Extra Class exam. Our XYLs sure look pretty in July QST, all nine of them.

SOUTHWESTERN DIVISION

LOS ANGELES — SCM, Samuel A. Greenlee, W6ESR — SEC: KSX. PAM: PIB. RMs: FYW, GJP. Section Traffic Nets: L. A. Section Net (LSN), Mon. through Fri. — c.w., 3600 kc. at 2130. El Capitan Net (ECN), 3655 kc. at 1930. BPL this month was made by HK, KYV, GYH, and WPF. In addition to our section c.w. traffic nets, the American Legion Net (3975 kc.) and the Mission Trail Net (3854 kc.) have gone on record as endorsing our SCM's stand on "screening" the type of messages handled. It is believed that elimination of the "junk" type of message will do much to dignify our services in the estimation of the public. We take this occasion to thank these fine nets, our ORS and OPS, and the many SCMs who have pledged support of this movement. DTY asks where the hot 40-meter c.w. operators have gone and says that he, ALJ, and IRQE are handling radar for the Navy; AAI is on 40 meters (with sky-wire troubles); ZKL may add extra plates to his 813s to handle the stuff from his pole-pig; and that the "mike varmint" who can't read their own calls on code are disgusting. (Amen to that.) Look fellers — there's a lot of fun in both c.w. and 'phone; why not try both of 'em for a swell feeling of being an all-around ham? KQS gave his mountain estate to Inglewood AREC for its annual picnic. MU wonders "wha hopenen" to 10? HLZ is oiling up his 44 to get the varmint who cuts his antenna down weekly. BLY says CEA's XYL now is FAN on 75; ZPC and YUY got lost in the hills on Field Day (got back though, before the posse found 'em); WGL is back in civvies on 2-meter mobile with a new car; LVQ (Field Day bossman) climbs oil derricks that even termites had quit as unsafe; EEA is high brass in RADEF. Thankya, Ira. "How duz he do it Dept.": COZ is spending vacation at the mountain camp of Camp Fire Girls! HK reports average message time Morocco to L. A. — 4 hours! COF is working on ground plane for 20 meters. GTE again is active in hamdon. Heard GJP's new rig — 600 watts, table top? Welcome to LYK (ex-BAQL). BHG made Master Traffic Handlers certificate. HOV suggests that all California hams write Senators and Assemblymen re license plates. BBK is mobile 10 and 75 meters on vacation tour. FMG is doing a wonderful job as Manager of LSN. NCP, the "flaming beam" man writes: "Still handling traffic with AK1BD and ICC at the North Pole; that ZPB and CSM worked on his new 20-meter beam. WPF is a Border Patrol man AND an FB operator. GEB asks how to AM modulate a kw. at little cost? (I) and says that during Field Day the Inglewood Club worked the world on c.w. with 30 watts and a "V" beam. FYW (RM) reports summer slump in ECN. WN6FBB (15 years old) made Gen. Class, according to KOY. ORI writes she is in the traffic game up to here and that the OM, ORW, made RCC. QIW says DYU has a new daughter. KSX has a new receiver on 8 meters. GYH still is way up there in traffic totals. KYV's new kw. is ready for F1, 2, and 3. Sweet rig, too! AREC notes per KSX: Nets seem to be holding up well this summer. IHK, former proxy of the 2-Meter & Down Club, is new EC and NCS of the long-established and smooth-working V.H.F. Net. Also reporting: CFL, CIX, CMN, EPL, LDR, MGF, PMS, and WN6NJU. Traffic: W6HK 2512, GYH 887, KYV 607, WPF 591, HOV 322, NCP 309, FMG 149, BHG 128, PMS 65, HLZ 62, KOY 56, QIW 49, WOO 45, HLY 39, GJP 36, MGF 20, ORI 15, KSX 14, COF 8, KQS 7, GTE 6, GEB 5, FYW 4, LDR 2, COZ 1.

ARIZONA — SCM — Albert H. Steinbrecher, W7LVR — Field Day saw six active groups around the State: JFT on Spruce Mountain, NGJ on Mingus Mountain, PEF at White Horse Canyon, NBZ and PZ in Tucson, FGG and UPF on Mt. Lemmon. Monthly Arizona C.W. Parties will start again the 3rd Sunday in September: 80 c.w. 7:30 to 9:30 A.M. and 7-10 P.M.; 40 c.w. 10-12 A.M. and 2-4 P.M. To enter, call CQ ARIZ. OPRC was honored by John Reinartz, K6BJ, of Eimac fame, with an FB demonstrative lecture on the method of increasing modulation beyond 100 per cent on peaks without carrier cut-off. PZ is getting close to DXCC with 112 worked, 98 confirmed. MDK is back from a trip to Vermont. OZM is back on the air with 20 watts. UPR moved to El Paso and now is 5IKH. JGZ moved to Tucson permanently. QJS worked Phoenix and Tucson on 10 meters. QWI has acquired a 522 and will be on 2 meters. LSK has 75-meter mobile rig. HUV reports 6 meters wide open and he worked 7 states at one sitting. RCK and RCJ are in New York on 10 meters. BIAA moved to Tucson and is on 20 meters. New Novice: RYN. New Gen'l. Cl.: QHD, QFG. New Adv. Cl.: TYL. Arizona MARS Net on 4025 kc., Tues. c.w., Thurs. 'phone at 9 P.M., needs more

(Continued on page 110)

GOSH! AN FM RADIO FOR \$16.95

NEW! JOHNSON VIKING-2

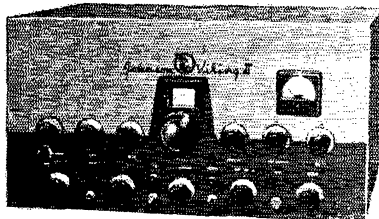

100W PHONE
130 W CW
XMTR KIT

\$279.50

Improved 1952 version of the famous Viking-1. 100% AM modulation. TVI suppression features. Bandswitching, with full output available on the 160, 80, 40, 20, 15, 10 meter amateur bands. All parts furnished including cabinet, punched chassis, wiring harness, wire, solder terminals, all tubes. Shielded coax output connector, antenna relay terminals, filtered power leads, complete shielding. 115V 50-60 cy. AC.

NEW! JOHNSON MOBILE XMTR KIT, \$99.50

Only 6-7/16 x 7-1/8 x 10-5/16" deep for under-dash mounting. All rf stages bandswitching! Amp input up to 60W 100% mod., 30W input at 300V. 807 output stage equipped with separate tank coils for 75, 20 and 10 meters. Less tubes and supply. The kit you've asked for!

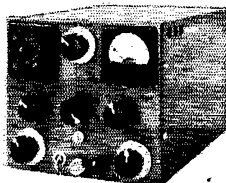

IMAGINE! ONLY \$1.11 FOR PLASTIC SPRAY,
\$1.23 FOR ENAMELS, ALUMINUM \$1.11



- CLEAR PLASTIC
- CHROME ALUMINUM
- GOLD LEAF
- CHINESE RED
- ROYAL BLUE
- BRIGHT GREEN
- LEMON YELLOW
- PURE BLACK
- PURE WHITE
- PURE GRAY

Here's push-button spray painting at its best and at its cheapest! No brush, no streaks, no messy cans, no tiresome stirring. Just the thing for chassis, antennas, shacks, shop, home, re-touch, toys, furniture, color-coding — a million uses! Order from this ad at these low Radio Shack prices: ACRYLIC CLEAR PLASTIC \$1.11. CHROME ALUMINUM \$1.11. GOLD LEAF \$1.23. And the following gleaming enamel colors at \$1.23 per can: CHINESE RED, ROYAL BLUE, BRIGHT GREEN, LEMON YELLOW, BLACK, WHITE, GRAY. Immediate delivery! Each can has a built-in mixer, just shake and spray! Note: a recent testing lab found the plastic spray superior to other famous brands in insulating characteristics!

COMPLETE AC/DC FM CHASSIS

FAMOUS-MAKE!

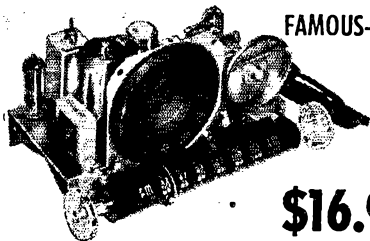

\$16.95

Save \$\$ while they last! Tunes the 88-108 mc FM broadcast band. Has built-in antenna, 4" PM speaker, 6 tubes — 12BA7, two 12BA6, 12S8GT, 35W4, 35B5. Instructions for conversion into tuner! Compact size: 8 1/2" x 4 3/4" x 5 1/2" deep. A steal!

EXCLUSIVE MICROPHONE BARGAIN

\$3.35

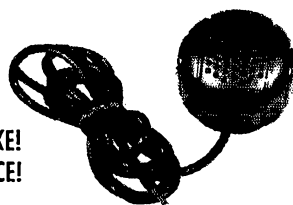

FAMOUS-MAKE!
LOWEST PRICE!

Never, NEVER have we seen a quality crystal mike at a price like this! 100-6000 cycle response, 6 1/2 ft. rubber cable, solid but compact gun-metal case. Ideal for P.A., ham, recording, entertainment!



OUR 1953
CATALOG IS
READY NOW!

Write for it today if you're not on our mailing list. Over 200 pages, triple-index, latest products. Biggest and best in all our 30 years!

RADIO SHACK

CORPORATION

167 Washington St., Boston 8, Mass.

Proven Performance

WITH

SONAR

**TWO-WAY COMMUNICATION
EQUIPMENT**

Two Complete Receivers

MOBILE OR FIXED



**AND HAM
STATIONS**

Equipped
with BFO
for CW,
SSB, or
spotting
weak phone
signals.

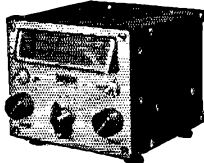

MODEL MR-3 5 BANDS • 8 TUBES

Ideally suited for mobile with its compact size, light-weight, the MR-3 is excellent for CD, CAP, or any emergency operations. The MR-3 is a COMPLETE 5 BAND RECEIVER—NOT a converter—for 80-75, 20, 10-11 mtr bands, with less than 1 microvolt of sensitivity—comes complete with 8 tubes, one of the best automatic noise limiters yet designed, voltage regulated oscillator, accurate slide-rule, dial and mounting brackets.....Net **\$8995**

and...

MODEL SR-9

- 2 MTRS
- 6 MTRS
- 10-11 MTRS

Here is the hottest little RECEIVER on the market today. Less than 1 microvolt of sensitivity (RMA Standards) the SR-9 really pulls in the weak signals. Many have used the SR-9 as the receiver in their fixed stations, it's so stable and sensitive. Many cities are now using the SR-9 in their CD operations with great success. Complete with 9 tubes, automatic noise limiter, voltage regulated oscillator, precision slide rule dial and mounting brackets. Net..... **\$7245**

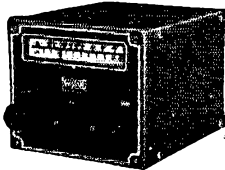

and a Companion Transmitter

FOR...

- 2 MTRS
- 6 MTRS
- 10-11 MTRS

MODEL MB-26

This 6 tube Transmitter is designed as the perfect companion to the above receivers, operating from the same power supply of 200 to 300 VDC at 100 ma., and instructions for cable connections make push to talk operation automatic. Crystal controlled (8 or 24 mc crystal), screwdriver adjustments, antenna loading network, power supply filter network, all stage meter switching, the MB-26 comes complete with mounting brackets and plugs—less crystal and meter.....Net **\$7245**

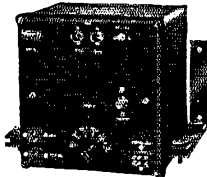

also...

Sonar makes a complete line of Commercial and Aircraft Equipment for both AM and FM. WRITE FOR DETAILS.

SEE YOUR DEALER—LITERATURE ON REQUEST

SONAR

RADIO CORPORATION

59 Myrtle Ave. • Brooklyn • New York

members. Contact SX, NEL, or LVR. PMD made BPL. Traffic: W7PMD 1126, PKU 25, OIF 21, LVR 8.

SAN DIEGO—SCM, Mrs. Ellen White, W6YYM—Asst. SCMs: Shelley E. Trotter, 6BAM; Richard E. Huddleston, 6DLN; Thomas H. Wells, 6EWU. RM: IZG. ECs: IOK and DEY. BAM takes a little breather in traffic-handling while JA2KW moves. ELQ made BPL for June traffic, as did IZG, and is following BAM's example by going vacationing, without a rig! IZG reports BRAT certificates were awarded to TET, 7BH, 6IZG, FCT; and MTHC to IZG. EWU spent two weeks in the north and worked out fairly well on 75 meters with low power. CYR has dropped the "N" from his call. HJG's XYL is waiting for her Novice ticket. ZE's son is awaiting a WN6 call, making three hams in the family. Jim's XYL plans to take the exam shortly. Yours truly is proud to be in a "4 ham" family too—APG, CHV, YYM, and YYN. 50-Mc. activity in Orange is on the upgrade. The new SDARC president is ZUR, who also is giving fine r.f. amplifier design talks at the club meetings these days! The Soledad Club took a first premium blue ribbon for its booth at the San Diego County Fair. Much interesting news has been received by your SCM on Field Day results. QZQ and ICN operated together on Santiago Peak in Orange and worked 303 stations on one transmitter! ELQ went out and worked 230 contacts with the help of ELQ's son and IZG, all c.w. The SDARC shared Kearney Mesa with the Helix and Soledad Clubs and made 646 contacts, doing especially well on 10 and 40 meters, which made 201 contacts each—exactly! The call used was GGK/6 The Helix group, MGJ/6, made 870 contacts, reports HDT. Sodedad, GER/6, made 672 contacts with 7 transmitters. Traffic: W6ELQ 546, TET 202, IZG 199, BAM 152, GTC 21 FCT 19, DEY 2.

WEST GULF DIVISION

NORTHERN TEXAS—SCM, William A. Green, W5-BKH—Asst. SCM, Joe G. Buch, 5CDU. SEC: JQD. RM: QHL PAM: IWQ. Midsummer static and vacations have caused some drop in activities. However, the emergency and traffic nets continue to function. The SCM and SEC attended the West Gulf Division Convention. RHP is pinch-hitting for LEZ as NCS of NETEN. NTEN elected CC and JOU as NCS and ANCS respectively. AREC and MARS are working together with EBW, the state director, participating in AREC liaison meetings and IWQ, JQD, and LEZ are holding responsible positions in both organizations. ASA and KPB are guiding the destinies of NTS and NTX, the latter now having 23 reporting stations. Texoma ARC elected ULY, pres.; IDZ, vice-pres.; UTB, secy-treas, and. POG, act. mgr.; and also helped in the licensing of WFFJ, WFK, WFL, WFM, and WFN, all Sea Scouts. Abilene ARC held its Field Day on the Kemper Ranch with San Angelo ARC at Lake Nasworthy. Bonham ARC hamfested visitors JQH and IZO. LIU reports AJG is on 144 and 220 Mc. After showing signs of life around the middle of the month 50 Mc. has become very poor. SIB, the son of QJD and RTT, now is Adv. Class. NWFY is in the Pacific aboard the USS *Montague*. LGY has a new transmitter and shack. Bonham new calls are VYY and PTC. KUP has an XYL. Greenville new calls are VYQ and VYX. TGV has a KZ5 on 40 meters. Traffic: W5BKH 176, VRX 116, PAK 85, TFB 53, KPB 24, CWE 21, ASA 18, CF 18, JOG 16, TGV 8, WNSUPP 8, W5QJY 6, RHP 6, SGR 6, SRQ 6, GUD 4, LGY 3, ISD 2, PYQ 2.

OKLAHOMA—SCM, Jesse M. Langford, W5GVV—SEC: AGM. RM: OQD. PAMs: GZK and ATJ. The Tulsa Radio Club combined Field Day with a simulated emergency in which the civil defense, Red Cross, and CAP were called out to assist shortly after midnight on a recent Saturday. According to all reports the cooperation was wonderful and the results very satisfactory. UVX, the club station of the Southwestern Okla. Radio Club, was very active during Field Day. HFN has purchased a new QTH and soon will be on with a new home rig. IOW has new 144-Mc. sixteen-element beam and GZK is putting up IOW's old five-over-five. RST, EHC, and GZK, along with BKH and GUD of the Texas gang, handled much of the traffic from the Powder Puff Derby. HYY has a new portable rig, the receiver and transmitter complete on a 14 x 17 x 18 chassis plate modulated. TME is operating on 40 meters. IJF now is on the SS *Baltore*. The Ardmore Radio Club has changed the date of its hamfest to October. SLC is in Canada on vacation. TEC built 10-watt 10-meter rig. UEK also is on vacation. UGF has moved to Washington, D. C. UZG has a new 14-Mc. vertical antenna. EHC is adding a new room to his home to be used as a ham shack. PA, AGM, and HXT attended the convention at Corpus. KS is in school at the Philco plant. The Lawton-Ft. Sill Club annual barbecue will be held Sept. 7th. Traffic: W5ROZ 129, GZK 113, FOM 61, MFX 55, HZZ 41, ESB 38, SWJ 31, SVR 21, KY 20, GVV 19, EHC 13, OQD 13, SLS 12, OFG 10, FKL 5, TNV 2, FOG 1.

SOUTHERN TEXAS—SCM, Dr. Charles Fermaglich, W5FJF—All of us who went to the West Gulf Division Convention in Corpus Christi will agree that it was an FB meeting. The boys of the Gulf Radio Club, HQP, chairman; IBT, program; QKF, adv.; AQK, secy.; NEV, treas.; HIF, regis.; NHV, publicity & publications; GEL, prizes; LOW,

(Continued on page 112)

NOW IS THE TIME

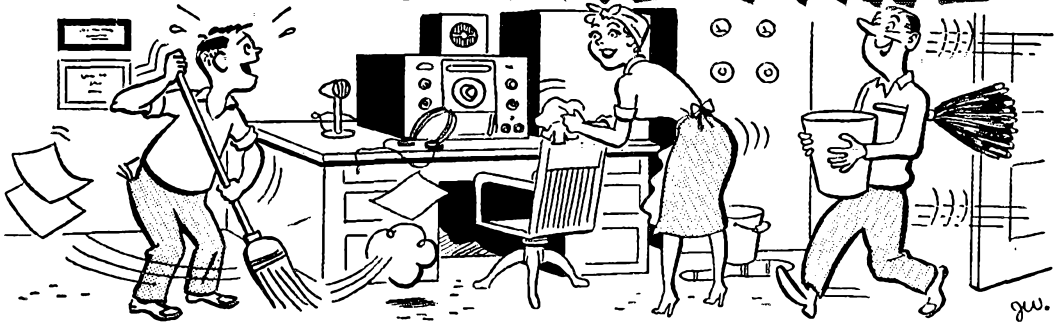

Yep, time to get ready for fall DX . . .

Clean house of all that old, outdated equipment and replace at a tremendous saving with a "SURPRISE" Trade-In deal. As always, the newest and best is available here and bigger-than-ever bargains are yours when you take advantage of the one and only "SURPRISE" Trade-In allowance on your used (factory built) test and communication equipment. So get your trade-in deal working today. Wire, write, phone or use the handy coupon below.



THE JOHNSON VIKING VFO KIT
Only \$42.75.

All prices f. o. b. St. Louis • Phone Chestnut 1125

Walter Ashe
RADIO CO.
1125 PINE ST. • ST. LOUIS 1, MO.

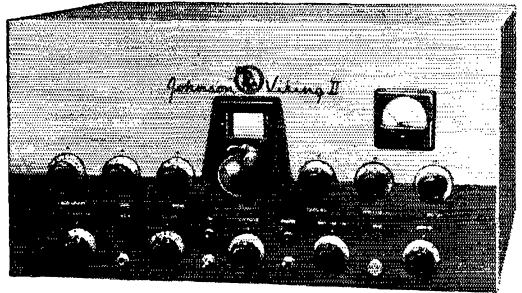

THE NEW JOHNSON VIKING II 100-WATT PHONE-CW TRANSMITTER KIT. Featuring effective TVI suppression. Complete kit with tubes. Only \$279.50.

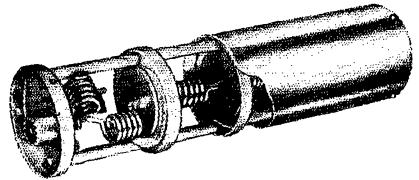

NEW JOHNSON LOW PASS FILTER. Greatly attenuates transmitter harmonics and spurious output above 54 MC. Will handle a full KW, 100% modulated. 52 ohms. Only \$16.50.

THE NEW JOHNSON TVI SUPPRESSION KIT for installation in present Viking I Transmitters. Only \$24.75.

FREE CATALOG! Send for your copy today

WALTER ASHE RADIO COMPANY
1125 Pine Street, St. Louis 1, Missouri

Q-9-52

Rush "Surprise" Trade-In offer on my _____

for _____
(show make and model No. of new equipment desired)

Place my name on your mailing list to receive latest catalog.

Name _____

Address _____

City _____ Zone _____ State _____

THE PERFECT TEAM

for

LOWEST NOISE CASCODE CIRCUITS!

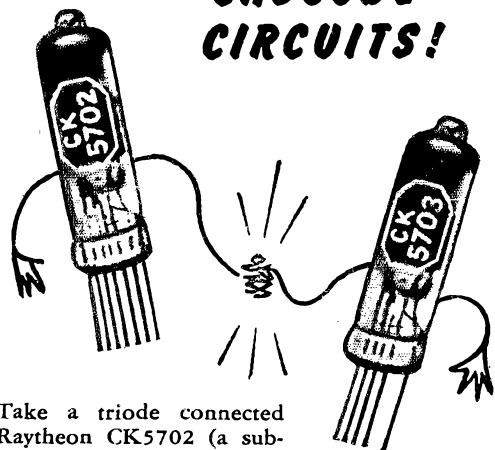

Take a triode connected Raytheon CK5702 (a subminiature 6AK5) and follow it with a grounded grid Raytheon CK5703 (a subminiature triode) and you have the perfect team for lowest noise cascode circuits.

You'll achieve a compact design and more efficient circuit operation, too, thanks to the small size, short lead length and low interelectrode capacitances of these precision made Raytheon Subminiature Tubes.

The Raytheon CK5702 and CK5703 are only two of a complete line of top quality Subminiature Tubes made by Raytheon, pioneers in the design and manufacture of all types of quality electron tubes—miniature, hearing aid, reliable, nucleonic, microwave, voltage regulator, voltage reference, rectifier and transmitting, crystal diodes and transistors.

Ask your Raytheon Tube Supplier to show you the advantages of the Raytheon CK5702 and CK5703 Subminiatures or write for free data sheets.



Excellence in Electronics

RAYTHEON MFG. CO.

Receiving Tube Division

Newton 58, Massachusetts

RELIABLE SUBMINIATURE AND MINIATURE TUBES

GERMANIUM DIODES AND TRANSISTORS

NUCLEONIC TUBES

RECEIVING AND PICTURE TUBES • MICROWAVE TUBES

contests; LRQ, display; GMT, pre-convention party; went all out. Plan now to attend the 1953 National Convention in Houston July 9-10-11-12, Shamrock Hotel, W5FJF, P.O. Box 907, general chairman. The 220-Mc. DX record is 288 miles, made by ONS and AJG, June 6, 0630 CST. FEK won a plaque for outstanding achievement on amateur frequencies above 144 Mc. in the West Gulf Division. JQ was active on 7-Mc. c.w. during the month, 100 watts to a 1/2-wave vertical. 4RZU/4 is trying to build a "beer can" vertical on 160 meters. Wonder who is paying for the beer. WNSTGJ was the first to report in to the SCM from Field Day. SOE, the West Texas Tequila Sippers Assn., had a gallon of fun on Field Day with 5 stations, 18 operators. 9 AREC members. RHH still is going to town with traffic. ABQ is going mobile and reports: JBZ is rebuilding to cure TVI; AFZ will have a new kw. on soon. NPX reports that WN5VQM passed away. WN5TYT, EIR, and NPX are on 144 Mc. and are looking for out-of-town stations. KJF is active in Texas State Guard and is on 75-, 40-, 20- and 75-meter mobile. Any time you hear me, call me and give me the low-down. QFA had an FB time at the Convention. The Texas State Guard radio did excellent work in the recent Corpus Fire. Many fixed and mobile units were dispatched and handled traffic. ACL soon will be back on with a new station. MN says that his first convention was Corpus in 1935; his second convention was Corpus in 1952. He enjoyed them both very much. We hope his third will be Houston in 1953. He still is making BPL every month. STEN is going to town and streamlining roll calls. JC is busy with government installations. EJT and his XYL are making FB progress on a new home. Fellows, send me some dope on yourselves and your friends by the first of each month. Traffic: W5MIN 558, W4RZU/5 63, W5RIH 54, FJF 49, QFA 37, ABQ 17, NIY 4.

NEW MEXICO — SCM, Robert W. Freyman, W5NXXE — SEC: PLK; RM: NKG, PAM; BIW, PAM v.h.f.: FAG. Nets: 3838 kc., Tue. and Thurs. at 6:00 p.m., Sun. at 7:00 a.m.; 3633 kc., Mon., Wed., and Fri. at 8:00 p.m. NXP, RHH, RMI, UVA, and ZU attended the West Gulf Division Convention at Corpus Christi. ZU and RMI now are mobile with Elmaes. SBJ now is 7ROZ in Keams Canyon, Ariz. QIT left for sea duty. The MARS picnic in Cimarron Canyon was attended by 18 hams and their families. RFL left for active duty with the Air Force. LLG has a new Viking. PLB has new homebrew with 250TH final, 100TH modulators on 75-meter net. WN5VWZ is active from Belen. Stations heard on Field Day: GGO, MPZ, NUN, PDO, DAI, and SRW. PLK has lengthened long wire to 1000 ft. and expects to extend from Santa Fe to El Paso next year. NKG, JZT, and RLL are holding the fort on 3633 kc. UVA is active on 75-meter mobile. NJR has new harmonic and is rebuilding transmitter. NZT is teaching Novice training course at Highlands U. His son, now 9PYD, recently married an Indiana YL. The final count on the attendance at Capillo Peak was 86 licensed hams, total about 135. Traffic: W5NKG 98, NXP 34, JZT 14, RMH 3.

CANADA

MARITIME DIVISION

MARITIME — SCM, A. M. Crowell, VE1DQ — SEC: FQ, EC: EK, RM: OM. Field Day messages were received from GM/1, AAM/1, FO/1, LC/1, HP/1, GH/1, and RC/1, and the reports indicate the usual FB time. DQ/m and FQ/m paid advance visit to the Field Day site of FO/1 and the latter issued route directions to the former and "talked him in." VE3DKJ/nl has been heard QSO some of the local boys on 3.8-Mc. mobile 'phone. Glad to hear NO is home from the hospital. Several of the Halifax mobile crew are thinking of trying 160 meters for short-haul work. IIC handled some emergency traffic from Sable Island when one of the jr. operators there suffered a broken nose. BC and AW continue to provide some interesting TV DX for the local gang when conditions permit. Both have very formidable antennas for this type DX. DQ and SI have been camping out at their summer QTHs week ends. XR put up new antenna at his summer home where he now is located. AB continues to QSO all mobiles on 3.8 Mc. High traffic man this month is MK. Traffic: VE1MK 130, FQ 122, HC 70, ABJ 28, YV 24, AAK 19, ABA 10.

ONTARIO DIVISION

ONTARIO — SCM, G. Eric Farquhar, VE3IA — The summer lull apparently is upon us. The report is scanty this month because no news was forwarded to your scribe. Please let's have some information, gang. AUU now is a member of RCC. AVS came south for his vacation, stopping en route at North Bay for the fine hamfest held there. Later he visited Niagara Falls and dropped into the QTH of IA for an evening's chew. JU headed north to the Sault and back-tracked to North Bay. DK1 was the outlet for traffic from Mount Hope during Air Force Day. Sorry there was no report from him or anyone who took part. With no information on the picnic sponsored by the Ontario 'Phone Club or on the North-Bay hamfest it is very difficult to give these outings the publicity they deserve. Please realize the

(Continued on page 114)

DICHLORODIPHENYLTRICHLOROETHANE

means D.D.T.

COMPLETE COVERAGE OF THE ENTIRE HAM RADIO FIELD

means **QST**

From the timely editorial—through the many technical articles, Happenings, News of M.A.R.S. and U.S.N.R., Hints & Kinks, World Above 50 Mc., How's DX, Operating News, the YL Page —to Station Activities, Ham-ads and latest information from manufacturers and distributors in the advertising pages, QST is cover-to-cover reading each month.

QST and ARRL Membership • \$4.00 in U.S.A.

\$4.25 in Canada • \$5.00 elsewhere

The AMERICAN RADIO RELAY LEAGUE, Inc. WEST HARTFORD 7, CONN.

ATTENTION MOBILE HAMS

Complete mobile package — nothing else to buy. Outstanding mobile signals use motorola equipment — backed by years of communication equipment experience — World's largest producer of 2-way mobile equipment.

A mobile transmitter with a double feature FM or AM at flip of the switch, the MOTOROLA FMT-30-DMS (27-30 MC.) ... **\$130.00**

P-7253 spring base rear antenna — mount **\$23.13**

New Gon-set Tri-Band Spread Converter... **\$47.60**

MOTOROLA P-69-13 or 18-ARS receiver with special noise limiter for use with any converter having 1440-3000 KC. **\$60.00**

3-30 famous Gon-set converter complete to connect to the P-69-13 or 18-ARS receiver. **\$44.75**

P-327-E Fire wall loud speaker.... **\$7.50**

The above comes complete with all necessary accessories and mounting hardware. Order direct or through the Motorola National Service Organization member in your area.

NOTE: This Receiver and Transmitter is equipment which has been returned from the field, modified and rebuilt for Amateur Service.

For further information write to

MOTOROLA INC.

Amateur Sales Dept. QST — September
1327 W. Washington Blvd. Chicago 7, Illinois
Attention: Harry Harrison, W9LLX, Tel. Taylor 9-2200 Ext. 161

MORE SIGNALS PER DOLLAR
From Money Invested in an Antenna

Self Supporting
STEEL TOWERS
For Rotary Beams, FM, TV

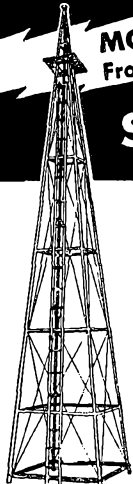

ATTRACTIVE—NO GUY WIRES!

- 4-Post Construction for Greater Strength!
- Galvanized Steel—Will Last A Lifetime
- SAFE—Ladder to Top Platform
- COMPLETE—Ready to Assemble
- Easy to Erect or Move
- Withstands Heaviest Winds

EASY MONTHLY PAYMENTS
Up to 12 Months to pay

Here is An Inexpensive Answer for
COMMUNITY TV ANTENNAS!

Width of Base Equal to 1/5 Height

Vesto Towers are available in a wide range of sizes to meet requirements of amateurs and commercial users alike. Note the low prices for these quality lifetime towers: 22'-\$94.75, 28'-\$115.75, 33'-\$135.75, 39'-\$157.75, 44'-\$178.75, 50'-\$217.75, 61'-\$279.75, 100'-\$1060.00. Towers are shipped to your home knocked down, FOB Kansas City, Mo. 4th class freight. Prices subject to change ... so order now! Send check or money order ... or write for free information.

WRITE TODAY FOR COMPLETE FREE INFORMATION AND PHOTOGRAPHS

VESTO CO., Inc.
20th and Clay
North Kansas City, Mo.



BEWILDERED?

Don't be! Now that the operating season will be getting into stride, you'll want short-cuts to solving inductance and capacitance problems.

Made to order for this type of puzzler is the ARRL Type A Calculator. For instance, if you know the inductance needed, you can find the various diameters and coil lengths, and also the largest size of wire that will fit in the given length. By multiplication, you find the number of turns.

This and other problems of a similar nature are readily solved by this easy-to-use handily designed calculator. Will save you hours of time.

Instead of guessing use the
ARRL
Type A Calculator

\$1.00 POSTPAID

The American Radio Relay League
 West Hartford 7, Connecticut

Philmore

MODEL
NT-200

NOVICE TRANSMITTER KIT

Including Power Supply Kit **\$29.40** AMATEUR NET COST

EASY TO ASSEMBLE—EASY TO OPERATE! 2 Bands: 3.7-3.75 Mc and 26.96-27.23 Mc. All necessary parts, Tubes, Key, 2 plug-in coils, pictorial diagrams, included. See this terrific new kit at your local jobber or write for literature to:

PHILMORE MFG. CO., INC. 113 University Place
New York 3, N. Y.

POWER
INPUT
25
WATTS

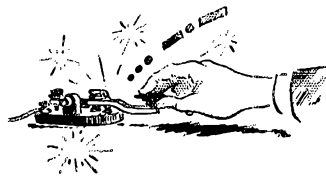
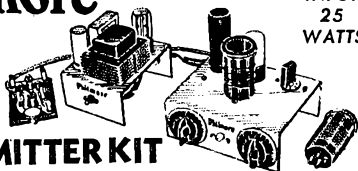

Now slowly key this mournful message
 Of the death of Jack Q. Dotage;
 He swore he got no chirps or clicks
 When keying the high voltage.

position your SCM is in and help out with some information. Traffic: VE3ATR 205, BMG 160, BUR 105, WY 99, IA 93, DGZ 76, DOU 38, BJV 37, EAU 23, AUU 9, EAM 6, KM 6.

QUEBEC DIVISION

QUEBEC—SCM, Gordon A. Lynn, VE2GL—SEC: BR. AQN is ex-CE2EL and is on 40 and 20 meters with a 6AG7/6L6 rig and is planning a high-power rig. BK reports into LEN on 10 meters each Thursday and he, BR, and KH are all mobile at summer QTH near Lachute; all worked KD, also mobile in Montreal on 10 meters, a distance of 60 miles. EC reports daily skeds with AEM and APE and says that he is always on 75-meter c.w. ACD gets on occasionally with his high-power on 75 meters. CA reports that 20 meters continues dead to the North Country, his usual stamping ground, with DX spotty and traffic light, but that he has been enjoying the short skip on 20 meters lately. AO took part in the Frequency Measuring Tests on May 23-24 and on two measurements showed an error of 10.9 parts per million, or 0.001 per cent! The Verdun Amateur Radio Club held elections recently and their choice of a new president was ANE. The father of AKM recently was discharged from the hospital after receiving several blood transfusions, donated by members of the Montreal Amateur Radio Club. AKK is the XYL of AIQ and is to be heard on 40- and 80-meter c.w. Traffic: VE2GI, 11, EC 10, BK 3.

VANALTA DIVISION

BRITISH COLUMBIA—SCM, Will Moorhouse, VE7US— May reports were received from AOB, YE, and TT. AMJ QSYed to Newton again and is active. A report was received from YM. DH is in Vancouver with ALL, QC, etc. on an AFARS visit. Vancouver Area c.d. is gradually taking shape. There are 32 mobiles in the section with 25 in Vancouver, most of them registered with AREC. FB is AEC for mobiles, ALA for 10 meters, and AC for 40 meters in the Vancouver section. US has given up his traveling job for an easier pursuit. AOU and ALW are heard on 75 meters. TM is on with Rothman system. Field Day gangs were active on Little Mt., Burnaby Mt., Burquitlam, and Strawberry Hill districts. Some WTs visited Vancouver at JB's QTH, on July 4th. YI hides behind trees. JT's mobile was heard on 75 meters. To repeat—3755 kc. is the "Calling and QRRR frequency" and AREC net uses it from 6-7 p.m. daily. Civil defense of Vancouver sent its No. 1 message via AREC to Victoria. This means c.d. used 3 links so far through AREC. Otherwise local c.d. heads are using amateurs "willy-nilly." Certain amateurs are forgetting that on joining AREC they accepted the rules of the organization and are part of a team—not the whole team. An appointment under AREC is FOR AREC ONLY. C.d. AFARS, etc., agreed to recognize AREC in Canada under Memorandum 56/51. Traffic: VE7QC 61, DH 17, AOB 12, YM 4.

PRAIRIE DIVISION

SASKATCHEWAN—SCM, Harold R. Horn, VE5HR— The Regina Club is to be congratulated on the fine hamfest they put on. Those attending enjoyed a good time and many took home some very good prizes. About 15 mobiles took to the road on Field Day and the transmitter hunt proved to be quite a hunt. DG finally was successful in locating JW and his XYL operating from the grounds of the jail. W5SLC came from the farthest point and won a dandy soldering iron. Your SCM is vacationing in VE7-Land so this report will be rather sketchy. JK was mobile VE7 and worked back to VE5 with a good signal that QRMed UQ mobile. The Saskatoon Club took an active part in the Annual ARRL Field Day with three transmitters in operation and plenty of operators for the 24-hour swing. A good score was made, and conditions were good. Next year let's see more clubs and others taking part, fellows, it's a lot of fun. Traffic: VE5HR 194, GI 16, QL 5, LY 4, MQ 4, MG 2.

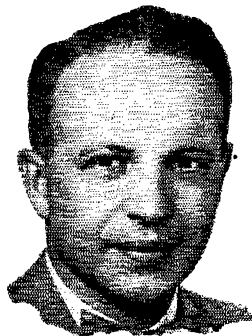

STRIKE WHILE THE IRON IS HOT!

NOW is the time to trade for a new receiver or transmitter. Our stocks are complete—our prices are LOW. TAILOR-MADE TERMS

• LIBERAL TRADE-INS • COMPLETE STOCKS • PERSONALIZED SERVICE • WRL — "One of the World's Largest Distributors of Amateur Radio Transmitting Equipment."

We Finance Our Own Paper — No Red Tape — No Delays. (Special attention given to foreign orders.)

Leo I. Meyerson WØGFQ
CU ON 10-20 & 75 METERS

"I RECOMMEND THE GLOBE KING TO ANY HAM"



"Dear Leo,
I am very satisfied with my Globe King Transmitter; it was the best money I ever spent on radio. The Globe King surprised me, and also my friends who visited me, with its good modulation and clear quality. One of my friends, KP4MO, ordered a Globe King from you and he is very happy with it. Now there are many Globe Kings in this

country. I recommend the Globe King to any ham. It is compact and its modulation is perfectly clear and very good quality. I have had no trouble with my Globe King Transmitter; although I have had it for a long time and use it every day.

Cordially yours,
Signed/ L. ESPASAS SIMO KP4BA
Hato Rey, Puerto Rico"

KIT FORM WIRED-TESTED
NEW WRL 400B GLOBE KING XMTR \$475.00 \$495.00

WRL 165 WATT GLOBE CHAMPION XMTR

(less accessories)

KIT FORM WIRED

\$329.50 \$349.50

WRL 40 WATT TROTTER XMTR

More Watts Per Dollar

KIT FORM WIRED

\$89.50 \$99.50

NEW ELMAC-A54 UNDER DASH XMTR

Mobile

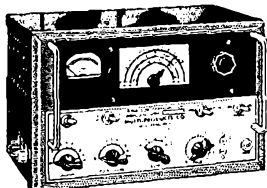

VFO or Crystal control. Direct-reading. VFO on all bands—75, 20, 11, 10. • Plate modulation • Completely band-switching, fone or CW. • 50 Watts max. input. Power required: 300-500 V.D.C. at 250 ma., 6.3 V AC or DC at 4.5A. • Uses 3-6AG5, 6AR5, 6C4, 12AU7, 2-6L6G, 807, (included). • Only 7 1/2" x 7 1/2" x 12", 14 1/2 lbs.

For carbon mike input\$139.00
For dynamic or crystal mike.....\$149.00
Power Supply, 110 Volt AC.....\$ 39.50

FREE

1952
WRL
CATALOG



160 METER CRYSTALS
1800-2000 K. C.

\$1.50 each while they last

80 METER
CRYSTALS

3500-3540 K. C.
3600-3700 K. C.
3750-3990 K. C.

99c
each
while they
last

40 METER
CRYSTALS

7020-7100 K. C.
7170-7425 K. C.

All crystals mounted in FT-243 holders and checked for activity before shipment. Crystals will only be furnished within the range of frequencies shown above. Will furnish as close to desired frequency as possible. When these are gone, no more available. Buy now!

RADIO REFERENCE MAP



25c
HANDY
WALL
SIZE

WRITE FOR DETAILED SPECIFICATION EQUIPMENT SHEETS

WRITE
WIRE

PHONE
7795

World Radio
LABORATORIES COUNCIL BLUFFS, IOWA
EVERYTHING IN RADIO

World Radio Laboratories, Inc.
744 West Broadway
Council Bluffs, Iowa

Q-9

Please send me:

- New Log Book
 New Catalog
 Radio Map
 ELMAC-A54 Info
 Globe King Info
 Globe Champion Info
 Used Equipment List

Name _____
Address _____
City _____ State _____

FUTURIZED

READY FOR 15m. & 40m. PHONE

the GONSET "Commander"

35-50 watt MULTI-BAND TRANSMITTER
for mobile or fixed station use

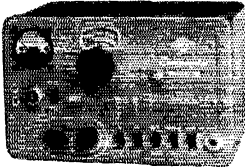

Complete with tubes and coils for 10-11, 15, 20, 40, 75, and 80 meters.
\$124.50 net

FEATURES

Covers 1.7 to 54 mc. continuous • Panel switch for crystal or external VFO or the new Gonset VFO adapter • Requires 300 volt power supply or can be operated from a PE-103 • Integral high level speech clipping • Microphone input from carbon, dynamic or crystal • Output matches coax, ribbon, open line, or Marconi antenna • Only 5 3/8" high, 8 1/8" wide, 7 1/8" deep.

THE NEW GONSET TUBELESS VFO ADAPTER, \$29.95



GONSET CO.

801 S. Main St. Burbank, Calif.

If You Telegraph You Need A

VIBROPLEX

Semi-Automatic Key

Twice as easy
as hand sending

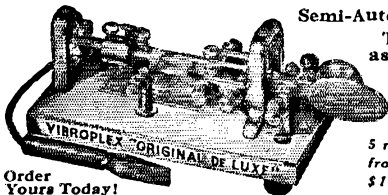

5 models to choose from, priced from \$12.95 to \$29.95

Order Yours Today!

No other key takes the strain and effort out of telegraphing like the Vibroplex. It brings to you the ease of semi automatic action, simplicity of operation and advantage of machine speed. The use of patented jewel movement assures smoother, easier operation and longer life. Don't wait for signs of arm trouble. Start using the Vibroplex to-day and see how easily and effortlessly you send . . . no arm-tiring effort . . . no strain. Everyone will notice the improvement in your keying. Whether you choose the Super DeLuxe Presentation with 24-K gold-plated base top and super-speed control main-spring that lets you send from dead slow to top speed, and requires no additional weights for slowest sending — or one of the other models — you'll get the finest key your money can buy. **ORDER YOURS TODAY!** Left-hand models, one dollar more. At dealers or direct. **FREE** catalog.

Headquarters for NEW portables, all models and styles of type. Also, **REBUILT** standard and portable typewriters with **ALL CAPITAL** letters and other styles of type. Immediate delivery. Get our prices before you buy!

THE VIBROPLEX CO., INC.

833 Broadway

New York 3, N. Y.



Miniature Mobile

(Continued from page 12)

R_3 are connected together at the strip which is mounted just to the right of the crystal sockets. The oscillator plate inductor, L_1 , is connected directly between the tube socket and prong No. 3 of J_3 .

Belden type 8885 shielded wire was used for the connections that go to the microphone jack. No. 16 tinned wire was used between the crystal sockets and S_{1A} .

Testing

Plate power requirement for the transmitter is 300 volts at 100 ma. and the heaters draw 2.1 amp. at 6 volts. A 6.3-volt a.c. transformer may be used to furnish heater power during the bench testing of the rig.

It is advisable to disconnect the modulation transformer lead that terminates at R_5 and R_6 before testing of the transmitter is started. This will remove high voltage from the final while the oscillator circuit is being checked. If a milliammeter is then plugged across R_4 , it should show an amplifier grid current of approximately 4 ma. when the power supply is turned on. Should there be a wide difference in grid-current readings as the crystal switch is alternated between the 3.5- and the 7-Mc. positions, it is an indication that L_1 is not resonated at the proper frequency. Making the inductance smaller will increase the 7-Mc. output of the oscillator and, of course, increasing the inductance will boost the 3.8-Mc. drive to the final.

The plate-voltage lead for the final should now be connected in place and the test meter should be transferred to jacks J_6 and J_7 . If a

Current-Voltage Chart

Tube	E_p	E_s	$I_s, Ma.$	$I_p, Ma.$	$I_k, Ma.$
Osc.	300	250	—	—	28
Amp.	"	200	4	35	—
12AU7					
Pin 1	90	—	—	—	15*
Pin 6	295	—	—	—	—
12AX7	300	—	—	—	10/25

* Total cathode current for tube with microphone removed from jack and cathode resistor connected to ground.

NOTE: Microphone voltage approximately 2.5 volts.

low-wattage lamp — one rated at something less than 15 watts is best — is connected to J_1 , the amplifier should load to approximately 25 ma. when the final and the coupler are resonated by means of C_7 and C_9 , respectively. The tuning of C_9 will be extremely broad at 3.8 Mc. because it is connected in parallel with C_{10} at this frequency.

The audio circuit is tested by plugging a carbon microphone into J_2 and by watching for a pronounced increase in load-lamp brilliance as speech is applied to the microphone. At a later

(Continued on page 118)

LOOK STEINBERGS LOOK

IMMEDIATE DELIVERY

NOVICE TRANSMITTER and POWER SUPPLY KIT

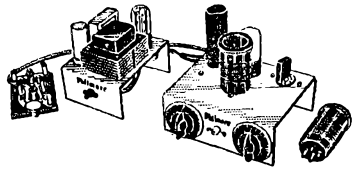

The newest of Philmore's famous kits. 25 watts input, 2-bands, 80, 11 meters. Pierce osc. 6V6, 6L6 output, pi-network to match any antenna. Power supply delivers 370 volts @ 100 Ma. All parts and tubes included except crystal, solder and hook-up wire. Key furnished. Very simple and complete instructions. Finest components throughout. A wonderful investment at only... **\$29.40**
 Bliley Novice Band 80 meter crystals... **\$ 2.80**
 Bliley 13 Mc. crystals, double to 11 meters... **\$ 3.95**

- VIKING 1 kit, with 4D32.....\$229.95**
- VIKING 1 wired, with 4D32.....\$269.45**
- COLLINS 32V3 Transmitter.....\$775.00**

CONDENSER SPECIAL

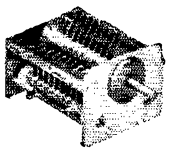

75 mmf. 4250 peak voltage, ceramic button insulation, adjustable spacing, straight-line capacity, precision construction, 3 1/4" long, 1 3/4" wide, shaft 1/4" x 1", adjustable tension, 89¢ double-bearing..... **89¢**

8/8/8 MFD. 500 V. D.C.

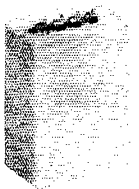

Triple 8 mfd. 500 working volt D.C. oil-filled condenser, common negative, solder terminals, hermetically sealed, 5" x 3 3/4" x 2 1/4". A one-time buy. **\$1.95**

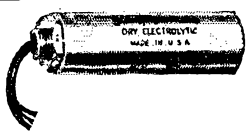

Triple 8 mfd. 450 V. electrolytic upright can condenser, separate negatives, all leads insulated from can. Nationally known mfr. Reg. dealer net \$2.58..... **ONLY 59¢**
 10 for **\$5.00**

PHOSPHOR BRONZE AERIAL



125 ft. of the finest aerial wire obtainable. 42-strand phosphor-bronze with linen center. Will not stretch, very high tensile strength, diameter approximately same as No. 14 copper, very flexible. Excellent for transmitting or receiving antenna, control cable, guy wire. Regular list \$4.95..... **90¢**

MINIMUM ORDER \$2.00. Send 20% deposit with COD orders. Please include sufficient postage or instruct us to ship by Express Collect. Overpayment will be refunded by check.

ELMAC-A54 Under-dash Mobile Xmtr.



VFO or Crystal control. Direct-reading VFQ on all bands—75' 20, 11, 10 • Plate modulation • Completely band-switching, fone or CW. • 50 Watts max. input. Power required: 300-500 V.D.C. at 250 ma., 6.3 V AC or DC at 4.5A. • Uses 3-6AG5, 6AR5, 6C4, 12AU7, 2-6L6G, 807 (included). • Only 7 1/2" x 7 1/2" x 12", 14 1/2 lbs.
 For carbon mike input..... **\$139.00**
 For Dynamic or crystal mike..... **\$149.00**
 Power Supply, 110 Volt AC..... **\$ 39.50**
 ELECTRO-VOICE 210 Mobile Carbon Mike..... **\$ 17.10**
 ELECTRO-VOICE 600D Mobile Dynamic Mike..... **\$ 23.10**

MORROW 3-BAND CONVERTER

- Single point tuning; high image rejection, birdies negligible
- Automatic Noise Limiter—Built In
- 1-Microvolt Sensitivity—All Bands
- Antenna Trimmer on Front Panel
- Beautiful Grey Hammer-tone Finish
- Low drift, Pre-calibrated Oscillator
- Full Width Dial—Calibration Accuracy 1%
- AVC On Preselector, No Strong Signal Blocking
- I.F. Amp. with 4 Tuned Circuits, Output 1525 Kc.
- Complete with Mounting Hardware, Manual
- Case—Height 4", Width 3 1/2", Length 6 1/2"

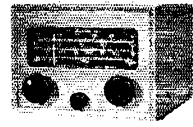

\$64.95

- HI-Q. 20 coil to base load 96" whip..... **\$8.95**
- HI-Q. 75 coil to base load 96" whip..... **\$7.95**
- 12" RG8/U coax, male plug each end..... **\$.70**

MASTER MOBILE UNITS

- All-band center-loaded antenna for 75-20-10, specify coil wanted, less mount..... **\$8.75**
 100-96S. Stainless Steel 96" threaded whip... **\$5.25**
 9-96T. Silicon-Chrome 96" threaded whip... **\$3.75**
 100-60S-60". "All-Band" top section only... **\$4.95**
 132. Tapered spring universal body mount..... **\$8.75**
 132X. Heavy-duty universal body mount. **\$9.85**
 132J. Junior model universal body mount. **\$4.17**
 140. Tapered spring bumper mount. **\$6.55**
 140X. Heavy-duty bumper mount. **\$7.65**
 140J. Junior model bumper mount. **\$4.17**



Steinbergs

Phone CHerry 1880

633 WALNUT STREET • CINCINNATI 2, OHIO

Your order will receive my personal attention and will be shipped the same day order is received. We distribute all top-flight amateur lines... let us know what you need.
 73, Jule Burnett, W8WHE

NOW . . . **AS FOR**
MANY YEARS . . .

THE
OVERWHELMING
FAVORITE
OF AMATEURS



ASTATIC

D-104 MICROPHONE

OLDTIMERS or newcomers—it makes no difference in the matter of microphone preference among Hams. Now, as for many years, an overwhelming majority prefer and use the famous Astatic Model D-104. Outstanding performance features are high output level (approx. —45 db) and definitely reduced R.F. feedback tendencies. A model employing ceramic element, with performance comparable to the crystal unit except for slightly lower output, is also available. If you would like complete details on the D-104 or other Astatic Mikes, please write.

THE
Astatic
CORPORATION
CONNEAUT, OHIO
IN CANADA: CANADIAN ASTATIC LTD., TORONTO, ONTARIO

EXPORT DEPARTMENT: 401 Broadway, New York 13,
N. Y. CABLE ADDRESS: ASTATIC, New York.

Terminal Radio Corp.

Open
thursday
evenings
till 9 p.m.

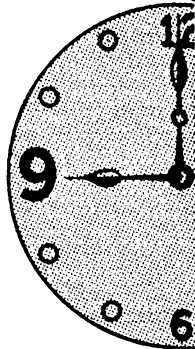

An "extra" Terminal service . . .
shop at your convenience in the
unrushed evening hours . . . if
you're driving you'll find ample
parking space after 6 p.m.

TERMINAL RADIO CORP.

85 Cortlandt St., N.Y. 7, N.Y. Worth 4-3311

date, when the transmitter has been placed on the air, the correct percentage of modulation is determined by regulating the volume of the speaking voice.

At this point it may be desirable to check all measurable currents and voltages of the transmitter. Values that may be expected at various points throughout the rig are listed in the accompanying chart.

It is entirely possible that the value of inductance specified for L_3 of the coupler will not be absolutely correct for all mobile antennas. However, if the coil is not cemented in place until the installation is completed, it will be a simple matter to make any necessary alterations.

Transmitting Loops

(Continued from page 14)

The small loop illustrated in this article showed narrow-band characteristics. It was not found advisable to use it more than 20 kc. either side of the frequency for which it was originally tuned. If the loop is located within easy reach of the operating position, or furnished with a remote control system, this is not a serious handicap. However, we got very tired of running up two flights of stairs to adjust the W4LW version!

An unexpected by-product of this antenna system is freedom from TVI. Although the loop was located about ten feet from a TV antenna, a transmitter with 100 watts input had no effect on TV. This effect was double-checked by trying the loop as a receiving antenna. There was a marked reduction in local QRN, and interference from the horizontal sweep oscillator of a neighbor's TV set disappeared entirely.

With a transmitter output of about 40 watts, reliable contacts have been made with this antenna system up to 1000 miles. Three contacts have been over 2500 miles.

The possibilities of this antenna system have not been explored fully. However, two facts have been established: it works, and it is a wonderful subject for conversation during QSOs!

W/VE Operation

(Continued from page 51)

70 per cent. In Canada, no operation by amateurs is permitted in airplanes.

In general terms the technical requirements for amateurs of both countries are about the same, except they may be a bit more strict in the U. S. and certainly are spelled out in considerable detail. VEs headed south should obtain a copy of the ARRL *License Manual* and familiarize themselves generally with U.S. regs.

Finally, don't forget your automobile driver's license and registration (if a motor trip), your ham ticket and your endorsement for operation in the other country.

And now — good luck!

— J.H.

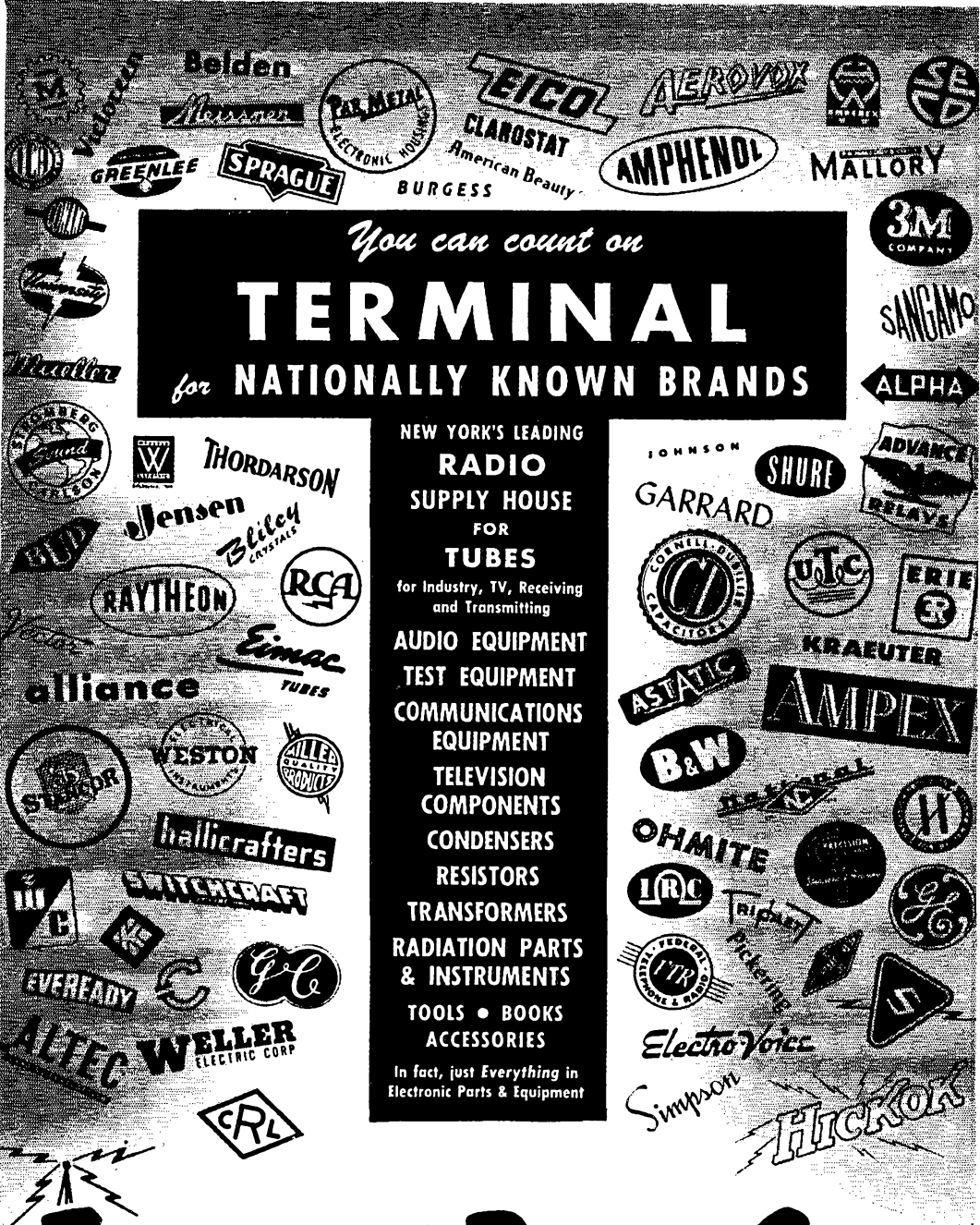

You can count on
TERMINAL
for **NATIONALLY KNOWN BRANDS**

NEW YORK'S LEADING
**RADIO
 SUPPLY HOUSE**
 FOR
TUBES
 for Industry, TV, Receiving
 and Transmitting

**AUDIO EQUIPMENT
 TEST EQUIPMENT
 COMMUNICATIONS
 EQUIPMENT
 TELEVISION
 COMPONENTS
 CONDENSERS
 RESISTORS
 TRANSFORMERS
 RADIATION PARTS
 & INSTRUMENTS
 TOOLS • BOOKS
 ACCESSORIES**

In fact, just Everything in
 Electronic Parts & Equipment

JOHNSON
SHURE
GARRARD
AMPEX
B&W
OHMITE
IRC
ElectroVoice
Simpson
HICKOK

Terminal Radio Corp.
 Distributors of Radio and Electronic Equipment
 85 CORTLANDT ST., NEW YORK 7, N.Y.
 phone: WOrth 4-3311

DOW CO-AX RELAY

FOR 52 OR 72 OHM LINE

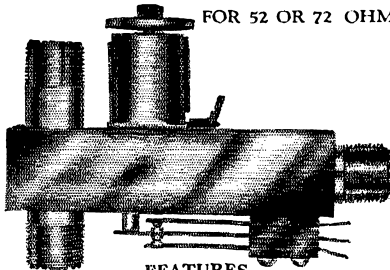

FEATURES

1. Causes negligible change in s.w.r. up to 100 Mc.
2. Handles power up to 1000 watts.
3. Fits standard connectors for co-ax.
4. No chatter. Specially built for "Silent operation".
5. Over-all length 4 1/4". Over-all width 3".
6. Externally mounted SPDT switch operated by relay can be used for opening B+ of receiver when transmitting, or for other control purposes. Add to prices below \$1.00.
7. When in transmit position a built-in shorting connector grounds receiver antenna lead. This protects receiver against injury from r.f. and reduces to a minimum the capacity coupling between receiver and relay contacts. Add to prices below, \$1.00.

AC Types (all voltages) Amateur Net.....\$10.50
 DC Types (all voltages) Amateur Net..... 9.50
 See your distributor, but if he has not yet stocked Dow Co-ax Relays, order now direct from factory. Send check, money order, or will ship C.O.D. Prices are Net, FOB shipping point: Warren, Minn., or Winnipeg and Montreal, Canada.

Dealer Inquiries Invited

THE DOW-KEY CO., INC. Warren Minnesota

578 Goulding Street
 Winnipeg, Canada

2310 Wilson Avenue
 Montreal, Canada

Matching Coax Line

(Continued from page 19)

of the radial ground-plane rods.
 The required stub reactance is given by

$$X_s = \frac{Z_1}{S} \text{ ohms,} \quad (7)$$

where X_s = inductive reactance of stub.
 The length of the shorted stub is

$$L_s = \frac{32.8VL}{f} \text{ inches,} \quad (8)$$

where L_s = stub length,
 V = velocity factor of line used in stub,
 L = length of stub in electrical degrees having required X_s .

L is equal to the angle whose tangent is X_s/Z_0 , where Z_0 is the characteristic impedance of the stub.

The length of each radial is given by

$$L_r = \frac{2953K_a}{f} \text{ inches,} \quad (9)$$

the length being measured from the center line of the radiator to the tip of the radial.

If the radials have a different diameter than the radiator (a common practice) the M and K_a for radials and antenna must be considered separately.

Sample Calculation

The use of the curves and formulas can be illustrated by a practical example. Assume a ground-plane antenna to be constructed from 3/8-inch tubing for a frequency of 146 Mc., to be matched to 72-ohm RG-11/U coaxial line by using a stub of the same line material. Then

$$\begin{aligned} f &= 146 \text{ Mc.,} \\ D &= 0.625 \text{ inch,} \\ Z_1 &= 72 \text{ ohms,} \\ Z_0 &= 72 \text{ ohms,} \\ V &= 0.66. \end{aligned}$$

$$\text{From (1), } M = \frac{5906}{146 \times 0.625} = 65.$$

From Figs. 2, 3 and 4, it is found that

$$\begin{aligned} M &= 65, \\ K_a &= 0.959, \\ K_x &= 3.8, \\ R_r &= 28.3. \end{aligned}$$

From (2),

$$R_o = 28.3 - \frac{72}{4 \times 28.3} = 27.7 \text{ ohms.}$$

The factor S , as given by (4), is

$$S = \sqrt{\frac{72}{27.7} - 1} = 1.265.$$

(Continued on page 122)



TURN "PRO" WITH THE "BIG" LEAGUE

... And you'll bat 1.000!!

YOUR AMATEUR EXPERIENCE MAY QUALIFY YOU FOR A HIGH-PAYING ELECTRONICS OR RADIO POSITION WITH BENDIX RADIO.

These jobs open:

- LAB. TECHNICIANS
- TECHNICAL WRITERS
- DRAFTSMEN

(Mech. & Elect.)

• ENGINEERING POSITIONS

We have openings in excellent positions which carry engineering responsibility. If you have a good background of practical experience, you need not have a degree.

Write, Wire or Phone MR. E. O. COLE Dept. L

Bendix Radio

DIVISION OF BENDIX AVIATION CORP.
 BALTIMORE-4, MD. Phone: TOWSON 2200

Are You a "Watt-Waster?"

Are you letting your rig really do its best to give you
 . . . More DX . . . Better QSO's . . . Maximum Pleasure?

One mobile operator made a 3 db improvement in his signal strength (equivalent to doubling the transmitter power!) while reducing final input by 25% — just by tuning-up with a field strength indicator.

These six different types of test and measuring instruments are a "must" in the shack of every ham who wants to get the most return for his time and money.

Simpson Wavemeter Modulation Indicator

Ideal instrument for hams. Use as a field strength indicator to determine radiation pattern and as a direct reading percentage modulation indicator. Provision for headphones to permit station monitoring and quality control. Separate plug-in coils for 10, 20, 40 and 80 meter bands. Dual sensitivity, 0-100 microammeter. With coils, 2 ft. antenna and instruction manual.

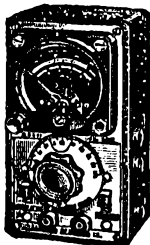

MODEL 380 **\$37.85**

Modernize Your Shack with New

B & W DIP METER

Covers 1.75 to 260 Mc
 in Five Calibrated
 Overlapping Bands



Invaluable for TVI chasing, antenna tuning, parasitic elimination, neutralizing, trap peaking, receiver aligning, beam adjusting, as a signal generator, frequency meter, CW and phone monitor, Q indicator, absorption wavemeter, etc. Measures resonant frequency of non-energized tuned circuits in transmitters, receivers, etc. For 110V., 60 cycles AC. With 5 color-coded plug-in coils, tube and instructions. Small size, light weight.

MODEL 600 **\$48.00**

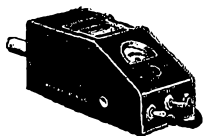

MILLEN GDO

Compact, completely self-contained. Has built-in transformer type AC power supply and internal terminal board to provide connections for battery operation. Range 1.7 to 300 mc on 7

direct reading bands. For 115V., 50/60 cycles AC. With tube, coils and rack for spare coils.

MODEL 90651 **\$61.50**

Millen SWR Bridge

Plug into your 50 or 75 ohm coaxial cable at any point, connect 0-1 DC MA and measure SWR. One of the best ways to tune antenna systems for maximum efficiency, interstage linkage, etc. Accurate over 1 to 150 mc.

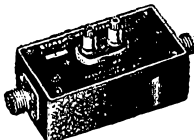

MODEL 90671 **\$16.80**

M. C. JONES

MicroMatch

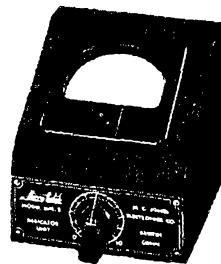
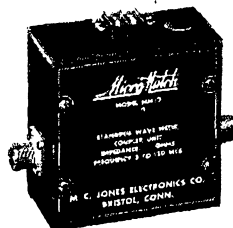

MM2 SERIES

Merely insert this instrument in your coaxial transmission cable and read the SWR. If it is more than 1.5 to 1, your antenna is rejecting too much of your precious output! Adjust your beam (or trim antenna length), get a better impedance match for the transmission line . . . and the MicroMatch will tell you when you are radiating at maximum efficiency. Also reads RF power output up to 500 watts. Accurate over 3 to 162 mc.

MM2 (For 52 Ohm Cable) **\$41.25**

MM3 (For 72 Ohm Cable)

MODEL MM1. For 10-1000 watt transmitters using open wire transmission lines. Single unit case. Range 3 to 30 mc. Line impedance 70 to 300 ohms. **\$32.50**

ELDICO Antennascope

Takes the guesswork out of adjusting and impedance matching to any beam or mobile antenna. Measures actual radiation resistance, transmission line impedance, frequency and impedance of matching sections and stubs, feed line SWR, receiver input impedance. Works with any GDO (or suitable source of low power RF). Complete kit including sensitive 100 microamp meter, cabinet and easy instructions. **KIT \$24.95**
 Factory wired & tested. **\$29.95**



Popular SIMPSON MODEL 260 TESTER

Fastest Selling, High Sensitivity VOM . . . More in Use Today Than All Others Combined
20,000 Ohms/Volt DC!

Handles most voltage, current and resistance measurements you'll ever need around the shack. Accurate . . . dependable . . . rugged. With leads, batteries and instruction manual.

MODEL 260 **\$38.95**

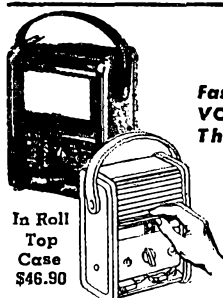

In Roll
 Top Case
\$46.90

HARRISON

RADIO CORPORATION

225 GREENWICH STREET NEW YORK 7, N.Y.

BARclay 7-7777

FREE! HARRISON HAM-A-LOG
 Send for your copy TODAY! It's filled with the latest Amateur Equipment and accessories.

LONG ISLANDERS! You Can Save Time By Shopping at our JAMAICA BRANCH: Hillside Ave. at 172nd St.

BUY OF A LIFETIME!

TRIED AND PROVEN THE WORLD OVER



LETLINE MODEL 240 TRANSMITTER WITH MOBILE CONNECTIONS AND A.C. POWER SUPPLY

This outstanding transmitter has been acclaimed a great performer throughout the world. It is excellent for fixed station, portable or mobile operation. Even if you have a transmitter of your own you can't afford to miss this wonderful buy, direct from our factory, ready to operate.

The 240 is a 40 watt phone CW rig for 160 to 10 meters, complete with: (8 x 14 x 8) cabinet, self contained A.C. power supply, MOBILE connections, meter, tubes, crystal and coils for 40 meters. Tubes: 6N7 osc., 807 final, 6S17 crystal mike amp., 6N7 phase inverter, 2 6L6's mod., 5U4G rect. Weight 30 lbs. TVI instructions included. 90-day guarantee. Price \$79.95.

\$25 deposit with order — balance C.O.D.

80, 20, 10 meter coils \$2.91 per set. 160 meter coils \$3.60. Also for CAP, Broadcast, MARS, Marine, State Guard.

LETLINE RADIO MFG. CO.

62 Berkeley Street

Valley Stream, N. Y.

From (3),

$$X_a = 1.265 \times 27.7 = 35.0 \text{ ohms.}$$

From (6),

$$K_b = 1 - \frac{35}{380} = 0.908$$

and from (5), the antenna length is

$$L_a = \frac{2953 \times 0.959 \times 0.908}{146} = 17.6 \text{ inches.}$$

To find the stub dimensions, the required reactance from (7) is

$$X_s = \frac{72}{1.265} = 56.9 \text{ ohms.}$$

The electrical length for this reactance is given by the angle whose tangent is $X_s/Z_0 = 56.9/72 = 0.79$. From a table of tangents the angle is found to be 38.4 degrees. Then from (8)

$$L_s = \frac{32.8 \times 0.66 \times 38.4}{146} = 5.7 \text{ inches.}$$

The length of each radial is given by (9),

$$L_r = \frac{2953 \times 0.959}{146} = 19.4 \text{ inches.}$$

Bandswitching Exciter

(Continued from page 23)

output terminal. From there on it takes some form of transmission line filter, and probably an antenna coupler, too, to complete the job with certainty.

Take Channel 6 reception at W1HDQ as an example. The exciter unit that the new job replaces runs on the same power supplies and cabling, uses the same crystals, and delivers the same power output, on 28 or 50 Mc. When used anywhere in the 10-meter band other than the high edge, it knocks TV reception completely out with its third harmonic. When the new rig is used with a suitable antenna coupler there is faint interference at the low end of the band, and with the transmitter operating anywhere in the 'phone assignment TV reception is clear. Addition of a low-pass filter would probably clear even the low-end trouble.

On 50-Mc. the old exciter knocks out Channel 6 when 8-Mc. crystals are used, as the result of the 10th harmonic falling in the channel. The new job (when used with an antenna coupler) shows no interference whatever. Feeding the antenna systems directly from the output terminal, J_3 , shows plenty of interference with the new rig. There is only this one hole through which the harmonics can get out, however, and thus a low-pass filter or an antenna coupler can do the rest of the job effectively.

Easy, fast way
to cut "Key"
and "D" openings
in chassis



No. 732 "Key" Punch



No. 733 "D" Punch

...with new GREENLEE Radio Chassis Punches

Now, in 1½ minutes or less make perfect "Key" or "D" holes for sockets and other equipment. Simply insert GREENLEE Punch and turn with an ordinary wrench... get a "clean" opening in a hurry! Write today for details on these as well as GREENLEE Radio Chassis Punches for round and square openings. Greenlee Tool Co., 186 Columbia Ave., Rockford, Ill.



IT'S Newark

FOR HAMS WHO INSIST

... on the Latest in Precision Equipment ... Low Prices ... and Fast, Efficient Service

AND IT'S LYSCO FOR TOP Amateur Equipment...

Latest in Low-Cost Ham Gear



All-Band TVI-Free Transmaster Model 600S.

All-Band TVI-Free Transmaster Model 600S. Features a built-in "clamp" tube modulator plus a switching arrangement whereby the power amplifier may be turned off to tune-up or zero-beat another signal without blocking the receiver or causing unnecessary interference to other stations on the frequency. This switch also provides a means for switching from phone to CW operation. Operates on 160, 80, 40, 20, 15 and 10 meter bands. Crystal or VFO operation possible on all bands. Temperature compensated. Uses 6AG7 oscillator, 6AG7 buffer, 807 amplifier, 5U4G rectifier. Power input, 35 watts. Output, low impedance 50 ohm line. Black wrinkle-finish steel case, 17x9x11". For 115 volts, 60 cycles. Wt., 50 lbs.

97F040. NET.....189.95

97F041. Model 600RS.

As above, rack mounted189.95



Mobile Transmasters

Mobile Transmasters for 10-11, 20 and 75 Meters. Series of compact mobile transmitters featuring 25 watts power, clamp type audio for 100% AM modulation, and built-in antenna relays for push-to-talk operation. All controls and crystal sockets on front panels. Have coax output for 52-ohm line. Require 500 volts DC at 125 ma and 6.3 volts at 1.35 amps. In black wrinkle finished case, 4x4 1/2 x 6". Available with tube lineup of 3-6AQ5 or 3-6V6GT. Supplied with tubes or less tubes—see listing below. Shpg. wt., 8 lbs.

Using 3-6AQ5's		WITH TUBES		LESS TUBES	
Band	Type	No.	Type	No.	
10-11 Meters	A129T	97F050	A129	97F049	
20 Meters	A114T	97F046	A114	97F045	
75 Meters	A175T	97F054	A175	97F053	
Using 3-6V6GT's		WITH TUBES		LESS TUBES	
10-11 Meters	B129T	97F052	B129	97F051	
20 Meters	B114T	97F048	B114	97F047	
75 Meters	B175T	97F056	B175	97F055	
NET EACH		33.55		29.95	



Model D11 Grid Dip Meter.

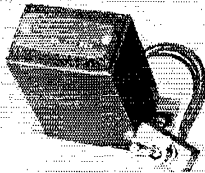

Model 30 Noise Limiter.

Model D11 Grid Dip Meter. Extremely versatile instrument that can be used as a grid dip meter, an absorption wave meter, a CW or phone monitor, a signal generator, or a field strength meter. Frequency range when used as grid dip meter, 3.4-160 mc; as signal generator, 3.4-300 mc. Includes 5 plug-in coils. Uses 955 tube. Size, 3x9x 3 1/2". Ready to operate, with meter, tube and power supply. For operation from 115 volts DC, or 110-120 volts, 60 cycles AC. Shpg. wt., 4 lbs.

97F043. NET.....39.95

Model 30 Noise Limiter. Fully adjustable peak noise limiter for use with any superhet receiver. Power requirements, 6.3 volts at 150 ma AC or DC; 100 volts at 6 ma DC. Uses 6AL5 tube. Size: 1 1/2 x 3 x 1 1/4". Wired and tested, with tube. Shpg. wt., 1 lb.

97F042. NET.....6.95

NEWARK
ELECTRIC COMPANY

Write DEPT. T-9 for NEWARK'S FREE CATALOG

223 WEST MADISON STREET, CHICAGO 6, ILLINOIS

WANTED Engineers and Scientists

Unusual opportunities for outstanding and experienced men

These top positions involve preliminary and production design in advanced military aircraft and special weapons, including guided missiles.

IMMEDIATE POSITIONS INCLUDE:

- Electronic project engineers
- Electronic instrumentation engineers
- Radar engineers
- Flight test engineers
- Stress engineers
- Aero- and thermodynamicists
- Servo-mechanists
- Power-plant installation designers
- Structural designers
- Electro-mechanical designers
- Electrical installation designers
- Weight-control engineers

Excellent location in Southern California. Generous allowance for travel expenses. Write today for complete information on these essential, long-term positions. Please include résumé of your experience and training. Address inquiry to Director of Engineering,

NORTHROP AIRCRAFT, Inc.
1029 East Broadway
Hawthorne (Los Angeles County), Cal.



Identifying Harmonics

(Continued from page 24)

the addition of many harmonic lines. However, the frequency can be determined quite easily and more accurately using simple algebra.

We know that the unknown frequency, f_x , is some multiple, n_1 , of some fundamental frequency, f_1 . Similarly, we know that f_x is also some multiple, n_2 , of another fundamental frequency, f_2 . So, we write

$$f_x = n_1 f_1, \text{ and also } f_x = n_2 f_2.$$

Since we are working with adjacent harmonics, we know that $n_2 = n_1 + 1$. Substituting this value of n_2 in the above equation, we get

$$f_x = n_1 f_1 = (n_1 + 1) f_2$$

$$n_1 f_1 = n_1 f_2 + f_2$$

$$n_1 f_1 - n_1 f_2 = f_2$$

$$n_1 (f_1 - f_2) = f_2$$

$$n_1 = \frac{f_2}{f_1 - f_2}$$

In the preceding example, $f_1 = 3600$ kc., and $f_2 = 2400$ kc. Therefore,

$$n_1 = \frac{2400}{3600 - 2400} = \frac{2400}{1200} = 2.$$

So the unknown frequency is the second harmonic of f_1 , or 7200 kc. As a check, we note that 7200 kc. is also the next-higher (third) harmonic of f_2 .

By substituting $\frac{f_2}{f_1 - f_2}$ for n_1 in the original equation for f_x , we get

$$f_x = \frac{f_2}{f_1 - f_2} \times f_1 = \frac{f_1 f_2}{f_1 - f_2}$$

This gives f_x directly without the need for first determining n_1 . Note that f_1 is always the higher of the two fundamental frequencies and f_2 is the lower.

In cases where the frequency-meter range is sufficient, it is well to check three or four adjacent pairs of fundamentals. This prevents overlooking a beat and averages out errors in dial readings. As an example, suppose beats are checked at 3973.684, 3775 and 3595.238. Taking the first pair,

$$f_x = \frac{3973.684 \times 3775}{3973.684 - 3775} = 75,500 \text{ kc.}$$

Using the second pair,

$$f_x = \frac{3775 \times 3595.238}{3775 - 3595.238} = 75,500 \text{ kc.}$$

If a beat is overlooked, the results will not check out.

The formula is an easy one to remember because it is similar to those for resistances in parallel or condensers in series, *except* that the sign in the denominator is minus instead of plus. Any two adjacent beats can be used, of course, for the calculations. The accuracy is limited only by the accuracy of the readings at the fundamental.

(Continued on page 126)

Raise Your Phone Power 8 Times with SINGLE SIDEBAND

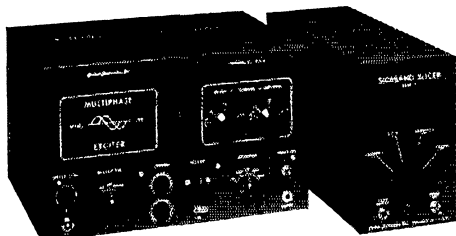

HARMONIC TVI VIRTUALLY ELIMINATED

MULTIPHASE EXCITER MODEL 10A Switchable Single Sideband with or without carrier. Double Sideband AM. Phase Mod. Break-in CW. Output approx 10 peak watts 160 to 20 meters, reduced on 15 & 10. VOICE OPERATED BREAK-IN. With coils for one band. Wired & Tested \$139.50. Kit \$99.50. Coils \$3.95/each.

SIDEBAND SLICER MODEL A Receiver Adapter. Selectable Single Sideband reception of SSB, AM, PM, & CW. Reduces heterodynes & interference at least 50%. Eliminates fading distortion. For receiver IF 450-500kc. Wired & Tested \$69.50. Kit \$47.50.

PS-1 PLUG-IN prealigned 90° phase shift network & socket \$7.50.

Send for Literature

Central Electronics, Inc.

2125 W. Giddings Street

Chicago 25, Illinois

Lafayette



WN2NID

Scotty Says

Meet another of the gang at Lafayette Paul Vazquez WN2NID plus 1st class radio telephone. Our South American friends will be pleased to know Paul is a bi-linguist, Spanish-English. 73

Duncan Scott W2LAL



J.F.D. Zoom-up Mast

Zinc-plated seamless, 16 gauge steel, telescoping antenna masts. Supplied with guy rings, clamps and insulation hardware (less guy wire).

- ZU12-20 20 ft. mast \$ 7.35
- ZU123-30 30 ft. mast 12.98
- ZU1234-40 40 ft. mast 20.41
- ZU12345-50 50 ft. mast 33.38



NEW! JOHNSON VIKING II

The Johnson Viking II transmitter kit incorporates all the desirable features of its predecessor plus those required for effective TVI suppression. 100 watts output on phone and 130 watts on CW on all bands 160 thru 10 meters. New final amplifier uses parallel 6146 tubes. All parts supplied, including copper plated steel cabinet, chassis, wiring harness, all hardware and tubes. Complete construction test and operation manual also supplied. Viking II Transmitter Kit..... **279.50**

LAFAYETTE — HEADQUARTERS FOR COMMUNICATIONS RECEIVERS

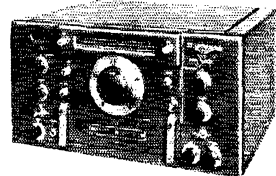
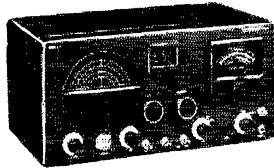

Lafayette has been the Headquarters for fine communications receivers for 32 years. All the latest models are available as soon as released by the manufacturers. Be sure to check Lafayette before you buy your new receiver.

HALLICRAFTERS

- \$-38C 49.50
- \$-40B 99.95
- \$-53A 79.95
- SX-62 289.50
- SX-71 199.50
- SX-73 975.00
- \$-76 169.50

NATIONAL

- SW 54 49.95
- NC 125 149.50
- NC183D 369.50
- HRO 60 483.50
- HFS 142.00

HAMMERLUND

- HQ-129X 199.50

Eldico Novice Course

- Complete course \$25.00
- Records only 17.00
- Theory course only 10.00

JOHNSON MOBILE TRANSMITTER KIT

New Johnson mobile transmitter kit, a bandswitching 4 band rig, 60 watts input, 100% modulated (30 watts on 300 volt supply) 807 final, microphone input—dynamic, crystal or carbon. Crystal or VFO control.

Viking Mobile Transmitter Kit (less tubes)..... **99.50**

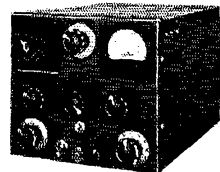

(less tubes) **\$99.50**



Novice Transmitter Kit

New! Philmore, one of the pioneers in designing radio kits, has just introduced this new novice transmitter kit. It is a complete kit, including power supply and key. Transmitter uses Pierce type crystal oscillator, PI type tuning amplifier. A6V6 tube is used in the oscillator and a 6L6 in the amplifier. The power supply uses a type 5Y3 rectifier and supplies 370 volts DC at 100 milliamperes. All parts needed are supplied except hook-up wire, solder, crystals and antenna. Instruction manual supplied to simplify work of constructing the kit. Priced right for that novice budget.

Philmore novice transmitter kit **\$294.00**

Lafayette TWO-WAY INTERCOM

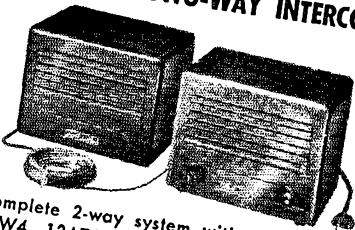

Complete 2-way system with tubes (50B5, 35W4, 12AT6), cord, plug and 50 feet of hookup wire. For 110V. AC or DC operation, P24999..... **1795**

Lafayette Radio Radio Wire Television Inc.

NEW YORK 13, N. Y.
100 SIXTH AVENUE
REctor 2-8600

BOSTON 10, MASS.
110 FEDERAL STREET
HUBbard 2-7850

NEWARK 2, N. J.
24 CENTRAL AVENUE
MArket 2-1661

BRONX 58, N. Y.
542 E. FORDHAM RD.
FOrdham 7-8813

WANTED:

Young men interested in operation and maintenance of electronic equipment.

Comprehensive training given in basic and advanced electronics as applied to geophysical exploration.

Paid vacations, insurance benefits, excellent advancement opportunities.

Address letter with your qualifications to

United Geophysical Company, Inc.
P.O. BOX M
PASADENA, CALIFORNIA

XTALS FOR ALL PURPOSES!

LOW FREQ.-FT 241A for SSB, lattice filter, 1/2" spc. 5th or 72nd harm channels listed by fund. Fractions omitted.		SCR 522 1/4" sp.	BC-610 2 banana plugs 1/2" spc.	FT234-1/2" spc.									
374	395	418	487	511	400	464	5910	2030	2435	4190	1015	5940	6640
375	396	419	488	514	440	466	6370	2045	2442	5030	1129	5973	6673
377	397	420	490	515	441	468	6450	2105	2532	5485	2045	6273	6706
379	398	422	491	516	442	470	6470	2125	2545	6040	3735	6306	6740
380	401	423	492	518	446	472	6497	2145	2557	6073	5305	6325	7440
381	403	424	493	519	447	474	6522	2165	3202	6106	5677	6340	7506
383	404	425	494	520	450	475	6547	2220	3215	6140	5706	6373	7506
384	405	426	495	522	452	476	6610	2258	3237	6173	5725	6406	7540
385	407	427	496	525	461	477	7350	2280	3250	6206	5760	6473	7606
386	408	431	497	526	462	479	7580	2282	3322	6773	5773	6475	7640
387	409	433	498	530	463	480	7810	2290	3510	6873	5800	6506	7650
388	411	435	503	531	99c ea.		8129	2300	3520	6906	5806	6540	7673
390	412	436	504	533	10 for		8350	2305	3550	7140	5825	6573	7705
391	413	481	506	537	\$9.00		8380	2320	3580	7773	5840	6575	7973
392	414	483	507	538			8410	2360	3945	7840	5873	6606	8250
393	415	484	508				8440	2390	3995	7873	5906	6625	8273
394	416	485	509				8470	2415	7940	7906	99c each		
49c each	10 for \$4.50							\$1.29 each	49c each		10 for \$9.00		

Add 20c for each 10 xtals or less for postage and handling

Two Station Intercom System

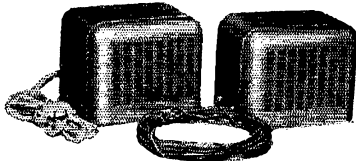

BRAND NEW NOW ONLY \$17.95

SUN RADIO
OF WASHINGTON, D. C.
938 F STREET, N. W. WASH. 4, D. C.

This method is restricted, of course, to the checking of frequencies where the fundamental range of the signal generator is appropriate to produce at least two adjacent beats with the unknown. In the example of Fig. 1, it is seen that the *minimum* frequency at which at least two beats will be obtained is 6 Mc., where the second- and third-harmonic lines first start to overlap. This minimum frequency is equal to the sum of the minimum and maximum fundamental frequencies of the signal generator. In this case, the fundamental range is 2 to 4 Mc. Therefore, the minimum frequency is $2 + 4 = 6$ Mc. If the 125-to-250-kc. range of the BC-221 is used, the minimum frequency will be $125 + 250 = 375$ kc.

As with any heterodyne method of frequency measurement, care must be exercised in distinguishing between spurious responses caused by harmonics generated in the device being checked and in the detecting system, and the real beats developed by harmonics of the frequency meter. One thing that helps, particularly when using a receiver as the detector, is to keep the input to the receiver as small as possible so that the spurious responses will be weak in comparison with the signal you want to hear.

Strays

So far as Miami W4s are concerned, Seattle W7s represent better DX (distance) than 43 DXCC countries.

A sharp beam aimed due south from Jacksonville, Fla., would miss all of South America.

Those interested in the dimensions of VQ4-ERR's operating layout as pictured on page 63 will find the data in the diagram below.

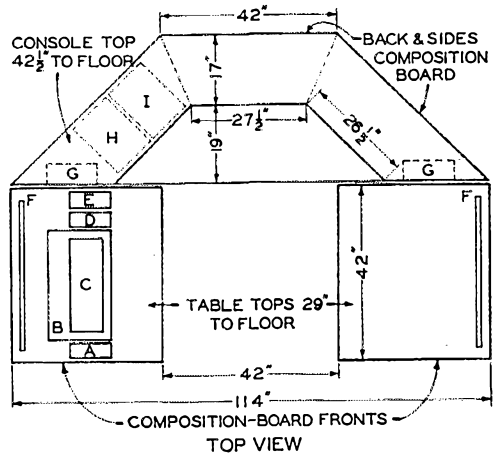

Station equipment and accessories indicated are A, transmitter control panel; B, receiver; C, VFO; D, beam indicator; E, beam control panel; F, a.c. power-plug strips; G, speakers; H, frequency meter; and I, band markers.



FORT ORANGE RADIO DISTRIBUTING CO., INC.

904 BROADWAY, ALBANY, NEW YORK, U.S.A.
 AMATEUR HEADQUARTERS FOR ALL HAM GEAR

DROP US A CARD WITH YOUR NAME-QTH & CALL LETTERS SO WE CAN PLACE YOU ON OUR SPECIAL MAILING LIST... 73... WATCH OUR AD IN QST

24 HOUR GUARANTEED SERVICE TO ALL AMATEURS



OVER 35 YEARS IN AMATEUR RADIO SERVICE - WITH THE BEST.....

RECEIVERS

Collins 75A2 with speaker.....	\$440.00
National HRO60 with speaker.....	499.50
National NC183D with speaker.....	385.00
National HFS with power supply.....	164.43
National SW54.....	49.95
National NCT25 with speaker.....	160.50
Hammarlund HQ-129X with speaker.....	214.00
RME-50 with speaker.....	213.50
Hallcrafters SX-73.....	975.00
Hallcrafters SX-62, less speaker.....	289.50
Hallcrafters SX-71, less speaker.....	199.50
Hallcrafters S-72, less speaker.....	109.95
Hallcrafters S72L, less battery.....	119.95
Battery for above.....	4.17
Hallcrafters S-76, less speaker.....	169.50
Hallcrafters S77.....	99.95
Hallcrafters S-40B.....	99.95
Hallcrafters S-38C.....	49.50
Hallcrafters R-46 speaker for model SX62, SX71, S76.....	19.95

TRANSMITTERS

Collins 32V3, less crystal or mike.....	\$775.00
Johnson Viking, less tubes, mike or crystal.....	209.50
Johnson Viking, wired and tested.....	259.50
Full kit of tubes for above including 4D32 tube.....	39.00
Johnson TV1 kit above.....	27.50
Johnson VFO kit, less tubes.....	42.75
wired and tested.....	52.75
kit of tubes.....	2.89
Elmac A54, less carbon mike or power supply.....	139.00
Elmac A54H, less crystal mike or power supply.....	149.00
Harvey-Wells TBS50C Bandmaster Senior.....	111.50
Harvey-Wells TBS50D Bandmaster Deluxe.....	137.50
Eldico 2-meter transmitter.....	74.95
kit form.....	49.95
Lysco B129 transmitter, less tubes, 10 meter.....	29.95
Lysco A175 transmitter, less tubes, 7.5 meter.....	29.95
Lysco A140 transmitter, less tubes, CAP band.....	29.95
Sonar MB26 transmitter—specify band required.....	72.45

MISCELLANEOUS

Web Jr. Ten-meter transmitter, 30-50 Watt on peak.....	\$ 39.95
Lysco 381 VFO.....	26.95
Lysco 401 modulator.....	19.95
Lysco 600 transmitter.....	149.50
Eldico antenna scope—kit.....	21.95
Eldico antenna scope, wired and tested.....	29.95
Eldico grid dip oscillator kit.....	29.50
Eldico Grid dip oscillator, wired and tested.....	43.00
4D32 tubes—immediate delivery.....	22.40

We stock many types of towers, antennas, and antenna rotators. Write us for quotations.

Millen 90651 grid dip oscillator.....	\$ 61.50
Morrow Converter, Model, 10-7.5 meter.....	54.95
Morrow Converter, Model, 3BR 10-20-7.5 meter.....	64.95
Gonset 3005 Triband converter.....	47.60
Gonset 3008 two meter.....	44.50
Gonset 3002 3-30 meter.....	44.75
Gonset steering-post bracket.....	3.90
Gonset noise clipper.....	9.25
Sonar MR3 triband receiver.....	89.95

BARGAIN SPECIALS

73 Ohm one-kilowatt twin polyethylene insulation .09/ft. Per C \$	5.00
300 ohm twin lead. Per ft.....	.03
Per C	2.50
RG8U cable coax., 2 ohm. Per ft.....	.16
RG11U cable coax., 73 ohm. Per ft.....	.19
RG-58U cable coax., 52 ohm. Per ft.....	.07
RG-59U cable coax., 73 ohm. Per ft.....	.09
4-5- and 6-prong ceramic tube sockets by Johnson, Each.....	.20
J-38 hand-transmitting key, Each.....	1.29
GE Plate Circuit relay, 8000 ohm DPDT contacts close @8ma. Each.....	1.95
Carbon mikes, single button, with push-to-talk button switch similar to T-17-B, Made in England, Each.....	3.95
Pyrex insulators, 7" heavy-duty type, Each.....	1.40
Acorn tube sockets, made by Johnson for 954, 955, etc.....	.20
Clarostat 50-watt rheostats, 250 ohm. Each.....	1.35
Lots of 10, Each.....	1.20
DeJur 50-watt rheostats, 50 ohm. Each.....	1.25
Lots of 10, Each.....	.99
De Jur 50-watt rheostats, dual 2000 ohm. Each.....	2.50
Lots of 10, Each.....	1.98
Two meter 4-element beam antennas, Each.....	7.95
Two meter 4-element beam antennas stacked, Each.....	16.50
2 mfd. 1000V pyranol cond. Each.....	2.95
2 mfd. 2000V pyranol cond. Each.....	5.95
4 mfd. 3000V pyranol cond. Each.....	9.95
.25 mfd. 1000V oil cond. 23F158GE, Each.....	.50
120-watt non inductive resistor, 2500, 7500, 10000, 25000 ohm. Each.....	2.50
or 50000 ohm—either value	
Blas or Isolation trans. .40, ma Prim. 110VAC, Sec. 126V tapped at 12, 24, 28, 42, 56, 74, 86, 111. Each.....	\$ 1.95

Variable condenser MB70938 mmfd. .1000 spacing dim 2L x 1 3/4" x 3 1/4" W. Each.....	.75
Variable condenser MAPT6 10, 75mmfd. .100 spacing dim 3 3/4 x 2 1/2, 2 3/4. Each.....	1.20
Variable condenser MAS0986, 25 per sec. .020 spacing—butterfly 1 3/4 x 1 1/4 x 1 1/4. Each.....	1.35
Variable condenser MA 60912, 10 mfd. .020 spacing dim 3/4 x 1 1/2 x 1 1/2	

USED EQUIPMENT

Hallcrafters SX28 with speaker.....	\$175.00
Hallcrafters S72 portable, like new.....	85.00
Gonset two meter converter, like new.....	39.00
RME-69 receiver with noise clipper and speaker.....	75.00
Hammarlund SP-200X with power supply and speaker.....	225.00
BC312N receiver 110 V AC.....	65.00
2 Webster Model 80 wire recorders, Each.....	50.00
Hallcrafters HT-9 transmitter with crystals.....	300.00
National HRO-5 with speaker and power supply.....	215.00
Meissner 150-B transmitter with full set of coils.....	315.00
including buffer doubler stage and exciter—factory converted to 10 meter	
Hallcrafters S-38 receiver.....	39.95
National NC-33.....	49.50

Wire for more complete list of used equipment. This list changes daily. Contact us if you are looking for something or wish to swap. Generous trade-in allowances.

ALL PRICES F.O.B. ALBANY • Long Distance Phone: 5-1594 ALBANY
 Foreign Trade Welcome • All Inquiries Answered • Cable Address: Uncle Dave

mobile specials

10-METER WHIP ANTENNA

96 inches tall, made of chrome silicon steel of exceptionally high tensile strength. Bend it to 90° and it will still come back to original upright position. Taper ground with corrosive resistant finish. For base below, or any standard base. 96" Whip Antenna - Regularly \$6.75
SPECIAL 3.75

SWIVEL BASE AND SPRING

Oil-tempered heavy spring steel - tough enough to take it! Not affected by shock, extreme temperature or vibration. Flexible lead through center of spring maintains constant electrical impedance. Instant response to contact with overhead obstructions. Has 3/4" threaded fitting to receive mast stud.

Swivel Base & Spring - Regularly \$7.25
SPECIAL 4.00

WHIP AND BASE COMBINATION

Another great Arrow Special. Order both whip and base above, together and save still more!

COMBINATION ABOVE, SPECIAL 7.00
MALLARD HI-Q 20 Loading Coil, Net.... 8.95
MALLARD HI-Q 75 Loading Coil, Net..... 7.95

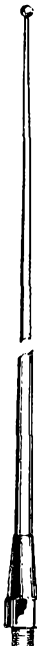

ARROW ELECTRONICS, INC.
 82 CORTLANDT ST., NEW YORK 7, N. Y., DIGBY 9-4714

BE SAFE WITH

Q-max

A-27

LOW-LOSS LACQUER & CEMENT

- Q-Max provides a clear, practically loss-free covering, penetrates deeply to seal out moisture, imparts rigidity and promotes electrical stability. Does not appreciably alter the "Q" of R-F coils.

- Q-Max is easy to apply, dries quickly, adheres to practically all materials, has a wide temperature range and acts as a mild flux on tinned surfaces.

In 1, 5 and 55 gallon containers.

Communication Products Company, Inc.

MARLBORO, NEW JERSEY
 (MONMOUTH COUNTY)
 Telephone: FReehold 8-1880



Happenings

(Continued from page 37)

the stations involved is not contemplated.
 2. AMEND SECTION 12.156 TO READ AS FOLLOWS:

§ 12.156 *Operation in emergencies.* In the event of an emergency disrupting normally available communication facilities in any wide-spread area or areas, the Commission, in its discretion, may declare that a general state of communications emergency exists, designate the area or areas concerned, and specify the amateur frequency bands, or segments of such bands, in addition to those provided by this section for use only by amateurs participating in emergency communication within or with such affected area or areas. Amateurs desiring to request the declaration of such a state of emergency should communicate with the Commission's Regional Manager of the area concerned. Whenever such declaration has been made, operation of and with amateur stations in the area concerned, using frequencies in the emergency communications bands, shall be only in accordance with the requirements set forth in this section, but such requirements shall in nowise affect other normal amateur communication in the affected area when conducted on frequencies not designated for emergency operation.

(a) The following segments of authorized amateur frequency bands, together with such authorized amateur frequency bands or segments of such bands as may be additionally specified by the Commission in its declaration of a general state of communications emergency, shall become amateur emergency communications bands and shall be available only for use by amateur stations actually engaged in communications essential to the protection of life and property, or the alleviation of human suffering and need:

Authorized Amateur Frequency Bands	Amateur Emergency Communications Bands
1800-2000 kc	1800-1825 kc 1875-1900 kc 1900-1925 kc 1975-2000 kc
3500-4000 kc	3500-3550 kc 3950-4000 kc
7000-7300 kc	7075-7125 kc 7275-7300 kc
14000-14350 kc	14000-14050 kc 14200-14250 kc
28.0-29.7 Mc	28.5-28.8 Mc 29.4-29.7 Mc
50.0-54.0 Mc	50.0-50.8 Mc 53.2-54.0 Mc
144-148 Mc	145.0-146.0 Mc 146.5-147.5 Mc
220-225 Mc	220.0-225.0 Mc

(b) All transmissions within all specified amateur emergency communication bands other than communications relating directly to relief work, emergency services, or the establishment and maintenance of efficient amateur radio networks for the handling of such communications, shall be suspended. Incidental calling, answering, testing or working (including casual conversation, remarks or messages) not pertinent to constructive handling of the emergency situation shall be prohibited within those bands.

(c) A 5-minute listening period for the first five minutes of each hour shall be observed, insofar as practicable, by all stations for the purpose of listening for initial calls of major importance or calls from isolated stations in the frequency band segments reserved in § 12.112 for initial calling and answering. During such listening period no transmissions shall be made on the designated calling and answering frequencies other than for initial calls and replies in connection with the emergency situation or for the handling of emergency communications of extreme importance.

(d) The Commission may designate certain amateur stations to assist in the promulgation of information relating to the declaration of a general state of communications emergency, to monitor the amateur emergency communications bands, and to warn noncomplying stations observed to be operating in those bands. Such station, when so desig-

(Continued on page 130)

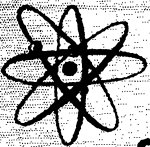

Ham's Paradise!

CONCORD - A Grand Old Name in ELECTRONICS



RME MC-54 MOBILE CONVERTER

for 2 Meters,
6 and 10-11 Meters

Complete with
Tubes & Cables **\$6660**
Amateur Net..

Converts any auto radio to
hi-freq. receiver! 1500 Kc out-
put. Covers 3 ranges: 26.5-

30 Mc, 49.5-54.5 Mc and 143.5-149.2 Mc, each with individual
coax input connector. Requires 200-250 V @ 30 Mils (avail-
able from car radio). AUTOMATIC NOISE CLIPPER CIR-
CUIT INCORPORATED. Overall size: 5 3/4" wide, 4 1/8"
high, 5 1/4" deep. Weight 4 lbs. Can be used with any com-
munications receiver.

SENSATIONAL OFFER!

SUPREME 680

AUDIO

SIGNAL GENERATOR

(Reg. Net. \$81.29)
CONCORD'S LOW **\$3995**
PRICE

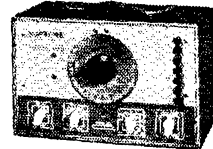

What a Value! BRAND NEW and GUARANTEED! This
versatile audio oscillator has flat freq. range 15 to 15000
cycles, over 280° of 6" dial. Output: 5000-500-250-0-250-500-
5000 ohms. Output volts 50 RMS at 5000 ohms, 9 and 14
Volts at 250 and 500 ohms resp. Size: 13 3/4" x 9" x 6 1/8". For
115 V AC. 20 lbs. ONLY A FEW LEFT, HURRY!

GONSET "COMMANDER"



NEW
35-50 Watt
Multi-Band
Transmitter
Net **\$12450**

Freq. Range: 1.7 to 54 Mc continuous.
Fixed or Mobile Operation. VERY
COMPACT: 5 3/4" high, 8 3/4" wide, 7 3/4"
deep. Suitable for under-dash. Tubes:
RF, 6AG7, 6146, AF: 12AT7, 2-6AQ5s.
Wired, tested, complete with all tubes,
2 hi-Q final tank coils.

MORROW MOBILE CONVERTER

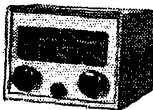

10, 20 & 75 Meters

1-microvolt sensitivity, all bands. Full
width dial, 1% accuracy. AUTOMATIC
NOISE LIMITER, BUILT IN. 3-gang
tuning cond. Tuned preselector, mixer,
osc. Separate isolated coils for each band
and stage. 1K Amp with 4 tuned cir-
cuits, 1525 Kc output. Antenna
trimmer on front panel. **\$6495**
Complete. Net.....



MALLARD

MOBILE
CONVERTERS
FOR
10 Meters
20 Meters
or 75 Meters

Slug-tuned, sensitive, stable as a rock!
Plenty of band spread, accurate cal-
ibration, large dial. Only **\$3995**
connections, all plug-in Ama-
teur Net. EACH.....
Mallard Hi-Q Base Loading Coils for 20, 75 M. Whips
Hi-Q 20.....\$8.95 Hi-Q 75.....\$7.95

SPECIAL SCOOP!

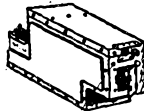

ARC-5/R-28
2-Meter
Receiver

One of the BEST 2-meter superhets
you've ever seen! 100 to 156 Mc in 4
xtal channels. (Easily converted to con-
tinuous tuning.) Tubes: 717 RF, 717A
Mixer, 2-12SH7 1st and 2nd IF (6.9 Mc)
12SL7 Det. AVC. Squelch, 12SL7 1st
aud. squelch amplif. 12A6 2nd Aud.
12SH7 RF Osc., 4th harm. gen., 717A
trip. 12th harm. gen., 717A Dblr., 12th
harm. gen. Complete with tubes **\$2495**
in new cartons. Stock No. 15085.
15085. Set, net.....

FREE with each ARC-5/R-28 Receiver:
Vol. 2, "Surplus Radio Conversion
Manual" (reg. \$2.50) contains circ. dia-
gram and full description of above
receiver.

ARC-5/T23 XMITTER

Famous aircraft 2 Meter Companion
to above receiver. Stock No. 15086
Net..... **\$4950**
Net.....

40 METER VFO
ARC-5/T22
TRANSMITTER
(Navy BC-459A)

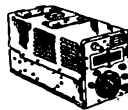

Easily converts to hot VFO or 50 Watt
CW Xmitter. 7.0 to 9.1 Mc. Furnished
with tubes, 8 Mc Xtal, wiring diagram,
and conversion suggestions. **\$2495**
less power supply. BRAND
NEW! Stock No. 15087. Net..

JOHNSON VIKING 1 XMTR KIT

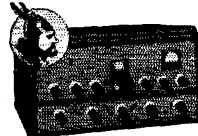

Here's your
"dream"
transmitter!

100 watts
phone, 125 watts CW, on 160, 80, 40, 20,
14, 11, and 10 meter bands, all switched
from front panel. Tubes: 4D3Z final,
6AU6 buffer doubler, 6AU6 osc., 2-807
mod. 6AU6 driver, 6AU6 speech amp.,
5Z4 Low-volt rect., 2-SR4GY hi-volt
rect., 6AL5 bias rect. Includes cabinet,
fully marked front panel, drilled and
punched chassis, hardware, **\$20950**
wiring harness, less tubes, **\$259.50**
xtals, key and mike. Net... **\$22.50**
Wired and Tested, Less Tubes...
Kit of Tubes (829B final).....

NEW VIKING 1 TVI SUPPRESSION KIT

Comprises all shielding and filters needed
for operating Viking 1 transmitter in any
location without TV inter-
ference! Complete instructions **\$2475**
furnished. Net each.....

Johnson Lo-pass Filter.....\$16.50

VIKING VFO KIT

For maximum
operation flexibility
with Viking 1 or
similar Xmtr. Two
controls: Freq.
control driving 5"
dial calibrated in
freqs. for 160, 80,
40, 20, 15 and 10
meter bands; and
bandwidth, P lug
cables for direct connection. **\$4275**
Simple to assemble! Com-
plete, less tubes.....
Wired, Tested Tubes, Net..... **\$57.75**

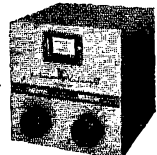

CONCORD RADIO

55 VESEY ST. - NEW YORK 7, N.Y.

GUARANTEE
OF SATISFACTION

Dept. Q-9-2

All items order-
ed must meet
with full approv-
al or your
money back.

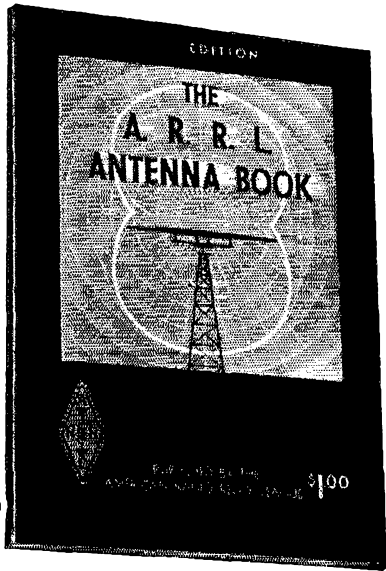

IN DEMAND

\$1.00 U.S.A. Proper, \$1.25 Elsewhere

THE AMERICAN RADIO RELAY LEAGUE
Incorporated
West Hartford 7, Connecticut

Master Mobile

ANTENNAS MOUNTS

NEW MASTER DELUXE 2-METER COAX ANTENNA—MODEL NO. 214

MASTER MOBILE'S engineer has designed a Superior New, Ruggedly Constructed, Vertically Polarized, Coaxial Antenna in the frequency range of 140 to 170 Megacycles.

Features: Completely waterproofed • furnished with approximately 10 ft. of 72 OHM Coax Cable • smart design enhances the appearance of any vehicle • very attractive highly polished chrome finish • delivered complete—ready for quick, simple installation.

Mounting Types: Type 1, on side—with 2 brackets furnished—as shown. Type 2: on master mount (No. 132X or 140X).

Mounts sold separately. Complete Antenna: Featured at **\$1595** Net Plus Postage. Approx. Ship. Wt.—3 lbs.

Master Mounts: No. 132X **\$985** No. 140X **\$765**

2-METER STANDARD MODEL—NO. 114 COAX VHF ANTENNA—At A Popular Price FOR OPEN TYPE VEHICLES using 140 MC to 165 MC. Mounts any convenient place with standard MASTER MOUNTS. Baked enamel finish. With 10' Coax Cable and 18" Adjustable Section. NET—ONLY **\$9.95.**

At Leading Distributors or Write

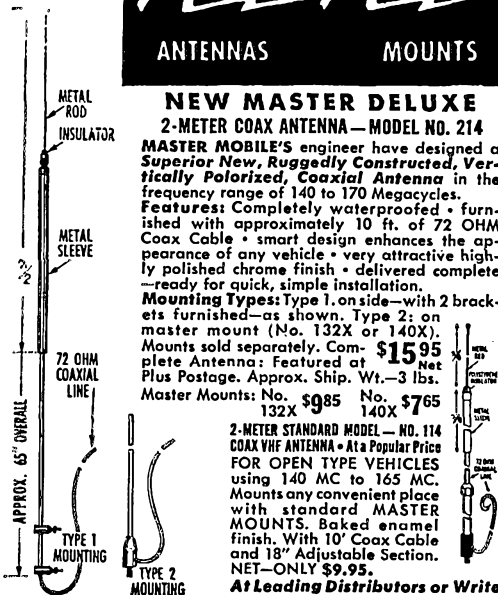

Master Mobile Mounts, Inc.

P. O. BOX 1817 · LOS ANGELES 36, CALIFORNIA
WAREHOUSE AND SHIPPING ADDRESS: 1306 BOND STREET

nated, may transmit for that purpose on any frequency or frequencies authorized to be used by that station, provided such transmissions do not interfere with essential emergency communications in progress; however, such transmissions shall preferably be made on authorized frequencies immediately adjacent to those segments of the amateur bands being cleared for the emergency. Individual transmissions for the purpose of advising other stations of the existence of the communications emergency shall refer to this section by number and shall specify, briefly and concisely, the date of the Commission's declaration, the area and nature of the emergency, and the amateur frequency bands or segments of such bands (other than those specified in this section) which constitute the amateur emergency communications bands at the time. The designated stations shall not enter into discussions with other stations beyond furnishing essential facts relative to the emergency, or acting as advisors to stations desiring to assist in the emergency, and the operators of such designated stations shall report fully to the Commission the identity of any stations failing to comply, after notice, with any of the pertinent provisions of this section.

(e) The special conditions imposed under the provisions of this section shall cease to apply only after the Commission, or its authorized representative, shall have declared such general state of communications emergency to be terminated; however, nothing in this paragraph shall be deemed to prevent the Commission from modifying the terms of its declaration from time to time as may be necessary during the period of a communications emergency, or from removing those conditions with respect to any amateur frequency band or segment of such band which no longer appears essential to the conduct of the emergency communications.

What Price Precision ?

(Continued from page 44)

around \$140.00, and is very portable. It behaved as follows:

1) The rock and circuit aged about 70 parts per million high — perfectly normal.

2) The oscillator was slightly affected by the load change between feeding the 100-kc. multivibrator and feeding the harmonic amplifier, and the output frequency changed 2 to 3 parts per million when going from the multivibrators to the crystal frequency. This was not considered too much of a drawback, because 1-Mc. points are normally used only for mileposts, fine settings being accomplished against 100-kc. or 10-kc. points, both of which held in good shape.

3) Changes in line voltage had relatively little effect on the frequency.

4) Since no temperature stabilization was provided, frequency changes of as much as 15 parts per million were experienced over an ambient temperature range of 17 to 30 degrees C.

5) The zero setter on this unit, as on the FS135Cs, was relatively coarse, and built to be adjusted with a screwdriver. A dial would have been a big help.

6) The harmonic amplifier functioned very well, but 10-kc. multiples were pretty weak at 30 Mc.

7) The multivibrators were not too stable. As long as the 6SN7 tubes used in them were new, and temperature variations not too violent, all was well. However, as soon as the peak wore off the tubes the multivibrators took off on their own, and could not be locked to the crystal with the adjustments provided. Investigation revealed that the time-constant condensers used in

(Continued on page 132)

*Build
YOUR
OWN*

Heathkit TEST EQUIPMENT



Heathkit
AUDIO GEN. KIT
\$34.50

Heathkit
VACUUM TUBE CHECKER
KIT
\$29.50

Heathkit
REVISION GENERATOR
KIT
\$39.50

Heathkit
PUSH-PULL OSCILLOSCOPE
KIT
\$43.50

Heathkit
SIGNAL TRACER
KIT
\$19.50

Heathkit
ELECTRONIC SWITCH
KIT
\$19.50

Heathkit
CONDENSER CHECKER
KIT
\$19.50

Heathkit
BATTERY ELIMINATOR
KIT
\$24.50

Heathkit
IMPEDANCE BRIDGE
KIT
\$69.50

Heathkit
RF-SIGNAL GEN. KIT
\$19.50

Heathkit
VACUUM TUBE VOLTMETER
KIT
\$24.50

Heathkit
HAND TESTER
KIT
\$13.50

Heathkits are completely engineered instruments supplied unassembled. Every kit goes together smoothly and easily. All drilling, punching, and painting has already been done for you.

It's easy and fun to build a Heathkit. All parts are furnished and are of highest quality for years of trouble-free, dependable operation.

Save money by constructing your own. All expensive wiring and assembly costs are completely eliminated.

Detailed construction manual shows clearly where each wire and part goes and tells exactly how to build the kit. Write for free catalog.

HEATH COMPANY
BENTON HARBOR 9,
MICHIGAN

EXPORT AGENT
ROCKE INTERNATIONAL CORP.
13 E. 40th St.
NEW YORK CITY (16)

EVERYTHING AT YOUR FINGERTIPS

with **SUBRACO MT-15 X**

GO "DASHBOARD" MOBILE-

WITH TUBES
High impedance input
\$109.50
Low impedance input
99.55

... with this high quality, compact, efficiently designed, 30 watt AM phone 10-11 meter transmitter, small enough to mount in most glove compartments or under any dash. For complete details write for catalog Q-528.

SUBURBAN RADIO COMPANY
158 CENTRAL AVENUE ROCHELLE PARK NEW JERSEY

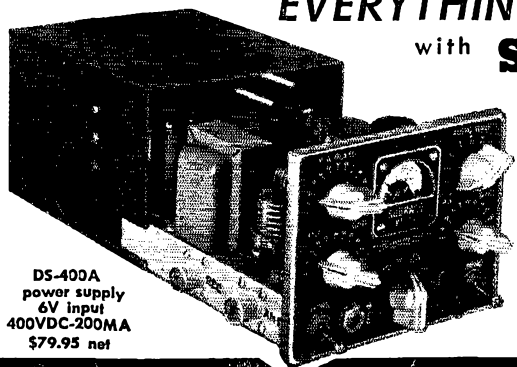

DS-400A
power supply
6V input
400VDC-200MA
\$79.95 net

Before
you
buy

or trade that Collins, Johnson, Hallicrafters or National piece of radio gear be sure to get our prices. Our service cannot be beat. Remember the name—

ADIRONDACK RADIO SUPPLY

32 Guy Park Avenue Amsterdam, N. Y.
Ward J. Hinkle, W2FEU, Owner

Remember also — Our telephone number is 73
Our P. O. Box number is 88

ANTENNAS

by JOHN D. KRAUS

Prof. of Elec. Engr., Ohio State Univ.



Expert advice for the advanced amateur who wants to find out more about antennas for all frequency ranges. Points up applications, and gives essentials the antenna builder must know to meet varied problems.

533 pp.
396 illus.
\$8.50

"Clear, systematic treatment" — *Radio & TV News*... "Can be confidently recommended." — *Science*.

10-DAY FREE TRIAL

McGRAW-HILL BOOK CO., Dept. QST, 327 W. 41 St., NYC 36

RECEIVING SENDING
CODES *speed* *without strain*

CHAMPIONS ENDORSE CANDLER WAY
Get skill, accuracy, speed with the highly endorsed Candler System. Learn to send and receive by telegraph or radio code. Government service and commerce need thousands of better trained operators. Air commerce, mail, freight, etc., demand expert, reliable operators. Good pay. Get the Candler System, the maker of champions. It teaches you the "knack" of sound sense, alertness, speedy sending and receiving without strain. Adventure — good pay. Learn at home or wherever you are. Rush name today for free book.

FREE!

CANDLER SYSTEM CO.

Dept. 4-K, Box 928, Denver 1, Colorado, U.S.A. and at
52b, Abington Road, Kensington High St., London W.8, England

these units were quite temperature-conscious, with the resistors associated therewith being pretty good. So, inasmuch as the 10-kc. section was giving the most trouble, new time-constant condensers (silver micas) were substituted for those originally furnished, and Allen Bradley type J potentiometers were used to replace the resistors. The 100-kc. section was cured by the substitution of silver-mica condensers for those originally used as time constants. When these changes were made, the 100-kc. and 10-kc. units were very stable, and tube aging no longer had much effect. No effort was made to correct the antics of the 25-kc. multivibrator; the author seldom has need for it.

8) The 1000-cycle modulator, while handy at times, is seldom used, and is considered to be a feature of doubtful value.

9) The comparison detector is almost never used, as a better job can be done using a receiver for this purpose.

Taken all in all, standard No. 3, while combining a number of features in a single cabinet, is not as good a deal as Nos. 1 and 2, if a little additional work is done on them. It was, however, designed to do a specific job with reasonable precision, and it does this job very well. I like it.

[EDITOR'S NOTE: Part II of this article will appear in a subsequent issue.]

M.A.R.S. IN FAR EAST

Stateside stations wishing to work DX — or stations desiring regular schedules with the Far East — will be glad to know that AD1GHQ, Headquarters Far East Command in Japan, is eager to work U. S. MARS or amateur stations.

AD1GHQ equipment consists of a kw. transmitter (c.w. only), a rhombic antenna oriented toward San Francisco, SP-600 receivers, an AN/FGC-9 teletypewriter bay, and a TG-7 printer. Normal operation is from 2300 to 1400 GCT but the station will arrange to meet any schedules. Correspondence should be addressed to: MARS AD1GHQ, 71st Signal Battalion, Headquarters, Far East Command, APO 500, c/o Postmaster, San Francisco, California.

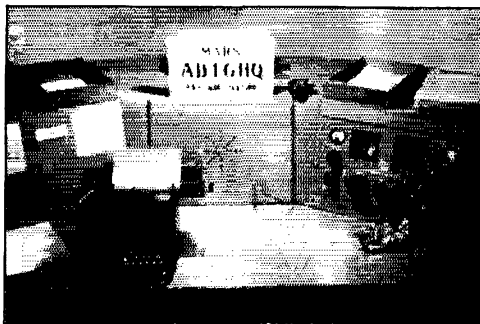

AD1GHQ, control station for Far East Command, operated by Lt. Robert Richardson, AD1AC, and Pvt. Robert N. Green, A2CFO. Radioteletype is available.

B&W

BX SERIES INDUCTORS

FOR POWERS UP TO 250 WATTS

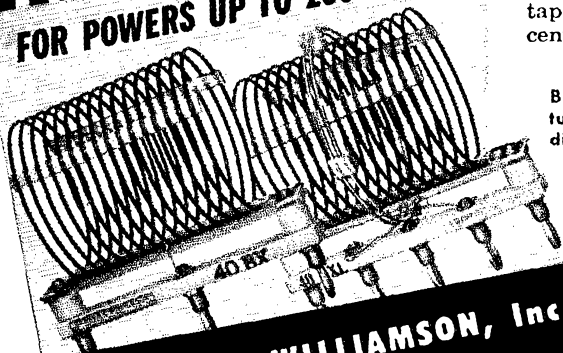

TOP-NOTCHERS for medium-powered rigs

Look to the B&W BX Series when you need an inductor to handle more power and provide greater efficiency in that new rig or the modification of your old one using higher powered bottles. You cannot buy a better inductor at any price.

Available in either straight center tapped (Type BX) or center-linked, center tapped (Type BX1) models.

B&W products are stocked and featured by leading amateur equipment distributors. Ask for them by name.

BARKER & WILLIAMSON, Inc. 237 Fairfield Avenue, Upper Darby, Pa.

AMAZING 2-FOR-1 OFFER

BE A LICENSED TV TECHNICIAN

LICENSED TV MEN MAKE MORE MONEY



L. C. Lane, B.S., M.A.
Pres. RTTA & Pierce Schools

COMPARE RTTA's EXTRA FEATURES

1. I furnish you ALL parts and equipment to build your own COMPLETE TV RECEIVER, plus training to qualify you as a TV TECHNICIAN in America's booming TELEVISION industry . . . within months. Many of my students pay for their entire training from spare time earnings, while training . . . start their own business.

2. Then—to qualify you for better pay . . . BETTER JOBS, I give you my . . .

*** FREE FCC LICENSE COACHING COURSE**

- Prepares you for your FCC License
- Included at NO EXTRA COST
- The best jobs in TV & RADIO require an FCC LICENSE.

NEW YORK ROUND TRIP—FARE FREE!

Yes, wherever you live in the U.S. or Canada, I pay your way to New York and return. After you finish your home study course, I give you two weeks of advanced instruction, 50 hours of shop training at famous Pierce School of Radio & TV. (Applied to complete Radio-TV course only.)

MY SIMPLE METHODS MAKE SUCCESS EASY!

I have helped hundreds of men—most of them with NO PREVIOUS TRAINING—get ahead in TV. Even with a grammar school education, you can master my practical methods and learn by doing. PREPARE NOW for thousands of new job opportunities coming right in your own state, with lifting of TV freeze. Don't delay. Mail the coupon and let my FREE BOOKS show you how easy it is.

YOU BUILD AND KEEP 15 BIG RADIO-TV KITS

INCLUDING BIG SCREEN TV . . .

Everything At No Extra Cost

Train for Success Like These Men



"Thanks to your training, I qualified for a good job as a Receiver Tester at Federal Telephone and Radio."
—Paul Frank Seler



"Your excellent instruction helped me get my present job as an airport radio mechanic for American Airlines."
—Eugene K. Basko



"I'm making good money in my own business repairing and installing radio & TV sets—thanks to your training."
—Irwin Polansky

NOW!

For Men Who Know Radio

ADVANCED FM-TV TRAINING COURSE PREPARES YOU FOR HIGHER PAY JOBS IN A FEW MONTHS

COMPLETE theory and practical training course . . . complete with 6 kits including large screen TV receiver. FCC License Coaching Course included FREE.

NO SALESMAN WILL CALL!

RADIO-TELEVISION TRAINING ASSOCIATION

Approved as a Correspondence School under the Laws of the State of N.Y.
1629 Broadway, Radio City Station, New York City 19, N. Y.

BOTH FREE! SEND NO MONEY! MAIL NOW FOR FREE FACTS!

Mr. Leonard C. Lane, President
RADIO-TELEVISION TRAINING ASSOCIATION
1629 Broadway, New York 19, N. Y.

Dear Mr. Lane: Mail me the facts on your amazing 2 for 1 offer with no obligation to me. I UNDERSTAND NO SALESMAN WILL CALL.

Age _____

NAME _____
ADDRESS _____
CITY _____ ZONE _____ STATE _____

I am interested in: Radio-TV Advanced TV-FM
VETERANS! If qualified under G.I. Bill, check here

A PUSH TO TALK MIKE CASE

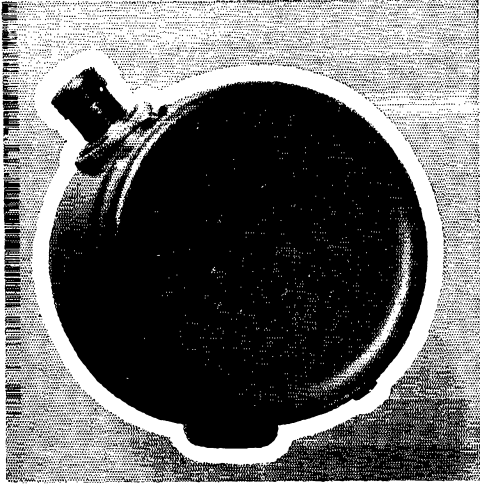

A push to talk mike case that will fit the famous F.1 Unit or a case to fit the new N.1. Both cases come in either push to talk or switch to talk. State preference.

\$3.95

Postpaid
in U.S.A.

BEAHM ELECTRONIC COMPANY

215 So. Kenmore Ave., Los Angeles 4, Calif.

BE A RADIO ENGINEER

You can enter this uncrowded, interesting field. Defense expansion, new developments in electronics demand trained technicians. Study all phases radio & electronics theory and practice: TV; FM; broadcasting; servicing; aviation, marine, police radio. 18-month course equal in radio content to 4 yrs. college. H.S. or equivalent required. Begin Jan., March, June, Sept. Campus life. Write for Catalog.

VALPARAISO TECHNICAL INSTITUTE
Dept. TN Valparaiso, Ind.



RADIO • TELEVISION • ELECTRONICS

in all Technical Phases
New Classes (Day & Evening) Start
1st of Dec., Mar., June, Sept.

FREE PLACEMENT SERVICE FOR GRADUATES
For Free Catalog write Dept. ST-52

RCA INSTITUTES, INC.
A Service of Radio Corporation of America
350 WEST 4th ST., NEW YORK 14, N. Y.

EAZON

Z Match Antenna Connector

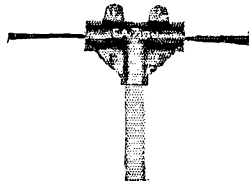

Pat. No. 2587676

A mechanical aid to good electrical matching. The type 3WA is dimensioned to allow the coax and center of the antenna to form a natural match when assembled. See the improvement over other methods of assembly. Types 3W and 4W make ideal junctions for stubs or harmonic traps. Made to fit RG/8U or 11/U. Wt. 4 ozs.

Type 3WA (see cut) Antenna Match\$4.60	Net
Type 4W Cross connector	3.60 Net
Type 3W Tee connector	3.00 Net

See your dealer or write to

DALLAS C. AKERS CO.

33 Greenwood Ave. East Orange, N. J.

YL News and Views

(Continued from page 45)



One of the "first ten" Novices to qualify for an award in the Hallcrafters WAS contest, Norma Jean Guile, now W1UBM, of Norwich, Conn., scores another YL first. Eighteen years old and a June graduate from high school, Norma passed her General Class exam two weeks after becoming a Novice. Active in civil defense communications, she operates 80, 40, 20, and 10, is Asst. EC for Norwich (her father, W1EBO, is EC), publicity agent for the Tri-City Radio Club, and NCS of the Club's net.

Club News

The YL Club of Los Angeles set up 1952 Field Day operations at Big Pines. Using the call W6CEE, W6s NLM (FD Chairman), CEE KYZ LBO UHA and WRT operated 2, 10, 20, and 75 'phone as well as 20 and 40 c.w. The girls' OMs proudly stood by and assisted as technicians and babysitters.

Present at the June luncheon meeting of the N.Y.C. YLRL Club, held at a Greenwich Village Restaurant, were W2s EEO EUL GPK MVV OWL PZA QGK QWL RAQ UXC and WN2IGA.

In this and subsequent issues, we'll introduce one of the District Chairmen of the YLRL for the 1952-53 term (ten W and one VE). As "keynote" of YL activities in her area, a D.C. can do much to stimulate bigger and better YL doings. This year we think an especially enthusiastic group of girls is at the helm, so we'll look for more YL "news and views" than ever before.

Numerically first is Esther Routhier, W1RYJ, of Amesbury, Mass., chairman of the First District. After several years of listening to her OM's (W1DOX) c.w., curiosity prompted Esther to learn the code and she earned her own ticket three years ago. Now Class A, this popular New England YL operates 10, 20, 75 'phone and 80 c.w.; she "loves 10 meters and DX." She holds Maritime Mobile Certificate No. 19 and has WAC and WAS on ten. Of the 98 countries she has worked, 82 are confirmed. Regular participation in the Deep Sea Drag Net of New England, membership in the Gypsy Radio Club, and activity in the amateur civilian defense program of her town round out Esther's busy schedule as an amateur.





MAKE THIS YOUR HOME FOR IMPORTANT WORK UNDER IDEAL CONDITIONS

- TV RECEIVER DESIGN ENGINEERS
- ELECTRONICS ENGINEERS
- FIELD ENGINEERS
- TEST & INSPECTION ENGINEERS
- LAB. TECHNICIANS

NEEDED TO WORK ON: Radar, G.C.A., Mobile Radio, Auto Radio, Airborne Communication & Navigation Equipment, Television, Antennas, Microwave Equipment, Servo Mechanisms, Guided Missiles and Test Equipment Design.

YOU BENEFIT AT BENDIX RADIO:
from high wages, a modern, air-conditioned plant, paid vacations and holidays, group insurance and a good chance for advancement.

Housing immediately available in the beautiful suburban and country areas that surround the Bendix Radio plant.

Write, Wire or phone
MR. E. O. COLE, DEPT. K

Bendix Radio

DIVISION OF BENDIX AVIATION CORPORATION
BALTIMORE-4, MD. Phone: TOWSON 2200

AN/APR-4 COMPONENTS WANTED

In any condition. Also top prices for: ARC-1, ARC-3, APR-1, APR-5A, etc.; TS-34 and other "TS-" and standard Lab Test equipment, especially for the MICROWAVE REGION; ART-13, BC-348, BC-221, LAE, LAF, LAG, and other quality Surplus equipment; also quantity Spares, tubes, plugs and cable.

ENGINEERING ASSOCIATES

434 Patterson Road

Dayton 9, Ohio

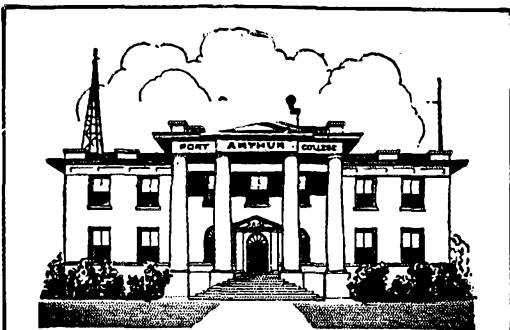

Founded in 1909
**RADIO TELEPHONY
RADIO TELEGRAPHY
RADAR & LORAN**

Courses ranging in length from 7 to 12 months. Dormitory room and board on campus for \$48.00 a month. The college owns K.P.A.C., 5 KW broadcast station with studios located on campus. New students accepted monthly. If interested in radio training necessary to pass F.C.C. examinations for first-class telephone and second-class telegraph licenses, write for details.

PORT ARTHUR COLLEGE PORT ARTHUR TEXAS
Approved for G. I. training

- 4 E 2 - - - - - \$875
2 MTR-4 ELEMENT YAGI
- 8 E 2 - - - - - 20⁵⁰
2 MTR-TWO 4 ELEMENT YAGI
- PD 3 E 10 - - - - - 24⁹⁵
PLUMBER'S DELIGHT
INCLUDES T MATCH
10 MTR-3 ELEMENT
CLOSE SPACED
- 3 E 10F - - - - - 42⁴⁰
FOLDED DIPOLE
10 MTR-3 ELEMENT
CLOSE SPACED
- 3 E 10T - - - - - 41⁸⁰
INCLUDES T MATCH
10 MTR-3 ELEMENT
CLOSE SPACED
- 3 E 15T - - - - - 58⁰⁰
INCLUDES T MATCH
15 MTR-3 ELEMENT
- 2 E 20T - - - - - 47⁹⁵
INCLUDES T MATCH
20 MTR-2 ELEMENT
- 6 E 10-20T - - - - - 98⁹⁵
STACKED 10-20
3 ELEMENT
INCLUDES 2 T MATCHES

Complete catalog on request: Dept. Q92

**HY-LITE
BEAMS
HY-LITE
BEAMS
HY-LITE
BEAMS
HY-LITE
BEAMS
HY-LITE
BEAMS
HY-LITE
BEAMS**

HY-LITE Antennae INC.

Makers of Fine Antennas for AMATEUR · FM · TELEVISION

242 EAST 137th ST., N.Y.C. 51, N.Y.

NEW

Master Mobile

HIGH Q

"BROADBANDER"

ONE OF THE
WORLD'S FINEST
IN MOBILE ANTENNAS
15-20-40-75 METER COILS

AT YOUR JOBBERS

Be the First —
with the Latest

Master Mobile Mounts, Inc.

P. O. BOX 1817 · LOS ANGELES 36, CALIFORNIA
WAREHOUSE AND SHIPPING ADDRESS: 1306 BOND STREET

TELEVISION • RADIO ELECTRONICS

Training in all branches of television, radio and electronics.
FCC exam. preparation. Write for free catalog.

COMMERCIAL RADIO INSTITUTE

(Founded 1920. Apprx. by MD. Board of Education)
Dept. B., 38 West Biddle Street Baltimore 1, Maryland

TEST EQUIPMENT WANTED

WESTON LABORATORIES is pleased to announce to its many friends the existence of a new policy in the procurement of military electronic test equipment. It is well known that we are constantly buying test equipment and gear of surplus origin to be used to augment that of our own manufacture in fulfilling current military demands. Effective at once we offer amateurs either cash or the cash value plus 15% in swapping standard brand amateur goods for test equipment as listed below.

As an example: if your test equipment was worth \$100.00 to us we could offer you merchandise equal in value to \$115.00 at regular net prices. Among the items we seek are: Spectrum Analyzers, TSX-4SE, TSS-4SE etc.; TS-120, TS-13, TS-14, TS-33, TS-35, TS-45, TS-146, TS-147, TS-148, TS-173, TS-174, TS-175, TS-338, etc. Write, wire, or phone for highest cash and trade offer.

WESTON LABORATORIES

Weston 93, Massachusetts
Telephone Boston, WEllesley 5-4500

How's DX?

(Continued from page 63)

on Truk (he has over 70 worked now) before he puts full time in working Ws. That's reasonable. With such a call, his DXCC QSL-return percentage should be pretty solid W1ZA intends to put a T15 call on the air at some near-future date Ex-KG6GU is stationed in Little Rhodie and hopes to have a W1 call on the air by October. His Guamanian QSL backlog is just about cleaned up HB9JB was behind the key at HB4FE during that Swiss military amateur station's recent DX spurge JY1XY says there is no JY1AY in Jordan. Les runs 260 watts to an 813 feeding either a vertical or a 3-element rotary; TZ40s modulate. JY1XY is workable on 2, 6, 10, 15 and 20 meters. An SX-28 and a BC348-with-converter do his receiving CPIBK is rejuvenating his receiver betwixt tries for WAS. Henry informs us that CPIBX is a new call down that way about to hit the air — 14,010, 14,020 and 14,030 kc. to be precise W6NZ is still slaving over the VP7NZ logs. He's the lad to write concerning your VP7NZ pasteboards A "WPW" (Worked Portuguese World) certificate award is now offered by REP (Portugal) and may be earned by amateurs who succeed in verifying contact with each of these DXCC countries: CT1, CT2, CT3, CR4, CR5, CR6, CR7, CR8, CR9 and CR10. QSLs, which must confirm QSOs made since

VK/ZL DX CONTEST

NZART (New Zealand) and WIA (Australia) invite world-wide participation in this year's VK/ZL Test to be held (c.w.) 1200 GCT, Oct. 4th, to 1200 GCT, Oct. 5th, and ('phone) 1200 GCT, Oct. 11th, to 1200 GCT, Oct. 12th. If competing in both periods, submit a separate log for each; operate any amateur bands. Details:

Serial Exchange: Six figures (five for 'phone) consisting of RST report plus QSO number — 001, 002, etc.

Scoring: One point per contact, each station worked once per band, this total to be multiplied by the number of VK/ZL numerical call areas worked of a possible 12.

Logs: Record date, GCT, call, serials sent-received and band for each contact. Use a separate sheet for each band worked and underline each new VK/ZL call area worked. Attach a summary sheet bearing total score and a signed declaration that contest rules have been observed. Logs must reach NZART, Box 489, Wellington, N. Z., on or before Jan. 23rd, 1953, to be eligible for certificates which will be awarded to the highest scorer in each country and U. S. call area.

July 29, 1947, should be submitted to REP. Only amateurs in countries having IARU-member societies are eligible; there are no fees involved Twenty-four Ws in all call areas but the Seventh have qualified for the LABRE (Brazil) WAA award. KP4KD, KZ5WZ and VE3AZ also made the grade. CX6AH is the only non-PY/LU to garner LABRE's WAB award Basking in VS, VU, KR6 and DU "local" QRM, W4VE drops us a line from Hokkaido where he soon hopes to put a new call on the air. Fred has 50 watts ready to go and did a lot of listening during our Field Day, looking for Potomac Valley Radio Club signals VK9XK should now be back behind the key at VK3XK, writes W6KIP. XK was in a last-minute rush to nab Vermont and Utah before pulling Papuan stakes JA2MB's big sig is produced by p.p. 304TLs driven by a 32V-2 and latched to a 7-element Gordon rotary 90 feet up. More 304TLs do the modulating and a 51J receives W8ZZU needs help in scraping together PZ1QM, HLIUS, VK1PG, VP2AA, VR5PL, CR4AH and ZP2KI confirmations W6SAI got back on the DX bands after a 2-year layoff. Bill observes that the signal-to-noise ratio on 20 is much poorer now than in '49 or '50. Same number of key clicks and yoooy notes, though! Old solderers never die One HLIAA told W7OEB he was running 500 watts to a long wire (14 Mc.). Hamming in Korea is still taboo at this

(Continued on page 158)



When You Plan Your Civil Defense
Nets, You'll Get
Longer Range
with Premax

ANTENNAS

Whether it's RACES, the Amateur Net in CD, a mobile job on 75 or 20, or a CAP or Marine fix, you'll find Premax Low-Cost Antennas will give you more range and stronger signals. Convenient, easy to install—just what you need.



Get the New Antenna
Bulletins Today

PREMAX PRODUCTS
DIVISION CHISHOLM-RYDER CO., INC.
5202 HIGHLAND AVE., NIAGARA FALLS, N. Y.

Sensational QH (QUICK HEADING)
**5-ELEMENT
NON-ROTATING
BEAM**

CALAMAR

18 RICHARDSON AVE., WAKEFIELD, MASS.

EASY TO LEARN CODE

It is easy and pleasant to learn or increase speed the modern way—with an Instructograph Code Teacher. Excellent for the beginner or advanced student. A quick, practical and dependable method. Available tapes from beginner's alphabet to typical messages on all subjects. Speed range 5 to 40 WPM. Always ready, no QRM, beats having someone send to you.



ENDORSED BY THOUSANDS!

The Instructograph Code Teacher literally takes the place of an operator-instructor and enables anyone to learn and master code without further assistance. Thousands of successful operators have "acquired the code" with the Instructograph System. Write today for full particulars and convenient rental plans.

INSTRUCTOGRAPH COMPANY

4709 SHERIDAN ROAD, CHICAGO 40, ILLINOIS

TOWERS
by
TRYLON

Amateur radio types • Guyed towers for FM-TV antennas • Vertical radiators • Microwave towers • Commercial communication towers • Transmission line supports, etc.

Completely fabricated by the most modern methods by 20-year tower specialists, Trylon towers offer top value for any installation—commercial or amateur. Special design and construction features assure maximum dependability.

Made only by
WIND TURBINE COMPANY
WEST CHESTER, PA.



NATIONAL

- Proven
- Dependable
- Quality

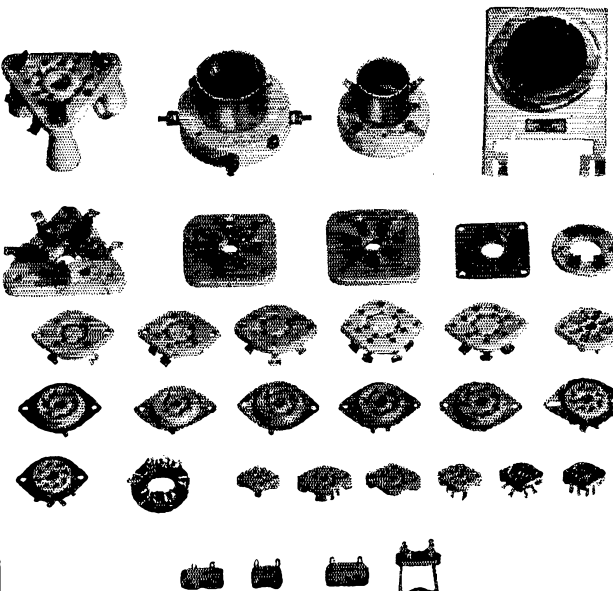

COMPLETE LINE OF SOCKETS

There is a National socket made for every popular tube type and for every circuit application. All feature low-loss electrical characteristics, firm tube support and easy, secure mounting. They are recommended wherever the highest quality is required. Write for drawings and specifications.

National



NATIONAL COMPANY, Inc.
 BOSTON, MASSACHUSETTS

writing Jots and jogs from W5KUC's WGDXC
DX Bulletin: FF8s DA, AI, RG, FQ8s AE and AF took
 time out for visits to France. . . . It's November rather
 than September for EABAW's Rio de Oro beachhead. . . .
 HZ1MY's projected Near East itinerary proceeds accord-
 ing to plan. . . . ZS6ZU is 'phoning on Marion Island.
 . . . YJ may be VR4AF's next stop. . . . F8BS and F9LQ
 are 3A2AKing once more. Twenty-five years ago
 this month you might have been found chasing stuff like
 fmN2TU, Tunis; amVS3AB, Malaya; ac8IB, Shanghai;
 aj3AA, Japan; es1CO, Finland; and EZ5, Canal Zone --
 all active on 20 meters in '27. IARU issues no special
 endorsements for 21-Mc. WACs. Applications already
 received have had to be returned. The old KA
 prefix rides again. W4VE notifies us that it supersedes the
 JA label affixed to occupation personnel in Japan. Calls
 are unchanged in other respects; e.g., JA3AD becomes
 KA3AD. Fred's own call will be KA9AA. We presume that
 J calls are by these means being reserved for the use of
 nationals.

Jeeves believes the first successful attempt to reach the top of Mt. Everest will be made by some enthusiastic club group scrounging about for a good v.h.f. location on Field Day. AC3PT/VU7?

V.H.F. QSO Party

(Continued from page 64)

- 6) Scoring: 1 point for completed two-way section exchanges on 50 or 144 Mc.; 6 points for completed two-way section exchanges on the higher v.h.f. bands. The sum of these points will be multiplied by the number of different ARRL sections worked; i.e., those with which at least one point has been earned. Reworking sections on additional bands for extra section credits is permitted.
- 7) A contact per band may be counted for each different station worked. Example: W1SNK (E. Mass.) works W1EIO (Maine) on 50, 144 and 220 Mc. for complete exchanges. This gives W1SNK 7 points (1 + 1 + 5 = 7) and also 3 section-multiplier credits. (If more Maine stations are subsequently contacted on these bands they do not add to the multiplier but they do pay off in additional contact points.)
- 8) Each section multiplier requires actual completed exchanges with at least one station. The same section can provide another multiplier point only when contacted on a new v.h.f. band.
- 9) Award Committee decisions shall be accepted as final.
- 10) All reports must be postmarked no later than October 10, 1952, to be entered for awards. (A message to HQ will bring a mimeographed blank for report on this contest.) Reports must show bands used, dates and contact times, calls of stations worked, names of ARRL sections worked, and score computations.

Reporting

Submit contest logs to Headquarters immediately, even if your score is small, to help in cross-checking the claims of others.

— F. E. H.

Answer to QUIST QUIZ on page 10

It depends entirely on the transmitter and how B
 a feed-line current (or voltage) indicator and the
 plate dissipation of the tube or tubes in the output
 stage. The coupling should be adjusted to the point
 that gives maximum feed-line current without ex-
 ceeding the safe plate dissipation — this dissipation
 may exceed the manufacturer's published figure in
 some cases without appreciably shortening the tube
 life. Using the same tubes and power supply, a c.w.
 transmitter can be operated at greater key-down
 plate dissipation than can a phone transmitter,
 because the c.w. triax has a chance to cool off during
 key-up periods.

COMPACT - CONVENIENT - CAPABLE

THE TURNER 80

This is the new TURNER 80 — a crystal microphone so tiny it hides in the palm of your hand, yet so strikingly designed it is the very picture of symmetry. Weighs less than five ounces, but its high output and unusually fine response characteristics make it a natural for amateur communications, home recording, dictating machines, portable recorders and dozens of other applications. Finished in beautiful satin chrome.

Level: Approximately 58 db below 1 volt/dyne/sq. cm.
Response: 80-7000 c.p.s. 7 foot attached single conductor shielded cable. List Price.....\$15.95

THE TURNER COMPANY

917 17th St.

Cedar Rapids, Iowa, U. S. A.

In Canada: Canadian Marconi Co., Ltd. Toronto, Ont., & Branches

Export: Ad. Auriema, Inc., 89 Broad St., New York 4, U. S. A.

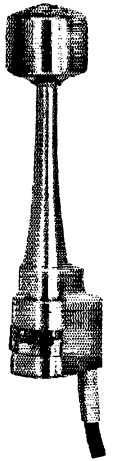
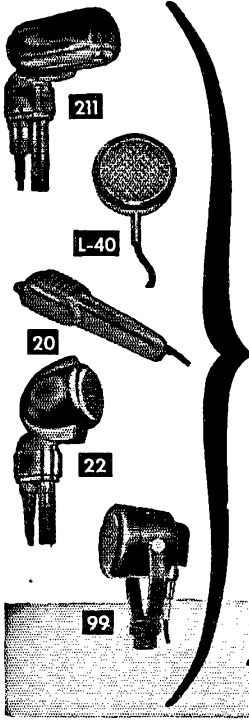

Microphones by **TURNER**



Crystals licensed under patents of Brush Development Co.

RADIO and TELEVISION

Over 30 years N.E. Radio Training Center. Train for all types FCC operators' licenses. Also Radio and Television servicing. FM-AM broadcasting transmitters at school. Send for Catalog Q.

MASS. RADIO SCHOOL

271 Huntington Avenue Boston 15, Massachusetts
Lic. by Comm. Mass. Dept. Educ.

Evans RADIO

Service to hams • "YOUR FRIENDLY SUPPLIER"
by hams. Nationally accepted brands of parts, tubes and equipment. Trade-ins and time payments. Write W1BFT.
10 HILLS AVENUE • CONCORD, N. H.

LEARN CODE!

SPEED UP Your RECEIVING with G-C

Automatic Sender

Type S
\$24.00 Postpaid in U. S. A.



Housed in Aluminum Case Black Instrument Finished. Small—Compact—Quiet induction type motor. 110 Volts—60 Cycle A.C.

Adjustable speed control, maintains constant speed at any setting. Complete with ten rolls of double perforated tape. A wide variety of other practice tapes available at 50c per roll.

GARDINER & COMPANY

STRATFORD • NEW JERSEY

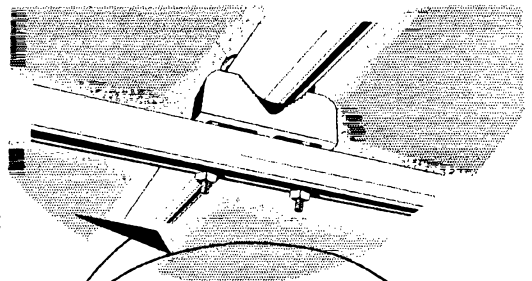

NEW and improved construction for amateur antennas

• FEATURING
**STRONGER CONSTRUCTION
LIGHTER WEIGHT
ADJUSTABLE SPACING**

The U-bolt and casting assembly shown above is the method used to hold the elements to the booms on all of our ten and twenty meter beams since July 1952. The castings are mounted on the boom and adjusted at the factory.

U. H. F. RESONATOR CO.

224 SEVENTH STREET RACINE, WISCONSIN

HAM-ADS

(1) Advertising shall pertain to radio and shall be of nature of interest to radio amateurs or experimenters in their pursuit of the art.

(2) No display of any character will be accepted, nor can any special typographical arrangement, such as all or part capital letters be used which would tend to make one advertisement stand out from the others.

(3) The Ham-Ad rate is 30¢ per word, except as noted in paragraph (6) below.

(4) Remittance in full must accompany copy. No cash or contract discount or agency commission will be allowed.

(5) Closing date for Ham-Ads is the 25th of the second month preceding publication date.

(6) A special rate of 7¢ per word will apply to advertising which, in our judgment, is obviously non-commercial in nature and is placed and signed by a member of the American Radio Relay League. Thus, advertising of bona fide surplus equipment owned, used and for sale by an individual or apparatus offered for exchange or advertising inquiring for special equipment, if by a member of the American Radio Relay League take the 7¢ rate. An attempt to deal in apparatus in quantity for profit, even if by an individual, is commercial and all advertising by him takes the 30¢ rate. Provisions of paragraphs (1) (2) and (5), apply to all advertising in this column regardless of which rate may apply.

(7) Because error is more easily avoided, it is requested signature and address be printed plainly.

(8) No advertiser may use more than 100 words in any one issue nor more than one ad in one issue.

Having made no investigation of the advertisers in the classified columns, the publishers of QSL are unable to vouch for their integrity or for the grade or character of the products or services advertised.

QUARTZ — Direct importers from Brazil of best quality pure quartz suitable for making piezo-electric crystals. Diamond Drill Carbon Co., 719 World Bldg., New York City.

QSLs: 100, \$1.95 up. Samples, 10¢. Griffith, WJFSW, 1042 Pine Heights Avenue, Baltimore 29, Md.

MOTOROLA used communication equipment bought and sold, WSECO, Ralph Hicks, 204 E. Fairview, Tulsa, Okla.

SUBSCRIPTIONS. Radio publications a specialty. Latest Call Books, \$3.00. Earl Mead, Huntley, Montana. W7LGM.

QSL's-SWL's Meade W6KXL, 1507 Central Avenue, Kansas City, Kans.

QSLs, SWLs, America's Finest! Samples, 10¢. C. Fritz, 1213 Briar-gate, Joliet, Ill.

QSLs. Brownie, W3CJI, 433 Chestnut, Emmaus, Penna.

QSLs: Fluorescent QSLs radiant and glowing with quality-control. QSLs Kromekote three colors and up, Rainbow maps, DX QSLs. Samples rushed, 10¢. Uncle Fred, Box 86, Lynn, Pa.

QSL and SWL cards. Samples. WISQF, Minner, Candia, N. H.

PHONE patch schematics, practical discussion, \$1.00. Nichols, W1MRK.

WANTED: Navy Selsyns, types 1F, 1G, 1CT, 5F, 5G, 6G, 7G, etc. Autogyros: AY1, AY5, AY101D, AY201, etc. Tubes, Test equipment, Signal Corps equipment. Send lists. Top prices. Electro, 110 Pearl St., Boston, Mass.

WANTED: Cash or trade, fixed frequency receivers 28-42 Mc. W9V1V, Troy, Ill.

HEATH V-5A VTVM, 18 ranges, brand new, accurately calibrated, \$39.50. W5AXI.

QSLs, SWLs. High quality. Reasonable prices. Samples. Write to Bob Teachout, W1FSW, 40 Elm Street, Rutland, Vermont.

10 and 20 meter beams, \$23.25 up. Aluminum tubing, etc. Willard Radcliff, Fostoria, Ohio.

WANTED: Early DeForest and Marconi Wireless apparatus. Also early tubes and early magazines, call books, text books and other literature. Franklin F. Wingard, Rock Island, Ill.

QSLs Taylor, (W5VME) Little Rock, Miss.

WANTED: Marconi multiple tuner, coherer, spark coil, magnetic detector, etc. DeForest receiver, coherer and other early equipment; Marconigraphs, Modern Electrics; Electrical Experimenter and early Call Books and text books of wireless. Franklin Wingard, Rock Island, Illinois.

CRYSTALS: Low drift, high activity, tailor-made. 3000 to 8500 Kc FT-243's. Desired frequency within 2 Kc, \$1.00 each. .01 % crystals, \$2.00 each. Hundley Crystal Co., 2951 No. 36th St., Kansas City 4, Kansas.

SALE: New, never used Collins 310B1 exciter, \$200.00. F.o.b. Biloxi, Miss. Capt. O. C. Fought, Box 238 OMR, Keester AFB, Biloxi, Miss.

FOR Sale: One 61' steel tower. Vesto, never used; \$150.00. Also one 35' Vesto steel tower with Mims Amphenol 10-20 signal squitter, like new. Special dural elements. Continuous rotation. Cost \$600.00. Want \$150.00 for complete job. Buyer must take down. Peck, W2OIF, 7 Exchange St., Auburn, N. Y.

CASH for your commercial or ham equipment: 75A1, 75A2, 32V1, 32V2, 32V3 HQ-129X, SP400A, SX-28A, SX-42, SX-43, SX-43, SX-71, SX-76, HT9 19 NC-125, NC-173, NC-183, HRO SR HROS-T, HRP7, HRO50, HRO50-1, RME-50. Rush full details, including best price for ham gear. Box 48, Grand Rapids, Michigan.

QSLs? SWLs? America's finest and largest variety super-gloss QSLs! Samples 25¢. Rus Sakkers, W8DED, Holland, Michigan.

FOR Sale: Hallcrafters SX-43 radio, with speaker, \$125.00. In good condition. J. Wilson, 77-72nd St., Brooklyn 9, N. Y.

FOR Sale: One T.C.S. transmitter and REC 160-80-40 meters, phone or c.w. Converted for 115V 60 c. AC power sup. \$60.00. Floyd F. Cayton, P. O. Box 463, Edenton, N. C.

NEED Wilcox Electric Mod. F-3 or CW-3 receivers for local civil defense. Write stating price and condition to: D. Sauer, 148 E. Beechwood Ave., Dayton 5, Ohio.

WANTED: Panadaptor, state model, condition and price. W1TJK, 150 Rocky Hill Ave., New Britain, Conn.

QSL's, SWL's. Super-gloss, 10 colors. Four card stocks. Seven styles. Samples, 10¢. Almar Printing Service, Farragut, Iowa.

FOR Sale: S-40 receiver. Only 20 hours operation. Good as new. \$70.00. W5IVF, 1608 Fairview Ave., Monroe, La.

WANTED: One each surplus IF cans marked T101-01, T102-01, T102-01 T103-01, T101-01. Will buy or trade. Samuel A. Selders, Box 241, Weaver, So. Dakota.

WANTED: Pair of 2-way transmitters and receivers on 460 to 470 Mc. band. Must be manufactured by commercial firm and F.C.C. approved for the Citizen Frequency Band and in good working condition. Either portable or fixed units are O.K. State manufacturer, condition, and price. George E. Clark, M.D., 407 11th St., Santa Monica, Calif.

SELL or swap: BC-221 frequency meter, complete; Dynamotor, 110 VDC in, 550V, 750A out; Solar constant voltage transformer, 500VA; SCR522, converted, in Bud cabinet; R-89/ARN-5A Glide Path receiver, complete; "Gold Plated" test oscillator; BC458 and BC459 in double rack; BC455, 40 meter receiver; 35 watt transmitter with 80 and 40 meter coils. Need good VFO and 10 meter beam. All inquiries will be answered. Donald Benn, W4JNR, 2482 Coleman Ave., Augusta, Ga.

SELL: BC610 with speech, TVI proof, \$500. F.o.b. Trenton, N. J. HRO50T1 one month, four coils, \$380. F.o.b. Will trade. R. R. Lamb, 887 Bellevue Avenue, Trenton 8, N. J.

WANTED: Armature for PE-103 Dynamotor or someone to rewind same; also need ART-13 modulation transformer. W. F. Anderson, 1808 Wake St., Raleigh, N. C.

SELL: Custom-built 300 watt phone now operating 75. DeLux quality and stability built into seven foot enclosed cabinet. Space factor forces sacrifice at \$275 or best offer. Orion Baker, 860 Beacon, Boston, W1NQA, Copley 7-4095.

FOR Sale: RC696A, \$10.00, BC457A, \$8.00; BC459, \$8.00. Command transmitters, like new. Dr. C. H. Scheitfy, Mayo Clinic, Rochester, Minn.

WANTED: Compact 160-10 meters fone and c.w. portable station. Write details. J. R. Barrett, W7PXS, Oakland, Oregon.

SELL: RCA AVR-11 revr, \$80; 222A frequency monitor, \$100; RCA 7715, 30 watt AM mobile xmitter, RCA 1000V, 250 mill. power supply, complete in inclosed cabinet, \$30; Jannett rotary converter, 110 DC to 110 AC, 200W, \$40. RCA WR53A FM sweep gen. \$75. Pioneer Dynamotor 6VDC to 375VDC, 260 mill., \$30. Pair GE recorder drive Selayn motors, type 5M3J7C4A, \$100. W2YXW, 904 Morgan Ave., Palmyra, N. J.

QSL's, SWL's, Samples, 10¢. Refunded. Harms, W2JME, 225 Maple Ave., North Plainfield, N. J.

FOR Sale: Temco 75GA transmitter TVI-ed lowpass filter. Coils 80, 40, 20, 15, 10. Excellent condition. Will ship. \$250.00, plus shipping. W9HP, 5328 East Drive, Rockford, Illinois.

VIKING transmitter, VFO, MIC, SX-71, Mon-Key, prop-pitch, a complete station for sale. Send for list. Paul Wells, W7OMX, 2708 106th Place S. E., Bellevue, Washington.

SELLING out: WRL Globe King, HT-18, NC-183, Hy-Lite beams, indicators, parts, modulation monitor, ten year collection. Silly prices. Don't miss this one. Send for list. Please state equipment or parts. W3RPG, 3664 Derry St., Harrisburg, Penna.

MOTOROLA FMT-30-DMS 27 to 30 Mc transmitter as new, microphone, cables, etc. Complete \$75.00. K. P. Roberta, W4WW, 405 Gaunon Road, Portsmouth, Va.

FOR Sale: 150 watt xmitter pp VT124 relay rack mounted 28" high, \$60.00; 35 watt xmitter c.w./10e meters, \$30.00. Bert Blood, 1900 Delmar Blvd., St. Louis 3, Mo.

FOR Sale: BC-223 transmitter with tubes and two tuning units \$20 F.o.b. Code machine with tapes, \$20. E. Beirne, Roxbury, N. Y.

NEW crystals for all commercial services at economical prices; also regrounding or replacement crystals for broadcast, Link, Motorola, G. F. and other commercial types, no amateur. Over 16 years of satisfaction and fast service. Eidson Electronic Company, phone 3-3901, Temple, Texas.

NC-183 and speaker, like new, \$165.00; RME VHF 152A, \$50; 60 ft. new RG/UT \$4.00; Vibroplex Champion, \$7.50; Mallory Vibrapack, VP-552 \$10.00; Fred S. Eggert, W8FIL, 11833 Wisconsin, Detroit 4, Mich.

HQ129X, \$125.00. Kilsheimer, 62 Lake Avenue, Tuckahoe, N. Y.

SWAP: Gonset triband, good condition. Want Gonset 10 meter converter. W6VDR, 679 46th St., Oakland, Calif.

RECEIVER BC348L, converted for AC but needs power supply. Shock mounted base. \$85.00. F.o.b. Kenmore, N. Y. W2SES, 429 Southwood Drive, Kenmore 23, N. Y.

SELL: Hallcrafters SP-44 Panadaptor, \$50.00; Components for 24-28 volt DC power supply at 15 amp., \$20.00; two chokes UTC 5/25 Hy, 300 Ma. \$4.00 each; PE103 DYN., w/base, \$25.00. A. Brocato, 101 Alden Place, New Orleans, La.

QSLs! FB samples, 10¢ Tooker, Lakehurst, New Jersey.

FOR Sale: Hallcrafters HT-9, coils 10 through 80, Meissner signal shifter. Complete set spare tubes for both. Best offer over \$230.00. W. F. Corbett ALL, US Coast Guard Air Det., Arlington, Va.

VFO, 6C4 osc, 2-6F6 buffers, supply, First \$32.00. Box 963, Yarnall, Irving, Texas.

FOR Sale: 32V2, like new condition, \$515.00. Pick up only. W2011, 519 Center Place, Teaneck, N. J.

IN Stock, for immediate shipment, new Collins KW-1, 32V-3, 75A-2. For amateur equipment in the Mid South, it's W & W Distributing Company, 639 Madison Avenue, Memphis, Tennessee.

FOR Sale: Webster-Chicago Model 81 wire recorder, like new, with many accessories, \$69.00; UTC S-33 choke, 20 hy., 300 Ma., \$4.25. WIBVR.

FOR Sale: Amphenol, 20/10 signal squirter beam. Best offer. Want 553 or comm rcvr (compact rcvr). Send for parts list. Radio W3BBV, P. O. Box 722, York, Penna.

BC654-A with PE103, PE104, cable, good, \$38.00; ARC-5 transmitters with tubes 1-3-21. Mc., new, \$15.00; BC457-A, \$6.00; BC458-A, \$6.00; BC459, new, \$10.00; receivers, 453B, \$12.00; BC454, \$10.00; BC455, \$8.00; 52-1.5 Mc., \$15.00; SCR 522 with tubes, good, \$30.00; BC645-A new, \$15.00; BC223AX less tubes, with 3000-4500 Kc., tuning unit excellent, \$20.00; BC221-N with A.C. supply, crystal, less book, good, \$35.00; UTC S-21, 110 watt universal modulation transformer, new, \$15.00; S-42 power transformer, new, \$14; tubes, RCA810, \$8.00; 100-TH, \$8.00; RCA 1K7 modulation transformer, 1:1 ratio with separate screen winding, \$15.00. E. L. Sielke, Box 6000, Torredale, Philadelphia 14, Penna.

FOR Sale: Leeco-Neville power package. Alternator, regulator, rectifier. Alternator, 1250 watt phase 50A per phase. Twin pulley belt-driven. 150A in output. For 12v systems. Any sensible offer considered. L. J. Smith, 1059 W. District, Tucson, Arizona.

FOR Sale: Harvey-Wells Bandmaster DeLux in excellent condition. \$100.00. Part of the Dynamotor, new and unused, \$25.00. K. W. Covey, W92QJ, Mahnomon, Minnesota.

LETTINE 240 wid coils for 4 bands and 2 xtals, \$70, HQ129X wid inker, very selective, \$150, Brush Sound Mirror tape recorder, cost \$229, will sell for \$135.00. Will take instructionals, \$40. RCA NC73 station intercom as part payment Blum, 2601 Dibble Avenue, Columbus 4, Ohio.

SELL: New, in carton, National 183T, with 12" coax speaker. \$275.00. R. Long, 184 L. Street, South Boston, Mass.

TBS 50C with D.C. Ant. relay and push-pull stage of speech added. DPS-50 Dynamotor. Push to talk mike. Premax ant. Master Mobile ant. and base mount. Gonsert Triband converter and noise limiter. \$250.00 for the works or sold separately. W1ERX, 494 Atlantic St., Stamford, Conn.

NOVICES: Am selling complete novice station. NC-57 receiver, BC-457 75-150 watts converted, less power supplies, veyr, headphones, xtals. Call Book and meter. Best offer over \$10.00. Send for particulars. W9QQK, 5545 Woodlawn, Chicago, Illinois.

SELL: Almost brand new National NC-183, with large Jensen 12" speaker, in original cartons, in perfect condition, \$225.00. expressed. Rosa B. Thorp, 23836 Cherry Hill, Dearborn 7, Michigan.

HQ-129X. Brand new. Unused. Best offer over \$185.00 takes it. F.o.b. Anoskie, N. C. Johnny Palmer, W4SSF, 321 Colony Avenue.

SELL: Pair BC-611 handie-talkies. Freq. range 3497-4035 Kc. Complete with coils, tubes, xtals, and batteries. Excellent condition. \$165.00 for pair. W2GGC, 80 Bogert Place, Bergenfield, N. J.

SCR522 unaltered with dynamotor, plugs and remote control head. Gonsert Triband converter, \$34.00, Master Mobile 10 m. whip and spring base, \$6.00, BC455 with speaker, dynamotor, 6V tubes and use limiter, \$24.00, 200 watt mobile xmitter and accessories. Write for details. S. R. Daniels, Box 261, Webster, Wis.

SELL: Two meter xmitter, three deck, described in QST Feb. '50, complete with xtal and mike, \$55.00. Two meter converter, 6AK5, 6J6, \$26.00; Linguaphone code record set, \$5.00; BC222, \$10.00; PE103, less base, \$15.00. Merell Hess, Meade Ave., Hanover, Penna.

SELL: Superior signal tracer \$25.00. Trade for Micro-Match anten-nascope V.T.V.M. W5ALA, 4531 Fairway, Dallas 19, Texas.

TELETYPE midget tape printers, \$45.00; teletype perforated tape transmitters, \$30.00; control relays, \$1.95. War surplus equipment wanted, cash or trade. Arrow Appliance, Box 19, Boston 1, Mass.

SELL or trade: Collins 75A1 clean and perfect for \$275.00 cash. Would consider HQ-129X or NC240D and \$140 in trade if condition excellent. Sell or trade new Thordarson T-19P61 2000 VDC 300 Ma transformer, 2-829Bs, 2-813s, 6-RK28As, all new. Want 4D32 or clean NC-81X in trade. W9BNF, 822 West 22 Street, Kearney, Nebraska.

WANTED: SX-42 receiver. Will sell or trade Rek-O-Kut 16" transcription turntable. All inquiries will be answered. C. Gutman, 7002 Somerled Avenue, Montreal, Quebec P., Canada.

FOR Sale: New Sangamo mica capacitors, type-F 2 E, μ -.001, Amps-2.1, KC-1000, volts-5000; price, \$2.95 each, F.o.b. Newark, N. J. Eas & Vee Sales, 327 Clinton Pl., Newark 8, N. J.

SELL or swap for 75A1 or 75A2, RCA AK-88 perfect condition. K. C. Agrelius, 4422 Brookfield Drive, Kensington, Maryland.

SWAP Remington portable, new cond for 40 or 50 watt c.w. xmitter A. Gillepie, Box 8693, Lantana, Fla.

WANTED: Mobile transmitter 10-75 meters. Also converter and power supply. State condition and price. W8OPR, 22750 Fox, Suite E, Euclid, Ohio.

WANTED: Chief operator for broadcast station. Some announcing duties. Chance for advancement. Amateur fixed and mobile experience desired. Must love good equipment and maintenance of same. First Class Radiotelephone License required. Contact I. A. Elliot, Manager, W7JMX, Sta. KRJF, Miles City, Montana.

BARGAINS: Extra special Motorola P-69-13 mobile receivers, \$29.50; Globe King, \$315.00; HT-9, \$199.00; HRO-50, \$275.00. Lyco 600 \$109.00; HRO-7, \$199.00; Collins 75A2, \$325.00; 75A1; \$275.00; HRO-5T, \$175.00; SX-71, \$159.00; SX-42, \$199.50; HRO Senior, \$119.50; RME 2-11, \$99.50, RME-45 \$99.00; Meissner EX Shifter, \$59.00; S-40A or SX-16, \$69.50; VHF-152, \$59.00; HF-10-20, \$59.00; Globe Trotter, \$79.50; Meissner Signal Calibrator, \$24.95; MB611 mobile transmitters \$19.95; 90800 exciter, \$29.50; RCA Chanalyt, \$69.50; XE-10, \$14.95; Gonsert 10-11 converter, \$19.95, and many others. Large stock of trade-ins. Free trial. Terms financed by Leo, W9GFO. Write for catalog and best deal to World Radio Laboratories, 740-42-44 West Broadway, Council Bluffs, Iowa.

BARGAINS: New and reconditioned Collins, Hallicrafters, National, Hammarlund, Johnson, Elmac, Harvey-Wells, Gonsert, Morrow, RME, Milen, Meissner, others. Reconditioned S38, \$29.00; S40A, \$69.00; S40B, \$79.00; SX43, \$119.00; S76, \$129.00; SX71, \$149.00; SX42, \$199.00; SX62, \$199.00; NC173, \$139.00; HRO5TA1, \$159.00; NC183, \$199.00; HRO50T, \$249.00; HRC050-1, \$299.00; HO129X, \$139.00; SP400X, \$259.00; Meck T60, \$59.00; DB22A, \$49.00; VHF152A, \$95; RME84, \$69.00; RME45, \$89.00; TBS50, \$79.00; TBS50D, \$99.00; Lyco 600, \$99.00; Collins 32V1, \$425.00; Collins 32V2, \$495.00; Collins 310C2, Collins 75A1, many others. Shipped on trial. Terms. List free. Henry Radio, Butler, Mo.

SELL: HT-17, all coils, meter, \$30.00. WITTC, Millers Falls, Mass.

866A Kit, two tubes, sockets transformer, \$6.98, Selenium rectifier and transformer kit 0-28 VDC/12 AMPS, \$31.98. Sell your surplus tubes and equipment. Free Tabogram, "TAB", 109 Liberty St., New York, N. Y.

JOHNSON announces the new TVI-ed Viking II transmitter kits now available; your cost, complete with tubes, \$279.50. We can also supply them complete, wired, tested, and with tubes, for \$309.95. The Viking VFO companion unit works equally well with both transmitters; we supply them complete, wired and tested with tubes for \$54.95. Write to Carl, WIBFT at Evans Radio, Concord, N. H. Also Harvey-Wells TBS-50C and TBS-50D as well as the new Gonsert Commander, Elmac A-54, and other popular mobile units available with terms and trades from "Your Friendly Supplier." Used equipment which we take in trade and re-condition for re-sale also available. Ask for our latest list.

GOOD condition, complete run of QST's 1923-1952 except for June 1923 and October, 1927. What is your offer? Wm. G. Davis, P. O. Box 253, Mitchellville, Iowa.

SELL: SCR-522, clean, unconverted, with tubes. Best offer over \$45.00. W3KHU, 234 Champlain Avenue, Wilmington 4, Delaware.

COMPLETE - CONVENIENT

is the way to describe the

ARRL LOG BOOK

It helps make the job of record keeping a pleasant one. Fully ruled with proper headings for all necessary entries, the Log Book not only helps you to comply with FCC regulations but also provides a lasting record of many pleasant QSOs.

in Looseleaf form (3-hole)

100 sheets - 75¢

Spiral bound, 39 pages - 50¢

(postpaid anywhere)

The American Radio Relay League
West Hartford 7, Conn.

Designed for



Application

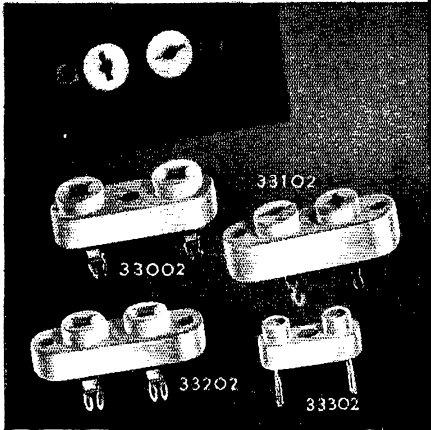

**Crystal Holder Sockets
33002, 33102, and 33202
Plus new 33302 for CR7**

In addition to the original 33002, 33102 and 33202 exclusive Millen "Designed for Application" steatite crystal holder sockets, there is now also available the new 33302 for the new CR7 holder. Essential data:

Type	Pin Dia.	Pin Spacing
33002	.125	.750
33102	.095	.500
33202	.125	.500
33302	.050	.500

**JAMES MILLEN
MFG. CO., INC.**

MAIN OFFICE AND FACTORY
MALDEN
MASSACHUSETTS



Index of Advertisers

Adirondack Radio Supply	132
Akers Company, Dallas C.	134
Allied Radio Corporation	105
American Radio Relay League, Inc.	
Course Book	106
QST	113
Calculator	114
Antenna Book	130
Logbook	141
Amperex Electronic Corporation	95
Arrow Electronics, Inc.	128
Ashe Radio Company, Walter	111
Astatic Corporation, The	118
Barker & Williamson, Inc.	133
Beahn Electronic Company	134
Belden Manufacturing Company	91
Bendix Radio Division	120, 135
Brush Development Company	92
Calamar	137
Candler System Company	132
Capitol Radio Engineering Institute	102
Central Electronics, Inc.	124
Chicago Transformer Co.	85
Collins Radio Company	2
Commercial Radio Institute	131
Communication Products Company	128
Concord Radio	129
Dow-Key Co., Inc.	120
Drake Company, The R. L.	94
Eitel-McCullough, Inc.	101
Eldico of New York, Inc.	75-80
Electro-Voice, Inc.	97
Engineering Associates	135
Evans Radio	139
Fort Orange Radio Distributing Co.	127
Gardiner & Company	139
General Electric Company	
Gonset Company, The	116
Greenlee Tool Co., The	122
Hallcrafters Co., The	4, 5
Hammilund Manufacturing Co., Inc.	89
Harrison Radio Corporation	121
Harvey Radio Company	103
Harvey-Wells Electronics	86
Hastings Instrument Company	104
Heath Company, The	131
Henry Radio Stores	107
Hudson Radio & Television Corp.	100
Hughes Aircraft Company	81
Hy-Lite Antennae, Inc.	135
Instructograph Company	137
Johnson Company, E. F.	82, 83
Knights Co., The James	143
Lettine Radio Manufacturing Co.	122
Mallory & Company, P. R.	87
Marmax Electronics	99
Mass. Radio & Telegraph School	139
Master Mobile Mounts, Inc.	130, 136
McGraw-Hill Book Co., Inc.	132
Millen Mfg. Co., Inc. The James	142
Motorola, Inc.	113, 144
National Co., Inc.	Cov. III, 73, 138
Newark Electric Company	123
Northrop Aircraft	124
Ohmite Manufacturing Company	93
Petersen Radio Company	7
Philmore Manufacturing Co., Inc.	114
Port Arthur College	135
Precision Apparatus Company	88
Premax Products Co.	137
Radio Corporation of America	Cov. IV
Radio Shack Corporation, The	109
Radio Wire Television	125
Radio Television Training Association	133
Raytheon Manufacturing Company	112
RCA Institutes, Inc.	134
Sonar Radio Corporation	110
Steinberg, Inc.	117
Suburban Radio Company	131
Sun Radio of Washington	126
Telrex, Inc.	90
Terminal Radio Corporation	118, 119
Triplet Electrical Instrument Co.	96
Turner Company, The	139
U.H.F. Resonator Company	139
United Geophysical Co., Inc.	126
United Transformer Company	Cov. II
Valparaiso Technical Institute	134
Vesto Company, Inc.	113
Vibroplex Company, The	116
Ward Products Company	108
Westinghouse Electric Corporation	98
Weston Laboratories	136
Wind Turbine Company	137
World Radio Laboratories, Inc.	115

keeping communications ON THE BEAM

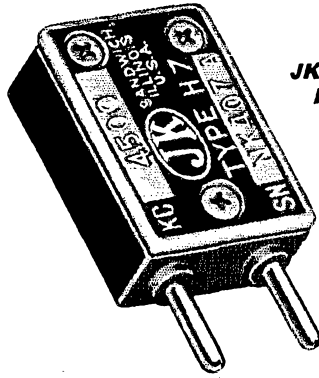

**JK STABILIZED
H-7 CRYSTAL**

FREQUENCY & MODULATION MONITOR

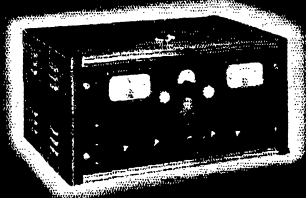

*the JK
FD-12*

Monitors any four frequencies anywhere between 25 mc and 175 mc, checking both frequency deviation and amount of modulation. Keeps the "beam" on allocation; guarantees more solid coverage, too!

CRYSTALS FOR THE CRITICAL

The H-7 crystal is in common use with two-way police radio systems. Frequency range: 3 to 20 mc. Water and dust-proof, it is pressure mounted, has stainless steel electrodes. Just one of many JK crystals made to serve EVERY crystal need!

Time-Saver to Prowl Cars, Life-Savers to Thousands!

In a split second your police station and the farthest cruising prowl car can respond as one man! Such "safety at your doorstep" is possible only through compactly efficient two-way radio. JK crystals and monitors are in constant use to keep police radio frequencies reliably "on the beam."

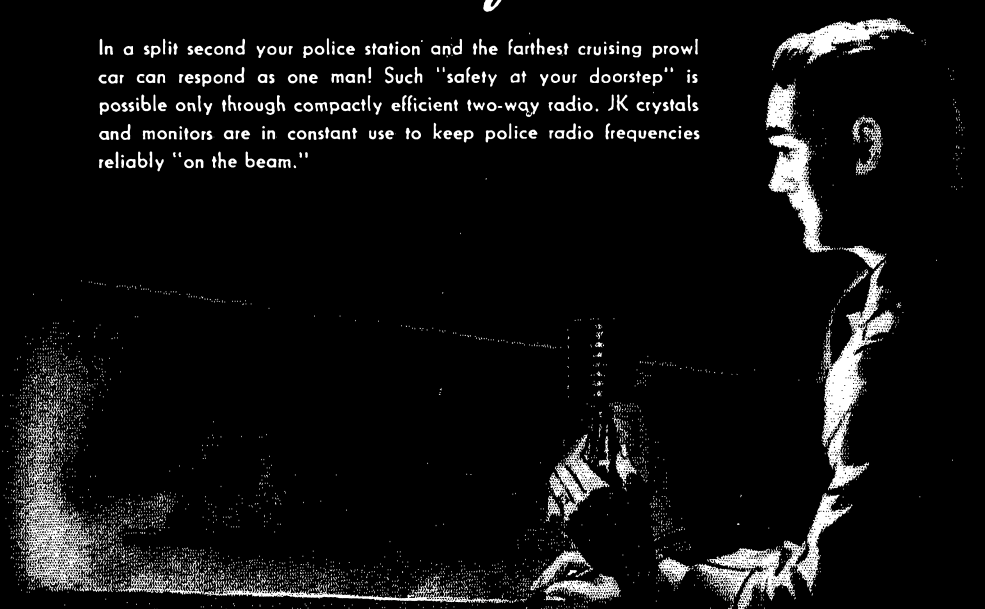

THE JAMES KNIGHTS COMPANY
SANDWICH 6, ILLINOIS

NEW MOTOROLA 460 Mc. with A.F.C.

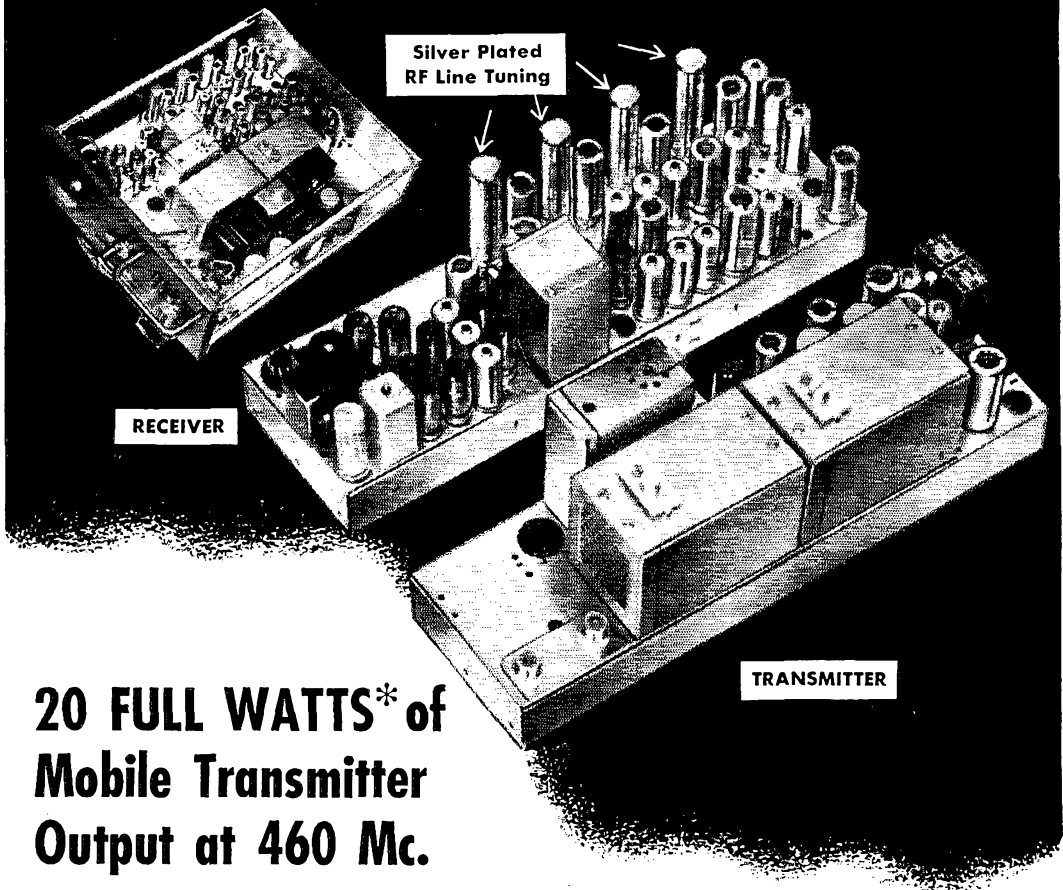

20 FULL WATTS* of Mobile Transmitter Output at 460 Mc.

AUTOMATIC FREQUENCY CONTROL

Motorola's new crystal controlled A.F.C. system provides positive barriers so that the receiver cannot jump to a strong adjacent channel signal.

This new Motorola A.F.C. technique is fortified with extraordinary system stability. The A.F.C. crystal controlled oscillator provides a full 10 to 1 correction ratio and keeps the receiver tuned on the nose to the distant transmitted carrier.

The new U. H. F. tuned circuits and research design cavities for ground grid amplifier operation provide phenomenal circuit stability, spurious rejection and extraordinary efficiency.

TRANSMITTER

The Motorola 460 Mc. system with 9 tuned circuits provides 18* to 20* Watts with *Efficiencies of more than 65%!*

SILVER PLATED SEALED TUNED CAVITIES

By use of silver plated line sections, high standards of selectivity protect the receiver from high power U.H.F., TV intermodulation.

Motorola

Communications & Electronics Division
4545 Augusta Blvd., Chicago 51, Illinois
Rogers Majestic Electronics Ltd., Toronto, Canada

*great news
to hundreds who
want maximum
selectivity
at minimum cost!*

NC-125



*the only receiver
with the famed
select-o-ject
built in!*

**NOW AVAILABLE FOR
IMMEDIATE DELIVERY**

Covers 550 kc. — 36 mcs. in 4 bands. Voice, CW, NFM (with adapter). Edge-lighted, direct-reading scale. Amateur, police, foreign, ship frequencies clearly marked. National Select-O-Ject built-in (rejects any selected audio frequency 45 db — boosts 38 db). Three microvolt sensitivity (for 10 db signal/noise ratio on 10-meter band). S-meter. AVC, ANL, ant. trimmer. Variable CW pitch control. Separate R.F. and audio gain controls. Volt. reg., stabilized oscillator. Jack for phono or NFM Adapter. Audio essentially flat to 10,000 c.p.s.

Now at last, you can get immediate delivery on the receiver that gives you more selectivity per dollar — the *only* receiver with the famed Select-O-Ject circuit built in! And that's only one of the many fine features that make the NC-125 tops in receiver value!

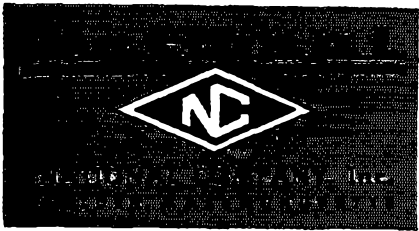

NC-125..... \$149.50*
NC-125TS (matching spkr.).... 1100

*Slightly higher west of the Rockies.

Vacuum Type

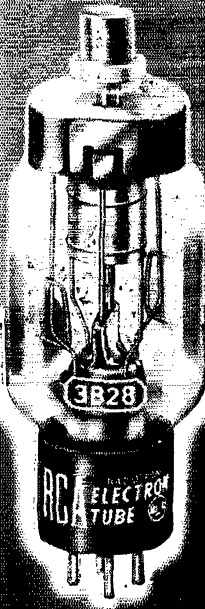

Gas Type

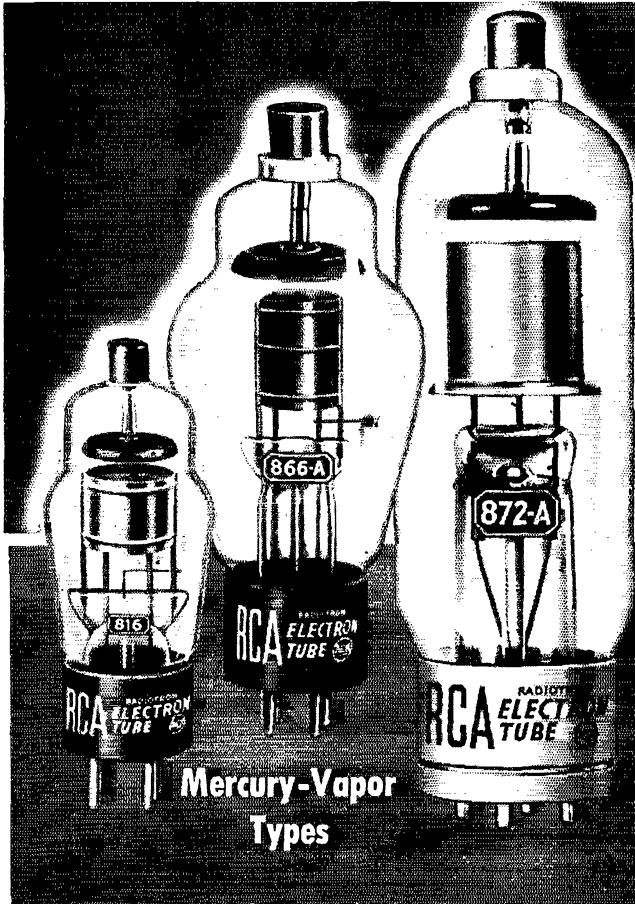

Mercury-Vapor Types

Gas...Vacuum... Mercury Vapor

—there's an RCA rectifier to solve your power problem

These RCA power rectifier tubes are built for 'round-the-clock duty in commercial services. You can count on them for steady, dependable power in *your* rig. The five types shown will satisfy any power requirements you are apt to have.

RCA-5R4-GY is a full-wave, vacuum rectifier with a heavy-duty coated filament. A single tube in a full-wave circuit with choke input will deliver 175 ma at 750 volts.

RCA-816 is a half-wave mercury-vapor rectifier using an edgewise-wound filament with an enormous emission reserve. A pair in a full-wave circuit with choke input will supply 250 ma at 2380 volts.

RCA-866-A is a half-wave mercury-vapor rectifier also using an edgewise-wound filament for longer life. A pair in a full-wave circuit with choke input will deliver 500 ma at 3180 volts.

RCA-3B28 is a xenon-filled, half-wave rectifier that provides exceptionally stable operation under wide variations in temperature. A pair in a full-wave circuit with choke input will deliver 500 ma at 3200 volts, or 1 ampere at 1600 volts.

RCA-872-A is a half-wave mercury-vapor rectifier with an edgewise-wound filament. A pair in a full-wave circuit with choke input will deliver 2.5 amperes at 3180 volts.

Free technical data bulletins on these rectifiers are available from your **RCA Tube Distributor** . . . or write RCA, Commercial Engineering, Section IM48, Harrison, N. J.



TUBES FOR THE PROFESSIONAL . . . PRICED FOR THE AMATEUR

The dependability of commercially proved RCA Tubes costs you no more. Buy genuine RCA Tubes and you buy the best. See your local RCA Tube Distributor.

TMK. (©)



RADIO CORPORATION of AMERICA
ELECTRON TUBES
HARRISON, N. J.