

# QST

March 1953

40 Cents

45c in Canada

devoted entirely to

# amateur radio



IN THIS ISSUE — "PROJECT MOONBEAM" — SEE PAGE 11

# ULTRA COMPACT UNITS...OUNCER UNITS

## HIGH FIDELITY . . . . SMALL SIZE . . . . FROM STOCK

UTC Ultra compact audio units are small and light in weight, ideally suited to remote amplifier and similar compact equipment. High fidelity is obtainable in all individual units, the frequency response being  $\pm 2$  DB from 30 to 20,000 cycles. True hum balancing coil structure combined with a high conductivity die cast outer case, effects good inductive shielding.

Type No.	Application	Primary Impedance	Secondary Impedance	List Price
A-10	Low Impedance mike, pickup, or multiple line to grid	50, 125/150, 200/250, 333, 500/600 ohms	50 ohms	\$16.00
A-11	Low impedance mike, pickup, or line to 1 or 2 grids (multiple alloy shields for low hum pickup)	50, 200, 500	50,000 ohms	18.00
A-12	Low impedance mike, pickup, or multiple line to grids	50, 125/150, 200/250, 333, 500/600 ohms	80,000 ohms overall, in two sections	16.00
A-14	Dynamic microphone to one or two grids	30 ohms	50,000 ohms overall, in two sections	17.00
A-20	Mixing, mike, pickup, or multiple line to line	50, 125/150, 200/250, 333, 500/600 ohms	50, 125/150, 200/250, 333, 500/600 ohms	16.00
A-21	mixing, low impedance mike, pickup, or line to line (multiple alloy shields for low hum pickup)	50, 200/250, 500/600	50, 200/250, 500/600	18.00
A-16	Single plate to single grid	15,000 ohms	60,000 ohms. 2:1 ratio	15.00
A-17	Single plate to single grid 8 MA unbalanced D.C.	As above	As above	17.00
A-18	Single plate to two grids. Split primary	15,000 ohms	80,000 ohms overall, 2.3:1 turn ratio	16.00
A-19	Single plate to two grids 8 MA unbalanced D.C.	15,000 ohms	80,000 ohms overall, 2.3:1 turn ratio	19.00
A-24	Single plate to multiple line	15,000 ohms	50, 125/150, 200/250, 333, 500/600 ohms	16.00
A-25	Single plate to multiple line 8 MA unbalanced D.C.	15,000 ohms	50, 125/150, 200/250, 333, 500/600 ohms	17.00
A-26	Push pull low level plates to multiple line	30,000 ohms plate to plate	50, 125/150, 200/250, 333, 500/600 ohms	16.00
A-27	Crystal microphone to multiple line	100,000 ohms	50, 125/150, 200/250, 333, 500/600 ohms	16.00
A-30	Audio choke, 250 henrys @ 5 MA	6000 ohms D.C.	.65 henrys @ 10 MA	1500 ohms D.C. 12.00
A-32	Filter choke 60 henrys @ 15 MA	2000 ohms D.C.	15 henrys @ 30 MA	500 ohms D.C. 10.00

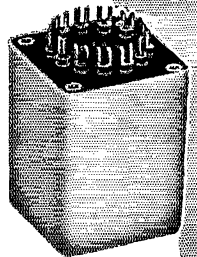

TYPE A CASE  
1½" x 1½" x 2" high

UTC OUNCER components represent the acme in compact quality transformers. These units, which weigh one ounce, are fully impregnated and sealed in a drawn aluminum housing ⅜" diameter... mounting opposite terminal board. High fidelity characteristics are provided, uniform from 40 to 15,000 cycles, except for 0-14, 0-15, and units carrying DC which are intended for voice frequencies from 150 to 4,000 cycles. Maximum level 0 DB.



OUNCER CASE

⅜" Dia. x 1½" high

Type No.	Application	Pri. Imp.	Sec. Imp.	List Price
0-1	Mike, pickup or line to 1 grid	50, 200/250, 500/600	50,000	\$14.00
0-2	Mike, pickup or line to 2 grids	50, 200/250, 500/600	50,000	14.00
0-3	Dynamic mike to 1 grid	7.5/30	50,000	13.00
0-4	Single plate to 1 grid	15,000	60,000	11.00
0-5	Plate to grid, D.C. in Pri.	15,000	60,000	11.00
0-6	Single plate to 2 grids	15,000	95,000	13.00
0-7	Plate to 2 grids, D.C. in Pri.	15,000	95,000	13.00
0-8	Single plate to line	15,000	50, 200/250, 500/600	14.00
0-9	Plate to line, D.C. in Pri.	15,000	50, 200/250, 500/600	14.00
0-10	Push pull plates to line	30,000 ohms plate to plate	50, 200/250, 500/600	14.00
0-11	Crystal mike to line	50,000	50, 200/250, 500/600	14.00
0-12	Mixing and matching	50, 200/250	50, 200/250, 500/600	13.00
0-13	Reactor, 300 Hys.—no D.C.; 50 Hys.—3 MA, D.C.	—	6000 ohms	10.00
0-14	50:1 mike or line to grid	200	½ megohm	14.00
0-15	10:1 single plate to grid	15,000	1 megohm	14.00

150 VARICK STREET

NEW YORK 13, N. Y.

EXPORT DIVISION: 13 EAST 40th STREET, NEW YORK 16, N. Y.,

CABLES: "ARLAB"

*You can be justly proud...*

**of the tribute paid to radio  
amateurs everywhere at the  
1952 Edison Award presentation.**

The recent ceremonies in Washington, D. C., at which the Edison Award and citations were announced, strongly evidence the high regard in which amateurs throughout the country are held.

Recognition of the contributions made by you radio amateurs, was enthusiastically given by national figures attending the presentation—from the American Red Cross Society, the Federal Communications Commission, and the Military Affiliate Radio System. In addition, you can take pride in the large number of individuals who gave so generously of their time to nominate candidates for the Award.

General Electric considers it a privilege to have helped focus public attention on the many humane and unselfish services performed by amateurs—and, with your help, will continue to call attention to these services by means of the Edison Award for 1953.

**GENERAL  ELECTRIC**

166-183

# TVI PROBLEMS ?



## *the 32V-3 has the answer*

Because even the fundamental carrier frequency can cause TVI, *there is no such thing as a TVI-proof transmitter*. In the 32V-3, however, spurious radiations have been reduced to an absolute minimum. A high order of spurious attenuation has been designed into the 32V-3 by engineering measures including the following:

- The one-piece cabinet contains numerous small holes which provide adequate ventilation but prevent radiation of spurious energy.
- The r-f section is completely enclosed in a separate shielded compartment inside the main cabinet.
- External connections for a-c input, key, mike, receiver disabling, and antenna relay operation are well filtered where they pass through the cabinet.
- Grounded studs are provided for mounting and grounding a 35C-2 low-pass filter at the rear of the cabinet. In fringe-area installations, the 35C-2 filter may be necessary in order to provide

additional attenuation of spurious radiations. Many fringe-area hams have found that the 35C-2 permits successful operation of TV receivers in the radio shack.

- A pi-L output network, developed by Collins, reduces radiations at frequencies higher than the carrier.
- Coaxial r-f output permits taking advantage of the inherent shielding and grounding of coaxial lines.

These TVI precautions are in addition to such well-known Collins features as precision frequency stability, a direct-reading, accurately calibrated dial, good audio quality, and clean keying without chirps or clicks.

The 32V-3 runs 150 watts input on cw and 120 watts on phone.

Net Domestic Prices:

32V-3 transmitter.....\$775.00  
35C-2 low-pass filter.....\$ 40.00

FOR THE BEST IN AMATEUR RADIO, IT'S . . .

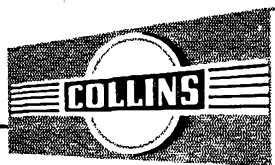

**COLLINS RADIO COMPANY, Cedar Rapids, Iowa**

11 W. 42nd St., NEW YORK 36

1930 Hi-Line Drive, DALLAS 2

2700 W. Olive Ave., BURBANK



MARCH 1953

VOLUME XXXVII • NUMBER 3

PUBLISHED, MONTHLY, AS ITS OFFICIAL ORGAN, BY THE AMERICAN RADIO RELAY LEAGUE, INC., AT WEST HARTFORD, CONN., U. S. A.; OFFICIAL ORGAN OF THE INTERNATIONAL AMATEUR RADIO UNION

STAFF

Editorial

A. L. BUDLONG, WIBUD

Editor

HAROLD M. McKEAN, WICEG  
Managing Editor

GEORGE GRAMMER, WIDF  
Technical Editor

DONALD H. MIX, WITS  
BYRON GOODMAN, WIDX  
Assistant Technical Editors

EDWARD P. TILTON, WHDQ  
V.H.F. Editor

C. VERNON CHAMBERS, WIJEQ  
LEWIS G. McCOY, WIICP  
Technical Assistants

ROD NEWKIRK, WIVMW  
DX Editor

ELEANOR WILSON, WIQON  
YL Editor

ANN B. FURR  
Production Assistant

WALTER E. BRADLEY, WIFWH  
Technical Information Service

Advertising

LORENTZ A. MORROW, WIVG  
Advertising Manager

EDGAR D. COLLINS  
Advertising Assistant

Circulation

DAVID H. HOUGHTON  
Circulation Manager

HAROLD K. ISHAM, WIMFA  
Assistant Circulation Manager

OFFICES

38 La Salle Road

West Hartford 7, Connecticut

TEL.: 3-6268

TWX: HF 88

Subscription rate in United States and Possessions, \$4.00 per year, postpaid; \$4.25 in the Dominion of Canada, \$5.00 in all other countries. Single copies, 40 cents. Foreign remittances should be by international postal or express money order or bank draft negotiable in the U. S. and for an equivalent amount in U. S. funds.

Entered as second-class matter May 29, 1919, at the post office at Hartford, Connecticut, under the Act of March 3, 1879. Acceptance for mailing at special rate of postage provided for in section 1102, Act of October 3, 1917, authorized September 9, 1922. Additional entry at Concord, N. H., authorized February 21, 1929, under the Act of February 28, 1925.

Copyright 1953 by the American Radio Relay League, Inc. Title registered at U. S. Patent Office. International copyright secured. All rights reserved. Quedan reservados todos los derechos. Printed in U. S. A.

INDEXED BY

INDUSTRIAL ARTS INDEX

-CONTENTS-

TECHNICAL-

The Transistor — Or 25 Miles on a Hunk of Germanium  
George M. Rose, K2AH 13

Combining the Antenna Coupler and Low-Pass Filter  
George Grammer, WIDF 17

TVG — An Aid to Break-In.....C. C. Miller, W2RDK,  
and F. T. Meichner, W2NVY 20

An All-Purpose Super-Selective I.F. Amplifier  
Byron Goodman, WIDX 23

A Handy Handful.....C. Vernon Chambers, WIJEQ 29

"Q"-Section Transformers  
William B. Wrigley, W4UCW 32

A Poor Man's DX-Getter....Edwin L. Spight, W6OXR 38

An Isolating Oscillator.....Richard Clay, W9JRO 40

MOBILE-

A One-Tube 75-Meter Mobile Converter  
J. G. Rountree, W5CLP 36

NOVICE-

Let's Listen.....Lewis G. McCoy, WIICP 43

GENERAL-

Lunar DX on 144 MC..... 11

The Radio Amateur Civil Emergency Service — PART I.. 50

"It Seems to Us . . ."	9	YL News and Views.....	53
Hamfest Calendar.....	10	World Above 50 Mc.....	54
Quist Quiz.....	10	In QST 25 Years Ago.....	56
On the TVI Front.....	16	How's DX?.....	57
Happenings of the Month.....	34	ARRL QSL Bureau.....	61
Military Affiliate Radio System	42	Feed-back.....	61
United States Naval Reserve..	42	Hints & Kinks.....	62
Silent Keys.....	47	Correspondence from Members.	64
WWV-WVVH Schedules.....	47	Operating News.....	66
On the Air with Single Sideband	48	With the AREC.....	70
		Station Activities.....	72

# "I Read

## Welcome Words!

### Hear them more often with Hallicrafters

It's true that Hallicrafters equipment lets you hear more. It's equally true that you hear better—and are heard better—when you depend on Hallicrafters equipment. That's why for twenty years Hallicrafters communications equipment has been top favorite with the most critical expert in the world, the American amateur.

You see, these sets are designed and built specifically for the ham operator. They are planned with an amateur's problems, and pocket-book, in mind. They enjoy the best reputation in the world with this critical group of experts. You can *hear* why every night in the year on the air. Just listen!

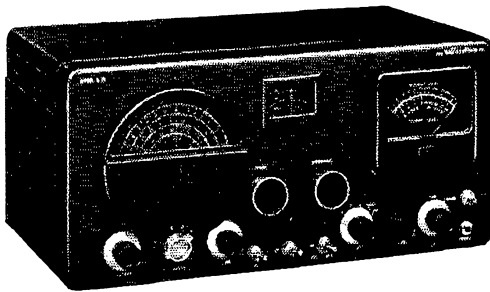

**Top Selectivity—Low Price! Model SX76**  
Dual Conversion Super with 50 kc amplifier for tops in selectivity, 500 cycles at 6 db down—3.5 kc at 60 db down. Giant 4-in. "S" meter. 540-1580 kc, 1.72-32 Mc in 4 bands. 1 r-f, 2 conversion, 2 i-f stages. 5 pos. selectivity. Phono input jack. 3 watt output. **\$179.50**

# hallicrafters

Chicago 24, Illinois

World's Leading Manufacturer of Precision Radio and Television

# You Five..."

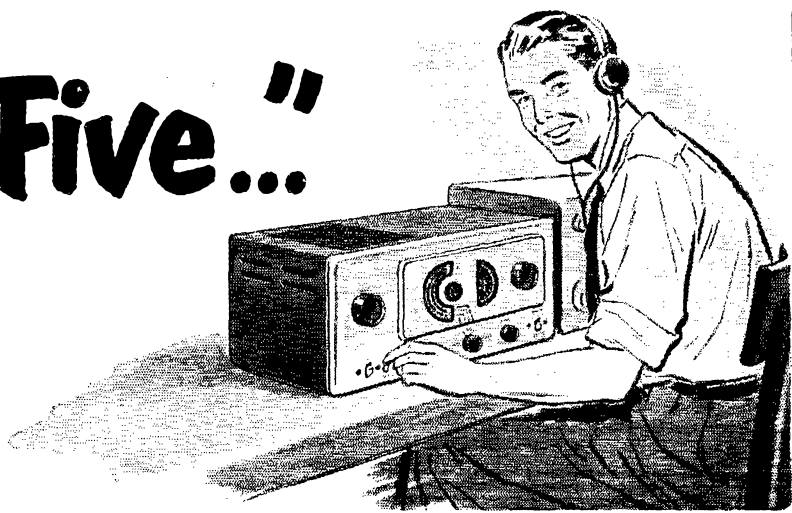

◀ **A Ham's Dream! Model SX71**—Com. Rcvr. especially designed for top ham performance. Double conversion, built-in NBFM limiter stage. 538 kc to 35 Mc, 46-56 Mc in 5 bands. Temp. Comp., voltage reg. 1 r-f, 2 conversion, w i-f stages. Xtal. filter, w-pos. selectivity, 18½" x 8⅞" x 12" deep. Ship. wt. 51 lbs. 115 V. AC, 11 tubes reg. tect. \$224.50

▶ **TVI Suppressed 100 Watter—Model HT20**—Here's the transmitter you've been waiting for! Continuous coverage from 1.7 Mc to 30 Mc. Full band switching, no more plug-in coils; choice of 10 crystals. Shielded, filtered r-f compartment plus low-pass 52 ohm coaxial line output filter cuts anything over 30 Mc. Only \$449.50

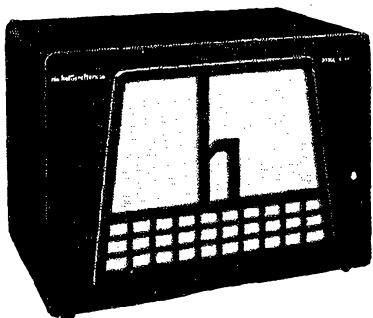

◀ **Matched Speaker, Model R46**—The perfect speaker for SW. Includes transformer of 500/600-ohm input. Voice coil impedance 3.2 ohms. 10" cone. Gives excellent response for either voice or cw. Heavy construction throughout for years of service. Black finish. 15" x 10⅞" x 10⅞" deep. Only \$19.95

## Section Communications Managers of the ARRL Communications Department

**Reports Invited.** All amateurs, especially League members, are invited to report station activities on the first of each month (for preceding month) direct to the SCM, the administrative ARRL official elected by members in each Section. Radio Club reports are also desired by SCMs for inclusion in *QST*. All **ARRL Field Organization appointments** are now available to League members. These include ORS, OES, OPS, OO and OBS. Also, where vacancies exist SCMs desire applications for SEC, EC, RM, and PAM. In addition to station and leadership appointments for Members, *all amateurs* in the United States and Canada are invited to join the Amateur Radio Emergency Corps (ask for Form 7).

ATLANTIC DIVISION			
Eastern Pennsylvania	W3BXE	John H. DuBois	2219 Rhawn St.
Maryland-Delaware-D. C.	W3EOK	Arthur W. Plummer	3804 Resmere Road
Southern New Jersey	W2UCV	Lloyd L. Gainey	Hoffman Ave. & Marlton Pike
Western New York	W25JV	Edward Graf	81 King St.
Western Pennsylvania	W3KWL	Ernest J. Hlinsky	509 Beechwood Ave.
CENTRAL DIVISION			
Illinois	W9KQL	H. F. Lund	3135 S. 5th St.
Indiana	W9DGA	Clifford C. McGuyer	1321 South Governor St.
Wisconsin	W9RQM	Reno W. Goetsch	922 S. 7th Ave.
DAKOTA DIVISION			
North Dakota	W0VKP	Everett E. Hill	1527 Fifth Ave., So.
South Dakota	W0RRN	J. W. Sikorski	1900 South Menlo Ave.
Minnesota	W0MXC	Charles M. Bove	1611 1/2 E. Lake St.
DELA DIVISION			
Arkansas	W5LUX	Fred Ward	520 South Maple St.
Louisiana	W5GHF	Robert E. Barr	Box 446
Mississippi	W5JHS	Norman B. Feehan	P. O. Box 491
Tennessee	W4CXY/WLG	Mark M. Bowelle	109 Dixie Lane
GREAT LAKES DIVISION			
Kentucky	W4TUT	Ivan C. Kelly	41 E. Mt. Vernon St.
Michigan	W8HKT	Fabian T. McAllister	RFD 1, Box 368
Ohio	W8AJW	John E. Siringer	2972 Clague Rd.
HUDSON DIVISION			
Eastern New York	W2ILI	Stephen J. Neason	794 River St.
N. Y. C. & Long Island	W20BU	George V. Conke	38-31 239th St.
Northern New Jersey	W2VQR	Lloyd H. Manamon	410 1/2 Fifth Ave.
MIDWEST DIVISION			
Iowa	W0PFP	William G. Davis	3rd St.
Kansas	W0ICV	Earl N. Johnston	624 Roosevelt
Missouri	W0GBJ	Clarence L. Arundale	1048 South Jefferson Ave.
Nebraska	W0CBH	Floyd B. Campbell	201 W. 8th St.
NEW ENGLAND DIVISION			
Connecticut	W1HYF	Roger C. Amundson	RFD 4
Maine	W1PTL	Orestes R. Brackett	Goodrich St.
Eastern Massachusetts	W1ALP	Frank L. Baker, jr.	91 Atlantic St.
Western Massachusetts	W1JYH	Roger E. Corey	67 West Allen Ridge Road
New Hampshire	W1GMEH	Carroll A. Currier	1426 Belmont St.
Rhode Island	W1JBB	Merrill D. Randall	22 Annandale Road
Vermont	W1FPS	Raymond N. Flood	2 Marlboro Ave.
NORTHWESTERN DIVISION			
Alaska	KL7NT	Glen Jefferson	938-3rd Ave.
Idaho	W7IWI	Alan E. Ross	2105 Irene St.
Montana	W7KGT	Edward G. Brown	421 Yellowstone Ave.
Oregon	W7MCG	J. E. Roden	519 N.W. Ninth
Washington	W7CZY	Laurence Sebring	Route 2, Box 384
PACIFIC DIVISION			
Hawaii	KH0RU	John K. Sanders	c/o Mackay Radio & Telegraph
Nevada	W7IU	Ray T. Warner	519 Birch St.
Santa Clara Valley	W6LZL	Roy I. Couzin	16615 Englewood Ave.
East Bay	W6JZ	Ray H. Cornell	909 Curtis St.
Sau Francisco	W6ATO	R. F. Czeikowitz	243 Colon Ave.
Sacramento Valley*	W6CKV	Willie van de Kamp	RFD 1, Box 492A
San Joaquin Valley	W6FYM	E. Howard Hale	747 E. Main St.
ROANOKE DIVISION			
North Carolina	W4DI-X	J. C. Geaslen	1832 Logie Ave.
South Carolina	W4ANK	J. Hunter Wood	1702 North Rhett Ave.
Virginia	W4FF	H. Edgar Lindauer	Route 1, Box 431
West Virginia	W8MCR	John T. Steele	
ROCKY MOUNTAIN DIVISION			
Colorado*	W0CDX	Earl Bruegenian	1945 Kearny St.
Utah	W7UTM	Floyd L. Hinshaw	165 East 4th, North
Wyoming	W7JDB	L. L. Daily	1205 Lewis
SOUTHEASTERN DIVISION			
Alabama	W4GJW	Dr. Arthur W. Woods	411 Woodward Bldg.
Eastern Florida	W4FWZ	John W. Hollister	3809 Springfield Blvd.
Western Florida	W4MS	Edward J. Collins	1003 E. Blount St.
Georgia	W4ZD	James P. Born, jr.	25 First Ave., N.E.
West Indies (Cuba-P.R.-V.I.)	KP4DJ	William Werner	563 Ramon Llovet
Canal Zone	KZ5NM/W4QBS	Nelson W. Magner	Box 373
SOUTHWESTERN DIVISION			
Los Angeles*	W6YVI	Howard C. Bellman	973 Mayo St.
Arizona	W7LVR	Albert Steinbrecher	Maple Road, RFD 5, Box 237
San Diego	W6FJH	Edgar M. Cameron, jr.	1450 So. Escondido Blvd.
Santa Barbara			
WEST GULF DIVISION			
Northern Texas	W5GF	William J. Gentry	1509 Avenue Q
Oklahoma	W5GUV	Jesse M. Langford	2005 W. Oklahoma Ct.
Southern Texas	W5HFJ	Dr. Charles Fergmaglich	618 Medical Arts Bldg.
New Mexico*	W5B1W	Dick Matthias	P. O. Box 548
MARITIME DIVISION			
Maritime	VE1DQ	A. M. Crowl	69 Dublin St.
ONTARIO DIVISION			
Ontario	VE3IA	G. Eric Farouhar	16 Emerald Crescent
QUEBEC DIVISION			
Quebec	VE2GL	Gordon A. Lyan	R. R. No. 1
VANALTA DIVISION			
Alberta	VE6MJ	Sydney J. Jones	10706-57th Ave.
British Columbia	VE7US	Wilf Moorhouse	808 Victoria Rd.
Yukon			
PRAIRIE DIVISION			
Manitoba*	VE4LC	Leonard E. Cuff	286 Rutland St.
Saskatchewan	VE5HR	Harold K. Horn	1044 King St.

\* Officials appointed to act temporarily in the absence of a regular official.



**SOLID  
AS A  
ROCK**

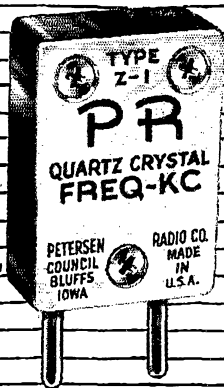

PRs STAY PUT! In aircraft, in the marine, in broadcast and point-to-point, in police and military installations . . . in fact, wherever frequencies MUST be in channel . . . you will find PRs on the job. PRs for commercial service are precision made . . . low drift cut for the utmost in stability . . . with temperature coefficient less than 2 cycles per megacycle per degree Centigrade . . . cali-

brated within .005 per cent of specified frequency . . . contamination and moisture-proof . . . weight less than  $\frac{3}{8}$  ounce. Power output is exceptional, both for fundamental and harmonic oscillators. Since 1934 PR has become a standard of excellence for crystal controls . . . in all fields — commercial, amateur and industrial. It's no wonder that amateurs prefer PRs in their rigs at all frequencies.

**PR**

*Crystals*



USE **PR** AND KNOW WHERE YOU ARE

**PETERSEN RADIO COMPANY, INC.**  
2800 W. BROADWAY • COUNCIL BLUFFS, IOWA

EXPORT SALES ONLY: Royal National Company, Inc., 75 West Street, New York 6, N. Y., U. S. A.

# THE AMERICAN RADIO RELAY LEAGUE, INC.,

is a noncommercial association of radio amateurs, bonded for the promotion of interest in amateur radio communication and experimentation, for the relaying of messages by radio, for the advancement of the radio art and of the public welfare, for the representation of the radio amateur in legislative matters, and for the maintenance of fraternalism and a high standard of conduct.

It is an incorporated association without capital stock, chartered under the laws of Connecticut. Its affairs are governed by a Board of Directors, elected every two years by the general membership. The officers are elected or appointed by the Directors. The League is noncommercial and no one commercially engaged in the manufacture, sale or rental of radio apparatus is eligible to membership on its board.

"Of, by and for the amateur," it numbers within its ranks practically every worth-while amateur in the nation and has a history of glorious achievement as the standard-bearer in amateur affairs.

Inquiries regarding membership are solicited. A bona fide interest in amateur radio is the only essential qualification; ownership of a transmitting station and knowledge of the code are not prerequisite, although full voting membership is granted only to licensed amateurs.

All general correspondence should be addressed to the administrative headquarters at West Hartford, Connecticut.



## Past Presidents

HIRAM PERCY MAXIM, W1AW, 1914-1936  
EUGENE C. WOODRUFF, W8CMP, 1936-1940  
GEORGE W. BAILEY, W2KH, 1940-1952

## Officers

**President** . . . . . GOODWIN L. DOSLAND, WØTNS  
Moorhead, Minn.

**First Vice-President** . . . . . WAYLAND M. GROVES, W5NW  
P.O. Box 586, Odessa, Texas

**Vice-President** . . . . . FRANCIS E. HANDY, W1BDI  
38 La Salle Road, West Hartford, Connecticut

**Secretary** . . . . . A. L. BUDLONG, W1BUD  
38 La Salle Road, West Hartford, Connecticut

**Treasurer** . . . . . DAVID H. HOUGHTON  
38 La Salle Road, West Hartford, Connecticut

. . . . .

**General Counsel** . . . . . PAUL M. SEGAL  
816 Connecticut Ave., Washington 6, D.C.

**Technical Director** . . . . . GEORGE GRAMMER, W1DF  
38 La Salle Road, West Hartford, Connecticut

**Technical Consultant** . . . . . PHILIP S. RAND, W1DBM  
Route 58, Redding Ridge, Conn.

**Assistant Secretaries:**  
JOHN HUNTOON, W1LVQ                      JOHN E. CANN, W1RWS  
38 La Salle Road, West Hartford, Connecticut

## DIRECTORS

### Canada

ALEX REID, VE2BI  
210 Logan Ave., St. Lambert, P. Q.  
*Vice-Director:* William W. Butchart, VE6LC  
10740 107 St., Edmonton, Alta.

### Atlantic Division

ALFRED C. HUCK, W3GEC  
515 Cedar Ave., Sharon, Pa.  
*Vice-Director:* Charles O. Badgett, W3LVE  
725 Garden Road, Glenside, Pa.

### Central Division

WESLEY E. MARRINER, W9AND  
344 N. Galena Ave., Dixon 7, Ill.  
*Vice-Director:* Harry M. Matthews, W9UQT  
Box 1195, Springfield, Ill.

### Dakota Division

ALFRED M. GOWAN, WØPHR  
325 S. Menlo Ave., Sioux Falls, S. D.  
*Vice-Director:*

### Delta Division

JAMES W. WATKINS, W4FLS  
220 N. Howell Ave., Chattanooga, Tenn.  
*Vice-Director:* George S. Acton, W5BMM  
Plain Dealing, La.

### Great Lakes Division

JOHN H. BRABB, W8SPF  
417 Ford Bldg., Detroit 26, Mich.  
*Vice-Director:* Harold E. Stricker, W8WZ  
247 W. 5th St., Marysville, Ohio

### Hudson Division

GEORGE V. COOKE, JR., W2OBU  
88-31 239 St., Bellerose 26, N. Y.  
*Vice-Director:* Thomas J. Ryan, Jr., W2NKD  
1082 Anna St., Elizabeth 4, N. J.

### Midwest Division

WILLIAM J. SCHMIDT, WØOZN  
306 S. Vassar, Wichita, Kansas  
*Vice-Director:* James E. McKim, WØMYG  
1404 S. Tenth, Salina, Kansas

### New England Division

PERCY C. NOBLE, W1BVR  
37 Broad St., Westfield, Mass.  
*Vice-Director:* Frank L. Baker, Jr., W1ALP  
91 Atlantic St., North Quincy 71, Mass

### Northwestern Division

R. REX ROBERTS, W7CPY  
837 Park Hill Drive, Billings, Mont.  
*Vice-Director:* Karl W. Weingarten, W7BG  
3219 N. 24th St., Tacoma 7, Wash.

### Pacific Division

KENNETH E. HUGHES, W6CIS  
3105 Crest Haven Drive, Sacramento, Calif.  
*Vice-Director:* Richard F. Czelkowitz, W6ATO  
243 Colon Ave., San Francisco 12, Calif.

### Roanoke Division

P. LANIER ANDERSON, JR., W4MWH  
428 Maple Lane, Danville, Va.  
*Vice-Director:* Gus M. Browning, W4BPD  
135 Broughton St., S. E., Orangeburg, S. C.

### Rocky Mountain Division

CLAUDE M. MAER, JR., WØIC  
740 Lafayette St., Denver, Colo.  
*Vice-Director:*

### Southeastern Division

LAMAR HILL, W4BOL  
104 Myrtle, Cochran, Ga.  
*Vice-Director:* Ernest W. Barr, W4GOR  
911 Rosemary Ave., SW, Atlanta, Ga.

### Southwestern Division

JOHN R. GRIGGS, W6KW  
3502 Chesapeake Ave., Los Angeles 16, Calif.  
*Vice-Director:* Walter R. Joos, W6EKM  
1315 N. Overhill Drive, Inglewood 3, Calif.

### West Gulf Division

A. DAVID MIDDLETON, W5CA  
9 Kay Road, Tijeras, N. M.  
*Vice-Director:* Carl C. Drumeller, W5EEC  
5824 N.W. 58th St., Oklahoma City 12, Okla.

# "It Seems to Us..."

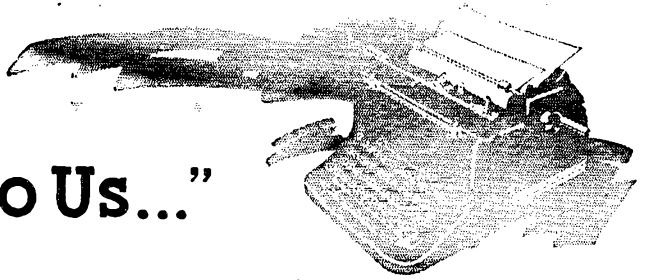

## HOW MANY AMATEURS?

It seems to us the time has come to set the record straight on a few facts bearing on the question of how many licensed amateurs are members of the League. As chronicled in "Happenings" this month, the annual report of the Federal Communications Commission for the year ending June 30, 1952, states that as of that date there were 110,968 amateur operator licenses in effect. Also as of that date, we say there were approximately 35,000 licensed amateur members of the League. Ergo, about one-third of the licensed amateurs are League members.

Ergo indeed! The League figure is correct. Unfortunately, the FCC figure has almost no relation to the actual number of amateurs currently licensed.

Before we explain how the Commission arrived at its figures, let us give you a few "for-instances." When the Novice and Technician licenses became available in 1951, Johnny Ham went up and got both. At the same time, Joe Doakes, who had taken out his ham ticket in 1946, found it was up for renewal. He'd lost interest in ham radio and didn't renew. At this point, we think it obvious we have one amateur on the books; Joe is out of the picture but Johnny replaces him. But no, says FCC. They say we have *three* amateur operator licenses "in effect"; they still include Joe's expired ticket in their totals, and they count Johnny twice, once as a Novice and once as a Technician!

Here's another one: During that first year of Novice license issuance let's say 10,000 hams took out Novice tickets. And let's say that, before their year was up, all 10,000 converted to General Class, and that every single one of them signed up as a member of the League. How're we doing? Well, we'd say 100% of those amateurs were members of the League. Not according to FCC's figures! They'd show only 50%; FCC counted the guys twice, once as Novice licensees and again as Generals. Their figure would have shown 20,000 — not 10,000 — new amateur operator licenses issued during the period, and no deletions. We can show only 10,000 members.

You can't win, against that kind of book-

keeping; FCC is counting licenses — we're counting people.

Let us now set the record straight on the Commission's figuring. It started issuing 5-year licenses in 1946. For the next five years, therefore, all license figures were purely cumulative; there were no deletions of these for expiring licenses, since none was expiring because of the 5-year term. In February, 1951, licenses did begin coming up for renewal, and many of them weren't renewed (we don't know how many — FCC just doesn't have figures). For just five months, from February to June of 1951, FCC did delete unrenewed licenses from its totals — and it is significant that during that time the over-all operator license figure started to drop. But then personnel shortages made it impossible to keep up with the deletions; from that time on, and up until at least December of 1952, the total operator licenses "in effect" have included *all* expired, unrenewed Advanced, General and Conditional licenses except those deleted for that brief five-month period nearly two years ago.

In midsummer of 1951, another "inflationary" element entered the picture when the Novice and Technician licenses began to be issued. FCC counts each Novice license issued as one new license; but when the Novice takes and passes his General or Conditional Class, it counts that as a second new license to be figured in the year's total growth. At least so far as the figures we're talking about are concerned, the Novice license wasn't "deleted" when the General Class was issued.

Another one: A Novice takes out a Technician ticket. FCC counts that as two new licenses. (We should add the poor guy is not counted a third time, if he thereafter gets his General license.)

In the light of these facts, it is impossible to estimate the actual number of amateur operators represented in FCC's June, 1952, total. There are no figures to indicate how many Novices converted to a higher grade. There are no figures to indicate how many Technicians had Novice licenses as well, although it is estimated to include most of them. There are no figures on how many thousands of licenses expired and were not renewed, since 1946. Without such figures it is hopeless to

attempt to correct the Commission's total.

Our League membership figures are determined each December 31st with scrupulous exactness. They are one-year figures, not cumulative five-year figures. We don't count people twice. We don't include non-renewing members in our membership totals. We think it is obvious at this point, therefore, that no conclusions can be drawn by comparing League membership figures with FCC's annual report figures. We just aren't speaking the same language.

For the record, we conclude with the good news that our licensed-amateur membership increased by 21.4% during 1952, and that as of December 31, 1952, our licensed-amateur figure in the U. S. and possessions was an all-time high of 38,910. To the many loyal members who have made it a personal matter to register that increase, our great thanks — and more power to you in 1953!

### DOCKET 10173

Most frequently asked question in connection with FCC's order on Docket 10173 (opening former "Class A" phone bands to General and Conditional Classes) is why the Commission took the action it did if the comment it received was overwhelmingly opposed — as an inspection of the docket file discloses was actually the case.

The answer is simple enough: FCC is under no obligation to make its decisions in terms of sentiment pro or con. It can, and in fact is, under law, obliged to decide as it sees fit. Many amateurs do not realize Congress has delegated to FCC both the power and responsibility for regulating the various radio services. In doing so FCC is not obliged to comply with those services' wishes if it believes one of its proposals to be in the best interests of a service and the public — and providing, of course, that it does not violate the law, or anyone's rights, and is not demonstrably in error in its reasoning or the facts on which it bases its judgment.

Careful study of FCC's order in Docket 10173 shows it didn't base its order on any misinterpretation of fact, or failure to consider relevant matter of fact. Its decision was based on policy; it thinks what it did is best for the amateur service. It had an idea for a change in our license and operating set-up, and its final conclusion was that despite overwhelming objection to it, it still was a good thing for amateur radio.

No one challenges FCC's right to take such action, or questions its sincerity of purpose. We think we speak for most amateurs, however, in expressing the belief that the Commission, in matters of this sort — essentially the concern only of the users of the service itself — should give more consideration than it did to the expressed desires of the majority of those users.

## Stays

W5UJM/5 and W5UJN/0 chorused an answer to one of W9VTN's recent 40-meter CQs.

— . . . —

W1NJM, acknowledging ARRL Net Directory registration of the Skiers Snow Service Net, noted that Arthur C. Winter, W2ADB, was doing the registering.

— . . . —

VE3PB might just as well have been named Murgatroyd. After fifteen years he finally had a QSO in which the operator at the other end could match his own first name — Stau.

— . . . —

Braille Technical Press Editor Robert W. Gunderson, W2JIO, reports the compilation of a list of more than 200 stations operated by blind amateurs. This roster appeared in the February number of the *Press*.

— . . . —

The fifth anniversary of formation of the Quarter Century Wireless Association was celebrated at a December, 1952, meeting in New York attended by 175 members. W2FX, W2IN, W2FIT and W2PF were reelected president, vice-president, secretary and treasurer, respectively. Membership in the Association increased from 54 in 1947 to a year's end 1952 total of 540 members in all the United States, Mexico, Canada, Cuba, Puerto Rico, Western Germany, Great Britain, Peru and Brazil.

### HAMFEST CALENDAR

MASSACHUSETTS — Friday, March 27th, in Worcester — the Central Massachusetts Amateur Radio Association will sponsor its Annual Gab Fest. For information, write to Pen Brown, W1UNB, % Station WTAG, Worcester.

OHIO — Saturday, March 21st, at the Biltmore Hotel, Dayton — the Dayton Amateur Radio Association will hold its Annual Hamvention. The day-long program will feature speakers on all phases of amateur radio. Ed Tilton, W1HDQ, of the ARRL Technical Department staff, will speak on v.h.f. Amateur license examinations will be given by the FCC, and a special program has been arranged for the ladies. The affair will wind up with a banquet and dance in the hotel ballroom. Tickets are \$5.00 in advance or \$5.50 at the door. Reservations may be obtained from Ed Pompea, W8FHJ, P. O. Box 701, Dayton 1, Ohio.

## Quiz

Our friend **A** claims that a low-powered c.w. station can operate legally on exactly 7000.000 kc. but that a high-powered station cannot, since the high-powered station takes up more room in the spectrum and thus "spills over" the legal limit. **B** says this is not so — there is no sharp dividing line between high and low power, so any c.w. station can operate as close to the edge as his frequency-measuring equipment can be depended upon. Who is right?

(Please turn to page 120 for the answer)

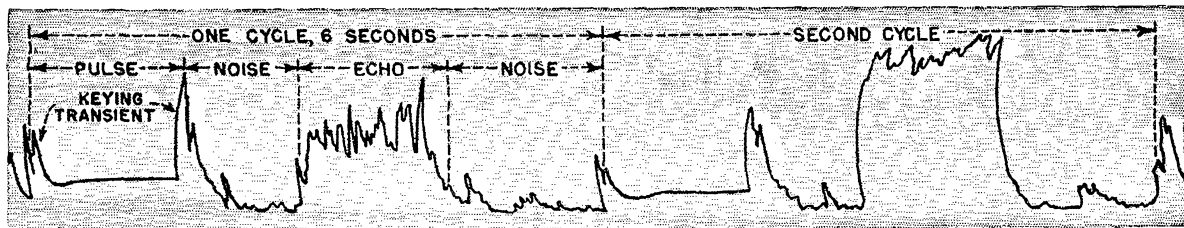

## Lunar DX on 144 Mc.!

*W4AO and W3GKP Bounce 2-Meter Signals Off the Moon*

**L**ISTENING to the wire recording from which the above graph was made, it doesn't sound like much; a one-second beep, an interval of receiver noise, then a wavering trailing bee-e-e-e-p barely discernible in the midst of the slightly musical rushing sound that is characteristic of high-selectivity reception. You wouldn't be impressed if you happened to hear it casually, but to Ross Bateman, W4AO, and Bill Smith, W3GKP, it was music of the sweetest sort; evidence that more years of thinking, figuring, building, re-building and testing were not in vain. An amateur signal had been sent to the moon and back, at last!

Bouncing signals off the moon is not new, of course. It was done on 110 Mc. by the Signal Corps back in 1946<sup>1</sup> and something approximating intelligence was sent from Cedar Rapids, Iowa, to Washington, D. C., on 400 Mc. more recently,<sup>2</sup> using the moon as a reflector. These were high-power projects, however, and their slim margin of success indicated that lunar DX for amateurs was a long-chance proposition. It was an end that just might be achieved, but only after the most painstaking effort, if at all.

The best available information indicated that it would take the level amateur power limit, pushed to the last watt. An antenna gain of at least 20 db. was required, and a degree of receiver performance to tax the ingenuity of the best engineers in the business was called for. Obviously, a 144-Mc. WAS, lunar style, was a long way off, but it was a challenge that a few enterprising and infinitely patient hams were bound to accept.

One such ham was Bill Smith, W3GKP, then of Silver Spring, Maryland. Smitty knew what he was about, and he went at the job with no illusions about aiming his beam at the rising moon

<sup>1</sup> Kaufman, "A DX Record: To the Moon and Back," *QST*, May, 1946.

<sup>2</sup> Sulzer, Montgomery, and Gerks, "An U.H.F. Moon Relay," *Proc. IRE*, March, 1951, p. 361.

◆  
Ross Bateman, W4AO, left, and Bill Smith, W3GKP, smile happily over the success of *Project Moonbeam*, after three years of trying. The high-power stages of the 1-kw. 2-meter transmitter are in the left-hand rack, as are crystal-controlled converters for 144 and 50 Mc. The large cabinet houses power supplies, modulator and control circuits.

some night and then sitting back to listen to the WGs. He knew the requirements, in a general way, and he felt sure that the trick could be turned, eventually. The first step was to find a co-worker, so that the burden of equipment development and construction could be shared. A ham with a kilowatt rig and a big beam for 144 Mc. would be a fine start. Several prospects were lined up, and early in 1950 a few transmitting tests were made, while W3GKP worked on his receiving gear, but none of the prospects had sufficiently good equipment to make reception possible at that stage of the game.

Other amateurs, among them W4AO, Falls Church, Va., had been working along similar lines. Learning of W3GKP's interest, Ross joined forces with Smitty, and *Project Moonbeam* was on its way in earnest. Ross brought to the operation the technical know-how and the enthusiasm and perseverance Smitty had been looking for, and he had a 2-meter rig capable of a full and efficient kilowatt, a 32-element array, a low-noise receiver and a quiet suburban location. After many evenings of discussion, planning and construction, the stage was set for a series of tests with a set-up that appeared to have some chance of succeeding.

The rig at W4AO was maintained on frequency precisely, and keyed in one-second pulses.

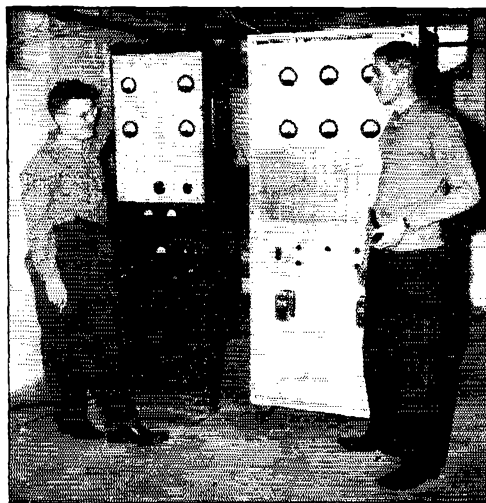

The required separation in frequency between the transmitter and receiver frequencies (to take care of Doppler effects resulting from movements of the earth and moon) had been calculated, and the receiver frequency set with elaborate stability precautions. A wire recorder was connected to the receiver output, to catch as permanent evidence any sign of a returned signal. The system was put in operation whenever the moon was in the right place, and no minor considerations like eating or sleeping were allowed to interfere.

At long last, at 5:03 A.M. on July 15, 1950, came something that sounded like an echo. It was faint and indefinite, but it started at the right time and it sounded like the real thing. What was more important, it was caught on the wire recorder. It was just one tiny beep after a long series of transmitter pulses, but it was enough to keep enthusiasm going.

Workers of lesser stature might have called in the press and announced their results to the world, but Ross and Smitty wanted something more solid than a single faint and somewhat dubious return on which to rest their case. Copies of the recording were mailed out to a few interested parties who could be trusted to say nothing until given the word, and *Moonbeam* went on and on. (A wire copy of that first success has rested in the desk of *QST*'s V.H.F. Editor for nearly three years.)

Test after test piled failure on failure, but still the beeps were sent. An infinitesimal improvement in receiver noise figure, another decibel of antenna gain, a correction of a degree of antenna aiming error, an improved method of "reading"

Part of the equipment used in *Project Moonbeam*, as it operates in the basement at W4AO, Falls Church, Va. At the control position is the Super-Pro receiver, flanked by microphone preamplifier and beam direction indicator. The rolling table, center, carries frequency-checking gear. On the workbench at the right are the frequency control units and exciter. The high-power stages of the transmitter are out of sight at the right, in racks that also house the crystal-controlled converters for the v.h.f. bands.



## OUR COVER

Aiming an antenna at the moon is an exacting proposition. Our cover shows W4AO, left, and W3GKP checking the alignment of the 20-wavelength stacked rhombics used for *Project Moonbeam*.

signals inaudible in the noise; any or all of these might tip the balance. Methods that were tried and found wanting will not be recounted here, but they were many.

Moving to a new home location necessitated the dismantling of the receiving set-up at W3GKP, so *Moonbeam* moved its entire facilities to the basement at W4AO. In November, 1952, a huge stacked rhombic was erected and tested, and it showed a gratifying improvement over the 32-element array. A system had been devised to tie in transmitter and receiver frequencies together accurately. A new receiver front end brought the noise figure down under 4 db.

Tests on November 30th and December 3rd brought no results, so a slight modification was made in the rhombic design, to radiate maximum signal at 2 degrees above the horizon, in readiness for the next round December 27th. There were some very faint returns this time, but nothing tangible on the 30th and 31st.

Meanwhile, the staff of *Moonbeam* had been augmented by the addition of Ted Tuckerman, W3LZD, of Dunmore, Penna., who erected a 30-wavelength rhombic array in time for tests

(Continued on page 116)

# The Transistor—Or 25 Miles on a Hunk of Germanium

*Some Background on the Tiny Devices That May Revolutionize the Electronic Art*

BY GEORGE M. ROSE,\* K2AH

• The first use of a transistor for transmitting purposes was reported in *QST* last month. Here the designer of the tiny rig that appeared on our February cover describes it in detail, and provides us with some basic information on transistors and their potential uses.

**M**OST HAMS who can qualify for the Old Timers Club remember with mixed feelings the time spent per evening searching for that elusive spot on their pet piece of galena which would bring in NAA at a readable level, if not exactly loud and clear. Neither they nor anyone else knew why or how the thing worked in the first place. When tubes finally became commercially and financially available it was the general hope that galena and its sister crystals silicon, carborundum, etc., would be properly disposed of. They did practically vanish from the electronic scene until World War II when silicon diodes were found to outperform tubes as microwave mixers. However, in some of the research laboratories scientific interest in these so-called solid-state semiconducting materials was very much alive. The usefulness of crystal diodes in military equipment intensified this interest and gave rise to some extensive research programs.

## *A Bit of Transistor History*

While engaged in semiconductor research at the Bell Telephone Laboratories, Messrs. Bardeen and Brattain<sup>1</sup> observed that if two cat whiskers were placed very near each other on a piece of germanium and current was made to flow between each cat whisker and the germanium, the two currents would react on each other. The remarkable thing was that a small change in current through one whisker would make a larger change in current through the other. This is amplification, and any electronic device which will amplify is of more than passing interest. Thus the transistor was born.

\* Manager, Advanced Developer (RCA Tube Department, Harrison, N. J.)

<sup>1</sup> J. Bardeen and W. H. Brattain, "Physical Principles Involved in Transistor Action," *Bell System Technical Journal*, April, 1949.

<sup>2</sup> B. N. Slade, "Survey of Transistor Development," *Radio & TV News*, Sept., Oct., and Nov., 1952.

Further research showed that power amplifications of 100 times or more could be readily achieved. From this point it takes little imagination to visualize the usefulness of such a simple device; no hot cathode, very small size, and apparently nothing to wear out or get used up.

In the short space of five years the amount of scientific effort and the number of dollars spent on the transistor family has ballooned to millions of man-hours and of dollars. Even more fantastic is the fact that most of this investment is still in development rather than in production.<sup>2</sup> Both industry and the government are gambling on the future of the transistor, but it looks like the odds are all favorable.

## *The Lowest-Powered Transmitter*

Now what has all this to do with the average ham? Actually nothing very much at this time,

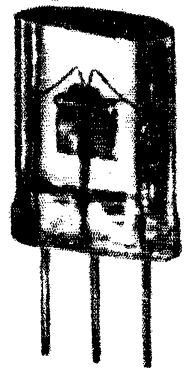

A point-contact transistor, three times actual size.

except that being a person possessing more than average scientific curiosity and ability he likes to anticipate his next or next-after-next project.

The writer, being fortunately situated with respect to transistor availability, was able not only to anticipate but also to carry out a pet ham project of many months' standing. This was to generate r.f. power, no matter how small, on two meters and see if the resulting signal could be heard beyond the confines of the shack. The two-meter band was chosen for two reasons. First, K2AH has a decent antenna (12-element beam) on two meters. Second, transistors were not supposed to work at frequencies as high as 146 megacycles. Ordinary transistors do not, but we in RCA had managed to put together some special ones which oscillated not only at 146 Mc. but which continued to do so above 300 Mc.<sup>3</sup>

A bit of arithmetical juggling of decibels and the known outputs of several 2-meter rigs came forth with the answer that anything over about 10 microwatts in the 12-element beam would be "gravy" over a path 15-20 miles long. It worked out just that way. We were sure of 30-50 microwatts from the transistor transmitter, so it was with considerable confidence that we asked Tommy Thomas, W2UK, of New Brunswick, N. J., to listen for us at 146 megacycles. He promptly came back and reported the signal RST 559. Tommy is a bit over 25 miles away as the signal flies. We then had contacts with W2KNI, Mountainside, N. J., and with W2DPB in East Orange, N. J., both of whom are about 15 miles away. Our own QTH is Mountain Lakes, N. J.

The transistor transmitter itself was simply a keyed crystal-controlled oscillator using about the same number of incidental components as one would find in the usual tube oscillator. The circuit is shown in Fig. 1. It will seem unfamiliar because the symbol for a triode transistor is different from that of a triode vacuum tube. However, in principle the circuit is a relative of the well-known Colpitts. Another feature which is perhaps also unfamiliar is the use of the quartz crystal as an r.f. by-passing element. Crystals can be made to operate as either high-impedance or low-impedance circuit elements at closely adjacent frequencies. In this case the low-impedance mode was used so that the series resistor in the transistor base lead would be by-passed and oscillation would occur only at the crystal frequency. Next to making the transistor work at 2 meters, the pleasantest surprise came in finding it was possible to get solid frequency control at the 9th overtone of a 16-Mc. crystal which was originally maximized for 5th overtone. Control was so tight that there was no noticeable keying chirp.

Power was supplied from a hearing-aid type 22½-volt "B" battery. The series dropping resistor reduced this potential to about 10 volts at

the transistor so that the total power to the oscillator was about 30 milliwatts.

We have not had the time at this writing to replace the series dropping resistor in the tran-

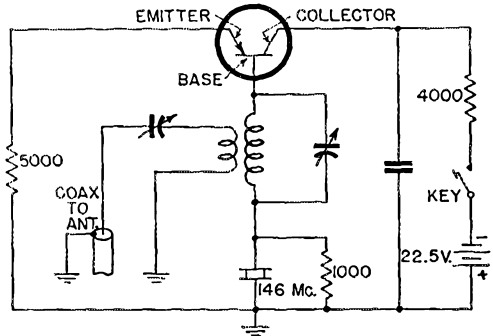

Fig. 1 — Schematic diagram of the transistor crystal oscillator used on 146 Mc. by K2AH. The only unfamiliar element is the symbol for the transistor itself. Values in the tuned circuits are dependent on the frequency used, but this general circuit works with crystals of much lower frequency as well.

sistor collector circuit with a modulating transistor, but this is possible and will be done in time.

Even though *Project Transistor QSO* is in the category of hobby-horse riding, its accomplishment does serve to underscore the potential importance of transistors in the field of electronics. Somewhere in the first few paragraphs we used the term "transistor family," and did so deliberately because there are already several different members. Many more will certainly be forthcoming.

### Types of Transistors

The kind used in the 2-meter ham rig is a "point-contact" transistor in development by RCA consisting of two phosphor-bronze "cat whiskers" touching a small piece of germanium at points less than a thousandth of an inch apart. Germanium is a basic element and, like silicon, galena, and certain other materials, is in the class of semiconductors. These are peculiar materials in that they are neither good insulators nor good conductors.<sup>4</sup> They have another property which is both interesting and useful. Any metallic contact which is made to them with fairly light pressure will be found to carry current more easily in one direction than in the other, and is thus rectifying. There is as yet no good explanation but the effect seems to be a combination of electrochemical and mechanical action which disturbs the atoms of the semiconductor in the region of the contact. Well-soldered contacts do not exhibit this rectifying effect. This "disturbed" region of the semiconductor is called a "barrier" and can be thought of as a swinging door having a stiff spring on one side and a light spring on the other.

The point-contact transistor then consists of two of these rectifying contacts closely adjacent to each other on a piece of germanium. Typical

<sup>3</sup>G. M. Rose and B. N. Slade, "Transistors Oscillate at 300 Megacycles," *Electronics*, Nov., 1952.

<sup>4</sup>W. Schockley, "Electrons and Holes in Semiconductors," published by D. Van Nostrand Co., Inc., 1950.



construction is shown in Fig. 2. Of all the various semiconducting materials explored so far germanium seems to work best, so most transistor development centers around its use.

One of these contacts, called the collector, is biased several volts (sometimes as high as 30 or 40 v.) in the direction of poor conduction, so that only a small amount of current flows. Figuratively, we are trying to open the door against the stiff spring. The other contact, called the emitter, is biased a few tenths of a volt in its direction of good conduction. As this emitter bias is applied, the collector current will be observed to increase substantially and will increase 2 or 3 times as rapidly as the emitter current increases. The emitter current, therefore, reduces the effectiveness of the "barrier" at the collector contact, or in effect reduces the stiffness of the stiff spring in our door analogy. We, in effect, get a "current gain" of at least 2 or 3 times. This in itself is not very impressive, but now let us measure two other electrical properties. The input or emitter circuit resistance is found to be about 500 ohms, and the output or collector circuit resistance about 20,000 ohms. A bit of arithmetic, using Ohm's law, shows we have a power amplification of about 100, which of course "ain't hay."

So much for the point-contact transistor, except to point out something you might have overlooked. The transistor is a current-controlled device in contrast with the vacuum tube which is a voltage-controlled device. This means that transistor circuitry will be different in many respects from the familiar tube circuitry. It also means that direct performance analogies between vacuum tubes and transistors can lead to considerable confusion and should be avoided.

These remarks apply almost equally well to another type of transistor which is receiving

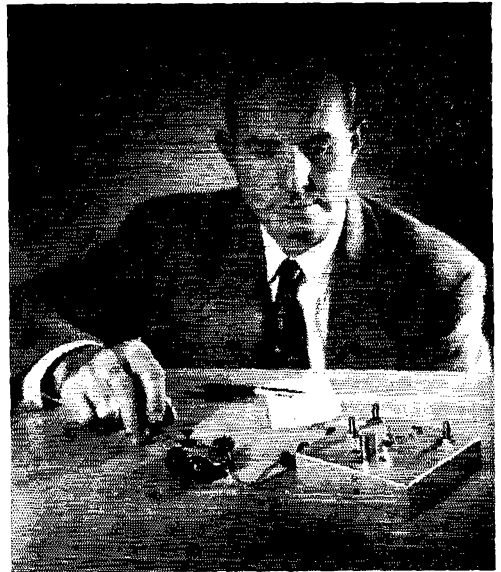

The author and his transistor rig.

One technique for creating these barriers, or junctions, is to diffuse another material, such as the metal indium, into two sides of a small slab of germanium. Electrical connections are made as shown in Fig. 2 to each of these junctions. The third contact in both types of transistor is a non-rectifying contact soldered to the body of the germanium piece and is called the "base."

The explanation for the occurrence of power amplification in the junction transistors is somewhat less complicated than is the case with the point-contact transistor, but is still too abstruse to attempt here except to again say that the two junction areas interact. A more thorough explanation calls for the use of the concept of conduction by "holes" in addition to conduction by electrons. Holes are places in the germanium crystal atomic structure where electrons could be but are not. Although this sounds ridiculous it has considerable foundation in fact. These holes do enter into the conduction process and behave as if they were positive electrons. There is no analogous effect in vacuum tubes.

It is quite possible to make transistors in which either electron or hole conduction is predominant. One can therefore make transistors which have almost identical electrical characteristics except that the applied battery potentials are exactly reversed in polarity. It would be just as if we could make positron tubes as well as electron tubes. This is particularly intriguing to circuit specialists because it makes certain types of circuitry possible with transistors which are either impractical or perhaps impossible with tubes.

(Continued on page 133)

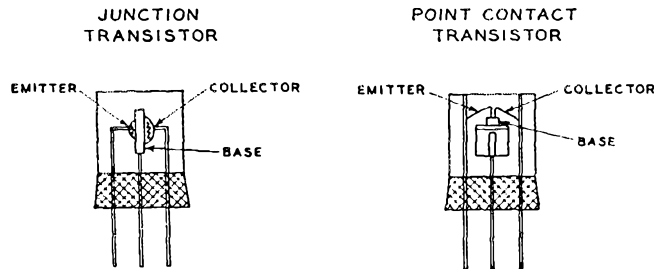

Fig. 2 — Basic details of junction and point-contact transistors.

about the same amount of technical attention as the point-contact transistor. This one is known as the "junction" transistor. It appears to be even more promising than the point-contact type, particularly at low and medium frequencies. Power gains as high as 100,000 in a single stage have already been measured. Physically the junction transistor is quite unlike the point-contact type, as can be seen from Fig. 2, although there is some similarity in principle. It, too, has two "barriers" but these are located opposite each other on or within a piece of germanium crystal.

# • On the TVI Front

## ARLINGTON, TEXAS, TVI FORUM

In mid-January the Arlington State College Radio Club sponsored a TVI forum aimed at improving understanding and liaison between radio amateurs and the TV servicemen and dealers of the Dallas-Fort Worth area.

F. M. Shook, W5IT, coauthor of "The Dallas Plan for TVI" (June, 1951, *QST*), served as spokesman for the amateur; F. N. Kasal, RCA Service Co., participated for the manufacturer; and Engineer-Investigator W. I. Abbott, Dallas District Office, acted as representative of FCC. A question-and-answer period followed addresses and demonstrations by these authorities.

Noteworthy in the breakdown of the registration of 145 persons attending was the fact that amateurs and dealers-servicemen were about equally divided, indicating a strong interest by the latter group in their responsibility to the TV viewer.

## ASSIST FOR TV VIEWERS

When an amateur has done "Everything in the book" to clean up his own rig, yet cannot operate in peace because of the lack of high-pass filters or adequate shielding in his neighbor's TV receivers, a special brand of strategy is called for. We learned recently of a new approach to this problem, devised by L. W. Franklin, W2BF.

"Ben" made heavy inroads on this discomfiting situation by preparing a form letter for use by his neighbors in writing to the service departments of their respective set manufacturers. The letter describes local conditions in technical language, and requests the installation of a high-pass filter or the making of other modifications which now are a part of the service policy of responsible TV set manufacturers. W2BF reports that he is still on speaking terms with his neighbors.

## ROSTER OF TVI COMMITTEES

As reported in February *QST*,<sup>1</sup> the number of local TVI committees is showing a healthy growth. We present in the adjoining column a listing showing cities which have one or more committees in operation; this compilation is based on data collected by FCC Regional Managers. This roster should prove of value to amateurs living in these communities, and to clubs in near-by localities who need advice on the formation of their own local committee.

<sup>1</sup>"Progress Report on TVI Committees," Turner, page 48, Feb., 1953, *QST*.

*Alaska:* Anchorage, Fairbanks  
*Alabama:* Birmingham, Montgomery  
*Arizona:* Tucson  
*Arkansas:* Fayetteville, Ft. Smith, Little Rock  
*California:* Albany, Benicia, Berkeley, Burlingame, Downey, El Cerrito, Inglewood, Livermore, Long Beach, Marin County, Monterey, Newark, North Hollywood, Oakland, Orange County, Palo Alto, Richmond, San Bernadino, San Bruno, San Diego (2 clubs), San Francisco, San Jose, San Mateo, Two Meter & Down Club (scattered locations), Turlock, Vallejo, Woodland  
*Connecticut:* Bridgeport, Hartford, New London, Norwalk, Norwich, Poquonnock  
*Colorado:* Boulder, Colorado Springs, Denver, Grand Junction, Greeley, Pueblo  
*Delaware:* None  
*District of Columbia:* Washington  
*Florida:* Ft. Lauderdale, Jacksonville, Miami, Pensacola, West Palm Beach  
*Georgia:* Atlanta, Augusta, Hapeville, Macon, Warner Robins  
*Idaho:* None  
*Illinois:* Berwyn, Decatur, Des Plaines, Freeport, Galesburg, Princeton, Rock Island, Wheaton  
*Indiana:* Elkhart, Ft. Wayne, Gary, Portland, South Bend, Vincennes  
*Iowa:* Davenport, Sioux City, Spencer, Waterloo  
*Kansas:* Leavenworth  
*Kentucky:* None  
*Louisiana:* Baton Rouge, Lake Charles  
*Maine:* None  
*Maryland:* Annapolis, Baltimore (2)  
*Massachusetts:* Boston, Lowell, Springfield, Worcester  
*Michigan:* Birmingham, Bloomfield Hills, Ferndale, Grand Rapids, Grosse Pointe, Grosse Pointe Park, Hazel Park, Pontiac, Royal Oak  
*Minnesota:* Fairmont, Red Wood Falls, Waseca  
*Mississippi:* Hattiesburg, Jackson, Keesler Air Force Base, Pascagoula  
*Missouri:* St. Louis  
*Montana:* None  
*Nebraska:* North Platte, Omaha  
*Nevada:* None  
*New Hampshire:* Concord  
*New Jersey:* Denville, Livingston, Morristown, Parsippany  
*New Mexico:* None  
*New York:* Binghamton, Brooklyn, Elmira, Hornell, New York, Niagara Falls, Penn Yan, Rochester, Roxbury  
*Syracuse, Watertown*  
*North Carolina:* Asheville, Winston-Salem  
*North Dakota:* None  
*Ohio:* Cleveland (6), Columbus, Dayton, Greenville, Middletown, Springfield, Zanesville  
*Oklahoma:* Clinton, Ft. Sill, Lawton, Tulsa  
*Oregon:* Pendleton, Salem  
*Pennsylvania:* Altoona, Dubois, Easton, Kingston, Lebanon, Lock Haven, New Brighton, Oil City, Philadelphia (2), Pittsburgh, Reading, Scranton, Sharon, Soleburg, Wilkes Barre  
*Rhode Island:* Westerly  
*South Carolina:* Florence  
*South Dakota:* Mitchell, Rapid City  
*Tennessee:* Chattanooga, Jackson, Knoxville, Oak Ridge  
*Texas:* Beaumont, Brownsville, Corpus Christi, Houston, Orange, Port Arthur, Woodsboro  
*Utah:* Ogden, Provo, Salt Lake City  
*Vermont:* Burlington  
*Virginia:* Fredericksburg, Newport News, Richmond, Roanoke  
*Washington:* Astoria, Bellingham, Bremerton, Everett, Kennewick, Pasco, Richland, Seattle, Tacoma  
*West Virginia:* Dunbar, Nitro, Parkersburg, St. Albans  
*Wisconsin:* Eau Claire, Kenosha, Milwaukee, Neenah, Racine  
*Wyoming:* Casper, Cheyenne, Cody, Gillette, Powell  
*Others:* MARS Net — Eight Western States: Interference Committee, Fourth Air Force, Attention: Captain Kennedy

# Combining the Antenna Coupler and Low-Pass Filter

*A Matching Unit for the 5763-6146 "75-Watt" Transmitter*

BY GEORGE GRAMMER,\* W1DF

ALTHOUGH the antenna-coupling unit shown in the accompanying photographs was built as a matching unit for the 75-watt transmitter described in December *QST*,<sup>1</sup> the construction is suitable for any transmitter running 100 watts or so. It combines a number of things, such as a low-pass filter for TVI and an r.f. voltmeter circuit for checking power output, into one coordinated unit, in contrast to the more common practice of building such accessories separately. The voltmeter circuit is arranged to use the same 1-mil meter (with its 5000-ohm series resistor) that makes all the other measurements in the December transmitter.

The individual circuits are not novel; both the voltmeter circuit and the inexpensive low-pass filter have been discussed in previous *QSTs*, and the antenna-coupling circuit is the standard one modified to permit series and parallel tuning of the conventional type as well as matching the feeders to a coax link through the familiar parallel-tuned matching circuit. The arrangement is identical with one described in the 1953 *Handbook*. Two variable condensers are turned together through a right-angle drive, but their shafts are insulated from each other and from ground so they may be connected in various ways. For matching a parallel-conductor feeder to a coax link, this makes about as "universal" an arrangement as it seems possible to find; practically any random combination of antenna and feeder length can be matched to a 50- or 75-ohm line by using one coupling circuit or the other. It is equally possible to match a single-

wire feeder or antenna working against ground, simply by grounding the center of the tank coil,  $L_7$  in Fig. 1, and treating the single wire as a one-sided feeder-system.

## Construction Notes

The coupler is built on a  $7 \times 9$ -inch chassis and fits in an  $8 \times 12\frac{1}{2} \times 8\frac{1}{2}$ -inch cabinet (8 by 10 panel). The antenna condensers,  $C_6$  and  $C_7$ , are mounted on triangular pieces of aluminum that in turn are supported from the chassis, at their corners, by 1-inch ceramic stand-offs. These assemblies are spaced so that there is room for insulated couplings between the condenser shafts and the right-angle drive unit, the shafts being cut off to suit. A little care should be used to line up the assemblies on the chassis so that the condensers can turn freely. The advantage of this mechanical arrangement is of course that the condenser capacitances are identical for a given dial setting, so that with the two rotors connected together the two operate together as a split-stator condenser. A regular balanced condenser could be used instead, but since such condensers have a shaft common to both sections the series-tuning connection cannot be used. As an alternative to the right-angle drive, a straight-through arrangement of two condensers mechanically connected through an insulated shaft coupling could be used, but there do not seem to be any condensers of the proper ratings available with tail-shaft extensions to make this possible.

For the parallel-tuned circuit the condenser rotors are connected together through a plug bar, made from aluminum, which fits into banana jacks mounted on the triangular plates. The jacks shown in the photograph are from

\* Technical Editor, *QST*.

<sup>1</sup> Grammer, "75 Watts with an 'Economy' Power Supply," *QST*, December, 1952.

◆

The combination universal antenna coupler, low-pass filter and r.f. voltmeter circuit is built in a small cabinet matching the 75-watt transmitter described in the December, 1952, issue. This illustration shows the set-up used for adjusting the coupler to match the impedance of the coax line connecting the two units. The s.w.r. bridge is a simple resistance type described in the *Handbook*.

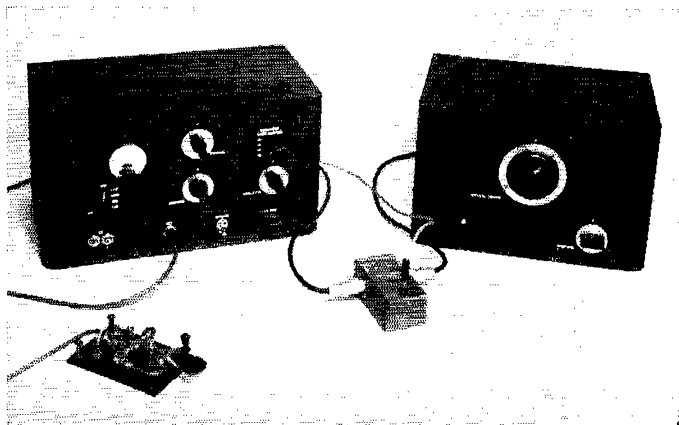

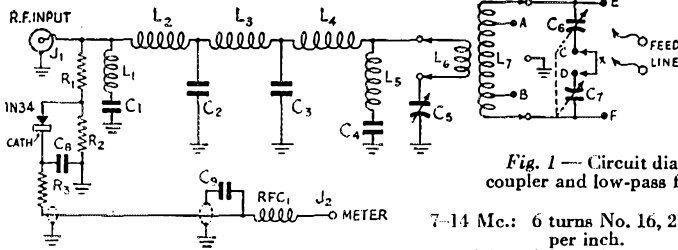

Fig. 1—Circuit diagram of the antenna coupler and low-pass filter.

- C<sub>1</sub>, C<sub>4</sub>**—40- $\mu$ fd. silver mica, 500 volts.  
**C<sub>2</sub>, C<sub>3</sub>**—120- $\mu$ fd. silver mica, 500 volts (50- and 70- $\mu$ fd. units in parallel).  
**C<sub>5</sub>**—300- $\mu$ fd. variable, 0.024-inch spacing (Bud M.C.-1860).  
**C<sub>6</sub>, C<sub>7</sub>**—300- $\mu$ fd. variable, 0.026-inch spacing (National TMS-300).  
**C<sub>8</sub>**—0.005- $\mu$ fd. disk ceramic.  
**C<sub>9</sub>**—0.001- $\mu$ fd. disk ceramic.  
**R<sub>1</sub>**—6800 ohms, 1-watt composition.  
**R<sub>2</sub>**—680 ohms, 1/2-watt composition.  
**R<sub>3</sub>**—1500 ohms, 1/2 watt.  
**L<sub>1</sub>, L<sub>5</sub>**—6 turns No. 16, 1/2 inch i.d., 15/16 inch long.  
**L<sub>2</sub>, L<sub>4</sub>**—9 turns No. 16, 1/2 inch i.d., 1 inch long.  
**L<sub>3</sub>**—13 turns No. 16, 1/2 inch i.d., 1 1/8 inches long.  
**L<sub>6</sub>**—3.5-7 Mc.: 10 turns No. 16, 2 inches i.d., 10 turns per inch.

- 7-14 Mc.: 6 turns No. 16, 2 inches i.d., 10 turns per inch.  
 14-28 Mc.: 2 turns No. 16, 2 inches i.d., 10 turns per inch.  
**L<sub>7</sub>**—3.5-7 Mc.: 20 turns No. 12, 2 1/2 inches i.d., 6 turns per inch.  
 7-14 Mc.: 10 turns No. 12, 2 1/2 inches i.d., 6 turns per inch.  
 14-28 Mc.: 4 turns No. 12, 2 1/2 inches i.d., 6 turns per inch.

NOTE: Length dimensions of L<sub>1</sub> to L<sub>5</sub>, inclusive, are measured between end turns and do not include lead lengths. Inductances should be adjusted as described in the text, if possible. L<sub>7</sub> is B & W type 3905-1 coil material; L<sub>6</sub> is B & W type 3907-1. L<sub>6</sub> mounted inside L<sub>7</sub> at center. L<sub>6</sub>-L<sub>7</sub> assembly mounted on Millen type 40305 plug.

**J<sub>1</sub>**—Chassis-type coax connector.  
**J<sub>2</sub>**—Insulated tip jack.  
**RFC<sub>1</sub>**—1-mh. r.f. choke (inductance not critical).

jack-top binding posts, most of the post body being sawed off so the remainder could be used as a nut. We didn't happen to have any regular jacks at the time. When the bar is removed and the flexible leads from the output posts are connected to the condenser frames the circuit is series tuned.

The coil socket (Millen 41305) is mounted on the same pillars that support the rear corners of the triangular plates, but there is no electrical connection between this socket and the plates. The center socket prong is grounded to the chassis directly underneath.

#### Low-Pass Filter Construction

To simplify the mechanical work there is no shielding between the individual sections of the low-pass filter in this unit; instead, the coils are separated and so oriented as to reduce coupling between them. It is recommended that the layout shown be followed fairly closely for this reason. It is also advisable to separate the coax input

<sup>2</sup>"Low-Cost Low-Pass Filters from Standard Mica Condensers." *QST*, December, 1952.

• The unit described in this article was built as a companion to the transmitter described in December *QST*, carrying through to the antenna feeders from the output terminal of that outfit. It is complete with a low-pass filter for TVI reduction and includes an r.f. voltmeter circuit for checking power output, using the 0-1 ma. meter built into the transmitter. The same type of assembly can be used with other transmitters, up to 100 watts or better, that have been designed to put their power output into a flat coax line.

terminal and the circuit formed by L<sub>6</sub> and C<sub>5</sub> as much as possible. From an electrical standpoint the arrangement used leaves something to be desired, at least theoretically, but concessions have to be made to the physical characteristics of components and their relationship to an acceptable panel layout.

The dimensions of the filter coils are given in Fig. 1 and should be closely duplicated, especially if there is no calibrated grid-dip meter available for making adjustments as described earlier.<sup>2</sup> The electrical constants of this filter are the same as those of filter B in the referenced article. The 1-inch ceramic pillars supporting the coils should be located as shown in the bottom view of the chassis. C<sub>1</sub> and C<sub>4</sub>, the condensers in the series-resonant circuits, should be grounded as close as possible to the input and output terminals, respectively. In this unit, C<sub>1</sub> is grounded at one of the screws holding the coax connector to the chassis, and C<sub>4</sub> is grounded to a lug under the pillar supporting the junction of L<sub>4</sub>, L<sub>5</sub> and the lead from L<sub>6</sub>. The latter lead then drops through a hole in the chassis and connects to the coil socket on the other side.

Although the harmonic attenuation of the filter will not be affected to an observable extent by small deviations from the optimum constants, the impedance characteristics in the passband—especially near the cut-off frequency—will be better if the values are right. While departures even in this respect are not likely to be really serious, it is worth while to use a grid-dip meter to set the coils if it is possible to do so. The method was described in December *QST*.<sup>2</sup>

#### Voltmeter Circuit

The voltmeter circuit is connected to the input side of the low-pass filter, since this is the point at which the impedance can be set at a known

value by means of a simple s.w.r. bridge. Also, harmonics generated by the rectifier circuit will be attenuated through the filter, which would not be the case if the voltmeter were connected at the output side. There is found to be a small power loss through the filter and coupler circuit, so the voltmeter does not serve to measure the actual power delivered to the feeders. However, this loss is generally inconsequential and does not in any way impair the principal function of the voltmeter, which is to give a check on transmitter adjustment versus power output. Provided the adjustments of the antenna coupler are left fixed, an increase in the voltmeter reading always accompanies an increase in actual power output as adjustments are made at the transmitter. However, the voltmeter readings are *not* useful in determining the proper antenna coupler adjustments.

The circuit components are mounted as close as possible to the coax input terminal, but with as little stray coupling to the low-pass filter components as the circumstances permit. The r.f. voltage divider,  $R_1R_2$ , reduces the voltage applied to the crystal to a safe figure for the level of power to be handled.  $R_3$  is used as a combination r.f. filter (in conjunction with  $C_9$ ) and calibration resistor. Since a small amount of harmonic is generated in the rectifier circuit this filtering is desirable, as is also the shielded lead to the output jack. This lead is by-passed by  $C_9$ , mounted right on its output end.  $RFC_1$  was found to be necessary to prevent fundamental-frequency current from flowing on the external lead to the milliammeter — this had some effect on the readings — and the end of the choke connected to  $J_2$  should not be by-passed.

The voltmeter is highly useful as a relative indicator even though not calibrated, and in such case the value of  $R_3$  should be chosen simply to keep the reading on scale with normal power output. The value given in Fig. 1 was selected to make a 0-1 milliammeter with a 5000-ohm resistor in series read directly in r.f. volts in a 75-ohm load. The scale reading is multiplied by 100 for this purpose; that is, 1 ma. corresponds to 100 volts r.m.s. The voltmeter can be calibrated by connecting the coupler to an antenna and adjusting to give a value of load at the input

◆

The arrangement of low-pass filter and voltmeter components is shown in this bottom view. An aluminum bottom plate goes on the chassis to complete the shielding of the filter.

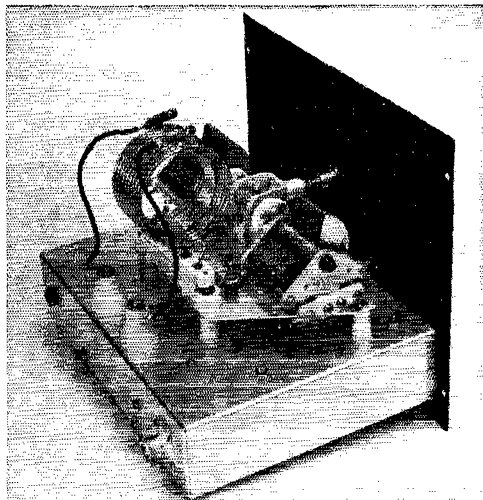

A side view of the coupler chassis. The Johnson clips are used sidewise to make a friction fit on soldering lugs used as taps on the coils and on the tuning condensers, a "quick-change" feature. The 6-32 spade bolts at the bottom of the rear wall of the chassis go through holes in the bottom of the cabinet and are fastened down with nuts after the assembly is in the cabinet; this holds the chassis firmly in place when a coil is pulled out of its socket.

terminals equal to the impedance of the coax link, using an s.w.r. bridge for the purpose, and then measuring the r.f. current into the unit with a regular r.f. ammeter. As the power output of the transmitter is varied the current and voltage readings may be compared and various values of  $R_3$  tried until the readings are consistent with Ohm's Law. With a 75-ohm load, 1 ampere corresponds to 75 volts,  $\frac{1}{2}$  ampere to 37.5 volts, and so on. The power is simply  $I^2R$  or  $E^2/R$ . Although the correspondence between the volt-

(Continued on page 118)

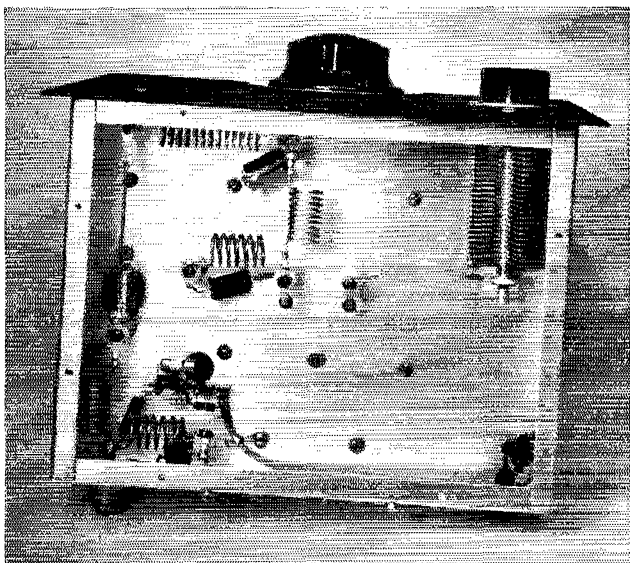

# TVG—An Aid to Break-In

## Automatic Receiver Silencing and Protection

BY C. C. MILLER,\* W2RDK, AND F. T. MEICHNER,\* W2NVY

• A perennial problem of the c.w. set, particularly the contest and traffic regulars, is smoother c.w. break-in operation. The solution described here will hold your receiver on the table and your ears on your head, despite the best efforts of your transmitter to the contrary.

**T**IME-VARIED Gain Control, abbreviated "TVG," is a method of rapidly decreasing the sensitivity of the receiver in a station just before the transmitter is keyed, and of letting the gain slowly return to normal after the keying is finished. We agreed, during the development of a commercial system incorporating TVG, that it ought to be FB for hams who still talk with their fingers on the lower frequencies. Nothing was done about it hamwise until the system was operating. Then W2RDK, who was planning to wear himself out in the annual SS Contest, saw it in operation and decided he couldn't live without one on the table in his ham shack.

A de luxe TVG can be made to "anticipate" one's keying; the simple system described here does so to a slight degree. Other forms of receiver protection had been tried out by W2RDK, but they were considered not to be the answer sought and were discarded. Rectifying r.f. from the transmitter and applying it as bias didn't furnish enough protection, and one could get burned coupling to the source of the r.f. In Goodman's "De Luxe Break-In System" a fast-operating relay is required. A good one cost real money, and a poor one didn't always work right; additional cathode bias supplied when the relay operated didn't do a good job of dropping the gain unless fairly high current was drawn through the biasing network.

The annual SS was about to begin when W2RDK saw the commercial version of TVG in operation, was instantly sold on it, and threw together the gadget to be described. Our system can be applied to most receivers with a minimum of connections to or work on the set. It can be switched in or out at will, does not actually require a relay, and can be built both small and inexpensively.

### The TVG Principle

Fig. 1 shows the a.v.c. line of a typical receiver, to which  $R_1$  and  $C_1$ , the two TVG timing components, have been added. If the line is discon-

nected from the receiver's a.v.c. diode and connected to a negative source through a momentary switch and  $R_2$ , it is easy to see that momentarily closing the switch biases down the receiver. If  $R_2$  is small, say a few hundred ohms, and  $R_1$  is large, say half a megohm,  $C_1$  is charged very rapidly and discharges quite slowly. If the switch were closed momentarily just before the key is closed for each transmitted dot or dash, the receiver sensitivity could be greatly decreased and held low until the keying was finished.

A practical circuit is shown in Fig. 2. The d.p.d.t. switch,  $S_1$ , disconnects the receiver's a.v.c. line from the diode, connects it to the "R1-er,"<sup>1</sup> and grounds out whatever a.v.c. bias is developed by the diode from the b.f.o.  $V_1$  is fed from a negative 125-volt d.c. source, and  $R_5R_6$  keep it beyond cut-off bias. Therefore there is no voltage across  $C_1$ , and the receiver operates normally under the control of its manual gain control. Applying a positive gating step to the grid of  $V_1$  through  $C_2R_3$  drives the tube into plate current saturation, rapidly charging  $C_1$  through the tube's (momentarily) very low plate resistance.  $R_1 + R_2$  is so high that  $C_1$  discharges quite slowly.

Variation of  $R_2$  ( $R_1$  establishes a minimum delay) changes the length of time before the receiver comes back to normal gain. This is variable from about 1/11 second to about 1 second for the values given.  $C_3$  helps to keep the cathode voltage of  $V_1$  from soaring during the time of conduction; a rising voltage here would tend to oppose the

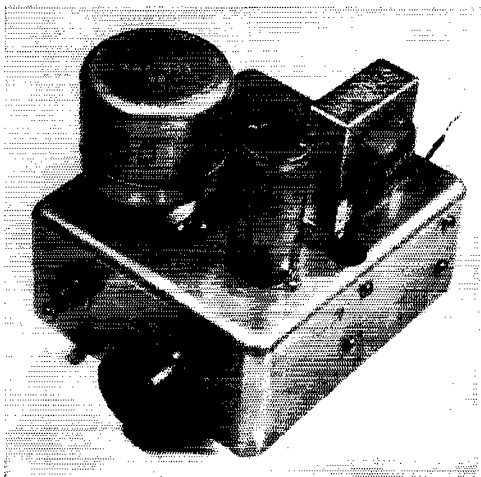

This little unit, the "TVG," protects the operator's ears by furnishing cut-off bias in advance of full power output from the transmitter and protects the receiver. Its use adds a lot to the enjoyment of c.w. operation.

\* Target Rock Corp., Huntington, L. I.

<sup>1</sup> "SI-er" of course is correct, but the pattern was set with the "R9-er," "Q5-er," etc.

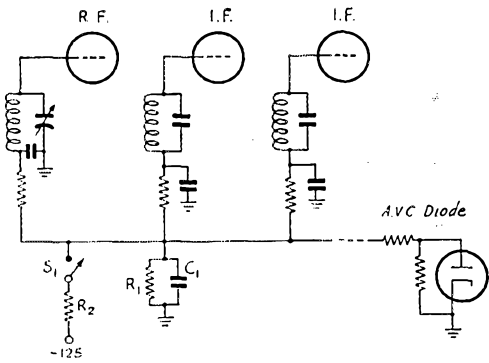

Fig. 1 — The basic principle of the TVG system can be illustrated by this schematic, which shows the a.v.c. line of a receiver disconnected from the a.v.c. diode and returned to ground through a long time-constant network,  $R_1 C_1$  (large  $R$  and  $C$ ). If  $R_2$  is small (a few hundred ohms),  $C_1$  will charge rapidly when  $S_1$  is closed and discharge slowly when  $S_1$  is opened.

gating voltage and thus reduce the current through the tube.

By "positive gating step" we mean some d.c. level that abruptly moves in the positive *direction*; i.e., from very negative to less negative, or from slightly positive to strongly positive. It can be derived from the transmitter, but not from the normal plate, screen, or grid terminals. These potentials drop under load and with excitation. The cathode end of an un-bypassed cathode resistor is positive-going, but the step there isn't "tall" enough to do much good.

At W2RDK, I take the positive gate from the plate of a 6Y6G that "clamps" the screen grid of my final amplifier in the well-known arrangement outlined in Fig. 3. This point rests at about 35 volts "key up" and rises very rapidly to 400 volts when grid current is developed through  $R_1$  under "key-down" conditions. The OD3 voltage-regulator tube is very important, since its finite ionization time serves in part as the "anticipator" in this simplified circuit. My receiver is cut off by the very rapid charge of the TVG capacitor ( $C_1$  in Fig. 2) through the low plate resistance of the gating tube,  $V_1$ . This happens before the screen voltage on the final is up to where much output is developed, because it takes time to ionize the OD3 and also to charge  $C_1$  through  $R_2$ . Setting frequency with the VFO, the final plate voltage is off and there is no positive-going gating pulse to the "R1-er" even though the 6Y6G has cut-off bias

applied to it. The receiver therefore works at full gain while "swishing." The actual delay of the keyed r.f. behind the receiver silencing wasn't measured. I finished the gadget described, checked it for operation with voltmeters, 'scopes, etc., and hurried home to lash it to my set before the SS battle got under way.

We added  $V_2$ ,  $R_6$ , and the relay, not for receiver silencing (which is done very nicely indeed by the TVG) but because RDK is about to put his kw. rig back on the air and was a little worried about burning up the antenna-coupling coil in his receiver. The relay is "surplus," fits a 5-pin socket, and carries the number K27J853-62. We understand they're still to be had for less than the price of a steak dinner. This relay operates positively at 4 ma., and has a 2100-ohm coil. Plus 150 volts at 4 ma. is borrowed from the receiver, and the relay is normally energized. Many relays, this one included, fall back faster than they pull up, so the relay is arranged to take off the receiver's antenna and short the receiver input when  $V_2$  is cut off by the developed TVG bias.

No constructional details are given, as we agree that nobody ever duplicates a gadget anyhow. The unit for W2RDK measures 5 by 4½ by 2 inches, including the selenium-rectifier type of power supply which delivers the 125 volts negative for the TVG tube. It sits behind the receiver in the shack at W2RDK, taking little space on the already-crowded operating table. If the relay scheme is incorporated, the r.f. leads from the antenna through the relay to the receiver must be kept as short as possible.

To hook up the "R1-er," disconnect the receiver's a.v.c. on-off switch and splice the "R1-er" terminals into the a.v.c. line to the receiver r.f. and i.f. tubes, as shown in Fig. 4. If the relay is used, "borrow" the 150 volts from the receiver and make the receiver antenna connections.

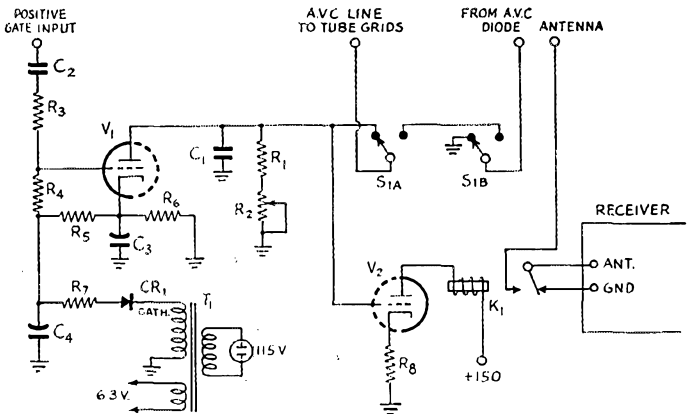

Fig. 2 — The practical TVG circuit.

- $C_1$  — 0.5- $\mu$ fd. 600-volt paper.
- $C_2$  — 0.1- $\mu$ fd. 600-volt paper.
- $C_3$  — 10- $\mu$ fd. 450-volt electrolytic.
- $C_4$  — 16- $\mu$ fd. 450-volt electrolytic.
- $R_1$  — 33,000 ohms, ½ watt.
- $R_2$  — 0.5-megohm potentiometer.
- $R_3, R_4$  — 0.47 megohm, ½ watt.
- $R_5$  — 20,000 ohms, 1 watt.
- $R_6$  — 0.1 megohm, ½ watt.
- $R_7$  — 100 ohms, 1 watt.
- $R_8$  — 620 ohms, 1 watt.
- CR1 — 100-ma. selenium rectifier, half-wave.
- $K_1$  — Relay, optional. See text.
- $S_1$  — D.p.d.t. switch.
- $T_1$  — 125 v. at 15 ma.; 6.3 v. at 0.6 amp. (Stancor P-8415).
- $V_1, V_2$  — 12AU7.

Twist the knob on  $R_2$  while sending a widely-spaced series of dashes until the recovery time suits your fancy, and settle down to enjoying c.w. again!

### General Considerations

The time constants of the circuit were designed for use with receivers whose normal a.v.c. time constants lie in the order of 2 to 5 milliseconds; i.e., whose individual a.v.c. filter resistors and capacitors per stage are of the order of 0.25 megohm and 0.01  $\mu\text{fd.}$ , respectively. If the time constants of a receiver are much longer than this, the gain may not be driven down fast enough to

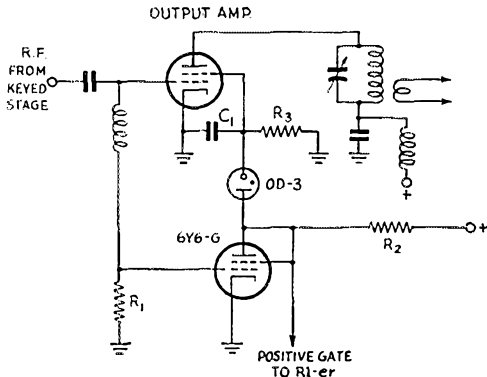

Fig. 3—The positive gate for the “R1-cr” can be obtained from the plate of the conventional clamp tube, as shown here.  
 $C_1$  — 0.005  $\mu\text{fd.}$   
 $R_1$  — Normal grid leak.  
 $R_2$  — Normal screen-dropping resistor.  
 $R_3$  — 0.47 megohm.

protect the receiver from the first transmitted dot. Some experimentation with the  $RC$  values in the receiver may thus be required in unusual cases.

The gating pulse should be picked off as early as possible in the transmitter after the keyed stage. If your tube line-up is VFO-2E26-6146-p.p. 4-400As and, as is common practice, you key somewhere in the VFO, you should operate your TVG from the 2E26. Otherwise, the signal at the grid of the stage from which you take the TVG gate may be loud enough to block the receiver, and you will also hear clicks in your receiver.

At W2RDK, my VFO is a two-tube job of well-known make that is modified to use a 2E26 output tube. It drives a 4-65A final running 125 watts input or so. The screen grid of the 4-65A is the “clamped” screen shown in Fig. 3. It is fed through a 15,000-ohm 50-watt resistor, and is bypassed by 0.001  $\mu\text{fd.}$  right at the tube socket. The

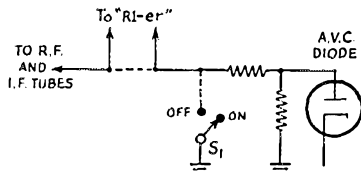
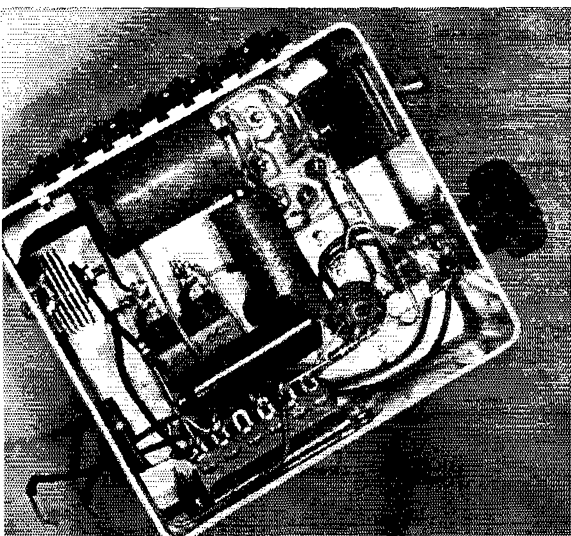

Fig. 4—Receiver changes necessary to add the “R1-cr” are shown by the dotted lines. The a.v.c. switch,  $S_1$ , is disconnected (or left open if it is a single-function switch), and the a.v.c. line is broken and connected to the points shown in Fig. 2.

actual operating screen voltage is a bit over 250 volts with the key down; the plate of the clamp tube varies from 35 volts with the key up to a little over 400 volts key down. This gives a very “tall” step to drive the TVG tube. It may be possible to take the gate pulse from the key in the “De Luxe Break-In Keying Unit” shown in the *Handbook*, as this point goes from a very negative potential with key open to ground with key closed and is thus a “positive-going” step.

Another point to watch out for is the maximum-allowable grid-bias voltage limitation imposed on some tube types. The 6BA6, for instance, has a rating of -50 volts maximum. That means you shouldn't use a strongly-negative voltage source to feed the TVG tube in such cases. Adjustment of the source voltage and the divider network in the cathode circuit of the TVG tube may be called for in some cases. Obviously, the developed TVG voltage *isn't* going to be measured with the usual low-impedance voltmeter — an oscilloscope is ideal, but a vacuum-tube voltmeter or high-impedance instrument will serve.

The authors feel that the unit described, while not a universal panacea, will work with most of the receivers used by hams just as described and that anyone trying the unit will be well repaid for the modest effort and expenditure involved.



◆  
 The underside of the TVG.  
 ◆



# An All-Purpose Super-Selective I.F. Amplifier

*Tricks with Parallel Amplifiers of Different Bandwidths*

BY BYRON GOODMAN,\* W1DX

**T**HIS is a description of an i.f. amplifier designed to handle c.w., a.m., and s.s.b. signals, utilizing the maximum usable selectivity in each case. The primary purpose of selectivity, of course, is to reject QRM and accept only the desired signal. As you increase selectivity you run into the law of diminishing returns, because the more selectivity a receiver has the fewer will be the occasions demanding this degree of sharpness. But, like the WAC on her first 24-hour pass, we wanted to be prepared for any emergency, and so quite a bit of selectivity was built into this job. There could be more, we admit, but we had to stop somewhere.

In a previous effort<sup>1</sup> we took a crack at variable selectivity and exalted-carrier reception by building an amplifier that gave two choices of bandwidth, and on 'phone boosted the carrier amplification above the sideband gain. It showed advantages but was hardly a final effort. The amplifier to be described uses a different approach, which we feel is the right track, and even if you haven't the slightest yen to build one like it, you may be interested in the reasoning and the results.

The thinking went something like this: A sharp amplifier, say 300 cycles wide at 6 db. down and with as much skirt selectivity as possible, makes a mighty fine c.w. amplifier, as

W9AEH pointed out and several others have confirmed.<sup>2</sup> This same amplifier, or one even sharper, will also do nicely as a carrier amplifier for exalted-carrier reception. Then if we have another amplifier alongside it, wide enough to pass one sideband of an a.m. signal, we can have any degree of carrier exaltation we want by controlling the relative gains in the two amplifiers. If we've lost you at this point, take a look at Fig. 1. The sketch at A shows a bit of single-frequency r.f. Key it and it's a c.w. signal — leave it alone and it's a carrier. Either way the same sharp i.f. amplifier (as at B) will pass it and reject adjacent signals. Add a b.f.o. and we have a "super-selective" c.w. i.f. amplifier.

But an a.m. signal looks like Fig. 1C, and in 'phone reception we have to pass the carrier and at least one sideband or we won't get the full audio range out at the detector. The sharp i.f. of Fig. 1B won't pass much more than the carrier or just a small section of one sideband. But if we add another amplifier, like Fig. 1D, paralleling the sharp one, we can add its output to the output of the sharp job, and we will have the carrier and one sideband at the detector. This then gives the audio output we want, and excludes everything else to the maximum possible degree. By controlling the relative gains in the two channels, we can "exalt" the carrier over the sideband by any desired amount.

Why this carrier exaltation? Why not just use the amplifier of Fig. 1D to receive a 'phone signal? Isn't that what we do with a BC-453 Q5-er or any other sharp amplifier? Yes, it is what we do, but it isn't the best way to do the

\* Assistant Technical Editor, *QST*.

<sup>1</sup> Goodman, "A Sharp I.F. Amplifier for 'Phone or C.W.," *QST*, Dec., 1950.

<sup>2</sup> Githens, "A Super-Selective C.W. Receiver," *QST*, August, 1948; Kaye & Kaye, "One Db. per Cycle!," *QST*, Nov., 1951; Pittman & Summers, "The 'Ultimate' C.W. Receiver," *QST*, Sept., 1952.

◆

The super-selective i.f. amplifier uses two channels in parallel — a sharp one for c.w. or for 'phone carrier, and a broad one for a 'phone sideband.

The sharp i.f. is the strip at the rear of the chassis, and the broad one is just in front of it. The two tubes at the right-hand end of the broad amplifier are the "product detector" described in the text. The b.f.o. can is at the front right, next to its tube, and the near-by tube and can are in the signal-metering circuit.

The controls, from left to right, are sideband selector switch, audio volume, broad i.f. gain, sharp i.f. gain, function switch, and b.f.o. pitch control.

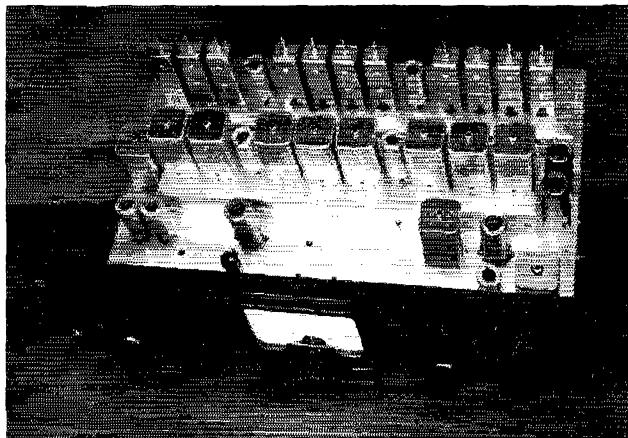

job. Look again at Fig. 1D. That amplifier doesn't even pass the carrier, so what demodulates the signal at the detector? The answer is "nothing," and to receive the signal you have to shift the tuning so that the carrier is passed through the amplifier together with the one sideband. Since no normal i.f. characteristic has perfectly square corners (and most aren't as good as the one shown in Fig. 1D), the carrier amplitude is always likely to be down from its original value, by comparison with the sideband amplitude. At the detector, the audio you hear is the beat between the highest-amplitude component and the other components, so unless the carrier is well above the sideband components you will get distortion. Further, in the presence of QRM, some of the QRM components might have the highest amplitude, and your desired signal demodulates against these and becomes fouled up. But if we can maintain the desired carrier higher in amplitude than any other component, everything will demodulate against it and we will stand the best chance of getting minimum distortion and fewest spurious audio components. This trick of boosting the carrier well above the sideband at the receiver is called "exalted-carrier reception" — at the detector it looks like a signal with a low percentage of modulation.

If you're still with us, you now have the idea behind this i.f. amplifier. We use two parallel channels — a sharp one for c.w. or carrier amplification, and a broader one for amplification of a single sideband (from an a.m. or s.s.b. transmitter) of a 'phone signal. The channels have independent gain controls, so we can set the carrier exaltation at whatever we want. It works.

For the sharp amplifier, we used tuned circuits using the 50-kc. coils from the Hallicrafters S-76 receiver. These coils have a  $Q$  of 100, and are the best thing we know of for the purpose at this frequency. The sharp curve in Fig. 2 shows the characteristic of this amplifier, which uses 11 of the circuits. The broad curve in Fig. 2 is the characteristic of the other amplifier, which uses stagger-tuned circuits made from RCA 205R1 Horizontal Oscillator Coils. These inexpensive coils have a  $Q$  of around 60, and are a good buy for anyone interested in selectivity. The dashed curve in Fig. 2 simply shows the reduction in gain through the sideband amplifier as the gain-control setting was shifted to a different position — the maximum gain in both amplifiers is represented by the solid lines.

### The Circuit

Since the amplifier is intended to be cut in on the 455-kc. i.f. of an existing receiver, the 455-kc. signals must first be converted to 50 kc. As shown in Fig. 3, crystal-controlled 6BE6 converters are used for this purpose. Two crystals are used, so that either the upper or lower sideband can be passed through the amplifier without retuning, in the McLaughlin selectable-sideband manner.<sup>3</sup> Switch  $S_1$  selects the oscillator fre-

<sup>3</sup>McLaughlin, "Exit Heterodyne QRM," *QST*, Oct., 1947.

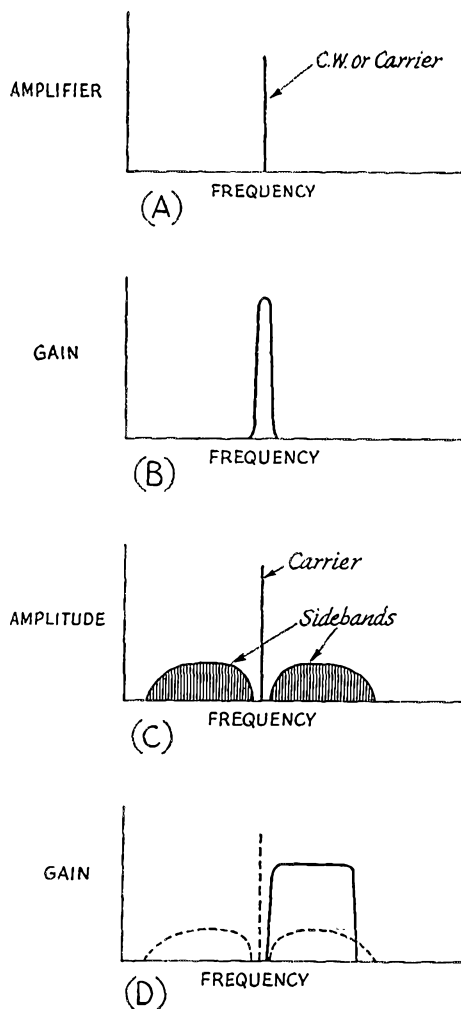

Fig. 1 — A single c.w. signal or an unmodulated carrier can be represented as at A. Obviously, a very sharp i.f. amplifier, as at B, can pass it without attenuation.

An amplitude-modulated signal consists of carrier and two sidebands, as at C, and a sharp amplifier (D) can receive one sideband without passing the carrier or the other sideband. Without the carrier present, this will give badly distorted demodulation at the detector.

quency, and hence the sideband, and is normally used in the middle or lower position. The upper position permits both crystals to become operative, during the alignment procedure mentioned later.

The two i.f. amplifiers follow the converter, and here two 6BJ6 variable- $\mu$  pentodes are used in each channel. Nothing is unorthodox in this part of the circuit, except that it will be seen that there are isolation condensers and resistors in each power lead, to prevent any over-all feedback. The common cathodes were a source of feed-back before  $RFC_3$ ,  $RFC_4$ ,  $C_{19}$  and  $C_{37}$  were added. The resistor,  $R_{50}$ , between gain control,  $R_{17}$ , and ground, was used to bring the relative

maximum gains of the two channels to the points shown in Fig. 2. The gain of the broad channel will vary with the degree of stagger tuning, so  $R_{50}$  should be inserted only after the alignment procedure has been completed. Its value, of course, may work out differently than that shown for this unit.

The detector uses two 12AU7 dual triodes in the "product detector" circuit,<sup>4</sup> one that is very well adapted to this type of use. Three of the triodes are cathode followers from the two i.f. amplifiers and the b.f.o., working into a common cathode resistor,  $R_{53}$ . The fourth triode also shares this cathode resistor, but has an audio load,  $R_{39}$ , in its plate circuit. The grid of this fourth triode is grounded for signal but has an adjustable negative bias from  $R_{33}$ . The signals mix in this fourth triode, but its adjustable bias permits setting the bias on one of the cathode followers (through the common cathode resistor) to the point where minimum detection takes place in the cathode follower. Thus, if the gain through the sharp amplifier is minimized (by removing a tube) and the b.f.o. is turned off, a modulated signal passed through the broad amplifier will yield no audio output from the detector at one setting of  $R_{33}$ . Turning on the b.f.o. or the gain of the sharp amplifier brings in the audio, because now the detector output is the product of the two channels. The advantage of the circuit is that it minimizes intermodulation at the detector and doesn't require a whopping big b.f.o. signal for exalted-carrier reception. An unexpected advantage of it is that a signal-level indicator circuit connected to the sharp amplifier doesn't indicate b.f.o. voltage, so the signal-level meter reads the same with b.f.o. on or off.

It might be well to discuss the signal-level circuit at this point. As can be seen from Fig. 3, where it is labelled "AVC-Rect.," it consists of a cathode follower driving a diode. In three positions of  $S_2$ , the rectified current simply works the meter, but an a.v.c. voltage is applied throughout the unit in the fourth position. The d.c. drop through the coil of  $LC_{21}$  biases the diode by a fraction of a volt and offers some slight delay in the a.v.c. action.

<sup>4</sup> From an unpublished paper by Murray Crosby. See "On the Air with Single Sideband," *QST*, May, 1952.

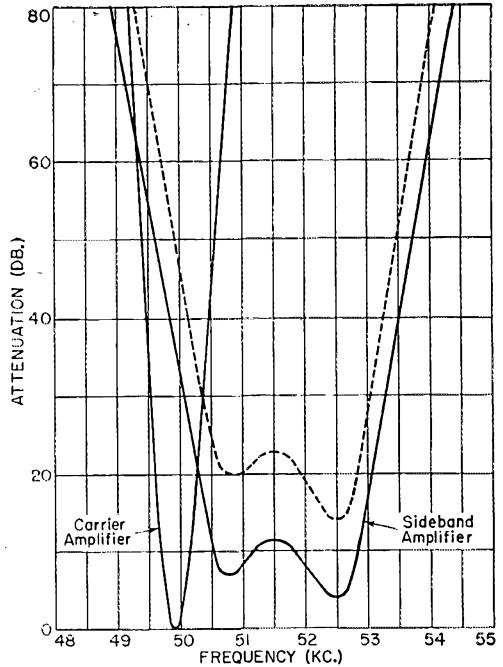
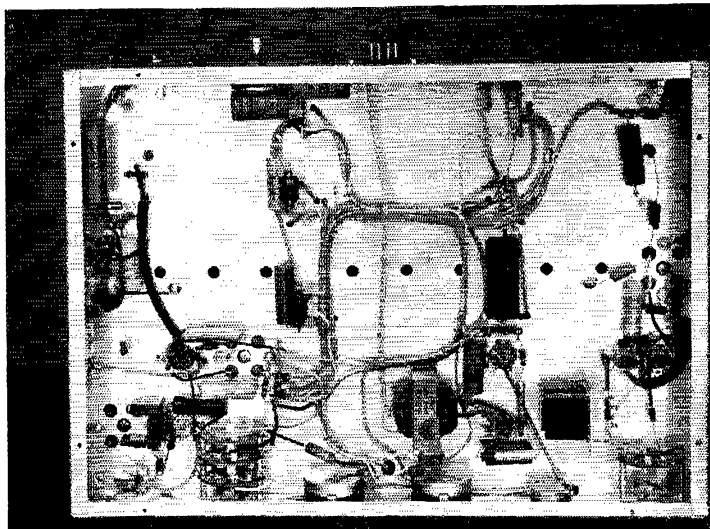

Fig. 2 — Selectivity curves of the two i.f. strips used in this amplifier. The dashed curve shows the response of the broad amplifier at reduced gain, indicating how the carrier exaltation can be controlled.

But the trouble with an i.f. system like this is that you can't use much a.v.c. without running into complexity or difficulty. As you tune through an a.m. signal, you have little or no a.v.c. voltage developed until the carrier falls within the passband of the sharp amplifier. (The sharp amplifier feeds the a.v.c. rectifier — signals in the broad amplifier develop no a.v.c. voltage.) Thus the a.v.c. does not protect both amplifiers until you are tuned to the signal, and the effect when tuning into a signal is not as smooth as with a conventional single-channel i.f. We even tried an amplified a.v.c. system, but this only made it worse when there was any detuning, and peaking signals on the meter resulted in lower audio volume than with slight mistuning.

This view underneath the chassis shows the two oscillator crystals at the lower right. Most of the shielded leads are power leads to the i.f. strips, although some of the low-level audio leads are also run in shielded wire. The eight holes across the center are for access to the tuning slugs of the broad i.f. strip.



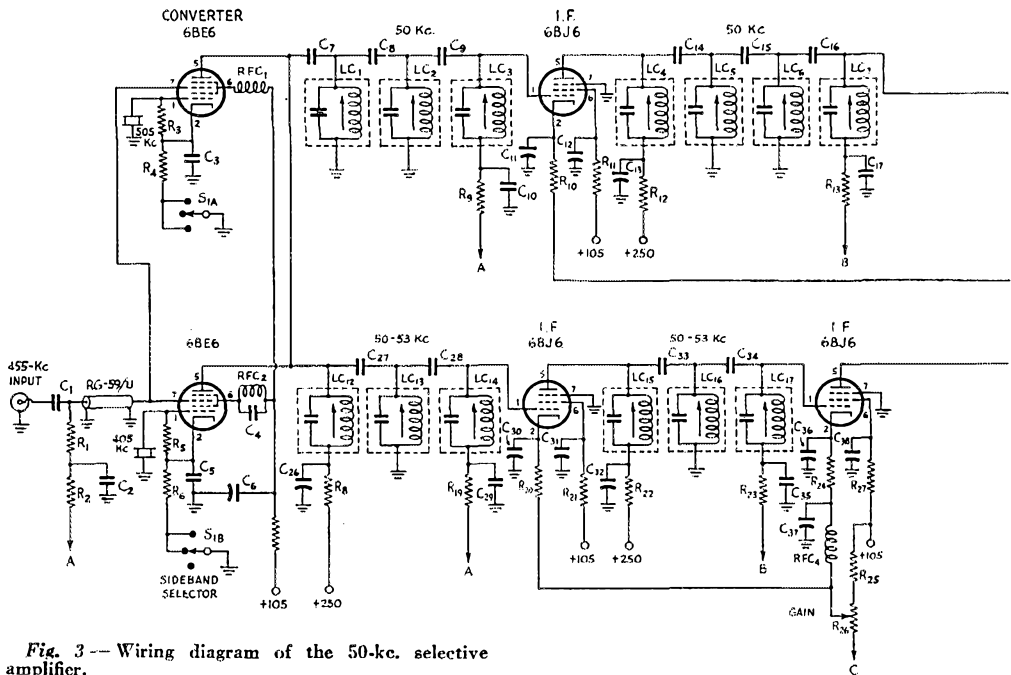

Fig. 3 -- Wiring diagram of the 50-kc. selective amplifier.

- C<sub>1</sub> — 0.005- $\mu$ fd. ceramic.
- C<sub>2</sub>, C<sub>6</sub>, C<sub>11</sub>, C<sub>12</sub>, C<sub>13</sub>, C<sub>18</sub>, C<sub>19</sub>, C<sub>20</sub>, C<sub>21</sub>, C<sub>26</sub>, C<sub>30</sub>, C<sub>31</sub>, C<sub>32</sub>, C<sub>36</sub>, C<sub>37</sub>, C<sub>38</sub>, C<sub>39</sub>, C<sub>42</sub>, C<sub>44</sub>, C<sub>46</sub>, C<sub>59</sub> — 0.1  $\mu$ fd., 400 volts.
- C<sub>33</sub>, C<sub>5</sub>, C<sub>10</sub>, C<sub>17</sub>, C<sub>29</sub>, C<sub>35</sub>, C<sub>43</sub>, C<sub>52</sub> — 0.01- $\mu$ fd. ceramic.
- C<sub>4</sub> — 47- $\mu$ fd. ceramic.
- C<sub>7</sub>, C<sub>8</sub>, C<sub>9</sub>, C<sub>14</sub>, C<sub>16</sub>, C<sub>16</sub>, C<sub>22</sub>, C<sub>23</sub>, C<sub>24</sub> — 2.4- $\mu$ fd. mica (two 4.7- $\mu$ fd. in series if lower value not available).
- C<sub>25</sub> — 100- $\mu$ fd. ceramic.
- C<sub>27</sub>, C<sub>28</sub>, C<sub>28</sub>, C<sub>34</sub>, C<sub>40</sub>, C<sub>41</sub> — 4.7- $\mu$ fd. mica.
- C<sub>46</sub>, C<sub>51</sub> — 16- $\mu$ fd. 450-volt electrolytic.
- C<sub>47</sub> — 0.002- $\mu$ fd. ceramic.
- C<sub>48</sub> — 250-970- $\mu$ fd. adjustable mica (El Menco 306).
- C<sub>49</sub> — 0.001- $\mu$ fd. ceramic.
- C<sub>50</sub>, C<sub>53</sub> — 10- $\mu$ fd. 50-volt electrolytic.

- C<sub>64</sub> — 470- $\mu$ fd. ceramic.
- C<sub>56</sub> — 35- $\mu$ fd. midget variable.
- C<sub>58</sub> — 220- $\mu$ fd. silver mica.
- C<sub>57</sub>, C<sub>58</sub> — 3300- $\mu$ fd. silver mica.
- C<sub>60</sub>, C<sub>61</sub> — 20- $\mu$ fd. 50-volt electrolytic.
- C<sub>62</sub> — 10- $\mu$ fd. ceramic.
- R<sub>1</sub> — 0.15 megohm.
- R<sub>2</sub>, R<sub>9</sub>, R<sub>13</sub>, R<sub>19</sub>, R<sub>22</sub>, R<sub>32</sub>, R<sub>40</sub> — 0.1 megohm.
- R<sub>3</sub>, R<sub>5</sub> — 0.12 megohm.
- R<sub>4</sub>, R<sub>6</sub> — 330 ohms.
- R<sub>7</sub>, R<sub>8</sub> — 2700 ohms.
- R<sub>10</sub>, R<sub>14</sub>, R<sub>20</sub>, R<sub>24</sub>, R<sub>48</sub> — 100 ohms.
- R<sub>11</sub>, R<sub>12</sub>, R<sub>15</sub>, R<sub>16</sub>, R<sub>21</sub>, R<sub>22</sub>, R<sub>27</sub>, R<sub>28</sub> — 10,000 ohms.
- R<sub>17</sub>, R<sub>26</sub> — 2000-ohm wire-wound potentiometer.
- R<sub>18</sub>, R<sub>25</sub> — 27,000 ohms, 1 watt.
- R<sub>29</sub> — 1500 ohms.
- R<sub>30</sub> — 1000 ohms.

There are undoubtedly methods that can be used in a system like this that will offer some smooth a.v.c. action, but they probably involve audio gating that opens up the audio only when the signal is tuned in on the nose. We prefer to use the amplifier this way, foregoing the ease of excellent a.v.c. for the advantages of selectivity and the physical effort of manual gain control.

The tuning meter is important, however. It permits the operator to center the carrier in the sharp amplifier with a minimum of effort, and it warns him when the amplifier is in danger of overloading. Overloading, of course, will tend to nullify the advantages of high selectivity, so it is important that the unit always be operated below this point. The manual gain controls will take care of about 60 db. range.

The remainder of the amplifier is conventional. The series trap, RFC<sub>1</sub>C<sub>43</sub>, is tuned to 50 kc., to by-pass the r.f. and prevent its getting on the audio grids. The b.f.o. circuit is a version of the series Colpitts (Clapp) that grounds the cathode

of the tube. The series circuit was used to utilize one of the RCA coils — at the LC ratio involved, a parallel-tuned circuit would probably have more drift. A choice of two low-impedance outputs from T<sub>1</sub> is provided, for 'phones and loudspeaker.

### Construction

There are only a few departures from conventional construction technique in this amplifier. Miniature tubes were used only to provide room for the tuned circuits — on a larger chassis or with a different layout, metal tubes should be perfectly satisfactory. However, no attempt should be made to save space by mounting the tuned circuits in anything but a straight line. The aluminum cans do not offer complete magnetic shielding at 50 kc., and it is possible to couple tuned circuits right through the thin aluminum. The high-Q coils have external iron pots as well as iron cores, and so their fields are confined, but the RCA coils use only an iron core.

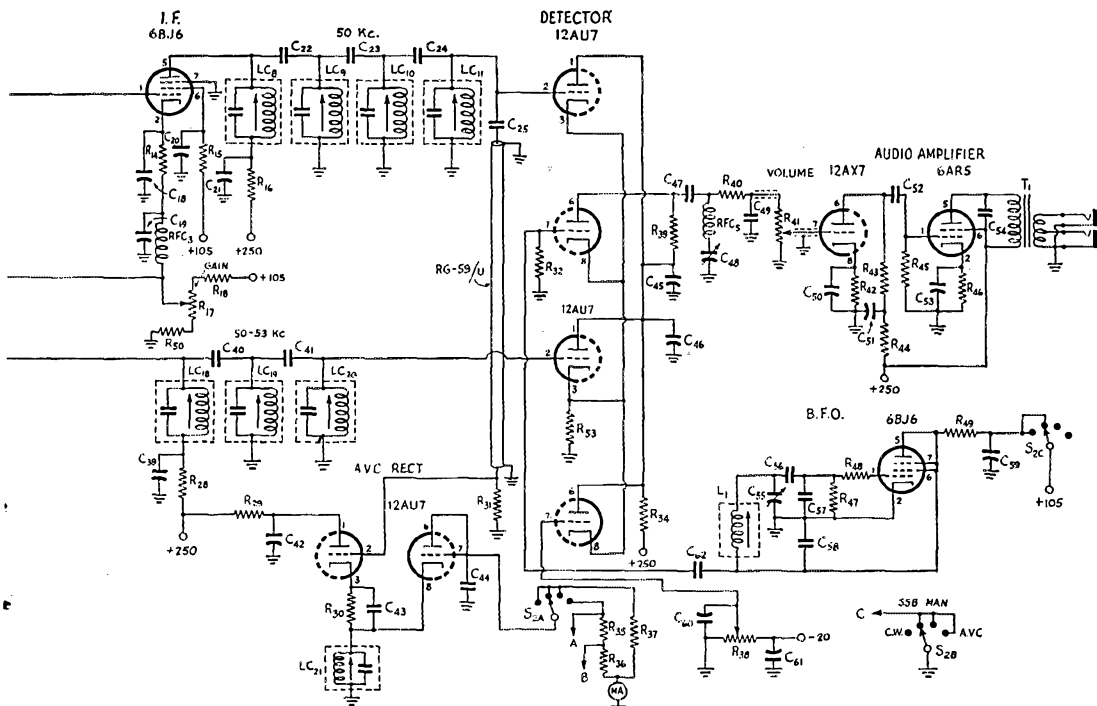

- R<sub>31</sub> — 1.5 megohms.  
 R<sub>34</sub> — 1500 ohms, 1 watt.  
 R<sub>35</sub> — 4700 ohms.  
 R<sub>36</sub> — 6800 ohms.  
 R<sub>37</sub> — 12,000 ohms.  
 R<sub>38</sub> — 5000-ohm wire-wound potentiometer.  
 R<sub>39</sub>, R<sub>44</sub> — 47,000 ohms.  
 R<sub>41</sub> — 0.5 megohm volume control.  
 R<sub>42</sub> — 2200 ohms.  
 R<sub>43</sub>, R<sub>45</sub> — 0.22 megohm.  
 R<sub>46</sub> — 450 ohms, 1 watt.  
 R<sub>47</sub> — 47,000 ohms, 1 watt.  
 R<sub>49</sub> — 68,000 ohms, 1 watt.  
 R<sub>50</sub> — 270 ohms; adjust to balance gains. All resistors  
 ½ watt unless specified otherwise.  
 R<sub>53</sub> — 330 ohms, 1 watt.

- L<sub>1</sub> — 50-mh. slug-tuned coil. (RCA 205R1 Horizontal  
 Oac. Coil. See text.)  
 LC<sub>1</sub> through LC<sub>11</sub> — 25-mh. slug-tuned coil shunted by  
 390-μfd. silver mica condenser. Q = 100 at  
 50 kc. (Hallicrafters 50B489).  
 LC<sub>12</sub> through LC<sub>21</sub> — 25-mh. slug-tuned coil shunted  
 by 390-μfd. silver mica condenser. Q = 60 at  
 50 kc. (RCA 205R1 Horizontal Oac. Coil mod-  
 ified. See text.)  
 RFC<sub>1</sub>, RFC<sub>2</sub> — 750-μh. r.f. choke (National R-33).  
 RFC<sub>3</sub>, RFC<sub>4</sub> — 10 mh. r.f. choke (National R-50-I).  
 RFC<sub>5</sub> — 25-mh. r.f. choke (Millen 34225).  
 MA — 0-200 microammeter.  
 S<sub>1</sub> — Two-circuit 3-position wafer switch.  
 S<sub>2</sub> — Three-circuit 4-position wafer switch.  
 T<sub>1</sub> — 8-watt output transformer (Merit A-2901).

The i.f. strips proper are built on aluminum channels, to isolate the input from the output to the greatest extent. All power leads are brought out through shielded wires, to minimize coupling via the common power circuits. Using the shielded wire is an aid to construction, in that the shields are soldered to lugs at points near the tube sockets, and the isolating resistors are then mounted between tube socket (or coil terminal) and the exposed ends of the shielded wires. One of the photographs shows the undersides of the i.f. assemblies. The Hallicrafters coils leave no room for the associated shunt condenser, so they are connected directly across the terminals. No mica condensers small enough (electrically) for coupling were available, so we had to use two 4.7-μfd. condensers in series for this purpose.

The RCA coils, used in the broad amplifier, must be reworked slightly before using. As supplied, the terminals come out of the top of the can, so the coil must be removed by untwisting four small tabs. The coil to be used is con-

nected to Terminals A and F, and another coil connected to Terminals C and D should have its leads snipped. The 390-μfd. silver-mica condenser can then be soldered to Terminals A and F before the assembly is replaced in the shield can.

The b.f.o. coil, L<sub>1</sub>, uses both coils of the RCA 205R1 connected in series. This is done by lifting the single wire from Terminal C and connecting it to Terminal F. Externally, Terminals A and D are used. We could find no trace of the b.f.o. getting into the i.f. strips when we tested it by disconnecting C<sub>62</sub> temporarily, thanks probably to the isolation in the power-supply leads and the shielding and physical separation.

The main chassis is aluminum, 12 by 17 by 2 inches, and the front panel is a standard relay-rack affair 7 inches high. The shielded leads from the i.f. strips proper are brought out through holes to tie points conveniently located away from signal circuits. Two short pieces of RG-59/U coaxial cable were used — one from the input jack

at the rear of the chassis up to the 6BE6 grids, and the other from the output of the sharp i.f. amplifier to the grid of the 12AU7 a.v.c.-rectifier. The input and output signal leads from the i.f. amplifiers are fed through Millen 32150 ceramic bushings, where the projecting wire serves as a tie point. The bias control,  $R_{38}$ , is mounted at the rear of the chassis, since it need not be touched after the original adjustment, except when a 12AU7 detector tube is replaced.

### Alignment

The best point in a receiver to take off the signal for this i.f. amplifier is at the grid of the first i.f. stage in the receiver. If the receiver has a crystal filter between mixer and i.f. stage, you won't be using it. The crystal filter can be used, of course, but it requires getting two oscillator crystals for the sharp i.f. amplifier of just the right frequency. The frequency to which the unit

is aligned is determined by the frequencies of the two crystals in the 6BE6 converters. Assume that the nominal i.f. frequency of the receiver is 455 kc., and that the crystals you get are 408 and 505 kc. The sharp i.f. will then be aligned to half the difference, or 48.5 kc. This will then work from an i.f. of 456.5 kc. ( $408 + 48.5$ ), but the fact that this is 1.5 kc. higher than the nominal 455 is nothing to worry about. The transformer between mixer and first i.f. grid in your receiver isn't sharp enough to attenuate a 456.5-kc. signal while passing one at 455 kc.

If you have access to a serviceman's signal generator, set it to half the crystal-oscillator difference (e.g., 48.5 kc.) and align the sharp channel by working back from the detector, introducing the signal first at the grid of the second 6BJ6 and aligning the following circuits, and then introducing the signal at the first 6BJ6 and then the 6BE6 mixer. Since the eleven tuned circuits offer considerable selectivity, you would be very lucky to be able to pump enough signal through from the mixer on the original alignment. The final touching up of the sharp amplifier is done by switching  $S_1$  to the point where both 6BE6s are operative and tuning a signal at 455 kc. until it "zero beats" with itself, as heard in the output. The sharp circuits are then given a final peaking, as indicated by the tuning meter. During alignment procedures, always work with a minimum signal and with the gain control  $R_{17}$ , advanced to maximum gain.

The b.f.o. is aligned by switching it on, setting  $C_{55}$  to the center of its range, and adjusting the slug in  $L_1$  to zero beat on a signal peaked through the sharp amplifier.

The broad i.f. amplifier is "stagger-tuned," which means that alternate circuits are tuned to the same frequency. First peak circuits  $LC_{12}$  through  $LC_{20}$  to a slightly higher (1.5 kc.) frequency than the sharp channel. While doing this, the lead from the meter circuit can be transferred from  $LC_{11}$  to  $LC_{20}$ , and the signal introduced to the grid of a 6BE6. Then set the signal source to a frequency 750 cycles higher than the frequency at which the sharp channel was peaked, and peak circuits  $LC_{12}$ ,  $LC_{14}$ ,  $LC_{16}$ ,  $LC_{18}$  and  $LC_{20}$ , as indicated by the meter. Then set the signal source to a frequency 2750 cycles higher than the sharp-channel frequency, and peak circuits  $LC_{13}$ ,  $LC_{15}$ ,  $LC_{17}$  and  $LC_{19}$ . Now, varying the frequency of the signal source, the response indicated by the meter will approach the form of the curve in Fig. 2, but the peak near the frequency of the sharp amplifier will be a good deal higher than the other. The peaks can be equalized, or nearly so, by readjustment of  $LC_{12}$ . The lead from the meter circuit can now be returned to  $LC_{11}$ .

If you have an audio output meter, you can get a final check on the response of the broad amplifier by setting the b.f.o. to the mid-frequency of the sharp amplifier and, with the sharp amplifier turned down, swinging the input signal across the range and watching the audio

(Continued on page 120)

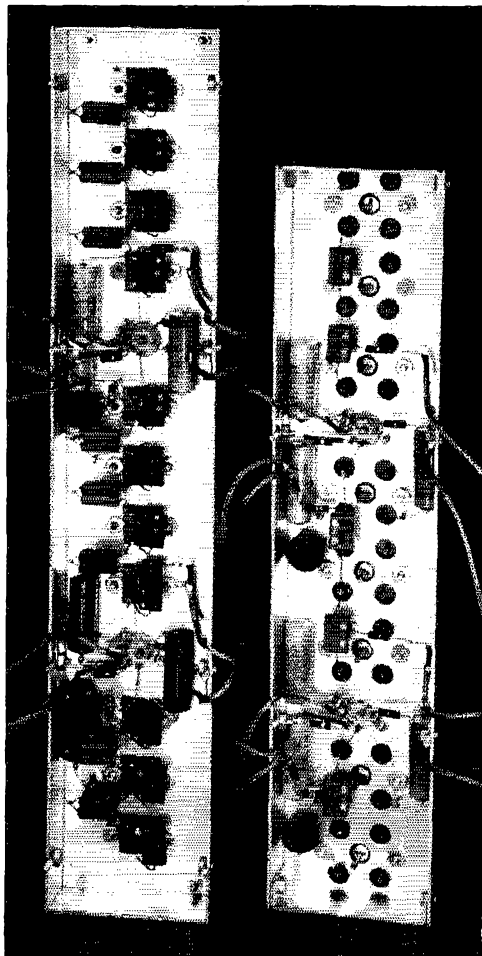

The sharp i.f. amplifier (left) and the broad one, before mounting on the chassis. The shielded power leads are soldered to lugs near the tube sockets, and their ends are used as tie points for the resistors. Spade bolts are used to hold the strips to the chassis.

# A Handy Handful

## Miniature Grid-Dip Meter Using a Magic-Eye Indicator

BY C. VERNON CHAMBERS,\* WIJEQ

• For those hard-to-get-at places, and for those times when your third hand isn't available, this little grid-dip meter is mighty useful. It's also a sensitive indicating wavemeter and an enclosure-free absorption wavemeter of the non-indicating type.

THE general pattern of construction followed by manufacturers of grid-dip meters, both ready-to-use and in kit form, is to house the oscillator and power supply in a single case. This has obvious advantages, but also means that the instrument is comparatively bulky and heavy. It would often be convenient to have a unit small enough and light enough to be held easily in one hand, and mechanically arranged so that the tuning dial can be operated with the same hand. There are many occasions when it is desirable, and sometimes necessary, to have the other hand free — to support the circuit being checked, for example, or to short-circuit a series-resonant circuit when checking a low-pass filter.

The oscillator itself can be put in a small-enough package without much difficulty, but with this type of construction the power supply and indicator must be separate. The two-unit arrangement has another advantage: if the power cord connecting the two can be disconnected at the oscillator, the latter then becomes a plain absorption-type wavemeter (without indicator) of quite compact construction and without excess weight or dangling cords. This is the basis of the grid-dip meter and power supply shown in the accompanying photographs.

The most suitable type of box for the oscillator unit is the  $1\frac{1}{2} \times 2\frac{1}{8} \times 4$ -inch "Channel-lock," which has just about the right shape for a hand-held instrument. To get the largest possible dial (for good calibration) without awkward overhang the tuning condenser should be mounted with its shaft projecting through the  $2\frac{1}{8}$ -by-4 side.

\* Technical Assistant, QST.

Unfortunately, when this is done the shallow depth of the box precludes the use of a split-stator tuning condenser having sufficient maximum capacitance for a reasonable range, so the Colpitts oscillator circuit usually employed in grid-dip meters cannot be used. Instead, the circuit shown in Fig. 1 uses a single-section condenser in the grounded-plate Hartley circuit. Because of the higher minimum capacitance of this arrangement the maximum frequency is limited to 160 Mc. This is probably no great disadvantage for most work, since the 144-Mc. and all lower-frequency bands are covered.

### Indicators

A sensitive indicator is definitely advantageous in a grid-dip meter, both in grid-dip operation and as an indicating wavemeter. It is common practice to use a microammeter or, at the most, a 0-1 milliammeter in order to get good sensitivity. However, there is no need for a *calibrated* instrument, since all the indications are based on a *change* in current rather than the actual value of current. The meter described here uses a magic-eye type indicator which has an effective sensitivity about equal to that of a 0-100 microammeter. When the instrument is used as an indicating wavemeter the magic eye is actually more sensitive than a meter that reads grid current directly, because it is voltage operated and hence gives larger indications with a high-resistance grid leak. In contrast, the sensitivity of a milliammeter or microammeter is seriously limited by the grid-leak resistance when the ordinary grid-dip meter is used as an indicating wavemeter.

A number of commercial grid-dip meters use an indicator circuit in which a portion of the grid current is bucked out in the meter by a small current, of opposite polarity, taken from the plate supply. When the oscillation is strong the grid current is high, and under these conditions the resonant dip, with a fixed degree of coupling to a circuit being checked, is larger, in actual current change, than when the oscillation is

The simplified grid-dip meter is a comfortable handful. Coils for the unit are mounted in a homemade wooden storage rack. The power-indicator unit is at the right in this view.

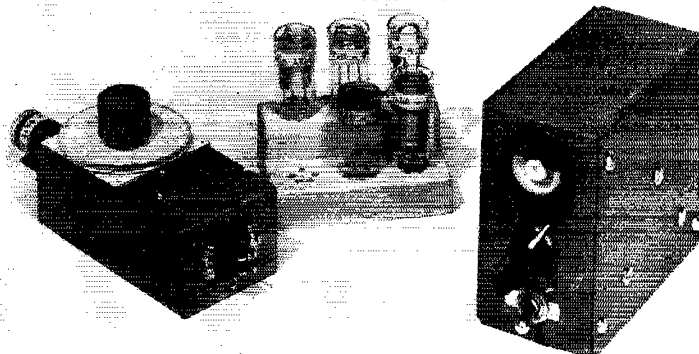

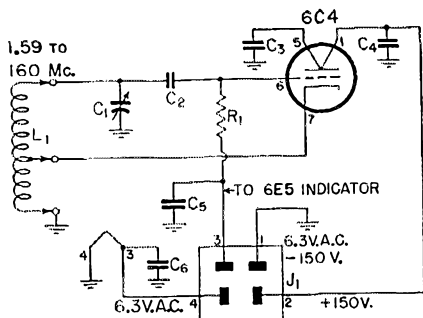

Fig. 1 — Schematic of the grid-dip meter.

- C<sub>1</sub> — 50- $\mu$ fd. variable (Hammarlund HF-50).
- C<sub>2</sub> — 100- $\mu$ fd. ceramic.
- C<sub>3</sub>, C<sub>4</sub>, C<sub>6</sub> — 0.001- $\mu$ fd. disk ceramic.
- C<sub>5</sub> — 0.01- $\mu$ fd. disk ceramic.
- R<sub>1</sub> — 22,000 ohms,  $\frac{1}{2}$  watt.

comparatively weak and the grid current small. If part of the grid current is bucked out the same *change* in current occurs, and if a sensitive meter is used this change represents a much higher percentage of the full-scale current than would be obtained with an instrument that read the total current. The bucking-current adjustment also serves to keep the reading on scale as the grid current varies with frequency.

This scheme represents a worth-while increase in effective sensitivity in grid-dip indications. Its disadvantage is that unless the bucking circuit is kept in optimum adjustment the current may considerably exceed the full-scale current of the d.c. instrument, and hence there is some danger of damaging it. On the other hand, the bucking circuit is equally useful with the magic eye and there is no possibility of damage. The bucking arrangement is incorporated in the circuit of Fig. 2.

#### Circuit Details

The 6C4 triode used in the circuit has both plate pins (1 and 5) by-passed to make the r.f. grounding as effective as possible. Feed-back for the oscillator is obtained by connecting the cathode of the tube back to a tap on the grid coil, L<sub>1</sub>. C<sub>1</sub>, the frequency control, provides a tuning ratio of approximately 2.1:1 when used with any one of the 6 plug-in coils. The oscillator grid leak consists of R<sub>3</sub> (Fig. 2) and R<sub>1</sub> (Fig. 1) in series. R<sub>3</sub> is mounted in the indicator-power supply unit and is connected to R<sub>1</sub> through the

- L<sub>1</sub> — 1.59–3.5 Mc.: 139 turns No. 32 enam. wire,  $\frac{3}{4}$ -inch diam.,  $1\frac{1}{4}$  inches long. Tap 32 turns from grounded end.
- 3.45–7.8 Mc.: 40 turns No. 32 enam. wire,  $\frac{3}{4}$ -inch diam.,  $\frac{3}{8}$  inch long. Tap 12 turns from grounded end.
- 7.55–17.5 Mc.: 40 turns No. 24 tinned wire,  $\frac{1}{2}$ -inch diam.,  $1\frac{1}{4}$  inches long (B & W 3004). Tap 14 turns from grounded end.
- 17.2–40 Mc.: 15 turns No. 20 tinned wire,  $\frac{1}{2}$ -inch diam.,  $1\frac{1}{4}$  inch long (B & W 3003). Tap 5 turns from grounded end.
- 37–85 Mc.: 4 turns No. 20 tinned wire,  $\frac{1}{2}$ -inch diam.,  $\frac{1}{4}$  inch long (B & W 3003). Tap  $1\frac{1}{8}$  turns from grounded end.
- 78–160 Mc.: Hairpin loop of No. 14 tinned wire,  $\frac{3}{8}$ -inch spacing, 2 inches long (total length including ends which fit down into coil-form prongs). Tap  $1\frac{1}{8}$  inches from grounded end.

NOTE: Coils having  $\frac{3}{4}$ -inch diam. are wound on Amphenol Type 24-5H polystyrene forms. Other coils fit inside of Type 24-5H forms.

J<sub>1</sub> — 4-prong chassis connector, male (Cinch-Jones P304AB).

cable that joins the units. R<sub>1</sub> is used principally as an r.f. filter, in conjunction with C<sub>5</sub>. The d.c. voltage across R<sub>3</sub> is the control voltage for the 6E5 indicator tube.

The circuit diagram for the indicator-supply unit is shown in Fig. 2. The half-wave power circuit employs a TV booster type transformer, a selenium rectifier and a condenser-input filter. The transformer supplies heater voltage for the 6C4 and 6E5. Potentiometer R<sub>4</sub> is connected to the 150-volt supply to provide the positive bucking voltage discussed earlier. The bucking circuit allows the 6E5 control-grid voltage to be adjusted for maximum sensitivity and is used to prevent overlapping of the eye when the grid goes too far negative. This latter condition occurs when the oscillator is operating within the low-frequency ranges.

S<sub>2</sub>, the plate switch for the 6C4 oscillator tube, is closed for grid-dip operation and opened when the 6C4 is used as a diode, converting the instrument into an indicating wavemeter.

#### Construction

The coil socket is centered on the end of the U-shaped member of the channel-lock box and C<sub>1</sub> is centered on the long surface of the U with the shaft located  $2\frac{1}{8}$  inches in from the coil end. C<sub>1</sub> should be mounted so as to permit direct contact between the rotor terminal arm and the coil socket. If this is done it also places the stator terminal within a fraction of an inch of the grid pin of the coil socket, thus keeping the tuned-

An inside view of the grid-dip meter. Layout is discussed in the text.



circuit leads as short as possible. A heavy lead is recommended for the stator-to-socket connection and a soldering lug does the job admirably.

The socket for the 6C4 is mounted on a small aluminum bracket located to the rear of  $C_1$ . The vertical section of the bracket is  $1\frac{1}{4}$  inches wide and is  $1\frac{1}{16}$  inches high, and the socket should be mounted with the center located 1 inch up from the bottom of the bracket with Pins 1 and 7 facing toward the tuning condenser. The bracket is mounted at an angle to permit removing the tube from the socket. Leads for the 6C4 heater, plate and grid circuits go through a rubber grommet in a  $\frac{5}{16}$ -inch hole at the bottom of the bracket directly below the tube socket. The d.c. grid lead,  $R_1$  and  $C_5$ , are joined at a tie point mounted on the tapped mounting foot of  $C_1$ .

$C_3$ ,  $C_4$  and  $C_6$  are all grounded to a soldering lug at the left end of the tube socket, as shown in the inside view of the assembly.  $C_2$  bridges the tuning condenser and is connected directly between Pin 6 of the tube socket and the stator terminal of  $C_1$ . A strip of flashing copper,  $\frac{1}{8}$ -inch wide, is used for the cathode-tap lead running between the tube and the coil sockets.

A word or two about tapping B & W Miniductors and handling polystyrene forms may be of assistance. The half-inch Miniductors have an outside diameter that is slightly larger than the inside diameter of the Amphenol 21-5H forms. These coils can be made to fit the forms by using fine sandpaper on the support bars. Taps on the Miniductors can be soldered readily if the section of the turn that is to be tapped is first forced in toward the center of the coil, thus making space for the connecting wire, and soldering from inside the coil with a small soldering iron.

The polystyrene can be protected while the pins are being soldered by using a metal plate (4 by 4 inches will do) that has been drilled to fit the coil-form pins. The holes should be as accurately placed as possible, should provide a snug fit for the pins, and the material should be at least  $1\frac{1}{16}$  inch thick. If this jig is held against the base of the form while soldering it will conduct the heat away from the polystyrene rapidly enough to prevent softening.

The dial indicator is cut from a sheet of  $\frac{1}{8}$ -inch Plexiglas and has a diameter of  $2\frac{3}{8}$  inches, thus extending  $\frac{1}{8}$  inch over each side of the  $2\frac{1}{8}$ -inch case.<sup>1</sup> The small extension on either side of the unit permits thumb control of the tuning. For fast tuning, a small knob is fastened to the Plexiglas disk by small machine screws threaded into tapped holes in the knob. The disk bottom should be marked with hairlines to reduce parallax.

<sup>1</sup> If Plexiglas cannot be obtained from a local hobby shop, it may be ordered from the Plastic Supply Co., 2901 N. Grand Blvd., St. Louis 7, Mo.

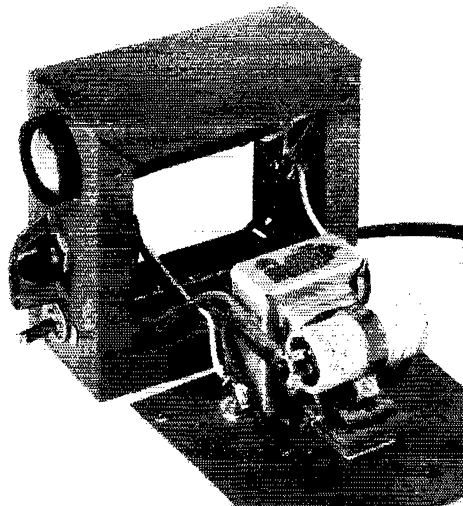

Four of the power-supply components may be pre-assembled on the side plate of the indicator compartment as outlined in the text. Leads approximately 6 inches long should be connected between the parts on the side plate and those mounted inside the case.

The power supply and the indicator tube are mounted in a  $2 \times 2 \times 4$ -inch metal utility box. As shown in the open view of the unit, the transformer, the dual filter capacitor, and the selenium rectifier are mounted on one wall of the case.  $R_1$ , the filter resistor, is supported by the terminals of the capacitor. The socket for the 6E5 is mounted on 1-inch metal pillars at the rear of the box just above the cable connector,  $J_1$ , and the 115-volt line cord. A  $1\frac{1}{16}$  hole in the front wall of the unit provides clearance for the face of the 6E5 and the light shield for the tube is made from cardboard held around the tube by Scotch tape. Several coats of black paint were applied to the shield to give light contrast and to stiffen it.

(Continued on page 124)

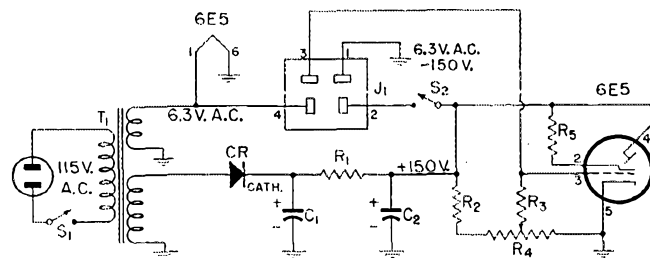

Fig. 2 — Schematic of the power supply-indicator assembly.

- $C_1$ ,  $C_2$  — 20- $\mu$ fd. 150-volt dual electrolytic.  
 $R_1$  — 1000 ohms,  $\frac{1}{2}$  watt.  
 $R_2$  — 27,000 ohms,  $\frac{1}{2}$  watt.  
 $R_3$  — 47,000 ohms,  $\frac{1}{2}$  watt.  
 $R_4$  — 25,000-ohm potentiometer.  
 $R_5$  — 1 megohm,  $\frac{1}{2}$  watt.  
 CR — Selenium rectifier; 20- or 65-ma. type.  
 $J_1$  — 4-prong chassis connector, female (Cinch-Jones S304AB).  
 $S_1$ ,  $S_2$  — S.p.s.t. toggle switch:  $S_1$  mounted on  $R_4$ .  
 $T_1$  — Power transformer: 150 volts a.c., 25 ma.; 6.3 volts, 0.5 amp. (Merit P-3046).

# "Q"-Section Transformers

## Impedance Matching with Single and Double Sections

BY WILLIAM B. WRIGLEY,\* W4UCW

A QUARTER-WAVE section of transmission line has impedance transforming properties which are very convenient and simple to apply to amateur antenna practice. There are certain properties of these transformers, principally selectivity, which are not generally appreciated, however. Also, while the formula for the impedance of a matching section is simple, a graphical procedure, whereby the various impedances can more or less be "seen," should prove quite helpful.

To match two lines of impedances  $R_1$  and  $R_2$  we insert a quarter-wave section of impedance

$$Z_0 = \sqrt{R_1 R_2}. \quad (1)$$

Mathematically, this means that  $Z_0$  is the geometric mean of  $R_1$  and  $R_2$ . Now if  $R_1$  and  $R_2$  were plotted on a logarithmic scale, the geometric mean would be halfway between the two, measured on a linear scale. Fig. 1 is plotted on a sheet of three-cycle semilogarithmic paper. The hori-

zontal scale represents impedance and the three cycles (1 to 1000 ohms) cover the practical range of interest. The vertical scale is linear and enables us to find the geometric mean simply by drawing a straight line or by properly orienting a straight-edge on the paper. A simple example is illustrated by line A, which shows that a 100-ohm "Q"-section will match a 33-ohm impedance to a 300-ohm impedance. When a design problem is at hand, the use of this chart permits a rapid search for a practical solution utilizing combinations of commercially available transmission lines or, in any case, lines of reasonable dimensions to construct. As we get into a discussion of "Q"-section selectivity and double "Q"-sections, the convenience of the semilog paper will become even more apparent.

A common practice is to match a three-element beam to a 300-ohm line with a quarter-wave section of 50-ohm coax. When the radiation resistance of the beam is slightly over eight ohms, line B on Fig. 1 shows this to be a perfect match at the design frequency. Tuning off the design fre-

\* Asst. Prof. Research, Georgia Institute of Technology. Home address: Route 3, Marietta, Ga.

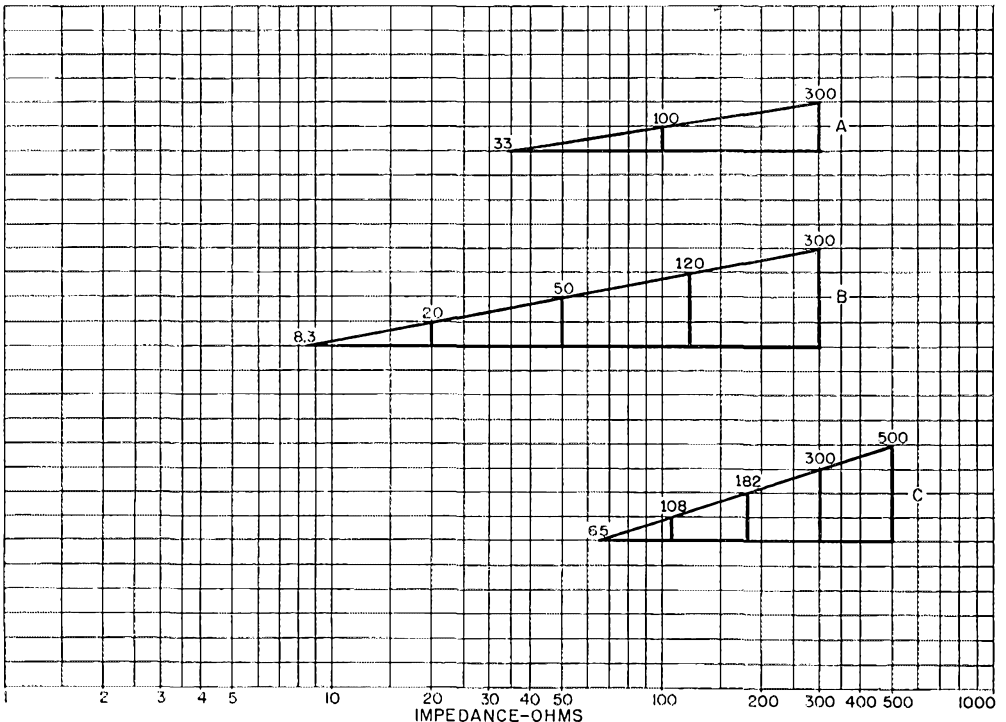

Fig. 1 — Equal lengths along the calibrated scale of semilog paper give equal ratios; thus the geometric mean of any two impedances can be found merely by drawing a straight line between the two values and dividing it into two equal parts. In the drawings above, the division is performed automatically by the vertical (linear) scale.

quency by even the small percentage bandwidth of the amateur bands produces a serious mismatch, however, since the matching section is then no longer a quarter wavelength. As would be expected, the greater the ratio between the impedances to be matched, the more selective the transformer appears. Fig. 2 shows the standing-wave ratio versus deviation from center frequency and the solid curve, labeled  $R_1/R_2 = 32, 1/32$ , represents the present case where the ratio is  $300/8.3 = 32$ . Fig. 2 shows the standing-wave ratio due to the quarter-wave transformer only;

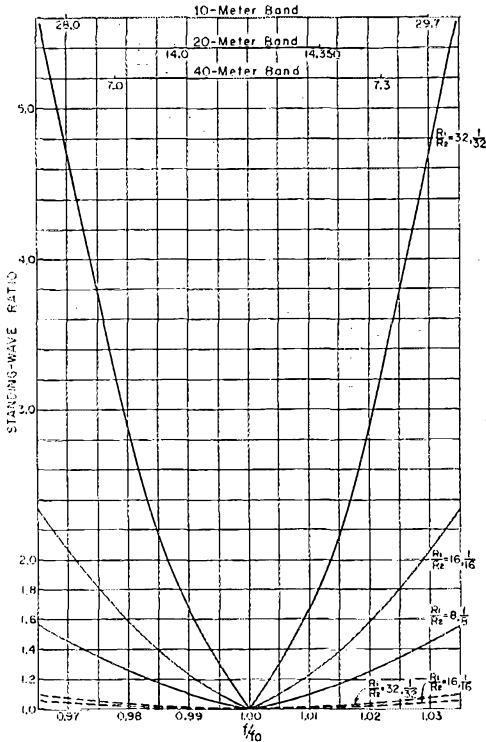

Fig. 2 — Effect of "Q"-section on selectivity, as expressed by the s.w.r. on the line to which the antenna is matched at the desired frequency,  $f_0$ . As shown, the selectivity depends critically on the ratio of the two impedances to be matched. These curves do not include the selectivity of the antenna itself.

that is, the variation of the impedance of the beam itself with frequency is not included. Since beams are inherently quite selective the complete system is actually much more selective than Fig. 2 indicates.

Incidentally, matching an 8-ohm beam to a 300-ohm balanced line with a 50-ohm coax transformer is not good engineering practice for reasons other than selectivity. Some of the current will be carried along the outer surface of the coax shield, resulting in difficulty from two standpoints. First, some of this energy will be dissipated by radiation, and secondly, the impedance of the transformer will not be the same as it

<sup>1</sup> Slater, J. C., *Microwave Transmission*, pp. 57-62, McGraw-Hill Book Co., Inc., New York, 1942.

• Here is a very simple graphical method for finding the required impedance of a quarter-wave transformer or "Q"-section for matching between two given impedances. It can be used just as easily for determining the required impedances in a double "Q," an inherently broad-band matching system.

would be if all the energy were confined to the inside dielectric region.

One possible solution to the selectivity problem is to use two quarter-wave transformers in cascade. If the impedance ratios are selected properly the reflection from one transformer can be made to cancel the reflection from the second transformer over a considerable bandwidth. This is not a new idea and is discussed in most modern transmission line texts.<sup>1</sup> The formula for the double section is

$$\frac{R_1}{Z_0} = \sqrt{\frac{Z_1}{Z_{00}}} = \frac{Z_{00}}{R_2}, \quad (2)$$

where  $Z_0$  is the impedance of the section adjoining  $R_1$ , and  $Z_{00}$  is the impedance of the section between  $Z_0$  and  $R_2$  as shown in Fig. 3. The dashed curve labeled  $R_1/R_2 = 32, 1/32$  in Fig. 2 shows the selectivity of this double "Q"-section and should be compared with the solid curve for the single-section transformer referred to previously.

Equation (2), while rather simple looking, is quite inconvenient; but it still involves geometric means (three, in fact) and our semilog paper will do the trick. Line B in Fig. 1 was arranged so that the vertical linear scale divided it into four equal parts and it is immediately obvious that a 20-ohm "Q"-section will transform 8.3 ohms to 50 ohms and a second "Q"-section of 120 ohms will transform this interim 50 ohms to 300 ohms. The third geometric mean

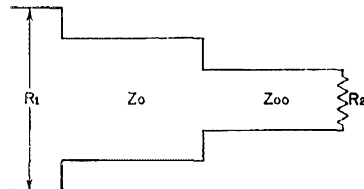

Fig. 3 — Double transformer matching.

required by equation (2) is also satisfied in that the 50-ohm interim impedance is the mean of 8.3 and 300.

This may not be a very elegant solution to our original problem, however, since 20-ohm balanced line is rather difficult to realize, although five parallel sections of RG-22/U (95-ohm twin-conductor coax) would be close enough. A more practical solution, although not involving double "Q"-sections, is to raise the impedance of the beam to 33 ohms by using a folded-dipole driven element and to match this to the

(Continued on page 126)

# Happenings of the Month

## 21-MC. PRIVILEGES EXPANDED

In late January the Federal Communications Commission amended the amateur rules to provide for additional modes of emission in our 21-Mc. band, *effective 3 A.M. EST, March 28, 1953*. FCC dropped its idea of splitting the 'phone band in two chunks, and instead adopted the League view in respect of voice suballocation, so that A-3 and n.f.m. will be permitted any amateur (other than Novice and Technician) in 21,250-21,450 kc. The Commission still thinks there ought to be Novice operation in this band, and has provided 21,100-21,250 kc., for Novice A-1 use, at the same time withdrawing the 11-meter band from the list of Novice bands. In accordance with its policy determined earlier, F-1 emission is to be permitted throughout the c.w. portion — 21,000-21,250 kc.

A simultaneous action, primarily editorial, was to eliminate the 235-240 Mc. band's availability as an alternate for 225 Mc. at certain aeronautical gateways; no practical effect on amateurs.

The text of the Commission's order appears at the end of this department.

## CANADIANS GET 7-MC. 'PHONE

The Department of Transport at Ottawa, we learn through Director Reid, in early January made 7200-7300 kc. available to Canadian holders of 'phone permits as of the 12th. This action has two significant aspects. One is that in effect the 40-meter voice band in Canada is made "Class A" — that is, requires the special 'phone license, just as 75 and 20 still do there, which of course now differs completely from FCC policy. The second is that, for the first time in our low-frequency bands, Canadian 'phones have an assignment identical with that of Ws, instead of the customary additional segment.

## W. Tredway Gravely, W4CB

With deep regret we record the death, on January 24th, of W. Tredway Gravely, W4CB, of Danville, Va. One of the pioneers in amateur radio, a staunch advocate of the League, and one of its first directors from 1917 until 1933, "Deacon" was one of the best-loved personalities in amateur radio. His death came, at the age of 74, as the result of complications resulting from a fall several years ago while working on his antenna, since which time he had been in gradually failing health.

## A.R.R.L. STAFF OPENING

We are looking for a young man to fill an immediate vacancy in the Secretarial Department of the Headquarters staff, someone who would like to make amateur radio his career. The work is non-technical, requires the ability to express one's self well both orally and on paper, and will involve a modest amount of travel. Any applicant should preferably be one with initiative who will be able to assume administrative responsibility readily.

If you are interested, write to Box S, ARRL Hq., West Hartford, Conn. State your age, marital status, and give a résumé of your educational and employment background and amateur experience.

Salary will be commensurate with ability and experience.

## MAER NEW DIRECTOR

We regret to announce the resignation from the ARRL Board, effective January 31st, of Franklin K. Matejka, WØDD, Rocky Mountain Division Director the past six years. OM Matejka is to spend two years in Turkey, as chief construction engineer on the Sariyar Project in Turkey. We wish him continued success, and hope to be hearing a new TA3 call soon.

Under the provisions of the Articles of Association, the Vice-Director accedes to the vacated post, so that Claude M. Maer, Jr., WØIC, is the new Director of the Rocky Mountain Division.

## LICENSE FIGURES

During 1952 the Federal Communications Commission issued a total of 22,172 new amateur tickets. Note we said *tickets*, not new amateurs, for in many thousands of cases amateurs are counted twice — once when they obtain a Novice license, and a second time when they obtain a Technician or higher class license.

Of the total issuances during the year, 12,087 were of Novice Class. That leaves 10,085 new *permanent* additions to amateur radio during the year — that is, five-year renewable licenses. Of these, 4371 were Technicians.

The annual report of the Commission covering the year ended June 30, 1952, has just been released (available from Superintendent of Documents, Government Printing Office, Washington 25, D. C., 40¢). As always, it speaks highly of the performance record of the amateur service. It indicates a total of 110,968 operator licenses outstanding as of June 30th. This figure, as explained

more fully in this month's editorial, must be taken with several grains of salt for the reasons of double counting mentioned above, and the fact that the Commission has deleted from its total only a small portion of the thousands of licenses which have expired in the past two years and have not been renewed.

Before the  
**FEDERAL COMMUNICATIONS COMMISSION**  
Washington 25, D. C.

In the Matter of

Amendment of Part 12, "Rules Governing Amateur Radio Service" to specify emissions and other particulars of operation in the amateur frequency band 21,000-21,450 kc, and for other purposes.

DOCKET  
NO. 10188

**REPORT AND ORDER**

Effective May 1, 1952, the Commission amended its rules governing Amateur Radio Service by adding a new frequency band, 21,000-21,450 kc, with A-1 emission. The Commission's order indicated that further amendments in the matter of specifying the various emissions and particulars of permissible operation in this band would be adopted at a later date. Thereafter the Commission adopted the Notice of Proposed Rule Making in this proceeding, and it was duly published in the Federal Register on May 10, 1952 (17F.R. 4303). The notice proposed to amend Section 12.23(e) of Part 12 by substituting for the Novice amateur frequency band 26.96 to 27.23 Mc, a segment of the new frequency band (21.15 to 21.30 Mc). The notice also proposed deletion of sub-paragraph 11 of Section 12.111(a); amendment of Section 12.111(a)(5) to specify emissions for use within the frequency band 21.00 to 21.45 Mc; amendment of sub-paragraph 10 of Section 12.111(a) to remove certain conditions respecting use of frequencies in the band 220-225 Mc, and amendment of Section 12.111 by re-numbering its paragraphs, numerically, to conform with the foregoing changes.

Following publication of the notice some 85 written comments were received from individual amateurs, amateur organizations, and groups. These comments, for the most part, were in favor of adoption of the proposed amendments, and suggested changes have been incorporated into the amended rules with certain exceptions which are herein-after described in detail.

Some comment was to the effect that frequencies in the band under consideration may be unsuited for use by Novice operators because of possible interference to television reception and while they are presently suitable only for local contacts, future propagation conditions will be such that these frequencies can later be expected to become effective for long distance communication purposes. The frequency band is expected to be so heavily occupied then that Novice operators would find it extremely difficult to use.

Relative to the possibility of interference to television reception from utilization of a segment of the frequency band

21,000-21,450 kc by Novice operators, the probability of television interference depends more upon the design of the television receiver and of the amateur transmitter, and the manner in which they are installed than upon a choice between operation in the 21 or 27 megacycle amateur bands. It is an accepted fact that television interference, attributable to operation of amateur transmitters, can be resolved satisfactorily by appropriate suppression measures. The allocation of frequencies in the 21 Mc band for Novice operation will afford the Novice opportunities to participate in long-distance communication. A slight shift of the Novice portion of the 21-megacycle band was, however, necessary because of the change made in the final rules respecting the position of the radiotelephone segment of the same band.

Some comments were to the effect that too much space was provided for radio-teleprinter operation and that not more than 25 or 50 kilocycles should be set aside for that purpose in view of the comparatively small number of amateurs engaged in radio-teleprinter operation. While the total frequency space allocated to the radio-teleprinter operation remains the same as that proposed, provision for such operation is shifted to the band 21.00 to 21.25 Mc because of the change made in the final rules regarding the position of the radiotelephone segment of this band. It is expected that, actually, only a small part of this frequency space will be occupied by radio-teleprinters as experience with other special types of operation in the amateur bands indicates that amateur teleprinter operators will tend to gravitate to a few spot frequencies rather than to utilize the entire band.

The original notice contemplated sub-dividing the frequency band 21,000-21,450 kc into two radiotelephone segments: 21,000-21,100 kc and 21,350-21,450 kc. Comment received overwhelmingly opposed the splitting of the radiotelephone band into two segments and, accordingly, the Commission is providing a single radiotelephone band, 21,250-21,450 kc, in the portion of the frequency band most generally recommended for that purpose.

The Maritime Mobile Amateur Radio Club requested that the Commission enlarge the proceeding by adopting an amendment of Section 12.91 to make the frequency band 21.00 to 21.45 Mc available for portable-mobile operation outside the continental limits of the United States. The club was advised that its comment in this respect cannot be considered in this proceeding since the rule making here is addressed only to the proposition of amending Section 12.111 of Part 12 to the extent that types of emission and operating procedures are specified and incidental amendment of Section 12.23(e) in respect to the use of a part of that band by Novice operators. Accordingly, the petition of the Maritime Mobile Amateur Radio Club is being separately considered by the Commission, and, if granted, will result in publication of a Notice of Proposed Rule Making in respect to amendment of Section 12.91 of Part 12. The amendments here adopted are designed only to provide maximum usefulness of the newly activated amateur frequency band in the interest of the various types of operation conducted by radio amateurs in the confines of the United States, its territories and possessions.

These amendments are issued pursuant to authority contained in Sections 4(i), 303(e), (f), (l) and (r) of the Communications Act of 1934, as amended. It is ordered that, effective 3:00 a.m., E.S.T., March 28, 1953, Sections 12.23 and 12.111 of Part 12, "Rules Governing Amateur Radio

(Continued on page 122)

◆

Don L. Mullican, W5PHP, winner of the 1952 Edison Radio Amateur Award for his outstanding emergency communications work during the Arkansas tornadoes a year ago, receives congratulations from ARRL President Dosland, W0TSN, while Dr. George B. Bean, W5DVI, who nominated Don for the award, looks on. Government and military agency representatives, including FCC Chairman Walker, Commissioners Webster and Sterling, attended the banquet and presentation ceremonies in Washington. The award, of which this is the first, will be made annually by the General Electric Company's tube department to the amateur adjudged to have performed an outstanding public service. W9NZZ, W8FYW, W6JJU and W1DBM received honorable mentions.



# A One-Tube 75-Meter Mobile Converter

## Crystal Control for Better Stability

BY J. G. ROUNTREE,\* WSCLP

WHEN the writer changed cars some months ago, he faced a problem with which all amateurs who are OMMs will appreciate (OMM: Old Married Man). The XYL was most emphatic in declaring that she did not want the new car cluttered up with the unsightly box on the steering wheel, which had served as a converter in the mobile installation in the previous car. Faced with the necessity of providing a suitable small converter for 75-meter reception, the writer scoured his junk box to see what might be available. For some months consideration had been given to the possibility of using a crystal-controlled converter with broad-band output, tuning the car radio to cover the 75-meter 'phone band. One of the desirable features of such a converter is that a desired amateur frequency can be set up on a push button of the car radio. This is particularly useful in tuning to a frequently-used net frequency.

A search through the junk box revealed a 3105-kc. crystal and a 6BE6 pentagrid converter tube which could be used, so consideration was given to the possibility of using these parts. The 6BE6 is a miniature pentagrid converter tube of the 6SA7 breed in which the cathode, first grid, and second and fourth grids serve as elements for a local oscillator, while the incoming signal is fed into the "downstream" (electron stream,

• Single-band mobile operation permits the use of a greatly simplified receiving system with better frequency stability. Everyone operating 75-meter car equipment should be interested in this crystal-controlled converter, not only because of its simplicity, but because it permits tuning the band with the b.c. tuning controls.

that is) third grid. The output frequency is taken from the plate. Since a 3105-kc. crystal was on hand, it was apparent that if this crystal were used to control the local-oscillator portion of the pentagrid converter and a broad-band output transformer were used to couple into the car radio, the 75-meter 'phone band could be covered by tuning the car radio from 695 kc. to 895 kc. A diagram was drawn up for such a device (see Fig. 1), and more scrounging in the junk box uncovered an i.f. transformer, a tuning condenser, and a few other odd parts that could be used. A hasty trip to the parts store completed the list of what was needed, and we were on our way!

### Construction

The converter was built in a  $3 \times 4 \times 5$ -inch aluminum box. This box is of the type in which the sides are made of two L-shaped sections, spot-welded together. The top and bottom (as used here) are  $4 \times 5$ -inch panels screwed to the box. In order to allow more room in which to work, and in order to allow the desired placement of parts, the spot welds were drilled through and the L-shaped sections separated. In reassembling the box, self-tapping screws were used. A  $3 \times 3\frac{1}{2}$ -inch chassis deck was mounted in the box to serve as a place to mount the tube and crystal sockets. The output transformer — a converted i.f. transformer — was mounted sideways at the back of the box (see photograph). No attempt will be made to describe hole-by-hole placement of parts, since the arrangement is not critical. Ordinary judgment in mounting of parts will suffice. The  $3 \times 4$ -inch front panel contains the antenna/filament switch and the knob for the input tuning condenser. It should be noted that if miniature parts were used throughout, it might be possible to build this unit in an even smaller box.

Separate inputs are used for the broadcast antenna and the 75-meter antenna. One pole of a double-pole double-throw toggle switch is used to switch the car-radio input between the b.c. antenna and the converter output. The other

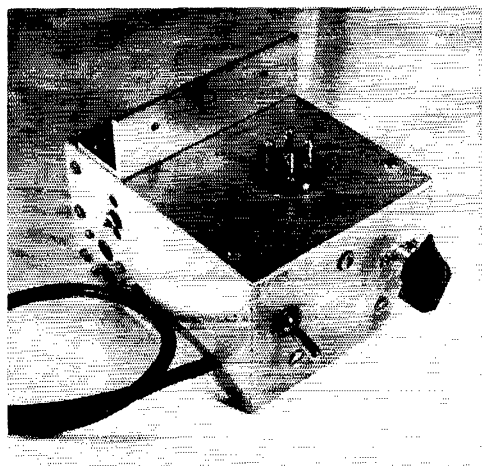

External view of the one-tube converter, showing the power plug and the mounting basket on top. The controls on the front are the antenna/filament switch and the input tuning knob. On the left side toward the rear can be seen the antenna input jacks and above them the access holes to the trimmer capacitors for the output transformer. The coiled lead goes to the antenna-input jack of the car radio.

pole is used to switch the converter filament off when the broadcast antenna is connected.

Since the local oscillator is crystal-controlled, no pulling of the oscillator occurs when the input circuit is resonated. Likewise, the crystal oscillator will not drift as the voltage varies, so that no voltage-regulator tube is required.

Filament and plate current are obtained through a 4-prong plug which is mounted in the top panel of the box. This plugs into a 4-prong socket mounted on the bottom of the car radio. To help hold the converter to the receiver, a bracket is fastened to the converter box. This bracket is fastened to the car radio with one self-tapping screw when the converter is in position.

#### Output Transformer

The output transformer is a small 455-kc. i.f. transformer which has had wire removed from each of its coils so as to allow the windings to resonate at 795 kc., corresponding to a received midband frequency of 3900 kc. The resonant frequency of each of the i.f. transformer windings and its associated tuning condenser was determined by placing each winding in series with the antenna lead of a communications receiver and observing at what frequency the coil-condenser combination acted like a wavetrap.<sup>1</sup> A surprising amount of wire had to be removed from each coil to reach the desired frequency. The i.f. transformer should be one in which the physical spacing of the windings can be varied. Final adjustment of the output transformer takes place with the converter in operation. With the primary and secondary windings separated as far as they will go, the car radio is tuned to 795

<sup>1</sup> This system of using the coil-condenser combination as a wavetrap was also used in checking the tuning range of the input circuit. A grid-dip oscillator can be used if one is available.

Exploded view of the one-tube converter, showing the input tuning capacitor and coil, the 6BE6 tube, the crystal holder, and the output transformer in its shield can.

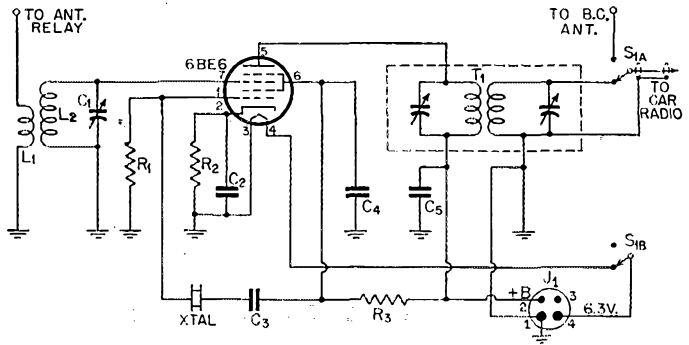

Fig. 1 — Circuit diagram of the one-tube crystal-controlled mobile converter for 75 meters.

- |   |   |
|---|---|
| C <sub>1</sub> — 75- $\mu$ fd. midget variable.   | L <sub>1</sub> — 16 turns No. 30 enam., $\frac{5}{8}$ -inch diam., close-wound.                                       |
| C <sub>2</sub> — 0.01- $\mu$ fd. disk ceramic.    | L <sub>2</sub> — 45 turns No. 30 enam., close-wound on same form and spaced $\frac{1}{8}$ -inch from L <sub>1</sub> . |
| C <sub>3</sub> — 0.001- $\mu$ fd. mica.           | J <sub>1</sub> — 4-prong male plug.   |
| C <sub>4</sub> — 220- $\mu$ fd. mica.             | S <sub>1</sub> — D.p.d.t. toggle switch.  |
| C <sub>5</sub> — 0.0047- $\mu$ fd. disk ceramic.  | I <sub>1</sub> — Output transformer (see text).   |
| R <sub>1</sub> — 22,000 ohms, $\frac{1}{2}$ watt. | Xtal — See text.  |
| R <sub>2</sub> — 500 ohms, 1 watt.                |   |
| R <sub>3</sub> — 15,000 ohms, 1 watt.             |   |

kc. and the transformer tuning condensers are adjusted for maximum noise or, if a modulated 3900-kc. signal is available, for maximum audio output. The windings are then moved closer together so as to be over-coupled. This results in a broad-band output circuit. The coils are fastened in position with transformer wax, tape, or other suitable material.

#### Adjustment

Operation is simplicity itself. The antenna/filament switch is thrown to the "on" position and the tube allowed to warm up. The car radio is tuned between 695 and 895 kc., and the input tuning condenser is resonated for maximum signal. In some cases, objectionable adjacent-channel interference can be minimized by detuning the input slightly in the opposite direction from the interfering signal. It has been found that the converter will not overload on strong signals, so that other mobile stations can be worked literally bumper-to-bumper.

Care must be taken to tune to the desired band. It will be found that if the input circuit is tuned to the vicinity of 7 Mc., the 40-meter

(Continued on page 128)

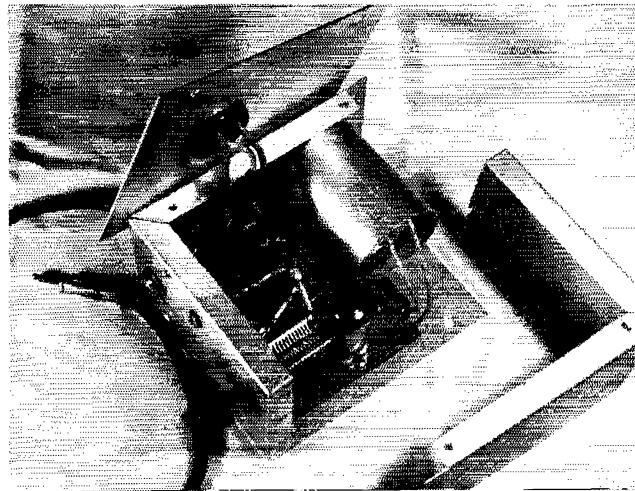

# The Poor Man's DX-Getter

## A Simple Ground-Plane Antenna for 20 Meters

BY EDWIN L. SPIGHT,\* W6OXR

• Unfortunately, not all of us have the space or the money for an elaborate high-gain antenna system. However, it is possible to concentrate more of the radiated energy at useful vertical angles, without departing from simplicity and low cost. W6OXR has found the ground-plane vertical an answer to his DX problems.

FOR years I had been jealous of our more affluent colleagues with their kw. rigs and fancy rotary-beam antennas. Desperation drove me to try first one antenna and then another in an attempt better to emulate my more fortunate brethren with my lowly 150 watts. First came the off-center-fed Hertz; then followed the end-fed Zepp. I ran the gamut of varying the wave pattern by shifting the location of the poles. It was getting so that I wasn't comfortable unless I could feel the weight of an antenna mast in my arms. Even at night I would sometimes awake in a lather of cold perspiration from the dream that the masts had fallen during a sudden midnight windstorm. Well do I remember the night during a rainstorm when it actually happened and the wife had to hurry outside in her nightdress to help hold the masts while I repaired the snapped guys.

Still not quite content with my lot, I continued to fish for any available information on new and different antennas. Finally, I decided to try the famous folded dipole. Finances wouldn't permit anything as elaborate as a rotary beam and there wasn't space for anything so extensive as a rhombic. The dipole was erected with appropriate ceremony, and properly christened with a few well-chosen, though hardly-printable, expletives — what with a few smashed fingers and assorted cuts and bruises. Well, to make a short story long, the dipole still left quite a lot to be desired, so I continued on my merry way, trying to decide just what could be done to alleviate the situation. Finally, one especially memorable day, I had the extreme good fortune to visit a radio wholesale store in the town of San Bernardino. Without that visit, this would be a jumble of meaningless words. However, it was there and then that the patron saint of all good hams was to smile upon me and somewhat enlighten a seemingly hopeless plight.

From the nether recess of one of the darker shelves was born the germ of an idea that even-

tually reached fruition in the most successful antenna that yours truly has ever had the pleasure of loading up with his 150-watt input. It was there that I discovered the necessary main ingredient for a vertical ground-plane antenna. This antenna completely solves the space problem as well as the bugaboo of cost. In a nutshell, as the resulting QSOs have proved, it was the answer to my prayers. Although it is a very effective and compact unit that requires only the roof of a garage or house for space, the whole system was constructed at a cost under \$15, lumber, wire, pipe and all. It is truly a face-saver as well as a space-saver.

For 20 meters, two 10-foot sections of 1½-inch steel tubing, such as is used in many localities for TV masts, are required. These are of very light-gauge steel and constitute the main ingredient of the antenna. Each section comes with one end crimped so that when it is forced into the next a very secure joint results. In addition, three 4-inch iron angle brackets mounted on Birnbach No. 867 metal-base stand-off insulators, enough RG-8/U coax cable to run from the antenna to the rig, about 75 feet of No. 14 enamel-covered wire for the ground plane, 75 to 100 feet

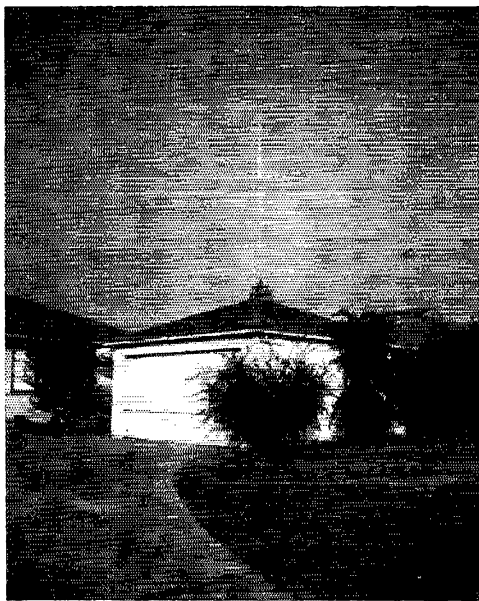

W6OXR's 20-meter vertical is mounted atop his garage. The ground-plane wires run to the four corners, along the roof, making the installation very inconspicuous.

\* 4147 N. Cutler Ave., Baldwin Park, Calif.



of guy wire, a dozen guy-wire insulators, plus enough wood to build a small roof-top platform are needed.

Cutting the metal tubing to a total of 16 feet 6 inches gives a fairly broad coverage of the 20-meter band.<sup>1</sup> In assembling the sections, give one section a few light taps with a hammer to assure perfect union. Then, if the pipe is properly cleaned, it will readily accommodate solder so that the joint may be further secured. The antenna should not be cut to length until after the sections have been fitted together, since the overlap at the joint for a snug fit may vary somewhat.

After the tubing has been cut to measure, the angle irons, equally spaced, may be fastened to the bottom end by means of  $\frac{3}{16}$ - or  $\frac{1}{4}$ -inch bolts  $1\frac{3}{4}$  inches long. (The bottom section should be the longer one.) The bolt holes must be made at different heights, of course, so they will not interfere with one another. For connecting the antenna to the inner conductor of the coax cable, I bolted a Fahnestock clip to the tubing in one of the spaces between the mounting angles. The surface of the tubing should be scraped bright and solder run around the clip to assure good contact. This step saves a difficult soldering job on the roof of the building.

The design of the wood mounting platform will, of course, depend somewhat on the type of roof on which it is to be mounted. The general idea is shown in the photographs. The legs are made from pieces of 2-by-3 lumber. For the top, I used a 1-inch board 12 inches wide and 18 inches long. If a wide board isn't available, two narrower boards can be cleated together, or a piece of  $\frac{3}{4}$ -inch plywood may be used. In any case, the wood should be protected from the weather with several coats of paint or marine varnish.

The four guy wires should be prepared in advance. Each guy should be broken up into sections of about 5 feet with small strain-type insulators. One of these insulators should be fastened to the antenna pipe for each of the guy wires. A single set of guys attached just above the joint between the two sections should be entirely adequate. If desired, a guying ring can be bought to fit the joint between pipe sections.

The ground-plane radials are of No. 14 wire and each is 17 feet long.<sup>1</sup> They are made by cutting two pieces of wire 34 feet long. The center of each piece is scraped bright for a distance of 2 or 3 inches. Then each piece is bent at the center to form a V, and the two Vs are linked together to form an X. The outer conductor of the RG-8/U is frayed out and wrapped around this junction and the joint soldered securely. The radials are run over the top of the platform so that the junction is immediately below the bottom of the antenna. The wires are then run out

<sup>1</sup> See DeCamp, "Matching Coax Line to the Ground-Plane Antenna," *QST*, Sept., 1952, p. 18. — Ed.

<sup>2</sup> This approximate half wave of coax will have an input impedance approximately equal to the antenna feed-point impedance. If a flat line is desired, follow the design of reference<sup>1</sup> above. — Ed.

to the four corners of the roof, allowing them to drop away with the slope of the roof. A small insulator should be placed at the end of each

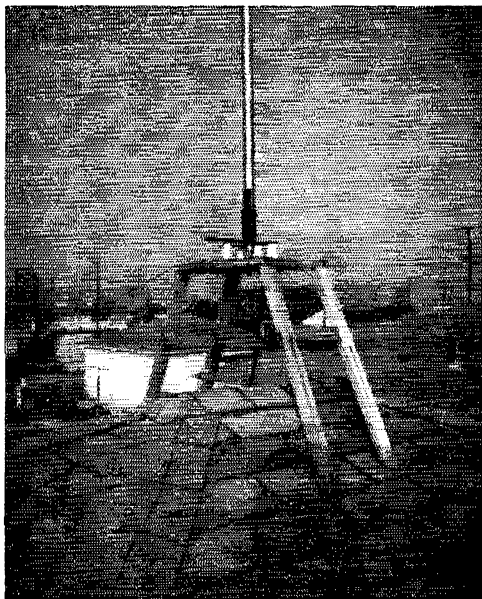

A simple roof mounting for the ground-plane vertical. The base of the antenna is mounted on heavy stand-off insulators by means of angle pieces.

radial. If necessary, the wires may be extended on the other side of the insulators to reach available anchorages.

The coax cable can be anchored to the platform with a pipe clamp and then brought down along the roof to the transmitter. I found that my transmitter loaded up best with a cable length of 27 feet 9 inches.<sup>2</sup>

This antenna has outperformed anything I have ever put up, making many good DX contacts possible that I doubt could have been made with earlier antennas through QRM with the power I am running. And, perhaps best of all, the thing has withstood several bad windstorms without a quiver. In my opinion, it represents the answer for the ham who is saddled with QRM and who has neither the cash nor space for anything but a simple antenna.

## Strays

Overheard by W1DF: W4BOL, with W5TVV at the key, working W4BCI.

— . . . . —

Amprex's new air-cooled transmitting triode, the 6078/AX-9906R, produces a rated output of over 108 kilowatts at 14 Mc. It should soon be available to amateurs.

— . . . . —

W6KFC and W9LEZ enjoyed a two-hour rag-chew in 1935. In 1952 W4KFC and W3LEZ did it again — not quite the same calls but the same two guys, still at it.

# An Isolating Oscillator

Novel VFO Circuit for 7 Mc.

BY RICHARD CLAY,\* W9JRO

WHEN designing a conventional oscillator using an inductance and capacitance to determine the frequency, considerable effort must be expended in the design and construction of the tank circuit to make certain that it has a high  $Q$ . However, when this tank circuit is used in the oscillator, certain capacitances and resistances in the tube tend to impose a load on the tank circuit.

If the tank is placed in the plate circuit of the oscillator tube, the plate resistance of the tube and the plate-to-cathode capacitance load the tank. On the other hand, almost all oscillators draw grid current, so if the tank circuit is used on the input side of the oscillator tube the grid will offer the same kind of loading.



A VFO using electronic isolation between the tank circuit and the oscillator tube. A 5963 dual triode serves both as oscillator and isolating amplifier. It is mounted along with its tank circuit in front of the shield. The decoupling stage is placed at the rear of the chassis.

The oscillator tube reacts on the tank circuit in two ways. The resistance which the tube places in the circuit lowers the effective  $Q$  of the tank, and variations in the tube capacitances change the resonant frequency. Both of these effects contribute to instability in the oscillator. It is apparent that more stable oscillators could be built if the loading effects of the oscillator tube could be isolated from the frequency-determining tank.

The series-tuned Colpitts circuit<sup>1</sup> is an excellent step in this direction. The grid current is drawn from the low-impedance circuit formed by the two fixed condensers from grid to ground and

• VFO circuits can always be depended upon to start a lively discussion in any ham hot-stove league. The novel circuit discussed by W9JRO in this article should prove to be no exception.

the effective  $Q$  of the tank circuit remains very high. The tube capacitances are in parallel with the same fixed condensers. These are made large so as to minimize the effect on the oscillator frequency of any changes in the tube capacitances. These considerations in the design of the series-tuned Colpitts circuit yield an oscillator which has proven to be exceptionally stable.

There is an alternative method for achieving isolation between the tank circuit and the oscillator tube. The isolation may be achieved electronically by the use of a 100 per cent feed-back amplifier. Fig. 1 shows a block diagram of such an amplifier. Since all of the output is fed back with negative polarity to the input, the voltage gain of such an amplifier is very close to unity. However, there is considerable power gain.

Suppose that the input impedance of the amplifier is called  $Z$ . Then, if there was no feed-back, the amplifier would draw an input current of

$$I = \frac{E_i}{Z}$$

If the feed-back is present, the amplifier input voltage is reduced to  $E_i - E_o$  and the input current becomes

$$I = \frac{E_i - E_o}{Z}$$

This is very small, since the output and input voltages are almost equal. Hence, the 100 per

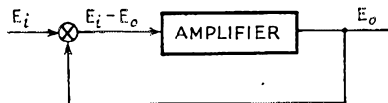

Fig. 1 — A 100 per cent feed-back amplifier can be used as an isolating amplifier because its input provides a very high effective impedance.

cent feed-back amplifier presents almost an infinite-impedance load to the source, and therefore it is well adapted to the problem of isolating a tank circuit from the oscillator tube. The Franklin oscillator, which this circuit resembles in some respects, does not make use of negative feed-back and therefore the tuned circuit is loaded heavily by comparison.

A simplified drawing of such a scheme is shown

\* RCA Engineer, Electromechanical Laboratories, Box 372, Cocoa Beach, Fla.

<sup>1</sup> "Technical Topics," *QST*, May, 1948.

in Fig. 2. The isolating amplifier is used to couple the tank circuit to the grid of the oscillator tube. The grid current of the oscillator is supplied by this amplifier.

It is always necessary to feed energy into an oscillating tank circuit to sustain the oscillation. This is accomplished in Fig. 2 by the feed-back coil in the plate circuit of the oscillator tube. It is true that this couples some of the resistance and capacitance of the tube back into the tank circuit,

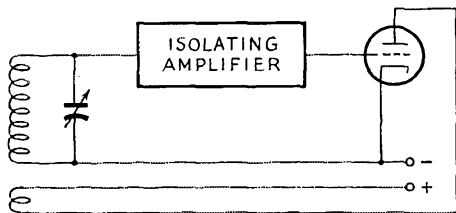

Fig. 2 — A simplified diagram showing how an isolating amplifier can be used to reduce the loading effects of the oscillator tube on the tank circuit.

but this is not as bad as it seems. The tank circuit is virtually isolated. If it is well insulated, and if the coil has low resistance, the  $Q$  will be high and the damping will be low. This means that only a small amount of energy need be fed back into the tank circuit to maintain oscillation. It is not necessary to couple the plate coil tightly to the tank circuit and the effect of the oscillator tube is minimized.

There is a direct analogy between the plate coil in this circuit and the two fixed condensers from grid to cathode and cathode to ground in the series-tuned Colpitts circuit. In each case this is the manner in which energy is fed back from the tube to the tank circuit and in each case this is the place where changes in the tube can cause fluctuations in the oscillator frequency.

It is possible to make certain general comparisons between the circuits concerning this point. The energy fed back in the series-tuned Colpitts circuit depends on the capacitance of the variable condenser used for tuning. If this capacitance is too low, there is insufficient feed-back and the

circuit will not oscillate. Therefore, the stability varies with frequency. In the isolating oscillator, the energy fed back tends to be more nearly constant over the range of an average-size condenser.

In the series-tuned Colpitts circuit the grid-to-cathode and cathode-to-ground tube capacitance form part of the resonant circuit and can affect the oscillator frequency. In the isolating oscillator only the plate-to-ground capacitance of the oscillator tube is coupled into the tank through the plate coil. This does not contribute greatly to frequency instability unless the tube is operated at excessive plate voltage.

The proper values for the fixed capacitances from grid to ground in the series-tuned Colpitts have been reasonably well determined. The degree of coupling for the plate coil in the isolating oscillator must be found by experiment. This should not be considered difficult, since it need be done only once in the lifetime of the oscillator.

It is well known that the major cause of frequency drift in a VFO is the physical distortion of the tank coil as a result of the heating effect of the tank current. In the isolating-oscillator circuit, the tank current can be very small, since the amount of power that need be supplied to the isolating-amplifier input circuit is negligible because the grid does not draw current. On the other hand, in the series-tuned Colpitts circuit, the grid excitation is derived from the voltage drop across the large capacitance from grid to cathode. To develop sufficient excitation, it is therefore necessary to have a relatively high circulating current in the tank circuit.

An oscillator has been built to demonstrate the above principles and is shown in the photograph. It uses miniature tubes and has small dimensions so that it can be used to replace an unsatisfactory VFO in existing equipment. The circuit appears in Fig. 3. The VFO was designed to operate in the 40-meter band and has a frequency range from 6.7 to 7.5 Mc.

The isolating amplifier is of the simplest possible type — a cathode follower using half of a 5963 dual triode. The grid bias is derived from a

(Continued on page 180)

Fig. 3 — Circuit of a practical isolating oscillator.

- $C_1, C_4$  — 82- $\mu\text{fd}$ . zero-temp. ceramic.
- $C_2$  — Dual midjet variable, 30  $\mu\text{fd}$ . per section, double-spaced (Hammarlund HFD-30-X).
- $C_3, C_6$  — 0.001- $\mu\text{fd}$ . mica.
- $C_5$  — 10- $\mu\text{fd}$ . mica.
- $C_7$  — 50- $\mu\text{fd}$ . mica.
- $R_1$  — 4700 ohms, 2 watts.
- $R_2$  — 33,000 ohms, 1 watt.
- $R_3$  — 22,000 ohms, 1 watt.
- $R_4$  — 2200 ohms, 2 watts.
- $L_1$  — 20 turns No. 18 d.s.c.,  $\frac{3}{4}$ -inch diam., close-wound
- $L_2$  — 5 turns No. 18, turns double-spaced, wound  $\frac{1}{4}$  inch from  $L_1$  on same form.
- $L_3$  — 25 turns No. 18,  $\frac{3}{4}$ -inch diam., turns double-spaced.
- RFC<sub>1</sub> — 2.5-mh. r.f. choke.

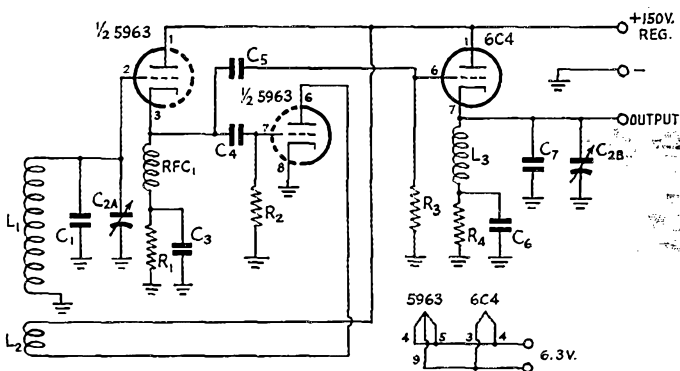



# M. A. R. S.



# U. S. N. R.



## *MARS Net Aids Red Cross During Inaugural Parade*

The practical use of amateur radio equipment for supervisory control of operational units was effectively demonstrated during the Inaugural Parade at Washington, D. C., January 20th.

Members of the Military Affiliate Radio System organized and operated a mobile net on MARS frequency 27,994 kc. to furnish radio communications for 15 Red Cross first-aid stations located along the Pennsylvania Avenue parade route. Fourteen of the mobiles operated from fixed locations; one was mounted in a Red Cross control headquarters.

Net control was established on the 9th floor of the Printcraft Building about five blocks north of Pennsylvania Avenue and centrally located along the line of march. A Viking-I transmitter and an HRO receiver were used with a vertical antenna which is erected atop the building and is part of W3PZA's station equipment.

Mobile stations included home-built, Elmac, and TBS-50 transmitters. Receivers in use included Gonsset Tri-Band and Morrow converters.

Net members in the order of their location along the parade route (from 3rd Street and Pennsylvania Avenue to 17th Street and Pennsylvania) were A4YS, AF3RRY, AF4SVV, AF4SID, AF4WDF, AF4NFD, AF3UVM, AF1MYZ, A4SQF, AF4VIU, A4FB, A4KMF, A4KDX, and AF4RGE. Operators at WAR were A3UWI and A4EEP.

## *Sam Kale MARS Net*

At 0900 hours, Sunday, December 14, 1952, the Pennsylvania MARS (Army) members were netted in a special one-time net honoring Lieutenant Colonel Samuel S. Kale of Pennsylvania Military District Headquarters. Colonel Kale has been transferred to Fort Monmouth, New Jersey.



Lt. Col. Samuel S. Kale, A2VU, trustee for Pennsylvania Military District Headquarters Station, AA3WAB, before reassignment to Fort Monmouth.

## *Amateur Study Classes*

Naval Reservists in the Beaumont, Texas, area have an excellent opportunity to become radio amateurs. Stationkeepers W. E. Hughes, RMC, USNR, (W5PYU) and W. Murphy, ETN2, USNR, (W5LQO) are currently conducting a weekly class at the training center (K5NBW) in preparation for FCC amateur license examinations. The class has a membership of fifteen Reservists studying on their own time to become amateur operators. This class is open to all Reservists in the area and has proven especially attractive to electronics personnel.

The Naval Reserve Training Center, Stillwater, Okla., (K5NRJ) is now conducting a Saturday afternoon class for amateur radio enthusiasts. Stationkeepers J. D. Miller, AL2, USNR, (W5MRT) and J. P. Bryan, ET1, USNR, (W5TUE) are in charge of the class.

Novice Class licenses form one of the major projects for the Anderson Radio Club of Anderson, S. C. This club meets on the first and third Fridays of each month at the Naval Reserve Electronics Facility (K4NBV). Although only five of the fourteen members are licensed amateurs, an active instruction program is expected to produce a new group of WN calls. Licensed members are W5VOI/4 (pres.), W4SSN (sec.-treas.), W4RKK, W4OBT and WN4YMU.

## *Here and There*

W2HJX, J. P. Hallet, RMC, and W2ZRZ, W. H. Bartels, are operators at K2NAD, Naval and Marine Corps Reserve Training Center, New Rochelle, N. Y. . . . W2UGV, W. A. Elliot, is chief operator at K2NAG, NROTC, Rensselaer Polytechnic Institute. . . . W2ALD, Cmdr. R. A. O'Neill, operates from K2NRM, Naval Reserve Training Center, Elizabeth, N. J. . . . W3MRS, Lt. F. H. Bower, is licensee and operator at K3NRA, Naval Reserve Training Center, Allentown, Penna. . . . W4ADP, Cmdr. F. B. Hoselton, is an operator at K4NRA, Naval Reserve Training Center, Miami, Fla. . . . W4CQ, Capt. E. G. Gluck, is an operator at K4NRG, Naval Reserve Training Center, Charlotte, N. C. . . . W5QHW, T. Galbreath, RM2, and W5MJJ, J. R. Joplin, ALC, operate from K5NAT, Naval Reserve Training Center, San Angelo, Texas. . . . W5BCF, CRE B. Freeman, jr., operates from K5NRA, Naval Reserve Training Center, Fort Arthur, Texas. . . . K5USN, Naval and Marine Corps Reserve Training Center, Austin, Texas, is operated by W5TNE, H. L. Selman, RMNSN. . . . W5SNO, Lt. F. J. Boudreau, is an operator at K5NRQ, Naval Reserve Training Center, Lafayette, La. . . . K5NRL, Naval and Marine Corps Reserve Training Center, Little Rock, Ark., is active with W5NSW, F. K. Noel, ET1, and W5NTT, R. Cratty, RMNSN, as operators. . . . Operators at K5NR, Naval and Marine Corps Reserve Training Center, San Antonio, Texas, are W5CLR, CHRELE C. A. Taylor and W5OSK, A. Zermeno, SN. . . . W8REKV, CHRELE F. O. Smith, and W8KVA, J. C. Leffel, operate from K8NRX, Naval Reserve Training Center, South Charleston, W. Va. . . . K9NAW, Naval Reserve Electronics Facility, Galesburg, Ill., is operated by W9IBR, W. R. Morrison, ETN3. . . . W9CFL, Capt. A. W. Hodge, and W9HIK, C. A. Fisher, ET1, operate from K9NRL, Naval Reserve Training Center, Kansas City, Mo. . . . The licensee of K9NRD, Naval Reserve Training Center, Des Moines, Iowa, is W9HOC, W. B. Wright, ET1. . . . K3USN, Naval Reserve Training Center, Naval Base, Philadelphia, is a member of the Eastern Pennsylvania Traffic Net. K3USN last made the Brass Pounders League in October, 1952.

A group of amateurs in the Sixth Naval District recently held a QSO party around 7250 kc. after their regular weekly Naval Reserve radio drill. Stations participating were K4s NBG NBL USN, W4s ADP ANK and RCR. K4USN acted as control station with W4PPC at the key.

# Let's Listen

## Hints on Using and Understanding Receivers

BY LEWIS G. McCOY,\* W1ICP

• If you don't understand just what your receiver is doing for you as you twist the dials and knobs, don't worry — you are not alone. But by not understanding you are probably not utilizing your receiver to best advantage. This is an article aimed at giving you some comprehension, in as non-technical language as possible, so that you can make your receiver work for you.

ALL too many amateurs work havoc on the family budget to garner the necessary shekels to buy a super-duper receiver and never get their money's worth because they fail to utilize the receiver to its full capabilities. If the amateurs who have never read their receiver instruction books were laid end to end, they would probably stretch from here to Tibet. If you are one of the hams who has never studied his instruction book, get it out sometime (if you can still find it!) and read it from cover to cover.

In this article we will try to pass along some ideas on uses of your receiver that will improve your operating enjoyment. But before getting into the actual handling of the receiver, let's take a minute to consider something else. An important point that is sometimes overlooked is the location of the receiver on the operating table. In c.w. work, right-handed operators often find it more convenient to have the receiver tuning knob placed a little on their left, while the right hand operates the key or bug and any switching arrangement. The most convenient height for the tuning knob is usually four to eight inches above the table top. You can find the best height to suit your particular needs by the placing of books under the receiver until you reach the most restful spot for your left hand and arm. Once the proper height is determined, it is a simple matter to build a small shelf to fit under the receiver. Incidentally, the space under the shelf makes a good spot to keep your log.

While on the subject of operating convenience it might be well to talk about the knobs on a receiver. Many times manufacturers design these with an eye toward beauty and not toward convenience. A good example of this is the use of small tuning knobs. It is no great problem to replace small knobs with larger ones, and it will be found that it is considerably easier to handle a receiver with a large tuning knob than with a small one. Some receivers don't have enough bandwidth to suit their users. The tuning ratio

\* Technical Assistant, QST.

can be increased in the order of 5 to 1 by installing a vernier type drive for the bandspread control. The writer has used a National type AM drive on a receiver and it was a great improvement over the original control. In cases where insufficient panel space prohibits the use of this type of drive, small 5-to-1 planetary drives are available that can be used. They don't look pretty, but they work fine.

The 'speaker can be placed either above or below the table, depending upon space requirements. If it is placed on top of the receiver there is a possibility of acoustic feed-back. Acoustic feed-back is caused by the vibration of the 'speaker making the receiver chassis vibrate and thereby producing a signal in the receiver's audio system. The signal is then passed along to the 'speaker, making the whole set-up unstable. There seems to be a tendency in the last few years for amateurs to depend more and more on 'speakers and less on headphones. With the exception of high-fidelity crystal headphones, nearly all other types are more selective than 'speakers, and selectivity is probably the most important feature of any receiving set-up in these days of crowded bands. When listening with a 'speaker, the ears must often contend with outside noises that cut down 100 per cent copy. Though the grunts, squeals, whistles and other assorted noises issuing from a 'speaker may be the sweetest music this side of heaven to a ham's ears, the

ASSORTED NOISES FROM A  
SPEAKER MAY BE SWEET MUSIC  
TO A HAM...BUT



family nerves and relations are inclined to become a bit strained by prolonged sessions. Give headphones a "thirty-day trial;" you'll be copying more than you ever did with a 'speaker.

### Antenna-Receiver Matching

When Joe Ham puts up an antenna system he wouldn't for a minute think of using it without first matching it to the transmitter. Whether it is with an antenna coupler or just by swinging the link in the final amplifier tank, it still must

be adjusted. However, few hams give the same consideration to coupling the input of the receiver to the antenna feedline. They expect the receiver to produce good results whether they use a few feet of wire or an elaborate array. The receiver should be properly coupled to the feed line for the receiver to give its maximum performance. This is particularly true at 14 Mc. and above. Proper matching can be obtained by using an antenna coupler such as described in the receiver chapter of the *Handbook*. Antenna couplers are not always necessary, of course, but they are simple and worth a try.

### Receiver Tuning

In visualizing what your receiver is doing, let's try a simple but accurate picture. For our purposes, we are going to "look" at a portion of the 80-meter band, the 3700-3750-kc. Novice section. In Fig. 1A, we see this frequency range with the various signals represented by vertical lines, the higher lines being the stronger signals. The receiver (with the b.f.o. turned off) can be represented by the paper strip in Fig. 1B, the "window" representing the "selectivity" or "passband" of the receiver. If this strip is cut out and laid across the "band" in Fig. 1A, moving it across the band will allow you to see whatever signals fall in the open window. One that falls in the center of the window will be passed at full height (strength), but one near either side of the window may have part of it cut off (attenuated), depending upon how close to the edge it falls. Moving the strip across the band is just the same as moving the tuning dial of your receiver — the receiver passes the signals that fall under the window and it rejects all others. A signal in the center of the window comes through at full strength — one near the sides will be attenuated. Obviously, if the window were made narrower, it would see fewer signals for any given position — this corresponds to a receiver with more selectivity.

But these c.w. signals are not readily audible unless the b.f.o. (beat-frequency oscillator) is turned on, as a moment's trial with your receiver will prove. The b.f.o. is represented in this example by a celluloid scale slipped over the paper strip, as shown in Fig. 1C. A line marked on the celluloid represents the beat-oscillator frequency. Moving the celluloid on the paper scale is the same as twisting the b.f.o. control on a receiver — it changes the relationship between the b.f.o. frequency and the signals coming through the receiver when the tuning knob is left in one position. But when the tuning knob is turned (sliding the paper scale across the band), the celluloid rides along with it, and the apparent relationship between b.f.o. frequency and the signals is also changed. However, the relationship between the b.f.o. and the "window" is not changed.

Now we have to digress for a minute and consider what the b.f.o. does. Because there is no modulation on a c.w. signal, the signal must be made audible in some way. You know from listen-

ing in a crowded 'phone band that two adjacent carriers generate on audio tone called a "heterodyne." The tone of this heterodyne (or "beat note") depends on the separation in cycles between the two carriers — a separation of 1500 cycles gives a 1500-cycle beat note. By introducing a second signal in the receiver (the b.f.o. output), we can set its frequency relative to an incoming signal to give an audible beat note of any frequency we wish.

Getting back to the paper and celluloid, it is obvious that as we tune across the band (move

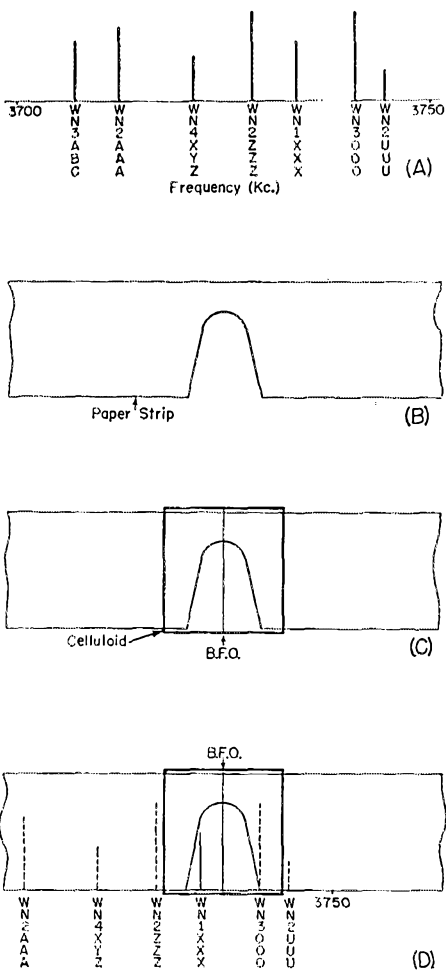

Fig. 1 — An illustration of some of the principles of receiver operation. At some given time, the 80-meter Novice band might look like A, the vertical lines corresponding to the signals of the calls given below.

The receiver can be represented by the strip of paper shown at B — laying it over the "band" at A allows some signals to be "seen" (heard) through the "window" while rejecting all others. Tuning the receiver corresponds to moving the strip from right to left or vice versa.

The b.f.o. corresponds to the celluloid slide shown in C. Its position can be changed relative to the paper strip, but it moves along with the paper strip.

Laying the paper-and-celluloid of C on the "band" of A gives the picture in D, where the signal from W1XXX is the only one that can be heard.

the paper scale) the relationship between the b.f.o. and the received signals changes. The frequency difference between the b.f.o. and the received signals determines the tones of the beats we hear. When the b.f.o. and incoming signal coincide, there is no frequency difference, and this is called "zero beat." Changing the relationship in either direction gives an audio tone.

Take, for example, the condition shown in Fig. 1D. The signal from WN1XXX passes through the receiver (window) and all others are rejected. A low-frequency beat note is obtained from WN1XXX. As we tune the receiver slightly in one direction (to the left, for example), the beat from WN1XXX will become lower. Tuning in the other direction, the signal from WN1XXX will become higher in pitch and weaker, and we will begin to hear WN3000 weakly with a high-pitched signal. Tuning far enough to the right would put WN1XXX out of the window, and the only signal to be heard would be WN3000. With WN3000 centered in the window, we would still have control of the beat note at which we heard him, simply by changing the b.f.o. setting.

Notice that tuning through any given signal, with the b.f.o. set somewhere within the confines of the passband (window), we start with a high-frequency beat note, gradually work down to zero beat, and then go up to a higher one until the signal disappears. Thus there are two settings of the receiver tuning that give the same audio output tone on any signal. There is actually only one signal present, but we can hear it at two places. If you arbitrarily say the signal is at one of these points, the other one is called the "audio image."

### C.W. Tuning

To set up the receiver for c.w. reception, the b.f.o. should be turned on and the a.v.c. (automatic volume control) should be off. The manual gain control (marked "Gain" or "Sensitivity" or "R.F.") should be operative — sometimes it is tied in with a switch, and this is where the instruction book can set you straight.

The audio gain is usually set higher than with 'phone reception. The sensitivity control is then used to control the strength of the incoming signals.

Many beginners are inclined to run the sensitivity control wide open and, in doing so, cause strong signals to block or overload the receiver. The r.f. control should be kept at a low enough setting to avoid such blocking but high enough to hear the "weak" ones. A little practice will determine the best setting. There is a limit to what any receiver will do, and there will be times when a strong signal is too close in frequency to a weak one to permit reception of the weak one. The more selectivity the receiver has, the better it will be in dragging weak signals out from under strong ones.

### Crystal Tuning

There are two schools of thought on how selective a receiver should be. One group holds

that the more signals you hear at any given moment, the better chance you'll have to hear stations that want to break in. This is particularly true in traffic nets where all stations are close together but not on exactly the same frequency. The other group feels that there is no such thing as "too much" selectivity. In these days of crowded bands they are interested in "pinpoint" reception only, striving more and more for QRM-free contacts. Without taking sides, methods of receiver tuning with more selectivity will be discussed.

Many times two signals close together and of the same signal strength make reception of either signal difficult. By varying the b.f.o. pitch control, it is sometimes possible to make either signal distinctive enough to be "good copy." If

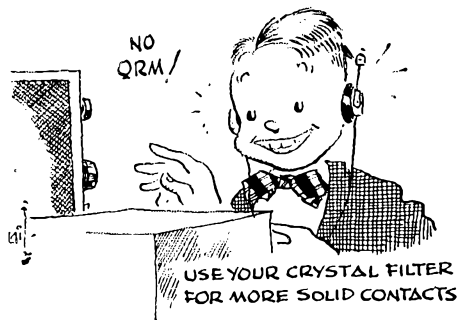

your receiver has a crystal filter it should be used whenever the QRM becomes bad. Learning to use the crystal filter will take some time and patience, but will repay you many times over in more solid copy.

With the receiver set up for c.w. reception find a good solid c.w. signal, preferably a commercial station that you know will be transmitting steadily. Turn the crystal to its sharpest position and carefully tune across the signal. You will notice that one side of the signal is stronger than the other. Tune to the stronger side and set your b.f.o. for the most pleasing note to your ear. Check the crystal position to make sure it is at its sharpest tuning. Now tune to the weaker side of the signal and adjust the crystal phasing control until the weak side either disappears or is phased to its weakest possible point. Your receiver is now operating at its maximum possible selectivity. It will surprise you to find how many more "solid" contacts can be made by making use of your crystal filter.

Going back to our visual indication of what happens in a receiver, Fig. 2 shows how a

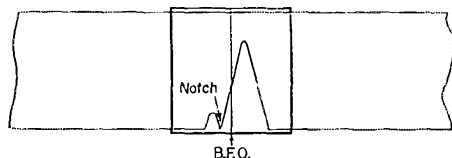

Fig. 2 — When a crystal filter is used, the passband (window) is made narrower, thereby increasing the selectivity. The phasing notch is useful for eliminating the audio image or an interfering signal.

crystal filter can change the shape of the "window" to exclude unwanted signals. With the crystal in the "sharp" position, a rejection notch appears in the window. The crystal phasing control varies the placement of the notch and if it is tuned properly, the audio image can be notched out leaving only one side of the signal audible.

### 'Phone Tuning

In tuning and listening to 'phone signals, the receiver is operated differently than for c.w. The a.v.c. is turned on, the b.f.o. turned off. Let's explain a.v.c. so we get a picture of what it accomplishes.

Automatic control of gain of a receiver is a distinct operating convenience in the reception of 'phone signals because it tends to keep the output level of the receiver constant, regardless of the input signal level. This is accomplished by taking a voltage developed by the received signal in the detector circuit and using this voltage to control the gain of several stages in the receiver. Since this voltage is proportional to the carrier amplitude of the incoming signal, the receiver gain is reduced as the input-signal strength increases.

In tuning in 'phone signals in crowded bands, the crystal filter may be required to reduce interference. Careful adjustment of the phasing control will help cut down heterodyne QRM, one of the most common interference problems on the 'phone bands. The setting of the crystal for 'phone is very similar to c.w. except that it may not be possible to use the "sharp" position and still keep 'phone signals intelligible. Crystal filters in different types of receivers have different characteristics, but a little practice will soon determine the best settings.

### S.S.B. Reception

For the reception of single-sideband signals a tuning procedure very similar to that of c.w. is used. Turn a.v.c. off, b.f.o. on, m.v.c. on and set the audio control at a high level. The r.f. gain control is reduced to the lowest level possible that will allow hearing the s.s.b. station. The receiver is tuned carefully to the signal and the b.f.o. pitch control is varied until the s.s.b. station becomes intelligible.

Without going into great detail about single sideband, it is a form of transmission where the carrier and one sideband is sharply attenuated or reduced. Because of the lack of carrier at your receiver, your b.f.o. is turned on and the signal from it is used for the carrier of the received s.s.b. signal. The pitch control must be varied so that the inserted carrier is in the proper relation frequency-wise to the sideband.

The various settings of the receiver controls

**TABLE I**  
**Receiver Control Settings**

Signal	B.F.O.	A.V.C.	M.V.C.	Audio	R.F.	B.F.O. Pitch	Crystal and Crystal Phasing
C.W.	On	Off	On	High	Vary to signal level	Vary for most pleasant tone	As needed
'Phone	Off	On	Not used	Comfortable	Full on	Off	As needed
S.S.B.	On	Off	On	High	Vary to signal level	Set carefully for best intelligibility	As needed

for receiving different types of signals are summarized in Table I.

As any DX man will tell you, it isn't always true that "if you can hear 'em, you can work 'em," but at least you'll be in a much better position for making contacts when your receiver is being handled properly.

## STAFF OPENINGS AT HQ.

Interested in making ham radio your career? Changes within the ARRL Headquarters Staff have resulted in vacancies, present and prospective, to be filled. Congenial working conditions, free insurance for permanent employees, hospitalization benefits, go with these positions.

One post, immediately available, involves editing *QST* copy and announcements pertinent to operational programs of the League, coordinating material needs for WIAW and bulletins for announcement, writing contest and activity reports and results analysis and other administrative duties. Applications indicating interest and availability for permanent assignment at WIAW are also welcomed. Positions involve the possibility of field contact travel. Salary in each case is commensurate with ability and experience.

Amateurs with initiative who can work with minimum supervision after becoming familiar with their assignments are wanted. Long experience is not required. Preference will be given to single men interested in making their hobby a career. Write to Box A, ARRL Headquarters, West Hartford 7, Conn., stating your age, type of amateur license held, and giving a brief résumé of your experience in amateur radio. We'll send you a personnel form on which you can submit the necessary additional information about yourself. All inquiries are welcomed and will be held confidential.



## VOICE OF AMERICA AMATEUR PROGRAM SCHEDULE

The following is the world-wide transmission schedule for the Voice of America's Radio Amateur Program. The locations given are transmitter points. Times and frequencies are subject to change with changing propagation conditions.

### Far Eastern and Pacific Service

0615 EST, Sunday: U.S.A. on 6060, 6075 and 9515 kc.; Manila on 15,245 kc.; and Honolulu on 6160 kc.

0530 and 1615 EST, Monday: Manila on 920 kc.

0545 EST, Monday: U.S.A. on 6060, 6075, 9515 and 9590 kc.; Manila on 15,245 kc.; and Honolulu on 6160 kc.

### European and Near Eastern Service

1415 EST, Sunday: U.S.A. on 9615, 9700, 11,755, 11,870, 15,165 and 15,270 kc.; Munich on 6105 kc.; Tangier on 9635 kc.; and England (BBC) on 6060 kc.

## WWW-WVVH SCHEDULES

FOR the benefit of amateurs and other interested groups, the National Bureau of Standards maintains a service of technical radio broadcasts over WWV, Beltsville, Md., and WVVH, Maui, Territory of Hawaii.

The services from WWV include (1) standard radio frequencies of 2.5, 5, 10, 15, 20, 25, 30 and 35 Mc., (2) time announcements at 5-minute intervals by voice and International Morse code, (3) standard time intervals of 1 second, and 1, 4 and 5 minutes, (4) standard audio frequencies of 440 cycles (the standard musical pitch A above middle C) and 600 cycles, (5) radio propagation disturbance warnings by International Morse code consisting of the letters W, U or N, together with digits from 1 through 9, indicating present North Atlantic path conditions and conditions to be anticipated. (See June, 1952, *QST*, p. 19, or the 1953 *Handbook*, p. 466, for details on interpretation of forecast symbols.)

The audio frequencies are interrupted at precisely one minute before the hour and are resumed precisely on the hour and each five minutes thereafter. Code announcements are in GCT using the 24-hour system beginning with 0000 at midnight; voice announcements are in EST.

The audio frequencies are transmitted alternately: The 600-cycle tone starts precisely on the hour and every 10 minutes thereafter, continuing for 4 minutes; the 440-cycle tone starts precisely five minutes after the hour and every 10 minutes thereafter, continuing for 4 minutes. Each carrier is modulated by a seconds pulse, heard as a faint clock-like tick; the pulse at the beginning of the last second of each minute is omitted.

Propagation notices are given during the announcement intervals at 20 minutes after and 10 minutes before the hour. These apply to transmission paths over the North Atlantic such as Washington to London or New York to Berlin.

## Strays



So this is where they come from! W7DKT stands at the outskirts of Farad, California, and W1PWK (CN8EG) poses himself a British Empire Radio Transmission Award at the entrance of a Tangier Zone clothing store.



Captain Henrik Kurt Carlsen, W2ZXM — "Captain Stay-put" of 1952 *Flying Enterprise* fame — received the KZ5 version of New York's traditional ticker-tape parade and the call KZ5HC upon his recent arrival at the Panama Canal in command of *Flying Enterprise II*.

While anchored off the Pacific entrance to the Canal the Captain was visited by KZ5s FL, GD, LR and WA. More than thirty KZ5 amateurs QSOd KZ5HC/MM in Canal Zone waters.

Watch for W2ZXM/MM aboard *Flying Enterprise II* from Pacific waters this year.

## Silent Keys

It is with deep regret that we record the passing of these amateurs:

W1DJI, Arthur E. Ruud, Winthrop, Mass.  
 W1NKW, Harold W. Ryall, Nahant, Mass.  
 W2HFS, Henry B. Lockwood, Hartsdale, N. Y.  
 W2RKB, Kenneth C. Hillman, Bronx, N. Y.  
 W3HYX, William A. Schulz, Philadelphia, Penna.  
 W4CB, W. Tredway Gravely, Danville, Va.  
 W4HVD, John H. Bledsoe, Langdale, Ala.  
 W6KWK, Gordon W. Anderson, San Leandro, Calif.  
 W6VWR, Anna L. Willomitzer, Arcadia, Calif.  
 W9ALG, Risser Cotton, Chippewa Falls, Wis.  
 W9DJK, Earl S. Ott, La Crosse, Wis.  
 W9KB, Clarence W. Kern, Hinsdale, Ill.  
 W9TLQ, Al H. Knodell, Grays Lake, Ill.  
 W9WIS, Walter S. Holt, Waukegan, Ill.  
 W6BTS, Wilbur I. Eckstrom, Penzance, Minn.  
 VE3AX, Edward A. D. Hutton, Clinton, Ont.  
 VE5EV, Leonard Ewert, Herbert, Sask.  
 VQ4KTB, A. F. Moy, Mombasa, Kenya.

# On the Air with SINGLE SIDEBAND

Claude Moore, W9HLF of Pekin, Ill., sends along the scoop on s.s.b. activity out his way. (In case you can't place that call immediately, W9HLF made amateur history back in the late '30s as the first — and, for some time, the only — W to work AC4YN in Tibet.) Claude reports Multiphase Exciters in use at W9QHH, W9NKM, W9RDI and W9HLF, and all with Multiphase Slicers on their receivers. W9QHH (Rudy Bartz of Peoria) has been active on 160, trying to drum up a little interest and practice before moving in on 75 and 20.

George Nibbe, W6BES at Van Nuys, has joined the ranks, starting out slowly on 75 with a few watts from a SSB jr., but a 200-watt 807s linear now gives him a real sock. . . . Joe Bair, W4NDE of Oak Ridge, Tenn., asks (with tongue in cheek, we hope) how soon he can match his 114-countries-on-a.m. with s.s.b. DX. A s.s.b. DXCC is a long way off, we're afraid, but he already knows how much better the s.s.b. gets through, as his Edmunds exciter plus 304TL amplifier has shown. . . . From Ritzville, Wash., Carl Eckhardt has W7BBK on the air with an Edmunds exciter. He has the following suggestions to make for improving the *Handbook* description of the exciter:

1) For  $T_3$ , use a Miller 1466 TV 4.5-Mc. sound i.f. transformer.

2) Use a shielded coil and a shielded variable condenser at  $T_4$ .

3) Try small resistors in the screen and grid leads of the Class A 6AG7, for eliminating instability.

You don't have to do much listening on the bands to realize that many of the new stations coming on use commercial exciters — either the Multiphase 10A (of W9DYV) or the SS75 (of W9OHM). Both of these units are proving to be highly satisfactory, and the collective hats of the s.s.b. gang are off to these two pioneers for making equipment available to those without facilities for building it. Both men report that business is good, and we're not telling tales out of school when we repeat (and confirm) the rumors that both are adding new units and accessories to their lines.

The s.s.b. gang in and around New York City is throwing an informal dinner and bull session on March 24th (a date that happens to fall during the I.R.E. Convention). Any out-of-towners interested in meeting the W2 gang at this shindig should get in touch with either W2NJR or W2MTJ for reservations. They need to know at least a week in advance, so don't put it off until the last minute. Last year about 35 ops from half the call areas were present, and a fine time was had by all.

## Voice-Controlled Break-In Circuit

Don Kinney, W8FSA of Ithaca, Mich., uses a break-in circuit with a couple of neat twists. Shown in Fig. 1, it uses two dual tubes and a relay for the major components. One half of a 6AL5 is used for the speech rectifier, while the other half is used as the negative-supply rectifier for biasing

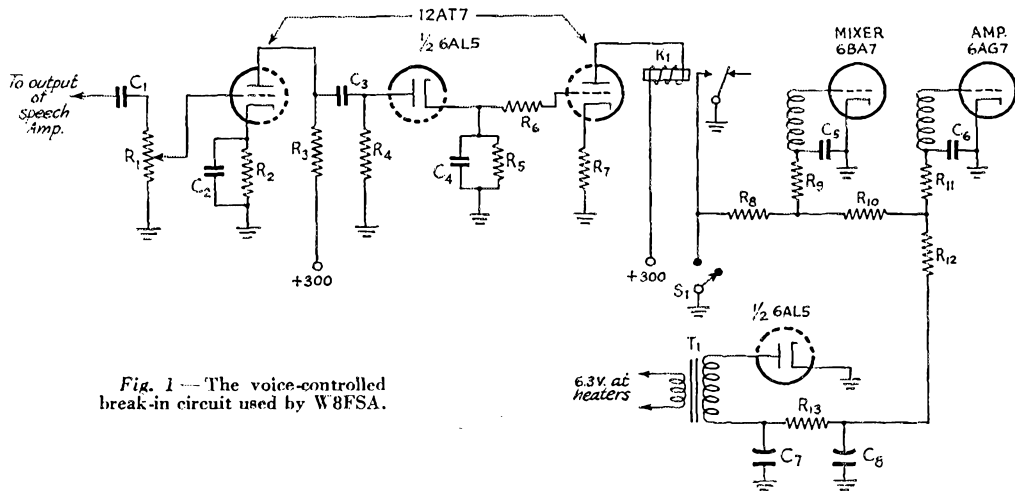

Fig. 1 — The voice-controlled break-in circuit used by W8FSA.

$C_1$  — 0.001  $\mu$ fd.  
 $C_2$  — 0.1  $\mu$ fd.  
 $C_3$  — 0.01  $\mu$ fd.  
 $C_4$  — 0.25  $\mu$ fd.  
 $C_5, C_6$  — 0.005- $\mu$ fd. mica.  
 $C_7, C_8$  — 20- $\mu$ fd. 150-volt electrolytic.  
 $R_1$  — 0.5-megohm volume control.  
 $R_2$  — 470 ohms.  
 $R_3$  — 0.1 megohm.  
 $R_4, R_5$  — 0.5 megohm.

$R_6$  — 1 megohm.  
 $R_7$  — 3300 ohms.  
 $R_8$  — 100 ohms.  
 $R_9, R_{11}$  — 10,000 ohms.  
 $R_{10}$  — 1000 ohms.  
 $R_{12}$  — 10,600 ohms.  
 $R_{13}$  — 470 ohms, 2 watts.  
 $K_1$  — Sensitive relay.  
 $S_1$  — S.p.s.t. toggle "tune-up" switch.  
 $T_1$  — Small 6.3-volt filament transformer.

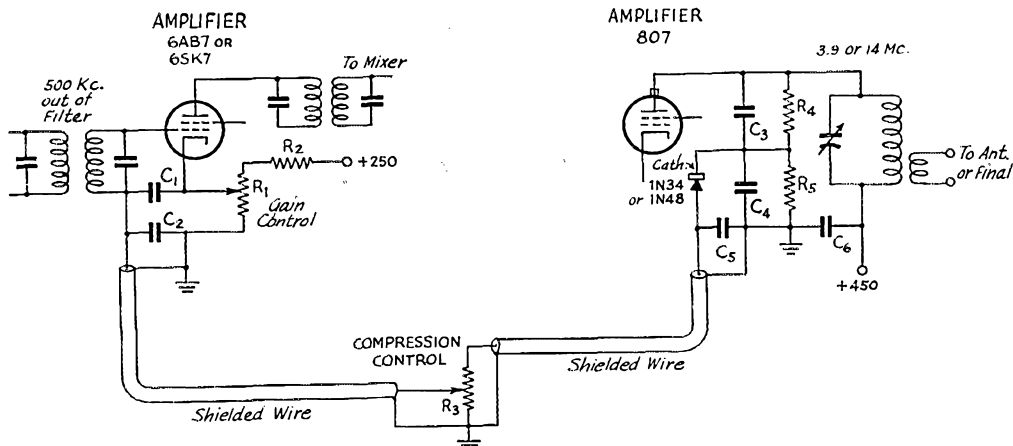

Fig. 2 — This peak-level control circuit, used at W6HLY, will readily handle variations in audio input over a 20-db. range.

$C_1$  — 0.01  $\mu$ fd.  
 $C_2, C_6$  — 0.002  $\mu$ fd.  
 $C_3$  — 15- $\mu$ fd. mica.

$C_4$  — 100- $\mu$ fd. mica.  
 $C_5$  — 0.1  $\mu$ fd.  
 $R_1$  — 10,000-ohm potentiometer.

$R_2$  — 0.22 megohm, 1 watt.  
 $R_3$  — 1-megohm volume control.  
 $R_4$  — 1 megohm.  
 $R_5$  — 12,000 ohms.

or cutting off a couple of stages in the exciter. The 6BA7 mixer and the 6AG7 amplifier grids sit at around -100 volts with no speech, but when the relay closes (or when  $S_1$  is closed), the 6BA7 grid drops to -1 volt and the 6AG7 grid goes to -11 volts, with the constants shown. Other operating biases would require other values of  $R_8, R_{10}$  and  $R_{12}$ , of course. The only restriction to the system is that the controlled stages do not draw grid current in operation, since the bias voltages would vary.

The pull-in voice level is set by  $R_1$  — the hold-in time is dependent upon the  $C_4R_5$  time constant. It will drop out faster if  $C_4$  (or  $R_5$ ) is made smaller.

### Peak-Level Control

Dave Mann, ex-W3MBY and now W6HLY of Woodland Hills, has a worth-while method for insuring that his s.s.b. rig isn't hit hard enough to be driven beyond the linearity limits. He finds this very useful with visitors, and particularly so with any 'phone-patch work, where the level may be down 20 db. or so from the station microphone. The pertinent parts are shown in Fig. 2, and it is no more than an output (or high-level) rectifier that is used to control a low-level r.f. amplifier. In Dave's case, some of the r.f. developed at the 807 is rectified and fed back (through level-setter  $R_3$ ) to the grid of a variable- $\mu$  r.f. amplifier following his sideband filter. The gain of the amplifier is set by  $R_1$ , but the fed-back control voltage is set by  $R_3$ .

The crystal rectifier is biased (through divider  $R_4R_5$ ), so it doesn't rectify immediately but only when this bias is exceeded. Thus the effect is more like limiter action than straight compression, but without introducing appreciable distortion. The capacity divider,  $C_3C_4$ , makes the r.f. voltage applied to the rectifier substantially independent of frequency.

The control circuit cannot be installed in every existing exciter without modification, because it requires that the existing exciter have 20 or 30 db. of gain to spare. However, installing the control tube in an existing design will insure that this requirement is met. In the interests of good linearity, the controlled tube should be used in the circuit at a point where the signal level is low (less than 1 volt). To avoid feed-back troubles, the controlled stage should be on a frequency different than that from which the control voltage is derived.

### Fixed-Frequency Audio Test Oscillator

Bill Parker, W8DXI of Toledo, Ohio, passes along a cute trick that he cooked up with his Multiphase Exciter, although it could probably be applied to any exciter, phasing or filter. His exciter had a spare socket hole (we don't know if they all do, but it shouldn't matter), so he used it for the extra tube required for a fixed-frequency audio oscillator. A low-distortion audio signal is desirable  
*(Continued on page 134)*

Another of the reliables on s.s.b.: W2EWL, Tony Vitale of Denville, N. J. Home station uses an Edmunds exciter into an 829B to drive a pair of 250THs, with a c.c. converter into a Super Pro and Signal Slicer for receiving. Tony's mobile s.s.b. rig is of special interest — it is probably the first one on 14 Mc. A miniature-tube version of the Edmunds, the 6AG7-driven 829B final runs around 100 watts. Receiver is a c.c. converter into a modified BC-453. Biggest mobile kick was a 7-way that included W6DMN, G2ALN and KT1DD.

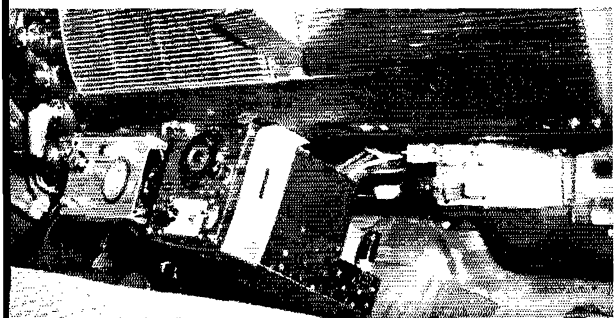
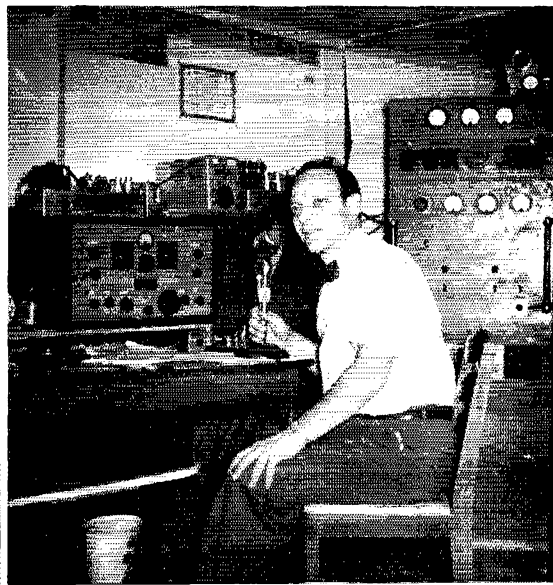

# The Radio Amateur Civil Emergency Service

## Part I—What It Is and What It Isn't

THE general subject of RACES is one which has received much discussion of late, in FCDA, FCC and ARRL circles, to say nothing of talk on the air (much of it, sad to say, uninformed and ill-advised) and by mail. Several FCDA conferences have been held in which RACES was one of the major subjects under discussion,<sup>1</sup> and close contact has been maintained throughout with FCC and FCDA officials concerned with regulation and implementation respectively.

But let's begin at the beginning and trace growth and development — just briefly, for background purposes. Many amateurs will remember the War Emergency Radio Service (WERS) of World War II, and the part we played in it. WERS was not implemented until almost a year after our entrance into the war, and then was beset with so many problems of detail that its effectiveness as an Air Raid Protection (ARP) service would have been seriously impaired had the need ever arisen. Fortunately, it never did, although WERS served in several natural disasters during the years 1943, 1944 and 1945. Three thoughts dominated the consciousnesses of the amateurs who took the lead in WERS at that

time: (1) that we should have started preparing for it years ago; (2) that we ought to have more frequencies than the "impractical" 2½- and 1¼-meter segments allocated to us; (3) that it should have been an *amateur* service to begin with.

Coincidentally enough, some of the same individuals at ARRL and FCDA (then OGD) who implemented WERS were involved in the birth of RACES, and so the practical lessons learned in WERS were remembered in formulating RACES. The rôle of the amateur was considered well in advance, and preliminary arrangements were made to obtain for civil defense-amateur use segments of frequencies in several bands, including some of the lower frequencies, the need for which was so greatly felt in WERS. These frequency segments, after being coordinated with and approved by the Department of Defense, were "earmarked" by FCC for use by amateurs in civil defense.<sup>2</sup>

All this was a matter of looking into the future, to a time when conditions of open warfare might exist, with the attendant necessity of complete shutdown of all casual amateur activity. The frequency segments earmarked for amateurs in civil defense were intended for continued use *after* war conditions existed, and before that time as necessary for drilling and testing purposes.

But *how* and under what restrictions these frequencies would be used by amateurs was a matter still to be worked out; and it took a *lot* of working out. Not until December 19, 1951, almost a year later, was proposed rule-making for a new Radio Amateur Civil Emergency Service (RACES) released by FCC, and not until August 15, 1952, were the regulations, modified in accordance with some of the comments made on the proposals, put into effect. We were off to the RACES.

### What RACES Isn't

Let's reverse the order of the title above and clear up the negative first. Ever since the release of earmarked frequency segments for RACES in 1951, there have been two opposite types of reaction in the amateur fraternity. On the one hand were those who felt the frequencies earmarked were not enough, and who bemoaned that they were not exclusive. On the other were those who looked upon the whole thing as a diabolical plot on the part of government agencies, commercial interests or both to grab off hunks of the amateur bands for non-amateur use by non-amateur personnel.

Actually, the RACES frequencies earmarked are a considerable improvement over those which were available for WERS — and this time we

<sup>1</sup> The reader might do well to review the report of the most extensive of these conferences which appeared in *QST* for Feb., 1952, p. 66.

<sup>2</sup> See insert facing p. 32, Feb. 1951 *QST*.

### *A Message from the Director, Warning & Communications Division, Federal Civil Defense Administration*

Ever since the Federal Civil Defense Administration was first established, the radio amateur has been considered an essential part of civil defense communications. That attitude on our part has not changed; on the contrary, it has intensified. Throughout the months of intensive preparation for possible enemy attack, with a constantly changing civil defense picture, we have looked forward to RACES becoming a reality. The Radio Amateur Civil Emergency Service is you; you are RACES. Go to it. Your value and potential are recognized; this administration is behind you.

— COL. WILLIAM M. TALBOT  
*Director, Warning & Communications Division,  
Federal Civil Defense Administration*

have them, and regulations for the part of the amateur service that is to use them, well in advance of the actual need. The door has been left open to obtain additional frequencies, but in any event this will be a long and complicated process involving changes in military plans to use present amateur frequencies for training and other purposes if war comes, and coordination with all other government agencies involved. The whole RACES frequency picture is one of long-range planning. As for being exclusive, suffice it to say that removal of big chunks of our bands from general amateur use before war comes would be most unpopular with the majority of amateurs, and this should not prove necessary unless it is found that RACES drilling and testing is impracticable due to QRM. In the unhappy event of *actual need* (i.e., war), these frequencies will automatically be exclusive to RACES. We should strive for voluntary cooperation — not necessarily in keeping these segments clear of all casual operation at all times, but in clearing them for the hour or two during RACES drills as required. This should not be interpreted as a threat of restrictions if voluntary cooperation is not effected, but only a simple, factual statement of the likelihood of increased pressure on FCC to make the RACES frequencies exclusive in the event voluntary cooperation does not work out. We think it *will* work out.

RACES is not a scheme to take away some amateur frequencies under the guise of civil defense. In the first place, it is a *temporary* service, and will be discontinued after the termination of the present national emergency. This is written right into its regulations. Secondly, it is an *amateur* service and in most localities will be run by us amateurs *as* amateurs. In effect, it is a specific service we are being asked to perform for the time being. We are being asked to plan to use only small segments of our bands for this purpose, since these will be all that can be spared in the event of actual warfare; but the assumption is that properly-authorized RACES operators and stations will continue to operate on these frequencies.

Non-amateur personnel? Of course. We'll need them, as we needed them in WERS. Most optimistic estimates indicate 25,000 amateurs might

◆

A lot of things have to fit into a Civil Defense Communications Control Center. Here is a perspective drawing of what an ideal one might look like. Note that it is below ground, has heavy concrete walls and an auxiliary power unit (*upper right*). The radio operators are at the bottom of the drawing, with the Radio Officer behind them, and transmitting equipment at lower left. Representatives of the various c.d. services are facing the map so they will know the exact situation at all times.

• While ARRL Emergency Coördinators and through them most AREC members have been kept pretty well informed on developments concerning the Radio Amateur Civil Emergency Service (RACES), correspondence has indicated a crying need for some first-hand information on the subject. This is the first installment of an article prepared jointly by FCC, FCDA and ARRL officials, intended to outline the facts and set the theme for our new Civil Defense venture. The remainder of the article will appear in a future issue of *QST*.

be available for RACES. FCDA estimates a total of 200,000 people will be needed to implement RACES. Where is the difference coming from? The answer is, of course, that some will have to be recruited from the ranks of existing commercial licensees, and still others must be trained, trained in great numbers, trained by us amateurs because *we are RACES*. True, their voices may and probably will be heard on parts of our amateur bands: the RACES parts. But they will operate under the closest surveillance, and they will operate only when specifically authorized by their Radio Officer to do so, and then in accordance with a pre-set operating procedure. They'll be there for a strict c.d. purpose. And when RACES disappears, they'll disappear

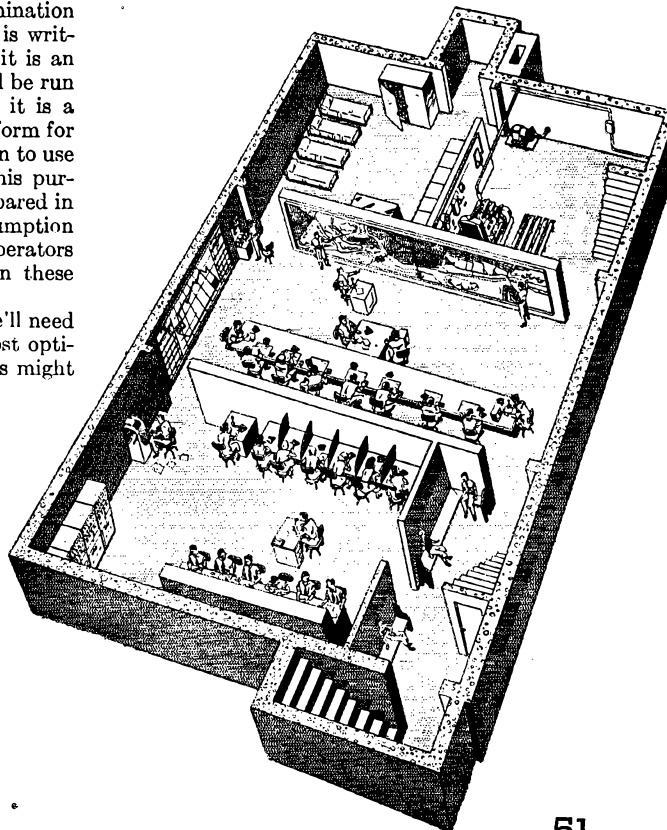



A typical Amateur Radio Civil Defense (RACES) control center in action during a drill. This one happens to be in Oakland, Calif. The fellows at the controls are all amateurs.

with it — except for those who are bitten by the bug and qualify for ham tickets.

One more thing that RACES is *not*, and that is a continuation of *casual* ham radio during the war, a thing unprecedented in history. Don't let anyone give you the impression that signing up with them or their group will be the only way you can continue customary casual ham radio if war breaks out. RACES is all that will be left and it will be strictly dedicated to public service. Some of us will have to change our amateur operating habits. We must look forward to devoting our maximum amateur effort to RACES, without counter attractions.

#### *What RACES Is*

The easiest way of describing what RACES is to say that it is an amateur service set up by amateurs under the sponsorship of the local civil defense organization to serve a civil defense communications purpose. It is both a part of civil defense and a part of amateur radio. It is a means by which we amateurs can serve civil defense now and *continue* to serve it in the event of a shooting war. It is a responsibility which has been given us because we wanted it. So far as the Amateur Radio Emergency Corps is concerned, it is the biggest part of our present job, may soon (but we hope not) become our *only* job, on a basis so expanded that we will need lots of help to put it over. Right now, we prepare; later on, perhaps, if worse comes, we shall serve. The value of our services then will depend on the extent of our preparations now. So let's look into what we should do to get organized.

#### *Setting the Local Stage for RACES*

The first thing you have to have is a local civil defense organization, as a unit of local government, complete with director appointed by the same person or group who appoints chiefs of police, fire chiefs, etc. If your local government (borough, town, city, county or what have you) has no civil defense organization, your responsibility to RACES cannot be implemented

until you have exercised your responsibility as a plain citizen, along with a lot of other plain citizens, to create an instrumentality of civil defense.

Naturally, your civil defense director will need a communications officer. Sometimes (quite often) this turns out to be a retired telephone company man, a retired Army or Navy officer, or the present holder of a communications job for one of the existing municipal services. Sometimes (more often than you think) he is a prominent local amateur, like the local Emergency Coördinator or president of the radio club. Whoever he is, either he or the civil defense director himself is the person to approach about RACES. Depending almost entirely on the past record of local amateurs, you will have a bigger or smaller selling job to do. If your community boasts an active and energetic AREC organization that has a past record of achievement and service, your civil defense people are going to be easily persuaded to go ahead with RACES. Otherwise, if you are starting from scratch, or if there are politics or personal prejudices or partialities involved, it is going to take some doing. In any event, it is always beneficial to have the local amateurs organize into one unit to present a solid front, and always just the opposite to have them demonstrate their inability to work together. We think the local amateur organization for this purpose should be the AREC, and its leader the EC. What could be more natural than to have the AREC organization, in whole or in part, become the RACES organization?

The man who spark-plugs the RACES organization is called the Radio Officer in FCC regulations, regardless of what title he might be given locally. Let's not get confused by a conglomeration of names. When we say RACES Radio Officer, we mean that man who has been certified to FCC as the Radio Officer for RACES. But the term Radio Officer alone may mean a local appointee who has radio responsibilities other than RACES or including RACES. We are not here concerned with whatever other duties he might have; we are only concerned with his RACES duties. But this does not mean that a RACES Radio Officer cannot be appointed by local civil defense unless he is at the same time certified to FCC as the RACES Radio Officer. On the contrary, he may and should be appointed as soon as possible so that he can get to work

(Continued on page 116)

# YL NEWS and VIEWS

BY ELEANOR WILSON,\* W1QON

## YL DXCC Members

We are proud to present and congratulate the YLs who hold postwar DX Century Club awards (as of January 1, 1953). If there are errors or omissions in the list below let us hear about them so we can start keeping records up-to-date for next year's list.

### RADIOTELEPHONE

W1MCW.....191 LU4MG.....147 W2PBI....113  
EA2CQ.....151 OE5YL....100

### 'PHONE AND C.W.

W4ITR.....123 W1FTJ.....113 W6UHA...102  
W6YZU.....120 W8RFQ.....110 G3ACC....100  
W2NFR.....115 ZS6KK.....109 W9TMU...100

## YLRL 13th Anniversary Party Results

'Phone Section — *Top scorers:* W3UUG 9690, W1FTJ 9469 and W4SGD 5786.

*Other scores:* W3MAX 5284, W3JSH 4352, W4KYI 3924, W8GYU 3922, W1SCS 3781, W8HLF 2993, W1UBM 2991, W2EEO 2991, W3QPJ 2800, W2YTI 2730, W1QON 2604, VE3AJR 2600, W3NXU 2160, W1RTB 1870, W1RYJ 1801, W2PVS 1600, W3PVH 1540, W4OMW 1200, W4RIG 990, W3LSX 880, W4LAS 800, W6WRT 606, W6EHA/5 160.

\* YL Editor, QST. Please send all contributions to W1QON's home QTH: 318 Fisher St., Walpole, Mass.



For the third consecutive year W3UUG, Miriam Blackburn, of Ingomar, Pa., (above) and W1FTJ, Dorothy Evans, of Bow, New Hampshire, (right) have placed first in the 'phone and c.w. sections, respectively, of the annual YLRL Anniversary Party. Since the inception of the Party thirteen years ago, they are the first YLs to win in three consecutive years. In recognition of their outstanding contest operation, the YLRL awarded them the cups shown in the pictures for their

KZ5LM 90, W1QJX 60, W1HPB 10, W3MSU 10, W6NAZ 10. (W1HPB, W3MAX, W4OMW were operated by YLs W1UQA, W3OQF and W4UTO, respectively.)

C.W. Section — *Top scorers:* W1FTJ 7416, W3JSH 3380 and W3MAX 910.

*Other scores:* W3SVY 800, W3QPJ 600, W4UTO 501, VE3AJR 481, W3LSX 401, W3CDQ 400, W2EEO 350, W1RLQ 250, W1OAK 120, W3MSU 91, W1RYJ 90, W8NKLZ 60, W1ZR 40, KZ5LM 10, W1QJX 10, W4RIG 10, W6NAZ 10, W8WUT 10, W9JTX 10.

Thanks go to W3JSH, Dottie, and W3QPJ, Kay, for checking the logs received.

## YL-CC Custodian

YLRL President Bea Austin, W7HHH, announces the appointment of W7GLK, Dorothy Dickey, as the Custodian of the YL Century Certificate award announced last month. Send QSLs for verification to Dot, whose address is 614 Siskiyou Blvd., Ashland, Oregon.

## Keeping Up with the Girls

W4MKP, Jane, is the second YL, of whom we've heard, who has her Extra Class license. . . . W3CUL's October traffic total was 5184! . . . W7OLY, Helen, has been portable-KL7 since July, '52. . . . KZ5DG expects to be in Massachusetts in May, and Grace hopes she will be able to meet many of the W1 YLs. . . . OM W6FJH, a science and radio teacher at Escondido Union High School, proudly reports a YL in his radio class (club call W6IAC) — 15-year-old WN6USS, Ann, and another girl who is working toward a license. . . . And OM W6HAW writes that he hears W0HQH, Carol, of Dunbar, Nebraska, on 80 c.w. or 160 'phone and WN0MPB, Dorothy, of Sabetha, Kansas, on 80 c.w. regularly. . . . The Aug.-Sept., '52, issue of the Spanish *Revista de Radio* had a nice write-up about W9AWI, Rosemarie. . . . Having finished wiring her Viking transmitter and VFO, W1BCU, Peg, is back on the air. . . . YLs present at the Los Angeles YLRC's annual Christmas party were W6s CEE CQV JMC KYZ LBO LMQ NLM NZP PJU PPY UHA WRT WSV, WN6s JCA and OBZ. . . . W5NES, Harriett, was elected secretary of the newly-formed Laredo (Texas) Amateur Club. . . . On Dec. 27th a number of D.C. hams participated in a different and successful project. W3NZF, Commander George Dixon, managed a "telethon" to benefit the Muscular Dystrophy Association.

(Continued on page 134)



permanent possession. More details can be found about Miriam in August '52, "YL News and Views." Dot is well known to countless amateurs who have either worked her or who have heard of her many amateur activities and accomplishments. And in just becoming the first YL ever to receive the WAS/YL Certificate, she has added still another "first" to her growing collection. Congratulations to both girls and to the other high scorers listed elsewhere on this page.

# The World Above 50 Mc.

1115-1300

2300-2450

3300-3500

5650-5925

10,000-10,500

21,000-22,000

35,000-9

CONDUCTED BY E. P. TILTON,\* WHDQ

**T**HANKS for the contact — see you after the contest!”

How many times did you hear this over the week end of January 10th and 11th? But how many of the fellows who concluded their contest QSOs in this way will be heard from before the June V.H.F. Party, or even the 7th V.H.F. Sweepstakes, next January?

We may as well recognize that there are many operators who go for any sort of contest, but who care little for other forms of hamming. We are doomed to disappointment if we expect to find them on the v.h.f. bands long after a contest is concluded; they'll be too busy getting ready for the DX contest, the next CD Party, or the Field Day. There is a tendency on the part of some v.h.f. regulars to deplore this contest-only activity, but we feel that a contest week end is one time when all of us might well shed our evangelistic robes and simply work the bands for all they're worth, welcoming every newcomer and attempting to extract no oath of fealty from anyone.

But there are others who say, "See you after the contest!" quite sincerely. They may not be the contest-happy type at all. Perhaps they were planning to get going on the v.h.f. bands for some time, and chose a contest week end to take the plunge. We saw several instances during the recent V.H.F. Sweepstakes where such newcomers to the world above 50 Mc. were pleasantly surprised by their first taste of v.h.f. activity and they honestly intend to spend a considerable part of their operating time on the v.h.f. bands from here on.

Whether they do so or not depends largely on the rest of us. If they make passes at 6 or 2 night after night and find little or nothing going on, their enthusiasm will wane, and we can't blame them. The average ham given a choice between raging QRM and complete silence will choose the loaded band every time. Many of us like to try other bands at this season of the year, but if we have the good of v.h.f. fraternity at heart we will not abandon regular operation on 6, 2, or higher bands entirely. By working the v.h.f. bands regularly, even if only a night or two a week, we can do a lot toward maintaining occupancy at an interesting level for all concerned throughout the year.

And what of the results of the V.H.F. SS? The reporting deadline was just appearing over the horizon as this is written, and anything we might say about the affair would be only half the story, so we are skipping it for now, hoping to have the complete report ready for next month.

\* V.H.F. Editor, *QST*.

## Here and There on the V.H.F. Bands

Countering the reports one hears of "low activity" on 50 Mc., W1DJ, Winthrop, Mass., sends in a list of 151 different W1s worked on 6 during 1952. Despite nearly two months of inactivity because of illness and vacation, Art had more than 2400 QSOs on 50 Mc. during the year. All but a few of these were local or "ground-wave" contacts, reflecting the high state of 6-meter interest in Eastern Massachusetts.

W2COT, Maplewood, N. J., has been keeping a continuous record of different stations worked on 144 Mc. since the opening of that band in the fall of 1945. Bruce worked 28 new stations during the V.H.F. Sweepstakes, bringing his all-time total of calls worked on 2 to 991!

Back to the Boston area, W1CTW, W1BGW, and W1KNW are set up for teletype operation on 6. They would be glad to hear of others similarly equipped, with the idea of setting up the first 50-Mc. DX teletype QSO during the spring sporadic-E season.

Some DX TVI is reported by W4NJE and W4VJX in Lewisburg, Tenn. During one of the better  $E_s$  openings of December, Mac and Marzee were hearing voices in the background of the TV program they were enjoying on Channel 2. By some readjustment of the fine tuning, the voices were brought up to readable level. You guessed it; they were 50-Mc. DX — W1s CTW OOO GJO and LSN, all coming through very nicely.

South American 50-Mc. DX reports have been few and far between in recent years, since the low ebb of the sunspot cycle made intercontinental DX on 6 unlikely, but CE3QC, Santiago, Chile, assures us that in Argentina and Chile, at least, there is still life in the band. At about 1845 on Christmas Day, CE3QC heard LUI DCK and LU6AAK chatting together. At the first opportunity for a call contact was established, with excellent signals prevailing. Soon the party was joined by LU3DDK, LU4DI, LU5ET and LU6DO. Around 1905, CE3QG came on the air, as did LU3DZO. The opening lasted until about 1920. CE3QG runs an 815 at 60 watts, and CE3QC has an 829, at up to 120 watts input. An 800-watt final stage is under construction at CE3QC, and both stations use 4-element arrays. Gear for 144 and 420 Mc. is also nearing completion.

W9FAN, Sheboygan, Wis., reports an experience familiar to many v.h.f. operators that demonstrates the utility of the 2-meter band for extended-local work. In a crossband contact with W9GFL, Green Bay, a distance of some 60 miles, the 2-meter signal was a solid S9-plus during an hour-long contact. W9GFL, who was on 75, was readable only about one fourth of the time, and was severely hashed up by QRM almost constantly. It seems impossible to convince them, but the facts are that the 75-meter gang could make a good many of their contacts far more easily and pleasantly on 6 or 2 meters — and often with a fraction of the power!

W9DSP, Chippewa Falls, Wis., 170 miles west of W9GFL, has also been working him crossband, helping to spread the gospel. All this must have had its effect, for W9DSP recently worked his 54th station on 144 Mc. This is quite an improvement over what would have been possible from northwestern Wisconsin a year or two ago.

Probably the best 2-meter DX of the V.H.F. Sweepstakes week end was the reception of W2NLY by VE3DIR. This is about 325 miles, not considered exceptional in the warmer months, but a haul that is rarely covered in midwinter, except when aurora conditions prevail.

The contest made it possible for W6MIW, Sacramento, Calif., to work W6NGR, Tulare, some 200 miles down the San Joaquin Valley. This was brought about through the assistance of W6VSV/6, whose elevated location enabled him to hear both ends of the path. Participating in his first v.h.f. contest, W6MIW found this willingness to help a competitor a refreshing contrast to the dog-eat-dog



operating that often characterizes contest operating on lower bands.

At San Luis Obispo, W6LB coöperates in a tri-weekly listening schedule with stations in the San Joaquin Valley. Distances are not great, but the nature of the terrain between the Salinas and San Joaquin Valleys is such that contacts are unlikely unless operation is conducted on some fixed schedule. So far this coöperative effort has resulted in contacts between W6NGR, Tulare, and W6MSG, Paso Robles, about 100 miles apart. W6MSG has also worked W6BUT at Taft, and several nearer San Joaquin Valley stations, as has W6LKF, also of Paso Robles. W6LB, W6ZRR and W6QHC, all of San Luis Obispo, are more in the shadow of the mountains, and thus far none of them has gotten over them.

W6LB also has 420-Mc. gear in operation, but has not yet heard of others similarly equipped within a 100-mile radius. He has his second complete station in the works. This will be farmed out to interested parties in the hope of getting 420-Mc. interest rolling in that area.

There is plenty going on 420 in the Los Angeles area most of the time, according to W6LLL. Since he came on 420 last April, Allan has worked 23 different stations, using nothing more than a pair of 6J6s and an ASB-7 receiver. Two of his stations worked are in San Diego, about 100 miles distant. The famous Los Angeles smog has one redeeming feature; Allan says, "It's a sure sign of good propagation conditions on 420 Mc. when the smog gets good and thick!"

More than half of the 420-Mc. stations in Southern California are crystal-controlled. New recruits come on with oscillator rigs, and are welcome; but they soon get the crystal-control sales talk from W6OJF, W6COU and others, and often they are converted. There are several mobiles, and one of these is crystal-controlled. Crystal-controlled converters using the new 6AJ4, 6AM4 and 6AF4 tubes are showing up, one of the first to make use of the new u.h.f. tubes being W6COU.

Some idea of the increasing interest in the bands from 220 Mc. up can be drawn from a perusal of the correspondence crossing your conductor's desk these days. In the past month nearly half of the mail received has related to "the world above 220 Mc." Technician licensees, particularly, are looking for activity on these bands. This is available, to some degree at least, in many of our larger cities, but in rural areas the picking is likely to be slim, at best. One fellow in this predicament is W4YVY, Littleton, N. C. Anyone on 220 Mc. in Northeastern North Carolina?

At least six stations are operating in a fixed-frequency net on 221.25 Mc. in the Chicago area, according to W9UDT. Equipment is mainly converted commercial f.m. gear, with a power output ranging from 4 to 30 watts. Receivers are dual-conversion crystal-controlled jobs. The present group consists of W9a CPF IWE KLB LLX QM and UDT. It is hoped that this can be built up to rival the 147.5-Mc. mobile f.m. net that now can cover an area from South Bend, Ind., to Aurora, Ill., and from Kankakee to the Wisconsin line.

In the Philadelphia area, W3TEC has gear for both 220 and 420 Mc. in the works, and would like to hear from others similarly interested.

W8FKC, Hudson, Ohio, has been making comparisons of the performance of various tubes as 420-Mc. mixers. So far he has tried a grounded-grid 6AM4 and grounded-cathode 6AK5 and 6AJ5, triode connected. The gain of the two latter tubes is somewhat more than the grounded-grid job, though the 6AM4 grounded-grid mixer seems to have a slightly better noise figure. Any of these tube mixers has an edge on crystal diode mixers Ralph has used to date, an observation that has been borne out in work done so far by your conductor.

W1RFU, who has a choice v.h.f. location atop Wilbraham Mountain, just east of Springfield, Mass., is getting set for 420-Mc. work. He has a crystal-controlled converter (June, 1952, *QST*) going, and a 64-element array. With these he has been pulling in the 432-Mc. signals of W1CLS, Waltham, Mass., on a high percentage of tries. This is a hop of about 70 miles, and far from line of sight, though Bill's high spot gives him a good start.

W0RLL, St. Cloud, and W0UYU, Albany, Minn., have converted BC-645s, hoping to work over a 30-mile path.

W3OTC/I, Cambridge, Mass., reports interesting 420-Mc. receiver work with Raytheon 5703 subminiature tubes. These little tubes are inexpensive, and may even be had free, if one knows the whereabouts of salvaged radio-sonde equipment using them. The radio-sonde units are used once, after which the transmitters, each containing a 5703

line oscillator, are discarded. Bob finds that these tubes work fine as grounded-grid r.f. amplifiers, and as mixers, at 420 Mc.

Another subminiature that has proven ability above 400 Mc. is the Sylvania 6AK4, very similar to the 5703. A dual triode, the 6BF7 by Sylvania, may have interesting possibilities. Several of the subminiatures are near equivalents to better-known miniature types, but the fact that they may be wired directly into circuits, without the added inductance and capacitance introduced by conventional tube sockets, raises their top frequencies appreciably. W3OTC/I says that his 5703s work best with no grid bias of any kind. He controls the plate voltage with a potentiometer, setting it so that the tube does not draw excessive plate current.

W9MBI, Coleta, Ill., and W9ZHB, Zearing, must have set some sort of 420-Mc. record when they completed two years of regular skeds on Christmas Eve. Some interesting results have been observed in this time. They always have a signal, but it is subject to marked variation in level, even though the distance is only about 40 miles. One night recently, there was an increase of about 40 db. in a matter of 10 minutes, the signal remaining at the high level thereafter for the duration of the contact, about one hour.

### Selectivity and Signal-to-Noise Ratio

Your conductor's case for selectivity in v.h.f. receivers as a means for improving weak-signal reception, as presented in January *QST*, in an article on page 41, brings a



W0ZJB.....48	W4BEN.....35	W8BFQ.....41
W0BJV.....48	W5VY.....48	W8OJN.....39
W0CJS.....48	W5GNQ.....46	W8LPD.....37
W5AJG.....48	W5MJD.....46	W9ZHB.....48
W9ZHL.....48	W5ONS.....45	W9QUV.....48
W9OCA.....48	W5JTI.....44	W9HGE.....47
W6OB.....48	W5ML.....44	W9PK.....47
W6INI.....48	W5JLY.....43	W9VZP.....47
W1HDQ.....48	W5JME.....43	W9RQM.....47
W1CLS.....46	W5SFW.....43	W9ALU.....47
W1CGY.....46	W5VV.....42	W9UIA.....45
W1LLL.....15	W5FAL.....41	W9UNS.....45
W1HMS.....43	W5FSC.....41	W9QIN.....47
W1LSN.....42	W5HLD.....40	W9DZM.....47
W1DJ.....40	W5HEZ.....38	W9DFM.....47
	W5LJU.....37	W9TKX.....47
W2AMJ.....46	W6WNN.....48	W9KYF.....47
W2RLV.....45	W6UXN.....47	W9HWV.....45
W2MEU.....45	W6ANN.....45	W9MVG.....44
W2IDZ.....45	W6TMI.....45	W9JOL.....44
W2FHJ.....44	W6IWS.....41	W9TJF.....44
W2GYV.....40	W6OVK.....40	W9JHS.....43
W2QYH.....38	W6GCG.....35	W9PKD.....43
W2ZUW.....35		W9IPI.....41
W3OJU.....45	W7HERA.....47	VE3ANY.....42
W3NKM.....41	W7ERA.....47	VE3AET.....38
W3MQU.....39	W7BQX.....47	VE1QZ.....34
W3RUE.....37	W7FDJ.....46	VE1QY.....31
W3OTC.....35	W7DYD.....45	C06WW.....21
W3FFH.....35	W7JRG.....44	XE1GE.....19
	W7BOC.....42	
W4FBE.....46	W7JPA.....42	
W4EQM.....44	W7FIV.....41	
W4QN.....44	W7CAM.....40	
W4FWH.....42	W7ACD.....40	
W4CPZ.....42		
W4FLW.....42	W8NSS.....46	
W4MS.....40	W8NQD.....45	
W40XC.....40	W8UZ.....45	
W4FNR.....39	W8CMS.....43	
W4IUF.....38	W8YLS.....41	
	W8RFW.....41	

Calls in bold-face are holders of special 50-Mc. WAS certificates listed in order of award numbers. Others are based on unverified reports.

critical response from W1OOP. Hank claims that the case is too strong, and he cites experiments conducted in the form of intelligibility tests to prove his point. As reported by Cunningham, Goffard and Licklider, these tests showed that at the threshold of intelligibility, selectivity had but little over-all effect on the readability of voice signals in the presence of fluctuation noise. W1OOP argues that this applies to the amateur case; that while an S-meter or an audio output meter will show a large increase in the margin of a signal

<sup>1</sup> "The Influence of Amplitude Limiting and Frequency Selectivity Upon the Performance of Radio Receivers in Noise." *Proceedings of the I.R.E.*, October, 1947, p. 1021.

over the receiver noise when the selectivity is increased, the actual readability of the signal is only slightly improved.

His point is well taken. Increased selectivity results in an increase in what might be termed the "signal-plus-noise to noise ratio," making the signal more readily observed in tuning across the band, but not necessarily improving the readability of a voice modulation to any marked degree. This signal-plus-noise effect is, however, an aid to c.w. readability, as can be demonstrated clearly by tuning in a weak c.w. signal and then varying the selectivity while maintaining the gain at a constant level.

It is our observation that the weak-signal readability of modulated signals is also improved, as selectivity is increased, up to the point where there is a marked reduction in the audio passband below 3000 cycles, which, of course, defeats its own purpose. Copying ham lingo, we feel, is not quite the same thing as distinguishing totally unfamiliar test words in the midst of artificially-produced noise. We do a certain amount of guessing in copying weak ham signals, and any slight improvement in intelligibility may serve to "fill us in" on key words or syllables, thus effecting a considerable improvement in readability of the signal for our purposes. It's a good point for discussion, in any event; let's have some more ideas and observations.

## 2-METER STANDINGS

Call States Areas Miles			Call States Areas Miles				
W1HDQ	18	6	850	W5SWV	7	2	—
W1IZY	16	6	750	W5FBT	6	2	500
W1RFU	15	7	1150	W5IRP	6	2	410
W1MNF	14	5	600	W5FSC	5	2	500
W1BCN	14	5	580	W5DFU	5	2	275
W1DJK	13	5	520				
W1CTW	12	4	500	W6PJA	3	3	1390
W1KLC	12	4	500	W6ZL	2	2	1400
				W6WSQ	2	2	1390
W2NLY	22	7	1050	W6NLZ	2	2	237
W2UK	21	7	1075	W6CGG	2	2	210
W2QED	18	7	1020	W6EXH	2	2	193
W2AZL	18	7	1050	W6ZEM	1	1	415
W2ORI	16	7	830	W6GGM	1	1	300
W2PAU	16	6	740	W6YYG	1	1	300
W2QNZ	14	5	400				
W28FK	13	6	—	W8WJC	21	7	775
W2DFV	13	5	350	W8BFQ	21	7	775
W2CET	13	5	405	W8WRN	19	7	670
W2UTH	12	7	880	W8WXV	18	8	1200
W2DPB	12	5	503	W8UKS	18	7	720
W2FHH	12	5	—	W8DX	17	7	675
W2BVU	12	4	260	W8EP	17	7	—
				W8WSE	16	7	800
W3RUE	19	7	760	W8RWV	16	7	530
W3NKM	19	7	660	W8BAX	15	6	655
W3QKI	17	7	820				
W3KWL	16	7	720	W9FVJ	22	7	850
W3LNA	16	7	720	W9EQC	21	8	820
W3FPH	16	7	—	W9BPV	20	7	1000
W3GKP	15	6	850	W9UCH	20	7	750
W3OWW	13	6	603	W9LF	19	—	—
W3KUX	12	5	575	W9WOK	17	6	600
W3PGV	12	5	—	W9MBI	16	7	660
W3LMC	11	4	400	W9BOV	15	6	—
				W9LEE	14	5	780
W4AO	20	7	950	W9AFT	14	—	—
W4HHK	19	6	710	W9UJA	12	7	540
W4JFV	18	7	830	W9GTA	11	5	540
W4MKJ	16	7	665	W9JBF	10	5	760
W4OXC	13	7	600	W9DSP	10	4	700
W4IKZ	13	5	550				
W4JFU	13	5	720	W8EMS	21	8	1175
W4CLY	12	5	720	W8GUD	20	7	1065
W4JHC	12	5	720	W8IHD	16	6	725
W4OLK	12	5	720	W8NFM	14	7	660
W4FJ	12	5	700	W8ZJB	12	7	1097
W4TMF	12	5	600	W8INL	12	5	830
W4LRR	5	2	900	W8WGZ	11	5	760
				W8OAC	11	5	725
W5JTI	14	5	670	W8JHS	9	3	—
W5RCI	14	4	790	W8HXY	9	3	—
W5QNL	10	5	1400				
W5CVW	10	2	1180	VE3AIB	17	7	850
W5MWW	9	4	570	VE3DIR	14	7	720
W5AJG	9	3	1260	VE3BFB	12	6	715
W5ML	9	3	700	VE3AQ3	11	7	800
W5ERD	8	3	570	VE1QY	11	4	900
W5ABN	8	2	780	VE3DER	10	6	800
W5VX	7	4	—	VE3BOW	8	5	520
W5VY	7	3	1200	VE3QN	7	3	540
W5FEK	7	2	580	VE3TN	7	4	480
W5ONS	7	2	950				



March 1928

... "Double-Detection Receivers with Band-Pass Filters and Screen-Grid Amplifiers," by Dr. Wilfred Taylor, describes a receiver in which are incorporated the latest developments for receiving sensitivity and selectivity.

... J. K. Clapp and Howard A. Chinn present a wealth of data on antenna radiation patterns, ground-height effects, beam configurations and feed methods in "Directional Properties of Transmitting and Receiving Antennas."

... "Radio Applied to Petroleum Prospecting," by Gerald R. Chinski, ex-5CA, is an interesting discussion of the "seismic radio method" for locating oil by means of a low-power 3000-kc. transmitter and regenerative detector.

... League Assistant Secretary A. L. Budlong and Communications Manager F. E. Handy pool their resources to demonstrate that interference with neighborhood BCL receivers is no insoluble problem "If You Only Try—"

... ARRL Director Allen H. Babcock, 6ZD, tackles one of the moot questions of the day—how far is it?—and puts logarithms and trigonometry tables to work to do the job accurately in "The DX Tape Measure."

... In "The Design of Variable Condensers for High-Voltage Operation," Bert E. Smith analyzes theoretical and constructional factors to be taken into consideration in the manufacturing of such critical high-power components.

... Frank Palmer furnishes details on the construction of a handy multi-purpose bench test set and P. H. Quinby, 9DXY, does an encore with more facts concerning the building of his popular *Handbook* "Tube-Base Receiver."

... In the Experimenters' Section, Herman Radloff, 9AIR, depicts a compact three-band thirty-watt portable transceiver using 201-A, VT-14 and UV-202 tubes and containing its own Marconi "Megger" hand-cranked generator.

... The Communications Department tells of current amateur radio activity by Putnam Arctic (VOQ), Canadian Government Hudson Straits (VDE) and MacMillan Arctic (WNP) Expeditions gathering data in the far north.

... Photographic portraits and background sketches of the following ARRL Section Communications Managers grace a full page of this month's issue of *QST*: 1ATJ, 2WR, 4LK, 5AIP, 6BUR, 6VR, 7ST, 9AAW, 9EGU and n5BJ.



# How's DX?



CONDUCTED BY ROD NEWKIRK,\* W1VMW

## How:

In regard to last month's Odyssean "Expedition to Brunei," by Clyde F. Norton, WØELA-VS5ELA, several inquiries forthcame relative to the manner in which Clyde and party got out of the jungle after concluding the on-the-air phase of the DXcursion.

Actually, there was a change in plans during their last few hours in the village of Kuala Belait. The details were included in the author's text but were necessarily deleted because of space limitations. Here's the recount in WØELA's own words:

"Some serious problems presented themselves when we desired to leave Kuala Belait. The small airplane on which we had flown into the jungle had lost an engine and was grounded. We were then informed that the only way in which we could get out of Kuala Belait was to go to the oil fields and charter a jeep; since there are no roads between Kuala Belait and Brunei town, it would then be necessary to wait for low tide and to drive along the shore for five hours to Brunei town. There we could obtain passage on a government launch to Labuan Island, where the big airport is located. However, we were fortunate during our last day in Kuala Belait to learn that a launch was being sent by the British Malayan Petroleum Company to take one of the company men out of the jungle because no air transportation was available. Late in the afternoon we completed arrangements which provided for our passage aboard the launch."

Getting back from the place was indeed a good part of the battle. We apologize to WØELA for our efforts to make him a permanent VS5!

## What:

We just have to lead off with good old *one-sixty* this month. DX conditions in the 1.8-Mc. bailiwick apparently have been just as good this season as they were bad last. Transatlantic Test nights really were something to observe—several dozen W/VEs banging away on c.w. within the space of very few kc. while assorted Europeans (plus South America and Oceania) pounded through consistently above and below. We thank W1BB for much of the following info . . . . . Among the highlights: W5ENE's QSOs with Gs 3PU 5JU and 6GM beginning January 4th. . . . Contact between W0NWX and ZL1NX December 28th. . . . VP4LZ's furnishing South America for W2EQS. . . . W1BB's working OI3NY . . . . W1LMIU and W2QHH, each running 16 watts to 61.6s, got across to G5RL. Howy also nailed EI9J. . . . W2EQS now has a dozen 160-meter countries and these include recent QSOs with GD3UB, GI2ARS, Gs 3PU 5JU 5RI 6GM 8KP, KP4s DV and KD . . . . Six countries and three continents have been hooked on 1.8 Mc. by W9PNE. Late ones are EI9J, G1W3FSP, Gs 2GGD 3PU 5RI and 6GM. Brice uses 160 watts, a 14-Mc. Vee and a BC224. . . . W2QHH's working KP4KD on 160 meters made it a total of seven bands on which the two stations have contacted. . . . Gs 3PU 5RI 5JU 6GM 8KP and KP4DV answered W3EIS;

W2EQS has been hearing ZL1s AH and NX on 1903 kc. . . . A Kytoon vertical gave W1BB some hectic week ends what with gales and sleet. Stew nevertheless caught Gs 3FGT 3PU 5JU 5RI 6GM, GW3FSP and EI9J. . . . The two-wavelength wire at W1LYV was reported peaking S9 in Europe and W0NWX got up a 1000-foot skyhook for the Tests. . . . From a ZL1NX letter to W2EQS: "[W0NWX] was my first QSO outside ZL on 160! I have . . . 50 watts input and the antenna is a long wire . . . [one end] at the top of one of ZL1MP's 80-foot masts! He is my next-door neighbor. ZL1MP is ex-G1W6AA, ZL1AH is ex-G3AH and I am ex-G6YS. . . . Ex-GW5OD and ex-G5WR are also in this locality." . . . . KP4KD joined the 160-meter fun and has been knocking 'em off near 1810 kc. . . . Other DX stations known to be active are Gs 2NU 3GKQ 6BQ 6GF 6GO 8JR, GI5UR and KV4AA (1823 and 1899 kc.) In addition to those previously mentioned, these stations were active on our side: W1s DWO EFN EYW HSC QCA QJM, W2s AMC ELK ESO HCW HH JPW KHC KNZ TRK UBS WC WWP, K2ANR, W3s AJS HLOKU RGQ SKN, W4s JBF LRN UPF VFD VFL, W8s BKII GDQ HMF KBT NJC, W9s CZT FIM MFV MXO NH QCC, W0s FUF NUI, VE1 1EA 1YW 2AIE 3AAZ and 3KE. W6KIP (1999) is an interesting arrival and is giving 160 a whirl from a Death Valley QTH some 280 feet below sea level. . . . We'll probably have more dope on this top band before the season closes up tight. So far so good!

Let's make *eighty* the next order of business—here's W6ZAT with a nice 3.5-Mc. WAC within 18 hours of routine DXing. G5WP, VS7NG, ZL1CI, VP4LZ, 5A3TU and a W assisted in turning the trick. Del also worked DL1FF, Gs 3RKF 5VB 6CJ, GI5UR, DLs 1FF 4MD, HB9KO, KC6QY, ON4HC, PA0NG, VK5s JE KO and ZS3K. W6ZAT has been trying skeds with AP2K and VU2AT . . . . Nice DX from Hawaii for KH6ARA was ZD4AB (3508) and DL1FF. . . . W9LMC and W8FRD were glad to grab VP4LZ (3524) for South America, W8FRD's fifth 20-watt 80-meter continent. . . . After working EI9J, KH6ARA and a G on c.w., W8PCS went up to 3.8-Mc. 'phone for VP7NB. . . . W6ZAT is expecting 3.5-Mc. activity on the parts of F08AA, VRs 1AA 2CG and 4AA. . . . A few good ones snagged by DL4JN: EA9AP (3512), HA5KBX (3512), I1NU/Trieste (3510), ZC4RX (3520) and 4X4RE (3520). MB9CA was heard. . . .

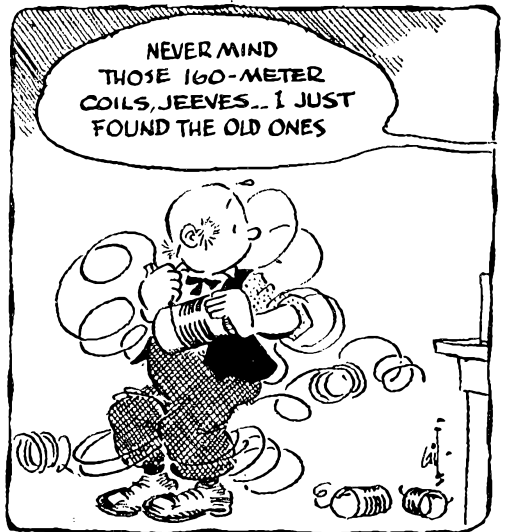

\* DX Editor, QST.

Other goodies giving the gang a run for their watts are FM7WD, LU1EP, PY7WS and 9S4AX (3540)..... WINJIM ran off with VP8AP (3508) and heard 5A3TU.

Next trip we'll undoubtedly have some 7-Mc. 'phone DX to report but this time it's strictly c.w. *Forty* was used by DL4JN to work AP2C (7020), FA3OA (7030), FF8s AG (7024), AJ (7050), ITIAGA (7023), JY3BUX (7030), LX1HH (7032), TA3MP (7037), SULXZ (7021), YIZAM (7041) and ZC4AK (7043). KC6QY was heard.....

Some assorted catches reported: PJ2CB (7020), by W8PCS; ZL3OZ (7058) by W9LMC; FQ8AC (7015) and YU3AQR (7020) at W1BTQ; CRYLU (7020) by KH6ARA. W9EAM is curious about one RV5J who worked a W1 near 7203 kc.....

One-hundred watts and a 100-foot c.f. antenna got FF8AJ, HH2LD (7040), TI2PZ (7015), VK6WT (7005), YU1AWX (7002) and scads of other VKs and ZLs for W2NZE.....

W5UTE/4 tried the band in Tallahassee and nabbed CT1CF (7006), HB9MQ (7008), LA3DB (7010), LU1EP (7015), PJ2AA (7005) and YU1ADI (7004).....

DL4LQ recommends AP2K (7004), GC3HFE (7007), ZSs 3K (7006) and 9I (7005)..... PJ2AD (7023) worked W9HUZ. So did FA8DA (7030), HC1AG (7013), OA4ED (7010) and W5QDF/KG6 (7032).....

On W9ESQ's list we see HR1AT, PJ2AJ, KG6FAD and YU3AIG..... Other 40-Meter goodies that may be of interest are TA3AA, YV5AO, ZB2I (7010), ZC5VS (7015), 5A3TR (7035) and LU9ZDV (7001) on South Shetland.....

W1VMW was lucky with ZS2MI (7045 t7e).

*Fifteen* is a good band on which to keep an eye. FF8AG (21.034), KG4AF (040), OA4N (030) and TA3AA (050) kept W9HUZ entertained.....

ZS3K (040) worked KH6ARA to complete his 21-Mc. WAC..... W2QHH caught up with GD3UB and W8HEV's first 15-meter effort brought him KH6ARA.....

WAC and 24 countries on this band have been worked by W5VIR. Recent QSOs were with KV4AA, ZL4GA, ZP9AH and ZS3K; the WAC sextet — HZ1MY, VK4HD, OQ5BQ, LU4DAY, T12TG and HB9LA — was worked with a Viking-I and a long wire.....

EL2P (060) and CP1BX (065) heartened W3AYS. He also raised I1BLF/Trieste, SM5s CO and KP.....

W2DEC zipped up to 17 countries fast with his 32V-1. An Asian would have given him a fast WAC — Urb knocked off five continents in an hour and a half.....

W6ZZ has over 21 countries (and 43 states) on 15 meters. Here are a few of Miles' late ones: CE3HL, CP1BX, LU5AAS (ex-VP8AD), OQ5BQ, KH6YL, VP9BC, VKs 3XK 4FJ, ZLs 1AH 1M Q 2FA 2GS 3JA, ZSs IMP 3K and 6I. W6ZZ sports a new 15-meter 3-element rotary and says Ws 4KRR 6VX and VK4FJ are real go-getters on the band.

Quick daylight openings characterize *twenty* nowadays. DL4JN worked CR7s LU (14.070), RF (070), KA2s OM (030), US (005), KG6FAA (010), MP4HBK (010), TA2AD (030), VSs 7YL (060) 9AW (101) and VU2JG. Still on Bill's stalk list are CR6CZ (039), FY7YC (078), HC2OT (012), KR6AC (080), LX1AF (040), VP9s AU (075), TT (072), VK1JC (080), VQ3HR (080), VS2DU (078) and VU2DF (078).....

CT2BO (075), FB8ZZ (050), FF8AJ (102), GC2FZC (042), GD3UB (070), HC6TG (038), ISGO (085), JA5AA (074), KB6AY (028), MP4BBD (050), OQ5CP (026), OY2Z (080), SV8WY (057), TFs 3SG (060), 5SV (070), TG9AC (042), VPs 2MD (050), 8AT (024), VQ4NZK (083), VS1PY (050), Y13BU (002), ZD2DCP (012), ZC4XP (110), ZE2KQ (034), 4X4s RE (020), CW (055), 5A3TR (055) and 9S4AX (060) are newly entered on the good side of W9HUZ's ledger.....

W8DLZ connected with FF8AT (070). PJ2s AI (032) and CF (099) while DL4LQ pounced on OY3HRS (040 t7)......

W2DEC is just



Another old-time DXer still going strong, 9S4AX has provided Saarland QSOs with a flock of W/VEs since his postwar return to the air. Fred's calls in the old days included EZ4SAX and TS4SAX. (Photo via DL4LQ)

getting warmed up to this DX business, knocking off people like FP8AP (066), KA9AA (056), OX3UD (078), TA3AA (019), VQ4BY (057), 5A2TR (007) and 5A3TY (025).....

At W6GPB we find FB8BB (020), MI3LK (060), VP8s AE AP (045), AU (050) and VQ8AL..... EL2P (065), HH3FL (150), HP1LA (006), FQ8s AG (015), AR (073), OE13HP (007), 5A3TZ (001) and a TA3 settled well with W8HEV.....

An ex-WN, W1UBC wasted no time getting a QSL collection underway. Dick checked off QSOs with CT3AB, EA8BF, FF8AN, HC2OT, KV4AQ, OA4AS, YU1DF, a TA3, ZD2 and 5A3 to bring him up to a fast 51 countries worked.....

W4KE raised KF3AA 'way up north on 14.085 kc. and W1MLJ captured OD5AD (030).....

CT2BO, PY7YB, TG9AQ, YS2RC, VQ2HR, ZB1KQ, ZE3JP, ZB1KQ and a TA3 look good on W9ESQ's 20-meter roster.....

Some times-of-QSOs via W5VIR (all CST): CN8FL 1319, CP1BX 1710, CX1BZ 1628, FF8AJ 1543, KG4AF 1357, KG6AEJ 1643, KJ6AX 1739, OAs 4AP 1736, 4AS 1622, OQ5LL 1609, OX3UD 1125, TF5SV 1645, TY2CR 1723, VP8s AT 1726, AU 1641, ZE2KQ 1502 and ZP6CR 0730.....

West Gulf DX Club's *DX Bulletin* specifies EA8AD (082), FB8ZZ (050), FK8AI (015), ISs SG (040), ZC (035), IS1FIC (094), LU4ZI (044), LZ1KAB (020-150), SU1GG (060), SV8WB (060), VKs 1PN (061), 9YY (095), VSs 6CG (092), 7BB (004), 7EA (170), VU2s EJ (018-095), JK (038), ZB1RM (020), ZC4s IP (054), XP (080), ZSs 3HX (065), 7D (040), ZE5JJ (105) and 4UAG (085). CR8NMC (117) came back to W5s BGP and KUC around 0930 CST one morn.....

W1BLF adds CR8AB (075).

It might be said that *twenty* 'phone is now a lot like old ten meters usta was — some will say it's like ten meters is.

W1BLF doesn't complain, though, and goes on working stuff like MP4s HBK (14,121), KAC (130), OD5A (140), SUSEB (120), VS7PW (140), ZD6HJ (195), ZSs 7C (210) and 9G (150).....

DL4LQ found AP2L (120) and OY2Z (195) available.....

PJ2AF (155) was a new one for W2DEC's 32V-1.....

W8HEV took his first crack at 14-Mc. A3ing and came out with CN8FI (310), HH4MV (171), HR1KS (194), OA4E (181), TI2SR (180), VP8s 3HAG (124) and 9G (147). Tom mentions that UA8AC acknowledged calls from a few Ws and then scrambled.....

WGDXC's constituents are on the prowl for 'phones FR7ZA (320), IS1EHA (348), HH2X (213), HZ1s AB (148), TA (121-145), MF2AA (151), MI3LK (160), MP4BBI (137), OD5s AB (125), AO (118), OE13HP (177), SU1JP (245), VK1JC (115), VP8s 1SJC (184), 5BF (148), VQs 3BM (170), 3CH (310), 5CY (347), VSs 8AW (140), 9AW (122-200), YIZAM (130), YK1AA (130) and ZD2RW (200) in the A.M.; CR6s AR (151), AT (143), BX (178), CT3AN (151-.....



CP1BX is just about your only bet right now for catching Bolivia on c.w. Ted hunts 20 and 15 meters, the latter on week ends only. CP1BX uses ex-CP1BK's 55-watt 807 rig, an SP-600JL receiver and conventional antennae.

QST for



Kuwait is still one of the more difficult countries to snag but MP4KAC does his part to make it possible Bill prefers 20-meter work.

171), EL9A (311), FF8s AP (145-176), AS (196), MI3MK (145-168), OQ5BG (153), VPs 1AB (177), 8AP (220), VQs 2AT (182), 2DT (135), 3BU (156), ZD4s AF (188), BK (191), BL (107-154), ZEs 1JE (151), 2JE (187) and ZS3S (122-132) during the p.m.

### Where:

"It was previously published that MP4K QSLs should be sent to P. O. Box 54, Kuwait, Persian Gulf, but that P. O. box has been discontinued. All QSLs for MP4K stations may now be sent to MP4KAC, % Kuwait Oil Company, Kuwait, Persian Gulf." So writes MP4KAC, adding that his XYL will help him out on this offer. Good girl!

DJ1JA, Flavius Jankauskas, W3JAK, P. O. Box 585, Stuttgart, Germany

F7BN, Capt. Kyle Johnson, USAF, 21 Place de Verdun, Loches (Indre et Loire), France

HC6TG, Box 93, Ambato, Ecuador

JA1AA, H. Shone, 4-882 Shimotakaido, Sugunami, Tokyo

JA1AB, H. Iohikawa, 6-1532 Sugamo, Toshima, Tokyo

JA1AC, K. Murai, 4-888 Kashiwagi, Shinjuku, Tokyo

JA1AF, S. Nakayama, Box 7, Nerima, Tokyo

JA1AH, Y. Komiya, % Egota P. O., Nerima, Tokyo

JA1BC, S. Sakuma, 126 Haramachi, Bunkyo, Tokyo

JA5AA, M. Kume, 655 Okinohamacho, Tokushima City, Japan

JA8AA, T. Hama, West 11th St. & South 6th Ave., Sapporo, Hokkaido

JA8AB, T. Ishida, East 4th St. & North 16th Ave., Sapporo, Hokkaido

K2FBC/VO4, (QSL to W2JBF)

KF3AA, (ex-W5AGB/FM) Box 143, Oakdale, La.

ex-KP4HU-NY4CM, (QSL to W4VNE)

ex-KR6JA, Bill Olney, W5TQX/4, 8405 Bayshore Dr., MacDill AFB, Fla.

KT1DD, Don Droegemeyer, VOA, American Embassy, 34 rue Moujahedine, Tangier, Tangier Zone

M3JV, John Loyal, APO 843, % Postmaster, New York, N. Y.

MP4HBK, R. Barry, AMWD, % RAF, Sharjah, % RAF, Bahrain, Persian Gulf

OA4N, M/Sgt R. D. King, USAF Mission, % U. S. Embassy, Lima, Peru

PJ2AI, J. Oorns, P. O. Box 80, San Nicolas, Aruba, N. W. I.

PJ2CA, S. Reitsma, % CPIM, Curacao, N. W. I.

PJ2CF, Marc De Pree, % Hato Airport, Curacao, N. W. I.

SU5EB, (QSL via RSGB)

SV5UN, (QSL via W3EWR)

VP6BM, Bill Sugars, Chelholme, Chelsea Gardens, Barbados

ex-VP6SD, (QSL via VE2UN)

ex-VP8AD, (QSL to LU5AAS)

VP8AP, (QSL via W6EUV)

VP8AT, (QSL via RSGB)

VQ2FU, Box 199, Livinstone, No. Rhodesia

VQ4NZK, (QSL via W1PIJ)

W2JAB/VO2, George Henf, APO 368, % Postmaster, New York



XE2OK, Rafael Elizondo C., Calle de Flores 10, Mesa Mexico, Santa Rosalia, Baja California, Mexico

YI3BU, (QSL via YI3ECU)

ZC5VS, (QSL via VS6CG)

ZD4BK, % G. P. O., Takoradi, Gold Coast, B. W. A.

ZS6B, E. A. Myers, P. O. Box 1628, Johannesburg, Union of South Africa

4UAG, Box 486, Karachi, Pakistan

5A3TY, P. O. Box 372, Tripoli, Libya

Don't thank Jeeves & Co. for the preceding roster — thank contributors W1s BLF BTQ UBC VG WPO, W2s DEC EQS LXP TXB, W3BXE, W4s IYT KE, W6s GPB ZZ, W8s DLZ HGW NOH PCS, W9s CFT HUZ KA, K2AIB, KP4KD, VS6AE, J. J. Hart and the *DX Bulletin*.

### Tidbits:

Asia — AP2R is ex-G3GJQ; Roy looks forward to much future DX activity from his new Pakistan diggings. He was especially interested in giving W/VEs some AP QSOs during the ARRL DX Test now in full swing. . . . W1WPO notes that HZ1HZ was awarded the second Saudi Arabian postwar DXCC (HZ1KE the other) . . . Ex-KR6JA is awaiting his W4 label from Washington and meanwhile bears the call W5TQX/4. . . . A previous "Where" item had KA8AB QRT and back in the U. S. but, as so often happens where multi-operator stations are concerned, just one of KA8AB's operators (W4NLY) came home. KA8AB, himself, will be at the same old stand in Misana at least until March of '54. The station runs 700 watts to a BC610, uses a 75A-2 receiver and features a 300-foot-per-leg, 60-foot-high rhombic aimed at North America. Harry also has a 3-element whirler available for use in other directions . . . . "At present Ws are coming through very well between the hours of 1430 and 1530 GCT and I am listening for them every day at that time. My operating frequency is 14,135 kc. and I will appreciate any W contacts." This from MP4KAC of the Kuwait MP4s — we're sure that appreciation of those QSOs will be mutual! . . . . JA1BC, via W4QCW, W8HGW and VE7WL, tells us more about hamming in Japan. Those 40-meter spot frequencies assigned to JAs are (phone) 7050 and 7087.5 kc.; (c.w.) 7032.5, 7065 and 7075 kc. "These two 'phone channels are very crowded by 2nd-class stations all day long, hi hi." There are now over fifty Japanese nationals licensed. JA1BC got his own ticket last November and W8HGW was his first W8 contact. Sumhisa is active on 40, 20 and 15 meters and he agrees that 14-Mc. conditions are mighty sad these days . . . . GR8NMC is, of course, none other than globe-trotting W6NMC.

Africa — The wildlife photography of VQ4NZK's safari (W6NZK at the key) has to do with a movie effort by Breakston-Stahl Productions of California. VQ4NZK has been very workable on 20 'phone and c.w. and it appears probable that the calls VQ3NZK and VQ5NZK will also see action. This via W1VG . . . . W1WPO hears that F8RAB will hit the air with a will in April. Togolandians have never been too abundant . . . . ZS6B wants it known that he just uncocked a stack of cards our way via ARRL QSL bureaus. Ed adds: "I suppose you are already aware that ZS hams are now on 21-Mc. 'phone and fairly good results are being achieved although band conditions are very erratic and most of us are using simple antennas (fold dipoles, etc.). I, for one, am greatly looking forward to working Ws on 21-Mc. 'phone when you get your 'phone subband." . . . . From VQ4RF via W1BLF we hear that the former has the *only*



Being one of few amateurs active in the Caroline Islands made KC6QL mighty popular during 1952. Bob will soon be back on with a KG6 call and will help keep Guam represented on 14-Mc. 'phone and c.w.

log for VQ1RF's activities and will be very happy to replace any cards upon proper request. If direct reply by air is desired, five IRCs should be sent; for surface mail replies two coupons are sufficient. . . . . Madagascar grows a little more liberal hamwise — about a half dozen new FB8s are slated to hit the air there ere long.

**Europe** — Relax, fellows; SV5UN is to remain active from the city of Rhodes, island of Rhodes (no, not Rhode Island, Jeeves), for another year or more. LeRoy (W3CHV) will raise power as soon as new gear arrives and all QSLs should continue to be sent via brother Dick, W3EWR. SV5UN's three-2E26s-paralleled 30-watt final may be found on 7010

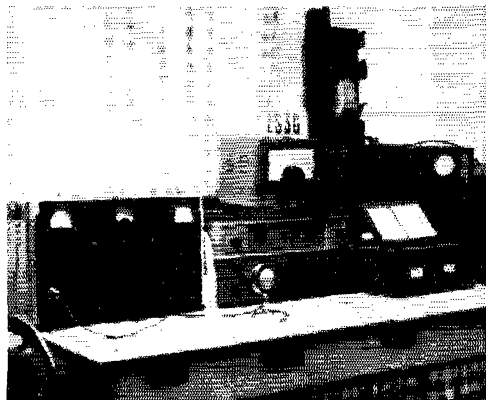

This trim layout at ZS3C of Windhoek, Southwest Africa, puts consistent signals through to North America on several DX bands.

kc. from 2000 to 2300 EST and on 14,030 kc. between 0700 and 1100 EST. He receives with a Super-Pro and gets along on a simple dipole skyhook. This info thanks to W3BXE . . . . . Quite-active DJ1JA is same guy as W3JAK, avid 7-Mc. DXer when on this side of the pond. May is soaking up a little schooling in Stuttgart. . . . . W2TXB hears there are two active Spitzbergers leaping through when the North Atlantic path is open. One is LB5ZC with 15 watts . . . . . As so often happens in such planned excursions, DL4LQ didn't quite make it to Helgoland for a little field-daying as scheduled. Bud did visit 9S4AX to find that Fred recently bandied a 30-watt 10-phone rig for action and will hit that band hard as soon as conditions give him half a break . . . . . F7BN finds a 50-watt power limit quite a letdown after his "Texas kilowatt" at W5BKJ. However, after finally completing the complicated rigamarole necessary to obtain an F7 ticket, Kyle is having a ball on 20 and 40. One-hundred watts input is permissible there on 10 meters but, as we too well know, DX conditions on 28 Mc. reek right now. F7BN receives with a BC348.

**Oceania** — Ex-KC6QL, formerly of Truk in the Carolines, will have caught up with all his KC6 QSLing by the time this gets around. It was quite a task! Watch for Bob with his new KG6 moniker in a month or so . . . . . KH6ARA has naught but scorn for DX operators who try to worm QSLs for nonexistent QSOs as one W8 attempted to do after hearing Pat on 80 c.w. Some guys are apparently incorrigible. More from KH6ARA: "My new QTH seems to be about the best receiving location I've ever been in as I am working low-power lads on 80 and giving them their first KH6s. My QTH is about 1000 feet above the sea on the side of 14,000-foot Mauna Kea with its snow cover [above] the blue Pacific. My new job keeps me busy but I still find time to get on the air on an evening and work the boys. The country itself is very beautiful and the climate very bland. Orchids grow wild in my back yard as do many other exotic flowers. Wild canaries, too, hang around and keep me company. Quite a place! Only bad angle is that we have spells of heavy rain with a yearly average of 200 inches." . . . . . KB6AY is another lad with a tropical-paradise shack: "The gear is located in a glassed-in lanai (Hawaiian for veranda) about 100 feet from the lagoon it faces. Very nice and airy with breezes coming off the water." Shades of Shangri-Lal

**South America** — "CR" of W1AW learns that GM3EYP of VP8AP will be back in Scotland by May and has been

trying to close out his Falklands WAS before leaving that area. VP8AP, around 2200 GCT, may be found on 3505, 7005 or 14,040 kc. depending upon which band shows the most promise at the time. Ala., Nev., S. C., S. Dak., Utah and Vt. were holdouts. . . . . "Conditions have been absolutely foul on both 14 and 21 Mc. here for weeks. About the only DX I can hear are a few VKs, ZLs and VSs about noon [local time] and an occasional ZS on 21 Mc. at 1400. My W contacts are limited to about 1900-2100 on 14 Mc." So writes CP1BX, adding that he contemplates 7-Mc. shenanigans in the near future.

**Herabouts** — Ex-VP6SD informs: "Leaving Barbados for Montreal and will be there by March 1st. All QSLs arriving here (Barbados) by the end of January will be answered and forwarded before leaving Barbados. All after this date will be forwarded from Canada. Hope to be on the air within a few weeks of arrival in Montreal." Hi, neighbor! . . . . . VO6N apologizes for slow QSL service caused by inclement weather up Cape Harrison way . . . . . W6EAY tells of W5JOI's intended three-year jaunt around the globe. Bill's itinerary will call for pauses at Hawaii, both Christmas Islands, Fanning, Pitcairn, Society Islands, Australia, Norfolk, Ceylon, Rhodes and Corsica, Chagos, Seychelles, Laccadives, Cyprus and Crete. Wow! Forty-five-foot schooner *Quissette* will provide the transportation and W5JOI will have an NC-183D and a Viking-II for c.w. and 'phone use. . . . . W6UXX/MM was frolicking in the immediate vicinity of Clipperton Island with a 28-Mc. 3-watt 'phone. Lack of a portable power source and proper authorization prevented Evan's going ashore for some DXCC-credit QSOs. Still has intentions, though. . . . . Nope, KF3AA doesn't go as a new country. That's W5AGB /FM's new call on Fletcher's Ice Island, quite close to the Pole. . . . . WAA (LABRE's) certificate No. 76 went to W6GPB. Joe is the 31st W and the 3rd W6 to nail that one

— . . . . —

We've just heard it said that a successful QRP DX man is one who speaks softly and carries a big antenna mast. Apologies to the late "T.R.!"

### WPR (Worked Puerto Rico) CERTIFICATE RULES

- 1) Basically, to obtain a WPR Certificate of the "25" or "50" type, it is necessary to have confirmation cards from either 25 or 50 bona fide KP4 stations. Cards must be mailed to: Puerto Rico Amateur Radio Club, P. O. Box 3533, San Juan, P. R. All cards must be accompanied by a self-addressed and stamped envelope for their return. The club assumes no responsibility for loss in the mails.
- 2) Specifically, bona fide KP4 stations are defined as follows: (a) All land stations operated from a permanent and fixed QTH in Puerto Rico. (b) All portable or mobile stations operating at any location in Puerto Rico or on any highway within Puerto Rico. (c) Amateur stations of the U. S. and possessions which have been moved to Puerto Rico and have not yet received KP4 calls. Such stations will sign as "portable" after their W or other federally-assigned call letters, in accordance with existing FCC rules and regulations.
- 3) Contacts with or by maritime, mobile or aeronautical, mobile stations are not entitled to count as contacts for WPR certificates.
- 4) Contacts made with bona fide KP4 stations, as defined in Rule 2 above, may be counted for WPR certificates, regardless of whether made with fixed, portable or mobile equipment. This gives a possibility of three separate confirmations from the same KP4 station.
- 5) WPR certificates issued by the club will normally bear no endorsement for contacts made on any or all bands. However, if a station submits either 25 or 50 confirmations indicating his Puerto Rico contacts were all on any one band, a special endorsement to that effect will be entered on the certificate if requested.
- 6) Contacts by the station claiming a WPR certificate must have been made from fixed locations within 100 miles radius of the location from which the first contact was made, by the same licensee with legally-assigned call letters.

## Strays

In twenty years "Hank" Yahnel, W2SN, ARRL's QSL Bureau Manager for the second call area, handled 670,434 QSL cards. At a conservative  $5\frac{1}{2}$ -inch average width they would make an impressive short-snorter 58 miles long.

W2ESQ worked W6LRT and VP4CQ on the same day not long ago. Subsequently he received their QSLs on the same day. Moreover, the operators of W6LRT and VP4CQ bear the same last name — Blankenship!

An XNS dispatch, called to our attention by W2DIC, reports that W4HUW, Raleigh, N. C., and W2ZDV, St. Albans, N. Y., recently gave urgently needed assistance to YV2AJ in the latter's efforts to obtain anti-leukemia serum for a critically-ill young patient in Coro, Venezuela. W4HUW intercepted and relayed the message to New York City via W2ZDV, where Lederle Laboratories dispatched a quantity of aminopterin for the necessary treatment.

## A.R.R.L. QSL BUREAU

The function of the ARRL QSL Bureau system is to facilitate delivery to amateurs in the United States, its possessions, and Canada of those QSL cards which arrive from amateur stations in other parts of the world. Its operation is made possible by volunteer managers in each W, K, and VE call area. All you have to do is send your QSL manager (see list below) a stamped self-addressed envelope about  $4\frac{1}{4}$  by  $9\frac{1}{2}$  inches in size, with your name and address in the usual place on the front of the envelope and your call printed in capital letters in the upper left-hand corner. For a list of overseas bureaus see p. 62, Dec., 1952, QST.

- W1, K1 — J. R. Baker, jr., W1JOF, Box 232, Ipswich, Mass.  
W2, K2 — H. W. Yahnel, W2SN, Lake Ave., Helmetta, N. J.  
W3, K3 — Jesse Bieberman, W3KT, Box 34, Philadelphia 5, Penna.  
W4, K4 — Thomas M. Moss, W4IYW, Box 644, Municipal Airport Branch, Atlanta, Ga.  
W5, K5 — Oren B. Gambill, W5WI, 2514 N. Garrison, Tulsa 6, Okla.  
W6, K6 — Horace R. Greer, W6TI, 414 Fairmount St., Oakland, Calif.  
W7, K7 — Mary Ann Tatro, W7FWR, 513 N. Central, Olympia, Wash.  
W8, K8 — Norman W. Aiken, W8LJS, 701 East 240th St., Euclid 23, Ohio  
W9, K9 — John F. Schneider, W9CFT, 311 W. Ross Ave., Wausau, Wisc.  
W0, K0 — Alva A. Smith, W0DMA, 238 East Main St., Caledonia, Minn.  
VE1 — L. J. Fader, VE1FQ, 125 Henry St., Halifax, N. S.  
VE2 — Austin A. W. Smith, VE2UW, 6164 Jeanne Mance, Montreal 8, Que.  
VE3 — W. Bert Knowles, VE3QB, Lanark, Ont.  
VE4 — Len Cuff, VE4LC, 286 Rutland St., St. James, Man.  
VE5 — Fred Ward, VE5OP, 899 Connaught Ave., Moose Jaw, Sask.  
VE6 — W. R. Savage, VE6EO, 329 15th St., North Lethbridge, Alta.  
VE7 — H. R. Hough, VE7HR, 1330 Mitchell St., Victoria, B. C.  
VE8 — W. L. Geary, VE8AW, Box 76, Whitehorse, Y. T.  
KP4 — E. W. Mayer, KP4KD, Box 1061, San Juan, P. R.  
KZ5 — P. C. Combs, KZ5PC, Box 407, Balboa, C. Z.  
KH6 — Andy H. Fuchikami, KH6BA, 2543 Namaau Dr., Honolulu, T. H.  
KL7 — Box 73, Douglas, Alaska

## ARRL Appointments:

### THE OFFICIAL OBSERVER

The amateur who takes on an Official Observer appointment is setting out to do a great service to amateur radio and his brother amateurs. One of the reasons for the great latitude we have always had in operating privileges is the fact that we are, to a great extent, self-regulating. The Official Observer appointee is one of the main reasons that our self-regulation is effective, for the OO is the one who "tips off" the erring amateur before FCC monitors can "cite" and enter the black mark on his (and our) amateur record.

We need Official Observers of all classes with a genuinely-helpful attitude toward violators of amateur regulations. In most cases an amateur does not realize he is committing a violation; a careless adjustment or spurious radiation may occur undetected. Where feasible to catch this, the operator is helped by the OO's friendly post-card notification. Official Observers, as such, are concerned with *FCC regulations only*, not with violations of amateur ethics.

There are four classes of Official Observers. Classes I and II are concerned with frequency measurements, and must qualify in ARRL Frequency Measuring Tests at least twice per year. Such tests to maintain the OO system are transmitted from W1AW quarterly. Classes III and IV are for 'phone and c.w. (including radioteletype) checks respectively and are not concerned with off-frequency operation. OOs must submit regular reports to their SCMs to retain appointment.

Just as the good amateur is one who will gratefully receive any well-intentioned tips concerning

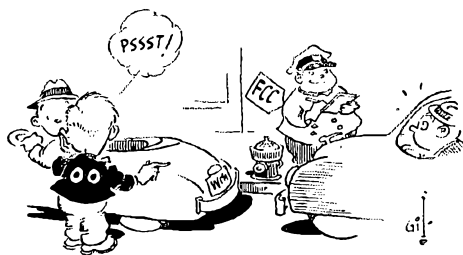

anything wrong with the operation of his station, the good OO is one who will disseminate such tips in a genuinely-helpful manner as contrasted to one who adopts the attitude of a policeman punishing a lawbreaker. There cannot be too many good OOs, so if you are interested in and qualified for this vital work, apply to your SCM for appointment.

### FEED-BACK

In the four-tube receiver described in the January issue, the wiring diagram (Fig. 2, page 21) should show the bottoms of  $L_1$  and  $L_2$  connected to ground and the common leads from  $C_1$ ,  $C_{2A}$  and  $C_{2B}$  connected to ground through  $C_3$ . As originally shown, there was no d.c. grid return for the signal grid of the 6SB7-Y.



# Hints and Kinks

## For the Experimenter



### IMPROVED STABILITY FOR THE ELMAC TRANSMITTER

SEVERAL fellows who use the popular Elmac mobile transmitter have reported frequency-modulation difficulties whenever operation is switched to VFO. After some experimenting, a very simple solution was found. Simply replace the 6AU6 oscillator tube with a Type 6AK6. No wiring changes are required. The new tube does have lower input and output capacitances than those of the 6AU6 and, as a result, the VFO calibration must be corrected by adjustment of the oscillator padder capacitor. Another slight advantage of the conversion is a 0.15-amp. reduction in heater current drain. — *William E. Rose, W9KLR*

### CRYSTAL-CONTROLLED CONVERTER FOR 21 MC.

THE circuit diagram of the popular crystal-controlled converter<sup>1</sup> that appears on page 377 of the 1951 *Handbook* can be easily modified for 21-Mc. coverage by those who cannot tune the band with an existing receiver. When converted for 21-Mc. work, the unit employs a 7.09-Mc. crystal operated at the fifth overtone, 35.45 Mc., thus enabling the full 21-Mc. band to be covered by a receiver that tunes 14.0 to 14.45 Mc. Alterations that must be made to the original parts list of the converter are as follows:

- C<sub>1</sub> — 25- $\mu$ fd. variable.
- C<sub>8</sub>, C<sub>9</sub> — 25- $\mu$ fd. trimmer.
- C<sub>11</sub> — 50- $\mu$ fd. trimmer.
- L<sub>1</sub> — 4 turns over cold end of L<sub>2</sub>.
- L<sub>2</sub> — 12 turns B & W 3007.
- L<sub>4</sub> — 28 turns No. 22 on  $\frac{3}{8}$ -inch slug-tuned form.
- L<sub>5</sub>, L<sub>6</sub> — 13 turns B & W 3004; 3/16-inch space between windings.
- L<sub>7</sub> — 8 turns B & W 3004, tapped 2 $\frac{3}{4}$  turns from crystal end.
- L<sub>8</sub> — 26 turns No. 22 on  $\frac{3}{8}$ -inch slug-tuned form padded with 3-30- $\mu$ fd. trimmer.

In the i.f. amplifier circuit of the converter (page 379, 1951 *Handbook*), L<sub>2</sub> was changed to 27 turns of B & W 3004 and was padded with a 75- $\mu$ fd. trimmer. L<sub>3</sub> of the same circuit was changed to 5 turns wrapped around the cold end of L<sub>2</sub>.

Although the converter took only a few hours to build, it has proven itself worthy of recommendation for 21-Mc. operation. In fact, the performance of the converter-receiver combination is probably superior to that of any standard 21-Mc. receiver that already covers the new band. — *Russel E. Martin, W3MFW*

<sup>1</sup> The circuit for the converter referred to above also appears on page 371 of the 1952 *Handbook* and in *QST*, September, 1950.

### ANTENNA GROUNDING SYSTEM

SHOWN in Fig. 1 is the circuit diagram of a switching system that automatically grounds the antenna whenever the station equipment is turned off by the master control switch. S<sub>1</sub> is a d.p.s.t. switch that feeds 115 volts a.c. to the power circuits and S<sub>2</sub> is a s.p.s.t. job that does the antenna grounding. The switches are arranged

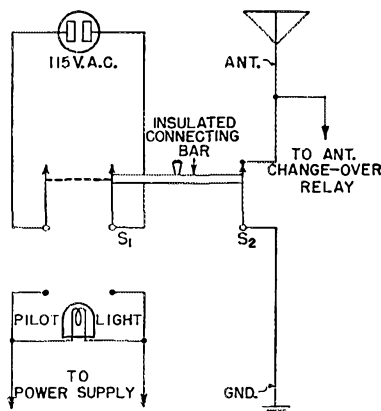

Fig. 1 — A switching circuit that automatically grounds the antenna when the main power switch is opened.

mechanically so that S<sub>2</sub> opens when S<sub>1</sub> is closed. An insulated connecting bar joins the control levers of the switches to permit the simultaneous manipulation of the two circuits.

The switches should have a power rating in keeping with the power level of their respective circuits and S<sub>1</sub> should be enclosed to prevent accidental contact with the a.c. line. — *E. M. Brownlee, VE2APO*

### INCREASED VOLTAGE RATING FOR VARIABLE CAPACITORS

WHILE trying out a low-power antenna tuner for the first time, it was discovered that the tuning capacitor did not have adequate spacing between plates. This problem was quickly remedied by applying a few drops of regular lubricating oil along the edges of the plates. The rotor shaft of the capacitor was then rotated until a thin film of oil had been spread across the entire surface of all the plates. Since the oil has a higher dielectric constant than that of air, the treatment raised the working voltage of the capacitor and thus allowed it to remain in use until a suitable replacement had been obtained — *John J. Schultz, W2EEY*



## BETTER KEYING FOR THE CONVERTED BC-487

I AM one of the fellows who has undertaken the job of converting a BC-457 for use on Novice frequencies and, like many others, have encountered considerable difficulty with oscillator instability and poor keying. W7KOG saved the situation for me by suggesting the substitution of a Type 12A6 tube for the 1626 ordinarily used in the oscillator circuit. The only alterations that need be made are the addition of a 20,000-ohm dropping resistor and a 0.001- $\mu$ fd. by-pass for the screen of the 12A6. With the circuit as modified, there is no longer any difficulty getting any crystal to oscillate and frequency drifting is a thing of the past. — *Vernon M. Slichter, WN7RKY*

## INSULATED SLIP COVERS FOR HIGH-VOLTAGE FEED-THROUGH INSULATORS

PLASTIC or rubber spark-plug covers make ideal insulated covers for the exposed terminals of small feed-through insulators that carry high voltage. The covers may usually be bought in sets of 6 at a cost of less than one dollar. — *Charles Wood, W2VMS/1*

## SIMPLE KEYING MONITOR

MOST keying monitors require special power supplies, relays, etc. The interrupters in several surplus equipments, such as telegraph set TG-5, can be converted easily to an excellent keying monitor used in conjunction with the station receiver and transmitter. The interrupter (howler) consists of a double carbon button mounted against the diaphragm of a telephone receiver. When a voltage of 1 to 4 volts d.c. is

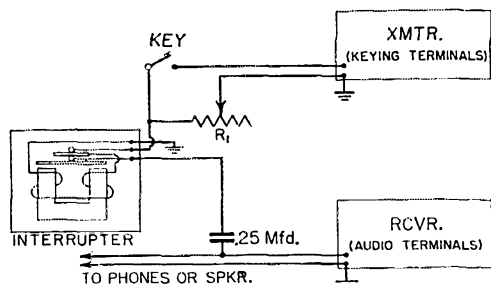

Fig. 2 — Circuit diagram of W4KE's simple keying monitor. The voltage control,  $R_1$ , for the interrupter should have a resistance of approximately 200 ohms.

applied, the interrupter produces a steady tone of approximately 1000 cycles per second. In the circuit shown, Fig. 2, this voltage is obtained by inserting a low-resistance potentiometer in the keying leads of the oscillator. The small voltage drop required will not normally cause any noticeable change in the operating of the transmitter. The variable resistor is used to control the volume of the keying monitor, or shut it off completely when it is not required, such as when operation on

'phone. The audio output of the interrupter is sufficient to drive either headphones or a loud-speaker. — *Lieut. Col. Lloyd D. Colvin, W4KE*

## COMBINATION PLATE BY-PASS AND NEUTRALIZING CAPACITOR

A TUBULAR plate by-pass capacitor used in an r.f. amplifier to provide a shorter return path for r.f. to cathode or ground has proved its worth. In most amplifiers a neutralizing capacitor is also required. Why not combine the two?

Fig. 3 shows how this type of capacitor can be made of thin-wall copper tubing. The outer sec-

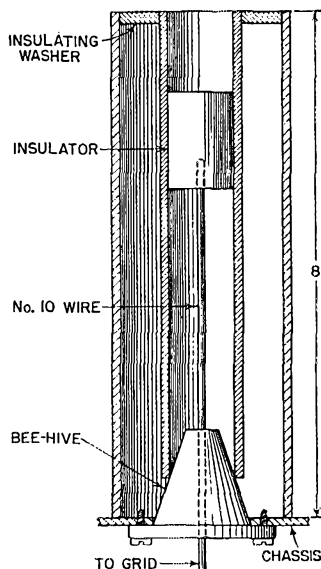

Fig. 3 — Combination plate by-pass and neutralizing capacitor used by W1CRU.

tion is an 8-inch length of  $1\frac{1}{4}$ -inch tubing fastened at one end directly to the chassis. The inner tube is a  $7\frac{1}{2}$ -inch length of  $\frac{5}{8}$ -inch tubing held concentric within the outer tube by an insulating spacer at the top end and by a beehive insulator at the lower end. The inner conductor is a length of No. 10 hard-drawn copper wire which slides through the hole in the beehive insulator and is held centered in the  $\frac{5}{8}$ -inch tubing by a porcelain pillar insulator cemented to the wire's top end.

The beehive insulator projects up through a hole punched in the chassis and is fastened to the chassis by self-tapping sheet-metal screws from the bottom.

Under the chassis the inner wire is held by a small copper alligator clip which is fastened to the grid wire coming from the opposite tube socket. Neutralizing adjustments are made by sliding the wire in or out of the plate or inner tube. After the amplifier is neutralized the extra length of the inner wire showing beyond the clip at the bottom can be clipped off, leaving an inch or so for future adjustments. — *George D. Littlefield, W1CRU*

(Continued on page 138)



# Correspondence From Members -

The publishers of *QST* assume no responsibility for statements made herein by correspondents.

## WELL SPENT MONEY

4600 Liberty St.  
Kansas City, Mo.

Editor, *QST*:

Your recent answer to my question about true north determinations was just another example of the prompt, courteous, and complete replies I have received to questions in the past. You are to be complimented.

In my opinion this is just a small sample of the many ways in which the ARRL serves the amateur and makes the membership fees some of the best spent dollars of the year.

— Eugene W. Farley, W0DAK

## ON THE WAGON

4237 Rainier Ave.  
Seattle, Washington

Editor, *QST*:

Just got married three months ago. Due to new responsibilities, including a ham-hating wife, I have tried vainly to dispose of this infectious hobby — main purpose being to preserve the great institution of marriage. I find trying to dispose of ham radio is harder than the worst alcoholic giving up drinking. Therefore, Dear Editor, please recommend me to the nearest Amateurs Anonymous. Please . . . it is understood that I will only accept the slow, tapering-off treatment.

— Thomas Tountas, W7MQB

## APPRECIATION

2619 Arnold, N.E.  
Albuquerque, N. M.

Editor, *QST*:

This is written in appreciation of the recent series of articles on "The Wavelength Factor" by Yardley Beers. It is my opinion that articles such as this, bridging the gap between the engineering profession and the serious amateur, have a definite place in *QST*. Mr. Beers is to be congratulated on his handling of this somewhat obscure (in amateur circles) but very important factor.

— H. H. Patterson, W5DAH

## BRAILLE TRANSCRIPTIONS

980 Waring Avenue  
New York 69, N. Y.

Editor, *QST*:

We here at *The Braille Technical Press* were somewhat disturbed upon reading in your "Happenings of the Month" for January, 1953, about *The Radio Amateur's License Manual*, since it in no way mentioned the work done by our organization. I can assure you that it was also through our efforts and those of our readers that it became possible to have this manual, along with *How to Become a Radio Amateur*, printed in Braille, under the sponsorship of the Library of Congress.

Editorially, we asked blind persons to write the Library as far back as June, 1950, requesting that these manuals be put into Braille. In addition, the American Printing House for the Blind, who are actually printing this material, asked us to transcribe the circuit diagrams into appropriate word descriptions, so that a book of this type will make some sense to Braille readers. . . . We have done all of these circuits for the two manuals now being printed, and I feel very strongly that *The Braille Technical Press* should be given credit where such credit is due.

I can assure you that if *The Braille Technical Press* is to continue, it must have the cooperation of all other radio amateur publications, the amateur himself and his radio club. If such cooperation is not forthcoming, it is quite

likely that we shall have wasted our efforts. As a blind amateur, I can assure you that I am most interested in the welfare of all amateurs, including those who are unfortunate enough to be without sight, and I plan to do everything possible to foster this cause. . . .

— R. W. Gunderson, Editor

2443 N. Cramer Street  
Milwaukee 11, Wisconsin

Editor, *QST*:

At a recent meeting, our members held an auction where all the items were donated by the membership and outsiders. The purpose of this was to raise some money for *The Braille Technical Press*.

We got \$100.85 from this project and forwarded same to that organization.

— Fred H. Zolin, W9ONY

## DOCKETS 10073 AND 10173

29-23 212th Street  
Bayside, L. I., N. Y.

Editor, *QST*:

This is to register my opinion in favor of the recent ruling by the Commission to allow all classes of amateurs (except Novice and Technician) to operate on 20- and 75-meter 'phone and on the newly created subband of 7200-7300 kc.

The Class A license, usually obtained after a year's operation, was a serious slap in the face of the younger and future hams and discriminated against them. . . .

— Peter Rosenbaum, W2GAW

2856 Adeline Drive  
Burlingame, Calif.

Editor, *QST*:

. . . I feel that the time, money and study that I spent to obtain an Advanced Class license has been wasted and thrown away by the FCC. I am absolutely unable to obtain the so-called Amateur Extra Class license because I was born in 1916 and am not a broadcast engineer. . . .

— Robert W. Pricolte, W6BZO

2228 Crawford St.  
Terre Haute, Ind.

Editor, *QST*:

At the regular monthly meeting of the Wabash Valley Amateur Radio Association held January 2nd considerable discussion was had regarding the rule changes announced by the FCC.

Class B and C operation on 75 and 20 'phone: for, 4; against, 14; not voting, 4.

Forty-meter 'phone: for, 22; against, 0.

Forty-meter Novice: for, 22; against, 0.

Frequency-shift keying on all c.w. bands: for, 0; against, 22.

— Wm. H. Siebenmorjen, W9IHO  
Corresponding Secretary

8421 8th Avenue, North  
Birmingham 6, Alabama

Editor, *QST*:

. . . To my way of thinking, the FCC made an about-face on this matter. . . . First they say that the exam needs to be more difficult, and then they say that it doesn't — to get on 75 and 20.

My interest in the matter is not from the conditions that will exist on 75 and 20, but from the viewpoint of how the FCC is trying to control the amateur operator too much. . . .

— Marc Molyneux, Jr., W4MVM

P. O. Box 334  
Grants Pass, Ore.

Editor, QST:

. . . The new regulations are met with enthusiasm by amateurs everywhere that are mature enough to see the road ahead clearly, and as the FCC release stated, the only real opposition was from those with a personal or sentimental reason. . . .

— Keith L. Beck, W7MEV

1902 W. Farwell Ave.  
Chicago 26, Illinois

Editor, QST:

. . . Although I have been an amateur for a very short time and a member of the League for a little over a year, I still feel very strongly about this matter. The extra privileges afforded by the Advanced and Extra Class licenses are mainly the factors that spurred me, and undoubtedly many others, to work for advancement. Now the FCC comes forward with an amendment that kills all the incentive and, far more important, it promises to make the already crowded 20- and 75-meter 'phone bands useless for anyone. And as if this were not enough, anyone who has taken the initiative to obtain the Advanced or Extra Class license has expended the extra effort for naught but a useless piece of paper. What a miscarriage of justice!

— William Schulz, W9GJZ

## BARGAIN?

130 Gledhill Ave.  
Toronto 13, Ont.

Editor, QST:

I would like to draw your attention to the article on page 15 of December QST, entitled "A Bargain (?) Novice Station," which I think is way below the high standard one expects of QST.

The article gives an entirely erroneous impression of surplus equipment since the author had obviously bought more war surplus than he knew what to do with, and his final estimate of costs includes such ridiculous items as iodine, bandages, new dress for XYL (explanation not obvious).

I sincerely believe that some surplus equipment can be of great assistance to Novices and perhaps others who find the cost of a manufactured receiver too high. Here in Canada the average American-built receiver is 50 per cent higher priced than in the U. S. A. . . .

. . . So please, try to keep articles of this type out of our magazine. . . . You do the Novices no good turn by discouraging them in any way. Tell them frankly that unless they have the know-how to make their own equipment or convert surplus, they should go out and buy ready made. . . .

— Ernest M. Kennedy, VE3DMR

133 Orange St.  
Modesto, Calif.

Editor, QST:

I just finished reading J. B. Work's article on "A Bargain (?) Novice Station." Roy, he's had it! I sure agree with him. After trying to convert a Command transmitter and get satisfaction out of it I know what he means.

I'm fully convinced that I'd have been money and time ahead to have built the simple rig described in your manual using a 6L6 tube and running just as much power. . . .

— Allen H. Simms, W6KFC

## "HOW TO BECOME" RIG

840 North Jefferson St.  
Milledgeville, Georgia

Editor, QST:

I just could not turn down my chance of telling other boys about my rig after reading about WN8LJO's.

I built about five rigs and out of the five, the 6V6 which you described in *How to Become a Radio Amateur* is still with me. The only change I made was to use the 6L6 in place of the 6V6. Two hundred and fifty to five hundred miles wasn't anything at all for this little rig.

I was running about 15 watts at the time I worked my best DX — Ohio, New Jersey, Michigan, Kansas, Pennsylvania, Wisconsin, Arkansas, Missouri and Arizona for

just a few. My reports were between 559x to 599x and never have I received a chirp from the transmitter.

I used old tube socket bases with the coils mounted above and taped with scotch tape. Just to show you how cheap one might build the transmitter, I only spent 45 cents on the rig. The antenna used was a half-wave doublet, fed with coax cable.

— William Moody, WN4WSZ

414 Maple Avenue  
Fulton, Kentucky

Editor, QST:

. . . With three months of operating time, I have worked sixteen states, had about 50 QSOs, and best DX is North Dakota (about 900 miles), plus a couple in New York.

My construction closely followed ARRL plans. The coils are resting on three popsicle sticks. A d.p.d.t. slide switch stuck right on the rig switches the antenna from send to receive. The antenna is 130 feet of Johnson copper-weld end-fed with 55 feet of 300-ohm Twin-Lead, about 25 feet up.

— Edwin Bondurant, WN4WXL

10523 Centennial Hall  
Minneapolis 14, Minnesota

Editor, QST:

. . . I worked eight states with it as a Novice. My best DX was 1200 miles but had consistent contacts to 800 miles. Still using the same rig. I worked ten states with it this past week while on vacation. This included both coasts. . . .

— Byron W. Engen, W0EBA

63 Hampshire Rd.  
Great Neck, N. Y.

Editor, QST:

. . . I just want to say that I have also built the low-power rig described in *How to Become a Radio Amateur*. I have had this rig on 40 meters for about two months, and I have worked 35 states, VE1, VE2, VE3, Cuba, and Germany with it. . . .

— Kenneth Kellermann, K2AOE

R.F.D. 1  
Blakesburg, Iowa

Editor, QST:

. . . I've worked 25 states with it, which include N. Y., N. J., S. C., Nev., Wyo. — all on the 80-meter Novice band except N. Y. and Wyo., which were made on 40 meters but with the same rig.

. . . So for my money this small transmitter will give you thrills a-plenty.

— Charles Horn, W0HTJ

## PLUMBER'S DELIGHT

603 East 4th St.  
Brooklyn, N. Y.

Editor, QST:

I found Mack Seybold's article on nonlinear systems very interesting, but I believe I have the worst problem of all. I have a Robert Hall clothing store next to me with over 200 pipe racks!

— Harvey Weiss, WN2NEW

IS YOURS ON FILE  
WITH YOUR QSL MGR?

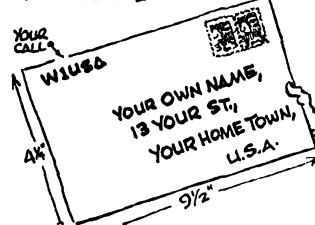

See page 61 for ARRL QSL Bureau Managers Listing.



# Operating News



F. E. HANDY, WIBDI, Communications Mgr.  
R. L. WHITE, WIWPO, Asst. Comm. Mgr., C.W.  
GEORGE HART, WINJM, Natl. Emerg. Coördinator

J. A. MOSKEY, WIJMY, Deputy Comm. Mgr.  
ELLEN WHITE, WIYYM, Asst. Comm. Mgr., 'Phone  
LILLIAN M. SALTER, Administrative Aide

**Network Calls Recognized in Amended Sec. 12.82(a).** FCC's clarification of procedure for call sign identification became effective February 20th. Station identification is required in all cases either by telegraphy using *International Morse*, or by telephony. When methods other than c.w. or 'phone are used or attempted (such as radioteletype, facsimile, etc.), prescribed identification shall also be transmitted by that method. The generally accepted identification of a network or call sign of station or stations called or communicated with or appropriate identification of transmission for another purpose shall be followed by the authorized call sign of the station transmitting.

This settles the matter that the identifying call shall come *last* in sequence. It recognizes our established networks and legitimatizes their operations using net calls. It provides for satisfactory monitoring as it must be provided for in a service as large as ours. Break-in practices continue to be provided for as implicit in the further specifications as to *when* identification must be inserted in transmissions:

- (1) At the beginning and end of each signal transmission; or
- (2) When each transmission is shorter than 3 minutes, at the beginning only (when series is less than three minutes); and
- (3) During a series of exchanges, having established communications, at least once every ten minutes (as soon after as possible if the "other" station is sending when your ten minute time to identify arrives); and
- (4) During any transmission more than ten minutes long, at least once every ten minutes.

**Novice Notes:** Learning the correct way to hold the telegraph key is important, since it contributes to the ease and enjoyment of all communications work throughout one's ham career. Daily practice and operating using the key are the best formula we know to permit *completely relaxed* muscular coördination for keying, which makes for smooth enjoyable c.w. contacts. For that matter familiarity through use is needed with either mike or key to permit the proper calm and relaxed approach that makes for most successful and enjoyable communication . . . and the more polished technique.

This subject was brought to attention in the new column for Novices in the *Beam News*, bulletin of the Birmingham Amateur Radio Club. WN4WJU and WN4YEH note the general difficulty in attaining the smooth relaxed operating approach in their quote, "After a first contact the other night I can hardly unclench my right hand. A bottle of liniment given each new Novice might help . . .!" On the matter of holding the

key properly, see page 10 of the ARRL booklet *Learning the Radiotelegraph Code*.

WN3TGH/1 writes with operating suggestions, which he says are for the benefit of those who conglomerate instead of contribute to the Novice spectrum:

- 1) Use the 3 X 3 CQ; how long do you expect a ham to await your "de" and call? Tune around well before you hit the key again.
- 2) Bend no faster than you can receive at any time. Leave bugs and automatic keys to old-timers. By sending at a proper speed you avoid having to ask QRS!
- 3) Play fair. Get two or three crystals and move around some. Give correct and honest RST reports by the definitions.
- 4) Answer CQs by calling with frequent identification for time enough to permit your signal to be tuned in. (You can lose more contacts by calling so long without the "de" another man gets the choice!)
- 5) Never close your key to put a steady unidentified signal on the air. Complete most of tune-up without coupling to the antenna. Use a lamp load per *Handbook* suggestions. Be quick and accurate in any final on-the-air adjustment.

**Earning Net Membership Recognition.** Any radio amateur can enjoy the benefits of net tie-in with the National Traffic System and distribution direct to any points in a particular net, just by reporting with traffic. The latchstring is always out! To become a regular certified member of an ARRL section net one has only to meet the requirements set up by the particular net manager. These vary from net to net depending on net purposes, frequency, and whether high or low standards in performance communications-wise are consistently stressed. Numerous net managers require newcomers coming to a net to establish a standard of performance and some contribution to the net before making the "guest" a regular member. Most messages require a newcomer to submit some messages consistently to prove status when reporting in. The Palmetto Net (Florida, 3675 kc.) for example has the following hurdles for the new man who would "belong." To be a certified member one must check into the net about every other night, making a total for any twenty-eight days of 20 messages originated and 10 QNIs. The new fellow must originate an average of 5 messages per week for 4 consecutive weeks . . . not really hard to do if one has serious intentions and good capabilities.

**On Keeping Operating Standards High.** The personal and group disapprobation for those who do not follow the letter or spirit of the rules is such as to maintain high standards in our activities of which we may all generally be proud. For a sportsmanlike and enjoyable amateur radio you and I and each amateur should continue to give personal support to a better operat-

ing program. Whenever you hear a poor note tell the operator about it, and that you don't think much of it! If you hear a ham sneak out of the band for a QSO and hop back in, tell him about it. Warn him. Make your opinion of this low sort of work clear.

It is just as important to be intolerant of the transmission on the air of any suggestive allusions or dubious remarks! Such cannot help but detract from the esteem and regard earned for our amateur service by the work of our traffic and emergency groups. Amateurs should continue to place a high value on our transmitting privileges and nail all such things at the source. Use your influence on the side of perpetuating amateur radio and the values in true sportsmanship and helpfulness; be intolerant of those things that tear down or reduce our stature and responsibility in the eyes of the public or our licensing authorities. — F. E. H.

### MEET THE SCMs

William J. Gentry, Northern Texas, who was first licensed in 1923, is no newcomer to the SCM post, since he held that office in the Oklahoma section from 1929 to 1931. In addition to his present call, W5GF, he has held 5BN, 5ATD, and portable 5BTN.

The station layout at W5GF consists of a Globe King 400-A, 7C5-2E26-p.p. V70Ds, and home-built p.p. 1625s on 75 and 40. For reception a DB-22A preselector and a

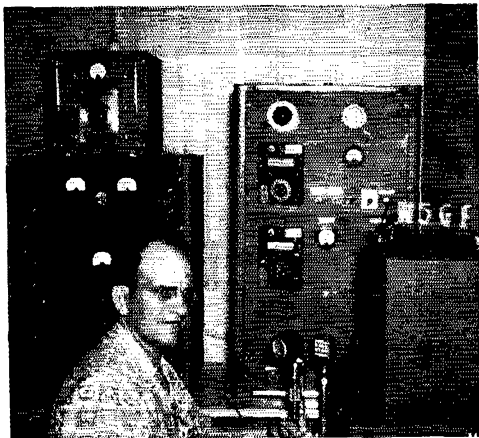

Collins 75A-1 are used. Antennas are a three-element Pre-max beam and a half-wave Zepp. Bill divides operating time equally on 10, 20, 40, and 80 meters.

SCM Gentry holds Official Experimental Station appointment and is active in the South Plains Amateur Radio Club as its vice-president.

Collecting old coins is another of Bill's hobbies and for recreation he likes to go fishing. He is president and manager of the R. & R. Refrigeration Corp.

### CODE-PROFICIENCY AWARDS

Have you received an ARRL Code Proficiency Certificate yet? Twice each month special transmissions are made to enable you to qualify for the award. The next qualifying run from W1AW will be held on March 18th at 2130 EST. Transmissions will be made simultaneously on 1887, 3555, 7120, 14,100, 28,060, 52,000 and 146,000 kc. The next qualifying run from W6OWP only will be transmitted on March 13th at 2100 PST on 3590 and 7138 kc.

Any person may apply; neither ARRL membership nor an amateur license is required. Send copies of all qualifying runs to ARRL for grading, stating the call of the station you

copied. If you qualify at one of the six speeds transmitted, 10 through 35 w.p.m., you will receive a certificate. If your initial qualification is for a speed below 35 w.p.m., you may try later for endorsement stickers.

Code-practice transmissions are made from W1AW each evening at 2130 EST. References to texts used on several of the transmissions are given below. These make it possible to check your copy. For practice purposes, the order of words in each line of QST text is reversed during certain of the slow-speed transmissions.

Date Subject of Practice Text from Jan. QST

- Mar. 2nd: Harmonic Radiation . . . p. 11
- Mar. 4th: A Good Four-Tube Superhet, p. 19
- Mar. 10th: A Novice 35-Watter, p. 32
- Mar. 12th: Another Coffee-Can Rig, p. 42
- Mar. 16th: Voltage Multiplying Circuits, p. 25
- Mar. 20th: Simple Remote Tuning for the VFO, p. 27
- Mar. 24th: Some ABCs of V.H.F. Receiver Design, p. 40
- Mar. 26th: An Inexpensive Radioteletype Converter, p. 44

### W1AW OPERATING SCHEDULE

(All times given are Eastern Standard Time)

Operating-Visiting hours:

- Monday through Friday: 1500-0300 (following day)
- Saturday: 1900-0230 (Sunday)
- Sunday: 1500-2230

General Operation: Refer to page 65, October, 1952, QST for a chart showing W1AW general operation. This schedule is still in effect and is not reproduced herewith for space considerations. Mimeographed complete master schedules of all W1AW operation in EST, CST or PST are available upon request.

On Saturdays and Sundays during which official ARRL activities are being conducted, W1AW will participate in the activity concerned.

Official ARRL Bulletin Schedule: Bulletins containing latest information on matters of general amateur interest are transmitted on regular schedules:

Frequencies:

- C.W. — 1885, 3555, 7130, 14,100, 21,020, 52,000, 146,000 kc.
- 'Phone — 1885, 3950, 7255, 14,280, 21,350, 52,000, 146,000 kc.

Frequencies may vary slightly from round figures given; they are to assist in finding the W1AW signal, not for exact calibration purposes.

Times:

- Sunday through Friday, 2000 by c.w., 2100 by 'phone.
- Monday through Saturday, 2330 by 'phone, 2400 by c.w.

Code-Proficiency Program: Practice transmissions are made on the above-listed c.w. frequencies, starting at 2130 daily. Speeds are 15, 20, 25, 30 and 35 w.p.m. on Monday, Wednesday and Friday, and 5, 7½, 10 and 13 w.p.m. on Sunday, Tuesday, Thursday and Saturday. Approximately ten minutes of practice is given at each speed. Next certificate qualifying run from W1AW is scheduled for March 18th; from W6OWP, March 13th.

### A.R.R.L. ACTIVITIES CALENDAR

- Mar. 6th-8th: DX Competition (c.w.)
- Mar. 13th: CP Qualifying Run — W6OWP
- Mar. 18th: CP Qualifying Run — W1AW
- Mar. 20th-22nd: DX Competition (c.w.)
- Apr. 3rd: CP Qualifying Run — W6OWP
- Apr. 11th-12th: CD QSO Party (c.w.)
- Apr. 16th: CP Qualifying Run — W1AW
- Apr. 18th-19th: CD QSO Party ('phone)
- May 9th: CP Qualifying Run — W6OWP
- May 15th: CP Qualifying Run — W1AW
- June 6th-7th: V.H.F. Contest
- June 7th: CP Qualifying Run — W6OWP
- June 15th: CP Qualifying Run — W1AW
- June 20th-21st: Field Day
- July 3rd: CP Qualifying Run — W6OWP
- July 14th: CP Qualifying Run — W1AW
- July 18th-19th: CD QSO Party (c.w.)
- July 25th-26th: CD QSO Party ('phone)

## TRAFFIC TOPICS

### BRASS POUNDERS LEAGUE

Winners of BPL Certificates for December traffic:

Call	Orig.	Recd.	Rel.	Del.	Total
W6LAB	108	5957	2689	3497	12251
W3CUL	311	4476	3592	822	9201
KG6FAA	489	3334	3103	141	7067
W6KYV	181	3143	1340	1772	6436
W2BTV	91	3129	2910	117	6247
W8TQD	13	2527	2423	52	5015
K4WAR	1922	895	160	1057	4034
KA2MB	1299	1287	424	863	3873
W2ZOL	10	2181	1092	51	3334
KA2US	1060	762	700	62	2584
W2BO	28	1010	1250	85	2373
W7IOQ	37	1009	38	990	2074
KA2HQ	506	742	406	315	1969
W4PL	22	950	810	110	1892
W4USA	97	650	1002	62	1811
W2VNJ	12	998	622	117	1749
W9JUI	15	934	739	12	1700
W7ONM	5	773	763	5	1546
W1CRW	39	693	652	30	1414
K6FAL	708	343	298	44	1393
W4PJU	13	659	519	140	1331
W8SCA	6	633	621	5	1265
W8CPI	7	576	550	26	1159
W6GYH	16	569	478	91	1154
W8RJC	35	548	422	118	1123
W8AUJ	16	529	487	33	1065
KG6ACH	786	123	87	31	1027
W8QXO	21	502	396	104	1023
W2AEE	14	588	263	77	942
W8QYZ	22	455	446	9	932
W6HKH	205	355	214	109	913
W2RUF	139	317	250	203	909
W6VHN	5	443	431	12	891
K5WAC	27	401	374	37	839
KZ5AA	83	367	302	65	817
W7BA	24	386	327	56	793
W8BDR	2	388	346	37	773
W6MNN	47	363	89	271	770
W8JXJ	5	374	325	49	753
W8NZZ	9	354	344	10	717
W9NZZ	91	302	1	299	693
W2CUI	35	324	308	14	681
W2IVS	20	299	245	103	667
W8TIG	33	307	283	23	646
W8BVL	13	309	285	16	623
W4SHJ	134	239	208	27	608
W6IZG	43	30	245	275	593
W9WWT	22	271	257	11	561
W2COU	23	269	222	40	554
W3BIP	8	257	236	14	515
W4PZT	10	252	238	14	514
W5QHI	45	211	253	3	512
W8NOH	142	189	138	39	508
W8FYO	4	255	207	40	506
W6LPW	15	265	220	3	503

#### Late Reports:

KG6FAA (Oct.)	584	1247	1024	163	3018
KG6FAA (Nov.)	427	1197	1073	124	2821
KA2UB (Nov.)	1321	456	361	95	2233
K4WAR (Nov.)	310	512	520	92	1434
KA2UB (Nov.)	1043	157	109	48	1357
KA7RC (Oct.)	1067	43	24	19	1153
KA2AG (Nov.)	171	391	432	67	1061
KA2HQ (Nov.)	315	358	122	236	1031
W9JUI (Nov.)	8	397	375	5	785
W4NBY (Nov.)	216	150	101	51	518

#### BPL for 100 or more originations-plus-deliveries:

W4DRD	200	W2IDK	111	W8ILP	104
VE2AMB	188	W8GQY	109	W8UCV	102
W2EC	176	W8YBV	108	W8BLI	101
W6BHG	164	W2MHE	107		
KZ5ML	125	W6YFE	106		
W5TFB	116	W4PFP	104		

The BPL is open to all operators who report to their SCM a message total of 500 or more or 100 or more originations-plus-deliveries for any calendar month.

Editorially, there is much that needs to be said concerning traffic handling, principally as a result of the rush experienced during December — but little that has not been said before, if we would harken back a bit. Let us, just the same, cover a few items which seem to be subjects of debate, if not controversy, today:

(1) *Counting Net Traffic.* This has nothing to do with the traffic count of individual stations participating in the net. The net traffic count is the number of messages transmitted and received for by stations in the net during the time that net is in directed session; in other words, the number of net message operations. This should be pretty obvious, but we understand there is some misunderstanding. The same message can be counted twice only if it is relayed in the net — in other words, only if sent and received twice in the net.

(2) *Radioteletype.* Soon we shall have radioteletypes on our c.w. bands. While there are still comparatively few RTTY equipments, the encouragement thus proffered should instigate more. RTTY operation is a "natural" for traffic work, and we understand it is being used on some MARS circuits now. Its use for point-to-point circuits where large quantities of messages are or can be handled should not be neglected in our traffic work. You radioteletypers interested in traffic work are urged to consider its use for this type of work, especially on the Transcontinental Corps of NTS. Applications will be gladly received.

(3) *ARRL Text Messages.* We regret to say that although most traffic men agree that numbered-text messages are beneficial during the rush holiday season, and that the ARRL list should not only be used but expanded to provide a wider selection, during the late Christmas traffic season we did not hear one — not a single one! — ARL-text message correctly transmitted, according to the recommendations appearing in *Operating an Amateur Radio Station*, page 12. Furthermore, we never heard anyone send the query "ARRL?" and get affirmation before going ahead with an ARL-text message. No wonder traffic reaches its destination so garbled! How about reading up on this before Easter, fellows?

(4) *Message Precedences.* Read "Traffic Topics" for Feb., 1952, *QST*, page 64. We still feel the same way about it, so why go over it again?

W6NIY, through *Midwest Clizs*, has created a "1000 Club," to consist of amateurs in the ARRL Midwest Division who have handled more than 1000 messages since World War II; "2500," "5000" and "10,000" clubs are also being formed for amateurs who qualify at those figures. Twenty extra points are given retroactively for each report submitted to the SCM. On this basis, November issue of the *Clizs* lists some 51 Midwest Division amateurs who qualify for one of the awards — 39 for the "1000 Club," 6 for the "2500 Club," 2 for "5000 Club" and 4 for "10,000 Club."

Trunk Line I, after a year's absence, is operating on 3690 kc. Principal stations are VE4HL, VE5BV, VE6CJ, VE6YZ and VE7QZ. VE5HR is manager. Stations are needed in VE1, VE2 and VE3. Contact VE5HR.

The following independent nets reported the following information for December traffic:

Name of Net	Sessions	Total	Avg/Session	Stations
Early Bird Transcon. 'Phone Net	—	236	17.6	44
Transcon. 'Phone Net	31	3454	111.4	42
Transcon. Relay Net	31	7569	308	9

*National Traffic System:* This will record the absorption of the NTS Twelfth Region by the Sixth Region. Traffic for the states of Arizona, Colorado, New Mexico and Utah will hereafter officially be routed through RN6. We understand that unofficially such traffic has been going via RN6 for some time. The NTS Sixth Region (RN6—W6JQB Manager) now comprises Arizona, California, Colorado, Nevada, New Mexico, Utah and Hawaii. The NTS Seventh Region (RN7) comprises Alaska, Alberta, British Columbia, Idaho, Montana, Oregon, Saskatchewan, Washington and Wyoming. The two regions together comprise the NTS Pacific Area (PAN). Thus ends the attempt (at least for now) to establish separate NTS nets in the MST Zone.

December Reports:

Net	Sessions	Traffic	High	Average	Most Consistent
1RN	28*	230	32	8.2	W. Mass.
2RN	46	544	45	11.8	NJN
3RN	34	506	59	15	E. Pa.
4RN	46	617	84	13.4	Va.
RN5	32**	290	37	9	N. Tex.
RN6	53	1429	76	27	BAN
RN7	56	610	65	10.8	Wash.
8RN	23	151	16	6	Mich.
9RN (TLJ)	27	718	100	26.7	Ind.
TEN	27***	1762	224	65	Kans., Mo., Ia., Minn.
TRN	48	140	16	2.9	Ont.
EAN	25	1123	93	45	1RN, 4RN
CAN	14***	448	65	32	TEN
PAN	24	881	209	36.6	—
Minn. (MSN)	24	195	23	8.1	—
Iowa (TLCN)	23	636	173	27.6	—
Kans. (QKS)	23	147	23	6.4	—
Total	553	10,427	224	65	
Record	766	10,766	224	45	

\* Out of 50 sessions held. \*\* Out of 46 sessions held. \*\*\* Incomplete report.

Note that two records are established above, for the Oct.-Nov.-Dec. quarter. The high-for-one-session during December made by the Tenth Regional Net is an all-time high and goes in the record book. However, the TEN average of 65 per session cannot go in the books because the report is incomplete, and complete reports might have reduced this average considerably. However, the EAN average of 45 still exceeds the previous record of 28.6 (as does also the PAN average of 36.6) so a new record is established.

W3BIP reports that 3RN lost 8 sessions due to bad conditions, and 2 as a result of Christmas Day.

W4MA and W4FPC have earned 4RN certificates.

W5QHI takes over RN5 from W5MRK.

RN6 is busy handling much GI-Pacific traffic.

W7PKX will take over RN7 from W7NH. Nellie is going to devote some time to PAN and TCC. RN7 certificates have been issued to W7PYV and W7KAB.

Besides the record-breaking 224 in one session, W0ITQ says they had reports of 188, 178, 172 and 130 on other nights, after four- and five-hour sessions.

We welcome W2RUF, W5KRX, W6GQY and VE3GI to membership in the Transcontinental Corps (TCC) of NTS. The following have also been active in TCC work: W1EMG, W2ZVW, W3COK, W3ONB, W4SHJ, W6BHV, W6ELQ, W7PKX, W8DSC, W8UPB, W9JUJ, W0BVE, VE3EAM and VE3WY. TCC is the place for good operators with good signals. If you can take a once-weekly stint as regular or alternate, it will help. Write WINJM for particulars.

SUPPLEMENT TO NET DIRECTORY

The following list of nets will supplement and correct the listings in 1952's November (p. 66) and January (p. 67) QSTs. This includes all information received between the dates of November 19, 1952, and January 20, 1953. This list can be used to correct the cross-indexed Net Directory which was distributed in mid-January. An asterisk (\*) indicates correction from previous QST listing. Another supplementary list will appear in May QST.

Name of Net	Freq.	Time	Days
Ala. Emerg. Net C.W. (AENB)*	3575	1900 CST	Daily
Ala. Emerg. Net 'Phone	3955	1730 CST	Daily
Aris. Emerg. Net (AEN)	3865	1900 MST	Tue.-Thu.
Arizona Net	3865	0730 MST	Daily
		1630 MST	
		1900 MST	
Atlanta C.W. Net	7150	2100 EST	Sun.
Atlanta Ten 'Phone Net	29,600	2230 EST	Sun.
Atlanta Two-Meter Net	144,050	2030 EST	Mon.
Birmingham Mobile Emerg. Net*	29,560	1300 CST	Sun.
		1900 CST	Thu.
		2000 EST	Daily
Boston Mobile Radio Net	29,680	2000 EST	Mon., Wed.
Boston Suburban Emerg. Net	28,700	2000 EST	Mon.-Sat.
B.C. AREC Net*	3755	1800 PST	Mon.-Sat.
B.C. 5-O'Clock Net	3797	1700 PST	Mon.-Sat.
B.C. Northern Net	3780	1730 PST	Mon.-Sat.
Broadcast Operators Net (BC)	7090	1000 EST	Mon.

Caravan Club (Texas)	3995	1300 CST	Sun.
CAA Net ('Phone)	29,150		
	3960	0800 CST	Sat.
Civil Defence Net (CDN) (Ont.)	3765	1900 EST	Tue., Thu., Sat.
Continental Bums Net *	7285	1930 PST	Wed.
Dog House Net	3860	1800 EST	Mon.
Eastern Pa. CD Net (EAA)	3915	0830 EST	Sun.
		0800 EST	Mon.
El Paso (Tex.) 10M Net	29,640	1900 MST	Mon.
Elkhart Co. (Ind.) Emerg. Net	29,620	2030 CST	Wed., Fri.
Fifth Regional Net (RN5)	3645	1945 CST	Mon.-Fri.
		2130 CST	
Finger Lakes Net (N.Y.)	145,350	2000 EST	Fri.
Fourth Regional Net (4RN)	3615	1945 EST	Mon.-Fri.
		2130 EST	
Framingham (Mass.) Radio Club Emerg. Net	28,700	2045 EST	Wed.
Ga. Cracker Emerg. Net	3995	0830 EST	Sun.
		1900 EST	Tue., Thu.
Gem Net (Idaho)	3638	2000 MST	Mon., Wed., Fri.
Golden Empire Emerg. Net (Calif.)	1920	2000 PST	Thu.
Goose River Net (N. Dak.)	1980	0900 CST	Sun.
Grand Rapids Emerg. Net	146,160	2000 EST	Mon.
High Plains Net	1995	1830 CST	Mon., Fri.
Inland Empire Emerg. 'Phone Net	1995	1900 PST	Sun., Wed.
Iowa 160-Meter Net*	1805	1830 CST	Daily
Iowa Tall Corn Net (TLCN)*	3560	1845 CST	Mon.-Fri.
Kent Emerg. Group (Ohio)	146,160	2000 EST	Mon.
Kentuck Corn Crackers (KCC)	3945	0700 CST	Daily
Kentucky 'Phone Net (KYP)	3945	1830 CST	Mon.-Fri.
Lake Erie Network (Pa.)	29,050	1315 EST	Sun.
Livingston (N. J.) Emerg. Net	146,300	2030 EST	Tue.
Maritime Traffic Net (MTN)*	3525	2000 AST	Mon., Wed., Fri.
Md. Emerg. 'Phone Net	3820	1830 EST	Mon., Wed., Fri.
		1900 EST	Sat., Sun.
McKean Co. (Pa.) Emerg. Net	3525	0900 CST	Sun.
Mesabi Range Net (Minn.)*	1895	1900 CST	Mon., Fri.
Mich. Hot Air Net	3930	1230 EST	Mon.-Sat.
Monmouth Co. (N. J.) Emerg. Net	147,150	2100 EST	Mon.
Montana State Net (MSN)	3520	1900 MST	Sun., Tue., Thu.
Nebraska 'Phone Net	3983	1230 CST	Mon.-Sat.
		0900 CST	Sun.
New England 75-Meter Net	3870	0900 EST	Sun.
N. J. Civil Defense Net (CDNJ)	3505	0630 EST	Tue.
N. J. Emerg. 'Phone Net	3900	0900 EST	Sun.
N. Y. State 'Phone Emerg. and Traffic Net	3980	1830 EST	Mon.-Sat.
		0830 EST	Sun.
Ninth Regional Net (9RN)	3565	1945 CST	Mon.-Sat.
NoDak Net	1920	1830 CST	Mon.-Sat.
N. Dak. 80-C.W. Net	3670	1830 CST	Mon.-Sat.
N. Dak. 75-'Phone Net	3845	1900 CST	Mon.-Sat.
N. Tex. Emerg. C.W. Net (NTS)	3760	0800 CST	Sun.
N. Texas Net (NTX)	3760	1900 CST	Mon., Wed., Fri.
Ont. Forty-Meter Net (QON)*	7285	1900 EST	Daily
Ontario 'Phone Net (OFN)	3765	1900 EST	Mon., Wed., Fri.
Oswego Co. Emerg. Net (N. Y.)	3965	1130 EST	Sun.
Oxford Co. (Me.) Net	29,500	2000 EST	Daily
Pacific Area Net (PAN)	3670	2030 PST	Mon.-Fri.
Polecat Net (Pa.)	3665	1130 EST	Sun.
Province of Quebec Net (PQN)*	3570	1900 EST	Mon., Wed., Fri.
Quebec Slow-Speed Net (QSS)	3570	1900 EST	Tue., Thu.
San Bernardino Area AREC Nets (Calif.)	29,200	1900 PST	Wed.
	145,600		
Seventh Regional Net (RN7)	3575	1945 PST	Mon.-Sat.
		2130 PST	
Show-Me Net (Mo.)	7272	1600 CST	Sun.
Sixth Regional Net (RN6)	3615	1945 PST	Mon.-Fri.
		2130 PST	
Skiers Snow Service Net	3980	1930 EST	Fri.
Sound Traffic Net (Wash.)	29,100	2200 PST	Mon.-Fri.
Sourdough Net (Alaska)	3892	2130 PST	Daily

(Continued on following page)

Sunrise Net	3950	1000 EST	Sun.
	145,200	1100 EST	Sun.
Traffic Exchange Net (TXN)	7135	1900 CST	Mon.-Fri.
Trunk Line I	3690	2030 MST	Mon.-Fri.
Vermont 'Phone Net	3860	0930 EST	Sun.
Virginia Novice Net (VNN)	3705	1830 EST	Mon.-Fri.
Westlake Amateur Radio Net (Ohio)	3950	1000 EST	Sun.
YLRL Net	3610	2100 EST	Wed.
	3900	0700 EST	Wed.
		0800 EST	Wed.
	7040	1900 PST	Fri.
	14,240	1400 EST	Thu.



Ever try mobile c.w.? We'll wager most of you mobileers never have, but we've had several reports from those who have tried it, and with surprising good success. So we tried it, too, and found that medium-distance contact was possible under circumstances in which you ordinarily couldn't get out of town on 'phone. In our case, contact was established with W2ZVW (150 air miles) and re-established every hour until we pulled into his back yard. We were using 40 watts input to a center-loaded whip on 3755 kc. W2ZVW managed to copy us every hour, although signals were often faint. Copying was much better when we were stationary, but still possible when we were in motion. We were within 15 miles before he reported the signal strong enough to try 'phone, and when we did the QRM buried us deep. All this was done in broad daylight, using a straight key strapped to our knee. The c.w. accomplishment is especially noteworthy when you consider that with the same rig, power and antenna, WINJM/mobile on 'phone has never worked anybody further away than 10 miles.

W5MU tells us he has both a vibroplex and straight key mounted on a board on the seat beside him, and that he finds c.w. operation on 40 meters "duck soup" even while driving, and has worked California, New York, Canada and many other states while in motion. We don't recommend operating while driving, either on 'phone or c.w. (in some states you'll get pulled in for it), but it's no harder on one than the other.

By mentioning only the above two cases, we don't mean to slight anybody; we know that many others have operated mobile c.w. also. We would like to point out that the increased range and freedom from QRM on c.w. is worth something in our emergency work, and those of us who are mobile should not neglect the increased versatility which provision for c.w. will afford. Put a key jack in your mobile rig, a b.f.o. on your car radio if you use a converter (see p. 24, Oct., 1952, QST) and give c.w. a whirl. You'll be surprised!

"To criticize? No, only to say that there is something wrong with us. It serves no purpose to become angry or bitter. The station who through a misguided moment behaved badly would not have done so maliciously. The thing that strikes me as the sad comment on us as amateurs is that we constantly prate of our importance, we speak of our service in emergencies, we howl when we do not get our publicity, we talk so much that we don't think, we talk so much about emergency work that we can no longer differentiate between an emergency and what we call emergencies. There are always a few to foul up the works."

Thus spoke plainly a West Coast amateur to his colleagues at the conclusion of a recent emergency operation which received high praise from officialdom — officialdom which knew only that the amateurs had performed a service. They were grateful for what had been done, and that was that. They did not know, as discerning participants knew, how much faster, more extensive and more efficiently-executed the service could have been if the amateurs had put into effect a preconceived plan under a single banner and coordinated, centralized leadership, instead of a haphazard spur-of-the-moment effort under no leadership or divided leadership, and under no banner or multiple banners. It is infinitely difficult to achieve the pinnacle of net operation when we are all volunteers, and when so many of us believe our individual pleasure more important than the service we might render, or believe our own ideas of how a net should be run or an emergency operation executed superior to the system being used, and conduct ourselves accordingly. But is it impossible?

On the evening of December 11th the northwest corner of Vermont was hit with a heavy wet snow storm. The wet snow caused the 'phone and power wires to load with snow. In some localities wires had six-inch coats on them.

At 1115 a telephone company official called to see if the amateurs were able to assist. By 1200 the Chittenden

### DXCC NOTES

Announcement is hereby made of the addition to the ARRL Postwar Countries List of the sultanate of Masqat and Oman, to be designated as Sultanate of Oman. DXCC credit will be given for any creditable Sultanate of Oman card dated on or after November 15, 1945.

In future ARRL DX Competitions, those making contact with Sultanate of Oman may claim credit for a separate country in accordance with DXCC rules.

To our knowledge the only amateur station to have operated from Sultanate of Oman is VS9AW.

Note that what has been previously called Oman is now split into two designations, Trucial Oman, and Sultanate of Oman.

### DX CENTURY CLUB AWARDS

#### HONOR ROLL

W1FH.....250	G2PL.....241	W6SN.....235
W8HGW....246	W6AM.....238	G6ZO.....235
W6VFR....244	W3GED....237	W2BXA....234
W8BES....244	W3JTC....237	W4BPD....234
W8YXO....242	W3KT....236	W6MEK....234
W6ENV....241	W3CPV....235	

#### RADIOTELEPHONE

W1FH.....223	W8HGW....202	W6DI.....195
PY2CK....222	W9BLI....200	W2APU....194
VQ4ERR....216	W1JCX....200	SM5EF....194
XE1AC....213	ZS6BW....200	W2BXA....192
W1NWO....204	W1MCW....195	

From December 15, to January 15, 1953, DXCC certificates and endorsements based on postwar contacts with 100-or-more countries have been issued to the amateurs listed below.

#### NEW MEMBERS

ZC4XP.....148	IIRC/T....122	CR6AI....101
W8CXN....140	HB9AT....105	CTIAS....101
W1RZD....127	G2KI....103	PA9HG....100
HZ1HZ....122	ZS3S....102	VE2CK....100
W2IRV....118	W1ODW....101	

#### RADIOTELEPHONE

W1RZD....120	M3LV....102	W3DYT....100
F8CW....103	HP1BR....101	

#### ENDORSEMENTS

W6FNA.....220	W8ZZU....160	W8NJC....130
W8SYC....210	SM6EU....157	OH2QQ....130
ZL1BY....200	ZL3CC....155	SM3ARE....130
W4CYY....187	W6VOE....151	CT1SQ....122
W6LBD....183	W6AIH....150	W2EQS....120
W6FFW....181	W6LMZ....144	W2YTH....120
W5CKY....171	W9AHP....142	W4GHP....119
KL7PI....170	W8MFB....132	DL1YA....116
W6GFB....163	K6CU....131	OH3NY....115
W8JBI....163	W8EKK....131	W1BTE....110
W8MPW....160	W3MDE....130	

#### RADIOTELEPHONE

W6BGP....190	YV5AB....150	PY4RJ....126
F9HE....160	W0NCG....140	KL7AFR....111
LU4MG....150	W1CLX....131	



County Emergency Corps had K1NAG on 3520 kc. At 1530 W1RNA was contacted on 3970 kc. Within an hour a net was in operation with W1RNA as NCS. Traffic was handled until 2300 when conditions became too bad. W3PYF assisted in relaying messages between Vermont stations.

Operation started at 0600 Saturday but band conditions were bad. The net opened again at 0700 Sunday with W4AFI out due to skip. Traffic was light and at 1215 the net was closed. At this time telephone service had been temporarily restored.

Traffic was handled for railroad, press, telephone, weather bureau, broadcast stations and general inquiries.

W1RNA did an especially fine job as NCS. W1NLO is due a vote of thanks for the time and energy he devoted keeping K1NAG supplied with operators. The equipment of the Naval Reserve Training Center of Burlington was turned over to the Chittenden County Emergency Corps and the station keepers were most cordial and eager to assist. Thanks to the New York Net and the New York Civil Defense Net for clearing the frequency and to all other stations that stood by to assist.

Stations reporting in all nets with or for traffic or to assist were: W1s AC AD AXN AZV BJP BRG BRO CGW ELJ ETE FN FPS GAG IDM IT JJY /PY KAS LBH/1 LYD MLJ NDB NLO OAK OKH OLM PTB PWB QA QNM QQN QVS RFZ RNA RPR SEL SET SFE SNI SPK TEW TJ TLI TOQT TZL UDU UFZ VEB VSA VTP VV, W2BTB, W3PYF, W4AFI and FU. — *W1JEN, SEC VI.*

### NATIONAL CALLING AND EMERGENCY FREQUENCIES

C. W.	'PHONE
3550 kc.	3875 kc.
7100 kc.	7250 kc.
14,050 kc.	14,225 kc.
28,100 kc.	29,640 kc.

During periods of communications emergency these channels will be monitored for emergency traffic. At other times, these frequencies can be used as general calling frequencies to expedite general traffic movement between amateur stations. Emergency traffic has precedence. After contact has been made the frequency should be vacated immediately to accommodate other callers.

The following are the National Calling and Emergency Frequencies for Canada: c.w. — 3535, 7050, 14,000; 'phone — 3815, 14,160 kc., 28,250 kc.

On Dec. 8th the extreme northern end of California experienced a heavy snow storm which disrupted communications and power services, and blocked a main highway and the Southern Pacific Railroad. The community of McCloud was completely isolated but radio contact was established by W6NCV and W6IIQ with W6JDN of Dunsuir and W6FKI of Mt. Shasta City to handle emergency traffic and assist in restoring power and telephone service. With all communications out between Dunsuir and Klamath Falls, Ore., the SPRR turned to amateur

radio with W7JRU at Klamath Falls holding down the northern end of the circuit, W7LJC/6 at Grass Lake and W6JDN at Dunsuir. W6CFU operated mobile on an SPRR snowplow which opened the line. The SPRR has made arrangements for a 2.5-kw. generator to be available at the clubhouse in Dunsuir for emergency use and the City of Dunsuir has had a 'phone installed and paid for. — *W6CKV, SCM Sac. Valley.*

An ultra-realistic bombing of Abraham Lincoln School in Philadelphia by a dozen Navy planes occurred on October 18, 1952. All communications from the scene to c.d. zone headquarters, mass feeding center, emergency care center, to the Tacony-Palmyra Bridge and Holmesburg Prison were handled via ham radio. W3KHR organized a combination 2- and 10-meter network to handle the flow of traffic. Twelve other amateurs participated in the work: W3s CPC KIW KMH ILK KHR PMU SAM SLP TPL, WN3s TNB TYU and TYX. All officials on the scene agreed communications were well handled. — *W3DYL, EC Phila. Co., Pa.*

At 1715 on October 15th, W4RWM was called by the U. S. Coast Guard and asked about the location of the ketch *Miru*, a sailing vessel bound from Wellington, New Zealand, for Boston, Mass., owned by Dr. Thomas R. A. Davis, ZK1AN. W4RWM had been maintaining schedules with ZK1AN/MM prior to this time and had lost contact with him on October 15th at 0630 when the *Miru* was about 245 miles off the Georgia coast in heavy seas.

After receiving the alert from the Coast Guard, W4RWM alerted the following amateurs on 75 meters: W4s ACH CVQ DLS DRD IYM JQ KGP KJW LCV LQQ MBR/M MV MVP NJG OIL PYE QDA ROD RSF RWM WS and W5KYC. The frequency 3840 kc. was monitored for 36 hours. Calls were made for five minutes on the half hour and hour during this period. The Coast Guard at Miami maintained contact with W4RWM by telephone and through W4DRD of Miami. At 1750 on October 16th, Coast Guard advised the net that the *Miru* had been located at Cape Charles, suffering only minor damage, all hands safe and well. The net was secured at 1815, October 16th. Many of these stations were on the air for a full 24-hour period. The U. S. Coast Guard plans letters of commendation to all stations who took part.

Widespread publicity was given the work done by amateurs, both in the newspapers and radio news broadcasts (also see p. 10, Jan., 1953, *QST*). Press associations were in contact with W4RWM, as was Harvard University and other interested persons including New Zealand foreign editors. — *W4RWM, EC Daytona Beach, Fla.*

Sixteen SECs submitted reports for November activities, representing 2604 AREC members. Next month we'll summarize reports for the year 1952.

You see, if every EC reported on a Form 5 every month to his SEC (this takes about 5 minutes) and every SEC reported to his SCM (and thru him to headquarters) every month (this might take all of a half hour), we would have not only a monthly indication of the total number of AREC members, but a statistical description of the status of each EC's AREC group. Don't you see, fellows, that we need these statistics? True, they don't tell the whole story, but they are something you can get your teeth into, something you can total up. Forms for EC and SEC reporting are always available from headquarters.

W1NLO operates at K1NAG while W1QVS punches the mill during the Vermont snowstorm emergency. K1NAG, located at the Naval Reserve Training Center in Burlington, was pressed into emergency service by the Chittenden County Emergency Corps under the direction of W1QQN, Emergency Coördinator. (Photo by Burlington Free Press.)



• All operating amateurs are invited to report to the SCM on the first of each month, covering station activities for the preceding month. Radio Club news is also desired by SCMs for inclusion in these columns. The addresses of all SCMs will be found on page 6.

### ATLANTIC DIVISION

**EASTERN PENNSYLVANIA**—SCM, John H. DuBois, W3BXE—SEC: IGW, RMs: AXA, BIP, PAM; PYF, E. Pa. Nets: 3610, 3915 kc. Because of pressure of business, ISE found it necessary to resign as SEC and as of Jan. 1st IGW assumed the duties of that post. Thanks from all for a fine job of organization, Warren. Also, please note appointment of PYF as PAM. All 'phone stations interested should report into E. Pa. 'Phone Net on 3915 kc. at 1900 EST, Mon. through Fri. E. Pa. Emergency Net is looking for additional members, possibly one from each county. This Net meets on 3610 kc. at 2030 EST, Mon. The following counties still lack ECs: Lycoming, Montour, Northumberland, Pike, Schuylkill, Snyder, Sullivan, Susquehanna, Tioga, Union, Wayne, and Wyoming. IGW will welcome applications from those areas. Traffic for December totalled 10,181, with CUL and BIP making BPL. HFT won the walkie-talkie building contest recently conducted by the Delaware-Lehigh ARC. The Philmont Mobile Club, in three years, has increased membership from 5 to 65, has built a communications trailer and now maintains a 100-copy mailing list for the club paper. The Car-Le RC announces the following officers for 1953: SER, pres.; OP, vice-pres.; AIW, secy.-treas.; SNZ, act. mgr. The Lancaster RTS now meets in the Naval Reserve buildings (complete with radio gear) and has a well-rounded schedule of activities planned for the coming season. The Hazelton ARC is starting the New Year with 100 per cent ARRL membership. ID, SKL, and SAA, all of the same family, passed their Advanced Class exams on Dec. 30th, the latter two after having been licensed for only a year. NOK now is NCS for Central and Western Pennsylvania 80-meter c.w. e.d. nets meeting at 3707 kc. Tues. TEY and UQX dropped the "N" from their calls. SNY now is on 10 meters with a new rig. CHV now is operating 8V5UN. Anyone need Rhodes? Traffic: (Dec.) W3CUL 9201, BIP 515, PYF 138, PDJ 72, AXA 45, BFF 39, AD 34, ADE 32, MLY 20, DUI 17, NOK 15, RCG 15, ELI 13, CDT 12, PVE 8, OML 5, (Nov.) W3BFF 12, HA 3.

**MARYLAND-DELAWARE-DISTRICT OF COLUMBIA**—SCM, James W. John, W3OMN—At the Dec. 15th meeting of the Baltimore Amateur Radio Club EQK showed color movies of his trip through the Southwest and into Mexico. On Dec. 1st PDJ demonstrated Audio Amplifiers and Automatic Gain Control Circuits to the BARC. TDB's topic at the Chesapeake Amateur Radio Club meeting of Dec. 8th was Radio Range and Direction Finder; LMC gave a 2-meter teletype lecture and demonstration at the Dec. 22nd meeting. The Washington Radio Club visited radio station WWV on Dec. 6th. The Capitol Suburban Radio Club met at the home of KAN in December, when nomination of officers was held. The Rock Creek Amateur Radio Assn. held a Christmas party on Dec. 12th at which GA gave a brief resume of DF's address before the New York radio clubs. MCG returned from a brief work assignment in New Mexico where he worked in the Sweepstakes from K5WSP. CDQ participated in the YLRK Contest during December. EQK reports his mobile worked FB on his trip West. CQS kicked his TVI with a new Viking. PZW and CVE headed an "Overseas Message Project" for the Washington Area. JE was appointed Civil Defense Radio Officer for the State of Maryland. The Washington Radio Club furnished mobile support for the Muscular Dystrophy Telethon on Dec. 27th. More than 60 mobiles participated to render an appreciated public service. Traffic: (Dec.) W3PZW 2526, CVE 363, JE 160, COK 108, QZC 82, JZY 62, JHW 58, NNK 48, QCB 35, UCR 33, HC 30, RJA 28, AKB 26, MCD 24, NOE 19, SQS 15, MCG 13, PRT 2, (Nov.) W3MCG 11.

**SOUTHERN NEW JERSEY**—SCM, Lloyd L. Gainey, W2UCV—SEC: K2BG. The SJRA held its annual election at the December meeting and elected JRO, pres.; EGP, vice-pres.; K2AFJ, treas.; SPV, corr. secy.; 3LTC/2, rec.

secy.; W2JAV, K2AER, W2YRW, EWN, FWY, KHW, and OBR directors. TAM is back in the States after a lengthy stay in Japan. TAV is down on 75-meter 'phone now and putting out a potent signal. BAY finally finished his all-band transmitter and is operating now on 75-meter 'phone with 160-meter operation on the way. ASG is back from a short visit to France and England. K2AJD now is operating 20-meter c.w. and doing a good job on DX running 35 watts. The SJRA Outstanding Amateur Award was awarded to both JRO and JAV for their activities during the past year. Ham radio throughout the section supplied communications for a Bomb Disposal Group operating out of Fort Dix on Dec. 13th. ZQ was State Net Control. Mobiles participating in Mercer County on 10 meters were KVV, UPS, IIA, LSS, and QKE. ZQ was manned by UAE, FDE, and ZI. In Camden County K2AA was local NCS with mobiles on 2 meters manned by EGP, DGN, K2BQW, and W2EWN. K2AA was manned by 3LTC with 2RG handling relay work on 80-meter c.w. Fixed stations assisting locally were QKO, PAU, K2ANW, W2KHW, JRO, and VX. The Army has expressed its sincere thanks for a job well done. UCV is nibbling at the teletype bug. SPV is tickled pink with his new 2-meter rig. Traffic: K2BG 344, W2RG 247, ASG 14, ZI 7, PTM 3, K2AJD 3.

**WESTERN NEW YORK**—SCM, Edward G. Graf, W2SJV—SEC: UTH. RM: RUF, PAM: GSS. NYS meets on 3615 kc. at 7 and 10 P.M., 3980 kc. at 6:30 P.M.; NYSS on 3595 kc. at 8 P.M.; NYS CD on 3509.5 and 3993 kc. at 9 A.M., Sun. DOM won the audio frequency measuring test at BARA. GRH worked a CR8 on 10 meters. UPH is on 75 and 40 meters. The Malone Radio Club meets at Airport Add Bldg. Contact CFY for dates and time. RUF has been reappointed RM and Manager of the NYS c.w. net. OPS appointments: YFZ, CYD, QLI, OZR, and CFY. KN2CBS is the XYL of CFY. Other new calls in the Malone Area are KN2CBT and KN2CUB. 8IUU/2 is on 2 meters from Seneca Ordnance Depot, where he is stationed. During a recent storm UXP lost his sixteen-element 2-meter beam and OWF has eight-element beam. UHI has taken up photography. Buffalo Area mobiles met at the home of ZQQ for a business meeting. FCG has p.p. 813s on 80 and de-TVed. The Black River Valley Amateur Radio Club has been organized. Contact KN2APW, the secretary, for details. MSF is attending Clarkston College. RUF made BPL in November. The Lockport Area mobile group is very active in simulated emergency tests. FAN renewed OPS appointment, QO renewed OO appointment. KEL has been appointed an OBS. ORS renewals: COU, RUF, and RUT. EC renewals: QY, TQ, and CYQ. DRQ now is Advanced Class. RZP has resigned as EC and AC because of expiration of license. The Finger Lakes Net meets each Fri. at 8 P.M. on 145.35 kc. If you are within a radius of 30 miles of Rochester a friendly welcome awaits your call-in. VZY is on 2 meters. ALL and AKM dropped the "N" from their calls. QY has a 522 on 2 meters. NES repaired antenna and is back on 2 meters. WZQ visited COU. SAW put up a 20-meter beam. BDY is at Strong Memorial Hospital in Rochester. FBA is on 20-meter mobile. SNI's hobby is stacking beams. He has a three-element 20 over which are 6, 2 and TV conicals. QNA is on a business trip to Michigan. ORI spoke at the Rochester v.h.f. meeting on interesting experiences on 2 and 420 Mc. YIE has 829 final on 2 meters. Free instructions in civil defense radio operating are conducted at the Niagara Falls High School each Tues. at 8 P.M. under the supervision of OWG, the Amateur Radio Officer for the City. BTB, ZOL, RUF, and COU make BPL for December. Traffic: (Dec.) W2BTB 6247, ZOL 3334, RUF 909, COU 554, KEL 60, ZRC 50, ZRZ 29, DJF 26, OE 21, IFP 20, JWU 15, RJJ 3, RUT 11, SJV 10, ZHU 9, ABC 6, CFY 5, (Nov.) W2HKA 7.

**WESTERN PENNSYLVANIA**—SCM, Ernest J. Hinsky, W3KWL—With the passing of the old year we look back to what has been accomplished in the line of activities in Western Pennsylvania. The overall picture, in my opinion, has been poor. However, credit must be given where credit is due. Thanks to the faithful who found time to keep this activity column from coming apart at the seams. Thanks to the club officers who kept their clubs' activity in the limelight with their monthly club bulletins. Thanks to the Notices who, through honest effort, kept this office informed of their struggle to become hams. Thanks to our Atlantic Division Director who has, in my opinion, so carefully and diligently taken his appointment to heart. Thanks to those who made the Western Pennsylvania traffic net possible, and to those who did a nice job on the 'phone traffic nets. Appointments went to 2IVS/3 and LXE, as ORS, AQK and KQD as OBS, and LXE as OPS. A new

(Continued on page 78)

*With the writer's permission, we print here another letter relating to the operation of HRO type receiving equipment, after being subjected to "unusual" treatment.*

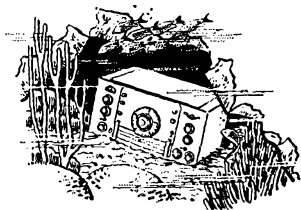

1301 Homewood Drive  
Woodland, California  
October 3, 1949

THE NATIONAL COMPANY  
Malden, Massachusetts

Gentlemen:

Relative to the ability of National products to withstand extreme abuse, I should like to relate to you an experience I had with a Navy model of the HRO, Jr., the RAS-3.

The salvage vessel in which I was serving was ordered to conduct salvage operations on a submarine chaser which had run aground on the great reef bordering the western coast of Australia. We reached the scene of the wreck two days after she had run aground, and commenced salvage operations. Foul weather forced abandonment of operations for almost a week.

When the weather permitted, we removed among other things all radio equipment that was at the time above water. Among the units was the above-mentioned HRO, Jr., complete with AC power supply and all general coverage coils. We brought the receiver aboard, and very carefully washed out all components with hot fresh water, and afterward with carbon-tetrachloride, then allowed the receiver to slowly dry in the engine-room heat for three days. We turned it on and it worked *perfectly*. We were still using it to copy daily press skeds and for other services when I left the ship four months later.

The point I wish to bring out is that the receiver was not just submerged in water, but for eight days had been alternately washed (by the action of the sea) in salt water, seaweed, and diesel oil, partially drying out between times. The alignment of the receiver and its stability had not been affected one bit. The only apparent damage was a swollen grommet on the power supply cable, and peeling of the paint on the panel, both caused by the action of the diesel oil.

*Very truly yours,*

JOHN E. PITTS, JR.  
W6CQK



# OPERATE YOUR OWN

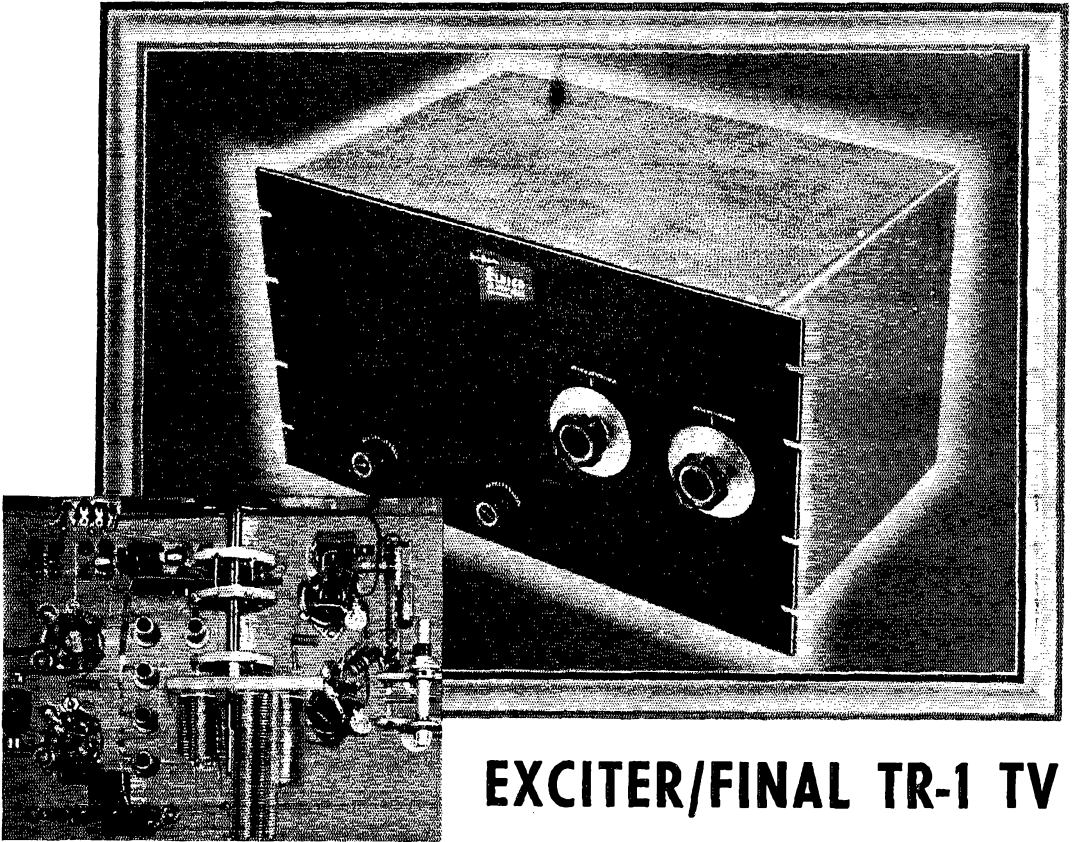

## EXCITER/FINAL TR-1 TV

Amateurs throughout the country have rigs which were ideal before the Tennessee Valley Indians. Too much time . . . too much money is invested in them to discard. Now Eldico has the answer. Use your present rig with the Eldico TR-1 TV Exciter/Final and operate TVI Proofed.\*

Just replace your R.F. Section with the TR-1 TV Exciter/Final. Use your own power supplies and modulator—and go on the air TVI Proofed\*—300 watts AM Phone or CW; Band switching 80-40-20-15-10 meters; Completely shielded tetrode final; Pi Network Output—Built in Low Pass Filter. Remember, **Operate your own rig—TVI Proofed.\***

*Signals of Distinction*

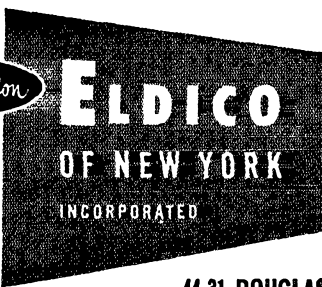

SEE DISTRIBUTOR  
TODAY  
OR WRITE ELDICO  
FOR COMPLETE  
SPECIFICATIONS

\* TVI Proofed means special circuitry, shielding, and filtering to eliminate spurious and harmonic energies that result in television interference.

44-31 DOUGLSTON PARKWAY, DOUGLSTON, L. I., N. Y. • BAyside 9-8686

# RIG-TVI PROOFED!\*

**ACK RADIO SUPPLY CO.**  
Birmingham 3, Alabama

**ALLEN & HURLEY**  
Trenton, New Jersey

**ALLIED RADIO CORP.**  
Chicago 7, Illinois

**ALMO RADIO CO.**  
Philadelphia 6, Penna.

**ALMO RADIO CO.**  
Atlantic City, N. J.

**ALMO RADIO CO.**  
Wilmington, Delaware

**ARROW ELECTRONICS INC.**  
New York 7, New York

**WALTER ASHE RADIO CO.**  
St. Louis 1, Missouri

**GEORGE D. BARBEY CO.**  
Reading, Penna.

**BLUFF CITY DIST. CO.**  
Memphis 3, Tenn.

**CAMERADIO CO.**  
Pittsburgh 22, Penna.

**CONSOLIDATED RADIO CO.**  
Philadelphia 6, Penna.

**CRAWFORD RADIO**  
Hamilton, Ont., Canada

**DE MAMBRO RADIO**  
Providence, R. I.

**DOW RADIO, INC.**  
Pasadena 4, Calif.

**M. N. DUFFY & CO.**  
Detroit 26, Michigan

**W. H. EDWARDS CO.**  
Providence 3, R. I.

**THE ELECTRONIC EQUIPMENT CO.**  
Fort Worth 3, Texas

**EVANS RADIO**  
Concord,  
New Hampshire

**FORT ORANGE RADIO DIST. CO.**  
Albany 7, New York

**R. C. & L. F. HALL, INC.**  
Beaumont, Galveston, Houston,  
Texas

**HARRISON RADIO CORP.**  
New York 7, N. Y.

**HARRISON RADIO CORP.**  
Jamaica 3, L. I., N. Y.

## LOOK AT THESE REASONABLE COSTS OF THE TR-1 TV TRANSMITTER

- Exciter/Final — completely shielded — 10½" x 19" panel space.  
Complete kit with Instruction Manual . . . . . **\$189.95**  
Factory wired and tested . . . . . **259.95**

- Speech Amplifier/Modulator. Hi Impedance Microphone Input. 7" x 19" panel space.  
Complete kit with Instruction Manual . . . . . **79.95**  
Factory wired and tested . . . . . **99.95**

- Power Supply—1500V DC @ 350 ma; 400V DC; 220 ma and negative bias. 8¾" x 19" panel space.  
Complete kit with Instruction Manual . . . . . **119.95**  
Factory wired and tested . . . . . **159.95**

- TR-1TV Transmitter—The three units above in standard 28" high Deluxe Cabinet.  
Complete with Instruction Manual . . . . . **379.95**  
Factory wired and tested . . . . . **499.95**

Chassis, panels, meters, tubes, components, hardware all included. Nothing else to buy.

**HARVEY RADIO CO. INC.**  
New York 18, N. Y.

**HENRY RADIO STORES**  
Los Angeles 25, Calif.

**HENRY RADIO STORES**  
Butler 1, Missouri

**HUDSON RADIO**  
New York 7, N. Y.

**HUDSON RADIO**  
New York 19, N. Y.

**KIERULFF & CO.**  
Los Angeles 15, Calif.

**MONTAGUE RADIO DISTRIBUTORS**  
Beaumont, Texas

**MYTRONIC CORP.**  
Cincinnati 2, Ohio

**NEWARK ELECTRIC CO.**  
Chicago 6, Illinois

**OFFENBACH & REIMUS CO.**  
San Francisco 2, Calif.

**OLSON RADIO WAREHOUSE**  
Akron 8, Ohio

**PURCHASE RADIO SUPPLY**  
Ann Arbor, Michigan

**RADIO, INC.**  
Tulsa, Oklahoma

**RADIO AMATEUR CENTER**  
Raleigh, N. Carolina

**RADIO ELECT. SERV. CO. OF PENNA. INC.**  
Philadelphia 6, Penna.

**RADIO ELECT. SERV. CO. OF PENNA. INC.**  
Allentown, Penna.

**RADIO ELECT. SERV. CO. OF PENNA. INC.**  
Easton, Penna.

**RADIO ELECT. SERV. CO.; OF PENNA. INC.**  
Wilmington 22,  
Delaware

**RADIO ELECT. SERV. CO. OF N. J.**  
Atlantic City, N. J.

**RADIO ELECT. SERV. CO. OF N. J.**  
Camden, New Jersey

**RADIO EQUIPMENT CO.**  
Lexington, Kentucky

**RADIO EQUIPMENT CO.**  
Norfolk 10, Virginia

**RADIO LABORATORIES**  
Charleston 5, S. C.

**RADIO PARTS, INC.**  
New Orleans 12, La.

**RADIO PARTS CO. INC.**  
Milwaukee 3, Wisconsin

**RADIO PRODUCTS SALES**  
Los Angeles 15, Calif.

**RADIO PRODUCTS SALES CO.**  
Denver 2, Colorado

**RADIO PRODUCTS SALES CO.**  
Seattle, Washington

**RADIO SHACK CORP.**  
Boston 8, Mass.

**RADIO TELEVISION RAYTEL S. A.**  
Mexico, D. F.

**RADIO WHOLESALE & SUPPLY CO.**  
Honolulu 11, Hawaii

**RADIO WIRE TELEVISION INC.**  
New York 13, N. Y.

**RADIO WIRE TELEVISION INC.**  
Boston 10, Mass.

**RADIO WIRE TELEVISION INC.**  
Newark 2, New Jersey

**THE RADIO CENTRE**  
Montreal, Quebec  
Canada

**SEATTLE RADIO SUPPLY**  
Seattle 1, Wash.

**SREPCO INC.**  
Dayton 2, Ohio

**VALLEY ELECTRONIC SUPPLY**  
Burbank, Calif.

**VALLEY RADIO DIST.**  
Appleton, Wisconsin

**VAN SICKLE RADIO SUPPLY**  
Fort Wayne, Indiana

**WESTERN DISTRIBUTORS**  
Salina, Kansas

**WIRELESS RADIO & TELEVISION**  
Canton, Ohio

**YUKON RADIO SUPPLY INC.**  
Anchorage, Alaska

# Right for the Job!

## DELCO-REMY EXTRA-OUTPUT GENERATORS AND MATCHING REGULATORS

(Medium Duty—40 and 50 Amperes)

Delco-Remy extra-output generators are an economical answer to the electrical needs of cruising taxicabs, suburban police cars, rural mail cars . . . other vehicles with additional lights, two-way radios, special electrical equipment in moderate to heavy-duty service. For this type of operation, these Delco-Remy extra-output generators offer the triple advantages of low initial cost, simple installation and economical maintenance.

DELCO-REMY 40-AMP. GENERATOR has low cut-in . . . charges at curb idle from 11 to 17 amperes . . . attains full output at 18 mph when using a three-inch pulley.

DELCO-REMY 50-AMP. GENERATOR has slightly higher cut-in, about 9 mph . . . attains full output at 19 mph . . . for vehicles customarily operating at higher speeds, with minimum of slow driving.

See your nearest United Motors distributor for further information and application data.

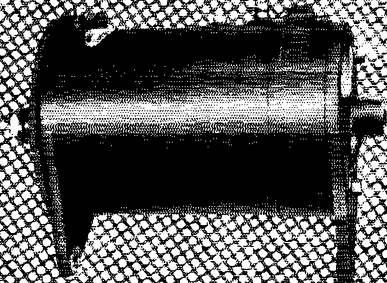

D.C. GENERATOR



REGULATOR

A GENERAL MOTORS PRODUCT  A UNITED MOTORS LINE

DISTRIBUTED BY WHOLESALERS EVERYWHERE

## DELCO-REMY

Division, General Motors Corporation  
Anderson, Indiana

WHEREVER WHEELS TURN OR PROPELLERS SPIN

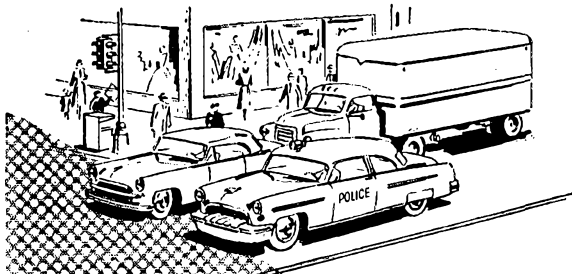

*Right  
for the  
Job!  
New*

**DELCO-REMY  
ALTERNATING  
CURRENT  
GENERATOR**

(ALTERNATOR)

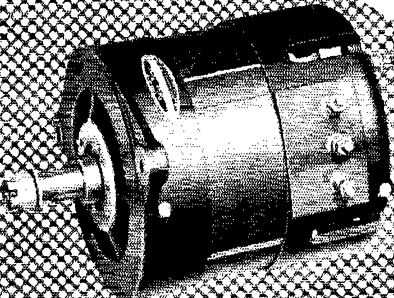

A.C. GENERATOR

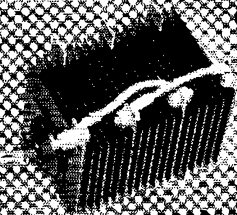

RECTIFIER

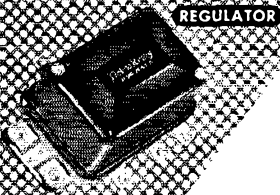

REGULATOR

A. C. - D. C. charging system for vehicles  
with extra-heavy electrical loads

Here's the answer for "problem" vehicles—Delco-Remy's new long-lived A.C.-D.C. charging system! It's specifically designed to meet the extra-heavy electrical demands of police prowl cars, big city taxis, and other vehicles equipped with two-way radio, floodlights or any extra electrical units . . . ample current reserve picks up discharged battery quickly in operation.

With output ranging from 30-40 amperes at curb idle to 90 amperes at higher engine speeds, the new Delco-Remy A.C.-D.C. charging system meets all electrical needs under the toughest operating conditions. Included in the new system is the A.C. generator (alternator), a matching regulator for accurate voltage control and a rugged, dependable dry-plate rectifier which converts generator A.C. output to direct current.

Application packages for popular makes of cars and trucks are now available. The conversion job is simple, complete and profitable. For further details and for application data, call on your nearest United Motors distributor.

A GENERAL MOTORS PRODUCT  A UNITED MOTORS LINE

DISTRIBUTED BY WHOLESALERS EVERYWHERE

**DELCO-REMY**

Division, General Motors Corporation  
Anderson, Indiana

WHEREVER WHEELS TURN OR PROPELLERS SPIN

# A Big Job Done by a Tiny Package

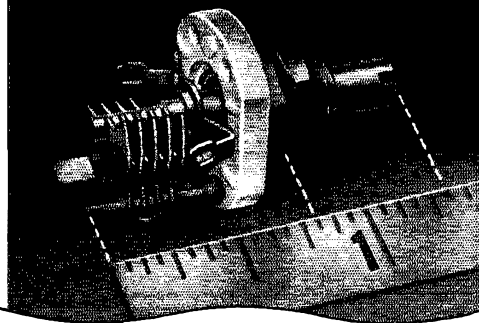

## New "MAC" meets miniaturization needs

To keep pace with the continuing efforts of the electronic industry toward miniaturization of components, Hammarlund now introduces a tiny variable capacitor, type "MAC." This component provides the low minimum capacity essential for use as a trimmer in the VHF range.

The silicone-treated base is only  $\frac{3}{4}$  x  $\frac{5}{8}$  inches. Its rotor and stator are soldered assemblies of brass, silver-plated for low losses. The wiper rotor contact is silver-plated beryllium-copper. Rotor and stator terminals are positioned to permit short leads. A threaded bearing is provided with flat sides to permit single hole mounting without turning.

The new units are available to fulfill capacity requirements between 1.4 and 19.6 mmf. Try one in your next piece of gear.



If you haven't received your copy of the Capacitor Catalog, write to The Hammarlund Mfg. Co., Inc., Dept. A, 460 W. 34th St., New York 1, N. Y.

# HAMMARLUND

(Continued from page 78)

radio club is the Bucktail Amateur Radio Club, of Emporium. My term as Sections Communications Manager is drawing to a close, but I feel I have accomplished what I started out to do, in keeping our section in the limelight, with reports of your activities, your clubs, and your accomplishments posted in this column. I wanted so much to see Western Pennsylvania on top in contests, Field Days and hamfests and a Western Pennsylvania ham elected a Division Director. I know that in my six years as SCM I have kept a promise and visions of a well-talented radio section have been realized. I am disappointed that the section is without a Section Emergency Coördinator and that Western Pennsylvania did not have an Atlantic Division Convention. My sincerest hope is that your next SCM will see to it that these two things are accomplished. May I again thank all of you for your cooperation and your honest efforts in helping me realize the things I set out to do. I want to urge each one of you to support your clubs and your officers. Fulfill your obligations to your appointments and, without fail, your obligations to your fellow amateurs. Thanks and good luck. Traffic: (Dec.) W3UHN 144, GEG 82, NUG 58, NRE 25, LXE 9, KWL 6, UVD 1. (Nov.) W3CA 14.

## CENTRAL DIVISION

ILLINOIS—SCM, H. F. Lund, W9KQL—Section Nets: ILN (c.w.) 3515 kc.; IEN (phone) 3940 kc. SEC: QLZ, PAM: UQT, RM: BUK. Members of both the c.w. and phone nets are willing to trade spring and summer QRN for long-skip difficulties which have plagued them all winter long. IFA made a nice showing during the 50-Mc. opening of Dec. 18th and 19th with several first- and second-district stations in the log. JLL does as well with 150 watts to the new Viking as he did with 450 watts on the old rig. SKR is building a portable rig for summer vacation use. OXZ divides his time between traffic on MARS channels and ragchews on 3.8-Mc. phone. MBI and ZHB have been keeping regular schedules on 420 Mc. for two years. TGY made Gen. Cl. The day after MAE received her Ad. Cl. papers the FCC made them unnecessary for 75 and 20 meters. SXL is probably the oldest member of ILN from the standpoint of service; Al has racked up 15 years in the c.w. net. LHS has gone v.h.f. with a 522 on 144 Mc. Chicago Suburban Club officers for '53 are PBJ, pres.; LQF, vice-pres.; GPV, secy.; and FVU, treas. OBN has returned to 3.8-Mc. phone. ICF put his TV antenna on the same mast with his 10-meter beam. UGI is newly licensed in Beardstown. Traffic: W9CSW 338, OKI 233, STZ 205, SKY 200, YIX 136, CEE 134, OKQ 134, LXJ 110, MRQ 80, W6CIW/9 79, W9KQL 54, CTZ 40, BUK 18, JLL 16, FRP 5, LMC 4, DOR 3, SKR 2.

INDIANA—SCM, Clifford C. McGuyer, W9DGA—WDS is new in Evansville. UNT, PQR, and POW received new bugs for Christmas. MCN has Adv. Cl. license. TT and JUJ received traffickers 10,000 certificates. UQP received his Tech. Cl. license. RZS had a good average in the last F.M.T. New officers of the Lake County ARC are GUX, pres.; DWF, vice-pres.; INU, treas.; KRJ, secy. ZIB has "taxi-talkie" for 147.3 Mc. SNQ reports Jay County amateurs are forming a club. Officers of the Madison ARC are PFC, pres.; PPO, vice-pres.; QOT, secy.; G. Whitaker, treas. IOH is a member of the Indiana State Police. PPO and PMV have Gen. Cl. licenses. QLW has station completed in Ft. Wayne now. New officers of the Indianapolis RC are FZW, pres.; JVF, vice-pres.; OVF, secy.; R. Mays, treas. The Indianapolis Club operated in the Hobby Show at the Fairgrounds. SEL is listed in Silent Keys. KXB has a three-element beam for 14 Mc. PUB has an excellent antenna. INU has gone into the TV business. JSY got married. PBS moved to Crown Point. ABB visited EGQ. TV is building new traffic rig. YVS has eliminated TVI. A new Novice in Garrett is WET. MDC is spending time in the State Legislature. LZI and TT handled the Indiana end of the Governors-to-President Relay. DHJ works 220 Mc. DLI has Ext. Cl. license. THC handles Hammond traffic on 144 Mc. KLR operated in the 10-meter WAS contest. New officers of DARA are HJJ, pres.; OMD, vice-pres.; DOK, secy.; NSF, treas. QID works on the railroad. SWM has Gen. Cl. license. New Novice in Martinsville is WIN. DKR received an 8-76 receiver from Santa Claus. CMT is a member of the Overseas Net. MEU has a new Globe King. KDV drives p.p. 813 with an Elmac. JBQ likes his new QTH in Jeffersonville. UNT built oscillator for 420 Mc. JBQ reports RFN traffic as 74. IHO has new ham shack in addition to his home. New Novice calls in Terre Haute are UIR, VMI, VMK, and WHZ. The Terre Haute group has 26 mobile and fixed stations on 50.6 Mc. SKP has VFO for all bands. NJR is TVI-proofing his rig. PPS has 807 final and is very much satisfied with it. VNV visited Mexico again. IZC is building new bandswitching rig. FOR is moving to a TVI-less QTH. RIV, RBX, and ET have new Viking II rigs. UHV received a new mike for Christmas. JP is the club call of the IRC. New appointments are RDJ and OHT as ORS, GUX as OPS, and WN9UHV as OES. Traffic: (Dec.) W9JUN 1700, NZZ 893, TG 646, WWT 561, YWE 348, TT 253, QLW 168, BKJ 164, HUV

(Continued on page 80)



# Stable I. F. Tuning...

*means peak  
response at  
center frequency  
always!*

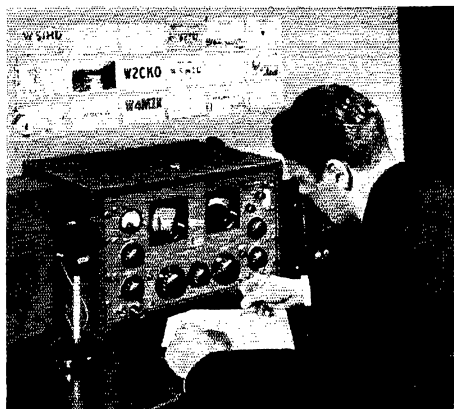
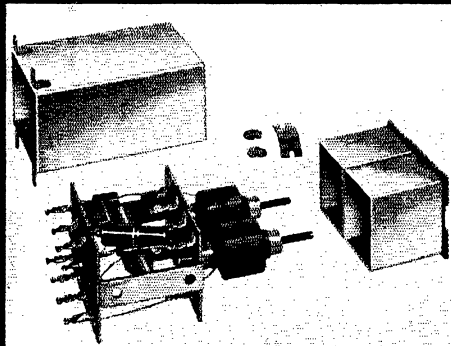

Newest techniques in the art of receiver design and engineering are incorporated into the "SP-600-JX" to make it outstanding in quality and unexcelled in performance. Regardless of your past experience as a radio amateur or short wave listener, you will be impressed by the superlative advantages of the "SP-600-JX".

Visit our booth, No. 4-214, at the I. R. E. Show in New York this month and operate this receiver. You'll also preview the "HQ-140-X", a new receiver that is bound to get amateur acclaim.

## Change the bandwidth without de-tuning when you operate an "SP-600-JX" Communications Receiver

The aim at perfection in engineering and manufacture of the "SP-600-JX" has yielded a design which permits selection of any of six bandwidths (0.2, 0.5, 1.3, 3, 8, and 13 kc) with no de-tuning from center frequency.

Furthermore, these I. F. stages are so stable that once set at the factory, they are unlikely to ever need re-alignment again. Even a change of I. F. tubes has no effect upon alignment of this superior receiver.

For full particulars write to The Hammarlund Manufacturing Company, Inc., Box A, 460 West 34th St., New York 1, N. Y.



# HAMMARLUND

# YOU CAN BE SURE WHEN YOU BUY FROM QST ADVERTISERS

“Advertising is accepted only from firms who, in the publisher’s opinion, are of established integrity and whose products secure the approval of the technical staff of the American Radio Relay League.”

Quoted from QST’s advertising rate card.

Amateurs and electronic engineers—practically everything you need can be supplied by the advertisers in QST. And you will know the product has the approval of the League’s technical staff

151, PPS 151, DHJ 90, OLY 86, FYM 85, CMT 78, KDV 60, JBO 55, VNV 53, NTA 50, DOK 49, FZW 28, LZI 26, NJR 23, QID 18, BDF 15, DGA 10, IZC 10, DKR 8, KLR 8, NTR 5, SKP 5, AZJ 4, INU 3, WN9UQP 3. (Nov.) W9JUI 785, OWZ 58, PAIT 44, ZIB 33, LZI 31, FZW 23, GUX 18, NH 1.

WISCONSIN — SCM, Reno W. Goetsch, W9RQM — SEC; OVO, PAM; ESJ, RMs: IQW and SFL, C.W. Net (WIN) 3625 kc. daily at 7 p.m.; slow-speed 6:30 p.m. Mon-Fri. Phone Net (BEN) 3930 kc. 6 p.m. daily. State mobile and c.d. frequency: 29,620 kc. (CXY received 9RN and TLJ Net certificates. Net certificates (BEN) were issued to AAA, OTL and QFL and (WIN) to VLL, UCR, NLH, and PVH. ESJ has the big rig back on with new 805 modulators. UCR skeds UDX for Oshkosh traffic. KMO is station manager at ODD, Marquette U. Ham Club. SDK is debugging his VFO. EIZ is QRT while at V.A. Hospital in Iron Mt. WN9SAP now is Tech. Class. IKY has new shack about completed. 144-Mc. activity is picking up in Green Bay, according to HDV. CFP has been experimenting with transistor circuitry. New officers of the DCARC are GJK, pres.; UIM, vice-pres.; SBH, secy.-treas. GJK replaces LIA as EC for Door County. We regret to record the passing of one of our fellow net members, ALG. The Kenosha Radio Communications Society elected GRX, chairman; PHJ, vice-chairman; WN9VCD, secy.-treas. ECI replaces ILR as EC for Kenosha County. DSP has new exciter with Collins VFO finished and completely de-TV’ed, and is working on 600-watt final. HHX, Milwaukee Sch. of Engineering club station, has a “full gallon” on 3.5, 7, 14, and 28 Mc. IRJ is Club pres.; NFG, vice-pres.; and SCH, faculty advisor. For the Governors-to-President Relay, TPS secured a message from Governor Kohler, with CBE as originating station. MRAC now has a ladies’ auxiliary with YLs MGT, OMZ, and WN9RUJ as officers. Participating in a successful c.d. drill Dec. 9th, were the following Milwaukee mobile units: BSR, BTQ, BPR, CUW, ESJ, FY, FDX, GIL, GPI, IDW, IZO, EKU, MDG, MGT, NLY, NKG, NNV, NRX, NMA, OOF, RUF, SNK, SUB, SZH, VLK, and WN9VBZ. KMO and OOA, from station ODD, also served. Newly-appointed ORS are UCR and VLL. SIZ renewed ORS appointment. VWX now has a TBS-50. NLE has moved back to Eau Claire. 144 Mc. News: GFL is on with 24Gs, 150 watts, sixteen-element beam 55 feet high and crystal-controlled converter into SX-17. QZO is on from Sheboygan with a 522 and five-element Yagi. As soon as crystal converter is ready GJK will be active from Sturgeon Bay. LEE’s new converter (cascode 6BQ7s) gives 18 db. more gain with little increase in noise. DSP worked #TKK for his 54th station on 2 meters. NPT joined REQ and DSP on 420 Mc. with a converted BC-645. Traffic: W9CXY 224, DR 78, UCR 53, ODD 52, IQW 50, LSK 48, SDK 39, EIZ 38, SFL 36, VLL 35, FCF 32, HDV 19, IHW 19, CFP 17, OVO 12, ERW 10, GFL 8, SDK 8, RQM 4.

## DAKOTA DIVISION

NORTH DAKOTA — SCM, Everett E. Hill, W0VKP — The lack of a column in previous months is due to the fact that all of you must be operating underground as I never hear from you. Since I am on the road most of the time now I must rely upon the mails for articles rather than getting them off the air. ITS now is Conditional Class. MPR is a new call in Grand Forks. NMV now is Advanced Class. The hams in the State did an FB job of airplane spotting in the recent test. It was reported that the only information the Filter Center had on the location of the attack was reported by the hams. New officers of the Jamestown Club are EOZ, pres. SWC, vice-pres.; YIZ, secy.-treas. What must your SCM do to push you hams into an AREC program for the State? I have a swell program outlined for the State complete with a map. Send a card for your copy. Even if you don’t want to participate you should have the plan on file for reference. Traffic: (Nov. & Dec.) W0EXO 33, UBB 27, NMV 23, NMV 18, EXO 12, DM 6, GWH 3.

SOUTH DAKOTA — SCM, J. W. Sikorski, W0RRN — SEC; GCP, RM: OLB, PAM; UVL. GCP is on his annual vacation in Oregon and is operating /7 with Command equipment on 75, 80, and 40 meters. The Prairie Dog ARC elected MMQ, pres.; WUU, vice-pres.; DTB, secy.-treas., IZA, custodian; GDE, chief operator; and L. R. Lauritzen, publicity mgr. At the December meeting the Club saw films of last spring’s flood in Sioux City. Several members of the Club assisted in emergency operations during the flood. RRN’s Christmas present was a Viking II and VFO. WN0LXQ made General Class. DTB swapped Lysco for Meissner 150B. BQS now is EC for Minnehaha County, CRY having resigned because of business reasons. GDE is running 75 watts mobile in a new panel truck. Ex-HAT now is KL7AIR at Anchorage. UVL has promoted an activity to furnish weekly reports to CAA on landing field conditions of small airfields in the State. WN0LXN has purchased an NC-57 and is converting Command set for transmitter. Traffic: W0PHR 136, OLB 130, K0FAL 49, W1SWX/0 31, W0AEN 2, RRN 2, BJV 1.

MINNESOTA — SCM, Charles M. Bove, W0MXC — Asst. SCM: Jean Walter, 0KYE, SEC: BOL, RMs: RPT.

(Continued on page 88)

# What do you want in a MICROPHONE?

Check the features and characteristics for which E-V microphones have become favorites in every field. Then take your choice, and know you can expect performance that is guaranteed by E-V research-engineering. Here are 9 models of today's most complete microphone line.

## 950 CARDAX

High level cardioid crystal microphone with dual frequency response for high-fidelity sound pick-up or for extra crispness of speech. Overcomes feedback and background noise. Wide range response. "On-Off" switch. Metal Seal crystal. List, \$42.50

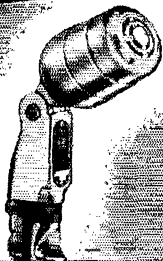

## 630 DYNAMIC

Popular high fidelity high output dynamic. Response 60-11,000 cps. Omni-directional. Exclusive Acoustalloy diaphragm. Extra rugged. Tilttable head. "On-Off" switch. Available in high or low impedances. Model 630. List, \$42.00



## MERCURY

Model 611 Dynamic and Model 911 Crystal. Smart design. Rugged and dependable. Response 50-8000 cps. High output level. Omni-directional. Tilttable head. "On-Off" switch. Available in high or low impedances. List from \$25.50 to \$35.50

## 208 MOBILE

Small size, high output, single-button carbon microphone for maximum intelligibility. Close-talking, noise-cancelling Differential\* type. High articulation. Blast proof, water proof, shock resistant. Comfortably hand-held. Press-to-talk switch. Panel mounting. bracket. List, \$16.50



## 600-D and 210

Dynamic and Carbon high articulation mobile microphones. Give high intelligibility speech transmission. Light weight, yet extra rugged. Easily held in hand. Press-to-talk switch. Model 600-D. List, \$38.50 Model 210. List, \$28.50

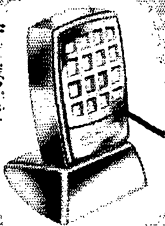

## CENTURY

Low-cost all-purpose Crystal, Dynamic and Ceramic models. Can be used in hand, or on stand. Remarkable performer. Satin Chrome finish. In high and low impedances. List from \$11.25 to \$18.50 Model 415 Desk Mount lists at \$1.70



## H-51/U HANDSET

Virtually indestructible. Transmits speech clearly and intelligibly under high ambient noise conditions. Noise-cancelling second order differential carbon microphone. 600 ohm receiver, black nylon handle, push-to-talk switch. 10" long. Weighs 1 lb. List, \$180.00

## 636 SLIMAIR

Slim, versatile dynamic of exceptional quality. High-fidelity response 60-13,000 cps. Output -55 db. Acoustically-treated grille head stops wind and breath blasts. Acoustalloy diaphragm. Tilts 90°. "On-Off" switch. High or low impedance selection. List, \$70.00



## TOUCH-TO-TALK

Model 428 "Break-in" Touch-to-Talk Stand with locking feature. Fits any microphone with standard 3/8"-27 thread. Lever-type switch gives finger-tip relay operation or microphone "On-Off." Single-pole double-throw. List, \$14.00



MICROPHONES • PHONO-CARTRIDGES  
HIGH FIDELITY SPEAKER SYSTEMS  
TV ACCESSORIES • PA PROJECTORS

See your E-V Distributor or Write for Bulletins

Crystal mikes licensed under Brush patents. E-V Pat. Pend.

# Electro-Voice INC.

404 CARROLL STREET • BUCHANAN, MICHIGAN  
Export: 13 East 40th Street, N.Y. 16, U.S.A. Cables: Arlab

\*Patent No. 2,350,010

**B&W****MODEL 600**

# Dip Meter



- ★ Frequency Range—1.75 to 260 MC. in 5 Bands
- ★ Adjustable Sensitivity Control
- ★ Wedge-shaped for Easy Access in Hard-to-get-at Places
- ★ Rust Proof Chassis, Sturdy Aluminum Case
- ★ Monitoring Jack and Diode Switch
- ★ Powered by 110 V. A-C Line

NEW LOW PRICE:

**\$39<sup>75</sup>**  
Net

## A HIGHLY USEFUL INSTRUMENT FOR THE

**Amateur • Engineer • Service Man  
Laboratory Technician • Experimenter**

The New B & W Model 600 Dip Meter provides you with a convenient means of doing the job in a minimum of time with dependable accuracy.

It is an extremely sensitive and reliable piece of test equipment having innumerable uses in the Ham Shack, Service Shop, Electronic Laboratory, or Production Plant.

Armed with this versatile and indispensable instrument, you eliminate the guess-work during measurement of—tank circuit frequencies, antennas, feed line systems, parasitics, and other pertinent tuned circuit characteristics, with speed and accuracy.

The handy instruction manual furnished with each instrument covers full information on how to use the Model 600 as an Absorption Meter, Auxiliary Signal Generator, R. F. Signal Monitor, and several special applications as well. See it at all leading electronic parts distributors throughout the U. S. A. and Canada; or write for descriptive bulletin.

**BARKER & WILLIAMSON, INC.**

237 Fairfield Avenue • Upper Darby, Pa.

DQL. PAMs: HEO, UCV. This was election time for clubs. The Minneapolis Radio Club elected RWF, pres.; ATT, vice-pres.; IEW, secy.; and HFU, treas. The Minnetonka Radio Club has elected QZ, pres.; WQN, vice-pres.; RKB, secy.; and EOP, tech. adviser. The Tonka Club has 22 members and has a net roll call every Friday at 1930 CST on 29,568 kc. The Minnesota Noon Fone Net nominated UCV as NCS, with FIT, EG, FDS, and NJQ as alternates. The evening MSN appointed JIE as NCS, with BUO, FYT, and TJA as alternates. PCV was shot down behind enemy lines in Korea on his 100th mission. IYP now is a married man and his new XYL just passed her Novice Class exam. Both are studying medicine at the U. of M. HKF has a new 813 rig with pi-network designed by BUO. HED has a new Viking. BRA has a new 32V-3 Collins. SAW and XYL have a new jr. operator. EAL built a new antenna coupler for his Johnson Viking. IFS has worked into Mississippi on 2 meters. There are about a dozen 2-meter boys meeting on 144 Mc. at 2100 CST every evening. EBA bought an HQ-129X and is running 120 watts to an 829B. CWU is on with a Viking II. EQS was in St. Paul to pass his Advanced Class exam. HFY soon will be on with a pair of 6146s. WQM has been ill but found company in his new SX-71 receiver. DYD now has his new Advanced Class ticket. Believe it or not, the Minnetonka Radio Club was "put in jail." The Village of Excelsior loaned its jail house to house the club equipment. Want to build up your code speed? Check into the MSN at 7:00 P.M. on 3595 kc. daily. Traffic: WQYZ 932, DQL 364, UCV 196, HFY 190, FDS 176, RXL 99, GQG 71, DYD 46, CWB 45, BUO 40, TJA 40, AIH 34, GTX 30, CTW 23, BWM 19, BQK 17, WQM 16, OPA 13, MXC 12, FIT 8, FTJ 8, KNR 5, BRA 1.

### DELTA DIVISION

ARKANSAS—SCM, Fred Ward, W5LUX—Two reports were received this month, so there must be very little amateur activity in Arkansas. Attendance on the Ozark Net has been very low and we have cut the meetings to one per week. Until interest builds up the net will meet only on Monday nights. Fellows, civil defense is a part of our job. Have you ECs been working on it? Do you have all the hams in your area signed up in the AREC? How about letting me and the SEC know what goes on in your area? Let's resolve this year to build up our emergency gear and show a little more activity. The Little Rock Club holds hidden transmitter hunts quite often, which all enjoy and are fine for keeping up interest. RYM is active on 75 meters now and VN has been representing Arkansas on the regional net. EA has been breaking into broadcast work and letting some of his ham activities go. We sure miss his regular attendance at every net drill. Traffic: W5VN 34, LUX 31, PX 2.

LOUISIANA—SCM, Robert E. Barr, W5GHF—The SCM humbly apologizes for the scarcity of reports in the past few months, both on the part of the SCM and of the operators throughout the State. Extreme skip conditions have brought net operations and QSOs within the State practically to a standstill, except for daylight hours, hence the definite lack of enthusiasm in the section. Thanks to the RM, NG, and to ORS MWE for their consistency, however. The Route Manager would like to hear from those Novices who would like to organize a Louisiana Novice net on 40 meters. Drop a card to NG. Thanks also for an FB report from WQX in the Crescent City. "El" is running 19 watts to a 616 oscillator and is getting out well with the low power on 7 Mc. TRQ is on 28-Mc. 'phone with a Harvey-Wells. TRQ has increased power from 25 watts to 75 watts and can be found on all bands. UZA soon will have that 750-watt rig going on 75- and 20-meter 'phone. RDD is making full use of the new privileges on 160-meter 'phone. VRA now has one of the strongest signals out of Shreveport. W5WU is on in Garyville with a BC-457B. Traffic: W5NG 266.

MISSISSIPPI—SCM, Norman B. Feehan, W5JHS—Promoted Novices are WQI and WEY. Santa brought WWJ a new Elmac. WLY's new QTH is Enterprise and he will handle Meridian traffic. JHS is sporting a new deluxe Vibroplex bug and case that the Hurricane Net members presented to him for Christmas. News from Korea: RUT is back and looking fine. RMC should be home by the time this is printed. JFE should be next slated for the States. TRK also has shown up over there. Since Lewie is coming home, how about you, Gorden, sending us the dope on the boys over there? 4YTK now is 5YOZ. SKA is Advanced Class now. OGN is on at Auburn, Ala., where he is going to school. JHS's son also is at Auburn. He has just passed his Novice Class exam and the OM hopes to keep in contact with him on the Novice band. RIM is looking for new members for the MARS Net. UOO is on in Biloxi with a very FB signal on 75 meters. Let's hear from more of the boys in the State. Traffic: K5FHB 331, W5RIM 154, JHS 103.

TENNESSEE—SCM, Mark M. Bowelle, W4CXY/WLG—SEC: AEE, RM: AGC. PAM: PEP. At this writing the screwy conditions on the 75- and 80-meter bands have all but put a crimp in the State net operations. When a Tennessee net has to ask an Iowa station to QSP between Tennessee stations, you can't say that conditions are en-

*(Continued on page 84)*

# FOR EXTREME STABILITY.. *Bliley* CRYSTALS PLUS *Bliley* TEMPERATURE STABILIZERS

Crystal frequency stability is a finite factor determined by ambient temperature variation. Bliley Temperature Stabilizers, used with Bliley Crystals, are thermostatically controlled ovens engineered to deliver extreme stability regardless of ambient temperature changes.

## TCO SERIES

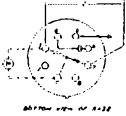
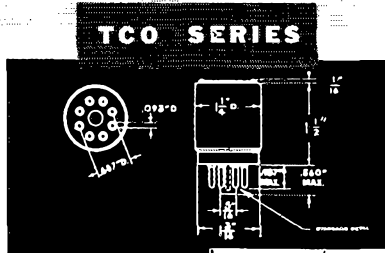

Designed specifically for use with Bliley types BH6A and SR11 crystal units. Standard models are supplied as indicated:

Model	Heater Voltage	Watts	Crystal Sockets	Control Temperature
TCO-1A	6.3	5.5	1	75°C or 85°C
TCO-1C	24 or 26.5	7.75	1	75°C or 85°C
TCO-2	6.3	5.5	2	75°C
TCO-2	6.3	7.8	2	85°C
TCO-2D	24 or 26.5	7.75	2	75°C or 85°C

## TYPES TC911-TC92-TC93

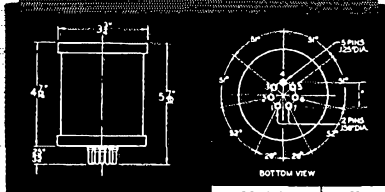

Designed specifically for use with Bliley Crystal units. Standard models are supplied, for crystal types, as indicated:

Model	Heater Voltage	Watts	Crystal Group	Control Temperature
TC911	115	10	B	70°C
TC92	6.3	10	A	60°C
TC93	18	10	A	60°C

Crystal Group A Types FM6, BH81A, MC7, AR4, AR5  
Crystal Group B Types BH8, MC75, MS46A

## TYPE TC97

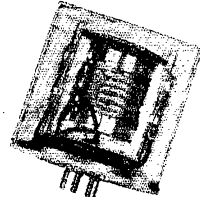
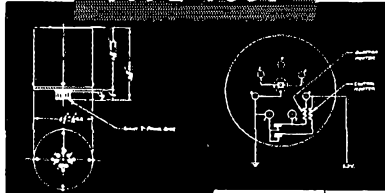

Exceptional temperature stability is provided by two separate heaters, individually regulated by separate thermostats. Ambient temperature variations are first minimized by outer stage (booster) heater with final regulation by inner stage (control) heater.

Model	Heater Voltage	Watts	Crystal Group	Control Temperature
TC97	6.3	11	A	75°C

Crystal Group A Types FM6, BH81A, MC7, AR4, AR5

**BLILEY ELECTRIC COMPANY**  
UNION STATION BUILDING, ERIE, PENNSYLVANIA

# VFO

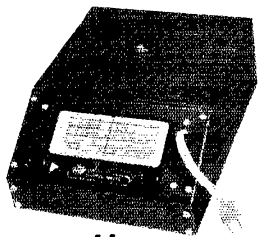

for your *Harvey*-WELLS  
**BANDMASTER**

**NOW IN PRODUCTION**

**FULL EFFICIENCY ON ALL BANDS  
THIS IS IT**

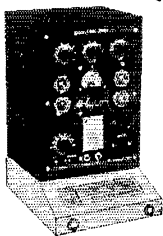

**OCCUPIES NO MORE DESK SPACE**

**WRITE NOW FOR  
DESCRIPTIVE  
LITERATURE**

• Ask your own  
supply house to  
reserve one for you.

**PRICE \$47.50**

**Harvey-WELLS ELECTRONICS, INC.**  
SOUTHBRIDGE, MASSACHUSETTS

EXPORT DEPT., — 13 East 40th Street, New York  
CANADIAN DISTRIBUTOR: Canadian Marconi Co.  
861 Bay St., Toronto, Ontario

firely normal. Kingsport, one of the most active club groups in the State, has a second club, the Bays Mountain Club, made up of Tennessee Eastman Co. employees with a roster that many clubs would envy. RHO vacationed in Florida, keeping in touch with the gang via 75-meter mobile. VAB is rebuilding and has 25-w.p.m. proficiency sticker. TYU is a new much-needed c.w. outlet in Knoxville. VJX again is pounding brass on Tennessee c.w., MARS and Davidson County nets. WQW is remodeling and now working all bands 160 through 10 meters. FLW is QRL de-TV'ing rigs. OGG is heading for 20 meters (can't say that we blame him with 80 conditions the way they are). Traffic: W4PL 1892, OGG 465, AGC 258, PFP 216, IIB 204, WAX 110, CXY 71, WQW 66, VJX 30, AEE 25, RMJ 16, TYU 13, RHO 4, FLW 2, VAB 1.

### GREAT LAKES DIVISION

**KENTUCKY** — SCM, Ivan C. Kelly, W4TUT — Congrats to KKG, outgoing SCM, on the swell job. This activity report can only be the report of you OMs, so let the reports fly. Lots of appointments are available, and endorsements will go out immediately. SMU and KZF still are strong in Northern Kentucky. BAZ and JPY are heavy on overseas traffic. CDA is fighting TVI. TFK started Governors-to-President greetings. Louisville is booming an all-mobile club. SZB is on phone with controlled carrier. QJU is the "mobilest" mobile in the State. NIS and MOP are installing mobile gear. K4WBG has made RPI, three times in a row. NPS reports the Paducah Club is holding training meetings for Novices and beginners. UWA is starting on a new rig. When is OXN going to show with the p.p. 813s? Word was received from MVL, now HH4MV in Haiti. Give a listen for him on 20 meters. MWX keeps right on plugging even though his new endorsement is slow in the mail. TQC and TQD, son and "pappy," respectively, are giving 80 a hard time. OMW added 22 new countries, which he credits to a new beam. WN4UNH made a score of 4050 during the Novice SS. Kentucky hams with the Atlanta Net and OPS and SLH helped to make a Merry Christmas with a party on Christmas Eve by radio for Doris Whitaker, a polio victim in Atlanta Hospital, to her friends in Somerset, via TUT. Traffic: (Dec.) K4WBG 314, W4MGT 206, BAZ 196, WBC 153, OMW 55, NBY 50, CDA 36, RFI 18, KKG 13, NBS 7, UWA 6, KZF 1. (Nov.) W4NBY 518.

**MICHIGAN** — SCM, Norman C. MacPhail, W8DLZ — Asst. SCMs: Bob Cooper, 8AQA; Joe Beljan, 8SCW; Mickey Wills, 8CPB. SEC: GJH. RMs: YKC, UKV. New appointments: OO (Class IV) to LKR. New officers of Cherryland Radio Club are JUY, pres.; ZWAI, vice-pres.; JEF, secy.; ZLK, treas. SYQ has completed a 200-watt 813 rig for the club station, KTV. JEF reports he has a 350-watt on the bench and that QPO's new rig "blew up on him" when he threw the big switch. New officers of the Niles Radio Club are SWG, pres.; ZXC, secy.; RAE, treas.; UPN, act. dir. Congratulations to YKC on his engagement to Joan Gibson. W8NLEM and W8LEQ are a new father-and-son team in Allegan. HJO dropped the "N" from his call. FSZ reports the Lansing gang, through the cooperation of c.d. officials, now have a Viking II, a Globe King, an SX-71, an RME 2-11, plus mikes, bugs, and beams for their emergency set-up. There is an example of real cooperation, boys and girls. And it's there for all of us if we'll go after it and prove we need the material and will put it to good public service use. Further proof of this — CYL reports new equipment in Detroit Red Cross station includes a 32V-2, Viking II, and a 75A-1. TIC reports UCG is back on the air again. PUV/8 is active on 2 meters. The new 2-meter net in Grand Rapids is going great guns. RJC is back in the saddle on 180 and 40 for top traffic score for December. THG reports TVI-proof operation on 80 — with an antenna ten feet above ground. FX is building a spark transmitter! Here we go, boys! Sooner or later it had to happen! FWG is all set for 40 meters with a new electronic key. To every traffic man in Michigan — whether phone or c.w., whether 160, 75, 80, 40, 20 or 10 — my deepest and most sincere thanks for your wonderful cooperation and assistance in making these past two years so pleasant. I know HKT, your new SCM, will continue to have your support. Let's keep Michigan at the head of the traffic list! Traffic: (Dec.) W8RJC 1123, NZZ 717, NOH 508, SCW 277, ILP 207, RTN 162, GNS 129, QIX 128, SPF 100, GBV/8 96, IKX 92, ZLK 85, IQJ 74, IV 60, ELW 56, WVL 55, DAP 48, DLZ 48, JYJ 34, COW 30, AQA 26, AUD 23, HKT 15, EGI 14, GJB 12, THG 12, SJF 11, FX 9, TQP 9, AHV 8, MGQ 8, TIC 4, PUV/8 2. (Nov.) W8CPB 89, FBV 13, FFG 12, CYL 11.

**OHIO** — SCM, John E. Stringer, W8AJW — Asst. SCMs: C. D. Hall, 8PUN, and J. Erickson, 8DAE. SEC: UPB. PAM: PUN. RMs: DAE and PMJ. FYO was the only one to make BPL this month. The OCARC met on Jan. 17th. The Council is endeavoring to bring more Ohio clubs into the fold and interested organizations may write WXG, temporary secretary. BN did a swell job in handling G. I. Christmas messages. Our live wire SEC, Carty, was in Toledo on Jan. 14th, at the request of State C. D. Headquarters and spoke on RACES. DG and ZJM are giving 21 Mc. a whirl. The pleasant voice of ACE, Dayton's Demon DXer, may be heard evenings on 75 meters. RO is the new

(Continued on page 86)

Available in seven sizes, covering a range of 3 to 520 megacycles. Two sizes rated at 600 ma, others at 1000 ma. Single-layer wound on low power-factor plastics or steatite cores. Moisture-proof coating.

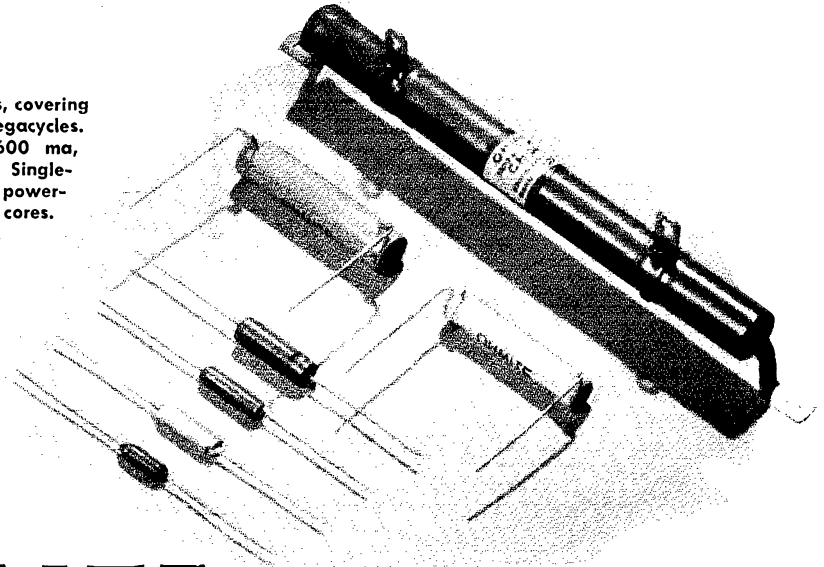

# OHMITE®

## "FREQUENCY-RATED" PLATE CHOKES

**IT'S EASY TO SELECT  
THE RIGHT UNIT**

You can be sure that the plate choke you use is "matched" to the particular frequency you need, with Ohmite Frequency-Rated Chokes. These plate chokes have had their frequency characteristics accurately pre-determined for excellent performance at the rated frequencies.

Ohmite plate chokes are invaluable for a multitude of TV, radio, and electronic applications. For instance, they can be used with suitable trimmer capacitors for tuned wave traps—series, parallel, or combination type—to reduce TV interference. Adaptable to either 300 or 72-ohm input.

OHMITE CHOKE	mmf at 3.5 Mc	mmf at 7 Mc	mmf at 14 Mc	mmf at 21 Mc	mmf at 28 Mc	mmf at 50 Mc	mmf at 56 Mc
Z-28	98	25	6.2				
Z-50		74	19	8.2	4.6		
Z-144			72	32	18	5.7	4.5
Z-235				6.9	39	12	9.7
Z-460						51	40

The above table shows the approximate capacity necessary to resonate OHMITE Frequency-Rated Chokes at various frequencies for tuned wave traps.

**write for Bulletin 133**

**OHMITE MANUFACTURING COMPANY**  
4864 Flournoy St., Chicago 44, Ill.

# OHMITE

**RHEOSTATS • RESISTORS • TAP SWITCHES • CHOKES**



**More Safety...Less Guesswork  
When You Use  
—PRECISION—  
TEST EQUIPMENT**

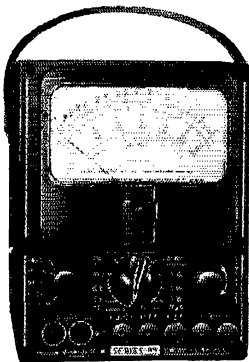

**Stay On The Air  
With "PRECISION"  
SERIES 85  
AC-DC  
Circuit Tester  
(20,000 Ohms per Volt)  
SELF-CONTAINED TO  
6000 volts,  
60 Megohms,  
12 Amperes, + 70DB**

A compact, laboratory type, *high sensitivity* test set indispensable for test and maintenance of modern amateur communications equipment.

20,000 Ohms per Volt D.C. — 1000 Ohms per Volt A.C.

**VOLTAGE RANGES:** 0-3-12-60-300-1200-6000 A.C. & D.C.

**CURRENT RANGES:** 0-120 microamps; 0-1.2-12-120-MA;  
0-1.2-12 Amps D.C.

**RESISTANCE RANGES:** 0-6000—600K—6 Meg—60 Megohms.

**DECIBEL RANGES:** From -26 to +70DB.

Complete with batteries and test leads..... **\$39.95**

**PLUS superior physical features:**

- ★ 4 3/8", 50 microamps, Easy Reading Meter.
- ★ Heavy duty bakelite case 5 1/2 x 7 1/8 x 3".
- ★ Deep etched, anodized aluminum panel.
- ★ Recessed 6000 volt safety jacks.
- ★ Only two pin jacks for all standard ranges.

**LC-1 LEATHER CARRYING CASE**—Custom designed, top-grain cowhide case with tool and test lead compartment. **\$9.50**

See Series 85 and other famous "Precision" instruments, on display at leading radio parts and ham equipment distributors. Write for latest catalog.

**Precision Apparatus Co., Inc.**

92-27 Horace Harding Blvd., Elmhurst 13, N. Y.

8RN NCS on Tuesdays. HNP is in charge of RACES in the Toledo Area. FJR has confirmed his 100th country in the form of a QSL from VP8BP. ZAU's XYL presented him with a new Viking II transmitter for Christmas. AQ has a new 8M-meter Zepp which made possible a QSO with VP8AP and other choice DX. PMJ is building a new rig for 80/160. LZE submitted his first traffic report in 12 years. 95FO will operate from Marietta College. SVK has a new all-band mobile rig. Case Tech. Radio Club held a pre-Field Day exercise on Dec. 28th. DAD built a new 100-watt 'phone/c.w. rig for all bands. CACARC will sponsor a 10-meter groundwave contest in April. Toledo's *Shack Gossip* reports that HN is considering s.s.b.s.c.; FBT and family are vacationing in Florida; FDK finally has gotten up a new antenna; and newly-licensed YL operators are MAD and MBL. WRL secured our Governor's message for the 7th ARRL Governors-to-President Relay. The O-6, out of Springfield, informs us that EQN has only four countries to go for his WAOC and that CSA and VZM have become addicted to star-gazing. Wonder if their interest lies in astronomy or astrology? The Dayton *R-F Carrier* states that a 14-year-old YL, LNZ, is the most recent licensee in the area. Cincy's *Mike and Key* mentions that PR is operating over DL4FD in Munich; TYM is heading for Salonika; and that the 2-meter boys are burning up the band. The *Queen Listening Post*, the Queen City's other publication, devoted most of its space in the last issue to summarizing what has transpired during 1952. The Columbus *Carascope* failed to appear this month so we'll have to catch up with you fellows in next month's *QST*. It is gratifying to note that traffic-handling was heavy during the holiday season. Keep up with the good work and let's keep the reports rolling in throughout 1953. Traffic: W8FYO 506, DAE 177, UPB 177, LMB 160, DG 123, RO 122, EQN 61, YGR 57, AL 42, RN 23, WAV 21, ZAU 18, QIE 17, AQ 9, AJW 8, PMJ 7, LZE 6, ET 4, MGC 2, ZJM 2.

**HUDSON DIVISION**

**EASTERN NEW YORK** — SCM, Stephen J. Neason, W2ILI — RMs: TYC, KBT, PAMs: IJG, K2CA, IFP has added six new countries to his list of 7-Mc. contacts. MEE has a new multi-element beam on 144 Mc. Frank is active on all bands, including 420 Mc. He also made BPL on originations this month. Sometime in 1936 Dr. Silvern, of Slingerlands, ceased to toy with ham radio and took up the fine art of earning a living. Now, one war and 16 years later, he is on the air as KN2BNI. He is active on 3714 and 3745 kc. with 72 watts input to a 1625. Dr. Silvern and his XYL will take the exam for General Class license soon. The Ladies' Auxiliary of the AARA held an FB Christmas party for the benefit of the general membership. APF is Advanced Class and is operating on 3.8, 28, and 144 Mc. OVV has been discharged from the Marine Corps and again is active on 3.8 Mc. Bob has plans to use single sideband soon. NYS meets on 3615 kc. Mon. through Sat. at 7 P.M.; Mon. through Fri. at 10 P.M. NYSB is on 3595 kc. at 8 P.M. daily. NYSBPN is on 3980 kc. at 6 P.M. (temporarily) daily and 8:30 AM. Sunday. Please give your cooperation to these nets; your help is badly needed. 25J has a new terminated folded dipole. 4RE now is located in Loudonville and is active in NYSBPN. A family get-together party was held by the RWARS. A Viking I was presented to NCC for Christmas by his many friends in the section. BKH has a new rig with an 813 final running 200 watts on 3.8 Mc. All applicants are requested to check their endorsement dates and to make regular monthly reports to avoid cancellation. Endorsement: EFU as QRS. Traffic: W2TYC 228, MHE 155, EFU 53, ILI 33, IFP 25, APF 19.

**NEW YORK CITY AND LONG ISLAND** — SCM, George V. Cooke, jr., W2OBU — Ast. SCM, Harry Danals, 2TUK, SEC: KTF, RM: VNJ, PAM: YBT. Using the call 2NSD/2, the Vim-Hallcrafters traffic station cleared more than 2000 messages via RTTY to the following stations: VNJ, BFD, QGH, MXJ, PAT, AEE, BO, EC, GP, and IVS. For this work VNJ, BO, EC, and IVS received BPL certificates. AEE and IDK also earned BPL with an assist from other traffic. New officers of the UHF Club for '53 are as follows: ZPG, pres.; OBH, vice-pres.; PQO, secy.; OKX, treas.; and DKH, FLIRC delegate. BZQ and CXF, brothers, now are at Duke University. BQM was re-elected president of the Lake Success Club with TNI, secy.-treas. and OBU, station trustee, YKQ. The Tu-Boro Club's election resulted as follows: YSM, pres.; HVD, vice-pres.; JSV, corr-secy.; IAG, fin. secy. The Astoria Radio Club's election wound up with AKE, pres.; AIQ, vice-pres.; KQC, secy.-treas. The Club operates a net on 146.23 Mc. Mon., Wed., and Fri. 1100 and clears traffic through RTTY circuits to Southern chain of RTTY stations. KQC has accepted OBS for net circulation. K2ACM made and presented the New York Radio Club with a mahogany gavel. CID and AMB are basking in that Florida sunshine. GTQ is the New York Club's most faithful member, having sent in his dues all the way from Pakistan. K2BAH, IBY, AXR, BMK, and AXS are the newest members of the Trylon Club and the Club is setting up a 2-meter station in the Jamaica Red Cross Building operated by AREC members. FDP is the proud daddy of a new jr. operator. Two new officers

(Continued on page 88)



# YOU CAN'T REPLACE EIMAC QUALITY



*Eimac*  
RMA 4D21  
**4-125A**  
MADE IN U.S.A.

## TYPICAL OPERATION

(Frequencies below 120 mc.)

Radio Frequency Power Amplifier and  
Oscillator Class C Telegraphy or FM  
telephony (key down conditions, one  
tube)

D-C Plate Voltage	2500 volts
D-C Screen Voltage	350 volts
D-C Grid Voltage	-150 volts
D-C Plate Current	200 ma.
Driving Power	3.8 watts
Plate Power Input	500 watts
Plate Dissipation	125 watts
Plate Power Output	375 watts

Write our Amateurs' Service Bureau for a free copy of the information filled 28 page booklet, "Care and Feeding of Power Tetrodes".

\*An Eimac trade name

Quality screen-grid tubes became popular eight years ago when Eimac introduced the 4-125A radial-beam power tetrode to the electronic industry. Since that time thousands of engineers and amateur radio operators have used the Eimac 4-125A in a wide variety of applications and have consistently received outstanding, dependable performance. This versatile tetrode contains the *pyrovac*\* plate, controlled emission grid wire, low inductance leads, thoriated tungsten filament, and input-output shielding. All of these advanced features are found only in Eimac tubes. Add to this, high power output with low driving requirements, simple circuit design that minimizes TVI, low grid-plate capacitances, and ability to withstand heavy momentary overloads, and you have the Eimac 4-125A — quality tetrode in the 125 watt field.

**EITEL-McCULLOUGH, INC.**  
**San Bruno, California**

Export Agents: Frazar & Hansen, 301 Clay St., San Francisco, California

*Eimac*  
TUBES

# TWIN-LEAD folded dipole



## Buy the kit and assemble your own HAM ANTENNA

Tested—tried and proven components from which to build your HAM ANTENNA—complete with full instructions for assembly. Build for permanence and performance with quality components.

complete kit... {

- 2 lengths of #16 copper-clad steel conductor twin-lead—cut to band length.
- 1 75-foot length of standard 300 ohm twin-lead for lead-in.
- 1 high strength laminated "T" block.

Assembly and installation instructions.

Cut to 10, 20, 40 and 80 Meters

We all strive for the best in transmission and reception characteristics—now with the Amphenol Amateur Antenna Kit you are assured of the *BEST*. Designed by electronics engineers for the most efficient service.

amateur net as low as  
**\$535** for 10 meters

see your **AMPHENOL**  
radio parts distributor

AMERICAN PHENOLIC CORPORATION

of the Radio Society of Queens are FJF, pres.; and EZJ, secy., and the Club is on the way toward League affiliation. The Queens Radio Amateurs elected GXC as its new president and held its annual dinner and dance in Forest Hills. IVU has been appointed ORS and WDT received OPS certificate. TUK has received MARS call AF2TUK and was active in the January V.H.F. Contest. ADO worked YU1AD and PA0TAU on 3505 kc. using Viking I. Look for KDO on 220 Mc. with his new rig. YBT now is operating on 2 meters with a new rig. PF/A2PF has gone s.s.s.b.-minded, built up an exciter and wrote a fine article on the subject for *MARS Bulletin*. DIC is on 144 Mc. again and put up an antenna for 21 Mc. IRK passed Class A exam and now runs 500 watts instead of 50. What good is it now? Traffic: W2BO 2373, VNJ 1749, AEE 942, IVS 667, EC 415, IDK 316, LPJ 214, ADO 210, GP 182, JZX 117, GXC 92, DIC 48, LGK 33, UXY 24, PF 21, IN 20, OBU 19, BQM 16, KYN 11, JXM 5, IVU 4, YBT 4, OJX 2.

**NORTHERN NEW JERSEY**—SCM, Lloyd H. Manamon, W2VQR—Asst. SCM, D. Reid, 2FMG. SEC: NKD. RMs: WCL and NKD. PAM: CCS. The Raritan Valley Radio Club started its twenty-sixth year with large attendances at business, technical, and social meetings. CUI used the facilities of the New Brunswick USO Club to originate a record high traffic total of 681 messages for December, making BPL. Here is a new type wrinkle which could be used by all of us at our local USO clubs. AJB is studying v.h.f. antenna designs. UK is planning a kilowatt for 144 Mc. HIA is busy with net traffic. Zone 5 stations are completing 220-Mc. c.d. equipment. DAS is the first licensed Civil Defense OPS, OPS, and EC in New Jersey. Dumont has a new ham in K2BPD. EWZ, ORS, is working Eastern Shuttle Net on 7120 kc. at 10:30 P.M. CVF is new OPS. CCS is doing a fine recruiting job as PAM. FMG played an important part during the recent search operations for a crashed Navy plane near Absecon, N. J. Northern New Jersey welcomes back 2COK, formerly 4COK and VP7NV. Bill is one of our leading DX men; his new QTH is 42 McLaren Street, Red Bank. Your SCM attended c.d. meetings in Bridgeton, Camden, Atlantic City, Dover, Jersey City, West Orange, Westfield, Paterson, and Clinton during the months of December and January. Amateur participation in the AREC-RACES program is excellent throughout the State. GVZ, OO, reports 19 Form 10 notices sent out during December. ZT is the only station reporting to date on the Nov. 17-18 Frequency Measuring Test. Let's have more activity among the OOs in this respect. GUM is back from a trip to Phoenix, Ariz., and now giving COK competition for DX honors. ENM, Area 9 Radio Officer, attended a district c.d. meeting at the home of ZI, Trenton, on Jan. 10th. DME is snooping around 21 Mc. with his 32V-2. MWW visited FCC recently, coming home with an Advanced Class ticket. KBI is hard at work on a new vertical for 40 meters. EGM is doing an excellent job in c.d. communications for Toms River Council. ZKS reports a new Bill going to the N. J. Legislature for call-letter license plates for New Jersey. We all appreciate the fine work ZKS and his committee have done in getting this new Bill lined up. NIE is pulling the dust covers off his 100THs in anticipation of 40-meter 'phone. The section is sorry to lose ZBY, who has accepted employment with the General Electric Co. in Schenectady, N. Y. CVF has taken over the duties of Area 1 CD Radio Officer, vacated by ZBY. Traffic: W2CUI 681, WCL 359, CCS 246, EAS 124, EWL 72, K2BCK 37, W2GVZ 37, EWZ 30, HIA 17, DAS/NCY 15, CJX 4.

### MIDWEST DIVISION

**IOWA**—SCM, William G. Davis, W6PP—Traffic looked up this month with SCA and BDR hitting new highs. The Indians got BDR, but he is getting an edge on 'em. CZ sends in his second traffic report since he got his license in 1915. LCX is looking for ORS appointment again after several years' lapse. QVA reports that LAC visited his son in West Virginia during the holiday season, and that the Iowa-Illinois Amateur Radio Club now meets in the Naval Reserve quarters. New stations on TLICN are EZS, FMZ and IFX. TLICN mourns the loss of HSW, a new member of TLICN, who recently passed away. AUL has a new 75A-2 and a Lyseo antenna coupler. NWX now reports on the Iowa 160 'Phone Net. NYX reports that PTL has been hospitalized. VRA reports on the activities of the AREC and things are looking up in that section, with good activity reported from Des Moines, Cedar Rapids, and Sioux City. Remember, fellows, it's nearly time to elect an SCM. Look well to the interests of the hams in the Iowa section and nominate the one you think can serve the best. The job needs new blood, new fire, new drive, and new and constructive ideas. Exercise your privilege of nominating someone who, in your opinion, will best serve. I wish to thank you fellows for the cooperation you have given me during my years as your SCM. Traffic: W0SCA 1265, BDR 773, CZ 172, YBV 170, LCX 168, QVA 164, YTA 141, PZO 88, BRZ 76, NYX 29, BQJ 24, BLH 16, ERP 12, SEF 2, LPH 1.

**KANSAS**—SCM, Earl N. Johnston, W0ICV—SEC: PAH. RM: KNL, PAM: CIK. The Eldorado Amateur Radio Club held a novel business meeting Nov. 27th on 160  
(Continued on page 90)

# Viking Mobile Now Being Delivered to Johnson distributors In Volume

**GREATER POWER  
INSTANT BANDSWITCHING  
100% MODULATION**

Another outstanding JOHNSON transmitter kit . . . the Viking Mobile! All stages metered and gang tuned . . . instant bandswitching, 100% modulation, sufficient audio gain for either high impedance or carbon microphones. Designed for maximum output on 75, 20 and 10 meters, the Viking Mobile is provided with a four position crystal selector switch, permitting 15 meter or other special frequency operation. Maximum PA input: 60 watts at 600 volts; up to 30 watts with only 300 volts. Under-dash mounting—all controls readily accessible and visible. Chassis may be quickly removed from cabinet without disconnecting power cables. In assembly, meter and crystal selector switch positions may be reversed for either right or left side mounting.

Several power supply options permit using any six volt power equipment, however, the Viking Mobile kit may be obtained with a complete 500 volt, 200 ma. dynamotor power supply capable of delivering 50 watts amplifier input. Exclusive in the Viking Mobile is its RF type bias supply for the final amplifier and modulator. Primarily for improving overall efficiency by reducing modulator idling current, it eliminates cathode bias, thus conserving full plate voltage. May be used with an external VFO without further modification.



AMATEUR NET

**\$99.50**

**Cat. No. 240-141—Viking Mobile Kit, less tubes, crystals, microphone, power supply, accessories**

**Cat. No. 239-102—Dynamotor supply including base completely assembled, price on request**

#### TUBE LINE UP:

6BH6 Oscillator  
6AQ5 Buffer/doubler  
807 Power Amplifier  
6BH6 Speech Amplifier  
6BH6 Driver  
807 pp Modulator  
12AU7 Bias Oscillator

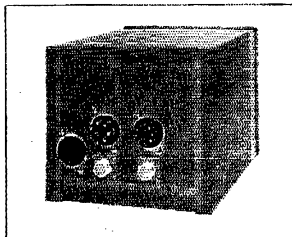
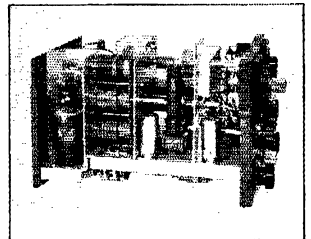

#### RECEPTACLES:

VFO RF input coaxial connector  
RF output coaxial connector  
Octal female VFO power receptacle  
Male octal power and control cable  
Male 7 prong receiver disabling, antenna and power transfer cable  
Microphone



## E. F. JOHNSON COMPANY

CAPACITORS, INDUCTORS, SOCKETS, INSULATORS, PLUGS, JACKS, DIALS, AND PILOT LIGHTS

210 SECOND AVENUE SOUTHWEST • WASECA, MINNESOTA

**OUR OWN "SY" DENBY - W2BNW**  
(OLD "BOLTS, NUTS & WASHERS" HIMSELF)

Says...

**I'M READY  
for  
40 METERS  
ARE YOU?**



**6 MFD  
1500 VOLT  
OIL-FILLED  
CONDENSER**  
ONLY **\$2.49**

**PR XTALS for 40 Meters**  
NOVICE XTALS  
7175 to 7200 Kc  
PHONE BAND XTALS  
7200 to 7300 Kc  
each **\$2.75**

**B&W 40-Meter Coils**

Type Baby  
M, MC, MEL, MCL, \$1.23 Ea.

Type J  
40JEL, 40JCL, .....  
40JDL ..... \$1.62 Ea.

Type B  
40B ..... \$2.14 Ea.  
40BEL, 40BCL ..... \$3.32 Ea.  
40BDL ..... \$2.68 Ea.

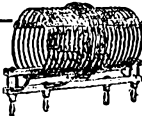

Type T  
40T ..... \$2.26 Ea.  
40TCL ..... \$3.88 Ea.  
40TVL ..... \$3.06 Ea.

Type HD  
40HD ..... \$4.85 Ea.  
40HDLC ..... \$8.08 Ea.  
40HDVL ..... \$6.47 Ea.

**TERRIFIC TUBE BUYS!**

1625	24¢	6V6GT	.80
1626		12AU7	.96
1629	each	12AT7	1.16
183	\$1.02	25T	3.95
1R5	.80	35TG	4.50
1T4	.84	100TH	8.95
1U4	.84	250TH	22.50
3V4	.80	805	4.25
5U4GT	.60	807	1.75
5Y3GT	.44	811	2.95
6AG5	.90	813	9.50
6AL5	.72	814	2.75
6AU6	.72	815	2.75
6BG6G	1.92	826	.75
6AQ5	.80	866A	1.25
6SN7GT	.88	1619	.35

**COPPERWELD #14  
ANTENNA WIRE**

Won't Stretch!  
  
Per 100 Ft. **\$1.43**

**KW 300 - OHM TWIN  
LEAD**

.185 Web. All Weather,  
extra heavy, all fresh. New  
low price. \$5.85 per 100 ft.  
Per Foot **6¢**

**20 AMP PORTABLE METER**



Brand new 20 Amp AC movement, set into a 4" fixed or portable case. 2 pointers red reads current, black records highest reading until reset to zero. Connecting terminals under removable name-plate. Provisions for hanging, or for permanent installation. A terrific buy! 6" high x 5" wide x 2 7/8" deep. Shipping weight 2 1/2 lbs.

Stock No. 99-A-AD120 ..... \$2.49 each

MINIMUM ORDERS \$5.00

**Concord Radio**

55 Vesey Street, New York 7, N. Y.

Phone DLgby 9-1132



meters, with TDW, president, at the helm. ONI, EHV ECD, FZB, HPE, and BVP participated. JTH is a new comer in Eldorado and operates on 75-meter phone. ECD has a new S-76 and operates on 160 meters with a Viking I. The Central Kansas Radio Club of Salina held its annual banquet January 7th with new officers, PKD as president and STC as secretary-treasurer. Director Schmidt, OZN, our SEC, PAH, and ICV were guests of Vice-Director McKim, MVG, and the Club. Impromptu talks were given by the guests of honor, Chief Salmans of local police, and MVG, FHC, of Great Bend, is a new AREC member who has an FB emergency outfit, which consists of 60-watt 1.8-2-Mc. rig, 10-meter converter and 1.5-kw. power unit. WGM, of Topeka, is new EC for Shawnee, Osage, Lyon, and Wabaunsee Counties. From reports received IUB, of Wichita, is one of our section's most active OOs. We need more OOs, fellows. If interested, drop me a message or card. GCU, of Oakley, visited with AHT and ICV recently. HAW keeps skeds with EZT/6 on 40 meters and is getting new ECO soon. ORR is starting on new 10-20 TVI-proof rig. WN0MOU and MPB, LHX's XYL, are new calls in Sabetha. FSE is putting that new Globe King to work on QKS and Nebraska nets. CTQ has a new mobile on 75 meters. Traffic: W0NIY 316, BLI 296, YFE 150, BET 123, PDJ 54, WGM 30, KSY 22, WMQ 22, ICV 20, FSE 12, GHR 12, GCJ 10, RUF 7, LIX 7, KEN 6, VBQ 8, EBB 5.

**MISSOURI**—SCM, Clarence L. Arundale, W0GBJ—At the recent Midwest Division Convention, HUI was elected temporary secy-treas. of the Federation of Clubs in the Midwest Division. A 2-meter f.m. net on 147.3 Mc is being organized in the St. Louis Area and old taxi-cab and police equipment is being used extensively. K0WBD has been having trouble with his transmitter. CKQ is off the air at present with receiver trouble. CPI is trying to eliminate TVI from the 310B-1. OUD now is using a long-wire antenna. IQY and CXE participated in the recent F.M.T. BYH is QRL with studies at Mo. U. CZE, VRR, and LLU have their new Adv. Cl. tickets. WN0MRQ wants to contact those interested in 2 meters. ARH received a new grid-dipper for Christmas. VWN is active with traffic. QMF is building a 2-meter beam. BVL reports the Early Bird Net averaged 17.5 messages per net session. New AREC members: W0CMZ, MNP, and W0LLUW. MEN operates on 3900 kc. Mon., Wed., and Fri. at 6:30 p.m. IJS is new traffic station in St. Louis, having moved from his former Ohio QTH. Skip is causing difficulties for QXO on some of his schedules. ETW is building modulator for 40-meter phone. Heavy December Traffic has earned BPL certificates for CFI, QXO, JXJ, and BVL. LF soon will be on all bands looking for traffic. WN0MRV operates from St. James. The SMARC elected the following officers: BYG, pres.; ICV, vice-pres.; CGJ, secy.; WN0LQC treas.; and GJZ, act. mgr. Traffic: (Dec.) W0CPI 1150, QXO 1023, JXJ 753, BVL 623, GBJ 253, CXE 173, IQY 104, GAR 100, IJS 94, LFL 64, ZLN 63, CFL 60, HUI 55, K0WBD 49, W0KIK 44, VWN 35, EBE 34, OUD 25, ETW 18, AZL 11, BUL 11, TGG 7, QMF 6, JEJ 4, WIS 3, CZE 2, CKQ 1. (Nov.) W0WIS 11.

**NEBRASKA**—SCM, Floyd B. Campbell, W0CBH—The North Platte Amateur Radio Club held its first Annual Banquet with 36 OMs and XYLS reporting in to the president, PGA and COU and XYLS were guests, and the opinion of all was to make the next bigger and better. EKP now is OBSING the Official Bulletins on Mon., Wed., and Fri. at approximately 7:00 p.m. New officers of the Ak-Sar-Ben Radio Club for 1953: QHG, pres.; NKG, vice-pres.; AQJ, secy.; JKE, treas. The Baker Section for Nebraska MARS Net is on 4080 and 2220 kc. with FMW as Net Control. LJO, NCS for c.w. net, reports FVD, IXL, RDN, THF, and ZAA as new members. The c.w. net now has a total of 142 members. WN0MAO is the first Novice from whom I have received a report. How about some of you other WNs sending your traffic report and station activities? TQD now is using low power on the c.w. net. ATU now is on R.F.D. route at Hershey, Nebr., with the antenna space wanted by all of us. AIN is on Nebraska C.W. Net, TEN C.W., Nebraska 75 Phone Net, and 20 meters daily. Besides all this Don takes incoming KA traffic from 61AB and twice weekly ragchews with 5HSA. Don lacks confirmation from Africa for WAC. FQB reports a new 24-hour clock for bigger and better times. He also is a member of TLON, Nebraska C.W. Net, and TEN. Traffic: (Dec.) W0TQD 5015, FQB 100, AIN 67, VYX 60, ZJF 59, SAI 56, CBH 22, KDW 22, AUH 13, FMW 12, YMU 11, EKP 10, YSK 9, BUR 8, HXH 8, WN0MAO 7, W0BEA 6, BJF 6, CC 6 UVU 6, GPX 4, IAY 4, THF 4, ZNI 4, LEF 3, VPR/M 3, UVQ 2, YWK 2, COU 1, HWM 1, VBJ 1. (Nov.) W0AUH 12.

**NEW ENGLAND DIVISION**

**CONNECTICUT**—SCM, Roger C. Amundsen, W1HYF—SEC: LKF, PAM; FOB, RM; KYQ, CN-3640, CPN-3880, CEN-29,680 kc. ADW reports that Danbury c.d. station VVA will be active shortly. IJ is marking his 29th year in hamdom and is busy with c.d. also. UNG plans 40-meter phone and a.s.b. TD still needs skyhook. NBP was laid up for ten weeks but is OK again. CUH has a new long wire. LV moved to: 110 Grove St., Naugatuck. BDI is

(Continued on page 92)

# MALLORY HAM BULLETIN

## Transmitter Bandswitching With The Mallory 160C Series Ceramic Section Hamswitches

Most of us will agree that bandswitching in a transmitter is a very desirable convenience which adds infinitely to our operating enjoyment. Even so, for one reason or another, most of us still operate rigs which require a bushel basket of plug-in coils to change from one amateur band to another.

Many Hams have avoided incorporating bandswitching in their rigs simply because they believed that bandswitching was inefficient, was difficult to build, or was too costly. Actually, though, none of these things are true, if a few simple precautions are taken when planning a bandswitching transmitter. Bandswitching can be made as efficient as plug-in coils, almost as simple to build, and inexpensive in relation to the benefits derived.

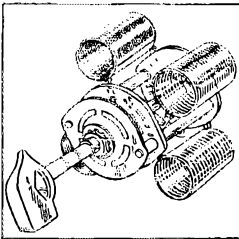

In planning a bandswitching rig, the bandswitch itself is the most important single component in the system. A little time spent in selecting the correct switch for the circuit involved will pay dividends. Be sure to get a switch with good ceramic insulation, high grade self-wiping silver contacts, and with sturdy lugs positioned so that the coils may be mounted directly on the switch. The Mallory 160C series of Hamband switches fill these qualifications to a "T" and are highly recommended for use in transmitters up to 100 watts of power. Figure 1 shows a suggested arrangement of coils on one of the Mallory Hamband switches.

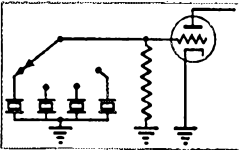

There are 5 basic circuits generally used in transmitter switching, and there is a Mallory 160C Hamband switch designed especially for each of these 5 circuits.

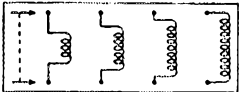

**CIRCUIT 1** is usually used for crystal switching, but may be adapted for individual stage switching. Mallory Hamswitch 161C is required.

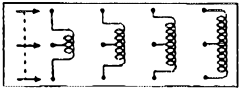

**CIRCUIT 2** requires Hamswitch 162C and is used where capacitive coupled coils must be switched.

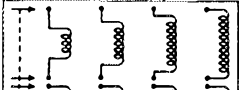

**CIRCUIT 3** incorporates Hamswitch 163C in transmitter plate circuits where neutralizing taps are found on the coils.

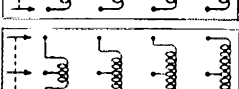

**CIRCUIT 4** permits simultaneous switching of tuned, untapped coils and associated links. Switch 164C is required.

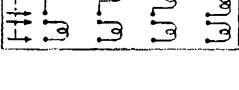

**CIRCUIT 5** permits switching an interstage link or antenna coupling coil simultaneously with the tuned coil of a neutralized stage.

There you have it! Not much to bandswitching, when you have the Mallory 160C series of Hamband Switches. When you buy them, you'll find a complete instruction sheet packed with each switch which will elaborate on the above brief suggestions.

Your Mallory Distributor will be glad to show you any of these switches, or any of the hundreds of other precision Mallory parts you need to make your rig better.

P. R. MALLORY & CO., Inc.  
INDIANAPOLIS 6 INDIANA

P. R. MALLORY & CO. Inc.  
**MALLORY**

# BA... HAS THE VALUES!

## 75 AND 80 METER CRYSTALS

IN REGULAR FT243 HOLDERS

**79c**

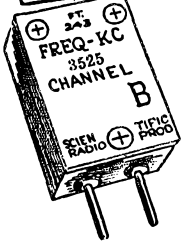

First quality guaranteed active oscillators made to Signal Corps specs. ... every one brand new and tested! Better get plenty while available. ... we doubt this lucky buy can be repeated.

Available in following frequencies:

- 3525 KC No. 15A1173
- 3655 KC No. 15A1174
- 3700 KC No. 15A1176
- 3735 KC No. 15A1177
- 3980 KC No. 15A1178

CHOICE EACH  
**79c**

You can easily change frequency if necessary by following crystal grinding instructions in any handbook.

Assortment of 4 Crystals—Our choice from above.

No. 17B818. Per Aast..... **\$2.45**

## POWER SUPPLY KIT 110 VOLT FILTERED DC at 40MA

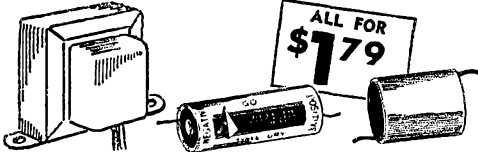

Here at a Big Saving you get Top Quality basic components for a Power Supply with many applications. ... for Mike or Phono Pre-Amp, Midget Radios or Audio Amplifiers, Photo Cell equip., Garage Door Openers, Code Practice Oscillators, TV Boosters, Test Equipment, etc.

Kit consists of a compact, fully enclosed Power Transformer, pri: 117 V. 60 cycle AC 110 V @ 40 MA. H.V. Sec., and 6.3 V @ 1 amp. for filament. A 35 MA-130 V. Selenium Rectifier and a 16 Mfd-150 V. DC wkg-225 V. peak electrolytic Filter Condenser ... both very compact and easy to mount with the tinned wire leads. Wt. 1 1/2 lbs.

You Get All Above  
No. 14B993. PER KIT..... **\$1.79**

## HI-SPEED COPE-SAW DRILL-BIT

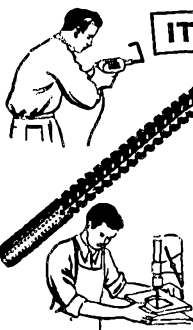

IT SAWS! IT REAMS!  
IT DRILLS!

**\$3.75**

Drill, saw, ream metal, wood, plastic, etc., with any electric drill. Drills own starting hole—upper part cuts, saws or reams circles, ovals, squares or scrolls. Abrasive resistant high speed steel. Withstands severe continuous use. 1/4" dia. x 3 1/2" long. Has two cutting sections.

No. 19B270..... **\$3.75**

INCLUDE ALLOWANCE FOR POSTAGE—ALL OVERPAYMENTS WILL BE REFUNDED



FREE!  
BIG 1953  
RADIO  
CATALOG

See the 148 Page B-A Catalog No. 531 for Many More Values! Write us if you don't have it.

## BURSTEIN-APPLEBEE CO.

1012-14 McGEE ST. KANSAS CITY, MO.

building 4-250A rig. APA moans about conditions. EMF saves high power for week ends and uses TBS-50D during the week. UDW got Advanced Class license one year after getting General Class. He attends college and is in MARS, too. WNIUVV/1, in Waterbury, a YL operator, is WAS-minded. UZJ is on 160-meter phone. FKQ and SUA have new Advanced Class tickets. MVH is working on s.s.b. rig. The Hamden ARA meets the 2nd and 4th Wed. at Whitneyville Fire Station. 2VMX/1 now is Class IV OO. Renewals: NBP as OPS, TD as ORS, KYQ as ORS, EMF as OBS, OGQ and EMF as EC. Traffic: (Dec.) W1SJO 482, AYC 370, KYQ 177, NJM 154, HUM 122, BDI 115, AW 89, FMF 80, RRF 54, CUH 53, LV 49, FOB 30, HYF 24, NRP 24, LIG 22, RFJ 19, KV 15, NEK 12, QJM 8, UNG 6, BVB 4, APA 2. (Nov.) W1EMF 77, NEK 12.

MAINE—SCM, Orestes R. Brackett, WIPTL—SEC: BYK, PAM: OLG, RM: LKP. The Pine Tree Net operates on 3596 kc. at 1900 Mon. through Fri.; the Sea Gull Net on 3960 kc. at 1750 Mon. through Fri. Well, folks, it finally has come to pass; the Conditional and the General Class have been granted the privilege of voice on both 75 and 20 meters by order of FCC, so it is up to us who are now here to give them all a helping hand in anything that will help them out so as to make things run more smoothly. WYE is on the air with a new ticket and doing a fine job on 10 meters with his 12 watts. TWR has his new Advanced Class ticket and is really having fun on 75 meters. It is with deepest regret that I have to report the passing of one of our very good friends, Lloyd Spiller, who was very active on the c.w. nets and was RM up until the time he joined CAA. His home was at Richmond, Maine. Well, Slinky is out of the hospital and guess he is going to be right back on top in no time flat. OTM has a new baby girl, Ronda, weight 8 lbs. 7 oz., born Jan. 7, 1953. Because of conditions on the 75-meter band the VE and W New Year Party did not turn out quite as well as in previous years in spite of the fact there were 54 stations logged by VE2XO, who was NCS. Most Wis had to be reported by W8s, etc. Better luck next year, we hope. Traffic: W1LKP 291, OHT 140, BX 70, PTL 39, SEJ 22, HXQ 21, AFT 13, RSB 12, EFR 11, QEK 5, SUK 3.

EASTERN MASSACHUSETTS—SCM, Frank L. Baker, jr., W1ALP—Our Eastern Mass. Net is on 3660 kc. at 1900 Mon. through Fri. JCK is RM for this Net. IBE is Rockport EC. Appointees endorsed: LJT Brockton, SH Dedham, IPZ Shirley, STA Haverhill, RRA Winchester, PST Brookline, PYT Ipswich, RSE Whitman, HRY Welleley, BHD Everett, as EC; LJT and JOJ as OBS; RP and RB as OPS; BB, LM, RRP, and PYM as ORS; BHD as OBS; RRP as OO. WKF is new ORS. DD (ex-1PK) and OOI are on 3.5-Mc. c.w. We regret to have to announce the deaths of DJI and NKW. IVI now lives in Lexington. Ex-1QMD now is 3UQV in Philadelphia. UQB and WLW have General Class. Heard on 28 Mc.: FRZ, JXM, TAV, URP, AAU, UOR, JBP, VAG, and OBT. UVY is on 3.9 Mc. QV and WNIUIK are on 144 Mc. TQP has Advanced Class license and a 10-meter beam. K1NAR has 522 on 144 Mc. SWG, now in Quincy, is on 10 meters. WAB now is General Class and building a VFO for 3.5 and 7 Mc. The Welleley Amateur Radio Society had a talk by Mr. Fred Sims, C.D. Director. The Eastern Mass. Club had a talk by Mr. Dellheim of B.U. and a Christmas party at the Smith House. The South Shore Club held a Ham-Radio Forum on TVI with AKY as moderator and a panel made up of WK, IVI, VOI, Mr. Hallenstein, our FCC inspector, and a man from RCA Service Co. The Eastern Mass. Net gang held a get-together in Boston. AVY has a certificate from the Deep Sea Dragnet. BB is busy with 160-meter DX tests and has a new Ford convertible for mobile work. KLC is in Florida until May. AAR and SMO are mobile on 28 Mc. Region 5 committee held its monthly meeting in Cambridge with all Sectors present: 1 DOF and KUC, 2 DFS, 3 KTG, 4 RM and BL, 5 ALP, 6 TQP. WNIWHD, Boston, has a Viking II on 3.7 Mc. The Southeastern Mass. Amateur Radio Assn. elected CTZ, pres.; AVY, secy.-treas.; PWL, vice-pres.; WU, director. The Gypsy Radio Club elected HP, pres.; SIX, vice-pres.; Bob Thornton, secy.; WNIWTK, treas. AWA, our 50-Mc. PAM, reports QY, CLS, CK, LSN, JDD, RO, DJ, NBI, OKY, ADS, ATD, ELP, CTW, THO, LPF, IHA, and DPI got on again. RP has a new VFO f.m. unit. The T-9 Radio Club held a meeting at HMC's QTH in Peabody. WMM is a new member. WNK has his General Class license. BHD, Everett EC, appointed the following as Asst. ECs: PJ, in charge of portable and fixed station activities; KUA, in charge of mobile work. STA has been appointed Sector 1 Region 4 Radio Officer. RSE has been revising his station. AAL is active on 7, 28, and 144 Mc. AWA is new president of Quannapowitt Radio Assn. IBE is active on 7 and 3.9 Mc. The Winthrop Net held a drill with HFJ, DJI, CMW, DJ, OIR, NMX, MQB, SBT, BDU, GGP, LVA, BB, and SSP on. WJZ is building a 5-watt rig. AQE sent his ORS and RM certificates in for endorsement. UTH now is VFO on all bands. SS says they took a 1-kc. crystal out of his gall bladder, so now he is VFO. UXK's XYL gave him a TBS-50. WNIWJD, now in Korea, says most of the hams in Japan use 500 watts. WLZ, a new ham in Brockton, has his General Class li-

(Continued on page 94)

# Rough Treatment FOR A CRYSTAL ...

**BOILED** 5 minutes to prove hermetic seal

**SHOCKED** Thermal-shocked from  $-60^{\circ}$  to  $+95^{\circ}\text{C}$  in 70 seconds

**SHAKEN** Vibrated from 10 to 55 cycles per sec. Stress equivalent to 5G pull

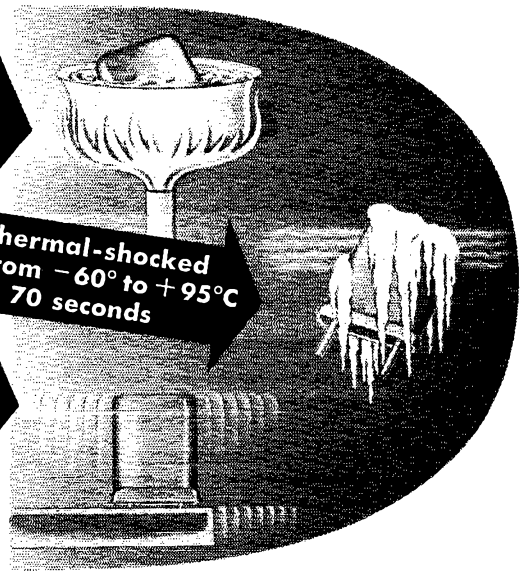

That Kind of testing is just one of the reasons why



## Midland CRYSTALS DO A BETTER JOB FOR YOU

**\*TYPE ML-1A**  
**RANGE:**  
 2.0—15.0 mc  
 Supplied per Mil type CR-1A when specified.

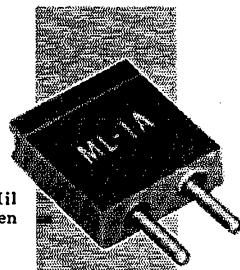

**\*TYPE ML-4**  
**RANGE:**  
 1.0—10.0 mc  
 Supplied per Mil type CR-6; CR-8; CR-10 when specified.

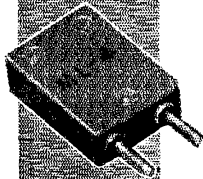

**\*TYPE ML-6**  
**RANGE:**  
 1.4—75.0 mc  
 Supplied per Mil type CR-18; CR-19; CR-23; CR-27; CR-28; CR-32; CR-33; CR-35; CR-36 when specified.

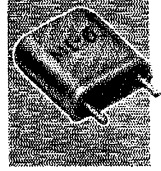

Yes, we get tough with our Midland crystals. You expect best performance, and we make sure you get it when you use Midland crystals for all your frequency control needs. The final test pictured above is just one of many quality checks we make at every step of Midland processing.

**Midland Quality Control** starts with the raw quartz. Using optical viewing equipment of high accuracy, we select only the "cream of the crystal crop." Then, as the crystal proceeds through the various steps of cutting, slicing, lapping, etching, plating, and sealing, it is checked repeatedly to turn up any defect that might develop.

**Stability, accuracy, high output, long life** — name anything about a crystal that makes it a better performer for you, and we guarantee you'll get it in fullest measure with Midland.

*WHATEVER YOUR CRYSTAL NEED—  
 CONVENTIONAL OR SPECIALIZED...*

**When It Has To Be EXACTLY RIGHT...Contact**



**MANUFACTURING CO., INC.**

3155 Fiberglas Road • Kansas City, Kansas

See Us at the Radio Engineering Show, Booth 4-613 Components Ave.

**ALL The World's Finest EQUIPMENT**

*Always in Stock at*

**HUDSON**  
RADIO & TELEVISION CORP.

*New!*

**MODEL 5BR  
MORROW  
CONVERTER**

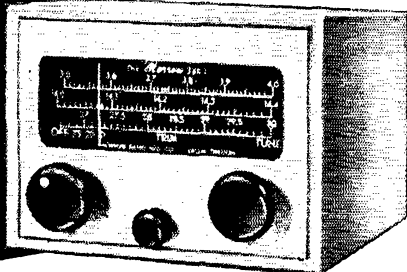

**MODEL 5BR.** High gain superheterodyne tuner for use with auto radios for the reception of 10-11-15-20-40-75 and 80 meters. Features 10 ceramic trimmers with 15 coils, RF amplifiers and mixers to improve image rejection ratio. Built-in series noise limiters and IF amplifiers also insure excellent reception. Slide-rule, edge-illuminated dials. Calibration accuracy, better than 1%. 1525 kc output. Sensitivity better than 1/2 microvolt. MO 3 gang tuning condensers with tuning ratios of 20:1. Separate isolated coils for each band and stage. Antenna trimmers on front panels. Tubes: 6BC5 RF, 12A7T Mixer, 12A7T Oscillator, 6BA6 IF, 6AL5 ANL. Powered by receiver — require 6 volts and 100 volts DC at 16 ma. Size, 4x 5 1/2 x 6 1/2". Wt., 5 lbs.

- Model No. 5BR  
97F117. NET ..... **\$74.95**
- Model 3BR. For 10, 20, 75 meters.  
97F115. NET ..... **\$63.65**

**HUDSON HAS EVERYTHING . . .**

ALL the Newest and Best Buys in Amateur and Industrial Electronic Equipment at **LOWEST PRICES.**

**FREE!** Newest . . . Greatest  
**MOST COMPLETE BUYING GUIDE**

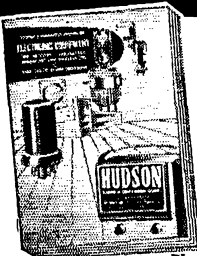

Everything in Electronics at your fingertips. Over 196 pages of the latest and largest selection of Radio, TV and Industrial Electronic Equipment, Ham Gear, Tubes, Test Instruments, Recording and High Fidelity Audio and Sound Equipment. Complete Lines! Wide Selection!

Send for your Copy

*One Call for All!*

**HUDSON**  
RADIO & TELEVISION CORP.

Write or come in and chat with **BOB GUNDERSON**, W2J10 at our uptown store Thursdays. Downtown Sats.

Uptown (Dept. Q-3)      Downtown  
**48 WEST 48th ST. • 212 FULTON ST.**

New York 36, N. Y. • Circle 6-4060 • New York 7, N. Y.  
Open daily, until 6 P.M. Thursdays till 9 P.M.

cense and an Eldico TR-75 and SX-24 receiver on 3.5 Mc. AYG is mobile on 28 and 1.9-3.9-Mc. 'phone/c.w. WN1WYI is on 144 and 3.5 Mc. in Brockton. WN1WNF is building rig for 3.5 Mc. KMS and WN1WMH are on 3.5 Mc. UG has a 266' flat-top antenna. LVN has a new QTH in Falmouth. SXD, RM, NAV, QZD, and QD are on 50 Mc. FUR has his beams up again. EK has a new converter for 50 Mc. PRM has new 152-A. PIW is rebuilding 10-meter rig. HXP and JGA are living in New Hampshire. JOW has a new HRO. LMU is rebuilding the rig for 50 Mc. and is on 1.9-Mc. 'phone. Traffic: (Dec.) W1EMG 413, JCK 198, TY 178, NUP 150, MX 133, FTH 82, SS 60, UTH 53, LM 50, AVY 34, WU 31, BY 28, IBE 15, BB 12, WKF 3. (Nov.) W1FTH 7, CTR 3.

**WESTERN MASSACHUSETTS**—SCM, Roger E. Corey, WIJYH—SEC; KUE, RM: BVR, PAM: RDR. WMN meets on 3560 kc. at 7 p.m., Mon. through Fri.; WMNS at 8 p.m., Mon., Wed., and Fri. New skeds for code practice are: VBG, 6:30 p.m., Tues. and Thurs., 29.5 Mc.; MNG, 7:00 p.m. Tues. and Thurs., 29.5 Mc. VBG sends at beginners' speeds and MNG at advanced speeds. New OPS are BVR and MNG. New ORS is MNG and new OES is RFU. TTL has a new 28-Mc. converter, crystal-controlled, and is now an authority on overtone oscillators. WN1WQN and WN1WQO are new members of the PRC. RFU has heard CJS, Waltham, several times on 432 Mc. and is rushing work on a 4X150-A rig to make it a two-way contact. Wilbraham is the latest town to organize a c.d. net with five members. TVJ is a skiing enthusiast. COI has his N-S rhombic completed and is waiting for warm weather to put up one for Europe. LUJ has a new Viking II and is looking for contacts on 1807.5 kc. after 10 p.m. TRB passed his Advanced Class exam. MUN again measured within 0.1 p.p.m. in the F.M.T. DXW has a new all-band rig using a 3E29 final. OBQ, MNG, BH, GVJ, ERZ, TSF, and WDR gave a shack-warming party for VNH, JLT now is AEW. AZW has finished a new TVI-proof rig. WN1UEY now is WIUEY. OKA exhibited and described his new Viking II at a recent PRC meeting. IZN has modified a Viking I, a la LFI, for 6 meters. HRC is new ORS and OPS. DVW, WEO, WDW, WVC, and WLE are new members of the HCRC. V.h.f. man, RFU, has nine antennas on his roof totalling 124 elements. MUN and RO gave talks for the Worcester Tech RC. New officers of the WTRC are RAN, pres.; 2YAY, vice-pres.; UJQ, secy.-treas.; and RCS, chief operator. It is with deep regret that we report the passing of UD, one of our best-known amateurs. Traffic: W1BVR 110, TVJ 72, HRA 50, MNG 48, TAY 21, JYH 16, AZW 13, OBQ 11, TZV 10, EOB 9, HRC 2, LLN 2, YK 2.

**NEW HAMPSHIRE**—SCM, Carroll A. Currier, W1GMH—SEC; BXU, RM: CRW. I am glad to report that BXU has accepted the appointment of SEC. Speaking of appointments, what say about reading pages 118 and 130 January QST and then getting busy? I have plenty of application forms and certificates. VAU has a four-element beam on 10 meters. AXL has Hy-lite beam on 10 meters and a new 8X-71 receiver. APK represented New Hampshire in the "Governor-to-President Message." Nashua has a husband-and-wife combination in N1WUQ and N1WUS. VGX has new Eldico TR-75TV on the air with an FB signal. Santa brought POK an NC-125. CRW has both kw. rigs working full blast and made BPL again in December. The Port City Radio Club members are working very hard to make the Club one of the best. They have an SX-71 and a new transmitter it is in the making. Attendance at the code classes is most gratifying. The Manchester Radio Club elected the following officers: TXK, pres.; N1WUG, vice-pres.; UNV, secy.; NKI, treas. CDX has his transmitter TVied at last. Thanks for the traffic reports, gang. Traffic: (Dec.) W1CRW 1414, GMH 58, QJX 40, POK 22, JNC 19, CDX 11, FZ 10, AXL 3, VGX 3. (Nov.) W1CDX 6.

**RHODE ISLAND**—SCM, Merrill D. Randall, W1JBR—SEC; MIJ, RM: BTV, PAM: BFB. RIN meets Mon. through Fri. at 1900 EST on 3540 kc. and is looking for recruits. R. I. CD Net meets Sun. at 1000 EST on 3993 kc. A most satisfactory evening was spent with PRA where we looked over—and heartily approved—Q1D's newest 2-meter mobile and where we discovered that ex-WIASZ, former ORS, soon will be back with us. PRA's activity roll-call is an innovation that, with the Club's permission, we are taking for our own. BBN's first harmonic started radiating Dec. 23rd—handle, Edith Louise. Installation of officers at PRA and NCRC took place early in January. GM, BBA, KRC, IF, TYO, PJM, JBB, AMD, BOP, TH, JRZ, QOL, CNZ, ULG, BUX, HOM, JFF, ZV, THO, CFI, BBN, TOL, FZU, GR, AM, AIJ, HDQ, MIJ, BPH, 3ZS, and VP9AV assisted Dr. Krause, of Brown University, in celebrating the birthday of his son, BCR. The Wassail was held at the Tavern in Portsmouth, R. I., on Jan. 5th. A quick glance at the calls of those present will convince the most doubtful Thomas that it was a very enjoyable evening. DHX has moved to Rhode Island from Massachusetts and is on 2 meters. Traffic: W1QYX 82, BBN 30, TGD 25, OIK 20.

**VERMONT**—SCM, Raymond N. Flood, W1FPS—SEC; JEN, PAM: AXN, RM: OAK. Asst. RM: TAN. SPK says the following members of the new Middle-

(Continued on page 96)



## to the **E. E. or PHYSICS GRADUATE**

*with experience in*

## **RADAR OR ELECTRONICS**

*Hughes Research and Development Laboratories, one of the nation's large electronics organizations, is now creating a number of new openings in an important phase of its operation.*



*Here is what one of these positions offers you:*

### **1. THE COMPANY**

Hughes Research and Development Laboratories is located in Southern California. We are presently engaged in the development of advanced radar devices, electronic computers and guided missiles.

### **2. NEW OPENINGS**

The positions are for men who will serve as technical advisors to the companies and government agencies purchasing Hughes equipment. Your specific job would be to help insure the successful operation of our equipment in the field.

### **3. THE TRAINING**

Upon joining our organiza-

tion, you will work in our Laboratories for several months until you are thoroughly familiar with the equipment you will later help the Services to understand and properly employ.

### **4. WHERE YOU WORK**

After your period of training (at full pay), you may (1) remain with the company Laboratories in Southern California in an instruction or administrative capacity, (2) become the Hughes representative at a company where our equipment is being installed, or (3) be the Hughes representative at a military base in this country—or

overseas (single men only). Compensation is made for traveling and for moving household effects, and married men keep their families with them at all times.

### **5. YOUR FUTURE**

You will gain all-around experience that will increase your value to the company as it further expands in the field of electronics. The next few years are certain to see a large-scale commercial employment of electronic systems—and your training in the most advanced electronic techniques now will qualify you for even more important positions then.

### **HOW TO APPLY**

If you are under thirty-five years of age, and if you have an E. E. or Physics degree, with some experience in radar or electronics,

write to:

## **HUGHES**

**RESEARCH AND DEVELOPMENT LABORATORIES**

*Scientific and Engineering Staff*

CULVER CITY, LOS ANGELES COUNTY, CALIFORNIA

*Assurance is required that relocation of the applicant will not cause disruption of an urgent military project.*

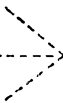

See Your  
**RAYTHEON**  
**TUBE SUPPLIER**

About these...

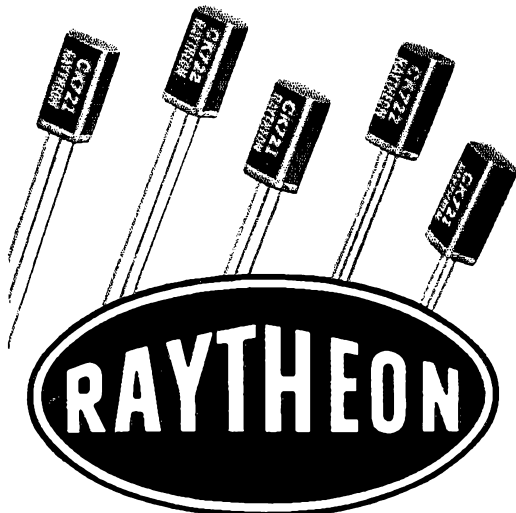

**PNP JUNCTION**  
**TRANSISTORS**

He has new Raytheon Transistors *in stock* and will be happy to fill your orders or give you complete operating and performance facts. Be the first to try Transistors on your pet projects and experiments.



*Excellence in Electronics*

**RAYTHEON MFG. CO.**

Receiving Tube Division  
 Newton 58, Massachusetts

RELIABLE SUBMINIATURE AND MINIATURE TUBES  
 GERMANIUM DIODES AND TRANSISTORS  
 NUCLEONIC TUBES

RECEIVING AND PICTURE TUBES • MICROWAVE TUBES

bury Mike & Key Club are now on the air: WNIWOC, WNIWOD, WNIWOF, WNIWOG, WNIWOH, WNIWIS, WNIWPT, WNIWPU, WNIWPZ, WITFB, and WISPK. JLZ is experimenting with bedspring antenna on 40 meters. AVP is recovering slowly. Good luck, Bill. OJM has a new folded dipole on 75 meters and uses a Pratt coupler. VVO says all antennas were downed by storm. VVI ditto, plus receiver trouble. TXY is working out well on 75-meter phone. NLO and JEN helped out at K1NAG during emergency operation "Snow Fall." Congratulations to all who participated. Much excellent work was done and a lot of experience gained. December traffic totaled 884 messages. Traffic: WIOAK 292, RNA 178, NDB 104, K1NAG 85, WISPK 49, IT 41, ELL 32, FFS 24, BJP 19, ANN 18, PTB 15, TXY 11, JLZ 6, OJM 6, DAQ 4.

**NORTHWESTERN DIVISION**

**IDAHO** — SCM, Alan K. Ross, W7IWU — Grangeville: KOG writes that he is being transferred to Coeur D'Alene sometime in March. Kellogg: WN7RWW reports that a fine club is going called the Shoshone Amateur Radio Club. Officers are HIQ, pres.; IIXN, treas.; WN7RWW, secy.; EQM and QFS, trustees. Lewiston: FRM left KRLC for the radio and TV business with CGJ. OWA has his own music and instrument repair business now. JWJ, from Pullman, is chief engineer of a new b.c. station. IDZ finally received a QSL from Delaware and now is waiting for WAS certificate to arrive. Meridian: MKS now is on 20-meter c.w. and phone, and worked KJ6AX, Frank Kinnison, an Idaho boy. Boise: A special meeting held in Boise elected MKS to head up the RACES program for Col. Doddridge, State C.D. Director. Traffic: W7NH 255, OOW 58, TCI 30, MKS 18, FIS 5, IDZ 1.

**MONTANA** — SCM, Edward G. Brown, W7KGJ — The Billings Club held a drawing on the mobile equipment donated by the Billings Police Department which consisted of 8 fixed receivers and 6 transmitters. Those drawing transmitters were CT, KJL, FIN, KGJ, FKW, and PLN. WN7RSJ, WN7RSI, and WN7RSR are planning to go up for their General Class tickets. WN7RSJ is building a new VFO for his TR-75TV. New calls in Harlowton are WN7SVY, WN7SWE, and WN7SWL. CT and KGJ have completed their shunt Select-O-Jects and say they work very satisfactorily. OJM has his mobile rig installed in his car and is experimenting with antenna loading coils. The Harlo Radio Club now is affiliated with ARRL. Net Manager CT reports net activity has hit an all-time low for this time of year. LCM has his 10-over-20 beams up but still needs the feed lines installed. Traffic: (Dec.) W7JDZ 26, WN7RSJ 2, (Nov.) W7CT 10.

**OREGON** — SCM, J. E. Roden, W7MQ — ONM makes BPL again with a total of 1546, almost all of it overseas traffic for the boys in Korea. She is to be commended very highly for her untiring efforts in this work. LNG reports new officers for the coming year for the Rogue River Valley Radio Club are as follows: HLF, pres.; LNG, vice-pres.; Norman Face, secy.; RE, treas. GDV reports his activity as traffic-handling on RN7. EDU reports activity on AREC in his community and is to be found mostly on 10 meters. GNJ is sparkplugging the Oregon amateurs into getting behind his efforts to put through the amateur license plates for Oregon amateurs during this session of the Legislature. Traffic: W7ONM 1546, HDN 148, GDV 25, MQ 13, EDU 2.

**WASHINGTON** — SCM, Laurence M. Sebring, W7CZY — RM: FIX, SEC: BTV, PAM: NRB. OOF has new SX-71, Viking II, and VFO. PQS rebuilt the rig. The Spokane Radio Club held its annual banquet. FWD handled the origination of the Governors-to-President Relay message. PUL made Advanced Class and 30-w.p.m. C.P. certificate. AWP has been ill. HRC completed new Viking from kit. IHJ made Advanced Class. DND also is on 75 meters. PXA has a ham station in TV store. RFP worked LU4. PCV and MS have new Elmac transmitters. PGY and others on Puget Sound have a traffic net on 29.1 Mc. On the BA/OEX team, BA takes record traffic and OEX the phone patch. CO is mobile again in new Ford. PBE has a kw. on 20 meters. DRA, from Nicosia, Cypress, passes along the information that the local hams are in dire need of parts. OE put up 40-foot mast and improved signals. LVB, PGT, and JEH are on 2 meters. PYV completed new final using 6146 tube and reports much improvement in signal reports. KTL moved to Oregon. JJK passed Extra Class exam. MICU is stationed at Astoria, Ore. HMQ has VFO for emergency use. PHF was home on furlough from Keesler AFB. PXY is MM on tugboat. IYU broke a piston in his Mercury and says that it attenuates his night life. PVP was home on furlough. PRF is with C.A.A. in Alaska. HCJ is building a new home with a large ham shack. NDZ moved to Spokane from Moscow. NXN has a new 32V-3, HZQ, OIH, NZP, and PXA have de-TV'ed their rigs. FLQ has new Viking II. RBG is operating mobile with TBS-50. ORK represents Whidbey Island on 160 meters. FXN is on 10 meters from Burlington. SHH is active at Arlington on 10 meters. AJ and NDZ spend their time on 20-meter phone. ORL is building a kw. OHW is active on 4) and 10 meters. QHB has a new beam. Traffic: W7IOQ 2074, BA 793, CZX 461, FIX 318, TH 155, AWC 145, PGY 135, PYV 132, FRU 111, KCU 69, AIB 48, OE 36, EVW

(Continued on page 38)

# TRANSISTORS

## ARE IN STOCK

FOR IMMEDIATE DELIVERY  
IN ANY QUANTITY...

## AT RADIO SHACK!

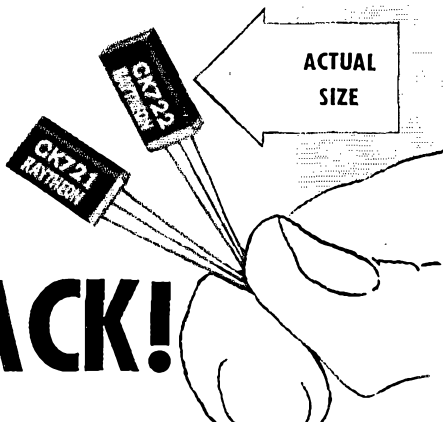

Raytheon PNP germanium junction transistors are now available for the first time. Heralded as the most revolutionary device since the vacuum tube, PNP transistors are now being used in hearing aids and other units *now being sold* or shortly to reach the market. Every lab and technician with a future in this business should become familiar NOW with this remarkable Raytheon product!

AV. CHARACTERISTICS AT 30° C		
Description	CK721	CK722
Collector voltage (volts)	-1.5	-1.5
Collector current (ma)	-0.5	-0.5
Base current* (ua)	-6	-20
Current amplif. factor*	40	12
Power gain* (db)	38	30
Noise factor* (1000 cy) (db)	22	22

\*Grounded emitter connection

CK721 (#38-386)

**\$12.50**

CK722 (#38-387)

**\$7.60**

## 12 PARTS TO BUILD YOUR OWN EXPERIMENTAL TRANSISTOR RECEIVER, \$21.95

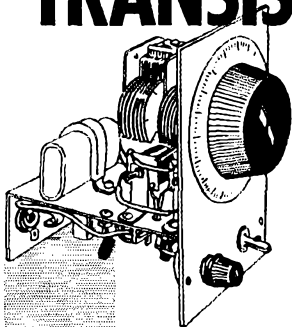

DESCRIBED (Pg. 35) IN THE  
FEBRUARY 1953 ISSUE OF  
RADIO & TELEVISION NEWS

*Note: sketch and diagram also adapted from same magazine article. Build this radio from the 12 basic parts: two CK722 Raytheon PNP transistors, volume control, resistor, two coils, 2-gang condenser, electrolytic condenser, switch, phone jack, binding post, battery. Kit does not include the following items*

which are readily available if desired: chassis (wood may be used), knobs for variable condenser and volume control, 2000 ohm headphones. *Includes* a full reprint of the magazine article which also gives constructional data on several microphone preamplifiers using the CK722 transistor and additional data on this unit.

ORDER NO.	DESCRIPTION	PRICE
QST-1	12-piece kit	\$21.95
R-4789Q	2000-ohm phones	1.89

### IMPORTANT FACTS ABOUT TRANSISTORS

Many new uses for PNP transistors will be released in radio magazines from month to month — others will occur to you at your bench. We suggest that the transistors you purchase for building the Radio & Television News receiver be kept intact for future use. Watch this and other magazines for new circuits!

TRANSISTOR RECEIVER SCHEMATIC!

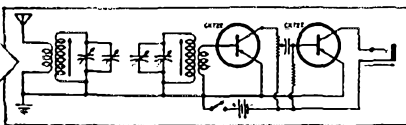

# RADIO SHACK

CORPORATION

167 Washington St., Boston 8, Mass.

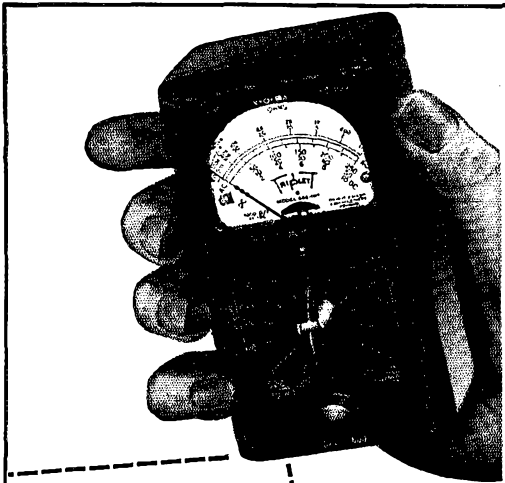

**Mighty  
Midget**

## of the Service World

Mighty Midget of all the V-O-M's! Slips into your pocket for making spot-analyses of D.C. and A.C. Voltage, Current, and Resistance. Has quick-reading scale, only one switch, 50" leads — alligator clips, banana-type jacks, self-contained snap-in type batteries, and plenty of ranges on the one-knob 14-position switch. Remarkable stability on voltage ranges. Completely insulated molded case. Get yours today! Triplett Electrical Instrument Co. • Bluffton, Ohio, U.S.A.

**Model 666-HH Volt-Ohm-Milliammeter**

ONLY \$24.50 AT  
YOUR DISTRIBUTOR  
(Price Subject to Change)

FOR THE MAN WHO TAKES PRIDE IN HIS WORK

# Triplett

TRIPLETT ELECTRICAL INSTRUMENT COMPANY • BLUFFTON OHIO U.S.A.

29, FWD 16, OEB 15, HNA 9, APS 6, ETO 2, LVB 2, NWP 2, NRB 1.

### PACIFIC DIVISION

**HAWAII** — SCM, John R. Sanders, KH6RU — Apologies for two absences from these pages, gang. I had believed that by now a new name would be heading this column, but I shall carry on as best I can. The increase in reports from the Far Pacific is very gratifying with no less than 5 BPLs this month! With three month's traffic figures on hand, the remainder of the column will be devoted to bringing that situation up to date. Keep up the good work, fellows! Traffic: (Dec.) KG6FAA 7067, KA2MB 3873, US 2584, HQ 1969, KG6ACH 1027, W6UWL/KH6 74. (Nov.) KG6FAA 2821, KA2US 1357, AG 1061, HQ 1031, KR6HW 841. (Oct.) KG6FAA 3018, KA2US 2233, KA8AB 1747, KA7RC 1153, KG6ACH 85.

**NEVADA** — SCM, Ray T. Warner, W7JU — SEC: HJ. ECs: KOA, LGS, NWU, OXX, TJY, VO, and ZT. OPS: JUO. Nevada State frequencies: 3660, 7225, and 29,360 kc. ZT has been appointed Nevada State Radio Officer and will be pushing the RACES program. Local Radio Officer appointments have been offered to all ECs. MRN is going strong with his new 60-ft. Vesto tower, 10- and 15-meter beams, and Johnson rotator. LGS and HJ should be on now with new 200-watt transmitters. 9CHP/7 has moved from Reno to the San Diego Area. 6ZJH/7 now is located in Las Vegas. JU has disposed of his kw. and hopes to be on with a Viking 11 by now. KJQ and JUO are now neighbors in Boulder City.

**SANTA CLARA VALLEY** — SCM, Roy I. Couzin, W6LZL — IUV has acquired a hot crystal-converter tuning 10-11-15 meters. CAZ is doing a lot of experimenting, a little ragchewing, and checks in on the Palo Alto Net on 146 Mc. MMG checks in on the Bay Area Net on 3635 kc nightly at 2015. DPE is checking in on the Bay Area Net. ZXS is back on 40 meters with about 10 watts; he also got a grid-dipper from Santa. YHM got a new final perking at long last and hopes the TVI nightmare is a thing of the past. WMM says his operating has been nil because of a heavy work schedule during the holiday season. HC is keeping busy on the nets and still has time to do a little experimenting besides his teaching schedule. DLX, ex-KW6, is home now and rebuilding his high-power rig. He says he heard G5WP on 3.5 Mc. recently. The SCCARA had GTF at its December meeting. He gave a very interesting talk on ham television with a demonstration of his own equipment. Prof. Cooper, of the Naval Line School, gave an interesting talk on linear amplifiers. He was the guest of the Monterey Bay Radio Club in December. The NPEC held its first meeting Dec. 5th and the main topic discussed was the coming Christmas party. The second meeting was the Christmas party, which was a real success. The SCCARA also held a very well-attended Christmas party. The CCRC meeting for December was held in Redwood City at the home of CTH. The Bill before the Assembly for license plates was the big discussion. Traffic: W6YHM 171, OFJ 56, HC 38, MMG 13, IUV 2.

**EAST BAY** — SCM, Ray H. Cornell, W6JZ — The year-end finds all of the clubs electing new officers. SARO: KKK, pres.; FZC, vice-pres.; RLB, secy.; UEM, treas.; AAU, com. mgr.; EBRC: VSV, pres.; DNX, vice-pres.; VNH, secy.; RLB, treas.; DKJ and JZ, directors. Mt. Diablo: RVC, pres.; DEK, vice-pres.; OPL, secy.-treas.; IHR, corr. secy.; YHQ and JYZ, directors. ORC: MNK, pres.; JKW, vice-pres.; PHI, secy.; ACN, treas. NBARA: CHI, pres.; LRT, vice-pres. and treas.; BUC, secy.; QEA, editor. Richmond: TWI, pres.; CIB, vice-pres.; QJA, secy.; PAV, treas.; KFU, agt.-at-arms. No. Calif. DX Club: DZZ, pres.; NIG, vice-pres.; LW, secy.-treas.; EJA, editor; FYH, photographer; CTL and RRG, directors. DNX has been elected president of the Central California Radio Council. Other officers are WXV, vice-pres.; LZL, secy.; ZBS, treas. The CCRC Field Day Trophy was awarded to the Palo Alto Amateur Radio Assn. Competition for this award and the commemorative plaque which goes with it is open to all Pacific Division clubs. Obtain details from the secretary, LZL. The Mission Trail Net is planning its annual get-together for June at Mt. Shasta, where the members are sure of a royal welcome because of the tremendous help given by amateurs in saving the town from fire several years ago. The Northern and Southern Calif. DX Clubs held their 4th annual DX Conference at Fresno Jan. 17-18 with the Northern Club being the host (WOW). The Mobileers had another Big Assist chalked up to their credit when TVS, arriving at the scene of a serious traffic accident near South San Francisco, summoned ambulance and police aid via BM and DNX. Congrats to our RM, IPW, who finally made BPL. He also has an Extra Class ticket which he obtained the hard way, also a 2nd-class Cond. Phone ticket. K6FAL makes BPL as usual. LGW has a new Viking II, LIL has a new 32V-3. WN6QES and WN6UPT are heard on 2 meters. PBO plans to get on 2-meter mobile. FZC has one of the Robert Dollar 2-meter mobile transmitters. FXX is an expert on 75-meter vertical installations. WXU recently toured the Pacific. The Mobileers are talking about 7296 kc. as the mobile frequency in the 40-meter band. HHX still is plugging away on BAN. LMZ has 170 countries worked.

(Continued on page 100)



## how to have every buying advantage



**FREE**

### Amateur Radio's Leading Buying Guide

You'll find everything you need in this 236-page ALLIED Catalog—not only all the station supplies you want, but the world's largest selection of industrial electronic equipment, special tubes, test instruments, recording and high-fidelity audio equipment, replacement parts—all at lowest, money-saving prices. You'll want to get and use the ALLIED Catalog—your reliable one-source Buying Guide.

**send for it—  
keep it handy**

**Everything for  
the Ham**



If you're doing business with us already, you *know* you get *every* buying advantage at ALLIED. If you're a newcomer to Amateur ranks or haven't yet done business with us, here's what you can *always* expect to get from us:

### you get **value**

We save you money on all your station needs, because we sell at the *lowest* market prices—often lower than you can buy elsewhere.

### you get **everything you need**

Yes, *everything* from *one* source because we carry the world's largest stocks of Amateur station and industrial electronic supplies—all the nationally-known dependable lines.

### you get it **fast**

We *prove* it—just mail, wire or phone your order—and you get what you want quick—from *stock*. Big order or small—you get the same fast, expert service.

### you get the **best terms**

You can't beat our Easy Payment Terms. You get full carrying charge refund on 60-day payment, 50% back on payment in half the required time. There's no red tape, no long delays—we finance the terms ourselves. Extra advantage: 15-day trial on all communications receivers.

### you get the **best trade-ins**

Just try us—we mean business—FB for you. Drop us a line or visit our Ham Shack. We'll go all-out to give you the best deal in the business.

### you get **real help**

We back up the buying advantages we give you with down-to-earth help. Our Ham staff will give you the straight dope you want. You'll like the personal kind of attention Amateurs have enjoyed at ALLIED for over 23 years. Try us today.

**ALLIED RADIO**

833 W. Jackson Blvd., Dept. 15-C-3  
Chicago 7, Ill.

# NO OTHER MICROPHONES OFFER YOU SO MUCH FOR SO LITTLE!!!

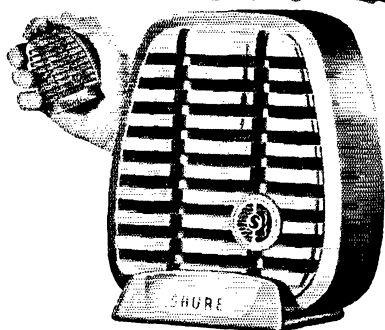

## ...The Shure Controlled Reluctance

**"HERCULES" Only \$15.00 List!**

A revolutionary new hand-held magnetic unit that provides clear reproduction, high speech intelligibility, high output, and ruggedness—at an amazingly low price! A tough microphone that can be used indoors or outdoors—fits snugly in the hand, sits firmly on a desk without tipping over, can be placed on a stand, Metallic Green finish. Complete with stand adapter. Die-cast case. 2 3/4" wide, 3 1/4" high, 1 1/2" thick.

MODEL	CABLE	OUTPUT LEVEL	IM-PEDANCE	SHPG. WEIGHT	CODE	LIST PRICE
510C	7 ft.	52.5 db below 1 volt per microbar	High	1 1/2 lb.	RUTUF	\$15.00
510S (with switch)	7 ft.	52.5 db below 1 volt per microbar	High	1 1/2 lb.	RUTUS	\$17.00

## ...The Shure Crystal

**"REX" Only \$10.95 List!**

A striking-looking low-cost crystal microphone. The "Rex" is a high output, hand-held microphone that fits snugly in the hand, sits firmly on a desk without tipping over, or can be placed on a stand. The "Rex" is recommended where good quality speech reproduction is required, and low cost is an important factor. Burgundy Red metallic finish. Complete with stand adapter. 2 3/4" wide, 3 1/4" high, 1 1/4" thick.

MODEL	CABLE	OUTPUT LEVEL	IM-PEDANCE	SHPG. WEIGHT	CODE	LIST PRICE
710A	7 ft.	50 db below 1 volt per microbar	High	1 1/4 lb.	RUDEL	\$10.95
710S (with switch)	7 ft.	50 db below 1 volt per microbar	High	1 1/2 lb.	RUDET	\$12.95

*Controlled Reluctance Microphones Built Under Shure Patents. Crystal Microphones Licensed Under Patents of Brush Development Company. Shure Patents Pending.*

# SHURE

## SHURE BROTHERS, Inc.

Microphones and Acoustic Devices

225 West Huron Street • Chicago 10, Illinois

Cable Address: SHUREMICRO

144 confirmed. Our TVI chairman, Mac McKinney, reports TV complaints are being processed at an average of about ten a month. An old-timer returns to activity at Walnut Creek under the new call W7SQF/6. (He was 3MI, VE1DN, and VE3NO and First Comm'l at sea.) Traffic: K6PAL 1393, W6IPW 503, JOH 205, HHX 90, EJO 2.

SAN FRANCISCO — SCM, R. F. Czirikowitz, W6ATO — Phone JU 7-5561. SFC: NI, PJ, 5-6457. Marin Area: EC: KNZ, Tamalpais Club EC: ZUB, ZQK reports the following news of the Tamalpais Club members: DIX is erecting a new 70-foot all-aluminum tower to support a vertical. He also is going to work 21 Mc, W6IHC/K6AIR, of Hamilton Air Force base, is mobile with 200 watts using an ART-13. TBF is a new member and holds a Tech. Class license, and operates MARS at Hamilton Field. FQS now is operating 75 meters with an Flmac. KJA is mobile on 160 meters. OZC, with the help of the club, is going to erect a 40-foot pole to carry a 10-meter beam. KZF is going on 160 meters to check in on the Marin c.d. amateur net, and hopes to get more of the Mill Valley amateurs on a local 160 net. Captain Wathen, Hamilton Air Force Base, MARS head, is sporting a new call, TFB, and is trying to start a c.w. net to give Novices a little G.I. training. HPM is in his new shack in the after compartment of his garage, and operated in the SS. ZUB is back down from his first-lookout job. He is confusing his neighbors by using his TV antenna as a top loader on 160 meters. KZF is the newly-appointed Phone Activities Manager for the San Francisco section, and would appreciate the cooperation of all active phone stations. The Marin Amateur Radio Club has regrettably said goodbye to its president, John Sharp, who is going to Japan for active duty in the Asiatic Area. The Marin Radio Club meets the 2nd Fri. in the American Legion Hall, Larkspur. The Tamalpais Club meets the 3rd Fri. at the home of OZC, 7 Loma Ave., Tiburon. Santa Rosa Area: EC: LOU. The Sonoma County Radio Amateurs now has 25 stations on the 2-meter net, which meets Tues. at 8 p.m. on 145.35 Mc. A 10-meter net also is active. The TVI committee is working with the PG&E on mutual interference problems. The Club is studying the possibility of attempting to have a city or county electrical interference ordinance passed, similar to that in effect in San Francisco. This type of ordinance specifically excepts any radio transmitter licensed by the FCC from the provisions of the ordinance. The SCRA meets the first Wed. in the Board of Supervisors room, County Court House, Santa Rosa. Eureka Area: EC: Ed Kirkwood. The local amateurs of Eureka set up a communications center in the c.d. headquarters on Nov. 23rd using ham gear and provided three circuits on the 10, 75-, and 160-meter bands for use of c.d. during the Statewide drill. Circuits were manned from 0800 to 1600. New calls in Eureka were GJA and TEX. The Humboldt Amateur Radio Club meets the 2nd and 4th Fri. in the YMCA rooms, Municipal Auditorium, entrance on "E" St. San Francisco Area: EC: BYS. Many thanks to the San Francisco Radio Club for the generously donated National Videometer, and to the High-frequency Amateur Mobile Society for the donation of e.d. a.c. line filters, both for the Television Interference Committee. They will help to keep up the fine record of the 20 volunteer hard-working members of the committee. Congratulations to DNX, WXU, and LZL, the new officers of the Central California Radio Council. DNX holding the president spot. The HAMS meets the 2nd Fri. at 1625 Van Ness Ave., and the SFRC meets the 4th Fri. at 71 Lakeshore Plaza, opposite 34th Ave. and Sloat Blvd. Traffic: W6ATO 8.

SACRAMENTO VALLEY — Acting SCM, Willie van de Kamp, W6CKV — MWR now is active on all bands after graduating from Novice Class. FYK now is located in Oroville. TFM is a new licensee in Chico. DRG lost his title as the most northerly ham in California to SIY. The Placer Radio Club is having good success with a club breakfast the 3rd Sunday of each month at 9 a.m. in Roseville. ZFD sold out a year ago but is back already. SYN is too busy with C.A.P. to haunt the amateur bands. OTN, of Sacramento, is bridging the gap to Palo Alto each night on 2 meters. HVB has moved to Redding. DDC and ASM have the 6-meter band to themselves. GDO is a consistent winner of hidden transmitter hunts. New officers of GERD for 1953 are TID, pres.; ICO, vice-pres.; QIV, secy.-treas. Traffic: W6JDN 108, CFU 20, IQ 8, NCV 4.

## ROANOKE DIVISION

NORTH CAROLINA — SCM, J. C. Geaslen, W4DLX — Here's hoping everyone had a nice holiday season as your SCM and that some of your good New Year's Resolutions pertained to ham radio. Not too much news was received this month. It seems that with all the new regulations, everyone is more worried over getting up 40-meter antennas than over the license changes. PIC and ULX, reporting from Greensboro, give a list of new officers for their club: ACY, pres.; JGA, vice-pres.; MR, secy.; AGD, treas. Plans have been made for a big list of activities for the coming year. The SCM would like some reports from other clubs about the State on their activities. BDU, in Charlotte, reports he made WAS one and one-half times in the last Sweepstakes. AKC, of Gastonia, finally made his 35-w.p.m. code endorsement. Traffic: W4IMH 287, AKC (Continued on page 108)



## HENRY RADIO offers YOU:

**LOW PRICES:** You can't beat my wholesale prices.

**FAST SERVICE:** You get fast service. I have big stocks of Collins, National, Hallicrafters, Hammarlund, RME, Johnson, Harvey-Wells, Lysco, Gonset, Millen, Morrow, Mallard, Elmac, Master Mobile, Hy-Lite, Babcock, all other receivers, transmitters, parts at lowest prices.

**BIG TRADES:** I want trade-ins. I trade big. Tell me what you want—what you have to trade. Get my offer. I pay cash for receivers and transmitters too.

**TIME PAYMENTS:** Get what you want and pay by the month. I give you better terms because I finance all terms myself. Write for details.

**SATISFACTION:** Try any communications receiver ten days—if you return it your only cost is shipping charges. I want you to be satisfied. Ask any ham about Henry Radio.

**PERSONAL ATTENTION:** You get personal attention. Bob Henry, WØARA, runs the Butler store. Ted Henry, WØUOU, runs the Los Angeles store. Bob Henry can be reached nearly 24 hours a day, 7 days a week. Write, phone, wire or visit either store. Send us your orders and inquiries. Export inquiries solicited too.

*Bob Henry*  
WØARA

Butler 1, Missouri  
Phone: 395

# HENRY RADIO STORES

"LARGEST DISTRIBUTORS OF SHORT WAVE RECEIVERS"

11240 Olympic Blvd.  
LOS ANGELES 64  
BRadshaw 2-2917

# CRYSTAL CONTROLLED CONVERTERS

FOR  
2, 6, 10-11, 15 or 20  
METERS

MODEL  
RC-1B

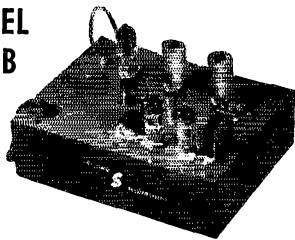

\$4500

NET

(Complete, with power supply, crystal and all tubes)

Designed for the ultimate in performance on any one amateur band, these converters have been widely accepted and very popular, giving all the benefits of dual conversion at low prices.

## FEATURES:

- Tube line-up: 2 band-pass 6BQ7-A grounded grid R.F. stages, 1—6J6 push-push mixer, 1—6BA6 I.F. amplifier; 1—6J6 crystal oscillator-multiplier.
- Built-in transformer type power supply using selenium rectifier.
- Built-in I.F. amplifier, one stage.
- Built-in gain control.
- Ruggedly built.
- Output frequency 7-11 Mc. on all but 20 meter model.
- Output frequency 3.5-3.9 Mc. on 20 meter model.
- Available for either 52 ohm or 75 ohm coax or 300 ohm line.
- 2¼" x 6" x 8" overall. Weight 4 lbs.
- Not a kit—completely wired, tested.
- More than 500 converters now in use.
- For further information, write Dept. Q-3.

Converter for any one band, complete with built-in power supply, crystal, tubes, output cable and input fitting for 52, 75, or 300 ohm line, \$45. Now available at leading distributors. Specify band and input impedance when ordering.

236, RRH 216, PIC 53, EDU 28, DLX 6, SOD/4 4.  
SOUTH CAROLINA—SCM, T. Hunter Wood, W4ANK—The Anderson Club had a chartering supper Dec. 12th to celebrate their ARRL charter, with RSK, SSN, OBT, YMU, and 5VOI/4 as charter members. The Club meets the 1st and 3rd Fri. of the month at 7:30 p.m. at the USNR quarters in the Post Office Building. YQC operates from Winnesboro during vacations and is 3PXM at other times. New officers of the Columbia Club are DNR, pres.; CEL, vice-pres.; MAP, secy.; GKD, treas.; DMX and HMG, directors. The following have received Advanced Class licenses: CXE, OWW, MTW, UPK, and UKV. UUB has 813 final on 80, 40, and 10 meters from Spartanburg. WN4YUI, formerly WN8JWM, is active in Greenville with daily sked with 8LEP. VIW has a mobile rig in Greenville. SGZ and HLC are new members of the 75 'phone net. MSN is on all bands with a pair of 813s. DBT has returned from the Far East. TNG is NCS of the c.w. net on Wednesdays. TTG plans to join the c.w. net, which meets Mon. through Fri. on 3525 kc. at 7 p.m. This is a slow speed net and you are invited to join. Report your activities monthly to the SCM. Traffic: W4ANK 259, FFH 84, JGM 14.

VIRGINIA—SCM, H. Edgar Lindauer, W4FF—The Potomac Valley and Frankford Radio Clubs held their 4th annual razzing session in Washington on an aftermath of SS competition. NTZ, FF, and KFC journeyed to HQN in Bumpass to assist in getting that rig ready for the DX Contest with additional antennas and a modulator, no less RACES is fast becoming a reality in Northern Virginia, with a planning and advisory staff assisting the Region Director of Civil Defense to set up a communications plan and necessary net works. Personnel will be required to man these nets, so get in touch with the EC of your area: KFC, Annandale; KRG, Fairfax County; KPK, Alexandria; LRI, Arlington. KFC has been appointed Radio Officer Northern Virginia RACES and is chairman of its planning and advisory staff. Serving with him are SBA, Deputy Radio Officer, KPK, KRG, LRI, and FF. Northern Virginia can help by rallying to its support organizationally and personnel-wise. NRO once more enjoys civilian bliss and the Navy suffers a heavy loss. UHG and FF are equally frustrated with electronic bugbits. Recent ORS appointees include TYC and VQZ. ORS appointments renewed: BZE, KFT, JTG, KVM, IPC, FV, CC, LRI, EMJ, SU, JHK, MWH, NQV, PYN, BCI, SHJ, SNH, EYX, and NF. UHG is RM, ORS, and OBS. Net certificates went to GR, SAD, TYC, TVI, KWZ, and VQZ. SHJ made BPL for the fourth consecutive month. VNN (Virginia Novice Net) operates on 3705 kc. Mon. through Fri. at 1830 EST. Novices and others desiring to QNI should get crystals on or very near that frequency. Net Manager is W4KSW, who is looking for stations qualified for NCS assignments. The following mobile stations participated in the National Muscular Dystrophy Drive: KDX, KRG, CJJ, KFC, OMR, ILW, EHO, OP, KMF, SQF, LKJ, BF, GEB, IIB, KPK, VHN, NEW, JCY, TNQ, FWO, CV, GMY, SRD, and KPS. Assisting mobile operators were SN, JTP, RIG, FF, LRI, WBC, NRQ, UCI, and NF. Traffic: W4SHJ 608, FV 329, JOT 322, UWS 136, FF 122, UHG 77, GR 68, NV 64, OGX 48, MWH 45, MAD 41, OVV 41, CFV 40, SPE 40, KX 37, KRX 30, KSW 27, JZG 22, HQN 18, IYI 18, JUJ 7, PWX 6, LK 5, PMF 2, WBC 2.

WEST VIRGINIA—SCM, John T. Steele, W8MCR—YPR, our SEC, reports that he is making progress with AREC. He has the Ohio River section covered except for counties in the northern panhandle. Anyone in that area, please contact him. AUJ again made BPL with 1065 messages reported. KDQ is a new ham in Princeton. FUS reports he now is in the TV business and says his Viking is TVI proof. Bill Parker, ex-801C, Inspector of Radio and Electronics with Boeing Aircraft at Wichita, Kans., writes he is going to be a W0 soon. HZA now has a Viking II on c.w., but can't get the 'phone to work. JBE, HXG, and IIV now are on 75 meters with new Advanced Class tickets. YMN still is rebuilding. HXG has a new Globe King, Lysco 600, and HQ-129X. The Princeton Amateur Radio Association extends a cordial invitation to all hams, SWLs, and others to visit the club, which meets the 2nd and 4th Thurs. at 7:30 p.m. Traffic: W8AUJ 1065, HZA 18, YPR 17, GGC 10, FUS 6.

## ROCKY MOUNTAIN DIVISION

COLORADO—Acting SCM, Karl Brueggeman, W0CDX—SEC: KHQ. Since TV reared its ugly head in Denver all hands are putting forth their best efforts to lick the Indians. BRM, CDX, and IPT have Viking II and are on the air. The Colorado Emergency 'Phone Net needs more outlets for traffic, so contact KHQ or AEE for schedules. K0FAM monitors 14,140 kc. continuously from 1430 to 2330 MST Mon. through Fri. The operators are FLC, GCQ, GVK, and KL7AKT/W0. It is with regret that we announce the death of OUI. Leo was one of the outstanding hams of our section. He also was one of the founders of the Denver Amateur Radio Club and an active leader in all League activities. The Denver Amateur Radio Net (DAR-NET) is planning a full scale c.d. drill sometime in March and is in need of operators to handle the new 2-meter pack

(Continued on page 104)

WILVAN  
**S** ELECTRONICS  
LABORATORIES, INC.  
393 NORTH PEARL ST., ALBANY, N. Y.



# Uncle Dave's Radio Shack

SUBSIDIARY OF  
**FORT ORANGE RADIO DISTRIBUTING COMPANY**

## ELMAC-A54

Under-dash Mobile Transmitter  
Measures 7 1/2" x 7 1/2" x 12";  
Weights 14 1/2 lbs.



For Carbon Mike Input.....Net \$139.00  
For Dynamic or Crystal Mike...Net \$149.00  
Power Supply, 110 volts AC.....Net \$39.50

**New PMR 6-A Receiver**  
6 Bands, 600 kc. to 29.7  
mc.; 10 tubes, dual con-  
version; size 4 1/2 x 8 1/2" **\$134.50**

## SUPERIOR POWERSTATS

Smooth, efficient voltage control, 0-135 volts output from 115 volt AC line. Models also for 230 volt input. Write for free literature. Models for table and panel mounting.



Type 20, 3 amp..... \$12.50  
116, 7.5 amps, table mtg.... \$23.00  
116U, 7.5 amps, panel mtg.... \$18.00  
1126, 15 amps..... \$46.00  
1156, 45 amps..... \$118.00  
.....and the nem:  
Type 10, 1.25 amps. (150-165 VA) .. \$8.50

## CONSET "COMMANDER"



**NEW**  
35-50 Watt  
Multi-Band  
Transmitter  
**\$124.50**  
Net

Freq. Range: 1.7 to 54 mc. continuous. Fixed or Mobile. Very Compact. Suitable for under-dash. Tubes: RF, 6AG7, 6146, AF: 12AT7, 2-6AQ5. Wired, tested, complete with all tubes, 2 hi-Q final tank coils. 5 1/2 x 8 1/2 x 7 1/2"

## LYSCO MOBILE TRANSMASTERS

Amateur and  
Civil Air  
Patrol  
Service



4 1/2 x 6 1/2" - 5 lbs. Models for 20, 10 and 75 meters. Uses 500 volts, 100 ma. power; 6.3 volt filament. Write for descriptive literature..

Eldico  
Hammarlund  
LySCO  
Hallicrafters

Elmac  
Harvey-Wells  
Sonar  
Sylvan



Uncle Dave, W2APF, wants you to know that he is very much interested in your "ham" problems. In the Shack the slogan is "If you don't see it, ask for it!" As in this advertisement all stock is not on display, that would be manifestly impossible. Thousands and thousands of items are regularly stocked for immediate delivery.

## Special for MARCH HAND MICROPHONE

Single Button Carbon, Removable Cartridge, with Push to Talk Switch, 4-ft. Cord and Plug. Made in England. While they last...ea. **\$375**

## COLLINS 32V-3 TRANSMITTER



VFO Controlled, Bandswitching, Gangtuned Transmitter. Covers 80, 40, 20, 15, 11 and 10 meters; 150 watts CW; 120 watts phone; entire RF section enclosed in metal shield for harmonic radiation reduction.

**\$775** Net

Uncle Dave Will be Pleased to Send You a Complete Description of this Wonderful Transmitter

## The NEW NATIONAL HRO-SIXTY

**\$483.50**

Matching Speaker \$16.00



Here's the latest and the greatest of the famous National HRO series! Features dual-conversion plus 12 permeability-tuned IF circuits! Many, many other newly designed features to make this the outstanding communications receiver value of the year!

We regularly stock all National receivers, accessories and parts

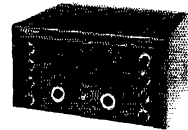

The All New  
National  
**NC-183D**

**\$396.60**

With Speaker

Every feature you want in a truly modern receiver. 540 kc.-55 mc. coverage. Let us send you descriptive literature on this great receiver. You will be amazed at the value offered. A truly superb instrument.

## The New Collins 75A-3 Receiver With Mechanical Filter

**\$550**

WITH SPEAKER



The familiar Model 75A-2, redesigned and modified to provide for the use of mechanical filters. Supplied with one 3 kc. filter, and facilities for two additional. A 3-position front panel switch permits selection of filter desired.

Additional Mechanical Filters: 1 kc. and 6 kc. ...each \$75.00

## TOP TRADE-IN ALLOWANCE

### Bargain Counter

Army Surplus LS-7 Weatherproof Speaker	\$3.95	Harvey-Wells TBS-50 (Used)	\$75.00
3" PM Speakers (Name Brand)	\$1.25	Hallicrafters SX-25 and Speaker (Used)	\$115.00
4" PM Speakers (Name Brand)	\$1.49	Hallicrafters S-38 (Used)	\$32.95
4" x 6" PM Speakers (Name Brand)	\$1.99	Hallicrafters S-40 (Used)	\$69.95
Burgess Vibrator Type Jig Saws	each \$9.95	Sonar VFX-680 All Band Exciter (Used)	\$60.00
J-38 Hand Keys	\$1.29	National NC-240D with Speaker (Used)	\$200.00
72-ohm KW Twin Lead	Per C \$5.00	Gonset Two-Meter Converter (Used)	\$39.00
RG-59U Coaxial Cable	Per Foot .08	Gonset Noise Clipper (Used)	\$5.00

**Fort Orange** RADIO DISTRIBUTING COMPANY  
904 BROADWAY, ALBANY, N. Y.  
TELEPHONE ALBANY 5-1594

Proven Performance

WITH

SONAR

TWO-WAY COMMUNICATION EQUIPMENT

... and Now ...

40 meter Phone with

SONAR MR-4

MULTI-BAND MOBILE RECEIVER

20-40-75-80 mtrs.

ALL FOR

\$89.95

Net

COMPLETE WITH TUBES LESS SPKR, PWR SUP. BFO • ANL

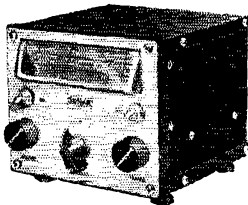

Ideally suited for mobile with its compact size, lightweight, the MR-4 is excellent for CD, CAP or any emergency operations. The MR-4 is a COMPLETE RECEIVER... NOT a converter... for 40-20-75-80 meters, with less than 1 microvolt sensitivity and comes complete with 8 tubes, one of the best automatic noise limiters yet designed, voltage regulated oscillator, accurate slide rule dial (illuminated), BFO, plugs and mounting brackets.

LOW PASS FILTER



\$16.50

Net

- 44 mc cutoff - 52 ohms
- 1 KW fully Modulated
- 75 db Har. Attenuation
- TEFLON insulation

... YOUR DEALER HAS THE

SRT-120

100 WATT TVI SUPPRESSED MULTI-BAND TRANSMITTER

\$198.50

Less PWR SUP.

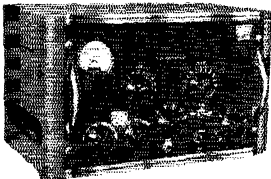

SONAR

RADIO CORPORATION

sets and handle-talkies. All interested, contact WJN or GQ. This drill promises to be the best yet. KHQ is planning a new Colorado, Wyoming, Utah, New Mexico slow-speed net at 1930 MST Mon. through Fri. on 3560 kc. Contact KHQ if you are interested and he will get the ball rolling. Traffic: (Dec.) W0EKQ 288, K0FAM 279, W0GQY 109, PGX 10. (Oct.) W0KHQ 493.

UTAH — SCM, Floyd L. Hinshaw, W7UTM — Ogden has a new EC, GPN. Carl reports the following newly-elected officers of the Ogden Club: NHQ, pres.; NXC, vice-pres.; and Lee Howe, secy.-treas. Trustees are OKA, MVD, and NAY. FYR says that skip has kept him from hearing State net signals, but he tries every night. NXB is a new member of AREC in Vernal. Dean, just out of the Navy, has a new Advanced Class ticket and is a member of the FARM Net. JVA says he has work QRM, as this is his busiest season. ZZZ has been operating portable atop Coons Peak, site of the highest TV transmitting antenna — low power, but high reports. Hi! Traffic: W7UTM 61, FYR 10.

SOUTHEASTERN DIVISION

ALABAMA — SCM, Dr. Arthur W. Woods, W4GJW — W4YPC is Jack Kennamer, of 1008 Wilbanks Ave., East Gadsden, and he has volunteered to coordinate all W4 activities, inquiries and organizational details. OAO is a newcomer to 75-meter phone and claims he likes to use it. PPK says the big package from Santa Claus turned out to be not a K-W-1 but a base fiddle! It's 30 db. over 9 in Birmingham. Frank. BFM is in a rut, answers into only 5 nets nowadays. Bi-monthly meetings of the Decatur Club now are being held, there being 17 licensed amateurs in that city. LEN has his shack in the trailer that formerly was his home. No faint echo of other news in the section has reached this writer's ear. Please send in your news items. Traffic: W4UHA 343, K4X 182, PPK 88, BFM 23, OAO 15.

EASTERN FLORIDA — SCM, John W. Hollister, jr., W4FWZ — All reports were flowery about A. L. Budlong's December visit to Jacksonville, Orlando, Miami, et al. BPL busters for December include PJU, PZT, and DRD. The new M.O. for the K. of Ke. is DDW, succeeding NKD. The new S.A. is SVB. Christmas traffic to overseas servicemen was extra heavy, thanks to all our good operators. For example, in St. Petersburg the SPARC got traffic through several civic clubs for "anywhere in the world" delivery. Those participating included PFC, KQR, HUY, KLF, TKE, and TMB. Good publicity got the news over in Pinellas. New ECs include RXX for Broward, SBV for Ft. Meade, NRT for Seminole, and UHY for Jacksonville. IM, the retiring EC for Broward, set an example in good organization that any ARRL section would be proud to report. Because of his health KJ has asked to be relieved as SEC after doing probably the best job at it for us I know of. IM has offered to take over. Ft. Lauderdale: The BARC's station call is W4AB, a memorial to Ernest T. Luscombe. New officers are MLS, RKN, IM, VCQ, and PPR. Jacksonville: New JARS officers are HKR, EOE, UHE, RTJ, and DAA. HKR reports 20 meters hot in December. UHE has new National 183D. NTU has returned to Jacksonville. Kissimmee: PXC was home for Christmas. Miami: VYU has a new Globe King and MVR got a new Super 6 Gonset from the XYL. SDI. MKP has Extra Class license now. Sarasota: New club president is BU. TFP has a very neat station with a Viking sender and RME on incoming. Bill uses 5-element on 28-Mc. phone and is ready for 7-Mc. phone. St. Petersburg: SPARC officers are TCF, VIP, JOU, KQR, TZW, EYI, and WMC. Tampa: BNI is back at aeroplane-driving, Florida to South America. More ORS and OPS are needed. Welcome to PSP and PTT on their annual visit. Traffic: (Dec.) W4PJU 1331, PZT 514, DRD 373, LMT 135, KJ 90, WS 90, RWM 40, IM 35, FWZ 25, DDW 21, IYT 4. (Oct.) W4DRD 216.

WESTERN FLORIDA — SCM, Edward J. Collins, W4MS/RE — SEC: PQW. EC: PLE. W4UYJ passed his Technician Class exam. W4YRF keeps the band hot with a sked to his brother, W4YFF. YFG, and YFH keep the rig hot. UUF and FHQ each have a new Viking II. PQW works portable from W5-Land. PTK/TTM keep 75 meters going. PAA/4 has been heard up Georgia way. AXP received RME-45 back from the factory. DAO has been giving 75 meters a whirl. UOZ has been building new gear. HJA is getting mobilized. UTR has been doing FB mobile work. VCB still is teaching Novices and doing an FB job. ERR has been meeting NARS drills. ART has been on 144 Mc. SZH keeps 75 meters going with high power. VR is having VFO trouble. QK is back on 10 meters and thinking about a high-powered rig on 75 meters. UC still is selling ham parts. RZV seems to be a traffic man but never reports totals to the SCM. 9CGO/4 received a Millen grid-dip meter from the XYL for Christmas. I would appreciate hearing from the fellows in other parts of the section so I can include them in the section report. CU on 40. MS still is on 20 meters and working with the 430 TV transmitter.

GEORGIA — SCM, James P. Born, jr., W4ZD — New officers of the Confederate Signal Corps of Atlanta are EJC, pres.; FOE, vice-pres.; YEK, secy.; GLX, treas.; and ORI, act. mgr. EJC will continue as editor of *The Bugle*, a monthly paper published by the Confederate Signal Corps. EGK

(Continued on page 106)

# 'Give and Take' Month!

IF THAT IS YOUR INCOME, HOW DO YOU EXPLAIN THIS TOP QUALITY EQUIPMENT HEH?

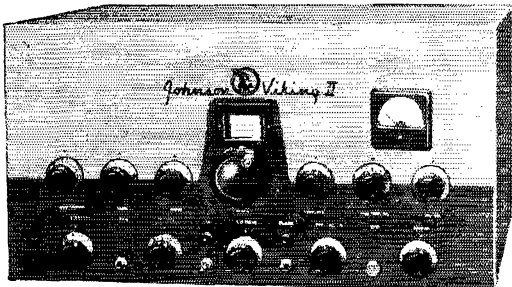
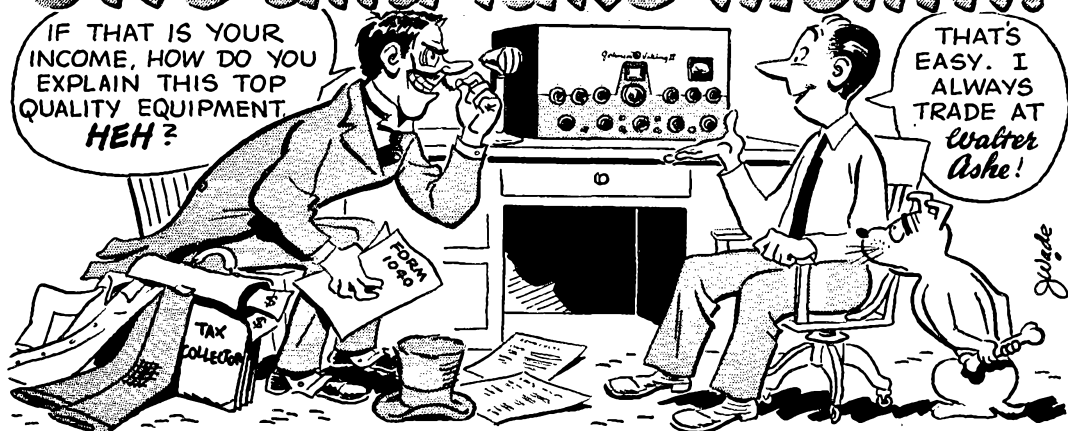

**JOHNSON VIKING II TRANSMITTER KIT.**  
Shpg. wt. 85 lbs. Only \$279.50  
**JOHNSON VIKING II Wired and Tested. Only \$336.50**

With a "Surprise" Trade-In Allowance on your used communication equipment, you not only get what's coming to you, but an extra bonus of satisfaction and real money saving. So join the thousands of Walter Ashe customers who have learned that the one and only "Surprise" trade in deal on used (factory-built) equipment is so much easier on the pocketbook. Get your trade-in deal working today. Wire, write, phone or use the handy coupon below.

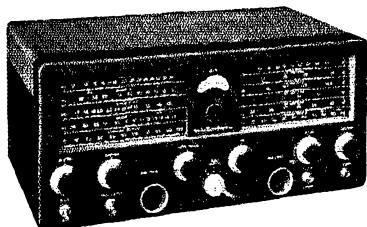

**HALLICRAFTERS SX-71**  
Less Spkr. Shpg. wt. 51 lbs.  
Only \$224.50

**NATIONAL NC-183D**  
Less Spkr. Shpg. wt. 65 lbs.  
Only \$369.50

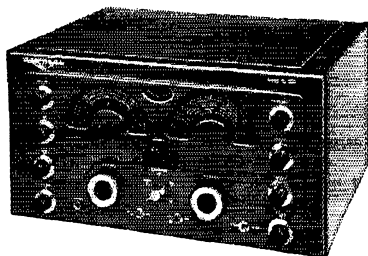

**All prices f. o. b. St. Louis**

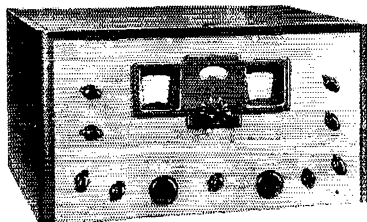

**HAMMARLUND HQ-129X**  
Less Spkr. Shpg. wt. 74 lbs.  
Only \$239.50

**COLLINS 75A-3**  
with 3 kc Mechanical Filter.  
Less Spkr. Only \$530.00



**Phone Chestnut 1125**

**Walter Ashe**  
**RADIO CO.**  
**1125 PINE ST. • ST. LOUIS 1, MO.**

**FREE CATALOG! Send for your copy today.**

WALTER ASHE RADIO COMPANY Q-53-3

1125 Pine St., St. Louis 1, Missouri

Rush "Surprise" Trade-In offer on my \_\_\_\_\_

(indicate make and model number of used equipment)

for new \_\_\_\_\_ (identify by model number)

Send new 1953 catalog.

Name \_\_\_\_\_

Address \_\_\_\_\_

City \_\_\_\_\_ Zone \_\_\_\_\_ State \_\_\_\_\_



type no.  
specs.  
circuit  
diagram

on decals  
of TRIAD plate  
power  
transformers

Triad Plate Powers—like other Triad transformers—have the essential information right where you want it—on the decal. Simplifies installation and reordering. Small size, low temperature rise, good regulation and low cost are other reasons why you will want Triad Plate Powers in your rig. In addition, these transformers are "Climatite" treated, and tested for proper operation—and their smart grey baked enamel finish will really dress up your gear.

Next time you buy transformers, ask for Triad.

Write for Catalog TR-52D

**TRIAD**  
TRANSFORMER MFG CO

4055 Redwood Avenue • Venice, California

was guest speaker at the Atlanta Radio Club's January meeting and gave an interesting talk and a demonstration on single sideband receiving and transmitting equipment. LXE is recovering from a serious case of electric shock, received while working on his rig. EDG now is located in Decatur and is active on all bands with a Collins 32V-2. TOW has moved to Eatonton and will be on 3.85-Mc. 'phone soon. K4WAR has a new 28- and 14-Mc. beam and is now looking for DX and hopes to make DXCC soon with 94 countries now confirmed. YMV is a new ham in Marietta and has a new TBS-50-D transmitter. KFL has returned to the air with a new 75-watt all-band transmitter. YUM is a new ham in Atlanta. HYW made DXCC. Your SCM thanks you for the many Christmas cards and wishes you all the success in the world in 1953. Members of any net in Georgia are eligible for membership in the Georgia Cracker Radio Club. Any net member interested, please contact the club secretary, W4MZO, 1084 Berkshire Road, N.E., Atlanta, Ga. Traffic: (Dec.) K4WAR 4034, W4USA 1811, EJC 69, ZD 40, MA 35, HYW 21, OPE 16. (Nov.) K4WAR 1434, W4HYW 18.

**WEST INDIES**—SCM, William Werner, KP4DJ—SEC: HZ, KD worked KV4AQ, KP4DV, and W2EQS on 1810 kc. running 22 watts. W4WHH, ex-K4GZR, is back in KP4. GP has been reappointed Arecibo District EC. RK reports, "RA has a new 32V-1 to match 75A-1 and a new shack. QV is active on 20- and 40-meter c.w. RK put up 80-meter Zepp and is working DX with 6V6 oscillator. TO is on 10 meters with a pair of 4-125As." CP transmits ARRL bulletins daily at 7 P.M. AST 7 days per week on 3925 kc. TQ is the first Novice anywhere to earn WPR25 certificate. UB reports to 3559-kc. AREC Net and keeps schedule on 160-meter 'phone with PZ. RK is assistant editor of PRARC *Ground Wave*. The PRARC proposes a suitable KP4 Award to be awarded the outstanding KP4 amateur at the March hamfest. Welcome to Navy Chief Lee Ellis, W4DRH/KP4, who operates on 20- and 75-meter 'phone. MO, back from Stateside school for the holidays, reported into the 3559-kc. Net. PQ now is UC at Camp Tortuguero. OS suggests that more 10-meter operators operate on 75 to facilitate traffic-handling into the San Juan Area during daylight hours. RA, RD, and PW received Advanced Class tickets and are now on 75 meters. ES has 1-kw. BC-508 operating all bands, remote control. What AREC net frequency do you fellows suggest for 40 meters? CP worked 26 countries on 75-meter 'phone this past year. KV4AI is on 75-meter 'phone with a Viking. KV4BB runs a kw. on all bands. RD is using 150B on 75-meter 'phone, 4-125A on 20- and 40-meter c.w. 8K moved to Caparra Terrace. TC and OW are using ART-13a. Traffic: KP4CP 60, DJ 12, DV 6, KD 4, RK 2, GP 1.

**CANAL ZONE**—SCM, Nelson W. Magner, KZ5NM—The KZ5 14-Mc. 'phone gang is very happy with authority to use 14,150 to 14,300 kc. for A3 emission for a period of six months, starting Jan. 1st. AA and ML make BPL. KZ5RT is the new president of the Crossroads Radio Club. Other officers are QA, vice-pres.; LM, secy.; JM, treas.; TG, act. mgr. The Crossroads Radio Club requested and was assigned the call KZ5PA in memory of Arnold Pincus, one of Canal Zone's oldest and best-known hams, the first to become a Silent Key. QRMary Net (XYLs) drills the first Tues. of every month on 28.9 Mc. at 7 p.m. We all will miss WJ and his XYL when they return to the U. S. in April. WA skeds HC8GI Mon. at 10 p.m. RM is busy rebuilding new rig, p.p. 4-65As. RT has new "V" beam working on 14 and 28 Mc. BC worked VR5AC on 14 Mc. Traffic: KZ5AA 817, ML 209, DG 65, NN 47, WA 38, IA 37, NM 26, AR 12, LM 8, FF 7, AE 6, GD 6, RM 4.

### SOUTHWESTERN DIVISION

**LOS ANGELES**—SCM, Samuel A. Greenlee, W6ESR—Asst. SCM Kenneth L. Kime, 6KSX. PAM: QR, RMs: FMG, FYW, GJP, JQB. Section Traffic Nets: LSN, Mon. through Sat. 3600 kc. at 2030; ECN, Mon. through Fri. 3655 kc. at 2030. BPL this month was made by KYV, GYH, HK, VHN, and BHG. FMG, RM, announces that a Section Net certificate was awarded to HIF, LQZ is a new member, and LSN welcomes traffic-minded c.w. ops in Pomona, Ontario, Upland, Whittier, Santa Monica, and Met. L. A. districts. Check into YOUR net, fellows, and get information from the N.C.S. MU is set to blast loose on 144. EPL reports from Florida. PWZ has rhombic perking on 20. DPL says that he still has TVI troubles, CCO is going high power, 80 has been rotten (he's telling us?), and that he is n.f.m. on 10. Love's Labor Lost: NNT went from first WN ticket to Advanced in less than 17 months—so now what's with the Advanced ticket? FYW's El Capitan Net seems to be rolling nicely. BLY reports that LVQ is new prexy and CAU, KHP, YUY, and WGL are new directors of Radio 50 Club (Whittier); that TVI went that-way for GTL (he hopes) with new Viking II. 'Tis said CMN's new "raddio" room is a dilly. A new boy in these parts: 9YTV/6—a hot c.w. traffic man. YSK really celebrated New Year's Eve by finally getting on 144! KYV is all set to go RTTY with his Pacific skeds. COZ writes that he has new SX-71; that JMY, HYO, and L.EI are back from A.F.; YMY now is on 20; HQX has Viking II; SGF and UTO are Tech. Class licensees; and UTO is new WN down Pomona Way. WPF

(Continued on page 108)

# EXCLUSIVE LAFAYETTE SCOOP!

## Famous Name HEARING AID

AT AN

# UNBELIEVABLE Price!

## BIG NAME BRAND HEARING AID

resale price **\$185.00**

our price **\$24.50**

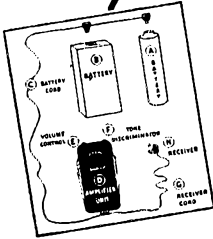

Now Anybody Can Afford One!

Unbelievable! But a fortunate purchase by Lafayette makes available a top-brand hearing aid regularly priced at \$185.00 for only \$24.50. Because of our low price we may not advertise the name but you will recognize the high quality of the manufacturer the moment you see it. Excellent as a spare aid, and a real opportunity if you could not afford one before. Brand new, packed in original manufacturer's jewelled case as illustrated. Supplied with receiver, receiver cord, battery cord and plug (less batteries). Order sample immediately. In lots of 3, \$23.50. Uses Burgess XX30E and 8R batteries at \$1.55 per set.

### HAMMARLUND HQ-129X COMMUNICATIONS RECEIVER

Net .....199.50  
10" PM Matching Speaker for HQ-129X Receiver. ....14.50  
Net

# Brand New!

## GUARANTEED!

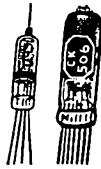

RAYTHEON HEARING AID TUBES  
Quantity Limited

- Stock No.
- CK-505AX, pentode volt. amp.
  - CK-506AX, pentode power amp.
  - CK-507AX, pentode power amp.
  - CK-536AX, pentode power amp.

**49c** ea.  
in lots of 10  
59c single, ea.

## HEADQUARTERS FOR GONSET AMATEUR EQUIPMENT

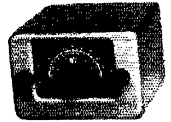
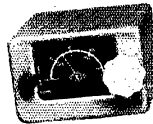

**GONSET 2-METER AMATEUR AND C.A.P. CONVERTER** For fixed or mobile use on 144-182.2 mc. High stability permits use with auto or home broadcast set. Super-imposition tuning and 1 mc (output) 10° doubles band-spread, speeds tuning and avoids images from TV, police and other stations outside 2 meter band. 50 ohm coaxial input. Easily adapted for use with open wire line or 300 ohm ribbon. High frequency and extended to cover C.A.P. frequency. Requires 135-250 V. DC, 20 MA; 6 V. DC. Draws power from receiver. Tubes: 6CB6, 12AT7, 6B2. Gray case measures 5 1/4" x 3 1/2" x 5 1/4". Supplied with tubes, cables and instructions. Shpg. wt. 4 lbs. ....NET 44.50

**Gonset No. 3008 2 Meter Converter**.....NET 44.50

**GONSET 3-30 MC SHORT WAVE CONVERTER** Continuous coverage from 3-30 mc on three bands. For use in all-band mobile station installations. 1500 kc output. High sensitivity on short whip. 4 tubes. Uses power supply of receiver to which attached. Size: 5 1/4" x 3 1/2" x 5 1/4". Shpg. wt. 4 lbs. ....NET 47.75

**Gonset No. 3002 Converter**.....NET 44.50

**STEERING POST MOUNTING BRACKET** — For installing any Gonset Converter on auto steering post. ....NET 3.90

**Gonset Steering Post Mount 3006**.....NET 47.60

**Gonset 3005 Tri-Band Converter**.....NET 47.60

**GONSET MODEL 3017 SINGLE BAND CONVERTERS** Available in 10, 15, 20 and 751 meter models (specify band) } NET EACH 39.95

**The NEW GONSET 2 Meter XMTR-RECEIVER** Complete 2-meter fixed-portable unit. ....NET 189.00

# Lafayette Radio

FAMOUS IN RADIO FOR 32 YEARS

NEW YORK, N. Y.	100 Sixth Ave.
BRONX, N. Y.	542 E. Fordham Rd.
NEWARK, N. J.	24 Central Ave.
PLAINFIELD, N. J.	139 West 2nd St.
BOSTON, MASS.	110 Federal St.

**DX**

# Announces a NEW 90° YOKE for 27" TUBES

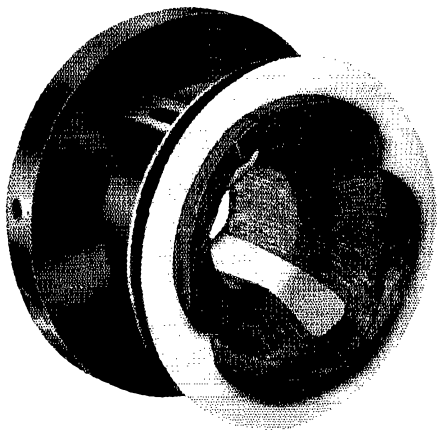

## It's Engineered for TOP PERFORMANCE ... in Production NOW!

This new DX 90° Deflection Yoke has everything a television receiver manufacturer wants . . . a sharp full-screen focus, a minimum of pincushioning, the ultimate in compactness and a price that's downright attractive. Because this yoke has been brilliantly designed for mass production on DX's specialized equipment, it warrants immediate consideration in your 27" receiver plans. Write us today.

DEFLECTION YOKES . . . TOROID COILS . . .

I. F. TRANSFORMERS . . . DISCRIMINATORS . . .

SPEAKERS . . . R. F. COILS . . .

TV TUNERS . . . CRYSTALS

ION TRAPS . . . TRANSFORMERS



## DX RADIO PRODUCTS CO.

GENERAL OFFICES: 2300 W. ARMITAGE AVE., CHICAGO 47, ILL.

is going great guns after a recent bout with medicos. Wonder why they call HLZ "Curley"? GEB only needs 2 for DXCC. NCA likes his new VT keyer. LB, JFP, and MSG are setting up trans-mountain 144-Mc. skeds. Rumor hath it that the new manager of one of our top c.w. nets is THAT WAY (QRT) about TV! HIF uses RR/M whenever he gets a chance — his flagman is KBG. KPM, ORB, HII, NSV, and NJU are working on "secret weapons" for the next Field Day (information via NJU). Oh-yeah-Dept.: GYH says he will cut down his traffic skeds! Nice to have CK back on the air. YVJ (OO) wishes the guys would monitor their own sigs! That feller VHN sure gets around the traffic nets, both c.w. and 'phone. QR, PAM, reports 22 members of the MTN 2-meter traffic net — they said it couldn't be done. DCB says he is rebuilding the big rig; MES and KER are running 800 watts on 75; FHE is sporting Viking II; GFU and WWU are reinstalling mobile rigs in their new cars. AREC Notes: Daylight Emerg. Net, ONI EC, invites checkings noon Thurs. at 146.8 Mc. Centinella Valley. OI EC, reports good acceptance of new 2-meter section. San Fernando Valley Net, GIO EC, is on 24-hour stand-by in case of winter floods. Long Beach Emerg. Net, FEI EC, now has two fully-equipped Control Stations. Hexagon, NCO EC, is one of the fastest growing nets in the section. We regret to announce the resignation because of business pressure of DCB, EC, of Mid Cities Net — a fine EC and a great organizer. Whittier, BLY EC, maybe the EC being one of the City Fathers has something to do with the fine control station and equipment utilized by this Net. Glen Area, VCU EC, threw a baug-up Christmas party. Traffic: W6KYV 6436, GYH 1154, HK 913, VHN 891, BHG 284, GJP 186, WRT 122, NTN 116, QR 115, FMG 104, PWZ 90, HLZ 72, WOO 72, ESR 70, YBF 64, FYW 51, QIW 41, DPL 35, BLY 30, CMN 25, COZ 16, NCA 16, YCF 14, HIF 13, CBO 8, GEB 8, NJU 5, CK 2. Others reporting: BUK, KLD, KQS, PIB, and YVJ.

ARIZONA — SCM, Albert Steinbrecher, W7LVR — Asst. SCMs: Kenneth P. Cole, 7QZH; Dr. John A. Stewart, 7SX. SEC: OIF, RM: JGZ. Arizona Fone Net: Tues. and Thurs., 7 P.M., 3865 kc.; Arizona C.W. Net: Mon., Wed., Fri., 8 P.M., 3515 kc.; Phoenix Net: Tues. and Thurs., 7 P.M., 29 Mc.; Tucson Net: Thurs., 8 P.M., 29 Mc.; Arizona 6&2 Net: Nightly 7 P.M., Arizona MARS: Tues. and Thurs., 9 P.M., 4025 kc.; Arizona Restricted Speed C.W. Net: Mon., Wed., Fri., 8 P.M., 3700 kc., 8-12 w.p.m. The outstanding event of December was the picnic-meeting held in South Mountain Park, Phoenix, for the purpose of establishing a state-wide mobile net. Those present included DJE, DRQ, JOK, JYH, KOY, KWB, LDS, LQB, LVR, MAB, MAL, MWQ, NAP, NRG, OIF, OQS, PLX, PZ, QED, QHT, QZL, RAB, SHR, UDI, 5PET, 6PEB, and 01AA. The OPRC was given a very interesting teletype demonstration by GDF and FGG. QZH has a new 75 antenna on metal towers. OAO is shielding his TV receiver. SIC has new 250-watt transmitter with Reinartz Modulation. NRF is on 40-meter c.w. with Command Set. QFQ is using a GP on 40 and 80 and it works. PUV is in the hospital after a traffic accident. LBN returned from France, where he was F7AY. GYK is back from a European tour. QQU departed for overseas. New calls: OUM, SIP, SSG, STW. New appointees: ORS — KOY, PLM, QFQ; OPS — KOY, PLM; ECs: JYH, QZH. Traffic: W7PLM 338, K7FAG 213, W7QFQ 188, KOY 129, LVR 40, MLL 14, KYM 7, LOC 3, SIC 1.

SAN DIEGO — Acting SCM, Thomas H. Wells, W6EWU — Asst. SCMs: Shelley E. Trotter, 6BAM; Richard E. Huddleston, 6DLN. SEC: SK. Asst. SECs: WYA, FOP, RM: AUE, EC: DEY. December reports indicate a special tribute should be paid the men who handled overseas Christmas traffic. They gave generously of their time. Many will go unsung but we do know about Ray and IAB, with a fantastic total of over 12,000. We also heard how AA and CGQ freely used their 'phone patch facilities. IAB now is using new ground plane on 40 meters for skeds with KG6ADZ, and building a new gallon for 20 and a mere 400 for 75 meters. HFT, FMJ, and TTW now are s.a.b. in the San Diego Area. CHV went strong in the SS Party. MGT and GTC passed the Advanced Class exam. DYM and SAK made General Class from Novice. Five Valley towns turned out for the December Palomar meeting and put the old club back on its feet. JAN is in the hospital and LWH injured his hand. HJG's XYL now is W6GRWM. The Fullerton Radio Club has its own call, ULI. BAM's nephew is leaving for AC but just made W6SYC. ZE has the car looking like an angry porcupine with antennas for 4 bands. Traffic: (Dec.) W6IAB 12,251, IZG 593, MUE 280, FCT 18, FJH 8, GTC 7. (Nov.) W6YDK 314, ELQ 264, MUE 40.

### WEST GULF DIVISION

NORTHERN TEXAS — SCM, William J. Gentry, W5GF — Asst. SCM: Thomas B. Craig, 5JQD. SEC: QHI, PAM: IQW. QHI took over as SEC Dec. 15th. JQD now is Asst. SCM to assist in coordinating emergency and traffic work. UZM was made an OBS. ROH is building a new rig with a pair of 812As in the final. SRQ has a new wire recorder. The South Plains Amateur Radio Club now has two transmitters, a Collins and a Meek. We are in need of a

(Continued on page 110)



LEO I. MEYERSON WØGFQ  
CU ON 10-20 & 75 METERS

# FELLOWS... LET ME PROVE that you can afford the world's best buy... a WRL GLOBE KING TRANSMITTER

We allow you more on trade-ins—our large volume of sales means faster turn-over and greater savings for you. We finance our own paper—there's no red tape. We accept low down payments—name your own terms. WRL buys more equipment—WRL sells more equipment. We offer the most personalized service anywhere.

It pays to deal with WRL—"One of the World's Largest Distributors of Amateur Radio Transmitting Equipment."

**"I FOUND GLOBE KING LOWER IN PRICE, HIGHER IN POWER, & EQUAL IN QUALITY TO ALL OTHER RIGS!"**

*Writes Jack Ashley, W40SC.*

"When I first began considering purchasing a new commercial transmitter, there were three main factors which I had in mind: Price; Power; and Quality. After several months of consideration, viewing the specifications of most all of the commercial rigs available on the market, I finally made my decision on the "GLOBE KING" . . . I found the Globe King lower in price, higher in power, and equal in quality to all other rigs . . . I've enjoyed using the GLOBE KING very much and it has held up to all my expectations. I can recommend it to any "Ham" who wants a transmitter with plenty of punch and at a reasonable price."

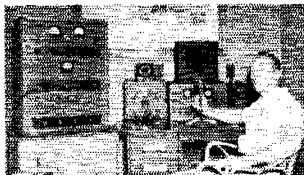

Jack Ashley with his Globe King

Signed/Jack H. Ashley W40SC, Box 254, Ware Shoals, S.C.

**NEW WRL 400-WATTS Phone-CW  
GLOBE KING XMTR**  
Send for complete data sheet

KIT FORM WIRED-TESTED  
**\$475.00 \$495.00**

## NEW ENGINEERING TRIUMPH! THE WRL GLOBE SCOUT

(50 WATTS PHONE — CW)

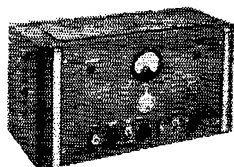

The WRL GLOBE SCOUT is the latest triumph of the WRL engineering staff. It is a beautiful, compact XMTR, completely self-contained, including power supply — 8H X 14½W X 8¼D. Contains new 6146 tube in final; covers 160M thru 10M. Metering provided for final grid and

final plate circuits. Complete kit includes all parts, chassis, panel, power supply, cabinet, tubes, meter and one set of coils. Can be used for mobile work with suitable power supply. (Auxiliary socket provided.) An ideal XMTR for the novice or the experienced ham.

### GLOBE SCOUT ACCESSORIES

Coil sets available for 160, 80, 40, 20, 15 and 11-10, per each set. . . . . \$3.00  
Crystals 160, 80, or 40M (40M used on 10-20) each. . . . . \$2.75  
Quality crystal microphone and stand. . . . . \$10.17  
Signal R-50 Key. . . . . \$1.43  
40 Meter Coils for new 40M Phone Band. . . . . \$3.00

KIT FORM WIRED  
(Incl. all parts (By our and tubes) engineers)  
**\$89.95 \$99.95**

**WRL 165 WATT  
GLOBE CHAMPION XMTR**

(less accessories) **KIT-FORM WIRED  
\$329.50 \$349.50**

**SEND NOW!  
FREE 1953 WRL CATALOG**

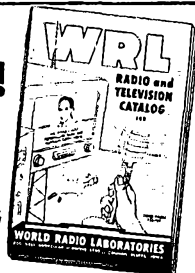

### GET READY FOR THE 40 METER PHONE BAND

See us for all of the latest 40 Meter Gear, including Gonset Super Six—\$52.50, and new Morrow 5BR—\$74.95. We will be first with the latest gear as it is released from the factory.

We have in stock 40 Meter crystals, coils, antennas. Crystals for new 40 Meter Phone Band.

7200-7300 K.C.—\$1.50 ea.

Amphenol 40 M folded dipol—\$7.80

Globe King XMTR 40 M Coils—\$7.75 per set

Globe Champion XMTR 40 M Coils—\$7.60 per set

### RADIO REFERENCE MAP



**25¢**  
HANDY WALL SIZE

WRITE FOR DETAILED SPECIFICATION EQUIPMENT SHEETS

WRITE WIRE

PHONE 7795



World Radio Laboratories, Inc.  
744 West Broadway  
Council Bluffs, Iowa

Q-3

Please send me:

- New Log Book 25c  
 Free Catalog  
 Radio Map 25c  
 Globe Scout Info  
 Globe King Info  
 Globe Champion Info  
 Used Equipment List

Name \_\_\_\_\_  
Address \_\_\_\_\_  
City \_\_\_\_\_ State \_\_\_\_\_

22 OUNCES  
total weight

CENTER - LOADED

# Web Wip

## MOBILE ANTENNA

Here is a new, light-weight antenna with excellent electrical characteristics achieved by effective utilization of the center-loaded principle.

### Lightweight...Strong...Streamlined!

The remarkable, strength-with-flexibility properties of certain glass fiber materials have made possible the complete elimination of heavy metallic supports, these being replaced by extremely sturdy, (but light in weight) fiber glass tubing columns. There are no joints or couplings between support column and loading section in this design since the loading section is wound directly on the upper portion of the high-dielectric fiber glass tube.

### Safe...Flexible...Weatherproof!

The whip used to provide additional height and top capacity is extremely flexible, (bends into a half circle without fracture) and is rendered weatherproof by a bonded-on jacket of fiber glass material. Whip is also demountable for storage. Both whip and support column bases have Chrome plated brass fittings with standard 3/8 SAE threads. Any standard base mount may therefore be used. Antenna is completely treated throughout for anti-corrosion and satisfactory operation under adverse weather conditions.

### Proven!

WEB-WIP center loaded antennas have been widely used by Military, commercial and marine services for many years. Ask any marine man about the WEBSTER "TIARE" antenna . . . over 8000 of these are in service. Successful, field-proven techniques for these exacting designs have been applied to the design and construction of the amateur WEB-WIP center loaded antenna.

WEB-WIP . . .  
Available for 80, 40 or 20. (Specify)  
Net.....\$18.00

(Antennas for higher and lower frequencies are also available on special order)

At your dealer, or write

**WEBSTER**  
Manufacturing Company.

Broadway & Davis Sts., San Francisco, Calif.

good RM for Northern Texas. Let's hear from some of you active traffic men. Traffic: W5QHI 512, TFB 417, BKH 186, PAK 135, LEZ 111, VRX 85, SRQ 59, RRM 54, UFP 27, ROH 4, GF 2.

**OKLAHOMA** — SCM, Jesse M. Langford, W5GVV — SEC: AGM. RM: OQD. PAMs: GZK and ATJ. December gave us two more fine hamfests, one in Enid and the other in Oklahoma City. There were 46 present at the Enid Amateur Radio Club's annual dinner and the principal speaker was Orin Gattlin the communications officer for civil defense. There were 125 present at the Oklahoma City dinner. Governor Murray spoke on civil defense and the proposed car tag bill. BDX now has a phase type single sideband. OZE now has First Phone license and is working at the station in Frederick. RD1 is rebuilding the rig into a cabinet. SWM is off the air while in Missouri. OXJ now is in Stillwater. UZG finds 7 Mc. best for skeds. VRV and HXL are keeping 144 Mc. alive. HLD now has Viking 11 on the air. TKC has new coax feeder and is running 225 watts. 1VT is moving from Tulsa to Oklahoma City. DRE and OQT have new mobile on 3.9 Mc. running 85 watts. ROZ has 32V3. WN5YQO is a new Novice in Enid. K5FAS, at VAFB, will be on soon with a kw. LWG is building a new rig. The Lawton-Ft. Sill Club held its annual dinner Feb. 15th. SWJ is on 3.9-Mc. phone. RST spent Christmas in Colorado Springs. JP is back from Florida. HGC is working in Oklahoma City. 1WJ aided the Enid gang with his mobile emergency truck by directing the mobiles to the dinner site. Traffic: (Dec.) W5GZK 293, SWJ 207, MRK 125, KY 100, ROZ 66, MQI 60, MFX 57, OQD 57, QAC 52, EHC 36, SVR 25, QVV 22, PA 21, GVV 20, ESB 11, ADC 9, OFG 8, PML 8, LWG 5, TKC 2. (Nov.) W5MRK 70.

**SOUTHERN TEXAS** — SCM, Dr. Charles Fermaglich, W5JFF — Your SCM had an enjoyable visit with the Galveston County Amateur Radio Club. Emergency Communication and the coming ARRL National Convention were discussed. PTV is pres.; ULN, vice-pres.; PZG, secy.; and VUS treas. of the Club, which meets on the 1st and 3rd Wed. of each month, at 7:30 at the Galveston County Health Unit in La Marque. K5WAC now has two TV stations and no TV1 so they are keeping their fingers crossed. QFA spent one week in California and saw lots of mountains and fog. SAH reports: UMH and SWC recently received General Class tickets. ABQ recently was laid up in bed for 30 days with an injured leg. He keyed the rig in his shack from his bed and made many contacts on 20-, 40-, and 80-meter c.w. His XYL had the chore of bringing up the rig by the chart. CLH has a 28-Mc. mobile. TOL broke an ankle playing football so now he has plenty of time to build a 50- and 25-watt rig. MN is handling lots of traffic. WXQ made Class B. 1QVK now is in Texas City. The Port Arthur Amateur Radio Club puts out a paper called *The Monitor*, edited by NNF. Revere Smith reports: VQM is building a new band-switching transmitter running 50 to 100 watts. WN5YNK is on 80 meters. His brother, WN5WRW, is quite proud of him as Robert is only 10 years old. WN5YFC is going up for a General Class license and his dad is going along to take the Novice Class exam. TFD has received his Advanced Class ticket and is back on with a new 4D32 for his Viking. He is on 20-meter phone but prefers 20-meter c.w. WKT is at S.M.U. and has his rig with him. UTR is using the club rig and doing FB. OYP, of Houston, wrote Cecil inviting all hams in Port Arthur to join the 80-meter c.w. net. WRE is working to get his rig on 80 meters. TEH and APX are back from Florida and they had lots of QSOs on a portable 80-meter rig. UUU has worked all states with 47 confirmed, and also has worked 11 countries. NUC has been commissioned as a captain in the Signal Corps of the Texas State Guard Reserve Corps. EYV is doing very well with his photography. Plan now to attend the ARRL National Convention July 10-11-12, 1953, in Houston. FJF is general chairman. Watch QST for details. Registration is \$13.50 per person and a swell program with lots of social functions is being planned. Bring the XYL — she will have a fine time. Traffic: K5WAC 839, W5MN 770, OYP 88, ABQ 14.

**NEW MEXICO** — Acting SCM, R. J. Matthias, W5BIW — With the advent of two new TV stations in El Paso, Tex., the amateurs in the southern section of New Mexico are experiencing their first brush with TVI. Many have been TVI-proofing their rigs and much concern is being shown by all members of the Mesilla Valley Radio Club to meet the situation and the problems it presents. For several hours on the afternoon of Dec. 28th the New Mexico MARS Net was in a state of anxiety. A5RFK and his OM, A5RFJ, had flown up to Roy, N. Mex., to visit with A5RTS and her OM, A5MOX. They left Roy about 2 and were due back in Alamogordo at 5 and had made a schedule. When they didn't show up for the sked by 6:30 or 7 all members of the net were beginning to worry about them, but they finally did get back. It seems they ran into strong head winds and ran out of gas and had to land on a road near Tularosa. It has been fairly definitely established that the State Ham Picnic will be held at Bottomless Lakes, a State Park near Roswell. The date still is not set but probably will be the latter part of May or early June.

(Continued on page 118)



# GREAT NEWS!

# Sun Radio

## NEW YORK'S FIRST

# ELECTRONIC SUPERMARKET

## 650 SIXTH AVENUE Corner 20th St.

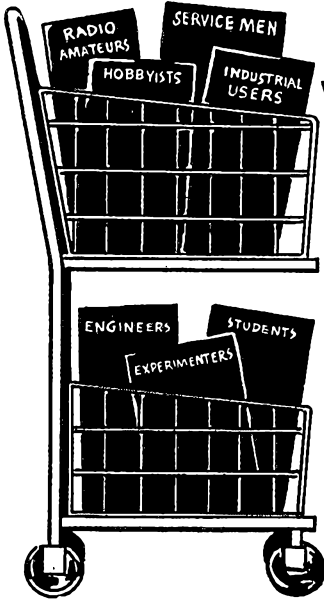

Stop in today. You can't afford to miss our tremendous values during our mammoth opening sale. Come in and browse or buy at your leisure. Every item in our tremendous stock has been specially priced for this event.

In order to keep up with modern buying trends, Sun Radio has moved to a bigger and more easily accessible location to bring you the first electronic shoppers' world. A paradise of everything electronic in over 20,000 sq. ft. of ground floor space.

### CHECK THESE INNOVATIONS:

- Over 150 ft. of counter space.
- Complete displays of all test equipment, transmitters, receivers, etc.
- Complete stock of radio and TV replacement parts.
- Complete stock of amateur radio equipment.
- Self-service TV antenna bar.
- 3 complete sound studios.
- Complete staff of qualified sales personnel.
- Easily accessible to Metropolitan New York, New Jersey and Long Island.

## over \$1,000.00 in Prizes

# FREE!

Stop in to see our new home, and please don't fail to register so that you may qualify for one of these valuable prizes. Drawing date will be on April 11th, 1953 and all winners will be notified if they are not present. Don't miss out on these great prizes. Stop in today and see the NEW . . . BIGGER . . . BETTER Sun Radio!

### FIRST PRIZE

RCA Master Voltomyst WV87A



- 2 RCA WV77 Junior Voltomyst
- 5 Eico 221K V.T.V.M. Kits

### SECOND PRIZE

Precision 612P Cathode Conductance Tube Tester

- 3 Eico 320 K Signal Generator Kit
- 5 Superior 770 Volt-ohm-milliameters

10 American Beauty #3138 Soldering Guns

### THIRD PRIZE

Simpson Model 303 V.T.V.M.

- 10 Weller WD 135 Solder Guns
- 50 \$5.00 Gift Certificates



**Sun Radio & ELECTRONICS CO. INC.**  
 650 Sixth Ave. at corner of 20th St., New York, N. Y. ORegon 5-8600  
 Open Daily & Saturday 8:30 - 6:00



\* **HEAT DISSIPATING  
CONNECTORS**

**Vacuum Tube Accessories  
by Eimac —  
Now Available!**

Type HR heat dissipating connectors are designed to provide an efficient method of heat transfer from tube elements and seals to the air. Also facilitate electrical connection to plate or grid leads of most popular transmitting tube types. Machined from solid dural rod, come complete with necessary machine screws for use.

- Write for new Eimac Catalogue Summary showing Eimac tubes and other accessories.

*Eimac*  
MILWAUKEE, WIS.

**EITEL - McCULLOUGH, INC.  
San Bruno, California**

**RECEIVING SENDING  
CODE *Speed*  
without  
strain**

**CHAMPIONS ENDORSE CANDLER WAY**

Get skill, accuracy, speed with the highly endorsed Candler System. Learn to send and receive by telegraph or radio code. Government service and commerce need thousands of better trained operators. Air commerce, mail, freight, etc., demand expert, reliable operators. Good pay. Get the Candler System, the maker of champions. It teaches you the "knack" of sound sense, alertness, speedy sending and receiving without strain. Adventure — good pay. Learn at home or wherever you are. Rush name today for free book.

**FREE!**

**CANDLER SYSTEM CO.**

Dept. 4-C, Box 928, Denver 1, Colorado, U.S.A. and at 52b, Abington Road, Kensington High St., London W.8, England

**CANADA**

**MARITIME** — SCM, A. M. Crowell, VE1DQ — SEC: FQ, EC: EK, RM: OM, FQ made an all-time high in northern traffic this month. QZ lost his 6- and 2-meter beams. HC has been active in c.w. in the Maritime Net. We hear OC and OM have been working a few on the 21-Mc. band. DB has been giving the new Lyco a workout with new tuned-Zepp antenna. MK reports for the Cabot C.D. Net — Mon. on c.w. at 6:30 p.m. AST. 3625 kc., and on 'phone at 7:00 p.m., 3985 kc. PQ, WL, and HJ have been working a bit of DX on 21 Mc. ABX has been transferred to Vimy, Ont. NP is going to f.m. the TA-12. SI now is in VE3-Land. HD is using the new Morrow converter with the mobile rig. The following is from VO6-I and via VO6U: Active in Goose Bay are 6AA, 6P, 6X, 6U; Hopedale, 6F; Hebron, 6S; Nain, 6M (on 3.8 Mc.) and old-timer 6B on 14 and 3.8 Mc. The Labrador Net meets nightly at 2045 GMT. 6L is running 50 watts on 80, 40, and 20 meters. 6N is on c.w. on three bands. 6P has a bandswitching 807 final 10 through 80 meters. 6T has an 829-B on 75-meter 'phone. 6B, with his faithful 814, has about 100 watts on 75- and 20-meter 'phone. 6U is handling QSLs for the VO6 boys and anyone with cards for unlisted VO6s can send them to Doug, % Dept. of Transport, Goose Bay, Labrador. Traffic: (Dec.) VE1FQ 290, VO6N 114, VE1HC 52, QZ 30, VO6L 30, 6S 26, 6AA 16, VE1MK 10, VO6R 8. (Nov.) VE1MK 31.

**ONTARIO** — SCM, G. Eric Farquhar, VE3IA — West-side Club of Toronto officials for the coming year are IZ, pres., UT, vice-pres.; AIB, secy. Plaudits to ATR and BMG for spark-plugging the new c.w. channel, which is receiving encouraging response. It is the (RSN) restricted speed net, operating on 3645 kc. at 1330 EST Sundays. Many newcomers are taking advantage of the opportunity to gain actual operating knowledge on this net. Other nets which are popular in this section are Ontario Section Net (OSN) 3535 kc.; QON, 7160 kc.; and MI.N, 7160 kc. BNC's new call is BB. Welcome to ACY on his joining hamdom. Congrats to the participants of the October CD party. Ontario section top scorers were BUR, EAM, and AVS. To ACS upon his retirement may we wish the very best and that he be spared to participate in and enjoy his hobby. BIG now resides in Miami. EAB has completed antenna overhaul. The name of the new club in Kapuskasing takes us back to the rotary gap days, "Northern Sparks Club." OJ and XZ keep 3.5-Mc. skeds. DOU cleaned up TVI and rebuilt the receiver. The Hamilton club held a turkey roll. Via the grapevine we learn the hams' New Year's party at Oakville was a humdinger. The Hamilton Emergency Corps with members of the Mohawk and Hamilton Clubs, gave a fine demonstration of emergency operation with mobile and fixed stations in the banquet room of A.F. & A.M. KM presided. ANA operated the rig; DGZ and IA spoke to the gathering. Traffic: (Dec.) VE3ATR 293, WY 278, BUR 248, IA 246, DGZ 192, EAM 100, BJV 98, EAU 37, IL 23, DFE 22, PH 21, DQA 17, OJ 16, VZ 15, AUU 12, BSF 12, AVS 2. (Nov.) VF3DOU 7, VZ 2.

**QUEBEC** — SCM, Gordon A. Lynn, VE2GL — AMB makes RPL this month, with 121 originated and 67 delivered to form part of a total of 371. JN reports that the St. Johns Area staged a public demonstration before local civic leaders and higher level civil defense representatives with SG, AEE, JN, and AOZ taking part with mobile and emergency stations. UM is active on 20-meter 'phone from Montreal. EC reports that LaTuque is now represented on 80 meters with ASK and NB. CA still complains of poor conditions, but in spite of this Phyl manages a nice traffic total. DR reports into QEN on Sundays and handles a bit of other traffic on 40 meters. KG transmits Official Bulletins on 28,440 and 28,608 kc. at 1900 and 2300 daily and at 1300 Sat. and Sun. The South Shore Amateur Radio Club held a very successful dance Dec. 9th with most of the hams on South Shore attending with their XYIs and YIs. Many good personal QSOs were had. Traffic: VE2AMB 371, CA 75, DR 14, EC 12, GL 7, JN 3, UM 2.

**ALBERTA** — SCM, Sydney T. Jones, VE6MJ — It is with sincere regret we record the passing of Colin Heseltine, VE6CH, of High River. Colin was an active member of the Alberta 'phone net and was highly regarded, not only in amateur radio circles but in his community. HM has returned after an enjoyable trip to Hartford and Halifax. LQ received a Christmas present of a new telephone. ZA and YP are new calls in Edmonton. OK has left Edmonton for greener pastures to the east. Good luck, Jake, in the new job. EH has been visiting the U.S.A. on business in connection with his work as a pilot. PE has his frequency standard completed. ZR is active on 3.5-Mc. c.w. DO is having trouble with his rig. DZ made an excellent showing in the November Frequency Measuring Test. The monthly reports have been very few, fellows. Let's make 1953 a banner year. Report your activity to your SCM not later than the 7th of each month. OD says conditions on 75 meters had better improve soon or the Alberta 'phone net will be non-existent. MJ is building a basement shack. Traffic: VE6OD 34, MJ 9.

**BRITISH COLUMBIA** — SCM, Wilf Moorhouse, VE7US — BF is getting ready for 20 SS. AQS is back on land. AQR is on 40 meters. JI is on 80-meter c.w. LP is in

(Continued on page 114)

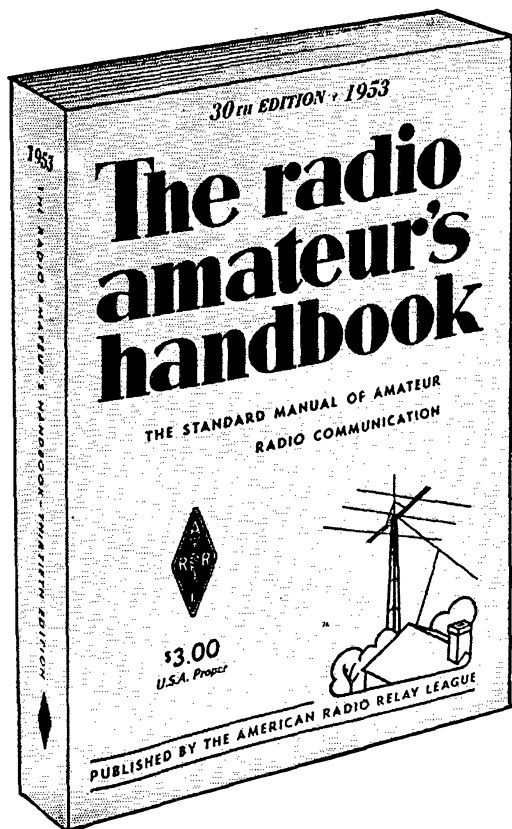

1953 edition  
now ON SALE

800 pages

700 photos-diagrams

466 tube base  
diagrams

*A* complete and comprehensive treatment of radio and electronics from simple to advanced radio theory and technique. A valuable asset, a constant reference source for the bookshelf of every amateur, engineer, experimenter and technician. Theory, construction, application . . . all are covered in this internationally accepted Handbook—plus a complete catalog section featuring leading manufacturers and suppliers of electronic equipment, components and tubes, providing an ideal buying guide for purchasing agents as well as individual users of parts and equipment.

\$3 USA proper

\$3.50 US Possessions and Canada

\$4 Elsewhere

Buckram Bound Edition \$5 Everywhere

The AMERICAN RADIO RELAY LEAGUE, Inc.  
WEST HARTFORD 7, CONN.

# ELECTRON TUBE TECHNICIANS

*We now have  
several openings  
for technicians  
to work in the fabrication  
and processing of  
advanced type electron  
tube research models.*

To qualify for one of these openings you should be experienced in experimental work for research and development in vacuum tubes, which includes the fields of mechanics, electronics, chemistry and high-vacuum techniques.

ADDRESS  
RESUME OF  
TRAINING AND  
EXPERIENCE  
TO

**HUGHES**  
**RESEARCH AND**  
**DEVELOPMENT**  
**LABORATORIES**

*Technical Personnel  
Department*

CULVER CITY, LOS ANGELES  
COUNTY, CALIFORNIA

## GET YOUR COMMERCIAL TICKET EASIER WITH ...

**RADIO OPERATOR'S LICENSE  
Q AND A MANUAL  
(4th Edition)**  
by Milton Kaufman  
Covers Elements 1 through  
8. Complete discussion  
of answers to every  
technical question in the  
F.C.C. Study Guide! Used  
by over 50 leading  
schools. Only \$6.60 at  
jobbers, bookstores  
or direct from—



**JOHN F. RIDER** Publisher, Inc.

480 Canal Street, New York 13, N. Y.

television. AKD/M visited VI. Letters were received from YM and AKI. TM is on 75 meters with f.m. rig. EB again is mobile. QZ and his XYL are back home after a Christmas trip. New ham in Victoria: KA's XYL. BCARA still is in operation on 3755 kc., although band conditions are very poor. QV is doing an excellent job of net managing during QC's absence. AHII has QSYed from Parksville to Vancouver. AMP, also in Vancouver, is busy with studies. Traffic: VE7QC 75. AOB 14, DH 11, AKI 10, YM 2.

**MANITOBA**—Acting SCM, Len Cuff, VE4LC—DL, NI, RV, and FU are now to be heard ether-busting on the 21-Mc. band. RY is a new one heard on 20-meter 'phone. HP has a new antenna up for 40 and 75 meters. CE is back on after fixing up filter trouble. QD still is off with transmitter troubles. MK is heard on 40 meters working Ws with only 20 watts. AR was a visitor to Winnipeg during the Christmas holidays. IF has returned to his business in Brandon and his XYL, GE, will follow soon. 5TE was a recent visitor to Winnipeg, complete with mobile rig. 5NH, ex-4GI, and his XYL, passed through the city recently on transfer to VE2-Land. To Doris, XYL of QV, we extend a very hearty welcome home after her lengthy illness. If you have some news items, fellows, will you please pass them along to I.C. Traffic: VE4HL 86, ER 20.

**SASKATCHEWAN**—SCM, Harold R. Horn, VE5HR—It is with deep regret that we record the passing of VE5EV. Len was a valued member of the 'phone net and our sympathy goes to Mrs. Ewert and Stan. VE7SJ. Another very successful communication drill was held at Fort Qu'Appelle and c.d. officials once again were pleased with the efforts put forth. AJ is getting out on 21 Mc. GO puts out a nice signal with new rig on 20- and 75-meter 'phone. JC has a new SX-71 and is working on transmitter. BV and HR are heard on TL "1" regularly and can QSP any East-West traffic. JK now is mobile on v.h.f. and after numerous attempts the first 50-Mc. contact between Regina and Moose Jaw was made. Reports would be appreciated from others on v.h.f. BZ would like reports from all ECs. The Regina Club held a novel Christmas Party. OF, TL, IW, and JK acted as hosts and used their rigs and UQ/mobile to move the parties from house to house. UQ had his sister from VK-Land as an honored guest. Thanks for a nice report. Jack. Traffic: (Dec.) VE5HR 74, GI 43, DR 25, DS 20, TE 20, GO 18, BV 15, LU 13, DD 8, QL 8, BZ 7, PJ 6. (Nov.) VE5BV 18, PJ 6.

### HAMS AT HEADQUARTERS

#### W1AW, ARRL Headquarters Station

The following calls and personal sines belong to members of the Headquarters gang:

W1BDI	F. E. Handy, "fl"
W1BUD	A. L. Budlong, "bud"
W1CEG	H. M. McKean, "mac"
W1DF	George Grammer, "gg"
W1DX	Byron Goodman, "by"
W1FWH	W. E. Bradley, "wb"
W1HDQ	E. P. Tilton, "ed"
W1ICP	L. G. McCoy, "lew"
W1JEQ	C. V. Chambers, "ve"
W1JMY	J. A. Moskey, "joe"
W1LVQ	John Huntoon, "jh"
W1MFA	H. K. Isham, "hk"
W1NJM	George Hart, "geo"
W1QIS	Murray Powell, "mp"
W1RWS	John E. Cann, "jc"
W1TS	D. H. Mix, "don"
W1VG	L. A. Morrow, "pete"
W1VMW	Rod H. Newkirk, "rod"
W1WPO	R. L. White, "bob"
W1WPR	C. R. Bender, "er"
W1WVRJ	A. Murray Rommé, "mr"
W1YYM	Ellen White, "in"
W2VAX/1	C. L. Wood, "chas"

## SWITCH TO SAFETY!



# See NEWARK! For "Up to the Minute" HAM EQUIPMENT

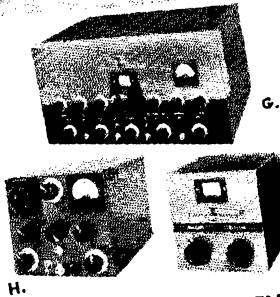

## E. F. JOHNSON EQUIPMENT VIKING II TRANSMITTER KIT

Fig. G. New version of the Viking I band-switching 100-watt phone/115 watt CW amateur transmitter kit. Incorporates all features of its predecessor plus TVI suppression. Full output is available on the 160, 80, 40, 20, 15 and 11 and 10 meter Amateur bands. With tubes, cabinet, punched chassis, wiring harness, wire hardware and detailed instructions. For 110-120 volts, 50-60 cycles. Shpg. wt., 91 lbs. **279.50**  
97F455. NET.....

## VIKING MOBILE TRANSMITTER KIT

Fig. H. Provides up to 60 watts on 75, 20 and 10 meter phone. Complete bandswitching and provision for one additional band. 4-position crystal selector switch, with additional position for external VFO. Requires 600 volts DC at 200 ma and 6.3 volts at 3.75 amps. Size: 6 $\frac{7}{16}$ x7 $\frac{1}{8}$ x10 $\frac{9}{16}$ ". With cabinet, chassis, parts and instructions. Less tubes. Wt., 16 lbs. **99.50**  
97F454. NET.....

## VIKING VFO KIT

Fig. I. Companion unit to famous Johnson Viking II Transmitter Kit. May also be used with similar transmitter. Only two controls: frequency control and bandswitch. Cabinet, frequency control and bandswitch. With all parts, plugs, cables, and instructions; less tubes. 7 lbs. **42.75**  
97F451. NET.....

## HAMMARLUND HQ-129X POPULAR AMATEUR RECEIVER

Fig. J. Representative of Hammarlund's precision craftsmanship, the model HQ-129X incorporates many outstanding features, such as high sensitivity, selectivity, and efficiency matic noise limiter. Provides continuous frequency coverage from 540 kc to 31 mc in 6 and a special tuning condenser which permits full 310 degrees of bandspread for each meter band—80, 40, 20 and 10 meters. Shpg. wt., 75 lbs. **239.50**  
97F400. NET.....

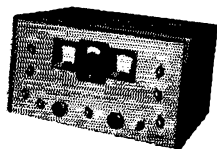

J.

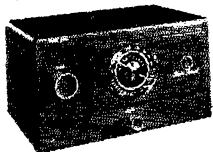
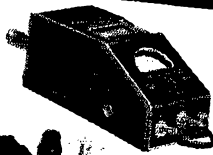

Fig. K. Compact new FM receivers covering police, fire, taxicab, truck, railroad, and other industrial frequencies. May also be used as stationary receivers or monitors in conjunction with the "Little-lone" systems. Have illuminated circular dial with main channels marked. Circuit: 12A17, 2-12BA6, 12AL5, 12SO7 and 50L6GT. Include selenium rectifier, headphone jack, and built-in PM speaker. Black wrinkle-finish steel cabinets, 12 $\frac{1}{2}$ x7 $\frac{1}{4}$ ". For 105-125 volts, AC or DC. Shpg. wt., 14 lbs. **49.50**  
98F017. Model S-81. Covers 152-173 mc. NET EACH.....  
98F018. Model S-82. Covers 30-50 mc.

## hallicrafters

CIVIL PATROL  
MODELS 5-81 AND 5-82



## MILLEN 90651 GRID DIP METER

Fig. A. Accurate measuring instrument using calibrated RF oscillator principle. 2 $\frac{1}{2}$  G.E. commonly used to find resonant frequency of non-energized tuned circuits. Other valuable uses include receiver tuned circuit alignment. Range: 1.7 to 300 mc, in 7 overlapping bands; separate plug-in coils for each. Calibrated 270 $\frac{1}{2}$  dial has 7 direct-reading, one universal scale, 7x3 $\frac{1}{2}$ x6x3 $\frac{3}{4}$ ". For 105-125 volts, 50-60 cycles. With coil rack, 7 coils and tube. Shpg. wt., 3 $\frac{1}{2}$  lbs. **61.50**  
97F208. NET.....



## MEISSNER MODEL 2-CW NOVICE TRANSMITTER KIT

Fig. B. Transmitter kit for the new novice class. Operate as transmitter with folded dipole antenna. 20 to 25 watts input. Terminal strip at rear of chassis for metering plate coil, punched chassis, all parts and instructions; less crystal and tubes. For 110-120 volts, 60 cycles AC. Wt., 7 $\frac{1}{4}$  lbs. **24.45**  
97F062. NET.....

## GONSET AMATEUR EQUIPMENT 3016 "COMMANDER" TRANSMITTER

Fig. C. Multi-band transmitter covering 1.7 to 54 mc continuous. Power requirements: 300 volts DC at 200-225 ma (phone) and 6.3 volts AC or DC at 3.15 amp. 35 watts input on phone. 50 watts on CW. Provision for all conventional feed lines. Tubes: 6AG7, 6146, 12AT7, 2-6AQ5. With tubes and two high Q final tank coils for 10-11, 15, 20, 40, 75 and 80 meters. Final coils for other frequencies available on special order. 8 lbs. **124.50**  
97F111. NET.....

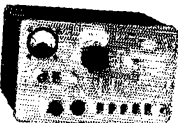

## Fig. D. 2 Meter Converter

For fixed or mobile stations. Super bandspread has twenty main tuning dial divisions for 144-146 mc as well as 146-148 mc. Output, 1 mc. Tubes: 6CR6, 12AT7, OB2. In gray case, 5 $\frac{1}{8}$ x3 $\frac{1}{2}$ x3 $\frac{1}{2}$ ". Shpg. wt., 5 lbs. **44.50**  
97F110. NET.....



Fig. E. Clipper Noise Limiter. Reduces interference from ignition noise, power leads, in any receiver in which second detector and first audio is in one tube. Mounts on chassis and cables. 2x4x1 $\frac{1}{2}$ ". Wt., 2 lbs. **9.24**  
97F104. NET.....

Write to Department T-33

Just Out!  
NEWARKS NEW  
CATALOG NO. 55

FREE!

196 Pages of the Latest Releases in Radio,  
TV, Industrial Electronics and High Fidelity.

**NEWARK**  
ELECTRIC COMPANY

223 W. MADISON ST. CHICAGO 6, ILL.

## BECOME A RADIO AMATEUR

# LEARN CODE AND THEORY FOR AS LOW AS \$6.95

ECONOMICAL HOME STUDY COURSES PREPARE YOU TO PASS AMATEUR AND COMMERCIAL CODE EXAMS, AND A M A T E U R THEORY EXAMS THE EASY, FAST WAY.



78 RPM

### 4 "AMECO" COURSES AVAILABLE: NOW! HERE'S OUR NEWEST COURSE. PREPARES NOVICE FOR GENERAL OR COMMERCIAL F.C.C. EXAM. . . .

**No. 4—NEW ADVANCED COURSE.** Prepares Novice operators for the amateur general class and second class commercial license tests. Contains 12 recordings — (8 through 18 W.P.M.) PLUS the complete code book — PLUS typical F.C.C. code examinations for general and commercial tests. All for only . . . . . \$6.95

**No. 1—NOVICE CODE COURSE.** You get and keep 10 recordings (alphabet through 8 W.P.M.). Includes typical F.C.C.-type code exams. Free instruction book on learning how to send and receive code the simplest, fastest way; plus charts to check your receiving accuracy plus an album all for the low price of only . . . . . \$7.95

**No. 2—SENIOR CODE COURSE.** You get and keep everything given the Novice Course except that you get 22 recordings (alphabet through 18 W.P.M.), plus typical F.C.C.-type code exams for General class and 2nd class commercial telegraph licenses. All this for only . . . \$12.95

**No. 3—COMPLETE RADIO THEORY COURSE.** A complete, simplified home study theory course in radio, covering the Novice, Technician, conditional, general, and advanced classes — all under one cover — with nearly four hundred typical F.C.C.-type questions to prepare you for license exams. No technical background required. You also get F-RBE, one year of consultation and a guide to setting up your ham station. All for the amazingly low price of . . . . . \$6.95

See your dealer. If he does not yet stock Ameco courses, order direct. Free Literature Available. Dept. Q-3

**AMERICAN ELECTRONICS CO.**  
2103 Bryant Ave., N. Y. 59, N. Y.

## Lunar DX

(Continued from page 18)

in late January. The receiver bandwidth at W4AO was shaved another notch for this try, too.

Ted arranged to listen for the ground-wave signal with his normal 2-meter array aimed at W4AO, and then switch to the moon rhombic to try for the echo. His low-noise crystal-controlled converter and communications receiver were equipped with a super-selective 50-kc. i.f. system built by W3LCK. On January 23rd, this combination produced its first positive results, and a series of weak echoes was received at W3LZD, at a time when nothing was detected by the set-up at W4AO.

Tests the following afternoon produced nothing, but beginning at 1533 EST on the 27th, a whole series of echoes was recorded at W4AO, two cycles of which are reproduced at the start of this article. Success, at last, and in sufficient quantity and quality to provide irrefutable evidence!

The equipment used in this and earlier stages of *Moonbeam* will be described by W4AO and W3GKP in a subsequent issue of *QST*. Now the question is, "Where do we go from here?" As Smitty puts it, "This is the end of Phase A — we've got an echo. Phase B will be to transmit intelligence to another station. Phase C will be to work somebody, two-way. Phase D will be to break the 2-meter record. Phases E, F — well, can go on almost indefinitely. After three years we're just getting started!"

— E. P. T.

## RACES

(Continued from page 62)

organizing and planning and formulating the *Communications Plan* which is the principal prerequisite to RACES authorization. Until this has been approved at all necessary levels, your local RACES unit isn't going anywhere.

FCDA Manual M25-1, entitled "Federal Contributions," goes into some detail on communications problems. In addition to a general guide on contributions and "matching funds," the chapter on communications contains annexes which constitute a guide for state and community communications plans and RACES frequency channelization and usage charts. Included are a number of charts showing the state and community organizational communications set-ups recommended by FCDA. Your civil defense director should have a copy of this manual, and copies are available (\$1.00 each) from the Superintendent of Documents, U. S. Government Printing Office, Washington, D. C.

[EDITOR'S NOTE: Part II of this article will appear in a future issue of *QST*, outlining the RACES Communications Plan and considering Radio Officer Certification, station authorizations, operator authorizations, funds for purchase of equipment, frequency allocations and equipment specifications. Watch for it.]



Founded in 1909

### RADIO TELEPHONY RADIO TELEGRAPHY RADAR & TELEVISION

Courses ranging in length from 7 to 12 months. Dormitory room and board on campus for \$48.00 a month. The college owns KPAC, 5 KW broadcast station with studios located on campus. New students accepted monthly. If interested in radio training necessary to pass F.C.C. examinations for first-class telephone and second-class telegraph licenses, write for details. New: Advanced TV Engineering Course.

**PORT ARTHUR COLLEGE** PORT ARTHUR TEXAS

Approved for G.I. training

## MORROW CONVERTERS

**NEW!**



New 5 band model covers 10, 11, 15, 20, 40, 75, 80 meters. Gives frequency at a glance for ease of operation. Full width dial has calibration accuracy of 1%. Built-in automatic noise limiter. 1 MV sensitivity on all bands. 3-gang tuning condenser with 20 to 1 ratio. Each stage well shielded for extra stability. Power input: 6V. filament; 100V. 16 ma. With tubes, mounting strap, instruction book and shielded cable and plug with socket assembly for easy installation to auto radio.

Morrow Model 5BR.....\$74.95  
 Morrow 3BR (10, 20, 75 meters) \$64.95  
 Model 03BR (10, 20, 40 meters) \$64.95  
 Above without noise limiter \$5.00 less.

### MORROW

Generator Chokes —  
 For 6, 10 or 20 meters... Each \$3.75



# New at Harrison

**NEW!**

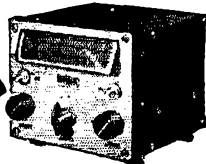

## SONAR RECEIVERS

No larger than a converter yet packed with features found in expensive full size jobs! Covers 80, 40, 20 meters. Automatic noise limiter... BFO... better than 1 MV sensitivity... 7 KC selectivity... voltage regulated... temperature compensated... 10 slug tuned circuits. Requires 200 to 300V. DC at 60 to 100 ma; 6.3V. at 2.4A. 5/4 x 4 1/2 x 5 3/4" D. With tubes.

SONAR Model MR-4.....\$89.95

## GONSET "Super Six"

**NEW!**



New successor to the popular Tri-Band Converter. Now covers all low frequency amateur phone bands from 10 through 75 meters, PLUS 19 and 49 meter SW broadcast. Plenty of bandwidth. High sensitivity on tenna switch for 40 and 75 meters. RF gain switch and separate broadcast antenna input jack. With tubes.

GONSET Model 3030.....\$52.50

**NEW!**

## ELMAC RECEIVER

10-tube dual conversion, 6-band receiver for mobile or fixed station. Covers 160 and broadcast, 80, 75, 40, 20, 15 and 10 meters. 10 tuned circuits. Built-in noise limiter and 250V. DC at 90 ma. 4 1/2 x 6 x 8 1/4" D. ELMAC Model PMR 6-A.....\$134.50

Power Supplies available for 6 and 12V. DC or 115V. AC.

LITERATURE ON REQUEST

## HY-LITE BEAMS

Include T matches.

2 element — 20 meters	2E20T	\$47.95
3 element — 20 meters	3E20T	\$64.95
2 element 10 & 2 element 20	4E10-20T	\$74.95
3 element 10 & 3 element 20	6E10-20T	\$98.95
3 element 10 & 2 element 20	3E10-2E20T	\$84.90

## HARRISON BARGAIN SPECIALS!

### POWER XFORMER VALUE!

Fully shielded, upright mounting. 115V., 60 cy. primary; 350-350V., 150 ma. DC sec. 5V. @ 3A rectifier; 6.3V. @ 6.5A filament. 3 7/8" H, 3 1/4" W, 4 1/8" D. Limited Qty.

P3173 — CLOSEOUT.....\$4.49

### FILTER CHOKE BUY!

12 hy., 110 ma. Enclosed and sealed commercial grade case. Upright mtg. 3 1/4" H, 2 1/2" sq. base. Limited Qty!

ORDER NOW! #81854.....99¢

TUBES — Limited Quantity  
 HK-24G... 5R4GY Each 79¢

## STEEL TOWERS at Low Prices!

Available from stock in 20, 30, 40 or 50 ft. heights. 3 post, self-supporting. Stronger... more durable design. Sturdy, heavy gauge steel. Easy to erect. Supplied complete with anchor posts, section bolts, washers and instructions. These towers are truly outstanding values! WRITE FOR DETAILS AND PRICES.

### AMATEUR TRANSMITTING TWIN LEAD CABLE

75 Ohm for 1 KW RF power.  
 AMPHENOL 14-023.....Per Ft. 6¢ 1000 Ft. Reel.....\$51.15  
 300 Ohm with copper-clad conductors.  
 AMPHENOL 14-022.....Per Ft. 5¢ 1000 Ft. Reel \$43.35

## FREE! HARRISON HAM-A-LOG

Includes New Gear, articles, bargains, ham kinks, etc.  
 Write today for your free copy.

## FOR YOUR SHOPPING AND PARKING EASE! OPEN NITES 'TIL 9

New York — Wednesdays  
 Jamaica — Fridays  
 SATURDAYS: 9-6

COMPLETE STOCKS...

LOWEST PRICES...

FAST, FRIENDLY SERVICE

**HARRISON HAS IT!**

Now in Stock!

## AMPHENOL AMATEUR ANTENNAS



COMPLETE KITS for

10, 20, 40 or 80 Meters

### TWIN-LEAD FOLDED DIPOLE

Includes 2 lengths #16 copper-clad steel conductor twin-lead cut to band length, 75 ft. 300-ohm twin-lead, laminated "T" block, complete assembly and installation instructions.

METERS	AMPHENOL NO.	LIST PRICE	NET
10	139-010	\$ 8.90	\$ 5.24
20	139-020	10.00	5.88
40	139-040	13.00	7.64
80	139-080	18.75	11.03



# HARRISON

RADIO CORPORATION

225 Greenwich St. • N. Y. 7, N. Y.

Barclay 7-7777

JAMAICA BRANCH: Hillside Ave. at 172nd St.

## MULTI-BAND OPERATION

S  
I  
N  
G  
L  
E

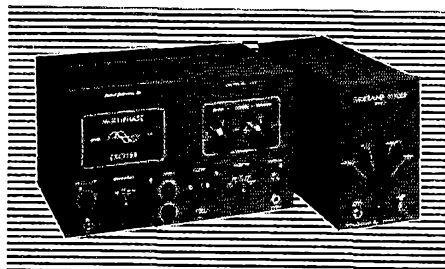

## SIDE BAND

8 TIMES THE VOICE POWER  
HARMONIC TVI VIRTUALLY ELIMINATED

**MULTIPHASE EXCITER MODEL 10A** (upper left). Approx. 10 watts peak output 160 to 20 meters, somewhat less on 10-15 meters. Will drive beam power tetrodes to more than 1 KW input from 20 to 160 meters. SWITCHABLE SSB, with or without carrier, double sideband AM, PM, break-in CW, VOICE OPERATED BREAK-IN and receiver disabling, it's ALL BUILT-IN to this truly versatile exciter. Built-in power supply also furnishes blocking bias for linear amplifier and voltage for optional VFO. With internal xtal and coils for one band. Wired and tested \$159.50. Complete kit \$112.50. Extra coil sets for \$3.95 per band.

**NOVICES — ATTENTION**  
Plug your 40 or 80 meter xtals into the MULTIPHASE EXCITER for break in CW operation. Later it's an excellent power exciter, for use with your General Class ticket. No expensive high-level modulator required.

**SIDE BAND SLICER MODEL A RECEIVER ADAPTER** (upper right). Improves any receiver. SWITCHABLE upper and lower sideband reception of SSB, PM, AM and CW. Cuts interference and heterodynes in half. Eliminates distortion caused by selective fading. Works into any receiver having 450-500 KC IF. Built-in power supply. Use a Model A Slicer — notice the "holes" in even our most crowded bands and hear signals you have never heard before. Wired and tested \$74.50. Complete kit \$49.50.

PS-1 Plug in prealigned 90° phase shift network and socket available separately for use with GE Signal Slicer and SSB Jr. \$7.95 postpaid.

WRITE FOR LITERATURE

*Central Electronics, Inc.*

2125 W. Giddings Street

Chicago 25, Illinois

## IF YOU TELEGRAPH YOU NEED A VIBROPLEX

Semi-Automatic Key

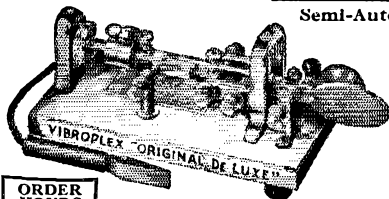

Suits any hand

Choice of five models

ORDER YOURS TODAY!

Twice as EASY as hand sending

Saves the arm, gives a professional performance without arm-tiring effort. Simple to operate. Suits any hand or any style of sending. Vibroplex has "touch" that lessens arm fatigue and makes sending easier for you. Patented Jewel Movement balance lets you send SMOOTHLY! EASILY! NATURALLY! No other key so easy on the arm. Any old key won't do — get Vibroplex and be sure. Choice of five models, \$12.95 to \$29.95. Left-hand models, one dollar more. ORDER YOURS TODAY! At dealers or direct. FREE catalog.

Headquarters for NEW portables, all models and styles of type. Also, REBUILT standard and portable typewriters with ALL CAPITAL letters and other styles of type. Immediate delivery. Get our prices before you buy!

THE VIBROPLEX CO., INC.

833 Broadway

New York 3, N. Y.



## Antenna Coupler

(Continued from page 19)

meter and ammeter readings should be fairly close, once they have been made to agree at one point, small departures are to be anticipated, especially at low readings. It is hardly to be expected that the ammeter itself will be 100 per cent accurate, for that matter. However, it has been our experience that the readings are closely in line with what is to be expected from a normally designed transmitter.

### Using the Coupler

There is little to add to what has already been said many times about the adjustment of an antenna coupler or matching circuit. The procedure is fully described in the *Handbook* chapter on transmission lines. The principal difference here is that the coupling adjustments are reflected through the low-pass filter to the coax link. This is a negligible variation, since in the passband the filter shows the proper value of impedance at its input terminals — that is, the characteristic impedance of the filter — only when it is "seeing," at its output end, the same impedance. Proper adjustment is all-important, in view of the use of small mica condensers in the filter,<sup>2</sup> and can only be carried out with an s.w.r. bridge. The bridge shown in the photograph of the complete set-up is a quite inexpensive one (its construction is described in the chapter on measurements in the 1953 *Handbook*) and uses the 0-1 milliammeter in the December transmitter as an indicator. With the transmitter "test-operate" switch in the "test" position the r.f. output of the set is just about right to operate the bridge when the meter switch is set to "external voltmeter." On most bands this will give close to a full-scale reading. The exact reading with the bridge open-circuited is not particularly important for the purpose of adjusting the antenna coupler, since the object is to set for the line impedance — i.e., to get a good null — rather than to measure standing-wave ratio.

The total capacitance available in  $C_6C_7$  as a balanced condenser (150  $\mu\text{f.d.}$ ) is sufficient to cover a 2-to-1 frequency range under most circumstances, depending on the antenna and feeder system. This is convenient since it is not necessary to change coils when going to an adjacent band.

Including  $C_5$  in the coupler circuit makes adjustment considerably easier, as compared with an untuned link-coil circuit where matching depends critically on placement of taps on the antenna coil. In most cases the tap positions will not be very critical. A 300-ohm load can be transformed to either 75 or 50 ohms by manipulating the two condenser controls only, if the taps are  $5\frac{1}{2}$ ,  $1\frac{1}{2}$  and  $1\frac{1}{2}$  turns in from the coil ends on the 3.5-7, 7-14, and 14-28-Mc. coils, respectively. The half-turns come about because the coils all have even numbers of turns so that

(Continued on page 120)



**NEW**

**I'LL TRAIN YOU FOR YOUR FCC LICENSE**

A Federal Communications Commission Commercial Operator's License puts you in line for a good job in Radio or Television Broadcasting, Police, Marine, Aviation, Two-way, Mobile or Micro-Wave Relay Radio. Mail coupon below for 64-page book FREE. It will give you complete facts about my NEW Communications course.

**YOU BUILD THIS TRANSMITTER**

with parts I send. With this Transmitter you practice how to put a station "on the air." You perform procedures demanded of Broadcast Station Operators, conduct many experiments, make many practical tests.

**LEARN COMMUNICATIONS by PRACTICING at Home in Spare Time**



**Get Practical Experience on Circuits Common to Radio & TV**

Ever think HOW FAST Radio-Television Communications is changing, developing, growing? Have you considered what this amazing progress can mean to you? Even without Television the industry is bigger than ever before. 105 million home and auto radios, 2900 Radio Broadcasting Stations, 108 TV Stations with 1800 more now authorized. Expanding use of Aviation and Police Radio, Micro-Wave Relay, Two-Way Radio for buses, taxis, etc. makes opportunities for Communications Technicians and FCC Licensed Operators. New jobs, more jobs for beginners! Better jobs, better pay for experienced men!

**Television Is Today's Good Job Maker**

In 1952, over 18,000,000 homes had TV sets. More are being sold every day. The "i-reeves" on building new TV stations has been lifted. The time to act is NOW! Start learning Radio-TV communications. America's fast growing industry offers good pay, a bright future, security. If you are a beginner, my course can help you get FCC License, prepare for the job you

J. E. SMITH, President National Radio Institute Washington, D. C. For 38 years, the leader in training men for Radio-Television.



**MY COURSE INCLUDES TELEVISION**

want. If you've had some training in Radio or Radar, or as a Licensed Operator, my course modernizes, increases the value of your knowledge.

**Includes New Developments**

Mail coupon now for facts about my practical course in Radio-Television Communications. Let me send you my FREE book. See the nine big Kits of Parts I send that "bring to life" theory you learn. You get practical experience by working on circuits common to both Radio and Television; also lessons on TV principles. Read about the Transmitter you build and operate, about the Electronic Multitester you get. All equipment is yours to keep.

My graduates are billing jobs, making good money in both Radio and Television. Remember, the way to a successful career in Television is through experience in Radio.

**Mail Coupon for Book FREE**

Send today! See what my Communications course is like. Find out how I get you ready for a brighter future, better earnings, more security in Radio-Television. Send coupon now in envelope or paste on postal. NO OBLIGATION, NO SALESMAN WILL CALL! My book, sent to you FREE, tells the full story. J. E. SMITH, President, Dept. 3CF2, National Radio Institute, Washington 9, D. C. Our 39th year.

**YOU BUILD** this Transmitter Power Supply used in the basic experiments in RF and AF Amplifiers, frequency multipliers, buffers, etc.



**YOU PRACTICE** setting up code, amplitude and frequency modulation circuits (put voice, music, etc., on "carrier signals" you produce). You learn how to get best performance.

**YOU MEASURE** current, voltage (AC, DC and RF), resistance and impedance in circuits with Electronic Multitester you build. Shows how basic transmitter circuits behave; need to maintain station operation.

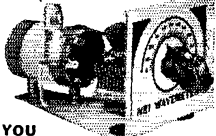





**YOU BUILD** this Wavemeter and use it to determine frequency of operation, make other tests on transmitter currents.

**Training Leads to Jobs Like These**

- |   |  |   |
|---|--|---|
| <b>BROADCASTING</b><br>Chief Technician<br>Chief Operator<br>Power Monitor<br>Recording Operator<br>Remote Control Operator | <b>GOVERNMENT RADIO</b><br>Operator in Army, Navy, Marine Corps, Coast Guard<br>Forestry Service<br>Dispatcher<br>Airways Radio Operator | <b>AVIATION RADIO</b><br>Plane Radio Operator<br>Airport Transmitter Operator                                   |
| <b>SHIP AND HARBOR RADIO</b><br>Chief Operator<br>Assistant Operator<br>Radiotelephone Operator                             | <b>POLICE RADIO</b><br>Transmitter Operator<br>Service Technician  | <b>TELEVISION</b><br>Pick-Up Operator<br>Voice Transmitter Operator<br>TV Technician<br>Remote Control Operator |

**I TRAINED THESE MEN**

- |  |  |
|--|--|
| <br>"My position with WNET is video control engineer on the RCA color project. I owe a lot of my success to your textbooks." —Vareca Deem, Malverne, N. Y. | <br>"I am a technician at WTOP in Washington and I like it very much. Most of my radio knowledge was from N.R.I." —John Britton, Hyattsville, Md. |
| <br>"My first job was with EDLR, obtained for me by your Graduate Dept. Now in charge of Radio Equipment for Police Dept." —T. S. Norton, Hamilton, O.     | <br>"A former employer recommended N.R.I. training. Now employed as transmitter operator at WKBO." —Albert Herr, New Cumberland, Pa.              |

**Servicing Training Also Offered by N. R. I.**

If you prefer a good-pay job in Radio-Television Servicing, or your own money-making Radio-Television Sales and Service Shop, I'll train you at home. My famous Servicing Course also includes many Kits of Radio Parts. You use them to get PRACTICAL EXPERIENCE with circuits common to Radio and Television. I also show you how to make \$5, \$10 a week or more EXTRA MONEY fixing neighbors' radios while training. Full information in my 64-page book. Mail coupon.

**MAIL NOW-BOOK FREE**

MR. J. E. SMITH, President, Dept. 3CF2 National Radio Institute, Washington 9, D. C. Mail me your 64-page Book about Radio and Television Communications opportunities and training. (No salesman will call. Please write plainly.)

Name..... Age.....  
Address.....  
City..... Zone..... State.....  
 Check if Veteran Approved Under G. I. Bill

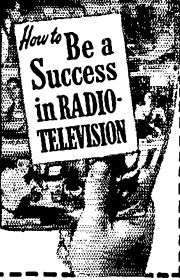

# HARVEY HAS IT

## For IMMEDIATE DELIVERY

### SONAR CALIBRATED FREQUENCY- CONTROL EXCITER

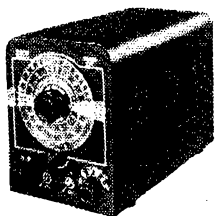

The Sonar CFC Exciter was designed to meet the needs of amateurs wanting good VFO control, with provision for CW keying and a built-in CW monitor. Can also be used as a low powered crystal-control transmitter for novice or as a portable.

Can be switched for either VFO or spot frequency crystal control. A 1000 Kc. secondary standard crystal, resonated with WWV, permits accurate check points for VFO on all amateur bands. All-band direct-calibrated dial with vernier control provides operating ease.

Complete with Tubes, 1000 Kc. Crystal and Built-in Power Supply.

Reg. \$59.75 — SPECIAL \$36.75



# Harvey

RADIO COMPANY, INC.

103 W. 43rd St., N. Y. 36, N. Y. • LU 2-1500

**MORE SIGNALS PER DOLLAR**  
From Money Invested in an Antenna

## Self Supporting STEEL TOWERS

For Rotary Beams, FM, TV

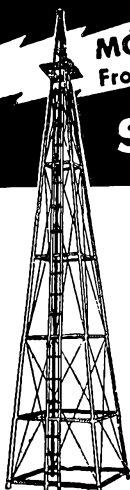

Width of  
Base Equal  
to 1/5 Height

Vesto Towers are available in a wide range of sizes to meet requirements of amateurs and commercial users alike. Note the low prices for these quality lifetime towers: 22'-\$94.75, 28'-\$115.75, 33'-\$135.75, 39'-\$157.75, 44'-\$178.75, 50'.

### ATTRACTIVE—NO GUY WIRES!

- 4-Post Construction for Greater Strength!
- Galvanized Steel—Will Last A Lifetime
- SAFE—Ladder to Top Platform
- COMPLETE—Ready to Assemble
- Easy to Erect or Move
- Withstands Heaviest Winds

Pay Only 1/3 Down!  
12 EASY MONTHLY PAYMENTS  
Freight Charges May Be  
Included in Financing

\$217.75, 61'-\$279.75, 100'-\$1060.00. Towers are shipped to your home knocked down, FOB Kansas City, Mo. 4th class freight. Prices subject to change... so order now! Send check or money order... or write for free information.

WRITE TODAY  
FOR COMPLETE  
FREE INFORMATION  
AND PHOTOGRAPHS

**VESTO CO., Inc.**

20th and Clay  
North Kansas City, Mo.

the center can be grounded at the bottom, if desired.

The cabinet is not a necessary part of the coupler but is used simply for appearance and for mechanical protection of the unit. If used, the lid should be kept closed when making adjustments for matching the coax link, since the proximity of the lid and the antenna coil changes the inductance slightly, as compared with its value with the lid open.

### I.F. Amplifier

(Continued from page 28)

response. It should be fairly flat from about 500 to 2700 cycles or so, dropping off rapidly beyond that.

Without access to a signal generator at 50 kc., it may be necessary to rig up a 50- or a 450-kc. oscillator with good stability and a slow tuning rate.

### Operation

The operator has his choice of several types of operation with this amplifier. For highly-selective c.w. reception, use switch  $S_2$  in the "C.W." position, with the b.f.o. offset to give the favorite beat note frequency. Signals will drop in and out rapidly as one tunes across a band, and a slow tuning rate is highly desirable. Our own preference is one around 25 kc. per knob rotation, which is slower than any receiver in current production. For less critical reception of c.w., or for net operation, switch to "S.S.B." and use the broad i.f. characteristic, reducing the gain in the sharp channel to a minimum. The same settings maintain for the reception of s.s.b. 'phone signals — the b.f.o. is set to the mid-frequency of the sharp channel and all tuning is done with the main tuning dial of the receiver.

Regular a.m. 'phone signals are received with  $S_2$  set either to "MAN" or "A.V.C.," depending upon the QRM conditions. In either case, the carrier is peaked on the meter for accurate tuning, and the two gain controls are set for best listening. In "MAN" operation this will usually mean riding gain on the sharp channel so that the meter never goes beyond half scale, and with the broad-amplifier gain control backed off proportionately. In "A.V.C.," both controls can be run wide open, but as one tunes across some signals the set will overload until the tuning is centered, as mentioned earlier. A heterodyne on one sideband will be eliminated by switching  $S_1$  — if there are heterodynes on both sides you are in QRM trouble, and an external Select-object is the best answer. "Practice" is the only advice one can give on handling the i.f. amplifier to its greatest capabilities, always remembering that you have the choice of two sidebands to listen to plus the ability to vary the relative amplitudes of carrier and sidebands.

As in all selective amplifiers, overload is your one enemy, and it is generally best to run

(Continued on page 122)

# HARVEY FIRST TO STOCK... FIRST TO DELIVER

## The COLLINS 75A-3 Receiver

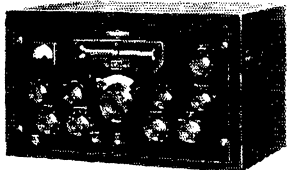

### With Mechanical Filter

The familiar Model 75A-2, redesigned and modified to provide for the use of mechanical filters. Supplied with one 3 KC filter, and facilities for one additional. A 2-position front panel switch permits selection of filter desired.

with speaker \$550.00  
1 KC Mechanical Filter..... 75.00  
COLLINS 75A-2 still continues  
in popularity.....with speaker 440.00

## COLLINS 32V-3 Transmitter

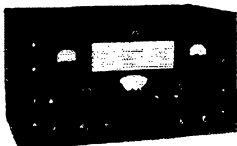

A VFO controlled bandswitching, gang-tuned amateur transmitter. 150 watts input on CW and 120 watts on phone. Covers 80, 40, 20, 15, 11 and 10 meter bands.

Dimensions: 21 1/8" wide, 12-7/16" high, 13 7/8" deep.  
Complete with tubes.....\$775.00



## COLLINS KW-1 Amateur Transmitter

The Collins KW-1 was engineered to provide the amateur with the maximum power permitted by his license. Covers frequencies: 10, 11, 15, 20, 40, 80, and 160 meters. Complete bandswitching of exciter, driver, and power amplifier is accomplished by means of a single front-panel control. Inherent design of the KW-1 reduces spurious radiation to an absolute minimum, particularly on TV frequencies. Tubes: Oscillator—two 6BA6... Exciter—one 6BA6, four 6AQ5, one 807W, two VR105, and one 6A10 Ballast Tube... Power Amplifier—two 4-250A... Speech Amplifier — one 12AX7, one 6AL5, two 12AU7, two 6B4G, and two 810... Rectifiers — two 872A, five 5R4GY, and three 5V4.

Complete with Tubes.....\$3,850

**NOTE:** In view of the rapidly changing market conditions, all prices shown are subject to change without notice and are Net, F. O. B., New York City.

## THE ORIGINAL WILLIAMSON HR-15 AMPLIFIER KIT

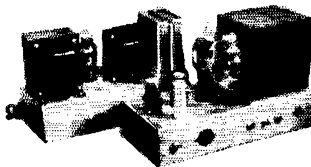

The famous, original Williamson HR-15... still acclaimed the leader... in kit form, with the original Partridge output Transformer. Assemble this Kit, and in 3 hours or less, enjoy the finest sound you ever heard. Operates from a tuner, phono-preamp, crystal pick-up, or other signal source. Absolute gain is 70.8 db with 20 db of feedback. Frequency response:  $\pm .5$  db, from 10 to 100,000 cps. Output impedances to match all speakers from 1.7 to 109 ohms. Kit is complete with 5 tubes (1-5V4, 2-6SN7, and 2-5881) (or 807 if requested), 2-Punched Chassis, 2-Resistor Mounting Strips, Sockets, Partridge WWFB Output Transformer, Assembly Instructions, and All Other Necessary Parts for Amplifier and Power Supply.....\$76.50

**PARTRIDGE OUTPUT TRANSFORMER**  
Available Separately. WWFB..\$26.00

**HR-15T WILLIAMSON Kit** —  
Furnished as above, with TRIAD  
Transformers and Chokes.....\$69.50

**NOTE:** HR-15 and HR-15T Kits  
may be had with British KT-66 Output  
tubes for \$3.00 additional.

## SUPERIOR POWERSTATS

Smooth, efficient voltage control, 0-135 volts output from 115 volt AC line. Models also for 230 volt input. Write for free literature. Models for table and panel mounting.



Type 10, 1.25 amps.....	\$ 8.50
20, 3 amps.....	12.50
116, 7.5 amps, table mtg.....	23.00
116U, 7.5 amps, panel mtg....	18.00
1126, 15 amps.....	46.00
1156, 45 amps.....	118.00

Complete Stock Always On Hand For Immediate Delivery

Complete Line in Stock  
**CAMBRIDGE THERMIONIC COILS**  
For Immediate Delivery



# Harvey RADIO CO., INC.

103 W. 43rd St., New York 36, N. Y. • LUXEMBERG 2-1500

## SONAR COMMUNICATIONS EQUIPMENT

### MOBILE Model MR-3 Rcvr.

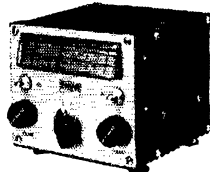

Complete coverage for 10-11-20-75 meters. 8 tubes. 4.5 watts audio output. Uses: 12AT7 RF stage and B.F.O., 6U8 oscillator mixer, (2) 6CB6 I.F. stages, 6AL5 2nd detector and noise limiter, 6AT6 1st audio, 6AQ5 audio output, OB2 voltage regulator. 1 Microvolt signal produces 0.5 Watt audio output. A.N.L. and B.F.O. are push-button operated. Requires 250 Volts at 60 to 80 mils. Size: 4-9/16" x 5-3/16" x 5-11/16". Complete with tubes... less power supply and speaker.

\$89.95

MR-4 same as above, except for 40 meter instead of 10 meter band.....\$89.95

## SONAR LOW-PASS FILTER Model LP-7 For TVI Suppression



A 4-section filter with less than .2% insertion loss providing harmonic attenuation in excess of 75db. Adjusts for maximum attenuation between Channels 2 and 6. Has 44 Mc cutoff. Handles 1 kw, fully modulated. Employs Teflon insulation, and is equipped with 50-239 connectors. Impedance: 52 ohms. Dimensions: 2 1/2" diam., 10" long.....\$16.50

## GONSET "SUPER 6"

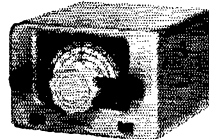

### Six Band Amateur Converter

A compact converter covering 10, 11, 15, 20, 40, and 75 meter phone bands. Also covers 6 mc. (49 meter) and 15 mc. (19 meter) short wave broadcast bands. Uses 6CB6 low noise rf stage, with panel controlled antenna trimmer, 6AT6 triode mixer, 6C4 modified Clapp oscillator, and 6BH6 if stage.

Complete with Tubes.....\$52.50

# DOW CO-AX RELAY

FOR 52 OR 72 OHM LINE

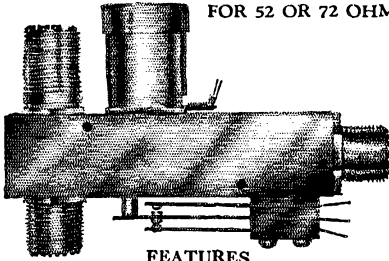

## FEATURES

1. Causes negligible change in s.w.r. up to 100 Mc.
2. Handles power up to 1000 watts.
3. Fits standard connectors for co-ax.
4. No chatter. Specially built for "Silent operation".
5. Over-all length 4 1/4". Over-all width 3". Note new magnet cover.
6. Externally mounted SPDT switch operated by relay can be used for opening B+ of receiver when transmitting, or for other control purposes. Add to prices below \$1.00.
7. When in transmit position a built-in shorting connector grounds receiver antenna lead. This protects receiver against injury from r.f. and reduces to a minimum the capacity coupling between receiver and relay contacts. Add to prices below, \$1.00.

AC Types (all voltages). Amateur Net. . . . . \$10.50  
 DC Types (all voltages). Amateur Net. . . . . 9.50  
 See your distributor, but if he has not yet stocked Dow Co-ax Relays, order now direct from factory. Send check, money order, or will ship C.O.D. Prices are Net, FOB shipping point: Warren, Minn., or Winnipeg and Montreal, Canada.

Dealer Inquiries Invited

**THE DOW-KEY CO., INC.** Warren Minnesota  
 578 Goulding Street  
 Winnipeg, Canada

**THE DOW-KEY CO.** 2310 Wilson Avenue  
 Montreal, Canada

- **4 E 2** . . . . . \$8.75  
 2 MTR—4 ELEMENT YAGI
  - **8 E 2** . . . . . \$20.50  
 2 MTR—TWO 4 ELEMENT YAGI
  - **PD 3 E 10** . . . . . \$24.95  
 PLUMBER'S DELIGHT  
 INCLUDES T MATCH  
 10 MTR—3 ELEMENT  
 CLOSE SPACED
  - **3 E 10F** . . . . . \$42.40  
 FOLDED DIPOLE  
 10 MTR—3 ELEMENT  
 CLOSE SPACED
  - **3 E 10T** . . . . . \$41.80  
 INCLUDES T MATCH  
 10 MTR—3 ELEMENT  
 CLOSE SPACED
  - **3 E 15T** . . . . . \$59.00  
 INCLUDES T MATCH  
 15 MTR—3 ELEMENT
  - **2 E 20T** . . . . . \$47.95  
 INCLUDES T MATCH  
 20 MTR—2 ELEMENT
  - **6 E 10-20T** . . . . . \$98.95  
 STACKED 10-20  
 3 ELEMENT  
 INCLUDES 2 T MATCHES
- Complete catalog on request: Dept. Q-33

**HY-LITE BEAMS**  
**HY-LITE BEAMS**  
**HY-LITE BEAMS**  
**HY-LITE BEAMS**  
**HY-LITE BEAMS**  
**HY-LITE BEAMS**

**HY-LITE Antennae** Inc.  
 Makers of Fine Antennas for AMATEUR - FM - TELEVISION  
 241 EAST 137th ST., N. Y. C. 51, N. Y.

the audio volume at or near maximum and the i.f. gain at the lowest usable value.

Earlier it was mentioned that we have no illusions about this being the ultimate in i.f. amplifiers. Frankly, we think one might go to 50 or 75 cycles bandwidth for the carrier amplifier, at which point an a.m. signal would be just about as critical to tune in as a carrierless s.s.b. signal is on any receiver. However, a nice slow tuning rate would simplify this considerably. Admittedly, the sideband amplifier shown here is open to improvement, and a crystal-lattice filter or the new Collins mechanical filter might be worthwhile. However, some anticipated slight distortion at low audio frequencies (due to the crossover of the two amplifier characteristics) never showed up, which only means that our ears aren't well trained or that the distortion is insignificant in amateur work.

In conclusion, it should be pointed out that the apparent complexity of this unit is necessary only because an effort was made to incorporate good a.m. reception. A design for the reception of only c.w. signals, or of only s.s.b. signals, could dispense with one of the two i.f. channels. But exalted-carrier reception of a.m. can only be done this way (with two channels) or with a locally-generated carrier that must be synchronized with the transmitted carrier. This latter method (as in the YRS-1) results in a beat note as one tunes into a carrier—the system just described overcomes that particular objection. Any selective system becomes critical to tune, and consequently requires a low tuning rate, so don't try to use this amplifier with a receiver that covers 200 kc. with a half twist of the tuning knob. Give it a chance with a tuner that has a decent tuning rate, and if you can't copy the other signal, it is *really* snowed under!

## Happenings

(Continued from page 36)

Service ARE AMENDED as set forth in the attached appendix.

FEDERAL COMMUNICATIONS COMMISSION  
 T. J. SLOWIE,  
 Secretary

Released: January 29, 1953

## APPENDIX

1. Amend Section 12.23(e) by substituting the frequencies 21.10 to 21.25 Mc for the frequencies 26.960 to 27.230 Mc.
2. Amend Section 12.111 in the following particulars:
  - (a) Delete present subparagraph (11) of Section 12.111 (a).
  - (b) Amend Section 12.111(a) subparagraph (5) to provide as follows:
    - (5) 21.00 to 21.45 Mc, using type A-1 emission; 21.00 to 21.25 Mc, using type F-1 emission; 21.25 to 21.45 Mc, using type A-3 emission and narrow band frequency or phase modulation for telephony.
  - (c) Amend Section 12.111(a)(10) to provide as follows:
    - (10) 220 to 225 Mc, using types A8, A1, A2, A3 and A4 emission and special emission for frequency modulation (radiotelephone transmissions and radiotelegraph transmissions employing carrier shift or other frequency modulated techniques).
  - (d) Amend Section 12.111(a) by renumbering paragraphs in numerical sequence in accordance with the foregoing addition and deletion.

# LOOK STEINBERGS LOOK

## IMMEDIATE DELIVERY

### Single Sideband Exciter SS-75

"Sideband" is sweeping the country... progressive amateurs are going SSSC by the hundreds... and one night spent in listening to a "sideband" QSO will impress you with the terrific "punch" carried by this method of operation—voice control, fast break-in, no heterodynes, the sharpness of tuning... it really "gets the signal through".

Here's single sideband with all the headaches removed. The SS-75 has been field-tested for over a year and is a complete self-contained, factory aligned single sideband transmitter-exciter, designed for operational ease, reliability of performance, freedom from maintenance problems, ready to transmit a high quality SSSC phone signal alone, or to drive a Class B linear final to 1 KW input.

Check these specifications and you'll see why the SS-75 is now the one piece of equipment that places all the advantages of single sideband at your finger tips:

- ★ Built-in stable VFO, with voltage regulation.
- ★ Carrier injection to receiver antenna terminals... tune in SSSC signals the same as AM, no other gadgets necessary.
- ★ Illuminated VFO tuning dial provides 31 inches of band-spread 3800-4000 KC in 4 bands, with 5 to 1 gear reduction.
- ★ Built-in voice control and receiver disabling circuit. Also provides for break-in CW operation.
- ★ Specially designed crystal filter network for maximum stability and reliability.
- ★ Carrier injection to transmitter available for working single sideband WITH CARRIER, for tune-up adjustments, or CW.

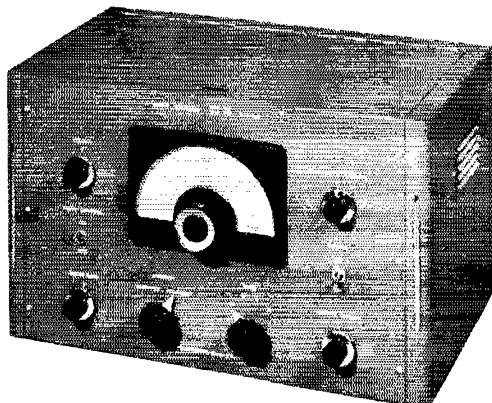

- ★ 10 watts output, with additional 807 socket for up to 100 watt operation with external power supply.
- ★ Handsome grey crackle cabinet, chrome trimmed, 20" x 12" x 12". Complete with 12 tubes, including one 807, operating manual..... \$245.00
- ★ Frequency conversion mixer for 40-20 meters, rack mtg. 3 1/2" x 19" less power supply ..... 75.00

A partial list of enthusiastic SS-75 users includes W1BBA, 1BGA, 1NSP, 4AYF, 4CIM, 4PAV, 8AV, 8FWT, 8GYJ, 8JYU, 8WHE, 9ARK, 9ELK, 9GSE. (Refer to By Goodman's article on page 42 Dec. 1952 QST)



#### WRIGHT T-R SWITCH

For break-in operation on CW, AM, or SSSC. Use one antenna for transmitting and receiving. It's instantaneous! No moving parts, no power needed to operate. Coax fitting for connections to antenna and receiver. With 75 meter plug-in coil..... **\$9.95**

Extra coils \$1.75 per band

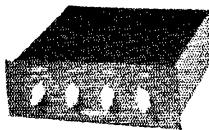

#### MAYNARD PREAMPLIFIER

Self-powered; 4-position record equalizer plus mike or tuner input; 20 db bass or treble increase or decrease; 3-12AX7, 6X4. Regularly \$62.50.

Limited quantity. **\$49.50**



#### PHOSPHOR BRONZE AERIAL

125 ft. of the finest aerial wire obtainable. 42-strand phosphor-bronze with linen center. Will not stretch, very high tensile strength, diameter approximately same as No. 14 copper, very flexible. Excellent for transmitting or receiving antenna, control cable, guy wire. Regular list \$4.95..... **90¢**

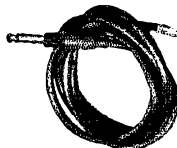

#### PL-55 PLUG AND CORD

Standard plug with 6 ft. rubber, 2-wire cord with spade lugs..... **85¢**



Triple 8 mfd. 450 V. electrolytic upright can condenser, separate negatives, all leads insulated from can. Nationally known mfr. Reg. dealer net \$2.58..... **ONLY 59¢**  
10 for \$5.00



#### 8/8/8 MFD. 500 V. D.C.

Triple 8 mfd. 500 working volt D.C. oil-filled condenser, common negative, solder terminals, hermetically sealed. 5" x 3 3/4" x 2 1/4"..... **\$1.95**

MINIMUM ORDER \$2.00. Send 20% deposit with COD orders. Please include sufficient postage or instruct us to ship by Express Collect. Overpayment will be refunded by check.

# Steinbergs

Phone CHerry 1880

633 WALNUT STREET • CINCINNATI 2, OHIO

Your order will receive my personal attention and will be shipped the same day order is received. We distribute all top-flight amateur lines... let us know what you need.  
73, Jule Burnett W8WHE

# New Heathkit GRID DIP METER KIT

MODEL GD-1  
SHIPPING  
WT. 4 LBS.

**\$19.50**

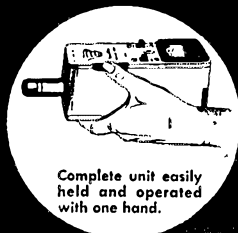

Complete unit easily  
held and operated  
with one hand.



A valuable  
addition to  
any ham shack.

The INSTRUMENT FOR HAMS — has numerous transmitter applications such as pretuning, neutralization, locating parasitics, correcting TVI, adjusting antennas, design and many others.

Receiver applications include measuring C, L and Q of components — determining RF circuit resonant frequencies, etc.

Covers the 80, 40, 20, 11, 10, 6, 2 and 1 1/2 meter bands. Complete coverage from 2-250 MC.

Easy one hand, one unit operation. Convenient thumb wheel drive of tuning condenser leaves one hand free for making circuit adjustments. No tuning head and meter with connecting cable to worry about. It's compact — case only 2 1/2" wide x 3" high x 7" long.

All plug-in coils (rack included) are wound and calibrated — no coil winding, drilling, punching, forming or painting to do — all fabrication is complete, and the kit goes together smoothly and easily.

The 500 microampere Simpson meter movement and sensitivity control allow operator to set instrument for easy detection of dips on all ranges. Instrument is transformer operated for safety. You'll like the appearance of this kit with its baked enamel panel and crackle finish cabinet.

Please include postage to cover parcel post and insurance for 4 pounds.

**HEATH COMPANY**  
BENTON HARBOR 9,  
MICHIGAN

## A Handy Handful

(Continued from page 51)

Without the oscillator connected the output voltage of the supply should be 165. It will drop to about 150 with the oscillator running. The 6C4 grid bias should cause the eye of the 6E5 to close either partially or completely. With the low-frequency coils the shadows may overlap. This can be corrected by adjustment of the bucking-voltage potentiometer. In general, this potentiometer should be adjusted for optimum 6E5 operation with each coil.

### Calibration

Chapter 21 of the *Handbook* explains how a grid-dip meter may be calibrated and used. If the construction shown here is duplicated as closely as possible the calibration scale given in

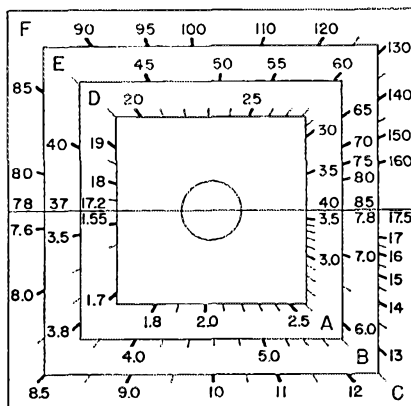

Fig. 3 — Actual size reproduction of the calibrated dial for the grid-dip meter. The half square allotted to each band of frequencies results in additional calibration area that would not be available with a semi-circular pattern.

Fig. 3 should be sufficiently accurate for ordinary purposes. If a more accurate calibration is needed it should be made point by point against a good frequency meter. A good method is to employ a blown-up scale (2 or 3 times actual size) while the frequency check points are being marked. The large-sized scale is easier to letter than a small one, and can be reduced to proper size photographically.<sup>2</sup> Unless the scale is made of thick material, it is suggested that it be cemented on 1/16-inch cardboard before being mounted in place. A layer of thin transparent plastic, clamped over it by the mounting nut for C<sub>1</sub>, will preserve the finish of the scale.

<sup>2</sup> This is no problem for hams who are also amateur photographers. Having it done by a professional photographer will cost about three dollars.

**SWITCH  
TO SAFETY!**



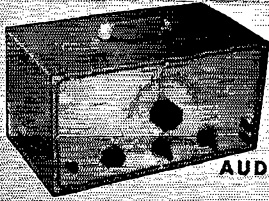

AUDIO GEN. KIT  
\$29.50

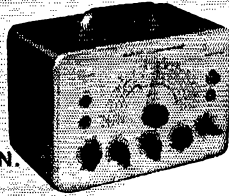

R. F. SIGNAL GEN. KIT  
\$19.50

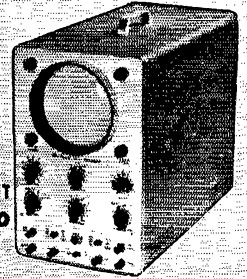

5" SCOPE KIT  
\$43.50



T.V. ALIGN. GEN. KIT  
\$39.50

BUILD YOUR OWN  
*Heathkit*  
TEST EQUIPMENT

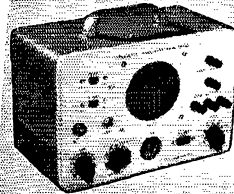

SIGNAL TRACER KIT  
\$22.50



VACUUM TUBE VOLT METER KIT  
\$24.50

Heathkits are completely engineered instruments supplied unassembled. Every kit goes together smoothly and easily. All drilling, punching, and painting has already been done for you. All parts are furnished and are of highest quality.

Detailed construction manual shows clearly where each wire and part goes and tells exactly how to build the kit. Write for free catalog.

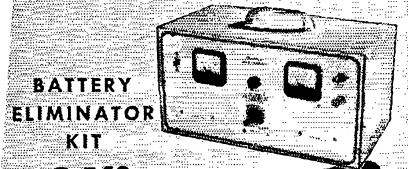

BATTERY ELIMINATOR KIT  
\$24.50

**HEATH COMPANY**  
BENTON HARBOR 9,  
MICHIGAN

EXPORT AGENT  
**ROCKE INTERNATIONAL CORP.**  
13 East 40th Street  
NEW YORK CITY (16)

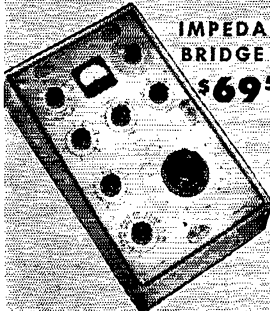

IMPEDANCE BRIDGE KIT  
\$69.50

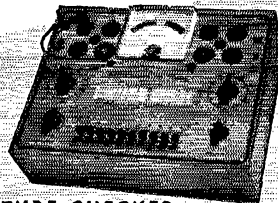

TUBE CHECKER KIT  
\$29.50



GRID DIP METER KIT  
\$19.50

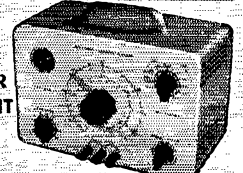

CONDENSER CHECKER KIT  
\$19.50

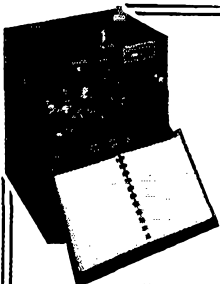

LOOK HERE,  
FELLOWS!

We will gladly pay the highest possible price for the purchase of any Heterodyne Frequency Meter as illustrated here, including the BC-221, the TS-173, the TS-174, the TS-175, and the TS-323.

Please write, giving complete information on nomenclature and condition to

**WESTON LABORATORIES, Inc.**  
Weston 93 Massachusetts

**LEARN CODE!**

SPEED UP Your RECEIVING with G-C  
**Automatic Sender**

Type S  
\$24.00 Postpaid in U. S. A.

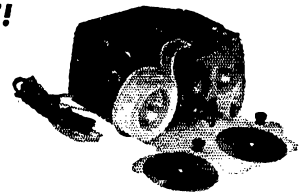

Housed in Aluminum Case Black Instrument Finished. Small—Compact—Quiet induction type motor. 110 Volts—60 Cycle A.C.

Adjustable speed control, maintains constant speed at any setting. Complete with ten rolls of double perforated tape. A wide variety of other practice tapes available at 50c per roll.

**GARDINER & COMPANY**  
STRATFORD NEW JERSEY

# ATTENTION MOBILE HAMS

Complete mobile package — nothing else to buy. Outstanding mobile signals use motorola equipment — backed by years of communication equipment experience — World's largest producer of 2-way mobile equipment.

A mobile transmitter with a double feature FM or AM at flip of the switch, the MOTOROLA FMT-30-DMS (27-30 MC.)... **\$130.00**

P-7253 spring base rear mount antenna **\$23.13**

New Gon-set Tri-Band Spread Converter... **\$47.60**

MOTOROLA P-69-13 or 18-ARS receiver with special noise limiter for use with any converter having 1440-3000 KC..... **\$60.00**

3-30 famous Gon-set converter complete to connect to the P-69-13 or 18-ARS receiver. **\$44.75**

P-327-E Fire wall loud speaker.... **\$7.50**

The above comes complete with all necessary accessories and mounting hardware. Order direct or through the Motorola National Service Organization member in your area.

NOTE: This Receiver and Transmitter is equipment which has been returned from the field, modified and rebuilt for Amateur Service.

For further information write to:  
**MOTOROLA INC.**

Amateur Sales Dept. QST — March  
1327 W. Washington Blvd. Chicago 7, Illinois  
Attention: Harry Harrison, W9LLX, Tel. Taylor 9-2200 Ext. 161

## NEW LOW-PRICED BETTER ANTENNAS

- 10 METER DIPOLE..... **\$6.95**
- 6 METER 2 EL-BEAM..... **9.95**
- 10 METER 2 EL-BEAM..... **11.95**
- 6 METER 3 EL-BEAM..... **12.95**
- 10 METER 2 EL-BEAM\*..... **12.95**
- 10 METER 3 EL-BEAM..... **16.95**
- 10 METER 3 EL-BEAM\*..... **18.95**
- 10 METER 4 EL-BEAM\*..... **24.95**

\* With T match.

Furnished complete, easy and quick to assemble. Instructions and all data included. Strong aluminum castings and tubing, less mast and wire. Made by hams and sold only to hams, no dealers. Literature on request. All antennas adjustable over entire band. ORDER NOW—IMMEDIATE SHIPMENT.

### HOW TO ORDER

Remit by check or money order. All shipments sent Railway Express, charges collect.  
Money back guarantee

**GOTHAM HOBBY** 107 E. 126 Street  
New York 35, N. Y.

## "Q" - Section Transformers

(Continued from page 33)

300-ohm line through a single balanced transformer consisting of two quarter-wave pieces of 50-ohm coax with the outer shields connected together. This match is illustrated by line A of Fig. 1 and, since  $300/33 = 9$ , the selectivity is slightly narrower than that shown in Fig. 2 by the curve labeled  $R_1/R_2 = 8, 1/8$ .

A more appropriate example of the use of the double "Q"-section is shown in W8JK's excellent book on antennas.<sup>2</sup> In his Fig. 14-44, Dr.

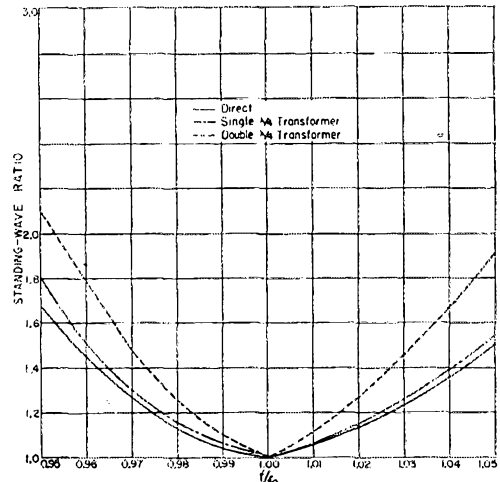

Fig. 4 — A special case showing a 65-ohm antenna matched by a 65-ohm transmission line (solid curve) and to a 500-ohm line through single and double "Q" transformers. (Data from Kraus, *Antennas*, McGraw-Hill Book Co., N. Y.)

Kraus shows the standing-wave ratios versus frequency deviation, including the antenna variation, for both a single and a double transformer matching a 65-ohm dipole to a 500-ohm line (see Fig. 4). The transformer impedances required in these examples are shown by line C of Fig. 1. The selectivity of the single transformer alone is approximately the same as the  $R_1/R_2 = 8, 1/8$  curve of Fig. 2, over the same frequency range.

<sup>2</sup> Kraus, John D., *Antennas*, p. 437, McGraw-Hill Book Co., Inc., New York, 1950.

### Answer to QUIST QUIZ on page 10

B is substantially right, although not for the reason given. Any c.w. station can operate as close to the edge as its frequency measurements can be depended upon to locate the edge and insure that none of its radiation (which includes key clicks either side of the nominal frequency) falls outside the band. Hence, all other things being equal, the station with the "softer" keying could operate a few cycles closer to the edge.

A is all wrong. He forgets that keying of any kind adds side-frequency components, and his assumption that high-powered signals occupy more spectrum space than low-powered ones is due to his lack of understanding of receiver selectivity.



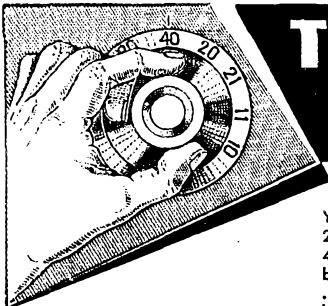

# The right combination for mobile on 40....

or any other band from 80 to 10

## "Super Six Converter"

You're set for 40 with the Super Six just as you will be for 21 when it opens for phone. Unit covers 10, 11, 15, 20, 40 and 75. High stability and sensitivity . . . adequate bandspread . . . sturdy construction . . . extremely compact . . . it's an essential part of an outstanding mobile combination. Front  $3\frac{1}{2} \times 5\frac{1}{4}$ ", Depth  $5\frac{1}{4}$ ". Net.... \$52.50

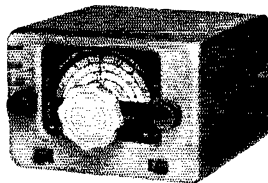

## "Commander" Transmitter

Judged from any standpoint . . . performance . . . frequency coverage . . . conservative design and ratings . . . ultra compactness . . . the Commander will show "High score" on every count. Frequency coverage 1.7 to 54 mc. Power input, 35 watts phone, 50 watts CW. Crystal or VFO, (separate). No loading problems, works into balanced or unbalanced lines. Front  $5\frac{1}{4} \times 8\frac{1}{4}$ ", Depth 6". See it at your dealers. Net... \$124.50

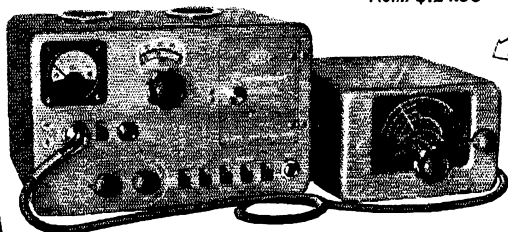

## V. F. O.

Specifically designed for use with the Commander and arranged for convenient external mounting. High Stability . . . "Battleship" mechanical construction. Front  $3\frac{1}{2} \times 5\frac{1}{4}$ ", Depth  $5\frac{1}{4}$ ".

Net... \$29.95

Don't miss the new

Gonset 2 meter

"Communicator,"

now in stock at

your dealer.



801 South Main Street Burbank, Calif.

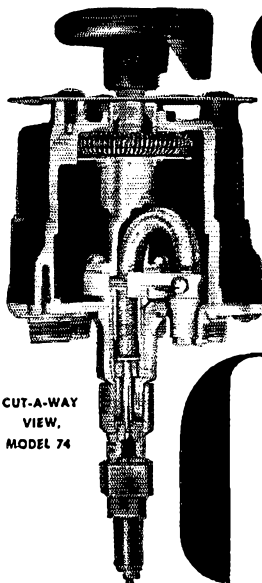

CUT-A-WAY VIEW, MODEL 74

# COAXSWITCH COAXIAL SELECTOR SWITCH

50 Ohms - Type N Connectors - Manually Controlled  
Low VSWR - 4 Models

The COAXSWITCH is an RF switch for use in coaxial circuits where it is important that the 50 OHM impedance of the cables be maintained. In a circuit sense, this switch consists of two pairs of "N" connectors spaced  $4\frac{1}{2}$ " apart using RG-8/U as the connecting link. The COAXSWITCH itself introduces no VSWR other than that of connectors. Characteristic impedance is maintained thru all switch details. Cut-a-

way view shows that shield as well as center conductor is switched. Beryllium copper contacts, on the gooseneck, mate directly with male "N" (Type UG-21B/U) connectors, which connect directly to back plate of switch. Since all connectors come out in line with axis of switch, right angle connectors are usually unnecessary.

Literature Gladly Sent

MODEL 74  
SINGLE COAXIAL CIRCUIT  
TWO POSITIONS  
(SELECTOR OR TAP SWITCH)

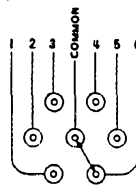

MODEL 71B  
SINGLE COAXIAL CIRCUIT  
EIGHT POSITIONS  
(SELECTOR OR TAP SWITCH)

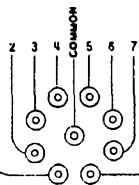

MODEL 72-2  
TWO COAXIAL CIRCUITS  
TWO POSITIONS  
(DPDT, etc.)

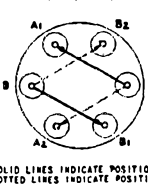

SOLID LINES INDICATE POSITION 1  
DOTTED LINES INDICATE POSITION 2

MODEL 72R  
TWO COAXIAL CIRCUITS  
REVERSING SWITCH  
(DPDT, etc.)

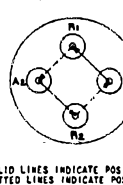

SOLID LINES INDICATE POSITION 1  
DOTTED LINES INDICATE POSITION 2



**BIRD**  
**ELECTRONIC CORP.**  
1800 EAST 38TH ST., CLEVELAND 14, OHIO  
**TERMALINE Coaxial Line Instruments**

**NEELY ENTERPRISES**  
Hollywood • San Francisco  
Albuquerque  
**EARL LIPSCOMBE ASSOCIATES**  
Dallas • Houston

# The Green Engraver

**ENGRAVES  
ROUTES  
PROFILES  
and MODELS**

Used and endorsed by tool and die, electronic, machine, plastics, radio, electrical and instrument manufacturers. A real money saver.

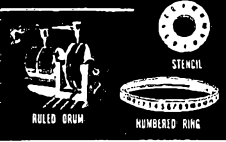

Specify the Green Engraver for precision engraving on metal, plastics, wood, glass, hard rubber etc. . . engraves panels, name plates, scales, dials, molds, lenses, instruments, instruction plates, directional signs . . . by simple tracing from master. *Routing, profiling and three dimensional modeling indicate its versatility.* Electric etching attachment available.

Special attachments and engineering service available for production work.

FREE: Brochure—yours upon request.

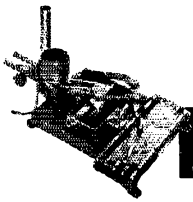

*Green Instrument Co.*  
INCORPORATED  
398 PUTNAM AVENUE • CAMBRIDGE • MASS.

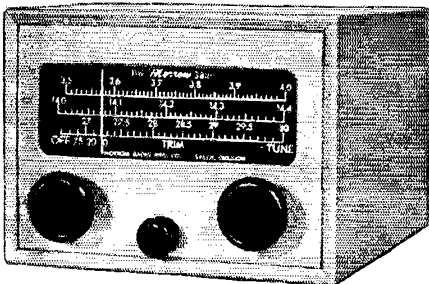

**2BR**  
10 & 40  
40 & 75  
10 & 75

**3BR**  
(Illustrated)  
10, 20 & 75  
10, 20 & 40

**5BR**  
10, 15, 20  
& 75

## 10 REASONS WHY YOU HEAR THEM BETTER WITH MORROW

- 1-Micro-volt sensitivity—all bands.
  2. Full width dial—calibration accuracy 1%.
  3. Automatic noise limiter—built in.
  4. Three gang tuning condenser, tuning ratio 20-to-1.
  5. Tuned preselector, mixer, oscillator.
  6. Separate isolated coils for each band and stage.
  7. Single point tuning: high image rejection, birdies negligible.
  8. I.F. Amplifier with 4 tuned circuits, output 1525 Kc.
  9. Low drift pre-calibrated oscillator.
  10. Antenna trimmer on front panel.
- 2BR—\$54.95      3BR—\$64.95      5BR—\$74.95**  
Deduct \$5.00 from prices if noise limiter not desired

At Your Distributor's



## Mobile Converter

(Continued from page 37)

band will be received between 790 and 1090 kc. (when a 3105-kc. crystal is used in the converter). This results from a difference frequency between the second harmonic of the 3105-kc. crystal and the 7000-to-7300-kc. signals in the 40-meter band.

While the converter described herein uses a 3105-kc. crystal, there is no reason why some other frequency could not be used, so long as the desired sum or difference frequency of the converter tube lies within the broadcast band. In fact, there seems to be no reason why a 3200-kc. crystal could not be used and the input circuit so arranged that it could tune either to the 40-meter band or the 75-meter band. In that way, the 40-meter 'phone band would be tuned by tuning

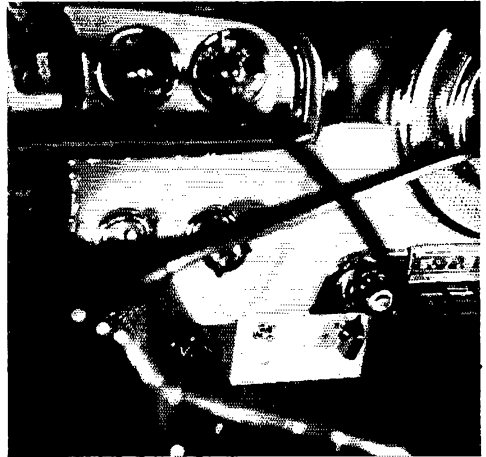

The one-tube converter installed in place, illustrating its small size and inconspicuous appearance.

from 800 to 900 kc. and the 75-meter 'phone band could be tuned from 600 to 800 kc. on the car radio. Front-end selectivity of the converter is good enough to discriminate against all but very strong local signals in the undesired band. It is suggested that the same antenna be used for receiving as for transmitting so as to improve over-all selectivity and sensitivity. Reasonably good bandwidth will result from choice of a crystal frequency such that the output frequencies of the converter tube lie at the low-frequency end of the broadcast band, since most car radios spread the low-frequency end of the band. Many surplus crystals of suitable frequency can be found, and with the change in private-aircraft operation from 3105 kc. to 3023.5 kc. during the coming year, many 3105-kc. crystals should become available at a low cost.



W2FET sends in a newspaper clipping on the subject of radio which mentions a "push-bull" amplifier. Is this something new?

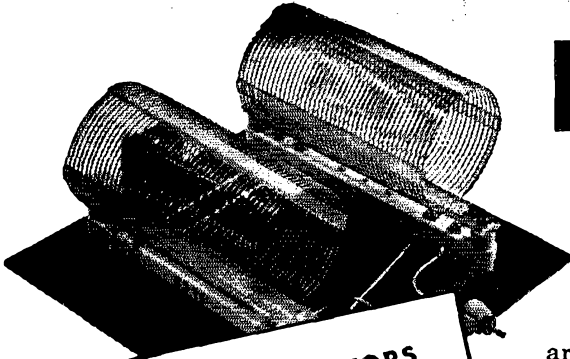

# BALUN COILS!

**B&W BALUN INDUCTORS**  
 Type 3975

NEW LOW PRICE:  
 \$3.75 each coil

These sturdily-built air-wound coils can be connected to match 75 ohm unbalanced transmitter outputs to 75 and 300 ohm balanced antenna feed lines.

These bifilar balun inductors are specially designed for use with Collins 32-V series and similar transmitters—see "The Impedance Matcher" as described in CQ Magazine for May 1951. Two coils mounted on an 8" square plate serve as a compact, highly efficient all-band (80-10 meters) unit for matching feed line systems to both transmitters and receivers. Full instructions included with each inductor.

Metal Base Plate & Connectors Not Supplied.

**B&W BARKER & WILLIAMSON, Inc.**  
 237 FAIRFIELD AVE., UPPER DARBY, PA.

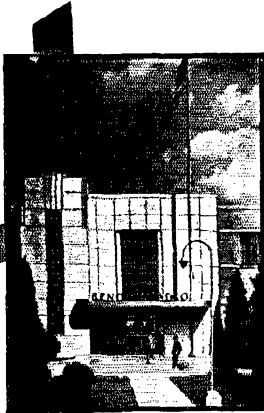

## MAKE THIS YOUR HOME FOR IMPORTANT WORK UNDER IDEAL CONDITIONS

- TV RECEIVER DESIGN ENGINEERS
- ELECTRONICS ENGINEERS
- FIELD ENGINEERS
- TEST & INSPECTION ENGINEERS
- LAB. TECHNICIANS

**NEEDED TO WORK ON:** Radar, G.C.A., Mobile Radio, Auto Radio, Airborne Communication & Navigation Equipment, Television, Antennas, Microwave Equipment, Servo Mechanisms, Guided Missiles and Test Equipment Design.

**YOU BENEFIT AT BENDIX RADIO:**

from high wages, a modern, air-conditioned plant, paid vacations and holidays, group insurance and a good chance for advancement.

Housing immediately available in the beautiful suburban and country areas that surround the Bendix Radio plant.

Write, Wire or phone  
 MR. E. O. COLE, DEPT. K

## Bendix Radio

DIVISION OF BENDIX AVIATION CORPORATION  
 BALTIMORE-4, MD. Phone: TOWSON 2200

# BUY OF A LIFETIME!

TRIED AND PROVEN THE WORLD OVER



## LETTINE MODEL 240 TRANSMITTER WITH MOBILE CONNECTIONS AND A.C. POWER SUPPLY

This outstanding transmitter has been acclaimed a great performer throughout the world. It is excellent for fixed station, portable or mobile operation. Even if you have a transmitter of your own you can't afford to miss this wonderful buy, direct from our factory, ready to operate.

The 240 is a 40 watt Phone-CW rig for 160 to 10 meters, complete with: (8 x 14 x 8) cabinet, self contained A.C. power supply, MOBILE connections, meter, tubes, crystal and coils for 40 meters. Tubes: 6V6 osc., 807 final, 6SJ7 crystal mike amp., 6N7 phase inverter, 2 6L6's mod., 5U4G rect. Weight 30 lbs. TVI instructions included. 90-day guarantee. Price \$79.95.

\$25 deposit with order — balance C.O.D.  
80, 20, 10 meter coils \$2.91 per set. 160 meter coils \$3.60.  
Also for CAP, Broadcast, MARS, Marine, State Guard, Novice.

### LETTINE RADIO MFG. CO.

62 Berkeley Street

Valley Stream, N. Y.

Easy, fast way  
to cut "Key"  
and "D" openings  
in chassis

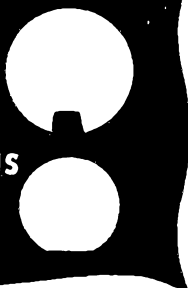

No. 732 "Key" Punch



No. 733 "D" Punch

### ...with new GREENLEE Radio Chassis Punches

Now, in 1½ minutes or less make perfect "Key" or "D" holes for sockets and other equipment. Simply insert GREENLEE Punch and turn with an ordinary wrench... get a "clean" opening in a hurry! Write today for details on these as well as GREENLEE Radio Chassis Punches for round and square openings. Greenlee Tool Co., 1863 Columbia Ave., Rockford, Ill.



## Isolating Oscillator

(Continued from page 41)

cathode resistor,  $R_1$ , and this is made somewhat larger than usual to make certain that the grid will never go positive and draw current through the tank circuit.

The other half of the 5963 is used as the oscillator. The small coil in the plate circuit,  $L_2$ , is wound in the same direction as the coil in the tank circuit and is placed at the grounded end of the tank. A 12AU7, 12AT7, or 12AX7 can be used in place of the 5963 without any change in wiring. However, it can be shown that the output of the VFO will decrease as the amplification factor of the tube increases. The position and number of turns in the plate coil should be adjusted for maximum frequency stability if different types of tubes are used.

In order to isolate the VFO from the load, a 6C4 is used as a cathode follower to provide the output. A resonant circuit,  $C_7C_{2B}L_3$ , is used in the cathode of the 6C4 to provide as much power gain as possible in this stage. Ganged tuning is used for the sake of convenience. The shielding between the two resonant circuits is not needed to prevent oscillation. It is used to decouple the output from the tank circuit which determines the frequency.

The output of the unit is sufficient to drive a tube of the same size as that used in the oscillator.

The frequency characteristics of the unit are excellent. After a ten-minute warm-up, the drift was found to be around 10 cycles for the next five-minute period. After a half hour of warming up, the oscillator was adjusted to zero beat with a crystal oscillator. An hour later there was no detectable beat. This is very good performance for a 7-Mc. oscillator.

The unit was compared directly with a series-tuned Colpitts circuit for voltage sensitivity. The same power supply was used for each. The electronically-isolated oscillator had a sensitivity of 22.5 cycles per volt and the series-tuned Colpitts had a sensitivity of 5.6 cycles per volt. This indicates that the unit should preferably be supplied from a well-regulated voltage source. The voltage sensitivity might be reduced by using a multi-stage feed-back amplifier in place of the isolating cathode follower, or by using a pentode in place of the triode for the oscillator tube. In spite of the increased voltage sensitivity, keying characteristics do not appear to suffer in comparison with the series-tuned circuit, and the stability against mechanical vibration is good.

The basic circuit shown in Fig. 3 can be adapted easily to larger tubes if greater output is desired. There is no need to use a dual triode. Different types of tubes can be used in the isolating cathode follower and oscillator, but care must be taken that the isolating amplifier is sufficiently well biased and has large enough power capabilities to drive the grid of the oscillator tube without drawing grid current itself.

The resonant circuit in the cathode of the output cathode follower may be eliminated with

(Continued on page 132)

## NOW OFF THE PRESS

... to meet the unprecedented demand: the 30th Edition of the Radio Amateur's LICENSE MANUAL ... complete, up to date, and revised to include the dope on the new license structure which is effective in February, 1953. Contains all the info on amended frequency privileges for these various classes, including new Novice band. And of course, it has the new exam schedule for the first half of 1953.

Order *YOUR* copy today.

PRICE **50¢** POSTPAID

(no stamps, please)



YOU don't have to grope for the dope . . . it's all here and easy to understand.

- NOVICE • CONDITIONAL
- TECHNICIAN • GENERAL
- EXTRA-CLASS

---

The **AMERICAN RADIO RELAY LEAGUE, Inc.**  
WEST HARTFORD 7, CONN.

---

# Premax

## Telescoping Adjustable Antennas

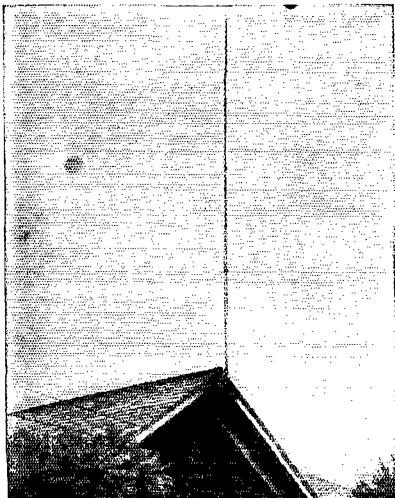

*Low-Cost, Light-Weight, Sturdy  
Tubulars for Land or Sea*

For land stations, heavy mobile rigs and marine use, Premax Telescoping Tubular Antennas are widely used and provide exceptionally strong signals. They are available in steel, aluminum and stainless steel. When used with Premax Base Mountings and Insulators, they provide low-cost installations that give complete satisfaction. Send for Bulletin showing the complete line of Verticals and Center Loaded Antennas.

**PREMAX PRODUCTS**  
**DIVISION CHISHOLM-RYDER CO., INC.**

5302 HIGHLAND AVE., NIAGARA FALLS, N. Y.

# TOWERS by TRYLON

Amateur radio types • Guyed towers for FM-TV antennas • Vertical radiators • Microwave towers • Commercial communication towers • Transmission line supports, etc.

Completely fabricated by the most modern methods by 20-year tower specialists, Tylon towers offer top value for any installation—commercial or amateur. Special design and construction features assure maximum dependability.

Manufactured by  
**WIND TURBINE COMPANY**  
WIND TURBINE COMPANY

HPB-957

## MORE WATTS PER DOLLAR

WITH A  
Model A173T

# LYSCO

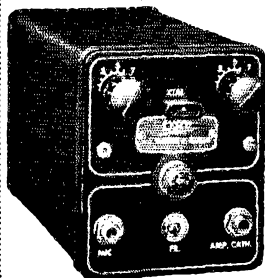

# 40

**METER  
CLAMP TUBE  
MODULATED  
MOBILE  
XMTR**

- Complete with tubes
- 500 VDC-125 ma
- 4" x 4 1/2" x 6"
- Changeover relay
- 50 ohm output

**25 WATTS  
PEAK**

**\$33.55**  
NET

40 mtr Converter  
\$39.00

For complete discussion of the operation and theory of Clamp tube Modulation (controlled carrier) see QST Nov 52 Pg 41

**LYSCO**

MFG. CO. INC. HOBOKEN, N. J.

LITERATURE ON COMPLETE LINE OF LYSCO EQUIPMENT FREE ON REQUEST TO DEPT. Q

some sacrifice in output. An r.f. choke must be inserted in place of the coil. The cathode circuits in the two cathode followers will then be identical, except for a possible change in the size of the biasing resistor.

In most cases it will not be wise to substitute an amplifier or doubler for the second cathode follower. Either of these may draw grid current and this tends to load the cathode circuit of the isolating cathode follower. If this loading becomes too great, the isolating amplifier may be forced to draw grid current and defeat its purpose.

### ARRL Appointments:

#### OFFICIAL EXPERIMENTAL STATION

The pioneering which precludes advancements on our v.h.f., u.h.f. and s.h.f. bands has for the most part been done and continues to be done by the "experimenter." Possessing an inherent interest in the development of successful communications systems at these frequencies, he might well be termed the Daniel Boone of the microwaves.

The relatively large operating regions reaching upward from our present six-meter band need specialized skills for both receiving and transmitting techniques. Understanding this, the OES is of great aid in the collection of propagation data applicable to these shorter wavelengths.

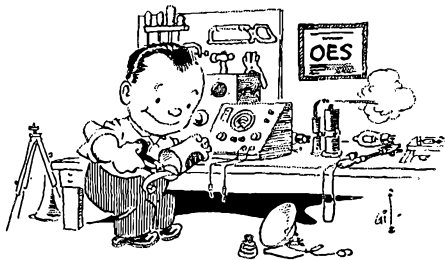

Bulletins go to OES appointees at intervals, and QST utilizes important information received in OES monthly reports in "The World Above 50 Mc."

The OES appointment is well suited for both Technician and Novice Class licensees while eligibility for all other field organization appointments requires possession of a General Class license. Experimentally-minded amateurs in this special category can join their fellow amateurs and contribute much to the over-all knowledge needed for the continuance of progress.

The qualifications to be met by an applicant for OES include operation on at least one of the amateur bands above 50 Mc., and adherence to the techniques and high standard of ethics the OES fraternity require. Applicants are required to report their progress each month to Headquarters via their SCM.

If you would like to join the active field organization of ARRL as an OES and make your contributions to high-frequency techniques, contact your SCM (page 6) and tell him so!

# WANTED COMMUNICATIONS and RADAR PERSONNEL WHO WANT TO EARN

**\$7,000**  
Per Year, Or  
**BETTER**

## PHILCO TECHREP DIVISION

*Offers Such Openings*

... to men who are qualified by experience or training in the design, maintenance and instruction of Communications, Radar and Sonar Equipment.

### FUTURE OPPORTUNITY AND JOB SECURITY

... are more than "sales talk" at Philco. Demands for our electronics installation and service work throughout the entire world have been coming to us with increasing regularity since 1941. This is YOUR best assurance of a future with us.

### PLUS — OF COURSE

... the fact that in Civilian Radio and Television PHILCO has led the Industry for 20 years.

### COMPENSATION IS TOPS!

Salary, bonus, subsistence up to \$6,500 stateside and \$7,500 foreign; PLUS, hospitalization, group insurance, profit sharing, retirement benefits, merit and faithful service salary increases and paid vacations.

### TRAINING PROVIDED

Philco provides all necessary refresher courses and new courses, where required on new equipments, to insure your qualifications before assignment. Pay while training.

WRITE for complete details to

## PHILCO TECHREP DIVISION

22ND & LEHIGH AVENUE

PHILADELPHIA 32, PA.

## Evans RADIO

Service to hams • "YOUR FRIENDLY SUPPLIER"  
by hams. Nationally accepted brands of parts, tubes and equipment. Trade-ins and time payments. Write W1BFT.  
10 HILLS AVENUE • CONCORD, N. H.



## RCA INSTITUTES, INC.

A Service of Radio Corporation of America  
350 West 4th St., New York 14, N. Y.

OFFERS COURSES  
IN ALL TECHNICAL PHASES OF  
RADIO, TELEVISION, ELECTRONICS

Approved for Veterans  
Write Dept. ST-53 for Catalog



- 1220 pages
- 80,000 items
- 8,000 illustrations
- 8" x 11" — 5 lbs.

Publisher's price  
\$6.50 — your price  
through your regular parts distributor **\$1.95**

### The right part when you need it for new gear or replacements

This permanent, hard cover Official Buying Guide of the electronic-TV parts and equipment industry with its comprehensive detailed index, eliminates the need for maintaining files of small catalogs and manufacturers' literature. Radio's Master catalogs 90% of TV and electronic equipment. Not merely part number listings — complete descriptions, specifications and illustrations written and compiled by each manufacturer. Enables you to make comparisons or substitutions right now!



UNITED CATALOG PUBLISHERS, INC.  
110 Lafayette St., New York 13

# WAREHOUSE CLEARANCE SALE

All Surplus **MUST Go!**

BC706D Switch Boxes .....	3 for \$1.00
35MMFD Double Spaced Var. Cond..	3 for 1.00
CD716 Cords W/PL55 & JK56 .....	3 for 1.00
BC-347 Interphone Amp.—less tube .....	1.00
Telescoping Whip Ant., 3-ft.....	1.00
Telegraph Key JK-38.....	1.25
Telegraph Key—knee mount.....	.75
Elevator Servo Amp. with tubes.....	3.95
Navy CW Xmr. 85-105MC less tubes.....	2.50
Ant. Relay Unit—BC442A.....	3.95
5BP4 Cathode Ray Tube.....	3.95
2-Gang Variable Cond. from SCR-522.....	1.29
3-Gang Variable Cond. from SCR-522.....	1.59

**NOTICE TO ALL HAMS:** TRADE IN your used communications gear on new Hallicrafters, National, RME, Hammarlund, Sonar, Elmoc, Gonset, Etc. equipment. Write for FREE ESTIMATE, attention "Pick" — W3PPQ.

**SUN RADIO**  
OF WASHINGTON, D. C.  
938 F STREET, N. W. WASH. 4, D. C.

BE SAFE WITH

# Q-max

A-27

LOW-LOSS LACQUER & CEMENT

- Q-Max provides a clear, practically loss-free covering, penetrates deeply to seal out moisture, imparts rigidity and promotes electrical stability. Does not appreciably alter the "Q" of R-F coils.

- Q-Max is easy to apply, dries quickly, adheres to practically all materials, has a wide temperature range and acts as a mild flux on tinned surfaces.

In 1, 5 and 55 gallon containers.

Communication Products Company, Inc.

MARLBORO, NEW JERSEY  
(MONMOUTH COUNTY)  
Telephone: Freehold 8-1880



## Single Sideband

(Continued from page 49)

for tune-up, and the circuit shown in Fig. 3 was finally arrived at, after a little cut-and-try. This circuit tunes to around 1225 cycles, and gives less than 1 per cent distortion.

The socket was installed in the hole, and the inductance  $L_1$  and the condensers were mounted nearby. The +300 volts was borrowed from the power supply, which also furnished the necessary heater voltage. The only addition to

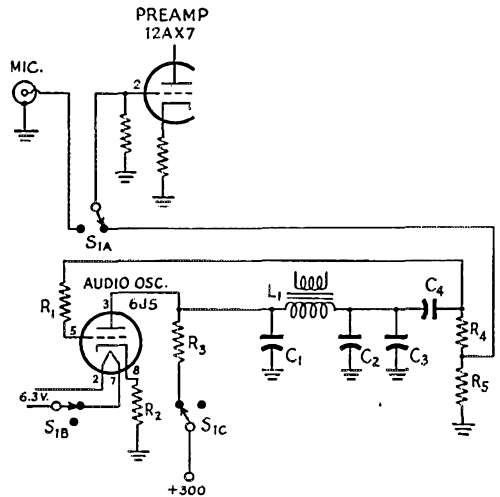

Fig. 3—Wiring diagram of the 1200-cycle audio oscillator added to the Multiphase 10A Exciter by W8DXI.

- $C_1$  — 0.02  $\mu$ fd. 600-volt paper.
- $C_2$  — 0.006- $\mu$ fd. 600-volt paper.
- $C_3$  — 0.002- $\mu$ fd. 600-volt paper.
- $C_4$  — 0.1- $\mu$ fd. 600-volt paper.
- $R_1, R_3$  — 2.2 megohms,  $\frac{1}{2}$  watt.
- $R_2$  — 1000 ohms,  $\frac{1}{2}$  watt.
- $R_4$  — 0.1 megohm,  $\frac{1}{2}$  watt.
- $R_5$  — 1500 ohms,  $\frac{1}{2}$  watt.
- $L_1$  — 4-watt output transformer, secondary not used (Merit A-2903).
- $S_1$  — 3-circuit 2-position nonshorting wafer switch.

the front panel was the switch,  $S_1$  — it was mounted between the Speech Level control and the SB1-SB2-AM-PM switch. The knob on the VOX control at the rear of the chassis was borrowed for the new switch, so that all front-panel knobs would match.  $S_1$  breaks power leads merely to minimize the power-supply drain —  $S_{1C}$  is not absolutely necessary, of course. The frequency can be changed by selecting different values of capacitance, and the value of  $R_3$  seemed to be the most critical in minimizing distortion. — B.G.

## YL News

(Continued from page 58)

tion on WTTG-TV. Fixed stations directed mobiles to pick up telephoned pledges. YLs who took part in this commendable project were W3s CDQ LSX MSU OQF PUG RXJ and W4RIG. . . . N.Y.C. YLRL election results: W2TBU, Kit, pres.; W2RAW, Catherine, v.-p.; W2EEO, Madeline, sec.; and Helen Zuparn, treas. . . . Santa left a Viking-II with VFO for 15-year-old W4UNO. NCS and Manager of the South Carolina C.W. Net, Jane warns her school dates not to call until the close of her net each evening. . . . W0BIC, Sandra, can be found on 40 c.w. often, and W4VJX, Marzee, checks into MARS daily. . . . Although W4HWR, Hilda, is not permitted to operate in England, she is enjoying the hospitality of English YLs, G2YL, Nell; G3ACC, Meg; and G8LY, Connie. . . . W1FTJ, the only YL who

(Continued on page 136)



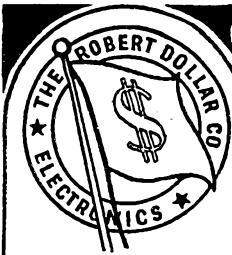

## More power for 2 meter mobile!

Introducing the "222" . . . a new two meter transmitter to meet the demand for greater power output and increased range from mobile units. The 222 is capable of power outputs from 5 to 7 watts with a 300 volt power supply yet satisfactory operation, at decreased output, is possible with 200 volt supplies. The output circuit includes a low-loss antenna changeover relay and an adjustable series-tuned, coupling link for operation into 52 ohm co-ax lines. High level plate modulation, (with P-P 6AQ5's) is used.

The basic intent of the overall design has been to produce a highly stable, (Crystal controlled) transmitter and to apply time-tried-and-proven commercial practice to a new and highly worthwhile piece of amateur equipment.

**FREQUENCY RANGE:** 144-148 mcs. (Also covers adjacent Civil Air Patrol frequencies)

**POWER OUTPUT:** 5 to 7 watts into 50 ohms. (300 V supply)

**TUBE LINEUP:** 6X8 Xcl osc & multiplier, 57G3 multiplier, 2E26 PA, 2-6AQ5 mods.

**XTL FREQ. RANGE:** 8 to 8.222 kcs, FT-243 holders.

**MICROPHONE:** F1 type required.

(Complete with tubes but less crystal, microphone, and power supply) **\$8950** net

**JOBBER INQUIRIES INVITED**

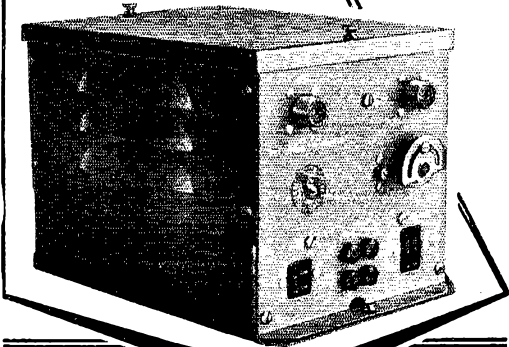

222

222

### THE ROBERT DOLLAR CO.

50 DRUMM ST. SAN FRANCISCO, CALIF.

COMMUNICATIONS  
EQUIPMENT DIVISION

EXPORT AGENTS: M. SIMONS & SON 23 WARREN ST., N. Y. C.

### AN/APR-4 COMPONENTS WANTED

In any condition. Also top prices for: ARC-1, ARC-3, APR-1, APR-5A, etc.; TS-34 and other "TS-" and standard Lab Test equipment, especially for the MICROWAVE REGION; ART-13, BC-348, BC-221, LAE, LAF, LAG, and other quality Surplus equipment; also quantity Spares, tubes, plugs and cable.

ENGINEERING ASSOCIATES

434 Patterson Road

Dayton 9, Ohio

## RADIO and TELEVISION

Over 30 years N.E. Radio Training Center. Train for all types FCC operators' licenses. Also Radio and Television servicing. FM-AM broadcasting transmitters at school. Send for Catalog Q.

**MASS. RADIO SCHOOL**

271 Huntington Avenue

Boston 15, Massachusetts

Lic. by Comm. Mass. Dept. Educ.

## EaZon

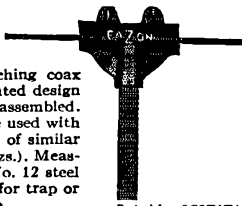

The ideal junction for matching coax to center fed antennae. Patented design permits a natural match when assembled. Extremely low SWR. May be used with RG/8U, 11/U or other cable of similar dimensions. Light weight (4 ozs.). Measured pull exceeds stress for No. 12 steel wire. Use types 3W and 4W for trap or stub junctions in coaxial cable.

Pat. No. 2587676

Type 3WA (see cut) Antenna Match. . . . . \$4.60 Net

Type 3W Tee Junction. . . . . 3.00 Net

Type 4W Cross Junction. . . . . 3.60 Net

See your dealer or write to

**DALLAS C. AKERS CO.**

33 Greenwood Ave.

East Orange, N. J.

## TURN "PRO" WITH THE "BIG" LEAGUE

. . . And you'll bat 1.000!!



YOUR AMATEUR EXPERIENCE MAY QUALIFY YOU FOR A HIGH-PAYING ELECTRONICS OR RADIO POSITION WITH BENDIX RADIO.

- TECHNICAL WRITERS AND TRAINEES
- COMPONENTS ENGINEERING TRAINEES
- LAB TECHNICIANS

We have openings in excellent positions which carry engineering responsibility. If you have a good background of practical experience, you need not have a degree.

Write, Wire or Phone MR. E. O. COLE Dept. L

## Bendix Radio

DIVISION OF BENDIX AVIATION CORPORATION  
BALTIMORE-4, MD. Phone: TOWSON 2200

Makers of the World's Finest Electronic Equipment

# SUPPRESS TVI

... with the Gotham Shielded Cabinet, the easy, fundamental method of reducing harmonic radiation from your transmitter.

The Gotham Shielded Cabinet is designed for complete shielding; it is all-steel and weighs twenty pounds; adequate overlaps are provided; seams are spot welded; there are no cooling vents, louvers, meter holes (instructions cover these points) nor open seams; it is unpainted for perfect electrical sealing; and it is big enough to contain most transmitters.

You do not alter your present rig, there is no loss of resale value or any danger of damage — in less than five minutes your rig is completely and thoroughly shielded.

Full step-by-step instructions are included to cope with TVI. End the bugaboo of FCC notices, quiet hours, and disgruntled neighbors with the Gotham Shielded Cabinet — try it at our risk, money back if not satisfied!

**HOW TO ORDER:** Send check or money order for \$12.95 and we will ship promptly by Railway Express, charges collect.

*Note:* The Gotham Shielded Cabinet is for transmitters smaller than 13 x 24 x 16. If your rig is bigger, send dimensions for special quotation.

**GOTHAM HOBBY** 107 East 126 Street  
New York 35, N. Y.

## EASY TO LEARN CODE

It is easy and pleasant to learn or increase speed the modern way — with an **Instructograph Code Teacher**. Excellent for the beginner or advanced student. A quick, practical and dependable method. Available tapes from beginner's alphabet to typical messages on all subjects. Speed range 5 to 40 WPM. Always ready, no QRM, beats having someone send to you.

**ENDORSED BY THOUSANDS!**

The **Instructograph Code Teacher** literally takes the place of an operator-instructor and enables anyone to learn and master code without further assistance. Thousands of successful operators have "acquired the code" with the **Instructograph System**. Write today for full particulars and convenient rental plans.

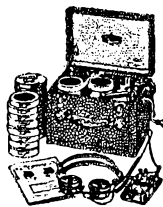

## INSTRUCTOGRAPH COMPANY

4709 SHERIDAN ROAD, CHICAGO 40, ILLINOIS

# Hold the Screw!

Drives it too!

Unconditionally  
Guaranteed

Quick-Wedge  
**SCREW-HOLDING  
SCREWDRIVER**

Ask for it at your Dealer

Kedman Co., 233 S. 5 W., Salt Lake City, Utah

has ever been a member of the Concord Brasspounders, was recently elected vice-president of that organization. . . . From Lima, Peru, comes word that ex-W5PTI and W6KXT, Rene, still doesn't have a call of her own, but she does have permission to operate under her OM's call, O44N. . . . W6UHA, Maxine, has recently added VS5ELA, ZC2MAC, 5A3TU, EA8BF, EA9DC, ZD7A and HZ1TA to her DX list. . . . At their December meeting the Canal Zone QRMarys elected KZ5LN, Lois, pres.; KZ5KA, Kay, v.-p.; KZ5AE, Sis, sec.; KZ5NN, Dec, activities mgr.; KZ5DW, Dot, certificate mgr. . . . We are sorry to report the passing on December 17th of W6VWR, Anna Louise Willomitzer. A charter member of the Los Angeles YLRC and the YLRL National Secretary in 1947, Louise worked hard in behalf of both organizations. She will be missed by her many friends.

### YLRL Net Activity Report

The following is a summary of activity in the YLRL nets from September, 1952, through January, 1953, as compiled by YLRL Vice-President, Dorothy Wickenhiser, W3JSH:

#### EAST

##### 75-Meter 'Phone —

0700 EST, 3900 kc., Wed.; W1SCS, Net Control. W1s LYR QON RTB RYJ SLL, W2s EEO WBN, W3s JSH MAX (OQF op), UUG, W4s CWV (LKM op), LAS SGD, W8s ATB HLF SPU.

0800 EST, 3900 kc., Wed.; W3MAX, Net Control (succeeded W4CWV Nov. 19th). W1s QON RTB SCS, W2s EEO JZX, W3s JSH NXU PVH UUG, W4s KYI LAS RIG SGD STH UNO (c.w.), W8s ATB HLF HUX.

0900 EST, 3900 kc., Wed.; W8ATB, Net Control. W1s FTJ MCW QON, W2s BNC RUF WBN, W3s JSH MAX NXU PVH QPJ UUG, W4s CWV KYI LAS SGD, W8s DJR FPT FYT GJX GYU HLF HUX HWX SPU VWL ZGT, W6IFK/8, W9s AXX KXL LRT, VE3sAJR DEX.

##### 20-Meter 'Phone —

1400 EST, 14,240 kc., Thurs.; W3UUG, Net Control. W1MCW, W3s JSH QPJ, W4LAS, W5TDB, W6EHA/5, W6s IFK NAZ WRT, W8s BWK HUX SPU, W9GME, W9RTH/8, W0YEF.

##### 80-Meter C.W. —

2100 EST, 3610 kc., Wed.; W3JSH, Net Control. W1s LYR OAK RLQ SVN TRE W6YYM/1, W3s QPJ SVY, W7GLK, W8HWX, VE3AJR.

#### WEST

##### 75-Meter 'Phone —

1500 PST, 3900 kc., Mon.; W7HHH, Net Control. W6s JMS PJF, W7s GLK GUQ JFB LXQ NBI NJS NNM NOB MUT ONM OOV OVW, VE6MP, VE7ASA.

0900 PST, 3915 kc., Wed.; W6PJF, Net Control. No report at this time.

##### 80-Meter C.W. —

2245 PST, 3680 kc., Mon.; W7GLK, Net Control. W3s JSH SVY, W6s PJF REF WRT WSG, W7s HHH JFB NNM OTI PTX.

All YLs are cordially invited to participate in any of the above nets.

In addition to duties as YLRL 7th District Chairman, Irma Aufang, W7OVW, relates that her foremost amateur activity is the maintenance and operation (along with OM W7BMG) of one of Tacoma's (Washington) amateur monitoring stations. Daily, from 7 A.M. until midnight, she monitors 29.6 Mc., the city's emergency net frequency — ever alert for distress calls. Irma does take time out though to call into the W7 YL net and is always pleased to make a sked and QSY for a rag-chew with members in her district.



# QST BINDERS

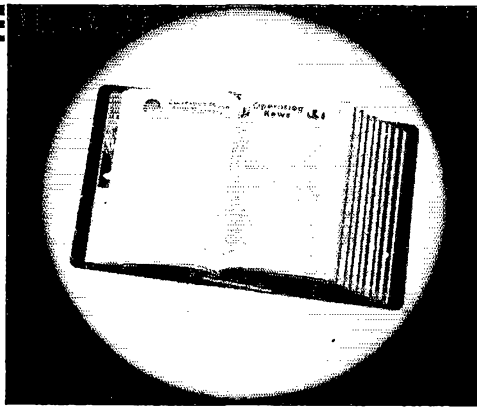

**HANDSOME**  
•  
**PRACTICAL**  
•  
**USEFUL**  
•

Keep your back issues of QST in a neat orderly way. No more fishing through a disordered stack of loose, dog-eared copies, digging for a back issue, and finding it the last one under the pile . . .

- Holds 12 issues of QST
- Opens and lies flat to any page
- Protects and preserves your copies
- QSTs always available for reference

**PRICE \$2.50** postpaid

Available only in United States and Possessions

## The AMERICAN RADIO RELAY LEAGUE, Inc. WEST HARTFORD 7, CONN.

### GET INTO ELECTRONICS

You can enter this uncrowded, interesting field. Defense expansion, new developments demand trained specialists. Study all phases radio & electronics theory and practice: TV; FM; broadcasting; servicing; aviation, marine, police radio. 18-month course. Graduates in demand by major companies. H.S. or equivalent required. Begin Jan., March, June, Sept. Campus life. Write for Catalog.

VALPARAISO TECHNICAL INSTITUTE  
Dept. TN Valparaiso, Ind.

We Carry a Complete Line of Amateur Equipment including: **National • Hallicrafters • E. F. Johnson Co. • Bud • Barker & Williamson, etc.**

**VARIETY ELECTRIC CO., INC.**

468-470 Broad Street, Newark 2, New Jersey

### BEAM ELEMENTS

BUILD YOUR ROTARY BEAM  
ECONOMICALLY WITH  
CALAMAR BEAM ELEMENTS

WRITE FOR USEFUL DATA  
SHEET AND PRICES

**CALAMAR**

18 RICHARDSON AVE., WAKEFIELD, MASS.

### LOOK FELLAS!

BANDSWITCHING  
10, 11, 15, 20, 40, 80  
METERS

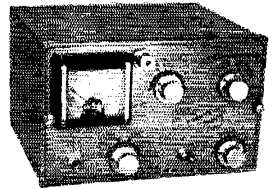

### BABCOCK MOBILE D-X MITTER

Can be tuned up to switch between 2 of the 6 bands with 2 crystals in each band — then one of the 4 frequencies and the proper antenna may be selected by the 4-position switch with no further tuning required.

- No plug-in coils
- The 4 xtals fit inside transmitter
- 8" wide x 5" high x 7" deep
- Tubes: 6AQ5 osc-doub-quad, 6146 final amp. 12AU7 speech ampl., 2 — 6AQ5 mods. Class AB
- Input to final amp. when using Babcock PS 4A power supply: 35 watts
- Complete metering, including RF output watts

**PRICE \$99.50**

including tubes and connecting plugs.

Write for Details

PS 4A 6VDC • Dual vibrator supply with vibrators, tubes and connecting plugs . . . . . \$67.50  
NET PS 1B 115VAC • Power supply for home station, with tubes . . . . . \$44.95  
LS 1 • 2-band antenna tuning unit . . . . . \$15.00

### C & G RADIO SUPPLY CO.

2505-6 Jefferson Ave.

Tacoma 2, Wash.



# NATIONAL

- **P**roven
- **D**ependable
- **Q**uality

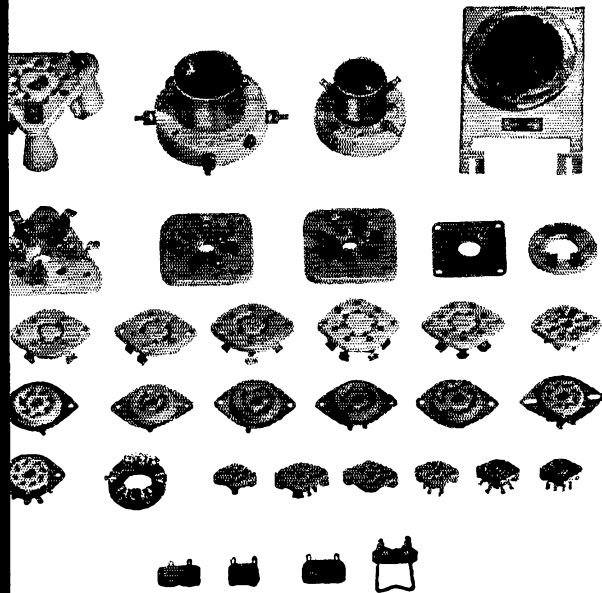

## COMPLETE LINE OF SOCKETS

There is a National socket made for every popular tube type and for every circuit application. All feature low-loss electrical characteristics, firm tube support and easy, secure mounting. They are recommended wherever the highest quality is required. Write for drawings and specifications.

### National

©



EST.

1914

NATIONAL COMPANY, Inc.

MALDEN, MASSACHUSETTS

## Transistor

(Continued from page 16)

### They Have Shortcomings, Too

Transistors in their present stage of development have many shortcomings such as temperature dependence, certain types of instability, excess noise, and power as well as frequency limitations. The encouraging thing, however, is the fact that no one has yet been able to prove that these defects cannot be overcome in time.

The main purpose of this article is not so much to explain transistors as it is to acquaint you with the fact that there is a new member of the electronics family which is already extremely important and about which you are certain to hear more and more. Unfortunately you will probably find it virtually impossible to lay hands on transistors suitable for v.h.f. experimentation. Be patient, because the day will certainly come when you can obtain them with ease.

## Hints & Kinks

(Continued from page 65)

### USING EMERY PAPER FOR CRYSTAL GRINDING

OUR civil defense net in Princeton recently solved the problem of regrinding crystals to get all stations on the same frequency. We worked out a fairly simple and economical method using surplus crystals and emery paper.

The actual grinding equipment consisted simply of a piece of plate glass plus sheets of 1/2, 0, 00 and 000 emery paper. To check frequency during grinding we used the same oscillator circuit shown in the Measurements chapter of the *Handbook*. A standard communications receiver was tuned to the oscillator and the various crystals were checked to zero-beat with the master crystal.

Most of our crystals came in FT-213 holders. To check frequency during grinding, we would merely reinsert the crystal in the holder and, rather than screw the plate back on, hold the spring in with our fingers. Final checking was done after complete assembly.

It's surprising how sloppy one can be and still get workable results. Place the emery paper on the glass and then simply rub the crystal by holding it with one or two fingers. Rotate the crystal 90 degrees every 10 or 20 strokes. We raised forty- and eighty-meter crystals as much as 65 kilocycles and noticed no reduction in activity. As a matter of fact, there was a definite improvement in several cases. As a rough gauge of how much rubbing is needed, 100 strokes on 000 paper will raise the frequency anywhere from 20 to 500 cycles, depending mostly on the pressure you use. The coarser papers will raise the frequency proportionately faster. The 1/2 grade should be used with care and only when you have a long way to go. Some simon-pures may be horrified but we didn't even clean the crystals during or after grinding; just wiped them off on our shirts. —

George R. Webster, W2CPT

# HAM-ADS

(1) Advertising shall pertain to radio and shall be of nature of interest to radio amateurs or experimenters in their pursuit of the art.

(2) No display of any character will be accepted, nor can any special typographical arrangement, such as all or part capital letters be used which would tend to make one advertisement stand out from the others.

(3) The Ham-Ad rate is 30¢ per word, except as noted in paragraph (6) below.

(4) Remittance in full must accompany copy. No cash or contract discount or agency commission will be allowed.

(5) Closing date for Ham-Ads is the 25th of the second month preceding publication date.

(6) A special rate of 7¢ per word will apply to advertising which, in our judgment, is obviously non-commercial in nature and is placed and signed by a member of the American Radio Relay League. Thus, advertising of bona fide surplus equipment owned, used and for sale by an individual or apparatus offered for exchange or advertising inquiring for special equipment, if by a member of the American Radio Relay League take the 7¢ rate. An attempt to deal in apparatus in quantity for profit, even if by an individual, is commercial and all advertising by him takes the 30¢ rate. Provisions of paragraphs (1), (2) and (5), apply to all advertising in this column regardless of which rate may apply.

(7) Because error is more easily avoided, it is requested signature and address be printed plainly.

(8) No advertiser may use more than 100 words in any one issue nor more than one ad in one issue.

Having made no investigation of the advertisers in the classified columns, the publishers of QST are unable to vouch for their integrity or for the grade or character of the products or services advertised.

**QUARTZ** — Direct importers from Brazil of best quality pure quartz suitable for making piezo-electric crystals. Diamond Drill Carbon Co., 719 World Bldg., New York City.

**MOTOROLA** used communication equipment bought and sold. W.B.C.O., Ralph Hicks, 204 E. Fairview, Tulsa, Okla.

**SUBSCRIPTIONS.** Radio publications, Latest Call Books, \$3.00. Earl Mead, Huntley, Montana. W.L.C.M.

**QSL's-SWL's** Meade WØKXL, 1507 Central Avenue, Kansas City, Kans.

**QSLs, SWLs.** Samples, 10¢. C. Fritz, 1213 Eriargate, Joliet, Ill.

**QSLs:** Fluorescent QSLs radiant and glowing with quality-control. QSLs Kromekote three colors and 4-p. Rainbow maps. DX QSLs. Samples rushed. 10¢. Uncle Fred, Box 86, Lynn, Pa.

**QSL Samples** 10 cents, Minner, WISQF Press, Candia, N. H.

**WANTED:** Cash or trade, fixed frequency receivers 28-42 Mc. WØVY, Troy, Ill.

**QSLs, SWLs.** High quality. Reasonable prices. Samples. Write to Bob Teachout, WIFSV, 40 Elm Street, Rutland, Vermont.

**WANTED:** Marconi multiple tuner, coherer, spark coil, magnetic detector, etc. DeForest responder, coherer and other early equipment; Marconigraphs, Modern Electrics; Electrical Experimenter and early Call Books and text books of wireless. Franklin Wingard, Rock Island, Illinois.

**MICROWAVE** test equipment wanted. Weston Laboratories Inc., of Weston 93, Massachusetts, will make you a high cash offer on any microwave test equipment, particularly such numbers as: TS-13, TS-120, TS-45, TS-35, TS-147, etc. To those more interested in trading, we offer any new standard ham item or a combination of cash. Write giving full description for prompt reply.

**WANTED:** All types of aircraft radios, receivers and transmitters. Absolutely top prices. W2KUW, 308 Hickory St., Arlington, N. J.

**WANTED:** Top prices paid: Navy selyns 1 DG, 1F, 1CT, 5CT, 5D, 5DG, 5G, 6G, etc. and BC-348, BC-1221, AN/ART-13, AN/ARC-1, AN/ARC-3, RTA-1B, AN/APR-4. Electronic Research, 719 Arch St., Philadelphia 6, Penna.

**WANTED:** BC610 or BC610 parts or components. State price and condition by letter. C. Porter, 8545 11th Ave., Silver Spring, Maryland.

**WANTED:** Selyns and syncros. Top dollar paid. Write full descriptions to: Box 84, Babson Park 57, Massachusetts.

**WANTED:** Navy Selyns, types 1DG, 1F, 1G, 1CT, 5F, 5G, 6G, 7G, etc. Autosyns: AY1, AY101D, AY201, etc. Tubes, test equipment, Signal Corps Equipment. Send Lists. Top prices. Electro, 110 Pearl St., Boston, Mass.

**QSLs:** Samples free. Big 18 page catalogue, 25¢. "Brownie," W3CJL, 3110 Lehigh, Allentown, Penna.

**GONSET** Triband Converter, new factory sealed cartons, guaranteed. Special, \$39.95. Variety Electric Co., Inc. 468-70 Broad St., Newark 2, N. J.

**QSLs** by Petty, W2HAZ, 17 Southard, Trenton, N. J. Samples, 10¢.

**WANTED:** Electro Importing, DeForest, Marconi, Wireless Specialty Apparatus; QST, Wireless Age, Electrical Experimenter, Marconigraphs before 1920. Early catalogs, etc. Please describe items in detail and give price wanted. Louis Rizoli, W1AAT, 100 Bay View Ave., Salem, Mass.

**CRYSTALS** — Those hard-to-get spot amateur freqs. 1.8 to 7.4 Mc., \$2.50. Pennsylvania Crystal Co., R 2, Knox, Penna.

**HEAT TVI.** One 7" television receiver, \$35.00. One 10", \$50. Excellent as monitor, other uses around shack. W4API, Spitz, 1420 South Randolph, Arlington, Virginia.

**QSLs? SWLs?** America's finest and largest variety of super-gloss QSL samples, 25¢. Ruy Sakkera, W8DED, Ham Print Shop, 53 East 7th St., Holland, Michigan.

**ATTENTION Bargain Hunters:** Are you looking for 32V1, 32V2, Viking 1, DB22, VHF152A, SX71, HQ129X, HRO7, HRO50; SX42, etc.? Our trade-in department is loaded with these and countless others. Many items of National, Collins, Johnson, Hallicrafters, Harvey-Wells, Hammarlund, RME, Elmac, Gonset and others both used and new. Write today for our latest bargain sheet. We offer you top trade-in allowances and tailor-made payment plan just for you. For the best in equipment, best deals and real consideration write Burghardt Radio Supply, Watertown, South Dakota.

**FOR Sale:** 40 watt modulator speech clipping and power supply, \$25.00. Small emergency or mobile rig 2E26 final, carbon input, \$20.00. WZABT 34 W. Girard Blvd., Kenmore 17, N. Y.

**EXCELLENT RME-84** receiver, \$50.00 or trade with cash for small factory-built transmitter. Frank Shopen, Cox Apartments, Omaha, Neb.

**ELDICO TR-1** in 20" deluxe cabinet, 80, 40, and 10 meter final coils, \$225.00. W8JZA, Howard Haebler, Akron, Mich.

**FOR Sale:** Enclosed steel rack on dolly, all bands, 500 watts PP813s modulated with 811s, \$225.00. HT-9 gray (latest model) 10, 20, 80, \$225.00; BC-221 AK AC supply, excellent condition, \$100.00; Meissner deluxe signal shifter, \$50.00; brand new PE10J, \$25.00; Eico scope, 2 spare 5B11s, new condition, \$40.00; Mark 11 transmitter, brand new, complete, \$25.00. W2ISS, H. H. Rogers, 118-36 — 224th St., Albany 11, L. I., N. Y.

**NOVICE QSLs:** duplex XYL-OM, cartoons, maps, fluorescent. Special Novice deal, 15¢. W9AVH, 12811 Sacramento, Blue Island, Ill.

**FOR Sale or trade:** BC-221AH, modulation and regulated power supply, like new, \$90. Triplet VOM 2400, \$20; Instructograph with audio osc., \$25.00; Heath VTVM-V-5A, \$32; T3 signal tracer, \$33.00; TC1 tube checker, \$35; Eico battery eliminator, \$32, all new. QSLs 1937 to 1952, \$5.00 per year. Want NC173. M. J. Marshall 44 Washington Ave., Lumbert, N. J.

**WANT:** QST's older than 1920. Have 200 copies 1932 to 1953, 25¢ each. WØMCK, 1022 No. Kock Hill Road, Kock Hill, Missouri.

**NOVICES!** \$1.00 brings ten monthly lists of late WN QTHs. W1QNV, Art Bates, Ingham, Mass.

**SELL BC-221** with modulation. Excellent condition. Crystal and calibration book, \$95.00. WØEBR Rt. 2, Box 7A, San Benito, Texas.

**CLEANING house:** Micomold XTR-1, extra filtering, w/ FB 40 mpa (now on air) 100-45 QST decoupled, w/ pwr supply (it chirps), \$12.50. 5C459A partly converted, FB condx, \$10; electronic keyer, CO design, with tube as relay, \$5; misc. tubes, \$5.00; box parts, no screwball stub, \$5.00; 78KRM player, extra Capehart pickup, \$15; P. J. Lawrence, P. O. Box 438, Charleston, S. C.

**SELL:** HT-9 postwar Hallicrafters transmitter, excellent condition, with coils, tubes, mike, \$185. W71V, 16833-19th SW, Seattle 60, Wash.

**FOR Sale:** 1 Model 5A0A Hallicrafters receiver, \$50; 2 National multi-band tanks, MB150, MB40, both \$22.50; 1 Model EX Meissner shifter, \$55.00; 1 Type "S" Gardiner auto sender, \$16.00. All like new. Express collect. Robert O'Neil, 211 S. Albany St., Ithaca, N. Y.

**SELL:** 500 watt transmitter, PP 100THs in cabinet. WØGJJ 922-16th St., Bismarck, N. Dak.

**WANTED:** BC-610-E, BC-614-E, BC-939, ARC-1, ARC-3, APR-4, APN-9, APK-SAX, AKT-13, A1C, DV-17, DY-12, TC5, SCKR-694, PE-237, BC-1306, GN-58, CR-284, PE-100, PE-104, GN-45, BC-344, BC-347, BC-348, PE-1407, PE-1408, PE-1409, PE-1410, RA-34, RA-42, RA-62, Technical Manuals, Signal Corps supply catalogs, TS, I, Test equipment, aelsyns, tubes. Arrow Appliance, Box 19, Boston 1, Mass.

**WTEC's** on 220 and 420 Mc and s interested in hearing from all 1 1/2 and 3/4 meter amateur stations in Philadelphia vicinity and others, on UHF bands, Phone ST 2-2176 or write Joe Zukauskas, 2227 Gtn. Ave., Philia, 33, Penna.

**WANTED:** HRO or HQ-129X or NC-183. For sale or swap: Radiant vibrator supply #454, prop pitch motor, never used; Hy-Q-75 2-meter xmitter, \$8.00; carbon microphones, phono oscillator, 78 rpm automatic record changer, \$5.00; 1000 V. dynamotor. W1UAD, Jack, 749 Wood Ave., Bridgeport, Conn.

**FOR Sale:** Hi-power components, Pair Eimac 4-250A brand new, Thordaron plate transformer 15P20, also brand new, Thordaron 872A fil. transformer; stancor fil. trans. for 4-250As, chokes, filter condensers, Weston and Simpson meters, relays. All of the above is either brand new or like new. Send for list. A. Martinka, 1253 Grace St., Chicago 13, Ill.

**WANTED:** Dynamotors, all sizes and ratings; tubes, all types, transmitting and receiving, crystal diodes, microwave gear, frequency meters, test sets, government surplus. We buy and sell and swap as well. "TAB", M. Blumberg, W2CPC, 111 Liberty Street, New York City, N. Y.

**CHOKES,** new 400 Ma. UTC S35, S36, \$7.00 ea.; 2 µ 4000 V. conde. new, \$3.50; 872A, new, \$1.50; Lyco "28" 10 meter transmitter, complete, \$15.00; Turner "BX" mike, new, \$5.00. W4SOR.

**FOR Sale:** Selling out, all top condx with instruction books; Sonar VFX-680, coils all bands, \$60.00; AMP-50, 75W amp., \$37.50; SR-9 10-11 Mob. revr, \$50.00; MR-3 five band Mob. revr, \$70.00; Elicio 2 mtr revr, sep. lev. tuning unit for mobile mounting, \$45.00; Gonset 10-11 convy. \$20.00; Speed-X key, \$3.50; F.o.s. NV, A. Clark Jr., W2PDH, 44 Lewis Lane, Syosset, L. I., N. Y.

**SELL:** S-38B, good condition, \$35.00; NC-125 speaker, new, \$10.00; a few parts and tubes. Write to Vasilie John Lucas, South Pass Rte, Lander, Wyoming.

**TELEVISION DX** information is needed for my study. Would be appreciated if you would send me this information. I would like to know when you have received TV-DX, how long it stayed in, and how good was the reception, etc. Den Nichols, 5486 Nichols Road, Mason, Michigan.

**TUBES,** Eimac 304TL's, \$15.00; 872A's, \$2.50. VT166, \$100 5CP1's, \$10.00. Kiefer, W2ZZV/3, 229 Warren Sq., Bethlehem Penna.

SELL new Gordon 1000 relay, new Millen 04200 condenser, two new 207Z's, Triple 1600 modulation monitor, EY signal shifter with FMX modulator, Navy 24-hour 8-day clock, new BC654A, RCA police transmitter modified for higher power and all bands, complete set B&W TVH coils. Make offer, W8UUS, 632 No. Terrace Dr., Wichita 6, Kans.

FOR Sale: 10 meter transmitter, 25W de-TV1'd, ready to go, beautiful, BC-459, separate HV and LV supply, PE-103 new, original box, VFO and many parts. Write for details. Peter Rosenbaum, W2GAW, 29 1/2 Idzth St., Bayside, L. I., N. Y.

VIKING I de-TV1'd, 4D32 final, \$250.00; NC173 E5 speaker 125 ant. box with B&W low pass, Balm coils, ant. relay ea meter, B-1 relay, 5 position, ant. selector, ground/operate switch 40; Viking VFO 40; 3-element H.D. w/spacing 20 m. beam, prop pitch motor in steel box, shielded cable; E5 indicator 100; the works \$500.00, all F.o.b. Biloxi, Miss. W9OSR/5, Paris Trailer Park, Pass Road, Biloxi, Miss.

SELL composite transmitter, 300 to 500 watts, in two five foot relay racks. Bud final, pair T-55s. Modulators pair 242-Aa. Write for further particulars. #275. Box 595, Hermiston, Oregon, Ralph L. Krause.

SELL: Complete pair of SCR-511 transceivers BC-745, power supplies, PE-157, chest units, 1-39. Best offer takes it. Will trade for 20-meter beam. J. P. Lapiante, 246 Lake St., St. Albans, Vt.

RME 2-6-11, \$85.00 or best offer. BC455, \$5.00; remote xtal selector switch, \$5.00; many tubes and parts. Send for complete list. W8KUT, 6280 Reber Place, St. Louis 9, Mo.

FOR Sale or swap: phone transmitter 10-20-40-80 single T-200 7 ft. Deluxe rack and panel, 8 meters, commercial appearance, no I.V.I. pair Walkie-talkies, BC322, 52 to 65 Mc, AC and DC power supplies. National receiver 1-10. Will ship. Write for bargain prices. I want Johnson Viking transmitter-I, or Collins J2V2. Write to Fred V. Rudolph, Stryker, Ohio.

X-TALSI Sell set HT-243 xtals, channels 270-388, and Astatic B-10 pickup. Robert Smithwood, W9VNT, 1530 N. King Ave., Indianapolis 22, Ind.

TWO 250THs, two 100THs, 2.5 volts, 10 ampere transformer. Best offer. Write W2KQI, 27-01 Oakland, Nashville, Tennessee.

FOR Sale: S53A Hallcrafters, brand new, AI-cond. Used only about 3 months. Best offer over \$50.00 takes it. Seymour Zaval, KN2AWX, 292 Riverdale Ave., Brooklyn, N. Y.

QSLs, stationery, samples, dime refunded. Gale, W1RD, Watertord, Conn.

SELL: HF-10-20 \$50; 4-250-A (8 hours), \$30.00. Write for list of other parts. W8FRW, 520 Loveman, Worthington, Ohio.

RECEIVER wanted. Emmet Weber, 31 Wolcott Road, Brookline, Mass.

SCR-522: Original condition. Will sell or swap. How much or what have you? W2KNQ, R. D. Hewitt, N. J.

LYSCO 600, like new. What am I offered? W7PBT, Box 150, Cedar City, Utah.

VFO Hallcrafters HT-18 condition like new. Charles Ritter, 1141 Garrett Ave., Niagara Falls, N. Y.

FOR Sale: BC654 with new, unused PE103, new tubes, Vibropack and power cable, complete, \$50. SX24 and spkr. \$50. Abbott TR4B, \$12. Want SX42 in good condition. W2HBR, John A. Schwerbel, 111 W. Hoffman Ave., Lindenhurst, L. I., N. Y.

WANTED: BC611 handle-talkie. Give price and condition. Richard Meirowitz, WISDS, 28 Einhorn Road, Worcester, Mass.

HANDBOOKS: 1931, 1934, 1941, 1945, 1948, 1949, 1951, \$1.25 each; QSTs, 1947 to 1952, \$10; TV Engineering, 1950-1951, \$2.50; QSTs 1932 to 1952, odd numbers. WITHM.

SELLING out: Transmitter 500 watts (pair 4-125A), Meissner Deluxe signal shifter, Bilcox CW3 receiver, BC459A and power supply, BC459, BC458 and power supply. Many other items. Send for list. Fred Graening, W9KHS, 414 St. Julian St., Pekin, Ill.

NOTICE: Sell new 50 watt c.w. transmitter for 40 and 80 meters, built by Max QST plans, \$40.00. Also new assembled Eico VTMV, \$40 and sell or swap (4) new 815's. Bobby Francisco, Glade Spring, Virginia.

SELL: Gonset TriBand converter, including 15 meter band. Excellent, used only 2 hours, \$30.00. W2ZPK, 606 Union Ave., Peckskill, N. Y.

WANTED: Skybuddy receiver. WIBB.

SELL: Collins 310-B1, 2000-1750, 300 Ma. power supply. Melvin Gardner 134 South Ferry, Ottumwa, Iowa.

QSLs. New designs. Among finest printed. Dortch, W4DDF, Jocelyn Hollow Rd., Nashville, Tenn.

FOR Sale: 400 watt transmitter, modulator trans. 4-203's, meter sell mod. separate, BC457 and 58 crystals, 75-240, 522 trans. rec. CQ-QST 1935 up. Bileey CCOAZ, BC645, 420 Mc. Reasonable. Thomas Kelley, RFD #3, Mendon Rd., North Smithfield, R. I.

FIRE extinguishers Underwriters approved, for shack, \$9.95 prepaid, Thompson, W3COS, 735 Silver Spring, Silver Spring, Maryland. Free Folder.

VIKING headquarters is the place to do business on Johnson Viking 11 kit, \$279.50, wired and tested, \$319.95; VFO kit with tubes, \$45.25, wired and tested, \$45.95. We take standard manufactured transmitters and VFO's in trade and offer terms. We also can supply the Viking II with built-in VFO. Write for prices and details to Carl, W1BFT, Evans Radio, Concord, N. H.

FOR Sale: 400-watt phone and c.w. transmitter. Includes HT18 exciter, commercial 15-watt speech amplifier, meters 250 watt modulator for 100% plate modulation and 813 final. Built-in 2 deluxe 30" cabinets. Power supplies of best quality. Operates 10 through 80 meters. Rig can be seen in operation. \$300.00 takes all. W1LOP, 182 Blue Hills Ave., Hartford, Conn.

SELL: Gonset 10 M converter, \$18.00; AT-3-B Harvey-Wells aircraft xmitter, 3105 Kc converts to 75 M fone, \$25.00, 12 V dynamotor 250 v, 60 m. ne, \$4.00. BC454, new, \$12.00. W8KDE, 109 N. Iroquois St., Laurium, Mich.

QSLSI Interesting samples, 10¢. Tooker Preas, P. O. Box 2, Lakehurst, New Jersey.

TRANSMITTERS: Motorola T-69-20A, 10 meter mobile with 6 v vibrator supply. Newly reconditioned, \$50. Harvey-Wells TBS-50-D deluxe, with APS-50 power supply. Used very little, in excellent condition, \$150.00 or best offers. Lynn M. Finch, W2MSJ, Franklin, N. Y.

DON'T fail! Check yourself with a time-tested "Surecheck Test", similar to F.C.C. tests. Novice, \$1.50. General \$1.75. Amateur Extra, \$2.75. Your money back if not satisfied. Amateur Radio Supply, 1013 7th Ave., Worthington, Minn.

WANTED: AN/APR-4, APR-5A, ARC-1, ARC-3, ART-13, etc.; TS-12 and other "TS", particularly Micro-wave equipment, even salvage; VHF frequency meters and signal generators; quantities of 723A/B, 3C22, etc.; tubes; any Laboratory equipment. Top cash or swap; ruah Engineering Associates, 434 Patterson Road, Dayton 9, Ohio

10, 15 and 20 meter beams, aluminum tubing, etc. Perforated aluminum sheet for shielding. Radcliff's, Postoria, Ohio.

PRECISION-made, custom built antennas for all bands . . . literature available. Antenna, Incorporated, Wakefield, R. I.

WANTED: Back issues of Electronic Engineering literature, such as "Wireless World", "Electronics", and the "Proceedings of the I.R.E.". Write to: Bob Bridy, 140 West 57th Street, New York 19, N. Y.

WANTED: RCH receivers, RBS receivers and SLK receivers, Navy type equipment. Also, I-145 Test sets. Write immediately stating condition and best price in first letter. GME, Inc, 7315 Varma Ave., North Hollywood, Calif.

BARGAINS: New and reconditioned Collins, Hallcrafters, National, Hammarlund, Johnson, Elmac, Harvey-Wells, Babco, Gonset, Grant, Avco, RME, Meissner, Miller, Sonar, etc. Low prices. Reconditioned S40A, \$69.00; S40B, \$79.00; S76, \$129.00; SX7L, \$149.00; SW54, \$135.00; NC57, \$69.00; NC125, \$129.00; NC173, \$139.00; NC184, \$199.00; RME 45, \$89.00; HF-10-20, \$49.00; VHF-152A, \$59.00; RME50, HRO50, HRO60, HQ129X, S404N, SX43, SX42, SX62, Collins 75A1, Collins 75A2, Collins J2V2, Collins J2V1, \$375.00; Viking I, others. Free trial. Terms. List free. Write to Henry Radio, Butler, Mo.

BARGAINS: Extra special! Motorola P-69-13, Mobile receivers \$29.50. Globe King \$315.00; HT-9, \$199.00; HRO-50, \$275.00; Lyrco 600, \$109.00; HRO-7, \$199.00; Collins 75A1, \$275.00; HRO-5T, \$175.00; SX-71, \$169.00; SX-42, \$189.50; SX-43, \$129.00; HRO Sr., \$119.50; RME 2-11, \$99.50; RME-45, \$99.00; Meissner EX Shifter, \$59.00; S-40A or SX-16, \$69.50; VHF-152, \$59.00; HF 10-20, \$59.00; HRO-50, \$169.50; A18611 mobile transmitters, \$19.95, 90000 exciter, \$29.50; XE-10 \$14.95; Gonset 10-11 converter, \$17.50 and many others. We need used receivers: we give highest allowances for S20R; S-40A, B; NC-57, NC-100, NC-125; SX-24, SX-25; HQ-129X, and similar receivers. Free Trial. Terms financed by Leo, W6GFQ. Write for catalog and best deal to World Radio Laboratories, 740-44 W. Hwy, Council Bluffs, Iowa.

SELL: Eldico TR75 with four crystals and coils for 10 and 80. Used about twenty hours. Professionally wired, perfect, \$70 F.o.b. A. Corbett, West Sayville, N. Y.

DELTA power transformer, new, AC V, 2000-1500-0, VA 500, Pri. V, 105-115-125, fully shielded, \$12.50. Variable voltage transformer, Japanese mfg., new, fully shielded. Japanese rating 1500 watts. \$12.50. W2EXR.

COLLINS transmitter J2V-2 or J2V-3, and/or 75A-2 or 75A-3 receiver wanted for cash. Best best price. Joe Harms, 225 Maple Ave., North Plainfield, N. J.

SELL NC-181D less speaker, perfect, \$300. Several 304TL, 10 pair, prop pitch motor, \$20. W9AMU, John Huey, 390 Hill, Elmhurst, Ill.

FREE list. Used Collins, Elmac, Hallcrafters, Hammarlund, Harvey-Wells, Lyso, National, RME, Sonar, etc. Lowest prices. Liberal trades. Dossett, W9BHV, 855 Burlington, Frankfort, Indiana.

WANTED: ART-13 transmitter and parts. Write B. Spivey, 7013 Rolling Road, Chevy Chase, Md.

HAMFEST time is June 7th with The Starved Rock Radio Club. See April and May Hamads for further details. W9MKS, Utica, Illinois.

TRANSFORMERS, chokes, meters, tubes, mobile xmitter, etc. No junk. Send for list. W6PMM/4, F. C. McDaniel, 55 Power Road, Thomason Park, Triangle, Virginia.

SELL BC-610E transmitter with BC-614E speech amplifier, coils, tuning units 10 to 80 meters. No tampering or altering, except for factory conversion to 10 meters. Condition like new \$490.00. W2NQR, 61 Henry St., Merrick, L. I., N. Y.

FOR cash, where can I get a portable "mill"? New or good used. W. W. Benson, W2ORM, Box 683, Rawlins, Wyoming.

SELL: QSTs, 1922 to 1950, 25¢ per copy; 12 copies minimum order. W3KA, 444 Delafield Pl., N.W. Washington, D. C.

WANT: Collins 75A2 receiver, New York vicinity only. W2DTE, BA-9-2449.

SELL: Crystals, all ham frequencies, FT243 and others. Two for a dollar. Specify frequency desired. Am VFO now. W2KJY, Kirshuber, Case Road, Neahcane Sta., New Jersey.

SELL: ERCO model MF-50 radiotelephone transmitter 1.7 to 15 megacycle frequency range, 50 watts output with self contained coils, P1 antenna network, electron eye modulation indicator, push to talk facilities. Perfect condition, with tubes, \$150. W2GYL, Riverdale Ave., Amityville, N. Y.

FOR Sale: Collins 30K-1 transmitter complete with 310-A1 exciter and tubes. Very good condition. New YRS-1 selector no modifications, YGS-3 signal generator. W7FUV, 1935 East 9th South, Salt Lake City, Utah.

SELL or trade, National HFS with power supply, \$125.00. Cash or trade for SW receiver or commercial transmitter. Rcvr in original carton and only used 10 hours. Paul J. Patrick, W9ZYM, 5251 So. Pennsylvania Ave., Cudahy, Wis.

SELL: BC-610-E, in excellent condition, clean, many extras, includes signal shifter, \$550.00. W6FIS, 38 Thelma Dr., Bakersfield, Calif.

IRE Proceedings for sale: 1950, 1951, 1952 Perfect condition, \$9.00 per year. Ferd Thiede, W2EC, 169 Buckingham Rd., West Hempstead, L. I., N. Y.

NEW YORK CITY area. Sell: Millen Variarm VFO, \$20.00; National NC110 with power supply, \$20.00; RAK-7, \$20.00; Stancor S102A-TV1 proof, 35TG PA, LP hiter and antenna relay built in, \$60.00; 52-10, \$10.00; Regency booster SB29, \$6.00; Sonar MB611 NFM and clamp-tube modulation, \$25.00; BC96 modified clamp tube modulation, \$25.00; Abbott TR4 on 420 MC, \$10.00; ARC-5 receiver with AC power supply, 10 meters, \$20.00. W2UWG, 515 East 85th St., New York 28, N. Y.

FOR Sale: Collins 32V2 and 75A1 like new, in original boxes, plus 3X mike and stand, \$650.00. Little time 75A1 since factory reconditioned. Victor Beale, W8NCO, 10140 Loraine, Komulus, Michigan.

WANTED: BC34 receiver. State price and condition. Write to R. Wegelin, 410 Cedar St., N. W., Washington, D. C.

SALE or Swap: Elincor folded dipole 10 beam coax cable. Tenna Rotor Beam rotor with indicator, DM 36 frequency expander. Weston decibel meter. S38 receiver, Globe Trotter transmitter, all in perfect condition, ship anywhere. Write KV4AC, St. Thomas, V. I.

WANTED: National 183 in good condition. Sell Hallcrafters S40B, good condition. Jake Leichty, WN7RLV, Route One, Box 3500, Albany, Oregon.

WANTED: Millen power amplifier 90881. State price and condition by letter to Wathen Brack, VE2ABR, The Canadian Bank of Commerce, La Sarre, Que., Can.

WANTED: Millen type, 500 watt amplifier, 90881 with or without tubes, power supply, coils. Bill Monk, Box 112, Liberty, Texas.

FOR Sale: Collins 310B shortwave amateur transmitter, complete with tubes and set of four 1A tubes, plus transfer relay. Covers amateur bands between 3.5 and 32 Mc. Carrier output 15 watts (\$200.00). Also Howard shortwave receiver covering all ham bands from 55 to 43 Mc. (\$30.00). R27/RAC 5 shortwave receiver, 40-meter band (6-9.1 Mc). Complete with power supply and speaker. Operates on 110 V-AC (\$25.00). R. M. Yearout, 1502 Anderson Pl., S.E., Albuquerque, N. M.

HAMVENTION is the biggest treat in ham radio. See Hamfest Calendar this issue for details.

BIRTH announcements, ham-styled: 25 for \$1.00. Narvestad, Granite Falls, Minnesota.

SELL: 75A2 perfect, speaker original boxes, \$350.00. Prop pitch and xformer, \$20; 20-m 3 ele. beam with tower, \$65; RCA 3 in. scope with new 3AP1 \$16; Dynatron DM35, \$10; transformer 870, VCT 400 Mil, \$5.00. W1FKW, P.O. Box 153, Belfast, Maine.

SELL: Carter Dynamotor 6 V.D.C. input; output 600 V.D.C. 170 Ma., new. \$35. J. Rando, 663 Crescent Ave., Bronx 58, N. Y., N. Y.

FOR Sale: 250 watt transmitter. Will deliver vicinity New York City. FB handwired phone/c.w. xmitter, completely metered with self-contained Variac and VFO shielded, 5 ft. rack, \$250. W2BJR.

SELL: Harvey-Wells Sr. with power supply, practically new, \$109; BD22A perfect condition, \$59.00; power supply rack panel modulated, 2250v or 1750v 300 mils filtered, \$50; modulator 811's with universal modulation transformer and speech amplifier on same chassis, \$35; Vibroplex Lightning Bug, new, \$11; Bud Deluxe relay rack cabinet, 36 in. panel space, \$15.00; 2 new 813's, \$7.00 each. Delivery within 150 miles. W3SAU, 407 Ann St., West Reading, Reading, Penna.

RCA-AR-88 with speaker, S meter, 2 stages RF, 3 stages (quadruple tuned) I.F., 25 or 60 cycle supply, Super selectivity, sensitivity, signal to voice ratio, \$235.00. Combined 10-20 meter beam, rotor, jacket for pole mounting, \$65.00. Command transmitters, receivers, 805, HK-257, 715B, 715C, HK-54, 592, Thordarson 1250 V.D.C., 350 Ma. Any reasonable offer. D. R. Gardner, W2GSS, 209 Knapp Court, Syracuse 4, N. Y.

RADIO amateur and commercial license preparation. International Morse code transcribed on magnetic tapes, recording wire and long playing microgroove discs. Disc-A-Method Recording Co., 317 East 48th St., New York, N. Y.

FOR Sale: Hallcrafters' SX-28, speaker, \$100. Field Curry, 313 Garland, Pittsburgh 18, Pennsylvania.

FOR Sale: PE-103, mobile whip assembly, speech amplifier. Box 382, Main P.O., Newark 1, New Jersey.

YOUR call-letters hand painted in gold color on a quality necktie, gift boxed, only \$1.50 postpaid. Choice of green, maroon or blue. W2NRO, C. Stager, Parker Avenue, Metedeconk, New Jersey.

WANTED: 75-meter mobile gear. Have some test and receiving gear for sale or for trade. W0HQE, Doehling, Surprise, Nebraska.

WANTED: HQ-129X or SX-71. Must be in excellent condition, \$135.00. L. G. Doak, 1309 Merrimack Ave., West Hyattsville, Md.

FOR Sale: S-76 Hallcrafters receiver with K-46 speaker, brand new, in original packing; \$150.00; Heath oscilloscope, \$25.00, W8EZX, Vogel, 15813 Invermere Ave., Cleveland 28, Ohio.

SPRING house-cleaning at WIJR on Mockingbird Hill in Gardner, Mass. Parts, tubes, test equipment, crystals, beams, etc. The XYL known as Lou says "Sell it or give it away". Write for list. 73 Rich, WIJR/W9ARE.

VIKING I, TVI-suppressed, with spare set tubes, low-pass filter, coax relay, Balun coils and Viking VFO, \$325.00. Collins 75A1 with speaker and built-in 100 Kc calibrator, \$225.00. Paul Weland, W0ESK, 1700 Beaver Ave., S.E., Cedar Rapids, Iowa.

WANTED: Bandwitching transmitter, VFO, on VFO-transmitter, 60 to 200 watts, c.w./phone. W5WUB, Mountain Home, Arkansas.

HALLCRAFTERS S-40B, like new, perfect condition, original instructions, little used. No reasonable offer refused. All inquiries will be answered. Jordan Polly, 2852 Brighton 6th St., Brooklyn 35, N. Y. SH 3-0104. K2AZL.

SELL or swap: 55 foot Vesto self-supporting steel tower, like new, ready for shipping. See any issue QST for full information. Price only \$185.00 or will swap for Collins 32V-1 or 2, Viking I or II, Globe King and consideration. W8IO9, 901 South 86th St., Omaha 8, Nebraska.

WANTED: CREI course, P&E No. 4 slide rule. Cash or trade. Richard Simonsen, 130 Pine, Chadron, Nebraska.

SWAP: Dual 10-20 beam, prop-pitch selayms, MicroMatch, PE103, lots of miscellaneous gear, for speed graphic or HO Railroad equipment. W7OMX, 2708 106th Place, S.E., Bellevue, Washington.

SELL: NC-57 in perfect condition, \$85.00. WANTED: NC-173 or equivalent receiver and ART-13 transmitter. W1VWP, Box 72, Revere, Mass.

SALE or trade: Washington, D. C. area: 1 S38C receiver, new condition; 2 5h 700 mil chokes; 1 dual 100µ 10,000 v var. cond. two 6-12 300-680 volt dynamotors; one 70C v. 200 mil power supply; 3HVL coils; BC-375-E tuning units; 872A and 304TL tubes; high voltage condensers; fixed and variable. Need: 2000v 300 mil power supply and 10v Sa int. trans. W. H. Leeth, W4UW, 4766 26th St., N. Arlington, Va., JA 7-2298.

NOVICE transmitter, BC654 receiver, both 40-80. \$200.00 each. W2EEJ, 821 Rutgers Road, Franklin Square, N. Y.

FOR Sale: BC-459, BC-458; 45 rpm record-player. Doug Ryan, 58-23 185th St., Flushing, L. I., N. Y.

HALLCRAFTERS S-72 portable, in new condition, current model, \$70; Lettine transmitter, coils for 4 bands, in gud condx, \$60; Lettine xmitter, coils for 2 bands, fair condx, \$45; Brush tape recorder wid BA 106 mike, \$100; combination 6 volt flashing red light and police sign FB for CD, \$25. L. Blum, 2661 Dibblee Ave., Columbus 4, Ohio.

WANTED: Panadator. State condition and price. Neil Baldwin, 6657 NE Stanton, Portland, Ore.

ATTENTION W7el Sell or trade factory acquired and converted BC610E and BC614E speech amp., 2 to 4 Mc, with technical manual, coils, cables, tuning unit, spare 250TH, pair 100TH, and rubber-tired dolly. Want: 75A-, 32V, HRO. W7JJK, 2511 W. Garland Ave., Spokane 13, Wash.

WANTED: BC344 or BC314 receiver, 150-1500 Kc or BC946, 550-1500 Kc. State condition and price. W8HKK, John Alexander, 2301 Jefferson Ave., St. Albans, West Virginia.

MEISSNER 150-B transmitter and exciter unit for sale: 300 watts c.w. and phone. Like new. Will sacrifice at \$150.00. Write to Robert G. Spinney, 31-A Sacramento St., Cambridge 38, Massachusetts or phone Tr 6-8601.

SELL: Custom-built 300 watt phone now operating 75 meters. Deluxe quality and stability in fully enclosed cabinet. Sacrifice at \$175 or best offer. Orion Baker, 860 Beacon, Boston, WINQA, Kenmore 6-2131.

WANTED: Information as to the type and whereabouts of the correct vibrator for the EC 2609 Vibrapack. A BC-611-C walkie-talkie to the first correct reply. W4QZC, Park View, Harrisonburg, Va.

SALE: Transmitter BC1072A, new, 150-200 Mca, 115V AC operation. Tubes: One 6J5, one 807, one 2X2/875, with technical manual, two 5U4G, two 826, two 900A, same listing over \$400.00. Contains Variac, milliammeter, AC blower and many other parts. Price \$29.50. W3CZE, 418 10th St., N.E. Washington 4, D. C.

FOR Sale: RCA Review, Vol. I through VI, Proceedings of IRE, 1941 thru 1948; RSI, 1947 thru 1948; BC-3480 with AC power supply, \$55.00; SX-4J in good condition, \$110; RCP model 322 tube-tester and battery powered signal generator with signal tracer, both for \$30.00. Want HRO-50T1, W5NID, G. Rupert, 2345A 48th St., Los Alamos, New Mexico.

SELL: Teletype equipment: Model 21A midget printers, Mod. 12 page printers, control panel relays, printer motors, distributor motors. Will trade. Want: ART-13, TCS, APR, BC-348, 30N, 4, DV-12, BC-610-E, manuals, tubes, test equipment. Tom Howard, W1AEN 46 Mt. Vernon st., Boston 8, Mass.

TWO Meters, converters, crystal controlled, wired, \$12.00. Transmitters, 15 watts phone, pre-assembled kits, \$34.50. LW Electronic Laboratory, Route 2, Jackson, Michigan.

WANTED: QST for D3C. Chesley Pickle, 1631 Massachusetts Ave., N.W., Washington D. C.

QUALITY QSLs, 10¢ for samples. D. Doscher, W2AOA Print, Box 54, Goshen, New York.

FOR Sale: SX-71, signal shifter, many other items. Send for list. Henry Blesse, 13-05B Sperber Road, Fairlawn, N. J.

WANTED: Any condition, RCA AR-88 receiver Will swap or pay cash. W1WVF, Box 466, Billerica, Mass.

TO beat offer: Hammarlund Super-Pro and power supply; all letters will be answered. Don Barnes, 6 Wright's Lane, Glastonbury, Conn.

W8VAE wants complete file of QST from 1930 or 1935 thru 1952. State price and condition. Donald Cameron, 1619 Milburn Ave., Toledo 6, Ohio.

WANTED: Two SW3's with band spread coils and power supplies. Must be reasonable and in good condition. W9ALI, Lombard, Ill.

GLOBE King 400A, push to talk. Coils for 75, 20 and 10, \$300.00. Jack Haley, 3804 Farnam, Omaha, Nebraska.

SELL: HRO 50-T-1, \$289.00. Has extras. RME-45 and spkr. \$95.00. Also new NC-125, R. Long, 184 L Street, So. Boston, Mass.

WANTED: Parts for Meissner 150-B and exciter unit; tank coils L207 and L208; also 3-ganged tuning condenser for exciter or just rotor shaft. Bob Caro, W1WVF, 20 Orchard st., Wellesley, Mass.

WANTED: National "NHU" receiver. Sell: Plate, filament, modulation transformers; chokes, meters, filter, blocking, tank condensers; Comand transmitters, large autotformer, "CO" oscilla and C meter, xtals, Knights frequency standard. Many other items. Write for list. Harry Williams, W0INI, Pleasant Hill, Mo.

SELL: NC57 with SOJ, \$80.00. W6QYB, Barton, Box 316, Topanga, Calif.

FOR Sale: RME station monitor complete, E-V speech clipper, Vibroplex key, Millen SW tuning bridge, Heath signal tracer, condenser, R. Krauss, W3ALE, 1220 Wheatshaf Lane, Abington Penna.

FOR Sale: 61 ft. Vesto tower with 3-element, 2-.25 spaced 20-meter beam, T-matched, rotor, Selsyn. In place, \$250 or best offer. Also custom-built 813 rig, \$650. Sonar S-9, 2-meter receiver, \$45. Write for details and pictures of all items. W3MFW, Box 244, Elizabethtown, Penna.

COLLINS 310-B-1, 40 watt VFO exciter. Top condition. \$200 F.o.b. Denver, Colorado, W0JBI, Box 345, Westminster, Colo.

Designed for



Application

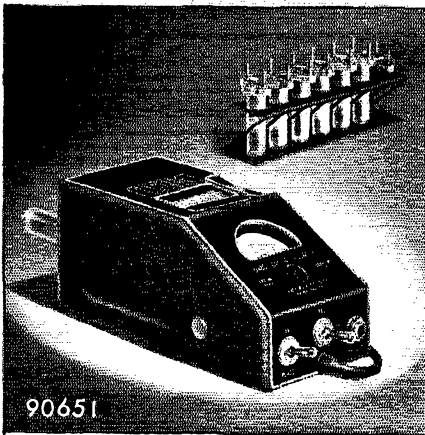

90651

**The No. 90651  
GRID DIP METER**

The No. 90651 MILLEN GRID DIP METER is compact and completely self contained. The AC power supply is of the "transformer" type. The drum dial has seven calibrated uniform length scales from 1.5 MC to 300 MC plus an arbitrary scale for use with the 4 additional inductors available to extend the range to 220 kc. Internal terminal strip permits battery operation for antenna measurement.

**JAMES MILLEN  
MFG. CO., INC.**

MAIN OFFICE AND FACTORY  
**MALDEN  
MASSACHUSETTS**



**Index of Advertisers**

Akers Company, Dallas C.	135
Allied Radio Corporation.	99
American Electronics Company.	116
American Phenolic Corporation.	88
American Radio Relay League, Inc.	
<i>Handbook.</i>	113
<i>License Manual.</i>	131
Binders.	137
Ashc Radio Company, Walter.	105
Barker & Williamson, Inc.	82, 129
Bendix Radio Division.	129, 135
Bird Electronic Corporation.	127
Bliley Electric Company.	83
Burstein-Applebee Company.	92
Calamar.	137
Candler System Co.	112
Central Electronics, Inc.	112
C & G Radio Supply Co.	137
Chicago Transformer Co.	144
Collins Radio Company.	2
Communication Products Co., Inc.	134
Concord Radio.	90
Delco-Remy Division.	76, 77
Dollar Co., The Robert.	135
Dow-Key Co., Inc.	122
DX Radio Products Co.	108
Eitel-McCullough, Inc.	87, 112
Eldico of New York, Inc.	74, 75
Electro-Voice, Inc.	81
Engineering Associates.	135
Evans Radio.	133
Fort Orange Radio & Distrib. Co.	103
Gardiner & Co.	125
General Electric Co.	1
Gouset Company, The.	127
Gotham Hobby Co.	126, 136
Green Instrument Co.	128
Greenlee Tool Company.	130
Hallcrafters Co.	4, 5
Hammarlund Mfg. Co., Inc.	78, 79
Harrison Radio Corporation.	117
Harvey Radio Co.	120, 121
Harvey-Wells Electronics, Inc.	84
Heath Company, The.	124, 125
Henry Radio Stores.	91
Hudson Radio & Television Corp.	94
Hughes Research & Develop. Lab.	95, 114
Hy-Lite Antennae, Inc.	122
Instructograph Co.	136
Johnson Co., E. F.	89
Kodman Company.	146
Knights Co., The James.	143
Lafayette Radio.	107
Lettine Radio Manufacturing Co.	130
Lysco Manufacturing Co.	132
Mallory & Co., P. R.	91
Mass. Radio & Teleg. School.	135
Midland Manufacturing Co., Inc.	93
Millen Manufacturing Co., Inc., The James	42
Morrow Radio Mfg. Co.	128
Motorola, Inc.	126
National Co., Inc.	Cov. III 73, 138
National Radio Institute.	119
Newark Electric Company.	115
Ohmite Manufacturing Co.	85
Petersen Radio Company.	7
Philo (TechRep Div.).	133
Port Arthur College.	116
Precision Apparatus Co.	86
Premax Products Co.	131
Radio Corporation of America.	Cov. IV
Radio Shack Corporation, The.	97
Raytheon Manufacturing Co.	96
RCA Institutes, Inc.	133
Rider Publisher, Inc., John F.	114
Shure Brothers.	100
Sonar Radio Corporation.	104
Steinberg's, Inc.	123
Sun Radio & Electronics Co., Inc.	111
Sun Radio of Washington	134
Sylvan Electronics Laboratories, Inc.	102
Triad Transformer Manufacturing Co.	106
Triplett Electrical Instrument Co.	98
United Catalog Publishers, Inc.	133
United Transformer Company.	Cov. II
Valparaiso Technical Institute.	137
Variety Electric Co., Inc.	137
Vesto Company, Inc.	120
Vibroplex Company, The.	118
Webster Manufacturing Company.	110
Weston Laboratories, Inc.	125
Wind Turbine Company.	132
World Radio Laboratories.	109



keeping communications **ON THE BEAM**

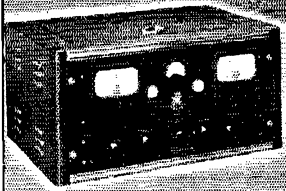

the JK FD-12

**FREQUENCY AND  
MONITOR MODULATION**

Monitors any four frequencies anywhere between 25 mc and 175 mc, checking both frequency deviation and amount of modulation. Keeps the "Beam" on allocation; guarantees 100% solid coverage, too!

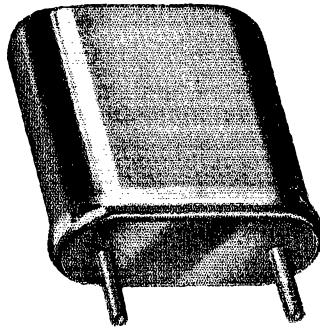

**JK STABILIZED H-17 CRYSTAL**

**CRYSTALS FOR THE CRITICAL**

The JK H-17 Crystal meets rigid airline requirements for compactness, light weight, rugged dependability. A Military type, it is hermetically sealed—dust and moisture proof—plated, quartz plate is shock mounted. One of many JK Crystals made to serve every need.

*Ceiling Zero... Communications 100%*

"Pea soup" over the field . . . and still the giants of air travel come in "on the beam". When visibility is poor, commercial pilots must rely on radio-radar equipment to bring their ship in safely. JK Crystals play an important role in this every day drama of keeping airlines communications "on the beam" in the air and on the ground.

**THE JAMES KNIGHTS COMPANY**  
**SANDWICH ILLINOIS**



# talk about a beating!

## multiplex radio telephony systems must take it...

that's why REL specifies

# CHICAGO

## World's Toughest Transformers

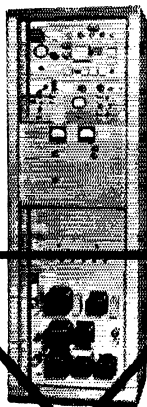
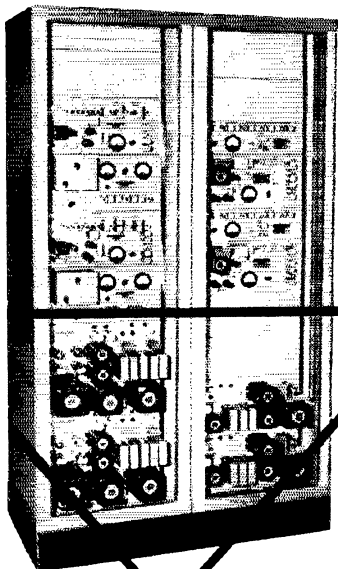

Illustrated at right: REL 900 MC Transmitter, Series 707-757. Illustrated immediately above: REL Model 759 70 MC Dual Transmitters and Receivers. These systems make wide use of CHICAGO C-Type "Sealed-in-Steel" transformer units.

### Free "New Equipment" Catalog

You'll want the full details on CHICAGO'S New Equipment Line—covering the complete range of "Sealed-In-Steel" transformers designed for every modern circuit application. Write for your Free copy of this important catalog today, or get it from your electronic parts distributor.

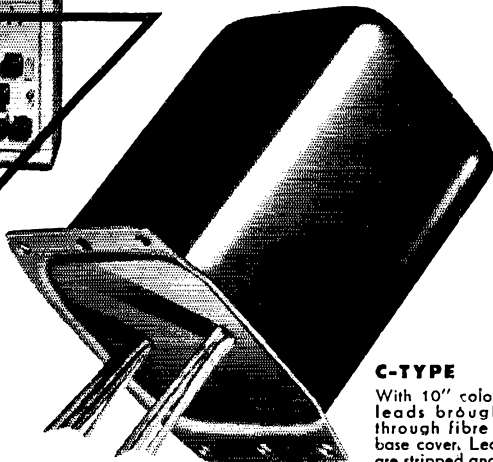

### C-TYPE

With 10" color-coded leads brought out through fibre board base cover. Lead ends are stripped and tinned for easy soldering. Flange-mounted unit.

## CHICAGO TRANSFORMER

DIVISION OF ESSEX WIRE CORPORATION

3501 ADDISON STREET, CHICAGO 18, ILL.



Export Sales Div.:  
Scheel International, Inc.  
4237 N. Lincoln Ave.  
Chicago, Ill., U.S.A.  
CABLE ADDRESS:  
HARSHEEL

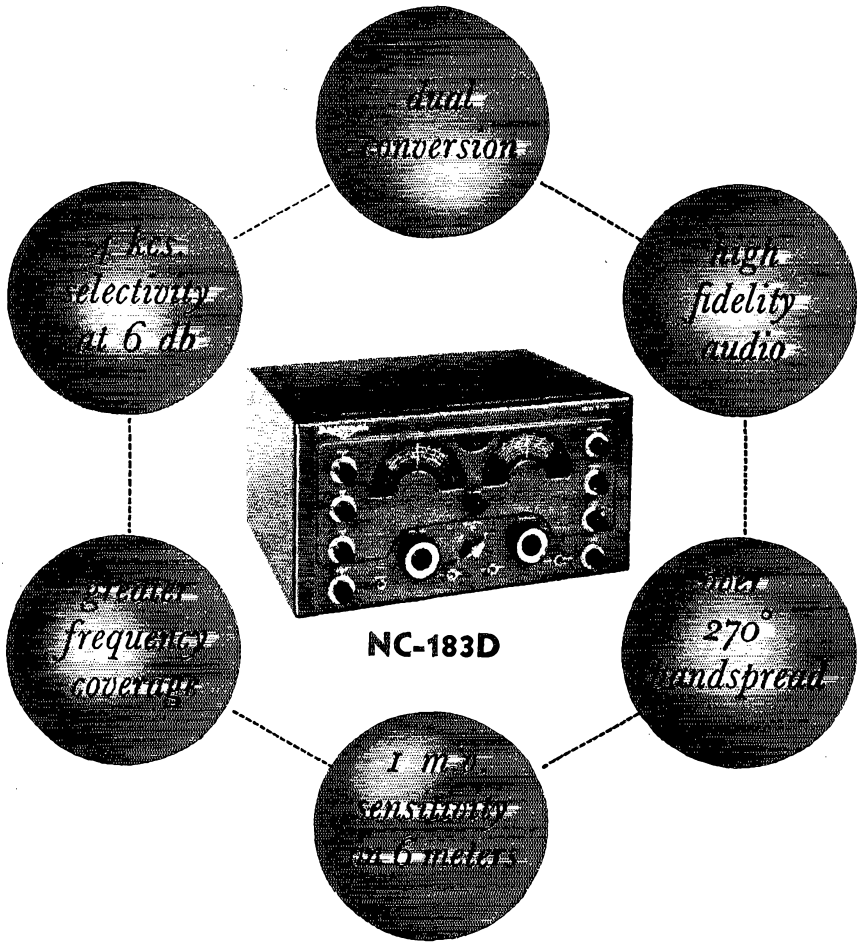

NC-183D

# GREAT NEWS! } NOW AVAILABLE FOR PROMPT DELIVERY!

If you're one of the many anxiously awaiting a new NC-183D, here's great news! NC-183D's are now being shipped to distributors in greater quantity.

And, when you see and hear the NC-183D, you'll be mighty glad you didn't settle for something less!

No other receiver selling for less than \$500 can give you so many great features! **\$369.50\***

(less speaker)

\*Slightly higher west of the Rockies

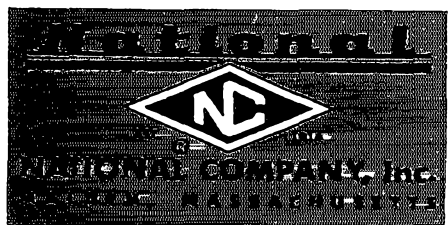

*All-band midget with a mighty wallop*

# 17 watts input\*

*... to 175 Mc!*

**NO BIGGER than your thumb . . .** yet capable of handling more power than any "miniature" in amateur radio . . . RCA-5763 is your answer for a compact beam power tube that will operate on any frequency up to 175 Mc—mobile, portable, or fixed service! Use the tube as an rf power amplifier (a 6AK6 drives it). Use it as a frequency multiplier (high emission—higher efficiency). Use it as an oscillator (VFO or crystal). Use it as a VHF driver for larger tubes (like the RCA-2E26 and 6146).

Beam power design—an RCA development—gives the 5763 high power sensitivity, makes it practical to use fewer stages, tubes, and components. High perveance makes it easy to get full power with only a 300-volt supply.

Put these benefits to work in your next design—use RCA-5763's. Your local *RCA Tube Distributor* carries them in stock. A technical bulletin is yours for the asking.

**Small but mighty**

\* ICAS ratings { max. input on CW 17 watts  
                  { max. input on phone 15 watts

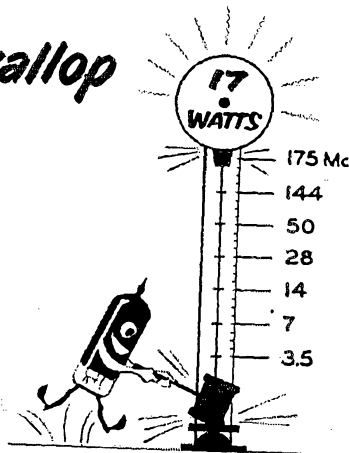

**RADIO CORPORATION of AMERICA**  
ELECTRON TUBES

HARRISON, N. J.