

20 GUINEAS CASH AND 200 OTHER PRIZES!

SEE INSIDE

Practical Wireless

3^D

Published every Wednesday by
GEORGE NEWNES LTD.

Vol. 4.—No. 81.
April 7th, 1934.

Registered at the G.P.O. as a Newspaper

AND PRACTICAL TELEVISION

EDITED BY F.J. CAMM

Building the

A.C. LEADER 3

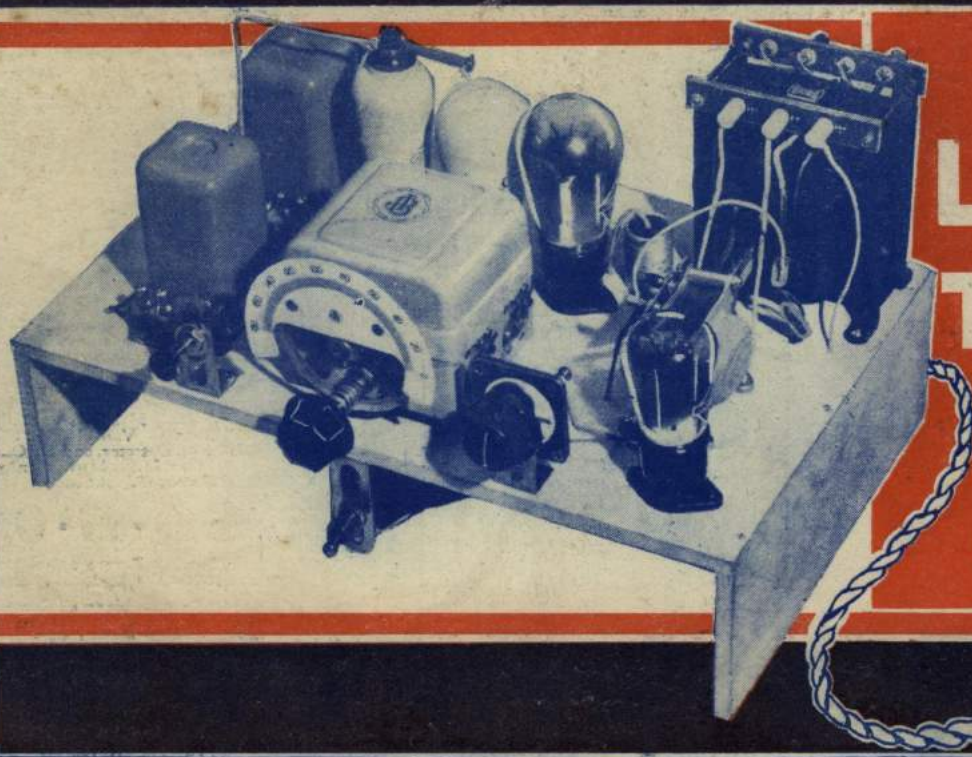

for
LESS THAN £8

SEVEN TIMES THE VOLUME

With Mains Quality and Power. **SIMPLY PLUGS-IN.**

PILOT Class "B" SPEAKER AMPLIFIER

SUITABLE FOR ANY BATTERY SET
Without Class "B" amplification your present Battery Set is obsolete. Realising this we have produced this marvellous self-contained Unit, comprising guaranteed Peto-Scott Class "B" Moving-Coil Speaker, Class "B" Transformer and B.V.A. Class "B" Valve. Gives 7 times the Volume... with mains quality and power. Low H.T. consumption. **SIMPLE TO CONNECT. JUST PLUG IN** the amazing 5-WAY Automatic Connector.

5/-

WITH ORDER balance payable in 11 monthly payments of 5/6. Carriage Paid to your door. Cash or C.O.D. **59/6** Carriage paid.



PETO-SCOTT CO. LTD., 77, CITY ROAD, LONDON, E.C.1.

Clerkenwell 9406-7.

ADVT.

**VARIABLE-MU
SCREENED-GRID CIRCUIT**

MOVING COIL SPEAKER

SINGLE DIAL TUNING



Distinguished in appearance, with beautifully-finished cabinet-work and capable of a magnificent performance, these Cossor Console Receivers enable you to enjoy up-to-date radio at an extraordinarily moderate price.

Their performance is remarkable, they bring you a wide choice of programmes free from interference. Their tone is rich, vivid and true-to-life. And their operation is simplicity itself.

Judge a Cossor Console for yourself—ask your Wireless Dealer to let you hear one of these fine Sets or send the coupon below for full particulars.

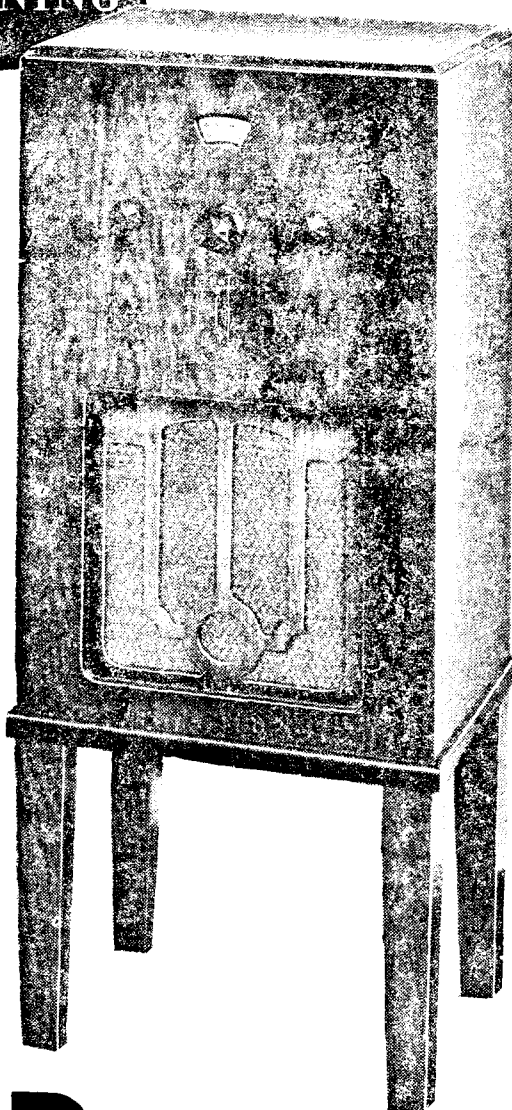

**CLASS "B" BATTERY
CONSOLE MODEL 3455**

Complete Receiver, as illustrated, with four Cossor Valves, viz., 220 VS Variable-Mu S.G., 210 HL Detector, 215 P Driver and 220B Class "B" Output, Single dial tuning, selectivity control and combined volume control and "on-off" switch. Wave change switch. Handsome walnut-finished Console Cabinet, 2 ft. 11 in. x 1 ft. 2 in. x 11 in., giving ample accommodation for batteries. Permanent Magnet Moving Coil Speaker of the latest type. Gramophone Pick-Up Plug and Jack.

£9-19-0

Hire Purchase Terms: 20/- deposit and 10 monthly payments of 20/-.
Price does not include accumulator or batteries.

**ALL-ELECTRIC CONSOLE
(for A.C. Mains) MODEL 3468**

Specification similar to Model 3456, but operating from A.C. Mains. Complete with four Cossor A.C. Mains Valves, viz., MVSG met., 41 MH met., 41 MP and 442 BU. Illuminated tuning dial. Energised Moving Coil Speaker. For A.C. Mains only, 200/250 volt; adjustable, 40/100 cycles.

£10-15-0

Hire Purchase Terms: 25/- deposit and 10 monthly payments of 21/-.

**ALL-ELECTRIC CONSOLE
(for D.C. Mains) MODEL 3469**

As Model 3468, but for D.C. Mains only. Complete with three Cossor D.C. Mains Valves, viz., DVSG met. Variable-Mu S.G., DHL met. Detector, and DP Output. For D.C. Mains only, 200/250 volts (adjustable).

£10-15-0

Hire Purchase Terms: 25/- deposit and 10 monthly payments of 21/-.

Legs are detachable on all Console Models, and the receivers can be used as table models with legs detached.

Prices do not apply in I.F.S.

COSSOR
RADIO CONSOLES

To A. C. COSSOR LTD., Melody Dept., Highbury Grove, London, N.5.
Please send me a copy of your photogravure catalogue of Cossor Receivers (B.20)

Name

Address

CASH PRIZE OF 20 GUINEAS AND 200 OTHER PRIZES! SEE PAGE 67.



Practical Wireless

EDITOR:
Vol. IV. No. 81 || **F. J. CAMM** || April 7th, 1934.
Technical Staff:
W. J. Delaney
H. J. Barton Chapple, Wh.Sch., B.Sc. (Hons.), A.M.I.E.E.,
Frank Preston, F.R.A.

ROUND *the* WORLD of WIRELESS

Our Cheaper Radio Campaign—Gratifying Success

OUR bold move in starting a cheaper home-constructed-radio campaign has met with an immediate gratifying and almost overwhelming success. It is fitting that PRACTICAL WIRELESS, which always takes the lead, should do so upon the thorny question of price. For many months our readers have complained of the competition of the cheap commercial receiver, and it was with the sincere desire to remedy this state of affairs that we embarked upon the vigorous policy of designing our receivers on a low-price-high-efficiency basis. The *Leader Three*, and the *A.C. Leader* are the first receivers to be designed on this system, and it is pleasing to us to learn that so many thousands of these receivers have been made up, notwithstanding fierce competition from other sources. Our thanks are due to the several manufacturers who have co-operated with us by designing special components at a low price, but of their usual high standard of efficiency. We shall continue this campaign with unabated enthusiasm, and welcome letters from our readers as to the style of receiver they would like so that we can plan well ahead.

Cash Prize of 20 Guineas, and 200 Other Prizes!

AS an earnest of our desire to serve our readers in the widest interpretation of that term, it is with extreme pleasure that we announce on another page of this issue, preliminary details of the fascinating competition with a first prize of 20 guineas and 200 other prizes. The object of this competition is to provide both ourselves and the manufacturers, namely, Messrs. Varley, Ltd., with data concerning their new device for overcoming the interference problem—we refer to their new bifocal coils. We feel sure our readers will appreciate our sincere motives in instituting a nation-wide test of this remarkable component. We want our readers to help us by testing these coils in their own receivers, and next week we shall give full details showing how they may be incorporated in a few moments into any of the usual circuit arrangements. As an inducement to the many thousands of readers who have already purchased these coils to send us this information (which we shall afterwards place at the disposal of the manufacturers—

Messrs. Varley, Ltd.) we offer a first prize of 20 guineas and 200 consolation prizes already referred to.

New Broadcasting Stations for Rumania

TWO new Marconi transmitters have recently been ordered by the Rumanian Broadcasting Company. One is of the "super-power" class, with an aerial energy of 150 kilowatts, and the other of 20 kilowatts aerial power, and both incorporate several interesting features such as "series modulation," aerial ice-melting plant, and specially developed water-cooled transmitting valves.

STILL LEADING THE WAY!

We are proud to be able to announce that we have secured the whole-hearted co-operation of a large number of important manufacturers in the production of cheaper high-class components for home-construction. As a result of our campaign, it is now possible for any reader to make up an efficient receiver at a fraction of the cost of the cheapest commercial receiver. SEE SPECIAL ANNOUNCEMENT ON PAGE 80.

Read also the preliminary details regarding our **TWENTY GUINEAS Cash Prize Competition**, with 200 other valuable prizes, on **PAGE 67.**

The 150-kilowatt transmitter is adaptable to operate on any wavelength between 1,030 and 2,140 metres, and its power may be increased at a later date without undue complication to an aerial input of 300 kilowatts, if desired.

Steady Growth of Wireless Licences

OVER 619,200 radio licences were issued by the British Post Office Authorities during February, 1933, bringing the grand total to 6,192,225. The "second best" in Europe is Germany, which on March 1st possessed 5,364,557 registered listeners, including an additional 90,481 in the previous month.

Half-past 16 O'clock

WITH the change over to British Summer Time on April 22nd, the B.B.C. will adopt the Continental twenty-four hour clock system, not only in connec-

tion with the timing of the programmes, but also with every phase of its work, whether spoken over the microphone or printed in official publications. Readers will bear in mind that 1 p.m. will therefore become 13.00 and midnight 00.00 (24.00). The awkward and frequently-forgotten suffixes a.m. and p.m. will be superfluous.

Rome's Third Station

IN addition to I-1RO, the main transmitter on 420.8 metres, and the short-wave station (I-2RO) on 25.4 metres, a 1-kilowatt relay is being tested in the Italian capital. It has been installed for the purpose of giving listeners an alternative programme by taking the broadcasts from Milan, Turin, and Genoa, which are common to the Northern group. The station may be heard working between G.M.T. 18.00-19.30 on 238.5 metres. It is also reported that in future all Italian studios will adopt the nightingale interval signal, so long associated with Milan, Turin, and Trieste.

Russia extends Her Wireless Net

A NEW decree issued in the Soviet Union calls for the construction of thirteen high-power transmitters, to be brought into operation before the end of 1935. As some of these are to be installed on the western and south-western frontiers, it is anticipated that their official opening will coincide with a wave of broadcast propaganda destined to neighbouring States.

Cairo Calling!

THE 20-kilowatt transmitter, which the Marconi Company is erecting on behalf of the Egyptian State Broadcasting Service at Abu Zabal, near Cairo, is rapidly nearing completion, and may start its initial tests during April on 483.9 metres, a channel which it will share with Brussels (No. 1). In addition to entertainments of a nature to interest the native population, special programmes will be transmitted for the foreign communities as well as daily news bulletins in Arabic, French, and English. Broadcasts are to be made of both Oriental and Western European dance music. Little use will be made of gramophone records, of which, so far, listeners in Egypt have had a surfeit through the small privately-owned stations. It is also hoped to make arrangements by which performances may be relayed from the Cairo Opera House.

ROUND *the* WORLD of WIRELESS (Continued)

"Old Yesterday"

A WELCOME return to the microphone will take place to-day, when Donald Calthrop will play in "Old Yesterday," a romance in one act. This is part of the Music-hall programme in which Alexander and Mose (Dark Subjects) and the Eight Step Sisters, dancers, also appear.

"Frederica"

RICHARD TAUBER will take part in the studio performance of "Frederica," by Lehar, on April 23rd (National) and 24th (Regional). The eminent tenor will sing in German, but will use English for the dialogue.

Regimental Band Concert from Midland Regional

FEW English broadcasting artists have sung from Italian stations. Constance Astington, the soprano, who will be heard in the Midland Regional programme tomorrow, had this distinction several times, both at Turin and Genoa. She will sing two of Sir Hamilton Harty's songs in an interlude in a concert to be given by the Band of the 2nd Battalion The King's Own Royal Regiment, conducted by Bandmaster A. T. S. Chandler, in the Midland studio.

The Musician at the Gramophone

LESLIE HEWARD, conductor of the City of Birmingham Orchestra, embarks on a new venture at the microphone on April 13th. He begins a series entitled "The Musician at the Gramophone," embodying programmes of serious music. The first recital is of Elgar's symphonic poem, "Falstaff"; it is to be followed by records of Verdi's opera on the same theme.

Strange Music of Other Peoples

"SWEET is the music of Arabia," says the poet. But is it? Listeners may find out for themselves by listening to Philip Thornton, who, starting on May 5th, will play for them on each successive Saturday music gathered from as many strange countries as train, boat, bicycle, aeroplane, or flat feet will permit. They will hear the music of other peoples, who have discovered great beauty in sounds quite unlike those to which we are accustomed in Europe. Music can often speak more effectively than words. Perhaps listeners will decide at the end of the series that differences are between individuals rather than between nations, even though they be separated by the width of the world.

Old Time Melodrama from the London Regional

IN the London Regional programme for April 9th, for an hour, listeners will have an opportunity of enjoying the full-blooded thrills and humours of old-time melodrama. From 9.15 to 10.15 p.m., Mr. Tod Slaughter and his famous company of

INTERESTING and TOPICAL PARAGRAPHS

Barnstormers will present the lurid melodrama, "Sweeney Todd, the Demon Barber of Fleet Street." Mr. Tod Slaughter recently broadcast with great success in a Music-hall programme, and this special radio version of "Sweeney Todd" should give him and his company full scope. London playgoers particularly have warm

SAY IT WITH MUSIC!

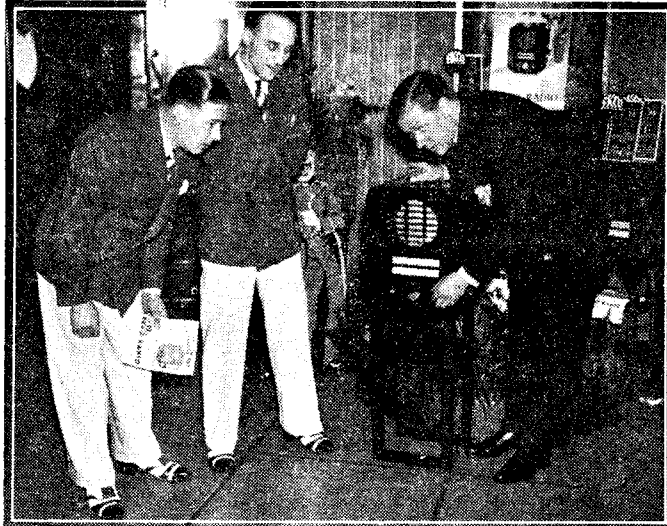

Jack Payne and two members of his famous band apply a critical ear to the tuning of an Ekco superhet during an interval at the Paramount, Manchester. Visitors to the theatre were invited to place in order of popularity six tunes played by the band, the winner being presented with an Ekco set.

memories of Tod's season of melodrama at the Elephant Theatre some years ago, and he has lately been appearing in the Old-Time Music-hall programmes at the Garrick Theatre. He has played melo-

drama in most parts of the country, and this broadcast should revive many happy play-going memories. The radio production, which is in the hands of Lawrence Gilliam, will include full measure of the dramatic musical accompaniment that does so much to heighten the atmosphere of this famous old play. Let it be noted, too, that this is no laugh up the sleeve for the highbrows, but a straight production of a really popular old drama.

"Down to the Sea in Ships"

EARLY in January a very popular programme was given for West Regional listeners by the Bristol Ship-lovers' Society, under the title, "Down to the Sea in Ships." Another edition will be given on April 9th. It will represent a typical meeting of the society in which a number of old salts, all of whom have sailed before the mast, will tell stories and sing shanties. These shanties will be sung as the sailors sang them and as the shanty usually was a working song, its tempo fitted in with the sailors as they worked. This method of singing them is the supreme merit of this particular broadcast, for the shanty men and sailors will not attempt to compete with professional singers who very often give renderings of these old sea songs.

"Owt About Owt"

THE second instalment of "Owt about Owt," a "broadcast magazine for the North, by the North, about the North," will be transmitted to-day. As before, it will consist of "feature" stories of distinctively Northern interest—broadcast interviews, dialect stories, queer musical recitals, and so on. The "signature-tune," is part of the third of Arthur Wood's Dale Dances.

Violin Solos by Andrew Morrison

ANDREW MORRISON will be solo violinist in the midday concert with the Scottish Studio Orchestra on April 10th. He will play works by Bach, Pugnani, Delius, and others. Morrison began violin playing at the tender age of nine, and after a series of local successes he passed on to the Royal Academy of Music, where he studied for four years under three professors—Marjorie Hayward, Rousby Woof and Spencer Dyke.

Prizewinners' Concert from the Guildhall, Londonderry

THE Prizewinners' Concert at the Feis Doire Colncille will be broadcast from the Guildhall, Londonderry, to Northern Ireland listeners to-day. The programme of this concert, of course, cannot be arranged until the actual morning of the broadcast, since the musical competitions only finish on the Friday evening. The Prizewinners' Concert generally lasts for at least four hours, and the excerpt which will be broadcast will consist of selected items as well contrasted as possible.

SOLVE THIS!

PROBLEM No. 81.

Broadman made up a three-valve A.C. mains receiver, employing S.G., detector and pentode stages. The receiver was unstable, so he decided to obtain metallised valves for the first two stages. When he used these results were still poor, although slightly improved, so he thought that perhaps the metal coating was not effectively earthed. He accordingly twisted some bare copper wire round the metal coating and joined this direct to earth, but results were then very much worse. Why? Three books will be awarded for the first three correct solutions opened. Address your envelopes to The Editor, PRACTICAL WIRELESS, Geo. Newnes, Ltd., 8-11, Southampton Street, Strand, London, W.C.2. Envelopes must be marked Problem No. 81, and must reach here not later than the first post April 9th.

SOLUTION TO PROBLEM No. 80.

By removing the rectifying valve from the A.C.-D.C.2 Nicholson had broken the H.T. circuit and thus prevented the receiver from working.

Only two readers successfully solved Problem No. 79, and books have therefore been forwarded to: C. Payne, 441, Green Lane, Goodmayes, Essex; C. T. Gilbert, 1, Kemble Street, Drury Lane, W.C.2.

PRELIMINARY DETAILS OF

OUR GREAT NATIONAL COMPETITION

First Prize: 20 GUINEAS Cash

200 Consolation Prizes of Wireless Valves, Speakers and Books

"Practical Wireless" Readers to Act as Independent Test Experts of a Marvellous New Selectivity Device

NO ENTRANCE FEE!

OUR readers have doubtless noticed recent advertisements of Messrs. Varley, Ltd., of their new bifocal coil, which they have specially produced to overcome in a simple and practical way the interference and the jamming problem. This really efficient and clever device is the result of many months of intensive research work on the part of the Varley engineers, to place before home constructors a really reliable selectivity device which can be incorporated quickly by any constructor in the usual circuit arrangements.

These bifocal coils have been exhaustively tested in various parts of the country, but obviously it is quite impracticable for it to be tried by the manufacturers in every village and hamlet. For one thing this would take up an inordinate amount of time, and, secondly, it would be extremely costly.

We have had one of these coils under test and find that the claims of the manufacturers detailed on this page are amply justified. Many hundreds of these coils are already in the hands of home constructors, and we have great pleasure in co-operating with Messrs. Varley Ltd. by inviting our readers to send in their reports on the results obtained from this coil so that a nation-wide analysis can be made of them. In other words, we seek the co-operation of our readers as independent test experts on this new and almost epoch-making radio device, which makes its appearance at a time when the selectivity problem has reached its most acute stage.

As an inducement to our readers to act in this way, we have great pleasure in announcing that we shall offer a Cash Prize of 20 Guineas, and 200 Consolation Prizes of Wireless Apparatus, Books, etc., for what the judges consider to be the best reports and circuit arrangements sent in. Full details and rules of this competition will be given in next week's issue, but we can say in advance that there will be no entrance fee and that a special staff of adjudicators will give special attention to every competition entry. Next week we shall also show you how to incorporate these new coils in most of the standard circuits arrangements. They may be added to your set quickly and the connections are quite simple, so that if you are not quite au fait you will stand the same chance of winning the prize as the more skilled experimenter. We shall give theoretical diagrams as well as wiring diagrams.

A point worthy of note is that it is not necessary to build up a special receiver for these coils, which enable you to focus your set to the station it is desired to receive. We feel quite certain that our readers, who have so enthusiastically supported us in the past,

will not hesitate to place their experience with this new device at the disposal of the manufacturers through the medium of this paper. The judges will be independent, and not associated with the radio industry, and will be presided over by the Editor of PRACTICAL WIRELESS. We give here some technical details of these coils.

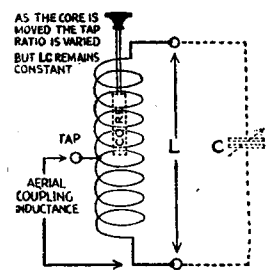

Diagram illustrating the method in which the iron core varies the coupling of the fixed tap.

TECHNICAL DETAILS OF THE VARLEY BIFOCAL COIL

Embodying a Novel System of Selectivity Control.

It is unnecessary to stress the point that modern broadcasting conditions demand a degree of selectivity greater than has ever previously been called for in any type of receiver. During the past year or so great strides have been made in the direction of obtaining increased selectivity with even the simplest kind of set, but in many instances a very important fact has been overlooked. It is all very well to make tuning ultra-sharp so that local transmissions can easily be eliminated, but it is useless to do this if the increased selectivity introduces such losses in efficiency that other more distant stations cannot be received. This state of affairs actually exists with certain selectivity arrangements in use, with a result that the systems in question are little more than valueless.

Variable Selectivity

What is actually required is variable selectivity so that a compromise can always be struck between selectivity and sensitivity. There are, admittedly, one or two quite old methods of securing a form of variable selectivity, one of which is to include a variable or semi-variable condenser in series with the aerial lead-in. This method has, however, a serious drawback, because the setting of the normal tuning condenser is affected to a fairly great extent by alterations in capacity of the series condenser. In other words, if a station is tuned in at, say, 30 degrees on the condenser, and then it is desired to increase the selectivity of the set, the condenser reading might have to be altered to something like 50 degrees in order to receive the same station. Besides this, the operation of changing the capacity of the series condenser introduces hand-capacity effects which make accurate tuning very difficult. Another method of varying the degree of selectivity is to transfer the aerial lead-in to variousappings on the aerial winding of the tuning coil. This has the same effect upon tuning as the previous method, in addition to which it is absolutely impossible to secure a gradual variation.

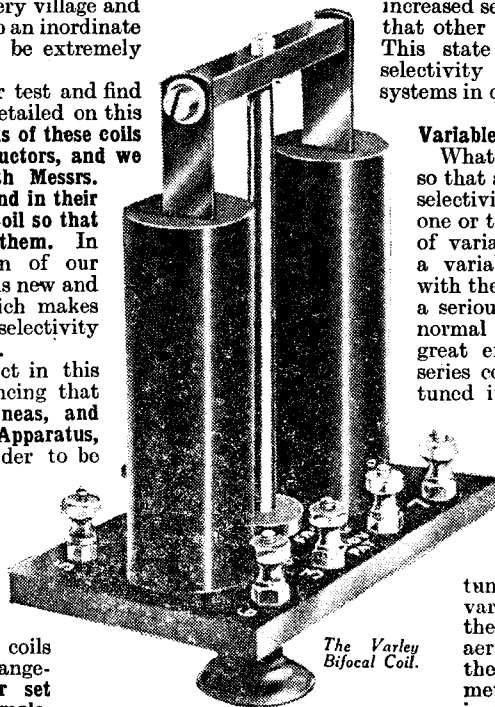

The Varley Bifocal Coil.

FULL DETAILS OF THIS GREAT COMPETITION NEXT WEEK

Selectivity "Focusing"

All the difficulties referred to above have entirely been overcome by the introduction by Messrs. Varley of an entirely new and revolutionary system in the form of what they call the bifocal coil. As the name implies, the system involves the use of two coils (one for long, and the other for medium-wave reception) which can be "focused," by means of Nicore plungers, so that the degree

of selectivity can be controlled with perfection over a wide range. Both coils are wound on ebonite tubes and have three windings, which are, respectively, the aerial winding, the (tuned) grid winding, and the reaction winding. Normally the first two are loosely coupled together so that maximum selectivity is

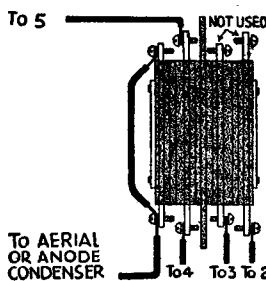

The switch that is intended for wave-changing and its connections.

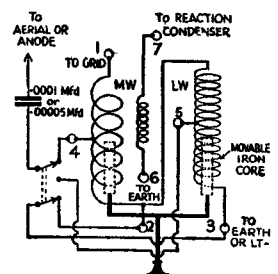

Diagram of the complete coil and its associated connections.

(Continued on page 82)

THE NEW A.V.C. UNITS

How to Incorporate Them in Your Receivers to Avoid Fading Difficulties.

By HARLAND R. KERRISON

FOR years we have had to put up with fading, knowing that we were quite unable to alter atmospheric conditions. But if your set contains at least one high-frequency stage, a few simple alterations and additions will allow you to receive all stations with practically no noticeable change of volume. Once you have handled a set incorporating "automatic volume control" you will never consider any receiver to be modern without

Figs. 1 and 2 show how the amplification is controlled by the variable resistance R1 in (a) and (b) for battery and mains variable-mu valves respectively. In order that a signal varying in strength, as in Fig. 3, may be audible at moments marked X, the bias must be adjusted in such a manner that at moments of peak signals the amplification would probably overload succeeding valve stages. Any greater bias would tend to make minimum signal voltages

inaudible. A.V.C. arrangements that the signal itself causes negative bias to be applied in proportion to the signal strength. A loud burst of signal will add to the grid-bias and lower the amplification, so automatically giving a reasonably constant signal output. It also has the effect of levelling up the signal strengths from the various stations received.

as in Fig. 4. The latter incorporates an H.F. choke, hence the one in the set must be removed when this unit is fitted. As the experimenter may wish to try out various resistance and condenser values for himself, approximate values are given for the additional components if added separately, as in Fig. 3. C2 controls the amount of H.F. energy fed through the A.V.C. unit, and may be any value between 0.0001 and 0.001 mfd. In some sets it may be found that the addition of the A.V.C. reduces the available energy for reaction, hence the value of C2 should be chosen with an eye to this, and, at the same time, the reaction condenser capacity may be raised by means of a small fixed condenser in parallel. This will only be necessary if it is found

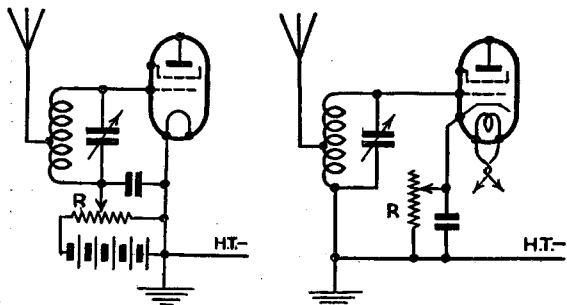

Fig. 1.—A simple method of controlling bias on an H.F. battery-operated valve. Fig. 2.—Varying the bias on an indirectly-heated S.G. valve.

its inclusion. There is no necessity to completely rebuild your receiver, and the additions need not be expensive; yet the outlay will never be regretted owing to the satisfaction which will follow the alterations.

Much has been written regarding the theory of A.V.C., but a brief resumé referring to its practice will assist readers when making the changes to be described. A variable-mu is preferable, but very satisfactory results can be obtained with an ordinary S.G. stage. The degree of amplification of any S.G. valve, for a given plate and screen grid voltage, depends upon the applied grid potential. The greater the negative bias the less the valve "mu" and the amplification per stage. The ordinary S.G. valve has a comparatively short grid base, and can only handle weak signals without distortion; a manual volume control must, then, be used to limit the input from strong signals. A variable-mu type will handle larger signal voltages and will allow of a greater degree of control due to its longer grid base. A manual volume control is then not a necessity when using A.V.C.

battery and mains-operated sets, by means of adding a diode rectifier. This could be a valve, but the addition to be considered is a Westector type of rectifier. The output from the detector valve includes a high-

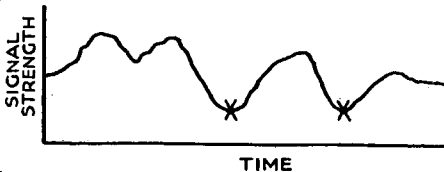
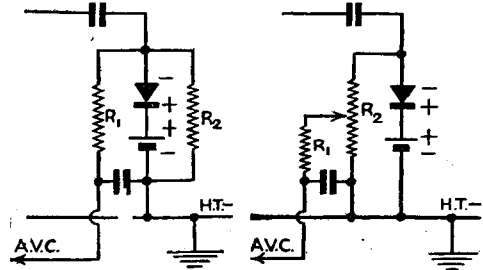

Fig. 3.—Diagram illustrating variation in signal strength.

frequency component which is normally by-passed to earth as an unwanted form of energy. This can now be suitably employed to control the bias on the preceding S.G. stage or stages without in any way detracting from the set performance. To ensure that no H.F. enters the L.F. stages the usual by-pass condenser C1 should be re-wired to the high potential end of the H.F. choke.

A great deal of trouble may be saved by employing the "Auto-trol Unit" made by Wearite or the Varley A.V.C. Unit. The former is wired as shown in Fig. 5, while the Varley Unit is arranged



Figs. 6 and 7.—The arrangement of a delayed A.V.C. circuit with and without a manual control.

that reaction cannot be obtained easily with the A.V.C. attached.

The Westector must be fixed with the positive end to earth. The resistance R1 should be about 250,000 ohms and is, together with the condenser C3, the circuit across which the rectified H.F. voltages are built up. C3 need not be higher than 0.1 mfd. This is "simple" A.V.C., and any voltage set up across R1 by an incoming signal is automatically applied to the grid of the S.G. valves. As there is a slight degree of control, even with a medium strength signal, the result may be an undesirable reduction of volume of weak stations. Fig. 6 illustrates the method of delayed A.V.C., in which the control only effects comparatively strong signals. The small grid battery of 0.9 or 1.5 volts provides a voltage across R2, also of 250,000 ohms, in opposition to that rectified by the Westector, and this delays the control until the rectified signal is of a greater value than the bias voltage. It may also be desired to set a limit to the volume of signal received, and this is done by making the resistance R2 a 250,000 ohms potentiometer in place of the fixed resistance. R1 is then joined to the slider so that we now have a manual control for the bias.

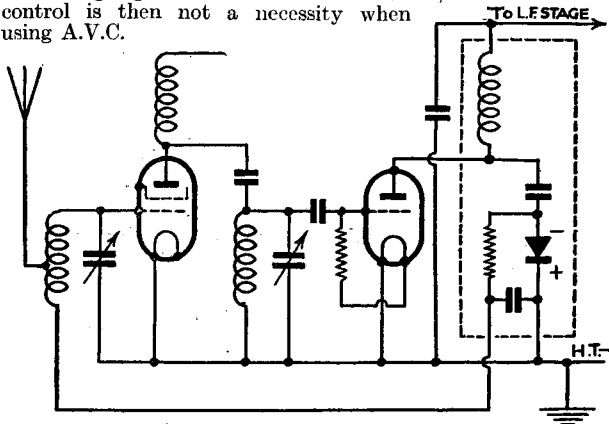

Fig. 4.—How to fit one of the standard A.V.C. units which incorporates an H.F. choke.

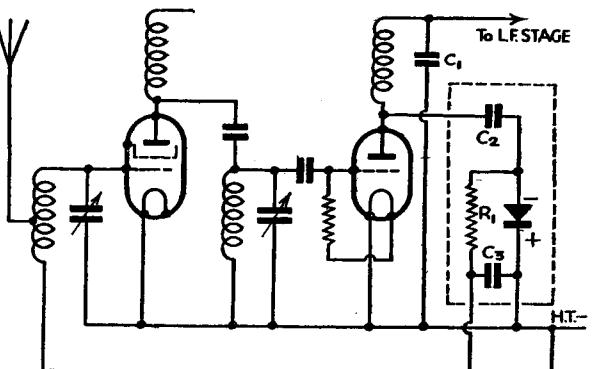

Fig. 5.—Adding an A.V.C. unit which does not include a choke.

SOME UNUSUAL H.T. SUPPLY SYSTEMS

Practical Details of a Few Unusual Methods of Obtaining High-Tension Current Are Given in This Article

By BERNARD DUNN

THE usual forms of H.T. eliminator are well known to nearly every reader, and constructional details for various types of unit have previously been given in these pages. In this article it is not intended to deal with any of the better-known systems of obtaining the high-tension supply, but to describe one or two simple and unconventional arrangements which will be of interest particularly to the experimenter and to the reader who likes to try out new ideas.

It is not generally realized that a neon lamp can be used as a rectifier—even though it is not an efficient one by any means—and that it may be connected in series with an A.C. supply to provide a small amount of D.C. A neon lamp is thus often very useful as a means of obtaining sufficient H.T. current for the operation of a single-valve receiver, or of a valve oscillator, directly from the A.C. lighting source. In the case of an oscillator, heterodyne wavemeter, or any other device which must be accurately calibrated, a perfectly steady and unvarying supply of high-tension current is essential; a neon lamp provides the simplest method of obtaining such a supply from A.C. mains. The actual output from a neon “rectifier” is very low, amounting to only about 30 volts at something less than 1 milliamp, but this is quite sufficient for many purposes.

Modifying the Neon Lamp

A neon lamp of the beehive pattern is most convenient, and before it is put into use the resistance must be removed from its cap. This does not present any great difficulty. The method is, first of all to

has a fixed resistance—consisting of a length of fine resistance wire wound on a fibre strip—in series with it. Remove the resistance and in its place attach a short length of wire for making subsequent contact with the “pip” on the cap. It then remains to re-fit the cap and solder the connections. The cap can be fixed by means of the same cement that was used before, if it is softened with

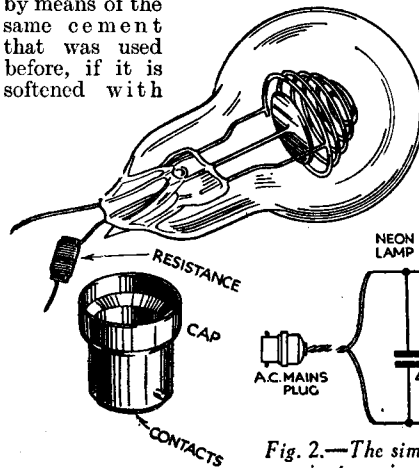

Fig. 1.—Showing the arrangement of the resistance to be removed from the base of the neon lamp when it is used as a rectifier.

may be considered to be about 2 milliamps. Before leaving the subject of the neon rectifier it should be mentioned that the arrangement described is not quite in accordance with the recommendations of the I.E.E., which say that all wireless H.T. circuits should be isolated from an A.C. mains supply by means of a mains transformer. In this case, however, the resistance of the neon lamp is quite sufficiently high to render the arrangement perfectly safe, and if a short-circuit did occur the only result would be that the neon would light up or possibly become damaged. Additionally it might be mentioned that the I.E.E. regulation referred to is widely disregarded nowadays, particularly in the case of “universal” receivers.

H.T. from L.T.

When there is no mains supply available the question of obtaining a high-tension supply without the use of H.T. batteries is rather more difficult of solution

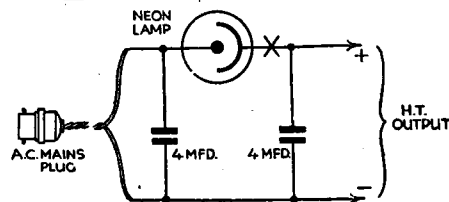

Fig. 2.—The simple circuit for an H.T. eliminator using a neon lamp as rectifier.

spirits, or a little glue may be used instead. Fig. 1 shows the arrangement of the bulb, cap, and

resistance in the neon lamp.

A Neon “Eliminator”

After the lamp has been prepared as explained it can be connected in series with one of the mains leads as shown in Fig. 2. When the anode (central electrode) is connected to one mains lead the cathode (spiral or beehive) will form the positive D.C. connection. The usual 4mfd. smoothing condensers should be connected as shown, but it will not generally be found necessary to employ a smoothing choke, due to the fact that the high resistance of the neon lamp provides a fair degree of smoothing. If the “rectifier” is being used with a single valve receiver and hum is noticed it will be desirable to include a smoothing choke (the primary winding of an old L.F. transformer will prove very convenient) in the positive lead at the point marked X in Fig. 2.

Somewhat greater D.C. outputs can naturally be obtained by connecting two or more neon lamps in parallel, but the arrangement is not suitable for high outputs in any case, and the maximum current

tion but there are one or two ideas that are worth experimenting with, and which have been used with fair success in a number of cases. The general principle of these ideas is the same as that of coil ignition systems used on motor-cars. In other words, a low D.C. voltage—provided by an accumulator—is fed to a high-ratio transformer through a make-and-break. The intermittent current flowing through the primary of the transformer produces a high A.C. voltage in the secondary winding. In the case of a car, this secondary voltage

(Continued overleaf)

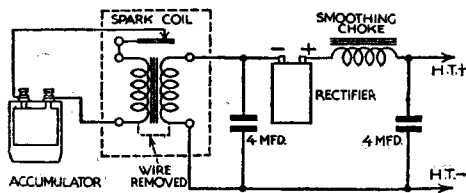

Fig. 3.—An arrangement for obtaining high tension from an L.T. accumulator. A motor-car spark coil is used in conjunction with a rectifier and the usual smoothing system.

soften the cement used for securing the glass bulb to the cap, and this can be done by standing the base of the lamp in a small jar containing methylated spirits. Allow the cap to soak for a few hours, and then wipe away all the surplus spirits. The next thing is to apply a hot soldering iron to the two contacts on the end of the cap, and at the same time to pull the glass bulb away from it. This can most easily be done by holding the soldering iron in a vice, so that both hands are free. When the cap has been removed it will be found that one wire from the bulb was connected directly to one of the contacts, but the other

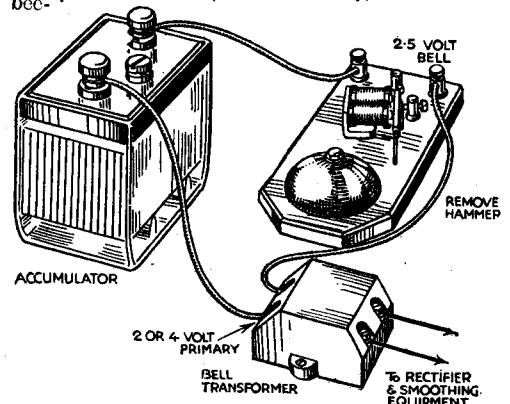

Fig. 4.—An alternative circuit to that given in Fig. 3. In this case a bell transformer is used, the primary current being interrupted by means of a small electric bell.

is employed to produce sparks at the plugs, but for the purpose under discussion it must be rectified and smoothed in the usual way.

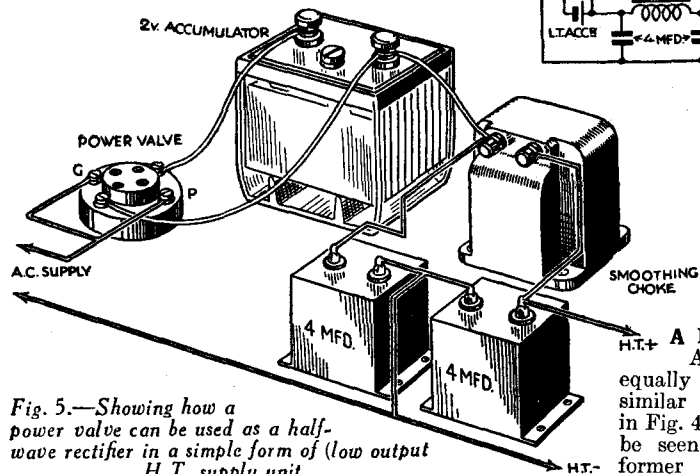

Fig. 5.—Showing how a power valve can be used as a half-wave rectifier in a simple form of (low output H.T. supply unit.

It is often possible to make use of a so-called spark coil taken from a car, and such coils can often be bought from car-breakers for a couple of shillings or so. These coils are generally provided with only three contacts, since one of these serves for one end of both primary and secondary. It is, therefore, necessary to separate the two leads so that the unit can be wired up as shown in Fig. 3. It will be seen that the secondary winding feeds into a rectifier (one of the metal type is represented) and the customary smoothing system. The accumulator used to energise the primary may be the same one that is normally employed for L.T. supply, although the required output of H.T. current might not be obtained unless a 4- or 6-volt accumulator is made use of. In any case the output will not be very high, and no more than 50 to 70 volts at

4 or 5 milliamps can safely be expected. Despite this, the arrangement is interesting and may very often prove distinctly useful. The drain on the accumulator is small (about .25 amp. for a 4-volt accumulator) and the "eliminator" is, therefore, quite economical in use.

A Better Arrangement
A better, though equally simple, device on similar lines is illustrated in Fig. 4, from which it can be seen that the transformer is of the "bell" type, being primarily intended to give an output of 2 to 6 volts A.C. when connected to the 200-250 volt A.C. mains. In this case, however, the windings are reversed, so that the low-voltage secondary acts as the primary, and the high-voltage primary as secondary. The interrupted D.C. supply to the "primary" is provided by means of an ordinary electric bell (with hammer removed) and an accumulator. An objection to this scheme is that the resistance of the bell windings is in series with that of the transformer "primary," with the result that a fair amount of loss occurs. This need not be serious, though, if the bell is one intended for working from 2.5 volts and if a 4- or 6-volt accumulator can be used. An alternative arrangement that is worth trying consists of connecting the "primary" of the transformer in parallel with the coils of the bell magnet.

If a bell transformer is not readily available there is no reason why one should not be made up easily and cheaply by using an iron core consisting of about three dozen No. 4 A stallo stampings. A winding spool should be made to fit this, after which 40 turns of 24 s.w.g. d.c.c. wire should be wound on. Cover this (primary) winding with two layers of empire tape and then wind 4,000 turns of 36 s.w.g. enamelled wire on top. Full details in regard to transformer construction were given in PRACTICAL WIRELESS dated January 20th, so there is no need to repeat the information here.

A Power Valve as Rectifier

As mentioned before, the rectifier shown in Fig 3 may be of the usual metal-oxide type, but a fair substitute when only a small output is required (say, up to 10 milliamps or so) may take the form of a small power valve whose grid and plate are joined together. The circuit arrangement for a rectifier of this type in conjunction with the necessary smoothing system is shown in Fig. 5. It will be seen that an accumulator is used to feed the filament of the valve used as rectifier, and it should be mentioned that this accumulator must be a different one from that used to feed the primary winding and contact breaker.

In fairness to readers it should be stated that the suggestions given above do not apply to what might be termed "fool-proof" or "ideal" systems, and that a fair amount of experiment will often be required before very satisfactory results will be obtained. Nevertheless, they are all practical and offer interesting scope for experiments in which odd parts which may be on hand can be utilized.

None of the systems are capable of supplying an output sufficient to operate a multi-valve receiver, nor would it be practicable or economical to attempt to modify them for that purpose. At the same time the units are well able to supply the high tension required by a one- or two-valve set or by a wavemeter oscillator or similar device.

ONE of the questions which the radio expert is frequently called upon to answer is: "How long should my valves last?" In one way, this question is very easy to answer; in another, it is most difficult. The simple reply is, that while no manufacturer can be expected to guarantee any definite life figure, because the valve is used under conditions over which the maker has no control, the user can quite reasonably expect a minimum life of about one thousand programme hours, provided the valves are not subjected to improper treatment, such as over-running the filament (*i.e.*, operating on too high a low-tension voltage), or called upon to pass too great an anode current (due to serious under-biasing, or operation without grid-bias). Indeed, numerous instances have been reported in which working lives of two, three, or even four thousand hours have been obtained from standard receiving valves.

The difficulty in giving sound advice on this point arises out of two or three facts. In the first place, although the filament may be intact after several thousand hours' life, it by no means follows that the emission of the valve is also unimpaired, or that its characteristics are as good as when the valve was new. In these circumstances, of course, it would definitely pay the user to replace his old valve with a new one.

NEW VALVES FOR OLD

A Certain Case

At the same time, it happens frequently that a valve survives three or four years of service with characteristics well up to standard. The question now arises, should the listener pension off his old valve and substitute a more modern valve, thus taking advantage of the improvements in valve design which have been brought about since his original valve was made. The answer to this question, again, depends on several factors—the extent of the improvements, the position for which the valve is required in the receiver, and the design of the receiver itself.

At the outset, it may be stated that, in the great majority of cases, a modern output valve may be substituted for one of older date with every confidence that improved volume and quality will be secured. This can be confirmed if a comparison is made between the characteristics of to-day's power valves and those of "yesterday." It will be observed that the more modern valve has greatly improved characteristics, and this applies to all makes. First of all a decrease in impedance will be noticed, and this ensures more efficient working, and in practice it will be found that, for equal signal input, the

up-to-date valve will give greatly increased volume, combined with vastly improved reproduction. In a few instances it may be necessary to look to the output circuit of the receiver in order to ensure that impedances are correctly matched, but, generally, the substitution can be effected without altering the set in any way.

Possible Instability

It is when we come to the earlier stage valves—the detector and first low-frequency valves—that some trouble may be encountered when substituting new and efficient valves in an old receiver. Most modern valves have both lower impedances and higher amplification factors than their prototypes of a few years ago, and when used in the early stages of an out-of-date receiver, these more efficient valves sometimes tend to give rise to a condition of instability. Careful attention to decoupling and some reduction in anode voltage frequently puts matters right, but, of course, if the set is hopelessly antiquated, it should really be remodelled or rebuilt.

One other point calls for special mention. Really old valves should never be used in a new and up-to-date receiver. Modern receivers are always designed with a view to utilizing the most recent types of valves, and an attempt to save a few shillings by retaining out-of-date valves defeats its own object, and all the skill and good design put into the new set is wasted.

USING *the* NEW WESTECTORS

Some Interesting Details Concerning the New Type of R.F. Metal Rectifiers.

By "DETECTOR"

THE metal rectifier as a means of rectifying alternating currents for H.T. supply is quite familiar; and, during the last year, the difficulties associated with the rectification of high frequencies have been partly overcome. Last March saw the introduction of the type "W" Westector, which is now extensively used as the second detector in superheterodyne receivers (where it works at intermediate frequencies of about 110 kilocycles), for all forms of automatic volume control and battery economy. The chief drawback of this type of Westector when used for detection is its high effective capacity, which throws a heavy damping on the circuit in which it is used, thus making its use impracticable at frequencies higher than about 200 kilocycles. During the last year, however, work has been proceeding in the research laboratories of the Westinghouse Company, with a view to making still smaller rectifying elements, with a corresponding decrease in capacity. This research has culminated in the production of a new type of Westector—the new "WX" which is of

"WX" Westector has a very high impedance, and a high load resistance of some 250,000 ohms must therefore be employed. A suitable reservoir condenser for all frequencies is .0001 mfd.

A suggested circuit for using the new "WX" as a detector in a "straight" receiver is shown in Fig. 1, where R is the load resistance and C the reservoir condenser. For satisfactory straight-line rectification the H.F. voltage applied to the Westector should be between 3 and 36 volts peak. It will be appreciated that the H.F. voltage applied to a detector circuit quite naturally varies with the strength of the signal being received. On local reception the H.F. voltage will be high, and the Westector need be preceded by

one H.F. stage only. Where a receiver, however, is intended for the reception of foreign programmes two H.F. stages will normally be required, but even this difficulty may be overcome. Just as screen grid valves may conveniently be biased for

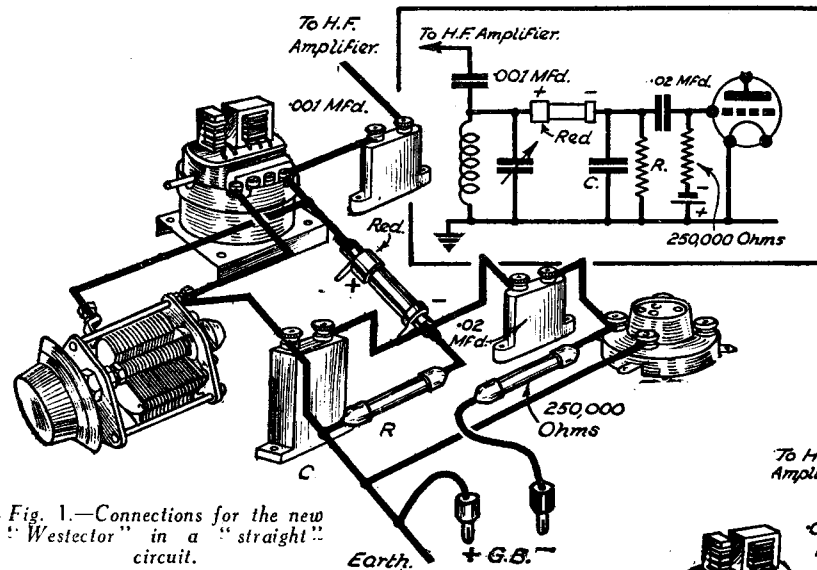

Fig. 1.—Connections for the new "Westector" in a "straight" circuit.

expressly low capacity, and which has been designed for high quality detection at radio frequencies. It is now possible to use a Westector in circuits working down to the lower wavelengths of the medium wave-band, without the excessive damping and consequent loss of selectivity which would occur were the "W" type Westector used for this purpose.

All readers will be familiar with the theory of the Westector, as practical use of its properties has been made in PRACTICAL WIRELESS receivers from time to time. We will content ourselves, therefore, with reminding readers that the Westector offers permanent straight-line rectification, that it cannot normally be overloaded, and that it requires neither H.T. nor L.T. supply. Our experience has shown that the most satisfactory circuit in which to use it is the half-wave circuit. The new

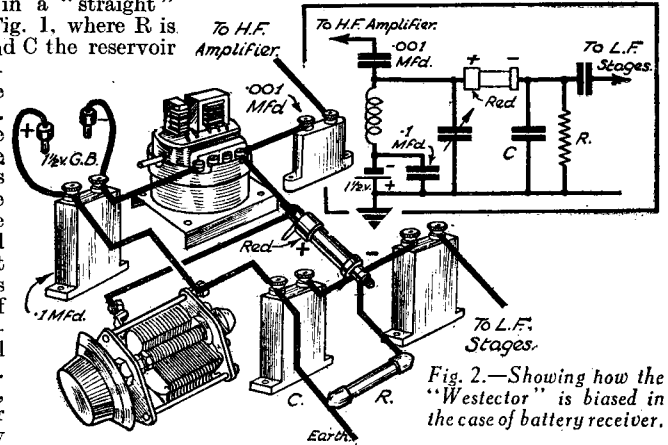

Fig. 2.—Showing how the "Westector" is biased in the case of battery receiver.

more efficient working, so may the new "WX" Westector be biased to a point of optimum rectification. Above a certain value of input the rectification characteristic of a Westector is a straight line, and there is no practical upper limit to this characteristic. Below this value the Westector works on a curve, and thus distortion will occur in the detector stage. By biasing this snag is removed, and experiments have shown that the point of optimum rectification occurs at a bias current of 13 micro-amps. This result is obtained by a bias of about 2 volts, and Figs. 2 and 3 show biasing arrangements for battery- and mains-operated receivers respectively. With such arrangements it is possible to obtain satisfactory results

(Continued on next page)

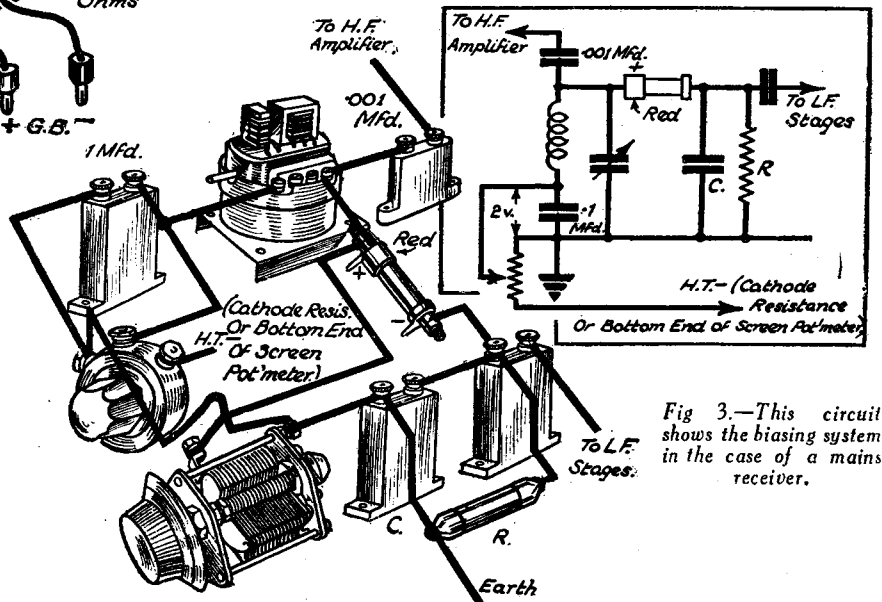

Fig. 3.—This circuit shows the biasing system in the case of a mains receiver.

(Continued from previous page)

when the peak H.F. input is as low as 0.2 volts, so that distortionless detection with one H.F. stage and receiving very distant stations is possible.

Circuit Arrangements—"Straight" receivers

The application of a "WX" Westector as a detector in a straight receiver is as simple as that of the type "W" when operating as a second detector in a superheterodyne receiver. In order to obtain full advantage from the straight-line characteristic, and thus obtain distortionless detection, the voltage handled should not be less than 3 volts, as explained above. Where a lower H.F. input is applied the Westector must be biased. A suggested skeleton circuit is shown in Fig. 4, where a typical S.G. det. L.F. receiver has been adapted to the equivalent of diode detection by using a "WX" Westector which has been suitably biased. It will be noticed that the detector valve now works solely as an L.F. amplifier, but, if one of the larger pentodes, such as the Mazda Pen.220A, is

coupling condenser and grid leak are 0.02 mfd. and 250,000 ohms respectively.

Reflex Receivers

Reflex receivers have rather fallen into disuse, owing to the inefficiency of the old-type valves, limited range of crystal rectifiers, etc.; but with modern valves, controlled by A.V.C. and employing diode rectification, the reflex circuit is becoming more popular. This type of receiver employs an ordinary type screen-grid valve for a dual purpose, viz., the amplification of both L.F. and H.F. This is done by feeding back the L.F. output from the detector stage into the grid circuit of the screen grid valve which is used as an H.F. amplifier. This L.F. signal is amplified once more and passed on to the output stage in the usual manner.

Fig. 5 shows a skeleton reflex circuit, using a "WX" Westector both for detec-

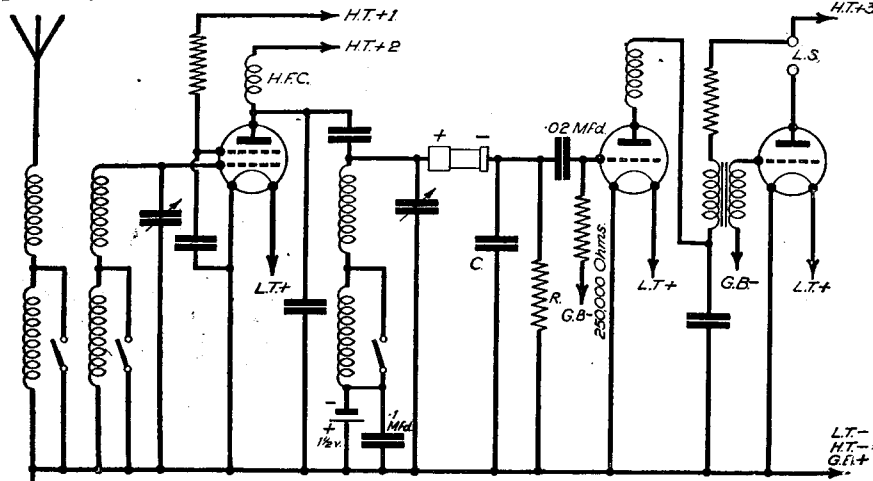

Fig. 4.—A suggested skeleton circuit in which the "WX" rectifier, suitably biased, is used in place of a diode.

used in the output stage in conjunction with a battery economy scheme, the intermediate L.F. valve may conveniently be omitted, and the Westector resistance capacity coupled direct to the output stage. In view of the very high impedance of the Westector it is inadvisable to use transformer coupling, and the best values of

tion and A.V.C. The L.F. output of valve V.1 passes through the coupling condenser C to the Westector, and thence through volume control P and resistance R to the grid of V.1, whence it passes to the output valve via the transformer Tr.1. At the same time a negative voltage in respect to earth is generated across P, by the H.F. present in this part of the circuit, and this voltage is fed back to the grid of V.1 to provide A.V.C. in the usual manner. The manual volume control P thus controls both L.F. and A.V.C. voltages to be applied to the grid of V.1, and effective control, with complete absence of distortion due to overloading, is obtained. The L.F. fed back from the Westector to the grid of V.1 could be amplified by feeding back through a transformer, in which case the manual volume control should be placed across the transformer. Otherwise, the grid of V.1 will have excessive H.F., L.F., and A.C.

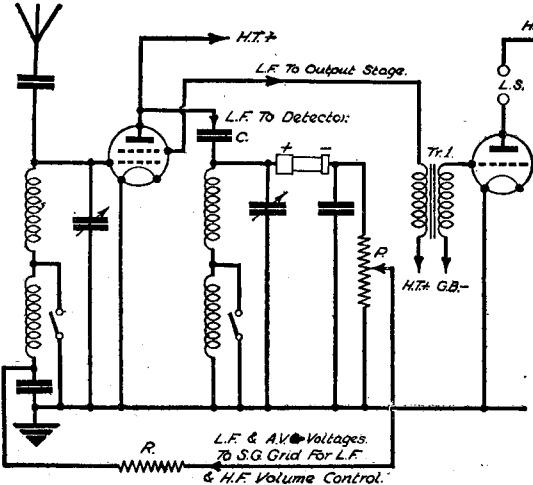

Fig. 5.—A skeleton reflex circuit in which a "Westector" is used for detection and A.V.C.

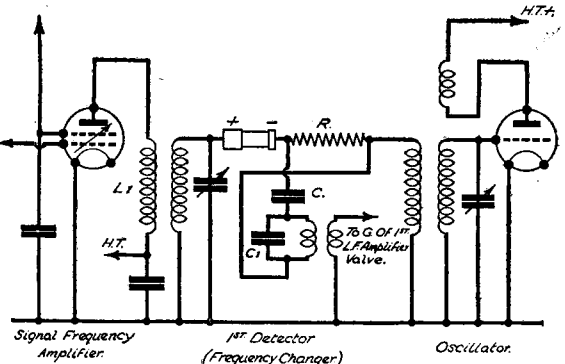

Fig. 6.—A "Westector" used as second detector, where it gives excellent results.

voltages applied to it when powerful signals are being received.

Superheterodyne Receivers

It is obvious that there is no great advantage to be gained by using a "WX" Westector as the second detector of a superheterodyne receiver unless the intermediate frequency is of a high value, such as 400 kilocycles. In fact, the greater power-handling capacity of the "W" type undoubtedly renders it more useful in this respect; but the "WX" Westector makes an ideal detector when used in the frequency changer stage (first detector). This stage of a superheterodyne receiver presents many snags to the unwary designer. It involves the acceptance of the incoming H.F. signal, the "mixing" with the generated oscillation, the rectification, the separation of the particular beat frequency required, and its amplification before passing on to the intermediate frequency stage. It is obvious that this is bound to complicate the stage, but the use of separate detectors and oscillators simplifies matters considerably. Even so, unless this stage has been well designed the bias applied to it in order to get a maximum heterodyne will have a serious effect on the valve employed, and its presence will considerably reduce the

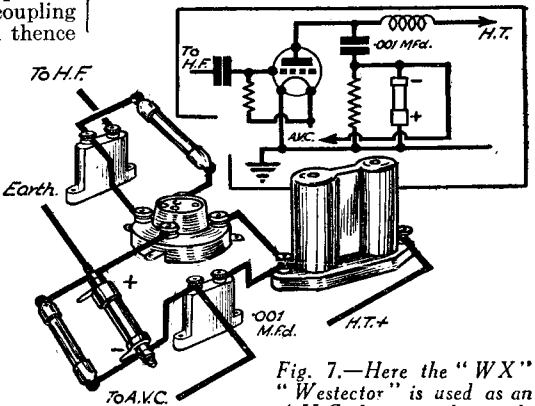
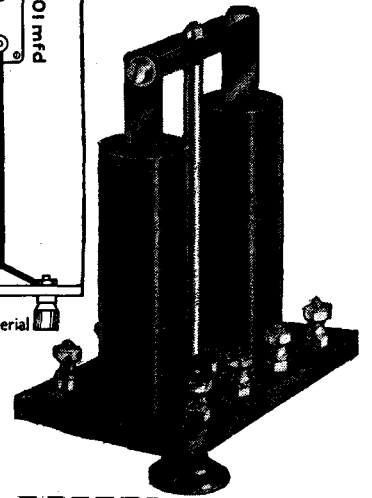
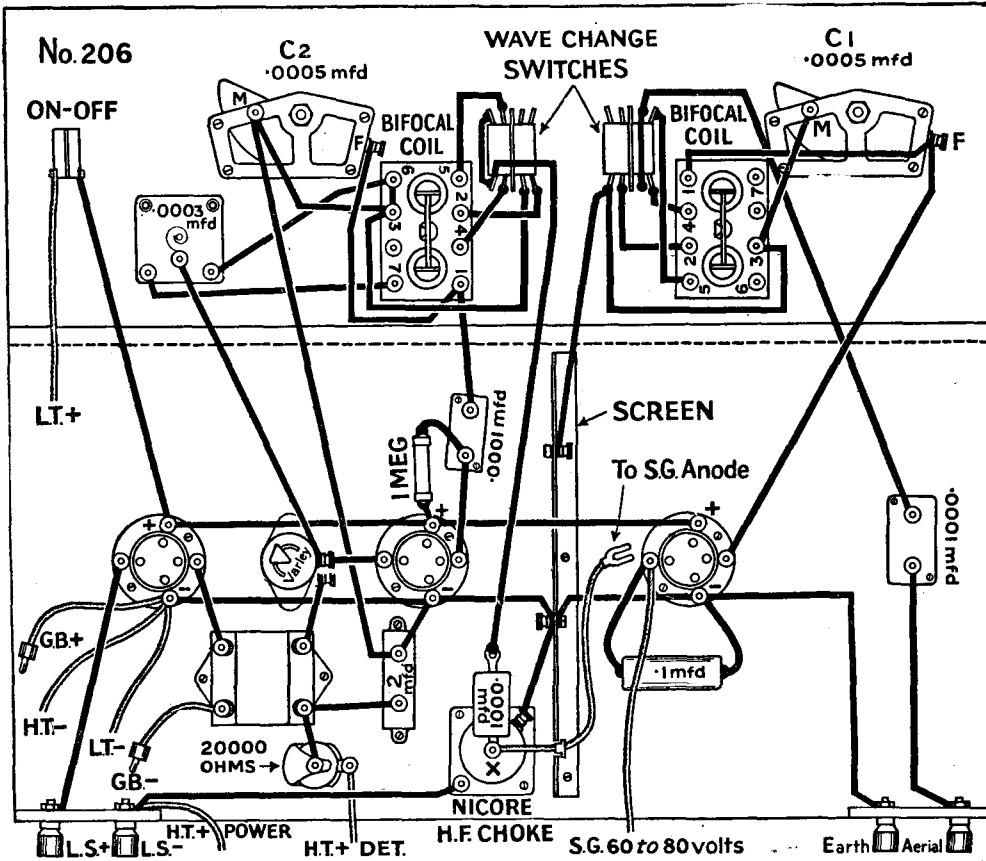

Fig. 7.—Here the "WX" "Westector" is used as an A.V.C. device in the anode circuit of the detector valve.

magnification of the valve compared with that to be obtained when the particular valve is used purely as an L.F. amplifier. And if, as is usual nowadays, A.V.C. is employed even separate detector and oscillator stages are bound to become complicated.

Here, again, the new "WX" Westector opens up an interesting possibility. A glance at Fig. 6 will show how its inclusion (Continued on page 84)

Two BIFOCAL FOCUSING COILS in a 3-valve S.G. Det.-Power Receiver.



Countless simple sets that were satisfactory when first designed are now incapable of dealing with the greatly increased number of stations in operation to-day. The advent of the Varley Bifocal Focussing Coil, with its revolutionary design, means a new life entirely to these sets.

- A typical circuit of a three-valve receiver incorporating two Bifocal Focussing Coils is shown in the diagram above. Read on page 67 how to incorporate Bifocal Focussing Coils into your existing set or into many other circuits.
- The installation of these new coils is so simple—the operation being no more difficult than any existing arrangement with a fixed aerial coupling.
- Forward the coupon to-day for full information and suitable circuits that take maximum advantage of this revolutionary new principle in radio.

To Messrs. VARLEY,
Kingsway House,
103, Kingsway, London, W.C.2.

Please send me full information of the new Bifocal Focussing Coils together with FREE Circuit diagrams.

Name.....

Address.....

When you see the word BIFOCAL it means



Reg. Trade Mark

WEARITE

SPECIFIED for the

A.C. LEADER

The WEARITE
**UNIVERSAL
COIL**

TUNES 180-550 &
850-1950 metres

PRICE
5/- per coil

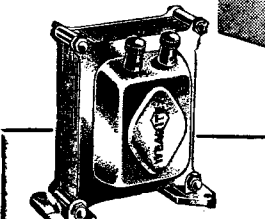
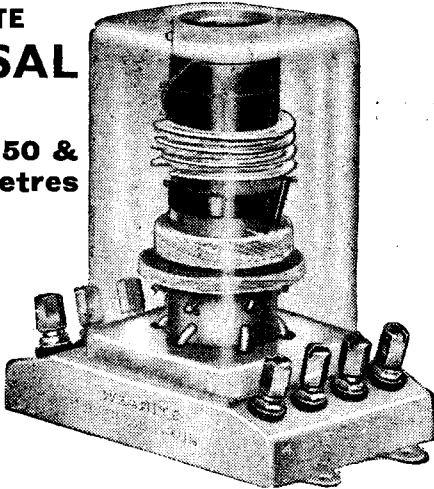

The WEARITE
**H.T. SMOOTHING
CHOKE H.T.25**

20 Henries
50 m/a
850 ohms

PRICE - **9/-**

The H.F.P.A.
CHOKE
PRICE 4/-



THE amazing tuning range—the way it covers the new Wavelength arrangement and the wonderful degree of selectivity made possible, are features which have prompted the designer to select the new "Universal" coils. Bear these points in mind—whatever the set you are contemplating—remember the "Universal" is designed for use for Aerial, H.F. and Band Passing. Send coupon for circuits.

Use the WEARITE
G.S.P. Switch

Positive action. PRICE
Self-cleaning. 1/-
One-hole fixing.

Type.	Impedance	Self Capacity	Induct.	D.C. Resist.	Price.
H.F.P.A.	15-2,500m.	45 mmfd.	250,000mh.	300 ohms.	4/-
H.F.P.	15-2,500m.	45 mmfd.	250,000mh.	300 ohms.	3/6
H.F.P.J.	100-2,100m.	7 mmfd.	220,000mh.	770 ohms.	2/-

Make sure of a good 'earth.'
Use a WEARITE
EARTH TUBE . . . PRICE 3/6



COUPON

To MESSRS. WRIGHT & WEAIRE, LTD.,
740, High Road, Tottenham, London, N.17.
Please send me your new booklet GN.2, together with literature on Class "B" Units, details of the NEW-Universal Coils, and H.T. Power Packs, with circuits.

NAME

ADDRESS

PRAC. 7.4.34

ACCURACY

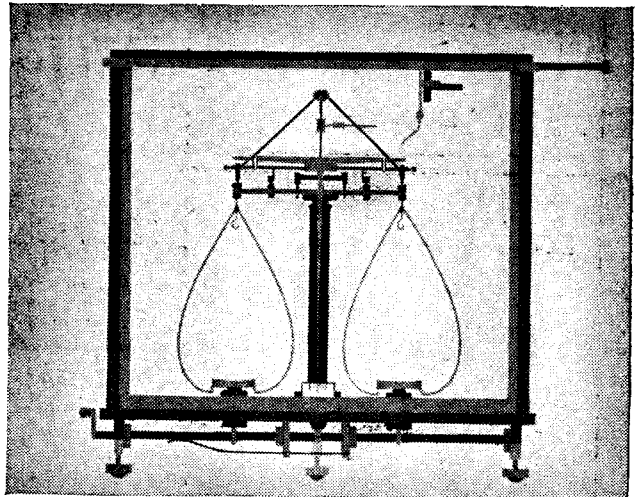

Chemistry or Radio—milligrammes or microfarads—accurate values are indispensable to successful working. That is why it is so important to equip your set with T.M.C. HYDRA condensers—they are accurate and remain accurate.

Strict scientific control of every manufacturing process ensures the accurate rating of every T.M.C. HYDRA condenser, and a perfect method of sealing prevents penetration of moisture, so maintaining the high electrical properties of the condenser.

Improve the working of your set with T.M.C. HYDRA condensers—they are made in all standard capacities with screw terminals or soldering tags at the same price.

Write to the Sole Sales Distributors if you have any difficulty in obtaining supplies.

T.M.C. Hydra Condensers are specified for the "A.C. Leader 3" described in this issue.

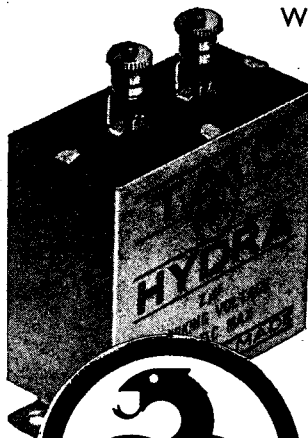

T.M.C.
BRITISH MADE
HYDRA
CONDENSERS

Price List from
SOLE SALES DISTRIBUTORS FOR
GREAT BRITAIN:

HARWELL LTD

The Sessions House, Clerkenwell Green, London, E.C.1
Telephone: Clerkenwell 6905

Made by TELEPHONE MANUFACTURING CO. LTD.



READERS' WRINKLES



Preventing Slip in Friction Drives

THE accompanying sketch will interest readers who have suffered from slipping in the friction drive of their condensers. The drawing is self-explanatory, but it is an improvement to rough the fixed washer

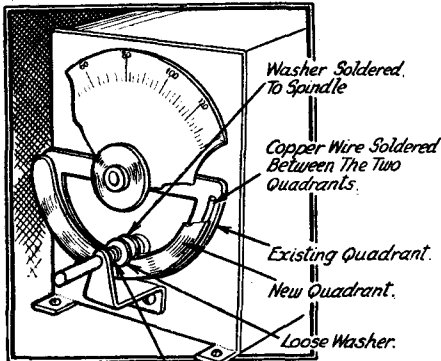

Light Spring Between Loose Washer & Bracket.

How to overcome slipping and backlash.

on both sides and the loose washer on the side nearest the condenser. The advantage is, of course, that the two discs get a firmer grip on the spindle than one does, and if after they have been in use some time slipping should occur again, it is a simple operation to squeeze the edges of the discs together again with a pair of pliers.—W. JOHNSON (West Smethwick).

A Rotary Radio-gram Switch

THE accompanying sketches show an easily made radio-gram switch. A small cylinder of hard wood, about 1in. diameter and 1/2in. thick, is marked off as shown, and the shaded portion cut off with a fret saw. After cutting the V-notches with a triangular file, a shallow trough is filed on the flat part of the large piece. A brass strip, taken from a used flash-lamp battery, is placed in this, and the small piece of the cylinder is screwed back into place. Other details are given in the sketch.—W. LOWENS (Manchester).

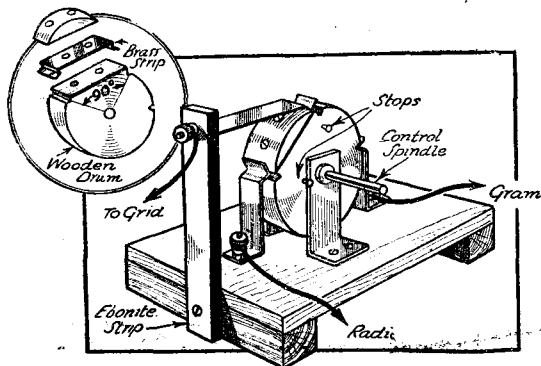

A single rotary radio-gram switch.

THAT DODGE OF YOURS!

Every Reader of "PRACTICAL WIRELESS" must have originated some little dodge which would interest other readers. Why not pass it on to us? We pay £1-10-0 for the best wrinkle submitted, and for every other item published on this page we will pay half-a-guinea. Turn that idea of yours to account by sending it in to us addressed to the Editor, "PRACTICAL WIRELESS," George Newnes, Ltd., 8-11, Southampton Street, Strand, W.C.2. Put your name and address on every item. Please note that every notion sent in must be original. Mark envelopes "Radio Wrinkles." Do NOT enclose queries with your wrinkle.

Converting a Meter

REQUIRING an ammeter to read up to 1 amp. (not critical), I decided to convert a cheap L.T. voltmeter into an ammeter. After experimenting with various lengths of wire (to give a certain

REAR VIEW

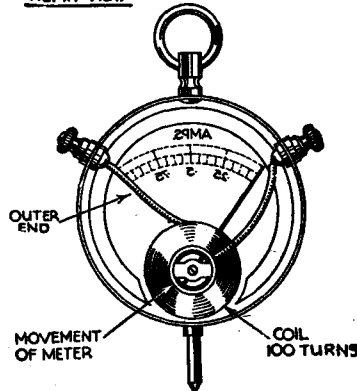

A modified meter.

number of turns), I found that 100 or slightly more turns were required for a full scale (i.e., 1 amp.) deflection, about 90 for 2 amps., and 80 for 3 amps. Gauge 22 enamel-covered wire was used, 100 turns being wound on a bobbin to fit in place of the existing bobbin of fine wire. Two terminals were fixed, one each side of the case, each being insulated from the metal, to which were attached the ends of the coil. The ammeter was roughly calibrated by measuring the L.T. current of the receiver. In my case, 3 volts equalled .5 amps. A combined voltmeter and ammeter can be made by winding the thicker wire over the thinner, with plenty of insulation between the two coils, the ammeter portion having separate terminals as indicated. It is advisable

to use as thick a wire as convenient, not less than S.W.G. 24 for 1 ampere, to keep the resistance low.—R. M. ROSS (AIness).

Simple Home-made Resistances

A SMALL stock of resistances is useful to the experimenter or home constructor. They are easily made. A length of ebonite rod is chased with a thread to carry a length of resistance wire. The wire is wound into the thread and secured at

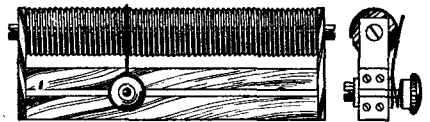

the ends by the screws which hold the brass trips in position, the ends of the rod being drilled and tapped to take the screws. Two strips of wood or ebonite are fastened to the brass strips by wood screws, leaving a gap between for the slider. The slider is made from an ordinary brass screw. A washer is placed at the back, and a small piece of springy brass or copper wire soldered on to another washer is placed on the front. A spring washer is placed on top, and the terminal head finishes the job.—R. BIRC (Southampton).

A Variable-tone Morse Practice Set

THE accompanying sketch shows an apparatus for the production of sound impulses, the tone of which can be varied. This apparatus will be found useful for the practising of morse. The old coil is a centre-tapped one having 500 turns, and this will probably be found in most amateurs' junk-boxes. The valve found most suitable was of the R.C.C. type, but others can be used with every satisfaction.

If a centre-tapped coil is not available, it is quite possible to employ two single coils of the plug-in type. Alternatively, a new coil can easily be made by winding 500 turns of 36 s.w.g. enamelled wire on a 2in. former, and taking a tapping after 250 turns.—W. CROSSLAND (Tankerton).

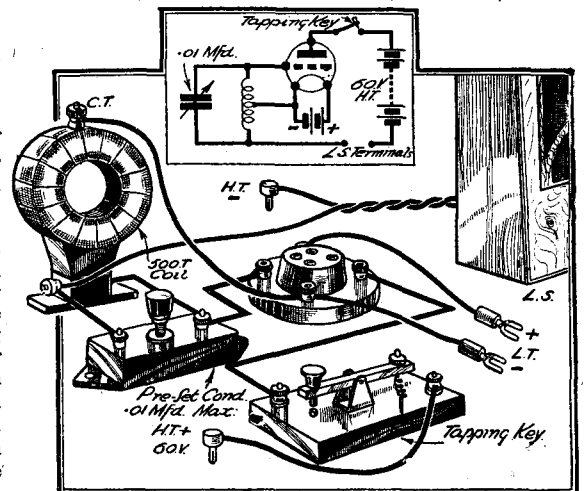

A very efficient code practice set.

R.M.S. VALUES EXPLAINED

A Simple Explanation of R.M.S. Values and How they are Ascertained.
By LAMBDA.

THERE are two kinds of current or voltage, direct and alternating. Direct current flows continuously in one direction, whilst alternating current changes its polarity many times per second. That is, it is continuously becoming positive and then negative.

The periodicity (or number of times per second that an alternating current changes its polarity) is called the frequency and is usually expressed as so many cycles per second. Fig. 1 illustrates an alternating-current wave. The line A—B represents the zero line and the current flows first in one direction, reaching a maximum at the point C, and then it falls and repeats the same process in the opposite direction, the distance from A to B representing one cycle of events.

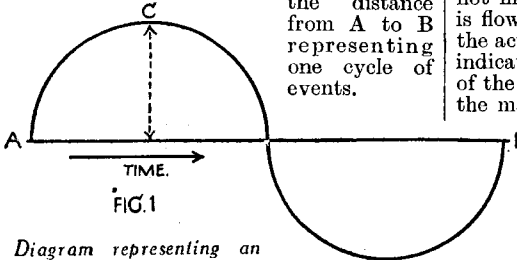

Diagram representing an alternating current.

Frequency

In dealing with low frequencies one might consider the usual frequency of the electric light supply, namely, 50 cycles per second. At the other end of the scale there are the very high frequencies met with in radio, which reach thousands and often millions of cycles per second.

The problem is to measure the alternating current. It is not constant, but fluctuating, therefore the method of measurement must be different from that employed for direct current. The wave above the zero line is equal to that below the zero line (Fig. 1) and, consequently, if these two waves be added together, that is one positive and one negative, it is quite obvious that the result will be zero.

We know, however, that this is not so, and that energy is dissipated in heat, otherwise electric fires would be of no use when connected to an alternating current supply.

Alternating current will therefore generate heat, and this fact is utilized in devising a system of measurement.

Defining the Effective Value

The useful or effective value of an alternating current is defined as the value, in amperes, of a steady direct current which would have the same average heating effect as a corresponding D.C. current. In the case of an electric fire the useful value of the alternating current, would be equal to the value of the steady direct current which would be required to radiate the same amount of energy in the form of heat.

When we take as a basis of measurement the heating effect of the current it does not matter in which direction the current is flowing, positive or negative. Although the actual value is continually changing, an indication will be given by the instrument of the average heating effect, and therefore the magnitude of the current flowing.

Finding the R.M.S. Value

The power expended in producing heat in a circuit is ascertained from the formula $I^2R = \text{Power in Watts}$, where I represents current and R the resistance of the circuit. This formula is arrived at by the following reasoning. First of all it is known

that $V \times I = \text{Watts}$, V representing voltage. Now, according to Ohm's Law, V is the product of $I \times R$, so that in place of V in the formula ($I \times R$) can be substituted; thus $(I \times R) \times I = \text{Watts}$. This may be written in a simpler manner as $I^2R = \text{Watts}$.

Having briefly considered the formula as applied to direct current we must see what relationship it bears to alternating current. Again consider the curve shown in Fig. 1, which is known as a sine wave. First of all it rises to the maximum point C and then falls, repeating the process in the opposite direction; but although now negative, the shape of the curve is the same.

Passing on to Fig. 2, which is one half of the complete cycle shown in Fig. 1 redrawn. If the alternating current be flowing through a resistance of, say, 1 ohm, then i^2R will be the value at any particular instant. If I is the value of the direct current which would have the same

average heating effect, then I^2R would be equal to the mean value of i^2R over a complete cycle. Now if $I^2R = i^2R$, then $I^2 = (\text{mean value of } i^2)$, so that the effective value would be

$$I = \sqrt{\text{mean value of } i^2 \text{ amps.}}$$

A complete sine wave is given in Fig. 3, where the base line A—B represents time, and the first half-wave is divided into eight equal parts. The distance from the base to the points where the vertical lines meet the sine wave represents the value at any particular instant; assuming the values in this case to be 1 to 4 amperes, the latter figure being the maximum value.

In order to ascertain the effective (R.M.S.) value it is necessary to square each of these values and plot them as a new curve about the same base line. In Fig. 4 we arrive at the values 1 to 16 amperes. It will be seen that this is an entirely new curve which is actually half the wavelength, or double the frequency, of the wave shown in Fig. 3. The centre of this new curve falls at a height above the base line which is equal to just half the maximum height and is indicated by the dotted line X—Y. Two curves are shown in order clearly to illustrate the shape of this new wave, but the calculations only apply to the first curves in each case. Half the height of the new wave will be 8 amperes, assuming the maximum height to be 16 amperes, and this is the mean square value.

Root Mean Square

Finally we have to ascertain the root of the mean square value of 8 amperes; this is written $\sqrt{8}$, and therefore $I = \sqrt{\frac{1}{2} \times 16} = I \times \sqrt{8}$ which is 2.83 amperes, R.M.S.

This method of calculation is, of course, a tedious process, especially if it has to be undertaken every time it is necessary to find the R.M.S. values, but fortunately we can simplify the process very considerably by a different method which will also prove that the calculations are correct.

Call the maximum value I_m , then the mean square value will be one-half of the square of the maximum value, namely, $\frac{1}{2}$ of I_m^2 written $\frac{1}{2} I_m^2$, then the Root Mean Square value will be written $\sqrt{\frac{1}{2} I_m^2}$, which simplified will be $\frac{I_m}{\sqrt{2}}$ which will give

us $I = 0.707 I_m$. This means that the effective or R.M.S. value of a sine wave of alternating current is equal to 0.707 of the maximum value, or 1.414 times the effective value.

Therefore the rule is: when the R.M.S. value is given, to obtain the maximum value multiply by 1.414, and when the peak value of the alternating current is given multiply by 0.707 to obtain the R.M.S. value.

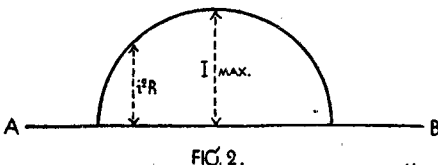

One half of the cycle of events shown in Fig. 1.

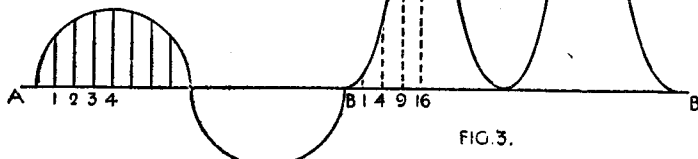

A complete sine wave as referred to in the text.

THE WIRELESS CONSTRUCTOR'S ENCYCLOPAEDIA

(2nd Edition)
By F. J. CAMM
(Editor of "Practical Wireless")

THIS invaluable encyclopaedia is written in plain language by one of the most accomplished designers and writers on wireless construction. The whole subject is fully covered, and the volume is remarkable for the number of practical illustrations it contains.

Obtainable at all Booksellers, or by post
5/6 from Geo. Newnes, Ltd., 8-11, Southampton Street, Strand, London, W.C.2.

5/-

THE SUPERHETERODYNE FREQUENCY CHANGER

The Various Methods of Producing the Intermediate Frequency are Reviewed and Described in this Article

By FRANK PRESTON

THE most important part of any superheterodyne receiver is that which serves to change the frequency of the received signals to that of the intermediate-frequency H.F. amplifier. Although the principle of frequency-changing is simple and unvarying, there are many different methods of putting it into practice, and it is the practical side of the question which it is proposed to deal with in this article.

In order to refresh the memory of those who are not very conversant with superheterodyne practice, it might be well briefly to explain the fundamental idea of frequency-changing. The intermediate-frequency amplifier is generally pre-tuned to either 110 or 126 kilocycles, and therefore, in order that the amplifier may be effective, it is essential that the signals passed to it should be of one of those frequencies. Obviously the signals picked up by the aerial circuit are of no definite frequency, generally varying between approximately 1,500 kilocycles (200 metres) to 150 kilocycles (2,000 metres), and they must therefore be modified in some way. The method is fairly simple and consists of "mixing" oscillations of some other frequency with them. For example, if a station working on 300 metres (1,000 kilocycles) were being received, oscillations of 1,110 or 890 kilocycles would have to be "mixed" with the signal oscillations in order to produce a "heterodyne," or intermediate-frequency, signal of 110 kilocycles which could be handled by the L.F. amplifier.

It has been said that the imposed oscillation may be of either 890 kilocycles (1,000 minus 110) or 1,110 (1,000 plus 110), but in practice it is generally found better to employ the higher frequency.

Having obtained a clear understanding of the requirements of the frequency-changer, the next thing is to learn how the system is applied. This clearly hangs upon the method of providing the new set of oscillations. A valve is well known as the best device for producing high-frequency oscillations, and it is this instrument which

is used. In some cases a separate valve is used specially for the purpose of producing the required oscillations, when the complete frequency-changer consists of two valves—the first detector, which handles the actual signal frequencies, and the oscillator. Other circuit arrangements are possible,

aerial to obviate the difficulty of interference with other receivers due to re-radiation. A skeleton circuit of a frequency-changer of this type is shown in Fig. 1,

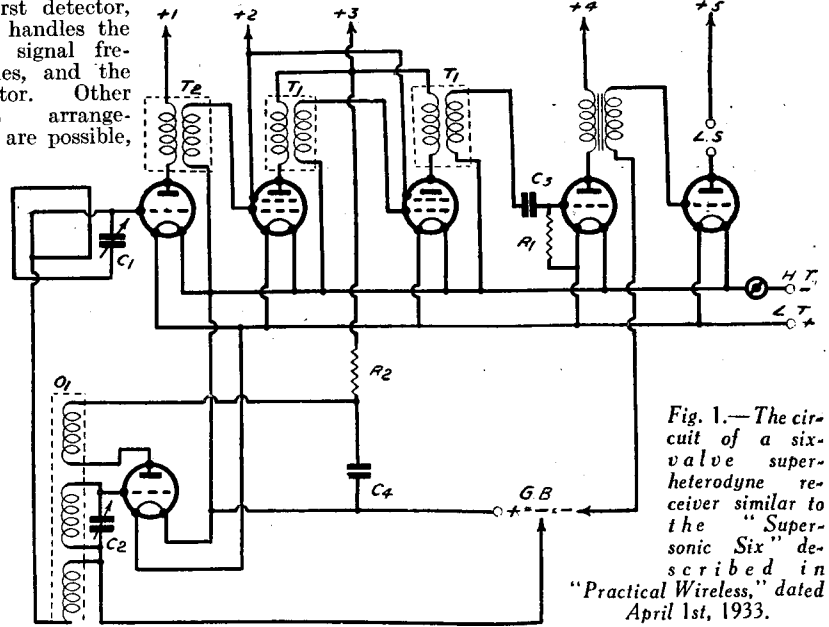

Fig. 1.—The circuit of a six-valve superheterodyne receiver similar to the "Supersonic Six" described in "Practical Wireless," dated April 1st, 1933.

however, where a single ordinary valve serves the two purposes; this is known as a combined detector-oscillator. Yet again, in other instances a pentode or screened-grid valve is used as combined detector oscillator, but at the present time it is becoming more usual to use a special valve for the two functions, this being of the heptode or pentagrid type.

Grid Coupling

It will be best to make a start by considering a frequency changer of the type which was most commonly employed from two to three years ago, when it was generally necessary to operate a superhet from a frame

the circuit actually being similar to that of the "Supersonic Six," described in PRACTICAL WIRELESS early in 1933. It will be seen that the oscillator valve is connected to a dual-range tuner (referred to as the oscillator coil) of which the anode winding is tuned in the usual way by a .0005 mfd. variable condenser, and is close-coupled to the grid winding which is untuned. The oscillations generated by the oscillator valve are fed back into the grid circuit of the first

(Continued on next page)

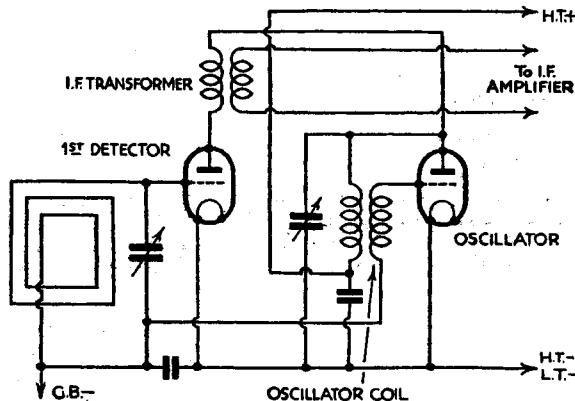

Fig. 2.—The frequency changer of an early pattern superhet, using a frame aerial, three electrode first detector, and separate oscillator.

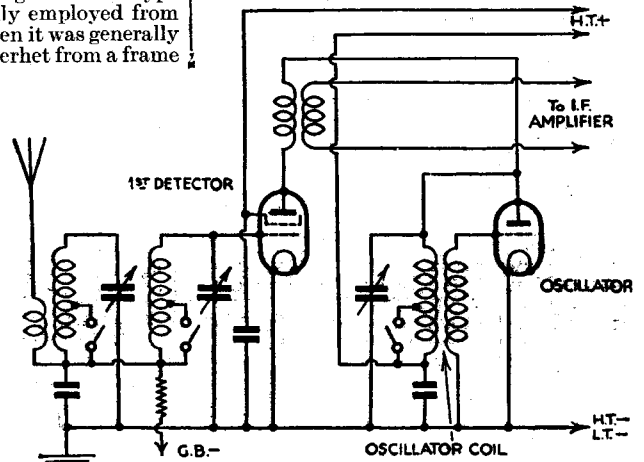

Fig. 3.—A modified and up-to-date arrangement of the circuit shown in Fig. 2. An elevated aerial is used in conjunction with a band-pass tuning circuit and screen-grid first detector.

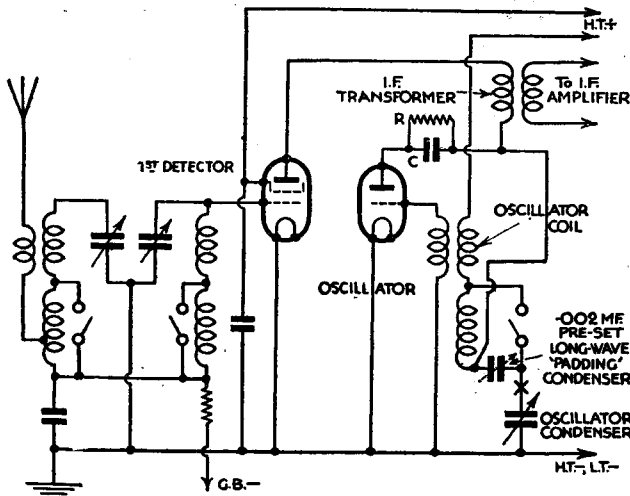

Fig. 4.—The first detector-oscillator circuit of the "Premier Super" described in "Practical Wireless," dated September 23rd and 30th, 1933.

experimenters soon found that it could be operated from an outside aerial provided that a screen-grid or pentode valve was used as first detector so as to avoid re-radiation. A circuit such as that shown in Fig. 3 was therefore evolved; this arrangement is, as a matter of fact, widely employed even at the present time, particularly in battery-operated sets. It will be noticed that a band-pass aerial circuit is used, this being a practical essential in order to avoid various forms of interference which have previously been referred to in these pages. The circuit shown in Fig. 3 is very similar to that shown in Fig. 2 and is simply a development of it.

detector by means of a small winding, which is coupled to the oscillator windings and connected to the centre-tapping of the frame aerial. This system functioned very well when a frame aerial was employed and

As superheterodynes became more popular it was natural that users should wish

Ganging the Tuning Controls

and one special section for the oscillator, whose fixed vanes are shaped differently from those of the other sections. It is not proposed to enter into the mathematics of the subject of designing the shape of the fixed vanes in the oscillator section, but reference might be made to an article in which this subject was more fully dealt with, and which was given in PRACTICAL WIRELESS dated October 21st, 1933.

"Tracking" Condensers

A PRACTICAL WIRELESS receiver using a modified arrangement of the circuit given in Fig. 3 is the "Premier Super," described in the issues dated September 23rd and 30th, 1933. A skeleton circuit of the first two valves in that set is given in Fig. 4. A special superhet-type gang condenser is employed for tuning, and this obviates the use of a "tracking" condenser. A long-wave "padding" condenser is used, however, and is connected between the "lower" end of the anode winding of the oscillator coil and the wave-change switch. This condenser is a pre-set of .002 mfd. maximum and serves for matching when receiving on the long-wave band.

Another refinement of this circuit is the inclusion of a fixed resistance of 100,000 ohms (R) and a .01 mfd. (C) by-pass condenser in the anode circuit of the oscillator

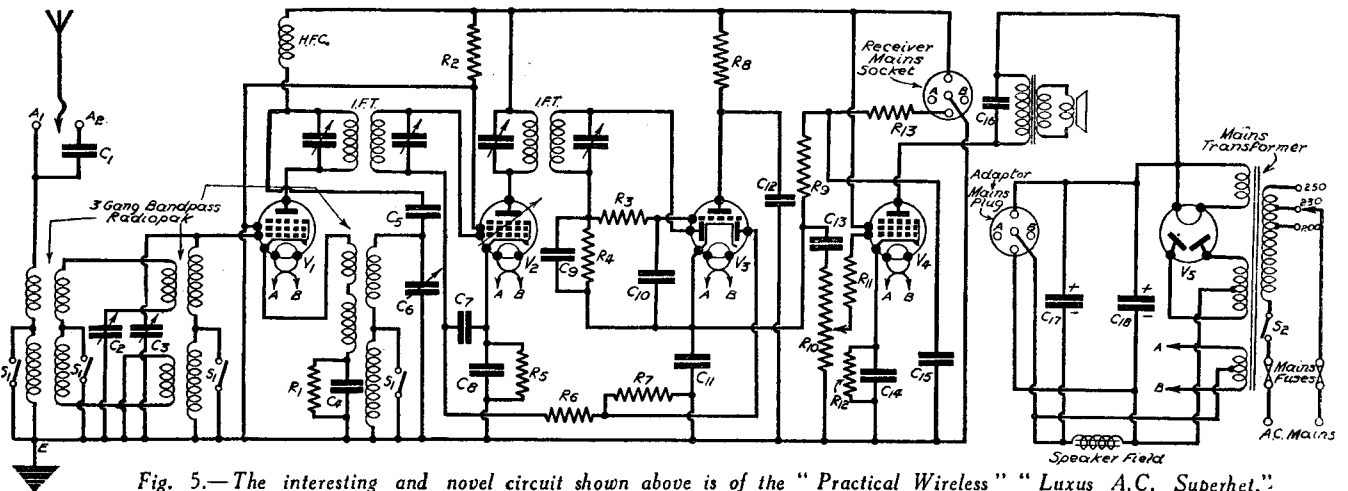

Fig. 5.—The interesting and novel circuit shown above is of the "Practical Wireless" "Luxus A.C. Superhet."

became standardized in most superheterodynes of similar type to that referred to. It had the disadvantage that it was practically essential to employ separate tuning condensers for the oscillator and first detector, but otherwise there was little fault to be found with it. The oscillator was reasonably efficient over the whole of both wavebands, provided that a suitable anode voltage was applied to it and that a valve of the L.F. type was employed.

Anode-circuit "Mixing"

An alternative arrangement which avoided the necessity for using a centre-tapped frame aerial was that shown in skeleton form in Fig. 2, and in this case both detector and oscillator were connected on the anode-bend system. "Mixing" in this case was obtained in the anode circuit of the detector by connecting the anode winding of the oscillator coil in series with the primary of the I.F. transformer. In this arrangement also, separate tuning condensers were required for the two tuned circuits.

After the superheterodyne receiver had become more popular, and after more experiment had been carried out with it,

to have the advantage of a single tuning control, such as was used with other types of circuits. The use of a three-gang condenser (one section for each of the band-pass coils and one for the oscillator) presented many difficulties because, although the frequency of the oscillator circuit must always differ from that of the signal circuit by a fixed and definite amount, the frequencies of the two circuits must be varied in different ratios in order to receive on various wavelengths. This makes it necessary to use "padding" and/or "tracking" condensers in conjunction with that section which tunes the oscillator coil. An alternative to the "tracking" condenser, however, is to use a gang condenser of special "superhet" type. This condenser, usually a three-gang component, has two plain sections (for tuning the band-pass circuit),

valve. This resistance-condenser filter is for the purpose of providing a uniform strength of oscillation over the whole of both wavebands. Incidentally it might be mentioned that it would be possible to use a normal three-gang condenser in this circuit simply by connecting a fixed

(Continued on page 90)

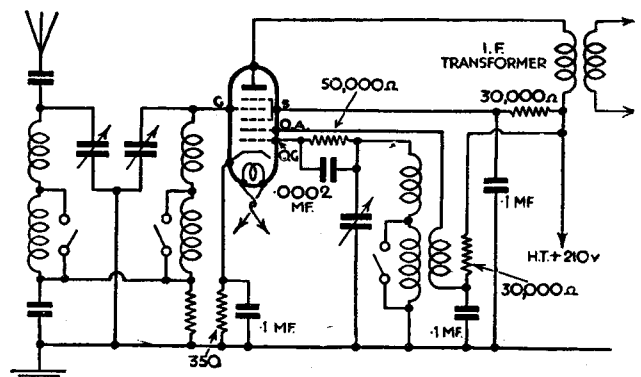

Fig. 6.—The frequency-changer of a modern superheterodyne where a Cossor Pentagrid is used as first detector and oscillator.

REVIEWS OF LATEST RECEIVERS

Tests of Standard Receivers
On Our
Aerial.

It can truly be said that three-valve receivers have become somewhat stereotyped during the last few years. It is, therefore, refreshing to come across such a departure from orthodox design as the new Cossor 435 mains receiver. This is one of the very few sets on the market using the screened high-frequency pentode as a detector; in fact, the whole combination of valves is unusual, since each is of the multi-grid type. A variable-mu S.G. is used in the H.F. stage, a screened pentode as detector, and a power pentode as output valve.

The circuit of the Cossor set under review is more or less conventional. The aerial tuner has the usual tapped winding, but includes a miniature choke, a feature of all Cossor receivers, to stop the tendency for medium-wave signals to break through at the bottom of the long waveband.

Pentode Detector

The MS/PEN screened H.F. pentode acts as leaky-grid detector, and is also arranged to function as the first L.F. amplifier when radio reception gives place to gramophone reproduction.

The "high spot" in the receiver is undoubtedly centred round the MS/PEN, which is resistance-coupled to the Cossor MP/PEN output valve, thus doing away with the low-frequency transformer. This probably explains why the set has such a wide frequency range and such an excellent high-note response.

There is little to be said about the output stage other than to remark on the fact that "stopper" resistances are included in both anode and screen leads, and that the moving-coil loud-speaker is mains energized, the field coil being used as the smoothing choke.

Simple Controls

The controls are few in number and simple to operate. The centre knob controls a two-gang condenser, and has in its centre a small knob that actuates a trimmer across the main-aerial condenser which, once set, does not require readjustments on either waveband except in most exceptional cases. This arrangement enables the receiver to give its best on a variety of different sized aerials.

The other two controls are reaction and volume control (variable-mu bias), and the selectivity of the set relies on the inter-dependent use of these two controls. The volume control also actuates the mains on/off switch, so that the first few degrees of rotation turn the set on or off as desired.

Wavelength-calibrated Dial

The tuning dial is calibrated in wavelengths, the ranges being 200 to 540 and 900 to 2,000 metres. The "pointer" takes the form of an oval spot of light that illuminates the appropriate dial reading. The long and short-wave scales are not combined, and so two oval spots of light are

COSSOR ALL-MAINS RECEIVER, MODEL 435.

necessary, one for each scale, the correct one being lit up by the wavechange switch. When the gramophone pick-up is inserted, both dials are illuminated.

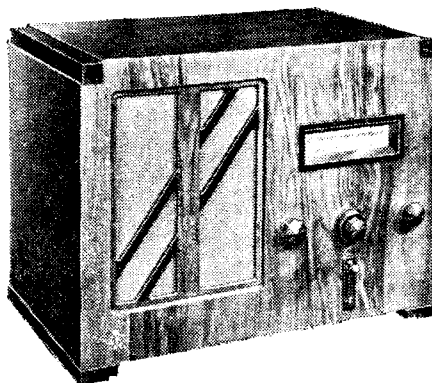

The Cossor All-mains Receiver, Model 435, priced at £9 15s. Od., in a walnut cabinet.

The general appearance of the chassis can be seen from the illustration on this page. It is very robust, being made of blue gun-finished steel, a substance which has much to commend it for this particular purpose.

The Set On Test

When the receiver was put on test much was expected from it, and we were not disappointed; the quality of reproduction was equal in every way to that associated with much more expensive receivers, while the reproduction of high notes is possibly not surpassed in any receiver on the market.

The available undistorted output from the MP/PEN was ample (it is about two watts), and the loud-speaker proved itself to be perfectly capable of accepting this input. Selectivity was excellent when the reaction and volume controls were used together; at twenty miles from the Brookmans Park stations the spread on each of the dials was only about 1/2 in. of the 5 in. scale, even without pushing reaction to the limit.

A remarkable feature of this receiver was its performance on a small in-

door aerial. Using only about ten feet on the ground floor some dozen stations could be tuned in at a volume level varying between 50 and 100 per cent. of the maximum. This flexibility is due to the wide compromise between selectivity and sensitivity, and to the close ganging made possible by the trimmer. Such an indoor aerial performance is rare with a receiver that is so selective on the orthodox outside aerial.

Gramophone Reproduction

A gramophone pick-up was also tried and the same degree of quality was obtainable. It was found that care had to be exercised when adjusting the pick-up volume-control because, after the optimum setting was reached, quality was impaired without materially increasing volume. This was, of course, due to the detector being overloaded.

The cabinet (illustrated) is made of soft, polished walnut, with jet black corners, tuning window, loud-speaker fret bars, and controls. This gives a modern but not futuristic appearance that blends with any furnishing scheme.

This receiver, Cossor Model 435, is available for A.C. mains only, 200 to 250 volts (adjustable) 40 to 100 cycles, and is sold complete with four valves, including rectifier, and mains-energized moving-coil loud-speaker, in walnut cabinet, 13 in. high, 17 1/2 in. wide, and 10 in. deep, with pick-up and gramophone motor plug, for £9 15s.

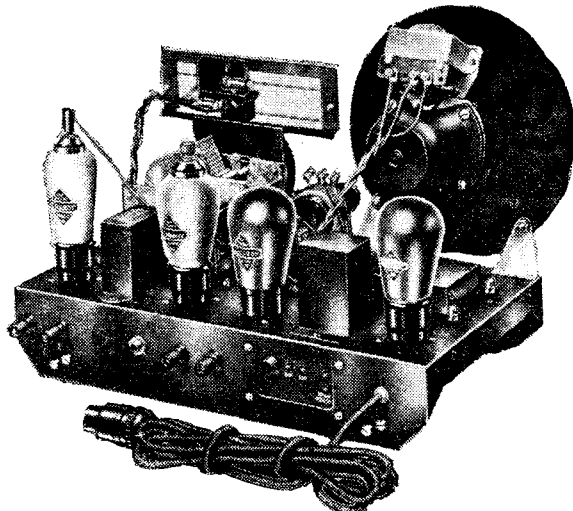

Three-quarter rear view of the chassis of the Cossor All-mains Model 435, showing the neat and compact layout.

BUILDING THE

An Amazingly Efficient Mains Version of the Receiver

THE Leader Three which we recently described met with a wonderful and unprecedented reception by the home-constructor public. That set has probably been built in greater numbers than any other which has been offered to the amateur set-builder for many years. Everyone is most enthusiastic about it, not only because it can be built at a remarkably low price, but because it combines the qualities of efficiency, simplicity, ease of construction, and neatness of design with a price quite out of keeping with the high quality of the components around which it was designed. In producing the battery model we had the enthusiastic co-operation of a large number of component manufacturers, and it was this which enabled us to present such a unique instrument to all readers of PRACTICAL WIRELESS. The Leader Three was symbolic of our new and important policy introduced expressly for the benefit of our readers who are anxious to build their own sets, but who insist upon doing so in an economical manner.

The A.C. Leader Three is a further practical example of our careful efforts to encourage the body of amateur wireless enthusiasts throughout the country (judging by the extraordinarily wide circulation of PRACTICAL WIRELESS, we might be excused for saying "throughout the world") to build their own receivers, thereby deriving the maximum amount of interest from their hobby. Ever since the battery model was described we have been receiving shoals of letters from readers who were anxious to construct a similar receiver which could be operated entirely from the A.C. mains. At first we were in some doubt as to whether an A.C. receiver could be made at a price which would compare with that of the

battery version. Experiments were taken in hand, all kinds of low-priced components were experimented with until the A.C. Leader which is illustrated on this page was produced. The results of our efforts and, be it noted, the results of the wonderful co-operation extended to us by component manufacturers, are most gratifying; no reader can fail to be impressed by the performance, appearance, and cost of the A.C. Leader Three.

Special Low-priced Components

Particular mention must be made of Messrs. Heyberd, who have supported our efforts in no uncertain way by producing a mains transformer to our special design at the remarkably low price of 16s. It must not be thought that this component is a "cheap" one in the generally-accepted sense of the word, for it is of the same magnificent workmanship which is typical of all Messrs. Heyberd's products. The smoothing choke which we have used is sold for the low price of 9s. by Messrs. Wright and Weaire, and this is just as effective in this particular circuit as many others on the market costing double the price. The same firm are responsible for the production of the very efficient screened coils which largely helped to make the original Leader Three so successful, and which are again used in this A.C. model.

Money has also been saved by using a number of tubular condensers made by Messrs. T.M.C.; these cost so little as 6d. each for the .0001 mfd. component and only 1s. 6d. for the .1 mfd. capacities. Despite their modest price, these condensers are tested at 1,000 volts, and therefore provide a very ample margin of safety. The double 4 mfd. condenser, of 400 volts

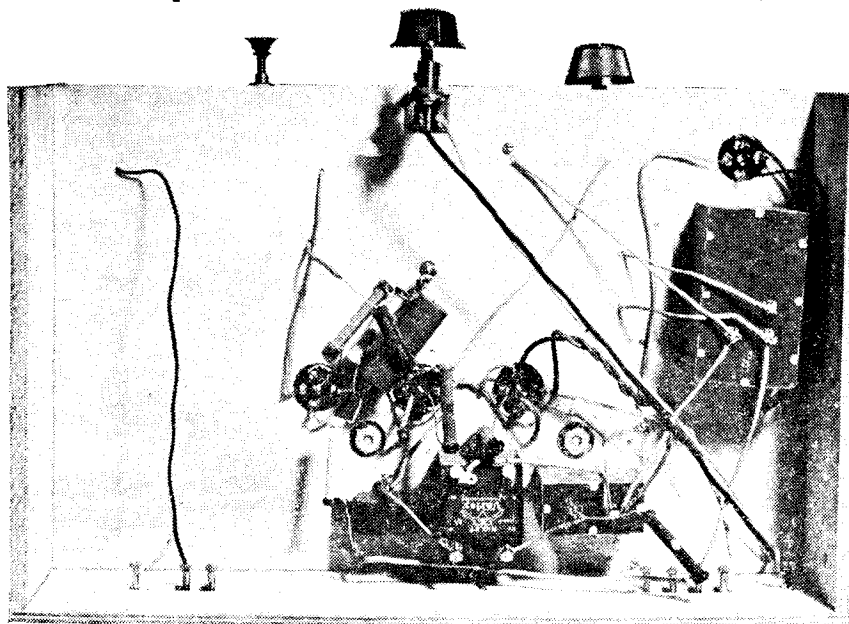
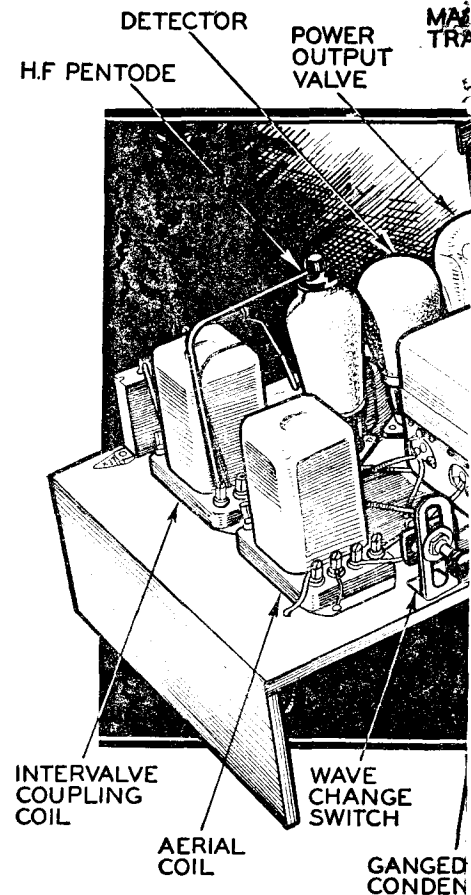

This sub-chassis illustration will assist you in wiring.

working, has been specially made for this receiver by Messrs. T.M.C., and the price is appreciably less than that of two single 4 mfd. condensers of similar working voltage.

Even the fixed resistances are lower-priced than most, but they are as good and reliable as any on the market; they actually cost 10½d. each, and are supplied by Messrs. Claude Lyons.

An Efficient Circuit Arrangement

It will be seen from the circuit diagram that a simple and well-tried arrangement

has been followed, despite such modern features as the high-frequency pentode, coils which cover every important wavelength under the Lucerne Plan, and ganged tuning control. The first coil is provided with a loose coupled aerial winding to ensure a

NOTABLE "LEAD"

THE LATEST COILS FOR THE LENGTHS
AN EFFICIENT SCREEN-GRI RECEPTION
TUNED-TRANSFORMER H.F. MUM SELECTIVITY
SELECTIVITY IN EXCELSIS ONE AND A QUARTER WAVE METALIZED CHASSIS CONDENSERS REMARKABLY EASY TO BUILD EQUALLY GOOD ON "RADIO" COSTS ONLY EIGHT POUNDS THE MOST POPULAR CIRCUIT GANGED TUNING CONTROL THE IDEAL SET FOR EVERY ABSENCE OF MAINS HUM NEGLIGIBLE CURRENT CON

E A.C. LEADER

ceiver which has Revitalized Home Construction

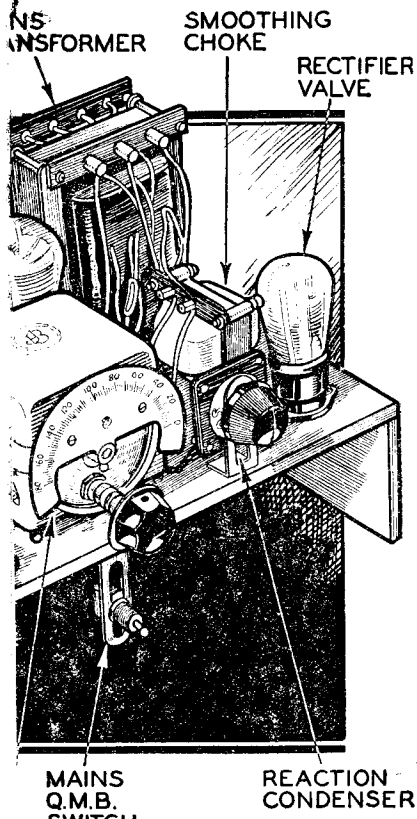

Our artist's impression of the A.C. Leader.

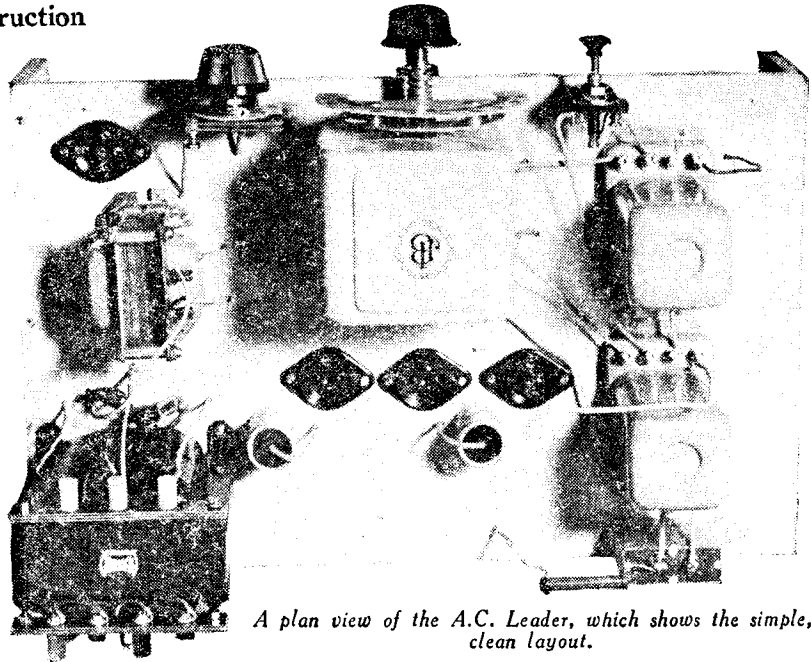

A plan view of the A.C. Leader, which shows the simple, clean layout.

Simple Construction

It need scarcely be explained that the construction of the A.C. Leader is as simple as it could be. There is a minimum number of connecting wires, and no awkward corners which are difficult to get into. The 4-volt leads from the main transformer to the filament of the rectifier and also to the heaters of the receiving valves are of rubber-covered flex, and come direct from the transformer. A metallized chassis is used, as in the case of all PRACTICAL WIRELESS designs, and this is used for a number of earth-returns, thus simplifying the constructional work.

A number of soldered joints are used, since we know that most of our readers prefer them, but there is no reason why anyone who is not accustomed to soldering should be afraid to make the set on that account. Practically all the soldering could be obviated if desired by attaching the ends of resistances, condensers, and other components to small terminals. Additionally, the larger fixed con-

densers, although they are supplied with soldering tags, can be adapted for terminal connections by fitting neat little clips which are supplied by the makers, if required.

The chassis can be obtained already drilled, but in case any reader wishes to drill his own, it might be mentioned that the fixing nuts of the two 20-mfd. electrolytic condensers must be recessed by making holes about 1/16 in. diameter and 1/8 in. deep on the underside of the chassis baseboard.

In mounting the components it will be found best to start by attaching all those parts which are fitted on the underside of the chassis, such as the double 4-mfd. smoothing condenser (C11 and C12), low-frequency transformer, H.F. choke, 2-mfd. fixed condenser, and the component bracket which holds the on-off switch. It will be seen from the wiring plans that the tubular

(Continued overleaf)

TUNING SERS

maximum degree of selectivity, whilst the second coil is used as an H.F. transformer for the same purpose and also to eliminate the necessity for an H.F. coupling choke and its associated condenser. The detector works on the popular leaky-grid system, provision being made for using this valve as an effective low-frequency amplifier when a pick-up is connected to the terminals provided. The output valve is a triode, and gives an undistorted signal output of no less than 1 1/2 watts. Decoupling throughout is so generous, but carefully-worked-out lines so that there is no possibility of

FEATURES

NEW "LUCERNE" WAVE-STAGE FOR DISTANT COUPLING FOR MAXI-

TS OUTPUT
CONSTRUCTION
D
" OR "GRAMOPHONE"
S FOR THE PARTS
IT ARRANGEMENT
OR EASE OF OPERATION
CONSTRUCTOR
UMPTION

instability under any circumstances. Hum is removed by the effective choke-condenser network, and also by the use of electrolytic condensers for by-passing the bias resistances in the cathode leads of the detector and power output valves.

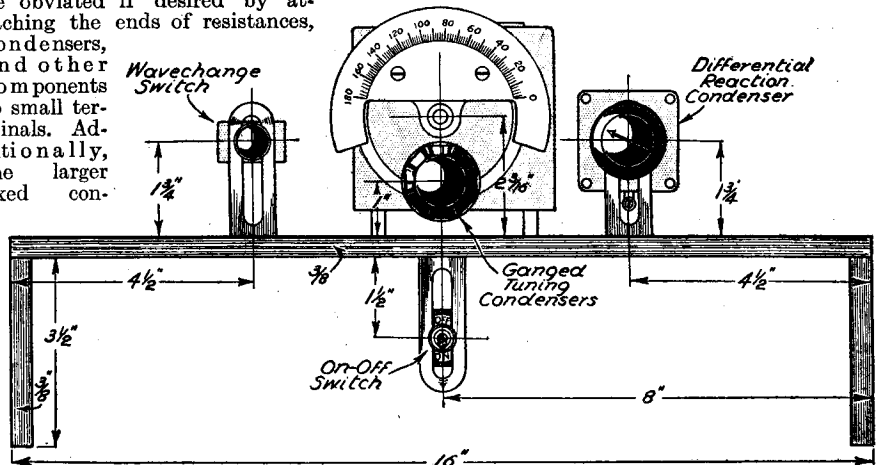

Use this diagram when drilling your cabinet front.

(Continued from previous page)

condensers and fixed resistances are not directly attached to the chassis, but are held in place by the wiring; they can therefore be ignored until later. The next step is to fit the terminal socket strips to the back edge of the chassis, after which the valve holders can be screwed in place on the top. The mains transformer, smoothing choke, and fixed condensers can next be attended to, leaving the tuning condenser and coils until last, so as to avoid the possibility of their being damaged.

It must be noticed carefully that the bracket upon which the reaction condenser is mounted is insulated from the metallized surface of the chassis, because if this point is not attended to there will be a short-circuit between the H.T. positive feed to the detector valve and H.T. negative. The necessary insulation is obtained simply by scraping away a square of metallizing about 1/4 in. wider than the base of the component bracket, and this can easily be done by means of the edge of a knife-blade, after scribing a line round the square.

The bracket supporting the wave-change

switch, however, must be in direct contact with the metallized surface, since it forms the earth-return from the switch contacts.

The method of adjusting the condenser trimmers and of operating the receiver will be dealt with in full next week. In the meantime, bear in mind that the A.C.

Leader Three, like all other PRACTICAL WIRELESS receivers, is fully covered by our unique guarantee. This means that, should any constructor experience the slightest difficulty in obtaining satisfactory results he is entitled to our free and un-stinted advice.

Theoretical circuit of the A.C. Leader.

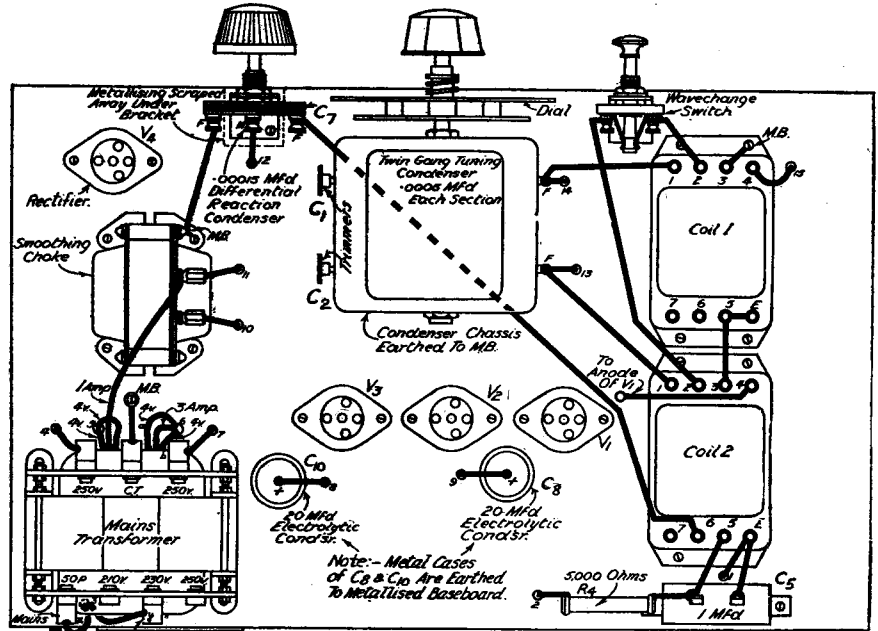

Note: Connections Marked To "M.B." Are Connected To Metallised Baseboard.

LIST OF COMPONENTS FOR A.C. LEADER.

- One Jackson Bros. Double-gang Condenser .0005 "Nugang" Type A (C1 and C2).
- Two Wearite "Universal" Screened Coils.
- One Graham Farish .00015 mfd. Differential Reaction Condenser (C7).
- One Bulgin Junior On-off Switch, type S.38.
- One Varley "Nictet" 5-1 L.F. Transformer.
- One Graham Farish "Snap" H.F. Choke.
- One Heayberd "Leader" Mains Transformer.
- One Wearite Smoothing Choke Type H.T.25.
- Three Zinc Component Brackets, British Radiogram.
- Two Clix Terminal Socket Strips (one marked Aerial and Earth, and one marked L.S. and P.U.).
- Six Solid Clix Plugs for use with terminal strips.
- One Claude Lyons "B.A.T." Type 728-L.T. Switch.
- Four W.B. chassis mounting 5-pin valve-holders.
- One Claude Lyons "B.A.T." 100,000-Ohm Resistor, Type R.1 (R9).
- One Claude Lyons "B.A.T." 50,000-Ohm Resistor, Type R.1 (R7).
- One Claude Lyons "B.A.T." 40,000-Ohm Resistor, Type R.1 (R2).
- One Claude Lyons "B.A.T." 30,000-Ohm Resistor, Type R.1 (R1).
- One Claude Lyons "B.A.T." 5,000-Ohm Resistor, Type R.1 (R4).
- One Claude Lyons "B.A.T." 1,000-Ohm Resistor, Type R.1 (R6).
- One Claude Lyons "B.A.T." 350-Ohm Resistor, Type R.34 (R8).
- One Claude Lyons "B.A.T." 250-Ohm Resistor, Type R.1 (R3).
- One Claude Lyons "B.A.T." 1-megohm Resistor, Type R.1 (R5).
- Two Dubilier 20 mfd. Electrolytic Condensers, Type 401 (C8 and C10).
- One T.M.C. 4-4mfd. fixed Condenser, Type 40 (C11 and C12).
- One T.M.C. 2 mfd. fixed Condenser, Type 40 (C9).
- One T.M.C. .0001 mfd. tubular fixed Condenser (C6).
- Two T.M.C. .1 mfd. tubular fixed Condensers (C4 and C3).
- One T.M.C. .1mfd. tubular fixed Condenser (C5).
- One Peto-Scott Metallized Chassis, 16in. x 10in. with 3/4in. runners.
- One Cossor MS-PEN Valve.
- One Cossor 41.MH Valve.
- One Cossor 41.MP Valve.
- One Cossor 506.BU Rectifier.
- Wire, screws, flex, etc.

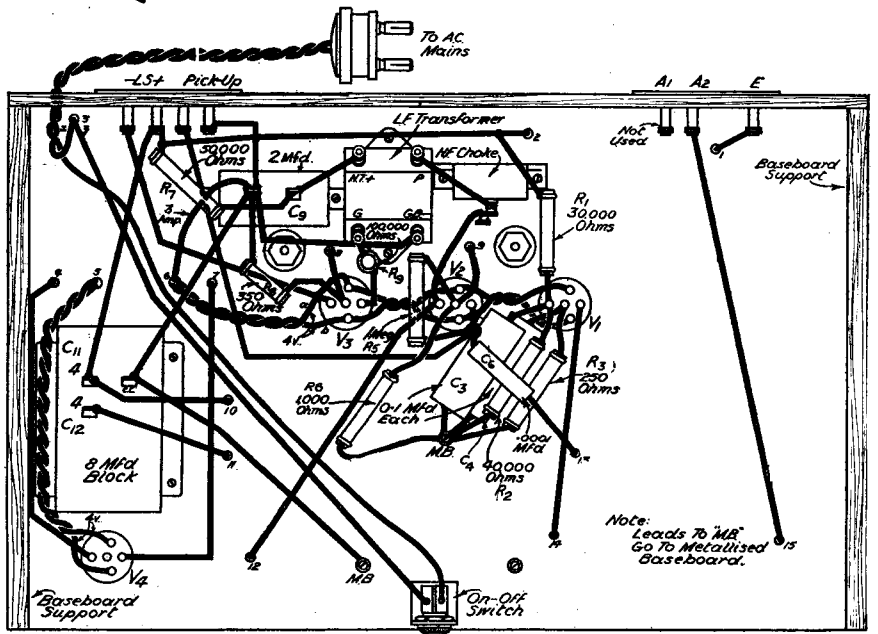

Top and sub-chassis wiring of the A.C. Leader.

OUR GREAT NATIONAL COMPETITION (Continued from page 67)

obtained, but by moving the plunger, which is operated by a neat knob, the degree of coupling, and therefore the sharpness of tuning, can be adjusted to any desired extent. As a matter of fact, the Bifocal coils are so designed that when the knob operating the plungers is pushed in selectivity is increased, whilst it is reduced when the knob is pulled out. By this very simple means the degree of selectivity can be controlled without affecting the setting of either the tuning or reaction condenser to any noticeable extent.

It is worthy of mention that, quite apart from any other consideration, the bifocal coils are remarkably efficient, and that the medium-wave windings consist of Litz wire, and the long-wave windings of single-strand wire of reasonably stout gauge.

There is no doubt that the Varley bifocal coil offers the simplest solution to the problem of bringing practically any type of older receiver entirely up to date. Additionally, of course, the new tuner can be used very effectively in a new receiver, employing any of the circuits given on this and other pages.



THE EASY ROAD TO RADIO

THE BEGINNER'S SUPPLEMENT

ELECTRICAL INSULATING MATERIALS

In This Article the Author Describes the Various Kinds of Insulation used in Wireless Work and their Methods of Manufacture. By G. H. WRAY, F.C.S.

ALMOST anyone who is interested in wireless is aware of the great importance of insulating materials in the efficient working of wireless apparatus. The name insulators is given to materials which have such high resistances that they can be used as non-conductors. To insulate a conductor is to surround or support it with insulating material in order to restrict the flow of electricity to a desired path, and insulators may be defined as any material which offers relatively high resistance to the passage of an electric current.

Insulating materials may be solid, liquid, or gaseous. The earlier types of insulating substances consisted of amber, glass, paper, silk, shellac, sealing wax, resin, sulphur, paraffin wax, and mineral oils. These have been supplemented by a great number of new ones, including gases at ordinary temperatures, electrical porcelain, varnished materials such as papers and cloth, synthetic resins and moulded compositions and artificial cellulose compounds, while active research in the insulation industry is resulting in the continual production of further substances. The oldest known insulator is, of course, dry air.

Insulators differ much in their physical properties as well as in their insulation resistance, and many materials which are efficient at ordinary temperatures gradually lose their insulating properties as the temperature is increased. If this increase continues until a chemical change commences in the composition of the insulation, the material may become a conductor of electricity. Other substances, such as glass, act as conductors without chemical change having taken place, when they are heated to softening point, and it may be said that at a temperature of about 1,800 degrees C. insulating materials cease to exist.

Dielectric Strength

The value of a material as an insulator varies according to its dielectric strength, which is the property of an insulating material which enables it to withstand electrical stress. In other words, the dielectric strength of an insulating substance is the maximum difference of potential that it will stand without being punctured. This is determined by placing a thin layer of the substance between two metal electrodes and gradually increasing the difference of potential between the electrodes until a spark passes through the dielectric. The general suitability of a material as insulation for any specific purpose depends upon its electrical, chemical, and physical properties. All insulating substances have different dielectric strengths; for instance, that of ebonite is four times as great as the dielectric strength

of glass, and insulators may be arranged in the order of their dielectric strengths in the same way that conductors are arranged according to their degree of conductivity.

Ebonite

Ebonite is probably the insulating material best known to wireless users. The term ebonite includes a large number of compounds produced by heating together mixtures of rubber and sulphur. The proportions may vary from between two parts of rubber to one of sulphur to eight parts of rubber to one of sulphur. Mineral matter may also be added, together with materials to assist vulcanization. The hardness and electrical properties of the resultant compound are governed by the percentage of sulphur and mineral filling present.

Ebonite has largely been displaced during recent years by synthetic moulded compositions of the bakelite type, which have a wider application and offer greater advantages and facilities for use in wireless manufactures. Composite mouldings are important in that they make possible the use of specially-shaped articles which, without moulding, would be expensive and difficult to produce. Good-quality mouldings are light and strong, have high insulating properties, and a clean, finished appearance. Mouldings in which the binder is of the synthetic type resist heat much better than those of the shellac, rubber compounds, or bitumen type, because of the liability of the latter class to soften under the influence of even moderate temperatures.

Composite Mouldings

Composite mouldings are produced by filling a mould with a powder consisting of a binder such as a synthetic resin of the phenolic type and a filler such as wood flour (obtained from pine or spruce trees), asbestos fabric or other materials, and subjecting the mixture to heavy pressure at the requisite moulding temperature. Attractively-coloured mouldings can be obtained by adding suitable colouring matter or pigments to the powder mixture. Many alternative substances are used in the manufacture of moulded and composite insulation, including blood albumin and casein, which is the albumin precipitated from milk.

Laminated bakelite sheets and tubes are manufactured chiefly from special paper impregnated with bakelite varnish. For sheets, the paper is first coated on one side with varnish by passing it through rollers, then cut to the size required for the sheets. The papers are then placed one on top of the other on a metal plate and pressed in a steam-heated hydraulic press into a solid sheet.

Composite sheet has taken the place of ebonite for wireless panels, but there is evidence that in its turn it is being displaced by wood as a material for this purpose. Incidentally, wooden panels usually coated with shellac varnish were employed in early wireless sets, as many readers will remember. Glass was also occasionally used, and the writer has vivid recollections of drilling by means of a copper bit the necessary mounting holes in a ½ in. plate-glass panel for a five-valve set, a task requiring infinite patience and labour. One of the chief disadvantages in the use of ebonite for panels is its susceptibility to ageing, resulting in a yellow discoloration of the surface. This can, of course, easily be removed by means of an abrasive powder and oil, but this necessitates removing the panel from the set, and the process of rejuvenating the surface is an extremely dirty one.

Shellac

Shellac still occupies the most important place amongst the natural gums. It comes mostly from India, and is the product of an insect which lives on the juice of trees such as the Mimosa and Acacia, and certain other trees rich in gum, which are specially grown for the insects. The twigs of the trees are coated with lac by the insects, and these twigs are detached and passed through rollers. The scales of lac together with woody matter thus obtained is known as stick lac, which is extracted with hot water and further purified to obtain the finished product, known as shellac. It has many uses apart from that of an insulator, notably for the preparation of certain polishes. Shellac is soluble in methylated spirit and in turpentine, but is insoluble in benzene.

Black adhesive insulating tape consists of unbleached calico coated with an adhesive of which rubber is usually the base. The adhesive is prepared by dissolving rubber in benzene, and resinous bodies, together with liquid asphalt, pine tar, and various oils, are added to form a viscous mass which is then spread on the calico (which is in a continuous width) by means of rollers. The treated calico is afterwards cut into strips of the required width by passing it through sharp cutting wheels. Adhesive tape is used in nearly all classes of electrical work, and it finds a place in the toolboxes of the majority of wireless amateurs.

Mica

Mica is the most important of the natural mineral insulations. It is found in many parts of the world, the chief bearing areas being in India and America. It is usually mined from the surface, and the vein is often worked to a depth of 200ft. Mica occurs in a form of rock called pegmatite, which is made up of mica, quartz, and feldspar. The mica is broken out of the pegmatite by means of steel wedges, after which it is sorted into various sizes and qualities, and then split ready for the mica market. Most of the splitting is carried out by native women, who, with the aid of the most primitive tools, such as an old table knife sharpened to a point, or a sharpened piece of hoop iron, can split mica to 1/1000 in. thick. Mica splitting is also done as a spare time work in native homes, where the children take part in the work, and in time become expert mica splitters.

Mica has a high dielectric strength and excellent thermal properties, and there is no real substitute for it in the electrical industry.

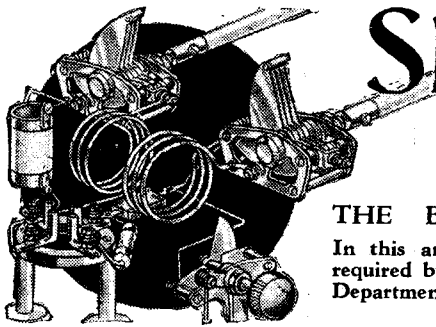

Short Wave Section

THE BROADCAST QUERY SERVICE

In this article an explanation is given of the data required by the "Practical Wireless" Broadcast Query Department when identifying stations received by readers.

By E. THURWAY.

IN the course of an evening's session with a broadcast receiver, many listeners come up against little worrying problems of which the solution greatly puzzles them. They tune in transmissions, and in view of the fact that the language is not understood, or because they have failed to recognize an interval signal, they are unable to identify their capture. Admittedly, listening to a broadcast of any description without knowing from which country or town it emanates detracts considerably from its interest. In addition to stations giving radio entertainments, inquiries are frequently received in regard to wireless fog beacons, lighthouses, lightships, and concerning almost every kind of telegraphy or telephony signal picked up in the ether.

Where short waves are concerned the field explored is a much larger one, as it comprises not only stations relaying regular radio programmes, but experimental transmitters, ships, transatlantic and other telephony, and the numerous morse transmitters dealing with Press, commercial, and other services.

"Continental" Time

It is to assist readers that the *Broadcast Query* feature was initiated, and if the back numbers of PRACTICAL WIRELESS are examined it will be found that a large number of replies have already been published. It must be borne in mind, however, that if a satisfactory answer is to be given, it is essential that the reader should supply as much information as he possibly can. When a "mystery" station has been located, it is useful to make notes of all data that can be gathered at the time; in fact, it is not infrequent that one little item of information submitted will provide the clue which eventually permits identification. In the case of broadcasts on so-called long or medium waves, give the date and time when heard; for the latter use the Continental twenty-four-hour system, which prevents confusion between p.m. and a.m. Many querists, as an example, state 12.30 p.m. when they intend to convey that the transmission was picked up at 12.30 a.m., i.e., after midnight. If you give the time in this instance as 00.30 no doubt can exist. (For all hours from midday, all that is needed is to add twelve to the reading of the clock.) The wavelength or frequency on which the broadcast has been heard is a very important item. It is not, I know, often possible to give this, even roughly, but in most instances you can state *between* which two stations the transmission was found on the condenser dial. To say that a broadcast was tuned in on 50 degrees serves no useful purpose, but if coupled to this it is added that the station was on that reading *between*, say, Scottish Regional and Midland

Regional, or between two other named foreign stations, valuable assistance is provided. If you can give some idea of language, or describe an interval signal, if heard, added to the class of entertainment broadcast at the time, there is every chance that a correct reply to your inquiry will be published. Details of the programmes are useful, inasmuch as if other data points to a transmitter it will permit an actual check-up of the published programme to secure confirmation.

If inquiries sent to the paper are drafted on these lines, readers will greatly assist in facilitating the necessary search and, except in cases where the information is very vague, thorough identification can be relied upon.

Short-wave Signals

In the case of short waves, the matter is somewhat more intricate, as we are dealing, as already mentioned, with other than ordinary broadcasting stations. Where, for instance, the location of amateur experimental transmitters is desired, it is essential that the exact call letters should be given. In the course of their transmissions these stations do not always repeat their international prefix—namely, the first letters, denoting the country in which they are situated—but as a rule the full call is given either at the beginning or end of the conversation. Moreover, on many occasions the call letters are replaced by words or names of cities or towns. As an example, may I cite one logged a few nights ago: *Huit Victoria Santiago*. Here you will see that the prefix was missing but was known by experience to be F. The call, therefore, read F8VS.

The question of wavelength or frequency when dealing with short waves is much more important than with broadcasts on the higher bands; so is the question of language, interval signal, and time of transmission. It is, as a rule, a wise move to note the portions of the short-wave band in which you may expect to hear certain kinds of stations. For instance, amateurs may be heard communicating with each other, either in telephony or morse, on four small bands of frequencies: 5 metres (56 megacycles), 10 metres (28 mc.), 20 metres (14 mc.), 40 metres (7 mc.), 80 metres (3.5 mc.), and around 100 metres (1.75 mc.). Here you will find no commercial or broadcast transmitters. On the other hand, the latter are allowed to work on the following wave-lengths: 11.27–11.7 metres (26.6–25.6 mc.), 13.9–14.0 metres (21.55–21.45 mc.), 16.85–16.9 metres (17.8–17.75 mc.), 19.55–19.85 metres (15.35–15.11 mc.), 25.2–25.6 metres (11.9–11.7 m.c.), 31.2–31.6 metres (9.6–9.5 mc.) and 48.8–50 metres (6.15–6 mc.). (The frequencies have been given in megacycles

to shorten figures; to obtain kilocycles, add two noughts.)

It will therefore be seen that the commercial stations (whether morse or telephony) will be found *between* and *outside* the enumerated sections of the band allocated to experimental amateurs or broadcasting stations. The noting of these facts on most occasions should enable the listener to estimate roughly the wavelength of the transmission he has picked up.

The Language Difficulty

Finally, the question of language. It is not assumed that it is always possible to distinguish the language of the broadcast heard; it is evident that definite statement to that effect would greatly facilitate a search. On the other hand, it is always useful to know whether the broadcast was in English or in a foreign tongue. Many correspondents on various occasions have carefully explained, for instance, that the announcer had mentioned the time or had given out details of an item in a programme, but it was not made clear whether the information was given in English or whether the querist understood the language spoken and was giving a free translation of the words heard.

To sum up, give all the details you can, irrespective of whether or not they may appear trivial; in these searches every particle of data is of valuable assistance.

USING THE NEW WESTECTOR

(Continued from page 72)

greatly simplifies matters, and, of course, due to the permanent nature of the Westector, the detector stage cannot be affected in the usual manner, such as by changes of valve characteristics, due to age, or the insertion of a new valve. Coil L1 is tuned to the frequency of the incoming signal it is required to receive, and the Westector is condenser coupled to the I.F. transformer. The filter circuit is made up of the usual load resistance R and the coupling condenser C and tuning condenser CI of the I.F. transformer. Note that a tuned anode oscillator stage is employed, which thus becomes independent of the strength of oscillation. By tapping off from the negative end of the Westector part of the D.C. voltage generated across R may be used for A.V.C. purposes in the usual manner.

Automatic Volume Control from Existing Detector Valve

Another application to which this new Westector lends itself is shown in Fig. 7, where it is used to obtain an A.V.C. voltage from the anode of an existing detector valve. The Westector is connected to the anode of the valve in place of the usual H.F. by-pass condenser, and the H.F. used to generate a voltage across the load resistance R. This voltage is fed back to the grid of the preceding variable- μ valve to obtain A.V.C. in the usual manner.

The foregoing gives a general idea of the uses to which the new "WX" Westector may be put; and we hope shortly to put these applications into practice by describing receivers incorporating this new and useful component. Its introduction opens up a new field for constructors, and we shall see to it that our readers are fully informed of the results of our experiments.

50 TESTED WIRELESS CIRCUITS

Edited by F. J. CAMM

Obtainable at all Booksellers, or by post 2/9 from Geo. Newnes, Ltd., 8-11, Southampton Street, Strand, London, W.C.2.

2/6

PENNY-IN-THE-SLOT RADIO

In this Article the Author Describes a Simple Coin-operated Automatic Time Switch Apparatus.

By J. McLEARY

To make this device, an alarm clock, an old .0005 variable condenser, a piece of three-ply wood, 7in. by $\frac{1}{2}$ in., two spring clips, two small brass strips, four small cubes of wood, a pair small hinges, and a few screws and bolts are required. First of all, get a piece of $\frac{1}{2}$ in. plywood 14in. by 9in., and cut a hole in it the exact size of the glass of the clock. Then cut a second piece of plywood into a hexagon with sides about 3in., and in that cut a hole just large enough to allow the minute marks on the dial to be seen from the front when the clock is fixed. Glue this piece on to the 14in. by 9in. piece in the exact position; that is, at the other hole. Now screw the clock at the back on to the front piece (the case is off and the feet and the ring holes are bent to allow for screwing) with three screws. Measure along from the winding screw of the clock about $3\frac{1}{2}$ in. and cut a hole 3in. by 1in. When that has been done, take a piece of wood about 8in. by $\frac{1}{2}$ in. and cut two pieces 3in. and two 1in. long, then with them make a box as shown in Fig. 7. Glue that behind the hole in the front piece, leaving the hole flush. Get a small piece of 3-16in. plywood of suitable size to cover the box already made and fix on the spring clips so that the opening at the extreme ends of the clips is slightly narrower than the two brass strips, which are about $1\frac{1}{2}$ in. long by $\frac{1}{4}$ in. wide, and must be slightly thinner than the penny. Bend both ends at right angles to each other, as shown in Figs. 3 and 4. Next take the 7in. by

$\frac{1}{2}$ in. piece and at the end glue on one of the cubes. Reverse the piece and do the same at the other end.

Next fix the small pair of hinges about

of the hinge pin. Next take two pieces of $\frac{1}{4}$ in. elastic, and with drawing-pins fasten them on to the tops of cubes A, leaving about $\frac{1}{4}$ in. slack between. The old spring used as a guide straightens them up when the clock unwinds itself. Let the drawing-pins overlap the cut just sufficient to make up for the cut. Now try the arm on the clock (the hinged part makes for easy winding up, as when winding one bends the hinged part over to clear the guides) then wind up full. Retard the arm until it is in a straight line with the guides and arrange so that it goes freely through them. When that has been done, fasten the piece of wood with the guides to the box. Then put on two terminals below, break the L.T. negative lead as shown in Fig. 5, and fix a single-pole switch as indicated for breaking the circuit of the penny apparatus, when required.

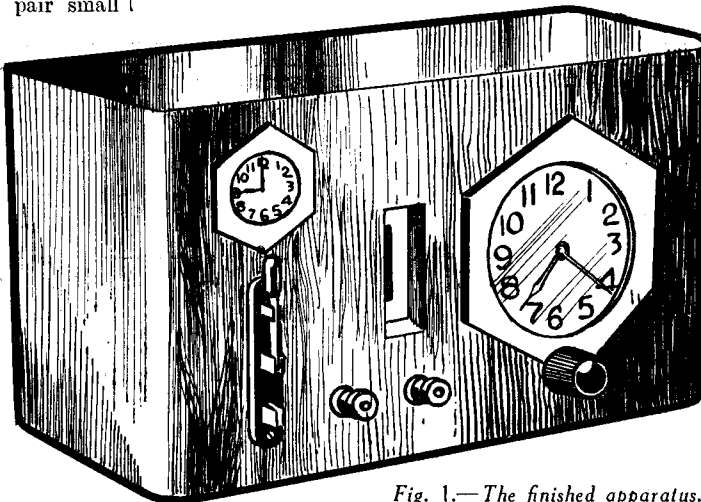

Fig. 1.—The finished apparatus.

The time indicator, seen just above the switch, consists of two clock hands fastened in place with a small brass screw which passes through a hole in the centre of the dial. The hexagon-shaped surround is cut out of a piece of plywood and glued in place. The hands are set to indicate the time that the set will automatically be switched off.

How it Works

With the apparatus illustrated, it takes 2 hours 40 minutes before the penny is knocked out. Then the brass end takes

the penny's place for about seven minutes until the clips drive the brass piece away

(Continued at foot of page 86)

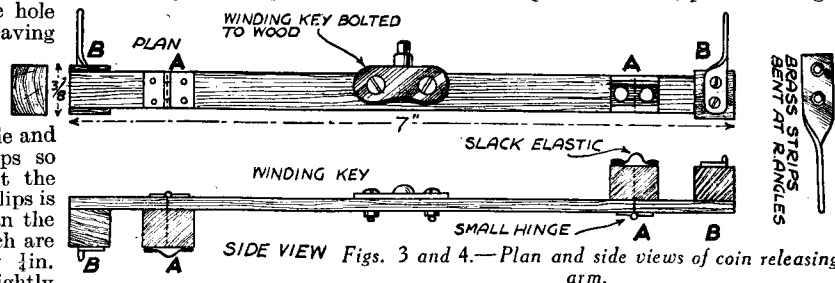

Figs. 3 and 4.—Plan and side views of coin releasing arm.

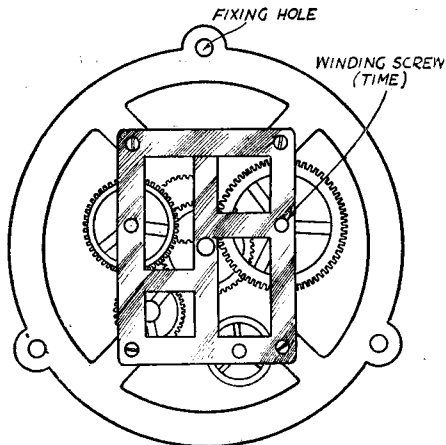

Fig. 2.—The "works" of an alarm clock which are screwed on to front of the cabinet.

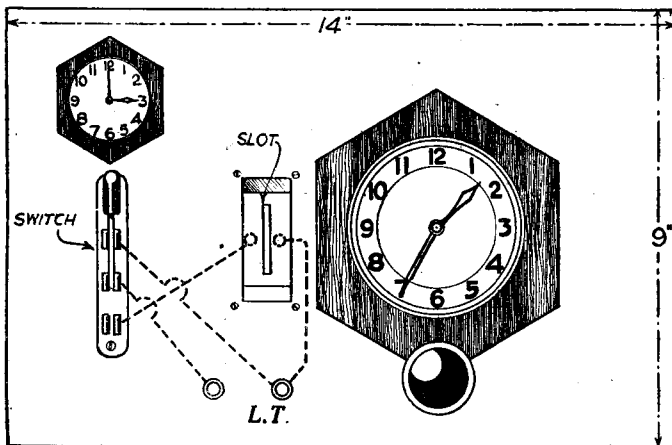

Fig. 5.—Front panel of the cabinet, showing the connections for the switch.

For the Technical Experimenter.

MAGNETISING THE MAGNET

BY: **D^r F.W. LANCHESTER**

In This Article the Author Concludes His Explanation of this Interesting Subject.

THE present-day practice appears to be to use the "make" rather than the "break," the sequence of operations being, first closing of the secondary circuit, consisting of one or more complete turns of copper round the pole of the magnet to be magnetized, and then closing the primary circuit. The secondary is then switched off before the primary circuit is broken, otherwise the magnet would be demagnetized by the rush of current in the opposite direction. Any article which ignores the commercial aspect of the subject with which it deals is liable to be deemed by practical men of only academic interest, and therefore a very brief outline is given of the more important equipments at present most widely used.

Messrs. Ferranti employ two alternative methods. Namely: (1) A multiple circuit of some twenty effective turns obtained in the manner already described (Method D), in which the upper part of the circuit consists in a number of hoops of copper rod, the prongs of which dip into mercury cups when the circuit is closed, the said cups being interconnected in such manner as to provide as many turns as there are hoop. Figs. 7 and 8. It has already been pointed out that a weakness of this system is the low conductivity of mercury (about 1/100th that of copper). And (2) a transformer system of which the following figures may be taken as typical:—

- Primary turns 80.
- Secondary turns 1.
- Maximum primary current 500 amperes.
- Maximum secondary current 25,000 to 30,000 amperes.

It is the latter system that is more generally regarded as the "Ferranti" method.

Messrs. W. E. Burnand and Co. market

a magnetizing plant which comprises a generator and transformer, diagrammatically represented in Fig. 9. One interesting feature of this installation is the comparatively small size of the generator, which is rated at only 1/4 h.p. Actually the power required during the period of activity is from 2 to 4 kilowatts, which may be taken as = 3 to 6 h.p.; but as this is only required for a second or two, and there is a period intervening—inevitably—of something approaching half a minute whilst the magnet to be operated upon is being changed, the mean or average power required is very small. By means of a flywheel on the generator shaft the generator torque is averaged, and it is due to this that a generator of 1/4 h.p. is sufficient to supply the energy required. During the active period the flywheel is slowed down, giving its *vis viva* up as electrical energy, and during the passive period the flywheel undergoes acceleration. Another feature of the Burnand equipment is the compact arrangement of the transformer casing as a foundation or stand for the magnetizing jig, by which means the massive copper leads required to carry the heavy magnetizing current are made as short and the connections as direct as possible, so that the ohmic resistance is reduced to a minimum. An example of the quick-acting magnetizing jig is illustrated in Fig. 10, and the manner of mounting same on the transformer casing in Fig. 11.

A typical example of the directly-generated-current type of magnetizing equipment is that supplied by Messrs. Canning. This comprises what is virtually a plating dynamo capable of supplying a current of 10,000 amps at from 3 to 6 volts. The current is delivered to the magnetizing jig by massive copper bars, and in order

to minimize resistance it is the accepted practice to mount the magnetizing jig on (or in immediate proximity to) the generator, this being analogous to the mounting of the jig on the transformer casing as described above.

Nearly all the manufacturing firms who supply magnet assemblies to the trade use one or other of these systems. Also the majority of manufacturers who build up their own assemblies use these or equivalent methods. The method of employing a separate magnet (Method A) is, for the purpose of moving-coil-magnet assemblage, entirely obsolete. The Lanchester magnetizing equipment (Fig. 6) is an exception, but this device, which is almost perfect and very economic for magnets of suitable design and construction, is not universally applicable.

Messrs. Darwin, who use the Ferranti equipment, appear to give each magnet a double dose, the direction of the current in the transformer being reversed, but the magnetic field is maintained in the same direction, the magnet being turned about. The idea of this is that there is always some residuary saturation in the core of the transformer, and this is "cashed in" when the field is reversed. According to particulars given by Messrs. Ferranti, they rely on a single "dose," but reverse the field after each magnet has been magnetized, and by this means equally good use is made of the residual saturation of the transformer core.

In magnetizing as above described by "impulse" from a transformer, it is of importance that the current should not be too suddenly built up or quenched. Every magnet electrically excited has a *time constant*—that is to say, it takes a certain time to build up its field to the maximum value, and this applies to a permanent magnet in the act of magnetization, just as much as it applies to any electro-magnet; the field magnet of a dynamo, for example. It is important that the duration of the magnetizing impulse should be greater than this time constant, for otherwise much of the energy is wasted in eddy currents and the magnet is not saturated uniformly through its section. Put briefly, this means that the time constant of a transformer must be considerably greater than that of the magnet being operated upon.

PENNY-IN-THE-SLOT RADIO

(Continued from previous page)

from the bottom for easy access of the next penny.

To avoid the necessity for continual winding before use it is worth while to fit a small brake to prevent the clock from working when not required. In Fig. 6 is

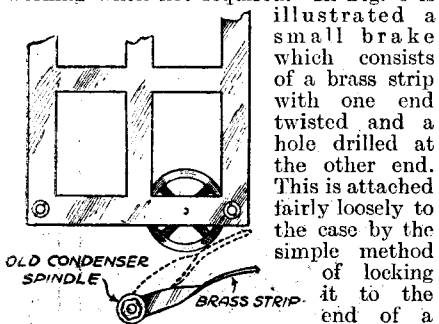

Fig. 6.—Showing how the brake piece of lever acts on the balance wheel of the clock.

illustrated a small brake which consists of a brass strip with one end twisted and a hole drilled at the other end. This is attached fairly loosely to the case by the simple method of locking it to the end of a 2BA studing or a

djsused condenser spindle. The knob is then attached to the front (below the clock dial) and a small rotation brings the balance wheel to a stop as the strip comes

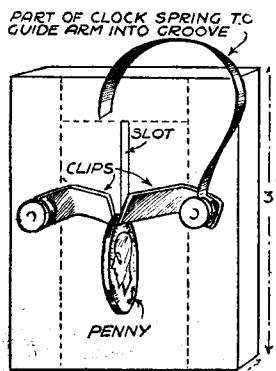

Fig. 7.—Showing a coin held between the contact strips.

into contact with it. When required for use, a small rotation of the condenser knob will start the clock.

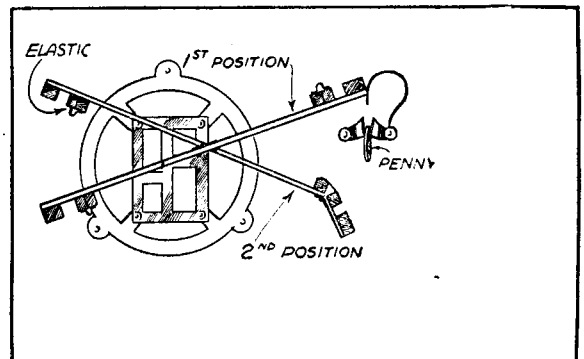

Fig. 8.—When a penny is pushed down, the brass strip on the side of the arm takes its place until the arm reaches the second position, when it bends at the hinge, as depicted, and allows room for the next penny to be inserted.

Practical Television

Conducted by H. J. Barton Chapple,
Wh.Sch., B.Sc., Etc.

APRIL 7th, 1934. Vol. 1. No. 14.

THE NEW B.B.C. TELEVISION STUDIO.

Television has Taken a Step Forward inasmuch as the B.B.C. Transmissions Now Take Place from a More Up-to-date Studio. Read About the Steps Leading Up to this Change.

ANY new move which will assist in the development of television is always watched with the greatest of interest, and the change of headquarters for the B.B.C. transmissions from Studio BB to a large converted, old-fashioned Regency drawing-room at No. 16, Portland Place is one of special significance. It is inconceivable to imagine the B.B.C. meeting the expense of the removal unless they intended to associate themselves very intimately with the development of the science.

Before dealing with the layout of the new premises, it is interesting to look back and see how material is the progress which has been made in studio technique. The original transmissions sponsored by the Baird Company were of head and shoulder images only. The spot-light transmitter and associated photo-electric cells were fixed in position, and it was necessary to make the artist or subject being televised keep his head within very narrow limits, so much so that a head outline was marked on the back screen to act as a positional guide. This is shown very clearly in Fig. 1, the black silhouette being quite conspicuous and proving a great help in those early days.

Improvements both in photo-electric cells and the amplifiers associated with them soon enabled programmes of a slightly more ambitious character to be attempted. With an increase in cell sensitiveness the light area scanned became larger, permitting a greater depth for back screen positioning, and consequently a little more latitude was given to artist movement. Occasionally small sketches with one, or perhaps two, characters were experimented with.

A more ambitious attempt materialized in July, 1930, when the B.B.C. co-operated to produce the first play to be televised. It was called *The Man with a Flower in his Mouth* by Pirandello. Special scenery of bold outline was prepared, and one of these, together with the three artists, is shown in the studio in Fig. 2.

Note that in Fig. 2 the four photo-electric cells are housed in a metal screening box mounted above the wall aperture through which the spot-light beam was thrown. They were also tilted towards the artist to bring about the greatest reflected light pick-up. Illuminated signal instructions for the assistance of the artist appeared on the screen below the aperture, while the microphone was in a convenient position to take control of the voice and thus complete the dual transmissions.

Continual Improvement

Continued intensive research work gradually gave greater rein to the studio manager's art. A more intense spot-light beam from a mirror-drum transmitter gave an even larger area of action, while



Fig. 1.—In the very early head and shoulder transmissions an outline guide was marked on the back screen for positioning purposes.

movable photo-electric cell stands, working in pairs suitably positioned, gave better and clearer signal response. Slightly improved sketches, physical culture demonstrations, special dances, black and white artists, and even conjurers lent definite entertainment value to a television programme which became very different from its prototype of two years previously.

It was at this juncture that the B.B.C. became sufficiently convinced that television demanded a more active co-operation on their part. Unfortunately, no provision had been made at Broadcasting House to accommodate a studio, control room, and transmitting apparatus, but this was

partly rectified by converting Henry Hall's Studio BB, together with the small adjoining listening room. This did service for a period of nearly eighteen months, and under the able direction of Eustace Robb quite a procession of notabilities made their debut before the camera-like structure of the new mirror-drum transmitter designed specially for the work.

The New Studio

Under the B.B.C.'s able direction the art developed rapidly, and it soon became apparent that greater accommodation was necessary if better programmes were to be the order of the day. No space being available in an already overcrowded Broadcasting House, new premises were leased at No. 16, Portland Place, and after a long preparation these were made use of for the first time on Monday, February 26th, 1934.

All the television programmes will now emanate from this studio, which undoubtedly is a great improvement on the old one. A rough idea of the layout is given in Fig. 3, which is a plan view. First of all the studio is at least 50 per cent. wider, and this factor alone will prove a great asset to the producer in arranging even more attractive programmes. The artists who dance or perform acrobatic feats have greater freedom, and they can be "followed" over a wider area by means of the mirror-drum transmitter, photographs of which have appeared quite recently in this supplement.

At an early date it is hoped to add another improvement to the transmitter. This will be a vertical "tilting device" to enable the scanning beam to move up and down over much wider limits than is now possible. The resulting flexibility will enable "shots" at various angles to be made almost the same as with a movie camera.

Technical Details

Adjoining the studio is the control room, which is at least four times as large as that provided at Broadcasting House. A large plate-glass window set at an angle separates this room from the studio, and against this is positioned the mirror-drum spot-light machine mounted bodily on rails for side movement, while it is also pivoted on a circular runner to allow the operator to turn it through quite a large angle. A

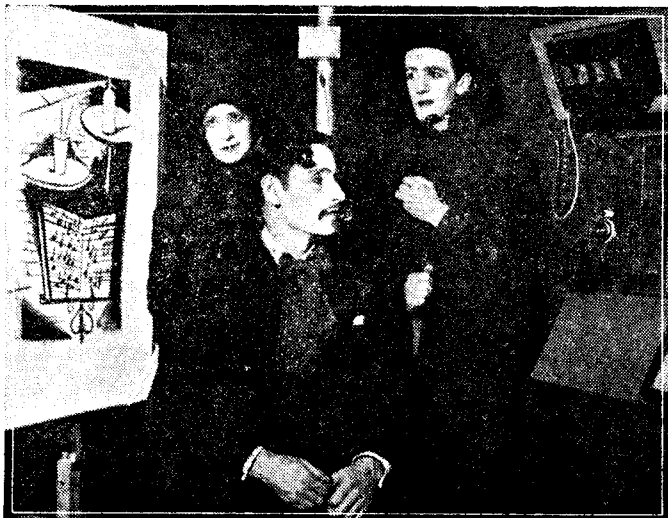

Fig. 2.—One of the "scenes" and three artists taking part in the first play to be televised. Note the fixed cell positions and small signal indicator.

high-intensity carbon arc serves as the light source, and after emerging from an apertured metal shield, the light beam passes through an optical system to the revolving mirror drum, which traces out the scanned light area in vertical strips side by side.

In addition to one or two individual photo-electric cells placed at vantage points there are four groups of cells mounted on movable stands. Each of these groups connect to a separate "A" amplifier of the two-stage type, a special form of low-capacity cable being used for the purpose. The outputs from these four amplifiers pass to a mixing panel and master control desk at which sits a control engineer. By a careful manipulation of the controls at this stage of the process various fading and lighting effects are produced. In addition, it is possible to switch right over to the "caption" transmitter (see Fig. 3) whereby announcements, small scenes, and objects are scanned to act as links in the complete programme.

After the signals have passed the control desk they are fed to two "B" amplifiers of the three-stage type with double outputs, and this in turn connects with three "C" type amplifiers of three stages. On the input side of these "C's" is a corrector network, designed to compensate for high-frequency attenuation, including the scanning-aperture factor.

It is important to note that in the new studio there is a correction on the lines to Brookmans Park radio transmitter up to 15 kilocycles, whereas before the cut-off occurred at 8 kilocycles. A very marked improvement in high frequencies is thereby obtained, and this is shown in the greatly

improved detail present in the television images.

All the inputs and outputs of the amplifiers are brought to the control panel, which, with the mixer and master control, is on a desk-like frame quite separate from any amplifiers, as a precaution against valve microphony due to the handling of the different controls. An interesting point in the inter-connection of the amplifiers is that no transformers are used except those which feed the lines to the main control room.

The line vision monitor receiver (a mirror-drum grid-cell machine) is immediately in front of the control engineer seated at the desk, and in addition a complete radio television receiver is positioned by its side so that an exact radio check on the images is provided.

Whereas in the old studio there was only one microphone, two are used in the new premises. Furthermore, sight and sound are now controlled together, whereas before they were handled quite independently. This is a big advantage, for the dual transmission is under the sole jurisdiction of the

director and his staff, the latter being already augmented by another engineer.

The walls and ceiling of the studio have been covered with acoustic board while the orchestra are screened off behind a large curtain in a section indicated in Fig. 3.

Undoubtedly the new arrangement will

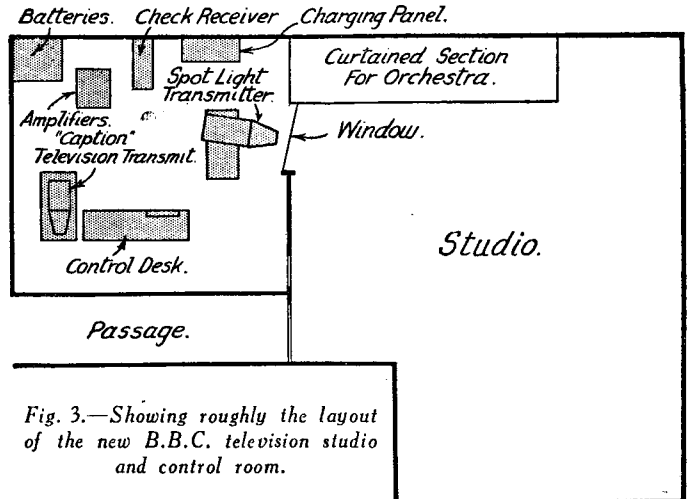
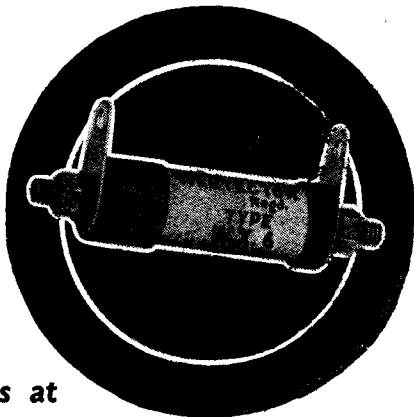

Fig. 3.—Showing roughly the layout of the new B.B.C. television studio and control room.

have a most beneficial effect on the programmes, and this in turn will stimulate interest among a larger number of amateur constructors who will be encouraged to look in solely for the entertainment, quite apart from the scientific and practical fascination.



Currents at frequencies of up to **1500 KILOCYCLES** may now be adequately rectified by means of the **WX WESTECTOR**—the new metal detector

WRITE FOR DESCRIPTIVE LITERATURE

THE WESTINGHOUSE BRAKE & SAXBY SIGNAL CO., LTD. (Dept. P.R.A.), 82, York Road, King's Cross, London, N.1.

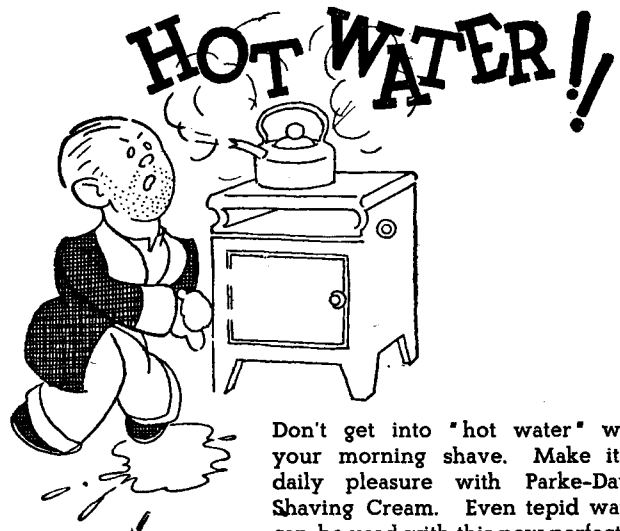

Don't get into "hot water" with your morning shave. Make it a daily pleasure with Parke-Davis Shaving Cream. Even tepid water can be used with this new perfected beard softener, and your skin will be left smooth, immaculate and wonderfully soothed.

PARKE-DAVIS Shaving Cream

EUTHYMOL, 182/24, 50, Beak Street, London, W.1
Please send FREE sample tube Shaving Cream

Name

Address

(Use block letters please)

A trial will prove it. Buy a 1/6d. tube from your chemist, or, if you prefer, send for a free 7-day sample. Made by the makers of Euthymol Tooth Paste

ADJUSTING AND OPERATING THE D.C. PREMIER

Notes on Operating the Set, Trimmer Adjustments, and Setting of the Bias Resistance.

By H. J. BARTON CHAPPLE, Wh.Sch., B.Sc., A.M.I.E.E.

IN carrying out the preliminary tests, first of all insert the V.P.20, H.L.20, Pen.20, and the barretter into holders V.1, V.2, V.3 and V.4 respectively.

Connect the aerial and earth leads to the pair of terminals so marked, and insert the fuse plug into a convenient mains socket. There is no necessity to test and ascertain which is the positive and negative main. If, after switching on and waiting for a minute the set refuses to function, switch off, reverse the plug, and switch on once more. If it fails to work in either plug position there must be a mistake in the wiring, which should be located and rectified.

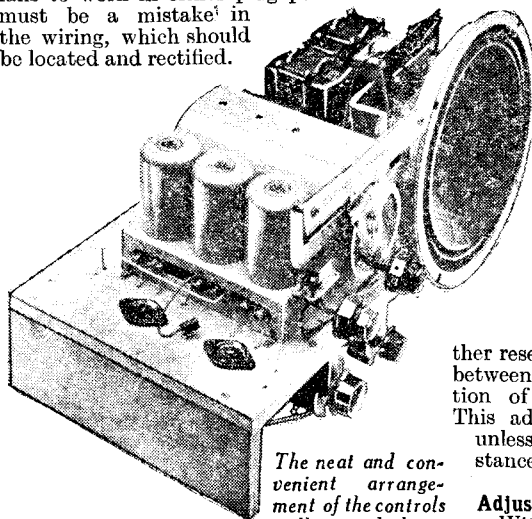

The neat and convenient arrangement of the controls is illustrated above.

The Controls

The four controls of the Linacore unit are conveniently arranged in two concentric groups. On the left are the switches, the smaller knob at the front being marked with a red line to indicate the long-wave position (800 to 2,000 metres), with a green line for the medium waves, which gives the range of 200 to 550 metres, while the white line indicates that the set is switched over for operation in conjunction with a gramophone pick-up. Behind this is a larger knob controlling a quick make-and-break single-pole on-off switch. As far as the right hand pair of knobs are concerned, the larger knob at the back tunes the triple-gang condenser for normal station selection, while the small knob in front operates a reaction condenser. The bottom left-hand knob serves to alter the bias on the variable- μ high-frequency valve, giving a very smooth and efficient pre-detector volume adjustment. The last knob—bottom right—alters the tone of the loud-speaker to suit individual taste or particular transmissions.

The tapping taken to the "trans-coupler" unit should be joined to the terminal marked "Low" for the first tests, and the only other adjustment provided is the variable bias resistance in the cathode lead of the pentode output valve. This is in series with a fixed resistance of 350

ohms and, according to the makers, the total bias resistance for the best working conditions should be 450 ohms. With the anode voltage provided in the set this gives an anode current of approximately 25 milliamperes, and where the constructor has a suitable instrument it is advisable for him to connect this in the anode lead and adjust this cathode resistance R_{10} until the current of 25 milliamperes is registered. When no instrument is available, set the moving arm of the resistance about one quarter of the way round.

First Aerial Tests

Set the range switch to medium or long according to which suits your local station, the reaction at zero and the volume control about one-third forward, and switch on. The cathodes will take about half a minute to heat up, but the barretter will show almost immediate incandescence. In normal situations there will not be any trace of mains hum, but if the district in which the set is being used happens to be notorious for its very raw supply, it might be necessary to add a further reservoir condenser of 2 mfd. capacity between the negative main and the junction of the speaker field and barretter. This addition, however, is very unlikely unless there are exceptional circumstances.

Adjusting the Trimmers

Without touching the reaction control, but merely operating the tuning knob and volume control, it will be found possible to tune in a large number of radio stations on both wavelength ranges. To ensure that the "Linacore" unit is working at its maximum efficiency the trimmers of the gang condenser may need a small alteration, although this should be very slight. The three trimmer positions were indicated last week, and the first thing is to tune in a fairly loud station broadcasting on a wavelength between 275 and 325 metres. Then reduce this station's volume so that the signal is only just comfortably audible. With a thin screw-driver turn slightly the middle trimmer in both directions and leave it set at the point where the station is heard loudest. Repeat this process with the rear trimmer and finally adjust the trimmer nearest to the control knobs.

Further Adjustments

Station searching can now be undertaken,

and the constructor will be agreeably surprised at the number which he can tune in at comfortable room volume. The selectivity obtainable is a most outstanding feature, while the sensitivity is remarkable when it is remembered that the D.C. Premier is only a three-valve set. Naturally, the user must gain experience in the proper handling of the three main controls—tuning, reaction, and volume—but it will be found that for most purposes the reaction setting can be left alone. It is only on the very distant stations or low-powered transmissions that the value of this control is shown to real advantage, and in any case reaction should be used sparingly whenever the best quality reproduction is desired.

As the valve makers state that the optimum anode resistance for the detector valve is 25,000 ohms, the lead joined to the terminal marked "low" on the trans-coupler should give the best results. It is advisable for the constructor to make quite sure, however, and in addition to make a test with the lead on the terminal marked "high."

Using a Pick-up

Before housing the set in its cabinet it is advisable to try it in conjunction with a pick-up. Set the top left-hand smaller knob to its white marking and the set is then ready for gramophone reproduction. As the H.L.20 detector valve is capable of handling an input voltage of 1.8 v. R.M.S. without distortion, it will handle the output from a sensitive pick-up and give a high effective amplification. This, together with the pentode output valve, is ample for ordinary room working, and the quality of reproduction is in the highest class.

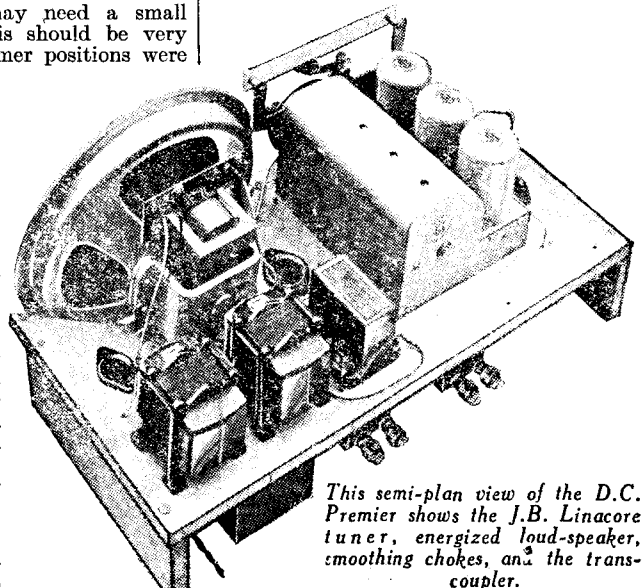

This semi-plan view of the D.C. Premier shows the J.B. Linacore tuner, energized loud-speaker, smoothing chokes, and the trans-coupler.



By the Editor.

European Valve Patent Battle

A LONG patent battle has been going on in Europe, Messrs. Philips and Tungsram being involved over some very interesting technical points. Of certain claims put forward by Philips, one of the most important of those disallowed by the Courts concerned the "Cascade" patent (re-tuned circuits) on which this company would have been entitled to royalties from Czechoslovakian set-makers, but which has been declared as not valid. Similarly, Tungsram succeeded in a case against the Centre Tapped Patent.

But a third patent of this group, the Grid Detection Patent, has simply been restricted in Czechoslovakia in such a way that it no longer covers all variations. In Hungary important issues centred round a Philips patent for horizontal electrode structure and one on cathode manufacture by vapour process. The Supreme Court has finally found both these to be invalid.

A new patent application on Slanting electrodes, put forward in Germany by the Valvo Company of Hamburg (a sister concern, by the way, of Philips) has been refused in the Supreme Court.

Twenty-four-hour Clock System for B.B.C. Programme Timings

THE B.B.C. announces that it will inaugurate on April 22 next, with the change-over to British Summer Time, the twenty-four-hour clock system in connection with its programme timings and all other phases of its work. The system has the advantage of avoiding confusion between a.m. and p.m., and is considered particularly applicable to broadcasting, as British programmes start at 10.15 a.m. and go on until midnight, while Empire programmes and occasional foreign relays occur at practically all hours. The twenty-four-hour system will be adopted by the B.B.C. in all its announcements, whether spoken over the microphone, printed in its journals, or issued to the public in other forms. Both this system and the old will be used conjointly until listeners have become accustomed to the change. The co-operation of listeners is invited in this experiment.

Battery Time

THE response of the trade and the public to the new "Indicator" fitted to Exide DTG and DFG radio batteries has prompted the Exide company to make available the DXG type with the same device. It will be known as the DXG-C, retailing at 10s. By the movement of a needle between the positions "full," "half" or "empty" marked on a dial, the indicator gives an accurate idea of the time a cell can be expected to last before recharging becomes necessary, and correctly indicates the condition of the cell.

Special Headphones for the Deaf

A RECENT experiment carried out by the His Master's Voice Company shows that deaf persons, providing their hearing organs have not been totally destroyed, can hear programmes from this company's radio-gramophones with the aid of special headphones. A well-known Knight, who, for some years, has only been able to hear music badly distorted through his ordinary hearing apparatus, approached the company with a view to ascertaining whether it would be possible for him to enjoy the programmes provided by the H.M.V. seven-valve radio-gramophone he had bought for his family. H.M.V. engineers, therefore, had a special pair of headphones wound to match the impedance of the radio-gramophone. These phones employ cones in the earpieces instead of the ordinary flat diaphragms, and are used throughout the world by Naval and Air Force radio installations. Although this gentleman cannot hear speech or music without his hearing apparatus, he is now able to enjoy a radio transmission or entertainment from records to the same degree as a person of normal hearing. The sounds of music and speech from the headphones, if worn by a person of normal hearing, would practically deafen him.

Some of the "His Master's Voice" radio-gramophones are now arranged so that a switch at the back makes it possible for a deaf listener to hear gramophone or broadcast entertainment whilst the loud-speaker in the instrument is at the same time disconnected.

Move in the War on Interference

SINCE radio first began, roughly ten years ago, the reception of programmes, both home and continental, has been marred by extraneous interferences. Radio has passed through many vicissitudes since Marconi first gave the world true home entertainments, and as time has gone on, various experts in the radio world have tracked these interferences to their individual sources and slowly but surely found cures and put them into effect. The question of "jamming," i.e., the overlapping of two programmes, has been thoroughly dealt with, and to all intents and purposes eliminated by the Lucerne Plan which has recently come into operation, and various other distractions which the listener commonly meets have been successfully overcome.

Two great bugbears, however, still exist, the first and by far the most serious being the interference experienced from electrical apparatus of all kinds, which can be referred to as "man-made static." The second is nature's own interference known as "atmospherics," and is the last stronghold to be taken in the war on interference.

The trouble caused by electrical machinery has been thoroughly investigated by Marconiphone engineers, and after years of intensive research a system has been evolved whereby those in charge of radio receivers (the selling and maintaining) can bring all the sources of science to bear towards eliminating such undesirable additions to radio programmes.

Scientists, experts, and engineers working at the Marconiphone Factory at Hayes in Middlesex, have split up the various sources of interference into "cause and effect," and a series of records has been made,

on which are noises characteristic of every type of interference commonly met. Some thirty different types of source of interference have been identified, and the noises they make in the normal sensitive receiver recorded. With this series of four records a thirty-six page manual is issued, describing how each type of interference arises, and how best it can be cured. If therefore, anyone is faced with a particular noise coming from an unknown source, it is necessary only to compare it with the noise recorded on one of the bands in the series of records. This will refer to a page in the manual, and on that page will be set out the results of Marconiphone experts' experience with that particular type of interference. This should provide a useful guide to the best method of dealing with the trouble.

It is, of course, impossible for one organization to undertake to search for and deal with each type of interference as it is met. Therefore, Marconiphone are issuing this manual and records to all its service dealers throughout the British Isles.

THE SUPERHETERODYNE FREQUENCY CHANGER

(Continued from page 78)

"tracking" condenser of .002 mfd. in series with the oscillator section at the point marked X in Fig. 4.

It has been shown above that the "frequency mixing" can be provided in either the grid or anode circuit of the first detector valve, and it can now be explained that "cathode coupling" or "cathode mixing" is also possible, this arrangement being made use of in the "Luxus A.C. Superhet," which was described in PRACTICAL WIRELESS dated October 14th and 21st, 1933. A complete circuit of the latter receiver is given in Fig. 5, and from this it can be seen that the "reaction" winding of the oscillator coil is wired in series with the cathode lead to the first valve, which serves the combined function of first detector and oscillator. Also in series with this winding is the usual bias resistance (R.1), shunted by a fixed condenser (C.4). The primary winding of the intermediate-frequency transformer is coupled to the oscillator coil by means of the fixed condenser marked C.5. By employing this form of coupling the cathode of the pentode valve is common to both the signal and oscillator frequencies, so that very thorough "mixing" is obtained and the circuit is uniformly efficient on all wavelengths.

The Pentagrid Frequency Changer

The latest, and probably the most efficient, type of frequency changer is the pentagrid or heptode valve, a circuit of which is given in Fig. 6. It will be seen that the pentagrid has five grids in addition to the usual cathode, anode and heater. The control grid (C.G.) acts in conjunction with the cathode and anode as a normal anode-bend first detector, whilst two other grids (marked O.G. and O.A.) act as the grid and anode respectively of the oscillator section. The control grid is screened on both "sides" by two other grids which are joined together and marked S. In the pentagrid there is no coupling, in the usually accepted sense, between the oscillator and detector portions, the "mixing" taking place within the glass envelope of the valve; this is generally referred to as "electron coupling." The values of components given in Fig. 6 apply to the recently-introduced Cossor pentagrid, but the circuit arrangement is applicable to other makes of similar valve.

Facts and Figures

Components Tested in our Laboratory

BY THE PRACTICAL WIRELESS TECHNICAL STAFF

AN IMPROVED SOLDERING TAG

THE illustration below shows a novel development of the ordinary soldering tag, a device which, whilst permitting of the connection of two or more wires to only one tag (with consequent reduction in thickness between clamping nuts), also gives a shock-free connection owing to the split-washer effect. The tags are manufactured and sold by International

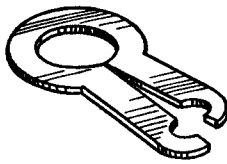

A new type of soldering tag which possesses many advantages.

Standard Radio Co., of 4, Westgate Street, Hackney, E.8, at 3d. per dozen, and although they are no larger than an ordinary soldering tag, they are able to accommodate more than one wire without the usual difficulty of fastening two or more wires on the short shank which most manufacturers provide on their components. The two ends of the tags are bent away from each other to provide the split-washer effect. Constructors will find these most useful.

SILVER GHOST HELIX AERIAL

FROM Lamplugh Radio Ltd., of Silver Ghost Works, Coventry, we have received a sample of an improved aerial consisting of seven strands of 26 gauge tinned copper wire covered by a weatherproof yellow fabric coating. Wound outside this covering in a widely spaced spiral is a further wire of 26 gauge (enamelled), and this is stated to act as a rejector system and to eliminate interference. The aerial is erected in the ordinary manner, with the inner conducting surfaces connected to the aerial terminal on the receiver. The outer rejector wire is intended to be joined either direct to earth or through the medium of a small pre-set having a maximum capacity of .0005 mfd. Where interference is very bad, then the outer wire is employed as the aerial and the inner wire as the rejector. The device works very efficiently and gives good results with a minimum of interference where an ordinary aerial would give troublesome results. The price of a 50ft. length of this aerial is 2s. 6d.

NEW MULLARD VALVES

A NEW indirectly-heated rectifier is announced by Messrs. Mullard, and this consists of a 500-volt 120 mA valve with a 2.4 amp. heater. The type

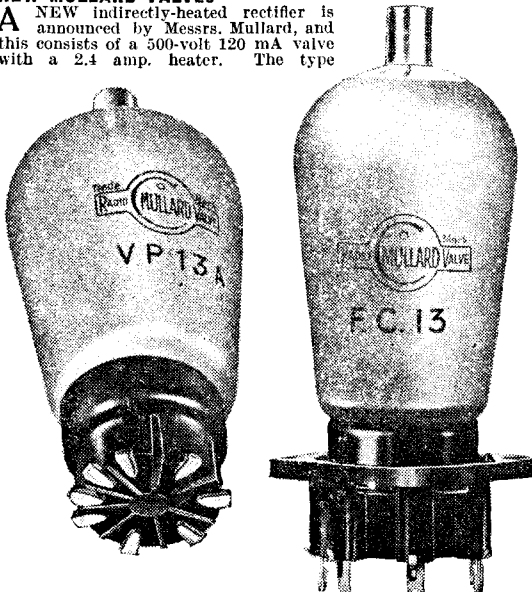

This illustration shows the new base which is being fitted to the new type Mullard valves, and also the new type connector on top which is now a grid connection.

number is I.W.4, and the price is 20s. The advantage of this type of rectifier, as has previously been pointed out, is the avoidance of a sudden surge when first switching on a mains receiver, and it therefore avoids the necessity of employing a thermal delay switch.

In addition to the above valve, Messrs. Mullard also announce the introduction of special Universal valves, which, apart from their electrical characteristics, also depart from standard practice in the design of the base and connecting points. So far six types are announced, and a further five types will be added in due course. The normal valves have heater ratings of .2 amps. at 13 volts, and the pentode (output) has 26-volt heater. The rectifier is rated at 20 volts. As may be seen from the illustration, small metal lugs project from the base, and to accommodate these valves a special holder is to be employed, and this has springy brass arms arranged down the side in small niches. Thus when the valve is pushed down into the holder it is non-rotatable and provides a really firm and sound electrical contact. Most of the valves will be provided with 8-point bases, and they are slightly smaller than existing types of valve, the approximate overall height being only 4ins. and the diameter 1 1/2 ins. Full details have not yet been released, and the actual date when they will be available to the public is not yet known.

BENJAMIN AUTOCONTROLA

A NEW type of battery economizing unit has been received from the Benjamin Electric Limited, of Brantwood Works, Tariff Road, Tottenham, N.17, and is illustrated on this page. It is an extremely small device, but is not fitted with the metal rectifier or the resistance which is required as part of the complete circuit. The four clips which may be seen below the two terminals are intended to accommodate these two accessories, the Westector being clipped in the upper pair of clips and

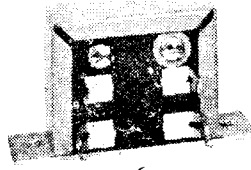

The Benjamin Autocontrola.

the resistance in the lower pair. Type W.6 Westector is required for the first position, and for the second the actual value of resistance must be chosen according to the type of valve which is employed. For a normal pentode a value of 100,000 ohms is needed, and for a super power and a small power the values are 20,000 and 50,000 ohms respectively. When the Autocontrola unit is attached to the receiver the grid bias applied to the output valve should be doubled in value to enable the unit to function in the correct manner and thus cut down the total current consumption of the receiver. As has been pointed out here in these pages, the bias, by being doubled, reduces the standing anode current of the output valve, and to remove the distortion—which would be caused by this increased bias—a potential is applied through the medium of the metal rectifier and the received signal. Thus a powerful signal will reduce the bias more than a weak signal and the average anode current consumption over a period of time will be much less than would be the case without the unit. The price is 7s. 6d.

DRYDEX BATTERY REDUCTION

USERS of battery-operated receivers will undoubtedly be pleased to note that the makers of the well-known Drydex battery (The Chloride) have announced a reduction in the price of the Type H.200 battery. This was formerly priced at 10s. 6d., but now cost only 7s. 6d.

20 GUINEAS CASH

And 200 other Consolation Prizes!

See page 67 for preliminary details.

ELECTRADIX BARGAINS

SELENIUM CELLS. Light sensitive resistance, gold grids, moisture-proof. L to D ratio 5 to 1. 5/- each. Mounted in Bakelite, 7/6. Super Model in Oxy-brass body with window, 10/-. Relays 7/6.

E.C.A. PHOTO CELLS, 2s/- B.T.P. 1s/- Osram C.M.G.8. £4 0 0

S. G. BROWN DOUBLE TURN-TABLE, in strong, steel portable case, fitted two powerful Universal electric motors and non-sync. turntables, with cinema pickups, double fader to outside amplifier or radio set. ... Price £22 10 0

RANGE FINDERS.—Barr and Stroud Artillery range finders, £80 type, £15. Gun-sight telescopes, 17/6. Navy spotting telescopes, 15/-.

BRIDGES.—Sullivan Lab. type, with marine reflector galvo., £31; G.P.O. Standard bridge, £7, with Weston galvo., £9 9/-.

LENSES.—Concave lenses, 1 1/2 in. diameter, in brass housing, 2 1/2 in. long; fitted snap shutter in centre of housing, 7/6. Concave lenses, 3 in. diameter, fitted in brass housing, 1 1/2 in. long, 12/6. Concave lens, 2 1/2 in. diameter, in brass tube, 3 1/2 in. long, 7/6. Concave lenses, 4 in. diameter, in brass housing, 7 1/2 in. long, focal length, 6 in., by Dallmeyer, 4s/-.

Concave lenses, 5 1/2 in. diameter, in brass housing, 10 in. long, focal length, 8 in., by Ross, 50/-.

PROJECTOR LAMPS.—Phillips' 220-volt, 600-watt, S.C. 2 at 17/6 each; Siemens, 100-volt, 400-watt, S.C. 2 at 15/- each; G.E.C. 10-volt, 500-watt, S.C. 15/-; 100-volt, 1,000-watt, S.C. 17/6; 18-volt, 500-watt, S.C. 15/-; 6-volt, 300-watt, S.C. 2 at 12/6 each; 9-volt, 1,000-watt, S.C. 21/-; 9-volt, 400-watt, S.C. 12/6; 12-volt, 48-c.p., C.O. 3/6.

Send for April Bargain List "N."

ELECTRADIX RADIOS

218, UPPER THAMES STREET, LONDON, E.C.4
Telephone: Central 4611.

Radio Receiver Servicing and Maintenance

By E. J. G. LEWIS

Here is the perfect book for radio listeners and service men. It gives complete assistance on every detail connected with the working and upkeep of wireless sets. Every reader can follow it with ease. Well illustrated, clear instructions. 7/6 net.

Order from a bookseller (to-day) or send 7/10 (to include postage) direct to:

PITMAN, Parker St., Kingsway, London, W.C.2

THE MOST Recommended METERS

MOVING COIL METERS. New dials make readings simple. Knife-edge pointers give greater accuracy. Mechanism perfectly balanced and tested. From 27/8

MAGNETIC CONTROLLED Recommended by leading technicians for general radio and charging purposes. Guaranteed accuracy within 4%. In moulded cases, 2 1/2 in. overall, 2 in. hole in panel. From 7/6

- KNIFE-EDGE POINTERS
- FINE SCALE DIVISIONS
- ACCURACY GUARANTEED

USE SIFAM METERS



SIFAM ELECTRICAL INSTRUMENT Co., Ltd.
York Wks., Browning St., S.E.17. Tel. Rodney 3573

★ PERMANENT H.T. LASTS YEARS AT LITTLE COST

Dead silent back—Why continually dip into your pocket for costly dry battery replacements and then endure poor results when they run down? Why not decide, as thousands of others, to end the problem for good with a Standard Leclanche Battery? Gives super pure current year in year out. Maintains voltage amazingly. Recharges itself overnight. Annual replenishment at small cost all that is necessary. Invest in this money-saving permanent H.T. NOW—pays for itself over and over again. 120V, 12,500 m.a., £2 complete, carr. pd. Write for details. **Send 6/2d.**

ALL STANDARD BATTERY SPARES SUPPLIED.
The Wet H.T. Battery Co. (Pr.), 26, Lisle Street, London, W.C.2

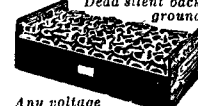

PRACTICAL LETTERS FROM READERS

The Editor does not necessarily agree with opinions expressed by his correspondents. All letters must be accompanied by the name and address of the sender (not necessarily for publication).

Our Tool Kit in Egypt

SIR,—Am pleased to say I received your tool kit safely and am highly satisfied with it. Being accustomed to using good tools I naturally appreciate the quality of material and general appearance of the tools, and shall find them of great use to me. Like your gift, your valuable paper, PRACTICAL WIRELESS, is up to a high standard, and I enjoy reading the many articles, which are clarity itself.—C. OXEY (Mustapha, Alexandria).

Distortion in Amplifiers.

SIR,—I have been a regular reader of your excellent paper for about eighteen months, and in my opinion it is the best wireless paper published. In a recent issue, however, there is a statement which to me does not seem right; I refer to the article by E. G. Rowe, on Distortion in Amplifiers, in the March 3rd issue, in which he says that a 60-henry choke has an impedance of 1,880 ohms at 50 cycles per second. I understand it should be $2\pi fL = 2 \times 3.14 \times 50 \times 60 = 18,840$. Also, he says an 0.0005 mfd. condenser has an impedance 0.16 at 50 cycles. As I work it out it should be $\frac{1}{2\pi fC} = \frac{1}{2 \times 3.14 \times 50 \times \frac{5}{10^{10}}} = 6,369,426.6$ ohms

which is vastly different from 0.16 ohms. I would be greatly obliged if you would clear up this point.—H. R. BRETT (Ilkley).

[Many thanks for pointing out these slips.—ED.]

A Home-made Photo-electric Cell: A Correction

SIR,—I would like to point out that in the article, "A Home-made Photo-electric Cell," in your March 24th issue, there are some errors respecting the chemical side of the construction. The writer says, "Place the sheet copper in the Bunsen burner so that a film of cuprous oxide is obtained." This, he states later, "is a black film." He suggests that underneath this film "is the cupric oxide which we require," whilst the black layer of cuprous oxide "must be removed by emery paper or dissolving in ammonia."

It may interest your contributor and other readers to know that cuprous oxide is red and cupric is black. It is not the cuprous oxide on the outside, but it is a film of black cupric oxide, which is removed by dissolving in ammonia solution. In the finished cell we have a film of reddish cuprous oxide left upon the plate. It may also be noted here that cuprous oxide is also affected by the action of emery paper and so this is not to be recommended.

It pleases me to add my appreciation of your weekly and my thanks for your "Everyman's Wireless Book."—K. M. BEVINS (Liverpool).

[Many thanks for pointing out the slip.—ED.]

A Reader's Appreciation: Our Data Sheets

SIR,—Since January I have become a regular reader of your journal. It appears to be the most useful "wireless" weekly I have seen, and invaluable to the beginner as well as the advanced explorer in wireless. It has occurred to me, therefore, that you might welcome any intimation as to the needs experienced at times by "beginners" or those inexperienced—as far as "wireless" is concerned—who desire to construct many of the simpler items required, and, at the same time, to obtain a proper conception and understanding of the reason for "this" or "that" concerning the items at the moment dealt with. For instance, taking my own case, there is a class of components which I could construct easily, but which, owing to the lack of mathematical ability and the required theoretical knowledge I cannot proceed with.

In such an instance as the above, it appears to me that if I had access to a simple set of tables, we will say, giving in one column rectangular sizes and metal surfaces, from the smallest practical minimum to a large surface, and perhaps in the next column the indication, as simple as possible, of its particular capacity in relation to I.M.F. In an additional column, the number of metallic rectangles of each particular size required to be assembled, with a specified dielectric, to safely hold the desired content, I should then be able to carry on and experiment with a far better

conception of what was taking place than I do at present.

If your valuable journal has not already dealt with such matters on these lines, I venture to hope that what I here refer to may be deemed worthy of your consideration.—A. W. LAUNDRY (Worthing).

[The information required has been published in our data sheets from time to time, and copies of these can be obtained for 2d. each, or a complete set for 2s.9d., post free from our publishing department.—ED.]

REPLIES TO BROADCAST QUERIES.

EDITOR'S NOTE: Querists must limit their queries to three per letter.

D. WOOD (Stoke): W1DW, K. J. Hovey, Sandy Lane, Warwick (Rhode Island); W1KX, P. E. Coolidge, 68, Tolman Street, West Newton (Mass.); W9BHT, W. P. Ingersoll, 251, East Chestnut Street, Canton (Ill.). Many thanks for your information. E. WEBSTER (Guernsey): Regret, cannot trace; possibly relayed by an amateur transmitter. SEARCHER (Glasgow): (1) HJ1ABB, Barranquilla (Col.) given as 46.5 m. but we believe this station is working on about 49.4 m.; (2) HJ3ABI, Bogota (Col.), 48.6 m.; (3) YV3BC, Caracas (Venezuela), 48.34 m. There are several channels around 20 m. used by Rocky Point (New York), i.e., WQV, 20.27 m.; WEB, 20.31 m.; WKJ, 20.7 m. D. A. BROWN (Streatham): K4SA, R. Bartholomew, Barrio de Sabana Hoyos, Garrochales, Porto Rico.

CATALOGUES RECEIVED

To save readers trouble, we undertake to send on catalogues of any of our advertisers. Merely state, on a postcard, the names of the firms from whom you require catalogues, and address it to "Catalogue," PRACTICAL WIRELESS, Geo. Neumes, Ltd., 8/11, Southampton St., Strand, London, W.C.2. Where advertisers make a charge, or require postage, this should be enclosed with applications for catalogues. No other correspondence whatsoever should be enclosed.

"LESDEX" VIBRANT MICROPHONES

EVERY type of "mike," from pocket voice amplifiers to stand instruments, is listed in a folder issued by Electradix Radios. Amongst the varied range are microphones for home recording, band repeating, and public address work. Also included in the folder is a range of microphone transformers, telephones, and microphone parts. Copies of the folder can be obtained from 218, Upper Thames Street, London, E.C.4, by enclosing a stamp for postage.

WESTINGHOUSE METAL RECTIFIERS

AN attractive handbook, entitled "The All-Metal Way, 1934," deals with the construction of H.T. battery eliminators and battery chargers embodying Westinghouse metal rectifiers. The book, which is primarily of interest to home constructors who prefer to build their own apparatus, deals fully with rectification, battery eliminator problems, mains conversion, and battery charging. There is also a section devoted to Westectors and their uses in various circuits. The book is well illustrated with diagrams which should be very useful to the home constructor. Copies of the handbook can be obtained for 3d. each, post free, from The Westinghouse Brake and Signal Company, 82, York Road, King's Cross, N.1.

NEW COSSOR "CLASS B" BOOKLET

READERS using battery receivers, and who wish to increase their output, will find much to interest them in the new Cossor booklet B.21 on Class B amplification. It should prove particularly useful to the constructor who hitherto has been restricted to the small output of a power valve. It tells him how to incorporate a Class B valve in his receiver to obtain output comparable with that of a mains receiver. Several circuits are given, together with advice on how this latest form of output may be most successfully used and added to suitable existing receivers.

Certain precautions may have to be taken and refinements added to ensure satisfactory results, and this book clearly explains what these additions are and how they are best utilized. A copy of the booklet is available free to readers of PRACTICAL WIRELESS, on application to Messrs. A. C. Cossor, Ltd., of High-bury, N.5.

HEYBERD MAINS EQUIPMENT

"MAINS Power for Your Radio" is the title of the new 1934 combined Handbook and Catalogue issued by Messrs. Heyberd. It contains a veritable mine of information for the home constructor, as, instead of being simply a list of their products and prices, this book gives technical hints and complete circuit diagrams for making up various types of eliminator. With the diagrams is a list of all the components for these eliminators, with prices, enabling any constructor to make up a mains unit to suit both pocket and technical requirements. Particulars are also given of a new type portable battery charger which delivers an output of 1 or 2 amps as desired by means of a change-over switch. A special television supplement is included, and this new and enlarged edition should prove even more popular than the previous ones. No constructor should be without one of these useful handbooks, a copy of which can be obtained for 3d., post free, from F.C. Heyberd & Co., 10, Finsbury Street, London, E.C.2.



THE HEART OF THE SET

BETTER THAN NEW WITH 362

Instal 362 and obtain the best possible results from your Set. 362 will give you the best of which your Set is capable and

AT HALF THE COST OF THE NEXT BEST ENTIRELY BRITISH—NON-MICROPHONIC—FULLY GUARANTEED

362	362 Battery Type Valves:	Post Free from
	H., HL, & L. 3/6	Power 4/-
	Super-Power 4/6	S.G. 7/6
	Var.-Mu. 7/6	"Class B" 9/-
	Pentode type 9/- (metallised 8d. extra)	3/6

Post free direct from makers, if unobtainable locally. Cash with order.

THE 362 RADIO VALVE CO., LTD. (Depl. W.), Stoneham Road, London, E.5

RADIO CLUBS AND SOCIETIES

Club Reports should not exceed 200 words in length and should be received First Post each Monday morning for publication in the following week's issue.

INSTITUTE OF SCIENTIFIC RESEARCH (EXPERIMENTAL RADIO SECTION)

On Saturday, March 17th, the members and friends of this Society paid a visit to the Crossgates Automatic Telephone Exchange. The apparatus room containing the fuses, line-finders, and control panel were first inspected, and next the battery and meter rooms were visited. The next meeting of the club will take place on April 21st, at which a lecture will be given entitled "Modern Wireless Telephony," at 2.30 p.m. Full particulars can be obtained from the Hon. Sec., E. H. Page, 6, Bridle Path Crescent, Crossgates, Leeds.

LEICESTER AMATEUR RADIO SOCIETY

The members of this Club were entertained with an interesting lecture at their last meeting. The lecture was given by Mr. S. A. Stevens, B.Sc., of the Westinghouse Brake and Saxby Signal Company. It was entitled "Westinghouse metal rectifiers." Mr. Stevens delivered his lecture by the aid of lantern slides, and describing the uses of half wave and full wave rectifiers, and how rectifiers are made. Mr. Stevens also displayed a very interesting cinematograph film showing the manufacture of rectifiers. This Society still takes an active interest in short-wave working, and its President, Mr. Storer (call sign 66JQ), is always willing to give advice to anyone who needs help in this direction. Interested readers are invited to get in touch with the Secretary, A. Stimpson, 88, Welford Road, Leicester.

SLADE RADIO

A lantern lecture on "Philco receivers" was given by Mr. G. T. Peck at the meeting last week. After dealing briefly with the question of carrier waves and modulation he went on to the superheterodyne principle. The Heaviside layer and direct and reflected waves came next, after which followed various types of receivers. Pentagrid or heptode valves, also car radio sets, were next dealt with, and in the case of car radio a description of the methods adopted to eliminate engine noise and other troubles was given. The latest type of receiver, No. 238, battery model, was then described and demonstrated. This receiver is not yet released, but by special arrangement it was available at the meeting. A special feature was the H.T. battery (144 volt type). All necessary leads, including grid bias, are taken to a multiple contact plug, which fits a special socket at the end of the battery.

A lecture on "Rotary transformers for radio, including car use," was given by Mr. R. H. Woodall, of Messrs. Rotax Ltd., at a recent meeting. In this he gave details of the developments which have taken place since 1924, and also described the latest models. A number of excellent slides were shown, including those of ripple voltage, with and without smoothing. Details of hand and pedal generators were given, after which followed car radio. The lecture proved one of great interest, and was enjoyed by the members. —Hon. Sec., 110, Hillaries Road, Gravelly Hill, Birmingham.

THE BURNT OAK AND DISTRICT RADIO SOCIETY

With the first quarter of 1934 at an end, the Burnt Oak and District Radio Society has become a firmly established body. Meeting every Thursday at 8 p.m. at the Centre, Orange Hill Road, talks have been given of both practical and theoretical nature and acceptable to amateur and novice alike. L.F. stage coupling, superhet. circuits, iron core coils, and common fault finding are just a few of the subjects that have been under discussion. All inquiries concerning membership will be welcomed by the Hon. Sec., A. Donati, 53, Horsecroft Road, Burnt Oak, Middlesex.

GLASGOW AND DISTRICT RADIO CLUB.

The above club has now held its fourth meeting, and will be pleased to hear from any reader in Glasgow who may be interested. A hearty welcome will be extended to novices and advanced amateurs alike. Full particulars can be obtained by sending a stamped addressed envelope to the Hon. Secretary—Treasurer, Henry Duff, 90, Budhill Avenue, Shettleston, Glasgow, E.2.

THE WIRELESS CONSTRUCTOR'S

SEE THIS?

T.C.C.

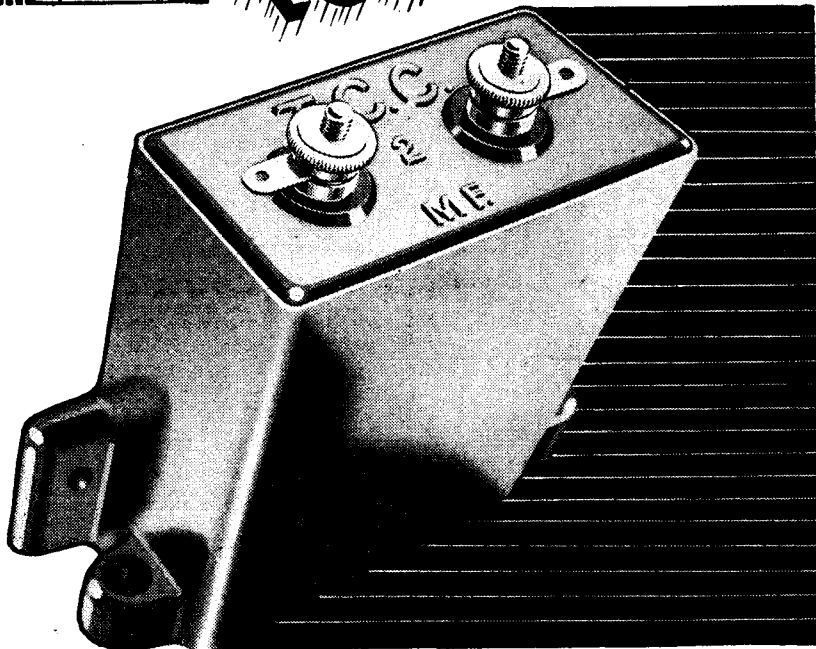

it means **SAFETY**
 at no extra cost ● Here's a 2 mfd. T.C.C. Type 50 paper condenser—specified for 200v. D.C. Working. D'you see the initials T.C.C.? . . . they mean perfect safety. Use it with 200v. D.C. across it (and, unofficially, shall we whisper?—a little more too!) and you know it won't let you down. The condenser plus this security costs you 3s. 6d.—not much to be sure.

It's the same throughout the T.C.C. range; the Type 141 is specified for 2,500v. D.C. Working—and it will—it bears the initials "T.C.C." Look to it that the condensers you buy are rated at the right voltage—then look to it that they carry the T.C.C. initials—then you've got the world's finest condensers

T.C.C.

REPLIES TO

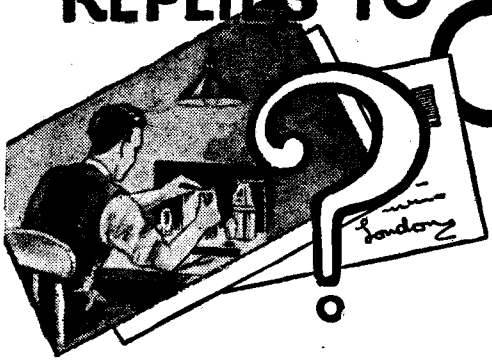
LET OUR TECHNICAL STAFF SOLVE
YOUR PROBLEMS

If a postal reply is desired, a stamped envelope must be enclosed. Every query and drawing which is sent must bear the name and address of the sender. Send your queries to the Editor, PRACTICAL WIRELESS, Geo. Newnes, Ltd., 8-11, Southampton St., Strand, London, W.C.2.

The coupon on this page must be attached to every query.

QUERIES and ENQUIRIES

by Our Technical Staff

SPECIAL NOTE.

We wish to draw the reader's attention to the fact that the Queries Service is intended only for the solution of problems or difficulties arising from the construction of receivers described in our pages, from articles appearing in our pages, or on general wireless matters. We regret that we cannot, for obvious reasons—

- (1) Supply circuit diagrams of complete multi-valve receivers.
- (2) Suggest alterations or modifications to receivers described in our contemporaries.
- (3) Suggest alterations or modifications to commercial receivers.
- (4) Answer queries over the telephone.

Please note also, that all sketches and drawings which are sent to us should bear the name and address of the sender.

MOTOR INTERFERENCE

"I have fitted a motor to my letbe in the workshop, but I find that it interferes badly with the radio set. I made up a suppressor consisting of two condensers and connected these across the brushes, but it did nothing to prevent the trouble. Can you suggest any other palliatives?"—W. O. S. (Liverpool).

It is probable that the interference is being picked up by the aerial, and therefore it will be necessary to enclose the motor in an iron box and connect the box to earth. Alternatively you could screen the aerial lead and connect the screening to earth. You will probably find, however, that it will be easier and more efficient to adopt the first-mentioned arrangement and this will no doubt cure the trouble.

D.C. ELIMINATOR WANTED

"Having taken your paper for only a few months and obtained much useful information from same, I wish to ask you whether you could let me have a blue-print or any back numbers relating to D.C. eliminators. I am desirous of building a cheap D.C. eliminator, input 240 volts, output 60, 80, and 120 at 20 mA."—E. G. D. (Muswell Hill, N.10).

We regret that we have no blue-prints of D.C. mains units, but a complete constructional article dealing with a unit which will fully meet your requirements was given in our issue dated July 8th last. Back numbers are obtainable from the Back Number Department at 4d. each post paid.

MAINS TRANSFORMER WINDINGS

"I have been looking through back numbers of 'Practical Wireless' and am rather doubtful regarding certain details relating to mains transformer windings. In one article I am told to wind nine turns per volt, and in another eight turns per volt. Furthermore, different gauges of wire are used, but this does not seem to account for the difference in the turns. Can you please explain?"—F. W. P. (London, E.7).

The number of turns per volt in a mains transformer depends upon the cross section of the core, the flux density of the material used for the core, the frequency with which it is proposed to deal and one or two other small features. The usual stallo material used for transformer laminations has a flux density of approximately 50 kilo-lines to the square inch.

structural details have already been worked out for you, and therefore you should adhere to the number of turns which are specified in the individual articles, as such points as heat dissipation, etc., have already been worked out by the designer and the various factors above-mentioned have been taken into account.

CLOCK DIAL TUNING

"I have heard of a new kind of tuning dial which acts like a clock. I believe the hour hand is geared to the condenser shaft so that it makes a complete revolution to the condenser's usual half revolution. Meanwhile the tuning knob is connected directly so as to turn the minute hand. Can you tell me if there is such a device on the market, and if so, from whom I can obtain it?"—T. H. F. (Repton).

We do not know of such a device obtainable as a separate component. There is a commercial receiver now obtainable in which a clock-face tuning dial is incorporated, but the dial is divided into two parts, one half being used for medium-wave calibration, and one half for long waves. Two separate pointers are used, one for each band. We have not seen the particular device you refer to where each hand operates separately.

USELESS STAMPINGS

"I have by me an old L.F. transformer which is burnt out, and I have taken it to pieces. I have enclosed a sketch showing the size of the laminations, and I have fifteen of each of these. Could I make an L.F. choke or a transformer for use in a trickle charger with these?"—H. K. (Daybrook).

QUESTIONS NOT TO ASK

"I have bought a moving-coil loud-speaker, but it has no name on it and I cannot identify the leads. There are three black wires, one red and one yellow. Is it possible for you to tell me how to connect this speaker to my own three-valve battery set?"

A number of readers are purchasing components which have been placed on the market after being dismantled from obsolete commercial receivers. It must be remembered that in many such cases the actual component may have been specially made for some particular circuit or receiver and is, therefore, entirely unsuitable for incorporation in a standard receiver. Where these "stripped" obsolete components are purchased, the purchaser should first make certain that he understands just what use they were intended for, as we are obviously unable in many cases to offer any suggestions as to use owing to lack of knowledge of the original design.

You have not sufficient iron for a transformer for trickle charging purposes, and there is hardly sufficient for a really efficient choke. However, if you wind the core full of No. 26 gauge enamel wire it will probably prove fairly effective as a choke for use in L.F. circuits, but we would not recommend its use for mains smoothing purposes.

A SIMPLE PROBLEM

"Could you please tell me what difference there is between the A.C. mains transformer described in 'Practical Wireless,' dated October 22nd, 1932, which only heats the cathodes of four valves to a transformer which will heat the cathodes of seven valves?"—G. L. W. (Cheshire).

As has been mentioned many times in our pages, the voltage output of a mains transformer winding is dependent upon the number of turns. Therefore, for a four-volt winding with a normal lin. cross-section to the core, you would require 32 turns of wire. The current which that winding has to carry will govern the gauge of the wire, and therefore if seven 4 volt 1 amp valves have to be fed, the wire for the 32 turns would have to be heavier to carry double the current required for four similar valves. Obviously as the wire is heavier, the former would have to be larger to carry the extra quantity of wire.

PICK-UP AND HUM

"I have an A.C. mains 3 radio-gram, and when on radio the mains hum is hardly noticeable. When I switch over to gramophone the hum amplifies, but not until I put the needle on the record, then you can hear the hum above the record on certain passages. I have shortened the pick-up leads but with no improvement."—A. G. (Cudworth).

You do not state the type of motor you are using. If this is of the induction type, then the hum is being picked up by the pick-up direct from the motor, and the only really effective remedy is to use a pick-up fitted with a hum-bucking coil. It may be that the cabinet is not sufficiently rigid and hum is causing the cabinet to vibrate, and this is, in turn, transmitted to the pick-up and then again amplified. Mount the motor on rubber gaskets and endeavour to get it "floating." If the motor is of the ordinary simple electric type you may cure the hum by covering the underside of the motor board with metal and connecting it to earth.

BLUE PRINT OF PORTABLE

"Could you tell me if you have a blue-print of a good five-valve portable? I should also like details of the winding of the coil for this set."—J. S. D. (Newbury).

Blue-print No. 15 (Hobbies) gives details for a four-valve portable of the type you require. We have no such details of a five-valver, and do not think such a circuit is required in these days. The circuit in question employs an S.G. stage and will give ample volume from a large number of stations. Separate frame-aerials are employed, with one stage of resistance-capacity coupling and one stage of transformer coupling. The Blue Print may be obtained from the Blue Print Department, price 1/-.

FREE ADVICE BUREAU COUPON

This coupon is available until April 14th, 1934, and must be attached to all letters containing queries.

PRACTICAL WIRELESS, 7/4/34.

Miscellaneous Advertisements

Advertisements are accepted for these columns at the rate of 3d. per word prepaid—minimum charge 3/- per paragraph—and must reach this office not later than Tuesday for the following week's issue. All communications should be addressed to the Advertisement Manager, "Practical Wireless," 8 Southampton Street, Strand, London.

PREMIER SUPPLY STORES

offer the following Set Manufacturers' Surplus New Goods at a fraction of the original cost: all goods guaranteed perfect; carriage paid over 5/- under 5/- postage 6d. extra (Ireland carriage forward). PREMIER SUPPLY STORES announce the purchase of the entire stock of a world-famous Continental valve manufacturer. All the following types of standard mains valves at 4/6 each. H. H. L. Power. Directly heated 6-watt Pentode. Directly-heated 9-watt Pentode. High magnification Screen-grid, low magnification Screen-grid. Variable-Mu Screen-grid. 250 volt 60 milliamp, full-wave rectifiers. The following types 5/6 each: 350 volt 120 milliamp, full-wave Rectifier. 500 v. 120 ditto, 6/6. Dario Factory Valves 4 v. filament. Set of 3, consisting of Screen-Grid, Detector and Power or Super-Power, 6/6 the lot. Power or Super-Power, 2/6. LIMINATOR Kits, including Transformer, choke, Westinghouse metal rectifier, Dubilier condensers, resistances and diagram, 120v, 29 m.a., 20/-; trickle charger 8/- extra; 150v, 30 milliamps, with 4v, 2-4 amps. C.T. L.T., 25/-, trickle charger 6/6 extra; 250v, 60 milliamps, with 4v, 3-5 amps. C.T. L.T., 30/-; 300v, 60 m.a., with 4 volts 3-5 amps. C.T. L.T., 37/6; 150 volts 50 milliamps, 27/6. AMERICAN Triple Gang 0.0005 Condensers, with 4 trimmers, 4/11; Premier chokes, 25 milliamps, 20 henries, 2/9; 40 milliamps, 25 hrs., 4/-; 65 milliamps, 30 hrs., 5/6; 150 milliamps, 30 hrs., 10/6; 60 milliamps, 80 hrs., 2.500 ohms, 5/6. HARLEY Pick-up, complete with arm and volume control, 12/6. BRITISH RADIOPHONE Wire Wound Potentiometers, with mains switch incorporated, 10,000 ohms, 3/6. PREMIER British-made Meters, moving-iron, flush mounting, accurate, 0-10, 0-15, 0-50, 0-100, 0-250 ma., 0-1, 0-5 amps.; all at 6/-. SPECIAL offer of Mains Transformers, manufactured by Philips, input 100-120v. or 200-250v., output 180-0-180 volts 40 m.a., 4 v. 1 amp., 4 v. 3 amp., 4/6; 200-0-200v., 4v. 1a., 4v. 3a., 4/6. ALL Premier Guaranteed Mains Transformers have Engraved Terminal Strips, with terminal connections, input 200-250v. 40-100 cycles, all windings paper interleaved. PREMIER H.T.S. Transformers, 250v. 60 m.a., rectified with 4v. 3-5a. and 4v. 1a. C.T. L.T. screen primary, 15/-; with Westinghouse rectifier, 25/-; 4 v. 3a. C.T., 6v. 2a. C.T., 9v. 1a., 12v. 1a., 7/6 each; 4v. 3-5a., 22v. 1a., 8/6 each; 10v. 3a., 14v. 4a., 10/- each. PREMIER H.T.9 Transformers, 300 v. 60 m.a., with 4v. 3-5a. and 4v. 1a. C.T., L.T. and screened primary, 15/-; with Westinghouse rectifier, 26/-. PREMIER H.T.10 Transformer, 200v. 100 m.a., rectified, with 4v. 3-5a. and 4v. 1a. C.T., L.T. and screened primary 15/-; with Westinghouse rectifier, 26/-. PREMIER Mains Transformers, output 135v. 80 m.a. for voltage doubling, 8/6; 4v. 3-4a., C.T., L.T., 2/- extra; Westinghouse rectifier for above, giving 200v. 30 m.a., 8/6. PREMIER Mains Transformers, output 250-0-250v. 60 m.a., 4v. 3-5a., 4v. 2-3a., 4v. 1-2a. (all C.T.), with screened primary, 15/-. PREMIER Mains Transformers, output 350-0-350v. 90 m.a., 4v. 3-5a., 4v. 2-3a., 4v. 1-2a. (all C.T.), with screened primary, 15/-. PREMIER Mains Transformers, output 400-0-400v. 100 m.a., 4v. 4-5a., 4v. 2-3a., with screened primary, 15/-. PREMIER Auto Transformers, 100-110/200-250v., or vice versa, 100-watt, 10/-. MULTI Radio Output Transformers, 4/6. Twin Screened Wire 3d. per yard. CENTRALAB Potentiometers, 50,000, 250,000 hlf meg, any value, 2/-; 200 and 400 ohms, 1/- RELIABLE, Canned Coils with Circuit, accurately matched dual range, 3/- per coil. Please state whether Aerial or H.F. required. Ditto iron core, 3/6. PREMIER L.T. supply Units, consisting of Premier Transformer and Westinghouse rectifier, input 200-250v. A.C. output, 2v. 2amp., 11/-; 8v. 2 amp., 14/6; 8v. 1 amp., 17/6; 15v. 1 amp., 19/-; 6v. 2 amp., 27/6; 30v. 1 amp., 37/6. MAGNAVOX D.C. 152, 2,500 ohms, 17/6; D.C. 154, 2,500 ohms, 12/6; D.C. 152 Magna, 2,500 ohms, 8/6; all complete with humbucking coils; please state whether power or pentode required; A.C. conversion kit for above types, 10/-; Magnavox P.M., 7in. cone, 18/6. RAMPIAN M.C. Loud-speakers, 2,500 ohm. field, 9in. cone, handles 5 watts; 21/- RAMPIAN P.M. Loud-speakers, 9in. cone, handles 4 watts; 18/6. WESTERN ELECTRIC Condensers, 250v. working, 2 mfd., 1/-; 2 mfd. 400v., 1/6.

(Continued at top of column three)

PILOT AUTHOR KITS Exact to Specification

LEADER THREE

KIT "A" Author's Kit of Specified Parts, including Peto-Scott METAPLEX Chassis but less Valves and Cabinet. Cash or C.O.D. Carriage Paid. Or 12 monthly payments of 5/6. £3 0 0

KIT "B" As Kit "A" but with Valves only. Cash or C.O.D. Carriage Paid, £4/11/8. Or 12 monthly payments of 8/6. KIT "C" As Kit "A" but with valves and Peto-Scott Table Cabinet. Cash or C.O.D. Carriage Paid, £5/9/0. Or 12 monthly payments of 10/-.

KIT "CC" As Kit "B" but with Peto-Scott and Baffle. Cash or C.O.D. Carriage Paid, £5/16/0, or 12 monthly payments of 10/6. If Peto-Scott Permanent Magnet Speaker required add 19/6 to Cash Price or add 1/9 to each monthly payment.

THE LEADER A.C. THREE

KIT "A" Author's Kit of First Specified parts, including METAPLEX ready drilled Chassis, but less Valves and Cabinet. Cash or C.O.D. Carriage Paid. Or 12 monthly payments of 10/6. £5/15/0

KIT "B" As Kit "A" but with set of Specified Valves. Cash or C.O.D. Carriage Paid. £8/12/6. Or 12 monthly payments of 15/9.

NEW W.B. P.M.A. MICROLODE PERMANENT MAGNET SPEAKER, complete with switch-controlled multi-ratio input transformer. Cash or C.O.D. Carriage Paid, £2/2/0. Balance in 7 monthly payments of 5/6. ATLAS C.A.25, for mains, Class B and Q.P.P. Four tapings: 60/80, 80/90, 120, 150, 225 m.a. Cash or C.O.D. Carriage Paid, £2/18/0. Balance in 10 monthly payments of 6/-. NEW LISSÉN SKYSCRAPER FOUR ALL-WAVE CHASSIS MODEL, complete kit comprises all components, including set of Lissen Valves. Cash or C.O.D. Carriage Paid, £2/12/6. Balance in 11 monthly payments of 10/3. NEW LISSÉN 7-VALVE SUPER-HEAT CHASSIS MODEL, complete with Lissen Valves in sealed Carton. Cash or C.O.D. Carriage Paid, £3/17/6. Balance in 11 monthly payments of 16/6. TELSEN 9.2, KIT less valves. Cash or C.O.D. Carriage Paid, £1/19/6. Balance in 9 monthly payments of 4/6. If valves required, add £1/19/0 to Cash Price; H.P., 12 monthly payments of 7/8. TELSEN 325 STAR KIT. Cash or C.O.D. Carriage Paid, £1/9/6. Balance in 5 monthly payments of 5/3. PHILCO 5-VALVE BALANCED SUPER-HET LOW BOY CONSOLE MODEL 58, including Loud-speaker and Cabinet. Original price 22 Gns. Our Price, Cash or C.O.D. Carriage Paid, £12/15/0. Balance in 17 monthly payments of 16/6.

PETO-SCOTT PERMANENT MAGNET MOVING-COIL SPEAKER. Power and Pentode Output. Complete with input transformer. Send only 2/6; balance in 8 monthly payments of 4/-, Cash or C.O.D. Carriage Paid, 19/6. 2/6 DOWN

IMPORTANT Miscellaneous Components Parts, Kits, Finished Receivers or Accessories for Cash, C.O.D. or H.P. on our own system of Easy Payments. Send us a list of your wants. We will quote you by return. C.O.D. orders value over 10/- sent carriage and post charges paid (GREAT BRITAIN ONLY). OVERSEAS CUSTOMERS CAN SEND TO US WITH CONFIDENCE. We carry a special export staff and save all delay. We give half carriage—packed free. Send full value plus sufficient for half carriage. Any surplus refunded immediately. Hire Purchase Terms are NOT available to Irish or Overseas customers.

PETO-SCOTT CO. LTD. 77, City Road, London, E.C.1. Telephone: Clerkenwell 9406-7. West End Showrooms: 93, High Holborn, London, W.C.1. Telephone: Holborn 3248. Dear Sirs,—Please send me CASH/C.O.D./H.P.

for which I enclose £..... Telephone..... CASH/H.P./DEPOSIT. NAME..... ADDRESS..... Pr. W. 7/4/34

(Continued from foot of column one)

B.T.H. Truespeed Induction Type (A.C. only) Electric Gramophone Motors, 100-250v.; 30/-, complete. Type YH 100/250v. A.C. or D.C., 42/-. SPECIAL Offer of Wire Wound Resistances, 4 watts, any value up to 10,000 ohms, 1/-; 8 watts, any value up to 15,000 ohms, 1/6; 15 watts, any value up to 50,000 ohms, 2/-; 25 watts, any value up to 50,000 ohms, 2/6. POLAR 3-Gang STAR, .0005, manufacturers type. Fully screened, 7/6, with trimmers, 1/6 extra. YLNDON Capacitors (Double Trimmer), 1/-. Utility .0005 2-gang Bakelite Condensers, concentric Uniknob Trimming and Disc Drive, complete, 3/6. DISON BELL Double Spring Gramophone Motors, complete with turntable and all fittings, a really sound job, 15/-. AMPLION Cone Loud-speaker Units, 1/9, complete with 12in. cone and chassis, 3/11 each. Worth treble. Larger Unit with 12in. chassis, 5/9. RMOND Condensers, 0.0005 2-gang, semi-shielded, 2/6; brass vanes, with trimmers, 3/6. WIRE Wound Potentiometers, 15,000 ohms, 1/6; 50,000 ohms, 2/-; 500,000 ohms, 3/6. HOME Radio Microphone, complete, 5/-; simply plug in to pick-up terminals. LARGE Selection of Pedestals, table, and radio-gram cabinets, by best manufacturers, at a fraction of original cost for callers. WESTERN ELECTRIC Mains Transformers, 500-0-500v. 150 m.a., 4v. 3-5a., 4v. 2-3a., 4v. 2-3a., 4v. 1a. C.T., 4v. 1a. C.T., 19/6. RELIABLE Intervale Transformers 3-1 or 5-1, 2/-. Dubilier, .05 mica, 1/9. C.C.C. Condensers, 250v. working; 2mfd., 1/9; 1,000 ohm, 150 m.a., variable, 2/-. T.C.C. Electrolytic Condensers, 440 volts working, 4 mf. or 8mf., 3/-; 15 mf., 50 v. working, and 50 mf. 12v. working, 1/-; 25 mf. 25 v. working, 1/3. M.V. Block Condensers, 400v. working; 4 x 4 x 1 x 1 x 1 x 1 x 0.1 x 0.1 x 0.1, 6/-; 4 x 2 x 1 x 1 x 1 x 0.5, 4/6. DUBILIER Condensers, 2 mf. 1,200v. working, 4/-; 8 mfd. dry electrolytic, 450v. working, 3/-. THE Following Lines 6d. each or 5/- per dozen.—Chassis valve holders, 5 or 6 pin, screened screen-grid leads, any value 1-watt wire end resistances, wire end condensers, 0.0001 to 0.1, trimming condensers, T.C.C. 6 mfd. 50 v. electrolytics. PLEASE mention PRACTICAL WIRELESS when ordering.

PREMIER SUPPLY STORES

20-22, High Street, Clapham, S.W.4. MACAULAY 2188. Close 1 o'clock Wednesdays; open to 9 o'clock Saturdays. Nearest Station, Clapham North Underground.

"UNIVERSAL" RADIO BARGAINS.—Stamp for our huge bargain list of Components, Kits and Sets.—"UNIVERSAL," 20, Victoria Road, Peckham, S.E.15, New Cross 4933.

RADIOVISION SUPPLIES, 94, Grove Vale, E. R Dulwich, S.E.22, offer—Ardron S.G. 3 Sets, complete Mullard valves, Batteries, Speaker, all housed in Walnut Cabinet, 77/6. Ready Radio 303 Kits with Walnut Cabinet and P.M. Moving Coil Speaker, 39/6. Iron Cored Dual Coils, 2/11. Bakelite Cascd Transformers, 2/3. 100 U Speakers, 12/6. Midget P.M. Moving Coil Speakers, Universal transformer, 14/9. Hercules H.T. Batteries, 60, 3/6; 100, 5/6; 120, 7/3. Utility 2-Gang Condensers, ideal for Leader 3, 9/6. Stamp for list now.

REPAIRS to Loud Speakers, 4/-; Blue-Spots, 5/-; R Transformers, 4/-; Moving Coils and Eliminators Quoted for. All repairs remagnetised free. Guaranteed. Discount for trade. Clerkenwell 9069. E. C. Mason, 44, East Road, N.1.

THE following unused set manufacturer's surplus for disposal, all goods guaranteed perfect; Magnavox 152 (9in. cone, 240v.). Magnavox 154 (7in. cone), 16/3, with 6,500 or 2,500 ohm field power or pentode transformers. Magnavox 254 P.M., 18/6. Dubilier electrolytic condensers, 8 mfd, 500v., 50v., 50 mfd, 4 mfd., 500v., 3/9. Dubilier or Erie resistors, 1 watt type, 7d. B.T.H. pick-up tone arms, 3/- "Clydesdale" mains units, 25ma output, D.C. type 12/6, A.C. type 25/- All types of brand new American valves in stock, first-class makes: 201A, 220, 227, 112A, 45, 30, 280, 8/-; 224, 235, 551, 57, 68, 59, 75, 77, 78, 89, 247, P.Z., 38, 36, 44, 2A6, 2A7, 6A7, 37, 40, 32, 82, 83, 12-1; UX250, UX281, UX210, 17/6. WESTINGHOUSE rectifiers: H.T.8, 10/-, H.T.9, H.T.10, 11/-. Regentone transformers for H.T.8 or H.T.9, with 4 amp. L.T., 7/6. Hot-wire meters, 0-500ma, 5/6; Radiopacs, superhet or 2-H.F. type, 37/6; Radiophone I.F. transformers, 6/6; Colloar Electro Gramophone Motors 37/6; Marconi K.19 pick-ups, 23/6; carriage paid, cash with order or C.O.D., immediate delivery; send for list.—Ward, 2nd Floor, 45, Farringdon Street, London, E.C.4. Telephone HOL 9703.

TELEVISION DISC KIT 50/-. Illustrated Constructors' Handbook 1/-. "P.W." Specifications Listed.—Bennett Television, 50a, Station Road, Redhill. RAD-AUTO-GRAM buy Modern Second-Hand Components for Cash.—89, Tulketh St., Southport. ERICSSON 8/1 L.F. Transformers. List Price, 17/8. New and guaranteed. Our price, 2/3 post free U.K.—Pioneer Radio, Coptic Street, London, W.C.1.

SOUTHERN RADIO'S Bargains.—Set manufacturer's guaranteed surplus.

COILS.—Igranite iron-core band-pass 3 coils unit. Screened. Ganged on base with switch, 16/- (list 33/-).

LISSEN Super-het 3 coils unit. Screened. Ganged on base with wave-change and filament switches. Type LN5181 for battery or mains, 12/6 (list 30/-).

LEWCO'S Coils.—Types O.S.C./126; T.O.S.; I.F.T.; T.B.F.; A.W.C.; 3/3 each. B.P.F. band-pass filter B.P.F., 4/- (list 12/-). All coils brand new in original cartons.

VARIABLE Condensers.—Lotus 3-gang 0.0005, 12/6; Lotus 2-gang, 0.0005, 8/6; Lotus Dyblock single, 0.0005, 4/9 (list 9/6); all these condensers are complete with dials, escutcheons, knobs, fully screened with trimmers, and boxed; Igranite variable, 0.0003 and 0.0005, 2/3; Hydra block condenser, 16 mfd. (2+2+8+2+1+1), 1,000 v. D.C. 7/- each; 20 mfd. (2+2+2+2+2+2+2+1+1+1+1+1), 1,500 v. D.C., with terminals, 11/6; Dubilier 4 mfd. (2+1+1), 1,000 v. D.C., 2/9; 4.5 mfd. (2.25+2.25) 1,000 v. for mains noise suppression, 3/-; Fixed 4 mfd., 2/3; 2 mfd., 1/6; 1 mfd., 1/-.

SPEAKERS.—Blue Spot Permanent Magnet with universal transformer for power, super power, pentode and Class B, 23/- (list 39/6). Celestion Soundex Permanent Magnet, 17/6 (list 27/6). Celestion P.P.M.W., 25/- (list 49/6).

BLUE Spot 66K, in cabinet, 16/- (list 42/6). G.E.C. Stork Speaker in magnificent Cabinet, 19/6 (list 38/15/-).

BLUE Spot. Genuine 100U, inductor speaker on chassis, 13/6 (list 39/6).

READY Radio D.C. mains energised moving-coil speakers with Humbucking coils and universal transformers. For all voltages, 16/6 (list 39/6). All new in cartons.

CONSTRUCTOR'S Kits.—Ready Radio Meteor "A" Kits 3-valve screen grid with cabinet and Celestion moving-coil speaker. Less valves, 33/7/6; with 3 specified Mullard valves, 41/10/- (list 48/17/6). S.T.400 kits, all specified proprietary components, 42/19/6 (list 44/17/6).

SPECIFIED Cabinets for Ready Radio Meteor kits, 17/6. "303" kits, 13/6.

IGRANPAK Complete Tuning Unit, comprising completely screened coils with wavechange switch; Igranite 3-gang condenser with cover; escutcheon disc drive assembly with pilot lamp attachment; mains switch; three 5-pin valve holders; grid leak and condenser; engraved terminal board, complete with circuit; actually made for A.C. mains, but can easily be adapted for battery sets; list price 57/6, our price 27/-, brand new, wired ready for use. **R**AME Aerials.—Lewcos dual wave superhet, 9/- each (list 27/6).

SPECIAL Bargain Offer of Lewcos Spaghetti Resistances, all sizes, in original sealed boxes, 4/- per dozen, assorted; special price to trade, 30/- per gross.

READY RADIO Instamat Transformers, for R matching any valve to speaker, Junior model 11/6 (list 27/6), Senior model 14/6 (list 37/6).

PICK-UPS.—B.T.H. latest Senior type (1934) Needle armature. Bronze, 30/- (list 40/-). Marconi "No. 19" (1934), 22/6 (list 32/6).

MAINS Transformers.—Auto. step-up or down, 0/250 v., 60 watts, 11/6; 100 watts, 14/3. Full list of Mains transformers and chokes sent Free. Specials can be supplied in 3 days. All transformers and chokes guaranteed 12 months.

MISCELLANEOUS.—Rotorohm and Radiophone volume controls, all values, 3/- each; with switch, 3/3 (list 10/6); S.T.500 coils, 5/6 per pair; Hellesen's 8 mfd. electrolytic condensers, 2/9 each; Westinghouse metal rectifiers, H.T. 6, 7, 8, 9/3 each; Ferranti chokes, 20 henry 60 m.a., 6/9 each; Ready Radio L.F. transformers, 5-1, 3-1, 3/3 (list 8/6); B.T.H. transformers, 3/6; Lewcos superhet 8-way bases, complete with valve-holders, grid leak, fixed condenser, type "48," 2/- each.

ALL Goods Guaranteed and Sent Carriage Paid.

BRANCHES at 271-275, High Rd., Willesden Green, N.W.10 and at 46, Lisle St., W.C.2; please send all post orders to 323, Euston Rd., N.W.1.

SOUTHERN RADIO, 323, Euston Rd., London, N.W.1 (near Warren St. Tube). 'Phone: Museum 6324.

REPAIRS—REWINDING—OVERHAULS. New cones and centres fitted any make M/c chassis, M/c's rewind. Mains transformers, etc. Receivers converted D.C. to A.C. Write Repair Dept. C.

WEEEDON P.L.R., Co., 80, Lonsdale Avenue, London, E.G. (Grangewood 1837.)

WANTED good Modern Wireless Parts, Sets, Eliminators, Motors, Valves, Speakers, etc. Spot Cash waiting. Send or bring. We pay more than any other dealer. Open 9-8.—University Radio, 142, Drummond St., Hampstead Rd., N.W.1.

LOUNDSPEAKERS, any make Re-wound and Re-magnetised, 3/6. Prompt Service, Years' Guarantee.—Breeze, Clapper House, Marden, Kent.

BUILD the A.C. Leader 3 with a Melfo-Rad solely specified kit, 44.14.6 complete (10/- monthly) Battery Model Leader 3, 43/- complete; ST300 Star, 63/6; ST500, 78/-; Orbit 3, 75/-.—Melford, 5, Queens Pl., Hove (Lists free).

a Complete Range of MINIATURE METERS

These compact little magnetic instruments have bezels finished in dead black with matt silvered dials fitted with unbreakable glass. Guaranteed + or - 5% accurate.

MILLIAMMETERS.

List No.	Scale	Ohms
D.M.14	0-8 mA.	1,040
Price 8/6 each.		
D.M.15	0-15	1,080
D.M.16	0-20	500
D.M.17	0-30	220
D.M.18	0-40	150
D.M.19	0-50	120
D.M.20	0-100	30
D.M.21	0-200	10
Price 7/6 each.		

VOLTMETERS.

List No.	Scale	Ohms
D.M.22	0-3 v.	40
D.M.23	0-8 v.	400
Price 7/6 each.		

AMMETERS.

List No.	Scale	V. Drop
D.M.4	0-0.5 A	0.5 v.
D.M.5	0-1 A	0.5 v.
D.M.6	0-3 A	0.5 v.
D.M.7	0-6 A	0.5 v.
Price 7/6 each.		

CENTRAL ZERO AMMETERS.

List No.	Scale	V. Drop
D.M.25	1.0-1.0 A.	0.5 v.
D.M.26	3.0-3 A.	0.5 v.
Price 7/6 each.		

Send for 80-Page Catalogue No. 153 "N." Enclose 2d. Postage.

A. F. BULGIN & Co. Ltd.
Abbey Road, Ealing

London Showrooms, 9, 10, 11, Cursitor St., Chancery Lane, E.C.4.

In a Class alone.

THE 'GOLD-MINE STORES'
Offer You 'The A.C. Leader III,' 49/6, post free. FREE APPROVAL COSTS YOU NOTHING.—Your satisfaction complete or money returned without question.

EXACT TO SPECIFIED VALUES THROUGHOUT.—The Leader III Kits (A.C. and battery models), are made up exact to specified values throughout. The price alone falls short of this standard.

WE GUARANTEE YOUR SATISFACTION so why pay more? We will send on full approval against cash or C.O.D.

BUILD THE A.C. LEADER III, KIT A, at 60% SAVING.—Complete to the last screw, with chassis, all components, sundries, blueprint and copy of PRACTICAL WIRELESS. Post paid, 49/6; battery model, 23/6. Please note since first advertised in PRACTICAL WIRELESS, March 3rd, we have not had one battery Kit returned, and now for the A.C. model, which is just as good.

BUILD THE A.C. LEADER III, KIT B, as above, but with matched set of three (and rectifier) British and fully guaranteed valves. Price 84/6; battery Kit, 36/6.

BUILD THE A.C. LEADER III, KIT C, as Kit B, but including high grade console cabinet and 4-pole bal. armature speaker unit, comprising the complete outfit. Price 99/6 (if Permanent Magnet speaker preferred, add 9/6); battery Kit, 47/6 (with batteries, 57/6).

3D. ONLY, POST FREE.—Enclose also 3d. stamps for your April number of THE 'RADIO GOLD-MINE.' By far the most comprehensive lists of up-to-date surplus goods (Kits, components and accessories) yet produced; April issue now ready, with a general price level lower than ever before. Avoid delay. Send (enclosing 3d. stamps) to-day.

W.B.; BLUE SPOT; AMPLION SPEAKERS CLEARANCE.—W.B. Permanent Magnet (ordinary or Class B type) (list 37/6), 18/10; Nuvoilion P.M., 16/10; Blue Spot 100VE (list 32/6), 15/10; 31K (list 25/6), 15/4; 66K (list 12/6), 7/3. Amplion Cone Units, 1/8. Special offer. P.M.M.C. speakers, 12/6.

BROWNIE COILS CLEARANCE.—All dual range B with reaction. New line, 1/6; also screened, 2/6; Special Iron Cored (diagrams included), 3/3; S-Wave, 2/10. Special Lucerne Coils, 3/3.

PHILLIPS MANSBRIDGE CONDENSERS CLEARANCE, 750 v. test, 1 mfd., 8d.; 2 mfd., 1/4; 4 mfd., 2/8; Dubilier Wet Electrolytic, 8 mfd., 2/9.

DUBILIER FIXED CONDENSERS CLEARANCE and Edison Bell, Mica, .0001, 2, 3, 4, 5 mfd.; .001, 2, 3, 4, 5, 6, 7, 8, 9 mfd.; Tubular mica type, .0001, .0003 mfd., all 3d. each; 2/9 doz.

BRITISH RADIOPHONE AND H.M.V. VARIABLE CONDENSERS CLEARANCE.—H.M.V. 3-gang, 5/9; Br. Radiophone, 2-gang with escutcheon, S.M. drive, panel light, etc., 6/11; .0003, .0005 mfd. air-spaced, 2/3; Slow Motion Type, 2/11; Mica Dielectric, .0003, .0005, 11d.; 'Duotune' Extenders (list 12/6), 2/11; S.M. Type (list 18/6), 4/10; Differential, 1/4.

ERIE, H.M.V., PHILCO RESISTANCES CLEARANCE.—H.M.V. 4 watt glass cased, 100,000 ohms, 4d.; Erie, 1 watt, all values to 60,000 ohms, 4d.; Dubilier, 1 watt, 100,000 ohms, 3d.; Philco, 2, 10, 15, 16, 20 and 32,000 ohms, 3d.; Edison Bell Carbon to 70,000 ohms, 4d.; to 150,000 5d.; to 350,000, 5d.; to 500,000, 6d.; Spaghetts, every size to 100,000 ohms, 3d.; Grid Leaks 1/2 to 3 megs., 3d. each.

AAMPLION AND SUNDRY COMPONENTS CLEARANCE.—L.F. Transformers (list 5/6), 3:1 and 5:1, 2/2; Cl. B. Driver, 3/11; Output Chokes, 3/11; Amplion Speaker Units (worth 7/6), 1/8; H.F. Chokes, 9d.; V-holders, 4 pin, 2d.; 5-pin, 3d.; 7-pin, 6d.; Switches, push-pull, 2-point, 4d.; 3-point, 5d.; Grid Leaks, 1/2, 1, 1 1/2 and 2 and 3 megs., 3d. each.

L.E.C. 'GOLD-MINE' KITS CLEARANCE represents absolutely unprecedented values. They cover a comprehensive range of up-to-date circuits which will meet every home constructor's requirements. Supplied complete with diagrams, instructions and all sundries in sealed cartons. Straight 2-valve, 8/6; 3-valve, 10/6; S.G.III, 18/6; S.G.IV, 25/-; SHORT WAVE KITS: 2-valve, 12/6; 3-valve, 18/6; Class B III, 27/6. ADAPTOR KITS: S.W. Adaptor, 8/6; Super-Het. type, 15/6; Class B Adaptor, 10/6; A.V.C., 14/6. CLASS B KITS: 3-valve, 22/6; S.G.IV, 29/6.

ELIMINATOR KITS, with full diagrams, 4 tappings to 150v. A.C. 25 ma. 21/6. Class B. 29/6. D.C. 9/6. (Westinghouse Rectifiers.)

UNIVERSE PICK-UPS AND SUNDRY CLEARANCES. Super Pick-up (list 20/-), with vol. control, 12/6; Igo. Electric Clocks (A.C. 100-240 v.), various colours (list 32/-), 12/6; Colaro Universal A.C. Motors, with Auto-Stop (list 22/10/0), 37/6.

LONDON EAST CENTRAL TRADING COMPANY (Dept. M.106), 23, Bartholomew Close, London, E.C.1 (telephone: NATIONAL 7473). Goods over 10/- value, postage free. Under 5/- value—cash only. Over 5/- cash or C.O.D.

3D. POST FREE.—Secure your copy of THE 'RADIO GOLD-MINE' TO-DAY.

The Miracle Medium in Modern Radio THE 'RADIO GOLD-MINE'

Soldered contacts are better ELECTRICALLY SOLDERED ARE BEST

Switch on a Solon Electric Soldering Iron and in three minutes it is ready for use. It plugs into a lampholder. Use a

7/6 for every handy man

SOLEN TRADE MARK ELECTRIC SOLDERING IRON

If unable to obtain, send us the name of your nearest dealer.

W. T. HENLEY'S TELEGRAPH WORKS COMPANY LTD.
Y.O.15, Dept.—HOLBORN VIADUCT—LONDON—E.C.1

MADE IN ENGLAND

PEARL & PEARL

190, Bishopsgate, London, E.C.2. All the following bargains guaranteed new goods. Cash or C.O.D. Carriage Paid.

LISSEN, type L.N.5181, superheterodyne 3-coil ganged unit, specially designed for use with battery or mains driven superhet receivers, 3 dual-range shielded coils complete with wave-change and filament switches, operated by one knob on an aluminium chassis, with leaflet of circuits and full instructions; list price 30/-, our special bargain offer 12.6.

LISSEN 17.6 Oak Cabinet Speakers; 10.6.

POLAR 2-ganged Screened Condensers, with trimmers, pilot lamp holder, calibrated scale and escutcheon; list 27.6, our price 8.11

1,900 Marconi 2-valve Sets (1934 models), with Marconi valves; list price 4 guineas, our price, complete with batteries, 45/-.

TRITON 4-pole Balanced Armature Speakers, type "B," sensitive, beautiful tone; list 22.6, our price 6.11.

INCOLN Stewart 20 millamp D.C. Eliminator, 3 output tappings, brand new and guaranteed; 13.11.

FREE. Send postcard for Bargain List "B."

All Mail Orders Direct to **PEARL & PEARL, 190, Bishopsgate, London, E.C.2.**

Callers only can also obtain all above bargains from our London branches: 100-101, Hornscliffe; and 11, Liverpool St.

Piano Tone RADIO GRAM CABINETS
As supplied w B.B.C.

65/- POLISHED 35/-
CABINET FOR 35/-
No Middle Profits.

Famous maker offers finest Radio Furniture. As supplied to B.B.C., a quality and value impossible to better. Beautifully hand polished. GUARANTEED Piano-tone acoustically.

DIRECT—on FREE TRIAL
(or 10/- monthly).
LIST FREE! From makers

PICKETT'S
Piano Tone

Cabinet (P.R.) Works, Albion Road, Bexleyheath, near London.

CHOSEN!
for the "A.C. LEADER THREE"

PRACTICAL WIRELESS Technicians required a strong, reliable Transformer for their latest Set—the result is that Heayberd have *specially constructed* a Transformer to suit their particular requirements. When making up this Set, you *must* use the model selected to ensure the best results.

MODEL LEADER 3,
PRICE 16/-

—POST NOW—

I enclose 3d. in stamps for 40-pp. booklet containing A SPECIAL TELEVISION SUPPLEMENT.

Mr.
..... PRA.

F. C. HEYBERD & Co.,
10, Finsbury St., LONDON, E.C.2.

HEYBERD
MONARCH OF THE MAINS.

UTILITY SALES CO.

LAST WEEK we received THOUSANDS of post cards demanding our LISTS. As we have not yet sent out FORTY THOUSAND, some Readers have NOT asked for theirs. A "P.C." TO-DAY and you SEE yours TO-MORROW. THE INTERESTING new BARGAIN Lines of the week are:—

RADIO TIME SWITCH. Can be set to turn off Radio at specified time, Clockwork Movement, fit any set, 3/6.

RADIO GRAM Electric Motor and Turntable, complete with accessories to run perfectly from 3 dry Cells or 4 Volt Accumulator, 15/-.

DUAL Wave Screened Iron Core Coil, matched for S.G. 3 diagrams, 2/6.

ELECTRIC Soldering Iron, any voltage (specify). Perfect, lasting, 4/6.

CONDENSERS: Variable Solid Dielectric with knob, .0003, .0005, 9d. .00013 Differential, a real good article, 1/6. "Ormond" .0003 for reaction list, 4/-, only, 1/6. "Preset" for Aerial selectivity, 9d. "Lotus" Dyblock, as before, 4/-. "Lotus" Twin .0005 with Slow-motion dial, no escutcheon, 7/11.

DARIO Valves, 2 Volt H.F., DET., L.F., R.C., 3/-. Power EAGLE, 1/6. Transformers, L.F. "DARIO" 3 or 5:1, 1/6. OF COURSE it's OUR LIST you want to SEE to order from:—
UTILITY SALES CO., 27a, Sale Street, London, W.2.

SEND TO FOYLES FOR BOOKS!

New and second-hand books on Wireless and all other subjects. Over two million volumes in stock. Catalogues free on mentioning your interests.

119-125, CHARING CROSS RD., LONDON, W.C.2.
Telephone: Gerrard 5660 (7 lines).

RADIO SUPPLIES

Send your list of Radio needs for our quotation. Kits, Parts, Sets, etc. Everything in Radio stocked, prompt delivery, 7 days' approval. Catalogue free. Taylex & Standard Wet H.T. replacements stocked. **N. TAYLOR, 9, GROVE ED., BALEHAM, S.W.12.**

A Wild West Yarn that Really Thrills

THIS stirring tale of the Wild West bristles with action, passion and hair-breadth escapes. "Sudden," the hero, is a fascinating character, and you will live and breathe the tense atmosphere of the untamed West in this masterly story.

THE MARSHAL OF LAWLESS

By **OLIVER STRANGE**

Obtainable at all Booksellers, or by post 2/10 from George Newnes, Ltd., 8-11, Southampton Street, Strand, London, W.C.2.

2/6

ADVERTISEMENT INDEX

	Page
British Pix Co., Ltd.	94
Bulgin, A. F. & Co., Ltd.	96
Cossor, A. C., Ltd.	Inside Front Cover
Electradix Radios	91
Foyles	Inside Back Cover
Heyberd, F. C., & Co.	Inside Back Cover
Heraud, E. J., Ltd.	Inside Back Cover
Peto-Scott, Ltd.	Front Cover Strip, 11
Parke-Davis	95
Picketts	Inside Back Cover
Pitmans	91
Sifam Electrical Instrument Co.	91
Solon Soldering Co.	96
Taylor, N.	Inside Back Cover
Telegraph Condenser Co.	93
Telephone Mfg. Co.	74
362 Radio Valve Co., Ltd.	92
Turnadge & Partners	Inside Back Cover
Varley, Ltd.	73
Westinghouse Brake & Saxby Signal Co., Ltd.	11
Wet H.T. Battery Co.	91
Wright & Weaire, Ltd.	74

EASY TERMS PROMPT DELIVERY

Any Amplion, Blue Spot, Baker, Celestion, Epoch, R. & A., Rola, Sonochorde, Gramplan, Igranic, Lamplugh, Magnavox, Ormond, W.B., or Ferranti Moving Coil Speaker Supplied

Send 5/- only

and pay the balance by monthly instalments. No references. Entirely private and confidential.

KITS, PARTS, SETS, ELECTRIC CLOCKS ON EASY TERMS.

Send for list of 83 Speakers, and state requirements.

TURNADGE AND PARTNERS, LTD.

Ludgate House, Fleet St., London, E.C.4.
Telephone: Central 1903.

ENJOY MAINS VOLUME FROM YOUR BATTERY SET

Send for the **ROLA CLASS "B" Speaker Unit.**

Combines the latest type Rola P.M. Moving-Coil Speaker with a complete, properly matched Class "B" Unit. Simply connect to your battery set and you obtain volume equal to an expensive all-electric set at very low use of H.T. current. **SEND ONLY 2/6 FOR 7 DAYS' TRIAL**, if satisfied pay further 2/6 at once, then 1/8 (Cash in 7 days @ 11).



E. J. HERAUD, Ltd., Dept. W.52, NUMBER ONE, EDMONTON, LONDON, N.18

WOBURN RADIO offer special purchase of T.C.C. Condensers.

T.C.C.—250v. working—0.01, 7d.; 0.1, 7d.; 1 mfd., 11d.; 2 mfd., 1/2; 1 x 1 x 1 mfd., 1/6; 1 x 1 mfd., 1/2; 0.01 x 0.01, 500v. working, 1/-; T.C.C. Electrolytics 50 mfd., 12v., 1/3 (dry); 4 mfd. and 8 mfd., 3/6 (wet); Dubilier dry electrolytics, 4 mfd. and 8 mfd., 500v., 3/6. All in metal cases. Wego condensers, 750v. test, in bakelite 1 mfd., 1/-; 2 mfd., 1/3; 4 mfd., 2/3. Ready Radio and Lotus Diffs., 0003, 00035, 00015, 1/-, 0005 reaction, 1/-.

WESTINGHOUSE Rectifiers (new): H.T. 7, 8, 9, 9/-; H.T. 10, 10/-; L.T. 5, 10/6. 10hy, 100ma. Chokes, 4/- each.

CLASS "B" Drivers and Chokes, 9/6 per pair, with C suitable valve (BVA) and 7-pin holder, 19/11; Binocular Chokes, 1/3; H.F. Chokes, 1/-; Valveholders, 4/5-pin chassis type, 1/6 half doz.; 7-pin, 6d. Columbia L.F. Transformers, 3/1 ratio, 3/-. Tubular Condensers 0.01, 0.1 and 0.05, 6d. Large Stock of Erie and Dubilier Resistances. Lucerne Dual Range Iron-cored coils, 3/6.

SINCLAIR P.M. Speakers with universal transformer, S or Class B 7in. Cone, 12 months' guarantee, 16/6. Sinclair Matched pairs, one 5in. one 7in. P.M.'s or Energised, 35/- (carr. 1/-).

ANYTHING on H.P. above 40/-. Quotations for A Kits and Components by return. Trade Enquiries invited.

WOBURN RADIO CO., 7, Woburn Buildings, W.C.1. Euston 1571. (Near King's X and Euston Stns. Back of St. Pancras Church.)

H.A. WIRELESS for everything radio. Marconi H.T. 2-valve receiver, complete with Marconi valves. H.2. Exide accumulator, 50/- carr. paid; H.A. twin magnet adjustable unit and chassis, 10/-; Celestion PPM retail 45/-, 19/6; Blue Spot 66K, 6/6; Lotus 2 gang, 8/3; single gang, 5/-; Regentone, 25 m/a D.C., list 37/6, 25/-; A.C., list 55/-, 37/6; Universe Super P.U., 11/-; Lucerne coils as specified, 6/6 pair; W.B. P.M. list 27/6, 15/-. Cash with order or C.O.D. Send lists of your requirements and we will quote by return. Specialists for Specified Kits, Radio Components, etc. All articles brand new and guaranteed. Send for lists.—H. A. Wireless (Shoreditch), 9 and 13, Hackney Road, Shoreditch, E.2. Telephone: BISHOPSGATE 8169 (PBX).

EMPLOYMENT IS OFFERED QUALIFIED RADIO ENGINEERS. Send for our booklet "Radio Progress," for particulars of Radio Opportunities and details of postal training for recognised Certificate. Free and post free. **RADIO TRAINING INSTITUTE OF GE. BRIT., 85, New Oxford Street, London, W.C.1.**

FASCINATING NEW DISCOVERIES

TOLD IN SIMPLE LANGUAGE AND PICTURES



EXPLORING THE STRATOSPHERE

AN intriguing article in the April issue (just published) deals entertainingly with the latest Realm of Scientific Exploration—the Stratosphere. It explains in everyday language what has been discovered and what it is hoped to discover, the purpose of the experiments and illuminating facts about rays. Other lavishly illustrated features are “Seeing Your Telephone Caller” (a new television device), “How to make An Electric Slave Clock,” “How a Torpedo Works,” “A Universal Lathe Holder,” “Movie Making for the Beginner,” “Helpful Aids to Mechanical Drawings,” “A Short-wave Three Valve Set,” “How Lenses Are Made,” “Working Model Road Tractor,” “Hints on Model Railway Planning,” “A Charge Indicator for Accumulators.”

THIS monthly magazine caters for those who wish to make things for themselves, and fosters the interest of those whose hobbies deal with matters practical. The range of subjects dealt with is bounded only by the limits of science itself.

NEWNES PRACTICAL MECHANICS is the only magazine dealing with modern subjects in everyday language. It is THE magazine for those who wish to keep themselves up to date with modern technical and mechanical tendencies. Every article in NEWNES PRACTICAL MECHANICS is the work of an acknowledged expert in the various fields and is fascinatingly presented to the non-technical reader. A well-equipped Science laboratory and workshop staffed by enthusiastic experts, is responsible for testing the latest devices and designing the various pieces of apparatus described.

NEWNES PRACTICAL MECHANICS tells you how to make and do things for yourself. It places the world's heritage of technical and scientific knowledge before you in an easily assimilable form. It provides everyone with the means of understanding the technical achievements nowadays of almost daily occurrence.

On sale at all Newsagents and Bookstalls, or by post 7½d. from George Newnes, Ltd., 8-11, Southampton Street, Strand, London, W.C.2.

6d

PRACTICAL MECHANICS

Geo. Newnes, Ltd.

P.W. Gift Stamp No. 14

Printed by NEWNES & PEARSON PRINTING CO., LTD., Exmoor Street, Ladbroke Grove, W.10, and published by GEORGE NEWNES, LTD., 8-11, Southampton Street, Strand, W.C.2. Sole Agents for Australia and New Zealand: GORDON & GORCH, LTD., South Africa: CENTRAL NEWS AGENCY, LTD. Practical Wireless can be sent to any part of the world, post free, for 17/4 per annum; six months, 8/8. Registered at the General Post Office for Transmission by Canadian Magazine Post.

* P.W. TOOL-KIT
GIFT STAMP No. 6

20 Guineas Cash Prize in Fascinating Competition! See Inside

Practical Wireless

3^D

Published every Wednesday by

GEORGE NEWNES LTD.

Vol. 4. — No. 82.

April 14th, 1934.

Registered at the G.P.O. as a Newspaper.

AND PRACTICAL TELEVISION

EDITED BY F.J. CAMM

BECOME A "PRACTICAL WIRELESS" TEST EXPERT

20 GUINEAS & 200 OTHER PRIZES



A SIMPLE FREE-FOR-ALL COMPETITION

PILOT TELEVISION KITS AND SPARES

PETO-SCOTT UNIVERSAL TELEVISION MOTOR

Ready fitted-for-synchronising gear. Heavy cast aluminium frame, self-oiling bearing, no noise, no mechanical vibration. A.C. or D.C. Mains 200-240 volts. Cash or O.O.D. Carriage Paid. 1 Pair of Controlling Resistances for above. Cash or O.O.D., 11/8. Or Television Motor and Pair of Resistances, 5/- Deposit and 8 Monthly Payments of 5/-.

30/-

Or Deposit 5/- and 8 Monthly Payments of 4/8

PETO-SCOTT SCANNING DISCS

Light gauge aluminium. Centre boss is an 8-ribbed black bakelite moulding, faced white to give true stroboscopic effect, and thereby visual speed indication. Scanning holes perfectly punched to secure uniform scanning without preventable lines. Made in 2 sizes and ready for immediate use.

16in. diam. 7/6

20in. diam. 12/6

Postage 9d. extra.



TRADE INQUIRIES INVITED.

SEND FOR LATEST LISTS

PETO-SCOTT CO. LTD. 77, CITY ROAD, LONDON, E.C.1.





ANODES—
built and assembled with
Microscopic Precision—

ACCURACY

In the making of Cossor Valves extraordinary care is taken to ensure uniformity of characteristics. Each individual element must be exact. Again and again it is checked and re-checked. Nothing is left to chance. Laboratory principles—laboratory precision—are rigidly applied throughout the factory. As a result, the Cossor Valve that you can buy is identical—in characteristics and in performance—with all others of its type and, most important of all, with the original design.

COSSOR

for UNIFORMITY

FREE !

72-page

WIRELESS BOOK

From cover to cover this Cossor 72-page Wireless Book is packed full of useful and interesting information—latest circuits—explanations of technical terms—list of broadcasting stations, etc. Send at once for a free copy—

USE THE COUPON

To A. C. COSSOR LTD., Melody Dept., Highbury Grove, London, N.5
 Please send me free of charge, a copy of the Cossor 72-page Wireless Book.

Name

Address

B.V. 33PRAC. 14/34

BUILD OUR LOW-PRICE A.C. LEADER!

SEE PAGE 99.



EDITOR:
Vol. IV. No. 82 || F. J. CAMM || April 14th, 1934.
Technical Staff:
W. J. Delaney
H. J. Barton Chapple, Wh.Sch., B.Sc. (Hons.), A.M.I.E.E.,
Frank Preston, F.R.A.

ROUND *the* WORLD *of* WIRELESS

The Baird High Definition Television System.

ELSEWHERE in this issue we give technical details of the new Baird Television Transmitting System which is, of course, sent out on the dual wavelengths of 6 and 6.25 metres. The Editor of this journal and members of the technical staff were present at a special demonstration at Film House, Wardour Street, to witness the reception of a television programme transmitted by the Baird System from the Crystal Palace. Parts of talking films were transmitted and other items in the programme included a mannequin demonstration, conjuring, violin solo, and the demonstration was prefaced by the appearance on the screen of Mr. H. J. Barton Chapple, who gave a technical explanation of the new system. The demonstration proved beyond all doubt that television in a practical and satisfactory form is here. The definition was perfect, the pictures quite steady and brilliant, and of real entertainment value. It cannot be long before we look in and listen in simultaneously.

Italy's Two Programmes

ARRANGEMENTS are being made by the E.I.A.R. authorities for the amalgamation of all Italian studios into two groups, thus giving each city an alternative programme. By the end of the year Bolzano will join the North Italian transmitters and in the beginning of 1935 Palermo will broadcast simultaneously with Rome and Naples.

New African Station

THE Italian Colony of Tripoli will shortly possess a wireless transmitter which is to be used not only as a broadcasting station, but also for a public wireless telephony service with Rome. It will be erected in the neighbourhood of the city, and will work exclusively on short waves, namely, between 15 and 80 metres with a power of 2 kilowatts (aerial).

Denmark's 500,000 Listeners

RECENT statistics published show that considerable increase has taken place during the past year in the number of Denmark's registered licence holders, as the figures now prove that one out of

every seven members of the total population is a broadcast listener.

New Bulgarian Station

A BROADCASTING transmitter built by radio enthusiasts at Sofia was recently formally opened; its power is 5 kilowatts and wavelength 214 metres.

For D.X. Listeners

HERE is an opportunity of hearing broadcasts direct from Zagreb (Jugoslavia). On the first night in each month the station will broadcast a special trans-

mission from G.M.T. 00.00-00.30 (midnight to 12.30 a.m.). The wavelength is 276.2 metres (1,086 kc/s), the power only 750 watts.

FREE-FOR-ALL COMPETITION

20 GUINEAS CASH

PRIZE

And 200 Consolation Prizes!

SEE PAGES 114 and 115

Become one of our independent Test Experts NOW!

Pilsen Demands Its Own Station

FOR some time past inhabitants of West Bohemia have clamoured for a transmitter and it is now reported that the Czech authorities are favourably considering their request. As, however, no exclusive channels are available, it is expected that a relay station will be built at Holoubkai, near Pilsen, to operate on one of the common waves allotted to that country. In the same manner, another small station may be erected in

How These Interval Signals are Produced

THE musical notes heard from the Frankfurt group of stations on 251 metres are carried out by means of four organ pipes set into action by a toothed wheel, the blowing as well as the movement being done electrically; a near-by microphone picks up the sounds which are superimposed on the carrier wave.

Radio and Geography

AS a rule a broadcasting transmitter takes its name from the site on which it has been erected. Some villages in this manner have become famous, such as Huizen, Langenberg, Junglinster (Luxembourg). In Switzerland, Munster was selected as the most favourable spot for a high power regional station and, owing to publicity given to the name, has now been authorised to adopt the same appellation as the transmitter, i.e., Beromunster. Formerly, the village was known as Muenster, but it was apt to be confused with a town of that name in Germany.

Short Waves for Amateur Transmitters

ACCORDING to the International Convention of Telecommunications at Madrid, the wavelengths to be used by amateur experimenters have been limited to the following categories: from 5 m.-5.357 m.; 10 m.-10.71 m.; 20.83-21.43 m.; 41.1 m.-42.36 m.; 75 m.-85.71 m. (excepting 75 and 78 m.); 15 m.-174.9 m. All other frequencies in the wave bands are prohibited.

Big Ben Takes a Rest

FROM April 30, for a period of six weeks, the B.B.C. will broadcast the time from the clock situated in the south-west tower of St. Paul's Cathedral; when required, the chimes will also be relayed. "Big Tom," the City's big bell, will take over the duties usually performed by Big Ben. It is only right that the latter should be given a rest as it has been cracked for over half a century and now celebrates the seventy-fifth anniversary of its birthday!

ROUND the WORLD of WIRELESS (Continued)

Prince George's Broadcast Speech

PRINCE GEORGE will be entertained at a banquet at Grosvenor House, London, on May 2nd, on the occasion of his return from South Africa. The banquet is to be given by the Royal Empire Society, the British Empire League, the African Society, the Victoria League, the Overseas League, and the British Empire Club. Prince George's speech will be relayed from Grosvenor House in the National programme.

The Beauties of the Vale of Evesham

THE Vale of Evesham in blossom-time attracts many sightseers. With a countryman's understanding, E. Moore Darling will describe it on April 18th. He is Vicar of St. Chad's, Shrewsbury, and an expert on Midland agriculture of to-day and yesterday. In the autumn he broadcast twice on this subject.

Two Sketches from the Midland Regional

ON the evening of April 18th, two sketches will be produced by Martyn Webster in the Midland Regional programme. John Gill, of the Oxford Repertory, and John Bentley, a young Birmingham amateur, take the chief parts in *The Debt*, by Colin Howard, a story of a Paris café, which has a surprise ending. The other sketch is *Showing up Shakespeare*, by Godfrey M. Hayes and F. Keston Clarke, authors of *This Radio Racket*. The idea is a controversy between two friends as to how far Shakespeare is up to date. Modernist versions of famous scenes—such as the Balcony Scene in *Romeo and Juliet*—are given to illustrate the argument. Stuart Vinden and William Hughes are the argumentative friends; John Gill and Victoria Marsh act the amusing parodies.

Brass Band Concert from Manchester

ERNEST BRADSHAW is to conduct Baxendale's (Manchester) Works Band when they broadcast from Manchester on April 14th. The Band was originally formed in 1913, but many of its members, including the bandmaster, were killed during the War, and it had to be completely reorganized in 1920. Their programme, in this instance, includes the march, *Mephistopheles*, of Shipley Douglas, and the Egyptian serenade, *Amina*, by Lincke. The bass soloist is Joseph Sutcliffe, a Rochdale man who has often broadcast previously: he is to sing *Purcell's Arise, ye subterranean winds*, and others.

Spring Concerts from Ulster Hall.

SIR HENRY WOOD is going to Belfast to conduct the first concert in the new Spring series given by the B.B.C. in co-operation with the Belfast Corporation, in the Ulster Hall. This concert takes place on April 14th. The series will be the third given in the spring months. When the suggestion was first made that the public would attend concerts despite the lure of the long evenings and outdoor sports, pessimistic forecasts were made by many people who could not believe that the attendances would justify the experiment. As it happened, they were entirely wrong, and sur-

INTERESTING and TOPICAL PARAGRAPHS

prisingly large audiences filled the Ulster Hall on every occasion. This season the concerts are again being given by special request.

THE LATEST H.M.V. RADIOGRAM.



Yvonne Printemps, the Star of "Conversation Piece," about to play one of her own H.M.V. records from the show on her "His Master's Voice" "Superhet Five-Forty" radiogram.

"Don Giovanni" Broadcast

ACT II of the Carl Rosa Opera Company's production of Mozart's *Don Giovanni* will be relayed from the King's Theatre, Edinburgh, and broadcast to the Scottish Region on April 18th. This performance is undoubtedly the high light of the company's Edinburgh season. Leyland White will play Don Giovanni; Helen Ogilvie will be the Donna Elvira; Mabel Baker, Donna Anna; and Ronald Stear, Leporello. Eric Warr will conduct.

Chamber Music from Midland Regional

IN a concert of chamber music for Midland Regional listeners on April 17th, the Alex Cohen Quartet will give the first performance of Alec Rowley's *Bergerettes*, comprising six pastorals. Victor Hely-Hutchinson's *Idyll and Diversions for Pianoforte and String Quartet* will also be given, with the composer at the piano; and the closing item will be Elgar's sonata for violin and pianoforte, which will be played by Alex Cohen and Hely-Hutchinson. The third of "The Musician at the Gramophone" series will follow. Leslie Heward has chosen Beethoven's Pastoral Symphony as his subject.

"The Week Abroad"

WITH the cessation of Mr. Vernon Bartlett's regular series of talks, the B.B.C. will continue the feature, "The Week Abroad," but in place of Mr. Vernon Bartlett will relay talks from the different capitals of Europe. These talks will be arranged as far as possible to coincide with events of special interest or significance in the various countries and the speakers will be experts in foreign affairs. The series will be given on Thursday evenings from April to June.

SOLVE THIS!

PROBLEM No. 82

Jackson ordered the parts for the Fury Four Super, but in order to save expense he made his own chassis. He constructed this from ordinary plywood, but covered it on both sides with aluminium foil. When finished results were very poor, the volume control and reaction condenser failing to operate in any manner, and only the very faintest of signals being obtained. What was wrong? Three books will be awarded for the first three correct solutions opened. Address your attempts to The Editor, PRACTICAL WIRELESS, Geo. Newnes, Ltd., 8-11, Southampton Street, Strand, London, W.C.2. Envelopes must be marked Problem No. 82, and must be posted to reach here not later than the first post April 16th, 1934.

SOLUTION TO PROBLEM No. 81

Broadman overlooked the fact that the H.F. valve had the metal-coating connected internally to its cathode, and that the cathode was connected to earth via a biasing resistance. Consequently, when he connected the metal-coating to earth he was short-circuiting the bias resistance, and this made the receiver still more unstable.

The following three readers successfully solved Problem No. 80, and books have accordingly been forwarded to them:

A. Warrington, 25, Norwood Road, March; A. Cameron, Hobart's, Monksleigh, Suffolk; H. F. Walker, 70, Ashenden Road, Clapton, E.5.

Whither Fécamp?

SO far Radio Normandie has faithfully stuck to the channel allotted to it by the French authorities; it is well heard on 206 metres. Difficulties, however, are looming up on the horizon, inasmuch as this wavelength has also been chosen for Eiffel Tower, when this station leaves the long-wave band in June next.

Iceland's Lonely Listeners

ROUGHLY speaking Iceland numbers only one hundred thousand inhabitants, of which a mere 8,300 are registered listeners to the Reykjavik programmes. With the exception of dwellers in the capital, most of them are situated in distant and almost inaccessible districts of the island. Broadcasting to them is not only a source of entertainment, but actually during the winter months their sole link with the outside world.

French Private Transmitters

IN view of complaints made by a number of French privately owned stations to the effect that broadcasts on common wavelengths seriously hamper their activities, the Ministry of Posts and Telegraphs is considering the question of permitting the use of channels allocated to State transmitters pending the reconstruction of the latter.

OPERATING

THE A.C. LEADER THREE

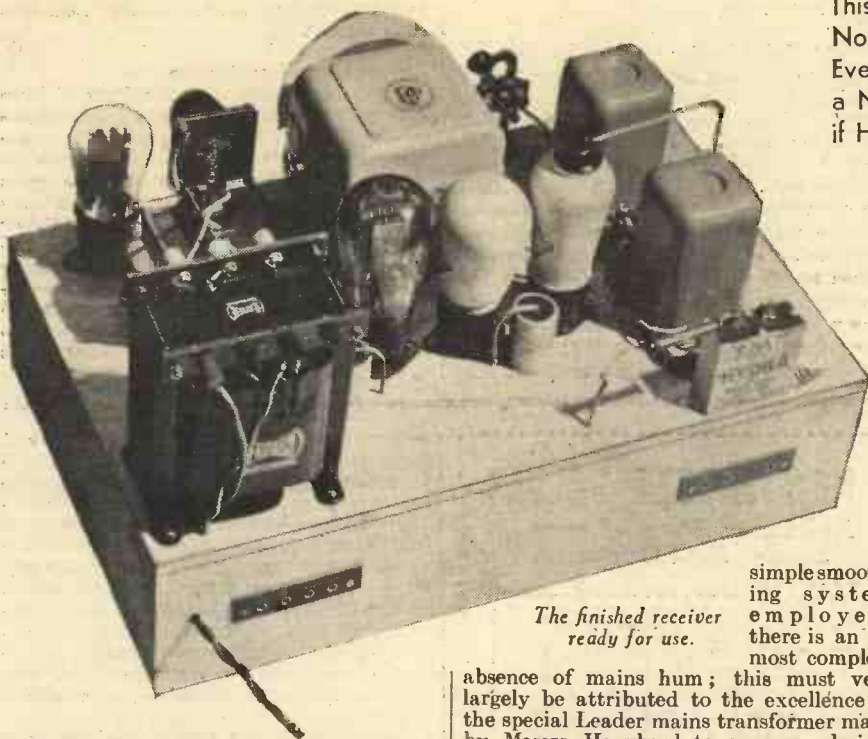

The finished receiver ready for use.

FULL constructional details, along with a complete wiring plan, of this new and successful receiver were given last week, and those readers who have already commenced the constructional work have found that it is simplicity itself. Meanwhile, we have been trying the set under varying conditions to find exactly how readers in different parts of the country are likely to fare in regard to receiving a wide selection of stations. It has been definitely proved that when a moderately good outdoor aerial is available the number of transmissions which can be received at really good loud-speaker strength is very great. Even in daylight it is possible to receive, in Central London, the Northern, Scottish and Western stations in addition to Fécamp, Rome, and Toulouse on the medium waves, with Daventry, Radio-Paris, Huizen, and Eiffel Tower on the long waves. Results were so good that we removed the aerial entirely and connected in its place a length of flex exactly a yard long; on this "aerial" Midland Regional was well received in daylight, whilst North Regional was audible on the speaker.

Dial Readings

There is no need to give a complete dial log, but the following tuning positions for a few of the main stations will enable users to make a few "landmarks," after which it will be an easy matter to compile a complete log. Medium waves: London National, 37 degrees; London Regional, 68 degrees; Midland Regional, 91 degrees; North Regional, 137 degrees. Long waves: Huizen, 155 degrees; Radio-Paris, 135 degrees; Daventry, 112 degrees.

It is worthy of mention that, despite the

absence of mains hum; this must very largely be attributed to the excellence of the special Leader mains transformer made by Messrs. Heyberd to our own design. As we mentioned last week, this transformer is a remarkably good component which is

being made expressly for constructors of the Leader. In accordance with our new and popular policy, this transformer is being sold, at the phenomenally low price of 16s., from which it can be seen that Messrs. Heyberd, among many other manufacturers, are giving us their unstinted support in our Cheaper Home-constructed Radio Campaign. This latter has been instituted for the benefit of PRACTICAL WIRELESS readers, hundreds of whom have already expressed their appreciation of our efforts on their behalf.

simple smoothing system employed, there is an almost complete

This Remarkable Low-priced Receiver is Noteworthy for its Excellent Performance. Every Constructor can be Sure of Receiving a Number of Alternative Programmes Even if He is Limited to the Use of a Short Indoor Aerial.

Trimmer Adjustments

Having connected the receiver to the mains by means of a length of flex and a plug appropriate to the wall or lamp socket in use, turn the Q.M.B. switch to the "on" position, set the reaction condenser to zero and wait a few seconds until the valves heat up. Whilst they are attaining their correct temperature a faint hum will be heard in the speaker, but this will fade out again once the cathodes are quite hot. By rotating the main tuning knob there will then be no difficulty in bringing in the local station, and this should be received at really good volume. Signal strength can then be still further increased, if desired, by advancing the setting of the reaction condenser (clockwise rotation).

Once it has been found that the set is working correctly the trimmers on the two-gang condenser can be adjusted. In doing this it is best, first of all, to tune in a station which is received at about 20 degrees on the tuning dial when the wave-change switch is in the medium-wave position (knob pulled out). A good station upon which to make the preliminary adjustment, by the way, is London National. Set reaction to

zero and if the station is still heard very loudly remove the aerial or replace it by a short length of wire until signals are only just nicely audible. After that the star-wheel trimmer on the first section of the

(Continued overleaf)

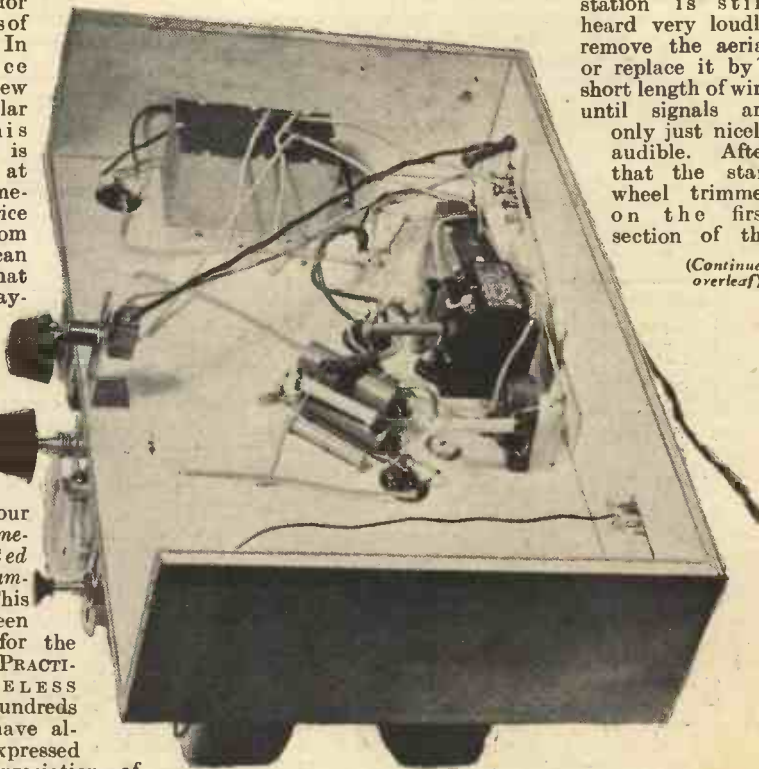

Note the compact assembly of the sub-chassis components.

OPERATING THE A.C. LEADER THREE (Continued from previous page)

condenser should be moved slowly first in one direction and then in the other until maximum strength is obtained. Whilst making this adjustment it is advisable also slightly to modify the main dial reading by slightly "rocking" the tuning knob.

If it is found that the trimmer has to be nearly full in or nearly full out, the other one should be altered so that correct matching of the circuits is obtained when the front trimmer is at its middle setting—that is, half-way in. After this has been done the settings can be checked by tuning in to another station of higher wavelength and repeating the trimmer adjustments. After that it should be found that a large number of stations can be received simply by rotating the tuning knob and occasionally modifying the reaction setting. For the normal reception of principal stations, however, it will be found that the reaction knob can be left entirely alone.

Selecting Adjustments

It will have been noticed that in the

wiring plan a flexible lead was shown from the aerial-terminal socket to terminal 4 on the first coil. The reason for this is that it is possible to increase signal strength on distant stations by transferring the lead to terminal 1. This reduces selectivity, but still allows of sufficiently sharp tuning on many stations, especially if the aerial in use is very short. Try the two alternative aerial connections.

Using a Mains Lead

The Leader can be made to operate very efficiently from a mains aerial in most cases, although no special provision was made for this in the original design. All that is required to use the set in this way is a .0005 mfd. fixed condenser, which should be connected between one supply terminal on the mains transformer and the aerial terminal. When this is done it is sometimes worth while to try the effect of reversing the mains plug in its holder, because one position might give better results than the other. If the mains supply is particularly "rough" it might be found that

the mains aerial introduces appreciable hum. If that is so it will be better to use a short indoor aerial if there are no facilities for erecting a good outside one.

It will be found that the Wearite coils specified are very selective, and since a loose-coupled aerial winding is provided there should be no need to employ a series-aerial condenser unless the aerial in use is unduly long, or it is situated very near to a local station.

Gramophone Reproduction

To use any type of gramophone pick-up it is only necessary to connect this to the two terminal sockets provided. Some pick-ups, however, have three leads of which one is joined to the metallic parts and also to a screened lead; in such cases the third wire should be joined to earth or to the metallized chassis. If the pick-up is not provided with a volume control—many of the modern types are, of course—one can easily be fitted by joining the centre and one "outside" terminal to the pick-up sockets and connecting the speaker leads to the two "outside" terminals.

THE recent introduction of very small receivers for Police use, and the increasing use of valves for deaf-aids and similar compact apparatus, has naturally led to the development of valves of very small dimensions. There have been several different styles suggested from time to time, and experimental valves have been made for these suggested uses.

Now, from the Marconi Valve Company, comes the news that valves of extremely small dimensions are to be produced and sold to the public, and samples which we have received have quite a number of points which will appeal to the experimenter. As may be seen from the illustration, the overall height of the complete valve is 60 mm. or 2 3/8 inches. In place of the usual pin connection (commonly referred to as the "valve leg") these new valves utilize a side contact, which, in addition to reducing the overall height is also an improvement in that it provides a much more reliable and rigid contact. Standard spacing is employed, or perhaps we should say standard lay-out for the connections, and these, in our view, represent a great improvement on the ordinary type of contact. A feature which has hitherto only been employed in the catkin

NEW MIDGET VALVES

Preliminary Notes of some Interesting Valve Developments

valves is also incorporated in these midgets. We refer to the special seal between the glass bulb and the base. This is shock-proof and much more reliable from every point of view than the usual process.

Characteristics

With regard to the actual electrical characteristics of these valves, they are not so dissimilar from the standard types. We have received two only so far, one of the H type and one of the L, or small

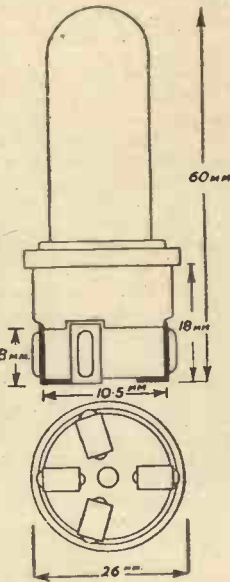

These illustrations show (above) dimensions of the new midget valves and (below) characteristic curves.

power, type. The filament rating is 1 volt at .1 amp, and consequently the type number of these valves is 11. The anode voltage is only 100 thus permitting the employment of small batteries. The curves below give the principal characteristics, and the output valve will be seen to be a very good one for its particular use. The price of these valves is 15s., and no doubt an extension of the range will be made in the future in order to include S.G. and pentode types. Supplies will be available shortly.

In addition to the uses which have been mentioned, these new valves will also be found most useful in the design and construction of midget portable receivers, and it is interesting to note that this problem has been engaging the attention of our Technical Staff for some time, as was mentioned in the article entitled "Problems of the Midget Set," which appeared in PRACTICAL WIRELESS dated March 17th, 1934. The photograph which appeared on the cover of that issue also included an advance sample of one of these midget valves, and its actual size may be gauged by comparison with the hand which is holding the valve, and by the size of the other components which are included in the illustration.

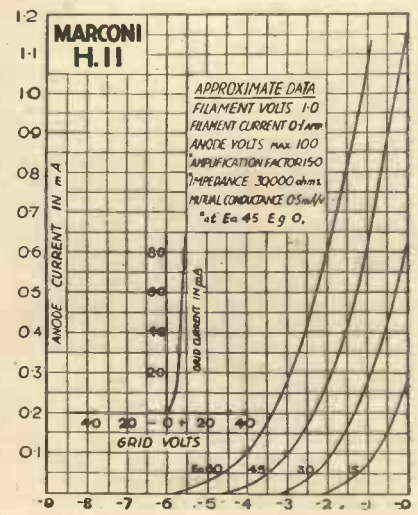
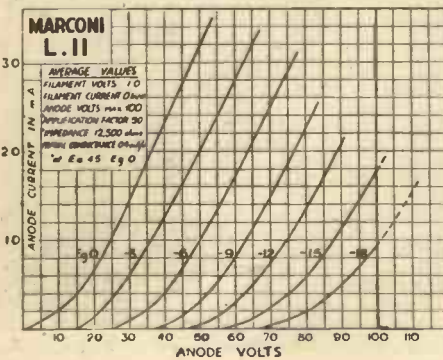
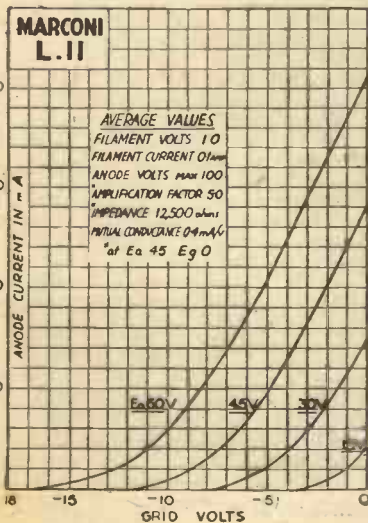

USING THE NEW VALVES

Useful Information Concerning the Use of a Few of the More Popular New Valves is Given in This Article.

THE numerous and rapid improvements which have taken place in valve design and construction during the past year or so have made it very difficult for the amateur to keep pace with all the developments. The many queries received by the PRACTICAL WIRELESS Free Advice Bureau show that there are many constructors who would like to

use, so modifying the connections which must be made to the valve-holders. Nine-pin, and, it is whispered, even eleven-pin valves may be introduced before so very long; these will still further add to the amateur's confusion, but the present article will refer only to those seven-pin valves which have lately come into common use.

Perhaps the most popular valve of the

seven-pin type is the indirectly-heated H.F. pentode. This valve was at first made with a five-pin base and, in fact, many makers still use this, but the seven-pin base (shown in conjunction with the theoretical symbol for the valve in Fig. 1) offers certain definite advantages. It will be seen that the suppressor grid, instead of being internally connected to the cathode, is brought out to a separate pin, the same thing applying to the metal coating on the glass envelope. It is thus possible

tried with advantage in particular circuit arrangements. The anode of the valve is still joined to the terminal on top of the valve envelope, and the connection to this is exactly the same as with the older types of S.G. and V.M. valves.

It is rather unfortunate that some little confusion exists at the moment with regard to the mode of numbering the terminals on the seven-pin valve-holders. Most manufacturers employ the numbering shown in Fig. 1, but the figures shown in Fig. 2 are also used in some cases. Having both diagrams side by side, however, it is a simple enough matter to compare them and to follow either set of connections.

Power Pentodes

A number of indirectly-heated L.F. or power pentodes are now made with seven-pin bases, and the method of connecting the electrodes to the various pins is shown in Fig. 3. It will be seen that in this case the suppressor grid is internally connected to the cathode, terminal 1 being left free. The seven-pin power pentode is far more convenient than its five-pin counterpart, chiefly because there is no side terminal, and therefore no "wandering" flexible lead to connect to it. This eliminates the possibility of a dangerous short-circuit due to the lead (which is connected to H.T. positive) coming loose and making contact with the metal chassis. It should be mentioned in passing that the characteristics of the seven-pin pentode are generally identical with those of the five-pin one, and that some makers can supply the valve with either kind of base for replacement purposes.

Double Diodes

Indirectly-heated double-diode triodes and double-diode pentodes are also made in seven-pin types. The terminal and circuit arrangements for the triode are shown in Fig. 4, and for the pentode in Fig. 5. The circuit shown in Fig. 4 is suitable for

(Continued on next page)

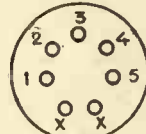
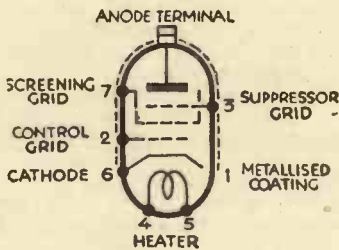

Fig. 2.—The terminal numbers shown above are used by some manufacturers in respect to seven-pin valve-holders.

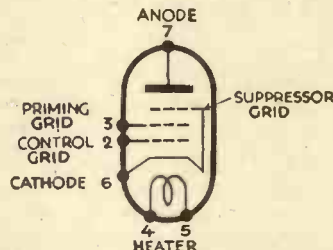

Fig. 3.—The terminal connections for an indirectly-heated power pentode; the numbers applying to the system of numeration shown in Fig. 1.

Fig. 1.—Showing the theoretical symbol for an indirectly heated H.F. pentode in conjunction with the corresponding value-holder connections. The value-holder is shown as seen from above.

modify their present receivers in order to incorporate new types of valves, but they have refrained from doing so, not knowing what alterations would be necessitated. A few practical notes in regard to a few of the more popular new valves will therefore serve to remove any misunderstanding and to give readers a clearer idea as to how the valves may be used to advantage.

Multi-Pin Bases

One thing which has served to add to the difficulties of the home constructor is that seven-pin valve bases have come into greater

use, so modifying the connections which must be made to the valve-holders. Nine-pin, and, it is whispered, even eleven-pin valves may be introduced before so very long; these will still further add to the amateur's confusion, but the present article will refer only to those seven-pin valves which have lately come into common use. Perhaps the most popular valve of the seven-pin type is the indirectly-heated H.F. pentode. This valve was at first made with a five-pin base and, in fact, many makers still use this, but the seven-pin base (shown in conjunction with the theoretical symbol for the valve in Fig. 1) offers certain definite advantages. It will be seen that the suppressor grid, instead of being internally connected to the cathode, is brought out to a separate pin, the same thing applying to the metal coating on the glass envelope. It is thus possible

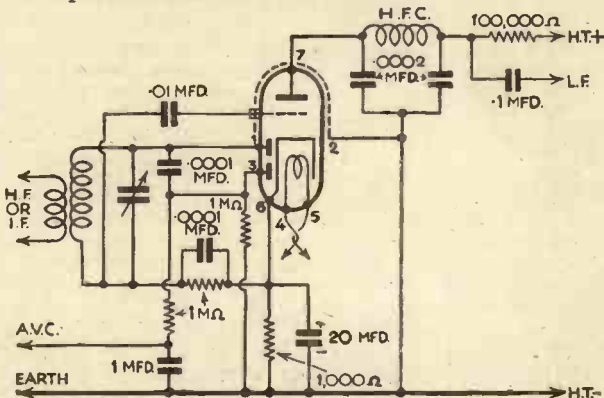

Fig. 4.—The circuit arrangement for a double-diode triode used as detector or second detector (in a super-het), L.F. amplifier, and A.V. control.

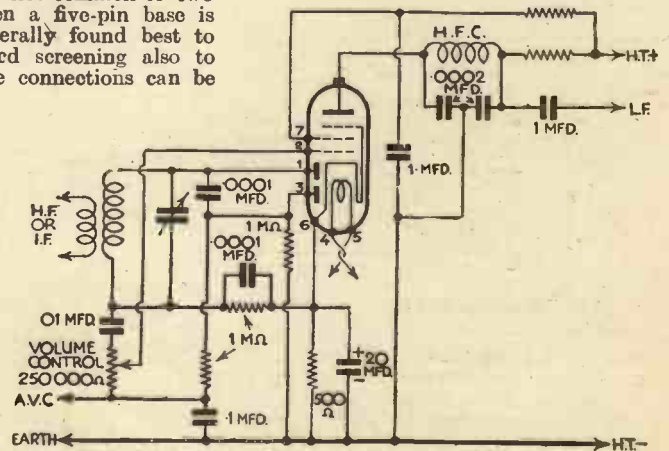

Fig. 5.—Circuit for a double-diode pentode used for "corrected" A.V.C. and connected as detector-amplifier. Values of components are approximate and may require to be modified according to the make of valve employed. A 250,000-ohm potentiometer is also included as a manual volume control on the pentode section.

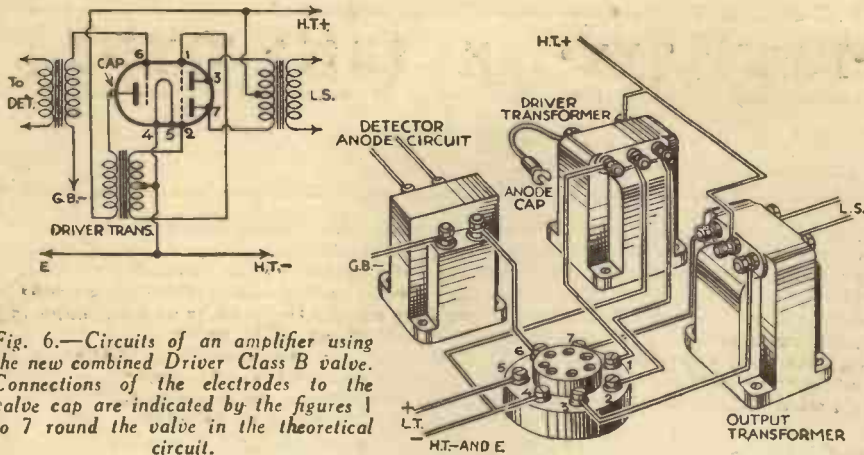

Fig. 6.—Circuits of an amplifier using the new combined Driver Class B valve. Connections of the electrodes of the valve cap are indicated by the figures 1 to 7 round the valve in the theoretical circuit.

(Continued from previous page)

use as a detector following one, or preferably two, H.F. stages, or as second detector in a superheterodyne. Delayed automatic volume control is provided by one anode of the diode, the other being used as a simple half-wave rectifier. The circuit is simple and presents very few practical difficulties. In order that complete A.V.C. should be obtained, however, it is essential that an appreciable amount of (variable-mu) H.F. amplification should be provided.

The double-diode pentode produces a more efficient A.V.C. action, whilst at the same time offering other important advantages; the first of these is that the pentode portion of the valve gives a higher degree of L.F. amplification, and the second is that the A.V.C. system is operative upon the pentode, as well as upon the preceding variable-mu stages. The result is what is known as "corrected" A.V.C. The circuit shown in Fig. 5 may be considered as a parallel one with that in Fig. 4, since it may be employed in the same way after a powerful H.F. or I.F. amplifier.

A Class B-Plus-Driver Valve

From the above remarks it might appear that all the popular new valves are for the mains user, but that is not quite true. The Class B battery valve was introduced some time ago, and it is now well known and widely used. This valve has many important advantages which have previously been pointed out in these pages,

glass bulb. It has a total filament current consumption of .3 amp. and a "standing" anode current of about 4 milliamps; the average H.T. current for a maximum signal output of 1,000 milliwatts is about 9 milliamps.

The driver B valve has a seven-pin base and similar connections to those for the standard Class B valve, excepting that the grid of the driver valve is connected to terminal 6 (which is normally left disconnected) and the anode of the driver is brought out to a terminal on top of the glass bulb. The usual driver transformer is required, and all the connections are shown pictorially in Fig. 6.

The Double Pentode

Another very important addition to the range of battery valves is the double pentode which has recently been placed on the market. This valve is used in the ordinary Q.P.P. circuit, and replaces the two separate pentode valves which were previously necessary. It was rather unfortunate in some respects that a year or so ago when Q.P.P. was first widely adopted in this country its popularity was considerably overshadowed by the introduction of the Class B valve, which was at that time both cheaper and more efficient. To-day, however, there is much to be said in favour of Q.P.P., and it should at least become as widely used as Class B. Since the new double valve can be used directly after the detector without any intermediate stage, the Q.P.P. amplifier is now

somewhat cheaper to make than a corresponding Class B one. Besides, it is more economical in running costs due to the extremely small amount of H.T. current consumption. Previous difficulties in the way of accurately matching the two pentodes in Q.P.P. by adjusting the voltages on the priming grids are now entirely removed with the double valve, so that no delicate preliminary adjustments of any kind are required. It should be mentioned that the signal output from the double pentode is only about half that from a Class B amplifier using a "large" Class B valve, but in any case an output of rather less than 1,000 milliwatts is more than ample for most requirements.

The circuit for a Q.P.P. stage employing the new double pentode with seven-pin base is given in Fig. 7, and it will be seen that it is simplicity itself. The input transformer should have a high ratio (between about 7 and 10 to 1) in order fully to load the output valve, and an ordinary Q.P.P. transformer can be used for this purpose. The anode-to-anode impedance of the double pentode is approximately 25,000 ohms, so that it becomes necessary to employ either a special speaker, or else to feed the speaker (which may be of the ordinary power or pentode valve type) through a tapped choke giving a step-down ratio of about 2 to 1.

Making An Output Choke

A suitable output choke can be made in the manner frequently described in PRACTICAL WIRELESS by using a core consisting of six dozen No. 4A stallony stampings. The spool should be wound with approximately 3,400 turns of 38 s.w.g. enamelled wire. Tappings should be taken after winding 850, 1,700 (centre-tap) and 2,350 turns. The ends of the winding will be connected to the two anodes, the centre tapping to H.T. positive, and the other two tappings to the loud-speaker (preferably through 1 mfd. fixed condensers).

FACTS ABOUT MICANITE

MOULDING micanite is composed of mica splittings built up to any required thickness by means of an adhesive such as shellac (phenolic synthetic resins are unsuitable), the built-up sheets then being pressed in steam-heated presses, the adhesive content of the finished sheets being about 20 per cent. When warmed the sheets become soft and flexible, and can be moulded to any desired shape in hot moulds, the mouldings regaining their hardness and rigidity on cooling.

Hard micanite, which is employed in the manufacture of commutators for electric motors, etc., is made in a similar manner, but is subjected to greater pressure during preparation than is moulding micanite, and the adhesive content is usually under 5 per cent.

Cellulose compounds are making rapid headway as insulators for electrical work. They are mostly of two kinds, cellulose nitrate or cellulose acetate. They are used with or without fillers, and mouldings of this material have a very pleasing finished appearance.

Insulating materials of all kinds depend for their efficiency upon the absence of free moisture, and insulation which is not maintained in a dry condition is subject to electrical leakage, the extent of such leakage being dependent upon the nature of the material and the applied voltage.

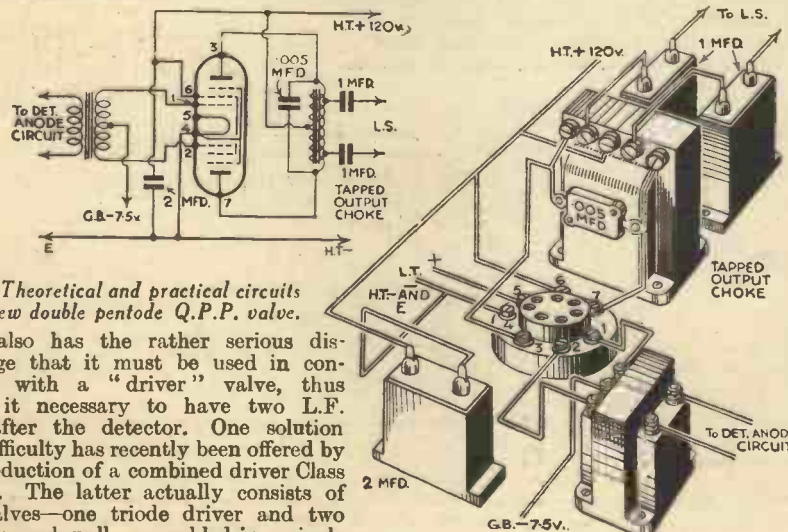

Fig. 7.—Theoretical and practical circuits for the new double pentode Q.P.P. valve.

but it also has the rather serious disadvantage that it must be used in conjunction with a "driver" valve, thus making it necessary to have two L.F. stages after the detector. One solution to the difficulty has recently been offered by the introduction of a combined driver Class B valve. The latter actually consists of three valves—one triode driver and two triodes in push-pull—assembled in a single

RADIO-GRAMOPHONE REFINEMENTS

A Variety of Useful Suggestions for the Improvement of the Radiogram Receiver Are Given in this Article

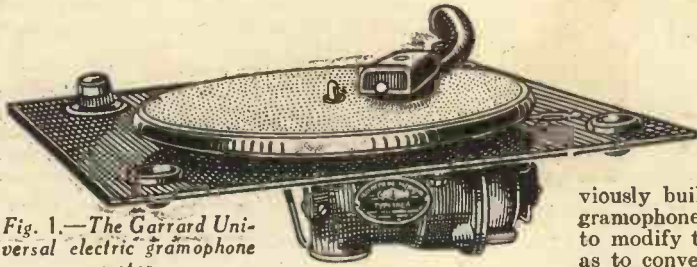

Fig. 1.—The Garrard Universal electric gramophone motor.

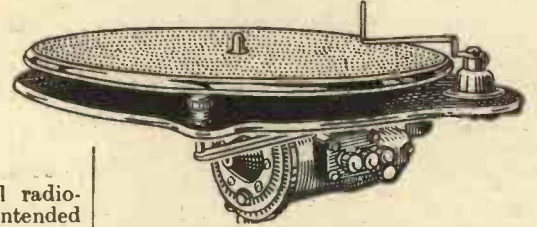

Fig. 2.—This is the B.T.H. "Truspeed" electric motor, which can be obtained for either A.C. or D.C. operation.

IN the earlier days of broadcasting it was generally considered that the advent of wireless would ruin the gramophone industry. That this idea has proved entirely wrong is evidenced by the tremendous increase in the sales of gramophone records during the past three or four years. In fact, it can truly be said that the use of wireless amplifiers for the reproduction of gramophone records has proved beneficial in many ways. The electrical gramophone provides a useful standby when there are no broadcasting programmes available, as well as when one wishes to hear any particular song or orchestral rendering. Because of the reasons just enumerated the use of combined radio receivers and gramophones has become extremely popular, with a result that probably 20 per cent. of the high-class wireless instruments sold to-day are of the so-called radiogram type; that is, they combine the standard wireless receiver with a gramophone turntable and pick-up. The principle of combining the two instruments in a single unit is a very likeable one, since it makes for economy, compactness and greater convenience.

A large number of readers who always build their own receivers prefer to add the comparatively simple gramophone equipment to their standard sets, and some particulars in regard to the method of doing this were given in a short article in PRACTICAL WIRELESS dated March 24th, as well as in the issue dated December 2nd, 1933, and at various other times. The particulars given in those articles were intended principally to assist those readers who had not pre-

viously built a special radiogram gramophone, but who intended to modify their existing sets so as to convert them into dual-purpose outfits. The present article is intended more to interest those who already have a radiogram of some kind or other, but who wish to bring it more up-to-date or to improve it in order to obtain the best possible results from the excellent records which are to-day available.

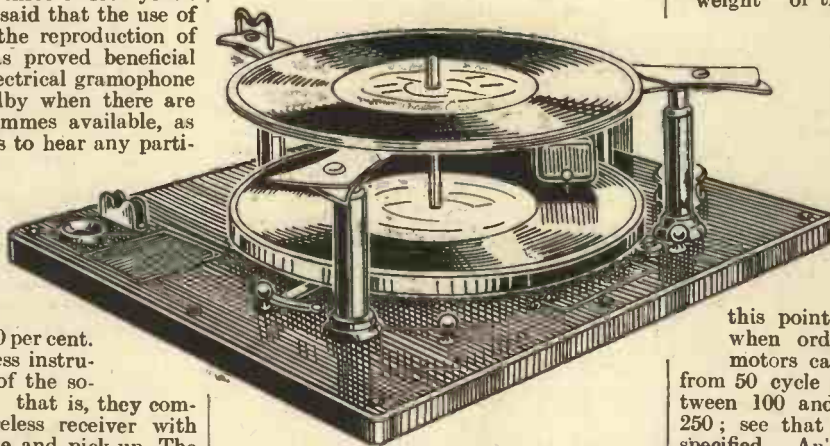

Fig. 3.—The above illustration shows a neat and inexpensive gramophone motor and record-changer; it is the G.E.C. model V 2900.

The Turntable Motor

It has been explained in previous articles that the motor employed to drive the turntable can have a pronounced effect upon the quality of gramophone reproduction to be obtained, this being especially noticeable when a really good amplifier is used in conjunction with the pick-up. There are very many spring motors of all types on the market, but in buying one it pays to

economy must be practised, however, it is always better to obtain a powerful, short-springing single spring motor than a double-spring one which simply gives a longer playing time. The reason is that uniform speed regardless of the "lightness" or "weight" of the passages being played is very important in the interests of quality.

When an electric supply is available it is obviously better to employ an electric gramophone motor. This not only obviates the necessity for constant winding, but generally gives more silent running at lower cost. Many of the motors available are made for A.C. operation only, and

this point should be borne in mind when ordering. In most cases the motors can be supplied for operation from 50 cycle mains having voltages between 100 and 125 or between 200 and 250; see that the correct voltage type is specified. An example of a really good motor at a reasonable price is the Garrard type 202A,



Fig. 4.—The Harlie pick-up with self-contained volume control.

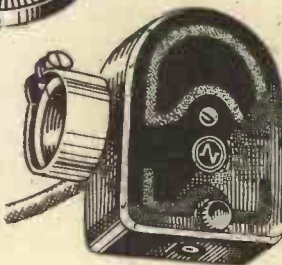

Fig. 6.—The Loewe pick-up, which can be fitted to any tone arm or tracking arm.



Fig. 5.—The Belling-Lee "Clip-On" pick-up and volume control which can easily and quickly be fitted to any type of gramophone.

secure the best that can be afforded and it is wise to obtain one of the multiple-spring type which is powerful and capable of playing a number of records for one wind. If strict

illustrated in Fig. 1. This costs £2 10s. 0d. and is supplied mounted on a steel plate (without pick-up, of course) and fitted with a speed indicator as well as with a fully automatic start-and-stop mechanism.

A D.C. Motor

The B.T.H. "Truspeed" motor shown in Fig. 2 can be obtained for operation from 100 to 120 volt or 200 to 250 volt D.C. mains at £3 7s. 6d., or for use on 100 to 250 volt, 50-60 cycle A.C. mains for £2 9s. 6d. Both

models are provided with an adjustable automatic start-and-stop switch and are particularly light in weight, so that they are especially useful in transportable radiograms. Incidentally, the consumption of the A.C. model is only about 7 watts, so that current costs amount to only about sixpence per year.

Automatic Record-Changer

Electric gramophone motors of the type fitted with automatic record changing devices have become justly popular during the last two years, and it is interesting to note that prices have been reduced considerably. As an example it might be stated that quite a short time ago a reliable automatic record changer was priced about 30 guineas, whilst the G.E.C. Model V 2900 shown in Fig. 3 now costs only £12 12s. 0d., despite the fact that it is fitted with all modern refinements. It can be obtained for A.C. working only, and is sold in two (high and low) voltage types. This complete electric turntable and record-changer will play eight 10- or 12in. records without any attention whatever, whilst any record can be rejected as desired by pressing a switch on front of the platform. By turning a single handle all the records are brought into position for playing at the same time as the pick-up arm is adjusted.

Pick-ups and Track Arms

It is scarcely necessary to point out that the pick-up employed has a very important bearing upon the quality of reproduction obtained with any radiogram. Consequently, those readers who already possess a radiogram instrument fitted with a pick-up made some years ago will find it well worth while to change it for a more modern one of some good make. A wide variety of the pick-ups at present on the market was dealt with in the issue of PRACTICAL WIRELESS dated December 2nd, 1933, and other interesting units are illustrated in Figs. 4, 5, 6 and 7. That shown in Fig. 4 is the Harlie Model 65 with volume control which sells at 18s.; it can also be obtained without volume control at 16s. 6d. This instrument has what is known as compensated characteristics so that it compensates for the deficiencies in average recordings. In other words it gives emphasis to the bass and slightly increased response to the upper register with a result that practically "straight-line" response can be obtained from the average records when reproduced through a good amplifier and loud-speaker. An additional advantage is that it incorporates a spring tensioning device by means of which the pressure of the needle on the record can be varied.

Fig. 5 shows the popular Belling-Lee "Clip-On" pick-up, which has been specially designed for use in conjunction with existing gramophones of the "mechanical" type. It can be fitted on the side of either



Fig. 7.—This sketch shows the Columbia pick-up which is well known for the excellent reproduction which it gives.

a cabinet or portable gramophone in an instant and, being provided with a special counterbalanced track-arm, it is capable

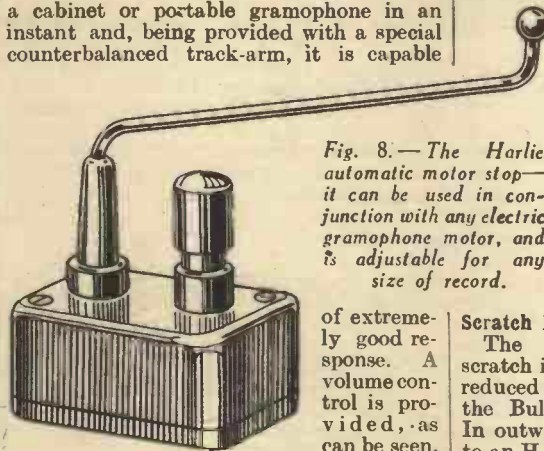

Fig. 8.—The Harlie automatic motor stop—it can be used in conjunction with any electric gramophone motor, and is adjustable for any size of record.

of extremely good response. A volume control is provided, as can be seen,

so that the instrument can be connected directly to any receiver which is provided with pick-up terminals. The Belling-Lee "Clip-On" is of particular interest at this time of the year, due to the fact that it lends itself admirably for use in conjunction with a portable gramophone and portable wireless receiver.

The pick-up head shown in Fig. 6 is the Loewe, and this can be fitted to an ordinary gramophone tone-arm or to a special tracking-arm as

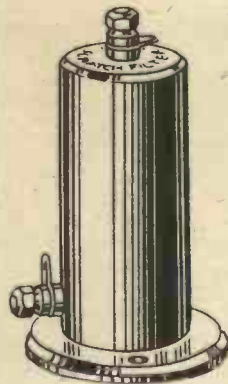

Fig. 9.—A scratch filter is a very useful addition to the standard pick-up. This illustration shows an excellent filter made by Messrs. Bulgin.

desired. It is one of the few pick-ups of this type now available, and sells at the low price of 11s. 6d., whilst a volume control for use with it can be bought for an extra 2s. 6d.

Fig. 7 shows the well-known Columbia pick-up and track-arm which is reputed for the high quality which it gives. This unit has a comparatively low voltage output and is therefore more suitable for use in conjunction with powerful receivers and where perfect reproduction is aimed at.

Useful Additions

Quite apart from the "essentials" which have been dealt with above, there are a number of small and generally low-priced units which go a long way towards improving the utility of the average radio gramophone, bringing it into the same sphere as the high-class and expensive commercial instruments. For example, the automatic stop shown in Fig. 8, and which costs only 4s. 6d., is a refinement which is suitable for use with any electric gramophone motor. It comprises an arm which is moved by means of the track-arm when the end of the recording is reached; the movement operates a quick make-and-break switch situated in the lower casing. This little unit is made by Messrs. Harlie.

Scratch Filters and Tone Controls

The complete elimination of needle scratch is perhaps impossible, but it can be reduced almost to inaudibility by means of the Bulgin-scratch filter shown in Fig. 9. In outward appearance the filter is similar to an H.F. choke and it is simply connected in parallel with the two pick-up leads. The unit actually comprises both a special choke and a fixed condenser and costs 7s. 6d.

Fig. 10 shows a combined "fader," or volume control, and tone control; it makes it possible to "fade out" the wireless signals and at the same time to "fade in" the gramophone reproduction. The tone control serves to compensate for deficiencies of the pick-up and of the record, besides being useful as a means of reducing needle scratch. This combined unit is made by Messrs. Bowyer-Lowe and sold at 10s.

Turntable Lights and Needle Cups

An ingenious needle holder is shown in Fig. 11. This delivers a single needle simply by pressing down and releasing the centre cylinder. The container is easily refilled by unscrewing the top flange; but it holds a stock of needles sufficient for many months' use. This device is made by Messrs. British Goldring and costs only 5s.

A turntable light (a Bulgin component) shown in Fig. 12 is of such a height that throws a clear light over the surface of the turntable, and gives a red warning signal whilst the motor or set is switched on. The device costs 2s. 6d., as illustrated.

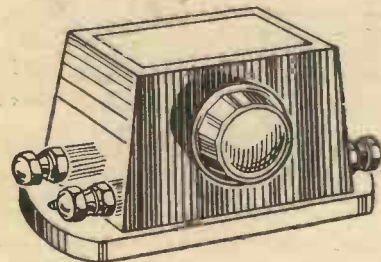

Fig. 10.—This shows the Bowyer-Lowe combined tone and volume control for use with any type of pick-up.

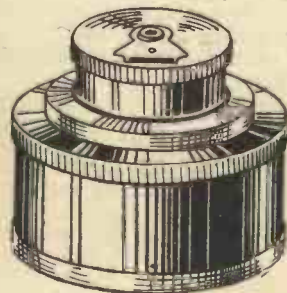

Fig. 11.—An automatic needle cup which delivers a single needle when the centre portion is depressed against the action of a spring.

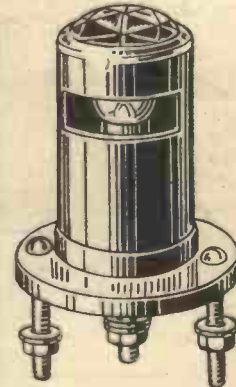
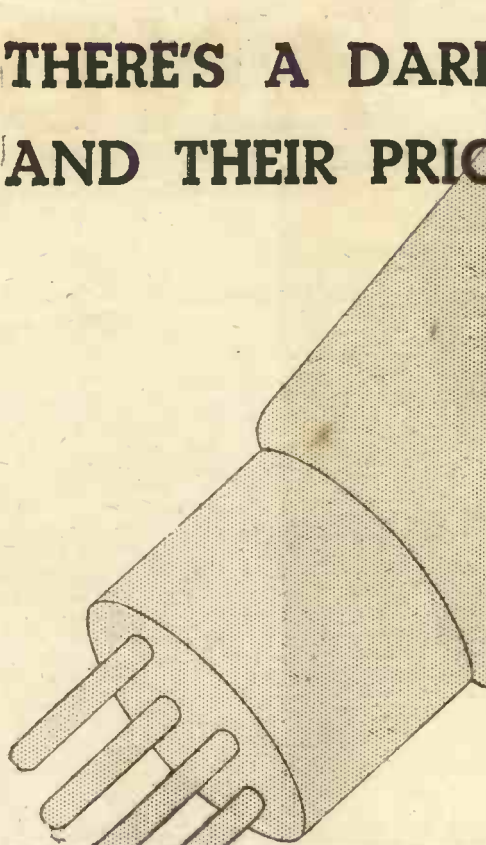

Fig. 12.—A neat turntable light which is made by Messrs. Bulgin.

THERE'S A DARIO VALVE FOR EVERY NEED AND THEIR PRICE MAY SAVE YOU POUNDS



● A full range of battery valves for 2-volts and 4-volts. A complete series of mains valves including H.F. pentodes, Diode-tetrodes, and D.C. valves with 20v. heaters. On one and all you'll save shillings.

Why! In equipping a 5-valve mains set with DARIO, you'd be something like £1.10.0 in pocket—and the saving wouldn't mean the slightest sacrifice in performance. The full DARIO range covers more than 39 efficient, up-to-the-minute valves for every position in any set.

Send for a list of popular types and a table showing DARIO alternatives for the leading standard valves.



VALVES

IMPEX ELECTRICAL LTD., 47, VICTORIA STREET, WESTMINSTER, LONDON, S.W.1

EXPERTS INSIST ON 'ATLAS'

For EVERY type of Set



All the leading radio authors specify "ATLAS" Units to give the most efficient, most reliable and most economical results with their receiver designs. They have proved it, in direct competitive tests, again and again. No other units have won the Olympia Ballot for two years running. None gives such high reserves of voltage and output—or are suitable for every type of set, even "Class B" and "Q.P.P."—or are made for 25 cycle A.C. Mains without any increase in price. Insist on "ATLAS." Mains power with an "ATLAS" Unit costs less than one shilling a year.

50 TIMES CHEAPER THAN BATTERIES

ATLAS

MAINS UNITS

H. CLARKE & CO. (M/CR.) LIMITED,
Atlas Works, Patricroft, Manchester.

Please send me a copy of Booklet 87 telling me how to convert my Battery Set to Mains Operation with an "ATLAS" Unit.

Name

Address 61/26

There is an "ATLAS" Unit to convert any Battery Receiver to Mains Operation in a few minutes without alteration to set or valves; giving more power, improved tone, sharper selectivity at one fiftieth of the cost of dry batteries.

Prices from **39/6** cash or 10/- down.

TRY ONE ON YOUR SET

Ask your dealer for a free demonstration and send coupon for FREE Booklet to H. CLARKE & CO. (M/CR.) LIMITED, Patricroft, Manchester. London: Bush House, W.C.2. Glasgow: G.E.S. Co., Ltd. 38, Oswald Street.

ASK YOUR DEALER — HE KNOWS

TEST IT—AND

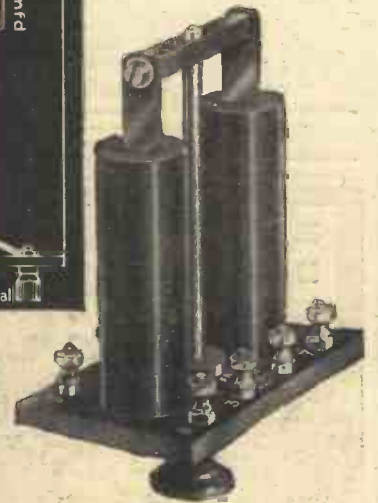
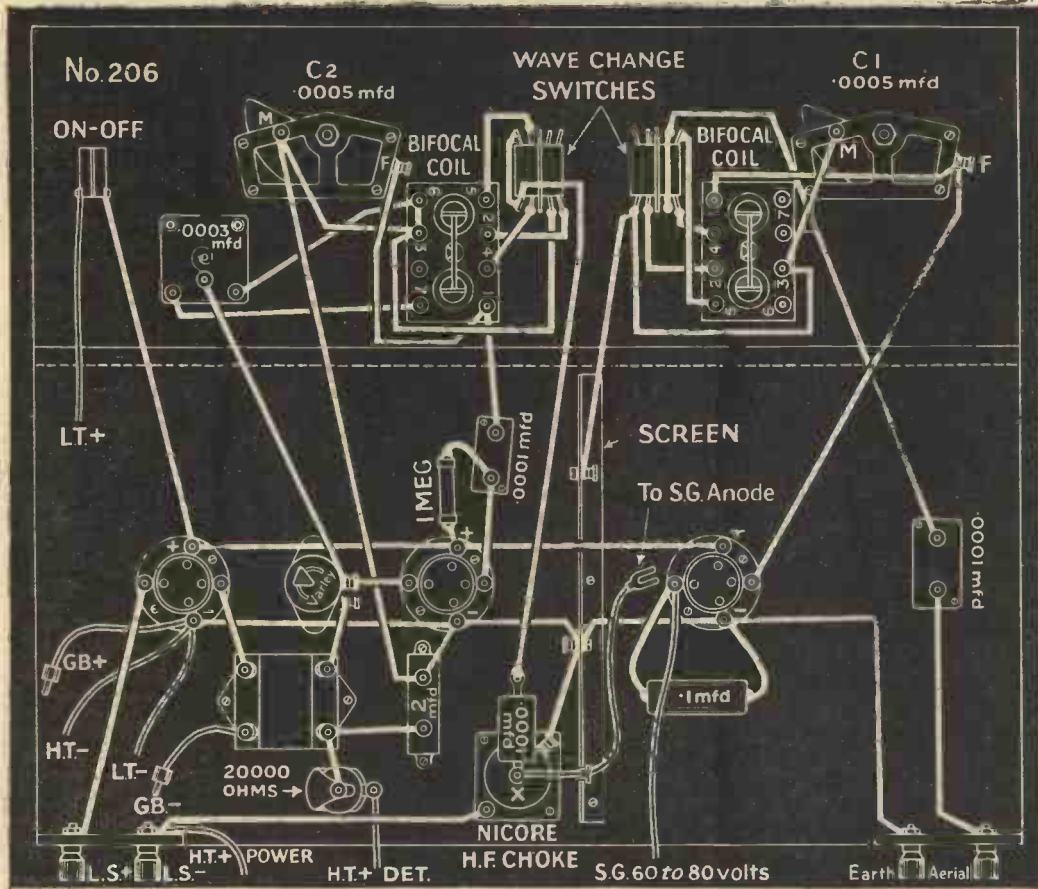

Countless simple sets that were satisfactory when first designed cannot now get the increased number of stations in operation to-day. The Varley Bifocal Focussing Coil, with its revolutionary design, means a new life entirely to these sets. (A typical circuit of a three-valve receiver incorporating two Bifocal Focussing Coils is shown in diagram No. 206. Diagram No. 202 shows the appearance of the new coil—No. 203 the theoretical circuit of the coil—and No. 204 illustrates the principle by which change of aerial coupling is obtained. Installing these new coils is so simple—the operation being no more difficult than any existing arrangement with a fixed aerial coupling.) Write for full information together with FREE circuit diagrams.

Varley

(Proprietors: Oliver Pell Control Ltd)

WIN A PRIZE

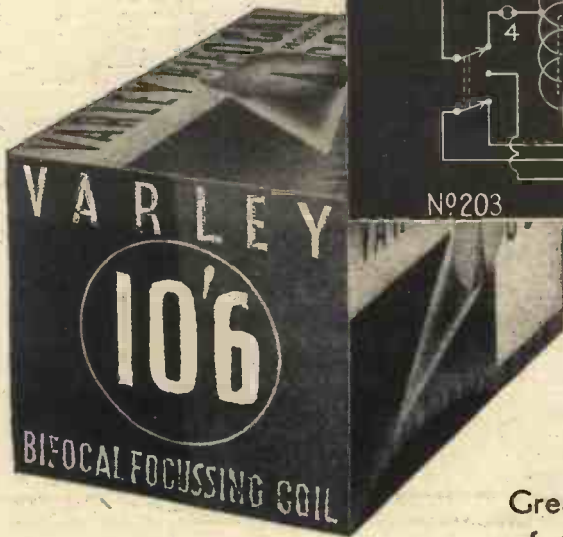
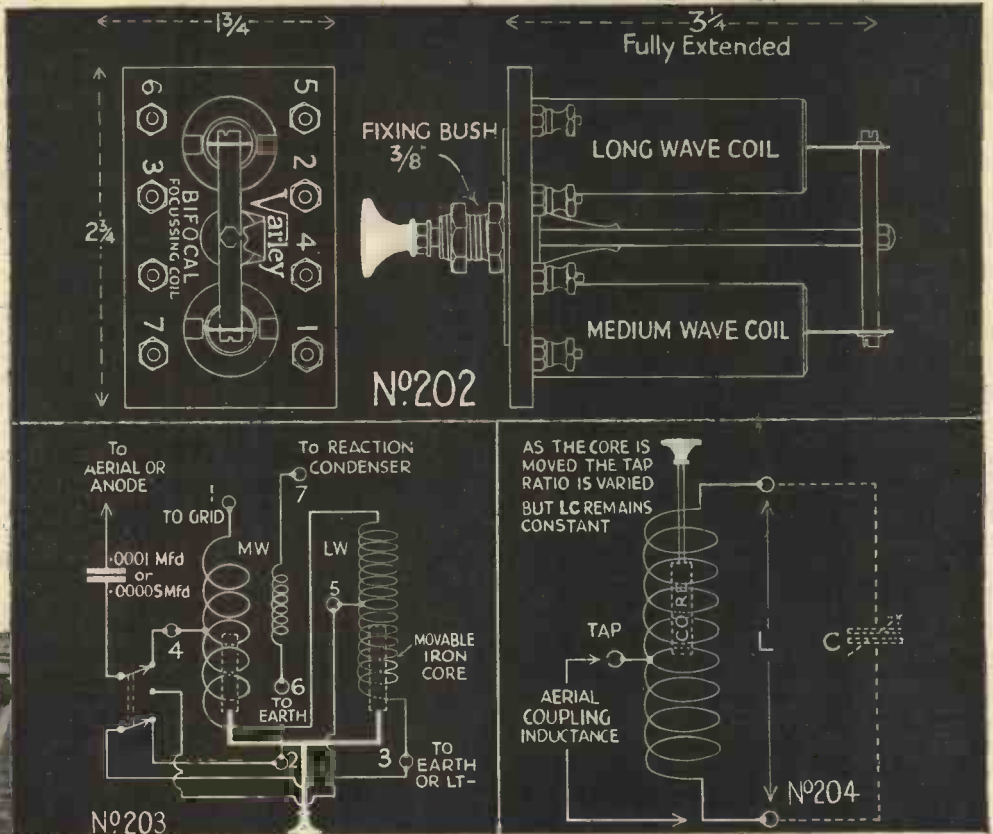

YOU, any one of you, can add immensely to the selectivity of your set—killing the bugbear of interference—at the same time winning one of the prizes (First Prize: 20 Guineas—200 Consolation Prizes) offered by "Practical Wireless" in their Great National Competition. You will find full details of this simple and interesting competition elsewhere in this issue.

Varley Bifocal Focussing Coil—get one to-day from your dealer.

Varley

(Proprietors: Oliver Pell Control Ltd)

Advertisement of Oliver Pell Control Ltd.; Kingsway House, 103, Kingsway, London, W.C.2. Telephone: Hol. 5303.

No 1**Ready April 12th****NEWNES****PRACTICAL****PHOTOGRAPHY****and AMATEUR CINEMATOGRAPHY****ABOUT 20
FORTNIGHTLY
PARTS****1¹/₂ EACH****Can You Answer These Questions?**

What steps would you take if the copyright for one of your photographs had been infringed?

How long does the copyright in a cine film and a photograph last?

What are the causes and remedies for the following defects in gaslight prints :-

Black Spots, Blisters, Brown Stains, White Specks, Yellow Stains?

What developer would you use for gaslight paper to give the most brilliant print? What developer would give softer contrast?

What printing process gives prints like oil paintings?

When must a cine camera be held upside down in shooting a scene?

When is f/8 stop not f/8?

How do lamps used for photographic studios differ from ordinary electric light bulbs?

What is the difference in lighting an indoor scene for cinematography as distinct from still photography?

How would you develop ultra rapid panchromatic plates and films?

What is the best type of camera to use for dog photography?

All these and hundreds of other practical questions are clearly answered in this splendid new work. Order your copy of Part 1 To-day.

Advisory Editors
GEORGE E. BROWN,
F.I.C., Hon.F.R.P.S.

PERCY W. HARRIS,
F.A.C.I.

Obtainable at all News-
agents and Bookstalls,
or by post 1/2 from
George Newnes, Ltd.,
8-11, Southampton St.,
Strand, London,
W.C.2.

**WORTH MANY TIMES ITS COST.**

Produced in the straightforward practical style for which the House of Newnes has become justly famous, this work deals with a subject which is full of fascinating possibilities for the practical man who aspires to a more intelligent photography than that so tersely described by the phrase: "You press the button, we do the rest." Never before has such a wealth of really practical information on this subject been brought together within such a small compass. Every article has been written by a man who has made himself expert on the subject upon which he writes, and yet the information is conveyed in such a manner that it can be put into immediate use by the reader. It is quite safe to say that, to the man who has a practical turn of mind, each part of this work will be worth many times its cost. Get a copy of Part 1 and you will fully endorse this statement.

PRACTICAL**AUTHORITATIVE****COMPREHENSIVE**

Practical Television

Conducted by H. J. Barton Chapple, Wh. Sch., B.Sc., Etc.

APRIL 14th, 1934. Vol. 1. No. 15.

LATEST TELEVISION DEVELOPMENTS.

That Television Has in No Way Been Standing Still was Demonstrated Very Forcibly by the Baird Company a Few Days Ago, and We Are Here Able to Furnish Readers with Details of the Latest High-definition Apparatus.

FOR some months now it has been common knowledge that intensive research work was being carried out to effect considerable improvements in the realm of high-definition television. The expression "high-definition" is perhaps somewhat of a misnomer, but it has been coined to imply transmission and reception with the number of scanning lines increased materially above the thirty-line service which is now being transmitted by the B.B.C. It was not anticipated, however, that the work had reached such an advanced stage, as was made evident by the Baird Company when they sprang their well-planned surprise on Tuesday, March 20th. On that day the chairman of the company, Sir Harry Greer, addressed the shareholders as a televised image. He was situated at the Baird Transmitting Studio at the Crystal Palace, but he was seen at Film House, Wardour Street.

Making History

It was a speech that made television history, because of the manner of its delivery, and this method was chosen as the most dramatic way of bringing home the fact that Baird television had definitely reached a stage which was far and away ahead of anything hitherto shown to the Press or public. Furthermore, it was revealed that the Prime Minister, Postmaster-General, and other high Government officials had been given a demonstration a week earlier.



Fig. 3.—One view of the talking-film television transmitter.

Stated briefly, the demonstration comprised the transmission of living subjects and talking films, the definition in both cases being that of 180 lines with twenty-five pictures per second. Ultra-short waves

provided the radio link, while at the receiving end the image was portrayed on the fluorescent screen of a very large cathode-ray tube. The images were bright,

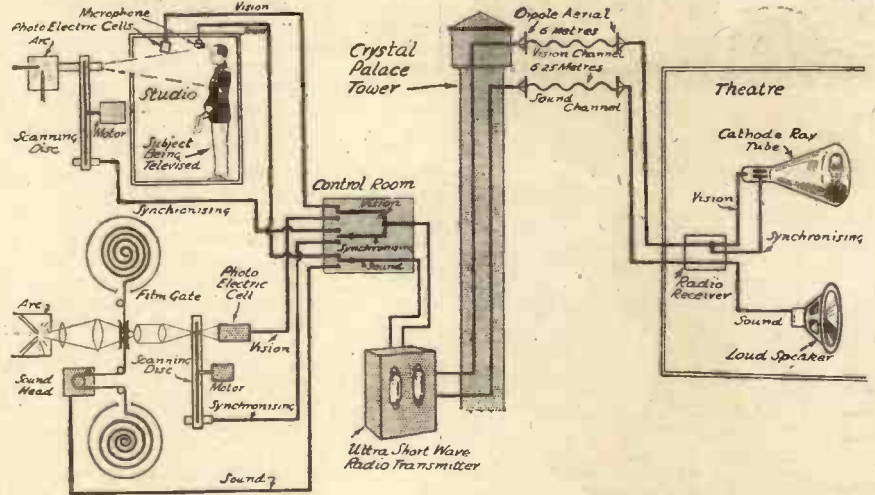

Fig. 1.—A pictorial representation of the complete Baird high-definition ultra-short-wave television scheme.

clear, and flickerless, and showed a wealth of detail which had hitherto been thought impossible.

Explaining the Scheme

Since this entirely new radio technique represents something so new in the television field, readers of PRACTICAL TELEVISION will naturally be interested in the technical details. A broad outline of the complete scheme is given in Fig. 1, so this will now be traced stage by stage.

First of all, the spot-light transmitter was built up from a large diameter disc enclosed in a strong metal case. The disc is driven at a speed of 3,000 revolutions per minute and around the periphery is a spiral of holes working in conjunction with an ingenious cam mechanism. Behind the disc at the top is a powerful arc lamp which has its beam of light condensed on to a top section of the disc so that as the holes pass across the beam a thin pencil of light passes through each individual hole. A rect-

angular scanned area made up from 180 horizontal lines is produced in this way, and by passing the light through a lens combination and then through a small glass window let into the partition separating the transmitter proper from the studio (see Fig. 1), it is focused on to the subject. Either a short-focus lens for close-up images (head and shoulders) or a long-focus lens (head and body) can be brought into play as desired. In this way a spot of light is made to move over the subject being televised with great rapidity (actually twenty-five pictures per second are transmitted with this apparatus) in a series of 180 horizontal lines in juxtaposition to one another.

Introducing the Photo-electric Cells

During the exploring process different parts of the individual features, clothes or objects reflect differing amounts of light,

and these are "picked up" or affect three very large photo-electric cells suspended in front so that the varying reflected light is changed to an equivalent form of varying electrical voltages. The cells are shown very clearly in Fig. 2, two of them being positioned so that they are one on each side of the person being televised, while the third

(Continued overleaf)



Fig. 2.—Showing Sir Harry Greer before the large photo-electric cells in the spot-light studio. Note the careful metallic screening,

is above. The cells are adequately screened by metal containers and wire-mesh covers, and with them are associated the "A" amplifiers.

The studio is sound-proof, and elaborate precautions are taken to "insulate" it against any form of electrical interference by using copper sheet, an important point when it is remembered that in this new process frequencies approaching a million cycles a second are dealt with by the amplifiers, *without amplitude or phase distortion*. The amplified electrical signals

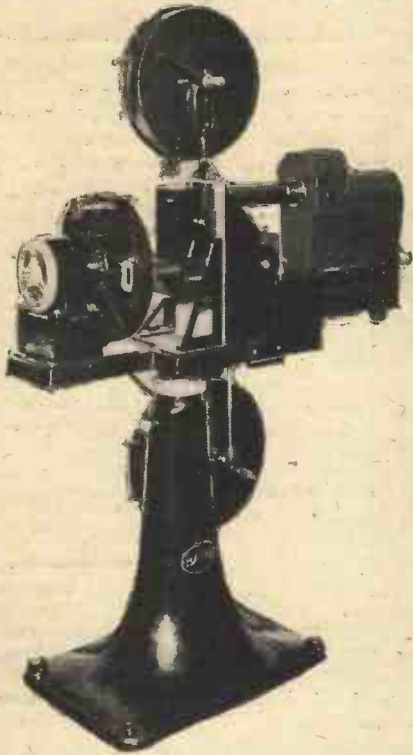

Fig. 4.—Showing the disc and optical arrangements together with the synchronizing aperture.

are now passed to the control room "B" amplifiers, as seen in Fig. 1. At the same time a sensitive condenser microphone transmits the sound from the studio to separate amplifiers also situated in the control-room. Last of all there is the synchronizing signal, which is produced separately (see Fig. 1) through the medium of the main scanning disc working in conjunction with a light source and single photo-electric cell. In this way a steady frequency is generated which also passes to the control-room amplifiers.

A Film Television Transmitter

Housed in the same building at the Crystal Palace is a film transmitter built specially for television, ordinary talking films being used. Hitherto only carefully chosen subjects with very little detail had been televised, but the development and perfection of this new piece of apparatus makes it capable of handling standard talking films such as are used in any public cinema. In a simple way the operation is shown in Fig. 1, while Figs. 3, 4 and 5 illustrate different views of the actual machine. Standard talking films (sound on film type) are passed through the "gate" of a continuously moving film projector. An arc source of light (seen on the left of Fig. 3) projects the individual pictures of the film through a focusing lens

on to a disc rotating in a dust-proof cover at a speed of 3,000 revolutions per minute. This section of the apparatus is seen on the right of Fig. 3. The disc has a circle (not a spiral as in the spot-light machine) of ninety minute holes arranged at equi-angular intervals near the periphery, and as the film pictures move downwards at right angles to the hole movement, variations of light pass through the scanning holes. Here they influence a single photo-electric cell and associated amplifier (not shown in the illustrations) to be converted into equivalent voltage variations and transferred to the control-room amplifiers.

The film passes continuously through the "gate" at the rate of 25 pictures per second, and as the disc revolves 50 times per second the 90 holes in the disc pass across each film picture twice in its travel; thus "breaking" it up into 180 horizontal lines. At the same time a synchronizing signal is generated at another aperture section of the disc casing—seen clearly as a white rectangle in Fig. 4—by means of a small projection lamp forcing light through the rotating disc holes to influence a single photo-electric cell mounted against the side of the disc casing. During this televising process the sound is picked up from the track at the edge of the film by passing through a standard film head, and this section of the apparatus, together with the television transmitter optical arrangements, are clearly seen in the enlarged section photograph of Fig. 5. The whole machine is mounted on a heavy cast-iron pillar, the base of which is bolted to the floor to ensure rigidity.

Ultra-short Waves

As will be gathered from Fig. 1, the vision, synchronizing and sound signals are transferred to the control-room, where a switchboard enables either the film or spot-light signals to be fed to the ultra-short wave radio transmitter situated at the base of the Crystal Palace South Tower. Actually the vision and synchronizing signals are "mixed" and are then made to modulate the carrier wave of the 6 metre vision channel, to be radiated into space from the dipole aerial situated right at the

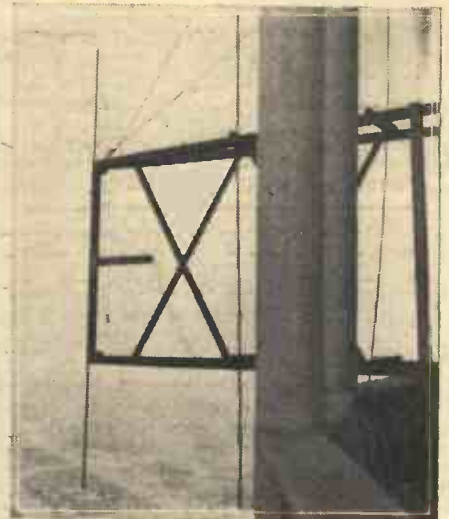

Fig. 6.—The dipole ultra-short-wave transmitting aerial at the top of the Crystal Palace Tower.

top of the tower and seen in Fig. 6. The structural support for the aerial had to be strong and rigid to withstand the high winds encountered at this height, and the twin wire feed can be observed together with a special radiation-meter check loop. The sound is radiated on a separate channel of 6.25 metres, using its own radio transmitter for this purpose.

Owing to the peculiar nature of these waves—sometimes called quasi-optical waves owing to their dispersion properties resembling those of ordinary light, and in consequence the receiving and transmitting sites should be within sight of one another—an extremely high transmitting situation is required, and it was for this reason that the Baird Company chose the Crystal Palace location, for the top of the South Tower is the highest point in London. The extreme value of this choice has been proved from the results of considerable tests.

(To be continued)

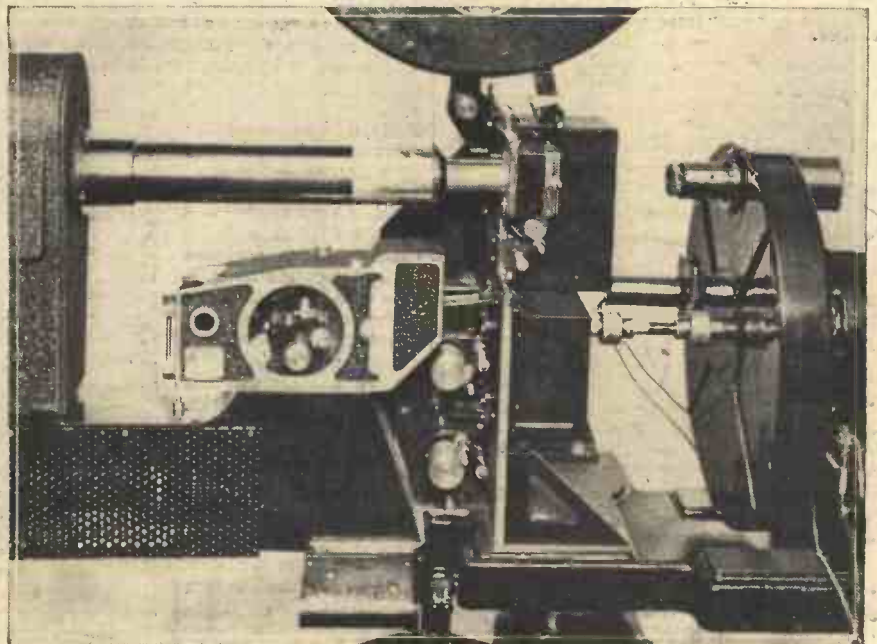
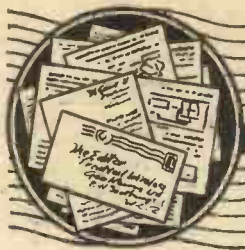

Fig. 5.—A close-up view of the sound head, film gate and scanning apparatus.



READERS' WRINKLES

THE HALF-GUINEA PAGE

Rubber Feet for a Radiogram Cabinet
 THE accompanying sketch shows a device for eliminating floor resonance in a radiogram cabinet, and, at the same

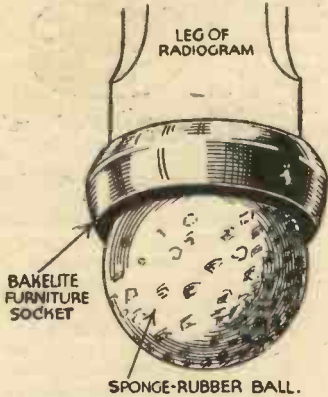

Sponge-rubber feet for a radiogram cabinet.

time, preventing slipping on a polished floor. My radiogram used to pick up noises from all loose panels and windows until fitted with this device, which is cheap but efficient. As will be noticed in the illustration the device simply consists of a cupped furniture socket which is screwed to the end of each leg of the radiogram. A sponge-rubber ball is then fitted into each socket as shown in the illustration.—L. WARBURTON (Levenshulme).

A Turntable for a Portable Set

HERE is a dodge for making a turntable for use with a portable wireless set, particularly those of the suitcase type which are very often difficult to turn. The materials required are as follow:—1 old gramophone turntable (10in. preferred), 2 discs of 5-ply wood 9in. diameter, 1 flat-headed bolt and a few screws, 1 spring washer as used for gramophone turntables. File out the hole in the turntable so that it will turn on the bolt evenly, sew the two discs of plywood together, put bolt through the centre, and fasten with a nut. Fit the turntable, and, after filing the groove for the spring washer, cut the bolt off level with turntable. If it projects slightly use

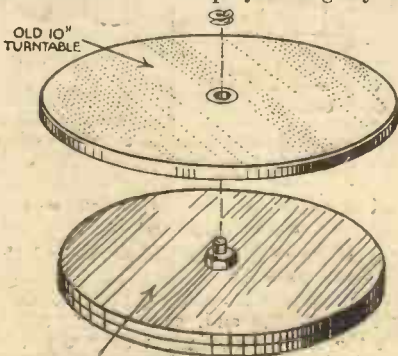

TWO 9" DIA. CIRCLES OF PLYWOOD, BOLTED TOGETHER

A simple turntable for a portable set.

THAT DODGE OF YOURS!

Every Reader of "PRACTICAL WIRELESS" must have originated some little dodge which would interest other readers. Why not pass it on to us? We pay £1-10-0 for the best wrinkle submitted, and for every other item published on this page we will pay half-a-guinea. Turn that idea of yours to account by sending it in to us addressed to the Editor, "PRACTICAL WIRELESS," George Newnes, Ltd., 8-11, Southampton Street, Strand, W.C.2. Put your name and address on every item. Please note that every notion sent in must be original. Mark envelopes "Radio Wrinkles." Do NOT enclose Queries with your Wrinkle.

a thin cork mat. The accompanying drawing shows the arrangement quite clearly.—C. HARNISS (Fulstow, Lincs).

Tool for Slotting Coil Formers

MANY constructors cut the slots in the ribs of coil formers with a file, but the following dodge is quicker and easier. Take a hack-saw blade and break

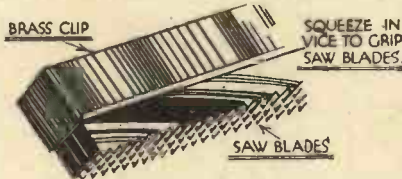

A handy tool for slotting coil formers.

it in three pieces. Place these side by side with the teeth pointing in the same direction and bend a thin brass or aluminium clip over the back to keep the saw blades in place, as indicated in the sketch. If the clip is made the right depth the tool can be arranged to cut the depth required, thus ensuring accuracy. If a wider or narrower groove is required the number of pieces of blade can be varied accordingly.—E. SMART (Coventry).

A Useful "Spanner"

QUITE a useful "spanner" can be made with the aid of an old or broken bradawl and a number of spade

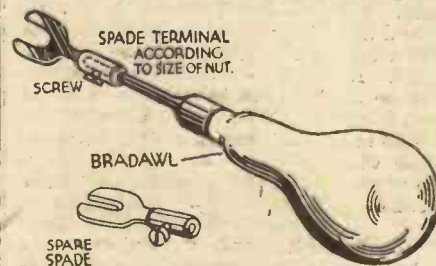

Using spade terminals as spanners.

terminals of various sizes. Unscrew the spade terminal and insert the awl in place of the usual wire, as shown in the sketch, and tighten up again. The spanner can be used in the ordinary way.

Various coloured spade terminals can be used for different sizes of nuts.—K. R. BIRD (Hornsey).

A Handy Inspection Lamp

THIS handy lamp is simple to make and consists of a small fuse-holder, an ordinary spring clothes-peg, and a piece of twin flex. This little device is very useful as it can be clipped anywhere in the set, leaving both hands

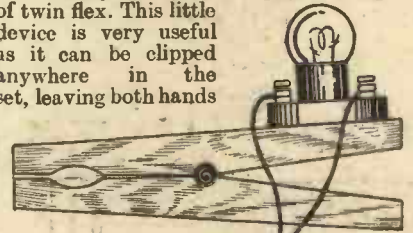

TO BATTERY.

A simple spring-clip inspection lamp.

free to work. The sketch shows the arrangement quite clearly.—G. H. L. (Kenton).

A Simple Microphone

THE accompanying sketch illustrates how a cheap but fairly efficient microphone can be constructed at home. The sound box consists of a deep cigar box minus the lid. This is inverted and mounted on rubber strips (to eliminate vibration). It is advisable to use a box with a thin bottom, as this constitutes the diaphragm. A piece of brass, drilled and bent as shown, is screwed to the diaphragm. A carbon block is fastened 1 1/2 in. away from the bracket by means of a terminal. Next a hole is drilled 1 in. away from the end of a 3in.-battery carbon. Through this hole a wire axle is passed to suspend the rod from the bracket. With the long portion of the rod touching the block, a coil of thick wire is wound round the short end. By sliding this coil along the rod the carbon can be made to rest very lightly on the block, as it should. A terminal screwed to the brass bracket constitutes the second terminal. The microphone described will be found to be very sensitive, if well made. It is used in the same way as the conventional type of microphone.—R. WILSON (Leeds, 6).

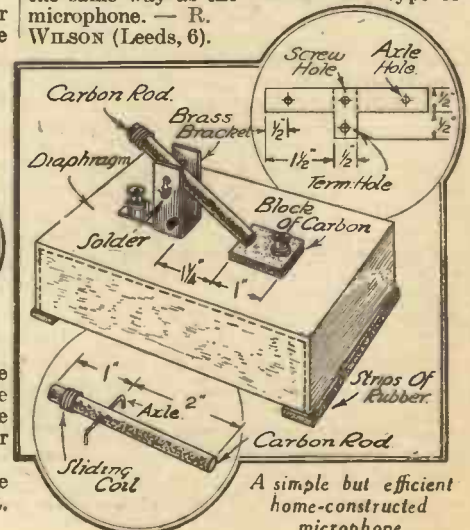

A simple but efficient home-constructed microphone.

READERS' WRINKLES

(Continued from previous page)

Switching Arrangement for a Battery Set

THE accompanying illustrations show an efficient method of simplifying the switching of a battery set having a metal oxide rectifying unit for the H.T.

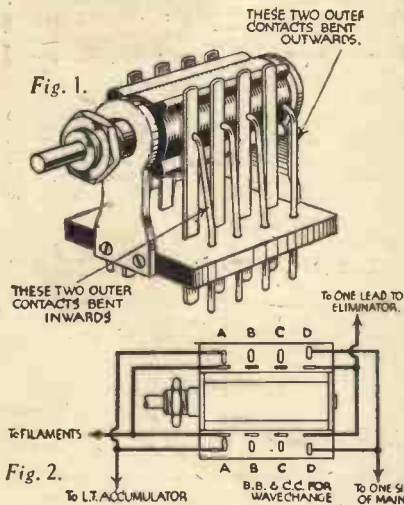

Rotary battery and wave-change switch for a battery set.

supply. The on-off + wave-change switch (Fig. 1) is of the multi-pole type, and this is modified so that it automatically switches on the L.T. before the mains are connected to the rectifier, and, when switching off, this order is reversed. Blades A, A, are used for filament switching; B, B, C, C, for wave-change; and blades D, D, for connecting mains to eliminator. The contacts of A, A, are bent in until there is only a very small gap between the blades and contacts with the switch in "off" position. The contacts B, B, C, C, are bent outwards until blades and contacts only just make satisfactory contact with switch in either "long" or "short" position. The wiring connections are shown in Fig. 2. When the contacts have been altered, as mentioned above, it is obvious that blades A, A, must make contact before blades D, D, which results in the filament being switched on before the H.T. Although this method introduces mains wiring into the set, and brings it quite close to part of the grid circuit of the detector valve, I can detect no trace of hum due to this.—E. ROBERTS (Hythe).

A Gas-heated Soldering Iron

THE soldering iron shown in the sketch is made up from gas tubing and a piece of copper, or better still monel metal, as it does not corrode like copper. The gas tubing may be from 1 in. to 1½ ins. in diameter, according to the size of iron required.

The end of the tube is recessed to take the copper bit, either screwed or riveted. About 2 ins. is cut away from the tube, leaving a narrow strip on each side, and holes are drilled to allow the flame to escape. The other end is screwed to take a smaller piece of piping to suit the flexible

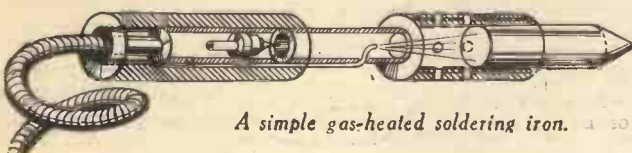

A simple gas-heated soldering iron.

tube from the gas supply. A plug is fitted in the tube, which is arranged to take a small piece of tubing with about a sixteenth hole. This is fixed in the plug at the side of it, a good fit, but able to slide in the plug. In the centre of the plug a hole is drilled and this is tapered to a needle point at the orifice.

When this is adjusted to the correct distance to suit the local supply, the pressure of the gas from the small orifice will be sufficient to keep the flame at the end of the small tube directed on to the bit, and will heat the iron in a short time. This small flame is also hot enough to braze small articles efficiently. I have used this type of blow flame for some time and found it very economical to use.—W. H. GRAYLING (Cambridge).

A Novel Automatic Station Log

THIS handy station log works as follows:—Rod B is free, rotates behind the panel, and is joined by paper through a slit in the panel to Rod A. Rod

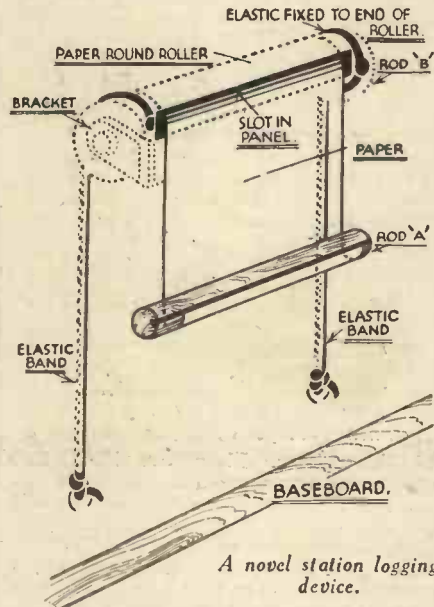

A novel station logging device.

B is also attached to the baseboard by an elastic band each side when Rod A is pulled, paper is unwound off Rod B and elastic band is wound on. When Rod A is released, the elastic causes the paper to be wound on to Rod B again. Stations, wavelengths and dial readings are written on the paper, which should be of a strong kind. The nails in each end of Rod B are passed through holes in right-angle brackets, which are mounted upon the back of the panel. Rod A should be of ¼ in. dowelling, and the other rod can be of larger diameter, each being about 3½ in. long. A longitudinal groove in Rod A, about ¼ in. deep should be made with a tenon saw, and the end of the paper is fixed in this with glue.—D. N. LAWSON (Haslemere).

An Easily-made Stand-off Insulator

THE accompanying sketch shows a form of stand-off insulator which I have contrived. Short-wave experimenters will find many uses for them. The insulator consists of one valve-holder (of the rigid type, with all fittings removed), one piece of ebonite tubing (cut from old lead-in tube), and one brass

terminal. The long screwed portion of the terminal is sleeved by the tubing, which allows the terminal to pass through a hole drilled in the centre of the valve-holder, a fixing nut being screwed on inside the holder. This insulator has a remarkably neat appearance, and has proved quite satisfactory in use. Its efficiency, of course, can be increased by raising it on pillars.—GEORGE D. FORBES (Glasgow).

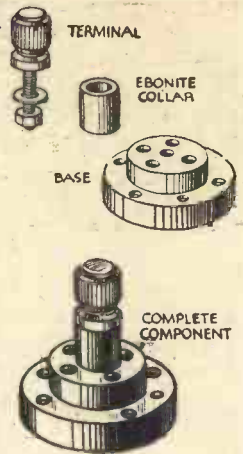

An improvised stand-off insulator.

A Combined Condenser and Wave-change Switch

A MIDGET condenser of the type shown in the sketch may be very easily transformed into a wave-change switch, while still being used as an aerial series condenser. One of the fixed plates at the end is removed and in its place is fixed a stout piece of fibre, cut and drilled and with two copper contacts fixed as shown. To the end of the spindle bearing the moving vanes, and which passes through the larger hole in the fibre, is fixed a switch arm which rotates, and makes contact with the copper contacts upon the fibre. The condenser is wired up as shown in the diagram. The strip of copper C is so arranged that when making contact with A, the capacity is at a minimum required for the short waves. When making contact with B the capacity of the conden-

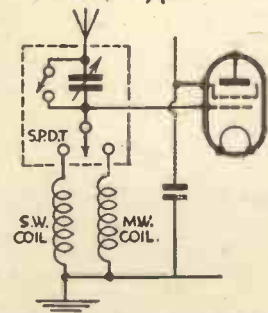
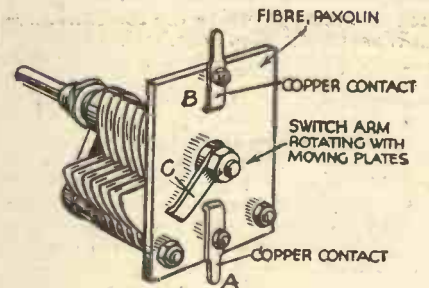

Adapting a condenser to operate as a wave-change switch.

ser is at its maximum. If so desired the condenser may be shorted for the long waves by giving the moving plates a slight bend up at one end, so making contact with the fixed plates when they are fully enmeshed. Any insulating material, such as ebonite, may, of course, be used, if thin enough.—D. STANLEY SCOTT (Steynsburg, S. Africa).

MAKING A START ON THE SHORT WAVES

An Article of Special Interest to those Readers Who Have Not Yet Taken an Interest in Short-Wave Reception. Practical Information is Given in Regard to the Construction of a Simple and Efficient Short-Wave Receiver.

By FRANK PRESTON

DESPITE the tremendous amount of interest which is to be gained from short-wave reception, it is rather surprising to find how comparatively few amateurs and experimenters there are who take an active interest in short-wave work. It would appear that, in many cases, readers are inclined to fight shy of short waves because they believe that the subject is tricky and abounding with "snags" and difficulties. As a matter of actual fact, however, this idea is entirely wrong, for short-wave reception differs very little from normal broadcast reception except, perhaps, that the receiver required for the reception of stations all over the world is *much simpler* than that which is generally employed for listening to broadcasting stations on the medium and long-wave bands.

Simplicity is the Keypoint

In nearly every case it is true to say that the best possible set for reception on wavelengths below 100 metres or so is the simplest one that can be devised. Simplicity is, in fact, the keypoint of the short-wave receiver, and as soon as amateurs realize this they almost invariably give the short wavelengths a trial. In too many instances, however, the results obtained are not so good as were anticipated; this is simply due to the fact that the amateur has failed to work on the right lines, or to give a little study to the matter before rushing wildly into it. The purpose of this article is to supply the information which is necessary in making a start, so that would-be short-wave listeners may avoid any of the mistakes that are commonly made and may be successful at the very first attempt.

Before going farther it might be as well to answer a simple question which is of frequent occurrence. The question is: "Is short-wave work really worth while, and are there sufficient programmes to justify the construction of a set to pick them up?" The answer is very definitely "Yes." It is probably no exaggeration to say that there are more stations working between, say, 15 and 20 metres than there

are between 200 and 2,000 metres. It is true that all these stations do not give regular programmes for eight to ten hours a day, but there are scores of them which do provide a reliable service in the way of musical entertainment and so on. Additionally, though, there are hundreds—probably thousands—of other stations, many of which are owned and operated by amateurs, which afford more interest to the

question. One of the first things that the amateur will want to know before he definitely decides to make a short-wave set is how much he will have to spend. In the following paragraphs it will be shown that

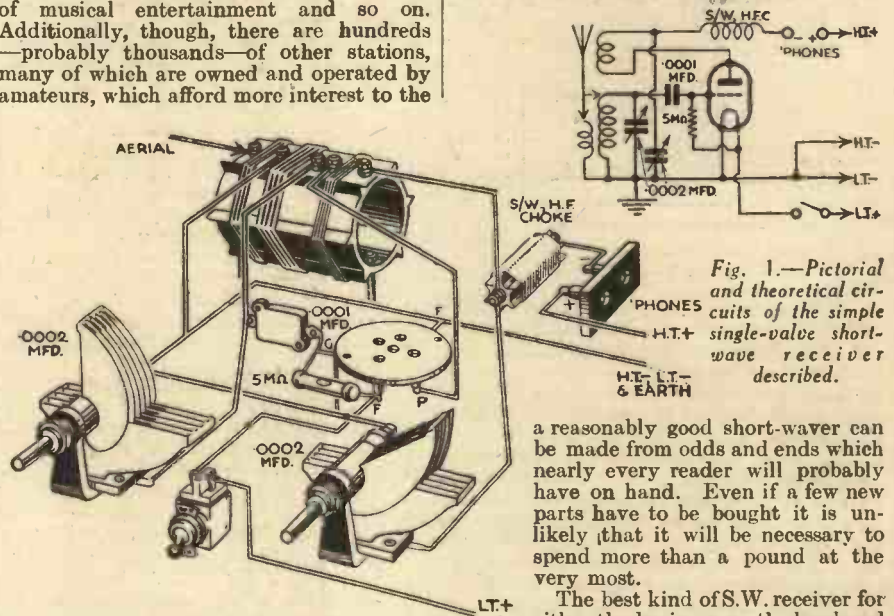

Fig. 1.—Pictorial and theoretical circuits of the simple single-valve short-wave receiver described.

a reasonably good short-waver can be made from odds and ends which nearly every reader will probably have on hand. Even if a few new parts have to be bought it is unlikely that it will be necessary to spend more than a pound at the very most.

real amateur and experimenter than do all the broadcasting stations in the world.

Another great feature of the short waves is that even quite low-powered transmitters can be received over incredible distances on the simplest possible type of receiver. It is by no means uncommon to receive a station in Australia, for example, on a single valve set costing no more than about a couple of pounds in components. Besides this, it is worth remembering that, on certain short-wave bands, reception is actually better in daylight than after dark. This is contrary to the conditions obtaining on the longer waves, where anything like long-distance reception is well-nigh impossible during the summer months. World-wide reception on short waves can be accomplished the whole year round; this fact will appeal strongly to the "DX" amateur who is inclined to lose interest in his hobby as the longer days draw on.

The best kind of S.W. receiver for either the beginner or the hardened short-wave "fan" is the single-valver of the "straightest" possible kind. A circuit of such a set, accompanied by a pictorial wiring diagram for the benefit of those few readers who still find it rather difficult to read a "theo," is given in Fig. 1. It will be seen that a simple tuner is used, and this

(Continued on page 116)

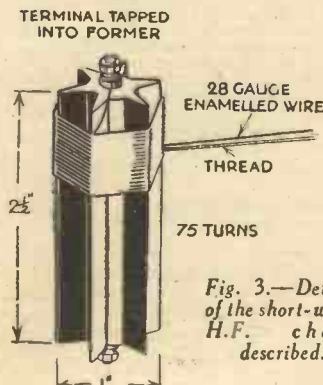

Fig. 3.—Details of the short-wave H.F. choke described.

Inexpensive Experiment

But enough has been said in praise of shortwaves, and it is time to get down to more practical aspects of the

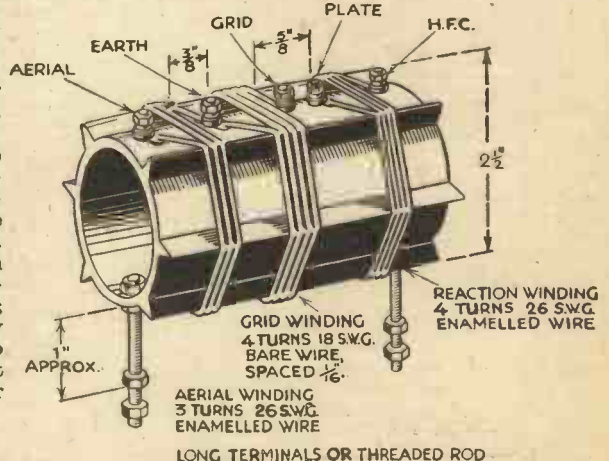

Fig. 2.—All details are given above for the construction of an efficient short-wave tuner to cover a wavelength range of 15 to 20 metres. Notice that all windings are wound in the same direction.

OUR GREAT NATION

First Prize: 20 GUINEAS CASH—And 200

Our Readers are Invited to Become Test Experts of the New
Testing, by Home Constructors

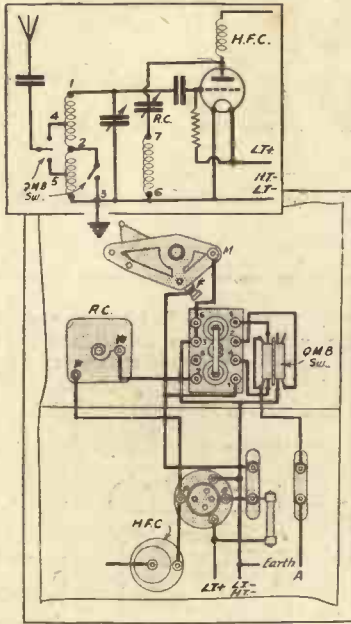

Fig. 1.—Here is a simple detector circuit which may be used alone or with L.F. amplification.

AS announced in last week's issue, we give this week complete details of our new scheme for testing new wireless components. We were induced to embark on this competition by virtue of the production by Messrs. Varley, Ltd., of their Bifocal coil which provides an excellent, cheap, and satisfactory solution to the selectivity problem. As previously mentioned, it is always our policy to act in the best interests of our readers, and we are gratified to know (so great is the faith of the manufacturers in this clever device) that Messrs. Varley, Ltd., welcome the co-operation of our readers in testing it for them. It would obviously be a lengthy and expensive process for them to send representatives all

over the country to test these coils, and PRACTICAL WIRELESS therefore made the suggestion that we should place the services of our readers at their disposal; in other words, that our readers should act as independent test experts and thus augment the data they have obtained as a result of their own exhaustive tests. We would say that these coils have been thoroughly tested in a number of ways, and in a number of districts, and have passed those tests entirely satisfactorily.

These Varley Bifocal coils have arrived at a time when the selectivity problem has become an urgent matter, and the problem has been by no means easy of solution, for a successful device such as the Bifocal coil had necessarily to be designed so that it could be quickly incorporated in any standard receiver. Additionally, it needed to be reasonable in price, and it is a tribute to the Varley engineers that they have been able in so ingenious a manner to solve the problem.

What we particularly desire is that the many hundreds of readers who have purchased these coils should send us, in accordance with the conditions printed below, their reports on the performance of this new coil. The diagrams on this page show how the coil can be connected into the usual circuits employed, but in case readers missed the preliminary announcement in last week's issue, brief technical details of the coils are given here.

Advantages of the Bifocal System

The principle upon which the Bifocal coil operates is very interesting from the technical point of view. It is, of course, well known that by employing a small coil connected directly between aerial and earth, and coupling this to the grid coil, it is possible to control the degree of selectivity by varying the relation between the two coils, or in other words varying their inductive coupling. Unfortunately, if two simple coils are employed in this manner, not only is the selectivity varied

as the coils are separated, but the amount of signal energy which is transferred is also varied, and the gain in selectivity is accompanied by reduction in signal strength. In the Bifocal coils the grid coil is simply tapped, thus providing an auto-transformer instead of a transformer coupling for the aerial. The actual point at which the aerial is tapped is one of the principal features which has to be calculated for optimum results, and arranged inside the coil is a small plunger of the new

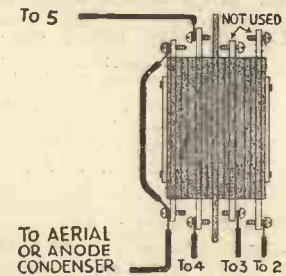

The Varley Bifocal coil.

The switch that is intended for wave-changing and its connections.

iron-core material. This is not so long as the coil former and it may thus be moved from one end of the coil to the other. It has already been explained in these pages that the insertion of this material inside a coil increases its inductance, and consequently, if it is moved so that it does not come within the portion which is utilized for the aerial section it will vary the inductance only of the grid coil. As, however, it is moved to embrace the turns which serve both as aerial coil and grid coil, the change in inductance will in effect vary the degree of "transformer coupling," whilst still giving the same overall inductance value to the complete coil, as the core is at all times within the

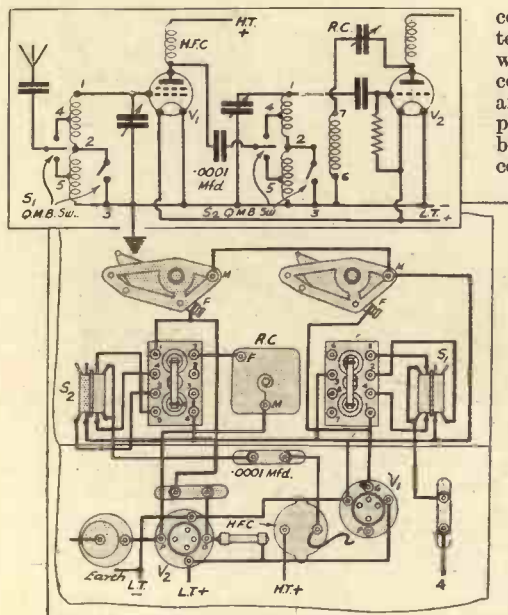

Fig. 4.—An H.F. and detector stage which employs two of the Bifocal coils.

CAREFULLY READ THESE RULES.

- (1) The First prize of 20 guineas cash will be awarded to the sender of what the judges (presided over by the Editor of "Practical Wireless") consider to be the best test report of actual experiences with the Bifocal coil. Consolation prizes will be awarded to the senders of the 200 next best test reports. Test reports may be accompanied by sketches, showing the competitor's own Bifocal arrangement. Reports of failure will stand an equal chance of winning a prize.
- (2) Each entry must be accompanied by proof of purchase of a Varley Bifocal coil, such as the receipt from Messrs. Varley, Ltd., or a receipt from your local dealer.
- (3) Competition entries must be received here not later than May 14th. Results will be given in "Practical Wireless," dated May 26th.
- (4) Test reports must be written on one side of the paper only and must not exceed 250 words in length.
- (5) This competition is only open to readers of "Practical Wireless," and each entry must be accompanied by a Query Coupon cut from any issue between April 14th and May 5th.
- (6) Competition entries should be addressed to the Editor, "Practical Wireless," Geo. Newnes, Ltd., 8-11, Southampton Street, Strand, London, W.C.2, and have the word "Bifocal" written in the top left-hand corner.
- (7) No correspondence can be entered into regarding this competition.
- (8) The Editor's decision is final and legally binding and is an express condition of entry.

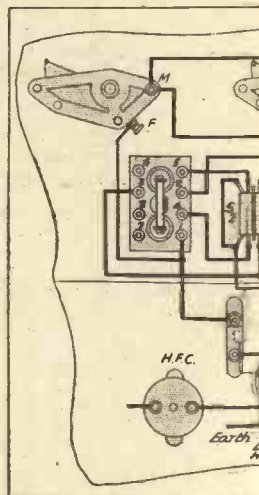
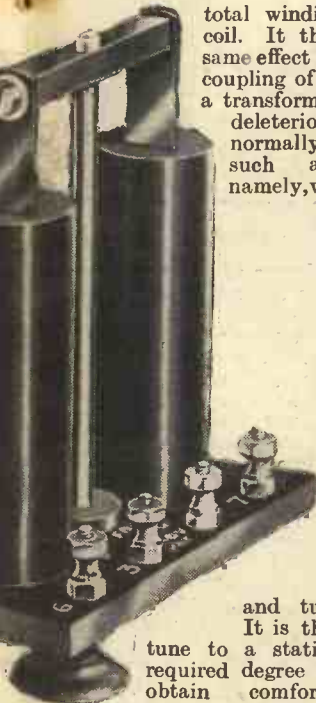

Fig. 3.—The Bifocal coil pass circuit as shown.

CONSOLE COMPETITION!

250 Consolation Prizes! No Entry Fee!

Varley Bifocal Selectivity Device. Our New Scheme for the Rapid of New Radio Components



total winding of the grid coil. It therefore has the same effect as changing the coupling of the primary of a transformer, without the deleterious effects which normally accompany such an alteration, namely, varying reaction

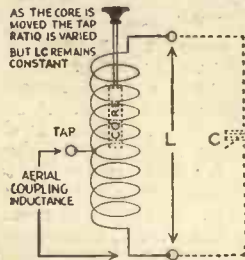

Diagram illustrating the method in which the iron core varies the coupling of the fixed tap.

is obtained from the novel variable tap principle incorporated in the Bifocal coil. By adjusting the coupling in this coil, the true selectivity of the circuit and the selectivity due to reaction can be varied entirely. This is not the case with the ordinary type of coil having only one tapping. With such a coil, if the station which it is desired to receive is interfered

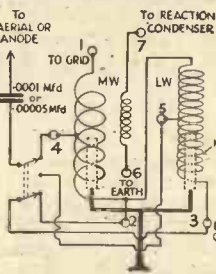

Diagram of the complete coil and its associated connections.

and tuning settings.

It is thus possible to tune to a station, apply the required degree of reaction to obtain comfortable signal strength, and then, if a change in the degree of selectivity is found to be necessary, the core may be moved to obtain the required selectivity without the necessity for alteration in the other settings.

overloading of the low-frequency stages.

Of course, the signal strength can be reduced by connecting a fixed condenser in the aerial lead, but this would alter the tuning and make the receiver more difficult to handle.

With the Bifocal coil, however, selectivity and reaction are quite independent. If the station it is desired to receive suffers from interference, the selectivity, or focusing control, is adjusted until the interfering station disappears, and then the strength of the desired station is brought up, if necessary, by increasing the reaction.

A Novel Bifocal Circuit

Circuit No. 2 shows a variation of the reacting detector circuit, reaction in this being partly capacitive and partly inductive, the inductive portion of the wiring

also acting as the aerial coupling. As the aerial coupling is increased the load on the tuning circuit will become greater, thus tending to reduce the selectivity. As the coupling is increased, however, the reaction feed-back effect will also increase, and thus the balance is maintained.

Band-pass Tuning with the Bifocal Coils

Circuit No. 3 shows an interesting method of obtaining band-pass tuning with two Bifocal coils. The .0001 mfd. fixed condenser is connected between the high potential end of the first coil and tapped on the second coil. By this means the band width passed by the filter can be varied, and the overall

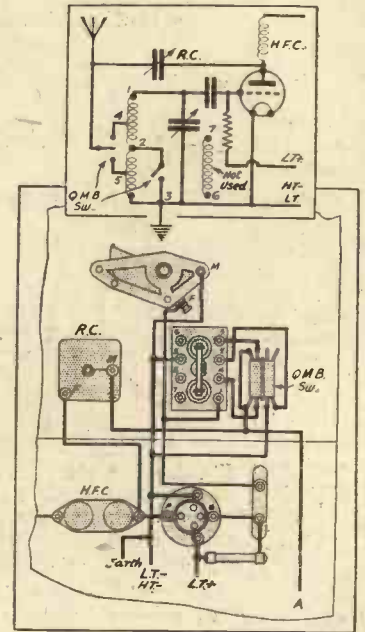
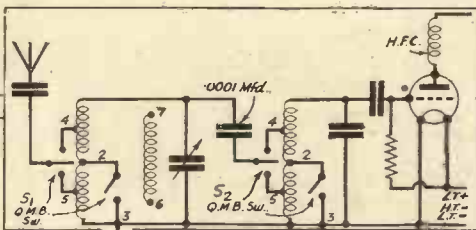

Fig. 2.—In some cases this detector circuit may prove more useful than that shown in Fig. 1.

response of the receiver suited to many different purposes. For instance, if the receiver was being used to receive television signals, a large band width could be employed, thus ensuring the addition of the extreme upper frequencies necessary for good definition. On the other hand, for normal radio reception, a narrower band width is required, and this is quickly obtained by suitable adjustment of the coupling.

It should be noted that if a two-gang condenser is employed, it should be of the type in which the aerial section is controlled by means of a panel-operated

(Continued on page 122)



The Bifocal in a Standard Detector Circuit No. 1 shows a standard detector circuit which can be varied by any of the usual low-frequency arrangements which are straight circuits, Q.P.P., or Class B. It is in this type of circuit perhaps that the greatest benefit

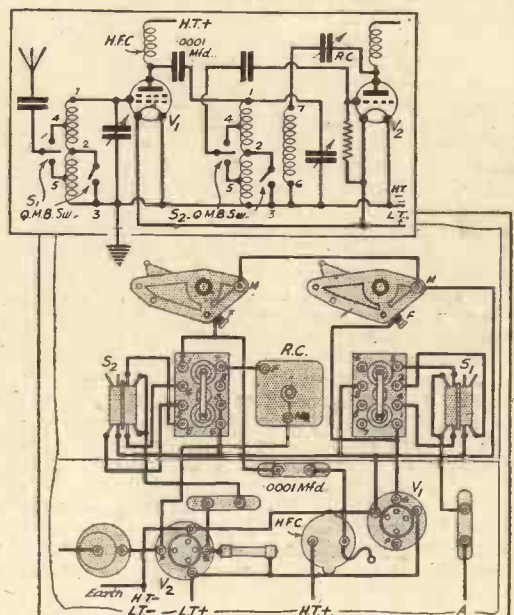

Fig. 5.—Here is an alternative H.F. and detector circuit with the grid tapped down to remove damping.

... may be used in a band-pass tuning circuit as shown in this illustration.

(Continued from page 113)

is provided with a loose-coupled aerial winding and also with a reaction winding. The aerial lead-in may be connected to one end of the loose-coupled coil or to the "grid" end of the grid coil as desired, although the former connection will be found better in the majority of cases, especially if the usual "broadcast" aerial is to be used. The grid coil is tuned by means of a .0002 mfd. variable condenser, whilst reaction is controlled by a second variable condenser of similar capacity. Leaky-grid rectification is employed, but the values of grid condenser and leak are rather different from those generally used in a set intended for use on the higher wavelengths; the condenser is of .0001 mfd. capacity and the leak has a resistance of 5 megohms. As a matter of fact, these values are not critical, but they are found to produce best results.

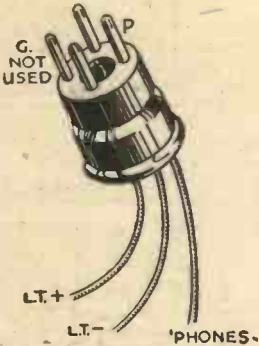

Fig. 4.—This sketch shows how an old valve-base can be used as a plug when the short-wave receiver is being used as an adaptor.

"Throttle-Control" Reaction

An H.F. choke of special short-wave type is connected in the anode circuit of the valve, and particulars will be given later in regard to the construction of this component. Those readers who are accustomed to following circuit diagrams will notice that the reaction condenser is not connected in the usual position, but is between the "H.T." end of the reaction coil and earth. This form of reaction is generally referred to as "throttle control" due to the fact that the condenser is used to "throttle" the oscillation of the valve. In other words the condenser, instead of increasing reaction as its capacity increases, produces the opposite effect by by-passing the H.F. currents appearing in the anode circuit to earth.

The connections are simplicity itself, as can be seen, so there will be no need to describe them. Instead, attention will first be turned to the construction of the special short-wave coil and H.F. choke. The coil is made on a 2 in. diameter ribbed ebonite former as shown in Fig. 2 and consists of three windings, one of which is in 16-gauge bare or tinned copper wire, and the other two in 26-gauge enamelled. Fig. 2 shows that the coil is intended for mounting on the baseboard on two long terminals or lengths of screwed brass rod. Terminals are used to receive connections from the ends of the windings and these are fixed in a line between two ribs on the former. The numbers of turns indicated in the drawing apply to a tuner covering a wavelength of approximately 15 to 30 metres in conjunction with the .0002 mfd. condenser previously referred to, but other coils for alternative ranges could very easily be made by employing proportionate numbers of turns. As an example, it might be stated that a tuner for a wavelength range of about 28 to 60 metres would require three, six and five turns, respectively, for the aerial, grid, and reaction windings.

Dual-Range S.W. Tuners

It would, of course, be a fairly simple matter to make a dual-range type of tuner, but for a start, and where maximum efficiency is the very first consideration, a simple component of the kind shown is strongly recommended. Then again, it would be easy enough to make a range of six-pin plug-in coils to cover the various ranges, but it is considered better to leave that until a later date, and until a little experience has been gained.

The H.F. Choke

The short-wave choke is the simplest component employed in any kind of wireless receiver. It must be made with reasonable care, though, and the details and dimensions given in Fig. 3 will prove useful. A short length of ribbed ebonite former, 1 in. in diameter, is employed to take the winding of 75 turns of 28-gauge enamelled wire, although it is permissible to use a length of 1-in. diameter paxolin or glass tube instead if this is more conveniently obtainable. It will be seen that, in order to reduce the capacity between the turns of the winding, a length of thread is wound on the former at the same time as the wire, so as to space the turns of wire.

The Tuning Condenser

After the two components just described, the most important is the tuning condenser. It is preferable to use one specially made for short-wave work, but as an alternative use can be made of any good .0005 mfd. condenser which is on hand, by dismantling this, discarding about one third of the vanes and then re-assembling, fitting double spacing washers between the adjacent vanes. This modification will materially

to pay more than three or four shillings for a really good one.

An alternative to the ultra-slow-motion drive is a double condenser arrangement, whereby a low-capacity (say about .00005 mfd.) variable condenser is wired in parallel with the main one. The smaller condenser is used for fine tuning after the set has been adjusted to the approximate wavelength by means of the normal condenser. This system is generally known among short-wave enthusiasts as "band-spread" and it has been fully described in these pages before. The small condenser, like the other one, should be of the air dielectric type, and can be made by rebuilding an ordinary .0001 mfd. component in the manner previously described, by removing some vanes and double spacing the remainder. Even when using the band-spread idea it is worth while to use a drive mechanism giving a fairly low reduction ratio on the lower-capacity condenser, but a plain 0-180 dial will be suitable for the .0002 mfd. condenser.

The Reaction Condenser

Any good air-spaced condenser of about .0002 mfd. can satisfactorily be employed for reaction control. A slow-motion drive is preferable, but can be dispensed with if a fairly large dial of the kind generally used for operation of the tuning condenser is fitted in place of the small knob supplied with it. It might be mentioned, however, that one firm of component manufacturers make a special reaction condenser for short-

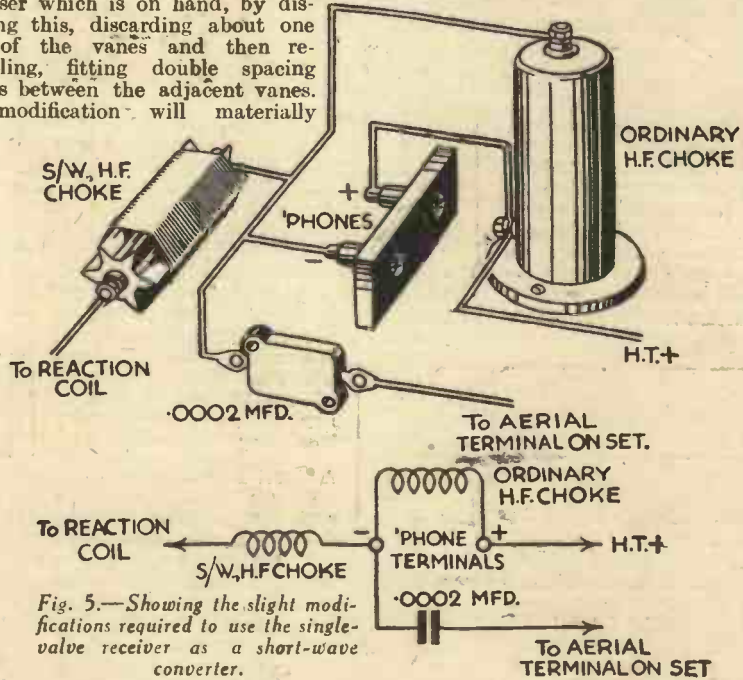

Fig. 5.—Showing the slight modifications required to use the single-valve receiver as a short-wave converter.

reduce the minimum capacity, thereby increasing efficiency and extending the tuning range with any particular coil. Extremely slow movement of the condenser vanes is absolutely essential on short waves, because of the wide frequency range "covered" by so small a variation in condenser capacity. It is therefore practically essential to employ a really good slow-motion drive in conjunction with the tuning condenser. The drive should preferably have a reduction gear of about 50 to 1, and the movement should be perfectly smooth and entirely free from backlash. There are several suitable vernier drives on the market and it is not necessary

wave use, which has a reduction drive of about 10 to 1; this gives an excellent and smooth control.

Assembling the Parts

The method of assembling the component parts shown in Fig. 1 calls for little comment. It should be mentioned, however, that it is very wise to employ either a metal or metalized chassis, since this goes a long way towards the elimination of any possible hand-capacity effects. A metal panel can also be used if desired, but I rarely find that this is necessary, provided that a good earth lead is employed. It is usually best to mount

(Continued on page 118)

FOR EVERY SET — there's a PILOT AUTHOR KIT

CASH — C.O.D. — or H.P.

LISSEN "SKYSCRAPER 3." Chassis model with (Lissen) S.G. Detector and Pentode valves. Cash Price, £4/9/6. Carriage Paid.
Balance in 11 monthly payments of 8/3.
ROLA FR6 PM23 CLASS "B" SPEAKER, with input transformer. Cash or C.O.D. Carriage Paid, £1/19/6.
Balance in 9 monthly payments of 4/6.
ROLA F6P.M. PERMANENT MAGNET MOVING-COIL SPEAKER, with input transformer. Cash or C.O.D. Carriage Paid, £2/9/6.
Balance in 8 monthly payments of 6/-.
BLUE SPOT 99 P.M. PERMANENT MAGNET MOVING-COIL SPEAKER. Complete with tapped input transformer. Cash or C.O.D. Carriage Paid, £2/19/6.
Balance in 10 monthly payments of 6/-.
NEW BLUE SPOT 45 P.M. MOVING-COIL SPEAKER, with input transformer. Cash or C.O.D. Carriage Paid, £2/5/0.
Balance in 7 monthly payments of 6/-.
W.B. P.M.6A MICROLODE PERMANENT MAGNET SPEAKER with switch controlled multi-ratio input transformer. Cash or C.O.D. Carriage Paid, £1/12/6.
Balance in 8 monthly payments of 4/3.
NEW LISSEN P.M. MOVING-COIL SPEAKER with input transformer. Cash or C.O.D. Carriage Paid, £1/5/0.
Balance in 4 monthly payments of 5/6.
CELESTION CLASS "B" UNIT, "B" Stage 9. Combined Class "B" Unit and P.P.M.9 Moving-coil Speaker.
Excluding "Class B" Valve.
Cash or C.O.D. Carriage Paid, £2/15/0.
Balance in 11 monthly payments of 5/-.
Send **8/3** only
Send **4/6** only
Send **6/-** only
Send **6/-** only
Send **6/-** only
Send **6/-** only
Send **6/-** only
Send **6/-** only
Send **2/6** only
Send **5/6** only
Send **5/-** only

IMPORTANT Miscellaneous Components, Parts, Kits, Finished Receivers or Accessories for Cash, C.O.D. or H.P. on our own system of Easy Payments. Send us a list of your wants. We will quote you by return. C.O.D. orders value over 10/- sent carriage and post charges paid (GREAT BRITAIN ONLY). OVERSEAS CUSTOMERS CAN SEND TO US WITH CONFIDENCE. We carry a special export staff and save all delay. We pay half carriage—packed free. Send full value plus sufficient for half carriage. Any surplus refunded immediately. Hire Purchase Terms NOT available to Irish or Overseas customers.

LEADER THREE

KIT "A" CASH — C.O.D. 60/- OR YOURS FOR 5/6

And 11 monthly payments of 5/6

KIT "A" Author's Kit of Specified Parts, including Peto-Scott **METAPLEX** Chassis but less Valves. £3 0 0
Cash or C.O.D. Carriage Paid. Or 12 monthly payments of 5/6.

KIT "B" As Kit "A" but with Valves only. Cash or C.O.D. Carriage Paid, £4/11/6. Or 12 monthly payments of 8/6.

KIT "C" As Kit "A" but with Valves and Peto-Scott Table Cabinet. Cash or C.O.D. Carriage Paid, £5/9/0. Or 12 monthly payments of 10/-.

KIT-BITS You pay the Postman. We pay post charges on all orders over

10/- GREAT BRITAIN ONLY		£	s.	d.
1 Peto-Scott Chassis 12 x 10 x 1 1/2 ins.		0	3	6
1 J.B. 2 gang condenser type Nugang "A"		0	17	6
2 Wearite Universal Screened Coils		0	10	0
1 Varley Niclet 5:1 L.F. Transformer		0	7	6
1 Set of Specified Valves		1	11	3
1 Peto-Scott Table Cabinet (Carr. 2/6 extra)		0	17	6

KIT "CC" As Kit "B" but with Peto-Scott Walnut Console Cabinet with Shelf and Baffle. Cash or C.O.D. £5. 16. 0 Carriage Paid.
Or 12 monthly payments of 10/6.

If Peto-Scott Permanent Magnet Speaker required add 19/6 to Cash Price or add 1/9 to each monthly payment.

TELSEN

323 STRAIGHT BATTERY THREE

Complete Kit of Parts in Sealed Carton, less Valves, Cash or C.O.D. Carriage Paid 29/6 or yours for 5/- down and 5 monthly payments of 5/6.
As above but with 3 Mazda Valves. Cash or C.O.D. Carriage Paid, £2/15/6, or 5/- down and 11 payments of 5/6.



As above, with Valves, but including PETO-SCOTT Compact Cabinet illustrated and PETO-SCOTT B.A. Speaker. Cash or C.O.D. Carriage Paid, £3/17/6, or yours for 7/6 and 11 monthly payments of 7/-.
If Peto-Scott Permanent-Magnet Moving-Coil Speaker required add 12/6 to Cash Price or 1/2 to each monthly payment.

YOURS FOR **5/-**

NEW BLUE SPOT "CLASS B" OUTPUT STAGE. As advertised. Complete with Osram B21 "Class B" Valve. Cash or C.O.D. Carriage Paid, 43/6.
Balance in 11 monthly payments of 4/-.
B.T.H. SENIOR PICK-UP AND TONE ARM WITH VOLUME CONTROL. Cash or C.O.D. Carriage Paid, £1/17/6.
Balance in 7 monthly payments of 5/-.
B.T.H. MINOR PICK-UP AND TONE ARM. Cash or C.O.D. Carriage Paid, £1/1/0.
Balance in 4 monthly payments of 4/6.
WREN-EASTON 3 KIT with ready-drilled panel, metaplex baseboard, less valves and cabinet. Cash or C.O.D. Carriage Paid, £4/10/0.
Balance in 11 monthly payments of 8/3.
J. B. LINACORE. Complete tuning unit comprising matched coils, condenser, type BPB (battery), type BPM (mains). Cash or C.O.D. Carriage Paid, £3/9/6.
Balance in 11 monthly payments of 6/6.
AVOMINOR NEW UNIVERSAL MODEL. Measures 0-0, 0-30, 0-120 M.a., 0-6, 0-120, 0-300 volts, 0-10,000, 0-60,000 and 0-1,200,000 ohms, complete with leads. Cash or C.O.D. Carriage Paid, £2/0/0.
Balance in 7 monthly payments of 5/6.
GARRARD AUTOMATIC RECORD CHANGER for A.C. mains. Mounted on unit plate, complete, ready for fitting in position, including Garrard pick-up and tone arm. Cash Price, £10/10/0. Carriage Paid.
Balance in 11 monthly payments of 18/6.

LEADER A.C. THREE

KIT "A" Author's Kit of First Specified parts, including METAPLEX ready drilled Chassis, but less Valves and Cabinet. Cash or C.O.D. Carriage Paid, £5/10/0
Or 12 monthly payments of 10/-.

KIT-BITS You pay the Postman. We pay post charges on all orders over 10/-.

KIT "B" As Kit "A" but with set of Specified Valves. Cash or C.O.D. Carriage Paid, £8/7/6.
Or 12 monthly payments of 15/6.

	2	s.	d.
1 Peto-Scott METAPLEX Chassis, as specified	0	3	9
1 Set of Valves, as specified	2	17	6
1 J. B. Nugang 2-gang, 0.005 mfd. condenser, Type A	0	17	6
2 Wearite Screened "Universal" Coils	0	10	0
1 Varley Niclet 5:1 L.F. Transformer	0	7	6
1 Heayberd A.C. Leader III Mains Transformer	0	16	0
1 Wearite Type H.T. 25 Smoothing Choke	0	9	0

1934 WALNUT ADAPTAGRAM



38 in. high
22 in. wide
15 1/2 in. deep
Speaker Compartment: 17 in. by 19 in. by 14 in.

YOURS FOR **8/3**

CONVERT YOUR EXISTING SET INTO A MODERN RADIOGRAM

As illustrated, Cash 63/- Direct from Factory. No MIDDLEMAN'S PROFITS. Built by master-craftsmen of the piano trade. Real inlaid walnut mortised, tenoned. French polished. With motor-board ready to take your set, speaker and power equipment. Plain front or vignettered panels, 14 in. by 7 in., special cut-out designs add 16 in. by 7 in., 18 in. by 8 in. 3/- extra to cash price or 3d. Baffle-board, 3/6 extra.
IN OAK OR MAHOGANY NO EXTRA.
Special drillings or other vignettered panels, 14 in. by 7 in., special cut-out designs add 16 in. by 7 in., 18 in. by 8 in. 3/- extra to cash price or 3d. Baffle-board, 3/6 extra.
—SEND FOR CABINET CATALOGUE—

PETO-SCOTT 30 Ratio



EXTENSION SPEAKER
Suitable for 1001 Receivers, including CLASS B, Q.P.P., Super-Power output. Instantly adjustable ratios. Cash or C.O.D. Carriage Paid, 29/6. Yours for 2/6; balance in 6 monthly payments of 4/6.

2/6 DOWN

Converts your present Battery Set to Class "B" Amplification. With driver transformer, Class "B" output choke, W.B. 7-pin valve-holder, B.V.A. 240B valve, wire and screws, etc. Full size Blueprint, assembly instructions and diagrams. Cash or C.O.D., 37/6. Balance in 7 monthly payments of 5/6.

CLASS B PILOT CONVERSION KIT

YOURS FOR **5/-**

37/6

PETO-SCOTT CO., LTD., 77, CITY ROAD, LONDON, E.C.1. Tel.: Clerkenwell 9406/7.
West End Showrooms: 62, High Holborn, London, W.C.2. Tel.: Holborn 3248.

Dear Sirs,—Please send me CASH/C.O.D./H.P. _____
for which I enclose £. _____ d. CASH/H.P. Deposit.
NAME _____
ADDRESS _____
Pr. W. 14/1/34.

(Continued from page 116)

the tuning and reaction condensers on the panel as near as convenient to the tuning coil, so that the connecting wires need be no more than a few inches long. The tuning condenser may be either on the left or right as desired, and according to the whims of the particular constructor. Personally, I find it better and more convenient to have the tuning knob on the left, despite the fact that I am distinctly right-handed.

Mount the coil with its axis parallel to the face of the panel and immediately behind the two (or three) variable condensers. The valve-holder should for preference be of the usual chassis-mounting type, with low capacity between the sockets.

It is, of course, necessary to use 'phones with a single-valve receiver, since there is insufficient output to operate a speaker. A pair of 4,000-ohm 'phones can be bought very cheaply from such firms as Messrs. Peto-Scott and these will be found very efficient. See that they are correctly joined to the positive and negative terminals shown in Fig. 1. A valve of the "Super Detector" or "L.F." type is nearly always best for a receiver of this type, and if two or more valves are available it is worth while to try them all, choosing the one with which the set "slides" smoothly into and out of oscillation as the capacity of the reaction condenser is reduced. The most suitable H.T. voltage will probably be between 30 and 70 volts, but experiment in this direction will be well repaid.

As S.-W. Adaptor

The single-valve described can be used as an adaptor in conjunction with any existing receiver, when additional volume is required for operating a loud-speaker. All that is required is to connect the L.T. terminals to the corresponding terminals on a valve-holder in the set, remove the detector valve from its holder and take a wire from the negative 'phone terminal to the anode terminal on the detector valve-holder.

A rather more convenient way of connecting the short-waver as an adaptor is to use an old valve base with flexible leads connected from it to the appropriate points on the "adaptor" as shown in Fig. 4. This plug will then simply replace the detector valve in the normal set.

The short-waver dealt with above can also be used as an efficient converter in conjunction with any battery set having one or more high-frequency amplifying stages. All that is necessary is to connect a good H.F. choke of the usual "broadcast" type between the 'phone terminals

(Continued on page 122)



B.B.C. Television Transmissions

THE B.B.C. announces that 30-line television transmissions by the Baird system will now be radiated on Tuesdays at 11 p.m. and on Fridays at 11 a.m., the duration of the transmissions being approximately half an hour. These transmissions will be continued until further notice, their duration being regulated partly by the use which is made of them by experimenters, and partly by the rate of development of high definition systems.

Marconi Direction Finder For Submarines

THE Marconi Company has introduced a new wireless direction finding equipment for submarines, utilizing a telescopic aerial system, which has proved its value under actual service conditions. This instrument, known as the Marconi Type D.F.g.9C direction finder, provides an important new navigational aid for submarines. When cruising beneath the surface a submarine is normally "blind" and "deaf," and must rely solely on compass readings, but this direction finder enables the navigating officer to take bearings on any known land station or vessel even when under water. Direction finding facilities are also, of course, of particular value if a submarine, having dived during clear weather, is enveloped in fog on rising, when the only method of ascertaining her position apart from wireless is by dead reckoning. The new apparatus comprises an ingenious telescopic aerial, which is raised above the normal superstructure of the submarine. When in position for operating it consists of two non-rotating loops mounted at right angles to each other about a vertical axis, forming a normal Marconi-Bellini-Tosi system.

Universal High Voltage Radio, Ltd.

ON March 26th the first general meeting of the new Universal High Voltage Radio, Ltd., was held at the offices, 28-29,

Southampton Street, Strand, W.C.2. This new company has been formed to take over the manufacture of receivers incorporating Ostar Ganz high voltage valves, formerly manufactured by Eugen J. Forbat. They will concentrate on Universal Receivers suitable for A.C. or D.C. mains, and will introduce Universal Receivers suitable for the colonial market.

New Broadcasting Station for Rumania

TECHNICAL details are now available of the two new transmitters which the Rumanian Broadcasting Company has recently ordered from the Marconi Company.

In appearance the new super-power transmitter resembles an electrical switchboard mounting the transmitter controls on the front of the panel, the valves and transmitting circuits being behind. The transmitting circuits provide for a two-stage high-frequency amplifier modulated on the series modulation system by means of a three-stage acoustic frequency modulator. The modulated output is amplified by means of a single power amplifier with six Marconi high-power water-cooled valves of the CAT.12A type, arranged in a push-pull panel circuit. The transmitted frequency is stabilized by means of the Marconi high precision valve drive, followed by a harmonic selector and high-frequency amplifier and isolator stages.

The power for the station will be generated by three Diesel engines driving three-phase alternator combinations, rectified by Brown-Boveri six-phase steel cylinder mercury arc rectifiers. The alternators deliver 450 kilowatts each, and normally two of these will be in use at one time, the third being a spare. The aerial is of the three-wire "T" type, suspended between two 250-metre lattice steel insulated stayed masts. An interesting point is that the aerial can be heated electrically if necessary during transmission to prevent the formation of ice on the wires.

As is usual in stations of this power, the high-frequency energy of the transmitter is conveyed to the aerial by means of a two-wire transmission line or feeder, terminated in a small feeder house placed underneath the aerial.

BLUE SPOT SPEAKER UNIT 100UE:

A Correction.

In the advertisement of Messrs. Pearl and Pearl which appeared in our issue for March 31st the price given for the above-mentioned speaker unit was incorrect. The correct price is 14s. 0d.

SAVE 50% ON VALVES

362

There are no better valves than 362. 362 are entirely British and non-microphonic. They are guaranteed for a minimum period of 6 months. No other valves are so guaranteed.

H.2	High Frequency and R.C. Coupling	3/6
HL.2	Detector and General Purpose	3/6
L.2	L.F. Transformer Coupling	3/6
LP.2	Small Power or Driver Valve	4/-
P.2	Medium Power Super Output	4/6
SG.2	High Mag. Screened Grid	7/6
VS.2	Variable Conductance S.G.	7/6
ME.2	L.F. Pentode Type Output	10/-
	362 "Class B"	9/-

Post free direct from the makers if unobtainable locally.

Cash with order. Cheques and P.O.'s must be crossed and made payable to: THE 362 RADIO VALVE CO., LTD. (Dept. W.), Stoneham Road, London, E.5. Trade Enquiries Invited



SPECIAL OFFER.

SEND 4d. POST FREE

for very interesting and useful Handbook of Tuning Coils for DUAL RANGE, BAND PASS, and SUPER-HET. Circuits, illustrated with data.

EBONITE PANELS, LOW LOSS FORMERS, TUBES, RODS.

The BRITISH EBONITE Co., Ltd., HANWELL, LONDON, W.7.

THE PROBLEM OF LOW-TENSION SUPPLY

With Instructions for Making a Simple Battery which will Operate Valves Direct, or Charge Accumulators, of Especial Interest to Country Dwellers.

By **ALBERT E. OAKLEY**

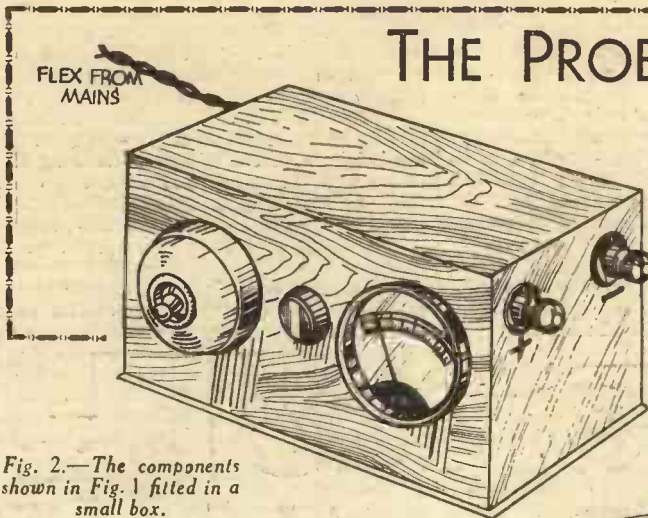

Fig. 2.—The components shown in Fig. 1 fitted in a small box.

FOR many users of battery-operated sets the supply of low-tension current is somewhat of a problem. An accumulator is generally used for the purpose, and the question is really, "How shall I charge it?" The answer will depend largely on local conditions. If current from electric mains is available this can be utilized in the following manner.

Charging from D.C. Mains

Supposing it is of the D.C. variety, we can connect the accumulator in series with a resistance lamp, preferably one that is in use for lighting, for if a powerful lamp has to be run specially for charging one or two accumulators the wasted energy will be out of all proportion to that actually utilized. If the supply is at 200 volts or more, the charging of one or two 2-volt accumulators will not dim the light appreciably, as each accumulator only absorbs 2½ volts. It should be remembered, however, that the charging current is low, a 40-watt lamp passing but one-fifth of an ampere at 200 volts, while a 100-watt lamp uses half an amp. For satisfactory charging, therefore, the lamp or lamps in circuit should have a total rating of at least 100 watts. Then there is the commercial "trickle charger," generally combined as part of an eliminator for H.T. supply. This method is wasteful of "juice" because so small a proportion of the voltage paid for is actually used by the accumulator, the difference being wasted in a resistance.

Using A.C. for Charging

If the supply is alternating, several methods are available. All of them require rectification of the alternating current, because, of course, the current passing through the accumulator must be unidirectional. The simplest and cheapest method, from the point of view of the apparatus required, is to use an electrolytic rectifier. Directions for making a charger of this type were given in PRACTICAL WIRELESS dated December 17th, 1932.

The most workmanlike and economical

job consists of a step-down transformer, to reduce the mains pressure to either 9 or 11 volts, and a metal

former and rectifier may be conveniently fitted into a small box with switch, resistance and ammeter mounted on the front and two charging terminals at the end for connecting the accumulator leads. (See Fig. 2.)

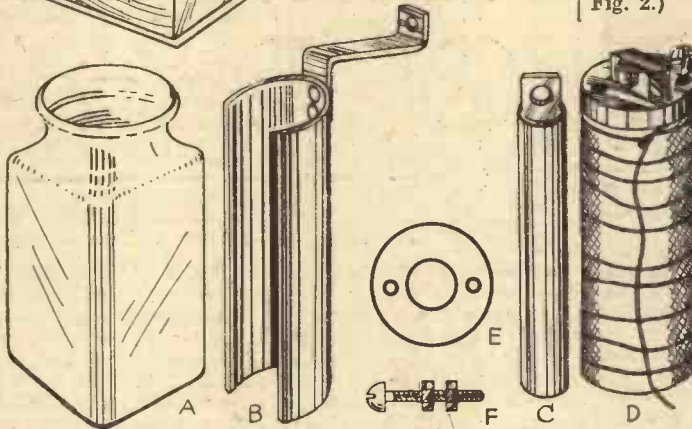

Fig. 3—(a) outer cell; (b) zinc element; (c) carbon rod; (d) sac assembly; (e) top disc; (f) terminal.

rectifier. This plan involves very little waste of energy, for the supply current is transformed from a high to a low voltage in the most efficient manner possible. The transformer preferably has one or two tappings on the secondary winding, the

cell for charging, or for heating valve filaments direct, is a special form of the Leclanché known as the "sac" pattern. Two of the cells about to be described will be satisfactory for the operation of a two or three-valve set under average conditions.

If the set is worked for long periods daily, a second set of cells will be advisable, so that one may change over, and thus avoid running the battery too low. The great advantage of this type of battery is that it will work for long periods without attention, is easily and cheaply charged, and does not use acids. Within reason, the larger the cell the better. The

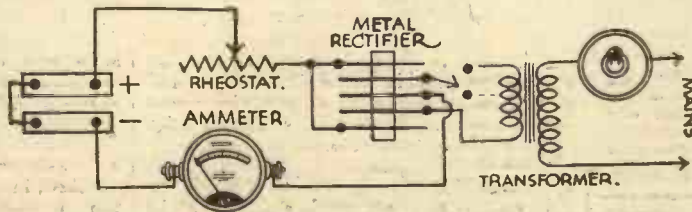

Fig. 1.—Arrangements of step-down transformer and metal rectifier for charging accumulators from A.C. mains.

connection being varied according to the number of cells being charged. It is necessary to include a variable resistance of about 5 ohms in the charging circuit, and an ammeter should also be used, at any rate when first setting up the apparatus, as the charging current must be kept within the rated output of the rectifier. The details of this arrangement are shown in Fig. 1. Suitable types of Westinghouse metal rectifier are L.T.2 and L.T.4, these giving a charging current of 0.5 and 1 amp. respectively. Either of these can be used with the following transformers: Varley E.P.3, Regentone W.L.T.1.2.4, Heayberd W.36. There is a Junit transformer corresponding with each rectifier, viz., W.L.T.2 and W.L.T.4. The trans-

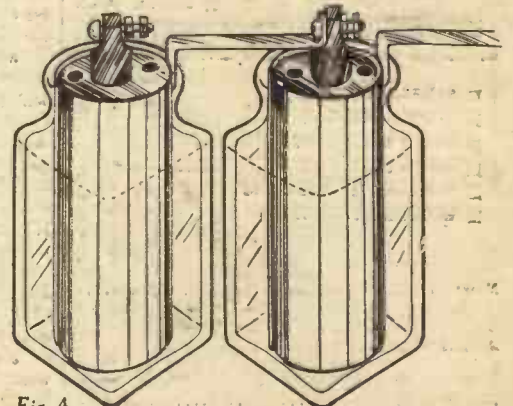
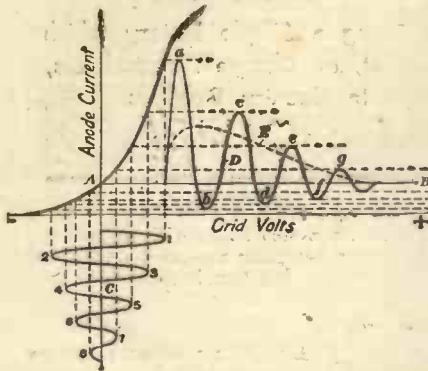

Fig. 4.—The battery completely assembled ready for use.

(Continued on next page.)

Do You Know What This Graph Means?



The man who can analyse these curves and understand what they indicate knows his job. But if they do not convey to him perfectly definite information, it would appear that he needs more training than he has had. He is not competent to fill a responsible position in wireless.

Radio has developed so rapidly throughout the last ten years that it has now greatly outgrown the supply of technically qualified men required for the better posts. Moreover, it continues to develop with such speed that only by knowing the basic principles can pace be kept with it.

The I.C.S. Radio Courses cover every phase of radio work. Our instruction includes American broadcasting as well as British wireless practice. It is a modern education, covering every department of the industry.

OUR COURSES

Included in the I.C.S. range are Courses dealing with the Installing of radio sets and, in particular, with their Servicing, which to-day intimately concerns every wireless dealer and his employees. The Operating Course is vital to mastery of operating and transmitting.

There is also a Course for the Wireless Salesman. This, in addition to inculcating the art of salesmanship, provides that knowledge which enables the salesman to hold his own with the most technical of his customers.

We will be pleased to send you details of any or all of these subjects. Just fill in, and post the coupon, or write in any other way, stating which branch of Wireless interests you—the information you require will be forwarded at once.

International Correspondence Schools, Ltd.,
Dept. 94, International Buildings,
Kingsway, London, W.C.2.

Without cost, or obligation, please send me full information about the Courses I have marked X

- COMPLETE RADIO
- RADIO SERVICING
- RADIO EQUIPMENT
- RADIO SERVICING AND SALESMANSHIP
- WIRELESS ENGINEERING
- WIRELESS OPERATORS

Name.....Age.....

Address

.....

(Continued from previous page)
size recommended for ordinary service has a capacity of about 2 quarts. Referring to the list of materials given below, a few explanations will be helpful. The jars may be of glass, stoneware, or china; square or cylindrical, but must have a wide mouth—about 4in. in diameter. If a large pickle jar is used it will probably hold a larger quantity of the electrolyte, but this is no disadvantage, as the cell will last longer before needing recharging. The "sac" is made from a piece of stout calico, duck, or similar strong material seamed into a cylinder 3½in. diameter and 7½in. long. This allows ¼in.

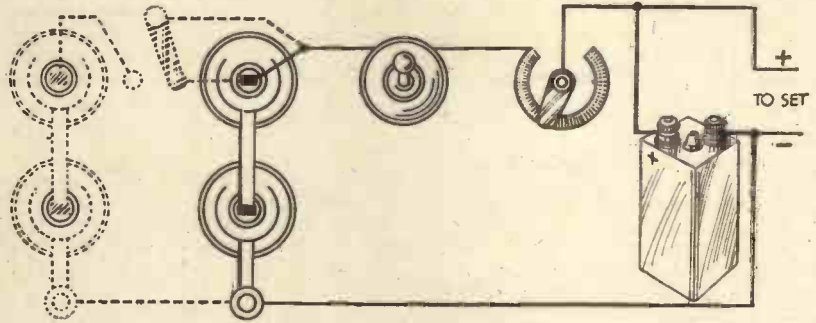

Fig. 5.—Shows connections for operating set from battery and charging accumulator. The dotted portion shows a second battery with change-over switch.

to turn over at the bottom end. A disc of cardboard is dipped in paraffin wax or asphaltum varnish, fitted into the bottom of the sac, and the material stitched across. It will be an advantage if a little hot pitch is poured into the sac to cover the bottom. The end is then dipped in wax or varnish to stiffen it up. The zinc plates are cut to the sizes given, and a lug or strip of lighter zinc riveted or soldered to them as shown in Fig. 3. It is best to use zinc rivets, as this avoids risk of galvanic action and consequent corrosion. One lug must be long enough to reach the positive terminal of the next cell; the other, which carries the negative terminal, may be rather shorter. The carbon rods are similar to those used for large arc lamps, and are obtainable from most electrical stores. Alternatively, carbon plates may be used, size about 2in. by ½in. by 7½in. The manganese dioxide looks like carbon, and should be in the form of granules about ¼in. diameter. It can be obtained from any chemist or most electrical stores.

The Sac Assembly

If carbon rods are used, a flat must be filed on each side of the top, and a ⅜in. hole drilled through to take a 2B.A. terminal or piece of screwed rod with nuts on either side. Before fitting the terminal the top of the rod should be well soaked in wax to prevent the electrolyte creeping over the terminal or through the carbon, which is porous. Hold the carbon in the centre of the sac, ¼in. off the bottom, and fill up with the previously-mixed manganese and broken coke (equal parts of each). The latter should be broken into small pieces and the dust rejected. Press the mixture tightly round the carbon, and when filled to within ¼in. of the top, drop in the waxed cardboard disc, shown in Fig. 3. Next insert two short lengths of glass or ebonite tube for the escape of gases, and pour in melted pitch so that the top of the sac has a smooth finish. Finally, wind tightly around the sac nine or ten turns of strong twine to give strength. The zinc plates must now be bent into

a circular form, with a diameter of 3½in., so that they encircle the sac, but leave sufficient space between to allow free circulation of the liquid. If the pieces of zinc are purchased from a metal worker, he will bend them to shape between his rolls. Otherwise it can be shaped by resting on the opened jaws of the vice, and tapping the inside with a hammer and a short piece of wood used as a punch. A piece of cardboard or cloth laid on the vice will prevent it scratching the zinc. The plate, when finished, will be about five-eighths of the circumference of a circle. Now the plates must be "amalgamated" or coated with a thin film of mercury in order to prevent

the slight but continuous chemical action which would occur due to the impurities in commercial zinc. This electro-chemical action would eat away the metal and use up the electrolyte to no purpose. Pour into a plate or saucer a little spirits of salts and water (half and half), then drop in about an ounce of the mercury. Take a piece of cotton wool or soft rag and, holding the zinc plate in the saucer, wipe it over with the acid solution, which will instantly make the surface clean and bright. Now bring the mercury into contact with the zinc, to which it will readily adhere, and it will be found quite easy to coax it over the entire surface (both sides) until the plate has the appearance of a mirror. Rinse in water to remove all traces of acid.

The assembly of the parts is easily seen from Fig. 4, but first the tops of the jars, zincs and the sac assemblies should be dipped for about 1½in. in hot wax or black varnish. The object of this is not merely to obtain a neat finish, but to combat the tendency of the electrolyte to creep, or form a crystalline coating which would, if unchecked, in time empty the cell and corrode the terminals. Dissolve 2ozs. of sal ammoniac per pint in warm water, stirring till entirely dissolved. Then pour the solution into the jars till they are a little over two-thirds filled.

The cells have an initial voltage of 1.55. On load this drops fairly soon to about 1.25, after which the further drop is slow, depending on the current demanded. While working, hydrogen is released by the chemical action on the zinc. This deposits on the cathode (the carbon and manganese); thus increasing the internal resistance and causing the drop in voltage. The manganese gives up oxygen which combines with the free hydrogen to form water. If the current taken from the cell is considerable the manganese cannot get rid of the hydrogen as fast as it is produced, and the output falls accordingly, but if given a short rest the cell will recover.

It is an advantage to use a small accumulator, connected as shown in Fig. 5, as this will keep the voltage absolutely constant.

THE OUTPUT VALVE

It is almost true to say that the whole design of a receiver should be worked out with a view to the output valve it is intended to use, and, at all events, the choice of output valve is one of the very first points to be decided. The value of the power output required from the wireless receiver depends, of course, upon the type of loud-speaker which it is intended to employ and upon the strength of the sound expected. In any case, it is as well to be liberal in this respect. Whatever output it is intended to obtain it will be possible to achieve it in two ways—by the use of a three-electrode output valve or by employing a pentode valve. Each kind of valve is available in types suitable for various anode voltages, for battery or A.C. mains operation.

The output triode is characterized by fairly low anode impedance and usually low amplification factor. As a consequence such valves require a somewhat larger grid excitation voltage in order to develop their full output. On the other hand, their comparatively long grid-base results in very uniform and good reproduction, the risk of frequency distortion being very slight provided the correct grid-bias is applied. Sometimes it is found that the triode output valves, designed primarily for use in the average broadcast receiver and rated for maximum anode voltages of 150 volts in the case of battery valves, and 200 or 250 volts in the case of mains valves, give scarcely sufficient output for particular purposes, and it is necessary frequently to employ two valves in parallel or push-pull.

Large Valves

Most valve manufacturers, however, produce a series of high-voltage, three-electrode output valves, giving ample reserve of power for those special cases of large outputs. These valves require an anode voltage of between 400 and 500 volts. Some have amplification factors of the usual order and, in consequence, are designed to have a big grid acceptance, but types are available which have a relatively high sensitivity and give their rated output for a comparatively small grid input voltage.

An important point in connection with these large modern output valves, which valve-makers are constantly stressing, is that special precautions must always be taken to avoid the possibility of high-frequency oscillations being set up in the output stage. Such oscillation, which is due entirely to the high mutual conductance of modern valves, can be set up by a sudden increase in grid input such as, for example, a strong transient signal. The practical effect is a large increase in anode current—often sufficient to damage the valve or apparatus included in its anode circuit—and distortion. The simplest and most effective precaution is to connect a resistance of about 80 to 100 ohms in the anode circuit, close to the anode terminal of the valve. The resistance must, of course, be capable of carrying the full anode current and must be non-capacitive both in design and in location, that is to say, it must be well spaced from other parts of the circuit. It is also important to avoid absolutely symmetrical arrangements of the wiring in the output stage, especially when valves are connected in parallel or in push pull.

There are few wireless experimenters who are not familiar with the pentode valve, so that there is no necessity here for a detailed description.

MICROLODE MATCHING FOR PERFECT BALANCE

Seventeen ratios for power or pentode valves, and four for Class B, Q.P.P., or push pull all on the one speaker. Accurate adjustment of load impedance by the simple setting of a switch.

By introducing this unique feature W.B. engineers make possible an accuracy of adjustment which must improve performance.

Nearly every leading technician has signified wholehearted approval of this new and extraordinarily efficient range of speakers. Users everywhere write in enthusiastic terms of the improvement a "Microlode" has brought to their sets.

Since last autumn Microlode speakers have been specified as first or sole choice in practically every published constructor receiver.

Hear one on your set to-day. You will be amazed at its performance.



30% cobalt steel stronger than a good magnet of equal weight. The crisp attack, excellent sensitivity, and surprising freedom from resonance are directly due to the unique properties of this exclusive W.B. magnetic system.

PM6 32'6 PM2A 79'6
PM4A 42'- PM1A 120'-

MANSFIELD MAGNET FOR GREATER SENSITIVITY.

Write now for the new folder.

Whiteley Electrical Radio Co., Ltd., Dept. D, Radio Works, Mansfield, Notts.

Sole Agents in Scotland: Radiovision, Ltd., 233, St. Vincent St., Glasgow, C.2.
Sole Agents in I.F.S.: Kelly and Shiel, Ltd., 47, Fleet St., Dublin.



ENGINEERS! LOOK WHAT YOU HAVE AT YOUR FINGER TIPS!

Do not let a first-class post slip through your fingers for the sake of a few letters after your name. Whatever your experience, age or education, you should send to-day for "ENGINEERING OPPORTUNITIES." This free 256-page Handbook shows the easiest way of preparing for the A.M.I.C.E., A.M.I. Mech.E., A.M.E.B., A.M.I.A.E., Metric, G.P.O., etc., exams. The book also gives details of courses in all branches of Civil, Mech., Elec., Motor, Aero., Wireless, and "Talkie" Engineering, and explains the unique advantages of our Appointments Department. Send for the valuable Handbook to-day—FREE and post free. BRITISH INSTITUTE OF ENGINEERING TECHNOLOGY, 390, Shakespeare House, 29/31, Oxford Street, London, W.1.

EASY TERMS PROMPT DELIVERY

Any Amplion, Blue Spot, Baker, Celestion, Epoch, R. & A., Rola, Sonochorde, Grampian, Igranic, Lamplugh, Magnavox, Ormond, W.B., or Ferranti Moving Coil Speaker Supplied

Send 5/- only

and pay the balance by monthly instalments. No references. Entirely private and confidential.

KITS, PARTS, SETS, ELECTRIC CLOCKS ON EASY TERMS.

Send for list of 83 Speakers, and state requirements.

TURNADGE AND PARTNERS, LTD.
Ludgate House, Fleet St., London, E.C.4.
Telephone: Central 1903:

Renowned for Reliability and long Service . . .



Dubilier High Voltage Dry Electrolytic Condensers are far ahead of any others on the market. You are assured of a real value-for-money condenser upon which you can rely for outstanding performance.

ELECTROLYTIC CONDENSERS

They are used in thousands by keen experimenters and constructors, and specified by the leading set designers for all their latest circuits. Six quality points are: 1. Entirely sealed. 2. No liquid. 3. No leakage of electrolyte. 4. Constant capacity. 5. Rapid reforming. 6. Low power factor.



4 mfd. 4/6.
6 mfd. 5/-
8 mfd. 5/6.

500 D.C. Max peak volts

DUBILIER CONDENSER CO. (1925) LTD., DUCON WORKS, VICTORIA ROAD, N. ACTON, W.3

MAKING A START ON THE SHORT WAVES (Continued from page 118)

and take a lead from the negative terminal to the aerial terminal on the set, through a .0001 mfd. fixed condenser. The H.T. + wander-plug on the short-waver must still be inserted into an appropriate tapping socket on the H.T. battery, whilst the L.T. leads should be joined to corresponding terminals on a valve-holder in the set.

When the unit is employed in this way the set is actually converted into a short-wave superheterodyne, of which the high-frequency stages act as an I.F. amplifier. For this reason the broadcast set should be tuned to a wavelength of approximately 2,000 metres, at which setting it can be left whilst all tuning is carried out on the single-valve set which is being used as a converter.

OUR GREAT NATIONAL COMPETITION (Continued from page 115)

trimmer, which is usually mounted concentrically with the main tuning knob. Suitable condensers of this type are made by Messrs. Jackson Bros., and Polar.

Bifocal Coils in a Tuned-grid Circuit

In Circuit No. 4 a tuned-grid circuit is shown, one Bifocal coil being used for aerial tuning and another for inter-valve coupling. With both coils adjusted for minimum coupling, the overall selectivity of the receiver is very great indeed, and should be sufficient for all requirements.

In this circuit, of course, the reaction is applied to the inter-valve circuit, and since the loading on the coil due to the shunt effect of the preceding screen-grid valve is not quite the same as that of an aerial, the constancy of reaction is not quite as good as with the detector + L.F. receiver, but it is superior to any ordinary type coil.

Another Bifocal Arrangement

The fifth circuit is a variation of the preceding arrangement, in which the input to the detector is taken to the tapping, so that the loading on the circuit due to the detector-grid circuit can be varied. This method can be applied in many other cases, such as a power-grid detector without reaction, a plain diode detector, whilst it is, of course, especially valuable when a metal rectifier is used as a detector, since with this type of detector damping of the tuning circuit is apt to be rather high, especially at very high frequencies.

The Bifocal coil can be employed with equal success in mains-operated receivers, either of the detector + L.F. type, or with those having a screen-grid stage. A screen-grid valve may be of the ordinary type, variable-mu, or H.F. pentode. It is not recommended, however, that more than one H.F. stage be employed with mains-operated valves.

The wavelength covered by the Bifocal coil is exceptionally large, and it is easily possible to get below 200 metres, thus ensuring good reception of the low-wave station, such as Bournemouth and Fécamp. The dynamic resistance is, approximately, 97,000 ohms measured at 800 kilocycles. It should be pointed out that the Bifocal coil is intended particularly for use in circuits employing reaction, where, after the necessary balanced condition has been obtained by adjusting the coupling, the desired signal strength can be obtained by adjustment of the reaction control.

BROWN M.C. SPEAKER UNIT

LIST PRICE 50/- OUR PRICE 32/6

New BROWN PERMANENT-MAGNET MOVING-COIL SPEAKER UNIT AND CHASSIS incorporating Tapped Transformer. Highly suitable to work with any set, giving deep, rich tone and wonderful volume without distortion. Overall size: 8 1/2 in. diameter, 4 1/2 in. deep, on baffle board 12 in. square. SEND ONLY 2/6; if satisfied pay further 5/- at once, then 6 monthly payments of 5/- (Cash in 7 days, 32/6.) Limited number only. Send at once.



E. J. HERAUD, Ltd., Dept P.54.
NUMBER ONE, EDMONTON, LONDON, N.18.
Satisfaction or Money Back Guaranteed.

OSBORN CABINETS

5/- to £10.
Catalogue containing

37

DESIGNS with amazing Osborn Box Baffle post free.

CHAS. A. OSBORN, Regent Works, Arlington Street, New North Road, Islington, London, N.1





THE EASY ROAD TO RADIO

THE BEGINNER'S SUPPLEMENT

ARRANGING THE COMPONENTS

Having decided upon a suitable circuit for his requirements, the constructor wishes to know how the components should be disposed: this article explains the matter.

THE success or otherwise of a home-constructed set—other than one made to a good complete design—depends upon three principal things; namely, the circuit employed, the correct choice of the components, and the proper disposition of the parts. Numerous circuits of all kinds appear in PRACTICAL WIRELESS every week, whilst the question of deciding upon correct values for the components has previously been dealt with. The point which now remains to be considered is the general lay-out and arrangement of the component positions.

understood by examining the typical three-valve A.C. mains-receiver circuit given in Fig. 1. High-frequency and tuning circuits are shown in heavy line,

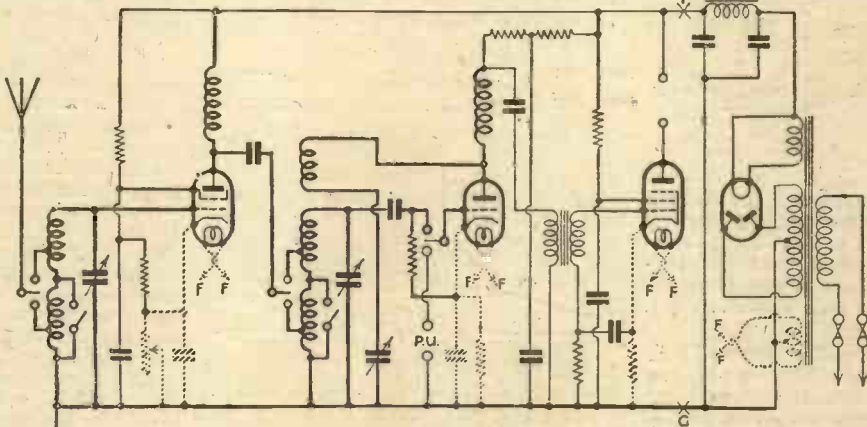

Fig. 1.—A typical three-valve (V-M-Det-Pen) A.C. circuit in which the H.F. and tuning circuits are shown in heavy lines, the L.T. and cathode circuits in broken lines, and the H.T. and L.F. circuits in thin lines.

The Circuit Is Not All-important

It is now generally realized that the actual circuit that is used for a set has not necessarily any direct bearing upon the efficiency or otherwise of the finished receiver; the circuit is undoubtedly important, but *not all-important*. We believe that this fact is now clearly understood by most readers, because our post-bag frequently contains inquiries regarding the best component lay-out for some circuit or other. Unfortunately, it is not possible to be very definite or dogmatic when suggesting any particular lay-out, because so much depends upon the components, the type of chassis and the cabinet into which the set is to be fitted. Technically speaking, perhaps, the matter of fitting the set into some particular cabinet should be ignored; one might be quite emphatic in saying that the cabinet must be made for the set, and not the other way round. But there are many readers who have a perfectly good cabinet, perhaps a large radiogram affair, which they would not dream of scrapping, or even modifying, for purely financial reasons.

It so happens, however, that by careful attention to detail practically any circuit can be so "interpreted" that the finished set can be made to fit some particular cabinet. In order to obtain such a result and at the same time to secure efficiency, it is necessary to give careful thought to the arrangement of the parts and to consider each section of the complete receiver circuit separately.

Isolating the Various Circuits

The latter point will more clearly be

low-frequency circuits and the H.T. and power-supply portion are shown by faint lines, whilst the low-tension and cathode circuits are indicated by broken lines: the main earth, or chassis, line, is also indicated as a heavy line. So far as the component lay-out is concerned the parts shown by heavy lines are most important,

and must be considered in priority to the other sections.

In the case of a set such as that represented by Fig. 1, there are two possible general arrangements of the receiver and power-supply sections. Both sections may be accommodated on the same chassis, or the power unit may be on a separate chassis; in the latter case connection to the receiver would preferably be made by means of a four-pin plug and socket of the type shown in Fig. 2. The plug would take the L.T. supply, as well as the main H.T. supply from the mains unit to the set, but all voltage-dropping and decoupling resistances would be housed in the receiver portion. As a matter of fact, the idea of having the mains unit separate from the receiver is nearly always to be preferred unless the constructor is fairly experienced, and is prepared to experiment to a certain extent with various arrangements of the power-supply components.

Use a Metallized Chassis

Having disposed of the question of the mains unit, the other sections of the circuit can be considered. Before going any farther we would say that, in every instance, the constructor is strongly advised to make use of either a metal or metallized chassis. This kind of chassis minimises inter-action, hand-capacity (in short-wave sets particularly), and the number of long connecting wires, besides providing very convenient earth-returns from every component in the set. The best way of arranging the three principal

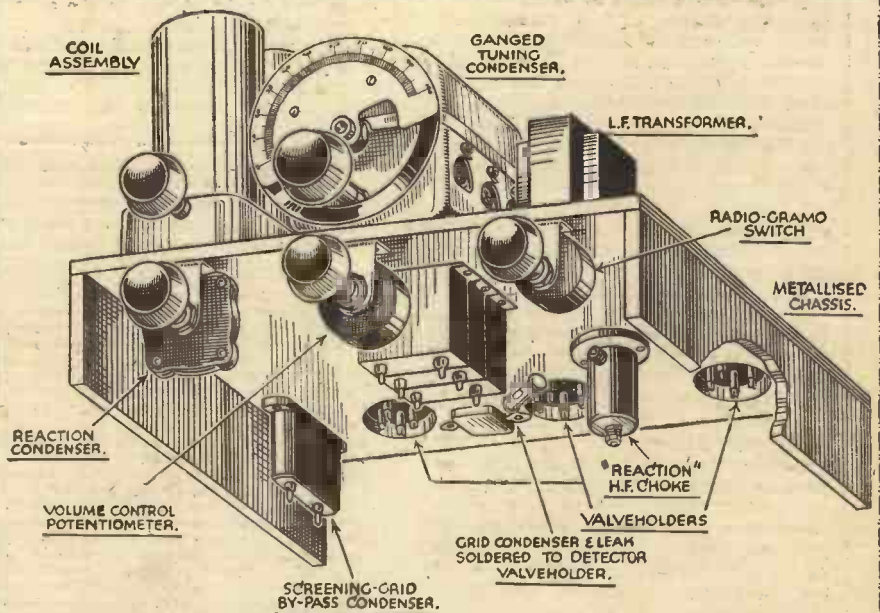

Fig. 3.—Showing a good component arrangement for a set using a circuit similar to that shown in Fig. 1.

receiver circuits which have been mentioned before is to place the H.F. portion near to the panel or front of the chassis and on the left, with the L.F. coupling components toward the right of the chassis and the high-tension, low-tension and cathode (in mains sets only, of course) circuits beneath the chassis baseboard. A general idea of what is meant can be obtained from Fig. 3, where the principal items are shown. In this example it is assumed that a pair of screened coils are used in conjunction with a gang-condenser, and quite a different arrangement would probably be necessary in the case of other types of compo-

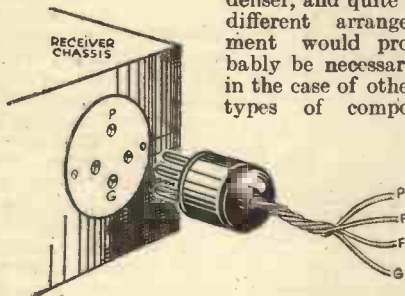

Fig. 2.—When the mains unit is built on a chassis separate from that used for the receiver a four-pin valve-plug and a valve-holder (of the chassis-mounting type) provide an excellent means of connection between the two. The letters correspond to those shown in Fig. 1.

nents. For instance, if unscreened coils were being used in conjunction with two separate tuning condensers the positions of these components, shown in Fig. 4, would probably prove best. It will be seen from Fig. 4 that the two coils are mounted at right-angles to each other as well as being disposed on opposite sides of the metallized baseboard of the chassis. By this means complete stability can be obtained in a reasonably simple circuit even when using old-fashioned components.

The Tuning Coils and Condensers

An important point to watch in regard to the positions of the corresponding tuning coils and condensers in any type of circuit is that they should be arranged as near together as possible so as to reduce the lengths of the inter-connecting wires. Another point to be watched, when separate coils are used in conjunction with a gang-condenser, is that the coils should be placed symmetrically about the condenser so that the connecting wires—and hence the stray capacities—in the various tuned circuits will be approximately equal. If this rule is not followed it might be found that the sections of the gang-condenser do not properly respond to the trimming adjustments.

There is an old rule that wires in H.F. circuits should be as far as possible apart, and that they should pass each other at right-angles, or as nearly so as can be arranged. Although that rule is often ignored nowadays, it is as useful as ever, provided that some wires are not made unduly long simply with a view to spacing them from other wires. A rule which is perhaps more important is that leads in the high-frequency circuits should be made as short and direct as the situation of components will allow. This has a two-fold effect: in the first place, it very much reduces the capacity between various

leads, and in the second it tends to eliminate direct pick-up of the local station. The latter point is worthy of more consideration, especially in respect of more sensitive receivers with which the apparent selectivity might be considerably reduced due to the fact that connecting wires are acting as small aerials and so picking up the signals from the local station. Such signals do not have to pass through the tuning circuits in the same way as the proper "aerial" signals have, and they are, therefore, often heard over a large part of the tuning dial of an otherwise selective receiver.

The Valve-Holders

It is not usually a very difficult matter to decide where the valve-

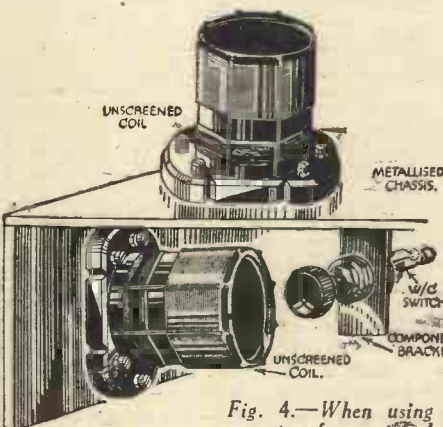

Fig. 4.—When using a pair of unscreened coils in conjunction with separate condensers it is well to arrange them at right angles and on opposite sides of the baseboard of the metallized chassis.

holders are to be placed on the chassis, but one should not be unduly influenced by the convention of arranging them in a straight line. Such an arrangement does make for simple filament or heater wiring, but it might be bad in other

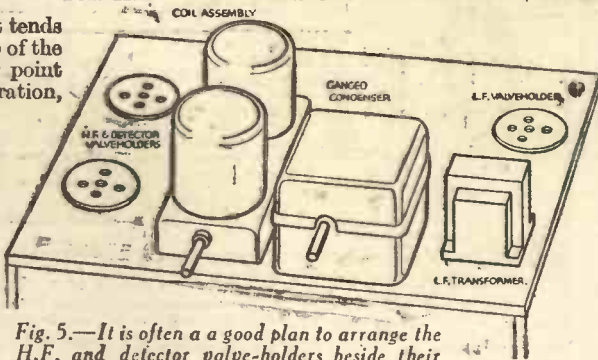

Fig. 5.—It is often a good plan to arrange the H.F. and detector valve-holders beside their associated coils as shown above.

respects. The point to watch is that the H.F. and detector valve-holders are as near as possible to the terminals on the coils which have to be connected to their grid sockets. For this reason it is often useful to place these holders beside the coils as shown in Fig. 5. With this arrangement the L.F. valve(s) and the associated L.F. transformer could be placed at the opposite end of the chassis, so obtaining an almost ideal disposition.

It is generally best to arrange the valve-holders in the same sequence as the corresponding valves appear in the circuit, but this is not an invariable rule. For example, if a pair of ganged coils were being used in which the aerial coil were at the back and the grid coil in front the detector valve would obviously be placed toward the front of the chassis, but the L.F. valve would probably be placed at the back.

With regard to the detector valve-holder it should be mentioned that the grid condenser and leak should, for preference, be placed as near to it as convenient. It is, in fact, frequently an excellent plan to solder the tag of the condenser, as well as the wire end of the grid leak, directly on to the grid terminal of the valve-holder. Another component which should be situated very close to the detector valve-holder is the H.F. choke, and a short wire from the anode terminal of the valve-holder to the choke should in every case be provided. The same rule applies to the lead from the same terminal on the holder to the reaction condenser or winding on the coil. If, however, the latter connection cannot be made very short (as is often the case) it should be screened with a length of metallic braiding. Pick-up Terminals and Switch

The situation of pick-up terminals is often a matter of difficulty, particularly when a radiogram switch is employed. The reason is that the detector grid-circuit leads, which are often made much too long, introduce serious damping, as well as back-coupling. Because of this it is often worth while to contend with rather inaccessible pick-up terminals and switch in order to avoid more serious troubles. Another method is to mount the radiogram switch and pick-up terminals close to the detector valve-holder and to operate the switch by means of an ebonite extension spindle.

TOPICAL TECHNICALITIES.
MUTUAL CONDUCTANCE.

This figure is always quoted in a list of a valve's characteristics, and is often referred to as the "slope" or the valve's "goodness factor." The expression is quoted in the form "1.5 mA/V," which means 1.5 milliamps. per volt, and this is the rate of change of anode current for each volt change in grid voltage with a given anode voltage. In other words if a certain valve is supplied with an H.T. potential of 100 volts and a grid bias potential of 3 volts we shall find, for example, that the anode current will be 6 milliamps. If, now, the grid bias voltage is increased to 4 volts the anode current will fall, say, to 5 milliamps., whilst if the bias voltage is reduced to 2 volts the anode current will rise, say, to 7 milliamps. Thus, we see in this example that for each change of 1 volt on grid bias we obtain a change in anode current of 1 milliamp., and the conductance, slope or goodness factor is, therefore, 1 mA/V. By taking a piece of squared paper and plotting the changes with grid volts as the ordinates and anode current as the co-ordinates we can join up the various points and so obtain the curve of the valve. It is generally preferable to choose a valve with the highest conductance for a given set of characteristics.

20 GUINEAS CASH PRIZE!
AND
200 CONSOLATION PRIZES
See pages 114 and 115.

FOR THE TECHNICAL EXPERIMENTER

THE LAST STAGE

A Practical Article Explaining the Various Characteristics of "Quiescent" and "Class B" Push-Pull Amplification

By F. W. LANCHESTER.

MOST readers are aware that the object of the push-pull circuit, or at least one of the objects, is to eliminate distortion due to the curvature of the valve characteristic. In the original push-pull system the fundamental idea is that two valves are so associated that the curvature of the one valve characteristic neutralizes

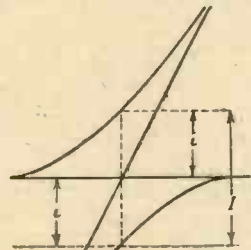

Fig. 1.—Curves in respect of two valves in ordinary push-pull.

that of the other, the valves being biased much the same as though they were being used singly. This is as illustrated in Fig. 1. One result is that two valves of any given denomination in push-pull take, approximately, twice the anode current of one valve used singly on an ordinary output circuit.

"Quiescent" and "Class B" Push-Pull

In the more modern forms of push-pull, namely, those known as the "quiescent" and "Class B," the same primary object of balancing one valve against the other is present to eliminate the effect of characteristic curvature, but there is a new idea, namely, that of economizing anode current. The ideal case may be represented as in Fig. 2, in which the valve characteristics are assumed to be of hyperbolic form. When two hyperbolas are associated, as in this figure, with common asymptotes, *XOX* and *YOY*, it may be shown that if biased to the point *O* the resultant of the two is a straight line characteristic *YY*. If it were possible to produce valves having this hyperbolic characteristic, a pair of such valves accurately biased would form a perfect output stage entirely free from distortion. The hyperbolic form is not the only one which is capable of giving perfection. It is quite evident, for example, that any other form of valve characteristic which, suitably paired, will give a straight line as resultant, is equally good, as, for instance, that illustrated in Fig. 3. In this a portion of each valve characteristic is shown as a straight line, and the two curved portions are of such form as to give as resultant a straight line transition from one to the other.

Both the "quiescent" push-pull and the "Class B" push-pull are attempts to materialize the conditions typically shown in Figs. 2 and 3, and from these figures it will be seen how great a saving there is in anode current in comparison to Fig. 1. Thus the combined static anode current *I*

may be as low as 2 or 3 milliamps. When a signal is being received the anode current immediately increases in some relation to the strength of the signal. In this it differs from the old type of push-pull; thus, if a milliammeter be connected in the power circuit, under the old regime, whether it be a single triode valve or two of such in push-pull, a flicker of the milliammeter needle indicates overload, whereas in the new type of push-pull the flicker of the milliammeter needle merely denotes that reception is taking place, that is to say, a signal is coming through.

The difference between what is termed "quiescent" push-pull and "Class B" is that in the former case the intention is to work both valves under conditions of negative grid volts, thus avoiding grid current; in the latter, namely, in "Class B,"

there is no applied grid-bias; the grids are normally at earth potential, and, alternately, become positive, and the valves run into grid current at every swing.

The difference between "quiescent" push-pull and "Class B" from the above description might be thought a matter of degree, that is to say, it might be imagined possible to arrange anything between "quiescent" push-pull and "Class B," introducing grid current to greater or less extent, and so, by varying the bias, change by imperceptible graduation from one system to the other. But this is not so; as soon as any question of grid current comes in, the penultimate or drive valve and its coupling circuit has to be treated as a power circuit in a small way of business; this is the real distinction between "quiescent" push-pull and "Class B." Thus, in Fig. 4, which is a rough plotting of the characteristics of the Cossor 240B valve, it is clear that with a grid swing of nearly 10 volts there is a grid current of nearly 4 milliamps, which has to be fed from the intervalve transformer.

Grid Swing in Q.P.P.

When we come to the actual practice and endeavour to associate a pair of triodes or pentodes in "quiescent" push-pull, we can see at once the limitations that exist, and the causes which prevent a straight line valve characteristic from being attained.

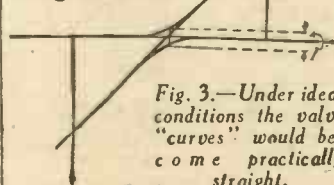

Fig. 3.—Under ideal conditions the valve "curves" would become practically straight.

The point at which the characteristic records zero plate current defines a point beyond which the companion valve is acting alone. In the old type of push-pull, this point was commonly beyond the range of grid swing, but in the modern "quiescent" push-pull the grid swing goes far beyond the zero points of the individual valves, and as the characteristics in these regions are never exactly straight the combined characteristic is not straight however good the transition section may be. Thus, in Fig. 5, the combined characteristic is made up of three sections—P1, Q1 and P2, Q2, each of which has a certain degree of curvature, and a transition section, P1, P2, which should blend conformably with the other two sections. The resulting curve may be anything from an approximately straight line to an undulating curve which is far from straight, and everything will depend upon the choice of valves and the adjustment of the grid bias. The predominating harmonics introduced will, generally speaking, be of greater frequency than those due to a single triode valve, but the contrast between the maximum and minimum inclination of the characteristic (which is the determining factor in the distortion which produces "rattle") will be less severe than in the single triode valve.

Whereas in the old style push-pull the A.C. impedance is twice that of a single valve, the impedance of a pair of valves, either in Q.P.P. or Class B, is four times that of a single valve. Thus the slope of the characteristic at the bias point is approximately half that of the upper part of the curve where impedance is usually measured, and half the slope denotes twice the impedance.

Using Pentodes in Push-Pull

In quiescent push-pull it is common practice to use pentodes, but it is not all plain sailing; owing to the high impedance the output transformer needs to have a very high inductance. Thus for the two valves the effective impedance will not be less than $40,000 \times 4 = 160,000$ ohms, and the optimum external impedance may be taken as $\frac{1}{4}$ th of this or 20,000 ohms. The effective resistance is slightly less than this, but the difference is negligible. Now the equation giving the inductance necessary

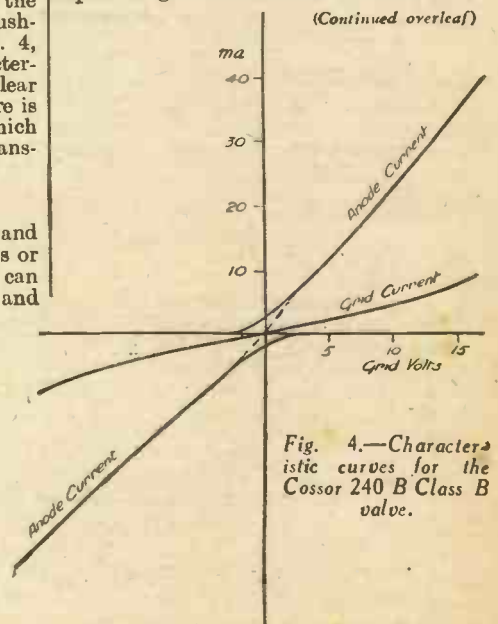

Fig. 4.—Characteristic curves for the Cossor 240 B Class B valve.

(Continued from previous page)

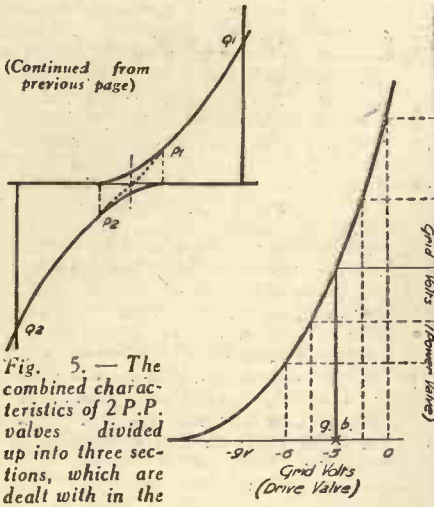

Fig. 5. — The combined characteristics of 2 P.P. valves divided up into three sections, which are dealt with in the text.

for a grid potential of 9 volts is 3 m.a., which gives 3,000 ohms as the impedance. (Fig. 4.) For the purpose of calculating the henrys required in the intervalve transformer, we may provisionally take the latter to be of 1 to 1 ratio.

At this juncture there are two lines of thought that lead to the same result. Firstly, we may recognise the fact that the valve grid impedance requires to be multiplied by 4 just as

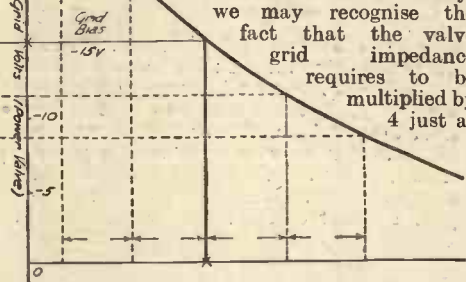

Fig. 6. — Curves in respect of a compensated class B stage.

for 3 decibels attenuation for a given frequency = f is:—

$$L = \frac{R}{2\pi f} \text{ henrys.}$$

If we take $f=66 \sim$ (which is the open C string of a cello) we have:—

$$L = \frac{12,000}{6.3 \times 66} = 48 \text{ henrys.}$$

For the purpose of comparison we will make the corresponding calculation for a push-pull circuit of the old style; the valves are ordinary triodes, say of 2,000 ohms impedance, or total valve impedance = 4,000 ohms. The external impedance may be taken as about twice this = 8,000 ohms. Next we calculate the effective resistance, the expression for which is:—

$$R_1 \times R_2 = \frac{4,000 \times 8,000}{R_1 + R_2} = \frac{12,000}{2,666} = 2,666 \text{ ohms.}$$

$$\therefore L = \frac{2,666}{6.3 \times 66} = 6.5 \text{ henrys,}$$

which is about the usual value, whether for a single triode output valve or two such in push-pull.

There is nothing impossible in the provision of an output transformer of 48 henrys, but it is distinctly an out-size, and proportionally expensive.

The Driver Circuit

It has been stated above that "Class B" amplification requires a power circuit to feed the power valve, that is to say, the penultimate or driver valve itself should be a power valve (commonly termed a super-power valve), and the transformer coupling between the penultimate and the power stage must be suited to the grid circuit resistance of the latter. The choice of power valve does not rest so much with the set designer as in the case of "quietest" push-pull. The "Class B" valve is a special type which embodies two valves in one, that is to say, it is in itself a push-pull pair. Ordinary valves are not suitable for a "Class B" circuit, on account of the fact that a valve for this service has to be designed and constructed specially in order to function on a minimum anode current at zero grid bias.

The essential factor in determining the design of the driver circuit in a "Class B" power stage is the impedance of the power valve grid circuit. Taking the Cossor 240B valve as an example, the grid current

in the case of the anode impedance in the Q.P.P. and Class "B" circuits. Alternatively, and this is the more fundamental viewpoint, we see that on each swing half the total secondary turns only are active, first one half then the other, so that a transformer having a 1 to 1 ratio must be regarded as one of 2 to 1 step down, and when the secondary resistance is referred to the primary circuit it must, therefore, be multiplied by 2², that is by 4. Hence the grid resistance referred to the primary circuit will be 12,000 ohms, and assuming the drive valve has an A.C. impedance of 4,000 ohms the equivalent total impedance will be:—

$$\frac{R_1 \times R_2}{R_1 + R_2} = \frac{12,000 \times 4,000}{16,000} = 3,000 \text{ ohms.}$$

And for a bass attenuation = -3 db @ 66 ~

$$L = \frac{3,000}{6.3 \times 66} = 7.25 \text{ henrys.}$$

If we call for a better bass emission, i.e., less attenuation, say, = -3 db @ 33 ~

$$L = \frac{3,000}{6.3 \times 33} = 14.5 \text{ henrys.}$$

Thus an inductance of 10 to 12 henrys for the intervalve or driver transformer is ample.

The output transformer differs little from normal. The effective anode impedance of the 240B valve is approximately 2,000 x 4 = 8,000, and assuming that the external impedance is no greater (it is usually less), the effective resistance is 4,000 and for -3 db @ 66 ~,

$$L = \frac{4,000}{6.3 \times 66} = 9.7 \text{ henrys.}$$

There is another interesting method of compensating the output stage of an amplifier which is little known and less practised. The idea is to make the curvature of the driver valve characteristic compensate for that of the power valve. The theory of this is made clear in Fig. 6 (diagrammatic). A symmetrical grid swing, fed to the driver valve, that is to say, a change of E.M.F. in equal steps above and below the grid-bias value, becomes an unsymmetrical swing as fed from the anode circuit to the grid of the power valve. If the coupling is correctly arranged, the lack of symmetry, or distortion, introduced in the penultimate stage is corrected, or partly corrected, in the power stage, with

the result that symmetry is restored. A harmonic fluctuation of E.M.F. fed to the grid of the driver valve appears as approximately harmonic in the output circuit.

CATALOGUES RECEIVED

To save readers trouble, we undertake to send on catalogues of any of our advertisers. Merely state, on a postcard, the names of the firms from whom you require catalogues, and address it to "Catalogues," PRACTICAL WIRELESS, Geo. Newnes, Ltd., 8/11, Southampton St., Strand, London, W.C.2. Where advertisers make a charge, or require postage, this should be enclosed with applications for catalogues. No other correspondence whatsoever should be enclosed.

POLAR TUNING GRAPH

ALTHOUGH wavelengths scales are used by a number of listeners, probably the majority of constructors use dials of 0-100 or 0-180 degrees, and the recent change of wavelengths necessitates a new tuning graph. To meet this demand Messrs. Wingrove and Rogers, Ltd., have just issued a tuning graph mounted on stiff card on the back of which are printed instructions for preparing a graph. These graph cards are now available and can be obtained from Wingrove and Rogers, Ltd., 188-189, Strand, W.C.2, for 3d., post free.

LOEWE RADIO PRODUCTS

WE have recently received from the Loewe Radio Company, Ltd., four leaflets giving particulars of various components marketed by this well-known firm. Two of the leaflets deal with paper condensers which are available with soldering tags or terminals. A recent addition to the range is a series of paper condensers for high voltage working and contained in moulded bakelite cases with screw terminals. These condensers are impregnated and sealed with carefully selected waxes under vacuum, thus eliminating the influences of air and moisture as far as possible, and ensuring a high insulation resistance. Full particulars of high vacuum resistances, fixed condensers, and tubular paper resistances are given in another leaflet. The high vacuum resistances are available with plain capped ends, screw caps, or wire ends, and are made by fusing the resistances into glass tubes, thus eliminating atmospheric and chemical effects, so that the ohmic values remain unvaried. The fourth leaflet gives particulars of the Loewe P.M. Midget M.C. speaker with an all-bakelite chassis. It has a three-ratio output transformer and is intended for use in a midget receiver. It is priced at 19s. 6d. Copies of either of these leaflets can be obtained from The Loewe Radio Co., Ltd., Fountayne Road, Tottenham, London, N.15.

B.B.C. TALKS-1934

THE B.B.C. have just published a handbook giving full particulars of their new Talks programme for April, May and June. An innovation is a series of short stories on Friday evenings at 10 o'clock, or soon after. These will be specially written for the microphone by such well-known writers as Mr. Walter de la Mare, Miss Agatha Christie, Miss Dorothy Sayers, and Mr. Compton Mackenzie. Included in the series are talks on "Science in the Making," "Economics in a Changing World," and "The Treaty of Versailles and After." On Mondays a "Boat Train" series will enable a number of interesting people to describe their travels and their reasons for going abroad. Many other interesting talks are included in the programme, copies of which may be had free on application to The British Broadcasting Corporation, Broadcasting House, Portland Place, London, W.1, or any B.B.C. Office. Applications by letter or postcard should be marked with the letter "T."

THE PIFCO ROTAMETER

FOR making accurate tests a high-class meter is essential, and one that is adapted for making a varied range of tests is a distinct advantage. The new Pifco Rotameter has a single needle pointer to eight separate dials which are arranged round an octagonal drum controlled by a knob at the side of the instrument. To make any test the knob is turned to show the desired dial of the drum to the front opening and connection made with two leads against the component or circuit to be tested. The Pifco Rotameter will make numerous tests of all kinds, in fact, anything in connection with radio can be efficiently tested in a few moments. The meter is of handy size and priced at 29s. 6d. Full particulars are given in a folder, copies of which can be obtained from Pifco, Ltd., High Street, Manchester.

REPLIES TO BROADCAST QUERIES.

PHONE MAD (Gillingham): We can trace the following: G2XU, C. Shillam, 36, Bayswater Avenue, Redland, Bristol; G5BK, W. Brown, 52, Winstonian Road, Cheltenham, Glos.; G2FO, R. Bradley, 5, Roker Tle, Yarm Road, Stockton-on-Tees; G5ML, F. Miles, "Tudor Lodge," Gibbet Hill, Kenilworth; G5XT, F. Robinson, 4, Cranford Gardens, Acklam, Middlesbrough; G6MS, A. Mason, 30, Marlborough Road, Cathcart, Glasgow.

RADIO CLUBS AND SOCIETIES

Club Reports should not exceed 200 words in length and should be received First Post each Monday morning for publication in the following week's issue.

ANGLO-AMERICAN RADIO AND TELEVISION SOCIETY

Radio 2AIU (Mr. K. T. Cause) demonstrated his all-mains 4-valve (S.G. followed by S.G. det. and two L.F. pentode output) receiver at the last meeting of the Uxbridge District Branch of the Anglo-American Radio and Television Society. Results were excellent, and the following stations were tuned in at good loud-speaker strength: YVIBC and 3BC, Caracas; 1XAZ, 3XAU, 3XAL, 8XK, VE-9GW, RW59, DJC and GSA. A successful television demonstration concluded the meeting. Full particulars of this branch and Society may be obtained from Mr. Leslie W. Orton, 11, Hawthorn Drive, Willowbank, Uxbridge.

INTERNATIONAL SHORT-WAVE CLUB (LEICESTER CHAPTER)

After reorganizing the Leicester Chapter, Mr. Vendy (2AWZ) held a meeting of members, of which there was quite a good attendance. Considerable interest was shown in Mr. Vendy's experimental transmitter. The question of a clubroom in which to hold meetings was discussed, and after a vote of members had been taken it was decided that the club needed a workshop and not a lecture-room. Meetings will be held every Wednesday in Mr. Vendy's room, commencing at 7.30 p.m., until a suitable workshop is found.—C. Cramp, Hon. Sec., 49, Avenue Road, Leicester.

THE HEATHFIELD SHORT-WAVE RADIO AND TELEVISION SOCIETY

Readers residing in the district will be interested to know that the above Society is now being formed and particulars can be obtained from the Hon. Sec., R. J. Lee, 9, Theobalds Green, Heathfield, Sussex.

INTERNATIONAL SHORT-WAVE CLUB (LONDON)

The first annual dinner and dance held by this organization took place on Thursday, March 22nd, at Maison Lyons, Shaftesbury Avenue, W.1. It was a great success and was attended by the American Consul, representatives of the B.B.C., and the radio manufacturers. It was a great honour to have with us at this time Mr. George F. Brooks, one of the pioneers of the I.S.W.C., who had just arrived in this country from the West Indies.—A. E. Bear, 10, St. Mary's Place, Rotherhithe, London, S.E.16.

THE CROYDON RADIO SOCIETY

Radio acoustics were discussed in a lantern lecture on Tuesday, March 20th, in St. Peter's Hall, South Croydon. The lecturer was the Vice-chairman, Mr. O. L. Amos, who was delivering the paper intended to be given by Dr. Hughes, who had unavoidably been prevented from attending. The lantern slides were very helpful, and one showed typical wave forms. It was pointed out that the twenty-third harmonic of a violin note existed, and for fidelity in reproduction the wave form as depicted must be reproduced in its entirety by the listener. The functioning of vocal cords and the behaviour of the ear received full attention in some interesting slides.—Hon. Secretary, E. L. Cumbers, Maycourt, Campden Road, South Croydon.

THORNTON HEATH RADIO SOCIETY

A meeting of this Society was held at St. Paul's Hall, Norfolk Road, on Tuesday, the 27th instant, Mr. S. J. Meares presided. Mr. O. L. Crossley gave another talk on the subject of light as applied to television, and on this occasion dealt with the polarization of light, which he illustrated by means of a micro-polariscope. He also explained how the process of polarization of light was applied to the mirror-drum system of television. Later Mr. Crossley demonstrated the actions and properties of light on various liquids.—Hon. Sec., Mr. Jas. T. Webber, 368, Brigstock Road, Thornton Heath.

SLADE RADIO

A lecture on "Coils, etc.," was given by Mr. A. F. Poynton at the last meeting of this society. The following items were dealt with:—

Aerial circuits and tuning, coils and condensers, oscillatory circuits and how they work, dynamic resistance and how calculated, selectivity, values for coils and condensers, coils and tappings, couplings, H.F. transformers, iron-core coils and their characteristics, and permeability tuning. The lecture proved one of considerable interest and at the conclusion a large number of questions were raised.—Hon. Sec., 110, Hillaries Road, Gravely Hill, Birmingham.

HACKNEY RADIO AND PHYSICAL SOCIETY

At our last two meetings, Mr. L. E. Coles has given talks on Power Packs. The first of these talks was confined to D.C. eliminators and the lecturer dealt at length with the design of the smoothing choke, values of smoothing condensers, and voltage dropping arrangements. At the second talk Mr. Coles spoke on the many methods used to rectify A.C. current and compared the merits of both the valve and metal types of rectifier. Local readers of PRACTICAL WIRELESS are invited to write for details of membership to A. F. Rogerson, Hon. Sec., 19, Sewdley Street, Clapton, E.5.



This is "FILT-FORTNIGHT"

You, who study wireless know how vitally important efficient Earthing is: Every expert does: But millions of non-technically minded listeners do not: Hence FILT FORTNIGHT—a nation-wide Campaign to stress the fact that an efficient Earth, the only direct Contact with the Transmitting Station, is the fundamental basis of good reception: Help this good work, reduce interference, increase Selectivity by using and advising your friends to use FILT, the ever-damp Earth that every Expert recommends.



GRAHAM FARISH FILT

PERCOLATIVE EARTH

ADVT. OF GRAHAM FARISH LTD., BROMLEY, KENT.

115 VOLTS AFTER ★ 12 MONTHS' USE!



Any voltage supplied.

Mr. R. G. Harrison, writing in "Prac. W." March 3rd, says: "The battery is a 120v. Standard Leclanche, which has the advantage of keeping its voltage; tapplings are at every 1½ volts, just right for O.P.P.I. It was installed last March and still shows 115 volts under load, so I am certainly saving on H.T." End H.T. problems with a Standard; replenishment at long intervals all that is necessary. 120 v. 12.500 m.a., £2 complete, carr. paid. ALL STANDARD BATTERY SPARES SUPPLIED. Write:—The Wet H.T. Battery Co. (Pr.), 26, Lisle St., London, W.C.2. Gerrard 6121.

7 DAYS' FREE APPROVAL!

H.T. ELIMINATORS AND TRICKLE CHARGERS:

BRITISH THROUGHOUT. 2 YEARS' GUARANTEE. A.C. models incorporate Westinghouse metal rectifier and a special power supply for illuminating tuning dials. Trickle charger 15s. 0d. extra.

Catalogue free from actual manufacturers:

V.M.C. RADIO COMPANY, A.C. 154, Homeleigh Road, LONDON, N.16. No Trade Discounts. 30/-

D.C. 15/-

PATENTS AND TRADE MARKS. KING'S PATENT AGENCY, LTD. 146b, Qn. Victoria Street, E.C.4, offer "Advice Handbook" and Consultations free. 49 years' references. Write, call, or 'phone. 'Phone: City 6161. Director, B. T. King, C.I.M.E., Reg. Patent Agent, G.B., U.S.A., and Canada.

RADIO SUPPLIES

Send your list of Radio needs for our quotation, Kits, Parts, Sets, etc. Everything in Radio stocked, prompt delivery 7 days' approval. Catalogue free. Trixler & Standard Wet H.T. replacements stocked. N. TAYLOR. 9, GROVE ED., BALHAM, S.W.12.

EXCLUSIVELY SPECIFIED

AGAIN a Heayberd Mains Transformer has been exclusively specified for "Practical Wireless" latest Set—the "A.C. Leader 3." This Transformer was specially designed to meet the requirements of "Practical Wireless" Technicians. When making up this set, use the model selected by experts, and you will ensure perfect results.

**MODEL LEADER 3,
PRICE 16/-**

POST NOW

I enclose 3d. in stamps for 40-pp. booklet containing a SPECIAL TELEVISION SUPPLEMENT.

Mr.

PRA.

**F. C.
HEAYBERD
& Co.,**
10, Finsbury St.,
LONDON, E.C.2.



FIT ANY VALVE

Whatever type of pins your valves may have you can be certain that the patent turned resilient sockets of Clix Chassis Mounting Valveholders will give you perfect full-surface contact—the more pins a valve has, the more important it is that you should use Clix Valveholders.

The range includes:—

FLOATING TYPE.
7-pin with terminals, ... 1/-
9-pin with terminals, ... 1/3

"Popular Wireless" said—
"Efficient contact is assured at each pin—to obtain such a completely successful result with nine pins is an achievement."

STANDARD TYPES.
5-pin with terminals, 9d.
4-pin with terminals, 8d.

AIRSPRUNG TYPE

5-pin with terminals 1/3
4-pin with terminals 1/2

All above models supplied without terminals for 3d. less.

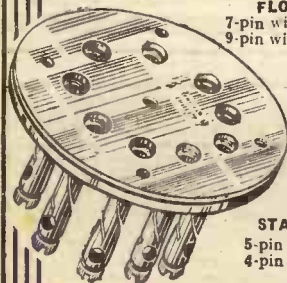

Ledro Linx
Ltd.,
79a, Rochester
Row, London,
S.W.1.

PRACTICAL LETTERS FROM READERS

The Editor does not necessarily agree with opinions expressed by his correspondents. All letters must be accompanied by the name and address of the sender (not necessarily for publication).

The H.F. Stage

SIR,—For the past year I have been perfecting my det. and 2L.F. set in range, selectivity, volume, and quality. Now I wish to add an H.F. stage without complications of extra tuning or without ganged condensers. I cannot find much information about this H.F. business and I speak for the average constructor. He knows a great deal about his L.F. amplifier and is greatly interested in the H.F. side, but gets no information whatever about it except tuned-anode, tuned-grid, etc. These involve extra tuning or ganging trimmers with their respective drawbacks. He also feels, as I feel, that when an L.F. amplifier has been perfected it should be added to an H.F. stage without alteration to any of its values. Consider the untuned aerial circuit of a short-waver with an S.G. valve. Or the untuned detector stage of a broadcast receiver. Keeping to simplicity more experiment should be made on these and similar lines, and a series of articles about H.F. would be a great impetus to such experiment and would be warmly welcomed by a large number of your readers.—P. THOMSON (Leith).

[Various articles on the subjects mentioned have appeared in past issues of PRACTICAL WIRELESS.—ED.]

A Universal A.C.-D.C. Leader

SIR,—I read with interest in the March 24th issue of PRACTICAL WIRELESS that a large number of readers are desirous of having a "mains" version of "The Leader," and that you have not had many requests for a D.C. version. Why not design a universal A.C.-D.C. circuit? There are many readers like myself who are in the unfortunate position of living in a town, one half A.C. and the other D.C., and the date for a complete change-over to A.C. is very uncertain. Universal valves have reached a high standard nowadays and compare favourably with A.C. or D.C. standard valves. I am quite sure the "Leader" would be an ideal, inexpensive and reliable "Universal" set.—JAMES WREN (Arbroath).

[In the near future we hope to publish a design for a universal set in the "Leader" series which should prove as popular as our "A.C. Leader."—ED.]

Schedule of W3XAL: A Correction

SIR,—With reference to Mr. Mann's letter in PRACTICAL WIRELESS dated March 24th, might I correct him on his schedule of W3XAL. Their new schedule is: W3XAL, Monday, Wednesday and Saturday, 10.0 p.m. to 6.0 a.m. G.M.T., 6,100 kc/s, 49.18 metres. The above particulars were given out during W3XAL's transmission on Monday, March 19th. Might I also agree with the remarks of "Quest" (Birmingham) in the same issue of PRACTICAL WIRELESS with regard to a special "Short-Wave Supplement."—J. P. BARNES (Faversham).

Overseas Market for Wireless Receivers

SIR,—I was very interested in a letter signed J. Haynes, Pretoria, published in

your issue of March 17th. I am afraid your correspondent will not get very much satisfaction from the British radio manufacturer.

As one who has spent a number of years in the East and in Africa (South and East), and who has been actively connected with wireless since 1913, I tried to interest manufacturers in the great market awaiting them abroad if, and only if, they could show a set capable of giving satisfactory reception, and offered to demonstrate sets in South Africa, Rhodesia, and the East African colonies, as I was doing a trip through Africa. One manufacturer of receivers, and one of loud-speakers, lent me special overseas models to demonstrate and report on. The overseas listener prefers British receivers if he can get them, and knows they are suitable, but the R.M.A. is too concerned with its local markets to enter those abroad, now being captured by American and Dutch competitors.—L. D. GOLDIE MORRISON (Henley-on-Thames).

[We think our correspondent is unduly harsh in his criticism. It is within our knowledge that manufacturers have investigated the possibilities of the overseas market, but we understand that the matter is not so simple of solution as our correspondent seems to think. We think, also, that he has overlooked the fact that quite a number of manufacturers market receivers specially designed for overseas conditions, but the healthy market which our correspondent seems to think was awaiting them has, we understand, not eventuated.—ED.]

CUT THIS OUT EACH WEEK.

Do you know

- THAT the A.V.C. section of a receiver may be tested by removing the aerial and attaching a length of wire in its place. This may then be moved to and from the earth wire to give a "fading" effect.
- THAT all decoupling components should be of the non-inductive type.
- THAT bias may be applied direct to the grid of an H.F. valve through the medium of a grid leak and condenser.
- THAT an indirectly-heated A.C. valve may be used "upside down," that is, with the cathode as the output side.
- THAT an H.F. filter is often advisable in the A.V.C. line of a powerful receiver.
- THAT a modern H.F. pentode may be used as a very efficient power-grid detector.
- THAT to increase the handling capabilities of a push-pull amplifier, two valves may be connected in parallel in each "leg" of the amplifier.

NOTICE.

The Editor will be pleased to consider articles of a practical nature suitable for publication in PRACTICAL WIRELESS. Such articles should be written on one side of the paper only, and should contain the name and address of the sender. Whilst the Editor does not hold himself responsible for manuscripts, every effort will be made to return them if a stamped and addressed envelope is enclosed. All correspondence intended for the Editor should be addressed: The Editor, PRACTICAL WIRELESS, Geo. Neaves, Ltd., 8-11, Southampton Street, Strand, W.C.2.

Owing to the rapid progress in the design of wireless apparatus and to our efforts to keep our readers in touch with the latest developments, we give no warranty that apparatus described in our columns is not the subject of letters patent.

Facts and Figures

Components Tested in our Laboratory

BY THE PRACTICAL WIRELESS TECHNICAL STAFF

EDDYSTONE SHORT-WAVE COILS

ALTHOUGH it is often stated in wireless journals that a discarded valve-base makes a good former on which to wind a short-wave coil, one would not expect to find a coil of such small size produced on a commercial basis. The Eddystone manufacturers (Messrs. Stratton & Co., Ltd., of Birmingham) have, however, produced some highly efficient coils of these dimensions and the illustration below, in which two such coils are shown in conjunction with a low-loss valve-holder, will give some idea of their size. The pins on the base are arranged in a standard 6-pin arrangement and thus the coils are adequately suited to plugging in to small coil-holders. The one shown in the photograph is one of these specially-designed coil-holders for use with these special coils on the



Two Eddystone short-wave coils and a special 6-pin low loss base which is suitable for use with them.

short waves. The former on which the coils are wound is ribbed and of high-quality material, thus reducing losses and self-capacity to a minimum. The wire is spaced and the turns are securely fixed to prevent variation in inductance values due to mishandling, etc. The coils are designed for use with a .00015 mfd. condenser, and for a range of 12 to 26 metres the cost is 4s. 6d. The cost is the same for a coil to cover the band from 22 to 47 metres, and for 5s. coils are obtainable to cover from 41 to 94 and from 70 to 170 metres. The special six-pin base which is illustrated costs 2s. 3d., and it possesses the novel virtue of having the socket and connecting point made from the same piece of material, thus avoiding losses due to a weak joint. The method of bringing out the connecting points in the manner shown assists in reducing losses and renders the holder highly suitable for use on the short waves.

MAGNUM DUAL-RANGE COIL

A NEW type of dual-range coil of the unscreened type has now been produced by Messrs. Burne Jones & Co., and is illustrated here. Unlike many coils this has completely separate aerial coupling coils, which are employed on each wave-band, the long-wave aerial coil being seen in the form of a lattice winding on the lower end of the former. The aerial coupling coil for the medium waves is overwound on the medium-wave grid coil; and the method of winding, the spacing, and the gauges of wire have all been so chosen that maximum results are obtainable on either band. Connection has to be made to the terminals arranged on the upper edge of the coil and these terminals are numbered for easy reference. We have not yet had



The new Magnum dual range coil.

the opportunity of thoroughly testing this coil in a receiver, but from the preliminary examination it would appear to be a very efficient component for a home-built receiver. The price is 5s.

"YOY"

THE above rather original name is applied to a product which is shortly to be marketed by Messrs. H. P. White & Co., of 14, Harp Alley, E.C.4, and which is intended to prevent corrosion of metal bodies through the action of the sulphuric acid from an accumulator. The accumulator terminals, for instance, often become covered with a green deposit which not only eventually ruins the accumulator but results in loss of voltage owing to the high resistance joint which is set up. To use this material, the terminal is thoroughly cleaned, as well as other metal parts which might come into contact with acid splashes or fumes, and they are then painted with Yoy, which prevents the action of the deleterious chemical fumes, etc. The price is 3s. per bottle.

GOLTONE LIGHTNING ARRESTER

IT is always advisable to protect an exposed aerial by fitting some form of static discharger, or lightning arrester, and the device illustrated on the right is manufactured by Messrs. Ward and Goldstone of Pendleton, Salford 6, and is extremely easy to fit. As may be seen from the complete and the dismantled apparatus, a small galvanised iron bracket is supplied, together with the bakelite enclosed spark-gap, and the latter is provided with large wing-nuts to facilitate the connection of aerial and lead. The bakelite moulding is in the form of a hollow cowl, and the lower wing-nut is attached to a heavy gauge brass rod which is screwed into the upper portion of the cowl. The upper wing-nut is similarly attached to a piece of rod and this is embedded in the bakelite and is non-rotatable. The ends of both of these rods are finished dead flat and before the lower rod is screwed into position, mica discs with a small central hole are dropped into the bakelite moulding, so that when the lower rod is screwed tightly home it is insulated from the upper rod, but a small air space exists in the centre through the medium of the perforated mica separators. Thus a heavy static charge may leak away to the lower rod and so to earth through a suitable earth lead, attached to the lower wing nut. With the advent of the summer months and consequent static discharges, such a device is a useful accessory to the aerial system, and it costs only 2s. 6d. complete.



The "Goltone" Lightning Arrester in both its assembled and un-assembled form.

THE "GUIDOR" HYDROMETER

IT has been repeatedly stressed in these pages that a volt-meter alone is not a satisfactory test for the condition of an accumulator, and every keen experimenter should provide himself with a hydrometer in order that the condition of the cell may be accurately judged. The ordinary type of hydrometer consists simply of a glass tube in which is a small floating tube and with this arrangement it is possible to break one or the other by forcibly squirting out the acid. Furthermore, the float generally manages to gyrate and move about whilst the reading is being taken and thus renders the operation tedious. The hydrometer illustrated, manufactured by Messrs. J. H. Collie and Co., of 10, Canning Place, Liverpool 1, is designed to overcome all difficulties usually associated with his type of instrument. Firstly, the rubber end is very substantial, and will fit over the vent of the accumulator to remove splashing. Secondly, the lower end of the float is fitted with a rubber ring which prevents jarring if the hydrometer is dropped or the acid is forcibly ejected. Thirdly, the bulb is moulded with a six-sided ridge which prevents the hydrometer from rolling off the table or bench, and has a moulded ring so that it may be hung up. Finally, and what is



An ingenious Hydrometer.

really the most important feature of the whole instrument, the float is provided at its upper end with a small celluloid guide which keeps the float in the centre of the tube and steadies it, so giving a dead-beat reading. This is a most useful accessory, and costs 4s. 6d., complete in a neat metal container.

NEW MAZDA VALVES

TWO interesting new valves for A.C. mains receivers have been received from the Edison Swan Electric Company. These are the A.C.2/Pen. and the A.C.2/Pen.DD. The former is an A.C. Mains Pentode valve with a 4-volt 1.5 amp. heater and a Conductance of 8. It is designed for use in the output stage of a receiver where the utmost sensitivity is required, or where it is desired to couple the detector to the output stage by means of resistance-capacity coupling without risking detector overload. In most receivers it will be possible to obtain adequate output without any intermediate L.F. amplification. The standard 7-pin base is fitted to this valve, and the anode is designed to operate with 250 volts H.T. The normal anode current is 40 mA.

The A.C.2/Pen.DD. is a similar valve, with the addition in the same envelope of two diodes. It may thus be used for diode detection, with A.V.C. with or without delay action. The makers do not recommend amplified A.V.C. unless a separate valve for the necessary amplification is provided, as high frequency signals cannot be accommodated by the pentode section of the valve without distortion of the audio-frequency output. A highly-efficient H.F. filter should be provided in the grid circuit of the valve for this purpose. In order to obtain the maximum undistorted output from the valve, the H.F. filtering must be very complete and the makers make several recommendations to ensure that this may be carried out. Such schemes as connecting the H.F. choke in series with

the load resistance; a .001 condenser between anode and cathode of the output pentode; a resistance of the composition type between grid of the pentode section and the input circuit, etc., are a few of the points which may be noted. The undistorted output is calculated at 3,400 milliwatts on the basis of 5 per cent. harmonic condition.

NEW BALDWIN CAPACITY BRIDGE

THE Baldwin Instrument Company of 91, Belle Grove Road, Welling, Kent, have recently brought out an improved capacity bridge which ranges from 7 micro-microfarads to 3,000 micro-microfarads with an additional control compensating for phase angle. The accuracy of this instrument is guaranteed ± 2 per cent., and the price is £6 10s.

MORE NEW EVER-READY H.T. BATTERIES

THE Ever-Ready Company have just introduced four more new high-tension batteries to meet the exact requirements of new sets. These batteries are as follows:—

- Battery No. W.1236 for Portadyme B.72 model.—136 volts combined H.T. (123v.) tapped 30, 40, 50, 60, 70, 80, and 123. G.B. (13.5v.) tapped every 1.5v. Measurements: 10½ins. x 5½ins. x 3½ins. Price 16s. 6d.
- Battery No. W.1253 for Philips 834B model.—132 volts, tapped 1.5, 3, 4.5, 9, 63, 69 and 132. Measurements: 9½ins. x 6½ins. x 3½ins. Price 16s.
- Battery No. W.1254 for Pegasus 4-Valve Type 1660.—126 volts, tapped positive and negative. Measurements: 9½ins. x 5½ins. x 2½ins. Price 11s. 6d.
- Battery No. W.1227 for Bush S.B.1 model.—144 volts combined H.T. (135v.) and G.B. (9v.). H.T. tapped 50, 54, 59, 63, 68, 72 and 135. G.B. tapped positive and negative only. Measurements: 10½ins. x 6½ins. x 2½ins. Price 13s.

50 TESTED WIRELESS CIRCUITS

Edited by F. J. CAMM

Obtainable at all Booksellers, or by post 2/9 from Geo. Newnes, Ltd., 8-11, Southampton Street, Strand, London, W.C.2.

2/6

REPLIES TO



LET OUR TECHNICAL STAFF SOLVE YOUR PROBLEMS

QUERIES and ENQUIRIES by Our Technical Staff

The coupon on this page must be attached to every query.

If a postal reply is desired, a stamped addressed envelope must be enclosed. Every query and drawing which is sent must bear the name and address of the sender. Send your queries to the Editor, PRACTICAL WIRELESS, Geo. Newnes, Ltd., 8-11, Southampton St., Strand, London, W.C.2.

SPECIAL NOTE.

We wish to draw the reader's attention to the fact that the Queries Service is intended only for the solution of problems or difficulties arising from the construction of receivers described in our pages, from articles appearing in our pages, or on general wireless matters. We regret that we cannot, for obvious reasons—

- (1) Supply circuit diagrams of complete multi-valve receivers.
- (2) Suggest alterations or modifications to receivers described in our contemporaries.
- (3) Suggest alterations or modifications to commercial receivers.
- (4) Answer queries over the telephone.

Please note also, that all sketches and drawings which are sent to us should bear the name and address of the sender.

L.F. INSTABILITY

"I have built a three-valver but get a curious effect which I have never experienced before. When tuning above Daventry and with reaction at zero the set breaks into a high-pitched whistle. This only occurs on long waves. Thinking it might be the circuit, I have now built the Leader circuit, using the correct coils and condenser, but I get the same effect. I have tried a 750-ohm resistance in series with the reaction condenser, but to no effect."—W. E. J. (Shirehampton).

The trouble may not be H.F. instability, and therefore the resistance has no effect on the whistle. Have you tried reversing the connections to the secondary of the L.F. transformer, or a high-resistance shunted across the secondary? There appears to be some effect between the frequency to which the receiver is tuned and the constants of the L.F. coupling, which is probably parallel-fed. The modifications to the secondary as above-mentioned should stop the trouble.

CONNECTIONS FOR H.F. UNIT

"I propose to build an H.F. Unit for my straight three (detector and 2 L.F.) set. I enclose the circuit, but I am not sure where to connect the lead from the .0003 condenser which is joined to the anode of the H.F. unit. Could you please give me this information?"—J. W. (Manchester 16).

The lead in question is joined to the aerial terminal on your present three-valver. It may, however, be necessary to make a slight modification, but this depends upon the type of tuning coil which is fitted in this receiver. If this is of the simple single-circuit type, then the lead should be attached to the "top" end of the tuned circuit, whilst if a tapped aerial coil is used, the lead may be joined to the tapping point which gives the best results. If you have a series aerial condenser in your receiver, it might be preferable to short-circuit this with a small piece of wire.

POOR MEDIUM-WAVE RESULTS.

"I have built up the Leader and on long waves I get very good results indeed. However, when I switch on to the medium waves I can get nothing. I have tried trimming and have checked the wiring, but with no results. I have had the circuit and wiring checked, and also another set of coils installed, and valves changed,

but with the same result. Can you help me?"—W. J. W. (Norfield).

As the receiver functions on long waves, this proves that the circuit as a whole is more or less correct, and that the components are not faulty. The only change that is made to receive medium waves is that a portion of the coil is short-circuited, and therefore you should look for the trouble at this point. Carefully examine the switch, which is of the two-point type, and relies for its function on the fact that the plunger is electrically connected to the mounting bracket, which is, in turn, in contact with the metallized baseboard. You may have insulated the bracket, or obtained the wrong switch. Failing this, we would advise you to examine the coils and make certain that you have the correct type. You need the Universal coils (not Type A) and this may be verified by examining terminal marked E. On the Type A coils this is marked "B" and has a connection to it, whilst the E terminal on the Universal coils has no connection internally, but is in electrical contact with the screening can.

ELIMINATOR FOR PORTABLE SET

"I have a transportable set made by Pye and using four valves. Is it possible to use an eliminator with this in place of the H.T. batteries?"—G. F. P. (No address).

You can use an eliminator for this particular receiver, and special small units are made by a number of firms. We would advise you to write to Messrs. Regentone Ltd., Regentone Works, Worton Road, Isleworth, Middlesex, or Messrs. E. K. Cole, Ltd., Ekeo Works, Southend-on-Sea, Essex.

QUESTIONS NOT TO ASK

"I wish to build up a small transmitter so that I can talk to my friend who lives about two miles from me. Could you give me details of the best type of circuit and the main operating details for such a set?"

First of all, before any transmitting experiments may be carried out it is necessary to hold a Post Office licence. Before you could obtain this you would have to show some knowledge, and as you are unable to decide upon a circuit and also wish to know how to operate the set, we are afraid you do not know sufficient to obtain the licence and we cannot therefore give you any information which might lead you to attempt transmitting experiments with consequent interference to the reception of listeners over a large area.

COIL WINDING DATA.

"I have had an accident with an unscreened dual wave coil and would like to re-wind it. Could you give me particulars of the windings for primary and reaction for medium and long waves? The former is 2 1/2 inches in diameter, has eight ribs, and six slots in the ribs."—C. W. S. (Sheffield 2).

Wind the unslotted part of the former with 50 turns No. 24 d.c.c. and take a tapping at the 15th turn from the lower end. In the first slot (next to the winding just put on) wind 35 turns of similar wire; this is the reaction winding, and should be joined to terminal 5 and 6. In each of the remaining five slots wind 42 turns of the same wire, but take a tapping at the end of the second slot. The commencement of this section of the winding, which is the long-wave loading coil, is joined to the end of the medium-wave winding and this is joined to one pole of a short-circuiting switch. The commencement of the medium-wave winding is joined to terminal 1, and the end of the long-wave winding is joined to terminal 2. The two tapping points must be joined to the arms of a change-over switch so that the aerial may be transferred when the change is made from long to medium waves. You may use a combined switch or two separate switches for the change-over.

NO DETAILS GIVEN

"In reference to the Leader Three, I notice that you state that you would have used iron-core coils instead of air-core if expense had not mattered. I have some iron-core coils and would be much obliged if you would give me some different connections (if any) to be able to use them with the Leader."—M. T. (Garden Town, N.W.1).

You do not state what coils you have, and we could not, therefore, give you the connections. Furthermore, as we have repeatedly stated, we cannot give instructions for modifying our Guaranteed circuits, as we can only give the guarantee when the circuits are built exact to specification.

CHASSIS FOR FURY FOUR

"I have bought a Kit for your A.C. Fury Four, but find that the baseboard seems to be drilled wrongly. When the choke is fitted it covers one valve-holder partly over, so I returned it to the dealer, who says it is the right one, the same baseboard being used for both battery and the mains set. Please could you tell me if the base is the right one."—W. L. (Battersea Park Road, S.W.8).

You do not state whether you are building last year's Fury Four or the new Fury Four Super. However, in both cases different dimensions were adopted for the battery and mains versions. In last year's models the valves were in a straight line for the A.C. version, and were staggered for the battery model, whilst in this year's receivers the valves were staggered for both types, but were situated slightly differently to accommodate the different components which had to be incorporated in the two types of receiver. You must, therefore, obtain the correct chassis in order to accommodate the components in the correct positions.

FREE ADVICE BUREAU COUPON

This coupon is available until April 21st, 1934, and must be attached to all letters containing queries.

PRACTICAL WIRELESS, 14/4/34.

THE WORLD'S HANDIEST AERIAL

SELF ADHESIVE BEST PICK-UP NEATEST

"BETTER EVEN THAN YOU SAID IT WAS . . . While I am writing this an organ recital from Broadcasting House is coming through loud and clear."

"BETTER THAN IT EVER HAS BEEN ON THE 40ft. AERIAL OUTSIDE." This is from an entirely unsolicited testimonial dated 21/2/34 from Mr. W. J. M., Bradley, Yorks., the original of which, with many others, may be seen at the offices of the British Pix Co., Ltd., 118, Southwark Street, S.E.1.

And apart from the fine reception you get, it's THE WORLD'S HANDIEST AERIAL. DOUBLE LENGTH 3/6

Press it and it sticks anywhere.

PIX INVISIBLE AERIAL. Sold everywhere.

2/-

Miscellaneous Advertisements

Advertisements are accepted for these columns at the rate of 3d. per word prepaid - minimum charge 3/- per paragraph - and must reach this office not later than Tuesday for the following week's issue. All communications should be addressed to the Advertisement Manager, "Practical Wireless," 8 Southampton Street, Strand, London.

PREMIER SUPPLY STORES

offer the following Set Manufacturers' Surplus New Goods at a fraction of the original cost; all goods guaranteed perfect; carriage paid over 5/- under 5/- postage 6d. extra (Ireland, carriage forward). PREMIER SUPPLY STORES announce the purchase of the entire stock of a world-famous Continental valve manufacturer. All the following types of standard mains valves at 4/6 each. H. H. L. Power. Directly heated 6-watt Pentode. Directly heated 9-watt Pentode. High magnification Screen-grid, low magnification Screen-grid. Variable-Mu Screen-grid. 250 volt 60 milliamp, full-wave rectifiers. THE following types 5/6 each. Indirectly heated Pentode, 350 volt 120 milliamp, full-wave Rectifier. 500 v. 120 ditto, 6/6. Dario Battery Valves 4v. filament. Set of 3, consisting of Screen-Grid, Detector and Power or Super Power, 6/6 the lot. Power or Super-Power, 2/6. ELIMINATOR Kits, including Transformer, choke, Westinghouse metal rectifier, Dubilier condensers, resistances and diagram, 120v, 20 m.a., 20/-; trickle charger 8/- extra; 150v. 30 milliamps, with 4v. 2-4 amps. C.T. L.T., 25/-; trickle charger 6/6 extra; 250v. 60 milliamps, with 4v., 3-5 amps. C.T. L.T., 30/-; 300v. 60 m.a., with 4 volts 3-5 amps. C.T. L.T., 37/6; 150 volts 50 milliamps, 27/6. AMERICAN Triple Gang 0.0005 Condensers, with trimmers, 4/11; Premier chokes, 25 milliamps. 20 henries, 2/9; 40 milliamps, 25 hrs., 4/-; 65 milliamps, 30 hrs., 5/6; 150 milliamps, 30 hrs., 10/6; 60 milliamps, 80 hrs., 2.500 ohms, 5/6. HARLEY Pick-up, complete with arm and volume control, 12/6. BRITISH RADIOPHONE Wire Wound Potentiometers, with mains switch incorporated, 10,000 ohms, 3/6. PREMIER British-made Meters, moving-iron, flush mounting, accurate, 0-10, 0-15, 0-50, 0-100, 0-250 ma., 0-1, 0-3, 0-5 amps.; all at 6/-. SPECIAL offer of Mains Transformers, manufactured by Phillips, input 100-120v. or 200-250v., output 180-0-180 volts 10 m.a., 4 v. 1 amp., 4v. 3 amp., 4/6; 200-0-200v., 4v. 1a., 4v. 3a., 4/6. ALL Premier Guaranteed Mains Transformers have Engraved Terminal Strips, with terminal connections, input 200-250v. 40-100 cycles, all windings paper interleaved. PREMIER H.T.8. Transformers, 250v. 60 m.a., rectified with 4v. 3-5a. and 4v. 1a. C.T. L.T., screen primary, 15/-; with Westinghouse rectifier, 25/-; 4 v. 3a. C.T., 6v. 2a. C.T., 9v. 1a., 12v. 1a., 7/6 each; 4 v. 3-5a., 22v. 1a., 8/6 each; 10v. 3a., 14v. 4a., 10/- each. PREMIER H.T.9 Transformer, 300 v. 60 m.a., with 4v. 3-5a. and 4v. 1a. C.T., L.T., and screened primary, 15/-; with Westinghouse rectifier, 26/-; PREMIER H.T.10 Transformer, 200v. 100 m.a., rectified, with 4v. 3-5a. and 4v. 1a. C.T., L.T., and screened primary 15/-; with Westinghouse rectifier, 26/-; PREMIER Mains Transformers, output 135v. 80 m.a. for voltage doubling, 8/6; 4v. 3-4a., C.T., L.T., 2/- extra; Westinghouse rectifier for above, giving 200v. 30 m.a., 8/6. PREMIER Mains Transformers, output 250-0-250v. 60 m.a., 4v. 3-5a., 4v. 2-3a., 4v. 1-2a. (all C.T.); with screened primary, 15/-; PREMIER Mains Transformers, output 350-0-350v. 90 m.a., 4v. 3-5a., 4v. 2-3a., 4v. 1-2a. (all C.T.), with screened primary, 15/-; PREMIER Mains Transformers, output 400-0-400v. 100 m.a., 4v. 4-5a., 4v. 2-3a., with screened primary, 15/-; PREMIER Auto Transformers, 100-110/200-250v., or vice versa, 100-watt, 10/-; MULTI Radio Output Transformers, 4/6. Twin Screened Wire 3d. per yard. CENTRALAB Potentiometers, 50,000, 250,000 half meg, any value, 2/-; 200 and 400 ohms, 1/-; RELIABLE, Canned Coils with Circuit, accurately matched dual range, 3/- per coil. Please state whether Aerial or H.F. required. Ditto iron core, 3/6. PREMIER L.T. supply Units, consisting of Premier Transformer and Westinghouse rectifier, input 200-250v. A.C., output, 2v. 1 amp., 11/-; 8v. 1 amp., 14/6; 8v. 1 amp., 17/6; 15v. 1 amp., 19/-; 6v. 2 amp., 27/6; 30v. 1 amp., 37/6. MAGNAVOX D.C. 152, 2,500 ohms, 17/6; D.C. 154, 2,500 ohms, 12/6; D.C. 152 Magna, 2,500 ohms, 37/6; all complete with humbucking coils; please state whether power or pentode required; A.C. conversion kit for above types, 10/-; Magnavox P.M., 7in. cone, 18/6. Ditto 9in. cone, 29/6. CRAMPIAN M.C. Loud-speakers, 2,500 ohm. field, 9in. cone, handles 5 watts; 21/-; CRAMPIAN P.M. Loud-speakers, 9in. cone, handles 4 watts; 18/6. WESTERN ELECTRIC Condensers, 250v. working, 2 mfd., 1/-; 1 mfd., 6d.; 4 mfd., 2/-; 1 mfd. 400v. 1/-; 2 mfd., 1/6.

(Continued at top of column three)

Easy Terms

Strict Privacy Guaranteed - we deal with you direct

N.T.S. CLASS 'B' SPEAKER-AMPLIFIER

SEND FOR IT ON 7 DAYS' TRIAL Gives Seven Times the Volume. Ready Assembled with Class "B" Valve.

5/- DOWN

Send only 5/- for 7 days' trial. If approved, balance in 11 monthly payments of 5/6. Cash or C.O.D. Carriage Paid, £22/19/6. Simply plug-in to your existing battery set.



ROLA CLASS 'B' SPEAKER-AMPLIFIER

SENT ON 7 DAYS' TRIAL Complete Class B Amplifying Unit, with Valve and Rola P.M. Moving-coil Speaker. Send only 5/- for 7 days' trial.

5/- DOWN

If approved, balance in 11 monthly payments of 6/6. Cash or C.O.D. Carriage Paid, £31/7/6. ROLA F.R.G. P.M. Class B Speaker. Send only 5/-. Balance in 8 monthly payments of 4/8. Cash or C.O.D. Carriage Paid, £19/10/6.



TELSEN S.G.3 KIT

Complete kit of parts for building. Send only 4/6, balance in 8 monthly payments of 4/6. Cash or C.O.D. Carriage Paid, £11/9/6. If valves ret. required add £1/19/6 to Cash Price of 7/3. Deposit and 11 monthly payments of 7/3.

4/6 DOWN

Send only 4/6, balance in 8 monthly payments of 4/6. Cash or C.O.D. Carriage Paid, £11/9/6. If valves ret. required add £1/19/6 to Cash Price of 7/3. Deposit and 11 monthly payments of 7/3.

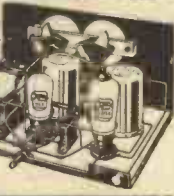

W.B.P.M. 4 MICROLODE MOVING-COIL SPEAKER

SENT ON 7 DAYS' TRIAL With Switch-controlled multi-radio input transformer. Send only 5/- for 7 days' trial.

5/- DOWN

If approved, balance in 8 monthly payments of 5/6. Cash or C.O.D. Carriage Paid, £22/8/0. W.B.P.M.5. Send only 2/6. Balance in 8 monthly payments of 4/2. Cash or C.O.D. Carriage Paid £11/12/6.



ATLAS ELIMINATOR

Send for it on 7 DAYS' FREE TRIAL Model CA.28. Suitable for all outputs, including Class "B" and Q.P.P.

3/6 DOWN

Send only 3/6 for 7 days' trial. If approved, balance payable in 11 monthly payments of 5/6 (or cash in 7 days), £22/19/6. Carriage Paid. D.C. Model 10/25. Cash or C.O.D. Carriage Paid £11/19/6 or 4/- down and 10 monthly payments of 4/-.



Any items advertised in this journal CASH. C.O.D., H.P., Send for quotation by return.

New Times Sales Co.

56, LUDGATE HILL, LONDON, E.C.4. Dear Sir: (a) Please send me (b) I enclose Cash/Deposit. NAME ADDRESS Pr. W. 14/4/34.

(Continued from foot of column one) B.T.H. Truesped Induction Type (A.C. only) Electric Gramophone Motors, 100-250v.; 30/- complete. Type YH 100/250v. A.C. or D.C., 42/-; SPECIAL Offer of Wire Wound Resistances, 4 watts, any value up to 10,000 ohms, 1/-; 8 watts, any value up to 15,000 ohms, 1/6; 15 watts, any value up to 50,000 ohms., 2/-; 25 watts, any value up to 50,000 ohms, 2/6. POLAR 3-Gang STAR, .0005, manufacturers type. Fully screened, 7/6, with trimmers, 1/6 extra. CYLON Capacitors (Double Trimmer), 1/-; Utility .0005 2-gang Bakelite Condensers, concentric Uniknob Trimming and Disc Drive, complete, 3/6. EDISON BELL Double Spring Gramophone Motors, complete with turntable and all fittings, a really sound job, 15/-; AMPLION Cone Loud-speaker Units, 1/9, complete with 12in. cone and chassis, 3/11 each. Worth treble. Larger Unit with 12in. chassis, 5/9. IRMOND Condensers, 0.0005 2-gang, semi-shielded, 2/6; brass vanes, with trimmers, 3/6. WIRE Wound Potentiometers, 15,000 ohms, 1/6; 50,000 ohms, 2/-; 500,000 ohms, 3/6. HOME Radio Microphone, complete, 5/-; simply plug in to pick-up terminals. LARGE Selection of Pedestals, table, and radio-gram cabinets, by best manufacturers, at a fraction of original cost for callers. WESTERN ELECTRIC Mains Transformers, 300-0-300v. 60 m.a., 4v. 1-2 amp., 4v. 2-3 amp. 8/6. 500-0-500v. 150 m.a., 4v. 3-5a., 4v. 2-3a., 4v. 2-3a., 4v. 1a. C.T., 4v. 1a. C.T., 19/6. RELIABLE Interval Transformers 3-1 or 5-1, 2/-; Dubilier, .05 mica, 1/9. T.C.C. Condensers, 250v. working; 2mfd., 1/9; 1,000 ohm, 150 m.a., variable resistance, 2/-; T.C.C. Electrolytic Condensers, 440 volts working, 4 mf. or 8mf., 3/-; 15 mf., 50 v. working, and 50 mf. 12v. working, 1/-; 25 mf. 25 v. working, 1/3. COLSTER-BRANDS Mains Transformers, Input 200-250 volt, output 350-0-350v. 100 m.a., 4v. 1 amp., 4v. 2 amp., 4v. 3-4 amp. 10/-; Ditto, input 100v. 5/-; IRMOND Brass Variable Condenser, .0005 complete with knob-dial 2/-, with slow motion 3/-; & A. Cone Unit and Chassis, a really sound job, 10in. diameter, 6/6. M.V. Block Condensers, 400v. working; 4 x 4 x 1 x 1 x 1 x 1 x 0.1 x 0.1 x 0.1, 6/-; 4 x 2 x 1 x 1 x 1 x 0.5, 4/6. DUBILIER Condensers, 2 mf. 1,200v. working, 4/-; 8 mfd. dry electrolytic, 450v. working, 3/-; THE Following Lines 6d. each or 5/- per dozen - Chassis valve holders, 5 or 6 pin, screened screen-grid leads, any value 1-watt wire end resistances, wire end condensers, 0.0001 to 0.1, trimming condensers, T.C.C. 6 mfd. 50 v. electrolytics. PLEASE mention PRACTICAL WIRELESS when ordering. PREMIER SUPPLY STORES 20-22, High Street, Clapham, S.W.4, M.Caulay 2188. Close 1 o'clock Wednesdays; open to 9 o'clock Saturdays. Nearest Station, Clapham North Underground. WOBURN RADIO offer special purchase of T.C.C. Condensers. T.C.C.-250v. working-0.01, 7d.; 0.1, 7d.; 1 mfd., 11d.; 1 x 1 x 1 mfd., 1/6; 1 x 1 mfd., 1/2; 0.01 x 0.01, 500v. working, 1/-; T.C.C. Electrolytics 50 mfd., 12v., 1/3 (dry); 4 mfd. and 8 mfd., 3/6 (wet); Dubilier dry electrolytics, 4 mfd. and 8 mfd., 500v., 3/3. All in metal cases. Wego condensers, 750v. test, in bakelite 1 mfd., 1/-; 2 mfd., 1/3; 4 mfd., 2/3. Ready Radio and Lotus Diffs., 0003, 00035, 00015, 1/-; .0005 reaction, 1/-; WESTINGHOUSE Rectifiers (new): H.T. 7, 8, 9, 9/-; H.T. 10, 10/-; L.T. 5, 10/6. 10hy. 100ma. Chokes, 4/- each. ELIMINATORS specially manufactured for us. R.C. 3 tappings, 25 m.a., 11/9; A.C., 25/-; Guaranteed for 12 months. CLASS "B" Drivers and Chokes, 9/6 per pair, with suitable valve (BVA) and 7-pin holder, 19/11; Binocular Chokes, 1/3; H.F. Chokes, 1/-; Valve-holders, 4/5-pin chassis type, 1/6 half doz.; 7-pin, 6d. Columbia L.F. Transformers, 3/1 ratio, 3/-; Tubular Condensers 0.01, 0.1 and 0.05, 6d. Large Stock of Erie and Dubilier Resistances. Lucerne Dual Range iron-cored coils, 3/6; Eston iron-cored coils with circuit, 3/-; SINCLAIR P.M. Speakers with universal transformer, S or Class B 7in. Cone, 12 months' guarantee, 16/6. Sinclair Matched pairs, one 9in. one 7in. P.M.'s or Energised, 35/- (cart. 1/-). ANYTHING on H.P. above 40/-. Quotations for Kits and Components by return. Trade Enquiries invited. WOBURN RADIO CO., 7, Woburn Buildings, W.C.1. Euston 1571. (Near King's X and Euston Stns. Back of St. Pancras Church). SEE FOR YOURSELF with "Daily Express" Television Receiver, complete £5/9/6. Carriage Paid. Order from Television Specialists.-Bennett Television Co., Station Road, Redhill. REPAIRS-REWINDING-OVERHAULS. New cones and centres fitted any make M/c chassis, Mc's rewound. Mains transformers, etc. Receivers converted D.C. to A.C. Write Repair Dept. C. WEDON P.L.R. Co., 80, Lonadale Avenue, London, E.6. (Grangewood 1837).

SOUTHERN RADIO'S Bargains.—Set manufacturer's guaranteed surplus.

COILS.—Igranite iron-core band-pass 3 coils unit. Screened. Ganged on base with switch, 16/- (list 33/-).

LISSEN Super-het 3 coils unit. Screened. Ganged on base with wave-change and filament switches. Type LN5181 for battery or mains, 12/6 (list 30/-).

LEWCO'S Coils.—Types O.S.C./126; T.O.S.; I.F.T.; T.B.F.; A.W.C.; 3/3 each. B.P.F. band-pass filter B.P.F., 4/- (list 12/-). All coils brand new in original cartons.

VARIABLE Condensers.—Lotus 3-gang 0.0005, 12/6; Lotus 2-gang, 0.0005, 8/6; Lotus Dyblock single, 0.0005, 4/9 (list 9/6); all these condensers are complete with dials, escutcheons, knobs, fully screened with trimmers, and boxed; Igranite variable, 0.0003 and 0.0005, 2/3; Hydra block condenser, 16 mfd. (2+2+8+2+1+1), 1,000 v. D.C. 7/- each; 20 mfd. (2+2+2+2+2+2+2+1+1+1+1), 1,500 v. D.C. with terminals, 11/6; Duplicator 4 mfd. (2+1+1), 1,000 v. D.C., 2/9; 4.5 mfd. (2.25+2.25), 1,000 v. for mains noise suppression, 3/-; Fixed 4 mfd., 2/3; 2 mfd., 1/6; 1 mfd., 1/-.

SPEAKERS.—Blue Spot Permanent Magnet with universal transformer for power, super power, pentode and Class B, 23/- (list 39/6). Celestion Souxend Permanent Magnet, 17/6 (list 27/6). Celestion P.P.M./W., 25/- (list 49/6).

BLUE Spot 66K, in cabinet, 10/- (list 42/6). G.E.C. B. Stork Speaker in magnificent Cabinet, 19/6 (list 43/15/-).

BLUE Spot, Genuine 100U, inductor speaker on chassis, 13/6 (list 30/6).

READY Radio D.C. mains energised moving-coil speakers with Humbucking coils and universal transformers. For all voltages, 10/6 (list 39/6). All new in cartons.

CONSTRUCTOR'S KITS.—Ready Radio Meteor "A" Kits 3-valve screen grid with cabinet and Celestion moving-coil speaker. Less valves, £37/6; with 3 specified Mullard valves, £41/0/- (list £37/6). S.T.400 kits, all specified proprietary components, £219/6 (list £417/6).

SPECIFIED Cabinets for Ready Radio Meteor kits, 17/6. "303" kits, 13/6.

IGRANIPAK Complete Tuning Unit, comprising completely screened coils with wavechange switch; Igranite 3-gang condenser with cover, escutcheon disc drive assembly with pilot lamp attachment; mains switch; three 5-pin valve holders; grid leak and condenser; engraved terminal board, complete with circuit; actually made for A.C. mains, but can easily be adapted for battery sets; list price 57/6, our price 27/6, brand new, wired ready for use.

FRAME Aerials.—Lewcos dual wave superhet, 3/- each (list 27/6).

SPECIAL Bargain Offer of Lewcos Spaghetti Resistances, all sizes, in original sealed boxes, 4/- per dozen, assorted; special price to trade, 30/- per gross.

READY RADIO Instamat Transformers, for matching any valve to speaker, Junior model 11/6 (list 27/6), Senior model 14/6 (list 37/6).

PICK-UPS.—B.T.H. latest Senior type (1934) Needle armature. Bronze, 30/- (list 40/-). Marconi "No. 19" (1934), 22/6 (list 32/6).

MAINS Transformers.—Auto. step-up or down, 0/250 v., 60 watts, 11/6; 100 watts, 14/3. Full list of Mains transformers and chokes sent Free. Specials can be supplied in 3 days. All transformers and chokes guaranteed 12 months.

MISCELLANEOUS.—Rotorohm and Radiophone volume controls, all values, 3/- each; with switch, 3/3 (list 10/6); S.T.500 coils, 5/6 per pair; Hellesen's 8 mfd. electrolytic condensers, 2/9 each; Westinghouse metal rectifiers, H.T. 6, 7, 8, 9/3 each; Ferranti chokes, 20 henry 60 m.a., 0/9 each; Ready Radio L.F. transformers, 5-1, 3-1, 3/3 (list 8/6); B.T.H. transformers, 3/6; Lewcos superhet 8-way bases, complete with valve-holders, grid leak, fixed condenser, type "48", 2/- each.

ALL Goods Guaranteed and Sent Carriage Paid.

BRANCHES at 271-275, High Rd., Willesden Green, N.W.10 and at 46, Lisle St., W.C.2; please send all post orders to 323, Euston Rd., N.W.1.

SOUTHERN RADIO, 323, Euston Rd., London, N.W.1 (near Warren St. Tube). Phone: Museum 6324.

HA. WIRELESS for everything radio. Specialists for specified kits, radio components, gramophone motors, etc. Send your lists and we will quote per return. Everything guaranteed and brand new. Send for lists.—H. A. Wireless (Shoreditch), 9 and 13, Hackney Rd., Shoreditch, London, E.2. Tel.: Bishopsgate 8169 (PBx).

LOUDESPEAKERS Re-wound, any make, 3/6. Mains Transformers quoted for. Years Guaranteed.—Breeze, Clapper House, Marden, Kent.

NEW LIFE FOR YOUR SET

Your aerial is robbing you if it's old and corroded. Try a new and better one; try SUPERIAL at our expense. Slipping up a shorter length, compare results. You'll get better reception all round or we'll refund your money.

100 ft.	75 ft.	50 ft.	25 ft.
3/6	2/6	1/9	1/-

From Dealers Everywhere.

The New London Electron Works, Ltd., 6, East Ham, E.8

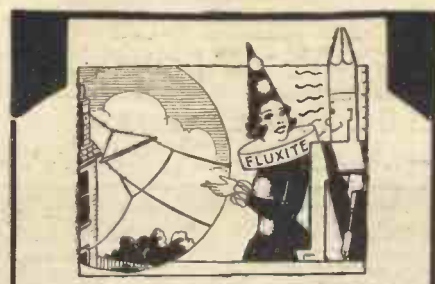

"We're Fluxite and Solder—the reliable pair—be sure not to shirk—" Famous for Soldering—known everywhere! —When fixing your aerial— "SOLDER" your connections— a good spot of work!"

See that Fluxite and Solder are always by you—in the house—garage—workshop—anywhere where simple, speedy soldering is needed.

ALL MECHANICS WILL HAVE

FLUXITE

IT SIMPLIFIES ALL SOLDERING

All Ironmongers sell Fluxite in tins: 4d., 8d., 1s. 4d., and 1s. 8d. Ask to see the FLUXITE POCKET SOLDERING SET—complete with full instructions—7s. 6d. Ask also for our leaflet on HARDENING STEEL with Fluxite.

FLUXITE, LTD.
(Dept. W.P.), BERMONDSEY, S.E.1.

FOR ALL REPAIRS!



ABSOLUTELY ACCURATE



Moving Iron Meters.

The unfailing standby of all Radio Technicians and Enthusiasts. Easiest to read. New knife-edge pointer; scaling divisions sharply defined on white cellulose dial. All parts individually tested and every meter guaranteed.

From 21/-.

Write for Fully Illustrated List of complete range.

SIFAM ELECTRICAL INSTRUMENT CO., Ltd.
York Works, Browning Street, London, S.E.17.
Telephone: Rodney 3573.



METERS FOR YOUR RADIO TESTS

are FULLY GUARANTEED

Magnetic Controlled Meters.

D.C. only. Thousands in daily use for radio and charging purposes. In attractive new moulded cases, 2 1/2 in. overall, with 2 in. aperture in panel.

From 7/6.

UTILITY SALES CO.

WE are advertising ONLY our SPECIAL WEEKLY BARGAINS, which are always VALUE for MONEY, if none interest you this week, ask for FULL LISTS.

RADIO TIME SWITCH. Can be set to turn off Radio at Specified time. Clockwork, fit any set, 3/6.

RADIO GRAM Electric Motor, complete with turntable, speed regulator switch, will work from 3 dry cells, 4 volt accumulator. Suitable for Television, 15/-.

OUR VERY SPECIAL Dual Wave Screened Iron Core Coil, matched for S.G., 3 diagrams, cheap but perfect. 2/6.

ELECTRIC Soldering Iron, any voltage (specify). Perfect, lasting, 4/6.

A REAL SNIP: "IGRANICOR" Bandpass and H.F. Unit, comprising 3 Screened Iron Cored Coils assembled on bakelite base, ready wired with dual Wave Switch, needle sharp selectivity with Bandpass tuning, diagram; listed 33/-, our price 18/6.

REMOTE Volume Control: No alteration to set required, control Volume from your Armchair, for permanent fixing, 2/-, with leather flap for armchair, leads and instructions, 3/6.

OUR NEW Lists will soon be ready. Only a Postcard to write to receive them regularly. Carriage PAID, Cash with order, 24 hours service.

UTILITY SALES CO.

27a, Sale Street, London, W.2.

SCREENED Iron Core Coils. Guaranteed first class job. Sold elsewhere at 7/6. Our special offer. Post paid 4/6. Money refunded falling satisfaction.—Bon Marche Radio, Dept., Ebbw Vale.

REPAIRS to Loud Speakers, 4/-; Blue-Spots, 5/-; Transformers, 4/-; Moving Coils and Eliminators Quoted for. All repairs remagnetised free. Guaranteed. Discount for trade. Clerkenwell 0069. E. C. Mason, 44, East Road, N.1.

ERICSSON 3/1 L.F. Transformers. List Price, 17/6. New and guaranteed. Our Price, 2/3. Post free U.K.—Pioneer Radio, Coptic Street, London, W.C.1.

WANTED good Modern Wireless Parts, Sets, Eliminators, Meters, Valves, Speakers, etc. Spot Cash waiting. Send or bring. We pay more than any other dealer. Open 9-8.—University Radio, 142, Drummond St., Hampstead Rd., N.W.1.

THE following Unused set Manufacturers' surplus, all goods guaranteed perfect; immediate delivery.

SUPER-HET, and 2-H.F. Radiopaks, 35/-; Radiophone coils (3in. gaug), 10/-; Radiophone I.F. transformers, 6/6.

FERROCART coils, G1-G2-G3 with switch, 30/-; G11-G12-G13-G14 with switch, 36/-; DUBILIER or Eric 1-watt resistors, 7d. 2-watt, 1/3.

MARCONI K19 pick-ups, 22/6. Westinghouse rectifiers, H.T.8, 9/6; H.T.9, H.T.10, 11/-; L.T.5, 11/6.

REGENTONE transformers for H.T.8 or H.T.9 with 4v., 4a. L.T. winding, 7/6. Wards transformers, output 350-0-350v., 60ma., 4v. 4a. 2a. 12/6.

ELIMINATORS, outputs 150v. 25ma., S.G. and Detector. D.C. type, 12/6; A.C. type, 24/-; DUBILIER dry electrolytic condensers, 8mf. or 4mf., 500v. working, 50v., 50mf., 3/6. Hot-wire ammeters for A.C. or D.C., 0-500ma. scale, 5/6. B.T.H. pick-up tone-arms, 3/-.

ALL types of brand new American valves in stock, first-class makes, guaranteed.

47, 35, 51, 89, 19, 40, 59, 6A7, 15, 42, 41, 38, 39, 78, 75, 57, 58, 24, 44, 36, 35, 43, 12/-.

UX171A, UX190, UX280, UX245, UX226, UY227, 8/-; UX250, UX281, UX210, 18/-.

BT.H.-RK 6-volt speakers, suitable for P.A. work, 27/6. A.C. type with field rectifier, £27/6.

MAGNAVOX speakers, complete with hum-bucking coils, output transformers, etc., 152 (9in. cone), 24/-; 154 (7in. cone), 16/3; Rola F.6 (7in. cone), 17/6, with either 2,500 or 6,500 ohm. fields. Rola F.6, P.M., 24/-; Magnavox P.M.254, 18/6. Carriage paid, cash with order or C.O.D. Send for list.

WARD, 2nd floor, 45, Farringdon Street, London, E.C.4. Telephone: Holborn 9703.

WANTED good Modern Wireless Parts, Sets, Eliminators, Meters, Valves, Speakers, etc. Spot Cash waiting. Send or bring. We pay more than any other dealer. Open 9-8.—University Radio, 142, Drummond St., Hampstead Rd., N.W.1.

"UNIVERSAL" RADIO BARGAINS.—Stamp for our huge bargain list of Components, Kits and Sets.—"UNIVERSAL", 20, Victoria Road, Peckham, S.E.15., New Cross 4933.

RADIOVISION SUPPLIES, 94, Grove Vale, E. Dulwich, S.E.22, offer.—Ardron S.G. 3 Sets, complete Mullard valves, Batteries, Speaker, all housed in Walnut Cabinet, 77/6. Ready Radio 303 Kits with Walnut Cabinet and P.M. Moving Coil Speaker, 39/6. Iron Cored Dual Coils, 2/11. Bakelite Cased Transformers, 2/3. 100 U Speakers, 12/6. Midget P.M. Moving Coil Speakers, Universal transformer, 14/9. Hercules H.T. Batteries, 60, 3/6; 100, 5/6; 120, 7/3. Utility 2-Gang Condensers, ideal for Leader 3, 9/6. Stamp for list now.

THE 'GOLD-MINE STORES'

Offer You 'The A.C. Leader III,' 49/6, post free, FREE APPROVAL COSTS YOU NOTHING.—Your satisfaction complete or money returned without question.

EXACT TO SPECIFIED VALUES THROUGHOUT.—The Leader III Kits (A.C. and battery models), are made up exact to specified values throughout. The price alone falls short of this standard.

WE GUARANTEE YOUR SATISFACTION so why pay more? We will send on full approval against cash or C.O.D.

BUILD THE A.C. LEADER III, KIT A, at 60% SAVING.—Complete to the last screw, with chassis, all components, sundries, blueprint and copy of PRACTICAL WIRELESS. Post paid. 49/6; battery model, 25/6. Please note since first advertised in PRACTICAL WIRELESS, March 3rd, we have not had one battery Kit returned, and now for the A.C. model, which is just as good.

BUILD THE A.C. LEADER III, KIT B, as above, but with matched set of three (and rectifier) British and fully guaranteed valves. Price 84/6; battery Kit, 36/6.

BUILD THE A.C. LEADER III, KIT C, as Kit B, but including high grade console cabinet and 4-pole bal. armature speaker unit, comprising the complete outfit. Price 99/6 (if Permanent Magnet speaker preferred, add 9/6); battery Kit, 47/6 (with batteries, 57/6).

3d. ONLY, POST FREE.—Enclose also 3d. stamps for your April number of THE 'RADIO GOLD-MINE.' By far the most comprehensive lists of up-to-date surplus goods (Kits, components and accessories) yet produced; April issue now ready, with a general price level lower than ever before. Avoid delay. Send (enclosing 3d. stamps) to-day.

W.B.; BLUE-SPOT; AMPLION SPEAKERS CLEARANCE.—W.B. Permanent Magnet (ordinary or Class B type) (list 37/6), 18/10; Nuvoilton P.M., 16/10; Blue Spot 100V (list 32/6), 15/10; 31K (list 25/6), 15/4; 60K (list 12/6), 7/8. Special offer. P.M.M.C. speakers, 12/6.

BROWNIE COILS CLEARANCE.—All dual range B with reaction. New line, 1/6; also screened, 2/6; Special Iron Cored (diagrams included), 3/3; S-Wave, 2/10. Special Lucerne Coils, 3/3.

PHILIPS MANSBRIDGE CONDENSERS CLEARANCE, 750 v. test, 1 mfd., 8d.; 2 mfd., 1/4; 4 mfd., 2/8; Dubilier Wet Electrolytic, 8 mfd., 2/9.

DUBLIER FIXED CONDENSERS CLEARANCE and Edison Bell, mica, .0001, 2, 3, 4, 5 mfd.; .001, 2, 3, 4, 5, 6, 7, 8, 9 mfd.; Tubular mica type, .0001, .0003 mfd., all 3d. each; 2/9 doz.

BRITISH RADIOPHONE AND H.M.V. VARIABLE CONDENSERS CLEARANCE.—H.M.V. 3-gang, 5/9; Br. Radiophone, 2-gang with escutcheon, S.M. drive, panel light, etc., 6/11; .0003, .0005 mfd. air-spaced, 2/3; Slow Motion Type, 2/11; Mica Dielectric, .0003, .0005, 11d.; 'Duotone' Extensers (list 12/6), 2/11; S.M. Type (list 18/6), 4/10; Differentials, 1/4.

ERIE, H.M.V., PHILCO RESISTANCES CLEARANCE.—H.M.V. 4 watt glass cased, 100,000 ohms, 41d.; Erie, 1 watt, all values to 60,000 ohms, 41d.; Dubilier, 1 watt, 100,000 ohms, 31d.; Philco, 2, 10, 15, 16, 20 and 32,000 ohms, 31d.; Edison Bell Carbon to 70,000 ohms, 44d.; to 150,000 5d.; to 350,000, 51d.; to 500,000, 6d.; Spaghetts, every size to 100,000 ohms, 31d.; Grid Leaks 1/2 to 3 megs., 3d. each.

AMPLION AND SUNDRY COMPONENTS CLEARANCE.—L.F. Transformers (list 5/6), 3:1 and 5:1, 2/2; Cl. B. Driver, 3/11; Output Chokes, 3/11; C.E.C. 20. Hen. Chokes, 3/6; H.F. Chokes, 9d.; V-holders, 4 pin, 21d.; 5-pin, 31d.; 7-pin, 6d.; Switches, push-pull, 2-point, 41d.; 3-point, 51d.; Grid Leaks, 1, 1, 1 1/2, 2 and 3 megs., 3d. each.

L.E.C. 'GOLD-MINE' KITS CLEARANCE represents absolutely unprecedented values. They cover a comprehensive range of up-to-date circuits which will meet every home constructor's requirements. Supplied complete with diagrams, instructions and all sundries in sealed cartons. Straight 2-valve, 8/6; 3-valve, 10/6; S.G.III, 18/6; S.G.IV, 25/-; SHORT WAVE KITS: 2-valve, 12/6; 3-valve, 18/6; Class B III, 27/6. ADAPTOR KITS: S.W. Adaptor, 8/6; Super-Het. type, 15/6; Class B Adaptor, 10/6; A.V.C., 14/6. CLASS B KITS: 3-valve, 22/6; S.G.IV, 29/6.

ELIMINATOR KITS, complete with full diagrams, 4 tappings to 150v. A.C. 25 ma. 21/6. Class B. 29/6. D.C. 9/6. (Westinghouse Rectifiers.)

UNIVERSE PICK-UPS AND SUNDRY CLEARANCES. Super Pick-up (list 20/-), with vol. control, 12/6; Igo. Electric Clocks (A.C. 100-240 v.), various colours (list 32/-), 10/6; Colaro Universal A.C. Motors, with Auto-Stop (list £3/10/0), 35/-.

LONDON EAST CENTRAL TRADING COMPANY (Dept. M.107), 23, Bartholomew Close, London, E.C.1 (telephone: NATIONAL 7473). Goods over 10/- value, postage free. Under 5/- value—cash only. Over 5/- cash or C.O.D.

3d. POST FREE.—Secure your copy of THE 'RADIO GOLD-MINE' TO-DAY.

The Miracle Medium in Modern Radio THE 'RADIO GOLD-MINE'

YOU CAN TAKE IT FROM ME!



ELECTRADIX BARGAIN SALE LIST Will Save You Pounds

ELECTRADIX "N.W." 11 TABLE RADIO MIKE should be with every Wireless Set. Be your own announcer. A bakelite production containing the high-ratio transformer. Fitted battery plug switch and output terminals. The excellent results and low price have made this one of our most popular models. Only As illustrated page 31, March 24th. **10/6** MICROPHONE BUTTONS are wonderfully interesting for experiments with 1/- Phones

1,000 other Bargains in our April Sale List "N" **ELECTRADIX RADIOS,** 218, UPPER THAMES ST., LONDON, E.C.4 Telephone: Central 4611.

Engineers' Guide

CONTAINING THE WIDEST CHOICE OF ENGINEERING COURSES in the WORLD Outlines The T.I.G.B.'s up-to-date, home-study Courses in Wireless, Electrical and Mechanical Engineering, etc. Shows how to become A.M.I.E.E., A.M.I.Mech.E., A.Rad.A., etc., and how to qualify for a well-paid post. Training until Successful Guaranteed.

WRITE NOW for Free Guide. THE TECHNOLOGICAL INSTITUTE OF GREAT BRITAIN, 42, Temple Bar House, London, E.C.4. (Founded 1917. 19,000 Successes.)



To Success 152 PAGES

EASY PAYMENTS

"There's no place like HOLMES." The first firm to supply Wireless parts on easy payments. Nine years advertiser in Wireless Press. Thousands of satisfied customers.

	Deposit.	Monthly Payments.
TELFEN Latest 323 Kit	29/6	4/5 7 of 4/1
Lissen Skyscraper 4	112/6	10/- 11 of 10/3
EXIDE H.T. Accum., 120v.	60/-	6/- 9 of 6/8
BLUE SPOT 29PM.	32/8	4/5 7 of 4/5
ATLAS ELIMINATOR, No. GA25	59/8	5/- 11 of 5/6
B.T.H. Pick-up	21/-	3/10 5 of 3/10
EPOCH 20th C. P.M.	35/-	4/10 7 of 4/10

Parts for any Kit Set. Any make of Speaker. New Goods Obtained for Every Order. Send us a list of the parts you require and the payments that will suit your convenience, and we will send you a definite quotation. Anything Wireless.

H. W. HOLMES, 29, FOLEY STREET, Great Portland Street, London, W.1.

*Phone: Museum 1414.

Add 50/- WEEKLY to your earnings

by charging accumulators in your spare time. Complete plant incorporating Westinghouse Rectifiers to charge 105 cells weekly. Trade price 4 guineas or 2/- monthly. Models for A.C. and D.C. mains. Also Charger for H.T. accumulators.



M.P.R. Ltd ROMFORD, ESSEX.

VALVES British Made. H.F., L.F. Det., 3/-; Power, 3/8; Super Power, 3/6; Screen Grid, 6/6. Fully guaranteed.—Charles Steed, 36, Albert Road, N.22.

PEARL & PEARL

190, Bishopsgate, London, E.C.2. All the following bargains guaranteed new goods. Cash or C.O.D. Carriage Paid.

LISSEN, type L.N.5181, superheterodyne 3-coil ganged unit, specially designed for use with battery- or mains-driven superhet receivers, 3 dual-range shielded coils complete with wave-change and filament switches, operated by one knob on an aluminium chassis, with leaflet of circuits and full instructions; list price 30/-, our special bargain offer 12/6.

POLAR 2-ganged Screened Condensers, with trimmers, pilot lamp holder, calibrated scale and escutcheon; list 27/6, our price 8/11.

1,000 Marconi 2-valve Sets (1934 models), with Marconi valves; list price 4 guineas, our price, complete with batteries, 45/-; or on deferred terms.

TRITRON 4-pole Balanced Armature Speakers, type "B," sensitive, beautiful tone; list 22/6, our price 6/11.

SOVEREIGN Iron Cored Coils, with circuits, 2/11.

SOVEREIGN Super H.F. Chokes, 1/9; ditto, binocular type, 1/6.

SOVEREIGN Screened Dual Range coils, 2/9 each.

IGRANIC Short-wave H.F. Choke, 10-120 metres, baseboard or panel mounting, 1/3 each.

THE "Lincoln Super" Permanent Magnet Moving-Coil Loud Speaker, all purpose universal tapped transformer for Q.P.F., Class B., pentode, power and super-power output, will carry 3 watts undistorted output; list price 42/-, our price 19/6.

2,000 Volt Test. Block condensers with soldering tags, terminals and earthing terminal. 2 mfd., 7/11; 1 mfd., 6/11. Limited supplies.

LINCOLN STEWART 20 m/amp. D.C. Eliminator. 3 output tappings. New, tested, and guaranteed, 13/11.

IGRANIC Pentode tapped choke, provides tappings from 1-1 to 6-1. List, 7/6; our price, 3/11.

COLARO Electric gramo. motor with pick-up and volume control incorporated. Brand New as listed at £4. Our price, 59/6.

HORIZONTAL Cabinets for set and speaker combined; solid walnut (made for Philco), 22in. wide; 10 1/2 in. deep; 11in. high. 500 sold to PRACTICAL WIRELESS readers at 6/11 each. We now offer small remaining stock (slightly scratched) at 4/11 each, carriage forward. Don't miss this wonderful bargain.

SPECIAL SUNDRY BARGAINS (Cash with order only.) Igranic 400 ohms, baseboard potentiometers, 9d.; Edison Bell pick-up arms, 1/6; lots of 3 doz. assorted Dubilier fixed condensers, 1/9 each lot; C.E.C. 1 mfd. condensers, 1/3 each; Chimax binocular H.F. chokes, 1/11 each; Silekton screened dual range coils, 2/11 each; Sovereign lightning arresters, 9d.; Sovereign toggle switches, 9d.; Sovereign spaghetti resistances, various values, 2/11 for 6 assorted. Igranic 2-pole rotary switches, 1/-; 4-pole, 1/3.

FREE. Send postcard for Bargain List "B."

All Mail Orders Direct to **PEARL & PEARL,** 190, Bishopsgate, London, E.C.2.

Callers only can also obtain all above bargains from our London branches; 100-101, Houndsditch; 11, Liverpool St.

BUILD The Leader Three with a Melford Solely Specified Kit, 43/-; A.C. Leader, 78/6, complete. The Premier D.C.3, £6. No alternatives. Write for Free Lists.—Melfo-Rad, 5, Queen's Place, Hove. (Trade Supplied.)

ADVERTISEMENT INDEX

	Page
British Blue Spot Co., Ltd.	Back Cover
British Ebonite Co., Ltd.	118
British Institute of Eng. Technology	121
British Pix Co., Ltd.	130
Clarke, H. & Co. (M/c), Ltd.	105
Cossor, A. C., Ltd.	Inside Front Cover
Dubilier Condenser Co. (1925), Ltd.	122
Electradix Radios	Inside Back Cover
Fluxite, Ltd.	132
Graham Farish, Ltd.	127
Hayberd, F. C. & Co.	128
Heraud, E. J., Ltd.	122
Holmes, H. W.	Inside Back Cover
Impex Electrical, Ltd.	105
International Correspondence Schools	120
King's Patent Agency	127
Lectro Linx, Ltd.	128
Mains Power Radio	Inside Back Cover
New London Electron Works	132
New Times Sales Co.	131
Osborn, Chas., A.	122
Peto-Scott, Ltd.	Front Cover, Strip, 117
Pifco, Ltd.	Back Cover
Sifam Electrical Instrument Co.	132
Taylor, N.	127
T.I.G.B.	Inside Back Cover
362 Radio Valve Co., Ltd.	118
Turnadge & Partners	121
Varley, Ltd.	106/7
V.M.C. Radio	127
Wet H.T. Battery Co.	127
Whiteley Electrical Radio Co., Ltd.	121

IF your set ought to get Rome - but nearly expires bringing in the local Regional

don't be puzzled
find out why

The reason for this lack of ambition may be due to weak valves, run down accumulator or any other cause. Whatever it is—you'll soon find out with a Pifco Trouble Tracker. Every component in radio can be tested quickly and surely by these wonder instruments. Don't endure faulty reception any longer. If trouble starts—solve the problem immediately with a Pifco Trouble Tracker.

Ask your dealer or electrician for a demonstration of a PIFCO.

● PIFCO "ALL-IN-ONE" RADIOMETER (above). For battery sets. Makes any test in a few seconds. Mottled bakelite case. Complete with leads. Price 12/6.

● PIFCO DE LUXE "ALL-IN-ONE" RADIOMETER (right). Moving Coil model, 125,000 ohms resistance. Tests everything. For electric radio, mains units or battery sets. Finished mottled bakelite, complete with leads and case. Price £2.2.0.

● PIFCO ROTAMETER. A radio testing instrument on entirely new principles. One needle operates on 8 separate dials. For electric or battery sets. Amazingly handy and accurate. No other instrument in the world like it. In black bakelite, complete with leads. Price 29/6.

Issued by PIFCO LTD., High St., MANCHESTER, or 150, Charing Cross Road, London, W.C.2.

INSIST ON A PIFCO AND SAVE TROUBLE.

PIFCO

Trouble Trackers

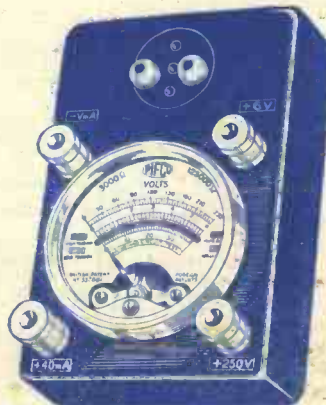

THE NEW MAGNET

SEND FOR CATALOGUE PR. 10.

CHASSIS PRICE

70/-



Blue Spot "Star"—the speaker with the new magnet—will cause a sensation in the Radio World. Its performance is as marked an advance on present-day standards as the Moving Coil Speaker on the old balanced armature speakers of a year or two ago.

● NEW MAGNET SYSTEM

The magnet material is enclosed in four chromium plated tubes. The high flux density and many other special features give a hitherto unattained degree of power and quality.

● UNIVERSAL MATCHING

The transformer is designed on unique and highly efficient lines and is arranged to match ANY OUTPUT STAGE from Power to Push-Pull Pentode and Class B. It can be used under all conditions and with any type of speech coil without loss of efficiency. Full instructions on back plate of speaker.

● ON-OFF SWITCH OR REMOTE VOLUME CONTROL

A switch-plug is provided to cut speaker out of circuit when desired. This switch is interchangeable with Blue Spot Remote Volume Control Unit.

● EXTENSION SPEAKER SOCKET

A socket is provided for an extension speaker to be plugged into the Blue Spot "Star."

● DUST PROOF

The cap in the centre of the cone and the special dust covers which surround the speech coil and magnet gap render the speaker completely dust proof.

● DIE CAST CHASSIS

Ensuring no loss of magnetism, complete rigidity and absence of chassis resonance.

● SPEECH COIL

Low resistance and high efficiency giving minimum variation of impedance with frequency. The entirely new design of outside suspension gives great freedom of movement with complete lateral rigidity.

BLUE SPOT "STAR"

THE BRITISH BLUE SPOT CO., LTD.
Blue Spot House, 94/96, Rosoman Street,
Rosebery Avenue, London, E.C.1.
Distributors for Northern England, Scotland and Wales: H. C. RAWSON (Sheffield and London), Ltd., Sheffield: 22, St. Mary's Parsonage, Manchester: 177, Westgate Road, Newcastle-upon-Tyne: 37, 38, 39, Clyde Place, Glasgow.



P.W. Gift Stamp No. 15

Printed by NEWNES & PEARSON PRINTING CO., LTD., Exmoor Street, Ludbrooke Grove, W.10, and published by GEORGE NEWNES, LTD., 8-11, Southampton Street, Strand, W.C.2. Sole Agents for Australia and New Zealand: GORDON & GOTCH, LTD., South Africa: CENTRAL NEWS AGENCY, LTD., Practical Wireless can be sent to any part of the world, post free, for 17/4 per annum; six months, 8/8. Registered at the General Post Office for Transmission by Canadian Magazine Post.

* P.W. TOOL-KIT
GIFT STAMP No. 7

Papworth
THE ELECTROSTATIC SPEAKER, By HANS VOGT

Practical Wireless

3^D

Published every Wednesday by

GEORGE NEWNES LTD.

Vol. 4. — No. 83.
April 21st, 1934.

Registered at the G.P.O. as a Newspaper.

AND PRACTICAL TELEVISION
EDITED BY F.J. CAMM

An **ULTRA SHORT-WAVE CONVERTER**



TUNING from
5 to 8 METRES

FURTHER DETAILS OF OUR GREAT NATIONAL COMPETITION!

Twenty-five Guineas Cash and 200 Consolation Prizes

TRADE INQUIRIES INVITED.

PILOT TELEVISION KITS AND SPARES



PETO-SCOTT UNIVERSAL TELEVISION MOTOR

Ready fitted for synchronising gear. Heavy cast aluminium frame, self-oiling bearing, no noise, no vibration. A.C. or D.C. Mains 200-240 volts. Cash or C.O.D. Carriage Paid 30/-. 6 volt (Battery Type) 35/-; All Models with Metal Stand

2/6 extra. 1 Pair of Controlling Resistances for above, Cash or C.O.D. 11/8. Or Television Motor and Pair of Resistances, 5/- Deposit and 8 Monthly Payments of 5/-

Yours For 5/-

and 8 Monthly Payments of 4/9

PETO-SCOTT SCANNING DISCS

Light gauge aluminium. Centre boss is an 8-ribbed black bakelite moulding, faced white to give true stroboscopic effect, and thereby visual speed indication. Scanning holes perfectly punched to secure uniform scanning without preventable lines. Made in 2 sizes and ready for immediate use.

10in. diam. 7/6
20in. diam. 12/6



PETO-SCOTT CO. LTD. 77, CITY ROAD, LONDON, E.C.1.

BRITAIN'S GREATEST RADIO VALUE

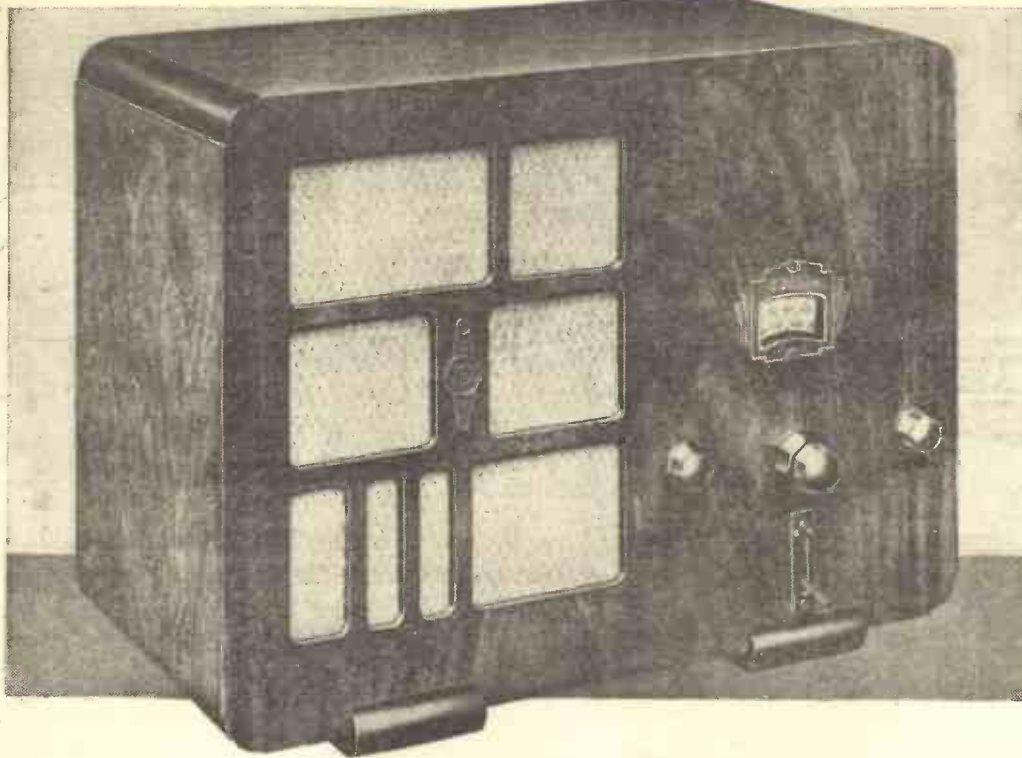

**INCORPORATING EVERY WORTH-WHILE
RADIO DEVELOPMENT**

**NEW
STATION
CHART**

Get one of the new Cossor Station Charts which gives the revised wave-lengths, etc., of over 80 foreign stations and has space for entering your own dial readings, price 2d. from your Dealer or write to A. C. Cossor Ltd., Melody Dept., Highbury Grove, London, N.5, enclosing 2d. stamp.

Variable-mu Screened Grid Circuit for range and selectivity — high-efficiency fully-screened coils — single dial tuning—gun-finished all-metal chassis—these are but a few of the many advanced features of the impressive specification of the Cossor Melody Maker. This fine, up-to-date Receiver will bring you the best European stations free from interference. It costs no more than the bare price of its parts. By assembling it at home you can save pounds. Send at once for Constructional Chart which gives full details—please use the coupon.

**COSSOR
MELODY MAKER**

To A. C. COSSOR LTD.,
Melody Dept., Highbury Grove,
London, N.5.

Please send me a Constructional
Chart which tells me how to build
a Cossor Melody Maker.

Model.....

State Model No. required.

Name.....

Address.....

PRAC. 21/4/34.

**FIVE
MAGNIFICENT
MODELS**

**BATTERY MODEL
KIT 340**
POWER OUTPUT
Moving Iron Cone Type
Speaker

Complete Kit of Parts, including
Cossor Variable-Mu S.G., Detector
and Power Output Valves, and all
necessary parts. Cabinet 18½" x
13½" x 10", space for batteries and
accumulator. Moving Iron Cone
Type Speaker, provision for gramophone
pick-up plug and jack. Switch
for Long and
Short Wave-lengths. Price **£5.7.6**

Hire Purchase Terms 12/- deposit and
9 monthly payments of 12/-.

**BATTERY MODEL
KIT 341**

Pentode Output
Complete Kit of Parts, similar to
Model 340 but with Cossor 220HPT,
Economy Pentode Output Valve.
Balanced Armature Loud Speaker.

Price **£6.7.6**

H.P. Terms 16/- deposit and 10
monthly payments of 12/6, or 20/-
deposit and 6 monthly payments of 20/-.

**BATTERY MODEL
KIT 342**

MOVING COIL SPEAKER
Complete Kit of Parts similar to
Model 341, except that it is supplied
with a permanent Magnet Moving
Coil Loud
Speaker. Price **£7.2.6**

Hire Purchase Terms 17/6 deposit and
9 monthly payments of 15/6.

**BATTERY MODEL
KIT 344**
CLASS "B" OUTPUT

Complete Kit of Parts as model
341, but with four Cossor Valves,
Class "B" Output Stage and Per-
manent Magnet
Moving Coil
Speaker. Price **£8.2.6**

Hire Purchase Terms 20/- deposit and
10 monthly payments of 16/-.

Prices do not include Batteries or
Accumulator.

**ALL-ELECTRIC
MODEL KIT 347**

Complete Kit of Parts, similar to
Model 341, but with four Cossor
A.C. Mains Valves (incl. Rectifier)
Power Unit and Mains Energised
Moving Coil Loud Speaker. For
A.C. Mains only 200/250 volts
(adjustable)
40/100 cycles. Price **£8.19.0**

Hire Purchase Terms 20/- deposit and
9 monthly payments of 20/-.

Prices do not apply in I.F.S.

ANOTHER £5 5s. FOR BIFOCALISTS! See Paragraph Below.



Practical Wireless

EDITOR:
Vol. IV. No. 83 || F. J. CANN || April 21st, 1934.
Technical Staff:
W. J. Delaney
H. J. Barton Chapple, Wh. Sch., B.Sc. (Hons.), A.M.I.E.E.,
Frank Preston, F.R.A.

ROUND *the* WORLD of WIRELESS

Our Bifocal Competition—Further £5 5s. for the Winner!

THE winner of our Bifocal Competition (the details of which are repeated elsewhere in this issue) will receive a further windfall of £5 5s. in the event of his bifocal coil having been purchased from Messrs. Peto-Scott, Ltd., who have very kindly donated this additional amount to augment the Twenty Guineas which we offer as a first prize. So Peto-Scott customers have a chance of winning *Twenty-five Guineas!* All readers, from whatever source they obtained their bifocal coils, stand an equal chance, of course, of winning our Twenty Guineas, or one of our 200 Consolation Prizes. We tender our thanks to Messrs. Peto-Scott, Ltd., for their friendly gesture, which is a further tribute to the manner in which the radio components manufacturers co-operate with us.

The Making of an Interval Signal

THE few notes which may be heard between items of programmes broadcast by the Hamburg station are produced by means of a cylinder of a type similar to that used in the toy musical boxes. It is studded with pins which on revolving strike small metal tongues of which the sounds are picked up by a microphone placed near the apparatus. The cylinder is electrically driven and can be put into action by a switch at the announcer's desk.

A Shakespeare Play from Stratford-on-Avon

FOR the first time in the history of broadcasting listeners will be given the opportunity of hearing a Shakespeare play: *Love's Labour Lost*, as performed on the stage of the Memorial Theatre at Stratford-on-Avon. It is given in celebration of the anniversary of the Bard's birthday.

France combats Electrical Interference

IN France the Anti-static Law governing electrical and other similar parasitic interference came into force on April 1st. From that date anyone marrying the reception of radio programmes is liable to prosecution by the police authorities. Is it not time a similar move were made in Great Britain?

New B.B.C. Maida Vale Studio

WORK on the Maida Vale disused Skating Rink is proceeding apace, and it will not be long before the B.B.C. will

find there a new and possibly permanent home for its National Symphony Orchestra. The main studio to be used for these concerts is much larger than the concert hall originally built for the purpose at Broadcasting House; its dimensions are 110ft. long, 72ft. wide and its height 35ft. When completed, it will be one of the finest studios in Europe.

New German Transmitter

WORK on the new 1.5 kilowatt Stettin relay station is nearing completion and it is expected that it will be brought into operation in the course of the next six

Not yet too late to enter our National Competition!

**FIRST PRIZE:
20 GUINEAS CASH**

(A Special and Additional Prize of 5 Guineas will be awarded by Messrs Peto-Scott Ltd. to the winner in accordance with the terms given in this issue.)

AND
200 Consolation Prizes!

weeks. Contrary to a previous report the station will not work on the German common wave but will share the Hamburg channel, namely 331.9 metres (904 kilocycles), with which transmitter it will be synchronized.

Further Aid to Identification

IN future, notwithstanding the similarity of language, it will be possible to discriminate between German, Austrian, and Swiss-German broadcasts as the German call will make the matter perfectly clear. All announcements from that country will be preceded by the call which will include the word *Reichssender* followed by the name of the city or town in which the studio is situated. You will hear: *Reichssender Berlin, Hamburg, Breslau*, and so on, as the case may be.

Europe's First Broadcast Programme

ALTHOUGH many countries have annually celebrated the anniversary of their adoption of broadcasting it was left to Belgium, on March 28th last, to give listeners a faithful copy of what was, we believe, the first radio programme heard in Europe twenty years ago. As a result of the keen interest shown by the late King Albert of Belgium in radio matters, some Brussels engineers constructed a transmitter in the grounds of the Laeken Palace near the Belgian capital and broadcast their first programme on March 28th, 1914. The entire installation was dismantled and destroyed on the approach of the German Army some few months later. In their faithful copy of this early programme Brussels reproduced the sound of the toy trumpet used as an opening and interval signal preceding the station call and, as was also customary, repeated all announcements twice, very slowly.

Three-quarter Mast Only!

ALTHOUGH signals from the new 100-kilowatt Mühlacker transmitter are much stronger than hitherto, the full benefit of the increased power will not be derived for another month or so. The aerial tower designed to reach the height of 190 metres, has not yet been completed owing to stress of weather, and the actual aerial has been connected to the 120 metres mark. The extra additional height to be used later, it is stated, will make an appreciable difference.

What is my Position?

KNOWN as the Marconi-Adcock System, a new direction-finding apparatus for aircraft has been installed at Lympne Airport following a three years' test at Pulham (Norfolk). In the event of an air pilot requiring assistance in regard to his position, bearings on his wireless signals are taken simultaneously at Croydon, Lympne, and Pulham, and the readings are transmitted to the London Airport, where they are plotted on a map. Within a few seconds the Control Tower is able to give the necessary information. Under the new system a much higher degree of accuracy has been obtained, especially at night.

ROUND *the* WORLD of WIRELESS (Continued)

Richard Tauber on the Air

TWO performances of Lehar's successful comic opera *Frederica* will be broadcast by the B.B.C. on April 23 (National) and 24 (Regional). Richard Tauber, the famous German tenor, will sing in German, but for the actual dialogue will use the English language.

Lend me your Ears

SEVERAL Copenhagen newspapers are giving prominence to letters received from Danish physicians in respect to the effects produced by radio on the human system. The Medical Faculty in that country appears to be divided into two camps, one asserting that in the case of crystal set owners the pressure of headphones on the ears tends to cause arterio-sclerosis and congestion, the other party maintaining that listening in such conditions re-educates the aural nerves. In the meantime, a filip is being given to the sales of mains-driven receivers!

Future of Radio Alger

AT a recent meeting of the Algerian Broadcasting Committee, a proposal was put forward to install in the neighbourhood of Algiers a high-power transmitter capable, if necessary, of 250 kilowatts output. Coupled to an aerial system carried by pylons 660 metres in height, broadcasts would be made accessible to the greater part of Southern and Western Europe.

Sunday Broadcasts Only

ALTHOUGH seldom mentioned, in addition to the better-known Hilversum and Huizen stations, Holland has possessed for many years a small station at Bloemendaal, near Delft. Its power has now been increased to 5 kilowatts and it may be heard every Sunday morning at 9.40 a.m., G.M.T. The station works on 245.9 metres (1,220 kc/s), and has been run by a local association for the rebroadcast of sacred services on Sundays only.

Radio Exhibitions

THE dates of the three main radio exhibitions to be held in Great Britain this year have been fixed as follows: Olympia, from Thursday, August 16th, to Saturday, August 25th; Glasgow, Friday, August 31st, to Saturday, September 8th, and Manchester, from Friday, September 14th, to Saturday, September 22nd.

Development of Estonian Broadcasting

THE Government of Estonia has decided to take over the broadcasting service as a State monopoly with a view to the extension of the network. So far, transmissions have been carried out by a 20-kilowatt station at Tallinn, with a small relay in the old capital of Dorpat. It is now proposed to erect a 40-kilowatt station in the latter city.

Radio "Cops"

POLICE patrols of Los Angeles (Cal.) have been equipped with small portable wireless receivers to permit them to keep in touch with headquarters. The instrument is carried on a belt around the waist, the aerial being fitted in a triangular

INTERESTING and TOPICAL PARAGRAPHS

strap, in rucksack fashion, which supports the equipment.

A NOVEL CABINET



This illustration shows how a reader overcame the difficulty of building a cabinet to present an unusual appearance. It is modelled on an organ.

The World's Highest Aerial Pylon

ALTHOUGH the new Budapest single aerial mast is higher than the Eiffel Tower, it does not hold the record as the loftiest construction, which is still retained by the Empire State building at New York. From insulator to summit the Romanian tower measures 314 metres (1,036ft.). At roughly 800ft., it is equipped with an automatic meteorological station with recording instruments for temperature, atmospheric pressure, direction and strength of wind, and rainfall gauge, on a similar principle to the Leningrad installation. This gigantic structure is capped by an illuminated crown consisting of electric lamps of several hundred thousand candle-power, as a warning to aircraft.

How Unlicensed German Amateurs are Strated

NEW licences have been granted to German short-wave experimenters; according to a recent decree, any person transmitting without permit, whether telegraphy or telephony, is liable to a prosecution for high treason.

Dutch Stations Exchange Wavelengths

THE Hilversum programme, for a further period of three months (as from April 1st), will be heard on 301.5 metres (995 kc/s), the Huizen broadcasts being carried out on 1,875 metres, or, possibly later on, 1,887 metres.

Little Orphan Annie

IF at any time, on the short waves, you listen at G.M.T. 10.30 to any N.B.C. station, you are sure to hear Little Orphan Annie in the WJZ, Boundbrook, programme. This portion of the Children's Hour recently celebrated its 1,000th performance.

Shirley Bell, who plays the leading part in this daily sketch, has done so since the first broadcast in 1930!

Broadcasts to the Byrd Antarctic Expedition

ON alternate Sundays the General Electric Company's stations at Schenectady (New York) transmit a special bulletin for the benefit of members of the Byrd Antarctic Expedition. For this purpose W2XAF, on 31.48 metres, is used with a special directional aerial and greatly increased power. Rebroadcasts from "Little America" are made in the Columbia Network (WABC, New York) every Saturday night.

Broadcast from a Captive Balloon

LISTEN to Radio Strasbourg (349.2 m.) on April 22nd, between midday and 2.0 p.m. G.M.T. if you wish to hear a transmission carried out from a captive balloon hovering over that city. Not only will a running commentary be given of the ascent, but two-way conversations will also be rebroadcast through the Strasbourg transmitter.

Lissen Price Reduction

WE are informed that Messrs. Lissen have reduced the price of their 5-valve portable receiver L.N. 8055 from 11 guineas to £9, as from the 9th inst.

(Continued on page 150)

SOLVE THIS!

PROBLEM No. 83

Marsh made up a three-valve receiver and operated it from a small home-made mains unit. Unfortunately, the set was unstable, and he traced the trouble to the fact that no part of the circuit was decoupled. He accordingly obtained a 20,000 ohm wire-wound resistance and a two microfarad condenser, and joined the resistance between the H.T. positive terminal of the set and the eliminator, with the condenser joined from the H.T. positive terminal to earth. This did not prevent the trouble. Why? Three books will be awarded for the first three correct solutions opened. Address your attempts to The Editor, PRACTICAL WIRELESS, Geo. Newnes, Ltd., 8-11, Southampton Street, Strand, London, W.C.2. Envelopes must be marked Problem No. 83, and must be posted to reach here not later than the first post April 23rd.

SOLUTION TO PROBLEM No. 82

The underside of the chassis for the Fury Four Super was of plain wood, and two component brackets were mounted on this. When Jackson covered this side with aluminium foil he omitted to insulate the two brackets and, consequently, the reaction condenser was shorted, and also the anode circuit of the detector valve.

The following three readers successfully solved Problem No. 81, and books have accordingly been forwarded to them:—

Mr. E. Ridgway, 14, Carlton Road, Godley, Hyde, Cheshire. Mr. G. Spencer, 106, Queen Street, Grimthorpe, Barnsley. Mr. L. Hills, 45, Gordon Road, Belvedere, Kent.

AN ULTRA-SHORT-WAVE CONVERTER

Full Constructional Details are Given for an Efficient and Inexpensive Unit for Use in Conjunction with an Ordinary Broadcast Set to obtain Reception on Wavelengths between 5 and 8 metres.

At the present time there is considerable activity in the ultra-short-wave field and many promising developments are likely to arise in this particular sphere. To keep abreast with the times, therefore, the experimenter should at least carry out some work. The cost involved need only be quite small in order to become

By H. J. BARTON CHAPPLE,
Wh.Sch., B.Sc., A.M.I.E.E.

There are many amateurs working on the 5-metre wavelength, and in addition it is public knowledge now that the B.B.C. are conducting ultra-short-wave television experiments on 7.75 metres. Added to this, we have the independent experiments being conducted by the Baird Company from the south tower of the Crystal Palace on a wavelength of about 6.25 metres.

A Simple Scheme

One way of carrying out your ultra-short-wave reception is to make up a special receiver, but another alternative is to add a unit to your own home radio set for the job. It is this latter method which I propose to deal with in this article, the "U.S.W. Converter" being a home-built converter which is linked to the aerial side of the receiver.

Fig. 1 shows the theoretical circuit used. There is really nothing specially novel in the circuit; the prime features are in its method of construction and use. It works on the super-heterodyne principle and must be employed with a radio receiver having at least one stage of high-frequency amplification. First of all, there is a small variable condenser C_1 in series with the aerial lead. This not only cuts down the load on the aerial tuning but is very useful for overcoming any "blind spots" that may be encountered. $L_1 C_2$ is the usual tuned-grid feed,

differing from normal waveband practice very considerably, however, inasmuch as C_2 is .0001 mfd. while L_1 has an inductance provided by three turns only. The grid leak and condenser, C_3

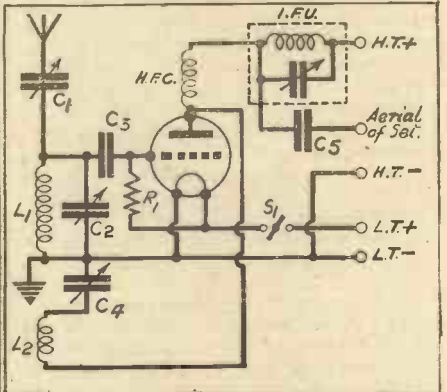

Fig. 1.—Circuit diagram of the ultra-short-wave converter described.

and R_1 , have values of .0001 mfd. and 3 megohms respectively.

The valve is made to oscillate through the medium of C_1 and L_2 , and here again we meet with quite small values—.0001 mfd. and two turns. Naturally the high-frequency choke (H.F.C.) is one of the ultra-short-wave variety. The method of coupling the unit to the existing radio receiver is of prime importance, and in this case a special intermediate frequency unit (I.F.U.) developed by Eddystone has been chosen. This must be tuned to the same wavelength (or frequency) as the home radio receiver, and in this way trouble from "dead spots" is entirely removed. The condenser C_5 , of .002 mfd. capacity, serves as the link between the unit and the set.

(Continued overleaf)

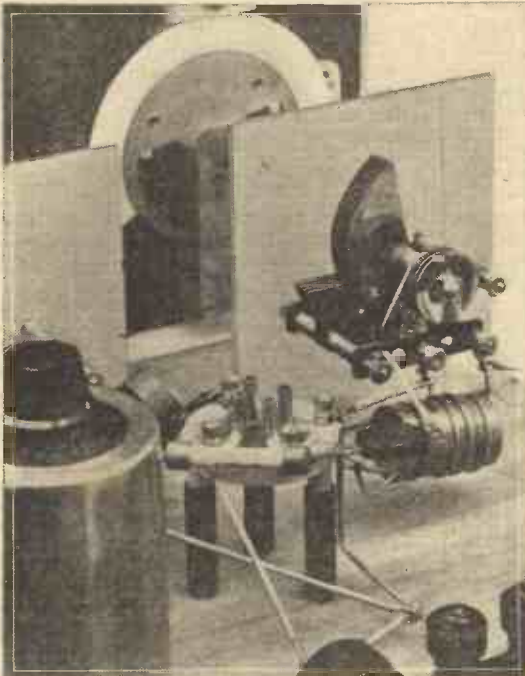

Fig. 2.—A close-up which shows the tuning coil and its associated condenser.

"acclimatized" and there is a tremendous fascination in working on these very high frequencies.

The Ultra-shorts

It has been pointed out before that ultra-short waves, that is, those below a wavelength of 10 metres, have peculiar vagaries. First of all, it is thought that the range of the signals is more or less confined to the optical path of the waves for any degree of service. That is to say, the receiving situation should be "within sight" of the transmitting aerial. This is because the waves, often spoken of as quasi-optical waves, are those whose refracted rays never return to earth except under rare conditions. Communication is therefore more or less confined to the surface ray, and as at the high frequencies used the earth losses become high, the range is limited and often seldom exceeds the actual visible horizon. This statement cannot be proved definitely, however, and already evidence has been forthcoming to show that signals have been received over distances exceeding the theoretical limit. This in itself should be sufficient to encourage the earnest amateur to probe matters for himself.

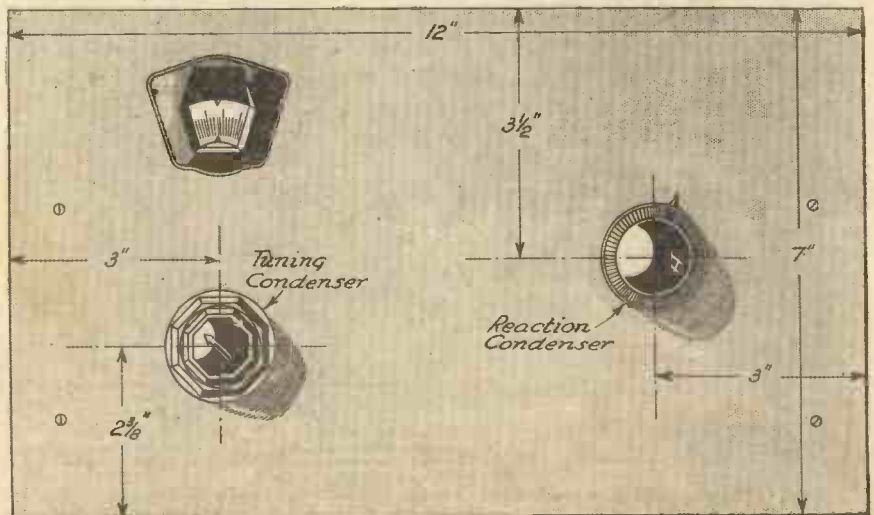

Fig. 3.—This drawing gives all panel dimensions and will be useful in drilling the ebonite.

(Continued from previous page.)

Constructional Work

Fig. 4 shows the component lay-out, and by using this in conjunction with the photographs on the front cover the constructional work should prove very straightforward.

One of the golden rules in ultra-short-wave work is to keep all leads as short as possible, especially those in tuning, grid and plate circuits. In consequence the tuning coil is mounted direct on the variable condenser, while to overcome hand capacity effects the operating controls are remote from the condensers. As we are dealing in such extremely high frequencies—five to six million—a very minute trace of stray capacity can materially upset performance.

Layout and Wiring

First of all take the baseboard and, after having mounted each condenser on its vertical aluminium screen, position the screens accurately according to the illustration given below. Now mark out the positions of the three legs which support the valve-holder, drilling holes in the baseboard so that the holding screws may pass right through. Six of the terminals are accommodated on normal mounts but the terminal aerial, which has to be joined to the radio receiver, is held on a Bulgin right-angled bracket (type E.H.5) as also is the filament switch. All this is shown in Fig. 4.

In wiring, note that both the grid leak and condenser are soldered direct to the grid connection of the valve-holder. The same remarks as to direct soldered connec-

tions apply to the ultra-short-wave high-frequency choke, the .002 mfd. coupling condenser, and the combined tuning and reaction coil. This coil, by the way, consists of three turns of No. 16 gauge wire wound on a 1in. former, each turn being separated by $\frac{1}{16}$ in. The reaction winding L_2 , separated $\frac{1}{16}$ in. from the last turn of the tuning coil L_1 , is just two turns of thin double silk-covered wire. Solder the two ends of coil L_1 direct to tags on the variable condenser C_2 and in this way support the coil just below the condenser back plate. The close-up of this section of the unit shown in Fig. 2 will indicate clearly how this is accomplished.

When every lead is in place and checked, proceed to drill the panel according to the dimensions given in Fig. 3. Having cut out the large hole to take the dial window, mount the vernier dial in place by following carefully the very explicit instructions given by the makers, and which need not be repeated here. Now add the condenser extension rods, panel brackets, and finally screw the panel into position. See that proper alignment is given to the condenser drives *via* the rods, or the movement will tend to be erratic. If necessary, alter slightly the positions of the vertical screen mounts to ensure that this smooth movement takes place. In addition, the extension rod to the reaction condenser is not quite long enough and it is necessary to screw in a length of about $\frac{1}{16}$ in. brass $\frac{1}{16}$ in. diameter, to take the knob of the reaction condenser.

The Aerial System

Join a 2-volt accumulator across the pair of L.T. terminals and a 100-volt H.T. battery across the two H.T. terminals. Disconnect the aerial and earth leads from the home radio receiver and join them to the pair of converter terminals so marked. It will be necessary to link the combined H.T.—L.T.—points of both unit and set, and finally to join the aerial 1 terminal to the aerial terminal of the set. Bear in mind that if the set has a series aerial condenser it should be shorted out when employing this unit.

Between 10 and 15ft. of wire, as a rule, is ample for the aerial, and better results will sometimes be obtained by dispensing with the earth connection.

Operation

The Eddystone I.F. coupling unit has a variable tuning range from 240 to 550 metres, and in consequence the set must be tuned to some setting within these figures. Actually, the unit is marked at the top in terms of kilocycles, but it is a very easy matter to convert wavelengths to kilocycles or *vice versa* from the well-known formula:—

$$\text{Wavelength} = \frac{300,000}{\text{kilocycles.}}$$

Having chosen one setting on the receiver, preferably where no ordinary radio transmission can be heard, turn the I.F. unit knob to about the same setting and switch on the converter by means of the rotary on-off switch at the back. Set the tuning dial at zero and then bring the unit into a state of oscillation by advancing the reaction control knob on the right. Remember that tuning on the ultra-short waves is exceedingly fine and it is quite easy to miss transmissions.

This was the main reason for including a two-ratio slow-motion dial, the outer knob giving an 8 to 1 reduction for "rapid" (this term is only used in a comparative sense) search, while the inner one gives a 150 to 1 reduction for very fine tuning. Each ultra-short-wave transmission will be heard in the loud-speaker at two distinct settings of the dial (this, as readers know, is usual in the superhet type of reception), and it may be found that one setting gives either better results or greater freedom from interference than the other.

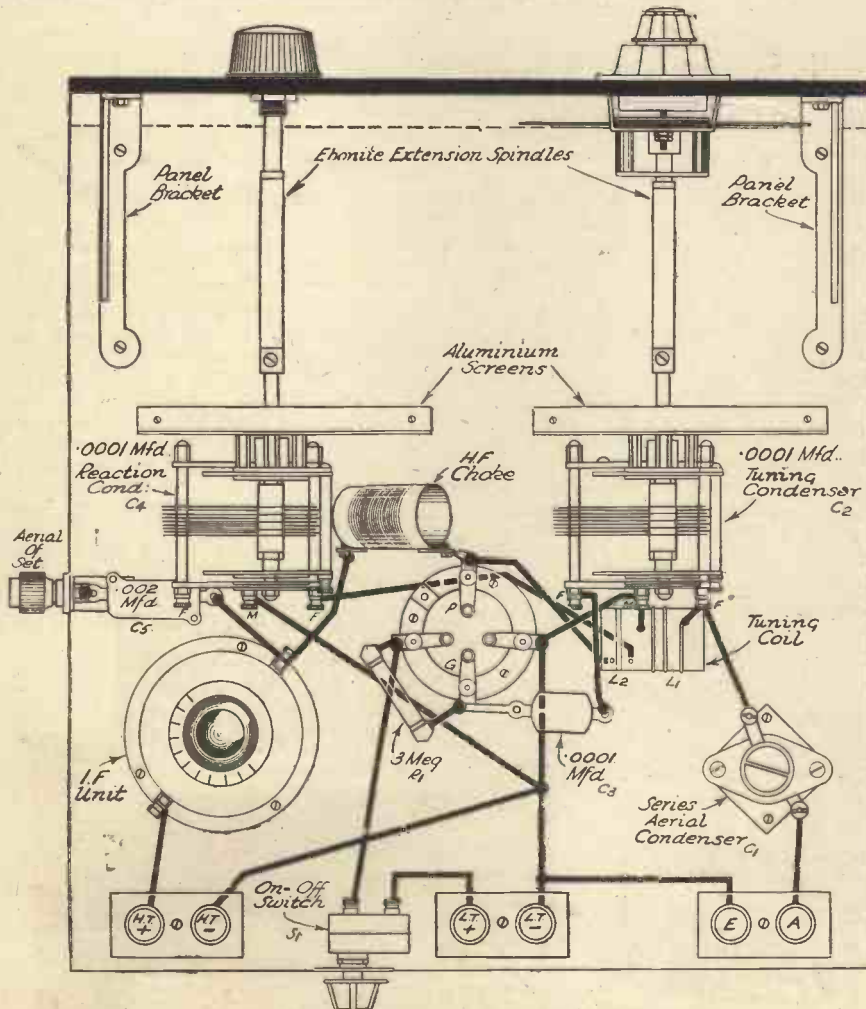

Fig. 4.—The complete wiring plan, which shows the simplicity of wiring.

LIST OF COMPONENTS FOR ULTRA-SHORT-WAVE CONVERTER

- One Ultra-Short-Wave valveholder (Eddystone).
- One I.F. Coupling Unit (I.F.U.) (Eddystone).
- One Skeleton Short-Wave H.F. Choke (H.F.C.) (Bulgin).
- One Combined U.S.W. Coil and Reaction Coil (L_1 and L_2) (Bulgin).
- One Neutralizing Condenser (C_1) (Jackson).
- Two .0001 mfd. Short-Wave "Special" Condensers (C_2 and C_4) (Jackson).
- Two $\frac{1}{16}$ in. Extension Shafts (Bulgin).
- Two Right-angled Brackets, Type E.H.5 (Bulgin).
- One .0001 mfd. Type 665 Condenser (C_3) (Dubilier).
- One .002 mfd. Type 670 Condenser (C_4) (Dubilier).
- Seven Type B Terminals, Aerial 1, Earth, H.T.—, H.T.+ , L.T.—, and L.T.+ (Belling and Lee).
- Three Terminal mounts (Belling and Lee).
- One Rotary on-off switch (S1) (Bulgin).
- Two Aluminium Screen Brackets (Jackson).
- One Two-Ratio Slow-Motion Dial (Jackson).
- One Ebonite Panel, 12in. by 12in. by $\frac{1}{16}$ in. (Peto-Scott).
- One Wooden Baseboard, 13in. by 12in. by $\frac{1}{16}$ in. (Peto-Scott).
- One Pair Panel Brackets (Peto-Scott).
- One 3-megohm Grid Leak, Wire Ends (R_1) (Dubilier).
- One PM 2DX Valve (Mullard).

CONSTRUCTION AND ACCESSIBILITY

Some Considerations and Methods of Achievement.

By W. H. DELLER

Layout of Controls

HOWEVER well made and finished a set may be, the one thing that can make or mar the appearance is the layout of the controls. For convenience in handling, control knobs should be grouped together, and for appearance they are arranged symmetrically. It is naturally desirable also to cut the number of controls down to a minimum, always bearing in mind, of course, the requirements of the circuit.

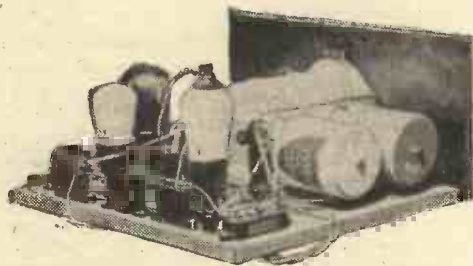

Fig. 1.—This view shows a novel coil mounting.



Fig. 2.—A rear view of the receiver.

Selection of Components

Much can be done in this direction by the careful selection of components. A typical example is to be found in the ganged coil unit incorporated in the set photographed in Figs. 1 and 2, as embodied in this component is a combined wave-change and filament switch. These coils, and the necessary arrangements for switching, are mounted on a channel section metal chassis, screw holes being provided for fixing purposes.

Fig. 3 is a sketch showing the relative positions that the switch and tuning and reaction condenser knobs would occupy if the coils were mounted as originally intended. From this it is apparent that the arrangement would be unsymmetrical, and that to put matters right either the left-hand knob requires raising or the right-hand one lowering. To do the former it would be necessary to raise the coil chassis up

on packings, but this would have the disadvantage of seriously increasing the head room required for the screening cans. Owing to the type of construction employed in this instance, it would not be possible to lower the position of the reaction condenser owing to its close proximity to the baseboard.

These difficulties were overcome by mounting the coils as shown in Fig. 4. Two holes were drilled in the web of the channel base for fixing bolts, with large dia. 1/2 in. distance pieces between the edge of the chassis and baseboard, to permit wiring to pass between. This arrangement does not hamper the operation of wiring or subsequent inspection; in fact it makes for accessibility.

Baffle-boards

To secure results approaching perfection from a loud-speaker of the moving-coil type it must of necessity be mounted on a large and fairly substantial baffle-board. While this presents no difficulty where the speaker is to be entirely separate from the set, the size of the baffle-board must necessarily be restricted when the speaker is mounted in the cabinet with the set in the usual manner.

The speaker in the set illustrated in Figs. 5 and 6 is mounted in a rather unusual way. The object of this becomes apparent upon inspection, for although the total height occupied by the speaker and board is less than that which would normally be required, the width of the board is increased by more than half.

This is an arrangement that is easily adaptable to almost any shape of cabinet, and is one that is worth bearing in mind. The board, by the way, is not attached directly to the framework, but is mounted with rubber buffers at the corners. The effect of these is to deaden the mechanical vibration set up by the speaker, and which,

if allowed to travel unchecked to other parts of the set, is bound to seriously affect the quality of the reproduction.

Accessibility

The rapidity with which troubles may

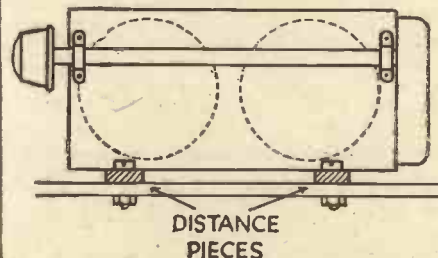

Fig. 4.—The distance pieces for the coils and the method of mounting.

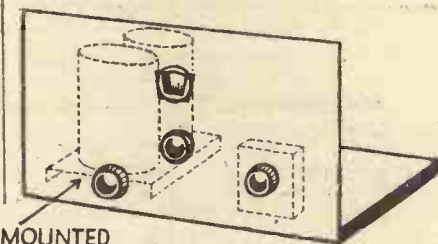

Fig. 3.—The normal position of the controls.

be traced and rectified as and when they arise largely depends upon the arrangement of components and method of construction adopted. Therefore, for this reason only, it is best to avoid, where possible, an arrangement in which control knobs have to be removed before the complete chassis can be withdrawn from the cabinet.

For ease in wiring and subsequent tracing of troubles components are most conveniently situated if they are all disposed on the upper surface of the chassis.

(Continued overleaf)

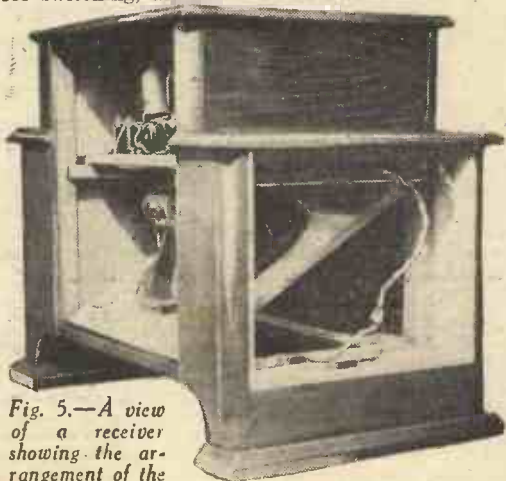

Fig. 5.—A view of a receiver showing the arrangement of the speaker.

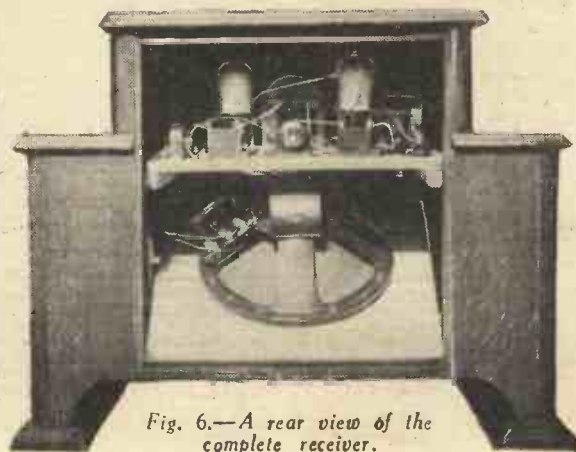

Fig. 6.—A rear view of the complete receiver.

CONSTRUCTION AND ACCESSIBILITY*(Continued from previous page)*

With a battery-operated set one important consideration is that the batteries require fairly frequent attention. Most sets are finally situated with the back close to a wall, and where the only way of getting at the batteries, either for replacement of low tension or adjustment of high tension, is via the back of the cabinet, the set has to be slewed round for this purpose.

To obviate having to do this, provision might be made to house the batteries in wings on either side of the cabinet. How convenient such an arrangement can be is readily discerned by reference to Fig. 7. This method has the added advantage of keeping the accumulator away from the metal work inside the set, but even so it is as well to provide a metal tray for it to stand in.

Where both or several L.T. batteries in

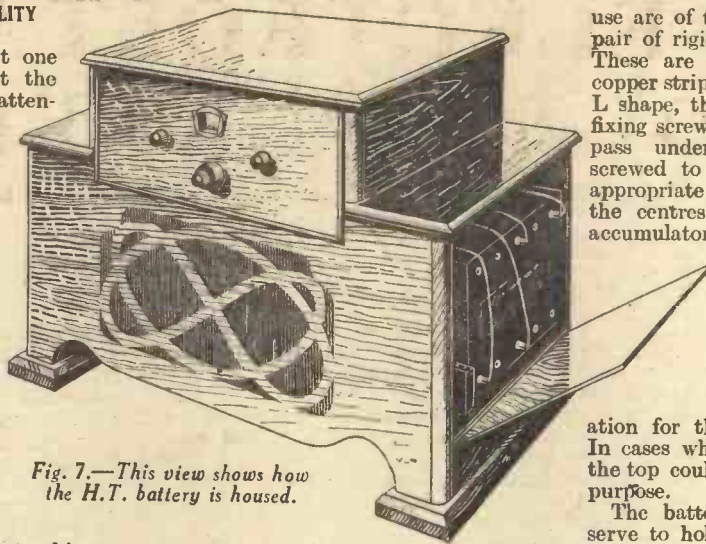

Fig. 7.—This view shows how the H.T. battery is housed.

use are of the same make and capacity a pair of rigid connectors can be provided. These are made from $\frac{1}{2}$ in. by 16 gauge copper strip. Two pieces are cut and bent L shape, the short ends being drilled for fixing screws, and the long ends slotted to pass under the terminals. These are screwed to the inside of the cabinet in appropriate positions, the distance between the centres being equal to that of the accumulator terminals. The leads from the set should be provided with substantial tag ends and secured under the screw heads holding the copper strips.

Addition or Conversion

This form of cabinet lends itself admirably to alteration for the addition of a gramophone. In cases where such a step is anticipated the top could be made detachable for the purpose.

The battery compartments also would serve to hold a metal rectifier and transformer in cases of conversion to all electric.

OUR GREAT NATIONAL COMPETITION TWENTY GUINEAS FIRST PRIZE, 200 Consolation Prizes

Some Further Notes Regarding the Bifocal Coils and the Method of Getting Best Results

MESSRS. PETO-SCOTT LTD. OFFER A SPECIAL PRIZE OF £5.5.0

WHILST it is true that the Bifocal coils may be fitted to practically any circuit without alteration, it is necessary, as with all things, to adopt some method which will enable the device to prove its worth. Just as it is useless to fit a good expensive moving-coil loud-speaker to a 4-year-old one-valve set, so it is a waste of time to fit these new aids to selectivity to a collection of old worn-out parts slung together and operated from a run-down H.T. battery. Remember that these coils, with their ingenious method of varying the coupling by means of a simply operated plunger, can show a real improvement on the methods which are at present employed for selectivity purposes. You should, therefore, adopt a circuit arrangement chosen from one of those which were illustrated last week and build up this circuit from really good parts. Do not be tempted to use some old parts which have been knocking about in your junk box, or which are offered at ridiculous prices by second-hand stores. To get best results, you must use the best parts, for a penny saved in initial expense may be regretted later on.

Using the Coils

It should be unnecessary to give detailed instructions for using these coils, as they make no difference whatever to the operation of the receiver. Therefore, the usual arrangement of station selection—ignoring the Bifocal coil adjustment—is carried out so that the accurate tuning point is located,

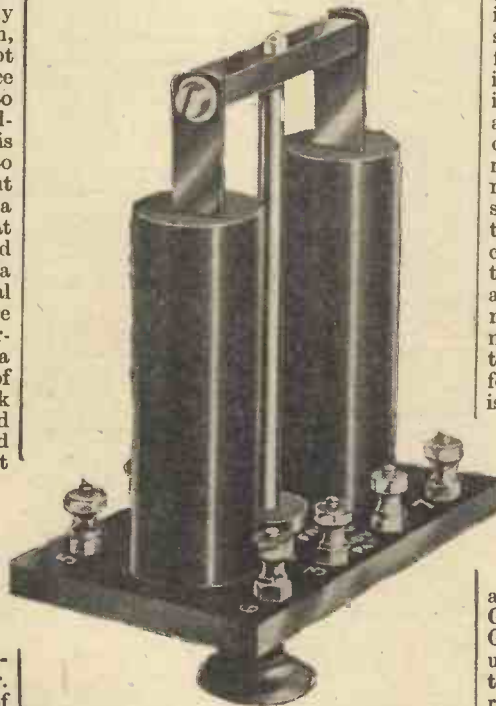

The Varley Bifocal Coil. Keep your receipt, as this must be included in your competition entry as evidence of purchase.

and if necessary the reaction control is adjusted to provide the required strength of signal. Then, if required, the focusing adjustment is made. Thus, if interference is experienced, the plunger is moved until the trouble is overcome, and, owing to the design of the Bifocal coils, this may be carried out without any necessity for retuning or altering the reaction setting. Similarly, if when the station is received it is found that it is too weak, owing to the looseness of the coupling, this may be tightened by operating the Bifocal plunger, the normal tuning adjustment being carried out in the usual manner. It will thus be seen that there is nothing to learn and nothing difficult to be understood in the adjustment of this focusing scheme, and, provided the receiver is of good design, and used in conjunction with a sound aerial and earth system, the results cannot fail to prove highly satisfactory.

Messrs. Peto-Scott's Offer

In connection with this competition, we have great pleasure in announcing that Messrs. Peto-Scott have made an additional offer of a prize of Five Guineas for the winner of our Twenty Guineas prize, should the Bifocal unit used by him have been purchased from that firm. We are sure that our readers will welcome and appreciate the enterprise and co-operation which is being shown by Messrs. Peto-Scott in this connection.

CAREFULLY READ THESE RULES.

- (1) The First Prize of 20 guineas cash will be awarded to the sender of what the judges (presided over by the Editor of "Practical Wireless") consider to be the best test report of actual experiences with the Bifocal coil. Consolation prizes will be awarded to the senders of the 200 next best test reports. Test reports may be accompanied by sketches showing the competitor's own Bifocal arrangement. Reports of failure will stand an equal chance of winning a prize.
- (2) Each entry must be accompanied by proof of purchase of a Varley Bifocal coil, such as the receipt from Messrs. Varley, Ltd., or a receipt from your local dealer.
- (3) Competition entries must be received here not later than May 14th. Results will be given in "Practical Wireless," dated May 26th.

(4) Test reports must be written on one side of the paper only and must not exceed 250 words in length.

(5) This competition is only open to readers of "Practical Wireless," and each entry must be accompanied by a Query Coupon cut from any issue between April 14th and May 5th.

(6) Competition entries should be addressed to the Editor, "Practical Wireless," Geo. Newnes, Ltd., 8-11, Southampton Street, Strand, London, W.C.2, and have the word "Bifocal" written in the top left-hand corner.

(7) No correspondence can be entered into regarding this competition.

(8) The Editor's decision is final and legally binding and is an express condition of entry.

THE ELECTROSTATIC LOUD-SPEAKER

Some Interesting Details Concerning the Design and Function of the Electrostatic Reproducer

By HANS VOGT

THE practical application of the static loud-speaker is of comparatively recent origin, but its fundamental principle dates back as far as fifty years. Edison and others were working on the problem without obtaining satisfactory results. The first static speakers which were used in practice were constructed by me and my two friends, Dr. Engl and Joseph Massolle,

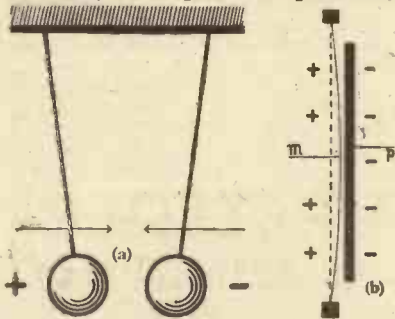

Fig. 1.—The principle of the static speaker: (a) electrostatic attraction; two little balls of ebonite when charged will approach each other. (b) The fundamental arrangement of the static speaker, consisting of one resting and one oscillating condenser electrode.

who produced the first sound films and developed the "Statophon" static speaker to reproduce the sound. In September, 1922, the first light-sound films of the world were shown in Berlin in the Alhambra Theatre with static speakers. Also, the first "Electric Teleconcert" on May 5th, 1923 (before broadcasting was introduced) in "Hochschule für Musik" in Berlin was realized by means of statophones. These first loud-speakers, however, showed several drawbacks, and therefore were ousted very soon by the moving-iron and moving-coil speakers, developed later on.

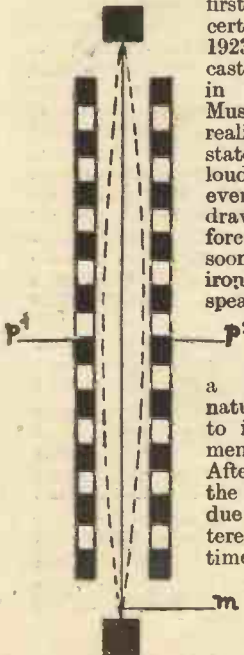

Fig. 6.—Principle of the bilateral speaker, consisting of a freely oscillating diaphragm "m" arranged symmetrically between two resting electrodes, "P1, P2," actuating the diaphragm from both sides. The diaphragm in this case will oscillate in an undistorted, symmetrical way, and the sound intensity is likewise doubled.

The drawbacks were not of a fundamental nature, but were due to imperfect arrangement and construction. After having dropped the sound-film matter, due to the lack of interest shown at that time by the film industry, I could not imagine any object more interesting for investigation than the static speaker. Theoretically speaking, this principle undoubtedly offers the best conditions for

constructing a loud-speaker for absolutely faithful reproduction. There is no paper cone, with its inertia and complicated acoustic conditions, and the extremely light diaphragm is impeded on its whole surface directly by the static field, and must therefore strictly follow even the finest shades of tone without distortion.

The Principle of the Static Speaker

The speaker is nothing more than a condenser, one plate of which is arranged free, so as to follow the attraction forces exerted by the electrostatic field (see Fig. 1). Therefore, it is also called the "sounding condenser," or "capacity speaker." Unfortunately, various additional measures are

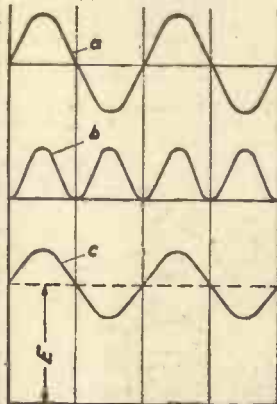

Fig. 2.—Why constant initial voltage is required: Curve (a) The alternating voltage (acoustic modulation). (b) The resulting movement of the diaphragm, if no constant initial voltage is applied. Frequency doubling will result, as the diaphragm is attracted once in the positive and once in the negative section of each period. (c) By imposing a constant initial voltage of a sufficient amount, the modulation is displaced to the positive section and frequency doubling by depolarization cannot occur.

the diaphragm will be attracted twice per cycle, that is, once in the positive and once in the negative section of the cycle, and so it will make 100 oscillations instead of 50. By imposing a high constant initial voltage the curve will be displaced and remain within the positive section (c).

The high voltage will not be dangerous, as the current which can result is very weak and far below the limit of danger, similar to the high-tension of an influence machine.

It is, of course, not possible simply to plug the static speaker into the "loud-speaker" terminals of the receiver, as it requires constant initial voltage and special matching to the output

valve. Therefore, if the receiver is already made and cannot be specially fitted for the static speaker, it is necessary to use a special output transformer, which is fitted to the loud-speaker, and moreover, an additional high-tension device is required, which, however, is very simple and cheap. Fig. 3 shows a circuit diagram of this kind. It is obvious that no direct current can flow over the condenser speaker, therefore a wattless constant initial voltage only is required, which is obtained from a very small step-up transformer connected directly to the mains, behind which a cheap half-wave rectifier tube is inserted. This

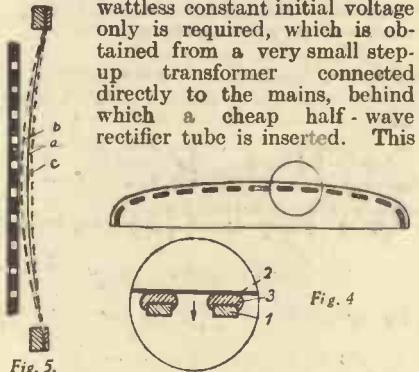

Fig. 4.—Supported diaphragm arrangement. (1) Resting electrode. (2) Diaphragm. (3) Elastic insulation between resting electrode and diaphragm. The diaphragm oscillates in form of many small partial diaphragms.

Fig. 5.—Freely oscillating diaphragm oscillating on the whole surface. This speaker has one resting electrode only. Therefore, the diaphragm is displaced by the field of the constant initial voltage, and as the attraction forces are all working from one side only, the diaphragm will swing in a distorted, non-symmetrical way. (a) Initial position. (b) Large amplitude towards the resting electrode. (c) Small amplitude away from the resting electrode.

may be any worn out amplifier valve, provided the distance between cathode and anode is high enough to prevent sparking-over due to the high tension of the electrodes.

The required initial voltage must be about four times higher than the modulation voltage to prevent distortion. If 400 volts modulation voltage are required to obtain sufficient sound intensity, about 1,500 volts constant initial voltage should

be applied. These are the values in the case of a "freely oscillating" diaphragm, and 0.4 to 1 mm. electrode distance between diaphragm and resting electrode. In the case of the

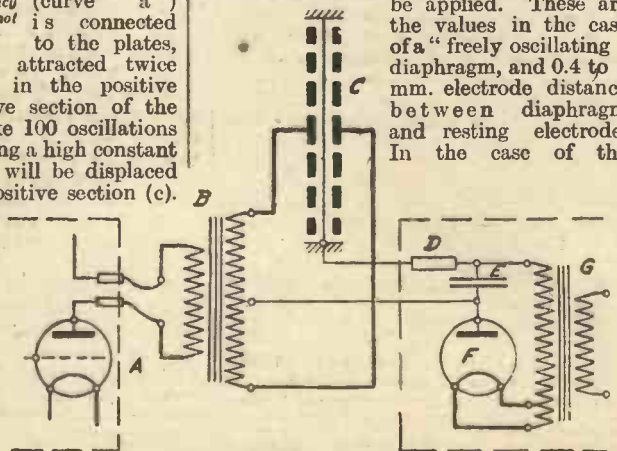

Fig. 3.—Example of a circuit diagram of a static speaker to be connected to an existing receiver: (A) Output valve. (B) Coupling transformer. (C) Static speaker. (D) Protection resistance. (E) Smoothing condenser. (F) Small rectifier tube. (G) Very small step-up transformer.

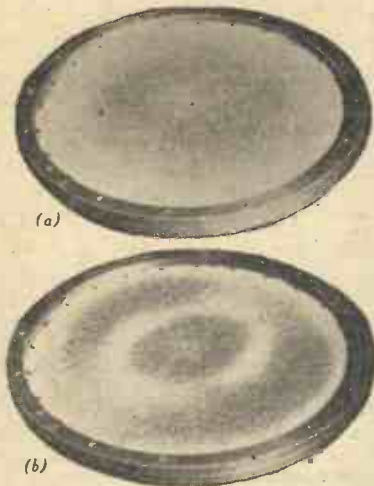

Fig. 9.—How a stretched diaphragm oscillates: (a) Bass tone (about 100 c.p.s.), (b) Third harmonic (about 250 c.p.s.).

“supported diaphragm” arrangement, a lower modulation voltage and initial voltage is admissible.

The Supported Diaphragm

The difference between the supported diaphragm arrangement and the freely-oscillating diaphragm arrangement is made clear in Figs. 4 and 5. In Fig. 4 is shown a supported diaphragm of rubber or similar material, which is supported by the resting diaphragm and oscillating in the form of many partial diaphragms only. Fig. 5 represents a freely-oscillating diaphragm, oscillating over its total surface. The supported-diaphragm arrangement offers the advantage that it is easier of operation, and that, as mentioned, due to the small possible electrode distance, the alternating voltage and so the constant initial voltage can be kept rather low. Another question, however, is whether it will be satisfactory from an acoustic standpoint. The fact is that the amplitude motions of the diaphragm are very small in this case, and therefore it will not be possible to get low tones, which require a large oscillating diaphragm surface. Furthermore, the high tones are not so well reproduced, because the diaphragm cannot oscillate freely, as it is prevented from very rapid oscillations by the support of resilient material on which it is resting. The difficulties in this respect are of a fundamental nature, and therefore induced me definitely to adopt the “freely oscillating diaphragm” system. Although with this system there were many more technical problems to be solved, the fundamental conditions in acoustic respect are much better in principle. The low tones can be reproduced very well, as the diaphragm is oscillating over its total surface with great amplitude. The high tones are, of course, likewise excellently reproduced, as the diaphragm is extremely light and can freely oscillate.

The Difficulties

There were two principal difficulties to be overcome: the material of the diaphragm and the construction of the resting electrode. The attraction force varies inversely with the square of the electrode distance, and therefore, when the diaphragm is attracted, the attraction force will grow more and more and cause the diaphragm to fall against the resting electrode. This must be prevented by a fairly high mechanical initial tension of the diaphragm, which is able to exert an

equivalent counter-force. In addition, the diaphragm must be highly elastic to obtain great amplitudes, and it must be very light in weight to prevent inertia. There was no available material found to be suitable. Therefore I developed a special foil alloy, mainly consisting of aluminium and silicon, with small additions of magnesium, iron; and copper. The alloy is rolled out after a special rolling process so as to improve the tensile strength and elasticity and to obtain foils of 0.016 mm. thickness. This light metal foil has the tensile strength of steel, but one-third of the weight of steel only, and is the most important part of a “freely oscillating type” static speaker, so that it can indeed be considered to be the “heart” of the speaker.

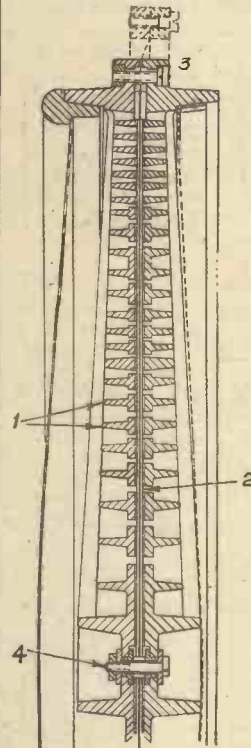

Fig. 7.—The construction of a bilateral static speaker with bakelite electrodes. (1) Resting electrodes. (2) Diaphragm. (3) Press screws. (4) Centric adjusting screw. (5) Conducting graphite layer on the resting electrode. (6) Insulating layer on the resting electrode. (7) Thin insulating layer on the diaphragm. Fig. 8.—Detail sketch, showing the insulation between the electrodes.

The electrode distance, in order to obtain the maximum efficiency, should be about 0.4-1 mm. only, and the resting electrode therefore has to be made with greatest accuracy, and must be free from any shrinking or warping so as to warrant an absolutely constant electrode distance. After many trials, bakelite was found to be suitable, if it is submitted to a

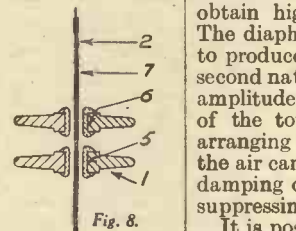

Fig. 8.

subsequent heat treatment after pressing to prevent warping.

To make the electrode conductive, its surface has been covered with a thin graphite layer. This graphite layer again is covered with a second layer of insulating varnish to prevent air discharge when the diaphragm is approaching the resting electrode. It was a very difficult problem to insulate the surface against such high voltages as 1,500 volts, the edges tending to spark as the varnish due to the surface tension will draw away from the edges. By a special insulating method, however, it has been possible to obtain satisfactory insulation.

The Original Design

The first speakers were

therefore built up as a perforated bakelite plate and a special (stretched) foil diaphragm; but I found out that, due to the constant initial voltage, the diaphragm will be drawn in a convex form towards the resting electrode, and as the attraction force acts from one side only, the diaphragm does not swing symmetrically, and so distortion will result (see Fig. 5). To overcome this defect, I arranged the diaphragm symmetrically between two resting electrodes (see Fig. 6), thus considerably increasing the efficiency due to the bilateral effect and avoiding the distortion. Moreover, in this way the diaphragm is protected against mechanical injury from both sides. A speaker of this kind, consisting of two resting electrodes and a light metal foil diaphragm between them, is known under the name of “Oscilloplane.”

In Fig. 7 the two resting electrodes 1 are pressed together at their border by screws 3, and the diaphragm 2 is squeezed between them. To obtain full response, even of the lowest notes, the diameter of this type has been increased to 40 cms. By ring ribs and radial ribs the resting bakelite electrodes are prevented from warping. The electrode distance can be regulated by the centre screw 4, and is increasing towards the centre. This is to obtain great swing space in the centre for the low notes and minimum electrode distance at the circumference, which is necessary for reproducing the high frequencies. The perforations of the resting electrodes are varied throughout the whole area. There are very few perforations in the centre and at two-thirds of the total diameter of the diaphragm, and this is to obtain high air-damping at these points. The diaphragm, although very light, tends to produce resonance points at its first and second natural frequency, having maximum amplitudes at the centre and at two-thirds of the total diameter (see Fig. 9). By arranging fewer perforations at these points the air cannot escape, and causes additional damping of these diaphragm portions, thus suppressing the resonance effects.

It is possible to compare the goodness of the different loud-speaker systems by objective measurement. The diagram (Fig. 10) shows the results of such a comparative measurement. The better response of the “Oscilloplane” to the critical high frequencies beyond 5,000 c.p.s. which are indispensable to give the tone its natural “transparent” sound

(Continued on page 143)

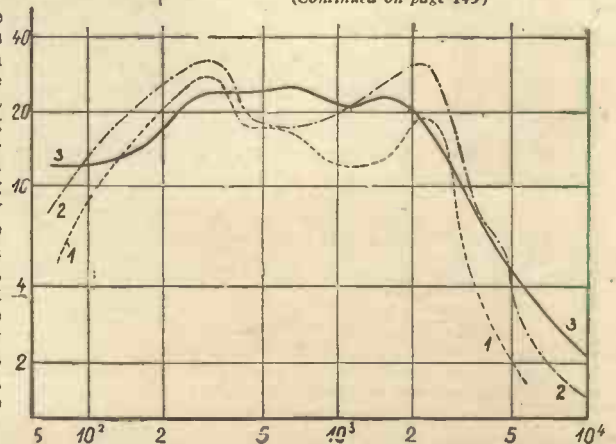

Fig. 10.—Comparative curves showing the sound intensity of the different systems independent of the frequency. Curve 1, Moving-iron speaker; 2, Moving-coil speaker; 3, Static speaker (Oscilloplane). The gain of the static type in the high range is obvious, while it has most uniform reproduction over the whole range even down to the lowest notes.

NEWNES'

PRACTICAL AND HELPFUL WIRELESS BOOKS

THE WIRELESS CONSTRUCTOR'S ENCYCLOPÆDIA 5/-

By F. J. CAMM (Editor "Practical Wireless"). (Third Edition.)
By post 5/6

Written in plain language by one of the most accomplished designers and writers on wireless construction. The whole subject is fully covered, and the volume is remarkable for the number of practical illustrations it contains; there are hundreds of circuits, wiring diagrams and layouts. Wireless terms and definitions are clearly explained. No matter in which branch of radio you are interested, you will find everything adequately dealt with here.

THE OUTLINE OF WIRELESS 8/6

By RALPH STRANGER. (Omnibus size.) (Fourth Edition.)
By post 9/-

A comprehensive work on wireless that everybody can understand. Specially written for the "man in the street" and covers the whole subject of wireless reception. 816 pages.

WIRELESS, THE MODERN MAGIC CARPET 3/6

By RALPH STRANGER. (Fifth Edition.) By post 3/10
Wireless simply explained at the beginning and seriously treated at the end.

THE ELEMENTS OF WIRELESS 3/6

By RALPH STRANGER. By post 3/10
The Author starts with elementary principles, covers the whole field of wireless reception, both from the theoretical and practical points of view; and finishes with a complete survey of a four-valve wireless receiver, explaining its working from the aerial terminal to the loud-speaker.

WIRELESS STEP BY STEP 2/6

By "DICTRON." (Tenth Edition.) By post 2/10
A book which shows the wireless enthusiast how to obtain the maximum enjoyment from his wireless set.

FIFTY TESTED WIRELESS CIRCUITS 2/6

By F. J. CAMM (Editor "Practical Wireless"). By post 2/10
This handbook contains every modern circuit, complete with instructions for assembling, component values, and notes on operation.

THE MATHEMATICS OF WIRELESS 5/-

By RALPH STRANGER. By post 5/4
This book is essential for the wireless amateur who desires to gain a fuller knowledge of his subject. Written by one who has the gift of explaining abstruse subjects in a simple fashion. Fully illustrated.

DICTIONARY OF WIRELESS TERMS 2/6

By RALPH STRANGER. By post 2/10
The author, who is master of lucidity, has produced in his "Wireless Dictionary" a valuable and fully-explained synopsis of technical terms that everybody can understand. An indispensable boon to every wireless enthusiast who reads technical books and journals.

FINDING FOREIGN STATIONS 3/6

By R. W. HALLOWS. (Long Distance Wireless Secrets.) By post 3/10
A book which will be eagerly welcomed by all wireless enthusiasts. It will solve your difficulties and enable you to obtain the best possible results of which your set is capable.

RADIO PLAYS 2/6

By L. DU GARDE PEACH. By post 2/10
Millions of wireless listeners who have been thrilled by such plays as "The Path of Glory," and "The Mary Celeste" can now read them in book form. Mr. du Garde Peach has written some of the most successful plays ever broadcast.

Obtainable at all Booksellers, or by post from
GEORGE NEWNES, LTD., 8-11, Southampton St.,
Strand, London, W.C.2.

Geo. Newnes, Ltd.

RELIABILITY



Battleships and T.M.C. HYDRA Condensers have this in common — both are built to give reliable service — both have to pass the strictest tests — and both are made only with the finest materials.

When you build a T.M.C. HYDRA Condenser into your set you can rest assured that it is the best your money can buy—it is a product of the most up-to-date condenser plant in the world—and tests, repeated at intervals throughout its making, have proved its quality and capacity to give you a long life of unequalled reliability. Equip your set, then, with T.M.C. HYDRA Condensers—you will get better results.

T.M.C. HYDRA Condensers are made in all standard capacities, with soldering tags or screw terminals at the same price.



Write to the Sole Sales Distributors if you have any difficulty in obtaining supplies of T.M.C. Hydra Condensers.

T.M.C

BRITISH MADE

HYDRA CONDENSERS

Price List from
SOLE SALES DISTRIBUTORS FOR
GREAT BRITAIN:

HARWELL LTD

The Sessions House, Clerkenwell Green, London, E.C.1
Telephone: Clerkenwell 6905

Made by TELEPHONE MANUFACTURING Co.Ltd.

Mr. H. J. Barton Chapple recommends

LINACORE

FOR THE D.C. PREMIER



The J.B. Linacore employs the latest type of iron-cored coils. It greatly simplifies set building—making the most of its super selective coils by accurate matching of condenser sections. Send coupon to-day for **free** Blueprints of an ideal battery or mains model Linacore circuit. Enclose 2d. only for postage. For Battery receivers type B.P.B. (as illustrated) **69/6**
For Mains receivers type B.P.M.

To JACKSON BROS.,
(London) Ltd., 72 St. Thomas Street,
London, S.E.1.
Please send Free Blueprint of Battery Model
 Mains Model
(Delete one not required).
I enclose 2d. in stamps for postage.
NAME.....
ADDRESS.....
Pr.W.....

Advertisement of Jackson Bros. (London) Ltd., 72 St. Thomas Street, London, S.E.1 Telephone: Hop. 1837

Metal detection

in "straight" receivers is now a practical proposition.....

Thanks to the new WX WESTECTOR

which adequately rectifies currents at frequencies of up to 1500 kilocycles

WRITE FOR LITERATURE "PRA"

The Westinghouse Brake & Saxby Signal Co., Ltd.,
82, York Road, King's Cross, London, N.1.

7 DAYS!



Send for a sample tube of Parke-Davis Shaving Cream, and for a week your shaving troubles will be things of the past. No more painful scraping! The close, creamy lather of Parke-Davis Shaving Cream makes the razor feel like a finger—and leaves your skin velvety and comfortable. Your chemist sells large tubes for 1/6.

PARKE-DAVIS Shaving Cream

If you have not yet tried Parke-Davis Shaving Cream, fill up and post the coupon now. British Made by the Makers of Euthymol Tooth Paste.

Box 182/26, EUTHYMOL, 50, Beak St., London, W.1.
Please send FREE sample tube Shaving Cream.

Name.....

Address.....

(Use block letters please.)

THE ELECTROSTATIC LOUD-SPEAKER

(Continued from page 140)

will be obvious, but also the low notes, which are the weak point of the static speaker in general, are reproduced at least as good as, or even better than, by the moving-coil and moving-iron speakers.

This particular type of speaker has so far found little practical application, on account of the fact that the moving-coil speaker in its present form can be sold at a very low price and very few people will be prepared to pay a higher price for the better sound quality of a good static speaker. Therefore, it is of no use to undertake to introduce the static speaker on a large scale. A construction will, no doubt, be found which, while maintaining its superiority over the moving-coil speaker in acoustical respect, can be

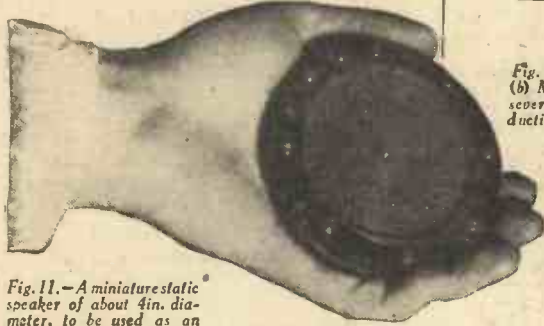

Fig. 11.—A miniature static speaker of about 4in. diameter, to be used as an additional high-tone device for moving-coil speakers, etc.

offered at the same or even a lower price to overcome the reserve naturally taken up by the public regarding any new development. I am convinced that it will be a matter of time only to overcome these

practical difficulties. I am now constructing a new model of a static speaker of the arrangement shown in Fig. 11, but on entirely new constructional lines with a minimum of cost for material and wages,

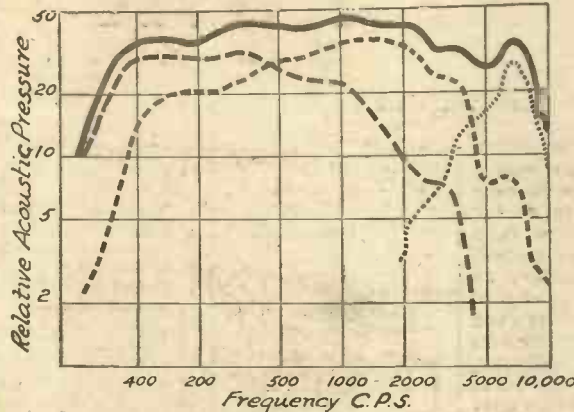

Fig. 12.—Comparative response curves. (a) Bass speaker curve. (b) Medium range. (c) High range. (d) Total radiation. By combining several static speakers of different characteristics, an ideal reproduction of all frequencies can be obtained at high-sound intensity (for sound film).

and I expect to have perfected this type in the near future so much that it will be mature for industrial manufacture. This type will be so low in price as to compete with the moving-coil speaker.

Combined Speakers

I am convinced that the static high-tone speaker used in combination with a moving-coil main speaker will be the ideal arrangement for many purposes. Although the static speaker, as explained before, when

duly constructed, is absolutely suitable to reproduce the whole frequency band, it will be difficult to produce very high sound intensity as required for special purposes (sound film, cafes, etc.). When combining,

however, a highly-efficient moving-coil speaker and a very small static high-tone speaker to reproduce the high frequencies which are not reproduced by the main speaker, you get full response and a marked improvement of the clarity and faithfulness at very small extra expense. The static speaker in this case may be very small, and can be directly connected to the receiver as it requires low initial voltage. I am about to perfect a speaker of this kind with a diameter of 4in. only developed in my laboratory for industrial manufacture, and I feel that the static high-tone speaker will be the first step for the introduction of the static principle of sound production in general.

I have also constructed a cinema arrangement which consists of several speakers of different characteristics for bass, medium, and high-tone response, but all of them being of the static type. This assembly gave very promising experimental results, but, unfortunately, I was so hindered by the development of the Ferrocart coils that I did not go farther along this line. I am, however, devoting full energy again to these problems, and it will be only a question of time before the static principle will play an important role in electric sound reproduction.

AS the use of the decibel as a unit of amplification or attenuation is rapidly increasing, it is not out of place to consider this unit briefly. Due to the fact that the human ear does not perceive simple increases of sound intensity as such, but tends to follow approximately a logarithmic law, the decibel is logarithmic in character and is independent of frequency.

If P_1 is the input power to an amplifier or attenuator, and P_2 the output power, then the simple power ratio is $\frac{P_2}{P_1}$. The logarithmic unit, the bel, is the logarithm of the simple power ratio, so that power ratio (bels) is $\text{Log}_{10} \frac{P_2}{P_1}$ (common logarithms to the base 10 being used). Since the bel, as a unit, is too large for practical purposes, the decibel is used, this being a tenth part of a bel; thus power ratio (decibels) is $10 \text{Log}_{10} \frac{P_2}{P_1}$.

Since the power output is proportional to the square of the voltage or current, when dealing with these units the power ratio becomes $10 \text{Log}_{10} \frac{I_2^2}{I_1^2}$, which is $20 \text{Log}_{10} \frac{I_2}{I_1}$.

The Decibel and Power Output

It is general to use the decibel as a unit when dealing with the power output of apparatus over a range of frequencies. As an example, in the case of loud-speakers it is becoming common practice to give a graph of the power output over the entire

THE DECIBEL

An Explanation of this Important Unit

By D. P. TAYLOR.

audio-frequency range in decibels above and below the output at some standard frequency such as Middle C (256 cycles per sec.). If the output is greater than the standard frequency then the ratio in decibels is positive, whilst if less it is negative.

It is interesting to note that a change of power output of three decibels is the smallest

TABLE (SHOWING THE RELATIONSHIP BETWEEN DECIBELS AND POWER RATIO.

Decibels	Power Ratio	Decibels	Power Ratio
1	1.25	- 1	$\frac{1}{1.25} = .8$
2	1.6	- 2	$\frac{1}{1.6} = .625$
3	2.0	- 3	$\frac{1}{2} = .5$
4	2.5	- 4	$\frac{1}{2.5} = .4$
5	3.2	- 5	$\frac{1}{3.2} = .3125$
6	4.0	- 6	$\frac{1}{4} = .25$
7	5.0	- 7	$\frac{1}{5} = .2$
8	6.0	- 8	$\frac{1}{6} = .166$
9	8.0	- 9	$\frac{1}{8} = .125$
10	10.0	-10	$\frac{1}{10} = .1$
20	100.0	-20	$\frac{1}{100} = .01$
30	1000.0	-30	$\frac{1}{1000} = .001$

change in intensity that can be detected by the average ear.

Power Level

In addition to its use in measuring power ratios the decibel is also sometimes used to express power level transmitted in a circuit. To use the decibel in this manner it is necessary to refer it to an arbitrary standard called zero level or 0 decibels, it being recognized that this shall represent .006 watts of audio-frequency power. Thus 10 decibels is .06 watts and 20 decibels .6 watts, etc. To express values below the zero level a negative sign is put in front of the sign for the decibel, so that -10 decibels is .0006 watts and -20 decibels .00006 watts.

The distinction between these two functions of the decibel in measuring power ratios and power levels is of the greatest importance.

CLOSED DOWN BY TROOPS

XER, Villa Anna (Mexico), the most powerful broadcasting station in South America, with a studio in Texas (U.S.A.), was recently closed down by Mexican troops by order of the Government. Its slogan: *The Sunshine Station between the Nations* did not bear out its policy, which was that of broadcasting advertisements for quack remedies and other medical articles vetoed by law. Its owner now threatens to install a power transmitter on a steamer outside the twelve-mile limit and thus reach his listeners in this manner. The floating station would contain its own studio.

Further Notes on the A.C. LEADER THREE

These Notes are Given as a General Reply to Those Few Readers who have not been Quite Clear Concerning One or Two Little Points in Connection with This Remarkable Receiver

THE tremendous number of letters which we have received in appreciation of the Leader Three is clear proof of the extreme popularity of our bold policy of designing a range of receivers to meet the financial needs of our readers. Of the many letters received, nearly all have referred to the utter simplicity of construction of the A.C. Leader and apparently only a very few constructors have experienced the slightest difficulty. It is apparent that the set has been made up by a large number of readers who have never before attempted the construction of even a battery-operated receiver, and this is good proof of the straightforwardness of the design which we followed.

The Component Brackets

One or two minor points have puzzled a few readers who are new to home-construction, so that some notes concerning such difficulties will be useful and will clear away any small difficulties which might possibly exist. In the first place, some constructors have not been quite clear in regard to the matter of the method of dealing with the three component brackets. Actually, one of these—that holding the two-point wave-change switch—is in contact with the metallized chassis and is screwed directly to the upper side. The reason for this will be appreciated when the circuit diagram is examined, because it will be seen that there are actually three contact points, one going to the earth line and one going to a tapping on each of the coils. But by mounting the two-point switch on the metal bracket, the mounting bush, and therefore the spindle, is automatically connected to earth, with the result that the two-point switch gives the same effect as a three-point component which would cost a little more.

The other two component brackets, holding the on-off switch and reaction

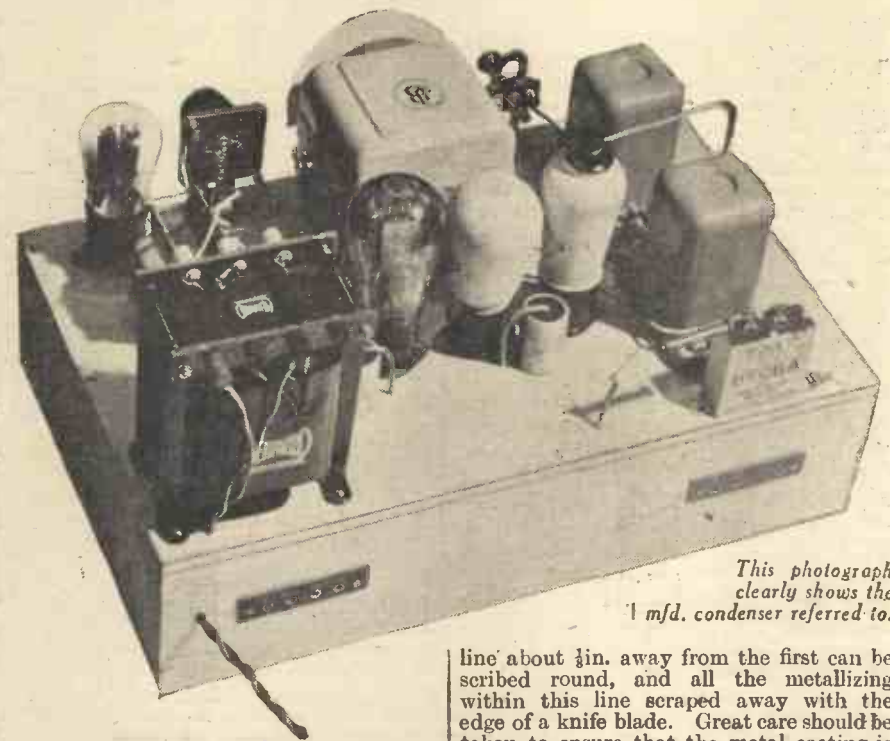

This photograph clearly shows the 1 mfd. condenser referred to.

condenser respectively, are insulated from the chassis. The former is automatically insulated by being attached to the underside of the chassis baseboard which is not metallized, but the latter must be insulated by some other means. The method of insulation recommended is to scrape away a square of the metallized surface a little larger than the base of the bracket. This can be done very simply by fitting the bracket in position and scribing a line round it; after removing the bracket, another

line about $\frac{1}{16}$ in. away from the first can be scribed round, and all the metallizing within this line scraped away with the edge of a knife blade. Great care should be taken to ensure that the metal coating is thoroughly removed or else there might be a short-circuit between the anode of the detector valve and earth (which is also H.T. negative). It is a good idea to go over the line with the sharp point of a scriber or with the point of a pocket knife so as to make a complete break in the metallized surface. Then, even if any trace of metal should be left it is unlikely that a short will occur.

It should be made quite clear that it is not sufficient to "insulate" the bracket by placing a strip of paper or card between it and the chassis, because there would still be the risk of the mounting screws making contact with the metal surface, thereby causing the short which it is necessary to prevent.

The 1 mfd. Condenser

Here we must point out a slight error which occurred in the list of components given last week, and in which "One T.M.C. 1 mfd. Tubular Fixed Condenser" was specified for C5. This condenser should have been listed as "One T.M.C. 1 mfd. Fixed Condenser, Type 40." The condenser in question is that used as an anode by-pass in connection with the S.G. valve, and it is mounted on top of the chassis behind the two coils; it can clearly be seen in the photograph reproduced on this page. We must apologise for this slip, and we might add that suppliers of kits of parts have already been advised, so that there is little danger of readers receiving the wrong component. A correct component specification is given on the left.

LIST OF COMPONENTS FOR A.C. LEADER.

One Jackson Bros. Double-gang Condenser .0005 "Nugang" Type A (C1 and C2).
Two Wearite "Universal" Screened Coils.
One Graham Farish .00015 mfd. Differential Reaction Condenser (C7).
One Bulgin Junior On-Off Switch, type S.38.
One Varley "Nictet" 5-1 L.F. Transformer.
One Graham Farish "Snap" H.F. Choke.
One Heyberd "Leader" Mains Transformer.
One Wearite Smoothing Choke, Type H.T.25.
Three 2in. Component Brackets, British Radiogram.
Two Clix Terminal Socket Strips (one marked Aerial and Earth, and one marked L.S. and P.U.).
Six Solid Clix Plugs for use with terminal strips.
One Claude Lyons "B.A.T." Type 728-L.T. Switch.
Four W-B chassis mounting 5-pin valve-holders.
One Claude Lyons "B.A.T." 100,000-Ohm Resistor, Type R.1 (R.9).
One Claude Lyons "B.A.T." 50,000-Ohm Resistor, Type R.1 (R7).
One Claude Lyons "B.A.T." 40,000-Ohm Resistor, Type R.1 (R2).
One Claude Lyons "B.A.T." 30,000-Ohm Resistor, Type R.1 (R1).
One Claude Lyons "B.A.T." 5,000-Ohm Resistor, Type R.1 (R4).

One Claude Lyons "B.A.T." 1,000-Ohm Resistor, Type R.1 (R6).
One Claude Lyons "B.A.T." 350-Ohm Resistor, Type R.34 (R8).
One Claude Lyons "B.A.T." 250-Ohm Resistor, Type R.1 (R3).
One Claude Lyons "B.A.T." 1-megohm Resistor, Type R.1 (R5).
Two Dubilier 20 mfd. Electrolytic Condensers, Type 401 (C8 and C10).
One T.M.C. 4+4mfd. fixed Condenser, Type 40 (C11 and C12).
One T.M.C. 2 mfd. fixed Condenser, Type 40 (C9).
One T.M.C. .0001 mfd. tubular fixed Condenser (C6).
Two T.M.C. .1 mfd. tubular fixed Condensers (C4 and C3).
One T.M.C. 1 mfd. fixed Condenser, Type 40, (C5).
One Peto-Scott Metallized Chassis, 16in. x 10in. with 3 $\frac{1}{2}$ in. runners.
One Cossor MS-PEN Valve.
One Cossor 41.MH Valve.
One Cossor 41.MP Valve.
One Cossor 506.BU Rectifier.
Wire, screws, flex, etc.

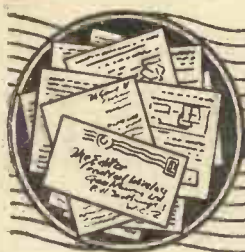

READERS' WRINKLES

THE HALF-GUINEA PAGE

Fitting Scanning Discs

TO overcome the obvious disadvantages that are likely to accrue from the employment of grub screws for the attachment of the boss of a scanning disc to the motor spindle, and to provide a ready

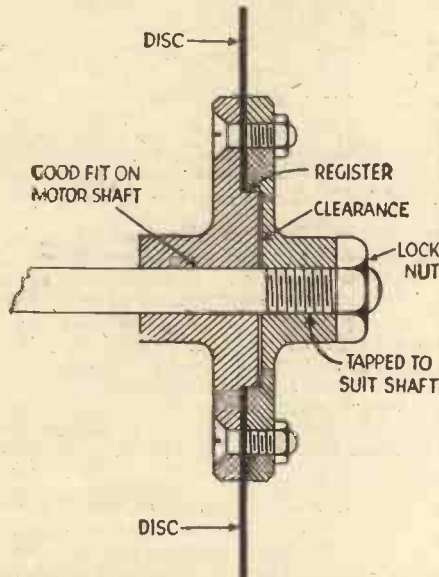

An efficient method of fitting scanning discs.

means of fine adjustment, the following method might be adopted:—

A boss with a central flange is made in two parts. The rear portion is bored a good sliding fit on the motor spindle, and on the face a true register locates the disc. The front part is tapped to suit a thread cut on the end of the spindle. A female register on the face of this ensures that the half bosses are in alignment, and bolts passing through the flanges and disc hold them together. Spanner flats are filed on the outside of the tapped boss as a means of holding while tightening the locking nut, fitted to the end of the spindle.—W. H. D.

Fixing an Aerial Mast

IN spite of the thousands of aerials one sees only a very small number are erected with a view to appearance as well as efficiency. A little trouble taken when the aerial is being installed will be amply repaid by increased service and will result in the aerial being less of an eyesore than would otherwise be the case.

A mast built on the lines of the accompanying drawing (which is self-explanatory) will be found very convenient in that it can be easily lowered for inspection and oiling by removing the bottom bolt and allowing it to swivel on the top one, the stays being loosened and used as guide ropes to assist in this operation. The concrete block, with the mast supports, is buried a few inches deep in the ground, its actual size depending upon the size and weight of the mast. For greater

THAT DODGE OF YOURS!

Every Reader of "PRACTICAL WIRELESS" must have originated some little dodge which would interest other readers. Why not pass it on to us? We pay £1-10-0 for the best wrinkle submitted, and for every other item published on this page we will pay half-a-guinea. Turn that idea of yours to account by sending it in to us addressed to the Editor, "PRACTICAL WIRELESS," George Newnes, Ltd., 8-11, Southampton Street, Strand, W.C.2. Put your name and address on every item. Please note that every notion sent in must be original. Mark envelopes "Radio Wrinkles." Do NOT enclose Queries with your Wrinkle.

strength the mast supports could project through the underside of the block and into the ground for some distance.—F. C. BIDDLECOMBE (Twickenham).

Two Useful Methods of Holding Wires in Position

TWO methods of holding wires in position are shown in the accompanying illustration. The first is partic-

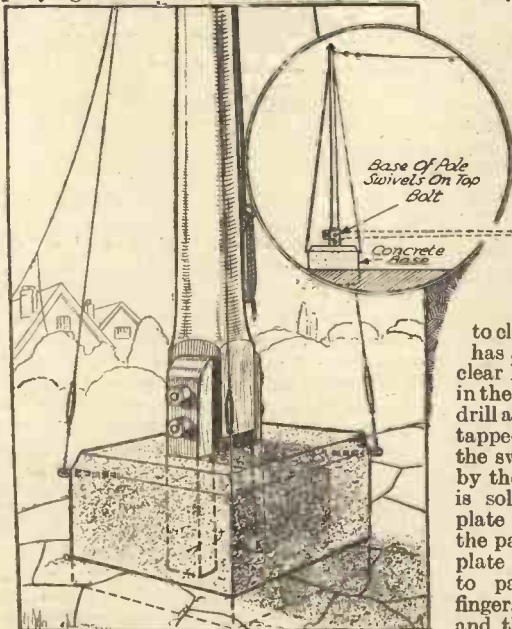

Mounting an aerial mast in a concrete block.

ularly useful for spacing flexible leads in portable sets. A piece of thin sheet fibre, about 1-32in. thick is the material to use. Holes are punched opposite to each other near the front and back edges for each wire. The diameter of the holes should be slightly larger than the wire.

The second arrangement may be used in lieu of cleats. The foregoing remarks with regard to material again apply. An angle piece is formed by cutting a strip about 1/4in. wide and scoring it down the centre to facilitate bending at right angles. Make holes with a bradawl along the centre of the vertical portion for the

wires and from the top edge make a cut with snips into each hole. Suitable holes are made in the base for fixing screws.

To insert the wires, slightly open the cut by bending the adjacent sides in opposite directions. This will allow the wire to be sprung into place. When the cuts are

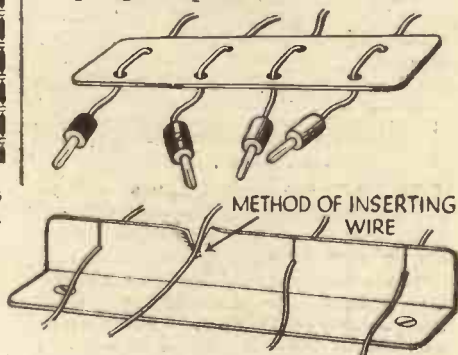

A useful dodge for holding flexible leads.

closed the fibre will securely grip the wires, providing that the holes are not too large.—W. H. D.

Push-pull Switch Position Indicator

THE necessary parts for making this switch consist of a rotating plate marked with the appropriate wording—"LONG," "SHORT"—"ON," "OFF," etc. There is a mask plate gripped between the switch bush and nut, with a washer underneath to allow the mask plate to clear the rotating plate. This mask plate has a window cut in the upper half and a clear hole to coincide with the central hole in the rotating plate. A short piece of twist drill about 1/4in. diameter is soldered to an arm tapped at the opposite end to screw on to the switch spindle. This is locked in place by the switch knob. A small piece of tube is soldered to the back of the rotating plate to form a bearing in a hole drilled in the panel. The central hole in the rotating plate is sufficiently large to allow the drill to pass through, but two small brass fingers are sweated partly across this hole, and these projections fit into the flutes of

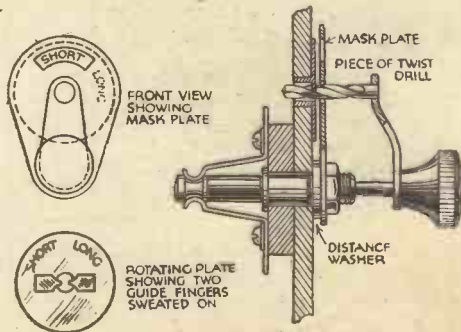

A handy push-pull switch position indicated.

READERS' WRINKLES

(Continued from previous page)

the twist drill. When the switch knob is pushed in, the forward movement of the drill causes the rotating plate to turn, exposing the required indication. With the knob in the "out" position the twist drill should project into the panel sufficiently to prevent the switch knob and spindle from rotating.—W. J. Woodcock (Edg-baston).

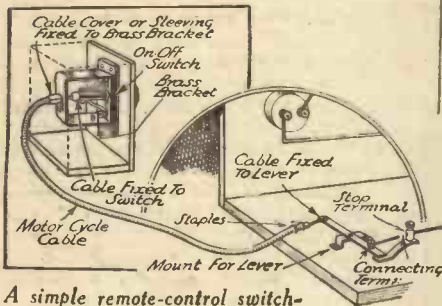

A simple remote-control switching arrangement.

A Simple Remote-control Switch

A RECENT article in PRACTICAL WIRELESS gave the inspiration for the simple remote-control switch shown in the accompanying sketch, which shows a simple method of extending a switch, with a cycle or motor-cycle brake cable. A piece of brass is shaped to form a bracket which is fixed over switch, and the cover of the cable is then attached to the bracket, as shown in the sketch. The other end of the cable is taken to the back of the set in whatever position it is required and then nailed down with staples. Fix the cable to the end of a lever switch, as illustrated, and make a contact piece with a bent piece of brass with a terminal fixed to one end, which acts as a stop block. This extension is useful when operating a set in a radio-gram cabinet. The switch is fixed at the back of the set and is operated from front of the panel.—N. T. STACEY (Hampton Wick).

An Easily Made Voltmeter

A SIMPLE voltmeter, working on the principle of the solenoid, may be made as shown in the sketch. Cut a base, 3in. by 3in. from 1/4in. wood. Cut a lever A and the pointer from stout tin, and pivot them to the base, using small nails and washers. Connect them with a piece of thread, C. Fix a weak spring at D to pull the pointer to the left, and put a nail E to act as a stop. To make the coil F, bend a piece of thin brass to form a flattened tube, as shown in the section, and wind on six

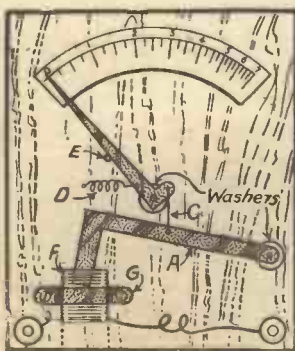

An easily made voltmeter.

layers of No. 36 D.C.C. wire. Secure the coil in position with a brass strip G, and connect the ends to two terminals. Glue a cardboard scale under the pointer, and the instrument is complete. If desired, it may be calibrated by testing it in conjunction with a standard voltmeter.

Handy Solenoid Switch

A VERY convenient remote control or reverse switch for speakers, motors, bells, lights, etc., is shown in the accompanying sketch. This instrument can be made from two bell bobbins, soft iron tube, brass rod, brass and copper strips, and a piece of steel wire for guide.

First fix the bobbins to a baseboard with copper strips, next push the iron tube through the bobbin, then run the brass rod through the iron tube and fit brass brackets and lock with nuts. Make sure the iron tube moves freely between bobbins. When bobbins are fixed, solder copper strip on centre of iron tube and also fix contacts. Contacts made from a very thin spring copper. Use 4 to 6 volts for working and note that measurements for the brackets

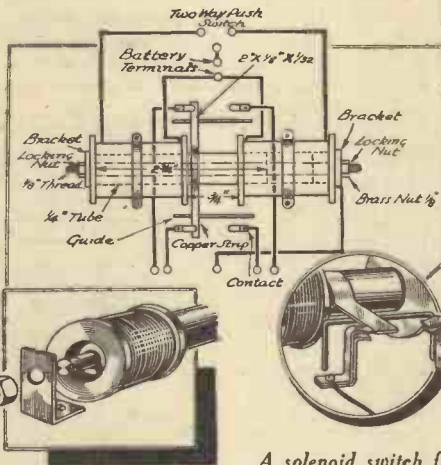

A solenoid switch for speakers or for remote control purposes.

depend entirely upon the sizes of the bobbins actually used.—F. W. MARLOW (Wembley).

Measuring Anode Voltages

IT is well known that accurate measurements of the actual voltage applied between the cathode and anode of a valve cannot be made by the apparently straightforward method of connecting a voltmeter between the two points concerned. The reason is that the meter is in parallel with the valve itself, with a result that the reading obtained is lower than the true voltage. The difficulty is still worse if the only voltmeter available is of the low-resistance type; in fact, anything approaching accuracy is impossible in such a case.

Amateurs do not always realize that it is possible to ascertain the voltage with almost 100 per cent. accuracy by measuring the anode current by means of a milliammeter and then making a simple calculation. After the current has been measured, the voltage of the H.T. supply and resistance of the anode-circuit components being known, the voltage-drop in the anode circuit can be obtained by multiplying the current reading (in milliamperes) by the anode-circuit resistance, and dividing by 1,000. The figure thus obtained is subtracted from the total H.T. voltage available in order to get the actual anode voltage.

Do not forget that, when automatic biasing is employed, the G.B. voltage must also be taken away from the H.T. voltage.

Making a Metal Chassis

THE accompanying sketch shows a jig which will be found useful by constructors who make their own aluminium chassis. It consists chiefly of two pieces of hard wood, of approximately the dimensions given, hinged together. The hinges should be placed so that when they are in the "closed" position there is a space of 1/4in.

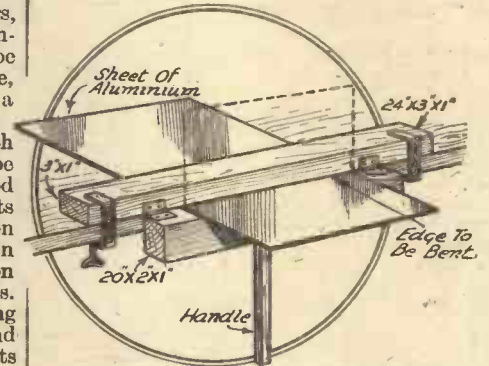

A handy clamp for bending sheet aluminium.

between the two pieces of wood. A handle is attached to the hinged part. A line is scribed on the aluminium, where the edge is to be bent, and it is then clamped down firmly, as indicated. On raising the handle the aluminium is bent with a clean sharp edge. To obtain the best results from this jig the hinges must be securely fixed to the wood and the wood tightly clamped to the table.—L. K. HOMYER (Portsmouth).

An Indoor "Earth"

MANY listeners who, of necessity, use an inside aerial, often experience difficulty in making a suitable earth connection; the possibilities of a "counterpoise earth" are frequently overlooked. As a matter of fact, an "earth" of this kind is often even more effective than a more conventional one, and it is certainly easy to arrange. All that is required is to take a second wire, similar and parallel to the aerial wire, and join the end of this to the earth terminal. This second wire must be insulated.

Automatic Brake for Spring Gramo-motor

A VERY useful brake for a spring-driven gramophone can be made by fixing a small brass strip to the revolving part of the pick-up arm, with a small felt pad at the end, as shown in the sketch. By bending the strip the brake can be made to press on the edge of the turntable when the pick-up is placed on one side, and so release the turntable as soon as it is moved towards the record for playing. The brass strip may be stained and varnished a dark brown to look like oxidized metal.—G. N. PATCHETT (Bradford).

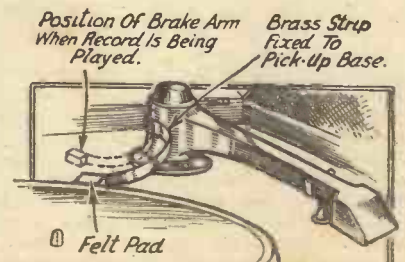

An automatic brake for a spring gramophone motor.

ALTHOUGH at least one complete design for a thoroughly up-to-date portable receiver will shortly be given in PRACTICAL WIRELESS, there are no doubt hundreds of readers who do not feel inclined to go to the expense of a completely new set of components, due to the fact that they have many useful parts on hand which they wish to make use of. It is therefore proposed to suggest a few circuits and approximate lay-outs of simpler types of portable receivers for the benefit of such readers.

Having decided to build a portable, the first question which arises is: must the set be really small and light, so that it can easily be carried by hand, or is it only required to make one which can be slipped in the car or sidecar for occasional

MAKING YOUR PORTABLE RECEIVER

There are Many Readers who wish to Make Up a Portable from Components which are on hand. Information in regard to the Best Methods of doing this is given below.

By **FRANK PRESTON**

high-frequency pentode valve—will be especially desirable.

A Simple Circuit Arrangement

Now that the preliminaries have been discussed a few useful circuit arrangements can be considered. One excellent circuit for local-station reception up to twenty miles or so on a loud-speaker, or over much greater distances with 'phones, is shown in Fig. 1. It will be seen that a screen-grid valve (which might be replaced by an H.F. pentode) is used as detector, this being followed by a 5:1 L.F. transformer and a pentode output valve. The circuit is similar to that used for an ordinary "fixed" set, except that a frame aerial, with reaction winding, is used in place of the usual aerial and coil. A "stopper" resistance is included

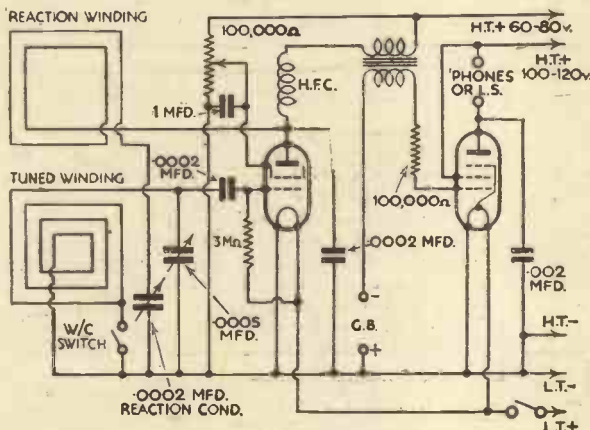

Fig. 1.—The above is a really good circuit for a simple type of portable receiver using modern valves.

week-end trips? In the former case it will be better to make the simplest kind of two- or three-valver, preferably housing the receiver proper in one container and the batteries in another. If weight and bulk are not very important considerations, a more pretentious and entirely self-contained outfit will be better. Another point which must be decided is whether loud-speaker or 'phone reception will be required. In most instances the speaker will be preferred, but those who are travelling without a car would do well to content themselves with 'phones, especially since the set will probably be used only for receiving news bulletins, weather reports, and the like.

In the majority of cases nothing more than local-station reception will be required, so that the use of a Det.-L.F. type of circuit might prove quite satisfactory. Where long-distance reception is specially wanted at least one H.F. stage—preferably using a

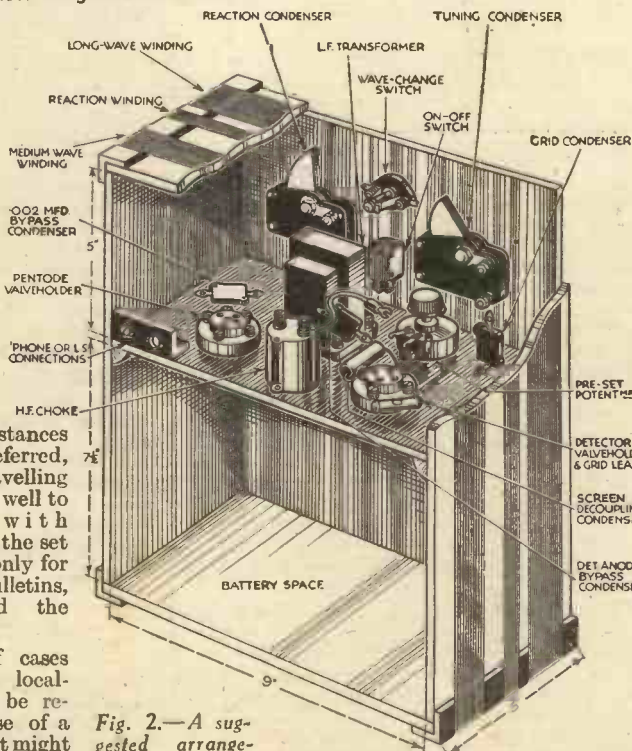

Fig. 2.—A suggested arrangement of a portable of the simplest type using the circuit given in Fig. 1. Dimensions are approximate and will have to be modified according to the batteries employed and if a speaker is to be accommodated.

in the grid circuit of the pentode, and a .002-mfd. condenser is connected between the anode of the pentode and H.T. negative to prevent L.F. instability. A variable potentiometer is shown for controlling the voltage on the screen of the detector, but this might well be a baseboard-mounting pre-set component, since it need not be touched after the preliminary adjustment has been made, so as to obtain smooth reaction control. A suggested arrangement of the components and frame aerial is given in Fig. 2, but this may be modified considerably so as to accommodate the parts in some available attache-case or other container. There is no need to give constructional details for the frame aerial here, since they were fully dealt with in another article on portable receiver design published in PRACTICAL WIRELESS dated February 4th, 1933.

When the set is to be accommodated in a case separate from that containing the batteries, it will be so small that a frame aerial wound round it would not prove very effective on account of its small size. It would, therefore, be better to replace the frame by a dual-range coil, as shown in Fig. 3, and to employ an external aerial. The latter may consist simply of a short length of wire thrown along the floor or over the branch of a tree, or it might be a connection to an earth point, such as a water-pipe. The idea of using an earth for an aerial might sound rather ridiculous to those who have not tried it, but in practice it often works very well. In the case of the other extemporized aerial systems mentioned, still better results will often be obtained by using an earth connection as well, this being joined to the negative terminal on the accumulator.

It might be mentioned at this point that a fairly effective and particularly convenient "self-winding" aerial can be devised from one of the steel tape measures which can be bought from sixpenny stores. The end of the tape is soldered or otherwise connected to the aerial terminal, so that to "erect" the aerial it is only necessary to pull out the case. After use the "aerial" is wound up simply by pressing the spring-release on the side of the case. A measure only a yard long can be used but, naturally, better results can be obtained by employing a greater length than this.

(Continued overleaf)

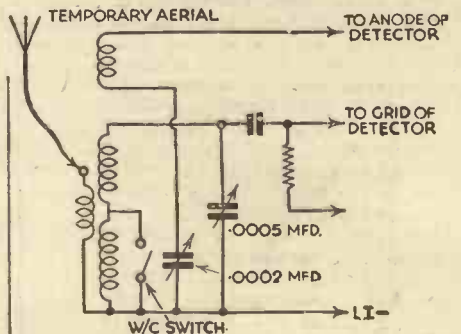

Fig. 3.—With a very small portable better results can often be obtained by replacing the frame aerial by a dual-range coil and using a short temporary aerial. The connections given above show how a coil is substituted for the frame aerial shown in Fig. 1.

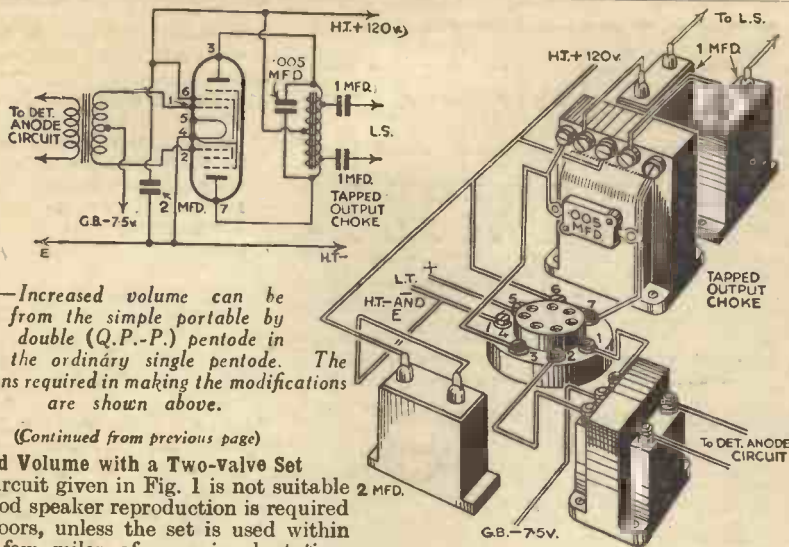

Fig. 4.—Increased volume can be obtained from the simple portable by using a double (Q.P.-P.) pentode in place of the ordinary single pentode. The connections required in making the modifications are shown above.

(Continued from previous page)

Increased Volume with a Two-Valve Set

The circuit given in Fig. 1 is not suitable when good speaker reproduction is required out of doors, unless the set is used within a very few miles of a regional station.

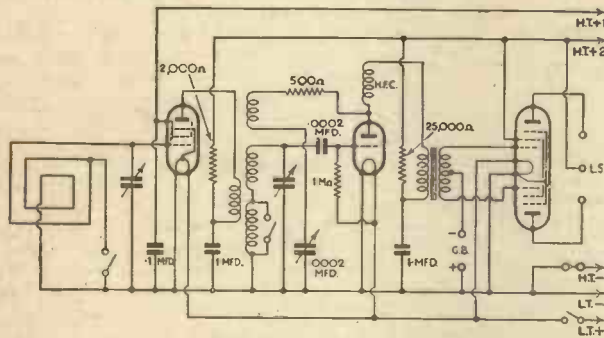

Fig. 5.—The circuit for an excellent and up-to-date three-valve portable. An H.F. pentode is used in conjunction with a detector and double output pentode.

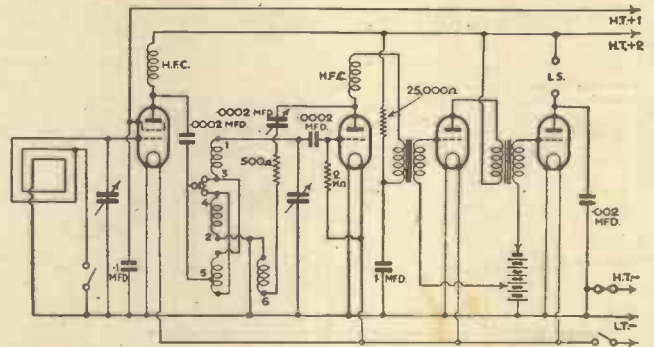

Fig. 6.—This circuit is for a simple four-valve portable which can be built from standard components which the average experimenter has on hand.

IT might appear unnecessary to have to explain how to ask a question, but it is surprising how many queries are received by us which either cannot be answered, or which are incapable of being replied to definitely owing to the obscure manner in which the query is put or the lack of information which is given. These notes are therefore written to assist not only our readers in solving their difficulties, but also to assist the Technical Department in quickly arriving at a decision regarding the problem which is placed before them.

First and foremost, brevity should be the principal point to observe. We do receive queries which occupy five and six pages, and which, when analyzed, could easily have been given in ten lines or so. Whilst we really appreciate communications from our readers and always welcome suggestions, etc., it is very difficult to pick out a query which is wrapped round with all sorts of other irrelevant matter. If you wish to write us regarding a fault or problem which is troubling you, and also wish at the same time to convey thanks for an article or appreciation of policy, etc., please write them on separate sheets. This will not cost you any more for postage, but will materially assist us in helping you. Secondly, if more than one query is to be raised, set them out on separate pieces of paper. We are sure that if you think for a moment you will realize that it is almost impossible to solve a problem where it is almost impossible to decide just what the difficulty is.

When you go to the doctor, it is of no use saying "I feel queer. Can you help

HOW TO ASK A QUERY

Some Points which should be borne in mind when asking for advice, in order to assist the Technical Department in solving your difficulties. By W. J. DELANEY.

me?" He will at once say, "What is wrong?" He will want to know whether you have any pains; where they are; how long you have had them; and many other small details which will assist him in deciding what is wrong with you and what treatment to administer. He might even be unable to tell from your statements what is wrong, and will be unable to help you until he has thoroughly examined you. It is the same with a wireless receiver which is out of order. If you just ask us what is wrong with it, we are helpless, as we do not know anything at all about it. We therefore must have details of the circuit or receiver first of all. Then we must know what is wrong with it. Does it function irregularly? Does it distort? Does it fail to give any signals at all? These may seem rather ridiculous points to raise, but we do receive questions in which similar points are not given, and our only reply in such cases can be, "You do not give sufficient details for us to help you." Try, if possible, to enumerate the faults which you are experiencing, or set out in order the points which you desire to have elucidated. If you have made a receiver and it is not giving satisfaction, just state how it fails. Let us know whether you get any signals, for instance. Give brief particulars of the aerial and

earth which are used. Let us know whether the voltage supplies are obtained from batteries or mains units. Mention if these are new or have been in use for some time.

More volume can be obtained fairly easily, however, by replacing the single output pentode by one of the new Q.P.P. double pentodes. This would necessitate the use of an 8 or 10 to 1 Q.P.P. transformer in place of the ordinary L.F. transformer shown in Fig. 1, whilst the loud-speaker would either have to be of Q.P.P. type or else fed through a special output choke. The double pentode circuit is given in Fig. 4, and this is simply added to the detector portion shown in Fig. 1.

Increased Range

Neither of the arrangements described so far is suitable for any other than purely local reception, and when the set is to be used at distances of more than twenty miles or so from the nearest transmitter, it is better to use a stage of H.F. amplification. An excellent circuit for a powerful three-valve portable receiver is shown in Fig. 5, where it will be seen that an H.F. pentode

(Continued on page 160)

We have for some weeks past been giving a small panel on the Queries and Enquiries page relating to those questions which you should not ask. These points are either impossible to explain or, for various reasons, are not of the type which can be given. If you refer to these panels you will see that there are certain points which are either not capable of solution, or which it is not politic to give. If you bear these points in mind, and when you are putting a query for solution carefully think first just what you wish to ask, we are sure you will be more satisfied with the answer which you will receive, and the work of our Technical Department will be greatly facilitated and a more accurate solution will be forthcoming.

To summarize the above points, therefore:—

- Use a separate sheet for each problem.
- Do not include other communications with your problem unless a separate sheet is used.
- Be brief.
- Give all the symptoms.
- Explain clearly just what it is you wish to know.
- Make certain the information has not already been published.

Attention to these points will help you and us to come to a speedy solution of your problem, and if you want a reply by post—don't forget to enclose a stamped and addressed envelope and the query coupon!

All About Mains Units—1

WHEN reading through my post the other morning, it occurred to me that the number of queries dealing with mains-units seems to be steadily increasing, and in view of the doubt which appears to exist regarding the advisability of changing over from battery to mains operation, and of choosing a suitable type of unit, I propose in this article to describe in some detail the principles underlying the design of units, both for D.C. and A.C., also giving advice regarding the choice and operation of them.

The current required for the anodes of receiving valves is, of course, *direct current*,

difference in potential. Self-inductance is frequently referred to as "electrical inertia," and it is this property which keeps back the ripple, but allows the direct current to pass through unhindered. The unit of self-inductance is the "henry," and thus we speak of a choke having an "inductance of so many henrys." The iron core surrounding the winding increases the effective inductance, preventing the flow of eddy currents, and thus reducing losses in the component. Although I have stated that the choke allows direct current to pass through unhindered, this is not entirely true as the winding possesses, of course, some ohmic resistance. Consequently, it will be seen that a smoothing choke should have a high inductance value and low ohmic resistance. Furthermore, as the effective inductance decreases with increase of direct current passing through the choke, in designing or purchasing

smooth direct current for the filaments of the valves. Reservoir condensers have the same effect.

This filter arrangement therefore converts the rough mains supply to a smooth direct current, which, however, is still unsuitable for our requirements, owing to the fact that its potential is the same as the mains input of perhaps 230 volts (less the slight voltage drop through the smoothing choke).

Reducing the Voltage

Consequently we have to reduce the voltage and, at the same time, limit the amount of current flowing in the circuit, and this is done by connecting a resistance (termed the "mains-resistance") in series with the negative side of the unit. In order to compute the value of this resistance, it is necessary, first of all, to determine the maximum voltage and total anode current consumption of the set, which can easily be done by referring to the curves published by the valve manufacturers. Assuming that the output valve requires 150 volts, then that is the maximum voltage required as, of course, the other valves will not require so much. Then from the curves estimate the anode current of each valve at a potential of 150 volts. It may be found that at this voltage the S.G. valve takes 3 milliamps, the detector valve 1 milliamp, and the power valve 16 milliamps, making a total current consumption of 20 milliamps at 150 volts. Having determined these figures, the rest is easily calculated by Ohm's Law! The formula in this case is $\frac{\text{voltage-drop} \times 1,000}{\text{current in milliamps}}$

which in our assumed case becomes: $\frac{80 \times 1,000}{20} = 4,000$ ohms. This, then, is

the total resistance required in circuit, but as the smoothing choke also possesses ohmic resistance, say 500 ohms, then this has to be deducted from the above figure, making the correct value for the mains-resistance 3,500 ohms. This resistance must, of course, be capable of carrying the total output from the unit.

Tapping the Output-Voltage

Now we are getting a little nearer, as we have smooth direct current available at 150 volts as required by the output valve, with a current equal to the total anode current consumption of the set. The S.G. and detector valves, however, do not want so much as 150 volts, and, therefore, our next task is to separate the total output into three or more tappings at various voltages as required by the individual valves.

This can be done in two ways, firstly, by the "potential-divider" method which consists merely of a resistance connected directly across the output, this being tapped at various points. This arrangement, while it permits of cheaper construction, is used only in the cheaper type of unit and cannot under any circumstances be recommended, as it offers a common resistance to all the anode circuits in the set, and is therefore peculiarly prone to introduce feed-back, with consequent instability usually evidenced by the familiar "motor-boating" noise.

The alternative arrangement is termed "series anode-feed resistance," and is much preferable in that each separate H.T. feed is individually decoupled, and this arrangement is in almost universal use. This circuit provides for a separate voltage-

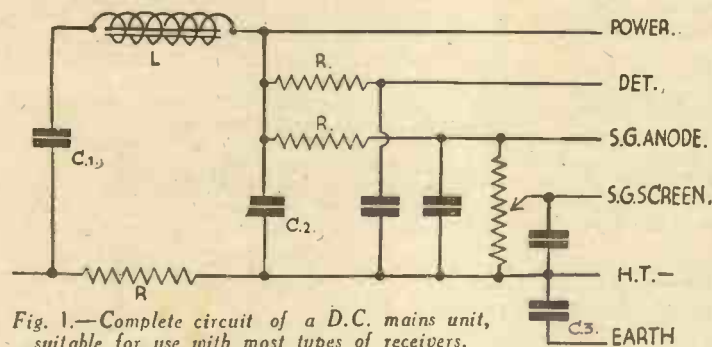

Fig. 1.—Complete circuit of a D.C. mains unit, suitable for use with most types of receivers.

and therefore the design of a unit for direct-current mains is the simplest proposition, and we will tackle that first. Fig. 1 shows the complete circuit of a D.C. mains-unit for deriving high-tension current from the mains and providing four separate tappings, including a variable one for the S.G. valve. One might think that as direct current is required for the valves, and current supplied through a D.C. main is already "direct," it would merely be necessary to break down the input to the voltage required by the valves. Unfortunately, this certainly is not so! The mains current is never *pure* direct current, and in some localities, particularly where the supply is derived from mercury-arc rectified A.C. there is a very considerable percentage of residual alternating current superimposed on the D.C., which if allowed to reach the anodes of the valves would make its presence felt in the shape of a devastating mains hum! In order to remove this A.C. component we use a combination of chokes (L) and condensers (C) which filters the alternating current from the direct current, and thus converts the irregular mains current to a *smooth* direct current suitable for the valves. The choke consists of a large number of turns of fine wire wound on a bobbin, and surrounded by iron laminations (called the core). To explain fully the action of the choke is somewhat beyond the scope of this article, but, in short, it may be said that this component acts on the principle that when an alternating potential difference is applied to a circuit possessing "self-inductance" (as any winding does), the variation of the resultant magnetic flux sets up an alternating electromotive force which tends to choke back the current, at the same time causing the current to lag in phase behind the applied

a choke it must be watched that the inductance is sufficient for the circuit, with the requisite direct current passing through. An important point! It is not sufficient to say "I require a 30-henry choke." You must ask for a choke "having an inductance of 30 henrys at 15 milliamps," or whatever the value may be. The choke is sometimes incorporated in the positive side of the unit, and sometimes in the negative, depending upon whether the positive or negative leg of the D.C. three-wire system is earthed. In some cases, where the supply is exceptionally rough (such as mercury-arc rectified A.C.) it may be necessary to use two chokes, one in each lead.

"Reservoir" Condensers

The two condensers (marked C1 and C2 in Fig. 1) are shunted in parallel with the mains, one before the choke and one after, and these must have a capacity of not less than 4 mfd. each and, of course, must be capable of withstanding the full mains input. These condensers act more or less as reservoirs, and are, in fact, termed "reservoir condensers," accepting the irregular flow of current and feeding it out in the form of smooth current. The condensers also act in some measure as "bypass" condensers, putting up an effective barrier to the passage of direct current, but providing a low impedance path to earth for the alternating currents. Quite a good analogy to the "reservoir condenser" is afforded by an ordinary low-tension accumulator which is being trickle-charged at the same time as it is feeding the filament circuit of the set. Under these conditions, the accumulator accepts the unsmoothed and irregular D.C. supply from the trickle, but feeds it out in the form of a perfectly

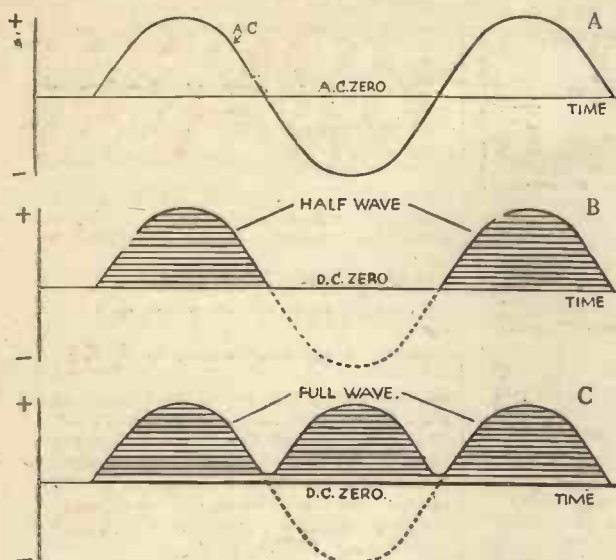

Fig. 2.—The above diagrams show: (A) the curve for an A.C. current; (B) the result of half-wave rectification; (C) the result of a full-wave rectification.

dropping resistance and by-pass condenser on each tapping, as is clearly shown in Fig. 1. The decoupling effect is obtained in this manner. The resistances not only regulate the voltages, but they also offer a high impedance to H.F. currents, which are conveniently disposed of by providing for them a low-impedance path to earth through the by-pass condensers connected between the low-potential end of the resistances and the negative side of the unit. The formula already given for computing the value of the mains resistance is also used for calculating the values of the various voltage-dropping resistances. It will be observed that the feed for the screen of the S.G. valve is obtained from the slider of a potentiometer (which is also by-passed). The current required by the screen is very small (less than 1 milliamp) and, with an ordinary variable resistance in this position, the voltage would tend to fluctuate considerably, and as some S.G. valves are very fussy—even to within a few volts—of the voltage applied to the screen, we cannot ensure optimum working conditions with a fixed resistance. The potentiometer arrangement overcomes both difficulties, providing a steady but easily adjustable voltage output. Perhaps it should be mentioned that all by-pass condensers should have a capacity of not less than 2 mfd. The condenser marked C3 in Fig. 1 is absolutely essential. A moment's thought will make it clear that the negative line of the unit, and of course the receiver, is connected directly to the negative side of the supply main, and consequently, if a direct earth were connected to the set or to the unit, one would—in effect—be connecting the negative main to earth. A very high current would immediately flow through the mains-resistance in the unit, causing this component to overheat and give up the ghost—this is the least damage one could expect! In order to overcome this difficulty the installation is earthed through the condenser, thus isolating the mains from earth, but at the same time retaining a path to earth for the speech currents. This isolating condenser is usually included in the unit by the manufacturers, and that is the reason that

mains, however, things are somewhat different, as we have to convert the alternating current to direct current before we can even begin to use it. A very useful property of A.C. is that any desired voltage, greater or smaller than the input voltage, can be obtained by using a mains transformer. This component consists of two or more coils, one primary and one or more secondaries wound on bobbins, and surrounded by iron laminations as in the choke. The voltage available from any secondary winding depends chiefly upon the number of turns of wire in it as compared with the number of turns in the primary. The primary is always connected to the A.C. mains (through fuses), the secondaries being used for a variety of purposes as will be explained later. Incidentally, this transformer effectively isolates the mains from the unit and receiver, and consequently no isolating earth condenser is necessary as it is in a D.C. unit.

Having now transformed the input voltage to the pressure required (this depending upon the characteristics of the rectifier used) we now have to convert or "rectify" the alternating current to direct current. This is effected by a component appropriately called the "rectifier" of which there are several types. There are only two types widely used, these being the thermionic valve and the dry metal-rectifier.

To explain the action of the rectifier, we must again resort to diagrams (Fig. 2A), which shows the wave-form of an alternating current. It will be seen that the current, starting at zero, gradually rises to a peak in one direction (which we may conveniently call the positive direction), returns to zero, drops to a peak of the same amplitude in the opposite or negative direction, and again returns to zero. This operation is one complete "cycle" and, in the case of a 50-cycle supply, occurs fifty times per second. In order to obtain a unidirectional flow of current we must suppress one-half of each cycle, thus obtaining a pulsating direct current, as shown in Fig. 2B. This is known as "half-wave" rectification as, of course, only one-half of the wave-form is utilized.

(To be continued)

they always state that the earth-wire must be removed from the set and connected to the earth terminal provided on the unit. Another point also crops up in this connection—if your aerial is connected directly to the grid coil in the receiver and the aerial should become accidentally earthed, the negative main is being earthed also through the grid coil. Therefore it is advisable to connect in series with the lead-in a small good-quality condenser having a value of, say, .004 mfd. This capacity will not upset the tuning of the receiver, but an increase in selectivity might be effected by using a smaller condenser, say .0003 or less.

Converting A.C. to D.C.

In the case of A.C.

ROUND THE WORLD OF WIRELESS

(Continued from page 134)

Powerful Signals from Mühlacker

AFTER broadcasting hours you may pick up tests carried out by Mühlacker with its new aerial system. The station will be brought into daily operation at full power towards the middle of April and will then rank as a full 100 kilowatt.

A Russian Station for Turkey

IT is reported in Continental quarters that the Soviet radio industry is now busy with the manufacture of material destined to the construction of a 150-kilowatt transmitter, to be erected at Ankara (Turkey). For some time past Soviet engineers have been anxious to secure orders for radio apparatus from neighbouring States. The same correspondent states that Riga has been using water-cooled valves of Russian make.

"The Other Side"

FROM the North Regional, on April 17th, there is to be an exchange of programmes between Northern Ireland and the North of England. The title of the programme is "The Other Side," and half of the programme will come from Liverpool, while the other will come from Belfast. Included in the Liverpool contributions will be a relay of variety from the Argyle Theatre, Birkenhead, and dance music by Jack McCormick's Ambassadors Dance Band from the Rialto Ballroom, while from Belfast will be heard a relay from the Empire Theatre and organ music from the Classic Cinema.

Linking Up Films with Broadcasting

BBROADCASTING and film link-up is a growing development. There is a "movie" of the B.B.C. in prospect, and John Watt, B.B.C. producer, is part-author of a film with a Ruritanian background. "Kentucky Minstrels," Harry S. Pepper's microphone revival, is also being spoken of as a musical film, while Leslie Sarony, broadcasting star, is lead in a recently-completed film with an all-star cast. Sarony is to broadcast a concert party show on April 19th (London Regional). He will have the assistance of the ubiquitous Leslie Holmes, as, indeed, is only natural, for the two Leslies have already earned top marks from listeners to variety. In addition he will bring to the microphone for the first time a singer and comedienne named Phyllis Stainer, who, he thinks, will prove "a winner."

Twenty-four-hour Timing

WE are sorry that we are two minutes late with the news to-night. The time is exactly twenty-one-0-two, or two minutes past nine." This will be the sort of microphone announcement which listeners will hear after April 22nd next. The B.B.C. announces that the use of both the old and new styles of timing will be continued until listeners are assumed to have become accustomed to the twenty-four-hour timing; a not very difficult matter for most people; although we have heard of one long-service naval man with a brilliant record in Higher Mathematics who admits that he has never adapted himself easily to the expression "twenty-two hours" for the more popular "10.0 p.m." His mind persists in thinking in multiples of ten, which causes him to translate 10.0 p.m. into twenty hours—an unfortunate partiality for the decimal system.

PETO-SCOTT

EVERYTHING RADIO—CASH C.O.D. or EASY TERMS

IMPORTANT Miscellaneous Components, Parts, Kits, Finished Receivers or Accessories for Cash, C.O.D. or H.P. on our own system of Easy Payments. Send us a list of your wants. We will quote you by return. C.O.D. orders value over 10/- sent carriage and post charges paid (GREAT BRITAIN ONLY). OVERSEAS CUSTOMERS CAN SEND TO US WITH CONFIDENCE. We carry a special export staff and save all delay. We pay half carriage—packed free. Send full value plus sufficient for half carriage. Any surplus refunded immediately. Hire Purchase Terms are NOT available to Irish or Overseas customers.

PILOT CLASS "B" FOUR KIT

GUARANTEED MATCHED



YOURS FOR 5/-

PROVED TESTED

Another PETO-SCOTT triumph—this latest Class B Battery 4 Kit at a popular price. Seven times the volume of an ordinary battery set, with outstanding performance equal to "mains" receiver. Kits supplied with detailed "Simple to build" instructions and assembly blue print. Matched and tested components. Guaranteed for 12 months by Peto-Scott. **KIT "A"** less Valves and Cabinet. Cash or C.O.D. Carriage Paid, £3/10/0, or 5/- deposit, balance in 12 monthly payments of 6/-.

KIT "B"—As Kit "A" but including 4 matched and tested Valves. Cash or C.O.D. Carriage Paid, £5/2/6, or 12 monthly payments of 9/6.

KIT "C"—As Kit "A" but including 4 matched and tested Valves and Peto-Scott Consolette Cabinet. Cash or C.O.D. Carriage Paid, £5/15/0, or 12 monthly payments of 10/6.

Recommended PETO-SCOTT SPEAKER, if required, add 2/6 to Cash Prices or 2/- to each monthly payment.

NEW W.B. P.M.4A. MICROLODE PERMANENT MAGNET SPEAKER, complete with switch-controlled multi-ratio input transformer. Cash or C.O.D. Carriage Paid, £2/2/0. Balance in 7 monthly payments of 5/9.

NEW BLUE SPOT 29 P.M. PERMANENT MAGNET MOVING-COIL SPEAKER. With input transformer. Cash or C.O.D. Carriage Paid, £1/12/6. Balance in 6 monthly payments of 5/-.

NEW ROLA CLASS B PERMANENT MAGNET MOVING-COIL SPEAKER AND AMPLIFIER. Complete with valve and input Transformer. Two Models "A" for P.M.2B. P.D.220 and 220 B. "B" for 240 B. and H.P. 2 (state which when ordering). Cash or C.O.D. Carriage Paid, £3/11/0. Balance in 11 monthly payments of 6/6.

EPOCH CLASS "B" COMBINATION SPEAKER, a complete Class "B" Adapter, carefully balanced to give superb quality with colossal volume. Complete with Class "B" Valve. Cash or C.O.D. Carriage Paid, £3/3/6. Balance in 11 monthly payments of 5/9.

R. & A. MULTIX EXTENSION SPEAKER for Commercial or Home-Built Receivers, past or present, no matter what the circuit. Chassis Model. Cash or C.O.D. Carriage Paid £1/10/0. Balance in 7 monthly payments of 4/0.

CELESTION P.P.M.19 PERMANENT MAGNET MOVING-COIL SPEAKER with Standard or Pentode Transformer. Cash or C.O.D. Carriage Paid, £2/7/6. Balance in 11 monthly payments of 4/3.

NEW GARRARD MODEL 202A, 12 - in. Turntable. Electric Motor for A.C. mains. Cash or C.O.D. Carriage Paid, £2/10/0. Balance in 8 monthly payments of 6/-.

ATLAS G.A.25, for Mains, Class B and Q.P.P. four tappings; 60/80, 50/90, 120, 150 25 m/A. Cash or C.O.D. Carriage Paid, £2/19/6. Balance in 10 monthly payments of 6/-.

ANY ITEM SUPPLIED SEPARATELY

LEADER 3

KIT "A" Author's Kit of Specified Parts, including Peto-Scott METAPLEX Chassis but less valves. Cash or C.O.D. Carriage Paid £3 0/0. Or yours for **5/6** Balance in 11 monthly payments of 5/6.

KIT "B" As Kit "A" but with Valves only. Cash or C.O.D. Carriage Paid, £4/11/6. Or 12 monthly payments of 8/6.

KIT "C" As Kit "A" but with Valves and Peto-Scott Table Cabinet. Cash or C.O.D. Carriage Paid, £5/9/0. Or 12 monthly payments of 10/-.

KIT "CC" As Kit "B" but with Peto-Scott Walnut Consolette Cabinet with Shelf and Baffle. Cash or C.O.D. Carriage Paid, £5/16/0. Or 12 monthly payments of 10/6.

If Peto-Scott Permanent Magnet Speaker required add 19/6 to Cash Price or add 1/9 to each monthly payment.

LEADER A.C. 3

KIT "A" Author's Kit of First Specified parts, including METAPLEX ready drilled Chassis, but less Valves and Cabinet. Cash or C.O.D. Carriage Paid, £5/10/0. Or yours for **10/-** Balance in 11 monthly payments of 10/-.

KIT "B" As Kit "A" but with set of Specified Valves. Cash or C.O.D. Carriage Paid, £8/7/6. Or 12 monthly payments of 15/3.

BIFOCAL COIL COMPETITION WIN AN EXTRA £5 5s.

As announced by Mr. F. J. Camm on page 133 of this issue, PETO-SCOTT are giving £5 5s. worth of Radio or Television components, to choice, to the 1ST PRIZE-WINNER in the Bifocal Competition. To qualify for this handsome additional prize you must have obtained your Bifocal Coils from PETO-SCOTT.

Set of 2 Varley Bifocal Coils, Cash or C.O.D. Carriage Paid £1-1-0. Send 2/6 or Balance in 5 monthly payments of 4/3. only

TELSEN S.G. 3, less Valves. Cash or C.O.D. Carriage Paid, £1/10/6. Balance in 9 monthly payments of 4/6. If Valves required, add £1/19/0 to cash price. H.P. 12 monthly payments of 7/3. **TELSEN 325 STAR KIT**. Cash or C.O.D. Carriage Paid, £1/9/6. Balance in 5 monthly payments of 5/3.

NEW SKYSCRAPER FOUR ALL-WAVE CHASSIS MODEL, in Sealed Carton. Cash or C.O.D. Carriage Paid, £5/12/6. Balance in 11 monthly payments of 10/3.

NEW LISSEN SKYSCRAPER 7-VALVE SUPERHET CHASSIS MODEL in Sealed Carton. Cash or C.O.D. Carr. Paid, £8/17/6. Balance in 11 monthly payments of 16/6. only

BARGAIN KIT GUARDIAN QPP 4-VALVE RECEIVER, formerly £3/19/6. **KIT "A"** Complete Kit of Parts in sealed carton with full instructions, less valves and cabinet. 11 monthly Cash or C.O.D. Carriage Paid, 59/6. payments of 5/6

PETO-SCOTT PERMANENT MAGNET MOVING-COIL SPEAKER

Power or Pentode Complete with input transformer, Send 2/6 with order. Balance in 5 monthly payments of 4/-.

Cash or C.O.D. **19/6** Carriage Paid.

2/6 DOWN

Class "B" Model, Cash or C.O.D. Carriage Paid £1/2/6 or 2/6 down and 6 monthly payments of 4/-.

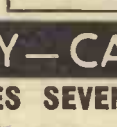

IMMEDIATE DELIVERY—CASH or C.O.D.

● ALL THE RAGE GIVES SEVEN TIMES THE VOLUME

PILOT CLASS "B" SPEAKER-AMPLIFIER

SUITABLE FOR ANY BATTERY SET Without Class B Amplification your present Battery Set is obsolete. Realising this, we have produced this marvellous, self-contained Unit, comprising guaranteed Peto-Scott Class B Moving-Coil Speaker, Class B Transformer, B.V.A. Class B Valve. Gives 7 times the Volume... with mains quality and power. Low E.P. consumption. SIMPLE TO CONNECT JUST PLUG-IN the amazing 5-WAY Automatic Connector.

SIMPLY PLUGS IN TO YOUR PRESENT BATTERY SET.

5/- WITH ORDER Balance payable in 11 monthly payments of 5/6. Cash or C.O.D. Carriage Paid, **59/6**



PETO-SCOTT CO. LTD., 77, CITY RD., LONDON, E.C.1. Tel.: Clerkenwell 9409/7. West End Showrooms: 62, High Holborn, London, W.C.1. Tel.: Holborn 3248.

Dear Sirs,—Please send me CASH/C.O.D./H.P. for which I enclose £..... d. CASH/H.P. Deposit.

NAME

ADDRESS

Pr. W. 21/4/34

ANY ITEM SUPPLIED SEPARATELY—ORDERS OVER 10/- SENT C.O.D. CARRIAGE AND POST CHARGES PAID



PRICE 22/6

With Volume control & connecting leads.

UNIVERSE 1934 PICK-UP

The "Broadcaster and Wireless Retailer" says

"NATURAL TONE — ENTIRELY RELIABLE"

"Super" Model. Output, nearly 4 volts—average, 2 volts. Base can be used in any position. Pick-up reed cannot go out of adjustment (pat. applied for). Ball-catch swivel head for easy needle-changing. Weight on record adjustable. Moulded in smart brown bakelite case. Fully guaranteed. If your dealer does not stock Universe 1934 Pick-ups, write us direct for illustrated folder.

COSMOCORD LTD. DEPT. P. UNIVERSE WORKS, ENFIELD MIDDX

BRITISH 362 VALVES

Why put up with inferior radio when new 362 valves—which will give you maximum results—are so inexpensive? Every 362 is fully equal to the most expensive of its type. 362 are the only valves sold with a definite Guarantee for a minimum period of 8 months. They are entirely British and Non-Microphonic. Post free direct from the makers if unobtainable locally.

SAVE YOU 50%

Post Free from

3/6

"362" BATTERY TYPE VALVES: H., H.L. & L., 3/6. Power. 4/- Super-Power. 4/6. S.G., 7/6. Var.-Mu. 7/6. "Class B." 9/- Pentode Type. 10/- (Metallised, 3d. extra.)

FULLY GUARANTEED

Cash with order. Cheques and P.O.'s must be crossed and made payable to: THE 362 RADIO VALVE CO., LTD. (Dept. W.), Stoneham Road, London, E.5.

Trade Enquiries Invited

Invaluable Practical Handbooks

This series covers a wide field and will prove of the greatest value to everyone interested in models and how to make them; woodwork and other crafts. Each book is clearly written and fully illustrated.

ACCUMULATORS

An up-to-date handbook dealing with every type of accumulator, methods of charging them at home, care and maintenance. This little handbook also explains how to erect a charging station.

SIMPLE ELECTRICAL APPARATUS

An excellent little book for those who wish to make simple and useful electrical appliances, such as galvanometers, electric motors, dynamos and Leyden jars.

THE HANDYMAN'S ENQUIRE WITHIN

Hundreds of practical ideas and hints of value to the man who is clever with his hands.

NEWNES'

HOME MECHANIC BOOKS

Ask Your Newsagent to Show You

Other Titles in This Helpful Series.

Obtainable at all Newsagents and Bookstalls, or by post 1/2 each from George Newnes, Ltd., 8-11, Southampton Street, Strand, London, W.C.2.

1/- each

Two BIFOCAL FOCUSING COILS in a 3-valve S.G.-Det-Power Receiver

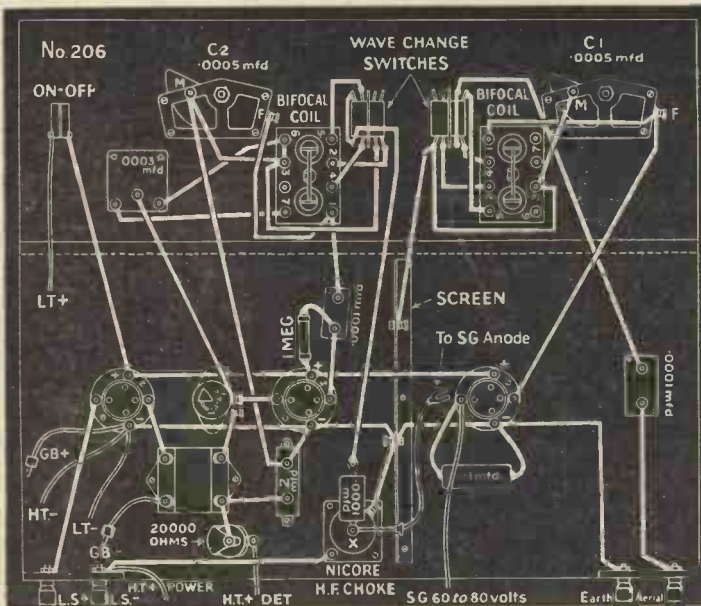

Countless simple sets that were satisfactory when first designed cannot now get the increased number of stations in operation to-day. The Varley Bifocal Focussing Coil, with its revolutionary design, means entirely new life to these sets. A typical circuit of a three-valve receiver incorporating two Bifocal Focussing Coils is shown in the diagram. Installing these new coils is so simple—the operation being no more difficult than any existing arrangement with a fixed aerial coupling. Send coupon for full information, together with FREE CIRCUIT DIAGRAMS.

To Messrs. VARLEY, Kingsway House, 103, Kingsway, London, W.C.2.

Please send me full information of Bifocal Focussing Coils together with FREE CIRCUIT DIAGRAMS.

NAME

ADDRESS

P.W.





THE EASY ROAD TO RADIO THE BEGINNER'S SUPPLEMENT

WHICH IS THE BEST CIRCUIT?

A Review of the Most Popular Circuits. By "LAMBDA."

BEFORE the introduction of the screen-grid valve, the straight circuit, consisting of a detector and one or two low-frequency stages, held the field. It was a universal favourite. Simple to construct and easy to handle, it could, by the judicious application of reaction, put up a very creditable performance. Selectivity also was sufficient for our needs. It still has many adherents, but gone are the days when it could be considered a universal favourite.

In the early days of broadcasting, neutralized H.F. stages were in evidence, but, owing to the difficulties in operating, they did not attain anything like the popularity of the modest straight set.

With the coming of the screen-grid valve a remarkable change was brought about.

to its prototype. Consider Mr. Camm's receiver, recently described in this journal, with a similar circuit evolved when screen-grid valves were first placed on the market. What a revolution! Construction has been simplified, and, in comparison with earlier types of receiver, it has changed almost beyond recognition.

Who thought of automatic volume

control a few years ago? Especially for such a circuit as that of Mr. Camm's. Iron-cored coils with their high efficiency were beyond even our wildest dreams. Many would have even asserted that the suggestion was not only impracticable, but impossible.

What about the intervalve coupling coil? Tuned grid, tuned anode, or H.F. transformer; which do you prefer? All have their advantages and disadvantages. At the present time the two systems, tuned-grid and tuned-anode, appear to vie with each other, and both systems have many adherents. Tuned-anode coupling is the simpler, needing fewer components, but, unless care is exercised in the layout of the receiver, instability may result much more easily than with tuned-grid coupling.

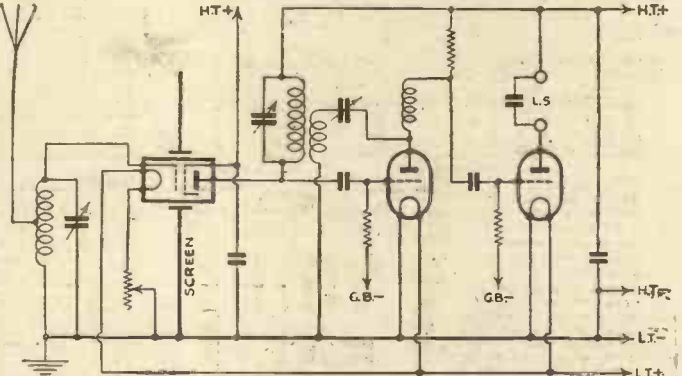

Fig. 1—Early circuit of H.F. stage receiver employing a screen-grid valve

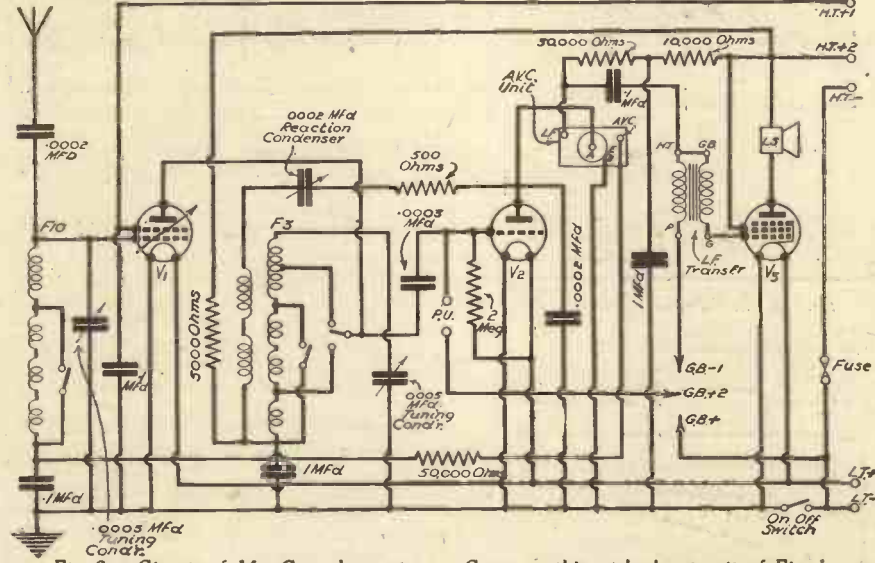

Fig. 2.—Circuit of Mr. Camm's receiver. Compare this with the circuit of Fig. 1.

First receivers with one screen-grid and then two screen-grid valves were introduced, and they were undoubtedly a great advance over the earlier types.

Three-valve Circuits

Consider the circuit employing one screen-grid H.F. stage. First of all it included two tuned circuits; ganged tuning condensers then became popular; next the introduction of small-diameter coils and the need for greater selectivity gave an impetus to sets employing a band-pass filter—three tuned circuits with triple ganged tuning condensers. Then we had the introduction last year of Class B amplification for battery circuits and iron-cored radio-frequency coils, so that this type of circuit now bears very little resemblance

If a really good high-frequency choke be employed in the anode circuit of the H.F. valve, tuned-grid coupling is very little less than with tuned-anode coupling. As the high-frequency choke is virtually in parallel with the grid coil, it is essential that it should be of good quality.

On the low-frequency side matters are fairly well defined. If a battery receiver is contemplated, then Class B amplification should be employed. With mains receivers we can employ a pentode output valve or two low-frequency stages with a high-voltage output valve giving five watts or more undistorted output, according to our own particular needs.

Four-valve Circuits

Now we come to the tuned radio-frequency receiver employing four or more valves. What is our choice? One high-frequency stage or two high-frequency stages, detector, and pentode output? The writer's choice would be the latter

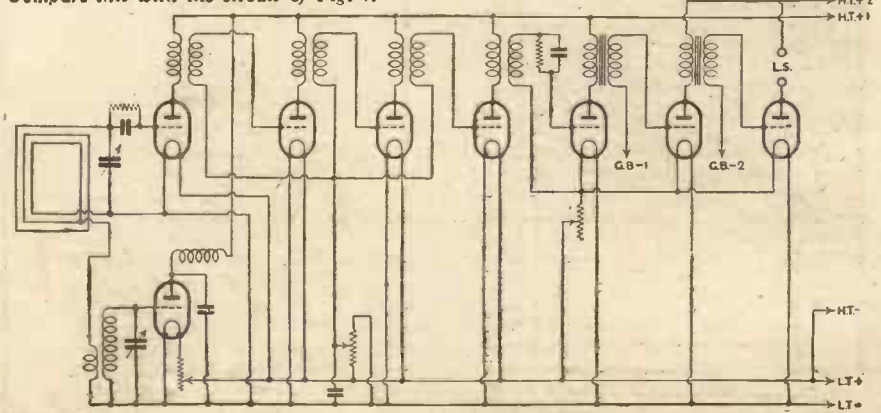

Fig. 4.—An early superhet circuit.

circuit. With two H.F. stages sensitivity is considerably increased, and the additional tuned circuit provides greater selectivity. Reaction can, of course, be employed, if desired.

The fundamental design of this circuit has followed fairly closely on that of the previous circuit discussed. When an additional H.F. stage is added, great care has to be exercised in the design of the receiver, however, in order to minimise unwanted coupling, otherwise instability may occur. The greater amplification of the two H.F. stages permits the employment of really satisfactory methods of automatic volume control, thus compensating for fading. Without the introduction of the variable-mu valve, and the employment of one of the various forms of diode detection, A.V.C. would not have been possible. The diode detector will handle a large input without distortion.

What about the intervalve coupling? Here again we have the choice of high-frequency transformers, tuned-anode or tuned-grid coupling.

If H.F. pentodes are employed the amplification obtainable is so great that care will have to be taken in the design of the receiver to obtain stability. In this case, the constructor is advised to follow the layout of a well-designed receiver rather than embark on the design himself unless he is really confident that he can evolve a really satisfactory layout.

With the introduction of iron-cored coils,

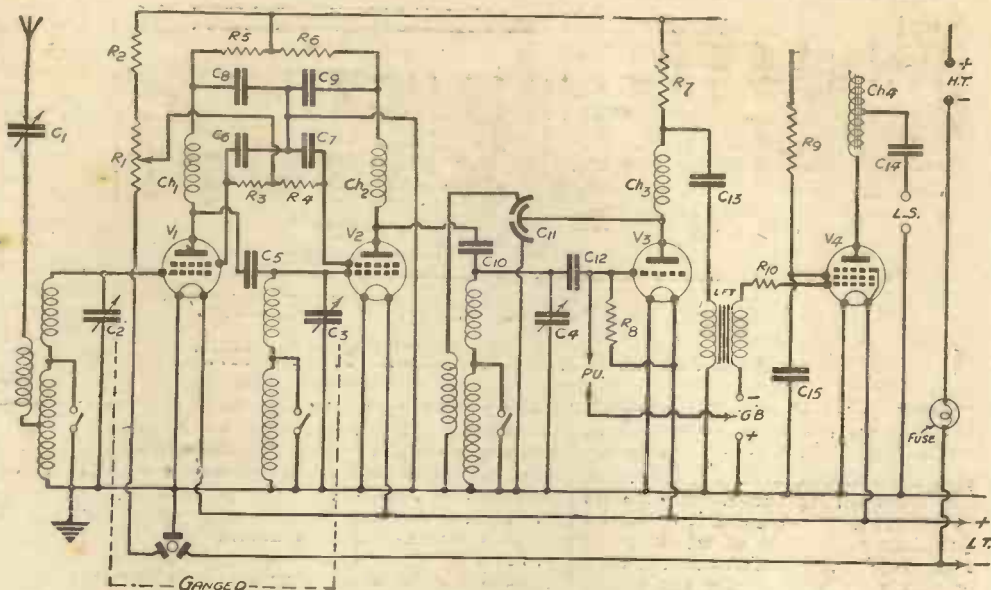

Fig. 3.—The "Fury Four" circuit, containing two S.G.H.F. stages.

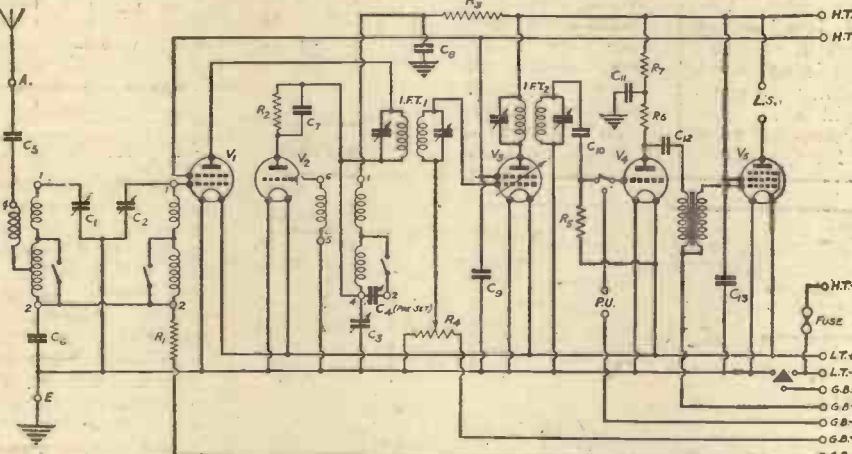

Fig. 5.—Compare this circuit of the "Premier Super" with the circuit in Fig. 4.

there has been a revival of interest in the tuned radio-frequency receiver. If a band-pass filter be employed, the additional tuned circuit will give a corresponding increase in selectivity—a great advantage if situated near a Regional transmitter. The selectivity obtained is practically equal to that of a superhet, and reception is free from the whistles which unfortunately mar the performance of some superhet circuits.

The Superhet

We now come to the superheterodyne circuit. It possesses a

degree of selectivity and sensitivity unequalled by any other type of circuit. Carefully designed it is undoubtedly pre-eminent. A poorly designed superhet, however, is capable of providing fearful results; whistles, instability and poor quality are some of the objections.

Whilst the tuned radio-frequency circuit has undergone remarkable changes, it is in the superhet circuit that the greatest progress has been made. Eight or nine valves were not uncommon in superhets of a few years ago. There were three intermediate frequency stages, a frame aerial, and, worst of all, poor quality. Screen-grid valves, pentodes, automatic volume control and the band-pass filter have now changed all that. The number of valves has been reduced, and a superhet with four valves, comprising detector-oscillator, one I.F. stage, double diode triode and output valve is now the order of the day. It is highly probable that this number will be reduced.

AERIAL SYSTEMS — No. 1

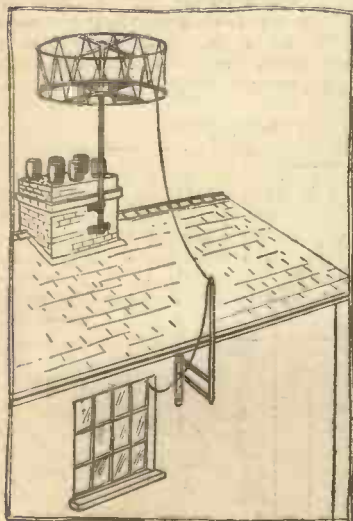

A birdcage-type aerial mounted on a short mast fixed above the roof of a house.

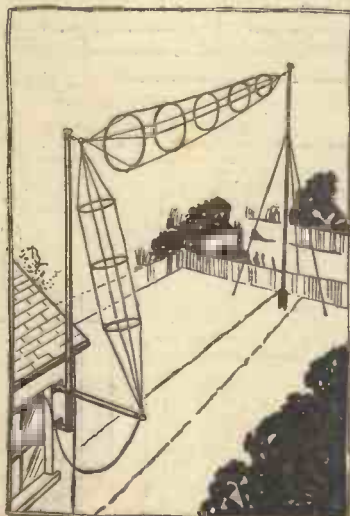

A "sausage" aerial, used chiefly for transmitting owing to its high self-capacity.

50 TESTED WIRELESS CIRCUITS

Edited by F. J. CAMM

Obtainable at all Booksellers, or by post 2/9 from Geo. Newnes, Ltd., 8-11, Southampton Street, Strand, London, W.C.2.

2/6

Practical Television

Conducted by H. J. Barton Chapple, Wh.Sch., B.Sc., Etc.

APRIL 21st, 1934. Vol. I. No. 16.

A LAMP UNIT FOR TELEVISION

In this Article the Author Describes a Method of Mounting a Neon Lamp for Giving an Increased Lighting Effect. By R. GRAPER

THE ordinary beehive pattern neon lamp will no doubt have found its way into many home-constructed television receivers, being so readily and cheaply procurable. Now, owing to the spiral incorporated in this type of lamp, it has

the light value quite considerably, converting it as it does into a diffused light.

Now, it is possible to use the direct light from this type of lamp, and this is the chief feature of the unit about to be described. To give a general idea of the scheme, instead of the usual ground glass or waxed paper screen, a condenser lens is interposed between the lamp and scanning disc, and, when adjusted, gives a uniform light over its whole area. This is masked slightly to agree with the picture size, and the resulting light area is then scanned in the usual way. In effect, this scheme is similar in principle to that used in the ordinary projection lantern, where a photographic slide is projected on to a screen, only in our case the scanning disc takes the place of the slide and we view the resulting light direct. In order to cut out the spiral in the beehive lamp the latter is mounted in an unusual position. If an ordinary Osglim or beehive pattern lamp is taken, and turned about, it will be found there is one

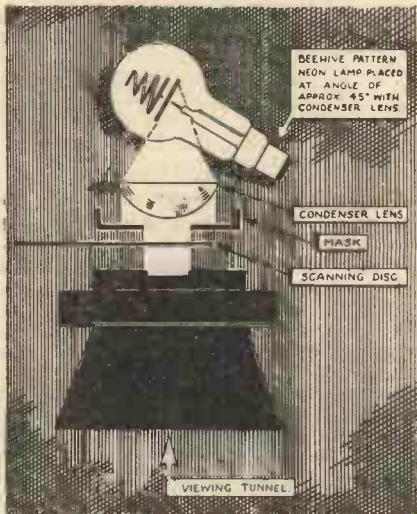

Fig. 5.—General arrangement showing the neon lamp, condenser lens, scanning disc and viewing tunnel.

usually been found necessary when using it for television purposes to include some form of diffusing screen between the lamp

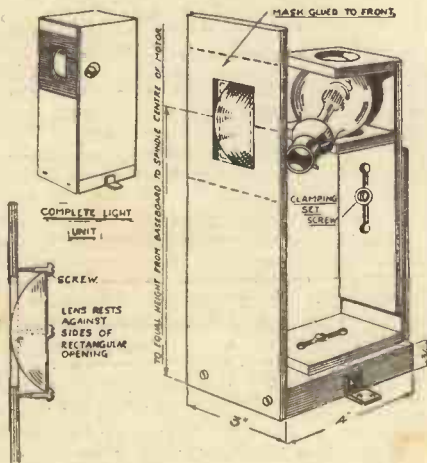

Fig. 4.—A simple method of mounting the condenser lens.

Fig. 2.—View of lamp fitted in an adjustable holder without cover.

and scanning disc to prevent the spiral making its appearance in the received picture. At its best the neon lamp gives off but a very weak light, and this screen lowers

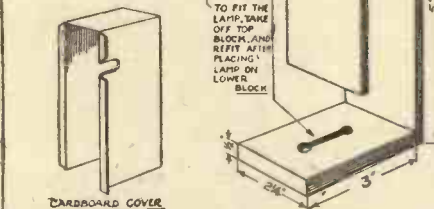

Fig. 3.—Showing how the parts for the holder are slotted to provide for adjustment.

position from which the circular plate can be viewed entirely free from the spiral, and this is when holding the lamp at an angle of about 45 degrees to the eyes. The disc thus seen will appear oval in shape, as in Fig. 1. This is the position utilized, and, although the area is quite small, it is sufficient to give a uniform light from the condenser lens.

Constructional Details

The construction of the unit can be clearly seen in Figs. 2 and 3, and consists of a three-ply front support for the lens, an adjustable holder for the lamp, and a simple cardboard cover. Several sizes are given for guidance, but these can, of course, be varied to suit personal requirements. Those given for the lamp holder should

be found suitable, as this component is adjustable, but the height to the centre of the lens will in most cases vary. This should be exactly equal to that of the height from the centre of the motor spindle to the baseboard. The condenser lens should be of short focus (about 2 1/2 ins. to 3 ins.), and for use with the standard disc should be about 2 1/2 ins. diameter. A simple method of mounting it is shown in Fig. 4, the aperture in the plywood front being cut so that the lens rests against the sides, and its periphery just comes flush with the front. Four screws hold the lens in place as shown. A certain amount of care should be exercised

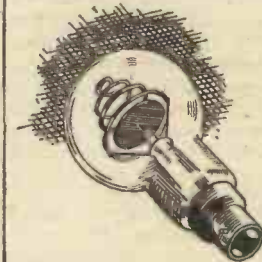

Fig. 1.—Perspective view of beehive lamp, showing disc electrode as seen when lamp is viewed from an angle of 45°. In this position the disc is not obscured by the spiral.

in mounting the lamp in the holder, and the holes in the two blocks should be levelled slightly on the insides if pressure tends to be excessive. The connections to the lamp may be made by aid of a standard socket, or wires can be soldered direct to the lamp's base. Before fixing on the cover, the lamp should be connected to the wireless receiver, and its position adjusted to give a uniform light when looked at from a distance of about 12 ins. The ordinary broadcast programme will do for this test. The cover can then be fixed, and the complete unit lined up behind the scanning disc and screwed to the baseboard. The televised image should be looked at through the viewing tunnel of the apparatus from a fairly frontal position, as there is a slight directional effect, but the extra brilliancy of the image, compared with that given by the diffused method, is very pronounced.

LATEST TELEVISION DEVELOPMENTS

(Continued from page 11, "Practical Television," April 14th issue.)

MANY tests by the company's engineers have revealed that the ultra-short-wave radiotransmission covers an area embracing the whole of Greater London for good signal strength, this comprising a population of over ten million people.

Why Ultra-short Waves?

Before proceeding to the receiving end it is natural to assume that readers will desire to know why it is necessary to use ultra-short waves for a high-definition television transmission of this character. The answer is linked up with the limitation of side-band spread, which is im-

(Continued overleaf)



A special large-ended cathode ray tube, developed in the Baird laboratories and giving a 10 by 8 ins. image without lens magnification.

(Continued from previous page)

posed when working on the medium-wave broadcast band. It is impossible to calculate exactly the frequency range covered for any form of television transmission, but as a basis of comparison the German "Bildpunkt" method can be quoted. Using this and taking the present B.B.C. service of 30 lines, 7 vertical by 3 horizontal ratio image and $12\frac{1}{2}$ pictures per second, the "Bildpunkt" required is 13,125 cycles. If the images per second are doubled to remove flicker, twice the side-band is required, while if only the scanning lines are doubled, four times the side-band is required to accommodate the new condition.

With a 180-line horizontal scan and a ratio of, say, 4 horizontal to 3 vertical and working at 25 pictures per second, the side-band is +540,000 cycles. On the London National station this transmission would spread from about 180 to 500 metres, which of course is ridiculous, so that it is necessary to go much further down the wavelength scale to accommodate the signal. The ultra-shorts are the best solution, and when it is remembered that the frequency difference between 5 metres and 6 metres is 10,000,000 cycles, it will be appreciated that there is ample "etheric" room for the work.

At the Receiving End

The signals radiated from the Crystal Palace were detected and amplified by a radio receiver located in Wardour Street. This situation was one of the worst receiving sites in London owing to interference problems (peculiar to ultra-short waves) arising from motor-cars passing along the neighbouring thoroughfare, and also from lifts, motors, flashing signs, arcs, etc., inside the building itself. In spite of this, however, the results shown were singularly free from any form of interference. The signals were passed to the control cylinder of a cathode-ray tube, where they effected an intensity modulation on the stream of electrons passing from the cathode to the fluorescent screen. The high velocity of the electron impingement on the screen rendered them visible to the eye, while a double time base synchronized automatically from the incoming signal produced the field sweep to trace out the image of the televised subject by wholly electrical methods.

The cathode-ray tube (shown on page 1) is a specially developed one of large screen size, giving a brilliant sepia-coloured image instead of the green colour associated with standard tubes. This is a big improvement, and it was noticed that the images were not lacking in detail due to a "fluffy" or misfocused spot, while a full range of contrast from light to dark half-tones was clearly visible. Actually the image area size on the tube itself was approximately 10ins. by 8ins., but this was magnified by a large diameter lens to accommodate the image to give clear vision to the large audience. Owing to the fine grain of the image this optical magnification can be effected between wide limits, whereas with the low-definition image this, of course, is not possible without being rewarded with a very coarse picture.

At the demonstrations which were staged the programmes included illustrated lectures, violinist, cartoonist, conjurer, accordion player, together with film excerpts, and the next stage will concern the facilities that must be provided to give a real service of high-definition television entertainment, and developments in this direction will be watched with the keenest interest.

Peto-Scott Television Kit

An Interesting Kit of Parts which Enables a Television Apparatus to be Easily Constructed Without Tools for 75/-

MANY amateurs have shown a keen interest in the television transmissions, but have not built a television receiver, either owing to lack of the necessary tools or owing to the apparent

a mains resistance, an adjustable resistance for regulating the speed of the motor, a motor, and a bracket upon which it may be mounted. To enable the size of the picture to be brought to suitable dimensions a good lens is supplied, and this is held in a very ingenious and simple mounting. The disc is well cut and appears very accurate, the centre plate being moulded from bakelite, which gives lightness combined with great rigidity. A lamp of the beehive pattern, with the resistance removed, is also supplied, so that all the purchaser of one of these kits has to do to receive the television transmissions is to fit the apparatus to a suitable receiver, without the necessity for the purchase of any other apparatus.



Fig. 1.—A view of the assembled Peto-Scott Television kit.

difficulty of obtaining the various parts which are required. Messrs. Peto-Scott have experimented with the standard method of assembling a television receiver, and as a result of their trials have now been able to produce a very simple kit of parts which will enable anyone, without any knowledge of workshop practice or mechanical ability to construct the necessary apparatus in a very short space of time. The illustration

(Fig. 1) shows the apparatus assembled, from which it will be seen that, in addition to a neat baseboard, the complete kit includes

RADIO, PHYSICAL AND TELEVISION SOCIETY.

AT a meeting of the above society on April 6th Dr. C. G. Lemon gave a lecture on the "Theory and Construction of Neon Tubes." In the lecture many interesting details were given, such as the theory of ionization, various types of electrodes used, the commercial form of neon signs for advertising purposes, different types of gas-filling, how the various colours are produced, and the voltages and current necessary for operation. Following the lecture a demonstration was given in the laboratory of an actual tube being constructed. Great interest was shown in the evacuation of the tube, and the various colour changes produced upon admission of different gases. New members are cordially welcomed by the society, and applications for membership should be sent to the Hon. Secretary, 72a, North End Road, West Kensington, W.14.

also supplied by Messrs. Peto-Scott in kit form, and Fig. 2 shows the parts from which this part of the apparatus is constructed. The toothed wheel is built up from laminations, and these are riveted together with copper rivets. Similarly,

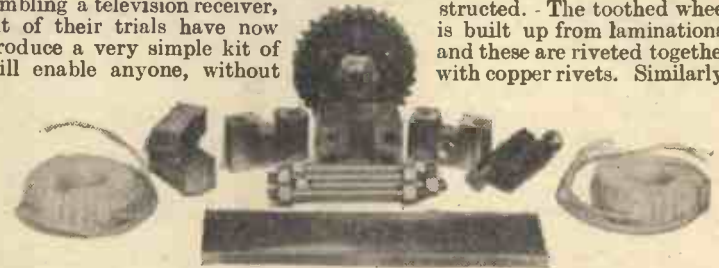

Fig. 2.—The synchronizing gear supplied as an extra and ready for assembly.

the two pole-pieces for the magnets are built from laminations held together in a similar fashion. The magnet coils are already wound, and the task of assembling these parts should not take more than fifteen minutes or so.

The price of the television kit is 75s., and the synchronizing kit costs 37s. 6d.

THE WIRELESS CONSTRUCTOR'S ENCYCLOPAEDIA

(2nd Edition)

By F. J. CAMM

(Editor of "Practical Wireless")

THIS invaluable encyclopedia is written in plain language by one of the most accomplished designers and writers on wireless construction. The whole subject is fully covered, and the volume is remarkable for the number of practical illustrations it contains.

Obtainable at all Booksellers, or by post 5/6 from Geo. Newnes, Ltd., 8-11, Southampton Street, Strand, London, W.C.2.

5/-

RADIO CLUBS AND SOCIETIES

Club Reports should not exceed 200 words in length and should be received First Post each Monday morning for publication in the following week's issue

SLADE RADIO

It was a "Members' Night" at the last meeting of this Society and the opportunity was taken to deal with a number of subjects. The most popular of these proved to be, as usual, the "Questions and Answers," in which members may raise points relating to lectures, etc., given during the past quarter, and also general questions. Replies were given by the technical experts, and members readily availed themselves of the opportunity to gain information.

The programme up to the end of May is as follows: April 26th: "Old Wireless Experiences," by Dr. Ratcliffe. May 3rd: "Is Television Worth While?" Debate. May 10th: A full description of all forms of A.V.C., inter-carrier noise suppression, and compulsory tuning, etc., by Mr. P. W. S. Valentine, D.F.H., A.M.I.E.E., of Messrs. Mullard Wireless Service Co., Ltd. May 13th: D.F. Test. Entries Wanted. May 17th: "Frequency Changers." Lecture by Mr. G. F. Clarke. May 24th: "Sound on Film Camera," by Mr. G. Palmer (General Picture News). May 31st: "Amateur Transmitting," by Mr. C. H. Young, G2AK. The Society still has room for more members and anyone interested is invited to write for full details to the Hon. Sec., 110, Hillaries Road, Gravelly Hill, Birmingham.

ANGLO-AMERICAN RADIO AND TELEVISION SOCIETY

The second lecture-demonstration (given by Mr. J. Louis Orton) to augment the funds of the Uxbridge District Branch of the above society was extremely successful. At the conclusion of the lecture Mr. H. E. J. Orton, a Vice-president of the society, remarked that the Anglo-American Radio and Television Society was founded some years ago by Mr. Leslie W. Orton and that its main interest to the general public was its aim to promote international goodwill. If a member of the audience wished to communicate with a member in, say, Cuba, they could do so. The society had some 3,000 members and had nearly doubled its membership in the last few months. There are no charges in connection with joining this society or the Uxbridge District Branch, and full particulars may be obtained from the Honorary President of the society and branch, Mr. Leslie W. Orton, "Kingsthorpe," Willowbank, Uxbridge, by enclosing a stamped, addressed envelope.

INTERNATIONAL SHORT WAVE CLUB (LONDON)

The London Chapter meeting, held at the R.A.C.S. Hall, Wandsworth Road, S.W.8, on Friday, April 6th, opened with a demonstration of reception of short-wave stations. The Allwave Superhet installed at the Chapter was used on this occasion. The main attraction of the evening was a "Junk Sale" which created much interest, and many fine bargains were obtained by the members.—A. E. Bear, Sec., 10, St. Mary's Place, Rotherhithe, London, S.E.10.

I. S. W. C. (MANCHESTER CHAPTER)

The sixth meeting of the above Chapter was held at the "Clarion Cafe," 50a, Market Street, Manchester, on April 3rd, at 8 p.m. There was no official business to be discussed, and it was announced that the visit to Barton Airport had been postponed for a month. The Assistant Technical Adviser, Mr. F. Fielding, gave a very interesting lecture and many demonstrations of various radio gadgets. He catered for the beginner as well as the expert, and his gadgets and tips were much discussed by members after he had finished. At the conclusion of the meeting the Secretary thanked Mr. Fielding and announced the date of the next meeting as May 1st, at 8 p.m., at the above address. The room will be open for the use of members from 6.30 p.m. and Morse instructions will be given for members interested from 7.15 to 7.45 p.m. All radio enthusiasts are invited to these meetings, and any PRACTICAL WIRELESS reader requiring any further information is invited to write to the Secretary, R. Lawton, 10, Dalton Avenue, Thatch Leach Lane, Whitefield, near Manchester.

THE CROYDON RADIO SOCIETY

The Society's final meeting of this session took place at St. Peter's Hall, Ledbury Road, S. Croydon, on Tuesday, March 27th, and was more informal than usual. A member, Mr. J. S. Salter, gave a musical programme with his E.M.G. radio-gramophone and Davey moving-iron pick-up. After an interesting evening the Chairman spoke of the considerable increase in members during the past session and thanked all concerned for making it such a success, while PRACTICAL WIRELESS' share in making their activities so widely known deserved the greatest gratitude. Next October the Society will be ten years old, and it is hoped that interested PRACTICAL WIRELESS readers will come along then and give the session a good start at the birthday programme.—Hon. Secretary, E. L. Cumber, Maycourt, Campden Road, S. Croydon.

There's no mystery about

T.C.C. SUPREMACY



IT'S HERE

INVARIABLY T.C.C. . . . first in the designer's specification, used in all the best commercial receivers, your own dealer's recommendation . . . There's no mystery about this insistence on T.C.C. when you realise that every important condenser development has found its birth in the T.C.C. laboratories. The B.B.C., the world's Broadcast Stations, all use T.C.C. No mystery here either . . . **DEPENDABILITY.** That is the keynote. Take the ever popular Type 50 for 200v. D.C. Working, a paper condenser . . . but what paper! the finest linen tissue, and the foil, the best obtainable. The whole hermetically sealed, proof against climatic changes. And then, tested and tested again, to be sure. That is how T.C.C. have attained Supremacy, thoroughness throughout. It's the same with every type too . . . Built for a special job and guaranteed to do it without fuss or complaint. Use T.C.C. and be sure.

T.C.C. ALL-BRITISH CONDENSERS

The Telegraph Condenser Co. Ltd., Wales Farm Road, North Acton, W.3.

Facts and Figures

Components Tested in our Laboratory

BY THE PRACTICAL WIRELESS TECHNICAL STAFF

FERRANTI MIDGET LOUD-SPEAKER

A FURTHER addition to the range of Midget components which we have been testing over the past few weeks is illustrated below. This is a Ferranti moving-coil loud-speaker (Type MG), and the overall diameter of the front plate is only 6½ in. whilst the overall depth is 2½ in. The front ring is made from a metallic alloy approximately one-quarter of an inch thick and thus the speaker is a very rigid affair which, besides ensuring constancy of performance, enables the speaker to be very firmly attached



The Ferranti Midget Loud-speaker.

to a cabinet or motor-car fitment. The magnet is of generous dimensions for such a small speaker and ensures good flux density in the gap, thus giving a high degree of sensitivity. The cone has an overall diameter of 6 in. and is of stiff paper material with a corrugated edge. The speech coil has a D.C. resistance of 5 ohms, and the connections for this are brought out to the two terminals seen on the lower part of the speaker. A transformer is not fitted, but it is a simple matter to arrange for a suitable matching transformer to be included in the output circuit of the receiver with which the speaker is employed. Where required a model of this speaker may be obtained complete with transformer. This model is known as M.G.T. and an extra charge is, of course, made for the transformer. For an instrument of such small dimensions the response curve is remarkably good, and the speaker may be highly recommended for a Midget receiver for use with car radio. The price is 25s. without transformer, and 31s. 6d. with transformer.

"PEAK" CONDENSERS

WE would remind our readers that the business of the manufacture of "Peak" condensers and condenser blocks, formerly carried on by Messrs. Wilburn & Co., of London, was taken over on April 1st by Messrs. W. Andrew Bryce and Co., of Woodfield Works, Bury, Lancs. This firm intends to improve and extend the range of condensers formerly sold under the "Peak" trade-mark.

RECORD STORAGE CABINETS

EVERY user of a radiogram finds it necessary to employ some kind of storage cabinet in which to house the large number of records which he accumulates, and although there are a number of small cases available, the use of a well-made cabinet, in a design to match the remainder of the furnishings or radiogram cabinet, is at all times recommended. The two cabinets illustrated on the right are manufactured by Smith's Cabinets, Ltd., of 18, Hertford Road, London, N.1.

Each of these cabinets holds 250 records, a shelf being provided in the centre of the cabinet. The cabinet on the left of the illustration costs £2 12s. 6d. in oak; £2 17s. 6d. in mahogany, and 3 guineas in walnut, whilst the other model costs £2 15s. in oak, £3 in mahogany, and £3 15s. in walnut.

BULGIN "SENATOR" TRANSFORMER

AN L.F. coupling component which comes well within the range of Midget apparatus is the Senator transformer manufactured by Messrs. A. F. Bulgin, of Abbey Road, Barking. This little component is supplied in a bakelite moulded case, and, although less than two inches in height it possesses very good electrical characteristics. The core is of nickel-alloy, and although of such small dimensions the inductance has a value between 75 and 95 henries. The transformer is intended primarily for resistance or parallel-feed coupling, with a condenser having a capacity between .5 and 1 mfd. Under the correct conditions, the amplification curve is practically straight from below 50 cycles to above 8,000 cycles. The turns ratio is 1 to 4, and standard G.B.A. terminals are fitted for connection purposes. If the transformer is used direct in the anode circuit of a valve the steady D.C. should not exceed 1 mA. in order to maintain the inductance at a sufficiently high value for good results. The list number of this component is L.F.12, and the price is 6s.

RAY-DIX METALLIZED BOARD

FROM Messrs. Ray-Dix Radio Products, of 42, Victoria Street, Chapel Allerton, we have received some samples of a metallized board, prepared especially for radio-receiver construction. This is of stout ply, finished in a matt black surface, with one side covered by a sheet of aluminium foil. This is firmly attached and does not easily come away from the board. It may be obtained in ordinary baseboard form, or as a chassis, the price of a 16in. by 10in. baseboard being 2s. 3d., and for a chassis of similar size the cost is 3s. A 10in. by 8in. baseboard costs 1s. 9d., and a 10in. by 8in. chassis costs 2s. 6d. This material is very useful for receiver construction, as it enables earth return leads to be kept to a very minimum and at the same time permits various components, such as variable condensers, etc., to be mounted direct without the necessity of a separate earth lead. Holes may be drilled, and the material may be cut away where necessary without any difficulty.

"B.A.T." SIDE ACTION SWITCHES

THE utility of the snap, or Q.M.B. switch, is too well-known to need description here, but the usual difficulty which arises when it is desired to incorporate this type of switch in a receiver is the lack of symmetry which arises in the controls. The side-action Q.M.B. switch removes this difficulty, and in addition to affording a positive action it enables a standard control knob to be fitted to match any existing control knob. The switches are similar to the standard snap switch, but are fitted with a standard one-hole fixing bush and a quarter-inch spindle. The normal method of arranging layers of insulating material with the contacts sandwiched between them is adopted, but the internal construction, in order to accommodate the rotary action, results in a slightly higher capacity than the normal toggle switch, and this prevents the use of side-action switch in H.F. circuits. The switch may be obtained in various types, such as Single Pole, Single-pole Double-Throw, Double Pole and Double-Pole Double-Throw. The prices of the above types are 1s. 9d., 2s. 6d., 3s. 6d., and 4s. respectively. The



Two gramophone record storage cabinets.

makers are Claude Lyons, Ltd., of 76, Oldhall Street, Liverpool 3. The London offices of this company are at 40, Buckingham Gate, S.W.1.

MULLARD BATTERY VALVES

THE two valves illustrated are the V.P.2 (left), and the T.D.D. 2, both battery-operated valves of the types which have recently become very popular. The former is an H.F. pentode having variable- μ characteristics, with a 2-volt, 18-amp. filament. It is rated for a maximum anode and auxiliary grid voltage of 150, and the impedance is 750,000 ohms. The standard 7-pin base is fitted, and the illustration, in which, of course, the glass bulb has been removed, shows the rigid manner of assembly of the electrodes. The T.D.D.2 is a double-diode-triode valve in which the triode characteristics are, impedance 12,000 ohms, amplification factor 16.5, mutual conductance 1.4 mA/V. The filament is rated at 2 volts, 1 amp, and the maximum anode voltage is 150. The standard 5-pin base is fitted, and the control grid is brought out to the terminal on top of the glass



For battery users. Two 'new' Mullard valves—the V.P.2 and the T.D.D.2.

bulb. The diodes may be employed for rectification and automatic volume control or for any other standard use to which two separate diodes may be put.

The prices of these valves are, V.P.2, 15s. 6d.; T.D.D.2, 9s.



This illustration shows the Anti-interference (or Impedance-Matching Aerial) Device manufactured by Messrs. Ward & Goldstone, this equipment was fully described in Practical Wireless dated 31st March last

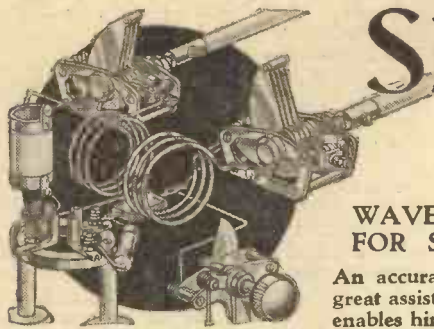

Short Wave Section

WAVE-METER CALIBRATION DATA FOR SHORT-WAVE ENTHUSIASTS.

An accurately calibrated absorption wave-meter is of great assistance to the short-wave enthusiast, because it enables him to identify stations by wavelength instead of waiting for station announcements—a difficult task during periods of high-speed fading.

By ALF. W. MANN.

THE usefulness of an absorption wave-meter is, of course, governed by the accuracy of the calibrations, and the purpose of this article is to place before readers data which it is hoped will assist them when calibrating their wave-meters to cover the short-wave bands.

To give a complete list of transmitters would be useless, and the writer has therefore selected certain transmitters which are located sufficiently wide apart and within a particular band of wavelengths. By searching for particular transmissions and checking them, the dial readings of the wave-meter when plotted will provide sufficient points to enable accurate curves to be drawn without difficulty.

Other transmitters, if heard, should be noted and readings checked in order to obtain the maximum number of calibration points.

Various Kinds of S.-W. Transmissions

There are three types of transmissions receivable on the short waves—i.e., broadcast, commercial telephony, and telegraphy. C.W. transmitters (morse code) are to be heard at all times of the day and, owing to the high power used, are receivable at good readable strength even when adverse conditions prevail for the reception of broadcast and commercial telephony. By taking advantage of these transmissions, calibration may be undertaken regardless of the prevailing reception conditions. One does not require an expert knowledge of the morse code in order to check these transmissions. The ability to read a series of Vs, followed by the letters D, E, and a three-letter call sign is sufficient.

As commercial telephones are now using speech inversion or scrambler apparatus, suppressed carrier waves, and in some instances automatic fading compensating apparatus, it is impossible to check them unless tests are being carried out on position B—i.e., with scrambler out of circuit, which makes speech intelligible. During these tests the call letters are usually announced.

The lowest wave-band in general uses lies between 13.93 metres and 13.97 metres—two transmitters—W8XK using the former and GSH the latter wavelength.

Within 14 metres and 16.81 metres twenty-eight commercial transmitters are located, the whole band being equally divided between commercial telephony and telegraphy stations. LSL Buenos Aires (14.18 metres) and DHO German (14.99 metres) are two of the commercial telephony stations, whilst amongst the telegraphy group are ORA Belgium (15.19 metres) and PLF Java (16.81 metres).

Details concerning such well-known transmitters as GSG Daventry (16.86

metres), 3XAL (16.8 metres), and DJE (16.89 metres) are almost unnecessary, as they are frequently heard by listeners in the British Isles. IAC, Coltano, Tuscany, Italy, on 16.90 metres, is a commercial telephony transmitter. On 16.48 metres FZR, Saigon (French Indo-China) working telegraphy is to be heard. The total number of stations using various wave-lengths in this band is twenty-eight, only four of which are broadcasting stations. W2XAD, IXAL, FYA, HVJ, etc., follow, and are located between 19.54 metres and 19.84 metres. (See various station lists.)

Thirty-six commercials occupy the band between 19 to 25 metres; amongst them are D10 (19.90 metres) Germany (telephony), FXQ (26.37 metres) France (telephony), and WMA (22.40 metres) America (telephony), SUW Egypt (25.19 metres) (telephony).

From 25 to 70 Metres

The 25-metres band is entirely devoted to broadcasting, with FYA (25.25 metres), 2RO (25.40 metres), DJD (25.51 metres), together with ten other transmitters, all of which are consistently received under favourable conditions in summer, and at intervals during the remaining parts of the year.

Within the 26.31-metre band are twenty-five commercial transmitters, seventeen of them working on telegraphy, Shanghai, XGR, on 26 metres, being the lowest in wavelength, with DHA (27.47 metres) (Germany), DIQ (29.16 metres) (Germany), and LQA (30.93 metres) (Buenos Aires).

Commercial telephones located in the U.S.A. and at Rugby, England, also transmit within this band on various wavelengths.

Seven broadcast transmitters work between 31.28 metres and 31.55 metres. The most important are W3XAU (31.28 metres) (U.S.A.), DJA (31.38 metres) (Germany), and GSB (31.35 metres) (Daventry Empire Service).

Another commercial channel follows containing forty-six transmitters. Five selected from that total are:—

WEF (31.91 metres) Rocky Point, N.J., U.S.A. (telephony).

GBC (34.56 metres) Rugby (telephony).
DHC (40.96 metres) Germany (telephony).

HAT (43.86 metres) Hungary (telephony).

DGX (44.91 metres) Germany (telephony).

The 49–50-metre band is, of course, devoted to broadcast transmissions, and amongst other stations working there are W8XK (49.86 metres), W3XAL (49.18

metres), 7LO (49.5 metres), and RW59 (50 metres). Located in U.S.A., Kenya Colony, and the U.S.S.R. respectively.

WEU (56.93 metres), and WQN (57.03 metres) are, of course, telegraphy transmitters located at Rocky Point, U.S.A., and the only commercial telephony transmitter working in the 50.08 metres—70.59 metres group is GBC (60.30 metres) Rugby.

In order to obtain full benefit from the foregoing data, the short-wave listener should have at least an approximate idea relative to the tuning range of the coils used in the receiver. It will be understood that guesswork during calibration is useless, as the results obtained will prove to be very misleading. Accuracy during the checking period will prove to be well worth the care and attention required in order to attain it.

REPLIES TO BROADCAST QUERIES.

EDITOR'S NOTE: Querists must limit their queries to three per letter.

E. A. H. WATHEN (Stroud): W8CMW, H. D. Cochran, Buffalo Street, Alexander (N.Y.); Call sign of station heard was W3DQ; W. S. Wilson, 405, Delaware Avenue, Wilmington (Del.); W9CGE is an amateur transmitter at Nebraska and W9CMF at Maplewood (Mo.). O. G. HICKS (St. Ives): F8NK, A. Nill, 13, rue des Trois-Pucelles, Saint-Nicholas-du-Port (Meurthe et Moselle), France; F8MK, G. Beck, Ingenieur Co. C. F. M., rue de la République, Rabat (Morocco); other station heard was possibly PDM, Kootwijk (Holland), on 38.65 m., but cannot confirm. G. LEE (North Shields): G5BJ, G. Brown, 62, The Ring, South Yardley, Birmingham; G2IG, R. Hammans, 119, Nelson Road, Gillingham, Kent. W. E. GATLAND (Penge): G5KH, H. Cullen, 144, West Hill, Wandsworth, S.W.15; G6NF, A. Gay, 49, Thornlaw Road, West Norwood, S.E.27; G6WY, H. Maxwell-Whyte, "Killiney," Worsley Bridge Road, Beckenham, Kent. We cannot understand your wavelength. F. G. BUTLER (Cheltenham): LSX, Monte Grande (Buenos Aires), calling KFZ (Admiral Byrd's Antarctic Expedition), Little America. The address of LSX is: *Transfudio Internacional*, 329, San Martin, Buenos Aires, Argentine (S.A.). L. J. STEVENS (Bristol): WIDNL, R. H. Lefkovich, 27, Johnston Road, Dorchester (Mass.); WILZ, H. G. Burnett, 16, Windsor Road, Somerville (Mass.); J. ELPHICK (Co. Durham); F8AP, J. J. Peugeot, Sous-Roches, Audincourt (Doubs), France; F8NW, A. Guillaume, Villa Saint-Jean, Hardelet-Plage (near Calais), France; other call heard was "de OKH" (from OKH), Podebrady, Prague (Czecho-Slovakia).

L. J. STEVENS (Bristol): WIDVK, W. T. Stubbs, 141, Fountain Street, Providence (Rhode Island); WIFET, W. Pettipas, 3, Chestnut Street, Stoneham, Mass.; WILZ, H. G. Burnett, 16, Windsor Road, Somerville, Mass.; W2GW, W. H. Bostwick, 1,334, Putnam Avenue, Plainfield, New Jersey; YP5AE; send details, under cover to: Lt. C. Bratescu, Str. Dr. Ciru Ilescu 6, Bucarest 6, Romania; VQ4CRP, Nairobi. In answer to your other query, the price varies with each edition.

 A fascinating new puzzle

HIS MAJESTY THE KING JIG-SAW PUZZLE

 THIS New Puzzle, printed in beautiful colours, is mounted upon 3-ply wood, cut interlocking so that when assembled the Puzzle can be moved about without risk of the pieces, of which there are nearly 60, becoming displaced. It can be handled and re-handled without the corners breaking, burring or becoming dog-eared. You simply must get one.

 On sale at all Newsagents, Stationers and Bookstalls, 1/-, or 1/4 (including postage) from George Newnes, Ltd., 8-11, Southampton Street, Strand, London, W.C.2. **1/-**

ELECTRADIX BARGAINS

METERS, TESTERS, CHARGERS



Meters: All Ranges and types in stock.

THE DIX-ONEMETER. The ideal of multi-range, moving-coil meters. Built to first-grade British Engineering Standard. 50 ranges in one meter. Measures Microamps to 20 amps., millivolts to 1,000 volts, 50 ohms to megohms. Six Ter. Complete minials. Two clear scales, mirror and knife-edge pointer for accurate reading. **60/-** (Multipliers extra.)

TESTERS. No. 108, with moving-coil meter and graded Rhms., 12/6. Silvertown astatic horizontal galvos, jewel pivots, 7/- Ammeters, all ranges to 20 amps., 7/- Recording Graph Voltmeters, 24 10s. Cambridge meters for Pyrometers to 1,200 cent., 35/- 3in. dial, 1,500 volts, D.C. Moving Coil panel, 35/- Testing Sets, Elliott, etc., E 108, 4 ranges amps. and volts, 37/6. A.O. Hot Wire, 3 amp., 5/-, 6 and 110 volts, 5/9. Cell testers, pocket, 15/-; with spikes, 30/- Bridges, 10,000-ohm 4-dial Wheatstone, with Galvo, £10. G.P.O. type, £7 10s. Mirror Galvos Reflecting Beam, by Paul Gambrell, Sullivan and Tinsley, £3 to £10. Standard Res. Boxes and Univer. Shunts, from 15s. Electrostatic Voltmeters to 2,000 volts, £2, 6,000 v., 8in. dial, £10. Record Circuits, 25/- Weston Moving Coil Panel Meters, 30 in. a., 17/6. 120 lb. Gauges, 2/6. Watch Movements, 1/6. First grade Moving Coil Meter movements for 5/-. In portable wood case, 7/6, or complete Portable Meters, 12/-, for home test sets.

MICROPHONES. A Range of 25 Models to suit Every Purpose. 20 designs to select from, each suitable for its particular job. All tested in our own Lab. before despatch, and guaranteed. Complete mikes from 5/6. Send for special illustrated list "N."

Ask us for latest Bargain List "N."

ELECTRADIX RADIOS,
218, Upper Thames Street, London, E.C.4.
Telephone: Central 4611.

SILVER-SOLDERING & BRAZING

BLO-IT-WIRE

SELF-BLOWING BLOWPIPE

WORKS FROM ANY GAS TUBE—AT HOME—IN THE GARAGE—OR WORKSHOP

12/6

SEND FOR ONE NOW!

NO BELLOWS REQUIRED

As supplied to H.M. GOVT.—RAILWAY CO.—CROCODATORS—TECHNICAL INSTITUTIONS—LEADING CAR MFRS. (ROLLS ROYCE & Co.)

SEND FOR ONE NOW!

This wonderful Blowpipe operates on the ordinary House Gas by small flexible tube, anyone can Silver-Solder or Braze with it. Thousands satisfied. Prices including Blowpipe, Silver-Solder, Brazing Wire and instructions.

Send for Free List. 12/6, 7/6, 5/- post free.

P. W. BOARDMAN, 2, Sedley Pl., London, W.1. Mayfair 1192.

EASY TERMS

Everything radio supplied on convenient terms. Send list of requirements—quotation and price lists will be sent by return. For really prompt delivery entrust your order to us. All goods carriage paid.

THE LONDON RADIO SUPPLY CO.,
11, OAT LANE, NOBLE ST., LONDON, E.C.
Phone: NATIONAL 1977. Established 1925.

AMPLION

PLASTAPE

INDOOR AERIAL

10 AIR SPACED	15 FEET	2/-
INSULATED	20 FEET	2/6
COPPER STRANDS	30 FEET	3/6

AMPLION (1932) LTD.

IMPRESSIONS ON THE WAX

"HIS Master's Voice" *Mamma mia, che vo sape* (Nutille) and *Musica Proibita* (Gastaldon), H.M.V. DB1585, is considered one of their outstanding successes. These two songs are sung by Gigli, the famous tenor. The rise of this singer has been meteoric in all countries in which he has sung. The son of an Italian cobbler, he now has an income of more than £50,000 a year. He never sings for less than £400 a concert.

South Winds (Percy Kahn) and *Vespere*, H.M.V. DA1343, is another fine record, sung by J. McCormack. Mr. Percy Kahn, who was Count John McCormack's accompanist during his recent concert tour and gramophone recording sessions in England, tells us of an interesting little story behind the composition of *South Winds*. After a recording session at the H.M.V. studios the well-known tenor took Mr. Kahn for a drive in his new Rolls. When they were passing through some beautiful Berkshire scenery, McCormack jocularly suggested that Kahn should write a song about the county. The latter told him that there were already some brilliant poems by a Berkshire man, and he would see what he could do. A few days later he produced one of them—"South Winds"—set to music by himself. On this record the composer and John McCormack have produced the result of an inspiration from an afternoon drive.

Dance Records

On a Steamer Coming Over and Everything I Have is Yours ("Dancing Lady"), H.M.V. B8107, is sung by Derickson and Brown, the well-known duettists. The first title is one of the most popular dance tunes of the moment. The second is from Clark Gable's new film. Derickson is an old friend of this well-known film star, and went to school with him at Meadville, Pennsylvania. They still keep in touch with one another, and Gable makes special

MAKING YOUR PORTABLE RECEIVER

(Continued from page 148)

is followed by a tuned transformer coupling, leaky-grid detector (a type H valve is very suitable), and a double pentode Q.P.P. output stage. The latter could, of course, be replaced by an ordinary pentode connected as shown in Fig. 1. When the set is being built as a separate unit the frame aerial would be replaced by a dual-range coil, and an "outside" aerial of one of the types mentioned above would be connected to it. Provided that the coil was of the same type as that used between the first two valves, a two-gang .0005 mfd. condenser could be employed for tuning. The component lay-out might well be very similar to that shown in Fig. 2, it being assumed that a frame aerial is to be employed, and that the set is to be entirely self-contained with its own loud-speaker and batteries. The dimensions will require to be at least 2in. greater in every direction than those shown in Fig. 2, to allow for the additional components, whilst an extra 4in. or so might be required in the width of the frame according to the particular loud-speaker used.

Using Old Components

Practically all of the arrangements suggested so far would entail the purchase

arrangements to import into America copies of all his friend's records.

Good Morning and You're Such a Comfort to Me, H.M.V. B8108, is sung by Pickens Sisters, and are two numbers from the film, "Sitting Pretty." The hits from this film are sung in exactly the same way as these artists sing them in the film itself.

Life Holds no Joy But You and *The Same Stupid Gosssoon am I*, sung by Danny Malone, H.M.V. B8086, are two songs written by Basil Charles Dean, the man who discovered the now popular Irish tenor.

Jazz Justice (Impersonations), Beryl Orde, H.M.V. B8104, is the first record of this new broadcasting discovery. She is only nineteen and believes in using in everyday life the voices of the people she imitates. Each day of the week she speaks in the voices of Greta Garbo, Gracie Fields, or one of the other artists she impersonates. A few months ago, when Greta Garbo was reported to be in England, she was having tea in a shop in the provinces and was talking to a friend in this film star's voice. A great crowd collected, believing the famous Swedish film star was having tea incognito. *At the End of the Day, You or No One*, H.M.V. B6445, *We All Went up, up, up the Mountain*, Mrs. Rush and her *Scrubbing Brush*, B6446, played by Terry Mack and His Serenaders, a new English band which has only just returned to this country after a series of engagements in Germany. We understand that they are likely to broadcast in the near future.

Rude Interlude and *Dallas Doings*, played by Duke Ellington and his Orchestra, H.M.V. B6449, is a typical Ellington record. Mrs. Constant Lambert, wife of the well-known composer-conductor, met Ellington at a party, when he was last in London. A record of *Mood Indigo* was being played in the room. "I always call that record 'Rude Interlude'" said Mrs. Lambert. "That's a good title," said Ellington, "I will write a 'Rude Interlude' and dedicate it to you." This is the first British performance of the tune Florence Lambert inspired.

of at least a few new parts, and therefore a circuit is given in Fig. 6 to show what can be done by using old and home-made parts throughout. The circuit is a standard one of the S.G.-Det.-L.F. and Power type, and operates from a frame aerial, the tuning coil being like that described on page 633 of PRACTICAL WIRELESS dated December 9th, 1933. Both H.F. chokes can be of any good screened, high-inductance type, or can be made as described in PRACTICAL WIRELESS dated December 16th, 1933. In the interests of compactness and light weight the two .0005 mfd. tuning condensers might be of the bakelite dielectric variety, although existing air-dielectric condensers which are on hand might be used if compactness is not insisted upon. In regard to the loud-speaker, this can be of the balanced-armature type, and a suitable unit can be bought for a few shillings at the present time. Slightly better results would be obtained by using a moving-coil, but that would add to the weight and bulk, besides being more expensive if a new one were to be bought.

Those readers who find it necessary to buy a few new components for use in conjunction with those they have would do well to study the article on midget components which are specially suitable for portable sets, given in PRACTICAL WIRELESS dated March 24th.

PRACTICAL LETTERS FROM READERS

The Editor does not necessarily agree with opinions expressed by his correspondents. All letters must be accompanied by the name and address of the sender (not necessarily for publication).

"Sound Energy"

SIR,—I feel I must write you about the article in the March 3rd issue by F. W. Lanchester on "Sound Energy, or The Acoustic Output of a Gramophone."

I know something of gramophones, because I make them (when ordered) on quite a unique and new principle. First, I don't like the look of his sound-box and its connection to the tone-arm, and I am frankly appalled at the flare—or horn—and connecting tube shown in Fig. 3. Mr. Lanchester, in his table of results, given on page 1,106, takes a well-known sound-box, tone-arm and machine as a standard comparison.

After reading those comparisons I immediately took two sound-boxes, one off each machine that I am using, and weighed them. The best sound-box, which is the lightest, weighed exactly 40zs. (this is a built-up sound-box); the other is a cast one, machined from a white alloy, and weighed 50zs. Now, both these sound-boxes I bought, and altered to my own ideas, and they are the most perfect sound-boxes I have ever handled.

Mr. Lanchester says 40zs. is not enough. With that I do not agree, as I find heavier sound-boxes wear the records too much, and stultifies the reproduction of sound. Although the lighter sound-box will reproduce "bass notes," lower in the scale, or just as good as my loud-speaker, the other sound-box, being heavier, slobbers over the reproduction of bass notes. Mr. Lanchester says it is one of the characteristics of the gramophone not to reproduce bass notes truly. Well, my machines will—perfectly—and, where the loud-speaker slobbers and jars the gramophone reproduces the very low notes of a bassoon without turning a hair.—G. B. HAZELL (Ashford).

D.C. Leader: Skeleton Components

SIR,—With reference to your remarks in the March 24th issue, concerning a D.C. version of "The Leader," I should be very pleased if one were forthcoming soon. I am aware that D.C. users are in the minority, but even so, I am sure there are enough to warrant the publication of a D.C. design of this receiver. Personally, I should like the circuit to be as follows: S.G. (var. mu), det., and pentode. I think that in a mains set most readers would prefer the variable-mu S.G. in lieu of the ordinary S.G., and also the extra volume provided by the pentode. I have studied the circuit of the D.C. premier. It is certainly a splendid circuit, but a bit on the expensive side for me, as I already have in use a pair of dual compensated speakers with 6,500 ohm fields, and as I naturally do not wish to scrap these, it means the expense of a separate smoothing choke, costing about 30s. Also, as the circuit of the "Leader" would be quite selective round here, the expense of the hand-pass assembly does not seem justified.

I have been taking your paper from No. 5 onwards, and as this is the first time

I have written to you, I would like to congratulate you on producing such a splendid paper, and also to thank you for such items as The Constructor's Encyclopaedia, Data Sheets, and Tool Kit. I also agree with those of your readers who want skeleton components. It is performance that counts and a beautifully polished cover can often house a cheap, shoddy component.—T. A. BRITNELL (High Wycombe).

[See editorial comment at foot of Mr. Wren's letter in the last issue.—ED.]

A Set for D.C. Mains Users

SIR,—I am in agreement with J. McRae, of Poplar, re D.C. sets. At Barking I have been on D.C. mains for five years, and yesterday the inspector called to inspect fittings and it is proposed to lay a larger cable, but definitely not with a view of changing to A.C. So you see I have no hope of a mains set unless one of the journals bring out a good five or six-valve D.C. set. Therefore I sincerely trust that you will publish a design for a good D.C. receiver in the near future. I have a D.C. amplifier, self-constructed, with 2 D.C. pentodes and 1 D.C. Gen. Purpose valves, together with a number of fixed condensers resistances, etc. The amplifier was not a success, so I would like to build a D.C. receiver with a good range.—GEO. DAVIS (Barking).

[In the issue dated March 31st you will find particulars for building the D.C. Premier, which we think will meet your requirements.—ED.]

CUT THIS OUT EACH WEEK

Do you know

- THAT the television system recently demonstrated has a frequency response up to one million cycles.
- THAT some types of resistance increase in value when overrun.
- THAT the reactance of an air-cored coil is ascertained by multiplying the inductance by 277.
- THAT a variable resistance connected across a reaction winding may be used as an alternative reaction control.
- THAT wire netting is as effective as a solid plate for screening H.F. radiations.
- THAT 6-metre television transmissions have been effectively accomplished.
- THAT ordinary cinema talkies (complete with the sound portion) may one day be receivable in the home by television.

NOTICE

The Editor will be pleased to consider articles of a practical nature suitable for publication in PRACTICAL WIRELESS. Such articles should be written on one side of the paper only, and should contain the name and address of the sender. Whilst the Editor does not hold himself responsible for manuscripts, every effort will be made to return them if a stamped and addressed envelope is enclosed. All correspondence intended for the Editor should be addressed: The Editor, PRACTICAL WIRELESS, Geo. Neaves, Ltd., 8-11, Southampton Street, Strand, W.C.2.

Owing to the rapid progress in the design of wireless apparatus and to our efforts to keep our readers in touch with the latest developments, we give no warranty that apparatus described in our columns is not the subject of letters patent.

THE ONLY EFFICIENT EARTHING IS 'FILT'

Faulty earthing causes more Radio troubles than anything else. FILT, the scientific Earthing device, will prove that your set (old or new, battery or mains) is capable of better results than you thought possible. A million listeners have experienced astounding improvements in reception with FILT. Try it and you'll marvel at the difference efficient earthing makes.



GRAHAM FARISH LTD., BROMLEY, KENT.

EASY TERMS PROMPT DELIVERY

Any Amplion, Blue Spot, Baker, Celestion, Epoch, R. & A., Rola, Sonochorde, Gramplan, Igranic, Lamplugh, Magnavox, Ormond, W.B., or Ferranti Moving Coil Speaker Supplied

Send 5/- only

and pay the balance by monthly instalments. No references. Entirely private and confidential.

KITS, PARTS, SETS, ELECTRIC CLOCKS ON EASY TERMS.

Send for list of 88 Speakers, and state requirements.

TURNADGE AND PARTNERS, LTD. Ludgate House, Fleet St., London, E.C.4. Telephone: Central 1903.

Television To-day & To-morrow

By SYDNEY H. MOSELEY and H. J. BARTON CHAPPEL, W.B.Sc., B.Sc.

THIS is a fascinating book for every wireless listener and enthusiastic constructor. It tells you what television is, describes the principles, and shows what television has achieved. If you want to experiment in this interesting field, you should read this valuable book immediately. Fourth Edition 230 pp. 7/6 net.

Order a copy from a bookseller or send 7/10 (to include postage) direct to:

PITMAN Parker St., Kingsway, London, W.C.2.

RADIO SUPPLIES

Send your list of radio needs for our quotation. Kits, Parts, Sets, etc. Everything in Radio stocked, prompt delivery. 7 days' approval. Catalogue free. Taylex & Standard Wet H.T. replacements stocked. N. TAYLOR, 9, GROVE RD., BALHAM, S.W.12.

LET OUR TECHNICAL STAFF SOLVE
YOUR PROBLEMS

REPLIES TO



If a postal reply is desired, a stamped addressed envelope must be enclosed. Every query and drawing which is sent must bear the name and address of the sender. Send your queries to the Editor, PRACTICAL WIRELESS, Geo. Hewnes, Ltd., 8-11, Southampton St., Strand, London, W.C.2.

The coupon on this page must be attached to every query.

QUERIES and ENQUIRIES

by Our Technical Staff

SPECIAL NOTE.

We wish to draw the reader's attention to the fact that the Queries Service is intended only for the solution of problems or difficulties arising from the construction of receivers described in our pages, from articles appearing in our pages, or on general wireless matters. We regret that we cannot, for obvious reasons—

- (1) Supply circuit diagrams of complete multi-valve receivers.
- (2) Suggest alterations or modifications of receivers described in our contemporaries.
- (3) Suggest alterations or modifications to commercial receivers.
- (4) Answer queries over the telephone.

Please note also, that all sketches and drawings which are sent to us, should bear the name and address of the sender.

A MODERNIZED RECEIVER

"I am in some trouble regarding my 3-valve set, diagram of which is enclosed. I have had the set about two years and thought I would take it to pieces and make a few modern alterations. I metallized the whole baseboard, made cans for the coils and used ganged condensers. Upon trying out the set on medium waves I found that the only stations I could get were the North Regional and Belfast. Unless reaction was employed nothing was receivable. On long waves there is nothing but a whistle from the top of the dial right down to the bottom. Can you tell me what is wrong?"—W. A. D. (Liverpool 7).

If you have rebuilt the set with all of the old components, that is, including the coils, you have probably fitted the screening cans too close to the coils and have thus completely upset their characteristics. That is to say, the tuning range may not now embrace the normal wave-band and thus the stations which were normally receivable may now be out of the range covered by the coils. In addition, the use of ganged condensers may prevent your tuning each coil to the same frequency at the same time, as the coils may be unmatched, either due to their method of winding, or the use of cans which are not within the same part of the coil field. The whistle is due to instability, and this is probably caused by the fact that you have used the metallized baseboard as an earth return for various parts of the circuit, and one of these earth return leads has been omitted. If you used aluminium paint for the metallizing, this would account for the trouble, as that material is useless for the purpose.

BLUE FLAMES

"I recently purchased a power valve for the last stage of my Det.-2 L.F. receiver. H.T. and G.B. are applied in accordance with the maker's instructions, but whilst sometimes reproduction is excellent there is a sort of choking occasionally, and blue flames are shooting inside the bulb from the base to the top all the time. What is the cause of this?"—H. G. B. (Gricklewood).

The blue glow is indicative of over-running, and this may be caused by too much H.T. or too little G.B. You state that you are applying the correct voltages, but are you certain that the bias is applied to the grid and that there is no break or partial break in the connection from grid to bias plug? If your L.F. transformer has a broken secondary you would still

hear signals of a sort; whilst if the connection to the secondary G.B. terminal was simply disconnected from the winding the bias would not be applied to the grid and signals would be of the kind which could be described as "choked." You should therefore examine this point.

150 kc/s I.F. TRANSFORMERS

"Will you please make it known where I can obtain I.F. transformers tuned to 150 kc/s? There seems to be a complete absence of advertising data regarding this type of component, and I would like to use them for short-wave superhets as described in a recent issue."—G. A. P. (Welwyn).

Messrs. Colvern can supply you with 150 kc/s I.F. transformers at the same price as the standard ones, namely, 12s. 6d. They are not a special line, but are included in that firm's catalogue.

THE ONE-VALVE PORTABLE

"I have built up the one-valve portable, but would now like to increase the volume so as to operate a speaker. Can you please give me the point-to-point wiring?"—J. McL. (Paisley).

You will need another valve-holder, either 4-pin or 5-pin, and the two filament (F) terminals on this holder should be joined to the same two terminals on the holder in the one-valve. A transformer with a ratio of 4 or 5 to 1 should then be wired with the G terminal to the G terminal on the new valve-holder, and the P and H.T. terminals connected to the 'phone terminals on the one-valve. A 9-volt grid-bias battery should be arranged with the positive socket connected to the L.T. negative line, and a flexible lead from the G.B. terminal on the transformer should be

QUESTIONS NOT TO ASK

"Please could you tell me the number of turns I will have to wind to make a mains transformer for A.C. 230 volts to give an output of 6-12 volts."

A question of this nature is unanswerable, owing to the fact that all the essential data is not given. The design of a transformer includes a knowledge of the cross-sectional area of the core, as well as the material from which it is made. In addition, it is necessary to know the size of the opening in the core so that the best gauge of wire may be chosen which will be accommodated in the space available. It will, however, generally be found that, using a core having a cross-sectional area of 1in. and made from the standard Stalloy stampings, for use on a 60 cycle A.C. supply, an average of 8 turns per volt will be required. The gauge of the wire will depend upon the current which has to be delivered.

plugged into the battery at the voltage recommended by the valve-makers. Terminal P on the new valve-holder should be joined to one side of your loud-speaker, and the other loud-speaker terminal should be inserted in the positive terminal of a 120-volt battery. This will have to be used in place of the smaller battery now employed with the one-valve set, and the H.T. positive lead on this must be inserted in a tapping at about 60 volts. The fifth connection to the pentode valve should be joined to the 120-volt positive H.T. tapping.

MATCHING THE SPEAKER

"I am using a pentode valve in my output stage and my loud-speaker is of the inductor type. I wish to match the output by means of a transformer and should be glad if you could recommend a suitable one and let me know the ratio."—J. T. (Dalmuir).

A number of firms can now supply a suitable transformer for your purpose, and it is preferable to purchase one with a number of different output tappings so that the present valve may be more accurately matched and also so that you may match up a new valve should you obtain one with different characteristics from that at present employed. You will see in our advertisement pages several advertisements by firms who can supply such a component.

CORRECT REACTION CONNECTIONS

"In looking through some back numbers I came across a circuit in which there appeared to be an error. In the theoretical diagram the reaction condenser is connected to the winding on the detector coil, but in the wiring diagram the reaction condenser has been joined to the winding on the aerial coil. Which is correct, please?"—E. S. B. (Edgware).

You can use either method. Actually it will generally be found that slightly better results are obtained when the reaction condenser is connected to the winding on the aerial coil, although in some cases instability results from this connection. In such cases the reaction winding on the detector coil should be employed.

DECOUPLING REQUIRED

"I have a 4-valve set which has been working very well for some time, but now I have bought an eliminator and am experiencing trouble with it. The point is that there is a terrible hum and I have tried many ways of stopping it, the best being to connect a resistance from the output choke terminal across to the H.T. terminal on the transformer. That stopped the hum, but signals are now too weak, just as they were when my H.T. battery was run down. I cannot remove the resistance because of the hum. Can you help me?"—E. J. P. (West Ham).

We are not quite clear regarding the connections of your resistance but it would appear that you are seriously shunting some part of the circuit with consequent loss of signal strength. Undoubtedly your trouble is due to instability, and you should insert decoupling resistances and condensers in the anode circuits of the detector and first L.F. valves, and if this is inadequate, similar steps should be taken with the H.F. stage.

FREE ADVICE BUREAU COUPON

This coupon is available until April 28th, 1934, and must be attached to all letters containing queries.

PRACTICAL WIRELESS 21/4/34.

INCREASE THE SELECTIVITY OF YOUR SET!

OVER 1,500,000 LISTENERS USE A



2/- WITH HANDY HOLDER 2/6

to separate those stations that overlap each other. Get rid of that annoying muzziness that spoils local reception. Just FIX A PIX in your aerial lead. You will be surprised how sharply your set tunes, and delighted at the number of new stations you can hear clearly. Try one to-day. Send us 2/-. If you are not completely satisfied, return it to us within 7 days for full refund.

BRITISH PIX CO., Ltd., LONDON, S.E.1.

PIX

Miscellaneous Advertisements

Advertisements are accepted for these columns at the rate of 3d. per word prepaid—minimum charge 3/- per paragraph—and must reach this office not later than Tuesday for the following week's issue. All communications should be addressed to the Advertisement Manager, "Practical Wireless," 8 Southampton Street, Strand, London.

PREMIER SUPPLY STORES

offer the following Set Manufacturers' Surplus New Goods at a fraction of the original cost; all goods guaranteed perfect; carriage paid over 5/-, under 5/- postage 6d. extra (Ireland, carriage forward).

PREMIER SUPPLY STORES announce the purchase of the entire stock of a world-famous Continental valve manufacturer. All the following types of standard mains valves at 4/6 each. H. H.L. L. Power. Directly heated 6-watt Pentode. Directly heated 9-watt Pentode. High magnification Screen-grid, low magnification Screen-grid. Variable-Mu Screen-grid. 250 volt 60 milliamp, full-wave rectifiers. The following types 5/6 each. Indirectly heated Pentode, 350 volt 120 milliamp, full-wave Rectifier. 500 v. 120 ditto, 6/6. Dario Battery Valves 4v. filament. Set of 3, consisting of Screen-Grid, Detector and Power or Super-Power, 6/6 the lot. Power or Super-Power, 2/6.

ELIMINATOR Kits, including Transformer, choke, Westinghouse metal rectifier, Dubilier condensers, resistances and diagram, 120v, 20 m.a., 20/-; trickle charger 8/- extra; 150v. 30 milliamps, with 4v. 2-4 amps. C.T. L.T., 25/-, trickle charger 6/6 extra; 250v. 60 milliamps, with 4v. 3-5 amps. C.T. L.T., 30/-; 300v. 60 m.a., with 4 volts 3-5 amps. C.T. L.T., 37/6; 150 volts 50 milliamps, 27/6.

AMERICAN Triple Gang 0.0005 Condensers, with trimmers, 4/11; Premier chokes, 25 milliamps. 20 henries, 2/0; 40 milliamps. 25 hys., 4/-; 65 milliamps. 30 hys., 5/6; 150 milliamps. 30 hys., 10/6; 60 milliamps, 80 hys., 2.500 ohms, 5/6.

HARLEY Pick-up, complete with arm and volume control, 12/6.

BRITISH RADIOPHONE Wire Wound Potentiometers, with mains switch incorporated, 10,000 ohms, 3/6.

PREMIER British-made Meters, moving-iron, flush mounting, accurate, 0-10, 0-15, 0-50, 0-100, 0-250 ma., 0-1, 0-3, 0-5 amps.; all at 6/-.

SPECIAL offer of Mains Transformers, manufactured by Phillips, input 100-120v. or 200-250v., output 180-0-180 volts 40 m.a., 4 v. 1 amp., 4v. 3 amp., 4/6; 200-0-200v., 4v. 1a., 4v. 3a., 4/6.

ALL Premier Guaranteed Mains Transformers have Engraved Terminal Strips, with terminal connections, input 200-250v. 40-100 cycles, all windings paper interleaved.

PREMIER H.T.8. Transformers, 250v. 60 m.a., rectified with 4v. 3-5a. and 4v. 1a. C.T. L.T., screen primary, 15/-; with Westinghouse rectifier, 25/-.

4v. 3a. C.T., 6v. 2a. C.T., 9v. 1a., 12v. 1a., 7/6 each; 4v. 3-5a., 22v. 1a., 8/6 each; 10v. 3a., 14v. 4a., 10/- each.

PREMIER H.T.9 Transformer, 300 v. 60 m.a., with 4v. 3-5a. and 4v. 1a. C.T., L.T., and screened primary, 15/-; with Westinghouse rectifier, 26/-.

PREMIER H.T.10 Transformer, 200v. 100 m.a., rectified with 4v. 3-5a. and 4v. 1a. C.T., L.T. and screened primary 15/-; with Westinghouse rectifier, 26/-.

PREMIER Mains Transformers, output 135v. 80 m.a. for voltage doubling, 8/6; 4v. 3-4a., C.T., L.T., 2/- extra; Westinghouse rectifier for above, giving 200v. 30 m.a., 8/6.

PREMIER Mains Transformers, output 250-0-250v. 60 m.a., 4v. 3-5a., 4v. 2-3a., 4v. 1-2a. (all C.T.); with screened primary, 15/-.

PREMIER Mains Transformers, output 350-0-350v. 90 m.a., 4v. 3-5a., 4v. 2-3a., 4v. 1-2a. (all C.T.), with screened primary, 15/-.

PREMIER Mains Transformers, output 400-0-400v. 100 m.a., 4v. 4-5a., 4v. 2-3a., with screened primary, 15/-.

PREMIER Auto Transformers, 100-110/200-250v., or vice versa, 100-watt; 10/-.

MULTI Radio Output Transformers, 4/6. Twin Screened Wire 3d. per yard.

CENTRALAB Potentiometers, 50,000, 250,000 half meg. any value, 2/-; 200 and 400 ohms, 1/-.

RELIABLE Canned Coils with Circuit, accurately matched, dual range, 3/- per coil. Please state whether Aerial or H.F. required. Ditto iron core, 3/6.

PREMIER L.T. supply Units, consisting of Premier Transformer and Westinghouse rectifier, input 200-250v. A.C. output, 2v. 1 amp., 11/-; 8v. 1/2 amp., 14/6; 30v. 1 amp., 17/6; 15v. 1 amp., 19/-; 6v. 2 amp., 27/6; 30v. 1 amp., 37/6.

MAGNAVOX D.C. 152, 2,500 ohms, 17/6; D.C. 154, 2,500 ohms, 12/6; D.C. 152 Magna, 2,500 ohms, 37/6; all complete with humbucking coils; please state whether power or pentode required; A.C. conversion kit for above types, 10/-; Magnavox P.M., 7in. cone, 18/6. Ditto 9in. cone, 29/6.

CRAMPIAN M.C. Loud-speakers, 2,500 ohm. field, 9in. cone, handles 5 watts; 21/-.

CRAMPIAN P.M. Loud-speakers, 9in. cone, handles 4 watts; 18/6.

POLAR 3-Gang STAR, 0005, manufacturers type. Fully screened, 7/6, with trimmers, 1/6 extra.

(Continued at top of column three)

Easy Terms

Strict Privacy Guaranteed —we deal with you direct

N. T. S. CLASS 'B' SPEAKER-AMPLIFIER

GIVES SEVEN TIMES THE VOLUME SENT ON 7 DAYS' TRIAL Ready Assembled with Class "B" Valve.

Advertisement for N.T.S. Speaker-Amplifier. Includes a 5/- DOWN badge and an image of the device. Text: Send only 5/- for 7 days' trial. If approved, balance in 11 monthly payments of 5/6. Cash or C.O.D. Carriage Paid, £2/19/8. Simply plug-in to your existing battery set.

TELSEN "323" KIT

Complete Kit of Parts for new Straight 3. Send only 2/6; balance in 8 monthly payments of 5/6. Cash or C.O.D. Carriage Paid, £1/9/8.

Advertisement for Telsen "323" Kit. Includes a 2/6 DOWN badge and an image of the kit. Text: If valves required, add £1/6/8 to cash price or 6/- deposit and 9 monthly payments of 6/-.

W.B.P.M. 4 MICROLODE MOVING-COIL SPEAKER

SENT ON 7 DAYS' TRIAL With Switch-controlled multi-ratio input transformer.

Advertisement for W.B.P.M. 4 Microlode Moving-Coil Speaker. Includes a 5/- DOWN badge and an image of the speaker. Text: Send only 5/- for 7 days' trial. If approved, balance in 8 monthly payments of 5/6. Cash or C.O.D. Carriage Paid, £2/2/0. W.B.P.M.6. Send only 2/6. Balance in 8 monthly payments of 4/3. Cash or C.O.D. Carriage Paid £1/12/6.

ATLAS ELIMINATOR

SENT ON 7 DAYS' TRIAL Model C.A.25. Suitable for all outputs, including Class "B".

Advertisement for Atlas Eliminator. Includes a 3/6 DOWN badge and an image of the device. Text: Send only 3/6 for 7 days' trial. If approved, balance payable in 11 monthly payments of 5/6 (or cash in 7 days), £2/19/6. Carriage Paid. D.C. Model 15/25. Cash or C.O.D. Carriage Paid £1/19/6 or 4/- down and 10 monthly payments of 6/-.

BLUE SPOT 99 P.M. MOVING-COIL SPEAKER

SENT ON 7 DAYS' TRIAL Complete with input transformer. Send only 5/- for 7 days' trial.

Advertisement for Blue Spot 99 P.M. Moving-Coil Speaker. Includes a 5/- DOWN badge and an image of the speaker. Text: If approved, balance in 11 monthly payments of 5/6. Cash or C.O.D. Carriage Paid, £2/19/6.

Any items advertised in this journal CASH. C.O.D., H.P. Send for quotation by return.

New Times Sales Co.

Form for ordering from New Times Sales Co. Address: 56, LUDGATE HILL, LONDON, E.C.4. Includes fields for Name, Address, and a note about payment terms.

(Continued from foot of column one)

WESTERN ELECTRIC Condensers, 250v. working, 2 mfd., 1/-; 1 mfd. 6d.; 4 mfd. 2/- 1 mfd. 400v. 1/-; 2 mfd. 1/3.

D.T.H. Truespeed Induction Type (A.C. only) Electric Gramophone Motors, 100-250v.; 30/- complete. Type YH 100/250v. A.C. or D.O., 42/-.

SPECIAL Offer of Wire Wound Resistances, 4 watts, any value up to 10,000 ohms, 1/-; 8 watts, any value up to 15,000 ohms, 1/6; 15 watts, any value up to 50,000 ohms, 2/-; 25 watts, any value up to 50,000 ohms, 2/6.

CYLDON Capacitors (Double Trimmer), 1/- Utility .0005 2-gang Bakelite Condensers, concentric Uniknob Trimming and Disc Drive, complete, 3/6. EDISON BELL Double Spring Gramophone Motors, complete with turntable and all fittings, a really sound job, 15/-.

AMPLION Cone Loud-speaker Units, 1/9, complete with 12in. cone and chassis, 3/11 each. Worth treble. Larger Unit with 12in. chassis, 5/9.

ORMOND Condensers, 0.0005 2-gang, semi-shielded, 2/6; brass vanes, with trimmers, 3/6.

WIRE Wound Potentiometers, 15,000 ohms, 1/6; 50,000 ohms, 2/-; 500,000 ohms, 3/6.

HOME Radio Microphone, complete, 5/-; simply plug in to pick-up terminals.

LARGE Selection of Pedestal, table, and radio-cabinet cabinets, by best manufacturers, at a fraction of original cost for callers.

WESTERN ELECTRIC Mains Transformers, 300-0-300v. 60 m.a., 4v. 1-2 amp., 4v. 2-3 amp. 8/6. 500-0-500v. 150 m.a., 4v. 3-5a., 4v. 2-3a., 4v. 2-3a., 4v. 1a. C.T., 4v. 1a. C.T., 19/6.

RELIABLE Intervar Transformer 3-1 or 5-1, 2/- Dubilier, .05 mica, 1/9.

T.C.C. Condensers, 250v. working; 2mfd., 1/9; 1,000 ohm, 150 m.a. variable resistance, 2/-.

T.C.C. Electrolytic Condensers, 440 volts working, 4 mf. or 8mf., 8/-; 15 mf., 50 v. working, and 50 mf. 12v. working, 1/-; 25 mf., 25 v. working, 1/3.

KOLSTER-BRANDS Mains Transformers, Input 200-250 volt, output 350-0-350v. 100 m.a., 4v. 1 amp., 4v. 2 amp., 4v. 3-4 amp. 10/- Ditto, input 100v., 5/-.

ORMOND Brass Variable Condenser, .0005 complete with knob-dial 2/-, with slow motion 3/-.

& A. Cone Unit and Chassis, a really sound job, 10in. diameter, 6/6.

M.V. Block Condensers, 400v. working; 4 x 4 x 1 x 1 x 1 x 1 x 0.1 6/-; 4 x 2 x 1 x 1 x 1 x 0.5, 4/6.

DUBILIER Condensers, 2 mf. 1,200v. working, 4/-; 8 mfd. dry electrolytic, 450v. working, 3/-.

THE Following Lines 6d. each or 5/- per dozen.—Chassis valve holders, 5 or 6 pin, screened screen-grid leads, any value 1-watt wire end resistances, wire end condensers, 0.0001 to 0.1, trimming condensers, T.C.C. 6 mfd. 50 v. electrolytics.

PLEASE mention PRACTICAL WIRELESS when ordering.

PREMIER SUPPLY STORES

20-22, High Street, Clapham, S.W.4, MACaulay 2188. Close 1 o'clock. Wednesdays; open to 9 o'clock Saturdays. Nearest Station, Clapham North Underground.

LOUDSPEAKERS, any make, rewound and re-magnetised, 3/6. Prompt service. Year's guarantee.—Breeze, Clapper House, Marden, Kent.

BIRMINGHAM RADIOMART'S Manufacturers' Surplus Stocks: Post free over 6/-; otherwise 6d. All goods, new and perfect.

RADIOMART—Utility W312B, screened 2-gang bakelite condensers disc drive, Uniknob trimming, 3/6.—Must be seen to be appreciated.

RADIOMART—Utility 1934. Bakelite tuning and reaction condensers, 0.0005, 10d.; 0.0003, 6d.; Ditto 0.0003, diff., 1/6.

RADIOMART. Igranite boxed, nickelcore, 3-1 transformers, 11st. 10/6, 3/11; Ditto, parallel feed, 2/11. Formo 2 mfd., 400v. wdg., with terminals, 1/8.

RADIOMART—Philco heavy duty Class "B" 1-1 driver transformer, boxed, 2/9; Valveholder, baseboard, 9d.; Chassis, 7d.

RADIOMART.—2 1/2 x 2 1/2 mfd. 500v. working, ideal for suppression mains interference, or use straight 4 1/2 mfd., 2/6.

RADIOMART.—Talsen boxed differential condensers with knob; 0.0001, 0.00015, 1/-; 0.0003, 0.00035, 1/3.

RADIOMART.—Centralab 50,000, wirewound with R switch potentiometers, boxed, 2/6; Igranite 400 ohms pot., 6d.; Plug in coil mounts, 2d.

RADIOMART. Ormond airspaced small 0.0003 log., the ideal reaction condenser, boxed, 1/6.

RADIOMART.—Non-inductive tubulars, 1,500v. test, 0.1 mfd. and 0.01 mfd., wire-ended, 6d.

RADIOMART.—Western Electric sensitive microphone insets, 1/-; special short-wave all brass 0.0001 mfd. variables, 1/9.

RADIOMART.—Metwec boxed, H.F. chokes; really efficient, 1/-; Utility, 2/6; Switches, 9d.

RADIOMART.—Ultra Panther Cabinet, beautifully inlaid two-tone walnut, new crated, 14/6. Carriage forward.

RADIOMART.—Famous "RAYMART" 2 1/2 in. flush milliammeters, readings above 20ma., 5/9; Super model, 6/9.

RADIOMART'S APRIL LIST Now Ready. Largest and most comprehensive published. Stamp essential.—19, John Bright Street, Birmingham.

SOUTHERN RADIO'S Bargains.—Set manufacturer's guaranteed surplus.
COILS.—Igranic iron-core band-pass 3 coils unit. Screened. Ganged on base with switch, 16/- (list 33/-).
ESSEN Super-het 3 coils unit. Screened. Ganged on base with wave-change and filament switches. Type LN5181 for battery or mains, 12/6 (list 30/-).
LEWCOS Coils.—Types O.S.C./126; T.O.S.; I.F.T.; T.B.F.; A.W.C.; 3/8 each. B.P.F. band-pass filter B.P.F., 4/- (list 12/-). All coils brand new in original cartons.

VARIABLE Condensers.—Lotus 3-gang 0.0005, 12/6; Lotus 2-gang, 0.0005, 8/6; Lotus Dyblock single, 0.0005, 4/9 (list 9/6); all these condensers are complete with dials, escutcheons, knobs, fully screened with trimmers, and boxed; Igranic variable, 0.0003 and 0.0005, 2/3; Hydra block condenser, 16 mfd. (2+2+8+2+1+1), 1,000 v. D.C. 7/- each; 20 mfd. (2+2+2+2+2+2+2+1+1+1+1), 1,500 v. D.C., with terminals, 11/6; Dubilier 4 mfd. (2+1+1), 1,000 v. D.C., 2/9; 4.5 mfd. (2.25+2.25) 1,000 v. for mains noise suppression, 3/-; Fixed 4 mfd., 2/3; 2 mfd., 1/6; 1 mfd., 1/-.

SPEAKERS.—Blue Spot Permanent Magnet with universal transformer for power, super power, pentode and Class B, 23/- (list 39/6). Celestion Sondex Permanent Magnet, 17/6 (list 27/0). Celestion P.P.M./W., 25/- (list 49/6).

BLUE Spot 66K, in cabinet, 10/- (list 42/6). G.E.C. Stork Speaker in magnificent Cabinet, 19/6 (list 33/15/-).

BLUE Spot. Genuine 100U, inductor speaker on chassis 13/6 (list 39/6).

READY Radio D.C. mains energised moving-coil speakers with Humbucking coils and universal transformers. For all voltages, 16/6 (list 39/6). All new in cartons.

J.400 kits, all specified proprietary components, 22/10/6 (list 24/17/6).

SPECIFIED Cabinets for Ready Radio Meteor kits, 17/6. "303" kits, 13/6.

IGRANIPAK Tuning Unit, comprising screened coils with wavechange switch; Igranic 3-gang condenser with cover; escutcheon disc drive; mains switch; three 5-pln valve holders; grid leak and condenser; engraved terminal board, complete with circuit; actually made for A.C. mains, but can easily be adapted for battery sets; list 57/6, our price 27/-, brand new.

FRAME Aerials.—Lewcos dual wave superhet, 9/- each (list 27/6).

SPECIAL Bargain Offer of Lewcos Spaghetti Resistances, all sizes, in original sealed boxes, 4/- per dozen, assorted; special price to trade, 36/- per gross.

READY RADIO Instamat Transformers, for matching any valve to speaker, Junior model 11/6 (list 27/6), Senior model 14/6 (list 37/6).

PICK-UPS.—B.T.H. latest Senior type (1934) Needle armature. Bronze, 30/- (list 40/-). Marconi "No. 19" (1934), 22/6 (list 32/0).

MAINS Transformers.—Auto. step-up or down, 0/250 v., 60 watts, 11/6; 100 watts, 14/3. Full list of Mains transformers and chokes sent Free. Specials can be supplied in 3 days. All transformers and chokes guaranteed 12 months.

MISCELLANEOUS.—Rotorohm and Radiophone volume controls, all values, 3/- each; with switch, 3/3 (list 10/6); S.T.500 coils, 5/6 per pair; Hellesen's 8 mfd. electrolytic condensers, 2/0 each; Westinghouse metal rectifiers, H.T. 6, 7, 8, 9/3 each; Ferranti chokes, 20 henry 60 m.a., 6/9 each; Ready Radio L.F. transformers, 5-1, 3-1, 3/3 (list 8/6); B.T.H. transformers, 3/6; Lewcos superhet 8-way bases, complete with valve-holders, grid leak, fixed condenser, type "48," 2/- each.

ALL Goods Guaranteed and Sent Carriage Paid.

BRANCHES at 271-275, High Rd., Willesden Green, N.W.10 and at 46, Lisle St., W.C.2; please send all post orders to 323, Euston Rd., N.W.1.

SOUTHERN RADIO, 323, Euston Rd., London, N.W.1 (near Warren St. Tube). Phone: Museum 6324.

ERICSSON 3/1 L.F. Transformers. List Price 17/8. New and guaranteed. Our Price, 2/3. post free U.K.—Pioneer Radio, Coptic Street, London, W.C.1.

REPAIRS—REWINDING—OVERHAULS. New cones and centres fitted any make M/c chassis, Mc's rewound. Mains transformers, etc. Receivers converted D.C. to A.C. Write Repair Dept. C.

WEDDON P.L.E. Co., 80, Lonsdale Avenue, London, E.6 (Granzewood 1837).

REPAIRS to Loud Speakers, 4/-; Blue-Spots, 5/-; Transformers, 4/-; Moving Coils and Eliminators Quoted for. All repairs remagnetised free. Guaranteed. Discount for trade. Clerkenwell 9069. E. C. Mason, 44, East Road, N.1.

H. A. WIRELESS for everything radio. Specialists for Specified Kits, Components, etc. Send your lists of requirements, and we will quote by return. Send for Lists.—H. A. Wireless (Shoreditch), 9 and 13, Hackney Road, Shoreditch, E.2. Telephone: BISHOPS-gate 8169 (PBX).

WANTED good Modern Wireless Parts, Sets, Eliminators, Meters, Valves, Speakers, etc. Spot Cash waiting. Send or bring. We pay more than any other dealer. Open 9-8.—University Radio, 142, Drummond St., Hampstead Rd., N.W.1.

BE SAFE!

THUNDERSTORMS NEED HAVE NO TERROR

If you fit the Genuine **SNAP ACTION LIGHTNING SWITCH**

Special features:

1. SPARK GAP
2. SAFETY FUSE
3. INSULATED
4. FOOLPROOF

Price 2/6 each.

Each switch includes £100 Guarantee Voucher

BULGIN

The Choice of Critics

Send for 80 p. Catalogue "N." Enclose 2d. Postage.

FREE £100 INSURANCE GUARANTEE for that in the event of any apparatus will be replaced

A. F. BULGIN & CO., ABBEY ROAD, BARKING.
 London Showrooms: 9, 10, 11, Curator St., Chancery Lane, E.C.4.

Micromesh

THE MODERN VALVE

Literature and prices on request, Standard Telephones and Cables, Ltd. St. Chad's Place, 366A, Gray's Inn Road, London, W.C.1. Terminus 6255

The Diploma of Radio Engineering is a passport to a well-paid post in the wireless industry

THIS BOOK WILL TELL YOU HOW TO QUALIFY FOR IT

TO THE NATIONAL INSTITUTE OF RADIO ENGINEERING 55-57 GUILDHALL STREET, PRESTON

Please send me free and post free a copy of "Wireless as a Career"

Name

Address

I CAN ASSIST YOU TO A BETTER POSITION IN RADIO.

Send for our booklet, "Radio Progress," for particulars of Radio Opportunities and my unique postal training for recognised certificate. Free and post free. **HARLAND E. KERRISON, Principal R.T.I.G.B., 85, New Oxford Street, London, W.C.1.**

UTILITY SALES CO.

OUR NEW enlarged LISTS, "Everything YOU REQUIRE for RADIO," has now been dispatched, if you have not yet applied, send a Post Card TO-DAY.

SPECIALS this WEEK:

UCERNE COILS as specified, 3/-, pair 5/6.

TRIOTRON 22/6 Balanced Armature speaker, a beauty, 6/6.

TIME SWITCH CLOCK to turn off Radio at specified time 3/6.

RADIOGRAM ELECTRIC Motor complete with Turntable, accessories, works from 4 1/2 Volts dry cell, 4 Volt accumulator 15/-.

IRON CORE SCREENED dual wave coil, matched for S.G. 3 diagrams, 2/6.

ELECTRIC Soldering Iron, specify voltage, handy, perfect, 4/6.

BANDPASS & H.F. Complete UNIT, bakelite base with 3 Screened Iron Core coils with dual wave switch, diagram for alteration, Superhet selectivity, 15/6.

Carriage PAID, Cash with order, 24 hours service. Utility Sales Co., 27a, Sale Street, London, W.2.

THE following Unused set Manufacturers' surplus, all goods guaranteed perfect; immediate delivery.

SUPER-HET, and 2-H.F. Radiopaks, 35/-. Radiophone coils (3ln. gang), 10/-. Radiophone I.F. transformers, 6/6.

FERRORCAT coils, G1-G2-G3 with switch, 30/-. G11-G12-G13-G14 with switch, 36/-.

DUBILIER or Erie 1-watt resistors, 7d. 2-watt, 1/3.

MARCONI K19 pick-ups, 22/6. Westinghouse rectifiers, H.T.8, 9/6; H.T.9, H.T.10, 11/-; L.T.5, 11/6.

REGENTONE transformers for H.T.8 or H.T.9 with 4v., 4a. L.T. winding, 7/6. Wards transformers, output 350-0-350v., 60ma., 4v. 4a. 4v. 2a. 12/6.

ELIMINATORS, outputs 150v. 25ma., S.G. and Detector. D.C. type, 12/6; A.C. type, 24/-.

DUBILIER dry electrolytic condensers, 8mf. or 4mf., 500v. working, 50v., 50mf., 3/6. Hot-wire ammeters for A.C. or D.C., 0-500ma. scale, 5/6.

B.T.H. pick-up tone-arms, 3/-.

ALL types of brand new American valves in stock, first-class makes, guaranteed.

47, 35, 51, 89, 18, 19, 46, 59, 6A7, 15, 42, 41, 38, 39, 78, 75, 57, 58, 24, 44, 36, 35, 43, 12/-.

UX171A, UX199, UX280, UX245, UX226, UY227, 8/-. UX250, UX281, UX210, 18/-.

B.T.H.-RK 6-volt speakers, suitable for P.A. work, 27/6. A.C. type with field rectifier, £27/6.

MAGNAVOX speakers, complete with hum-bucking coils, output transformers, etc., 152 (9in. cone), 24/-; 154 (7in. cone), 10/3; Rola F.6 (7in. cone), 17/6, with either 2,500 or 6,500 ohm. fields. Rola F.6, P.M., 24/-; Magnavox P.M.254, 18/6. Carriage paid, cash with order or C.O.D. Send for list.

WARD, 2nd floor, 45, Farringdon Street, London, E.C.4. Telephone: Holborn 9703.

WOBURN RADIO offer special purchase of Westinghouse Rectifiers (new); H.T. 7, 8, 9, 9/-; H.T. 10, 10/-; L.T. 5, 10/6. 10hy. 100ma. Chokes, 4/- each.

DUBILIER dry electrolytics, 4 mfd. and 8 mfd., 500v., 3/6; 50 mfd., 50v., 3/6. Wegco Condensers, 750v. test, in bakelite, 1 mfd., 1/-; 2 mfd., 1/3; 4 mfd., 2/3. Ready Radio and Lotus Diffs., 0003, 00035, 00015, 1/-.

ELIMINATORS specially manufactured for us, D.C. 3 tappings, 25 m.a., 11/9; A.C., 25/-.

Guaranteed for 12 months.

CLASS "B" Drivers and Chokes, 9/6 per pair, with suitable valve (BVA) and 7pin holder, 19/11; Binocular Chokes, 1/3; H.F. Chokes, 1/-; Valve-holders, 4/5-pln chassis type, 1/6 half doz.; 7-pin, 6d.

Columbia L.F. Transformers, 3/1 ratio, 3/-. Tubular Condensers 0.01, 0.1 and 0.05, 6d. Large Stock of Erie and Dubilier Resistances. Lucerne Dual Range iron-cored coils, 3/6; Eston iron-cored coils with circuit, 3/-.

SINCLAIR P.M. Speakers with universal transformer, or Class B 7in. Cone, 12 months' guaranteed, 16/6. Sinclair Matched pairs, one 9in. one 7in. P.M.'s or Energised, 35/- (carr. 1/-).

ANYTHING on H.P. above 40/-. Quotations for Kits and Components by return. Trade Enquiries invited.

WOBURN RADIO CO., 7, Woburn Buildings, W.C.1. Euston 1571. (Near King's X and Euston Stns. Back of St. Pancras Church.)

Piano Tone CABINETS

65/- RADIO-GRAM 35/- CABINET FOR NO MIDDLE PROFITS. Finest Radio Furniture as supplied to B.B.C.

LIST FREE. PICKETT'S

Piano Tone CABINET (P.R.) WORKS, Bechleybeath, Nr. London.

THE 'RADIO GOLD-MINE'

for 3d. stamps only. Radio's Greatest Investment, **3D. ONLY, POST FREE.**—Enclose 3d. stamps to-day for your April number of THE 'RADIO GOLD-MINE.' By far the most comprehensive lists of up-to-date surplus goods (Kits, components and accessories) yet produced, with a general price level lower than ever before. Avoid delay. Send (enclosing 3d. stamps) to-day.

L.E.C. 'GOLD-MINE' KITS CLEARANCE represents absolutely unprecedented values. They cover a comprehensive range of up-to-date circuits which will meet every home constructor's requirements. Supplied complete with diagrams, instructions and all sundries in sealed cartons. Straight 2-valve, 3/8; 3-valve, 10/6; S.G.III, 18/6; S.G.IV, 25/-; **SHORT WAVE KITS:** 2-valve, 12/6; 3-valve, 18/6; Class B III, 27/6. **ADAPTOR KITS:** S.W. Adaptor, 8/6; Super-Het. type, 15/6; Class B Adaptor, 10/6. **CLASS B KITS:** 3-valve, 22/6; S.G.IV, 29/6.

ELIMINATOR KITS, complete with full diagrams, 4 tapplings to 150v. A.C. 25 ma., 21/6. Class B, 29/6. D.C., 9/6. (Westinghouse Rectified.)

BROWNIE COILS CLEARANCE.—All dual range with reaction. New line, 1/6; also screened, 2/6; Special Iron Cored (diagrams included), 3/3; S-Wave, 2/10. Special Lucerne Coils, 3/8.

W.D.; BLUE-SPOT; AMPLION SPEAKERS CLEARANCE.—W.B. Permanent Magnet (ordinary or Class B type) (list 37/6), 18/10; Nuvoion P.M., 16/10; Blue Spot 100VE (list 32/6), 15/10; 31K (list 25/6), 15/4; 66K (list 12/6), 7/8. Special offer. P.M.M.C. speakers, worth double, 12/6 each.

BRITISH RADIOPHONE AND H.M.V. VARIABLE CONDENSERS CLEARANCE.—H.M.V. 3-gang, 5/9; Br. Radiophone, 2-gang with escutcheon, S.M. drive, panel light, etc., 6/11; .0003, .0005 mfd. air-spaced, 2/3; Slow Motion Type, 2/11; Mica Dielectric, .0003, .0005, 11d.; "Duoctone" Extensers (list 12/6), 2/11; S.M. Typo (list 18/6), 4/10; Differentials, 1/4.

PHILIPS MANSBRIDGE CONDENSERS CLEARANCE, 750 v. test, 1 mfd., 8d.; 2 mfd., 1/4; 4 mfd., 2/8; Dubilier Wet Electrolytic, 8 mfd., 2/9.

DUBILIER FIXED CONDENSERS CLEARANCE and Edison Bell, Mica, .0001, 2, 3, 4, 5 mfd.; .001, 2, 3, 4, 5, 6, 7, 8, 9 mfd.; Tubular mica type, .0001, .0003 mfd., all 3d. each; 2/0 doz.

ERIE, H.M.V., PHILCO RESISTANCES CLEARANCE.—H.M.V. 4 watt glass cased, 100,000 ohms, 4d.; Erie, 1 watt, all values to 60,000 ohms, 4d.; Dubilier, 1 watt, 100,000 ohms, 3d.; Philco, 2, 10, 15, 18, 20 and 32,000 ohms, 3d.; Edison Bell Carbon to 70,000 ohms, 4d.; to 150,000, 5d.; to 350,000, 5d.; to 500,000, 6d.; Spaghettili, every size to 100,000 ohms, 3d.; Grid Leaks 1 to 3 megs., 3d. each.

COLUMBIA AND SUNDRY COMPONENTS CLEARANCE.—Columbia L.F. Transformers (list 10/6), each 2/11; Cl. B. Driver, 3/11; Output Chokes, 3/11; C.E.C. 20. Hen. Chokes, 3/6; H.F. Chokes, 9d.; Y-holders, 4 pin, 2d.; 5-pin, 3d.; 7-pin, 6d.; Switches, push-pull, 2-point, 4d.; 3-point, 5d.; Grid Leaks, 1, 1 1/2, 2 and 3 megs., 3d. each.

UNIVERSE PICK-UPS AND SUNDRY CLEARANCES. Super Pick-up (list 20/-), with vol. control, 12/6; Igo. Electric Clocks (A.C. 100-240 v.), various colours (list 32/-), 10/8; Colaro Universal A.C. Motors, with Auto-Stop (list £2/10/0), 35/-.

BUILD THE LEADER III, KITS at 60% SAYING.—Complete to the last screw, with chassis, all components, sundries, blueprint and copy of PRACTICAL WIRELESS. Battery model, 25/6; A.C., 49/6. Please note since first advertised in PRACTICAL WIRELESS, March 3rd, we have not had one Kit returned. The value will really astonish you.

FREE APPROVAL COSTS YOU NOTHING.—Your satisfaction complete or money returned without question.

EXACT TO SPECIFIED VALUES THROUGHOUT.—The Leader III Kits are made up exact to specified values throughout. The price alone falls short of this standard.

WE GUARANTEE YOUR SATISFACTION so why pay more? We will send on full approval against cash or C.O.D.

BUILD THE LEADER III, KIT B, as above, but with complete matched set of British and fully guaranteed valves. Battery Kit, 36/6; A.C., 84/6.

BUILD THE LEADER III, KIT C, as Kit B, but including high grade console cabinet and speaker unit, comprising the complete outfit. Battery Kit, 47/6 (with batteries, 57/6); A.C. model, 99/6.

LONDON EAST CENTRAL TRADING COMPANY (Dept. M.108), 23, Bartholomew Close, London, E.C.1 (telephone: National 7473). Goods over 10/- value, postage free. Under 5/- value—cash only. Over 5/- cash or C.O.D.

3D. POST FREE.—Secure your copy of THE 'RADIO GOLD-MINE' TO-DAY.

The Miracle Medium in Modern Radio
THE 'RADIO GOLD-MINE'

SPECIALLY CONSTRUCTED for the "A.C. LEADER 3"

A new design of Heayberd Mains Transformer was exclusively specified for the "A.C. LEADER 3." This Transformer was specially constructed to meet the requirements of "Practical Wireless" Technicians. Be sure you use this Transformer when making up the set.

MODEL LEADER 3, PRICE 16/-

Post coupon NOW, with 3d. in stamps, for 40 pp. booklet.

..... PRA.
F. C. HEAYBERD & CO.,
10, FINSBURY STREET, LONDON, E.C.2

LATEST BLUE SPOT PICK-UP



SEND ONLY 2/6 and have this superb Blue Spot Pick-Up for 7 DAYS' TRIAL. If satisfied, pay further 2/6 at once, then 7 monthly payments of 5/- (Cash, in 7 days, 35/-). Full instructions enclosed. Send to-day!
E. J. HERAUD, Ltd. (Dept. P. 55),
NUMBER ONE, EDMONTON, LONDON, N.18
Subscription or Money Back Guaranteed.

ENGINEERS! ARE YOU EARNING LESS THAN £10 PER WEEK?

If so, you cannot afford to carry on without reading our 256-page Handbook. The book explains clearly and definitely many ways of carving out a successful career. Among other things, it explains the Service of our unique Appointments Department, outlines Home-Study Courses in all branches of Civil, Mechanical, Electrical, Motor, Aero, Wireless, "Talkie" Eng. Building, etc., and gives details of B.Sc., A.M.I.C.E., I.E.E., A.M.L.Mech.E., A.M.I.A.E., G.P.O., MATRIC., and all Exams. We alone Guarantee—"NO PASS—NO FEE." Whether you be an old hand or a budding apprentice, get this book to-day—FREE and POST FREE.
BRITISH INSTITUTE OF ENGINEERING TECHNOLOGY,
390, Shakspeare House, 29/31, Oxford St., London, W.1.

THE MOST Recommended METERS

- MOVING COIL METERS. New dials make readings simple. Knife-edge pointers give greater accuracy. Mechanism perfectly balanced and tested. From 27/8
- MAGNETIC CONTROLLED. Recommended by leading technicians for general radio and charging purposes. Guaranteed accuracy within 5%. In moulded cases, 2 1/2 in. overall, 2 in. h/6 From 7/0
- KNIFE-EDGE POINTERS
- FINE SCALE DIVISIONS
- ACCURACY GUARANTEED

USE SIFAM METERS
SIFAM ELECTRICAL INSTRUMENT Co., Ltd.
York Wks., Browning St., S.E.17. Tel. Rodney 3573

PEARL & PEARL

190, Bishopsgate, London, E.C.2. All the following bargains guaranteed new goods. Cash or C.O.D. Carriage Paid.

LISSEN, type L.N.5181, superheterodyne 3-coil ganged unit, specially designed for use with battery- or mains-driven superhet receivers, 3 dual-range shielded coils complete with wave-change and filament switches, operated by one knob on an aluminium chassis, with leaflet of circuits and full instructions; list price 30/-, our special bargain offer 12/6.

POLAR 2-ganged Screened Condensers, with trimmers, pilot lamp holder, calibrated scale and escutcheon; list 27/6, our price 8/11.

1,000 Marconi 2-valve Sets (1934 models), with Marconi valves; list price 4 guineas, our price, complete with batteries, 45/-; or on deferred terms.

TRIOTRON 4-pole Balanced Armature Speakers, type "B," sensitive, beautiful tone; list 22/6, our price 6/11.

SOVEREIGN Iron Cored Coils, with circuits, 2/11.

SOVEREIGN Super H.F. Chokes, 1/9; ditto, binocular type, 1/6.

SOVEREIGN Screened Dual Range coils, 2/9 each.

IGRANIC Short-wave H.F. Choke, 10-120 metres, baseboard or panel mounting, 1/3 each.

THE "Lincoln Super" Permanent Magnet Moving-Coil Loud Speaker, all purpose universal tapped transformer for Q.P.P., Class B., pentode, power and super-power output, will carry 3 watts undistorted output; list price 42/-, our price 19/6.

2,000 Volt Test. Block condensers with soldering tags, terminals and earthing terminal. 2 mfd., 7/11; 1 mfd., 6/11. Limited supplies.

LINCOLN STEWART 20 m/amp. D.C. Eliminator, 13 output tapplings. New, tested, and guaranteed, 1/11.

IGRANIC Pentode tapped choke, provides tapplings from 1-1 to 6-1. List, 7/6; our price, 3/11.

COLLARO Electric gramo. motor with pick-up and volume control incorporated. Brand New as listed at £4. Our price, 59/6.

HORIZONTAL Cabinets for set and speaker combined; solid walnut (made for Philco), 22in. wide; 10 1/2 in. deep; 11in. high. 500 sold to PRACTICAL WIRELESS readers at 6/11 each. We now offer small remaining stock (slightly scratched) at 4/11 each, carriage forward. Don't miss this wonderful bargain.

SPECIAL SUNDRY BARGAINS (Cash with order only.) Igranic 400 ohms, baseboard potentiometers, 9d.; Edison Bell pick-up arms, 1/6; lots of 3 doz. assorted Dubilier fixed condensers, 1/9 each lot; C.E.C. 1 mfd. condensers, 1/3 each; Climax binocular H.F. chokes, 1/11 each; Slekton screened dual range coils, 2/11 each; Sovereign lightning arresters, 9d.; Sovereign toggle switches, 9d.; Sovereign spaghetti resistances, various values, 2/11 for 6 assorted. Igranic 2-pole rotary switches, 1/-; 4-pole, 1/3.

FREE. Send postcard for Bargain List "B."

All Mail Orders Direct to PEARL & PEARL, 190, Bishopsgate, London, E.C.2.

Callers only can also obtain all above bargains from our London branches; 100-101, Houndsditch; 11, Liverpool St.

VALVES REPAIRED whether burnt out or broken. 2v. H.F., L.F., Det., E.C., 2/9. Power, 3/7 1/2. S.P., 4/1, S.G., Pentode, 6/6, Rect., 4/9. Satisfaction guaranteed or money refunded.—Valve Repairing Company, 1a, Summer Street, London, S.E.1.

ADVERTISEMENT INDEX

	Page
Amplion (1932) Ltd.	160
Boardman, P. W.	160
British Institute of Engineering Technology	Inside Back Cover
British Pix Co., Ltd.	162
Bulgin, A. F., and Co., Ltd.	164
Cosmocord, Ltd.	152
Coscor, A. C., Ltd.	Inside Front Cover
Electradix Radios	160
Graham Farish, Ltd.	161
Harwell, Ltd.	141
Heyberd, F. C. & Co.	Inside Back Cover
Heraud, E. J., Ltd.	Inside Back Cover
Jackson Bros. (London), Ltd.	142
Kerrison, Harland R.	164
London Radio Supply Co.	160
National Institute of Radio Engineering	164
New Times Sales Co.	163
Parke-Davis	142
Peto-Scott, Ltd.	Front Cover Strip, 151
Picketts	164
Pitmans	161
Sifam Electrical Instrument Co.	Inside Back Cover
Standard Telephones & Cables, Ltd.	164
Taylor, N.	161
Telegraph Condenser Co., Ltd.	157
362 Radio Valve Co., Ltd.	152
Turnadge & Partners	161
Varley, Ltd.	152
Westinghouse Brake & Saxby Signal Co., Ltd.	142

Part 1

Now On Sale

NEWNES

PRACTICAL

PHOTOGRAPHY

and AMATEUR CINEMATOGRAPHY

ABOUT 20
FORTNIGHTLY
PARTS

1/2 EACH

Advisory Editors

GEORGE E. BROWN,
F.I.C., Hon.F.R.P.S.PERCY W. HARRIS,
F.A.C.I.**Can You Answer These Questions?**

- What steps would you take if the copyright for one of your photographs had been infringed?
- How long does the copyright in a cine film and a photograph last?
- What are the causes and remedies for the following defects in gaslight prints :-
Black Spots, Blisters, Brown Stains, White Specks, Yellow Stains?
- What developer would you use for gaslight paper to give the most brilliant print? What developer would give softer contrast?
- What printing process gives prints like oil paintings?
- When must a cine camera be held upside down in shooting a scene?
- When is $1/8$ stop not $1/8$?
- How do lamps used for photographic studios differ from ordinary electric light bulbs?
- What is the difference in lighting an indoor scene for cinematography as distinct from still photography?
- How would you develop ultra rapid panchromatic plates and films?
- What is the best type of camera to use for dog photography?
- All these and hundreds of other practical questions are clearly answered in this splendid new work. Get a copy of Part 1 To-day.

Obtainable at all News-
agents and Bookstalls,
or by post 1/2 from
George Newnes, Ltd.,
8-11, Southampton St.,
Strand, London,
W.C.2.

WORTH MANY TIMES ITS COST.

Produced in the straightforward practical style for which the House of Newnes has become justly famous, this work deals with a subject which is full of fascinating possibilities for the practical man who aspires to a more intelligent photography than that so tersely described by the phrase: "You press the button, we do the rest." Never before has such a wealth of really practical information on this subject been brought together within such a small compass. Every article has been written by a man who has made himself expert on the subject upon which he writes, and yet the information is conveyed in such a manner that it can be put into immediate use by the reader. It is quite safe to say that, to the man who has a practical turn of mind, each part of this work will be worth many times its cost. Get a copy of Part I and you will fully endorse this statement.



PRACTICAL

AUTHORITATIVE

COMPREHENSIVE

Geo Newnes, Ltd

P.W. Gift Stamp No. 16

Printed by NEWNES & PEARSON PRINTING CO., LTD., Elmoo Street, Ladbroke Grove, W.10, and published by GEORGE NEWNES, LTD., 8-11, Southampton Street, Strand, W.C.2. Sole Agents for Australia and New Zealand: GORDON & GOTCH, LTD., South Africa: CENTRAL NEWS AGENCY, LTD. Practical Wireless can be sent to any part of the world, post free, for 17/4 per annum; six months, 8/8. Registered at the General Post Office for Transmission by Canadian Magazine Post.

* P.W. TOOL-KIT
GIFT STAMP No. 8

THE PRIMA MAINS THREE!

Practical Wireless

3^p

Published every Wednesday by

**GEORGE
NEWNES
LTD.**

Vol. 4. — No. 84.
April 28th, 1934.

Registered at the G.P.O. as a Newspaper.

AND PRACTICAL TELEVISION
EDITED BY F. J. CAMM

**Making an
Ingenious**



**GENERAL-PURPOSE
TESTING UNIT**
for CONDENSERS,
TRANSFORMERS,
INSULATION, ETC.

**OTHER SPECIAL
FEATURES!**

- MAKING L.F. TRANSFORMERS
- ALL ABOUT MAINS UNITS
- HOW THE SUPERHET WORKS
- THE VALVE VOLTMETER
- CHOOSING VALVES
- SHORT-WAVE SECTION
- Etc., Etc.

ALWAYS SPECIFIED

Obtainable from
all Good Dealers.

In cases of difficulty send direct to:

Sole Wholesale Distributors:

BRITISH RADIO GRAMOPHONE CO. LTD.

Pilot House, Church Street, Stoke Newington, London, N.16.

METAPLEX

USED EXCLUSIVELY BY MR. F. J. CAMM
The metallised Baseboard
that has come to stay.

BASEBOARDS



COSSOR All-Electric RECEIVER

MODEL
435

VARIABLE-MU
S.G. CIRCUIT



PENTODE
DETECTOR



PENTODE
OUTPUT



ENERGISED
MOVING COIL
SPEAKER

A powerful combination of FOUR Cossor Valves — Variable-mu S.G., Pentode Detector, Pentode Output and Full-wave Rectifier—gives this handsome Receiver an outstanding performance. Its reproduction is superb. PRACTICAL WIRELESS reports: "... reproduction equal ... to that associated with much more expensive receivers ... high notes not surpassed in any set on the market." AMATEUR WIRELESS says: "... quality extremely good ... as value for money this set is without parallel." Send at once for full details of this remarkable Cossor Receiver. Please use the coupon.

SPECIFICATION

Cossor All-Electric Receiver Model 435 as illustrated complete with Four Cossor A.C. Mains Valves, viz.: MVSG Variable-mu Screened Grid, MS/PEN Screened Pentode Detector, MP/PEN Pentode Output and 442 BU Full Wave Rectifier. Mains Energised Moving Coil Speaker, single-knob tuning, illuminated full-vision scale calibrated in wavelengths (200/540 and 900/2,000 metres), wave-change switch, combined volume control and on-off switch. Handsome walnut-finished cabinet 13 in. high, 17½ in. wide, 10 in. deep, with Gramophone Pick-up plug and socket, terminals for extension Loud Speaker and plug and sockets for connecting gramophone motor. For A.C. Mains only. 200/250 volts (adjustable), 40/100 cycles.

£9:15s.

Hire Purchase Terms: 20/- deposit and 20 monthly payments of 20/-.

To A. C. COSSOR LTD.,
Melody Dept., Highbury
Grove, London, N.5.

Please send me a copy of your
photogravure catalogue of
Cossor Receivers (B.20).

Name

Address

B.20.

PRAC. 28/4/34.

Prices do not apply in I.F.S.

♥ 4856

ENTER NOW FOR OUR BIFOCAL COMPETITION! See page 180.



ROUND *the* WORLD of WIRELESS

The Liberty Transmitter

IT is reported from the United States that a proposal has been put forward to erect a high-power transmitter on Bedloe's Island, New York. In view of the intense harbour traffic, it could not be connected by submarine cable to the mainland studio, but would receive the programmes through a short-wave station. The site is the island on which the famous bronze statue of Liberty was erected to commemorate the centenary of America's independence.

Car Radio in U.S.A.

WIRELESS equipped cars have attained so great a popularity in the United States that it is estimated that for this purpose 700,000 radio sets were sold last year. Of some twenty million vehicles belonging to private owners it is computed that one in seventeen is equipped for broadcast reception. In New York alone one company running ten thousand taxi-cabs has had them all fitted with wireless sets for the benefit of both driver and passenger.

June 12th and the Lucerne Plan

THE world's largest gathering of broadcasting experts will meet in London on June 12th next to discuss amongst other matters the results of the Lucerne Plan. Some 130 delegates, including representatives from Russia, America, and also from British Colonies and Dominions overseas, will take part in the proceedings. The Conference will be under the Presidency of Admiral Sir Charles Carpendale, Controller of the B.B.C.

How Interval Signals are Produced

THE short musical phrase heard in the intervals of the Danzig (Germany) programme on 230.2 metres is produced by means of three metal rods tuned to different notes. These are automatically struck by three hammers, brought into action by an electrically driven cylinder furnished with steel pins. The sounds obtained are not reproduced by a microphone, but in a similar way to a gramophone pick-up are transformed into electrical frequencies by means of small coils, duly amplified and conveyed by cable to the transmitter.

Germans to Increase Power of Stations

WITH the exception of Frankfurt-am-Main, all German main stations are to see their power increased to 100 kilowatts. In addition, the transmitters of Königsberg, Cassel, Hanover, Bremen, Freiburg and Stettin are to be reconstructed to secure a higher output.

German Night Concerts

FOR some time past a regular series of late concerts starting at 23.00 and lasting until 01.00 has been broadcast

Radio Lisboa

IT is reported that tests have already been carried out by the new transmitter at Barcarena, near Lisbon. The official opening of the station may take place in the course of a month or so. Before final tests can be carried out, it is necessary to await the completion of the laying of the special cable connecting the transmitter to the studio in the Portuguese capital.

Temporary 40-Kilowatt at Rennes

ALTHOUGH work has already started on the high-power station at Thourie (France) to be later known as Radio Ouest, in the meantime Radio Rennes is to be endowed with a 40-kilowatt transmitter which will be formally launched in the course of the summer months.

Broadcasting School in Paris

AS complaints have been fairly frequent in respect to the lack of experience displayed by speakers and others in French studios, a syndicate of radio journalists is founding in Paris a broadcasting school, which is to open in October next. Instruction will be given by the best French orators, newspaper reporters, authors, and dramatists.

Aeroplane Transmissions On Long and Short Waves

THE Fokker express aeroplane *Rijstvogel*, which ensures the regular service between Amsterdam and Batavia (Java), has been equipped with long- and short-wave transmitting and receiving apparatus in order to permit continuous communication with either Bandoeng or with Kootwijk (Holland) during its journey. When the aeroplane is flying over India the connection with the Dutch East Indies is made by means of the short-wave transmitter, whereas when the distance is increased long waves alone are used.

Listen to Leningrad In May

DURING the period May 20th-30th, a musical festival will take place at Leningrad in which a number of symphony orchestras, conducted by both Russian and other foreign musical directors, will take part. Most of these broadcasts will be relayed to the Leningrad and Moscow high-power stations.

OUR GREAT NATIONAL COMPETITION Closes on May 14th 20 GUINEAS FIRST PRIZE and 200

Consolation Prizes! See page 180

We are always first to **SUCCEED** Where others **FAIL!**—*Verb. Sap.*

by the Langenberg station. Announcements are made not only in German but also in the French and English languages. As the transmissions have been appreciated by foreign listeners, Hamburg has now imitated this example. In view of its close proximity to Denmark, Norway, and Sweden, announcements are also given in the Scandinavian tongues.

Rome's Second String

ROME III on 238.5 metres (1,258 kilocycles) is now working nightly; it shares a wavelength with San Sebastian (Spain). The station is used for the re-broadcast of the North Italian programmes only.

ROUND *the* WORLD of WIRELESS (Continued)

Radio In Police Helmets!

NOT a Utopian idea, but may become a reality within a very short time. Experiments are now being carried out by the Research Department at Scotland Yard with a view to the designing of a new portable receiver for the police. The advent of the midget valve now placed on the market will greatly help in solving the problem.

No Radio Tax in Holland

ALTHOUGH suggestions have been put forward to introduce a tax on both wireless receivers and valves, it is reported that so far no measures are to be taken in this respect and that the broadcasting stations must continue to rely on private donations and subscriptions from their listeners.

New Norwegian Relay

THE 10-kilowatt transmitter erected at Vadsø, in the Varangerfjord, will be formally opened on May 17th. This is the Finmark station to which the Lucerne Plan allotted a wavelength of 845 metres (355 kilocycles). Not only is this channel the last one usable in the No. 2 band, but Vadsø itself is the most northerly of all European transmitters. It is proposed to connect the studio with Oslo by landline, but, in the meantime, the programmes from the Norwegian capital are relayed through the Jeløy short-wave station. Aalesund will also shortly be endowed with new 5-kilowatt plant, as it is used not only for broadcasting radio entertainments but also for transmissions to the fishing fleet operating in the Arctic Seas.

Broadcasts from Berlin Opera House

THE Berlin Municipal Opera House, which for some time has been in financial difficulties, has been taken over by the German Ministry for Propaganda and Enlightenment; in future it will become the centre of operatic art in keeping with the true Nazi spirit. To secure the full benefit of these teachings a number of relays of performances will be carried out regularly by the German wireless stations, thus making the programmes available to listeners throughout the country.

The Responsibility of French Wireless Dealers

FOR having supplied a customer with a faulty all-mains receiver with the result that the former was electrocuted, the dealer and his traveller, together with a mechanic who installed the instrument, were condemned at Amiens (France) to pay as damages a compensation of 80,000 francs to the widow of the deceased, the same amount to his daughter, and a further ten thousand francs to the parents of the victim!

Radio Nations

CONTRARY to the rumours current on the Continent to the effect that the League of Nations transmitter at Prangins (Switzerland) might be used for the broadcast of concerts or other artistic performances, it is now officially stated that the suggestion, although actually put forward, was rejected by the authorities.

INTERESTING and TOPICAL PARAGRAPHS

The station will restrict its broadcasts on short waves to official communications of the League of Nations.

FERRANTI'S LATEST SUPERHET



Tuning in on a Ferranti "Arcadia Magna," a high-class 5-valve A.C. mains superhet provided with electric tuning indicator, fully delayed A.V.C., and continuous tone control. The price of this receiver is 20 guineas.

SOLVE THIS!

PROBLEM No. 84

Bradley built up a receiver for operation from the D.C. mains, and obtained 4 2-volt valves for the purpose. He worked out the required voltage drop to heat these valves from the D.C. supply, and found that he required a resistance of 1,000 ohms to enable him to supply the required heater voltage. He accordingly purchased a standard 1 watt resistance of this value and wired it into the correct position, but found that results were extremely poor. After two nights he could obtain no results at all. The circuit was carefully checked and all valves were found to be correct. Where had he gone wrong? Three books will be awarded for the first three correct solutions opened. Address your envelopes to The Editor, PRACTICAL WIRELESS, Geo. Newnes, Ltd., 8-11, Southampton Street, Strand, London, W.C.2. Entries must be marked Problem No. 84, and must be received not later than the first post Monday, April 30th, 1934.

SOLUTION TO PROBLEM No. 83

By connecting a resistance between the H.T. positive terminal on the receiver and the eliminator Marsh had not decoupled the valves, but had simply reduced the H.T. applied to the receiver. The decoupling resistance should, of course, have been inserted in the anode lead of one of the valves.

The following three readers successfully solved Problem No. 82 and books have accordingly been forwarded to them:—

H. Bottomley, 15, Barrett Avenue, Kearsley, nr. Bolton, Lancs. A. Gent, Ash Leigh Lodge, Chorley New Road, Heaton, Bolton. H. Hamer, 135, Lumb Carr Road, Holcombe, Bury, Lancs.

Night Transmissions

THE fact that the power of the Zagreb station for its monthly midnight transmission (night of the first day in each month) is only 750 watts should not deter listeners from an attempt to hear the broadcast. It may be recalled by radio fans that in 1927 when Radio Berne on 1 kilowatt carried out similar experiments the transmissions were well heard over the greater portion of Europe, namely, from Sweden to the Balkan States.

Radio Listeners by Order!

A NEW Order in Council published in Germany decrees that all military barracks are to be equipped with receiving sets, and that officers are required to listen nightly to all official communications.

Broadcasting in Siam

ALTHOUGH mention is seldom made of radio in Siam, there exists a transmitter working on 350 metres in the neighbourhood of Bangkok. It was installed in the old Phya-Thai Palace. The programmes usually consist of Siamese music, but an exception is made on Fridays when European and American compositions are given. Unfortunately, although the station possesses a short-wave transmitter, it is only on rare occasions that it is used for the relay of radio entertainments.

Metronome versus Musical Interval Signal

ALTHOUGH the Vienna studio has been anxious to introduce a more melodious signal than the metronome ticking now used, it has decided not to make any alteration. Listeners, it is stated, soon tire of a small musical phrase, whereas the dull thud of a metronome does not disturb them. It may be recalled that the Bow Bells signal used by the B.B.C. is only a temporary measure and is being experimentally tried out. Perhaps, after all, the ghost in goloshes is best.

Berlin Short-wave Transmissions

A NEW schedule has now been worked out for broadcasts during April to Asia, Africa and two American continents. DJB (19.73 m.) is on the air from G.M.T. 05.35—07.15; DJA (31.38 m.) from 11.45—14.45; DJD (25.51 m.) from 17.30—21.00 with S.B. by DJC (49.83 m.). From G.M.T. 22.00—01.00 DJA is again brought into operation, and to close the broadcasts both DJD and DJC work from 02.00—04.30. The free periods, namely, G.M.T. 07.15—11.45; 14.45—17.50; 21.00—22.00; and 01.00—03.00 respectively are used by the various transmitters for the relay of international programmes, and it is on these channels and at these times that it is possible to listen to programmes emanating from the United States or from other distant lands.

S O S and Police Messages

OF roughly 858 broadcasts made through the B.B.C. stations during 1933, 44.75 per cent. proved successful in reaching the interested parties; 49.18 per cent. failed to do so, and the result of 6.07 per cent. was unknown.

A CONDENSER TESTING UNIT

In This Article the Author Describes the Construction and Uses of a Cheap but Efficient Multi-Purpose Testing Unit.



Fig. 2.—General view of the complete unit ready for use.

FIXED condensers have long remained a mystery to the average home constructor in the sense that he has no effective means of testing them. The usual shorting test can be applied either by means of a meter or bulb in conjunction with a battery, but this is by no means accurate, and a much better test can be made by means of the unit to be described.

The unit illustrated on this page is built in a wooden box, the dimensions of which are 7 1/2 in. by 4 1/2 in. by 5 1/2 in. (Fig. 1). You will notice that a small brass bracket is attached to the lid near the hinge side (Figs. 2 and 6). Fixed to this bracket, so that it swivels, is a connecting strip, the other end of which is attached (again with a swivel connection)

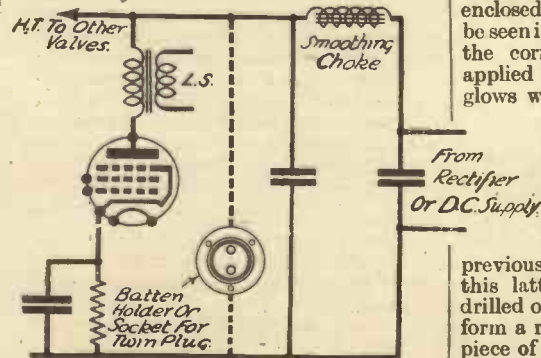

Fig. 3.—Showing the best position to connect the socket or holder on the set.

to an arm fixed on the spindle of an off-on switch. When the lid is opened it pulls this connecting strip and consequently the switch arm, thus rotating the switch to the "off" position. The actual switch movement is very small, and if the connecting strip were to be joined directly to the arm, the lid would not open very far. To overcome this difficulty a slot is made in the end of the strip instead of a hole, the strip then slides until the end of the slot reaches the screw in the switch arm. A slight continuation of the opening or shutting movement will then move the switch to the opposite position. When the lid is opened, the testing unit is switched off, making it fool-proof and shock-proof because it cannot be switched on without shutting the lid.

Of particular interest is the method of leakage indication used. There is only one cheap and efficient indicator, the neon lamp, and it is around one of these that the unit is based. Even so, the usual neon lamp is similar in size to the standard 60-watt bulb, and this presented a rather difficult problem when the factor of compactness was being considered.

This was overcome by using what is known as an "indicator neon" in place of the larger type. This is a small neon, the approximate dimensions being 3/4 in. by 2 in., and the current consumed is only .5 watt. These miniature neons are only made to work between 200 and 250 volts, consequently this pressure will have to be used to operate the unit. The question of a suitable supply will be dealt with later on in the article.

The neon lamp will be seen projecting through the hole in the raised panel, the holder for this being underneath the enclosed part. This can be seen in Fig. 2. When the correct voltage is applied to the neon it glows with an orange tint. It is essential that the lamp be seen when the lid is shut, so a 1 1/2 in. hole was cut in the lid directly over the lamp and a circular piece of glass fitted in the manner shown in Fig. 2. A 1 1/2 in. hole was drilled partly through from the inside of the lid

previous to the 1 1/2 in. hole, this latter hole being then drilled on the same centre to form a recess into which the piece of glass was fitted. It is held in position by the heads of screws inserted around the circumference.

It was intended to use a plain piece of glass in the original model, but a pocket magnifying glass, obtained from a multiple store, was found more suitable as it enlarged the neon.

The second switch, seen in Figs. 2 and 6, is a single pole change-over switch (hereafter referred to as the discharge switch) one connection of which is still "live" with the lid open. This would

not matter normally, but the unit can be used on D.C. mains, and so it was considered necessary that both the power supply connections must be capable of being broken. The discharge switch then was wired to disconnect the other power lead, and in the "off" position (i.e., with the knob towards

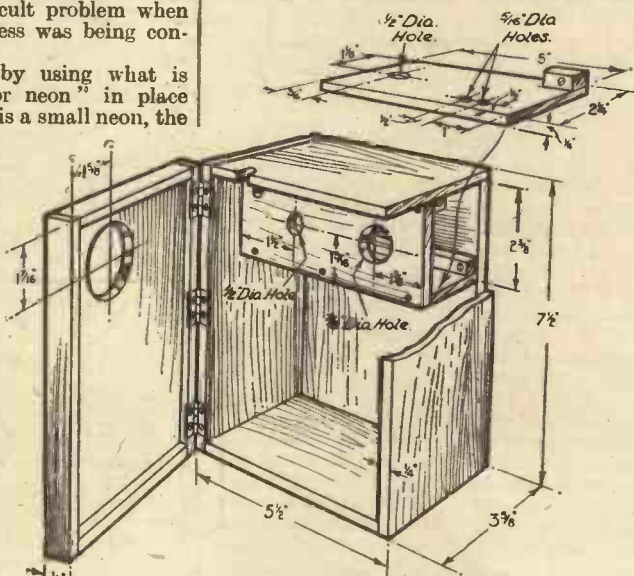

Fig. 1.—Constructional details of the cabinet.

the hinges) to connect a resistance across the testing points.

From the foregoing it will be seen that the unit is as fool-proof as it is possible to make it. The connections to the condenser under test are made with short lengths of flex terminating in crocodile (Continued overleaf)

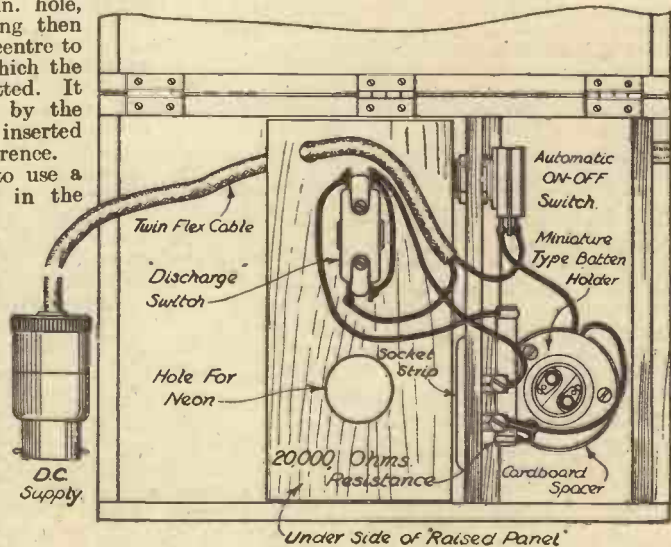

Fig. 4.—Wiring layout of unit.

(Continued from previous page)

clips, the other ends of the leads being joined to plugs. These plugs fit into a neat socket strip, the strip being attached to the side of the enclosed part, the connections being made internally. The sockets are not marked in any way to indicate their connections, as this is unnecessary.

The construction of the cabinet, that is if you intend to make it yourself, should

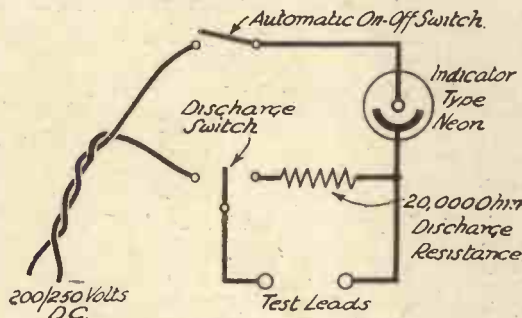

Fig. 5.—Theoretical circuit of unit.

present no difficulties. The original model was made from 1/2 in. satin walnut (planed) obtainable commercially and all that was necessary was to cut the various parts to size, clean up the edges, and assemble. The cabinet could be polished, if desired.

Power Supply

The only factor that remains to be dealt with, as far as the constructional side is concerned, is that of a suitable power supply. As already explained "indicator neons" only work on 200 to 250 volts. They function irrespective of the type of current; it can be either A.C. or D.C., but for testing purposes D.C. current must be used, so it remains to find the most convenient method of supplying this current. The rated wattage of the neon is .5; this means theoretically that the current consumed is only 2 milliamps., and as this is borne out in practice it will be apparent that the unit will not impose any overload on whatever source of power is used.

The current can conveniently be supplied from dry batteries, such as the H.T. battery of a set, always providing that the voltage is sufficient, or the unit can be used directly on D.C. mains; either method will be found to be satisfactory.

A great proportion of listeners are now using A.C. mains for their sets, and these require some method of rectification before the set will function. Most of them use a pentode in the output stage, the AC/PEN and Pen.4V. being examples of the type usually used, and the rated maximum voltage of these is 250 volts. This must be D.C., otherwise the valve would not

function, and so it can be said that practically all A.C. sets have a potential supply of 250 volts D.C. This is suitable for the unit, so—for convenience in connection—a wall-plug or batten-holder could be fitted somewhere on the set. Choose a place that is convenient but not obtrusive.

Concerning the connections for this, one terminal will be connected to H.T.—, the other to H.T.+ . Perhaps the best way of connecting to the latter point is to try the lead on both of the primary connections of the speaker output transformer, or on the L.S. connections of the set. This operation can be carried out with the set switched on, and the unit closed—with the discharge switch in the "test" position—and the test leads shorted.

When the unit is plugged in it will be found that the neon lights with the connection made in either position, but one is definitely brighter than the other. The former is the correct position, and as a further check this position will give the weaker click in the speaker. The connections can then be made permanently, and all that requires to be done is to switch on the set and plug in the unit when testing is to be carried out. The

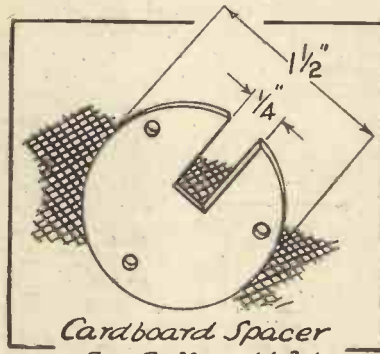

Cardboard Spacer for Batten Holder

set can be used for reception in the normal way while using the unit, the only difference being an occasional "click," which will probably be so weak as to pass unnoticed. By the way, when carrying out the above tests grip the lead by the rubber insulation, and not by the bare end—250 volts can give a nasty shock!

If the constructor is not "at home" with mains sets, it would be as well to switch off during the operation of changing from one terminal to the other. The H.T.— connection can be made to any earth point on the set. For reference purposes a typical smoothing circuit is given (Fig. 3) showing the best point to connect the plug.

Method of Testing

When testing, the first consideration is the working voltage of the condenser. All condensers of repute should be capable of standing a pressure of 240/250 volts

(D.C.) indefinitely, so it is safe to say that any condenser can be tested on the unit.

Those that have a rated working voltage in excess of 240 volts can also be tested, because a condenser which is absolutely sound when tested on 240 volts would in any case be fairly efficient at the higher voltage even if it is not definitely "leak-proof." It must be emphasized that the unit cannot be used for testing electrolytic condensers, because this type passes a continuous current of a few milliamps., this current being quite sufficient to light the neon at full brilliancy.

Continuing with the testing, a condenser is put in the testing compartment, the test leads connected up, the discharge switch placed in the "test" position and the lid is shut. The neon is seen to light for a second and then go out, remaining in this condition indefinitely. This indicates that the condenser is sound. It is the charging current that makes the neon glow for a short time. When the condenser is fully charged the current ceases and to all intents and purposes no further current should flow irrespective of the time the unit is left on.

If the condenser happens to be faulty there are two things which might happen. It may be found that the neon gave a continuous (but not necessarily steady) light. In this case the condenser is definitely faulty and should be discarded.

In the other case the neon may flash at regular intervals, there being no glow between the flashes. This would indicate that the condenser was not absolutely useless because it would obviously take a certain amount of the charge. The more charge it takes before leakage takes place (indicated by the neon) the higher would be the safe working voltage.

If the neon does not flash more than once a second the condenser can be used in positions where little or no voltage is applied, such as between band-pass coils and earth, or for bias decoupling. A condenser which "leaks" only once a minute is fairly sound and can be used with voltages up to 200. It requires very little practice to judge the condition of a condenser once the neon has indicated the amount of leakage.

Additional Uses

The unit may also be used for insulation tests between the windings of transformers, between the windings and the core, etc.

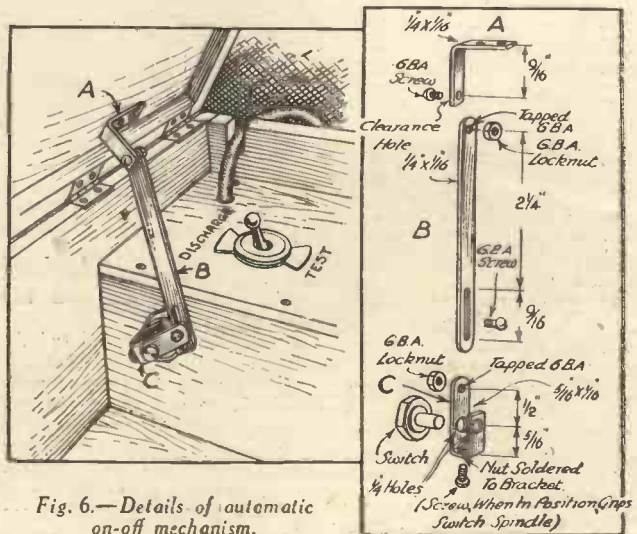

Fig. 6.—Details of automatic on-off mechanism.

MATERIAL REQUIRED

- One indicator neon (Osram).
- One S.B.C. holder (baseboard-mounting type).
- One rotary on-off switch (Bulgin S.91).
- One two-way toggle switch (Bulgin S.103).
- Two crocodile clips.
- Two yards of twin flex. (See text.)
- One mains adaptor.
- One wall-plug or batten holder. (See text.)
- One 20,000-ohm resistance (Eric).
- One socket strip with plugs (Belling-Lee 1047).
- One piece of glass 1 1/2 in. diameter, or magnifying lens.
- One cabinet, or wood for same.
- Three hinges.
- Wood screws; 6 in. single flex; one piece of cardboard 1 1/2 in. diameter.
- Total cost, excluding cabinet, approximately 13s.

Choosing and Making L.F. and Output Transformers

An Article Packed with Useful Information for the Home Constructor.

By FRANK PRESTON

IN previous issues of PRACTICAL WIRELESS there has been a good deal of information concerning the construction of various components, including mains transformers and chokes. And, despite the rather tedious work involved in the making of such components, readers have shown a tremendous amount of interest in the work. A large number have become so proficient at making their mains components that they have asked for details concerning low-frequency and output transformers, and it is because of this that this article is being written. Incidentally, it might be mentioned that constructional details for transformers of the "hedgehog" type were given in the issue dated January 14, 1933, but since proper stalloy stampings can now be bought cheaply from a number of firms, it is preferable that they should be used; not only are they more efficient than a bundle of ordinary soft-iron wires, but they are more convenient and produce a neater result.

Size of Core Stampings

Before such details as the numbers of turns on the primary and secondary windings can be decided upon it is necessary to know the size of stampings to be used, and also the required specification of the finished component. In the majority of cases it will be found that the most suitable sizes of "T" and "U" stampings will be numbers 5, 30, 30A, 30B, and 4A, and the actual dimensions of these can be obtained from Fig. 1, and the table given at the end of the article. It will be noticed that all these stampings are comparatively large by comparison with those used by component manufacturers, but there are good reasons for this. In the first place, most manufacturers employ core stampings of special alloys which have a higher permeability than stalloy, with a result that a higher inductance can be secured with any given number of turns and a smaller core volume. These special stampings are not generally available to the amateur, however, and if they were it would be found very difficult to wind on them the necessary numbers of turns of extremely fine wire.

In order to obtain a high degree of efficiency combined with reasonable ease of construction, therefore, it is much better to use the larger stampings and thicker wire. As a matter of fact, this form of construction has decided advantages because the finished transformer can be used for directly feeding the L.F. valves without there being any danger of core saturation or large voltage-drop across the primary.

So as to simplify the information to be given, it will be assumed that, when No. 5 stampings are employed, the core will be built up from three dozen pairs, whilst with any of the other sizes given in Table 1, only two dozen pairs will be used. By following this rule the numbers of turns for any particular transformer will be just the same regardless of the core size.

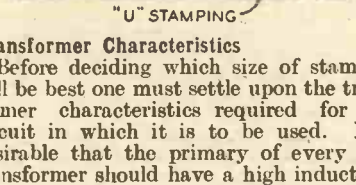
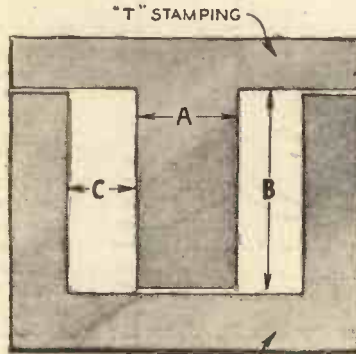

Transformer Characteristics

Before deciding which size of stamping will be best one must settle upon the transformer characteristics required for the circuit in which it is to be used. It is desirable that the primary of every L.F. transformer should have a high inductance

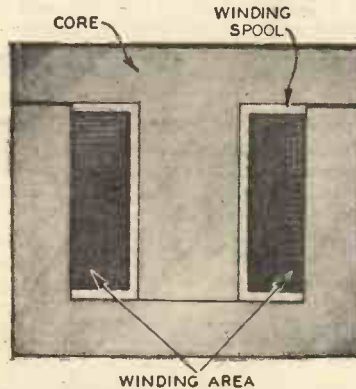

Fig. 2.—Showing the winding area available after fitting the spool on the core stampings.

when carrying the normal amount of anode current taken by the valve preceding it. The inductance of any transformer becomes less as the current passing through the primary is increased, and as the fre-

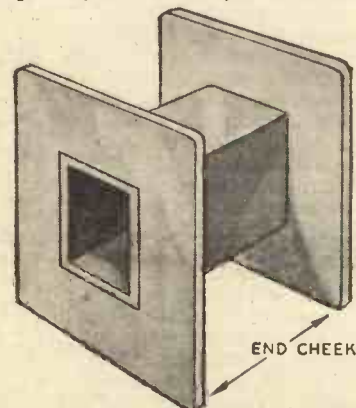

Fig. 3.—A built-up winding spool of the type referred to.

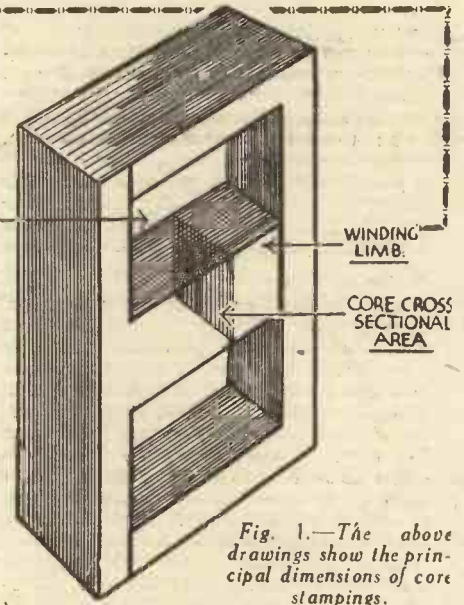

Fig. 1.—The above drawings show the principal dimensions of core stampings.

quency of the L.F. currents with which it is dealing is reduced. Fortunately, however, both of these difficulties are very largely overcome by employing a comparatively massive core of the type previously described.

A suitable inductance for the primary winding of a normal L.F. transformer, connected in the anode circuit of a medium impedance detector valve taking about 3 milliamps H.T. current, is 35 henries, and approximately this value can be obtained by winding 6,000 turns of wire on one of the cores previously specified. This primary winding can safely be adopted for any L.F. transformer whose primary current does not exceed about 5 milliamps, since when the current is increased, as it will be if the preceding valve is of comparatively low impedance, the inductance is proportionately reduced, whilst if the current is reduced (by using a higher-impedance valve, for instance), the inductance becomes higher. The result is that reasonably correct matching is obtained with any type of valve.

The Most Suitable Ratio

The number of turns required for the secondary winding depends upon the step-up ratio desired. For instance, if a ratio of 1 : 5 was wanted the secondary should consist of 30,000 turns. On the other hand, if a step-up of only 2 : 1 was called for the secondary would require to have only 12,000 turns.

The choice of ratio depends upon two principal factors—the type of valve used after the transformer and the extent to which quality of reproduction is to be considered. As further explanation of this point it should be explained that if too high a ratio were used, there would be a danger of overloading the following valve, so that the additional amplification given by the transformer would be more than useless. Moreover, an increase in the number of secondary turns means also an increase in capacity. And capacity necessarily causes a loss of amplification of the higher notes, so that reproduction is bound to suffer. For this reason it is nearly always desirable to use the lowest transformer ratio with which a sufficient degree of amplification can be obtained. This generally means that if two low-

Continued overleaf)

(Continued from previous page)

frequency stages are to be employed best results can be secured by using two transformers whose ratios are about 1 : 2. When a single L.F. valve of the power type (having a fairly low amplification factor) is being used the transformer ratio can, with advantage, be about 1 : 4 or 1 : 5 ; it is not generally worth while to exceed the latter ratio. If the only L.F. valve in use is a pentode (giving a high amplification) the best ratio is usually about 1 : 3.

Choice of Wire

After having decided upon the principal requirements of the transformer the practical details can be considered. The first item is the gauge of wire to be used, and this must depend to a certain extent upon the ratio and, hence, upon the total number of turns to be accommodated upon the core. Wherever possible it will be desirable to use wire of a gauge not finer than 40, because thinner material is by no means easy to handle. Even 38-gauge wire is to be preferred for the primary winding, but this is too thick for the secondary in the majority of cases. However, the matter of wire gauge can best be settled by making reference to Tables 1 and 2 which give, among other data, the number of "Turns per square in." for three alternative gauges of wire, and the "Winding Area" afforded by the different core stampings specified. It should be mentioned that the "Winding Area" given makes allowance for the space taken by a spool of the kind shown in Fig. 2, but not for the insertion of insulation between layers of the secondary winding. As the latter is desirable in order to keep down capacity the "Turns per square in." should be

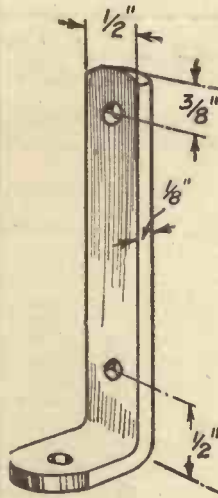

Fig. 4.—Principal dimensions of core clamps.

fibre (see Fig. 3). After the spool has been made it should be given a coat of thin glue or shellac varnish to make it rigid and to fix the end cheeks more securely.

Winding the Transformer

Then solder a short length of flex to the end of the wire to be used for the primary and anchor this by passing it through two small holes made in one end cheek. Cover the soldered joint by applying a blob of sealing wax, and wind on the correct number of turns. At the end of the winding solder a second length of flex and anchor

reduced by about 25 per cent. in respect of the secondary winding.

The method of constructing the transformer, after all the preliminary details have been settled, calls for little explanation since this matter has previously been dealt with in these pages. A start must be made by either building up or buying a winding spool to fit the stampings to be used. There are several firms who can supply ready-made spools, but there is no difficulty in making them from a strip of stout card or

this as before. The whole winding should then be covered by means of a strip of oiled silk for insulation purposes. (This can be obtained cheaply from chemists in square sheets.) It is important that no secondary turns should be allowed to slip past the insulation, and it is therefore best to make the silk a little wider than the spool so that it will bend up against the end cheeks. Solder a length of flex to the wire for the secondary, anchor this, and commence the winding. It is desirable that the turns should be wound as nearly as possible in layers and a little care is required to ensure this. After every two layers cover the winding with a strip of thin oiled silk or waxed paper; this is to reduce the capacity. On completion the wire can be terminated as before and the spool covered with a couple of layers of oiled silk or similar material.

Correct Connections

Finally the core stampings can be fitted into the spool, making sure that they are packed tightly, and suitable clamps fitted. The latter can be bought ready-made or constructed from strips of hard brass or iron as described in several previous issues (see Fig. 4). Connection to the transformer can be made either by means of the loose flexible leads already fitted or by means of terminals mounted on strips of fibre or ebonite which are attached to the core clamps. In any case the connections will be as follows: "Beginning" of primary winding to plate of previous valve; End of primary to H. T. +; "Beginning" of secondary to grid-bias negative; "End" of secondary to grid of following valve.

(Continued on page 188)

FROM MOVING IRON TO MOVING COIL

By G. W. DAVEY

WHEN a moving-coil speaker is to be employed it is especially important that the output valve and the speaker must be "matched up," that is to say, the impedance of the loud-speaker must be correctly proportioned in regard to that of the valve. From the early days of wireless up to a year or two ago the loud-speaker was usually placed directly in the anode circuit of the output valve. The impedance of the high-resistance speakers then used being about correct for the average output valve employed, everything was all right. Then came the pentode, the high-impedance output valve, and it was found the matching was not so good, especially as the low-impedance moving-coil speaker was becoming popular. As a result an output transformer had to be used. This transformer is supplied as an integral part of the moving-coil speaker nowadays, so that correct matching should be possible. In regard to the output valve, make sure that it is not being overloaded. The moving-iron loud-speaker, good though it often was, suffered always from the tendency to cover up distortion caused by the set; this the moving-coil will not do. An overloaded valve, a worn-out one, a poor quality transformer, all will show up in a moving-coil loud-speaker in the shape of poor reproduction, so it is advisable to look over the set and see if a few shillings or so cannot be expended in improving the quality of reproduction which it gives. If the transformer is two or three years old, or

of doubtful manufacture, spend five or six shillings on a modern one; you will be surprisingly pleased at the improvement in tone it will give. And the valves—have they been hard at work for maybe two or three years? If so, try a new one or two: especially is a new output valve to be advised. If a little more H.T. voltage can be spared, it is worth while to get a valve capable of giving a larger output, for here is another point to bear in mind regarding the proposed loud-speaker change-over. The permanent-magnet moving-coil loud-speaker will probably be slightly less sensitive than the moving-iron one it is to replace. That is to say, for the same input it will give rather less volume than the speaker previously employed. The permanent-magnet loud-speaker as made nowadays is quite sensitive enough to give moderate volume on a good two-valver; in fact, it is far more sensitive than ever it was. It must be remembered, however, that the balanced-armature speaker is one of the most sensitive units ever made. The reader is, therefore, recommended to try and get a little extra undistorted output from the set, to make up for any lack of sensitivity the new loud-speaker may have.

A word about the choice of a moving-coil speaker. Do buy a good one. There are many foreign, out-of-date, and liquidated stocks of them on the market just now.

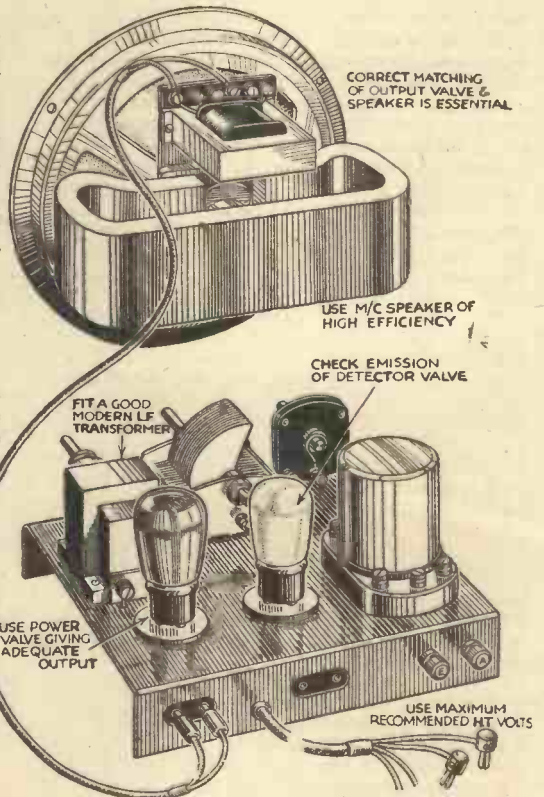

Important points to be noted when fitting a moving-coil speaker to a receiver are indicated in the above illustration and are explained in the text.

THE VALVE VOLTMETER

Some Interesting Notes Regarding the Use of an Ordinary Valve for Voltage-measuring Purposes

By D. P. TAYLOR

AN instrument of great value to the amateur experimenter is the valve voltmeter: this is an instrument utilizing the rectifying properties of an ordinary receiving valve to measure alternating potentials. It has the advantage

negative half-cycles will cause the anode current to fall to zero. Owing to the fact that the valve is being operated at the knee of the curve the rise due to the positive half cycles will be greater than the fall due to the negative half cycles, and the mean anode current will be greater than the normal value.

Advantages of the Voltmeter

This type of voltmeter has the advantage that it is not necessary to calibrate it against alternating current instruments, as the alternating voltage can be calculated from the readings of the grid voltmeter. It has also the advantages that it does not impose a load on the circuit under test, as it requires no current from the alternating current circuit, and that the anode current is low and its exact value need not be measured. It suffers, however, from the disadvantage

The negative bias should be now increased until the anode current is reduced to its normal value, then if V1 is the original value of the bias voltage then V2 is

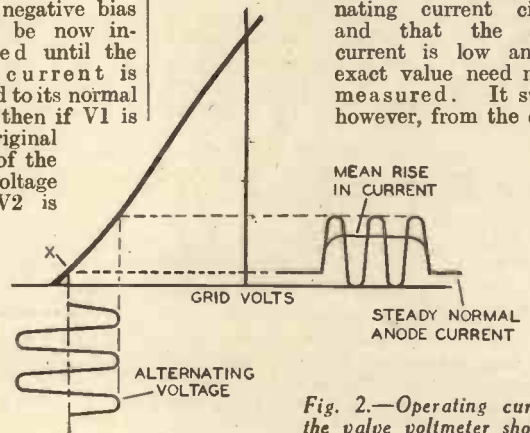

Fig. 2.—Operating curve of the valve voltmeter shown in Fig. 1.

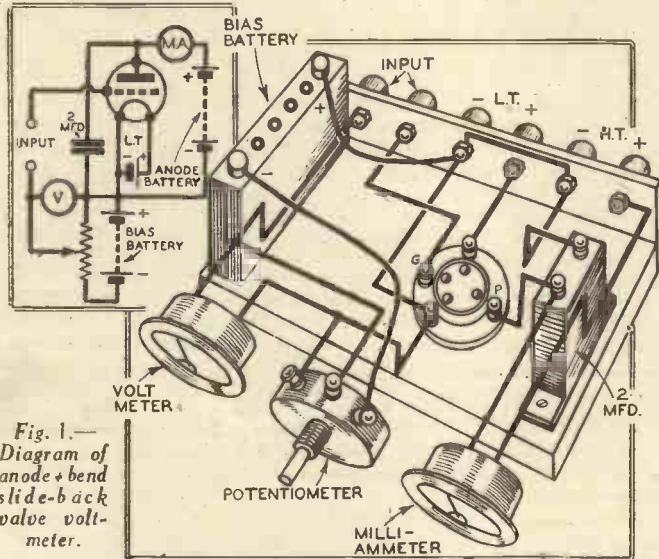

Fig. 1.—Diagram of anode-bend slide-back valve voltmeter.

that it is extremely easy to construct, in fact, most amateurs will already possess the necessary apparatus to construct this invaluable instrument. It has also the advantages that it can be used on alternating potentials practically independent of frequency, and in one case it is not necessary to have access to alternating-current instruments to calibrate it.

Valve voltmeters can be divided broadly into two classes: (a) Those which operate on the bend in the grid-volts grid-current characteristic of the valve, and (b) Those which operate on the bend in the grid-volts anode-current characteristic of the valve.

A Simple Instrument

The simplest instrument is the anode-bend slide-back valve voltmeter, which is shown diagrammatically in Fig. 1, and this will be considered first. Here a sensitive milliammeter is connected in the anode circuit of a triode valve working with a fixed anode potential, whilst a voltmeter of the direct-current type is connected to measure the variable-bias voltage applied to the valve. If the two input terminals are short-circuited and the bias voltage is varied, the anode current would vary, as shown by the curve in Fig. 2, this being the normal grid-volts anode-current curve of the valve at the anode potential used.

To operate as a valve voltmeter the bias should be adjusted with the input short-circuited to the point marked X at the knee of the curve and the anode current, which will be of a low value, noted. If, now, an alternating potential is applied to the input terminals, then the positive half-cycles will cause a rise in the anode current, whilst the

the bias voltage required to overcome the increase in anode current. This increase of bias voltage (V2-V1) is, approximately, equal to the maximum value of the alternating potential applied to the grid. This type of instrument can be simplified, as shown in Fig. 3; here, the grid voltmeter is eliminated and a switch fitted to enable the anode-current meter to perform the dual purpose. The grid voltage is measured by the current which the voltage causes to flow through resistance R. The value of this resistance should be chosen according to the normal bias voltages used.

vantage that it cannot be used in a circuit which has a direct current component, such as, for example, across a loud-speaker in the anode circuit of a valve, and that it is not satisfactory for use in circuits where the alternating current is constantly varying.

The first disadvantage can be eliminated by the use of the circuit shown in Fig. 3, here the bias voltage is not applied through the alternating current circuit, but through

(Continued overleaf)

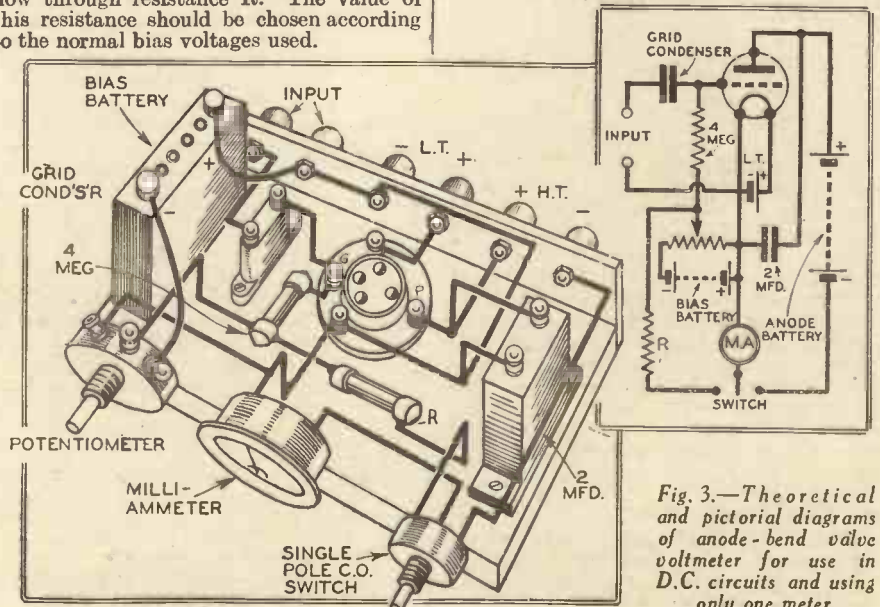

Fig. 3.—Theoretical and pictorial diagrams of anode-bend valve voltmeter for use in D.C. circuits and using only one meter.

(Continued from previous page)

a high resistance, whilst the grid is isolated from the direct current by means of a fixed condenser. These instruments can be used at any voltage within the normal voltage rating of the components used in their construction, providing a sufficiently high-bias voltage is available.

An Alternative

We come now to valve voltmeters which operate on the bend in the grid-current characteristic of the valve. This type of instrument is similar in connection to the grid-leak type of detector used in wireless receiving sets except in the values of the components used. The value of the grid condenser should be chosen so that it has a small impedance at the frequencies used normally. If the voltmeter is used at speech frequencies .25 mfd. is a suitable value, whilst, if used at radio frequencies, .005 mfd. is a good value. Care is necessary in the choice of these condensers to ensure that they are non-inductive, and that they do not allow any leakage of direct current to the grid of the valve.

As the valve is operated at the bottom bend of the grid-current curve, as shown in Fig. 2, when an alternating potential is applied to the input terminals the positive half cycles cause grid current to flow. This grid current gives the grid condenser a

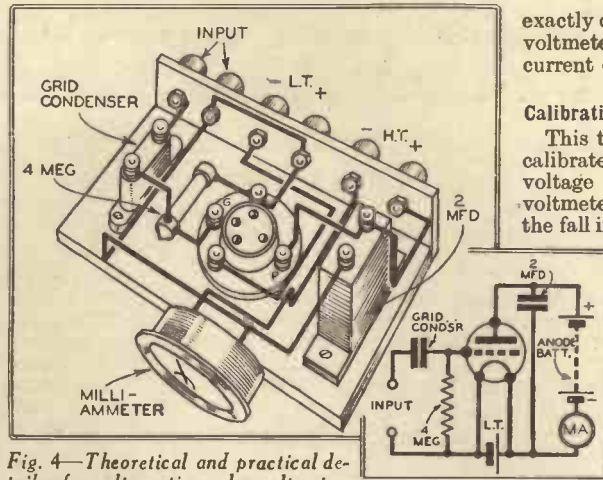

Fig. 4—Theoretical and practical details of an alternative valve voltmeter.

charge which causes the potential of the grid to be negative with respect to the filament. But for the presence of the grid leak the potential of the grid would become so negative as to cut off entirely the anode current, but, as it is, the grid potential becomes steady at a value depending upon the amplitude of the applied alternating voltage.

Thus the application of an alternating voltage to the input terminals causes a fall in the steady anode current which is

exactly opposite to the anode type of voltmeter where a rise in anode current occurs.

Calibrating the Meter

This type of voltmeter has to be calibrated on a source of alternating voltage against a standard A.C. voltmeter, a chart being made of the fall in anode current for a given voltage on the grid of the valve. It has also the disadvantage that the standing anode current is high, making it necessary to balance out the current by passing another current of the same value through the milliammeter. In this way the normal meter reading is zero, and thus the maximum accuracy in reading the change in current obtained. It has, however, the advantage that the change of current for a given alternating potential is greater as the valve functions as a two-electrode rectifier followed by an amplifier.

By the use of these instruments he can learn a great deal as to the operating conditions of his receiver, and this will repay the small expense in their construction.

MY job as a service engineer brings me into daily contact with many and various types of radio-grams, and not infrequently the motors require attention. In fact, my experience tells me that motors are probably the most neglected part of any radio equipment. It is curious to reflect that many men, who at regular intervals oil and grease their motor-cycles or cycles, expect their gramophone motor to function incessantly without any attention, or, at the most, a casual oiling at intervals of perhaps a year.

This is, of course, a wonderful indication of the reliability of modern motors, but,

ARMATURE WINDINGS

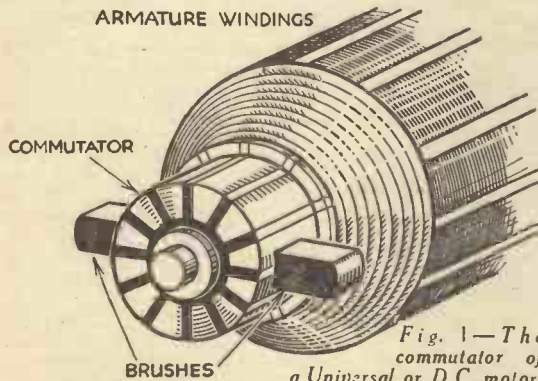

Fig. 1—The commutator of a Universal or D.C. motor.

nevertheless, a little intelligent attention at regular intervals will repay the enthusiast.

Electric motors may be roughly divided into two main types: (a) Universal and D.C.; (b) Induction and synchronous. The latter type of motor will work off A.C. only. For D.C. mains one of the former types must be used, but a Universal motor is, of course, applicable to either A.C. or D.C.

The Commutator

If you examine a motor in class (a) you will invariably find a commutator, and this sooner or later is certain to give trouble. A commutator is really only a multiple-pole

THE CARE OF ELECTRIC GRAMOPHONE MOTORS

Some Useful Hints in Connection with the Maintenance of the Gramophone Motor. By "SERVICE"

rotary switch and the contacts all have friction surfaces. A commutator takes the form of a copper cylinder which is split up into segments, each of which is carefully insulated from its neighbour with a layer of non-conducting material which is almost always mica (see Fig. 1). On the outer circumference of the commutator, and diametrically opposite, will be found two "brushes" which take the form of oblong carbon blocks.

If, when the motor is running, any sparking occurs at the points of contact it will very probably be picked up by the amplifier and will result in a very unpleasant continuous crackle in the loud-speaker. After a period of use the brushes wear down and a deposit of carbon dust is formed on the commutator. This must be cleaned off by revolving the motor by hand and holding some very fine glasspaper on the commutator.

A word of warning is, perhaps, called for here. Under no circumstances should emery cloth be used—indeed, this should be avoided when doing any electrical work. The grade of glasspaper to use is called "flour" and is very fine.

It may be that the brushes are badly worn after a long period of use. In this case they should be replaced with new ones which can be purchased from the manufacturers for a few pence. The method of doing this will be obvious, although it varies with different makes. If it is uncertain whether the brushes require replacement or not, the point to watch

is that there must be no danger of the metal holder touching the commutator.

"Skimming" and Slotting the Commutator

In some cases it will be found that glass-papering will not cure the fault. If this is so, a careful examination will show that the mica is a trifle "proud" or sticking up slightly above the copper. It may be also found that there are scores or ridges in the commutator. The cure for this is known as "skimming and slotting" and calls for a certain amount of dexterity and workshop facilities.

The first thing to be done is to take down COPPER SEGMENTS SHOWN WHITE

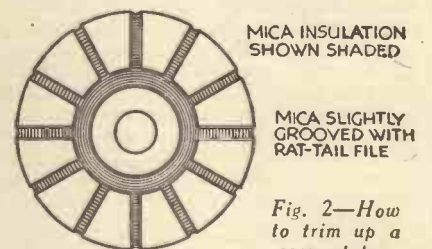

Fig. 2—How to trim up a commutator.

END VIEW OF COMMUTATOR

the motor and remove the armature complete. This should then be revolved in a lathe and a very thin "skim" or cut taken off the surface of the commutator. If there is no lathe handy, almost any garage will undertake this job for a small sum. Care should be taken to see that no more than necessary is taken off—just sufficient to remove the scores.

A very thin file known as a "rat tail" is used in the next operation. All the small layers of mica should be filed down so that they are slightly below the level of the copper (see Fig. 2). I should, perhaps, here repeat the warning given above: take off very little.

When re-assembling the motor, it should be cleaned carefully with a clean rag and fresh oil should be applied to all bearings.

(Continued on page 188)

How to Choose and Use the BEST VALVES — Part IV

Class "B" Valves are Dealt With in This Final Article

By H. J. BARTON CHAPPLE, Wh.Sch., B.Sc., A.M.I.E.E.

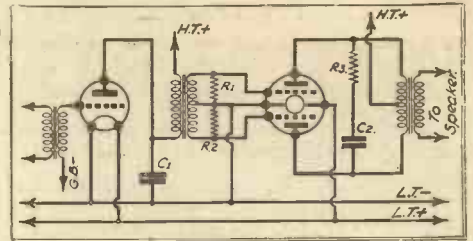

THE Class "B" is a special form of valve designed to give a very large maximum output—an output much greater than that obtainable from any single battery valve of Class "A" type—and at the same time to limit the consumption of high-tension current to a value within the capacity of a small and inexpensive high-tension battery.

First of all, it is very important to understand exactly what is meant by the "output" of a valve, and what by the term "maximum output." By "output" is meant that portion of the power taken from the high-tension battery which is available for operating the loud-speaker. It will be shown later that in the case of an ordinary, that is Class "A," valve, this proportion is quite small, and certainly not reaching 50 per cent.

Maximum Output

The useful maximum output of a valve is the maximum power that can be taken from it without introducing noticeable distortion.

In order to give the necessary "light and shade" to a musical item, bands, and so forth, which, while playing at normal loudness during most of the programme, sometimes play more softly and sometimes more loudly than the average, and occasionally work up to a fortissimo climax. So that these gradations shall be reproduced in listeners' speakers, broadcasting stations see to it that the programme energy radiated from their aeri-als varies with the loudness of the music. Thus, while the radio-frequency power radiated remains substantially constant, the "programme energy," or "modulation" as it is termed, varies from moment to moment.

If a receiver is so adjusted that, during normal portions of the programme the output valve is giving its maximum undistorted output, any loud passages which occur will be reproduced badly, there will be distortion and blasting, so it is necessary to employ a valve which, while giving the desired volume with average programme modulation, has sufficient reserve of output to handle, without undue distortion, the fully modulated passages.

Somewhat Wasteful

Unfortunately, with ordinary valves, this is an expensive and somewhat wasteful proceeding. The actual output of a valve comprises variations in the instantaneous value of the high-tension current above and below a certain mean value, and if the output has to range from a moderate amount during most of the programme to a very

large amount at special periods, the mean or average value must be high. Thus, a Class "A" super-power valve may take a steady high-tension drain of 15 milliamps all the time the set is switched on, irrespective of whether a programme is being received, or whether the music is soft or loud. Fifteen milliamps at 150 volts represents a high-tension consumption of 2¼ watts, and yet, with a fully-modulated signal, the valve would give an output of only a little more than half a watt, while the average power during an evening's use will be very much less.

The standing current of a Class "B" valve is very small—usually about 3 milliamperes, but it draws more current just as it is needed when the signal input increases. For this reason, the losses in a Class "B" valve are very much less, while the proportion of the total high-tension drain which is available as actual power output is very high, amounting to about 65 per cent. as against some 25 per cent. in the case of a power or super-power triode.

Thus it comes about that it is possible for a Class "B" valve to have a maximum undistorted output of 1¼ watts, yet the mean anode current over a representative period of use is less than 8 milliamps. A similar maximum output from battery-operated triodes would necessitate several valves being used in parallel, and taking a constant drain of about 60 milliamperes, or nearly eight times as much as the Class "B" valve.

How it is Done

A Class "B" valve really consists of two complete triode valves contained in a single bulb. These valves have a very high amplification factor, and are so designed that the value of the anode current at zero grid volts is very small—about 3 milliamps. The incoming signal is applied through a transformer with a centre-tapped secondary as shown in Fig. 1, so that when the grid of one-half of the valve is dealing with a positive half-cycle of the signal, the other grid is dealing with a negative half-cycle, and vice versa. But as the anode current at zero grid volts is very small, the negative half cycles will be wiped out entirely, so that the two grids work alternately in a kind of push-pull arrangement.

We have previously become used to the idea that all output valves should be given the appropriate negative grid bias, but in the case of most Class "B" valves no bias is used at all, the grids being allowed to become positive during the working portion of each cycle. As a result of

driving the valve positive, a fairly large grid current will flow. This represents a definite amount of power which must be supplied by the previous valve in the receiver. In practice, therefore, a Class "B" output valve must be preceded by another low-frequency stage, known as the driver stage, capable of delivering an appreciable amount of power.

Referring to Fig. 1, the transformer used for coupling the driver to the Class "B" valve must be considered. This must be a step-down transformer, unlike those used for Class "A," and the ratio must be that recommended by the valve maker. It is also important that the secondary winding shall have a low resistance of between 200 and 400 ohms. It will be seen that the outputs of the two halves of the Class "B" valve are combined in an output transformer with a centre-tapped primary. Alternatively, a centre-tapped choke may be used. The transformer ratio must, of course, be chosen to suit the loud-speaker used, but it is important that the D.C. resistance of the primary winding shall be low—usually no more than 1,000 ohms.

Two other points about the circuit require special attention. In the first place, it is important that means be taken to prevent H.F. oscillation in the grid circuits, and for this purpose two resistances of 10,000 ohms R_1 and R_2 connected between the ends of the input transformer secondary and the centre tap are recommended.

Then it must be remembered that the characteristics of a Class "B" valve are very similar to those of a pentode, so that, in the event of the speaker being accidentally disconnected when the valve is in use, very serious peak voltages may be generated which may damage the valve or even cause the insulation of the output transformer to break down.

This risk can be avoided by connecting a 10,000 ohm resistance R_1 and a .005 mfd. condenser C_2 in series across the output transformer primary.

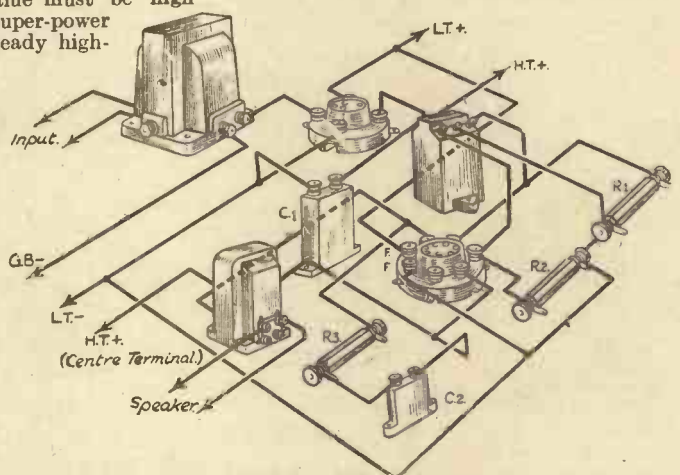

Fig. 1.—Pictorial and theoretical circuits of a typical "Class B" amplifier, including the driver stage.

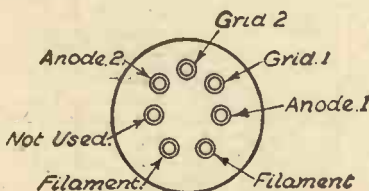

Fig. 2.—The connections for a seven-pin "Class B" valve are shown in this drawing, which shows the valve base as seen from below.

INTRODUCING— THE PRIMA MAINS THREE

An Easy-to-build and Cheap Mains Receiver which Incorporates a Ready-made Mains Unit and a Simple Standard Circuit

THESE are a large number of readers, as is proved by our correspondence bag, who, whilst they would very much like to build a receiver to operate from the A.C. Mains, are rather shy of

receiving which has all the advantages of the usual simple home-construction and yet confers the

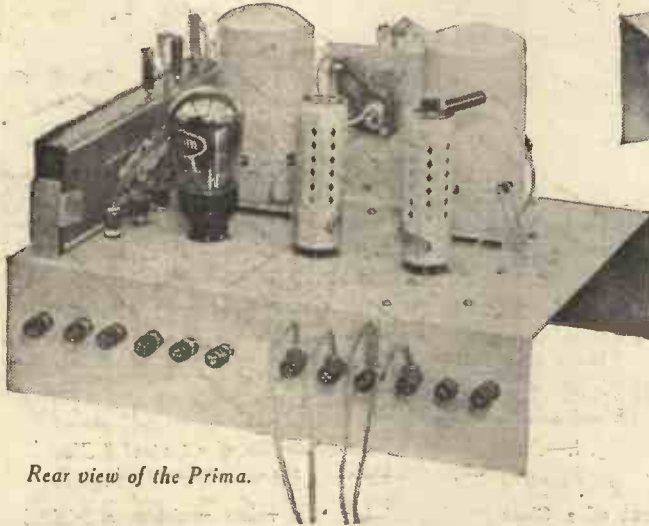

Rear view of the Prima.

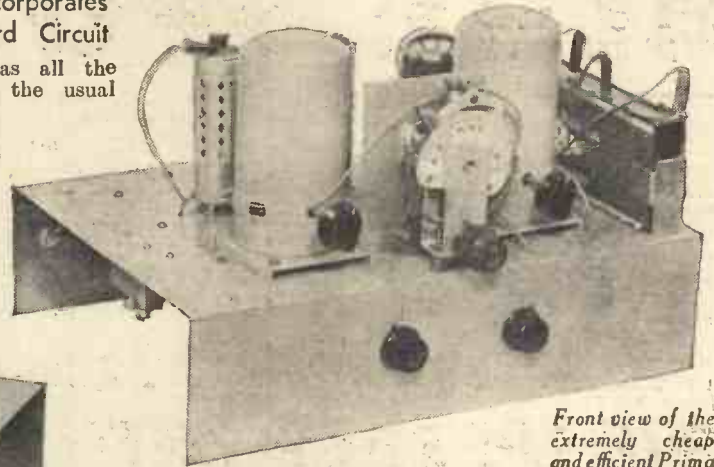

Front view of the extremely cheap and efficient Prima

benefits of a good mains receiver.

The Circuit

As may be seen from the circuit and the illustrations a complete mains unit is employed, and this is manufactured by

Messrs. Mains Power Radio, Ltd. The receiver proper is provided with leads after the fashion of a standard battery receiver, and these leads are plugged into the sockets of the mains unit to provide the H.T. and L.T. supplies. Mains valves are employed, the H.F. and detector valves being of the indirectly-heated type, and the output valve having a directly-heated filament. This is of the type designed to operate with raw A.C. and, therefore, a 4-volt A.C. supply is provided on the mains unit. The circuit is of the standard H.F. detector and pentode type which has proved time and time again to provide the best results, combined with simplicity of operation. The aerial circuit consists of a simple tapped coil, the aerial being joined to a transfer tapping which is changed over upon the operation of the normal wave-change switch. The H.F. valve is of the variable- μ type, and the bias is

varied by means of a potentiometer joined in the cathode-screening-grid circuit. In place of the customary potentiometer across the H.T. supply, the screening-grid is provided with a flexible lead which is plugged into the mains unit, and although this is a little unusual, it has been found to provide excellent stability, and reduces the initial costs.

Coupling between H.F. and detector valves is carried out by a tuned-grid coil, and to relieve the damping of the grid leak a special tapping is provided on the coil and thus the load of the detector valve is placed across only part of the coil.

Direct-fed transformer coupling is provided between detector and output valves, and the speaker is intended for connection in the anode circuit of the latter valve. As this is of the directly-heated type, grid bias is applied, through the medium of a standard battery, to the lower end of the secondary of the transformer, and this arrangement offers certain advantages, besides reducing the initial cost by enabling a directly-heated valve to be employed for this stage.

Pick-up terminals are provided, and one of these is intended to be joined direct to the grid of the detector valve, whilst a wander lead should be attached to the other

(Continued on page 188)

LIST OF COMPONENTS

- One "Prima" Steel Chassis—Peto-Scott.
- One "Prima" Special Two-gang Tuning Condenser—Ormond R.366 (C1 & C2).
- Two Tuning Coils; one Type KGO and one Type KGR—Colvern.
- One .0003 mfd. Differential Reaction Condenser—Graham Farish (C5).
- One 10,000 ohm Potentiometer—Cosmocord Log Type (R3).
- Three 5-pin Chassis-mounting Valve-holders—Clix.
- Three Strip Wire-wound Resistors—Colvern Flat Type (100 ohms, 10,000 ohms and 15,000 ohms) (R4, R1, R2).
- Two 1-mfd. Fixed Condensers, 500 volt D.C. working—Peak (C3 & C7).
- One H.F. Choke—Graham Farish "Snap."
- One .0002 mfd. Fixed Condenser—Graham Farish (C6).
- One .0005 mfd. Fixed Condenser—Graham Farish (C4).
- One 1 megohm Grid Leak—Graham Farish (R5).
- One 3½:1 L.F. Transformer—Ormond.
- One pair Grid Bias Battery Clips—Bulgin No. 1.
- Fifteen Terminals, one each marked L.S.+ L.S.—, A, B, G.B.—1, G.B.—2, G.B.—, H.T.—, Screen, H.T.+1 and H.T.+2; two each marked L.T.A.C. and Pick-up—Belling Lee Type R.
- One Packet Terminal Insulating Washers—Belling Lee.
- One Safety Anode Connector—Clix.
- Seven Wander Plugs—Clix.
- Four Spade Terminals—Clix.
- Connecting Wire, Flex, Screws, etc.
- One Ormond Loud-speaker.
- Three Valves (Osram VMS4, MH4 (Catkin) and PT425).
- One Mains Power Radio Mains Unit—Type A.C.4.
- One 6 volt Dial Light Bulb—Bulgin.
- One 16 volt G.B. Battery—Lissen.

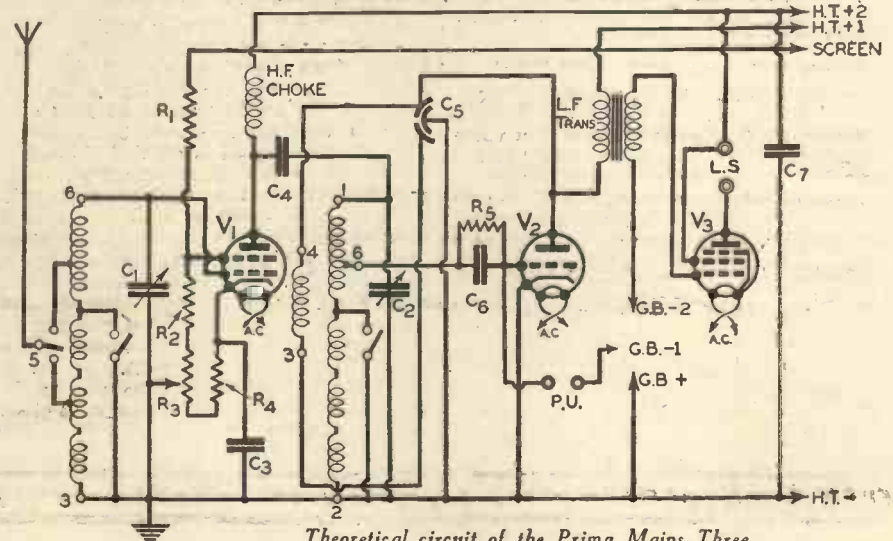

Theoretical circuit of the Prima Mains Three.

attempting to build up equipment which has eventually to be plugged into the high-voltage house circuit. Whether or not this is because they think there is some danger to be guarded against, or whether they are afraid the apparatus might be damaged with consequent risk of expense for replacements, etc., we do not know, but there is definite proof that such a hesitancy does exist. The object of the Prima is to overcome such difficulties and to present to the home-constructor a complete mains re-

BLUE SPOT "STAR"

The new Blue Spot "Star" has already aroused an enormous amount of interest and those who have heard its remarkable performance have nothing but the highest praise for this very remarkable speaker. Here are the principal features.

● **NEW MAGNET SYSTEM**

The magnet material is enclosed in four chromium-plated tubes. The high flux density and many other special features gives a hitherto unattained degree of power and quality.

● **UNIVERSAL MATCHING**

The transformer is designed on unique and highly efficient lines and is arranged to match ANY OUTPUT STAGE from Power to Push-Pull Pentode and Class B and can be used as an extension loudspeaker from the speech coil circuit of an existing loudspeaker of any impedance without loss of efficiency. Full instructions on back of plate of speaker.

● **ON AND OFF SWITCH OR REMOTE VOLUME CONTROL**

A switch plug is provided to cut speaker out of circuit when desired. This switch is interchangeable with Blue Spot Remote Volume Control and "on" and "off" Unit.

● **EXTENSION SPEAKER SOCKET**

A socket is provided for an extension speaker to be plugged into the Blue Spot "Star." The controls of each loudspeaker remaining completely independent.

● **DUST-PROOF**

The cap in the centre of the cone and the special dust covers which surround the speech coil and magnet gap render the speaker completely dust-proof.

● **DIE-CAST CHASSIS**

Ensuring no loss of magnetism, complete rigidity and absence of chassis resonance.

● **SPEECH COIL**

Low resistance and high efficiency, giving minimum variation of impedance with frequency. The entirely new design of outside suspension gives great freedom of movement with complete lateral rigidity.

Write for Catalogue No. P.R. 11.

CHASSIS PRICE 70/-



THE SPEAKER WITH THE NEW MAGNET

THE BRITISH BLUE SPOT COMPANY LTD
BLUE SPOT HOUSE • 95/96 ROSOMAN STREET • ROSEBERY AVENUE • LONDON E 6

Telephone: Clerkenwell 3570. Telegrams: "Bluspot, Isling, London."
Distributors for Northern England, Scotland and Wales: H. C. RAWSON (Sheffield and London). Ltd., Sheffield; 22, St. Mary's Parsonage, Manchester; 177, Westgate Road, Newcastle-on-Tyne; 37, 38, 39, Clyde Place, Glasgow.



A VALVE FOR EVERY PURPOSE AT A MONEY-SAVING PRICE

● We make no claim that DARIO valves are better than anything else on the market. But we do assert that, whatever you pay for a valve, you can get none more efficient than a DARIO. And, what's more, there's a DARIO valve for every position in any set. Our price list gives you complete characteristics and working data of 39 popular DARIO valves at prices which save shillings on each valve. It gives you, too, a table of DARIO alternatives—mains or battery, simple triode, or highly modern valves like the Variable- μ H.F. pentode.



DARIO VALVES

STUDY AT HOME **U** IN YOUR SPARE TIME

CAN HAVE A COLLEGE TRAINING IN ALMOST ANY CAREER FOR A FEW SHILLINGS MONTHLY.

MATRICULATION

There are many ways of commencing a career, but Matriculation is the jumping-off board for all the best ones.

CIVIL SERVICE

Suitable to both sexes. Ages 15½ to 24.

G.P.O. ENG. DEPT. CUSTOMS AND EXCISE: INSP. of TAXES. Etc. NO EXPERIENCE REQUIRED. OPEN EXAMS.

We prepare candidates for all

INSTITUTE EXAMS.

TECHNICAL, INSURANCE, COMMERCIAL, GENERAL, POLICE, Etc., Etc.,

ENGINEERS ALL BRANCHES

There are examinations which are open and suitable to you, others which are not. Get our advice before deciding.

The Commercial Side of

THE MOTOR TRADE

offers exceptional opportunities for young men of good education.

LET ME BE YOUR FATHER

Let me give you that fatherly advice which is FREE to you, but which may mean so much to you in the future.



We do not profess to act as an employment agency, but we certainly are in a position to give fatherly advice on all careers and the possibility of employment therein.

DO NOT DELAY

There may be chances for you today for which you may be too late to-morrow.

Every day counts in a man's career.

THE MOST SUCCESSFUL AND MOST PROGRESSIVE CORRESPONDENCE COLLEGE IN THE WORLD

We teach by post in all parts of the world and specialise in all examinations.

- | | | |
|---|--|--|
| Accountancy Examinations | All Commercial Subjects | Naval Architecture |
| Advertising and Sales Management | Commercial Art | Pattern Making |
| A.M.I. Fire E. Exam. | Concrete and Structural Engineering | Police. Special Course |
| Applied Mechanics | Draughtsmanship. All Branches | Preceptors, College of Pumps and Pumping Machinery |
| Army Certificates | Engineering. All branches, subjects and examinations | Radio Reception |
| Auctioneers and Estate Agents | General Education | Road-Making and Maintenance |
| Aviation Engineering | G.P.O. Eng. Dept. | Salesmanship |
| Banking. Boilers | Heating and Ventilating | Sanitation |
| Book-keeping, Accountancy and Modern Business Methods | Industrial Chemistry | Secretarial Exams. |
| B.Sc. (Eng.) | Insurance | Shipbuilding |
| B.Sc. (Estate Management) | Mathematics | Shorthand (Pitman's) |
| Building, Architecture and Clerk of Works | Matriculation | Structural Engineering |
| Civil Engineering | Metalurgy | Surveying |
| Civil Service | Mining. All subjects. | Teachers of Handicrafts |
| | Mining, Electrical Engineering | Telephony and Telegraphy |
| | Motor Engineering | Transport Inst. Exams. |
| | Motor Trade | Weights and Measures Inspector |
| | Municipal and County Engineers | Wireless Telegraphy and Telephone Works Managers |

If you do not see your own requirements above, write to us on any subject.

IT COSTS NOTHING TO ENQUIRE

Note Address Carefully:— **DEPT. 192, THE BENNETT COLLEGE LTD., SHEFFIELD.**



The **VARIABLE COLVERSTAT**

Type S.T.5.C.

The supreme variable resistance, with unique smoothness of control and complete freedom from noise. Protected windings. Rating 5 watts. Standard values 250 to 25,000 ohms.

3/6

THE FINEST VARIABLE RESISTANCE YOU CAN BUY

You cannot buy a better variable resistance than the Colverstat. for, like all Colvern products, it is beautifully, accurately and precisely made. Specify Colvern products for your set and you can depend on getting the best results.

Write to-day for the latest Colvern booklet, Radio List No. 12, to Colvern Ltd., Romford, Essex. ★

COLVERN

SCRAP THOSE "DRUNKEN" POLES!

NO-MAST

THE WORLD'S BEST AERIAL

REQUIRES NO POLE

Only outdoor aerials give the best results. Follow the example of leading Radio experts and B.B.C. officials and install the "No-Mast" Aerial, which costs much less to buy and erect than the unsightly, troublesome pole aerial. The "No-Mast" Aerial is scientifically made, and will definitely improve range, volume and selectivity. A boon to flat-dwellers, enabling them to have an efficient outdoor aerial.

Improved 1934 Model

COUPON

To: **CENTRAL EQUIPMENT LIMITED,**

188, LONDON ROAD, LIVERPOOL, 3.

Please send to my address:

- 1. ONE NO-MAST AERIAL.** (P.O. for 10/6 enclosed.)
- 2. DESCRIPTIVE FOLDER** (Strike out item not required.)

NAME.....
ADDRESS.....

Pr.W. 28/4/34. BLOCK CAPITALS, PLEASE

ENABLES YOU TO TUNE IN AND SEPARATE STATIONS NEVER HEARD BEFORE ON YOUR SET.

10/6
POST FREE U.K. and N. IRELAND
Complete with fittings.

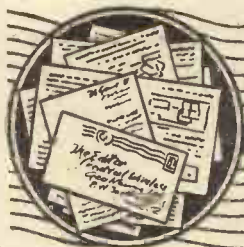

READERS' WRINKLES

THE HALF-GUINEA PAGE

A Midget Loud-speaker

SOME types of motor car electric horns can be used as successful midget loud-speakers by making the small alterations shown in the accompanying sketch. It will be seen that the contacts of the

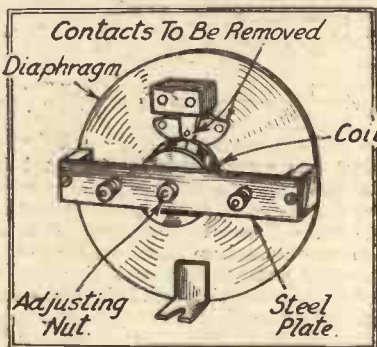

An improvised midget loud-speaker.

ordinary make-and-break are removed and the winding is then connected to the speaker terminals of the receiver. The resistance of the winding is quite low and it is therefore necessary to connect it to the set through a suitable step-down transformer having a ratio of about 25 to 1 when the output valve is of the small power type, or 35 to 1 in the case of a pentode.

It will be appreciated that a speaker made according to the method described is not extremely sensitive whilst it cannot be considered a "quality" instrument. Nevertheless, it will give fairly good results in most cases, whilst an improvement can often be made by removing the normal winding and replacing it with one of very fine wire such as 38-gauge enamelled.—A. Cox (Alesford).

Gas Heater for a Soldering Iron

WHEN heating a soldering iron over an ordinary gas ring a quantity of gas is usually wasted, and this may be overcome by resorting to the method here illustrated. A tin lid with a centre hole $\frac{1}{2}$ in. diameter is lined around the inside with a strip of asbestos, and the edge of the tin cut away to accommodate the gas feed

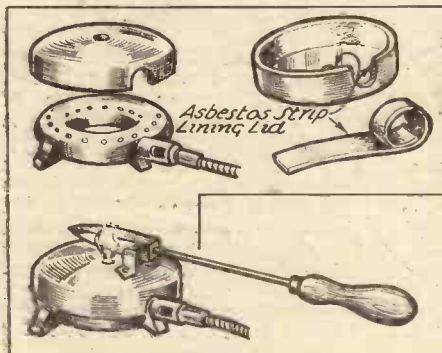

A gas-economising device for heating a soldering iron.

THAT DODGE OF YOURS!

Every Reader of "PRACTICAL WIRELESS" must have originated some little dodge which would interest other readers. Why not pass it on to us? We pay £1-10-0 for the best wrinkle submitted, and for every other item published on this page we will pay half-a-guinea. Turn that idea of yours to account by sending it in to us addressed to the Editor, "PRACTICAL WIRELESS," George Newnes, Ltd., 8-11, Southampton Street, Strand, W.C.2. Put your name and address on every item. Please note that every notion sent in must be original. Mark envelopes "Radio Wrinkles." Do NOT enclose Queries with your Wrinkle.

pipe. After placing the lid over the gas ring, as shown, it will be found that very little gas is required to produce a flame adequate for heating a soldering iron, and no gas will be wasted.—A. G. ACKROYD (Forest Gate).

Improving the Appearance of Control Knobs

MANY knobs and escutcheons on amateur-built sets are of different colours, and although knobs may be purchased of the



Improving the appearance of control knobs.

same colour, the purchase of an escutcheon is a different matter. It is quite easy to make all knobs and escutcheons any desired colour by the following method. Some

fancy sealing-wax, methylated spirits and a brush are the only requirement. Break up the sealing wax so that it will go into a 2oz. bottle, just cover the wax with methylated spirit, give it a shake or two and let it stand until next day, when the wax will be dissolved. A small camel's hair brush will be found suitable to paint the wax on the knob or other article to be treated. In two days the finish will be found to be quite hard and of high polish. Any colour can be obtained, such as bronze, red, green or aluminium. Stationers and art stores supply suitable wax in sticks about 5 or 6 in. long.—W. PRESTON (Dewsbury).

(The sender of this wrinkle forwarded

samples of ebonite treated in the above manner, and these were certainly of attractive appearance.—Ed.)

A "Low Loss" Valve-holder

AN efficient low-loss valve-holder for an ultra-short-wave receiver can be made in the following manner. Four

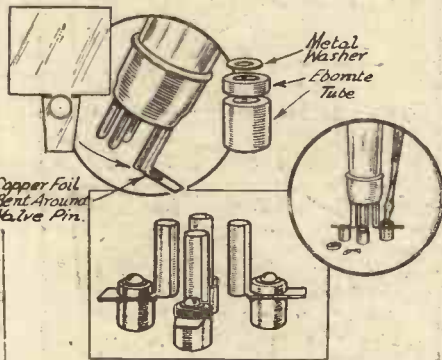

A simple method of making a low-loss valve-holder.

pieces of copper foil or thin sheet brass are cut and bent around a valve pin, as shown in the sketch. The mounting and insulating washers can be cut from an old ebonite lead-in tube. In mounting, use the valve as a guide to get the correct positions by pushing the four sockets on the pins and screwing down while held in position on the base board.—T. H. SKINNER (London, E.C.).

Automatic Station Selection

WANTING a choice of three stations without the trouble of tuning. I evolved the idea illustrated in the accompanying circuit. The stations which were tuned in were: London Regional, 5XX, and Radio-Paris. The switch was turned to the centre position; condenser C was tuned to Radio-Paris. The switch was then turned to connect condenser A to earth, and the latter was then tuned to 5XX. The switch was then turned to the third position and London Regional was

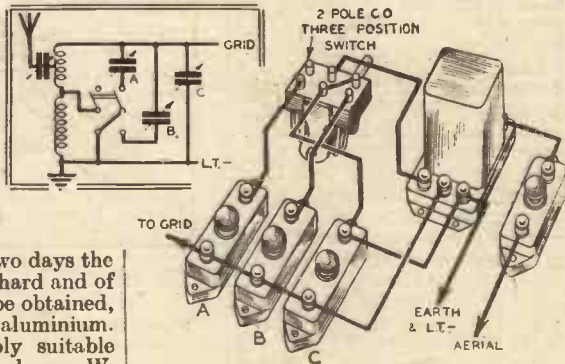

A switching arrangement to provide for automatic station selection.

READERS' WRINKLES

(Continued from previous page)

tuned in with condenser B. The preset condensers A, B and C were .0001, .0003 and .0002 mfd. respectively. The switch is, of course, of the D.P.D.T. three-position type.—C. P. O'CONNOR (Brighton).

An Automatic Gram. Switch

THE accompanying sketch shows a simple method of arranging an automatic stop on an electric gramophone. The relay is made from an old electric bell

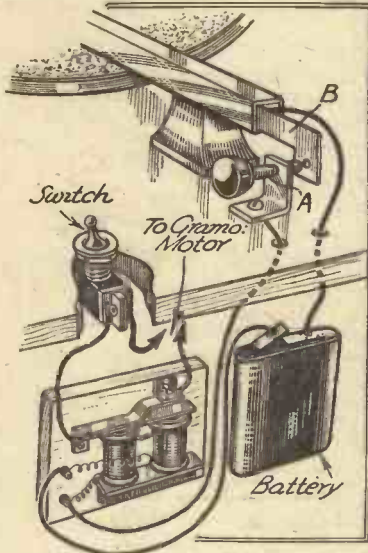

An efficient automatic gramo-switch.

movement, with connections altered as shown. The contact piece B is made from thin springy brass and can either be soldered on to pick-up arm or, if the arm is made of bakelite, it can be drilled and bolted on. The contact screw A is made from a piece of 2B.A. screwed rod 2in. long, and a brass or aluminium bracket is tapped to take the screwed rod. An old ebonite knob, as used on the early condensers, can be screwed on one end of the rod for adjustment purposes. The battery can be an ordinary flash-lamp battery or an accumulator.

To adjust the auto-stop, put pick-up on the run-off groove of record and turn knob until A and B make contact. Then switch on motor and play record in normal way. When the record is ended the pick-up will run into the groove, close contacts A and B, which will cause relay magnets to be energized by battery, thereby attracting the armature and breaking relay contacts, which will switch off the motor. Upon lifting the pick-up the motor will restart itself and if the gramophone is not required immediately the motor can be switched off in usual way.

The auto-stop never fails to act if properly adjusted, and is more certain in its action than the normal type of automatic stop. The relay and battery should be placed inside the cabinet to avoid the risk of anyone touching the live contacts to the relay.

As the battery will run down if left with contacts A and B closed, the pick-up should be taken off the record and the motor switched off in the normal manner

when the gramophone is not in use.—LESLIE J. HILLS (Belvedere).

A Useful Combination Tool

A HANDY pocket tool, which can be used for wire stripping and several other purposes, is shown in the accompanying sketches. In one end of a piece of steel tubing, 1½ in. long, two pieces of spring steel, bent as shown, are firmly fixed. One bent-over end is notched, and the other filed to a sharp edge. On the side of the tube, at the other end, a small metal block is soldered which holds a short length of a round file arranged to be held in position along the side of the tube when not in use. It is clamped by a small milled-head screw. A short piece of spring steel, notched in the middle, is fixed to the end of the tube, and projects about ½ in.

For cleaning valve pins the tool is used as shown in Fig. 1, and terminals can be cleaned as depicted in Figs. 2 and 4. Wire can be quickly stripped, as shown in Fig. 3, and the tool is used for cleaning the sockets in valve-holders, as shown in Fig. 6. An alternative method of making the tool with one piece of spring steel is illustrated in Fig. 5.—J. W. HOBLEY (Wellingborough).

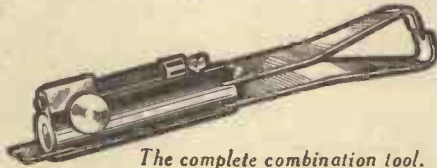

The complete combination tool.

THE FIRST PAPER TO SHOW
HOW TO FIT BIFOCAL
COILS IN STANDARD RE-
CEIVERS! ALWAYS FIRST!

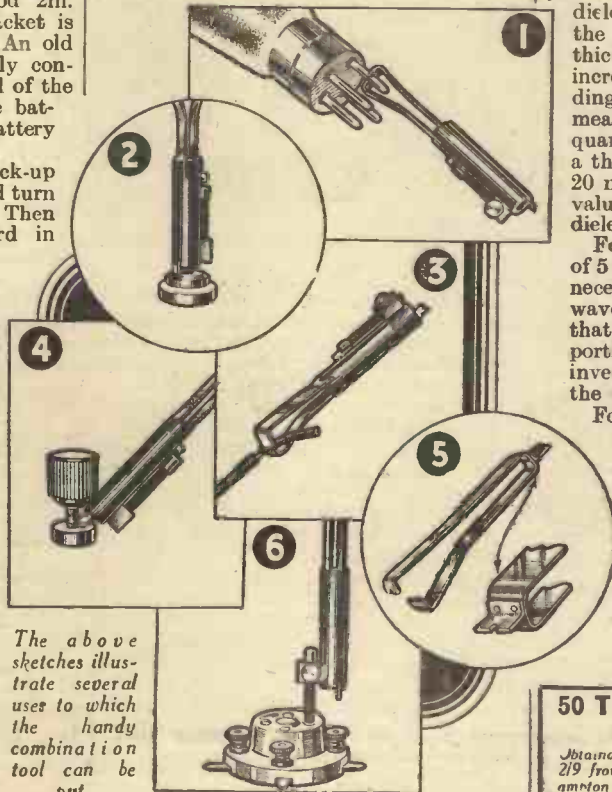

The above sketches illustrate several uses to which the handy combination tool can be put.

Anchoring Multiple Battery Leads

AN old valve-holder of the terminal type makes a good connector for constructors who use multiple battery cords or flex, as shown, and is a safeguard

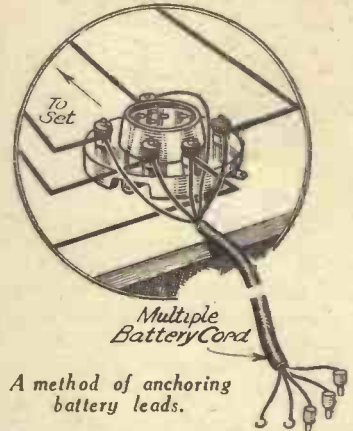

against any components in the set being damaged through wires being tucked round valves, etc., and then being pulled by accident. The valve-holder can be mounted on the base board to the rear of the other components, and the battery flex taken through a small hole in the back of the cabinet.—C. HEATON (Bolton).

Micro-condensers

FOR some types of band pass coupling, and for coupling an additional tuned circuit to early types of receivers that are unselective under modern conditions, condensers of 20 micro-micro-farads are frequently specified.

These components are not usually stocked, so that it is useful to know that the capacity of two pennies separated by a piece of thin typewriting paper measures just about 20 micro-micro-farads. The dielectric value of paper is approximately the same as air but if mica of similar thickness is used, the capacity will be increased six times, more or less, depending on the particular specimen, which means that two metal plates less than a quarter of an inch square, separated by a thin slip of mica, will give a capacity of 20 micro-microfarads. For such small values it is more practical to use air dielectric.

For calculating still smaller capacities of 5 and 10 micro-micro-farads which are necessary in the aerial lead of ultra-short-wave receivers it is useful to remember that the capacity of a condenser is proportional to the area of the plates and inversely proportional to the square of the distance between them.

For the reception of the 7.75 metre experimental transmissions being made from Broadcasting House, an aerial series condenser of about 5 micro-micro-farads is required.

A useful tip for a small coupling capacity is to connect in circuit the grid and anode pins of an old type burnt out valve with a solid base. Most of these have a capacity approximating to 20 micro-micro-farads.—B. T. WALLACE (Norbury).

50 Tested Wireless Circuits

Edited by F. J. CAMM

Obtainable at all Booksellers, or by post 2/9 from Geo. Newnes, Ltd., 8-11, Southampton Street, Strand, London, W.C.2.

2/6

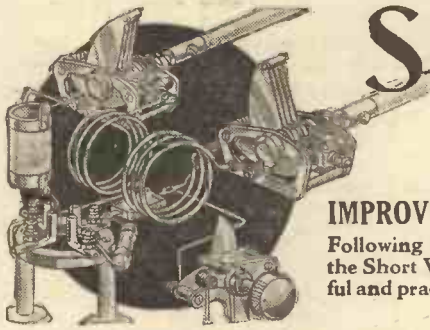

Short Wave Section

IMPROVING THE SIMPLE SHORT-WAVER

Following our previous article on "Making a Start on the Short Waves," the Author now gives some more useful and practical information concerning S.W. reception.

By FRANK PRESTON

IN the issue of PRACTICAL WIRELESS dated April 14th I gave sufficient information to enable anyone unaccustomed to short-wave reception to make a good start in this most interesting branch of radio. Those who have tried the simple single-valve receiver described will no doubt have been already "converted" to the short waves, although it might be mentioned in passing that conditions for good short-wave reception have been by no means ideal during the past few weeks. At the same time there has been a great deal of activity on the "amateur" wavelengths of 80, 40, and 20 metres, and no one can have failed to tune in a number of amateur transmissions on Sunday mornings.

Having made a successful start, the constructor will no doubt wish to carry out further experiments on the short waves and to improve the efficiency of his simple apparatus. The greatest objection to the single-valve S.W. receiver of the type previously described is that a fair amount of skill is called for in getting the best out of it; reaction control is critical and varies enormously over the range of the tuning condenser. The reason for this is principally that the damping effect of the aerial is vastly different at different wavelengths. An improvement can often be obtained by changing over to another aerial, preferably a vertical one of 25 feet or so, whilst a .0002 mfd. variable condenser in series with the lead-in might be very helpful. It will be found that a setting can be located at which the optimum position of the reaction condenser "holds" fairly well over the complete waveband. A much better method of simplifying the operation of the set, however, is to add an H.F. amplifying stage. As a matter of fact, the extra valve will not increase the range of recep-

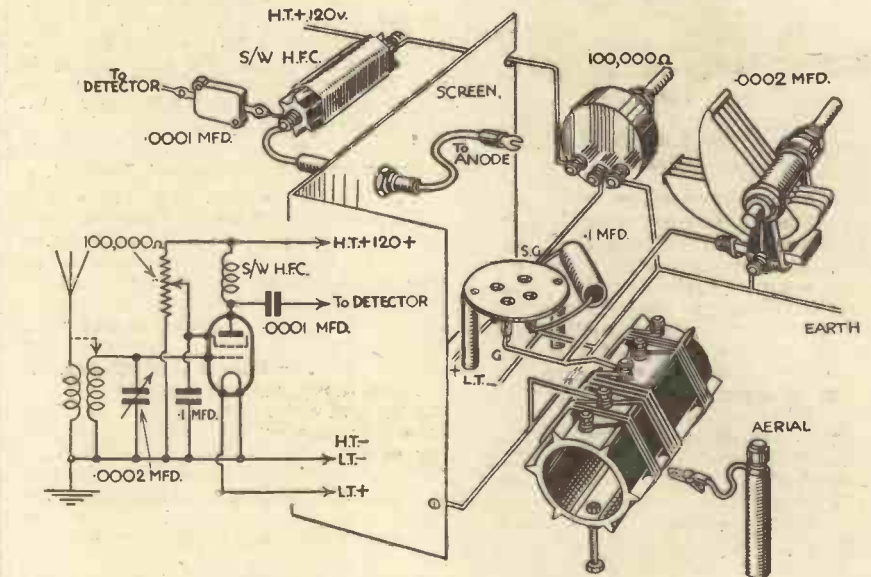

Fig. 1.—Theoretical and pictorial circuits for an H.F. "buffer" stage for use prior to the detector.

tion to any appreciable extent, but it will remove the damping effect of the aerial on the detector valve almost entirely. The H.F. stage—often referred to as a "buffer"—may be either tuned or aperiodic, and although it will probably prove slightly more efficient when tuned, it will be more difficult to handle.

Adding a "Buffer" Stage

The circuit and connections for a tuned H.F. amplifier using an ordinary S.G. valve is given in Fig. 1, where it will be seen that

tuning circuits it is preferable to erect an aluminium screen in the approximate position shown. All components excepting the H.F. choke are on the left of the screen.

The amplifier or "buffer" will be connected to the same batteries that are used for the detector stage, the L.T.+ and combined L.T.—H.T.—leads being joined to the appropriate terminals on the detector valve-holder. A 120-volt high-tension battery should be used, and the H.T.+ lead from the S.G. stage should receive the full voltage, but the detector lead will require to be tapped down to a voltage between about 30 and 80, depending upon the particular valve used in the detector position.

An Aperiodic Aerial Circuit

If it is proposed to make the amplifier aperiodic, or untuned (and this will be better in most cases), it will only be necessary to remove the aerial tuning coil and its associated condenser, replacing these with either a second H.F. choke or a fixed non-inductive resistance having a value between 100,000 and 250,000 ohms. Most experimenters will prefer to try all three aerial arrangements, especially since it is a very simple matter to change from one to the other.

The complete two-valve S.W. outfit is not only suitable for use as an ordinary receiver, but it can be used as an adaptor or converter by connecting the detector as described and illustrated in the earlier article referred to before. As a matter of fact, the two-valve circuit makes an almost

(Continued on next page)

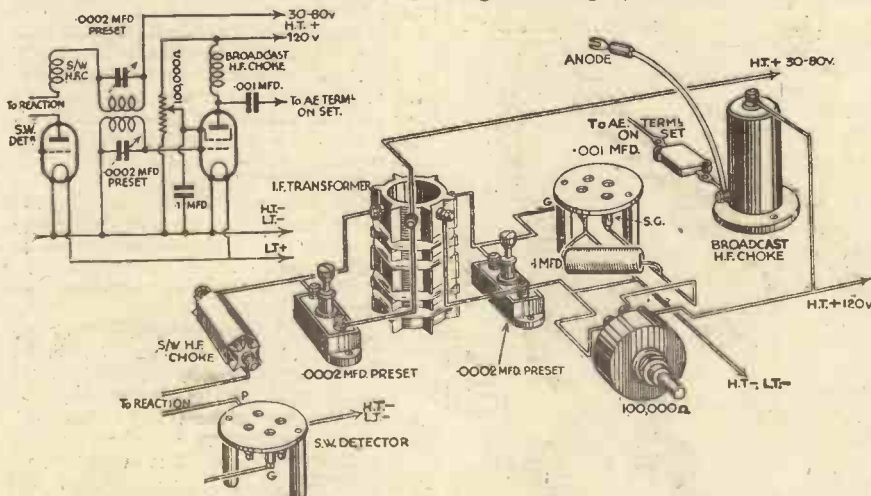

Fig. 2.—The above drawings show the arrangement of an intermediate frequency H.F. amplifier for use with a S.W. converter and non-S.G. broadcast receiver.

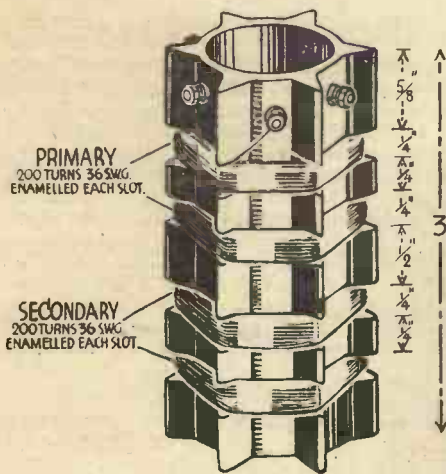

Fig. 3.—Constructional details of a 150 k/c. I.F. transformer.

(Continued from previous page)

ideal converter, and when used with a good broadcast receiver having an H.F. amplifier it is possible to obtain good loud-speaker reception over considerable distances. Needless to say, the two-valve arrangement can be used quite satisfactorily as an adaptor by connecting the second valve in place of the detector valve in the broadcast receiver in the usual way.

Making a Converter with I.F. Stage

It has been stated several times in these columns that a S.W. converter is almost invariably much more satisfactory and efficient than an adaptor, but it is known that a converter can only be used along with a broadcast receiver having at least one H.F. stage which can act as an intermediate frequency amplifier. Experimenters who favour the det.-L.F. type of broadcast receiver can, however, make a special converter for use with it. The converter must have, in addition to the single-valve detector-oscillator, a valve which can act as an I.F. amplifier, and this should preferably be tuned to a frequency of about 150 kilocycles (2,000 metres).

An excellent unit of this type can be made by employing the circuit arrangement shown in Fig. 2; only the anode circuit of the detector valve is shown for simplicity. It will be seen that an intermediate-frequency transformer is used to couple together the detector valve and the I.F. stage, and the construction of this component calls for special mention. Perhaps it should also be mentioned here that a number of readers have lately asked for constructional details of this component, and therefore the following details will be of general interest.

A 150 K/c. I.F. Transformer

The transformer may conveniently be wound on a former consisting of a length of 6-ribbed ebonite tube 1 1/4 in. diameter with slots made in the positions indicated in Fig. 3. Both primary and secondary windings consist of 400 turns of 36-gauge enameled wire wound in two sections. The ends of the windings are brought out to terminals mounted on the end of the ebonite former. It is desirable to screen the trans-

former, although this is not essential if it is arranged well away from other components, and with its axis at right-angles to those of the coils and H.F. chokes. The screening might consist of an old valve screening box or it might be built up in rectangular form from a sheet of copper. In any case, the metal should not be within about 1/4 in. from the end, or 1/4 in. from the ribs, of the former. In use the transformer is tuned by means of two .0002 mfd. pre-set condensers, one of which is connected in parallel with each winding.

Reverting to the circuit arrangement, it will be seen that the I.F. valve is connected to the first valve in the receiver by means of an S.G. choke and a .001 mfd. by-pass condenser. If there is a series-aerial condenser in the set this should be short-circuited when the converter is in use, and the set should be tuned to the same wavelength as the I.F. amplifier—approximately 2,000 metres.

A Converter with a Broadcast Superhet.

A number of readers have asked if it is possible to employ a short-wave converter in conjunction with a broadcast superhet receiver. Generally speaking, the usual type of simple converter is not suitable for use in this way, unless one is prepared to disconnect the first detector and oscillator valves, connecting the converter directly to the first I.F. amplifier. A circuit of the type shown in Fig. 2, however, can be used quite successfully with many types of superheterodyne without modifying any of the connections. The idea is that "double frequency-changing" is employed; in other words, the incoming signals are first changed to the frequency of the first I.F. stage, after which they are rectified and again changed to the frequency of the second I.F. amplifier, which forms a part of the complete broadcast superhet. The idea appears somewhat complicated, but it has often been used very successfully in practice, and it is especially useful when working on wavelengths of 20 metres and less. It can be tried very easily by building a unit using the circuit shown in Fig. 2. It will generally be found better, in this case, to use a higher intermediate frequency than 150 kilocycles and, in fact, a frequency of about 600 kilocycles is generally found to be as good as any. A transformer for this frequency can be made in the same manner as was previously described, but by putting only 60 turns of wire in each slot instead of 150. The pre-set condensers can be reduced from a maximum of .0002 to .0001 mfd. with advantage.

(Continued on page 188)

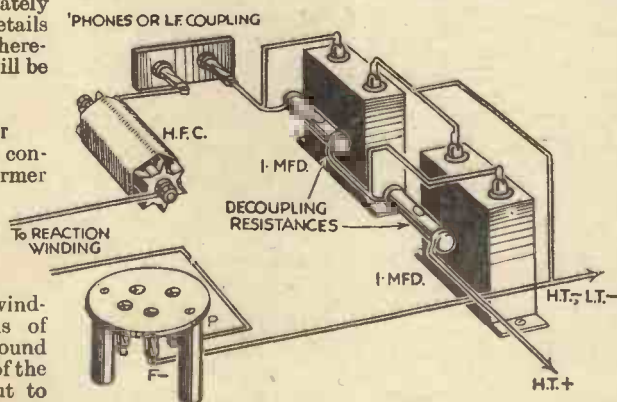

Fig. 4.—Showing the idea of "double" decoupling in the detector anode circuit.

OUR BIFOCAL COMPETITION

Some Further Details concerning the Bifocal coils, which are the subject of our Great Twenty-guinea Competition.

OUR Postbag reveals the fact that great interest has been aroused by the new form of tuning which has been described during the past few weeks, and which has been introduced by the ingenious variable-permeability tuning device marketed by Messrs. Varley. We have so far had very few queries regarding the use of the coils, all the data which we have published having proved sufficient to enable the majority of listeners to utilize this type of coil in one type of circuit or another. One problem which has seemed to occur to more than one reader concerns the possibility of ganging two of these coils together, so that the operating controls on the panel may be reduced in number. From a mechanical point of view, there is, of course, nothing difficult in carrying this idea into effect, a thin strip of insulating material being used to link the two plungers, and a rod attached to the centre of this link provided the required movement through the medium of a knob on the panel front. The two coils could be attached to small component brackets, or a strip of ebonite mounted on the baseboard or chassis top.

Disadvantages of Ganging

There will, however, be found to be a disadvantage in coupling two of these coils together. It has already been pointed out how the movement of the plunger on one of the coils varies the degree of coupling between the "primary" and "secondary," and thereby increases the selectivity. If two such coils are employed, one in the aerial circuit of an S.G.-Detector-L.F. receiver, and one in the grid circuit of the detector valve, it will be obvious that the movement of either plunger will effect the selectivity of the circuit in which it is included. Therefore, if the coils are mounted separately, it will be possible to obtain a very fine degree of selectivity adjustment by moving either plunger, a kind of vernier adjustment being obtained if one is moved to a greater degree than the other. In other words, you have two separate adjustments which may be juggled with to obtain the required results. If, however, these two controls are linked, not only is the degree of adjustment restricted, but it will probably be found that the increase in selectivity is too sudden to permit of the accurate setting of the control, as both circuits are varied at once. However, there is no reason why readers should not try out the scheme if they so desire, and the above details will enable them to connect the two coils in the required manner. To prevent any possibility of instability due to interaction, mount the coils as far away from each other as possible, and a thin sheet of aluminium, connected to earth, should preferably be arranged in the centre of the two units.

Full details of this competition were given on pages 114 and 115 of our issue dated April 14th, together with circuit and wiring diagrams showing how the Varley Bifocal coils can quickly be fitted into any standard circuit. The closing date of this competition is May 14th. There is no Entrance Fee, and we would remind our readers that the First Prize is 20 guineas cash, which will be augmented by 200 consolation prizes and a special prize of 5 guineas will be awarded by Messrs. Peto-Scott, Ltd.

Practical Television

SUPPLEMENT TO
PRACTICAL WIRELESS

APRIL 28th, 1934. Vol. 1. No. 17.

WILL MY SET OPERATE A TELEVISION RECEIVER?

A Clear Reply to an Oft-repeated Question.

IN replying to the query contained in the title it is necessary, first of all, to know what type of television apparatus is proposed to use. There is a vast difference in the method of operating disc, mirror-drum, mirror-screw, and cathode-ray tube devices, for instance. Perhaps it will be best to start by saying that to operate a cathode-ray viewer it is necessary to have a special time-base apparatus in addition to the receiver proper. Beyond this, however, there is no very great difficulty, and the time-base equipment can be fed from most types of receiver which are capable of delivering an undistorted output of two watts or so.

Minimum Signal Output

The mirror-drum and mirror-screw types of machines, generally speaking, require greater inputs of audio-frequency energy than do disc machines, and it is nearly always found that a minimum of three watts undistorted signal energy is required to operate them at all satisfactorily. Additionally, a polarising voltage of about 400 is required by the mirror machines, and this naturally presents a rather serious problem to the user of an average type of wireless receiver. It is, of course, possible to obtain the required voltage from dry batteries, but this method is both inconvenient and expensive, besides which it is well-nigh impossible to obtain the required audio-frequency output from a battery-operated receiver. Even with a mains set a rectified D.C. voltage of 400 is unusual and necessitates the use of a Class C rectifier, which gives a D.C. output of 500 volts at 120 milliamps. From the foregoing remarks it will be obvious that mirror machines are suitable only for operation from good quality power amplifiers, where high H.T. voltages are available.

The disc type of television receiver is undoubtedly most popular, and it can successfully be fed from any moderately good set. A minimum figure for the necessary output should be considered to be approximately 500 milliwatts, although it is sometimes possible to get passable pictures with less audio-frequency output than this. On the other hand, however, there is no doubt that an undistorted output of not less than two watts (2,000 milliwatts) is desirable when really good reception is desired. It is scarcely necessary to point out that for really satisfactory results it is absolutely essential that the receiver should be capable of really high-class reproduction, for nothing shows up the failings of a set or amplifier more than a television apparatus.

The Synchronizing Impulse

It was stated above that an undistorted signal output from 500 milliwatts upwards

could satisfactorily be employed to operate a disc machine. This statement should be qualified, however, by pointing out that the synchronizing gear is seldom effective if it is fed with anything less than 1½ watts. Thus, although the output from a comparatively modest battery receiver might be sufficient to modulate the glow from the neon lamp, it will not be of any real use for maintaining synchronism. At the same time it will be understood that the synchronizing device is by no means essential, although it is extremely useful and adds considerably to the pleasure of looking-in.

Another point which must be borne in mind when feeding the neon of a disc machine from a battery set is that a striking voltage of about 200 is required for the plate-type neon lamp of the kind specially made for television purposes. Thus, it becomes necessary to supplement the normal H.T. battery by using a second one in series with it. The two batteries can also be used together to supply the anode current for the valves in the set, but it is more economical to leave the H.T. supply circuits in the set unaltered, and to connect the second battery so that it (in conjunction with the original battery) feeds the neon alone.

Neon Connections

When a disc television machine is used in conjunction with a mains set the difficulty of obtaining a suitable neon striking voltage does not usually exist. Unless there is a large surplus of output voltage from the rectifier over that required for the anode of the output valve it is best to parallel-feed the neon lamp (which is usually wired in series with the synchronizing coils for convenience). When there is an excess of H.T. voltage the neon can conveniently be wired in series between the anode of the output valve and H.T. positive. In both instances it is necessary to take into consideration the current passed by the neon lamp and also the voltage-drop which it produces. This point was, however, dealt with rather fully in an article which appeared in this Supplement dated March 3rd, 1934, and any readers who require further information are requested to turn up a copy of the issue concerned.

GERMAN TELEVISION TRANSMISSIONS

TELEVISION broadcasts are being carried out by the new Berlin ultra-short-wave station on 6.985 metres (42,950 kc/s) with 180-line pictures. The times are as follows: B.S.T. 09.00—11.00 and from 15.00—16.00 (Mondays and Wednesdays); 09.00—11.00 and 20.30—22.00 (Tuesdays and Thursdays) and on Saturdays from 09.00—11.00 only.

NEON LAMPS FOR TELEVISION

A Simple Explanation of their Characteristics and Uses.

DESPITE their extensive use in television receivers of the disc type, the average user is inclined to look upon neon lamps as rather marvellous scientific devices. As a matter of fact, however, they are simple in the extreme and consist of nothing except two metal electrodes supported within a glass bulb filled with neon gas at low pressure. Neon, in common with one or two other comparatively rare gases, has the property of "ionizing," or splitting up into its positive and negative constituents, when a pressure of electricity is applied to it. Thus, when a voltage is applied to the two electrodes in the neon lamp the gas becomes ionized and then becomes luminous, due to the electronic bombardment which takes place.

No "Time Lag"

The principal feature of the neon lamp, from the television point of view, is not its ability to produce an orange-red glow, but to flicker when the voltage applied to its electrodes is varied. Of course, an ordinary electric lamp flickers when the applied voltage is varied over a fairly wide range, but there is a considerable "time lag" in the light variation. In other words, the light changes comparatively slowly after the voltage has been changed, due to the fact that the filament does not cool very quickly. The television lamp, on the other hand, has to respond very rapidly to changes of voltage, and it is because of this that the neon is so well suited for the purpose; it has no perceptible "time lag" or "inertia."

Neon lamps are available in several types, but the best for television purposes is that having one large flat electrode. This particular type is made especially for use in television receivers, and it is undoubtedly the best. The only objection is that of price, for its costs twenty-five shillings, and it is because of this that many television enthusiasts of limited means prefer to use the cheaper "beehive" or "letter" lamps. The former can be recognized by the beehive shape of the cathode, whilst in lamps of the latter kind the cathode takes the form of a letter.

Using Ordinary Neon Lamps

Most neon lamps other than the flat-plate type have a fixed resistor fitted in their caps, this being designed to limit the voltage applied to the electrodes when the lamps are connected directly to the 200-250-volt lighting mains. For television purposes the resistance must be removed, for otherwise the lamp will not properly respond to the rapidly-fluctuating voltages which form the signal output from the wireless receiver. Additionally, the total resistance of the lamp plus the resistor is too high for most purposes. It is a perfectly simple matter to remove the resistance, and the method was both described and illustrated on page 69 of PRACTICAL WIRELESS, dated April 7th.

When buying a neon of any type other than that having a flat plate it is better to obtain one of the "letter" type (preferably "H" or "M"), because the beehive lamp casts awkward shadows across the lens, and these tend to obscure the picture. If a beehive lamp is already in use its effectiveness might in many cases be increased by covering the bulb with a piece of thin tissue paper.

IMPORTANCE OF CORRECT MOTOR SPEED

The Most Important Consideration in
Television Reception.

WITH all mechanical forms of television receiver the results depend entirely upon the rotation of a disc, mirror drum, or screw, which must be maintained at a speed exactly the same as that at the transmitting end. It has already been explained in these pages how the terms synchronism and isochronism are applied to the running of two discs at distant points, and for the reception of the present television transmission a speed of 750 revolutions per minute is called for. If we examine the catalogues of any electric motor manufacturers we shall find that a speed of 1,000 r.p.m. is a good average, and therefore if a motor of this type is utilized it will have to be adjusted to run slightly below its normal speed, and although this should not be difficult, it will be found generally that constancy is not easily obtainable. Provided, however, that the synchronizing gear which is fitted is supplied with a really strong impulse it should be maintained at a sufficiently even rate of revolution to prevent the picture from wandering very much.

Use a Proper Motor

Obviously, therefore, it will pay you to obtain a motor which has been designed to rotate at a speed of 750 r.p.m. when carrying the load of a disc or mirror-drum, and such motors are obtainable from a number of firms whose advertisements may be found in this paper. Having obtained the motor, it will be found that, whilst the actual voltage applied to it is not absolutely critical, there will be a value which will provide most even control, and therefore a good scheme is to obtain a tapped resistance, provided with a number of equal tapping points, and to connect this in series with a small value variable resistance, both of which must be chosen with due regard to the current which has to be carried. These two resistances should be joined in series and connected in one lead from the mains, and it should not then be found difficult to choose a tapping point on the fixed resistance which will enable the speed to be adjusted by means of the variable to give smooth and even control round about 750 r.p.m., so that a perfectly steady picture may be obtained. To enable the motor to be run up to the desired speed before the transmission commences a stroboscopic device will be found most useful. For 50-cycle mains eight equal segments are required. For other periodicities the exact details may be worked out from the formula:—

$$\text{No. of lines} = \frac{120 \times \text{Frequency}}{750}$$

THE B.B.C. AND 30-LINE TRANSMISSIONS.

READERS should note that the B.B.C. have curtailed the hours of transmission of the normal Baird 30-line television transmission on the normal broadcast wavebands. The hours of these transmissions are now as follow: Tuesday 23.00 (11 p.m.); Friday 11.00 (11 a.m.). The reason given by the B.B.C. for these restricted times of transmission is that sufficient interest has not been displayed by the public and they, therefore, wish to experiment with systems which are capable of giving higher definition. No definite information is forthcoming

(Continued at foot of col. 2)

THIS WEEK'S HINT

ADJUSTING SYNCHRONIZING GEAR.

How to Set the Gap Between Teeth and
Magnet Poles.

Although you may have purchased your synchronizing gear complete, it may have worked loose and fail to act in the desired manner. The main point, providing the design is correct, is that the minimum distance should separate the teeth of the synchronizing wheel and the magnet pole-pieces. To obtain this minimum distance, a good plan is to loosen the pole-pieces and to place a piece of thin paper between the wheel and the pole-piece and to force the latter up against the paper. Lock it in position, and tear away the paper. If this is done with each magnet the gear should be found to act in a satisfactory manner. Make certain, of course, that the synchronizing wheel is firmly locked to the motor spindle.

SCANNING DISC TROUBLES

Obtaining the Best From a Scanning Disc.

ALTHOUGH the simplest method of building up a television receiver is to use a disc of aluminium perforated with thirty holes, the picture depends upon the accuracy of the holes. The disc may, of course, be purchased from a reputable firm, but there are one or two points which must receive attention in order to enable a perfectly good picture to be seen. It has been explained many times how each hole has to line up with its neighbour, and although when made this point may have received careful attention, dust or paint in the holes will cause dark lines on the received image. The discs are generally coated with black paint of some kind to prevent light halation, and therefore the disc should be slowly turned by hand, with the lamp glowing, and each hole examined carefully through the lens. If the corners of each hole are not perfectly square, a very fine paint brush should be used to clean out the corner. Do not use a pin or other hard metallic surface or you may tear the soft aluminium and make matters worse. When the disc is rotating at speed there should be a clean rectangle of light, any dark or light lines indicating that the individual holes are out of alignment. This may be remedied in most cases by the following schemes.

Altering the Position of a Hole

A dark line indicates that the edges of adjacent holes are not meeting, and the disc should be turned slowly until the pair of holes are identified, and then each side of the pair should be carefully filed with a fine watchmaker's file. Do this extremely carefully, repeatedly running the disc until the exact amount has been removed from each hole and the dark line has disappeared. If a white line is seen it will indicate that two holes overlap and this may be remedied by marking the holes, and removing the disc. The latter should then be laid on a hard surface and the offending edges carefully tapped with a flat-ended object to spread the metal. Repeated tests should be made so that only the required amount of spread is given to enable the holes to line up.

concerning the wavelength upon which such experiments are being made, nor the hours concerning such transmissions. However, the keen experimenter will no doubt find some interesting material for his investigation on the wavelengths between 6 and 8 metres. In this connection the ultra-short-wave Converter described last week will no doubt prove of interest.

MIRROR DRUMS AND MIRROR SCREWS

Some Hints for Users of Television Apparatus Which Employs These Devices.

THE illumination of the disc-type television receivers is afforded only by a neon lamp, and the brilliancy is of such a low value that it is generally necessary to view the received picture in a darkened room. The mirror-drum and mirror-screw device, however, enable a much more brilliant picture to be obtained, and with a projection scheme which at the same time affords a larger image. If you have built the Mirrorvisor or a similar type of receiver, the image will be thrown on to the rear of a screen in a similar fashion to the daylight cinema projectors, and this will enable the picture to be seen in a moderate light. To attempt to view the picture with direct light falling on the front of the screen, however, will destroy the advantage so gained, and therefore a collapsible hood should be constructed to screen the front of the apparatus. Ordinary stiff card, cut to suitable shape and size, will be found quite satisfactory, and the best arrangement will be found to be a pyramid-shape, with the smaller opening just large enough to fit round the screen. To enable it to be folded away when not required it will best be made in four sections, ordinary linen or linen-tape (obtainable from stationers on small reels) being used to form a hinge. Dead-black, obtainable from a photographic dealer's, will enable a nice surface to be imparted to the finished article and there will then be no need to darken a room when viewing the picture.

To obtain maximum detail the screen must be of the finest grain possible, and undoubtedly a photographic screen will be found the simplest to obtain. This material is used for focusing purposes in various cameras and it can generally be obtained cut to any desired size at a very modest figure. Alternatively, very fine "detail" paper may be stretched across a small wooden frame and the front protected by means of a piece of ordinary glass.

Mirror Adjustments

If the mirrors are fitted to the drum by ordinary nuts, a periodical examination should be made to ensure that they are locked tightly. Keep the mirrors clean, and to prevent moisture due to condensation on the surface of the mirrors, with consequent loss of brilliancy, clean each surface thoroughly, polish with a dry cloth, and then carefully wipe each surface with one of the commercial preparations sold by opticians for similar use on spectacles. The surfaces of a mirror-screw should be similarly treated, together with the other optical apparatus in a totally-enclosed receiver.

THE WIRELESS CONSTRUCTOR'S ENCYCLOPAEDIA

(2nd Edition)

By F. J. CAMM

(Editor of "Practical Wireless")

THIS invaluable encyclopedia is written in plain language by one of the most accomplished designers and writers on wireless construction.

Obtainable at all Booksellers, or by post
5/6 from Geo. Neumes, Ltd., 8-11, Southampton Street, Strand, London, W.C.2.

5/-



PRIMA Mains Three LEADER 3 • LEADER A.C.3

PILOT AUTHOR KIT EXACT TO SPECIFICATION



The Pilot Kit SERVICE was founded in 1919.

See the PILOT on the carton. It's a real guarantee.

IMPORTANT Miscellaneous Components, Parts, Kits, Finished Receivers or Accessories for Cash, C.O.D. or H.P. on our own system of Easy Payments. Send us a list of your wants. We will quote you by return. C.O.D. orders value over 10/- sent carriage and post charges paid (GREAT BRITAIN ONLY). OVERSEAS CUSTOMERS CAN SEND TO US WITH CONFIDENCE. We carry a special export staff and save all delay. We pay half carriage—packed free. Send full value plus sufficient for half carriage. Any surplus refunded immediately. Hire Purchase Terms are NOT available to Irish or Overseas customers.

1934 WALNUT ADAPTAGRAM



38 in. high
22 in. wide
1 1/2 in. deep.
Speaker Compartment, 17 in. by 19 in. by 14 in.

YOURS FOR **8/3**

CONVERT YOUR EXISTING SET INTO A MODERN RADIOGRAM

As illustrated. **63/-** Cash or C.O.D. Carriage 2/6 extra. Or 8/3 Deposit and 11 monthly payments of 5/9 (Carriage Paid). In Oak or Mahogany no extra. Special drillings or other special cut-out designs add 3/- extra to cash by price or 3d. to each monthly payment.

Direct from Factory. No MIDDLEMAN'S PROFITS. Built by master-craftsmen of the piano trade. Real inlaid walnut mortised, tenoned. French polished. With motor-board ready to take your set, speaker and power equipment. Plain front or vignette panels. 14 in. by 7 in., 16 in. by 7 in., 18 in. by 8 in. Baffle-board, 3/6 extra.

SEND FOR CABINET CATALOGUE

LISSEN "SKYSCRAPER 3." Chassis model with (Lissen) S.G. Detector and Pentode Valves. Cash Price, £49/6. Carriage Paid. Balance in 11 monthly payments of 8/3.

TELSEN 323 KIT with set of three Valves. Cash or C.O.D. Carriage Paid, £2/15/6. Balance in 11 monthly payments of 5/-.

BLUE SPOT "STAR"



PERMANENT MAGNET MOVING-COIL SPEAKER

—the Speaker with the new magnet. Complete with Extension Speaker Sockets, on-off Switch and Universal transformer for matching.

ANY OUTPUT STAGE

Cash or C.O.D. SEND

Carriage Paid. **70/-**

6/6

ONLY

or 12 monthly payments of 8/6.

TELSEN GLASS "B" KIT. Less Valves. Cash or C.O.D. Carriage Paid, £4/9/0. Balance in 11 monthly payments of 8/3.

ROLA FR6 PM23 CLASS "B" SPEAKER, with input transformer. Cash or C.O.D. Carriage Paid, £1/19/6. Balance in 9 monthly payments of 4/6.

W.B. P.M.6A MICROLODE PERMANENT MAGNET SPEAKER with switch controlled multi-ratio input transformer. Cash or C.O.D. Carriage Paid, £1/12/6. Balance in 8 monthly payments of 4/3.

BLUE SPOT 99 P.M. PERMANENT MEGNET MOVING-COIL SPEAKER. Complete with tapped Input Transformer. Cash or C.O.D. Carriage Paid, £2/19/6. Balance in 10 monthly payments of 6/-.

AVONINOR NEW UNIVERSAL MODEL. Measures 0-6, 0-30, 0-120 M.A., 0-6, 0-120, 0-300 volts, 0-10,000, 0-60,000 and 0-1,200,000 ohms, complete with leads. Cash or C.O.D. Carriage Paid, £2/0/0. Balance in 7 monthly payments of 5/6.

GARRARD AUTOMATIC RECORD CHANGER for A.C. mains. Mounted on unit plate, complete, ready for fitting in position, including Garrard pick-up and tone arm. Cash Price, £10/10/0. Carriage Paid. Balance in 11 monthly payments of 18/6.

J. B. LINACORE. Complete tuning unit comprising matched coils, condenser, type BBF (battery), type BPM (mains). Cash or C.O.D. Carriage Paid, £3/9/6. Balance in 11 monthly payments of 6/6.

PRIMA MAINS THREE

CASH - C.O.D.

£3. 12. 6 Carriage Paid.
or yours for **6/9**
and 11 monthly payments of 6/9.

THESE ARE THE PARTS THE AUTHOR USED

1 Peto-Scott Prima Steel Chassis as specified, with screws.	5	6
1 Ormond Prima Special 2-Gang Variable Condenser with Dial	10	0
2 Colvern Tuning Coils (1 K.O.O., 1 K.G.R.)	19	0
1 Graham Farish .0003mfd. Differential Condenser	2	0
1 Cosmoood 10,000 ohms pot. log type without switch, with knob	4	0
3 Chix 5-pin chassis mounting valveholders	2	3
3 Colvern strip w.v. Resistances, 1 each 100 ohms. 10,000 ohms, 15,000 ohms	5	3
2 Peak Imfd. Fixed Condensers 500-roots D.C. working, type C.B.7	5	0
1 Graham Farish Snap H.F. choke	2	0
1 Graham Farish .002mfd. Fixed Condenser	1	0
1 Graham Farish 1 meg. Grid Leak	10	0
1 Ormond L.F. Transformer, type R.5/531 3:1	7	8
1 pair Bulgin G.B. Battery Clips	6	0
15 Belling Lee marked Terminals (type B) with washers	4	0
1 Chix Safety Anode Connector	3	0
2 Distan 4 pieces for Ormond Condensers	2	0
7 Wander Plugs	10	0
1 Bulgin 6-volt dim light bulb	9	0
1 Graham Farish .0003mfd. Fixed Condenser	1	0
1 Connecting wire, screws, flex, etc.	2	0
KIT "A" Cash or C.O.D.	£3	12 6

KIT "A" Author's Kit of first specified parts, excluding M.P.R. Mains Unit, Valves, Cabinet and Speaker. Cash or C.O.D., Carriage Paid, £3 12 6 and 11 monthly payments of 6/9

KIT "B" as Kit "A", but with set of 13 specified valves only. Cash or C.O.D. Carriage Paid, £6 4 0 or 12 monthly payments of 11/3

KIT "C" as Kit "A", but with set of 13 valves and Peto-Scott Ltd. Compact Cabinet, less M.P.R., Mains Unit and Speaker. Cash or C.O.D. Carriage Paid, £6 19 0 or 12 monthly payments of 12/9

If M.P.R. Mains Unit is required add £2 15 0 to Cash or C.O.D. Price or 5/- to each monthly payment.

If Ormond R.404 Speaker is required add £1 6 0 to Cash or C.O.D. Price or 2/6 to each monthly payment.

LEADER 3

KIT "A" Author's Kit of Specified Parts, including Peto-Scott METAPLEX Chassis but less valves. Cash or C.O.D. Carriage Paid £3,0,0. Or yours for **5/6** Balance in 11 monthly payments of 5/8.

KIT "B" As Kit "A", but with Valves only. Cash or C.O.D. Carriage Paid, £4/11/6. Or 12 monthly payments of 8/6.

KIT "C" As Kit "A", but with Valves and Peto-Scott Table Cabinet. Cash or C.O.D. Carriage Paid, £5/9/0. Or 12 monthly payments of 10/-.

KIT "CC" As Kit "B" but with Peto-Scott Walnut Console Cabinet with Shelf and Baffle. Cash or C.O.D. Carriage Paid, £5/16/0. Or 12 monthly payments of 10/6.

If Peto-Scott Permanent Magnet Speaker required add 19/6 to Cash Price or add 1/9 to each monthly payment.

LEADER A.C.3

KIT "A" Author's Kit of First Specified parts, including METAPLEX ready drilled Chassis, but less Valves and Cabinet. Cash or C.O.D. Carriage Paid, £5/10/0. Or yours for **10/-** Balance in 11 monthly payments of 10/-.

KIT "B" As Kit "A" but with set of Specified Valves. Cash or C.O.D. Carriage Paid, £8/7/6. Or 12 monthly payments of 15/3.

PETO-SCOTT 5/6 PRIMA CHASSIS

Post 9d. extra. Pressed steel chassis, ready drilled for all components and connecting wires, finished in attractive grey. With fixing screws. Cash or C.O.D. TRADE SUPPLIED—USUAL DISCOUNTS

ANY ITEM SUPPLIED SEPARATELY—ORDERS OVER 10/-

SENT C.O.D. CARRIAGE AND POST CHARGES PAID

Converts your present Battery Set to Class "B" Amplification. With driver transformer, Class "B" output choke, W.B. 7-pin valve-holder, B.V.A. 240B valve, wire and screws, etc. Full size Blueprint, assembly instructions and diagrams. Cash or C.O.D., 37/6. Yours for 5/- Balance in 7 monthly payments of 5/6.

CLASS B PILOT CONVERSION KIT

YOURS FOR **5/-**

37/6

PETO-SCOTT CO., LTD., 77, City Road, London, E.C.1. Telephone: Clerkenwell 9406/7. West End Showrooms: 82, High Holborn, London, W.C.1. Telephone: Holborn 3248. Dear Sirs,—Please send me CASH/C.O.D./H.P.

(for which I enclose £.....) CASH/H.P./DEPOSIT.

NAME
ADDRESS
P.R.W., 28/4/34.

IMMEDIATE DELIVERY—CASH—C.O.D. or H.P.

LOUD-SPEAKER FRETS

The Author Gives Much Practical Information Concerning the Question of Improving the Set's Appearance

By DEREK ARCHER

THE appearance of radio cabinets, especially those in which the loud-speaker is also fitted, can be greatly enhanced by the design of the speaker fret. The actual design of the fret is, of course, largely a matter of individual preference, but there are several factors which must be taken into consideration. If the unit employed is fitted to the front of the cabinet, some provision must be made in the design of the fret for securing the unit. Fig. 1 shows such an arrangement. The unit A is secured to the front of the cabinet B by the screws C. The silk, or other material, which covers the open parts of the fret, is shown as D. Silk, and other material used for this purpose, in time becomes dirty,

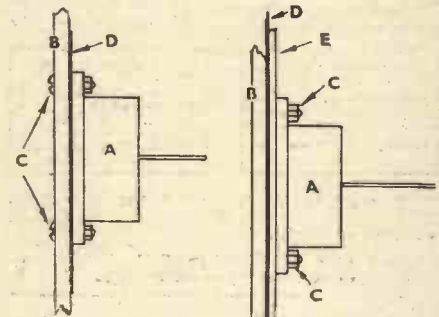

Figs. 1 and 2.—Methods of securing the fret and unit to the cabinet front.

and the only way it can be properly cleaned is to wash it. This, obviously, cannot be done whilst it is in the cabinet. The best way to remove the material from the cabinet is to damp it, preferably with a hot wet rag, drawing the material away as the glue softens. It will be necessary to scrape off the old glue before applying new.

Replacing the Silk

The best method of replacing or renewing the silk is as follows. Glue along the top of the fret and stretch the top edge of the silk and place it on the glue. Hold the silk in position for a few seconds until it holds, and then firmly press the silk all the way along. It is necessary to see that this edge is holding firmly before proceeding. Then glue down the sides and the bottom edge, stretch the silk and press it into position. Turn the cabinet round so that you can see the front and work the silk down and sideways accordingly, so as to get the web and warp of the silk straight. This is not important where a well-figured silk is used, but is very important if a good appearance is to be observed when the material is plain or striped. The replacing of silk in a simple cabinet is rather awkward, and the scheme of using a separate baffle, which holds the unit, is shown in Fig. 2. The material D is glued

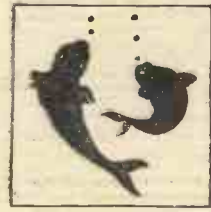
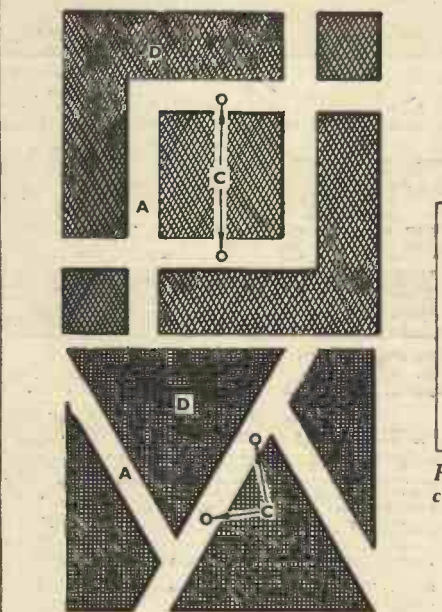

Fig. 9.—An ornamental fret cut from thin plywood.

to the baffle E, which is fixed to the front of the cabinet B by four screws, which can, of course, be easily unscrewed at any time



Figs. 5 and 6.—Two simple designs for frets, showing the fixing holes for unit.

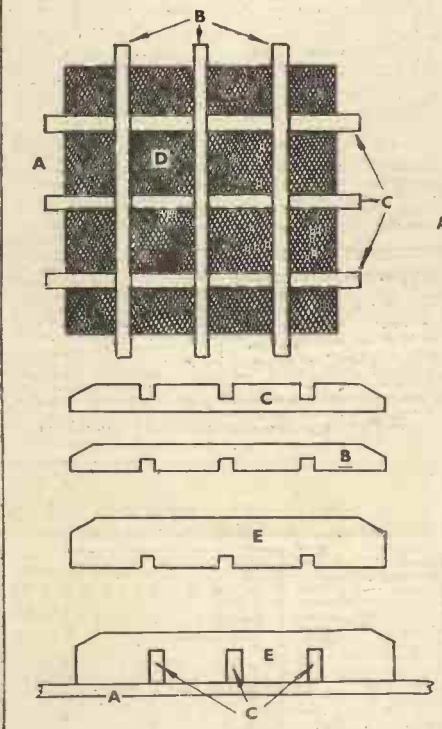

Fig. 8.—An effective and simple design for a fret, and method of arranging the bars.

and a new piece of material fitted. It is also possible to fix the material with small pins or even drawing pins, without the use

of glue. The shape of the baffle is shown in Fig. 3, and usually would be made of wood, but a metal strip, as shown in Fig. 4, can also be used, but the material would have to be fitted to the cabinet. An advantage which is to be obtained from the use of a separate baffle lies in the fact that it is not necessary to design the fret to cover the fixing holes for the loud-speaker. Two very simple designs for frets are given in Figs. 5 and 6, the unit fixing holes being shown at C.

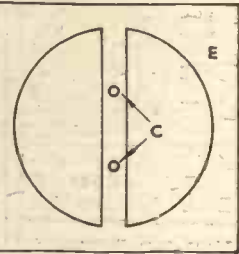

Fig. 3.—A baffle with centre strip showing fixing holes for unit.

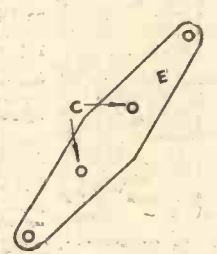

Fig. 4.—A shaped metal strip for holding the unit.

Replaceable Frets

Fig. 7 shows another method of dealing with replaceable frets. The fret A is cut from thin ply (about 3 mm. will do), and is secured to the front of the cabinet with four small screws. This idea makes possible the altering of an existing fret to suit furniture. The loud-speaker unit can remain fixed to the front of the cabinet B, or can be fitted to a separate baffle. The silk should be taken out of the cabinet and all except the necessary parts of the fret cut out. The new material should then be glued to the new fret, which can then be screwed into position. No allowance need be made for fixing the loud-speaker on this type of fret, and the design can be arranged irrespective of the centres of the loud-speaker unit.

A Neat Design

A very effective type of design for frets, generally known as "prison bars" and employed by a well-known firm of manufacturers, is shown in Fig. 8.

(Continued on page 190)

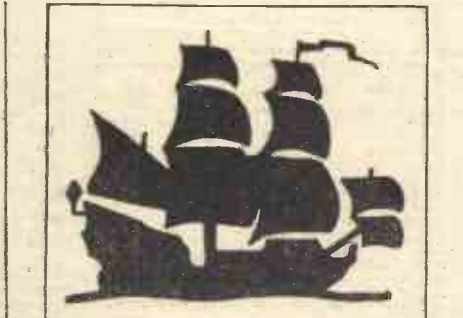

Fig. 10.—An attractive ship design for a fret which can easily be cut with a fret-saw.



THE EASY ROAD TO RADIO

THE BEGINNER'S SUPPLEMENT

THE SUPERHET SIMPLY EXPLAINED

THE average amateur is inclined to look upon the superheterodyne system of reception as complicated and beyond his understanding. As a matter of fact, however, there is no reason why this should be the case, because the principles underlying the superheterodyne are particularly straightforward and by no means difficult to understand.

In order to get a clear idea in regard to the function of the superheterodyne circuit there are one or two simple points

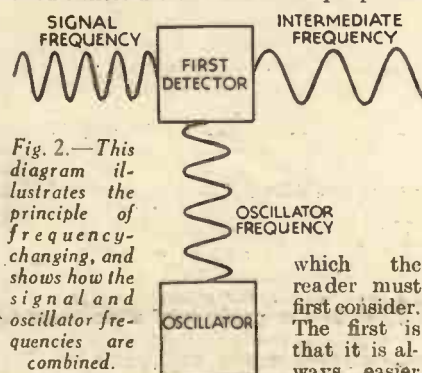

Fig. 2.—This diagram illustrates the principle of frequency-changing, and shows how the signal and oscillator frequencies are combined.

which the reader must first consider. The first is that it is always easier to design a high-frequency amplifier for operation on a comparatively long wavelength than it is to make it function efficiently on short waves. Another is that the efficiency of an amplifier varies to a certain extent according to the frequency (or wavelength) to which it is tuned, so that it can be made to function best at some particular fixed frequency. It is because of these facts that the principal H.F. amplifier of the superhet—it is called the intermediate-frequency amplifier—is always tuned to a definite low frequency, or high wavelength. The particular frequency chosen is generally 110 kilocycles, which corresponds to a wavelength of about 2,700 metres, but intermediate frequencies of 126 and 150 kilocycles are employed in certain instances.

Simple Analogies

The first question which must be answered is "How can the frequency or wavelength of the received signals (generally called the signal frequency) be changed to the frequency at which the I.F. amplifier works?" Baldly stated, the answer is "By mixing oscillations of other frequencies with the signal frequencies." The idea underlying this will more readily be understood by taking a mechanical analogy. For instance, all readers will have noticed,

when travelling in a car or omnibus, that the exhaust note appears to change when another motor vehicle is being passed. The reason is that the note or sound made by the car in which the observer is travelling is "mixed" with the sound made by the other vehicle, with a result that a so-called "beat note" is produced. Generally the note will be of very low frequency and might be heard as a series of "thumps"; as a matter of fact, this often causes a certain amount of discomfort to the driver of a car, because the noise

gives the impression that the engine has suddenly developed a peculiar fault.

Another analogy is afforded by the organ. When a low chord is played one can often hear, in addition to the sound of the two or more notes struck, a periodic "bumping" sound. The latter is again a "beat note" and is of lower frequency than any of the notes actually being played. For example, if one note had a frequency of 50 cycles a second and the other of 60 cycles per second the "bumping" sound would have a frequency of 10 cycles per second or, in other words, the "bumps" would be heard ten times every second.

Superheterodyne "Mixing"

And now the "mixing" of high-frequency electrical impulses can be compared with the examples just given. If a signal on a wavelength of 300 metres or a frequency of 1,000 kilocycles was tuned in on the first valve of a receiver, and then mixed with oscillations having a frequency of 1,110 or 890 kilocycles there would be a resultant frequency of 110 kilocycles. On the other hand, if oscillations of 1,150 or 850 kilocycles were mixed with the received oscillations a frequency of 150 kilocycles would be produced.

Once the above points have been clearly grasped it is easy to follow the behaviour of a superheterodyne receiver which consists essentially of the units shown in Fig. 1. First of all there is the first detector, to which the aerial and earth leads are connected. The aerial circuit is tuned in the usual manner by means of a coil and condenser, whilst an oscillator (also tuned) is coupled to the first detector and is used to supply the oscillations necessary to convert the frequency of the received signals to the pre-tuned frequency of the intermediate

frequency amplifier. After the two sets of oscillations have been "mixed" they are passed on to the I.F. amplifier in which they are amplified in the normal manner before being applied to the grid circuit of the second detector.

The second detector functions exactly the same as the detector in a "straight" set by separating the unwanted high frequencies forming the carrier wave and the audio-frequency vibrations which constitute the sound being transmitted. The latter are then passed through the low-frequency amplifier and to the loud-speaker in the very same manner as in any other kind of receiver.

Fig. 1 shows only the main essential of the superheterodyne arrangement and in practice the first detector is often preceded by an S.G. high-frequency stage whilst the oscillator function is combined with that of the first detector in a single valve of the S.G., pentode, pentagrid, or heptode type. It might interest some readers to know that the practical problems of frequency-changing were dealt with fairly fully in the article entitled "The Superheterodyne Frequency Changer" which was given in PRACTICAL WIRELESS dated April 7th, 1934.

A diagrammatic illustration of the process of frequency changing is given in Fig. 2, where "waves" of different lengths are drawn to represent the various frequencies, and the underlying principles will be clearly apparent from this.

It will be realized that, in any superheterodyne circuit there must be at least two variable tuning circuits in addition to the fixed pre-tuned circuits of the I.F. amplifier. One circuit is connected between the aerial and earth prior to the first valve, and the other tunes the oscillator section. Both must be operated simultaneously to ensure that the oscillator frequency is greater or less than the signal frequency by the amount of the

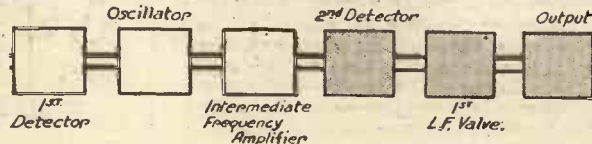

Fig. 1.—Diagrammatic representation of the elements of a simple superheterodyne receiver.

fixed frequency of the intermediate amplifier. It is possible to gang the two tuned circuits, but when this is done a special gang condenser must be employed because the frequency of the oscillator must vary in a different ratio to that of the first detector. It is because of this that special superheterodyne gang condensers are made, these having specially-shaped vanes. As an alternative to the special condenser, however, it is possible to employ an ordinary two-gang component and to connect suitable "padding" and "tracking" condensers in the oscillator tuning circuit.

The principal feature of the superhet is its extreme selectivity, this being obtained by ensuring that the pre-tuned circuits of the I.F. amplifier will only "accept" signals of a definite frequency. And as these are obtained by correct adjustment of two preceding circuits it will be seen that the latter have to be operated with great accuracy. Contrary

to what used to be general belief, the superheterodyne is also capable of reproducing signals of excellent quality, largely due to the fact that a reasonably-wide band width can be accommodated by the inter-

mediate-frequency amplifier. Yet another important advantage of the modern super-het is that it can very easily and efficiently be provided with an automatic volume control. The reason that A.V.C. is more

effective in a superhet than in most types of "straight" circuits is that A.V.C. devices operate most efficiently at comparatively low frequencies such as are handled by the I.F. amplifier and second detector.

THE terms "in series" and "in parallel," are constantly met with in wireless literature, and this article is intended to make clearer the meaning of these expressions, and to explain the effect obtained by these systems of connection, as applied to wireless.

Two or more conductors are said to be in series when they are so connected that they are traversed by the same current. In the case of batteries, series connection is made, of course, by connecting together terminals of the opposite polarity. In a series circuit, the current is the same at any instant at every point.

Conductors are said to be in parallel with one another, when the current flowing in the circuit is divided between the conductors. Batteries, electrolytic condensers, transformers, etc., are connected in parallel when terminals of the same polarity are connected together. Series-parallel is a method of connection in which the components are connected, some in series and some in parallel. "In shunt" and in parallel are the same thing, and a circuit is said to be in shunt with another, or to be shunted across another, when it is connected in parallel with it. Any circuit which serves as a by-pass to another circuit is termed a shunt.

Condensers in Series

Series and parallel methods of connection have widely differing results when applied to different components in a set. If it is required to increase the high-tension supply to a battery-operated set, another battery is connected in series with the existing one, and the available voltage will then be the sum of the voltages of the two batteries, but if it is required to increase the capacity of a 2 mfd. condenser by the addition of a 1 mfd condenser, series connection would have the opposite effect, and the resultant capacity would be less than 1 mfd. When condensers are connected in series, they will act as one condenser having a lesser capacity than either of them would have separately.

The joint capacity of condensers connected in series is the reciprocal of the sum of the reciprocals of their capacities separately. Where only two condensers are employed in series, their joint capacity may be obtained by multiplying their respective capacity values together and dividing this figure by the sum of their capacities, thus, $R = \frac{r' \times r''}{r' + r''}$. Therefore, in the case of a 2 mfd. and 1 mfd. condenser being connected in series, the resultant

SERIES AND PARALLEL CONNECTIONS

By G. H. WRAY, F.C.S.

capacity would be $\frac{2 \times 1}{2+1} = .66$ mfd. If the two condensers which are connected in series each have the same capacity value, the joint capacity will be half that of one of them separately, thus: $\frac{.5 \text{ mfd.} \times .5 \text{ mfd.}}{.5 + .5} = .25$ mfd. Connected in parallel, the joint capacity of condensers is the sum of their separate capacities.

Resistance Connections

Exactly the opposite effect is obtained in the case of resistance connections. If two or more resistances are connected in parallel, the total resistance will be less than that of the lowest resistance,

because the current is provided with more than one path, and the relative strengths of the current flowing through each of the resistances will be inversely proportional to their resistance values.

The popular idea that a current will always take the line of least resistance is incorrect in ordinary electrical practice, although it does apply in the case of heavy spark discharge, such as lightning. Only part of the current will take the path of least resistance. What proportion of the total current that flows that way will depend upon the relative resistance of that path to the rest of the circuit.

The joint resistance of a number of resistances connected in parallel is determined by the same means as capacity in the case of a number of condensers connected in series. For example, supposing that three resistances, 2,000 ohms, 5,000 ohms, and 10,000 ohms respectively, are connected in parallel. The reciprocal of the combined resistance

is $\frac{1}{2,000} + \frac{1}{5,000} + \frac{1}{10,000} = .0008$, and the reciprocal of this figure is $\frac{1}{.0008} = 1,250$ ohms.

As also in the case of only two condensers in series, the resistance value of two resistances connected in parallel is equal to the product of their separate resistances divided by their sum, and where the two resistances are of equal value the combined resistance will be half the value of one of them separately.

If two or more resistances are connected in series, then the whole of the current passing through one must pass through the others, and the total resistance is, therefore, the sum of their separate resistances. $R = r' + r'' + r'''$.

In the case of mains transformers, where more than one is connected to the supply mains, the primary circuits are connected in parallel. Series connection of transformer primary windings is impracticable, owing to the fact that any variation in the current drawn from the secondary circuit of one transformer effects the output from the other transformers.

Aerials 2

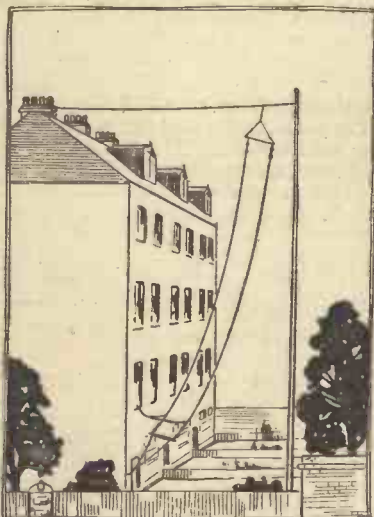

An aerial constructed as shown in this sketch proves valuable in a confined space and is also non-directional.

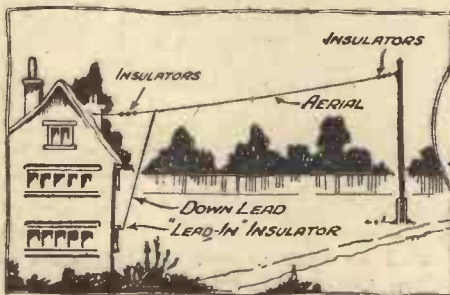

"L" TYPE AERIAL. KEEP FREE OF TREES. SEE THAT DOWN LEAD IS CLEAR OF GUTTERS, ETC.

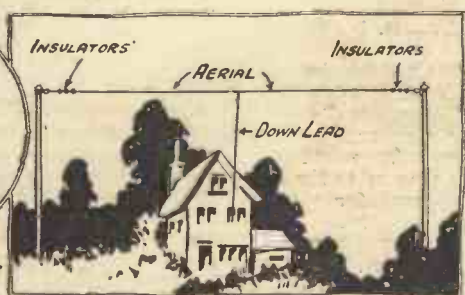
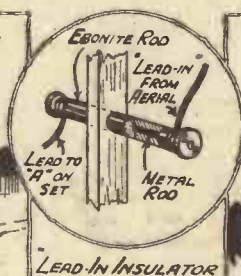

"T" TYPE AERIAL. DOWN LEAD TAKEN FROM CENTRE OF AERIAL WIRE, CLEAR OF ROOF, TO "LEAD-IN".



The Aristocrat of Mains' Units. Exclusively specified for the

"PRIMA MAINS THREE"

The 'MPR' A.C./4 model, supplies not only ample H.T. current, but also L.T. supply for valve filaments.

The amateur can now build an up-to-date A.C. Receiver without the slightest risk of failure.

The A.C./4 is fitted with safety fuse, and mains switch.

Even if you do not intend building the "Prima Mains Three" it will pay you to write for full particulars of other models, prices from 21/-, which will enable you to run your present set off the mains at less than 2/- per year.

MAINS' POWER RADIO, LTD.,



A.C./4. Price 55/- or 7/4 monthly.

Eastern Road,
Romford,
Essex.
Romford 338.



MICRION IRON CORE COIL

Give superhet selectivity to your old or new set by merely substituting "MICRION" in place of your existing coils. No recalibration or troublesome alterations—a simple screw adjusts inductance to your aerial tuning condition. "MICRION" is the outstanding coil development of 1934—it is made by R. I., whose name is greatest as makers of everything in radio—described by *Wireless World* as 40% better than other coils. Ask your dealer or write for brochure describing how to fit "MICRION" to new and old sets.

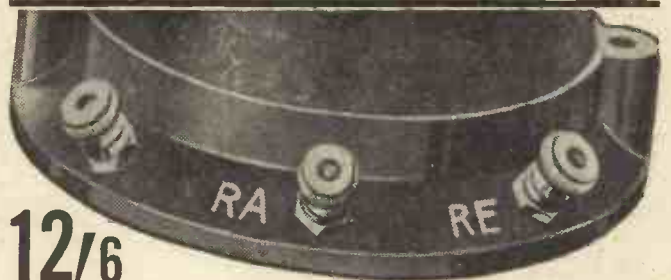

12/6

The Advertisement of Radio Instruments Ltd., Croydon, Surrey.

Specified for the
"PRIMA Mains THREE"



With these three most important components tested and proved for their efficiency and reliability, there should be no doubt in your mind as to your choice. Benefit from this latest tribute to Ormond's leadership by having nothing less than the best—Ormond QUALITY yet lowest in price.

THE ORMOND PERMANENT MAGNET MOVING-COIL CHASSIS.

A perfectly-balanced frequency response ensures sustained brilliance of tone. Fitted with a pressed-steel chassis and large permanent magnet to give reliability with long life. Complete with output transformer. Cat. No. R/494.

26/-

ORMOND L.F. TRANSFORMER.

This highly efficient transformer is fitted with a nickel iron core and has a primary inductance of 50 Henries with a ratio of 3:1 to 1. Contained in a handsome walnut bakelite cover. Overall size: Length 3ins. Width $\frac{11}{10}$ ins. Height 2 1/2 ins. Weight, 8 ozs. Cat. No. R/531.

7/6

TWO-GANG CONDENSER WITH DISC DRIVE AND TRIMMER.

This assembly comprises the Disc Drive complete with Trimmer and fitted with two low law solid dielectric Condensers in gang form, separated by a screening plate. Cat. No. R/366. Price complete

10/-

THE ORMOND ENGINEERING CO., Ltd.,
ORMOND HOUSE,
ROSEBERY AVENUE, LONDON, E.C.1.

Telephone: Clerkenwell 5334-5-6 and 9344-5-6.
Telegrams: ORMONDENG, ISLING.



R/531.



Brit. Regd. Trade Mark.

UNIVERSE POTENTIOMETER

THE ONLY POTENTIOMETER SPECIFIED BY "PRACTICAL WIRELESS" FOR THE "PRIMA MAINS 3" (TYPE 10,000 OHMS LOGARITHMIC).
PRICE 3/6.



Wire wound type supplied in 5,000, 10,000 and 50,000 ohms. Perfectly noiseless in operation. Switch capable of handling heavy mains current (3 amps.). Robust construction. Moulded in all-brown bakelite. One hole fixing. Ideal as a volume control in all circuits.

If your dealer does not stock Universe 1934 Pick-ups, write us direct for illustrated folder. COSMOCORD, LTD. (Dept. P), Universe Works, Enfield, Middlesex. Phone: Enfield 4022/3.

THE ELEMENTS OF WIRELESS

By RALPH STRANGER

Indispensable to everybody who wants to understand the working of wireless receivers. The Author starts with elementary principles, covers the whole field of wireless reception, both from the theoretical and practical points of view, and finishes with a complete survey of a four-valve wireless receiver, explaining its working from the aerial terminal to the loud-speaker.

3/6

Obtainable at all Booksellers, or by post 3/10 from George Newnes, Ltd., 8-11, Southampton St., Strand, London, W.C.2

Do You Know What This Graph Means?

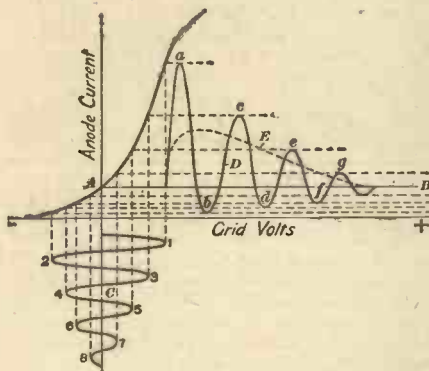

The man who can analyse these curves and understand what they indicate knows his job. But if they do not convey to him perfectly definite information, it would appear that he needs more training than he has had. He is not competent to fill a responsible position in wireless.

Radio has developed so rapidly throughout the last ten years that it has now greatly outgrown the supply of technically qualified men required for the better posts. Moreover, it continues to develop with such speed that only by knowing the basic principles can pace be kept with it.

The I.C.S. Radio Courses cover every phase of radio work. Our instruction includes American broadcasting as well as British wireless practice. It is a modern education, covering every department of the industry.

OUR COURSES

Included in the I.C.S. range are Courses dealing with the Installing of radio sets and, in particular, with their Servicing, which to-day intimately concerns every wireless dealer and his employees. The Operating Course is vital to mastery of operating and transmitting.

There is also a Course for the Wireless Salesman. This, in addition to inculcating the art of salesmanship, provides that knowledge which enables the salesman to hold his own with the most technical of his customers.

We will be pleased to send you details of any or all of these subjects. Just fill in, and post the coupon, or write in any other way, stating which branch of Wireless interests you—the information you require will be forwarded at once.

International Correspondence Schools, Ltd.,
Dept. 94, International Buildings,
Kingsway, London, W.C.2.

Without cost, or obligation, please send me full information about the Courses I have marked X

- COMPLETE RADIO
- RADIO SERVICING
- RADIO EQUIPMENT
- RADIO SERVICING AND SALESMANSHIP
- WIRELESS ENGINEERING
- WIRELESS OPERATORS

Name.....Age.....

Address.....

THE CARE OF ELECTRIC GRAMOPHONE MOTORS

(Continued from page 172)

Care should be taken to use only oil of the grade recommended by the makers. In the case of the worm gear on the governor assembly light grease should be used. Vaseline does quite well for this purpose.

One point should receive particular attention, and that is the governor pad. This should be completely soaked with oil until it is soft and pliable. Most cases of erratic running and that troublesome fault, oscillating governors, is caused through the governor-pad becoming "dry," and it should be particularly watched at reasonably close intervals. Be careful to remove all surplus oil.

There is one important frictional point that is nearly always missed when oiling, even by experienced mechanics; it is the governor slide. This will be found situated on the main governor spindle between the balls. It consists of a sleeve which slides up and down the spindle, and it is essential that it is absolutely free.

In most makes of motors the bearings that carry the governor spindle are held in the frame by means of a small grub screw and are capable of being rotated. The actual hole that carries the spindle is eccentric and therefore the degree of mesh between the worm and pinion, and the alignment of the spindle, can be controlled by turning the bearings in the frame. This adjustment should be carried out with the motor running on the bench. The points to watch are that the motor should run freely, and silently.

In high speed motors, that is, when the armature runs at a speed greater than the turn-table, a faint hum is inevitable and is caused by the rotating parts beating the air.

The above remarks apply to all motors that have commutators and governors, and the notes regarding the governors apply to induction motors which have no commutators.

To those readers who possess synchronous motors which have neither commutator or governor the above notes will not be of use.

IMPROVING THE SIMPLE SHORT-WAVER

(Continued from page 180)

There is another point which calls for some mention in this article, and concerns the question of whether or not it is satisfactory to operate a short-waver from the mains. In the majority of cases this presents very little difficulty, provided that ample smoothing and decoupling is provided in the H.T. supply unit. But it is necessary to take every precaution in this direction, for otherwise only the more powerful stations will be heard above the hum. It is also desirable, when 'phones are being used, to isolate them from the main H.T. source, and this can best be done by using a 1 : 1 output transformer or a choke-capacity output filter

of the usual type. When short-wave reception is obtained by means of a separate unit (adaptor or converter) it is usually desirable to build this with its own separate supply unit, unless it is known for certain that there is sufficient "reserve" current output from the H.T. and L.T. system of the broadcast receiver. In the latter case there is no harm in connecting up to the rectifier and mains transformer by means of a valve plug-and-socket or similar device. The short-wave detector must be adequately decoupled, and in this respect it will often be found worth while to use "double" decoupling, as illustrated in Fig. 4; two fixed resistances are wired in series, a 1-mfd. condenser being connected between the end of each resistance and H.T.—

CHOOSING AND MAKING L.F. AND OUTPUT TRANSFORMERS

(Continued from page 170)

An excellent output transformer suitable for use with either pentode or power valves can be made by using as core 3 dozen pairs of No. 4A stalloy stampings. The primary will consist of 5,000 turns of 34 gauge enamelled wire, whilst the size of the secondary will depend upon the ratio required. The number of turns for the secondary can easily be found from the formula:—

Secondary turns = $\sqrt{\frac{\text{Optimum Load of Output Valve}}{\text{Speaker Impedance}}} \times 5,000$

For most purposes, however, it is very

convenient to wind 5,000 turns of 38-gauge enamelled wire for the secondary, and take tapings after every 1,000 turns, so that a number of alternative ratios are readily available.

TABLE 1.—Details of Core Stampings

Size No.	Dimensions (in.)			Winding Area (square in.)
	A	B	C	
5	1 1/16	1 1/8	3/8	2 1/2
30A	15/16	13/16	1/8	9/16
30B	15/16	17/32	3/16	1/3
4A	15/16	1 1/8	1/8	1

TABLE 2.—Wire Data for Enamelled s.w.g. Wire

Gauge	Turns per Square in.	Yards per Pound.
38	20,400	2,810
40	32,500	4,516
42	44,300	6,576

THE PRIMA MAINS THREE

(Continued from page 174)

terminal and this should be connected to a tapping on the grid-bias battery to enable the detector to function as an L.F. valve for gramophone-record reproduction.

It will be seen, therefore, that the receiver itself may be regarded almost as a battery instrument, and the only difference in its construction is the provision of twisted leads for the low-tension supply.

The chassis is of all-metal construction, and this provides the benefit of short earth returns, etc. It is obtained already drilled, and thus the construction will simplify

itself to the mere tightening of nuts and bolts. It will, of course, be essential to obtain the specified parts in order that the holes will correctly align themselves. The variable condenser is mounted on a small metal plate, and to enable this to be accommodated in a suitable position on the chassis two special distance pieces are provided by the makers of the chassis. The components which are attached to the front of the chassis have been chosen so that the necessity for fitting insulating washers has been avoided, and the chassis provides the connection to those parts of the potentiometer and reaction condenser which have to be connected to earth.

ALL ABOUT MAINS UNITS-2

THE half-wave thermionic valve circuit is shown in Fig. 3, from which it will be seen that the rectifying valve differs from the familiar receiving valve in that it possesses only a filament and an anode, but no grid. The filament and the anode are connected to two secondaries on the mains transformer, and consequently upon connecting the primary to the mains, current flows in the secondaries, heating the filament and at the same time causing the anode to be at a comparatively high potential. Electrons, attracted by the anode, proceed to flow rapidly from the filament to the anode (positive half-cycle), but any electrons attempting the return journey (negative half-cycle) encounter very considerable opposition, with the result that the positive half-cycle is allowed to pass, the negative half-cycle being suppressed. The metal-rectifier, consisting of a large number of copper and copper-oxide discs in contact, operates on a chemical principle, but has exactly the same effect in that it offers no opposition to one-half of the cycle, but holds back the opposite half. The half-wave metal-rectifier is shown in Fig. 4.

By using a rectifying valve having two anodes, it is possible to make use of both halves of the cycle, each anode taking care of one-half. The circuit is shown in Fig. 5, the equivalent metal-rectifier circuit being shown in Fig. 6. This form of rectification is called "full-wave" and, except for small outputs, is always employed. The metal-rectifier circuit shown in Fig. 6 is the widely-used "voltage doubler" circuit, which has the advantage over other circuits in that it enables us to use an input voltage actually less than the required D.C. output, and, in addition, the condensers in series with each section of the rectifier minimize to a considerable extent the possibility of damage.

Heater Circuit Supply

As already mentioned, it is possible to wind several secondaries on one mains transformer, the additional windings being used to supply raw A.C. at 4 volts for the heater circuit of an indirectly-heated A.C. valve receiver, or to supply another rectifier to obtain unsmoothed D.C. for charging accumulators. These windings are shown respectively in Figs. 5 and 6. Various types and sizes of both valve and metal rectifiers are obtainable, depending on the D.C. output required, and the transformer secondaries are, of course, wound to supply the voltages required by the rectifier used. It will be understood that the output from the rectifier, whatever the type, is not actual direct current, but is a pulsating, unidirectional current which has to be smoothed down by chokes and reservoir condensers as in the D.C. unit. From the rectifier onwards, the A.C. unit circuit is exactly the same as the D.C. unit.

Accumulator Charging Circuit

With further reference to Fig. 6 in which is also shown an accumulator charging circuit, it will be noted that the secondary winding is tapped at three points, rendering the apparatus suitable for 2, 4, or 6 volt cells. The same result can

be achieved by using a tapped resistance. It is essential to include in the D.C. side of

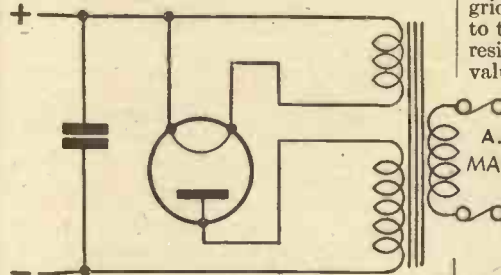

Fig. 3.—Circuit of a half-wave rectifying valve.

the charging circuit a small resistance to regulate the flow of current. The value depends on the charging rate.

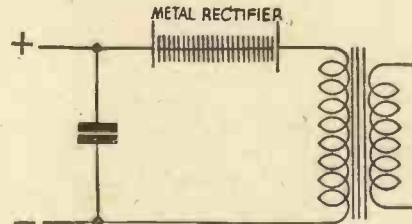

Fig. 4.—This circuit shows how a half-wave metal rectifier is connected.

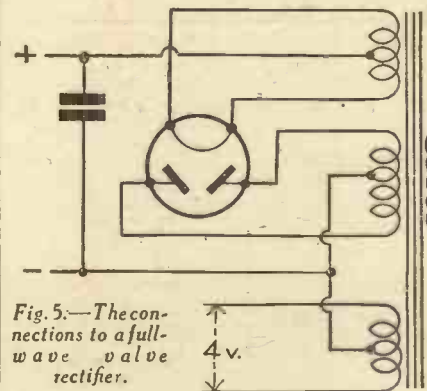

Fig. 5.—The connections to a full-wave valve rectifier.

Automatic Grid Bias

In the case of indirectly-heated A.C. valves, it is a simple matter to arrange for

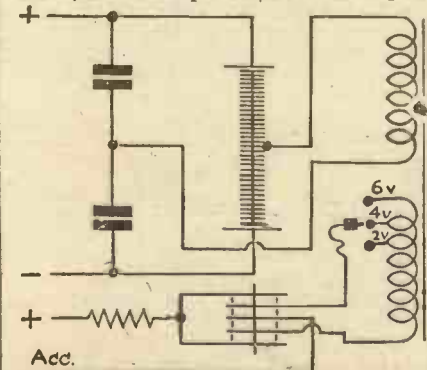

Fig. 6.—A rectifier circuit employing full-wave metal rectifiers.

automatic grid bias by utilizing the voltage-drop across a resistance in the cathode lead of the valve. The position of this resistance is shown and marked R in Fig. 7, and it will be clearly understood that the anode current of the valve must pass through this resistance and, therefore, a voltage is developed across it. The top end of this resistance is of course at a higher potential than the earth end, and thus, by connecting the grid return lead to the earth-end the grid is negative with respect to the cathode to the extent of the voltage drop across the resistance. Calculation of the resistance value is again computed by Ohm's Law, the

formula being:—

$$\frac{\text{Voltage of grid-bias required} \times 1,000}{\text{Anode current of valve}}$$

For example, assume the case of a valve requiring a bias of 10 volts, its anode current being 10 milliamps, then the value of the cathode resistance is:—

$$\frac{10}{10} \times 1,000 = 1,000 \text{ ohms.}$$

The cathode resistance must always be shunted with a fixed condenser in order to provide a low-impedance path to earth for any unwanted H.F. or L.F. currents. That then is a general outline of the principles and design of mains units.

Now any reputable make of mains unit, used under correct conditions, is an entirely satisfactory proposition, and will do all that the makers claim for it, but the same unit used under *incorrect* conditions can turn a well-behaved set into a howling horror. The error made by many purchasers of mains units is that they choose the smallest (and consequently the cheapest) model available, regardless of the requirements of the receiver. Literally dozens of instances have come to my attention in which I have found that the owner of a S.G.-Det.-Pentode set requiring some 20 milliamps or more has blithely purchased a unit designed to give 10 or 12 milliamps, the result being that the smoothing in the unit is hopelessly saturated, the valves are trying to work with only a few volts on their anodes, hum, instability, motor-boating, and a host of other objectionable troubles occur, and very often the poor manufacturer is called over the coals—quite undeservedly of course. The safest way of deciding upon a mains unit for use in an existing battery-driven set, is to connect a milliammeter in the negative lead of the set when it's operating from a new 120 v. H.T. battery. The reading obtained will be the total anode current consumption of the set, and a unit having the next highest rated output should be chosen. For example, if your milliammeter reading was 17 milliamps, and there are two units available having outputs of 15 and 20 milliamps respectively, always plump for the larger one! It may cost a bit extra in the first place, but it will certainly save much trouble, annoyance, and expense in the long run.

Eliminating Hum and Instability

However, even though the output from the unit is ample for the set, hum and instability can still occur, due mainly to the comparatively high internal resistance as compared with that of a battery in good condition. Instability, often evidenced by motor-boating, usually occurs where two or more anode circuits are fed from one H.T. tapping, none of the anode circuits being decoupled. The decoupling effect

(Continued overleaf)

(Continued from previous page)

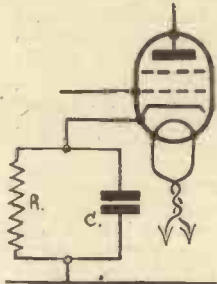

Fig. 7.—Showing the position of an automatic bias resistance in the cathode circuit of an indirectly heated valve.

in the unit is not always sufficient, and in order to ensure a completely stable set it is advisable to decouple each stage of the set by means of series resistances and condensers as shown in Fig. 8. If not already done, the loud-speaker should be isolated from the direct current in the anode circuit of the output valve by using an L.F. choke and condenser as shown. Here again, the choke should have a high inductance value, and the capacity of the condenser should not be less than 2 mfd., as otherwise some of the bass is likely to disappear. On D.C. mains it is also advisable to connect another condenser of similar capacity on

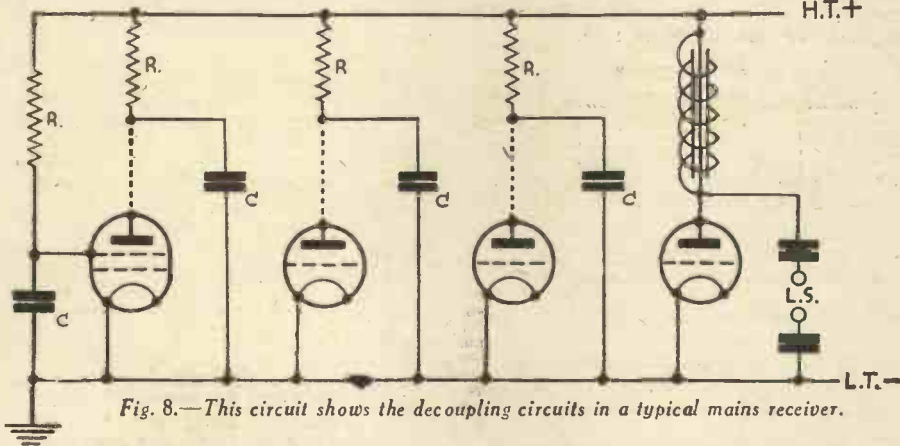

Fig. 8.—This circuit shows the decoupling circuits in a typical mains receiver.

the other side of the loud-speaker as shown. All decoupling condensers should be of the 2 mfd. variety, except in the case of the screen of the S.G. valve, in which position a 1 mfd. condenser can be used but which should be of the "non-inductive" type. The values of the decoupling resistances can be calculated more or less exactly by Ohm's Law, but so far as the detector and low-frequency valves are concerned, experiment with values between 20,000 and 50,000 ohms will quickly prove which is best. In any event, these values are not at all critical.

The causes of hum are many and varied. Here are some of them. Inefficient earth—try another earth including an entirely new lead, and on D.C. mains try a .004 condenser in series with the earth wire. Pick-up on aerial—temporarily remove lead-in from receiver; if the hum ceases try running the aerial at right angles to the original position and see that the lead-in is clear of all electric wiring, etc. Pick-up in set—remove the unit as far as possible from the aerial end of the set, and try rotating the unit through an angle of 90°. Induction in set—fit an earthed shield over the coils (not too close), earth the cores and cases of transformers and chokes, and try altering the positions of these components. Faulty grid leak—try a new one, and if connected across the grid condenser, try connecting it between the detector grid and L.T. positive. Wiring—all by twisted and carried as far away from other wiring as possible. Another cause of hum is H.F. ripple superimposed on the mains. To overcome this it is necessary to connect a special choke in one or both of the mains leads, also connecting two fixed condensers across the mains, taking the centre connection to earth as shown in Fig. 9.

Other Forms of Interference

In addition to these causes, interference similar to hum can be picked up from electrical apparatus used in the vicinity of the receiver, such as vacuum cleaners, hair-dryers, home cinematographs, etc. If you are suffering from interference of this nature, nothing can be done at the receiving end, and the only thing to do is to write to the Interference Dept. of the B.B.C. who may, or may not, be able to help you. Distortion upon connecting up a mains unit in place of a battery can often be traced down to the fact that the grid-bias values have not been readjusted to compensate for the increased voltages from the

Other Forms of Interference

unit. This is a point which is not always obvious at first sight.

Use a Good Voltmeter

Always remember, too, not to judge your unit by the readings obtained with a cheap voltmeter. A cheap voltmeter always has a very low resistance, and, consequently, a heavy current consumption at full deflection. When connected across the unit, the current consumption is, of course, added to the legitimate valve consumption, with the result that as voltage decreases with increase of current, the output appears to be absurdly low. In order to obtain even approximately accurate readings, a meter having a resistance of 1,000 ohms per volt must be used, and the measurements must be taken under working conditions. Otherwise there will be no current flowing in the circuit, with the result that the readings will be very much higher than they should be.

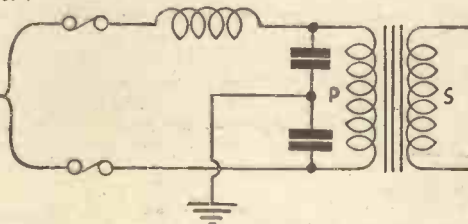

Fig. 9.—A method of preventing modulation hum by connecting two condensers in series across the secondary of the mains transformer.

LOUD-SPEAKER FRETS

(Continued from page 184)

A plain, square hole is cut in the front of the cabinet, and backed up by the material. The bars, which are half-lapped with each other, as shown in the two details as A and B, are secured to the front of the cabinet with glue and thin pins. A better effect can be obtained by making one set of bars wider than the other, as shown in E, and mounted in position as shown in the lowest sketch.

A scheme which does not appear to have been suggested before in connection with loud-speaker frets, and is offered to readers of PRACTICAL WIRELESS as something new, is that of silk-suspended frets. The silk generally used for backing frets is reasonably thick and is stretched into position and is capable of supporting loose frets. The idea allows of an infinite variation of schemes and offers an unlimited scope for the inclusion of practically any design.

Normally, designs for frets must be arranged so that they are attached to the main woodwork of the cabinet, but in this scheme separate pieces of wood, cut to the desired shape, can be attached to the silk without reference to any other pieces. Fig. 9 shows a design which would be favoured by radio—Isaac Walton's—and is included to show how separate pieces can be used to get a very fine effect. The two fish could be cut from thin ply and painted black on the faces with gold edges, whilst the bubbles can be thin pieces of black cardboard. Another scheme is shown in Fig. 10, and the thinness of the supporting pieces has been deliberately emphasized because sufficient support will be obtained when the cut-out is fixed to the silk with glue. An inspection of the drawing will show that there are no holes in the design, which can be cut without opening the fret saw.

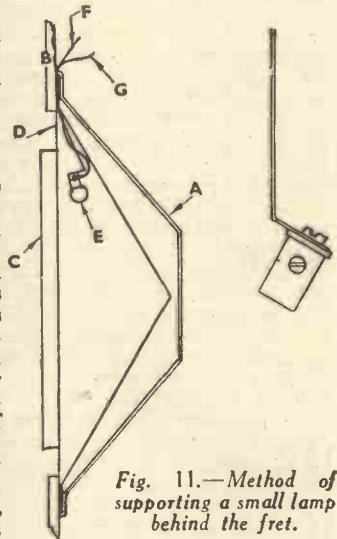

Fig. 11.—Method of supporting a small lamp behind the fret.

This type of fret can also be enhanced in appearance by fitting small lamps behind the fret, and details are given in Fig. 11. The ordinary miniature screw-bulb holder is used and can be supported inside the cone on stiff wire, or a strip of aluminium, which forms one of the connections to the holder, can be used. If a metal chassis is used as shown in Fig. 11, the strip can be clamped under one of the fixing screws, and the second lead brought out and insulated by a piece of sleeving or wrapped round with a piece of black tape. The design of fret shown in Fig. 9 looks exceptionally well if the lamp is fitted near the top of the cone, but the design in Fig. 10 requires the lamp to be fitted directly in front of the centre of the cone for the best effect. The two leads from the lamp are connected to the filament terminals of the nearest valve-holder.

Facts and Figures

Components Tested in our Laboratory

BY THE PRACTICAL WIRELESS TECHNICAL STAFF

FERRANTI RESISTANCES

A NUMBER of new products from Messrs. Ferranti, Ltd., of Hollingwood, Lancs., have been received, and on the right is an illustration of some neat resistances and potentiometers. The latter are the thinnest components we have seen in this particular class, and the movement is very ingenious and smooth in operation. The actual back-of-panel space is only $\frac{1}{4}$ in., and the overall diameter is less than 2 ins. The element is of the composition type, the ends being eyeletted to a strip of insulating material, and the metal which clamps the end is continued to form a soldering lug. The spindle is anchored to a strip of insulating material, and this is provided with a copper disc and contacting point which, whilst it makes good contact with the resistance element, is designed to prevent wear. There is thus little likelihood of trouble arising at some future date due to a path being cut in the element and poor contact so arising. An interesting and noteworthy feature is that the construction has been arranged so that the spindle is "dead," and thus no special care has to be taken when mounting the component to insulate it. These potentiometers may be obtained in values of 50,000, 100,000, 250,000, 500,000 ohms, and 1 meg., and the price is 3s. 9d.

The resistances, as may be judged by comparing them with the potentiometers, are also extremely small components, although the manufacturers have been sufficiently far-seeing to provide really long wire ends for connection purposes. It is, of course, a simple matter to cut off unwanted wire, where it is difficult to lengthen a wire which is too short. The total length provided on these resistances will enable them to be wired direct into almost any part of a normal receiver without the use of additional leads. The resistances are clearly colour-coded, the usual spot having been dispensed with and a band of colour used for the final marking, and this is a refinement which enables the value of a resistance to be ascertained without the necessity for turning it about to locate the dot. The price of these resistances, which are of the $\frac{1}{4}$ -watt type, is 6d.

GARD LIGHTNING ARRESTER

WITH the arrival of the warm weather, there is the likelihood of thunderstorms or heavy static discharges on the aerial-earth



Some of the new Ferranti potentiometers and resistances.



A useful aerial safeguard.

system, and it will be worth while to install some sort of protector, even although the risk of an aerial being struck by lightning is extremely remote. The peace of mind which will arise from the knowledge that adequate protection is afforded by a reliable device will well repay the small expense which such a fitting will cost. The

Graham Farish device which is illustrated is known as the Gard, and it is neat and very simple to fit. A rain protector is fitted to prevent leakage due to moisture, and the spark-gap is fully enclosed, and thus will offer no troubles due to a coating of soot or other dirt which might prove conductive after a time. The nuts which are provided for the attachment of the lead-in and earth wires are sufficiently large to enable the fitting to be carried out by hand, without recourse having to be made to a spanner. Washers prevent looseness due to strands of wire coming adrift as the nuts are tightened. The price of this safeguard is only 1/6d., and some such device should be included in every aerial system.

PIFCO "ROTAMETER"

IN our issue dated March 3rd, we illustrated a small meter which we regret was inadvertently described as the Pifco All-in-one-meter. This was not, in fact, a Pifco product, the meter to which we referred being provided, in addition to the normal voltage readings, with a special unique valve testing device. The latest pattern of this meter, which is manufactured by the Provincial Incandescent Fittings Co., Ltd., of Pifco House, High Street, Manchester, is known as a Rotameter and is a great improvement on the small pocket meter. It provides no less than eight different test ranges, each of which has its own scale. The pocket meter, of course, has these scales printed one below the other, and the respective scales have to be read according to the particular test which is being carried out. In the Rotameter an octagonal knob is provided on the side of the rectangular case, and this knob is engraved with the various ranges. The readings for the different scales are printed on the sides of an octagonal roller which occupies practically the whole width of the case, and a window is provided just sufficient to permit the whole of one side of this roller to be viewed. Thus, when the knob is rotated a new scale is brought to view and no misunderstanding can possibly exist regarding the actual range which is being utilized. There are only two terminals, and the rotatable knob carries out the required change of connections, insertion of shunt resistances, etc., and all difficulties are thus removed. It is, in effect, as the makers point out, eight separate meters in one case, and the ranges include all those which are essential for the wireless experimenter, in addition to the popular Pifco valve-testing device, in which a valve is inserted in a valve-holder mounted in the top of the case, and the range-knob turned to "valve test." A battery contained in the meter is thereby joined in series with the meter and valve, and the pointer swings over on the scale to indicate that the filament is intact. A fuse is incorporated to

protect the movement from damage due to the application of a high voltage to an incorrect setting of the scale. The finish is in black bakelite and plated fittings, and heavy insulated leads and spade terminals. The price is 29s. 6d.

MAGNUM DUAL RANGE COIL

IN our issue of the 14th of April last we described a new dual-range coil produced by Messrs. Burne-Jones and Co., Ltd. We regret that the price of this component was wrongly given. It costs 4s.

T.M.C. AND HYDRA CONDENSERS

AN important marketing scheme has just been arranged by the Telephone Manufacturing Company, Ltd., of Hollingsworth Works, West Dulwich, London, S.E.21, the well-known makers of "T.M.C. Hydra" condensers and telephonic equipment, etc. The Telephone Manufacturing Company, Ltd., is forming a new company to be known as T.M.C.-Harwell Sales, Ltd., to take over Harwell, Ltd., of the Sessions House, Clerkenwell Green, London, E.C.1, and the agencies held by that concern, including those for the P. H. British Electrical Works, Ltd., of West Norwood, London, S.E.27 (makers of the noted "P.H.B." electrical accessories), and Agro Electrical Co., Ltd., of Aylesbury. The new company will also act as trade distributors for all "T.M.C." products except public telephone equipment, marine telephone and electrical apparatus, and the "New System" telephones handled by the Subsidiary Companies of Telephone Rentals, Ltd. The Telephone Manufacturing Company, Ltd., will specialize in electrical accessories and similar products on a large scale, and, with that object in view, the company has purchased the P. H. British Electrical Works, Ltd. Mr. H. M. Harris will be managing director of T.M.C.-Harwell Sales, Ltd., and Mr. C. J. Abercrombie will be sales director, both these gentlemen having held similar positions with Harwell, Ltd.

Mr. W. A. Jackson, M.I. Mech. E., general sales manager of the Telephone Manufacturing Company, Ltd., will be on the board, and the Chairman will also be appointed by the Telephone Manufacturing Company, Ltd. Commodious premises in central London are to be taken for the new sales company, which—supported by the extensive resources of the Telephone Manufacturing Company, Ltd., and with the excellent connection of Harwell, Ltd.—will occupy an important position in the electrical and radio industries.

ROLA CLASS B SPEAKER

LISTENERS who wish to modernize their existing equipment, especially with a view to the employment of Class B amplification and a modern moving-coil loud-speaker of high quality, will be very interested in the unit illustrated below. This is a British Rola product, incorporating a high-class

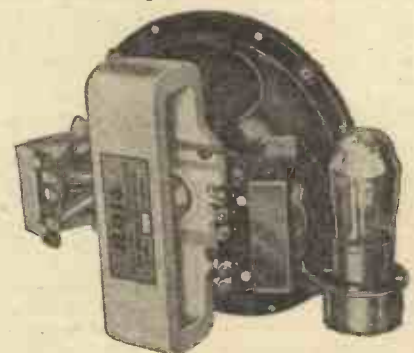

The Rola Class B unit and combined loud-speaker.

moving-coil loud-speaker together with the associated Class B amplifying stage, and no difficulty at all should be experienced in incorporating this with an existing receiver. All problems of correct matching, etc., are dispensed with, and provided the apparatus with which it is employed is capable of delivering a good quality signal to the Class B valve, it should be found a most valuable acquisition in the interests of better quality and greater volume. The price of the unit is 57s., and it may be obtained in two types—one suitable for Mullard PM 2B, B.T.H. PD220, Cossor 220B, Standard 13B1, Hivac B220, Marconi B2, G.E.C. B21, and Clarion B22 valves, and the other suitable for Cossor 240B, Ferranti HP2 and Clarion B24 valves. The price does not, of course, include the valve.

THE WIRELESS CONSTRUCTOR'S ENCYCLOPEDIA (2nd Edition)

By F. J. CAMM (Editor of "Practical Wireless")

THIS invaluable encyclopedia is written in plain language by one of the most accomplished designers and writers on wireless construction. The whole subject is fully covered, and the volume is remarkable for the number of practical illustrations it contains.

Obtainable at all Bookellers, or by post 5/6 from Geo. Neumes, Ltd., 8-11, Southampton Street, Strand, London, W.C.2.

5/6

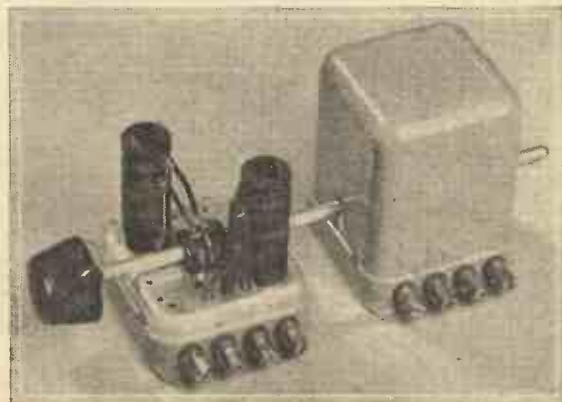

The Wearite "Nucleon" Coils—Universal type as used in the Leader receivers.



REVIEWS OF THE
LATEST RECORDS

IMPRESSIONS ON THE WAX

By
T. Onearm

MMUSIC to suit all tastes, excellently recorded by popular artists, is the keynote of some recently issued discs of the British Homophone Company. It is not often that Charlie Kunz, the popular conductor of the Casani Dance Band, records without his band, but he does so on both sides of *Sterno* 1342. This record is an excellently played pianoforte solo, which introduces such well-known tunes as *Some of These Days*, *With a Song in My Heart*, *Night and Day*, *If You Could Care, Kiss Me Again*, and a waltz from *Bitter Sweet*, the play that had such a long run in London. You should certainly hear this record, which is appropriately called the *Kunz Medley*. The Barnstormers, who have recently made a number of fine records, give of their best on *Sterno* 1344, 1345, and 1346. The former record, *The Buggy Song* and *La-di-da-di-da*, is two popular novelty quick-steps, the other two being *I'll be Faithful* and *Moonlight Down Lover's Lane*, and *Three of Us* (which is one of the latest hit tunes) and *You're Gonna Lose Your Gal*. Another fine dance record is *Sterno* 1343, which introduces *By a Waterfall* and *Shanghai Lil*, both tunes being from the film, *Footlight Parade*, and played by the Casani Dance Band, directed by Charlie Kunz. *Medley of Popular Songs* will certainly appeal to those music lovers who like pianoforte solos. Stan Bradbury, who records on this record, indulges in some fine syncopated playing of many of the most popular tunes of the moment on *Homochord* H.R.64. Other up-to-the-minute tunes, all excellently recorded on *Homochord* records, are *When You were the Girl on the Scooter*, from the film *Broadway Thru' a Keyhole*, and *Without that Certain Thing*, two popular fox-trots played by Al Gold and his band on *Homochord* H.R.61; *I'm Learning to Play the Guitar*, *I Am* and *We all Went Up, Up, Up the Mountain*, two amusing tunes played by Billy Hart and his Boys on *Homochord* H.R.66; *Moonlight Down in Lover's Lane* and *Three of Us*, played by Dick Rose and his Band on *Homochord* H.R.58; *On a Steamer Coming Over* and *Did You Ever See a Dream Walking?* played by Archie Mercer's Band on *Homochord* H.R.57; *Moonlight and Melody*, Parts 1 and 2, played by Al Gold and his Band on *Homochord* H.R.60, and *La-di-da-di-da* and *Eddie was a Lady* played by Mellors Dance Orchestra on *Homochord* H.R.59.

Light Music

Those who like accordeon bands are catered for on *Sterno* 1350 and *Homochord* H.R.63, two fine records on which these instruments are heard at their best. The former record is a clever-piece of recording by Zigano's Accordeon Band, the tunes played being *The Ziganos in Spain* and

Crimoline. The other record, *The Elegant 80's*, Parts 1 and 2, introduces a number of old-time tunes that will always be popular, played by the Del Rio Accordeon Band. Reginald King and his Band make a welcome appearance on *Sterno* 1347. This record, *Canzonetta*, is delightfully played as only Reginald King and his Band can play.

Hawaiian bands have a fascination that is all their own, and *The Song of the Islands* and *Palikiko Blues*, played by Val's Hawaiian Players, is a typical record that you should make a point of hearing. *None But the Weary Heart* and *Senorita*, played by Mantovani and his Band on *Sterno* 1343, and *The Herd Girl's Dream* and *Serenade*, played by Pierre Fol and his Quartet of Strings on *Sterno* 1349, are two records both of which are excellent fare for the music lover, and I have every confidence in recommending them.

Vocal Records

George Baker, the popular baritone who is often heard on the "air," has made a fine record for the above company in *The Floral Dance* and *The Yeomen of England*, *Sterno* 1351, two songs that will never grow old. Most readers will, no doubt, recollect the popularity of that cowboy ditty *Headin' for the Last Round Up*, and *Home on the Range* is a similar type of song that is equally good. On the other side of this record is *The Prisoner's Song*, both tunes being sung by Monte Hunter and his Texas Rangers on *Homochord* H.R.65. Fred and Leslie Douglas, the two popular duettists, sing *Mine, All Mine* and *Roll on Blue Moon*, on *Sterno* 1352, and add one more record to their list of successes.

Plaza Records

These records, which are slightly smaller than *Sterno* and *Homochord*, but play just as long, are excellent value for 6d.

Most of the above tunes are obtainable on *Plaza* records, so that the reader may obtain all the latest up-to-the-minute numbers for quite a small outlay.

FLUXITE CHANGE OF ADDRESS

FLUXITE LIMITED—well known to our readers as the sole proprietors and manufacturers of Fluxite Soldering Paste—have now moved to larger premises at Dragon Works, Bermondsey Street, S.E.1. Telephone Hop. 2632. Fluxite Simplifies All Soldering, and is obtainable in small and large tins—of all ironmongers. A leaflet on Hardening Steel with Fluxite will be sent upon application to any reader interested who mentions this journal.

RADIO CLUBS AND SOCIETIES

Club Reports should not exceed 200 words in length and should be received First Post each Monday morning for publication in the following week's issue

ANGLO-AMERICAN RADIO AND TELEVISION SOCIETY

At the nineteenth meeting of the Uxbridge District Branch of the Anglo-American Radio and Television Society, Mr. Leslie W. Orton's latest short-wave receiver was demonstrated. W-3XAL, 8XK, 9GW, DJC, GSA, GBR, PTF, RKK, NCK, etc., were all heard at good strength. Mr. K. T. Cawse (Radio 2AIU) remarked that he was obtaining G.P.O. sanction to bring his transmitter (AA) to Uxbridge for a demonstration. Full particulars of the U.D.B. may be obtained from Mr. Leslie W. Orton, 11, Hawthorn Drive, Willowbank, Uxbridge.

LEICESTER AMATEUR RADIO SOCIETY

This Society held their annual dinner on April 10th. The meeting, which was a great success, was attended by the Vice-Presidents of the Radio Society of Great Britain, and also the Secretary of that Society, Mr. J. Clarricoats, who mentioned, during a speech, several instances of public services rendered by wireless amateurs, and remarked that Professor Fleming was an amateur when he discovered the possibilities of the two-electrode valve.

Dr. Marsden (call sign G2PD), who is in charge of Central England in the Admiralty scheme for recruiting amateurs as emergency operators, also spoke.

He said that two years ago when the suggestion was first mooted, 400 amateur operators were required by the Admiralty. Only fourteen were now needed to bring that auxiliary up to strength.

Dr. Marsden had several interesting films to show, including one of a tour of the Rugby long and short-wave stations.—Hon. Secretary, A. M. Stimpson, 88, Welford Road, Leicester.

THORNTON HEATH RADIO SOCIETY

A meeting of this Society was held at St. Paul's Hall, Norfolk Road, on Tuesday the 10th instant. Mr. J. Hodges, in a talk on Records and Recording, stated that strictly speaking gramophone records did not come under the heading of wireless apparatus, but as practically all commercial sets now incorporated a pick-up, or terminals to which a pick-up could be attached, he considered the subject was one which should be dealt with more fully than it had been hitherto. Mr. Hodges dealt with records which were produced in the early days by the acoustic method, and afterwards with the present-day electrical recording. The Hon. Sec. is Mr. Jas. T. Webber, 368, Brigstock Road, Thornton Heath.

SLADE RADIO

A lecture on the "Universal A.C./D.C. Receiver" was given by Mr. N. B. Simmonds at a recent meeting. After a few words on mains, output circuits and batteries, also early circuits and valves, he went on to describe the universal receiver. Full details of the circuit were given, also difficulties in the design which had been encountered were explained at some length. A demonstration showed that the set which comprises three pentodes, H.F., detector and output, gave ample volume, good quality and proved quite selective. The lecture proved very interesting, and a large number of questions were raised.

Another lecture on "Metal Spraying, etc." was given by Mr. Geoffrey G. Hoare, of Messrs. Metallisation, Ltd., at the last meeting of this Society. After referring to his previous lecture he went on to deal with further applications of the metal spraying process. The treatment of containers, wireless valves, baseboards, transmitting equipment, etc., was dealt with, and the spraying pistol was also described. Slides were then shown of the pistol and its mechanism, a mass coating drum, treatment of pylons, gasometers, loco boilers, coils, gas burners, railway bridge girders, aero engine exhausts, rolls for paper works, anchors and various applications in the shipping industry, and ornamental windows. During the evening he gave a description and demonstration of a new type of loud-speaker which has apparently very great possibilities.—Hon. Sec., 110, Hillaries Road, Gravelly Hill, Birmingham.

REPLIES TO BROADCAST QUERIES.

EDITOR'S NOTE: Querists must limit their queries to three per letter.

C. SANDERS (Hull): (1) R. A. F. transmissions, 65-70 m. (2) IAC, Coltano, Pisa, Italy (45.11 m.).

BUY YOUR VARLEY BIFOCAL COILS
NOW, AND ENTER FOR OUR TWENTY
GUINEAS COMPETITION

PRACTICAL LETTERS FROM READERS

The Editor does not necessarily agree with opinions expressed by his correspondents. All letters must be accompanied by the name and address of the sender (not necessarily for publication).

A Highly Instructive Work

SIR,—I beg to acknowledge with thanks the safe delivery of my copy of "Everyman's Wireless Book." It is an extremely interesting and highly instructive work. The compilation of the book could not be bettered. Every wireless enthusiast should have a copy.—JAS. FERGUSON (Edinburgh).

Stripped versus Screened Components

SIR,—I am interested in the letters regarding stripped components which have been published in PRACTICAL WIRELESS recently. I have been a constructor of sets for twelve years and find from experience that the all-metal method of construction is the best; this means that all H.F. and L.F. Chokes, Transformers, Tuning Coils and Condensers should be shrouded in metal cases, with provision for earthing the same. If components are bought with due regard to working curves, etc., you will find that they come under the above heading. Components thus made are guaranteed to be within a certain percentage of a master component, and it is only adequate screening to prevent interaction with other components that enables this to be done. With modern manufacturing methods the additional cost over stripped components is only a fraction of the total cost. Stripped components have been obtainable for a long time, in fact the first ones were of this type, but the advantages of screening outweigh the slight additional cost and, for all-round use, screened components are best. As regards soldering versus terminals, provision is made for both on high-grade components, and where a set is to be permanent soldering can be used, but for experimental work terminals are to be preferred.—F. A. H. (Stourbridge).

"A Mine of Information"

SIR,—I have just received the gift book, "Everyman's Wireless Book," quite safely, and am very pleased with it. Good paper, large print, clear illustrations, a mine of information without being too technical, are the leading features of this grand volume. Every home constructor should have a copy. I wish PRACTICAL WIRELESS every success and hope you will still continue your policy of helping the man who likes to build his own sets.—WM. ALLCROFT (Worksop).

Violent Static

SIR,—I have been observing for the last three years a curious fact which I have never seen noted. With a north or north-west wind a shower (especially hail) produces a continuous roll of static on speaker. On a bare aerial wire this was loud enough to drown even the loudest programme but on my present heavily insulated aerial I have cut down static by about 75%. The most curious part is that the noise often starts as much as two or three minutes before a shower starts, and continues sometimes for same period after the shower. Also the noise at times stops completely for thirty seconds or so during shower. I know that the north wind is a

thunderly one, but this does not explain all the above. My aerial is quite exposed and on high ground in open country. I should like to know if any of your readers have noticed a similar phenomenon or could explain same. The noise may be due to electrical discharge from rain clouds but why does it appear before the rain starts? It is hard to describe the noise but it is not the usual atmospherics. With pre-detector volume control full on it becomes absolutely deafening.—J. H. CLEGGETT (Oughterard, Co. Galway).

"A Volume to be Proud Of"

SIR,—I received my copy of "Everyman's Wireless Book" safely, for which many thanks. It is indeed a volume to be proud of, and what I like most is the style in which it is written—easy to read and easy to understand.—E. L. VERNON (Roscrea, Tipperary).

A Satisfied Reader's Appreciation

SIR,—I thank you for the safe return of my wireless set which I sent you for inspection and overhaul. It is now working entirely satisfactorily and is certainly a "gem" of a set. In design and performance it is well ahead of many higher priced sets on the market. In view of the fact that you have been able to fit the A.V.C. device in this three-valve set at so little cost, I am rather surprised you are not continuing it with all the models you are now bringing out, i.e., Leader Three, etc., but in any case the readers who build any of these models will have good value for money.—A. A. FROST (Hereford).

CUT THIS OUT EACH WEEK

Do you know

- THAT a millimeter cannot be used in the output circuit of a Q.P.P. arrangement to identify distortion.
- THAT a new type of disc television receiver will be necessary to receive high-definition systems.
- THAT multiplying schemes to enable standard discs to be used may be possible.
- THAT elaborate potentiometer voltage-supply schemes are rendered unnecessary with modern H.F. pentode screening grids.
- THAT separate grid-biasing circuits are preferable for indirectly-heated push-pull valves.
- THAT there are at present four different types of push-pull circuit.
- THAT the above four types are Quiescent, Paraphase, Duophase, and Ordinary push-pull.

NOTICE.

The Editor will be pleased to consider articles of a practical nature suitable for publication in PRACTICAL WIRELESS. Such articles should be written on one side of the paper only, and should contain the name and address of the sender. Whilst the Editor does not hold himself responsible for manuscripts, every effort will be made to return them if a stamped and addressed envelope is enclosed. All correspondence intended for the Editor should be addressed: The Editor, PRACTICAL WIRELESS, Geo. Newnes, Ltd., 8-11, Southampton Street, Strand, W.C.2.

Owing to the rapid progress in the design of wireless apparatus and to our efforts to keep our readers in touch with the latest developments, we give no warranty that apparatus described in our columns is not the subject of letters patent.

CATALOGUES RECEIVED

To save readers trouble, we undertake to send out catalogues of any of our advertisers. Merely state, on a postcard, the names of the firms from whom you require catalogues, and address it to "Catalogue," PRACTICAL WIRELESS, Geo. Newnes, Ltd., 8/11, Southampton St., Strand, London, W.C.2. Where advertisers make a charge, or require postage, this should be enclosed with applications for catalogues. No other correspondence whatsoever should be enclosed.

PROGRAMME OF B.B.C. LONDON MUSIC FESTIVAL, 1934

THIS year, as in 1933, the B.B.C. has again organized a Festival of Music, to consist of six concerts in the first two weeks of May. These will be given in the Queen's Hall.

The first three concerts (Friday, May 4th; Monday, May 7th; and Wednesday, May 9th) will be conducted by Adrian Boult. Friday's programme will include Bach's *Brandenburg Concerto in F*, Beethoven's *Violin Concerto*, with Carl Flesch as soloist, and the third symphony of Brahms. A repeat performance of Hindemith's oratorio, *Das Unaufhörliche (The Perpetual)* is arranged for the concert on Monday, May 7th. Wednesday's programme will include Elgar's "Enigma" *Variations* and Tchaikovsky's *B Flat Minor Pianoforte Concerto*, with Vladimir Horowitz as soloist.

On Friday, May 11th—the first of the concerts to be conducted by Bruno Walter—Schubert's *Seventh Symphony*, Wagner's overture, *The Mastersingers*, and Strauss's *Don Quixote*, with Emanuel Feuermann as solo cellist, will be played. On the following Monday (May 14th), the programme will include Weber's overture, *Der Freischütz*, and Mozart's *D Minor Pianoforte Concerto*, with Bruno Walter as soloist. The concluding concert of the Festival will be on Wednesday, May 16th.

The B.B.C. Orchestra (leader, Arthur Catterall) will play throughout the Festival.

Copies of the prospectus, giving full programmes and details of subscription and single ticket rates, are now available; and analytical programmes (one for each concert) will be available from Monday, April 23rd, price 6d. each, or 3s. for the set of six.

WEARITE POWER TRANSFORMERS

WHERE a modern all-electric receiver derives its power supply from a mains transformer, this instrument must be built to conform to rigid specifications if it is to maintain trouble-free operation of the receiver. "Wearite" transformers are the result of many years of experience in power transformer construction, and are designed to give maximum efficiency under all conditions. All the raw materials are tested before use, and the laminations are made to conform to specification for iron loss, permeability, etc. A range of these transformers is shown in a folder (M.T. 15233) which we have received from Wright and Weaire, Ltd., 740, High Road, Tottenham, N.17. These transformers are made in three sizes. Types "A" and "B" embody a new type of input selector and gift finish, and type "C" is fitted with terminals for the various input voltages. In each range there are a number of types for different outputs. Copies of the leaflet can be obtained from the firm at the address given above.

FERRANTI A.C.-D.C. CIRCUIT TESTER

MESSRS. FERRANTI have recently produced a high-grade A.C.-D.C. tester capable of taking nearly all measurements commonly required in radio testing and servicing, and having at the same time a wide application in other fields of electrical industry. The instrument is contained in a polished black case of moulded bakelite, and has a scale 110°, 24in. long, with knife-edge pointer for accurate reading. Only two scales are used; one for both A.C. and D.C. readings, and one for resistance. A Westinghouse metal rectifier is employed in connection with the A.C. ranges. Further particulars are given in a folder (Wa. 520), copies of which can be obtained from Ferranti, Ltd., Hollinwood, Lancashire.

NEW EKCO RADIOGRAM

A NEW all-electric radiogram, Model R.G.84, has just been put on the market by E. K. Cole, Ltd., to meet the demand for a high-class instrument embodying all the latest refinements at a moderate price. In an attractive broadsheet issued to the trade the outstanding features of this remarkable model are set forth, amongst which are full A.V.C., band-pass tuned superhet circuit, Collaro induction type gramophone motor with 12in. turntable, light-beam and shadow-tuning, and moving-coil speaker. The instrument has five valves, including rectifier, and is housed in a handsome inlaid walnut cabinet with semi-matt finish. The price of the A.C. model is 21 guineas, and the D.C. model, 22 guineas, and hire purchase terms are approximately 4s. 6d. per week. Readers looking for an up-to-date quality radiogram should write for further particulars to E. K. Cole, Ltd., Ekco Works, Southend-on-Sea.

REPLIES TO

LET OUR TECHNICAL STAFF SOLVE YOUR PROBLEMS



If a postal reply is desired, a stamped addressed envelope must be enclosed. Every query and drawing which is sent must bear the name and address of the sender. Send your queries to the Editor, PRACTICAL WIRELESS, Geo. Newnes, Ltd., 8-11, Southampton St., Strand, London, W.C.2.

QUERIES and ENQUIRIES by Our Technical Staff

The coupon on this page must be attached to every query.

SPECIAL NOTE.

We wish to draw the reader's attention to the fact that the Queries Service is intended only for the solution of problems or difficulties arising from the construction of receivers described in our pages, from articles appearing in our pages, or on general wireless matters. We regret that we cannot, for obvious reasons—

- (1) Supply circuit diagrams of complete multi-valve receivers.
- (2) Suggest alterations or modifications of receivers described in our contemporaries.
- (3) Suggest alterations or modifications to commercial receivers.
- (4) Answer queries over the telephone.

Please note also, that all sketches and drawings which are sent to us, should bear the name and address of the sender.

BUILDING A TAPE RECORDER

"Can you send me a diagram showing how to build a tape recorder for recording Morse messages which I receive on my set?"—L. S. T. M. (Nottingham).

It should not be difficult to build an instrument to enable Morse signals to be recorded, as it is only necessary to arrange for a length of narrow paper tape to be moved along past a pen point at a regular speed, and then to feed the Morse signals to an electromagnet, to the armature of which the pen is attached. Thus, as the armature is attracted the pen point would be brought into contact with the paper and if a dash was being received the pen would be held down and thus mark a line. A description of a suitable instrument is given in *Simple Electrical Apparatus* (1s. 3d. by post from these offices).

D.C. UNIT ON A.C. SUPPLY

"I have a commercial D.C. mains unit rated for an input of 240 volts. Is it possible to build a rectifier for it so that I can run it on a 240 volts A.C. supply, and what type of transformer, etc., will be required?"—W. S. J. (Chatham).

The D.C. mains unit may be considered as the smoothing section of a standard A.C. mains unit, and the only requirements for the conversion will be a mains transformer, a rectifying valve or metal rectifier, and a 4 mfd. condenser. The mains transformer should be obtained to work with a Class A rectifier or similar metal rectifier, and the 4 mfd. condenser should be joined across the input terminals of the D.C. unit. It will probably be found worth while for you to obtain a transformer having secondary windings for indirectly-heated valves to save future expense. Get a copy of the little book issued by Messrs. F. C. Heayberd whose address will be found in our pages. This gives various circuits and you should find one to suit your requirements.

A.C.-D.C.2

"I am building the Universal Two-valver described last October but am in some doubt regarding the method of mounting the 7-pin valve-holder. You mention bending a lug round to make contact with the top disc. On the valve-holder which I have bought this disc is connected to the rest of the assembly by an eyelet. Have I to join this to earth?"—E. L. B. (Pontypridd).

There is no necessity to carry out the instructions you refer to with the particular valve-holder which

you have obtained. The holder was originally supplied in separate parts, and the instructions were given to enable the parts to be assembled in the correct manner. As the makers now fix the parts together you can ignore that part of the constructional work.

A NEW CIRCUIT

"I enclose a diagram of my set and shall be glad of some help. It produces a rumbling noise which disappears on reducing the reaction, only to return on further attempts at tuning."—A. W. G. (Ipswich).

There are some other points which A. W. G. mentions in his letter, but the diagram which he sends is of a circuit which is quite new to us. He has apparently mistaken the connections to a valve and has the grid condenser and leak joined to the anode together with the reaction winding and transformer primary. No doubt if he removes the condenser and leak and joins these to the grid in the same manner as they are at present joined to the anode, he will find the circuit will function satisfactorily.

DATA SHEET No. 76.

Cut this out each week and paste it in a notebook.

CLASS B OUTPUT VALVES.

Maker	Fil.	Anode Grid	Max. Anode	Max. Anode	Type	Price
	Cur.	Volts	Bias	Swing	Load	
Cossor	.2	150	0	35	12,000 1,250 B 220	14/-
	.4	150	0	50	8,000 2,000 B 240	14/-
Ferranti	.4	150	0	50	8,000 2,000 HP 2	14/-
Hivac	.2	150	0	—	14,500 1,250 B 220	10/6
Lissen	.1	150	0	30	14,000 1,200 B 2	8/-
	.4	150	0	50	8,000 1,500 BB 240	14/-
Marconi & Osram	.2	150	-6	50	12,000 2,300 B 21	14/-
Mazda	.2	150	-5	40	12,500 2,500 PD 220	14/-
	.2	150	-5.5	50	10,000 2,900 PD 220A	14/-
Mullard	.2	150	0	35	14,000 1,250 PM 2B	14/-
Six-Sixty	.2	150	0	35	14,000 1,250 S 220B	14/-
Triotron	.3	150	0	35	20,000 1,350 E 220B	19/6
Tungsram	.2	150	0	28	16,000 2,500 CB 220	11/-
362	.2	150	0	30	10,000 1,500 BA 2	9/-
	.4	150	0	60	7,000 3,000 BX 2	9/-

"THE BABY GRAND"

"I have a three-valver in my possession which was described some time ago by you. It is known as the 'Baby Grand Three.' This gives me splendid results, but I should like to modernize it if this is possible. Could you suggest any improvements?"—A. C. N. (Kenton).

Unless you wish to redesign the layout, the only real improvement that can be made to this particular receiver is the fitting of a pentode in place of the present output valve. To do this you can buy a four-pin pentode, and plug this in place of the present output valve, and take a flexible lead from the terminal on the side of the pentode valve base to H.T. positive. Alternatively, you can obtain a five-pin valve-holder and mount this in place of the four-pin holder, connections to the usual four pins being made in the same manner as at present. The extra terminal is then connected to H.T. positive. A five-pin pentode should then be purchased. The grid bias will have to be adjusted for the new valve and the maker's instructions should be carried out in this respect. If

you wish, you could fit modern composition or wire-wound type resistances in place of the spaghetts, although this will not improve results other than giving greater security.

LOUD-SPEAKER PROBLEM

"I should be glad if you could help me out of my difficulty. I enclose a photo of my speaker and should like to know the resistance of the speech coil and the ratio of the transformer and the optimum load of the valve to use with it."—E. B. (Barnsley).

The photograph is of a standard commercial speaker, and this is supplied with a transformer already fitted. There should therefore be no need to bother with the resistance of the speech coil, etc. The transformer is wound to provide accurate matching with any type of valve. However, for your information, the resistance of the speech coil is 5 ohms, and the transformer which is fitted is designed to work with a valve requiring an optimum load between 10,000 and 18,000 ohms.

RESISTANCE OF WIRE

"Could you please settle an argument. What is the relationship between the thickness of copper wire and its resistance. My contention is that a thick wire will have a smaller resistance than a thinner wire of the same type."—J. G. A. (Clontarf).

The thicker a piece of wire, the lower its resistance, and consequently the greater current it will carry. You have only to visualize the wire as a water-pipe. Thus a two-inch diameter pipe will permit the flow of a greater quantity of water (at a given pressure) than a one-inch pipe, simply because, owing to its greater section it offers less restriction (or resistance) to the flow of water. By way of example, 18 gauge copper wire has a length of 53 yds. to the ohm, whilst 28 gauge copper wire (which is nearly one-third of the diameter of the former wire) has a length of only 7 yds. to the ohm.

CORRECT I.F. TRANSFORMERS

"I have started to buy components for the 4-valve short-wave superhet, the circuit of which you gave in February. I am doubtful as to whether I can make and use successfully the I.F. transformers, details of which were given in your 'Making your Own Screened Coils' series. The reason is that you stipulate an I.F. transformer tuning to 150 kc/s, but those in the coils series were 110 kc/s. Can I use these? If not, what must I do?"—L. Z. (Wandsworth).

The choice of the I.F. transformer frequency will depend upon the design of the frequency changing system, and if the latter is designed to change the signal frequency to 150 kc/s it would be useless to use an I.F. stage which would reject that frequency. Therefore, you must use either the correct I.F. transformers, or alternatively, design the frequency-changer to suit the I.F. transformers which you wish to use. Having decided upon the arrangement which you wish to utilise the actual working data should not be difficult to ascertain. It will probably be easiest to wind I.F. transformers for the 150 kc/s range, which will entail only the removal of a few turns of wire to the primary and secondary of the transformers which were described in the 'Making Your Own Screened Coils' series. Constructional details of such a transformer are given in this issue of PRACTICAL WIRELESS.

FREE ADVICE BUREAU COUPON

This coupon is available until May 5th, 1934, and must be attached to all letters containing queries.

PRACTICAL WIRELESS, 28/4/34.

B.B.C. ADVISE
AERIAL OVERHAUL AT LEAST ONCE A YEAR

Save yourself the trouble with a roll of PIX INVISIBLE AERIAL. Just unroll it and press it to the wall or anywhere in the house and it sticks. Everlasting lightning-proof, reduces static and sharpens tuning. Mr. W. J. M. Bradley, Yorks, who uses one, says: "Reception better than it has ever been on the 40ft. aerial outside."
The World's Handiest Aerial.
Press it and it Sticks anywhere.
BRITISH PIX CO. LTD., LONDON, S.E.1.
PIX INVISIBLE AERIAL.



Miscellaneous Advertisements

Advertisements are accepted for these columns at the rate of 3d. per word prepaid - minimum charge 3/- per paragraph - and must reach this office not later than Tuesday for the following week's issue. All communications should be addressed to the Advertisement Manager, "Practical Wireless," 8 Southampton Street, Strand, London.

PREMIER SUPPLY STORES

offer the following Set Manufacturers' Surplus New Goods at a fraction of the original cost; all goods guaranteed perfect; carriage paid over 5/-, under 5/- postage 6d. extra (Ireland, carriage forward).

PREMIER SUPPLY STORES announce the purchase of the entire stock of a world-famous Continental valve manufacturer. All the following types of standard mains valves at 4/6 each. H. H.L. L. Power. Directly heated 6-watt Pentode. Directly heated 9-watt Pentode. High magnification Screen-grid, low magnification Screen-grid. Variable-Mu Screen-grid. 250 volt 60 milliamper, full-wave rectifiers.

The following type 5/6 each. Indirectly heated Pentode, 350 volt 120 milliamper, full-wave Rectifier. 500 v. 120 ditto, 6/6. Dario Battery Valves 4v. filament, Set of 3, consisting of Screen-Grid, Detector and Power or Super-Power, 6/6 the lot. Power or Super-Power, 2/6.

ELIMINATOR Kits, including Transformer, choke, Westinghouse metal rectifier, Dubilier condensers, resistances and diagram, 120v, 20 m.a., 20/-; trickle charger 8/- extra; 150v. 30 milliamper, with 4v. 2-4 amps. C.T. L.T., 25/-, trickle charger 6/6 extra; 250v. 60 milliamper, with 4v., 3-5 amps. C.T. L.T., 30/-; 300v. 60 m.a., with 4 volts 3-5 amps. C.T. L.T., 37/6; 150 volts 50 milliamper, 27/6.

AMERICAN Triple Gang 0.0005 Condensers, with trimmers, 4/11; Premier chokes, 25 milliamper, 20 henries, 2/9; 40 milliamper. 25 hys., 4/-; 65 milliamper. 30 hys., 5/6; 150 milliamper. 30 hys., 10/6; 60 milliamper, 80 hys., 2,500 ohms, 5/6.

HARLEY Pick-up, complete with arm and volume control, 12/6.

BRITISH RADIOPHONE Wire Wound Potentiometers, with mains switch incorporated, 10,000 ohms, 3/6.

PREMIER British-made Meters, moving-iron, flush mounting, accurate, 0-10, 0-15, 0-50, 0-100, 0-250 m.a., 0-1, 0-3, 0-5 amps.; all at 6/-.

SPECIAL offer of Mains Transformers, manufactured by Phillips, input 100-120v. or 200-250v. output 180-0-180 volts 40 m.a., 4 v. 1 amp., 4 v. 3 amp., 4/6; 200-0-200v., 4v. 1a., 4v. 3a., 4/6.

ALL Premier Guaranteed Mains Transformers have Engraved Terminal Strips, with terminal connections, input 200-250v. 40-100 cycles, all windings paper interleaved.

PREMIER H.T.S. Transformers, 250v. 60 m.a., rectified with 4v. 3-5a. and 4v. 1a. C.T. L.T. screen primary, 15/-; with Westinghouse rectifier, 25/-.

4 v. 3a. C.T., 6v. 2a. C.T., 9v. 1a., 12v. 1a., 7/6 each; 4v. 3-5a., 22v. 1a., 8/6 each; 10v. 3a., 14v. 4a., 10/- each.

PREMIER H.T.9 Transformer, 300 v. 60 m.a., with 4v. 3-5a. and 4v. 1a. C.T. L.T., and screened primary, 15/-; with Westinghouse rectifier, 26/-.

PREMIER H.T.10 Transformer, 200v. 100 m.a., rectified, with 4v. 3-5a. and 4v. 1a. C.T., L.T. and screened primary 15/-; with Westinghouse rectifier, 26/-.

PREMIER Mains Transformers, output 135v. 80 m.a. for voltage doubling, 8/6; 4v. 3-4a., C.T., L.T., 2/- extra; Westinghouse rectifier for above, giving 200v. 30 m.a., 8/6.

PREMIER Mains Transformers, output 250-0-250v. 60 m.a., 4v. 3-5a., 4v. 2-3a., 4v. 1-2a. (all C.T.); with screened primary, 15/-.

PREMIER Mains Transformers, output 350-0-350v. 90 m.a., 4v. 3-5a., 4v. 2-3a., 4v. 1-2a. (all C.T.), with screened primary, 15/-.

PREMIER Mains Transformers, output 400-0-400v. 100 m.a., 4v. 4-5a., 4v. 2-3a., with screened primary, 15/-.

PREMIER Auto Transformers, 100-110/200-250v., or vice versa, 100-watt, 10/-.

MULTI Radio output Transformers, 4/6. Twin Screened Wire 3d. per yard.

CENTRALAB Potentiometers, 50,000, 250,000 half meg, any value, 2/-; 200 and 400 ohms, 1/-.

RELIABLE Canned Coils with Circuit, accurately matched dual range, 3/- per coil. Please state whether Aerial or H.F. required. Ditto Iron core, 3/6.

PREMIER L.T. supply Units, consisting of Premier Transformer and Westinghouse rectifier, input 200-250v. A.C., output 2v. 1/2 amp., 11/-; 8v. 1/2 amp., 14/6; 8v. 1 amp., 17/6; 15v. 1 amp., 19/-; 6v. 2 amp., 27/6; 30v. 1 amp., 37/6.

MAGNAVOX D.C. 152, 2,500 ohms, 17/6; D.C. 154, 2,500 ohms, 12/6; D.C. 152 Magna, 2,500 ohms, 37/6; all complete with humbucking coils; please state whether power or pentode required; A.C. conversion kit for above types, 10/-; Magnavox P.M., 7in. cone, 18/6. Ditto 9in. cone, 29/6.

RAMPAN M.C. Loud-speakers, 2,500 ohm. field, 9in. cone, handles 5 watts; 21/-.

RAMPAN P.M. Loud-speakers, 9in. cone, handles 4 watts; 18/6.

POLAR 3-Gang STAR, .0005, manufacturers type. Fully screened, 7/6, with trimmers, 1/6 extra.

(Continued at top of column three)

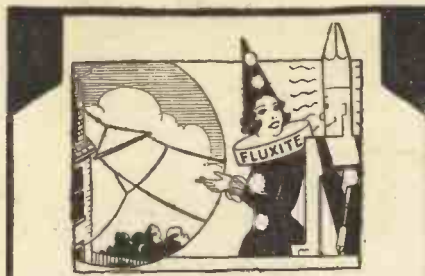

"We're Fluxite and Solder—the reliable pair; Famous for Soldering—known everywhere!"

When fixing your aerial—be sure not to shirk—"SOLDER" your connections—a good spot of work!"

See that Fluxite and Solder are always by you—in the house—garage—workshop—anywhere where simple, speedy soldering is needed.

ALL MECHANICS WILL HAVE

FLUXITE

IT SIMPLIFIES ALL SOLDERING

All ironmongers sell Fluxite in tins: 4d., 8d., 1s. 4d., and 1s. 8d. Ask to see the FLUXITE Pocket Soldering Set—complete with full instructions—7s. 6d. Ask also for our leaflet on HARDENING STEEL with Fluxite.

FLUXITE, LTD. (Dept. W.P.), Dragon Works, Bermondsey Street, S.E.1.



FOR ALL REPAIRS!

Advertisement for Engineers' Handbook with circular logos for I.E.E., A.M.I.C.E., B.S.C., A.M.I. Mech. E., and A.E.I. Text: "ENGINEERS! LOOK WHAT YOU HAVE AT YOUR FINGER TIPS!"

Do not let a first-class post slip through your fingers for the sake of a few letters after your name. Whatever your experience, age or education, you should send to-day for "ENGINEERING OPPORTUNITIES," this free 256-page Handbook shows the easiest way of preparing for the A.M.I.C.E., A.M.I. Mech. E., A.M.I.E.E., A.M.I.A.E., Metric, G.P.O., etc. exams. The book also gives details of courses in all branches of Civil, Mech., Elec., Motor, Aero., Wireless, and "Talkie" Engineering, and explains the unique advantages of our Appointments Department. Send for the valuable Handbook to-day—FREE and post free. BRITISH INSTITUTE OF ENGINEERING TECHNOLOGY, 390, Shakespeare House, 29/31, Oxford Street, London, W.1.

Advertisement for Utility Sales Co. with text: "YOU'VE NO IDEA OF THE BARGAINS OBTAINABLE IN RADIO, ELECTRICAL, SCIENTIFIC AND DOMESTIC GOODS OF ALL DESCRIPTIONS. YOUR NAME WILL BE ADDED TO OUR MAILING LIST ON RECEIPT OF P.C. WE CAN INTEREST YOU. UTILITY SALES CO., 27a SALE STREET, PADDINGTON, LONDON, W.2"

Advertisement for M.P.R. Ltd. with text: "Add 50/- WEEKLY to your earnings by charging accumulators in your spare time. Complete plant incorporating Westinghouse Rectifiers to charge 105 cells weekly. Trade price 4 guineas or 8/- monthly. Models for A.C. and D.C. mains. Also Charger for H.T. accumulators. M.P.R. Ltd ROMFORD, ESSEX."

(Continued from foot of column one)

WESTERN ELECTRIC Condensers, 250v. working, 2 mfd., 1/-; 1 mfd., 6d.; 4 mfd., 2/-; 1 mfd., 400v., 1/-; 2 mfd., 1/6.

B.T.H. Truespeed Induction Type (A.C. only) Electric Gramophone Motors, 100-250v.; 30/-, complete. Type YH 100/250v. A.C. or D.C., 42/-.

SPECIAL Offer of Wire Wound Resistances, 4 watts, any value up to 10,000 ohms, 1/-; 8 watts, any value up to 15,000 ohms, 1/6; 15 watts, any value up to 50,000 ohms, 2/-; 25 watts, any value up to 60,000 ohms, 2/6.

CYLDON Capacitors (Double Trimmer), 1/- Utility .0005 2-gang Bakelite Condensers, concentric Uniknob Trimming and Disc Drive, complete, 3/6.

EDISON BELL Double Spring Gramophone Motors, complete with turntable and all fittings, a really sound job, 15/-.

AMPLION Cone Loud-speaker Units, 1/9, complete with 12in. cone and chassis, 3/11 each. Worth treble. Larger Unit with 12in. chassis, 5/9.

ROMOND Condensers, 0.0005 2-gang, semi-shielded, 2/6; brass vanes, with trimmers, 3/6.

WIRE Wound Potentiometers, 15,000 ohms, 1/6; 50,000 ohms, 2/-; 500,000 ohms, 3/6.

HOME Radio Microphone, complete, 5/-; simply plug in to pick-up terminals.

LARGE Selection of Pedestal, table, and radio-gram cabinets, by best manufacturers, at a fraction of original cost for callers.

WESTERN ELECTRIC Mains Transformers, 300-0-300v. 60 m.a., 4v. 1-2 amp., 4v. 2-3 amp. 8/6. 500-0-500v. 150 m.a., 4v. 3-5a., 4v. 2-3a., 4v. 2-3a., 4v. 1a. C.T., 4s. 1a. C.T., 19/6.

RELIABLE Intervalve Transformers 3-1 or 5-1, 2/- Dubilier, .05 mica, 1/9.

C.C. Condensers, 250v. working: 2mfd., 1/9; 1,000 ohm, 150 m.a., variable resistance, 2/-.

T.C.C. Electrolytic Condensers, 440 volts working, 4 mf. or 8 mf., 3/-; 15 mf., 50 v. working, and 50 mf. 12v. working, 1/-; 25 mf. 25 v. working, 1/3.

KOLSTER-BRANDES Mains Transformers, Input 200-250 volt, output 350-0-350v. 100 m.a., 4v. 1 amp., 4v. 2 amp., 4v. 3-4 amp., 10/- Ditto, Input 160v., 5/-.

ROMOND Brass Variable Condenser, .0005 complete with knob-dial 2/-, with slow motion 3/-.

A. & A. Cone Unit and Chassis, a really sound job, 10in. diameter, 6/6.

M.V. Block Condensers, 400v. working; 4 x 4 x 1 x 1 x 1 x 0.1 x 0.1 x 0.1, 6/-; 4 x 2 x 1 x 1 x 1 x 0.5, 4/6.

DUBILIER Condensers, 2 mf. 1,200v. working, 4/-; 8 mfd. dry electrolytic, 450v. working, 3/-.

THE Following Lines 6d. each or 5/- per dozen—Chassis valve holders, 5 or 6 pin, screened screen-grid leads, any value 1-watt wire end resistances, wire end condensers, 0.0001 to 0.1, trimming condensers, T.C.C. 6 mfd. 50 v. electrolytics.

PLEASE mention PRACTICAL WIRELESS when ordering.

PREMIER SUPPLY STORES

20-22, High Street, Clapham, S.W.4, MA Caulay 2188. Close 1 o'clock Wednesdays; open to 9 o'clock Saturdays. Nearest Station, Clapham North Underground.

THE following Unused set Manufacturers' surplus, all goods guaranteed perfect; immediate delivery.

SUPER-HET, and 2-H.F. Radiopaks, 35/- Radiophone coils (3in. gang), 10/- Radiophone I.F. transformers, 6/6.

FERROCART coils. G1-G2-G3 with switch, 30/- G11-G12-G13-G14 with switch, 36/-.

DUBILIER or Erie 1-watt resistors, 7d. 2-watt, 1/3.

MARCONI K19 pick-ups, 22/6. Westinghouse rectifiers, H.T.S. 9/6; H.T.9, H.T.10, 11/-; L.T.S. 11/6.

REGENTONE transformers for H.T.8 or H.T.9 with 4v., 4a. L.T. winding, 7/6. Wards transformers, output 350-0-350v., 60ma., 4v. 4a. 4v. 2a. 12/6.

ELIMINATORS, outputs 150v. 25ma., S.G. and Detector. D.C. type, 12/6; A.C. type, 24/-.

DUBILIER dry electrolytic condenser, 8mf. or 4mf., 500v. working, 50v., 50mf., 3/6. Hot-wire ammeters for A.C. or D.C., 0-500 ma. scale, 5/6.

B.T.H. pick-up tone-arms, 3/-.

ALL types of brand new American valves in stock, first-class makes, guaranteed.

47, 35, 51, 89, 18, 19, 46, 59, 6A7, 15, 42, 41, 38, 39, 78, 75, 57, 58, 24, 44, 36, 35, 43, 12/-.

UX17A, UX199, UX280, UX245, UX228, UY227, 8/- UX250, UX281, UX210, 18/-.

B.T.H.-RK 6-volt speakers, suitable for P.A. work, 27/6. A.C. type with field rectifier, 42/7/6.

MAGNAVOX speakers, complete with hum-bucking coils, output transformers, etc., 152 (9in. cone), 24/-; 164 (7in. cone), 16/3; Rola F.8 (7in. cone), 17/6, with their 2,500 or 6,500 ohm. fields. Rola F.6, P.M., 24/-; Magnavox P.M.254, 18/6. Carriage paid, cash with order or C.O.D. Send for list.

WARD, 2nd floor, 45, Farringdon Street, London, E.C.4. Telephone: Holborn 9703.

TIME Switch easily made, cheap, efficient On or Off. Radio, Lights, Signs, etc. Full details, P.O. 2/-—B. 3, Norfolk Rd., W.11.

PEARL & PEARL. Bargain List "B" Free—190 Bishopsgate, London, E.C.2.

SOUTHERN RADIO'S Bargains.—Set manufacturer's guaranteed surplus.
COILS.—Igranic iron-core band-pass 3 coils unit. Screened. Ganged on base with switch, 16/6 (list 33/-).
LISSEN Super-het 3 coils unit. Screened. Ganged on base with wave-change and filament switches. Type LN5181 for battery or mains, 12/6 (list 30/-).
EWCO'S Coils.—Types O.S.C./126; T.O.S.; I.F.T.; T.B.F.; A.W.C.; 3/3 each. B.P.F. band-pass filter B.P.F., 4/- (list 12/-). All coils new in original cartons.

VARIABLE Condensers.—Lotus 3-gang 0.0005, 12/6; Lotus 2-gang, 0.0005, 8/6; Lotus Dyblock single, 0.0005, 4/9 (list 9/6); all condensers are with dials, escutcheons, knobs, fully screened trimmers, and boxed; Hydra block condenser, 16 mfd. (2+2+8+2+1+1), 1.000 v. D.C. 7/- each; 20 mfd. (2+2+2+2+2+2+2+1+1+1+1), 1.500 v. D.C., with terminals, 11/6; Dubilier 4 mfd. (2+1+1), 1.000 v. D.C., 2/9; 4.5 mfd. (2.25+2.25) 1.000 v. for mains noise suppression, 3/-; Blue 4 mfd., 2/3; 2 mfd., 1/6; 1 mfd., 1/-.
SPEAKERS.—Blue Spot Permanent Magnet with universal transformer for power, super power, pentode and Class B, 23/- (list 39/6). Celestion Soundex Permanent Magnet, 17/6 (list 27/6). Celestion P.P.M./W., 25/- (list 49/6).

BLUE Spot 66K, in cabinet, 16/- (list 42/6). G.E.C. Stork Speaker in Cabinet, 19/6 (list £3/15/-).
BLUE Spot. Genuine 100U, inductor speaker on chassis 13/6 (list 39/6).

READY Radio D.C. mains energised moving-coil speakers with Humbucking coils and universal transformers. All voltages, 16/6 (list 39/6). All new in cartons.

ST.400 kits, all specified proprietary components, £2/19/6 (list £4/17/6).
SPECIFIED Cabinets for Ready Radio Meteor kits, 17/6. "303" kits, 13/6.

GRANIPAK Tuning Unit, comprising screened coils with wavechange switch; Igranic 3-gang condenser with cover; escutcheon disc drive; mains switch; three 5-pin valve holders; grid leak and condenser; terminal board, with circuit; actually made for A.C. mains, but easily adapted for battery sets: list 57/6, our price 27/-, brand new.

FRAME Aerials.—Lewcos dual wave superhet, 9/- each (list 27/6).
SPECIAL Offer of Lewcos Spaghetti Resistances, all sizes, in original sealed boxes, 4/- per dozen, assorted price to trade, 36/- per gross.

READY RADIO Instant Transformers, for matching any valve to speaker, Junior model 11/6 (list 27/6), Senior model 14/6 (list 37/6).

PICK-UPS.—Marconi "No. 10" (1934), 22/6 (list 32/6).
MAINS Transformers.—Full list of Mains transformers and chokes sent Free. Specials supplied in 3 days. All transformers and chokes guaranteed 12 months.

MISCELLANEOUS.—Rotorohm and Radophone volume controls, all values, 3/- each; with switch, 3/3 (list 10/6); Hellesen's 8 mfd. electrolytic condensers, 2/9 each; Westinghouse metal rectifiers, H.T. 6, 7, 8, 9/3 each; Ferranti chokes, 20 henry 60 m.a., 6/9 each; Ready Radio L.F. transformers, 5-1, 3-1, 3/3 (list 8/6); Lewcos superhet 8-way bases, complete with valve-holders, grid leak, fixed condenser, type "48", 2/- each.

ALL Goods Guaranteed and Sent Carriage Paid.

BRANCHES at 271-275, High Rd., Willesden Green, N.W.10 and 46, Lisle St., W.C.2; please send all post orders to 323, Euston Rd., N.W.1.

SOUTHERN RADIO, 323, Euston Rd., London, N.W.1 (near Warren St. Tube). *Phone: Museum 6324.

LOUDSPEAKERS Rewound, any make, 3/6. Eliminators, etc., quoted for. Year's Guarantee. —Breeze, Clapper House, Marden, Kent.

METERS and Clean Components Purchased or Good Part Exchange Allowance. Send stamped envelope for reply. Cash waiting.—Tele-Radio Supplies, 305, King's Road, S.W.3. Flaxman: 9710.

TELE-RADIO have purchased manufacturer's surplus stock. All guaranteed perfect. Westinghouse H.T. rectifiers. We have a limited supply of H.T.'s, 120v. 20 m/a @ 5/11. H.T.5, H.T.7, H.T.8, 8/9. H.T.9, 9/11. H.T.10, 10/3.

1 Watt Resistances, wire ends all values, 6d. Dubilier 1 watt resistances, wire ends all values, 8d. We have purchased a large stock of meters, prices from 4/11 to £7 7s. Send for list, stating type you require.

ELIMINATORS, 150v. 25 m/a from 10/11. Guaranteed.

AMERICAN Rolas from 17/11. All types of goods stocked. State your requirements. We quote Less!

CASH with order or C.O.D. Carriage paid.
TELE-RADIO SUPPLIES, 305, King's Road, S.W.3. Flaxman: 9710.

RADIO SUPPLIES
 Send your list of Radio needs for our quotation. Kits, Parts, Sets, etc. Everything in Radio stocked, prompt delivery. 7 days' approval. Catalogue free. Taylex & Standard Wet H.T. replacements stocked.
W. TAYLOR, 9, GROVE RD., BALEAM, S.W.12.



BUILD YOUR OWN MAINS UNIT

Build your own Mains Unit with a Heayberd Assembled Kit of Parts. This is a simple job—the components are mounted on a metal baseboard, and all you have to do is to take the wire from one point to another. Easy-to-follow blueprints supplied with each Kit.

Cut out this advt. and send NOW with 3d. in stamps for 40 pp. booklet describing these Kits, etc.

F. C. HEYBERD & Co.,
 10, FINSBURY STREET, LONDON, E.C.2.

EASY PAYMENTS

"There's no place like HOLMES."

The first firm to supply Wireless parts on easy payments. Nine years advertiser in Wireless Press. Thousands of satisfied customers.

	Depos.	Monthly	Payments.
TELSEN Latest 323 Kit	29/6	4/-	7 of 4/1
Lissen Skyscraper 4	112/6	10/-	11 of 10/3
EXIDE H.T. Accum., 120v.	60/-	6/-	9 of 6/8
BLUE SPOT 29PM.	32/6	4/5	7 of 4/5
ATLAS ELIMINATOR, No. 0A25	59/6	5/-	11 of 5/6
B.T.H. Pick-up	21/-	3/10	5 of 3/10
EPOOH 20th O. P.M.	35/-	4/10	7 of 4/10

Parts for any Kit Set. Any make of Speaker.
 New Goods Obtained for Every Order. Send us a list of the parts you require and the payments that will suit your convenience, and we will send you a definite quotation. Anything Wireless.

H. W. HOLMES, 29, FOLEY STREET,
 Great Portland Street, London, W.1.
 *Phone: Museum 1414.

IS YOUR AERIAL A ROBBER?

Your aerial is robbing YOU if it is old and corroded. Try a new and better one, try SUPERIAL at our expense. Sling up a short length and compare results. You'll get better reception all round or we'll refund your money in full.

100 ft.	75 ft.	60 ft.	24 ft.
3/6	2/6	1/9	1/-

The New London Electron Works, Ltd., 6, East Ham, E.6

SAVE 50% ON VALVES

362

"362" BATTERY TYPE VALVES: H., H.L., & L., 3/8. Power, 4/- Super-Power, 4/8. S.G., 7/8. Var. Mu., 7/8. "Class B," 9/-. Pentode Type, 10/- (Metalised, 3d. extra.)
POST FREE.

THE 362 RADIO VALVE CO., LTD.
 (Dept. W.), Stoneham Road, London, E.5.

Micromesh
 TRADE MARK
THE MODERN VALVE

Literature and prices on request. Standard Telephones and Cables, Ltd. St. Chad's Place, 364, Gray's Inn Road, London, W.C.1. Telephone G255

WOBURN RADIO offers special purchase of Westinghouse Rectifiers (new); H.T. 7, 8, 9, 9/- H.T. 10, 10/-; L.T. 5, 10/6. 10hy. 100ma. Chokes, 4/- each. DUBILIER dry electrolytics, 4 mfd. and 8 mfd., 500v., 3/6; 50 mfd., 50v., 3/6. Wego Condensers, 750v. test, in bakelite, 1 mfd., 1/-; 2 mfd., 1/3; 4 mfd., 2/3. Ready Radio and Lotus Diffs., 0003, 00035, 00015, 1/- 0005 reaction, 1/-.
ELIMINATORS specially manufactured for us, D.C. 3 tappings, 25 ma, 11/9; A.C., 25/- Guaranteed for 12 months.

CLASS "B" Drivers and Chokes, 9/6 per pair, with suitable valve (BVA) and 7-pin holder, 19/11; Binocular Chokes, 1/3; H.F. Chokes, 1/-; Valve-holders, 4/5-pin chassis type, 1/6 half doz.; 7-pin, 6d. Columbia L.F. Transformers, 3/1 ratio, 3/- Tubular Condensers 0.01, 0.1 and 0.05, 6d. Large Stock of Eric and Dubilier Resistances. Lucerne Dual Range iron-cored coils, 3/6; Eston iron-cored coils with circuit, 3/-.

SINCLAIR P.M. Speakers with universal transformer, or Class B 7in. Cone, 12 months' guarantee, 16/6. Sinclair Matched pairs, one 9in. one 7in. P.M.'s or Energised, 35/- (carr. 1/-).

ANYTHING on H.P. above 40/-. Quotations for Kits and Components by return. Trade Enquiries invited.

WOBURN RADIO CO., 7, Woburn Buildings, W.C.1. Euston 1571. (Near King's X and Euston Stns. Back of St. Pancras Church.

H. A. WIRELESS for everything Radio. Sutra flush mounting voltmeter, 0-6, 0-120, 4/6; Celestion PPMW, retail 45/-, 19/6 (a few left); H. A. Twin Magnet Adjustable Cone Speaker, 10/-; Regentone eliminators, 33% per cent. discount. Send for list. W. B. P. M., retail 27/6, 15/-; Igranic 3-1 and 5-1 Transformers, 3/-; Lotus 2-gang, 8/3; Single, 5/-; Blue Spot 66K, retail 15/-, 6/6; Marconi 2-valve Battery set complete, 44/-.

MAY we quote you for the latest sets and components? No order too small or too large. Television parts supplied. Send for lists. Cash with order or C.O.D. All articles brand new and guaranteed.

H. A. WIRELESS (Shoreditch), Dept. MO1, 9 and 13, Hackney Road, Shoreditch, E.2. Telephone, BISHOPSGATE 8169 (PBX).

WANTED good Modern Wireless Parts, Sets, Eliminators, Meters, Valves, Speakers, etc. Spot Cash waiting. Send or bring. We pay more than any other dealer. Open 9-8.—University Radio, 142, Drummond St., Hampstead Rd., N.W.1.

REPAIRS—REWINDING—OVERHAULS. New cones and centres fitted any make M/c chassis, M/c's rewind. Mains transformers, etc. Receivers converted D.C. to A.C. Write Repair Dept. C.

WEEDON P.L.R. Co., 80, Lonsdale Avenue, London, E.6. (Grangewood 1837.)

ERICSON 3/1 L.F. Transformers. List Price. 17/6. New and guaranteed. Our price, 2/3, post free U.K.—Pioneer Radio, Coptic Street, London, W.C.1.

D.O. 26's, 15/- Ferranti and Regentone 2v., 4v. 6v., Trickle chargers, 12/6.

PHILLIPS 150v. 30m/a H.T. Units, 15/- 400v. 75m/a Mains Transformers, 12/6. Above 200-250v. A.C. Everything below at 10/- each.

D.O. 20's, S.P.4's, U.12's, U.8's, A.C.P.1's, M.P.T.4's, U.10's, A.C.S.1/V.M.'s. Varley Push-Pull 25-1 output Transformers, 25-1 ordinary output Transformers, 20 hy. 75 m/a L.F. Chokes. Amplion A.C. 6-valve sets, 27.—Donald Young, South Street, Corsham, Wilts.

PATENTS AND TRADE MARKS. KING'S PATENT AGENCY, LTD., 146b, Qn. Victoria Street, E.C.4, offer "Advice Handbook" and Consultations free. 49 years' references. Write, call, or 'phone. 'Phone: GUY 6161. Director, B. T. KING, C.I.M.P. Reg. Patent Agent G.N. U.S.A. and Canada.

You will be fascinated by
The PRINCE of WALES JIG-SAW PUZZLE

THIS New Puzzle, a charming subject in beautiful colours, is mounted upon 3-ply wood, cut interlocking so that when assembled the Puzzle can be moved about without risk of the pieces, of which there are nearly 60, becoming displaced. It can be handled and rehandled without the corners breaking, burning or becoming dog-eared. You simply must get one.

On sale at all Newsagents, Stationers and Bookstalls, 1/-, or 1/4 (including postage) from George Newman, Ltd., 8-11 Southampton Street, Strand, London, W.C.2

1/-

THE PRIMA MAINS THREE

Offered on Free Approval. 30/- only Post Free.

WE GUARANTEE YOUR SATISFACTION, SO WHY PAY MORE? 30/- ONLY. The Prima Mains Three Kit is made up exact to specified values and of first quality components throughout. The price above falls short of this standard. We will send on full approval against cash or C.O.D.

BUILD THE PRIMA MAINS THREE, KIT A.
Complete to the last screw, with chassis, all components, sundries, and copy of PRACTICAL WIRELESS. Post paid, 30/-.

BUILD THE PRIMA MAINS THREE, KIT A.1.
As above, but with the addition of the A.C. Mains power unit. Price 48/-.

BUILD THE PRIMA MAINS THREE, KIT B.
As Kit A.1. but with matched set of three British and fully-guaranteed valves, of exact specified types. Price 75/-.

BUILD THE PRIMA MAINS THREE, KIT C.
As Kit B, but including high-grade console cabinet and speaker. The complete outfit. Price 89/6.

3 D. ONLY, POST FREE. Enclose also 3d. stamps to-day for your (late issue) April number of THE 'RADIO GOLD-MINE.' By far the most comprehensive lists of up-to-date surplus goods (kits, components and accessories) yet produced, with a general price level lower than ever before. Avoid delay. Send (enclosing 3d. stamps) to-day.

COLUMBIA AND SUNDRY COMPONENTS CLEARANCE.—Columbia L.F. Transformers (list 10/6), each 2/11; Cl. B. Driver, 3/11; Output Chokes, 3/11; C.E.C. 20. Hen. Chokes, 3/6; H.F. Chokes, 9d.; V-holders, 4 pin, 2½d.; 5-pin, 3½d.; 7-pin, 6d.; Switches, push-pull, 2-point, 4½d.; 3-point, 5½d.; Grid Leaks, ½, 1, 1½, 2 and 3 megs., 3d. each.

BROWNIE COILS CLEARANCE.—All dual range with reaction. New line, 1/6; also screened, 2/6; Special Iron Cored (diagrams included), 3/3; S.-Wave, 2/10. Special Lucerne Coils, 3/3.

LOTUS VARIABLE CONDENSERS CLEARANCE.—0003, 0005 mfd., 1/-; differentials .00015, .0003, 1/4; 2-gang .0005 mfd., with escutcheon, S.M. drive, panel light, etc., 8/11; 3-gang, 11/6. Ready Radio 'Duotune' Extenders .0005 mfd. (list 12/6), 2/11; S.M. type (list 18/6), 4/10.

PHILIPS MANSBRIDGE CONDENSERS CLEARANCE, 750 v. test, 1 mfd., 8d.; 2 mfd., 1/4; 4 mfd., 2/8; Dubilier Wet Electrolytic, 8 mfd., 2/9.

DUBILIER FIXED CONDENSERS CLEARANCE and Edison Bell, Mica .0001, 2, 3, 4, 5, mfd.; .001, 2, 3, 4, 5, 6, 7, 8, 9 mfd.; Tubular mica type, .0001, .0003 mfd., all 3d. each; 2/9 doz.

ERIE, H.M.V., PHILCO RESISTANCES CLEARANCE.—H.M.V. 4 watt glass cased, 100,000 ohms, 4½d.; Erie, 1 watt, all values to 60,000 ohms, 4½d.; Dubilier, 1 watt, 100,000 ohms, 3½d.; Philco, 2, 10, 15, 16, 20 and 32,000 ohms, 3½d.; Edison Bell Carbon to 70,000 ohms, 4½d.; to 150,000, 5d.; to 350,000, 5½d.; to 500,000, 6d.; Spaghetts, every size to 100,000 ohms, 3½d.; Grid Leaks ½ to 3 megs., 3d. each.

E.C. 'GOLD-MINE' KITS CLEARANCE represents absolutely unprecedented values. They cover a comprehensive range of up-to-date circuits which will meet every home constructor's requirements. Supplied complete with diagrams, instructions and all sundries in sealed cartons. Straight 2-valve, 3/6; 3-valve, 10/6; S.G.III, 18/6; S.G.IV, 25/-; SHORT WAVE KITS: 2-valve, 12/6; 3-valve, 18/6; Class B III, 27/6; ADAPTOR KITS: S.W. Adaptor, 3/6; Super-Het., type, 15/6; Class B Adaptor, 10/6. CLASS B KITS: 3-valve, 22/6; S.G.IV, 29/6.

E.C. VALVES CLEARANCE.—All British and guaranteed: 2v. battery H.F. Det., L.F., 2/11; Power, 3/3; S.G. 4/10; Class B, 8/10.

E.C. ELIMINATOR KITS, complete with full diagrams, 4 tappings to 150v; A.C. 25 ma, 2/6; Class B., 29/6. D.C., 9/6. (Westinghouse Rectifier.)

W.B.; BLUE-SPOT; SPEAKERS CLEARANCE.—W.B. Permanent Magnet (ordinary or Class B type) (list 37/6), 18/10; Nuvoion P.M., 16/10; Blue Spot 100VE (list 32/6), 15/10; 31K (list 25/6), 15/4; 66K (list 12/6), 7/3. Special offer. P.M.M.C. speakers, worth double, 12/6 each.

HARLIE PICK-UPS AND SUNDRY CLEARANCES.—Super Harlie Pick-up with arm, 11/6; Igo Electric Clocks (A.C. 100-110, 200-240v.), various colours (list 32/-), 10/6. Ultra 'Blue Fox' console walnut cabinets (worth 25/-), each 10/6.

LONDON EAST CENTRAL TRADING COMPANY (Dept. M.109), 23, Bartholomew Close, London, E.C.1 (telephone: NATIONAL 7478). Goods over 10/- value, postage free. Under 5/- value—cash only. Over 5/- cash or C.O.D.

3 D. POST FREE.—Secure your copy of THE 'RADIO GOLD-MINE' TO-DAY.

For Everything Surplus in Modern Radio

THE 'GOLD-MINE STORES'

For the

"PRIMA" MAINS THREE



The designer specifies all these

CLIX components.

CHASSIS MOUNTING VALVE-HOLDERS

Three 5-pin with terminals 9d. each
Without terminals .. 6d. each



SPADE TERMINALS

(Three required)

The specially designed collar prevents corrosion. Contact is perfect.
Large type, 2d.; small, 1½d. each.

WANDER PLUGS

(Seven required)

Clix wiring device provides positive METAL to METAL contact, whilst full surface contact is obtained with ALL battery sockets with internal diameters from ½ in. to 5/32 in. Curved ends for easy insertion. Long shanks and insulators for H.T. Short shanks and insulators for 1½d. G.B. each



In our Folder "N" over 30 Clix contact components are illustrated. Send a Post Card now for a Free Copy.



LECTRO LINX LTD., 79a, Rochester Row, S.W.1.

ENJOY MAINS VOLUME FROM YOUR BATTERY SET

Send for the ROLA CLASS "B" Speaker Unit.

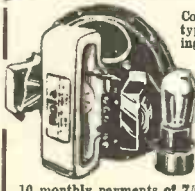

Combines the latest type Rola P.M. Moving-Coil Speaker with a complete, properly matched Class "B" Unit. Simply connect to your battery set and you obtain volume equal to an expensive all-electric set at very low use of H.T. current. SEND ONLY 2/6 FOR 7 DAYS' TRIAL, if satisfied pay further 2/6 at once, then 10 monthly payments of 7/6 (Cash in 7 days £3.11).



E. J. HERAUD, Ltd., Dept. W.56, NUMBER ONE, EDMONTON, LONDON, N.18

EASY TERMS

Everything radio supplied on convenient terms. Send list of requirements—quotation and price lists will be sent by return. For really prompt delivery entrust your order to us. All goods carriage paid.

New BLUE-SPOT STAR P.M. UNIT (just released). Cash price, £3. 10. 0, or 6/5 with order and 11 monthly payments of 6/5.

THE LONDON RADIO SUPPLY CO., 11, OAT LANE, NOBLE ST., LONDON, E.C. Phone: NATIONAL 1977. Established 1925.

5 YEARS' SPLENDID RESULTS SOLVE H.T. PROBLEM FOR GOOD



Any voltage supplied.

Another example of the H.T. Problem solved for good with a Standard Wet Battery. B. H. W. of Yarm-on-Tees, writes: "May I say I have had splendid results and am very pleased that I bought a Standard Battery in 1929?" Why continually dip into your pockets for dry battery replacements and then endure poor results? Join the thousands who get better results at a 50 per cent. saving and more. Replenishments at long intervals all that is necessary. 120v. 12,500 m.a. £2 complete, carr. paid. Write for details. ALL STANDARD BATTERY SPARES SUPPLIED. The Wet H.T. Battery Co. (Fr.), 26, Lisie Street, London, W.C.2. Gerrard 6121.

DICTIONARY OF WIRELESS TERMS

by Ralph Stranger

TWO AND SIXPENCE

The author who is a master of lucidity has produced in this book a valuable and fully explained synopsis of technical terms that everybody can understand. It will prove indispensable to everybody who reads technical books and journals. Fully illustrated throughout.

Obtainable at all Booksellers, or by post 2/10 from George Newnes Ltd., 8-11 Southampton Street, Strand, London, W.C.2.

An Invaluable Handbook ACCUMULATORS

An up-to-date practical handbook dealing with every type of accumulator, methods of charging them at home, care and maintenance. Also explains how to erect a charging station.

This is one of NEWNES'

HOME MECHANIC BOOKS

Ask your Newsagent to show you other Titles in This Helpful Series.

Obtainable at all Booksellers, or by post 1/2 each from George Newnes, Ltd., 8-11, Southampton Street, Strand, London, W.C.2. 1/- EACH

ADVERTISEMENT INDEX

	Page
Bennett College, Ltd.	176
British Blue Spot Co., Ltd.	175
British Institute of Engineering Technology	195
British Pix Co., Ltd.	194
Central Equipment Ltd.	176
Colvern, Ltd.	176
Cosmocord, Ltd.	187
Cosor A. C., Ltd.	Inside Front Cover
Fluxite, Ltd.	195
Hayberd, F.C. & Co.	196
Heraud, E. J., Ltd.	Inside Back Cover
Holmes, H. W.	196
Impex Electrical, Ltd.	175
International Correspondence Schools	188
King's Patent Agency, Ltd.	196
Lectro Linx, Ltd.	Inside Back Cover
London Radio Supply Co.	Inside Back Cover
Mains Power Radio	187, 195
New London Electron Works	196
Ormond Engineering	187
Peto Scott, Ltd.	Front Cover Strip, 183
Radio Instruments, Ltd.	187
Standard Telephones and Cables, Ltd.	196
Taylor, N.	196
362 Radio Valve Co., Ltd.	196
Utility Sales Co.	195
Wet H.T. Battery Co.	Inside Back Cover

The Magazine that
 ILLUSTRATES your
 RADIO PROGRAMMES



Albert Sandler, whose regular broadcasts for the past five years have made him the pre-eminent violinist on the air. Known as the Kreisler of Radio he has made himself as much a part of the Sunday time-table as the mid-day joint. His career, from the time when he was the son of an East-end cobbler, to his present international fame, is the greatest romance of broadcasting.

ALL the glamour of life in the broadcasting studios is revealed in RADIO MAGAZINE, the deluxe pictorial for listeners.

Page after page is devoted to the personalities of the microphone who have hitherto been mystic voices in the ether. What the stars wear, how they dress their hair, what their horoscopes foretell, how they prepare their work, why they became broadcasters—these and scores of other interesting subjects are exhaustively dealt with.

RADIO MAGAZINE is the big "extra something" that makes all the difference to listening. It pulls down the walls of Broadcasting House and gives a right-through view of the B.B.C. at work and play.

**MAY NUMBER ON
 SALE APRIL 26TH**

6^D

**RADIO
 MAGAZINE**

On sale at all Newsagents and Bookstalls, or by post 7d., from George Newnes, Ltd., 8-11, Southampton Street, Strand, London, W.C.2.

Geo. Newnes, Ltd.

Printed in Great Britain by NEWNES & PEARSON PRINTING CO., LTD., Exmoor Street, Ladbroke Grove, W.10, and published by GEORGE NEWNES, LTD., 8-11, Southampton Street, Strand, W.C.2. Sole Agents for Australia and New Zealand: GORDON & GOTCH, LTD. South Africa: CENTRAL NEWS AGENCY, LTD. Practical Wireless can be sent to any part of the world, post free, for 17/4 per annum; six months, 8/8. Registered at the General Post Office for Transmission by Canadian Magazine Post.

P.W. Gift Stamp No. 17