

*Mr. Bonefille*

# BBC

## ENGINEERING DIVISION

# MONOGRAPH

---

NUMBER 53: JULY 1964

Aerial distribution systems for receiving  
stations in the l.f., m.f., and h.f. bands

by

J. B. IZATT, Ph.D., B.Sc.(Eng.)  
(Research Department, BBC Engineering Division)

---

BRITISH BROADCASTING CORPORATION

PRICE FIVE SHILLINGS





BBC ENGINEERING MONOGRAPH

No. 53

AERIAL DISTRIBUTION SYSTEMS FOR RECEIVING  
STATIONS IN THE L.F., M.F., AND H.F. BANDS

by

J. B. Izatt, Ph.D., B.Sc.(Eng.)  
(Research Department, BBC Engineering Division)

JULY 1964

BRITISH BROADCASTING CORPORATION

## FOREWORD

**T**HIS is one of a series of Engineering Monographs published by the British Broadcasting Corporation. About six are produced every year, each dealing with a technical subject within the field of television and sound broadcasting. Each Monograph describes work that has been done by the Engineering Division of the BBC and includes, where appropriate, a survey of earlier work on the same subject. From time to time the series may include selected reprints of articles by BBC authors that have appeared in technical journals. Papers dealing with general engineering developments in broadcasting may also be included occasionally.

This series should be of interest and value to engineers engaged in the fields of broadcasting and of telecommunications generally.

Individual copies cost 5s. post free, while the annual subscription is £1 post free. Orders can be placed with newsagents and booksellers, or BBC PUBLICATIONS, 35 MARYLEBONE HIGH STREET, LONDON, W.1.

# CONTENTS

<i>Section</i>	<i>Title</i>	<i>Page</i>
	PREVIOUS ISSUES IN THIS SERIES . . . . .	4
	SUMMARY . . . . .	5
1.	INTRODUCTION . . . . .	5
2.	DISTRIBUTION SYSTEMS . . . . .	5
3.	DISTORTION IN VALVES AND TRANSISTORS . . . . .	6
3.1	Distortion in Valves . . . . .	6
3.1.1	General Comments . . . . .	6
3.1.2	A Figure of Merit for Low Distortion in Valves . . . . .	7
3.1.3	Methods of Reducing the Intermodulation Products . . . . .	8
3.2	Distortion in Transistors . . . . .	9
4.	WIDE-BAND AMPLIFIERS . . . . .	10
4.1	The Two-valve Cascade Amplifier . . . . .	10
4.1.1	The Circuit . . . . .	10
4.1.2	Gain, Bandwidth, and Noise Factor . . . . .	10
4.1.3	Intermodulation Products . . . . .	10
4.1.4	The Effects of Component Tolerances . . . . .	12
4.2	Push-pull Amplifier Arrangements . . . . .	12
5.	OCTAVE AMPLIFIERS . . . . .	14
5.1	The Wide-band Amplifier with External Filters . . . . .	14
5.2	The 'Integrated' Octave Amplifier . . . . .	15
6.	CONCLUSIONS . . . . .	17
7.	ACKNOWLEDGMENTS . . . . .	17
8.	REFERENCES . . . . .	17
	APPENDIX I . . . . .	18
	APPENDIX II . . . . .	19

## PREVIOUS ISSUES IN THIS SERIES

No.	Title	Date
1.	<i>The Suppressed Frame System of Telerecording</i>	JUNE 1955
2.	<i>Absolute Measurements in Magnetic Recording</i>	SEPTEMBER 1955
3.	<i>The Visibility of Noise in Television</i>	OCTOBER 1955
4.	<i>The Design of a Ribbon Type Pressure-gradient Microphone for Broadcast Transmission</i>	DECEMBER 1955
5.	<i>Reproducing Equipment for Fine-groove Records</i>	FEBRUARY 1956
6.	<i>A V.H.F./U.H.F. Field-strength Recording Receiver using Post-detector Selectivity</i>	APRIL 1956
7.	<i>The Design of a High Quality Commentator's Microphone Insensitive to Ambient Noise</i>	JUNE 1956
8.	<i>An Automatic Integrator for Determining the Mean Spherical Response of Loudspeakers and Microphones</i>	AUGUST 1956
9.	<i>The Application of Phase-coherent Detection and Correlation Methods to Room Acoustics</i>	NOVEMBER 1956
10.	<i>An Automatic System for Synchronizing Sound on Quarter-inch Magnetic Tape with Action on 35-mm Cinematograph Film</i>	JANUARY 1957
11.	<i>Engineering Training in the BBC</i>	MARCH 1957
12.	<i>An Improved 'Roving Eye'</i>	APRIL 1957
13.	<i>The BBC Riverside Television Studios: The Architectural Aspects</i>	JULY 1957
14.	<i>The BBC Riverside Television Studios: Some Aspects of Technical Planning and Equipment</i>	OCTOBER 1957
15.	<i>New Equipment and Methods for the Evaluation of the Performance of Lenses of Television</i>	DECEMBER 1957
16.	<i>Analysis and Measurement of Programme Levels</i>	MARCH 1958
17.	<i>The Design of a Linear Phase-shift Low-pass Filter</i>	APRIL 1958
18.	<i>The BBC Colour Television Tests: An Appraisal of Results</i>	MAY 1958
19.	<i>A U.H.F. Television Link for Outside Broadcasts</i>	JUNE 1958
20.	<i>The BBC's Mark II Mobile Studio and Control Room for the Sound Broadcasting Service</i>	AUGUST 1958
21.	<i>Two New BBC Transparencies for Testing Television Camera Channels (Out of Print)</i>	NOVEMBER 1958
22.	<i>The Engineering Facilities of the BBC Monitoring Service</i>	JANUARY 1959
23.	<i>The Crystal Palace Band I Television Transmitting Aerial</i>	FEBRUARY 1959
24.	<i>The Measurement of Random Noise in the presence of a Television Signal</i>	MARCH 1959
25.	<i>A Quality-checking Receiver for V.H.F. F.M. Sound Broadcasting</i>	JUNE 1959
26.	<i>Transistor Amplifiers for Sound Broadcasting</i>	AUGUST 1959
27.	<i>The Equipment of the BBC Television Film Studios at Ealing</i>	JANUARY 1960
28.	<i>Programme Switching, Control, and Monitoring in Sound Broadcasting</i>	FEBRUARY 1960
29.	<i>A Summary of the Present Position of Stereophonic Broadcasting</i>	APRIL 1960
30.	<i>Film Processing and After-processing Treatment of 16-mm Films</i>	MAY 1960
31.	<i>The Power Gain of Multi-tiered V.H.F. Transmitting Aerials</i>	JULY 1960
32.	<i>A New Survey of the BBC Experimental Colour Transmissions</i>	OCTOBER 1960
33.	<i>Sensitometric Control in Film Making</i>	DECEMBER 1960
34.	<i>A Mobile Laboratory for UHF and VHF Television Surveys</i>	FEBRUARY 1961
35.	<i>Tables of Horizontal Radiation Patterns of Dipoles Mounted on Cylinders</i>	FEBRUARY 1961
36.	<i>Some Aspects of Optical Lens Performance</i>	APRIL 1961
37.	<i>An Instrument for Measuring Television Signal-to-noise Ratio</i>	JUNE 1961
38.	<i>Operational Research on Microphone and Studio Techniques in Stereophony</i>	SEPTEMBER 1961
39.	<i>Twenty-five Years of BBC Television</i>	OCTOBER 1961
40.	<i>The Broadcasting of Music in Television</i>	FEBRUARY 1962
41.	<i>The Design of a Group of Plug-in Television Studio Amplifiers</i>	APRIL 1962
42.	<i>Apparatus for Television and Sound Relay Stations</i>	JULY 1962
43.	<i>Propagational Factors in Short-wave Broadcasting</i>	AUGUST 1962
44.	<i>A Band V Signal-frequency and a Correlation Detector for a VHF/UHF Field-strength Recording Receiver</i>	OCTOBER 1962
45.	<i>Vertical Resolution and Line Broadening</i>	DECEMBER 1962
46.	<i>The Application of Transistors to Sound Broadcasting</i>	FEBRUARY 1963
47.	<i>Vertical Aperture Correction using Continuously Variable Ultrasonic Delay Lines</i>	MAY 1963
48.	<i>The Development of BBC Internal Telecommunications</i>	MAY 1963
49.	<i>Apparatus for Measurement of Non-linear Distortion as a Continuous Function of Frequency</i>	JULY 1963
50.	<i>New Methods of Lens Testing and Measurement</i>	SEPTEMBER 1963
51.	<i>Radiophysics in the BBC</i>	NOVEMBER 1963
52.	<i>Stereophony: the effect of cross-talk between left and right channels</i>	MARCH 1964

# AERIAL DISTRIBUTION SYSTEMS FOR RECEIVING STATIONS IN THE L.F., M.F., AND H.F. BANDS

## SUMMARY

The factors affecting the design of distribution systems for monitoring services or other receiving stations operating in the low-, medium-, and high-frequency bands (such as those for relaying transmissions) are considered and a number of experimental amplifiers is described. The intermodulation products generated in the amplifiers are at a very low level, and the methods of achieving the linearity required are discussed.

### 1. Introduction

It has been found convenient at monitoring stations to supply many receivers from one aerial rather than to provide one aerial for each receiver, because aeriels for the range 100 kc/s to 30 Mc/s are very large physically. Methods of distributing the signals from the aeriels to the receivers are considered in this report and, in particular, possible types of distribution amplifier are examined in some detail. Except for certain arrangements employing octave amplifiers, the only amplifiers considered are those which provide the full frequency range at each outlet.

If the number of receivers is not too great, passive distribution systems have many advantages. Systems of this type are considered in Section 2. On the other hand, as the number of receivers is increased, amplifiers become necessary in order to overcome the distribution loss. The amplifiers may be either wide-band or restricted-band depending on the type of aerial,\* and both types are considered. Several factors govern the choice of active element employed for amplification, and consideration of the merits of valves and transistors is given in Section 3.

When amplifiers are used at monitoring stations where very weak signals must be received, or at relay stations where good reception is required in the presence of strong signals from nearby transmitters, the intermodulation products must be at a very low level. The discussion of amplifier performance will therefore be mainly concerned with this aspect. Experimental work on wide-band and octave amplifiers is described in Sections 4 and 5.

### 2. Distribution Systems

Because the available signal power from the aerial must be shared among a number of receivers, the use of passive distribution systems must result in some insertion loss between the aerial and any particular receiver. Further loss may also arise in the resistors which are included for matching purposes and in transformers. The overall effective noise factor when a receiver is connected to an aerial depends not only on the insertion loss but also on the

\* In the past, the aeriels have generally been either of restricted bandwidth (e.g. one octave) and omnidirectional or wide-band and directional.

aerial-noise factor<sup>1</sup>  $F_a^*$  and the receiver-noise factor  $F_r$ . The case of a single receiver connected directly to the aerial with zero insertion loss is taken as a reference. Fig. 1 then shows the loss  $L_i$  that may be permitted between aerial and receiver if the degradation is not to exceed 1.5 dB and Fig. 2 indicates the permitted loss for a degradation of 3 dB.

Median values of  $F_a$  have been tabulated,<sup>1</sup> and the design of a system can make allowance for the variation in  $F_a$  found in practice. For example, if  $F_a$  is less than 15 dB for a negligible fraction of the time, and the receiver-noise factor is 5 dB, it can be seen from Fig. 1 that the insertion loss may be as much as 7 dB without causing a degradation exceeding 1.5 dB. For an 'ideal' distribution system with no inherent losses, the use of five receivers fed from one aerial would be permissible (provided that the receivers have the necessary reserve of gain).

Although a number of forms of distribution system is possible, only two are in widespread use. Fig. 3 (a) shows one of these constructed from hybrid transformers. If the transformers are lossless, the insertion loss of each hybrid is 3 dB. In practice, the insertion loss per hybrid is about 3.5 dB and a minimum isolation of 20 dB can be maintained over the whole band. The hybrid system is most useful where the number of receivers is small (say two or four) but becomes complicated and expensive for a larger number of receivers, for which the transformer system shown in Fig. 3 (b) is more suitable. In the latter system, with  $m$  outlets, the insertion loss between the aerial and any one receiver is

$$10 \log_{10}(2m - 1) \text{ dB} \quad (1)$$

and the isolation between receivers is

$$20 \log_{10}(2m - 1) \text{ dB} \quad (2)$$

Expressions (1) and (2) have both been derived assuming matched conditions throughout but, although this is not realized with practical receivers, the effects of receiver mismatch are not great. If, for example,  $m - 1$  outlets are short-circuited, the drop in signal level at the remaining outlet cannot exceed 3.5 dB. From equation (1) it may be

\*  $F_a$  is the noise power available from the aerial relative to the thermal noise power that would be available from the aerial if its temperature and the radiation temperature of the surroundings were both 288°K.

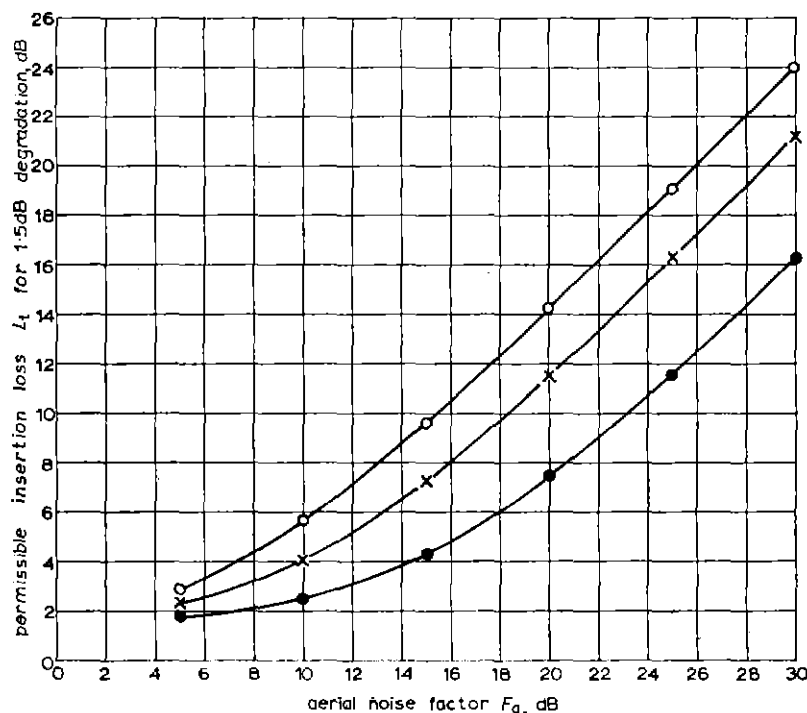

Fig. 1 — Permissible insertion loss  $L_1$  between aerial and receiver for a degradation of 1.5 dB

- Receiver-noise factor  $F_r$ , 2 dB
- × Receiver-noise factor  $F_r$ , 5 dB
- Receiver-noise factor  $F_r$ , 10 dB

deduced, for example, that three receivers could be used for an insertion loss of 7 dB. As already indicated, the degradation in signal-to-noise ratio would not then exceed 1.5 dB if the receiver-noise factor is 5 dB and  $F_a$  is 15 dB. In noisy situations the minimum value of  $F_a$  may well be higher, say 25 dB. There is then a moderate increase in the permissible loss and this allows a large increase in the number of receivers. Thus, for a minimum value of  $F_a$  of 25 dB, an insertion loss of 16 dB is permissible and twenty receivers may be used.

Where the total insertion loss including the transmission-line losses exceeds the allowable value, an amplifier must be placed before the distribution network. Assuming that the power gain  $A$  of the distribution amplifier is equal to the succeeding loss, Fig. 1 or 2 may be used (as before) to find the permissible transmission-line loss between aerial and distribution amplifier if a correction term  $k$  is subtracted from the loss in decibels as indicated by the graph, where

$$k = 10 \log_{10} \left( 1 + \frac{F_a}{F_r} - \frac{1}{AF_r} \right) \text{dB} \quad (3)$$

and  $F_a$  is the noise factor of the distribution amplifier.

Although distribution amplifiers can improve the overall noise factor and sensitivity of a receiving system, they do introduce intermodulation products of the various input signals. This fact is the dominating problem in the design of such amplifiers. When a large number of re-

ceivers has to be supplied it may be difficult to design a single distribution amplifier with sufficiently low intermodulation products. Improved performance may then be obtained by using a small number of similar amplifiers supplied from the aerial, with each amplifier feeding a small number of receivers.

### 3. Distortion in Valves and Transistors

#### 3.1 Distortion in Valves

##### 3.1.1 General Comments

The transfer function of a valve is inherently non-linear, and this effect was found to be the principal source\* of distortion in the amplifier examined. One method of assessing non-linearity is to measure the harmonics generated in the valve when the input is a pure sine-wave but there is some difficulty in generating a sufficiently pure wave at frequencies above 100 kc/s. A more convenient method is to apply at the input terminals two e.m.f.s of different frequencies  $f_1$  and  $f_2$  and to measure the intermodulation products (i.p.s). Neither generator need have a very pure waveform for measurements of the second-order i.p.s, viz.  $f_1 \pm f_2$ , but for measurements of the third-order i.p.s, viz.  $2f_1 \pm f_2$ ,  $2f_2 \pm f_1$ , either one generator must have little or no second harmonic or there must be

\* Hysteresis loss in the output transformer might be expected to cause distortion but with modern ferrite cores of high resistivity this was not found to be so.



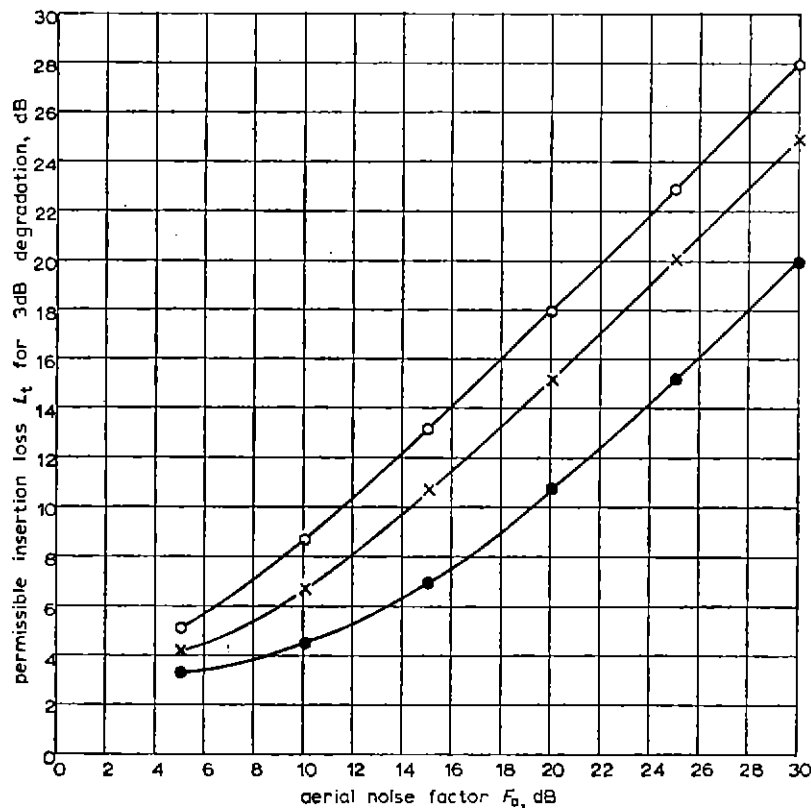

Fig. 2 — Permissible insertion loss  $L_t$  between aerial and receiver for a degradation of 3 dB

- Receiver-noise factor  $F_r$ , 2 dB
- × Receiver-noise factor  $F_r$ , 5 dB
- Receiver-noise factor  $F_r$ , 10 dB

little or no second-order non-linearity in the equipment under test. With these mild restrictions, measurements of the second- and third-order i.p.s are straightforward: higher order i.p.s are generally negligible by comparison and have not been considered.

Let  $I_0$  be the mean anode current in the valve,  $I_1$  be the peak current swing due to either of two equal inputs at frequencies  $f_1$  or  $f_2$ ,  $I_{B2}$  be the (peak) amplitude of either second-order i.p.s., and let  $I_{B3}$  be the (peak) amplitude of any of the third-order i.p.s. Then to a first approximation:

$$\frac{I_{B2}}{I_1} = \frac{1}{\alpha} \cdot \frac{I_1}{I_0} \quad (4)$$

and

$$\frac{I_{B3}}{I_1} = \frac{1}{\beta} \cdot \left(\frac{I_1}{I_0}\right)^2 \quad (5)$$

where  $\alpha$  and  $\beta$  are constants. If the valve were an ideal space-charge-limited device obeying the three-halves power law,<sup>2</sup>  $\alpha$  would be 6 and  $\beta$  would be 72. Fig. 4 shows some measured second-order i.p.s for three valves and it can be seen that  $\alpha = 6$  is an excellent approximation. Results for the third-order i.p.s showed much greater varia-

tion and  $\beta$  was usually less than 72. It was rarely less than 20, however, and the latter value may be used to estimate the order of magnitude of the third-order i.p.s.

### 3.1.2 A Figure of Merit for Low Distortion in Valves

The second-order i.p.s are usually the more important, and a figure of merit may be constructed which will describe the suitability of a valve for the present application. Assuming that the output stage is transformer-coupled to the load, it can be seen from equation (4) that by increasing the step-down ratio of the transformer so that the peak output-current swing for a given load power is reduced, the second-order i.p.s are reduced. The transformer ratio is limited by the shunting effect of stray capacitance at high frequencies, however, and thus the second-order i.p.s are proportional to the square root of the valve output capacitance,  $C_0$ . Also from equation (4) the level of second-order i.p.s is inversely proportional to  $I_0$  and hence a simple figure of merit would be

$$\frac{I_0}{\sqrt{C_0}}$$

If, however, negative feedback is applied in the manner described in Sections 4 and 5, the feedback is roughly

proportional to the mutual conductance,  $g_m$ , and a better expression for the figure of merit is

$$g_m \frac{I_0}{\sqrt{C_0}} \quad (6)$$

Applying expression (6) to some particular valves yields 42 for type EF80, 124 for type E180F, 865 for type E810F, and 882 for type E55L. It can be seen that the E810F and E55L are much better than the others and, in fact, no other valves were found to be comparable.

### 3.1.3 Methods of Reducing the Intermodulation Products

Once the best valve has been found, the effects of valve non-linearity may be reduced further by suitable circuit design. The three techniques of most interest are (1) the octave principle, (2) cancellation, and (3) negative feedback.

In the octave principle, the bandwidth of the amplifier is deliberately restricted to one octave both at the input and at the output. Thus all harmonics and both second-order i.p.s fall outside the band and the only i.p.s of any interest are the third and higher orders. As these are generally at a much lower level, the apparent linearity of the amplifier is greatly improved. The technique is most useful with restricted-bandwidth aerials but could, in principle, be used to provide a wide-band amplifier by paralleling suitable combinations of the different octave amplifiers.

For a simple two-valve wide-band amplifier, the second-order i.p.s may be cancelled either by using a push-pull stage or by using two stages in cascade in which the contribution from the first stage equals the contribution from the second stage (when allowance has been made for the difference in signal level between the two stages). The main disadvantage of both systems is the difficulty of maintaining adequate cancellation throughout the life of the

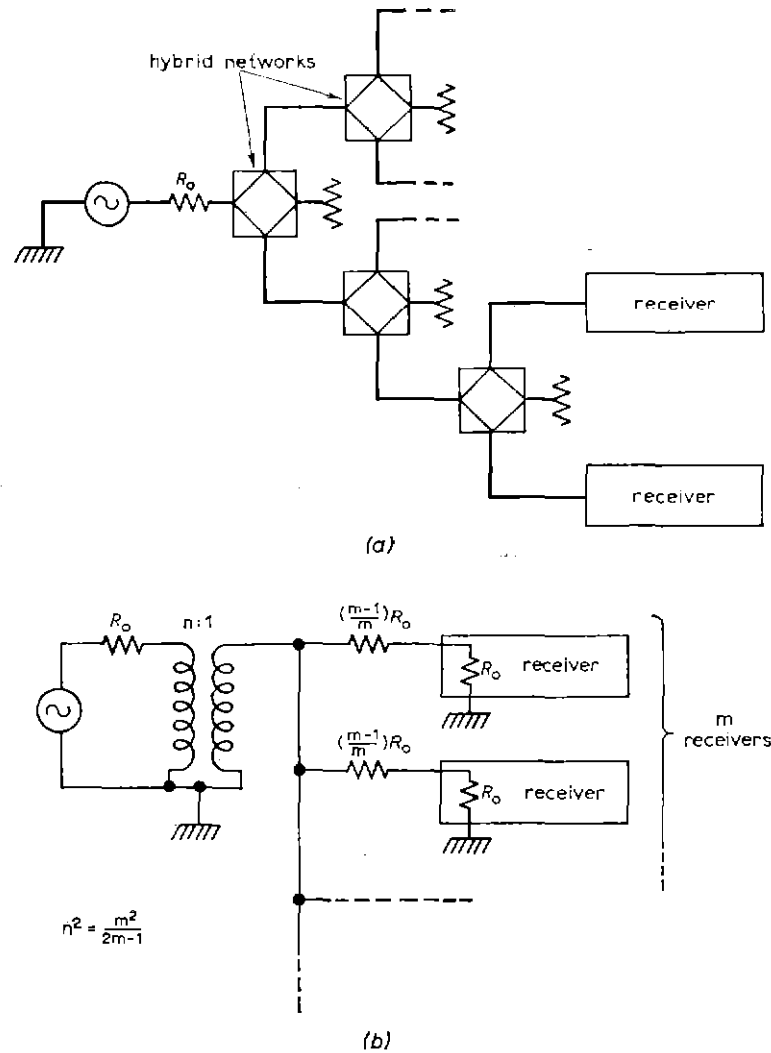

Fig. 3 — Two possible forms of distribution network

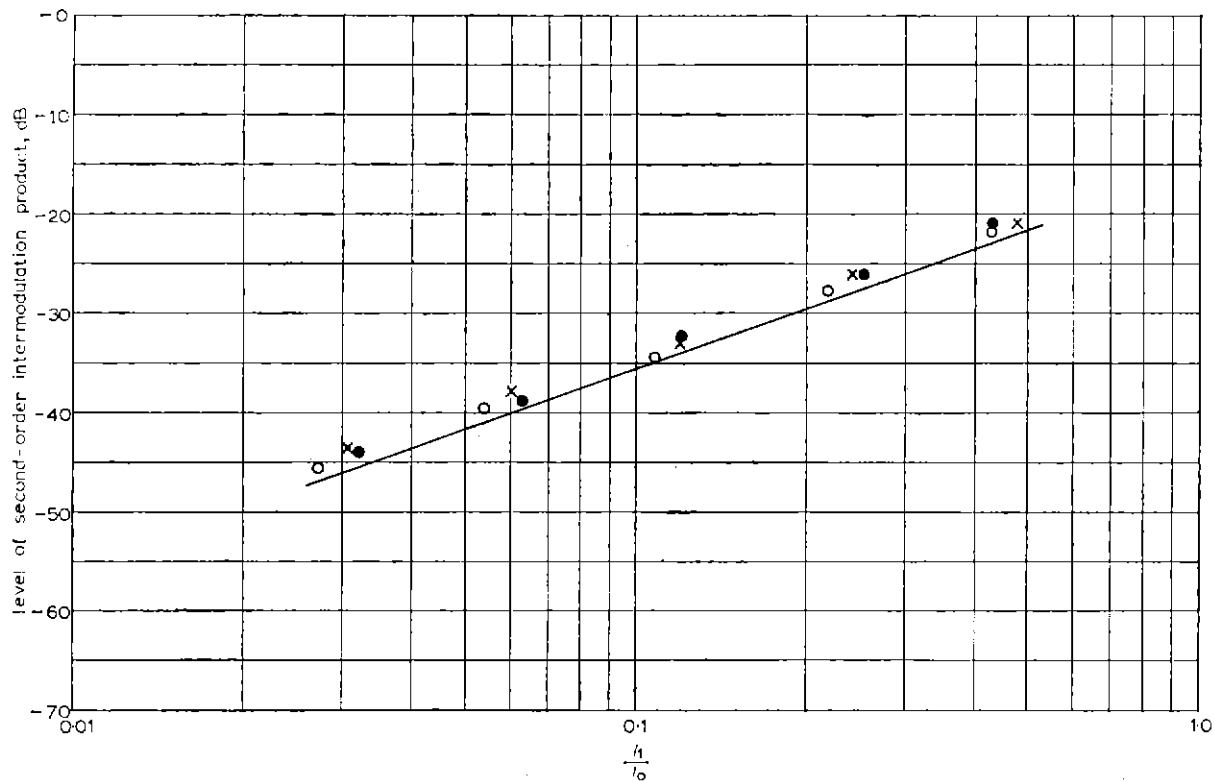

Fig. 4 — Measurements of second-order intermodulation products in valves

○ E810F No. 1  
● EF80

× E810F No. 2  
—  $I_1/6I_0$

amplifier. The push-pull amplifier is generally easier to balance and also has the very minor advantage that all other even-order i.p.s are cancelled. The cascade circuit suffers from the additional disadvantage that cancellation can never be as good at the high frequencies owing to the phase shift in the interstage coupling, although this is not very important in practice because the largest interfering signals occur at frequencies below 2 Mc/s. The principal advantage of the cascade circuit for a two-valve amplifier is the much greater gain-bandwidth product which means that greater use may be made of negative feedback. It will be found that a push-pull circuit is best for low gains (10 to 15 dB), but that a cascade circuit is best for high gains (20 to 30 dB).

The overall bandwidth of conventional feedback amplifiers is always greater than the loop bandwidth and therefore the feedback provides no protection against distortion at the highest frequencies. This difficulty can be overcome in the type of circuit shown in Fig. 5 where the feedback makes the output current proportional to input voltage;<sup>3</sup> by using a sufficiently large anode load resistor, subject to the time constant giving sufficient bandwidth, the overall bandwidth can be made less than the loop bandwidth. The distortion is then controlled at all frequencies in the pass-band. It is generally considered advantageous to apply the feedback round more than one stage because a greater loop

gain can be achieved<sup>3</sup> but it may be shown that, when overall bandwidths of about 30 Mc/s are involved, the loop cut-off frequency is about 120 Mc/s; the excess phase shifts due to transit time and the physical length of the loop may then cause instability. This can be overcome only by reducing the loop gain but it was found that the loss in performance is so great that more feedback can be applied in a single stage by omission of the decoupling capacitor across the cathode resistor.

### 3.2 Distortion in Transistors

Transistors have become available which have the required gain-bandwidth product, and some measure-

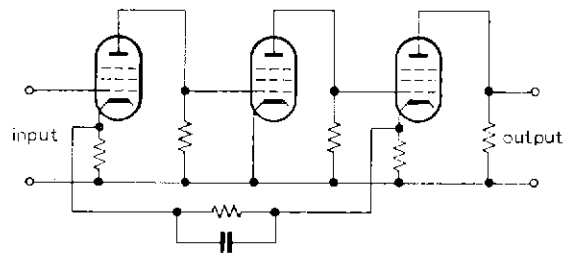

Fig. 5 — A possible form of wide-band negative feedback amplifier

ments were carried out to assess the level of distortion. These measurements showed that, with suitable circuit design, the i.p.s will be roughly equal to those of a valve with the same standing current and working into the same load impedance. Thus, in order to give a performance comparable with the E810F, the transistor will require to pass 35 mA and to have an output capacitance of about 3 pF. With a load impedance of 400 ohms this implies a maximum collector-to-emitter voltage of about 30V and a continuous dissipation of half a watt, while the voltage gain-bandwidth product will require to be greater than about 150 Mc/s. At present, only provisional specifications of transistors approaching these requirements have been issued. It therefore seems unlikely that there will be any significant advantage in using transistors until further improvements in performance have been made.

## 4. Wide-band Amplifiers

A two-stage wide-band amplifier was constructed in order to obtain an idea of the practical performance attainable with modern valves. The frequency range was taken as 100 kc/s to 30 Mc/s and the maximum gain as 34 dB with the input matched to 100 ohms and the load impedance equal to 100 ohms. The details are given in Section 4.1 and some circuits with improved performance are considered in Section 4.2.

### 4.1 The Two-valve Cascade Amplifier

#### 4.1.1 The Circuit

Fig. 6 shows the basic circuit used. The step-up ratio of transformer  $T_1$  is determined by the stray capacitance to ground at the grid of  $V_1$ ,  $R_1$  being chosen to provide a match at the input. Likewise,  $R_3$  is governed by the stray capacitances at the anode of  $V_1$  and the grid of  $V_2$  while the ratio of transformer  $T_2$  is determined by the stray capacitance at the anode of  $V_2$ . Cathode negative-feedback is provided by  $R_2$  and  $R_4$ , these being adjusted to meet two requirements. First, the total feedback for the two stages must allow the required overall gain to be obtained. Second, more feedback is applied to  $V_2$  than to  $V_1$  so that, in spite of the greater signal current in  $V_2$ , the amount of second-order distortion is the same in each valve; under these circumstances there is nominal cancellation of the second-order i.p.s in the complete amplifier because they are of opposite phases in the two stages.

A full circuit diagram of an experimental amplifier using E810F valves is given in Fig. 7. It is true that the E55L has a

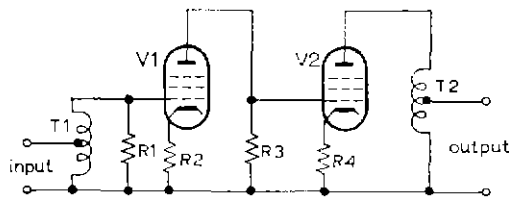

Fig. 6 — Basic diagram of the cascade wide-band amplifier

higher figure of merit (Section 3.1.2) but by a small margin only and the much greater h.t. consumption was thought to be undesirable. The peaking inductance in the anode circuit of  $V_2$  has been added to improve the performance at the higher frequencies. Large (decoupled) resistors are used in the cathode circuits to stabilize the working points of the valves and common screen- and control-grid potentials are provided. For practical reasons the suppressor grids are not at the same potential but this is unimportant because the suppressor grid base is large.

#### 4.1.2 Gain, Bandwidth, and Noise Factor

Fig. 8 shows the gain/frequency response of the amplifier for the three combinations of feedback resistors shown in Fig. 7. When the feedback resistors were changed the peaking coil was readjusted in order to maintain the gain up to 30 Mc/s. This compensated for the different effects of stray capacitances at the different gains.

The noise factor was 7 dB at frequencies below 5 Mc/s and rose gradually above this frequency to about 9.5 dB at 30 Mc/s. This performance is considered adequate.

#### 4.1.3 Intermodulation Products

The non-linearity of the amplifier was tested by applying two inputs of equal amplitude but different frequencies, the resulting i.p.s being measured.

The third-order i.p.s showed little spread when different valves were used and little variation with frequency; Fig. 9 gives, for a typical case, the measured levels of these products (relative to one of the wanted signals) as a function of the signal output level. The differences between the curves are less than the total changes in feedback for the three conditions. This is because the feedback has to be changed by more in the first valve than in the second valve to maintain the condition for cancellation of the second-order i.p.s. The third-order i.p.s are produced mainly in the output stage, but the phases of these terms are such that the smaller contribution of the first stage is always additive.

The second-order i.p.s showed, at low frequencies, a much greater variation with changes in valve characteristics as their level depends on accurate cancellation of the contributions from the two stages. At higher frequencies, these changes are masked by the deterioration caused by a phase shift between the stages, as mentioned in Section 3.1.3.

It is operationally an advantage to use unmatched valves in the circuit and an attempt was made to measure the effect of random selection of the valves. Eight valves were available and, since there are two possible positions for each valve, there was a total of fifty-six different combinations. Frequencies were chosen at which the cancellation ought to have been good and the level of second-order i.p.s was measured. Fig. 10 shows a histogram of the results. For the conditions of the test the cancellation varies from about 6 dB for the worst arrangements to 25 dB for the best arrangements. This is quite a wide range but it can be seen that most of the results are below -62 dB corresponding to a cancellation of 10 dB, which is a

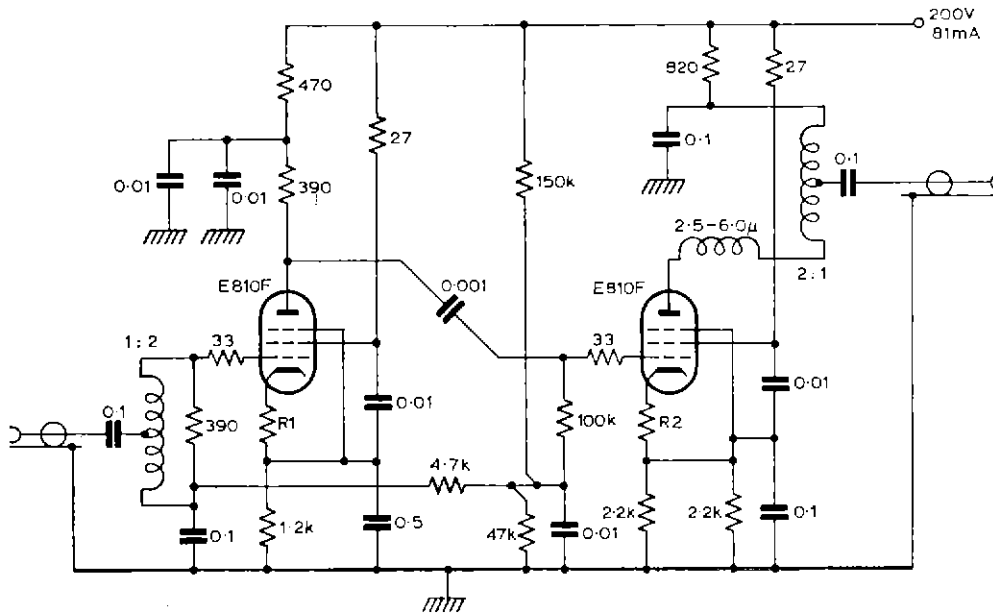

Fig. 7 — Practical circuit of the cascade wide-band amplifier

Overall gain dB	$R_1$ ohms	$R_2$ ohms
34	10	90
28	27	120
18	82	180

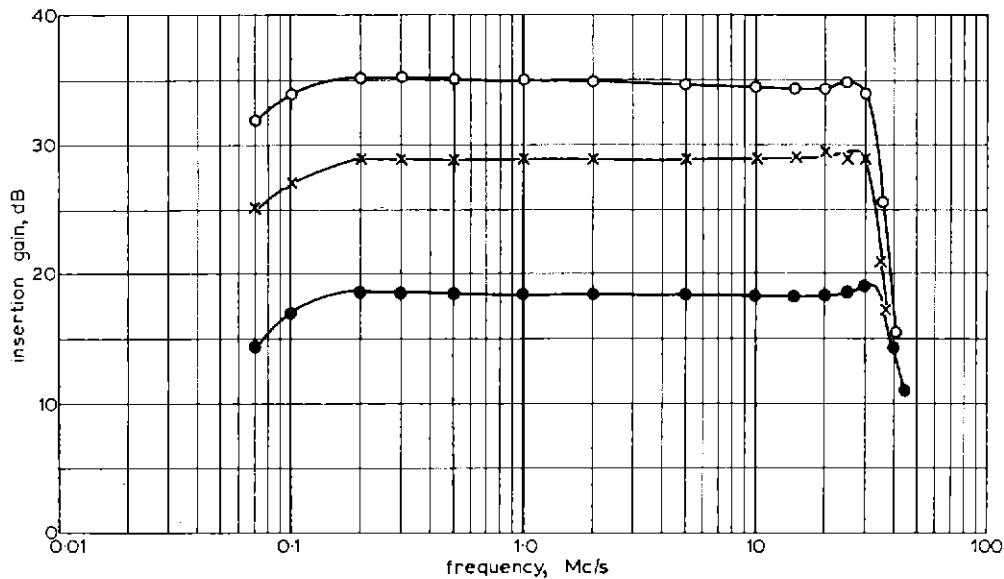

Fig. 8 — Frequency response of the wide-band amplifier of Fig. 7

- Feedback resistors 10 ohms, 90 ohms      × Feedback resistors, 28 ohms, 120 ohms  
 ● Feedback resistors 82 ohms, 180 ohms

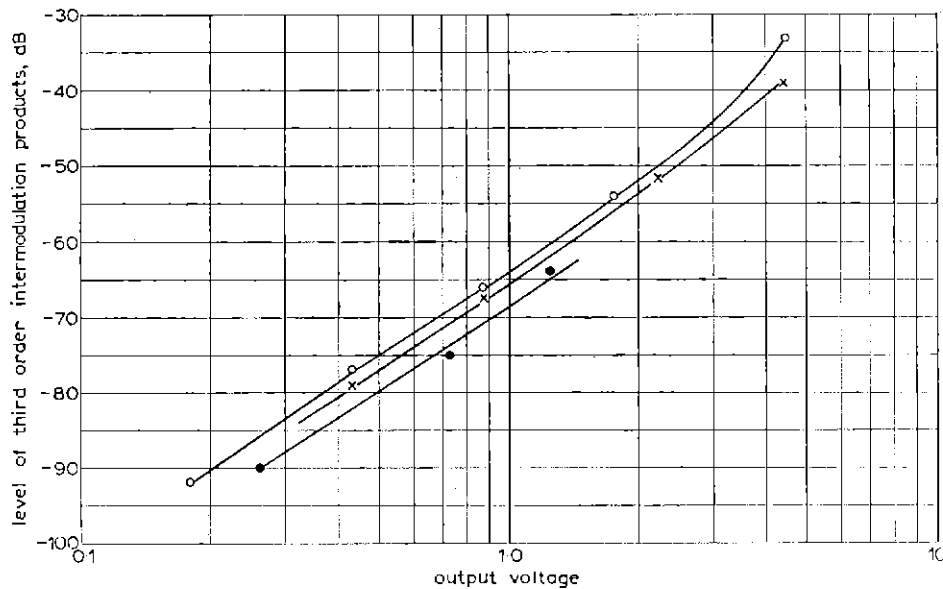

Fig. 9 — Third-order intermodulation products in the amplifier of Fig. 7

○ Gain = 34 dB      × Gain = 28 dB      ● Gain = 18 dB

reasonable performance although it may not be adequate for some applications.

#### 4.1.4 The Effects of Component Tolerances

Although the feedback (d.c. and a.c.) stabilizes most of the properties of the amplifier, the degree of cancellation is vulnerable to changes in certain components. Therefore, 2 per cent tolerance resistors were specified for the a.c. feedback resistors and for the anode load of  $V_1$  but, because of the power rating, the d.c. feedback resistors had to be wire-wound types on which the tolerance is 5 per

cent. Simultaneously increasing the  $1.2 \text{ k}\Omega$  resistor (Fig. 7) in  $V_1$  by 5 per cent and reducing both  $2.2 \text{ k}\Omega$  resistors in  $V_2$  by 5 per cent changed the second-order i.p.s by a maximum of 3 dB when the cancellation was very good, and, as this represents an unlikely extreme condition, the effect may be neglected.

Variations of  $\pm 15$  per cent in the h.t. voltage produced about 1 dB increase in the second-order i.p.s and so the circuit may be run from an unstabilized supply. A 15 per cent increase in heater voltage produced a similar increase of 1 dB but reduction of the heater voltage had a more drastic effect. A reduction of 5 per cent caused no change but the second-order i.p.s rose rapidly as the heater voltage was further reduced, increasing by about 4 dB for a 10 per cent reduction and by 8 dB for a 15 per cent reduction. Operation of valves with these reduced voltages seriously affects the expected life and should therefore be avoided. The makers recommend that the heater voltage be within  $\pm 5$  per cent of the nominal value.

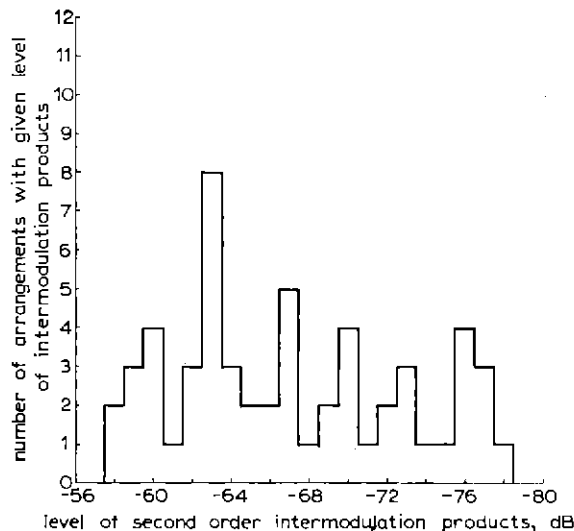

Fig. 10 — Histogram showing the effect of random selection of valves

#### 4.2 Push-pull Amplifier Arrangements

The principal limitation in the performance of the amplifier described in Section 4.1 is the level of the second-order i.p.s and, although some improvement can be obtained by using a 'balance potentiometer' in order to vary the control-grid potential of one of the valves, greater cancellation is obtained over only a limited range of frequencies and signal levels.

On the other hand, when a push-pull stage is used, the cancellation should remain constant over a wide range of signal levels and frequencies. Fig. 11 shows the circuit of an amplifier with a gain of 16 dB (assuming no loss in the transformer) in which there is 12 dB of feedback. This push-pull amplifier may be compared with a cascade am-

plifier of similar gain in respect of second-order i.p.s as follows. For completeness, comparison is also made with a four-valve amplifier described later.

tained by combining the cascade and push-pull circuits as shown in Fig. 12. In this circuit the third-order i.p.s are minimized, the condition for this being that the first and

TABLE I  
Contribution to reduction of second-order i.p.s

	Cascade amplifier	Push-pull amplifier	Four-valve amplifier
Feedback	21 dB	12 dB	19 dB*
Cancellation	$K_1$ dB	$K_2$ dB	$K_3$ dB
Use of push-pull circuit	0 dB	3 dB	3 dB
Total	$(21 + K_1)$ dB	$(15 + K_2)$ dB	$(22 + K_3)$ dB

\* This figure is 4 dB greater than the first-stage feedback as explained in the text.

Thus, to equal the performance of the cascade stage, the cancellation in the push-pull stage must be 6 dB better. In practice, values of  $K_2$  of the order of 30 to 40 dB, are quite feasible, while for the cascade amplifier  $K_1$  may be only 6 to 25 dB as already mentioned. Therefore, a net improvement of the order of 15 dB is possible.

Some further improvement in performance can be ob-

final stages should produce equal relative third-order i.p.s. As indicated previously, they cannot be made to cancel and the condition simply allows the maximum benefit to be derived from feedback. For 16 dB gain this means that the feedback on the output stage is 23 dB and on the input stage is 15 dB. Considering the output stage, the feedback is 11 dB more than in the circuit shown in Fig. 11 but,

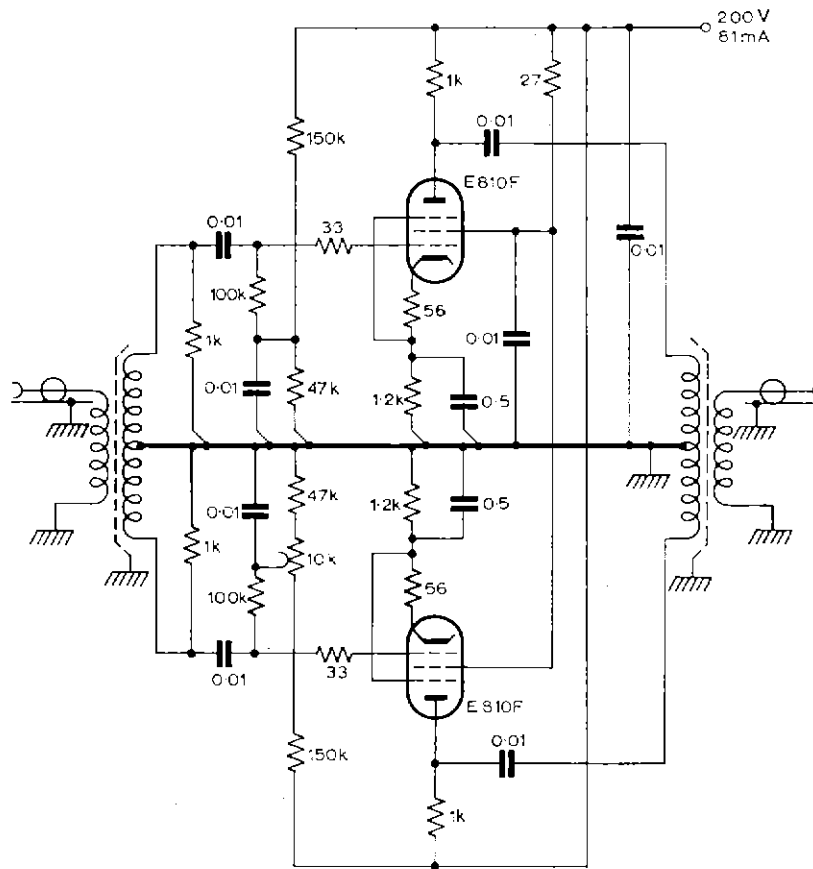

Fig. 11 — Push-pull amplifier with 16 dB gain

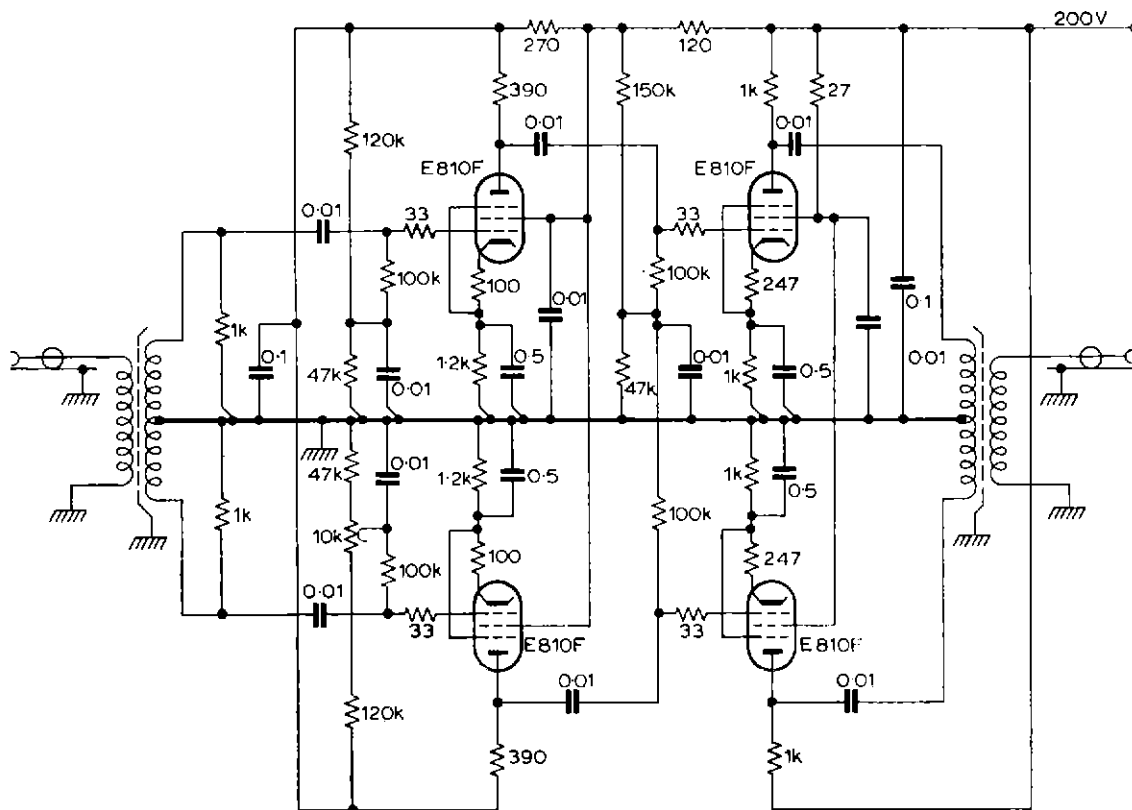

Fig. 12 — Four-valve distribution amplifier with 16 dB gain

when the equal-amplitude contribution from the input stage is included, the net improvement in the third-order i.p.s is only 5 dB.

Because the ratio of signal currents has been arranged so that the third-order i.p.s are comparable in the input and output valves, the second-order i.p.s arise mainly in the input stage. The feedback for this stage is only 15 dB but there is a current gain of 4 dB between the input and output stages; the effective advantage is therefore 19 dB as shown in Table I above. The net improvement in the second-order i.p.s is seen to be 7 dB when compared with the simple push-pull amplifier, assuming an equal degree of cancellation ( $K_3 = K_2$ ). There will, in addition, be up to about 6 dB of 'cascade cancellation' but this has been neglected to compensate for the difficulty in maintaining the same degree of push-pull cancellation.

While some improvement in performance is obtained with the circuits given in Figs. 11 and 12, it should be noted that two balanced transformers are required. The full improvement may not be realized in practice unless the balance is reasonably good. Although techniques for wide-band transformers are well known,<sup>4</sup> the additional cost and possible difficulties of manufacture of these special components must be borne in mind.

## 5. Octave Amplifiers

It was noted in Section 3.1.3 that if the distribution

amplifier bandwidth is restricted to one octave the second-order i.p.s are eliminated. This is a convenient bandwidth for a simple omnidirectional aerial, and systems have been constructed using this principle.<sup>5</sup> In a typical case the frequency range of interest may be 0.1 Mc/s to 27 Mc/s, this being divided into the following bands:

- 0.1 to 0.2 Mc/s
- 0.2 to 0.4 Mc/s
- 0.5 to 1 Mc/s
- 1 to 2 Mc/s
- 2 to 4 Mc/s
- 4 to 8 Mc/s
- 8 to 16 Mc/s
- 16 to 27 Mc/s

It will be observed that the highest frequency-band is, for practical convenience, made smaller than an octave and that a gap occurs between 0.4 and 0.5 Mc/s, a band which is not used for broadcasting and contains the receiver intermediate frequency.

There are two arrangements that may be adopted in an octave amplifier: suitable filters may be placed before and after a wide-band amplifier, or the amplifier may be so designed that the filters form part of the amplifier circuit. Both arrangements were tried and the details are given in the following Sections.

### 5.1 The Wide-band Amplifier with External Filters

The wide-band amplifier described in Section 4.1 was



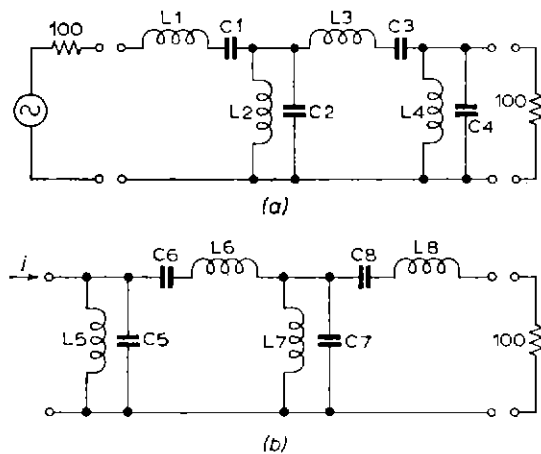

Fig. 13 — Input (a) and output (b) filters for use with the wide-band amplifier

used with the input and output filters shown in Fig. 13. The feedback resistors were arranged to give a gain of 34 dB, and the peaking inductance was removed. Each filter was designed initially as a low-pass, maximally flat filter, by means of the tables given by Weinberg.<sup>8</sup> The band-pass filter design was then obtained by resonating each element of the filter at a frequency equal to the geometric mean of the limiting frequencies of the required pass-band.

Filters for two octaves were constructed: 0.5 to 1 Mc/s and 8 to 16 Mc/s. For the 0.5 to 1 Mc/s octave the component values were such that it was merely necessary to adjust the inductances to the required values at 1 Mc/s and the capacitances to the required values at 1 kc/s to obtain

the required response upon assembly. For the 8 to 16 Mc/s octave, the terminating capacitor in each filter was significantly reduced in value in order to allow for the stray terminal-capacitance of the amplifier, but no difficulty was experienced in constructing the filter. For the 16 to 27 Mc/s filter the stray capacitance is still low enough to permit the required circuit values to be obtained. In practice the residual reactances in the amplifier output circuit produced rather a humped response but this was not considered serious; Fig. 14 shows the overall response.

The values of the components of the input and output filters for all eight octaves are given in Appendix I: no allowance has been made for stray reactances or for the amplifier terminal impedances.

### 5.2 The 'Integrated' Octave Amplifier

While it is convenient in many applications to use a standard wide-band amplifier with suitable input and output filters as described in Section 5.1, a further improvement in performance can be obtained by making the filters part of the amplifier. There are two reasons for this. First, a higher impedance step-up ratio is possible with a band-pass filter following the output valve than is possible with wide-band low-pass coupling for the same maximum frequency; hence the required current swing for a given output power is lower and the i.p.s are reduced according to equations (4) and (5). Second, there is an increase in gain which may be exchanged for more feedback which also reduces the non-linearity.

An octave amplifier for the 8 to 16 Mc/s octave was constructed, the design of the input and output filters being based on those described in Section 5.1, but arranged to include the necessary impedance transformation. The

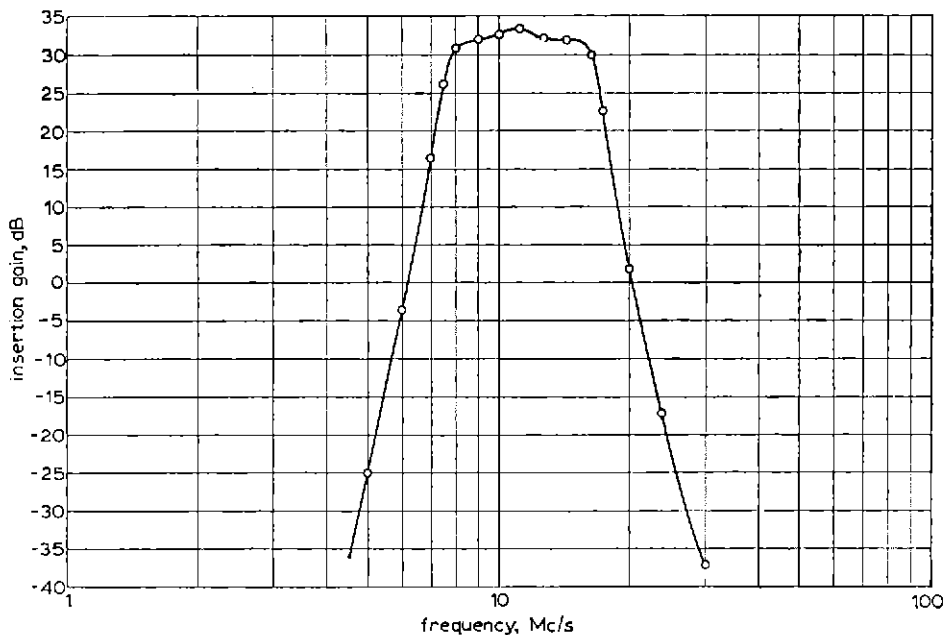

Fig. 14 — Insertion gain of wide-band amplifier plus filters for the 8-16 Mc/s octave

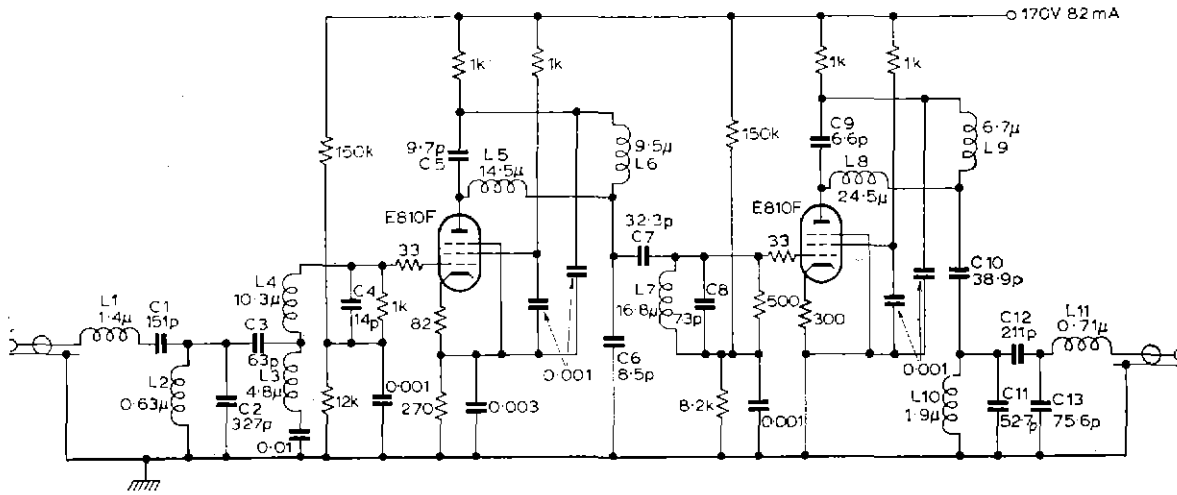

Fig. 15 — The circuit of the 'integrated' octave amplifier. All capacitances are the total required values and make no allowance for stray capacitances

inter-stage coupling was a simple three-section network designed to give a maximally flat bandwidth of 12 Mc/s which is more than adequate. The design does not represent the best possible as the design effort was limited by the time available. It is, however, sufficiently near the optimum to show the advantages to be gained by this type of circuit.

Fig. 15 shows the circuit of the amplifier constructed for the 8 to 16 Mc/s octave and Fig. 16 shows a comparison of the third-order i.p.s for the two types of octave amplifier. Also plotted in Fig. 16 is the curve for one of the existing

octave amplifiers at Caversham.<sup>5</sup> It can be seen that the wide-band amplifier (plus filters) is about 14 dB better than the existing Caversham amplifiers but is up to 25 dB short of the performance attained with the 'integrated' octave amplifier. There was, however, great difficulty in measuring the integrated amplifier because the levels approached the limit set by the measuring apparatus; it is thought that the true curve would show the expected improvement (26 dB) over the whole range. It should also be noted that the overload level is about 4 or 5 dB higher in the integrated amplifier and therefore use of the other

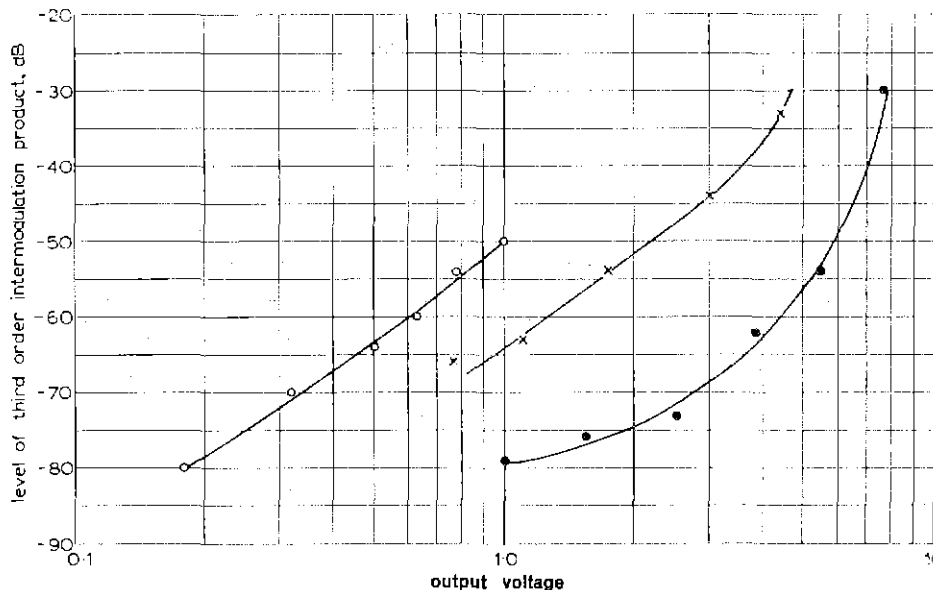

Fig. 16 — Measured third-order i.p.s in octave amplifiers

- Integrated octave amplifier
- × Wide-band amplifier plus filters
- Octave amplifier (Caversham)

arrangement involves a considerable sacrifice in performance.

The bandwidth to be amplified depends on the values of the inductances and associated capacitances, those for the 8 to 16 Mc/s band being given in Fig. 15. The values for all octaves are given in Appendix II, together with the modified circuits for the 16 to 27 Mc/s band.

## 6. Conclusions

Because of the world-wide increase in transmitter powers and the large number of new transmitting stations being built, the principal difficulty in the construction of distribution amplifiers arises from the need to avoid intermodulation between the various signals. Passive distribution systems avoid this possibility and in many situations the degradation in overall noise factor is well worth the freedom from intermodulation products, provided that the overall sensitivity is not limited by lack of gain. Where it is not permissible to use a passive system, narrow-band amplifiers should be used if possible and the octave system is particularly valuable in this respect because it has the greatest bandwidth which may be used if the second-order i.p.s are to be eliminated.

Where there is no alternative to a wide-band amplifier, the design may be based on the principles given in Section 3. In general the second-order i.p.s are the most difficult to eliminate. The levels of these may, however, be predicted with reasonable accuracy from the circuit diagram of the amplifier.

In practice, the signals from the aerials will arise from a very large number of transmissions, but for test purposes it is sufficient to assume that there are only two interfering signals. As an example, the performance of the wide-band amplifiers has been computed when two 60 mV signals are applied. It is assumed that each amplifier has a gain of 16 dB and that the distribution loss following each amplifier is also 16 dB. Assuming that both of the interfering signals and the i.p.s of interest fall within the pass-band of the amplifier, Table II below shows the magnitude of the principal i.p.s at the input terminals of the monitoring receivers. Some spread about these values will occur in practice but the degree of variation should be about the same for each amplifier.

A similar table has been drawn up for the octave amplifiers based on measured results. As before, two 60 mV signals have been assumed to be present at the input and the amplifier gain has been taken as 30 dB (with a distribution loss of 30 dB). In this case only the third-order i.p.s are of interest:

TABLE III

Type of octave amplifier	Fig. No.	Level of third-order i.p.s $\mu V$
Caversham octave	Ref. 5	105
Cascade plus filters	7, 13	21
Integrated	15	3

The signal levels in the last column of Table III above are much higher than those in the fourth column of Table II because the amplifier gain assumed is 14 dB greater. Distortion products at other signal levels may be estimated from the simple power laws given in equations (4) and (5), provided that the output voltage is less than about half the maximum possible output voltage. Above this level the distortion products rise more rapidly as can be seen, for example, in Fig. 16.

## 7. Acknowledgments

The valuable help of Mr C. J. W. Hill, lately Engineer-in-charge of the monitoring station at Caversham, and of the present Engineer-in-charge, Mr F. Masterman, in the practical assessment of the performance of various operational and experimental amplifiers is gratefully acknowledged.

## 8. References

1. Revision of Atmospheric Radio Noise Data, CCIR Report No. 322, International Telecommunication Union, Geneva, 1963.
2. Parker, P., *Electronics*, Edward Arnold (Publishers) Ltd, 1950.
3. Thomason, J. G., *Linear Feedback Analysis*, Pergamon Press Ltd, 1955.

TABLE II

Type of wide-band amplifier	Fig. No.	Level of second-order i.p.s $\mu V$	Level of third-order i.p.s $\mu V$	Degree of cancellation assumed dB
Cascade	7	3.4	0.34	14
Push-pull	11	1.1	0.30	30
Four-valve	12	0.48	0.17	30

NOTE: The levels of second and third harmonics generated from one 60 mV signal are obtained by dividing the voltages given for second- and third-order i.p.s by two and three respectively.

4. Maurice, D., and Minns, R. H., *Very-Wide Band Radio-Frequency Transformers*, *Wireless Engineer*, 24, June 1947, 285, p. 168, and July 1947, 286, p. 209.
5. Hill, C. J. W., and Bishop, H. S., *The Engineering Facilities of the*

*BBC Monitoring Service*, BBC Engineering Division Monograph No. 22, January 1959.

6. Weinberg, L., *Network Analysis and Synthesis*, McGraw-Hill Book Co. Inc., 1962.

## APPENDIX I

### *Component Values for the Octave Filters (Fig. 13)*

The values shown are the total values required: that is, no allowance has been made for stray reactances or the amplifier terminal impedances.

#### *Input Filter*

<i>Frequency band Mc/s</i>	$L_1$ $\mu H$	$C_1$ $pF$	$L_2$ $\mu H$	$C_2$ $pF$	$L_3$ $\mu H$	$C_3$ $pF$	$L_4$ $\mu H$	$C_4$ $pF$
0.1 to 0.2	108	12100	50.1	26100	261	5010	121	10800
0.2 to 0.4	54.1	6050	25.1	13100	131	2510	60.5	5410
0.5 to 1.0	21.6	2420	10.0	5230	52.3	1000	24.2	2170
1.0 to 2.0	10.8	1210	5.01	2610	26.1	501	12.1	1080
2.0 to 4.0	5.4	605	2.51	1310	13.1	251	6.05	541
4.0 to 8.0	2.70	303	1.25	653	6.53	125	3.02	270
8.0 to 16.0	1.35	151	0.626	327	3.27	62.6	1.51	135
16.0 to 27.0	0.98	60.7	0.251	238	2.38	25.1	0.607	98

#### *Output Filter*

<i>Frequency band Mc/s</i>	$L_5$ $\mu H$	$C_5$ $pF$	$L_6$ $\mu H$	$C_6$ $pF$	$L_7$ $\mu H$	$C_7$ $pF$	$L_8$ $\mu H$	$C_8$ $pF$
0.1 to 0.2	62.5	21000	228	5730	81.9	16000	57.0	23000
0.2 to 0.4	31.2	10500	114	2870	41.0	7990	28.5	11500
0.5 to 1.0	12.5	4190	45.7	1150	16.4	3200	11.4	4590
1.0 to 2.0	6.25	2100	22.8	573	8.19	1600	5.70	2300
2.0 to 4.0	3.12	1050	11.4	287	4.10	800	2.85	1150
4.0 to 8.0	1.56	524	5.71	143	2.05	400	1.43	574
8.0 to 16.0	0.78	262	2.86	71.6	1.02	200	0.71	287
16.0 to 27.0	0.31	191	2.08	28.8	0.41	145	0.52	115

## APPENDIX II

### *Filter Component Values for the Integrated Octave Amplifier (Fig. 15)*

The values shown below are the total values required: no allowance has been made for stray reactances.

#### *Input Circuit*

<i>Frequency band Mc/s</i>	$L_1$ $\mu H$	$C_1$ $pF$	$L_2$ $\mu H$	$C_2$ $pF$	$C_3$ $pF$	$L_3$ $\mu H$	$L_4$ $\mu H$	$C_4$ $pF$
0.1 to 0.2	108	18100	50.1	26100	5010	383	827	1080
0.2 to 0.4	54.1	6050	25.1	13100	2510	191	414	541
0.5 to 1.0	21.6	2420	10.0	5230	1000	76.5	165	217
1.0 to 2.0	10.8	1210	5.0	2610	501	38.3	82.7	108
2.0 to 4.0	5.4	605	2.51	1307	251	19.1	41.4	54.1
4.0 to 8.0	2.70	303	1.25	653	125	9.57	20.7	27.0
8.0 to 16.0	1.35	151	0.626	327	62.6	4.78	10.3	13.5
16.0 to 27.0	0.98	61	0.251	224	39.1	*	4.84	9.84

\* This element in this filter consists of 1.24  $\mu H$  in parallel with 21.6  $pF$ .

#### *Interstage Filter*

<i>Frequency band Mc/s</i>	$C_5$ $pF$	$L_5$ $\mu H$	$L_6$ $\mu H$	$C_6$ $pF$	$C_7$ $pF$	$L_7$ $\mu H$	$C_8$ $pF$
0.1 to 0.2	779	1160	762	677	2580	1344	581
0.2 to 0.4	389	580	381	338	1290	672	290
0.5 to 1.0	156	232	152	135	517	269	116
1.0 to 2.0	77.9	116	76.2	67.7	258	134	58.1
2.0 to 4.0	28.9	58	38.1	33.8	129	67.2	29
4.0 to 8.0	19.5	29	19.0	16.9	64.7	33.6	14.5
8.0 to 16.0	9.74	14.5	9.52	8.46	32.3	16.8	7.26
16.0 to 27.0	See Fig. 17 (a)						

#### *Output Circuit*

<i>Frequency band Mc/s</i>	$C_9$ $pF$	$L_8$ $\mu H$	$L_9$ $\mu H$	$C_{10}$ $pF$	$L_{10}$ $\mu H$	$C_{11}$ $pF$	$C_{12}$ $pF$	$C_{13}$ $pF$	$L_{11}$ $\mu H$
0.1 to 0.2	524	1960	537	3110	151	4220	16900	6050	57
0.2 to 0.4	262	981	268	1550	75.5	2110	8452	3020	28.5
0.5 to 1.0	105	392	107	622	30.2	843	3380	1210	11.4
1.0 to 2.0	52.4	196	53.7	311	15.1	422	1690	605	5.70
2.0 to 4.0	26.2	98.1	26.8	155	7.55	211	845	302	2.85
4.0 to 8.0	13.1	49.1	13.4	77.7	3.78	105	423	151	1.43
8.0 to 16.0	6.55	24.5	6.71	38.9	1.89	52.7	211	75.6	0.71
16.0 to 27.0	See Fig. 17 (b)								

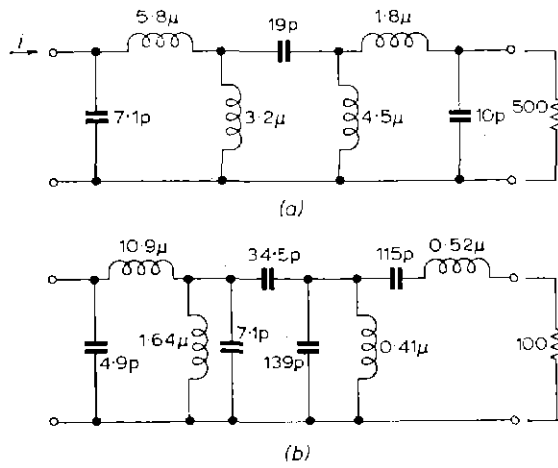

Fig. 17 — The interstage and output filters for the 16 to 27 Mc/s 'integrated' octave amplifier

© THE BRITISH BROADCASTING CORPORATION 1964