

# RADIO TUNER UNIT MANUAL

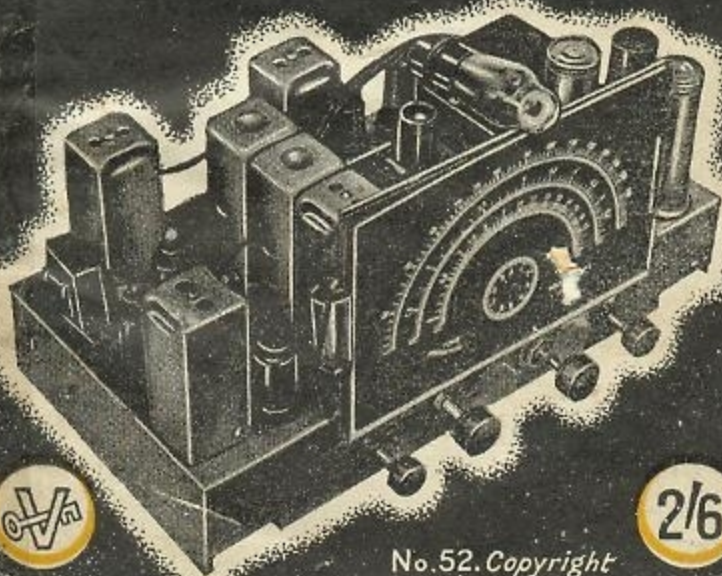

No. 52. Copyright



# Radio Tuner Unit Manual

---

---

by  
"Radiotrician"

No. 52

---

---

BERNARDS (PUBLISHERS) LTD — LONDON W 6



BERNARDS (PUBLISHERS) LTD  
LONDON W 6

COPYRIGHT 1946

## RADIO TUNER UNIT MANUAL.

### Introduction.

The amplifier has become a popular instrument for all purposes where the reproduction of speech or music is required, and it needs only a simple tuning stage coupled to the input side to make any amplifier round off its list of possible functions as a radio receiver. Such stages are sometimes incorporated without a great deal of thought or experiment and are therefore disappointing to the user, but in actual fact very high quality reception is obtainable. The amplifier in general has a wider range of controls than the audio section of the standard receiver - a more comprehensive tone control, for example, or optional negative feedback - so that provided the radio stage is selective and at the same time is able to pass the transmitted band of frequencies the tone and volume of the composite instrument will be excellent.

It may be said at this point that all the tuning systems illustrated in this Manual were tested five miles from Brookman's Park. No circuit for broadcast reception was allowed to become "razor sharp" in the interests of good quality, but no circuit was passed which did not allow clear reception without interference of the three main stations.

This, of course, relates particularly to the first section of the Manual which, it is felt, will be most in demand. The user of the Tuner-Amplifier is chiefly concerned with quality reproduction of the local station which means a simple tuning stage without the complication of wavechange switching, the only band received being the Medium waves.

For the reception of foreign stations other circuits are given, necessarily more selective and with greater amplification. The Short wave and Ultra short wave tuners are included for the reason that programme value on the short wave bands is now high whilst the resumption of Television broadcasts will provide an Ultra short wave station transmitting high quality sound, not to mention a valuable test station for experimenters.

In designing tuning circuits for amplifiers two points must be kept well in mind - the power will be drawn from the amplifier supply and therefore must be kept to as small a limit as possible especially so far as heater supplies are concerned, and secondly the output from the tuner must be of good quality in all respects and hum free in particular.

So far as power supplies are concerned 6 volt heater valves are in general much more economical than the 4 volt type and also as they are more usually found in amplifiers the circuits are shown as for 6 volt valves. A table of equivalent valves is given in Section 8.

With regard to the second point any chance of hum or noise from the tuning stage will be reduced by having an earthed output. Accordingly all the circuits of Sections 1 and 2 with the exception of Fig. 4 have detecting or demodulating stages in which the audio voltages are set up in isolation from the positive supply line - that is they are drawn from the cathode in the case of the triode detector



(the infinite input impedance detector), or the detector is of the diode type, supplying audio output and also a measure of A.V.C.

A list of components accompanies each circuit together with any operating notes of interest.

Constructional details appear in Section 6, and include notes on waveband switching should it be required to add long wave reception to the medium wave circuits.

### SECTION 1.

#### Tuning Stages for Local Station Reception.

FIGURE 1. List of Components.

L1, L2.	PHF2. Wearite Coils.
C1.	.0005 mfd. Solid dielectric variable.
C2, C3.	.0005 mfd. 2-gang variable, with trimmers.
C4.	.0001 mfd. Mica.
C5.	.5 mfd. 350 v.w.
C6.	.0005 mfd. Mica.
C7.	.1 mfd. Paper.
R1.	25,000 ohms, 1 watt.
R2.	150,000 "
R3.	.25 megohm Potentiometer. Volume control.
V1.	Octal valveholder.
V1.	6C5.

This detector is of the infinite input impedance or negative feedback type and gives good quality and selectivity. A disadvantage of the system is that A.V.C. cannot easily be supplied by the circuit so that in a more complex tuner with R.F. stages it is not so useful as the diode. This detector, however, is not easily overloaded whilst, like the diode, it has a slope linear between wide limits. The 100% feedback gives output of a high quality from a strong local station.

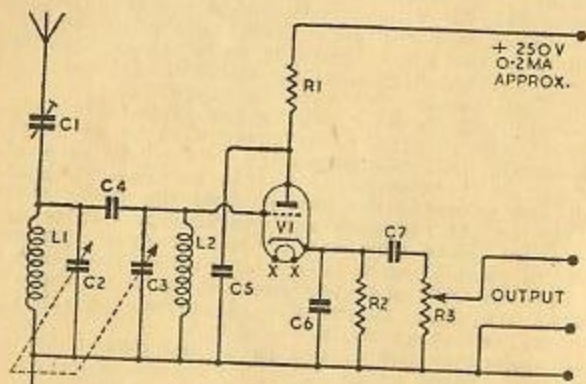

SECTION 1 LOCAL STATION TUNING  
FIGURE 1 UNIT FOR GOOD RECEPTION AREAS

Trimming the bandpass circuits is simple. With C1 at half capacity tune to a low wavelength station and adjust the trimmers on the gang condenser to obtain maximum volume, the grid circuit first and the aerial circuit second. As the trimming is completed vary C1 to give the desired selectivity and volume.

FIGURE 2. List of Components.

L1, L2.	PH 2 Wearite Coils.
C1.	100 m/mfd. Trimmer.
C2, C8.	.0005 2-gang condenser with trimmers.
C3.	.05 mfd. non-inductive, paper type.
C4, C5, C6, C7.	.1 mfd. non-inductive, 350 v.w.
C9, C10.	.0003 mfd. Mica.
C11.	.02 mfd. non-inductive paper, 350 v.w.
R1.	.25 megohms, 1 watt.
R2.	350 ohms.
R3.	30,000 "
R4.	40,000 "
R5.	25,000 "
R6, R9.	1 megohm "
R7.	.25 megohm Pot. Volume Control.
R8.	20,000 ohms, 1 watt.
3	Octal valveholders.
V1.	6K7.
V2.	6H6G.
V3.	Y63.

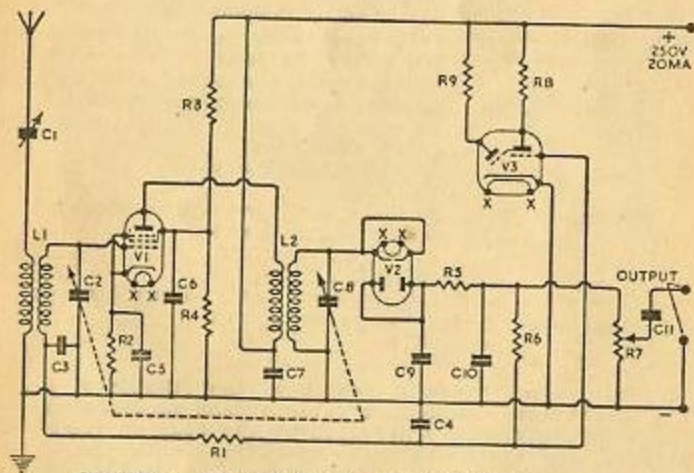

SECTION 1 LOCAL STATION TUNER STAGE (WITH MAGIC EYE)  
FIGURE 2 FOR FAIR RECEPTION AREAS.



In this circuit the Magic Eye tuning indicator is a pure refinement and may simply be cut out of the tuning stage if so desired. The valve and leads are removed from the circuit of Fig. 2 by omitting the target and anode feed resistors, the cathode-earth lead and the grid lead to the bottom end of R6.

The Eye, however, takes so little current both in heater and anode consumption that it is worth retaining if desirable. It can be used as a valuable guide in trimming the circuit for it is acting as an output meter.

To trim the circuit, connect the aerial to the tuner stage with the trimmer at half capacity and tune to a weak station low in the band, adjusting the trimmers on the 2-gang condenser to bring up the volume to maximum or, if the Magic Eye is being used, to give the greatest degree of closing of the shadow. Trim the detector circuit first, rocking the tuning condenser slightly as the adjustment is made (by rocking is meant turning the spindle slightly one way and then the other, so that the signal is tuned through) and then the R.F. amplifier circuit.

The aerial trimmer may then be adjusted to give good volume consistent with selectivity, and in poor reception areas it may be necessary to omit or short circuit this condenser (C1).

The voltage feeding the Magic Eye is also tapped into the R.F. amplifier grid circuit to give A.V.C. which is of great help on strong signals.

If the Magic Eye is excluded, the current drain will fall to approximately 15 m/as.

FIGURE 3. List of Components.

L1, L2.	PHF2 Wearite Coils.
C1.	100 m/mfd. trimmer.
C2, C6.	.0005 2-gang condenser with trimmers.
C3, C4, C5, C9.	.1 mfd. non-inductive, 350 v.w.
C7.	.5 mfd. " " "
C8.	.0003 mfd. Mica. " "
R1.	30,000 ohms, 1 watt.
R2.	30,000 " " "
R3.	10,000 " Pot. Volume Control.
R4.	250 " 1 watt.
R5.	25,000 " " "
R6.	150,000 " " "
R7.	.25 megohm. Pot. Volume Control.
2	Octal valveholders.
V1.	6K7.
V2.	6C5.

This is a different version of the circuit of Fig. 2, using the infinite impedance detector and so dispensing with A.V.C. The volume is controlled by the bias on the R.F. amplifier, and in the trimming operations this should be set to maximum provided that a weak station is used for the adjustments.

Trimming is carried out as for the preceding circuit. Should the stage be very badly out of trim at the commencement, a rough trim may be made on a strong station,

the final trimming, as before, being carried out at the low end of the band.

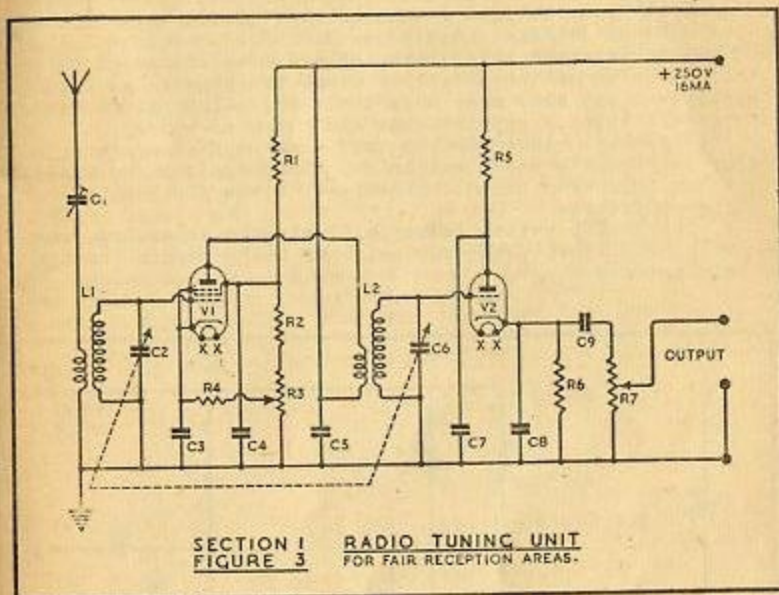

SECTION I RADIO TUNING UNIT  
FIGURE 3 FOR FAIR RECEPTION AREAS.

FIGURE 4. List of Components.

L1, L2.	PHF2 Wearite Coils.
C1.	100 m/mfd. trimmer.
C2, C3, C4, C8,	.0002 maximum preset or trimmer
C9, C10.	condensers.
C5, C6, C11, C13.	.1 mfd. non-inductive, 350 v.w.
C7.	.0005 mfd. Mica or Ceramic.
C12.	.0005 mfd. Mica.
R1.	100,000 ohms, 1 watt.
R2.	250 " " "
R3.	10,000 " Pot. Volume Control.
R4.	30,000 " 1 watt.
R5.	40,000 " " "
R6.	.5 megohms " "
R7.	80,000 ohms " "
S1, S2.	Yaxley type S.P. 3-way ganged switches
2	Octal valveholders.
V1.	6K7.
V2.	6C5.

In this receiver the tuning is performed by preset condensers so connected across the coils that the mere turning of a switch brings in the required station. As



shown the circuit is suitable for receiving the two main stations, Home and Forces, with provision for a third station such as the European service, but the scheme may be either compressed or expanded as desired. The first point of consideration is that good condensers, of a type allowing a low minimum capacity must be used, the best choice being 200 m/mfd. trimmers which have the added advantage of being easily mounted on the chassis. Since the condensers should be screened yet also must have their adjusting screws easily accessible it is suggested that each bank of three condensers is included in the coil screening compartment below the chassis (see Section 6), the chassis being drilled to allow insertion of the screwdriver blade for the lining-up process.

The Yaxley switch leaves will also be separated, one to each compartment, the two switches being ganged through a long spindle.

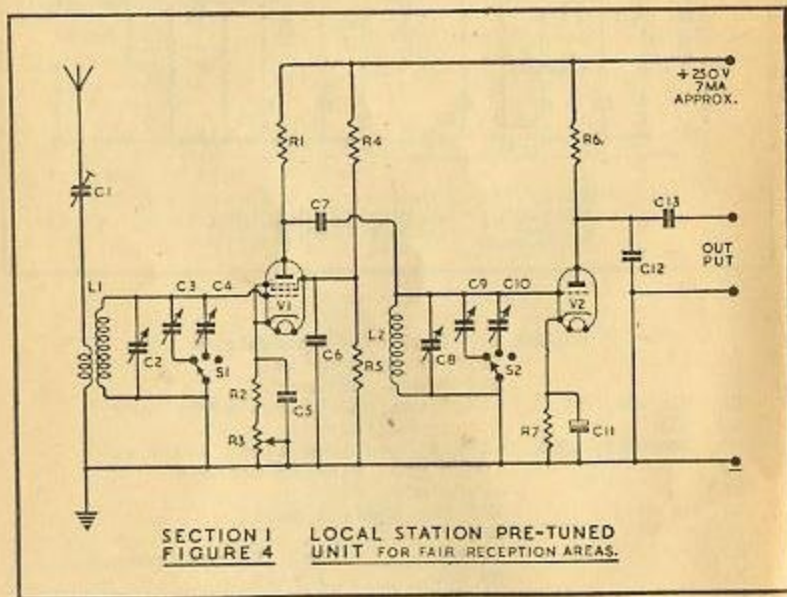

The detector circuit of Fig. 4 is of the Plate Rectification type where the demodulation is carried out in the anode circuit. This detector has more sensitivity than the diode type whilst maintaining good linearity, selectivity and ample overloading limits, but either the diode or infinite impedance detector may be substituted if it is so desired.

To line up the circuits connect the aerial with the aerial condenser at half capacity, and turn the switch to the off position so that only one condenser is in circuit with each coil. Trim these condensers from minimum capacity towards full capacity, keeping the two tuned circuits roughly in step, and when the first required station is heard, that with the lowest wavelength, obtain full volume first with the detector condenser adjustment and then with the R.F. amplifier adjustment.

Turn the switch to the next position and commence to trim the second pair of condensers to bring in the next required station, leaving the first condensers, naturally, as already set, and repeat with the third switch position and the last pair of condensers in circuit. Should a required station be very high in the band, say, at about 450 or 500 metres, it will be necessary to make the last pair of condensers of .0003 mfd. maximum capacity, but for the usual stations this will not be necessary.

Finally make any required adjustment to the aerial trimmer for selectivity or volume. General volume control is given by the cathode potentiometer in the R.F. amplifier stage.

FIGURE 5. List of Components.

- L1, L2, L3. PHP2 Wearite Coils.
- C1. 100 m/mfd. trimmer.
- C2, C8, C10. .0005 3-gang condensers with trimmers.
- C3. .01 mfd. non-inductive.
- C4, C5, C6, C7, C9. .1 mfd. non-inductive, 350 v.w.
- C11, C12. .0003 mfd. Mica.
- C13. .02 mfd. non-inductive paper, 350 v.w.
- R1. 100,000 ohms, 2 watt.
- R2. 25,000 " 1 "
- R3. 33,000 " "
- R4. 250 " "
- R5. 2,000 " "
- R6. 50,000 " "
- R7. .25 megohm Pot. Volume control.
- R8. 1.5 megohm, ½ watt.
- 3 Octal valveholders.
- V1. 6K7.
- V2. 6J7.
- V3. 6H6.

This receiver, for local station listening in poor reception areas is also suitable for receiving the stronger European stations in the better reception areas, using a good aerial, and has good sensitivity and selectivity.

The most important constructional detail is good screening between the three tuned circuits, discussed in Section 6. Any interaction between the coils will lead to instability and parasitic oscillation.

If it is desired a Magic Eye tuning indicator may be operated from the A.V.C. line as in Fig. 2, tapping the grid to point A through a 100,000 ohm ½ watt resistor and by-passing the Magic Eye grid to earth through a .1 or .05 mfd. condenser of any ordinary working voltage, but this will mean an extra heater consumption which, with four



valves in circuit, will be rather high. The extra H.T. consumption will be about 5 milliamps.

Trimming, as usual, is performed by coupling in the aerial and lining up the stages on a weak station, working from the detector tuned circuit back towards the aerial.

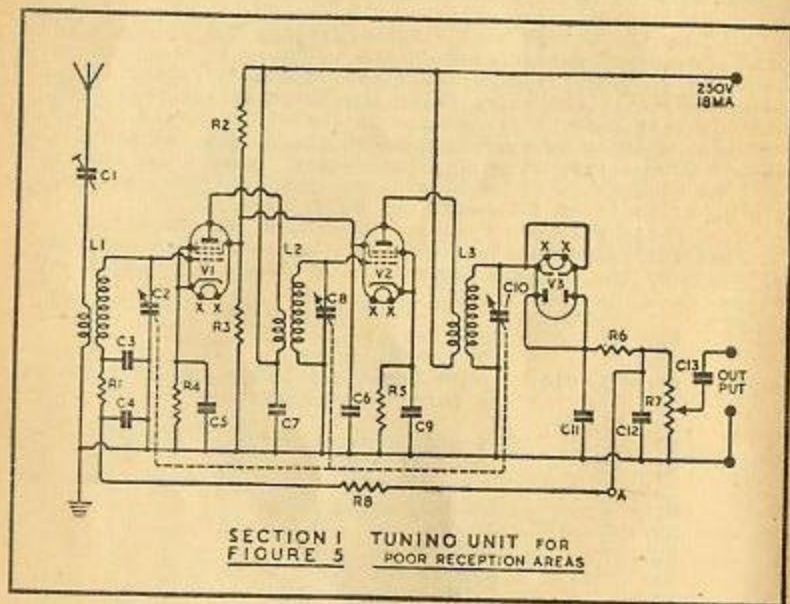

SECTION 1  
FIGURE 5 TUNING UNIT FOR  
POOR RECEPTION AREAS

It might be mentioned that for good reception areas the tuning condenser could be a 2-gang condenser working on the first two stages, the diode detector being coupled in, as at present, through a H.F. transformer without the secondary being tuned. This will reduce the selectivity of the circuit with consequent loss of amplification and increased quality, but no hard and fast rules can be given as results will depend to a great extent on local conditions. With the amplification of the first two stages the untuned circuit might permit some degree of break through, and the system is only mentioned for the benefit of the experimenter. Band pass tuning on the previous stages would be more suitable than single circuit tuning.

#### SECTION 2.

Superheterodyne Stages For General Reception.

FIGURE 1. List of Components.

- |     |                    |
|-----|--------------------|
| L1. | PHF1 Wearite coil. |
| L2. | PHF2 " "           |

- |   |   |
|---|---|
| L3.   | PHF3 Wearite coil.                                      |
| L4.   | PO1 " "   |
| L5.   | PO2 " "   |
| L6.   | PO3 " "   |
| C1, C2, C3,<br>C12, C14.                            | 100 m/mfd. trimmer, postage stamp type                  |
| C4, C18.  | 60 m/mfd. " " " "                                       |
| C5, C7, C8, 39,<br>C18, C19, C20,<br>C21, C22, C26. | .1 mfd. non-inductive paper, 350 v.w.                   |
| C6, C11.  | .005 mfd. 2-gang variable.                              |
| C10, C25.   | .0001 mfd. Mica.  |
| C13.  | .0002 mfd. Padder.                                      |
| C15.  | .0005 mfd. Padder.                                      |
| C17.  | .005 mfd. preset (semi-variable)<br>padder.             |
| C23, C24.   | .0003 mfd. Mica.  |
| C27.  | .01 mfd. non-inductive, paper, 350 v.w.                 |
| C28.  | .02 " " "   |
| R1, R15.  | 100,000 ohms, 1 watt.                                   |
| R2, R7, R11.  | 20,000 " " "  |
| R3.   | 380 " " "   |
| R4.   | 25,000 " " "  |
| R5.   | 50,000 " " "  |
| R6, R9.   | 2,000 " " "   |
| R8.   | 60,000. " " "   |
| R10.  | 350 " " "   |
| R12.  | .25 megohm Pot. Volume control.                         |
| R13, R14.   | 1 megohm, 1/2 watt.                                     |
| T1, T2.   | 465 kc. I.F. transformer.                               |
| 3   | Octal valveholders.                                     |
| V1.   | X65.  |
| V2.   | 6K7.  |
| V3.   | 6H6.  |
| S1, S4.   | Yaxley S.P. 3-way switch.                               |
| S2, S3.   | Yaxley S.P. 3-way switch with shorting<br>bars or ring. |

In the superheterodyne receiver intended for reception of British and Continental stations together with the more powerful short wave transmitters selectivity and sensitivity are generally sufficient, when using the frequency changer as the input valve, to warrant the exclusion of a stage of R.F. amplification, and whilst band-pass tuning might be used on the first tuned circuit (the aerial stage) the sensitivity would drop as the selectivity rose. This circuit, therefore, shows a straight tuned superhet with the frequency converter as the first valve, followed by a stage of I.F. amplification and a diode detector supplying A.V.C. to the previous circuits.

Figure 2 of this section shows the method of adding a stage of R.F. amplification to the superhet to enhance selectivity, thus preventing any second channel interference or heterodyne whistles and also to improve the signal-noise ratio of the receiver on the weaker stations.

The first check to be made on the circuit of Fig. 1 is to ascertain that the oscillator sections controlled by switches S3 and S4 are actually working. By far the best



method is to use a low reading milliammeter in the grid leak oscillator circuit, for at the same time it will then be possible to check each set of coils for their correct and even amplitude of regeneration.

The method is to break the connection of R5 to the cathode line and insert between the cathode and grid resistor a 1 milliamp instrument, or, preferably, a 500 microamp instrument. Manufacturers state the peak grid volts which should appear on the oscillator triode grid, the voltage in the case of the X65 being 10 volts, and since the oscillator will be running into grid current this can be used both as an indicator of regeneration and also as a measure of the constancy of the oscillations. If no current is registered by the instrument the circuit is not oscillating, most probably due to the coil connections being incorrect phased, and reversing the connections to the anode coil will probably give oscillations immediately. Failure of the circuit to oscillate after this adjustment means faulty components or wiring.

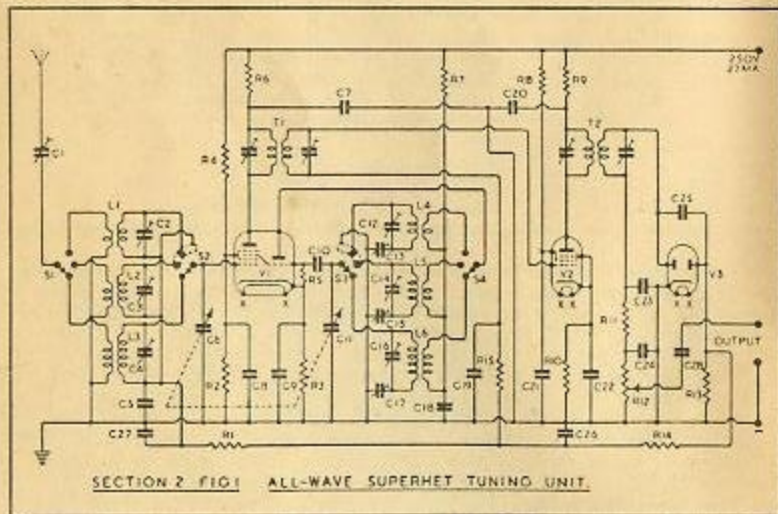

With the 50,000 ohm grid leak the current indicating a grid voltage of 10 is of the order of 160 microamps, and the

variable condenser should be completely rotated whilst the instrument reading is watched. The reading should fluctuate only slightly, and if at all or any positions of the condenser it rises above 170 microamps with any of the coils then the oscillator is giving too much output and must be damped. Damping is best carried out by inserting an extra resistance in parallel with the tuned circuit concerned, the resistance needed being found experimentally, the aim being to obtain a grid current which remains constant over the whole scale.

The author had no trouble in the experimental circuit from this source, but with individually built superhets it is only wise to make this test on each receiver since differing layouts and components can give widely varying results.

Should the grid current be low, indicating a low oscillatory amplitude, the effect of reducing R7 to increase the strength of regeneration should be tried.

If instruments are not obtainable it is simple to ascertain whether or not the triode section of V1 is oscillating by connecting headphones to earth on one side and through a .1 mfd. condenser to the pentode anode of V1 on the other. Oscillations injected into the pentode will be heard as a characteristic hiss while, if a wire is connected to the triode grid and the variable condenser is rotated the heterodyne chirps of stations will be heard. It is impossible, however, correctly to test the oscillator amplitude by this method and all that can be done is to ensure that regeneration does not become so strong that "squegging" occurs, "squegging" being that condition where the triode, already oscillating strongly, breaks into a secondary oscillation identifiable by very loud and harsh hissing.

With the oscillator working correctly on each range it is now necessary to align the I.F. transformers and to trim and pad the oscillator coils, a signal generator being required for these operations, while the best method of output indication is to use an output meter, although aural indications using the loud-speaker may be used. See Bernard's "Modern Radio Test Gear Construction Manual" No 43.

Switch on both receiver and signal generator and allow them to reach their operating temperatures. Short circuit the triode grid of V1 to put the oscillator out of action and couple the signal generator to the signal grid of V1. Tune the generator to 465 kc. and adjust the I.F. transformers so that the signal which will be received is brought to a maximum, using as little output from the generator as possible and tuning the transformers from the diode detector back to the anode circuit of V1, sweeping the generator frequency to check for curve shape.

Set the oscillator back into operation and recouple the signal generator into the aerial-earth sockets of the receiver, using the generator's artificial aerial. Switch the set to the medium wave range and, if a calibrated dial is being used, tune to 215 metres or to a suitable point on an uncalibrated dial, tuning the generator to 215 metres



also. Trim C14 for maximum volume, keeping the generator output as low as possible, and making certain that the trimmer condenser is at its point of minimum capacity so that the adjustment is made by increasing the condenser capacity. The first point of maximum volume is the point required; if the capacity is increased further other points of resonance will be found but the first point is the correct one.

Retune the receiver to 500 metres and tune the generator to 500 metres, once again adjusting for maximum volume, this time on the paddler, C15. This, of course, will slightly upset the trimming adjustment, so return to 215 metres and retrim, then return to 500 metres and repad, repeating this process three or four times until a nice balance is obtained.

Next trim the medium wave signal circuit for maximum response at 215 metres by trimming C3, using a weak signal from the generator.

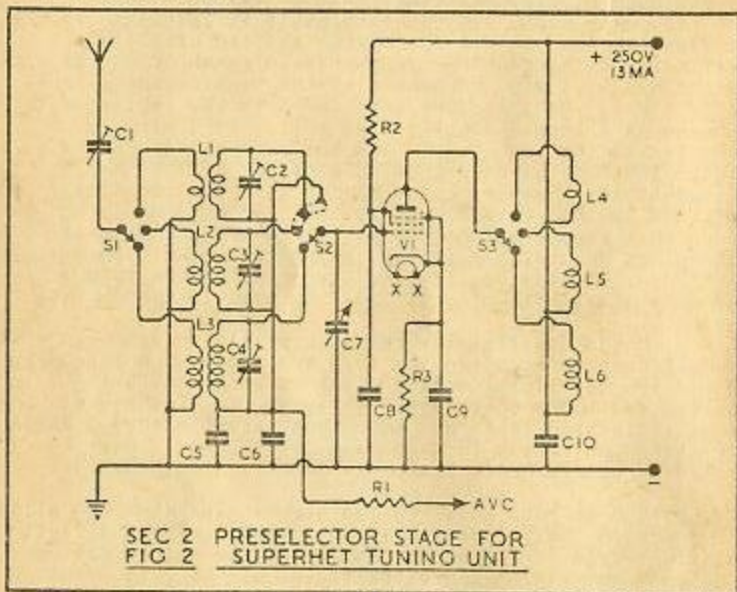

Repeat these trimming and padding processes for the long waves, using 900 metres for trimming and 1,800 metres for padding, and on the short waves, trimming at 20 metres. Padder adjustment will probably be negligible, but any necessary padding may be performed at 45 metres.

Remember in each case to commence trimming with the trimmer at minimum capacity.

If the circuit for pre-selection or R.F. amplification shown in Figure 2, Section 2, is added to the superhet stage it will be seen that few changes need to be made. The aerial coupling coils of Fig. 1 become the anode coils of

H.F. transformers whilst the two-gang condenser of the superhet becomes a three-gang condenser. A.V.C. is coupled into the pre-selector by connecting R1 of Fig. 2 to the junction of R1 and C28 in Fig. 1 whilst R13 of Fig. 1 is reduced to .75 megohms. The wave-change switches of Fig. 2 must be ganged with those of Fig. 1 and particular attention must be paid to the screening between the pre-selector coils and frequency changer coils to prevent feedback and spurious oscillation at signal frequencies.

Alignment of the I.F. and oscillator circuits is as already described, the two R.F. sections being trimmed together, but if they are badly out of gang as shown by difficult tuning or weak signals they may be lined up more closely before the major trimming and padding operations although it is very unlikely that this will be necessary.

Screening and other constructional points are dealt with in Section 6.

**FIGURE 2. List of Components.**

- |                  |  |
|------------------|--|
| L1.              | PHF1 Wearite coil  |
| L2.              | PHF2 " "   |
| L3.              | PHF3 " "   |
| L4, L5, L6.      | Primary (aerial) coils of L1, L2, L3, Figure 1, Section 2. |
| C1, C2, C3.      | 100 m/mfd. trimmer, postage stamp type.                    |
| C4.              | 60 m/mfd. " "  |
| C5.              | .01 mfd. non-inductive, paper.                             |
| C6, C8, C9, C10. | .1 mfd. non-inductive, 350 v.w.                            |
| C7.              | 1 section of 3-gang .0005 mfd. tuning condenser.           |
| R1.              | 100,000 ohms $\frac{1}{2}$ watt                            |
| R2.              | 60,000 " 1 "   |
| R3.              | 350 " "  |
| S1.              | Yaxley switch, S.P. 3-way.                                 |
| S2.              | " " " with shorting bars or ring.                          |
| S3.              | Yaxley S1 of Figure 1, Section 2.                          |
| 1                | All switches ganged with those of Figure 1.                |
| V1.              | Octal valveholder. 6K7.                                    |
- Operational notes in preceding pages.

### SECTION 3.

Tuning Stages for Short Wave Reception

**FIGURE 1. List of Components.**

- |         |   |
|---------|---|
| L1.     | PHF4 Wearite coil.                                |
| L2.     | PHF5 " "  |
| C1.     | 3-30 m/mfd. trimmer, ceramic.                     |
| C2.     | .0005 mfd. variable, plain drive                  |
| C3.     | .0001 mfd. Mica.                                  |
| C4, C7. | .1 mfd. non-inductive, 350 v.w. paper             |
| C5, C6. | .0003 mfd. Mica.                                  |
| R1.     | 250,000 ohms, $\frac{1}{2}$ watt.                 |
| R2.     | 100,000 " 1 "                                     |
| R3.     | 20,000 " "  |
| R4.     | 20,000 ohm Pot. Regeneration control, wire wound. |
| H.F.C.  | Short wave choke, 10-100 metres.                  |



S1, S2. Yaxley switches, S.P. 2-way, ganged, with shorting bars or ring.

1 Octal valveholder.

V1. 6J7.

The one valve short wave set has always been the amateur's stand-by, and with reasonable conditions is able to receive stations in all continents. The circuit of Fig. 1 of Section 3 covers from approximately 12 to 100 metres, the lower limit being controlled to some degree by shortness of wiring and compactness in the switch assembly, and all the main bands of interest lie between these limits

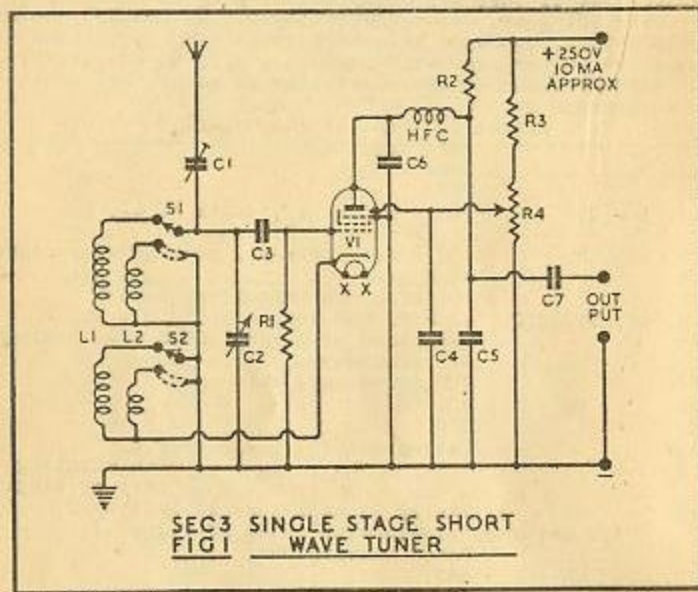

Reaction, of course, is applied to the circuit, the secondary coil being in the cathode circuit in this case with the feedback control in the screen circuit. The result of this arrangement is that regeneration is extremely smooth and quiet with no de-tuning effects - all very valuable attributes.

Since the coils chosen are designed for use with a 0005 mfd. condenser tuning is very sharp and selectivity excellent. A good slow motion drive must be used with the condenser, and a band-spread condenser might also be used if desired. To include a band-spread condenser it is only necessary to mount on the panel as near as possible to the main tuning condenser a .00005 mfd. tuner, connected directly in parallel with C2. The desired band is then selected on C2 with the band-spread condenser at half mesh, when the band can be spread over practically the whole rotation of the smaller condenser.

Tuning condensers with integral slow motion actions should not be used. Whilst they are perfectly satisfactory at broadcast frequencies they inevitably introduce noise into the short wave circuit. Solid brass components with plain drives are the best type.

Since the circuit has only one tuning stage screening is of no great importance so long as the receiver is not in any transformer field or in a position to pick up low frequency interference. The most important point in the construction is the use of short direct wiring with a compact layout, and this is discussed in Section 6.

Aerial loading must be very carefully adjusted by C1, for the aerial will absorb power from the circuit and if its own wavelength is tuned at any point by the receiver the circuit will go out of oscillation unless the coupling is reduced. Interference with neighbouring receivers is also caused by heterodyning, so that C1 should be worked at the minimum possible capacity to give good results.

FIGURE 2. List of Components.

- |               |   |
|---------------|---|
| L1, 2, 3, 4,  | See Text.   |
| C1.           | 3-30 m/mfd. trimmer, ceramic.   |
| C2, C6.       | See Text.   |
| C3, C7.       | .0001 mfd. short wave tuning condensers with extended spindles for ganging. (Raymart type). |
| C4, C5, C11.  | .1 mfd. non-inductive, 350 v.w. paper.  |
| C8.           | 60 m/mfd. ceramic.  |
| C9.           | 100 m/mfd. ceramic or mica.   |
| C10.          | .0003 mfd. reaction condenser.  |
| R1.           | 300,000 ohms, 1 watt.   |
| R2.           | 2,000 " "   |
| R3.           | 1 megohm, " "   |
| R4.           | 50,000 ohms, " "  |
| H.F.C. 1 & 2. | Short wave choke, 10-100 metres.  |
| 1             | Coupling link for ganging condensers.   |
| 1             | High insulation bracket bearing.  |
| 2             | Octal valveholders, ceramic.  |
| V1.           | 6J7.  |
| V2.           | 6C5.  |

A tuned R.F. amplifier stage is of great benefit to the short wave receiver, for although the gain is not as high as with broadcast receivers the oscillating detector is isolated from the aerial loading and dead spots are thus non-existent while stability of operation is generally improved.

In this receiver the tuning condensers are lower in capacity so that the bands are, in effect, wider on the tuning dial, whilst to suit the condensers and to obviate high frequency switching the coils are of the plug-in type and are home made. Coil data is as follows:-

In all cases L1 is identical with L4 and L2 with L3.

- |               |     |                                     |
|---------------|-----|-------------------------------------|
| 15-30 metres. | L1. | 5 turns S.W.G. 24 enamelled copper. |
|               | L2. | 9 " " " " " "                       |
| 30-55 metres. | L1. | 7 turns S.W.G. 24 enamelled copper. |
|               | L2. | 18 " " " " " "                      |



Both tuning condensers should be fitted with good, slow motion drives, and if the dials are of a type which can be calibrated or bear clear figure markings which can be logged the process of tuning will be materially assisted.

#### TUNING.

The best method of calibration or logging is to use the signal generator, commencing with the higher range. Set the generator to give a signal, reasonably strong, in the 15 metre band and, beginning with both C2 and C7 at their minimum capacity slowly tune up the scale. When the generator signal is heard tune to full volume using both controls and leave C2 set while C7 is tuned progressively farther. The signal will vanish, but as the second heterodyne point is reached, with C7 well up the scale, it will return. The first point, i.e., the lower capacity, is the point to choose for all normal work.

It is a good plan to tune to one or two well marked bands in this way, using a generator signal, marking or noting the dial positions so that the two condensers can be kept in step easily.

#### SECTION 4.

Tuning Stages for Ultra Short Wave Reception.

FIGURE 1. List of Components.

- L1. 2 turns 18 S.W.G. bare copper,  $\frac{1}{4}$ " diam.
- L2. 6 turns 18 S.W.G. bare copper,  $\frac{1}{4}$ " diam. turns spaced by own thickness.
- H.F.C. 4 feet of 30 S.W.G. d.s.c. copper spaced in single layer on  $\frac{1}{4}$ " glass tube.
- R.F.C. H.F. choke, ordinary radio type.
- C1. 3-30 m/mfd. trimmer, ceramic base.
- C2. 25 m/mfd. tuner, H.F. insulation.
- C3. 50 m/mfd. ceramic.
- C4. .005 mfd. mica.
- C5. .0003 mfd. mica.
- C6. .1 mfd. 350 v.w.
- R1. 10 megohms, 1 watt.
- R2. 20,000 ohms "
- R3. 100,000 " Pot. regeneration control.

- 1 extension spindle.
- 1 coupling link.
- 2 high insulation bracket spindle bearings.
- 4 small stand-off insulators.
- 2 large "
- 1 Acorn triode holder (commercial or made).
- V1. Acorn, 955.

Particular care must be paid to the constructional notes in Section 6.

This receiver is by no means designed for quality reception. The super-regenerative principle enables it to respond to weak high frequency signals with a broad tuning effect so that selectivity is greatly reduced whilst sensitivity is enhanced to a remarkable degree, but in order to do this the valve is swept in and out of its most efficient operating condition at a high frequency - in other words, the valve is oscillating on the wavelength it is required to receive, 5 to 7 meters, but this oscillation is

under the control of a second slower regenerative effect at the rate of about 20,000 cycles per second. This is approaching audio limits so that the net result is a loud hiss which extends over the tuning range as soon as R3 is sufficiently far advanced. When a station is received, however, this hiss diminishes to vanishing point allowing the signal to be heard clearly, but quality does suffer and the circuit is not intended as a high quality receiver. It is useful, however, for any experimenter who requires a small tuner with which to explore the U.S.W. band and in the reception area of the television station where the signals will be sufficiently powerful to overcome the super-regeneration effect entirely results will be good.

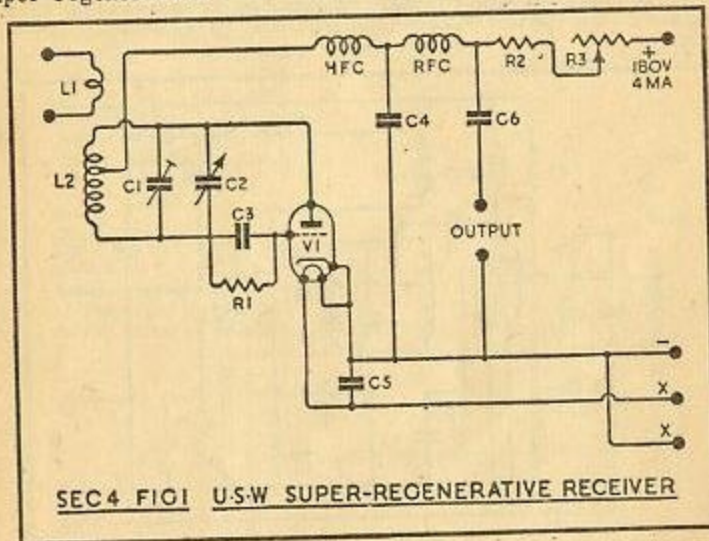

The aerial, for proper working, should be a vertical half-wave dipole, the usual television type aerial, erected in the open with twisted feeders running down to the receiver, but since it is unlikely that a special aerial will be set up for such a small receiver the result of taking an ordinary broadcast aerial to one side of the coupling coil can be tried, the other side of the coil, L1, being connected to an earth if desired.

Figure 3, Section 4 shows the desirable aerial, the two wire halves being supported vertically and separated at the middle by insulators. The length of each half should be a quarter of the wavelength it is desired to receive, while the twisted feeders, which can be of ordinary lighting flex, may be of any desired length. Thus for 5 metre working the aerial will be  $1\frac{1}{4}$  plus  $1\frac{1}{4}$  metres long, the metre being 39.37 inches.

This possibility of tuning an aerial closely to a desired low wavelength can also be used to establish the



50-100 metres.

L1. 9 turns S.W.G. 24 enamelled copper.  
L2. 33 " 22 "

All the coils are wound in the same "direction" on ribbed formers of 1½" diameter, of the best material available, preferably ceramic, and two holders must be provided into which the coils are plugged, the type depending on the number of pins in the former.

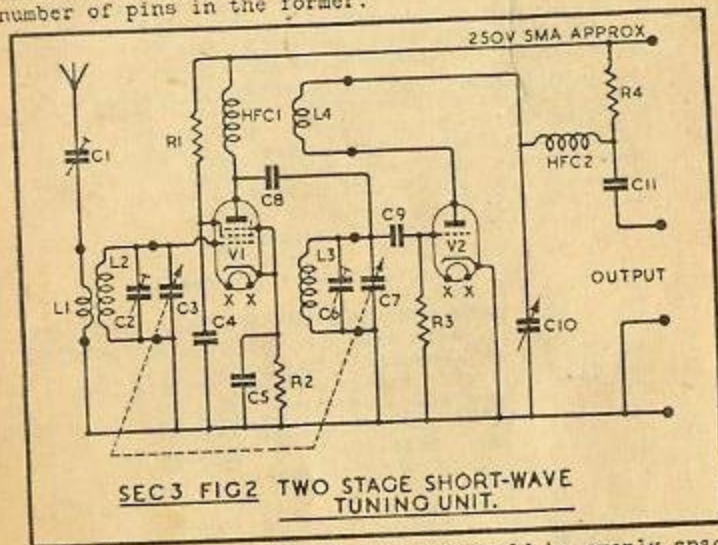

In each case the L2 winding should be evenly spaced over a length of 1½" whilst the reaction or aerial coupling coil is close wound, with turns touching, and is spaced ½" from L2, being wound at the bottom of the former. The bottom lead from L2 is the earth lead.

Each pair of coils must be symmetrical since they have to tune in gang.

The trimmers C2, C8 are 3-50 m/mfd. ceramic postage stamp type, and one is connected across each grid coil and mounted at the top of each coil former so that its adjusting screw is accessible.

The coil is shown in Fig. 3 of this Section while layout and construction of this receiver are dealt with in Section 6.

To line up the receiver plug in each pair of coils in turn and proceed for each waveband as follows:-

Tighten the coupling link between the condensers so that they rotate in gang, both reaching maximum and minimum points together. Set C1 at about half capacity and if a signal generator is not available tune from the high frequency end of the band towards the low frequency end until a signal is received. With C8 set at half capacity trim C2 to obtain full volume and proceed through the band to test the ganging between the tuned circuits. If the

coils have been properly made the tuning should stay in gang without any trouble but slight closing or opening of the turns on the coils will cure small errors.



SECTION 3 FIG3. COIL ASSEMBLY FOR FIG2, SHOWING TRIMMER ON TOP OF FORMER.

If the detector refuses to oscillate, reverse the leads to L4. Keep the receiver on the edge of oscillation when searching for stations. The reaction control will be found perfectly smooth in operation.

FIGURE 4. List of Components.

- |              |  |
|--------------|--|
| L1.          | PHF4 Wearite coil.                               |
| L2.          | PHF5 " "   |
| L3.          | PO4 " "  |
| L4.          | PO5 " "  |
| C1.          | 200 m/mfd. trimmer, ceramic.                     |
| C2, C7.      | .0005 mfd. tuners, short wave type, plain drive. |
| C3, C4, C10, | .1 mfd. non-inductive, 350 v.w.                  |
| C11, C12.    | .02 mfd. " paper, 350 v.w.                       |
| C5, C15      | .0001 mfd. Mica.                                 |
| C6.          | .005 mfd. non-inductive, paper.                  |
| C8.          | .0025 mfd. " "                                   |
| C9.          | .0003 mfd. Mica.                                 |
| C13, C14.    | 25,000 Ohms, 1 watt.                             |
| R1.          |  |



R2, R5, R8.	200,000 Ohms, 1 watt.
R3.	50,000 " "
R4.	300 " "
R6.	300,000 " "
R7.	2,000 " "
R9.	.5 megohm Pot. volume control.
S1, S4.	Yaxley, S.P. 2-way.
S2, S3.	" " with shorting bars or ring, all switches ganged

3 Octal valveholders.

V1.	X65.
V2.	6J7.
V3.	6HG.

In this simplified superheterodyne receiver for the short wave bands the first point to notice is that tuning is not by ganged condensers but by two separate tuning condensers, C2 and C7. C2 is tuning the pentode section of V1, while C7 is tuning the oscillator so that the intermediate frequency of 465 kc. is obtained by adjustment of the oscillator tuning in step with the aerial tuning. This, at first, might appear to be a difficult process, but it is one widely adopted, especially among American amateurs, and with practice it is mastered in a very short time.

The advantages of the method are that the circuit is easier both to construct and trim whilst there are, for all practical purposes, no tracking errors. The aerial tuning is quite broad so that bands and stations are easily found, and whilst the oscillator is kept at the higher frequency (465 kc. above station frequency) for general work it can, if desired, be used at the lower beat frequency.

Band spreading can be added to the oscillator circuit if desired by connecting a .00005 mfd. tuner in parallel with C7 and using this condenser for fine tuning.

To line up the receiver it is only necessary to adjust the I.F. transformers to their frequency of 465 kc. with the aid of a signal generator in the usual way, feeding the generator output to the signal grid of V1 and tuning the transformers for maximum response and correct peaking from the detector back with the oscillator out of action. The oscillator is checked for even amplitude as in Section 2, Fig. 1, by inserting a sensitive meter between the earth end of R3 and the cathode lead. If no current is indicated the anode coil of the range under test should have its connections reversed to bring the circuit into oscillation, when the instrument should show a grid current of not over 160 microamps over both ranges, currents higher than this indicating too strong an oscillation which must be damped by resistors across the anode coil, the values determined experimentally.

It is unlikely that trouble will occur over this point, but individual components and layouts make it desirable that the test is carried out if possible.

There is no trimming or padding to be performed, for the padders, C8 and C9, are fixed condensers and with isolated working of the two tuning condensers trimming is carried out automatically.

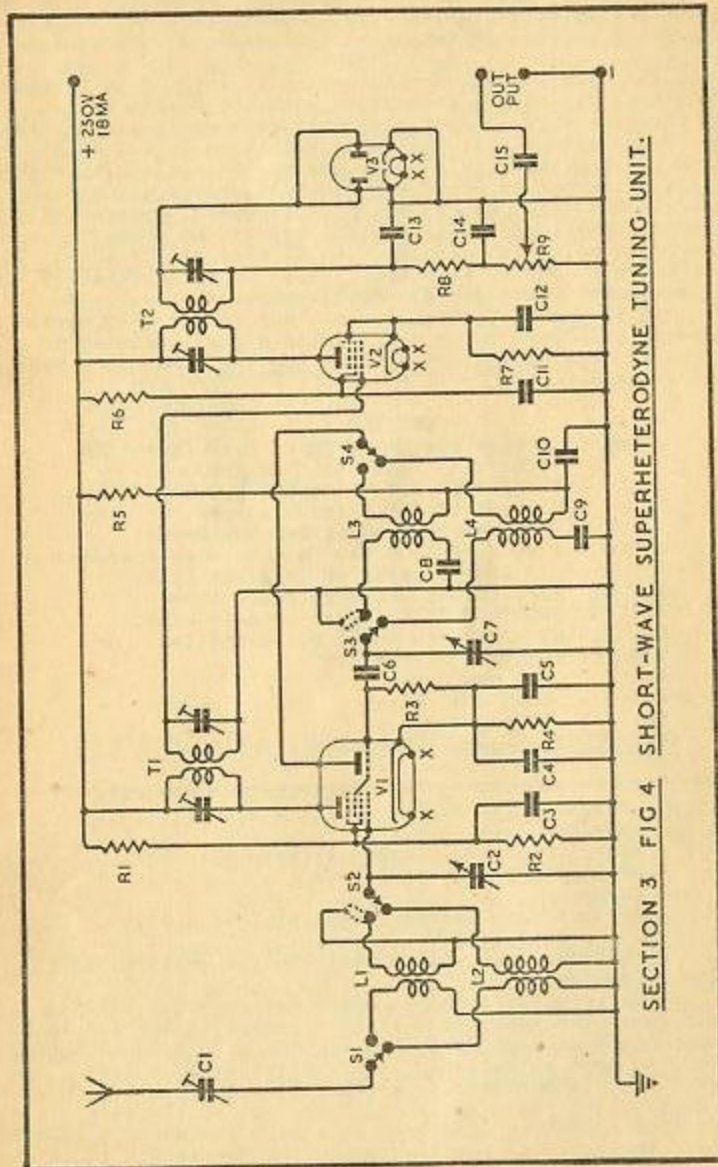

SECTION 3 FIG 4 SHORT-WAVE SUPERHETERODYNE TUNING UNIT.



band on which the receiver is operating, a necessary test since the slightest difference in coil and condenser sizes at these high frequencies can have a large effect upon the working frequency of the set. A wire, one half wavelength long of the desired wavelength is erected in the room at any angle so long as it is reasonably clear of walls, pipes, etc., and one end of it is connected through a trimmer condenser of about 50 m/mfd. capacity and a lead of only an inch or two long to the grid side of the tuning coil. When the receiver is tuned to the wavelength of the aerial (twice the aerial length in metres), it will fail to oscillate or will oscillate only weakly, the super-regeneration hiss returning sharply on either side of the dead spot. The aerial connection should then be removed to ascertain that it was an absorption effect and not due to some receiver fault.

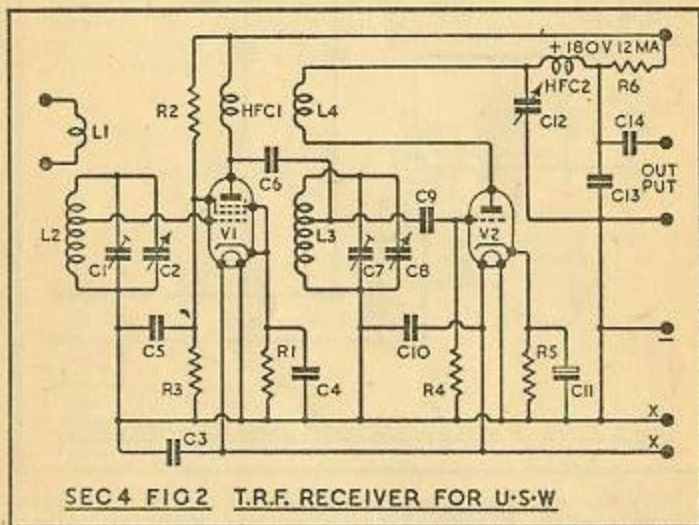

To check operation on 7 metres, therefore, a wire  $3\frac{1}{2}$  times 39.37 inches long, or 11' 7" would be coupled as shown above, and it would be found that the dead spot could be brought to the middle of the tuning range by spreading out or pinching together the turns of the tuning coil.

A super-regenerative set should not be used near any house containing television apparatus. One fault of the circuit is that it re-radiates interference on its hiss frequency which would completely mar picture and sound reception.

FIGURE 2. List of Components.

- |         |  |
|---------|--|
| L1      | 2 turns 18 S.W.G. bare copper, $\frac{1}{4}$ " diameter.   |
| L2, L3. | 6 turns 18 S.W.G. bare copper, $\frac{1}{4}$ " diameter, spaced wire's own thickness, tapped two turns down. |

- |                |  |
|----------------|--|
| L4.            | 3 turns 30 S.W.G. d.s.c. copper, close wound on same former as L3 and spaced $\frac{1}{4}$ " from earthed end of L3. |
| HFC 1 & 2.     | 4 feet of 30 S.W.G. d.s.c. copper, spaced in single layer on $\frac{1}{4}$ " glass tube.                             |
| C1, C7.        | 3-30 m/mfd. ceramic trimmer.   |
| C2, C8.        | 30 m/mfd. U.S.W. tuning condenser, with spindle extended for ganging.  |
| C3, C4, C5,    |  |
| C10, C11, C13. | .0003 mfd. mica.   |
| C6.            | 50 m/mfd. ceramic.   |
| C9.            | 100 m/mfd. ceramic.  |
| C12.           | .0001 mfd. U.S.W. variable reaction condenser.   |
| C14.           | .1 mfd. 350 v.w.   |
| R1.            | 500 ohms, 1 watt.  |
| R2.            | 15,000 " "   |
| R3, R6.        | 50,000 " "   |
| R4.            | .5 megohm " "  |
| R5.            | 750 ohms, " "  |
| 1              | Acorn triode holder.   |
| 1              | " pentode "  |
| V1.            | " 956 "  |
| V2.            | " 955 "  |
| 8              | small stand-off insulators.  |
| 2              | large " "  |
| 3              | coupling links.  |
| 2              | extension spindles.  |
| 5              | high insulation bracket bearings.  |

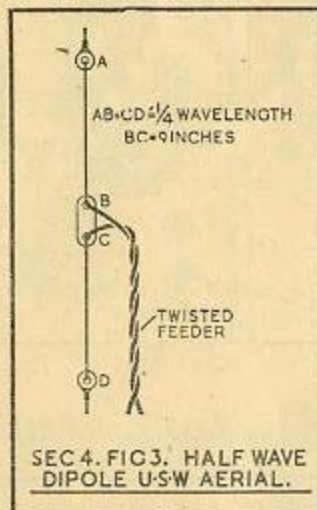

In this circuit super-regeneration is not used, so that selectivity is very high and quality is quite good. The R.F. amplifier stage gives little in the way of gain



but serves to isolate the detector from the aerial load, thereby increasing the stability of the receiver, and, at the same time, prevents re-radiation, since the detector is an oscillator, so that no interference on neighbouring sets can be caused.

It will be noticed that the grid circuits of both valves are tapped down the tuning coils. This is to give less damping in the circuit, and results in an overall improvement in the working of the receiver.

Trimming the two circuits into line will take a little patience, and in the absence of identifiable signals it is as well to establish the band on which the oscillating detector is working, as before. Remove V1 and stretch in as free a space as possible a wire as long as half the wavelength that it is desired to receive, tapping one end through a trimming condenser and a very short lead to the grid end of the tuning coil of V2. With the tuning condenser at half mesh and the detector oscillating (oscillations are controlled by C12), adjust the band set trimmer until the aerial dead spot appears. Disconnect the half wave aerial to ensure that the dead spot is due only to the loading.

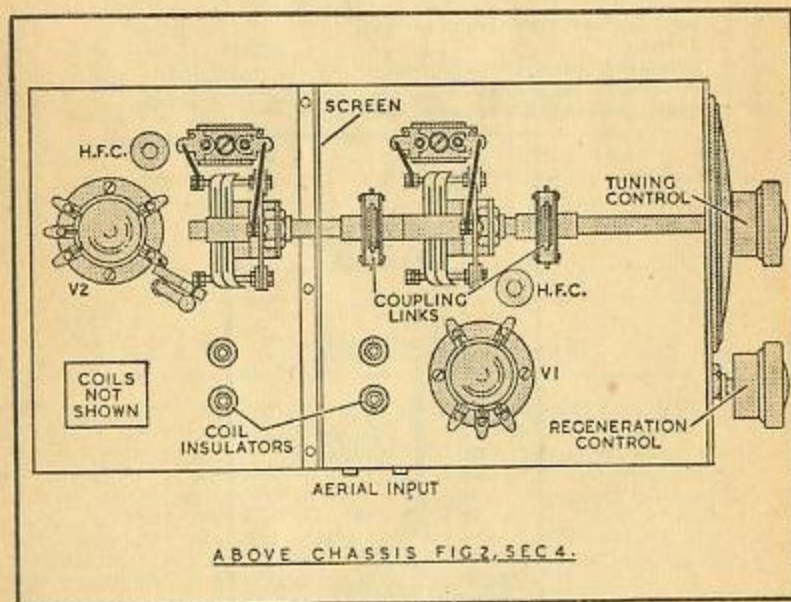

Replace V1 and couple the receiving aerial to L1. The R.F. circuit has now to be trimmed into line with the detector circuit, and probably noise or valve hiss will

be the only indication obtainable unless, of course, a high frequency signal generator is obtainable or is made up from a simple oscillating circuit with some form of sound modulation included - A.C. mains hum will serve. Set the two tuning condensers to minimum capacity and tighten the coupling link joining their spindles so that they rotate in gang. Whilst they are still at minimum capacity adjust the band set trimmer on the R.F. stage until hiss from this stage is tuned into the detector circuit (or until a Signal Generator note is tuned to maximum volume), the detector being worked at the edge of oscillation. Next rotate the tuning condensers to inspect the ganging. If the R.F. stage goes out of alignment loosen the coupling link and discover whether the stage is brought into line by more or less tuning capacity, pinching the turns of the R.F. tuning coil together in the first case or spreading them a little in the second case, recoupling the condensers and relining at minimum capacity as before. Retest for ganging and continue until the circuits are in alignment for the full condenser rotation.

Maintain the detector on the edge of oscillation when searching the band for signals.

A note on coils:- It is possible to obtain coils commercially for such a receiver as this, those of the Eddystone range for example, but since the inductances are so small they are quite convenient to wind by hand. Since in this receiver a reaction winding is employed the tuning coils should both be wound on formers, the reaction winding as already noted on the same former as L3. These formers must be the best obtainable so that they have no effect on the efficiency of the circuit, and are best of ceramic tubing although good quality paxolin may be used.

Alignment will be best performed by using headphones across the output terminals.

#### SECTION 5. Amplifiers.

FIGURE 1. List of Components.

- |        |   |
|--------|---|
| R1.    | 2 megohm $\frac{1}{2}$ watt.  |
| R2.    | .25 " 1 watt.   |
| R3.    | 1 " " "   |
| R4.    | 1,200 ohms, " "   |
| R5.    | 1 megohm Pot. tone control.   |
| R6.    | .5 " " volume "   |
| R7.    | 150 ohms, 1 watt  |
| C1.    | .5 mfd. 250 v.w.  |
| C2.    | .02 mfd. " "  |
| C3.    | .1 mfd. " "   |
| C4, 05 | 8 mfd. 450 v.w.   |
| T1.    | Output transformer matched to 7,000 ohms.                                     |
| T2.    | Mains transformer with screen, 350-0-350 v.<br>100 m/a. 5 v. 2 a. 6.3 v. 3 a. |
| L1.    | 20 henry L.F. choke to pass 80 m/a or 1,000 ohm<br>speaker field.             |
| S1.    | D.P.S.T. mains switch (may be on volume control).                             |
| F.     | Fuse. 2.5 volt flash-bulb in insulated holder.                                |
| 2      | Octal valve holders.  |



- 1 4-pin valve holders.
- V1. 6J7.
- V2. PP6C Tungfram or EL33.
- V3. 5Y3G.

Attention must be paid to the note on page 32 regarding the coupling of tuners to amplifier input circuits.

FIGURE 2. List of Components.

R1.	2 megohms,	$\frac{1}{2}$ watt.
R2, R8.	30,000 ohms,	1 watt.
R3, R9, R11.	250,000 "	"
R4, R10.	1 megohm	"
R5, R7.	1,200 ohms,	"
R6.	.5 megohm,	"
R12.	50 ohms	"
R13.	170 "	"
R14.	1 megohm Pot.	feedback control.
C1, C14, C18.	50 mfd.	25 v.w.
C2, C12.	.5 mfd.	350 v.w.
C3, C13, C16.	8 mfd.	500 v.w.
C4, C11.	.1 mfd.	"
C5.	.005 mfd.	"
C6.	.0005 mfd.	"
C7.	.00005 mfd.	"
C8.	.01 mfd.	"
C9.	.005 mfd.	"
C10.	.001 mfd.	"
C15, C17.	4 mfd.	"
T1.	Speaker matching transformer,	loaded to 2,500 ohms.
T2.	Mains transformer, shielded,	350-0-350v. 120 m/a. 5v. 3a. 6.3v. 4a.
L1.	20 henry choke to pass 100 m/a or	500 ohm speaker field.
S1.	S.P. 4-way Bass cutting switch.	
S2.	S.P. 4-way Treble cutting switch.	
S3.	S.P.D.T. Feedback selector.	
S4.	D.P.S.T. Mains switch.	
F.	Fuse. 2.5v. flashbulb in insulating holder.	
3	Octal valve holders.	
1	4-pin valve holder.	
V1, V2.	6J7.	
V3.	6L6.	
V4.	5U4.	

Attention must be paid to the note on page 32 regarding the coupling of tuners to amplifier input circuits.

The circuit of this amplifier, as shown, will give an output of 6 watts which is sufficient to cover a wide range of uses, but should it be desired to obtain an output approaching 10 watts, the following changes must be made.

The output valve must have fixed battery bias of 18 volts. This means that C14 and R13 are removed from the circuit, the cathode being connected directly to earth, as is the positive side of the bias supply. The battery must be kept in good condition. The earthed end of R11 is

disconnected from earth and connected to 18 volts negative. The main H.T. line positive voltage must be raised to 350 volts on the anode of the 6L6, the screen being maintained at 250 volts through a potential divider, the resistors being 10,000 ohms from the H.T. positive line to the screen and 35,000 ohms from the screen to earth, this resistor being by-passed from screen to earth by a further 8 mfd. 350 v.w. condenser, both resistors being of 3 watts rating.

The extra H.T. supply voltage may be obtained by using a 450-0-450 v. mains transformer, allowing for a 500 ohm speaker field or choke, and the working voltages of C16 and C17 must be increased, preferably to 750 volts working.

The loading on the speaker transformer is changed to 4,000 ohms.

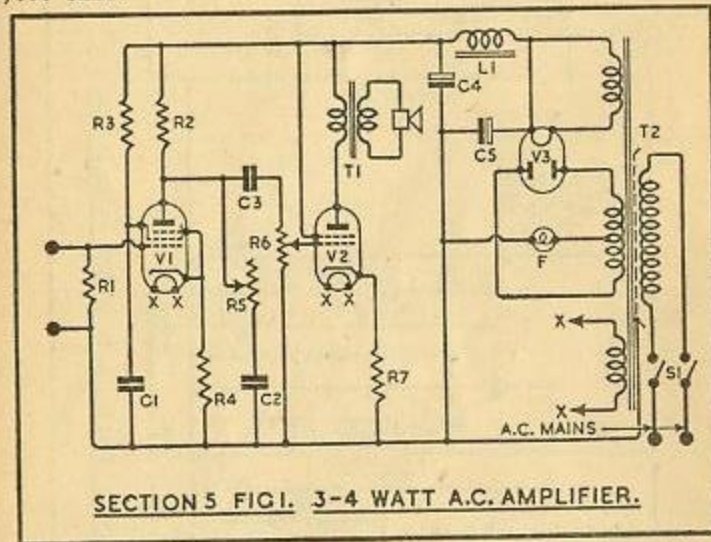

SECTION 5 FIG. 1. 3-4 WATT A.C. AMPLIFIER.

The loud-speaker transformer ratios depend on the stated output valve load and the speech coil impedance of the speaker at 400 c.p.s. and are discovered from the formula

$$R = \frac{\sqrt{\text{Valve anode load}}}{\text{Speech coil impedance}}$$

For a 3 ohm speaker, therefore, the ratio of a transformer to match the speaker into the PP6C of Figure 1 of this Section would be

$$R = \frac{\sqrt{7,000}}{3}$$

$$\text{or } 48.3 : 1$$

whilst for the 6L6 of Figure 2 the ratio for a 3 ohm speaker would be 29 : 1 or, for the modified 10 watt circuit, 36.5 : 1.



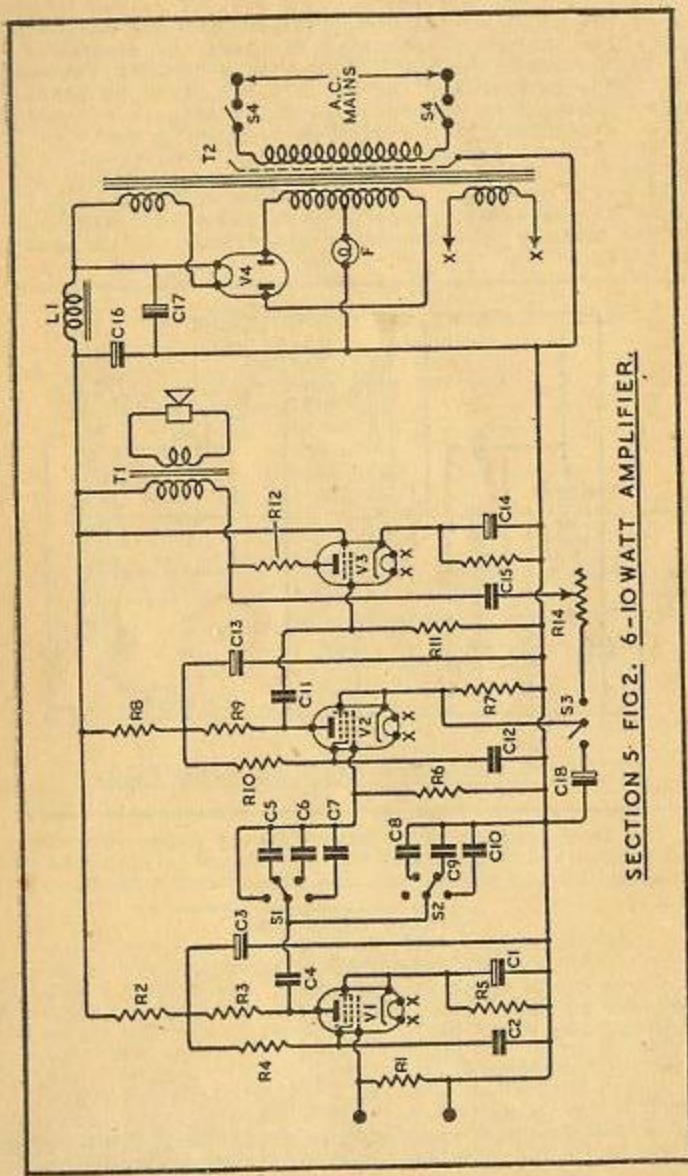

SECTION 5 - FIG. 2. 6-10 WATT AMPLIFIER.

In both amplifiers it will be found an advantage if the smoothing condenser can be made of higher capacity - the condensers C4 in Figure 1, Section 5, and C16 in Figure 2, Section 5, can be increased to 60 mfd. with consequently improved smoothing. The working voltages of course, must be maintained.

SECTION 6.  
Constructional Notes  
COUPLING CIRCUITS.

1. - POWER SUPPLIES.

The circuits given in the foregoing Sections are all designed to work with a 250 or 180 volt H.T. supply, and since many amplifiers have the main supply line working at from 300 to 400 volts a voltage dropping system must be included between the amplifier and the tuning stage. Overrunning the tuning stage might easily result in decreased efficiency due to instability, and the dropping circuit consists merely of a series resistance in the positive H.T. lead, the value of the resistance being calculated by dividing the current taken by the tuner, as shown on each diagram, into the voltage it is required to drop. The resistance is by-passed to earth on the tuner side of the circuit, the system being shown in Figure 1, Section 6.

For example, suppose the tuner to require 6 m/a at 250 volts whilst the amplifier delivers 350 volts from the power pack. It will be required to drop 100 volts at the stated current, and it must be remembered that the current must be converted into amperes for the formula. Since

6 m/a can be expressed as  $\frac{6}{1000}$  amperes, the resistance is given by

$$R = \frac{V}{I} = \frac{100}{\frac{6}{1000}} = \frac{100 \times 1000}{6} \text{ or } 16,666 \text{ ohms, -}$$

in practice anything between 15,000 and 17,000 ohms would be suitable. The watts rating of the resistor is found by multiplying together the current in amperes by the voltage dropped across it so that in this case the watts lost in the resistor are

$$W = VI = \frac{6 \times 100}{1000}, \text{ or } .6 \text{ watt,}$$

so that a 1 watt resistor would be perfectly adequate.

In many cases, however, it will be found that a smaller resistance with a higher watts rating will be required.

The resistor together with its by-pass condenser should be mounted in the tuner chassis, and the capacity of the condenser varied with the output system of the tuner, as shown below.

CAPACITY OF "C" IN FIG. 1, SECTION 6.

For Circuits No. 1, 2, 3, 5, SECTION 1, No. 1, 2, SECTION 2, No. 4, SECTION 3, the capacity of "C" is .1 mfd., 350 v.w



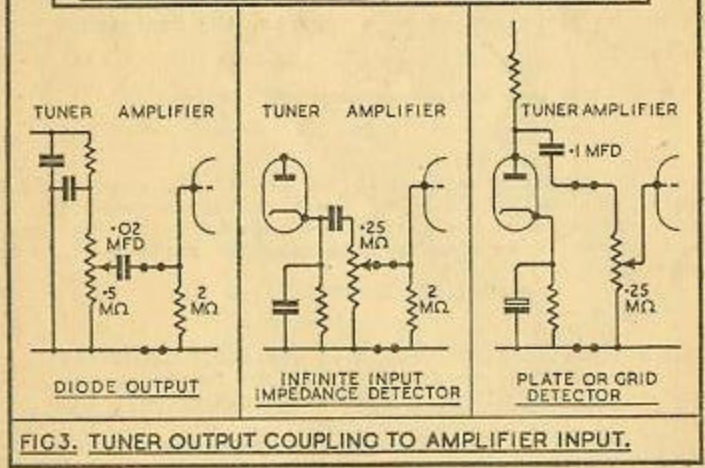
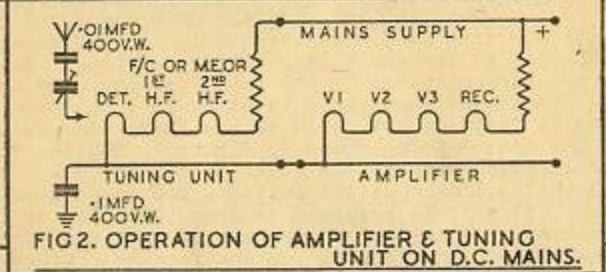
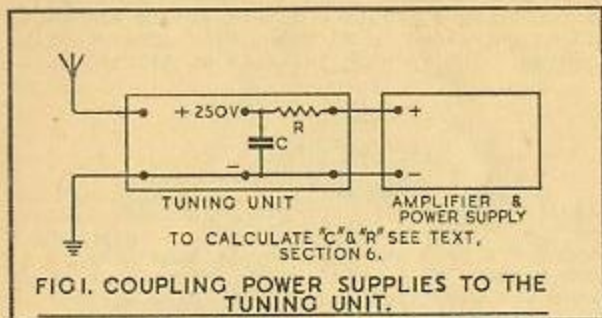

SECTION 6.

For Circuits No 4, SECTION 1, No. 1, 2, SECTION 3, No. 1, 2, SECTION 4, the capacity of "C" should be 4 mfd. or preferably 8 mfd., 350 v.w. for the reason that in these circuits there is some chance of audio feedback unless the tuner is de-coupled. Where this second set of circuits is to be coupled to a power supply which is already at a voltage of 250 volts so that no voltage dropping is required, the tuner should be connected across the smoothing condenser of the power pack and tested for feedback. Should any instability become apparent, then some tuner voltage must be sacrificed by including a resistor and condenser as de-coupling, 20,000 ohms for currents up to 3 m/a, 10,000 ohms for currents up to 5 m/a and 5,000 ohms for currents above 5 m/a, the watts rating to be calculated as already shown. In each case the condenser should be of 8 mfd. capacity, 350 v.w. If it is found that mains hum is introduced by a tuner stage the effect of .1 mfd. condensers from either side of the heater to earth should be tried. The heater winding should have one side earthed wherever possible.

**EARTHING.**  
In almost all cases the tuners are shown earthed, but if any circuit is adapted for use with a D.C. amplifier it must be remembered that under certain conditions of supply the amplifier and tuner chassis will be at mains potential to earth. For D.C. working the earth lead must be in series with a 1 mfd. 400 v.w. condenser, whilst the aerial must also be isolated from the tuner by a .01 mfd. 400 v.w. condenser in addition to the trimmer, if used.

For D.C. working probably the best method of obtaining the heater volts would be to use a separate dropping

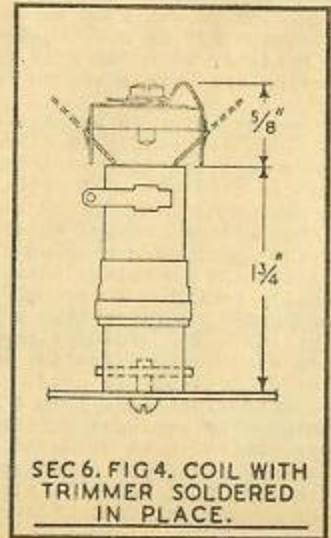



resistor for the tuner heaters, drawing the H.T. as before from the amplifier power pack. With valve heaters in a series chain, as they must be for this method of working, only one heater can be at earth potential whilst there is some danger of introducing hum unless both the detector and first amplifier valve have their heaters at earth level. At the same time the current rating of the tuner valves might differ from that of the amplifier valves, and whilst the circuit would not be economical due to the large losses in the tuner's dropping resistor it would save both hum and possibly re-wiring. The only precaution necessary is to see that both amplifier and tuner chassis are connected to the same side of the mains. Figure 2 of this Section makes the system clear.

The calculation of the dropping resistance for the heater supply is simple. Subtract from the mains supply voltage the voltage required by the valves in series. This gives the voltage it is necessary to drop, and the resistance is found by dividing the current in amperes used by the tuner heaters into this voltage. The watts rating, if required, is calculated as before.

Valves used in series must, of course, all have the same current rating.

By-pass one side of each heater to earth (except the detector) through a .1 mfd. condenser of the low voltage (up to 250 v.w.) paper type.

#### 2. - TUNER OUTPUT INTO AMPLIFIER INPUT.

It will be seen that the two amplifiers shown in Section 5 have input resistors of 2 megohms in place of the more usual  $\frac{1}{2}$  or  $\frac{1}{4}$  megohm volume control potentiometer. This is to make the circuits suitable for use with diode detector outputs, and should it be desired to use the amplifiers with other apparatus the volume control should be built into this apparatus or the grid resistor of V2 in each of the amplifier circuits may be made a potentiometer instead of a fixed resistor with the grid of V2 in each case connected to the moving arm. This method has been used in Fig. 1 of Section 5.

Whilst the diode detector is capable of excellent linearity its efficiency is greatly impaired by a low A.C. shunting resistance across the load resistance. In the tuners where a diode is used the load resistance is also the volume control, in the usual manner, and it is the shunting resistance across this volume control which needs careful consideration. If the tuner were coupled into the ordinary amplifier input circuit the shunting, through the .02 mfd. condenser, might easily be below  $\frac{1}{2}$  megohm, and the quality, which should be very good, would contain a very high percentage of distortion. The ordinary amplifier, therefore, when used with these circuits, will need modification if a diode detector is used. The input valve should have a fixed grid resistance of a 2 megohms (up to 5 megohms may be tried with pentodes of the 6J7 type) and the amplifier volume control must be moved back to the next stage - generally a more efficient arrangement in any case, since valve noise in the input valve is also controlled at the same time as the overall volume. When using the tuner

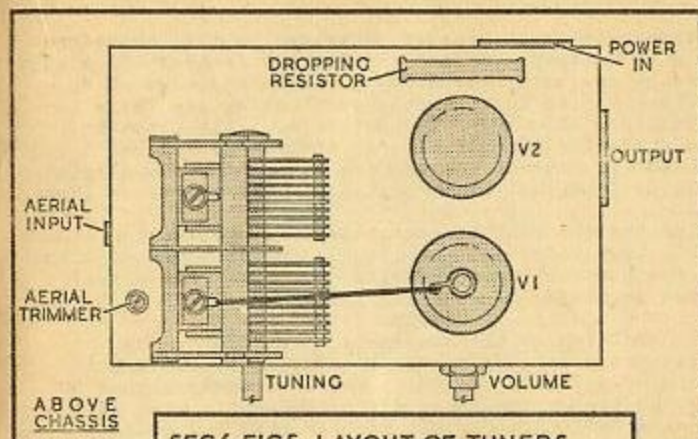

SEC 6 FIGS. LAYOUT OF TUNERS.

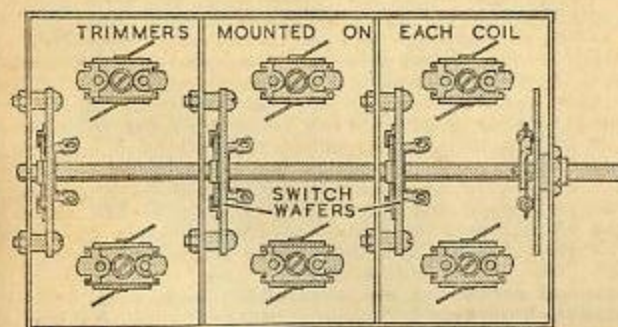
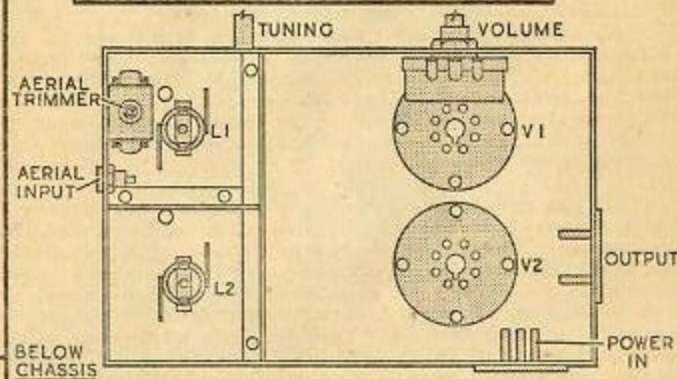

ARRANGEMENT OF COILS IN SCREENING BOXES FOR MEDIUM & LONG WAVES. SWITCHING OF SIX TUNED CIRCUITS.



with the amplifier the amplifier volume control should be set to a comfortable maximum and further control of volume obtained by operating the tuner's volume control.

The infinite input impedance detector can be connected into this type of input circuit also, but the detectors of SECTION 1, Figure 4, SECTION 3, Figures 1 and 2 and SECTION 4, Figures 1 and 2 are designed to be coupled into a  $\frac{1}{4}$  or  $\frac{1}{2}$  megohm volume control in the amplifier input circuit.

The various methods are clearly summarised in Figure 3, Section 6, and this figure should be studied to obtain the best all-round results possible. The actual connector should be of screened cable.

#### CONSTRUCTION.

In addition to the components listed with each amplifier there will be needed a chassis, probably with some form of enclosing cabinet, and a suitable method of driving the tuning condenser or condensers, a slow motion drive being desirable for all the circuits and essential to some. The chief purpose of these notes is to give some idea of the chassis size for each receiver and more particularly the suitable layout of the tuning systems.

No attempt has been made to give final sizes, for with the present shortage of supplies it has not been thought advisable to specify by name components other than the coils, so that the chassis must be obtained or made with a view to including the parts which have been procured, but minimum sizes are given which will allow of proper coil screening compartments.

#### The Coils.

In the circuits of Sections 1 and 2, together with two of the circuits of Section 3, the coils are mounted below the chassis. Where the coils are fitted with trimmers the makers advise that these should be of the postage stamp type so that they may be supported by the coil tags, as shown in Fig. 4 of this Section. The main or tuning winding terminates in the two long upright tags while the winding used for aerial or anode coupling terminates in the two shorter horizontal tags.

The coil is secured to the chassis by a 6 B.A. bolt passed through the chassis from above, and from the dimensions shown in the figure it will be seen that the minimum depth for the chassis is  $2\frac{1}{2}$ " for clearance of the high frequency wiring, whilst a 3" chassis is to be preferred. Although the chassis must be inverted for the trimming operations this gives rise to no disadvantage, and the coils are both screened and protected by the sub-chassis method of mounting.

As much clearance as possible must be left round the coils, and no earthed metal, such as the side of the chassis or the screen should approach the coil nearer than  $\frac{1}{4}$ " or the inductance of the coil will be seriously affected.

#### Section 1.

Chassis and screening compartments: Sheet iron.

Panel: Metal or wood.

For layouts as shown in Fig. 5 of this Section, with the two-gang condenser mounted on edge for economy in space

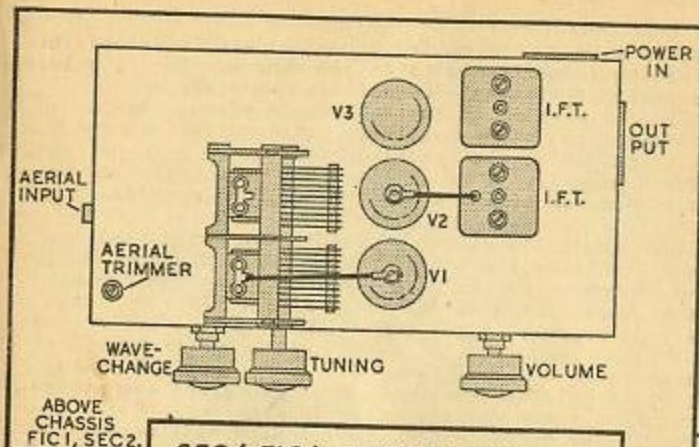

SEC 6 FIG. 6. LAYOUT OF TUNERS.

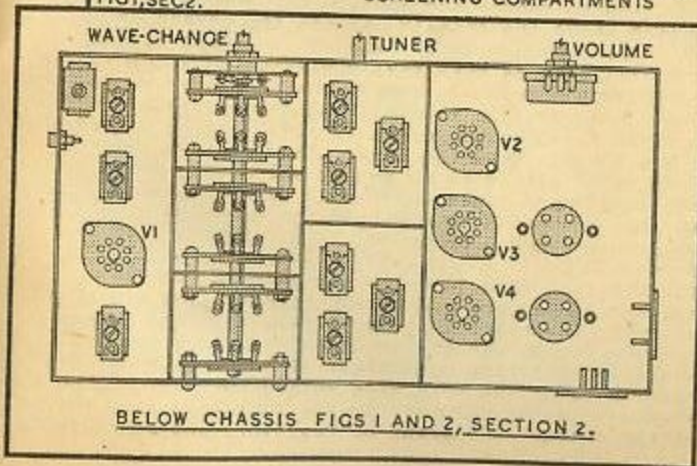
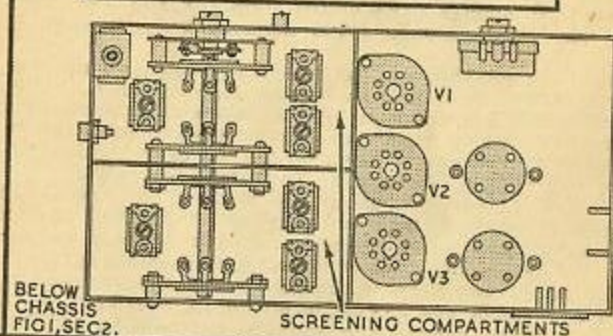



the chassis size should be about 6" x 5" x 3" which allows the screening compartments to be 2½" square, the coils being mounted centrally between the walls. The screening compartment is carried to the full depth of the chassis with leads to the coil, where necessary, passing through holes, bushed, if possible, with rubber grommets.

This chassis will be sufficiently large for Figs. 1, 3 and 4 of Section 1, and possibly for Fig 2, depending on the mounting chosen for the Magic Eye.

Since the coils can be mounted below the ganged condenser the leads can be very short, as also can the lead from the condenser to the grid cap in the case of pentode circuits. These leads should be of rubber covered flex; obviously no screened leads must be used in the tuner stage except for the lead from the output plugs to the amplifier input sockets.

Flat twin lead covered cable is excellent for heater wiring of both tuner and amplifier valves.

For Figure 5, Section 1, the chassis will need to be slightly larger since the screening compartments must not be cramped and screening must be complete. A chassis 7½" x 7½" x 3" should give ample room for the components, however, the compartments still measuring 2½" square and 3" deep.

If it is desired to include long wave tuning the PHF1 coils should be used, and in Figure 5, Section 6, it will be seen that these are mounted beside the medium wave coils, the Yaxley switch spindle running between them. The screening compartments will now have to be expanded to put at least ½" between the coils, so that a suitable compartment will measure about 4½" x 3" x 3", the breadth also being increased to give room for the switch leaf which is fastened to the rear compartment wall by long screws and spacers. Note, also, that when wave change coils are used they must be fitted with trimmers as already described.

In all cases the resistor which is included in the main H.T. line to reduce the applied voltage to 250 volts is best mounted above the chassis, as are the screen dropping networks where they are used. The small amount of heat generated will then be more easily dissipated - any cabinet over the chassis should, of course, have an open or fretted back in any case so that the valve heat can escape. Whilst these resistors can be supported by stiff wiring passed through the chassis from the connecting points below, a neater and safer method is to employ one or two small stand-off insulators, when there will be no chance of the H.T. line being shorted to earth in the event of a resistor's being shaken or knocked into contact with the chassis.

The small components below the chassis such as resistors and condensers can be supported in the wiring in the usual way, but again a firmer fixing is of advantage. Paxolin group boards can easily be made - one quite small board would hold all the components of the smaller circuits - the paxolin being cut to a size suited to the components obtained which can be soldered to tags mounted along the two edges of the board. The group of resistors and condensers

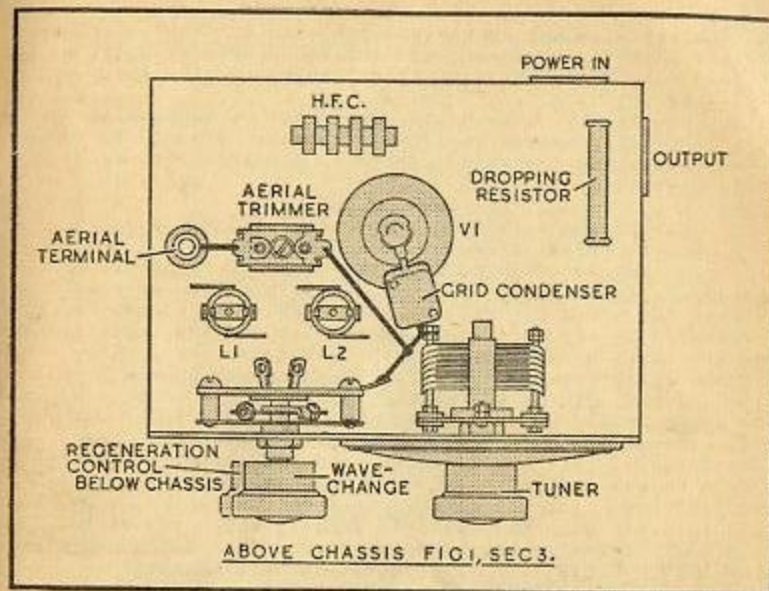

### SEC 6 FIG. 7. LAYOUTS OF SHORT-WAVE TUNERS.

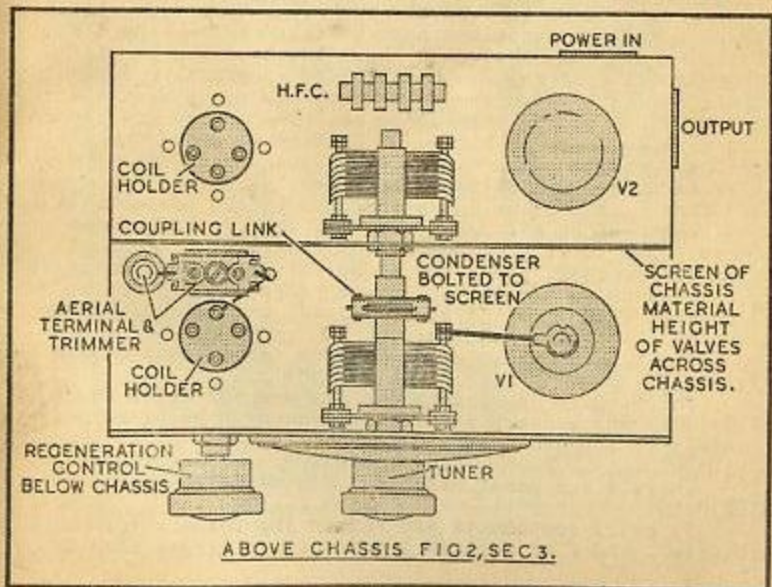



is then fixed in any convenient position by means of short lengths of studding which hold the board away from the chassis, the final position being chosen to give short and direct wiring runs.

Grid or H.F. components should not be mounted in this way. A grid condenser and leak are better if held by the direct wiring to the valve, the wiring being stiff to prevent vibration.

### Section 2.

Chassis and screening compartments: Sheet iron.  
Panel: Metal or wood.

The suggested layout for the tuner of Figure 1,

Section 2, is shown in Figure 6, Section 6. Interaction between the tuned circuits is not troublesome since they are working at widely separated frequencies and the coils not in use are short circuited to earth by the switches. The minimum sizes for the screening compartments should be fixed at 4" square, making the minimum width of the chassis 8" and the depth should be 3". The length will need to be such as will accommodate the ganged condenser, valves and I.F. transformers, laid out as shown, and the actual components should be set out and measured before the final figure is decided upon. It will be somewhere in the region of 9", but this is based upon the author's chassis which was fitted with small transformers, and the sizes of these components vary a good deal. If possible, it is best to obtain transformers whose trimming condensers appear at the top of the screening can, since those with base trimmers take up more room and are more difficult to adjust. The transformers are mounted above the chassis, the coils below in the usual way, and the components supported in the wiring or on group boards as before. The circuit is very stable and no special precautions need be taken unless the H.F. pretuning stage is included. Here the two sets of radio tuning coils will need to be screened carefully one from the other, and if a third screening compartment is used the minimum width of the chassis is extended to 12". A second method is as shown in Figure 6, Section 6, where the aerial coils are mounted in a narrow compartment which assists the screening. It must be noted that the switch compartment is also broken up by screens separating the various switch leaves. The total addition to the length of the chassis need not be great, since the added valve, which becomes V1 in the composite circuit is mounted over its own coils, being separated from the other valves, on the chassis top view, by the 3-gang condenser.

The minimum width of the narrow compartment should be 2", the coils being spaced equidistantly.

The padding condensers must be mounted below the chassis in the compartments, each condenser being as near as possible to its own coil.

### Section 3.

Chassis and panel material: non-magnetic, e.g., aluminium.

If small components are chosen the chassis for circuits 1 and 2 of Section 3 need not be larger than 7"

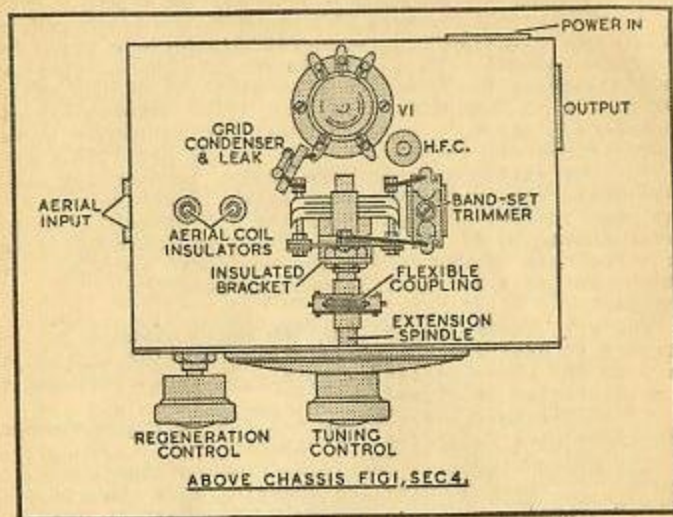

SECTION 6 FIG 8. LAYOUTS OF U.S.W. TUNERS.

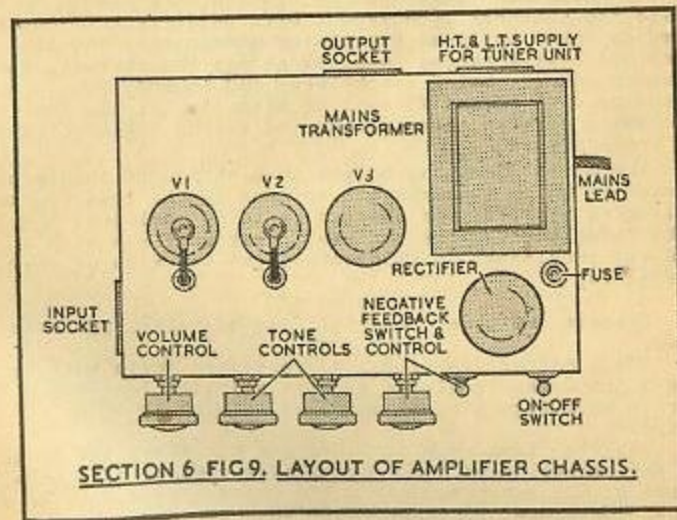

SECTION 6 FIG 9. LAYOUT OF AMPLIFIER CHASSIS.



square, but it will be best to lay out the items on a sheet of paper in order to check on the layout and final chassis size. In both tuning stages all the H.F. grid components are above the chassis, the regeneration controls being below so that the chassis need not be deeper than will accommodate the potentiometer R4 in Figure 1, Section 3, or the variable condenser C10 in Figure 2, Section 3. The layouts are shown in Section 6, Figure 7, and the chief precaution is to make sure that wires are as short and direct as possible.

For the second circuit, the holders chosen for the plug-in coils should have ceramic bases to cut down H.F. losses, and the screen separating the two stages in this receiver should be of the same material as the chassis and panel. The hole through which the condenser spindle passes should be cut to a size sufficient to clear the moving parts.

The H.F. chokes may be held on small stand-off insulators if desired, but stiff wiring passing through the chassis to the other soldering points is sufficient provided that no vibration is allowed.

Good slow-motion drives on all the tuning condensers of the short wave receivers are essential.

The superheterodyne receiving stage of Section 3, Figure 3, is arranged below the chassis as is the circuit of Section 2, but whilst there are only two coils to each screening compartment in place of the three shown in the layout of Figure 6, Section 6, it is suggested that the size of the compartments is not reduced.

The variable condensers C2 and C7 of Figure 3, Section 3, are mounted below side on the chassis or front panel, their dials calibrated as already suggested. On the chassis top, however, the layout will be different, due to the space taken by these two tuning condensers, and the valves are best arranged in a row across the chassis, the frequency changer being set between and behind the condensers with V2 and V3 in line with it. At the rear of the chassis between their respective valves are mounted the I.F. transformers.

The aerial feed may be led to a stand-off insulator on the chassis which supports the trimmer in the lead to the coupling coil or, if the chassis is to be enclosed, the lead may be taken through the chassis, preferably via such a stand-off insulator, to plug sockets at the side or rear of the chassis.

#### Section 4.

Chassis and panel material: non-magnetic, preferably copper.

The construction of U.S.W. receiving units must be as sound a job mechanically as electrically for losses may occur in many ways with frequencies as high as 50 or 60 megacycles.

The high frequency circuits are all above the chassis with the exception of the regeneration control of Figure 2, Section 4, the condenser C12. The chassis need only be deep enough, therefore, to accommodate this condenser or the control potentiometer R3 of Figure 1, Section 4. The

chassis sizes will be about 5" square for the first circuit and 5" x 8" for the second, where the two circuits are separated by a copper screen. Since the chassis in each case should be enclosed by a copper box made to fit the chassis soundly and to rise to a height of about 5" above it, the screen should be as high as the internal height of the box.

The Acorn is mounted in its clamps which are built up on a ring of high frequency insulating material - if a holder can be obtained having a ceramic base so much the better, but it may be made of polystyrene sheet or high-grade paxolin if nothing better offers. The dimensions of the holder are given in the sheet accompanying the Acorn valve.

For Figure 1, Section 4, the holder should be mounted sufficiently near to the rear of the condenser to allow the grid clamp to be connected directly to the tuning unit via the grid condenser, the valve holder being supported above the chassis by small stand-off insulators.

The tuning condensers are mounted on brackets and driven by short extension spindles which eliminate any hand capacity effects, this spindle and the condensers all coupled together by coupling links. Across the tuning condenser to one side is soldered the band set condenser (the trimmer) by leads as short as possible, the condenser being supported by these leads alone.

The tuning coil is mounted above and across the variable condenser, the leads being the extended ends of the coil winding left only long enough to clear the moving vanes. The aerial coil is supported on the same level as the tuning coil, spaced between  $\frac{1}{4}$ " and  $\frac{1}{2}$ " from its grid end, the smaller coil being supported by two large stand-off insulators. The position of the aerial coil, and therefore its coupling to the tuning coil should be varied till optimum results are obtained.

The anode feed coil, tapped on to the tuning coil, is mounted vertically on a small stand-off insulator by securing the glass tube on which the choke is wound on to the insulator terminal thread with cellulose glue.

As it is desirable that the whole receiver should be enclosed in a screening box the aerial coil sockets are best brought out in the side of the chassis, mounted in a polystyrene or ceramic strip, the leads from the sockets being led to the aerial coil by connections running up through the chassis via the stand-off insulators.

In the circuit for Figure 2, Section 4, the R.F. and detector stages are separated by a copper sheet screen, and it should be noted that this has a hole sufficiently large to allow the spindle of the detector stage condenser to pass through without touching. A rubbing contact would almost certainly introduce noise into the circuit and possibly other defects. The extended spindles of the condensers are coupled by a flexible coupling link.

The layouts for the two circuits are shown in Figure 8, Section 6. Good slow motion drives should be fitted to both tuner stages



### Amplifiers.

Since it is presumed that most readers already have an amplifier constructed, it is not proposed to deal in any detail with the many different types of amplifier. A characteristic layout, suitable for the two circuits given, is shown in Figure 9 of this Section, and for the two-valve circuit it is only necessary to delete V3 and such controls as are not included.

The most necessary precaution to take is the avoidance of mains hum. All the grid leads of the first stage must be made with screened cable, whilst the grid resistor should be mounted parallel with and close to the chassis, which is best made of sheet iron or steel to give magnetic as well as electrostatic shielding. The mains transformer should be well shrouded and have an earthing screen between the windings.

Group board construction below the chassis is the neatest method of obtaining direct wiring, a small board for each stage mounted beside its respective valve holder being preferable to a single large board.

Potentiometers may be of the composition type, but since noise is so easily introduced wire-wound components are preferable.

For the power supplies to the tuning stage a small distributing board at the back of the chassis makes either screwed or plugged connections simple to make and break, and screened cable leads from this board to the tuner will also be an advantage. Insulation must be perfect both in the leads and the terminal boards.

Input and output circuits should be divided by the length of the chassis, as shown.

All components, especially condensers, must be in excellent condition to avoid noise and breakdown. Working voltage and wattage specifications must always be adhered to.

### Section 7.

#### Valve Equivalents.

Whilst it is not possible to find an exact equivalent for all the stated valves in the 4-volt range, the following substitutes are sufficiently close in characteristics.

8-volt type.		4-volt type.
6J7.	Mullard	SP4. Bias with 750 ohms.
6K7.	"	VP4B.
6CS.	"	244V.
6H6.	Mazda	DD41.
Y63.	"	ME41. Total H.T. cons. 1.5 mas.
X65.	"	ACTH1. 0 sc. Grid current in 50,000 ohm leak 150 microamps.
PP6C	Tungsram	APP4B.
6L6.	Mazda	AC4 Pen. Bias 150 ohms. Load 3,300 ohms.
955.	Mullard	AT4. or use Tungsram HL4.
956.	"	AP4. " " VP4.

It will be realised that in the case of the Acorns where the HL4 and VP4 are used, the layout will no longer hold good. A layout as similar as possible should be used, with ceramic valveholders and wiring rearranged to be as

short as possible. Lifting the valveholders above the chassis level so that 50 H.F. leads are taken through the chassis will be necessary.

It is NOT recommended that the super-regeneration circuit of Section 4, Figure 1, be built with any valve other than the Acorn type.

### APPENDIX.

#### NOTES ON COIL-WINDING.

Since almost all the coils specified in the foregoing pages are at the moment in short supply it has been thought desirable to include details and constructional notes so that equivalent coils can be made by the reader if he so desires. The windings have been calculated by the formulae of Wheeler and Bunet.

All the coils are designed to be wound on  $\frac{1}{2}$ " diameter formers, preferably of heavy gauge paxolin tubing. Solid formers of ebonite or even of wood well boiled in paraffin wax may be used, although in these cases the percentage of losses would probably rise.

#### Construction.

Before the windings are put on the formers, these must be cut to size and, if of wood, treated with wax as above. Each former is  $\frac{1}{2}$ " outside diameter, and  $1\frac{1}{2}$ " long. At one end, afterwards referred to as the TOP are securely fastened four soldering tags, spaced equidistantly round the tube, with their lugs projecting beyond the former so that the leads from the external circuit may be anchored to them. There are two windings on each former, and it is convenient to anchor the ends of a winding to diametrically opposite tags.

At the other end of the former, afterwards referred to as the BOTTOM provision must be made for mounting the coil as a whole onto the chassis. Several methods may be used; the paxolin tube may be plugged with a short cylinder of wood cemented firmly in place and drilled and tapped to take an 8 or 6 B.A. screw or simply bored for a wood screw passed through the chassis. A metal bracket may be shaped to the curve of the former and bolted to it or a length of studding might be set into the former by means of a plug, the chassis either being tapped to take the thread or drilled so that the studding may be secured by a nut.

Where the windings are multilayer the first layer of wire is wound round the former until the winding is  $\frac{1}{2}$ " long, the turns of the next layer being turned back and wound over the first layer just put on, this being continued, layer by layer, until all the turns are on.

A convenient method of keeping a multilayer winding to the correct length is to mark the winding space of  $\frac{1}{2}$ " on the former and to bind narrow pieces of insulation tape along the edge of each mark, thus leaving a clear space of the former to be occupied by the wire. When the winding is complete the tape is removed.

Before winding the former should be marked out for both windings, that nearer the top end being the grid coil and that nearer the bottom being the aerial, anode or reaction coil, according to how the coil is used. In the marking out it should be ensured that this coil does not



approach nearer than  $\frac{1}{4}$ " to the bottom of the former, in order that the characteristics of the coil may not be altered by proximity to an earthed metallic mass such as the chassis or a screen.

When the windings are complete the coil may be impregnated if desired if it is of the multilayer type. It may be brushed over with (preferably) polystyrene varnish or a good shellac varnish or the whole coil and former may be dipped into hot paraffin wax and well drained. If the short wave coils show any tendency to slipping turns they may be fixed with a dab of good insulating varnish.

It should scarcely be necessary to point out how careful the constructor must be to make coils which are to be used in ganged circuits absolutely identical in all respects. A very small percentage error in inductance, due for example, to miscounted turns, might have a great effect on the tuning of the circuits. Some check on the matching of coils is highly desirable, that most easily carried out by the home constructor being the measuring by means of a valve voltmeter of the potential set up across the coil by a R.F. signal fed to it from a signal generator. It is felt that the method will be well known to those possessing the apparatus, so is not dealt with in detail here.

#### DETAILS OF WINDINGS FOR TUNING COILS.

- Coil Specified. Coil to be wound.
- PHF1. Grid. 440 turns multilayer, 34 S.W.G. enamelled wire. Wind  $\frac{3}{8}$ " long and  $\frac{1}{4}$ " high.  
Aerial. 200 turns multilayer, 34 S.W.G. enamelled wire. Wind  $\frac{3}{8}$ " long and  $\frac{1}{4}$ " high. Space  $\frac{1}{8}$ " from Bottom end of grid coil.
- PHF2. Grid. 250 turns multilayer, 30 S.W.G. enamelled wire. Wind  $\frac{3}{8}$ " long and  $\frac{1}{4}$ " high.  
Aerial. 120 turns multilayer, 34 S.W.G. enamelled wire. Wind  $\frac{3}{8}$ " long. Space  $\frac{1}{8}$ " from Bottom end of grid coil.
- Coil specified. Coil to be wound.
- PHF3. Grid. 14 turns 24 S.W.G. enamelled wire, turns spaced by their own thickness.  
Aerial. 7 turns 34 S.W.G. D.S.C. wire, wound between the turns of the grid coil commencing at the Bottom end.
- PHF4. Grid. 6.5 turns 24 S.W.G. enamelled wire, turns spaced by their own thickness.  
Aerial. 3 turns 34 S.W.G. D.S.C. wire, wound between the turns of the grid coil commencing at the Bottom end.
- PHF5. Grid. 30 turns 24 S.W.G. enamelled wire, spaced over  $\frac{3}{8}$ ".  
Aerial. 12 turns 34 S.W.G. D.S.C. wire, wound between turns of the grid coil commencing at the Bottom end.

- P01. Grid. 187 turns multilayer, 32 S.W.G. enamelled wire. Wind  $\frac{3}{8}$ " long and  $\frac{1}{4}$ " high.  
Anode. 80 turns multilayer 34 S.W.G. enamelled wire. Wind  $\frac{3}{8}$ " long. Spaced  $\frac{1}{8}$ " from Bottom of grid coil.
- P02. Grid. 87 turns multilayer 28 S.W.G. enamelled wire. Wind  $\frac{3}{8}$ " long and  $\frac{1}{4}$ " high.  
Anode. 40 turns multilayer 34 S.W.G. enamelled wire. Wind  $\frac{3}{8}$ " long. Space  $\frac{1}{8}$ " from Bottom end of grid coil.
- P03. Grid. 13 turns 24 S.W.G. enamelled wire, turns spaced by their own thickness.  
Anode. 7 turns 34 S.W.G. D.S.C. wire, wound between the turns of the grid coil commencing at the Bottom end.
- P04. Grid. 6.5 turns 24 S.W.G. enamelled wire, turns spaced by their own thickness.  
Anode. 4.5 turns 34 S.W.G. D.S.C. wire, wound between the turns of the grid coil commencing at the Bottom end.
- P05. Grid. 28 turns 24 S.W.G. enamelled wire, spaced over  $\frac{3}{8}$ ".  
Anode. 13 turns 34 S.W.G. D.S.C. wire, wound between the turns of the grid coil commencing at the Bottom end.

Where enamelled wire is to be used it must be new and of good quality, for short-circuiting turns would be almost impossible to detect and the coil would be useless should they occur.

Where the grid and anode or aerial coils are interwound the windings must be tested for insulation one to the other at the voltage which will be maintained between them, or preferably at the full 250 volts of the supply. A neon lamp as used for house lighting would serve as an indicator if a meter is not available. Any signs of an insulation breakdown means that the anode coil must be rewound. If the varnish is applied sparingly the turns of the anode coil between those of the grid coil may be fixed and insulated by setting them in shellac, or a little cellulose cement may be used.

To wind a coil so that its turns are spaced accurately by their own thickness the best method is to wind on two lengths of the wire, side by side. One of the lengths is then removed, leaving the other in turns which are separated one from the other by their own diameter.

In all the coils the windings have their ends taken through small holes in the former and are led up the inside of the tube to the soldering tags where they are anchored. The ends of the wires must be cleaned thoroughly before soldering.



The anode windings of the superhet oscillator coils were determined experimentally, being wound to give the correct grid leak current as has been already explained. Small differences in coil size and spacing have quite large effects upon this current, and it is highly desirable, therefore, that the tests already detailed should be made. The most likely effect is a drop in the grid current of the oscillator at the low frequency end of each band: if this occurs it can most easily be countered by increasing the value of the oscillator grid condenser from .0001 mfd. to .0003 or even .0005 mfd.

Too great a current is reduced by shunting the anode coils with a resistor to be determined experimentally, perhaps with an extra series resistor as well.

## BERNARDS' TECHNICAL BOOKS.

No. 1	Annapamated Engineering Ref. Tables	1/-
" 2	" Little Marvel " Vegetable Ref. Book	1/-
" 3	Services Signalling Manual	1/-
" 4	Radio Pocket Book	1/-
" 5	Elements of Mathematics	1/-
" 6	Electrical Engineers Handbook	1/-
" 8	Manual of Modern Automatic Guns	1/-
" 9	Manual of Photography	1/-
" 10	Manual of Mathematical Tables	1/-
" 11	Manual of Cycle Maintenance and Hints	1/-
" 12	Manual of Commando and Guerilla Tactics:	1/-
" 13	Manual of Commando and Guerilla Tactics:	1/-
" 14	Manual of Small Arms and Special Weapons	1/-
" 15	Manual of Wartime Household Repairs	2/-
" 16	Illustrated Engineering Practice	2/-
" 17	Manual of Rifles, usual series	1/-
" 18	Weapons and Armaments of the Modern German Army	2/-
" 19	Manual of Map and Compass Reading	2/-
" 20	Manual of Gliding and Motorless Flight	2/-
" 21	Manual of Science. Mechanics, Physics, etc.	2/-
" 22	Manual of Radio Circuits.	2/-
" 23	Manual of Hand Grenades, Mines and Bombs	2/-
" 24	Uniform, Rank Badges and Intelligence Data on the Modern German Armed Forces	2/-
" 25	Strategy and Tactics of the German Army	2/-
<hr/>		
No. 26	Tanks at War—Friend or Foe?	2/-
" 28	Income Tax for the Working Man	1/-
" 30	Manual of Radio Valves, British and American	3/6
" 31	Explosives.—Nature, variety and uses as Projectile fillings, Propellents, Mines, Demolition Charges, etc., etc.	2/-
" 32	You can Fly. flying made easy, fully illustrated	2/-
" 33	Invasion Tactics. Here and on the Continent	2/-
" 34	Guerillas v Tanks	2/-
" 35	Mathematical Dictionary	2/-
" 36	Defence against Gas	2/-
" 37	Manual of Direct Disc Recording	2/-
" 38	Aeronautics Illustrated	2/-
" 39	Tool Makers' and Engineers' Manual	1/-
" 40	Carpenter's Handbook	1/6
" 41	Wireless Amplifier Manual	2/-
" 42	Short-Wave Radio Handbook	2/-
" 43	Modern Radio Test-Gear Construction	1/6
" 44	Radio Service Manual	2/6
" 45	Radio Reference Handbook	10/6
" 46	Motor Car Queries	2/6
" 48	Radio Coil and Transformer Manual	2/-
" 49	Shoe Repairing at Home	1/-
" 50	World-wide International Short Wave Radio Station List	1/-
" 51	Cathode Ray Oscilloscope Manual	2/-
" 52	Radio Tuner Unit Manual	2/6