

No. 99

I/6

ONE VALVE RECEIVERS

*Comprehensive instructions for
building 8 single valve sets.*

1. PORTABLE TRIODE RECEIVER
2. DOUBLE-DIODE-TRIODE RECEIVER
3. MIDGET PENTODE RECEIVER
4. DOUBLE-TRIODE MAINS RECEIVER
5. THE " OSCILLODYNE "
6. TRIODE-PENTODE REFLEX RECEIVER
7. TRIODE-PENTODE RECEIVER
8. ELECTRON-COUPLED PENTODE RECEIVER



BERNARDS RADIO MANUALS

BERNARDS RADIO MANUALS No. 99

General Editor: W. J. MAY

First Published 1951
Second Edition 1952
Reprinted 1953
Reprinted 1954
Reprinted 1955
Reprinted 1956
Reprinted 1957
Reprinted 1958
Reprinted 1960
Reprinted 1961

CONTENTS

	PAGE
Portable Triode Receiver (Fig. 1)	5
Double-diode-triode Receiver (Fig. 2)	6
Midget Pentode Receiver (Fig. 3)	8
Double-triode Mains Receiver (Fig. 4)	9
The "Oscillodyne" (Fig. 5)	12
Triode-pentode Reflex Receiver (Fig. 6)	14
Triode-pentode Short-wave Receiver (Fig. 7)	16
Electron-coupled Pentode Receiver (Fig. 8)	1b

PORTABLE TRIODE RECEIVER (Fig. 1)

INTRODUCTION

Most people with an interest in radio have constructed a crystal receiver at one time or another. Many enthusiasts feel that until now the gulf between this simple type of receiver and the more ambitious valve receiver has not received the attention it merits. While it is easy to airily discuss the construction of four- and five-valve receivers on paper, many intending constructors are disheartened by the apparent complexity of such receivers and feel that their chances of obtaining satisfactory results are remote at least until such time as they have gained the right kind of experience with smaller receivers.

All the designs in this manual are well-tried circuits, and no specialised components are called for. In many cases specifications are given to enable the constructor to build his own coils. In all cases the type of wire used on the original is given; but it is pointed out that where D.C.C. or enamelled wire is specified it is quite in order to use any available covering such as D.S.C. or rayon-covered wire—winding space permitting. As a guide, using 24 S.W.G. enamelled wire, 42 turns per inch can be wound; 40 with double silk (D.S.C.); and 30 with D.C.C. (double cotton). If plain cardboard is used for coil formers it should be treated in a bath of beeswax—paraffin wax should NOT be used. Regarding layout provided the usual precautions are observed—such as keeping control grid and anode leads as short as possible and apart from each other—the layout can be arranged to suit individual tastes.

Reference to the components lists will show that some capacitor values are given in micro-farads and others in pico-farads. The reason is that the unit of capacitance is the Farad, which is too large for radio work and values are often expressed in micro-farads (mfd), 1 mfd being equal to a millionth of a Farad. Even this unit is often cumbersome and it is usual to express small values of capacitance in micro-microfarads or pico-farads (pfd), 1 pfd being equal to one millionth of 1 mfd. From this it will be seen that while a given capacitor value can be expressed as say 0.0005 mfd, it is also correct to show it as 500 pfd.

It sometimes happens that an interesting item is put on the air late at night, and, in the absence of a suitable receiver, one has to stay up late or miss it altogether. A single-valve headphone receiver will therefore be found to be very convenient for use in the bedroom.

The receiver shown in Fig. 1 requires no external aerial connection provided the listener is within reasonable distance of the transmitter. If, however, it is found desirable to have some external pick-up source it is suggested that a connection be made from a spring-bed mattress or other aerial through a 100 pfd pre-set condenser to the grid condenser C2 on the tuned circuit side, i.e. the junction of C1-C2. As far as the choice of V1 is concerned, almost any triode of the HL class should prove suitable: most amateurs have a selection of such valves in their junk boxes. The author found an old Cossor 210HF which worked very well, and later an Osram HL2 was tried without any noticeable difference in performance.

The frame aerial former should be constructed of stiff cardboard with

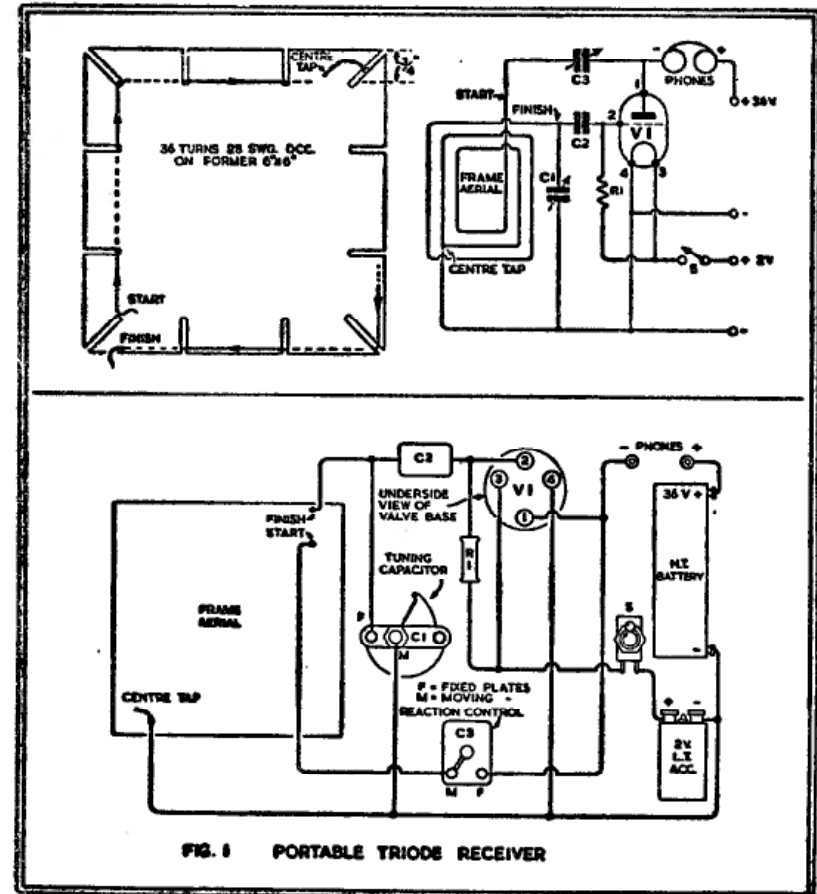

slots cut as shown on Fig. 1. The wire should be locked through two adjacent holes at the start leaving about six inches for connection purposes. The former should be held firmly and the wire wound alternately over and under each slot until 18 turns have been completed. At this point a tap is required; no break in the wire should be made, but a loop some six inches long brought out which may be twisted throughout its length. Having completed the tap, a further 18 turns should be added bringing the total to the required 36. The direction of the winding is of no consequence: the important point is that the whole winding is wound in the same direction.

Layout is not critical and the constructor can use any form he pleases. It is suggested, however, that the receiver be built on a small baseboard with a front panel to take the tuning and reaction controls (C1, C3) together with the On-Off switch (S). The frame aerial may be conveniently screwed to the rear of the baseboard. Operation of the receiver is simple. The required station is tuned in by means of C1 to its optimum setting and, since a frame aerial is being used, the receiver rotated to give maximum signal strength. The reaction condenser (C3) is advanced at the same time resetting the tuning condenser (C1). Best results will be obtained when the reaction control is set just short of the point of oscillation.

COMPONENTS LIST Fig. 1

R1	3.3 MΩ resistor	S	S.P. toggle switch
C1	500 pfd tuning condenser	V1	see text
C2	300 pfd mica fixed condenser	T1	1 B4 valve holder (or to suit valve)
C3	300 pfd variable reaction condenser (solid dielectric type)		Phones, terminals, connecting wire, batteries, etc.

DOUBLE-DIODE-TRIODE RECEIVER (Fig. 2)

Twenty years or so ago it was not uncommon to find circuits utilising triodes with grid and anode strapped functioning as diodes. This compromise had to be effected since there were no commercial diodes available. Used in this way the valve required no HT supply; but the results were no better than obtainable from a crystal set, and the only advantage was that no cat's-whisker adjustment was necessary. The circuit of Fig. 2 combines the principles of diode detection and low frequency amplification in one valve. Since there is no regeneration, reception is limited to local stations, but the quality of the reproduction is excellent in every way. The lack of regeneration has other advantages. The number of controls is reduced to a minimum and the receiver is admirable for the children's nursery, as there is no fear of the receiver going into a state of oscillation and ruining reception for the entire neighbourhood. The coil assembly is constructed on a one-inch diameter former four inches long, which may be of waxed cardboard or bakelite construction. All three coils are close wound with No. 34 S.W.G. enamelled copper wire and it is important to observe that the three windings are wound in the same direction. The general construction can be clearly seen from the diagram. The entire receiver can be mounted on a small wooden baseboard with a front panel

to take the tuning condenser and switch. Valve type KBC 32 requires a heater supply of 2 volts at 50 mA and if required it can be run from dry cells as the consumption is very low. This may be accomplished by wiring two U2 cells in series, which will produce three volts, and wiring a 20Ω resistor in series with the positive filament lead. A 20kΩ resistor can be made up of two 10kΩ ½ watt 10% resistors wired in series. If a different type of valve is used it may be necessary to add a grid bias battery of some 1½ volts. This should be connected between the bottom end of the LF transformer secondary and LT and HT negative. If instability occurs connect HT-, LT- to the earth terminal.

COMPONENTS LIST Fig. 2

1	Int. Octal holder	C1	200 pfd trimmer condenser
V1	KBC 32	C2	150 or 200 pfd tuning condenser
T1	LF intervalve transformer	S	S.P. toggle switch
4 oz.	34 S.W.G. enamelled wire		Phones, terminals, connecting wire, etc.

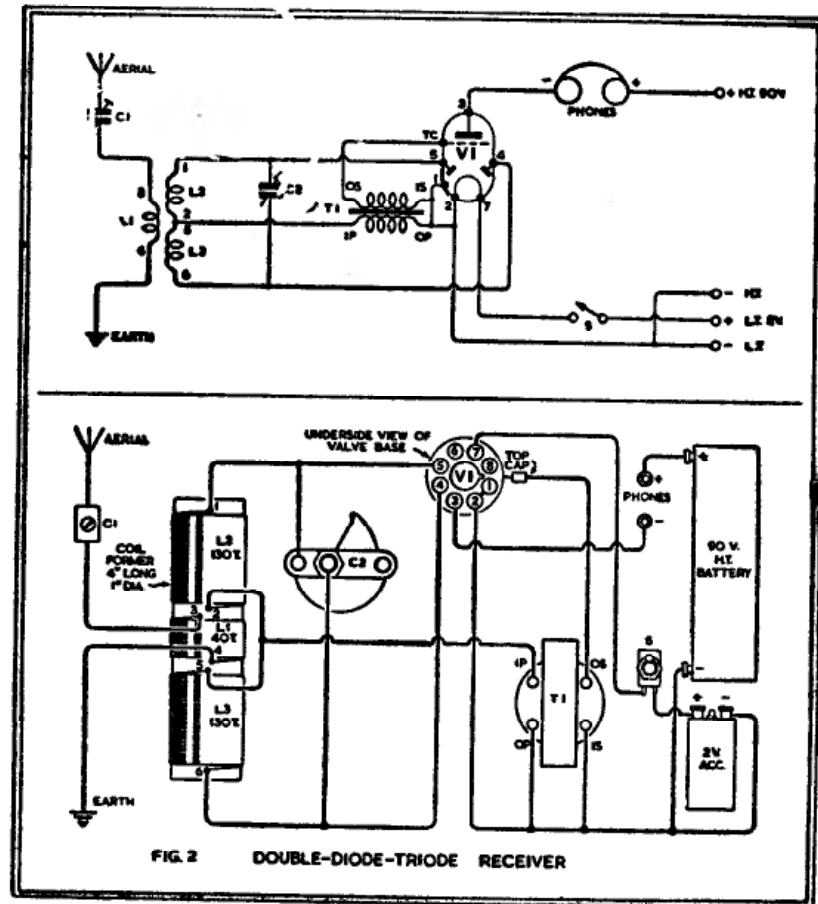
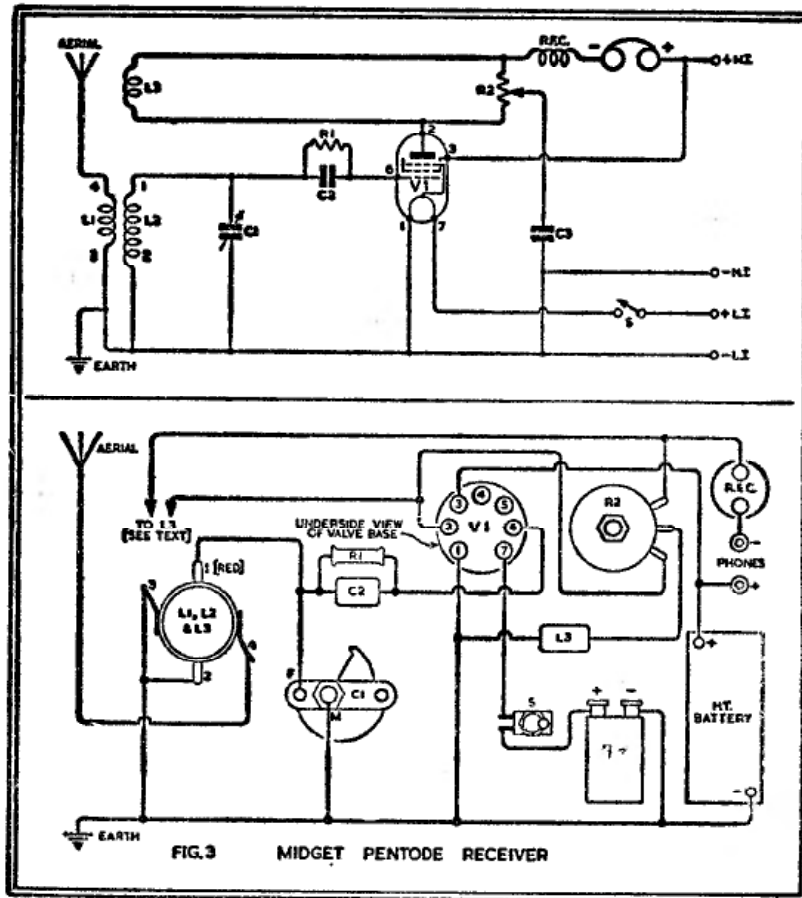

FIG. 2 DOUBLE-DIODE-TRIODE RECEIVER

MIDGET PENTODE RECEIVER (Fig. 3)

The midget receiver shown in Fig. 3 is designed to use one of the B7G range of RF pentodes. In the original, a 1T4 was used as these are often available from surplus dealers at a very attractive price. The coil used was a Wearite PA2 suitably modified by the addition of a reaction winding (L3). This winding consists of 25 turns of 36 S.W.G. D.S.C. wound over the earthy end of the grid winding (L2). A suitable chassis may be constructed from sheet aluminium, the ends being bent down at right angles. The overall size should be about 3½ inches × 3 inches when completed; the depth will be governed by the size of the reaction control R2, since this component, together with the switch S, is mounted below the chassis. A 2.5 mH RF choke is satisfactory for RFC and should be mounted on the rear apron of the chassis, the tuning condenser C1, together with the coil, are mounted on the top side. The valve holder is, of course, chassis mounting and the remainder of the components may be suspended in the wiring. On completion of the wiring, batteries and



'phones should be connected, the receiver switched on and a station tuned in by means of C1. To bring the signal to maximum strength, the reaction control should be advanced so that the slider travels towards the anode end of its path. As the control is rotated, signals should increase until the receiver bursts into oscillation. If, however, this does not occur and it is found that the signal strength weakens it is a sign that the reaction winding is connected in the wrong sense and the two connections to L3 should be reversed.

COMPONENTS LIST Fig. 3

L1-2-3	PA2 Wearite	C3	500 pfd mica fixed condenser
RFC	2.5 mH choke	R1	3.3 MΩ resistor
S	S.P. switch	R2	20 kΩ variable potentiometer
C1	350-500 pfd tuning condenser	V1	1T4 or DF 91
	(solid dielectric type)	I	B7G valve holder
C2	200 pfd mica fixed condenser	HT	45 or 67.5 v.
		LT	1.5 v. cell
	Phones, terminals, connecting wire, etc.		

DOUBLE-TRIODE MAINS RECEIVER (Fig. 4)

When contemplating the construction of single-valve receivers majority of constructors automatically think in terms of battery receive. There are, however, a number of worth while designs using mains equipment and Fig. 4 shows an ingenious application of the B36 double triode. One half of the valve is used as a leaky grid detector, regeneration being effected by L2-C2. The output of the detector is transformer-coupled to the grid of the second half of the valve which is used as a normal LF amplifier. One of the special mu-metal-cored transformers can be used for the coupling as it is parallel fed so that no DC flows through the primary. Although designed for AC operation only, the circuitry follows DC/AC practice in that half-wave rectification is used and one side of the mains is connected to chassis (which prohibits the use of a direct con-

nection between earth and chassis). Any such connection must be made via a condenser as shown on the diagram. The heater is supplied from a bell transformer or any filament transformer capable of delivering 12 volts at 0.6 amp. If it is desired to use the receiver on a DC supply the bell transformer may be replaced by a resistor or line cord as shown in dotted outline in the diagram. For a 240-volt supply, a value of 760 Ω rated at 70 watts is necessary. If it is intended to use the receiver in this way, it is much better to use a 25 SN7 valve which has a lower current rating; the required resistor value is 1430 Ω at 32 watts.

While the receiver is capable of giving loud-speaker results on the more powerful local stations, many constructors will wish to use headphones for distant reception, and it is emphasised that headphones should be connected only through an isolating output transformer. A 1:1 or 2:1 is quite satisfactory; the primary is wired in the same way as T1 on the diagram, and the headphones are connected across the secondary. The

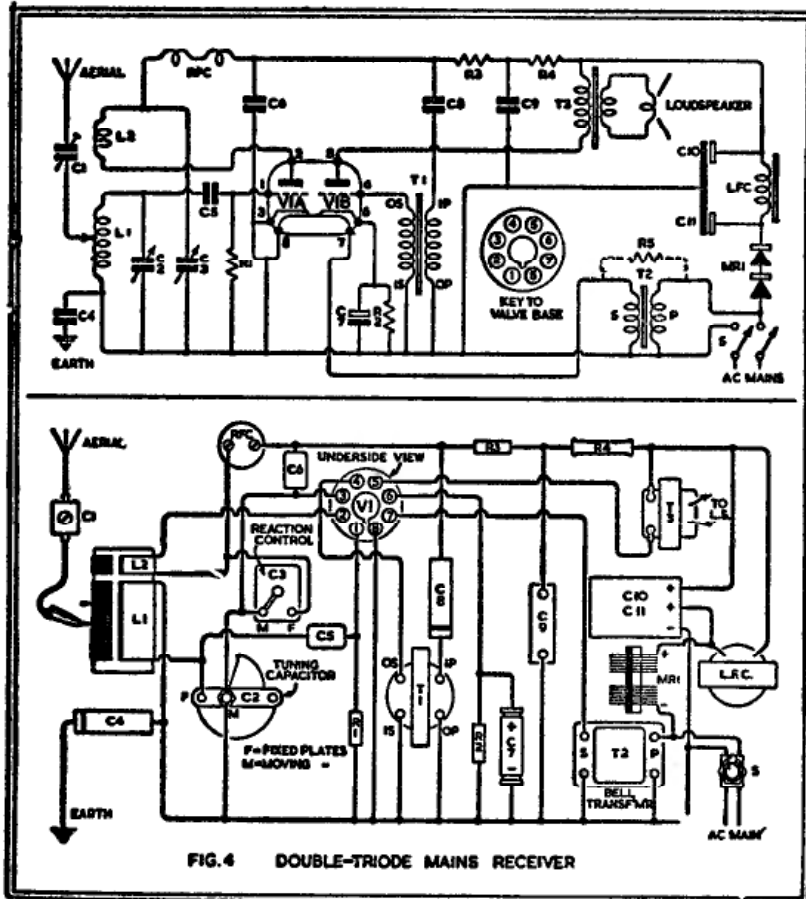

FIG. 4 DOUBLE-TRIODE MAINS RECEIVER

coil construction will present no difficulties. It is wound on a three-inch diameter former, three inches long, and the grid winding L1 consists of 45 turns of 22 S.W.G. enamelled wire with looped taps brought out at 15 and 30 turns. L2 is wound in the same direction and requires 28 turns of the same gauge wire. Constructional details of the coil are shown in Fig. 4.

Assembly may be carried out on a small wooden baseboard with a suitable front panel. Care should be taken to keep the LF transformer well away from the LF choke and bell transformer, otherwise hum will be picked up. When mounting the components, the core of the LF choke should be at right angles to that of the heater transformer. On completion, even with precautions, it may be found that hum is being picked up by the LF transformer and if this is suspected it should be unscrewed from the baseboard and rotated until a minimum pick-up point is found.

When operating the receiver, the aerial lead should be connected to the tap which gives the required selectivity in conjunction with C1. If advancing the reaction condenser weakens rather than strengthens the sensitivity it is a clear indication that the reaction winding is connected in the wrong sense and connections 3 and 4 should be reversed.

The ratio of T3 will depend on the impedance of the speech coil. For either of the valve types specified the required anode impedance is 21000 Ω and the transformer ratio may be found from the following formula:

$$\text{Ratio} = \sqrt{\frac{21000}{\text{Speech coil impedance}}}$$

Example—For a speech coil impedance of 15 Ω :

$$\text{Ratio} = \sqrt{\frac{21000}{15}} = \sqrt{1400} = 37.4 \quad \text{say } 37$$

COMPONENTS LIST Fig. 4

C1	100 pfd trimmer condenser	R1	470 K Ω resistor
C2	500 pfd tuning condenser	R2	1.5 K Ω resistor
C3	300 pfd reaction condenser	R3-4	47 K Ω resistor
C4	0.05 mfd paper condenser	R5	See text
C5-6	100 pfd mica condenser	T1	LF transformer
C7	25 mfd 12-volt Electrolytic condenser	T2	Bell transformer
C8	0.25 mfd paper condenser	T3	Output transformer. See text
C9	2.0 mfd paper condenser	MR1	SB3 rectifier (Brimar)
C10-11	16 - 8 mfd electrolytic condenser (C10 = 16 mfd)	S1	DPDT switch
		RFC	HF choke
		L1-2	See text
		V1	B36 or 12 SN7GT
		1	Int. Octal valve holder

Phones, terminals, connecting wire, etc.

THE "OSCILLODYNE" (Fig. 5)

The sphere of the single valve is by no means limited to the broadcast band. Many hours of entertainment are assured by the construction of a receiver which will cover the short waves. Many years ago the author constructed a receiver from the American magazine "Short Wave and Television." This receiver was called the *Oscillodyne* and its performance certainly was excellent. Shortly before World War II this magazine (now called "Radio and Television") published a revised circuit suited to a more modern valve. The performance is as fine as ever and the circuit is shown in Fig. 5. It consists essentially of an HF pentode used as a regenerative detector. Regeneration is controlled by R2 and will be found to be very smooth. The success of any regenerative short-wave receiver depends on the smoothness of the regeneration control, and constructors will find that this circuit is beyond reproach in this direction.

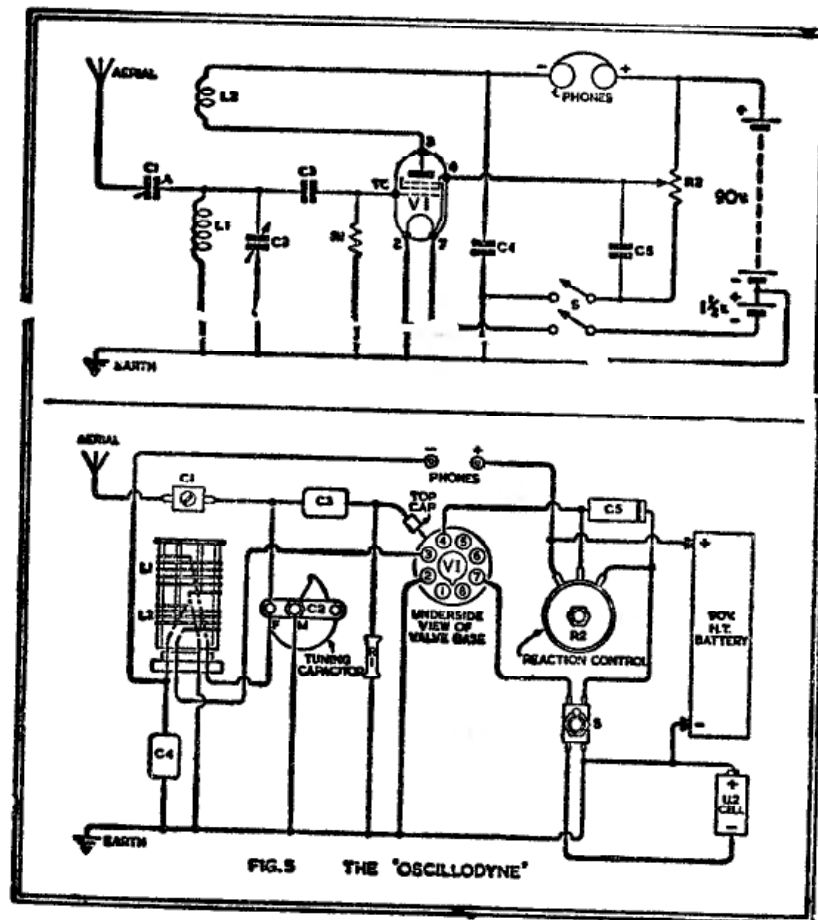

The coils are wound on 1½-inch diameter plug in coil formers. The author used Eddystone 6-pin formers which are readily obtainable in England though, of course, there is no reason why the constructor should not make up his own.

The two windings should be spaced about ¼ inch.

The gauge of wire required for L1-2 is not critical. Enamelled wire is suitable; the two lower wave bands may be wound in 18 S.W.G. and for the remainder 24 S.W.G. may be used.

A slow-motion drive is essential for the tuning condenser C2 owing to the delicate tuning encountered on the short wave bands. When using the receiver the regeneration control R2 should be advanced until it is just short of the point of oscillation and, the tuning condenser slowly rotated, C1 should be set for optimum signal strength. Adjustment of this condenser will probably affect the regeneration control setting. As with the other regenerative receivers shown in this book care must be taken to see that L2 is connected in the correct sense, as failure to obtain regeneration may be due to the connections on this coil being reversed.

COIL DATA

Waveband (Metres)	Number of turns	
	L1	L2
14/25	4	6
23/41	7	9
40/85	14	12
83/125	23	23
120/200	36	36

COMPONENTS LIST Fig. 5

R1	3.3 MΩ resistor	C3	100 pfd mica condenser
R2	50 kΩ variable potentiometer	C4	500 pfd mica condenser
L1-2	See text	C5	0.1 mfd paper condenser
C1	25 pfd trimmer condenser	V1	IN5G/GT
C2	100 pfd tuning condenser	S	DPST switch

Phones, terminals, connecting wire, etc.

TRIODE-PENTODE/REFLEX RECEIVER (Fig. 6)

The receiver shown in Fig. 6 is a single-valve reflex receiver. This circuit is definitely not recommended for newcomers who have little or no experience of receiver construction. The idea of the reflex originated in the 1920's when valves and components were even more expensive than

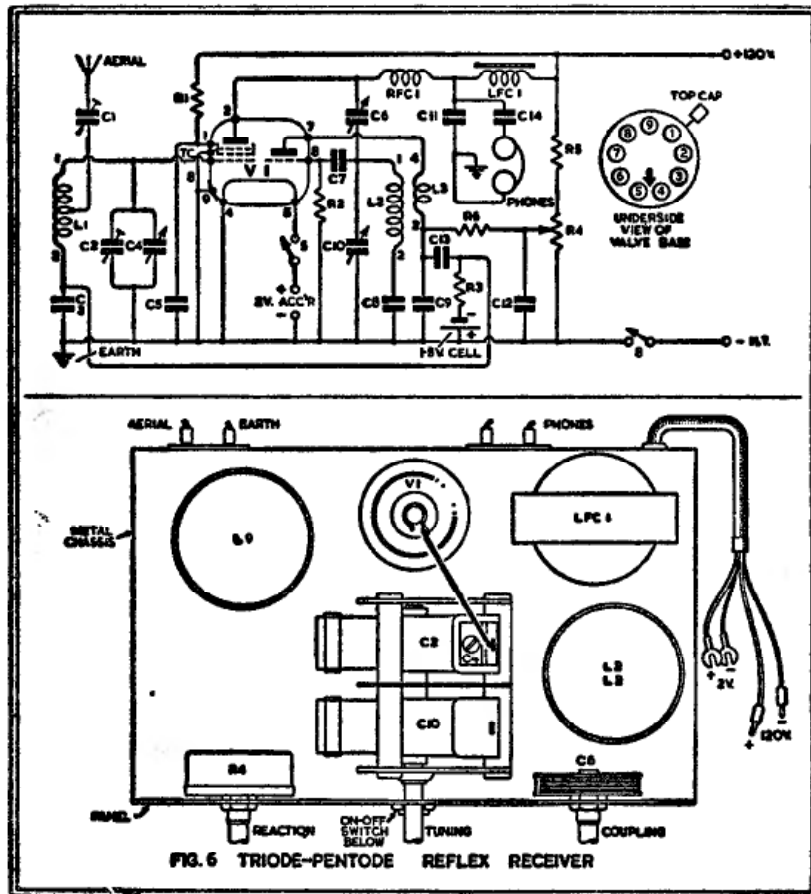

FIG. 6 TRIODE-PENTODE REFLEX RECEIVER

to-day, and any method by which parts could be dispensed with was considered a major advantage. In a reflex receiver, one valve is made to perform the duty of two or more by shunting the signal round the circuit, by-passing any unwanted portion and returning it to its point of entry for yet further amplification. This system is not to be confused with the more orthodox process of using, perhaps, a double triode in a straight circuit one half as a detector and the other half as an amplifier.

The circuit of Fig. 6 combines three distinct functions in one valve. Admittedly the valve is in reality two valves in one envelope, but by using a straight circuit only two functions would be possible. Careful analysis of Fig. 6 will show that the signal is fed to the control grid of V1, a triode pentode primarily designed as a frequency changer. From the anode it passes via C6 to the grid of the triode section. Constructors will observe that the tuned circuit L1-C2 is quite in order as the bottom end of the coil is by-passed by C3. The value of this component is critical as will be seen later when the pentode section is used as an audio amplifier.

The triode section functions as a normal leaky grid detector and the rectified output is passed back to the grid of the pentode section. If C3 is too large, audio will be lost; and if too small it will be ineffective as an RF by-pass. This point illustrates why specified values must be adhered to in a reflex circuit and why such circuits are unsuitable for beginners since the novice would have no idea where to look for trouble, whereas the more experienced constructor can analyse the symptoms and decide what part of the circuit is at fault. Having arrived back at the pentode section control grid the signal will be amplified, and ignoring C6 and C11 (provided their values are not too high) will appear across the L.F.C. From here it is picked off in the normal way through C14 to the headphones. Unfortunately it is necessary to use crystal headphones with this circuit because the impedance of the pentode section is too high to allow the use of ordinary headphones. No practical diagram is given with this circuit as experienced constructors will not require it; a suggested layout however, is shown on the diagram. The chassis may be of aluminium $\frac{1}{8}$ inch thick, a suitable size is 7 inches \times 9 inches \times 2 inches deep. Almost any TRF coils can be used for L1-2-3 but a specification is included for those wishing to make their own. L1 consists of 45 turns 26 S.W.G. enamelled copper wire on a $2\frac{1}{4}$ inch former 2 inches long, which is tapped 20 turns from the start. L2, 45 turns on a $2\frac{1}{4}$ inch former $2\frac{1}{2}$ inches long. The start of these windings is No. 1 and the end No. 2. Spaced $\frac{1}{4}$ inch from the end of L2, L3 is wound. This winding has 25 turns, and the start is No. 3, the end No. 4. On completion, the headphones and batteries should be connected and the receiver switched on. As the regeneration control (R4) is advanced the usual hiss should become apparent, and as the tuning dial is rotated, stations should be received. Tune in a station at the high-frequency end of the band and adjust C4 for maximum volume; once this trimmer has been set it will not require further adjustment. If, when R4 is advanced, signals become weaker, it is a sign that L3 is connected in the wrong sense and the two connections (3 and 4) should be reversed. If, however, signals increase in volume, but not to the point of oscillation, it will be necessary to adjust the setting of C6, decrease the value of R5, or add a few extra turns to the reaction winding L3. The receiver should burst into oscillation with the control R4 set at about three-quarters of its travel. A poor quality RFC will lead to endless trouble: lack of signals, no regeneration, etc., and only a component of repute should be used. One possible source of trouble is

the capacities of C3-9-11, but if the values specified are should be encountered.

COMPONENTS LIST Fig. 6

C1	100 pfd trimmer condenser	R1-6	68 kΩ resistor
C2-10	2 × .0005 mfd tuning condenser	R2	2.2 MΩ resistor
C3-8	.002 mfd mica condenser	R3	220 kΩ resistor
C4-6	50 pfd trimmer condenser	R4	50 kΩ variable resistor
C5-14	.1 mfd paper condenser	R5	47 kΩ 1-watt resistor
C7	100 pfd mica condenser	RFC1	RF choke
C9	500 pfd mica condenser	LFC1	100 - 300 henries LF coupling choke
C11	.003 mfd mica condenser	L1-2-3	See text
C12	1 mfd paper condenser	V1	TP22 Mazda
C13	.01 mfd paper condenser	S	DPDT switch
		I	B9 valve holder

Phones, terminals, connecting wire, etc.

TRIODE-PENTODE SHORT-WAVE RECEIVER (Fig. 7)

The use of a dual-purpose valve such as the TP22 makes possible a receiver of far greater sensitivity than that normally associated with a single valve. It is regrettable that in this country the range of single dual-purpose valves is limited as compared with America and Australia. Some of their types make possible all manner of elaborate designs without recourse to more than a single valve. However, we are fortunate in still having the TP22 which enables the advantages of a pentode detector to be fully utilised. The anode impedance of the pentode is too high to have headphones connected directly in its anode circuit (unless, of course, crystal phones are used), but the triode section permits a reasonable match to be obtained, at the same time obtaining the amplification of an extra triode stage. Turning to the circuit design, it will be noticed from Fig. 7 that the regeneration arrangements differ considerably from the conventional. As every short-wave listener is well aware a smooth

regeneration control is the most important factor governing efficient operation with simple T.R.F. designs. For this reason every care has been taken with the design of the regeneration circuits. First, there is the normal inductive-capacity coupling governed by C2; in addition there is a variable control feeding the screening grid, which provides a vernier regeneration control.

The coil design is by no means critical. Similar coils to those used for the "Oscillodyne" circuit could be used. However, those who do not wish to make their own will find the Wearite "P" range quite satisfactory. The circuit diagram has been numbered for these coils.

Ranges obtainable are as follows:—

Wave-band (Metres)	Type
12/35	PA4
34/100	PA5
90/261	PA6

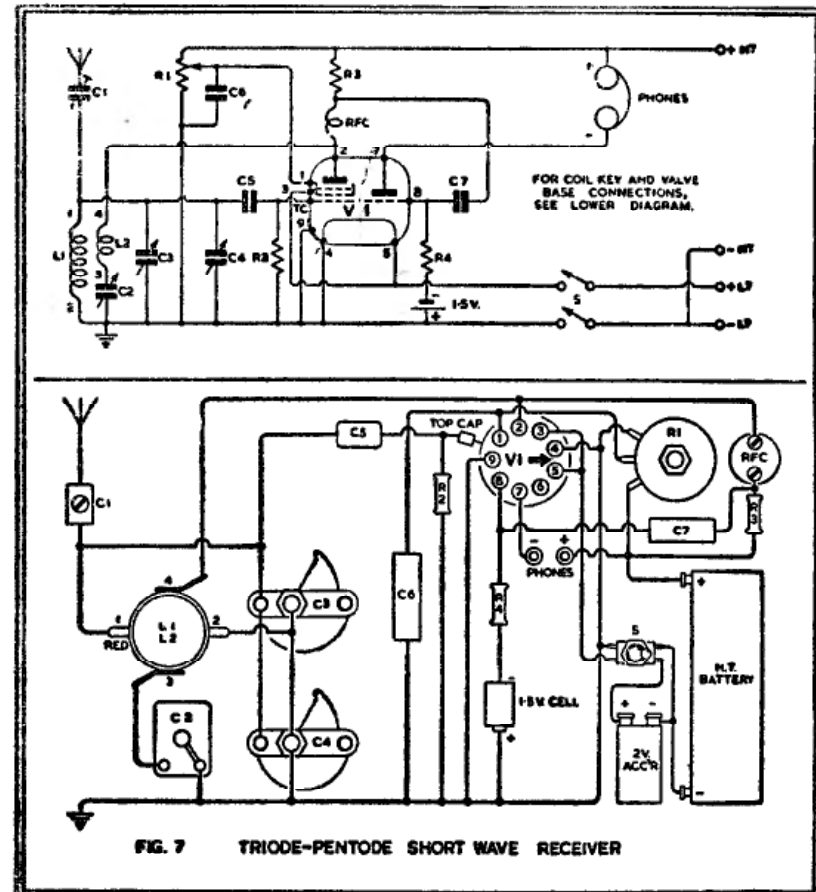

If required, the range may be extended to cover the long and medium wave bands as well as the short waves by means of the PA2 and PA1.

Another refinement in this circuit is the provision of bandspread tuning. C3 is the band-set condenser with which the desired part of the band is selected. C4 is the band-spread condenser which provides a fine tuning control over the part of the band selected. In this way the receiver can cover a very large band of frequencies compared with a receiver fitted with a single tuning condenser. When using the receiver, HT voltage of 100-120 is suitable although it will function on lower voltages.

The method of operation is similar to that of any other regenerative receiver, but a little initial experiment should be carried out to find the best average setting for R1. In most cases this will be found to be about one-third of its travel between minimum and maximum travel. After this position has been found for smooth regeneration, the regeneration control condenser C2 is used in the normal way.

If the receiver is used for medium and long-wave reception the band-spread condenser C4 should be left with the vanes disengaged, i.e., at minimum capacity since, apart from the fact that band-spread facilities are unnecessary on these bands, the total capacity of C4 is too small to cover any useful part of the band.

COMPONENTS LIST Fig. 7

C1	100 pfd trimmer condenser	R2	3.3 M Ω resistor
C2	300 pfd reaction condenser	R3	100 K Ω resistor
C3	500 pfd tuning condenser	R4	470 K Ω resistor
C4	60 pfd tuning condenser		See text
C5	100 pfd mica condenser	V1	TP22 Mazda
C6-7	.01 mfd paper condenser	R.F.C.	All wave HF choke
R1	100 k Ω potentiometer	1	B9 valve holder
		S	DPST switch

Phones, terminals, connecting wire, etc.

ELECTRON-COUPLED PENTODE RECEIVER (Fig. 8)

As most constructors will already be aware the success or failure of a single valve receiver designed for short-wave reception depends largely on the smoothness of the reaction control. The earliest receivers used the swinging coil principle to obtain regeneration; this offered possibilities as far as smooth control was concerned. The variation of circuit capacity caused by this swinging coil however, introduced serious de-tuning in the grid circuit which rendered the circuit useless from the short wave point of

view (though it enjoyed a certain amount of popularity among broadcast-band constructors). One of the oldest, and perhaps the most popular regeneration systems, is the Reinartz.

One system which does not appear to have gained the popularity it deserves is electron-coupled regeneration as used in Fig. 8. It will be noticed that the negative side of the filament is returned to the supply through a tapping on the grid coil, the precise position of this tap governing the amount of regeneration available. A little experiment will decide the best position for the tap. R.F.C.1 should be a good quality component: R.F.C.2 may be home-built and consists of 36 turns 24 S.W.G. enamelled copper wire on a $\frac{1}{2}$ -inch diameter former some 3 inches long. A length of wooden dowelling could be used provided it is impregnated. Each turn should be spaced by its own thickness and the easiest way to wind the choke is to wind on two lengths of wire side by side, treat them with Durafix, and, when dry, remove the unwanted winding.

The receiver may be constructed on a wooden baseboard with a front

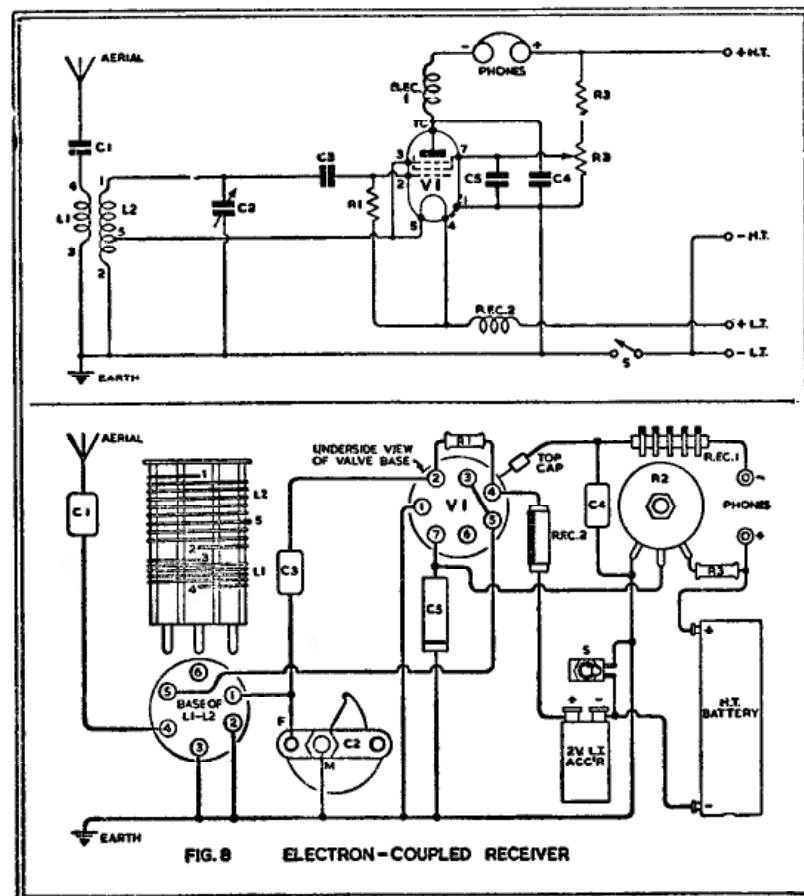

FIG. 8 ELECTRON-COUPLED RECEIVER

panel of metal. V1 should be mounted horizontally to avoid having the anode lead unnecessarily long. The coils L1-2 are best wound on 6-pin formers, obtainable from any supplier dealing with short-wave components, complete with sockets to fit. Eddystone-threaded formers were used on the original. Three coils are usually sufficient to cover the popular bands, and the table gives the required turns and wave-band covered.

COIL DATA

Wave-band	L1	L2	S.W.G.
15/30 Mc	2	4	22 enam.
6·5/14 Mc	5	9	22 "
3/6·5	10	25	22 "

L2 is wound on first and L1 immediately underneath. Note that L1 is wound *in the same direction* as L2. On the 3-6·5 Mc band L1 must be piled wound in a slot cut round the former as there is insufficient length to permit a spaced winding.

The tap is best found by experiment. Counting from the earthy end L2 should be tapped $1\frac{1}{2}$ turns up on the 15-30 Mc Coil, 3 turns up on the 6·5-14 Mc Coil and 8 turns up on the 3-6·5 Mc Coil. This tapping position may be considered satisfactory when R2 gives smooth regeneration over the whole wave-band. Care must be taken when tapping the coil; the required turns should be pulled forward with a knife blade, the enamel cleaned off with emery paper and a good soldered joint made.

In conclusion it should be stated that only a good mica component should be used for C5, otherwise results will be disappointing.

COMPONENTS LIST Fig. 8

C1-3	100 pfd condenser mica	R2	25 kΩ potentiometer
C2	140 pfd tuning condenser	R3	47 kΩ resistor
C4	500 pfd condenser mica	S1	S.P. switch
C5	0·01 mfd condenser mica	V1	SP2
RFC1	High quality HF	1	B7 valve holder
RFC2	See text	L1-2	See text
R1	2·2 MΩ resistor		

Phones, terminals, connecting wire, etc.