

BERNARDS

**SHORTWAVE
CIRCUITS
& GEAR FOR
EXPERIMENTERS
& RADIO HAMS**

BY

B. B. BABANI

NO. 215

85p

**SHORTWAVE
CIRCUITS &
GEAR FOR
EXPERIMENTERS
& RADIO HAMS**

**BY
B. B. BABANI**

BERNARDS [publishers] LTD

The Grampians
Shepherd's Bush Road
London W6 7NF
England

Although every care is taken with the preparation of this book the publishers will not be responsible for any errors that might occur

The compiler of this book wishes to express his most sincere thanks to 'ELECTRONICS AUSTRALIA' the leading radio, TV and electronics magazine published in that continent, and to Syndication International Ltd., their agents, for permission to use much of the material in this book which appeared originally as articles in that magazine.

© 1975 by Bernard B. Rubart

ISBN 0 900162 55 4

First Published October 1975

Printed & Manufactured in Great Britain
by C. Nicholls & Company Ltd, Manchester M11 4AU

CONTENTS

AN ADD IN CRYSTAL FILTER	5
ADDING AN "S" METER IN YOUR RECEIVER	6
CRYSTAL LOCKED HF RECEIVER	11
EXPERIMENTAL AM TUNER USING A PHASE LOCKED LOOP	20
SHORTWAVE CONVERTER FOR 2 MHz to 6 MHz	27
THE HOMODYNE TUNER - ANOTHER APPROACH	33
TWO SOLID STATE RF PREAMPLIFIERS	36
40 to 800 MEGAHERTZ RF AMPLIFIER	48
BASIC RECEIVER FOR SLOW SCAN TV FOR AMATEUR TRANSMISSIONS	49
14 Mc HAM BEAM USES TV AERIAL PARTS	63
AERIALS FOR THE 52, 144 Mc BANDS	71
AN FM DETECTOR FOR AMATEURS	86
A SOLID STATE CRYSTAL FREQUENCY CALIBRATOR	88

AN ADD-IN CRYSTAL FILTER

This crystal filter was built for considerably less than a commercial unit, and while it may not be up to some commercial standards it is more than adequate for good SSB and AM reception. I used crystals on a frequency of 6.5MHz but crystal frequency is not important except that a frequency should be chosen that does not clash with any frequency to be received. The crystals XL1 and XL2 should be about 1.5kHz apart and XL3 should be 455kHz (or the first IF) from the centre of XL1 and XL2. RFC1 should be self resonant at approximately the filter frequency.

The circuit has a gain of about 2dB and it can be added to an existing receiver with little modification. The output of the filter can go straight to the detector if necessary. The filter must be enclosed in a metal box and the positive supply rail must be well filtered.

When completed, L1 is aligned at the centre frequency of XL1 and XL2. This reduces the double hump and flattens the top of the response curve. Ct is a small capacitor of about 1 or 2pF, a "gimmick" or pair of insulated wires twisted together for about 2 to 3cm should be enough. This capacitor assists in steepening the sides of the response curve, but if too large it will cause side lobes to appear. The capacitor must be across the higher frequency crystal as it will widen the response curve if it is connected across the lower frequency crystal.

The filter which I have made has a bandwidth of 2kHz at 6dB down and 9kHz at 60dB down. This type of filter may also be used immediately following the mixer in a single conversion receiver with a tunable oscillator.

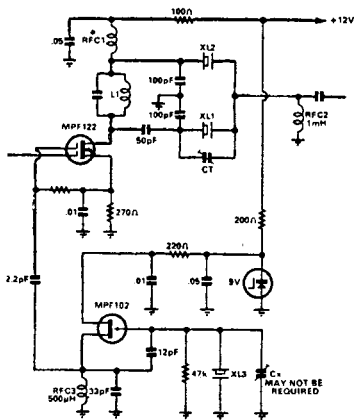

* SELF RESONANT APPROX. CRYSTAL FREQUENCY

ADDING AN S METER IN YOUR RECEIVER

This article answers the often repeated questions: How does an S-meter work? How can one be added to an existing receiver? How may it be calibrated? While it refers to valve receivers in particular, the basic ideas are applicable to transistor receivers.

At the outset it must be emphasised that, for the most part, S-meters (i.e. signal strength meters) give comparative rather than absolute readings.

Among the reasons for this are:

1. The sensitivity of most receivers varies over their range, so that meter readings may vary from one input frequency to another for signals of the same nominal strength.
2. The signal fed to the receiver depends of the pick-up of the aerial and this varies widely with frequency and directivity.
3. Even assuming that the "zero signal" and "maximum signal" limits of the meter scale are reasonably defined, the law of the readings in between may vary randomly from one combination to the next.
4. S-meter readings are frequently affected by the setting of manual RF and IF gain controls and may be misleading unless these controls are operated normally at full-on.

Despite these problems, S-meters can usefully indicate a difference in strength for signal to signal or from day to day, and recorder S-meter readings have a definite advantage over a mere, aural impression and memory. However, only if an S-meter has been specifically designed into a receiver and then calibrated with the aid of a signal-generator will its reading mean much in terms of input signal micro-volts.

The simplest type of S-meter or tuning indicator is a 5mA or 10mA meter wired in series with the cathode resistor of an AVC controlled IF amplifier. (See Figure 1) With no input signal, or with the aerial terminal shorted to chassis, the meter reads near maximum current.

When a signal is tuned by the receiver, a negative voltage is developed on a AVC line and applied to the IF amplifier control grid.

The IF amplifier draws less current, with the result that the meter in the cathode circuit shows a reduced reading. Hence the meter reading varies with the AVC voltage applied to the IF amplifier and this, in turn, is directly related to the signal strength of the station to which the receiver is tuned.

To achieve the maximum sensitivity with this S-meter circuit, it is desirable that the IF amplifier associated with the circuit be arranged to operate with high natural gain for weak signals. This will give the greatest swing of cathode current for an applied AVC voltage variation.

es
If two IF amplifier stages are in use, it should be possible to determine experimentally whether the meter can be operated most effectively in the cathode return circuit of either one or both together.

rt,
If the cathode current should exceed the meter rating, a shunt across the meter can be used to give fullscale reading under no-signal conditions.

ige,
With this circuit, the meter reads deflected to the right with no signal input, but returning towards zero as the strength of an incoming signal increases. With a very strong input signal, the cathode current may fall to about 10 per cent of full scale.

Technically, there is no special disadvantage in a reverse-reading scale, the only requirement being that it be suitably calibrated, either with figures hand-lettered on to the meter face or pasted on to the front of the meter glass.

For those who may wish to achieve a simple "forward reading" scale, the meter may be mounted upside-down with the needle pointing to the bottom of the front panel.

In the design of commercial equipment, it has been an accepted standard that an S-point calibration should equal an increase in signal strength of 6dB.

By way of example, in calibrating the S-meter on a typical communications receiver some time ago, we set S1 as being equivalent to a one micro-volt signal at the aerial terminal. As each succeeding S point was equal to a 6dB increase in signal strength, S9 resulted from a 256-micro-volt signal. While it thus takes quite a signal to give an S9 reading, at least the readings are realistic and do convey some meaning when the input signal per S point is quoted.

With the particular receiver, there was no special problem about this calibration, because the internal circuitry of the front-end unit was arranged to maintain a substantially constant order of gain over the entire range of frequency coverage. In receivers where the gain varies from band to band, it may be necessary to strike some kind of an "average", or calibrate for the band of greatest interest or add to the bandswitching some provision to modify bias or screen voltage to even things out.

For those who do not have access to standard signal generators, it is not practical to calibrate an S-meter on this basis and an arbitrary calibration must be made.

A logical approach to the problem is to set S9 on the meter as being a very strong signal, with no background noise, received from a station other than a nearby neighbour. From this point the meter reading could be evenly divided to provide calibrations of 1 to 9 S points. However, if you receive a request for an accurate S meter report, it is only fair to explain the arbitrary way in which the S-meter calibrations of your receiver have been determined.

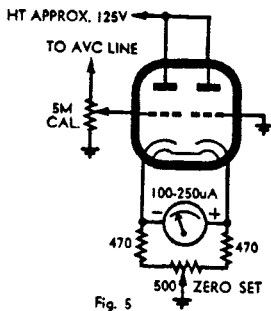
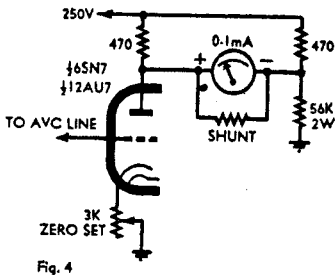
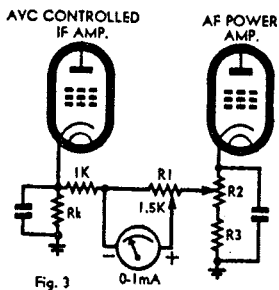
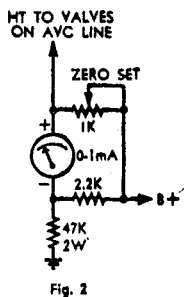
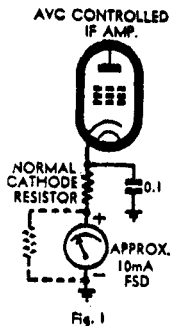

As distinct from the simple cathode current measurement of figure 1, various circuits have been devised to produce an inherently forward reading type of S-meter, in which the pointer is deflected "up-scale" to the right as the strength of the incoming signal increases. In such circuits, it is also usual to arrange matters so that the meters read from near zero for no input signal to near full scale for maximum signal, so that the full length of the meter scale is used.

A line of approach is to use a fairly sensitive meter, typically a 1-milliamp movement, in what is virtually a bridge circuit and so arranged that a decrease in the plate current of one or more AVC controlled amplifiers produces an increase in the current flowing through the meter.

A simple form for this bridge circuit, frequently used in communication receivers, is shown in figure 2.

With about 250V HT, about 5mA would flow through the 2.2 and 47K resistors, putting the junction between the two about 11 volts below the HT line. In the other arm of the bridge, set to the full 1,000 ohms, the same voltage drop would be evident with about 1mA flowing to the metered valve; under these conditions, the meter would read zero.

Application of an AVC voltage to the metered valve would reduce its current, reduce the voltage drop across the 1K potentiometer and allow the positive side of the meter to approach more closely the HT line, causing the meter to read forward.

Adjustment of the 1K potentiometer allows the meter to be set to zero, under no signal conditions, for a total metered current higher than about 1mA. For currents less than this figure, it may be necessary to revise the value of the 2.2K resistor.

The amount of forward deflection depends on the meter sensitivity but can also be varied by shunting the meter or by modifying the value of the 2.2K resistor and the setting of the 1K pot.

Adjustments as outlined in the two preceding paragraphs are commonly necessary with forward reading type S-meters. They are aimed at (1) securing zero meter deflection with no input signal and (2) controlling the sensitivity of the circuit so that the meter will read S9 (256uV) at less than full scale, with a margin for those signals (S9 plus) which are even stronger than this.

A somewhat different circuit arrangement is shown in figure 3. Resistor Rk is the normal cathode resistor of an AVC controlled IF amplifier. Resistors R2 and R3 should add up to the normal resistance for the cathode circuit of the audio power amplifier. These resistors should be selected in value so that the moving arm of R2 can be set to a voltage equal to that at the cathode of the IF amplifier under no-signal conditions.

In some cases it might be necessary to reverse the positions of R2 and R3. It also may be possible to use a single potentiometer instead of R2 and R3 but this will decrease the vernier effect of the series resistor. To adjust the S-meter set R2 with the aerial shorted for zero reading; set the sensitivity control, the 1500-ohm potentiometer (R1) for full-scale reading with the IF valve removed from its socket.

The idea of obtaining a balancing voltage from another valve has the advantage that voltages are applied to both sides of the meter at about the same time, as the two valves begin to draw current. With figure 2, on the other hand, voltage is applied via the 2.2 and 47K resistors immediately voltage appears on the HT line. The meter therefore is subject to a reverse voltage before the controlled valves begin to draw current. This is not likely to damage the meter but it does not look the best.

The remaining circuits illustrate forward reading S-meters using additional valves. These tend to give an approximate linear dB scale without undue crowding.

In figure 4 a milliammeter is incorporated in a bridge in the plate circuit of the additional valve. To adjust this system either remove the additional valve from its socket or open the cathode circuit so that the valve does not draw current. While the circuit is in this condition adjust the shunting resistor across the meter until full-scale reading is obtained. The value of the shunt will depend on the internal resistance of the meter used. With the valves mentioned on the diagram the approximate current flowing in the meter will be 2.5mA.

With the valve, or circuit, restored to normal the aerial of the receiver should be shorted to chassis and the zero set potentiometer set to give zero reading on the meter. Increase of signal strength will be registered to the stage where the AVC voltage is high enough to cut-off the additional valve's plate current. This will normally occur with approximately 15 volts on the AVC line, which represents a very strong signal.

The final circuit is one which can be fitted easily to most receivers, either internally or externally. It incorporates a twin triode valve in what is essentially a valve voltmeter circuit. Again two pre-set controls are used to set the parameters of the meter readings. The zero set may be used to adjust the meter to minimum reading with no signal other than receiver noise. The calibrate control can be arbitrarily set to give a S8 or S9 reading at between mid to threequarter scale.

While there are many other S-meter circuit configurations, the ones given here will probably allow the selection of a suitable type for most receivers. If mounting an S-meter on an existing receiver, where space is at a premium, consideration could be given to the use of edge type meters now available in Australia, some of which are available with S-meter calibrations.

CRYSTAL LOCKED HF RECEIVER

Here is a receiver designed for use on specific HF communications or broadcast channels. Crystal controlled, it may be used on any number of channels for which crystals can be provided. Designed around the TAA840 IC it is cheap and easy to build.

There are many uses for such a receiver, some of them at professional and semi-professional level. Those organisations which already operate communications systems in the HF band, often have need for extra receivers to monitor their channels. This little set would seem to be an ideal unit for the job.

There are still many applications where a fixed tuned receiver would be useful. There are several frequency and time standard transmitters scattered throughout the world and our receiver would be a logical choice for monitoring them.

Another obvious application is to monitor the various university radio transmitters. We are often asked for a receiver which will operate exclusively on one of these channels, and this design would seem to be the answer.

Again, certain overseas or local shortwave broadcast stations may interest individuals to the point where they would be happy to be able to monitor the channel with a high degree of reliability.

The receiver is designed around the TAA840 IC, a unit originally intended as the major portion of portable broadcast receivers, and requiring a minimum of peripheral components to make it work.

Since the introduction of the TAA840, many people have experimented with it to find if it is suitable for HF reception, up to, say, 15MHz.

Experiments have shown that the oscillator section of the IC restricts operation beyond the broadcast band, but that it is capable of working well into the HF band if it is provided with an external oscillator.

On consulting the makers for information relative to highest frequency operation of the IC with an external oscillator, it was felt that it could possibly achieve an upper limit of at least 14-15MHz, but no data was available to confirm this. It was suggested that the limiting stage would be that originally used as the oscillator but which, under the new arrangement, becomes the mixer.

Apart from the external oscillator and the IF system, the TAA840 applications information circuit was followed. A few alterations to circuit values allows it to be operated from a 9-volt battery.

So much for the general aspects of the unit.

A brief description of the circuit will help the reader appreciate how the set functions. The aerial feeds into a conventional tuned circuit, except that it is a fixed tuned arrangement, adjusted to suit the selected crystal. The crystal and tuned circuit may be contained in a plug-in module, if more than one channel is to be monitored.

The BF194 transistor functions as a form of Pierce oscillator in conjunction with the selected crystal. This oscillator will operate over a wide range of frequencies, by simply plugging in the appropriate crystal. Output is taken from the emitter and coupled to pin 3 of the IC via a 330pF capacitor.

Also coupled to pin 3 is a ceramic filter resonant at 455KHz. Within the IC pin 3 connects to the emitter of what is now the mixer transistor. The ceramic filter, which has minimum impedance at resonance, functions as a bypass across a 2.2K resistor in the emitter circuit, and makes it better able to handle signals at 455KHz.

Pin 2 is the collector of this same transistor, and connects the external IF components. These consist of two IF transformers, top coupled, and another ceramic filter. Output of the filter goes back into the IC at pin 12. A volume control connects between pins 9, 11 and common, and the audio is taken from pin 7 and fed to a complementary - symmetry pair, AC187/AC188.

On the construction side, the whole receiver is assembled in a small, sloping-front instrument case. Layout can be judged from photographs of the prototype.

The circuit board carries almost all components closely associated with the operation of the IC. Components external to the board are the aerial tuned circuit, crystal, loudspeaker, volume control, and off/on switch.

In the prototype, we mounted the aerial coil and crystal in a small metal box so that channel changing could be achieved simply by plugging in a suitable pretuned module.

Readers may have their own ideas on channel selection, and we leave this portion of the construction to the individual's ingenuity. One alternative arrangement could use a miniature rotary switch, selecting the desired number of coils and crystals. For single channel operation, a single coil and crystal could be wired permanently.

Whatever system is used, make sure that leads are kept short and that there is a metal screen between the aerial coil and the crystal. This is necessary to minimise the risk of instability, particularly at the higher frequencies.

For readers who wish to duplicate our module arrangement, connection is made to the receiver circuit by a dual "phono" connector strip. The module itself carries two phono plugs mounted at the same centres as the connector strip ($\frac{1}{2}$ in). One is soldered directly to the module box, and the other insulated from it in an oversize hole and fastened with an epoxy such as "Araldite".

This provides four connections to the module. The crystal is connected to the soldered phono plug, the centre pin being the "hot" lead to the base of the oscillator transistor. The shell of the same socket is used for the crystal common return and the coil common return. The aerial coil is connected to the insulated phono plug; the tapping to the pin, and the aerial input lead to the insulated shell. The aerial input socket is a similar type of single phono plug mounted on the front panel.

The aerial tuned circuit consists of a fixed capacitor and an adjustable coil wound on a Neosid former with adjustable core. The coil is mounted so that the core is accessible through a hole in the side of the module. The winding is closewound with enamel wire to the specifications given in the accompanying table.

Although we have shown data for only two aerial coils, the choice of capacitor value will allow any frequency from 2 to 11MHz to be covered. With a lower value capacitor, it may be possible to extend the frequency up to 15MHz or so.

If separate aerial coils are wound to cover these higher frequencies it would be advisable to select a grade 900 core for the coil former. The grade 500 specified is intended for use only up to about 10MHz.

If you wish, you can make your own IF coils to the data given.

The IFs are scramble wound on small Neosid "cotton reel" type E cores, assembled with a small cup and threaded tuning cores.

With the aerial coil data specified, the sensitivity for 50mW in the speaker was of the order of $1.5\mu\text{V}$. This may vary slightly between individual ICs, but is adequate for most situations. With increase of RF input, the AGC control was within specifications of the IC data.

As we said earlier, there is very little information available as to the highest frequency at which these ICs will work. If a particular unit will not work up to 14 or 15MHz, it may be worthwhile to select a different IC. A batch identification code is usually placed in small letters under the type number and one from a different batch may work better.

The crystal frequency should be the signal frequency plus or minus the IF. This may present a problem in some cases, since the actual IF will be determined by the response of the particular SFD455B ceramic filter. These are made to a nominal 455KHz, but with a tolerance of plus or minus 2%.

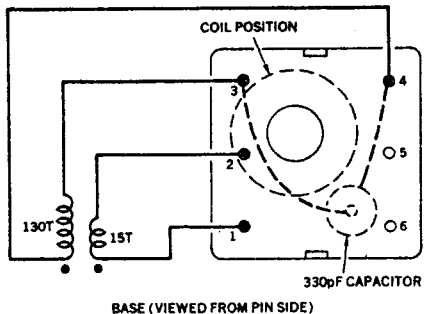

Position of components and base connections for IF coils.

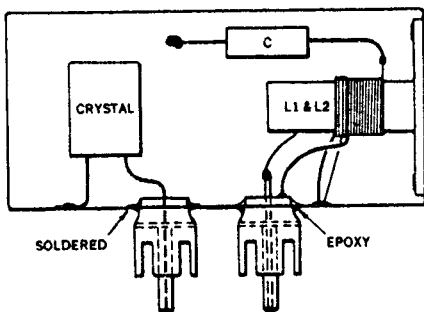

Plug-in crystal module showing position of components and phono plugs.

Ideally, the IF filter frequency characteristics should be quoted when ordering a crystal, but very few constructors have the equipment to measure the natural resonance of the ceramic filters with the accuracy necessary to order a "spot on" crystal.

In these cases, there are one or two tricks that can be employed to minimise possible errors. One is to "pull" (shift) the crystal frequency by a small amount.

"Pulling" can be achieved, within limits of reliable oscillation, by inserting capacitance in series with the crystal to slightly increase its frequency or in parallel to reduce its frequency. A small air trimmer can be used for this.

A more complete solution, at some cost in selectivity, is to eliminate the SFD455B filter. This will allow the IF response to be determined by adjustment of the remaining IF transformers. The crystal can then be determined by adjustment of the remaining IF transformers. The crystal can then be ordered on the basis of a 455KHz IF, the IF channel being ultimately adjusted to this on the basis of best reception of the signal. Subsequent crystals could be ordered on the same basis.

The ceramic filter is eliminated by bridging the output of the tunable IFs to the input of the IF AMPLIFIER (pin 12) with a 0.047 μ F ceramic disc capacitor. (Shown dotted in the circuit.) The effect of the BFB455A ceramic filter can be neglected in these circumstances.

Another decision to be made before the crystal is ordered is whether it should operate on the high or low side of the wanted signal. While either will work equally well, the matter of possible images must be considered. Particularly at high frequencies, the simple aerial tuned circuit may not be able to reject a powerful signal which could be located 910KHz (twice the IF) away from the wanted signal.

For example: If the wanted signal is on 10MHz the crystal could operate at either 10.455MHz or 9.545MHz. Working at 10.455, the image would occur at 10.910, while working at 9.545 would put it at 9.090 MHz. If there was a powerful signal on either of these two image frequencies it would be wise to select the other one.

If a signal generator is available it could be used as a substitute for the crystal, temporarily, to allow both image conditions to be investigated. When a decision has been made, the crystal can be ordered.

The only type of crystal which will work reliably in the Pierce oscillator circuit is one cut for the **fundamental** mode. "Overtone" cut crystals may or may not operate in the circuit. If they do, they will operate on their fundamental, which will be approximately some odd sub-multiple of the figure stamped on the case.

The
the
sup
the

Cry
eit
cry
is r
the

As
lar
as

Mo
fal
an
ciu

A:
fin
br
ex
ci
tt
tt
o
P

M
fl

I
s
v

/
g
i
i

There should be no difficulty in obtaining fundamental crystals up to the likely limit of this receiver. In fact fundamental crystals can be supplied up to 40MHz, although they are quite fragile. Up to 15MHz there are no special difficulties.

Crystals, if bought new, should ideally be "wire in" types when used in either the module or wired to a rotary switch. This obviates the use of crystal sockets, which can take up more room than necessary. There is no hard and fast rule to this, but it makes handling of components that much easier.

Assembly of the receiver should not present any problems. Drill all large and small holes for mounting and controls in the panel. Cut holes as necessary for the speaker, and module (if used).

Mount the speaker on the panel with a piece of expanded aluminium or fabric between. Mount the volume control (with its shaft shortened for an appropriate knob), the on/off switch, aerial connector, and two in circuit board pillars.

Assemble the circuit board starting with the IC and smaller components first; then the flying connecting leads to the volume control, speaker, battery and switch; and finally, the module connector. Care should be exercised in orientation of the IC on the circuit board. Damage to the circuit board and/or the IC may result if the IC is soldered in place and then has to be removed. To this end, an arrow indicator is etched in the foil of the circuit board, and the corresponding notch on the top side of the IC at one end should be at the arrow head (see printed wiring pattern) between pins 1 and 14.

Mount the completed circuit board on the brass pillars and connect the flying leads into circuit. Check for shorts, etc.

If everything is ship-shape, a rushing sound should be audible in the speaker when the receiver is switched on, and should be variable with volume control setting.

Alignment should be relatively simple. It will be a little easier if a signal generator is available, but this is not essential. If a generator is available, it should first be used to adjust the IF transformers. The generator is fed into pin 1 of the IC via a $0.1\mu\text{F}$ capacitor. Connect an output meter, or multimeter on the low AC range, across the speaker terminals.

Feed in a signal at approximately 455KHz. The exact frequency will be determined by the second ceramic filter, and the idea is to set the two transformers so that they are at the same frequency as the filter. Final adjustment is to the aerial circuit, which may be set approximately by means of the signal generator, and precisely when the wanted signal is received. Output from the generator should be kept at a minimum at all times, and the volume control of the set advanced to maximum.

If the circuit has been built without the ceramic filter, the generator should be set as close to 455KHz as possible and the IF transformers adjusted to this. When the wanted signal is received, the transformers can be touched up for best results.

If no signal generator is available it will be necessary to wait until it is known that the wanted signal is available and then adjust the IF and/or aerial coils until the signal is received and brought to maximum strength. Ideally, the aerial circuit should be worked with the set connected to the aerial with which it is to work.

Finishing the receiver off is simply a matter of placing the whole assembly into its plastic cabinet and inserting the four anchoring screws in the appropriate positions.

Parts List

- 1 Plastic cabinet with front panel.
- 1 3 inch 15 ohm loudspeaker.
- 1 9 volt battery.
- 2 Connectors for above.
- 1 Circuit board.
- 2 IF transformers.
- 2 Neosid type "E" adjustable inductance assembly, 36B&S or 40SWG DTE wire, and two miniature 330pF capacitors.
- 1 Neosid former type 3511 with 6mm x 12mm 500 grade core and 34B&S, 28B&S or 30SWG DTE wire for aerial coil.
- 1 Murata SFD455B filter unit 38SWG.
- 1 Murata BFB455A filter unit.
- 1 AC187/188 complementary transistor pair or RS276-2001 and RS276-2005.
- 1 TAA840 integrated circuit.
- 1 Phono socket.
- 3 Phono plugs.
- 1 Dual phono receptacle assembly.
- 1 Miniature single pole toggle switch.
- 1 BF194 or RS276-2009, 2N3694, BF115-121-163.

RESISTORS (½ watt)

- 1 220K
- 1 100K
- 1 22K
- 1 15K
- 2 10K
- 1 1K
- 1 470 ohm
- 1 330 ohm
- 1 270 ohm

1
1
1
1
1
Cr
2
1
1
2
3
2
1
1
1
1
1
1
1
Cr
Sp
etc
IF
IF
Ne
Wi
Wi
Ac
Fc
3.
4.
5.
7.
L1
3n

- 1 120 ohm
- 1 82 ohm
- 1 68 ohm
- 1 150 ohm thermistor.
- 1 5K potentiometer, curve C (log).

CAPACITORS

- 2 125 μ F 12VW
 - 1 50 μ F 6VW
 - 1 25 μ F 3VW
 - 2 0.1 μ F ceramic or polyester.
 - 3 0.047 μ F ceramic or polyester.
 - 2 0.022 μ F ceramic or polyester.
 - 1 0.01 μ F ceramic or polyester.
 - 1 0.0047 μ F ceramic or polyester.
 - 1 0.001 μ F ceramic or polyester.
 - 1 330pF miniature polystyrene (Ducon DF-B112 or similar).
 - 1 68pF NPO ceramic.
 - 1 22pF NPO ceramic.
 - 1 10pF NPO ceramic.
- Polystyrene capacitor(s) to resonate aerial coil (see coil data).

Crystal(s) to suit desired channel (see text).

Small control knob. Hookup wire. Expanded aluminium or suitable speaker fabric. Metal strip for battery clamp. Nuts, bolts, brass pillars, etc.

IF and Aerial Coil Data

IF Coils:

Neosid type "E" adjustable inductance assembly.

Winding wire: 36B&SDTE or 40SWG.

Windings: Resonant: 130 turns.

Coupling: 15 turns.

Aerial Coils:

Former: Neosid type 3511; Core: Neosid 6mm x 12mm, "500" grade.

f	L1	L2	C	Wire
2-3MHz	3 turns	40 turns, tap at 5 turns	220pF	34B&S or 38SWG
3.7-5MHz	as above	as above	150pF	as above
4.4-6MHz	as above	as above	100pF	as above
5.8-8MHz	2 turns	15 turns, tap at 2 turns	270pF	28B&S or 30SWG
7.8-11MHz	as above	as above	150pF	as above

L1 to commence at end nearest mounting flange, and placed approx. 3mm from this end. L2 to be wound over L1.

EXPERIMENTAL AM TUNER USING A PHASE-LOCKED LOOP

Those who would like to experiment with one of the new "phase-locked loop" ICs should find this article particularly interesting. It explains the operation of the devices, and describes an experimental AM broadcast tuner.

When phase-locked loops or "PLLs" became available in IC form recently, our immediate reaction was that it should be possible to use one of these devices to produce a simple yet high performance synchrodyne-type AM radio tuner. After many frustrations and a good deal of experimental work we have finally managed to produce such a unit, and it does work quite well – most people who have heard it have been very impressed.

It's not quite as simple as we had hoped, for reasons which will become apparent. However it is still quite easy to build and get going, and will not cost very much. We are not claiming it to be the ultimate design for a tuner or receiver of this type, by the way – merely one which works quite well and should serve as a good starting point for those who would like to experiment further.

For the benefit of those not as yet familiar with PLLs, we should perhaps point out the concept is not new. It was actually proposed by a Frenchman named de Bellescize in 1932, in an article titled "La Reception Synchrone". As this suggests he was in fact proposing it as a system for radio reception, although more recently it has been used for many other applications such as signal processing, frequency synthesis, and noise filtering. The application of the idea to radio reception was proposed again in 1947 by D.G. Tucker, who first coined the name "Synchrodyne".

Actually the concept of the PLL should already be quite familiar to many readers, because there is a PLL in virtually all modern TV receivers. This is the so-called horizontal automatic frequency control or AFC circuit, used to lock the horizontal sweep oscillator in phase with the incoming sync pulses.

You can see the similarity to this type of circuit in Figure 1, which shows the basic arrangement of a PLL. In simple terms, the frequency and phase of the voltage-controlled oscillator or "VCO" are locked to the input signal by comparing them in a phase comparator, filtering the resulting error voltage and using it after amplification to control the VCO.

Practical PLLs do not actually lock the VCO phase directly to that of the incoming signal, but because of the way they perform the phase

SE-

se-locked
plains
broad-

n recent-
one of
dyne-
of
nit, and
een very

become
nd will
sign for
works
o would

d
sed by
a
g it as a
sed for
thesis,
n was
ne

to
receivers.
FC
the

h
ency
d to
ng
rol

it of
se

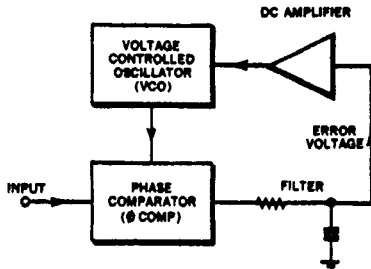

FIG. 1 BASIC PHASE-LOCKED LOOP (PLL)

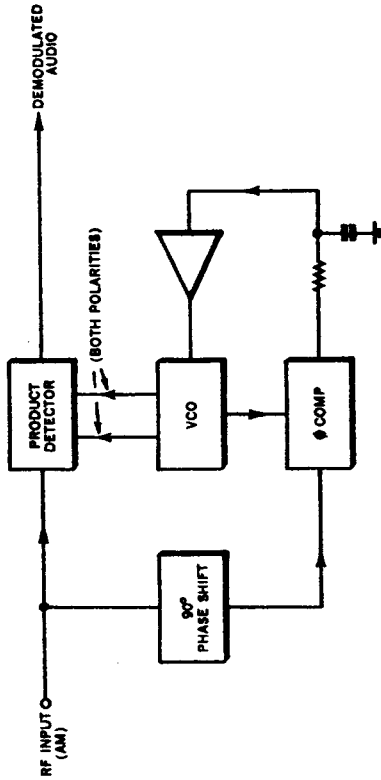

FIG. 2 USING A PLL FOR SYNCHRONOUS AM DETECTION

comparison there is a fixed phase difference of 90 degrees. For most applications this is not important, but when the PLL is to be used for synchronous detection of AM signals the 90 degree difference must be removed. This is done by feeding the signal used to lock the PLL through a 90-degree phase shift network, as shown in Figure 2.

The two 90-degree phase shifts effectively cancel, because regardless of the actual phase of the VCO - zero or 180 degrees relative to the input signal - both polarities of its output are fed to the product detector used to produce the demodulated audio.

As you can see from Figure 2, using a PLL for AM detection is in fact the Synchrodyne system. We beat the incoming AM signal with an oscillator of the same frequency and phase as its carrier, in a product detector, and thus produce the original audio information. The PLL is used to ensure that the local oscillator is accurately locked to the carrier.

It was with the general scheme of Figure 2 in mind that we bought a Signetics type NE 561-B integrated PLL a short time ago. The NE 561-B is a high performance device which includes not only the basic PLL elements of Figure 1, but also a product detector for AM detection. Typical devices will work from less than 1Hz to more than 30MHz, and will lock to input signals as small as 100 μ V.

A simplified block diagram of the NE 561-B is shown in Figure 3. Note that the PLL error voltage is amplified and brought out to pin 9, because the basic PLL can be used for FM demodulation merely by feeding in a frequency modulated signal. The modulation forces the PLL to follow it in frequency, so that a replica of the original modulating signal is generated as a component of the error voltage. A capacitor can be connected to pin 10 for de-emphasis if desired.

At the time we bought the device, only very scant applications literature was available. Undaunted, we hooked it up on the bench with the necessary components and power supply, making ample use of the "third dimension". An aerial formed by a length of hookup wire draped around the workshop was coupled directly into the PLL input via a 0.2 μ F capacitor. After a short while clean, crisp music emanated from the loudspeaker of the bench amplifier connected to the birds-nest. However after a few quick checks it soon became clear that there were a couple of nasty snags.

With the NE 561-B, tuning of the PLL's nominal frequency can be done using either a conventional tuning gang capacitor (but one with a rather odd value), or a pot in conjunction with a fixed capacitor. The pot is used to adjust bias current for the VCO, which is basically an emitter-coupled multivibrator. Tuning with a pot seemed both novel and simpler, so we had chosen this method. As a result we had no RF preselection ahead of the PLL.

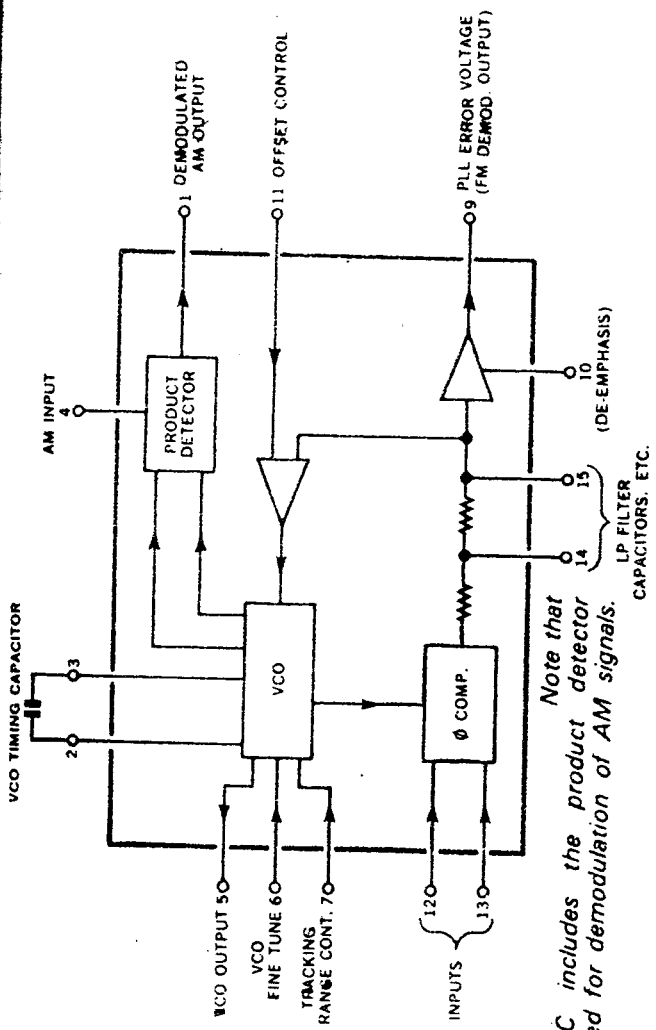

Note that the IC includes the product detector required for demodulation of AM signals.

FIG. 3 BLOCK DIAGRAM OF NE561B PLL

The most obvious problem was that without the preselection, the capture effect of the PLL resulted in it virtually ignoring the weaker stations, effectively "seeing" only the two strongest ones in our area — we could have either one or the other, and nothing else! There was also a pronounced distortion on transients, which we put down to a lack of sufficient carrier amplitude to reliably maintain PLL lock on negative modulation swings.

We also found that a filter was required at the AM output to attenuate the residual RF components from the product detector. When we tried a simple low-pass R-C filter it tended to chop the audio highs, so it was obvious that a not-so-simple filter would be needed.

To solve the first two problems we decided to use an RF stage, with at least a basic amount of preselection and gain. This more or less ruled out the pot approach for tuning the PLL, at least if it was to be tuned to each carrier in true synchrony fashion. We balked at the idea of trying to track a pot and a capacitor!

We tried two ways around this, one using a two-gang tuning capacitor and the other using push-button tuning. The latter seemed a good idea because of the heterodyne whistles which traditionally plague synchrony reception, although as it later transpired, this is not nearly the problem expected when a PLL is used.

Both of the approaches we tried seemed to lead nowhere. The mere fact that we were trying to make the PLL and front end track over the 1MHz range covered by the broadcast band seemed to produce all sorts of instability and component drift problems, and re-adjustment was constantly needed. Somewhat despondently we shelved the idea for a while, and only tinkered with it occasionally when time permitted.

Some time later we hit upon the idea of getting around these problems by using the superhet principle. The advantages were pretty obvious: with the PLL operating at a fixed intermediate frequency, the tuning and tracking problems would disappear. It would also do away with the inevitable compromise in the 90 degree phase shift network, which could be adjusted for optimum operation. Even the filter in the AM output circuit could become a simple IF trap, using a standard IF transformer. Sure, it was getting away from the classic synchrony approach, but we would still have the advantages of synchronous detection. And so was born the basic idea of the "super-synchrony".

The circuit and photographs show the experimental tuner that has been the initial outcome of all this activity. It uses a ferrite rod aerial and a simple autodyne mixer, with a FET RF stage in between the two. A BC109 or similar transistor is used as an amplifier to drive a voltage-doubling detector used to develop AGC for the RF stage, to overcome overload problems.

As you can see, the unit we built is wired on a piece of matrix board and uses a number of components resurrected from the junk box. The "germanium diodes" used in the AGC detector are actually the base-emitter junctions of two old germanium transistors, because we didn't have any OA91's or similar handy.

We also found it necessary to fit a small earthed shield around the 0.22 μ F bypass on the spare RF input of the IC (in 12), otherwise there was evidence of instability.

In you build this unit up, the free-running frequency of the PLL should be set up to 455kHz using the 50k pot, in the absence of signal. Ideally this should be done with a calibrated CRO or a frequency meter, but failing this the circuit can be roughly set by first aligning the front end and then adjusting the 50k pot until the IC will lock on the smallest signal. Probably the best way to do this is to use an aerial attenuator and keep tuning the signal down and re-adjusting the pot until you feel the optimum has been reached.

You will find that with a reasonable aerial and earth, the tuner gives quite impressive results. And perhaps the most surprising thing about it is the almost complete absence of the loud zeroing-in whistle usually found with synchrodyne. Because the PLL "jumps out and grabs" the signal as you approach it with the tuning, there is nothing more than a rapid "swish". In fact many people have tried tuning stations with the unit and have not realised that it is a synchrodyne until they have been told!

We are sure this is not the only approach by which you could get good results using the NE 561-B for high quality AM reception. However it is at least a starting point, and one which has been shown to give good results. The rest is up to you, largely. One addition which might make a worthwhile improvement is a tuning meter, which could be arranged fairly easily as an add-on to the existing AGC circuit.

SHOR

We prev
range 6
from 2-
to lister

As a log
the mo:
latest u
range b
speciali
commu

It is no
previou
two un:
reader
referen

As may
tuned c
has bee
require
to thos
althoug
assemb
higher
has bee

In addi
we hav
a nomi
any ch:
tuning
becaus
the rec
2.055M
this sig
outside

Due to
and os
longer

While
constr
aerial c
second
wire. I
small p
end du
of the

SHORT WAVE CONVERTER FOR 2MHz TO 6MHz

We previously described a simple converter covering the frequency range 6–19MHz. This is another version which is designed to cover from 2–6.5MHz, and should thus be of interest to readers who wish to listen to the marine and other transmissions within this range.

As a logical follow-on from our Basic Short Wave Converter covering the more popular short-wave bands between 6MHz and 19MHz, this latest unit covers the lower end of the short-wave spectrum: the range between about 2MHz and 6MHz. This band is somewhat more specialised, in that it includes quite a number of marine and other communications bands, but it can be quite rewarding.

It is not proposed to repeat all the constructional details as given previously. Rather, we will concentrate on the differences between the two units, giving sufficient information so that the more experienced reader will be able to construct this new version without much if any reference to the previous article.

As may be anticipated, the main differences lie in the coils and tuned circuits generally. The padding capacitor in the oscillator circuit has been changed from .0015 μ F to 470pF, to meet the new tracking requirements. The printed wiring board and metalwork are identical to those used previously. This includes the dial drive assembly, although this of course has a new scale. As mentioned earlier, this dial assembly has been modified and the new one requires a somewhat higher front panel although the mounting centres are the same. This has been taken care of in our metalwork drawing.

In addition to the more obvious changes from the previous converter, we have also made a slight change in the intermediate frequency, from a nominal 1.6MHz to a nominal 1.5MHz. This can be done without any change to component values, it only being necessary to adjust the tuning slug in the output transformer. This change has been made because when an IF of 1.1MHz was first used the local oscillator of the receiver into which the converter was being fed appeared at 2.055MHz on the converter dial. By changing to an IF of 1.5MHz, this signal from the receiver oscillator is on 1.955MHz, which is outside the tuning range of the converter.

Due to the somewhat larger number of turns required on the aerial and oscillator coils for the lower frequency range, we have used the longer type of Neosid coil formers.

While we are on the subject of coils, perhaps a good place to start construction would be to wind the aerial and oscillator coils. The aerial coil consists of a primary and a secondary winding, with the secondary wound first. This consists of 85 turns of 28 SWG enamel wire. The start and finish of this winding may be anchored with a small piece of adhesive tape. This is slipped under a few turns at each end during winding. The end protruding is then folded over the top of the winding when completed. The primary winding of 10 turns

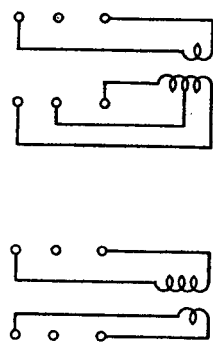
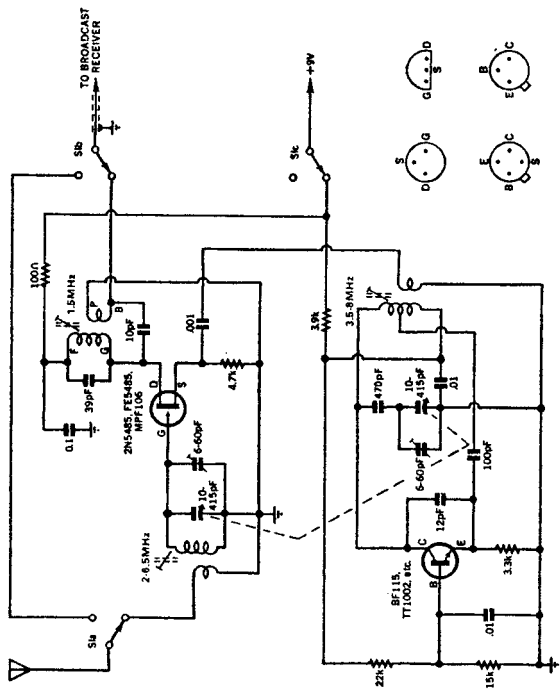

COIL CONNECTIONS VIEWED FROM ABOVE
 The coil connections. These should be followed carefully, as it is necessary to match the board connections.

2-6.5MHz SHORT-WAVE CONVERTER

This circuit is fundamentally the same as the original but with the necessary changes to allow for the new frequency coverage.

of 28 SWG enamel is wound over the bottom end of the secondary, after having placed a piece of tape over that part of the secondary. Again, tape is used to anchor the winding in place.

The oscillator coil is treated in much the same way as the aerial coil, bearing in mind that the frequency stability of the oscillator largely depends on this coil. It should therefore be wound firmly and finished in a workmanlike manner. The larger (primary) winding consists of 60 turns centre tapped, of 28 SWG enamel wire. The tap on the coil may be effected in a number of ways. One simple method is to scrape the enamel from about 1/8-in of the wire at the tapping point. Another short piece of the same wire is soldered on to act as a lead. To avoid a short circuit, a small piece of adhesive tape should be placed under that turn at the tap. The secondary winding of 10 turns of 28 SWG enamel is wound over the "earthy" end of the primary (that bypassed by the .01uF capacitor).

To ensure that the windings stay firmly intact, they should now be given a coat of cellulose lacquer or other suitable material. When dry, the leads should be terminated such that when the coil is fitted to the vero board, the pins correspond with the relevant parts of the circuit. This is shown in the diagram.

As the board was made to accommodate Neosid coil formers, we found it desirable to use an IF transformer as output, some care is needed in fitting this transformer. The following fitting procedure is suggested.

Bend each of the four pins over so that they lie across the corners of the can. Then the pins are bent in dog-leg fashion such that they will enter the four holes in the printed board. The can mounting lugs must also be bent inwards and in a similar manner so that they will also pass through the respective holes in the board. This done, the can may be mounted—but care must be taken to ensure that it is orientated correctly, according to the code on the circuit and that moulded adjacent to the pins.

As we mentioned earlier, the dial we used is no longer made but if you have one on hand, then it may be used, as the mounting holes remain the same. Alternatively, the new dial may be used as suggested, or you may make your own arrangements as you see fit, possibly by still making use of the dual ratio dial drive by Jackson Bros.

The complete dial assembly is supplied with a scale, having in addition to a 0-100 logging scale four blank ranges which may be calibrated according to actual needs. However, calibration of this converter may present problems to those readers who do not have any instruments for calibrating. To get around this problem, we are making scales available which are ready calibrated from 2-6.5Hz. It is then only necessary to identify a signal of known frequency towards each end of the scale and make adjustments which will be described later on.

Having completed the mechanical work, the converter is ready to be put into operation. Quite a number of items must be considered here. We will assume that you have a suitable broadcast receiver into which to feed the converter. A source of 9 volts DC at a couple of milliamps should also be available. Ideally, if the receiver has a suitable supply, then the converter may share it. On the other hand, a separate 9V battery may be used just as well. We will also assume at this stage that there is a suitable aerial.

Connect the converter to the receiver, a suitable source of power and an aerial. Assuming that no signal generator is available, set the receiver to 1500Hz on the dial before connecting the converter. Switch on the converter and tune in any station that may be audible, adjusting the slug in the output transformer for maximum response. This tunes the transformer to the IF of 1500kHz.

Now tune to a signal towards the low frequency end of the dial and one whose frequency is known. Having tuned the station, more than likely it will not be in the right place on the dial. In this case retune the dial to the correct frequency and adjust the slug in the oscillator coil until the station is again being received.

Now tune a station of known frequency towards the high frequency end of the dial. Once again, having tuned in the reference station, it is not likely to be in its correct position. Set the pointer to the correct point and adjust the trimmer on the oscillator section of the gang until the station is retuned. As always, when aligning a superhet receiver, this process must be repeated several times until the stations are set at the correct points at each end of the dial respectively. The slug is used for the low end, and the trimmer for the high end.

Each time the oscillator coil slug or trimmer is adjusted, the slug or trimmer on the aerial coil should also be adjusted.

If you have a signal generator or you have access to one, then the process of alignment is made that much easier, but the principles are the same. With an accurately calibrated signal generator, you may also calibrate your own dial scale.

If a signal generator is not available, there are some readily identifiable stations which can provide reference points.

The US standard stations, WWV and WWVH both radiate on 2.5MHz, 24 hours a day. In most cases they should be audible during the hours of darkness.

There may be instances where a reader is located close to one of the stations on the suggested IF of 1500kHz, possibly resulting in breakthrough. A way out of this problem is to retune the broadcast receiver away just far enough to avoid this problem. It will be necessary to return the output transformer to the new frequency. In an extreme case it may even be necessary to tune slightly higher than 1600kHz, but this is hardly likely. Furthermore, it would reintroduce the spurious signal just above 2MHz, as well as changing the dial calibrations somewhat.

THE SINFO CODE

S	Signal strength	1	Barely audible	4	Good
		2	Poor	5	Excellent
		3	Fair		
I	Interference (QRM)	1	Extreme	4	Slight
		2	Severe	5	Nil
		3	Moderate		
N	Noise (QRN)	1	Extreme	4	Slight
		2	Severe	5	Nil
		3	Moderate		
F	Fading	1	Extreme	4	Slight
		2	Severe	5	Nil
		3	Moderate		
O	Overall rating	1	Unusable	4	Good
		2	Poor	5	Excellent
		3	Fair		

THE SINPFEMO CODE

S	Signal Strength	1	Barely audible	4	Good
		2	Poor	5	Excellent
		3	Fair		
I	Interference (QRM)	1	Extreme	4	Slight
		2	Severe	5	Nil
		3	Moderate		
N	Noise (QRN)	1	Extreme	4	Slight
		2	Severe	5	Nil
		3	Moderate		
P	Propagation Disturbance	1	Extreme	4	Slight
		2	Severe	5	Nil
		3	Moderate		
F	Frequency of Fading	1	Very fast	4	Slow
		2	Fast	5	Nil
		3	Moderate		
E	Modulation Quality	1	Very poor	4	Good
		2	Poor	5	Excellent
		3	Fair		
M	Modulation Depth	1	Continuously over-modulated		
		2	Poor or nil		
		3	Fair		
		4	Good		
		5	Maximum		
O	Over-all Rating	1	Unusable	4	Good
		2	Poor	5	Excellent
		3	Fair		

Providing that you have a broadcast receiver of reasonably good sensitivity and a good aerial system, this simple converter is capable of giving a good account of itself.

A point which must be considered however, is the situation where the broadcast receiver to be used is fitted with a ferrite rod aerial. Many receivers are likely to come under this category, but if there is pro-

vision for an external aerial then there is no problem of coupling it from the converter. At the same time, many receivers do not have provision for an external aerial and it becomes necessary to gain access to the rod to add a coupling winding.

About three turns of light hookup wire should be wound over the earthy end of the coil on the rod. Tape the winding in place and connect the end nearest the earthy end of the main winding to some convenient earth point. The other end goes to the centre conductor of the coax from the converter, while the shield braid of the coax goes to the same earth point used for the earthy end of the added winding.

When using converters with ferrite rod aerials, there is a potential problem caused by the fact that the rod continues to pick up broadcast stations, regardless of the fact that the converter is connected to it. This can cause interference, particularly at night.

Should trouble be experienced, then the receiver may be retuned slightly.

PARTS LIST

- 1 Chassis-panel, 6½in long x 5½in high x 5in deep
- 1 Cabinet to suit
- 1 Dial assembly
- 1 Flexible coupling, ¼in x ¼in
- 1 Miniature toggle switch, 3-pole, 2-position
- 2 Terminals, 1-red, 1-black
- 4 Rubber feet
- 1 Rubber grommet for coax cable
- 6 Spacers, ½in long x ¼in diameter, tapped 1/8in Whitworth
- 1 Printed board, 6in x 3in, 73/3c
- 1 Aerial coil, 2 to 6MHz
- 2 Neosid coil formers, 7.6mm x 2.5mm with grade 900 slug can
- 1 Transistor, 2N5485, MPF106 or similar
- 1 Transistor, BF115, or similar

RESISTORS (½W)		1 100pF 630V polystyrene
1 100 ohms	1 4.7k	1 415pF 2-gang variable
1 3.3k	1 15k	1 470pF 630V polystyrene
1 3.9k	1 22k	1 .001µF 100V polyester (or polystyrene)
		1 .01µF 100V polyester
		1 0.1µF 25V ceramic

- CAPACITORS**
- 1 10pF NPO ceramic
 - 1 12pF NPO ceramic
 - 1 39pF NPO ceramic
 - 2 60pF Philips trimmers

- MISCELLANEOUS**
- Hookup wire, 2ft coax cable, solder, screws

Note: Resistor wattage ratings and capacitor voltage ratings are those used for our prototype. Components with higher ratings may generally be used providing they are physically compatible. Components with lower ratings may also be used in some cases, providing the ratings are not exceeded.

THE HOMODYNE TUNER: ANOTHER APPROACH

Due to problems with supplies of suitable ICs for the homodyne tuner, the author has developed an alternative version. Although simpler than the original, it will be of interest to many readers, particularly those who are experimentally inclined.

Previously the author discussed the principles of the "homodyne" method of reception and followed with a practical broadcast band tuner using ICs. Unfortunately the detector IC specified (the Motorola MC1330P) is temporarily out of stock.

This situation appears to be part of a general world-wide shortage of many types of ICs due to a resurgence in the electronics industry. As there is no direct substitute for MC1330P available and because of an apparent ready demand from hobbyists for a circuit that can be assembled using more readily available semiconductors, the author has developed an alternative version of the Homodyne Tuner employing field effect transistors in place of ICs.

Although readers are referred to the original articles for detailed discussion of the basis of design, briefly the operation of this circuit is as follows:

T1 is a junction FET RF stage whose output is coupled in parallel paths to T3, a product demodulator and T2, the second RF amplifier-limiter. The output of T2 is tuned to the incoming signal but amplitude variation (i.e., modulation) is limited by the shunt diodes D1 and D2, giving a carrier of about 1 volt peak-to-peak for injection to Gate 2 of the dual gate MOSFET demodulator.

The output from the demodulator is a relatively low-level audio signal which is amplified by transistor T4 before feeding an external power amplifier. The emitter circuit of T4 has an adjustable negative feedback control (P1) which is used to set the audio output level to the minimum acceptable to the following amplifier.

The printed board layout is to the same dimensions as the IC version and employs the same tuning unit. Alignment is quite simple, as L1-C4 determine the tuning range while L2-C9 may be set adequately by adjusting for best audio quality. It is normal to adjust the trim capacitors C4 and C9 only, as the permeability tuning unit is supplied pre-aligned.

Unfortunately this tuner has no AGC facility as had the IC version but in practice the dynamic range of the MOSFET detector has proved to be such that it is able to handle a large variation in station signal level without affecting operation. Adjustment of audio levels from station to station is therefore by means of the main amplifier volume control. An audio derived AGC was attempted but was found to be generally unacceptable on musical programmes.

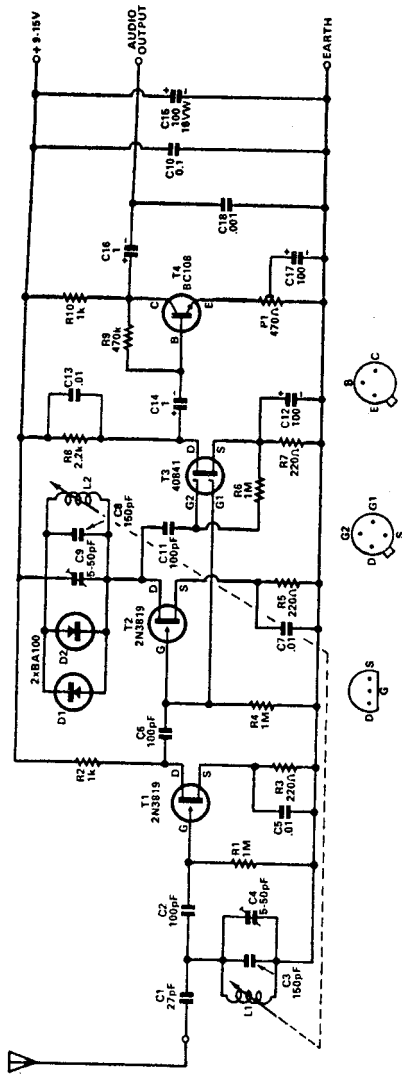

The circuit of our contributor's alternative Homodyne tuner design. It is still quite simple and easy to build, but lacks the AGC facility provided by the original design.

Editorial note: Soon after it became known that there were problems in obtaining the type MC1330P IC specified for the homodyne tuner previously described and before we were advised of the new design, we set about investigating the possibility of designing a similar type of tuner but using a readily available IC. The task was not an easy one but we have since overcome the obstacles and we have now completed the development of a very satisfactory unit.

Our tuner uses a National LM1351 IC, which is modestly priced, together with three transistors. The unit uses the superhet principle and features AGC, a 10kHz whistle filter and a tuning meter. There is still a considerable amount of work before it is ready for presentation.

An approach would be to make a tracing from the board pattern overlay on the diagram above, using carbon paper to transfer the pattern directly to the copper. We have reproduced the above pattern actual size, to allow this to be done if desired.

Permeability tuning units suitable for this and the earlier version of the Homodyne are currently available. In some cases the value of the resonating capacitors across the coils of the tuning unit may have to be altered to permit tuning of the full broadcast band, depending upon the actual coil inductance.

PARTS LIST

- 1 Permeability tuner, "Q" Inductance 164, or similar
- 1 Printed board, 73/tu11
- 1 Dial assembly, as required
- 1 Set of metalwork, as required
- 1 Transistor, 40841 (RCA)
- 2 Transistors 2N3819 (Texas)
- 1 Transistor, BC108
- 2 Diodes, BA100

RESISTORS (½ watt)

- 3 220 ohms
- 2 1k
- 1 2.2k
- 1 470k
- 3 1M
- 1 470 ohms trim pot

CAPACITORS

- 1 27pF NPO ceramic
- 1 5-50pF Philips trimmers
- 3 100pF polystyrene
- 2 150pF polystyrene
- 1 .001uF polyester
- 3 .01uF polyester
- 1 0.1uF disc ceramic
- 2 1uF tantalum or 160V polyester
- 3 100uF 16VW electrolytics

TWO SOLID-STATE RF PREAMPLIFIERS

An RF amplifier for short-wave receivers, with a wide frequency range, has always been a stage in which the design presents more than its share of problems. This was the case with valves and is now somewhat more so with solid-state devices. Here, we present some ideas as to how this problem may be approached with a satisfactory degree of success.

In the previous article we described a solid-state RF preamplifier for short-wave receivers. This design used a single low cost FET as the active element, together with four switched ranges to cover from 1.5 to 30MHz. Apart from the interest centred on the FET, the coils were all wound on ferrite toroids. These toroids allowed a high-Q coil, with all its advantages, together with a minimum space requirement and ease of construction.

This design proved to be quite successful.

An important point which emerged, when this RF Amplifier was integrated into a Communications Receiver, was the very good signal-to-noise ratio which was achieved. This has turned out to be so good that one gets the impression that the receiver is "dead" until a signal is tuned in. On the other hand, cross-modulation was evident, needing to be combated, with reasonable success, by introducing some aerial attenuation.

In valve amplifiers, the "cascode" has a reputation for low noise, with good cross modulation and AGC characteristics. The cascode configuration has recently been introduced into the field of solid-state devices and we therefore decided to make up an amplifier along these lines.

First of all, we decided to stay with the original idea of using junction FETs, but a change to a high frequency type was considered to be a forward step. The 2N5459 was therefore replaced with a 2N5485.

If we are to use a cascode circuit, shall it be series or parallel fed? This one was fairly easily solved. Since this type of FET should preferably be fed from a source of about 12 volts and since the supply voltage was to be 12 volts, each FET would only have a supply of half this value if we used series feed. By parallel feeding, each FET would have the full available supply voltage; and so it was.

What prompted us to look deeper into the RF amplifier problem, is the need for the best possible design, within reasonable limits. The main circuit diagram shows the details of development thus far. It could serve as the basis for an RF preamplifier to put in front of an existing receiver or as the basis for the first stage in a new receiver.

If your receiver is reasonably modern and has an RF stage, more than likely it will be adequately designed for good sensitivity and signal-to-noise ratio, as well as such other considerations as image rejection. Such being the case,

you are unlikely to be interested in an outboard RF preamplifier. On the other hand, if your receiver is an old one, with an old type valve in the RF stage, or if it does not have an RF stage at all, you may be interested in the designs which we are about to present.

We have already mentioned having settled for an amplifier using the "cascode" configuration. Let us take a look at the main circuit diagram, ignoring for the time being the coils and tuning systems generally. The cascode actually consists of two distinctly defined stages. The first is a straightforward grounded source (cathode or emitter) with signal input to the gate (grid or base) and with the output from the drain (plate or collector). This is followed by a grounded gate (grid or base) amplifier, with input to the source (cathode or emitter) and output from the drain (plate or collector).

Looking at each part separately, a grounded source stage normally has a high input impedance and a high output impedance. A grounded gate stage normally has a very low input impedance and a high output impedance. As can be seen from the combined circuit of these two parts, the output of the first section is looking into or shunted by the input of the second section. This means that the output of the first stage is severely loaded and the amplification of this section is greatly curtailed. However, the second section is able to provide its full amplification and most of the amplification from the system comes from this latter section.

Note that the overall cascode circuit has a high input and high output impedance, free from the embarrassments which a low impedance circuit can sometimes cause.

The first section of the cascode uses a type 2N5485 FET, with the tuned circuits looking into its gate. A bias resistor of 150 ohms, shunted by a .01 μ F capacitor, is in the source return path. These two items are normally grounded, although they are shown in series with a bipolar transistor. More will be said about this transistor later on. The value of 150 ohms for the bias resistor is a design centre value for this type of FET and normally should be adhered to. The drain load is a 2.5mH RF choke.

The second part is fed from the source of the preceding stage, via a .001 μ F blocking capacitor. The gate is grounded directly. In the source circuit, is another 150 ohm bias resistor. So that the input impedance of this stage will not be any lower than necessary, a 1mH RF choke is connected in series with the 150 ohm resistor. The drain load for the second part is complex, in that there is a resistive load of 680 ohms, in series with a parallel tuned circuit. The latter circuit is resonant a little lower than the upper tunable frequency of the system, which is 30MHz. The idea of this arrangement is to try to keep the gain of the system reasonably constant over the whole tunable range.

The parallel resonant circuit in the source load of the second stage is heavily damped to smooth out the gain near the high frequency end,

between about 25 and 30MHz. The two RF chokes involved between the two parts were chosen to have different values as a precaution against possible spurious oscillation.

As the output impedance of the cascode amplifier is relatively high and we want to feed it into a low impedance circuit, such as the aerial terminal of a receiver to retain the gain achieved, we have used an emitter follower stage to effect the impedance transformation.

Having discussed the amplifier section of the circuit, let us now turn to the tuned circuits. In line with our previous efforts, we are again using coils wound on ferrite toroids. These give coils which are reasonably easy to wind, are compact and have a high Q, making them ideal for our purpose.

From the aerial, the signal is directed to the appropriate coil primary, via a rotary switch. It will be noted that in most cases there is a series capacitor in this circuit. These have been introduced in an effort to further even out the overall amplification of the system. These values could be subject to some experiment, if the reader so desires.

To restrict the frequency coverage of each coil, using a 415pF tuning capacitor, a fixed capacitor is connected between the tuning capacitor and each coil, where this is necessary, with individual values selected to suit the required range. These capacitors are interposed between the coil and its switch contact.

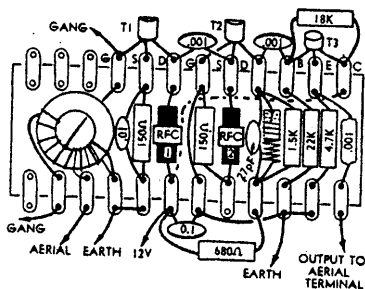

the wiring diagram showing how we wired the board for the multiple tuned version. It is substantially the same as the component board for the switched coil version.

The signal level across the variable capacitor is limited to the ratio of the variable and fixed capacitor, and is less than the full value as measured across the coil. It is therefore necessary to take the signal from across the

d between the
ion against

ely high and
: aerial
sed an emitter

low turn to
again using
asonably easy
for our

I primary,
is a series
ffort to further
es could be

RF tuning
: capacitor and
cted to suit the
coil and its

I for the
ponent

ratio of the
measured
n across the

coil. This involves using a third switch section on the range selector switch, the rotor feeding directly to the gate of the FET.

To restrict further the frequency coverage of each band, this time at the high frequency end, where necessary, a fixed capacitor is connected across the coil.

External fields around the toroidal coils are very small and coils of various ranges may usually be located close together without serious problems with "suckout". Nevertheless, we did detect some evidence of the effect and as we had a spare section on the range selector switch, we used it to short out certain coils.

So much for the basic design of the system. When this unit was being discussed earlier on, it was suggested that it might be a good idea to present an alternative and much simpler tuning system, still feeding into the same amplifier. The tuning system referred to is one which has been around for a long time.

The circuit of this tuning system is shown as an alternative tuning system, along with the main circuit diagram. Instead of the five separate coils, with their capacitors and switching system, there is only one coil with a two gang variable capacitor, instead of the single gang used above. It will be noted that there is a tap on the secondary of the coil, with a single winding for the primary.

With this arrangement, we can cover from 2MHz to over 30MHz in one sweep of the dial. This may seem incredible and even impossible at first sight. However, at the risk of a little over simplification, this is how it works.

Consider the full winding first, with one section of the gang across it. This is a simple parallel tuned circuit and could reasonably be expected to cover from some low frequency, say about 2.5MHz, to about 10MHz. In addition to this function, however, the other section of the gang is connected across the tapped section of the coil. This has much less overall effect than the first section, but might augment the former to make the overall tuning range from say 2MHz to 10MHz.

Now consider the small tapped part of the coil, with one section of the tuning capacitor across it. On its own, it is reasonable to assume that this circuit will resonate over some higher frequency range than that of the full coil and tuning capacitor.

In fact, that part of the coil winding above the tap is somewhat larger than that part below the tap and, at high frequencies, this larger part of the coil "looks like" an RF choke. This RF choke effect virtually isolates the lower resonant circuit from the rest of the circuit over the higher frequency range. By correct selection of the tapping point on the coil we can make this circuit tune from say 10MHz to above 30MHz.

This is just what happens and we have a second tuning range from 10MHz to well above 30MHz. To limit the upper frequency of this range, we have added a variable trimmer across this section of the gang, so we can adjust it to cover from 10MHz to 30MHz for our purpose.

The two ranges just cited, 2MHz to 10MHz and 10MHz to 30MHz, are, in fact, the ranges of our tuning system and we have plotted these on a graph, which is reproduced in these pages. From this can be clearly seen the two frequencies for any particular position on the tuning calibration.

As mentioned during our discussion of the switched coil system, there is always the problem of keeping the gain reasonably constant from the lowest to the highest tuned frequency. In the normal course of events, the gain falls off seriously at the high frequencies, where it is most needed and the gain is highest at the low frequencies where it is least needed! (Murphy's Law perhaps.) In the multiple tuning circuit, it will be noted that the gate of the amplifier is fed from the tap on the coil. This gives the full voltage to the amplifier from the high tuning range but taps down for the low tuning range, just what we need. It helps to level out the gain in quite a neat fashion.

From the discussion of the multiple tuning circuit, it would seem reasonable to ask, why go to all the bother with the other system using switched coils? This is a fair question. In fact, there are some "catches" to the multiple tuning system. It will be up to the reader to sort out the pros and cons.

Although we only have one coil and need no switch, a two-gang tuning capacitor is required. This is probably a minor point. Also, with this system, it is not easy to get coverage right down to the broadcast band while going up to 30MHz. A no less important point is the fact that this system tunes to two frequencies at once. In some circumstances, this could mean that a wanted signal could be interfered with by an unwanted signal coming through on the second tuned frequency.

Under most conditions of use, this RF amplifier and tuner would be used with a receiver which would be tuned to the wanted frequency and would be able to discriminate well enough against the unwanted signal. However, if we went to the trouble to make the system cover the broadcast band as well, it is almost certain that problems would be encountered with strong local broadcast stations breaking through where they were least wanted. But, to sum up, this system is well worth a trial.

Earlier we mentioned the application of AGC to the RF amplifier. Normally, when this unit is used outboard, AGC would not be applied. Later, we will deal with some means of manually controlling this stage. In the main circuit, we show a bipolar transistor in series with the bias resistor of the first stage. This transistor can be part of an elaborate and very effective AGC system of a complete receiver.

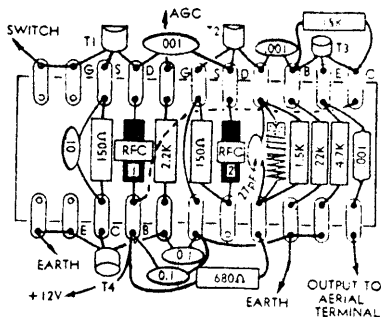
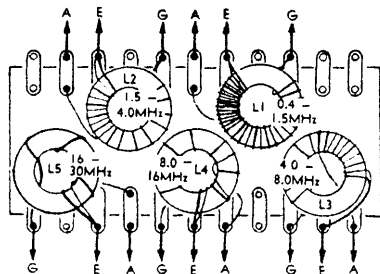

This wiring diagram gives details of the component board for use with the switched coil version. The two above boards should be orientated carefully to make for short wiring leads.

Under full gain conditions, the bipolar transistor needs to be so biased by the AGC system as to be "bottomed" or fully conducting. This means that the effective ohmic resistance between collector and emitter will be very low indeed. This resistance is effectively in series with the amplifier source circuit, and, being very small, will have negligible effect on the amplifier.

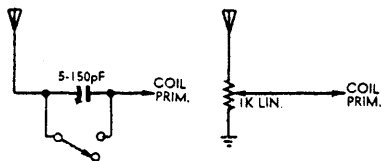

These aerial attenuators are suggested methods for limiting signal input. Either one can be used, depending on which seems best to meet the particular situation.

When the AGC becomes operative, the forward bias to the bipolar transistor must be reduced progressively. This effectively causes an increase in the collector-emitter resistance of the transistor and this in turn is introduced into the source circuit of the amplifier. This resistance is not bypassed to RF and so has a degenerative effect on the signal into the amplifier. This effect increases or decreases according to the strength of the received signal. With this system of AGC, it is possible to get a very high degree of control and it is one of the better systems in use today.

An alternative AGC system may be applied to this type of amplifier. The system consists of applying an increasing negative control voltage with increasing signal strength, to the gate of the first part of the RF amplifier. To do this, a "gate leak" must be introduced into the gate circuit, with a DC blocking capacitor. The AGC voltage is fed into the lower end of the "gate leak" resistor. Instead of the shunt feed system just described, the AGC voltage could be series fed via the tuning coils.

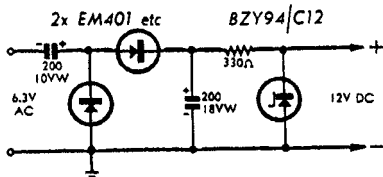

This circuit may be used to power the RF amplifier from a source of 6.3 volts AC, such as the heater supply of an existing receiver.

For those not requiring an AGC facility, an effective manual control may be fitted by introducing a variable resistor in the form of a potentiometer, in series with the 150 ohm bias resistor, in the position shown for the bipolar AGC transistor. The maximum value of the potentiometer may be between about 10K ohms and 50K ohms.

Another problem relating to RF amplifiers and which was mentioned earlier, is that of cross modulation and other related problems. An effective method of dealing with this nuisance is to insert some form of attenuator in the aerial circuit. Two simple methods of doing this are shown in an accompanying diagram. One is simply a 1K potentiometer across the aerial input, with the rotor of the potentiometer feeding the primary of the relevant coil. Another method is to use a midget variable capacitor of about 150pF maximum, in series with the aerial lead to the coil primary. Both systems are effective and both could be tried and the one adopted which meets the need in the better way.

As we have two different approaches to the tuning of the RF Amplifier and the physical requirements are different, we will run through each one separately. Firstly, we will do the more conventional one, with the switched coils.

With the exception of the aerial attenuator, whatever type may be used, and the tuning capacitor, all components are integrated into one assembly. Most of the components are mounted on a strip of tag board, with 11 pairs of tags. The five toroidal coils are mounted on another similar size tag board. Both of these are shown in the respective sketches.

A logical place to start is winding the five toroidal coil units. This task is straightforward but a few comments may make the job a little easier. The number of turns quoted in the coil table may be considered as the number of times the wire passes through the hole in the toroid. It is a good idea to make an estimate of the quantity of wire required for the secondary and then locate the centre of the length. Pass one end through the toroid and bring the wire to the centre point, thus leaving equal amounts to be wound with half the number of turns each way. This means that there is less wire to thread through each time. Care should be taken not to scrape the enamel from the wire against the edges of the toroid.

At one end of the secondary winding, which will become the earth end, the primary is wound on. The common earth ends of the two windings should be bared, tinned and soldered together.

The number of turns on each winding and the disposition of the windings should be closely adhered to, as given in the table. However, the gauge of wire specified is simply a guide. If you do not have the exact gauge specified, something close to it should suffice. At the same time, particularly for the higher frequency coils the gauge of wire should be as heavy as practicable, to reduce the RF resistance of the coil and so give a higher Q.

With the five coils wound, they can be mounted on the tag board in the relative positions shown in the diagram. The respective ends of the windings are terminated at convenient adjacent tags on the board. In the case of the lower frequency coils, which are wound with relatively fine wire, this is not sufficient to fix the coil securely to the board. This is best done by simply tying the toroid to the board with a piece of nylon cord. While not so necessary with the coils wound with heavy wire, it is a good idea and ensures that they do not move about.

The main component board is next and is wired up according to the diagram. The usual care should be taken not to overheat any of the components, particularly the transistors. Make sure that all the interconnecting wires are complete before any attempt is made to take the assembly of this board any further. The three capacitors in series with the tuning capacitor are not wired in at this stage, however.

The two above sub-assemblies are mounted on the end of the range selector switch and separated from each other and the switch with $\frac{1}{2}$ in long spacers. The first step in assembly involves fitting the first pair of spacers to the rear ends of the two switch retaining screws. Generally, there is about $\frac{1}{16}$ in of thread protruding beyond the nuts. The screws

used,
assembly.
11 pairs
tag board,

task is
ier. The
number
idea to
ry and
id and
e
ere is
scrape

end,
ings

ndings
age of

rticularly
as
her Q.

the
vind-
case
vire,
t done
While
dea

dia-
ponents,
ires are
ard any
ot

in
if
,
ws

used in MSP switches are 5BA and the threaded spacers which are readily available are 1/8in Whitworth. These dissimilar threads do not mate very well but due to the short length of the thread, it is possible to screw spacers on, provided due care is taken. If you can substitute Whitworth screws, so much the better.

Having mounted the spacers, check the centre-to-centre dimension between the spacers with that of the third hole from each end of the two boards. More than likely you will find that the two holes are too close together. A little filing with a small round file will put this right.

The board with the coils is mounted against the spacers at the end of the switch, with the coils away from the switch. The second board is spaced

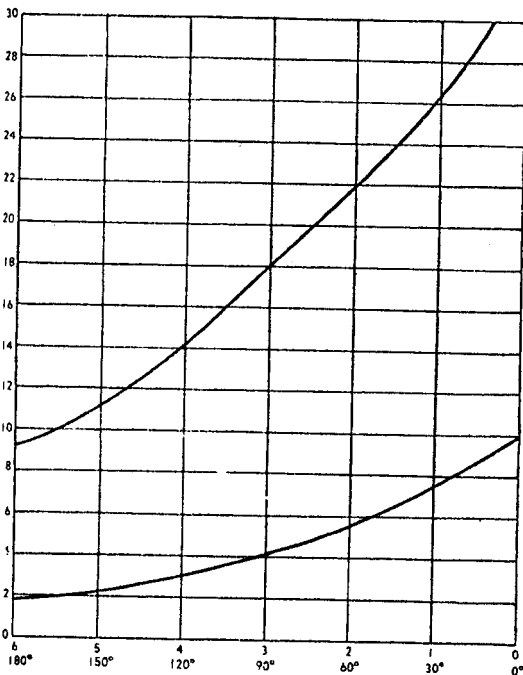

The graph at left shows how the multiple tuned circuit tunes to two frequencies at any one time. Duplicated amplifiers by readers may not coincide exactly with these curves but they should be a close approximation.

away from the coil board with the second pair of 1/2in spacers. Two round-head screws, 1/8in x 3/4in are used to secure the two boards to the spacers on the switch.

The assembly is now ready for the outstanding wiring and components. The various sections of the switch are used as follows: One section of the wafer nearest the clicker plate is used to switch the aerial into the primaries of the coils. The corresponding section on the other wafer (nearest the line of transistors) switches the tuning capacitor to the relevant series capacitors. The other section of the same wafer selects the top of the secondary of each coil. Finally, the otherwise spare section of the wafer nearest the clicker plate is used to short-circuit certain coils as required. This should be wired carefully, as mistakes are easy to make here.

The wiring involves the interconnections between the various contacts on the switch and coils, together with the series tuning and aerial capacitors. The latter capacitors are wired with a very short lead, to anchor them close to the lugs on the switch. The other leads up to the coil board will need to be fairly long and these should be run directly and with the use of some nylax tubing for insulation where necessary.

This almost completes the assembly, but we must bring the tuning capacitor into the picture. The final choice is up to the builder but, for the sake of convenience in presentation, we made up the final assembly on a small "U" shaped bracket, similar to the way it would be assembled on a chassis. The complete unit is shown in the photograph. We have not accommodated the aerial attenuator on this assembly, but readers again will be able to decide the best place for this on individual merits.

For those readers who choose to make up the multiple tuner version of the RF amplifier, here are some comments which we hope will be of assistance. Looking at the main circuit and replacing the inset giving the multiple tuner details, you will see that it is much simpler. The earlier comments relating to the aerial attenuator still apply as do all other comments on the rest of the circuit, except the coils and switching.

Instead of the overall assembly centred around the switch, we have a slightly modified wiring board, similar to the amplifier board for the other units, but extended in length to 12 pairs of tags. It will also be noted from the wiring diagram for this board that the special transistor and components for the AGC transistor have been omitted. This will normally be the case for the other board, unless readers wish to use the AGC system. The resulting extra length of board is sufficient to accommodate the one coil needed.

Details for the above coil are given in the coil table and this should be wound first, with the previous comments applying. In addition to the primary and secondary windings as before, the secondary is tapped at eight turns from the earth end.

Next, the board should be wired up as shown in the diagram, care being taken as with the other one, that components should not be overheated. With this wiring completed, the coil can be fitted and if thought desirable it may be held in place with a tie of nylon cord.

As mentioned much earlier, the multiple tuner requires a 2-gang capacitor. It will also be noted from the circuit that the section of the gang across the tapped part of the coil is shunted with a 3-30pF variable trimmer. This is fitted to restrict the upper tuning limit to a little above 30MHz.

Rather similar to the previous case, the wiring board and the 2-gang capacitor are finally assembled in an "L" shaped bracket, as shown in the photograph. The capacitor stands on the horizontal part, with the wiring board screwed to the vertical part.

When mounting the wiring board it is necessary to stand it off the bracket by $\frac{1}{8}$ in to $\frac{1}{2}$ in, to allow sufficient clearance for wiring soldered joints and any protruding components. This can be done simply by using screws of appropriate length and using extra nuts so that the amount of clearance is achieved.

This completes the description of two versions of the RAF Amplifier but it is still necessary to provide a source of a minimum of 9 volts and preferably 12 volts D.C. as a power supply. This can be met quite readily with a battery but a small supply can be built up to operate from a source of say 6.3 volts AC. This supply may be obtained from the heater supply of the receiver proper where convenient. On the other hand, a small heater transformer rated at 6.3 volts and up to one amp would be suitable. A circuit of the suggested power supply is shown in a separate diagram.

Testing of either unit is quite simple. The usual wiring check should be made before applying power. The output of the amplifier is fed into the aerial terminal of the receiver, preferably via a short length of coaxial cable. A suitable aerial is connected to the amplifier input.

Select the appropriate range (in the case of the switched unit) to suit the frequency to be tuned on the receiver. Tune the wanted station on the receiver and then peak the signal by tuning the RF Amplifier. As a preliminary check, this procedure should be carried out across the full coverage of the system. More than likely, signals will not be available over such a wide range at any given time. If a signal generator is available, it could be used to advantage.

The RF Amplifier is now complete and the method of using will be clear by now. At the same time, a little experience will soon show the best way to use this device. In some cases, it will be possible to tune the RF Amplifier to the "image" signal, rather than the wanted one. This must be carefully guarded against, where this condition exists.

Such a condition can occur, in single conversion receivers using an intermediate frequency of 455KHz (or lower) and at signal frequencies from about 7MHz, getting progressively worse as the frequency is increased. In the case of a 455KHz IF, with the local oscillator tuned to the high side

of the wanted signal, another signal at twice the IF, or 910KHz higher, will also get through the system and cause interference. However, with the RF Amplifier, extra RF selectivity is achieved and the image frequency will be either eliminated or reduced in severity.

COIL WINDING DETAILS

- L1 Sec. 100 turns 25 SWG En. to occupy 100 per cent of former. Prim. 3 turns interwound at earthy end of sec.
 - L2 Sec. 50 turns 23 SWG En. to occupy 100 per cent of former. Prim. 7 turns interwound at earthy end of sec.
 - L3 Sec. 18 turns 23 SWG En. to occupy 50 per cent of former. Prim 3 turns interwound at earthy end of sec.
 - L4 Sec. 8 turns 18 SWG En. to occupy 50 per cent of former. Prim 2 turns 23 SWG En. interwound at earthy end of sec.
 - L5 Sec. 4 turns 18 SWG En. to occupy 33 per cent of former. Prim 1 turn 23 SWG En. interwound at earthy end of sec.
 - L6 Sec. 27 turns, tapped at 8 turn, 21 SWG En. to occupy 75 per cent of former. Prim 2 turns interwound at earthy end of sec.
- L1 to L6 all wound on type F4040/2 ferrite toroid formers, of Q2 material.
 L7 12 turns 23 SWG En. straight on thread of 7.6mm x 1/2in. long iron dust slug. Neosid grade 900 or similar. Exact diameter not important.

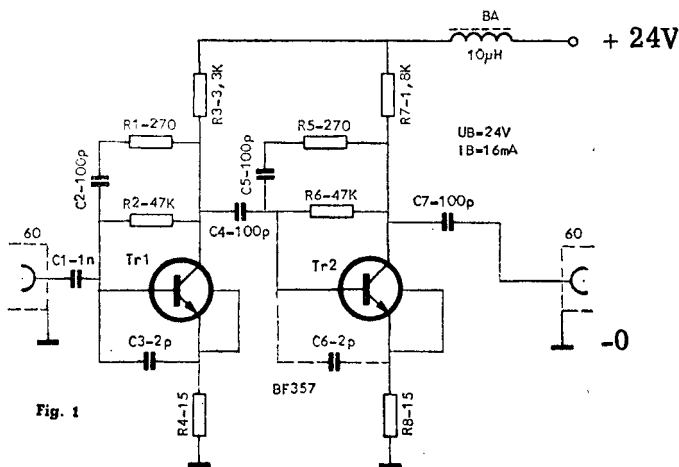

40 to 800 megahertz RF amp

BF357=RS276-2011/2015, BF377-378, MPS918, 2N918-3570, BFY90, BFS17R

BASIC RECEIVER FOR SLOW-SCAN TELEVISION

Here is a new design for a monitor to display slow-scan TV pictures, of the type being transmitted by increasing numbers of radio amateurs. It uses four valves, four transistors, an IC and two SCRs, each performing the circuit functions for which they are best suited. This simplifies the unit and makes it easy to build, without sacrificing performance.

Slow Scan TV, or SSTV for short, has become very popular in the United States and activity is beginning to quicken in this country as well. However, many amateurs possibly do not realise just what a fascinating and absorbing branch of amateur radio is available to them, at quite a modest outlay in cost and equipment. Very little has been published in this country on the subject of SSTV and we propose to remedy that at least in some measure.

Without doubt, the best place to start in SSTV is with a monitor. Involving no more complexity than a modest CRO, a monitor can be used with the existing shack receiver, so that you can really "read the mail" of any amateur SSTV transmissions, either locally or from overseas. Equipment for the transmission of amateur SSTV signals is a little more involved and for the present at least, we will confine our efforts to describing a new monitor.

For those not yet familiar with SSTV, it is basically rather similar to conventional television except that the rate of scanning is slowed down from one picture every 1/25th of a second to approximately one every 8 seconds. This reduces the bandwidth required to transmit the signals from the usual 5MHz or so right down to a figure well within the audio spectrum. And as a result, SSTV signals can be transmitted and received using almost any of the established types of radio equipment, whether it employs AM, FM, SSB or other types of modulation system. Actually the SSTV "video" signal itself is not used to modulate the RF carrier directly. Because of the low scanning rate, the video is largely made up of very low-frequency components, and for these to be transmitted and received properly the transmitter and receiver would have to be fitted with much longer time constants than usual in the coupling circuits and other sections. To avoid this, the SSTV video signal is used to frequency modulate an audio subcarrier.

The subcarrier is made to vary between the limits of 1200Hz and 2300Hz. Synchronising pulses correspond with 1200Hz, black level is 1500Hz, and white level is 2300Hz, with shades of grey in between black and white. Horizontal sync pulses have a duration of 5mS, with 30mS for vertical pulses.

The number of scanning lines is 120. Due to the fact that the United States uses a 60Hz standard for their supply mains while we, Britain and many other countries have a 50Hz standard, and as the mains frequency

is used as a reference for synchronising pulses, a compromise has had to be struck. The result is a 15Hz sweep rate (60/4) for the US and a 16-2/3Hz sweep rate (50/3) for Britain, etc. To tie in with the set 120 horizontal lines, the vertical rate is 8 seconds and 7.2 seconds for 60Hz and 50Hz mains frequencies respectively.

The question may well be asked as to how this works out when an amateur in Britain is in SSTV contact with an amateur in the United States. In fact the differences in sweep rates are not very great and are well within the synchronising capabilities of the equipment involved. The pictures stay in lock, but the picture size will vary slightly.

Our approach to the design of an SSTV monitor has been along lines already established overseas. However, in order to encourage newcomers into this fascinating field, we have made some effort to simplify circuitry as much as possible, together with an eye to keeping costs down.

Apart from the usual precautions with the installation of a CRO tube with respect to magnetic fields, layout does not seem to be at all critical.

Let us turn our attention to the circuit diagram and go through it, discussing the various circuit functions. The frequency modulated SSTV subcarrier is fed to the input. This may be from a communications receiver, tape recorder, etc. To avoid excessive input to the 741 op-amp, a pair of 1N914A diode clippers are included. The signal is amplified by the op-amp and emerges as a square wave. In series with the output is an inductor, about 200mH, shunted by 0.022uF which tunes it to 2300Hz. This LC combination is the "video discriminator" and is effectively a rejector circuit at 2300Hz. The FM signal passing through the discriminator is effectively changed into an AM type signal, rather like the well established "slope detection" used in AM receivers for receiving FM signals.

This AM signal passes through a level or "contrast" control and is then amplified by TR1. The output at the collector is stepped up in voltage by the transformer, where it is detected in the bridge consisting of four silicon diodes. The video voltage from the detector is then fed directly between the cathode and grid of the cathode ray tube, where the beam is modulated to give shades of grey between black and white levels.

Returning now to the output of the video discriminator, a split is taken via a sync level control, to the sync discriminator. The level available from the video discriminator is quite high, much too high for our purpose and so the need for the 220k series resistor and the 470 ohm resistor shunting the 47k potentiometer.

The sync discriminator is, in effect, a frequency conscious amplifier, using a twin-T network and peaked to the sync frequency of 1200Hz. This circuit was selected in preference to an LC circuit similar to the

video discriminator because a fairly high Q circuit is required and readily available coils did not come up to this requirement.

Following the sync discriminator is a two-stage sync separator using TR3 and TR4. In the collector of TR4 is a light emitting diode, which blinks on every sync pulse and is very useful for adjustment purposes. Sync pulses appear across the 0.15 μ F capacitor and are fed via a 10k isolating resistor to the gate of the SCR in the horizontal deflection circuit.

The 30ms-long vertical sync pulses are a little tricky to separate out cleanly, but by using the two-stage sync separator, an integrator consisting of the 27k resistor and 1 μ F capacitor, together with a vertical sync level control, very successful vertical synchronising has been achieved. The vertical sync pulses are fed into the gate of the SCR of the vertical deflection circuit.

As the vertical sweep rate is very slow, between 7.2 and 8 seconds, it often happens that when receiving a transmitted picture, you have just missed a vertical pulse. This would normally mean that you have to wait a very considerable time before you start to get the next picture. To avoid this, it is fairly standard practice to include a manual vertical triggering button. This is simply a 1M resistor from the high tension in series with a "make" press button on the front panel.

The sawtooth generators are perhaps of more than just passing interest. The simplicity is such that it is difficult to image anything simpler. Fundamentally, the generator consists of a resistor and capacitor time constant, with an SCR to initiate flyback. The sawtooth appearing across the capacitor is DC connected to the grid of the relevant deflection valve. There are only two extra components additional to those already mentioned. A 22k resistor from the gate of the horizontal SCR to ground is added to ensure a reasonably low impedance so that there is less likelihood of spurious triggering, while 6.2V zener diodes are used to limit the maximum voltage across each capacitor.

The foregoing describes both horizontal and vertical generators in principle. The horizontal circuit has an 8.2M resistor and a 470k in series with a 0.47 μ F capacitor. The 470k resistor may have to be modified during adjustment but more will be said about that later on. The vertical circuit has an 8.2M and a 5.6M in series with a 47 μ F tantalum capacitor. Instead of the 22k resistor from the gate of the SCR to ground, the in-circuit resistance of the 100k vertical sync level control is substituted.

Each deflection circuit consists of two 6BX6 valves in a "long-tail pair". Direct coupling from the valve plates permits the use of amplified trace positioning. This is achieved by an adjustable voltage via a potentiometer to the undriven grid of each pair. The grid is bypassed for signal frequencies with a 0.01 μ F capacitor. Gain of the stage and so sweep size, is controlled with a resistor between the cathodes of each pair. These are set during adjustment and will be covered later in detail.

Before leaving the two deflection amplifiers, it may be seen that the horizontal amplifier has a 4uF electrolytic bypassing the screen grids. On the other hand, no bypass is included in the vertical stage screens. To be effective at such a low frequency the capacitance would be prohibitively large. Happily the stage works quite satisfactorily without any bypass.

The power supply system is of necessity rather complex. However, we have managed to simplify it as much as possible and only one transformer is involved. There are two 6.3V windings, one for the CRT heater while the other supplies the deflection valve heaters, together with the plus and minus 15V supplies for the solid state circuits. These use voltage doubling, with the output stabilised by 15V zener diodes. Additional filtering was found to be necessary on the positive rail and this is provided with a 1000uF electrolytic across the output.

High tension for the deflection amplifiers is obtained by full wave rectification from a 250-0-250 volts secondary winding. It was found that a considerable amount of filtering of the HT line was necessary. This is achieved with a two-stage filter, making use of four 24uF 350VW capacitors in one can, with two 1k 3W resistors.

EHT of nearly 700 volts is obtained by voltage doubling from one side of the HT winding. The output capacitor consists of two 8uF 450VW units in series. The DC voltage across each unit is established by connecting their junction to the junction of the 100k focusing pot and the 220k resistor of the EHT voltage divider chain. A 39k resistor between the cathode of the CRT and the EHT rail sets the brightness level, and may need adjustment during final setting up.

So much for the circuit. Now a few comments about components may be helpful. As mentioned earlier, our prototype is a much rebuilt 3in Oscilloscope and as such, uses the original metalwork. The only change of note, is that a new front panel overlay was needed. More than likely readers will have their own ideas about this and a suitable panel could be made up from a piece of aluminium.

Resistors and potentiometers should present no problems. The capacitors should all be available, with one possible exception. The can type housing four 24uF 350VW units may be difficult to obtain but substitutes in the form of separate capacitors should be easy enough to obtain. The capacitors which we used are either electrolytics or polycarbonates, with two exceptions. They are the two 47uF, 6.3VW tantalums. Diodes should present no problems. Either the types specified or their equivalents may be used. The only possible exception is the LED. This may be any small ruby coloured unit, with a bezel for mounting it on the front panel. A wide variety of suitable LEDs are currently available.

The two SCRs which we used are made by ITT but any low power SCR should be quite suitable; the circuit is quite undemanding. Similarly the 741 IC comes in various makes and packages. The one we used is in a 14-pin dual-in-line package but no trouble should be experienced in adapting almost any mechanical arrangement. The transistors, of which there are only four, are all readily available. However, if substitution of the BFY51 video amplifier is considered, care should be taken to make sure that the substitute will do the job.

The 6BX6 valves should still be readily available but if you have some other types on hand, then they may be used provided they will do the job. The pentode section of a 6BL8 is quite satisfactory and we imagine that other types such as 6AU6, 6AM6, etc. would be satisfactory. The CRT is special in that it has a long persistence phosphor. When ordering the tube, a mu-metal shield may be ordered at the same time. The orange perspex filter which we fitted, although not essential, does seem to help to give a better picture. Pieces of suitable material should be available from suppliers.

The small transformer feeding the detector is actually a miniature 240/12.6V heater transformer. The mains transformer is not quite so easy. The type of reader who is likely to make up one of these slow scan monitors is also likely to have a transformer of similar specs in his junk box. It may be necessary to add a shorting strap to reduce the stray field. In any case, we feel that we can leave this problem for each individual to solve in his own way.

From the constructional point of view, we will assume that readers will be following the method which we used. Any deviations can safely be left to the individual to sort out for himself. We will also assume that you have a suitable set of metalwork.

A good place to start is with the subassemblies. There are five main boards, each with components mounted on miniature tag board and we have given wiring diagrams to make the job somewhat easier than if you had to work it all out for yourself.

One board includes the signal input, IC op-amp, video discriminator, video amplifier and detector. The detector transformer is mounted separately. It is straightforward except for the IC and the 200mH coil. We used a socket for the IC and we snipped off all the unused lugs. With the socket correctly located on the board, we drilled five small holes corresponding to pin positions 4, 5, 6, 10 and 11. The socket is located in these holes and the lugs are connected to the tagstrip as indicated, by means of thin tinned copper wire. Before mounting the 200mH coil, carefully cut off the extreme end at the moulded shoulder. Cut off all four corner lugs and bend the remaining two active lugs out at right angles for soldering to the appropriate lugs on the board.

The board containing the sync discriminator and sync separator presents no problems. The trim pots are mounted vertically and it may be seen

Connects with drawing on Page 54

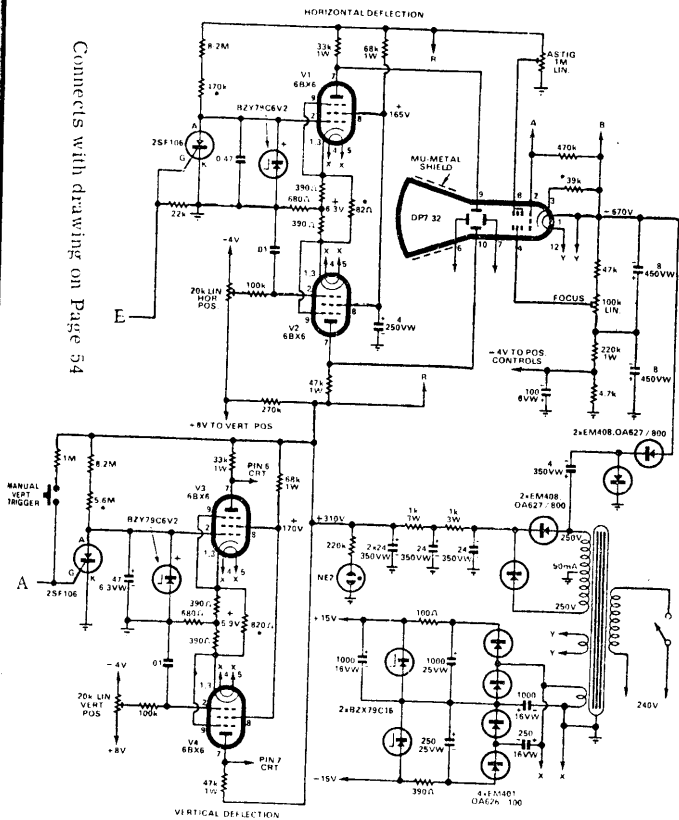

that in common with the other boards, some resistors and capacitors are also mounted vertically to save space. For the same reason some items are mounted underneath the board.

The board containing the two sawtooth generators and the board carrying most of the small components for the two deflection amplifiers are quite straightforward. The last board, which mainly includes components for the two 15 volt supplies is rather crowded and needs some care in fitting the electrolytics. Two pairs of lugs at one end carry a 220k 1W resistor and an 800 PIV diode. These belong to the CRT EHT circuit.

The pictures show the location of all the major components and apart from a few details readers should be able to assemble the unit without difficulty. In our case, the power transformer is stood off the back skirt of the chassis with four spacers. A small panel of aluminium is fixed to one side of the transformer to accommodate a couple of tagstrips for power supply wiring.

A vertical panel, about 11cm long and 8cm wide, is fixed below the main chassis and on it are mounted three board assemblies. The one including the input to detector circuits is mounted nearest the underside of the chassis, with the board containing the sync discriminator and sync separator immediately below. The board with the sawtooth generators is mounted immediately on the opposite side of the panel. With the boards in these positions, it is possible to get to all the adjustments without hindrance.

The board with the deflection circuit components is mounted atop the chassis. The horizontal deflection valves are those above the chassis and the vertical deflection valves are mounted upside down on the other side of the chassis. The detector transformer is above the chassis between the horizontal valves and the front panel. Focusing and astigmatism potentiometers are mounted on a bracket above and at the rear of the chassis and the horizontal and vertical shift controls are immediately below and mounted on the back skirt of the chassis.

The power supply board is mounted immediately behind the CRT socket and the board is stood off the chassis by a cm or so to clear any components mounted under the board. This also applies to all the other boards. If you are not using a can type multiple electrolytic assembly, then some ingenuity may be needed to fit the substitutes in the space available.

Apart from the tube face, with its hood and filter, the only other items on the front panel are the input socket, trigger and mains switch, LED and mains indicator lamps and contrast control. The panel is held in place by the trigger switch and contrast control.

Having built the SSTV Monitor, the next task is to put it into operation. Some suggestions as to how to go about this are added. Although it is

not necessary in most cases, we stress that the 700 volts of EHT and the 300 volts HT line can be dangerous, particularly as the source impedance is quite low in each case. Apart from the more obvious danger points, the detector components which at first sight seem innocent enough, are in the EHT circuit and a bite from this is not recommended.

Before switching on for the first time, it is always wise to make a thorough check of wiring to make sure that there are no errors or omissions. Having done this, a helpful move is to set all adjustment points to a position which will help the adjustment procedure. The vertical position, horizontal position, focus and astigmatism controls are set to mid-position. The sync level, contrast and vertical sync level controls are all set right off. Set the frequency adjust pot to a value of 27k and the feedback pot to 15k. The slug in the video discriminator coil may be set so that the slug is fully inside the coil, with the respective ends about flush.

For adjustment purposes, the use of a CRO, an audio generator and possibly a VTVM will be assumed. After switching on, a routine check of voltages may be made. Make sure however, that there is not a well focused bright spot on the CRT screen, which may lead to phosphor burning. With voltages checked and if the aforementioned spot has not yet appeared, rotate the horizontal and vertical position controls until the spot is found. A rough adjustment of the focus and astig controls may be made and then the spot should be shifted just off the screen for the time being at the bottom right.

Connect the CRO (or VTVM) to the junction of the 2.7k resistor and the 10uF electrolytic at the op-amp output, and connect the audio generator to the input socket. Feed in any frequency between 1200Hz and 2300Hz. Limiting should occur with less than 100mV input and the saturated output will be about 30V peak-to-peak.

To adjust the video discriminator coil, connect the CRO to the junction of the coil and 18k resistor. Set the audio generator to 2300Hz and output level to 100mV. Adjust the slug in the coil for minimum indication on the CRO.

Now connect the CRO to the collector of the video amplifier, TR1. Make sure you do not come into contact with the detector, if the unit is switched on! Set the generator to 1500Hz and advance the contrast control until clipping appears, then back off until the clipping disappears. The output should be about 15V peak-to-peak. With 2300Hz input, the output level should fall to about 1V peak-to-peak.

Adjustment of the sync discriminator calls for a little more care and patience than the foregoing adjustments. Advance the sync level control by about one quarter of its full travel. This may need to be adjusted more closely later on. Connect the CRO to the collector of TR2, and feed in 1200Hz at 100mV from the audio generator. While specific frequencies mentioned so far are quite important as regards

accuracy, it is particularly vital to be sure that the 1200Hz is known accurately. Having made this point, we can leave the rest to the reader's own ideas as how best this may be achieved.

Vary the frequency adjust pot to obtain maximum response on the CRO. It will be found to be quite sharp. Reduce the audio input to zero and all indication on the CRO should also disappear. If not, the stage is oscillating and the feedback control should be reset just below the point of oscillation. Do not try to get too close, as this can be a trial of patience and the extra gain and selectivity are not needed anyway. Switch on the audio input and make any slight adjustment to the frequency adjust control. This should be achieved without the stage oscillating of course.

Having taken the adjustments to this point, we now need a video signal to complete the adjustments. A signal may be taken directly off air from say, 14 or perhaps 7MHz, or even one of the VHF bands. In doing this, it is most important that the signal be tuned in "on the nose". Possibly the easiest way to do this is to adjust the receiver on the same transmission, on speech, after which it will be correctly tuned for the picture. If a tape or cassette recorder is available, it can be very helpful to record a signal and this may be used as required, over and over, for adjustment or other purposes. A fellow amateur who is in the position to do so, may be only too pleased to provide you with some signals straight from his camera, etc., which you may record.

Assuming a source of signals, it should be fed into the monitor and it is reasonable to expect a horizontal trace video modulated. The trace should now be centred on the screen with the horizontal shift control. Press the vertical trigger button and the trace should immediately go to the top of the screen and slowly advance towards the bottom of the screen. Now advance the vertical sync level control until the trace goes to the top of the screen when a horizontal pulse appears. Further advance the sync control until the trace goes to the top of the screen and stays there. Set the control midway between these two positions, which should give correct vertical sync.

Now centre the picture vertically with the vertical shift control. The two initial picture centring operations will have been tentative and the size of the picture should now be considered and adjusted if necessary. The picture should be square and of such a size that not too much of the corners are cut.

The size of the picture is governed both by the natural frequency of each of the sawtooth generators and the deflection amplifiers. The gain of the deflection amplifiers may be adjusted by altering the resistor between the two cathodes. Reducing the resistor value increases the gain and vice versa. Slowing down the sawtooth generator time constant will also reduce the picture size, and vice versa. The time constant can best be changed by altering one of the two series resistors.

In order to help readers of this book, we are reproducing the R-S-T code here.

R-S-T SIGNAL REPORTS

To facilitate accurate reports of signal quality, the R-S-T (Readability-Strength-Tone) system is employed internationally. It assigns numerical values to these characteristics according to the following scales.

Readability

1. Unreadable
2. Barely readable, some words distinguishable
3. Readable with considerable difficulty
4. Readable with practically no difficulty
5. Perfectly readable

Signal Strength

1. Faint signals, barely perceptible
2. Very weak signals
3. Weak signals
4. Fair signals
5. Fairly good signals
6. Good signals
7. Moderately strong signals
8. Strong signals
9. Extremely strong signals

Tone (Telegraphy only)

1. Extremely rough hissing note
2. Very rough AC note, no trace of musicality.
3. Rough low-pitched AC note, slightly musical
4. Rather rough AC note, moderately musical
5. Musically modulated note.
6. Modulated note, slight trace of whistle
7. Near DC note, smooth ripple
8. Good DC note, just a trace of ripple
9. Purest DC note

If the signal has the characteristic of crystal control, add the letter X to the RST report. If there is a chirp, the letter C may be added. Similarly, for a click, add K.

This reporting system is used on both telegraphy and telephony, leaving out the "tone" report on telephony.

An accepted convention is to rate one S point calibration as equal to an increase in signal strength of 6dB. For example, if S1 is taken as 1uV at the aerial terminal of a receiver, S9 results from a 256uV signal. A number of other standards have been used, mainly by commercial manufacturers of short-wave receivers. One rates S9 as 128uV (S1 equal to 0.5uV), and another puts S9 as low as 100uV. However, both systems retain 6dB as separation between S points. Others have both different S9 values and separation values.

Where a standard signal generator is not available, an S meter may be calibrated arbitrarily. S9 is set as being a very strong signal, with no background noise, from a station other than a near neighbour. The meter reading is then divided to provide 1 to 9 S points. If asked for an accurate S-meter report, it is only fair to explain the way in which the calibrations of the receiver have been determined.

If necessary, the horizontal time constant may be changed by altering the 470k resistor, and the vertical by altering the 5.6M resistor.

It is not very likely that there will be any trouble due to component value spreads changing sawtooth generator time constants and causing lack of sync. However if you should be unlucky enough for this to happen, then the appropriate one or both of the resistors just mentioned should be changed accordingly.

Brightness of the trace is controlled by the automatic bias resistor of 39k at the cathode of the CRT. Although it is not likely to need alteration, the brightness can be adjusted by altering the value of this resistor. Do not reduce the value unnecessarily in an attempt to increase brightness. It must be remembered that the afterglow brightness is quite limited and SSTV viewing is normally done in very subdued light.

Considering the simplicity of our monitor, we are pleased with its performance and we hope that our efforts will encourage other amateurs to embark on this fascinating aspect of amateur radio.

List of Parts

- 1 Case, 12.7cm wide x 19cm high x 21.6cm deep, with front panel and chassis.
- 1 Carrying handle.
- 4 Rubber feet.
- 1 Set of brackets, including tube hood and support ring.
- 1 Perspex orange filter.
- 1 Power transformer, 240V primary, 250V-0-250V secondary at 50mA, 6.3V at 1A, 6.3V at 3A, low radiation type (see text).
- 1 Miniature detector transformer, 240V primary, 12.6V at 150mA.
- 1 200mH variable inductor.
- 1 Coaxial input socket.
- 1 CRT socket.
- 4 9-pin miniature valve sockets.
- 1 Miniature toggle switch, SPDT.
- 1 Miniature press-on switch, SPDT.
- 1 Knob.
- 1 NE-2 neon bulb, in pilot bezel.
- 1 Rubber grommet, $\frac{3}{8}$ in.
- 1 Rubber grommet, $\frac{1}{2}$ in.
- 2 7-lug tagstrips.
- 1 3-lug tagstrip.
- 2 Miniature tag boards with 16 prs tags.
- 1 Miniature tag board with 15 prs tags.
- 1 Miniature tag board with 12 prs tags.
- 1 Miniature tag board with 9 prs tags.
- 2 Diodes, BAW62, 1N914A.
- 4 Diodes, EM401, OA626/100.
- 4 Diodes, EM402, OA626/200.

- 4 Diodes, EM408, OA627/800.
- 2 Zener diodes, BZY79 6V2.
- 2 Zener diodes, BZX79 C15.
- 2 SCR, 2SF106 or similar.
- 1 LED (see text).
- 1 IC, 741.
- 1 Transistor, BFY51.
- 1 Transistor, BC108.
- 2 Transistors, 2N3638A.
- 1 Neon indicator, NE-2.
- 4 Valves, 6BX6.
- 1 CRT, DP7-32, with mu-metal shield type 55530.

CAPACITORS

- 1 0.0033uF 100V polycarbonate.
- 2 0.0047uF 100V polycarbonate.
- 5 0.01uF 100V polycarbonate.
- 3 0.022uF 100V polycarbonate.
- 1 0.039uF 100V polycarbonate.
- 1 0.15uF 50V polycarbonate.
- 1 0.33uF 50V polycarbonate.
- 1 0.47uF 50V polycarbonate.
- 1 1uF 50V polycarbonate.
- 1 4uF 250VW electrolytic.
- 1 4uF 350VW electrolytic.
- 2 8uF 450VW electrolytics.
- 4 10uF 25VW electrolytics.
- 4 24uF 350VW electrolytics (in one can).
- 2 47uF 6.3VW tantalums.
- 1 100uF 6VW electrolytic.
- 1 250uF 16VW electrolytic.
- 1 250uF 25VW electrolytic.
- 2 1000uF 16VW electrolytics.
- 1 1000uF 25VW electrolytic.

RESISTORS (1/2W unless stated otherwise)

- | | |
|------------|-----------|
| 1 82 ohms | 2 33k 1W |
| 2 100 ohms | 1 33k |
| 1 270 ohms | 1 39k |
| 5 390 ohms | 3 47k |
| 2 470 ohms | 2 47k 1W |
| 2 680 ohms | 1 56k |
| 1 820 ohms | 2 68k 1W |
| 2 1k 3W | 4 100k |
| 1 2.7k | 2 220k |
| 3 4.7k | 1 220k 1W |
| 2 10k | 1 270k |
| 1 15k | 2 470k |
| 1 18k | 2 1M |
| 2 22k | 1 5.6M |
| 1 27k | 2 8.2M |

- 2 20k linear potentiometers.
- 3 47k linear trimpots.
- 2 100k linear potentiometers.
- 1 100k linear trimpot.
- 1 1M linear potentiometer.

MISCELLANEOUS

Hookup wire, solder, solder lugs, 3-core flex and plug, cable clamp, screws, nuts.

SEMICONDUCTOR EQUIVALENTS

1N914A=RS276-1136, BAW62, BA211, BAY38-61, 1N4151-4446.
 EM401=RS276-1139, OA626/100, BAY219, BY126/100, 1N4002.
 EM402=RS276-1002/1137, OA626/200, BY126/200, 1N4003, BY127
 EM408=RS276-1114, OA627/800, BY126/800, 1N4006, BY127
 BFY51=RS276-2014, BFR19, BSY46-85, 2N2193/4-2218-2410-3053-3252-4046.
 BC108=RS276-2009, 2N3565-3711-4134, BC148-168-208-318. SK3020-3122
 2N3638A=RS276-2021, 2N5447, SK3025, BC328/16, T1S50.
 6BX6=6BW7, 6F41, 6P6, 8D6, EF80-800-860. Z152-719, 64SPT, CV1376-5092-5817.

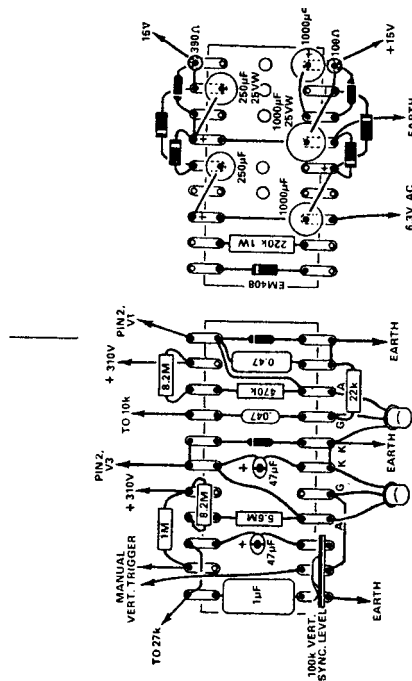

The picture at the top shows a close-up of the vertical and horizontal sweep generators, with the inverted amplifier valves. Below are wiring diagrams for the two sweep generators and the low voltage power supplies.

14MC BEAM USES TV AERIAL PARTS

Although it is lightweight in construction, there is very little sag in the elements of the antenna and it should withstand wind velocities up to 100 mph or so. When checked against a dipole for reference, the forward gain was measured at just over 8db, while the front-to-back ratio was in excess of 25db. Those familiar with antenna theory will know that these figures are only slightly below the theoretical maximum obtainable for such an array.

With these requests in mind, we decided to see what could be done about constructing a satisfactory yagi.

Actually, the main problems of design were mostly practical ones and not theoretical. It is mainly a question of knowing exactly what bits and pieces are available as standard lines and figuring out how these parts can best be utilised to construct a satisfactory antenna.

So that you can better understand why the antenna is constructed the way it is we will endeavour to discuss some of the problems which arose and the manner in which they were solved.

The first problem occurred when we considered what should be used for a boom on which to mount the elements. The textbooks say that the maximum gain in a three element yagi is achieved with a spacing of 0.2 of a wavelength between driven element and reflector and 0.3 of a wavelength between the driven element and the director. At 14 Mc this would mean a boom length of approximately 34 feet.

BOOM LENGTH

As we considered this length to be cumbersome and impractical we looked again at the figures and found that a spacing of 0.1 and 0.2 wavelengths would mean a length of around 20 feet and would result in only 0.5 of a db loss in gain for the antenna. We decided we would settle for a boom length of 20 feet or thereabouts.

From experience gained with the quad we knew that no single piece of the antenna should exceed ten feet in length because of the packaging and transport problems incurred with lengths longer than this. In the quad we used 2" aluminium tubing for a boom, but the quad only had an 8'6" boom. If 2" tubing was to be used for the yagi we would need two ten foot lengths, one swaged to fit into the end of the other. Unfortunately, however, TV aerial manufacturers are not equipped to swage 2" tubing.

It would, of course, be possible to have a special die made to accomplish the swaging but this would add to the cost of the antenna and we decided to look for an alternative way out of the problem.

We remembered that it was once common practice to use a section of an extension ladder as a boom for a 20 meter yagi. The extension ladder is actually a "twin boom" and if it worked in timber, why not in aluminium?

It was accordingly decided to use two lengths of 1½" O.D. aluminium tube for the boom and to allow the elements themselves and the support brackets for the mast to form the bracing and joining between the two sections of the boom.

Aluminium of 1½" diameter is easily swaged so four pieces, each ten feet long, and with two pieces swaged to 4" at one end, were joined together to form the 20 feet long twin boom. Because there is some sag in a boom of this nature, we found it necessary to brace the ends against the middle. This was quite easily accomplished by allowing the

supporting mast to protrude approximately 18 inches above boom level and taking a strainer wire from each end of the boom to the protruding section of mast.

Each of the antenna elements is secured to the boom by means of two double U-bolt next assemblies, one "nest" to each of the twin boom pieces. The final strength achieved with this method of holding is such that, at extremely high wind velocities, the antenna elements could bend right out of shape, but the clamps to the boom would still hold fast.

ELEMENT SIZES

The steel mast tube on which the antenna is mounted is also attached to the boom with two of these double U-clamp assemblies. We used a piece of $1\frac{1}{2}$ " diameter by 16 gauge steel tube 10 feet 6 inches long for this mast, mainly because that is a standard TV mast size and it fitted very nicely into the strengthened TV chimney clamp mounted atop the author's telegraph pole. More about this later.

With aerials of this size, it is common practice to manufacture the elements from several different diameters of tubing, commencing with a reasonably large diameter in the centre and winding up with a fairly small to medium diameter at the tips of the elements.

In order to minimise sagging of the elements we decided to use 16 gauge material since it was felt that 18 gauge would be a little on the light side. The wall thickness of this material is approximately $1/16$ " and the stock sizes run in $1/8$ " increments so, at first glance, it looked as if the outside diameter of one size would neatly fit into the inside diameter of the next size up.

It seems, however, that the inside diameter of this tubing averages around $4/1000$ " on the small side of the outside diameter of the next size down. With some wangling it is possible to find two pieces of tubing whose tolerances are such that they will mate together but the process of trial and error involved makes it far from a commercial proposition.

It was at this stage that we decided to fit the tubing with one size difference in between the two pieces and simply secure them by means of several self-tapping screws. It seems that such a practice is fairly common in the commercial field and has always been found satisfactory in the past.

Before committing ourselves to this form of construction for the antenna we tried it out experimentally on two pieces of spare tubing. The tubing was overlapped 12" and joined with three $\frac{1}{4}$ " by 8 cadmium plated self tappers. Subjected to severe vibration and loading tests the joint held firm under all conditions. In the final test, so much weight was placed on the tubing that it bent and broke, but still the joint held firm. We considered these tests to be fairly conclusive evidence that it WAS indeed a good method of construction and accordingly based our design on this.

By means of some practical experiments and a few elementary calculations we found that a diameter of $1\frac{1}{4}$ " for the centre of the element, then down to 1" in the middle of each side and $\frac{3}{4}$ " at the tips was optimum for the antenna. Diameters any smaller than this resulted in so much sag, even with 16 gauge tube, that the antenna was most unsightly. Larger diameters imposed too high a strain on the boom and securing clamps at hurricane-force wind velocities. A third point was the torque imposed on devices required to rotate the antenna, but we will come to this later.

leveling

vertical

to

reference

16"

pro-

of

maintaining
fixed
position

assembly

at
direction

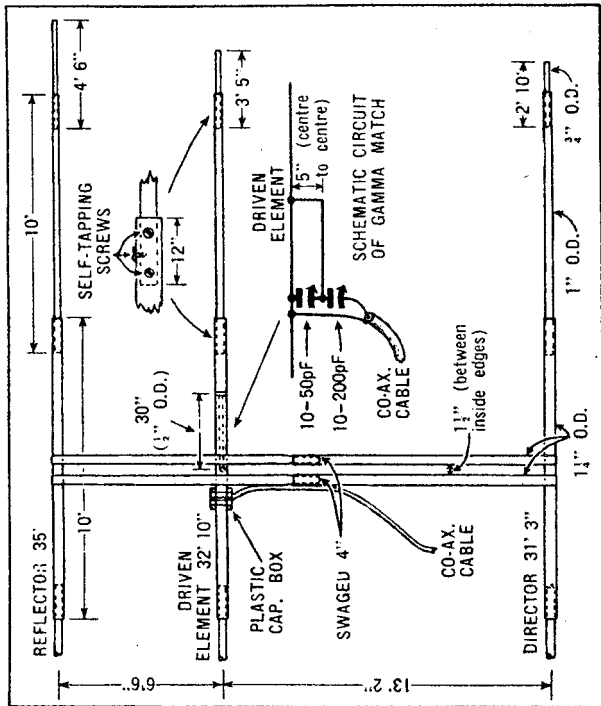

This diagram shows the principal dimensions of the antenna. The twin boom arrangement is stronger than a single large diameter tube and considerably simplifies the packaging and transportation problems of the unit.

The diagram of the antenna shows the sizing for the various elements. In each case, a 10 foot length of $1\frac{1}{4}$ " tube is used at the centre with two 10 foot lengths of 1" tubing overlapped 12" into each end of it. Short lengths of $\frac{3}{4}$ " tubing at each end make the elements up to the required length. The reason for the 10 foot lengths throughout is fairly obvious, when one considers the fact that this tubing is supplied from the manufacturer in standard lengths of 20 feet.

The next problem concerned the manner in which the antenna should be fed from the transmitter or to the receiver.

The text books tell us that the impedance at the centre of the driven element in a three element yagi with spacings of .1 wavelength from driven element to reflector and .2 wavelength from driven element to director is approximately 15-20 ohms. If we were to "split" the driven element in the middle so that it could be fed with co-ax in the manner of a dipole, the standing wave ratio on the feedline would be much the same as the impedance mismatch, or roughly 4/1.

We could turn our driven element into a folded dipole and, with the 4/1 impedance step up this would give us, so arrive at a figure much closer to the impedance of the feedline. This, however, would complicate matters mechanically and ideally, would still call for some form of balun or matching device to account for the balanced to unbalanced condition which exists when a co-ax cable is coupled into a folded dipole.

When all of these considerations had been taken into account we realised that we could not do better than adopt the same form of feed which had been used on the Qad, namely the gamma match. This time, however, we decided to make the tuning and adjustment of the match easier by using the modified version, sometimes known as the omega match.

In the gamma matching system impedance transformation between the transmission line and the driven element depends on the electrical length of the matching rod. When adjusted to provide the correct terminal impedance for a 50 or 70 ohm co-ax feed, the section is always shorter than a quarter wave and, as a result, appears to the system as an inductive reactance. To correct this a series capacitor can be added to introduce an equivalent capacitive reactance into the system, making the feedpoint appear resistive.

The gamma matching section is equivalent to a short circuited line section a quarter wave or less in length and may, in effect be physically shortened by connecting a capacitor across its open end. The degree to which the line is electrically lengthened or physically shortened depends on its characteristic or surge impedance.

If the spacing between the gamma rod and driven element is such that the shorted section has a surge impedance of 300 to 500 ohms, the effective electrical length of the matching section may be varied by adding capacitance from the open end of the rod to the centre of the element. The length of the gamma rod, with capacitive loading, is 50 per cent to 75 per cent less than that required for the regular gamma match arrangement. The main advantage of the modified system is not the physical saving in space, however, but the ease of adjustment it brings by eliminating the necessity to re-position the gamma shorting bar in the regular arrangement.

Details of the tuning procedure will be given later in the chapter but we are not exaggerating when we say that the total time taken to tune the antenna for a standing wave ratio of 1.1/1 on 14.2Mc was exactly 10 minutes, including the warming up time of the transmitter and connecting the line into the SWR bridge.

P
e
g
p
t
s
F
P
w
c
t
I
t
e
I
t
c
c
V
I
e
c
v
t
t

ts. In
o 10
ngths
1. The
e con-
stan-
l be
ele-
riven
stor
ent in
le, the
mped-
4/1
oser to
atters
match
lised
ad be-
we de-
; the
ie
e-
n-
as
dded
ting
ec-
y
e to
ends
it the
tive
pacit-
leng-
ent.
; in
the
ge-
we
; ant-
inu-
the

Practical construction of the antenna could be commenced by assembling each of the elements to the pre-determined length as shown on our diagram. If the five pieces of aluminium which make up each element are pre-cut to the lengths shown it is only necessary to mark-off accurately the sections which have to be overlapped 12", place them together and insert three self-tapping screws into each overlapped section.

For greatest strength and minimum sag it will be best if a self tapper is placed 2" in from each "end" of the overlapped section in a line which will ultimately become the top of the element and one self-tapper is placed in the centre of the overlapped section at an angle of 90 degrees to the other two.

In order to prevent unpleasant noises from disturbing your sleep and that of your neighbours, do not forget to place some corks in the end of each element and the ends of the twin boom sections.

In the Quad antenna no difficulties were experienced with wind vibrations in either the diagonals or the actual elements. This was probably due to the relatively short unsupported length of the diagonals and the damping effect caused by the elements strung at their tips.

When first placed atop the mast we had trouble with severe vibrations in the reflector and director of our new antenna, however. The driven element did not vibrate, probably because of the damping effect of the components in the gamma matching system.

Various means were tried to overcome this nuisance and it was found that the easiest method was to place a small weight on one side of the element roughly five to six feet from the boom. Two standard TV "Flat Back Nests with 1/4" U-bolts", each weighing a few ounces, were used for this purpose and no further troubles were experienced with vibrations. The major advantages of using these U bolts and nests as the vibration preventing weights is that they are easy to affix and being cadmium plated will not result in a galvanic action which could eventually destroy the antenna. Incidentally, this latter point is one which should be carefully watched during construction.

Because of galvanic action, the best metal to use in contact with a piece of aluminium is another piece of aluminium. Failing this, cadmium plated steel makes an excellent "second string" choice. On NO ACCOUNT should brass be used where it will come into contact with the aluminium. The potential difference of around 1.6 volts between the two metals will destroy the structure in double quick time.

ASSEMBLY

Assembling the elements to the boom is mainly a matter of following the directions given with the double U-bolt "nests" except for one important detail. The assembly instructions show a 3/16" bolt holding the two sections of the clamp together through a hole drilled in the tubing. This bolt plays no part in the final assembly, but is only a refinement which aids in the actual assembly job. In a lightweight TV antenna, it would be of no consequence, but it might tend to weaken the structure in a unit as large as this so is best left out.

The spacing between the twin tubes of the boom should be equal to the diameter of the meast used plus about one inch (introduced by the clamps which join mast to boom). Assembly of the unit on the ground will be facilitated if the elements are placed on the underside of the boom and the U-bolts placed so that their threads project upwards. If the elements are placed on top of the boom, it will not be possible to fit in the gamma match correctly.

The gamma match is made from a 30" length of $\frac{1}{2}$ " aluminum tube spaced from the mast by approximately 4 - 5 inches by means of an aluminum bracket at one end and a special insulator and two aluminum brackets at the other end. The diagram of Fig. (1) shows the dimensions of the aluminum brackets associated with the gamma match.

The bracket (A) in Fig. (1) folds around the driven element and attaches to the rear of the plastic box in which the gamma matching capacitors are mounted, (B) folds around the centre of the driven element and attaches to one end of the gamma insulator, (C) folds around the open end of the gamma leg and attaches to the insulator while (D) has one end folded around the driven element and one around the gamma leg so that it forms the spacing bar and shorted end of the gamma match.

In our prototype model, a phenolic resin insulator obtained from a disposals store was used at the end of the gamma match.

The gamma tuning capacitors are completely protected from the weather by enclosing them in a small plastic box and sealing all entrance and exit holes with some epoxy resin.

The box we used measured approximately 5 x 3 x 3 inches and was originally sold as a butter container (half pound size) by one of our larger chain stores. The bracket shown as (A) in Fig. (1) is bolted to the base of this box and the two tuning capacitors are mounted side by side in the lid.

CAPACITORS

In our prototype, we used special transmitting type capacitors which were silver plated and double spaced. To prevent the possibility of a short circuit occurring during modulation peaks and reduce the dangers from moisture forming between the plates, we would suggest you use similar capacitors.

A half-inch hole is drilled in the bottom of the box and a short (6-inch) length of co-ax is passed through this hole and soldered to the gamma capacitor in the box. The other end of the co-ax is fitted with a coaxial plug. Two $3/16$ " holes are drilled in one side of the box to accommodate the leads which connect to each side of the insulator in the gamma match.

The use of the co-ax fitting in the line from the transmitter to the gamma match enables the antenna to be erected on the top of the mast without the inconvenience of a co-ax cable sagging around nearby projecting objects and generally getting in the way. It also means that a SWR bridge may be connected in the line close to the gamma for adjusting the matching.

When mounting the plastic box on to the element be sure that the two control knobs face away from the reflector as otherwise it would be rather difficult to reach the controls from the mast or a suitably placed ladder. The next step in construction is the coupling of the mast to the boom and the installation of the anti-sag strainer wire across the top. It will be noticed that there is no measurement on the main diagram which shows where the mast is installed. This is not an oversight on our part, but is simply because the position is best located by picking the whole antenna up and determining this point by balance.

The same type of clamps which are used to hold the elements in place are also used to secure the boom to the mast; they are simply turned through 90 deg. The mast should be allowed to protrude about 18" above the top of the boom to accommodate the anti-sag strainer wire. The wire is passed through a $\frac{1}{4}$ " hole drilled in the top of the mast.

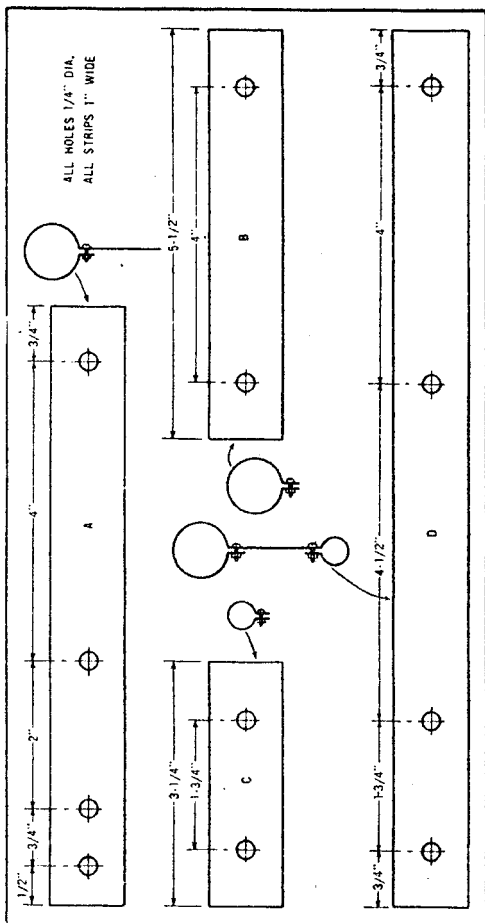

The brackets used in the gamma match are made from 1" aluminum strip and this diagram will aid in their construction. The actual tubes of the antenna should be used as a jig when bending the brackets into shape.

From the photographs of the aerial it can be seen that the author has used a telegraph pole for a mast and a TV type chimney mounting to hold the antenna. It should be noted that this chimney mount is a special reinforced unit, fitted with a reversed ball-bearing guy ring to act as a bearing for the antenna. A standard chimney mount will definitely NOT hold the weight of the antenna, as we can testify from sad experience. Not shown is a standard TV type rotator which we have added to the aerial. These little units will stand up to the wear and tear of turning an antenna this size provided they don't have to stand the weight of the antenna and that some form of locking device is installed to prevent high winds damaging their gears.

Before placing the antenna atop the mast, it is wise to apply some form of protective coating to it: a brand of silicone compound in a push-button spray pack is excellent for the job. Failing this, some heavy grease can be dissolved in spirits and painted on the antenna, paying particular attention to the threads on the mountings. Some day you will want to lower the antenna for service, and a thick coating of rust will not assist you in your work.

Although it is possible to use a field strength meter or other means to adjust the gammas match, the only really satisfactory method is the use of a SWR bridge in the co-ax line from the transmitter. For preference the bridge should be installed as close as possible to the antenna both for physical (ease of reading, etc) and electrical reasons.

Unless you operate on only one small portion of the band it will be best if the antenna is tuned with the transmitter set to 14.2 Mc. If a SWR of 1.1 is achieved at 14.2 Mc (and this is not too hard to do), the SWR at 14.35 Mc should not be higher than 1.4/1 and at 14.0Mc it should not exceed 1.65/1. These figures are so low that they are hardly worth considering. Adjustment of the gamma match is as follows. Set the series capacitor (10-200 pF) to slightly more than halfway in mesh and adjust the parallel capacitor (10-50 pF) for a minimum reading on the SWR bridge (reflected position). Alternately adjust the capacitors until the reflected reading is as low as can be achieved. This is all there is to it, and, if you have constructed the antenna fairly close to our specifications, the entire proceedings should not take longer than a minute or so.

PARTS LIST

2 1 $\frac{1}{4}$ " O.D. tube 10' long swaged 4" one end.	
5 1 $\frac{1}{4}$ " O.D. tube 10' long.	3 feet of 1" x 16g al. strip.
6 1" O.D. tube 10' long.	4 1" x $\frac{1}{4}$ " whit. nuts and bolts (cad plat)
2 $\frac{3}{4}$ " O.D. tube 4'6" long.	2 $\frac{1}{2}$ " dia. solder lugs (cad plate).
2 $\frac{3}{4}$ " O.D. tube 3'5" long.	6 $\frac{3}{4}$ " dia. plastic plug buttons.
2 $\frac{3}{4}$ " O.D. tube 2'10" long.	2 $\frac{3}{4}$ " U-bolts
8 U-bolt assemblies	2 capacitors.
1 length 1 $\frac{1}{4}$ " dia. 16g steel pipe.	1 plastic box 5 x 3 x 3 inches
30 feet of 7/20 guy wire.	1 gamma insulator (see text)
1 $\frac{1}{2}$ " O.D. tube 32" long.	2 Rope grip (3/16').
50 $\frac{1}{4}$ " x 8 cad plated self tappers.	

Sundries : epoxy glue, wire, co-ax cable, knobs,
co-ax socket, can of silicone spray, support
bracket for mast, rotator etc.

AERIALS FOR THE 52, 144 MC BANDS

For effective reception and transmission on either of these bands, a resonant aerial system is required, properly coupled and matched to the feeder cable and, ultimately, to the receiver or transmitter. If not already appreciated, the reasons for this statement are well covered on other literature.

Among the simplest of the resonant aerials are the "ground plane" and "coaxial" types, vertical in their general configuration and predominantly responsive to vertically polarised signals. Their simplicity stems from both their basic structure and from the fact that they are non-directional in the horizontal plane; this latter feature obviates the necessity for any form of rotating mechanism.

Unfortunately, vertically polarised antennas, as a class, are more susceptible to noise pick-up than are horizontally polarised types, this being one reason for their lack of popularity. A second point, discussed further on in the text, is that of the "cross-polarity" loss, when used to communicate with stations equipped with the alternative - and generally preferred - horizontally polarised type of aerial.

However, the number of vertically polarised aerials on "6-metres" at least, indicates that, for many, their basic simplicity outweighs the aforesaid disadvantages.

The so called "ground plane" antenna, as illustrated in figure 1, consists of a vertical quarter wave radiator working against a ground-plane of four radials. These radials need to be slightly longer than the vertical portion, as shown in the illustration.

A ground-plane antenna has a feed point impedance of approximately 37.5 ohms and some method of matching to a coaxial feeder is required. For a 75 ohm feeder we may use a quarter wave stub, made from a length of 50 ohm cable. This will be approximately 37.5" long as indicated in figure 1.

To match a ground plane directly to a 50-ohm feeder it is only necessary to droop the four radials by 45 degrees and attach the feeder directly, connecting the shield to the radials and the inner conductor to the vertical element.

As mentioned earlier, the ground plane antenna is vertically polarised and this poses some problems with local contacts to horizontally polarised stations. It is very effective, however, for working mobile stations using vertical whips. The cross polarity on local contacts gives an approximate loss of between 10 and 30 dB, depending on the path between stations, compared with a horizontally polarised dipole. In most cases, signal strength is still ample for good contact.

On the credit side, the ground-plane antenna has a low angle of radiation which is very effective in working DX signals. Cross polarisation is less serious for DX signals, since these become quite randomly polarised en route. A further bonus with vertically polarised antenna is that the cross polarity loss previously mentioned does help alleviate TVI in areas where the TV stations use horizontally polarised antennas. This, of course, assumes minimum pick-up in the TV aerial feeders.

COAXIAL ANTENNA

The second antenna featured has the disadvantage that more mechanical work is required but it will repay this trouble in results achieved. This array is also vertically polarised but has an extremely low angle of rad-

lation. The coaxial dipole will therefore give good results with DX contacts as well as mobile stations. The ground-plane elements, as shown in the illustration, are not essential but the addition of this extra "hard ware" improves the apparent gain of the antenna by up to 3dB mainly by lowering the angle of radiation.

The sizes of the elements depend on the supporting mast to be used. Assuming the supporting mast to be $1\frac{3}{4}$ " diameter the sleeve could be 3" in diameter and the rod $\frac{1}{2}$ " in diameter. In several references consulted there is disagreement regarding the length of the sleeve element. One suggestion is that the sleeve should be shorter than the rod, taking into consideration the diameter to length ratio. Others put forward the idea that it is necessary to lengthen the sleeve to cancel out the reactance produced by the proximity to the mast. However, if the sleeve is cut to the dimensions given in figure 2 the SWR of the antenna should be under 2:1.

If measuring equipment is available, it is a good plan to make the antenna elements slightly longer, or adjustable, and adjust the lengths for correct operation at the transmitter frequency. The 75-ohm coaxial cable feeds through the centre of the mast with the inner conductor connected to the rod, and the outer conductor to the sleeve. The sleeve is electrically connected to the supporting mast at the top only, being insulated at the bottom.

For a horizontally polarised antenna the four-element beam is very popular on 52MC. As illustrated in figure 3, this antenna uses a folded dipole to give an acceptable match to 75-ohm feeder. If the constructor prefers to use a centre-fed dipole for the driven element, a quarter wavelength matching stub may be used to connect a 75-ohm feeder. This stub should have an approximate impedance of 36 ohms and either 39-ohm coaxial cable or two parallel lengths of 75-ohm cable may be used. The length of the series stub would be approximately 37.5" as already indicated in figure 1.

Aluminium for construction of this beam can be bought at reasonable prices and we recommend that the elements be fabricated from $\frac{1}{2}$ " diameter thin wall tubing or $\frac{3}{8}$ " diameter thick wall tubing. TV aerial fittings are freely available and provide a good source of mechanical parts for fabricating VHF aeriels.

USING TV AERIALS

As the aerial stands, a 4:1 balun can be used conveniently, both to reduce the apparent impedance and to provide the necessary balance-to-unbalance transformation. As indicated in figure 4, such a balun may be made from coaxial cable, usually a piece cut to the required length from the main cable. The impedance of the cable used for the balun is not critical.

For an exact match, 75 ohm feeder cable should be used, with a $\frac{1}{4}$ " wave stub of 50 ohm cable at the feed point to the balun.

However, even if the balun is fed directly from a 50 ohm cable, an SWR of better than 1.4:1 can be achieved.

STACKED ARRAYS

If two of these antennas are stacked, using one wavelength spacing and stacking bars, the centre of the stacking bars may be fed with 75 ohm cable. The stacking distance would be approximately 19'6" with an expected increase in forward gain of approximately 3dB.

XX con-
 shown
 a "hard
 inly by

ed.
 id be 3"
 onsulted
 . One
 ng into
 e idea
 nce
 s cut
 be

te ante-
 s for
 ial
 r con-
 ve is
 g in-
 ry

con-
 , a
 m
 ms
 i
 di-

ble
 'ech-

re-
 in
 ed
 the

and
 hm
 1

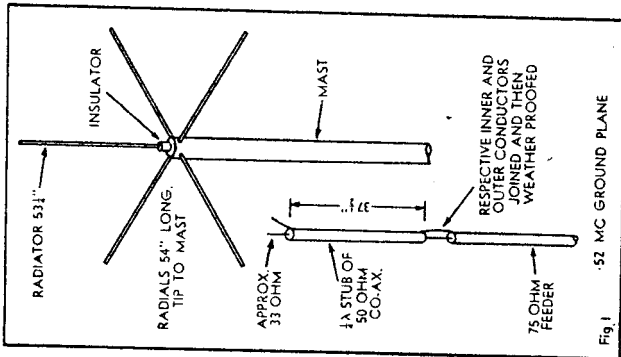
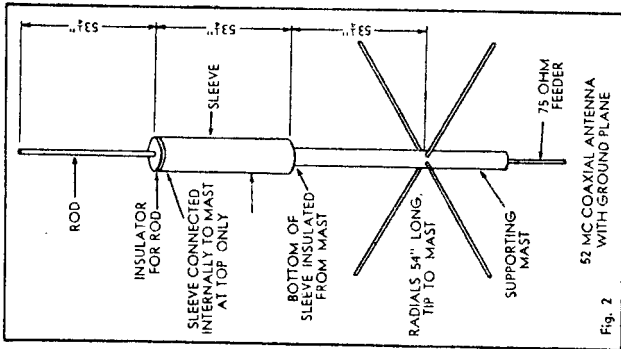

The ground-plane and coaxial antenna shown above are quite effective for long distance and mobile contacts. Being vertically polarised, all-round coverage is achieved, no rotating mechanism being required. The dimensions given are for 52MC. Relevant details for 144MC are mentioned in the text.

Using $\frac{1}{2}$ -wavelength sections of coaxial cable for stacking, the separation would be under 13'. Better than 1.2:1 SWR should still be achieved by feeding the array at the junction of the two half-wave stacking sections. The velocity factor of the coaxial cable must be allowed for when calculating the lengths of these stacking sections.

THE 144MC BAND

On the 144MC band, suitably proportioned ground-plane and coaxial designs are possible but find very little use among local amateurs. Purely for the sake of the record, element lengths would be $19\frac{1}{4}$ " for the vertical whip sections and coaxial sleeve whereas the ground-plane radials in both aerials would be $19\frac{1}{2}$ " long from tip to mast.

For general inter-station working on 144MC a horizontally polarised aerial system is desirable, along with some means of rotating it to cover the desired directions. At this stage, the problems of rotating the array must be left to the ingenuity of individual amateurs.

On 144MC, the "basic" type of aerial is again the four-element beam shown in figure 3; the figures which apply are those in brackets. For a simple, yet effective, beam this design will take a lot of beating. Being relatively widespaced, the frontal lobe is quite broad whilst still exhibiting a reasonable gain. With Yagi antennas the gain characteristic flattens out drastically after the first three or four elements and it is necessary to use many more elements to achieve a worthwhile increase. The next design, shown in figure 5 illustrates this point. A Yagi beam antenna of ten elements has been required to achieve an approximate forward gain of 12.5dB. In other words, it is necessary to add 6 directors to achieve a further approximate gain of 4dB over the four-element beam. It will be noticed that these beams are staggered director or element lengths; this is to achieve a reasonable band width. Both antennas will operate over two megacycles with very little worry about feeder mismatch.

The driven element of the 10 - element beam is shown designed for 300-ohm feeder. If 75 ohm coaxial feeder is to be used all that is necessary is the four-to-one balun shown in figure 4. Note that, for 144MC the length of the balun would be approximately 27 inches. The price paid for long Yagi antennas is that the frontal lobe is quite narrow and the beam must therefore be positioned carefully for maximum effectiveness.

As with 52MC we now have a related TV channel "5A", to the 144MC band.

Antiference supplies a 10-element Yagi for channel "5A", type 109/5A, which may be easily converted for 144MC. The gain quoted by the manufacturer is 12.5dB which should still apply to the modified antenna.

The modifications required are as follows: (1) cut the reflector to 43" (2) cut the first and second director to $36\frac{3}{4}$ "; (3) cut the third director to $35\frac{3}{4}$ "; (4) cut the fourth director to $35\frac{1}{2}$ " (5) cut the fifth director to 35"; (6) cut the sixth director to $34\frac{3}{4}$ "; (7) cut the seventh and eighth directors to $34\frac{1}{4}$ " (8) adjust the shorting pieces on the folded dipole to 39", centre to centre, the hangover being $1\frac{1}{2}$ " long.

The array, as it stands, may be matched to a 75-ohm feeder with a four-to-one balun on the folded dipole feeding into a quarter wave stub of 50 ohm impedance and then into the feeder. If two arrays are stacked one wavelength (81") apart using stacking bars (unit velocity factor) a good match will be achieved when feeding the centre of the stacking

ed

er
y

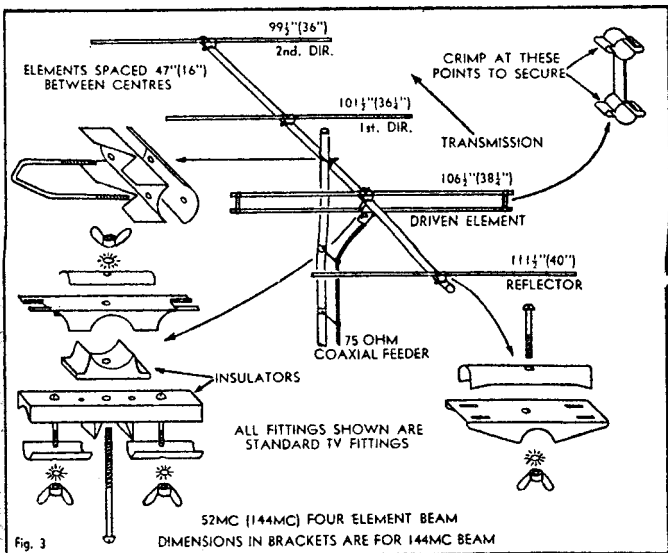

The four element beam configuration given above is capable of excellent results on either 52 or 144MC. Use is made throughout the construction of TV aerial fittings. While not strictly necessary, these fittings make light work of beam construction.

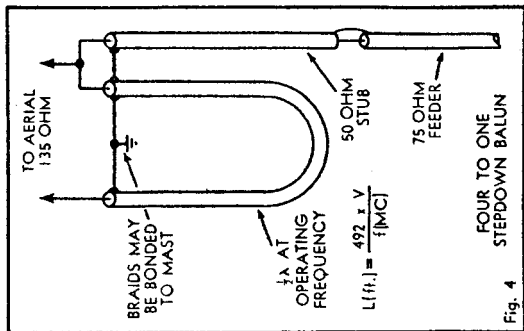

The four-to-one balun is ideal for the beam designs given in this article. Typical lengths of the "U" piece are 52MC, 75 inches; 144MC, 27 inches.

bars with 75 ohm feeder. The same feed point will provide better than 1.3:1 SWR when fed with 50-ohm cable. The gain of this system would be approximately 15.5dB.

ALTERNATIVE TYPE

Channel Master also manufacture a 10-element aerial for channel "5A" type 1005A, with a quoted gain of 10dB. The simple alterations necessary to operate this array on 144MC are as follows: (1) Cut the reflector to $40\frac{3}{4}$ "; (2) cut the driven element to an overall length of $36\frac{3}{8}$ "; (3) cut the first director to $35\frac{5}{8}$ "; (4) cut all other directors except the eighth to $33\frac{1}{4}$ "; (5) cut the eighth director to $33\frac{7}{8}$ ". The unusual size of the last director is brought about by the style of mounting plate used for the director which has an electrical shortening effect on the element.

This aerial can be fed directly with 300-ohm ribbon or via a four-to-one balun with 75 ohm coaxial cable. Stacking of this aerial again relies on the removal of one bar from the folded dipole to give similar matching arrangements to that for the Antiference 109/5A.

So much for single-band aerials, simple and not so simple. Recently, the writer has been doing a considerable amount of work with composite arrays, suitable for use on both the 52 and 144MC bands. While these arrays are necessarily more complex than single band units, they have an advantage for the amateur desiring to work both bands but restricted in terms of space.

Aerials intended for use with the OSCAR satellite need, ideally, to have equal gain at all polarities. This is due to the random polarity signal likely to be emitted by this vehicle. While the antenna to be described does not achieve this ideal its performance is very close for a simple configuration. With a minimum gain of 9.5dB for any polarity of OSCAR's signal excellent results are possible.

As a basis of this aerial we suggest that you use two Antiference 109/5A TV antennas. These two antennas should be modified in element lengths as previously described. One boom is discarded and the elements from it are mounted on the complete antenna at right angles to the existing elements. The aerial now becomes virtually one horizontally polarised Yagi and one vertically polarised Yagi. To give equal response through 180 degrees of polarity change the two arrays must be connected together in correct phase.

This phasing for the required coverage is 90 degrees. Ninety degrees phase change is achieved by the use of a quarter wave section. The impedance of the quarter wave section in this application should be 150 ohms. In this case we would recommend the use of two lengths of 75 ohm coaxial cable bound together with plastic tape, the inner conductors only being used to equal an impedance of 150 ohms. Taking into account the velocity factor, the length of this section will be approximately 13.5".

Having proceeded as outlined, a good match to 75 ohm cable may be made by connecting it directly to either folded dipole. Incidentally, this aerial will also give very good results when working mobile stations, notwithstanding the polarity of the original signal, as the polarity may often shift over the path between the vehicle in motion and the fixed station.

Quite often the amateur operator is restricted in the space, finance or times available to devote to his hobby. With this in mind, some study and experiment have been directed to the possibility of combined

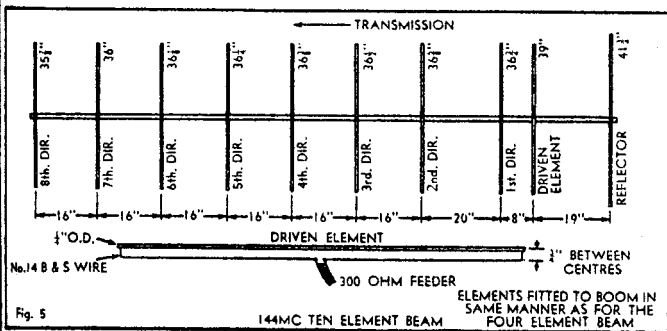

This ten element beam exhibits an approximate forward gain of 12.5dB. Staggered director element lengths are used to achieve reasonable bandwidth.

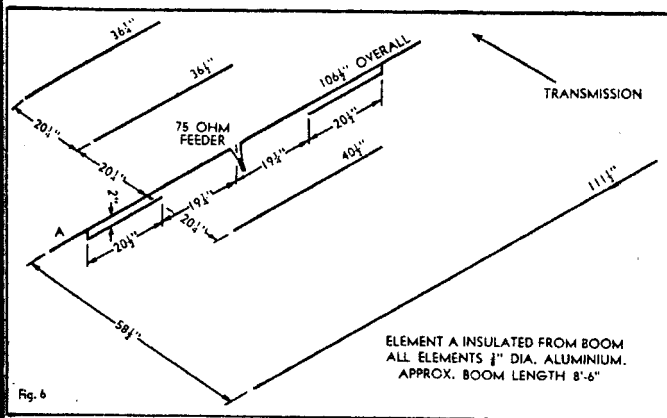

This relatively simple 2-band array uses a composite driven element, providing a 2-element beam on 52MC and 4 elements on 144MC. It could be fed via a single 75-ohm coaxial cable.

aerials for 52 and 144MC.

Not surprisingly, the objective of a two-band aerial array suggests a variety of approaches, some of them influenced by the intensive research that has gone into multi-channel television arrays. But it is a lot easier to generalise and theorise than physically to build-up and test possible designs.

For this reason, we begin by mentioning a number of approaches which we didn't try but which may appeal to readers interested in doing so.

The beam configuration illustrated in figure 6 uses a common driven element consisting of a dipole cut for 52MC, with a total length of 106.5 inches. A centre portion of this dipole, length 38.5 inches, is made to function as a 144MC dipole by isolating it from the remainder of the element with quarter wavelength shorted stubs. Thus, when fed with 52MC energy, the full length of the dipole is used but, when fed with 144MC energy, the quarter wave stubs effectively isolate the outside sections of the dipole, leaving only the 38.5" portion. The stub length as shown is calculated for a velocity factor of 1.

The initial construction of this array should be tackled as follows: Cut the driven element to the sizes given, making the quarter-wave stubs in such a manner that they may be shifted along the element. One suggestion for this is the use of folded dipole links used in TV aerials. Feed the driven element with RF at the desired 144MC operating frequency and, using a VSWR bridge or antenna impedance bridge, set the stub positions for correct operation.

Normal assumption for the dipole alone would be for a 75 ohm centre impedance and a 75 ohm coaxial feed cable.

Change over to 52MC and adjust the length of the outer ends of the driven element for correct operation. This may mean the reduction of the element to well below the figure given. However, this reduction should be made in small steps till resonance is achieved. It may be necessary to re-check the element several times on both frequencies. The next step would be to fit the 52MC reflector and adjust its spacing for minimum SWR, still assuming a 75 ohm impedance. Now fit the remainder of the elements. The impedance at 144MC will be somewhat lower than 75 ohms but the SWR should still be below 2:1, which is considered tolerable.

Theoretically, on 52MC, a gain of approximately 5dB should be obtained and, on 144MC, an approximate gain of 8.5dB. Additional directors may be added for 144MC, as long as the SWR can be maintained at a reasonable figure. It is understood that this type of aerial may be subject to some "beam splitting" on the higher frequency, the front lobe tending to assume a heart shape, with a slight null directly in the line of the boom.

The second design, shown in figure 7, uses a different feed system. On 52MC the beam acts as a two element array with an approximate gain of 5dB. Energy is not dissipated in the 144MC section, at the 52MC frequency, as the feedline between the two arrays and the folded dipole combine to form a shorted quarter wave at 52MC; this reflects a high impedance at the feeder attachment point. At 144MC the assembly acts as a 5-element array with an additional and interesting advantage.

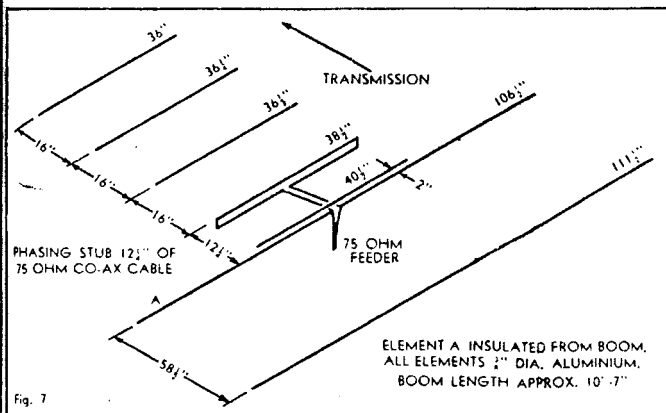

An efficient 5-element 144MC array is combined with a 2-element 52MC antenna above using a single feeder. Because the reflector acts as a phasing stub, the adjacent 52MC element behaves as three half-waves in phase on 144MC.

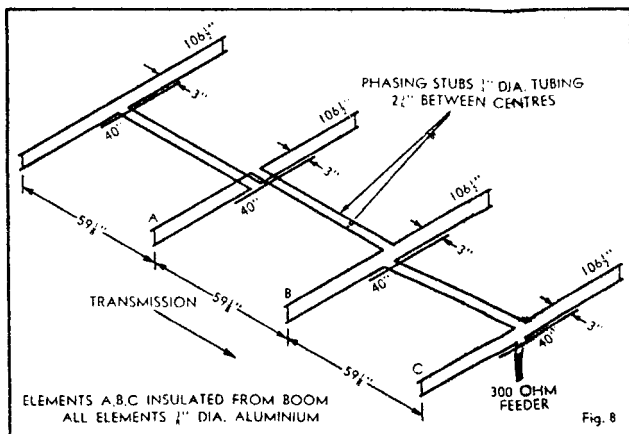

The series phased array shown above is designed primarily for 52MC. However, the siting of phasing elements in close proxim-

ity to the driven elements achieves efficient transmission on 144MC. It should not require critical on-site adjustment.

When operating at 144MC, energy will also be fed to the 52MC dipole. This element will radiate, functioning as an (approximate) three half wavelength radiator. Normally, radiation in this mode produces a "clover leaf" field pattern but the reflector element for the 144MC array in close proximity to the 52MC dipole, acts as a phasing element, making the dipole act as three 144MC half wave elements in phase. The "in phase" operation minimises the "clover leaf" effect and produces a relatively narrow frontal lobe.

Some juggling of the director spacings may be necessary to achieve a reasonable SWR on 144MC. Properly adjusted, a gain of approximately 9.5dB could be expected from this antenna on 144MC.

An entirely different approach to the problem of a dual band beam is given in figure 8. Mechanically this configuration presents more problems than the other two arrays but, electrically, it should be possible to fabricate the aerial without need for subsequent adjustment. An SWR of 2:1 or better is theoretically possible, while the use of 300-ohm feeder makes an SWR of up to 3.5:1 readily acceptable.

At 52MC the beam consists of four driven elements in what is commonly known as a series phased array. Each driven element is joined by a phasing stub to the following element, the stub length shown in the illustration being a compromise figure for both bands. For correct phasing of the elements, these phasing stubs should be a quarter wave length or multiples of a quarter wave length, at the operating frequency. This is automatically achieved with this aerial as the phasing stubs are approximately one quarter wavelength at 52MC and three quarter wavelength at 144MC.

PHASING ELEMENTS

At 144MC the aerial would normally radiate two major lobes with a split between them in line with the boom. However, by adding four phasing elements close to the driven elements, these lobes are brought together to form one major lobe. This type of construction is commonly used in TV aerial construction where channels available have an approximate 3:1 allocation in frequency. The approximate gain of this array would be 6dB at 52MC and 10dB at 144MC.

The simplest array found in any reference was that illustrated in figure 9. This array is patterned on the double vee antenna, popular in TV circles. The gain figures quoted for the beam, 4dB at 52MC and 9dB at 144MC, seem a little optimistic. However, this simple configuration could be fashioned from a double vee TV antenna, or fittings, and may be worth some experimental work.

For those who might like to build the double vee array, we would suggest that the arms be made adjustable and set for the best SWR compromise between the two bands. As 300-ohm feeder is used, an SWR of up to 3:1 would be quite acceptable.

Several references have been already made to the SWR exhibited by arrays when connected to various feeders. Just what this means in terms of lost signal is explained in the next few paragraphs, the figures quoted being extracted from charts given in the ARRL Handbook, 39th edition.

For reference purposes, let us consider what additional loss in a feeder cable is brought about by a SWR of 2:1. A mediocre 75-ohm coaxial cable, with an average length of 100 feet, having an SWR of 1:1 exhibits a loss at 50MC of 2dB and at 144MC a loss of 4.5dB. Increa-

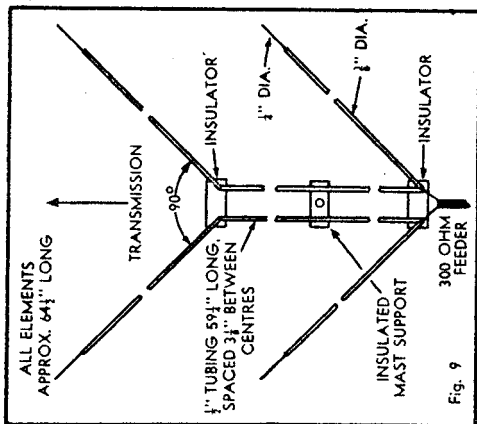

Fig. 9

This simple dual band configuration is similar to the Vee-type TV aerial.

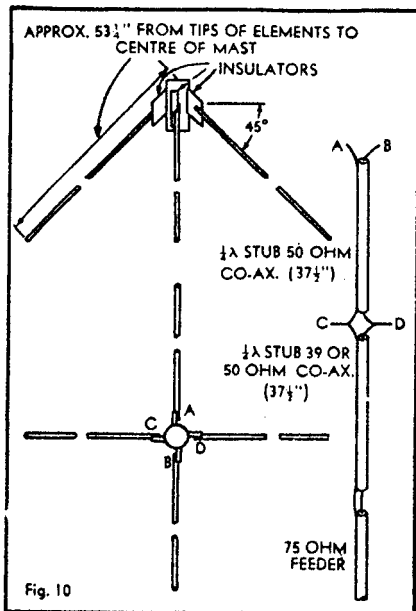

Fig. 10

Another simple 2-band configuration derived from the turnstile array which has an equal response to both vertically and horizontally polarised signals. The quarter-wave 50-ohm stub has to be bent into "U" shape. Two TV V-shaped insulating blocks, sawn in half, can simplify construction.

sing the SWR to 2:1 the additional loss will be 0.35dB and 0.45 respectively. A good coaxial cable under the same conditions shows a loss of 1.25dB and 2dB respectively at an SWR of 1:1, while an SWR of 2:1 gives an additional loss of 0.275dB and 0.3125dB at the respective frequencies.

From the above figures for coaxial cables it will be appreciated that the additional loss caused by an SWR of 2:1 is not sufficient to cause concern when operating on 52 or 144MC.

Standard 300 ohm TV ribbon has an approximate loss, over 100 feet, of 0.8dB and 1.5dB at these frequencies when the SWR is 1:1. Increasing the SWR to 2:1, the additional loss is 0.175dB and 0.274dB respectively. Further increasing the SWR to 3:1 the additional loss is still only 0.4dB and 0.68dB respectively. It is obvious, therefore, that the use of 300 ohm ribbon will allow the SWR to be higher than coaxial cable before the loss of signal is equalled. A closing thought on this subject is that most amateurs would not have a feeder run exceeding approximately 50 feet and therefore, these losses would be reduced accordingly.

A noted aerial for horizontally polarised, all-round coverage and one which the writer used for a time, is the turn-stile. An adaptation of this aerial, nick named by a Sydney amateur the "Quadpod" has proved quite successful in dual-band operation.

A turn-stile aerial consists of two dipoles crossed at right angles and fed 90 degrees out of phase. The phase change is achieved by the use of a quarter-wave cable section between the dipoles. The "Quadpod" aerial consists of a turnstile aerial in which four arms are drooped at an angle of 45 degrees. (Raising them to produce the same included angle has been suggested as an alternative.)

Drooping the elements has three effects on the aerial: The first effect is that the feed impedance of each section of the aerial is lowered and is closer to 50 ohms than 75 ohms. This means that the feed point of the aerial becomes approximately 25 ohms. The second is an alteration in the electrical length of the antenna. In practice this effect can be ignored, provided the included angle of the dipole is not less than 90 degrees. The third effect is the polarisation of the aerial. With this final configuration equal response is achieved from both vertical and horizontally polarised signals.

In figure 10, the aerial is shown wired ready for assembly. The two dipoles should be mounted at right angles, in close proximity, on the supporting mast and the elements drooped at 45 degrees. When used on the lower frequency band, the SWR of the aerial varied from 1.2:1 at 53MC to 1.8:1 at 52 and 54MC. On the 144MC operating frequency, the SWR was measured at 1.7:1. The performance of the aerial in an attic of a block of flats proved to be reasonable on both bands. The matching stubs do not give perfect matching as they can only be correct for one band. However, the match is near enough for all practical purposes, as results have proved.

Figure 11 shows one dual band aerial which exhibited quite good characteristics, was cheap to construct but proved a little unwieldy to rotate. It was an adaptation of the Lenfo array and, when adjusted, was capable of less than 2:1 SWR on both bands. Full measurements were not taken on the array but approximate figures were as follows: Forward gain, 52MC approximately 4.5dB, 144MC approximately 9dB. The array could be fed directly with 300 ohm ribbon, or with 75 ohm coaxial cable by using a four-to-one balun. By adjusting the length of wire on the end

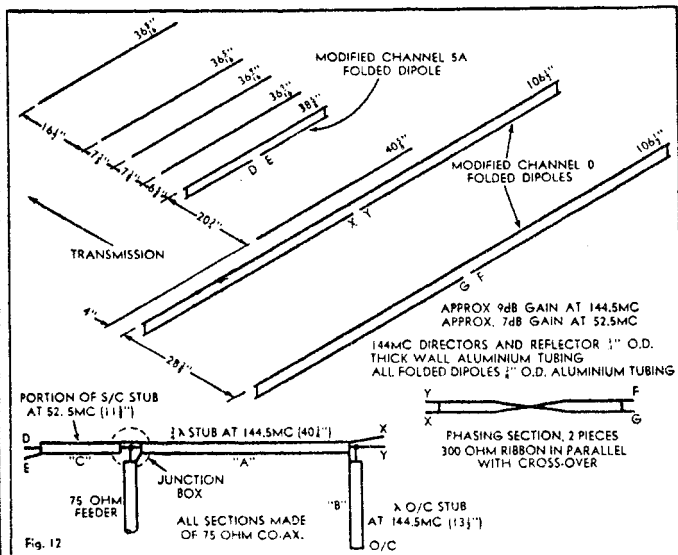
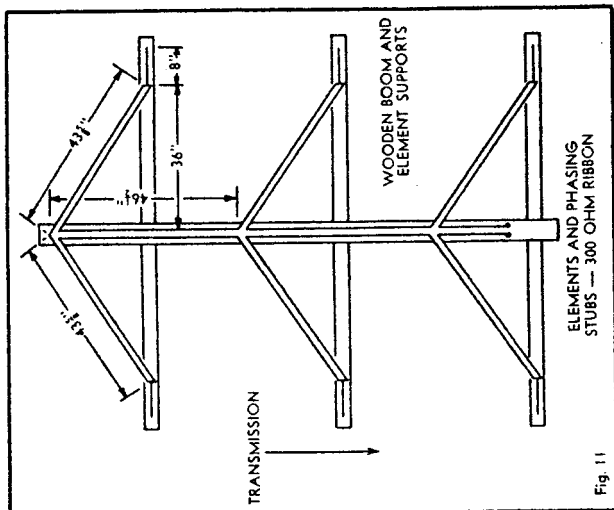

This practical design makes maximum use of TV components and is capable of excellent results even in confined spaces. A picture of the finished beam is shown at the head of the article. It folds into a fairly compact bundle for handling or transport.

of each element the SWR may be set at a compromise for both bands. The dual-band beam finally adopted by the writer is illustrated in figure 12. There is nothing extraordinary about this array other than the use of only one feeder and the method used to obtain freedom from reactive effects from the antenna portion not in use. When operating on 144MC it is effectively a six element Yagi, the other two elements being isolated from the feeder by the stubs "A" and "B". The approximate gain of this array is 9dB with a front to back ratio better than 20dB. The remaining two elements of this beam are operated on 52MC in a configuration commonly known as a "ZL special".

The phasing line is made from two 28 3/8 inch lengths of 300 ohm ribbon connected in parallel. An easy way to take approximately 62 inches of 300 ohm ribbon and fold it in half. The two halves should be taped flat together with plastic insulation tape. Where the bend was made the wires are exposed taking care not to break them, and made ready to connect to one folded dipole. At 28 3/8" from this end the other ends are bared and connected without crossing, ready for joining to the second dipole.

Before final connection, the phasing line is given a half turn to reverse the feed connection. The folded dipole at the end of the boom is fed 135 degrees out of phase with the other folded dipole achieving the propagation of the radiated signal along the line of the boom in the same direction as the 144MC signal.

As the two folded dipoles are very closely spaced, 1/8" wavelength, it has been postulated that the interaction causes the radiation resistance of each folded dipole to drop to approximately 180 ohms. This would give a feed point impedance of approximately 90 ohms. In practice we found that a reasonable SWR could be achieved when 75 ohm coaxial cable was used to feed the array.

When the array is operated on 52MC, stub "C" combines with the 144 MC folded dipole to make a shorted quarter wavelength stub on 52MC thus isolating the 144MC array from the feeder. Checked in situ when the aerial resonances had been adjusted the beam exhibited better than 2:1 SWR on both bands with no noticeable interaction between the two sections.

To make the task easy when constructing this array, all TV parts were used. The three folded dipoles were purchased complete with insulators and boom locking blocks, and slightly modified to achieve resonance on the two amateur bands. As indicated on the illustration, one channel "5A" and two channel "O" folded dipoles were used. The clamps holding the other elements were also TV fittings which allowed the whole array to be folded for transport. The clamps used on the prototype were for split elements but we would recommend the use of clamps, which are available, which do not require the elements to be split in two.

The gain of the "ZL special" has been claimed in various magazines as being 7dB. According to the best aerial references, two dipoles spaced by 1/8 wavelength and fed out of phase by 135 degrees will exhibit a maximum gain of 4.5dB. In practice the aerial has averaged out to between 4 and 5dB gain on a number of tests. These gain figures are quoted in reference to a half wave dipole in free space.

The "ZL special" configuration was chosen for the 52MC portion of this aerial because of the space saved by the close spacing of the elements. However, there is no reason why any other 52MC configuration cannot be used as long as it exhibits the correct feed impedance of 75 ohms. The

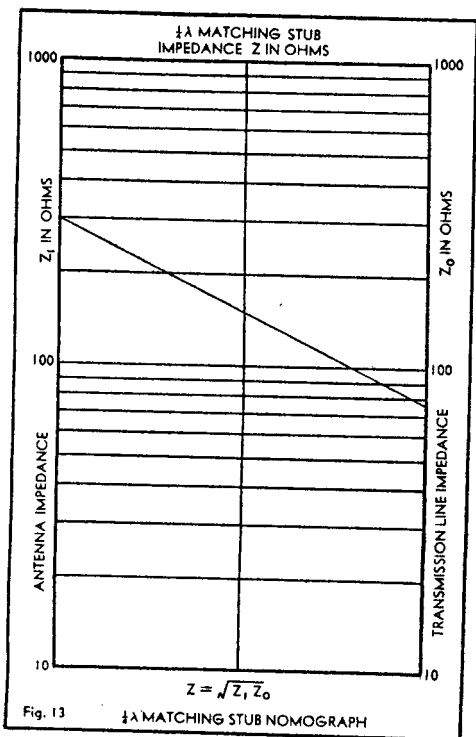

To save tedious calculations, this nomograph only requires the use of a straight-edge to show the correct impedance for a quarter wave matching stub.

same applies to the 144MC section which could be enlarged as long as a reasonable SWR can be maintained.

Figure 13 consists of a nomograph which makes the calculation of quarter wave matching stub impedances a simple task of applying a straight edge to a chart. An example is shown on the graph for an aerial with an impedance of 300 ohms which is to be used with a 75 ohm feeder. Reading off the value on the centre line we find that a quarter wave stub with an impedance of 150 ohms can be used to achieve the correct match between the aerial and the feeder.

AN FM DETECTOR FOR AMATEURS

This relatively straightforward outboard FM strip using a low cost phase locked loop IC may be of interest to those radio amateurs who, like myself, have until now been operating mainly on the "tuneable" part of the VHF bands using AM. I have built it into my existing home-brew tuneable IF receiver, and it gives very clean demodulation of the many relatively wide deviation FM signals found on the FM net channels.

Like others before me, my first attempts to provide the tuneable-IF receiver with an FM demodulation facility involved alternative detector circuits at the end of the existing 455kHz IF strip. But while this approach can give good results with narrow deviation FM signals, it is virtually useless for the wide-deviation signals produced by many of the converted FM-mobile transceivers in use on the VHF net channels. The reason is, of course, that these signals cannot pass through the relatively narrow 455kHz IF passband of the usual AM/SSB receiver. The only real way around the problem is to add not just a separate detector, but a complete parallel IF channel with an adequately wide passband. If a conventional approach were used, this would become quite a job, but luckily modern semiconductor technology can again come to the rescue. In this case, it comes in the form of the NE-565, a low cost phase-locked loop IC made by the Signetics Corporation. This lends itself very readily for use as an FM detector at up to about 500kHz, and has almost enough gain as well to operate directly from the mixer output.

It does need a little additional gain in order to cope with weaker signals, together with a modest amount of 455kHz preselection - mainly to stop the loop from jumping across to a stronger signal on an adjacent channel! The circuit shown seems to meet these requirements fairly well, and yet is quite straightforward. It takes the 455kHz signal from the low impedance secondary of the first IF transformer in my solid state receiver, but has a fairly high input impedance and could probably be connected into the mixer plate circuit of a valve receiver without undue loading.

Alignment must be done on a weak signal, as a strong signal will pull the PLL and give deceptively good results even when the circuit is badly misaligned. Basically the procedure is quite simple - use an aerial attenuator or the RF gain control of the receiver to progressively reduce the signal level, and adjust both the IF transformer and the VCO tuning pot to give clear demodulation for the smallest possible signal level.

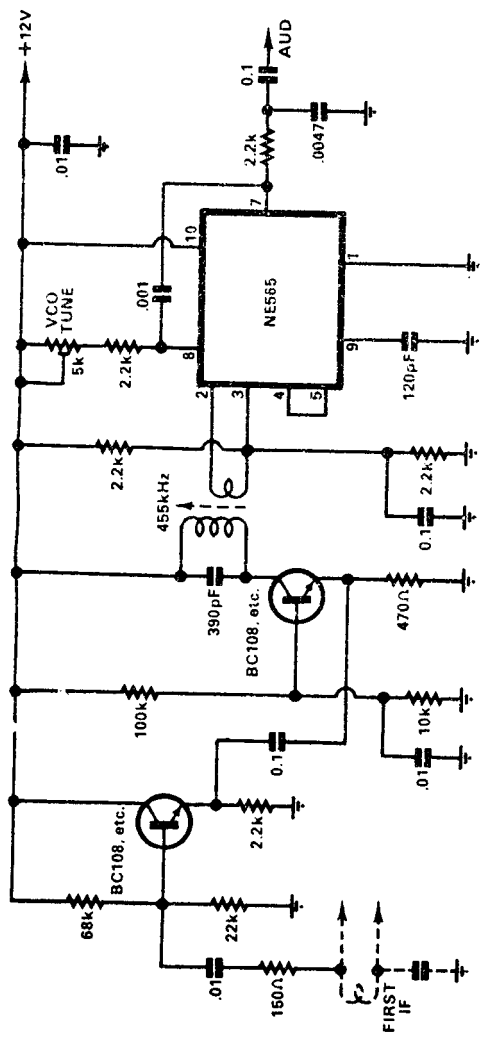

BC108=RS276-2009, BC148-168-208-318, 2N3711
 NE565=RS276-1720

A SOLID STATE, CRYSTAL FREQUENCY CALIBRATOR

A compact instrument which may be used to deliver any of thirteen accurately controlled and stable test frequency signals, all derived from a quartz crystal oscillator and having a fast-transition rectangular waveform of high harmonic content. It should be found invaluable for calibration of receivers and instruments, and would also be useful as an audio oscillator, square-wave generator, digital circuit tester or as the heart of a crystal-controlled chronometer.

A source of accurately controlled and stable test frequency signals vastly simplifies and facilitates the frequency calibration of short-wave receivers, signal generators and other equipment, both during initial calibration following construction, and for "spot check" purposes during critical operation. Such a source can also serve as a marker generator for sweep-frequency alignment, and as a time-period reference for such applications as the calibration of an oscilloscope timebase.

The instrument to be described in this article delivers any one of thirteen quartz-crystal derived fundamental test frequencies, each of which is accompanied by a series of its harmonics extending well up into the VHF spectrum. It is therefore well suited for the above applications, as well as for more general use as an audio-video squarewave generator and as a digital "clock" generator. It might also form the basis of a quartz-crystal chronometer, or the timebase system of a digital counter.

Although functionally very flexible, the instrument is basically quite straightforward in design. It is also very compact, and will involve but a modest outlay. When built up in its complete form, for example, it should cost no more than about \$50. However, if the full range of output frequencies is not required, this figure may be significantly reduced.

The key to the attractive high flexibility/low complexity ratio offered by the instrument lies in its use of integrated digital microcircuits to perform all the active functions. In fact, apart from the single quartz crystal and the power supply components, the instrument consists of nothing more than a handful of microcircuits and a few bypass capacitors.

The microcircuits used are all of the low-cost "RTL" (resistor-transistor logic) variety. Only two device types are used, both from the MC700P range manufactured by Motorola Semiconductors. One type MC799P dual buffer device is used in the crystal oscillator, while up to thirteen type MC790P dual J-K flip-flop devices are used in the calibrated divider chain used to derive the various output frequencies. All devices are in the 14-pin "DIL" (dual in-line) package.

All of the active circuitry of the instrument is mounted on a small single-sided printed wiring board, making assembly of the unit a simple and straightforward operation. The board measures only 3¼in x 5¼in, but

provides adequate space for the quartz crystal and all fourteen microcircuits, together with minor components and wiring.

Heart of the instrument is the crystal oscillator, shown in figure 1. This uses an MC799P dual-buffer device connected basically as an astable multivibrator, with the quartz crystal in one feedback link. A capacitor/trimmer combination connected in series with the crystal allows vernier adjustment of the frequency of oscillation and permits standardisation of the instrument against a reference such as the NBS standard transmissions of WWV or WWVH.

The crystal used in the oscillator is a "D-type" unit, having a nominal frequency of 2MHz (2,000KHz). This frequency was chosen in contrast with the more usual figures of 1MHz and 100KHz because it would appear that, where modern crystals are concerned, 2MHz represents a considerably more attractive performance/cost compromise.

Typically a modern 2MHz crystal costs slightly less than half that of a 1MHz crystal of comparable tolerance and frequency stability, and less than one third the cost of a comparable 100KHz crystal. Naturally, the use of a 2MHz crystal involves additional frequency division, and this tends to reduce the cost advantage. However, with the use of low cost microcircuits in the divider chain the additional division is provided very economically, so that the advantage of employing a 2MHz crystal is still quite significant.

The crystal used in the prototype instrument is a .003 per cent adjustment tolerance AT-cut type, specified for operation at ambient temperatures. It was kindly supplied by Pye Pty. Ltd., who advise that similar units can be supplied to readers on order, either direct or via normal parts suppliers. The Py designation of the unit in terms of tolerance and stability is class "FEF", with the holder code "Q12A" and the nominal intended shunt capacitance 30pF.

Similar crystals of different manufacture may be used, and even a disposals crystal may be tried if available. The oscillator circuit is not critical, and will operate with a wide variety of crystals. However, it should be borne in mind that the ultimate frequency stability of the instrument depends almost completely upon the crystal, so that a low-grade unit may seriously prejudice usefulness.

It may be noted that the capacitor and trimmer connected in series with the crystal are both NPO ceramic components, to ensure that the temperature stability of the oscillator is not significantly less than that of the crystal itself. It is for the same reason that the .001uF coupling capacitor is specified as a polystyrene type.

The 2MHz output from the crystal oscillator could be used directly as the highest fundamental output frequency of the instrument, although this would require the use of a third buffer element to ensure that output loading would not degrade the frequency stability. In the final design of the

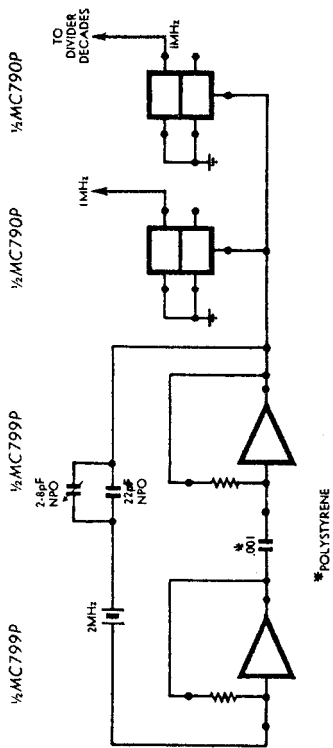

Figure 1
 $\frac{1}{2}$ MC790P

CRYSTAL OSCILLATOR/BUFFER DIVIDER
 $\frac{1}{2}$ MC790P

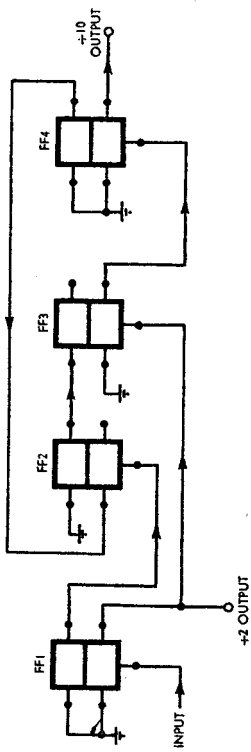

Figure 2

instrument we have not followed this course, but instead have settled upon 1MHz as the highest fundamental output frequency.

This has allowed the use of an MC790P dual J-K flip-flop both as an oscillator buffer and as the initial 2:1 divider. Both flip-flops of the device are connected in toggling mode and operated from the 2MHz oscillator output, as may be seen in figure 1, one effectively providing a buffered 1MHz output and the other providing an independent 1MHz signal for the following divider chain.

The divider chain of the instrument consists of a series of 10:1 divider decades, each using the configuration shown in figure 2. The configuration divides in what may be called a "quibinary" or (5 x 2) fashion, with the first element FF1 dividing the input by two, and the remaining three elements dividing by five.

The actual configuration used is particularly attractive from the point of view of economy, for as may be seen it requires no separate gating elements to perform the required decade division. Only four J-K flip-flop elements are required, all gating being performed by the elements themselves. (The four elements used are provided by two MC790P dual flip-flop devices.)

Quite apart from its economical use of elements, the configuration has a further attraction. From the output of element FF1 may be taken a useful auxiliary output signal, representing a 2:1 division of the input signal. Thus in terms of frequency multiples, each decade of the divider can provide both a "X1" signal (FF4 output) and a "X5" signal (FF1 output).

Space is provided on the printed wiring board for up to six divider decades, in addition to the crystal oscillator and the initial buffer divider. Whether or not all of these decades are wired will depend solely upon the needs of the constructor concerning the available range of output frequencies.

If all decades are wired, the range of frequencies available extends from 1MHz down to 1 Hz in a 10-5-1 sequence. However the sequence may be terminated at any desired point simply by omitting the redundant microcircuits. If both devices of any redundant decades are omitted, the lowest available frequency will be a multiple of 1 (or 10); however, it is entirely permissible to wire in only one device of the lowest decade involved, in order to provide the appropriate "X5" signal.

Hence if the constructor desires to provide only those frequencies extending down to 10KHz, he would wire in only the first two decades following the crystal oscillator and buffer divider. This would involve a total of only six microcircuits, and result in a considerable saving.

Another of the many possible variations would be where those frequencies down to 50Hz are required, but not those lower. This would require four full decades, together with the first device only from the fifth decade. In this case a total of eleven microcircuits would be involved.

Output voltage for all signals is approximately 2V peak to peak.

The design of the printed wiring board and circuitry is such that any or all of any decades or part-decades omitted when the instrument is first made could easily be added at a later time if the need arose for the provision of lower frequencies. It would also be feasible to add additional decades to the six allowed for on the board, in order to obtain still lower frequencies than 1Hz. However if this is contemplated it should be borne in mind that the power supply may have to be re-designed to cope with the additional current demands.

As may be seen from the main circuit diagram, the oscillator/divider board forms the heart of the instrument. The remainder of the circuitry consists of a simple regulated power supply delivering a nominal 3.6V DC for the microcircuits, and a straightforward switching system to permit selection of the desired output signal.

The printed board pattern will be supplied to interested board manufacturers, so that boards should be available in the near future. The pattern is coded 69/c9.

The power supply consists of a conventional full-wave rectifier followed by a simple series-pass regulator using an NPN power transistor. Reference voltage for the transistor is obtained using a 4.3V zener diode. The transistor base supply is filtered to ensure that the transistor also acts as a dynamic filter.

As the current drain of the oscillator/divider board is approximately 500mA when all divider decades are wired, the quiescent power dissipated by the series-pass transistor can exceed one watt. In view of this it is desirable to employ in this position a device with a rated dissipation of 3W or more at 40 degrees C., to allow adequate safety margin.

The TO-66 type power devices specified on the circuit have adequate ratings for this purpose, and are thus quite suitable. However, a device with higher ratings could be used if on hand. Alternatively it would be possible to use medium-power silicon TO-5 devices such as the 40408 or AY8116, providing they were fitted with the appropriate clip-on heat radiator to limit case temperature.

The output signal selection, circuitry has been arranged for simplicity and operating convenience. The 1MHz output signal has been taken directly to one output connector, both because it is in a sense "thirteenth man" and because this permits the instrument to be calibrated to greatest accuracy using this signal, even when one of the other signals is being used simultaneously for another purpose.

The selection of the remaining twelve output signals is performed by a two-pole six-position switch and a two-position toggle switch, the latter connecting to a second output connector. Isolating resistors (1.5K) are fitted in series with each of the output connectors to prevent damage or malfunction due to severe loading or short-circuits.

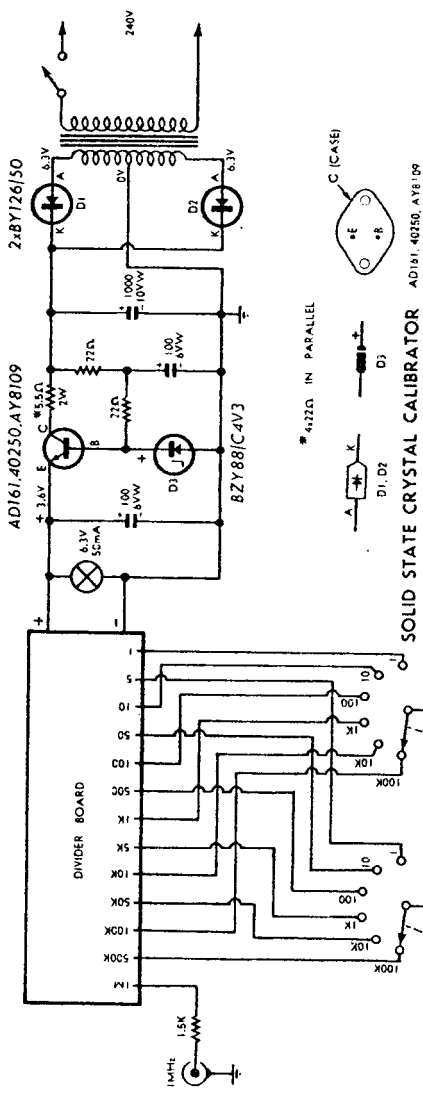

The circuit of the calibrator, showing its essential simplicity. The number of microcircuits used on the divider board and the number of switch positions wired will depend upon the output frequencies required; the circuit shows the system as fully wired.

AD161=RS276-2006, 2N3252, MC140-800-810.
 BY126/50=RS276-1141, 1N4139-5400

The instrument is housed in a small rectangular instrument case similar to that used for many of our recent designs, and measuring $7\frac{1}{2}$ in x 5in x 4in. The front panel controls consist of the frequency selection switches, the output connectors and the mains switch and pilot bezel.

Inside the case, the printed wiring board is supported by two right-triangular brackets which are in turn clamped to the front panel by the input connector screws at one end, and the mains switch and bezel at the other. A hole in the bracket adjacent to the crystal end of the board and a similar hole in the appropriate end of the case permit the crystal oscillator trimmer to be adjusted for calibration once the instrument is fully assembled.

The two miniature toggle switches and miniature pilot bezel used in the instrument are available from I.R.H. Components Pty. Ltd. The switches are N.K.K. type 2-2012, while the bezel is a Rodan 6V 50mA type. Both components may be ordered via the usual parts suppliers.

Using the wiring diagram provided, assembly of the components on the printed wiring board should be simple and straightforward. The main point to watch is that a small, well tinned iron should be used, and the joints made rapidly in order to avoid over-heating either the printed board conductors, or the microcircuits. Care should be taken that the solder does not form bridges between conductors in places where the spacing is relatively narrow.

Note that all wire links and bypass capacitors mounted on the board must be fitted, regardless of whether or not all of the divider diodes are wired. The links are essential for continuity of the supply line, while the bypass capacitors ensure that operation of the microcircuits is not disturbed by supply line transients.

The NPO ceramic trimmer which forms the calibration adjustment for the crystal oscillator is a special type designed for printed-board mounting and side adjustment. The unit employed in the prototype and for which the printed board has been designed is marketed in Australia by the Imported Components Division of Plessey Ducon Pty. Ltd., and may be ordered via normal parts suppliers. The type number is DV11-PR8A.

The power supply section of the instrument is mounted in the lower rear of the case, with the power transformer mounted toward the case end opposite to that of the quartz crystal, in order to reduce thermal drift effects. The main cord terminations are mounted on one side of the transformer, while the rectifier and regulator components are mounted on the other side on an 8-lug section of miniature resistor panel.

The regulator series-pass transistor is mounted centrally on the rear of the case, being insulated electrically by means of the usual mica washer and plastic bushes. In this way the case itself acts as the heat radiator for the device.

The power supply wiring is not critical, and the constructor may deviate from the layout of the prototype if desired. However, care should be taken to ensure that the power cord is clamped securely upon entry via the usual grommetted hole, to prevent strain on the connections. The cord earth conductors should be taken to a solder lug clamped under the adjacent transformer counting screw.

When the power supply section is completed, it would be wise to apply power and check its output voltage before the oscillator/divider board is connected. This will ensure that if an error has occurred, it can be rectified before damage could be caused to the relatively costly microcircuit array.

Without the microcircuits connected, the voltage delivered by the power supply should be between 3.8 and 4.5V DC; if it lies within this range, everything is probably in order and the microcircuits may be safely connected. However if the voltage is markedly higher than 4.5V with no load, switch off and look for a wiring or component fault.

As virtually all the functional wiring is provided by the printed wiring board, connection of the 3.6V supply to the completed board should result in full and correct operation. The only aspect of construction which will remain at this stage is calibration of the crystal oscillator against a known reference.

As explained earlier, this operation is performed when the unit is completed and assembled, using the small ceramic trimmer. Adjustment of the trimmer is carried out using a small insulated alignment tool, introduced through the holes provided in the end of the case and the board support bracket.

Two methods of calibration may be used. One simply involves measurement of the 1MHz output of the instrument using a high-accuracy digital frequency meter. This is a very efficient technique, and will no doubt appeal to those with the appropriate facilities. However, it should be noted that the frequency meter used should be one having a timebase system whose accuracy and stability are at least within 1 part per million, otherwise the exercise will have little validity. The reason for this is that the calibrator itself is likely to have a performance approaching 10 parts per million, when set up.

The electrical setup for the alternative method of calibration is almost as simple, and may be more convenient. It involves only a conventional shortwave or communications receiver capable of receiving a standard frequency transmission such as those radiated by station WWV on 2.5, 5.0, 10.0, 15.0, 20.0 and 25.0MHz, or by station WWVH on 5.0, 10.0 and 15.0MHz. The 1MHz signal from the calibrator is simply fed into a rudimentary aerial near the receiver, and the calibrator trimmer adjusted for zero beat.

The procedure is to switch both the calibrator and the receiver on and let them run for about 15 minutes to allow the case temperatures to stabilise. At this stage no connection should be made to the ~~putput~~

connectors of the calibrator, in order that radiation should be minimal. Then tune the receiver carefully to whichever of the standard frequency signals is currently available at a level adequate for convenient and reliable reception.

A foot or two of hookup wire may then be inserted into the 1MHz output connector, whereupon a beat note should become audible in the receiver output. It may in some cases be necessary to place the wire close to the receiver aerial lead-in, or perhaps even twist the two together, in order to obtain sufficient coupling.

Adjustment of the calibrator trimmer should allow the beat note to be reduced in frequency below audibility, although continued trimming of the trimmer in the same direction should result in the note re-appearing and rising in pitch once again. The zero-beat condition lies in the centre of the inaudible-beat segment of adjustment, and with many receivers it may have to be estimated by interpolation. However, if the receiver is fitted with an "S" meter it should be possible to observe the beats on the meter when they are near zero, and a more accurate setting may be achieved. Once set up in this fashion the calibrator should retain its calibration for a considerable period. The oscillator circuit is relatively insensitive to temperature, and is also free from many of the aging effects which are found with other circuits. However, before critical measurements are to be made using the instrument, it would be wise to re-check its calibration using the above techniques.

PARTS LIST

1 Case, 7½in x 5in x 4in, with wrap-around front panel, board brackets.

1 Printed wiring board, 60/c9.

1 Stepdown transformer, 240V to 12.6V CT, at 1A.

1 2.000MHz quartz crystal (see text).

1 Two-pole six-position rotary switch.

2 SPDT miniature toggle switches.

1 Miniature pilot lamp, bezel, 6V at 50mA.

2 Co-axial connectors.

CAPACITORS

1 2-8pF NPO ceramic trimmer (see text).

1 22pF NPO ceramic.

1 .001uF polystyrene, 400V or lower if available.

3 .047uF 25VW ceramic.

2 100uF 6VW electrolytic.

1 1000uF 10VW electrolytic.

SEMICONDUCTORS

2 BY126/50 diodes or similar

1 BZY88/C4V3 or similar 4.3V zener diode.

1 AD161, 40250, AY8109 or similar NPN power transistor.

1 MC799P dual buffer microcircuit.

13 MC790P dual J-K flip-flop microcircuits (see text).

RESISTORS

6 22 ohms ½watt.

2 1.5K ½watt.

Mains cord and plug; grommet and cord clamp; 8-lug section of miniature resistor panel; 3-lug miniature tagstrip; case handle, rubber feet; screws, nuts, connecting wire, solder, etc.

BERNARDS & BABANI PRESS RADIO AND ELECTRONICS BOOKS

BP1	First Book of Transistor Equivalents and Substitutes	40p
BP2	Handbook of Radio, TV and Ind. & Transmitting Tube & Valve Equivalents	60p
BP3	Handbook of Tested Transistor Circuits	40p
BP4	World's Short, Medium & Long Wave, FM & TV Broadcasting Stations Listing (International Edition)	60p
BP5	Handbook of Simple Transistor Circuits	35p
BP6	Engineers and Machinists Reference Tables	30p
BP7	Radio and Electronic Colour Codes and Data Chart	15p
BP8	Sound and Loudspeaker Manual	50p
BP9	38 Practical Tested Diode Circuits for the Home Constructor	35p
BP10	Modern Crystal and Transistor Set Circuits for Beginners	35p
BP11	Practical Transistor Novelty Circuits	40p
BP12	Hi-Fi, P.A., Guitar & Discotheque Amplifier Design Handbook	75p
BP13	Electronic Novelties for the Motorist	50p
BP14	Second Book of Transistor Equivalents	95p
BP15	Constructors Manual of Electronic Circuits for the Home	50p
BP16	Handbook of Electronic Circuits for the Amateur Photographer	60p
BP17	Radio Receiver Construction Handbook using IC's and Transistors	60p
BP18	Boys & Beginners Book of Practical Radio & Electronics	60p
BP22	79 Electronic Novelty Circuits	75p
BP23	First Book of Practical Electronic Projects	75p
BP24	52 Projects using IC741 (or Equivalents)	75p
BP25	How to Build Your Own Electronic and Quartz Controlled Watches & Clocks	85p
100	A Comprehensive Radio Valve Guide - Book 1	40p
121	A Comprehensive Radio Valve Guide - Book 2	40p
126	Boys Book of Crystal Sets	25p
129	Universal Gram-Motor Speed Indicator (Combined 50 & 60 ∞ model)	10p
138	How to make Aerials for TV (Band 1-2-3)	25p
143	A Comprehensive Radio Valve Guide - Book 3	40p
150	Practical Radio Inside Out	40p
157	A Comprehensive Radio Valve Guide - Book 4	40p
160	Coil Design and Construction Manual	50p
161	Radio, TV and Electronics Data Book	60p
170	Transistor Circuits for Radio Controlled Models	40p
177	Modern Transistor Circuits for Beginners	40p
178	A Comprehensive Radio Valve Guide - Book 5	40p
183	How to Receive Foreign TV Programmes on your Set by Simple Modifications	35p
195	High Fidelity 14 Watt Amplifier Design Chart	15p
196	AF-RF Reactance-Frequency Chart for Constructors	15p
197	Inexpensive Push-Pull Amplifier Construction Chart	15p
200	Handbook of Practical Electronic Musical Novelties	50p
201	Practical Transistorised Novelties for Hi-Fi Enthusiasts	35p
202	Handbook of Integrated Circuits (IC's) Equivalents and Substitutes	75p
203	IC's and Transistor Gadgets Construction Handbook	60p
204	Second Book of Hi-Fi Loudspeaker Enclosures	60p
205	First Book of Hi-Fi Loudspeaker Enclosures	60p
206	Practical Transistor Circuits for Modern Test Equipment	60p
207	Practical Electronic Science Projects	75p
208	Practical Stereo and Quadrophony Handbook	75p
209	Modern Tape Recording Handbook	75p
210	The Complete Car Radio Manual	75p
211	First Book of Diode Characteristics Equivalents and Substitutes	95p
215	Shortwave Circuits and Gear for Experimenters and Radio Hams	85p
216	Electronic Gadgets and Games	85p
RCC	Resistor Colour Code Disc Calculator	10p

BABANI PRESS & BERNARDS (PUBLISHERS) LIMITED

The Grampians, Shepherds Bush Road, London W6 7NF

Telephone Number: 01-603 2581/7296