

amateur



transmitters' construction manual

No. 61



Nett

GOOD NEWS

RADIO NEWS, foremost American Radio magazine, can now be obtained direct by post from America; the only sure way of receiving copies regularly.

RADIO NEWS unfolds, month by month, the complete story of radio research and development. Editorially and in presentation, printing and production, it maintains the highest American standards. Each issue contains from 136 to 160 pages of news, articles, pictures and advertisements, brilliantly written and illustrated.

Radio technicians, dealers, business and factory executives, radio specialists in the services, amateurs, "hams," officials, research specialists, constructors, all are fully catered for. The scope of RADIO NEWS, in all that matters, is complete.

For a subscription of £1 5s. 0d., inclusive of postage, payable in advance (equal to 2s. 1d. a copy), the postman will deliver a copy at the door every month for a year. For two years the rate is £2 5s. 0d. and for three years £3 0s. 0d.

Subscription orders may be placed through your Radio dealer or newsagent or, in case of difficulty, send your order (name and full address in BLOCK LETTERS, please) with remittance covering the period required, to us at the address below.

. . . . *RADIO NEWS*

POPULAR PHOTOGRAPHY, FLYING, PLASTICS.

From the same publishers come these three superb magazines, each completely fulfilling, in its own sphere, the same essential purpose as RADIO NEWS. Informative to the highly skilled operator or technician, yet understandable and interesting to the amateur: intensely practical, yet never dry or stodgy. Brilliantly written, copiously illustrated and beautifully produced, each magazine maintains the highest standards for which American magazines are famous.

Particulars of subscription rates and facilities on request.

ZIFF DAVIS LIMITED,
GRAMPIANS BUILDING, WESTERN GATE, LONDON, W.6.
Telephone: SHEPHERDS BUSH 4794.

AMATEUR TRANSMITTER'S CONSTRUCTION MANUAL

by

"RADIOTRICIAN"

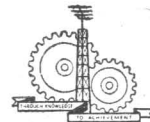

BERNARDS (PUBLISHERS) LTD.

LONDON · W. 6

First Published 1947

CONTENTS

| | | | | | | | |
|--|-----|-----|-----|-----|-----|-----|---------|
| INTRODUCTION | ... | ... | ... | ... | ... | ... | Page 4 |
| Chapter 1. FUNDAMENTAL PRINCIPLES | ... | ... | ... | ... | ... | ... | Page 5 |
| Chapter 2. TRANSMITTER STAGES | ... | ... | ... | ... | ... | ... | Page 12 |
| Chapter 3. MODULATING OR SPEECH AMPLIFIERS | ... | ... | ... | ... | ... | ... | Page 38 |
| Chapter 4. POWER SUPPLIES | ... | ... | ... | ... | ... | ... | Page 46 |
| Chapter 5. AUXILIARY APPARATUS | ... | ... | ... | ... | ... | ... | Page 50 |
| Chapter 6. PRACTICAL TRANSMITTING CIRCUITS | ... | ... | ... | ... | ... | ... | Page 55 |

INTRODUCTION

This Manual has been written chiefly for the newcomer to Amateur Transmitting, and is intended as a guide to the construction of transmitting gear. It must, therefore, immediately be pointed out that no transmission may take place with unlicensed apparatus, and that under the new governing rules, all would-be transmitting amateurs must pass an examination, held regularly at appointed places. Details of such examinations may be found in the radio periodicals.

Whilst this book deals with the practical side of transmitter construction, and not in preparation for the theoretical side of such examinations, no apology is made for the fact that the first pages deal, very briefly, with the broader points of fundamental principles.

At the time of writing, the new rules governing amateur transmissions are still in a state of flux, especially as regards the frequency bands open to amateur work. The latest figures for the permitted bands are as follows:—

| | | | |
|----------|--------|------------|---------------|
| 1.715 — | 2.0 | Megacycles | 10 watts max. |
| 3.5 — | 3.635 | „ | 150 „ |
| 3.685 — | 3.8 | „ | 150 „ |
| 7.0 — | 7.3 | „ | 150 „ |
| 14.0 — | 14.4 | „ | 150 „ |
| 28.0 — | 30.0 | „ | 150 „ |
| 58.5 — | 60.0 | „ | 25 „ |
| 2300.0 — | 2450.0 | „ | 25 „ |

2300 to 2450 megacycles may be used for frequency modulation but not pulse.

Class A amateurs are allowed to use telegraphy communication only, and are licensed for a power of 25 watts, whilst Class B amateurs may use radio telephony in addition to telegraphy, and may be licensed for powers up to 150 watts.

Since the usual power rating before the war was in the nature of 10 watts for many stations, this represents a considerable advance. Excellent work has always been possible on powers of a low order however, and many amateurs have made contacts all over the globe on the 10 watt rating.

The American amateur is perhaps the most fortunate of all at the moment, in having available for his use bands extending from 4 Mc. right up to the purely experimental frequencies of 30,000 Mc., and is also allowed on certain bands to test with frequency modulation, pulse modulation and facsimile and television signals. It is only to be expected, therefore, that major developments in amateur transmission will come from America until the authorities give the British amateur a rather wider scope of permitted activities.

It may be felt by some readers that rather too much mention is made in the following pages of circuits using American type valves. These valves, however, are often chosen by amateurs, for several reasons, including their abilities to handle the higher powers and their lower heating requirements. It may be said, too, that when designing a transmitter it is more simple to obtain operating data for the American types, and these valves are becoming easier to obtain every day.

CHAPTER 1.

FUNDAMENTAL PRINCIPLES.

A transmitter, like a radio receiver, is concerned with alternating current at high frequencies, but whereas the receiver is used to detect and amplify small charges received on an aerial, the transmitter is used to generate high frequency power, drawing on a source of direct current power to obtain the necessary energy, and to feed the generated power to an aerial as efficiently as possible.

The working frequency of the transmitter is controlled by a device which prevents the frequency from drifting, and intelligence is conveyed either by interrupting the generated power so that a series of "spurts" of energy corresponding to an accepted code is sent out, by impressing an audio tone on the main or carrier frequency so that the same code is transmitted as long or short tones or notes all on the same pitch, or, finally, by modulating, *i.e.*, varying the carrier amplitude, by speech currents amplified up from a microphone circuit. Pulse modulation and frequency modulation cannot be dealt with in these pages.

Common to the transmitter and to the receiver, therefore, are tuned circuits, speech amplifiers and, so far as superhets are concerned, oscillating circuits, although the coupling of the stages is different in the transmitter as is also the power generated and supplied.

A circuit is tuned when it has a natural frequency, an effect which, of course, can only obtain with alternating currents. To direct current a circuit presents only resistance—for example, the resistance of an ordinary tuning coil is low, whilst that of a condenser with either air or mica dielectric is infinitely great. To an alternating current, however, both the coil, better termed an inductance, and a condenser or capacitance present very different characteristics.

When a current flows through a coil a magnetic field is set up round the wires of the coil, and when a magnetic field changes in strength any wire which is cut by a line or lines of energy has induced in it a current proportional in strength to the strength of the magnetic field. Thus, in any coil into which current is flowing a field is acting, and acting in such a way that it opposes the current which causes the field. The current, therefore, grows only slowly in value. If the current is reduced or the circuit is broken, the magnetic field again changes, and again the currents induced by the field tend to oppose the change of original current, so that the magnetic field round a coil may be regarded as a store of energy.

To an alternating current, therefore, the coil has not only a resistance, precisely the same resistance, when the frequency is low, which it presents to direct current, but also a reactance. A reactance, however, although affecting current flow, does not use up energy so that there is no energy loss in a pure reactance but, in the case of the coil, a transfer of energy from the electrical circuit to the magnetic field and back again, any losses which occur being caused by the resistance of the wire.

Since the reactance, however, can be shown to be proportional to $\frac{E}{I}$ it is usually measured in ohms.

A condenser also presents a reactance to A.C. When a D.C. voltage is applied to the plates of a condenser there is a momentary re-arrangement of electrons which leaves one plate positive and the other negative in charge, the charges then remaining static as long as the source is left connected to the condenser. A current measuring instrument will therefore show no deflection if connected in the circuit. An alternating source connected across the condenser, however, will not allow the static condition to obtain, for as soon as the electron flow from plate to plate has commenced the alternating source reduces in potential and then changes polarity, so that the electron transfer must also reverse, the electrons flowing back through the circuit. An instrument which will measure alternating current, if connected into circuit with an A.C. source and condenser, will therefore show a flow of current apparently through the condenser, which thus may also be said to have a reactance.

In both the inductance and capacitance the effect of the reactance is to cause a change of phase between the voltage and the current due to the alternating source. In a simple circuit, voltage and current will change together, that is they will remain in phase, but the effect of an inductance in an A.C. circuit is to cause the current to lag behind the voltage. In a condenser, however, the current leads the voltage. When discussing reactances, therefore, it is necessary to know whether inductive or capacitive reactance is meant, and reactance is written as X_L if it is inductive, or X_C if it is capacitive.

Further, it may be shown that:—

$$X_L = 2\pi fL.$$

Where 2π is taken as 6.283, f is the frequency in cycles per second and L is the inductance of the coil measured in the fundamental units of Henrys. A coil has an inductance of 1 Henry when a rate of current change of 1 ampere per second causes a pressure of 1 volt to be induced across the coil.

The usual units for radio coils are milli- and microhenrys, which correspond respectively to thousandths and millionths of a Henry.

X_L , as given by the above formula, is in ohms.

The reactance of a condenser is given by the formula

$$X_C = \frac{1}{2\pi fC}$$

where 2π and f are in the same units as before and C is the capacity of the condenser measured in Farads. X_C is again given in ohms, and it should be noted that the quantity is expressed as a negative value, where considerations of phase apply.

The capacity of a condenser depends on the size, number and shape of its plates, the distance between them and the substance between them, differing insulating substances having differing dielectric constants. Condensers as used in radio work are generally of capacities denoted by micro- and picofarads, corresponding respectively to millionths and million-millionths

of a Farad. A condenser may be said to have a capacity of 1 Farad when a further addition to its charge of 1 ampere for 1 second causes a rise in potential difference of 1 volt.

Reactance is unlikely to occur in a circuit unaccompanied by resistance, however, and the combination of reactance with resistance is known as the impedance of a circuit, the value most often referred to. Reactances may be added together to obtain a total reactance for a circuit (always remembering that capacitive reactances are negative), but where resistance has also to be taken into account straightforward addition is not possible, and the square root of the sum of the squares is taken instead.

Thus the impedance, Z , of a tuned circuit where there is a resistance R ohms, an inductance of L Henrys and a capacitance of C Farads in series is

$$Z = \sqrt{R^2 + \left(2\pi fL - \frac{1}{2\pi fC}\right)^2}$$

It will be seen from the above formula, however, that the capacitive reactance is subtracted from the inductive reactance, so that when the two reactances are of equal value the impedance of the circuit reduces to its resistance, and the current in the circuit will be at its maximum value. This means that for maximum current

$$\frac{1}{2\pi fC} = 2\pi fL$$

and, bringing out f ,

$$f = \frac{1}{2\pi \sqrt{LC}}$$

This result shows the frequency at which the circuit is resonant, that is to say the frequency to which the circuit is naturally tuned, but to reduce the units to working values it is more convenient to express the formula as

$$f = \frac{1,000,000}{6.28 \sqrt{LC}}$$

where f is in kilocycles, L is in microhenrys and C is in picofarads.

So far the effect of a series tuned circuit, as in Fig. 1a, have been considered, and it has been shown that a series tuned circuit is one in which the current is highest and the impedance lowest. The parallel tuned circuit of Fig. 1b is more usual, however, and in this case the resonant frequency is that at which the impedance of the combination is at its highest and the current at a minimum. The previous formula for resonant frequency holds good.

The resistance of a coil changes with frequency, since high frequency currents travel through the "skin" of the wire, and the excellence (or otherwise) of a tuned circuit may be gauged by the term Q , which is the ratio of the coil's reactance to its high frequency resistance. A good coil has a high Q , or in other words the impedance of the circuit is mainly dependent upon the coil's reactance rather than on its resistance. It is only

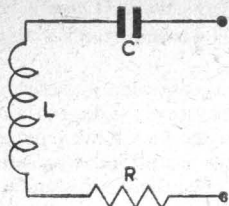

FIG. 1A. Series tuned circuit.

(R in each case the resistance of the coil.)

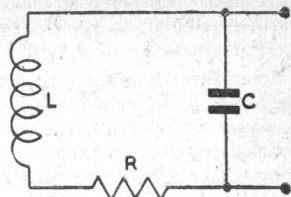

FIG. 1B. Parallel tuned circuit.

at very high frequencies that the resistance of the condenser need be taken into account, so that the coil is the chief deciding factor in the selectivity and voltage amplification of a tuned circuit. For this reason, also, high frequency coils are wound with heavy gauge wire or even tubing, to increase the surface area over which the H.F. currents are flowing, thus reducing the H.F. resistance. Q also gives the amplification factor of a resonant circuit.

Tuned circuits may be coupled by a capacity or inductively. Tuned circuits coupled by a condenser have good energy transfer from one to the other through quite a small condenser, providing reasonably efficient circuits are used, especially in the secondary circuit, Fig. 2a, and inductive couplings can take several forms, as shown in Figs. 2b-2e. In each case there is a mutual inductance between the coupled coils, that is the inductances are coupled through their mutually acting magnetic fields. The type of coupling shown in Fig. 2e is of particular use in transmitters, since it provides a method of linking two circuits which may be separated by quite some distance, or which may require shielding one from the other. It is known as the Link coupling, and the smaller coils are often mounted variably beside the main coils to be coupled, the smaller coils, only of a turn or two in size, being connected by twisted feeders or spaced transmission lines.

A circuit can be resonant to a frequency without being a coil and condenser combination. A half-wave resonant aerial is one example of this property. If an electrical charge is fed into a long wire the charge travels to the end of the wire where, if the wire is open circuited or insulated, the charge is reflected back along the wire. The charge travels at something

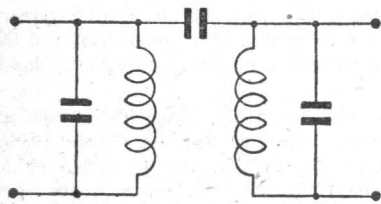

FIG. 2A.—Capacitive coupling.

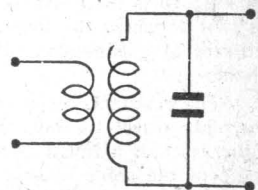

FIG. 2B.—Tuned secondary coupling.

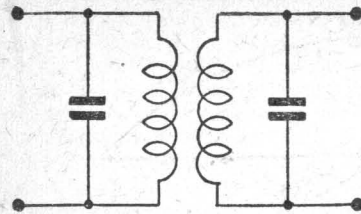

FIG. 2C.—Tuned secondary coupling.

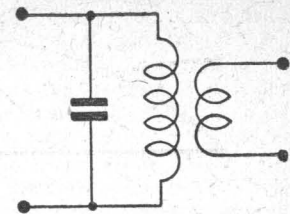

FIG. 2D.—Tuned primary coupling.

less than the speed of light. It will be appreciated that if the wire is cut to the correct length the charges can be made to reinforce each other, and that high frequency alternating current, fed into such a wire, will set up a wave along the wire when the wire is half the wavelength of the alternation, wavelength and frequency being related in the formula

$$W = \frac{300,000}{f}$$

where W is the wavelength in metres and f is the frequency in kilocycles. If current is travelling along the wire in a time equal to one half-cycle of operation the phase differences resulting cause a "standing wave" to be set up along the wire, the current and voltage distributions being as shown in Fig. 3. With the current at its maximum in the centre of the wire, the impedance is obviously lowest at that point and is almost purely resistive, the common figure for a half wave aerial centre point being about 72 ohms, depending on the height above ground. The impedance at the ends of the aerial is highest since the voltage reaches a maximum at these points, and is, approximately 2,500 ohms. Thus the wire or aerial can be either current or voltage fed, the feed being taken to the appropriate point.

If the half wavelength of wire is bent back on itself to a folded halfwave with sides approximately one-quarter wavelength long, as in Fig. 4, the conditions of maximum current and voltage, together with the standing wave still apply, and given a short wavelength so that a quarter wavelength is of convenient size, a different tuned circuit is then available for incorporation into transmitting gear. The long-lines oscillator, Chapter 6, working on 5 metres, is no more than such a resonant circuit, and the tuning is variable by using a sliding bar to short the two quarter wave wires.

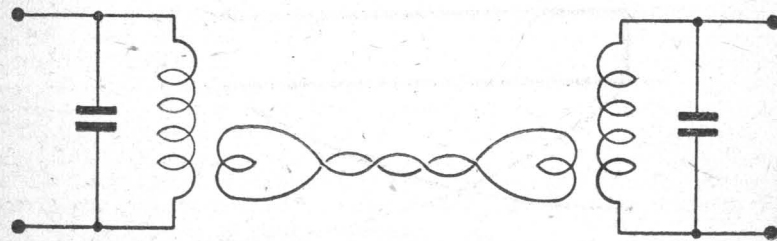

FIG. 2E.—Link coupling.

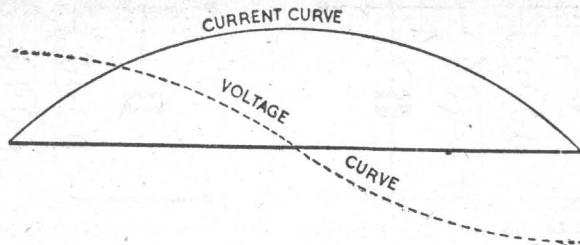

FIG. 3.—Current and voltage distribution over a resonant wire.

The power from the D.C. supply is converted into radio frequency energy by a valve oscillator, which may take one of several forms. First, however, it must be noted that simply discharging a charged condenser through an inductance results in the generation of alternations or oscillations, for current flows from the condenser through the coil, the condenser thus receiving a charge of opposite polarity, which then discharges again through the coil, the action continuing until the energy in the circuit has all been lost in overcoming the circuit resistance. The oscillations are thus damped, that is, each peak of potential or current is lower in amplitude than that preceding it as energy is lost. If energy is fed in a correct manner to such a circuit, therefore, the oscillations will no longer be damped, but will build up to a level depending upon circuit characteristics and be maintained at that level. A valve can be arranged to feed into a tuned circuit in such a way that oscillation is maintained at a high level.

One of the simplest arrangements is shown in Fig. 5. Any valve used for the generation of oscillations must be capable of amplification, and there must be some arrangement of positive feedback from the anode to the grid. In the circuit shown this is provided by coupling the anode coil to the grid coil in such a manner that a charge on the grid of the valve affects the

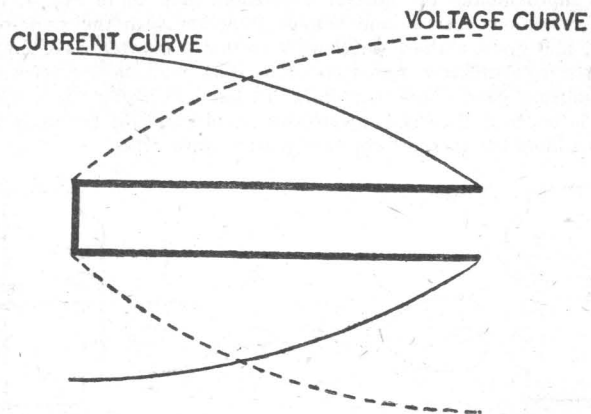

FIG. 4.—Distribution of current and voltage on a folded half-wave.

anode current, and therefore the magnetic field coupling the two coils, so that the varying anode current induces a further charge in the grid coil, and thus on the grid, in such a way that the new charge is added to the effect of the original charge. Thus the grid circuit is excited by the anode circuit, and any small electrical surge in either current, such as is provided by switching on, is sufficient to set the whole circuit oscillating. Due to the amplification of the valve there is more than sufficient energy in the anode circuit to keep the grid circuit excited, the anode circuit always being in phase with that of the grid, so that the oscillations build up to a level set by the valve's operating conditions and are maintained whilst power is fed to the circuit from a D.C. supply.

It may also be shown that positive feedback over a valve circuit is equivalent to connecting a theoretical negative resistance across the grid circuit. As the feedback increases the value of the negative resistance

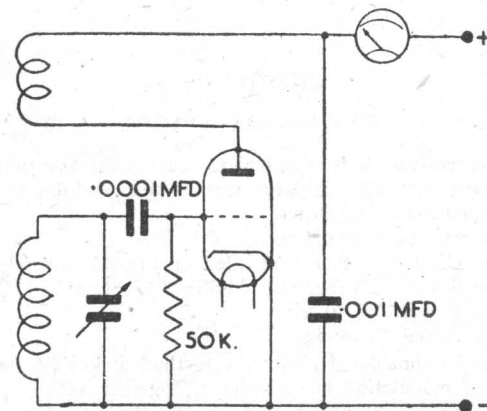

FIG. 5.—Simple valve oscillator.

becomes lower than the value of the positive or actual resistance until the effective resistance of the grid input circuit becomes wholly negative. When such a condition obtains, it may be said that the grid circuit is a source of energy which sets up a potential which is further amplified by the valve.

In a simple self-excited oscillator of this type a bias potential is automatically supplied to the grid by the condenser and resistance in the grid circuit. As the circuit goes into oscillation the grid of the valve is run to a positive potential for a fraction of each cycle, which means that there is a flow of grid current. This current flow through the grid leak causes a voltage drop across the resistor, the grid thus acquiring a negative charge. The charge is held on the grid by the action of the condenser and leak, which are chosen to have a suitable time constant. The time constant of a condenser-resistance combination refers to the time taken to discharge (or charge) the condenser through the resistance, so that if the time constant of the grid leak and condenser of a self-excited oscillator is made considerably greater than the time of one cycle of oscillation, the grid bias will be fixed and constant for all practical purposes.

The effect of this automatic bias may be seen by coupling a D.C. milliammeter in series with the anode supply to a simple oscillator, preventing oscillation from taking place by some such method as shorting the grid circuit or removing the anode coil from the grid coil. As soon as oscillation is permitted there is a sharp dip in the instrument reading, proving that the grid is negatively charged and consequently is reducing the anode current.

Self-excited oscillators are seldom used in amateur transmission, however, except for work on the highest frequencies, and even here they are being replaced to a wide extent by controlled oscillators. It may be imagined that a self-excited circuit has little inherent stability, and as soon as modulation is applied to such an oscillator the frequency varies with the variations in anode current.

Controlled oscillators, together with other valve circuits as used in the transmitter proper, are dealt with in the next chapter.

CHAPTER 2.

TRANSMITTER STAGES.

As with the receiver, it is practical to discuss the transmitter stage by stage, commencing with the oscillator section and working through to the aerial coupling and matching device.

The stages may be outlined as:—

- The Oscillator, Self controlled or Crystal controlled,
- The Buffer or Frequency Multiplying Stage,
- The Power Amplifier,
- The Aerial Coupling.

In addition must be considered either the method of keying, for telegraphy, or the method of modulation for telephony, together with

- The Speech Amplifier, and, finally, the
- Power Supply.

Out of the many self-controlled oscillators available, the most stable and convenient circuit that can be chosen is probably the Electron Coupled Oscillator (E.C.O.). In any self-oscillating circuit a degree of positive feedback must be supplied, and in the majority of oscillators this is magnetic (coupled coils) or capacitive, the inter-electrode capacity of the grid and anode inside the valve providing sufficient feedback for oscillations to build up. In such oscillators, however, stability falls as soon as any power is drawn from the circuit, and the self-excited oscillator should in any case be used as a frequency control rather than as a driving unit.

In the E.C.O. the electrodes are shielded one from the other by the use of a tetrode valve, however, so that the anode circuit can be given over to the supplying of output power, the oscillating circuits being connected to the grid and the screen grid via earth. The screen grid, therefore, is acting as the anode of a triode oscillator and the grid, screen grid and cathode are acting as a Hartley oscillator.

The tuned circuit in the anode lead receives the output power and may thus be used as a coupling to a further stage. An advantage of the E.C.O.

is that it is a good generator of harmonics, so that not only may the fundamental frequency of the oscillating circuit be obtained from the anode circuit, but also double that frequency and, with a good circuit, three and four times the fundamental frequency as well. The fundamental frequency can also be varied by the simple tuning circuit connected to the grid. The E.C.O. is shown in Fig. 6.

All frequency multiplying that takes place in a transmitter relies on harmonic operation. Consider a coil and condenser tuned to, say, 10 megacycles and coupled to a circuit which has a 5 megacycle oscillatory current circulating in it. Any second harmonic components will be 10 megacycles and will excite the circuit tuned to them and will keep it oscillating at double the fundamental frequency—in other words, will be working on the second harmonic. If a circuit is working on the third harmonic, its frequency is three times that of the fundamental, and so on.

Generally, however, a crystal controlled oscillator is used, the crystal being a slice of piezoelectric material such as quartz. Such a slice, cut from the mother crystal of natural mineral along certain well defined planes, acts by itself as a tuned circuit of very high Q. A piezoelectric crystal, as is well known from its use in pickups and microphones, etc., demonstrates the property of twisting or distorting when a potential is applied across its faces, or, conversely, generates a potential when it is mechanically stressed. A slice of such crystal, then, cut to its natural oscillating frequency, can take the place of a coil and condenser in the grid circuit of an oscillator, and since it is ground and polished to size it has very great frequency stability.

The thickness of the crystal is the major frequency determining factor, so that the crystal slice requires to be ground thinner as the operating frequency rises. The majority of crystals for amateur use are, therefore, ground to operate in the 1.7, 3.5 or 7 megacycle bands, frequency doubling circuits being used to obtain higher frequencies. Harmonic crystals are now made, however, which oscillate at the third harmonic of the natural frequency which might be expected for their dimensions, and these crystals can be used for controlled transmitters directly, without frequency multiplication, on the 14 and 28 Mc bands.

Crystals are usually supplied in holders, which are fitted with sprung electrodes to contact the slice and hold it in position. The crystal must

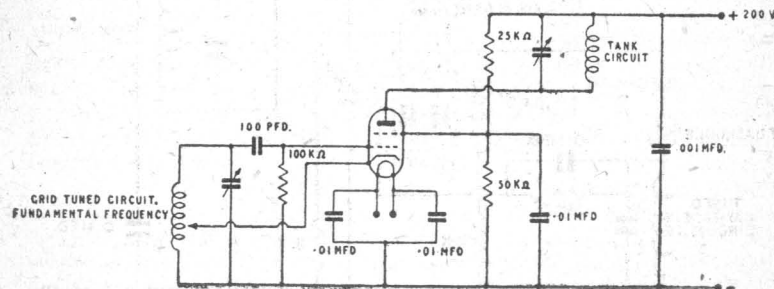

FIG. 6.—The electron coupled oscillator.

always be handled with care, and should it refuse to oscillate it is probably greasy and requires cleaning with carbon tetrachloride. The crystal should always be handled with tweezers, and only when it is absolutely necessary.

It is required that an amateur transmitter be kept within the limits of the specified frequency bands, so that it is possible to shift the frequency of the transmitter within the band—there may be interference on the station frequency, for example. With some crystals it is possible to change their frequency of working within small limits by providing the crystal holder with an adjustable electrode, so that there is either a small airgap over the crystal or, in other cases, the electrode pressure on the crystal is variable.

The chief cause of frequency drift in a crystal, however, is temperature change, differing types of crystals having differing temperature coefficients. It is, therefore, desirable to keep the crystal and its holder at an even temperature, but in addition to external temperature changes must be taken into account the fact that the crystal itself is dissipating energy and becoming warmed in the process. Grid losses are always present in an oscillator, due to the flow of grid current, but there are, in addition, high frequency currents flowing through the crystal itself. Too high a current will crack or fracture the crystal, and consequently it is common practice to include a small flashbulb in series with the crystal circuit, not only to indicate that oscillations are present and to give a visual warning of too heavy a current, but also to act as a fuse bulb should the current become too high. The bulb, therefore, should be chosen to suit the crystal's permitted current.

Once again there are many possible crystal oscillator circuits, but the Tri-tet and the Grid-Anode circuits are shown respectively in Figs. 7 and 8. The Tri-tet oscillator gives good harmonic output on the odd harmonics, the Grid-Anode oscillator gives good output on the even harmonics, and so a choice can be made between the circuits to suit the work in hand.

The circuits are chosen, also, for the fact that they operate well with ordinary beam tetrodes as used in the output stages of audio amplifiers. The 6L6 in particular is an excellent oscillator for use with a crystal, although it should be noted that its inter-electrode capacities are such that

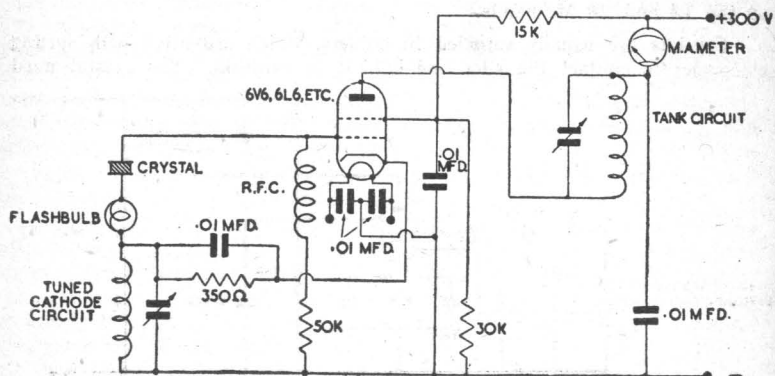

FIG. 7.—The Tri-tet crystal controlled oscillator.

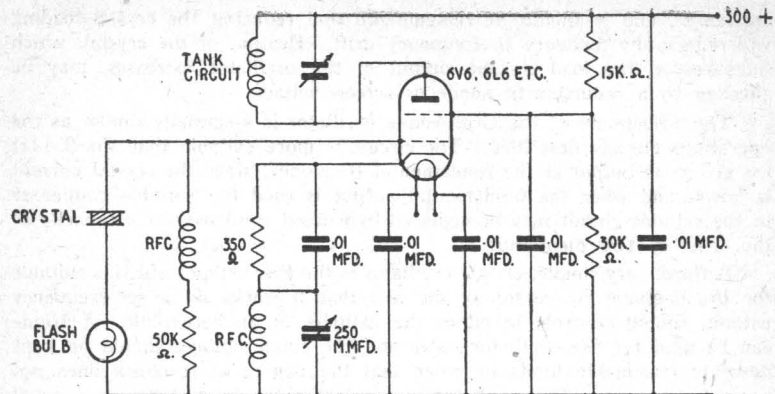

FIG. 8.—The Grid-anode crystal controlled oscillator.

it should not be used in the Tri-tet oscillator if the anode circuit is to be tuned to the fundamental frequency, since then feedback will become so great that the H.F. currents in the grid circuit may easily damage the crystal.

The tuned circuit in any anode lead of a transmitter is usually known as the tank circuit, and will be so called from this point. It is the purpose of the tank circuit, in general, first to tune to the desired output frequency, in the case of the oscillator tank, and then to supply power, at this frequency, to the following stage. Accordingly, it is necessary to have some method of discovering the frequency to which the tank circuit is being tuned, a calibrated absorption wavemeter being of value here.

The operation of the oscillator depends to some degree on the L/C ratio of its tank circuit. The ratio of inductance to capacity in a tuned circuit can obviously be varied considerably for any particular frequency, since capacity can rise as inductance falls, and vice-versa, but since the H.F. resistance depends chiefly on the inductance, there is an optimum ratio for most purposes. In a self-controlled oscillator, for example, it is found that results are best with a low L/C ratio, the capacity being high and the inductance low, the coil being wound, moreover, with large diameter wire in order that heating may be reduced. In addition, the higher capacity helps to swamp out changes in stray and inter-electrode capacities, and a condenser is less subject to mechanical variation than is a coil.

In the tank circuit of a crystal-controlled oscillator the capacity used must vary with the frequency of operation, the capacity falling when harmonic operation is needed.

The adjustment to working conditions of the two oscillators shown is as follows. With the Tri-tet circuit, turn the cathode condenser well towards maximum capacity, when the crystal should be oscillating. Turning the tank condenser will show a point at which there is a low dip in anode current. The following circuit is then coupled in so that power is taken from the oscillator, when the anode current dip will be less well defined and not so deep. The power output is improved by reducing the capacity of the cathode

condenser, and it should be remembered that reducing the crystal loading will reduce any tendency to frequency drift. Heating of the crystal, which increases as the load on the output of the oscillator increases, may be checked by a reduction of anode or screen voltage.

The adjustment of the Grid-Anode oscillator is essentially similar as the operations already described. The circuit is more suitable than the Tri-tet for giving an output at the fundamental frequency, since the crystal current is lower, and when the fundamental output is used the variable condenser in the cathode circuit may be replaced by a fixed condenser of a capacity of the order of 100 picofarads.

A third, very simple, crystal oscillator is the Pierce type, which is suitable for the beginner by reason of the fact that it works on a set frequency without tuning controls in either the cathode or anode circuit. A triode can be used for the oscillator valve and the anode voltage should be kept down to reasonable limits in order that the degree of feedback does not become excessive. The oscillator is coupled to the next stage via a small capacity. The circuit is shown in Fig. 9.

The second stage of the transmitter may be the power amplifier itself or a frequency doubling stage. With a self-controlled oscillator it will probably be unnecessary to multiply the frequency, by reason of the fact that one advantage of the self-controlled oscillator is that it may be made and adjusted to suit practically any fundamental frequency, but owing to the fact that the loading on such an oscillator must be kept as low as possible, the second transmitter stage will then be a buffer amplifier, its frequency being controlled by the self-controlled oscillator and its function being to supply driving power to the power amplifier.

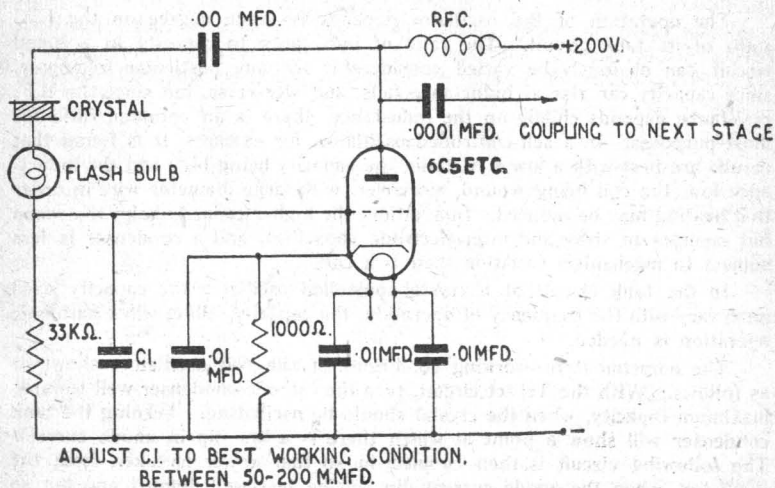

FIG. 9.—Pierce crystal controlled oscillator.

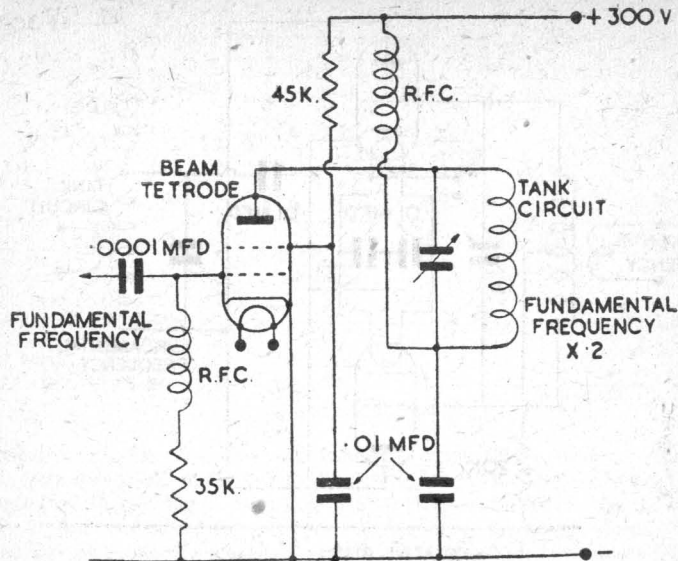

FIG. 10.—Basic frequency doubler circuit.

Again, it is stressed that power is lost in transmitter grid circuits, so that it is power which is passed on from stage to stage. In an audio amplifier, for example, the chief work of the early stages is to provide voltage amplification to build up the signal level to a point where the final stage can deliver power into an output load. In the transmitter, however, it is power, rather than an amplified voltage, which is required.

A Tri-tet oscillator, using a 6L6, can develop as much as 15 watts output power, making it quite a useful transmitter on its own account, without further stages.

A basic frequency doubling circuit is shown in Fig. 10, where the grid of the valve is coupled capacitively to the oscillator and the tank circuit is tuned to the second harmonic. It will be noted that once again, as with the self-controlled oscillator, grid bias is dependent upon grid current, and therefore upon excitation of the doubler circuit by the oscillator. Should the oscillator fail for any reason the grid bias on the second stage drops to zero, and the consequent increase in anode current may, in some cases, be sufficiently great to damage the valve.

It is common practice, however, to obtain bias for the doubler or buffer stage by the self-biasing method, but when this is undesirable battery or power bias may be introduced. When bias is supplied from an outside source perhaps the most satisfactory type of doubling or buffer stage is as shown in Fig. 11, where a double valve or two separate valves are used in push-pull, the anodes being connected in parallel.

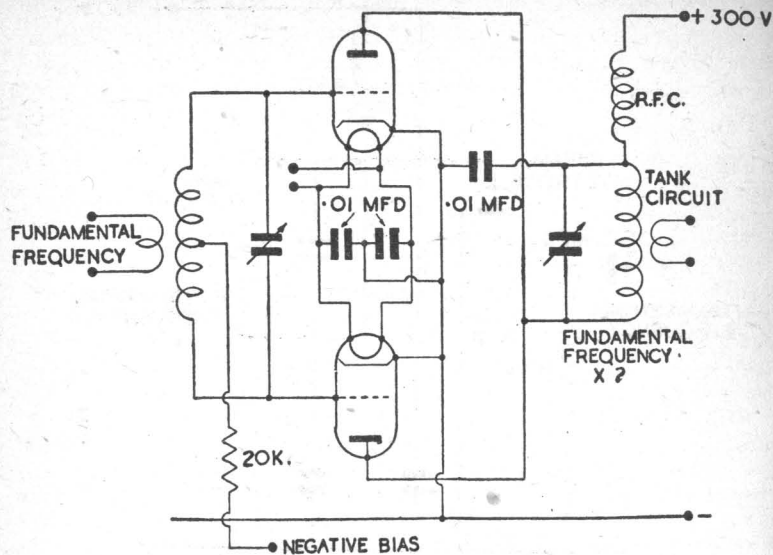

FIG. 11.—Basic frequency doubler, P-P circuit.

A push-pull frequency multiplier with a centre-tapped tank circuit can also be used, but will be suitable for working only on odd harmonics, since even harmonics will tend to cancel out in the tank circuit, whilst the circuit as shown is good only for even harmonics.

Owing to certain considerations connected with operating angle, described later, it is not possible to get the same efficiency from a doubler stage as is obtained with a straight amplifier, and in some cases, whilst grid drive must be increased, both the grid current and the anode current should only be half their D.C. rated values, although peak values may be higher. A good practice is to use a high L/C ratio in the grid circuit—that is, a fairly large coil with a fairly small condenser, with grid bias reduced, if possible, although the anode dissipation of the valve must not be exceeded.

Particular attention must be paid to a buffer amplifier which has both its input and its tank circuit working on the same frequency. Since the grid and anode are both tuned to, say, the fundamental oscillator frequency, the feedback through the valve itself, or through stray capacitive couplings, is sufficient to cause the buffer stage itself to oscillate. This is, of course, a most undesirable state of affairs, giving rise to instability, loss of control, incorrect excitation of the following stage, spurious signals and a host of troubles. The simplest method of nullifying the feedback is by neutralisation—that is, providing a degree of negative feedback just sufficient to neutralise the positive feedback which is causing the trouble.

Consider the simple circuit of Fig. 12, where grid and anode are tuned to the same frequency. The valve immediately acts as one of the oldest of self-controlled oscillators, the Tuned Plate Tuned Grid, feedback being sup-

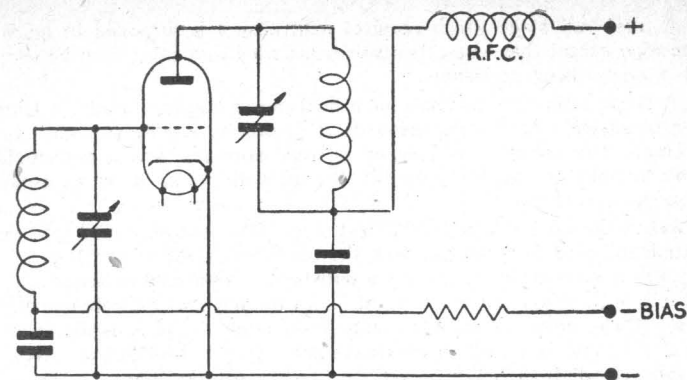

FIG. 12.—Basic buffer stage.

plied through the inter-electrode capacities even if the coils are screened one from the other. Negative feedback over the valve itself is required, the simplest method being to rearrange the tank circuit so that it has an earthed centre point, so far as R.F. is concerned, when a feedback potential in the necessary phase becomes available at the end of the tank coil remote from the anode. The feedback is taken via a very small, finely adjustable condenser to the grid of the valve, the condenser set to capacity by a method to be described, and the troublesome positive feedback is neutralised, allowing the stage to work in the manner desired. The new circuit, using a split-stator tank condenser, is shown in Fig. 13. For circuits working at normal anode voltages, the split-stator condenser may be made up of two small tuning condensers, their spindles being ganged mechanically and connected electrically. The new loading on the valve requires that each condenser should be of only half the capacitance of the original single condenser.

An advantage of the neutralising method shown is that since the tank coil finds its own R.F. earth point the neutralisation holds even when the coil is changed for another band.

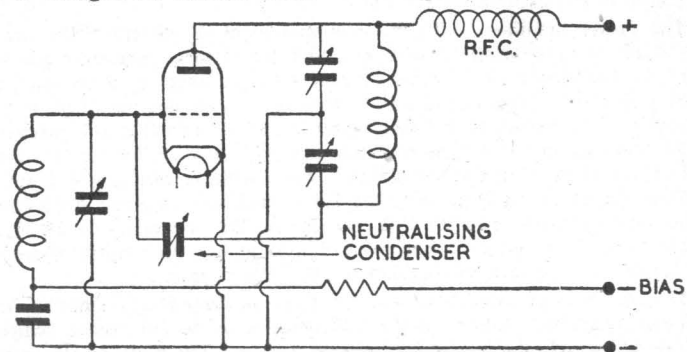

FIG. 13.—Neutralised buffer stage.

A push-pull stage which requires neutralising is arranged in much the same way, except that where two valves are used they must each be supplied with a neutralising condenser.

A stage, either intermediate or a final power amplifier stage, is adjusted for neutralisation by disconnecting its H.T. supply, leaving the valve heater working. The oscillator is allowed to work normally, and a milliammeter is connected into its anode supply line, the oscillator being tuned as usual, for an anode current dip.

When the oscillator is set the next stage, if a separate tuned grid circuit is used, is tuned to resonance with the oscillator. One of the uses of grid leak bias is seen at this point, for a milliammeter connected in series with the grid leak will show when grid current is drawn, and thus indicate correct grid tuning of the buffer or amplifier stage even when the H.T. is disconnected. The grid circuit is tuned for maximum grid current through the meter, and the tank circuit is then tuned over the band by rotating the tank condenser. As the tank circuit goes through resonance with the grid circuit the indication of the grid current meter will change, showing a sharply defined dip. The neutralising condenser, or condensers, are then adjusted experimentally until the grid current shows no change as the tank is tuned through resonance. The circuit is then neutralised.

If the grid of the stage to be neutralised is capacitively coupled to the oscillator, and has no tuned circuit of its own, the oscillator anode current meter will act as the neutralising indicator. Tuning the tank circuit of the stage to be neutralised (still with no H.T. on the stage) will vary the reading of the oscillator anode current meter as the second stage tank circuit goes through resonance and, by reason of the capacitive feed through the second stage valve, draws more power from the oscillator. Again, the neutralising condenser is adjusted experimentally until swinging the tank circuit through resonance with the oscillator tank gives no change in oscillator anode current.

Many transmitting valves are now made with sufficient internal screening to obviate the need for neutralisation, although, of course, this can apply only to tetrode and pentode types. Practically all triodes need neutralisation except when used in the oscillator stage itself.

The power amplifier, with modern equipment, is generally the second stage itself of most small transmitters, and the remarks already made with regard to the tuning of doublers or buffer stages apply to a second stage power amplifier. Moreover, the P.A. can be its own doubler stage as well as providing the output to the aerial, and it can be seen that a 7 megacycle crystal, working in the 40 meter band, can control a 28 Mc. or 10 metre band output in two transmitter stages. The oscillator can supply a second harmonic output on 14 Mc., using the Tri-tet oscillator to give a good output on the even harmonic, and the P.A. can double this frequency to 28 Mc. A straight P.A., however, is rather more desirable, especially when there are considerations of speech modulation to take into account.

The method of operation of the P.A. is important, since a high efficiency is required—that is, as much as possible of the D.C. power supplied must be converted to a useful R.F. output power. The plate efficiency of a valve may be termed the ratio of A.C. or R.F. power output to the D.C.

power input, and is given as a percentage. The D.C. power input may be expressed, of course, as the product of the anode voltage and the anode current of the valve (the current being expressed in amperes, not milliamperes), so that any method of operation which will reduce the anode current of the P.A. whilst keeping the R.F. output high will improve the efficiency of the stage.

For this reason, Class C operation is often used.

A valve operates under Class C conditions when the grid is biased, with no signals applied, to a potential twice that needed to cut off the anode current. If R.F. or any other signal is then applied to the grid, only the tops of the positive peaks will overcome the bias and allow the anode to draw current, the grid passing grid current at the same time, whilst for the highest efficiency the anode current, when it does flow, should reach the saturation point, i.e., the point at which all the available electrons in the valve are flowing to the anode and when no increase of anode voltage will increase the current. The tank circuit thus receives energy in a series of heavy, though short, pulses, and again the flywheel effect comes into play, allowing the tank circuit to oscillate at high power even though the D.C. power supply to the valve is cut off for the major part of each cycle of operation.

Naturally such a method of operation is only permissible when the energy is supplied to a tuned circuit. Audio amplifiers, for example, cannot work in such a way, the nearest analogy being the audio Class B. circuit, where two valves in push-pull supply one half cycle of the full operating cycle each to the output load. The grid current in Class C operation causes a distorted anode peak, the tuned circuit accepting the distorted power as "flick" energisation and delivering a smooth and practically undistorted output.

The plate efficiency of a Class C amplifier is as high as 60 to 80 per cent, and whilst the grid requires a relatively high driving power, this is generally easily supplied. As an example may be quoted the characteristics of the well-known 807, a transmitting tetrode, which may be operated at the full ratings on a frequency as high as 60 Mc., using the transmitter on telephony. With the grid bias of -90 volts, the grid driving power required is approximately 0.4 watts, whilst the carrier output power is approximately 42.5 watts. The grid current is 4 mAs., and with an anode voltage of 600 volts the plate current is 100 mAs. Comparison of the D.C. watts input with the R.F. power output shows that the D.C. power is approximately 60 watts, the output power being about 42.5 watts, showing that there is a loss of power amounting to 17.5 watts. This power is dissipated in the anode and its circuit as heat, and the anode of a power amplifier, and, indeed, of other valves in a transmitter, is often run at red heat. The maximum anode dissipation in watts for the 807 is given as 30 watts.

The newcomer to amateur radio is often puzzled by the figure given for anode dissipation, finding in some cases that whilst only a low power anode dissipation is permissible the valve is quoted as having a high wattage output. It must be remembered, of course, that the anode dissipation is the power lost in the anode itself, and that the overall power handled by the valve is much greater, the actual amount depending on the percentage anode efficiency.

The efficiency in the above example is obviously given by

$$\%E = \frac{42.5 \times 100}{60} \text{ or } 70.8\%$$

The L/C ratio used in the P.A. tank is important in obtaining the best working conditions, for the plate efficiency is reduced by any losses which occur (inevitably) in the tank and aerial coupling circuits, and it may be noted, also, that grid driving power, as given in valve tables, takes no account of losses in the coupling circuits by which the grid of the P.A. is supplied, the losses growing as the frequency rises. A generally accepted figure for the overall tank efficiency of the power amplifier is a Q of about 12 for the whole circuit, and methods are available for choosing the optimum L/C ratio to suit such a figure for any frequency band and for any type of tank circuit. There is not room in a book of this size for a full discussion of the topic, however, and as experience is gained the amateur can pursue the subject in more advanced reference works. It may be noted, however, that the transmitter circuits which appear in later pages are designed about the optimum value figures.

Some mention, too, should be made of the "operating angle" of a Class C stage. As has been shown, anode current flows for only a part of each cycle, and since a cycle may be regarded as an angular unit of 360 degrees the duration of anode current flow may also be measured in terms of degrees. In the Class C stage the operating angle lies usually between the limits of 120 to 150 degrees, the optimum angle being quoted for some valves under certain conditions by the manufacturers or designers of apparatus.

Just as an audio output stage requires to be matched into its load, i.e., the loudspeaker, so must the P.A. be matched into the aerial load in order that the fullest energy transference may take place, and the optimum load resistance (the load may be considered as purely resistive since the tank is tuned to resonance, the reactances thus cancelling out) may be defined as that load resistance where, for the maximum permitted anode current peak the anode voltage drops to the same figure to which the grid voltage rises. It must be remembered that these values are instantaneous, and apply only to the moment when the grid is driven to its maximum positive point. The large flow of anode current must, obviously, cause the anode voltage to fall due to the drop across the load, the instantaneous voltage being as low in some cases as one-tenth of the D.C. anode voltage, that voltage which would be shown by a voltmeter as being present.

Some valves, again, require a higher bias than twice the rated cut-off figure to secure a suitable operating angle, but most makers specify the Class C operating bias, together with the grid current which should be registered. When bias is obtained from any source other than self-biasing through a gridleak the source must clearly be of a nature which can operate under the widely varying conditions which range, in each cycle, from a high negative bias to a high positive grid potential with a flow of current. A bias supply drawn from an A.C. operated power pack must therefore have a stabilising valve or voltage regulator in circuit, and many workers still prefer battery biasing.

The load of the aerial is adjusted into the tank of the final stage by a method chosen as being most suitable from the many circuits available, the type of aerial and the feeders to it being in most cases the deciding factor.

For a fuller discussion on aerials the reader is referred to the "Aerial Manual," No. 56 in Bernards' List, since only the broad outlines of the subject can be sketched in here.

It has already been shown that the simple halfwave aerial can be fed with current at its centre point where it presents a load impedance of about 72 ohms. To connect such an aerial to the transmitter, however, a feeder or a twin connecting line is necessary, and it is found that such a combination has a characteristic of its own at high frequencies, for any wire carrying such currents will tend to radiate energy. Since the aerial is chosen for the radiation, however, and is given a form which will enable the power to be directed to the desired points, feeder radiation must be regarded as waste and a method of construction of the feeder must be found which will prevent the loss of power before it reaches the aerial.

The problem is overcome by using two parallel wires, so that the field around each wire tends to neutralise the field around its partner, and such a pair of wires has what is known as a characteristic impedance. This may be said to be the impedance which a long line of the type referred to would present to a charge travelling along the line. A common figure is 600 ohms, which is suitable for many purposes, and since the characteristic impedance depends upon the diameter of the wires used and their spacing between them, it is possible to construct such a feeder or transmission line. The formula connecting the values is

$$Z = 276 \log \frac{x}{y}$$

Where Z is the characteristic impedance, x is the spacing from centre to centre of the wires and y is the radius of the wire, x and y being taken in the same units (inches, centimetres, etc.). It is probably more useful to say, however, that a 600 ohm line can be made by spacing two 14 S.W.G. copper wires, enamelled, 6 inches apart, special line spacers being obtainable commercially.

A high impedance feeder line, however, cannot be fed into a low impedance aerial, such as the halfwave type, without some form of matching. In ordinary circuit techniques a transformer would be used to match a 600 ohm load into a 72 ohm load, and much the same thing is done with the feeder and the aerial. The feeder is matched into an aerial by one of many methods, but as an illustration it will be simplest to describe the matching stub.

It has already been shown that a quarter wave double line has a voltage-current distribution, which gives it, in effect, a high impedance at one end of the lines, or stub, as the combination is called, and a low impedance at the opposite end—in other words, the stub can act as a high-frequency matching transformer.

If a 600 ohm line has to be matched into the centre of a halfwave aerial the stub is suspended from the centre of the aerial, which is, of course, cut into two halves, the ends being supported by an insulator. The

centre impedance of the aerial is 72 ohms, and the stub end impedance is the same figure, the aerial acting in the same way as the short circuited end of a plain stub, as shown in Fig. 4. The far end of the stub has a high impedance, so that there is an impedance gradient down the stub, and if the point can be found along the two parallel wires where the impedance is equal to 600 ohms, the feeder, connected at this point, will be matched without energy loss into the aerial. The correct connecting point is found by experiment, the feeder being connected at a test point to the stub and the aerial cut to the correct resonant length, an R.F. ammeter being connected across the two halves of the aerial for the purpose and the aerial length being adjusted for maximum current indicated for the same transmitter settings.

The feeder line matching is then tested by the method known as a standing wave check, the meter being removed from the aerial and used to measure current along the feeders, it being provided for the purpose with two arms which carry at their ends sharp edges which enable good electrical contact to be made with the feeder wires through their insulation. By the use of these arms the meter may be tapped across 2 feet of feeder line.

A standing wave is set up along a feeder when it is terminated by any resistance other than its own characteristic impedance—in other words, if a 600 ohm line is fed into a load of 600 ohms no standing wave will be set up right along its length, but several standing waves will be set up along the line if it is terminated in any other value of load. It has been seen from the halfwave aerial that a standing wave is accompanied by a point of maximum current (called a current loop, a minimum point being called a current node, points of minimum and maximum voltage also being termed nodes and loops), so that a feeder incorrectly terminated may be expected to show varying currents along its length, accompanied, of course, by varying voltages. Such is the case, and the current along the feeder which requires matching into the stub is measured at different points along its length. If a set of varying current readings is obtained, the current being high in some places and low in others, the point of connection of the feeder to the stub is incorrect, and it must be varied until the ammeter gives substantially the same reading at any point. Alternatively, it may be simpler to test for voltage loops along the line, the test being made by a neon lamp held in the hand. Should the lamp light at some points when contacted to a feeder wire and not at others standing waves are indicated, and the feeder connection to the stub must be adjusted until the lamp either does not light at any point or else remains at the same brilliancy right along the feeder wire. It must be realised that the current, or voltage, measurement is not made between the two wires of the feeder, but along one wire only of the pair.

The halfwave aerial, with a matching stub and a feeder connected to it, are shown in diagram form in Fig. 14.

In the case under review there is now a halfwave aerial with a feeder line matched into it at the current point, the feeder acting as a *non-resonant* line, that is, it has no standing waves set up along it. (In practice it is difficult to eliminate a standing wave, but providing the *standing wave ratio* is kept low no harm is done. The standing wave ratio is measured by taking the ratio of the highest current at a current loop in the feeder to the lowest

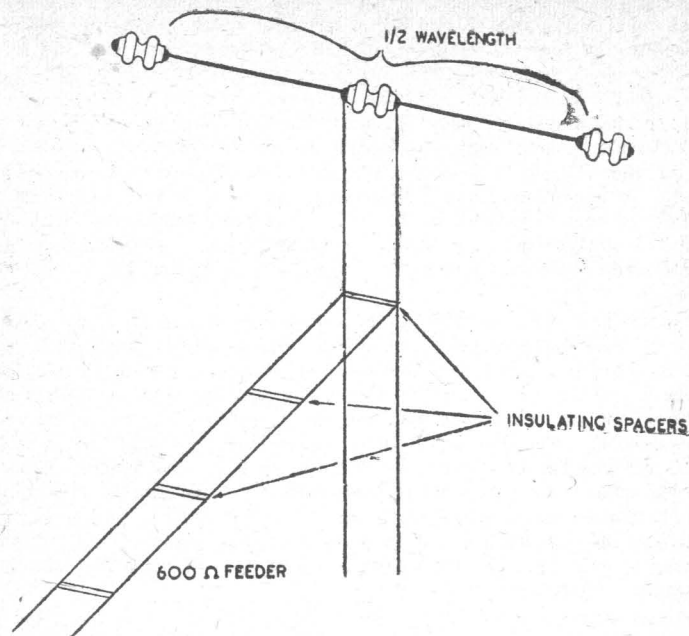

FIG. 14.—Half-wave aerial current fed via a quarter wave stub transformer.

current at a current node, so that the standing wave ratio is

$$R_{st} = \frac{I_{max}}{I_{min}}$$

This means that the feeder is supplying the aerial with current (centre fed halfwave aerial), and in turn the transmitter has to supply current, rather than voltage, to the feeder.

Coupling such a non-resonant line into the final tank of the transmitter is a simple process, for it is generally sufficient to connect the feeders to a coil of one or two turns of wire, this coil being supported at the earthy end of the tank coil on a mounting which allows the distance between the two coils to be varied. The tank and the final stage is tuned by observation of the final anode current, the condenser being adjusted in the usual way to give a current dip, and then the feeder coil is brought up to the tank coil. Energy will therefore be fed into the aerial system, and as a result the current in the final stage anode circuit rises. The tank is checked for resonance and the anode current brought up to the rated figure by increasing the feeder coil coupling with the tank coil.

A simpler non-resonant feeder system is one where the characteristic impedance of the feeders is made equal to the impedance at the aerial's

chosen connecting point, so that no feeder-aerial matching device is required. For connecting into the centre of a half-wave aerial, therefore, the feeder impedance would need to be 72 ohms approximately, although such a feeder line would not be simple to build, for the wires would need an inconveniently short spacing between them. Feeders are made commercially, however, which have a characteristic impedance as low as 72 ohms obtained by running the wires in a flat strip of rubber, or by similar means. These feeders, being surrounded by dielectric, have somewhat lower efficiencies than a good open line, but if chosen to suit the aerial impedance they can be connected straight in and matched at the transmitter end for current or voltage feed, whichever is required. Generally, of course, the current feed applies.

So far, however, non-resonant lines have been described, that is, feeder lines with no standing waves on them. A *resonant line* is constructed in the same way, but is connected to the aerial in such a manner that current and voltage loops are formed on the feeder line and are made to fall in such positions that the line can be fed from the transmitter and will in turn feed into the aerial. The line length is chosen so that the feeder line is an odd or an even number of quarter waves long, so that it is tuned. Since an electrical quarter wave does not coincide with a physical quarter wave, due to the reduction of charge velocity in a wire and other causes, the line is cut to length as nearly as possible, and then matched in by a tuning unit, as shown in Figs. 15 and 16. The tuning, or coupling, unit in these diagrams is of the simplest type.

Again, a coil coupled inductively to the final tank coil is used, but for resonant feeders the coupling coil is tuned in such a way that the feeders are, in effect, lengthened or shortened to the required number of quarter wave lengths. Where the feeder requires to be supplied with current the unit must be series tuned, as in Fig. 15, a parallel tuned unit being used when voltage feed is necessary, as in Fig. 16.

A resonant or tuned line feeding a Zeppelin aerial has been chosen for illustration in Fig. 17. The Zeppelin aerial is essentially an end fed half-

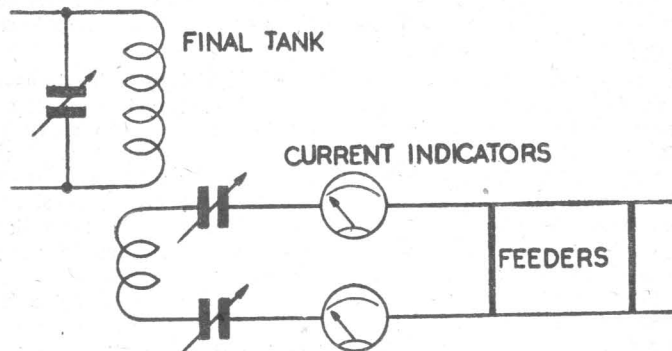

FIG. 15.—Feeder, inductively coupled, series tuned (Low input impedance).

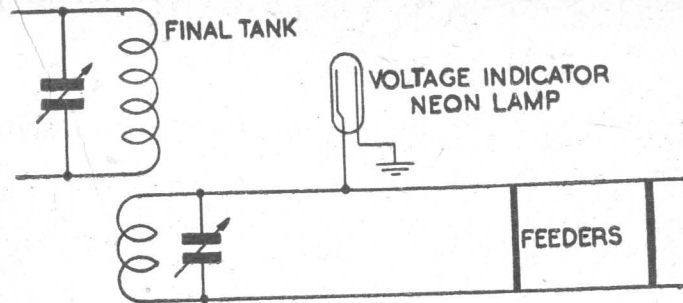

FIG. 16.—Feeder, inductively coupled, parallel tuned (High input impedance).

wave aerial, that is, it is fed with voltage rather than with current. Under these circumstances a line which contains an even number of quarter waves will require a voltage feed at the transmitter and a parallel tuned coupler, whilst a line containing an odd number of quarter waves will require a current feed, and thus a series tuned coupling at the transmitter. Note in the diagram that one side of the feeder is left open at the aerial end.

As in the case of a feeder, the electrical length of an aerial does not coincide with mechanical or physical length. An "end effect" comes into play, so that the length of any type of straight wire aerial, whether halfwave

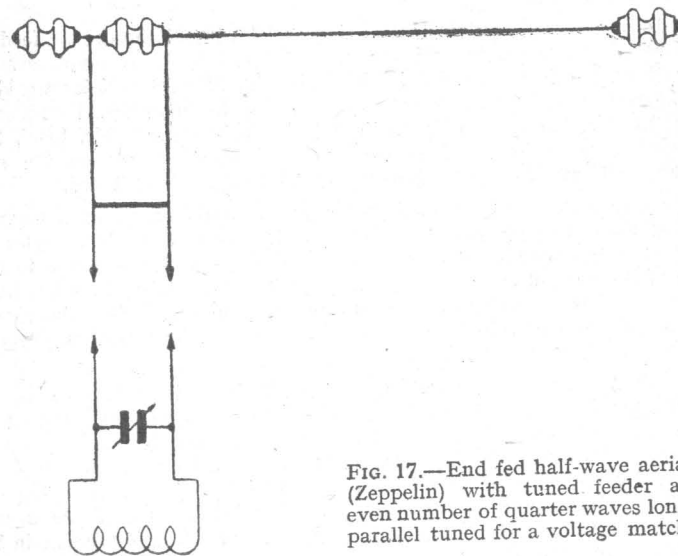

FIG. 17.—End fed half-wave aerial (Zeppelin) with tuned feeder an even number of quarter waves long, parallel tuned for a voltage match.

or longer, is cut a little shorter than the calculated figure. A formula for the aerial length where straight wire radiators are used is

$$L = \frac{492 (n-0.05)}{f}$$

where L is the length of the aerial wire in feet, n is the number of halfwave lengths in the aerial and f is the frequency in megacycles.

Longer aeriels than the halfwave are possible, and by their use it is possible to radiate on two or more bands, the transmitter being tuned to the frequency desired. A long aerial is shown in Fig. 18, and it can be seen from the diagram that standing waves are still set up along a wire even

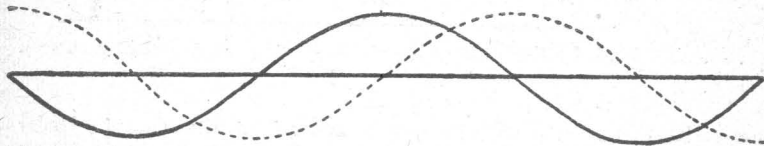

FIG. 18.—A long wire, working on its third harmonic, showing standing waves.

though it is 2 or 3 halfwaves long. A useful length for a longer aerial is to make the wire one halfwave length long at the lowest operating frequency, that is, of course, the longest wavelength, using tuned or resonant feeders which are a multiple of a quarter wavelength long at the same frequency. Thus 135 feet of 600 ohm feeder, connected into the centre of an aerial wire 272 feet long and parallel tuned at the transmitter for high impedance input characteristics will operate well on most of the bands listed in the introduction as open to amateurs.

It is, of course, possible to feed the aerial without the use of feeders if the aerial is brought to the transmitter for end feed. A simple system where the aerial is voltage fed is shown in Fig. 19, the radiator working harmonically on 7, 14 and 28 megacycles and at its fundamental frequency in the 3.5 Mc. band. If it is required to work in the 1.7 Mc. band, the coupling coil must be tuned by inserting the condenser between the coil and the earth connection, so that the aerial is then current fed.

Different aeriels have different radiating characteristics, a halfwave aerial radiating most strongly in a broadside direction, that is, at right angles to the wire. Long aeriels, however, tend to radiate at a sharper angle to the length of the wire, depending on the method of feed, whilst all aeriels have different radiating angles in a vertical direction, the angle being chosen for the type of contact desired. Once again, however, the reader is referred to a fuller work for aerial details.

Coupling resonant feeders to the final tank circuit is again a matter of adjusting the coupling coil, either directly or via a link coupling, so that it accepts energy from the tank circuit. Energy in the feeder and aerial circuit can be checked by the inclusion of ammeters in the feeder lines, as shown in Fig. 15, whilst the loading of the aerial on to the final stage is checked by a milliammeter in the anode circuit of the last valve. As usual, the anode current will dip at resonance, and the aerial load is brought in by

bringing the coupling coil closer to the tank coil until the current rises to the manufacturer's stated figure for the valve being used. As the aerial coupling is increased the feeder current should rise in sympathy, but in some cases the feeder current will show a rise to a peak and then a reduction, even though the loading is still not sufficient on the final tank.

This is an indication that the aerial is cut to an incorrect length or that the feeder matching is inaccurate, and that some adjustment is required in the aerial system as a whole.

The transmitter should never be allowed to run unloaded, and also never be allowed to run for any length of time off tune. Bringing the circuits into resonance is generally required for the correct biasing to be applied to the grids of the valves, whilst running the transmitter unloaded will result in the final valve's working at the wrong level. In some cases anode current can rise as much as 100 per cent. when the stage containing the valve is off resonance, and in a transmitter using high power valves with a consequent high value of supply voltage, the anode voltages are often dropped to less than half of their final values until the transmitter is tuned up and the danger of high anode currents due to lack of bias is past.

TRANSMITTER KEYING AND MODULATION.

So far the various stages of the transmitter have been explained, and it is now necessary to see how the output of the apparatus can be interrupted by the transmission of Morse code characters or modulated with speech signals.

So far as telegraphy is concerned it is obviously simple to make the transmitter work in short bursts of power, since it is only necessary to break the supply current to any of the valves in order to prevent the stage from working, and thus the transmitter, as a whole, from radiating. One of the most convenient points for breaking the power supply is in the cathode of one of the valves. The stage to be keyed must be chosen with care, however. The crystal oscillator generally lends itself to keying, but if an oscillator is keyed and the following stages are biased by grid leaks, whenever the excitation from the oscillator is interrupted the bias on the follow-

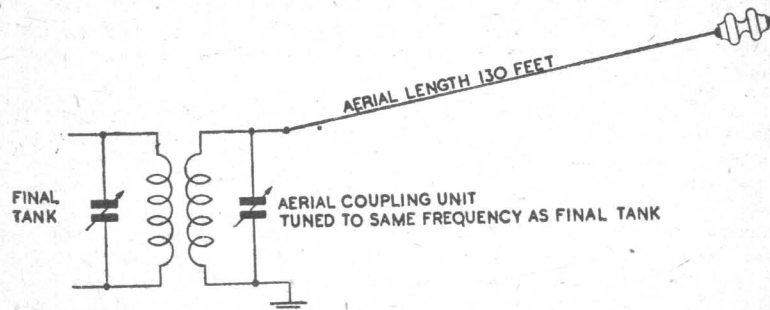

FIG. 19.—Simple long wire aerial for harmonic working.

ing stages falls to zero with a consequent heavy rise in anode current. Not only does this impose a dangerous overload on the valves, but it also leads to poor keying tones.

In a single stage transmitter, the oscillator must, of course, be the keyed unit, but in a multistage transmitter it is wise to key in a later stage, for then the oscillator is permitted to work without interruptions, and there is no chance of causing frequency fluctuations.

There are several possible positions for the key with and without a keying relay, ranging from the primary of the supply transformer to grid, suppressor grid, cathode and anode keying, but in the circuits to be shown the keying position will be given in the cathode lead, since this is, in general, the safest and simplest position. In cases where directly heated valves are used the key is then situated in the lead from the centre tap of the heater transformer to earth.

Starting and stopping oscillatory power in a transmitter leads to the production of spurious current surges if the interruptions are too abrupt, and for this reason most keying circuits have a key click filter in series with the key. The function of the filter is to smooth out the sudden make and break of supply current, and its use prevents interference on neighbouring receivers, even in the broadcast band, which might otherwise occur. The filter includes an inductance and capacitance, and the introduction of such a filter prevents sparking at the key contacts, which is the chief cause of key click interference.

Another efficient keying method is to key a transmitter stage via an auxiliary valve, known as the keying valve. The anode current for the transmitter stage passes through the keying valve and the key is used to reduce the bias of the keying valve whenever the contact is made. Thus the valve is enabled to pass current to the transmitter stage. The use of such a valve, or circuit, comprising, in some cases, several valves, is of particular value in a high power stage where the key, if inserted directly into the transmitter circuit, would have to deal with very heavy currents and would be difficult to filter as well as being possibly unsafe. Using the keying valve means that the key has only a few volts of grid bias to interrupt, whilst at the same time the characteristics of the keying valve can be so adjusted that the interruptions of current flow are cushioned and keying interference made negligible. A gas-filled valve can be used as the keying valve, to reduce voltage drop across the auxiliary circuit and loss of power which should be supplied to the transmitter stage.

A suitable keying filter circuit is shown in Fig. 20, and the component values depend upon the type of load which is to be interrupted. A low current circuit, as in the cathode of a small valve where less than 10 mAs. are flowing, would require an inductance of about 20 henrys with a capacitance of about 0.1 mfd., whilst a heavy current circuit would need an inductance of about 5 henrys or less and a capacitance of about 0.5 to 2 mfd. The condensers, for safety, should have a high working voltage rating. In addition to this filter, which acts as a lag circuit to smooth out the current flow, it is generally wise to include an R.F. filter, consisting, as shown in Fig. 20, of two R.F. chokes bypassed by a 0.01 mfd. condenser.

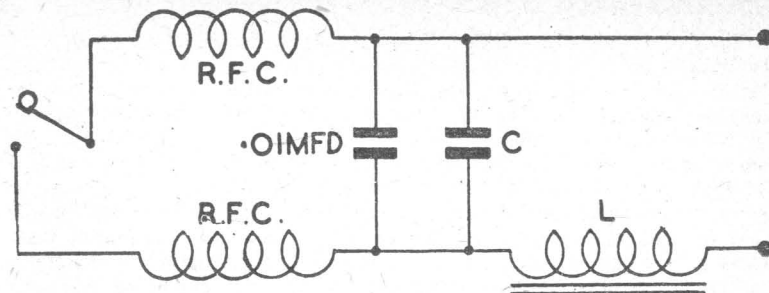

FIG. 20.—Keying filter. See text for values of C and L.

The inductance of the chokes should be varied to find the most suitable value, but the normal 1.5 millihenry choke is generally suitable.

Transmitter modulation with speech signals is rather more complicated than keying, and once again there are several methods available, all with advantages and disadvantages.

To modulate an R.F. carrier wave it is necessary (forgetting frequency modulation) to vary the amplitude of the wave in accordance with the instantaneous strength of the speech currents as drawn from the microphone.

Fig. 21 shows an unmodulated carrier wave, an audio speech wave, and the carrier modulated by the audio wave. It can be seen immediately that the modulated carrier wave has changes of amplitude which make it, in some places, greater in amplitude than the unmodulated wave and in other places less. Speech, then, directed into the microphone, must be made in some way to vary the actual strength of the transmitter output, and the first obvious solution, making the speech signals vary the anode voltage of the final stage of the transmitter, is a practical method.

There are other methods of modulating the carrier wave, for the speech signals may be introduced into the grid biasing circuit of the final transmitter stage, or into the cathode circuit or suppressor grid of a pentode valve used as the final transmitter valve, but of these modulation methods chief attention will be paid to anode and suppressor grid modulation.

A wave may be modulated to any depth up to 100 per cent. and the modulated wave shown in Fig. 21 is 100 per cent. modulated. The depth of modulation can be shown by the values of A, B and C in the figure, dividing A, the carrier amplitude, into either B or C, whichever is the larger, and multiplying the result by 100 to obtain the percentage. An over-modulated carrier can be obtained, giving rise to bad distortion and wide sidebands with consequent interference to neighbouring signals.

Obviously as great a modulation depth as possible is required except for local work where it is often advantageous to cut down the modulation depth, but the full 100 per cent. is not always obtainable. A depth of 80 per cent. is generally quite satisfactory however.

Inspection of the modulated wave figure will show that the final stage of the transmitter must not work at full power when the carrier wave is unmodulated, for there is a further power rise necessary to carry the output

to the full modulated amplitude. The excursions of output, moreover, must be linear—that is, must follow the modulating signal along a proper characteristic—otherwise distortion will again be introduced. This means that the average output of the final or modulated transmitter stage must increase by 50 per cent. when the carrier is modulated to a depth of 100 per cent. since, with a sine curve type of modulating signal the average power in a 100 per cent. modulated wave is one and a half times as great as the power in an unmodulated wave. This again means that where anode modulation is used, the speech amplifier feeding into the final transmitter stage must supply half as much power as the rated power output of the transmitter, or, in other words, a transmitter with a rated output of 50 watts requires a 25 watt undistorted output speech amplifier.

One of the advantages attached to both grid-bias and suppressor grid modulation is that the carrier can be modulated with considerably less output from the speech amplifier. A 5 watt amplifier will provide sufficient output to modulate quite a high power transmitter, but with this type of modulation the valve does not work with the same overall efficiency of the anode modulated stage.

The best method of anode modulation is to vary the anode potential of the final transmitter stage by transformer coupling it to the speech amplifier. The figures as given, that a 50 per cent. output from the speech amplifier will modulate the carrier wave to full depth does not hold for speech, since the figure is calculated as stated, from a sine wave modulating

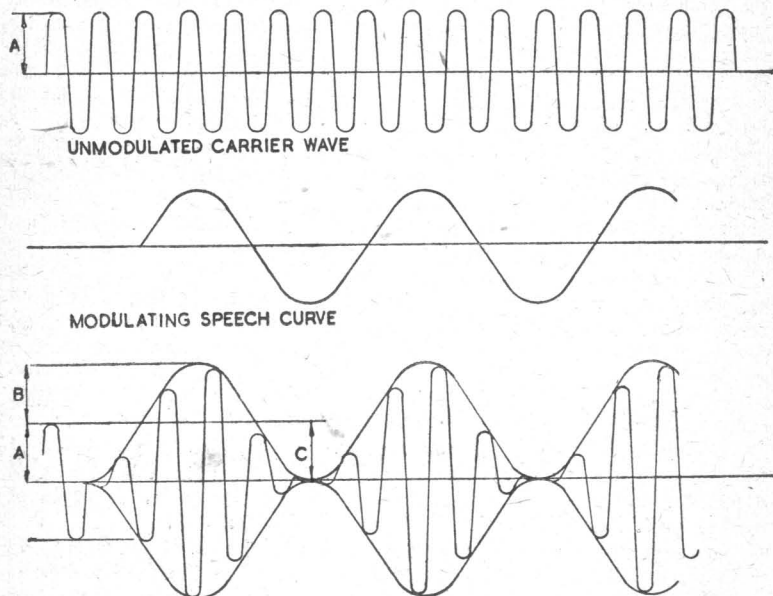

FIG. 21.—Carrier, unmodulated and 100% modulated.

wave which contains more power than a typical speech wave, but the figure must be allowed to stand since it also applies to instantaneous peak powers. For the best approximation to a linear modulation characteristic it is found that the final stage of the transmitter should work under Class C conditions, and that about half of the necessary bias should be supplied from a fixed source, such as a battery, the rest of the bias being supplied by excitation through a grid leak. This also provides a safety factor in that with a failure of excitation for any cause the valve is still biased to the cut-off point.

Where a triode is being used as the final transmitter valve, the modulation transformer secondary is simply connected into the anode circuit, but where a pentode is used modulation should be supplied both to the screening grid and the anode.

The transformer loading between the transmitter stage and the speech amplifier must be carefully adjusted in just the same way as the transformer feeding a loudspeaker must be adjusted to impose the correct load on the speech amplifier, and it is thus necessary to know both the correct load to be placed on the final speech amplifier valve and the *modulating impedance* of the final transmitter stage. This impedance (which may be likened to the impedance of a loudspeaker speech coil) can be obtained from the D.C. anode voltage applied to the final stage and the current which flows in the final transmitter valve due to this voltage, the impedance then being

$$Z = \frac{E}{I}$$

where Z is the modulating impedance, E the D.C. anode voltage and I the D.C. anode current in amperes, the last two values being measured *before modulating signals are allowed to pass*, and with the final stage loaded correctly into the aerial.

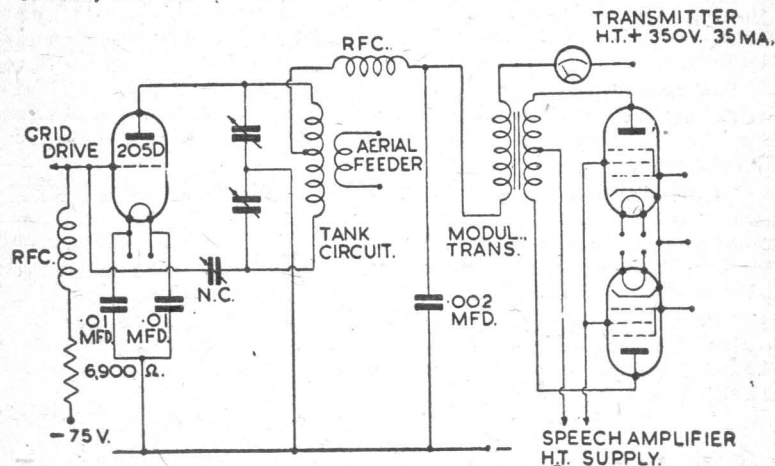

FIG. 22.—Anode modulation of a triode final stage.

The modulator should for preference be a push-pull output amplifier, the valves working at either Class A or Class B ratings, or mixed ratings, and the transformer must obviously be capable of handling the required load in watts. As an example of what might be expected, the diagram of Fig. 22 shows a final transmitter stage using a small transmitting triode, the 205D. The Class C ratings for this valve, to give an output when anode modulated of about 7 watts are anode voltage 350, anode current 35 mAs., whilst at full drive the grid bias requires to be -144 volts with a grid current of 10 mAs.

A fixed bias source of -75 volts is provided, so that the further 69 volts required for the full bias must be drawn from the grid leak, the resistance of which can immediately be calculated from Ohm's Law,

$$R = \frac{69 \times 1,000}{10} \text{ or } 6,900 \text{ ohms, remembering to multiply the voltage by } 1,000 \text{ in order that the current may be expressed in amps.}$$

The modulating impedance is

$$Z = \frac{350 \times 1,000}{35} \text{ or } 10,000 \text{ ohms.}$$

This means that the transformer coupling the speech amplifier into the transmitter final stage has to present this 10,000 ohm load as the correct load to suit the valves used in the amplifier.

The rated output of the transmitter is a little over 7 watts, so that a speech amplifier whose output stage gave 4 watts would be perfectly suitable. Neglecting for the time being the previous circuits of such an amplifier, reference to a set of valve tables such as The Radio Valve Manual, No. 30 in Bernards' List, shows that 4 watts output can be obtained from practically any output valve pair, so that a speech amplifier can be built with a good reserve of power whilst the valves even then will not be running at full load.

For simplicity, however, a pair of 6F6 pentodes are chosen, and connected into the circuit shown. These valves are rated to give full output at a Class A rating with an anode voltage of 315 volts into a load of 10,000 ohms.

By choosing these valves, then, the speech amplifier load has been made equal to the modulating impedance of the transmitter stage and the transformer requires to be a simple 1 : 1 ratio component capable of handling 4 watts at least or preferably 10 watts, so that with the higher power rating it can handle the full amplifier output if called upon to do so.

Other valves, however, may not correspond so well as regards the loading impedances. A pair of 6L6 output valves requires a load of 5,000 ohms, for example, when the ratio of the modulating transformer must be calculated from the formula

$$R = \sqrt{\frac{Z1}{Z2}}$$

where R is the windings ratio and Z1 and Z2 are the impedances to be

matched. Thus, for the 6L6 valves the transformer ratio would be

$$R = \sqrt{\frac{10,000}{5,000}} \text{ or } \sqrt{2} \text{ which is } 1.414.$$

The transformer would be connected, naturally, with the 1 ratio winding in the speech amplifier circuit, centre tapped, and the 1.4 ratio winding in the anode lead of the transmitter final stage.

It is also possible to modulate the transmitter by a speech amplifier fed from the same H.T. supply line, the speech voltage fluctuations being forced to modulate the final transmitter stage by incorporating an audio choke in the line. Since the method is of use only in very low power transmitters it is not dealt with here in fuller detail.

Where a tetrode or pentode valve is used in the final transmitter stage and the screen is modulated with the anode, the circuit takes the form shown in Fig. 23. The screen must be fed from the anode supply line through a dropping resistor, and the anode and screen currents together be used when calculating the modulating impedance. Returning to the valve mentioned in an earlier example, the 807, the anode voltage required is 600 volts with an anode current of 100 mAs., whilst the screen voltage is 275 volts with a screen current of 6.5 mAs.

The one supply line must therefore give 100+6.5 mAs. and the screen dropping resistance is found by calculating that it will require to drop

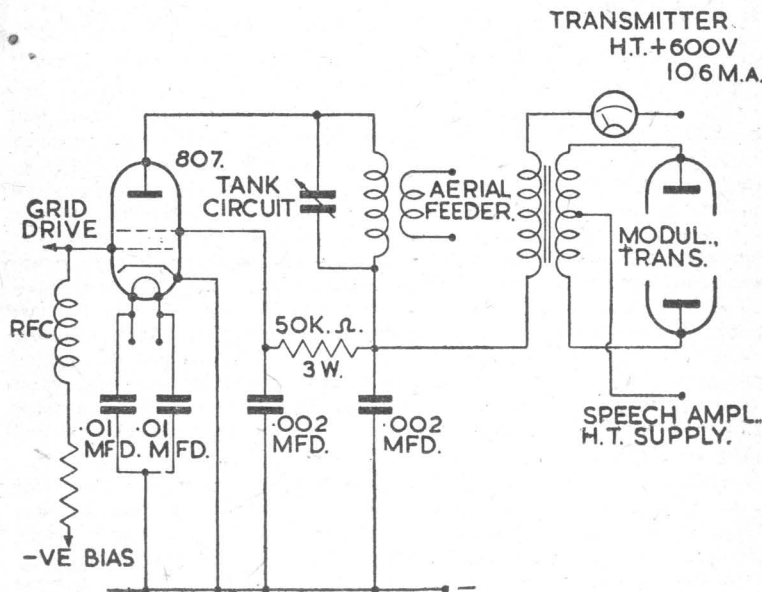

FIG. 23.—Anode-screen modulation of a tetrode (or pentode).

600 — 275 volts or 325 volts at the screen current of 6.5 mAs. Using Ohm's Law again, the resistance is therefore

$$R = \frac{325 \times 1,000}{6.5} \text{ or } 50,000 \text{ ohms, whilst the power rating of the resistor is}$$

$$\text{Watts} = \frac{325 \times 6.5}{1,000} \text{ or } 2.1 \text{ watts. A 3 watt rated resistor would be more than adequate.}$$

The modulating impedance is now found, remembering that the current in the line is 106.5 mAs.

$$Z = \frac{600 \times 1,000}{106.5} \text{ or } 5,633 \text{ ohms, and since the rated transmitter output}$$

is, for Class C plate modulated operation, 42.5 watts, the speech amplifier must be capable of giving 20 to 22 watts output in order fully to modulate the transmitter.

A pair of 6L6 valves used in push-pull and driven to Class AB1 operation will give 24 watts into a load of 9,000 ohms, so that this combination can be used as the output stage of the speech amplifier. The ratio of the modulation transformer is calculated to be

$$R = \sqrt{\frac{9,000}{5,633}} \text{ or } 1.3 \text{ nearly, so that the ratio of the transformer must be } 1:1.3 \text{ and it must be connected as a step-down transformer. It must, moreover, be capable of handling 25 watts.}$$

The more economical though less efficient suppressor grid modulation circuit is shown in Fig. 24. Once again the modulation is applied through a transformer, but since the power output from the speech amplifier is, relatively, small the transformer also is smaller and for practically all purposes a Class A 6L6 single output valve in the speech amplifier will be quite sufficient. The transformer ratio is generally taken as 1:1 with suppressor grid modulation, and the load on the amplifier adjusted by connecting across the secondary of the transformer (that is, on the suppressor grid side) a resistance equal in value to the rated output load of the last speech amplifier valve. Thus, using the 6L6 as suggested, the transformer would be a 1:1 ratio instrument, rated at 6 or 7 watts, and the loading resistor would have a value of 2,500 ohms with a rating also of at least 6.5 or, preferably, 10 watts. The load on the amplifier must be adjusted in this way since the suppressor grid requires purely a voltage swing and draws no current.

The R.F. bypass condensers on all modulated transmitter valves must be small in order that audio power is not bypassed through them as well, a common value being, as shown in the figures, 0.002 mfd., and in anode modulated equipment the speech amplifier should never be switched on until the final transmitter stage is operating. Not until the transmitter is drawing current is the speech amplifier output stage loaded up through the transformer, and no amplifier should be operated in this condition.

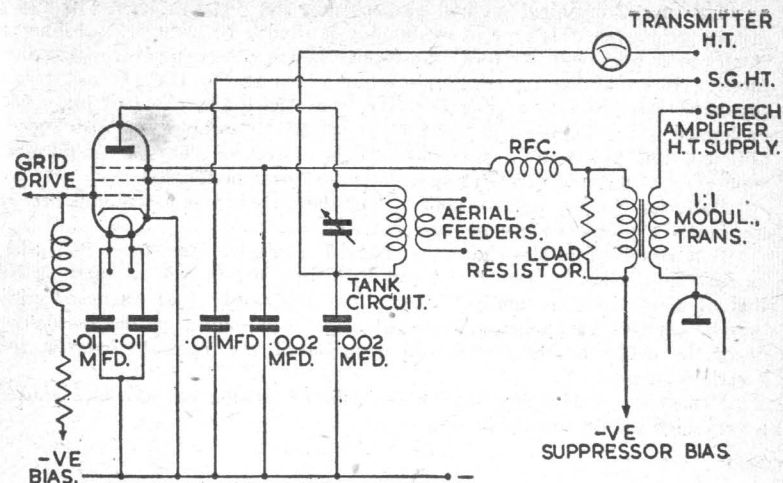

Fig. 24.—Suppressor grid modulation.

MODULATION ADJUSTMENTS.

Anode Modulation.

Provided that the correct transformer ratios are calculated and used, and that neutralisation, where necessary, is good, whilst grid bias, grid current and the loaded anode current are as specified by the makers for the valve used as the final transmitter stage, little or no adjustment is required where anode modulation is used. The speech amplifier gain should be brought up towards maximum until the current indicated as passing through the transmitter final stage valve just fluctuates slightly, when the gain control can be backed off to give a steady P.A. current. Since increases in anode input to the P.A. are balanced by corresponding decreases, the average supply current, which is measured by the milliammeter in the H.T. line, remains steady.

Suppressor Grid Modulation

To adjust the modulation level when using suppressor grid modulation, the final transmitter stage should be driven to the correct degree of grid current with the rated grid bias applied to the valve. The suppressor grid, however, should have had its negative bias removed and be connected to earth (or to a positive potential if the makers' figures specify a positive suppressor grid for telegraphy working).

Next, swing in the aerial loading until the anode of the transmitter P.A. stage shows double the rated current on its milliammeter, and then, with the aerial loading left at this adjustment, supply negative bias to the suppressor grid until the anode current is back to its normal rated value, whilst at the same time the R.F. current as indicated in the feeders should also fall to half the value at which it stood with the plate at its highest current figure.

The most convenient method of supplying the negative bias to a suppressor grid when this type of modulation is used is to include a subsidiary small power pack with its own transformer in the power supply, with good filtering to avoid the introduction of hum, feeding the D.C. output to a regulator valve and to a potentiometer from which the negative bias can be tapped, since the bias with some types of valve is as high as -300 volts, although this refers to a very high power valve, of course. A normal suppressor voltage is -50 , using suppressor grid modulation.

Batteries can be used, of course, and their replacement will not prove too costly a problem since no current is drawn.

Batteries for grid bias should be checked regularly. Remember that grid current is passing in opposition, and that their life is not so long as is that of a normal bias supply battery. Remember, too, that whenever grid bias is supplied by excitation through a grid leak, failure of the oscillator or of the excitation for any reason may permit the valve to overrun to a serious degree.

Remember that tuning any tank circuit off resonance may also cause a very high anode current to flow.

CHAPTER 3.

MODULATING OR SPEECH AMPLIFIERS

It has already been seen that the required output power of the speech amplifier is entirely dependent on the type of modulation used and the output power of the transmitter itself, a small speech amplifier sufficing for suppressor grid modulation, when the transmitter output will be reduced, or a larger amplifier being necessary for anode modulation, with a power output equal to half the transmitter's rated output.

The steps in designing a speech amplifier, therefore, are as follows.

First, choose the output valves, with reference to valve tables, in order that a combination capable of giving the full required output is found, and decide on their method of working, whether Class A, AB or B.

Again from the tables discover what their required grid swing voltage amounts to, and decide upon the amount of amplification necessary with the microphone which is to be used. Probably the majority of amateur stations use carbon microphones, since these are quite capable of giving good speech quality, especially if one of the transverse type is procured. Crystal microphones, however, are also popular and their output is not of too low an order for a fairly simple amplifier to deal with. Unless the speech amplifier is to do duty elsewhere, as a reproducer for music, etc., it should be kept along as simple lines as possible, and need have no controls other than the gain or volume control and on-off switch.

Only in the smallest power transmitter should the speech amplifier be supplied from the same power source as the transmitter itself; it is far better practice to isolate the power supplies, giving the speech amplifier its own power pack. In any case, this will be essential where a Class B speech amplifier is used, for with this type of operation the power pack load must be fluctuating, and must be separate from the load of the other gear.

The speech amplifier must be well filtered to avoid the introduction of hum to the carrier wave, the amplifier being built for preference on an iron or steel chassis with an enclosing shield over the components on top of the chassis. It must always be remembered that the amplifier is working in a strong R.F. field, and precautions taken that no R.F. is picked up and amplified with the speech currents and fed either inductively or capacitively back to the transmitter final stage, which would probably result in spurious oscillations or some other form of feedback effect.

It is good practice, on this account, to include an R.F. filter in the microphone leads, which in any case should be as short as possible and well shielded.

The shielding of the microphone lead should be extended over any transformer which may be necessary at the microphone and also over all the grid wiring including the input resistor of the first amplifier stage, whilst it is worthwhile also to use screened slip-on cable braiding for all the interstage connections. Such braiding consists of the ordinary insulated sleeving as used over bare copper wiring covered with a woven screen. It may be obtained commercially without trouble.

Apart from this the amplifier construction should follow the normal procedure, heater wiring being twisted and laid along the chassis to prevent a hum field round the cabling, good condensers with perfect insulation used for anode-grid couplings, adequate screen bypassing and all wiring as short and direct as possible.

There follow circuits for three amplifiers, with rising output powers, the power packs for the circuits also being shown. Each amplifier is made suitable for crystal microphone working, and should a microphone with greater output be used, it will be possible in many cases to omit the first stage.

As a rough guide, all types of crystal microphones, both of the cell and the diaphragm variety, together with moving coil, ribbon and condenser microphones will load these amplifiers. This being the case, the first stages of the amplifier have been given very high gain characteristics, and shielding must be perfect.

A transverse current carbon microphone can be connected straight into the same input circuit, but the gain control will require to go right back to avoid overloading, whilst an ordinary carbon microphone should feed into the second stage, the first stage of amplification being omitted. The microphone, even so, will still give more than sufficient input voltage, in the majority of cases, and it may be possible to omit the second stage of the amplifier as well.

When carbon microphones are used it is necessary to apply an energising voltage to the microphone, this voltage varying with make, although it is generally of the order of from 3 to 9 volts. It is possible to obtain this energising voltage from the amplifier power pack, dropping down from the H.T. voltage through a smoothing and decoupling circuit, but this method is not advised since it is extremely likely that hum will be introduced to the amplifier and amplified with the speech currents. A microphone battery is much more desirable, and since the microphone can be fitted with a "push to talk" button or a similar economising device, the battery drain will not be too great.

The newcomer to amateur transmitting should note that these speech amplifiers are of the simplest type. It is possible to build amplifiers with integral volume compression, for example, or with clipping and filtering circuits, or with recording sections which are switched in to record incoming signals, but experience with simple gear is a necessity before proceeding to more ambitious and complicated apparatus.

Since crystal microphones give only a small output, they are generally connected into the first amplifier stage directly, the gain control coming at a later point in the circuit where it has the added advantage of reducing any valve noise in the previous stages as well as the sound signal level. If, therefore, a low power carbon microphone is used straight into the amplifiers as shown, this volume control directly across the secondary of its transformer as shown in Fig. 25, this volume control being set to load the first valve correctly and then left. The second volume control at a later circuit stage should then be used to adjust the final amplifier output.

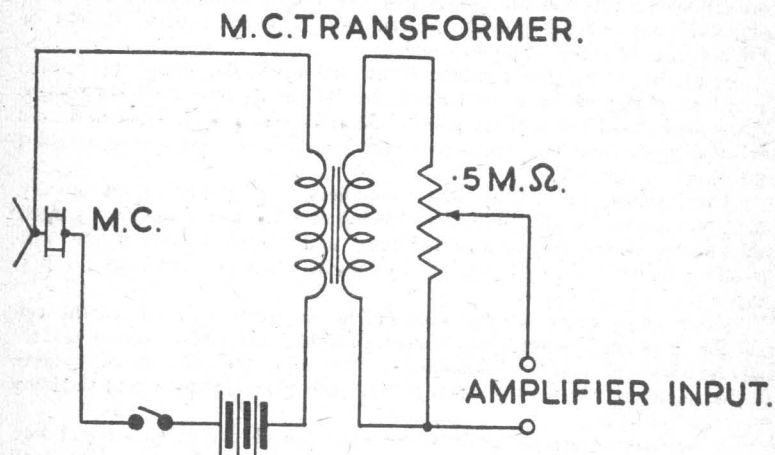

FIG. 25.—Carbon microphone circuit with gain control.

Components List for Circuit of Fig. 26.

| | |
|--------------|----------------------------------|
| C1, | 0.5 mfd. Non-inductive, 350 v.w. |
| C2, C5, C8, | 25 mfd. 25 v.w. Bias condensers. |
| C3, C6, C10, | 8 mfd. 500 v.w. Electrolytic. |
| C4, C7, | 0.1 mfd. Non-inductive, 500 v.w. |
| C9, | 16 mfd. 500 v.w. Electrolytic. |
| R1, | 5 megohms, ½ watt. |
| R2, | 1.5 " " |
| R3, R7, | 22,000 ohms " |
| R4, R10, | 220,000 " " |
| R5, | 1,200 " " |
| R6, | 1 meg. Volume control. |
| R8, | 100,000 ohms ½ watt. |

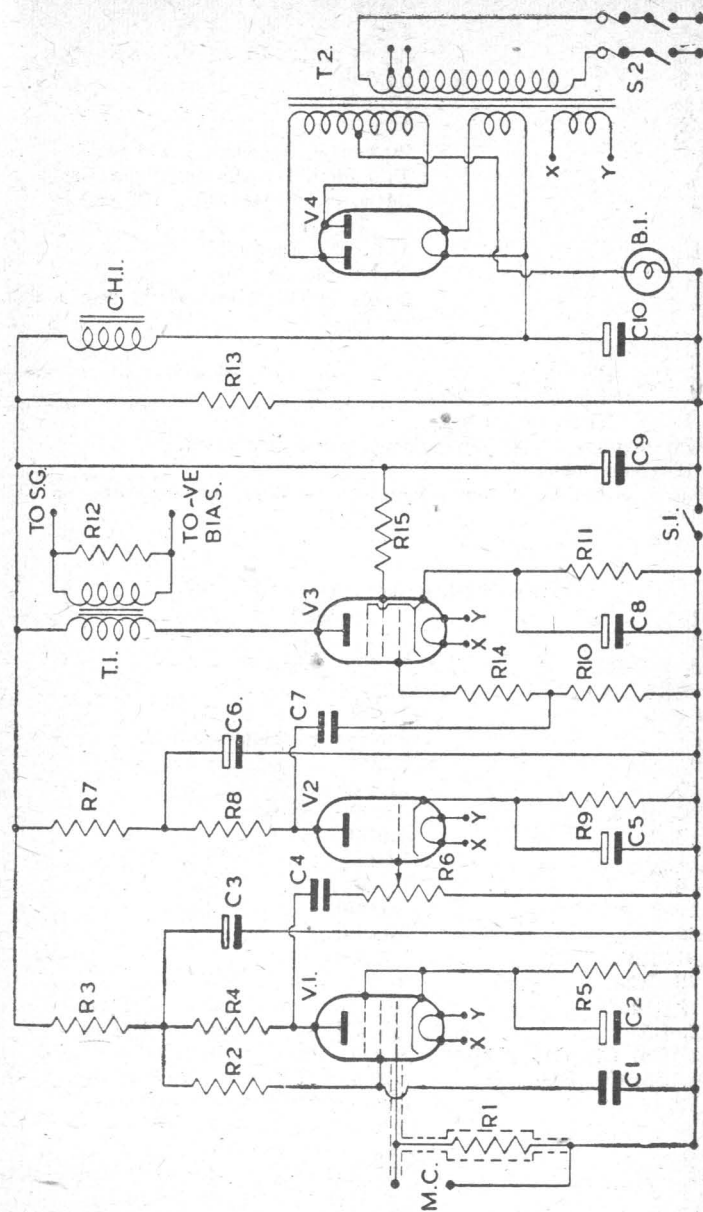

FIG. 26.—6 watt speech amplifier.

- S3, 2-pole On-Off Mains switch with 1 amp. fuses.
 T1, Modulation Transformer, 20-25 watt.
 T2, Speech amplifier load, 9,000 ohms.
 T3, 240v. in 350-0-350v. 150 mAs.
 5v. 3a. 6.3v. 3a. 6.3v. 1a.
 20 henrys, 200 mAs. 150 ohms.

- Ch1, V1, 6J7.
 V2, 6SF5.
 V3, 6C5.
 V4, V5, 6L6.
 V6, 83 (Mercury Vapour Rectifier).
 5 International Octal valveholders, chassis mounting.
 1 4-pin U.X. " " "
 1 Fusebulb holder.

Input and Output sockets, Chassis, Knob, Wire, Screened sleeving, etc.

NOTE.—The circuit as shown has a mercury vapour power rectifier in the power supply, in order that a larger transformer may be avoided, the power pack voltage drop being kept low. If desired, however, the mercury vapour rectifier can be replaced by a 5T4 rectifier, when S2 can be removed from the circuit.

If a mercury vapour rectifier is used, its heater must at all times be switched on for 1 minute before H.T. is applied to the circuit. If a Thermal Delay Switch is not obtained, then S2 must be an On-Off switch, left open till the rectifier is heated up. New mercury vapour valves, and those which have stood in stock for some time, should have a 5 to 10 minute heating run before H.T. is applied.

Components List for Circuit of Fig. 28.

| | | |
|-------------------|-------------------|---------------------|
| R1, | 5 megohms, | $\frac{1}{2}$ watt. |
| R2, | 1.5 " | " |
| R3, R7, R12, R14, | 51,000 ohms, | " |
| R4, R8, | 220,000 " | " |
| R5, | 1,200 " | " |
| R6, | 1 Megohm | Volume control. |
| R9, | 3,300 ohms, | $\frac{1}{2}$ watt. |
| R10, R15, R16, | 0.5 megohms, | " |
| R11, | 33,000 ohms, | " |
| R13, | 1,000 " | " |
| R17, | 750 " | 1 " |
| R18, | 5,100 " | 2 " |
| R19, | 6,200 " | 2 " |
| R20, | 27,000 " | 3 " |
| R21, | 36,000 " | 5 " |
| R22, R23, | 400 " | 5 " |
| C1, C15, | 0.5 mfd. 350 v.w. | Non-inductive. |
| C2, C5, | 25 mfd. 12 v.w. | Bias condensers. |

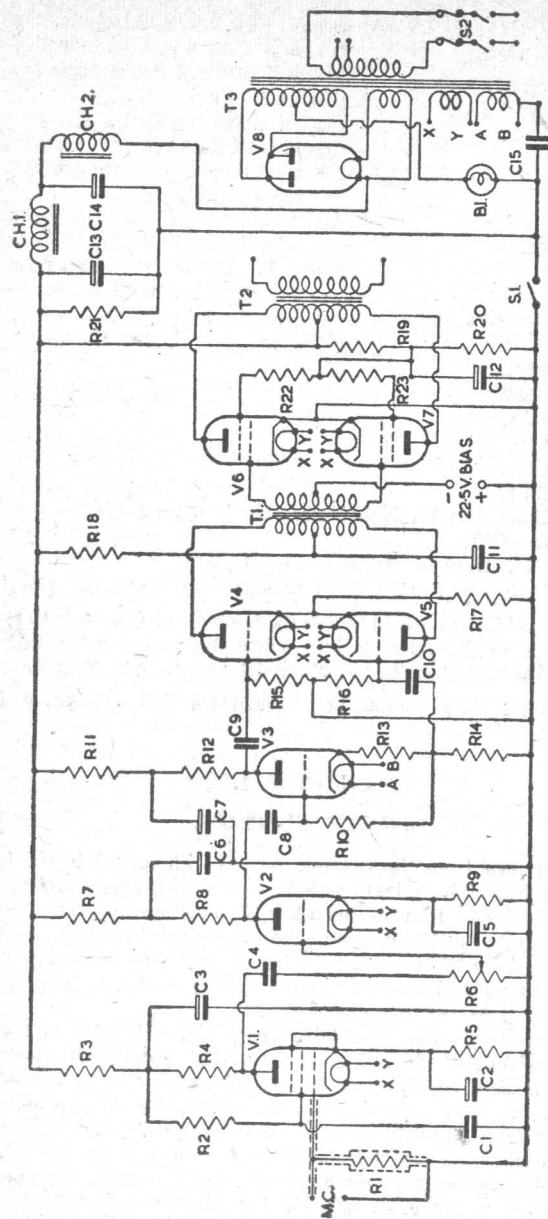

Fig. 28.—40 watt speech amplifier.

| | |
|----------------------------|---|
| C3, C6, C7, C11, C12, C14, | 8 mfd. 600 v.w. Electrolytic. |
| C4, C8, C9, C10, | 0.1 mfd. 500 v.w. Non-inductive. |
| C13, | 16 mfd. 600 v.w. Electrolytic. |
| B1, | 300 mAs. Fusebulb. |
| S1, | On-Off Standby switch. |
| S2, | 2-pole On-Off switch with 1 amp. fuses. |
| T1, | Class AB2 coupling transformer, centre tapped windings. |
| T2, | 40-50 watt Modulating transformer. Speech Amplifier load 3,800 ohms. |
| T3, | 240v. in. 425-0-425v. 250 mAs. 5v. 2a. 6.3v. 3a. 6.3v. 1a. |
| Ch1, | 20 henrys, 250 mAs. 200 ohms. |
| Ch2, | 5-20 henrys Swinging Choke. |
| V1, | 6J7. |
| V2, | 6SF5. |
| V3, | 6C5. |
| V4, V5, | 6J5. |
| V6, V7, | 6L6. |
| V8, | 5T4. |
| | 8 International Octal valveholders, chassis mounting. |
| | 1 Fusebulb holder. |
| | 1 22.5 volt battery for supplying fixed bias. |
| | Chassis, Knob, Input and Output sockets, Wire, Screened sleeving, etc. |

NOTE.—The bias for the output stage is obtained from a battery source, since self-biasing of the valves is impractical due to the fluctuating current drawn and to the fact that the grids are driven into grid current.

The biasing battery should be checked for full voltage at frequent intervals.

CHAPTER 4. POWER SUPPLIES.

As can be seen from the example quoted with regard to the type 807 transmitting valve, H.T. voltages well in excess of normal receiver voltages are often called for in transmitting work, the voltage and current demands increasing, naturally, as the power of the transmitter increases. In addition, it is often necessary to supply bias voltages, and then there are the lower voltages and currents demanded by the anodes of the oscillator, and, in some cases, the buffer or doubling stages.

The lower voltages can be obtained from the main high voltage supply by dropping resistors of adequate current-carrying capacity and power ratings, so long as the main supply transformer and rectifier valve are capable of supplying the full load current. The use of a large valve, however, with a good transformer, generally gives a power pack which can handle the full load of a reasonably powerful transmitter, the most costly items being the transformer (or transformers, since separate heater supply transformers are sometimes required for some valves), the chokes and the high voltage condensers.

The use of mercury vapour rectifying valves has been mentioned in the speech amplifier chapter, and the caution is here repeated, that separate anode switching, preferably through an automatic time delay switch, is generally absolutely essential when these valves are to be used. The heater must be allowed to reach operating temperature and thus vapourise any condensed mercury drops, otherwise there is a chance of a direct short-circuit through the valve which would ruin both valve and transformer. Again, with a mercury rectifying valve the voltage drop across the valve is very small—of the order of 15 volts—and it remains constant, whether a high or low current is flowing. This is, of course, an advantage, assisting in the good regulation of the power pack, but it also means that in the event of an unforeseen leakage or accidental short-circuit the current through the rectifier can rise to a dangerous degree. The ordinary high-vacuum rectifier exercises at least some control over a rising current, since the voltage drop across the valve rises with the current, but in any case no power pack, from the smallest output upwards, should be operated without a fuse in circuit.

This fuse has been shown in the speech amplifier power packs and is shown in the power packs described in this chapter, a small fusebulb being used in the main negative transformer line to earth. In this position, the fuse passes all the current drawn from the transformer so that in the event of a failure in rectifier, condenser or the apparatus being supplied, the fuse bears the full load. It must have an overload rating, of course, so that it can deal with momentary surges—it has to carry condenser charging current, for example—but the only fault it cannot guard against is a breakdown in the transformer itself.

When choosing a rectifier valve, The Valve Manual should again be consulted for all the valve's characteristics, since the load placed on the valve can vary with a variation in the type of H.T. smoothing filter used. The normal condenser-choke-condenser filter, known as a condenser-input filter, reduces the maximum R.M.S. voltage which can be applied to the rectifier anodes although the output voltage from the filter to the apparatus to be fed is proportionately a little higher than that obtained from a choke input filter, where a reservoir condenser straight across the rectified output is not used. Useful rectifier valves are the British UU8, which with a condenser input filter can handle 250 mAs. at 350 volts per anode; the British UU5, which can handle 120 mAs. at 500 volts per anode; the British FW4/500, handling 250 mAs. at 500 volts per anode; the British GU50, a half-wave rectifier of the mercury vapour type, which can handle 250 mAs. at 1,500 volts, although a pair of valves is required for full-wave operation; and in the American range there are the 5T4, which, with the same type of filter, can handle 225 mAs. at 450 volts; the 5U4G with the same rating; the mercury vapour 83 (not to be confused with the 83-V high vacuum rectifier), rated at 225 mAs. 450 volts full wave and, for those fortunate enough to be able to obtain them, rectifiers like the 866A/866, which are half-wave rectifiers capable of handling peak currents up to 2 amps. at 2,000 peak volts.

This type of valve, of course, is for the experienced amateur with the high-power station, and for some of the circuits to be shown a small receiving type power pack provides sufficient power.

It has already been said that the modulator should provide its own power supply.

Regulator valves of the neon type are useful for supplying very steady voltages to circuits needing this type of feed, especially the oscillator, where the frequency is dependent on the stability of the anode voltage as well as temperature. The stabilising valve—or, better, tube—draws current in parallel with the load, so that fluctuations either in the supply or the demand are balanced by a corresponding opposite fluctuation in the current passed by the tube. The tubes must be used with limiting resistors which protect them from overload in the event of the disconnection of the main load. The "Stabilovolt" and the American VR 150-30 are perhaps the best-known examples. The VR 150-30, for example, is designed to work with 150 volts across it (the striking voltage being 180), whilst the current passed by the tube varies from 5 to 30 mAs. Regulating tubes can be used in series, so that two VR 150-30's, for example, can be used to control a 300 volt circuit, whilst a 150 volt circuit can still be controlled from the junction of the tubes.

Using a single tube, the current required by the load should not exceed 25 mAs., and the circuit for a simple regulating system is shown in Fig. 29. Since the tube requires a striking voltage in excess of its working voltage, the line must be higher in voltage than is needed, the limiting resistor being connected as shown.

The value for the limiting resistor is given by the formula

$$R = \frac{D}{I}$$

where D is the difference in volts between the supply line voltage and the tube's rated voltage, and I is the maximum permissible tube current in amperes, the resistor wattage rating being calculated in the usual manner.

Where choke input filters are used, the first choke should be of the "swinging" variety, that is, it should have the property of a variable inductance which depends on the current passing. Mercury vapour rectifiers are best fed into a filter of this description, since the delayed anode switching means that a surge of current is taken to charge the power pack condensers, a swinging choke reducing this surge effect very considerably. The swinging choke, moreover, gives better voltage regulation, and although the voltage output of the filter is rather lower than that of the condenser input filter, the rectifier anode voltage can be increased by using a rather larger transformer.

It is also possible to use tapped transformers for transmission work, each half of the secondary giving a high overall voltage—1,000 volts, for example, this being rectified by a pair of mercury vapour diodes, with a centre tap in each side of the secondary giving 500-0-500 volts, which can be dealt with by an ordinary rectifier, the two outputs being common to the same centre tap and thus the same earth and providing H.T. for the different stages.

Where a high voltage is to be rectified it is definitely preferable to have a separate heater transformer not only for the transmitter valves but also for the rectifier heaters.

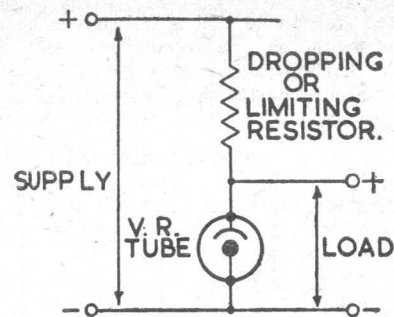

FIG. 29.—The voltage regulator tube circuit.

In Fig. 30 is shown a high voltage and medium voltage power pack using the tapped transformer method, with separate heater transformers. The separate heater transformer for the rectifier heaters also overcomes the delayed anode switching problem, for one switch controls the rectifier and transmitting heaters, H.T. not being applied until the second mains switch is thrown.

In Fig. 31 is shown a small bias supply depending for its regulation on a fairly heavy current through the bleeder resistance. Only one bias voltage should be taken from such a supply, since if two differing voltages to two differing stages are taken, changes in value for one stage will affect the second stage and thus cause interaction and other troubles. Wherever possible, battery bias is strongly advised.

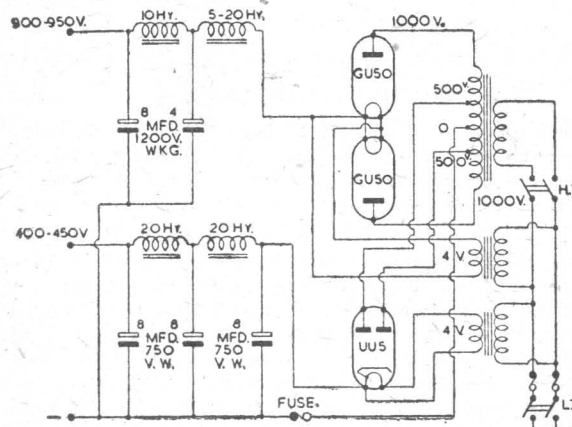

FIG. 30.—Specimen power supply circuit for high voltage, using a tapped transformer.

It must always be remembered that a transmitter has circuits at high potential open to the touch, and when adjusting tank circuits, coupling between stages, aerial loading and making changes of any sort in the transmitter, care must always be taken. More than one amateur has been killed by his own power pack.

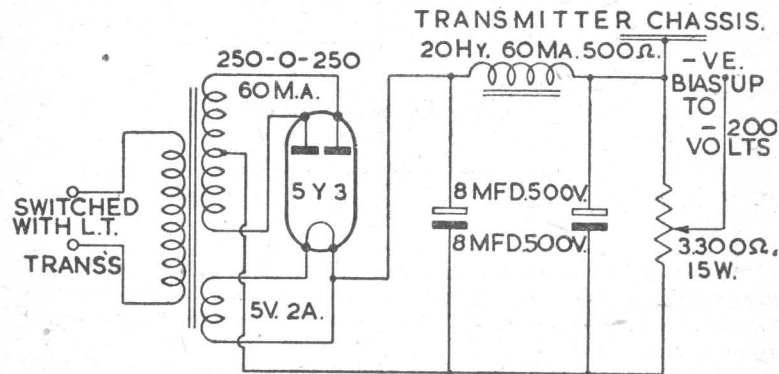

FIG. 31.—Simple bias supply.

Besides the H.T. potentials, there are also high voltages at radio frequency on the tanks and couplings, especially on the final tank. These, too, can be dangerous, and need to be treated with respect. A rubber mat in front of the transmitter is a sensible precaution, and insulation should always be good, especially in metering gear, jacks and plugs, sockets and the like.

CHAPTER 5. AUXILIARY APPARATUS.

Every amateur transmitting station should, of course, include the finest receiver possible, and it is usual to employ a commercially-made communications receiver for the purpose. A good set has a reliable frequency calibration which is of considerable value, for since each station should possess a wavemeter of some type the receiver will also act in this capacity.

A smaller wavemeter is necessary, however, to assist in the setting-up and tuning of the transmitter, particularly when frequency multiplying stages are used on the higher frequencies. The wavemeter may consist of a condenser, inductance and some indicating device such as a low wattage bulb or flashbulb which lights on the R.F. current in the tuned circuit at the resonance point. The circuit of such a wavemeter is shown in Fig. 32, and it is only necessary that a good condenser drive be used together with former wound coils, so that the unit can be handled readily without any fear of its losing calibration due to component movement or wiring distortion. The calibration can be made using a small variable frequency oscillator calibrated in its turn against the main receiver.

The absorption wavemeter is used merely by holding the unit in the proximity of the tank circuit to be checked and rotating the wavemeter tuning condenser until resonance is reached as indicated by the lamp. The condenser drive reading, checked against the calibration chart, then gives the frequency at which the tank is working.

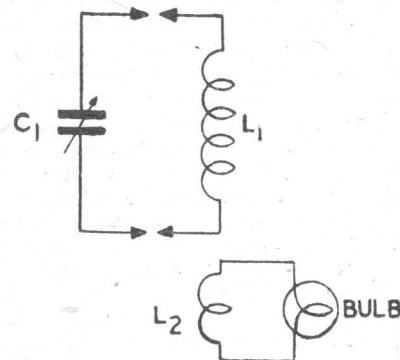

FIG. 32.—The absorption wavemeter.

Suitable component values for the wavemeter are as follows:—

Components for Circuit of Fig. 32.

- C1, 60 mmfd. Microdenser, Eddystone 1093.
- 1 2" Direct Drive Knob, Eddystone 595.
- 1 2.5 volt flashbulb, with holder.
- L1, L2, Tuning and Lamp coupling coils. (See below.)

The tuning and lamp coupling coils are wound on low-loss formers, the Eddystone 538 type former with threaded ribs being used. Note that the lamp is inductively coupled to the tuned winding, the circuit damping under these conditions being less than with the lamp connected directly into the tuned circuit.

- The coil formers are 1½" in diameter, the windings being as follows:—
- | | |
|-----------------|----------------------------|
| 60 megacycles : | 3 turns 18 S.W.G. copper. |
| 28 " : | 5 turns 20 S.W.G. copper. |
| 14 " : | 10 turns 20 S.W.G. copper. |
| 7 " : | 21 turns 24 S.W.G. copper. |

The lamp coupling winding L2 should be wound immediately below L1 on each former, so that fairly tight coupling is obtained, although there should be no chance of the two windings touching. A spacing of 1/16" is suitable. The lamp winding may in all cases be one full turn of 18 gauge copper wire, taken to two pins on the former and, via the coil base, directly to the lamp.

The coils should be plugged into an Eddystone coil base No. 964.

To cover the two low frequency ranges, 3.5 and 1.75 megacycles, a larger condenser and coil should be used in the wavemeter, and the lamp

coupling winding found experimentally, although 1 or 2 turns should still prove adequate.

For these ranges C1 should be a 160 mmfd. condenser, such as the Microdenser, Eddystone 1131, whilst for the 3.5 Mcs. range the threaded former as before should be wound with 25 turns of 26 S.W.G. copper. For the 1.75 Mcs. band the plain, unthreaded former Eddystone type 537 should be wound with 50 turns of 26 S.W.G. enamelled wire, the winding length being an inch, the wire being laid with turns touching.

Besides a wavemeter, a monitor is essential to every transmitting station. It is impossible to tune in the transmitter on the ordinary station receiver for the first tuned circuits would become extremely overloaded, so that a small receiver, generally of the diode type, is kept for monitoring. By the use of this set the general working of the station, as well as the speech quality, can be readily checked, whilst operating in the normal way if desired. The monitor usually requires no aerial, but if it is built into a well-shielded case a small vertical rod of about 6" in length may be necessary to give sufficient pickup. The telephony monitor requires no H.T. supply, whatever its circuit, so that in many cases a battery triode is used, with grid and anode strapped together, the filament being supplied from a battery included in the monitor case.

If the monitor is frequency or wavelength calibrated it acts as a further check on output frequency, but in some cases it is found sufficient to switch a coil into circuit, the size of the coil depending on the output frequency of the station, a fixed condenser being used to give the tuning. A properly tuned monitor is more pleasant to handle, however, and a simple circuit with plug-in coils is shown in Fig. 33. This is a telephony monitor, for a monitor for telegraphy should be able to oscillate in order that the heterodyne note is heard.

A monitor for telegraphy, however, can use the same circuit providing a reaction coil of a few turns is wound beside the tuned coil and coupled to the triode anode in the usual way, the valve now having the grid-anode connection removed and with a small H.T. battery provided to give reaction. For the H.T. battery it should be sufficient to use a pair of 9 volt grid bias batteries connected in series to give 18 volts. The reaction windings should, in general, have about one-third of the number of turns used on the tuned windings.

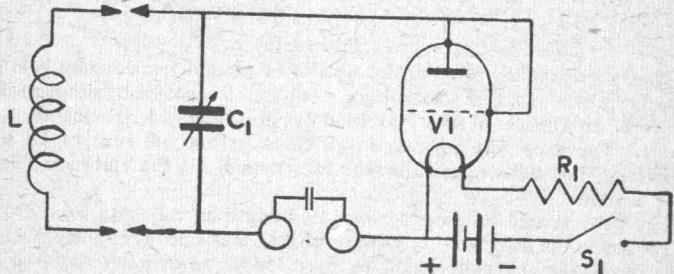

FIG. 33.—'Phone monitor.

The monitor tuned circuit, C1 and L in the figure, may have the same constants as the capacities and inductances used in the wavemeter, and the coil winding data for Fig. 32 may also be applied to Fig. 33.

Components List for Circuit of Fig. 33.

- | | |
|-----|------------------------|
| C1, | As for Fig. 32. |
| L, | As for Fig. 32. |
| V1, | HR210. |
| R1, | 7 ohms, wirewound. |
| | 1 4-pin valveholder. |
| | 1 pair output sockets. |
| | 1 3 volt battery. |
| S1, | On-Off switch. |

It should be noted that if the transmissions to be monitored are on one of the lower frequency bands the valve may be replaced by a Westector metal detector, the detector with the headphones in series with it being connected directly across the tuned circuit. The only precaution necessary is to keep the input to the monitor at a low level when a metal detector is being used, since a current of over approximately 0.2 mAs. will damage the rectifier.

Other valves suitable for monitoring are the 1.4 volt range of battery valves, which require a smaller filament battery and no series dropping resistor, the 1E4 being one example of such a triode, whilst a 1.4 volt diode is also listed, the 1A3. On the other hand, the mains type valve can be used as a monitor, suitable double-diodes which can be worked with the sections in parallel or with one section out of circuit being the 6H6 for 6 volt heater working and the DD41 for 4 volt working.

Transmitter, receiver and aerial switching also requires consideration under the heading of auxiliary apparatus since this switching can be highly complicated in a big transmitter, and the system is affected by the method of working.

The ordinary 'phone contact calls for no special switching arrangements, since it is a question of transmitter on, receiver off, and vice-versa, the aerial being switched from transmitter to receiver if the one aerial is used, the aerial switching generally being automatically controlled via a relay from the transmitter H.T. switch. The transmitter and receiver standby switching is performed only in the H.T. line, of course, so that the valves are always heated and ready to operate. The transmitter speech amplifier should also be switched to standby automatically with the transmitter, since the cessation of H.T. current through the final transmitter stage unloads the amplifier which has already been shown to be an undesirable condition.

With "Duplex" working, however, the transmitter and receiver are both working continuously, separate aeriels being used for transmission and reception. The conversation with the second station proceeds in something like the manner of a telephone conversation, the two stations generally being separated in their working frequencies by practically the whole width of the band. Duplex telephony working is extremely interesting, but should only be by schedule and at a time when D.X. conditions are usually poor, whilst the higher frequency bands should be used.

"Break in" operation really refers to a method of telegraphy where once again transmitter and receiver work at different frequencies on different aeri-als. In the interruptions between the code characters the transmitter is not interfering with the receiver which then brings in the message from the station being worked, whilst for any part of the message which has not been received a repeat signal can be sent simply by holding down the transmitter key when the distant sender immediately receives the unbroken carrier and knows that a repeat is necessary.

"Break in" operation, however, is now sometimes applied to telephony working where the stations use a "press to talk" button—one press button, through relays, operating the transmitter and receiver—so that the stations do not sign off and give the "over" signal, but reach almost the Duplex type of operation, exchanging question and reply in the minimum of time. This type of break in, however, can be worked using one aerial and the same transmitting frequency for both stations.

Mention should also be made here of the V.F.O., or variable frequency oscillator, which is becoming popular. Instead of the crystal oscillator, a self-controlled oscillator of the electron coupled type is used to control the transmitter frequency, buffer amplifiers supplying the R.F. input to the final P.A. The oscillator is stabilised by careful construction, ventilation against heat and the use of voltage regulator tubes, and has a tuning control calibrated in frequencies and marked to show the band limits. The transmitter may thus be operated in any part of the band by changing the master frequency, the tank circuits of the following stages being made sufficiently broad in their tuning to allow of adjustment or constructed for simple and rapid readjustment.

A V.F.O. circuit is not included here, however, since once again the construction of a unit together with the use of such a control is really only for the experienced amateur.

Again, since commercial receivers vary in the provision made in their circuits for standby switching, no attempt has been made to outline a transmitter-receiver-aerial switching stage. The amateur generally discovers his own requirements along these lines and develops his own gear.

Since it is so often necessary to take current checks not only in anode but also in grid circuits, it may appear that an expensive item on the transmitter components list will be the series of milliameters for inclusion in the circuit. One instrument, however, can be made to do all the work, since in any case a transmitter has to be lined up stage by stage, and some time ago a popular manner of including the milliammeter in each successive circuit was by an array of closed-circuit jack sockets, the milliammeter being external to the transmitter with its leads terminating in a jack. The jack, therefore, could be inserted into the socket of whichever circuit was to be metered, the socket would open circuit and the current forced to flow through the measuring instrument.

This method of metering has now been superseded in the equipment of many amateurs by building the milliammeter into the transmitter and connecting it into circuit by means of a two-pole rotary switch of the Yaxley type. The circuits to be metered are not opened and closed, but into each line where a current check has to be taken is wired a 50 ohm or similar resistance. The instrument is switched in parallel with this resistor, and,

providing it is of good make and of low internal resistance, as any good milliammeter should be, the current will immediately choose the path offered by the instrument and the 50 ohm resistance in the circuit will give very little shunting error. When the milliammeter is out of circuit, however, the 50 ohm resistance will be of small account in a circuit with a total resistance of some thousands of ohms, as in a grid circuit, or in a high tension lead where current is high, and the transmitter may thus be metered in a simple and speedy manner, which at the same time causes no surges by making and breaking circuits and gives a negligible error in the reading.

CHAPTER 6.

PRACTICAL TRANSMITTING CIRCUITS.

There follow in the next pages the circuits and components lists for several transmitters, most of which can be used for either C.W. or telephony transmission, the different working levels for the two classes of operation being given. None of the circuits has been allowed to become over-elaborate, and the simplest methods of coupling and tuning have been used. In many cases, also, such arrangements as parallel tank feed have been chosen, since with this type of feed it is possible to mount the tank variable condenser directly on to a metal chassis without the use of insulating pillars, whilst at the same time H.T. is kept off the tank circuit. Care in handling the circuit should still be taken, however, since R.F. voltages will, of course, be present.

Probably no transmitter circuit can be built from a design without at least a little experimental work in the final stages in the adjustment of inter-stage feed and optimum aerial coupling, etc., for with every circuit built there will be some deviation from the original which can affect the R.F. currents. Even the distance of a wire from the chassis can change the amount of coupling required, for example. The amateur transmitter should always be prepared, therefore, to obtain a final result by testing and experiment, although the circuits as given here are sufficiently simple to be built by the newest hand. This does not mean that efficiency has been sacrificed, however, and each transmitter is capable of good work.

TRANSMITTER NO. 1.

A 60 Megacycle Oscillator-Transmitter.

The first transmitter circuit shown is of a single-valve oscillator (the valve is actually a double triode in one envelope) of the self-controlled type, the frequency stability being reliant upon the tuned circuits used. The anode-connected tank circuit, from which aerial power is drawn, is of conventional design, but the grid circuit is a "long lines" arrangement, actually a double quarter wave line made of copper tubing, so that the grid frequency depends on mechanical and physical constants rather than on changeable characteristics.

The long lines tuned circuit is more convenient on the ultra high frequency bands, but even at 60 Mcs. it is not unduly unwieldy and the transmitter, whilst simple to build and operate, can give good experience in high frequency working.

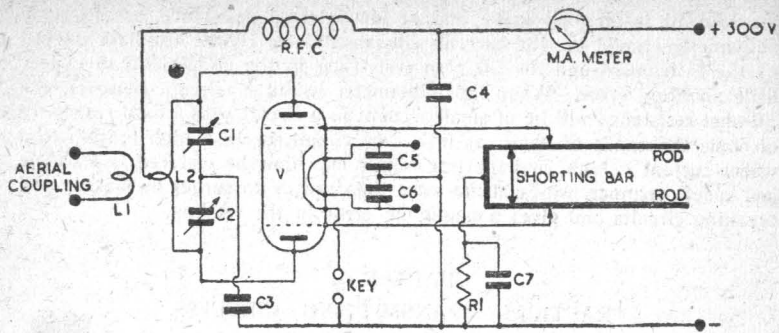

FIG. 34.—5 metre oscillator.

As can be seen from Fig. 34, the long lines are the usual folded half-wave, the low impedance or current end being near the grids of the valve. This end of the double quarter wave section can therefore be grounded directly through the self-biasing resistor R1 without affecting the working of the lines. The grids are shown as tapped connections which should be as near as possible to the shorted end of the line in order that the loading on the line is kept low and that it can work at its natural frequency.

The grid circuit is tuned by the shorting bar, which must be made to run along the lines and afford excellent contact with the tubing. One method is to make the clamps which actually contact with the lines of sheet copper with fastening screws so that the shorting bar can be slackened off and run up the lines, then re-clamped firmly in its new position. Not a great deal of travel will be required, however. A second method of making the shorting bar is to choose a length of copper tubing which will just fit easily over the grid tubes, which are of $\frac{1}{2}$ " copper, and to cut from this larger tube two pieces 2" long. These pieces are then given sawcuts at each end, the cuts 6 or 8 in number, being parallel with the axis of the tube. The ends can then be compressed to a slightly smaller diameter by light hammer blows, so that the 2" long cylinders become a tight sliding fit upon the grid tubes, ensuring good electrical contact. The cylinders are finally sweated to a copper strip between them.

The grid taps to the lines may be determined experimentally and then soldered in place.

The line length is 48", so that the transmitter is best built on a long hardwood board with the valve and tank circuits mounted at one end on a small copper chassis, arranged so that the grid leads to the lines can be as short as possible. A suitable starting-point for the grid taps would be about 8" from the shorted end.

As the shorting bar is moved along the lines the frequency rises, so that control is simple. The lines may appear a little long, since the frequency will be rather lower than might be calculated, by reason of capacity effects, and the error in any case is on the right side. It may be pointed out, however, that instead of making the lines long and then decreasing

their effective length by shorting them with the bar, the lines can be made short, to set the frequency at the high end of the band, with sliding copper rods in the open ends of the lines which may be pulled out to increase the line length and thus lower the frequency, the rods again being a good push fit in the tubes and held in place by means of grub screws, the tube walls being drilled and tapped for the purpose.

The transmitter layout is shown in Fig. 35, which is intended more as a guide than as a set of measurements. The circuit oscillates freely and quite a number of valves may be substituted for the DET19 or RK34, although not with the same output obtainable. A pair of PX4's should give good results, however, although the grid bias resistance value should then be increased to about 20,000 ohms. The valves as specified for the circuit have high grid current ratings, which accounts for the low value of R1.

The rated output of the transmitter on C.W. is 16 watts, the power input being about 24 watts, and for Morse the keying may be as shown, in the cathode circuit. To anode modulate the transmitter with speech, a 6 watt amplifier will be required, the transmitter H.T. line then being dropped to about 250 volts, the modulating impedance of the transmitter then being about 3,600 ohms.

All the bypassing condensers should be carried to the same earth point, a single soldering point on the copper chassis, and for 60 Mcs. working their capacities can be kept low, 0.001 mfd. capacities being sufficiently large.

Components List for Circuit of Fig. 34.

| | |
|--|--|
| C1, C2, | 160 pfd. Raymart VC16OX. |
| C3, C4, C5, C6, C7, | 0.001 mfd. Mica. |
| R1, | 1,800 ohms, 1 watt. |
| R.F.C. | Transmitting R.F. choke, Eddystone 1022. |
| Rods, | $\frac{1}{2}$ " diameter copper tube, 48" long, spaced 2" apart on centres. |
| Shorting bar, | See text. |
| V | DET19 British or RK34 American. |
| 1 Ceramic American 7-pin valveholder, | chassis mounting, Raymart VA7. |
| 4 Standoff insulators for Grid rods, | Raymart Type SP. |
| Milliammeter, | 0-100 mAs. |
| 1 Flexible coupler for C1, C2, | Raymart Type FC. |
| 2 Adjustable mounting brackets, | for C1, C2, Eddystone No. 1007. |
| 1 Knob, | Tank Tuning. |
| L1, | Aerial coupling coil, 2 turns 18 S.W.G. enamelled, 1" diameter. |
| L2, | Tank coil, 2 turns copper strip $\frac{3}{4}$ " wide, $1\frac{1}{4}$ " diameter. |
| 2 Standoff insulators to carry L1 and for feeder connection, | Raymart Type SS. |
| Chassis, | sheet copper 20 gauge, 6" x 6" x 2". |

The transmitter is built as shown in Fig. 35, and wired as Fig. 34, all wires being kept as short and direct as possible and all R.F. leads being of heavy gauge. The shorted ends of the two grid tubes or rods should be connected by thin copper sheet sweated to the ends of the tubes, R1 and

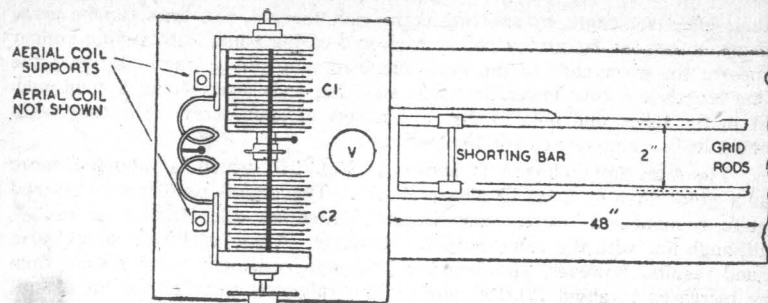

FIG. 35.—Layout for Fig. 34.

C7 being taken direct from the centre of this sheet to the common earthing point on the small chassis. The valveholder should be positioned so that the grid leads come out by the shortest route to their taps on the tubes.

The centre tap on the tank coil may be drilled in the copper strip with a small drill, the wire end of the choke being inserted and soldered into place, the choke lead being led away through the chassis by a rubber grommet or a length of insulating sleeving. The two tuning condensers which make up the tank condenser are each supported by an insulated mounting bracket, back to back, their extended spindles then being coupled together by the flexible coupler so that they turn together. They should, of course, be ganged, reaching maximum and minimum mesh together. Their moving vane connections must be connected, providing the centre tap for C3, the fixed vane soldering lugs providing the support for L2 which is soldered directly to the fixed vane lug at each end.

Testing.

Make up a "loop and lamp," the amateur's R.F. tester, by connecting a bulbholder to a single loop of 18 S.W.G. copper, one or two inches in diameter, and screw a small bulb, such as 100 mAs. fusebulb, into the holder. With the grid taps on the rods and the tank condenser at about half mesh, switch on the transmitter, watching the milliammeter. When the valve is heated, rotation of the tank condenser should give a sudden reduction of anode current to about 50 mAs. or less, and the loop and lamp, brought near to the tank coil, should light. The aerial coupling coil may be connected either to a dummy load or to the actual aerial to be used, preferably a dipole with a 72-ohm feed line. The frequency of the transmitter may be adjusted by adjustment of the shorting bar, the tank being retuned to resonance at each change of position, and the aerial loading set by bending the aerial coupling coil, L1, so that it enters between the two turns of the tank coil. As the coupling tightens and the aerial draws power, the milliammeter reading will increase, and may be run up to as much as 75 or 80 mAs.

When using a dipole aerial it should be cut to resonate at the required frequency and the transmitter matched to the aerial. This may be done by setting the aerial coupling to draw reasonable power from the transmitter

and then varying the transmitter frequency by means of the shorting bar and the tank condenser. When the anode current registered by the milliammeter is at its highest reading, and further adjustment causes it to fall, the transmitter is in tune with the aerial and the aerial coupling may be finally adjusted to draw the correct power.

CRYSTAL-CONTROLLED TRANSMITTERS.

Before passing on to crystal-controlled designs, it should be noted that crystals require selection for working frequencies according to the type of transmission that is to be used. For telegraphy or C.W. working it is usual for the frequency to be at the low frequency end of the band to be worked, whilst for telephony the transmitter should work at the higher frequency end of the band.

This is not so much a matter of ruling as one of courtesy, and observance of this point gives better operating conditions and less interference (QRM).

TRANSMITTER NO. 2.

A 1.7 to 14 Mcs. Oscillator Transmitter.

This circuit, shown in Fig. 36, may almost be described as a classic, since it has been used for many purposes, both as a transmitter in its own right and as a driver for further stages. It uses the versatile 6L6 which, although not designed for high frequency work, has been used in practically all transmitter stages from the speech amplifier to the P.A. final.

No layout diagram is needed since the simplicity of the circuit is immediately apparent, and the oscillator may be built either on a chassis or on a baseboard, parallel tank feed obviating the need for tank insulation so far as D.C. is concerned.

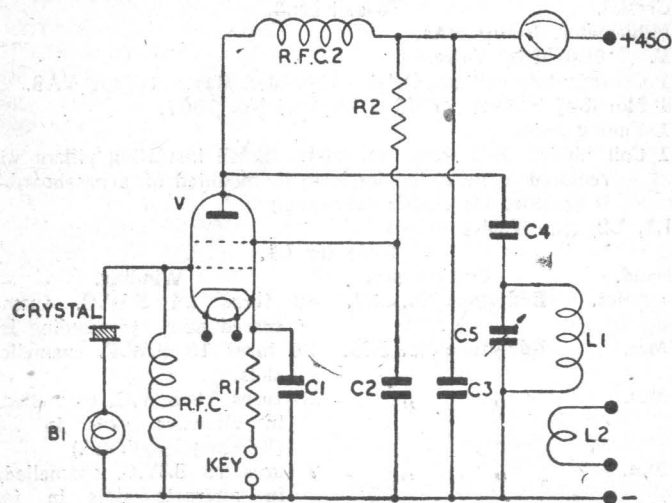

FIG. 36.—Simple 1 valve C.C. transmitter.

The transmitter may be keyed or anode modulated. For C.W. working the anode voltage may be as high as 500 volts, although 450 volts will give a sufficiently high output and prevent the valve from working too hard, and the anode current may then be allowed to reach 80 to 85 mAs. The input power will then be in the nature of 36 watts and the output power about 20 to 25 watts.

For telephony, using anode and screen modulation, the anode voltage should be dropped, without modulation, to 325 volts, the bias also being dropped slightly, when a 10 watt speech amplifier will be needed to modulate the valve. The circuit of Fig. 36 may be used for telephony working, the voltage being dropped so far as the H.T. supply line is concerned but without other circuit changes, apart from the different screen resistor. The modulating impedance will be, for a fully-loaded oscillator, about 3,500 to 3,600 ohms.

Components List for Circuit of Fig. 36.

- | | |
|--------------------------|--|
| C1, | 0.01 mfd. Non-inductive, 350 v.w. |
| C2, C3, | 0.002 mfd. Non-inductive, 500 v.w. |
| C4, | 0.001 mfd. Mica. |
| C5, | 250 pfd. Tuning condenser, |
| | Raymart VC250X. |
| R.F.C.1, | 1.25 mH. Eddystone No. 1010. |
| R.F.C.2, | 1.25 mH. Eddystone No. 1022. |
| R1, | 220 ohms, 2 watts. |
| R2, | For C.W.: 22,000 ohms, 2 watts. For Telephony: 11,000 ohms, 1 watt. |
| B1, | 2.5 volt flashbulb, with holder. |
| Crystal, | To suit band. |
| Milliammeter, 0-100 mAs. | |
| V, | 6L6 Metal Valve. |
| 1 | Ceramic International Octal valveholder, Raymart Type VA8. |
| 1 | Mounting bracket for C5, Eddystone No. 1007. |
| 1 | Tuning knob. |
| 1 | Coil holder, Eddystone No. 964. (Small insulating pillars will be required if the coilholder is to be mounted on a baseboard, as it is designed for chassis mounting.) |
| L1, L2, | (See Tables below). |

Table for L1.

| Band. | Coil Former. | Winding. |
|------------|--------------------|---|
| 1.7-2 Mcs. | Eddystone No. 537. | 40 turns 24 S.W.G. enamelled, spaced over 1½" winding length. |
| 3.5 Mcs. | Eddystone No. 538. | 20 turns 18 S.W.G. enamelled, in slots. |
| 7 Mcs. | " " | 15 turns 18 S.W.G. enamelled, laid in alternate slots in former. (Winding length 2".) |
| 14 Mcs. | " " | 7 turns 18 S.W.G. enamelled, laid in alternate slots in former. (Winding length 1".) |

The tank coil is coupled to an aerial tuning unit via link coils and a line, and the tank link is wound at the bottom, earthy, end of each tank coil, spaced ⅜" away from L1. In each case the link coil may be wound with 18 S.W.G. wire, enamelled, the turns being spaced by their own diameter, except in the 1.7 Mcs. coil, where smaller gauge wire, 22 S.W.G. enamelled, may be used.

For the 1.7 Mcs. coil the link coil should be 8 turns; for the 3.5 Mcs. coil, 4 turns; for the 7 Mcs. coil, 3 turns; and for the 14 Mcs. coil, 2 turns. These link coils are coupled to further link coils in an aerial coupling unit to be described later, and the figures given are the starting-points for coupling adjustments. Where the link coils are wound on the tank coil former the aerial coupling must be finally adjusted by varying the link coil size. In larger and more powerful gear it is wise to make the link coils on a movable former which can be varied in respect to its proximity with the tank coil.

Besides link coil coupling to an aerial tuner unit, a simple half-wave or long wire aerial a number of half-waves in length can be tapped directly on to the tank coil, the coupling being adjusted by tapping the aerial on to the coil from the bottom earthed turn up, the loading increasing as the tapping proceeds up the coil.

Testing.

The transmitter should be built to the circuit shown, all wires being kept short and direct and of heavy gauge. The coilholder should be mounted beside the tank condenser and at the end of the chassis or baseboard in order that the aerial coupling can be kept clear. A single earthing point is advisable, all bypass components being brought to this one connection. The resistors and chokes should be self-supporting on the wire ends.

The crystal should be plugged into the holder and the correct coil for the band plugged into the coilholder before the transmitter is switched on. When the valve has heated and the key is depressed, the anode milliammeter will indicate, the usual dip in current as the tank circuit is tuned to resonance occurring as C5 is rotated. The aerial loading is now adjusted either by varying the link coils when the aerial coupling unit is in use, or by tapping the simple aerial up the turns of the tank coil. At each advanced tapping point the anode current will rise, the final current reading being about 75 to 80 mAs. The transmitter should be tested for keying, however, since some crystals may require the circuit to be more lightly loaded. As the aerial load is brought in, especially when the aerial is tapped on to the tank coil, the tank circuit must be retuned.

It must be noted that this oscillator is not intended to be used as a frequency multiplier, so that a crystal to suit the band chosen must always be used.

An Aerial Coupling Unit.

It has been seen that when resonant or tuned feeder lines to the aerial are used the length of the line determines the type of unit which must be used to couple and adjust the aerial load into the final tank circuit of the transmitter. For a feeder an even number of quarter-waves long, the coupling at the transmitter end must be able to give the same type of feed

as that given by the feeder to the aerial—that is, for a feeder connected to the aerial at a current loop the transmitter-feeder coupling must also be for current, whilst for a feeder an odd number of quarter-waves long, the transmitter feed to the feeder must be of the opposite type to that from the feeder to the aerial. For a current feed into the feeder the coupling unit must be series tuned, whilst for a voltage feed from transmitter to feeder the unit must be parallel tuned. The latter condition is less simple to adjust and work with, but owing to the difference in any feeder system of the actual length and the electrical length of the wires, which can also be modified by their positioning and by the proximity of earthed or screening bodies, it is practically impossible to cut the feeders to exact length, and a coupling unit should be capable of both series and parallel tuning.

This may be accomplished by arranging a pair of condensers in the feeder circuit with clip-ended leads so that by cross-connection of the condensers are placed in parallel with the coil.

The coil, a plug-in, former wound inductance, changed for different frequency bands, is calculated for parallel tuning, and for series tuning it is generally necessary to use a smaller coil—that for the next higher band is suitable. The coils are wound in two connected halves with a link coupling coil between the two half-windings.

For low powered transmitters, such as are dealt with here, the aerial unit coils can be wound on the ordinary small formers as already specified, and here again it will be necessary to experiment with the link coupling coils for the best results, the number of turns given being the starting-point for further work, should this prove necessary.

The tuning unit condensers should be mounted on an insulated panel or in insulating bushes in a metal panel, or the condensers and coilholder may be mounted on a small chassis, the condensers being supported on insulating brackets and fitted with skirt type knobs to give hand protection from the possibility of touching metal parts which may possibly carry fairly high R.F. voltages.

The circuit of the coupling unit is shown in Fig. 37.

Components List for the Circuit of Fig. 37.

| | | |
|-------------------------------------|---------------------------|--|
| C1, C2, | 100 pfd. Raymart, VC100X. | |
| 1 Coilholder, Eddystone No. 964. | | |
| 2 Flexible leads with copper clips. | | |
| L1, L2, as following tables. | | |
| Band. | Former. | Winding. |
| 1.7—2 Mcs. | Eddystone No. 537. | 22 turns each half, 24 S.W.G. close wound. |
| 3.5 Mcs. | Eddystone No. 538. | 12 turns each half, 20 S.W.G. wound in neighbouring slots. |
| 7 Mcs. | " " | 7 turns each half, 20 S.W.G. wound in neighbouring slots. |
| 14 Mcs. | " " | 3 turns each half, 18 S.W.G. wound in alternate slots. |

Between the half-windings must be left space for the link coil, L2, the first trial windings being made as for the transmitter coils of Fig. 36.

The link coils may be wound with 20 S.W.G. except for the 1.7 Mcs. coil, where 24 S.W.G. should be used. The link coils are of 8, 4, 3 and 2 turns for the bands in order.

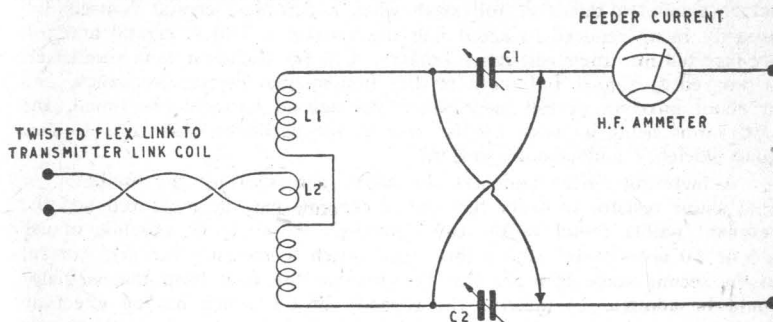

FIG. 37.—An aerial tuner unit.

The experimenter who takes the trouble to drill a former and mount a rotatable link coil inside the tuning coil, and in the same plane, will have a readily adjustable link.

The aerial coupling to the next transmitter is a simple though not often seen method of loading the final tank with an unbalanced or straight wire aerial of practically any length. The tank, again with parallel feed, takes the form of a reactance transformer with the transformer ratio dependent on the ratio of capacities of the variable condensers on either side of the tank coil.

TRANSMITTER NO. 3.

An 80-40-20 Metre C.W. Transmitter.

This circuit, using the Tri-Tet oscillator, is intended for C.W. working on the central amateur bands of 3.5, 7 and 14 Mcs., the keyed stage being the final amplifier. The Tri-Tet oscillator permits the input frequency to the second stage to be on either the fundamental or the second harmonic, although a valve must be used which will not give undue feedback at the fundamental frequency and thus overrun the crystal. The 6V6 is suitable for this type of operation.

Thus the one crystal, for 3.5 Mcs., may be used for all the bands, since not only can the frequency be doubled in the oscillator itself but also in the final stage as well, but such a crystal, with the present band limits, would require careful choice in order that its harmonics would fall satisfactorily within the bands at the higher frequencies, and in actual practice one or two crystals with differing frequencies would be needed. This being so, it is as satisfactory to use a 7 Mcs. crystal for the 14 Mcs. band, running the final stage as a straight amplifier and doubling in the oscillator stage. Rather better output will be obtained when the final stage is not used as a doubler.

The circuit is shown in Fig. 38, and the straightforward layout in Fig. 39.

The tuned circuit in the cathode line of the oscillator stage, as is usual in Tri-Tet operation, works at a higher frequency than does the crystal. A variable condenser is provided, and with the coils specified should be set at about two-thirds of full mesh when a 3.5 Mcs. crystal is used, the capacity being reduced to about half mesh when a 7 Mcs. crystal and coil are inserted into their respective holders. C5, the oscillator tank condenser, is worked at almost full mesh on the fundamental crystal frequency, and at about one-fifth of full mesh when the second harmonic is tuned, the L/C ratios being adjusted by the size of the oscillator tank coils to give good efficiency and smooth working.

A metering switch connects the meter across either the oscillator or final shunt resistor in order that anode currents may be measured and the resonant points found in the usual manner. It would be possible to use a 5 or 10 mAs. meter with a three-way switch to measure the grid current in the second stage in order that the drive to the final from the oscillator could be adjusted by altering the capacity of C1 which has an effect on oscillator output, but this would mean calculating and making the anode shunts to have low resistances so that their effect would be to increase the meter range to 100 mAs. automatically when it was switched into the H.T. supply lines. This, however, is not really necessary, although if desired the grid current in V2 may be checked by a second meter whilst the transmitter is still in the construction stage.

The switch insulation must be good, and a two-pole two-way toggle switch is specified, although a rotary Yaxley type switch may be used if desired. It will, however, take up more chassis room.

C5, C10 and C11 may be mounted directly on the chassis, but it must be noted that the bias on the oscillator is obtained by both cathode and grid leak bias, so that the frame of C1 is above earth potential. C1 is correspondingly mounted on an insulating bracket.

C5 is mounted below the chassis on the front side.

Components List for Circuit of Fig. 38.

| | | |
|-----------------------------------|--------------------------------|-----------------|
| C1, C10, C11, | 250 pfd. Variable. | Raymart VC250X. |
| C2, C3, C7, C8, | 0.01 mfd. Non-inductive, | 500 v.w. |
| C4, C9, | 0.001 mfd. Mica. | |
| C5, | 160 pfd. Variable. | Raymart 160X. |
| C6, | 0.0001 mfd. Mica. | |
| R1, | 220 ohms, | 1 watt. |
| R2, | 51,000 " | ½ " |
| R3, R6, | 51 " | " " |
| R4, R5, | 22,000 " | 1 " |
| R7, | 330 " | " " |
| R8, | 16,000 " | 2 " |
| L1, L2, L3, | (See Tables below.) | |
| R.F.C.1, | R.F. choke, Eddystone, | No. 1010. |
| R.F.C.2, R.F.C.3, | " " " | No. 1022. |
| Crystal and socket. | | |
| B1, | 2.5 volt flashbulb and holder. | |
| 3 Coilholders, Eddystone No. 964. | | |

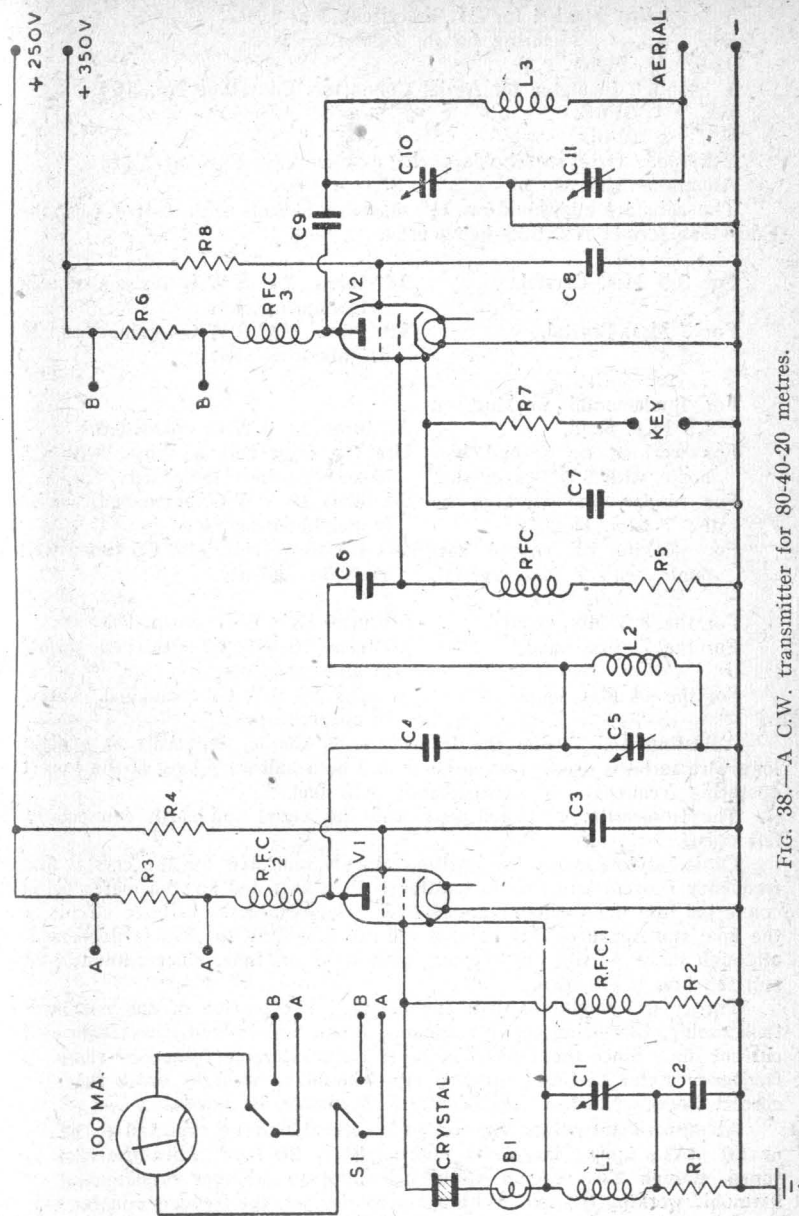

Fig. 38.—A C.W. transmitter for 80-40-20 metres.

- 1 Insulating bracket for C1, Eddystone No. 1007.
 S1, Metering switch, 2-pole, 2-way.
 100 mAs. Meter.
 1 Standoff insulator for Aerial Connector, Eddystone No. 564.
 V1, 6V6G.
 V2, 6L6G.
 2 Ceramic Octal valveholders, chassis mounting, Raymart VA8.
 Aluminium chassis, 16" x 8" x 3".
 The coils are all wound on 1½" diameter formers with slotted ribs, the Eddystone former No. 538 being used.

L1.

- For 3.5 Mcs. Crystal, 14 turns 24 S.W.G. enamelled, in neighbouring slots.
 For 7 Mcs. Crystal, 10 turns 24 S.W.G. enamelled, in neighbouring slots.

L2.

- For fundamental working on 3.5 Mcs. band, 32 turns 24 S.W.G. enamelled.
 For working on second harmonic, with 3.5 Mcs. crystal, Use the same coil as above, with C5 tuned well down in capacity.
 For fundamental working on the 7 Mcs. band, 14 turns 20 S.W.G. enamelled, wound in neighbouring slots.
 For working on second harmonic, with 7 Mcs. crystal, Use the above coil, with C5 tuned well down in capacity.

L3.

- For the 3.5 Mcs. band, 32 turns 18 S.W.G. enamelled.
 For the 7 Mcs. band, 16 turns 18 S.W.G. enamelled, wound in alternate slots.
 For the 14 Mcs. band, 8 turns 18 S.W.G. enamelled, wound in alternate slots.

Adjusting and testing the transmitter is simple, especially as a plain long wire aerial is used. The aerial should be a half-wave long at the lowest operating frequency, or approximately 132 feet.

The transmitter is tested first with the aerial and earth connections left open.

C1 is set to roughly the position already indicated for the crystal and frequency chosen, and the transmitter is then switched on, the meter being connected into the oscillator anode line. The key in the cathode circuit of the final stage ensures that current will not flow until the key is depressed, although the P.A. will not overrun, even when off tune, since cathode bias and self bias is provided.

The crystal should oscillate immediately, irrespective of the oscillator tank tuning, this being set to resonance in the usual way by observation of current dip. Since the tank coils cover a considerable frequency range, a frequency meter of the absorption type should be used in order that the correct frequency, either fundamental or harmonic, is chosen.

At off-resonant points the oscillator current may be expected to be 50 or 60 mAs., falling sharply to approximately 20 mAs. when the tank is tuned, though this reading varies according to whether fundamental or harmonic working is used. With the oscillator set, the frequency meter may

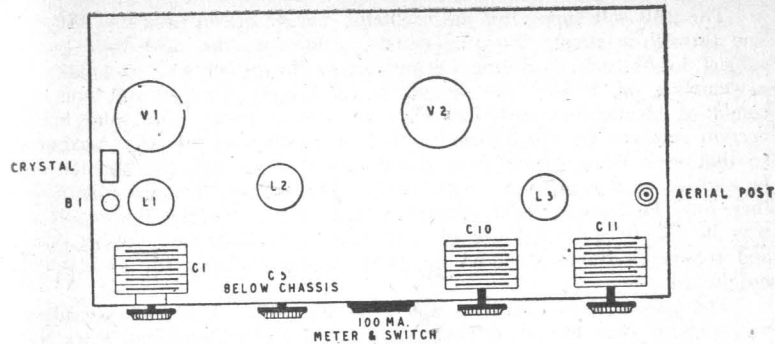

FIG. 39.—Chassis layout for circuit of Fig. 38.

be used to check the final tank, the key being depressed and the meter being switched into the final supply line. Here the current will be between 60 and 80 mAs. when the tank is off tune, but as the tuning condenser C10 is rotated the current at resonance will drop to a very low figure, relatively, whilst coupling between the frequency meter and the tank should be kept small. With the tank operating properly, the aerial and earth connections may be made, the aerial being connected in through an H.F. ammeter or a small bulb rated at 200 or 250 mAs., 6 volts. The aerial coupling condenser control should at first be fairly well meshed.

The tuning condenser C10 will now need readjustment, and the current at the resonant point will not be so low as formerly. By decreasing the capacity of C11 the aerial loading on the tank is increased, and, by operating the two condensers together to keep the tank in resonance, the anode current of the final valve may be brought up to a value of 50 or 60 mAs.

The aerial ammeter or bulb should show increasing aerial current as the anode current of the valve rises, and should the aerial current reach a peak and then decrease as the anode current continues to rise, the coupling is inaccurate and should be readjusted.

With the aerial drawing power, the tank circuit of the oscillator should be re-checked, switching the meter back for the purpose, and retuning for correct resonance if required. If, on any band, there should be a sudden rise of current on one side of the resonant point and a smoother rise on the other, the operating setting of the condenser should be towards that side of resonance where the current rise is smooth.

Any tuning correction in the oscillator stage should be followed by a further check on the final tank and aerial circuit, when the H.F. ammeter or bulb in the aerial should be short-circuited and the transmitter is then ready for working.

The cathode condenser in the oscillator stage should be reduced in capacity as far as possible, since this, whilst reducing the output of the oscillator stage as a whole, also runs the crystal under easier conditions.

The 250 volt supply for the oscillator may be drawn from the 350 volt line through a simple dropping resistor, but since the 350 volts line is subject to fluctuations during keying, unless the power pack regulation is extremely good, it has been thought better to take the 250 volt line to a combined bleeder-potential divider in the power pack. The total loaded current required for the transmitter is in the region of 90 mAs. maximum, so that even using ordinary receiving power equipment, the bleeder may be allowed to pass 30 mAs. with safety. The voltage on the oscillator will then only be correct under resonant conditions, and whilst the regulation may be improved by the use of neon stabilisers, these are not necessary and frequency stability should be good, especially since the oscillator is not keyed.

The power pack circuit is shown in Fig. 40. It is not considered necessary to show the power packs for the first two transmitters, since they follow conventional receiver type design, apart from the slightly higher voltage output of that for working the 6L6 oscillator-transmitter.

The transmitter will give a useful output, properly loaded with the aerial, of about 16 watts.

TRANSMITTER NO. 4.

A 40 Watt Transmitter for 10 and 20 Metre Telephony.

This, the final transmitter to be described, is a two-valve circuit capable of good output in the two really useful DX bands with a not too high requirement so far as the power pack is concerned. The oscillator, a Tri-Tet of usual design, gives output from a 7 Mcs. crystal in either the 14 or 28 Mcs. band—that is, the oscillator works on either the second or fourth harmonic, and since the fundamental is not used in the tank circuit, a valve with a fairly high output rating can be used. Accordingly, the oscillator stage is built round a 6L6, and the final stage, an 807, can work as a straight amplifier without frequency multiplying, so that the efficiency of the final stage is kept high.

The transmitter circuit is shown in Fig. 41, and since the stages are simple and few in number, no layout diagram is necessary. The transmitter can be accommodated with ease on a 14" chassis, the chassis depth being

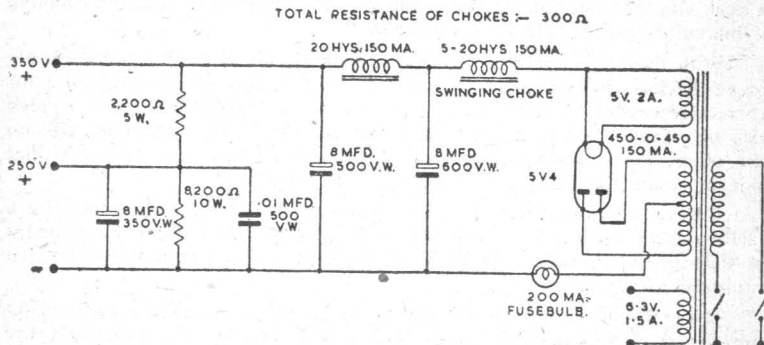

FIG. 40.—Power pack for transmitter No. 3.

3". Since the oscillator cathode circuit is set at the one frequency to suit a 7 Mcs. crystal, the tuned circuit of L1, C1 may be fixed, the coil being an air wound, self-supporting inductance mounted across the condenser, the unit being fixed beneath the chassis.

In this circuit the two tank circuits are at a high D.C. potential as well as at R.F. potentials above earth, so that the tank condensers are supported on insulating brackets, whilst the coilholders must be well insulated from the chassis.

The aerial coupling to the final tank circuit is shown as a simple loading coil to supply an untuned feeder matched into a resonant aerial. The coil can, however, be made into a link coil connected to an aerial coupling unit such as that already shown.

Components List for the Circuit of Fig. 41.

| | |
|-------------------|--------------------------------------|
| C1, | 100 pfd. Mica. |
| C2, C4, C5, C6, | 0.01 mfd. Non-inductive, 750 v.w. |
| C3, C9, | 160 pfd. variable, Raymart VC160X. |
| C7, | 30 pfd. Ceramic, high voltage. |
| C8, C10, | 0.002 mfd. Non-inductive, 1,000 v.w. |
| R1, | 220 ohms, 2 watt. |
| R2, | 22,000 " 1 " |
| R3, R7, | 22 " 1 " |
| R4, | 16,000 " 2 " |
| R5, | 12,000 " 2 " |
| R6, | 51,000 " 25 " |
| R.F.C.1, R.F.C.2, | R.F. choke, Eddystone, No. 1010. |

- 1 7 Mcs. Crystal with socket.
- B1, 2.5 volt flashbulb with holder.
- 2 Coilholders, Eddystone, No. 964.
- 2 Insulating brackets for C3, C9, Eddystone, No. 1007.
- 2 Standoff insulators for C1, Eddystone, No. 1019.
- 2 Aerial coil terminals, Eddystone, No. 564.
- V1, 6L6.
- V2, 807.

- 1 Ceramic Octal valveholder, chassis mounting, Raymart VA8,
- 1 Special 807 5-pin holder.

Chassis, Knobs, etc.

1 45 volt battery for fixed bias.

1 200 mAs. meter, and 2-pole 2-way metering switch.

L1: 6 turns 24 S.W.G. enamelled, 1½" diameter, ½" long.

L2: Wound on Eddystone formers, No. 538.

For 14 Mcs. working,

8 turns 18 S.W.G. enamelled, wound in alternate slots.

For 28 Mcs. working,

4 turns, 18 S.W.G. enamelled, wound in alternate slots.

L3: Wound on formers as above, coils as above.

Since the final amplifier is working at the same frequency in both its input and output circuits, the coils should not be allowed to approach each other too closely, to prevent feedback. The 807 will work in this way

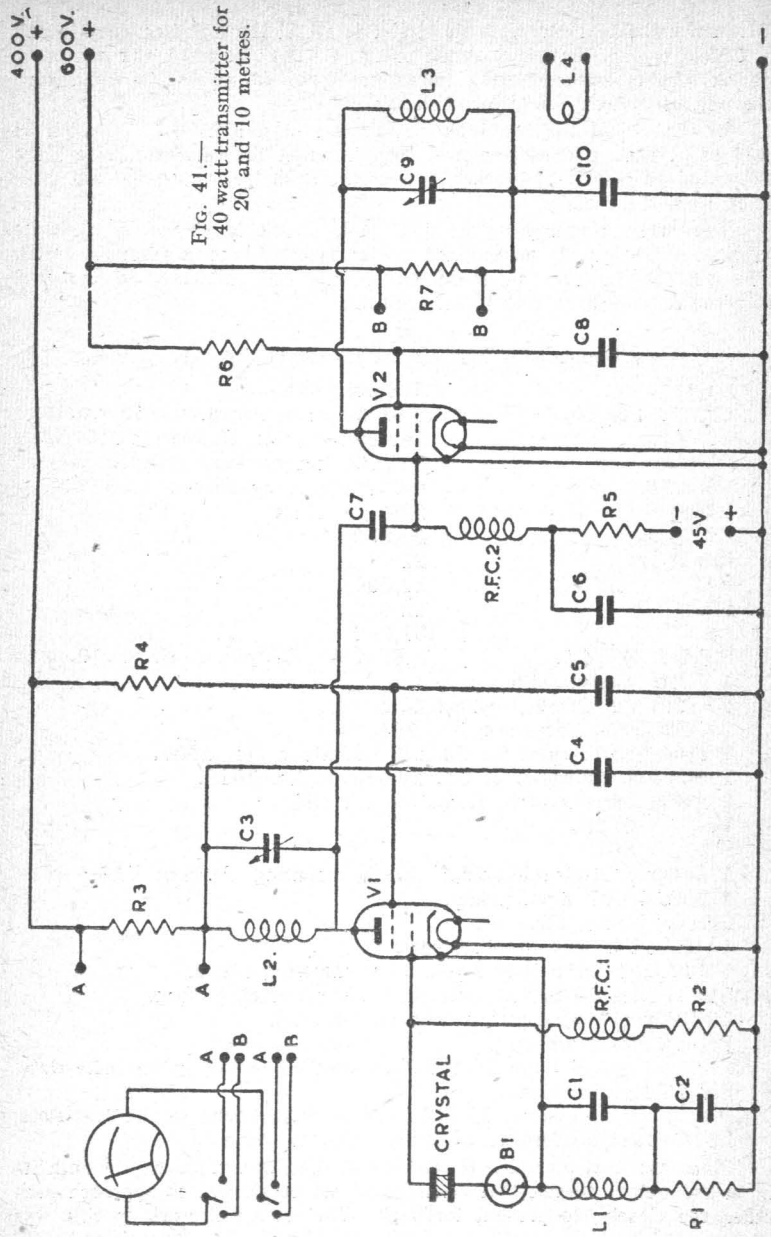

TOTAL RESISTANCE OF CHOKES :— 350 Ω

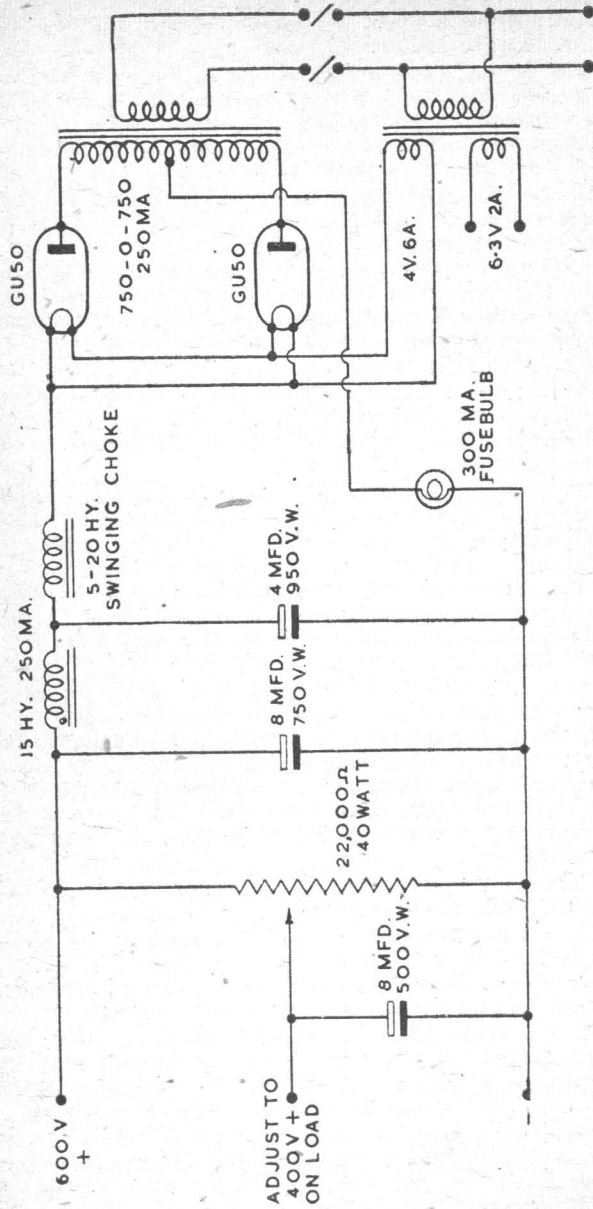

Fig. 42.—Power pack for circuit of Fig. 41.

without neutralisation, however, but the operation of the stage should be inspected for parasitic oscillations.

L4.—This is wound at the bottom—that is, the earthy end of L3 on each former, and should be determined experimentally to suit the aerial or link coupling used. For a starting-point, L4 may be 3 turns for the 14 Mcs. band and 2 turns for the 28 Mcs. band, and not only the number of turns but the coil's proximity to L3 should be varied.

When tuning the transmitter, some method of breaking the 807 supply circuit is required so that the H.T. can be switched on and off to this valve as required, for until the tank circuit is in resonance the current in the anode line will be rather heavy despite the fixed battery bias supplied. The 807 should never be run in the unloaded state, since screen dissipation under such conditions is also excessive, and a dummy load, such as a 40 watt lamp, should be in circuit with the output coupling coil.

Before applying H.T. to the final stage, the grid current should be checked and the oscillator output adjusted to give the correct drive to the 807. The grid current, rated at 4 mAs., may be allowed to reach 5 mAs., but should not be higher. A 5 mAs. meter is thus suitable for checking the grid current.

With the design as shown, the grid current should be around the figure quoted, but it may be necessary to make some adjustment. The simplest method of correcting the grid drive, since capacitive coupling is used between the two stages, is to vary the oscillator supply line voltage, increasing the H.T. on the 6L6 if the drive is low, and vice versa. The potentiometer supplying the oscillator will, in any case, be of a high current rating, and a resistor with a sliding tap should be chosen so that the voltage adjustment is simple.

With the correct drive to the 807, the H.T. may be applied and the tank tuned to resonance, there being a very appreciable dip if the load is lightly coupled in. The frequency in the final tank must be checked with the frequency meter. The loading may then be brought in to increase the anode current, resonance being retuned as necessary, until the total anode and screen current stands at about 100 mAs. The maximum permitted figure for the anode and screen is slightly above 105 mAs., but some margin should be allowed.

With the current at 100 mAs., the modulating impedance will be, for a 600 volt H.T. line, 6,000 ohms.

A 20 watt speech amplifier is required to modulate the transmitter, modulation level being set in the usual manner, by turning up the speech gain control until a fluctuation is seen on the anode millimeter, then backing off the gain till a steady reading is again obtained.

The total load of the transmitter is approximately 80 mAs. at 400 volts for the oscillator and 100 mAs. at 600 volts for the final stage. Mercury vapour rectification is therefore advisable, and, as already indicated, the oscillator supply should be drawn from a heavy duty voltage divider.

The power pack is shown in Fig. 42, with two GU50 mercury rectifiers operating from a 750-0-750 volt transformer. There is thus a generous input voltage to allow of potential drops due to choke resistance and to the use of a choke input filter.

“TECHNI-GEN” CONSTRUCTORS' ENVELOPES

Correspondence with many thousands of purchasers of our well-known Radio books has revealed a considerable demand for Radio designs in sheet form, and has indicated the types of sets desired.

The new “TECHNI-GEN” series of Radio Constructors' Envelopes is based upon this information.

Each envelope has an attractive cover design in two colours and contains a broad-sheet, size 22½ in. by 17½ in., giving a chassis blueprint, a picture of the set which, in each case, has been built and fully tested, circuit diagrams and explicit instructions.

Lewis George, the well-known Radio designer and author, is responsible for the production of the Series and British component manufacturers have co-operated in developing the designs.

- No. 1. **HOW TO MAKE A 3-VALVE PLUS RECTIFIER AC/DC TRF RECEIVER.** For medium waves (200-557 M. only). This receiver is provided with a tone control and a method of using an energised loudspeaker is illustrated and described.
- No. 2. **HOW TO MAKE AN “ECONOMY” 4-VALVE PLUS RECTIFIER AC/DC SUPER-HET. RECEIVER.** For medium waves (200-557 M. only). A.V.C. and Tone Control is incorporated.
- No. 3. **HOW TO MAKE “ALL-DRY” 4-VALVE BATTERY SUPER-HET. PORTABLE RECEIVER.** For medium waves (200-557 M. only). A.V.C., Tone Control and a Frame Aerial are incorporated. Provision is also made for the use of an outside aerial.
- No. 4. **HOW TO MAKE AN AC/DC “QUALITY” RECEIVER.** For medium and long waves. This receiver is suitable for both local station reception and for the more powerful Continental stations. Approximately 8-watts push-pull output is provided.
- No. 5. **HOW TO MAKE A 20-WATT “QUALITY” AMPLIFIER.** Separate treble and bass tone controls are incorporated and the output stage comprises two tetrodes in push-pull with negative feedback.
- No. 6. **HOW TO MAKE A PORTABLE AC/DC PUBLIC ADDRESS AMPLIFIER.** 10-watts output with provision for mixing two microphone inputs and a gramophone pick-up. A suitable carrying case is illustrated.
- No. 7. **HOW TO MAKE A DE LUXE TUNING UNIT FOR THE 20-WATT “QUALITY” AMPLIFIER.** Both straight and super-het circuits are incorporated allowing wide-band local station as well as all-wave reception. Continuously variable tone control circuits are included.

Retail price 2s. each

Obtainable from your dealer or, in case of difficulty, write direct

BERNARDS (PUBLISHERS) LIMITED,
GRAMPIANS BUILDING, WESTERN GATE,
LONDON, W.6.

Telephone: SHEPHERDS BUSH 251.

BERNARD'S RADIO BOOKS

FOR THE HOME & AMATEUR CONSTRUCTOR

| | | |
|-----|---|------|
| 3. | SERVICES SIGNALLING MANUAL | 1/- |
| 4. | RADIO POCKET BOOK | 1/- |
| 6. | ELECTRICAL ENGINEERS HANDBOOK | 1/- |
| 22. | MANUAL OF RADIO CIRCUITS | 2/- |
| 30. | RADIO VALVE MANUAL | 3/6 |
| 37. | MANUAL OF DIRECT DISC RECORDING | 2/- |
| 41. | WIRELESS AMPLIFIER MANUAL | 2/- |
| 42. | SHORTWAVE RADIO HANDBOOK | 2/- |
| 43. | MODERN RADIO TEST GEAR CONSTRUCTION | 1/6 |
| 44. | RADIO SERVICE MANUAL | 2/6 |
| 45. | RADIO REFERENCE HANDBOOK | 12/6 |
| 48. | RADIO COIL AND TRANSFORMER MANUAL | 2/- |
| 50. | INTERNATIONAL SHORTWAVE RADIO STATION LIST | 1/- |
| 51. | CATHODE RAY OSCILLOSCOPE MANUAL | 2/- |
| 52. | RADIO TUNER UNIT MANUAL | 2/6 |
| 53. | RADIO CONSTRUCTORS' MANUAL | 3/- |
| 54. | RADIO RESISTOR CHART | 1/- |
| 55. | HANDBOOK OF RADIO CIRCUITS No. 2 | 2/6 |
| 56. | RADIO AERIAL HANDBOOK | 2/6 |
| 57. | ULTRA SHORTWAVE HANDBOOK | 2/6 |
| 58. | RADIO HINTS MANUAL | 2/6 |
| 59. | TELEVISION CONSTRUCTION MANUAL | 3/- |
| 60. | RADIO REPAIRS MANUAL | 2/6 |
| 61. | AMATEUR TRANSMITTERS' CONSTRUCTION MANUAL | 2/6 |
| 62. | CAR AND PORTABLE RADIO CONSTRUCTORS' MANUAL | 2/6 |
| 64. | SOUND EQUIPMENT MANUAL | 2/6 |
| 65. | RADIO DESIGNS MANUAL | 2/6 |

Other Titles in Preparation

| | | |
|-----|--|--|
| 63. | RADIO CALCULATIONS MANUAL | |
| 66. | COMMUNICATIONS RECEIVERS' MANUAL | |
| 67. | RADIO VALVE EQUIVALENTS MANUAL | |
| 68. | FREQUENCY MODULATION RECEIVERS' MANUAL | |
| 69. | RADIO INDUCTANCE MANUAL (<i>Coil and Transformer Construction</i>) | |
| 70. | LOUDSPEAKER MANUAL | |
| 71. | MODERN BATTERY RECEIVERS' MANUAL | |
| 72. | EXPERIMENTAL CIRCUITS MANUAL | |
| 73. | RADIO TEST EQUIPMENT MANUAL | |