

# RADIO TEST EQUIPMENT MANUAL

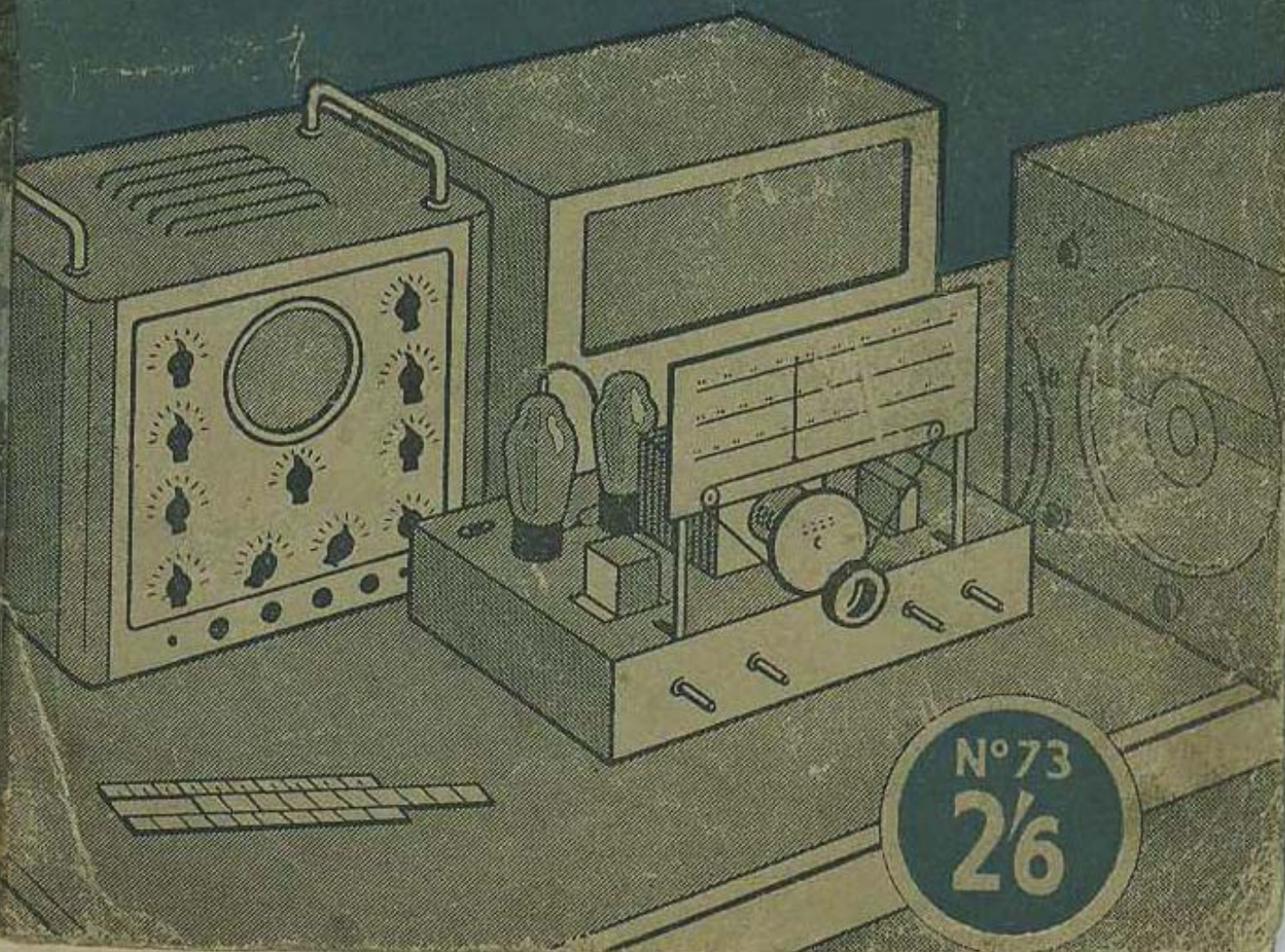

N°73  
2/6

# RADIO TEST EQUIPMENT MANUAL

by

“RADIOTRICIAN”

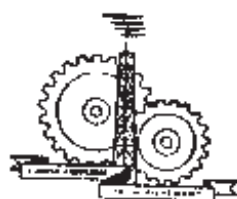

BERNARDS (PUBLISHERS) LTD.  
LONDON

CHAPTER I

AN OUTLINE OF RADIO TESTING

Probably at no time since the inception of broadcasting has the work of the radio service man, both amateur and professional, been of such importance as at the present time. Scarcity of materials and labour means that the majority of listeners are using old sets and that there is little chance of replacement of these worn-out receivers; whilst, for the same reason, there is a scarcity of test-gear on the market and both receivers and test equipment, when obtainable, are highly priced.

The amateur, therefore, is once again coming into his own, both as a constructor and service engineer, and it is felt that a Manual devoted to amateur-constructed test-gear of modern types of equipment will fill a definite need.

This book deals chiefly with the equipment itself, rather than in the use of the equipment, although all necessary notes are given. A brief résumé of the accepted methods of testing radio receivers will not be out of place, however.

Whatever the type of receiver under repair, the tests should always commence with an inspection of the power pack or, if a battery set is under consideration, with a measurement of the resistance presented by the receiver to the battery leads, such tests obviously being made with no power applied to the receiver. A common fault in A.C. and especially Universal receivers is a breakdown of the reservoir condenser, and even if a fuse is fitted to the receiver a shorting reservoir condenser more often than not means a ruined rectifier valve and possibly a damaged transformer. If a visual inspection of the power pack reveals no obvious trouble, therefore, such as a white incrustation around a smoothing condenser or a darkened patch on the transformer windings, the rectifier valve may be removed from its socket, the set switched on and the output voltage of the transformer measured across each half of the H.T. secondary with an A.C. voltmeter. The heater secondaries may also be checked with a lower voltage range on the A.C. voltmeter, and the set run for ten minutes or so with the rectifier valve still out of circuit to test for heating up of the transformer. Heated windings after this short run would reveal a case of shorting turns which might not be shown by a voltage check. Where a Universal set is under test the voltage check across the transformer may be replaced with a current check to ensure that the valve heaters are passing the correct current. If there is any reason to suspect the reservoir and smoothing condensers, the H.T. supply line may be disconnected from the anode of the rectifier valve for the preliminary tests on this type of receiver, since it is not possible to remove the rectifier valve without breaking the continuity of the heater circuit.

The heater current should be measured with an A.C. or D.C. ammeter according to the mains supply, or the current may be measured indirectly by measuring the voltage drop set up by the current across a low resistance,

CONTENTS

	PAGE
Chapter 1. AN OUTLINE OF RADIO TESTING . . . . .	3
Chapter 2. TEST-GEAR USING MOVING COIL METERS . . . . .	5
Chapter 3. HIGH FREQUENCY MEASUREMENTS . . . . .	17
Chapter 4. THE SIGNAL GENERATOR . . . . .	23
Chapter 5. THE OUTPUT METER . . . . .	33
Chapter 6. THE CATHODE RAY OSCILLOSCOPE . . . . .	38
Chapter 7. SIGNAL TRACING . . . . .	48
Chapter 8. AUDIO OSCILLATORS . . . . .	53
Chapter 9. L, C AND R BRIDGES . . . . .	58

Reservoir and smoothing condensers may be checked in the same manner whatever the type of receiver into which they are fitted. A sensitive milliammeter in series with a battery may be applied to the condenser which should have one side disconnected from the receiver-circuit in order that no alternative current path may exist. The milliammeter should then show a quick deflection as the condenser is brought into circuit and charges, the reading then returning to zero. Any signs of a leakage current means that the condenser should be tested further, using a voltage equal to the rated working-voltage of the condenser and testing for short circuits or leaks with a neon lamp. The milliammeter should not be used for this test since a heavy current may flow.

The reservoir condensers of Universal sets are especially suspect since there is in these components a heavy A.C. or ripple current due to the fact that they are working in a half-wave rectifying circuit. A condenser with adequate ripple rating should always be used as the reservoir of an A.C./D.C. receiver, the rating being at least for 100 mAs. A.C. and preferably more.

Chokes, loudspeaker fields, dropping resistors, and the like, may all be tested with an ohmmeter. In the case of dropping resistances it must be remembered that the resistance at the working temperature will be higher than the cold resistance.

With the power pack in order an examination of the receiver should be made before applying H.T. to the set to ensure that there is no short circuit or low resistance leak across the power pack or battery. The receiver resistance across the H.T. supply lines may be measured with an ohmmeter with valve heaters both hot and cold.

Testing of the receiver proper may be carried out by means of voltmeter and milliammeter readings, since a faulty stage may often be indicated by such measurements, or the testing may be made both quicker and simpler by the use of a signal tracer. In the former method stage measurements should be made from the output stage back to the aerial, whilst with the signal tracer testing proceeds from the aerial to the output stage, a strong signal being supplied to the receiver either from the local station or, preferably, from a signal generator.

It may be desired to take measurements of R.F. or I.F. voltages across tuned circuits of the set, in which case a valve voltmeter will be required, and advanced gear which may be used with the signal generator is a "Wobbulator," or Frequency Modulated Generator, together with a Cathode Ray Oscilloscope, by means of which the I.F. amplifier of the receiver may be aligned in short time to as excellent a response characteristic as possible.

Failing these instruments, an output meter will be required when the receiver is aligned, so that visual rather than merely aural indications of I.F. peaking are obtained, whilst for the testing and repair of amplifiers, gramophone players and reproducers, P.A. gear and cinema equipment, the signal generator must be replaced with a variable tone audio oscillator.

To test receiver components or to measure inductance and capacitance, fairly simple bridge circuits can be built up, supplied once again from the audio oscillator, and here, once more, the valve voltmeter can be used as an indicator or measuring device.

Particular care must be taken with the power supplies of test-gear, which must be arranged in such a way that the gear may be connected to a receiver or amplifier in any way necessary with no chance of power leakages or crossing of the mains supply common to both pieces of gear. With A.C. operation this is a simple matter, since the test-gear can have its own self-contained supply which is isolated from the mains and other equipment by the mains transformer windings, but when it is necessary to run the test-gear from D.C. every precaution against a mains short circuit must be taken. The best method is to make the connection between the test-gear and the receiver under test through a neon lamp which will light if the mains leads are crossed, thus indicating the need for reversing the polarity of one of the two mains plugs yet permitting no damage.

In some cases the test-gear is designed for portable operation and is operated from batteries, in which case connections to A.C. or D.C. or Universal receivers or amplifiers can be made without taking any more precautions than are usual. The service engineer should always guard against the chance of electric shock, of course, especially if headphones are being used, as they are with one type of signal tracer to be described.

Test-gear using Universal valves and power supplies is not shown. If the constructor is forced to use this type of valve and circuit he will be able to substitute the correct valve for the A.C. type specified and add his own voltage dropper in the heater line, but since this type of operation for test-gear is definitely unsafe and undesirable, it has been thought better to omit such circuits altogether.

## CHAPTER 2

### TEST-GEAR USING MOVING COIL METERS

Equipment using the moving coil meter (or, more correctly, the moving coil instrument) is invaluable and indispensable to the service engineer. It must always be remembered that the moving coil instrument is an ammeter or milliammeter, no matter how the scale is calibrated, for the instrument measures current. A milliammeter or ammeter is directly calibrated in terms of high or low current, and a voltmeter is calibrated in terms of the current which is forced by the applied potential through a high resistance. Moving iron instruments should be avoided for radio and low power work, unless they are used for measuring mains voltages or heavy currents where current consumption is of little moment. Voltage can, of course, be measured by electrostatic voltmeters where a true potential is indicated on the scale with no current consumption, apart from a fragmentary leak, but this type of instrument is of little use except for television and high voltage work and has a range so restricted that its cost to the service engineer is not justified.

Whilst separate voltmeters and milliammeters are useful and enable two readings to be taken on a circuit at the same time, it is by now common practice to use a circuit analyser or combined instrument sometimes supplemented by a multi-range voltmeter. The analyser is arranged to measure several ranges of volts and milliamps D.C. and the same voltage ranges in

A.C., whilst some models will also give measurements in alternating current between the limits of about 0.2 to 10 amps.

The heart of an analyser is a milliammeter of as high a sensitivity as possible. Commercial models often use a 100 microamps instrument, but the amateur or constructor who desires to build an analyser will be well advised to use a 0.1 mA. moving coil instrument.

To measure voltage with such an instrument a circuit must be so arranged that the voltage across the circuit can be read off in terms of the current through the instrument. For example, the 1 mA. instrument might have resistance added to it until the whole resistance of the instrument was 10,000 ohms. (The resistance of the instrument alone would be of the order of 20 to 50 ohms.) Adding this high resistance would naturally not affect the sensitivity of the movement proper, which would still register full-scale deflection for 1 mA., but to cause 1 mA. to flow through the 10,000 ohms circuit 10 volts would need to be applied across the circuit. Thus, the 0.1 mA. instrument would now act as an 0.10 voltmeter.

(Remember that by Ohm's Law  $E = IR$ , or  $R = \frac{E}{I}$ , or  $I = \frac{E}{R}$ , where

$E$  is volts,  $R$  is ohms and  $I$  is amperes. Thus, in the above example,

$$E = 0.001 \times 10,000 \\ = 10 \text{ volts.}$$

Note that 1 mA. is shown as 0.001 ampere, 10 mAs. are shown as 0.01 ampere, and 100 mAs. are, of course, shown as 0.1 ampere.)

To make the moving coil measure various ranges of volts (D.C.) is therefore quite simple, since all that is necessary is to add resistance to the instrument, the required resistance being given by Ohm's Law. Remember, however, that the instrument has resistance which must be subtracted from the total necessary resistance, the remainder being the actual resistance to be added. This only applies to the low voltage ranges, since the instrument resistance is, or should be, low. If 100,000 ohms is to be added to a 1 mA. instrument to give a voltage range of 100 volts, there is obviously little point in correcting the external resistance of 100,000 ohms to compensate for the fact that the instrument or internal resistance is, say, 50 ohms. 50 ohms is but 0.05% of the total resistance of 100,000 ohms and, considering the fact that the instrument will probably have an integral accuracy of 1% of the full-scale reading, there is no need to correct for the internal resistance until it is 0.5 or 1% of the total resistance.

To measure higher currents with a 1 mA. instrument it is necessary to pass only a fixed portion of the current through the movement, the rest of the current being by-passed or shunted past the instrument. Thus, the resistance used for this type of measurement are known as shunts, whereas the external resistances added to the instrument to enable voltage ranges to be measured are known as multipliers. It is from the multiplier that the meter sensitivity in ohms per volt is obtained. An 0.1 mA. instrument will, with multipliers, give a sensitivity of 1,000 ohms per volt, since for every volt to be measured 1,000 ohms must appear in the full circuit resistance.

Unlike the multipliers, shunts are of low and very low resistances which makes their installation and adjustment a less simple matter. Fortunately,

the adjustment can be made by a trial and error method, and unless a really good bridge is available this type of adjustment should be used.

It is now possible to give the two formulæ by which multiplier and shunt values can be determined for any moving coil instrument.

*Multiplier Resistances.*

$$R_m = \frac{V}{I}$$

where  $R_m$  is the required multiplier resistance,  $V$  is the required full-scale voltage to be measured, and  $I$  is the full-scale current of the instrument in amperes.

For low voltage ranges the multiplier resistance is given by

$$R_m = \frac{V}{I} - r$$

where  $r$  is the internal resistance of the instrument. A good instrument should have the value of  $r$  printed on the scale. If the value does not appear, however, and is required, a query should be made to the manufacturers of the instrument.

*Shunt Resistances.*

$$R_s = \frac{r}{n-1}$$

where  $R_s$  is the required shunt resistance,  $r$  is again the internal resistance of the instrument, and  $n$  is the factor by which the normal full-scale current reading is to be multiplied. Thus, if it is desired to read up to 100 mAs. on a 1 mA. instrument,  $n$  becomes 100 and the formula becomes

$$R_s = \frac{r}{99}$$

Supposing  $r$  to be a value of 20 ohms, the shunt resistance should thus be 0.202 ohms.

#### ALTERNATING CURRENT AND VOLTAGE

To measure alternating current and voltage on a moving coil instrument requires that the current be rectified, for the moving coil cannot respond to alternations of mains frequency except to give a rapid and very small vibration of the instrument pointer about the zero mark. Various small rectifiers known as instrument rectifiers are readily obtainable commercially at prices averaging on 10/- for the 1 mA. type. By the use of such a rectifier alternating voltages can be measured with very fair accuracy although the instrument must be re-calibrated for voltages below about 100 volts full-scale. Alternating current is measured less easily, however.

The rectifier must be used only for its stated current, and has a fairly high impedance of about 700 ohms for the 1 mA. type. Thus, the rectifier is not of great use for measuring a current of even 1 mA. A.C. since the chief necessity in a current-measuring instrument is that it should have a low resistance. To measure high currents of about 1 amp. A.C. the current must

flow through a special transformer whose secondary supplies a 1 mA. current to the rectifier and instrument. The transformer is thus known as a current or instrument transformer, and the design of such components is extremely complicated. It is of little use to buy such a transformer, moreover, even if available, since the windings must suit the actual rectifier and instrument used. The simplest method of measuring alternating current is therefore either to use a separate instrument altogether of the thermo-ammeter type, or to measure the voltage drop caused by the alternating current across a low resistance of non-inductive characteristics. This latter method is the cheaper and gives very good results for workshop use. The radio engineer chiefly needs to measure valve heater current, especially in Universal sets where a dropping resistor has to be set to the correct tapping or adjustment in order that the valves are suitably supplied with current, and in this type of application the dropped potential method is perfectly satisfactory. The current is measured as a voltage on the lowest voltage scale of the instrument, a simple mental calculation then giving the current.

It is unfortunate that the instrument requires re-calibration for low ranges of A.C. volts, but this is necessitated by the changing characteristics of the rectifier. Added to this there is a loss in the rectifier, as might be expected, so that 1 mA. A.C. through the rectifier results in a D.C. output of only approximately 0.85 mA. D.C. In commercial instruments this is offset by making the true sensitivity of the moving coil instrument 0.85 mA., so that it may be used with the rectifier direct, a high resistance shunt reducing the D.C. sensitivity to the required 1 mA. The problem is solved rather differently in the comprehensive analyser of Fig. 2, however. Here the instrument sensitivity is already 1 mA., so that a 1 mA. output from the rectifier is needed. To obtain this an input of 1.11 mAs. must be supplied to the rectifier, and so the A.C. multipliers are calculated to pass this current on each A.C. volts range.

In Fig. 1 a moving coil instrument is shown in a variety of circuits to measure different currents and voltages both A.C. and D.C., and these diagrams should be studied before that of the full analyser. In addition, the instrument is shown in a circuit for measuring resistance.

The simplest methods of measuring resistance are either to pass a known current through the resistance and to measure the volts dropped across the resistance, or to apply a known voltage across the resistance and to measure the current which this potential passes through the resistance. The second method is the one shown in Fig. 1. The battery voltage is taken as being constant, and the test prods are pressed together to short circuit the instrument-battery-rheostat circuit. The rheostat (R1) is then adjusted to give full-scale deflection of the instrument pointer, the prods are separated and then connected across the unknown resistance. Current again flows, but will be lower in value so that a reading below the full-scale is shown. The resistance may then be calculated from a formula or may be calibrated direct on to the instrument scale. The range of resistances which can be measured depends on the full-scale deflection current of the instrument and the battery voltage employed, and in this respect the various milliamp ranges of the analyser operate as resistance range multipliers.

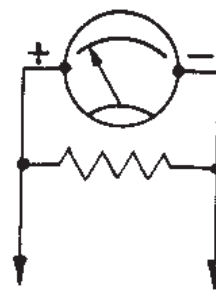

D.C. Milliammeter.

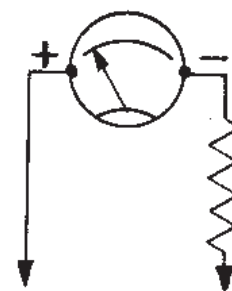

D.C. Voltmeter.

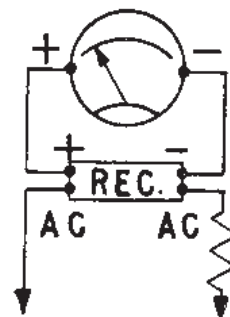

A.C. Voltmeter.

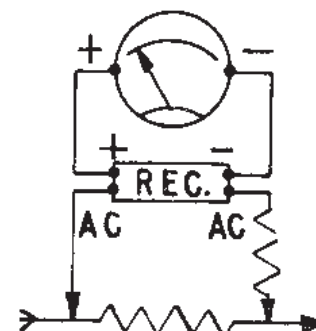

A.C. Voltmeter used to measure A.C. Amps.

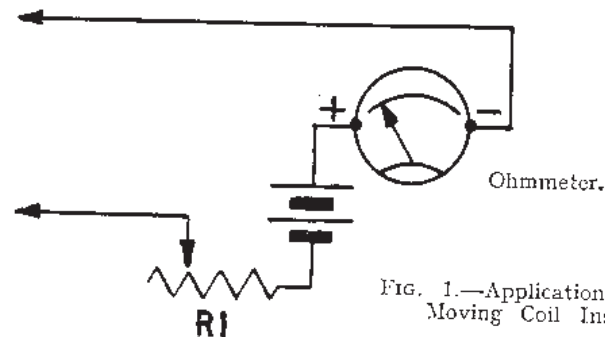

Ohmmeter.

FIG. 1.—Applications of the Moving Coil Instrument.

The formula by which the unknown resistance may be calculated if the readings are not to be calibrated on the scale is

$$X = \frac{R I_1}{I_2} - R$$

where  $R$  is the internal resistance of the ohmmeter as a whole,  $I_1$  is the full-scale current, and  $I_2$  is the new current reading. The value of  $R$  is given automatically by the battery and current range used. For example, if a 3-volt battery is in circuit and the full-scale current is 1 mA., then  $R$ , when the rheostat is set to give full-scale deflection with the test prods shorted out, must be 3,000 ohms. Similarly, if a 3-volt battery is used and the instrument is set to measure 10 mAs., then  $R$  must be 300 ohms.

Given this, the application of the formula is simple. If a 1 mA. instrument is used with a 3-volt battery, and the reading, when the instrument has been set to the full-scale mark and the prods are then applied to an unknown resistance, falls to a value of 0.2 mA., the unknown resistance is given as

$$X = \frac{3,000 \cdot 1}{0.2} - 3,000$$

and  $X = 12,000$  ohms.

If a 10 mAs. instrument is used, or the original instrument is shunted to a full-scale current of 10 mAs. and the reading falls to 2 mAs., the unknown resistance will then be

$$X = \frac{300 \cdot 10}{2} - 300$$

and  $X = 1,200$  ohms.

We see, therefore, that if the same battery is used, the milliamp shunts act perfectly as resistance range multipliers (or "dividers") and, presuming that the instrument can be read with accuracy to 0.02 mA. on the 1 mA. range, using the 3-volt battery gives the resistance measuring ranges as

- 1 mA. range — 150,000 to 0 ohms, approx.
- 10 mAs. range — 15,000 to 0 ohms, approx.
- 100 mAs. range — 1,500 to 0 ohms.

Thus, the 1 mA. shunt switch may also be marked  $R$ , the 10 mAs. shunt switch may be marked  $R \div 10$ , and the 100 mAs. shunt switch may be marked  $R \div 100$ .

Higher resistances may be measured by making provision for connecting a higher voltage battery into circuit with a suitable rheostat.

The complete analyser of Fig. 2 uses the 1 mA. instrument in all the circuits and applications of Fig. 1 by switching. The switches employed must be of good quality, especially where shunts are switched across the instrument, for here the switch resistance plays an important part since it is included in the overall low shunt resistance. A switch whose contact resistance is liable to change will therefore completely upset the current readings.

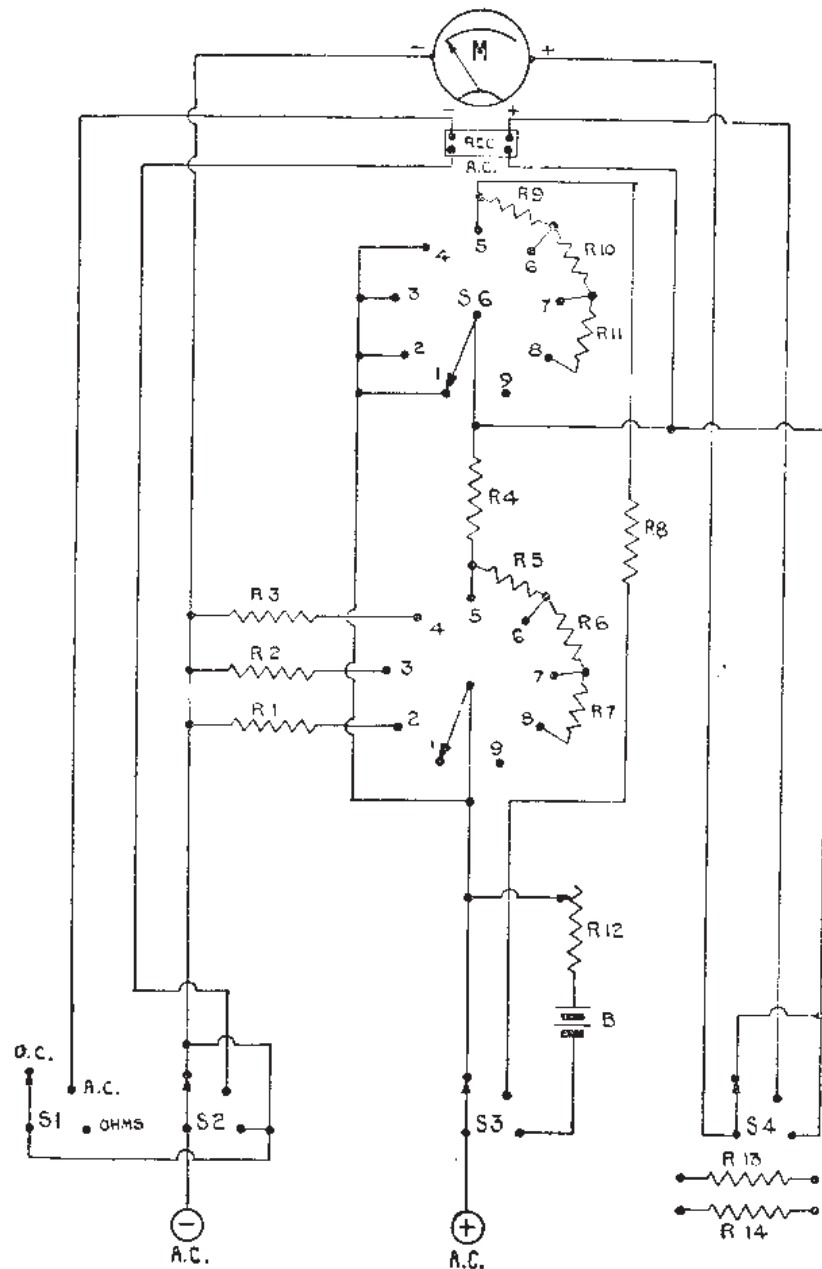

FIG. 2.—The A.C./D.C. Analyser.

A components list is shown for the analyser, and it is possible to give the multiplier resistances exactly, since these are independent of the instrument's internal resistance. The shunts, however, have a resistance which is entirely dependent on the instrument's internal resistance, but since these may be made by the trial and error system, the final resistance is of less importance than would otherwise be the case.

#### BUILDING THE ANALYSER (FIG. 2)

The analyser should be built into a stout case with the switch-gear and input terminals neatly arranged on the panel. It is advised that the instrument be mounted horizontally—a poor-grade instrument will probably work better vertically mounted since horizontal mounting increases any likelihood of "tap" error, but such a mounting makes the instrument far more easy to read. Both shunts and multipliers must be mounted on tag boards, so that the wiring is neat and no strain is imposed on the resistors and their soldered joints. The tag board used for the shunts, and the soldering tags by which the shunts are mounted, must be especially stout and robust. The shunts are made with the whole current circuit wired up, since the switch and wiring resistances affect the shunt resistances.

#### ADJUSTING THE SHUNTS

For all adjustments it is presumed that the 0-1 mA. instrument specified is being used, and that it is calibrated from 0 to 1 in ten steps, the readings being 0, 0.1, 0.2, etc., to give 10 cardinal points on the scale.

With the instrument switched to read 1 mA., connect the analyser in series with an external battery and rheostat to give a full-scale current of 1 mA. The higher the battery voltage and rheostat resistance the better, and a 12-volt accumulator battery would be excellent, the rheostat resistance then being 12,000 ohms. A wirewound rheostat of 20,000 ohms maximum resistance could be used.

Set the rheostat to give a full-scale current of 1 mA.

The shunts should have been prepared by soldering a piece of resistance wire to each tag on the shunt board, as shown in Fig. 3, these wires being twisted together in pairs to complete each shunt circuit. The approximate resistances required will be of the order of 10, 1 and 0.1 ohms for the respective current ranges of 10, 100 and 1,000 mAs. Using Manganin resistance wire, which may be obtained from any good stockist, the 10 mAs. shunt should consist of a little over 2 yards of 30 S.W.G. Manganin, the 100 mAs. shunt of 8" of 30 S.W.G. Manganin, and the 1,000 mAs. shunt of 2" of 25 S.W.G. Manganin.

(Note that the approximate shunt resistances as given are for instruments with an internal resistance of 100 ohms. Instruments with lower internal resistances will require proportionately lower shunt resistances with proportionate reductions in the lengths of resistance wire.)

Cut each shunt wire in half, baring the ends of each length of wire, and thus forming the shunts with a variable adjustment at their centres as shown in Fig. 3. The longest shunt will, of course, be wound round the shunt board. The shorter shunts will not require this treatment.

With the instrument set at 1 mA. full-scale deflection, and with the central ends of the 10 mAs. shunt twisted together, switch the range switch to the 10 mAs. reading. The current flowing will still be 1 mA., but since the instrument is now shunted the reading will fall. By baring the cut ends of the 10 mAs. shunt and twisting them together until the instrument reads to one-tenth of full-scale—i.e. until the pointer rests at the 0.1 cardinal—the shunt is adjusted. This range now reads up to 10 mAs., and the external battery and rheostat must be adjusted to pass the full 10 mAs. exactly. With this current indicated, turn the range switch to 100 mAs., and again adjust the next shunt for a reading of one-tenth full-scale, twisting the two halves of the shunt together, the wire being cleaned as necessary, until the correct reading is obtained. Finally, set the external battery and rheostat to give a full-scale current of 100 mAs. on that range and then switch to the 1,000 mAs. range and adjust that shunt until once more a one-tenth scale reading is obtained. With this method of calibration there is a possibility of a cumulative error, and where possible the higher current ranges should be checked against a reliable instrument.

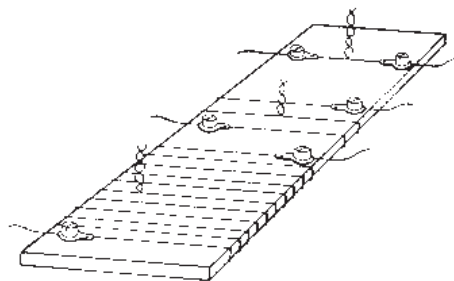

FIG. 3.—The Shunt Board.

Secure each shunt, where the wires are twisted together, with a touch of solder, making sure that the tinning does not run beyond the twisted portion of the wires, and cut off surplus wiring. The adjustment of the shunts will take some little time, but is worth careful and painstaking work.

The instrument is now adjusted for D.C. current.

The D.C. and A.C. volts ranges are set, and need no adjustment, but the 10 volts A.C. range requires calibration. This may be carried out using the circuit of Fig. 4, two 6-volt windings on a mains transformer being connected in series to give a 12 volts A.C. source.

The analyser is compared against a standard 10 volts A.C. voltmeter (which perhaps could be borrowed for the purpose), the two instruments being set to the full scale reading and then, by adjustment of the 10,000 ohms potentiometer, brought step by step down the scale from 10 to 0 volts.

At 9, 8, 7, 6 volts, etc., the analyser may be calibrated in pencil directly on the scale, its cover being removed for this operation, or a careful reading made of the pointer position on the scale for each voltage.



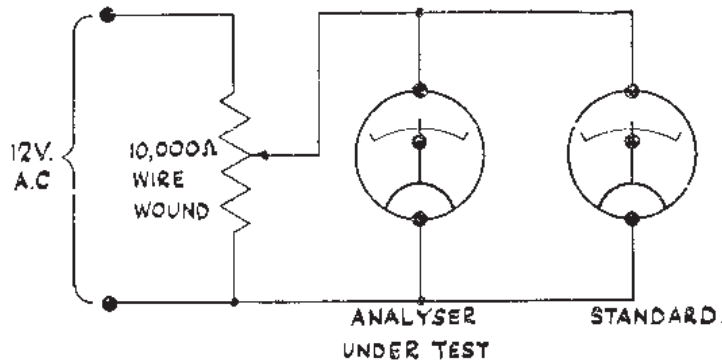

FIG. 4.—Calibration of 10 volt A.C. Range against Standard or Comparative Analyser.

With the calibration completed the new points for the 10 volts A.C. range may be printed on the scale as described below.

On voltages of 100, and above, the existing scale markings—that is, the D.C. scale—can be used for reading off A.C. voltages. The new calibrations refer only to the 10 volts A.C. range.

To add calibrations to the instrument scale, the instrument must be removed from the box or cabinet in which it is mounted and the cover taken off by unscrewing the small retaining screws. The scale is then unscrewed, using especial care if the pointer stops are held by the scale screws, and the scale gently slipped off in a direction away from the pointer. Do not touch the hair-springs, balance weights or pointer at any time. With the scale removed, immediately slip the cover back on the instrument to exclude dust. Use care, and ensure that the zero setting slip does not catch in the pointer or any other part of the movement.

Securely pin down the scale on to a sheet of thick card. One method of adding a low A.C. volts range is shown in Fig. 5, this method being suitable when the range has been re-calibrated on to the scale in pencil. If scale readings are noted, then the low A.C. volts cardinals must be produced from the original scale as shown in Fig. 6. The ohms readings can also be printed on to the scale above the original arc.

When fresh arcs are to be printed on to the scale, the centre of the original arc must first be found so that the arcs are concentric. The new scale lines and figures may be drawn in Indian ink, but greater distinctiveness is obtained if a good red ink is used. A mistake can usually be erased by careful scraping with a sharp razor blade, but since this removes the white scale background material only one erasure at any spot can be made. There is always the chance of scraping away the white backing and exposing the scale metal. If the scale is found to be made of paper mounted on to metal, corrections must be made with white body ink.

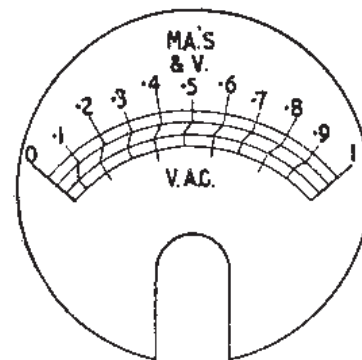

FIG. 5.—Adding an A.C. Scale for low A.C. volts.

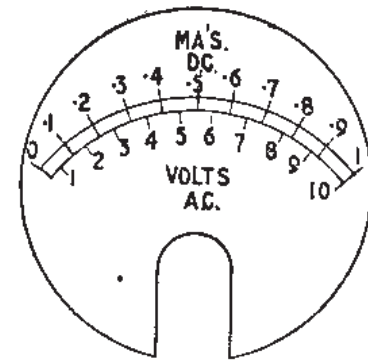

FIG. 6.—Producing the A.C. scale from the Arc.

The scale must be re-assembled on to the instrument with even greater care than that with which it was removed, and the pointer must not be touched or snagged. When replacing the scale screws adjust the pointer stops, if these are retained by the scale screws, to give the pointer full play over the scale.

The high current resistances across which the A.C. voltmeter is tapped to measure alternating current must each be mounted across its own pair of heavy duty terminals, and the resistances are best bought ready-made. Non-inductive resistances must, of course, be used. Connecting the A.C. 10 volts range across the 1 ohm resistance will give readings up to 10 amps, reading the volts scale as amperes (if the resistance is rated to take that current), whilst connecting the same A.C. volts scale across the 10 ohms resistance will give readings up to a maximum of 1 amp. In each case the maximum watts lost will be rather high, and unless it is required to measure heavy currents the constructor is advised to use only the 10 ohms resistance, since this will enable 0.2 and 0.3 amp voltage droppers to be adjusted, etc.

*Components List for the A.C.-D.C. Analyser, Fig. 2.*

M,	0-1mA. Moving Coil Instrument.
Rec,	1 mA. Instrument Rectifier (Westinghouse).
R1, R2, R3,	Shunt resistances made as described.
R4,	10,000 ohms, 1% accuracy.
R5,	90,000 " " "
R6,	400,000 " " "
R7,	500,000 " " "
R8,	8,250 " " "
R9,	82,000 " " "
R10,	360,000 " " "
R11,	450,000 " " "
R12,	5,000 ohms, wirewound, variable.
R13,	1 ohm Noninductive, to carry 10 amps.
R14,	10 ohms Noninductive, to carry 1 amp.

All resistors except R12-R14, 1 watt type.  
 B, 3-volt battery.  
 S1, 2, 3, 4, 4-pole 3-way rotary switch.  
 S5, 6, 2-pole 9-way rotary switch.  
 3 Control knobs.  
 2 Tagboards, for shunts and multipliers.  
 2 Input terminals, plus and minus.  
 4 Heavy duty terminals for R13 and R14.  
 Test leads, prods, cabinet, etc.

#### TEST RANGES

##### Milliamps D.C.—

Switch S1-4 to D.C.

0-1 mA.	with S5, 6,	in position 1.
0-10 mAs.	with S5, 6,	in position 2.
0-100 mAs.	with S5, 6,	in position 3.
0-1,000 mAs.	with S5, 6,	in position 4.

##### Volts D.C.—

Switch S1-4 to D.C.

0-10 v.	with S5, 6,	in position 5.
0-100 v.	with S5, 6,	in position 6.
0-500 v.	with S5, 6,	in position 7.
0-1,000 v.	with S5, 6,	in position 8.

##### Volts A.C.—

Switch S1-4 to A.C.

0-10 v.	with S5, 6,	in position 5,	read on separate scale.
0-100 v.	with S5, 6,	in position 6.	
0-500 v.	with S5, 6,	in position 7.	
0-1,000 v.	with S5, 6,	in position 8.	

##### Amps, A.C.—

Pass current through appropriate resistance R13 or R14. Switch analyser to 10 volts A.C. Allow resistance of external circuit to reach operating temperature (if valve heaters, dropping resistors, etc.) then apply test prods across the terminals of R10 or R11. Read amps. as volts A.C. directly for R10, or divided by 10 for R11.

Position 9 of S5, 6, is the OFF position.

##### Ohms—

Switch S1-4 to Ohms, and use the first 3 positions of S5, 6, to give R, R+10 and R+100.

The positions of S5, 6, may therefore be coded as

Position 1,	0-1 mA.,	D.C. & R.
Position 2,	0-10 mAs.,	D.C. & R+10.
Position 3,	0-100 mAs.,	D.C. & R+100.
Position 4,	0-1,000 mAs.,	D.C.
Position 5,	0-10 volts,	D.C. & A.C.
Position 6,	0-100 volts,	D.C. & A.C.

Position 7,	0-500 volts,	D.C. & A.C.
Position 8,	0-1,000 volts,	D.C. & A.C.
Position 9,	OFF.	

Always switch the analyser to OFF when a measurement has been made. Set to range required before connecting into circuit. Never switch from range to range with current flowing.

## CHAPTER 3

### HIGH FREQUENCY MEASUREMENTS

Whilst the analyser as described will measure current and voltage on both A.C. and D.C. circuits, it cannot be used to measure comparable currents and voltages at audio and radio frequencies. An instrument rectifier will give quite good indications on its associated instrument on audio signals, so that the analyser may be used as an output meter where comparison between readings is all that is required, but as the frequency increases the efficiency and stability of calibration of the rectifier-moving coil instrument falls, so that for all intents and purposes it is useless at frequencies much above 50 cycles.

The valve voltmeter overcomes the difficulty of measuring high frequency voltages, and can also be used for D.C. measurements. The advantage of the latter application may not be obvious until it is recalled that any voltmeter applied across a circuit causes an error in the voltage indicated by the pointer, simply because the voltmeter itself draws a current thus causing the voltage registered to appear lower than it actually is. The valve voltmeter overcomes this defect to a considerable degree by reason of the fact that it can be made to have a very high input resistance. The analyser described in the last chapter is designed to have a resistance of 1,000 ohms per volt, so that the voltmeter resistance to a 1,000 volt circuit is 1 megohm. A valve voltmeter, even of the simplest type, can present a constant input resistance of 10 megohms, and by using special design techniques the input resistance can be advanced towards infinity.

The salient features of a good valve voltmeter, then, are that it may be designed to measure either D.C. or A.C., including R.F., or both, that the input resistance is very high, the instrument thus imposing a light load on the measured circuit, and calibration accuracy can be held practically constant over a wide frequency range. Against these advantages are various disadvantages such as the need for heater and H.T. supplies for the valve, the fact that the calibration curve is usually not linear, so that the instrument must be calibrated, and, in some cases, the fact that the indicating instrument is affected by the emission current from the valve or one of the valves used, so that a zero error must be allowed for.

The principle of a valve voltmeter is for all practical purposes the principle of the valve itself. A change of grid potential causes a change of anode current which may be used to give an indication on a moving coil instrument. If A.C. and R.F. is to be measured, the valve is allowed to work as a rectifier or a further valve may be used as a combined probe and rectifier.

## A "POCKET" VALVE VOLTMETER

A really small valve voltmeter for A.C. and R.F. test work may be made from a diode, using only a filament battery. Practically any diode may be used, but a 1.4-volt valve is advisable since then the filament battery consists only of a single cell. If a suitable valve is to hand, such a valve voltmeter can be constructed even more cheaply than a rectifier-moving coil instrument A.C. voltmeter, with the added advantage that the calibration holds over A.C., audio and R.F.

No range resistances are used since the instrument is intended only for operation over the low voltage range of about 0.7 volts, taking in heater A.C. voltages, R.F. heterodyne voltages, etc., and the circuit will also serve to show resonance in tuned inductances and similar applications. The benefits of a more elaborate valve voltmeter are, to a large extent, lost, especially the high input resistance, but this midget instrument is still capable of good work.

It is advised that the valve voltmeter be individually calibrated, even if the same valve type is used as is shown in Fig. 7. The calibration may be made on the scale of the instrument or may again take the form of a conversion card or graph, the volts applied on the input side being plotted against the indicated current.

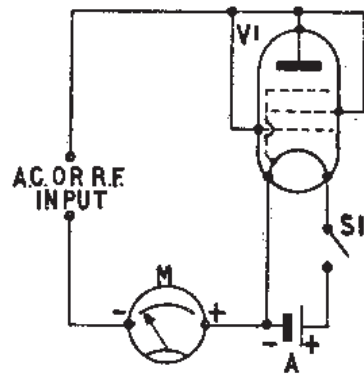

FIG. 7.—The "Pocket" Valve Voltmeter.

The conversion card of the original instrument is shown in Fig. 8, but since the "Pocket" valve voltmeter is used, more often than not, as an R.F. indicator, the instrument scale has not been calibrated in terms of volts.

Again, a 1T4 valve was used in the original, with screen and grid strapped to the anode. It will be seen that a 2 mAs. full-scale moving coil instrument is used as the indicator. A 1 mA. instrument gave full-scale readings at too low an input voltage, although the more sensitive instrument could be used with another valve—the HY113, for example. If it is desired to use a 1 mA. instrument in such a circuit, however, it is a simple matter to shunt the movement to read 0.2 mAs. full-scale.

By connecting the instrument to the negative side of the filament cell no indication is obtained until a potential is applied to the input terminals.

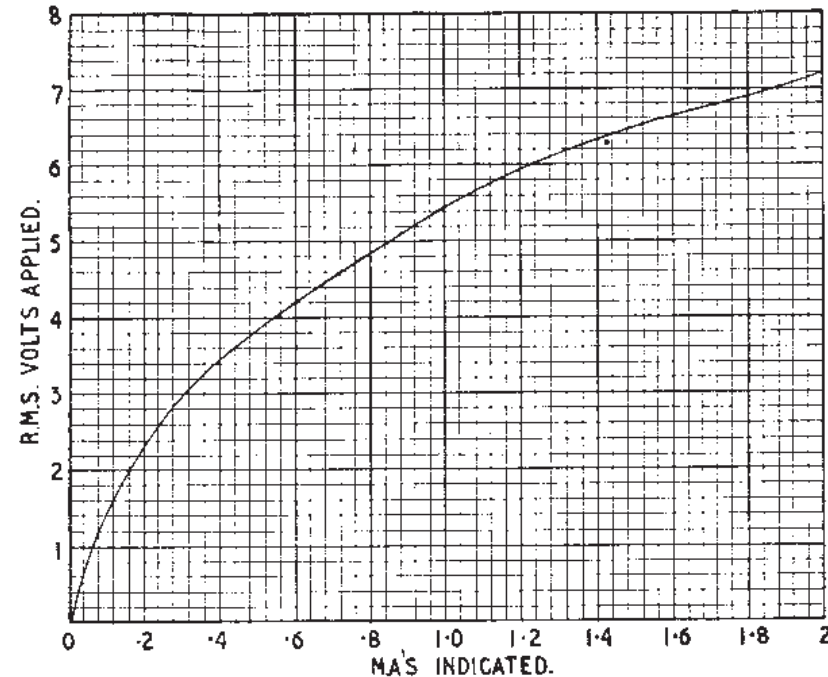

FIG. 8.—Calibration Card for V.V. of Fig. 10.

Connecting the instrument to the positive side of the filament cell enhances the sensitivity of the valve voltmeter but gives a zero current, unless the valve voltmeter is connected into a very high resistance.

### Components List for the "Pocket" Valve Voltmeter Fig. 7.

M,	0.2 mAs. Moving coil instrument.
V1,	1T4 with B7C holder.
S1,	S.P.S.T. On-Off switch.
A,	1.5-volt cell.
	Terminals or prods, small cabinet, etc.

The "Pocket" valve voltmeter can be built into practically any small case or tin for easy portability.

The advanced worker will, however, require a more comprehensive valve voltmeter than those so far shown, and the circuit of Fig. 9 is of a mains-operated instrument complete with a valve probe for measuring D.C., A.C. and R.F.

Basically, a probe-valve voltmeter is a D.C. measuring instrument, the probe being plugged into circuit when it is desired to measure A.C. and R.F. The probe head contains a diode or double diode valve, the chief function of which is to rectify the R.F. applied to the valve voltmeter, thus passing a D.C. potential for measurement to the main circuit of the valve voltmeter.

Using a straight diode in the probe head gives a zero error, however, since the valve emission causes the valve voltmeter indicator to register when no A.C. or R.F. is applied to the probe. This emission current can be neutralised by a battery, but a more useful method is to employ a double diode in the probe head connected in a self-biasing or "bucking" circuit, and such a probe is included in the circuit of Fig. 9.

The first section of the diode rectifies the applied signal, whilst the second diode causes an emission current to flow through the variable resistance R1, thus setting up a potential across this resistance. The potential is applied to the first diode section in opposition to the emission current potential generated by that section, thus neutralising out the zero error and enabling the signal potential to be applied to the valve voltmeter proper with no diode potential.

The probe head can be made very small if an American 6H6 metal valve is used, since the valve and control resistance can then be mounted into a small square box. If a British valve, such as the DD41, is used, the probe head will necessarily be larger, but by using a cylindrical can rather than a box the probe can still be made convenient to handle and use.

Whatever type of valve and probe head is used, the assembly must be connected to the valve voltmeter through a shielded cable with three cores, the cable shield acting as the common lead for connection to the signal potential with the three cores carrying the diode heater current and the return or positive line of the rectified signal potential.

Diode probes give peak value readings on A.C. or R.F., although these values may, of course, be calibrated as R.M.S. values. If the valve voltmeter is calibrated against a rectifier-moving coil instrument A.C. voltmeter and an A.C. supply of good wave-form is used, then R.M.S. calibrations will be automatically obtained, whilst if the valve voltmeter is calibrated against a commercial or standard valve voltmeter giving peak readings the calibrations will automatically be peak value calibrations.

Generally speaking, peak value calibrations are rather more desirable, but in any case there will be some error caused by departure from a true sine wave-form if it is desired to change the peak readings to R.M.S. or vice versa.

In any case, more than one calibration is necessary since whilst for the higher ranges the peak values of the applied A.C. or R.F. can be read off from calibrations made on D.C., below 10 volts R.M.S. the indications no longer hold true, and the instrument should have calibration scales or charts for 0-10 volts A.C.

The D.C. voltmeter section of Fig. 9 is a bridge circuit, two valves being used with a sensitive moving coil instrument connected between the cathode loads. These loads are sufficiently high to give negative feedback to their respective valves, so that a substantially linear calibration is obtained enabling the scale fitted to the instrument to be used without the need for a re-calibration or calibration card on the D.C. ranges. The calibration is originally set by the control provided and periodically checked.

It has not been found possible to check the operation of this circuit when using 4-volt valves, and accordingly the component values are shown as for the 6-volt 6J5 type valves used in the bridge circuit. There would appear

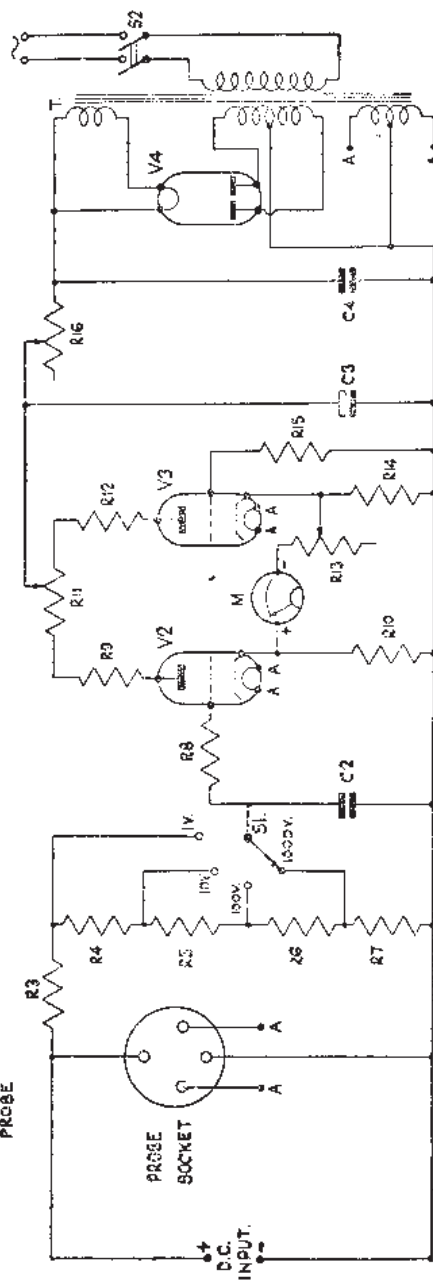
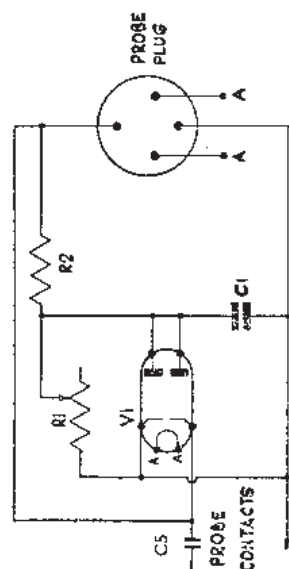

FIG. 9.—D.C.—A.C.—R.F. Valve Voltmeter, with Probe.

to be no reason why 4-volt type valves should not give equally satisfactory results, however, and valves of the 354V or similar types might be tried.

If voltage stabilising tubes become available, it will be found advantageous to stabilise the H.T. line to a set 150 volts into the anode circuit of the two valves to eliminate drift errors caused by changes or fluctuations of the mains supply. The bridge circuit, however, has a stabilising effect, and the circuit will operate quite satisfactorily without the stabilising tube. The H.T. line may be set at 150 volts by adjusting R16 and measuring the H.T. voltage with an analyser or high resistance voltmeter.

Whether a 4-volt or 6-volt valve is used in the probe head, it should not be used at voltages higher than 150 R.M.S. to avoid chances of overload, although manufacturers' ratings are generally conservative and quick measurements might be taken up to a limit of 300 volts R.M.S.

Besides the shielding of the probe head itself (the shield case should be built of copper or aluminium, not iron or magnetic material), shielding should also be used on the input grid circuit of the D.C. valve voltmeter proper to avoid chance of stray pick-up, and the whole instrument should be built into an aluminium case.

The grids and probe condensers, C1 and C2, should be of the mica separation type, and may be built up from smaller values if the specified values are difficult to obtain. The high resistances in this valve voltmeter, as in the other circuits, must be built up from standard value resistances, and once again the range resistances must bear the correct relationship one to another if the ranges are to be accurate.

*Components List for the D.C.-A.C.-R.F. Valve Voltmeter, Fig. 9.*

R1,	10,000 ohms	Midget potentiometer.
R2,	20 megohms,	$\frac{1}{4}$ watt.
R3,	5 "	$\frac{1}{2}$ "
R4,	4.5 "	$\frac{1}{2}$ "
R5,	450,000 ohms,	$\frac{1}{2}$ "
R6,	45,000 "	$\frac{1}{2}$ "
R7,	5,000 "	$\frac{1}{2}$ "
R8, R15,	470,000 "	$\frac{1}{2}$ "
R9, R10, R12, R14,	10,000 "	1 "
R11, R13,	15,000 ohms,	wirewound potentiometers.
R16,	20,000 ohms,	wirewound potentiometer.
C1, C2, C5	0.02 mfd.	Mica.
C3,	8 mfd.	350 v.w. Electrolytic.
C4,	2 mfd.	500 v.w.
V1,	6H6.	
V2, V3,	6J5.	
V4,	5Y3G.	
4	International octal chassis	mounting valveholders.
S1,		Single-pole 4-way range switch.
S2,		D.P.S.T. On-Off switch.

T,	200-250 volt primary.
	250-0-250 volt. 60 mAs.
	5v. 2a. 6v. 1a.
M,	0-100 microamps moving coil instrument.

Control knobs, chassis with screening cover, etc.

To test and set the instrument, use on D.C. with the probe unplugged. It is wise to shunt the movement with a very low resistance until it is known that all wiring and connections and valves are in order. Switch on, allow to reach operating temperature, and adjust the instrument to zero by adjusting R11, removing the shunt when the instrument is roughly set, and finally adjusting with full sensitivity. Adjust the H.T. line to 150 volts.

Switch the range switch to 10 volts and apply a known D.C. input to the test terminals. Adjust R13 until the reading on the instrument M corresponds to the input potential—on a 0-100 scale micro-ammeter 3 volts on the 10 volt range will read as 30, 2.5 volts as 25, etc.

Test for linearity.

To test the A.C. and R.F. ranges, plug in the probe head and switch to the 1 volt or 10 volts range. As the probe valve heats up the pointer of the indicator will shift from zero. Return the pointer to zero by adjusting R1 in the probe head.

Apply the probe to a suitable voltage, and calibrate or prepare calibration cards for the low voltage ranges against an A.C. voltmeter or standard valve voltmeter.

## CHAPTER 4

### THE SIGNAL GENERATOR

Apart from the A.C.-D.C. analyser the signal generator is probably the most used instrument on the service engineer's bench. A commercial model is expensive, however, and not only the amateur but also the professional service man often prefers to construct his own generator to suit the conditions under which he works and the type of receiver used in his locality.

Whatever the type of signal generator to be built, the mechanical side of the construction must always be treated as being of the same importance as the electrical circuit and layout. Every component must be anchored rigidly, and every wire soldered firmly into place, heavy gauge wiring being used so that no knock or vibration will loosen a wire or, nearly as bad, cause it to bend out of shape with possible upsetting of the calibration. The generator must always be heavily shielded—in the home-built generator this point is often overlooked—and if the instrument is to be mains-operated good ventilation should be provided in order that frequency drift with heat is minimised as far as possible.

In the writer's opinion, the first step towards the construction of a generator is the purchasing or building of a suitable case. Aluminium or, better still, copper, should be used, and if the case is made up from stock with jointed corners particular attention must be paid to the bonding of the sides in electrical contact. The use of angle brass strip as side and corner braces with the sides, ends and bottoms of the case drilled and tapped to

the strip gives strength and good electrical contact. The lid may be a push fit or hinged and fitted with a catch, but once again it must be in perfect contact with the rest of the case when it is closed down.

The generation and modulation of an R.F. signal is a relatively simple matter, and there are many circuits from which a choice can be made. Standard coils and tuning condensers may be used—indeed, the use of commercial components is strongly recommended—and the difficulties attached to generator construction really begin with the attenuator and output circuit and reach their peak with the calibration of the finished instrument.

The attenuator is provided to give a range of output signal strengths, and it may be said straight away that this feature of the generator may be omitted as useless, whether it is of a simple or elaborate type, unless the generator screening is perfect. Even the ventilation holes of a mains-driven generator must be screened, although this is a simple matter since it is only necessary to sweat or bolt over the inside of the ventilation hole a piece of fine copper gauze which will give a perfect airflow and yet screen the generator.

The attenuator may be calibrated to give definite steps of R.F. voltage, in which case the attenuator will be of the elaborate constant impedance type arranged in several steps, or a simple "volume control" type of attenuation may be employed. It may be said immediately that a calibrated attenuator is difficult to set for constant output over the whole range, and in a home-constructed generator the calibrated attenuator should have its own built-in valve voltmeter. The simple attenuator is usually all that is required for field work, and a portable generator using peanut valves and small batteries is of great value to most service men.

A good deal has been written on the calibration of signal generators by using the carriers of a number of radio stations, but besides being a wearisome and painstaking business the method finally presents the builder with a series of points separated by widely varying frequencies, so that the best that can be done is to prepare a drawn calibration curve to use against the dial graduations of the generator. A signal generator definitely needs a calibrated dial showing, in as many arcs as there are tuning ranges, the frequencies directly tuned, and it is now possible to obtain dials with slow motion drives which give provision for such calibration along plain arcs printed on a dial card. These drives and dials are reasonably priced and are regularly advertised in the radio periodicals.

The generator fitted with such a dial should be calibrated against a commercial or standard signal generator whose own accuracy has been checked against radio stations—a better use for the broadcast carriers than attempting to calibrate the generator against them—and it is often possible to borrow or hire a good generator to act as a standard for the purpose. If this is impossible, however, a frequency standard can be built using a crystal and multivibrator circuit, such a standard always being of use in the workshop, and a circuit of proven merit is shown in this chapter. Suitable crystals are easily obtainable at the time of writing as surplus stock, and are priced quite cheaply. Whilst the frequency standard gives a range of

set points over the scale, unlike the standard signal generator which can be tuned in step with the generator to be calibrated, these points are regularly spaced at intervals of 100 kcs. so that sub-divisions are readily made between the main calibrated points on the dial, whilst further key points may be obtained, if desired, from broadcast carriers.

The first generator shown, that of Fig. 10, is designed for portability in order that it may be packed easily into the service bag. Peanut valves of the 1T4 type are used, since these give a very good output with an H.T. voltage of only 36 volts, and the current drain is so low that a layer-built type of battery can be used. In the original generator, however, four grid bias batteries in series gave the H.T. current. The attenuator is of the simplest type and cannot be calibrated, and output over various ranges is not constant. This is of little moment, however, when it is necessary only to re-align I.F. transformers or R.F. trimmers in simple outside repairs.

It is quite possible to use cheaper valves of the 2-volt filament variety in place of the midget pentodes although the carrying case will then have to be increased in size. Suitable valves would be triodes of the 30 or 11R210 or similar types, although in this case it would be advisable to use a 3-volt filament battery with a fixed or variable dropping resistance to bring the filament voltage up to the required 2 volts. For normal valves of the 2 volt 0.1 amp. type the dropping resistance would be 5 ohms with a minimum rating of  $\frac{1}{2}$  watt.

It might also be found necessary to increase the H.T. voltage, using battery triodes.

Commercial coils of the Wearite P range are specified, and tuned by a small 0.0005 mfd. tuning condenser.

It is found that the 1T4 pentodes will not oscillate at frequencies above about 20 mcs. unless the H.T. voltage is increased. It is not often that higher frequencies are required from this type of instrument, however, and in any case the second harmonics are strong and have been used up to 30 mcs. with good results.

In the usual way the audio note for audio modulation is obtained from a transformer-oscillator stage. Standard values for modulation are 400 cycles modulating the carrier to a depth of 30%, but in the majority of home-built generators not too much attention is paid to standard requirements in this respect, and it is usually sufficient to tune the transformer acting as the oscillating inductances to a suitable note by a small condenser across either the secondary or primary winding. In the generator of Fig. 10 no tuning was needed, and since the amplitude of the audio oscillation is low no grid blocking occurs so that no grid condenser and leak are necessary.

The audio modulation is introduced into the grid of the R.F. oscillator and can also be tapped off as straight audio via a switch for testing gram. input terminals and speaker transformers, etc.

A screened lead should be used to couple the generator into the receiver under test, the screen acting as the earth return. Since the generator is battery-operated no precautions other than those against shock need be taken whether working on A.C., D.C. or Universal receivers.

Components List for the Battery Signal Generator, Fig. 10.

N.B.—Tuned and reaction windings, tuned windings in the grid circuit, are denoted by a,a, b,b, etc.

a,a,	Wearite PHF3,	16-47	metres.
b,b,	Wearite PHF5,	35-100	"
c,c,	Wearite PHF6,	95-255	"
d,d,	Wearite PHF7,	250-750	"
e,e,	Wearite PHF1,	700-2,000	"
C1, C3, C5, C7,	0.1 mfd, 100 v.w. Non-inductive.		
C2, C4, C6,	0.0003 mfd, Mica.		
C8,	0.0005 mfd, Variable tuner.		
R1,	0.01 megohms, Volume control.		
R2,	47,000 ohms, ½ watt.		
R3, R4, R5,	33,000 ohms, ½ watt.		
Rs,	(See text note below.)		
R.F.C.1,	Screened all-wave choke.		
R.F.C.2,	R.F. choke. 40 turns of 30 S.W.G. enam. on ½" diam. former to 1" length.		
T,	3 : 1 Inter-valve transformer.		
S1, S2,	Ganged 2-pole 5-way range selector.		
S3,	D.P.S.T. On-Off switch, ganged on R1.		
S4,	S.P.D.T. R.F.-Audio switch.		
V1, V2,	1T4 valves, with holders.		
Chassis and case,	slow-motion drive, control knobs, etc.		
A,	1.5 volt dry cell.		
B,	36 volt H.T. battery.		

Note.—Rs shunts the reaction winding of the PHF7 coil since on this range a rather high amplitude of oscillation is obtained, leading to a chance of squegging. Rs in the original instrument was a 10,000 ohms resistance. For different valves or layouts the value might require modification, or the resistance could be included in series with the winding instead of in shunt, when the resistance value would need to be found experimentally, the starting value being about 500 ohms.

A mains-operated signal generator is shown in Fig. 11, a triode-heptode frequency changer valve being used as the combined R.F.-Audio oscillator. A modulated or unmodulated signal is available on the R.F. side, whilst straight audio can also be obtained for amplifier testing. Commercial coils are again used, one advantage being that the frequency bands are covered in a number of steps so that the high frequency ranges are not crowded as is so often the case where home-made coils are used.

Once again the highest fundamental frequency is about 20 mcs., but much higher frequencies are covered by the second, third and, if desired, the fourth harmonics of the highest frequency coil, with but little diminution in strength of the second harmonic as compared with the fundamental frequency output. A more elaborate attenuator is included in the circuit, with coarse attenuation selected by a switch and fine graduations of output obtainable through the use of a potentiometer. A low impedance load appears at both the input and output sides of the attenuator.

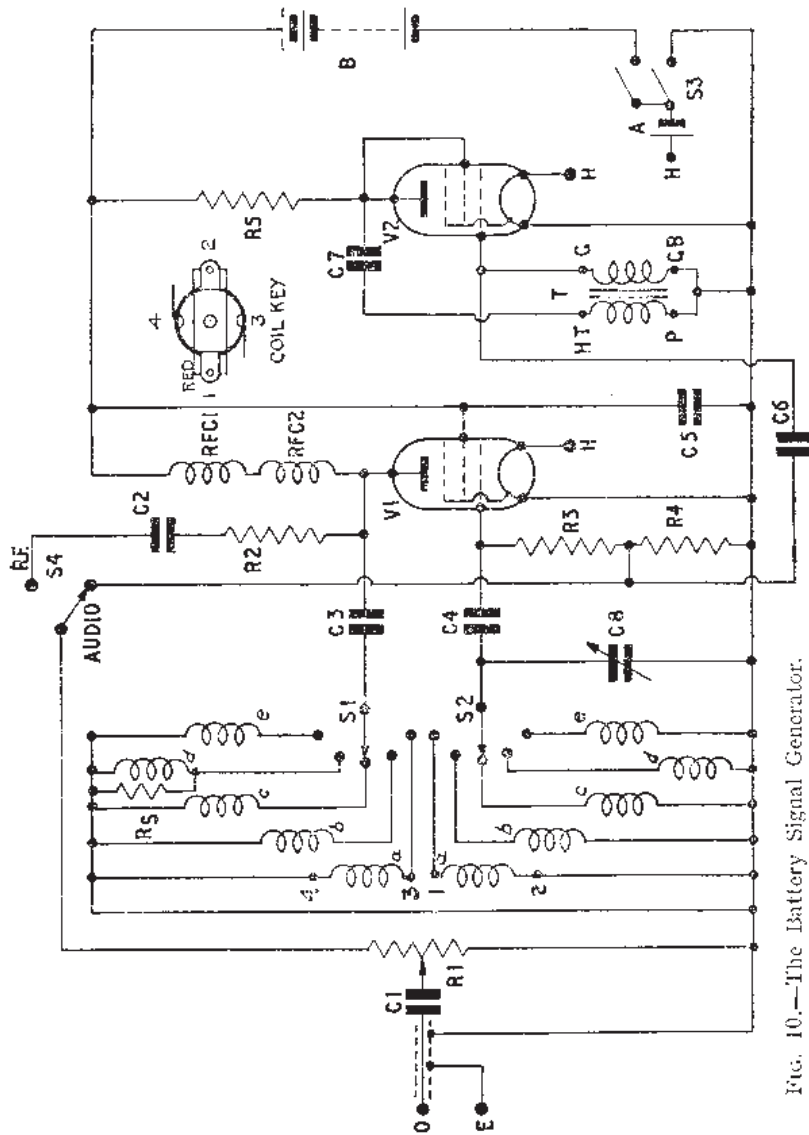

Fig. 10.—The Battery Signal Generator.

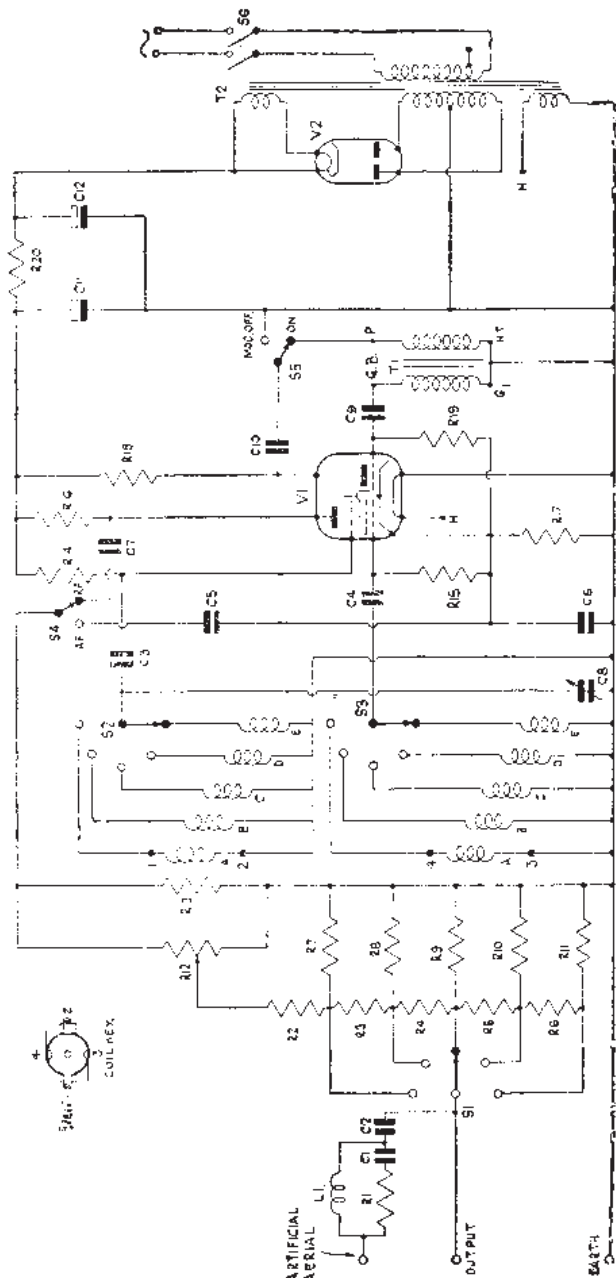

FIG. 11.—The Mains-Operated Signal Generator.

The output may be taken directly from the attenuator or through an artificial aerial. The attenuator and artificial aerial should have extra shielding within the shielded box or cabinet containing the signal generator, whilst all earthed points and by-pass connections should be taken to one central earthing junction so that no R.F. currents flow through the screening.

The audio oscillator whose coils are again the windings of an inter-valve transformer may be tuned by connecting small capacitances experimentally across either the primary or secondary winding until a suitable note is obtained. A switch is provided through which the audio output can be fed to the attenuator, as well as an audio On-Off switch.

The audio oscillator is connected to the triode section of the valve with the R.F. oscillator connected across the grid and screen of the heptode. This is not a usual arrangement, but has the advantage that the heptode anode is left free of oscillating circuits, thus being readily available as the output electrode, whilst rather greater output is supplied by using the heptode as the R.F. oscillator. Grid reaction with a tuned anode winding is used, so that in the event of squegging on any range a fixed resistance can be inserted in series with the grid coil and grid condenser to reduce the amplitude of oscillation, the resistance being found experimentally, using values between 50 and 500 ohms. Such resistances were not found necessary on the original model, but different coils or components from those specified may make them essential. Squegging in a signal generator is immediately obvious—instead of a clear-cut signal with a pure audio note, a band of frequencies is transmitted, the modulation being in the form of a harsh hissing with the audio note central in the band. Such an output can be obtained by increasing the R.F. grid capacitance from 50 mmfds. to 500 mmfds.

*Components List for the Mains-Operated Signal Generator, Fig. 11.*

N.B.—Tuned and reaction windings denoted by a, a, b, b, etc.

a, a,	Wearite PHF3, 16-47	metres.
b, b,	Wearite PHF5, 35-100	"
c, c,	Wearite PHF6, 95-260	"
d, d,	Wearite PHF7, 250-750	"
e, e,	Wearite PHF1, 700-2,000	"
L1,	60 turns 28 S.W.G. on $\frac{1}{2}$ " Rod.	
C1,	0.0004 mfd. Mica.	
C2,	0.0002 mfd. Mica.	
C3, C6,	0.01 mfd. 350 v.w. Non-inductive.	
C4,	50 mmfds. Silver Mica.	
C5, C10,	0.1 mfd. 350 v.w. Non-inductive.	
C7, C9,	0.001 mfd. Mica.	
C8,	0.0005 mfd. Variable tuner.	
C11, C12,	8 mfd. 500 v.w. Electrolytic.	
R1,	390 ohms, $\frac{1}{2}$ watt.	
R2, R3, R4, R5,	200 "	$\frac{1}{2}$ "
R6, R7, R8, R9,	2,000 "	Variable, fine attenuator
R10, R11,	100 "	$\frac{1}{2}$ watt.
R12,		
R13,		



R14,	33,000 ohms,	1 watt.
R15, R16, R19,	47,000 "	1 "
R17,	330 "	½ "
R18,	68,000 "	1 "
R20,	5,000 "	2 "
S1,	S.P. 5-way coarse attenuator selector.	
S2, S3,	D.P. 5-way range selector.	
S4,	S.P.D.T. A.F.-R.F. selector.	
S5,	S.P.D.T. Modulation On-Off.	
S6,	D.P.S.T. Mains On-Off.	
T1,	3 : 1 Inter-valve transformer.	
T2,	200-250 volt primary.	
	250-0-250 volt 60 mAs.	
	4v. 2a. 4v. 2a.	

V1, ACTH1.  
V2, EU6.

1 British 7-pin chassis mounting valveholder.

1 Mazda octal chassis mounting valveholder.

Chassis, aluminium, with screening box or cabinet.

Slow-motion drive, control knobs, etc., output sockets, screened cable, plugs, etc.

The crystal-controlled frequency standard against which generators and other tuned apparatus including receivers may be calibrated is shown in Fig. 12. A triode-heptode has the heptode section connected as a crystal oscillator, thus automatically injecting a controlled signal to the triode circuit which, together with an external triode, is a multivibrator adjusted to work at a frequency of 100 kcs. A multivibrator, as is well known, can be controlled easily by an external frequency within the tenth harmonic of the fundamental, and the circuit gives an extremely high number of harmonics.

By omitting a smoothing condenser in the calibrator's power pack the output is slightly hum-modulated in order that the carrier may be easily identified.

A simple attenuator is fitted, with a fairly high output impedance, but a more comprehensive switched attenuator can be fitted, although this has not been found necessary so long as the whole unit is shielded in the same way as is a signal generator.

Only one adjustment is necessary to align the multivibrator circuit. With the apparatus constructed and tested, first check the operation of the crystal oscillator by running a line from the output socket to an ordinary broadcast receiver. With the receiver and calibrator switched on, remove V1, the calibrator triode, thus putting the multivibrator out of action. With a 1,000 kcs. crystal in the heptode circuit, tune the receiver to 300 metres, when a strong carrier will be heard. If a 100 kcs. crystal is used, this test cannot be made since the crystal will then be radiating on a 3,000 metres wavelength. It may be possible to hear a harmonic of the crystal at 300 metres or at 1,500 metres, but a small neon lamp touched to the grid of the heptode will give a positive test by lighting if the striking voltage of the lamp is not more than approximately 100 volts.

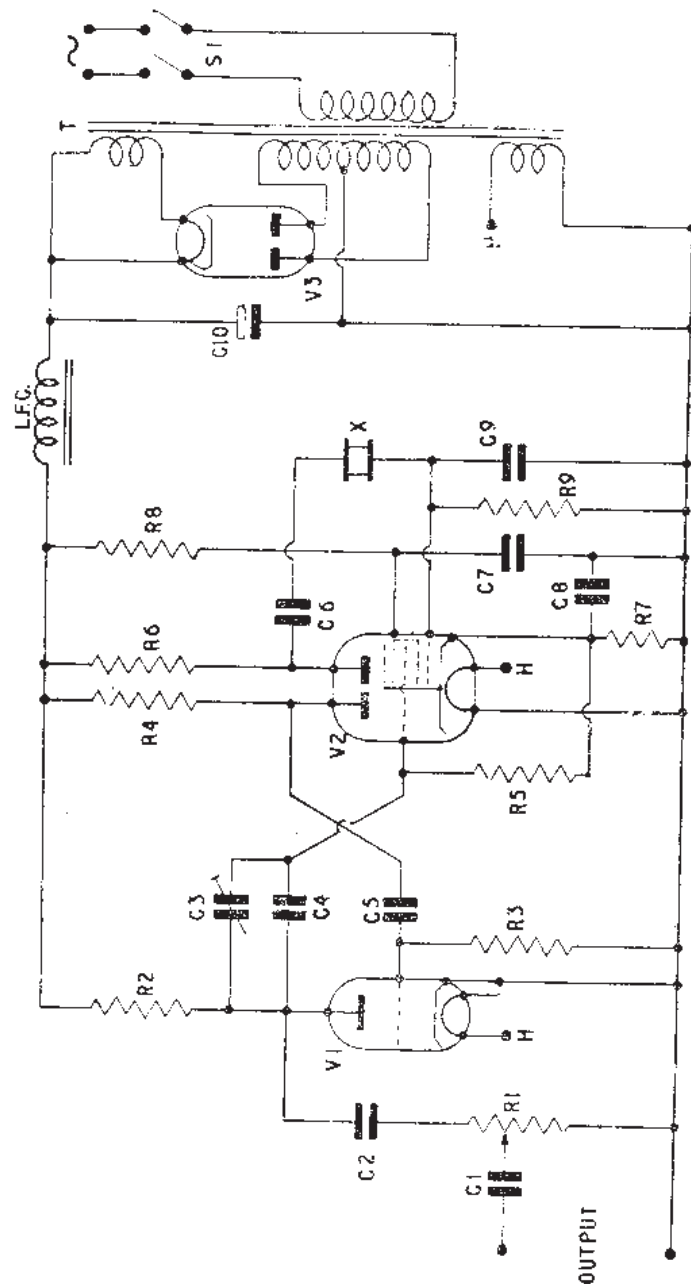

FIG. 12.—The Calibrator and I.F. Standard.

With the crystal oscillator working, replace V1 and allow the vibrator circuit to come into operation. Tune the broadcast receiver, connected with its aerial socket to the output socket of the calibrator, two earths also being connected, from 300 to 250 metres. A series of strong, slightly hum-modulated carriers will be heard.

The multivibrator can now be corrected for frequency. Adjust C3 until tuning the broadcast receiver from 200 to 300 metres—that is, from 1,500 kcs. to 1,000 kcs.—brings in 6 carriers on and between the two points at the frequencies

1,500 kcs.  
1,400 „  
1,300 „  
1,200 „  
1,100 „  
1,000 „

This, of course, presumes that the receiver used is reasonably accurate. No trouble should be experienced in finding the setting of C3 which gives the 6 carriers.

The calibrator is now set with the multivibrator working at the fundamental frequency of 100 kcs. delivering a whole chain of carrier waves spaced one from the other by 100 kcs. from 100 kcs. up to approximately 15 or 20 mcs.

To use the calibrator, connect it into a broadcast receiver along with the gear to be calibrated—a signal generator, for example—using the smallest coupling capacitances possible to obtain audible signals. Switch the audio oscillator of the signal generator out of action so that an unmodulated R.F. carrier is obtained. As a test point, tune the receiver to 300 metres, 1,000 kcs., thus picking up one of the calibrator harmonics. Tune the generator on the appropriate band to the same frequency. As the generator frequency approaches 1,000 kcs., a beat note will be heard in the receiver, falling in tone and then rising again as the generator is tuned right through frequency. Adjust the generator for zero beat note with the calibrator—that is, tune the generator until the beat note falls in frequency to inaudibility, when the generator and calibrator are both on the same frequency. The generator scale may then be calibrated with the 1,000 kcs. mark. Tune the broadcast receiver up to the next calibrator harmonic, which must be situated at 900 kcs. Tune the generator to beat again, and then to zero beat, thus setting the generator frequency at 900 kcs., and add a further calibration point to the scale. Continue at points through the whole frequency range of the signal generator.

Should it not be desired to use such a calibrator, or should closer calibration points be required on some ranges—for example, between 400 and 500 kcs. for I.F. adjustment—the generator may be calibrated against a known signal generator or even against a good calibrated receiver which has been checked against broadcast station frequencies or some other standard. The 400 to 500 kcs. range cannot, of course, be directly received on any normal set, but the second harmonics should be heard clearly at points between 800 to 1,000 kcs. on the medium wave range. Tune the generator, therefore, to the required points between 400 and 500 kcs., receiving and

calibrating by the harmonics between 800 and 1,000 kcs. The same technique used with the calibrator will obviously give calibrations at 50 kcs. points as well as at 100 kcs. points. Care must be taken when using harmonics, however, to ensure that the correct harmonic points are taken. This is usually simple at the lower frequencies, and careful count will be all that is necessary at high frequencies.

#### Components List for the Calibrator and Frequency Standard,

Fig. 12.

C1, C5,	50 mmfds. Silver Mica.
C2, C9,	0.0001 mfd. Mica.
C3,	4-50 mmfds. Adjustable trimmer.
C4,	10 mmfds. Silver Mica.
C6,	0.01 mfd. 350 v.w. Non-inductive.
C7, C8,	0.1 mfd. 350 v.w. Non-inductive.
C10,	8 mmfds. 500 v.w. Electrolytic.
R1,	50,000 ohms variable, output control.
R2, R3, R4,	
R5, R8, R9,	47,000 ohms, 1 watt.
R6,	68,000 „ 1 „
R7,	1,000 „ 1 „
SI,	D.P.S.T. On-Off switch.
L.F.C.,	10 or 20 Henrys, 60 mAs.
T,	200-250 volt primary.
	250-0-250 volts, 60 mAs.
	4v. 2a. 4v. 2a.
	100 kcs. or 1,000 kcs. crystal.
X,	
V1,	354V.
V2,	ACTH1.
V3,	UU6.
	1 British 5-pin chassis mounting valveholder.
	1 British 7-pin chassis mounting valveholder.
	1 Mazda octal chassis mounting valveholder.
	Chassis, aluminium, with screening cover.
	Control knob, output sockets, etc.

Since crystals have varying oscillating characteristics it may be found necessary to make some slight alteration in the value of C9 to obtain stable oscillation.

## CHAPTER 5

### THE OUTPUT METER

Directions for the use of signal generators, whether in text-books or supplied with commercial instruments, generally advise that the alignment of a receiver with the signal generator shall be carried out with an output meter connected in place of the receiver's loudspeaker. By watching the indications given by the output meter the effect of trimming the I.F. transformers or of trimming and padding oscillator and selector circuits can readily be seen, and the indication is definite. If the receiver is aligned by

listening to the audio note from the loudspeaker the ear rapidly becomes dulled to slight changes in the intensity of the sound and cannot retain the idea of a "reference level" such as can be chosen on the meter.

For this type of use the output meter can be calibrated in any way at all, for so long as there are graduations on the scale the ultimate power supplied to the meter is of little moment, a comparison between output levels is all that is required. So long as the output meter is correctly matched to the receiver it can be either a current or voltage measuring instrument, and the A.C.-D.C. analyser can be used as an output meter simply by connecting the low A.C. volts range across a suitable resistance which is, in turn, connected across the secondary of the output transformer.

It may also be desirable, however, to have a meter which will actually read in terms of watts, or in volts across a certain impedance or resistance, or in decibels, and here the analyser is not of great use. Since most output measurements are made at a frequency of 400 cycles, the instrument rectifier does not hold to the same calibration as that obtaining at 50 cycles, so that the analyser has a percentage of error for the audio frequencies.

The valve voltmeter can, of course, be used, or an instrument rectifier-moving coil instrument may be calibrated for 400 cycles operation, the calibrations being made against a standard instrument or against a valve voltmeter.

As a simple uncalibrated output meter a Magic Eye tuning indicator can be used to give good results. The instrument may be mounted in a small case and supplied with power—the demand is very small—from the receiver under test. This type of output meter should be connected across the primary of the output transformer rather than across the secondary.

Whatever the type of output meter used, and whether or not it uses the output transformer in the receiver, remember that the output valve must work with the correct load in its anode circuit. Should the voice coil of the loudspeaker be disconnected for any reason, a similar load must be connected across the output transformer secondary in its place—generally a 3-ohm load for the majority of receivers. The output meter may measure the relatively high voltage across the output transformer primary as with the Magic Eye output meter, or the relatively low voltage across the resistance connected to the output transformer secondary in place of the voice coil, or a thermoelectric ammeter may be used to measure the current in this low resistance, the three methods being shown in Fig. 13.

The Magic Eye output meter is shown in Fig. 14. Either a 4 or 6 volt Eye may be used to suit the heater transformer of the receiver under test.

*Components List for the Magic Eye Output Meter, Fig. 14.*

- |         |  |
|---------|--|
| C1, C2, | 0.01 mfd. 350 v.w. Non-inductive.                                  |
| R1,     | 100,000 ohms variable, input control.                              |
| R2,     | 1 megohm, $\frac{1}{2}$ watt.                                      |
| V1,     | ME41 for 4-volt operation or Y63 for 6-volt operation.             |
|         | 1 Mazda octal or international octal chassis mounting valveholder. |

Either this type of output meter, or the A.C. volts ranges of the analyser, will do all that is required so far as comparative output readings for set alignments are concerned. The low A.C. volts range should be used across

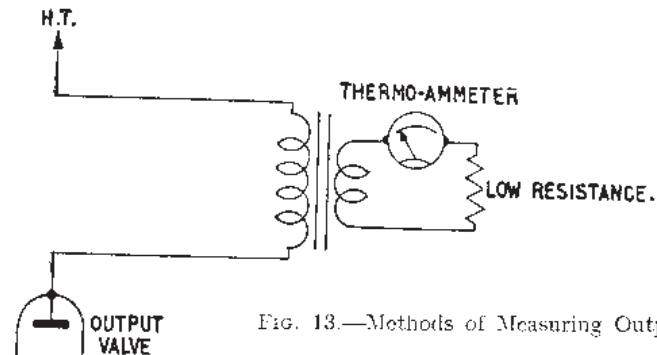
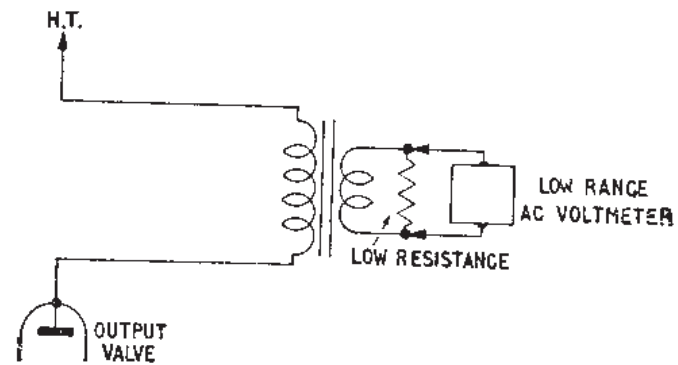
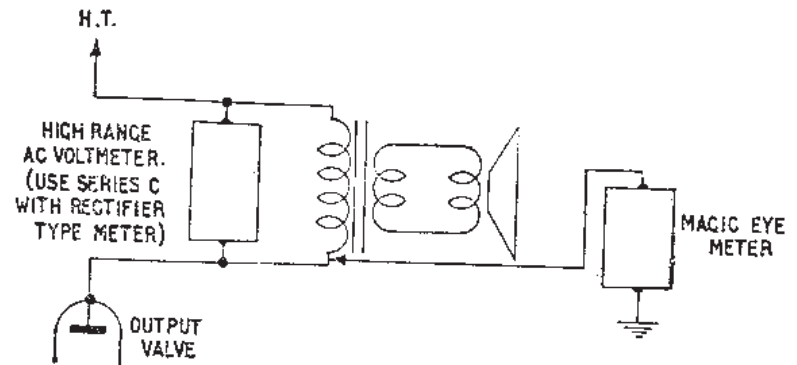

FIG. 13.—Methods of Measuring Output.

the voice coil of the loudspeaker or across a low substitute resistance. If the reading thus obtained is too low, the higher A.C. volts ranges may be used, connected across the primary of the output transformer with a 0.1 mfd. condenser connected in series with the analyser to block the passage of D.C.

To make actual output measurements the simplest method is to use a thermo-electric ammeter in series with a suitable low resistance across the secondary of the output transformer, or the ammeter may have its own

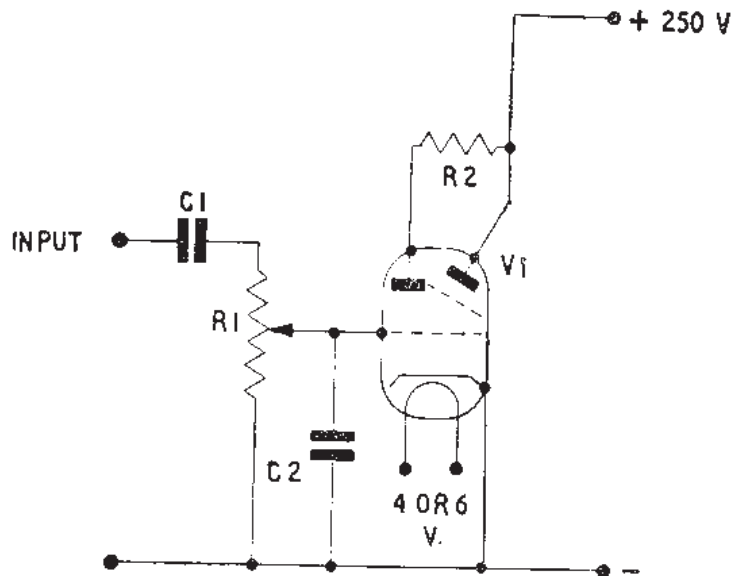

FIG. 14.—Magic Eye Output Meter.

multi-tapping transformer which can be matched into any receiver or output stage. Since watts can be taken as

$$W = I^2 R$$

where  $I^2$  is the square of the current in amperes and  $R$  is the total resistance of the circuit (including the ammeter resistance, which is marked on the scale of a good thermo-electric ammeter), the scale can be re-calibrated in terms of watts if desired, or the watts easily calculated from the ammeter reading. The thermo-electric ammeter, moreover, holds its calibration right through the audio frequencies and up into the radio frequencies, and the readings will be substantially accurate for the average instrument between frequency extremes of approximately 50 to 1,000,000 cycles, or higher.

The resistance used must be non-inductive, but since the total resistance connected to the secondary of the output transformer will seldom be greater than 10 or 15 ohms the construction of a suitable component is a simple matter. The correct length of resistance wire should be cut off, tested for

resistance (with the ammeter resistance deducted from the total required resistance), and the wire should then be doubled and wound on a small former as a pair of wires. The resistance will then be non-inductive.

If the meter is provided with its own transformer for matching into various output stages, the use of a 10 ohms resistance in the secondary circuit will simplify calculations. Specimen outputs into 10 ohms would give

10 watts,	current = 1 amp.
5 watts,	current = 0.7 amp.
2 watts,	current = 0.45 amp.
1 watt,	current = 0.32 amp.

etc.

Thermo-electric ammeters have the disadvantage of poor overload capacities, so that care must always be taken when using such a meter that the instrument is not overloaded, as the heater wire would then be burnt out.

To measure output in terms of volts the same type of circuit may be used with a valve voltmeter or rectifier voltmeter connected across the low resistance instead of in series with it. The valve voltmeter must, of course, be calibrated for A.C. operation, whilst a rectifier instrument should be calibrated at 400 cycles rather than at 50 cycles. Different rectifiers give different frequency errors, however, and it may be found that the 50 cycle calibration of the analyser 10 volt A.C. scale is sufficiently accurate, since this scale can be used directly across a low resistance without the need for a series blocking condenser.

When using the voltmeter, watts can be taken as

$$W = \frac{V^2}{R}$$

where  $V^2$  is the square of the indicated voltage across the low resistance. Thus, specimen voltages across a 10-ohm resistance for various output powers would be

10 watts,	voltage = 10 volts.
5 watts,	voltage = 7 volts.
2 watts,	voltage = 4.47 volts.
1 watt,	voltage = 3.2 volts.

Or a reading could be taken across a voice coil of known impedance; or, better, across a substituted resistance with non-inductive characteristics connected across the secondary of an output transformer if a special transformer with a selection of tappings is not available.

Where it is desired to express a reading in decibels, as, for example, where the overall gain of an amplifier is being measured, an A.C. voltmeter scale can be calibrated in terms of decibels. A reference level must, of course, be chosen, and since the standard reference level for zero decibels is 0.006 watts in 500 ohms, this level is used in the conversion chart shown below.

By means of this chart any A.C. voltmeter can have a decibel range added to its scales giving decibels and power levels in 500 ohms loads directly.

*Decibels, Watts and Volts Tables.*

Volts across 500 ohms Load.					
db.			Watts.		Volts.
-20	...	...	0.00006	...	0.173
-15	...	...	0.0002	...	0.316
-10	...	...	0.0006	...	0.550
-5	...	...	0.002	...	1.00
0	...	...	0.006	...	1.733
+5	...	...	0.02	...	3.16
+10	...	...	0.06	...	5.48
+15	...	...	0.2	...	10.0
+20	...	...	0.6	...	17.3
+25	...	...	2.0	...	31.62
+30	...	...	6.0	...	54.8
+35	...	...	20.0	...	100.0
+40	...	...	60.0	...	173.2
+45	...	...	200.0	...	316.2
+50	...	...	600.0	...	547.7

To find the number of decibels corresponding to any power level with the zero or reference db level at 0.006 watt, divide the power level by 0.006 watt and multiply the logarithm of the quotient by 10, or

$$\text{dbs} = 10 \log_{10} \frac{W}{0.006}$$

where W is in watts.

To find the number of decibels corresponding to any voltage level with the same reference level of 0.006 watt in 500 ohms, divide the square of the voltage by 3 and multiply the logarithm of the quotient by 10, or

$$\text{dbs} = 10 \log_{10} \frac{V^2}{3} \quad \text{where V is in volts.}$$

## CHAPTER 6

### THE CATHODE RAY OSCILLOSCOPE

It is hardly necessary to mention the many uses in radio and electronics servicing and testing of the cathode ray oscilloscope. On the screen of the cathode ray tube can be drawn the actual curves of voltage and current waves, R.F. carriers, response curves of tuned circuits and the curves of valve characteristics. Readers who require full information on the principles and uses of the oscilloscope should refer to the Cathode Ray Oscilloscope Manual, No. 87 on Messrs. Bernard's List—in this chapter there is room only for a new oscilloscope circuit and details of aligning receivers by the use of an oscilloscope and frequency modulated oscillator, more generally known as a "Wobbulator."

The oscilloscope circuit is shown in Fig. 15, the tube having a screen diameter of 1½", which is ample for most workshop uses, reducing the first cost of the apparatus and making the instrument readily portable. A wide range of frequencies is given by the single hard valve time base, a modifica-

tion of the time base type used in the author's television receiver described in the Television Constructor's Manual. A single power pack is used for tube, time base and amplifier, the H.T. being supplied from a purely conventional transformer and rectifier. As a result construction must be carried out with some care in the insulation of circuits, since the common line is the negative rather than the positive—that is, the chassis and shielding case are connected to the negative rather than to the positive H.T. line unlike most small oscilloscopes. This means that for direct connection to the X and Y plates the positive H.T. line must be brought to an input socket mounted on the case.

If it is desired to use a larger tube the same power pack, time base and amplifier circuits will still be suitable since there is a margin of output and gain sufficient to work a 3" tube efficiently.

The time base is so designed that a variable sweep amplitude output is available from a potentiometer in the anode of the valve whilst the full output can also be led out to external apparatus if desired, since output can be drawn from the time base with respect either to the H.T. positive or negative lines. By connecting a potentiometer across the Sweep Out sockets variable sweep amplitude rather than full amplitude is also available externally.

When the deflection signals to the Y plates need amplification the signals are fed to the Y amp. sockets, but large signals may be applied directly to the Y plates by feeding into the Y.D. or Y Direct sockets, the input amplitude then being adjusted by the control R15. It must always be remembered when using these or the X.D. sockets that the external apparatus is then connected to the positive line of the oscilloscope, and thus will be alive to the oscilloscope case. The external gear can be connected either directly to the Y.D. or X.D. terminals or via a condenser. The actual arrangement will, of course, depend on the external signal source.

Note also that there is no input control across the X.D. terminals since these will not often be used and may be omitted if thought undesirable. Control of an external signal amplitude to the X plates can be effected by a potentiometer connected externally across these sockets.

R5, the synchronisation control, should never be advanced beyond an effective working position, since too great a synch. signal results in distortion of the whole trace on the screen.

The layout of the oscilloscope components may be dictated by the cabinet or box in which the apparatus is built, since the circuit is very stable and any layout may be used as long as the wiring is neat and clean and good insulation is maintained. The usual practice of placing the mains transformer and choke behind the base of the cathode ray tube should, however, be observed, since any stray magnetic fields from these components will give a lateral deflection to the spot on the screen if they are mounted in any other position.

The potentiometers used for the voltage divider supplying the tube and other purposes, especially when wirewound potentiometers are used, should be inspected to ensure that the moving arm is insulated from the spindle so that these components may be mounted on an earthed metal panel without short circuits.

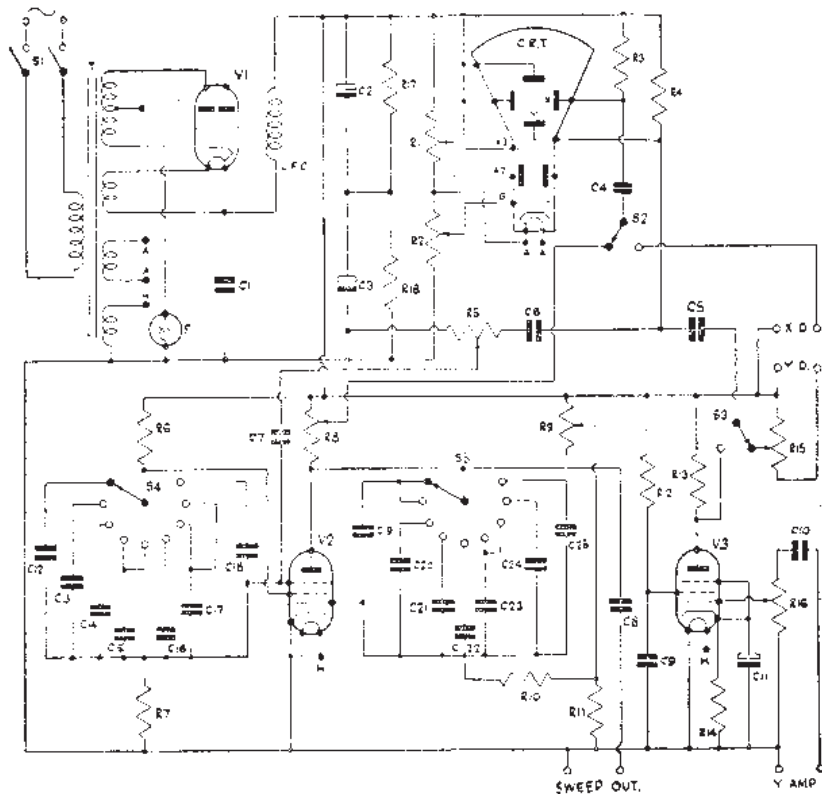

FIG. 15.—The 1½-in. Oscilloscope.

The output and input sockets should be of the type mounted in pairs on paxolin boards. The panel may then be cut away and the board mounted so that the sockets are spaced from earthed metal to give high insulation.

Note that two 16 mfd. electrolytic condensers are connected in series to give a high working voltage 8 mfd. smoothing condenser. If desired, these condensers may be of 8 mfd. capacitance each to give a final capacitance of 4 mfd., but the fuller smoothing is recommended.

Remember that the spot intensity must always be kept very low when no deflecting signals are applied to the X and Y plates, and that even a stationary curve or trace can burn the screen badly if left at full or high brilliance for any length of time. The gear should always be operated with the brilliance control, R2, turned to as low a point as possible.

*Components List for the 1½" Oscilloscope, Fig. 15.*

- |              |   |
|--------------|---|
| R1,          | 0.5 megohm variable, Focus control.       |
| R2,          | 50,000 ohms variable, Brilliance control. |
| R3, R4, R10, | 1 megohm, ½ watt.                         |

- |   |  |
|---|--|
| R5,   | 1 megohm variable, Synchron. control.  |
| R6,   | 100,000 ohms, 2 watts.   |
| R7, R11, R12,   | 470,000 " ½ "  |
| R8,   | 0.5 megohm variable, Time base Sweep Amplitude control.                      |
| R9,   | 2 megohms variable, Fine Frequency control.                                  |
| R13,  | 100,000 ohms, 1 watt.  |
| R14,  | 1,000 " ½ "  |
| R15,  | 1 megohm variable, Y Direct input control.                                   |
| R16,  | 0.5 megohm variable, Y Amplifier input control.                              |
| R17, R18,   | 470,000 ohms, ½ watt.  |
| C1,   | 2 mfd. 1,000 v.w. Oil-filled.  |
| C2, C3,   | 16 mfd. 500 v.w. Electrolytic.   |
| C4, C5, C8, C9,   | 0.1 mfd. 500 v.w. Non-inductive.   |
| C6,   | 0.001 mfd. Mica.   |
| C7,   | 0.0005 mfd. Mica.  |
| C10,  | 0.02 mfd. 350 v.w. Non-inductive.  |
| C11,  | 25 mfd. 25 v.w. Electrolytic.  |
| Time base condenser set No. 1, with S4, from left to right, |  |
| C12,  | 0.02 mfd. 350 v.w. Non-inductive.  |
| C13,  | 0.01 mfd. 350 v.w. Non-inductive.  |
| C14,  | 0.005 mfd. Mica.   |
| C15,  | 0.001 mfd. Mica.   |
| C16,  | 0.0005 mfd. Mica.  |
| C17,  | 0.00015 mfd. Mica.   |
| C18,  | 0.00005 mfd. Mica.   |
| Time base condenser set No. 2, with S5, from left to right, |  |
| C19,  | 0.01 mfd. 350 v.w. Non-inductive.  |
| C20,  | 0.005 mfd. Mica.   |
| C21,  | 0.003 mfd. Mica.   |
| C22,  | 0.001 mfd. Mica.   |
| C23,  | 0.0005 mfd. Mica.  |
| C24,  | 0.00015 mfd. Mica.   |
| C25,  | 0.00005 mfd. Mica.   |
| S1,   | D.P.S.T. Mains On-Off switch.  |
| S2,   | S.P.D.T. X deflection internal or external.                                  |
| S3,   | S.P.D.T. Y deflection amplified or direct.                                   |
| S4, S5,   | S.P. 9-way Double-Bank Yaxley type switch. Coarse Sweep frequency control.   |
| T,  | 200-250 volt primary.<br>250-0-250 volts, 60 mAs.<br>4v. 2a. 4v. 2a. 4v. 2a. |
| L.F.C.,   | 20 Henrys. 60 mAs.   |
| F,  | 100 mAs. Fusebulb, with holder.  |
| CRT,  | G.E.C. Type E-4103-B-4.  |
| V1,   | UU5.   |
| V2, V3,   | SP41.  |

- 1 CRT holder, 9-pin.
- 1 British 4-pin chassis mounting valveholder.
- 2 Mazda octal chassis mounting valveholders.
- 4 Double input sockets, paxolin mounted.
- 8 control knobs.
- 2 shielded grid clips.
- Chassis, metal case or cabinet, etc.

The oscilloscope can be used without other apparatus—apart from the signal generator—to trace distortion and hum in a receiver, and interesting screen traces can be obtained by tapping the Y plates, via the amplifier, across the I.F. transformers, I.F. valve, diode detector and amplifying and output stages of a set to which a steadily modulated signal is being supplied. The oscilloscope time base must be adjusted to give a complete number of audio cycles to the trace—for example, if a 400 cycles audio modulation note is used in the signal generator the time base could be set to run at a sweep frequency of 100 cycles to give four audio cycles in the trace. From the I.F. stages will be obtained a picture of the "Modulation envelope," the actual I.F. carrier with the audio modulation curve on either side, whilst from the detector and amplifying stages the plain audio curve is obtained.

By testing the signal generator to determine the actual shape of the audio modulation signal, and then tracing the signal through the receiver, distortion can be observed. Ripple and hum can also be seen if these are entering the audio stages of the receiver.

One of the chief uses of the oscilloscope, however, is in combination with a "Wobulator" for the alignment of superhet receivers. It is well known that the response curve of I.F. transformers and similar inductances should be adjusted so that the curve is symmetrical about the central frequency—about 465 kcs. in the usual superhet—with reasonably steep sides and a slightly double-humped or band-pass top. Using a signal generator and output meter it is difficult to estimate the shape of the I.F. response curve, but with the oscilloscope the curve can be inspected and adjusted. It is necessary, however, to use a variable oscillator which will sweep across the whole frequency width of the response curve to give what might be termed a "scanning" effect. Suppose, for example, that a 465 kcs. transformer is under inspection. The variable generator would commence its sweep at, say, 450 kcs., and the oscilloscope, connected to the diode detector with its deflection proportional to the signal energy delivered from the I.F. stage would show practically no deflection at all, since the 465 kcs. transformer would pass little of a 450 kcs. signal. The generator, however, sweeps in frequency towards 465 kcs. so that the transformer passes more and more of the signal energy as the generator frequency comes towards the central tuned frequency, and the oscilloscope deflection accordingly also grows greater. As the generator frequency sweeps through the central double-humped portion of the response curve, the oscilloscope deflection rises to a peak on the first hump, drops slightly, and then rises to a peak once again on the second hump. The generator frequency then continues to sweep on towards 480 kcs., its upper sweep limit, and the signal thus passed by the transformer grows less as the frequencies diverge, the oscillo-

scope deflection falling in sympathy with the falling signal voltage delivered to the detector.

The oscilloscope, therefore, measures the signal voltage delivered through the transformer to the detector and, if the oscilloscope time base is set to operate at the same frequency as the speed with which the variable oscillator sweeps across its frequency range, the voltage measurement given by the oscilloscope will turn into a true picture of the shape of the response curve itself. Displacement of the band-pass humps, lack of symmetry in the curve, and similar defects, will all be clearly shown, and the transformer trimmers can be adjusted with the curve still on the screen until a response, as perfect as possible, has been obtained.

The design of a variable frequency signal generator, however, requires some consideration. Obviously the frequency variation must proceed at a regular and steady pace between fixed limits, and the operation must be reasonably fast in order that a continuous picture shall be produced on the oscilloscope screen. A rotating condenser could be used to produce the changes of frequency, but a more usual method is to use a frequency modulating valve. In an ordinary triode an increase in the internal resistance of the valve gives the effect of an increased input capacitance—the Miller effect—so that a valve operated under suitable conditions can be connected across an oscillating circuit so that changes in the grid bias or the anode load of the controlling valve cause the frequency of the oscillating circuit to change between limits.

Since the controlling valve must be operated at the same rate as the time base sweep of the oscilloscope, one method of control is to feed the time base sweep voltage to the controlling valve, the oscillator frequency thus being swept over its range in time with the oscilloscope sweep frequency a sweep frequency of about 25 cycles per second being chosen.

Alternatively, a triangular wave may be generated from the mains supply sine wave curve and fed to both the X plates of the oscilloscope and the frequency controlling valve. Using a triangular wave means that the frequency and screen spot sweep evenly from side to side of their limits so that the sweep-flyback jerkiness is avoided. The extra complication of the apparatus needed for generation of a triangular wave can be dispensed with, however, and the oscilloscope time base used instead.

The controlled oscillator, whose frequency is being varied between limits of about 30 kcs., should be maintained at a fixed central frequency, however, for if this oscillator is tuned to different central frequencies the bandwidth of the sweep will vary considerably. Accordingly, the frequency sweep is generated about a central frequency of approximately 700 kcs., and the required output frequency is obtained by beating this varying frequency centred on 700 kcs. with a suitable steady frequency obtained from the ordinary signal generator.

Thus, to obtain a variable frequency centred on 465 kcs. for I.F. transformer alignment, the signal generator is set to either 1,165 kcs. or to 235 kcs., and these frequencies will beat with 700 kcs. in a frequency changer circuit to give a final sweeping frequency centred on 465 kcs. in just the same way that a broadcast signal beats with a receiver's local oscillator to produce an I.F. signal.

Unmodulated signals are used in both oscillators for this work.

The "Wobbulator" shown in Fig. 16 was designed by the writer to work with the oscilloscope of Fig. 15, but will work with other oscilloscopes, instruments with a fairly high time base sweep amplitude giving the best results since then there is a wider frequency swing on the controlled oscillator. In the diagram, V1 is the reactance modulator, being controlled directly from the oscilloscope time base. In the majority of cases, connecting the input load of this valve into the time base will cause a variation in the speed of the sweep frequency, but since the X plates of the cathode ray tube are connected to the same source this is of little consequence. The one effect which must be guarded against is the slowing down of the flyback time. The flyback is always something of a nuisance in this type of work, and a faint image behind the true image will usually be obtained. Slowing of the flyback will give a strong mirror image, however, and whilst the experienced worker will be able to disregard the effect it is best avoided.

The reactance modulator valve acts as a variable reactance to the oscillator circuit built around the triode section of the triode heptode, thus varying the frequency of that circuit about its central frequency, the amount of variation being under control through the input potentiometer to V1. Into the heptode section of V2 is fed a strong signal from the signal generator proper, the frequency being chosen so that it beats with the 700 kcs. frequency generated in the triode of V2 to produce the required final frequency.

This final frequency is tuned by the tuned circuit in the heptode anode line and supplied to an output attenuator from which it is fed to the receiver under test.

Commercial coils are again specified for use in the "Wobbulator."

*Components List for the "Wobbulator," Fig. 16.*

R1,	100,000 ohms,	1 watt.
R2,	1,000 "	" "
R3,	47,000 "	" "
R4,	1 megohm variable,	frequency variation control.
R5,	4.7 megohms,	$\frac{1}{2}$ watt.
R6,	62,000 ohms,	1 "
R7,	47,000 "	1 "
R8,	330 "	$\frac{1}{2}$ "
R9,	470,000 "	$\frac{1}{2}$ "
R10,	200 ohms variable,	output attenuator.
C1,	25 mfd. 25 v.w.	Electrolytic.
C2, C6,	50 mmfds.	Silver Mica.
C3, C8, C9,	0.1 mfd. 350 v.w.	Non-inductive.
C4, C5,	0.0005 mfd.	Mica.
C7,	200 mmfds. max.	variable trimmer.
C10,	0.0001 mfd.	Mica.
C11,	0.001 mfd.	Mica.
C12,	0.0005 mfd.	Tuner.
C13,	0.01 mfd. 350 v.w.	Non-inductive.

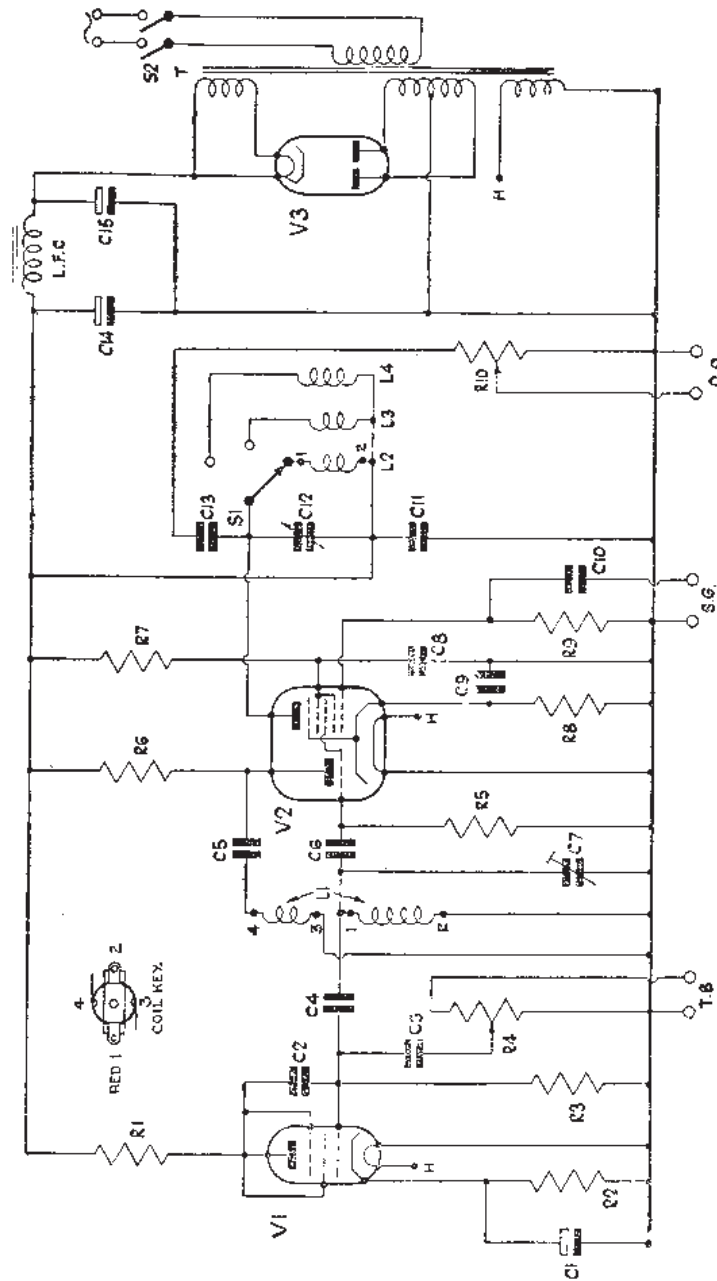

FIG. 16.—The "Wobbulator."



C14,	16 mfd. 500 v.w. Electrolytic.
C15,	8 mfd. 500 v.w. Electrolytic.
L1,	Wearite PIH7.
L2,	Wearite PA3, 16-47 metres.
L3,	Wearite PA7, 250-750 „
L4,	Wearite PA1, 700-2,000 „
L.F.C.,	20 Henrys, 60 mAs.
T,	200-250 volts primary. 350-0-350 v., 60 mAs. secondary. 4v. 2a. 4v. 3a.
S1,	S.P. 3-way range selector switch.
S2,	D.P.S.T. On-Off switch.

V1, (See note below.)  
V2, ACTH1.  
V3, LU6.

1 British 7-pin chassis mounting valveholder.

1 Mazda octal chassis mounting valveholder.

1 holder to suit V1 type used.

3 pairs of input sockets, paxolin mounted.

4 control knobs.

Chassis, aluminium, with screening cover.

Shielded output lead, grid clips, etc.

Insulating bracket or bushes for C12.

Note.—The valve used for V1 in the original model was of the type SP41. It seems probable, however, that even better results might be obtained from a VP41 or VP4B or similar variable-mu pentode. Alternatively, a high gain triode such as the AC2HL might be used. The value of R2 should suit most valves in this position, but different bias resistances might also be tested with different valves.

#### OPERATION

With the "Wobbulator" constructed and tested, and L1 connected in circuit so that oscillations are obtained, the tuned circuit of L1, C7 must first be brought to 700 kcs. Setting the "Wobbulator" near an ordinary broadcast receiver will allow the carrier due to the triode oscillator to be tuned on the receiver, and C7 should be adjusted until the unmodulated carrier is heard with the receiver set at 700 kcs.—that is, 428.5 metres.

Connect the T.B. terminals of the "Wobbulator" to the Sweep Out terminals or sockets of the oscilloscope of Fig. 15, making sure, of course, that the earthed terminal of one pair is connected to the earthed terminal of the other pair. With the oscilloscope time base in operation at a low frequency (about 25 c.p.s.), turn up R4 on the "Wobbulator" to give frequency modulation of the 700 kcs. carrier. The sharply tuned unmodulated carrier from the "Wobbulator" will change to a broad carrier modulated by a low, harsh note due to the time base frequency, and will be tuneable over several degrees on the receiver dial.

With the frequency modulation of the oscillator assured, the signal generator of Fig. 11 or a similar instrument can have its output sockets connected to the S.G. sockets of the "Wobbulator." Feed in a frequency

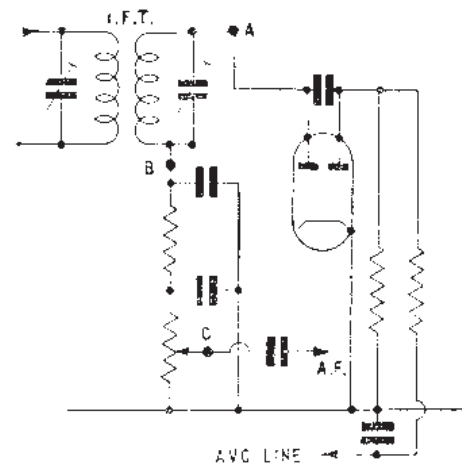

Fig. 17.—Points for connection of Oscilloscope to a Diode Detector.

differing from the 700 kcs. oscillator frequency by the intermediate frequency of the set under test—for example, 465 kcs. Thus, the signal generator should be tuned to 1,165 or 235 kcs., and tests will show whether both these frequencies give equally good results—as they should—or whether the higher or lower frequency is to be preferred.

From the O.O. sockets of the "Wobbulator," take the screened feed-in lead to the grid of the I.F. valve of a receiver, so that the 465 kcs. frequency is injected into the last I.F. transformer. Take the Y Amp. sockets of the oscilloscope to the diode detector circuit, as shown in Fig. 17, and turn up the oscilloscope gain. According to the way in which the Y amplifier is connected to the diode detector circuit, an R.F. or Audio envelope or trace should be obtained on the oscilloscope screen, the shape of the trace or envelope giving the response curve of the last I.F. transformer. The trace may, of course, be upside down, according to the internal oscilloscope connections to the Y plates, but the validity of the curve will not be affected by this. An R.F. envelope will give both an upward and downward curve.

The tuned circuit controlled by C12 in the "Wobbulator" must, of course, be tuned for maximum output at the desired frequency, but the tuning condenser need not be driven through a slow-motion device. Remember, however, that this condenser must be mounted on an insulating bracket or on insulating bushes, since it is in the anode line of V2 and neither the stator nor rotor is earthed directly.

Only three coils are shown in the output tuned circuit of which C12 forms a part, covering the most used short-wave range, the medium and I.F. wave band and the long-wave band. The "Wobbulator" may thus be used for work on ordinary tuned circuits as well as I.F. transformer alignment. Should it be desired to cover a wider frequency range with the "Wobbulator," further coils and a suitable switch may be included in the output circuit of V2.

The tuning condenser C12 may be calibrated against a receiver in terms of frequency. Set the "Wobbulator," as before, to 700 kcs. for the tuned

oscillator connected to the triode section of V2, and inject a 900 kcs. carrier from the signal generator. Do not connect in the time base control voltage to the T.B. sockets. With the "Wobbulator" O.O. sockets connected into the Aerial and Earth sockets of a good receiver, tune the receiver to 200 kcs. and tune C12, with the long-wave coil switched across it, to bring up the signal in the receiver to maximum. C12 should tune quite sharply. The dial of C12 may then be calibrated at that point "200 kcs." and the signal generator tuning adjusted to inject a 1,000 kcs. signal to the "Wobbulator." Tune the receiver to 300 kcs., adjust C12 for maximum signal in the receiver, and calibrate that point on the dial of C12 as "300 kcs." By carrying out this process round the bands, C12 can be calibrated for frequencies and hunting for the position of C12 will thus be eliminated.

It will be found in practice that R4 should not be advanced much beyond the  $\frac{3}{4}$  full position, since V1 will then overload and distortion in the trace will result.

The oscilloscope of Fig. 18 contains its own coupling condenser in the Sweep Out circuit, so that these sockets may be directly connected to the "Wobbulator" T.B. sockets. When another oscilloscope is being used, however, a coupling condenser between the Sweep Out sockets and the "Wobbulator" may be necessary, and the oscilloscope circuit should be inspected with this in view before the connections are made.

In Fig. 17 are shown the points at which the Y amplifier of the oscilloscope may be connected to the detector circuit of the receiver. If an R.F. envelope trace is required, the connection should be made through a small capacitance—say, 10 to 50 mmfds.—whilst the connection may be direct to the Y amplifier sockets of Fig. 15 for an A.F. trace, although once again other types of oscilloscope may require a further coupling condenser of 0.1 mfd. to be connected between the detector and the oscilloscope amplifier.

The type of curve to be expected for various circuits may be seen from the sketches shown in Fig. 18.

## CHAPTER 7 SIGNAL TRACING

Signal tracing as a method of receiver testing and fault-finding is rapidly gaining popularity because of the ease with which a faulty stage in a receiver or amplifier or similar piece of apparatus can be isolated and repaired. Broadly speaking, signal tracing consists of following a signal through the receiver from aerial input to loudspeaker, tapping off the signal from each stage in succession until a faulty stage is reached.

The essentials for signal tracing are first a strong signal, which may be supplied by a local station or, preferably, by a signal generator, and secondly, the tracer itself.

The simplest signal tracer is a pair of headphones, although these, of course, are effective only for audio frequency stages. For amplifier or P.A. equipment testing, however, headphones fitted with isolating condensers and volume controls are very useful. The amplifier under test should be connected to an audio source, circuits for which are shown in the following

Single Tuned Circuit.

Bandpass or I.F. Tuned Circuits

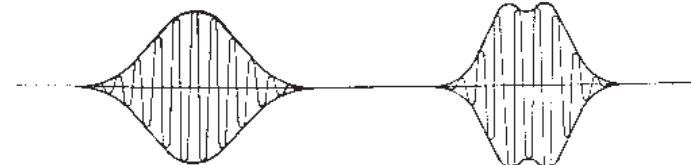

R. F. Envelopes.

Point A, Fig. 17.



A.F. Traces with Residual R.F.

Point B, Fig. 17.



A.F. Traces.

Point C, Fig. 17.

FIG. 18.—Response Curves.

chapter, and a signal fed into the amplifier. The headphones are then connected first across the input terminals, then across the anode of the first valve, on to the second valve's grid circuit, and so on, the signal gaining in amplification as the tracing proceeds. A stage where distortion is introduced will speedily be found, as will a stage where a breakdown causes no output from the amplifier's loudspeaker or a stage where hum is introduced possibly through a breakdown in the heater-cathode insulation of the valve.

With the stage itself isolated, the tracer may be used to discover whether the fault is in the grid or anode circuit and the breakdown can then speedily be remedied.

Headphones, however, are of little use for signal tracing in a radio receiver for they will only work in the detector and audio stages, and some apparatus able to detect R.F. signals will be required for the tuned circuits preceding the detector. A valve voltmeter for R.F. can be used, since this will indicate the presence of a carrier, but this will not show distortion of the audio content or similar faults. The best type of signal tracer, therefore, is one which will work on R.F. and audio, demodulating the R.F. carrier to allow the audio content to be heard.

Such a tracer can be extremely involved. Certain commercial models contain their own signal generator with Magic Eye indicators, I.F. filters and other circuits, but a useful tracer can be quite simple in design. The chief requirement is an input circuit which will detect or demodulate a carrier or allow the tracer to work on an audio circuit without switching or changing of components, and a one-valve "Pocket" instrument designed by the writer is shown in Fig. 19. In this circuit a 1S5 Peanut valve, obtainable in surplus gear at a reasonable price is used, since this valve is a diode pentode. The diode can be used as a detector for R.F. whilst A.F. is passed straight to the pentode for amplification. As might be expected, such a simple instrument is rather restricted in its range, and a fairly strong R.F. signal is required for the tracing operation to be carried out swiftly, but as a portable tester the instrument has many uses. It may also be used in place of the simple headphone, condenser and volume control tracer for amplifier and P.A. work, since the measure of amplification given by the pentode section of the 1S5 is extremely useful for work on low gain audio stages.

*Components List for the Simple Signal Tracer, Fig. 19.*

R1,	1 megohm volume control.
R2,	4.7 megohms, $\frac{1}{4}$ watt.
C1,	0.0003 mfd. Mica.
C2,	0.1 mfd. 150 v.w. Midget.
H,	4,000 ohm headphones.
S1,	D.P.S.T. On-Off switch.
V1,	1S5.
I	B7G holder.
A,	1.5 volt dry cell.
B,	4.5 volt layer-built battery.

Small case, input prods and leads, etc.

A more comprehensive tracer circuit which can still be built up into portable form is shown in Fig. 20. In this circuit, which is mains-driven, the first valve is arranged to have a self-demodulating, self-biasing input circuit so that modulated R.F. is "detected" by V1, the audio content amplified and passed on to V2 for further amplification and output to the loudspeaker. It will be seen that in this case the tracer is connected into circuit by means of a probe containing C1, the isolating condenser, and this probe, as well as the whole of the first stage, must be well shielded.

C1 should be included in the body of the probe, which may be made of ebonite or paxolin tubing, the condenser being shielded by copper gauze wrapped round the component and earthed to the tracer chassis via the screening of the probe cable. The circuit is completed by attaching the earth clip E to the chassis of the receiver under test.

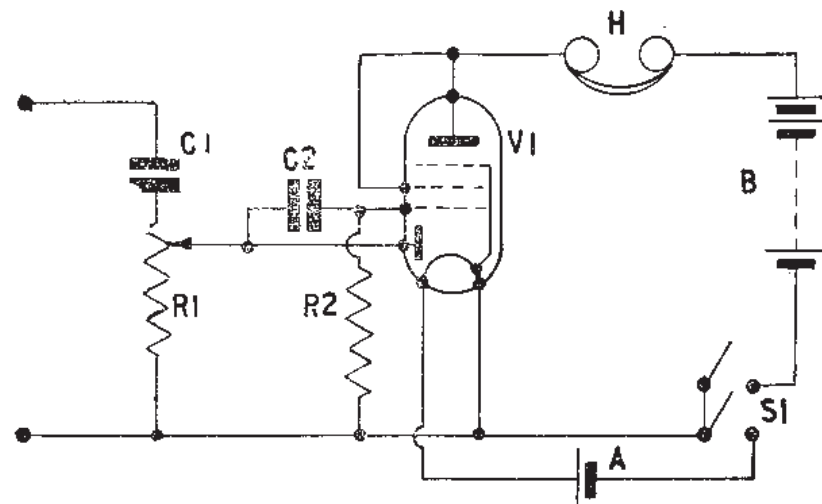

Fig. 19.—Simple R.F.—A.F. Signal Tracer.

With the tracer switched on, and a strong signal from a local station or signal generator fed to the receiver, the tracer probe should be first tapped on to the aerial terminal. The signal generator audio note will be heard in the tracer loudspeaker, the local station, if used, will be heard only if the carrier is fairly strong. Connect the probe to the grid of the first valve. The carrier should now be heard rather more strongly, after amplification by the first tuned circuit. The probe capacitance will cause the tuned circuits to go slightly out of tune so that the receiver tuning condenser must be rocked slightly to readjust the circuits and to compensate for the probe capacitance.

Tracing may be continued through the R.F.—I.F. portions of the receiver, the signal strength increasing from stage to stage, until the detector or demodulator is reached. Here the tracer probe may be connected to the audio circuits and the self biasing first stage of the tracer will give a clear audio note free from distortion.

Applying the probe to the output stage anode or to the loudspeaker connections on the output transformer will give a very loud signal from the tracer loudspeaker, but still no distortion will be caused by overloading of the tracer's input stage, although the volume control, R1, will require to be reduced considerably to prevent too loud a signal.

Since the grid of the first tracer valve is isolated from earth by 4.7 megohms the shielding of the first stage and probe head and cable must be perfect to prevent feedback over the tracer itself. Any "motor-boating" or howling will almost certainly be due to poor shielding and consequent feedback.

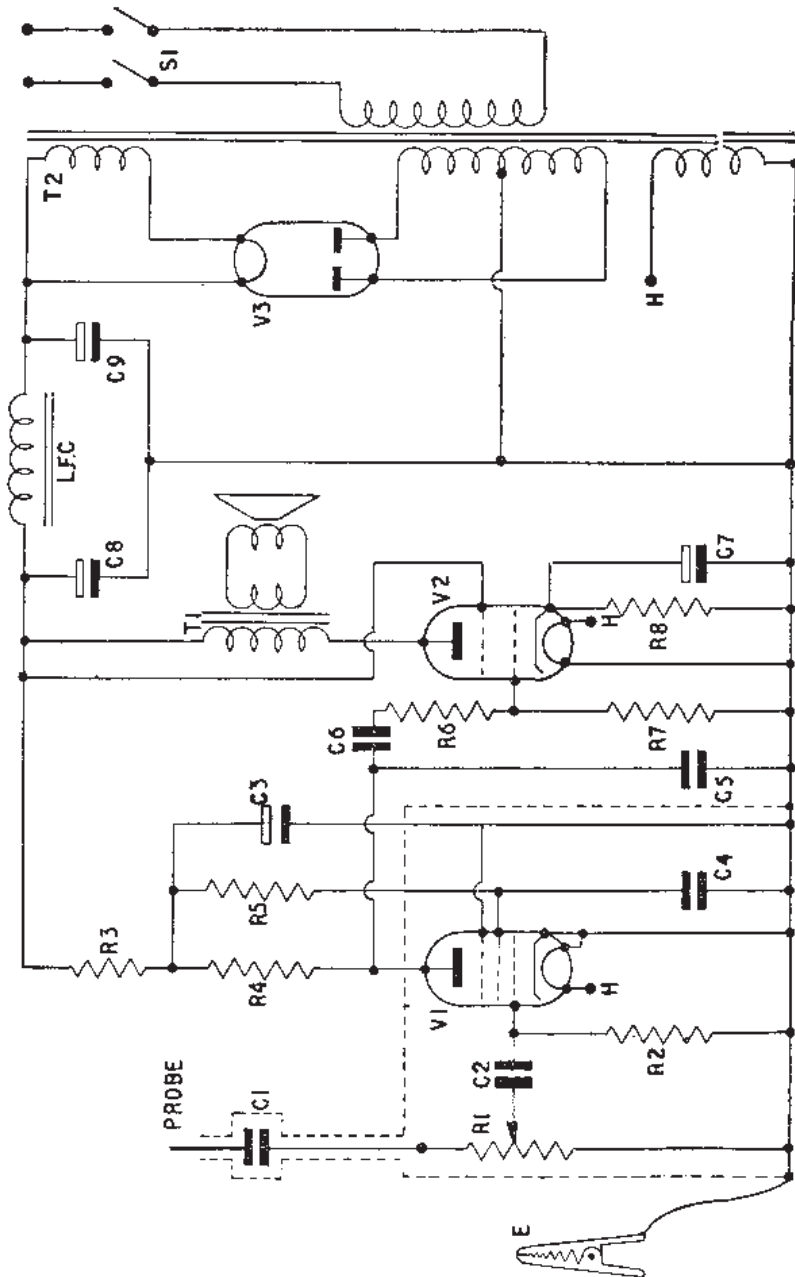

FIG. 20.—Mains Signal Tracer.

Components List for the Signal Tracer. Fig. 20.

- |   |  |
|---|--|
| C1,   | 0.0003 mfd. Mica.  |
| C2, C5,   | 50 mmfds. Silver Mica.   |
| C3, C8, C9,   | 8 mfds. 500 v.w. Electrolytic.   |
| C4,   | 0.5 mfd. 350 v.w. Non-inductive.   |
| C6,   | 0.1 mfd. 350 v.w. Non-inductive.   |
| C7,   | 50 mfds. 25 v.w. Electrolytic.   |
| R1,   | 1 megohm volume control.   |
| R2,   | 4.7 megohms, $\frac{1}{2}$ watt.   |
| R3,   | 47,000 ohms, $\frac{1}{2}$ watt.   |
| R4, R7,   | 220,000 ohms, $\frac{1}{2}$ watt.  |
| R5,   | 1 megohm, $\frac{1}{2}$ watt.  |
| R6,   | 33,000 ohms, $\frac{1}{2}$ watt.   |
| R8,   | 430 ohms, 1 watt.  |
| T1,   | Output transformer to match speaker to 7,000 ohms anode load.                  |
| T2,   | 200-250 volts primary.<br>350-0-350 v. 60 mAs. secondary.<br>5v. 2a. 6.3v. 2a. |
| V1,   | EF39   |
| V2,   | 6F6.   |
| V3,   | 5Y3G.  |
| 3 International octal chassis mounting valveholders.                          |  |
| S1,   | D.P.S.T. On-Off Switch, ganged with R1.  |
| L.F.C.  | 20 Henrys 60 mAs.  |
| Chassis, aluminium, shielding cover.  |  |
| Valve shield for V1, shielded cable for probe, grid clip, earthing clip, etc. |  |

CHAPTER 8

AUDIO OSCILLATORS

Many service engineers provide themselves with adequate facilities for R.F. testing with signal generators, signal tracers and oscilloscopes, but neglect to provide a proper audio source. For amplifier and sound stage testing reliance is often placed upon a turntable, pickup and gramophone record, and whilst tests on actual music and speech can often be of use, for serious testing of sound equipment an audio source under control both as regards frequency, volume and duration, is a necessity. The term duration is included for the reason that so often a gramophone record plays to an end in the middle of a test, so that a pause occurs whilst the record is changed or whilst the pickup is lifted and started again at the track commencement, and in any case the wide variations in frequency, modulation and volume, together with the fact that music at all frequencies is being played at once, make the record very unsuitable for satisfactory testing. Effects in the bass may be masked by over-riding treble, and vice versa. The need, therefore, is for a simple audio source producing a variable frequency.

Test records are procurable and have the excellent features of calibrated frequencies and known volume levels, but these do not overcome the fact that each series of tests must be made in a restricted time. The final characteristic of the audio signal, moreover, depends on the characteristics of the pickup and needle used to play the records, whilst the problem of record wear is ever present. At the same time the audio oscillator has one highly valuable use and that is as an energising source for capacitance, resistance and, in some cases, inductance bridges, and for this purpose frequency records are not at all suitable.

Two types of audio oscillator stand out from other circuits by reason of their simplicity and, in the case of the Wien bridge oscillator, its great frequency range. The first of these oscillators—which is not really an oscillator at all—is the simple neon audio source.

The neon audio source is suitable for bridge energisation first and foremost, and if a source is required for this work alone the neon oscillator is all that need be constructed. It is also very useful for field work, for testing amplifiers, cinema equipment and similar apparatus, but by reason of its restricted frequency range and small output, together with the fact that it gives an impure waveform, it leaves much to be desired when compared with the Wien oscillator.

The neon audio source is shown in Fig. 21 in its simplest form, and in a rather better form in Fig. 22, where the source is isolated from the load by a transformer.

In each circuit the working principle is the same—the capacitance shunted across the neon lamp charges slowly through the high value limiting resistance until the condenser potential is sufficiently high to strike the neon. The condenser immediately discharges through the tube until the potential falls below the neon lamp's extinguishing potential. The lamp ceases to glow, the discharge is stopped and the condenser then commences to charge up again, the cycle of operations being continued for as long as the circuit is connected to a suitable D.C. supply at a rate giving audible current changes.

The rate of discharge is controlled by the resistance of the limiter, the capacitance of the shunt condenser and the striking and extinguishing potentials of the neon lamp, so that variation of the resistance and capacitance give corresponding variations of output frequency.

An ordinary household neon lamp may be used, although the " beehive " type is not suitable and a lamp of the disc and ring construction gives better results, in which case the D.C. voltage source will need a potential of approximately 350 volts. It is preferable to use a smaller lamp, however, the Bulgin neon lamp N.L.1 can be worked from a 200 volt source, the current drawn being so low that a pair of 100 volt batteries can supply the driving voltage without strain should such batteries be to hand. Alternatively the neon oscillator can be connected to the power supply of the apparatus under test or to D.C. mains, although in this case the common line to both neon oscillator and test equipment must be found and a high voltage coupling condenser be used unless transformer isolation is employed.

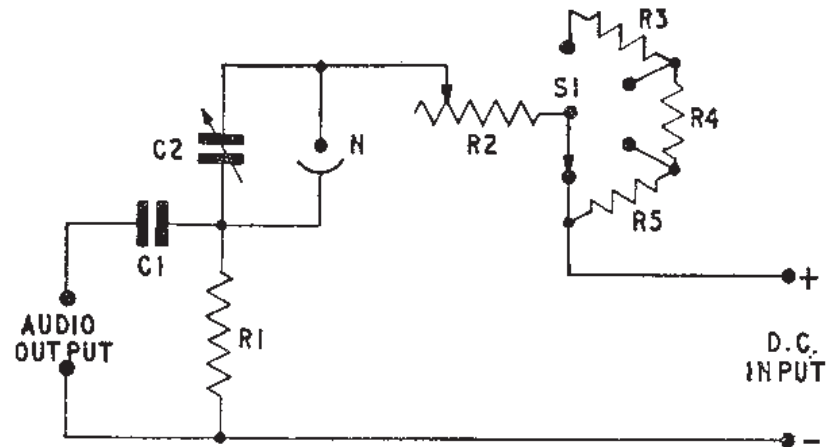

FIG. 21.—A Neon Audio Source.

Final capacitance and resistance values depend on the actual energising potential used, and if the potential is too high the lamp will strike and only extinguish when the higher resistances are switched into circuit. The arrangements shown will give quite a good frequency range over a fairly wide input voltage range, however.

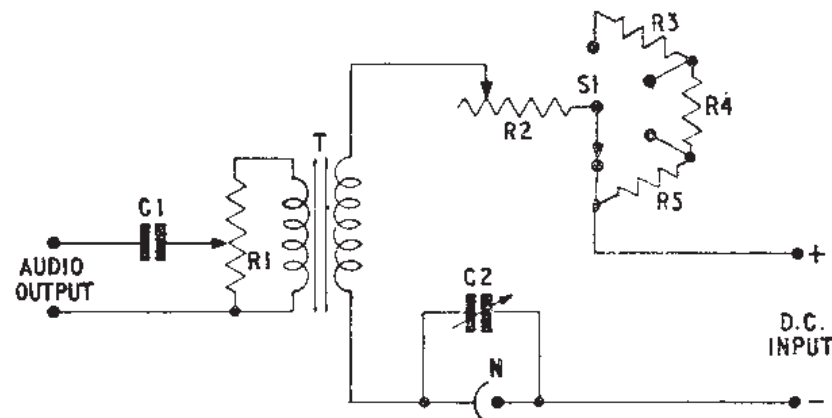

FIG. 22.—A Neon Audio Source with Isolated Output.

Components List for the Neon Oscillators. Figs. 21 and 22.

C1,	0.01 mfd. 500 v w. Non-inductive.
C2,	0.0005 mfd. variable. See note below.
R1, Fig. 21,	47,000 ohms, $\frac{1}{2}$ watt.
R1, Fig. 22,	0.25 megohm volume control.
R2,	2 megohms, fine frequency control.
R3, R4, R5,	1 megohm, $\frac{1}{2}$ watt.

- S1, S.P.4-way selector switch.
- T, 3.1 Intervalve transformer.
- N, Neon lamp, Bulgin N.L.1 or Phillips 240 volt disc and ring type.

D.C. input, 200 volts for the N.L.1 neon or 350 volts approximately for the 240 volt neon.

Note.—There are two fine frequency controls in the circuit, R2, the 2 megohm potentiometer and the variable condenser C2. The frequency range can be further extended by using a small double-gang condenser for C2 with the stators connected together as are the rotors. The maximum capacitance of C2 will then become 0.001 mfd.

Should the neon lamp glow steadily with all resistances in circuit and without giving an audio output, the D.C. energising potential is too high, and must either be reduced or extra resistance must be included in series with the circuit.

The Wien audio oscillator, shown in Fig. 23, is probably the simplest and yet one of the most useful audio sources that can be built. The circuit operation depends on controlled feedback from the second to the first valve through a resistance-capacitance bridge-connected network, the frequency of oscillation being set by the resistance and capacitance values. Commercial Wien bridges are generally controlled as to frequency by variable condensers of high maximum capacitances, but in the circuit of Fig. 23 the resistances are made variable, thus reducing the cost of the apparatus and giving a broad frequency range with no range switching.

One unusual feature of the circuit is that a pair of ganged potentiometers is necessary. Such potentiometers are often advertised in the technical press however, whilst the mechanic would have little trouble in mounting and ganging a pair of separate potentiometers. Components of the log. taper type should be used whenever possible, not only for the ganged potentiometers but also for the feedback and output controls.

*Components List for the Wien Bridge Audio Oscillator. Fig. 23.*

- R1, R2, 1 megohm ganged potentiometers, frequency control.
- R3, 25,000 ohms variable, output control.
- R4, 100,000 ohms variable, feedback control.
- R5, R8, 47,000 ohms, 1 watt.
- R6, R9, 1,500 ohms, 1 watt.
- R7, 1 megohm, 1 watt.
- C1, 0.001 mfd. Mica.
- C2, 0.003 mfd. Mica.
- C3, 0.05 mfd. 350 v.w. Non-inductive.
- C4, 0.1 mfd. 350 v.w. Non-inductive.
- C5, C6, 8 mfd. 500 v.w. Electrolytic.
- L.F.C., 20 Henrys 60 mAs.
- T, 200-250 volts primary.
- 250-0-250 v. 60 mAs. secondary.
- 4v. 2a.      4v. 2a.

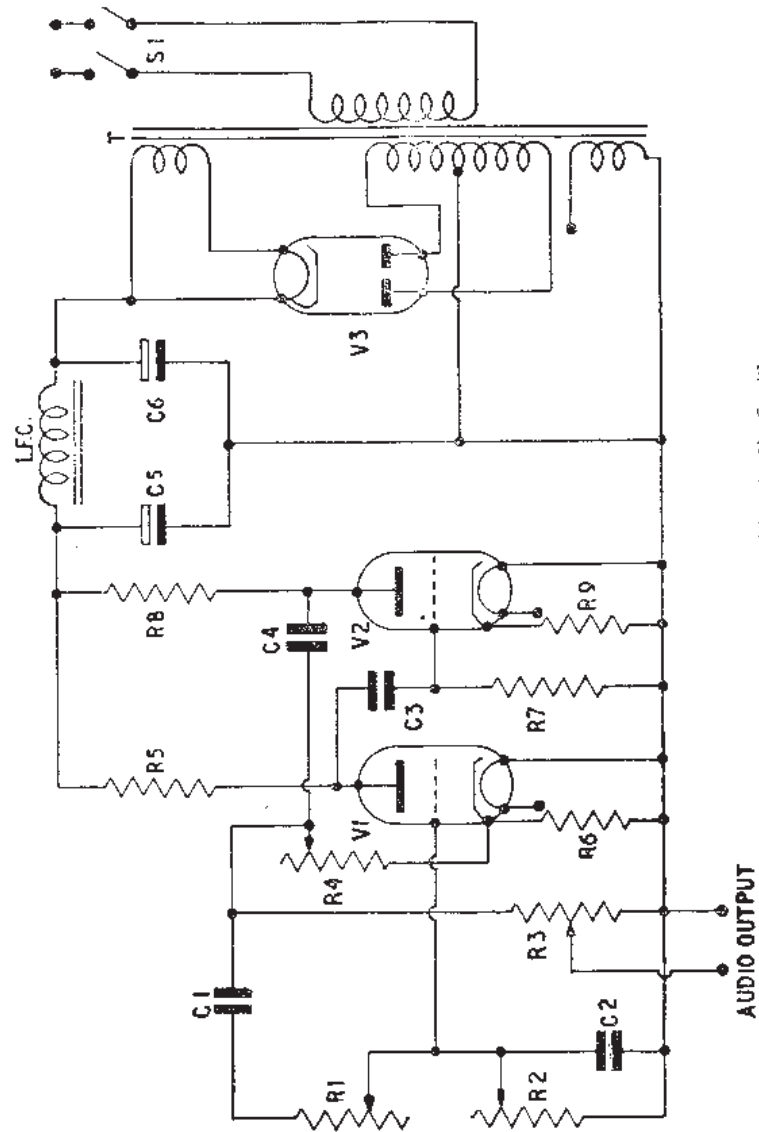

Fig. 23.—The Wien Bridge Audio Oscillator.

S1, D.P.S.T. On-Off Switch, ganged with R3.  
 V1, V2, ACHL.  
 V3, UUG.

2 British 5-pin chassis mounting valveholders.

1 Mazda octal chassis mounting valveholder.

Chassis, output sockets, control knobs, etc.

If, upon testing, the frequency variations appear crowded to one end of the travel of the arms of R1, R2, this will probably be due to connection in the wrong sense to one of the potentiometers and may be corrected by reversing the leads to either of the potentiometers in the ganged pair.

Oscillation is controlled by R4 and this control should not be advanced much beyond the point where oscillations commence or the output wave form will deteriorate. At the highest frequency travel of the ganged potentiometers oscillation may cease, but since this effect should occur outside of the audio range this will cause no trouble.

The output should always be run into a high impedance load, wherever possible. If it is desired to calibrate the instrument for frequency the calibrations will hold only when the load on the output terminals is of a high impedance, and the setting of R4 should also be calibrated. Calibrations are best made against an audio frequency standard instrument or by beating the oscillator output against a known audio frequency on the oscilloscope screen, when a series of Lissajous' figures will be traced.

Further details of frequency determination by means of Lissajous' figures may be obtained from the Cathode Ray Oscilloscope Manual, No. 87, in Messrs. Bernards' List.

## CHAPTER 9

### L, C AND R BRIDGES

Whilst all workers are familiar with the Wheatstone resistance bridge, many are not so familiar with capacitance and inductance measuring bridges, or know only of the commercial and advanced forms of these bridges. It is quite possible, however, to build very simple bridges by means of which measurements of resistance, capacitance and inductance may be made, and whilst, of course, a simple bridge circuit with a simple indicating device such as a pair of headphones will not give laboratory precision, measurements sufficiently accurate for workshop use can be made.

To use headphones as indicators means that the bridge must be energised from an audio source, and the neon or Wien bridge oscillators are excellent in this respect. The frequency used should be in the region of 1,000 cycles, and the audio voltage injected should be as low as will give good results, although it should be remembered that bridge sensitivity is enhanced by stepping up the input.

The bridge should be connected to the audio source via a transformer.

The circuit of a very simple bridge is shown in Fig. 24, where capacitance and resistance are measured. Two standards are included within the bridge circuit, a 1,000 ohms resistance and a capacitance of 0.001 mfd. and the accuracy of the final results will depend to a large extent on the

accuracy of these components. With the unknown capacitance or resistance connected across the X terminals the switch S1 is turned to the appropriate standard and the slider of the potentiometer moved across its arc of travel until a point is reached where the audio note is not heard in the headphones, or at least where the strength of the note is considerably weakened. The value of the unknown component is now greater or smaller than the standard component by a factor which is the ratio of the resistances on either side of the potentiometer arm. To give direct reading, therefore, the potentiometer must be calibrated in some way.

The simplest method of calibrating the potentiometer is to connect a series of resistances or capacitances across the X terminals, ranging from either 20 to 100,000 ohms, the resistance measuring range, or from 0.02 to 0.0001 mfd., the capacitance measuring range, calibrating the potentiometer, fitted with a small card scale, accordingly at each null point where the headphone signal dies away. Alternatively the potentiometer may be calibrated against an ohmmeter, although since it is necessary to calibrate it, by this method, not in steps of resistance but in steps of ratios of resistance, the process is rather long and painstaking. The switch S2, reversing the potentiometer connections, is necessary to allow both resistance and capacitance to be read from the one scale, since the capacitance readings proceed in the opposite direction to the resistance readings.

Resistance and capacitance measurements may be multiplied by using more than one resistance and capacitance standard, but the standards must be in correct ratio one to the other if the scale is to be accurate over its range.

#### Components List for the Resistance-Capacitance Bridge, Fig. 24.

R1,	1,000 ohms, precision resistance.
R2,	10,000 ohms, wirewound potentiometer.
C1,	0.001 mfd. Mica. 1% accuracy.
S1,	S.P.D.T. R-C selector switch.
S2,	D.P.D.T. Scale correcting switch.
H,	High Impedance Headphones.

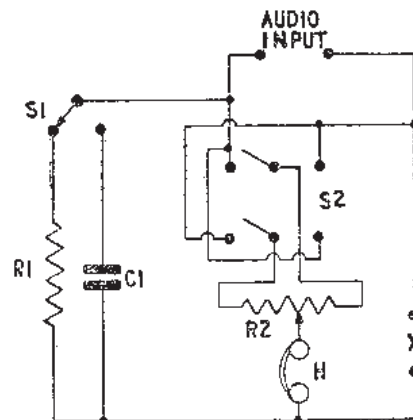

FIG. 24.—R—C Bridge.

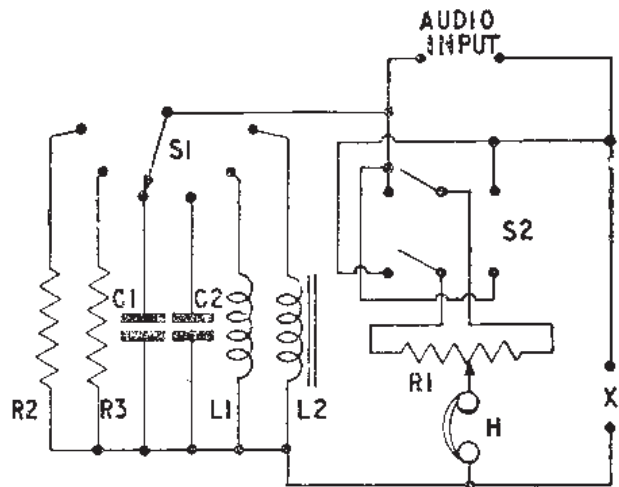

FIG. 25  
C-R-L Bridge.

An adaptation of the same bridge circuit is shown in Fig. 25, where provision is made for measuring inductance as well as resistance and capacitance, the measurements being made in two ranges. Finding suitable inductance standards may be troublesome—in any event their values will depend on the inductance ranges it is required to measure—but assuming that measurements over the radio coil and smoothing choke inductance ranges is required a 1.5 millihenry choke and a 15 Henry L.F. choke will give sufficient coverage over their two respective ranges. It must be remembered that ordinary L.F. chokes are rated for inductance with D.C. flowing, and when the inductance is measured without a D.C. flow the value will be different from the rated value by a large amount.

Once again the bridge will be most easily calibrated by calibrating it first in terms of resistance and capacitance and then transferring these readings as multiplying and dividing ratios for the inductances. For example, using the 100 ohms standard and measuring 1,000 ohms in the unknown position gives a 1,000 ohms calibration point on the potentiometer scale, the same point also being a Standard  $\times 10$  point on the potentiometer scale. Using the 1.5 millihenry choke as a standard, an unknown inductance giving a null reading at the same point on the bridge would be 10 times the standard inductance, or 15 millihenry.

*Components List for the C.R.L. Bridge, Fig. 25.*

R1,	10,000 ohms wirewound potentiometer.
R2,	100 ohms, precision resistance.
R3,	10,000 ohms, precision resistance.
C1,	0.01 mfd. 1% accuracy.
C2,	1.0 mfd. 1% accuracy.
L1,	1.5 millihenry choke, Eddystone 1022.
L2,	15 Henrys L.F. choke.
S1,	S.P. 6 way Standard Selector Switch.

S2,  
H,

D.P.D.T. Scale correcting switch.  
High Impedance Headphones.

It is also possible to measure inductance as a function of resistance and capacitance rather than against a standard coil, however, two examples of such inductance measuring sets being the Maxwell and Hays bridges. The circuit of Fig. 26 shows a really comprehensive bridge controlled by switches to make it either a Wheatstone bridge for measuring resistances between 10 ohms and 1 megohm, a capacitance bridge, measuring capacitances between 10 mmfds. and 100 mfd. and a Hays bridge measuring inductances from 10 microhenrys to 100 Henrys. All the measurements are made on a single calibrated potentiometer, using headphones as a detector or, if desired, a more sensitive detector. Another popular detector is the cathode ray tube null detector, where one set of plates are connected to the detector position of a bridge, the other set being connected to the bridge oscillator, with the null balancing point of the bridge shown as a single horizontal line trace.

The potentiometer R1 of Fig. 26 must be calibrated against a good ohmmeter or Wheatstone bridge in the following manner. Measure, on the Wheatstone's bridge or ohmmeter, the resistance values across one end of the potentiometer and the moving arm, calibrating the potentiometer (which is actually used as a rheostat) at the positions shown in the table below.

Resistance of R.1.	Res. of X	Induc. of X	Cap. of X
100Ω	10Ω	10 $\mu$ h	0.00001 mfd.
150Ω	15Ω	15 $\mu$ h	0.000015 mfd.
200Ω	20Ω	20 $\mu$ h	0.00002 mfd.
250Ω	25Ω	25 $\mu$ h	0.000025 mfd.
300Ω	30Ω	30 $\mu$ h	0.00003 mfd.
350Ω	35Ω	35 $\mu$ h	0.000035 mfd.
400Ω	40Ω	40 $\mu$ h	0.00004 mfd.
450Ω	45Ω	45 $\mu$ h	0.000045 mfd.
500Ω	50Ω	50 $\mu$ h	0.00005 mfd.
550Ω	55Ω	55 $\mu$ h	0.000055 mfd.
600Ω	60Ω	60 $\mu$ h	0.00006 mfd.
650Ω	65Ω	65 $\mu$ h	0.000065 mfd.
700Ω	70Ω	70 $\mu$ h	0.00007 mfd.
750Ω	75Ω	75 $\mu$ h	0.000075 mfd.
800Ω	80Ω	80 $\mu$ h	0.00008 mfd.
850Ω	85Ω	85 $\mu$ h	0.000085 mfd.
900Ω	90Ω	90 $\mu$ h	0.00009 mfd.
950Ω	95Ω	95 $\mu$ h	0.000095 mfd.
1000Ω	100Ω	100 $\mu$ h	0.0001 mfd.
1500Ω	150Ω	150 $\mu$ h	0.00015 mfd.
2000Ω	200Ω	200 $\mu$ h	0.0002 mfd.
2500Ω	250Ω	250 $\mu$ h	0.00025 mfd.
3000Ω	300Ω	300 $\mu$ h	0.0003 mfd.
3500Ω	350Ω	350 $\mu$ h	0.00035 mfd.
4000Ω	400Ω	400 $\mu$ h	0.0004 mfd.



4500Ω	450Ω	450 $\mu$ h	0.00045 mfd.
5000Ω	500Ω	500 $\mu$ h	0.0005 mfd.
5500Ω	550Ω	550 $\mu$ h	0.00055 mfd.
6000Ω	600Ω	600 $\mu$ h	0.0006 mfd.
6500Ω	650Ω	650 $\mu$ h	0.00065 mfd.
7000Ω	700Ω	700 $\mu$ h	0.0007 mfd.
7500Ω	750Ω	750 $\mu$ h	0.00075 mfd.
8000Ω	800Ω	800 $\mu$ h	0.0008 mfd.
8500Ω	850Ω	850 $\mu$ h	0.00085 mfd.
9000Ω	900Ω	900 $\mu$ h	0.0009 mfd.
9500Ω	950Ω	950 $\mu$ h	0.00095 mfd.
10000Ω	1000Ω	1000 $\mu$ h	0.001 mfd.

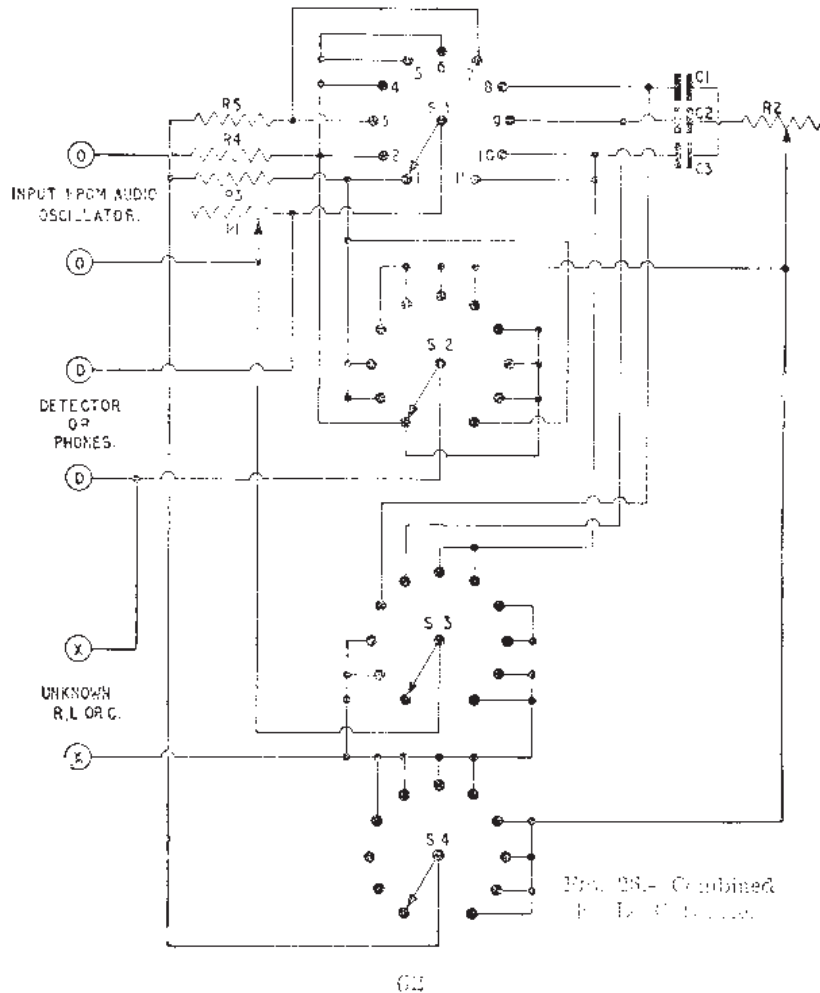

These readings, of course, are only for the lowest ranges and must be multiplied by the correct factor as applied to the range switch. The resistance ranges are 10-1,000 ohms, 1,000-100,000 ohms, and 100,000-10 megohms, the capacity ranges are 0.00001-0.001 mfd., 0.001-0.1 mfd., 0.1-10 mfd. and 10-1000 mfd. The inductance ranges are 10-1,000 micro-henry, 1-100 milli-h., 100 milli-h. to 10 Hs. and 1-100 Hs.

*Components List for the R.L.C. Bridge. Fig. 26.*

R1,	10,000 ohms wirewound variable resistor calibrated as described.
R2,	10,000 ohms wirewound variable resistor.
R3,	10,000 ohms precision resistor.
R4,	1,000 ohms precision resistor.
R5,	10 ohm precision resistor.
C1,	0.0001 mfd. mica precision condenser.
C2,	0.01 mfd. mica precision condenser.
C3,	1 mfd. paper precision condenser.
S1, 2, 3, 4,	Single pole 4 bank rotary selector switch.

*Selector switch position.*

position.	Range.
1.	Ohms x 1. 10-1,000 ohms.
2.	Ohms x 100 1,000-100,000 ohms.
3.	Ohms x 10,000 100,000 ohms-10 megs.

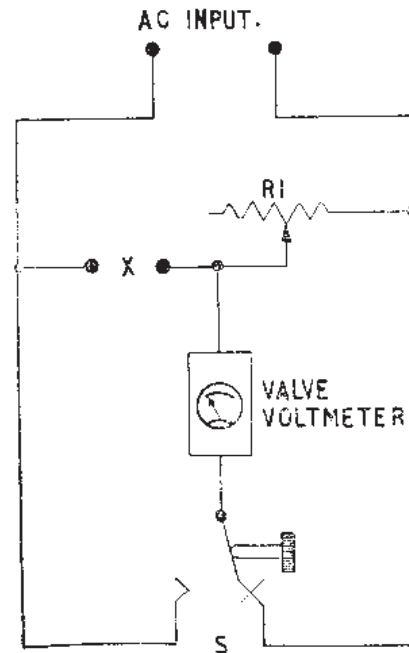

FIG. 27.—Impedance Bridge.

4.	Capacity x 1.	0.00001-0.001 mfd.
5.	Capacity x 100	0.001-0.1 mfd.
6.	Capacity x 10,000	0.1-10 mfd.
7.	Capacity x 100,000	10-1000 mfd.
8.	Inductance x 1	10-1,000 micro-h.
9.	Inductance x 100	1-100 milli-h.
10.	Inductance x 10,000	100-10,000 milli-h.
11.	Inductance x 100,000	1-10 Henrys.

The variable resistance R.2 is only in circuit on the Capacity and Inductance ranges and is used to balance the resistive losses in the unknown condenser or inductance. The balance or null position is first found by adjusting R1, and R2 is then adjusted so as to make this null point as sharp as possible. The setting of R1 should then be rechecked.

In Fig. 27 is shown a simple Impedance "Bridge"—not a true bridge circuit, although it is operated in a rather similar manner. When it is required to discover the impedance of a capacitance, inductance or a combination of the two, possibly including resistance, the impedance may be measured by a simple substitution.

A.C. or audio power at the required frequency is fed to the input terminals, a low voltage being all that is necessary, and the unknown impedance is connected across the X terminals. The switch S may be an ordinary S.P.D.T. switch, although a spring loaded double contacting plunger is simpler to use, and may be easily made up from old relay contacts. The switch is pressed and released so that the valve voltmeter is alternatively connected across the unknown impedance and the calibrated rheostat, the rheostat being turned whilst the alternations of contact are made until the reading of the valve voltmeter remains the same, no matter on which side the switch is contacting. The impedance, in ohms, then equals the resistance in ohms of the rheostat setting.

The rheostat must, of course, be non-inductive, so that a good composition track will probably be better than a wirewound component. The rheostat maximum resistance must be at least as high as the impedances to be handled.

The rheostat may be calibrated in ohms against a Wheatstone's bridge or a good ohmmeter.

# BERNARDS RADIO BOOKS

10.	Manual of Log and Maths. Tables	1/-
35.	Dictionary of Mathematical Data	2/-
39.	Tool Makers and Engineers Manual	1/-
56.	Radio Aerial Handbook	2/6
57.	Ultra-Shortwave Handbook	2/6
58.	Radio Hints Manual	2/6
61.	Amateur Transmitter's Construction Manual	2/6
63.	Radio Calculations Manual	3/6
64.	Sound Equipment Manual	2/6
65.	Radio Designs Manual	2/6
66.	Communications Receivers' Manual	2/6
68.	Frequency Modulation Receivers' Manual	2/6
69.	Radio Inductance Manual	2/6
70.	Loudspeaker Manual	2/6
71.	Modern Battery Receivers' Manual	2/6
73.	Radio Test Equipment Manual	2/6
78.	Radio and Television Laboratory Manual	2/6
80.	Television Servicing Manual	4/6
81.	Using Ex-Service Apparatus	2/6
82.	AC/DC Receiver Construction Manual	2/6
83.	Radio Instruments and their Construction	2/6
86.	Midget Radio Construction	3/6
90.	Wireless Amplifier Manual No. 2	2/-
91.	Handbook of Radio Circuits No. 3	2/6
93.	Power Pack Manual	4/6
94.	Practical Circuits Manual	3/6
95.	Radio Data Book	1/6
96.	Crystal Set Construction	1/-
97.	Practical Radio for Beginners, Book 1	2/-
99.	One Valve Receivers	1/6
100.	A Comprehensive Radio Valve Guide, Book 1	5/-
101.	Two Valve Receivers	1/6
102.	40 Circuits Using Germanium Diodes	3/-
103.	"Radiofolder" A. The Master Colour Code Index for Radio and Television	1/6
104.	Three Valve Receivers	1/6
106.	Radio Circuits Handbook No. 4	2/6
109.	High Fidelity Radio; Design and Construction by N. Bonavia Hunt	3/6
111.	"Radiofolder" B. A Practical Oscilloscope	2/6
114.	"Radiofolder" E. An Inexpensive Tape Recorder	2/6
115.	Constructors' Handbook of Germanium Circuits	2/6
117.	The Tele-King: Constructional Envelope	6/-
118.	Practical Coil Construction for Radio and Television	3/-
119.	The Practical Superheterodyne Manual	3/-
120.	Radio and Television Pocket Book	2/6
121.	A Comprehensive Valve Guide Book 2	5/-
122.	Wide Angle Conversion: for Home Constructed Televisors: Constructional Envelope	3/6
123.	"Radiofolder" F. The Beginners' Push-Pull Amplifier	1/6
124.	"At a Glance" Valve and Tube Equivalents for Radio and Television	5/-
125.	Listeners' Guide to Radio and Television Stations of the World	2/6
	A Magnetic Tape Recorder	3/6
	The Electronic Photographic Speedlamp: How to Make it and How to Use it	3/6
	Universal Valve Guide	15/-
	International Radio Tube Encyclopædia, 1954 Edition	42/-