

# **40**

## **CIRCUITS USING GERMANIUM DIODES**

*By*

**SYLVANIA ELECTRIC PRODUCTS INC.**

*Applications for*

Receivers	Television
Transmitters	Test Instruments
Remote Control	Electronic Equipment
Noise Limiters	Power Supplies

**40 CIRCUIT DIAGRAMS**

*Comprehensive Germanium Diode Characteristics Chart*

**BERNARDS (PUBLISHERS) LTD.**

**L O N D O N**

**THREE SHILLINGS NET**



40

CIRCUITS USING  
GERMANIUM DIODES



40  
CIRCUITS USING  
GERMANIUM DIODES

BERNARDS (Publishers) LTD.

LONDON

First Printed October, 1951  
Reprinted October, 1957  
Reprinted January, 1961

Printed for Bernards (Publishers) Ltd., The Grampians, Western Gate,  
London, W.6, by V Cooper & Partners Ltd., Flitcroft Street,  
London, W.C.2.

# TABLE OF CONTENTS

Page

<i>List of Illustrations</i>	7
<i>Foreword</i>	8
<i>Foreword to British Edition</i>	9
<i>Comparative Crystal Tables</i>	10

## CHAPTER I

<i>Receivers and Receiver applications</i>	11
--	----

1.1 Simple Crystal Receiver; 1.2 Push-Pull Crystal Receiver; 1.3 Bandpass Crystal Receiver; 1.4 Use of Audio Amplifier with Crystal Sets; 1.5 Crystal Video Detector; 1.6 Crystal DC Restorer for Television; 1.7 Second Detector A.V.C. Circuit; 1.8 FM Detectors; 1.9 Compact Series-Shunt Impulse Noise Limiter; 1.10 Combined Second Detector and Noise Limiter.

## CHAPTER II

<i>Transmitter and Amplifier Applications</i>	15
---	----

2.1 Transmitter Failure Alarm; 2.2. Transmitter Adjusting Gimmick; 2.3 Low-Powered Frequency Doubler; 2.4 Carrier-Operated Inverse Feedback Circuit; 2.5 Pre-Modulation Speech Clipper; 2.6 Low-Voltage Bias Supply.

## CHAPTER III

<i>Instruments and Gadgets</i>	22
--------------------------------	----

3.1 Simple Sideband Generator; 3.2 Tubeless DC Amplifier; 3.3 Voltage Multiplier Circuits; 3.4 Audio Frequency Meter; 3.5 Frequency Tripler; 3.6 Two-Way Relay Circuit; 3.7 Standing Wave Indicator; 3.8 Simple Field Strength Meter; 3.9 Sensitive Field Strength Meter; 3.10 AF-RF Ammeter; 3.11 External Modulator for Signal Generators; 3.12 RF Probe; 3.13 Audio Extractor for Signal Generators; 3.14 Tubeless Tone Generator; 3.15 Tubeless Audio Oscillator; 3.16 Crystal Diode Wave Shaper; 3.17 AF-RF Wattmeter; 3.18 Sensitive AF-RF Signal Tracer; 3.19 Distortion Meter; 3.20 Simple Selective Telephone Circuit; 3.21 Selective Telegraph Circuit; 3.22 Modulation and Carrier Shift Meter; 3.23 Receiver for Model Control; 3.24 Crystal Voltmeter.

<i>Ratings and Characteristics of Germanium Diodes</i>	45
--	----





## LIST OF ILLUSTRATIONS

<i>Figure</i>	<i>Title</i>	<i>Page</i>
1-1	Simple Crystal Receiver	11
1-2	Push-Pull Crystal Receiver	12
1-3	Band Pass Crystal Receiver	13
1-4	Crystal Video Detector for Television	13
1-5	Crystal DC Restorer for Television	14
1-6	Second Detector—AVC Circuit	14
1-7	FM Detectors	15
1-8	Shunt Impulse Noise Limiter	16
1-9	Combined Second Detector, AVC and Noise Limiter	17
2-1	Transmitter Failure Alarm	18
2-2	Transmitting Adjusting Gimmick	19
2-3	Low-Powered Frequency Doubler	19
2-4	Carrier Operated Inverse Feedback Circuit	20
2-5	Pre-Modulation Speech Clipper	21
2-6	Low-Voltage Bias Supply	21
3-1	Simple Sideband Generator	22
3-2	Tubeless DC Amplifier	23
3-3	Crystal Voltage Multiplier Circuits	24
3-4	Indicating Audio Frequency Meter	25
3-5	Frequency Tripler	26
3-6	Two Way Relay Operating at Two Different Values of an Increasing or Decreasing DC Voltage	26
3-7	Standing Wave Indicator for Twin-Lead RF Transmission Line	27
3-8	Simple Field Strength Meter	28
3-9	Sensitive Field Strength Meter	29
3-10	AF-RF Ammeter (0-100 Mc)	30
3-11	External Modulator for RF Test Oscillator	31
3-12	RF Probe for DC Vacuum Tube Voltmeter	32
3-13	Audio Extractor for RF Signal Generators	33
3-14	Tubeless Tone Generator	33
3-15	Tubeless Audio Oscillator	34
3-16	Crystal Diode Wave Shaper	35
3-17	AF-RF Wattmeter	36
3-18	Sensitive AF-RF Signal Tracer	37
3-19	Distortion Meter	38
3-20	Simple Selective Telephone Circuit	40
3-21	Selective Telegraph Circuit	41
3-22	Percentage Modulation and Carrier Shift Meter	42
3-23	144 Mc Receiver for Model Control	42
3-24	Crystal Voltmeter	43

## FOREWORD

The crystal detector is almost as old as radio itself. In every generation since the early days of wireless, thousands of enthusiastic adults and youngsters have constructed crystal sets and picked up signals with them. The fascination of the crystal seems to be endless.

For a long time after vacuum tubes became sufficiently low-priced for experimenters to afford them in numbers, the crystal came to be looked upon as a fragile novelty with few practical applications outside of the toy radio receiver field. By the end of World War II, however, the highly stable germanium crystal diode was available. This device, typified by the popular Sylvania 1N34, has restored the crystal to a position of importance in the electronic field. Many useful tubeless devices now may be constructed around crystal diodes.

Sylvania has carried on considerable research into the production of better germanium diodes and from time to time has published pamphlets showing new and interesting applications of these crystals. This latest booklet brings together the largest published collection to date of miscellaneous crystal diode applications.

In this booklet will be found receiver, transmitter and amplifier applications, instruments, and gadgets. It has been our aim to present a variety of applications in each of which one of the various distinct groups of radio people might find interest. The casual hobbyist and young experimenter will find on these pages interesting gadgets he can build—and the serious technician will find time-saving devices and simplified circuits to serve him.

No license is to be implied with respect to any inventions described herein, and no responsibility is assumed for the application or interpretation of the information contained herein, or for any infringement of patent or other rights of third parties which may result from the use of that information.

All of the circuits described have been tested and proved. Since it has been impossible to include every possible crystal application, we have selected the most generally useful ones from our large collection.

SYLVANIA ELECTRIC PRODUCTS INC.

## FOREWORD TO BRITISH EDITION

The germanium crystal has now firmly established itself as a useful replacement for the more usual thermionic diode. The field is as yet by no means saturated and new types are constantly being designed to fulfil the function of specialised diodes in every branch of electronics. The advantages of the germanium crystal is not confined to the saving of heater current and size, it also has wide frequency range, low self-capacitance and almost unlimited life. Bernard's (Publishers) Ltd. take pride in presenting this manual of circuits devoted entirely to the use of this remarkable crystal. The circuits and letterpress are reprinted by courtesy of Sylvania Electric Products Inc., Emporium, Pennsylvania, U.S.A. This great Company will need no introduction to British readers, as their name has been associated with all that is finest in the thermionic valve field from the very early days, and at the present time they are probably the largest manufacturers of germanium crystals on the continent of America.

With the co-operation of the leading British manufacturers a comparative table has been introduced so that readers in the U.K. can substitute a crystal of British origin should the original Sylvania crystal prove difficult to obtain. It is pointed out that because of fundamental differences between British and American television transmissions Fig. 1.5 has been re-designed to conform with the British system.

BERNARD'S (PUBLISHERS) LTD.

## SUITABLE BRITISH CRYSTALS

Fig. No.	Westinghouse	B.T.H.	Fig. No.	Westinghouse	B.T.H.
1-1	WG 4 B	CG 6-M	3-4	WG 4 B	CG 6-M
1-2	WG 4 B	CG 6-M	3-5	WG 4 B	CG 5-M
1-3	WG 5 A	CG 6-M	3-6	—	CG 6-M
1-4	WG 4 A	CG 5-M	3-7	WG 4 A	CG 5-M
1-5	WG 7 A	CG 4-C	3-8	WG 7 B	CG 5-M
1-6	WG 7 A	CG 6-M	3-9	WG 7 B	CG 5-M
	(alter diode load to 100kΩ)		3-10	WG 7 B	CG 5-M
1-7	WG 7 A	CG 5-M	3-11	WG 7 B	CG 5-M
	(each shunted with 220kΩ 10%)		3-12	WG 7 B	CG 5-M
1-8	WG 7 B	CG 6-M		(Up to 50 v.)	
1-9	CR 1 =	CR 1 =		WG 7 C	
	WG 7 A	CG 5-M		(Up to 100 v.)	
	CR 2 & 3 =	CR 2 & 3 =	3-13	WG 5 A	CG 5-M
	WG 7 B	CG 6-M	3-14	WG 4 B	CG 6-M
2-1	WG 7 B	CG 5-M	3-15	WG 4 A	CG 6-M
2-2	WG 7 B	CG 5-M	3-16	WG 7 B	CG 6-M
2-3	WG 7 B	CG 5-M	3-17	WG 7 B	CG 5-M
2-4	WG 5 A	CG 5-M	3-18	WG 7 B	CG 5-M
2-5	WG 7 B	CG 6-M	3-19	WG 7 B	CG 6-M
2-6	WG 4 B	CG 6-M	3-20	WG 7 B	CG 6-M
3-1	WG 7 B	CG 6-M	3-21	WG 7 B	CG 6-M
3-2	WG 7 B	CG 6-M	3-22	WG 7 B	CG 6-M
3-3	WG 4 B	CG 4-C	3-23	WG 7 B	CG 5-M
	(up to 6 v.)		3-24	WG 7 B	CG 5-M

### G.E.C. CRYSTALS

Where a Sylvania type 1 N 3 4 is specified a G.E.C. type G E X 45/1 can usually be substituted, and where a 1 N 5 4 is called for a G E X 55/1 is suggested. For Fig. 1-5 a G E X 55/1 will be suitable.

### B.T.H. CRYSTALS

The letter following the type number on these crystals indicates the form of construction, C indicates metal and glass and M a moulded plastic form of construction. The electrical characteristics are the same for either form of construction.

## CHAPTER I

### RECEIVERS AND RECEIVER APPLICATIONS

**1.1 SIMPLE CRYSTAL RECEIVER.** The crystal receiver has had universal appeal to a multitude of radio experimenters since the early days of wireless. Its continued fascination, even at present when tubes are inexpensive, has been due to the fact that the crystal detector requires no power supply and gives remarkably clear and lifelike reproduction. Furthermore, a crystal set is simple in principle and easy to build.

The audio output of a crystal set is low. This means that a good, long, outside antenna and a good ground must be used in most localities for best results. These requirements do not detract from the popularity of this simple receiver, however, and thousands are built each year by hobbyists in all walks of life.

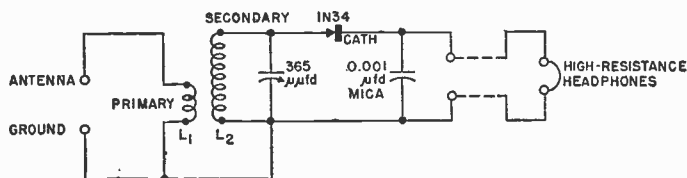

L<sub>1</sub> AND L<sub>2</sub> ARE THE PRIMARY AND SECONDARY OF ANTENNA COIL WITH FREQUENCY RANGE OF 540-1750 KC

Figure 1-1. SIMPLE CRYSTAL RECEIVER

Figure 1-1 shows one of the simplest circuits which may be employed to receive broadcast stations. A set of this type may be built in a single evening by an inexperienced person. While the reader might wind his own coils, the manufactured coil specified in Figure 1-1 is so low in price as to make the labor of making the coil at home unattractive.

The set covers the standard broadcast band. That is, 540 to 1750 kc which is actually a little more than the broadcast band limits. All tuning is done with the single 365- $\mu$ f variable capacitor.

Under ordinary conditions, the range of the receiver will not be greater than about 25 miles. Loudest signals will be picked up from the most powerful stations. Best signal strength will be obtained when the antenna is outside, between 40 and 100 feet long, and situated as high as practicable above the ground and other objects. A good ground, such as a tight connection to a *cold* water pipe, might be used.

**1.2 PUSH-PULL CRYSTAL RECEIVER.** The crystal receiver circuits shown in Figure 1-2 deliver somewhat louder signals than the simpler sets described in Section 1.1, and separates stations more effectively.

The improved operation of this circuit is obtained by use of double tuning (by means of tuning capacitors  $C_1$  and  $C_2$ ) and two crystal diodes in a full-wave detector circuit. If desired, a Sylvania Type 1N35 duodiode unit may be used in place of the two separate 1N34's. Details of the special coupling coil, which can be built easily by the reader, are given in Figure 1-2.

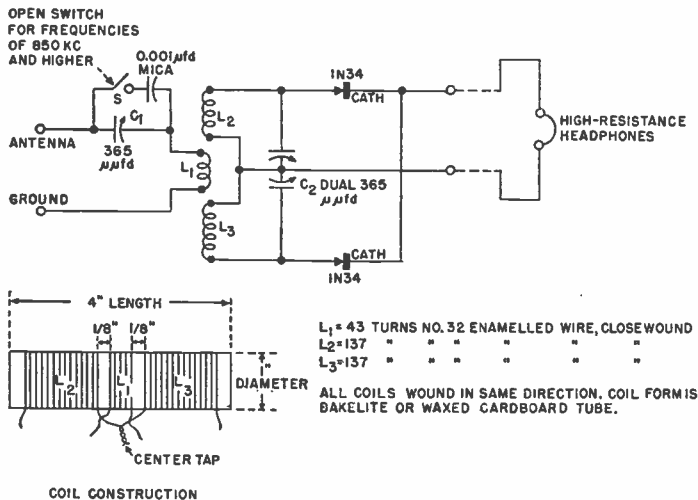

Figure 1-2. PUSH-PULL CRYSTAL RECEIVER

Operation of the set is not complicated. (1) If the station to be received operates on a frequency lower than 850 kc, close switch S. If the station frequency is 850 kc or higher, open the switch. (2) Tune-in the station closely by adjusting capacitor  $C_2$ . (3) Finally, adjust capacitor  $C_1$ , to improve the headphone volume and to reduce at the same time interference from other stations.

**1.3 BANDPASS CRYSTAL RECEIVER.** A highly-selective crystal broadcast receiver circuit is shown in Figure 1-3. The ability of this circuit to separate stations more effectively than earlier sets is made possible by a tuned bandpass filter made up with manufactured coils. These coils are obtainable as a kit. Single-dial tuning is entirely by means of the dual 365- $\mu$ fd variable capacitor.

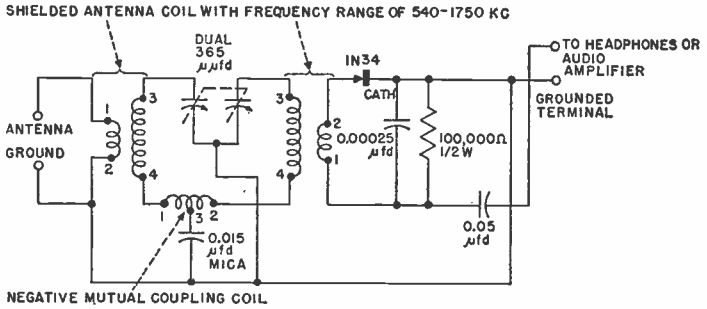

Figure 1-3. BAND PASS CRYSTAL RECEIVER

The audio output of this circuit is somewhat lower than that afforded by the receivers described in Sections 1.1 and 1.2. However, the circuit was designed originally for use as a broadcast tuner to be used with a high-fidelity audio amplifier. The amplifier gain compensates for the low volume of the crystal detector output.

#### 1.4 USE OF AUDIO AMPLIFIERS WITH CRYSTAL SETS.

While crystal receivers ordinarily are thought of as being used with headphones, any crystal set may be used ahead of an audio amplifier when loudspeaker operation is desired. Because of the increased linearity of the crystal detector at low signal levels, a combination of crystal receiver and audio amplifier will give true-to-life reproduction.

**1.5 CRYSTAL VIDEO DETECTOR.** Because the dynamic resistance of the germanium crystal diode is very low and the crystal capacitance also is low, the crystal diode offers improved operation in video second detector circuits in television receivers. The crystal diode also gives excellent linearity at low signal levels and is free from contact potential effects.

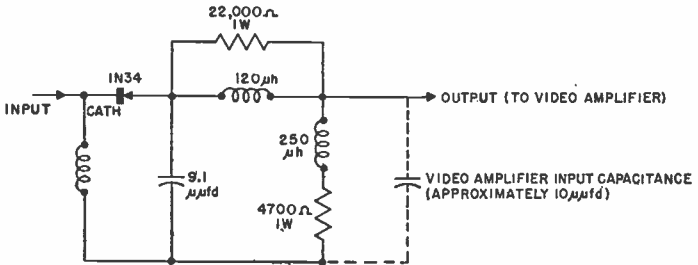

Figure 1-4. CRYSTAL VIDEO DETECTOR FOR TELEVISION

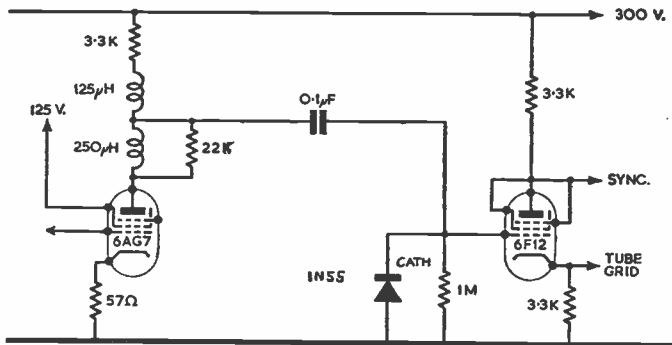

Figure 1-5. CRYSTAL DC RESTORER FOR TELEVISION

Figure 1-4 is the circuit of a video detector employing the 1N34. This circuit will be of interest to builders of home-made television receivers who wish to reduce the amount of tube space on the chassis, while at the same time taking advantage of the additional improvements offered by the crystal detector.

**1.6 CRYSTAL DC RESTORER FOR TELEVISION.** The function of dc restoration in a television receiver is accomplished proficiently by a crystal diode because of its low dynamic resistance.

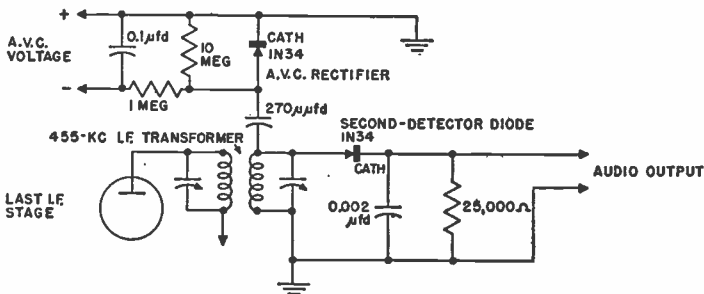

Figure 1-6. SECOND DETECTOR—A.V.C. CIRCUIT

Figure 1-5 shows a typical dc restorer circuit. Several new crystal diodes developed by Sylvania have the ability to withstand relatively high negative dc voltages and are well suited to use in the dc restorer circuit. These new diodes are the 1N55 which is rated at 150 volts, 1N57 at 80 volts, and 1N58 at 100 volts.



**1.7 SECOND DETECTOR—AVC CIRCUIT.** Considerable space saving and circuit simplification are made possible in the radio receivers, especially in short-wave and all-wave sets, by using crystal diodes as 2nd detector and avc rectifiers.

In Figure 1-6, one 1N34 is employed as a series-diode 2nd detector, and a second 1N34 as a shunt-diode avc rectifier. The capacitance and resistance values given in this circuit are for the popular 455 kc intermediate frequency.

The crystal diodes may be mounted under the chassis of the receiver with the capacitors and resistors associated with the circuit.

**1.8 FM DETECTORS.** Germanium diodes simplify the circuits and construction of the frequency modulation 2nd detectors. The 1N35 duo-

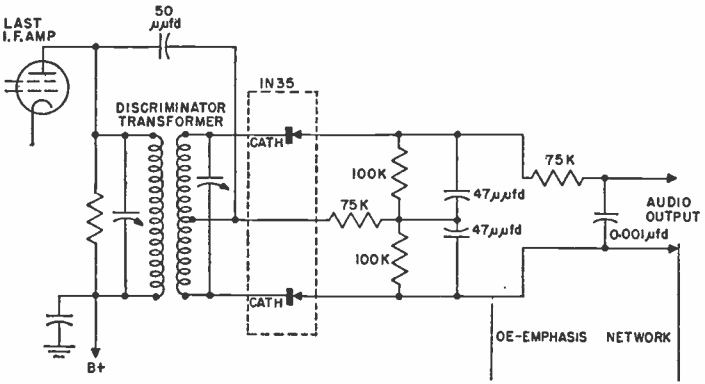

(A) DISCRIMINATOR

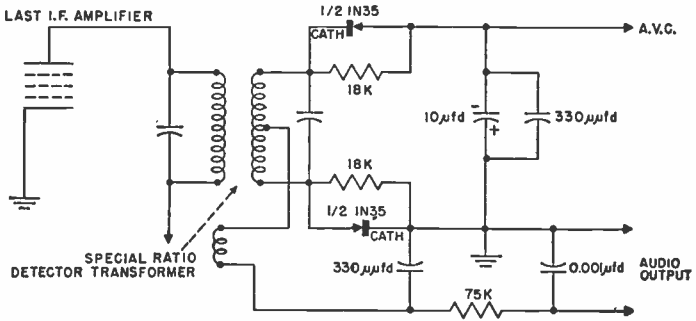

(B) RATIO DETECTOR

Figure 1-7. FM DETECTORS

diode, consisting of two factory-matched crystals, is especially suitable for this application.

Figure 1-7 shows the connection of the crystals in discriminator (A) and modified ratio detector (B) circuits for second detectors in both FM broadcast receivers and in the sound channels of television sets. Circuit B is a special adaptation of the conventional ratio detector for use with 1N34 or 1N35 crystals. Both of these circuits are suited for frequencies of the order of 10 to 30 megacycles.

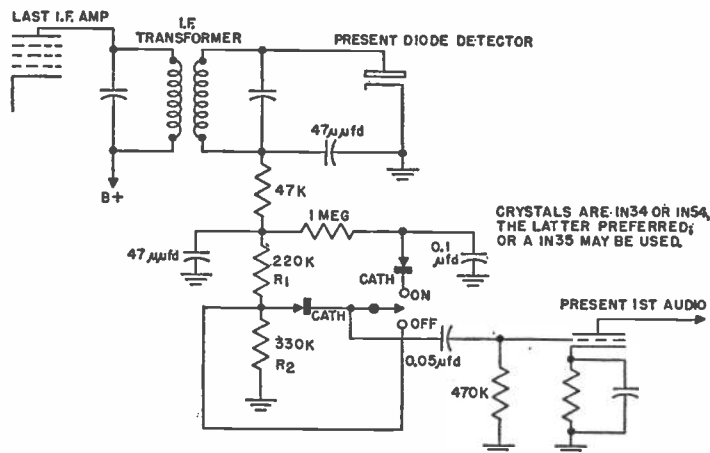

NOTE: LIMIT LEVEL DECREASES AS  $R_1$  IS MADE SMALLER WITH RESPECT TO  $R_2$ . RATIO OF  $R_1$  TO  $R_2$  SHOULD BE ADJUSTED FOR EFFECTIVE LIMITING WITH LOW AUDIO DISTORTION.

Figure 1-8. SHUNT IMPULSE NOISE LIMITER

### 1.9 COMPACT SERIES—SHUNT IMPULSE NOISE LIMITER.

Figure 1-8 shows the use of two 1N34 and 1N54 crystals, or a single 1N35 duo-diode unit, in a compact yet extremely effective impulse noise limiter of the series-shunt or compound type. This simple limiter can be installed in a communications receiver in a short time. Once installed and adjusted, it requires no further attention, since it is self-adjusting to various strengths of signal, and various noise conditions.

All of the parts, including the crystals, may be mounted on a small bakelite strip and should be enclosed in a metal shield can, to prevent hum pickup. The single-pole-double-throw switch allows the limiter to be cut out when not needed.

This simple noise limiter will be found extremely effective in the reduction of ignition interference in mobile receiver installations.

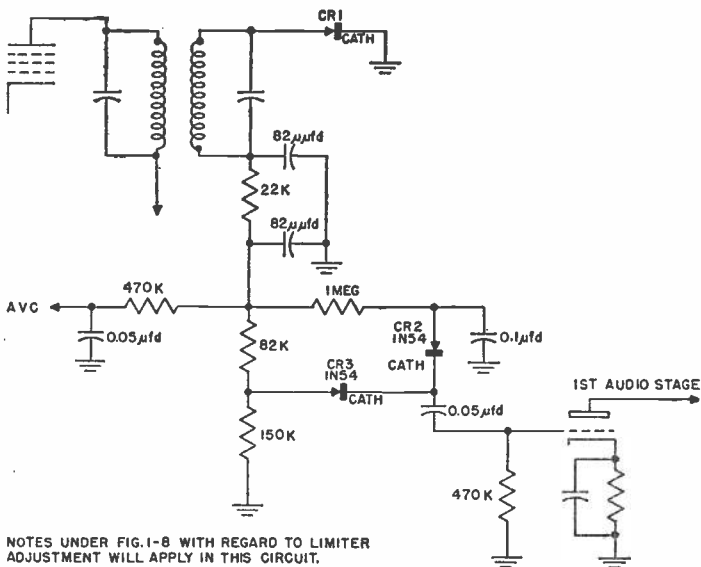

Figure 1-9. COMBINED SECOND DETECTOR, A.V.C. AND NOISE LIMITER

### 1.10 COMBINED SECOND DETECTOR AND NOISE LIMITER.

The circuit of Figure 1-9 can be combined with that of Figure 1-1 to make a simple three-crystal circuit to perform the functions of detection, avc, and noise limiting, in a superhet receiver. CR1 is the detector-avc diode, and CR2 and CR3 are the limiter crystals.

Tube economy as well as circuit simplification will result from use of this circuit in a home-made receiver. The noise limiter effectively clips noise pulses at a level slightly below that of the signal, giving improved operation under difficult noise conditions.

## CHAPTER 2

### TRANSMITTER AND AMPLIFIER APPLICATIONS

**2.1 TRANSMITTER FAILURE ALARM.** It often is necessary to alert transmitting station personnel other than operators in the transmitter operating room when the station accidentally leaves the air. A monitoring receiver tuned to the transmitter frequency ordinarily is used, but this is not always a desirable method. A continuously running receiver can become a nuisance.

Figure 2-1 is the circuit for an automatic alarm which goes into operation whenever the carrier is interrupted. No direct connection to the transmitter is required. The crystal detector simplifies receiver and control circuits.

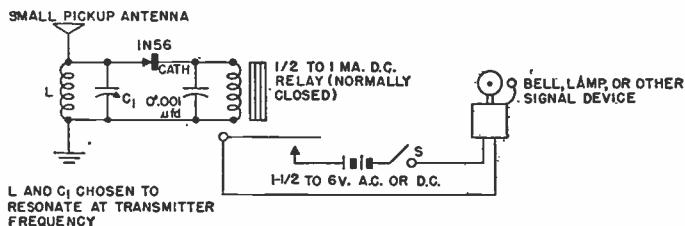

Figure 2-1. TRANSMITTER FAILURE ALARM

The values of coil L and variable capacitor C<sub>1</sub> are selected to tune to the station frequency. C<sub>1</sub> can be a screwdriver-adjusted trimmer. A 1N56 high-conduction diode is employed to insure maximum possible relay current. The pickup antenna may be a short inside or outside antenna, as receiving conditions dictate, or it may be a short vertical rod.

When the station is on the air, the relay will be energized by the crystal diode and the relay contacts will open. Switch S then is closed manually. If the station goes off the air, current will cease to flow through the relay coil, the contacts will close, and the alarm device (bell, horn, or lamp) will be operated.

**2.2 TRANSMITTER ADJUSTING GIMMICK.** The untuned, rf-operated crystal device illustrated in Figure 2-2 will find a host of uses in transmitter tuning-up and adjustment. When the small pickup coil is held near the plate or grid coil in any transmitter stage, it will pick up a small rf voltage which will be rectified by the 1N34 and caused to deflect the milliammeter. Adjustment of the 1000-ohm rheostat will prevent "pinning" of the meter by strong signals.

This gadget may be used as an rf indicator in neutralizing adjustments, stage tuning, exploring for parasitics and stray rf, and testing

the effectiveness of shielding. Many other applications will occur to the reader. Headphones may be plugged into the jack for aural monitoring of amplitude modulated signals and for hum and noise tracing in transmitter stages.

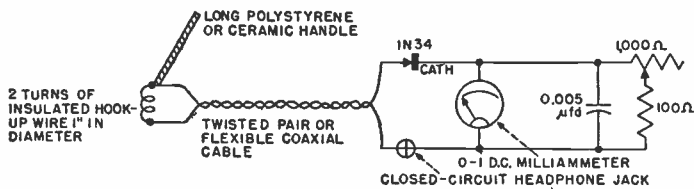

Figure 2-2. TRANSMITTER ADJUSTING GIMMICK

**2.3 LOW-POWERED FREQUENCY DOUBLER.** Where space is at a premium, frequency doubling can be achieved by means of a pair of crystal diodes in the circuit shown in Figure 2-3. This circuit operates on the principle that the output of a full-wave rectifier has twice the frequency of the ac input voltage. The doubling action is enhanced by the tank circuit  $L_2-C_2$  which is tuned to twice the input frequency. The input tank circuit ( $L_1-C_1$ ) is tuned to the input frequency. Two of these simple doubler stages in cascade will quadruple the input frequency.

Because of the low power-handling ability of the crystal diodes,

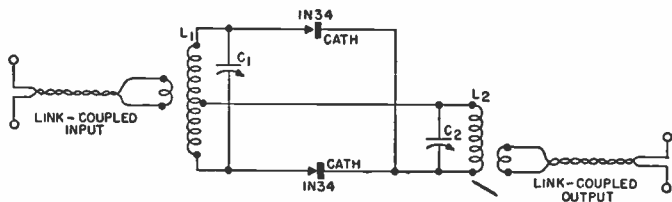

Figure 2-3. LOW-POWERED FREQUENCY DOUBLER

operation of this circuit is limited to input power levels of less than 1 watt. The crystal doubler accordingly can be used only ahead of pentode or beam power rf amplifiers having very high power sensitivity (that is, amplifiers requiring low grid driving power). Slightly higher power ratings are obtained with a pair of 1N56 diodes.

The crystal doubler is suitable for operation at frequencies up to 200 megacycles.

**2.4 CARRIER-OPERATED INVERSE FEEDBACK CIRCUIT.** Inverse feedback is invaluable in a modulated transmitter for improving quality and reducing hum and noise. It is not so easily applied, how-

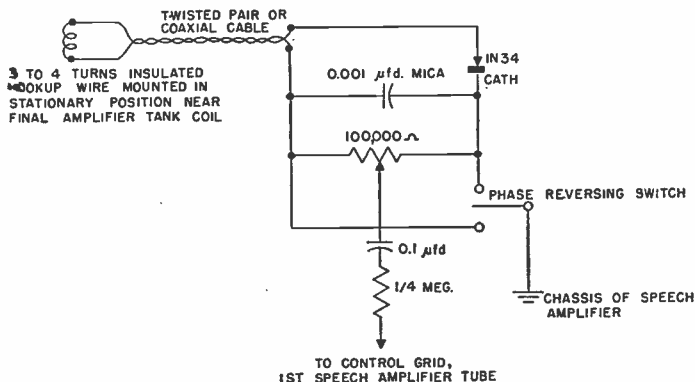

Figure 2-4. CARRIER OPERATED INVERSE FEEDBACK CIRCUIT

ever, to efficiency-modulated circuits, such as grid-modulated, screen-modulated, cathode-modulated, and class-B linear amplifiers.

The crystal circuit shown in Figure 2-4 overcomes this difficulty by "sampling" the modulated carrier. The picked-up rf is demodulated by the crystal, and the audio voltage obtained by this process is applied to the control grid of the first speech amplifier tube. The 100,000-ohm potentiometer enables the operator to adjust the fed-back audio voltage to the proper level for best results.

When using this system, it is advisable not to include more than one iron-core transformer in the feedback loop. If oscillation occurs, throw the phase reversing switch to its opposite position.

**2.5 PREMODULATION SPEECH CLIPPER.** The obvious advantages of speech clipping may be obtained in an existing amplitude modulated transmitter by including a satisfactory clipper unit between the first and second stages of the speech amplifier.

Figure 2-5 shows a 2-crystal clipper circuit which may be connected conveniently in any speech amplifier. The original gain control ( $R_A$ ) of the amplifier becomes the clipper control. This control is set by experiment to the desired level at which clipping is to take place and is not disturbed afterward. A second potentiometer ( $R_B$ ) is installed as the amplifier gain control. The 1N35 duo-diode unit supplies two factory-matched crystals for this circuit.

The filter, consisting of a choke and three capacitors in the plate circuit of the 2nd speech amplifier stage, rounds off the speech waves after the clipping operation has squared them. This filter thus removes objectionable harmonics.

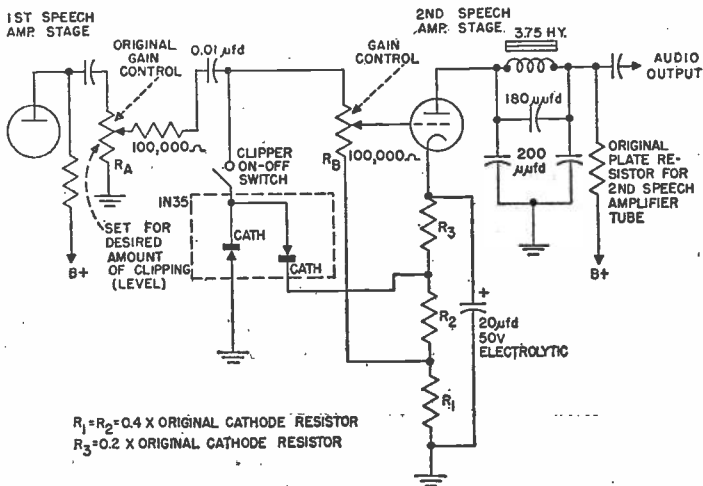

Figure 2-5. PREMODULATION SPEECH CLIPPER

**2.6 LOW-VOLTAGE BIAS SUPPLY.** Fixed grid bias voltages between 1 and 3 volts for audio amplifiers may be obtained from the 6.3-volt tube heater terminals in the amplifier through a crystal rectifier and filter.

Figure 2-6 shows a 4-crystal, full-wave bridge circuit which makes an excellent bias supply which is compact and requires no attention. The dc output voltage may be varied by changing the resistance value of  $R_2$ . As  $R_2$  is decreased, the output voltage decreases, and vice versa.

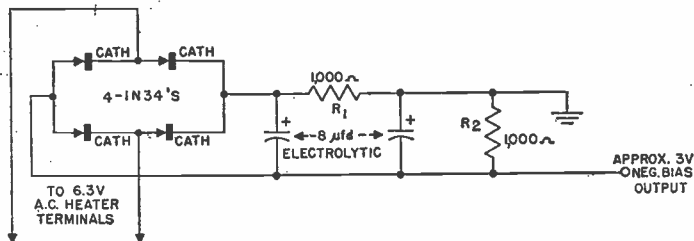

Figure 2-6. LOW-VOLTAGE BIAS SUPPLY

## CHAPTER 3

### INSTRUMENTS AND GADGETS

**3.1 SIMPLE SIDEBAND GENERATOR.** Figure 3-1 shows four matched crystal diodes connected in a "ring modulator" circuit. In lieu of four separate crystals, a Sylvania Type IN40 or IN41 Varistor may be used. The Varistor is a small, compact unit containing four matched diodes.

In this circuit, the rf carrier is fed into one pair of terminals, and the modulation (usually an audio frequency) into the other pair. The carrier is suppressed by the circuit action and accordingly does not appear in the output. The output contains only the upper sideband and lower sideband.

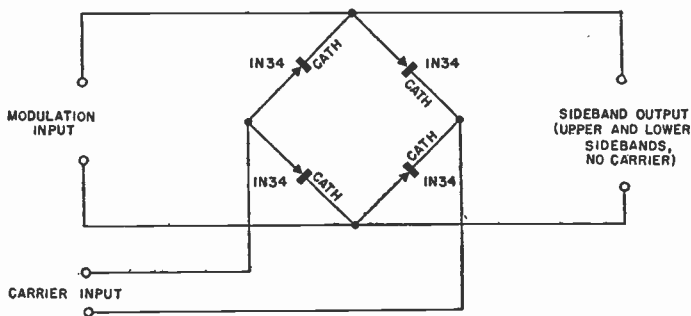

Figure 3-1. SIMPLE SIDEBAND GENERATOR

The upper sideband consists of the carrier frequency plus the modulating frequency. The lower sideband consists of the carrier frequency minus the modulating frequency. Thus; if the carrier is 1000 kc and the modulating frequency 1000 cycles, the upper sideband is 1001 kc and the lower sideband 999 kc. If desired, a suitable filter may be connected in the output to eliminate (suppress) one of the sidebands and pass the other. In this way, single sideband output may be obtained.

**3.2 TUBELESS DC AMPLIFIER.** This circuit (See Figure 3-2) is another application of the 4-crystal ring modulator. In this case, however, a dc voltage is substituted for the carrier. An ac voltage of  $1\frac{1}{4}$  volt, derived from half of a  $2\frac{1}{2}$ -volt filament transformer secondary, is delivered to the 4-crystal circuit as the modulating voltage.

The ac voltage switches the dc voltage on and off at a rate equal to the ac frequency in much the same manner that a mechanical vibrator



might interrupt the dc circuit. This interrupted dc voltage then is stepped up through transformer  $T_2$  and induces an ac voltage across the secondary of this transformer. The fifth IN34 rectifies this voltage and delivers it to a vacuum tube voltmeter such as the Sylvania Polymer Type 221. The Polymer should be switched to the dc indicating position. Thus, a small dc voltage may be stepped up to a value high enough to be read on the scale of the meter. The amount of amplification obtained depends upon the turn ratio of transformer  $T_2$ .

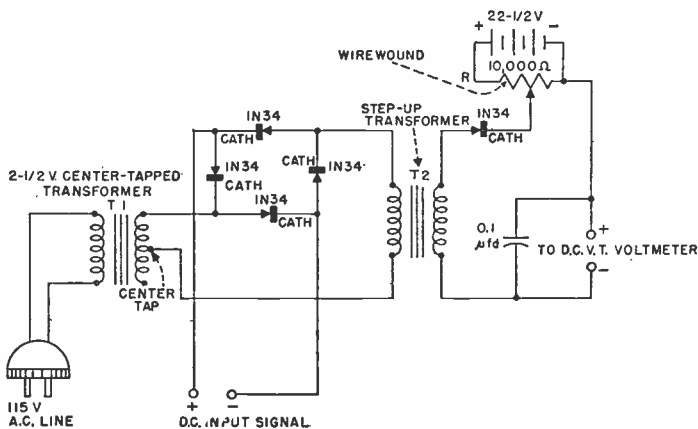

Figure 3-2. TUBELESS DC AMPLIFIER

To operate the device: (1) Set the Polymer to zero on its lowest range. (2) Plug the amplifier circuit into the ac line and connect the voltmeter to the amplifier output terminals. (3) The meter will be deflected upward. Adjust potentiometer R to bring the meter pointer back to zero. (4) Apply the unknown dc voltage to the dc input terminals of the amplifier. (5) Read the voltage on the meter and divide this value by the turn ratio of the transformer to obtain the true value of the unknown voltage.

Best accuracy will be obtained if accurately-known small voltage values are fed into the amplifier and their corresponding meter deflections noted on a chart or graph.

**3.3 VOLTAGE MULTIPLIER CIRCUITS.** Figure 3-3 shows voltage doubler, tripler, and quadrupler circuits employing crystal diodes. These circuits are especially useful, since they can be operated at radio frequencies as well as at power-line and audio frequencies. At frequencies between 60 and 10,000 cycles, use 8- $\mu$ fd electrolytic capacitors throughout. At all higher frequencies, use 0.01- $\mu$ fd mica capacitors:

At low output current drains, the doubler circuit will deliver a dc voltage equal approximately to 2.8 times the r.m.s. value of the ac input voltage. The tripler dc output voltage will equal 4.2 times the ac input voltage. The quadrupler dc output voltage will equal 5.6 times the ac input voltage.

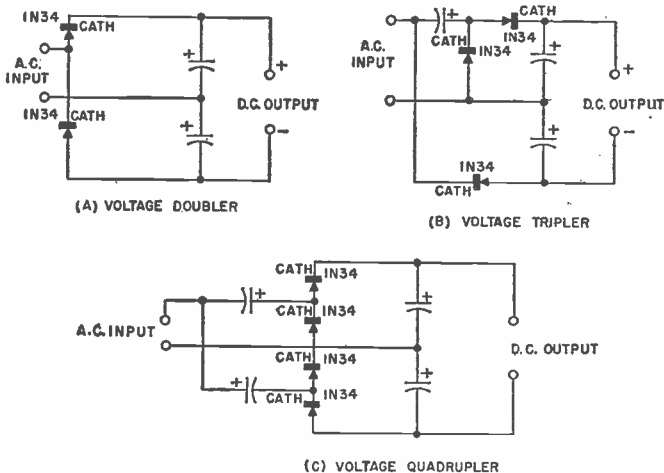

Figure 3-3. CRYSTAL VOLTAGE MULTIPLIER CIRCUITS

**3.4 AUDIO FREQUENCY METER.** This instrument (See Figure 3-4) will identify an unknown audio frequency directly in cycles per second. The circuit is "balanced" in a manner similar to the balancing of a bridge. The Wien bridge circuit is employed.

In operation, the unknown frequency is fed into the audio input terminals and the main dial, which is attached to the dual potentiometer,  $R_4$ - $R_5$ , is adjusted for null (lowest lip of microammeter M). Then, an adjustment of auxiliary potentiometer  $R_2$  will sharpen the null point without upsetting the calibration. At this point, the unknown frequency is read from the calibrated  $R_4$ - $R_5$  dial. The frequency range of the instrument is 25 to 10,000 cycles.

The audio frequency meter is easy to build and requires no critical components, except the capacitors, each of which should have 1% tolerance.

The instrument may be calibrated by feeding in various known frequencies (obtained from an audio oscillator) between 25 and 10,000 cycles, adjusting  $R_4$ - $R_5$  and  $R_2$  for null, and marking each frequency setting on the dial of  $R_4$ - $R_5$  at corresponding null points. If an oscillator

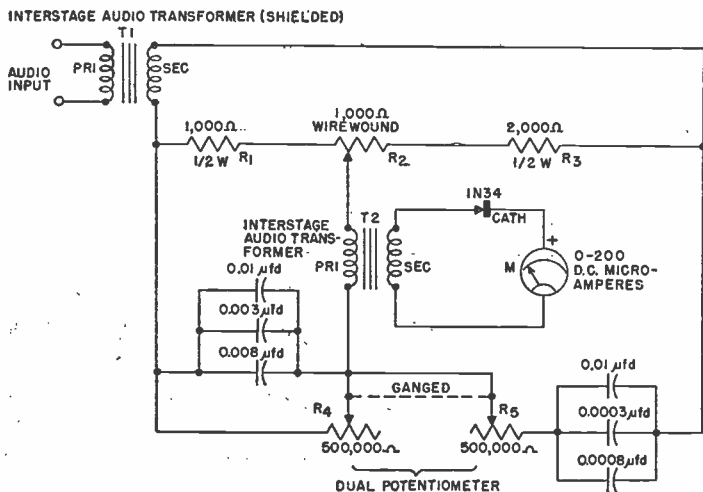

Figure 3-4. INDICATING AUDIO FREQUENCY METER

is not available, a good ohmmeter or resistance bridge may be used to calibrate the  $R_4$ - $R_5$  dial according to the following table which shows the frequencies corresponding to various resistance settings of  $R_4$ - $R_5$ .

FREQUENCY (cycles)	RESISTANCE (ohms)	FREQUENCY (cycles)	RESISTANCE (ohms)
25	461,000	700	16,500
30	386,000	800	14,400
40	289,000	900	12,800
50	231,000	1000	11,500
60	192,000	1500	7,700
75	154,000	2000	5,780
100	115,000	2500	4,620
150	77,000	3000	3,850
200	57,800	3500	3,300
250	46,200	4000	2,890
300	38,500	4500	2,570
350	33,000	5000	2,130
400	28,900	5500	2,090
450	25,700	6000	1,920
500	21,300	7000	1,650
550	20,900	8000	1,440
600	19,200	9000	1,280
650	17,700	10,000	1,150

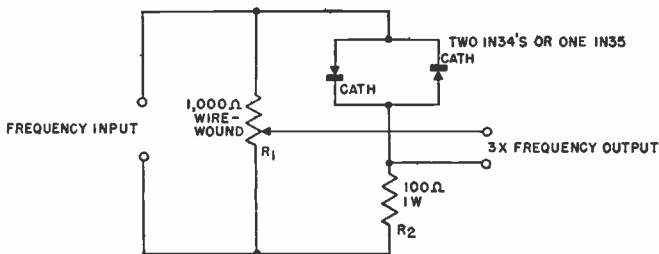

Figure 3-5. FREQUENCY TRIPLER

The resistance of either section,  $R_4$  or  $R_5$  may be measured, since both sections read the same or very nearly so.

**3.5 FREQUENCY TRIPLER.** Figure 3-5 shows a simple non-linear bridge circuit for tripling any frequency fed into its input terminals. This circuit is recommended for use at low ac levels, up to  $1\frac{1}{2}$  volts r.m.s. The output is not true sine wave.

The circuit is based on the fact that the bridge, having a crystal rectifier as one arm, may be balanced at only one voltage. This is because the crystal resistance changes with voltage. Consequently, as an applied ac half-cycle rises from zero and falls back to zero, the null voltage value is passed twice and the output voltage accordingly is zero four times during this half cycle: The output frequency thus is  $1\frac{1}{2}$  cycles for each input half-cycle. By connecting two crystals back-to-back, as shown in

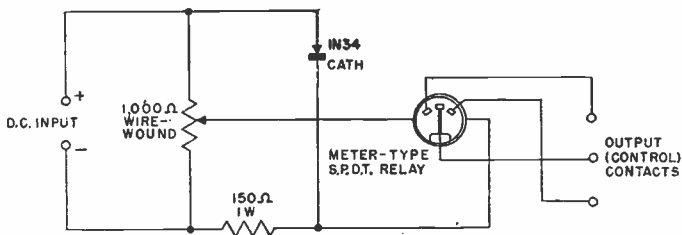

Figure 3-6. TWO-WAY RELAY OPERATING AT TWO DIFFERENT VALUES OF AN INCREASING OR DECREASING DC VOLTAGE

Figure 3-5, each half of the applied ac cycle is multiplied by  $1\frac{1}{2}$ , resulting in a total multiplication of 3. This accounts for the tripling action.

**3.6 TWO-WAY RELAY CIRCUIT.** A non-linear crystal bridge, similar to the one just described in Section 3.5, may be used to operate

a single-pole double-throw ("left-right" type) dc relay at two different values of voltage, one higher than the other. This is convenient in many forms of signalling or indicating set-ups in which a control voltage rises from one value to another and must give indication of one voltage without interfering with the other.

In operation, set the bridge initially (by adjusting the 1000-ohm potentiometer) at the lowest value of input voltage at which the relay is to close. When the circuit is adjusted properly, the relay armature will swing over to one contact. As the input voltage then is increased, the bridge will pass through null, due to changing crystal resistance, whereupon the relay will open. As the voltage is increased further, the crystal resistance will undergo additional change and the bridge will unbalance in the opposite direction causing the relay to close on the other side.

Various phenomena, such as temperature, current, and frequency variations, may be converted into voltage changes and made to operate this relay to sound alarms or to record changes.

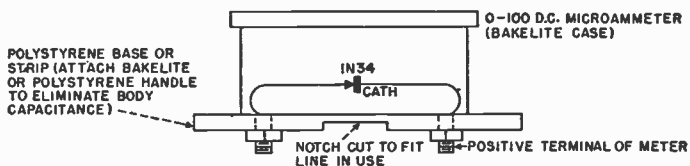

FIGURE 3-7. STANDING WAVE INDICATOR FOR TWIN-LEAD RF TRANSMISSION LINE

**3.7 STANDING WAVE INDICATOR.** Figure 3-7 shows a handy arrangement of a crystal diode and dc microammeter for testing for standing waves along a flat, twin-lead transmission line such as the 300-ohm lines used between amateur transmitters and antennas. No direct electrical connection to the line is required.

The crystal diode is wired in parallel with the meter. The notch or slot cut into the polystyrene base back of the meter is just wide enough to clear the transmission line edges comfortably. As the instrument is slid along the line, with the transmitter in operation, the meter will deflect up-scale to indicate peaks and down-scale to indicate nulls.

**3.8 SIMPLE FIELD STRENGTH METER.** This instrument (Figure 3-8) is indispensable for checking the gain and field pattern of transmitting antennas and for checking for presence of harmonics and interference. The entire unit may be built into a small metal radio utility box.

A Type 1N56 crystal diode is recommended since this crystal gives more dc output current than the 1N34 and accordingly will produce a higher meter deflection with a given rf signal.

Commercial short-wave plug-in coils may be used. Special coils for the ultra-high-frequency amateur bands may be wound according to specifications found in the amateur radio handbooks.

If the tuning dial of the field strength meter (attached to tuning capacitor C) is calibrated directly in megacycles by means of an rf test oscillator or signal generator, the instrument will be suitable as an absorption wavemeter for frequency measurements.

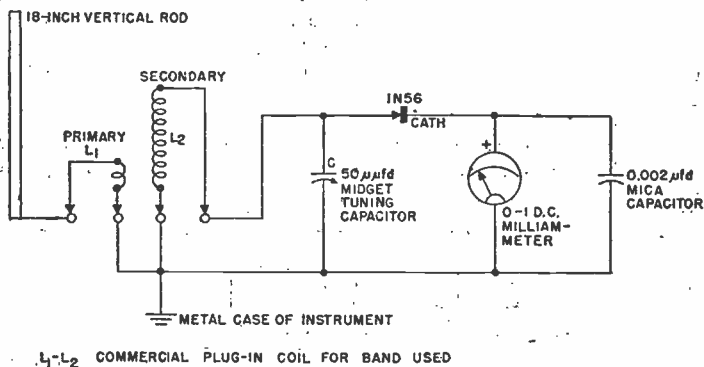

Figure 3-8. SIMPLE FIELD STRENGTH METER

**3.9 SENSITIVE FIELD STRENGTH METER.** Sensitivity of the field strength meter may be increased by employing (1) full-wave detection with two matched crystals and (2) a sensitive dc microammeter in place of the milliammeter.

The full-wave detector circuit in Figure 3-9 consists of a center-tapped, double-tuned secondary coil ( $L_2$ ) and a 1N35 dual crystal diode.

Instructions are given in Figure 3-9 for winding the required tapped, plug-in coils for continuous coverage of the frequency range 3.5 to 200 megacycles.

**3.10 AF-RF AMMETER.** A radio-frequency ammeter which can be used at frequencies up to 100 megacycles or better is a handy device for the amateur station, laboratory, or radio workshop. A simple meter of this type is shown in Figure 3-10.

This instrument consists basically of a crystal voltmeter (crystal diode plus a dc milliammeter) connected so as to measure the voltage drop across a non-inductive 1-ohm resistor. The unknown current flowing through this resistor sets up the voltage drop. By Ohm's Law, the voltage measured across the 1-ohm resistor will be equal to the current flowing through the resistor. Consequently, if the meter is calibrated 0.1 volt, it will indicate also 0.1 ampere.

Calibration of the instrument is simple. Apply an accurately-known ac voltage of 1 volt (60 cycles will do, but 1000 cycles will be better) to the input terminals. Then adjust the 300-ohm rheostat for full-scale deflection of the milliammeter. The meter indicates at full-scale as current flow of 1 ampere through the 1-ohm resistor. Reduce the input voltage to 0.9 volt and record the milliammeter reading. Repeat at various lower-voltage points in 1/10-volt steps, to obtain a calibration curve similar to the one shown in Figure 3-10. This chart then may be referred to when making measurements, to convert milliamperere indications to amperes. Or a special ampere scale may be prepared from it for the milliammeter.

Because of the wide frequency range of the crystal, the ammeter can be operated at radio as well as audio frequencies.

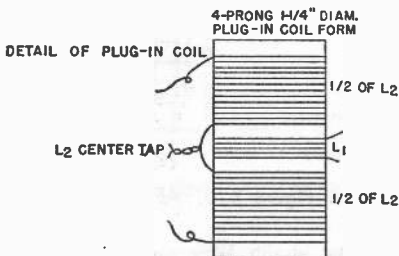
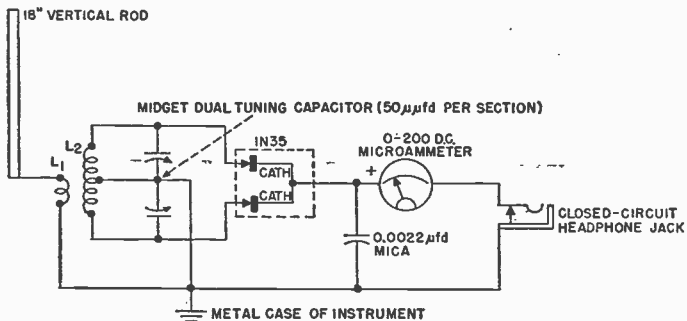

COIL TABLE  
L<sub>2</sub>

3.5-7 MC-	86 TURNS NO.26 ENAMELLED WIRE CLOSEWOUND								
7-14 MC-	36 TURNS NO.24 ENAMELLED WIRE CLOSEWOUND								
14-28 MC-	20 TURNS NO.22 ENAMELLED WIRE SPACED TO WINDING LENGTH OF 1 INCH								
28-54 MC-	12 " " " " " " " " " " " "								
50-100 MC-	5 " " " " " " " " " " " "								
100-200 MC-	2-1/2 " " " " " " " " " " " "								

L<sub>1</sub> IN EACH CASE IS 1 TURN OF NO.24 ENAMELLED WIRE WOUND IN THE SPACE BETWEEN THE HALVES OF L<sub>2</sub>

THE 2 HALVES OF L<sub>2</sub> ARE SPACED SLIGHTLY TO ACCOMMODATE L<sub>1</sub>

Figure 3-9. SENSITIVE FIELD STRENGTH METER

### 3.11 EXTERNAL MODULATOR FOR SIGNAL GENERATORS.

Most rf signal generators and test oscillators are modulated internally at an audio frequency of 400 cycles. It often is desirable to modulate the rf signal at some frequency other than 400 cycles, but this entails tampering with the internal wiring of the oscillator.

The simple 4-crystal device shown in Figure 3-11 can be connected to the rf output terminals of the signal generator and to the output terminals of any audio oscillator. It will combine the two signals and deliver a radio-frequency signal modulated at the frequency of the audio oscillator. In this way, the signal generator circuit need not be altered in any

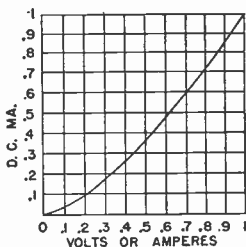
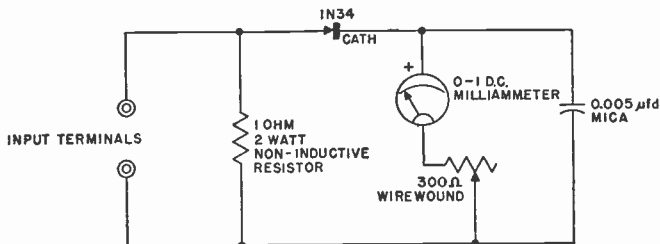

CALIBRATION CURVE

Figure 3-10. AF-RF AMMETER (0-100 MC)

manner. The circuit is a type of diode modulator similar to those described in Sections 3.1 and 3.2.

When using the device, connect the output terminals of the signal generator to the rf input terminals of the modulator circuit. Switch-off the internal modulation of the signal generator so as to obtain a c.w. signal. Connect the audio oscillator output terminals to the audio input terminals of the modulator. Connect the receiver, or other equipment under test, to the modulated rf output terminals. Adjust the output voltage control of the audio oscillator to give the desired modulation intensity.



Actually, this modulator suppresses the carrier frequency and delivers the two sidebands which result from the amplitude modulation process. But for audio frequencies up to about 2500 cycles, the modulated signal will be tuned-in on a receiver dial at the same point as the regular signal generator signal. Only at modulation frequencies above 5000 cycles will the receiver dial show the two sidebands as separate signals, one above and one below the carrier frequency point.

**3.12 RF PROBE.** DC vacuum tube voltmeters now are standard equipment in laboratories, stations, and shops. A number of these instruments have no provision for checking rf voltages. It is advantageous to be able to measure rf voltages in receiver signal tracing and in various forms of experimental work.

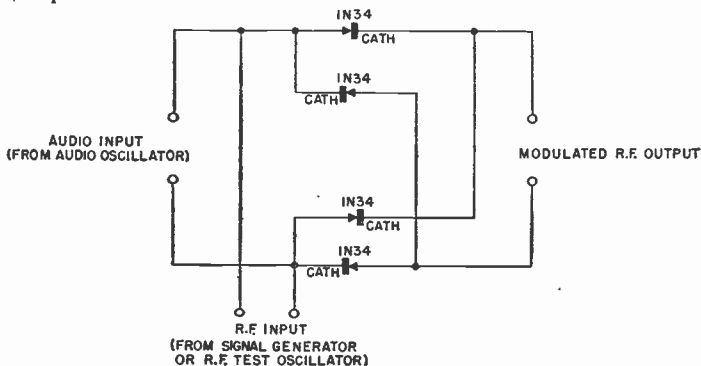

Figure 3-11. EXTERNAL MODULATOR FOR RF TEST OSCILLATOR

Figure 3-12 shows details of a crystal-type rf probe which may be used in conjunction with any dc vacuum tube voltmeter. This is one of many types of such probes which have been developed since introduction of the germanium crystal diode.

This probe will handle frequencies up to 200 megacycles. The maximum voltage which may be checked with it will be 20 volts r.m.s. The 0.01- $\mu$ fd input capacitor isolates the crystal and protects it and the circuit from harmful dc voltages which may be present in the circuit under test. The indication obtained on the dc scale of the VTVM will be equal to approximately 1.4 times the r.m.s. value of the applied rf voltage. For best accuracy, the probe should be calibrated by applying to it a number of accurately-known rf voltages (checked by means of another voltmeter) and observing the corresponding readings of the dc vacuum tube voltmeter.

**3.13 AUDIO EXTRACTOR FOR SIGNAL GENERATORS.** While all signal generators and rf test oscillators are modulated internally, only

a few of these instruments deliver an audio output signal in addition to rf. The audio voltage is useful for testing audio amplifiers and the audio channels of radio receivers, and for various other experimental purposes requiring a single test tone.

The circuit in Figure 3-13 extracts the audio signal from the modulated rf output of a signal generator. This device, which may be built

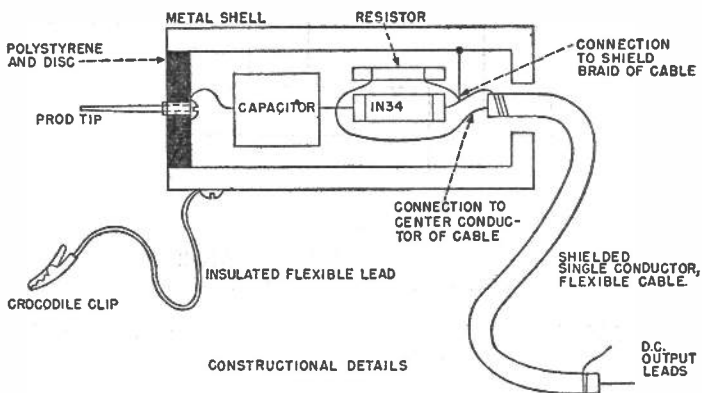
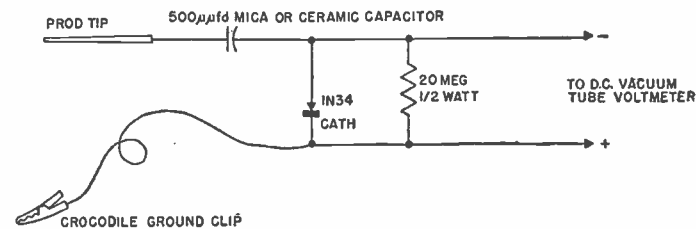

Figure 3-12. RF PROBE FOR DC VACUUM TUBE VOLTMETER

easily into a small can or box, is connected to the output terminals of the signal generator and requires no tampering with the internal circuit of the instrument.

**3.14 TUBELESS TONE GENERATOR.** When an ac signal is applied to two crystals connected in a *full-wave* rectifier circuit, the output current delivered by the crystals is a pulsating dc having twice the frequency of the applied voltage. The full-wave circuit thus becomes a frequency doubler. A second full-wave circuit, added in cascade to the first one, will double the frequency again, thereby delivering 4 times the

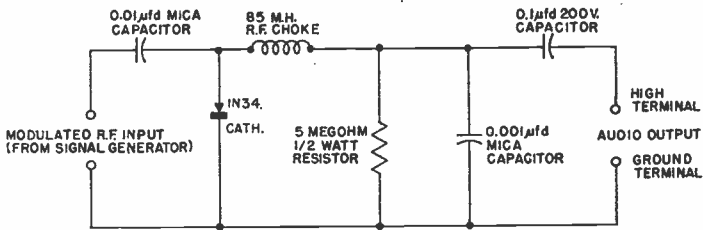

Figure 3-13. AUDIO EXTRACTOR FOR RF SIGNAL GENERATORS

frequency of the input signal. Any additional full-wave circuit will double the frequency it receives, and the multiplication process may be carried on to a point at which the output voltage finally becomes too low to be useful. In this way, a number of stages may be cascaded, each stage output giving a tone which is an even multiple of the input frequency.

Figure 3-14 shows a circuit of this kind for doubling and quadrupling any audio frequency within the range of the coupling transformers. The input signal may be taken from the ac power line or from an audio oscillator. Three audio transformers and four crystal diodes are employed. If the builder desires, two Sylvania 1N35 duo-diode units may be used in place of the four separate 1N34's.  $T_1$  and  $T_2$  are ordinary interstage audio transformers with single-ended primaries and push-pull secondaries.  $T_3$  has a single-ended primary and secondary.

A closed-circuit jack in the first stage delivers output at twice the input signal frequency, while the output terminals of transformer  $T_3$  delivers 4 times the input frequency. Thus, if a 60-cycle voltage is applied to the signal input terminals, the jack will deliver 120 and the output terminals 240 cycles.

The output of this tone generator is not true sine wave. If the builder requires pure tones, it will be necessary to employ bandpass filters in the output circuits to transmit the desired frequency only.

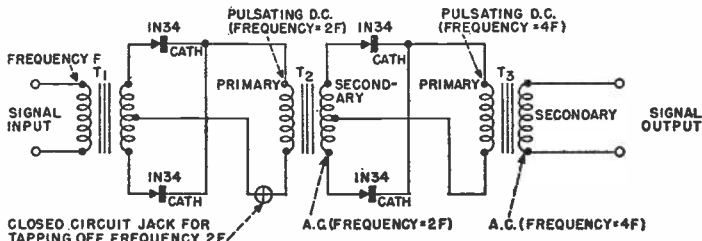

Figure 3-14. TUBELESS TONE GENERATOR

**3.15 TUBELESS AUDIO OSCILLATOR.** When a germanium diode is connected in the "back direction" (that is, with its cathode to the positive dc power supply terminal) in a suitable circuit, it will oscillate, provided the applied dc voltage is high enough to reach the negative resistance region in the reverse-conduction curve of the crystal.

An audio oscillator circuit applying this principle is shown in Figure 3-15. The constants of this circuit are such that the frequency of oscillation is approximately 1200 cycles. The frequency may be increased by decreasing the capacitance of the capacitor, and may be lowered by increasing the capacitance. This circuit delivers an output of about 30 volts r.m.s. across a pair of 2000-ohm headphones.

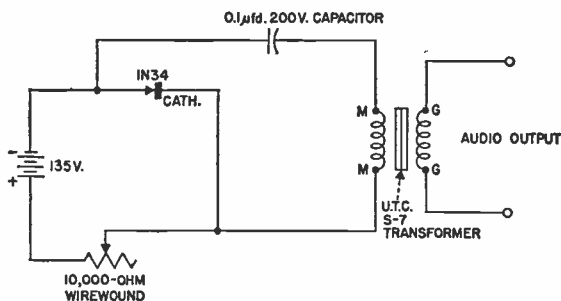

Figure 3-15. TUBELESS AUDIO OSCILLATOR

Adjustment of the oscillator is very simple: Rotate the 10,000-ohm potentiometer until the point is reached at which the circuit breaks into oscillation. Then, reduce the potentiometer setting slightly.

This oscillator is suitable only for intermittent use, such as it might receive in signal injection or signal tracing in audio amplifier testing, or as a code practice oscillator. Sustained operation of the crystal in its oscillating negative resistance condition produces appreciable internal heating and will ultimately destroy the unit. Nevertheless, this circuit will be found extremely useful, especially for applications requiring a miniature instrument.

**3.16 CRYSTAL DIODE WAVE SHAPER.** In various forms of radio and electronic testing, it is desirable to have a signal consisting either of positive peaks only, negative peaks only, or square waves. Pulse generators for producing special signals of these types are complicated equipment and therefore costly.

The circuit illustrated in Figure 3-16 takes a sine-wave signal, which may be obtained easily from an audio oscillator or from a stepdown transformer operated from the ac power line, and converts it into either one of the special signals described above. While pulses obtained in

this manner are not perfect, they will be suitable for a wide variety of experimental work.

Operation of the circuit is based upon the *clipper* or *limiter* principle. When both switches are open, the output voltage of the device has the same sine-wave shape as the input signal (See pattern A). When switch  $S_2$  is closed and  $S_1$  opened, the first crystal diode and 1½-volt cell clip the negative peaks from the input signal and deliver an output signal consisting almost entirely of positive peaks (See pattern B). When

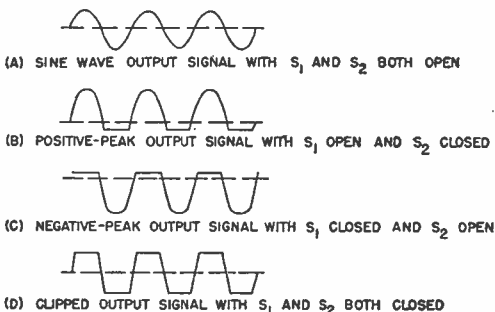
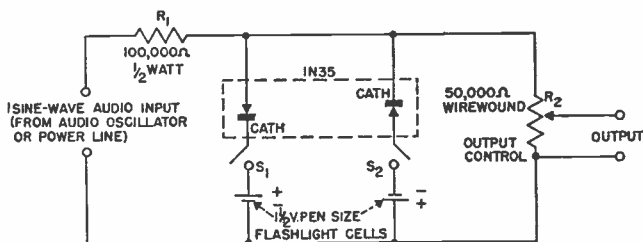

Figure 3-16. CRYSTAL DIODE WAVE SHAPER

$S_1$  is closed and  $S_2$  open, the second diode and cell clip the positive peaks from the input signal and deliver an output signal consisting almost entirely of negative peaks (See pattern C). When both  $S_1$  and  $S_2$  are closed, positive and negative peaks are both clipped and the output signal is very nearly a square wave. (See pattern D). Best squareness will be obtained when the input signal is at least 30 volts r.m.s.

Potentiometer  $R_2$  is an amplitude control for adjusting the strength of the output signal to suit individual conditions.

When the device is not in use, both switches must be thrown to their *open* position to prevent battery drain through the crystals.

**3.17 AF-RF WATTMETER** The instrument shown in Figure 3-17 will indicate audio-frequency or radio-frequency power up to 100 watts, either directly on a specially-drawn meter scale or by reference to a calibration curve such as the one shown below the circuit diagram. This wattmeter may be built into a small metal meter box.

After the circuit has been wired, the instrument must be calibrated in

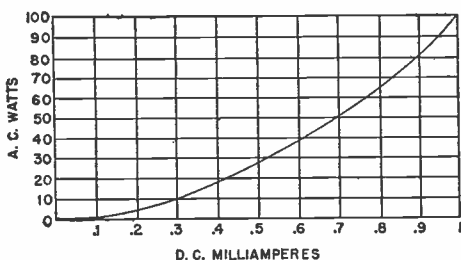
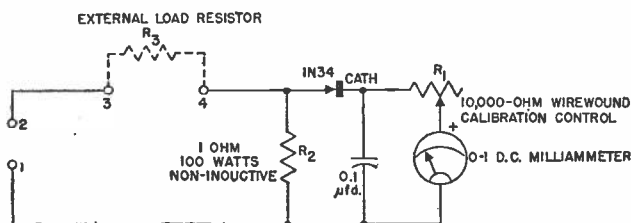

Figure 3-17. AF-RF WATTMETER

the following manner. Disconnect temporarily one end of resistor  $R_2$ , and short-circuit terminals 3 and 4. Apply an accurately-known 10-volt r.m.s. signal (60 cycles will do) to input terminals 1 and 2, and adjust rheostat  $R_1$  for exact full-scale deflection of the milliammeter. Because of the linearity of the crystal-meter combination in this voltage range, only the single-point check need be made. Do not disturb the setting of  $R_1$  unless a recalibration is required later on. Remove the signal voltage from terminals 1 and 2, remove the short-circuiting jumper from terminals 3 and 4, and reconnect resistor  $R_2$ .

This wattmeter is very simple to use. The following procedure is recommended. (1) Determine the output impedance of the amplifier, oscillator, or other device to be tested. (2) Connect to terminals 3 and 4 a 100-watt resistor (preferably non-inductive) which has a resistance value equal to 1 ohm less than the impedance of the power-delivering device. It may not always be possible to obtain a resistor having the exact resistance value required. In this case, it will be necessary to use a

wirewound unit with a slider set to the desired ohmic value. If the output impedance of the power-delivering device is 1 ohm, do not use an external resistor at all. Instead, short-circuit terminals 3 and 4. (3) Connect terminals 1 and 2 to the output terminals of the power-delivering device. (4) Read output watts on the meter scale, or by reference to the curve given in Figure 3-17. (5) Multiply this meter reading by the output impedance of the device under test when this impedance is higher than 1 ohm.

When checking the power output of an audio amplifier, disconnect the loudspeaker voice coil from the amplifier; connect terminals 1 and 2 of the wattmeter in place of the voice coil, and connect a resistor to terminals 3 and 4 equal in ohmage to the voice coil impedance minus 1 ohm. The external resistor must be rated to handle at least 2 times the power output of the amplifier.

**3.18 SENSITIVE AF-RF SIGNAL TRACER.** Numerous crystal diode signal tracers have been designed by radio writers. The instrument shown in Figure 3-18 has the advantages that it will give meter readings, as well as headphone signals, at very low values of signal input voltage. This tracer may be used for trouble shooting in all of the rf, detector, oscillator, if, and audio stages of a radio receiver, and in audio amplifier systems.

A Type 1N54 high-efficiency diode is used for improved performance. The 0.01- $\mu$ fd input capacitor protects the diode, headphones, and meter from any dc voltage which may be present in the circuit under test. The 200,000-ohm rheostat acts as a gain control to adjust the meter current

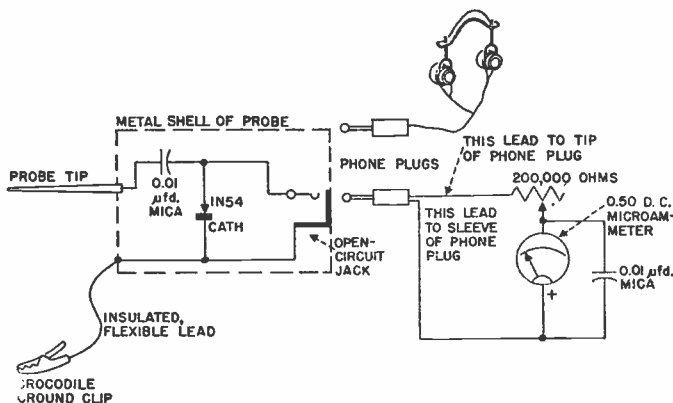

Figure 3-18. SENSITIVE AF-RF SIGNAL TRACER

to a readable value. The meter circuit is plugged into the jack in the end of the handle of the exploring probe for visual indications; the headphones for aural indications. A modulated signal is necessary to operate the headphones, but the meter will be actuated by either a modulated or unmodulated signal.

**3.19 DISTORTION METER.** This instrument (See Figure 3-19) can be used to measure the distortion percentage of audio amplifiers and oscillators. It consists of a bridged-T null network and a 3-range crystal voltmeter. With Switch  $S_2$  in its top position, the instrument range is 0-100% distortion; with  $S_2$  in its center position, the range is 0-10%; and with  $S_2$  in its lower position, the range is 0-5%. The instrument operates at 400 cycles. The null network (consisting of the choke, two

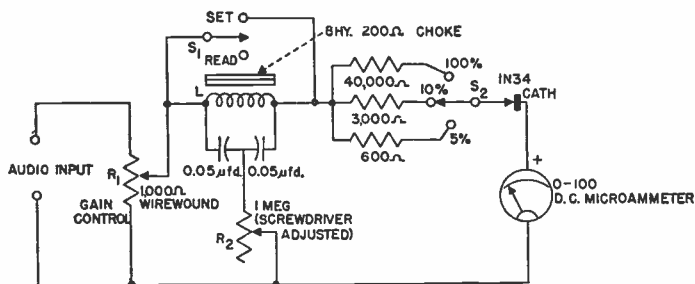

Figure 3-19. DISTORTION METER

0.05- $\mu$ fd. capacitors, and 1-megohm rheostat) removes the 400-cycle fundamental frequency. Any voltage remaining is due to harmonics and is measured by the crystal voltmeter.

After the instrument has been completed, it must be calibrated in the following manner: The microammeter needs no special calibration on the 0-100% scale, it being read directly in percentage. The 0-10 and 0-5 scales must be calibrated separately, however, because of non-linearity of the crystal at the lower voltages. Apply a variable-voltage source to the audio input terminals of the distortion meter (60 cycles will do), set gain control  $R_1$  to the top of its range, throw switch  $S_1$  to its SET position, and set switch  $S_2$  to its 10% position. Adjust the voltage in 1/10-volt steps from 0.1 to 1 volt, marking the meter scale or making a calibration chart. The voltage scale then will show distortion percentages in the following manner:



RMS INPUT VOLTS	% DISTORTION
0.1	1
0.2	2
0.3	3
0.4	4
0.5	5
0.6	6
0.7	7
0.8	8
0.9	9
1.0	10

Next switch  $S_2$  to its 5% position and apply a variable input in 1/10-volt steps from 0.1 to 0.5 volt and prepare another meter scale or reference chart as follows:

RMS INPUT VOLTS	% DISTORTION
0.1	1
0.2	2
0.3	3
0.4	4
0.5	5

For the initial adjustment: (1) Connect the input terminals of the distortion meter to a variable-frequency audio oscillator. (2) Set output control of oscillator to maximum. (3) Throw switch  $S_1$  to SET. (4) Set oscillator dial to 400 cycles. (5) Adjust gain control  $R_1$  (with  $S_2$  on 5% range) for full-scale deflection of microammeter. (6) Throw  $S_1$  to READ, noting drop in meter deflection. (7) Tune oscillator above and below 400 cycles, noting that meter deflection passes through null. Retune dial carefully for lowest dip in microammeter reading. This setting of oscillator dial should be 400 cycles. If it is not, due to inaccuracies in the capacitors and choke in the distortion meter, mark exact point on oscillator dial for quick re-tuning. (8) Adjust rheostat  $R_2$  carefully for an improvement in the null. (9) When the best null point is obtained, the meter very likely will not read exactly zero. The reading at this point indicates the distortion percentage of the oscillator. This figure must be recorded, since it should be subtracted from any distortion readings obtained later on when this oscillator is employed.

To use the distortion meter, follow the instructions: (1) Connect the audio oscillator (set to the 400-cycle test frequency) to the input terminals of the amplifier under test. (2) Connect the input terminals of the distortion meter to the output terminals of the amplifier (that is, across the loudspeaker voice coil or across a substitute load resistor having the ohmic value of the voice coil impedance). (3) Set  $S_1$  to SET. (4) Set  $S_2$  to 100%. (5) With the oscillator and amplifier in operation, adjust  $R_1$  for a meter reading. (6) Set  $S_1$  to READ. (7) Read distortion percentage on the meter scale or by reference to the calibration chart. If a readable deflection is not obtained, throw  $S_2$  to a lower range.

**3.20 SIMPLE SELECTIVE TELEPHONE CIRCUIT.** Figure 3-20 shows a simple wire telephone circuit by means of which either one of two remote listeners (both on a single, 2-wire line) may be addressed without the other one hearing. This scheme will appeal to Scouts, summer campers, and house-to-house telephone enthusiasts.

The circuit operates in this way: Listener A has a crystal diode "forward connected" in series with his headphones. In the forward direction, this crystal introduces very little resistance into the circuit and station. A accordingly hears clearly whatever is said into the microphone. Listener B, however, has a crystal "back connected" in series with his headphones. In the back direction, this crystal introduces a very high resistance into that portion of the circuit which includes headphones B. The currents flowing through these headphones therefore are too small to reproduce sound. Station B hears nothing.

In order to reverse the procedure and talk to station B, to the exclusion of A, simply reverse the polarity of the battery at the sending station,

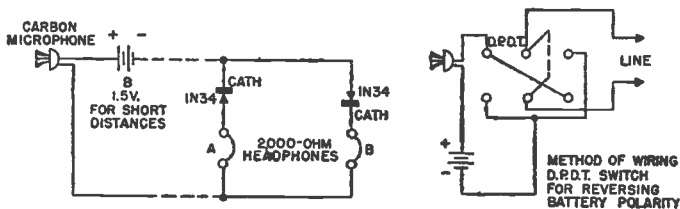

Figure 3-20. SIMPLE SELECTIVE TELEPHONE CIRCUIT

whereupon the crystal A becomes a high resistance and cuts out that station, while B receives.

For short distances, the battery can be a  $1\frac{1}{2}$ -volt dry cell. For longer distances, the voltage must be increased to overcome the resistance losses in the wires. The best voltage for a given distance must be determined experimentally. For simplicity, only a one-way circuit is shown in Figure 3-20.

**3.21 SELECTIVE TELEGRAPH CIRCUIT.** By employing the same principle described in Section 3.20, a 2-wire line may be used for sending telegraph signals separately to either one of two receiving stations connected across the line. Instead of telegraphing, a bell or other alarm may be operated at will at either one of the stations without disturbing the other. Figure 3-21 shows the circuit used.

Each receiving station has a sensitive relay and crystal diode connected in series across the 2-wire line. At Station A, the crystal is forward-connected and allows between 2 and 3 milliamperes to flow through its

associated relay coil when the key or switch is closed at the transmitting station. This current is sufficient to operate the relay. At Station B, the crystal is back-connected and passes only about 100 microamperes through its relay coil. This small current is insufficient to pick up the relay. When the polarity of the transmitting battery is reversed, the relay at Station B is actuated because its crystal anode then is connected to the positive battery terminal (forward connection), and the one at Station A is dead.

The relays may be used to operate telegraph sounders, bells, horns, lamps, locks, valves, or other electromechanical or electrical devices.

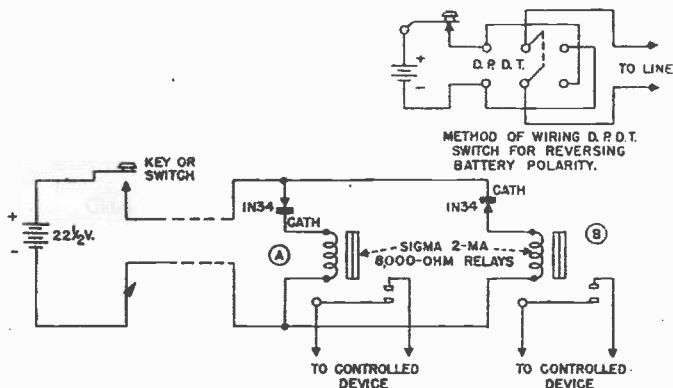

Figure 3-21. SELECTIVE TELEGRAPH CIRCUIT

The 22½-volt battery is adequate for operation up to several hundred feet when the wire used in the line is at least No. 18 in size. For longer-distance communication, the battery voltage must be increased, the most suitable voltage being determined by experiment.

**3.22 MODULATION AND CARRIER SHIFT METER.** The instrument shown is circuit schematic in Figure 3-22 will give direct indications of modulation percentage on either positive or negative peaks, and will indicate carrier shift when used to monitor an amplitude-modulated radio transmitter. This is the circuit of the popular Sylvania Mod-meter.

The input terminals of this instrument are link coupled (by means of a small pickup coil and twisted-pair or coaxial line) to the final amplifier plate tank coil of the modulated transmitter. With the ganged switch,  $S_1$ , thrown to its rf position, the coupling between the pickup coil and the plate tank is varied while the 100- $\mu$ fd. tuning capacitor is adjusted to deflect the milliammeter to a reference point near full-scale. This reading will not change unless carrier shift is present in the transmitted signal.

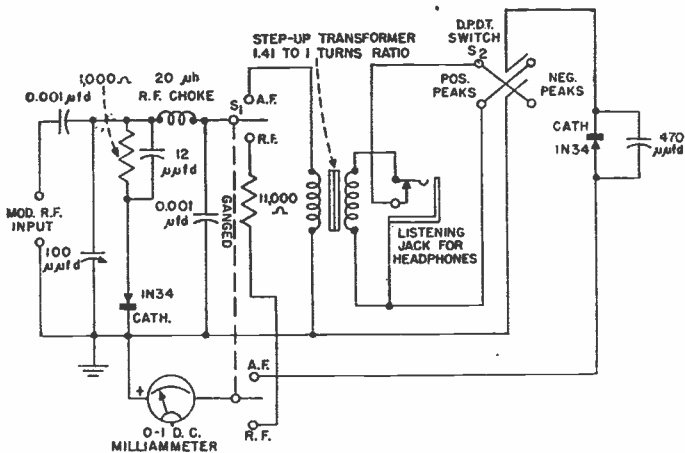

Figure 3-22. PERCENTAGE MODULATION AND CARRIER SHIFT METER

When Switch  $S_1$  is thrown to its af position, the meter will indicate modulation. The meter scale may be calibrated to read modulation percentage directly by means of modulated signals of variable percentage and an oscilloscope set up to show modulation patterns. See the Sylvania book *How to Service Radios with an Oscilloscope* for an explanation of these patterns, how to obtain them, and how to interpret them. When switch  $S_2$  is thrown to its left-hand position, positive-peak modulation will be indicated by the meter. With this switch in its right-hand position, negative-peak modulation will be indicated.

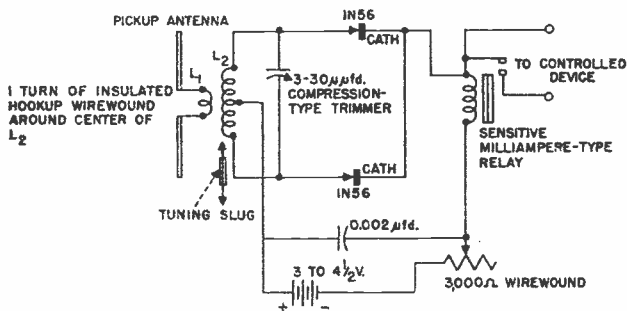

Figure 3-23. 144-MC RECEIVER FOR MODEL CONTROL

Headphones may be plugged into the closed-circuit listening jack for the purpose of monitoring the modulated signal for voice quality and for the presence of noise or hum. When making modulation percentage checks, however, the headphones must be removed.

**3.23 RECEIVER FOR MODEL CONTROL.** Figure 3-23 gives the circuit diagram of a 144-Mc-band crystal receiver for model control. This set has the particular advantage of small size and light weight, features which suit it well for airplane and small boat control.

Increased sensitivity is obtained in this circuit by the use of two Type 1N56 high-conduction crystal diodes in a full-wave detector circuit, and by use of a bias battery. The battery current through the relay coil is adjusted (without a received signal) to the point at which the relay is just about to operate. The rectified crystal voltage, due to the received signal, then will be required to furnish only the small *additional* current necessary to pick up the relay. Greater sensitivity is obtained in this way than is possible with single-crystal reception without the battery.

For simplicity and foolproof operation, a manufactured coil is specified in Figure 3-23.

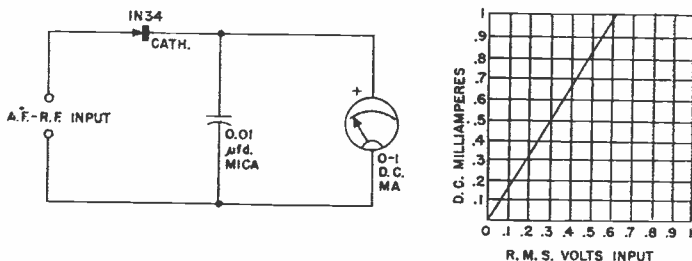

Figure 3-24. CRYSTAL VOLTMETER

**3.24 CRYSTAL VOLTMETER.** The crystal voltmeter has the advantages that it is capable of instant operation; requires no zero setting; has a wide frequency response extending from power-line frequencies to 200 megacycles or more; is compact enough to be built easily as an output indicator into other instruments such as wavemeters, oscillators, bridges, and monitors; and requires no batteries nor other power supply for its operation. Its input impedance, however, is low compared to a vacuum tube voltmeter. But this does not detract from its usefulness in many applications.

Figure 3-24 shows the simplest crystal circuit, employing a 1N34

diode, 0-1 dc milliammeter, and bypass capacitor. This meter will find a host of uses in the radio room.

The basic range of the meter is less than 1 volt r.m.s. signal input for full-scale deflection. Figure 3-24 shows a sample calibration curve for this instrument. The builder must calibrate his own meter, however, since individual crystals vary in conduction characteristics. The basic range of the meter may be extended, as in other ac meters, by use of multiplier resistors.

GERMANIUM CRYSTAL DIODES

Type	Max. Reverse		Min. Forward ImA at + 1v.	Mean ImA	Transient Surge ImA	Remarks	Maker
	Volts wkg.	I, $\mu$ A					
CG1-C or M	80	1000 at -50v.	4	50	400	Detector	BTH
CG4-C	100	10 at -10v.	2.8	50	400	Detector	"
CG5-C or M	30	500 at -10v.	2.8	50	400	Mixer	"
CG6-C or M	50	100 at -10v.	2	50	400	Limiter, Sync. Sep. DC restorer	"
CG8-C or M	25	2 at -10v.	5	20	—	Detector with high fwd. slope and inverse resistance	"
CK705	60	50 at -10v. 800 at -50v.	5	50	500	General purpose diode	Raytheon
CK706	40	200 at -10v.	—	35	300	Vision detector	"
CK707	80	8 at -5v. 100 at -50v.	3.5	35	500	DC restorer	"
CK708 G7	100	625 at -100v.	3	35	500	DC restorer UHF design freq. 300 mc. max. op. freq. 3000 mc.	GE
G8	4 matched	IN48 10% tol.					"
G8A	4 matched	IN52 10% tol.					"
G8B	4 matched	IN63 10% tol.					"

GERMANIUM CRYSTAL DIODES

Type	Max. Reverse		Min. Forward ImA at + 1v.	Mean ImA	Transient Surge ImA	Remarks	Maker
	Volts wkg.	I, $\mu$ A					
GD3	25	40 at -10v.	6	30	300	Wide band VHF detector	S.T.C.
GEX35	30	1000 at -10v.	3	50			G.E.C.
GEX44/1	60	100 at -10v. 2000 at -50v.	1	50	500	Noise or spot limiter	"
GEX45/1	75	33 at -10v. 800 at -50v.	5	50	500	Narrow band Det.	"
GEX55/1	75	200 at -50v.	1	50	500	Instrument Rect. Mixer up to 1000 mc.	"
GEX66	60			100		Detector only	"
GEX00						Wide band VHF detector	Westing- house
WG4A	20	1000 at -10v.	2	50	500	Crystal receiver	"
WG4B	20	1000 at -10v.	5	50	500	Narrow band VHF detector	"
WG5A	40	100 at -10v.	1	50	500	FM ratio detector	"
WG5B	60	1000 at -10v. 1000 at -50v.	5	50	500	Spot or noise limiter	"
WG6A	60	30 at -10v. 600 at -50v.	1	50	500	DC restorer. Sync. sep. FM discriminator	"
WG7A	80	10 at -10v. 350 at -50v.	1	50	500	Instrument rectifier	"
WG7B	40	2 at -1v. 10 at -10v.	5	50	500	High performance general purpose diode	"
WG7C	100	2 at -1v. 200 at -50v.	5	50	500		"



GERMANIUM CRYSTAL DIODES

Type	Max. Reverse		Min. Forward ImA at + 1v.	Mean ImA	Transient Surge ImA	Remarks	Maker
	Volts wkg.	I, $\mu$ A					
1N34	60	50 at -10v. 800 at -50v.	5	50	500	General purpose diode	Sylvania
1N34A	60	30 at -10v. 500 at -50v.	5	50	500	Glass sealed general purpose diode	"
1N35	50	10 at -10v.	7.5	22.5	100	Matched duo-diode 100v. diode	"
1N38	100	6 at -3v. 625 at -100v.	3	50	500		"
1N38A	100	5 at -3v. 500 at -100v.	4	50	500	" "	"
1N39	200	200 at -100v. 800 at -200v.	1.5	50	500	200v. "	"
1N40	25	40 at -10v.	12.75 at +1.5 v.	22.5	100	Plug-in resistors consisting of 4 matched diodes on an octal base	"
1N41	25	40 at -10v.					"
1N42	50	6 at -3v. 625 at -100v.					"
1N43	—	—	5	40	500	General purpose diode	West Elec.
1N44	—	1000 at -50v.	3	40	400	" "	"
1N45	—	410 at -50v.	3	40	400	" "	"
1N46	—	1500 at -50v.	3	40	500	" "	"
1N47	—	4 at -3v. 410 at -50v.	3	30	350	" "	"
1N48	85	833 at -50v.	4	50	500	" "	G.E.
1N49	—	200 at -20v.	4	—	—	Obsolete	—
1N50	—	80 at -20v.	4	25	300	"	—
1N51	50	1667 at -50v.	2.5	50	500	General purpose diode	G.E.

**GERMANIUM CRYSTAL DIODES**

Type	Max. Reverse		Min. Forward ImA at + 1v.	Mean ImA	Transient Surge ImA	Remarks	Maker
	Volts wkg.	I, $\mu$ A					
1N52	85	150 at -50v.	4	50	500	General purpose diode	G.E.
1N54	35	10 at -10v.	5	50	500	High inverse resistance diode	Sylvania
1N54A	50	7 at -10v.	5	50	500	" "	"
1N55	150	100 at -50v.	3	50	500	150v. diode	"
1N55A	150	300 at -100v.	4	50	500	"	"
1N56	40	800 at -150v.	4	50	500	"	"
1N56A	40	500 at -150v.	15	60	1000	High conduction for activating relays, etc.	"
1N58	100	300 at -30v.	15	60	1000		"
1N58A	100	800 at -100v.	4	50	500	100v. diode	"
1N60	25	600 at -100v.	5	50	500	"	"
1N63	125	30 at -1.5v.	—	40	500	Wide band VHF detector	"
1N64	20	50 at -50v.	4	50	500	General purpose diode	G.E.
1N65	85	—	2.5	50	150	Wide band VHF detector	"
1N67	80	—	4	35	500	High inverse resistance diode	"
1N69	60	5 at -5v.	—	—	—	50v. DC restorer	Raytheon
1N70	100	50 at -50v.	5	40	400	General purpose diode	G.E.
1N71	40	0.05 at -10v.	3	30	350	" "	"
1N72	5	0.85 at -50v.	15	60	1000	" "	"
1N73	—	0.01 at -10v.	—	25	—	Low impedance varistor	Sylvania
1N74	—	0.41 at -50v.	15 at +1.2	22.5	100	UHF diode	G.E.
1N75	125	300 at -30v.	15 at +1.3	22.5	100	Plug-in varistor	"
		0.05 at -10v.	—	50	500	Similar to 1N73 but with wider matching tol.	"
		0.05 at -10v.	—	—	—	High inverse resistance diode	"



# BERNARDS RADIO BOOKS

No.		
35.	Dictionary of Mathematical Data	2/-
56.	Radio Aerial Handbook	2/6
57.	Ultra-Shortwave Handbook	2/6
58.	Radio Hints Manual	2/6
64.	Sound Equipment Manual	2/6
65.	Radio Designs Manual	2/6
68.	Frequency Modulation Receivers' Manual	2/6
73.	Radio Test Equipment Manual	2/6
83.	Radio Instruments and Their Construction	2/6
86.	Midget Radio Construction	3/6
96.	Crystal Set Construction	1/-
97.	Practical Radio for Beginners, Book 1	3/-
99.	One Valve Receivers	1/6
100.	A Comprehensive Radio Valve Guide, Book 1	5/-
101.	Two Valve Receivers	1/6
102.	40 Circuits using Germanium Diodes	3/-
103.	"Radiofolder" A. The Master Colour Code Index for Radio and Television	1/6
104.	Three Valve Receivers	1/6
106.	Radio Circuits Handbook No. 4	2/6
107.	Four Valve Circuits	1/6
108.	Five Valve Circuits	2/6
112.	"Radiochart" Electronic Multimeter Construction	2/6
121.	A Comprehensive Radio Valve Guide, Book 2	5/-
123.	"Radiofolder" F. The Beginners' Push-Pull Amplifier	1/6
126.	Boys' Book of Crystal Sets and Simple Circuits	2/6
127.	Wireless Amplifier Manual No. 3	3/6
129.	Universal Gram-Motor Speed Indicator	1/-
132.	Reactance—Frequency Chart for Designers and Constructors	1/6
133.	Radio Controlled Models for Amateurs	5/-
134.	F.M. Tuner Construction	2/6
135.	All Dry Battery Portable Construction	2/6
138.	How to make T.V. and F.M. Aerials Bands, 1, 2 and 3	2/6
139.	Practical Radio for Beginners, Book 2	3/6
140.	Television Servicing for Beginners, Book 1	4/6
141.	Radio Servicing for Amateurs	3/6
142.	Modern T.V. Circuits and General Faultfinding Guide	4/6
143.	A Comprehensive Valve Guide, Book 3	5/-
145.	Handbook of AM/FM Circuits and Components	2/-
146.	High Fidelity Loudspeaker Enclosures	5/-
147.	Practical Tape Recording Handbook	5/-
148.	Practical Transistor Receivers, Book 1	5/-
149.	Practical Stereo Handbook	3/6
150.	Practical Radio Inside Out	3/6
151.	Transistor Superhet Receivers	7/6
153.	Miniature Portable Oscilloscope	2/6
155.	Portable Transistor Radio and Radiogram	2/6
156.	Practical Transistor Circuits Manual 1	2/6
157.	A Comprehensive Radio Valve Guide Book 4	5/-
158.	Radio, Television, Industrial Tubes, Semiconductor and Diodes Equivalents Handbook (208 pages)	9/6
159.	Realistic High Fidelity	5/-
160.	Coil Design and Construction Manual	5/-
162.	High Fidelity Stereo Gramophone	5/-
163.	Transistor Circuits Manual, No. 2	2/6
164.	High Fidelity Tape Recorder	2/6
165.	Hartley on Hi-Fi Tuners	5/-
166.	Public Address Systems	8/6
167.	Transistor Circuits Manual No. 3	2/6
	Resistor Colour Code Disc Calculator	1/6
	Engineers' Reference Tables	1/6
	International Radio Tube Encyclopaedia—3rd edition	63/-