

# SOUND EQUIPMENT MANUAL



**2/6**  
No. 64

---

## GOOD NEWS . . . .

RADIO NEWS, foremost American Radio magazine, can now be obtained direct by post from America; the only sure way of receiving copies regularly.

RADIO NEWS unfolds, month by month, the complete story of radio research and development. Editorially and in presentation, printing and production, it maintains the highest American standards. Each issue contains from 136 to 160 pages of news, articles, pictures and advertisements, brilliantly written and illustrated.

Radio technicians, dealers, business and factory executives, radio specialists in the services, amateurs, "hams," officials, research specialists, constructors, all are fully catered for. The scope of RADIO NEWS, in all that matters, is complete.

For a subscription of £1 5s. 0d., inclusive of postage, payable in advance (equal to 2s. 1d. a copy), the postman will deliver a copy at the door, every month for a year. For two years the rate is £2 5s. 0d. and for three years £3 0s. 0d.

Subscription orders may be placed through your Radio dealer or newsagent or, in case of difficulty, send your order (name and full address in BLOCK LETTERS, please) with remittance covering the period required, to us at the address below.

## . . . . RADIO NEWS

---

### POPULAR PHOTOGRAPHY, FLYING, PLASTICS.

From the same publishers come these three superb magazines, each completely fulfilling, in its own sphere, the same essential purpose as RADIO NEWS. Informative to the highly skilled operator or technician, yet understandable and interesting to the amateur: intensely practical, yet never dry or stodgy. Brilliantly written, copiously illustrated and beautifully produced, each magazine maintains the highest standards for which American magazines are famous.

Particulars of subscription rates and facilities on request.

---

ZIFF DAVIS LIMITED,  
GRAMPIANS BUILDING, WESTERN GATE, LONDON, W.6.  
Telephone: SHEPHERDS BUSH 4794.

# SOUND EQUIPMENT MANUAL

by

“RADIOTRICIAN”



BERNARDS (PUBLISHERS) LTD.  
LONDON

**First Published 1948**

# CONTENTS



Chapter 1. GENERAL CONSIDERATIONS	...	...	Page 5
Chapter 2. THE MICROPHONE	...	...	Page 7
Chapter 3. GRAMOPHONE PICKUPS	...	...	Page 12
Chapter 4. PRE-AMPLIFIER, MIXER AND AMPLIFIER	...	...	Page 15
Chapter 5. THE POWER SUPPLY	...	...	Page 41
Chapter 6. THE LOUDSPEAKER SYSTEM	...	...	Page 46



## CHAPTER 1.

### GENERAL CONSIDERATIONS.

The aim of this Manual is to show, first in broad outline and then in detail, the requirements of a sound amplifying system suitable for use in halls for dances, social gatherings, concerts and speaking and also in the open air. The amplifier is becoming widely used at such functions, and good equipment can do much to make the occasion a success, particularly when handled by an operator who has conscientiously studied the needs of the particular gathering for which he is catering. It should be pointed out, straightaway, that operating the amplifier is a full-time task, and the technique must be mastered particularly when fading music into speech, for example, or controlling the level for all types of stage work.

Whether the sound equipment is to be used in one particular hall or location, or whether it is to be used in several different places, the first point to come under consideration is the required output—how large must the amplifier, and therefore the reproducing loudspeaker or speakers be, in terms of watts? It is probably correct to say that the constructor, dealing with this problem for the first time, is inclined to over-estimate, probably by a large amount. As an example, it may be said that one of the largest cinemas in London uses a main amplifier for all purposes whose output is no more than 40 watts, whilst the standby amplifier, often used, has an output of only 10 watts. The high efficiency of the system, especially where the loudspeakers are concerned, ensures that the available power is used to the fullest advantage.

There is no hard and fast rule for calculating the required power to fill any given hall. The shape of the building, the materials used in its construction, the size of the audience, and whether they will be seated, as for a concert, or moving, as at a dance, all enter the considerations. The writer, who has used amplifiers for speech and music in many locations and for many different purposes, has never required an output larger than 15 watts, and for most purposes has found a 6 watt amplifier perfectly adequate.

In connection with this question of required output it must be realised, too, that there is an optimum sound level to be attained. For dancing, naturally, the sound level must be such that the music is heard with perfect clarity at all parts of the hall, over the background of sound which is always present—conversation, the noise of the dancers' feet and the like—but for concert and speech work the sound level drops. The amplifier must never allow its "personality" to intrude into the real personality of a speaker or entertainer. Its task is to assist the person at the microphone, not to drown him, and there is no doubt that the real criterion for the sound system used for these purposes is that the audience shall hear the entertainer perfectly without ever realising that the voice is coming to them via loudspeakers.

This is a far from simple attainment. To reproduce a voice without change of tone is difficult, and so the amplifier should be capable of high quality which, at the same time, may be adjusted judiciously in order that various needs may be met.

The heart of the system, therefore, is a high quality amplifier with a degree of tone control, the control having effect at both top and bottom of the range. The control, moreover, must be of the smooth type rather than the stepped control which is more useful for work such as recording, and there should be separate bass and treble controls.

The input to the amplifier will come from either pickups or microphones, and, at times, from both, when a system of fading from one input to another will be required. This is complicated by the fact that practically any type of pickup will give a greater input to the amplifier than a microphone, so that the microphone circuit must first include a pre-amplifier with a large gain and a good individual volume control, so that microphones of different types may be used. The ribbon microphone, for example, gives excellent quality, but its output is lower than that of the moving coil microphone. This in turn has, in many cases, an output lower than that of the crystal microphone whilst the carbon microphone, of either the double button, or transverse, or straight variety, has an output sufficient in many cases to make a pre-amplifier unnecessary. The carbon microphone is not advised, however, for it does not give a good quality output and whilst its use assists in the design of the amplifier the tone of the reproduction, for public work, is never satisfactory and the speech sounds "canned."

A pre-amplifier for the microphone, coupled by a fading system into the first gramophone pickup stage should therefore be provided.

At the other end of the amplifier is the loudspeaker system, and this is no longer the simple loudspeaker in a box which provides adequate tone and volume in the home. The number of speakers to be used, their type, their mountings and, most important of all, their positioning, all depend on the particular function and here once more, no hard and fast rule can be given. The distribution of loudspeakers is a matter for experiment and experience, and takes up more time than any other part of the installation.

For dancing, or the general distribution of music, loudspeakers must be placed in such a way that there are no concentrated beams, whilst for speaking or microphone work the first consideration must be the prevention of feedback from loudspeaker to microphone, which, if not actually causing howling, gives distortion and echo effects and seriously hampers the use of the gain control. Again it must be decided whether it is advisable to have all the sound coming from the direction of the platform, or whether the sound may come from several different angles. It is disconcerting, for example, to see a lecturer on the platform and yet hear his voice coming from the side wall.

The speakers, at the same time, must be capable of handling the full output and must be matched together for equal sharing of the load. As the number of speakers increases, therefore, they may be reduced in size.

The type of speaker must depend on the situation chosen for it. One or two speakers, placed near the amplifier, may be mains energised, but



speakers hung from the walls, or at the rear of the hall should be of the permanent magnet type, in order that the wiring may be as simple as possible. Again, each speaker may have its own output transformer or, preferably, may be fed from a central transformer, and the speakers must be phased so that the diaphragms move together, and not in opposition.

This, then, is the general outline of the system. The details may now be considered one by one, following the logical sequence Microphone—Pickup—Pre-amplifier, Mixer and Amplifier—Power Pack—Loudspeaker system.

## CHAPTER 2.

### THE MICROPHONE.

The choice of a microphone requires some thought and care and whenever possible one or two different types of instrument should be tried in order that the most suitable microphone may be picked for the work it is to perform.

For quality reproduction the ribbon microphone is excellent but it is not robust and should therefore be used only in fixed sound systems, that is where the equipment is built to suit one certain hall, and is not required to travel.

The ribbon microphone, as the name implies, has as its moving part a finely corrugated ribbon of very thin aluminium foil, this ribbon being suspended perpendicularly between two long magnetic poles. Sound waves cause the ribbon to vibrate between the poles so that a very small current is induced in the ribbon and flows in any circuit of which the ribbon forms a part. Naturally the impedance of the ribbon is extremely low, of the order of 0.5 ohm, and in order to match this impedance into the input impedance of the amplifier, generally of the order of 100,000 ohms, or more, a transformer system is essential. Immediately there is the chance of hum pickup in the transformer windings, especially where the leads from the ribbon to the transformer are of any length, so a compromise is usually made. Two transformers are used, one mounted immediately below the microphone, on the microphone stand, the other at the amplifier. The first transformer matches the microphone impedance to a low impedance line, of say from 250 to 500 ohms impedance, and the second transformer then matches this line impedance into the preamplifier or amplifier. The line between the microphone and its transformer and the amplifier transformer must therefore be well shielded to prevent hum induction, and coaxial cable is ideal for the purpose, the woven outer conductor acting as both shield and earth return.

The ratios to be used for the two transformers are worked out in the usual manner. For impedance matching the ratio of any transformer is given by the simple equation

$$R = \sqrt{\frac{\text{Imp. 1}}{\text{Imp. 2}}}$$

and taking the microphone transformer, with the ribbon impedance as 0.5

ohm and the line impedance as 250 ohms, the ratio therefore becomes

$$R = \sqrt{\frac{250}{0.5}}$$

or  $R = 22.36$  and the transformer ratio is 22 : 1.

The primary need contain only very few turns, since it is to be in the ribbon circuit, and using a small core and former the two windings would satisfactorily be of 50 turns for the primary and 1,100 turns for the secondary.

The transformer at the input end of the amplifier is required to match the 250 ohm line into a load of approximately 100,000 ohms, so that here the ratio of the windings is

$$R = \sqrt{\frac{100,000}{250}}$$

and  $R = 20.0$  and the ratio is 20 : 1.

This transformer would be rather more troublesome to make by hand, since the primary must suit a 250 ohm circuit, but suitable instruments may be obtained commercially.

The most serious defect of the ribbon microphone is that the ribbon is open to vibration on both sides, so that sound from the back of the microphone has as much effect as sound from the front. This means that the microphone is rather prone to feedback effects, and when used must be shielded from the loudspeakers. The ribbon microphone is therefore of greatest use for speeches and the like, when the loudspeakers may be placed on either side of a stage, backed by the auditorium arch, or below the stage, backed by the front of the platform or the apron.

The constructor interested in building a microphone is well advised to build one of the ribbon type, using a strong magnet or pair of magnets with pole pieces machined out of soft iron. The ribbon may be made of any really thin aluminium foil, the ribbon being approximately  $\frac{1}{2}$ " wide and, finally corrugated, 3" long.

The essentials of a ribbon microphone system are shown in Figs. 1a and 1b.

A microphone with a similar low output with quite good response characteristics is the condenser microphone. Here a heavy metal backplate carries an insulating ring which in turn supports a very thin metal diaphragm, the backplate and diaphragm thus forming the two plates of an air-separated condenser. Speech waves cause the thin diaphragm to vibrate and thus the capacity of the condenser varies in accordance with the waves, the potential across the capacitance also varying. The condenser is troublesome, however, especially in portable apparatus. A polarising voltage must be supplied, since the condenser must be charged, and the pre-amplifier must be situated at the microphone, with consequent trouble in carrying power supplies to the microphone head. The pre-amplifier is also likely to pick up hum, since the first valve has a very high resistance gridleak, across which the small potential fluctuations appear, and the pre-amplifier should therefore have both filaments and anodes supplied from batteries.

For studio and amateur transmission working the condenser microphone is very useful, but for public address work of any type it is more hindrance than help.

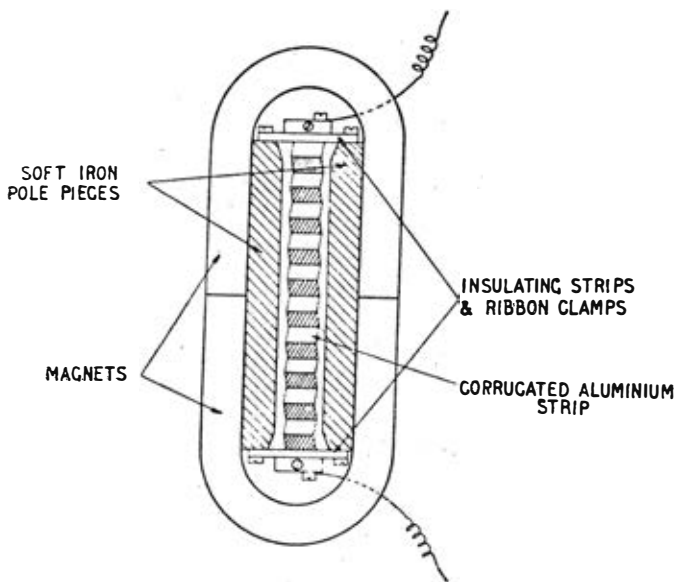

FIG. 1A.—The Ribbon Microphone.

The moving coil microphone, like the ribbon microphone, uses an input transformer to match its impedance into that of the amplifier, but one transformer suffices and a low impedance cable can be used over quite a long run between the microphone and transformer. Moving coil microphones operate in the same manner as moving coil speakers, a small diaphragm carrying the coil which vibrates in sympathy with the sound waves impinging on the diaphragm in an intense magnetic field. The coil thus has small currents induced in its windings.

Under favourable circumstances the moving coil microphone is so free of hum pickup tendencies that the lead from the microphone to the transformer, situated at the amplifier, need not be shielded, and the author has seen ordinary bell wire used as the line. A shielded cable is much to be preferred, however, and again coaxial cable is excellent, although any single

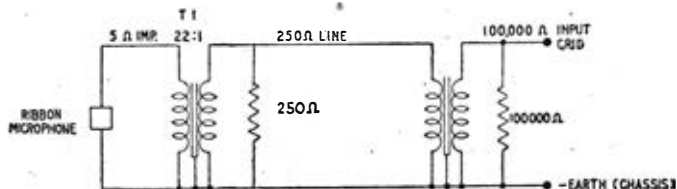

FIG. 1B.—Ribbon Microphone Circuit.

core cable can be used, the outer covering acting as both shield and earth return. The moving coil microphone, being fitted with a solid back, is far more directional than the ribbon microphone, and feedback effects are easier to avoid.

Since different makes of microphone have different impedances the microphone transformer should be bought with the microphone in order that a suitable instrument is obtained, but in general the ratio of such a transformer is between 25 and 35: 1.

Crystal microphones are of two types, the cell and the diaphragm microphones. The cell type gives good quality but has an extremely low output, since the microphone is made in such a manner that a piezo-electric unit is held in the path of the sound waves, the unit vibrating as a whole. Naturally the vibration, and therefore the output, is small.

The diaphragm type of crystal microphone, as the name suggests, vibrates the piezo-electric unit through the agency of a diaphragm, the vibration and thus the output being correspondingly greater. At the same time the diaphragm crystal microphone has a solid back, giving it directional qualities, whilst the cell type is merely surrounded by a metal mesh in the shape of a sphere, protecting the cell mechanically but allowing it to receive sound waves from all directions.

Crystal microphones of either type naturally require no input transformer, but may be fed directly, or through a simple resistance network, to the grid of the first valve of the pre-amplifier, the output from a crystal device being potential in character.

If a carbon microphone is used at any time, it should be of the transverse current variety, since quality is better with this type than with the old solid back microphone. As has already been said, however, carbon microphones cannot be recommended. They require a polarising current, preferably battery supplied, and an input transformer, and are liable to "pack" (that is, the carbon granules stick together, giving a sudden reduction in output accompanied by distortion) or to hissing, all without warning.

The choice of microphone, then, appears to fall on either the crystal or moving coil type, the final deciding factor being the ultimate use of the microphone. Where the equipment is to be used in several different locations the microphone must be robust as well as reasonably sensitive, so that the diaphragm crystal type is indicated, whilst for a fixed location the moving coil microphone gives good results or, given rather more preamplification, the ribbon microphone may be used. The crystal cell type may also be chosen, if really good preamplification can be supplied.

Where microphones are fed into the amplifier or pre-amplifier through transformers the circuit is obvious, and is shown in Fig. 2. There is no need to provide a gain or volume control for the first stage, since the first valve will hardly ever be in danger of overloading, no matter how great the volume of sound, so that the transformer-grid connection may be short, direct and well shielded with no extensions to a control. The microphone transformer mounted at the amplifier end of the cable must, however, be extremely well shielded and when troubles with hum pick up are experienced, the transformer is almost always the point of hum introduction.

In some instances it may be found that the microphone transformer cannot be mounted on the amplifier chassis without hum pick up, and in such a case it is necessary to couple the transformer into the microphone line a foot or two from the amplifier. In one case, using a ribbon microphone, the writer found that the line-amplifier transformer, even when shielded by one mu-metal and two copper cans, could not be mounted on the amplifier chassis without trouble although when the transformer was connected to the amplifier by a foot or so of cable and placed on the floor (in close proximity to power wiring) the gain could be fully advanced without any trace of hum.

The mounting and shielding of the input transformer must therefore be a matter for experiment. The shielding just described is excellent if the materials are at hand, the transformer being entirely encased in a copper case or can with a mu-metal can surrounding this. Where such provision cannot be made the shielding must be of iron—thick soft iron rather than steel being used—and tinfoil is practically useless.

The shielding, however, depends on the location of the microphone, its lead, and the transformer, and will vary widely from place to place.

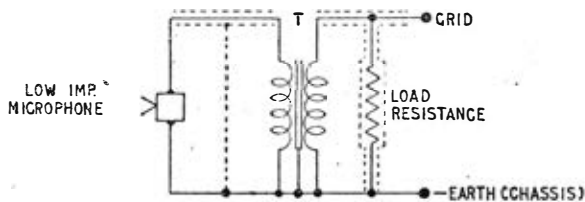

FIG. 2.

In Fig. 2, the diagram of the input circuit of a microphone transformer, the resistance across the transformer secondary introduces the correct loading into the system and has a value related to the ratio of the transformer and the microphone's rated load. Calling the microphone load  $L$ , then the resistance is the product of  $L$  and the square of the transformer ratio, or  $LR^2$ , or, in other words, is the impedance by which the ratio of the transformer is found. Thus in the input of the amplifier, when low impedance microphones are being used (by which is meant microphones requiring input transformers) the resistance may be 100,000 ohms or higher, and, across the line between the two transformers of a ribbon microphone, 250 ohms.

Crystal microphones, on the other hand, may be connected directly between earth and the grid of the first valve, a resistance from grid to earth providing the input load and a bias path, but crystal microphones generally require a very high load resistance of the order of 5 megohms. A load of 5 megohms from grid to earth is too high for the majority of valves, although it can be used with types such as the 6J7, but a better method of providing the load for the microphone whilst keeping the grid-earth resistance within reasonable limits is shown in Fig. 3, where a 3 megohm resistance is in series with the cable and a 2 megohm completes the circuit across the valve.

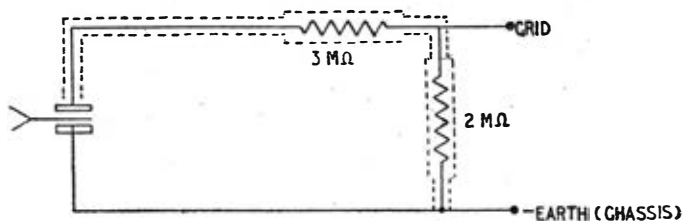

FIG. 3.—Crystal Microphone Input Circuit.

There is, of course, some loss of gain caused by the series resistance, and once again it is wise to experiment with the alternative method where the whole resistance is placed across the valve, since different microphones will give different effects.

In some cases the resistance may be lower than 5 megohms, but the optimum working conditions should be supplied with any good microphone.

## CHAPTER 3.

### GRAMOPHONE PICKUPS.

Pickups, like microphones, can be obtained in different forms, and again the choice depends on the final use of the apparatus. Pickups may be classed broadly as crystal, moving coil and moving iron or armature types, and, like microphones, their output levels and input circuits vary.

The crystal pickup has a high output, and the defect of increased output for the higher audio frequencies, at one time quite common, has been overcome to a large degree, the frequency response of a good crystal pickup being relatively level. It is common, however, to include a filter in the pickup leads to give some treble attenuation.

The moving coil pickup is generally accepted as providing the highest quality output as well as being the lightest and best type from the mechanical point of view. The low impedance of the coil is matched to the amplifier input impedance by means of a transformer, the transformer generally being supplied with the pickup and made to give a rising bass characteristic, of which more later. The moving coil pickup, however, is delicate, and it is not suitable for use with apparatus which is required to travel or, if the sound system is a fixed fitting, for use by different operators. The moving coil pickup should be used by the same operator, who has a full understanding of its delicacy, and a succession of operators means that in all probability the pickup will be damaged in time.

The moving iron or armature pickup is the type known to most users of radiograms. Several makes of the instrument are far too heavy, but a good armature pickup, with a fairly light head and a simple tone arm, can give excellent results.

Certain precautions must be taken whatever the type of pickup chosen.

The instrument must be mounted on the motor board exactly in the manner shown by the tracking chart supplied with all pickups, in order that there shall be no undue record wear, the needle point moving across the record in such a manner that the drag is reduced as far as possible. Any pickup should have a smoothly moving arm with no friction or harshness in the swivelling joint, and whilst there must be a certain amount of weight in the pickup to prevent chatter and to keep the needle in the groove, the weight of the head should be as small as is practically possible. The arm, moreover, should be bent or curved.

Provided with all good pickups is the recommended input circuit which not only provides for correct matching but also gives in most cases any required treble attenuation. Treble attenuation—or bass boost—is required since records are cut with a falling bass. The cutting head is made to follow a "constant amplitude characteristic" for frequencies below about 250 cycles per second in order that the increasing swing of the cutting stylus with reduced frequencies shall not cut through the groove walls. Consequently there is a loss in the bass which must be made up in the reproducing gear, and even when some compensation is introduced by a filter circuit connected in the pickup leads it is often advisable to give further compensation by a bass-boosting pickup pre-amplifier, details of such a circuit being given in the chapter dealing with the amplifier circuit.

Should there be no recommended input resistance for the pickup, it is generally satisfactory to use a .5 megohm volume control.

Whilst microphones may be fed directly into the grid circuit of the input valve, the position with a sensitive pickup is rather different. It is quite possible to overload the valve with the output from the pickup on heavily recorded passages, and so an input volume control is a necessity, especially when using a crystal pickup.

Crystal pickups require a lower loading resistance than crystal microphones, but if the resistance is made lower than that specified by the manufacturers there will be loss of bass.

The controversy concerning the respective merits of steel needles, fibre (or thorn) and the sapphire stylus still carries on. The writer finds that the sapphire stylus is inclined to mark records, showing wear, unless it is used in the lightest of pickups, and uses thorn needles invariably. The reputed loss of the higher frequencies certainly is not apparent to the ear, and whilst it is argued that the thorn accepts dust and grit particles and thus becomes abrasive and gives record wear to a degree approaching the wear of steel needles, this again is not found to be the case in practice, especially when the elementary precaution of dusting the record is taken.

One disadvantage of the thorn needle, however, is the difficulty of using this type of needle with a needle armature pickup. As is well known, the ordinary armature pickup has a light magnetic armature suspended, by rubber damped members, in the centre of a coil of wire, the whole being in a strong magnetic field. The needle is clamped to the armature so that the whole unit vibrates, thus causing variations in field strength which in turn causes an induced current in the coil and a potential across its ends, the potential varying with the needle vibrations and thus reproducing the recorded sound. In the needle armature type of pickup the needle itself

is the only magnetic armature, so that a steel needle is chiefly used. It is possible to use specially capped thorn needles, a small iron sleeve being fitted over the top of the needle to act as the magnetic armature, and the writer has seen thorn needles used in such a pickup with the needle butt wound with a small coil of iron wire.

The aim of the needle armature pickup is to reduce the mass of the vibrating part, but the head often appears to be heavier than that of the more usual armature type. Nevertheless, it is possible to obtain excellent reproduction with needle armature pickups, and if there is no objection to using steel needles, or if the capping of thorn needles presents no difficulty, a needle armature pickup may be installed with confidence.

Should the amplifier be used for record reproduction only, the crystal pickup with its high level of output may be used to cut down the number of amplifying stages to the minimum, but in general the constructor is advised to use an ordinary armature type of pickup. It is robust, so that for a transportable amplifier it is a natural choice, whilst its output is sufficiently high to make a preamplifier unnecessary, and it will take any type of needle.

If at any time the quality obtained from such a pickup should appear to fail, the trouble most probably lies in perishing of the damping rubbers. The damping is easily removed, and the pickup should be dismantled so that the armature can be separated from the pole piece lugs which retain it. Whenever dismantling a pickup, treat the coil with great care, since the windings are of very fine wire. When the armature is removed it will be found to have two spindles, one drilled and tapped for the needle retaining screw, each spindle having a thin rubber damping membrane clamped between it and the pole piece lugs, whilst the top of the armature is gripped in a small slotted block of rubber, usually held in place by an open frame.

The simplest replacement for the rubber membranes on the spindles is a length of ordinary cycle valve tubing, cut into two short pieces and a piece fitted over each spindle of the armature. The rubber block, if this requires renewing, may be replaced by a similarly sized block cut from a piece of old inner tube (car tyre) or rubber of similar texture.

Any old rubber which has perished and stuck to the metal parts of the pickup should carefully be removed, and when re-assembling the instrument the armature must be adjusted so that it may vibrate within the coil without touching or friction or rubbing at any part of its travel, otherwise there will be serious chattering.

Damage or defects in a crystal or moving coil pickup cannot be repaired as easily as is an armature pickup, and such instruments should be returned to the manufacturer when requiring attention.

The pickup leads, whatever type of pickup is used, must, of course, be shielded, and should be as short as possible, and any transformer or filter circuit should also be shielded, whether it is mounted on the amplifier chassis or on the motor board.

A metal motor board is preferable to a wooden board, since the metal board can be earthed, thereby earthing all the apparatus mounted on it, but if a wooden board is necessary, then the frame of any electrical gramophone motor attached to it should be earthed. The pickup, in its travel



across the record, moves directly through any stray hum field which might exist around the motor coils, and any type of pickup, especially the armature type, will be likely to respond to such fields unless proper precautions are taken. Earthing the motor frame also earths the turntable, which acts as an efficient screen between the motor and the pickup, but in any case, where there is variable hum on the amplifier it is as well to test for motor-pickup induction, allowing the motor to rotate the turntable and, with the gain control fully advanced, holding the pickup just above the turntable and moving it across its arc of travel. A varying hum output indicates field leakage, and a further screen of, say, copper foil, should be interposed between the motor and the pickup. Where a metal motor board is available this defect is most unlikely to occur, but on a wooden motor board it might arise. In such a case the extra screening could easily be attached to the underside of the board, the area screened extending for some inches beyond the outline area of the motor and both screen and motor frame being bonded together and to earth. (Earth, in this context, should always be taken as referring to the MAIN AMPLIFIER CHASSIS. Whether or not this chassis has an actual physical earth connection depends on circumstances to be discussed.)

Before finally connecting the motor frame and board to earth, it is always wise to test for any leakage between the motor coils and its frame. To make such a test, earth the motor frame to the main chassis via a neon lamp in series with the earthing lead, using, if possible, a 100 volt neon lamp. Serious leakage indicating insulation weaknesses, will be shown by lighting of the neon, showing that a partial short circuit exists in some way through the mains circuit between amplifier and motor. (The most likely leakages will occur with A.C./D.C. apparatus.)

Any leakage should be investigated and cured, since even if there is no actual danger either of shock to the operator or damage to the equipment, there is always the chance of a greatly increased hum output.

With A.C./D.C. apparatus, apparent leakage can sometimes be checked by reversing the mains connection to the motor, and in stubborn cases of hum induction reversing the mains lead connections can also be of considerable help, even on normal A.C. supplied equipment.

## CHAPTER 4.

### PRE-AMPLIFIER, MIXER AND AMPLIFIER.

The microphone pre-amplifier is necessary for all microphones other than the carbon type microphone, to bring the speech or microphone sound up to the same level as the output from the pickup, in order that the two signals may be mixed and then amplified to the required degree by the main amplifier.

It is only wise to design the pre-amplifier in such a way that it will provide adequate amplification for even the most insensitive microphone, and as a guide it may be said that the sound cell, or crystal cell microphone,

gives for normal speech a grid voltage in the first stage of perhaps less than 0.01 volt.

A crystal pickup may provide an input voltage of as much as 2 or 4 volts to its own stage, whilst an armature pickup can give 0.5 volt or more, so that the pre-amplifier must have a very high gain.

For high gain at low input levels the R.F. pentode is an excellent valve, and properly used it introduces very little distortion. For 6 volt working the 6J7 or the EF39, and for 4 volt working the SP41, are all excellent valves, and two valves of any of these types may be used in cascade with no difficulty provided that the grid-anode leads and couplings are as short and direct as possible.

Theoretically it is possible to obtain gains per stage with R.F. pentodes of well over 100, so that two pentodes in cascade can give an overall gain of 10,000, but obviously such a very high gain could only be used with a very low input.

It is found to be good practice to have several gain controls throughout the amplifier, the final control being the general volume adjuster for all channels. The gain controls at earlier stages throughout the equipment may then be set so that the microphone pre-amplifier and the pickup input stage and the mixing stage are all working at correct full levels, without overloading, the final control thus having a range of from no output to full volume.

The tone controls are usually included in the main amplifier, working on both gramophone and microphone signals. Where there is to be a considerable amount of fading from speech to music, as in a stage production, it may be more desirable to have separate controls for the two input channels, but in general the control on the main amplifier is satisfactory.

The final volume control should be as near to the output stage as is practical, in order that any noise introduced onto the signal by the previous stages—valve hiss, etc.—is reduced along with the signal.

Whenever possible the amplifier should be designed for A.C. working, so that low voltage heater valves may be used, their heaters being connected in parallel in the usual manner. If it is necessary to use A.C./D.C. valves of the 0.2 or 0.3 amp. heater type, their heaters must be connected in series, and this gives greater chances of heater-cathode leakage hum, since the heater voltages become progressively higher above earth as the number of valves in the chain increases.

The writer's preference is for the British 4 volt range of valves, since it is then possible to use triodes of the PX4 and PX25 type. Triodes require greater grid driving or grid swing potentials than output tetrodes or pentodes, but there can be little doubt that high quality can be obtained far more readily when using triodes. For very high outputs the American 6L6 type is easily driven, and as much as 40-50 watts of audio output is obtainable from one pair of valves, but harmonic distortion is inclined to be high, and for satisfactory working the screens require feeding from a separate power pack.

A pair of PX4's can supply 8 to 10 watts output, adequate for most indoor purposes, whilst a pair of PX25's for practically the same grid

swing can deliver up to 12 or 15 watts, which gives a margin of power available.

The power required for open-air work is often overestimated, as is that for indoor work. 10 watts fed to a single permanent magnet speaker can be heard over a  $\frac{1}{4}$  mile, and a 15 watt amplifier with a good speaker system properly placed and directed will be found adequate for supplying music or speech for such functions as garden parties, etc. A public address system, pure and simple, is designed to work with higher outputs either to cover wide areas or to drown distracting sounds, the speakers being designed to give fairly directional beams, but it is seldom that the home constructor requires equipment and power outputs of this type.

It has been remembered, however, that at times an amplifier will be required to work in districts where mains supplies are not available, and in such a case it will be necessary to use 6 or 12 volt secondary batteries with a vibrator H.T. supply. The vibrator pack is obtainable commercially, and it is advised that a pack should be bought, rather than made, since the highest efficiency possible must be obtained. It is necessary, too, to design the amplifier to give a high output for as low an anode current consumption as can be achieved, so that output beam tetrodes are used and every precaution taken to ensure good quality.

Negative feedback can be used with good effect when tetrodes or pentodes are used in the output stage, and, if pentodes are used in the first stages of the main amplifier, these also may have negative feedback to keep the harmonic distortion content over the whole amplifier low. When triodes are used in the output stage, however, it is worth while using triodes in the previous stages except, of course, in the pre-amplifier, where as much gain as possible must be obtained from as few stages as possible.

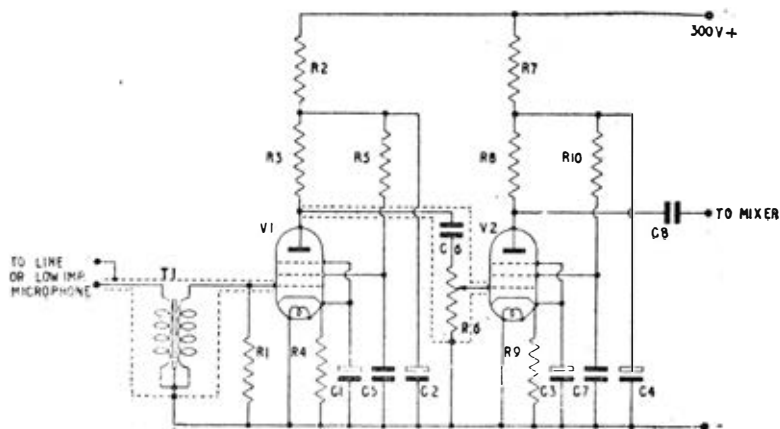

FIG. 4.—Microphone Pre-amplifier.

### The Pre-amplifier.

In Fig. 4 is shown the practical circuit for the pre-amplifier, for use with either 6 or 4 volt valves, the component values for the two types of valve being given in separate tables. The pre-amplifier will, of course, be built on the main amplifier chassis, remote from the power pack end or, if the power pack is accommodated separately, remote from the output stage end.

A separate chassis for the power pack is advisable, for then there will be little chance of hum induction from the mains transformers and chokes into the input transformers or leads.

The circuit shows that interstage leads are screened as well as the input leads, and if screened insulating sleeving is used this screening is carried out as easily as slipping ordinary sleeving over the wire. All screening used in the amplifier itself should be earthed to the chassis at each end.

#### Components List for Pre-amplifier, using 4 volt valves.

(Fig. 4)

R1,	100,000 ohms $\frac{1}{2}$ watt, or as specified for microphone and transformer used.
R2, R7,	33,000 ohms, $\frac{1}{2}$ watt.
R3, R8,	75,000 " " "
R4, R9,	1,000 " " "
R5, R10,	300,000 " " "
R6,	0.5 megohm volume control.
C1, C3,	25 mfd. 25 v.w. Electrolytic.
C2, C4,	8 " 350 v.w. "
C5, C7,	1 " 350 v.w. Non-inductive.
C6, C8,	0.1 " 350 v.w. " "
T1,	Transformer to suit microphone used. (Low impedance type.)
V1, V2,	SP41
2	Mazda octal chassis mounting valveholders.

#### Components List for Pre-amplifier, using 6 volt valves.

(Fig. 4)

R1,	100,000 ohms., $\frac{1}{2}$ watt, or as specified for microphone and transformer used.
R2, R7,	47,000 ohms, $\frac{1}{2}$ watt.
R3, R8,	220,000 " " "
R4, R9,	1,200 " " "
R5, R10,	1.2 megohm, " "
R6,	0.5 megohm volume control.
C1, C3,	25 mfd., 25 v.w. Electrolytic.
C2, C4,	8 mfd. 350 v.w. Electrolytic.
C5, C7,	0.5 mfd. 350 v.w. Non-inductive.
C6, C8,	0.1 mfd. 350 v.w. " "
	Transformer to suit microphone used. (Low impedance.)
V1, V2,	6J7.
2	International octal chassis mounting valveholders.

For the sake of clarity the screening on the interstage coupling from the anode of V1 to the grid of V2 is not shown in further pre-amplifier circuits (Fig. 11 and following).

The pre-amplifier in the diagram has its input circuit as it would be arranged for working from a line or moving coil microphone. For a crystal microphone T1 would be removed and the resistor R1 would have a value of from 2 to 5 megohms, arranged to suit the microphone as explained in Chapter 2.

One side of the heater of each valve is earthed, so that heater wiring can be carried out rather more simply, one wire being used to connect the live sides of the heaters, the earthed heater pin being connected directly to earth at each valve socket, a soldering tag being anchored under one of the socket fixing bolts for the purpose. The single heater wire should be run flat along the chassis, in order that its stray fields shall be shielded. If desired the heaters can be twin wired by twisted flex in the usual manner, the earth connection then being made at one valve socket, and really excellent heater wiring can be made, in a roomy chassis, by using twin cored lead cable, the heavy sheath providing rigidity and good shielding. If such cable is used, it should be anchored flat along the underside of the chassis with small clamps cut from brass strip and secured by 6 B.A. bolts.

The chassis may be of heavy aluminium or lighter gauge steel, and whilst steel gives magnetic shielding it is also possible for stray fields to pass along the chassis, exciting hum in the input transformer. Aluminium is easier to work, and gives a perfectly satisfactory result both as to finish and performance.

When using 6 volt valves, an attempt should be made to obtain the all-metal type for the pre-amplifier, but these are less easily procured and most probably the glass type will be used. If hum troubles arise, the effect of valve screening cans should be tested, and the cans fitted over the valves permanently if a cure is thus provided.

It is also possible for feedback to occur, indicated by motor boating or whistling as the gain control into the second stage is advanced. If valve cans have no effect on this defect, faulty and indirect wiring is almost certainly the cause. Screening must be thorough, the valves must be close together, so that short leads can be used, and the wiring from the anode of the first valve, the gain control itself, and the grid lead to V2 must be included in the screening. To keep the wiring as short as possible R6 may be mounted on the chassis beside or between the valves, if desired, rather than on the front panel, since it is a pre-set control to all intents and purposes, being adjusted fully to load V2 and then left alone, further microphone control being obtained in both the Mixer and the main amplifier circuits.

#### *The Pickup Input Stage.*

When it is required to give a degree of bass boosting to the pickup the problem may be attacked from two angles, depending on the input circuit of the amplifier and whether or not mixing with microphone signals is to be used.

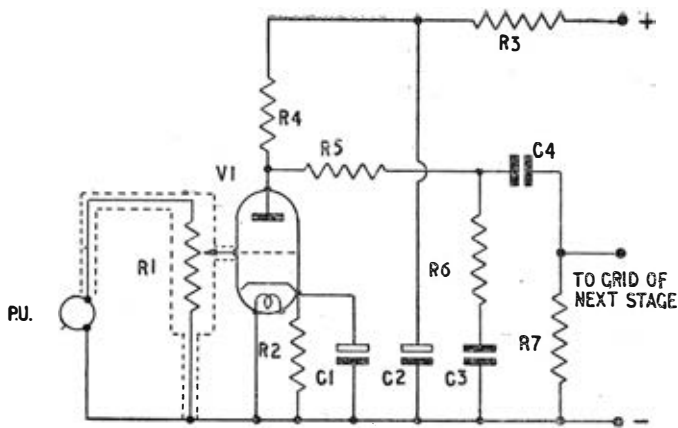

FIG. 5.—Bass Boosting Pickup Input Stage.

When the amplifier is to be used for recorded music alone, so that the pickup circuit is the only input circuit, the bass boosting may be introduced into the anode circuit of the input stage, in the manner shown in Fig. 5.

(It should be noted here that "boosting" is actually a misnomer. "Bass boosting" would appear to indicate extra amplification of the bass frequencies, whereas in actual fact the bass frequencies are left at their original level whilst the middle and top frequencies are attenuated. True boosting occurs only in control circuits where inductances are used.)

Generally, however, the pickup will feed straight into the mixer, a pair of valves (or a double valve) with equal and similar anode loads and circuits. The mixer also amplifies to an extent, but a bass boosting network cannot be included in the anode circuit of the valve working from the pickup input for the balance between the two anode circuits must be maintained. The output level from the mixer must be suitable for driving the main amplifier.

A valve could be introduced between the pickup and the mixer to accommodate the bass boost circuit, but in this case the pickup signal would overload the mixer and the balance obtained between the level of the two input signals would be totally upset. This extra stage could be introduced if a pickup of the moving coil variety were to be used, since the low output of such a pickup requires a further stage of gain, but the transformer supplied with such a pickup almost invariably has bass boosting characteristics already.

The second course, therefore, must be taken when the pickup signal is to be mixed with a microphone signal and requires bass boosting at the same time; the course of introducing a boosting network into the pickup leads.

When using a crystal pickup, the maker's recommendations should be followed exactly, and accordingly no crystal pickup filter is shown here. In Fig. 6, however, is shown a filter suitable for use with a moving iron or

armature pickup, the network, in this instance, giving a pickup load of 0.5 megohm, and giving a suitable degree of boost. If a loading on the pickup other than 0.5 megohm is required, the values of the resistances shown in the diagram should be multiplied or divided by the factor of the difference and the value of the capacitance should be divided or multiplied by the same factor. For example, if the filter was required to give a load of 0.25 megohm instead of 0.5 megohm, the resistance values should be divided by 2 and the value of the capacitance multiplied by 2. The specified loading is that which obtains at the middle and top frequencies.

Since these frequencies are attenuated to give the effect of a bass boost, the overall output from the pickup will obviously be reduced. The mixing and amplifier circuits to be shown have sufficient gain to deal with this loss in the filter, but it must be admitted that to some ears the filter will merely reduce volume without giving obvious benefit. In such a case the use of the filter must be a matter of choice as is, finally, the use of any bass boosting device.

The bass boosting input stage is shown in Fig. 5 as a triode circuit, and whilst a pentode may be used the gain with such a valve will be more than is required. The component values given in the following list are suitable for use with either 4 or 6 volt triodes.

#### Components List for Bass Boosting Pickup Input Stage.

(Fig. 5)

R1,	0.5 megohm volume control, or to suit manufacturer's specification for P.U.
R2,	750 ohms. $\frac{1}{2}$ watt for 354V. (4 volt type).
	1,000 ,, ,, ,, ,, 6C5G. (6 volt type).
R3, R6,	22,000 ohms, $\frac{1}{2}$ watt.
R4,	47,000 ,, ,, "
R5,	68,000 ,, ,, "
R7,	1 megohm, ,, "
C1,	25 mfd. 25 v.w. Electrolytic
C2,	8 ,, 350 v.w. ,,
C3,	0.05 ,, 350 v.w. Non-inductive.
C4,	0.1 ,, 350 v.w. ,,
V1.	354V for 4 volt working.
	6C5G for 6 volt working.

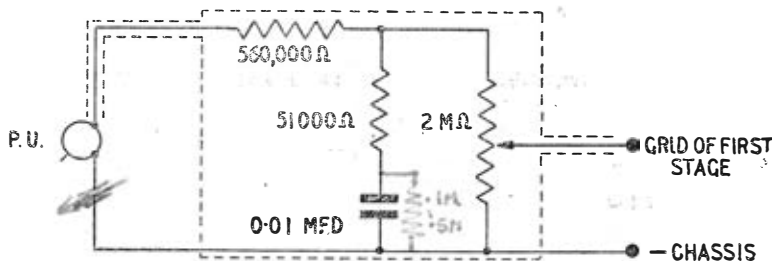

FIG. 6.—Bass Boosting Filter.

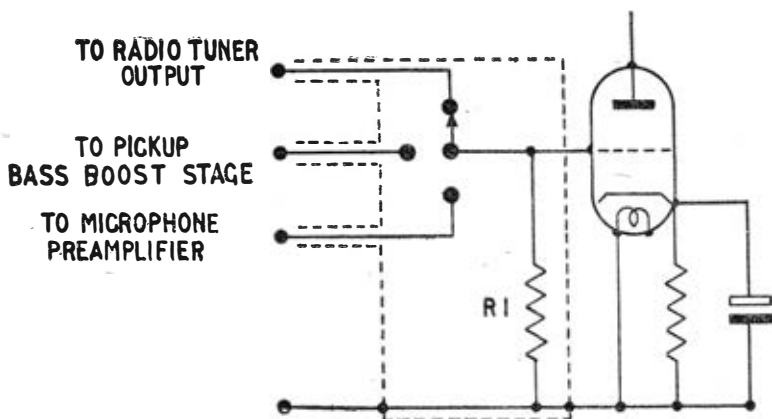

FIG. 7.—Selective Switching in place of Mixer Stage.

The gain of the stage as a whole is naturally reduced by the frequency discriminating network, and the overall gain with the 354V is very approximately 6 to 8 times, whilst with the 6C5 it is approximately 3 to 5 times. Greater gains are not required in the majority of cases, however, and such a stage will feed directly into the phase splitter of many types of paraphase amplifier to give full loading of the output stage.

If a mixing circuit can be dispensed with in favour of a plain switching circuit, then the bass boost stage can be used for pickup work whilst the microphone pre-amplifier can be switched in for direct sound. There are many occasions when mixing is far from necessary, and the only precaution to be observed when switching circuits in this way is to reduce the main gain or volume control to zero before switching over from one circuit to another, so that there shall be no crashing. It is not necessary to open grid circuits in the switching, for the two (or more) inputs can be switched in turn across the grid resistance of the first common stage or the phase splitter, whichever is acting as the first stage of the main amplifier, so that the grid does not "float."

The switching circuit for three input channels—e.g. pickup, microphone and radio—is shown in Fig. 7.

R1, the grid resistance, may be as shown in Fig. 5, where the grid leak for the next stage is shown as a 1 megohm resistance, and, of course, if the circuit of Fig. 5 was coupled to the amplifier via the circuit of Fig. 7, R7 in Fig. 5 would be omitted, its place being taken by R1 of Fig. 7.

#### *The Mixer.*

To mix signals from two channels many circuits can be used, but the most usual arrangement is shown in Fig. 8. For economy a double valve such as the 6N7 may be used, but since these valves are in short supply the diagram shows a pair of valves.



Each valve deals with one channel, the output being fed into a common load which supplies the next stage, the two grid volume controls determining how the two channels are fed through the system to be combined or selected as desired.

The common load for the two anodes of the mixer stage is perhaps not obvious, since the isolating resistances R6 and R7 separate the anodes from the coupling condenser and the anodes have their own load resistors. Each anode, however, sets up its own quota of signal potential across the grid resistance of the following stage, and whilst the anodes could feed into a single resistance between themselves and the power line, this would bring the two valves into shunt connection and give an incorrect loading.

Once again the circuit may be used for either 4 and 6 volt valves with changes only in the biasing resistors, although the total stage gain for 4 volt valves, using the type 354V will be approximately double that obtained from the 6C5. With the four volt valves the gain will be in the nature of 10 or 12 over the stage.

The lower gain with 6 volt valves is, of course, compensated by extra gain, if required, in the 6 volt main amplifier.

If high gain is required pentodes may be used with anodes strapped together and screens strapped together, for the connecting of pentodes in shunt in this way is a more practical proposition. It is felt, however, that the mixer stage for all ordinary purposes should not have high gain which might make it rather "lively" or sensitive to handle.

The volume controls used in the grid circuits should have direct contact between the moving arms and earth when turned fully down, so that there shall be no signal from the channel which is turned off.

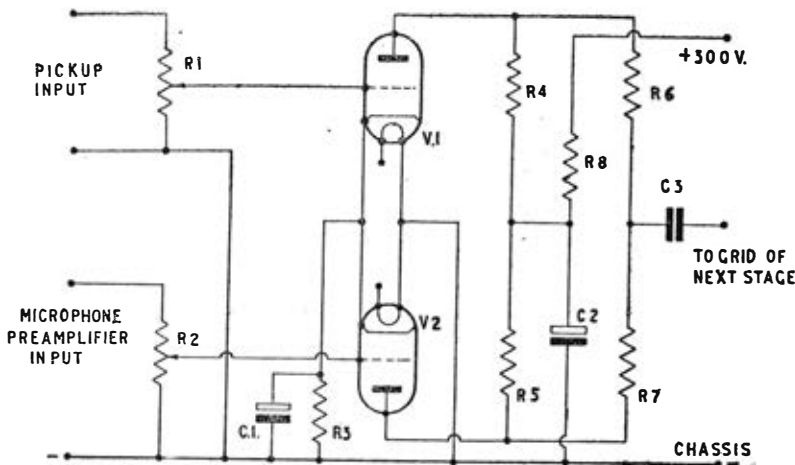

FIG. 8.—The Mixer Stage.

## Components List for Mixing Stage.

(Fig. 8)

R1, R2,	0.5 megohm, or to suit the required loading of apparatus coupled in.
R3,	390 ohms, $\frac{1}{2}$ watt for 4 volt working. (354V type valves.)
	510 ohms, $\frac{1}{2}$ watt for 6 volt working. (6C5 type valves.)
R4, R5,	100,000 ohms, $\frac{1}{2}$ watt.
R6, R7,	470,000 " " "
R8,	22,000 " " "
C1,	25 mfd., 25 v.w. Electrolytic.
C2,	8 " 350 v.w. "
C3,	0.1 " 350 v.w. Non-inductive.
V1, V2,	354V for 4 volt working.
	6C5G for 6 volt working.

The two volume controls or mixing controls in the grid circuits must be chosen to give the correct loading on their associated apparatus. Thus R1 would require to be a 2 megohm potentiometer if it was used as the final control in the boosting network shown in Fig. 6.

Unless absolutely necessary the resistance across the grid circuit should not be higher than this, and a lower value helps to prevent hum and is more suited to the correct working of the valve.

The tone controls are introduced into the circuit after the mixer stage, and several different types of control are available. After considerable experiment, however, the writer is of the opinion that for really simple control, and wide working range, a pair of attenuators, one working on the high and one on the low frequency bands, are most satisfactory. Whilst there are several controls giving true boost, or control stages given over to tone manipulation in which the whole response band can be adjusted to almost any requirements, their use entails either inductances, with consequent serious liability to hum, or extra valves, and in neither case does the increased expense seem justified. If the amplifier can give good quality it will be found that only small changes in tone are needed at odd times, and the circuit of Fig. 9 can deal adequately with these adjustments. The control unit is fitted between two valves, as an anode-grid coupling, and in a small "straight" amplifier with a single ended output stage, the unit may come between the first and second stages with the volume control either before or after the tone control. In a paraphase amplifier, however, the tone control and final volume control can be combined as shown in the diagram, and if desired the whole unit—tone and volume controls—can be made into a semi-remote control box coupled into the main amplifier by 3 or 4 yards of shielded twin core cable. For some stage purposes this can be of great use, since it enables the operator to stand in the wings and watch the proceedings whilst retaining full control over the sound apparatus. The control unit is shown feeding into a "concertina" phase splitter, and whilst centre tapped transformers can be used to give the two phase driving

input to the final stages of the amplifier, a valve in this position, whilst giving no gain, introduces no distortion and is, in general, cheaper than the high performance transformer which is required to perform the same operation.

For remote control, the cable and screen extensions are inserted at X, Y and Z. For panel control the unit is built straight into the amplifier. The remote control unit must be built into a perfectly screened box, either of metal or with a stout gauze lining, and the cable shielding, which also provides the earth return, must be of a really good woven mesh. Provided these precautions are taken there should be no hum introduced into the control extension or wiring. A socket on the amplifier panel can receive a plug in which the unit cable is terminated, thus allowing the control unit to be detached for transporting, and but little ingenuity would be required to provide a switching unit to give tone and volume control both on the amplifier panel and also by remote control. Such switching, however, would also require shielding.

The cable introduces some small "tone control" on its own account, due to the shielded lead capacitance, but the effect is small and is swamped by the range of control obtained with the attenuators.

#### Components List for Main Tone and Volume Control Unit.

(Fig. 9)

R1,	Treble attenuator	0.25 megohm, variable.
R2,	Bass attenuator.	0.25 megohm, variable.
R3,	Main Volume Control.	1.0 megohm.
C1,		0.005 mfd. 350 v.w. Non-inductive.
C2,		0.001 " " "

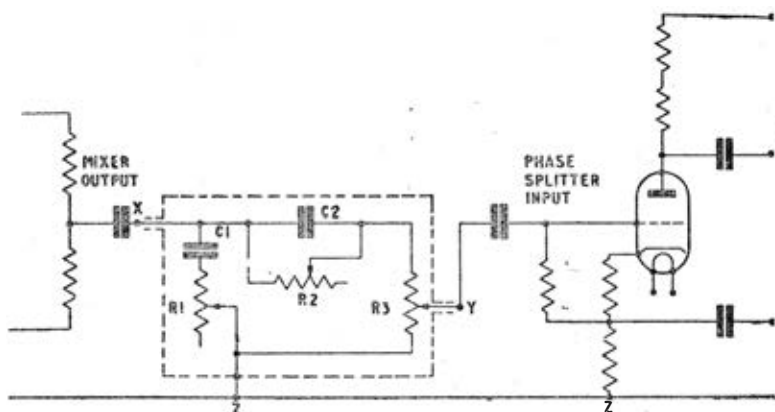

FIG. 9.—Remote or Panel Main Tone and Volume Control Unit.

## *The Main Amplifier.*

So far the various stages or units preceding the main amplifier have been shown in individual detail with their own components lists, for the benefit of those constructors who have a main amplifier and require details of such accessory apparatus, and it is now proposed to show a main amplifier, from the phase splitting to the output stage, in a similar manner. The diagram of Fig. 10 shows such a circuit, and it may be coupled with the units already described. For the benefit of those who are building a complete system, however, the circuits of Figs. 11, 12, 13, 14 and 15, show complete amplifiers from pickup and microphone to loudspeakers.

All the output stages shown are in paraphase—that is, two valves are used. It is possible to obtain 10 watts from a single valve—for example, the 6L6 will give 10 watts with a fairly high anode voltage and fixed battery bias, but the use of two valves allows the stage to give good power without overworking the valves and at the same time second harmonic distortion is cancelled out.

Little need be said concerning amplifier layout and construction, for if the valves and stages are allowed to follow in logical sequence, the input stages being remote from the output stages and the power supply, there should be no trouble either with hum or instability, and the valve sockets may be arranged so that the coupling condensers run directly beneath the chassis between anode and grid sockets. In two-valve stages, as in the main amplifier, the valves may be side by side, so that the layout follows the same plan as the circuit diagram.

Controls along the panel—that is, along the chassis front edge—should be positioned in such a way that the leads to them are as direct and short as possible, and if a lead does need to take a circuitous route it will be as well to shield it with slip-on insulated screening.

If a single output transformer is to be used, it should be mounted on the chassis behind the output stage valves, and leads to and from the chassis-microphone, pickup and loudspeaker leads should be connected into circuit either by plain plugs and sockets or, preferably, by plug-jacks and sockets, the input leads from pickup and microphone being grouped at one end of the chassis and the output leads at the other.

Conventionally, the chassis layout follows circuit diagram practice, in that the input end is at the left with output and power supplies, if fitted on the same chassis, at the right, but this may be modified to suit requirements.

If the amplifier is enclosed in a solid metal box adequate ventilation should be provided, not only in the lid, which may be louvred for the best appearance, but also in the chassis itself, so that air can pass from beneath the chassis and around the valves.

A cover can be made from perforated zinc or copper gauze to fit and screw to the chassis, the chassis being tapped for 8 or 6 B.A. fixing bolts, and in this case the ventilation, so far as the top of the chassis is concerned, will be automatically ensured.

The chassis, whether of steel or aluminium, should be of such a gauge that it will take a 6 B.A. tapping and give firm anchorage to 6 B.A. screws, and earth connections are best tapped in rather than bolted on or, in

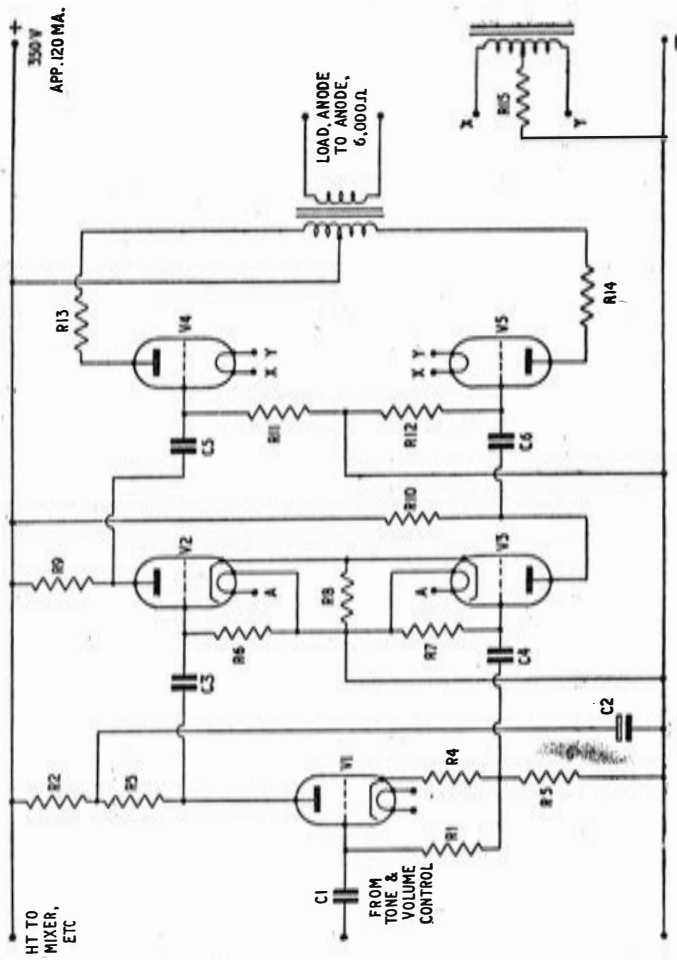

FIG. 10.—8-10-watt Amplifier (4-volt type).

the case of steel, soldered on. Soldered joints to a steel chassis must be made with a really big iron, and must be carefully tested for dryness.

Where a network or unit is mounted below the chassis and requires further shielding, the chassis may be subdivided by aluminium sub-panels into bays or, preferably, a small cover of copper gauze can be cut and soldered into shape and arranged to fix over the unit and be held by screws tapped into the chassis. The extra work of such shielding is well worth while, adding to appearance as well as to efficiency.

Group board construction is also of great help in attaining neatness of wiring, but small group boards should be used rather than one long board, so that pre-amplifier and mixer and main amplifier groups not only may be identified without trouble, but also are separated against feedback or instability.

When matched pairs of valves can be obtained these should be used for the output stage and other stages where two valves work together, but their use is not vitally important. Again, in these double stages, resistances are used in pairs—for example, in Fig. 10, R6 and R7 are equal, R9 and R10 are equal, etc., as are the two main load resistances in the phase splitter, R3 and R5.

An attempt should be made to pair these resistances so that their two values are as nearly equal as possible, using 5% tolerance resistors if obtainable, or checking a number of 20% tolerance resistors on a bridge, if possible, picking two equal values. The final value is not so important as the balance between the two values in each case, a few per cent. above or below the stated value having little effect on the working of the amplifier.

Where directly heated output triodes are used, namely, the PX4 and PX25 types, attention should be paid to the method of biasing. In Fig. 10 is shown the mains transformer secondary feeding the heaters of a pair of PX4's, biasing being obtained by connecting the bias resistor between the centre tap of the heater secondary and the chassis.

The mains transformer used with these valve types should therefore have at least one centre tapped heavy duty 4 volt winding, but it is now common practice to centre tap all windings so that there should be no difficulty on this account.

The phase splitter, in each circuit, is the only valve shown with no earth connection to its heater. The reason for this is that the cathode, by reason of the high voltage drop across the cathode load resistance (R5 in Fig. 10, for example) is at a fairly high potential above earth, and direct earthing of one side of the heater may result in a breakdown of heater-cathode insulation. Whenever possible the phase splitter should have a separate heater winding on the mains transformer. If this cannot be spared the phase-splitter's heater must, of course, be wired in with the other heaters and "take its chance"—the writer has not met with a failure in heater-cathode insulation of a valve in such a circuit with one side of the heater connected to earth—but if a spare heater winding can be given over to this one heater, then there is the satisfaction of knowing that there is no undue strain on the valve. The heater, however, should be bypassed in some way or other to earth, and one satisfactory method is to connect a 0.1 mfd. condenser between the centre tap of this heater winding and the chassis.

The effectiveness of the bypassing may be heard in the loudspeaker with no signals passing. Hum due to the phase splitter will vanish when the condenser is connected in place. If the condenser is not fully effective in removing hum, it may be substituted by a 22,000 ohm resistor. The heater and its supply winding will then be earthed, but in such a way that any small leak is protected by the resistive path.

In each circuit the anode-to-anode load which should be presented to the output stage by the loudspeaker system via the output transformer is shown. The question of matching up to this required load is dealt with in a later chapter.

The amplifiers are shown without power supplies. Power packs are shown and discussed in the next chapter.

#### Components List for the 8-10 watt Main Amplifier. (Fig. 10)

R1,	1.8 megohms, $\frac{1}{2}$ watt.
R2,	22,000 ohms, 1 watt.
R3, R5,	33,000 " " "
R4,	1,000 " $\frac{1}{2}$ "
R6, R7,	470,000 " $\frac{1}{2}$ "
R8,	360 " " "
R9, R10,	47,000 " 1 "
R11, R12,	330,000 " $\frac{1}{2}$ "
R13, R14,	68 " 1 "
R15,	470 " 5 "
C1,	0.02 mfd. 350 v.w. Non-inductive.
C2,	8 mfd. 500 v.w. Electrolytic.
C3, C4, C5, C6,	0.1 mfd. 500 v.w. Non-inductive.
V1, V2, V3,	354V.
V4, V5,	PX4.
3	5 pin chassis mounting valveholders.
2	4 " " " "
T1.	Output Transformer to handle 10 watts. Ratio to suit speaker requirements.
Chassis, wire, etc.	

Since for all the circuits shown the chassis size will depend on the layout adopted by the constructor, whether or not a pre-amplifier is fitted and whether or not the power supply is built on to the amplifier chassis, it is not possible to give chassis sizes in the components list.

Deciding on size is a simple matter, however, if the size of the components is studied and the layout planned on paper, remembering that valvesockets are accommodated by one and one-eighth inch holes and arranging the valves in a chain as already suggested.

#### Components List for 12 watt Amplifier. (Fig. 11)

Note.—The amplifier is shown with the pre-amplifier input circuit arranged for a crystal microphone. R1 may be replaced by the transformer

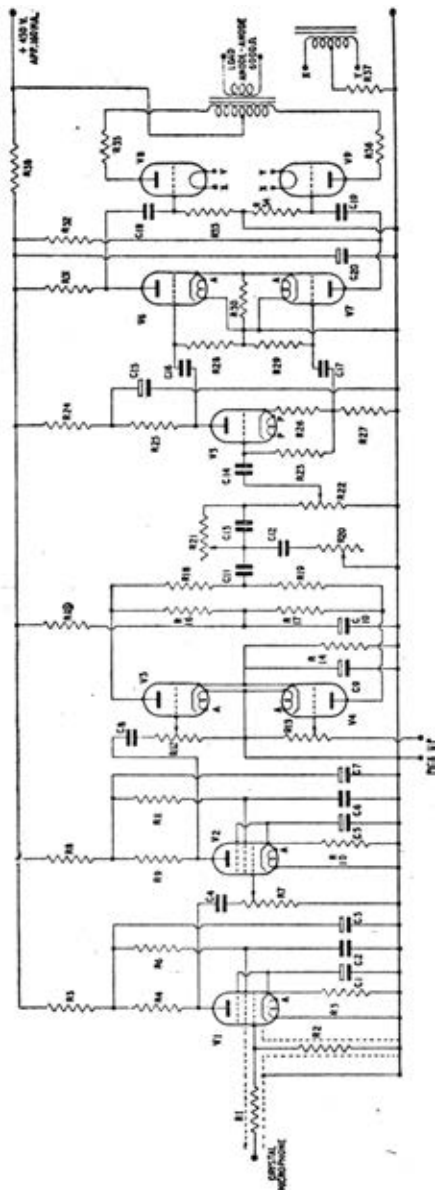

FIG. 11.—12-watt Amplifier (4-volt type)



of a low impedance microphone, R2 being changed to give the required loading.

R1,	3 megohms, $\frac{1}{2}$ watt.
R2, R23,	1.8 " $\frac{1}{2}$ "
R3, R8, R15, R24,	33,000 ohms, 1 "
R4, R9,	75,000 " 1 "
R5, R10, R26,	1,000 " $\frac{1}{2}$ "
R6, R11, R33, R34,	330,000 " $\frac{1}{2}$ "
R7, R12, R13, R22,	0.5 megohm Volume Control.
R14, R30,	360 ohms, 1 watt
R16, R17,	100,000 " 1 "
R18, R19, R28, R29,	470,000 " $\frac{1}{2}$ "
R20, R21,	0.25 megohm Tone Controls.
R25, R27, R31, R32,	47,000 ohms, 1 watt
R35, R36,	47 " 1 "
R37,	270 " 3 "
R38,	4,700 " 5 "
C1, C5, C9,	25 mfd. 25 v.w. Electrolytic.
C2, C6,	1 mfd. 350 v.w. Non-inductive.
C3, C7, C10,	
C15, C20,	8 mfd. 500 v.w. Electrolytic.
C4, C8, C11, C16,	
C17, C18, C19,	0.1 mfd. 350 v.w. Non-inductive.
C12,	0.005 mfd. 350 v.w. "
C13,	0.001 mfd. Mica.
C14,	0.02 mfd. 350 v.w. Non-inductive.
T1,	15 watt output transformer to suit loud-speaker—output stage matching.

V1, V2, SP41.

V3, V4, V5, V6, V7, 354V.

V8, V9, PX25.

2 Mazda octal chassis mounting valveholders.

5 5 pin " " "

2 4 pin " " "

Chassis, control knobs, etc.

Heater connections marked A and chassis to 4 volts 5 amp heater winding.

Phase splitter, P-P to 4 volt 1 amp heater winding. (See text.)

Heater connections from output stage, X-Y, to 4 volt 4 amp. centre tapped heater winding.

To set volume controls, set tone controls to mid position, all volume and mixer controls to "off."

Set Main Gain control, R22, fully advanced (full volume).

With pickup on record, advance R13 towards full, to test for pickup overloading. If overloading occurs, reduce R22 to test for overloading of main amplifier. If distortion is reduced, main amplifier is overloading. If not, the mixer is overloading. The simplest method of correcting overloading (which depends on the type of pickup used) is to mark the mixer

control R13, so that it shall not be advanced more fully than will fully load the amplifier. A second method is to arrange a fixed potentiometer across the pickup input terminals, discovering the correct ratio experimentally. For the first test, wire across the pickup terminals two  $\frac{1}{2}$  watt 220,000 ohm resistances, removing the lead to the top of R13 from the pickup input terminal and connecting it to the centre connection between the two resistances, thus reducing the pickup input by approximately half.

Alternatively, connect an 0.5 megohm volume control across the pickup at the motor board, connecting one side to earth and the centre connection (the moving arm) to the top end of R13.

Reduce pickup output by means of the new volume control till R22 and R13 are fully advanced, loading the amplifier correctly.

With the pickup input thus correctly adjusted, reduce R13 to test for smooth fall of volume, or fade, and check that no signal is heard with the mixer control to "off."

To adjust the pre-amplifier, arrange for normal speech into the microphone at normal using distance. Fully advance R12 and then open R7 until the full output is obtained, without overloading. If overload position is reached, back off R7 till distortion ceases. Leave R7 set, and test the mixer as before by reducing R12 to "off" and ascertaining that no signal then passes. Test for mixed outputs from both inputs, and test for main gain control with R22.

#### Components List for Small 10 watt Amplifier. (Fig. 12.)

NOTE.—This amplifier is intended for transportable or other use where a small instrument is desirable. Accordingly a single stage of preamplification is provided, and the mixer is replaced by a simple switch. Beam tetrodes in the output stage enable the full loading for the stage to be achieved with less overall amplification. A mixer may be included in the circuit in the usual way, being connected in as shown in previous diagrams.

The microphone input circuit may be changed to suit a crystal microphone.

R6 is the overall volume control, and should always be turned to the "off" position when switching inputs.

R1,	100,000 ohms, $\frac{1}{2}$ watt.
R2, R7, R12,	33,000 " 1 "
R3, R17, R18,	330,000 " $\frac{1}{2}$ "
R4,	75,000 " 1 "
R5, R15,	1,000 " $\frac{1}{2}$ "
R6,	0.25 megohm Volume Control.
R8, R13, R16,	47,000 ohms, 1 watt.
R9,	680 " 1 "
R10, R11,	0.25 megohm Tone Controls.
R14,	1.8 megohms, $\frac{1}{2}$ watt.
R19,	82 ohms, 1 "
R20,	2,200 " 2 "
R21,	16,000 " 5 "
R22, R23,	470 " $\frac{1}{2}$ "
R24, R25,	100 " $\frac{1}{2}$ "
C1,	1 mfd. 350 v.w. Non-inductive.

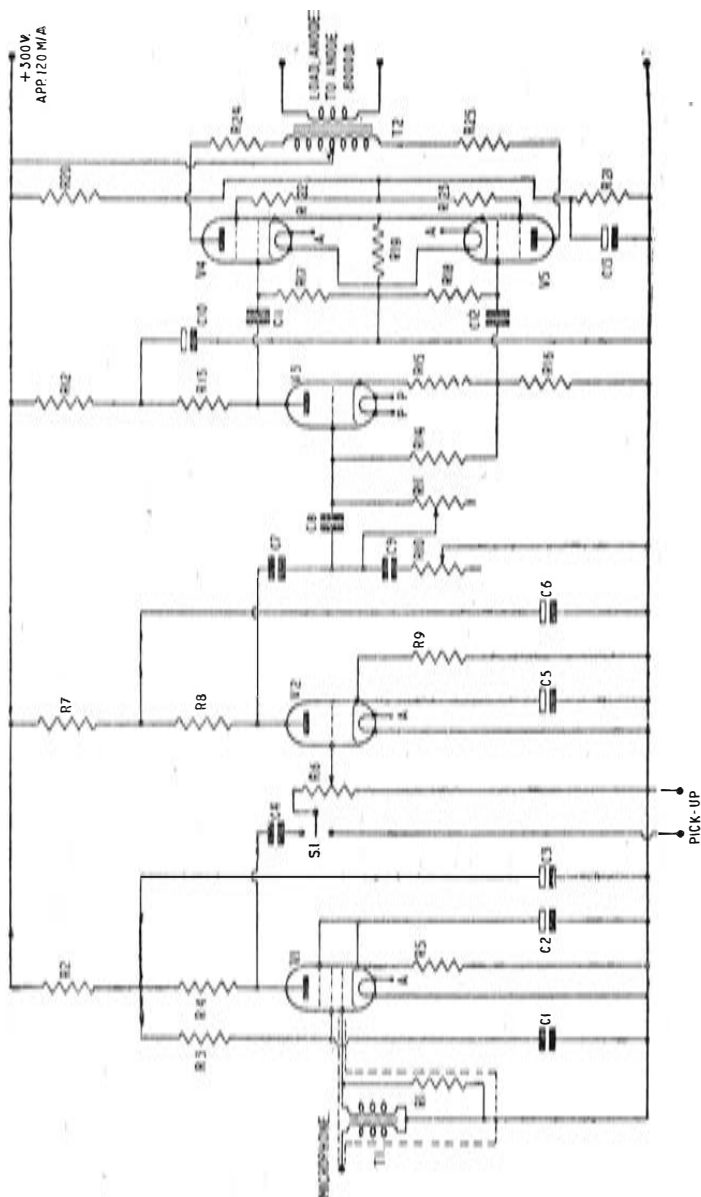

FIG. 12.—10-watt Amplifier (4-volt type).

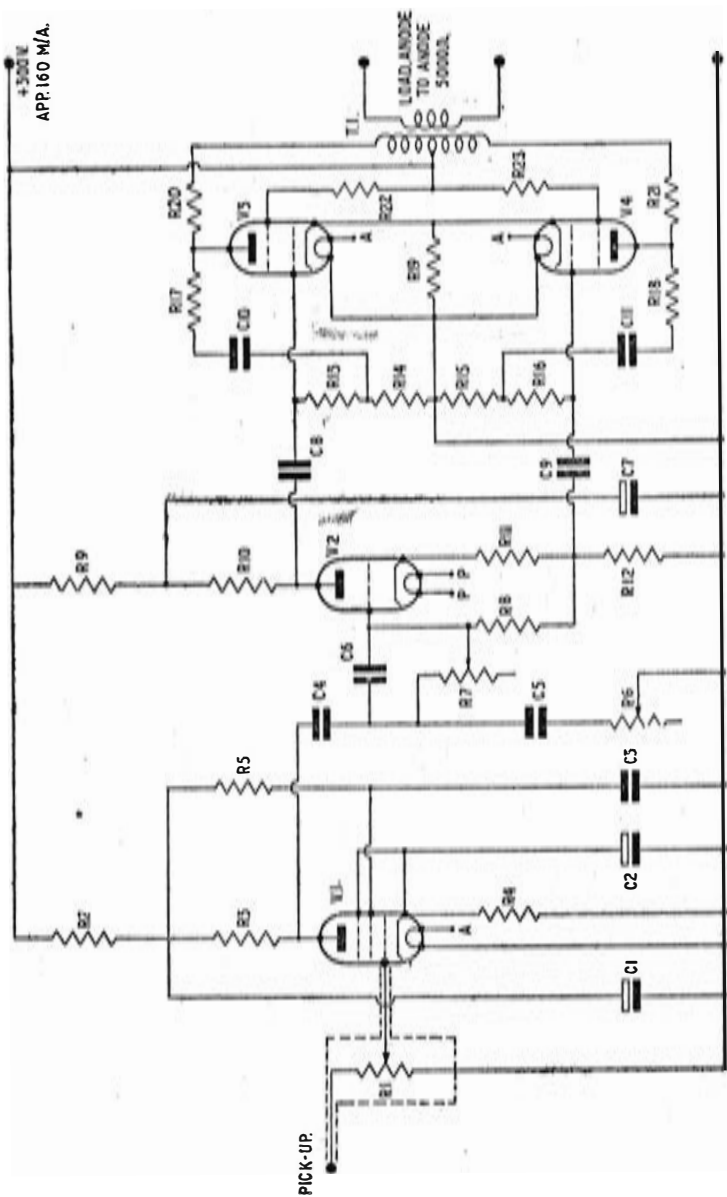

Fig. 13.—15-watt Amplifier for Pickup Operation (6-volt type).

C2, C5,	25 mfd. 25 v.w. Electrolytic.
C3, C6, C10, C13,	8 mfd. 350 v.w. Electrolytic.
C4, C7, C11, C12,	0.1 mfd. 350 v.w. Non-inductive.
C8,	0.001 mfd. Mica.
C9,	0.005 mfd. 350 v.w. Non-inductive.
S1,	Single pole double throw selector. (Yaxley type switch.)
T1,	Input transformer to suit microphone.
T2,	12 watt capacity output transformer to suit loudspeaker load.
V1,	SP41.
V2, V3,	354V.
V4, V5,	Pen 45.
3 Mazda octal chassis mounting valveholders.	
2 5 pin " " "	
Chassis, control knobs, etc.	
Points marked A and chassis to 4 volt 6 amp heater winding.	
Phase splitter heater, points P-P, to 4 volt 1 amp heater winding, or include on 4 volt 6 amp winding with points A.	
Screen selector switch, S1, and main volume control, R6.	

#### Components List for 15 watt Amplifier, using 6 volt valves. (Fig. 13.)

NOTE.—The amplifier is shown as a 3 stage 4 valve circuit, with high gain throughout, designed to give a high output from an ordinary pickup. Negative feedback in the output stage gives good quality.

If desired a pre-amplifier and mixer circuit may be inserted in place of V1, feeding into V2, the phase splitter, in the usual way.

A satisfactory arrangement would take the form:—

Microphone pre-amplifier, 2 6J7's, as Fig. 4.

Pickup amplifying and boosting stage, 6C5, as Fig. 5.

These both feed into the mixer, 2 6C5's, as Fig. 8.

The tone and main volume control unit is then inserted between the mixer and the phase splitter.

R1,	0.25 megohm Volume Control, or as specified for the pickup.
R2, R9,	33,000 ohms, $\frac{1}{2}$ watt.
R3,	220,000 " $\frac{1}{2}$ "
R4,	1,200 " $\frac{1}{2}$ "
R5, R8,	1.2 megohms, $\frac{1}{2}$ "
R6, R7,	0.25 megohm Tone Controls.
R10, R12,	39,000 ohms, $\frac{1}{2}$ watt.
R13, R16, R17, R18,	100,000 " $\frac{1}{2}$ "
R14, R15,	10,000 " $\frac{1}{2}$ "
R19,	130 " 3 "
R20, R21,	100 " $\frac{1}{2}$ "
R22, R23,	470 " $\frac{1}{2}$ "
C1, C7,	8 mfd. 350 v.w. Electrolytic.
C2,	25 mfd. 25 v.w. "
C3,	0.5 mfd. 350 v.w. Non-inductive.

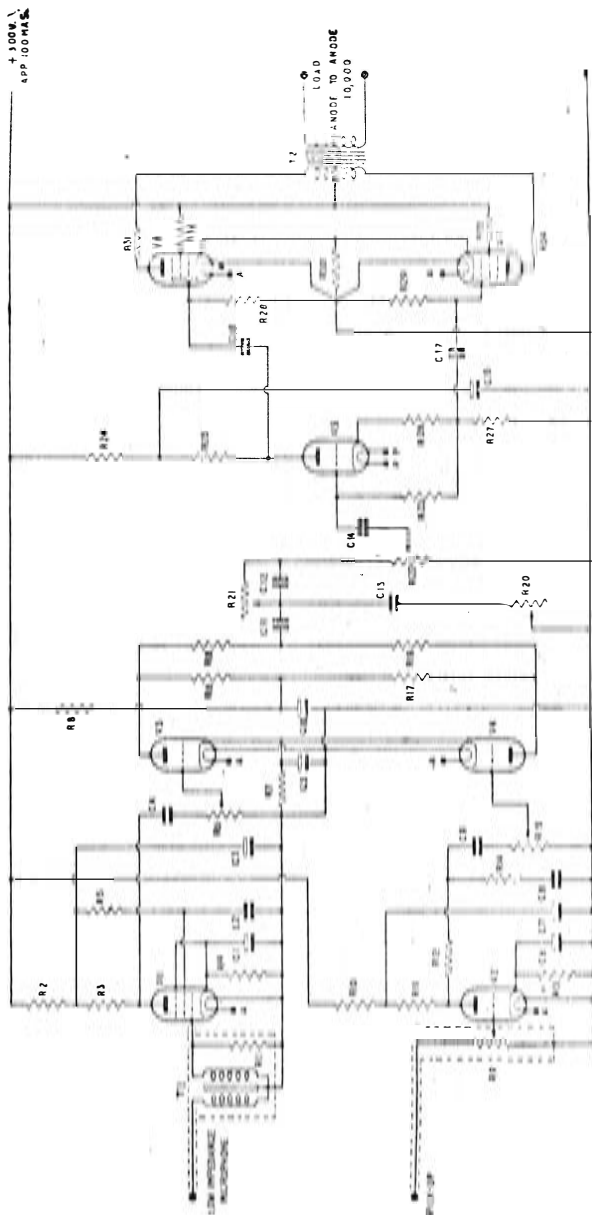

FIG. 14.—10-watt Amplifier for A.C. mains or battery operation (6-volt type).

C4, C8, C9,	0.1 mfd. 350 v.w.	”
C5,	0.005 mfd. 350 v.w.	”
C6,	0.001 mfd. Mica.	
C10, C11,	0.05 mfd. 500 v.w. Non-inductive.	
T1,	15 watt capacity output transformer, to suit loudspeaker load.	

V1,	6J7.
V2,	6C5.
V3, V4,	6L6.

4 International octal chassis mounting valveholders.

Chassis, control knobs, etc.

Connect points A and chassis to 6.3 volt 2.5 amp heater winding.

Connect phase splitter heater, points P-P to 6.3 volt 1 amp heater winding.

#### Components List for 10 watt Amplifier for A.C. mains or Battery-Vibrator Operation. (Fig. 14.)

NOTE.—The minimum number of stages are shown in the design in order that the power drain of the amplifier shall be as low as possible. The overall gain is such that the output stage will be fully loaded if a moving iron pickup of reasonable sensitivity is used to feed into V2, a moving coil or similar microphone feeding into V1. A full mixing stage is included, with the tone control and main gain control feeding from the mixer into the phase splitter. Negative feedback is not included since further gain in the early stages would then be necessary.

R1,	100,000 ohms, $\frac{1}{2}$ watt, or as specified for microphone used.
R2, R8, R10, R24,	33,000 ohms, 1 watt.
R3,	220,000    "    1    "
R4, R26,	1,200    " $\frac{1}{2}$ "
R5, R23,	1.2 megohms, $\frac{1}{2}$ watt.
R6, R15, R22,	1 megohm Volume Controls.
R7,	510 ohms, 1 watt.
R9, R20, R21,	0.25 megohm Volume Controls.
R11, R25, R27,	43,000 ohms, 1 watt.
R12,	68,000    " $\frac{1}{2}$ "
R13,	1,000    " $\frac{1}{2}$ "
R14,	22,000    " $\frac{1}{2}$ "
R16, R17,	100,000   "    1    "
R18, R19, R28, R29,	470,000   " $\frac{1}{2}$ "
R30,	330    "    3    "
R31, R34,	100    " $\frac{1}{2}$ "
R32, R33,	470    " $\frac{1}{2}$ "
C1, C5, C6,	25 mfd. 25 v.w. Electrolytic.
C2,	0.5 mfd. 350 v.w. Non-inductive.
C3, C7, C10, C15,	8 mfd. 350 v.w. Electrolytic.
C4, C14,	0.02 mfd. 350 v.w. Non-inductive.
C8,	0.05 mfd. 350 v.w.    "
C9, C11, C16, C17,	0.1 mfd. 350 v.w.    "
C12,	0.001 mfd. Mica.

C13,  
T1,  
T2,

0.005 mfd. 350 v.w. Non-inductive.  
Input transformer to suit microphone.  
12 watt capacity output transformer to  
suit loudspeaker load.

V1,                   6J7.  
V2, V3, V4, V5,   6C5.  
V6, V7,             6F6.

7 International octal chassis mounting valveholders.  
Chassis, control knobs, etc.

*For Mains Operation:—*

Points marked A and chassis to 6.3 volt 3 amp heater secondary winding.

Heater of phase splitter, points P-P to 6.3 volt 1 amp heater secondary winding.

*For Battery Operation:—*

Points P-P must be joined one to chassis and one to points A. Heaters are then connected, all in parallel, across 6 volt battery which also supplies Vibrator Power Pack.

Suitable power packs are the Masteradio Fully Smoothed Vibrator packs, No. 6A300S using synchronous vibrator, or No. 6B300S using cold valve rectification. Both packs give 300 volts at 100 mAs.

It is safe to earth the chassis of the main amplifier, and thus all the apparatus earthed to the chassis, when using an A.C. power pack, since the equipment is isolated from the mains supply by the transformer. A stubborn case of hum is often cured by an earth connection to an actual physical earth point, such as the earthed line to the mains switchboard, but if the amplifier is carefully constructed there should be little or no trouble from hum.

*A.C./D.C. Amplifiers.*

Where the amplifier is required to work from D.C. mains it will, of course, be necessary to use A.C./D.C. type valves. It has already been pointed out that in this case there will be greater chances of hum when the amplifier is used on A.C. mains, and, at the same time, the restricted H.T. voltage which is available—not more than 240 volts on the rectifier, which will be reduced to approximately 200 volts on the output stage anodes—precludes a very high output.

A circuit is given here, however, using a pair of pentodes of the 0.2 amp heater type, which should give 6 to 8 watts output, sufficient for many purposes.

The valves are rated at 3 watts output each. Pentodes in the A.C./D.C. range are available to give 4 watts output, but using a pair of these valves would mean, at the same time, using a pair of half wave rectifiers, thus putting up the cost of the equipment and also making the heater chain difficult to feed, since only a very low voltage barretter would then be necessary, whilst for all this complication only small extra output would be obtained.

It must be said at this point that the circuit given is intended for further experiment and development. It has been carefully designed to suit



the valve types chosen, with regard to valves in supply at the time of writing. The circuit should give good results, but it is stressed that it is intended only as a basis for experiment and adaption by the experienced home-constructor.

The heater chain has been arranged in such a manner that the microphone pre-amplifier has one side of its heater earthed, since this is the most sensitive stage in the circuit. The phase splitter, moreover, has its heater at an average potential of 115 volts above earth, so that there is but a slight difference between the cathode potential and the heater potential.

It will be seen that in this case the circuit is of the whole amplifier including the power supply. For D.C. working the power must be applied with the correct polarity.

Under both A.C. and D.C. conditions of working, the chassis of the amplifier is alive to the mains supply, and, in some cases, will thus be alive to earth. The amplifier, therefore, must on no account actually be earthed unless a 0.01 mfd. condenser with a working voltage of at least 400 volts is connected in series between the chassis and the earth connection.

Care also should be taken to ensure that no shock can be obtained from screened sleeving, pickup arms, microphone stands, etc., and the amplifier at all times must be handled with caution until it is known that the particular conditions obtaining at the time occasion no danger to the operator.

In the event of undue trouble from hum, the effect of bypassing the heaters to earth with 0.01 mfd. condensers, or slightly larger capacities, may be tried.

#### Components List for A.C./D.C. 6-8 watt Amplifier.

(Fig. 15.)

R1,	100,000 ohms, $\frac{1}{2}$ watt, or as specified for use with microphone.
R2, R9, R18,	33,000 ohms, 1 watt.
R3, R10, R11,	100,000 " 1 "
R4,	360 " $\frac{1}{2}$ "
R5, R22, R23,	330,000 " $\frac{1}{2}$ "
R6, R8,	0.5 megohm Volume Controls.
R7,	680 ohms, 1 watt.
R12, R13,	470,000 " $\frac{1}{2}$ "
R14, R15,	0.25 megohm Tone Controls.
R16,	1 megohm Volume Control.
R17,	1 megohm, $\frac{1}{2}$ watt.
R19 R21,	47,000 ohms, $\frac{1}{2}$ "
R20,	1,500 " $\frac{1}{2}$ "
R24,	91 " 1 "
R25, R26,	470 " $\frac{1}{2}$ "
R27, R28,	100 " $\frac{1}{2}$ "
C1, C5,	25 mfd. 25 v.w. Electrolytic.
C2,	1 mfd. 350 v.w. Non-inductive.
C3, C6, C11, C15,	8 mfd. 350 v.w. Electrolytic.

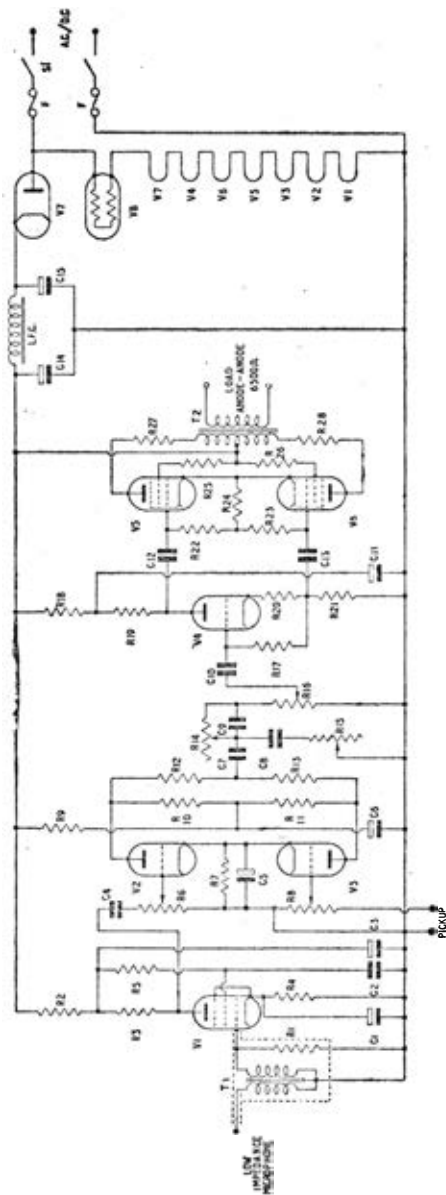

FIG. 15.—A.C./D.C. 6-8-watt Amplifier.

C4, C7, C12, C13,	0.1 mfd. 350 v.w. Non-inductive.
C8,	0.005 mfd. 350 v.w.        "
C9,	0.001 mfd. Mica.
C10,	0.02 mfd. 350 v.w. Non-inductive.
C14,	16 mfd. 350 v.w. Electrolytic.
T1,	Input transformer to suit microphone.
T2,	10 watt capacity transformer to suit loudspeaker load.
F,	0.5 or 1 amp fuses.
S1,	Double pole On-Off switch.
V1,	VP133.
V2, V3, V4,	HL133.
V5, V6,	Pen 3520.
V7,	U403.
5 Mazda octal chassis mounting valveholders.	
2 7 pin	"        "
V8, Miniwatt Regulator C2 or C9	"        "
(or Barretter with voltage range around 78 volts, as 60-120 volts or 35-100 volts, for 0.2 amp.).	

Holder to suit regulator lamp or Barretter.

L.F.C. 20 Henrys, 150 mAs. 150 ohms.

All components used in amplifier construction must be of good quality, especially the coupling condensers. A leak in an anode-grid coupling condenser will result in a positive potential on the grid, so that in a serious case the valve will be seriously damaged whilst in any case there will probably be distortion and other ill effects.

## CHAPTER 5.

### THE POWER SUPPLY.

Apart from the A.C./D.C. experimental amplifier, where the power pack is shown included in the circuit, the amplifiers described in Chapter 4 are designed to work from an ordinary A.C. power pack. The main difference from the simple receiver-style power pack is that in some cases the current required in the H.T. line is rather high, and thus provision must be made for the greater drain. At the same time it is wise to include a bleeder resistance in the circuit, provided that the extra current required can be supplied without strain, the bleeder assisting in the regulation of the supply and ensuring that no condensers are left charged on switching off.

All the amplifiers are intended to work with the output stage in Class A conditions, so that there are no wide current swings such as occur when working in Class B or AB conditions, the power pack thus being simpler to design.

No provision is made, in the power pack for any amplifier, for the energising of loudspeaker magnets. If energised speakers are used they should be supplied with their own power packs, rectification being carried out by metal rectifiers. In general the distance between the amplifier and even the simplest speaker system will be such that running energising

power to the speaker will be a complicated business, and in any case the fairly high H.T. currents used would cause high potential drops across the speaker pots, with a consequent necessary rise in the output voltage of the mains transformer.

Suitable speaker-energising supply packs will be shown in circuit detail in the chapter dealing with the speaker system, and they may be made sufficiently small to mount on the speaker baffle.

In Figs. 10 to 14 inclusive the approximate H.T. current required is shown, and it should be remembered that in Fig. 10 the current given, 120 mAs., is for the main amplifier only. Previous input stages will also require current, so that this amplifier, in its final state, can hardly be supplied from the usual 120 mA. type rectifier. The amplifier shown in Fig. 12 is rated at 120 mAs. H.T. drain, but here again a 120 mA. type rectifier would be working at its limit, and there would be no provision for bleeder resistances (although the potential divider, R20; R21, would perform some bleeder functions).

The only circuit which may safely be driven from the ordinary small rectifier valve is that of Fig. 14, where the consumption has been kept to 100 mAs. in order that a Vibrator Power Pack may be capable of feeding the amplifier from a 6 volt heavy duty battery of accumulators.

In each case, it is advised that a condenser-input filter be used, a double section filter with two L.F. chokes and two smoothing condensers being preferable to a single section filter. Low D.C. resistance chokes should be obtained, in order that the potential drop over the whole power unit shall be small and the mains transformer kept to a reasonable size.

The simplest power pack, that for the amplifier of Fig. 14, is shown first, in Fig. 16.

One section filtering is used and no bleeder is incorporated in order that the power pack may be kept small and inexpensive. The filtering, however, is adequate, and should give no more than 0.15% ripple.

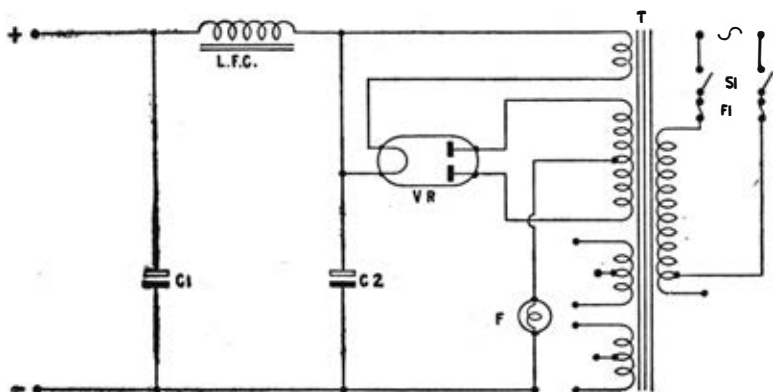

FIG. 16.—Small Power Pack,

## Components List for Power Pack to give 300 volts, 100 mAs.

Amplifier of Fig. 14.

(Fig. 16.)

T,

200-230-250 volt primary.

350-0-350 volts, 100 mAs. H.T. secondary.

5 volts, 2 amps, Rectifier Heater secondary.

6.3 volts, 3 amps, Amplifier Heater, secondary.

6.3 volts, 1 amp, C.T. Heater secondary (or the phase splitter heater may be connected into the 3 amp. heater winding).

S1,

Double pole On-Off switch.

F1,

0.5 or 1 amp fuses.

F2,

200 mAs. Fuse bulb with holder.

L.F.C.

20 Henrys, 100 mAs. 425 ohms.

C1, C2,

8 mfd. 500 v.w. Electrolytic.

VR,

5Y3G.

1 International octal chassis mounting valveholder.

The power packs for the amplifiers shown in Figs. 10 to 13 inclusive all take the same form, so that one circuit only is shown in Fig. 17. Different components lists give the values suited for use with each amplifier, however, so that care must be taken to use the correct components list.

In each case the transformer and L.F. choke ratings are taken from the lists of Messrs. Coulphone Radio and Messrs. the Premier Radio Co., so that only apparatus in supply is specified.

This means that in some cases it is necessary to feed the heater of the phase splitting valve from the same heater winding as the rest of the amplifier heaters. If a similar transformer with an extra heater winding is available, it may be used and the phase splitter's heater fed separately.

## Components List for Power Pack to suit Amplifier of Fig. 10

(Power Pack circuit, Fig. 17).

T,

200-230-250 volt primary.

450-0-450 volt, 200 mAs. H.T. secondary.

4 volts, 4 amp. Rectifier heater secondary.

4 volts, 4 amp. C.T. output stage heaters.

4 volts, 8 amp. C.T. heater secondary. approximately 625 ohms. SEE NOTE.

R1,

22,000 ohms, 10 watts.

R2,

C1, C2,

8 mfd. 500 v.w. Electrolytic.

C3,

8 mfd. 750 v.w. ,,

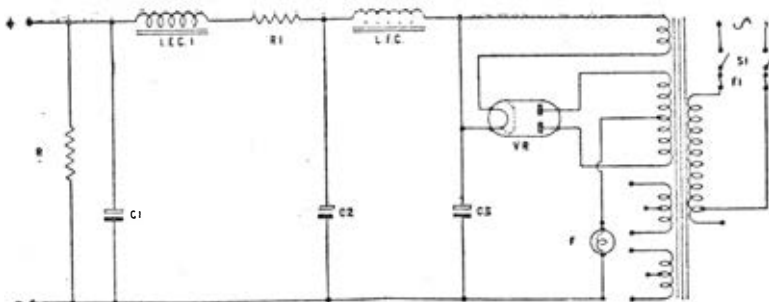

FIG. 17.—General outline for Power Pack.

LFC1, LFC2,	20 Henrys, 200 mAs. 150 ohms.
S1,	Double Pole On-Off Switch.
F1,	1 amp fuses.
F2,	250 mAs. Fuse bulb with holder.
VR,	FW4/500.
1 4 pin chassis mounting valveholder.	

NOTE 1.—Remember that the biasing circuit for the output stage is shown on the amplifier diagram, Fig. 10, where R15 must be taken to the centre tap of the 4 volt 4 amp. heater winding.

NOTE 2.—An extra current drain has been allowed for the operation of input and preamplifying stages. R1 should therefore be adjustable, in order that the correct final potential may be supplied to the H.T. line. Since the resistor must have a high power rating, a 0.2 amp dropping resistor is therefore used, mounted vertically on the chassis for ventilation, and adjusted, when the amplifier is up to working temperature, to give 350 volts to the amplifier and associated apparatus.

Components List for Power Pack to suit Amplifier of Fig. 11  
(Power Pack circuit, Fig. 17).

T,	200-230-250 volt primary. 450-0-450 volt, 200 mAs. H.T. secondary. 4 volts, 4 amp. Rectifier heater secondary. 4 volts, 4 amp. C.T. output stage heaters. 4 volts, 8 amp. C.T. heater secondary.
R1,	Not used. (Straight connection between LFC1 and LFC2.)
R2,	30,000 ohms, 10 watts.
C1, C2,	8 mfd. 500 v.w. Electrolytic.
C3,	8 mfd. 750 v.w. Electrolytic.
LFC1, LFC2,	20 Henrys, 200 mAs. 150 ohms.
S1,	Double Pole On-Off Switch.

<b>F1,</b>	<b>1 amp fuses.</b>
<b>F2,</b>	<b>250 mAs. Fuse bulb with holder.</b>
<b>VR,</b>	<b>FW4/500.</b>
	<b>1 4 pin chassis mounting valveholder.</b>

Biasing is again shown in the amplifier diagram, R37 going to the centre tap of the 4 volt 4 amp. secondary.

**Components List for Power Pack to suit Amplifier of Fig. 12**  
(Power Pack circuit, Fig. 17).

<b>T,</b>	<b>200-230-250 volt primary.</b>
	<b>350-0-350 volt, 150 mAs. H.T. secondary.</b>
	<b>4 volts, 3 amp. Rectifier heater secondary.</b>
	<b>4 volts, 6 amp. Heater winding.</b>
	<b>4 volts, 2 amp. C.T. Phase splitter heater winding.</b>
<b>R1,</b>	<b>100 ohms, 3 watt.</b>
<b>R2,</b>	<b>20,000 ohms, 5 watt.</b>
<b>C1, C2, C3,</b>	<b>8 mfd. 500 v.w. Electrolytic.</b>
<b>LFC1, LFC2,</b>	<b>20 Henrys, 200 mAs. 150 ohms.</b>
<b>S1,</b>	<b>Double Pole On-Off Switch.</b>
<b>F1,</b>	<b>0.5 or 1 amp fuses.</b>
<b>F2,</b>	<b>200 mAs. Fuse bulb with holder.</b>
<b>VR,</b>	<b>UUS. SEE NOTE.</b>
	<b>1 Mazda octal chassis mounting valveholder.</b>

**NOTE.**—The UUS rectifier valve has an indirectly heated cathode, shown by a broken line in Fig. 17. The only precaution necessary is to ensure that the H.T. line is taken from the heater pin to which the cathode is connected internally.

**Components List for Power Pack to suit Amplifier of Fig. 13**  
(Power Pack circuit, Fig. 17).

<b>T,</b>	<b>200-230-250 volt primary.</b>
	<b>425-0-425 volt, 200 mAs. H.T. secondary.</b>
	<b>5 volts, 3 amp. Rectifier heater secondary.</b>
	<b>6 volts, 3 amp. C.T. Phase splitter heater winding.</b>
	<b>6 volts, 5 amp. Heater winding.</b>
<b>R1,</b>	<b>approximately 300 ohms. SEE NOTE.</b>
<b>R2,</b>	<b>15,000 ohms, 10 watt.</b>
<b>C1, C2,</b>	<b>8 mfd. 500 v.w. Electrolytic.</b>
<b>C3,</b>	<b>8 mfd. 750 v.w. „</b>
<b>LFC1, LFC2,</b>	<b>20 Henrys, 200 mAs. 150 ohms.</b>
<b>S1,</b>	<b>Double Pole On-Off Switch.</b>

**F1,** 1 amp. fuses.  
**F2,** 250 mAs. Fuse bulb with holder.  
**VR,** 5U4G.

1 International octal chassis mounting valveholder.

**NOTE.**—R1 is again a 0.2 amp voltage dropping resistance, adjusted to feed 300 volts to the H.T. line.

**GENERAL NOTE.**—The working voltages specified for the reservoir and smoothing condensers are for the power pack under full load conditions. No loads, or light loads on the power pack may allow the voltage to rise above the working conditions, so that the amplifier should always be connected in.

## CHAPTER 6.

### THE LOUDSPEAKER SYSTEM.

We have now dealt with the input from microphones and pickup to the amplifier, the amplifier and its power supply, and arrive at the final link in the chain, the loudspeaker system. Whatever the number and type of loudspeakers used, they must be matched into the final stage of the amplifier through a matching transformer, they must be capable of taking the full output load in watts, and must be positioned to give the best results possible, bearing in mind whether music or speech is being reproduced, and how it should be distributed.

Each speaker, whether large or small, must be mounted on or in a baffle, which may consist either of a baffle board, the speaker being mounted centrally, or of a box baffle where the speaker is enclosed in a heavy wooden cabinet.

Obviously the choice of baffle will primarily depend on whether or not the whole amplifying system is to be transportable. If this is the case, and, as is most likely, the unit is to be carried by car, the flat baffle board is rather more easily packed. At the same time the number of speakers must be limited, and on many occasions one speaker alone will take up as much space as can be spared.

When a single speaker is to carry the full output from any of the amplifiers described, it must have a capacity of up to 15 watts, so that a 12" speaker is a necessity. Excellent 12" speakers are made by Vitavox and Goodmans, amongst other manufacturers, and can be obtained with permanent magnets. It is most usual for a 12" speaker to be fitted with a 15 ohm impedance voice coil, and the output transformer must, therefore, be capable of matching a 15 ohm load into the output load of the amplifier.

The ratios of output transformers are calculated by the same formula as that already given, which may be expressed for this purpose as

$$R = \sqrt{\frac{\text{Output load (anode to anode)}}{\text{Voice coil impedance.}}}$$



Thus, to match a 15 ohm voice coil to the amplifier of Fig. 11, where the anode to anode load is 6,000 ohms, the output transformer ratio is

$$\begin{aligned} R &= \sqrt{\frac{6,000}{15}} \\ &= \sqrt{400} \\ &= 20 \end{aligned}$$

and thus the transformer must have a ratio of 20 : 1 and must be capable of handling at least 12 watts, preferably rather more.

It is possible to build output transformers to specification, but the constructor is not advised to take such a course. The requirements of a good output transformer are a high primary inductance, interwound secondaries, low self capacity and low leakage inductance, and it is no more expensive and certainly more satisfactory to buy a good commercial component. The writer recommends the transformers supplied by the Premier Radio Company which have multi-ratio windings to match many valve and voice coil loads and which may be bought in 7, 15 and 30 watt sizes.

Whatever the make of transformer obtained it must, of course, have a centre tapped primary.

Where a single speaker is to be used on a plain baffle the board should be as large as convenient—5 feet square would be a good size but probably too large for carriage. The writer has known excellent results to be obtained with a 12" speaker mounted centrally in a 3' x 2' 6" baffle, the board being of 5-ply wood bordered round each edge with stout battening, stained and polished and mounted on a pair of feet so that it could be stood on or below a stage. It is well worth while to add to the appearance of a baffle board by staining and polishing the wood, or by painting it with an enamel paint to conform to a colour scheme, if the speaker is part of a fixed installation.

If a box baffle is used it has the added advantage that a bass reflex enclosure can be constructed. In this type of speaker box, the high frequencies coming from the back of the cone are absorbed by a pad of suitable material, fastened to the rear of the enclosure immediately behind the speaker, whilst the bass frequencies from the rear of the cone are allowed to pass out through an aperture in the lower part of the box, beneath the speaker opening, and they add to the bass response coming from the front of the cone. The outlines of such a box baffle or speaker chamber are shown diagrammatically in Fig. 18, and the sizes and box measurements for various speakers are given below:—

Speaker size.	Box Dimensions.
6"     ...     ...     ...	18" x 15" x 9"
8"     ...     ...     ...	22" x 17" x 10"
10"    ...    ...    ...	27" x 19" x 11"
12"    ...    ...    ...	31" x 22" x 12"

These figures give the external dimensions of the box, which should be built of stout wood as thick as possible— $\frac{3}{4}$ " or 1" material for preference.

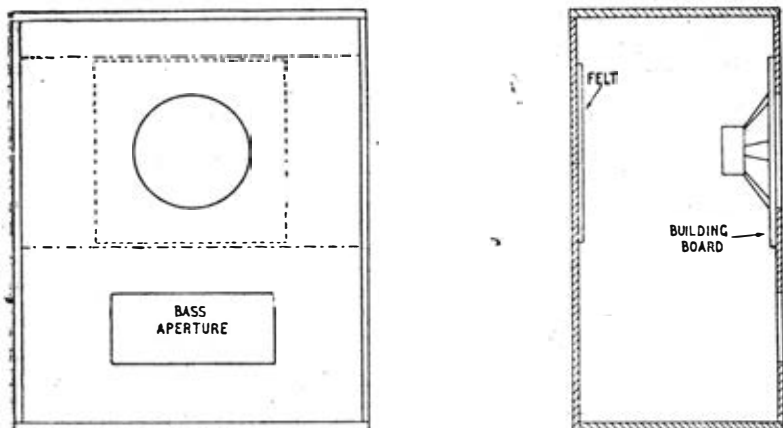

FIG. 18.—Reflex Bass Type of Speaker Chamber (to  $\frac{1}{4}$  scale for 6" speaker).

The figure shows the chamber to scale for a 6" speaker, the proportions being followed for larger sizes, although the only necessary change, apart from the increased size of the box itself and the increased speaker aperture, is to drop the bass aperture. The aperture can remain the same size, about 7" x 3", for all speakers.

The loudspeaker should be mounted on a square of non-resonant material, the fibrous type of building board being very suitable, an 8" square accommodating a 6" speaker, or in proportion. The sound-absorbent pad at the rear of the cabinet should be of heavy felt, glued down to the wood, and here the felt should be in a strip 8" wide for the 6" speaker, or in proportion, and of length sufficient to stretch right across the back of the chamber.

Since the speaker transformer will, in most cases, be mounted on the amplifier chassis itself, there will be no other gear in the box baffle apart from the speaker and if a small mains unit is used for energising the speaker magnet, this unit should be mounted outside the chamber, all leads being taken through small holes at the rear.

Both speaker and bass aperture should be covered with fine cloth or metal gauze to prevent entry of dust and to protect the speaker from mechanical damage. If metal gauze is used, it must be firmly clamped with battening screwed down all along each edge, and every precaution taken to prevent "tizzing" or rattling which would ruin the whole effect of the chamber.

Either the plain or the box baffle may be provided with stout screw-eyes by means of which the speaker may be hung at above floor height.

When the single speaker is used, several positions should be tested for coverage and audibility.

### *Multi-Speaker Systems.*

Whenever more than one speaker is to be used the loudspeakers must first of all be "phased," that is, their input leads must be coded so that the cones move in and out together.

The simplest method is to use a pair of red and black wires, or red and black flex, as the extended conductors from the voice coil connecting tags, and, before attaching these wires, to phase each speaker with a small flashlamp battery. Lightly rest the fingers on the speaker cone as the battery is connected across the voice coil (or across the speaker transformer primary, if a separate transformer is being used for any reason) and note whether the cone moves in or out as the battery makes contact—the movement is easily felt.

The red and black wires may then be connected to the tags in accordance with the battery polarity, red to the terminal connected to the positive pole and black to the terminal connected to the negative pole. This speaker then becomes the standard by which the others are phased.

If the cone of the standard speaker moves outwards, the battery must then be connected to the other loudspeakers in turn in such a manner that their cones move outwards also, and vice versa, the coded wires again being attached to the speaker tags to agree with the battery polarity. Finally then, the loudspeakers will all have a red and a black wire, and when any black and red pair are connected to the positive and negative poles of the battery, the speaker cone will move in the same direction as the cone of any other speaker under the same conditions.

The actual direction of movement, in or out, does not matter so long as all cones move in the same direction.

The speakers may now be connected in series by connecting up red-black-red-black, etc., just as batteries are connected in series, or in parallel by connecting all reds and all blacks.

Under all ordinary circumstances, loudspeakers should only be connected in series or in parallel when the speakers are all identically similar, so that the load is equally shared between them. For example, it may be desired to have four loudspeakers working from a 12 watt output, each taking the same load as the others. Then each speaker will be handling 3 watts, so that an ordinary 8" speaker will serve admirably in each position.

Moreover, the voice coil impedance of the usual 8" speaker is 3 ohms. Connecting the speakers (in phase, of course) in series will give a total impedance of 12 ohms, whilst connecting them in parallel will give a total impedance of below 1 ohm.

The matching transformer may have a 12 ohm tapping, but it is also possible to connect the speakers in series-parallel, so that two pairs of speakers in series are then connected in parallel, so that two 6 ohm loads are paralleled to give a final 3 ohm load, the impedance being the same as for one speaker although the load is shared between four.

The various methods of connecting the four speakers are shown in Fig. 19.

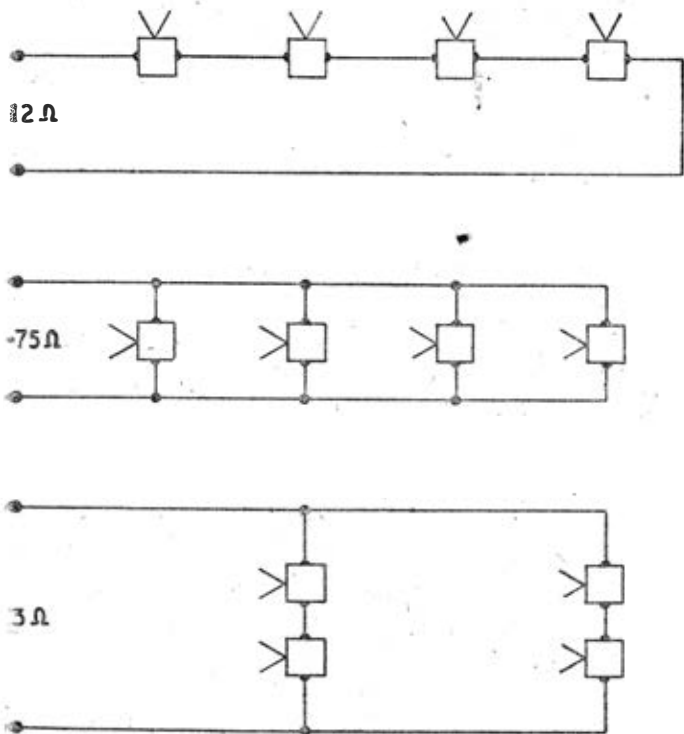

FIG. 19.—Typical connections for 4 Speakers (3-ohm voice coils).

Note, however, that the method holds good only for similar speakers, preferably of the same make and code number. If one of the speakers had a voice coil impedance of say 5 ohms, another of 2 and another of 15 ohms, the whole system would be totally mismatched to the transformer and the load would not be equally shared.

Losses due to mismatching are high, and the power output available falls as does the quality. It should be noted, also, that the voice coil impedance is not discovered by measuring the D.C. resistance of the coil, for the value required is the impedance to A.C., usually at 400 cycles. To discover the impedance of an unmarked speaker, enquiry should be made of the manufacturer, quoting the speaker code number.

The simplest system of loudspeakers, therefore, will have a number of identically similar speakers which may be connected in any way required to give a convenient final impedance, when all the speakers will receive an equal share of the available output power.

Each speaker will be fed from the one output transformer and thus the extension leads will be carrying a relatively high current at low potential. The leads to the speakers should therefore be of stout flexible cable, a good quality household type of flex being suitable.

By using a number of loudspeakers it is possible to do much to cure the directional effects observed when only one speaker is in operation, but the constructor who is installing a fixed system in a hall or large room may still find some localised sound areas with a multiple system. Experiments were conducted some time ago in which it was found that 4 or 5 identical speakers in one cabinet were capable of giving very good distribution. The speakers were located on the four sides (or, using 5 loudspeakers, on the four sides and the bottom) of a heavy wooden cubical box, 24" x 24" x 24" in dimension. When 4 speakers were used the box was allowed to stand on the floor, but the best results were obtained when 5 speakers were in operation and the box was suspended from the centre of the ceiling. The speakers were mounted in a perfectly straightforward manner, the only internal arrangement being two diagonal partitions within the cube so that each speaker in a side was enclosed within a triangular space, the diagonal partitions being recessed to fit over the speaker in the floor of the box.

For halls where music for dancing is the chief requirement such an arrangement might be tried with excellent results. The unit is heavy, since thick wood must be used, and so, if suspended, must be made safe by being held by substantial chains from well fitted hooks.

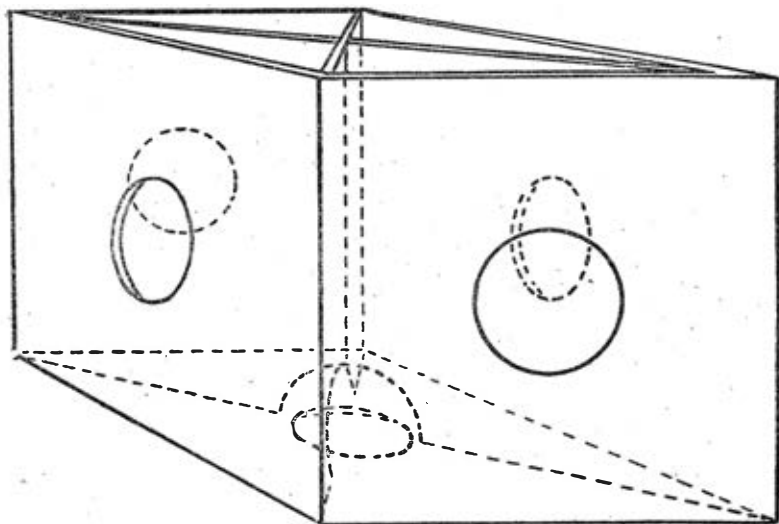

FIG. 20.—Cubical Loudspeaker Mount for 4 or 5 Speakers.

The cubical loudspeaker system is shown diagrammatically in Fig. 20.

Another multiple loudspeaker system is the "woofer-tweeter" arrangement, where one large speaker deals with the bass frequencies and a smaller speaker with the treble. The system is seldom used for sound distribution in halls or for public work, but it would appear necessary to give the warning that when two speakers are used in this way, not only should they be mounted in close proximity on a single baffle, but they must also be provided with a cross-over network which will ensure each speaker being supplied with its correct portion of the output, so far as the frequencies are concerned. The cross-over frequency should be in the region of 1,000 cycles for the usual speaker combinations, the woofer, or low frequency speaker response tailing away fairly sharply for frequencies over this figure with the tweeter or high frequency speaker response tailing away for frequencies below.

The network coupling the two speakers may take several forms, and must be designed to suit the speakers and output load into which they are matched, as well as the cross-over frequency, so that no one example can be given to cover several requirements, whilst, at the same time, the speakers should be fed from a triode output stage or a pentode stage with a good degree of negative feedback and the condensers in the filter network, for ordinary low impedance voice coils, are inconveniently large.

The choice of triodes rather than pentode or tetrode output stages for high quality reproduction may be explained by showing the effect of the valve type on the damping of the loudspeaker. Every speaker has a natural damping factor—that is, the mechanical damping of the vibration of the cone, which should be high so that transients and similar sounds may be reproduced properly. The natural loudspeaker damping, however, requires assistance and this is obtained if the valve acts as a shunt resistance across the loudspeaker, a low anode resistance (internal) reflecting a low damping impedance through the transformer.

The damping factor of an output stage may be described as the ratio of the load resistance to the anode resistance, and so where a triode is used the load resistance is almost invariably greater than the anode resistance and the factor is fairly high. The ratio,  $\frac{R_l}{R_a}$  for a PX4, for example, is  $\frac{4,000}{830}$ , using the maker's figures from valve tables, giving a damping factor of approximately 4.8.

The 6V6 beam tetrode, again using the maker's figures, has a factor of only  $\frac{5,000}{52,000}$  or approximately 0.1, and one of the functions of negative feedback is to improve this figure by reducing the effective anode resistance.

#### *Dividing the Output.*

We have dealt now with the single speaker and with the system which uses several speakers all of identically similar type with the same voice coil impedances so that the speakers may be connected together in various ways yet still divide the load equally. There are occasions, however, when it is

not necessary or even desirable to share the output from an amplifier equally between a number of speakers. For example, it may be required to divide a 10 watt output so that 9 watts are fed to one main speaker with 1 watt fed to a small monitor speaker in the operating room, or, alternatively, it may be desired to feed a number of outputs to separate rooms, as in a school, the power being regulated by the size of the room.

In this case the power in each loudspeaker branch, as well as the voice coil impedance of each loudspeaker, must be taken into consideration, and the speakers are fed from separate secondaries on a main output transformer.

To discover the ratio of each secondary winding to the primary winding, the whole transformer being designed to handle the total power output in watts, the following formulæ are used:—

Where L is the anode load required by the output stage (or anode-to-anode load) and Z1, Z2, Z3, Z4, etc., are the various voice coil impedances, whilst the percentage of total power to the various loudspeakers are a, b, c, d, etc., then the transformer ratios needed are given by

$$R1 = \sqrt{\frac{100L}{aZ1}}$$

$$R2 = \sqrt{\frac{100L}{bZ2}}$$

$$R3 = \sqrt{\frac{100L}{cZ3}}$$

$$R4 = \sqrt{\frac{100L}{dZ4}} \quad \text{etc.}$$

As a typical example of the use of these formulæ, a hypothetical case may be considered. An amplifier, whose output load is 6,000 ohms anode-to-anode, is required to feed 7 watts into a 15 ohm speaker, 2 watts into a 3 ohm speaker and 1 watt into a 2 ohm speaker, the total output of the amplifier being 10 watts.

The percentages of the total output are thus 70%, 20% and 10%, and the ratios become

$$R1 = \sqrt{\frac{6,000 \times 100}{70 \times 15}}$$

$$R2 = \sqrt{\frac{6,000 \times 100}{20 \times 3}}$$

$$R3 = \sqrt{\frac{6,000 \times 100}{10 \times 2}}$$

These ratios work out to

R1 = 24:1 approx., R2 = 100:1 and R3 = 173:1 approx.

The three loudspeakers, connected to secondaries with these ratios to the primary winding, will then be properly matched in to draw the required

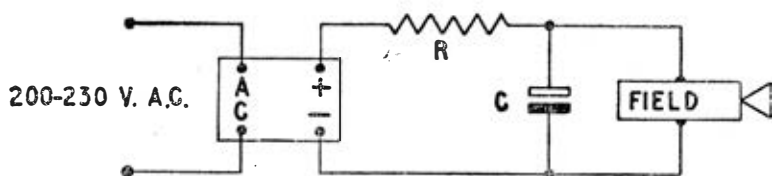
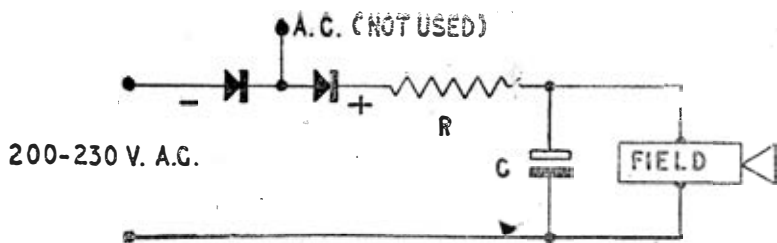

FIG. 21.—Speaker Field Energisation . (For R. and C, see text.)

proportions of the load and supply the correct matching impedance to the output stage.

Since the transformer ratios, for widely different speakers, fall between widely separated limits, a special transformer may have to be wound for a large installation, but the same results could be obtained by using separate transformers, their ratios being calculated by the same formulæ, their primaries being connected in parallel and their secondaries feeding the various speakers as already described.

#### *Field Energisation.*

When loudspeakers with energised fields are to be used, a small power pack must be provided to supply the energised current. If the system is working from D.C. mains, then obviously all that is required is a smoothing condenser across the field and, possibly, a dropping resistance in series with the field and the supply, depending on the current required and the potential set up across the field winding.

For A.C. mains, the only extra component necessary is, a metal rectifier. Smoothing is simple, the field acting as its own L.F. choke, and again a single condenser is all that is required, although its capacity is best determined by experiment, commencing with 4 or 8 mfd. and adding capacity if desirable. Electrolytic condensers may be used, since the supply is rectified.



Loudspeaker fields have resistances generally of the order of 1,000 and 2,000 ohms. It is possible to obtain very low resistance field speakers, designed for car operation from a 6 or 12 volt battery, but these types should be avoided, since it will then be necessary to transform down from the mains and to use a low tension type rectifier with a smoothing condenser of several hundreds of mfd's. The condenser is easily obtainable, since a bias condenser can be used, but the transformer introduces unnecessary expense.

The field of a good speaker should be marked with its resistance and also with its voltage and current or voltage and wattage ratings, and from these figures the power pack is easily designed. If only the resistance is given, however, the current which may safely be passed can only be assumed, and is most probably 100 mAs. or less. With 10" or 12" speakers, however, it should be safe to pass 100 mAs. Here again, however, the makers should be approached in cases of doubt.

The rectifier may be either of the Half or Full wave type, capable of passing the current required to energise the field. A suitable Half wave rectifier is the Westinghouse H.T. 17, rated at 200 volts, 100 mAs., although if a lower current is required the H.T. 15, rated at 200 volts, 30 mAs., or the H.T. 16, rated at 300 volts, 60 mAs., may be used instead.

The connections for both Half and Full wave rectification are shown in Fig. 21.

The dropping resistance will be used with the lower resistance fields. Assume, for example, that a 1,000 ohm field is marked as 100 volts, 10 watts. The current, then, will be 100 mAs, since

$$W = V \times I$$

where I is the current in amperes, and so, allowing the output of the rectifier on 230 volt A.C. mains to be 200 volts, this means that we shall have to drop 100 volts at 100 mAs. in a resistance, leaving a further 100 volts across the speaker winding.

The resistance, of course, must therefore be the same as that of the field, 1,000 ohms, and be rated at 10 watts also.

Here again, the cheapest and simplest method of supplying the resistance is to use a 0.2 amp. voltage dropper, with an overall resistance of 1,000 ohms, the usual rating for such droppers. The resistance will dissipate the heat easily, and, moreover, has a variable tapping by means of which the current in the circuit can be finally adjusted.

A 2,000 ohm field, wound to carry 100 mAs., will require no dropping resistor, for by Ohm's Law the potential set up across the winding is

$$V = I \times R,$$

$$\begin{aligned} \text{or} \quad &= .1 \times 2,000 \\ &= 200 \text{ volts.} \end{aligned}$$

I is again the current in amperes, and 100 mAs. = 0.1 amp.

A smaller speaker, however, may not require more than 30 or 50 mAs. — a 6" monitor speaker, for example, would need no greater current than

this—so a rectifier with a lower rating is chosen to supply the current and the dropping resistor calculated from the details available—namely, the field resistance and the current.

If 30 mAs. are to flow, then the current, expressed in amperes, is 0.03 amp.

A likely field resistance would be 1,500 ohms, so that the potential across the field winding would therefore be

$$\begin{aligned} V &= I \times R \\ &= 0.03 \times 1,500 \\ &= 45 \text{ volts.} \end{aligned}$$

Assuming that the rectifier output is 200 volts, this means that a resistance to drop 200-45 volts or 155 volts at 0.03 amp. is required in series with the field winding. By Ohm's Law

$$\begin{aligned} R &= \frac{V}{I} \\ &= \frac{155}{.03} \end{aligned}$$

= 5,166.6 ohms, the nearest standard value being 5,100 ohms.

The watts rating of the resistance is given by

$$\begin{aligned} W &= 155 \times 0.03 \\ &= 4.65 \text{ watts, so that a 5 watt resistance would be satisfactory.} \end{aligned}$$

To test for hum in the energised speaker, when deciding on the required capacitance across the field, short circuit the voice coil. Field hum will then induce currents in the voice coil and the hum become fully audible.

# "TECHNI-GEN" CONSTRUCTORS' ENVELOPES

Correspondence with many thousands of purchasers of our well-known Radio books has revealed a considerable demand for Radio designs in sheet form, and has indicated the types of sets desired.

The new "TECHNI-GEN" series of Radio Constructors' Envelopes is based upon this information.

Each envelope has an attractive cover design in two colours and contains a broadsheet, size 22½ in. by 17½ in., giving a chassis blueprint, a picture of the set which, in each case, has been built and fully tested, circuit diagrams and explicit instructions.

Lewis George, the well-known Radio designer and author, is responsible for the production of the Series and British component manufacturers have co-operated in developing the designs.

**No. 1. HOW TO MAKE A 3-VALVE PLUS RECTIFIER AC/DC TRF RECEIVER.** For medium waves (200-557 M. only). This receiver is provided with a tone control and a method of using an energised loudspeaker is illustrated and described.

**No. 2. HOW TO MAKE AN "ECONOMY" 4-VALVE PLUS RECTIFIER AC/DC SUPER-HET. RECEIVER.** For medium waves (200-557 M. only). A.V.C. and Tone Control is incorporated.

**No. 3. HOW TO MAKE "ALL-DRY" 4-VALVE BATTERY SUPER-HET. PORTABLE RECEIVER.** For medium waves (200-557 M. only). A.V.C., Tone Control and a Frame Aerial are incorporated. Provision is also made for the use of an outside aerial.

**No. 4. HOW TO MAKE AN AC/DC "QUALITY" RECEIVER.** For medium and long waves. This receiver is suitable for both local station reception and for the more powerful Continental stations. Approximately 8-watts push-pull output is provided.

**No. 5. HOW TO MAKE A 20-WATT "QUALITY" AMPLIFIER.** Separate treble and bass tone controls are incorporated and the output stage comprises two tetrodes in push-pull with negative feedback.

**No. 6. HOW TO MAKE A PORTABLE AC/DC PUBLIC ADDRESS AMPLIFIER.** 10-watts output with provision for mixing two microphone inputs and a gramophone pick-up. A suitable carrying case is illustrated.

**No. 7. HOW TO MAKE A DE LUXE TUNING UNIT FOR THE 20-WATT "QUALITY" AMPLIFIER.** Both straight and super-bet circuits are incorporated allowing wide-band local station as well as all-wave reception. Continuously variable tone control circuits are included.

Retail price 2s. each

Obtainable from your dealer or, in case of difficulty, write direct

**BERNARDS (PUBLISHERS) LIMITED,**  
GRAMPIANS BUILDING, WESTERN GATE,  
LONDON, W.6.

Telephone : SHEPHERDS BUSH 2581

# BERNARD'S RADIO BOOKS FOR THE HOME & AMATEUR CONSTRUCTOR

3.	SERVICES SIGNALLING MANUAL ... ..	1/-
4.	RADIO POCKET BOOK ... ..	1/-
6.	ELECTRICAL ENGINEERS HANDBOOK ... ..	1/-
22.	MANUAL OF RADIO CIRCUITS ... ..	2/-
30.	RADIO VALVE MANUAL ... ..	3/6
37.	MANUAL OF DIRECT DISC RECORDING ... ..	2/-
41.	WIRELESS AMPLIFIER MANUAL ... ..	2/-
42.	SHORTWAVE RADIO HANDBOOK ... ..	2/-
43.	MODERN RADIO TEST GEAR CONSTRUCTION ... ..	1/6
44.	RADIO SERVICE MANUAL ... ..	2/6
45.	RADIO REFERENCE HANDBOOK ... ..	12/6
48.	RADIO COIL AND TRANSFORMER MANUAL ... ..	2/-
50.	INTERNATIONAL SHORTWAVE RADIO STATION LIST ... ..	1/-
51.	CATHODE RAY OSCILLOSCOPE MANUAL ... ..	2/-
52.	RADIO TUNER UNIT MANUAL ... ..	2/6
53.	RADIO CONSTRUCTORS' MANUAL ... ..	3/-
54.	RADIO RESISTOR CHART ... ..	1/-
55.	HANDBOOK OF RADIO CIRCUITS No. 2 ... ..	2/6
56.	RADIO AERIAL HANDBOOK ... ..	2/6
57.	ULTRA SHORTWAVE HANDBOOK ... ..	2/6
58.	RADIO HINTS MANUAL ... ..	2/6
59.	TELEVISION CONSTRUCTION MANUAL ... ..	3/6
60.	RADIO REPAIRS MANUAL ... ..	2/6
61.	AMATEUR TRANSMITTERS' CONSTRUCTION MANUAL ... ..	2/6
62.	CAR AND PORTABLE RADIO CONSTRUCTORS' MANUAL ... ..	2/6
64.	SOUND EQUIPMENT MANUAL ... ..	2/6
65.	RADIO DESIGNS MANUAL ... ..	2/6

*Other Titles in Preparation*

- 63. RADIO CALCULATIONS MANUAL
- 66. COMMUNICATIONS RECEIVERS' MANUAL
- 67. RADIO VALVE EQUIVALENTS MANUAL
- 68. FREQUENCY MODULATION RECEIVERS' MANUAL
- 69. RADIO INDUCTANCE MANUAL (*Coil and Transformer Construction*)
- 70. LOUDSPEAKER MANUAL
- 71. MODERN BATTERY RECEIVERS' MANUAL
- 72. EXPERIMENTAL CIRCUITS MANUAL
- 73. RADIO TEST EQUIPMENT MANUAL