

# electronics today

DECEMBER 1978

INTERNATIONAL

45p

## **FIVE CHANNEL LIGHT SHOW**

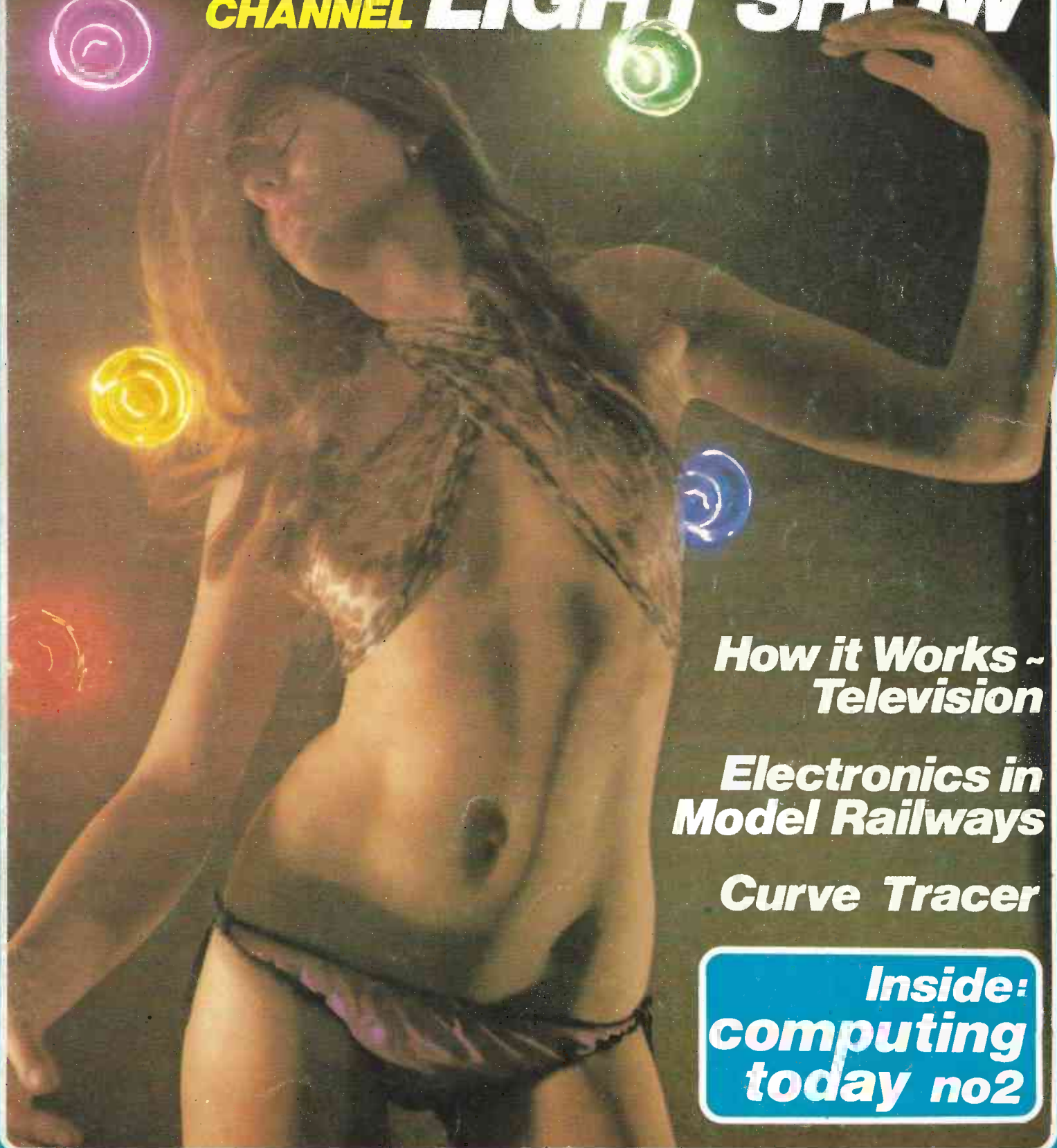

**How it Works ~  
Television**

**Electronics in  
Model Railways**

**Curve Tracer**

**Inside:  
computing  
today no2**

... NEWS . . . . PROJECTS . . . . MICROPROCESSORS . . . . AUDIO . . .

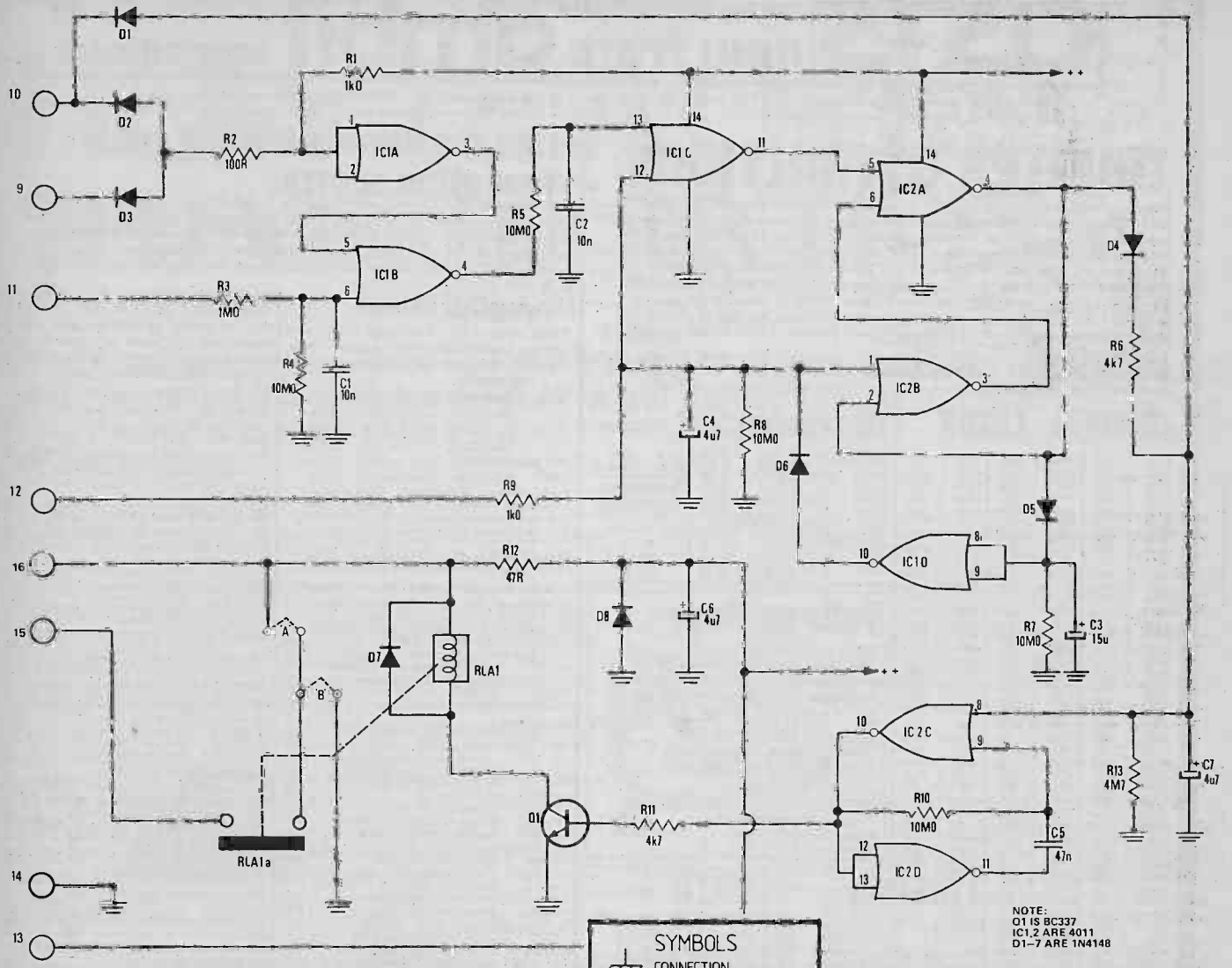

Circuit diagram of the main control unit.

**SYMBOLS**

- CONNECTION TO EARTH
- CONNECTION TO TERMINAL OR TAPE-SPLICE
- 1/4 RECEPTACLE ON WIRE
- EARTH CONNECTION WITH 6BA HARDWARE

NOTE:  
C1 IS BC337  
IC1,2 ARE 4011  
D1-7 ARE 1N4148

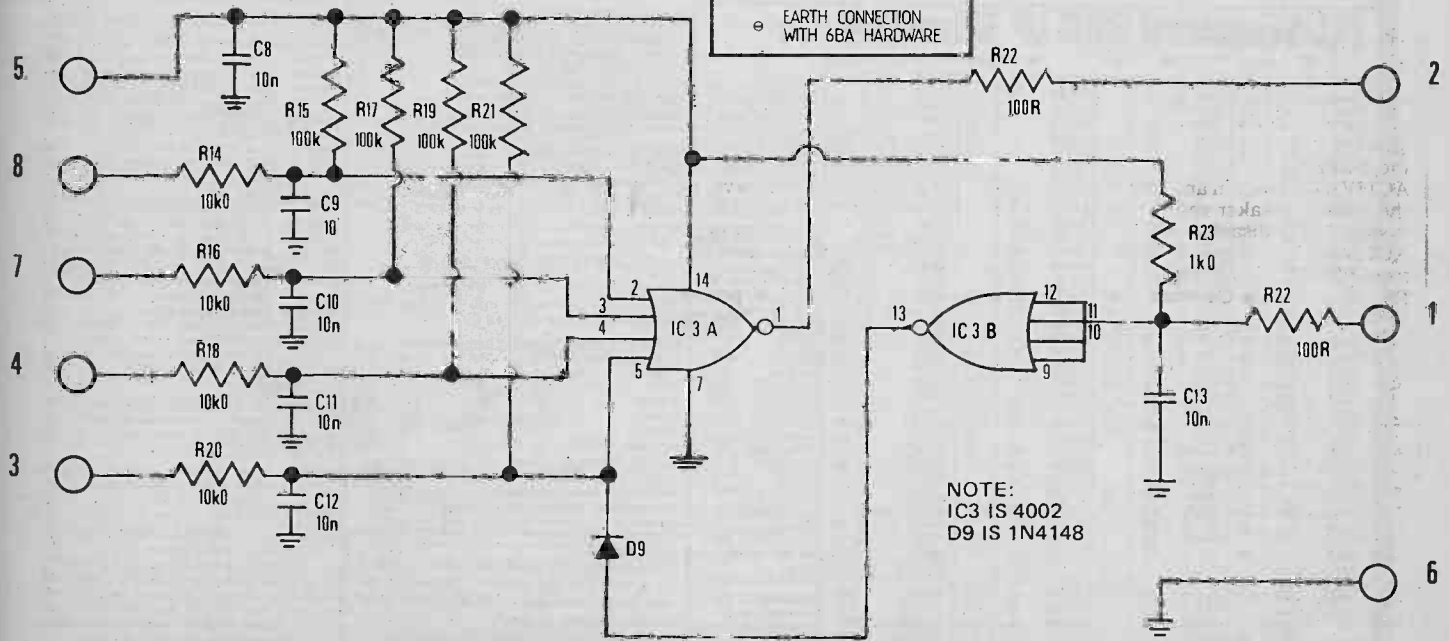

NOTE:  
IC3 IS 4002  
D9 IS 1N4148

# HOW IT WORKS~ TELEVISION RECEIVERS

Ever wondered just how your TV actually works — all those cunningly interconnected and interrelated bits of high-voltage circuitry? Gordon King takes a good long look in this, the first of a series of How It Works articles based around consumer electronics products.

THIS FIRST ARTICLE in the 'How It Works' series looks at monochrome television based on a recent mains/battery chassis from Thorn Consumer Electronics. In addition to providing an insight into modern television technology the article is also styled to give a fair impression of how the picture is developed on the screen of the picture tube. The basic principles are common to all receivers except that for the reception of colour there are circuit additions for the decoding of the colour information (and a tricolour tube for display!)

Sound and vision signals are modulated on to two carrier waves, the former using frequency-modulation (FM) and the latter amplitude-modulation (AM). On the prevailing UK 625-line system the signals are transmitted in Bands IV and V which are located in the UHF spectrum. Each channel occupies a width of 8MHz with the sound carrier being 6MHz above the vision carrier. For example, Channel 21 has sound and vision frequencies of 477.25 and 471.25 MHz respectively,

while the frequencies for Channel 68 are 853.25 and 847.25 MHz.

Vision modulation is negative-going (see Fig. 3) and is transmitted in 5.5MHz upper sideband and 1.25MHz lower sideband. Peak FM deviation is 50kHz (as distinct from 75kHz on FM sound radio) based on 50µs pre-emphasis. Ratio of peak vision to peak sound power is 5:1. Further information on the signal is given later.

## Tuner-Front-End

The start of any television receiver is the 'front-end' or tuner (Fig. 1); whose job it is to select the required channel and to convert the sound and vision carriers to lower frequency ones for subsequent intermediate-frequency (IF) amplification and response tailoring. In Fig. 1 the aerial signals are coupled to an aperiodic RF amplifier, VT1, through an 'isolator' for preventing spurious mains voltages in the receiver from reaching

Fig 1. Circuit diagram of UHF varicap tuner, which uses two RF amplifiers and a mixer stage. Resonant lines tuned by capacitor-

diodes select the required channel and provide the necessary front-end selectivity.

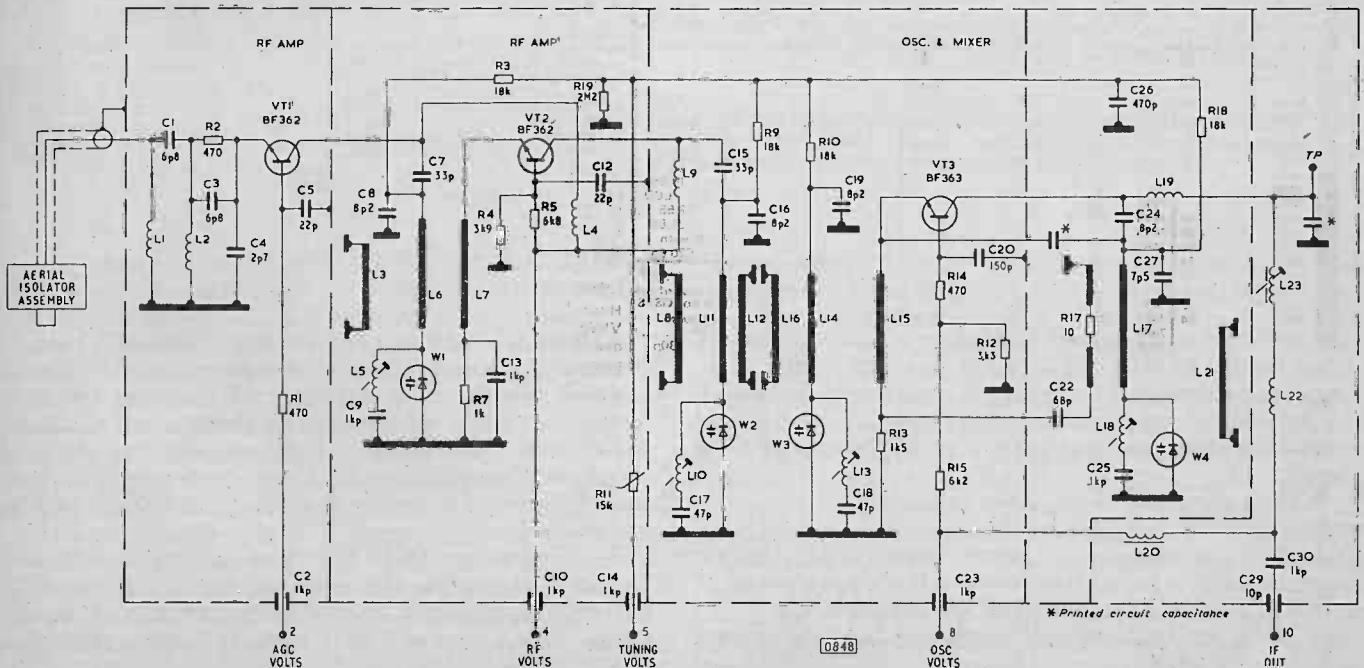

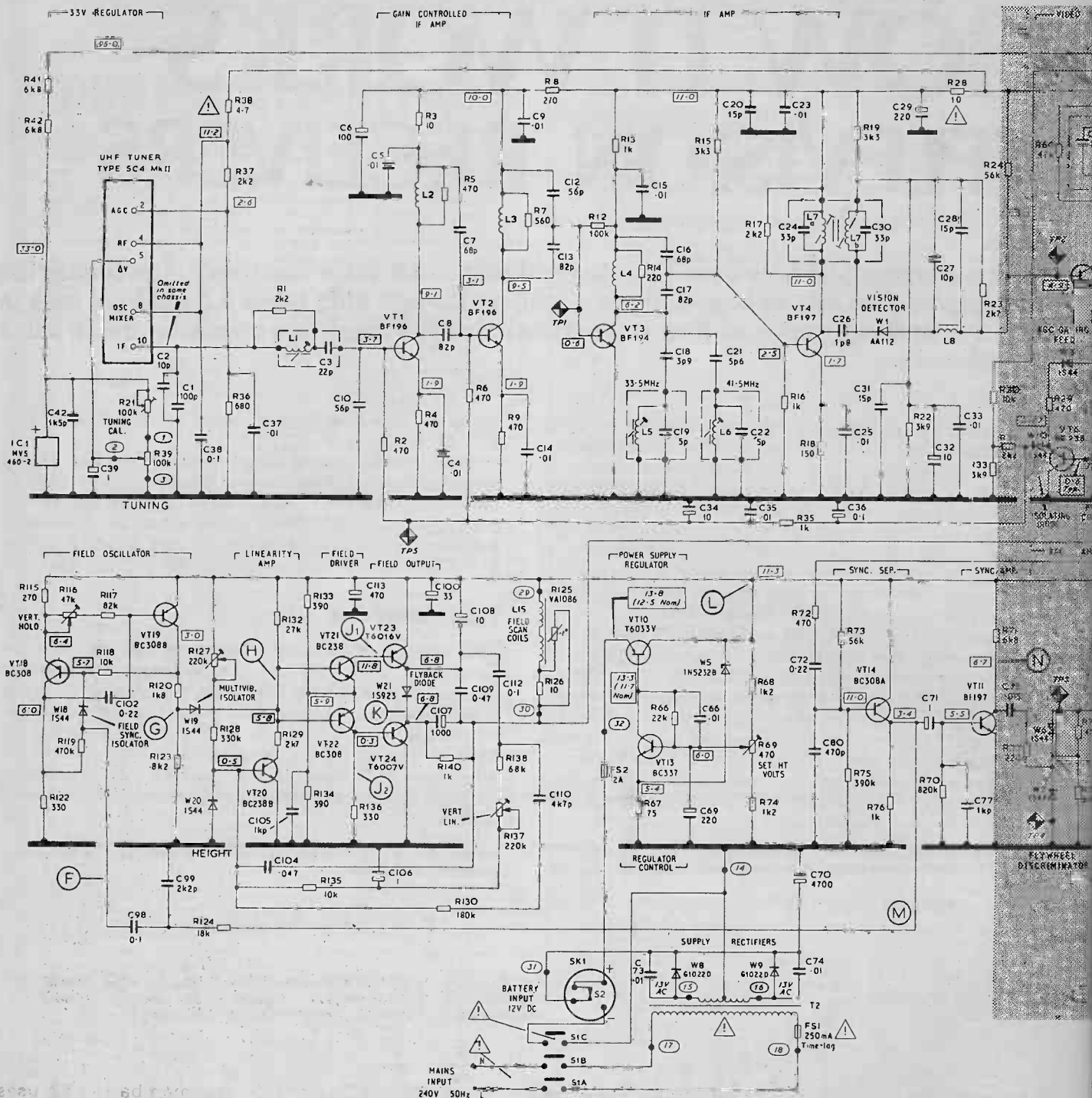

the aerial at lethal power! The transistor is in common-base mode so that the input is applied to the low-impedance emitter. Further input matching is provided by the emitter components and the base is biased either from a constant potential or from an AGC potential (see later).

VT2 is a tuned RF amplifier, also in common-base mode, but the tuning is by resonant lines rather than coils. Any transmission line whose length is adjusted to correspond to a tuned frequency is the equivalent of a tuned LC circuit. An open-circuit line is resonant at 1/2, 3/2, 5/2, etc. wavelength. Excluding velocity factor,

the physical length of a line for, say, Channel 33 would be around 280mm. Happily, it is possible to reduce the physical length while retaining the required electrical length by cutting off the ends of the line and replacing them with capacitance, which reduces the physical length to about 50mm. Moreover, tuning the channels then becomes a question of varying the capacitance at one end.

Looking at line L6 in Fig. 1 shows that the bottom connects to varicap W1 and the top to C8 and VT1 collector capacitance. A varicap is essentially a junction diode. As the reverse bias is increased so the depletion

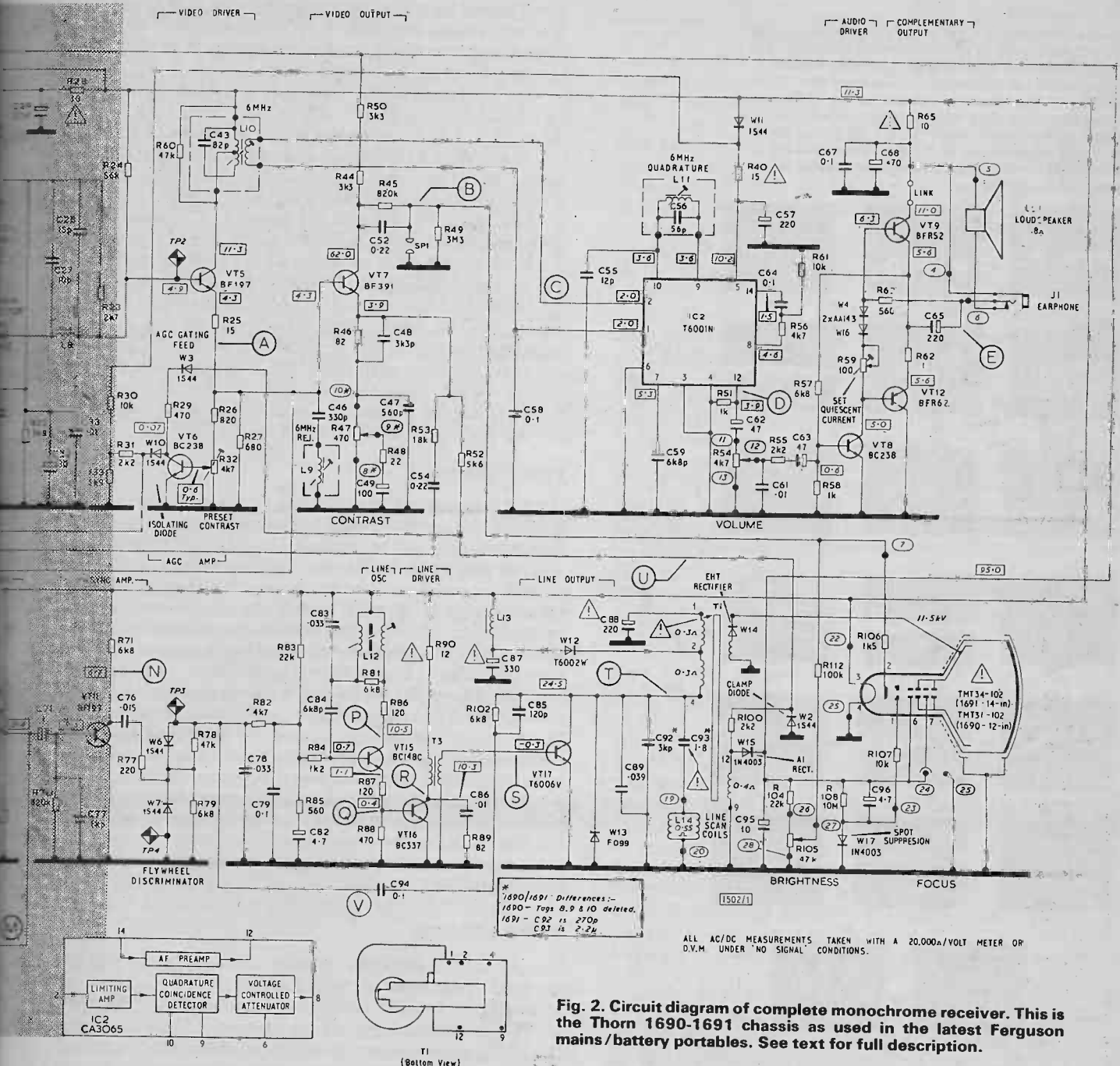

**Fig. 2. Circuit diagram of complete monochrome receiver. This is the Thorn 1690-1691 chassis as used in the latest Ferguson mains/battery portables. See text for full description.**

region widens, and as this constitutes the dielectric between the n and p regions. The effect is tantamount to the two plates of a capacitor being moved away from each other, with a consequent reduction in capacitance. The four varicaps in Fig. 1 are biased by a positive potential being applied to the 'tuning volts' input. The potential is obtained from a stabilised (by IC1) supply in the main chassis (Fig. 2) via tuning potentiometer R39. Thus as this control is tuned so the resonance frequency of the lines alter in step and tune over the UHF channels.

The second RF amplifier stage VT2 starts to give selectivity. Emitter coupling is via low impedance aperiodic line L7. Further selectivity is provided by the bandpass coupling between VT2 collector and VT3 emitter formed by lines L11, L12, L16 and L14, tuned

by varicaps W2 and W3. Common-base VT3 uses collector/emitter feedback for the local oscillator tuned by line L17 and varicap W4. Line L15 couples the RF signal to the oscillator/mixer stage. The circuits are trimmed by L5, L10, L13 and L18 (so they all tune in step), while the closed lines L3, L8 and L21 also assist with the tuning and matching.

The oscillator is arranged to operate at the IF frequency above the input frequency, and additive mixing yields the IF output, which is resonated by L23 and associated components. The IF signal is coupled to the IF input of Fig. 2 via C30. The high degree of selectivity minimises spurious responses such as image, IF, repeat spot, etc., while also providing a good 3rd-order intermodulation rejection ratio. This is further

## Oscillograms

These were taken from a typical receiver at the points indicated by corresponding letters in the circuit diagram. The voltage and time figures refer to the sensitivity per division of the graticule. The receiver was set up for normal reception (test card with tone on sound) and the oscillograms were taken via a +10 probe having an input capacitance of 12pF in parallel with 10M $\Omega$ . The mixed mode timebase facility was used for G and M.

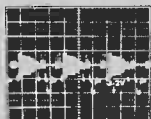

A 0.5V, 20 $\mu$ s: 15Vpp

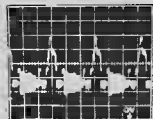

B 10V, 20 $\mu$ s: 43Vpp

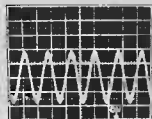

C 1V, 0.1 $\mu$ s: 3.8Vpp

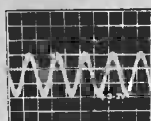

D 0.5V, 0.5ms: 15Vpp



E 0.5V, 0.5ms: 2.3Vpp

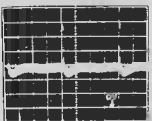

F 2V, 5ms: 7.6Vpp

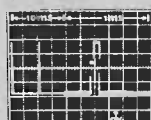

G 2V, 10ms & 1ms: 7.6Vpp

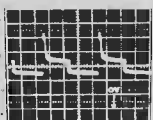

H 2V, 5ms: 5.8Vpp



J1 0.5V, 5ms: 0.9Vpp

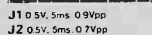

J2 0.5V, 5ms: 0.7Vpp

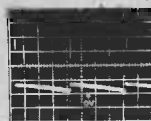

K 20V, 5ms: 74Vpp

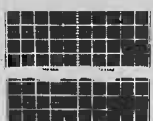

L 50mV, 5ms: 50mVpp

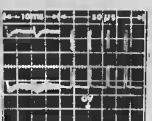

M 2V, 10ms & 50 $\mu$ s: 9.5Vpp

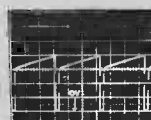

N 2V, 5ms: 8Vpp

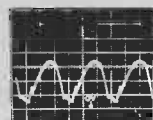

P 5V, 20 $\mu$ s: 15Vpp

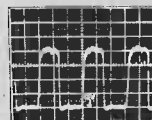

Q 0.2V, 20 $\mu$ s: 0.88Vpp

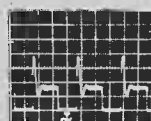

R 10V, 20 $\mu$ s: 38Vpp

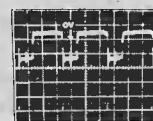

S 2V, 20 $\mu$ s: 11Vpp

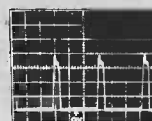

T 50V, 20 $\mu$ s: 200Vpp

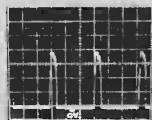

U 5V, 20 $\mu$ s: 20Vpp

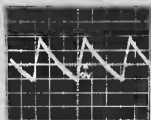

V 2V, 20 $\mu$ s: 6Vpp

aided by the nature of the transistor and design of the first stage VT1.

The circuit also reveals various signal coupling, decoupling and isolating components, which are essential for the stable performance of this important part of the receiver. The tuner is built into a fully screened box with feed-through capacitors for the inputs and outputs.

## IF Channel

Sound and vision signals of the selected channel undergo amplification with bandpass and selectivity tailoring in the IF channel comprising VT1/2/3/4. Tuner signal is applied to VT1 base from the tuned coupling L1/C3, and the amplified and bandpass defined output is yielded by transformer L7a/b. Gain is controlled automatically (AGC) to suit the level of the

input signal by a bias fed to the bases of VT1 and VT2. The four stages are each in common-emitter mode, and impedance matching at the couplings is achieved essentially by capacitor divide-down.

The bandpass characteristic is provided in the main by L1/C1/C3/C10/R1 at the input and by L7a/b at the output. Additional selectivity is provided by collector inductors L2/L3/L4, while sound and adjacent channel sound rejections are introduced at 33.5MHz by L5/C18/C19MHz and at 41.5MHz by L6/C21/C22.

With the 625 line system (system 'I' is used in the UK) the sound carrier is 6MHz *above* the vision carrier, but because the local oscillator of the tuner is working at the IF above the signal frequencies, the IF appears at 33.5MHz for sound, which is 6MHz *below* the 39.5MHz vision IF. The sound and vision signals are handled simultaneously by the IF channel, which is possible because frequency modulation (FM) is used for the sound signal. Vision bandwidth of the 'I' system is 5.5MHz upper sideband, accommodated by the IF bandwidth, and overall channel width 8MHz.

## Vision Detector

Sound and vision signals from L7b are coupled to vision detector W1, which yields a changing amplitude output corresponding to the picture information (Fig. 3) and also an output at 6MHz resulting from intermodulation of the sound and vision signals by the diode non-linearity, the difference frequency of the two signals being 6MHz. The intercarrier sound signal (as it is called) retains the FM of the sound signal because this is one of the components from which it is derived.

If the ratio of the levels of the sound and vision signals is incorrect a buzz occurs on sound — called intercarrier buzz. Hence the reason for the 33.5MHz trap, which sets the sound signal level below that of the vision carrier while helping to establish one side of the bandpass. The 41.5MHz trap avoids the sound signal from the next channel causing interference while helping to establish the other side of the bandpass. The vision carrier is set 6dB down the response to equalise for the single side band signal.

## Video Channel

Picture and intercarrier signals from W1 are directly coupled to the base of the video driver VT5 via low-pass filter L8/C27/C28, which removes residual IF signal. VT5 collector is loaded into transformer L10 which tunes the 6MHz intercarrier signal and couples it to the sound section for FM demodulation and subsequent pre and power amplification for driving the loudspeaker.

VT5 also serves as an emitter-follower for the video signal with network R26/R27/R32 as the load. The signal across this is directly coupled to the base of the video output transistor VT7, which feeds negative-going picture signal to the cathode of the picture tube from its collector. A series rejector L9/C46 tuned to 6MHz is also active at VT7 base to prevent intercarrier signal from getting into the video output stage, where it would cause picture interference. The level of video signal reaching the tube is adjustable by R47, the contrast control, which is a kind of current feed-back control working by the progressive shunting effect across R47 emitter resistor by R48. C49 is a DC isolator. Video-frequency compensation is also provided by capacitors in the feedback loop.

## Automatic Gain Control (AGC)

VT5 base is biased from a resistive divider complex (R24/R33/R22/etc.) from the supply rail. It is also partly biased from rectified IF signal at W1 anode, and since direct-coupling is used an increase in IF signal level results in a reduction in positive bias at VT5 base and hence a fall in potential across VT5 emitter load.

The voltage across R32 (the preset contrast control part of the load) is fed to the base of the AGC amplifier VT6 at a level established by the setting of the control. Because VT6 collector is energised via W3 from positive-going 5Vpp pulses derived from a winding on the line output transformer (bottom right-hand corner of Fig. 2, next to the picture tube), the transistor conducts only during the line sync pulses when there is no picture content which the AGC circuit might otherwise falsely read. The degree of conduction and hence the level of the collector potential are determined by the DC level of the line sync pulses at VT6 base. This is called line-gated AGC.

Thus with increase in input signal level (such as when tuning to a stronger channel) VT6 is turned down and the positive potential at its collector rises. This is reflected via forward conducting W10 to the bases of VT1 and VT2 by way of R2/R6 and the filter consisting of C34/C35/C36/R35, which removes line pulses. The small-signal transistors VT1 and VT2 are the type designed for forward AGC; that is, increased gain reduction resulting from positive-going AGC potential.

The preset contrast control R32 sets the operating range of the AGC. With a test card signal of average strength the control is adjusted for 1.5Vpp picture *plus* sync signal at VT5 base.

Some sets include delayed AGC for the tuner RF amplifier which comes into effect after the gain has been reduced initially on a strong signal by the IF AGC; but for the monochrome portable this is barely necessary as maximum front-end gain is generally necessary for most of the time for the best signal-to-noise ratio when a simple set-top aerial is utilised. It will be seen that the tuner 'block' in Fig. 2 has an AGC input which, in this model, is terminated to a supply potential-divider.

## Field Timebase

The electron beam needs to be deflected both vertically and horizontally to build up the raster upon which the picture appears. The vertical deflection is handled by the field timebase which deflects the beam from the top to the bottom (scanning stroke) and then very swiftly back to the top again (retrace) at 50 Hz repetition rate.

This is achieved by a 50Hz sawtooth current passing through the field scan coils (L15) on the tube neck. The oscillatory requirements are provided by the field oscillator VT18/19, which is an RC multivibrator. The retrace is initiated by the arrival of a field sync pulse at VT18 base (see later), while the repetition rate is determined by the vertical hold control R116 with R117/118 and C102.

Consider the circuit during the scanning stroke when a rising voltage (ramp) occurs at the base of high-gain amplifier VT20 owing to C104 charging through R127/128. This turns on VT20, VT22 and VT24, and turns off VT21 and VT23. At the conclusion of the stroke VT24 is fully 'bottomed', at which time a positive-going

pulse from VT19 collector 'hits' the bases of VT21 and VT22 via the multivibrator isolating diode W19. The pulse is initiated from the field sync action. The retrace is thus triggered by VT21 and VT23 turning on, and VT22 and VT24 turning off.

During the retrace, VT24 collector voltage rises at a rate established by the L/R ratio of the scan coils, and when the supply line voltage is exceeded W21 goes into reverse conduction and VT23 is isolated. The rate of rise is then defined by C109. After a peak, the retrace voltage falls until W21 goes into forward conduction again. This allows the remainder of the retrace energy to be fed back into the supply line, after which the scanning stroke recommences.

The resulting rise in current through the field scan coils during the scanning stroke produces a magnetic field such that the electron beam is drawn downwards. To avoid vertical non-linearity for the display the *rate of change of current* must be linear. Owing to resistive losses in the scan coils and circuit non-linearities, a slight correction to the current waveform is required, and this is achieved by a parabola waveform produced by R138/R137/C106 being added to the ramp via the linearity amplifier VT20. The degree of correction is adjustable by the vertical linearity control R137.

When the retrace is initiated the rapid reversal of scan coil current deflects the beam swiftly upwards to start a new downward scan, and during the retrace diode W20 goes hard into forward conduction so that the base of VT20 is clamped to earth.

## Line Timebase

Horizontal deflection of the beam is achieved by the line timebase driving a sawtooth current wave through the line scan coils (L14) during the scanning stroke. Deflection is from left to right, and at the end of the scanning stroke a swift reversal of current deflects the beam back to its starting point again. During the retrace a considerable amount of energy stored in the inductive elements of the line output stage is released to provide the extra high tension (EHT) for the final anode and the high voltage for the first anode (A1) of the picture tube. Boosted voltage is also used to energise the line output transistor VT17 once the line oscillator has started.

Line repetition rate of the 625 line system is 15625Hz. Thus the horizontal rate is significantly greater than the vertical rate. We have seen that in the UK the vertical rate is 50Hz. This means, then, that a raster of 312½ lines is produced (15 625/50). For a complete picture there are two vertical scans, each producing a raster of 312½ lines, so that the complete picture is made up of 615 lines and produced every twenty-fifth of a second (in actual fact not all the lines are used for the picture as some occur during the field sync period when the electron beam is cut off).

A complete full-line-picture is achieved because the scanning lines of one field *interlace* in the spaces between the lines of the partnering field. To obtain 625 lines without interlacing the line frequency would need to be increased to 31 250Hz. This in turn would call for a greater rate of change in beam intensity and hence spot brightness to trace out the fine detail over each line, and because a greater rate of change of signal amplitude involves a greater bandwidth, more radio space would be needed to accommodate the picture detail of each

channel. With the 5.5MHz vision bandwidth of the '1' system good definition is obtained at the 15 625Hz line rate.

Interlacing *could* be avoided without using up extra radio space by reducing the field rate to 25Hz, but then the picture would suffer bad flicker (subjectively apparent up to about 45Hz). Interlacing thus solves the problems of bandwidth and flicker without unduly detracting from the displayed information.

Returning to the circuit in Fig. 2, the line frequency is established by a blocking oscillator incorporating VT15 Forward base bias through R83 turns the transistor on so that the current through the collector winding of L12 rises. The reversed phase of the other winding puts a negative-going pulse on the base which cuts the transistor off. The on/off cycles are timed by L12/C83/C84 with the oscillator in the free-running mode, the frequency being set by L12 core. The oscillator is synchronised to the line pulses of the signal (as will be explained later).

VT16 amplifies and shapes the pulses from VT15 emitter and transformer T3 couples them to the base of output transistor VT17. The pulses switch this transistor on during the scan so that current flows through the upper left-hand windings of the line output transformer (LOT) T1 and scan coils L14. Because the coils are essentially inductive the current rises as a fairly linear ramp. However, because the effective length of the beam changes with scanning stroke owing to the wide scanning-angle and flat screen of a contemporary tube, 'S-correction' is required. This is achieved by C93 which reduces the rate of scan at the start and end of a line with respect to the centre. Further linearity correction and width adjustment are provided by a closed-loop sleeve set under the scan coils. The field produced by the current induced into this counteracts the non-linearity of the field produced by the scan coils themselves.

VT17 switches off at the end of a scan and the swiftly collapsing current through the scan coils and LOT windings returns the beam to its starting point and yields a high voltage pulse owing to the sudden release of the inductively-stored energy. The repetitive pulses are increased in voltage by the overwind at the top right-hand side of T1, rectified by W14 and smoothed by a capacitance formed by the inner and outer conductive layers on the tube flare, the inner connected to the final anode. The result is a potential of 11.5kV for the final anode. After rectification by W15, pulses from the lower right-hand winding charge C95 to yield a 95V line for the tube first and third anodes, video output VT7 (to provide about 50V video swing for the tube) and varicap tuning.

Oscillatory energy is rectified by the booster diode W12 conducting during the retrace to charge C87/C88. This not only damps the unwanted energy which would otherwise cause vertical lines at the left of the picture, but the potential developed from it is used to energise VT17 collector, and contribute to the line scan, thereby improving the efficiency of the line output stage. The stage also adopts 3rd harmonic tuning of the pulses. This tends to flatten the tops of the pulses, which leads to improved EHT regulation. The tuning capacitor is C89 in parallel with a low-inductance disc capacitor C92 providing flashover protection.

## Sync Stages

Video signal at VT5 emitter is coupled to the base of the sync separator transistor VT14 through R72/C72. On the 625 line system the picture signal is negative-going (modulation level falling with increasing brightness), and at the end of each line a line sync pulse occurs whose tip reaches 100% amplitude, as shown in Fig. 3 a.

Composite video (picture plus sync) from VT5 emitter is fed to the base of VT14 (sync separator) which is biased to conduct only during the sync pulses so that they resolve free from picture signal at the collector. For line sync, coupling is to VT11 (sync amplifier/inverter), whose output drives 'flywheel' discriminator W6/W7 etc. The discriminator is also fed positive-going line pulses from the LOT via C94 which, after RC integration,

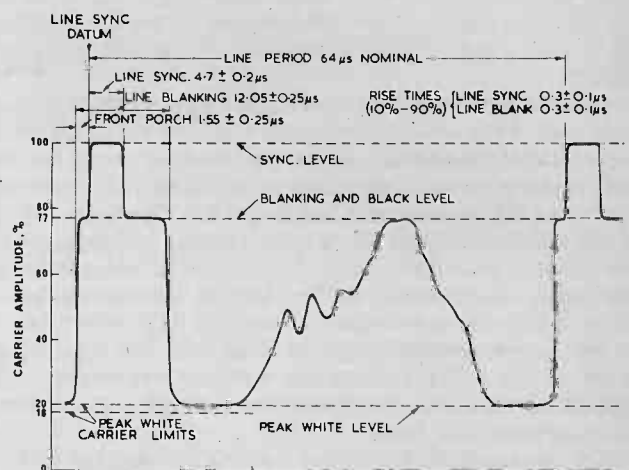
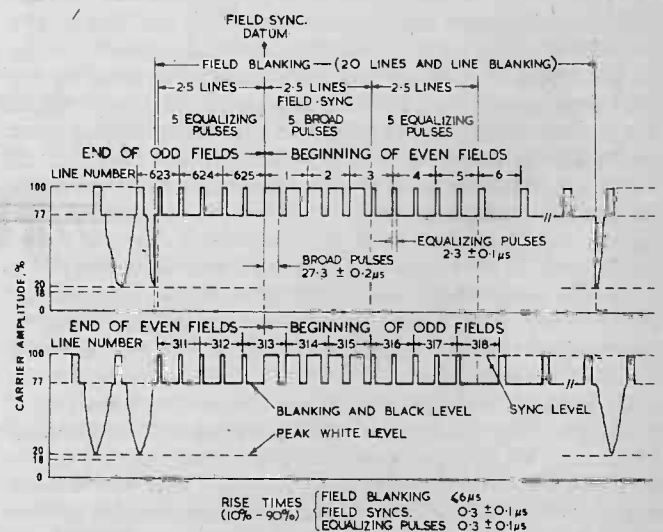

Fig. 3. BBC 625-line television signals. (a) One line of signal showing sync pulses. These keep the line scan in step with that at the transmitter, while the picture signal causes the deflected scanning spot on the face of the picture tube to change in brightness at a rate determined by the detail of the transmitted picture and by an amount governed by the brightness of the transmitted scene at any instant. (b) Pulses transmitted during the synchronising period at the end of one field scan and the start of the next (upper end of odd fields and beginning of even ones, and lower end of even fields and beginning of odd ones). The pulses provide correct interlacing while keeping the line timebase in sync during the field synchronising period (see text).





form a ramp whose phase is compared with that of the line sync pulses. Phase error results in a potential at the top of R78 which, after being filtered by C78/C79/R82 to remove pulse residual, is applied to the line oscillator. As this is a VCO, frequency correction and hence line synchronisation are achieved.

From the end of one field scan to the start of the next one, five narrow equalising pulses are followed by five broad field sync pulses and then by another five equalising pulses. The width and spacing of the pulses keep the line synchronised during the field sync period, while the equalising pulses ensure equal blanking on both even and odd fields, and also identify the two fields for accurate interlacing by cutting off the picture half way through a line at the end of odd fields and starting it after a line is half over at the beginning of even fields, as shown in Fig. 3 (b).

It is worth noticing that test signals and certain teletext data are transmitted on blank lines — the latter at a bit rate of 7 megabits per second. The 1.55 and 5.8 $\mu$ s front and back porches to the line sync pulses provide time for the line retrace, and it is the 5.8 $\mu$ s porch which carries colour burst signal.

The positive-going field sync pulses at VT14 collector are integrated by C99/R124 and applied to VT18 base through W18. The integration builds up a composite pulse for triggering the field retrace and attenuates line pulses.

## Tube Biasing and Video Feed

During normal working the tube grid is held at chassis potential by W17. When the set is switched off W17 is reverse-biased and the charge held by C96 drives the grid negative, thereby suppressing the beam, while the supply voltages collapse.

Beaming current cut-off is set by R105 (brightness control) which merely adjusts the tube cathode potential. Video signal from VT7 collector is also applied to the cathode, and as the signal is negative-going the beam current increases with increasing picture brightness. Beam cut-off or black-level is set by the brightness control so that the sync pulses drive the tube below black.

## Sound Channel

Intercarrier signal from L10 is fed to IC2 which incorporates a 6MHz limiting amplifier; quadrature coincidence detector tuned by L11; voltage-controlled attenuator operated by the volume control R54 and an audio preamplifier for driving the class B push-pull output transistors VT9/VT12 via driver VT8. The bases of the output transistors are driven together from VT8 collector, which is possible because VT9 is NPN and VT12 PNP (a complementary pair). Quiescent current is set by R59 at 8mA. Negative feedback is from the emitters of the output pair via R57 to VT8 base. Since the mains supply is isolated by transformer T2 it is possible to use a headphone set or earphone connected to jack J1.

For those not familiar with the quadrature FM detector the following brief description may help. After passing through the limiting amplifier chain, the inter-carrier signal is changed to squarewave and the signal fed two ways: one way to a synchronous detector and

the other way to a 90-degree phase shift circuit and thence to the synchronous detector. The synchronous or coincidence detector combines the two inputs vectorially so that the output consists of the vector sum which, relative to the fixed 90-degree phase shift, changes with the FM deviation. The result is a variable width squarewave (pulse width modulation) which, after integration, yields the audio signal.

## Power Supplies

The receiver can be operated from a 12V car battery or the mains supply. On mains, isolation is provided by transformer T2 and full-wave rectification by W8/W9, with C70 the reservoir. The supply is fed to the emitter of series regulator VT10. VT13 is the error amplifier which compares a ratio of the collector output voltage with a reference potential provided by zener W5. Starting current is provided by R66 and the base potentiometer R69 sets the output voltage for the correct value of EHT voltage. Stabilisation is effective over a mains input of 220-264V. The high  $V_{be}$  rating of VT10 provides automatic protection against reversed battery polarity.

## Final Points

Finally, one or two minor points: SP1 at VT7 collector is a spark gap which liberates energy in the event of a flashover inside the tube, directing current away from VT7 collector. The tube is a quick-heat type whose heater is energised from the 11.3V line and one which is happy with a relatively low focus electrode voltage.

## Acknowledgement

I would like to thank Thorn Consumer Electronics and Mr. R. V. Arnaboldi and Mr. D. A. Pike of this Company for permission to use the circuit of the 1690-1691 chassis in this article.

ETI

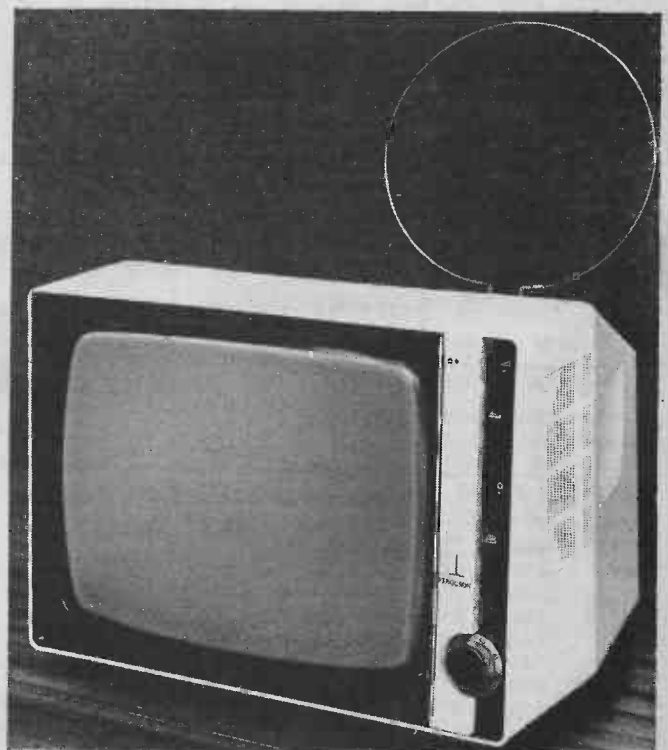

# WINE TEMPERATURE METER

Ensure your wine is at the correct temperature with this little idea from our project team

WINE, WOMEN AND SNOG — no not another misprint but ETI's updated version of that phrase that so aptly describes that which a young man's fancy turns to in spring, or any other time of year for that matter. We at ETI can't do much about the provision of the above items but this project will at least ensure that when you get your hands on one of them it will be in perfect condition. Before going any further let's make it clear that its the wine we're talking about in this connection.

In use the wine temperature meter's sensor is clipped to the plonk of your choice and the condition of the booze, with regard to temperature, read off from the three LEDs on the meter's front panel. To set up the instrument consult our table showing the range of temperatures considered acceptable



Above, the complete unit while below the sensor, a bicycle clip painted black with the sensor epoxied to it.

for the various types of wines. Turn RV2 fully anticlockwise and bring the sensor to a temperature that is in the middle of the desired range. Adjust RV1 until the centre LED just lights

Next lower the temperature of the sensor until it is at the lower temperature limit. Adjust RV2 until the lower LED is just extinguished.

Construction of the project is quite straightforward. Assemble all the components according to the overlay shown. Space is at a premium if the case chosen for our prototype is used so keep everything tidy.

Our sensor was made from a bicycle clip. The thermistor was epoxied to the clip — we smeared a small amount of silicon grease on the clip before mounting the sensor — this provides a good thermal contact. We coated the sensor in a layer of black paint when it was complete leaving the area under the sensor as bare metal.

Insert the battery and start getting your grapes as they should be enjoyed.

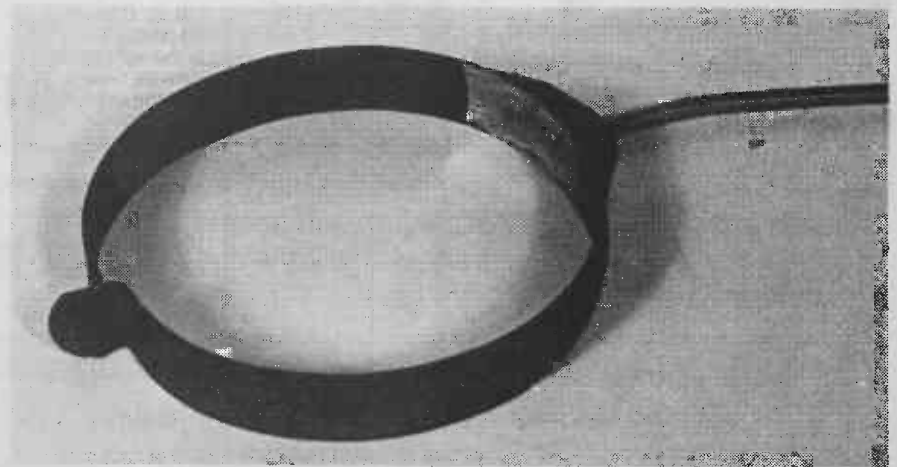
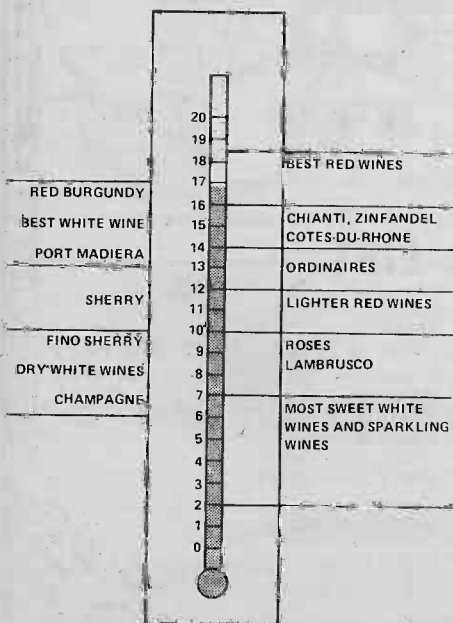

## HOW IT WORKS

The project is based on the TCA965 window discriminator IC. This device can be used in a number of different modes, the one selected for this application allows the potentiometers RV1 and RV2 to set up a "window height" and "window width" respectively.

R1 and thermistor TH1 for a potential divider connected across the supply lines. The value of R1 is chosen such that at ambient temperature the voltage at the junction of these two components will be approximately half supply.

As the temperature of the sensor changes so the voltage will change and it's the temperature dependent voltage that is input to IC1.

RV1 will set the point which corresponds to the centre voltage of a window the width of which is set by RV2. The switching points of the IC feature a Schmitt characteristic with low hysteresis.

The outputs of IC1 indicate whether the input voltage is within the window or outside by virtue of being either too high or too low.

The outputs of IC1 are all open collectors capable of providing up to 50mA. In our circuit however they are only required to drive a LED via a current limiting resistor.

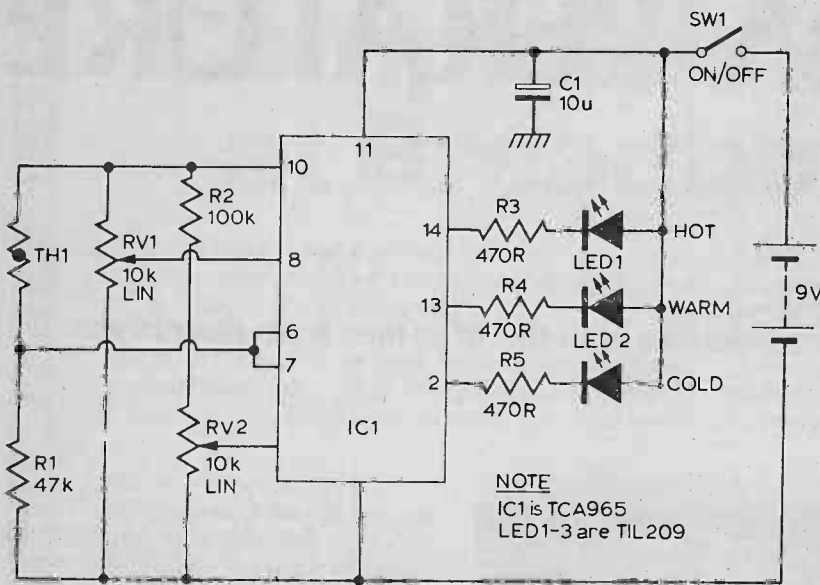

Circuit diagram of the wine temperature meter.

## BUYLINES

All the components for this project should be available from most local shops — no problems.

Foil pattern of the wine temperature meter.

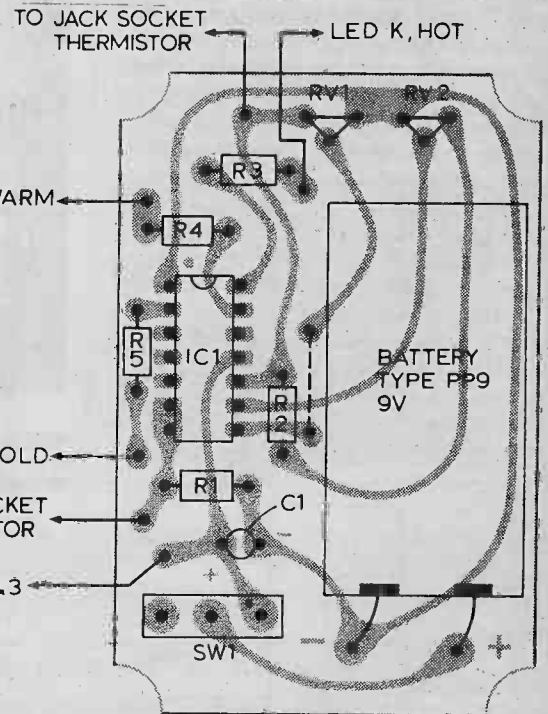
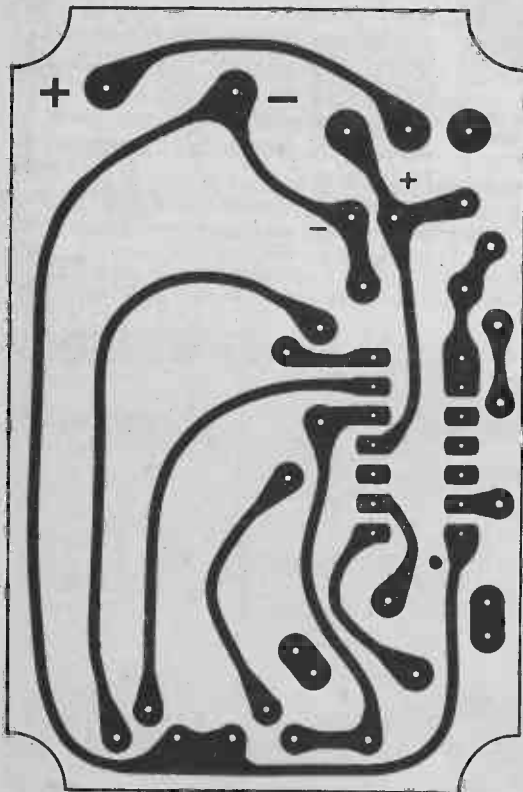

## PARTS LIST

### RESISTORS

R1 47k  
R2 100k  
R3, 4, 5 470R

### POTENTIOMETERS

RV1, 2 10k sub. min. preset

### CAPACITORS

C1 10u 10V tantalum

### SEMICONDUCTORS

IC1 TCA965  
LEDs1-3 TIL209

### SWITCH

SW1 SPDT

### MISCELLANEOUS

PCB as pattern, Vero potting box, 2.5mm jack socket, battery wire, wire etc.

# electronics today

DECEMBER 1978 VOL. 7 NO. 12

INTERNATIONAL

## FEATURES

NEWS DIGEST	7	Latest on the latest
HOW IT WORKS — TELEVISION	21	A new series on circuits
ELECTRONICS IN MODEL RAILWAYS	36	Tips for the living room express drivers!
INDEX 78	53	A listing of all we've done since April 77
IONOSPHERE	61	An atmospheric article!
DATA SHEET	69	Amplify at speed
MICROFILE	77	Micro-men take note
AUDIOPHILE	88	Strathern speak to us, and Sony arm us!
TECH TIPS	93	All your own work



Leave a trace p.73

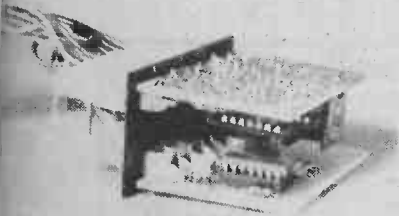

Keep your wheels p.16



A project for a fling p.44

## PROJECTS

CAR ALARM	16	Hang on to what's yours!
WINE TEMPERATURE METER	31	Don't make them the grapes of wrath!
LIGHT SHOW CONTROLLER	44	Five channels to run a disco through
CURVE TRACER	73	Not 36-24-36 — but useful nonetheless
AUTOCHORD PART 2	80	Full construction details

## INFORMATION

SUBSCRIPTIONS	8	Make it easy on yourself
BINDERS	9	Take care of us!
BACK NUMBERS	11	Wot we got and wot we ain't
ETIPRINTS	29	The only boarding card you need
ETI BOOK SERVICE	43	Good sound stuff all in fine print
COME AND JOIN US	51	ETI needs you — well 3 of you anyway!
MARKETPLACE	57	Timely offers!
ETI JANUARY PREVIEWED	59	On its way to you
SPECIALS	67	All our wares on show
HOBBY ELECTRONICS	87	Coming up up in number two

### INTERNATIONAL EDITIONS

AUSTRALIA	Cathy Rivers Publisher Les Bell Acting Editor
Holland	Anton Kriegerman Editor-in-Chief
CANADA	Steve Braithwood Editor Graham Wideman Assistant Editor
GERMANY	Udo Wittig Editor



ABC

EDITORIAL AND ADVERTISEMENT OFFICE  
25-27 Oxford Street, London W1R 1RF. Telephone 01-434 1781/2. Telex 8811898

Halvor W. Moorshead	Editor
Ron Harris B.Sc.	Assistant Editor
Gary Evans	Project Editor
Jim Perry	Specials Editor
Phil Cohen B.Sc.	Editorial Assistant
Pete Howells	Production Editor
Paul Edwards	Technical Illustrator
John Koblanski	Project Design
Steve Ramalho	Project Development
Margaret Hewitt	Administration
Andrew Scott	Office Manager
Kim Hamlin, Brenda Galloway	Reader Services
Tim Salmon, Val Tregidgo	
Mark Strathern	Advertising Manager
David Sinfield	Provincial Advertising Manager
Tom Moloney, Joy Cheshire	Advertising Assistants

PUBLISHED BY Modmags Ltd. 25-27 Oxford Street, London W1R 1RF  
DISTRIBUTED BY Argus Distribution Ltd. (British Isles)  
Gordon & Gotch Ltd. (Overseas)  
PRINTED BY QB Limited, Colchester

Electronics Today International is normally published on the first Friday of the month prior to the cover date

COPYRIGHT: All material is subject to world wide Copyright protection. All reasonable care is taken in the preparation of the magazine to ensure accuracy but ETI cannot be held responsible for it legally. Where errors do occur a correction will be published as soon as possible afterwards.

# ELECTRONICS IN MODEL RAILWAYS

**A profile of how electronics is applied to a hobby which is essentially scale modelling. By Peter J. Thorne.**

"PLAYING WITH TRAINS" is probably how most readers would describe Model Railroading, the latter being the much preferred expression. Of course, there's a heck of a lot more who do just "play with trains". Names such as Hornby Dublo or Triang bring back memories of bygone youth to many an adult.

However, the hobby is not just one of running a train around a circle of track under the Christmas tree; the mature model railroader invests a great deal of effort into scale realism of operating models, structures, scenery and track. And if you tie that need for realism into the extensive growth of electronics as a hobby in the last ten years or so, you'll see why the expert on precision scale operation is keenly interested in how electronics can help this hobby.

Or, to look at it another way, there are so many variables possible in controlling several trains on a model railroad—as indeed there is in a real one—that it's not surprising that several companies have used model railroads at trade shows to demonstrate microprocessor versatility. A recent example was discussed in Byte magazine for July 1977.

Apart from computer control, which is really outside the scope of this short article, there are several uses for both digital and analog electronics in the model train empire. Let's discuss them in stages—control, signaling, lighting and sound.

## Control

Most model locomotives use 3, 5 or 6 pole DC permanent magnet motors. A few use brushless, ironless rotor motors and a very few AC motors. Power is picked up directly from the two rails, and reversal of track polarity reverses the locomotive direction except in the case of the AC motors, where an extra "kick" of AC triggers a reversing contact in the locomotive.

The Christmas train set power pack is nothing but a full wave rectifier delivering pulsating unfiltered DC to the track via a 100ohm variable resistor as speed control. This gives very poor control at low speeds for the simple reason that stall current on a permag motor is much higher than its low speed current. Consequently there's a tendency for jackrabbit starts. Now the dyed-in-the-wool hobbyists want precise control of low speeds because nearly all layouts have miniature freight yards: box-cars and cabooses have couplers operated by magnet remote control so the operator can make up and break down his trains. The more or less ideal speed control—or one approach there to anyway—looks like the circuit of Fig. 1. A simpler version shows on the lead photo. This type of control has several features; the variable DC output has a pulse ripple added at lower speeds to vibrate the motor armature and reduce motor cogging and "stiction", secondly it has a low source

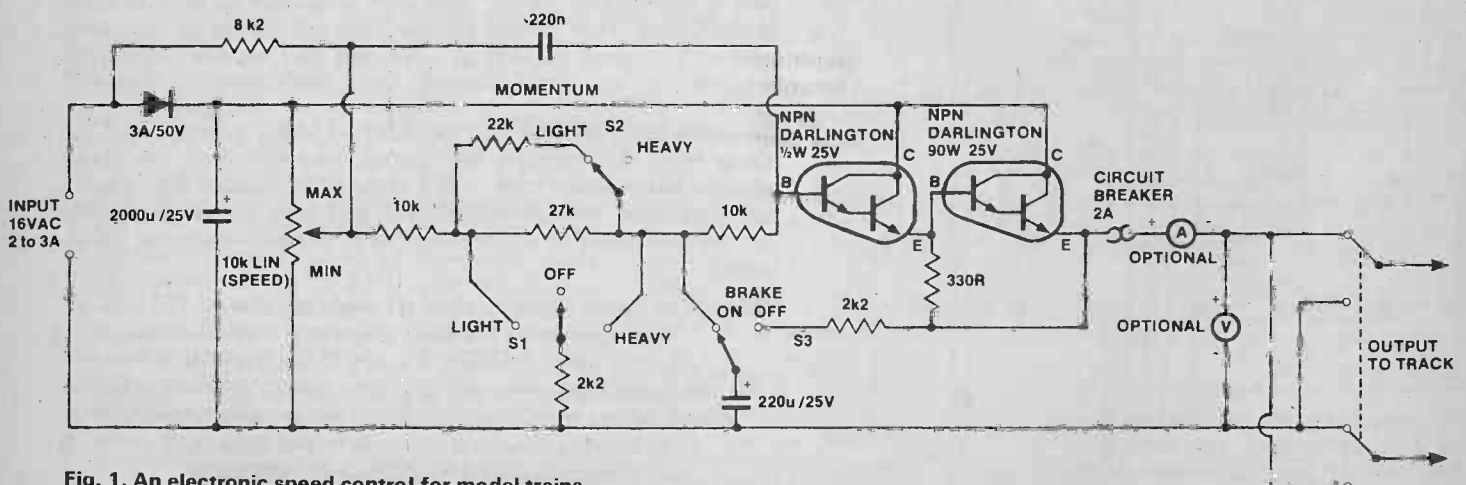

Fig. 1. An electronic speed control for model trains.



impedance for the motor, thirdly a delayed action can be switched in and out so that the controlled inertia of a heavy train can be simulated together with brake levers; and lastly it's short-circuitproof by virtue of heavy duty transistors and an overload trip. The last is indeed essential because short-circuits abound on the model railroad!

Though the circuit I've shown uses two darlington transistors, commercial versions are available, particularly from the USA, using op amps, SCR control or pulse width modulation. Even the renowned Heathkit has introduced a version. The most important feature is probably that superimposed pulse, for if it's too small in amplitude or too high in frequency, it is not effective; but if it goes too far in the opposite direction, the resulting buzz or rattle from the motor becomes objectionable. Anyway, you electronic fans with a dusty train set in your attic, dig it out, build a momentum-pulse-throttle and you just might pick-up an extra hobby!

In terms of current rating, the power pack shown should be capable of about 2A5 at 12V. This is adequate for any HO scale models, which scale 1:87, even with double heading locomotives. As you'd anticipate, the current requirements decrease with scale size—the second most popular scale is 1:160 (n for Nine mm, which is the track width) scale. Going up asize to O scale (1:48) many motors will need the full 2A5. By the way, in case you home computer builders are thinking "why waste money on electronics for toys" some of these "toy" locomotives retail for over £500 apiece and lately have been appreciating in value at well over 20%.

## Signals

A natural for digital IC application is signaling. Model signals in two (red and green) or three aspect (red, yellow, green) with operating miniature 12V 60mA lamps are available. Until recently, relays were widely used by modellers to operate these lamps in controlled sequence and often automatically disconnected a section of track ahead of a red signal for automatic train control. The relays used were typically low resistance coils in series with the power supply to the track. When the locomotive entered a particular track section, the relay contacts closed. All model railroads use track sections from 2 to 20 feet long insulated from each other and switchable to alternate power packs. This facilitates the operation of multiple trains.

Complete model railroads still exist using these series relays for automatic control and signalling; but they're a maintenance nightmare for their intermittently proud owners. Up to date techniques use TTL gates driving red, yellow and green LED's for signals.

Relay driver ICs can be added to drive the small 12 V signal lamps if preferred and also to operate good solid 12 V relays for automatic stops and starts.

The interface between train and TTL is a little more tricky; you've noticed, of course, that the track has only two rails which are required to conduct power (in either direction) to the locomotive. The requirement to detect locomotive presence led a few years back to a widely used detector circuit known as a "Twin-T".

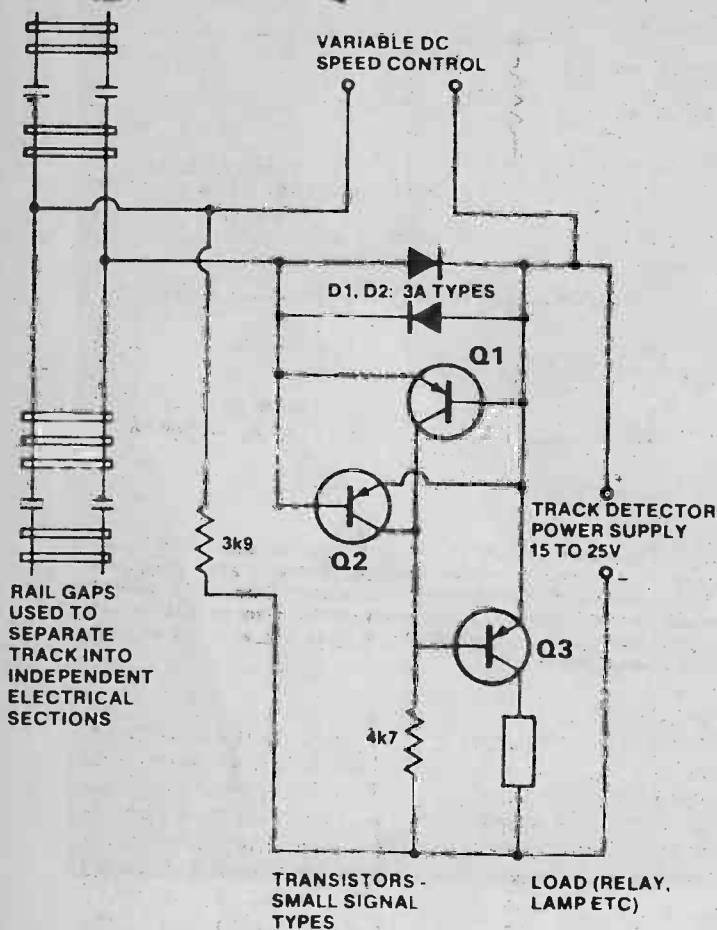

Fig. 2. Widely used "Twin T" track detector circuit. Q3's load de-energises whenever a resistance appears across track in the section being detected, regardless of whether power is connected to that track section. Consequently presence of any train or item of rolling stock can be sensed remotely.

The simple circuit is shown in Fig. 2. The circuit detects resistance between the rails as high as 50k, but is insensitive to the connection of the power supply in the circuit, so it will respond only to the presence of a locomotive motor or any rolling stock with a 10k to 47k resistor wired between its wheels. Other less subtle interfaces are magnetic reed switches between the track, triggered by disc magnets under rolling stock—ideal for JK flip-flop operations, or opto-electronics, where ambient light can be interrupted by the movement of rolling stock to trigger or detriquer a light activated SCR, for example.

With a light activated system, the light source and the opto detector must be angled to the track to avoid gaps between moving rolling stock causing light modulation.

All three track detection systems are, of course, suitable input interface for microprocessor control of signals . . . and track voltage, polarity, etc.

## Turnout Control

Turnouts, (switches, or points) control train routing. Remote control of these, on the models as on the prototype has nearly always been electric. The usual method is the use of a solenoid motor (Fig. 5). A soft iron armature can be moved into either of two high flux

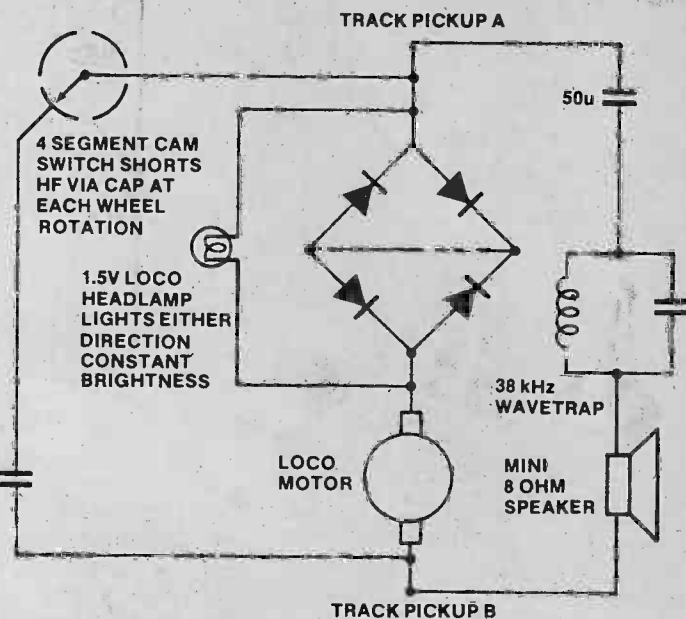

Fig. 3. These components, mounted in locomotive tender reproduces audio signals superimposed on DC motor voltage. Cam switch signals synchronization of "chuff" sound to trackside audio generator.

copper wound coils, depending on which is energised — using 16 Volt AC or DC. The armature is linked mechanically to the movable track section to control the train's alternate paths. These coils of necessity are about 2 to 4 ohms resistance and hence can draw a 4 A: if left connected to the supply for more than a second or so, the 50 W of heat show—rapidly. So recently the electronically minded modeller adopted capacitor discharge.

Typically a 220 u capacitor charged to 25 V stores enough energy to operate a couple of the low resistance coils and as you can see from the circuit, there's no fire hazard if the power is left on. Also a small transformer can be used. Also shown is a method of discharging the capacitor into the coil via an SCR, which permits the controlling push button to carry only the low SCR gate current, instead of a contact-blowing multi-ampere current.

Again, this basic control circuit is adaptable to TTL control.

## Sound

Now you hi-fi fans know it's impossible to reproduce the sound of a gigantic steam locomotive without a 100 W amp and a 4 cubic foot bass reflex enclosure. Except those model railroad nuts don't believe you! Quite expensive, at about US \$350, is a Pacific Fast Mail sound unit that transmits sound and motor power through just those two rails. The sound is synchronized to the piston position, that is for a two cylinder steam engine there are four "chuffs" per driver wheel revolution. Plus bell sound and the required wailing steam chime can also be sent from the trackside to be nicely reproduced in a miniature speaker located in the locomotive tender.

**Fig. 4. Model railroad signals.** Normally supplied with 12 V lamps, LED's can be fitted.

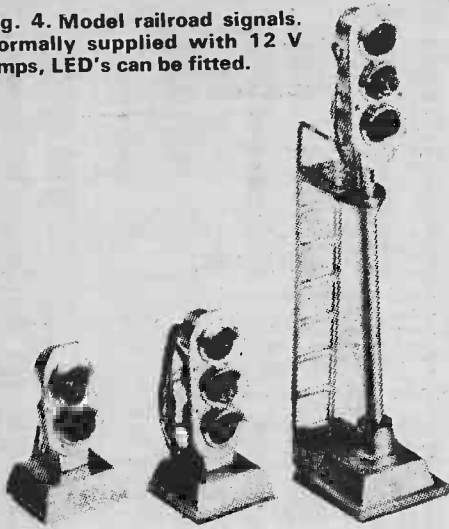

The PFM unit synchronizes the "chuff" sounds by transmitting a 2 V 38 kHz (approx.) signal superimposed on the DC motor voltage going to the track. The DC voltage source (a transistorized circuit, which is a simplified version of the circuit shown in Fig. 1) has a low resistance choke in series with its output: this prevents the 38 kHz and the audio tones from disappearing into the speed circuitry. When the 38 kHz reaches the locomotive, it is intermittently shorted out in a capacitor (see Fig. 3). The capacitor is grounded four times per drive wheel revolution via a phosphor-bronze contact, which rubs on the inside of a drive wheel equipped with insulated quarter sections. As the 38 kHz signal shorts out, a relay operates in the track-side unit, sending out transistorized hiss to the locomotive-borne speaker. Being highly inductive, the locomotive motor bypasses neither the 38 kHz nor hiss—nor bell nor steam chime sounds, all of which are solid-state generated in the PFM box with full operator control. And even though the speaker is less than 2 inches in diameter, the sound is very effective.

Another electronic gimmick in the PFM system is the bridge rectifier of Fig. 3. There's a constant voltage drop of 1V4 across the bridge, since it's in series with the motor—regardless of the motor/voltage polarity. Connect a miniature 1V5 headlamp across the bridge and presto—constant brightness, regardless of motor speed.

A California based firm — Modeltronics, produces sound systems that are completely contained in the model — also synchronized for "chuff". The supply voltage for the noise generator and miniature amplifier is derived from the track voltage much as the PFM "constant lighting section". Of course, the Modeltronics system does not offer bell or chime — yet.

### LED Hazard Flashers

Pop a 3mm red or yellow LED into the cabin roof of a model diesel, drive it from an internal LM3909 flasher integrated circuit, oscillating at 0.3 Hz, powered up from 0V5-3V, and you've duplicated real life on the "Atcherson Topeka and the Santa Fe".

**Grade crossing flashers** in model form are available ready made, with miniature 12 V lamps, just like signals. To flash, take on 555 IC timer, put one pair of lamps from IC output to + rail, another pair from output to-rail, apply 12 V, time at 20 / minute and grade flashers are in business.

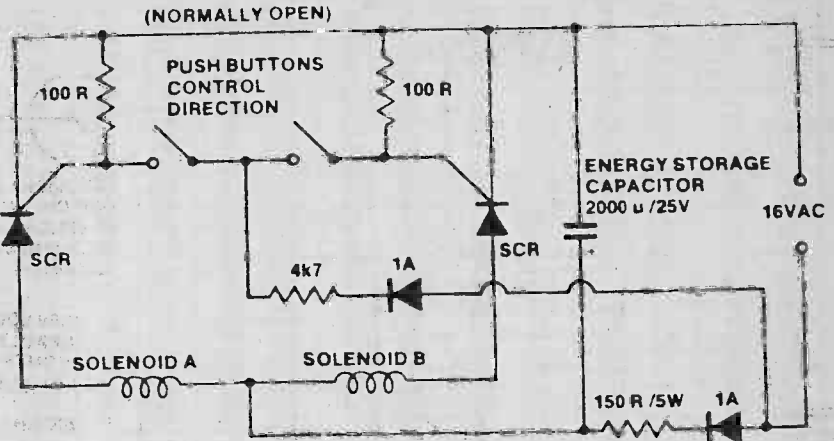

**Fig. 5. Capacitor discharge system enables solenoids to be thrown with small average energy. System also prevents solenoid burnup if accidentally left powered-up. SCR switch control enables small current push buttons to switch heavy current. The SCR's automatically switch off when capacitor stored charge zeroes.**

### Lighting

Whole passenger trains can be lit up using a super-sonic generator at around 25-40 kHz. This can be fairly easily constructed using a 10 W audio power amplifier with the conventional negative feedback rephased to positive. Connected in parallel with the train motor power, with a blocking choke between the two, constant lighting can give a superb visual effect with artificial twilight on a layout. Switch off the generator — and the lights go out. Each train group of lights uses a 220nF capacitor in series to block the otherwise additive lighting power from the DC motor voltage.

### Radio Control and Carrier Control

As a purely personal observation, I feel the next and imminent step in electronics with model railroads is radio control. At least one experimental, but practical circuit has already been published. Taken to the ultimate, needed are very low current motors powered by rechargeable NiCd batteries together with the radio receiver, variable speed and direction controls, and sound generator circuit plus amplifier. Of necessity the concept requires extreme miniaturization because for HO scale (the most widely used size), the space available for everything is hardly more than 5 or 6 cubic inches. The entire receiver and motor drive circuit can easily be derived from model aircraft RC designs, particularly if the new Signetics NE544 motor/servo driver chip is employed. On-board sound — for example a diesel horn sound, can use a 556 IC in the self-oscillating mode generating two tones, each around 250 Hz, amplified by an LM380 audio chip.

Individual function control is practical using 555 tone generators in the transmitter with phase lock loop decoders in the receiver. The advantage of this type of control is that the modeller has become free of the power-to-the-rails restriction.

In summary, I hope this overview shows how another hobby can adapt techniques of electronics in order to add to the fun. Maybe I've tempted you to pop round to your nearest Model Railroad emporium.

**ETI**



# SOUND~TO~LIGHT UNIT

**Designed by Richard Bekker of Powertran, especially for ETI, this superb light show can act as strobe, linear five channel sound-to-light or random switching unit and can be digitally controlled!**

OVER THE YEARS several lighting control units have appeared, some performing switching and others performing modulation of the light output according to the musical input. The Chromattheque combines both of these functions in a most original way. It is capable of controlling five banks of lamps — of up to 500 watts each in either analogue or digital mode. By being a five channel controller not only is the sound to light modulation made more exciting than three or four channel systems by virtue of the extra colours, but linear and random sequencing between the channels gives a tantalizing effect which could not occur with a smaller number of channels.

## Singled Out

Being conceived as a single board design wiring is minimal and construction very simple. All components are cheap, readily available items but a complete kit is being made available by Powertran of Andover, including metalwork.

## Modes

In the analogue mode the audio signal first passes through an amplifier stage with automatic gain control. This ensures that sound to light modulation occurs smoothly even when the overall sound level changes. After this the signal is split into active filter bands the outputs of which are used to phase control triacs which determine the current in the lamps.

By doing this channel 1 (red) responds to the lowest frequencies varying the light in time with the bass notes in the music. Channel 5 (blue) responds to the highest frequencies. The other 3 channels handle the intermediate frequency bands. separate light level control is provided for each channel to allow for intensity adjustment to personal taste to suit different types of music.

## Fingers and Digits

In the digital mode TTL integrated circuits are used to

selectively switch either all the lamps in strobe fashion or alternatively one lamp at a time either sequentially or randomly. The speed at which the switching is carried out is controlled either manually with a potentiometer on the front panel or automatically. In this case the switching rate increases with the level of the audio signal. This is particularly effective in the sequential or random switch positions — a crescendo sets the lights racing whilst they freeze when the music stops.

On music with a heavy beat the lights will step round one position on each beat.

Because of the light level controls, the lamps can be turned just partially on to suit the mood of the occasion.

## Construction

Start by assembling the board. This is entirely straightforward — just follow the overlay. All the potentiometers mount directly on the board though the switches are hardwired.



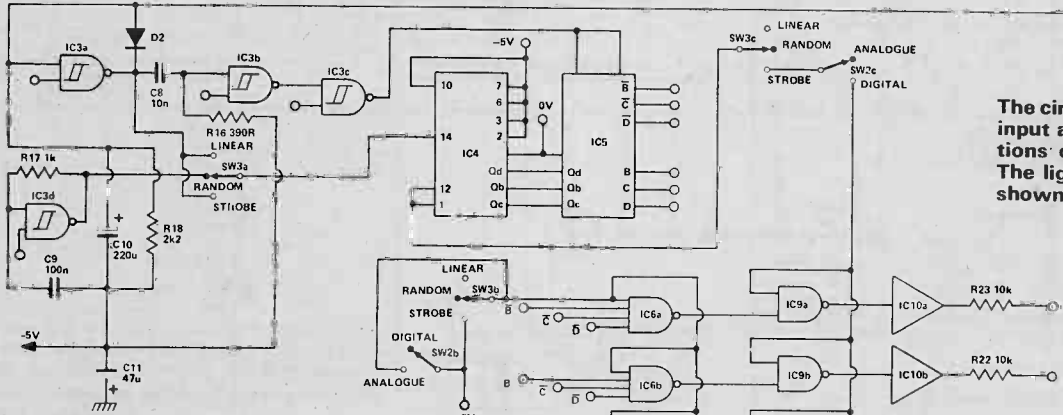
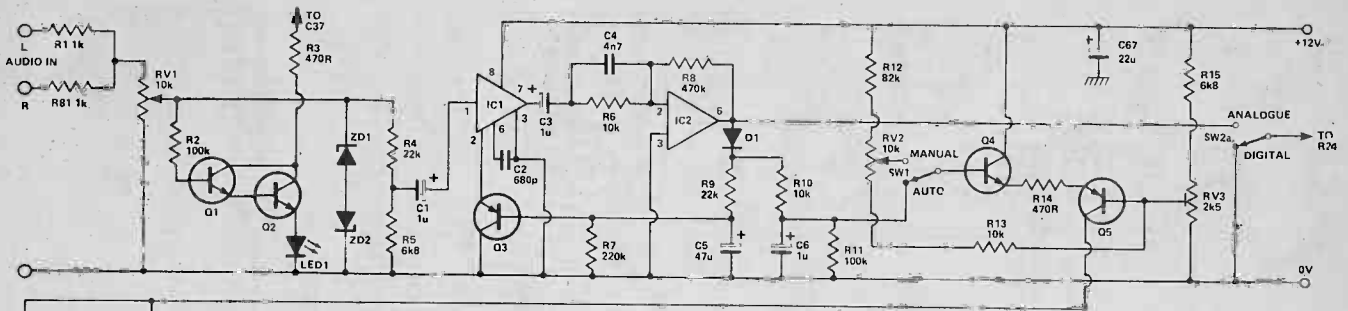

The circuit diagram for the audio input and digital switching sections of the lightshow circuit. The light drivers and filters are shown overleaf.

## HOW IT WORKS

### Input section:

Audio is applied across RV1. Q1,2 drive a LED which indicates when excess signal is being taken off RV1. ZD1,2 clip the signal in cases of gross overload. ICI is a variable attenuator, the output of which is amplified by IC2. This feeds a 'diode' pump setting up a voltage on C5 which rises as the output increases. This voltage is used to control Q3 which in turn controls the attenuation of ICI.

### Digital section:

IC3 is a block of 4 Schmidt triggers two of which are used to form oscillators. C9,R17 determine the speed of the fast oscillator and fast clock pulses are produced at pin 8. The slow oscillator rate is determined by the rate at which C10 is charged via Q5, the current through which is either varied by RV2 or else the signal on C6, depending on the position of S1. D2 is a germanium type for the benefit of its low turn-on voltage. In the linear sequencing or strobe mode the low speed clock is applied to IC4 which is a +2, +5 counter, the outputs of which are applied to decoding ICs 6,7,8 via 4 bit latch IC5. The outputs of IC6,7,8 are taken via gates in IC9 and half of IC8 to inverters in IC10 to provide negative turn voltages to the triac driver stages. In the linear mode only one of the inverter outputs a,b,c,d,e is negative at any instant whilst in the strobe mode all the outputs are at 0V. In the random mode the fast clock is applied to the counter, the output of which is sampled at a low rate by means of the slow clock being applied to IC5. C8 and two trigger sections of IC3 convert the slow clock into narrow pulses suitable for this sampling. As the two clocks are independent the sampling will be at a totally random point of the count by IC4 thereby making the lamp selection truly random.



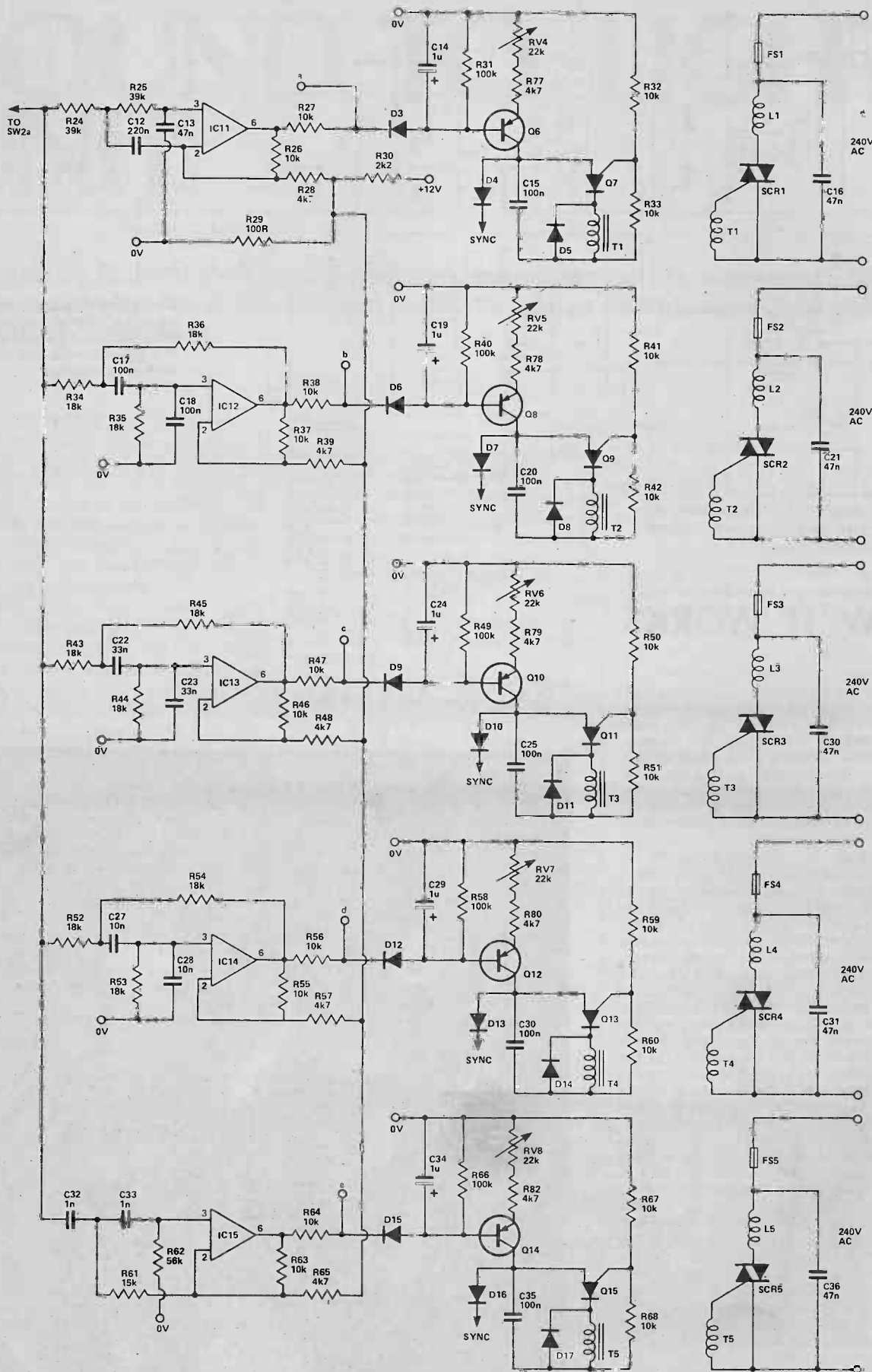

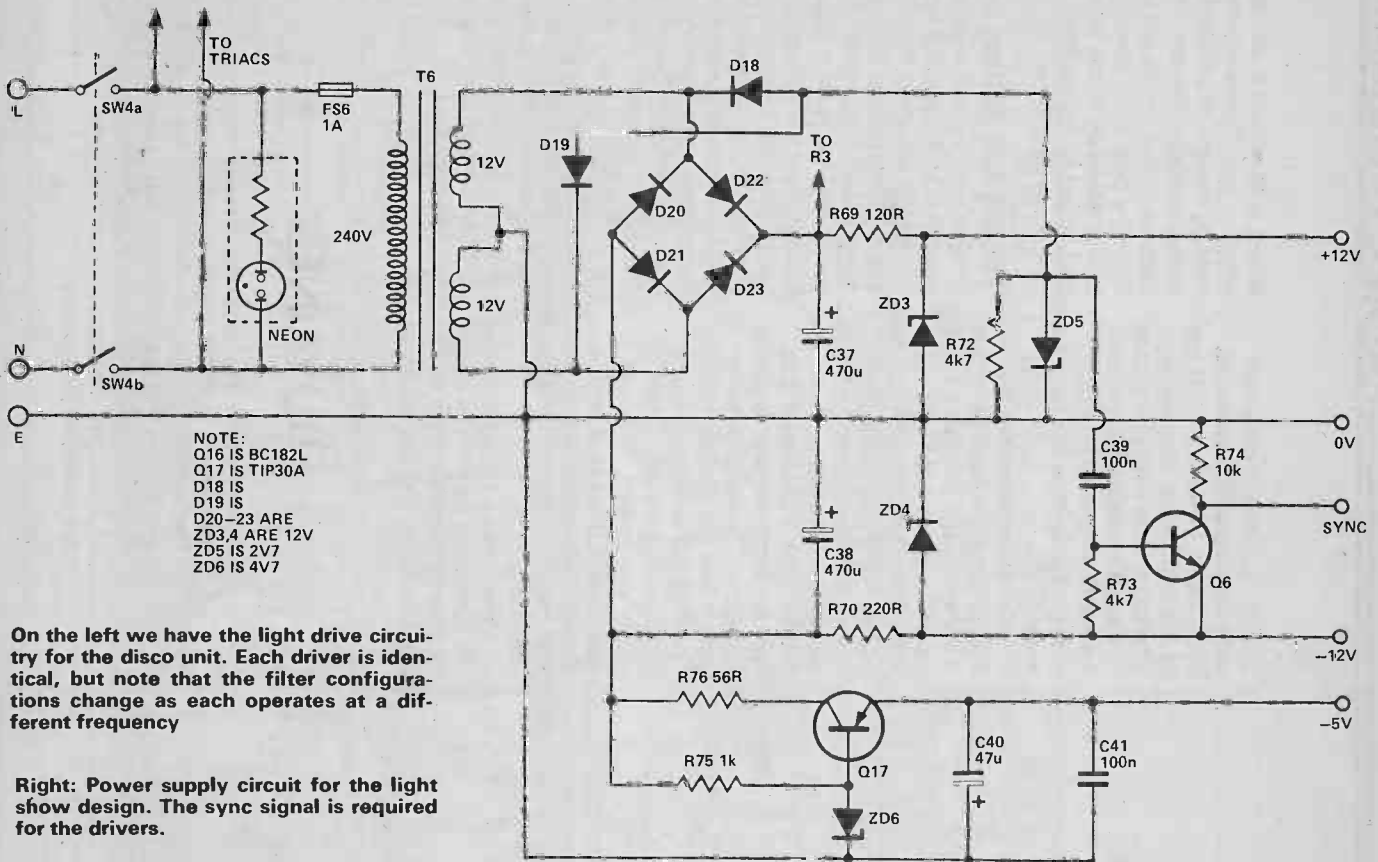

On the left we have the light drive circuitry for the disco unit. Each driver is identical, but note that the filter configurations change as each operates at a different frequency

Right: Power supply circuit for the light show design. The sync signal is required for the drivers.

## HOW IT WORKS

### Filter section:

The output of IC2 is taken to 5 active filters based round IC11-15. IC11 is the low pass filter, IC15 the high pass and IC12-14 band-pass. The cut-off and centre frequencies are 40 Hz, 120 Hz, 400 Hz, 1200 Hz, 4 KHz. R29,30 are used to bias the filters to give a small negative offset voltage at the outputs which are applied to the triac driving stages. This means that the series diodes are biased on and control of the lamp can start even when the signal level is very low thereby improving the smoothness of the modulation.

### Triac drivers:

All 5 stages are identical so only the low frequency one will be considered. Signal from IC11 charges C4 via R27,D3. The voltage

across C4 causes Q6 to conduct and charge C15. When this reaches about 6 volts PUT Q7 suddenly conducts discharging C15 through transformer T1 generating a pulse to turn on the triac SCR1. At the zero voltage point of the 50 Hz mains cycle a sync. pulse is generated which discharges C15 via D4. For a given charging, current C15 will always reach 6 V at the same point in the mains cycle. We therefore have phase control which is dependent on Q6 current which in turn is dependent on the audio signal level and the setting of RV4. Phase control is used in preference to burst control because of its superiority in producing smooth flicker free modulation of the lamps. Filtering of the switching surges is performed, most effectively

by C16,L1 and the RF interference generated is substantially less than that from a domestic light dimmer.

### Syncing:

To generate the 100 Hz sync pulses the 12 V. AC output of T6 is full wave rectified by D18, 19 and without smoothing is applied to ZD5 across which is produced a spikey waveform. This is then applied via C39 to Q16 which is sufficiently turned on by the spikes to sink the charge on C15,C20 etc.

### Power supply:

Highly stable voltages are unnecessary and the 12 V lines for the op. amps are taken off simple zener regulators whilst the TTL-5 V line is regulated by a single series transistor Q17.

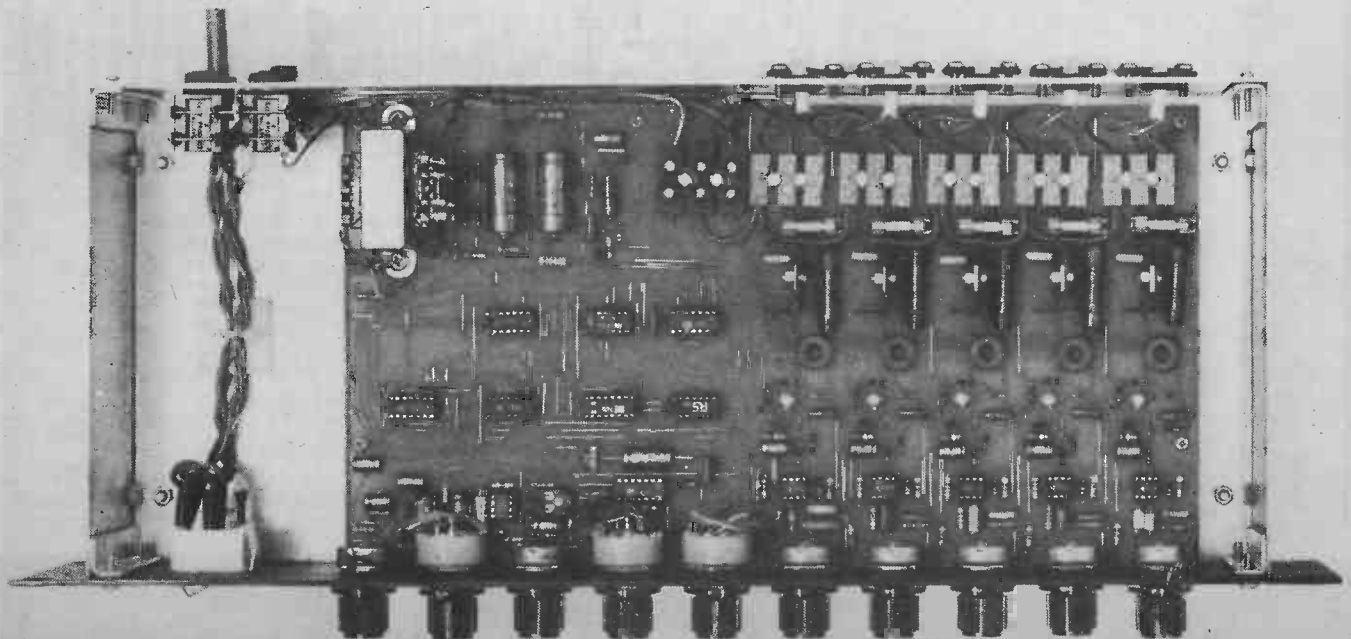

## PARTS LIST

RESISTORS 1/4W 5% except where stated

R1, 17, 71, 74, 81  
R2, 11, 31, 40, 49, 58, 66  
R3, 14  
R4, 9  
R5, 15  
R6, 10, 13, 19, 23, 26, 27,  
32, 33, 37, 38, 41, 42, 46  
47, 50, 51, 55, 56, 59, 60,  
63, 64, 67, 68, 73  
R7  
R8  
R12  
R16  
R18, 30  
R24, 25  
R28, 39, 48, 57, 65, 72,  
76-80  
R29  
R34-36, 43-45, 52-54  
R61  
R62  
R69  
R70  
R75

1k  
100k  
470R  
22k  
6k8  
10k

SEMICONDUCTORS  
Q1, 2, 4, 16  
Q3, 5, 6, 8, 10, 12, 14  
Q7, 9, 11, 13, 15  
Q17  
SCR1-5  
IC1  
IC2, 11-15  
IC3  
IC4  
IC5  
IC6-8  
IC9  
IC10  
D1, 3-19  
D2  
D20-23  
ZD1, 2, 6  
ZD3, 4  
ZD5

BC182L  
BC212L  
BRY39  
TIP30A  
8A Triac  
MC3340p  
741  
74132  
7490  
7475  
7420  
7400  
7405  
IN4148 or IN4151  
OA95  
IN4002  
4V7 zener  
12V zener  
2V7 zener

4p 3w adjustable stop  
rotary  
illuminated mains switch  
DPDT 10 Amp

FX3008 with 10 turns 35g  
for both windings  
240V to 15V-0-15V at  
200mA

FX1089 with 40 turns 25g

2A fast  
1A anti surge

MISCELLANEOUS  
Two 1/4" mono jack sockets, 5 cooling clips,  
13A mains cable, cable clamps, five 3 ter-  
minal 5A connector blocks, 3 terminal 10A  
connector block, fibre glass ready drilled PCB,  
metalwork to suit ten knobs, grommets,  
spacers, nuts, bolts etc.

POTENTIOMETERS  
RV1  
RV2  
RV3  
RV4-8

10k log  
10k lin PCB mounting  
2k5 preset  
22k lin

CAPACITORS  
C1, 3, 6, 14, 19, 24, 29, 34  
C2  
C4  
C5, 11, 40  
C7  
C8, 27, 28  
C9, 15, 17, 18,  
20, 25, 30, 35, 39, 41  
C10  
C12  
C13  
C16, 21, 26, 31, 36  
C22, 23  
C32, 33  
C37, 38

1u 63V electrolytic  
680p polystyrene or  
ceramic  
4n7 polystyrene  
47u 10V electrolytic  
22u 25V electrolytic  
10n polycarbonate  
100n polycarbonate

TRANSFORMERS  
T1-5  
T6

INDUCTORS  
L1-5

FUSES  
F1-5  
F6

Use 3" lengths of coloured wire for these. The switches supplied in Powertrain kits are of the adjustable stop variety. The tag on the stop plate goes in the hole stamped 2 for two way switches and the hole stamped 3 for the 3 way switch.

Mains transformer T6 is bolted onto the board and the 15 V windings connected to the board by means of short wire links from the tags down to the holes directly beneath them.

Pulse transformer T1-5 you wind yourself. Wrap round the ferrite rings 10 turns of 35g wire for both the primary and secondary. It doesn't matter which you call the start or the finish of the windings as the circuit operates with them either way round. The wire supplied in the kits is self fluxing polyurethane covered and can be soldered directly to the board.

Wind coils L1-5 with about 35 turns of 25g wire. A smear of glue on the windings will help them stay in place before

fitting and reduce buzzing when in use. The triacs are kept cool by means of a finned tab bolted to each of them. The outputs to the lamps are taken from the board via connector blocks screwed to the board and linked to it with short lengths of 18g wire.

### Testing and Setting Up

Plug in the unit between your amplifier and speakers, wire in the lamps securing the cables with the clamps on the rear panel, turn all controls anticlockwise, switch on and set auto level to where the LED only comes on occasionally.

Switch SW2 to A and turn up the level controls and watch the lamps operate smoothly in time with the different frequency bands in the music. Switch SW2 to D, SW3 to S, SW1 to A, adjust the level controls for the lamps to be equally turned on by the strobing and set the one and only pre-set (RV3) for a strobe rate as fast as the lamps will follow.

## BUYLINES

A complete kit of parts including metalwork is to be made available by Powertran Electronics. Address from the inside front cover. The PCB will be available only from them as it is their design. All components are available separately.

ETI

Below: Component Overlay for the lightshow

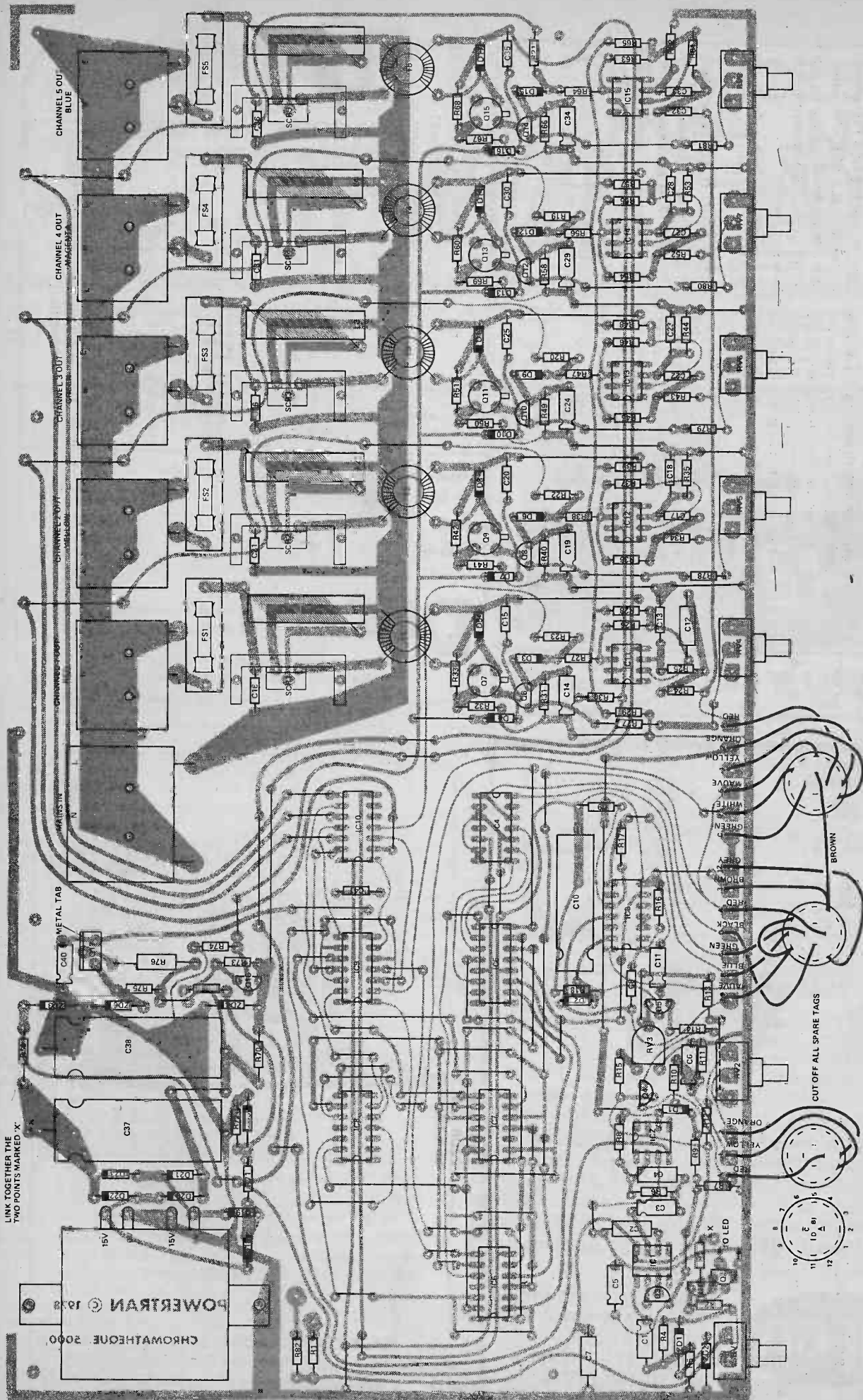

# news digest

## Be boring better!

This is known as a Bimdrill (Don't blame us — it's their name). It costs £19.50 + VAT and comes complete as you see it here. It

is mains powered, runs at 7500 RPM, and looks very useful indeed. Any more questions to: Boss Mouldings Ltd, Higgs Industrial Estate, 2 Herene Hill Road, London SE24 0AU.

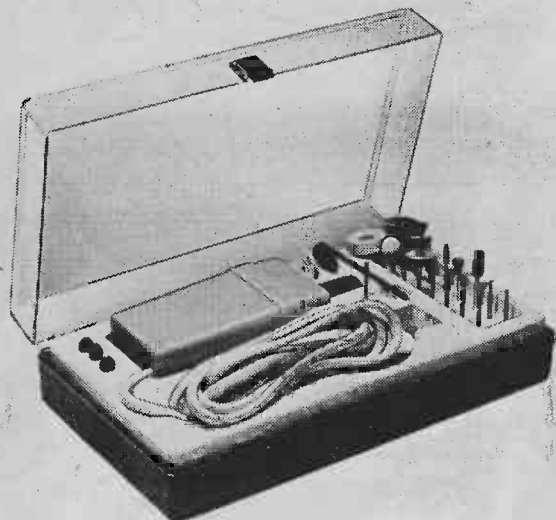

## Catch these

Two more companies sent us in catalogues this month. The first was ACE who do a 36 page affair for 30p. The range they stock is pretty good as are the prices. A nice touch is the new range of new kits for the beginner. Worth having.

The other was Stevenson. This catalogue is produced superbly and as it's free it's worth a look just to see how these things

should be done. IC's are a strong point here, and a range of books is also included. Some very useful data is given in the back of the booklet which should also be on your bookshelves.

Addresses for these people appear on their ads elsewhere in this issue. Catalogues are things you should collect if you're serious about the hobby, as there is always something you'll want from somewhere at sometime or other!

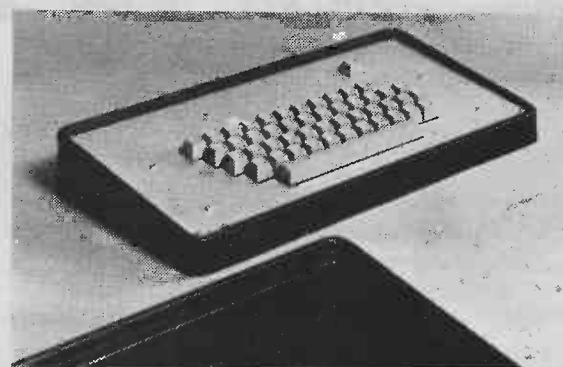

## Key feature

New from Vero of box frame is this new keyboard enclosure. Supplied as a kit it comes complete as a one piece ABS enclosure, anodised aluminium cover plate with self adhesive

feet and all fixings. It will house a standard key-board or individual keys as required — ideal for small desk-top terminals. Vero Electronics Ltd, Industrial Estate, Chandlers Ford, Eastleigh, Hampshire.



## Just the thing for Casanova?

Timetrac is a new little helper for people with busy lives and lousy memories. It contains a calendar preprogrammed, and can sound alarms

when required. Two stopwatch facilities are also included.

Power is normally from AC adaptor, but battery power is provided as standby. Optimisation Ltd, 45 South Street, Bishop's Stortford, Hertfordshire.

## Time to calculate?

'Credit card' calculators do have advantages. Here's another one that can tell you how long you took to spend a fortune. Called the ST 24, it is a four-function plus % and stopwatch calculator. Maximum time to be

watched — 23hrs 59mins 59secs. Lap timing, second place timing normal stop/start and 1/10th sec indication are all possible.

The calculator can be used while the timers (with possible repeat option) or stopwatch is being used. The most you'll pay for it is £24.95 anywhere. Available now.

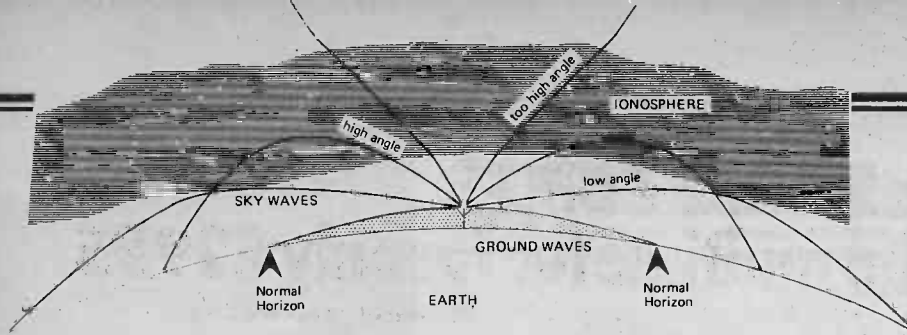

# IONOSPHERE

**Radio communications beyond the horizon in the high frequency (HF) spectrum between 3 MHz and 30 MHz are carried on as the result of the bending of the radio waves in the ionosphere, that region of our atmosphere extending from about 60 km to about 1000 km above the earth.**

THE IONOSPHERE CAN bend radio waves so that they return to earth from hundreds of kilometres to many thousands of kilometres distant.

Without the existence of the ionosphere, long distance radio communications, shortwave broadcasting, amateur radio 'DX' etc. would not be possible — and one G. Marconi would probably have died an unknown pauper!

The ionosphere enables shortwave radio stations such as Radio Peking, The Voice of America etc to broadcast programmes across the world. It enables radiotelephone communications to ships at sea and contact with international aircraft.

## The Solar Prime Mover

The sun, which dominates almost every phase of our lives, influences all HF radio communications beyond the horizon. The sun generates the ionosphere; solar activity has a considerable influence on this area of our atmosphere and thus affects propagation of HF radio waves.

Ionisation of the upper atmosphere is brought about largely by ultraviolet radiation from the sun, along with solar X-ray radiation. This solar radiation strips electrons from the atoms of the rarified atmospheric gases existing in our upper atmosphere.

The result is not a single, thick region of 'band' ionisation, as you may suppose. The ionosphere separates into several readily defined regions having varying densities, located in layers at different heights.

Each layer has a relatively dense region, called the *peak* of the layer, the ionisation tapering off above and below this region. The peak is not necessarily located in the centre of the layer, nor does the ionisation always disappear completely between layers.

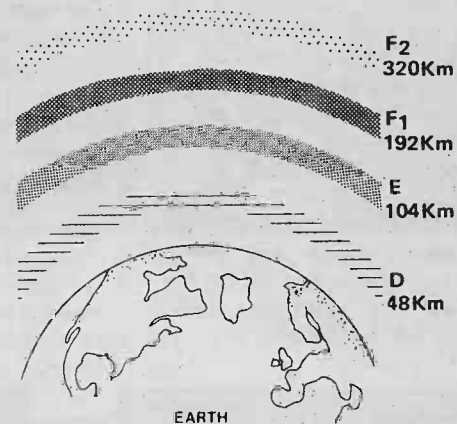

**Figure 1. The ionosphere divides into readily defined regions which have been designated as illustrated here. The amount of ionisation in each layer varies diurnally (i.e.: throughout the day), seasonally (through the year) and through the 11-year sunspot cycle. Disturbances on the sun have a variety of effects on the ionosphere and thus on radio communications.**

## Spotting Good Propagation

The sun's UV radiation output varies over an approximately 11-year cycle, greatly influencing the behaviour of the ionosphere. For many years this cyclic behaviour of the sun has been monitored by means of sunspots - dark areas which appear on the face of the sun, and over the last two decades, by measurement of the *solar flux* (RF noise radiation) at 2800 MHz (10.7 cm wavelength).

Sunspots are enormous areas on the sun's surface which are cooler, and thus do not appear as bright as the surrounding area. Hence they look like 'spots' on the face of the sun. Their size can range from several hundred kilometres across to greater than 100,000 km. By comparison, the earth's diameter is only 13,000 km.



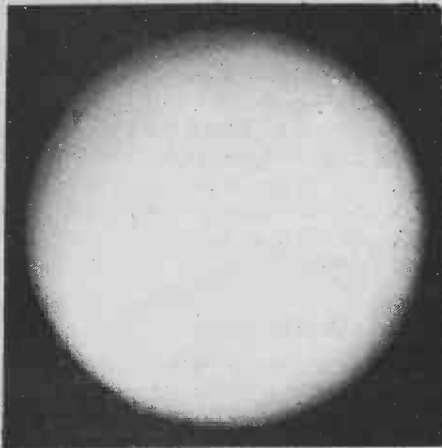

Figure 2. The sun as viewed in the visible light region showing several small spots, a relatively large spot and sunspot groups. (Photo courtesy of the Ionospheric Prediction Service.)

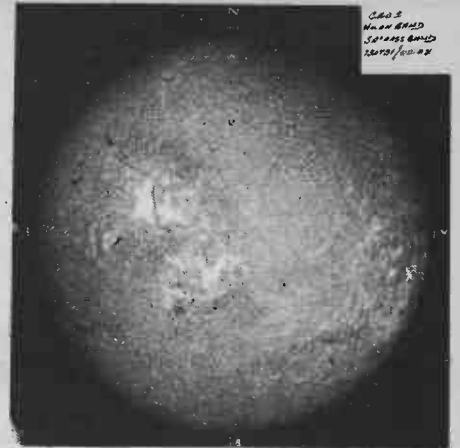

Figure 3. The sun as viewed in the red wavelength region emitted by hydrogen — H-alpha emission. Two large active regions can be seen along with associated 'filaments'. (Photo courtesy of the Ionospheric Prediction Service.)

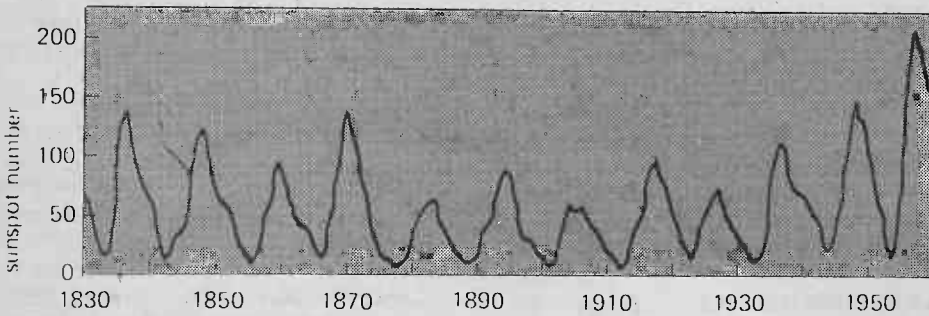
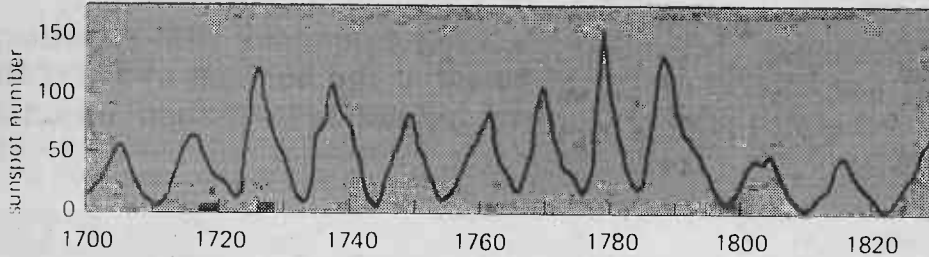

Figure 4. The 11-year solar cycle is clearly evident from this plot of the Sunspot Number from 1700 to 1960.

Rate of production of electrons

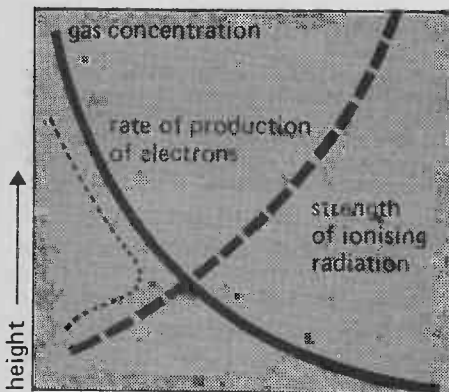

Fig. 5. How a layer of electrons is produced when ionising radiation comes from above the atmosphere. The gas concentration increases with decreasing height while the radiation strength decreases. Peak production of electrons occurs at the height where the curves cross.

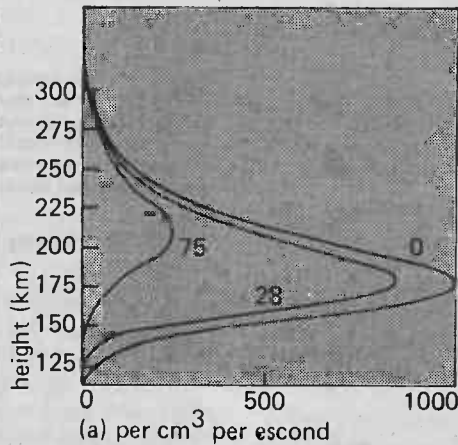
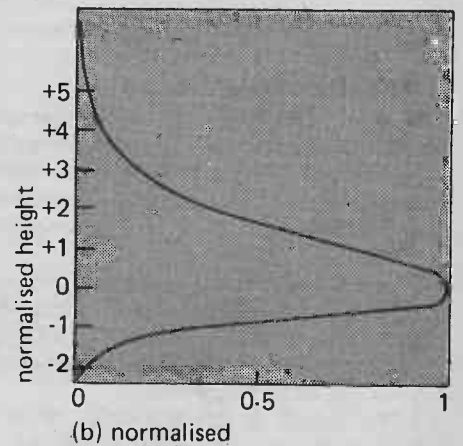

Fig 6. (a) Theoretical 'Chapman' layers showing how electron production is affected by the angle of the sun's rays — best when sun is overhead ( $0^\circ$  zenith angle).



(b) If all curves are 'normalised' about peak height, regardless of the sun's zenith angle, they all have the same shape.

Records of systematic sunspot observations date back some 300 years. However, reasonably reliable data is only available since about 1850.

The sun is monitored continuously from a number of observatories around the world. Sunspot observations are statistically smoothed to provide a continuous record — this is termed the Zurich Sunspot Number, which is a statistical 'fudge factor' on which ionospheric propagation predictions are based. More of this later.

## On the Spot

Sunspot Number does not mean 'numbers of sunspots'. It is a statistical term which allows comparison with past figures and provides an index of sunspot activity.

The sunspot number has a cyclical variation with a mean period of 11 years. Periods between sunspot peaks have been as short as nine years and as long as 13 years. The sunspot number between the peaks and minimums of the cycles also vary greatly. The sunspot cycles have been 'numbered', for the convenience of reference, back for 200 years. Cycle 18 peaked in 1947, cycle 19—the biggest on record — peaked in 1957 with a sunspot number in excess of 200. Cycle 20 peaked in 1969 reaching a sunspot number of about 120, which is about average intensity.

If you thought the DX wasn't anything spectacular in 1969-70, you should have been around in 1907 when the sunspot number barely reached 60 during the peak!

Sunspot cycle minimums don't always reach zero levels. Some minimums however have shown little or no activity for many months.

The sunspot cycle, while having an 11-year mean period as observed between peaks, has been identified in recent years as actually being a roughly 22-year period based on the magnetic field variations of the sun. Alternate sunspot cycles show a pole reversal in the solar magnetic field.

## Solar Disturbances

On occasions, the surface of the sun is disturbed by sudden 'storms'. These disturbances are not normally visible but are readily detected when the sun is viewed at a particular red light wavelength, known as H-alpha, emitted by hydrogen.

These very intense, localised outbursts increase very rapidly to a peak taking a minute or less, and then the intensity of the H-alpha emission decreases to its normal value in about half an hour or so.

This phenomenon is called a *solar flare*, usually occurring near, or associated with, a sunspot.

Solar flares generate enormous amounts of energy, and increased solar X-ray radiation from these regions cause disturbances to the ionosphere and to communications. Electrons and protons are also emitted from solar flares, and these travel through solar wind towards the earth. The particles are emitted in a stream and are much more numerous than move at greater velocities than those particles contained in the normal solar wind.

Upon reaching the region near the earth these particles have a considerable influence on the earth's ionosphere and magnetic field, producing sudden and dramatic changes as well as precipitating other events — such as aurorae — which will be described in more detail later.

Apart from flares, disturbances not associated with sunspots also cause disturbances to the ionosphere and the earth's magnetic field. *Hot Spots* — which are of longer duration than flares, are emitting regions on the sun's surface that expel streams of particles which affect the ionosphere. These, and other areas on the sun's surface which emit persistent streams of particles, have longer durations than flares but the effects of the particles emitted is less severe.

## Formation of the Ionosphere

As mentioned previously, the ionosphere is produced principally by ultraviolet radiation from the sun. The amount of ionisation produced is almost wholly dependent on the strength of the UV radiation and its wavelength. Different wavelengths of the radiation ionise different gases.

The process of ionisation absorbs energy from the UV wave, and as the radiation proceeds down through the atmosphere, it is almost completely absorbed in this way.

This process of creation of ions and free electrons in the ionosphere is offset by recombination which is continually taking place between the two to form neutral atoms once again.

In the lower atmosphere, the molecular density is so great that recombination occurs almost immediately after ionisation, the rate of recombination is very rapid. However, in the upper atmosphere, where the number of molecules is very much smaller, the chances of a free electron meeting up with an ion is very much less. Hence, recombination occurs at a much slower rate.

These two opposing mechanisms result in regions in the upper atmosphere where a large amount of ionisation is present, the amount being determined by the balancing forces between the rate of ion production and the recombination rate.

The gases of the upper atmosphere which the solar UV radiation meets first are very rarified, hence little ionisation results and little of the radiation energy is lost. As the radiation penetrates further, the molecular density of the gases increases and hence the ionisation increases.

## Height Maximum

More and more energy is extracted from the ionising radiation as it penetrates further and at some stage the amount of ionisation which the radiation can produce begins to decrease. There is thus a certain height at which ionisation is maximised. The region around this height is known as an ionisation layer.

This is how the ionosphere comes to derive its name. It is the region of the upper atmosphere where appreciable ionisation can take place.

The lower limit of the ionosphere is about 50 km and it extends to beyond 1000 km.

Sydney Chapman, a British scientist, investigated the production of ionisation in the early 1930s and showed that the rate of production of ionisation would vary with height as shown in figure 6. The corresponding layers of electrons have been called Chapman layers.

The height of the 'peak' is determined by the concentration at particular heights of the atmospheric gas and by the ability of the gas to absorb the solar radiation. The less easily absorbed wavelengths of the radiation penetrate lower in the atmosphere before forming a layer of electrons. The *height* of the layer does *not*

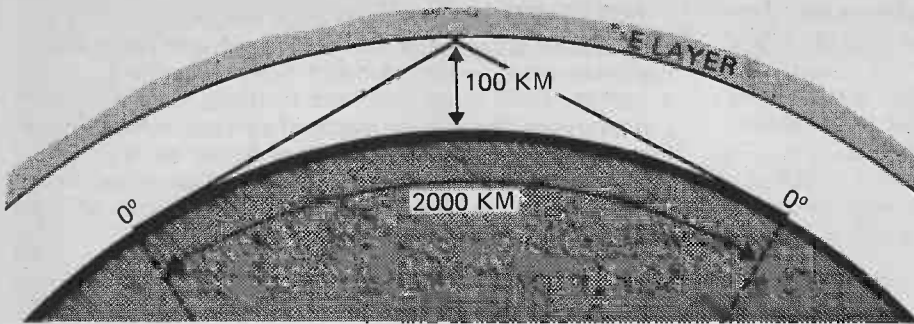
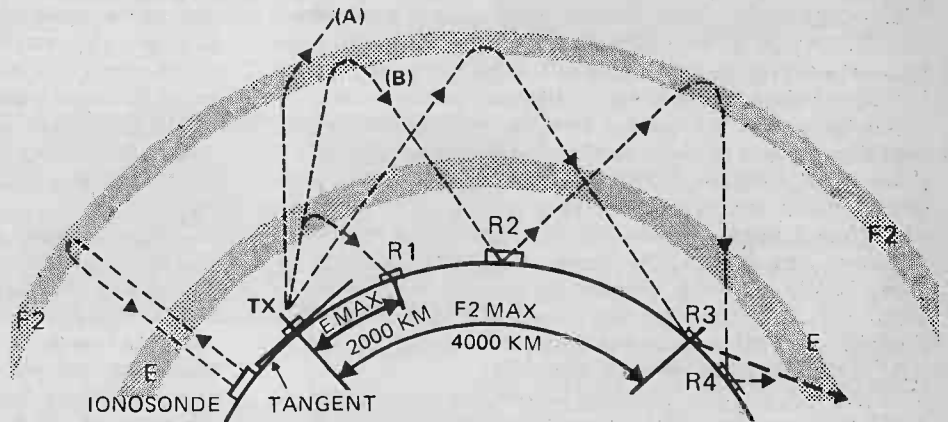

Fig. 7. Geometry of E-layer propagation. As the layer height is about 100 km, low angle radiation from a transmitter will reach distances of about 2000 km maximum.

Fig. 8. The transmitter (TX) radiating RF at several different angles illustrates how signals are propagated by the various layers. A wave radiated at a high angle will be deviated by one or both of the layers, but unless the layer is dense enough, will pass through (A). A ray at a lower angle (B) will skip a relatively short distance and may do so several times (R2-R4 etc). A low angle ray from TX will skip a maximum of 4000 km from the F2 layer (TX to R3) and subsequently further. The ionosonde measures the heights and critical penetration frequencies of the layers vertically.



depend on the strength of the ionising radiation.

The production rate of electrons at the peak of the layer depends on the strength of the ionising radiation and on its direction of arrival. When the radiation is vertically incident on the layer, ionisation is maximum, less when it arrives at an angle.

When curves representing the production rate of electrons of all possible shapes are 'normalised' with respect to the layer peak, they all look the same.

### The Three Regions

There are three main regions of the ionosphere. They are designated by the symbols 'D', 'E', and 'F.' The F-layer actually divides into two layers, F<sub>1</sub> and F<sub>2</sub>, which I will go into shortly.

The structure of the ionosphere varies widely over the earth's surface as the strength of the sun's radiation will obviously vary with geographical latitude.

### The D-layer

This is a region of low ionisation density which does not show the well-defined 'peak' of maximum ionisation density associated with the other layers.

The D-layer only appears during daylight hours and extends rather diffusely from about 50 km to about 90 km. The density of electrons in the D region is generally insufficient to cause appreciable bending of radio waves but they do suffer considerable attenuation in passing through this region.

Solar X-ray radiation with wavelengths less than about 20 Angstroms contributes to some of the ionisation in the D-layer. This radiation can ionise all the gases present at these heights in the atmosphere, but this alone does not account for the level of free electrons found in this region.

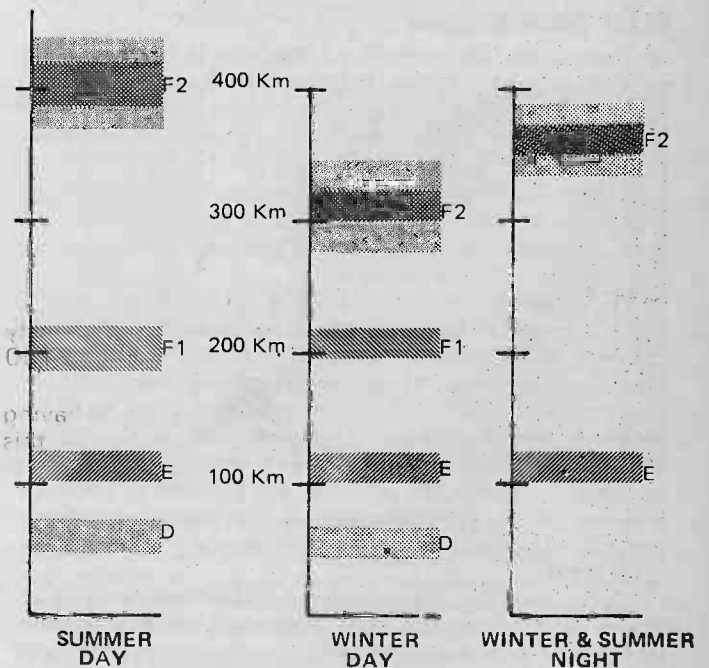

Fig. 9. Illustrating the diurnal and seasonal variations in the various layers.

Nitric oxide (NO) is formed at heights between 60 and 90 km by a photochemical process that diffuses atomic nitrogen down from the E-layer above 100 km. This nitric oxide is ionised by UV radiation from the sun having a wavelength of 1216 Angstroms — the Lyman-Alpha wavelength.

Hydrogen in the sun radiates very strongly at this wavelength which coincides almost exactly with a 'spectral window' in the atmosphere which allows this radiation to penetrate to very low levels in the atmosphere with little attenuation.

Because it penetrates down to where the nitric oxide is produced there is an abundant supply of electrons which contribute to the general ionisation of the D-layer at a height of around 75 km. Solar X-ray and Lyman-Alpha radiation contribute in roughly equal proportions to the ionisation of the D region. However, the strength of the X-rays varies by a large factor both daily and through the solar cycle as well as with solar disturbances. There is no appreciable change in the strength of the Lyman-Alpha radiation.

## Up the X-rays

Increased X-ray radiation associated with solar flares can increase the ionisation of the D layer thus causing increased absorption of radio waves travelling through the D region. These solar disturbances can be the cause of a complete 'radio blackout' at times.

As cosmic rays are deviated by the earth's magnetic field ionisation of the lower D region is greater near the magnetic poles than it is near the equator.

Since the D-layer absorbs radio waves it affects the propagation of radio signals. During the day signals below about 5 MHz are almost completely absorbed. Only signals radiated at a very high angle, and above a critical frequency where all signals are absorbed, manage to pass through the layer, being subsequently reflected by the E-layer.

Communication during daylight hours on the lowest frequencies of the HF spectrum from 3 MHz to about 5 MHz or so is thus limited to short distances, not much beyond ground-wave coverage.

Low angle radiation on these frequencies during the day travels a long way through the D-region and is thus absorbed.

The D-layer of course affects higher frequencies but its attenuation effect lessens as the frequency is increased.

## The E-layer

This occurs during daylight hours, the maximum density or peak of the layer lying between about 100 and 150 km. It remains weakly ionised at night.

E-layer ionisation is produced jointly by X-rays having wavelengths less than about 100 Angstroms — this ionising oxygen and nitrogen in the upper atmosphere at heights close to 100 km — as well as UV radiation with wavelengths near 100 Angstroms which ionise oxygen.

The atmosphere in the E-region is still dense enough for recombination to take place fairly rapidly. As a consequence, the E-layer can only maintain its signal reflecting ability when it is continuously in sunlight.

Ionisation is generally the best around noon, disappearing rapidly some time after local sunset. (The sun sets on the ionosphere at a height of 100 km about half an hour after local sunset.)

## The F-layer

The F-layer is that region of the ionosphere above about 150 km extending up to 800 km and beyond.

During daylight hours, two distinct layers appear in the F-region of the ionosphere — the lower is known as the F<sub>1</sub> layer, the upper as the F<sub>2</sub> layer.

The F<sub>1</sub> layer generally occurs around a height of 200 km and does not vary greatly in height. Its ionisation density is lower in winter than in summer.

As one would expect, the F<sub>2</sub> layer, being the uppermost has the considerable variations in density and height.

There is only one layer during the night in the F-region which is likewise dependant on atmospheric temperature. The height and density of the nighttime F-layer is also very variable owing to a number of factors.

The principal ionising agent of the F-layer is the extreme ultra-violet region (EUV). Solar UV with wavelength between about 200 and 800 Angstroms does most of the work in this respect. Radiation at these wavelengths ionises molecular nitrogen and atomic oxygen at heights between about 150 and 180 km.

The resulting electronic distribution with height does not always show a peak at this level — when there is a peak it is usually that of the F<sub>1</sub> layer.

The shape of the F<sub>2</sub> layer electron distribution, and thus the height of the peak, is largely determined by the variation with height of the loss process and by diffusion of the electronics to other regions. Ions and electronics diffuse above the peak of the layer, the production and loss of electronics (by recombination, etc) below the peak determine both the position of the peak and the shape of the layer. The peak then occurs at a height where the effects of diffusion and loss of electrons reaches an equilibrium.

The F-layer will provide communications out to a range of 4000 km on a single 'hop,' multi-hop propagation being used for distances greater than this.

The F<sub>1</sub> layer will provide communications up to about 9 or 10 MHz during the day. The F<sub>2</sub> layer will support propagation beyond 30 MHz under favourable conditions, even higher in frequency and for longer durations at lower frequencies, during a sunspot maximum.

The maximum usable frequency of the F-layer varies seasonally, being greater during summer than during winter.

## Summary So Far

The *daytime* ionosphere consists of an absorbing region — the D-region — with three reflecting ionised layers above that — the E, F<sub>1</sub> and F<sub>2</sub> layers.

The *night-time* ionosphere consists almost entirely of the F-layer.

It should be noted that the allocation of the letters of these layers above that — the E, F<sub>1-52</sub> and F<sub>2</sub> layers.

The *night-time* ionosphere consists almost entirely of the F-layer.

It should be noted that the allocation of the letters of these layers was made by Sir Edward Appleton. It was he who did most of the early investigative work on the ionosphere. The F-layer, which he discovered, is also known as the "Appleton Layer." The E-layer was originally named the "Kennelly-Heaviside Layer" (or just the Heaviside Layer) after the two gentlemen who discovered its existence.

ETI

# data sheet

LH0063/LH0063C DAMN FAST BUFFER

NATIONAL

## TYPICAL APPLICATIONS

The LH0063/LH0063C is a high speed, FET input, voltage follower/buffer designed to provide high current drive at frequencies from DC to over 100MHz. It will source or sink 250 mA into 50 ohm loads (500 mA peak) at slew rates of up to 6000V/us. In addition, it exhibits excellent phase linearity up to 20 MHz.

It is intended to fulfil a wide range of buffer applications such as high speed line drivers, video impedance transformation and high impedance input buffers for high speed A to Ds and comparators.

It can also be used as a diddle yoke driver for high resolution CRT displays\*.

## FEATURES

- Damn fast **6000V/us**
- Wide power bandwidth **DC to 100 MHz**
- High output drive **+ or - 10 V with 50 ohm load**
- Low phase non-linearity **2 degrees**
- Fast rise times **2 ns**
- High current gain **120dB**
- High input impedance **10 000 M**

These devices are constructed using specially selected junction FETs and active laser trimming to achieve guaranteed performance specification. The LH0063 is specified for operation from -55 to +125 C, while the LH0063C is specified from -25 to +85 C. Both are available in a 5W 8-pin TO-3 package.

\*NOTE: In VDUs where the basis of operation is for the beam to be pointed at the start of the character and then 'diddled' by means of a separate set of coils in order to form the shape of the character on the screen, the beam being switched on and off as required.

Gamma Ray Pulse Integrator

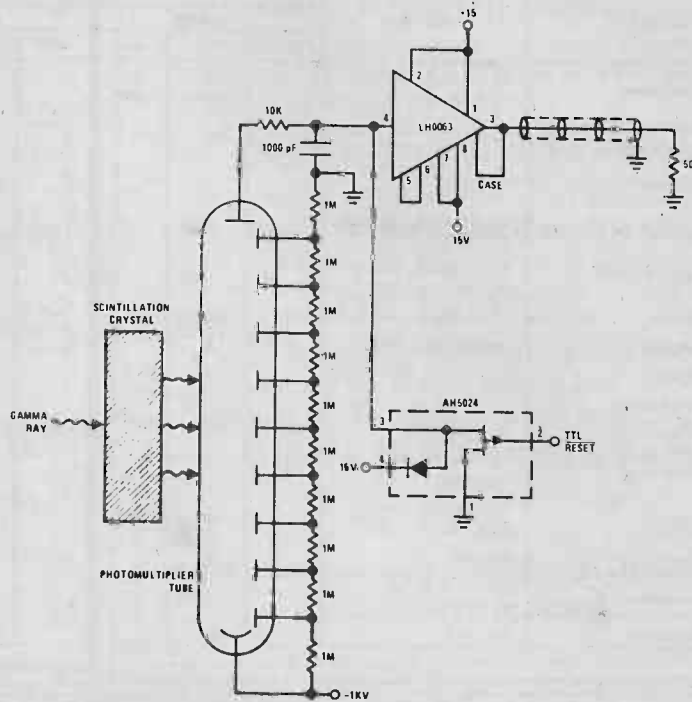

1W CW Final Amplifier

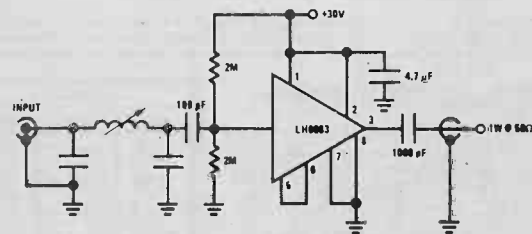

4.5 MHz Notch Filter

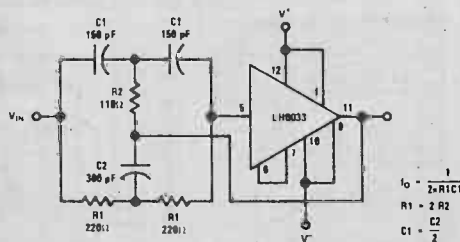

Nuclear Particle Detector

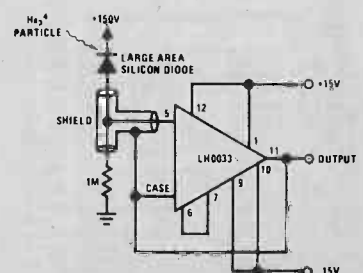

LH0063/LH0063C DAMN FAST BUFFER

NATIONAL

DC ELECTRICAL CHARACTERISTICS

LH0063/LH0063C (Note 1)

PARAMETER	CONDITIONS	LIMITS						UNITS
		LH0063			LH0063C			
		MIN	TYP	MAX	MIN	TYP	MAX	
Output Offset Voltage	$R_S \leq 100 \text{ k}\Omega$ , $T_C = 25^\circ\text{C}$ $R_S \leq 100 \text{ k}\Omega$		10	25		10	50	mV
Average Temperature Coefficient of Output Offset Voltage	$R_S \leq 100 \text{ k}\Omega$		300			300		$\mu\text{V}/^\circ\text{C}$
Input Bias Current	$T_C = 25^\circ\text{C}$		.1	.2		.1	.2	nA
Voltage Gain	$V_{IN} = \pm 10\text{V}$ , $R_S \leq 100 \text{ k}\Omega$ , $R_L = 1 \text{ k}\Omega$	.96	.98	1	.96	.98	1	V/V
Voltage Gain	$V_{IN} = \pm 10\text{V}$ , $R_S \leq 100 \text{ k}\Omega$ , $R_L = 50\Omega$ , $T_C = 25^\circ\text{C}$	.94	.96	.98	.92	.96	.98	V/V
Input Resistance		$10^{10}$	$10^{11}$		$10^{10}$	$10^{11}$		$\Omega$
Input Capacitance	Case Shorted to Output		8			8		pF
Output Impedance	$V_{OUT} = \pm 10\text{V}$ , $R_S = 100 \text{ k}\Omega$		1	4		1	4	$\Omega$
Output Current Swing	$V_{IN} = \pm 10\text{V}$ , $R_S \leq 100 \text{ k}\Omega$	.2	.25		.2	.25		Amps
Output Voltage Swing	$R_L = 50\Omega$	$\pm 10$	$\pm 13$		$\pm 10$	$\pm 13$		V
Output Voltage Swing	$V_S = \pm 5\text{V}$ , $R_L = 50\Omega$ , $T_C = 25^\circ\text{C}$	5	7		5	7		V <sub>P-P</sub>
Supply Current	$T_C = 25^\circ\text{C}$ , $R_L = \infty$ , $V_S = \pm 15\text{V}$		60	75		60	80	mA
Supply Current	$V_S = \pm 5\text{V}$		50			50		mA
Power Consumption	$T_C = 25^\circ\text{C}$ , $R_L = \infty$ , $V_S = \pm 15\text{V}$		1.80	2.25		1.80	2.40	W
Power Consumption	$V_S = \pm 5\text{V}$		500			500		mW

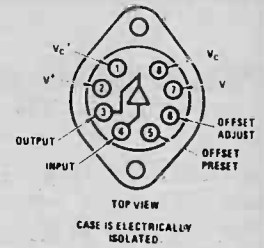

LH0063 Small Signal Rise Time

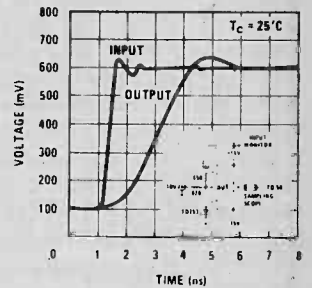

LH0063 Supply Current vs Supply Voltage

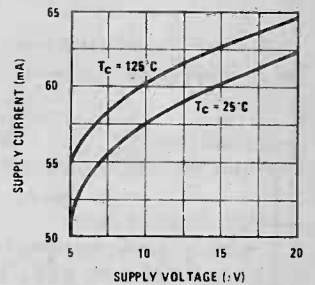

**NOTE 1:** Unless otherwise specified, these specifications apply for +15V applied to pins 1 and 2, -15V applied to pins 7 and 8, and pin 5 shorted to pin 6. Unless otherwise

noted, specifications apply over a temperature range of -55 C to 125 C for the LH0063 and -25 C to 85 C for the LH0063C. Typical values shown are for 25 C.

AC ELECTRICAL CHARACTERISTICS

LH0063/LH0063C: ( $T_C = 25^\circ\text{C}$ ,  $V_S = \pm 15\text{V}$ ,  $R_S = 50\Omega$ ,  $R_L = 50\Omega$ )

PARAMETER	CONDITIONS	LIMITS						UNITS
		LH0063			LH0063C			
		MIN	TYP	MAX	MIN	TYP	MAX	
Slew Rate	$R_L = 1 \text{ k}\Omega$ , $V_{IN} = \pm 10\text{V}$		6000			6000		V/ $\mu\text{s}$
Slew Rate	$R_L = 50\Omega$ , $V_{IN} = \pm 10\text{V}$ , $T_C = 25^\circ\text{C}$	2000	4000		2000	4000		V/ $\mu\text{s}$
Bandwidth	$V_{IN} = 1 \text{ Vrms}$		200			200		MHz
Phase Non-Linearity	BW = 1 to 20 MHz		2			2		degrees
Rise Time	$\Delta V_{IN} = 5\text{V}$		1.6			1.9		ns
Propagation Delay	$\Delta V_{IN} = 5\text{V}$		1.9			2.1		ns
Harmonic Distortion			<0.1			<0.1		%

LH0063 Large Signal Pulse Response

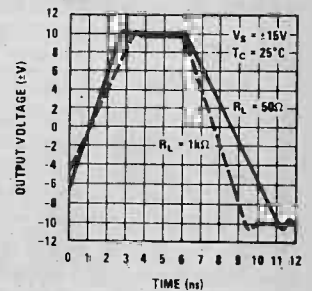

LH0063 Frequency Response

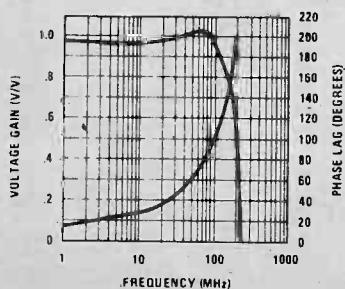

LH0063 Power Dissipation

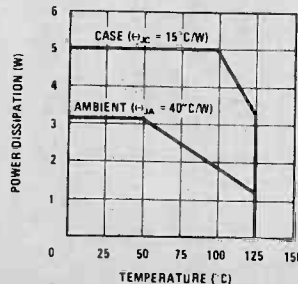

LH0063 DC Safe Operating Area

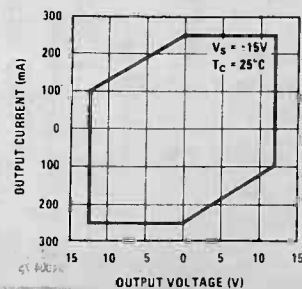

LH0063 Output Voltage vs Supply Voltage

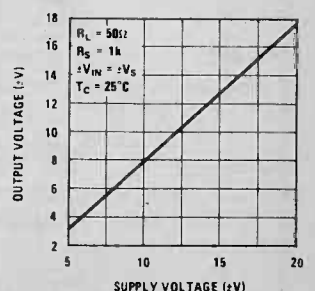

# CURVE TRACER

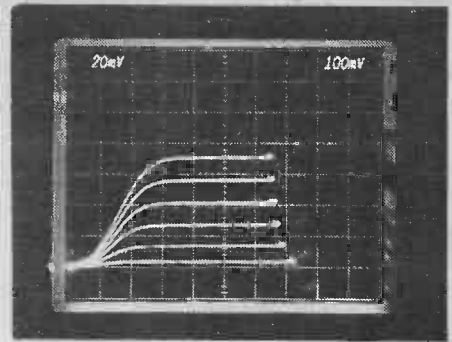

Display the dynamic characteristics of a variety of semi conductor devices with out curve tracer. Design by J. H. Adams.

THE CURVES INVOLVED in this design are not unfortunately those of the Bardots and Welchs of this world but curves that, to some, are just as interesting. The design will allow the dynamic voltage-current characteristics of diodes and transistors to be displayed on the screen of a DC 'scope capable of taking an external X input.

The performance of the unit will not be up to that of a commercial machine but considering such commercial designs are priced in the thousand pound range while our design could be built for around five pounds, we're not doing too badly.

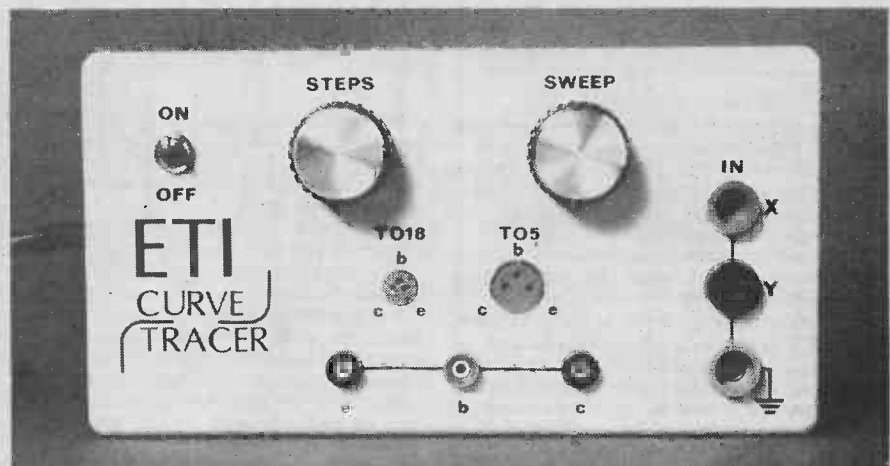

View of the internal layout of the prototype version

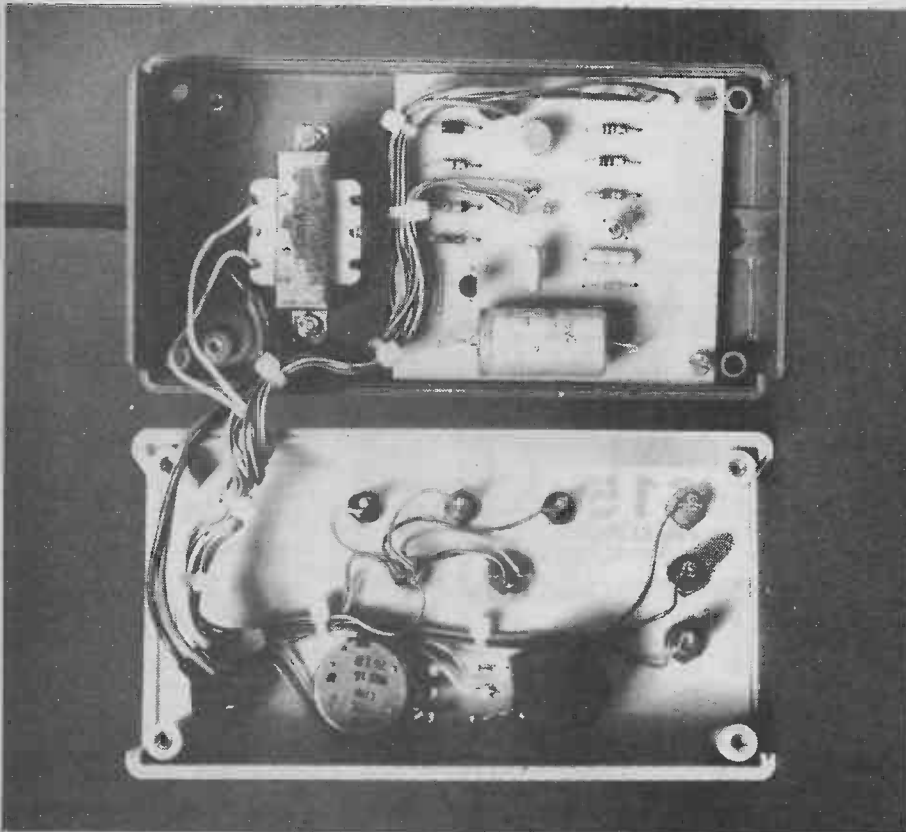

Construction of the curve tracer is straightforward. Mount all the components on the PCB according to the overlay. The internal layout of our prototype is shown in the photographs. The unit is mains powered and a battery supply is not suitable for this circuit.

Initially try the curve tracer with a high gain npn transistor, a BC108 will be ideal. Connect it to one of the tracer's sockets and connect the unit to the 'scope. Set the Y gain on the 'scope at maximum and set up the maximum required level of collector voltage by adjusting RV1. RV2 will control the number of steps displayed on the screen. The X sensitivity of the 'scope should be 1V per division.

The performance of the unit is degraded by the slight drop in the DC potential on C1 during the 10mS sweep and the slight effect of the 100R sampling resistor, in that its volt drop is included in the observed collector potential. However as stated above the unit will give a good indication of the dynamic performance of a wide range of semiconductor devices (as the photograph shows) at a price that is a fraction of similar commercial equipment.

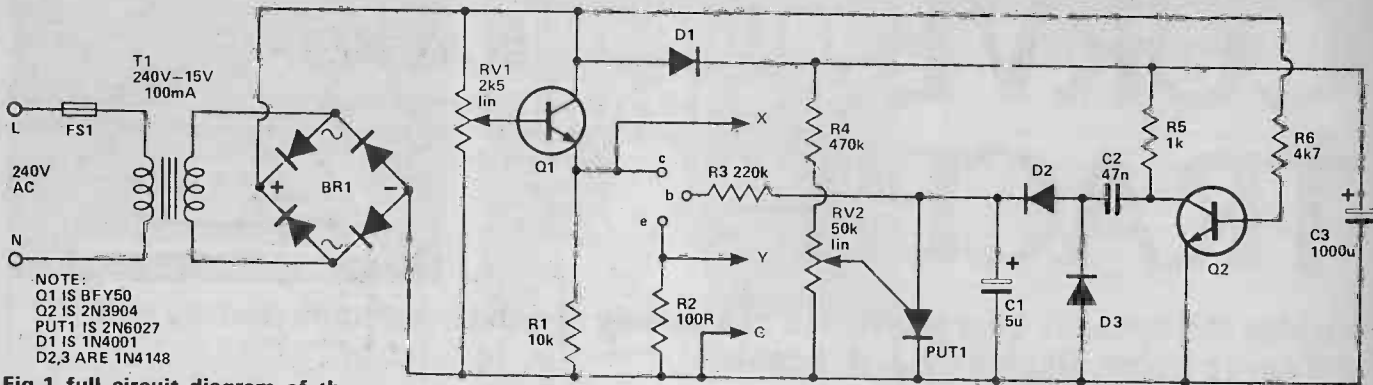

Fig. 1 full circuit diagram of the curve tracer.

## HOW IT WORKS

The principles of the full circuit can perhaps be best explained by consideration of a simpler form of the circuit. Figs. 2 and 3 show circuits for investigating the dynamic characteristics of a diode and transistor (at fixed base current) respectively.

The 'diode circuit' will, unless an inverter is available, produce a trace that will appear upside down.

Operation of this circuit is quite straightforward. RV1 allows the peak value of the AC supply to be adjusted. This is then applied to the device under test via a current limiting resistor as well as to the X input of the 'scope. The current flow in the device at any time is proportional to the voltage developed across a low value sampling resistor in the current path. This voltage is fed to the Y input of the scope.

The simple transistor tester functions in much the same way. RV1 allows the base current to be adjusted within the range 10µA to 100µA.

The characteristics of an N-Channel FET (2N3819) may also be examined with this basic building block. The output characteristics are displayed for a gate voltage selected by RV1. Transfer characteristics (gate voltage vs. Drain Current) may be shown by transferring lead X to the gate terminal and mining the 1000µF capacitor to the 15V supply (observing the change in polarity).

Moving now to the full circuit of Fig 1 that allows a far more informative display providing, as it does, simultaneous displays of the characteristic curves for several equally spaced values of base current.

The circuit operates as follows. Every 10 ms the collector supply swings up and back over a half cycle of the full-wave rectified supply. At the end of each half cycle, there is a short period during which the supply potential is below about 0.6 V, and during this time, Q3 turns off, sending a pulse from its collector into the charge store C1 C2 D3 D2. Each pulse increases the potential in C1 by approximately 0.2 V. This would go on until the potential on C1 was 20 V were it not for Q2, the little known and much mis-described programmable unijunction transistor, PUT. This device is the semiconductor version of a neon lamp, insulating up to a certain p.d. and conducting heavily at potentials above this breakdown value, but with the added advantage in that, through a third terminal, this breakdown potential is programmable over quite a wide range. Varying this control potential through the setting of VR2 sets the

number of steps that will occur before the potential on C1 is great enough to make Q2 fire, reducing the capacitor's potential to approximately 0.6 V and so re-starting the sweep sequence.

The tracer can hardly be expected to match all the performance of a commercial curve tracer, the prices of which range into thousands of pounds. There are errors, due to the slight droop in d.c. potential on C1, and hence in base current, during the 10ms sweep, and due to the slight effect of the 100R sampling resistor, in that its volt drop is included in the observed collector potential, but as can be seen, these are quite insignificant as regards the final display. The only problem which may arise is the appearance of Radio 4 on the current axis (seen as a thickening of the trace). This is easily cured by placing a 10n disc capacitor across the actual Y-inputs of the oscilloscope.

A suitable transistor for the device under test is any reasonably high gain npn transistor, e.g. BC108. VR1 controls the maximum collector voltage, whilst VR2 sets the number of sweeps displayed. With the values given, the difference in base current between one step and the next is approximately given by:

$$\frac{1}{5R} \mu\text{A}, \text{ where } R \text{ is in megohms.}$$

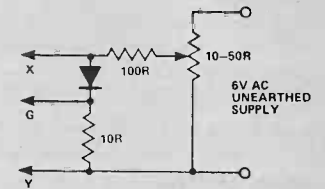

Fig. 2 simple diode tester

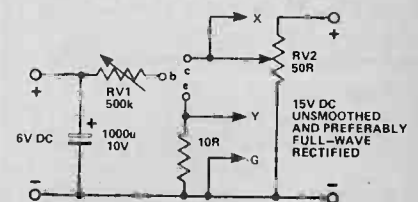

Fig. 3 fixed current transistor tester

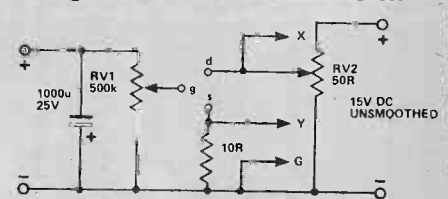
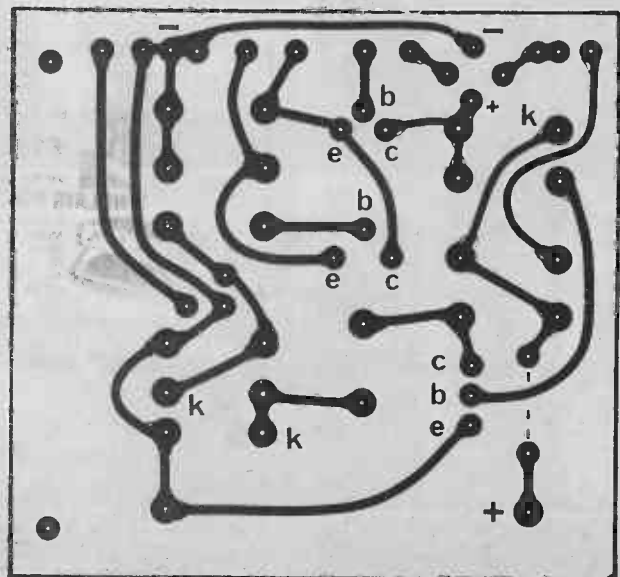

Fig. 4 circuit for investigating FET transfer characteristics.





## PARTS LIST

### RESISTORS

R1	10k
R2	100R
R3	220k
R4	470k
R5	1k0
R6	4k7

### CAPACITORS

C1	5u0 25 V electrolytic
C2	47n polyester
C3	1 000 25 V elec- trolytic

### SEMICONDUCTORS

Q1	BFY50
Q2	2N3904
PUT1	2N6027
D1	1N4001
D2,3	1N4148
BR1	0.9A 400V

### POTENTIOMETERS

RV1	2k5 1in
RV2	50k 1in

### MISCELLANEOUS

PCB as pattern, case to suit, sockets, knobs, cable, etc.

## BUYLINES

The components used in this project should in the main, be generally available — the only component likely to cause problems is the PUT, but this should be available from the larger mail order outlets.

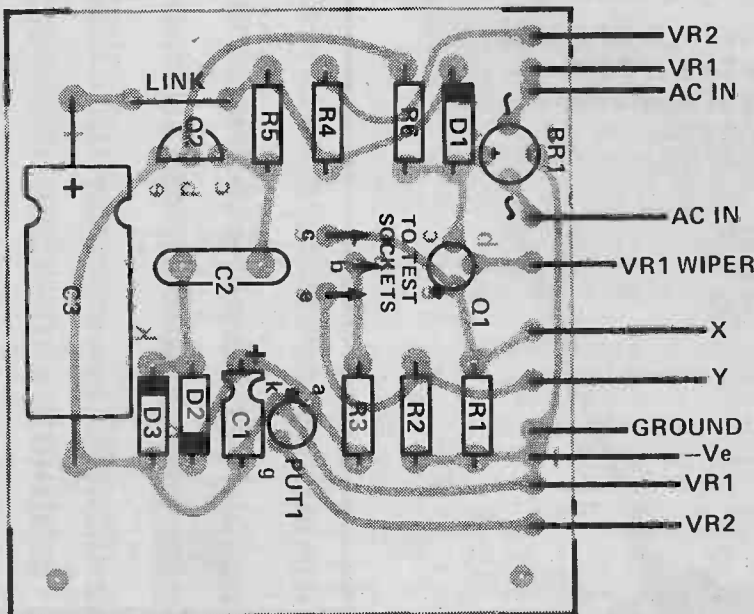

7400 TTL	74151	.58	74522	.38	27X500	.18	
7400	74154	1.00	74537	.38	2K2853	.20	
7401	74156	.50	74551	.25	2K2854	.57	
7402	74157	.54	74564	.20	2K3055	.57	
7403	74160	1.04	74574	.38	2K3072	.12	
7404	74162	.80	745112	.66	2K3074	.12	
7406	74163	1.18	745124	3.25	2K3819	.29	
7409	74164	.87	MICRO'S		DIODES		
7410	74165	.93	MEMORIES		8A15		.05
7411	74175	.67	745185	2.40	1N914	.05	
7412	74176	.84	745186	3.99	1N4148	.05	
7413	74180	.86	2705	7.96	1N4151	.04	
7414	74181	1.04	2102-1	1.22	1N4001	.06	
7416	74192	.98	2114	10.53	1N4002	.06	
7417	74193	.98	8080A	7.02	1N4003	.08	
7417	74194	.86	8251	7.06	1N4004	.10	
7420	74196	.86	LINEAR		1N4005	.11	
7426	74197	.86	LM380-14	.80	1N4005	.11	
7427	74198	1.41	LM3900	.48	1N4007	.12	
7430	74199	1.41	LM741-8	.21	1N4500	.16	
7432	74LS00 TTL	.18	LM741-8	.21	1N4504	.21	
7433	74LS01	.18	NE555	.29	ELECTROLYTICS		
7437	74LS02	.18	NE565	1.14	UF/V		
7438	74LS04	.19	NE566	1.43	.47/100	.08	
7440	74LS05	.21	NE567	1.62	1/63	.08	
7441	74LS08	.21	REGULATORS		22/63	.08	
7442	74LS09	.21	7805	.80	47/35	.08	
7443	74LS10	.21	7812	.80	47/63	.08	
7445	74LS11	.21	7905	1.39	10/16	.08	
7446	74LS14	1.10	7912	1.39	10/35	.08	
7447	74LS20	.18	LM309	.86	10/63	.09	
7448	74LS21	.21	LM723	.24	22/16	.08	
7450	74LS32	.24	LM723	.24	22/35	.13	
7451	74LS37	.26	TRANSISTORS		47/16	.09	
7453	74LS38	.29	AC128	.23	22/63	.12	
7454	74LS40	.25	AC176	.23	33/16	.08	
7450	74LS42	.54	BC107	.10	33/35	.11	
7410	74LS51	.29	BC108	.10	33/63	.13	
7472	74LS74	.32	BC109	.10	47/16	.09	
7473	74LS86	.33	BC177	.18	47/35	.12	
7474	74LS90	.86	BC178	.18	47/63	.15	
7475	74LS93	.86	BC179	.18	100/16	.11	
7476	74LS107	.34	BC184	.15	100/63	.13	
7477	74LS107	.34	BC187	.32	100/63	.24	
7453	74LS112	1.00	BC187	.32	220/46	.17	
7485	74LS123	.85	BC478	.24	220/25	.17	
7486	74LS124	2.20	BC478	.24	330/16	.18	
7489	74LS151	.95	BC479	.24	330/35	.31	
7490	74LS153	.64	BD131	.54	470/63	.14	
7491	74LS157	.64	BD132	.54	470/35	.30	
7482	74LS164	1.14	BFY50	.23	1000/15	.38	
7493	74LS175	1.05	BFY52	.23	1000/25	.48	
7495	74LS193	1.33	BFY52	.23	2200/16	.54	
7496	74LS194	2.06	BSY95A	.17	1000/25	.48	
74104	74S TTL	.36	DC71	.20	2200/16	.54	
74105	74S TTL	.36	DC72	.36	BURROUGHS 9 Dig.		
74107	74S00	.36	DC200	.45	7 Seg. Panaflex Display.		
74109	74S05	.38	TIP 2955	.85	0.25" Neon Type with		
74121	74S08	.38	TIP 3055	.68	Red Bezel and Socket.		
74122	74S10	.38	TIS43	.33	C2.25		
74123	74S11	.38	Z1X300	.17			
74141	74S11	.38	Z1X300	.17			

**IBEX SYSTEMS**  
32 Dunsville Drive, Coventry CV2 2HS

### THE SINCLAIR PDM35 digital Multimeter

Now a digital multimeter at an analogue price and look at the spec!

**D.C. VOLTS** 1mV-1000V (1% - 1 count) 10mΩ input.

**A.C. VOLTS** 1V-500V, 40Hz-5kHz (1% + 2 counts).

**D.C. CURRENT** 1 inA-200mA (1% count).

**RESISTANCE** 1Ω-20mΩ (1.5% + 1 count).

**£29.80** cash with order or £30.95 company purchase order. Adaptor £3.20. Padded case £3.20. 30kV probe £18.64

### THE SINCLAIR MICROVISION

The amazing pocket T.V. that will pick up programs throughout the world, complete with rechargeable batteries.

**£189.95** inc. VAT  
Sae (for detailed Brochure ex-stock)

### SINCLAIR DM235

Portable 3 1/2 digit 6 function Multimeter.  
DC volts 1mV to 1000V  
AC volts 1mV to 750V  
AC & DC current 1µA to 1A  
Resistance 1Ω to 20mΩ  
Diode test 0.1µA to 1mA  
10mΩ input, DC acc. 1.0% AC acc 1.5% 30Hz-10KHz.

**£52.80** inc VAT or £53.70 on company purchase order

### PORTABLE ALARM CLOCK

Only **£18.20** inc. P&P

- Battery operated
- Quartz crystal accuracy
- Back light
- Simple to set
- Electric Alarm
- Snooze button
- Colour Rrwn

**CA-08AL**  
Case £8.95. Adaptor £3.75  
We accept gov't. / company purchase orders on all goods.

## KRAMER & CO

We will match any lower advertised price on a cash with order basis if competitor has goods in stock  
9 October Place, Holders Hill Road, London NW14 1EJ  
Telex 888941 Attn. Kramer K7. Tel. 01-203 2473  
Mail order only. SAE for data sheets. Export enquiries welcome

### ETCH RESIST TRANSFER KIT SIZE 1:1

Complete kit 13 sheets 6in x 4 1/2in **£2.50** with all symbols for direct application to P.C. board. Individual sheets 25p each. (1) Mixed Symbols (2) Lines 0.05 (3) Pads (4) Fish Plates and Connectors (5) 4 Lead and 3 Lead and Pads (6) DILS (7) BENDS 90° and 130° (8) 8-10-12 T.O.5. Cans (9) Edge Connectors 0.15 (10) Edge Connectors 0.1 (11) Lines 0.02 (12) Bends 0.02 (13). Quad in Line.

### FRONT AND REAR PANEL TRANSFER SIGNS

All standard symbols and wording. Over 250 symbols, signs and words. Also available in reverse for perspex, etc. Choice of colours, red, blue, black, or white. Size of sheet 12in x 9in. Price **£1**.

### GRAPHIC TRANSFERS WITH SPACER ACCESSORIES

Available also in reverse lettering, colours red, blue, black or white. Each sheet 12in. x 9in contains capitals, lower case and numerals 1/8in kit or 1/4in kit. **£1** complete. State size.

**All orders dispatched promptly.**  
**All post and VAT paid**  
Ex U.K. add 50p for air mail  
Shop and Trade enquiries welcome  
Special Transfers made to order

**E. R. NICHOLLS**  
**P.C.B. TRANSFERS**  
Dept. HE/1  
46 LOWFIELD ROAD  
STOCKPORT, CHES.061-480 2179



**KEY:**

- 1: The bit of chocolate you thought you'd leave for later.
- 2: Coffee stains (instant).
- 3: A useful-sized bit of stiff paper to stop the window from rattling.
- 4: Rough calculations for your new combined egg timer/laser cannon project.
- 5: ETI makes a fair soldering iron stand.
- 6: The dog insisted on carrying your copy to you along with your slippers.

## WHAT A BIND!

Half our orders for binders are repeats: we think that says a lot for their quality. At £3.00 all inc. you get a great deal of peace of mind too!

ETI Binders  
25-27 Oxford Street,  
London W1R 1RF.

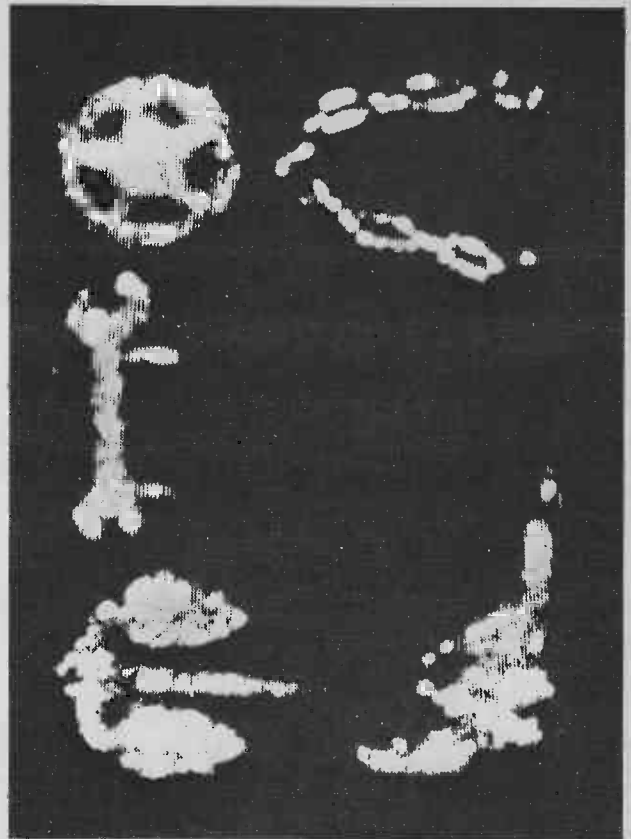

### The image of it

The picture shows images achieved in lousy conditions by EMIs new wonder underwater TV system. The system has just won the IR100 award in America for its solving of the problems associated

with the quartz and frequency troubles earlier systems experienced.

The whole thing is comparatively simple, and uses 201 lines per frame, 12½ frames per second. A range of several meters is possible even in atrocious conditions.

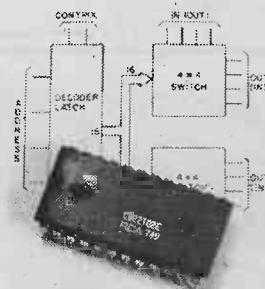

### Cross point

Now available from Jerbyn are 2 new Crosspoint Switches complete with control memory which are ideally suited where numerous analogue or

data lines have to be switched.

These CD22101 and CD22102 devices consist of 4x4x2 arrays of crosspoint transmission gates, 4 to 16 line decoders and 16 latch circuits, with any one of the 16 crosspoint pairs being selected by applying the appropriate four-line address and any number of crosspoints being ON simultaneously.

Bandwidth is 10 MHz and low ON resistance is typically 75ohms @ 12 Volts  $V_{DD}$ . Other significant features include closely matched switched characteristics, high linearity and standard CMOS noise immunity.

Mogul Electronics Ltd, 272 High Street, Epping, Essex CM16 4DA.

# microfile.....

**Gary Evans has been out and about this month, taking in a Personal Computer show and visiting a TV studio amongst other things.**

THE NUMBER OF shows/seminars concerning themselves with many aspects of Microprocessors and personal computers has, like the hardware itself, shown a dramatic increase over the past few years. Unfortunately not all these events live up to their initial promise and some are not worth the cost of travelling to the venue, let alone the extortionate prices charged for admission to some of these gatherings. The PCW show towards the end of September was a refreshing change.

When it comes to exhibitions, about the only thing to do is to get as many people with products likely to be of interest to visitors to set up a stall. If you can arrange to have some new products launched, a competition and some interesting activity going on in the sidelines — all well and good. PCW did just this and it worked.

I'd have liked to have gone to all three days of the show in order to attend the various seminars held — as it was, last month's ETI was printed at the same time as the show and I was only able to get to the exhibition on the Saturday morning. I suspect the seminars were up to the general high standard of the rest of the event however.

The fact that the exhibition was crowded when I was there, it took me all my time trying to get from one stall to another amongst the multitude of people who see their role in life as standing in the middle of gangways, is not a criticism, more a testament to the show's success.

I look forward to more shows along these lines in the future.

## Anita Harris — Pet?

A couple of months ago I went to the recording of a TV show pilot where one of the stars of the show, along with Anita Harris and Roger Elliott, was a Pet Computer.

I'll say more about the show but may I just digress for a couple of lines to tell one of the few after dinner stories I know — this desire having been brought on by the mention of the word pilot above.

If you do certain jobs, being a pilot or trendy journalist are amongst them, when at parties that information is dragged out of you the same string of inevitable questions pour out — different questions for different jobs — but the same questions for the same jobs — if you know what I mean. Very boring. Well, my story concerns a pilot who, being fed up with the situation, in response to the next such interrogation replied "I travel in aluminium tubing" — that a least provened no questions. That's the story then — not very exciting but it's the way I tell 'em

Back to the PET and the TV show however and to why the PET was there. One of the computer's co-stars may have given some of you a clue. Roger Elliott is the TV Times astrologer and — slight groan — the PET was put to the task of flashing Anita's details (astrological) over it's screen.

They say that an actor should never go on stage with animals or small children, for fear of being upstaged. To this list, although for a different reason, should be added small computers. The reason is they very rarely behave for any length of time as Roger Elliott found out when the PET started promising that it was "Time for a song" when Anita obviously was ready for no such thing.

The program was made by HTV who's main claim to fame, or is it eternal damnation, in my book to date is that they produce Mr and Mrs. While not in that league — the pilot was much better — I did not enjoy the show that much but the production team seemed to think it was OK so maybe you'll see it on your screens at some time in the future.

I can't resist just one more tilt at Mr and Mrs — it appears that four of these dreadful things are reeled off in the same day — not all in front of the same audience, who could stand the strain?, especially when you consider that the people who have parted with their hard earned time to watch this entertainment are in the main, old age pensioners, who should really be taking things easier at their age.

I mustn't be too unkind to Mr and Mrs though, after all there is Nicholas Parsons.

## Pet Problems

When Julian Allason of PETSOFTE phoned this month to ask if I had any problems I was just about to mention the fact that my car had just fallen to bits, and that my dog had a limp amongst other things when he explained that he was merely reading from the screen of PET which was running a new program called Eliza. Eliza simulates a consultation with a psychiatrist and my encounter with the machine went something like this.

PET: What is your problem?  
 ME: Emotional insecurity  
 PET: Do you have any psychiatric problems?  
 ME: Yes  
 PET: Are you sure?  
 ME: Yes  
 PET: Do not repeat yourself.  
 ME: Oh God!  
 PET: What does that suggest to you?  
 ME: I'm not sure  
 PET: Did you come to be because you're not sure?  
 ME: Yes  
 PET: I see  
 ME: Where do we go from here?  
 PET: Why do you ask?  
 ME: Because I'm not sure  
 PET: How long have you been not sure?  
 ME: Five years  
 PET: I see

Well, follow that — Petsoft have probably the widest range of PET software in this country with 70 titles in their current catalogue and aims for 100 in the next. A reciprocal arrangement with Personal Software Inc, whereby Petsoft material will be distributed in the United States and Canada and the best of Personal Software's material sold over here means even more to choose from.—If you have a PET, Petsoft are worth knowing.

PETSOFT,  
P.O. BOX 9,  
NEWBURY,  
BERKSHIRE, RG13 1PB.

**Put A Chrysler Sidelight In Your Life**

I've been exposing myself this month, but before you get the wrong idea — although I suspect most of you already have, I mean to say that I've been out and about talking to computer clubs.

The meetings ranged in size from the 400 or so at the first meeting of the North London Computer Club,

through a 100 or so at Sussex University to the twenty or so at the Thames Valley group of the ACC's meeting. I enjoyed myself at each event, and picked up some very good ideas from the very high calibre of people that numbered among the audience at each event. Among the handy things I learn't at Sussex was that the exact sequence of operations required to turn the sidelights of a Chrysler Sunbeam on this could not be discovered by your humble reporter, a number of undergraduates and a lecturer in mathematics, but had to be resolved by a call to the car hire firm.

All the clubs would welcome new members — The North London Computing Club is held at the North London Polytechnic, Holloway, LONDON N7 8DB. Tel. Stephanie Bromley — 01-607 8663 (Office), 01-359 2282 (Home), or Mike O'Reilly, — 01-607 2789 ext 2100.

The Thames Valley ACC group meets on the first Thursday of every month at the Griffin (A pub—good move ACC) 10 Church Road, Caversham, Reading, Berkshire.

For the Sussex University Group — who will welcome outsiders to their meeting with open arms and hands, for the money you know — Contact: Pete Guile, University of Sussex, Falmer, BRIGHTON, Sussex.

ETI



**WIRE WRAPPING CENTRE**



HOBBY WRAP  
Model BW 630



Battery Wire-Wrapping Tool Complete with Bit and Sieve.

NEW

WIRE-WRAPPING TOOL for .025" (0.63mm) sq. post "MODIFIED" wrap. Positive indexing, anti-overwrapping device.

A For AWG 30	BW-630
B For AWG 26-28	BW-2628
C Bit for AWG 30	BT-30
D Bit for AWG 26-28	BT-2628

At £26.75 B£31.95 C£2.82 D£7.44

DIP/IC EXTRACTOR TOOL £119

The EX-1 Extractor is ideally suited for hobby enthusiast or lab engineer. Featuring one piece spring steel construction. It will extract all LSI, MSI and SSI devices of from 8 to 24 pins. Extractor Tool EX-1.



DIP/IC INSERTION TOOL WITH PIN STRAIGHTENER

£279

INS-1416

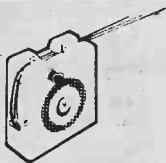

3 IN 1 WIRE DISPENSER

New wire dispenser cuts and strips three different colours of wire. Quick and easy to use pocket size. Wire Size: 30 AWG. 50 ft. Red, Blue, White Kynar insulated.

£4.07

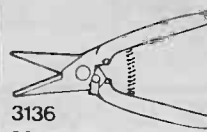

3136  
£346

OK PLIERS AND CUTTERS UNIVERSAL CUTTER Cuts everything. Leather, wire, plastic, tin-plate, cardboard. Stainless steel blades. Just one of the range of high quality pliers, cutters, tweezers and screwdrivers.



WIRE WRAPPING KIT

Contains: Hobby Wrap Tool WSU-30 M, Wire Dispenser WD-30-B, (2) 14 DIP's, (2) 16 DIP's, Hobby Board H-PCB-1, DIP/IC Insertion Tool INS-1416 and DIP/IC Extractor Tool EX-1.

Wire-Wrapping Kit WK-4B (Blue)

£19.22



IC TEST CLIPS £2.97

FOR DUAL-IN-LINE PACKAGES

- Solve probe attachment problems.
- Simplify prototype and production testing, field service work, and quality control.

- Provide full access to integrated circuit DIP leads.
- Remove DIP's damage free.
- Available in sizes to accommodate all DIP's; TC-14 fits 14-pin DIP's etc.

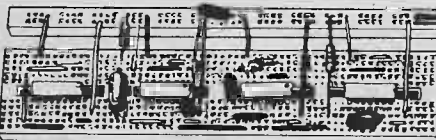

FROM 80P TERMINAL AND DISTRIBUTION STRIPS

Bread boarding building blocks with universal matrices of solderless plug-in tiepoints.

- Facilitate quick, solderless circuit build-up and check-out on universal .1" x .1" matrix.

- Are offered in ten configurations.
- Accept all components with leads up to .032" diameter.
- Require no special patch cords.
- Includes integral non-shorting instant mounting backing.



HOBBY WRAP TOOL

Wire-wrapping, stripping, unwrapping tool for AWG 30 on .025 (0.63mm) Square Post.

A £4.74. B £5.07

Regular Wrap A	WSU-30
Modified Wrap B	WSU-30M

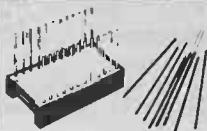

FROM 29p

DIP SOCKET Dual-in-line package, 3 level wire-wrapping, phosphor bronze contact, tin inlay finish pins .025 (0.63mm) sq., .100 (2.54mm) centre spacing.

14 Pin Dip Socket	14 Dip
16 Pin Dip Socket	16 Dip

RIBBON CABLE ASSEMBLY £2.92

With 14 Pin Dip Plug - 2" Long	DE 14.2
With 14 Pin Dip Plug - 4" Long	DE 14.4
With 14 Pin Dip Plug - 8" Long	DE 14.8
With 16 Pin Dip Plug - 2" Long	DE 16.2
With 16 Pin Dip Plug - 4" Long	DE 16.4
With 16 Pin Dip Plug - 8" Long	DE 16.8



See us at  
BREAD BOARD '78  
21st-25th November.  
Seymour Hall, London  
Stand Nos. A5-A6

OK Machine & Tool U.K.  
Limited

48a The Avenue Southampton SO12SY

Telephone Southampton (0703) 38966 7 Telex 477222 Cablegram OKMAC

DISTRIBUTORS  
WANTED\*\*\*

# AUTOCHORD PART TWO



THIS MONTH WE complete the description of the auto chord instrument. Last month's article covered the circuit descriptions of the various blocks that make up the unit and of the operation of the complete design.

This month we complete the project by describing the construction of the instrument.

## Construction

The components should be mounted on the PCBs according to the overlays shown. Pay particular attention to the diodes, capacitors and other polarity sensitive devices.

The project involves a great deal of interwiring between the various boards and switches of the design.

The interconnections are shown in the accompanying diagrams and great care should be taken to ensure that no errors are made at this stage — they will prove difficult to trace at this stage.

We give no details of the housing of the project as this will depend entirely upon the instrument in which the auto chord is to be installed.

The finished unit can be added to most organs, being easiest to fit to a unit that uses DC keying. In use the project should add an extra dimension to even the most limited of musicians efforts.

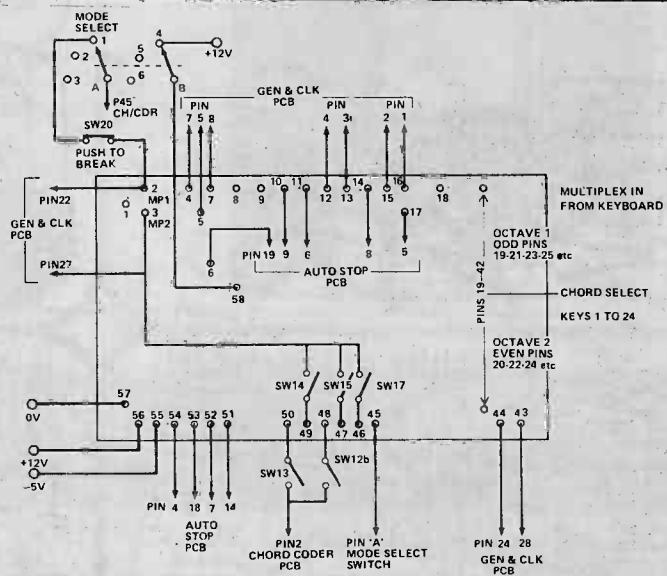

Above and below interconnection details for the generator and coder boards

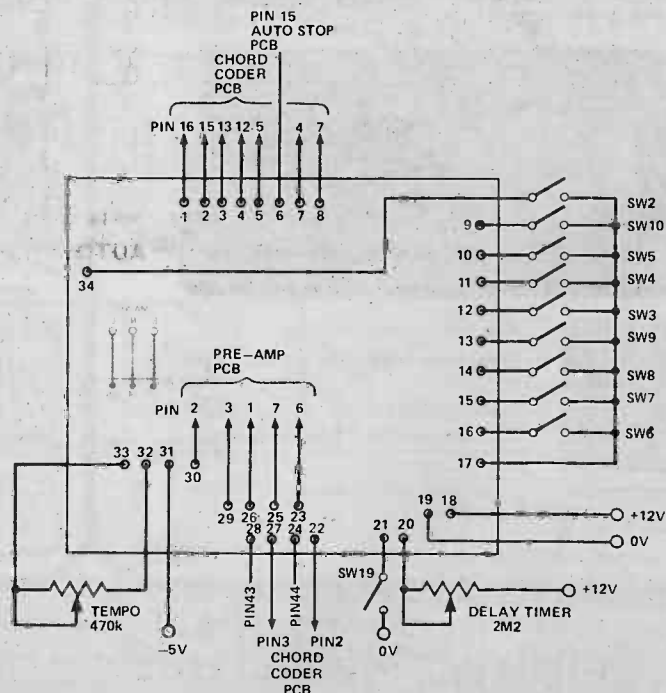

Part two of the autochord project details  
the construction of the instrument

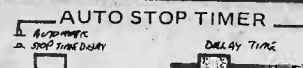
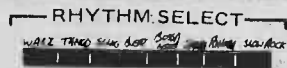
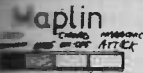

Auto Organ

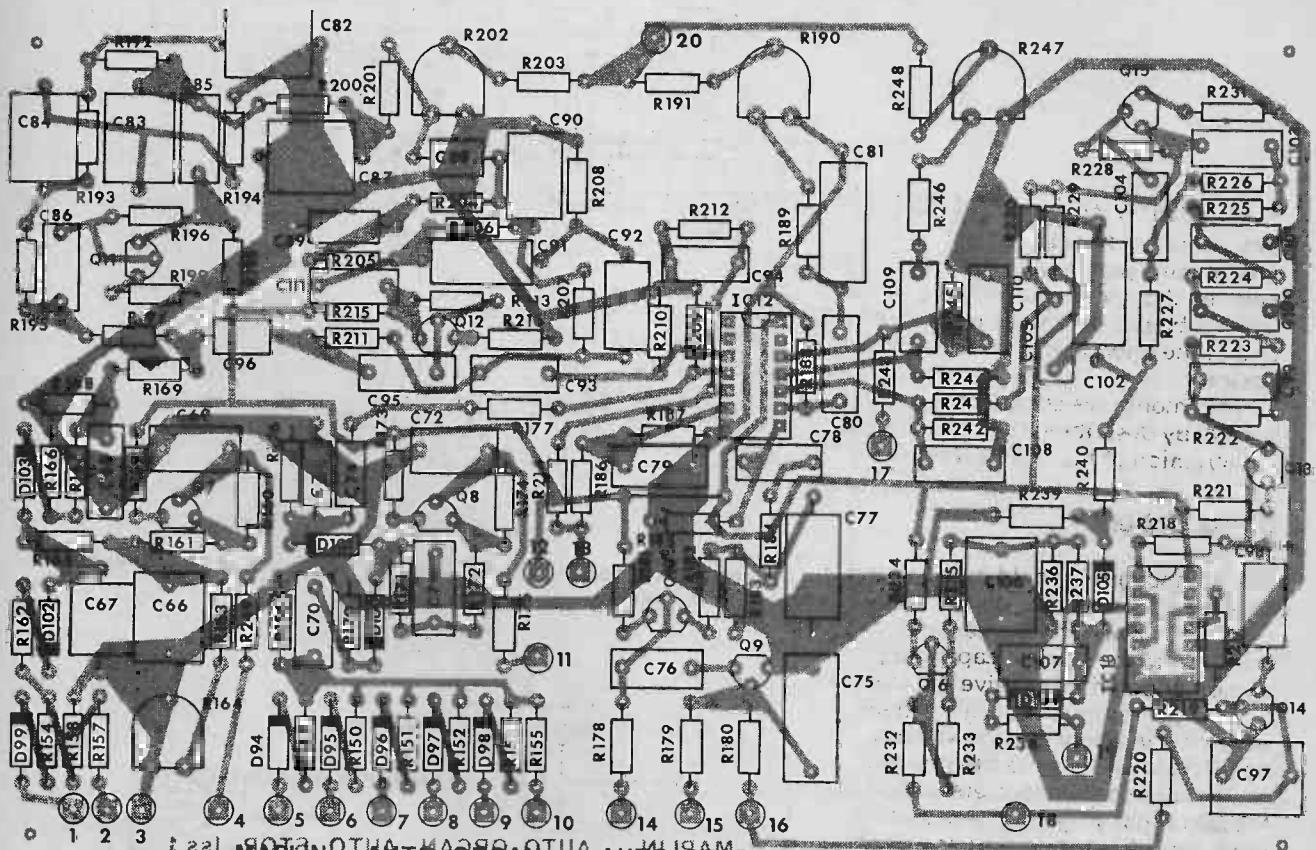

Power supply and voice generator connection details

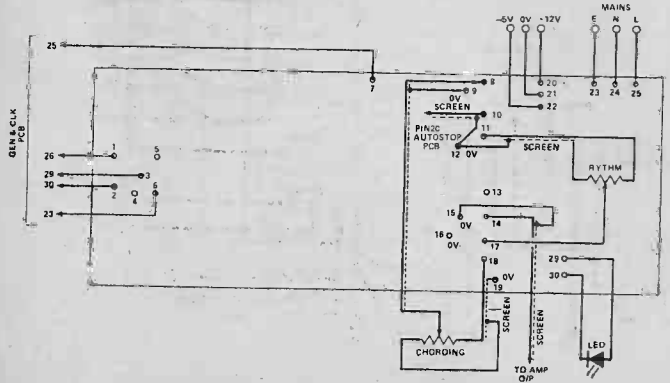

BUYLINES

Maplin Electronics will supply a complete kit of parts, including screened boards; for this project. See their advert for address and telephone number.

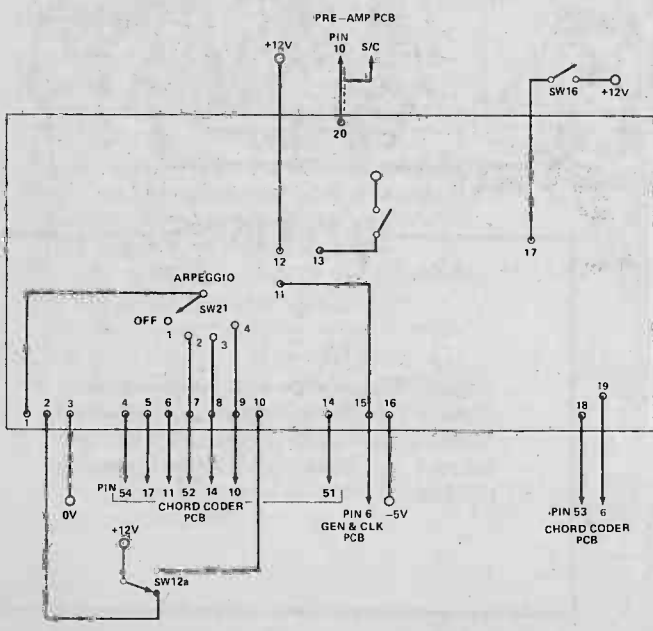
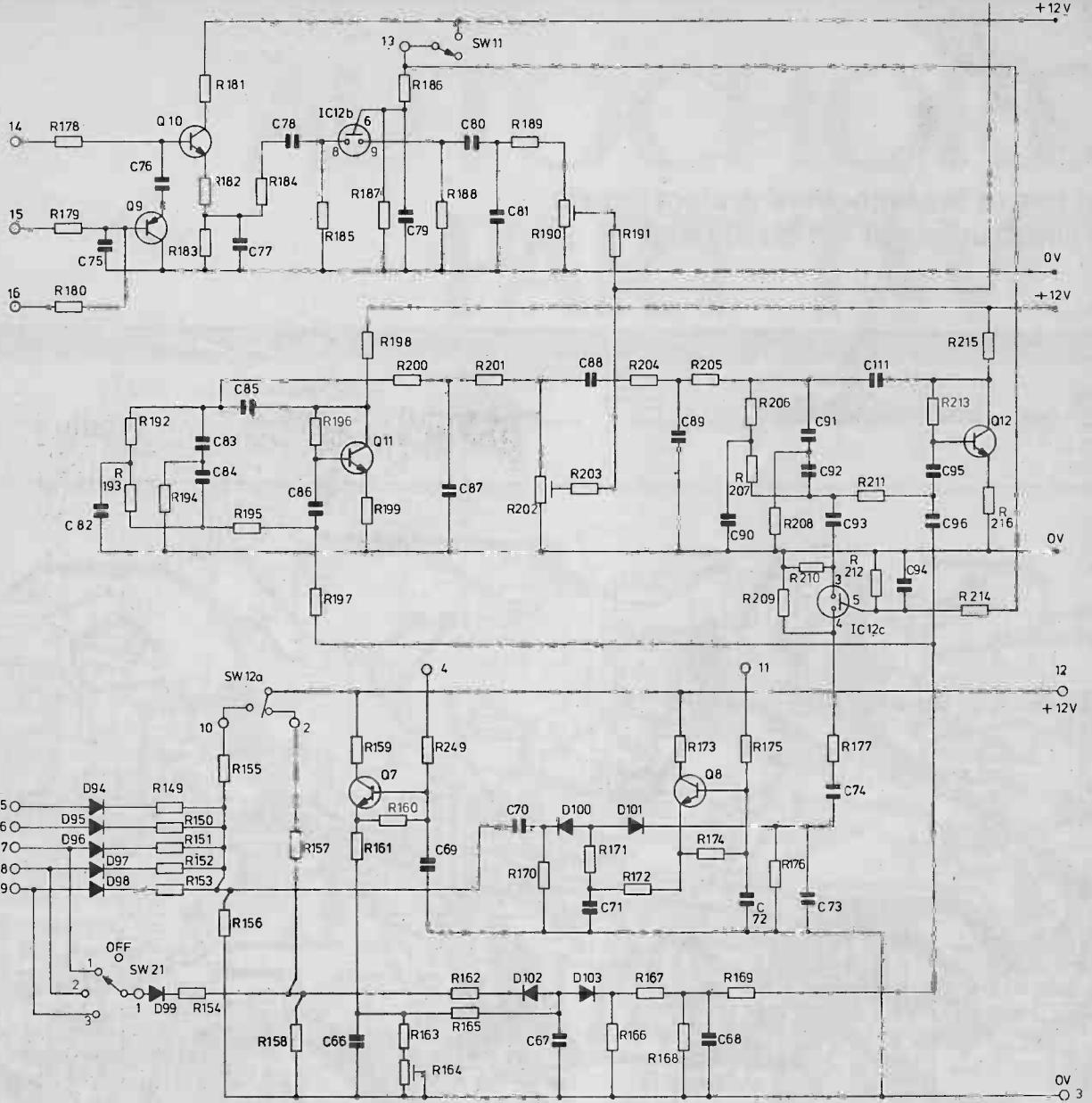

**KEYING ARRANGEMENTS**

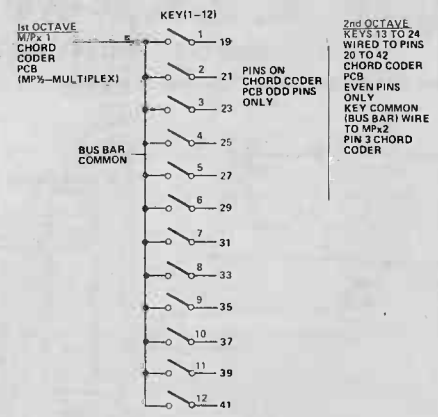

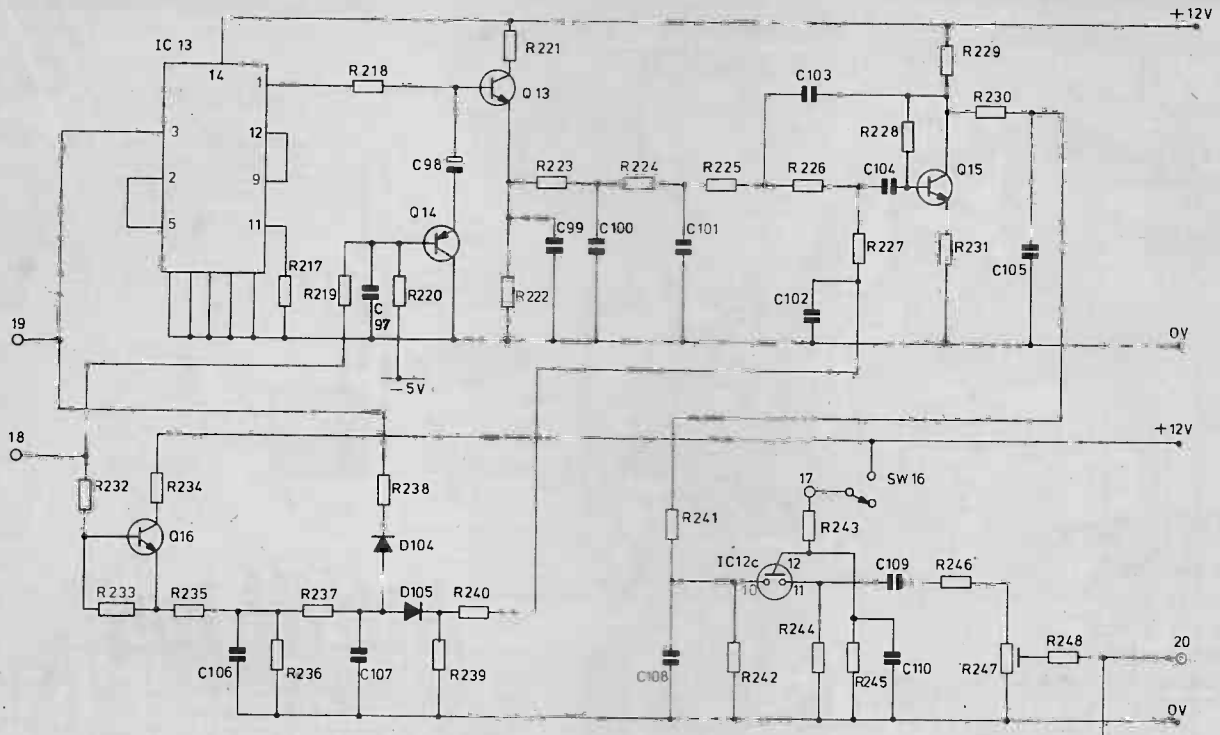

Above, and to the left, circuit diagram of the auto stop module

The overlay for the chord coder is shown below take care that all the diodes are inserted in the right position.

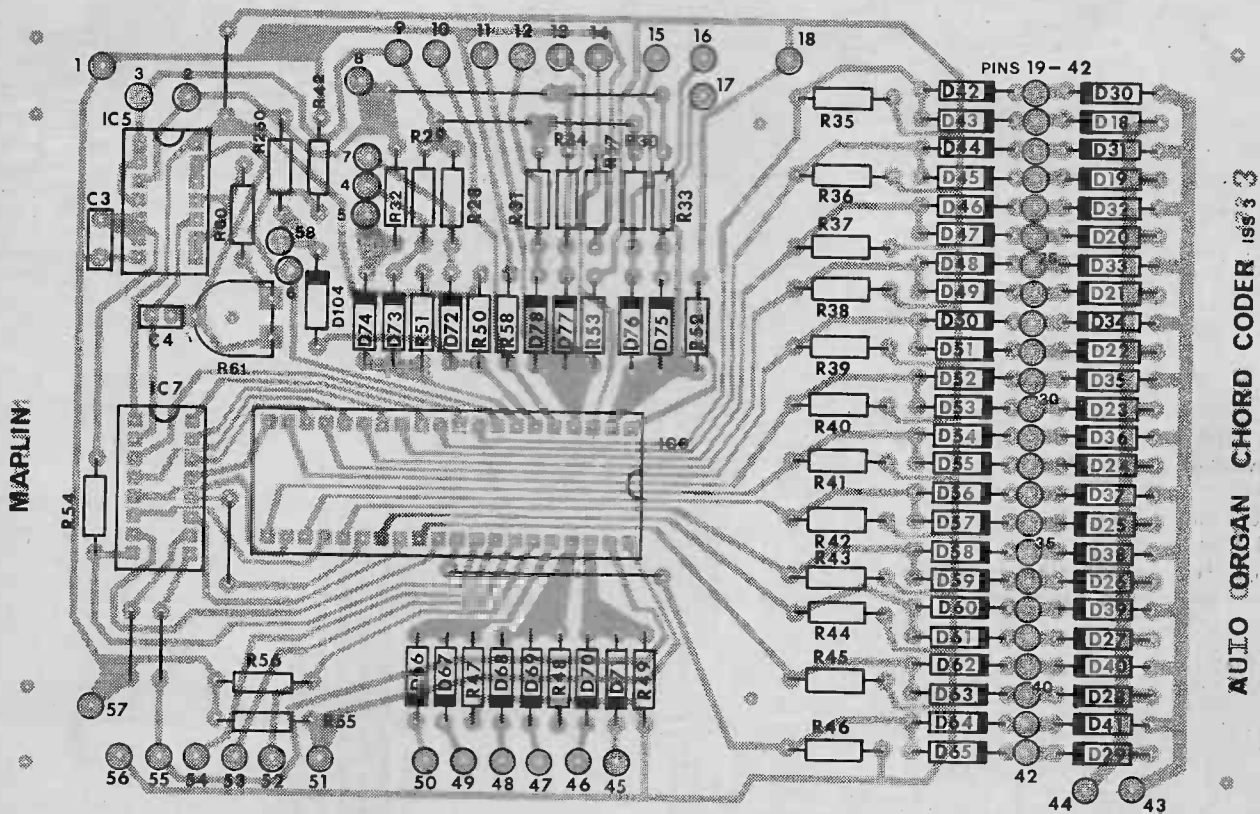



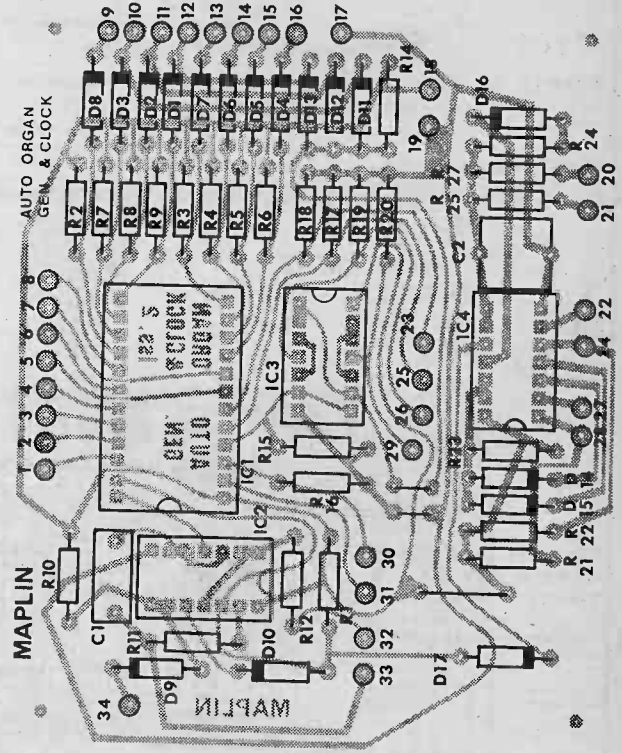
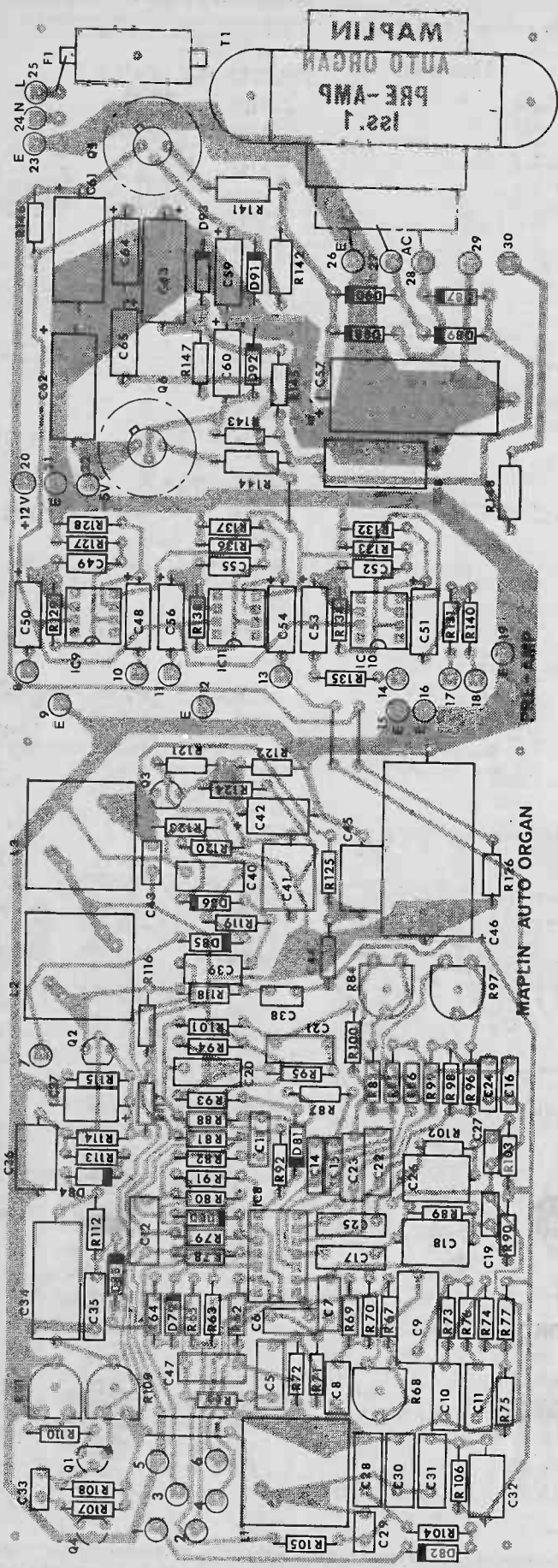

Left is the overlay for the generator and clock section of the auto organ.

Above the power supply and pre-amp board of the auto organ. The interconnections between this and the rest of the boards are shown in the accompanying drawings.

# audiophile

**Ron Harris takes to the high seas this month — well the Thames anyway — to discover a remarkable new drive unit from Strathearn. Back on dry land news of a linear motor tone arm . . . .**

IT WAS ENOUGH to make Nelson spin in his grave. One of Her Majesty's ships, battle-worn from the fire of enemy guns, put to use as an area to hold a press reception! And for something as totally unmaritime as loudspeakers!

Mind you, HMS Belfast can only be considered appropriate, for it was Strathearn Audio (based in Belfast and government owned) who sent me the music echoing through the wardrooms.

The occasion was the launching — for once no pun intended — of their new speaker system, the 21000. This is a 'four box' affair with the base units cast loose from the rest. Frequencies up to 500Hz are handled by the 8" bass drivers reflex mounted in the enclosures. Above 500Hz everything is produced by the real star of the system, Strathearn's new driver, the SLC2.

## Film Star?

The principle on which these speakers operate is very similar to that of the Wharfedale Isodynamic headphones. In the SLC2 an aluminium conductor, about a metre long, is bonded onto a polyester film which is stretched inside a moulded frame about 130mm x 600mm. Rows of magnets flank the diaphragm creating a high uniform field in the vicinity. When the signal current passes through the conductor it is driven by the force generated due to its being in a magnetic field.

Thus the polyester film is the speakers 'cone' if you like. Since this will radiate from both front and back (dipole radiation) the unit has damping pads fitted to absorb the anti-phase rear radiation. Mass of the driver is very low, so very little overhang to worry about. As the area is effectively all driven, it should not 'break up' at all on any input signal.

The only drawback is the very low impedance of the aluminium strip itself about OR5 in fact. In order to make this usable Strathearn have transformer coupled — which at least makes the unit adaptable to any required input impedance.

To claim, however, that this produces a purely resistive load is at best extremely optimistic, at worst

## Sound Track

I'm going to reserve judgement on the 21000 system as a whole until I've had an opportunity to listen under more favourable conditions than HMS Belfast at 100 F with 49 other people crowding me lugholes! It was clear though that the SLC2 is a remarkable unit, and is perhaps worthy of better. We shall see.

The system sells for £375 RRP, and is expected to have appeared in the shops by the time you can get down there.

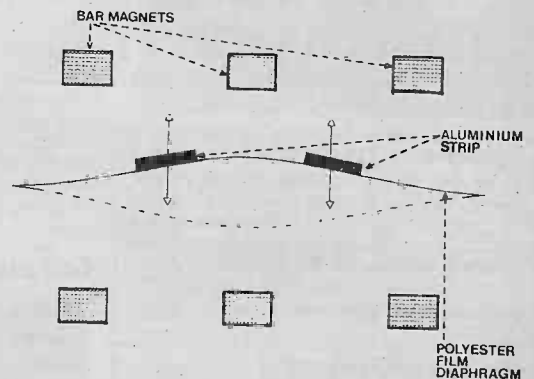
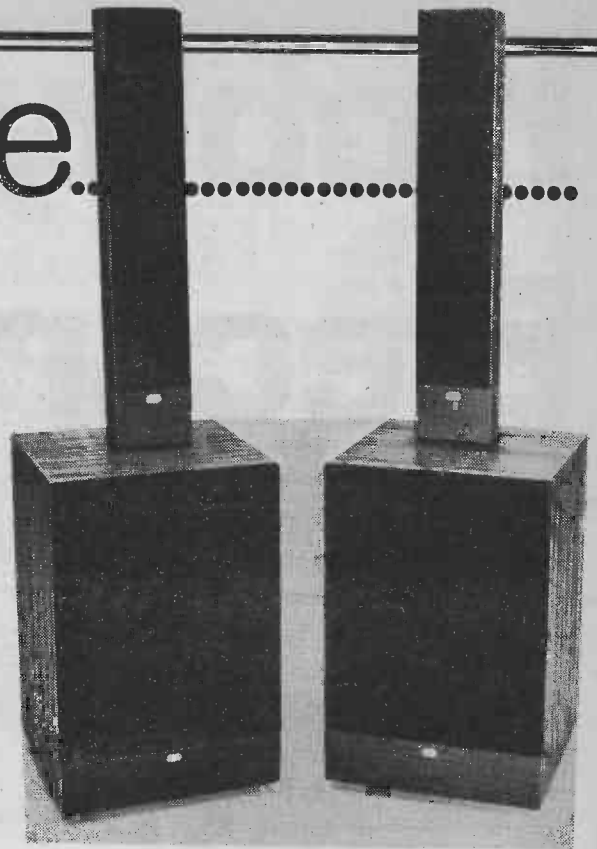

**The 21000 from all angles. At the top we have the full system. Below that the diagram shows the operating principle of the SLC1. The polyester diaphragm acts as the speaker cone. Below this caption two internal views of the unit. The radiating areas can be seen in the top diagram, and the lower rear view illustrates the damping material to control rear radiation.**

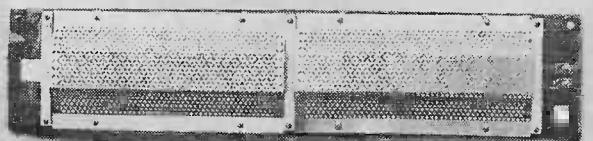
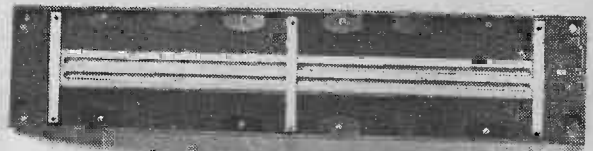

**Decked Out**

At the same demo Strathearn were using their SM2000 turntable as the sound source. It was a good advert. They had a line of Sonus, Supex, ADC, Shure and Ortofon cartridges all neatly installed in spare carry arms, and all of which tracked very well when asked to. Several people — me included — were surprised at the ease with which the SM2000 handled these devices and

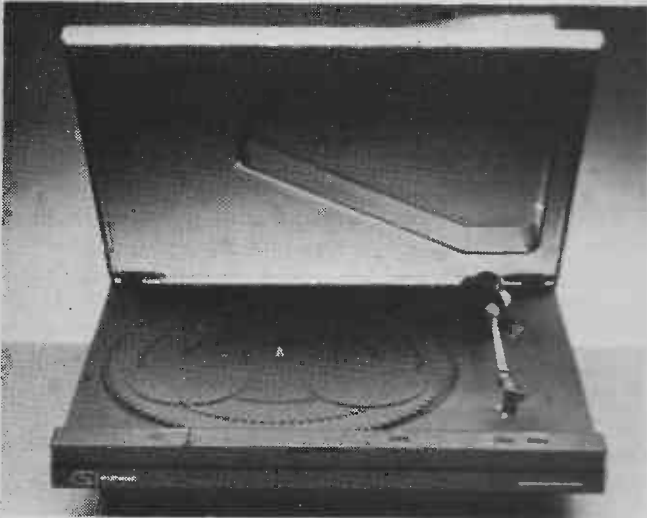

how well the sound each is capable of was preserved. Indeed on this evidence the SM2000 is a very capable unit indeed — a comparison with some better established machines (including schhh — you know what) might be very interesting indeed. How about it, Strathearn?

Details of both from Strathearn Audio Ltd, Kennedy Way Industrial Estate, Kennedy Way, Belfast.

**Arms Against The British?**

There can be only two basic ways of doing a job — simple and complicated. Both can take vast amounts of thoughts to realise (who said simple meant obvious?) and are capable of excellent results. Witness belt and direct drive turntables as represented by the Linn and the Technics SP10.

Sony have applied the latter approach to pickup arm design with the result that they end up with two linear motors, two velocity sensors, two position sensors, a deal of electronics and potentiometers to set tracking weight!

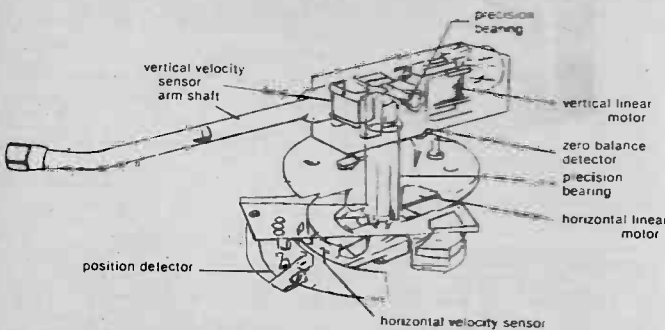

Exploded view of the Sony motorised pickup arm. Tracking weight is applied by a potentiometer mounted remotely on the plinth.

In fact the velocity sensors are simply two more linear motors used as generators. Servos drive the motors which take the arm across the record in the proper manner. In the vertical direction too all control of the arm movement is down to a linear motor. Arm resonance is suppressed, by varying the current to the coils — from somewhere around 25dB in an undamped system to about 3dB in the Sony system using their XL55 cartridge.

Right: A close up of the linear motors used in the arm design. These double as position sensors by using the same device as a generator, i.e. allowing them to be moved by the arm and measuring the current generated in the coils.

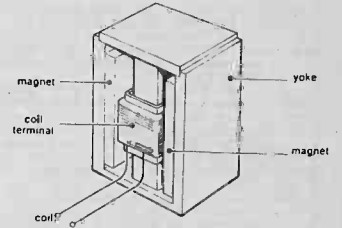

**Advantage Complications**

Gains from this method are claimed to be insensitivity to external vibration, improved tracking and better definition and imaginery. Bias of course can be forgotten, as the motor controls movement across the vinyl canyons, and tracking weight can be changed while the stylus is in action.

All this sounds well-nigh perfect does it not? On paper the design looks marvellous (so did the Titanic — cynic) but we shall have to wait until they market it in this country to find out how good it is. Meanwhile eat your heart out SME!

**From Service to Taste**

A little congratulation and a whoopee cushion to finish on. Firstly many thanks to Celestion for some fast excellent service this month. Some nameless person from the pit (no not me — another one!) blew a bass unit in one of our Ditton 66's. One phone-call later I was on my way to pick up a replacement from Ipswich. And that four years after buying the speakers — and it was our fault. Nice to be able to commend a big hi-fi firm for service for a change.

Now Audiophile enquiry service is normally dealing with people with impeccable taste. However it appears there is one exception. So that this person does not have derision heaped upon his unworthy shoulders and be cast from the company of his peers let us refer to him as Mr Smith.

This person wrote in — nothing wrong there you may say — he even dated his letter. Again nothing amiss about that. Trouble was he 'dayed' and timed it too. I quote with shaking head and furrowed brow . . .

"So at 8.05 pm on Thursday evening I am turning off some corny comedy on the television set to write enquiring about . . ."

There we have it. The heronious crime is in the open. Thursday eh? 8.05 eh? Corny comedy eh? The only comedy on TV at that time is the 'Good Life' — which any human male with a micro-gram of taste and appreciation of the opposite gender should be watching avidly for the glorious presence of Felicity Kendal!

Oh Mr Smith may your hi-fi forgive you — I cannot!

ETI

### 'Cold-start' For CD Units

T. Lyons

Many cars are fitted with cold-start coils, which operate at full current only on starting, then are fed via a ballast resistor. This resistor is normally discarded when CD ignition is fitted, and the coil is run at 'full power' all the time. It's a simple matter to arrange for the cold-start circuit to operate a relay inside the CD unit which switches in a second capacitor C2 across the main one, thus increasing the energy of the spark when the engine is starting. After starting, C2 is no longer in circuit and the main capacitor C1 alone supplied current to the coil, thus alleviating any charging problems with attendant loss of power at high revs.

RLA is any 12 volt relay, and C2 can have the same value as the existing capacitor C1, usually 470n or 1u0.

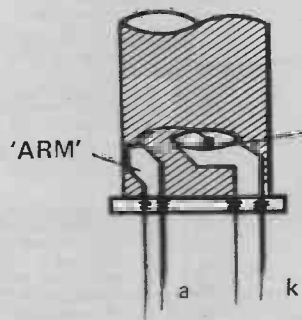
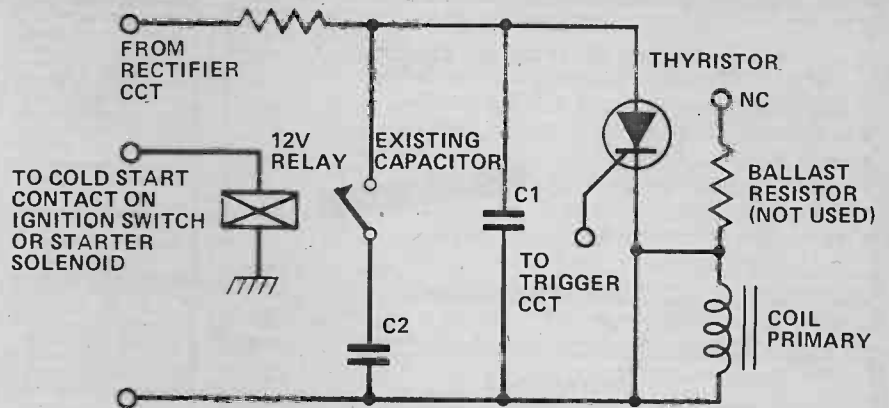

### LED Spotting

A. Kenny

Since the leadout on LED's varies according to the manufacturers preference, leadout diagrams are not always worthy of the trust placed in them. In some cases a reverse connection will destroy the device being used.

A simple way to avoid this is to use the following technique:

If the LED is held up to the light, the structure can be clearly seen. There is a "cup" and an "arm" carrying a fine wire to the LED itself, which is in the "basin" of the cup (see drawing).

The lead with the cup is the cathode, and the other is the anode (of course).

### TV Game Resurrection

S. Rice

Now that the novelty of TV games has worn thin and most of the units are gathering dust in the corner reserved for other five-minute wonders, here's a chance to add new spice to leisure time. The circuit is an oscillator clocking at about one cycle per 4 seconds. This switches the ball angle "randomly" making the game unpredictable and difficult. Also this prevents

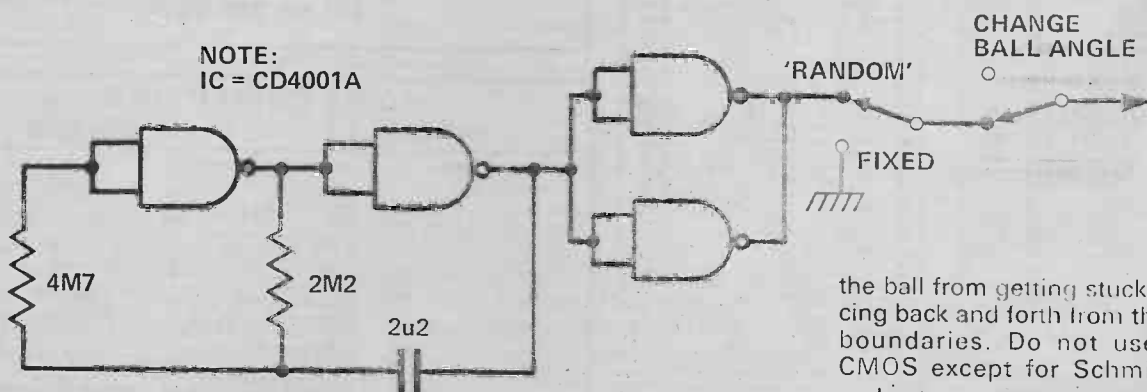

the ball from getting stuck and bouncing back and forth from the bats and boundaries. Do not use B suffix CMOS except for Schmidt trigger and gates.

Tech-Tips is an ideas forum and is not aimed at the beginner. We regret we cannot answer queries on these items.

ETI is prepared to consider circuits or ideas submitted by readers for this page. All items used will be paid for. Drawings should be as clear as possible and the text should preferably be typed. Circuits must not be subject to copyright. Items for consideration should be sent to ETI, TECH-TIPS, Electronics Today International, 25-27 Oxford St., London W1R 1RF.

# digest



## Less than (h)armless?

This mechanical arm is controlled by a microcomputer and has been designed to enable even the most severely paralysed patients to fend for themselves. The electronic super-arm of the future was amongst new developments shown for the first time at a two-day 'Aids to Independence' exhibition organised by North Surrey, Community Health Council at Ashford Hospital, Middlesex.

Although the arm is only in its prototype form, Dr. Jackson Todd of Queen Mary College, London (pictured above), demonstrated that it could be programmed to carry out separate or a series of quite delicate movements. A patient only able to move his head could con-

trol it using a stick held in his mouth to activate control buttons.

The so-called bionic arms that are now becoming available depend on the patient having some muscle movement. But this microprocessor controlled version can be programmed to carry out any type of function independently of the patient. The project has been underway at Queen Mary College for about a year and the control system, believed to be the first of its kind in the world, is complete. The next step is to produce a properly engineered prototype arm and integrate it with the input devices and the microprocessor control unit.

For further information contact:  
Tom West, Director of Public Relations, Surrey Area Health Authority.



## It's not all old hat

A new magazine is to be launched soon — January

— specifically for enthusiasts of vintage sound equipment. It will be bi-monthly and on subscription only. Among the areas covered will be wireless equipment, gramophones and cylinders, valves pre-war pioneering exploits and tales of the companies involved.

It will begin life as a 32 page job and sample Nols can be obtained for 65p all inc. Subs rates will be £5.80.

U.K. Sounds Vintage, 28 Chestwood Close, Billericay, Essex.

## NON-SUBSCRIBERS START HERE

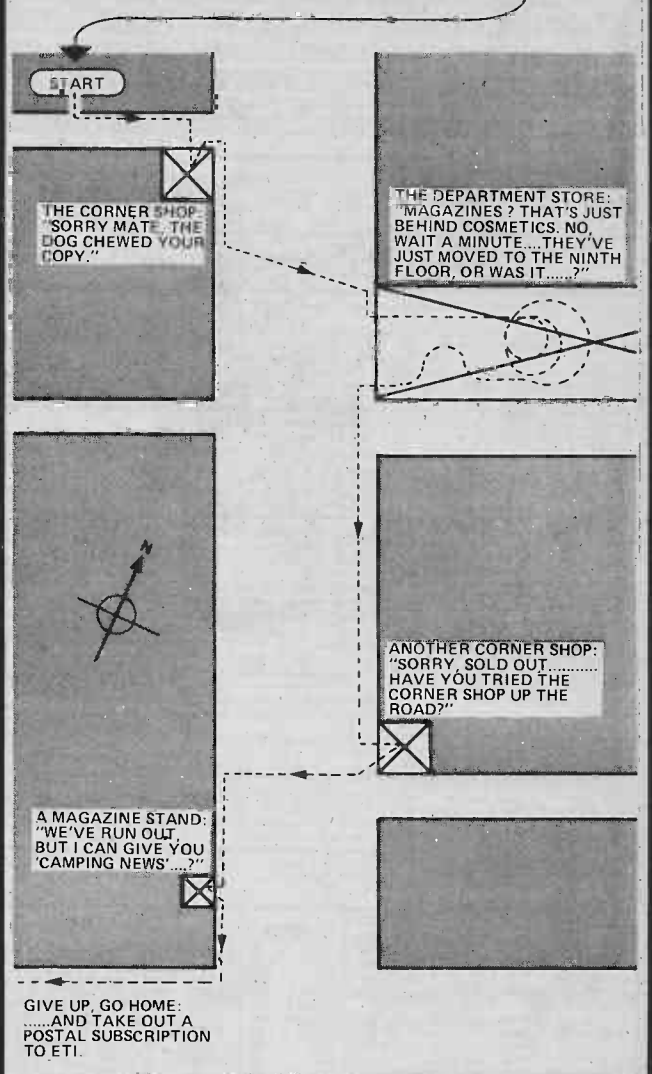

It can be a nuisance can't it, going from newsagent to newsagent? "Sorry squire, don't have it — next one should be out soon."

Although ETI is monthly, it's very rare to find it available after the first week. If it is available, the newsagent's going to be sure to cut his order for the next issue — but we're glad to say it doesn't happen very often.

Do yourself, your newsagent and us a favour. Place a regular order for ETI; your newsagent will almost certainly be delighted. If not, you can take out a postal subscription so there's nothing for you to remember — we'll do it for you.

For a subscription, send us £7.00 (£8.00 overseas) and tell us which issue you want to start with. Please make your payment (in sterling please for overseas readers) to ETI Subscriptions and keep it separate from any other services you want at the same time.

**ETI Subscription Service**  
**Electronics Today International**  
**25-27 Oxford Street, London W1R 1RF**

### Automatic Stereo Tuner

J. P. Macaulay

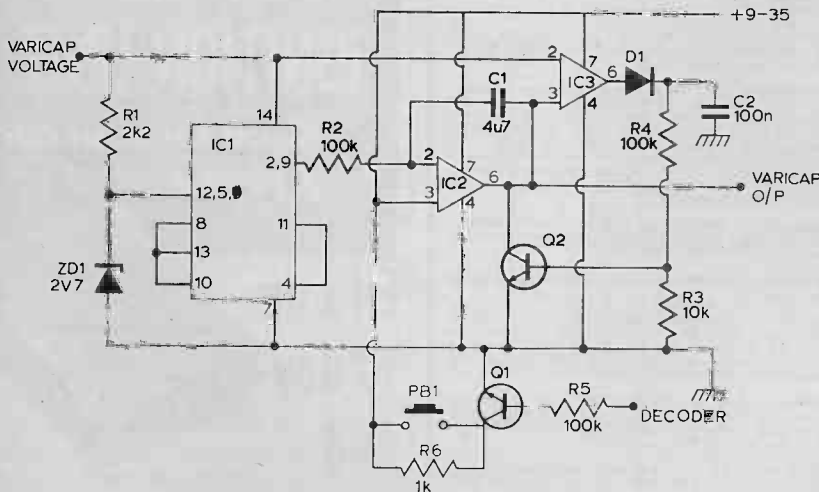

The circuit shown will automatically tune an FM tuner to stereo broadcasts only. On switch on the indicator pin of the stereo decoder is at 0V. In consequence Q1 is biased off and pins 6 and 3 of IC1 are at the positive varicap supply voltage. As this IC, a 4007, is wired as a transmission gate this voltage holds the gate on. The impedance across the gate is in the region of 300 ohms. IC2, a 741, is used as an integrator, the input voltage from across ZD1 is connected through the gate. The output of this IC therefore is a positive going ramp which is fed to the varicap tuning diodes.

On reception of a stereo broadcast the voltage at the decoder indicator pin goes positive driving Q1 into saturation and closing the transmission gate.

Since the closed position of the gate places an impedance of the order of  $10^9$  ohms in series with the integrator the output is "frozen" keeping the station in tune. This state of affairs continues until PB1 is pressed, whereupon the integrator will once again start to ramp positively in search of another station.

A second 741, IC3, is used as a comparator. The varicap voltage is sampled by the inverting input whilst the tuning voltage feeds the non-inverting input. As soon as the tuning voltage reaches the same level as the varicap voltage the comparator's output swings positive forward biasing Q2 and discharging C1. The circuit will now go through the entire sequence again.

The varicap voltage must not exceed 15V unless the transmission gate is operated from a stabilised supply of less than 15V output. The supply line to the op amps should be several volts greater than this.

### Rain Alarm/Door Bell

S. Lamb

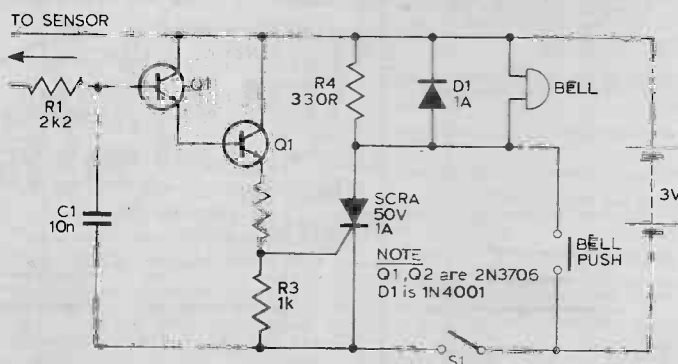

With S1 open the circuit function as a doorbell. With S1 closed, rain falling on the sensor will turn on Q1, Q2 and the thyristor will trigger activating the

bell. R4 provides the holding for the thyristor while D1 prevents any damage to the thyristor from back EMF in the bell coil. The sensor is

made from 3 square inches of copper clad board with a razor cut down the centre. C1 prevents any mains pickup in the sensor leads.

### Unijunction Pulse Stretcher — Door Bell Extender

D. Wedlake

The circuit presented is a practical monostable timer which was designed to extend the ringing time of a door bell. It can be useful in cases when the bell push button might not be engaged long enough to attract attention, though it could be used in many other applications.

When the push button is closed the thyristor will switch on delivering power to the unijunction transistor timing circuit and energising the relay, the contacts of which are used to control the bell circuit. At the same time, capacitor C2 quickly charges to the load voltage potential via R3. After a time interval given approximately by  $0.8 C1 R1$  (about 6 seconds in this case) the unijunction transistor will fire and the corresponding output pulse which is coupled to

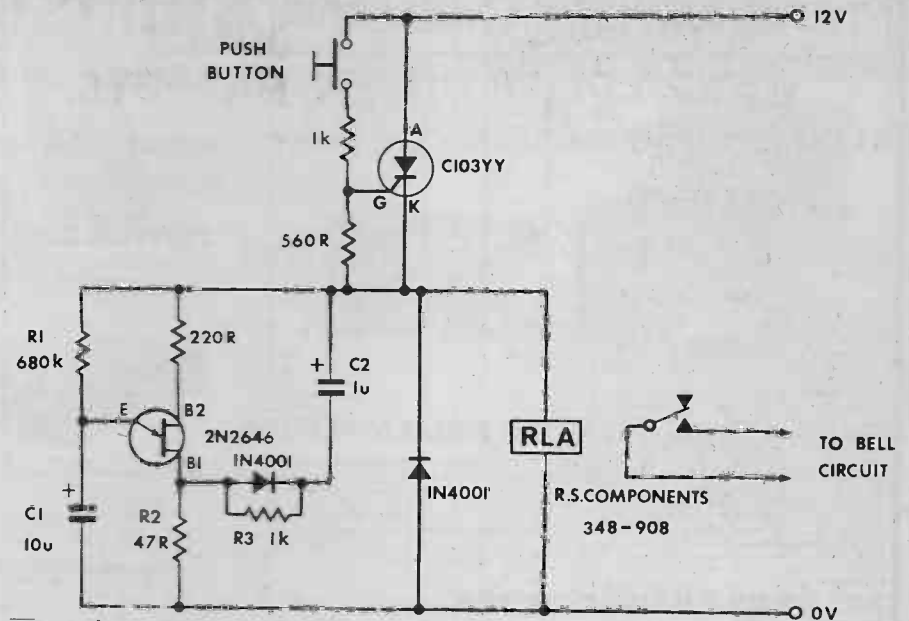

the cathode of the thyristor via C2 will put the thyristor in reverse bias switching it off. With these values the relay will become energised for at least 6 seconds.

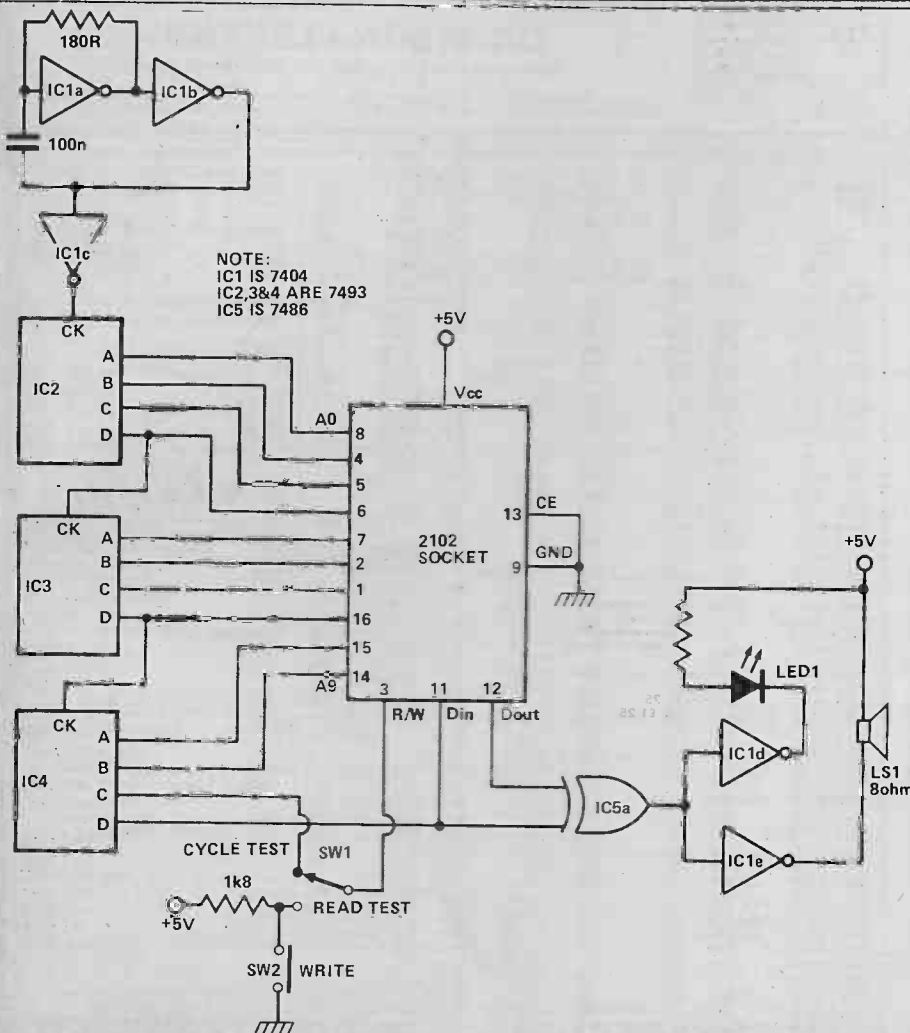

### 2102 Memory Tester

S. Sunderland

This circuit provides for the testing of 1024 Bit X1 memories, such as the 2102 series, in two modes. Mode-1 cycles the memory continuously through write and read, alternately writing zeros and ones then reading to ensure the write was successful. Mode-2 allows the write of a signal onto the memory, then continuously reads it to ensure the data is stable.

In both modes, the output from the memory is compared with what should be there, and if there is a difference, an LED flashes, accompanied by a click from the speaker. In mode-2, on power on, a continuous noise will be heard from the speaker, on pressing the 'WRITE' button this should vanish, similarly, a brief pulse of noise will be heard in mode-1 before the write is completed. The oscillator frequency is about 20 kHz with components shown.

In mode-2, when the supply voltage drops below 4.5V memory is not stable for more than a fraction of a second, although this does not show up using mode-1.

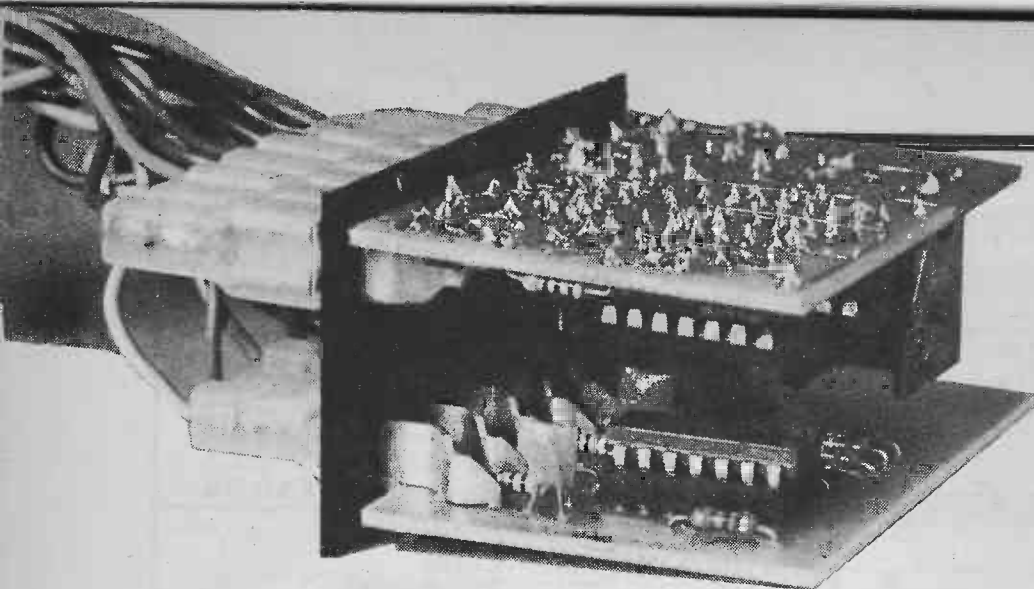

**A straightforward, low cost design, with a number of sophisticated features, that should protect your car from unwelcome attention.**

# CAR ALARM

THERE IS ONLY ONE way to ensure that you never have a car stolen and that is not to be stupid enough to buy one in the first place. However accepting the fact that many of us will feel the need to own a car how do we ensure that it remains ours amongst the ever increasing crime levels in this country. Well you could do worse than to fit the alarm system described here. Not only does this system protect the car itself, monitoring all doors and disabling the ignition when set, but also offers protection to the car's accessories.

The alarm provides an entry and exit delay before the horn is sounded, this means that there is no need to fit an external lock switch to the car. When leaving, the concealed alarm switch is activated whereupon the owner has 30 seconds before the alarm is set. On entry a 15 second delay is provided.

When triggered the system will sound the horn intermittently for two minutes before resetting. However, if the initial cause of the alarm is still present, the alarm will retrigger.

The alarm provides for both active high and active low inputs allowing all types of sensor to be employed.

An additional accessory protection module provides an independent monitor of the car's accessories.

Construction is quite straightforward. The use of Incar connectors will allow the unit to be readily fitted and removed from any

## BUYLINES

Compu-Tech Systems of 7 Sandhole Lane, Lt Plumstead, Norwich, NR13 5HZ will supply a complete kit of parts for this project.

car. These connectors should be fitted first. The rest of the components can then be fitted as shown in the appropriate overlay. Note that any polarity sensitive device is mounted in the correct position. The main board's jumper should be fitted when construction is complete. If your car's horn has one wire coming from it fit jumper A, if it has two wires with one going to earth also fit jumper A. If the horn has two wires neither going to earth, fit jumper B.

With construction complete the PCBs can be glued into the housing chosen for the alarm.

Installation of the alarm in the car must be left up to the constructor. The overall interconnection diagram is shown and it should be clear how to proceed in general. The detailed installation will however vary widely from car to car.

## PARTS LIST

### RESISTORS

R1,9	1k0
R2	100R
R3	1M0
R4,5,7,8,10	10M0
R6,11	4k7
R12	47R
R13	4M7

### CAPACITORS

C1,2	10n ceramic
C3	16u 16 V tantalum
C4,6,7	4u7 16 V tantalum
C5	47n polyester

### SEMICONDUCTORS

IC1,2	4001
Q1	BC337
D1-7	1N4148
ZD1	15 V 400mW

### SWITCH

SW1	DPDT
-----	------

### RELAY

RLa	12 V 85R with 15A contacts
-----	----------------------------

### MISCELLANEOUS

PCB as pattern, connectors, case to suit, cable, etc.

### RESISTORS

R14,16,18,20	10k
R15,17,19,21	100k
R22,24	100R
R23	1k0

### CAPACITORS

C8-13	10n ceramic
-------	-------------

### SEMICONDUCTORS

IC3	4002
D9	1N4148

### SWITCH

SW2	SPST
-----	------

### MISCELLANEOUS

PCB as pattern, connectors, cable, etc.



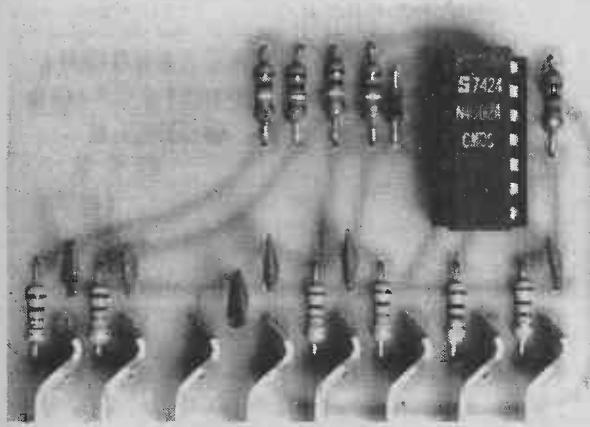
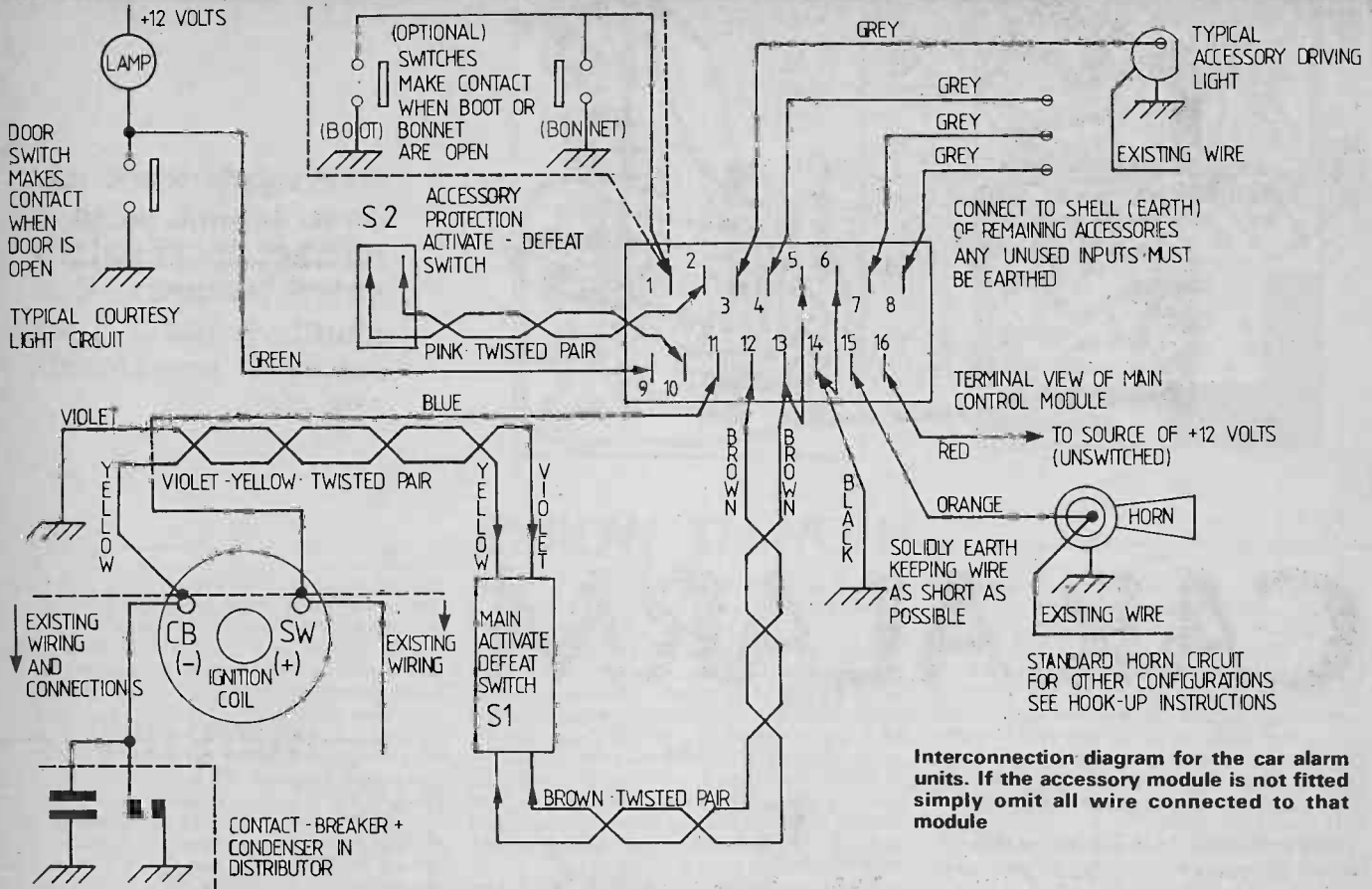

Overlay for the accessory protection board.

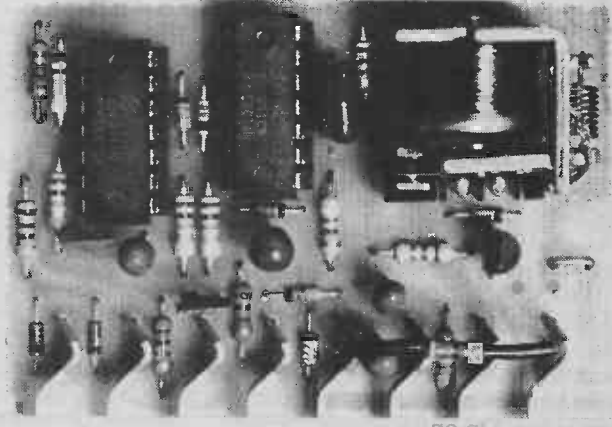

Overlay for main control board.

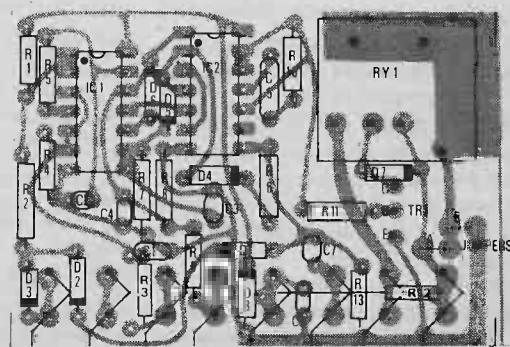
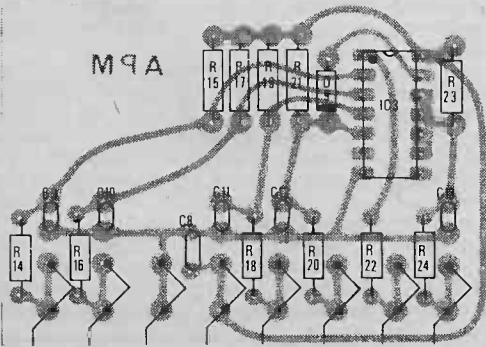

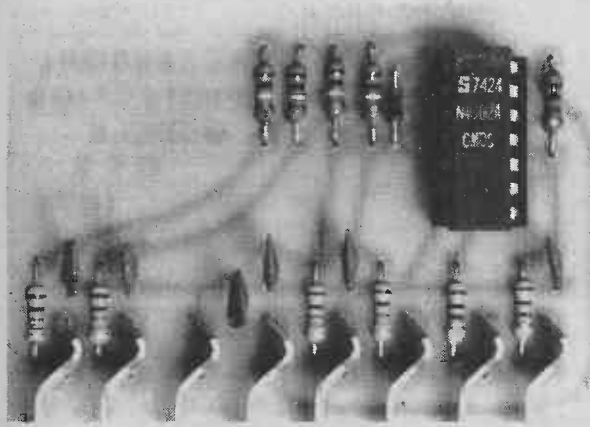
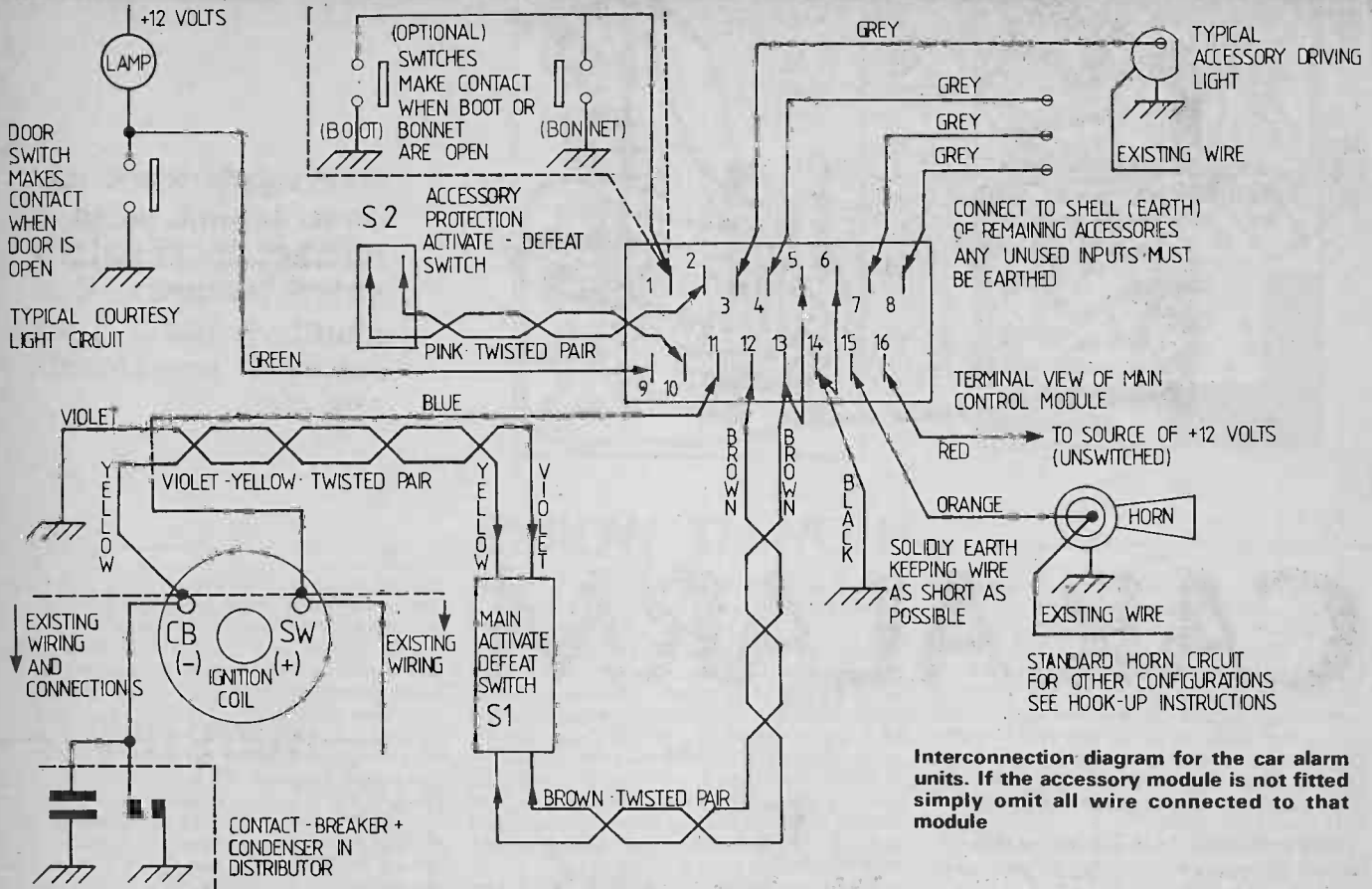

Overlay for the accessory protection board.

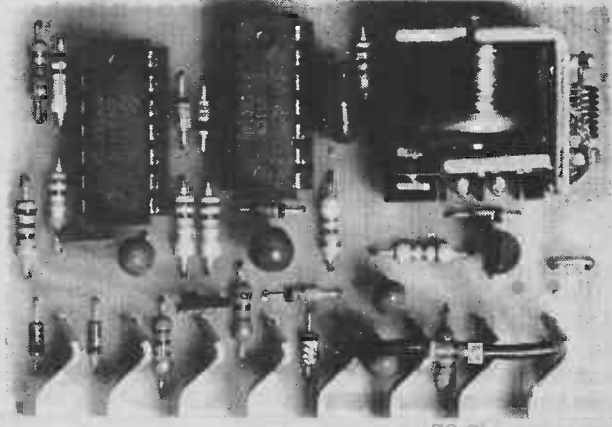

Overlay for main control board.

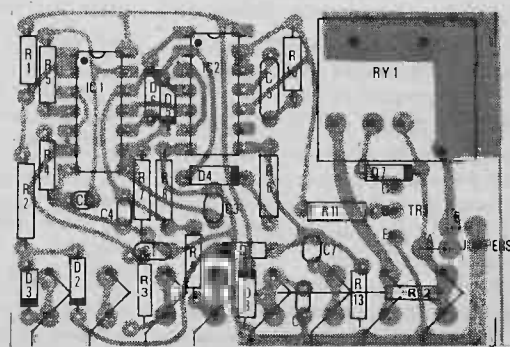
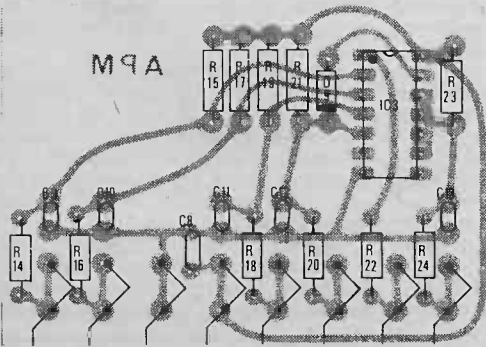

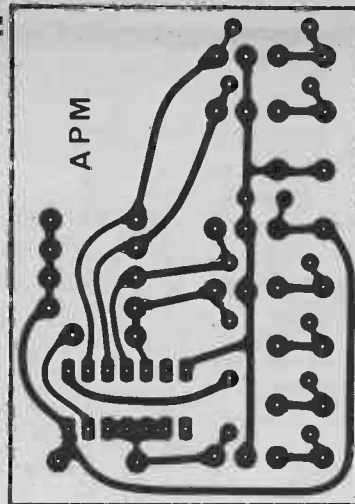
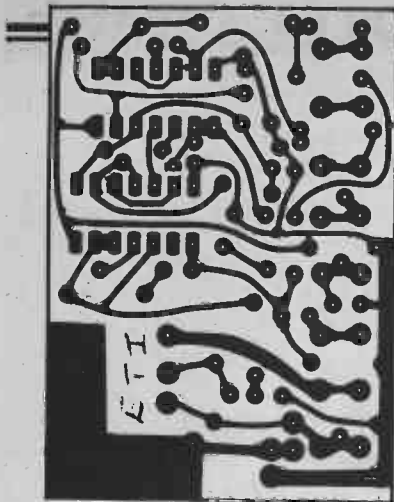

To the far left is the foil pattern for the main control unit while left is the accessory module's PCB layout.

## HOW IT WORKS

In the quiescent state with the alarm defeated via S1 the following logic levels are present at the outputs of the gates indicated. IC1a-0, IC1b-1, IC1c-0, IC1d-0, IC2a-1, IC2b-0, IC2c-0, IC2d-1, transistor Q1 is cut-off, and RY1 is de-energized. R12, ZD1 and C6 form an overvoltage and electrical noise suppression circuit that protects the power supply rail of the circuit from spikes and battery overvoltage. The input of IC1a is held at logic 1 by pull-up resistor R1. R2 protects the input of IC1a from noise spikes.

If an earth appears at the inputs taken to D2 and D3 the logic 1 normally present at the input of IC1a changes to logic 0 which is inverted to a logic 1 by IC1a and connected to pin 5 of IC1b. D2 and D3 isolate the two inputs from each other. The input at D2 has a special function which is explained at the end of the text. Pin 6 of IC1b is held at Logic 0 by pull-down resistor R4. R3 and C1 form a noise suppression circuit for this input. If this input goes to +12 volts a logic 1 will be present at pin 6 of IC1b. Thus under normal conditions both inputs of IC1b are at logic 0 and in any alarm condition the input(s) will be at logic 1. Any logic 1 at the input of IC1b will force its output to logic 0. R5 and C2 form another noise suppression circuit to increase the noise immunity and prevent any noise spikes from reaching pin 13 of IC1c.

Whenever S1 is in the DEFEAT position a logic 1 is present at pin 12 of IC1c and pin 1 of IC2b. This logic 1 is buffered by R9 (spike protection). With a logic 1 at pin 12 of IC1c the output of this gate will remain logic 0 and ignore the input at pin 13. The vehicles ignition system works normally with S1 in the DEFEAT position. By placing S1 in the ACTIVATE position an earth is placed across the contact breaker and the vehicles ignition system will be disabled. Also when S1 is in the ACTIVATE position the logic 1 is removed from R9 and C4 will begin to discharge thru R8. D6 prevents C4 from discharging into IC1d.

In approximately 30 seconds C4 will have discharged to the threshold of IC2b pin 1 and IC1c pin 12 and a logic 0 will now be present at these points. The logic 0 present at pin 12 of IC1c will enable it and any alarm condition sensed by the inputs will be reflected by a logic 1 being present at the output of IC1c which is passed to IC2a pin 5. The 30 second delay after S1 changes states to the ACTIVATE position and IC1c being enabled is the EXIT delay.

IC2a and IC2b form a set reset flip-flop with the normal state as a logic 1 at pin 4 of

IC2a. It is set by a logic 1 at pin 5 of IC2a (alarm condition) and is reset by a logic 1 at pin 1 of IC2b (defeated or timed reset/validate condition). Once the flip-flop changes states it can only be changed back again by applying a logic 1 to the opposing input. Thus even a momentary logic 1 at pin 5 of IC2a would latch the flip-flop into the alarm status and initiate the alarm sequence. A momentary logic 1 would be generated by opening one of the vehicles doors and then closing it. When the flip-flop senses a logic 1 at pin 5 of IC2a it will change state and lock with a logic 0 at pin 4 of IC2a.

When the logic 0 appears at pin 4 two things happen: First C7 will begin to discharge through R13, D4 prevents C7 from discharging into IC2a. In approximately 15 seconds C7 will have discharged to the threshold of IC2c and a logic 0 will be present. With a logic 0 at pin 8 of IC2c the 1 Hertz astable multivibrator formed by IC2c, IC2d, R10 and C5 is enabled. Pin 10 of IC2c will alternate between logic and Logic 1 at a 1 Hertz rate driving Q1 in and out of conduction via R11. As Q1 goes in and out of conduction RY1 energizes and de-energizes, closing and opening the contacts. These contacts are wired thru jumper "A" or "B" providing a pulsating +12V or pulsating earth which is connected to the horn circuit sounding the horn and raising the alarm. The 15 second delay between the flip-flop changing states (alarm detected) and the horn beginning to sound is the ENTRY delay.

The second thing that happen when the flip-flop changes states is that C3 will begin to discharge thru R7, D5 prevents C3 from discharging into IC2a. In approximately 2 minutes C3 will have discharged to the threshold potential of IC1d and a logic 0 will be present. IC1d inverts this to a logic 1 and presents it via D6 to pin 1 of IC2b resetting the flip-flop and to pin 12 of IC1c inhibiting the alarm condition (if present) from reaching IC2a. When the flip-flop resets a regenerative action takes place and begins to recharge C3 and C7. When C3 has charged past the threshold of IC1d a logic 0 will be present at its output and IC1c will be enable in a few seconds as the small charge placed on C4 prior to the regenerative action will have discharged thru R8. If the alarm is no longer present C3 and C7 will completely charge and the alarm will reset and wait for another intrusion. If the alarm condition is still present the flip-flop will again latch and the small charges that developed on C3 and C7 will discharge thru R7 and R13 respectively

in a few seconds. Thus every two minutes the alarm will reset itself for approximately 3 seconds and then start over again.

This cycle is the RESET/VALIDATE cycle and is provided to prevent the battery from being completely discharged by a momentary intrusion. The input T(OD)2 is a special function input and is for use with the accessory protection module. When this input goes to earth C7 is immediately discharged via D1 and the alarm will begin to sound. R6 prevents IC2a from being destroyed by the pull-down action. This earth is sensed by IC1a and will latch the alarm (providing the exit delay cycle is complete). This input is verified by the RESET/VALIDATE cycle in the manner described above. The main ACTIVATE/DEFEAT switch S1 does not affect this input making it completely independent of the main system.

### Accessory Protection Module — Theory of Operation

In the quiescent state IC3a output is logic 1 and the output of IC3b is logic 0. Under normal conditions, i.e. no alarms sensed, all inputs to IC3a will logic 0 (sunk to earth via R14, R16, R18, R20 and the sense wires). The input to IC3b will be open or at +12 volts, R23 being the pull-up resistor for an open circuit, R23-C13 are noise suppression components. C8 by-passes any noise present on the supply rail to earth. If any of the sense wires open R15, R17, R19, or R21 will pull the respective input to logic 1. C9 thru C12 in conjunction with R14, R16, R18, R20 form a noise suppression circuit for these inputs. Any logic 1 present at IC3a inputs will result in a logic 0 at the output which is connected via buffer resistor R22 to the unit's output. This is connected through ACTIVATE/DEFEAT switch S2 to the main control unit. S2 has been provided to make the accessory protection system independent of the main system and will normally be activated continuously.

An earth at the active low I/P will force the output of IC3b to logic 1. This logic 1 is coupled via D9 to IC3a forcing pin 5 to logic 1 regardless of the status of the sense wire this will result in a logic 0 at the output of IC3a as explained above. D9 is provided to that IC3b can only force pin 5 of IC3a to logic 1, it cannot force it to Logic 0.

Any time a logic 0 is present at terminal ( ) and S2 is in the activate position the alarm will sound immediately as explained in the description of the main control unit.