

Easy to build projects for everyone

AUG. 81

60p

Everyday ELECTRONICS



FUND RAISING FUN FOR ALL



CMOS METRONOME

L.E.D. SANDGLASS

SIMPLE pH METER

GIANT SUPERPRINTS PLUS FREE FILM

30% MORE PRINT AREA



Fast, efficient, high quality film processing is now as close to you as your nearest post box. Hundreds of thousands of magazine readers are delighted with this reliable Colour Print Film Service—and the replacement film that comes free every time they use it! So why don't you give it a try?

Here's what you do. Send any make of colour print film inside the envelope enclosed in this issue. Or fill in the coupon below and send it with your colour film in a strong envelope to:

Everyday Electronics Colour Print Service, Freepost, Teddington, Middlesex TW11 8BR. No stamp is required.

SEND NO MONEY

We are so confident in the reliability of the service and the quality of our prints, (each one is date stamped with the month and year of developing) that you don't pay until you have received them!

LUXURY COLOUR PRINTS

You will be amazed at the beautiful colours and hi-definition

In the event of any query, please write to: Customer Relations Dept., Colour Print Express Ltd., 19-21 Lower Square, Isleworth, Middlesex, or phone 01-568 6565.

sheen finish of the prints we supply... with elegant rounded corners and borderless to give you maximum picture area. And now with the new Giant Superprints you get 30% more picture area than the standard enprints at no extra cost.

UNBEATABLE VALUE

The new Giant Superprints cost you only 17p each and a further charge of £1.10 is made towards developing, postage and packing. That's all you pay and, when we send your prints, a replacement film, of the size you use, is included absolutely free. That's a saving of up to £2.19.

The offer is limited to the U.K. For Eire, C.I. and B.E.P.O., a handling surcharge will be made.

Offer etc. Minolta & Sub-miniature film. Roll film 2 1/2 inch format. 400 ASA. 2 1/2 inch format. Superprints can only be produced from Kodacolor II, C41 and Agfa CNS cassette and cartridge film not half frame. Prices correct at time of going to press.

FREE ALBUM SHEETS

One album voucher is sent with each film we process. Collect 3 vouchers and we send you a set of FREE album sheets to fit into our specially designed album to show off both superprints and standard prints.

MORE BENEFITS TO YOU

You benefit in two additional ways. Firstly, you enjoy a personal service with every care taken over each individual order. And secondly, you pay only for what you get—with no credit vouchers as with many other companies. An invoice comes with your prints, so it is a straight business transaction.

Your prints will normally be despatched within five working days of receipt, but please allow for postal times and possible delays.

Use this label if you have no envelope, or pass it to a friend. It is used to send your prints and FREE film.

From: Everyday Electronics Colour Print Service, Freepost, Teddington, Middlesex, TW11 8BR. Please print my film Superprint/Standard Enprint size (delete one which is not required).

Mr/Ms _____

Address _____

Postcode _____ EE 8/81

Make us your No. 1 SUPPLIER OF KITS and COMPONENTS for E.E. Projects. We supply carefully selected sets of parts to enable you to construct E.E. projects. Kits include ALL THE ELECTRONICS AND HARDWARE NEEDED. Printed circuit boards (fully etched, drilled and roller tinned) or veroboard are, of course, included as specified in the original article, we even include nuts, screws and I.C. sockets. PRICES INCLUDE CASES unless otherwise stated. BATTERIES ARE NOT INCLUDED. COMPONENT SHEET INCLUDED. If you do not have the issue of E.E. which includes the project—you will need to order the Instruction reprint at an extra 45p each. Reprints available separately 45p each + p. & p. 40p.

BURGLAR ALARM SYSTEM, June 81 Less bell, loop switches, & microphones	£34-82
TAPE AUTO START, June 81	£10-88
TREMOLO, June 81 Less case	£9-51
LOOP AERIAL CRYSTAL SET, June 81	£4-98
LIGHTS REMINDER AND IGNITION LOCATOR E.E., May 81	£4-81
SOIL MOISTURE INDICATOR E.E., May 81	£3-49
T. V. INTERFERENCE FILTERS E.E., May 81. LOW PASS less tinplate £2-62. HIGH PASS £1-42	
GUITAR HEADPHONE AMPLIFIER E.E., May 81	£3-60
PHONE BELL REPEATER/BABY ALARM E.E., May 81	£4-81
Rectangular case.	
AUDIO TEST SET E.E., May 81, £40-84. Less case. Case extra	£6-95
DIGITAL RULE (ultrasonic), April 81	£27-46
INTERCOM, April 81	£18-88
FREEZER ALARM, April 81	£11-30
SIMPLE TRANSISTOR & DIODE TESTERS, Mar. 81	
Ohmmeter version	£1-72
Led version	£2-33
MINI SIREN, Mar. 81	£6-84
LED DICE, Mar. 81	£7-18
LED FLASHER, Mar. 81	£3-70
MODULATED TONE DOORBELL, Mar. 81	£5-65
BENCH POWER SUPPLY, Mar. 81	£47-98
TREBLE BOOST, Mar. 81	£6-22
CAR ACTUATED DRIVEWAY LIGHT, Feb. 81 less socket	£21-73
THREE CHANNEL STEREO MIXER, Feb. 81	£15-89
SIGNAL TRACER, Feb. 81	£6-95 less probe
FOUR BAND RADIO, Feb. 81	£39-98
Ni-Cd BATTERY CHARGER, Feb. 81	£11-57
ULTRASONIC INTRUDER DETECTOR, Jan. 81 less case	£45-98
AUTO SLIDE CHANGER, Jan. 81	£8-44
PHASER SOUND EFFECTS, Jan. 81	£32-83
LOGIC PULSE GENERATOR, Jan. 81	£6-80
2 NOTE DOOR CHIME, Dec. 80	£8-78
LIVE WIRE GAME, Dec. 80	£9-95
SOUND TO LIGHT, Nov. 80, 3 channel	£18-95
GUITAR PRACTICE AMPLIFIER, Nov. 80	£10-96 less case
Standard case £3-58. High quality case £8-33.	
SOIL MOISTURE MONITOR, Nov. 80	£4-94 inc. probes
TRANSISTOR TESTER, Nov. 80	£9-89 inc. test leads
AUDIO EFFECTS UNIT FOR WEIRD SOUNDS, Oct. 80	£11-15
PHONE CALL CHARGE JOGGER, Oct. 80	£6-19
BICYCLE ALARM, Oct. 80	£8-80 less mounting brackets
IRON HEAT CONTROL, Oct. 80	£4-99
DARKROOM CONTROLLER, Oct. 80	£21-65 case differs
BEDSIDE RADIO, Sept. 80	£15-98
TTL LOGIC PROBE, Sept. 80	£4-41
TTL POWER SUPPLY UNIT, Sept. 80	£13-72
CRICKET GAME, Aug. 80	£17-42
WEATHER GAME, Aug. 80 (less case £39-98)	£73-78
AUDIO MILLIVOLTMETER, Aug. 80	£17-86
AUTOPHASE, June 80. Rectangular Case	£21-41
COURTESY LIGHT DELAY, June 80	£6-09
A.F. SIGNAL GENERATOR, June 80	£22-54
AUTOWAA, June 80. Rectangular Case	£21-33
G.P. AMPLIFIER, June 80	£6-60
SIGNAL TRACER, June 80	£3-50
ZENER DIODE TESTER, June 80	£5-67
4 STATION RADIO, May 80	£13-94 less case
AUTOFADE, May 80	£9-96

LIGHTS WARNING SYSTEM, May 80	£3-99
BATTERY VOLTAGE MONITOR, May 80	£4-21
AUDIO TONE GENERATOR, May 80	£3-53
GAS SENTINEL, April 80	£26-32
AUTO LEVEL CONTROL, April 80	£7-69
CABLE & PIPE LOCATOR, Mar. 80	£3-50 less coil former
KITCHEN TIMER, Mar. 80	£12-46
STEREO HEADPHONE AMPLIFIER, Mar. 80	£15-43
5 RANGE CURRENT LIMITER, Mar. 80	£4-24
MICRO MUSIC BOX, Feb. 80 £13-82	Grey Case £3-63 extra.
SIMPLE SHORT WAVE RECEIVER, Feb. 80	£21-98
Headphones £2-98.	
SLIDE TAPE SYNCHRONISER, Feb. 80	£10-46
MORSE PRACTICE OSCILLATOR, Feb. 80	£3-93
SPRING LINE REVERB. UNIT, Jan. 80	£21-98
UNIBOARD BURGLAR ALARM, Dec. 79	£5-13
BABY ALARM, Nov. 79	£8-30
OPTO ALARM, Nov. 79	£5-77 inc. optional ports
MW/LW RADIO TUNER, Nov. 79	£15-50 less dial
ONE ARMED BANDIT, Oct. 79	£22-37
HIGH IMPEDANCE VOLTMETER, Oct. 79	£15-87
CHASER LIGHTS, Sept. 79	£19-98
VARICAP M.W. RADIO, Sept. 79	£8-98
SIMPLE TRANSISTOR TESTER, Sept. 79	£6-26
ELECTRONIC TUNING FORK, Aug. 79	£9-15
Suitable microphone & plug £1-59 extra.	
WARBLING TIMER, Aug. 79	£6-25
9V POWER SUPPLY, Aug. 79	£9-94 inc. pcb
SWANEE WHISTLER, Aug. 79	£3-19
DARKROOM TIMER, July 79	£2-47
TREMOLO UNIT, June 79	£11-26
ELECTRONIC CANARY, June 79	£4-99
LOW COST METAL LOCATOR, June 79	£5-44
Handle & coil former parts extra £5-55.	
QUAD SIMULATOR, June 79	£6-25
INTRUDER ALARM, May 1979	£16-71
Less Ext. Buzzer & Lamp and Loop Components.	
THERMOSTAT. 'PHOTO' SOLUTIONS, May 79	£16-02
Less socket, tube and grease.	
TRANSISTOR TESTER, April 79	£4-85
TOUCH BLEEPER, April 79	£3-52
ONE TRANSISTOR RADIO, Mar. 79. Less case	£6-93
MICROCHIME DOORBELL, Feb. 79	£13-48
AUDIO MODULATOR, Feb. 79	£1-56 less case and pins
THYRISTOR TESTER, Feb. 79	£3-22
ADJUSTABLE PSU, Feb. 79	£28-98
HEADPHONE ENHANCER, Jan. 79	£2-60
FUZZ BOX, Dec. 78	£6-20
MIC. AMP, Dec. 78	£2-80
AUDIBLE FLASHER, Dec. 78	£1-21
VEHICLE IMMOBILISER, Inc. PCB, Dec. 78	£5-74
AUDIO EFFECTS OSCILLATOR, Nov. 78	£3-99 inc. board
PASSIVE MIXER, Oct. 78	£3-72
FUSE CHECKER, Oct. 78	£1-97
TREASURE HUNTER, Oct. 78	£17-86 less handle & coil former
GUITAR TONE BOOSTER, Sept. 78	£4-99 in. p.c.b.
SOUND TO LIGHT, Sept. 78	£6-98
FILTER, Sept. 78	£1-66
CAR BATTERY STATE INDICATOR, Sept. 78. Less case	£1-79
R.F. SIGNAL GENERATOR, Sept. 78	£22-77
SLAVE FLASH, Aug. 78	£3-20 less SK1
LOGIC PROBE, July 78	£2-53
IN SITU TRANSISTOR TESTER, June 78	£5-76
FLASHMETER, May 78	£12-84 less calc and diffuser
POCKET TIMER, April 78	£2-98
WEIRD SOUND EFFECTS GENERATOR, Mar. 78	£4-80
CHASER LIGHT DISPLAY, Feb. 78	£28-80
AUDIO VISUAL METRONOME, Jan. 78	£5-12
ELECTRONIC TOUCH SWITCH, Jan. 78	£2-33 less case
RAPID DIODE CHECK, Jan. 78	£2-34
AUTOMATIC PHASE BOX, Dec. 77	£9-55 inc. p.c.b.
VHF RADIO, Nov. 77	£14-36
ULTRASONIC REMOTE CONTROL, Nov./Dec. 77	£16-89
ADD-ON CAPACITANCE UNIT, Sept. 77	£5-99
PHONE/DOORBELL REPEATER, July 77	£6-38
ELECTRONIC DICE, March 77	£4-83

1981 ELECTRONICS CATALOGUE

KITS
I.C.s
TRANSISTORS
CAPACITORS

Hundreds of illustrations, product data, circuits, and details of all our kits and educational courses.
Up to date price list included. All products are stock lines for fast delivery. Send 70p in stamps or add 70p to order.

TOOLS
RESISTORS
HARDWARE
CASES

ADVENTURES WITH ELECTRONICS by Tom Dunbar

An easy to follow book suitable for all ages, ideal for beginners. No Soldering. Uses an 'S Dec' breadboard. Gives clear instructions with lots of pictures. 16 projects—including three radios, siren, metronome, organ, intercom, timer, etc. Helps you learn about electronic components and how circuits work. Component pack includes an S-Dec and the components for the projects.
Adventures With Electronics £1-96. Component Pack £18-72 less battery.

ADVENTURES WITH MICROELECTRONICS

Same style as above book. 11 projects based on integrated circuits—includes: dice, two-tone doorbell, electronic organ, MW/LW radio, reaction timer, etc. Component pack includes a Bimboard, 1 plug-in breadboard and the components for the projects.
Adventures With Microelectronics £2-35. Component pack £26-95 less battery.

MEMORY BANK SYNTHESISER

Miniature synthesiser featuring vibrato, envelope, tempo, volume & pitch controls. Uses 24 push button switches in a keyboard style layout. Based on a custom designed i.c. The accessible memory stores a 32 beat length sequence of notes & spaces. Can be played 'live'. Fitted with an internal speaker. Jack socket allows the use of an external amplifier if wished. Memory Bank Synthesiser £33-85.

3 BAND S.W. RADIO

Simple T.R.F. Design. Covering most Amateur Bands and Short Wave Broadcast Bands. Five controls. Bandpass. Bandspread. Reaction. Wavechange and Attenuator. Coil section is by Wavechange Switch. Use with Headphones or a Crystal earpiece. Kit contains all the components required including the P.C. Board and Case. Instructions are included with this kit. KIT £18-87. Headphones extra £2-88.

MAGENTA ELECTRONICS LTD.

EL30, 135 HUNTER ST. BURTON-ON-TRENT, STAFFS., DE14 2ST. 0283 85435. MON.-FRI. 9-4. MAIL ORDER. CALLERS BY APPOINTMENT. ADD 40p P. & P. TO ALL ORDERS. ALL PRICES INCLUDE 15% V.A.T.

OFFICIAL ORDERS WELCOME. (BY) REPUBLIC & B.F.P.O. EUROPE. Deduct 10% from prices shown Payment must be in Sterling. ACCESS AND BARCLAYCARD (VISA) ORDERS ACCEPTED BY PHONE OR POST.





DOUGLAS TRANSFORMERS FROM TITAN

NEW FRANCHISE AT FANTASTIC PRICES - EX STOCK

12/00V RANGE FR120/240V				15/00V RANGE FR120/240V				25/00V RANGE FR120/240V				3000V RANGE FR120/240V			
TYPE	AMPS	PRICE £	P/P	TYPE	AMPS	PRICE £	P/P	TYPE	AMPS	PRICE £	P/P	TYPE	AMPS	PRICE £	P/P
240	12	1.70	0.40	112	13	3.47	0.75	102	24	3.88	1.43	124	20	2.92	1.43
217	0.7	2.23	0.70	79	2	3.06	0.88	103	1	3.40	1.43	126	3	8.78	1.43
18	4	3.34	1.43	2	4	3.04	1.43	104	4	7.64	1.73	127	4	7.12	1.73
64	3	3.25	1.43	30	6	3.09	1.73	105	8	5.13	1.90	125	6	10.73	1.90
80	3	3.32	1.43	51	10	7.80	1.90	106	8	11.18	1.90	123	8	13.28	2.00
100	4	3.36	1.73	117	11	14.87	2.00	107	12	8.79	1.90	40	10	15.55	2.00
72	10	8.29	1.90	89	20	16.92	2.00	118	16	20.67	2.15	120	12	17.73	2.25
114	12	8.37	1.70	70	24	19.84	2.00	119	20	34.92	2.55	121	16	35.89	2.65
17	16	10.32	2.00	71	20	21.36	2.00	120	24	38.38	2.90	122	20	29.87	4.00
187	20	17.43	2.45	92	40	30.98	3.50					189	24	32.81	4.40

12/00V RANGE FR120/240V				AUTOTRANSFORMERS 240/225-125V				CASED AUTOTRANSFORMERS				LINE ADJUSTMENT AUTOTRANSFORMERS			
TYPE	AMPS	PRICE £	P/P	TYPE	VA	PRICE £	P/P	TYPE	VA	PRICE £	P/P	TYPE	VA	PRICE £	P/P
430	40	4.14	1.43	25	55	3.82	1.10	50W	20	3.22	0.28	415C	50	2.13	0.58
431	3	7.22	1.73	64	80	4.40	1.10	64W	80	7.63	1.43	416C	100	3.13	1.10
432	4	11.87	3.00	69	150	5.64	1.43	40W	150	9.63	1.73	417C	200	3.65	1.43
433	8	14.47	3.30	53	120	9.77	1.90	80W	250	11.94	1.90	418F	350	5.43	1.43
434	8	16.43	3.40	67	350	11.99	3.20	64W	300	18.47	3.20	419F	500	4.13	1.73
435	10	36.18	3.80	81	750	13.42	3.20	80W	1000	26.95	3.20	420E	750	7.40	1.90
436	12	33.39	4.40	64	1000	16.88	3.65	10W	2000	48.45	8.00	421F	1000	10.53	2.00
437	16	33.77	4.40	71	3kVA	21.34	4.20								

Mains Isolating Safety Screens				Mains Isolating Safety Screens			
TYPE	VA	PRICE £	P/P	TYPE	VA	PRICE £	P/P
149F	60	7.35	1.73	141F	60	7.35	1.43
150F	100	8.41	1.73	142F	100	8.41	1.73
151F	200	12.15	2.28	143F	200	12.15	2.00
152F	300	14.75	2.28	144F	300	14.75	2.20
153F	500	18.32	2.55	145F	500	18.32	2.55
154F	500	22.70	2.85	146F	1000	27.70	2.85
155F	750	33.98	2.90	149F	150	33.98	6.50
156F	1000	41.24	2.90	250F	1000	41.24	6.50

INVERTOR				Mains Adaptors			
TYPE	VA	PRICE £	P/P	TYPE	VA	PRICE £	P/P
INV. 1	CaseD-PVC covered steel case with 8A 3-pin socket	£28.85	p.p. £2.35	100	6-7.5-9v	250	3.85
INV. 2	Open frame for DIN	£28.85	p.p. £2.35	101	6-7.5-9v	300	4.70

SEND TODAY 50p (REFUNDABLE WITH FIRST ORDER) FOR CATALOGUE
TITAN TRANSFORMERS AND COMPONENTS
 CENTRAL HALL CHAMBERS GRIMSBY DN32 1EG HUMBERSIDE
 MAIL ORDER ONLY - PRICES INCLUDE 15% VAT

TECHNICAL TRAINING IN ELECTRONICS AND TELECOMMUNICATIONS

ICS can provide the technical knowledge that is so essential to your success; knowledge that will enable you to take advantage of the many opportunities open to you. Study in your own home, in your own time and at your own pace and if you are studying for an examination ICS guarantee coaching until you are successful.

- City and Guilds Certificates:**
 Telecommunications Technicians
 Radio, TV, Electronics Technicians
 Technical Communications
 Radio Servicing Theory
 Radio Amateurs
 Electrical Installation Work
 MPT Radio Communications Certificate

- Diploma Courses:**
 Colour TV Servicing
 Electronic Engineering and Maintenance
 Computer Engineering and Programming
 Radio, TV, Audio Engineering and Servicing
 Electrical Engineering, Installation
 and Contracting

POST OR PHONE TODAY FOR FREE BOOKLET

ICS To: International Correspondence Schools

Dept K 261 Investment House, London SW2 4LJ or telephone 622 3911

Subject of Interest

Name

Address

Tel.

Age

MIGHTY NINETY PACKS

SUPER VALUE PACKS ALL AT 50p EACH
 POSTAGE 20p PER PACK UP TO FOUR PACKS
 FIVE OR MORE POST FREE
BUY SIX PACKS AND GET A SEVENTH PACK FREE!

- MN1. 50 1/2-watt Resistors pre-formed for PAC Mg.
- MN2. 200 1/2-watt Resistors.
- MN3. 100 1/2-watt Resistors.
- MN4. 50 1/2-watt Resistors.
- MN5. 100 mixed oxide resistors: 1%, 5% and 5%.
- MN6. 15 axial potentiometers.
- MN7. 25 axial skeleton pre-set Resistors.
- MN8. 30 axial Electrolytic Capacitors.
- MN9. 100 axial Ceramic Capacitors, P10, P100, 100 and 1000pF etc.
- MN10. 100 mixed capacitors. Polyester, Polystyrene, Metallized, Radial and Axial Types.
- MN11. 30 axial Silver Mica Capacitors.
- MN12. 5 Tantalum Bead Capacitors (axial).
- MN13. 30 axial Transistors, BC, 2N Series + Power etc.
- MN14. 40 1N4148 Diodes.
- MN15. 3 Light Sensitive Devices.
- MN16. 20 mixed, mixed-axial Tubes.
- MN17. 2 1N4148 Relays. Ex. newly new stock.
- MN18. 3 Encapsulated Reed Relays, 6-10v, coil, 4-pole and 1-pole.
- MN19. 2 24-volt Relays. Ex. newly new stock.
- MN20. 1 240-110 to 110-volt, 100mA Transformer.
- MN21. 1 240-110 to 24-volt 100mA Transformer.
- MN22. 1 2" 1/2" LED's with clips. 1 red, 2 yellow, 3 green.
- MN23. 50 axial screws, nuts, washers, self-tappers etc.
- MN24. 100 axial, small springs.
- MN25. 50 axial, pop rivets.
- MN26. 30 axial, insulated springs.
- MN27. 200 mixed, 6-pin, 8-pin, 9-pin, 14-pin, 16-pin, 18-pin, 20-pin, 24-pin, 28-pin, 30-pin, 36-pin, 40-pin, 44-pin, 48-pin, 52-pin, 56-pin, 60-pin, 64-pin, 68-pin, 72-pin, 76-pin, 80-pin, 84-pin, 88-pin, 92-pin, 96-pin, 100-pin, 104-pin, 108-pin, 112-pin, 116-pin, 120-pin, 124-pin, 128-pin, 132-pin, 136-pin, 140-pin, 144-pin, 148-pin, 152-pin, 156-pin, 160-pin, 164-pin, 168-pin, 172-pin, 176-pin, 180-pin, 184-pin, 188-pin, 192-pin, 196-pin, 200-pin, 204-pin, 208-pin, 212-pin, 216-pin, 220-pin, 224-pin, 228-pin, 232-pin, 236-pin, 240-pin, 244-pin, 248-pin, 252-pin, 256-pin, 260-pin, 264-pin, 268-pin, 272-pin, 276-pin, 280-pin, 284-pin, 288-pin, 292-pin, 296-pin, 300-pin, 304-pin, 308-pin, 312-pin, 316-pin, 320-pin, 324-pin, 328-pin, 332-pin, 336-pin, 340-pin, 344-pin, 348-pin, 352-pin, 356-pin, 360-pin, 364-pin, 368-pin, 372-pin, 376-pin, 380-pin, 384-pin, 388-pin, 392-pin, 396-pin, 400-pin, 404-pin, 408-pin, 412-pin, 416-pin, 420-pin, 424-pin, 428-pin, 432-pin, 436-pin, 440-pin, 444-pin, 448-pin, 452-pin, 456-pin, 460-pin, 464-pin, 468-pin, 472-pin, 476-pin, 480-pin, 484-pin, 488-pin, 492-pin, 496-pin, 500-pin, 504-pin, 508-pin, 512-pin, 516-pin, 520-pin, 524-pin, 528-pin, 532-pin, 536-pin, 540-pin, 544-pin, 548-pin, 552-pin, 556-pin, 560-pin, 564-pin, 568-pin, 572-pin, 576-pin, 580-pin, 584-pin, 588-pin, 592-pin, 596-pin, 600-pin, 604-pin, 608-pin, 612-pin, 616-pin, 620-pin, 624-pin, 628-pin, 632-pin, 636-pin, 640-pin, 644-pin, 648-pin, 652-pin, 656-pin, 660-pin, 664-pin, 668-pin, 672-pin, 676-pin, 680-pin, 684-pin, 688-pin, 692-pin, 696-pin, 700-pin, 704-pin, 708-pin, 712-pin, 716-pin, 720-pin, 724-pin, 728-pin, 732-pin, 736-pin, 740-pin, 744-pin, 748-pin, 752-pin, 756-pin, 760-pin, 764-pin, 768-pin, 772-pin, 776-pin, 780-pin, 784-pin, 788-pin, 792-pin, 796-pin, 800-pin, 804-pin, 808-pin, 812-pin, 816-pin, 820-pin, 824-pin, 828-pin, 832-pin, 836-pin, 840-pin, 844-pin, 848-pin, 852-pin, 856-pin, 860-pin, 864-pin, 868-pin, 872-pin, 876-pin, 880-pin, 884-pin, 888-pin, 892-pin, 896-pin, 900-pin, 904-pin, 908-pin, 912-pin, 916-pin, 920-pin, 924-pin, 928-pin, 932-pin, 936-pin, 940-pin, 944-pin, 948-pin, 952-pin, 956-pin, 960-pin, 964-pin, 968-pin, 972-pin, 976-pin, 980-pin, 984-pin, 988-pin, 992-pin, 996-pin, 1000-pin.
- MN28. 1 PCB with 8-pin control IC (e.g. IC).
- MN29. 1 capacitor PCB leads of 100 components (no data).
- MN30. 50 Polystyrene Capacitors.
- MN31. 10 BC107 Transistors.
- MN32. 10 BC107 Transistors.
- MN33. 10 screw fit 3.5" C.O. min, slide switch.
- MN34. 1 25V, 1,000 mA/H, Mercury battery 6in diameter x 6in high.
- MN35. 1 CA 702 voltage regulator.
- MN36. 1 2-pin 1-pole mini switch.
- MN37. 1 2-pin 1-pole mini switch.

PLEASE QUOTE NO. OF PACKS WHEN ORDERING

CHORDGATE LTD.

75 FARINGDON ROAD, SWINDON, WILTS.
 Tel. Swindon (0793) 33877. Retail shop at above address.



CUBE MANIA—FREE OF CHARGE!

With purchases totalling over £17.50. Only on request, at time of ordering. Offer closes 31/8/81. Subject to availability.

BECOME AN INSTANT MUSICIAN NO EXPERIENCE NECESSARY

The success story of 1981. Hundreds sold already! As featured on "Tomorrow's World"

Create your own music with a VL-TONE. You combine the sound, rhythm and tempo and the VL-1 plays it back... beautifully!

CASIO VL-TONE (VL-1)
Electronic Musical Instrument
and Calculator



(R.R.P. £39.95)
ONLY £35.95

VL-1 records and plays back up to 100 notes as a melody. One Key Play or Auto Play of Piano, Violin, Flute, Guitar and Fantasy, or create your own unique sounds with A.D.S.R. 10 built-in Auto Rhythms and Tempo control. LCD digital readout of notes and tempo. Also a calculator. Battery powered with memory and program retention. Integral amplifier/speaker. Output jack. With Song Book. Dims: $1\frac{1}{2} \times 11\frac{1}{2} \times 3\frac{1}{2}$ ".

CASIOTONE POLYPHONIC KEYBOARDS

With built-in amplifier and loudspeaker

MT-30



(R.R.P. £115)
ONLY £95

22 instruments over 3 octaves. 4-position sound memory. Battery or mains. O/P jack. Dims: $24 \times 22\frac{1}{2} \times 6\frac{1}{2}$ " 6lb.

★★ NEW ★★ CASIOTONE CT-202

"Son of success... The two harpsichords demonstrate the Casiotone's talent for sparkling, crystal clear tones... Even more impressive is the clav..." (Melody Maker).



49 instruments over 4 octaves. 4-voice memory function with push button selection. 3 vibrato settings and sustain. Pitch control. O/P jacks. AC only. $3\frac{1}{2} \times 34\frac{1}{2} \times 11\frac{1}{2}$ " 15.8lbs.

CT-301



(R.R.P. £285)
ONLY £245

14 instruments over 4 octaves. 8×2 rhythm accompaniments. Vibrato and delayed vibrato. Start/stop, synchro start, tempo control, tempo indicator, and rhythm volume. Pitch control. AC only. O/P jacks. $4\frac{1}{2} \times 31\frac{1}{2} \times 12\frac{1}{2}$ " 27lbs.

CT-401



(R.R.P. £345)
ONLY £295

As 301 plus following: 16 rhythm accompaniments, with fill-in. Casio Auto Chord for one finger or auto accompaniment. Plays major, minor and 7th chords with bass. Balance control, C.A.C. lever, chord lever, memory lever and octave switch. Dims as 301. Weight 28-2lbs.

CASIO SCIENTIFIC CALCULATORS WITH LIQUID CRYSTAL DISPLAY

for long, long battery life



FX81



FX100



FX510

FX81. 8 digits. 30 scientific functions. 4,000 hours battery life. Auto Power Off. $\frac{1}{2} \times 3 \times 5\frac{1}{2}$ ". £12.95
FX100. 10d, 44f. 7,500 hours. A.P.O. $\frac{1}{2} \times 3 \times 5\frac{1}{2}$ ". £16.95

FX550. Replaces FX510 shown above. 1 lithium battery lasts 13,000 hours. A.P.O. 10d, 50f. $\frac{1}{2} \times 2\frac{1}{2} \times 5\frac{1}{2}$ ". £19.95

SUPER SCIENTIFICS WITH TIME DIMENSION

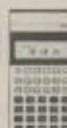

FX6100



FX7100



FX8100

FX8100. 46f. Clock, calendar, alarm, hourly chimes, count-down alarm, stopwatch. $\frac{1}{2} \times 2\frac{1}{2} \times 5\frac{1}{2}$ ". £24.95

FX7100. Card version without calendar. £24.95
FX6100. Hand-held version of FX7100. £17.95

CASIO PROGRAMMABLES

with A.P.O. and memory and programme retention

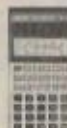

FX180P



FX3500P



FX502P

FX180P. 10d, 55f. 2 programmes. 38 functional steps. Integrals and Regression analysis. $\frac{1}{2} \times 3 \times 5\frac{1}{2}$ ". £19.95

FX3500P. As FX180P but 61f. $\frac{1}{2} \times 2\frac{1}{2} \times 5\frac{1}{2}$ ". £22.95

FX602P. Similar to FX502P, shown above. Alpha-numeric display with dot matrix. 32-512 (maximum) program steps. 22-88 (maximum) registers. 33 parentheses at 11 levels. Jumps: Unconditional, 10 pairs. Conditional, up to 9 subroutines up to 9 levels. £74.95

CASIO MELODY ALARM CLOCK CALCULATORS

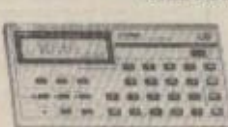

UC365

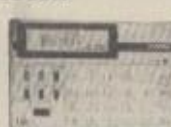

UC360

UC365. 3 melodies, universal calendar, date memories, two date alarms, daily alarm, hourly chimes, countdown alarm/stopwatch, time memory. $\frac{1}{2} \times 4\frac{1}{2} \times 2\frac{1}{2}$ ". £19.95

UC360. Card version of above. $\frac{1}{2} \times 3\frac{1}{2} \times 2\frac{1}{2}$ ". £19.95

UC3000. Office version. $1\frac{1}{2} \times 4 \times 6\frac{1}{2}$ ". £27.95

MQ1200. 12 melodies, 2 alarms, hourly chimes, date memories, anniversary memories, calendar. $1\frac{1}{2} \times 6 \times 2\frac{1}{2}$ ". £19.95

ML-90. Wallet version of above, with stopwatch. £14.95

ML-75. Card version of ML-90. $\frac{1}{2} \times 3\frac{1}{2} \times 2\frac{1}{2}$ ". £15.95

ML2000. Office version of MQ-1200. $1\frac{1}{2} \times 4 \times 6\frac{1}{2}$ ". £22.95

THESE SPACE INVADERS WILL ALARM YOU— THE PRICE WON'T

Casio's most amazing watches ever!

CA-90 (left)
£24.95



CA-901 (right)
£29.95

Time and auto calendar, calculator, alarm, hourly chimes, stopwatch, dual time, DIGITAL SPACE INVADER GAME.

100 METRE WATER RESISTANT WATCHES

with alarm and stopwatch



W-150 (left)
£32.50



W-150C (right)
£25.95

Time and auto calendar, alarm, hourly chimes, countdown alarm timer with repeat memory function, stopwatch. Time is always on display, regardless of mode. Stainless steel.

W100 (left)
£19.95



UC50W (right)
50m W/R
£19.95

W100. Resin case/strap version of W150 (same specification).

UC50W. 50 metre water resistant with universal full month calendar display with forward/backward stepping. Alarm, hourly chimes and stopwatch. Stainless steel.

12 MELODY ALARMS AND STOPWATCH



M12 (left)
Resin
£17.95



M1200 (right)
S/S
£29.95

7 Daily melodies, one for each day, 3 anniversary melodies, 2 date memories, hourly chimes, countdown alarm timer with countup after zero, or stopwatch.

LCD ANALOGUE/DIGITAL with amazing "starburst" display. Dual time (analogue and digital), alarm, hourly chimes, countdown alarm timer, stopwatch, auto calendar.

AA81 Chrome £29.95. AA82 S/S £39.95.

AA81G Gold £49.95.

Also: F81 Alarm, stopwatch, etc. Resin case/strap. £12.95

SYMPHONIC ALARM CLOCK

MA-1
£9.95

Mozart No. 40 or buzzer. Hourly chimes. Snooze facility. $1\frac{1}{2} \times 4\frac{1}{2} \times 3\frac{1}{2}$ ".

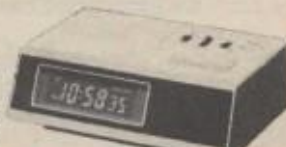

SEND 20p FOR DETAILS OF SELECTED CASIO AND SEIKO PRODUCTS

PRICE includes VAT and P&P. Send cheques, P.O. or phone your ACCESS or BARCLAYCARD number to:

TEMPUS

Dept. EE, FREEPOST, 164-167 East Road, Cambridge CB1 1DB
Tel: 0223 312866.

New! Sinclair ZX81 Personal Computer. Kit: £49.⁹⁵ complete

Reach advanced
computer comprehension
in a few absorbing hours

1980 saw a genuine breakthrough – the Sinclair ZX80, world's first complete personal computer for under £100. At £99.95, the ZX80 offered a specification unchallenged at the price.

Over 50,000 were sold, and the ZX80 won virtually universal praise from computer professionals.

Now the Sinclair lead is increased: for just £69.95, the new Sinclair ZX81 offers even more advanced computer facilities at an even lower price. And the ZX81 kit means an even bigger saving. At £49.95 it costs almost 40% less than the ZX80 kit!

Lower price: higher capability

With the ZX81, it's just as simple to teach yourself computing, but the ZX81 packs even greater working capability than the ZX80.

It uses the same micro-processor, but incorporates a new, more powerful 8K BASIC ROM – the 'trained intelligence' of the computer. This chip works in decimals, handles logs and trig, allows you to plot graphs, and builds up animated displays.

And the ZX81 incorporates other operation refinements – the facility to load and save named programs on cassette, for example, or to select a program off a cassette through the keyboard.

Higher specification, lower price – how's it done?

Quite simply, by design. The ZX80 reduced the chips in a working computer from 40 or so, to 21. The ZX81 reduces the 21 to 4!

The secret lies in a totally new master chip. Designed by Sinclair and custom-built in Britain, this unique chip replaces 18 chips from the ZX80!

Proven micro-processor, new 8K BASIC ROM, RAM – and unique new master chip.

Built:
£69.⁹⁵
complete



Kit or built – it's up to you!

The picture shows dramatically how easy the ZX81 kit is to build: just four chips to assemble (plus, of course the other discrete components) – a few hours' work with a fine-tipped soldering iron. And you may already have a suitable mains adaptor – 600 mA at 9 V DC nominal unregulated (supplied with built version).

Kit and built versions come complete with all leads to connect to your TV (colour or black and white) and cassette recorder.

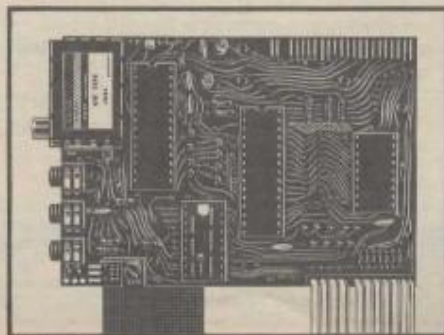

New Sinclair teach-yourself BASIC manual

Every ZX81 comes with a comprehensive, specially-written manual – a complete course in BASIC programming, from first principles to complex programs. You need no prior knowledge – children from 12 upwards soon become familiar with computer operation.



```

<N IIR T=N THEN GO TO 6
X=N TO N
B(X)=I(X)
J=X
J=J+1
>N OR J=N THEN GO TO 46
T=J+1
OT A(J)A(T) THEN GO TO
P=J
X=J
X=J+1
<1 THEN GO TO 16

```

New, improved specification

● Z80A micro-processor – new faster version of the famous Z80 chip, widely recognised as the best ever made.

● Unique 'one-touch' key word entry: the ZX81 eliminates a great deal of tiresome typing. Key words (RUN, LIST, PRINT, etc.) have their own single-key entry.

● Unique syntax-check and report codes identify programming errors immediately.

● Full range of mathematical and scientific functions accurate to eight decimal places.

● Graph-drawing and animated-display facilities.

● Multi-dimensional string and numerical arrays.

● Up to 26 FOR/NEXT loops.

● Randomise function – useful for games as well as serious applications.

● Cassette LOAD and SAVE with named programs.

● 1K-byte RAM expandable to 16K bytes with Sinclair RAM pack.

● Able to drive the new Sinclair printer (not available yet – but coming soon!)

● Advanced 4-chip design: micro-processor, ROM, RAM, plus master chip – unique, custom-built chip replacing 18 ZX80 chips.

sinclair ZX81

Sinclair Research Ltd,
6 Kings Parade, Cambridge, Cambs.,
CB2 1SN. Tel: 0276 66104.
Reg. no: 214 4630 00

If you own a Sinclair ZX80...

The new 8K BASIC ROM used in the Sinclair ZX81 is available to ZX80 owners as a drop-in replacement chip. (Complete with new keyboard template and operating manual.)

With the exception of animated graphics, all the advanced features of the ZX81 are now available on your ZX80 – including the ability to drive the Sinclair ZX Printer.

Coming soon- the ZX Printer.

Designed exclusively for use with the ZX81 (and ZX80 with 8K BASIC ROM), the printer offers full alphanumeric across 32 columns, and highly sophisticated graphics. Special features include COPY, which prints out exactly what is on the whole TV screen without the need for further instructions. The ZX Printer will be available in Summer 1981, at around £50 – watch this space!



16K-BYTE RAM pack for massive add-on memory.

Designed as a complete module to fit your Sinclair ZX80 or ZX81, the RAM pack simply plugs into the existing expansion port at the rear of the computer to multiply your data/program storage by 16!

Use it for long and complex programs or as a personal database. Yet it costs as little as half the price of competitive additional memory.



How to order your ZX81

BY PHONE – Access or Barclaycard holders can call 01-200 0200 for personal attention 24 hours a day, every day.
BY FREEPOST – use the no-stamp-needed coupon below. You can pay by cheque, postal order, Access or Barclaycard.

EITHER WAY – please allow up to 28 days for delivery. And there's a 14-day money-back option, of course. We want you to be satisfied beyond doubt – and we have no doubt that you will be.

To: Sinclair Research Ltd, FREEPOST 7, Cambridge, CB2 1YY.

Qty	Item	Code	Item price £	Total £
	Sinclair ZX81 Personal Computer kit(s). Price includes ZX81 BASIC manual, excludes mains adaptor.	12	49.95	
	Ready-assembled Sinclair ZX81 Personal Computer(s). Price includes ZX81 BASIC manual and mains adaptor.	11	69.95	
	Mains Adaptor(s) (600 mA at 9 V DC nominal unregulated).	10	8.95	
	16K-BYTE RAM pack(s).	18	49.95	
	8K BASIC ROM to fit ZX80.	17	19.95	
	Post and Packing.			2.95
TOTAL £				

Please tick if you require a VAT receipt

*I enclose a cheque/postal order payable to Sinclair Research Ltd, for £ _____

*Please charge to my Access/Barclaycard/Trustcard account no. _____

*Please delete/complete as applicable.

Please print.

Name: Mr/Mrs/Miss _____

Address _____

FREEPOST – no stamp needed.

EVE08

EDITOR

F. E. BENNETT

ASSISTANT EDITOR

B. W. TERRELL B.Sc.

PRODUCTION EDITOR

D. G. BARRINGTON

TECHNICAL SUB-EDITOR

S. E. DOLLIN B.Sc.

ART EDITOR

R. F. PALMER

ASSISTANT ART EDITOR

P. A. LOATES

TECHNICAL ILLUSTRATOR

D. J. GOODING

EDITORIAL OFFICES

Kings Reach Tower,
Stamford Street,
London SE1 9LS
Phone: 01-261 6873

ADVERTISEMENT MANAGER

R. SMITH
Phone: 01-261 6671

REPRESENTATIVE

R. WILLETT
Phone: 01-261 6865

CLASSIFIED MANAGER

C. R. BROWN
Phone: 01-261 6762

MAKE-UP AND COPY DEPARTMENT

Phone 01-261 6615

ADVERTISEMENT OFFICES

Kings Reach Tower
Stamford Street,
London SE1 9LS

Projects... Theory...

and Popular Features ...

FUND RAISER

Everyone enjoys a flutter, and there's always some good cause in need of a fund raiser. The modern art of electronics has its part to play here, for it enables the updating of traditional fairground or bazaar amusements, making them suitable for voluntary neighbourhood events—indoors or out.

Our all-electronic version of that old favourite the *Wheel of Fortune* operates either from a 12 volt car battery or directly from the mains. It is quite portable so if the need arises it can be rapidly transferred to that alternative indoor venue which prudent fête organisers always announce on their bills, in recognition of the vagaries of the British summer.

CHILD PROOF

The child-proof medicine container does not always live up to its name. Little fingers often discover the secret of the safety bottle cap and, hey presto, the lid is off before a parent is alerted as to what is going on.

Locking the medicine cabinet is one sure way of preventing such hazards, but for family reasons this is not always desirable. Another way to thwart an infant's explorations in a danger area is to fit a simple alarm device that sounds off whenever the cabinet door is opened. This is just one example of possible uses for the *Door Alarm* described this month.

MATTER OF TIME

How many beats to the bar? Soft or hard boiled? Two well known instruments that cater for these rather different needs have their electronic counterparts in this issue.

The *CMOS Metronome* produces a steady ticking which is often preferred by musicians to the tick-tock of the traditional clockwork driven beat-marker. The *L.E.D. Sandglass* uses a column of lights to register the passage of time from two minutes to four-and-a-half minutes, in half-minute intervals.

MORSE PRACTISE

Are some CB Breakers getting the Amateur Radio bug, as well? At any rate, the number of Licensed Amateurs is increasing and a demand for a learning aid such as our *Morse Practise Oscillator* is apparent. A fact underlined by those readers who complained about the omission of this project from last month's issue. We apologise for the error in mentioning the Morse Practise Oscillator on the July cover and so inadvertently raising expectations not fulfilled by the actual contents. The one-month delay in waiting for this project we trust will not have cooled anyone's ardour to acquire an Amateur Radio Licence.

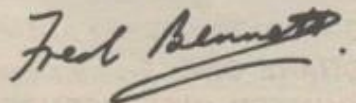

Our September issue will be published on Friday, August 21. See page 543 for details.

**Readers' Enquiries**

We cannot undertake to answer readers' letters requesting modifications, designs or information on commercial equipment or subjects not published by us. All letters requiring a personal reply should be accompanied by a stamped self-addressed envelope.

We cannot undertake to engage in discussions on the telephone.

Component Supplies

Readers should note that we do not supply electronic components for building the projects featured in **EVERYDAY ELECTRONICS**, but these requirements can be met by our advertisers.

All reasonable precautions are taken to ensure that the advice and data given to readers are reliable. We cannot however guarantee it, and we cannot accept legal responsibility for it. Prices quoted are those current as we go to press.

Everyday ELECTRONICS

VOL. 10 NO. 8

AUGUST 1981

CONSTRUCTIONAL PROJECTS

- L.E.D. SANDGLASS** Mounting columns of l.e.d.s show time elapsed by F. G. Rayer 522
- MORSE PRACTISE OSCILLATOR** Useful learning aid by F. G. Rayer 524
- WHEEL OF FORTUNE** All electronic game for fetes and fairs by C. J. Bowes 528
- SIMPLE pH METER** Laboratory instrument at low cost by P. N. Roberts 540
- DOOR ALARM** Audio entry alert by D. J. Edwards 548
- CMOS METRONOME** Inexpensive alternative to the traditional machine by I. Hickman 556

GENERAL FEATURES

- EDITORIAL** Fund Raiser; Child Proof; Matter of Time; Morse Practise 520
- SHOP TALK** Product news and component buying by Dave Barrington 535
- DISCRETE SEMICONDUCTORS EXPLAINED** Part 3: Unijunctions, thyristors, triacs and thermistors by J. B. Dance 536
- INTRODUCTION TO LOGIC** Part 4: Transistor as a switch; Boolean algebra by J. Crowther 544
- BACK TO BASICS** Part 3: More about amplifiers by George Hylton 546
- JACK PLUG & FAMILY** Cartoon by Doug Baker 549
- EVERYDAY NEWS** What's happening in the world of electronics 550
- SEMICONDUCTOR NEWS** Some recently introduced discrete and i.c. devices 552
- RADIO WORLD** Summer storms; satellite confusion by Pat Hawker G3VA 555
- READERS' LETTERS** Your news and views 558
- FOR YOUR ENTERTAINMENT** Flat screen TV by Barry Fox 561
- SQUARE ONE** Beginners' Page: Components—Polarised capacitors 564
- COUNTER INTELLIGENCE** A retailer comments by Paul Young 565
- CIRCUIT EXCHANGE** A forum for readers' ideas 566

Back Issues

Certain back issues* of EVERYDAY ELECTRONICS are available worldwide price 80p inclusive of postage and packing per copy. Enquiries with remittance should be sent to Post Sales Department, IPC Magazines Ltd., Lavington House, 25 Lavington Street, London SE1 0PF. In the event of non-availability remittances will be returned.

* Not available: October 1978 to May 1979.

Binders

Binders to hold one volume (12 issues) are available from the above address for £4.40 (home and overseas) inclusive of postage and packing. Please state which Volume.

Subscriptions

Annual subscription for delivery direct to any address in the UK: £10.00, overseas: £11.00. Cheques should be made payable to IPC Magazines Ltd., and sent to Room 2613, Kings Reach Tower, Stamford Street, London SE1 9LS.

© IPC Magazines Limited 1981. Copyright in all drawings, photographs and articles published in EVERYDAY ELECTRONICS is fully protected, and reproductions or imitations in whole or in part are expressly forbidden.

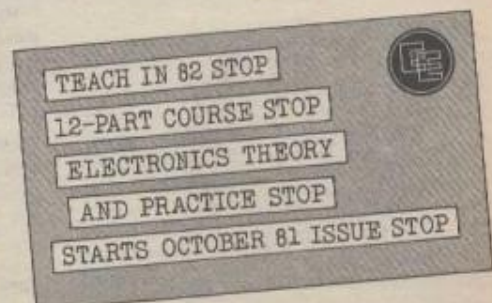

L.E.D. Sandglass

BY F.G. RAYER

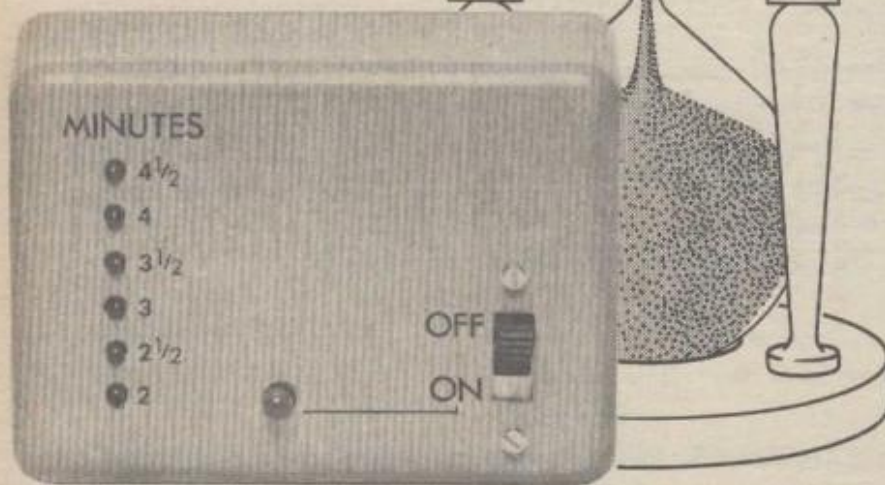

THE unit described in this article was designed to be an electronic replacement for the conventional sand-in-glass type of egg timer, but it could also find other applications for short duration timing in and around the home.

Rising illuminations in a column of six light emitting diodes shows times in half-minute intervals from 2 minutes (for lightly boiled small eggs) to 4½ or 5 minutes for hard boiled eggs.

The way in which time is passing is indicated by the position of an illuminated l.e.d. stepping along the column. This is different from many other egg timer projects in that the display indicates the position reached in the timing cycle.

CIRCUIT DESCRIPTION

The circuit diagram is shown in Fig. 1. Pulses are generated by TR1, a unijunction transistor. C1 charges up via R1 and VR1 and when a certain threshold voltage is reached, the capacitor rapidly discharges into the emitter of TR1 and through b1 into R3. The result of this is the generation of a narrow voltage pulse at b1. As soon as C1 is discharged, it begins to charge up again to repeat the process. The result is a train of pulses.

VR1 is a preset which allows the repetition rate to be adjusted. These pulses are produced for as long as the unit is turned on.

IC1 is a binary counter where pulses reaching its input, pin 14 are counted, and the number received outputted in binary at pins 12, 9, 8 and 11. IC1 counts up to ten and then

returns to zero and repeats; it may be manually reset by briefly putting S1 in its upper position.

IC2 is a decimal decoder, accepting a binary input and decoding this to cause one of its outputs to be logic 0 with the remainder at logic 1. Which output is "on" is decided by the binary count at its input, pins 3, 6, 7 and 4.

The four least significant outputs are not used since they correspond to time intervals of zero to 1½ minutes assuming the pulses are arriving at a rate of one every half-minute. The result of the input pulses therefore is to cause the l.e.d.s D1 to D6 to successively turn on every half minute from two minutes after initialisation.

Each l.e.d. remains lit for half a minute and extinguishes when the next one lights up. Time passing is thus shown at half minute intervals against a scale on the case.

A further green l.e.d., D7, lights when the unit is switched on and thus functions as a power-on indicator.

Control is by S1, a three-position slide switch. Both sections are shown off in Fig. 1. At S1b, both centre and on positions close the battery circuit. S1a only closes the reset circuit (grounds pins 2 and 3) of IC1 in the fully up position. In use, the switch is moved from OFF to RESET and back to ON to start timing. This ensures that IC1 is always started in the state corresponding to the "0" output of IC2, to allow correct indication by the l.e.d.s.

The l.e.d. connected to IC2 comes on after 4½ minutes, and remains on for a half minute. It thus extinguishes at 5 minutes. If it is preferred for this l.e.d. to remain on, a diode may be connected, anode to positive of C1,

The complete circuit diagram of the L.E.D. Sandglass.

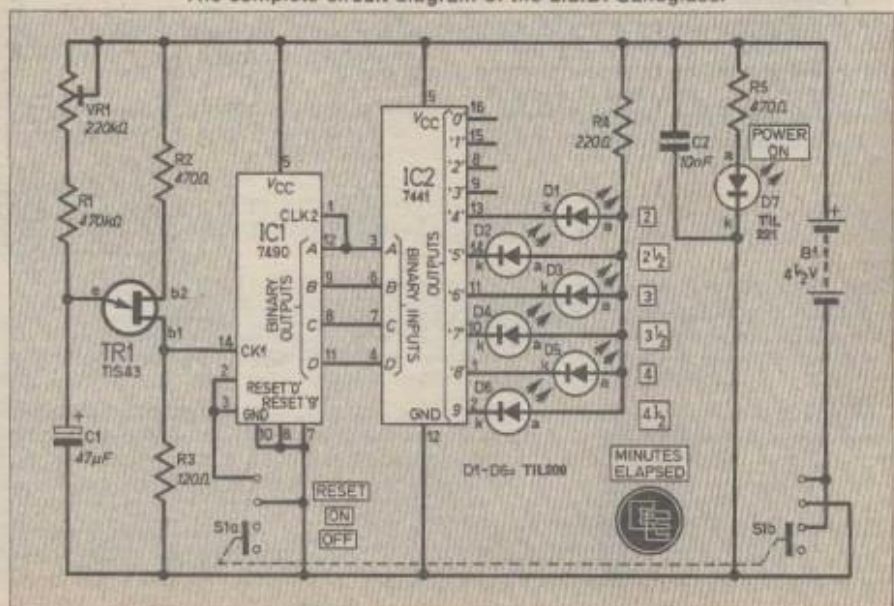

COMPONENTS

Resistors

R1 470kΩ
R2 470Ω
R3 120Ω
R4 220Ω
R5 470Ω

All ¼ watt carbon ± 5% page 535

Capacitors

C1 47µF 6V elect. radial leads preferred
C2 10nF ceramic or plastic

Semiconductors

TR1 TIS43 n-channel unijunction transistor (E5567 and UT45 also suitable)
IC1 7490 TTL binary counter
IC2 7441 TTL decimal decoder
D1-D6 TIL209 0.15in. red l.e.d. (6 off)
D7 TIL221 0.2in. green l.e.d.

Miscellaneous

VR1 220kΩ horizontal skeleton preset
B1 4.5V type 1289
S1 2-pole 3-position slide switch

Stripboard: 0.1 inch matrix size 21 strips by 19 holes; i.c. sockets: 14-pin d.i.l., 16-pin d.i.l.; short length of brass strip for making battery connectors; plastic case, size 100 × 75 × 45mm (approx.)

See
**Shop
Talk**

COMPONENTS
approximate
cost £5.50

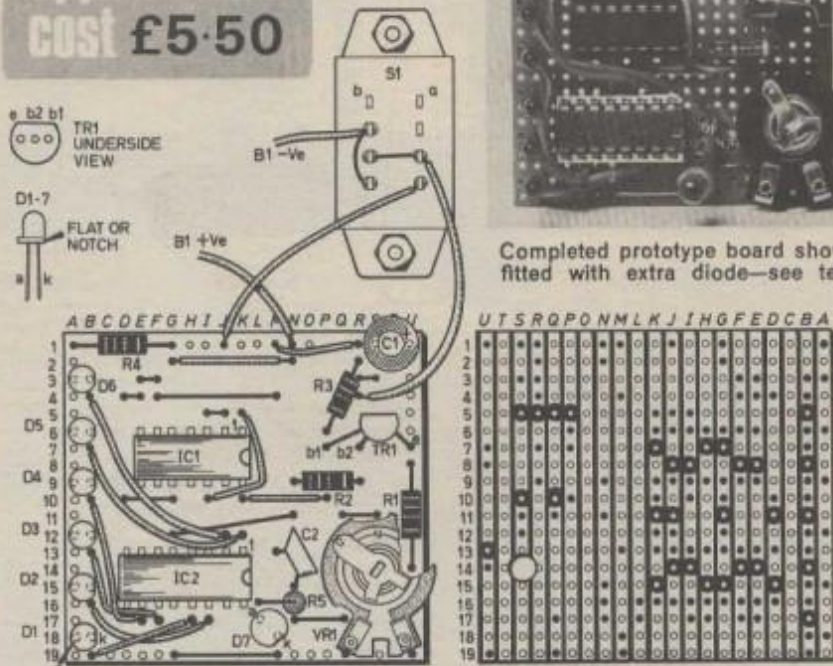

Fig. 2. The layout of the components on the topside of the stripboard and underside view showing breaks and connections to be made.

Completed prototype board shown fitted with extra diode—see text.

cathode to IC2, pin 2. Then when the 4½ minute l.e.d. lights, C1 will no longer charge, and pulses will cease.

BOARD ASSEMBLY

The board used in the prototype was 0.1 inch matrix stripboard size 21 strips by 19 holes. The layout of the components on the board topside are shown in Fig. 2, together with the breaks to be made on the underside. Check that each point really is completely cut, and that fragments of foil do not touch adjacent strips.

If necessary, check polarity of the l.e.d.s in advance, with a 5V or similar supply and 470 ohm resistor. Set them in line at the same height on the board. The cathode is usually marked by means of a notch on the body alongside this terminal.

A hole centrally under VR1 allows this to be adjusted by means of a small screwdriver.

Several different types of unijunction were found to work satisfactorily. If base 1 pulses do not step on the counter slightly increasing the value of R3 can be expected to correct this.

External connections consist only of those to battery and switch. S1b is for the negative line, and S1a must com-

plete the reset line IC1 only after S1b is closed, or the count may start with other outputs to give an erroneous timing interval.

One way to set VR1 is to clip a voltmeter across R3, and adjust for pulses at 30 second intervals. After switching on, a meter test should show pins 15, 8 and 9 on IC2 going low at half-minute intervals, followed by the l.e.d.s stepping on at this rate.

CASE

A plastic box approximately 100 x 75 x 45mm will take the board and battery. The l.e.d.s emerge through holes drilled in the case top. Exact drilling can be easily arranged by marking through a spare piece of 0.1in board. A scale marked for 2, 2½, 3, 3½, 4 and 4½ minutes should be made to fit alongside the appropriate l.e.d.s. Letraset was used

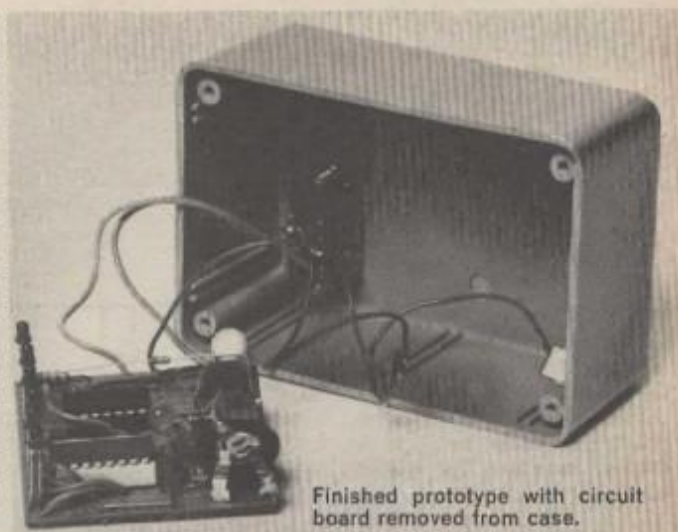

Finished prototype with circuit board removed from case.

on the prototype and protected by a spray of varnish.

Logic i.c.s in the 7400 series, as used here, normally operate from 5V. This may of course be used. A 4.5V supply was found satisfactory, but 6V must not be employed, unless a series diode (IN4001, IN4148 for example) is put in the positive battery lead to drop 0.6 volts making the supply 5.4 volts. This is acceptable by 7400 series logic i.c.s. □

MORSE PRACTISE OSCILLATOR

by F. G. Rayer

THE USE of Morse code is one of many Scout activities and a knowledge of the code is also necessary to obtain an Amateur Class A licence. This unit is suitable for practise alone, with a companion or with a group. It is designed for mains running but a battery supply is a practical alternative.

UNIUNCTION

Referring to the circuit in Fig. 1, TR1 is a unijunction transistor connected as a relaxation oscillator. Frequency is determined by C1, R1 and VR1 and the output appears at base 1 of the transistor. The frequency may be varied by changing the time constant of the RC combination (C1, R1 and VR1), and this is achieved by varying the value of VR1.

The output of this oscillator is taken from base 1 of TR1 and fed via C2 to the volume control VR2. This varies the input to IC1, an audio power amplifier. Little need be said about this stage as all signal processing is carried out inside the chip.

The audio output appears at pin 8 and is fed via C5 directly to the loudspeaker. Although any impedance up

to 50 ohms is specified greatest volume is obtained with the lower impedance types—say eight or even four ohms.

POWER

For battery running a 12 volt supply is suitable. Positive is taken to point A on Fig. 1 and negative to point B. An on-off switch could be included in the positive battery lead.

Where mains running is envisaged, T1, D1, D2 and C6 will be included. Double-pole switching is provided by S1. This is the ON/OFF switch. Mains power is stepped down to low voltage by T1 and then rectified by D1 and D2 and smoothed by C6 to provide a d.c. voltage rail.

COMPONENTS
approximate
cost £9.50
excluding case

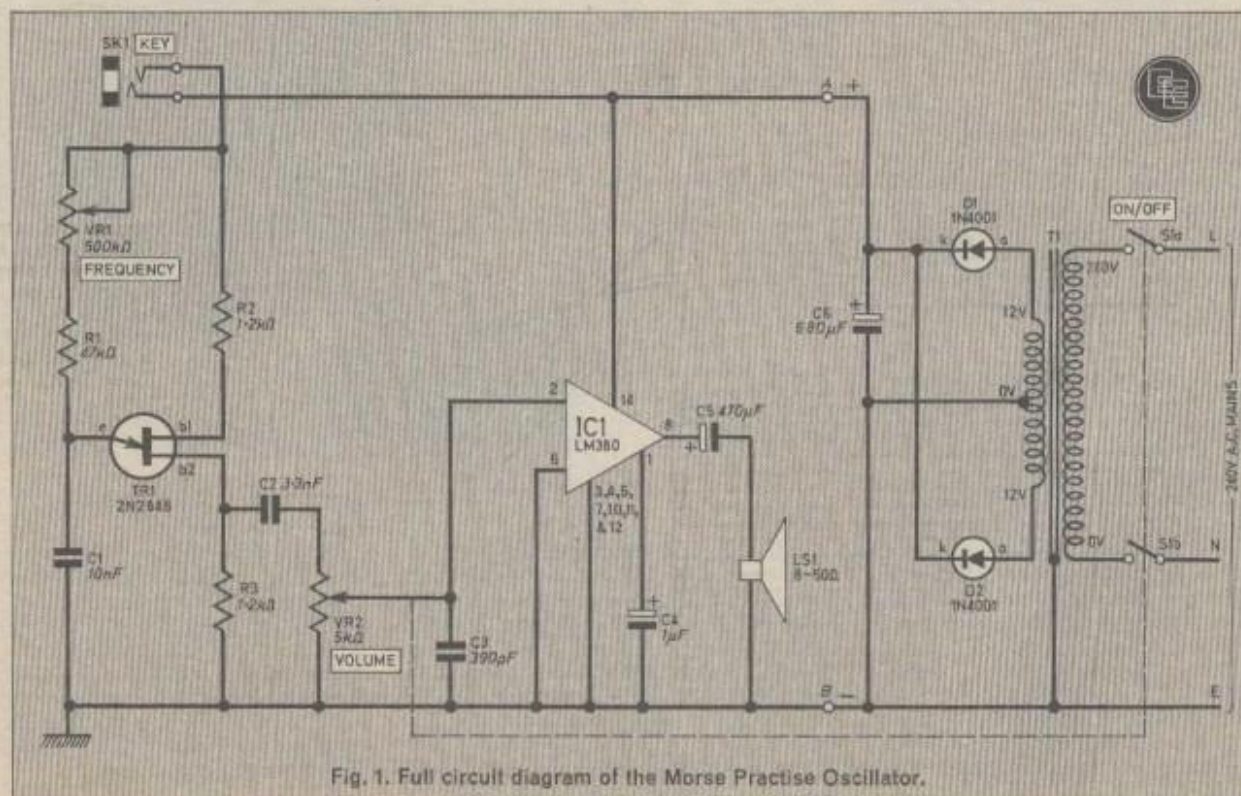

Fig. 1. Full circuit diagram of the Morse Practise Oscillator.

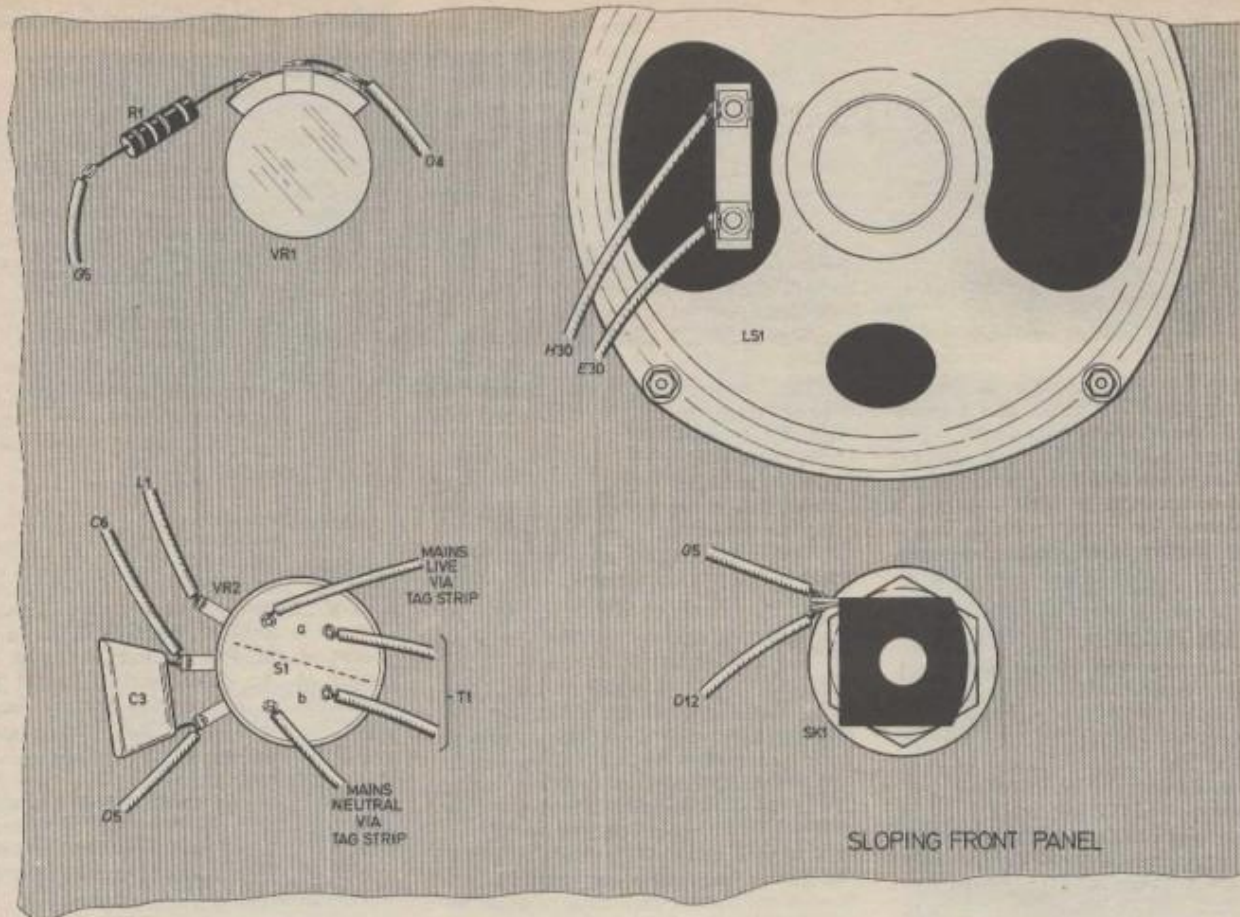

Fig. 2. Circuit board layout and internal interwiring. Note that the board is earthed to the case via the tag bolted under one of the mounting pillars. (See inset below left.)



CIRCUIT BOARD

The majority of components are mounted on a piece of 0.1 inch matrix stripboard, size 18 strips by 30 holes according to the layout in Fig. 2. The breaks are made in the copper strips with either a spot face cutter or a small twist drill. Check that the breaks are clear of fragments and that there are no short circuits between adjacent strips.

The power amplifier chip, IC1, may be soldered directly into place although a 14-pin d.i.l. socket would be preferred. Flexible leads should be attached for the off-board connections.

The board is mounted inside the case with 6BA nuts, bolts and spacers. One bolt is used as an anchor point for the solder tag that provides an earthing connection between board and case.

The other fixing bolt should not provide a short circuit between any copper strips and the case. This can be arranged by breaking the strips round the bolt position and placing an insulating washer between the spacer and the underside of the board.

CASE

The unit is built into an aluminium sloping front case, 200×150×150mm in size, and Fig. 2 shows the layout and all connections inside. The transformer, T1 is bolted directly to the case.

A three-way tag strip anchors the live, neutral and earth conductors of the main cable, and a three-pin plug with a 1A fuse should be used. Don't forget that any hole in the case through which cables pass, must be fitted with a rubber grommet.

Before commencing assembly, the front panel of the case should be drilled to take the socket, loudspeaker and two variable resistors.

A large cutout is needed for LS1 and this is best achieved using a chassis punch although drilling a ring of small holes to make a cutout and then filing the edges to a smooth finish may work.

Note that the jack socket, SK1, should be an all-plastic type so that neither of its contacts are short-circuited to the case when mounted in position.

Other boxes or cases may be used, either of metal (in which case the case must be earthed), or insulating material. A case could easily be constructed of thin wood.

Setting up is very simple. After checking all aspects of construction thoroughly, plug in a Morse key, turn the unit on and listen. With the key held down, adjust the potentiometers for the required frequency (VR1) and volume (VR2).

MORSE CODE

Morse code consists of long and short sounds obtained by pressing the key and is written as dashes and dots, with a dash the length of three dots.

However, when learning the code, it should be thought of as a series of "dits" and "dahs" rather than dots and dashes. This is because a sense of rhythm is necessary for sending and receiving Morse and this cannot be achieved if the code is thought of as a series of dots and dashes.

COMPONENTS

Resistors

R1 47k Ω
R2 1.2k Ω
R3 1.2k Ω

All $\frac{1}{4}$ W carbon $\pm 5\%$

Potentiometers

VR1 500k Ω lin. carbon
VR2/S1 5k Ω log. carbon with d.p.d.t. mains switch

Capacitors

C1 10nF C280 polyester
C2 3.3nF polystyrene
C3 390pF polystyrene
C4 1 μ F 25V elect.
C5 470 μ F 25V elect.
C6 680 μ F 40V elect.

Semiconductors

TR1 2N2646 unijunction with n-type base
IC1 LM380 N-14 audio amplifier i.c.
D1, 2 1N4001 1A, 50V rectifier diodes (2 off)

Miscellaneous

T1 mains primary/12-0-12V, 100mA secondary
LS1 loudspeaker, 8 to 50 ohms impedance
SK1 fully-insulated mono jack
Aluminium sloping front case, 200 × 150 × 150mm, H. L. Smith or similar; stripboard, 0.1 inch matrix, 18 strips × 30 holes; knobs (2 off); 3-core mains cable; interconnecting wire; 6BA nuts, bolts and spacers to mount board; solder tag.

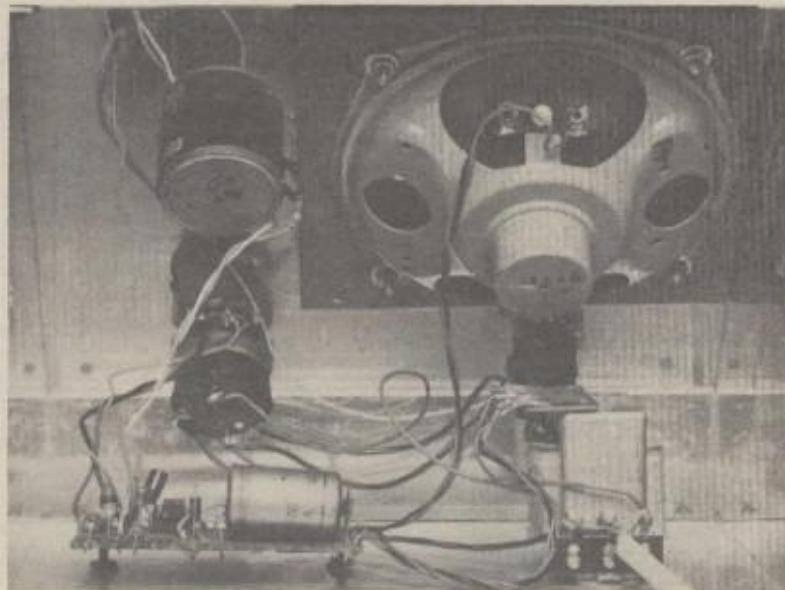

Interior view of the completed unit. The circuit board is mounted on the base of the case to the left and the transformer to the right. Front panel components can be seen above these. The panel in fact, slopes backwards.

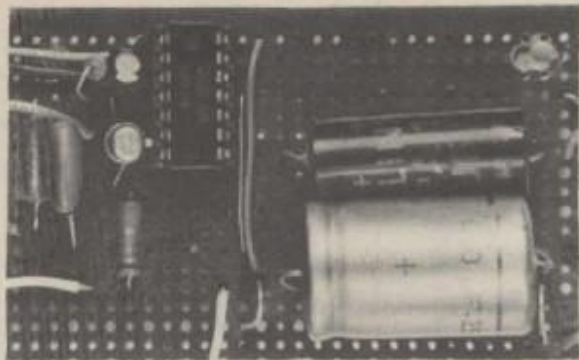

Top view of the completed circuit board.



Without this rhythm, character recognition when receiving becomes very difficult and your sending style may well become stilted.

The alphabet and numbers are given in Table 1 and can be memorised a few at a time. Always practise by making the sounds with an oscillator, such as the unit described here, rather than trying to write down dots and dashes. It is convenient if two or more persons learn together or you could try to enlist the aid of someone who already knows the code.

A useful solo reading exercise would be to listen to the slow Morse transmissions which are available, or by making tape recordings from the unit.

LETTER SQUARE

If you are going to make these recordings, it is necessary to adopt random letters, or the memory will fill in too much material. For this purpose, squares such as the one on the right can be constructed and can be read vertically, left to right, right to left and diagonally.

Note that you have to hang the odd letter underneath the square because, of course, there are 26 letters in the alphabet and these won't form a perfect square.

When recording, place the microphone near the loudspeaker and set the input level so that the recorder is not overloaded. After recording for ten minutes or so, play back to

A typical letter square

A	T	H	E	Q
U	I	C	K	B
R	O	W	N	F
Y	D	G	J	L
M	P	Z	S	V
		X		

develop your reading skills. It is best to form each letter quickly (though correctly of course) and leave longer spaces between letters. The actual sound will then be more nearly the same as that obtained when working at higher speed.

MORE PRACTICE

It is also easy to make 6 by 6 letter squares, putting in those letters which present the most difficulty twice, or including numbers.

When the code is thoroughly known by this means, it is best to move on to some other means of practising Morse reading, such as listening to the R.S.G.B. Slow Morse transmissions, or joining a reputable amateur radio club.

Sending is generally much easier than reading, and can be practised alone. Have a comfortable desk or table, so that the arm can rest on it, with fingers curved over the key.

Practising for short periods several days a week is much better than long periods at wide intervals. It will be found that fluency and speed slowly increase. Once again an amateur radio club will help. □

Table 1

INTERNATIONAL MORSE CODE

A	di-dah	N	dah-dit
B	dah-di-di-dit	O	dah-dah-dah
C	dah-di-dah-dit	P	di-dah-dah-dit
D	dah-di-dit	Q	dah-dah-di-dah
E	dit	R	di-dah-dit
F	di-di-dah-dit	S	di-di-dit
G	dah-dah-dit	T	dah
H	di-di-di-dit	U	di-di-dah
I	di-dit	V	di-di-di-dah
J	di-dah-dah-dah	W	di-dah-dah
K	dah-di-dah	X	dah-di-di-dah
L	di-dah-di-dit	Y	dah-di-dah-dah
M	dah-dah	Z	dah-dah-di-dit
1	di-dah-dah-dah-dah	6	dah-di-di-di-dit
2	di-di-dah-dah-dah	7	dah-dah-di-di-dit
3	di-di-di-dah-dah	8	dah-dah-dah-di-dit
4	di-di-di-di-dah	9	dah-dah-dah-dah-dit
5	di-di-di-di-dit	0	dah-dah-dah-dah-dah

Note

One "dah" should be equal to three "dits" in length

The space between parts of the same letter should be one "dit" in length

The space between characters in a word should be three "dits" in length

The space between words should be two "dahs" in length.

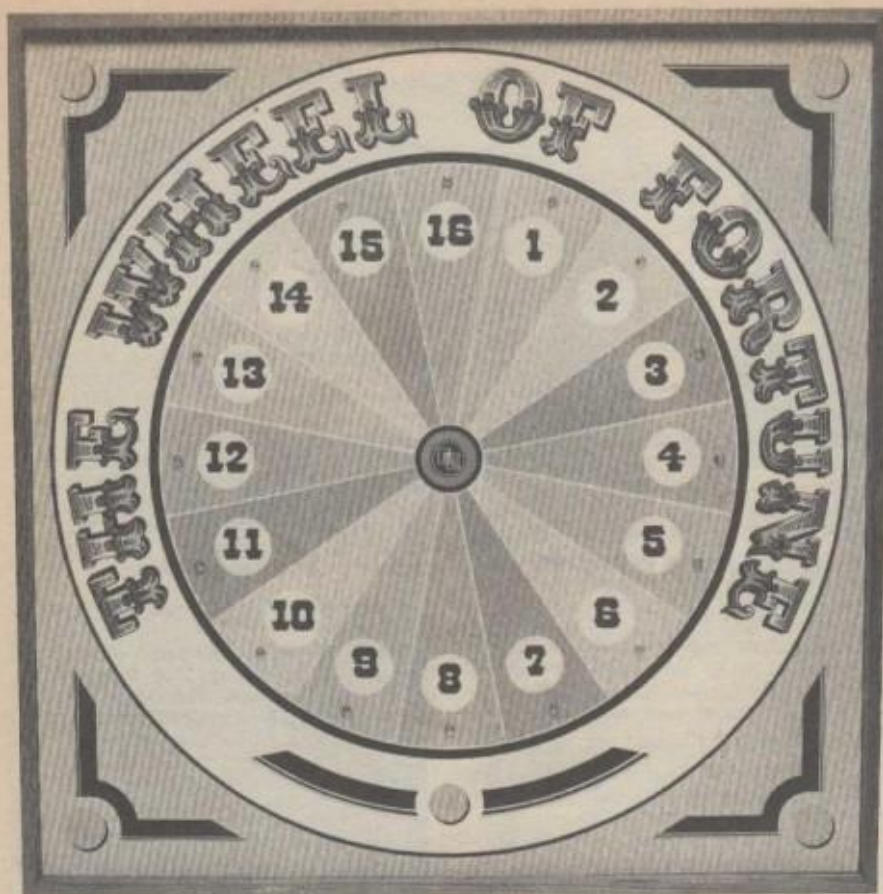

By C. J. Bowes

THE gambling device known as the Wheel of Fortune has been in existence for many years, and is a popular attraction at many garden fêtes and fairs, often in its original form of a wheel fitted with a pointer which is spun and then allowed to come to rest opposite a number of positions around the perimeter, thus indicating the winner.

The mechanical device suffers from the main drawback of being somewhat difficult to read since it often comes to rest between two numbers. Attempts to overcome this electronically have usually suffered from the problem of the devices being somewhat predictable, since they use time delays of various forms which tend to have a fairly constant delay period.

The design described in this article overcomes the former problem by using lights for a display, so arranged that only one can be on at a given time. A random number generator is used to determine the outcome of the display long before it stops. This makes the game completely unpredictable.

MAINS OR BATTERY

The machine has been designed for use either from an internal mains powered supply when available, or,

from 12 volt batteries for use when remote from a mains socket. The d.c. current consumption of the device is approximately 250mA with the specified lamps, thus making its operation from lantern batteries feasible, although a car battery can also be used.

CIRCUIT DESCRIPTION

The complete circuit is shown in Fig. 1, and for ease of description can be split into the following sections: (1) power supply (2) random number generator (3) display decoder driver circuit.

The power supply is a conventional 12 volt d.c. power supply except for the inclusion of the external d.c. socket SK1 and the position of the smoothing capacitor, C7.

The mains connection is made to a chassis mounted plug so that the mains lead may be removed when the unit is in operation from a battery supply. Mains voltage is first transformed down to 9V a.c. by the mains step-down transformer T1 and is then rectified by the rectifier bridge D1-4 and smoothed by C7 to give 12V d.c. S2 is a double-pole switch arranged so as to act as an on/off switch in either battery driven or mains driven modes.

SK1 is a two-pole switched (normally closed) jack socket which acts as a battery input socket and at the same time disconnects the output of the rectifier bridge from the rest of the circuit when an external battery is plugged in. Capacitor C7 is placed after this socket in order to provide decoupling for the logic circuitry in the battery power option.

RANDOM NUMBER GENERATOR

The random number generator consists of a source of high speed pulses fed into a counter and read by a latch which is operated by the START switch, S1. When this is released the binary number at its input is latched in and determines the number at which the display will eventually stop.

The counter is deliberately fed with high speed pulses in order to ensure that the number generated is random, with no chance of it being predetermined by the operator.

IC1a is half of a 556 timer (operating as a 555 timer) and is connected in the astable mode to provide pulses at a rate determined by R1, R2 and C1. The values given produce a square wave output at a frequency of approximately 1kHz. These pulses are fed into IC2a, which is half of a 4520 dual binary counter. This counts through the binary numbers for 0 to 15 before returning to 0 again and repeating the process.

The output from the counter is fed to the data inputs of IC3, a quadruple latch in a rather unusual manner. The reason for this is purely to make the manufacture of the printed circuit board easier. This is possible since the object of the circuit is purely to generate a random number and hence an accurate output corresponding to the number generated in the counter is not necessary. In fact this process, and similar connections made later in the circuit for the same reasons, increases the randomness of the result.

There are two control inputs on IC3, E₀ and E₁, and these are connected so that a falling edge applied to pin 6 causes the data at the inputs to be latched in to appear at the outputs.

As shown, pin 6 is held low by the action of S1a, a normally closed section of the start switch. In this condition the last data present on the data input lines (pins 4, 7, 13 and 14) are held in the latch. When the switch is pressed, the voltage on pin 6 is pulled up to logic 1 by the pull up resistor R3. In this condition the changing data input to the latch appears on the output pins of the device.

When S1 is released S1a closes again and the voltage on pin 6 is

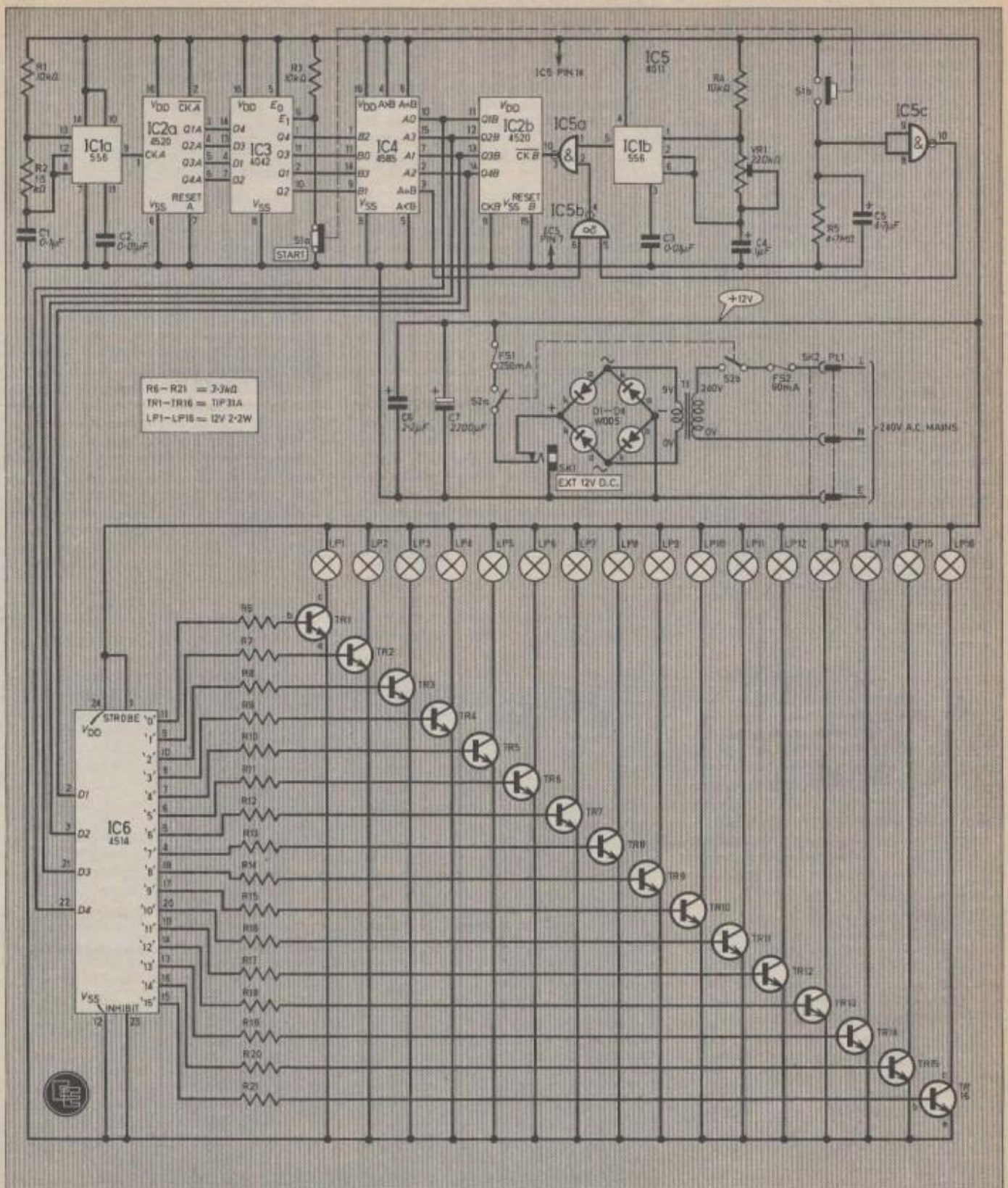

Fig. 1. The complete circuit diagram for the Wheel of Fortune.

returned to logic 0 producing a falling edge. The data presented to the latch by the counter at this instant is then held in the latch to determine the stopping position of the display.

MAGNITUDE COMPARATOR

This latched information reaches one set of inputs on IC4, a 4-bit magnitude comparator i.c. The other set of inputs to IC4 are derived from a

second pulse source and counter, IC1b and IC2b respectively. The output from IC2b is also decoded by IC6 to sequentially switch on the ring of display lamps.

A slow running astable circuit is constructed using the other half of the 556 timer (IC1b) the speed of which is set by R4, VR1 and C4. VR1 is included in order to set the speed at which the display pulses round to a suitable rate.

The output from IC1b reaches one of the two clock inputs to the counter IC2b via a two-input NAND gate IC5a. The other input to this gate determines whether or not the pulses reach the counter. This control signal is derived from a comparator output gated with the output from a simple RC timer circuit.

IC4 compares the values of two 4-bit binary numbers and gives outputs showing whether the number on input A is larger, smaller or equal to the number on input B. In this application the device is wired so that it gives an output when the two numbers are equal, pin 3 provides this. A logical 0 is produced until the numbers are equal where a logical 1 is outputted. This provides one input for IC5b.

In both cases the actual bit position of the numbers inputted to IC4 are wired in a manner which facilitates ease of printed circuit board design, and actually increases the randomness of the final result.

RC TIMER

The simple timer circuit consists of a resistor-capacitor arrangement, R5 and C5, which is charged up by the closing of the normally open contacts of switch S1b. Whilst the switch is operated the capacitor is charged up to +12V. When the switch is released capacitor C5 begins to discharge through resistor R5.

The output of the circuit is fed to an inverter made up of a two-input NAND gate (IC5c) with its inputs connected together. This gives a logic 0 output while C5 voltage is above 2V and provides a sharp edged output, as opposed to the more gently sloped output of the time delay circuit, when the charge level falls below 2V. The component values shown, give a time delay of approximately 22 seconds.

Thus at the start, just after S1 has been released, the input to IC5b from the timer is at logic 0 with the input from the comparator being at logic 0 for most of the time, changing to logic 1 when the two comparator inputs are equal. Therefore pulses are fed to the counter IC2b for at least 22 seconds. The next logic 1 from IC4 pin 3 after the timer times out (produces a logic 1) inhibits the pulses from being passed on to the counter. This stops the display from being moved on. The display then remains at the position set by the random number generator until S1 is again operated.

DISPLAY DECODER/DRIVER

The binary coded number generated by the display counter (IC2b) is fed to IC6 which is a 4514, one-of-sixteen decoder. This decodes the binary number from the counter and uses the information to switch one of its sixteen output lines from logic 0 to logic 1 as appropriate to the information fed into it.

Each of the output lines are connected to a driver transistor (TR1-TR16) via a 3.3 kilohm base resistor. The presence of a logic 1 voltage (+12V) causes the transistor to turn on and the associated lamp in the transistor collector line to be lit.

In this part of the circuit it is important that the data lines are connected in the correct sequence and this is facilitated by locating the decoding and driving circuitry on a separate printed circuit board; C6 is placed on this board to provide adequate decoupling.

The display of the device is a ring of sixteen filament lamps which are switched on in sequence in a clockwise pattern around the board for a period of time. The display is merely cosmetic since the position at which it will stop has been predetermined.

CONSTRUCTION

starts here

DISPLAY PANEL

The display consists of a square panel containing a circle divided into sixteen segments, each one of which contains a filament lamp (in holder) arranged in a circle. The lamps are wired to the display printed circuit board, which is mounted on the back of the display panel. This is in turn connected to the second p.c.b. containing the logic circuitry. The controls are mounted on a panel inset into the side of the case.

The letters and designs of the display could be painted or applied directly to the display panel after this has been suitably treated, but a better alternative we suggest would be to produce the design on paper or card and glue this to the panel when the unit is complete. In this way the

View into the back of the completed prototype wheel showing looming of all lamp and other wiring in the system. You can see the mains inlet panel sited at bottom left.

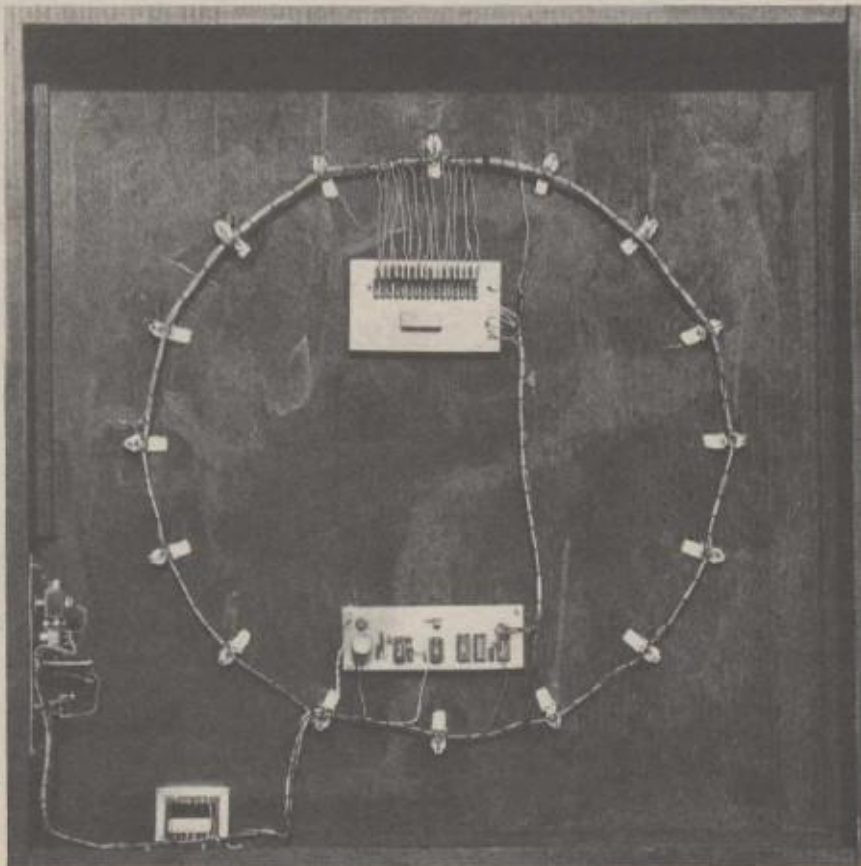

THE WHEEL OF FORTUNE

COMPONENTS

Resistors

R1 10k Ω
R2 1.5k Ω
R3 10k Ω
R4 10k Ω
R5 4.7M Ω
R6-R21 3.3k Ω (16 off)
All $\frac{1}{4}$ W carbon film $\pm 5\%$

See
**Shop
Talk**

page 535

Capacitors

C1 0.1 μ F ceramic disc
C2 0.01 μ F ceramic disc
C3 0.01 μ F ceramic disc
C4 1 μ F 16V tantalum bead
C5 4.7 μ F 16V tantalum bead
C6 2.2 μ F 16V tantalum bead
C7 2200 μ F 16V elect. radial leads

Semiconductors

D1-D4 W005 bridge rectifier
1A 50V
TR1-TR16 TIP31A silicon *n*p*n* (16 off)
IC1 NE5556 dual timer i.c.
IC2 4520 CMOS dual binary counter
IC3 4042 CMOS Quad *D*-type latch
IC4 4585 CMOS 4-bit comparator
IC5 4011 CMOS Quad 2-input NAND gate
IC6 4514 CMOS 4-to-16 decoder

Miscellaneous

LP1-LP16 12V 2.2W m.e.s. bulbs (16 off)
T1 mains primary/9V 0.5A secondary
SK1 standard jack socket with n.c. switched contact
SK2 mains chassis mounting
PL1 to suit SK2
S1 d.p.d.t. miniature momentary action push switch
S2 d.p.s.t. toggle
FS1 250mA 20mm
FS2 60mA 20mm
Single-sided p.c.b. sizes 135 x 53mm and 105 x 69mm; 20mm panel mounting fuseholders (2 off); m.e.s. lampholders and mounting brackets (16 off each); d.i.l. sockets for i.c.s; 24-pin (1 off), 16-pin (3 off), 14-pin (2 off); 4BA fixings for lampholders and p.c.b.s including spacers; aluminium for control panel; wood, sizes to suit.

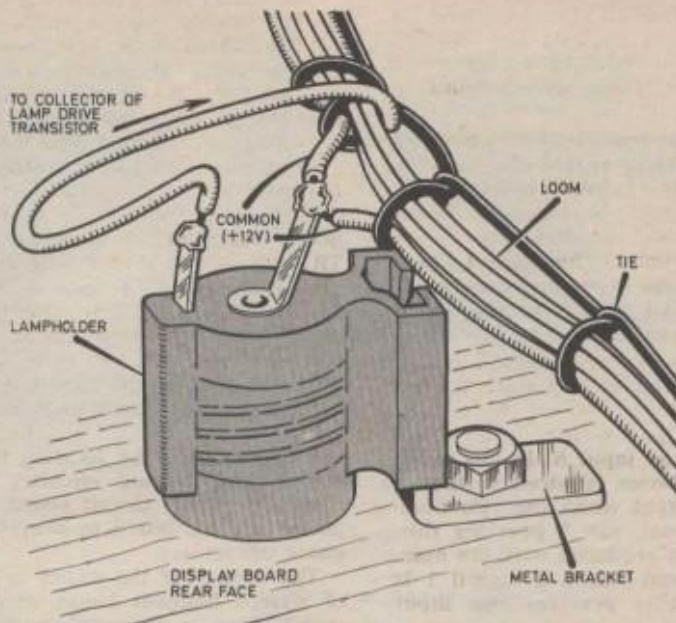

Fig. 2. Details of wiring for a lampholder. This is repeated for all sixteen lampholders. The wire running from these to the display board should take the shortest route through the loom.

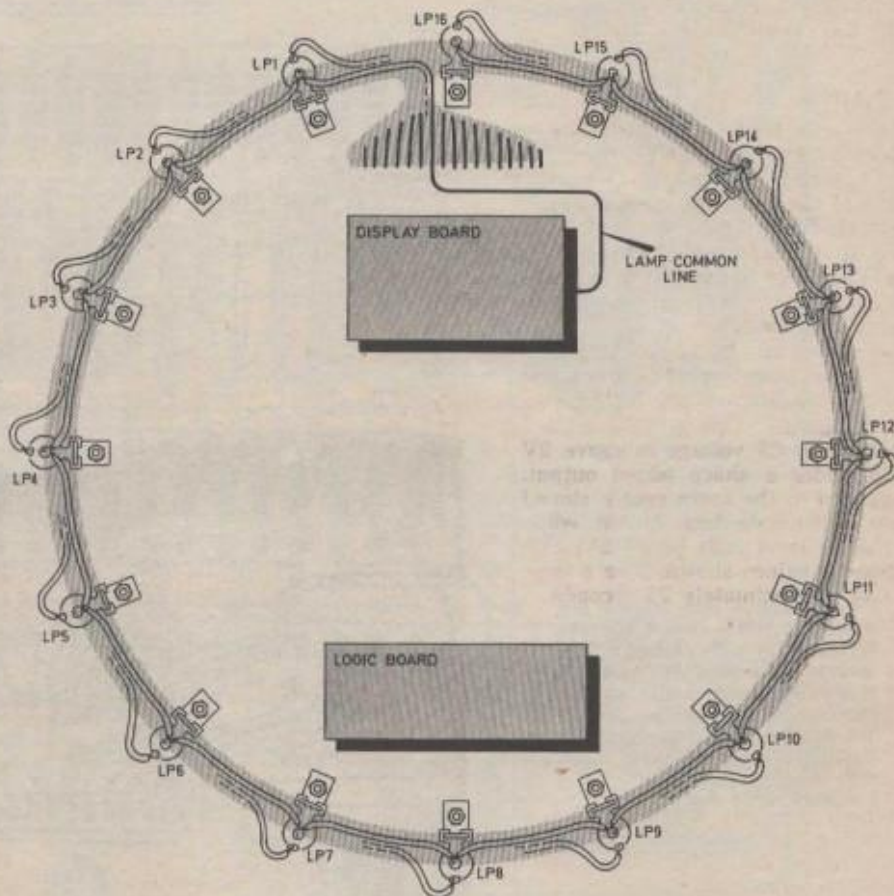
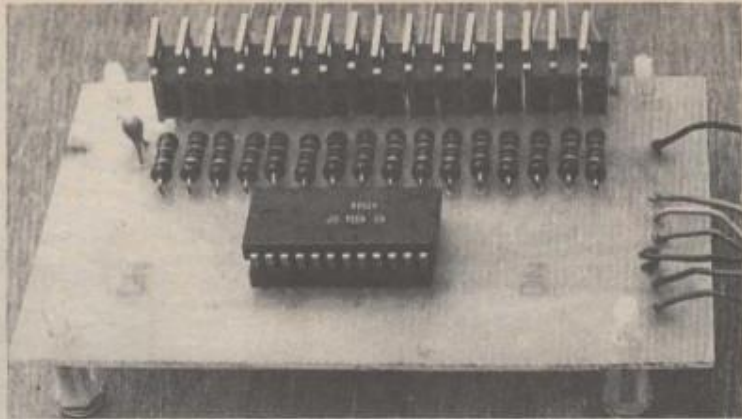

Fig. 3. Arrangement of the lampholders fitted to the display panel. The tinted ring represents the loom shape of all wires connecting to the display board.

THE WHEEL OF FORTUNE



Close-up view of the display board in position. Note that plastic supports have been used for mounting the board to the panel. This allows easy removal if necessary.

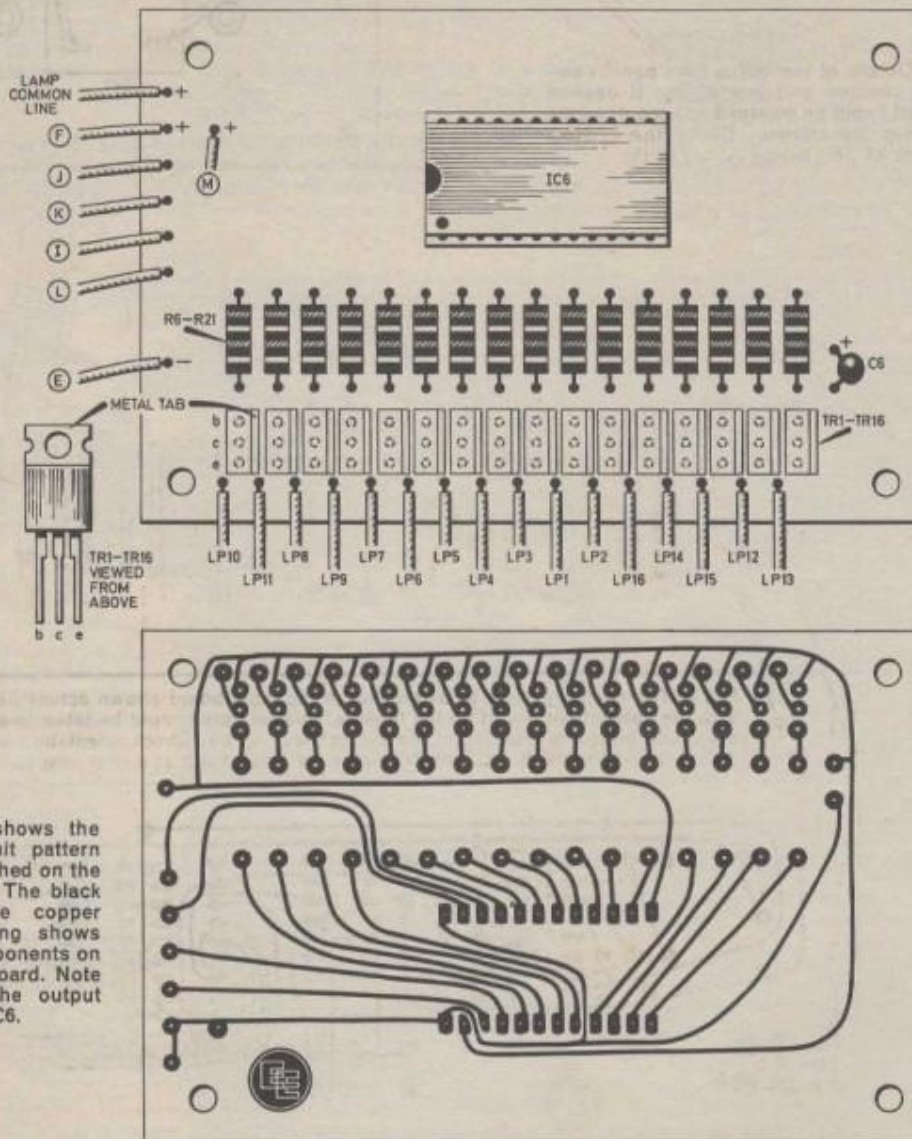

Fig. 4. Lower half shows the master printed circuit pattern (actual size) to be etched on the display driver board. The black areas represent the copper tracks. Upper drawing shows the layout of the components on the topside of this board. Note the orientation of the output transistors, C6 and IC6.

COMPONENTS
approximate
cost £28
 excluding
 cabinet

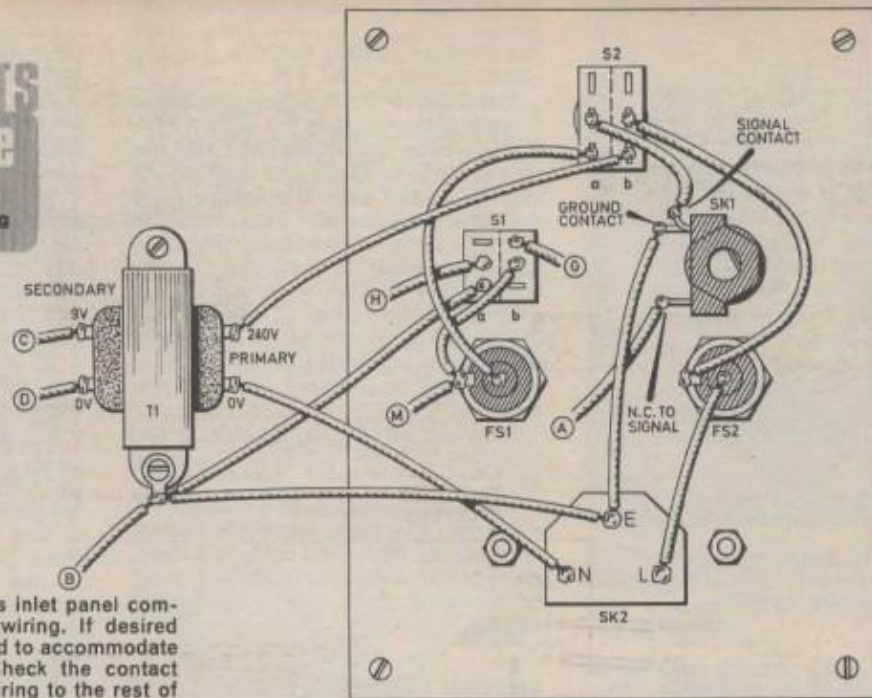

Fig. 6. Details of the mains inlet panel component position and interwiring. If desired the panel could be enlarged to accommodate the mains transformer. Check the contact functions of SK1 before wiring to the rest of the circuitry.

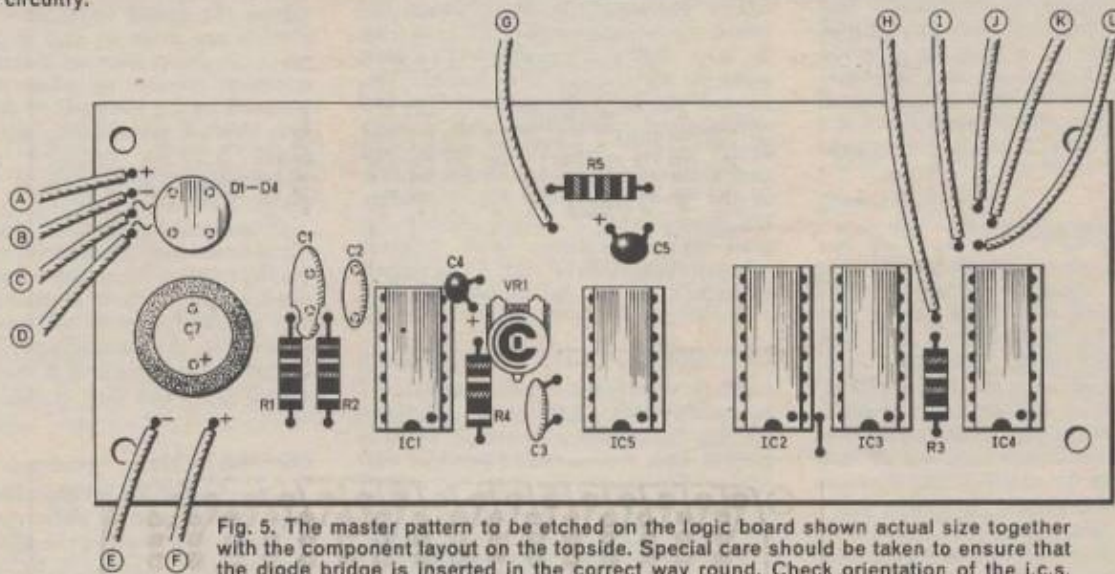
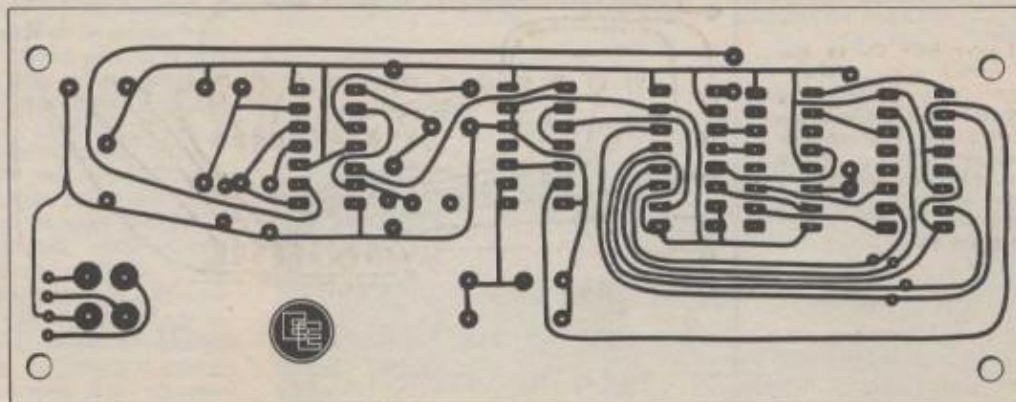
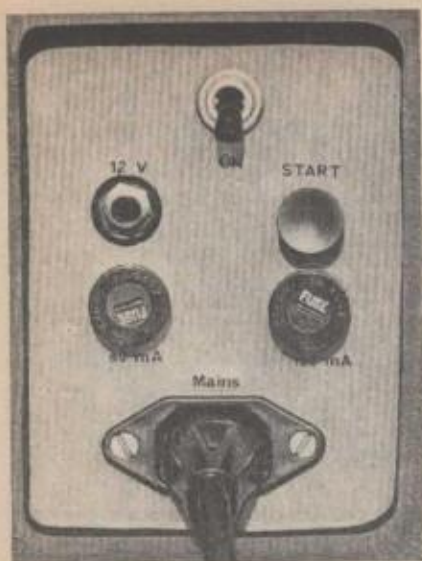

Fig. 5. The master pattern to be etched on the logic board shown actual size together with the component layout on the topside. Special care should be taken to ensure that the diode bridge is inserted in the correct way round. Check orientation of the i.c.s. before insertion which incidentally should be carried out at a later stage.





The completed mains inlet panel fitted beneath a cut-out in the side of the cabinet with the mains plug inserted.

lampholder fixing screws and p.c.b. fixing screws will be concealed.

In the version illustrated on the front cover, the coloured display was on card glued to a 90 x 90cm piece of 6mm thick plywood and the case was made from 150 x 18mm veneered chipboard, but these sizes may be altered to suit individual requirements.

PREPARING PANEL

Find the centre of the board by joining the opposite corners of the square to each other and taking the centre as the point where the two diagonal lines cross. Using this point as a centre, draw a circle of radius to suit lamp positions from centre. The circle marks the points where the holes for the lamps will be drilled and needs to be divided into sixteen equally spaced points.

To do this place a protractor centred on the intersection of the two diagonal lines to mark off angles of 22.5, 45 and 67.5 degrees in each of

the quadrants. Extend each of these angles from the centre until the lines intersect the circle. The lamp holes can then be drilled through using a 10mm diameter drill bit.

The lampholder brackets require a 3.5mm diameter hole (to take a 4BA screw) to be drilled through the display board. To mark the position of this hole make up a lampholder, bulb and bracket assembly. Place the bulb through each of the lamp holes in turn and mark the position of the hole in the bracket where this coincides with the radius to the position of the hole for the lamp. The holes required to mount the p.c.b.s can also be marked and drilled at the same time.

Next fit all the lampholders and brackets in place and also the p.c.b. fixing screws.

The board can then be painted with a primer, and when dry rubbed down and painted with gloss colours, letters, numbers and designs that you want to appear if these are to be applied directly.

WIRING LAMPHOLDERS

The lampholders should each be wired up as shown in Fig. 2. It can be seen that a common (+12V) wire joins up one tag on each holder. The second tag is to be connected to the appropriate position on the display driver circuit board. All wires are tied to form a circular loom as seen in the photograph and Fig. 3. Different colour wire is recommended for ease of construction and tracing. Alternatively labels can be attached to each free end during wiring up.

CIRCUIT BOARDS

The electronic construction is reasonably straightforward, with most of the components mounted on two p.c.b.s. The foil patterns for the two p.c.b.s are shown as Figs. 4 and 5 together with the component layout on each topside.

These are single-sided boards and can be produced fairly easily. Because of the close packing of some of the

tracks it is best to use either a photographic process or etch resistant transfers and track tape in preference to hand drawing the design with an etch resistant pen.

Because of the use of CMOS devices all the i.c.s except for ICI should be mounted using sockets. The use of a socket for ICI is also recommended.

With the exception of the i.c.s the components can be mounted in any convenient order, but the boards should be fully completed, checked for solder bridges and later connected to the rest of the circuitry before the i.c.s are inserted.

WIRING UP

Lay the two p.c.b.s in situ on the panel and interwire and connect to the ring of lamps according to the information in Figs. 3, 4 and 5. Form a tied loom for interboard connections for neater appearance as seen in the photograph. Connect the remainder of the wires to the boards that are to run to the mains input panel. The boards may now be fastened in position.

The next stage of construction involves the mains inlet panel. Details of this are seen in Fig. 6. This is a piece of aluminium with fixing holes at each corner to allow it to be screwed to the inside face of the case side over a rectangular cut-out. The panel is thus recessed and this affords some protection to the components here.

Prepare the panel, fix the components and wire up according to Fig. 6. The mains transformer should be sited close by, and in the prototype was screwed directly to the case side as seen in the photograph. With this complete and checked it may now be wired up to the rest of the circuitry.

OPERATION

Upon switching on the unit the display should start to pulse round until it reads the number in the random number latch (often 0 lighting position 1, LP1). When the START switch is pressed the display will pulse round at a speed determined by the setting of VR1 for about 22 seconds and will eventually stop at a number, remaining there until the START button is again pressed.

After the device has been tested and VR1 set for the required pulse rate, the panel should be enclosed in a suitable case to prevent damage to the circuitry and to avoid the possibility of stray fingers being poked into the mains driven power supply. A square framework with back panel should be made so that the display panel is recessed. Finally glue the display card artwork in place, suitably varnished for protection, to complete the unit. □

The completed prototype logic board.

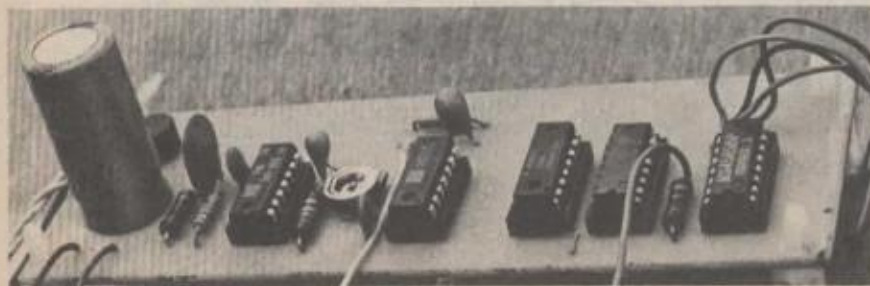



By Dave Barrington

Special Offer

Reading the May/June Newsletter put out by J. Bull (Electrical) Ltd., I was reminded that just about one year has elapsed since Mr. Jessie Bull moved his long established business from West Croydon on the southern edge of the London conurbation out to Haywards Heath in the Sussex countryside.

These Newsletters always provide a "good read", being packed with intriguing electrical items generally of a manufacturers' surplus nature. As likely as not there will be listed the kind of electrical equipment required to provide the motive power or muscle for some electronic project featured in EE.

In this latest newsletter the "opening offer" is really something extra-special, and not likely to be repeated. Mr. Jessie Bull informs his readers that he is approaching retirement, and after more than 30 years in the controlling director's chair now wishes to hand over to a younger man. An opportunity that will surely be seized upon by some enterprising fellow, with the requisite capital of counsel.

These bi-monthly news-sheets are available free to readers (mention EE).

Project Kits

A piece of news which may be of interest to advertisers and shops is the announcement from the Hobby Products Division of OK Machine & Tool (UK) Ltd., that they are looking for distributors of their range of Electronic Kits.

The kits usually retail for between £5-99 to £8-60 and include such projects as dice, roulette and reaction tester. For further information write to OK Machine & Tool (UK) Ltd., Dept EE, Dutton Lane, Eastleigh, Hants, SO5 4AA.

Another good selection for constructional/educational kits is the excellent range of Chip Shop Kits from Electroni-Kit.

There are twenty kits all told and cover such subjects as a light sensitive switch, transistor tester, lie detector and transistor radio. All projects are transistor based, include loudspeaker, were required, and come with an attractive plastics case for the finished model.

The kits seem excellent value for money and range from £3 to £5. For details of nearest stockists contact Electroni-Kit Ltd., at Dept EE, Rectory Court, Chalvington, Sussex, BN27 3TD.

TEST PROBE

A multiple tester with i.e.d. and neon indication for checking a.c./d.c. voltages from 4.5V to 415V is one of the many ranges of new Probe Checkers from Steinel K.G.

The Hobby Check will indicate a.c. voltages in three steps, 110V, 240V and 415V, via three neons inset in the indicating handle probe. The direct current polarity indication is by two i.e.d.s, only one illuminating to indicate the polarity at the handle tip. Alternating current is present when both i.e.d.s appear to be on.

Information on the complete range of Probe Checkers can be obtained from Steinel K.G., Dept EE, Unit 9, Armoury Road, Trading Estate, Small Heath, Birmingham B11.



Hobby Check from Steinel K.G.

Best Seller

It must be very gratifying to component suppliers when orders for their catalogues pour in. But should stocks become exhausted before a new batch can be obtained from the printer, delight must change to chagrin if it becomes necessary to return money to would-be purchasers. This is the predicament Marshalls found themselves in recently. However, June Marshall informs us that a new supply of catalogues is now in their hands and she would like us to pass on her company's apologies to any temporarily disappointed customers.

Closing the Door

Things happen suddenly in business. We were just examining a new summer edition of the Doram catalogue when the news reached us that the Dutch owners of Doram Electronics have decided to close down this UK based firm. It is a sad end to a business originally set up by Electrocomponents, the parent company of RS Components Ltd., to cater for the hobbyist.

Manager Mike Hutchinson tells us that enquiries about outstanding orders should be addressed directly to Doram Electronics Ltd., De Boer Elektronika, Kleine Berg 41, Eindhoven, Holland, 5611 JS.

CONSTRUCTIONAL PROJECTS

Simple pH Meter

Problems may be encountered when trying to locate a supplier for the NE536 i.c. in the pH Meter although it is available through any stockist of Mullard products. Pin for pin equivalents are the CA3140T or the LF356T although these have not been tried in the prototype.

Perhaps of more importance is the probe. Readers who are associated with Educational establishments should be able to obtain a suitable item from the equipment suppliers Griffin and George. However this is a strictly trade-only company and do not supply direct to the public.

Other sources of supply are Hogg Laboratory Supplies, Sloane St, Birmingham, B1 3BW, who have a suitable probe priced £21 including postage and packing. This company hopes to have some cheaper probes in stock in the near future.

There is also Castle Laboratories, 7 Guest Rd, Barnsley, S. Yorks, S75 2SR, who can supply probes that have passed their recommended shelf life for £6-75. They also have a "no-quibble" replacement guarantee.

Metronome

Few difficulties should be encountered when ordering components for the CMOS Metronome. Virtually any loudspeaker of suitable size can be used so long as its impedance is not less than about 35 ohms. The case used in the prototype was a Bimbox type 2005/15 made by Boss Industrial Moulding Ltd and available from most component suppliers, although virtually any small plastics box will do just as well.

Door Alarm

Two items may cause a few problems with the Door Alarm. The key switch is one although a suitable item is available from Maplin, order number FH40T. The other item is the bleeper. In fact any solid-state 6V warning device will do here although many of these devices are not particularly loud and perhaps would not be much good as an alarm. Marshalls sell a 6V buzzer which they claim has a "very loud note" although in our prototype we fitted a buzzer from Tandy, type number 273 049.

L.E.D. Sandglass

It is expected that the three-position slide switch in the L.E.D. Sandglass will be difficult to locate. Constructors may obtain this from T. Powell. See their advertisement for full address. The remainder of the components should be readily available.

Wheel of Fortune

No buying problems are envisaged for the Wheel of Fortune. The mains transformer fitted in the prototype had a secondary rating of 500mA but any rating down to 250mA will be suitable. Resistors, capacitors, bridge rectifier and transistors should be in strict accordance with the parts list otherwise they may not fit the p.c.b.s.

Morse Practise Oscillator

Any one of a number of morse keys can be used in the Morse Practise Oscillator and several advertisers such as Home Radio, Watford, and Maplin carry stocks.

DISCRETE

SEMICONDUCTORS

EXPLAINED

PART THREE

BY J.B.DANCE

THIS MONTH we will discuss other devices containing *pn* junctions together with heat and voltage sensitive devices.

THE UNIUNCTION DEVICE

The unijunction transistor (sometimes known as the double base diode) has the structure shown in Fig. 3.1. A bar of lightly doped *n*-type silicon has base connections at each end and part of the way along this bar, nearer to base 2 than to base 1, a pellet of *p*-type silicon is used to form a rectifying contact. This electrode is known as the emitter and forms the single junction from which the device derives its name.

The circuit symbol for a unijunction device is shown in Fig. 3.2. It is also possible to obtain unijunction devices with the opposite polarity to that shown in Fig. 3.1 (although they are not so common). In this case the silicon bar is of *p*-type material and the emitter pellet of *n*-type. The symbol for the complementary devices has the arrow pointing in the opposite direction to that shown in Fig. 3.2. This discussion relates to devices with the Fig. 3.1 polarity.

The action of the unijunction transistor is illustrated in Fig. 3.3. The bar of silicon is equivalent to the resistors R_2 and R_1 in series so that when a voltage of V_{BB} is applied between the two bases, the potential at point *A* becomes equal to $R_1/(R_1 + R_2)$ times V_{BB} . The factor $R_1/(R_1 + R_2)$ is known as the intrinsic stand-off ratio η .

When the potential applied to the emitter is less than $\eta \times V_{BB}$ no conduction occurs in the emitter circuit, since the junction is reverse biased. As the emitter potential increases above this value, however, conduction occurs and the device is rapidly switched on.

When the junction conducts, holes are injected from the emitter into the silicon bar and move towards base 1.

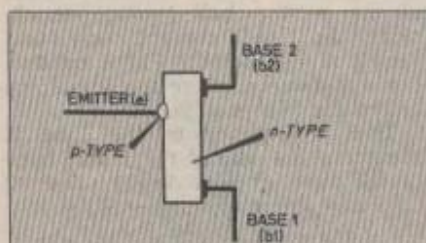

Fig. 3.1. The structure of a unijunction transistor.

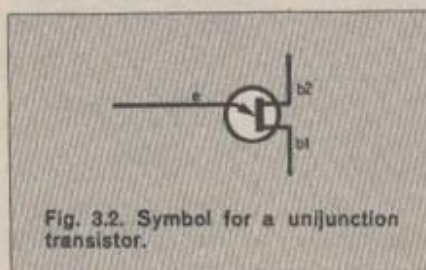

Fig. 3.2. Symbol for a unijunction transistor.

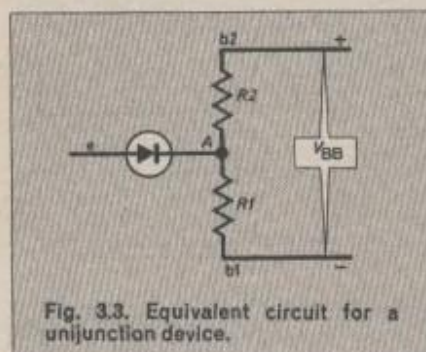

Fig. 3.3. Equivalent circuit for a unijunction device.

Electrons are injected from base 1 to maintain neutrality. There are now plenty of charge carriers in this region and the resistance falls very rapidly between base 1 and the emitter. This causes a large drop in the effective resistance R_1 of Fig. 3.3 and hence a fall in the potential at point *A*. This in turn gives rise to more emitter current and switching by this positive feedback effect.

PRACTICAL OSCILLATOR

Unijunction transistors enable the very simple type of relaxation oscillator shown in Fig. 3.4 to be constructed. This is the basis of most unijunction oscillator and timer circuits.

The capacitor C_1 charges through R_1 until the emitter potential is adequate to cause the unijunction device to be switched to conduction C_1 then discharges through the emitter circuit and R_3 until conduction ceases.

The frequency of oscillation is determined mainly by the product of C_1 and R_1 and can be up to about 100kHz. Positive going output pulses can be obtained from across R_3 which are suitable for firing a thyristor device.

If the value of R_1 is too low, it will pass enough current to keep the circuit conducting so that it will not switch back to the off state. Similarly, the value of R_1 must not be too high or the unijunction will not be switched to conduction.

WIPER CONTROL

A practical application for a unijunction oscillator circuit shown in Fig. 3.5 is for a delayed, single sweep car windscreen wiper control. The ON/OFF switch S_1 ganged with the potentiometer enables firing pulses to be fed to (D2) a C122D thyristor at intervals between about 1 second (determined by R_1) and 1 minute (determined by the setting of VR_1).

This closes the relay and the relay contacts are used to cause the wiper motor to operate. The self-parking switch then closes, the C122D conduction ceases and the wipers park at the end of their single sweep.

The exact connections depend on the type of wiper motor, but VR_1 can be adjusted to suit all weather conditions and to automatically keep the windscreen clear without the wiper blades scraping on a nearly dry windscreen.

THE THYRISTOR

The thyristor or silicon controlled rectifier (s.c.r.) is a *pnpn* device as shown in Fig. 3.6. When a firing pulse is fed to the gate circuit, this initiates conduction from the anode to cathode. Conduction in the main anode-to-cathode circuit continues until the anode-to-cathode current falls below a certain minimum value (known as the holding current) required to maintain conduction.

The thyristor then remains non-conducting until a further firing pulse is applied to its gate electrode. Thyristors are widely used in series with a load across an alternating current mains supply, as shown in Fig. 3.7, since gate pulses can then be used to fire the thyristor into conduction at a desired point in the mains cycle. Switching to the off state is automatic as the alternating waveform from the mains passes through its zero voltage point.

ALTERNATING WAVEFORM

In Fig. 3.8 we see the alternating mains waveform. If pulses are applied to the thyristor gate electrode of Fig. 3.7 each time the positive half cycles of Fig. 3.8(a) reach their peak, the current in the load will have the waveform shown in Fig. 3.8(b). The current flows in the load only during

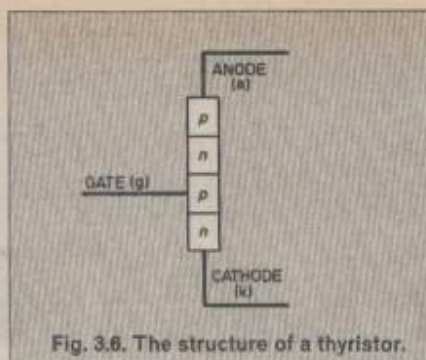

Fig. 3.6. The structure of a thyristor.

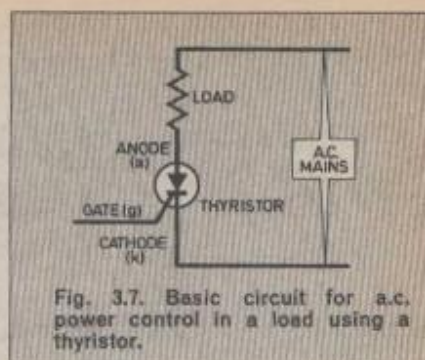

Fig. 3.7. Basic circuit for a.c. power control in a load using a thyristor.

the part of each positive half cycle after the peak voltage is reached.

If the gate triggering pulses are now applied somewhat earlier in each of the positive half cycles, one obtains the load current waveform shown in Fig. 3.8(c), where conduction commences before the waveform has reached its peak value.

Thus the power to the load is greater in the case of Fig. 3.8(c) than in the case of Fig. 3.8(b). Thus a thyristor circuit can be used to control the amount of power supplied to an electric motor.

The thyristor chosen for use in the type of circuit shown in Fig. 3.7 must have a breakover voltage high enough to prevent the device from switching to conduction under the applied

anode-to-cathode voltage when no gate pulse is being fed to the device. Thus the breakover voltage of the selected thyristor should exceed the peak value of the alternating mains voltage ($\sqrt{2}$ times the r.m.s. value).

Some types of thyristor can be turned off by suitable pulses applied to their gate electrodes. The silicon controlled switch is similar to the thyristor except that there are two gate electrodes, one gate being connected to each of the inner layers of the structure shown in Fig. 3.6.

THE TRIAC

The thyristor will conduct only in the one direction in which the conventional current passes from the

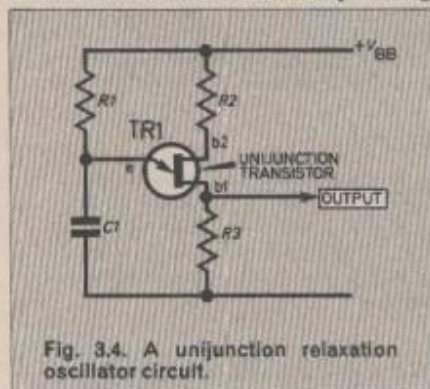

Fig. 3.4. A unijunction relaxation oscillator circuit.

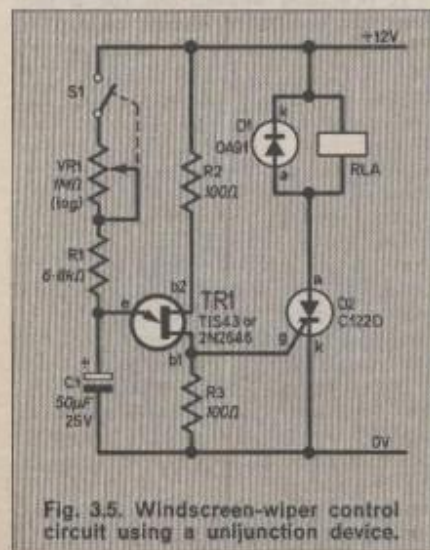

Fig. 3.5. Windscreen-wiper control circuit using a unijunction device.

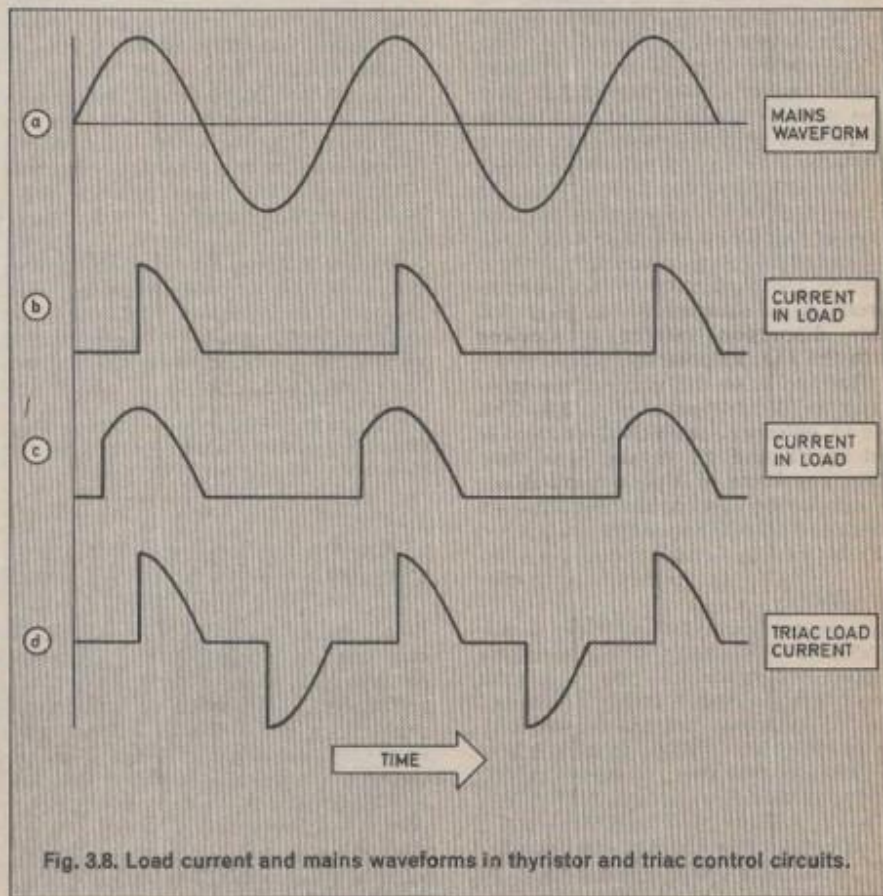

Fig. 3.8. Load current and mains waveforms in thyristor and triac control circuits.

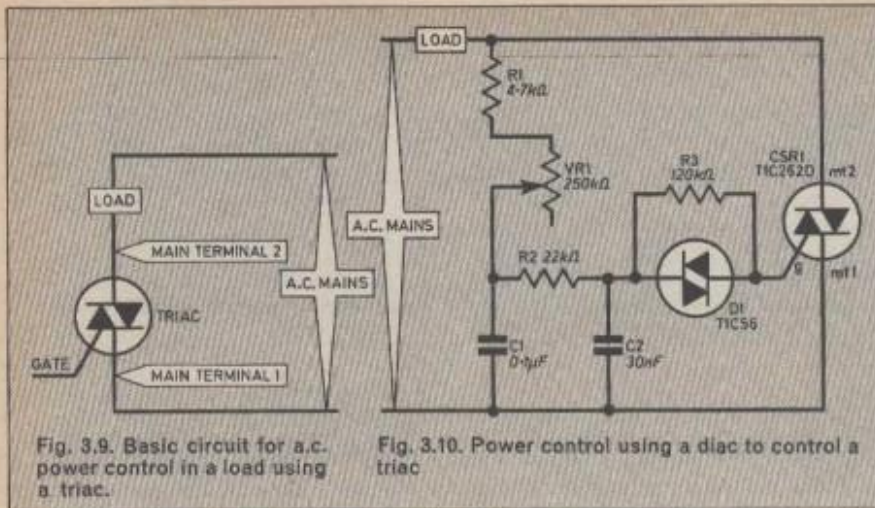

Fig. 3.9. Basic circuit for a.c. power control in a load using a triac.

Fig. 3.10. Power control using a diac to control a triac

anode to the cathode. It is obvious from Figs. 3.8(b) and 3.8(c) that the use of a thyristor in series with a load across the a.c. mains will greatly reduce the maximum power in the load. Even if the current flows for the maximum time of each full positive half cycle, the power will be reduced to one half of what it would be without the thyristor.

One solution to this problem is to employ two separate thyristors, one of which conducts during each alternate half cycle of the mains supply. However, it is usually more convenient to employ a device known as a triac. This is very similar in operation to a thyristor, but can conduct in either direction. The circuit symbol for a triac is shown in Fig. 3.9. It is a *pnpn* device like a thyristor. Conduction is initiated by means of a pulse to the gate electrode and the device then continues to conduct until the current falls below the holding current for the particular triac concerned. Fig 3.8(d) shows the waveform of the load current in the triac circuit Fig. 3.9 when the gate pulse is applied each time the half cycle of the mains supply voltage reaches its peak.

Apart from the gate, the electrodes of the triac are the Main Terminal 1 and the Main Terminal 2 which are abbreviated mtl and mt2 respectively. Triacs can be turned on by gate pulses of either polarity.

THE DIAC

A practical circuit designed by Texas Instruments for controlling the power developed in a load is shown in Fig. 3.10. Apart from the triac, this circuit employs a small *pnpn* device known as a diac. The diac automatically switches to conduction when the voltage across it becomes greater than a certain value known as the breakover voltage for the device concerned. The circuit in Fig. 3.10 is suitable for resistive but not

for inductive loads, since in the latter type of load the current and voltage are out of phase in the load.

The resistor-capacitor network in the circuit of Fig. 3.10 ensures that smooth control can be obtained at all angles of phase delay. However, R2, R3 and C2 can be omitted and the left hand side of the diac connected to the junction of VR1 and C1.

THERMISTORS

Thermistors are rods, discs, beads or a similar block of a semiconductor material with two leads attached. The material is made by sintering certain mixtures of metallic oxides (such as nickel, cobalt, iron, manganese), so the material is very different from previous semiconductors.

The resistance of a thermistor changes with temperature. The resistance of most thermistors falls rapidly with increasing temperature, but positive temperature coefficient types known as p.t.c. thermistors are also available whose resistance increases with increasing temperature.

Thermistors can be used in the externally heated mode in which they sense the temperature of their en-

vironment and provide an appropriate electrical signal. For example, they can be used in circuits to provide a warning when the external temperature falls below freezing point or some other value.

vironment and provide an appropriate electrical signal. For example, they can be used in circuits to provide a warning when the external temperature falls below freezing point or some other value.

In other applications they are self-heated. For example, they may be connected in series with a tungsten filament lamp to prevent the initially high peak current which can cause lamp failure. When the circuit is switched on, the thermistor is at room temperature and has a relatively high resistance. However, the current flowing through the lamp and the thermistor warms the latter and its resistance falls to a small value so that the lamp reaches its full brilliance within a short time.

Thermistors are also used in the self-heating mode in much more complex equipment to provide a delayed turn-on of the power. They have the advantages of being small, simple, reliable and rugged and are available with resistances of less than one ohm up to about one hundred megohm.

The variation of resistance with temperature may be expressed as the ratio of the resistance of the thermistor at 0 degrees Celsius to that at 50 degrees Celsius, but for thermistors intended for use in the self-heating mode, it is often convenient to specify the performance as the resistance at 25 degrees Celsius and the resistance when carrying a certain current at a specified ambient temperature.

RESISTANCE

The resistance of a thermistor, R , is an exponential function of temperature and is given by the equation:

$$R = Ae^{b/T}$$

where A and b are constants, e is the natural number 2.718 and T is the absolute temperature. In practice this means that the resistance can change by about 6 per cent for each degree Celsius change at room temperature. For comparison, one may mention that the resistance of plati-

Power thyristors. On the left is a stud mounting type. The one on the right is mounted like a power transistor

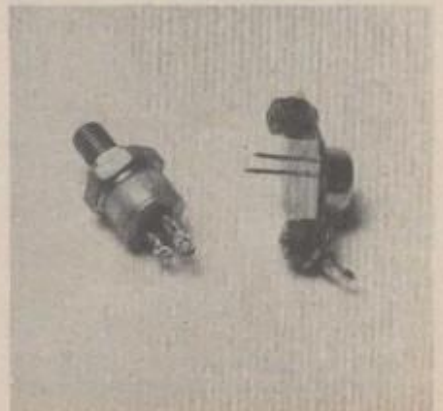
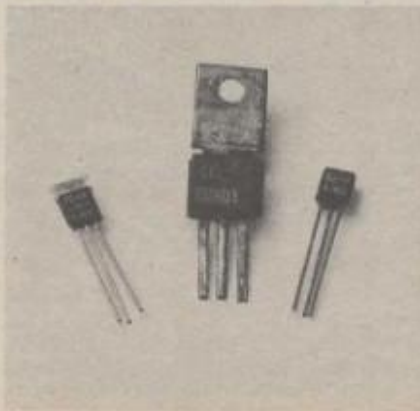

num changes by only 0.36 per cent per degree Celsius.

Thus thermistors can be used to provide large output changes when the temperature alters. Thermistors may be used at temperatures from a few degrees above the absolute zero up to about 300 degrees.

Positive temperature coefficient thermistors are used in warning and trip circuits for detecting excessive temperature rises in industrial equipment, such as electric motors.

TRANSIENT SUPPRESSORS

Large transient voltages of very short duration (microseconds) appear on electrical power lines, on telephone lines, and so on. They arise in various ways such as atmospheric electrical discharges and the switching of inductive loads. Transient peaks of 1kV can occur on 240V domestic mains supplies, smaller transients occurring more frequently than the larger ones.

The effects of such transients range from "clicks" in audio equipment to the faulty operation of computers. Large transients can damage semi-

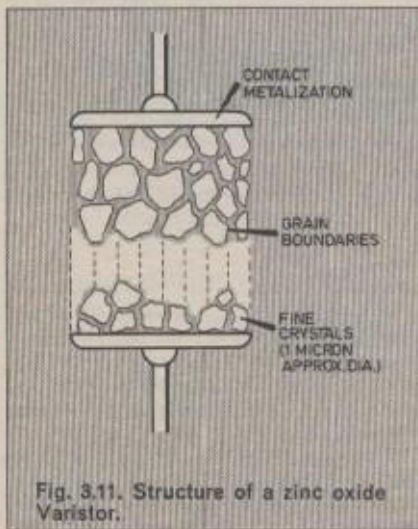

Fig. 3.11. Structure of a zinc oxide Varistor.

Rod and disc thermistors. A rod type is shown in the centre and two views of the same disc type are shown on either side.

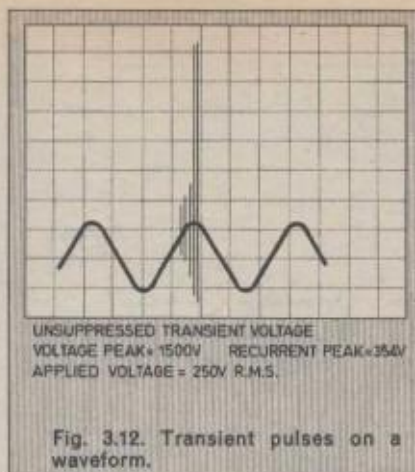
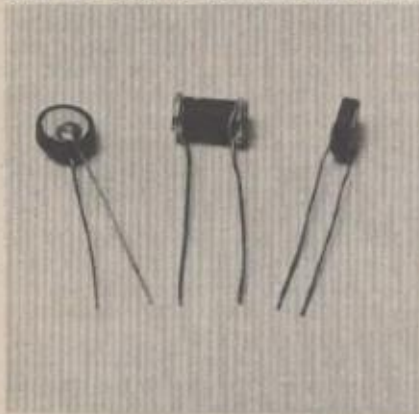

Fig. 3.12. Transient pulses on a waveform.

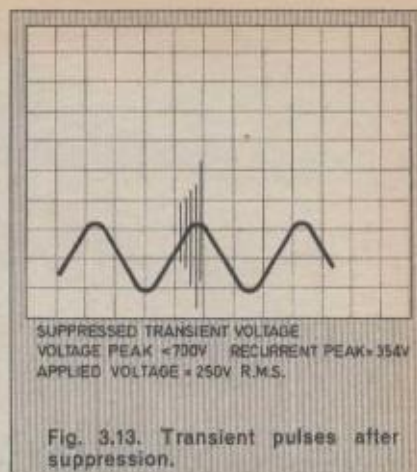

Fig. 3.13. Transient pulses after suppression.

conductor devices because their ratings are exceeded for a very short time.

Most of the large semiconductor manufacturers produce transient suppression semiconductor devices. One type of suppressor is the well-known Varistor which has a resistance which falls rapidly with increasing voltage. Such a device can be soldered across the line to be protected and will short-circuit any transient voltage peaks whilst leaving the normal wanted voltages unaffected.

Another type of widely used device is a specially designed Zener diode which will break down in the presence of an over-voltage and thus short it out. No matter which type of device is to be used, it is vital that it acts very quickly before equipment can be damaged.

The non-linear current-voltage relationship in a Varistor may be expressed in the form:

$$I = K V^a$$

where I is the current, V is the voltage and K and a are constants. In the case of a metal, a resistor or other material obeying Ohm's Law, $a=1$, but in Varistors the higher the value of a , the better the transient limiting.

Glass bead thermistors. At the top is the popular RA53 type, and below that is a miniature and then subminiature type.

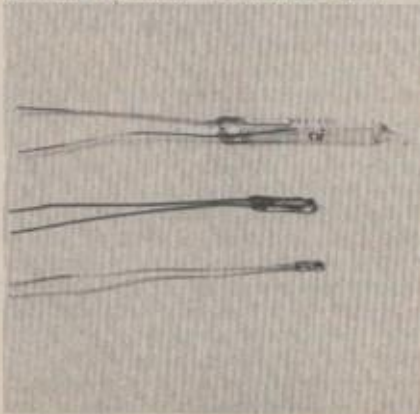

Silicon carbide "Metrosil" devices have values of a of about 4 to 5, some selenium devices have values of about $a=10$, whilst zinc oxide Varistors and Zener diodes have values for a of at least 30.

ZINC OXIDE

International General Electric of the USA introduced a range of zinc oxide varistors some years ago and in 1978 introduced their improved GE-MOV II range, while International Rectifier produced their "Zenamic" range and somewhat similar products are available from Iskra, Matsushita, Siemens and Thomson-CSF.

As shown in Fig. 3.11, a zinc oxide Varistor contains small crystals of this material between two parallel plates. The high resistance at the surfaces of the grain boundaries results in a voltage drop of some 3V across each grain, the properties of the devices being due to charge tunnelling through the grain boundaries.

Fig. 3.12 shows transient voltages on a line and Fig. 3.13 the same voltages after suppression by a zinc oxide Varistor. Each type of Varistor will suppress only those transients which have a high enough voltage to render the device resistance relatively low. It follows that a device designed for 240V a.c. mains suppression will not provide good suppression on, say, 150V a.c. lines. Siemens offer devices for use at normal operating ranges of 14V to 1000V r.m.s. or 18V to 1465V d.c., time for operations, 25ns.

In addition to voltage rating, a zinc oxide Varistor should be chosen so that it can absorb the transient peak energy. The volume of a Varistor determines its energy rating and the current rating is determined by the area of its disc. International General Electric offer devices with energy ratings from 0.13J to 600J with peak current ratings of 40A and 25kA respectively.

Next month: Optoelectronics

SIMPLE pH METER

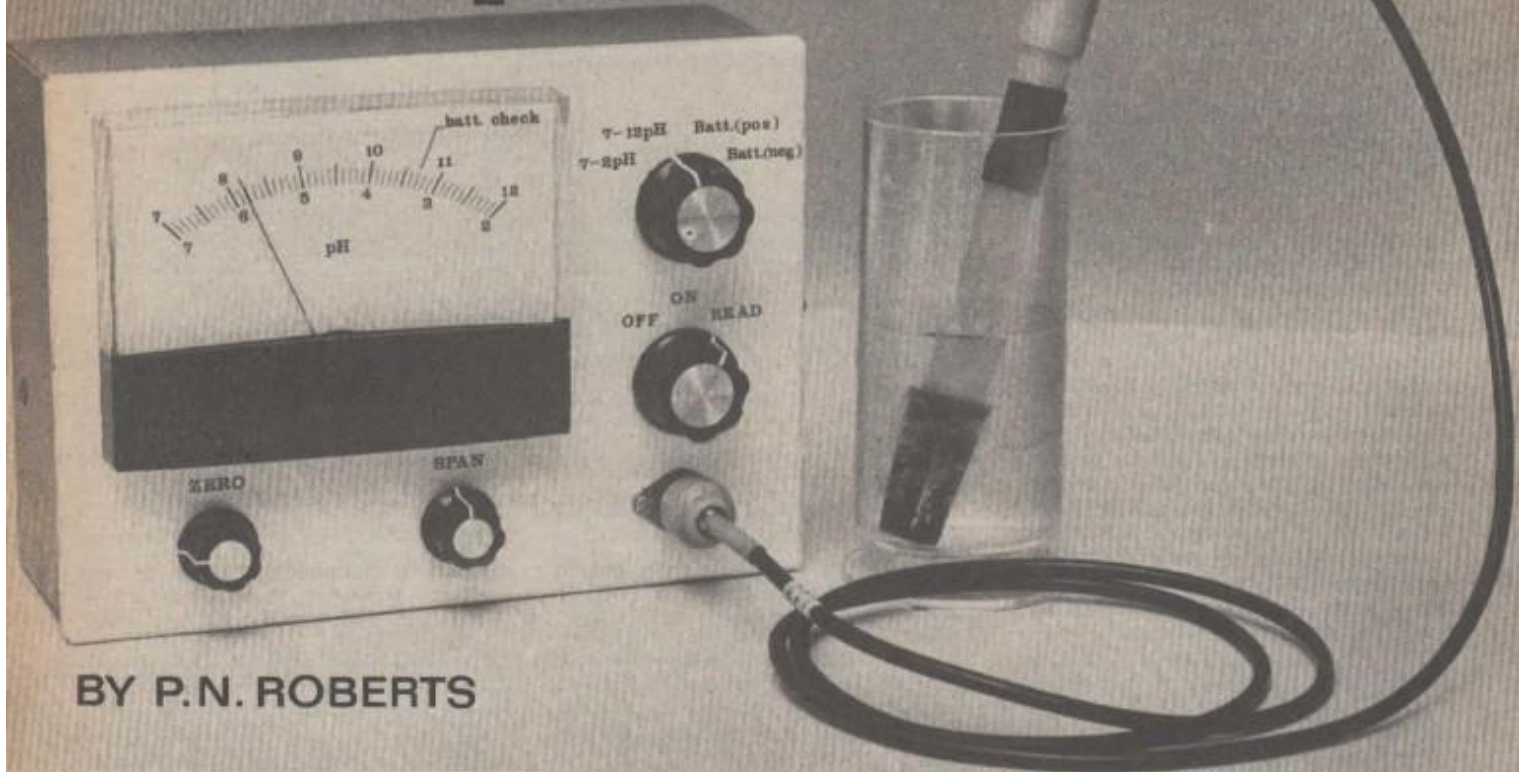

BY P.N. ROBERTS

THE INSTRUMENT to be described was originally designed for use in determining the alkalinity of photographic colour developers and, although somewhat rudimentary, it has proved more than adequate for this task. As such, it offers a simple means of more generalised pH measurements for those readers who are now taking an active interest in electrochemistry.

THE MEASUREMENT OF pH

Before describing the instrument, a simple explanation of the term "pH" and how it is defined will clarify the principles by pH measurement.

As the result of the phenomenon known as dissociation, all solutions contain a certain equilibrium ratio of hydrogen ions (H^+) and hydroxyl ions (OH^-). The product of the hydrogen ion concentration and the hydroxyl ion concentration is always the same.

In an acid solution there are more hydrogen ions than hydroxyl ions. The degree of acidity can therefore be defined in terms of the hydrogen ion content of the solution.

The value of acidity, that is the pH, is expressed as:

$$pH = -\log_{10}(H^+)$$

where (H^+) represents the hydrogen ion concentration in gram-ions per litre of solution.

As pure water contains 10^{-7} gram-ions/litre, it can be seen that the pH of pure water is 7.0. If the pH is less than 7.0, the solution is acidic. Conversely, values greater than 7.0 indicate an alkaline solution. It should be noted that the pH of a given solution can be very dependent upon temperature.

PROBES

The theory behind the operation and design of the various types of pH probe is a science in its own right but in simple terms it can be regarded as a voltage cell with the solution under test acting as the electrolyte. The voltage output and the polarity will be dependent upon the hydrogen ion concentration, that is the acidity of the solution under test.

Unfortunately, unlike the normal electric cell or battery, the probe is unable to supply sufficient current to deflect a conventional moving coil meter. Any attempt to do so could cause permanent damage to the probe.

Any pH meter is therefore basically a high input impedance circuit driving a moving coil meter. As the minimum acceptable input impedance is typically 500 megohms, an f.e.t. input 741 type op-amp will provide a suitable basis for such an instrument.

Conveniently, the voltage output from the probe results in a linear pH

scale and it is therefore a relatively simple matter to modify the meter to read directly in terms of pH.

GENERAL DESCRIPTION

The instrument is intended for use with a full range (2 to 14pH) "combination electrode" type of probe. As such, it has been kept as simple and inexpensive as possible commensurate with an adequate reading accuracy.

One simplification is to dispense with the temperature compensation normally incorporated in a commercial instrument. As the meter can be easily calibrated at the envisaged solution temperatures, this is a minor inconvenience.

A physical limiting factor on reading accuracy is the scale length of the meter. As long scale meters are difficult and expensive to obtain, a simple changeover switching arrangement is used to effectively double the scale length of a normal meter. This uses the inherent characteristics of the probe whereby the voltage polarity changes at 7.0pH.

The meter thus has two scales, 7 to 12pH and 7 to 2pH. With this arrangement the direct reading accuracy is 0.1pH which allows interpolation to within 0.05pH. If readings in excess of 12.0pH are required, then there is no reason why an alternative scale range shouldn't be adopted.

As the current drain of the circuit is only a few milliamps, the instrument is battery powered to obviate the expense of a mains supply. A battery check circuit has been incorporated.

CIRCUIT OPERATION

The circuit of the simple pH meter is shown in Fig. 1. The probe is connected via a co-axial socket SK1 and switch S1 which also acts as the ON/OFF switch. The op-amp IC1, is connected as a voltage follower, the output being fed to the meter ME1 via the potentiometer VR2 and switch S2. VR2 is the SPAN control which sets the meter deflection for a given probe output.

The operation of S2 is such that in position 1 the meter is connected so that it reads 7 to 2pH. Position 2 reverses the meter polarity so that it reads 7 to 12pH. Positions 3 and 4 monitor the state of the batteries via R1 or R2 as appropriate. The batteries can be checked with or without the instrument being switched on, thus giving a better indication of their condition.

Variable resistor VR1 is the ZERO control. At first sight such a control may appear redundant. However, al-

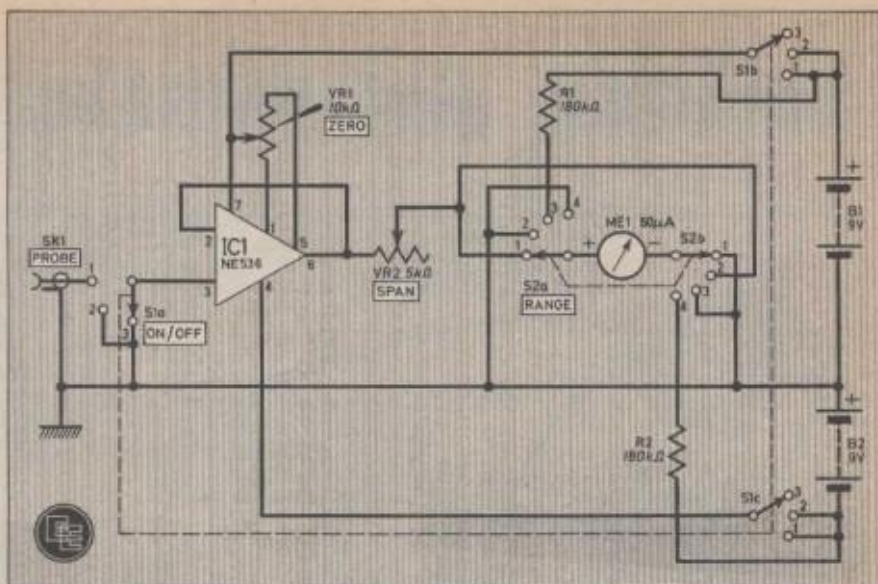

Fig. 1. Full circuit diagram of the Simple pH Meter.

though in theory the probe output should be exactly zero at 7.0pH, in practice there will be a small voltage present. This is due to the probe construction and internal geometry.

In this particular application it is a convenient and perfectly satisfactory method to use the off-set control of the op-amp to set the instrument zero.

The intermediate switch position for S1 is quite important as it allows the op-amp to stabilise while the input is still grounded. It is only necessary to briefly hesitate in this position before switching through to the read position.

The larger sized PP6 batteries are used for B1 and B2. With the use envisaged, they should give a working life of some 200 hours.

CONSTRUCTION
starts here

HOUSING

The complete instrument is contained in an aluminium box measuring 150×100×50mm, and the full layout is shown in Fig. 2. Because there are so few components involved, there is no need for a circuit board as such. A small piece of 0.1 inch matrix stripboard is attached to the meter terminals to provide a convenient mounting point for the op-amp. To avoid possible damage due to static charges, handling of the op-amp was kept to a minimum by using an i.c. socket.

Actual component layout is not critical. However, it is important to note that the limiting factor on the input impedance will depend on the insulation properties of the components, stripboard, and so on, rather than on the op-amp itself.

Every attention should be taken to ensure that the items used in the input circuit are of a high quality in this respect. The two resistors are wired directly onto the switches before final interwiring is completed.

In this context, if the instrument is likely to be stored in a relatively damp environment, it is recommended that the assembled stripboard be given a protective coating of polyurethane varnish.

With the type of meter as used in the prototype, the scale plate is easily removed for modification to read directly in terms of pH.

The battery check mark is also incorporated at this stage. The resistors R1 and R2 have been chosen so that fresh batteries will give approximately full scale deflection with a meter having an internal resistance of 1000 ohms. The value of R1 and R2 can be changed in direct proportion for meters having a different internal resistance. The minimum acceptable voltage is marked at 75 per cent of f.s.d.

CALIBRATION

To calibrate the instrument it is necessary to obtain at least two buffer solutions. These solutions are formulated to provide an accurate and stable value of pH at a given temperature.

Every care should be taken in the preparation of the solution be it from a tablet or a sachet of powder. During subsequent use, avoid any con-

COMPONENTS

Resistors

R1, 2 180kΩ ¼W carbon ± 5%
(2 off)

Potentiometers

VR1 10kΩ carbon lin.
VR2 5kΩ carbon lin.

Semiconductors

IC1 NE536 f.e.t. input op-amp,
TO-99 metal can

Miscellaneous

ME1 50μA d.c. f.s.d. moving coil
meter
S1 three-pole, three-way
rotary
S2 two-pole, four-way rotary
SK1 Co-ax socket to suit probe
B1, 2 9V, PP6 type (2 off)
Aluminium case, 150 × 100 ×
50mm; stripboard, 0.1 inch matrix,
20 holes by 7 strips; battery
connectors (2 off); 8-pin d.i.l. i.c.
socket; knobs (2 off); intercon-
necting wire.

Probe

A suitable probe for this unit is the B17 DA type from Griffin and George (Gallenkamp). For readers not able to order from this company suppliers of other Full Range Combination Electrode type probes are listed in Shop Talk on page 535.

Guidance only
Approx. cost

£12.00
excluding probe

SIMPLE pH METER

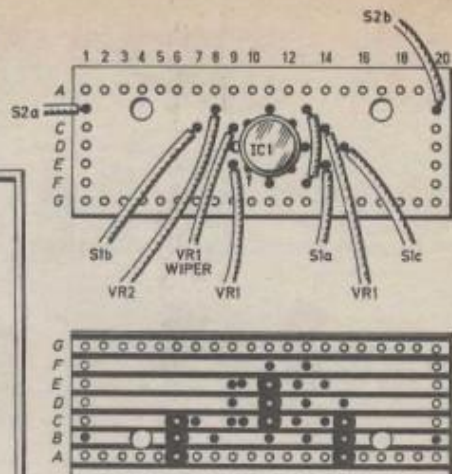
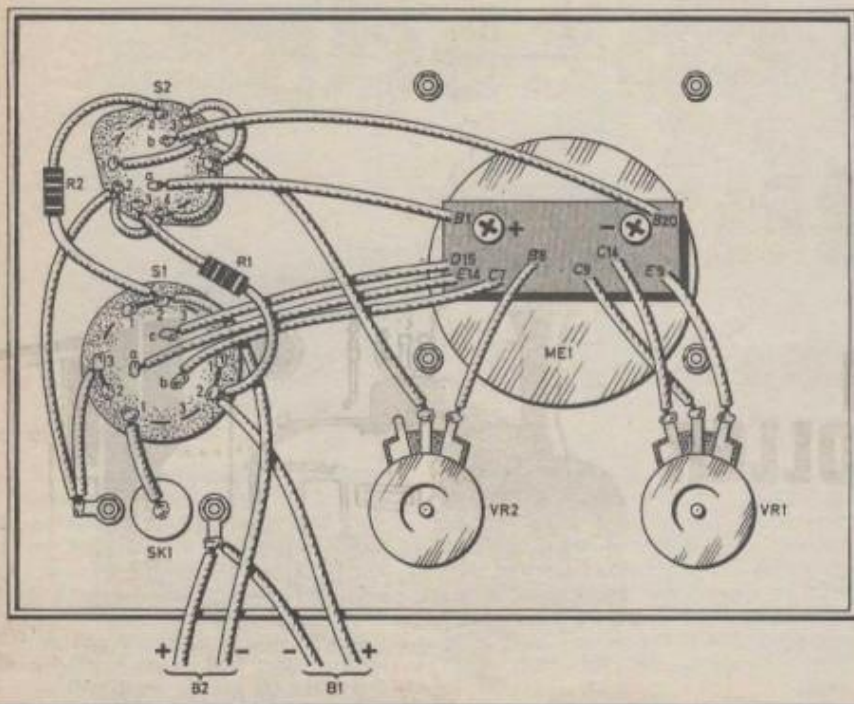

Fig. 2. Diagram above shows circuit board layout, and full interconnections can be seen on the left. Note that there are no obvious connections to the meter. In fact contact is made between the meter terminal posts and the underside of the stripboard at positions B4 and B17 when the board is fastened in place on the back of the meter. When completed the whole of the circuit board, the switches and potentiometers and associated wiring should be sprayed with a moisture repellent protective coating, such as polyurethane varnish to keep the damp out.

tamination of the solutions. This includes the indiscriminate carrying over of water used for rinsing the probe.

For setting the instrument to zero, a 7.0pH buffer solution is the obvious choice. When choosing a second buffer to adjust the SPAN control, maximum accuracy will be achieved by selecting a value close to that of the anticipated measurement. Ideal as this may be, there could be difficulty in obtaining other than a 9.0pH buffer.

Before any calibration is undertaken, it is essential to ensure that the meter is mechanically at zero when the instrument is switched off and is in the preferred operating position, that is vertical or horizontal.

Select the 7 to 12pH range, connect the probe and place it in the 7.0pH buffer. Switch the instrument to read (S1 set to position 1) and use the ZERO control to set the meter needle to the 7 on the scale. As a cross check, temporarily switch the instrument to the 7 to 2pH range. The needle should not move if the zero has been set correctly.

Switch the instrument off and remove the probe from the buffer. Rinse it carefully in distilled water and, having drained off the excess water, transfer it to the 9.0pH buffer solution. Turn S1 to position 1 again and

adjust the SPAN control until the meter reads the correct value.

In theory, on the assumption that the probe output is symmetrical about 7.0pH, the instrument is now calibrated on both of the ranges.

In practice, however, errors of up to 0.1pH have been noted when using the 7 to 2pH range after calibrating on the 7 to 12pH range. When more precise measurements are required the 7 to 2pH range should be calibrated separately using a 4.0pH buffer solution.

OPERATION

Any measurements are now simply a matter of placing the probe into the solution to be checked. There are, however, one or two points to observe. The switch S1 should never be

switched to the read position unless the probe is connected and immersed in a solution. Because there is virtually no warm up drift, there is no advantage in leaving the instrument in the on position between measurements. Accordingly, it is best switched off to avoid draining the batteries.

The pH probe is a fairly delicate item and normally comes with a plastic shroud to provide a measure of protection—even so it should not be used as a stirrer! To prolong the life of the probe it is important that the instructions be observed.

Some readers may experience difficulties if the equipment becomes damp. In the author's experience a few hours in a warm dry place, like an airing cupboard soon cures the trouble. □

Interior view of the completed prototype. The two PP6 batteries can be seen secured in place under an aluminium strip in the rear of the case. Compare this photo with the diagram in Fig. 2.



A smoother ride at all speeds with this

MODEL TRAIN SPEED CONTROLLER

Uses a pulse-width-modulation technique to maintain a smooth, steady ride even at low speeds. Features include a continuously variable speed control, automatic starting and stopping to give realistic performance, brake and accelerator controls.

AUDIO COMPRESSOR -MIXER

A wide compression range of around 30dB is available and can be used either for instantaneous short term compression or for automatic level control in tape recording. It also has application in suppressing the level of music whilst speech announcements are superimposed. Provision for mixing microphone and high level (music) signals is included.

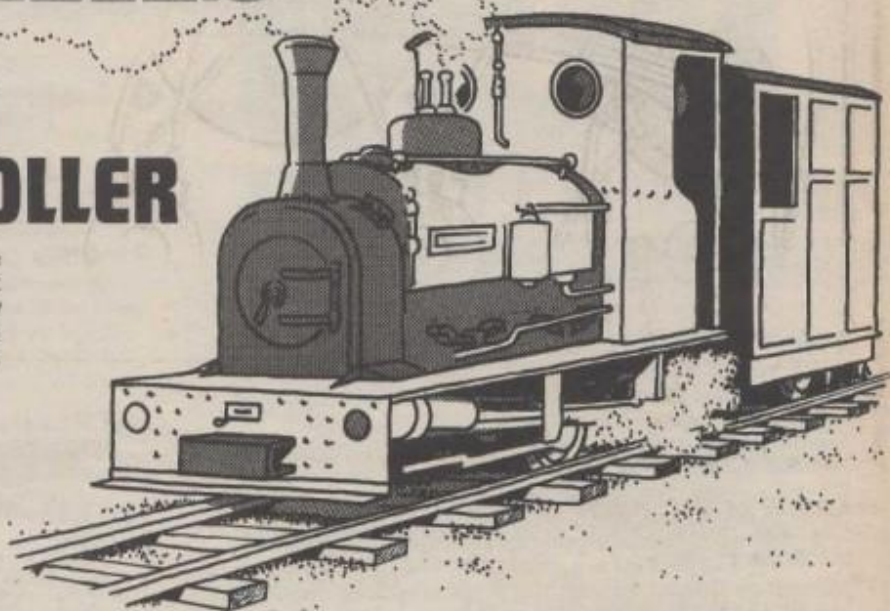

ANTI - THEFT DEVICE

Protection for any number of displayed goods by a simple loop linking all items. Strident alarm sounded if this is interfered with.

0-12V POWER SUPPLY

A well smoothed and regulated output adjustable from zero to 12 volts. Incorporates audio alarm which sounds when the selected current limit (40, 100 or 400mA) is approached.

Everyday ELECTRONICS

SEPTEMBER 1981

ISSUE ON SALE
FRIDAY, AUGUST 21

INTRODUCTION TO LOGIC

PART 4 BY J. CROWTHER

THE TRANSISTOR AS A SWITCH

For an *npn* silicon transistor to conduct its base must be 0.6 volts above the emitter voltage. If the voltage between the base and the emitter is less than 0.6 volts the transistor will not conduct. Therefore it can be seen that a transistor can be switched *on* and *off* by two voltage levels, above and below 0.6 volts. These two voltage levels are referred to as **logic 1** for on (a result), and **logic 0** for off (no result).

If these two voltage levels were too close together, for example 0.5 and 0.7 volts, there is a chance that, due to tolerance and temperature changes the transistor would not always switch on and off, so logic levels are usually not too close together, logic 1 may be 6V and logic 0 below 0.25V with nothing inbetween.

Consider the circuit shown in Fig. 4.1.

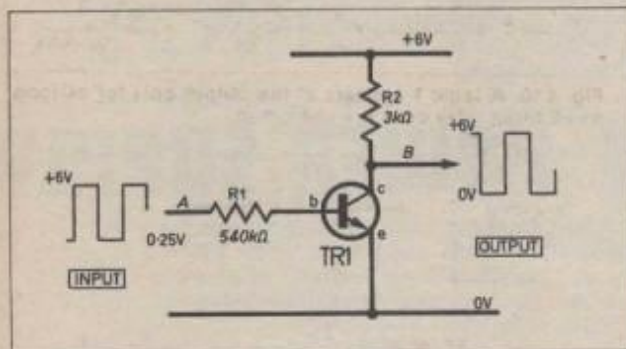

Fig. 4.1. Using the transistor as a switch.

If 0.25 volts is applied to the base at A, the transistor would not conduct, no current would flow through the 3 kilohm resistor, so there is no volts drop across it and the output at B would be 6 volts. This is equivalent to the switch being on and giving a result—logic 1.

Now suppose 6 volts were applied to the base at A, the transistor would start to conduct. The voltage between the base

and the emitter would now be 0.6 volts giving a voltage drop of (6—0.6) volts across the 540 kilohm resistor. The base current I_b would now be equal to:

$$I_b = 5.4V/540k\Omega = 0.01mA$$

If the h_{FE} (gain) of the transistor was 200, the collector current would be $I_b \times h_{FE} = 0.01 \times 200 = 2mA$. This would give a voltage drop across the 3 kilohm resistor of $3k\Omega \times 2mA = 6$ volts and the output would fall to zero, equivalent to a switch being off and giving no result—logic 0.

Therefore it can be seen that a transistor can be switched on and off by a squarewave pulse of two voltage levels as shown in Fig 4.2.

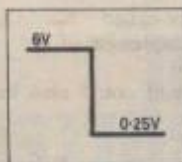

Fig. 4.2. The transistor in Fig. 4.1 will be switched on by 6V level and off by the 0.25V level.

TYPES OF LOGIC

In practice it does not really matter which voltage level is referred to as logic 1, so long as the transistor switches on and off, and we know which level the designer has used and we use the same. For convenience in design two types of logic are possible:

(1) Positive Logic

Where the positive half of the wave form is referred to as logic 1, and gives a result, see Figs. 4.3 and 4.5.

(2) Negative Logic

Where the negative half of the wave form is referred to as logic 1, and gives a result, see Figs. 4.4 and 4.6.

Positive logic is the more common and is used in all E.E. projects and features.

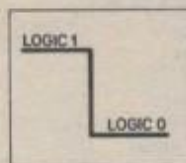

Fig. 4.3. Positive logic.

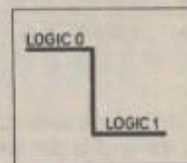

Fig. 4.4. Negative logic.

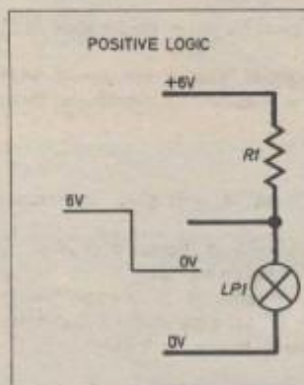

Fig. 4.5. High level lights lamp to give result.

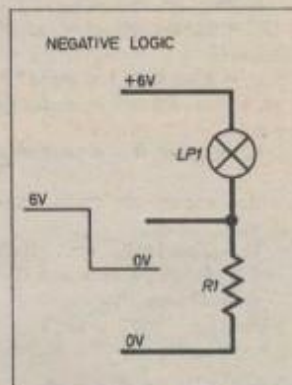

Fig. 4.6. Low level lights lamp to give result.

BOOLEAN ALGEBRA

George Boole (1847) invented a system of algebra now called **Boolean algebra** with its own special rules, to look into a two state system, his two states being *true* and *false*. This system was later adapted to deal with the two states of a switch, on and off.

Consider a relay as a switch (see Fig. 4.7), and let *A* be the input to the coil of the relay, and *S* the output from the main contacts.

Let *A* be the supply to the relay (logic 1), if *A* were applied to the coil the relay would close giving an output at *S*.

In Boolean this is written as:

$$A = S$$

which means an input at *A* (logic 1) gives an output (logic 1) at *S*, and represents a normally open switch or relay.

A line above a letter, for example \bar{A} , is called "bar *A*", "A bar" or "not *A*", and is said to be the complement of *A*.

Therefore \bar{A} means no pulse at *A* or logic 0.

The Boolean equation for the above circuit could also be written as:

$$\bar{A} = \bar{S}$$

which means no pulse at *A* (logic 0) gives no output at *S* (logic 0), which is also true for the above circuit.

Therefore $A = S$ is the same as $\bar{A} = \bar{S}$ which shows that in Boolean a "bar" can be added to both sides of an equation and it still remains true, providing the bar covers all the terms on each side of the equation.

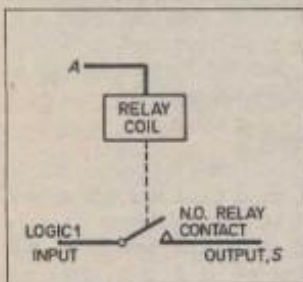

Fig. 4.7. Energising relay coil causes logic 1 to appear at the output.

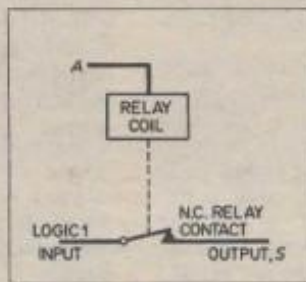

Fig. 4.8. Energising the relay coil causes logic 1 to be removed from the output.

example

$AB = S$ is the same as $\bar{A}\bar{B} = \bar{S}$
 but, $AB = S$ is not the same as $\bar{A}\bar{B} = \bar{S}$.

Now consider a relay which is normally closed as in Fig. 4.8. A supply or logic 1 applied to the coil at *A* will open the relay, and there will be no output (logic 0) at *S*.

In Boolean this is written as: $A = \bar{S}$

which means an input at *A* (logic 1), gives no output at *S* (logic 0).

It is also true for the above circuit, that if no supply were applied to the coil at *A*, the relay would remain closed and there would be an output at *S*.

In Boolean this is written as:

$$\bar{A} = S$$

which means no input (logic 0) at *A*, will give an output (logic 1) at *S*.

Therefore in Boolean algebra $\bar{A} = S$, is the same as $A = \bar{S}$, and represents a normally closed relay or switch.

This shows that in Boolean algebra it is permissible to transfer a "bar" from one side of an equation to the other providing the "bar" covers all the terms on each side.

example

$\bar{A}\bar{B} = S$ is the same as $AB = \bar{S}$
 but, $\bar{A}\bar{B} = S$ is not the same as $AB = \bar{S}$.

Note

Boolean equations are normally written to give an output.

examples

$$A = S \text{ and } \bar{A} = \bar{S}$$

SWITCHES IN SERIES

Consider the circuit in Fig. 4.9.

To get an output at *S*, relays *A* and *B* must both be energised.

In Boolean this is written as $AB = S$. *A* times *B* in Boolean means *A* AND *B*.

Therefore $AB = S$ means an input (logic 1) at *A*, AND an input (logic 1) at *B* will give an output (logic 1) at *S*, and represents two normally open switches in series.

Boolean algebra is not limited to two elements.

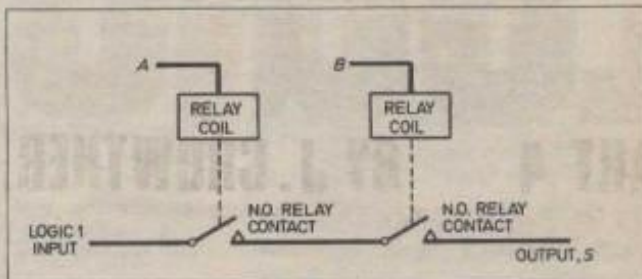

Fig. 4.9. Both relays need to be energised to produce a logic 1 at the output.

example

In a three-element system, $ABC = S$ means to get an output we must have *A*, AND *B*, AND *C*, and it represents the state in Fig. 4.10.

Also $\bar{A}\bar{B}C = S$ means to get an output we must have *A*, AND NOT *B*, AND *C*, and it represents the circuit shown in Fig. 4.11.

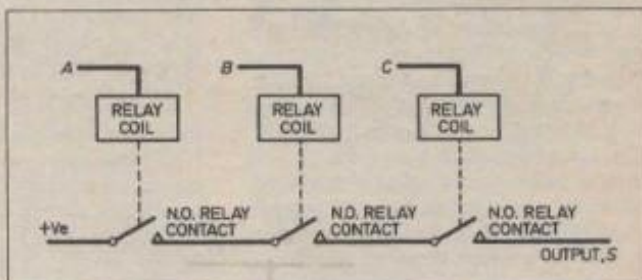

Fig. 4.10. A logic 1 appears at the output only for as long as all three relay coils are energised.

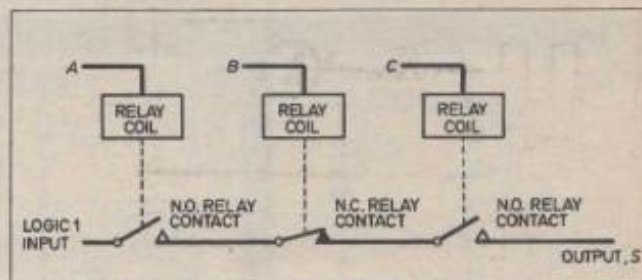

Fig. 4.11. A logic 1 results at output when first and last relays only are energised.

Answers to Exercises in Part 3

- 3.1. (a) 00000011 (b) 11111101 (c) 00010000 (d) 11110000
 (e) 01111111 (f) 11111111

TO BE CONTINUED

BACK TO BASICS

More About Amplifiers

In the previous article we saw that the active devices (transistors) in amplifiers can be regarded as means of controlling the amount of current drawn from the battery.

Now, the current from a battery can flow only in one direction. It is d.c. (direct current), not a.c. (alternating current). Transistors are also d.c. devices. But most of the signals which have to be amplified are a.c. ones. (Engineers say "a.c. signals" even if they are talking about signal voltages rather than signal currents.)

How can a d.c. device like a transistor amplify an a.c. signal?

WOBBLING D.C.

The answer (hinted at in an earlier article) is first to set up the circuit so that a steady current (d.c.) flows through the transistor. The effect of applying an a.c. signal of small size is to make the steady current increase when the a.c. goes one way and decrease when it goes the other way. In other words, the a.c. signals put a "wobble" on the d.c. through the transistor.

The resulting wobbling d.c. is exactly the same thing as would be produced by mixing up a genuine small a.c. signal with a larger d.c. flow. When two things are indistinguishable there is a good chance that they are truly identical. This is the case with our wobbling d.c. in the transistor. It really is a mixture of a.c. and d.c.

Common sense suggests that it might be possible to unscramble the two and extract the a.c. part by itself, to feed to some other circuit such as another stage of amplification.

Fig. 3.1. (a) A transistor with d.c. biasing via R1. (b) The same arrangement drawn in a slightly abbreviated fashion.

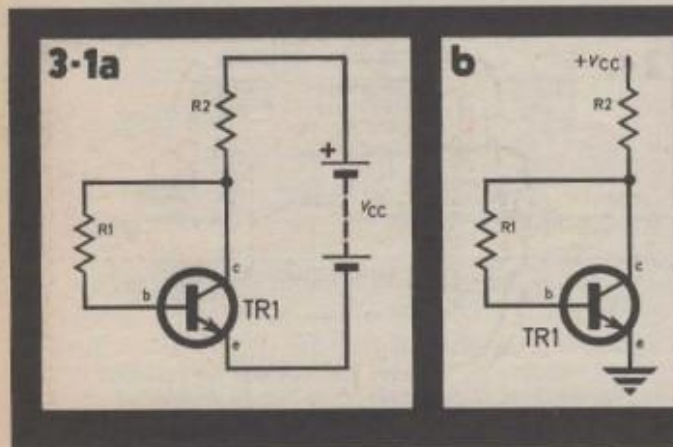

BIASING

Before we look at how to do it, we must first think about how to set up the circuit so that the required steady d.c. flows.

Practical transistor amplifiers are more complicated than the simple circuits in the last article because they contain extra components for setting up the steady currents. This setting-up process is called **biasing**, and in the case of a bipolar transistor (i.e. a *pn*p or *np*n transistor as opposed to a **field effect transistor**) biasing takes the form of feeding a steady trickle of d.c. into the base-emitter region of the transistor.

A common arrangement is shown in Fig. 3.1a. Here R1 is the biasing resistor. A small current flows from the battery through R2 then R1, then the base, the emitter and to the other side of the battery to complete the circuit.

This **base bias current** causes a much larger (typically 100 times larger) collector current to flow (also through R2, then collector and emitter and back to battery).

Fig. 3.1b repeats the same circuit in a shorthand form which you will come across often. The battery is not actually drawn in, and connection to the common side of the circuit is indicated by an "earth" symbol.

The method of biasing a field effect transistor depends on what sort it is.

Enhancement mode f.e.t.s have to be turned on in much the same way as bipolar transistors, except that they draw no input current to speak of and are therefore turned on by a voltage rather than a current.

Depletion mode f.e.t.s pass current even when unbiased. In their case a negative bias is often required to reduce the standing current to what is reasonable for the job.

INTERSTAGE COUPLING

The a.c. part of the current in a transistor may be very small indeed. This is because the a.c. signal may be very small. The aerial of a sensitive radio receiver may deliver only a few millionths of a volt or a few billionths of an ampere. A typical transistor may amplify these signals a hundredfold, but they are still pretty small compared with the steady voltages and currents in the circuit.

If these steady quantities were passed on to the next transistor they might well overload it. So what is required is some sort of filter to allow only the small a.c. signals to pass on while excluding the d.c. voltages and currents. Such a circuit is called an a.c. **interstage coupling**.

CAPACITORS

One way of separating a.c. from d.c. is to use a **capacitor**. A capacitor is a device which can store an electric charge. Capacitors take many shapes and forms but the essence of them all is a thin sheet of insulating material sandwiched between two metal plates. This is reflected in the symbols for capacitors, which show the plates sideways on, with a gap in between to represent the insulator.

In practice the "sandwich" is often rolled up to save space, and encapsulated for protection, giving a component with two leadouts, one connected to each plate.

Fig. 3.2. Showing the charging and discharging of a capacitor. Note the direction of current flow as shown by the arrows.

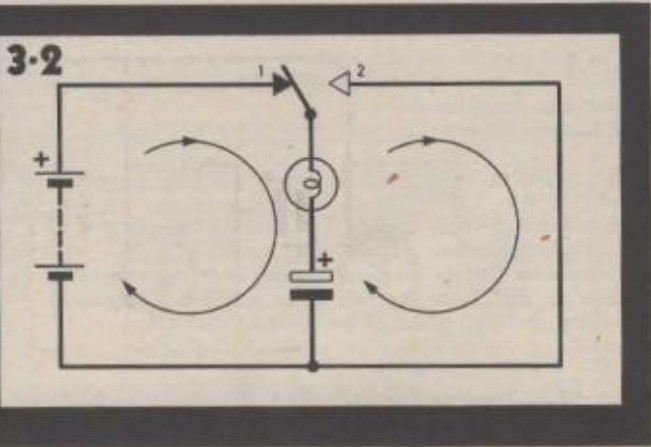

By George Hylton

It is obvious that the insulating material (known as the dielectric) must prevent d.c. from flowing through the capacitor. However, if a battery is connected to a capacitor there is a momentary flow of current as the capacitor charges. Then no further current flows because of the dielectric.

If the battery is taken away the capacitor remains charged up to the battery voltage. It can be discharged by connecting its leadouts together. There is then a momentary rush of current in the opposite direction to the original inflow of charge. (Don't try it! The outflow may be violent enough to damage the capacitor itself.)

CHARGING AND DISCHARGING ACTION

Charging and discharging can in principle be demonstrated by the circuit of Fig. 3.2, which contains a battery, a capacitor, a lamp and a changeover switch. I say "in principle" because unless the capacitor is capable of holding enough charge to light the lamp no sign of the circuit operation will be visible.

With the switch contact at position "1", the capacitor charges, and if the inrush of current is big enough the lamp flashes momentarily then goes out. The capacitor is now charged, and if the switch is changed to position "2", it discharges through the lamp (which limits the current) and the lamp flashes again momentarily.

The arrows show which way the current flows round the circuit in each case. During charging, current flows downward through the lamp. During discharging, it flows up.

Fig. 3.3. A two-stage amplifier. The coupling capacitors C1, C2 and C3 allow the a.c. input signal to pass but are a barrier to the steady d.c. supply applied to the transistors.

A.C. PASSES THROUGH CAPACITOR

If the switch is moved repeatedly from one position to the other the lamp receives a succession of current impulses and flashes each time, the current through it flowing first one way then the other and so on. This is an alternating current and to all intents and purposes it flows through the capacitor as well as the lamp. But no d.c. flows through the lamp, as is proved by the fact that it does not stay lit when the switch is left in position "1".

Evidently a.c. can flow through a capacitor but d.c. cannot. This is just what we need for separating a.c. from d.c. in our amplifier circuits.

TWO-STAGE AMPLIFIER

A practical bipolar transistor two-stage amplifier using capacitors for a.c. coupling of the stages is shown in Fig. 3.3. Here resistances R1 and R3 are for biasing. An a.c. input signal causes a small current to flow to and fro through C1. It also flows through the base and emitter of the first transistor, TR1. An amplified version of this current flows from the collector to and fro through C2 and thence to the base-emitter circuit of the second transistor TR2. Further amplified, it flows via C3 to whatever circuit follows.

STEERING THE CURRENT

Without R2, all the collector current of TR1 would pass uselessly through the battery instead of the a.c. part passing via C2 to TR2. So the job of R2 is to

steer the a.c. to where it is wanted. Current always takes the easiest path. If R2 is big enough (electrically, that is) most of the a.c. goes to TR2.

This can be illustrated by analogy with water flow (Fig. 3.4). A current of water flows into a branching arrangement of pipes. More water flows through the thick lower pipe than the thin upper one because the thin pipe has more frictional resistance because of its smaller cross sectional area. The thick pipe represents the easy path for the current via C2 while the thin pipe represents R2.

When an electric current has a choice, more flows through a low resistance than through a high one. For obvious reasons resistances connected in the same configuration as the two pipes are said to be connected "in parallel".

NOISE

If TR1 amplifies by a hundred times and TR2 by a further hundred the overall amplification is by $100 \times 100 = 10,000$. By "cascading" stages of amplification in this way enormous amounts of amplification are in theory obtainable. In practice, however, all this amplification cannot be used and three or four stages can reach the useful limit of about a million times.

The reason for this disappointing result is that all circuits contain noise, that is unwanted voltages and currents. Noise gets amplified along with the signals and if too strong it just obliterates them.

Continued next month

Fig. 3.4. Water flow in a system of pipes provides an analogy with electric current flow in circuits composed of high and low resistance paths.

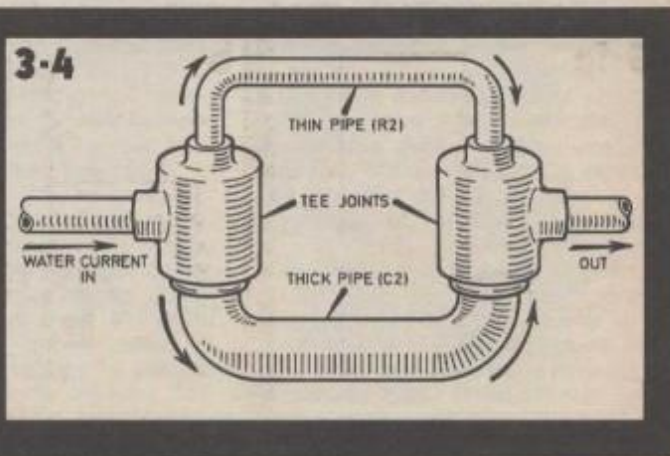
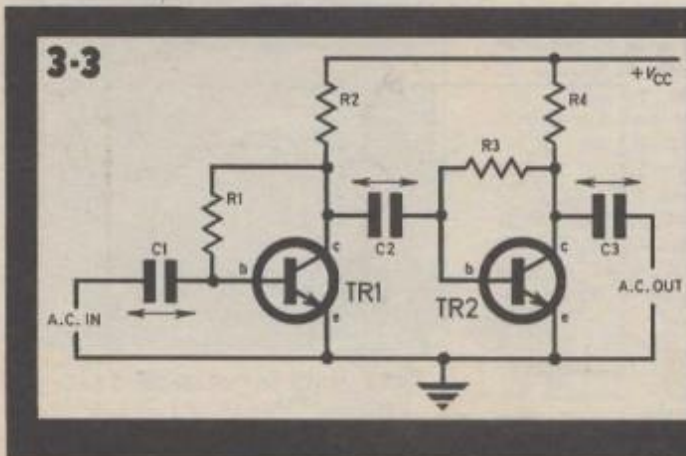

DOOR ALARM

D.J. EDWARDS



A self-contained unit for use with all kinds of doors.

EVERY YEAR countless children are poisoned by medicines left unsecured in bathroom cabinets and unattended on dressing tables. Even when they are put away, parents often underestimate the ingenuity of little children in finding out how to open cabinets and cupboards that most people would consider beyond their capabilities.

Clearly what is needed is either a stout lockable cabinet, very expensive nowadays, or failing that, a cupboard placed as far out of reach as possible with a warning device to alert the parents immediately to any unauthorised tampering. The project described in this article is just such a warning device.

It is completely self-contained and could do equally well as a shop door-bell or even a cordless burglar alarm.

The current drain when the alarm is set is a trivial $9\mu\text{A}$ ensuring a long battery life. When triggered this rises

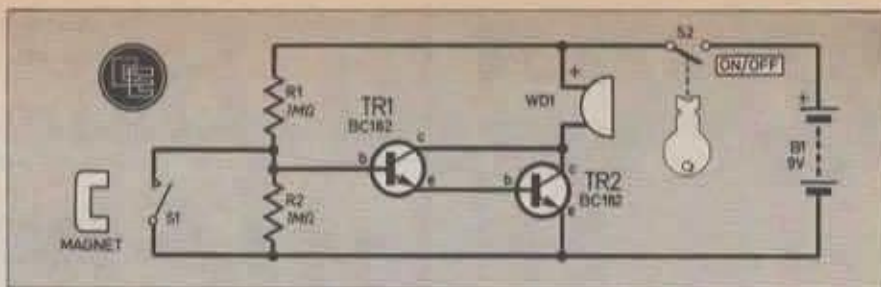

Fig. 1. Complete circuit diagram of the Door Alarm. S1 is a magnetically operated dry-reed switch.

to approximately 80mA which is high for a PP3 but no-one is going to have this alarm on for long!

DARLINGTON PAIR

The heart of the unit is TR1 and TR2 which have been arranged as a Darlington pair, that is they can be regarded as one transistor with a very large current gain (h_{FE} of TR1 multiplied by the h_{FE} of TR2). The complete circuit is shown in Fig. 1.

In the "alarm set" condition (unit switched on and reed switch S1 held closed by the magnet) the transistors are off due to the fact that the base of TR1 is short-circuited to the negative rail.

When the magnet is moved away from the reed switch ("alarm triggered"), the reed switch goes open circuit allowing the base of TR1 to rise to +4.5V (set by the potential divider action of R1 and R2). TR1 switches on, which switches on TR2 causing TR2 collector voltage to fall and allowing current to flow through the buzzer, WD1.

Finally the reed switch, S1 should also be secured inside the case with epoxy resin close to one of the case sides such that when the case is mounted in its final position the exterior magnet will be able to operate the reed switch successfully.

A keyswitch for S2 is imperative in the unit so as to prevent a child (or burglar) switching the unit off quickly.

INSTALLATION

The unit should be installed somewhere on the cabinet or other door such that when the door is closed, the fixed magnet holds the reed switch closed and the alarm is off. When the door is opened the reed switch opens and sounds the alarm.

Other possible methods of mounting would be to have the whole unit inside the door with just the bezel of S2 showing on the outside, or to cut away part of the door leaving the whole of the front panel visible.

The magnet will of course be mounted somewhere on the interior

CONSTRUCTION starts here

PLASTICS BOX

For practical reasons it is important to use as small a case as possible and a full layout is shown in Fig. 2. Make sure that the front is big enough for the buzzer and the switch and that a PP3 battery will also fit in.

The circuit board consists of a very small piece of 0.1 inch stripboard 12 strips by 6 holes and can be fixed where it is most convenient. In the prototype this was attached to the front panel using double-sided self-adhesive foam strip.

Before fixing the buzzer, drill a matrix of small holes in the panel in the position where it is going to lie. This is to let the sound out. The buzzer can then be glued in position.



View of the rear of the front panel showing circuit board and other components.

COMPONENTS

Resistors

R1, R2 1M Ω (2 off)
both $\frac{1}{4}$ W carbon $\pm 5\%$

Semiconductors

TR1, 2 BC182 npn silicon (2 off)

Miscellaneous

S1 reed switch with one set of normally open contacts

S2 s.p.s.t. key operated switch

WD1 6V solid state warning device

B1 9V, PP3 type battery

Plastics case, with aluminium front panel, 100 x 64 x 50mm; stripboard 0.1 inch matrix, 12 strips by 6 holes; suitable magnet to operate S1; battery clip; double-sided self adhesive foam strip; interconnecting wire.

Approx. cost **£6**
Guidance only

See
**Shop
Talk**

page 535

of the cabinet such that it keeps S1 closed when the door is closed.

In the case of access door, the magnet will need to be embedded in the framework.

Try to place the magnet as close as possible to the position of the reed switch in the case. Magnets come in all shapes and sizes, and it should not be too difficult to find a small one, with a hole in its centre by which it can be screwed in position.

If the unit is to be used in a shop to attract the shop keeper's attention a resistor will need to be inserted in series with the buzzer to reduce the current consumption and the volume. Use a 1 kilohm preset potentiometer to set this value.

DOOR ALARM

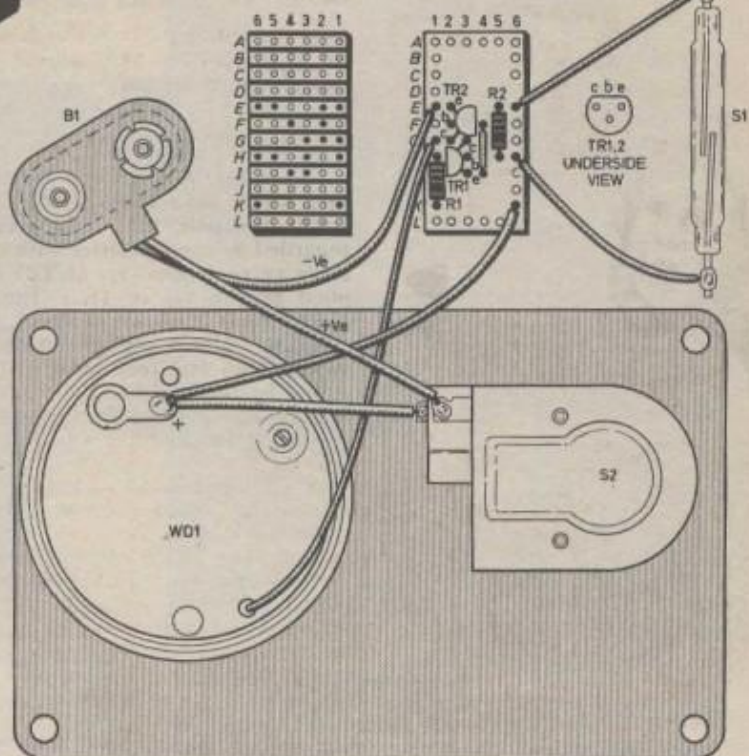

Fig. 2. Complete wiring diagram showing circuit board layout and all interconnections. Note that S1 should be glued to the case side so that it will be as near to the operating magnet as possible when the alarm is in the "set" condition.

JACK PLUG & FAMILY...

BY DOUG BAKER



Everyday News

SILICON CHIPS OR FISH AND CHIPS

Micro-electronics comes to the Hotel and Catering Industry

The Hotel and Catering industry is often regarded as very conservative in this country—especially so when it can draw on a vast number of low paid workers.

However it seems that no company can avoid the effects of modern technology and micro-electronics has made such advances in the hotel and catering trades that there is now a special exhibition and conference called, appropriately enough, Electronic Hotel.

This exhibition, held at the West Centre Hotel, Fulham, serves to bring together manufacturers offering electronic equipment or services to the trade and these suppliers can really be divided into two camps—those who supply computer based accounting and management systems, and those who supply electronic entertainment packages.

As with most data-processing systems, the computer based hotel management equipment can be made as comprehensive as you like. For instance you could start with simple front desk register which would store and process fairly rudimentary information about each guest, and then expand this to take in annual accounts, staff salaries, restaurant and

bar stock control, and so on, ad infinitum.

A typical system for a 20-bed hotel might cost about £300 per month to hire although this price would depend very largely on the size of the hotel and the degree of sophistication required.

In fact this year's exhibition was dominated by computer equipment suppliers, due, no doubt, to the fact that many manufacturers regard this as a key growth area, a point made by the organisers when they said that they wanted to bring together suppliers of equipment and "the hoteliers and restaurateurs who are having to learn as much about the silicon chip as they are about potato chips."

Apart from a multitude of



The Plantime Electronic Restaurant Management System

front-desk systems, one rather eye-catching exhibit was the Plantime Electronic Restaurant Management Scheme illustrated above. Apart from aiding stock control and accounting, it also means that the chef is actually going to cook what the waiter ordered and not what he thought the waiter ordered—a bit of an improvement on "two number threes and a number five with rice" shouted down the service lift shaft.

On the entertainment side it seems that the video revolution has begun to

catch up with the hotel trade. Systems are now available that allow the hotelier to show feature films on the in-house TV system in addition to ordinary TV programmes. Teletext and Viewdata are also trying to make an impact although progress is slow—even though June was national Teletext month.

So—all in all the hotel and catering trade are being computerised one way or another. Let's hope it results in better personal service and the end of that exasperating "waiting for chips."

Robots on the March

An industry expert has forecast a market in the UK and EEC of 2,000 robots a year by 1984. Many British firms are entering the market with Japanese partners manufacturing under licence or in joint ventures. Hall Automation, the all-British robot manufacturer, contends that the Japanese can teach them little or nothing, a view also shared by the British Robot Association who claim there is no need to depend on imported technology. The joint venturers, mainly engineering rather than electronic companies, say they have no intention of spending money on "re-inventing the wheel".

Steam locomotives could be back again in the United States before long. American Coal Enterprises (ACE) of Ohio is building a steam prototype locomotive, the ACR 3000 with microprocessor control. With electronic monitoring and control, combustion thermal efficiency in the fire-box can be improved by a factor of two or three. Such a system, however, would be commercially viable (compared with diesel or electric traction) only because of the availability in the USA of cheap coal.

The explosive growth of personal computers continues. Apple claim over 200,000 systems sold worldwide and the new Commodore VIC 20 is selling at the rate of 10,000 systems a month in Japan alone. The VIC 20 follows on from the Pet which has clocked up 44,000 sales in the UK. The VIC 20 offers both colour and sound, large memory and full range of peripherals. It should be available in UK stores by October and Commodore expect UK sales to average about 1,000 a week.



ANALYSIS

THE SURVIVOR

When you next switch on your TV, and before you become absorbed in the programme, spare a thought for the curious story of the cathode ray tube on the faceplate of which your TV picture is almost miraculously traced out.

You may imagine you are looking at a modern invention but you would be quite wrong. The cathode ray tube is in fact the earliest of all electronic devices. Sir William Crookes observed electrical discharges in exhausted glass tubes as early as 1879 and it was largely through his experiments and with similar crude forms of cathode ray tubes that J. J. Thomson, nearly 20 years later in 1897, was able to prove conclusively the existence of the electron.

Thomson's work led directly to the invention of the thermionic valve, first the diode by Ambrose Fleming, soon followed by the triode invented by Lee de Forest which he patented in 1907, and it was the thermionic valve which gave birth to the electronics industry.

Except for the generation of large amounts of power in industrial radio frequency heating, and in the output stages of radio and TV transmitters, the thermionic valve is all but dead, having been supplanted by the solid state device. But the cathode ray tube, even older than the valve, is the one great survivor from the earliest days.

Naturally there have been many dramatic improvements over the years. Early TV picture tubes and oscilloscope tubes of the 1930's look very dated today. And now, despite the addition of colour and other technical advances, the cathode ray tube is basically the same as ever.

Far from disappearing, the cathode ray tube is more in demand than ever with a great new mass market in word processors. Every office as well as every home will have the small screen.

The first working oscilloscope using a cathode ray tube is attributed to Karl Ferdinand Braun of the University of Strasbourg. He made it in 1897, the same year as Thomson discovered the electron. Such old timers weren't so dim!

Brian G. Peck

Time Gentlemen Please

BBC technology responsible for the BBC2 logo and clock is to be made available to other broadcasters. It will be manufactured by McMichael Ltd under licence from the BBC and will allow other organisations to benefit from this advanced technology.

The equipment, which is all electronic, was developed by Richard Russell of the BBC's Engineering Designs Department. It was designed to replace a whole host of slide scanners, mechanical clocks and the like and is far more reliable, not to mention cheaper.

It can produce static logos such as the Open University Symbol, and simple animated logos, quite apart from the TV clock.

SONY TRIUMPH

Sony's ferrochrome audio cassette tape has been chosen as an international standard. It is the first time a Japanese tape has been selected as a world reference for other manufacturers.

INFO TECHNOLOGY

Information technology is now absorbing about half the energy of the newly associated National Enterprise Board and the National Research Development Corporation. NEB financial expertise will be married to NRDC technology management. The two organisations are operating in parallel pending a full merger and will be called the British Technology Corporation.

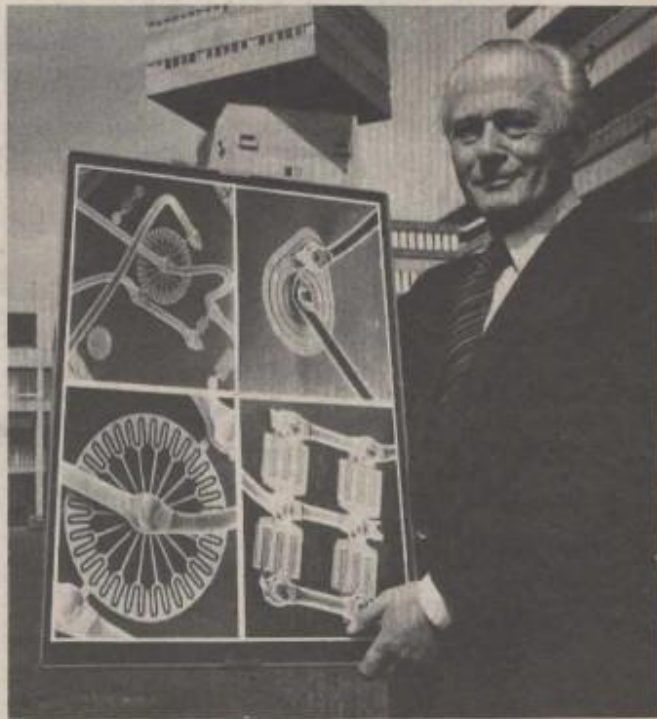

Dennis Baker, winner of the 1981 Martlesham Medal, holding a set of photographs of his silicon transistors.

Silicon Pioneer Wins Award

The 1981 Martlesham Medal has just been awarded to Mr Dennis Baker. This silver medal—marking outstanding achievement in telecommunications science and engineering—is reserved for former or present members of British Telecom and was only introduced last year when it went to Tommy Flowers for his work with the early post-war computers.

Dennis Baker's outstanding achievement was the development of silicon transistors for underwater telephone repeaters and so good was his design that despite ten years of continuous operation there have been no failures.

Following this remarkable advance he now leads the team which in 1969 coined the term "microprocessor" and is at present closely concerned with the very small geometry of the integrated circuits for System X.

Mr Baker's favourite hobby is repairing and restoring clocks and watches so this 4 inch diameter medal which he received at a special ceremony in London, will make a handsome addition to his mantlepiece.

Electronics easily dominated the world of invention last year according to the annual report of the Comptroller General of Patents, Trade Marks and Designs. Microprocessor applications were top and fibre optic technology and applications were a strong feature.

Over 300,000 video recorders were delivered in the UK in 1980. Most went to TV rental companies for hire to clients.

Biggest volume manufacturer would appear to be Sony who plan to manufacture 1.5 million units this year.

Semiconductor News

BREAKTHROUGH IN THERMAL IMAGING

A major advance in thermal imaging technology has just been announced by Mullard with the introduction of the **SPRITE** (Signal Processing In The Element) detector. This is a new kind of mercury cadmium telluride infra-red detector designed expressly for high performance thermal imaging systems. According to the manufacturers it represents an extremely important advance—if not the most important recent advance—in thermal imaging technology.

The basic difference between this device and previous imaging systems lies in its manner of use. In the old fashioned type of system separate imaging elements are laid side by side in a line and their output is sampled one by one along the line. In order to achieve this, the array needs to be connected to pre-amplification, time delay and summation circuitry—all very costly and complicated.

The **SPRITE** system is fundamentally different in that it consists of a single strip of photo-sensitive material with just three connections. Two of these are to provide a bias current and the third is a readout connection. When infra-red light falls on any part of the strip, excess current carriers are generated in that region. These drift towards the

readout connection at a velocity that depends on the characteristics of the strip material and the magnitude of the bias current. There is no need for time delay and summation circuitry, cutting down on associated circuit components, and the reduction in the number of package connections greatly improves noise performance.

In manufacture, the **SPRITE** detector will incorporate not one but eight infra-red sensitive strips. This allows its advantages to be exploited in serial-parallel scanning systems and up to eight lines can be scanned simultaneously. The detector is designed for operation in the 8 to 14 micron wave band and like similar detectors needs to be cooled to 77 degrees Kelvin and so is mounted in a Dewar encapsulation.

MOTOROLA/PHILIPS/ SIGNETICS PACT

In an era of cut-throat competition, two of the world's major electronics manufacturers have agreed to a five-year pact for the development of 16-bit microprocessors.

The Semiconductor Group of Motorola and a team of Philips and Signetics have jointly announced an agreement under which they will jointly develop both hardware and software for Motorola's M68000 microprocessor family.

The aim of the agreement is to produce an enriched family of integrated circuits and software tools and create the industry's strongest 16-bit product line.

The two companies will produce pin-for-pin compatible products as well as developing new ones which may be manufactured by both participants and by the

end of 1983 they hope to have added twelve or more new M68000 designs to the family portfolio.

Strangely enough, while the agreement covers product development, manufacturing, marketing and sales will be conducted competitively.

CUSTOM L.C.D.

Not so much a new product, more a new service is how you would describe the new facilities being offered by Hamlin Electronics for custom built l.c.d. displays.

Panel sizes up to 152 x 76mm are available and a variety of annotations and symbols can be produced. Bar graphs, arrows, units and monetary symbols are just some of the features that can be built in and there is also a wide choice of display fluids for even the most stringent applications.

FLASH CONVERTER

Described as a "major accomplishment in i.c. design", **TRW LSI Products** have just announced their new 9-bit A/D convertor, the **TDC 1019J**. This new single chip "flash" converter operates at 20 megasamples per second by accepting an analog input from 0V to 2V and comparing it with an internal voltage reference before activating a pre-set proportion of its 511 differential comparators.

The comparator's action is followed by a 511:9 encoder which supplies a digital input to a 9-bit latch providing complementary ECL outputs. From these a **CONVERT** signal produces a digital output at rates from d.c. to 20 megasamples per second, all without any external sample and hold circuitry.

The inputs can handle signals with frequency components as high as 7MHz making the device ideal for use in such applications as TV special effects equipment. The analog video signal is converted to digital format and back using A/D and D/A converters to permit storage of digitalised video in semiconductor memory and generation of effects such as shrinking, fades, mirror imaging and freeze frames.

Commonly used 8-bit equipment limits the number of usable conversion passes to about ten whereas this 9-bit device allows anything up to twenty passes before distortion is visible.

The **TDC 1019J** is housed in a 64-pin d.i.l. package and is available now at a cost of £330.

CHANNEL PLATES

The latest addition to the range image intensifier products marketed by Mullard is the **G12** range of micro-channel plates (MCPs) which have microchannel diameters of 12.5 microns and are available in three different diameters.

MCPs are used principally as the amplifying heart of modern image intensifier tubes and also find applications in research as well as in commercial mass spectrometers and fast CRT tubes.

This new range has an improved spatial resolution compared with the 25 micron series they will eventually replace. Gain is typically 1000 when biased with 1000V although much higher gains can be achieved using matched pairs.



BOOST FOR PLASTIC POWER TRANSISTORS

No fewer than twelve new families have been added to Mullard's range of amplifying and switching power transistors, all in the company's TO-220 encapsulation. Current ratings range from 1A to 15A and maximum voltage is 140V. Switching speeds are more than adequate for modern power control systems.

The new components are numbered **BDT29**, **BD239**, **BDT31**, **BD241**, **BDT41** and **BD243** with complementary pnp types one number larger (**BDT50**, and so on). All the **BDT** types are European equivalents for types in the **TIP** series and their type numbers are consequently related.

ADD-ON FOR LOW LEVEL LIGHT TV CAMERA

The latest addition to the range of Mullard image intensifier products is an add-on module designed to fit onto any closed circuit TV camera fitted with a C-mount lens incorporating a 2/3 inch camera tube. This converts the camera into a low light level TV camera (LLTV).

The basis of the module is the Mullard **XX1500** image intensifier. This has a gain of 70,000 and is effective below starlight level. The makers claim that this outperforms other LLTV systems and is considerably cheaper than a standard LLTV camera. The add-on unit plus CCTV camera costs around £3,000.

Obvious applications include security surveillance, especially where standard TV lighting would be inappropriate, home video where bright lamps are impractical and nature photography.

NEW

PRACTICAL ELECTRONICS

STEREO TUNER KIT

This easy to build 3 band stereo AM/FM tuner kit is designed in conjunction with Practical Electronics (July issue). For ease of construction and alignment it incorporates three Mullard modules and an I.C. IF System.

Features

VHF - M.W. - L.W. Bands, Interstation muting and A.F.C. on VHF. Tuning Meter. Two back printed P.C.B's. Ready made chassis and scale. Aerial: AM - Ferrite Rod, FM - 75 or 300 ohms. Stabilized power supply with "C" core mains transformer. All components supplied are to P.E. strict specification. Front scale size 10 1/2" x 2 1/4" approx.

Complete with circuit diagrams and instructions.



INTRODUCTORY PRICE-ONLY

£17.95

plus £2.50 p&p

PRACTICAL ELECTRONICS CAR RADIO KIT (Constructors pack 7)



2 WAVE BAND MW LW

- * Easy to build * 5 push button tuning
- * Modern styling design * All new unused components
- * 6 watt output * Ready etched & punched P.C.B.
- * Incorporates suppression circuits * Now with tape input socket

All the electronic components to build the radio, you supply only the wire and solder as featured in the Practical Electronics March issue. Features: Pre-set tuning with five push button options, black illuminated tuning scale, with matching rotary control knobs, one, combining on/off volume and tone-control, the other for manual tuning, each set on wood simulated fascia.

The P.E. Traveller has a 6 watts output, neg ground and incorporates an integrated circuit output stage, a Mullard IF module (LP1181) ceramic filter type, pre-aligned and assembled and a Bird pre-aligned push button tuning unit. The radio fits easily in or under dashboards.

Complete with instructions.

£10.50

plus £2.00 p&p

CONSTRUCTORS PACK 7A

Suitable stainless steel fully retractable locking aerial and speaker (approx. 6" x 4") is available as a kit complete

£1.95 p&p £1.15



30 + 30 WATT STEREO AMPLIFIER BUILT AND TESTED

Vicoulet IV unit in teak simulate cabinet silver finished rotary controls and pushbuttons with matching fascia, red mains indicator and stereo jack socket. Functions switch for mic magnetic and crystal pickups, tape and auxiliary. Rear panel features fuse holder, DIN speaker and input socket 30 + 30 watts. RMS 60 + 60 watts peak for use with 4 to 8 ohm speakers. Size 14 1/2" x 10" approx.

READY TO PLAY **£32.90**

plus £3.80 p&p

HI FI STEREO AMPLIFIER MODULES



- Mullard LP1183 built preamplifier suitable for ceramic and auxiliary inputs. £1.95 plus 70p p&p.
- Mullard LP1184 built preamplifier suitable for magnetic/ceramic and auxiliary inputs. £4.95 plus 80p p&p
- Matching I.C. 10 + 10 Stereo Power amplifier kit. £3.95 plus £1.15 p&p
- Matching power supply kit with transformer. £3.00 plus £1.86 p&p
- Matching set of 4 slider controls complete with knobs for bass, treble and volumes. £1.70 plus 80p p&p.
- Complete with application notes.



£14.95

plus £2.90 p&p

10+10 WATT STEREO AMPLIFIER KIT

- Featuring latest SGS/ATES TDA 2006 10 watt output I.C.'s with in-built thermal and short circuit protection.
- Mullard Stereo Preamplifier module.
- Attractive black vinyl finish cabinet. Size 9" x 8 3/4" x 3 3/4" approx.
- Converts to a 20 watt Disco amplifier

To complete you just supply connecting wire and solder. Features include din input sockets for ceramic cartridge, microphone, tape or tuner. Outputs—tape, speakers and headphones. By the press of a button it transforms into a 20 watt mono disc amplifier with twin deck mixing. The kit incorporates a Mullard LP1183 pre-amp module, plus power amplifier assembly kit and mains power supply. Also featured 4 slider level controls, rotary bass and treble controls and 6 push button switches. Silver finish fascia panel with matching knobs and contrasting ready made black vinyl finish cabinet and ready made metal work. For further information instructions are available price 50p. Free with kit.

SPECIFICATIONS

Suitable for 4 to 8 ohm speakers
Frequency response 40Hz — 20KHz
Input Sensitivity P.U. 150mV Aux. 200mV Mic. 1.5mV
Tone controls Bass ± 12db @ 80Hz
Treble ± 12db @ 10KHz
Distortion 1% typically @ 4 watts
Mains supply 220-250 volts 50Hz

BSR chassis record deck with manual set down and return, complete with stereo ceramic cartridge. **£8.50** plus £3.15 p&p when purchased with amplifier.

Available separately **£10.50** plus £3.16 p&p.

8" SPEAKER KIT 2 8" approx. twin cone domestic use speakers. **£4.75** per stereo pair plus **£1.70** p&p when purchased with amplifier. Available separately **£6.75** plus **£1.70** p&p.

STEREO MAGNETIC PRE-AMP

CONVERSION KIT. All components including P.C.B. to convert your ceramic input on the 10+10 amp to magnetic. **£2.00** when purchased with kit featured above. **£4.00** separately inc. p&p.



323 EDGWARE ROAD, LONDON W2
21A HIGH STREET, ACTON W3 6NG

ACTON: Mail Order only. No callers
ALL PRICES INCLUDE VAT AT 15%.
All items subject to availability. Price correct at 1/6/81 and subject to change without notice.
For further information send for instructions
20p plus stamped addressed envelope.

NOTE: Goods despatched to mainland and N. Ireland only.
Persons under 16 years not served without parent's authorisation.

RTVC LTD. reserve the right to alter, update or improve their products without notice.

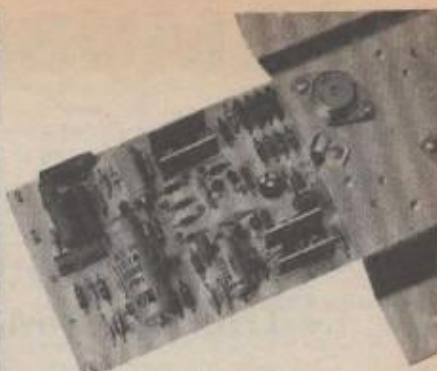

HIGH POWER MODULE KITS

125 WATT MODEL **£10.50**

plus £1.15 p&p (illus)

200 WATT MODEL **£14.95**

plus £1.15 p&p

SPECIFICATIONS

Max. Output power 125 watt RMS
Operating voltage (DC) 50-80 Max.
Loads 4-16 ohms
Frequency response measured at 100 watts 25Hz-20KHz
Sensitivity for 100 watts 400mV @ 47K
Typical T.H.D. @ 50 watts 4 ohms load 0.1%
Dimensions 205 x 90 and 190 x 38 mm

The power amp kit is a module for high power applications—disco units, guitar amplifiers, public address systems and even high power domestic systems. The unit is protected against short circuiting of the load and is safe in an open circuit condition. A large safety margin exists by use of generously rated components, result, a high powered rugged unit. The PC Board is backprinted, etched and ready to drill for ease of construction, and the aluminium chassis is preformed and ready to use. Supplied with all parts, circuit diagrams and instructions.

ACCESSORIES

Suitable LS coupling electrolytic for 125W model

£1.00

plus 25p p&p

Suitable LS coupling electrolytic for 200W model

£1.25

plus 25p p&p

Suitable Mains Power Supply unit for 125W model

£7.50

plus £3.15 p&p

Suitable Twin Transformer Power Supply for 200W model

£13.95

plus £4.00 p&p

MULLARD LP1183 STEREO PREAMP

Original listed price over £5.00. Suitable for ceramic and auxiliary inputs, when you purchase 2 power module kits.

FREE!

50 WATT MONO MIXER AMPLIFIER

Six individually mixed inputs for two pick ups (Cer. or Mag), two moving coil microphones and two auxiliary for tape, tuner, organs etc. Eight slider controls - six for level and two for master bass and treble, four extra treble controls for mic and aux. inputs.
Power output 50 watt R.M.S. (continuous) for use with 4 to 8 ohm speakers. Finish: Attractively styled black vinyl case, with matching fascia and knobs. Complete and ready for use.

£39.95

plus £3.70 p&p



100 WATT MONO DISCO AMPLIFIER

Brushed aluminium fascia and rotary controls. Size approx 14" x 4" x 10". Five vertical slide controls, master volume, tape level, mic level, deck level, PLUS INTER DECK FADER for perfect graduated change from record deck No. 1 to No. 2, or vice versa. Pre fade level controls (PFL) lets YOU hear next disc before fading it in. VU meter monitors output level.

£76.00

Output 100 watts RMS 200 watts peak.

plus £4.60 p&p

Personal Shoppers EDGWARE ROAD LONDON W2 Tel: 01-723 8432. 9.30am-5.30pm. Closed all day Thursday ACTON: Mail Order only. No callers GOODS DESPATCHED TO MAINLAND AND N. IRELAND ONLY

DIY MUSIC & EFFECTS KITS

AUTOWAH UNIT

Automatically gives Wah or Swell sounds with each guitar note played.
Kit order code SET 58 £16 04

GUITAR EFFECTS UNIT

Modulates the attack, decay and filter characteristics of a signal from most audio sources, producing 8 different switchable sounds that can be further modified by manual controls.
Kit order code SET 42 £14 11

GUITAR FREQUENCY DOUBLER

Produces an output one octave higher than the input. Inputs and outputs may be mixed to give greater depth.
Kit order code SET 96 £16 53

GUITAR MULTIPROCESSOR

An extremely versatile sound processing unit capable of producing, for example, flanging, vibrato, reverb, fuzz and tremolo as well as other fascinating sounds. May be used with most electronic instruments. Some SW's not incl. in kit—see list for selection.
Kit order code SET 85 £12 98

GUITAR OVERDRIVE

Sophisticated versatile fuzz unit incl. variable controls affecting the fuzz quality whilst retaining the attack and decay, and also providing filtering.
Kit order code SET 56 £19 80

GUITAR PRACTISE AMPLIFIER

A 3 watt mains powered amplifier suitable for instrument practise or as a test gear monitor. Drives 8 or 15 ohm speakers (not incl. in kit).
Kit order code SET 106 £19 72

GUITAR SUSTAIN

Maintains the natural attack whilst extending note duration.
Kit order code SET 75 £11 77

PHASER

An automatically controlled 8 stage phasing unit with internal oscillator. Depth can be increased with extension.
Main kit code SET 88 £18 34
Extension kit EXT 38 £7 31

PHASING & VIBRATO

Includes manual and automatic control over the rate of phasing & vibrato. Capable of superb full sounds. A separate power supply is included.
Kit order code SET 70 £42 85

SMOOTH FUZZ

As the name implies Order code SET 91 £11 98

SPLIT-PHASE TREMOLO

The output of the internal generator is phase-split and modulated by an input signal. Output amplitude, depth & rate are panel controlled. The effect is similar to a rotary cabinet.
Kit order code SET 102 £27 55

SWITCHED TONE TREBLE BOOST

Provides switched selection of 4 preset tonal responses.
Kit order code SET 89 £10 91

AUDIO EFFECTS UNIT

A variable siren generator that can produce British & American police sirens, Star-Trek red alert, heart beat monitor sounds, etc.
Kit order code SET 105 £12 91

FUNNY TALKER

Incorporates a ring modulator, chopper & frequency modulator to produce fascinating sounds when used with speech & music.
Kit order code SET 99 £15 43

WIND & RAIN EFFECTS

As the name says! Order code SET 28 £9 94

DISCOSTROBE

A 4-channel 200-watt light controller giving a choice of sequential, random or full strobe mode of operation.
Kit order code SET 57 £36 52

LIST

Send stamped addressed envelope with all U.K. requests for free list giving fuller details of PCBs, kits and other components. Overseas enquiries for list—Europe send 50p, other countries send £1 00.

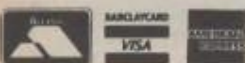

TERMS: C.W.O., Mail Order or Collection by appointment. Tel. 01-382-0184 (Mon-Fri).

KIMBER-ALLEN KEYBOARDS

Claimed by the manufacturers to be the finest moulded plastic keyboards available. All octaves are C-C, the keys are plastic, slope fronted, spring loaded, fitted with actuators and mounted on a robust aluminium frame.
3-Octave £25 96, 4-Oct £32 25, 5-Oct £39 58. Gold-leaf contacts (1 needed for each note) type GJ (SPCO) 33p each. Type GB (2-PR n/o) 38p each.

CHOROSYNTH

A standard keyboard version of the published Elektor 30-note chorus synthesiser with an amazing variety of sounds ranging from violin to cele and flute to clarinet amongst many others.
Kit plus keyboard & contacts SET 100 £114 12

FORMANT SYNTHESISER

For the more advanced constructor who puts performance first, this is a very sophisticated 3-octave synthesiser with a wealth of facilities, including 6 oscillators, 3 waveform converters, voltage controlled filter, 2 envelope shapers and voltage controlled amplifier. Case and hardware not included—see our lists for further details.
Kit plus keyboard & contacts SET 66 £323 35

P.E. MINISONIC SYNTHESISER

A very versatile 3-octave portable mains operated synthesiser, with 2 oscillators, voltage controlled filter, 2 envelope shapers, ring modulator, noise generator, mixer, power supply and sub-min toggle switches to select the functions. A case is excluded, but the text gives comprehensive constructional details.
Kit plus keyboard & contacts SET 38 £189 89

PRICES INCLUDE

VAT @ 15% & U.K. P. & P.

NEW KIT MAKE-UP

—SEE BELOW

128—NOTE SEQUENCER

Enables a voltage controlled synthesiser, such as the P.E. Minisonic, to automatically play pre-programmed tunes of up to 32 pitches and 128 notes long. Programs are initiated from the 4-octave keyboard and note length and rhythmic pattern are externally variable.
Kit plus keyboard & contacts SET 76 £114 89

16—NOTE SEQUENCER

Sequences of up to 16 notes long may be pre-programmed by the panel controls and fed into most voltage controlled synthesisers. The notes and rhythms may be changed whilst playing, making it more versatile than the name would suggest.
Kit order code SET 56 £68 13

DIGITAL REVERB UNIT

A very advanced unit using sophisticated I.C. techniques instead of noise-prone mechanical spring lines. The basic delay range of 24 to 90MS can be extended up to 450MS using the extension unit. Further delays can be obtained using more extensions.
Main kit order code SET 78 £67 22
Extension kit EXT 78 £45 94

RING MODULATOR

Compatible with the Formant and most other synthe sizers.
Kit order code SET 87 £11 69

WAVEFORM CONVERTER

Converts saw-tooth waveform into sinewave, mark-space squarewave, regular triangle, or squarewave with variable mark-space. Ideally one should be used with each synthesiser oscillator.
Kit order code SET 87 £20 13

BASIC COMPONENT SETS

Include specially designed drilled & tinned fibre-glass printed circuit boards, all necessary resistors, capacitors, semi-conductors, potentiometers, and transformers. They also include basic hardware such as knobs, sockets, switches, a nominal amount of wire and solder, a photocopy of the original published text, and unless otherwise stated, a robust aluminium box. Most parts may be bought separately. For fuller kit and component details see our current lists.

Kits originate from projects published in PE, EE, and Elektor.

RHYTHM GENERATORS

Two different kits—The control units are designed around the M252 and M253 rhythm-gen chips which produce pre-programmed switch-selectable rhythms driving 10 effects instrument generators feeding into a mixer.
12-Rhythm unit SET 103-253 £64 16
15-Rhythm unit SET 103-252 £57 26

6—CHANNEL MIXER

A high specification stereo mixer with variable input impedances. Specs given in our lists. The kit excludes some SW's—see lists for selection. The extension gives two extra channels.
Main kit code SET 90 £88 99
Extension kit EXT 90 £11 74

3—CHANNEL STEREO MIXER

Full level control on left and right or each channel, and with master output control and headphone monitor.
Kit order code SET 107 £18 68

3—MICROPHONE STEREO MIXER

Enables stereo live recordings to be made without the 'hole in the middle' effect. Independent control of each microphone.
Kit order code SET 108 £12 31

HEADPHONE AMPLIFIER

For use with magnetic, ceramic or crystal pick-ups tape deck, or tuner, and for most headphones. Designed with RIAA equalization.
Kit order code SET 104 £18 18

VOICE OPERATED FADER

For automatically reducing music volume during disco talk-over.
Kit order code SET 30 £7 80

DYNAMIC NOISE LIMITER

Very effective stereo circuit for reducing noise found in most tape recordings.
Kit order code SET 97 £12 67

DYNAMIC RANGE LIMITER

Automatically controls sound output levels.
Kit order code SET 82 £9 91

TUNING FORK

Produces 84 switch-selectable frequency-accurate tones with led monitor displaying beat-note adjustments.
Kit order code SET 46 £34 58

TUNING INDICATOR

A simple octave frequency comparator for use with synthesizers where the full versatility of KIT46 is not needed.
Kit order code SET 89 £14 41

PULSE GENERATOR

Produces controllable pulse widths from 100NS to 25Sec. Variable frequency range of 0-1Hz to 100KHz.
Kit order code SET 115 £25 48

SIGNAL TRACER & GENERATOR

Allows audio signals to be injected into circuits under test and for tracing their continuity. Includes frequency & level controls.
Kit order code SET 109 £15 31

WAVEFORM GENERATOR

Provides sine, square and triangular wave outputs variable between 1Hz & 100KHz up to 10V P-P.
Kit order code SET 112 £21 58

SPEECH PROCESSOR

Improves the intelligibility of noisy or fluctuating speech signals, and ideal for inserting into P.A. or C.B. radio systems.
Kit order code SET 110 £9 25

FREQUENCY COUNTER

A 4-digit counter for 1Hz to 99KHz with 1Hz sampling rate.
Kit order code SET 79 £42 30

EXPOSURE TIMER

Controls up to 750 watts in 0.5sec steps up to 10 minutes, with built-in audio alarm.
Kit order code SET 93 £36 44

EXPORT ORDERS ARE WELCOME

Postage rates are shown in our lists. All payments must be cash-with-order, in sterling by international money order or through an english bank. We do not offer a C.O.D. service. To obtain list—Europe send 50p, other countries send £1 00.

MORE KITS AND COMPONENTS ARE ON OUR LISTS

Prices are correct at time of press. E. & O.E. subject to availability.

PHONOSONICS • DEPT EE16 • 22 HIGH STREET • SIDCUP • KENT DA14 6EH

RADIO WORLD

Summer storms

Unusually severe thunderstorms early in June brought almost an inch of rain lashing down over much of southern England: the weather forecasts, the day before, stated, a trifle blandly in the circumstances, "sunny with showers . . . outbreaks of rain".

The public believes that the Government department that most consistently gets its forecasts wrong is the Meteorological Office from its headquarters in Bracknell, despite all the enormous advances in the use of large number-crunching computers, cloud-cover satellite pictures, balloons, unattended sensors linked only by telemetry, and the like. In defence, the Met men always point out (with justification) that the short-term prediction of rain is the most tricky thing to forecast correctly . . . and that forecasts are now very much better than they used to be.

The Met Office now has the support of a worldwide communications network capable of passing enormous amounts of data and facsimile weather maps. This operates under the aegis of the World Meteorological Organization (WMO) representing some 150 countries and one of the very few international bodies to have its own international radio call sign prefixes (C7A to C7Z).

The main trunk circuit stretches right round the globe relaying messages by means of automatic computer-type switching centres. Paris, Bracknell, Washington DC, Tokyo, New Delhi, Moscow, Cairo, Prague, Offenbach (Germany) are all on the weather hot line and there are many regional circuits: Paris for example is not only on the main trunk circuit but has direct links with Rome, Oran, Dakar, Casablanca, Madrid, Brussels, Zurich and so on.

Many ground stations in different parts of the world receive information from weather satellites and in Europe form part of the European Space Agency's "Ethernet" system.

All that data

The scale of the WMO operation is indicated by some recent French figures: Paris transmits and receives about 20-million characters of data and about 230 graphical documents every day. Links between national and international switching centres operate at the high speed of 9600 bits per second, with the main trunk route mostly 2400 bit/s duplex channels. For the spur links, microprocessor-controlled teleprinters are increasingly being used and both analogue and digital facsimile systems are in use.

Much of this worldwide network has been established during the past 10-15 years and follows an appeal to the United Nations by President Kennedy in 1961 for further co-operative efforts between all nations in weather prediction and eventually weather control—though the prospect of "weather control" is fraught with problems.

By Pat Hawker, G3VA

International co-operation goes back a lot further. In 1873 some 32 countries meeting at Vienna set up the International Meteorological Organization to supplement an even early European storm warning system. The IMO formally became the WMO in 1951.

The business of weather

Weather forecasting and its supporting technology has become big international business. British radio firms have sold both line and radio systems to many countries: weather data is passed by single-sideband telephony transmitters in many countries in the Middle East and Africa. Some of the elaborate satellite and balloon experiments have had large budgets.

Accurate rainfall predictions require not only massive computers but also enormous numbers of observations to feed into the voracious memories. Forecasters would like to have stations at 25-mile intervals reporting conditions at around ten vertical levels and thousands of free-floating balloons reporting temperature, humidity, pressure and wind data at heights up to about 50,000ft, though the full implementation of such systems is still some way off. Satellite weather photographs have proved one of the most useful and spectacular new forms of technology.

Satellite confusion

The publication by the HMSO of the 100-page booklet "Direct Broadcasting by Satellite" (£4.50) represents many months of study by the Home Office of the various options that are opening up. But unfortunately, although the report itself is clear and readable, many of the media comments on the report have added to the confusion in the mind of the public.

It has not always been appreciated that the study was concerned with direct broadcasts to the home, using transmitters (about 150 to 250 watts output) sufficiently powerful to be picked up on small dish aerials of 1-metre diameter or less. It was not concerned with the use of distribution satellites (typically 5 to 10 watts output) such as those now widely used in North America and elsewhere for the distribution of television programmes to cable operators or terrestrial transmitters.

The difference is an important one in terms of the technology and the costs since current distribution satellites can carry some 30 different programmes whereas so far nobody has

Weather at war

Not everybody realises that the Met Office, with an annual budget of around £50 million, is part of the Ministry of Defence. Similarly, the French bureau was set up after 400 sailors were lost at sea when a violent storm destroyed part of the French fleet during the Crimean War.

In World War II, in the UK weather forecasts were kept secret and both sides expended time, effort and lives in order to provide their airmen with forecasts of weather conditions likely to be encountered over enemy territory.

The Germans set up a number of secret weather ships and stations in the North Atlantic, including some in Greenland, though these were usually rapidly detected by the Allies through interception of the radio communications.

The RAF was provided with daily forecasts of weather conditions over Europe, partly based on information passed to the Met Office from the British Secret Service who had an effective clandestine h.f. radio link with a group of experienced weather men within the Belgian Resistance—a service that kept going virtually throughout the Occupation despite all the efforts of the German direction-finding teams.

Record entry for RAE

Despite all the talk of examination-less Citizens Band (or perhaps because of it), the number of candidates who sat for the Radio Amateurs Examination in May reached the remarkable figure of about 5,500 so it seems certain that many new call signs will soon be heard on the amateur bands. Early this year licences in the G6-three-letter sequence began to be issued to Class B (v.h.f.) stations and many of these can now be heard on 144MHz.

put up a direct broadcast satellite (DBS), even experimentally, with more than two programme channels. A multichannel DBS needs a good deal of electrical power, calling for very large solar panels to give perhaps a 5 or 10kW and there are still questions of reliability in connection with high-power travelling wave tubes.

Then again many commentators noted that the report was generally in favour of an early project but failed to note the qualifications of Mr William Whitelaw, the Home Secretary. He wrote: "The Government believes that a positive approach to the challenge is the right one . . . we are prepared to give serious consideration to the option for as early a start as possible with perhaps one or two television channels and possibly other information services. . . . This approach would need to be consistent with, and indeed build on, our existing broadcasting arrangements and institutions. In particular, any new DBS services would need to be subject to the same programme standards as apply to existing broadcasting services. . . ."

CMOS Metronome

BY I. HICKMAN



THE author's daughter was recently advised that she should use a metronome, as her violin playing—whilst creditably in tune—was distinctly wayward as far as keeping time goes.

Now a real metronome, the good old-fashioned wind-up clockwork type, is pretty expensive nowadays—it can cost you £20 or more. Further, despite the attractiveness of its polished wooden case, its beat tends to be uneven especially at the slower settings, and particularly so if not standing on an exactly level surface.

The beats themselves are not exactly identical, tending to sound like "tick - tock - tick - tock", which is fine for march time and common time but decidedly off in waltz time. So for this and other (financial?) reasons the author decided to make an electronic metronome.

Numerous designs for electronic metronomes have appeared in the past. Some were masterpieces of ingenuity using only a couple (or even just one) transistor, while others seemed unnecessarily complicated with flashing l.e.d.s as well as an audible output, or facilities for emphasizing the first beat of the bar.

The design presented here however is very straightforward, and consequently it is easy to understand how it works. It is also simple to get going and there is no adjustment or setting up.

LOGIC GATES

The circuit diagram of the metronome is shown in Fig. 1, and may be explained as follows. IC1a and b are two of the gates of a CD4011 CMOS quad 2-input NAND gate i.c., used as inverters. They form an oscillator running at just over 2kHz—the best frequency for audibility of the metronome's beat.

Gates IC2a and b are two of the inverters in the CD4069 CMOS i.c. and form another oscillator whose frequency is adjustable from four beats a second, that is 240 beats a minute, down to a sixth of this speed by means of the 500 kilohm potentiometer VR1. The squarewave output of this oscillator is differentiated by C4 and R5 to give narrow positive-going spikes of peak amplitude equal to the supply voltage, which is obtained from the ever popular PP3 9V type battery.

These positive spikes briefly enable NAND gates IC1c and IC1d resulting in antiphase 2kHz square waves appearing at pins 10 and 11. These are buffered by the remaining four sections of the hex-inverter and drive the directly coupled 40 ohm loudspeakers. Thus 9V appears at one terminal of the loudspeaker and 0V at the other, and then vice versa at a 2kHz rate, giving an 18V peak to peak speaker drive waveform.

SPEAKER IMPEDANCE

The quoted 40 ohm resistance of the speaker is of course the d.c. value; at a frequency as high as 2kHz its impedance has risen dramatically. Consequently the complete circuit draws less than 2.5mA from the battery, which should therefore last a long time if the metronome is not accidentally left on.

Fig. 1. Complete circuit diagram of the CMOS Metronome.

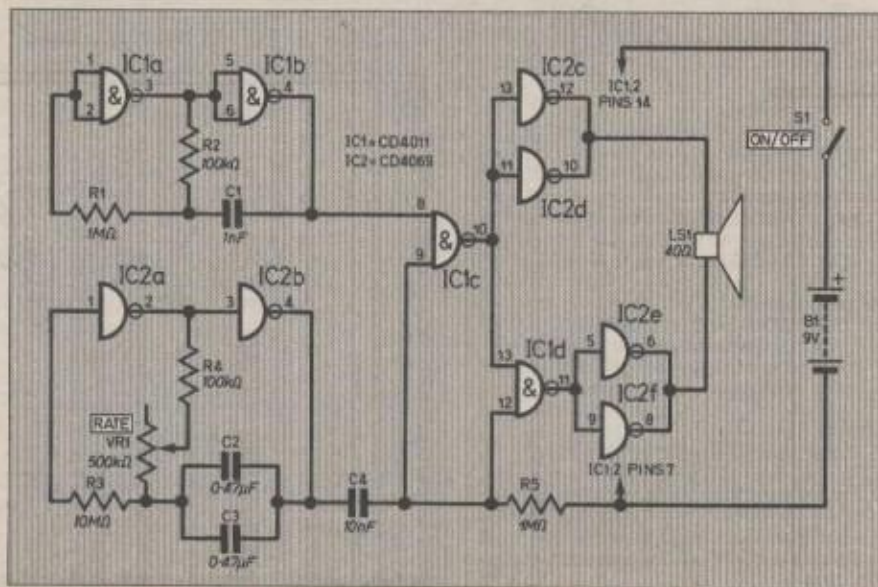

This is not likely to happen anyway, as its steady ticking, whilst not annoyingly loud, is all pervasive and can be heard all over a quiet house!

Note that by gating both IC1c and d, both terminals of the loudspeaker are at the same potential (0V) between ticks. This enables it to be direct coupled as shown without drawing any standard current, and also avoids the annoying click which is produced when the speaker's drive voltage is not symmetrical about its quiescent level.

CONSTRUCTION starts here

PLASTICS BOX

The author constructed the metronome in a bright orange plastic box about 40 x 80 x 160mm as shown in Fig. 2. Behind the holes drilled for the speaker grille, a piece of perforated zinc, sprayed matt black, was glued into place using an ABS adhesive.

When this was dry, the speaker was glued into place similarly. All the components except the battery (which was mounted under a tin retaining

COMPONENTS

Resistors

- R1 1M Ω
- R2 100k Ω
- R3 10M Ω
- R4 100k Ω
- R5 1M Ω

All $\frac{1}{4}$ W carbon $\pm 5\%$ page 535

See
**Shop
Talk**

Capacitors

- C1 1nF ceramic
- C2, 3 0.47 μ F polyester (2 off)
- C4 10nF polyester

Semiconductors

- IC1 CD4011 CMOS quad 2-input NAND gate
- IC2 CD4069 CMOS hex inverter

Miscellaneous

- VR1 500k Ω carbon lin. potentiometer
 - S1 s.p.s.t. toggle
 - LS1 miniature loudspeaker, 25-40 ohm coil impedance
 - B1 9V, PP3 type
- Plastics case, 160 x 80 x 40mm;
0.1 inch matrix stripboard, 36 strips by 17 holes; interconnecting wire;
6BA nuts, bolts and spacers (2 off each) for mounting board;
control knob; battery connector.

CMOS Metronome

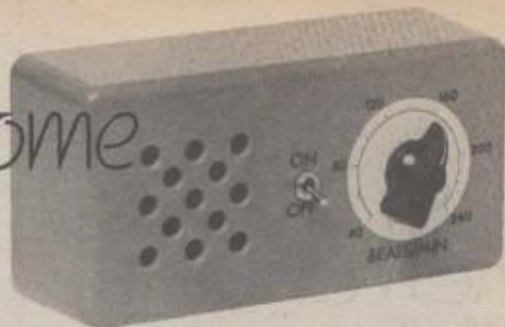
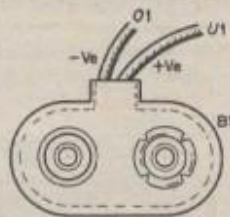
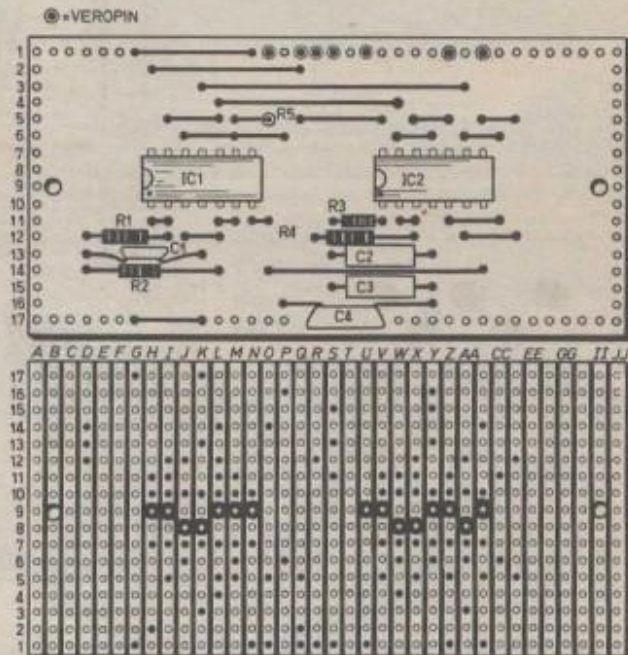

Fig. 3. Strip-board layout. When soldering in the CMOS i.c.s make sure that you use a properly earthed soldering iron to minimise damage due to static electricity. A suitable alternative would be to use i.c. sockets although you may then have to allow for an extra row of holes on each side of the i.c. as some sockets are quite wide. You can also see that there are a large number of wire links.

Care should be taken to get these in the correct positions. All connections to off-board components are made using Veropins positioned along the top of the board.



COMPONENTS
approximate
cost £7

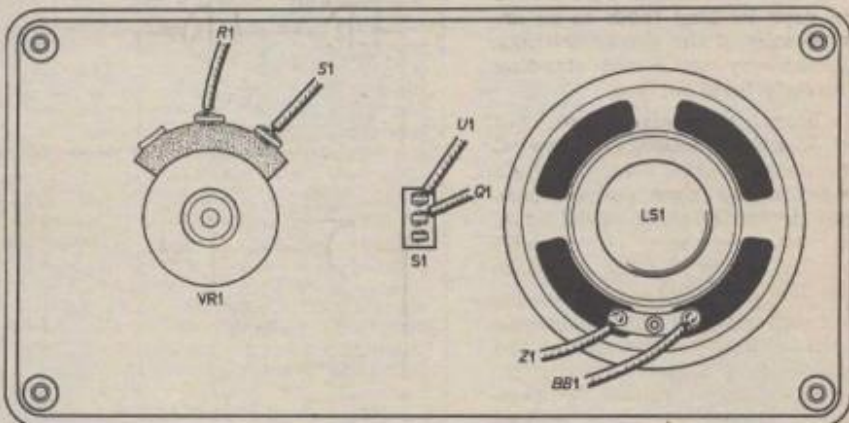
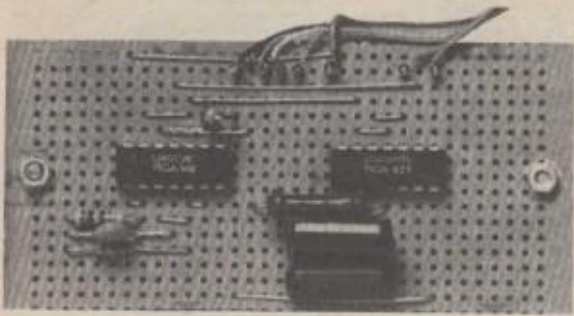
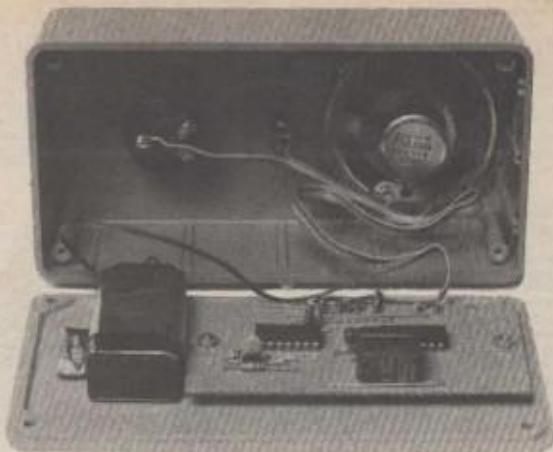

Fig. 2. Front panel layout showing relative positions of off-board components and connection points on stripboard.



Close up view of the prototype circuit board. The final layout in Fig. 3 differs from this because all underside links have been brought out on top of the board and components re-arranged so that they are not one on top of the other.



The assembled unit showing the rear of the front panel and mounted components and the circuit board and battery mounted in position on the rear panel of the case.

strap), S1, and VR1 (which are on the front of the box) were mounted on a piece of 0.1 inch matrix stripboard 17 holes by 36 strips (see Fig. 3).

The copper tracks run across the width of the board and of course the 7 tracks that run under each i.c. must be broken to avoid shorting opposite pins on the two sides of each pack. Take care when mounting the i.c.s or use slimline i.c. sockets.

It is well worth taking a little care with the construction as this always pays off in the long run. In particular, a length of colour coded ribbon cable makes a very neat job of the interconnections from front panel components to circuit board.

Use enough to allow the back of the box carrying the circuit board and battery to come well clear of the box for battery replacement. The spare cable folds neatly away inside the box when assembled. The circuit board is held in place using 6BA nuts, bolts and spacers.

MODIFICATIONS

There is plenty of scope for tailoring the circuit to your liking. For instance, increasing C4 to 22nF will give a beefier "pip", whilst at 47nF the sound is more like a "bleep".

The value in Fig. 1 gives quite a good imitation of the tick of a tradi-

tional clockwork metronome. Capacitor C3 can be omitted—a useful economy—if R4 is changed to 180kΩ and VR1 to 1MΩ, and almost certainly any impedance speaker from 25 to 80 ohms would work satisfactorily.

The final touch is to mark the beat rate in beats per minute on the front panel using dry transfer lettering. For various settings of VR1 count the beat rate and mark it on the front panel as appropriate. There is little variation of beat rate with battery voltage down to 6V.

Below this the speed of the beat rate departs more markedly from the indicated tempo until at about 5V the circuit ceases to function altogether. □

LETTERS

False Alarm

I would like to make a point concerning the *Ultrasonic Burglar Alarm*. It may be that I haven't understood it properly, but if there is a switch off delay on entering the room of say 10 to 20 seconds, then surely it would be possible for an intruder to pass through the guarded area (say a hallway), in this short period undetected.

A. J. Burt

New Eltham, London SE9

The delay referred to will activate the system as soon as the intruder enters the guarded area, but the alarm will not sound until about 15secs. have elapsed, whether the intruder is in the area or not.

Another delay built into this project is a short period between initialising the system and it becoming operative. This is to allow the operator to set the alarm and then leave the room without triggering it. Of course if an intruder happens to be already in the area before the alarm is set, and if he is aware of

what is happening and can take advantage of it, then he may well be able to pass through this guarded area undetected.

Buffered Reaction

The 13-year old son of an office colleague ordered a kit for the *Reaction Tester* (Nov. 80) and when he assembled it the result was disappointing. The result was that "dad" came to me. I found that one of the i.c. pins had curled up without entering the socket, and that was cured in 30 seconds flat. However the lamps did not cease on D18 but kept on cycling. I found that the current being drawn from the output pins of the 4017 i.c. was only a little over 1mA but that even this was seriously pulling down the output voltage so there was insufficient to activate the enable line to pin 13 via D7. My temporary suggestion was to insert a BC107 transistor as a buffer for D18 with a 10 kilohm resistor in the base lead. This achieved successful working. I am not sure why this problem has arisen. Would a buffered output 4017 have been better?

J. W. Robson

Newcastle upon Tyne

An interesting point. The use of a buffered 4017 would not make any difference as the term "buffered" simply means that the terminal pins are protected against static discharges. It is possible that there may be

an un-noticed high resistance path to earth from pin 9 of IC3 or components may be right at the edge or out of tolerance resulting in a high current drain. Changing D7 to a germanium type would help although the insertion of a buffer transistor is the more elegant solution.

Wrong Number

Being an 82-year old pensioner interested in electronics I thought I would interest myself in the Logic series, something new to me. I carried out all the exercises but came unstuck on exercise number 1.4d on page 333 in the May issue. It appears to me that the question is either a misprint or I am in error.

The answer given on page 405 in the June issue is 887 and the binary number should be 1101110111 whereas your number is 11011101111 which in my reckoning is 1911. Working back from 887, I came up with 1101110111.

W. G. Chastney
Norwich, Norfolk

Mr Chastney is of course quite right. The binary equivalent of 887 is 1101110111. You can take your pick as to whether the question is wrong and should have been 1101110111 or the answer was wrong and should have been 1775 (that is 1024 + 512 + 128 + 64 + 32 + 8 + 4 + 2 + 1) and not 1911. We apologise for this mistake.

FREE OUR CURRENT BARGAIN LIST WILL BE ENCLOSED WITH ALL ORDERS.

TRANSMITTER SURVEILLANCE*

Tiny, easily hidden but which will enable conversation to be picked up with FM radio. Can be made in a matchbox — all electronic parts and circuit. **£2.30.**

RADIO MIKE*

Ideal for discos and garden parties, allows complete freedom of movement. Play through FM radio or tuner amp. **£6.90** comp. kit.

SAFE BLOCK

Mains quick connector will save you valuable time. Features include quick spring connectors, heavy plastic case and auto on and off switch. Complete kit. **£1.95.**

8 WAVEBAND SHORTWAVE RADIO KIT

Bandspread covering 13.5 to 32 metres. Based on circuit which appeared in a recent issue of Radio Constructor. Complete kit includes case materials, six transistors, and diodes, condensers, resistors, inductors, switches, etc. Nothing else to buy if you have an amplifier to connect it to or a pair of high resistance headphones. Price **£11.95.**

SHORT WAVE CRYSTAL RADIO

All the parts to make up the beginner's model. Price **£2.30.** Crystal earpiece 60p. High resistance headphones (gives best results) **£3.75.** Kit includes chassis and front but not case.

RADIO STETHOSCOPE

Easy to fault find — start at the aerial and work towards the speaker — when signal stops you have found the fault. Complete kit **£4.95.**

INTERRUPTED BEAM

This kit enables you to make a switch that will trigger when a steady beam of infra-red or ultraviolet light is broken. Main components — relay, photo transistor, resistors and caps etc. Circuit diagram but no case. Price **£2.30.**

OUR CAR STARTER AND CHARGER KIT

has no doubt saved many motorists from embarrassment in an emergency you can start car off mains or bring your battery up to full charge in a couple of hours. The kit comprises: 250w mains transformer, two 10 amp bridge rectifiers, start/charge switch and full instructions. You can assemble this in the evening, box it up or leave it on the shelf in the garage, whichever suits you best. Price **£11.90 + £2.50** post.

GPO HIGH GAIN AMP/SIGNAL TRACER.

In case measuring only 5 1/2" x 2 1/4" x 1 1/2" is an extremely high gain (70dB) solid state amplifier designed for use as a signal tracer on GPO cables, etc. With a radio it functions very well as a signal tracer. By connecting a simple coil to the input socket a useful mains cable tracer can be made. Runs on standard 45v battery and has input, output sockets and on/off volume control, mounted flush on the top. Many other uses include general purpose amp, cueing amp, etc. An absolute bargain at only **£1.80.** Suitable 600hm earpiece 60p.

NEW KIT THIS MONTH!

CB RADIO — Listen in with our 40-channel monitor. Unique design ensures that you do not miss sender or caller. Complete kit with case and instructions only **£5.90.**

8 POWERFUL BATTERY MOTORS

For models, Meccanos, drills, remote control planes, boats etc. **£2.50.**

WATERPROOF HEATING WIRE

90 ohms per yard, this is a heating element wound on a fibre glass coil and then covered with p.v.c. Dozens of uses — around water pipes, under grow boxes in gloves and socks. **23p** per metre.

COMPONENT BOARD Ref. W0998

This is a modern fibreglass board which contains a multitude of very useful parts, most important of which are: 35 assorted diodes and rectifiers including 4 3amp 400v types (made up in a bridge) 8 transistors type BC107 and 2 type BF 751 electrolytic condensers. SCR ref 2N 5082, 2N4017 100v DC and 100uF 25v DC and over 100 other parts including variable, fixed and wire wound resistors, electrolytic and other condensers. A real snip at **£1.15.**

FRUIT MACHINE HEART. 4 wheels with all fruits, motorised and with solenoids for stopping the wheels with a little ingenuity you can defy your friends getting the "jackpot". **£9.95 + £4** carriage.

4-CORE FLEX CABLE

White pvc for telephone extensions, disco lights, etc. 10 metres **£2.** 100 metres **£15.** Other multicolour cable in stock.

MUGGER DETERRENT

A high-note blower, push latching switch, plastic case and battery connector. Will scare away any villain and bring help. **£2.50** complete kit.

EXTRACTOR FANS — Mains Voltage

Ex-computer, made by Woods of Colchester, ideal as tower, central heating systems, fume extraction etc. Easy fixing through panel, very powerful 2,900 rpm but quiet running. Choice of 2 sizes, 6" **£5.50.** 6" **£8.50.** post. **£1** per fan.

POCKET AUDIO COMPONENT TESTER

With it you can quickly test diodes, rectifiers, transistors, capacitors, check wiring and p.d. boards for open circuits, find the anode and cathode of a diode or rectifier and whether a transistor is PNP or NPN, which are the base collector and emitter connections. Condensers, if bad give a continuous signal but if good, give intermittent signals of varying length depending on their value. The test current is very low (2uA) and the voltage only 1.4v, so it is also possible to check MOS devices, as well as sensitive transistors with out fear of damaging them. The unit is supplied complete with internal battery, which should last many months. Price **£3.45p.**

* (Not licenced in the U.K.)

SUPER HI-FI SPEAKER CABINETS

Made for an expensive Hi-Fi outfit — will suit any decor. Resonance free cut-outs for 8" woofer and 4" tweeter. The front material is carved Mason, which is thick and does not need to be stuck in and the completed unit is most pleasing. Colour black. Supplied in pairs, price **£8.90** per pair (this is probably less than the original cost of one cabinet!) carriage **£3.50** the pair.



LOUDSPEAKERS

8" woofer and 4" tweeter, 4 ohms 35 watts power rating **£8.90** per pair. Ditto but 8 ohms, **£11.50** per pair. Post **£2.00.**

Vu METER SNIP.

Approximately 1 1/2" square, suitable for use as a recurring level meter, power output indicator or many similar applications. Full vision front, cover easily removable if you wish to alter the scale. Special snip price **£1.00**, or 10 for **£9.00.**



MOTORISED DISCO SWITCH

With 10 amp changeover switches. Multi-adjustable switches all rated at 10 amps, this would provide a magnificent display. For mains operated 8 switch model **£6.25**, 12 switch model **£7.25.**

3 CHANNEL SOUND TO LIGHT KIT

Complete kit of parts for a three-channel sound to light unit controlling over 2000 watts of lighting. Use this at home if you wish but it is plenty rugged enough for disco work. The unit is housed in an attractive two-tone metal case and has controls for each channel, and a master on/off. The audio input and output are by 1/4" sockets and three panel mounting fuse holders provide thyristor protection. A four-pin plug and socket facilitate ease of connecting lamps. Special snip price is **£14.95** in kit form or **£19.95** assembled and tested.



THIS MONTH'S SNIP REED SWITCHES

Wire ended, glass encapsulated. Contacts make when magnet brought near. Very many uses, i.e. combination locks, anti-intruder window & door switches, wind direction indicator, computer keyboard, secret switches, etc. etc. **SNIP OFFER: 10 SWITCHES FOR £1.00**, inc. post and VAT. Purchasers receive circuits and details of some suggested uses.

FLOUORESCENT TUBE INVERTER

For camping — car repairing — emergency lighting from a 12v battery you can't beat fluorescent lighting. It will offer plenty of well distributed light and is economical. We offer an inverter for 12" 8 watt miniature tube for only **£5.25.** (With tube and tube holders as well).



12v MOTOR BY SMITHS

Made for use in cars, these are series wound and they become more powerful as load increases — they will in fact burn themselves out if overloaded to stopping point. Size 2 1/2" long by 3" dia. These have a good length of 1/2" spindle — price **£4.45.** Ditto, but double ended **£4.25.**



MINI-MULTI TESTER

Deluxe pocket size precision moving coil instrument, jewelled bearings — 2000 o.p.v. mirrored scale. 11 instant range measures: DC volts 10, 50, 250, 1000. AC volts 10, 50, 250, 1000. DC amps 0 — 100 mA. Continuity and resistance 0 — 1 meg ohms in two ranges. Complete with test leads and instruction book showing how to measure capacity and inductance as well. Unbelievable value at only **£6.75 + 50p** post and insurance.



FREE Amps range kit to enable you to read DC current from 0 — 10 amps, directly on the 0 — 10 scale. It's free if you purchase quickly, but if you already own a Mini-Tester and would like one, send **£2.50.**

MULLARD UNILEX

A mains operated 4 + 4 stereo system. Rated one of the finest performers in the stereo field this would make a wonderful gift for almost anyone. In easy to assemble modular form this should sell at about **£30** — but due to a special bulk buy and as an incentive for you to buy this month we offer the system complete at only **£16.75** including VAT and post. **FREE GIFT** — buy this month and you will receive a pair of Goodman's elliptical 8" x 6" speakers to match this amplifier.



VENNER TIME SWITCH

Mains operated with 20 amp switch, one on and one off per 24 hrs. repeats daily automatically correcting for the lengthening or shortening day. An expensive time switch but you can have it for only **£2.95.** These are new but without case, but we can supply plastic cases (base and cover) **£1.75** or metal case with window **£2.95.** Also available is adaptor kit to convert this into a normal 24hr. time switch but with the added advantage of up to 12 on/off per 24hrs. This makes an ideal controller for the immersion heater. Price of adaptor kit is **£2.30.**



DELAY SWITCH

Mains operated — delay can be accurately set with pointers knob for periods of up to 2 1/2 hrs. 2 contacts suitable to switch 10 amps — second contact opens a few minutes after first contact. **£1.95.**



LEVEL METER

Size approximately 1 1/2" square, scaled signal and power but cover easily removable for re-reading. Sensitivity 200 uA. 75p.

STEREO HEADPHONES

Japanese made very good quality. 8 ohm impedance padded, terminating with standard 1/4" jack-plug. **£2.99** Post 60p.



BRIDGE RECTIFIER

1 amp 400v 30p each. 10 for **£2.50**, 100 for **£20.00**



TIME SWITCH BARGAIN

Large clear mains frequency controlled clock, which will always show you the correct time — start and stop switches with the dial. Comes complete with knobs. **£2.50.**

12V SUBMERSIBLE PUMP

Just join it to your car battery, drop it into the liquid to be moved and up it comes, no messing about, no priming, etc. and you get a very good head. Suitable for water, paraffin and any non-corrosive liquid. One use if you are a camper, make yourself a shower. Price **£8.50.**

POPULAR SNIP — STILL AVAILABLE

And it still carries a free gift of a desoldering pump, which we are currently selling at **£3.95.** The snip is perhaps the most useful breakdown parcel we have ever offered. It is a parcel of 50 neatly all different computer panels containing parts which must have cost at least **£500.** On these boards you will find over 300 IC's, Over 300 diodes, over 200 transistors and several thousand other parts, resistors, condensers, multi-turn pots, rectifiers, SCR, etc. etc. If you act promptly, you can have this parcel for only **£8.50**, which when you deduct the value of the desoldering pump, works out to just a little over 4p per panel. Surely this is a bargain you should not miss! When ordering please add **£2.50** post and **£1.27** VAT.

SOLENOID WITH PLUNGER

Mains operated **£1.99** 10 — 12 volts DC operated **£1.50.**

YOUR LAST CHANCE FOR THIS BARGAIN

100 twist drills, regular tool shop price over **£50**, yours for only **£11.50.** With these you will be able to drill metal, wood, plastic, etc. from the tiniest holes in P.C.B. right up to about 1/2". Don't miss this snip — send your order today.

MINI MONO AMP

on p.d.b., size 4" x 2" approx. Fitted volume control and a hole for a tone control should you require it. The amplifier has three transistors and we estimate the output to be 1 W rms. More technical data will be included with the amplifier. Brand new, perfect condition, offered at the very low price of **£1.15** each, or 10 for **£10.00.**



J. BULL (Electrical) Ltd.

(Dept. EE), 34 - 36 AMERICA LANE,
HAYWARDS HEATH, SUSSEX RH16 3QU.

J. BULL (Electrical) Ltd — Established 25 years. MAIL ORDER TERMS: Cash with order — please add 60p to all orders under £10, to offset packing, etc. ACCESS & BARCLAYCARD WELCOMED. Our shop is open to callers. BULK ENQUIRIES INVITED. Telephone: Haywards Heath (0444) 54563.

B.K. ELECTRONICS—A SOUND CHOICE



STEREO CASSETTE TAPE DECK MODULE

Full record and play-back facilities. Supplied as one complete unit for horizontal installation into cabinet or console of own choice. Brand new, ready built and tested. Smart silver and black finish. Features: Three digit tape counter, Auto stop, Six piano type keys, Record, Rewind, Fast Forward, Play, Stop and Eject. Automatic record level control. Main inputs plus secondary inputs for stereo microphones. Input sensitivity 100mV to 2V. Output level 400mV nominal. Wow and flutter 0-1%. Ideal for hi-fi, disco and computer applications etc. Easily connected. Dimensions—top panel 5½" x 11½". Supplied complete with circuit and connecting diagrams. Power supply required—18V DC at 300mA. PRICE £26-70 + £2-50 post and packing. Power supply kit (including transformer) £3-00.

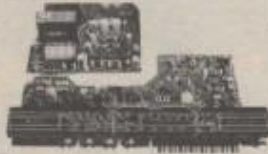

G.E.C. TUNER AMPLIFIER CHASSIS—AM/FM

Originally designed for installation into a music centre. Supplied as two separate fully built and tested units which are easily wired together. Circuit diagram and inter-connecting wiring diagram supplied. Rotary controls—tuning, volume, balance, treble and bass. Push button controls—mono, tape, disc, A.F.C., F.M. (VHF), L.W., M.W., S.W. Power output—7 watts RMS per channel into 8 ohms. Tape sensitivity Output typically 150mV. Input 300mV. Disc sensitivity 100mV (Ceramic cartridge). Stereo Beacon indicator LED or bulb. Dimensions—Tuner 2½" x 15" x 7¼". Power amp. 2" x 7¼" x 4½". PRICE £23-50 + £2-50 post and packing.

NEW RANGE QUALITY POWER LOUDSPEAKERS (15", 12" and 8")

These loudspeakers are ideal for both hi-fi and disco applications. Both the 12" and 15" units have heavy duty die-cast chassis and aluminium centre domes. All three units have white speaker cones and are fitted with attractive cast aluminium (ground finish) fixing escutcheons.

15" 100 watt R.M.S. Impedance 8 ohm, 2" aluminium voice coil. Resonant Frequency 20Hz. Frequency Response to 2-5KHz. Price £32 each. £2-50 Packing and Carriage each.

12" 100 watt R.M.S. Impedance 8 ohm, 2" aluminium voice coil. Resonant Frequency 25Hz. Frequency Response to 4KHz. Price £23-70 each. £2-50 Packing and Carriage each.

8" 50 watt R.M.S. Impedance 8 ohm, 1" aluminium voice coil. Resonant Frequency 40Hz. Frequency Response to 6KHz. Price £8-90 each. £1-25 Packing and Carriage each. Other units available.



PIEZO ELECTRIC TWEETERS—MOTOROLA

Join the Piezo revolution. The low dynamic mass (no voice coil) of a Piezo tweeter produces an improved transient response with a lower distortion level than ordinary dynamic tweeters. As a crossover is not required these units can be added to existing speaker systems of up to 100 watts (more if 2 put in series). FREE EXPLANATORY LEAFLETS SUPPLIED WITH EACH TWEETER.

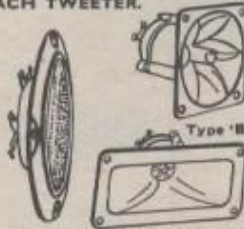

Type 'A' Type 'C' Type 'D'

Type 'A' 3in round with protective wire mesh. Ideal for bookshelf hi-fi speakers. Price (Type 'A') £3-45 each.

Type 'B' 3in super horn. For general purpose speakers disco and PA systems, etc. Price £4-35 each.

Type 'C' 2in x 5in wide dispersion horn. For hi-fi systems and quality disco etc. Price £5-45 each.

Type 'D' 2in x 6in wide dispersion horn. Frequency response extending down to mid-range (2000 c/s) suitable for hi-fi systems and quality disco. Price £6-90 each.

Post and Packing, all types, 15p each (or SAE for Piezo leaflets).

B.K. ELECTRONICS

Dept. EE, 37 Whitehouse Meadows, Eastwood, Leigh-on-Sea, Essex SS9 5TY

★ SAE for current lists. ★ Official orders welcome. ★ All prices include VAT. ★ Mail order only. ★ All items packed (where applicable) in special energy absorbing PU foam. Callers welcome by prior appointment. Please phone 0702-527572



ANNOUNCING A NEW SET OF BASIC ELECTRONICS

This 5 volume set contains over 500 pages. Bound in stiff linen. Cover size 8½in x 5in. Price £10.00 per set (we pay the postage).

- Book 1. Introducing Electronics Book 4. Meters/Voltage-dividers
Book 2. Resistors/Capacitors Book 5. Transistor Project Circuitry
Book 3. Inductors/Diodes

The manuals are unquestionably the finest and most up-to-date available and represent exceptional value.

This series has been written in a fascinating, absorbing and exciting way, providing an approach to acquiring knowledge that is a very enjoyable experience. Suitable for industrial trainees, City and Guilds students, DIY enthusiasts and readers of electronic journals.

Each part explains electronics in an easy-to-follow way, and contains numerous diagrams and half tone blocks with construction details and circuit diagrams for making the following transistor projects: Lamp Flasher, Metronome, Wailer, Photographic/Monostable Timer, Metal Locator, Geiger Counter, Radio Receiver, Intercom., Intruder Alarm, Electronic Organ, Battery Eliminator, Anemometer, Sound Switch, Light and Water-operated Switches, Pressure-operated Switches, Light meter, Radio Thermometer, Ice Alarm.

Order now:
Selray Book Company
11, Aspen Copse,
Bromley,
Kent, BR1 2NZ.

OUR 100% GUARANTEE

Should you decide to return the set after 10 days examination, your money will be refunded by return of post.

Amount enclosed: £

Name:

Address:

EE 8

TRANSFORMERS

Panel Meters, Bridge Rectifiers, Power Supply Units
Multimeters - Semi Conductors - Timers - Safeloc

Minimum & Sub Miniature			
Volts	Milli-amps	Ref. No.	Price £ P&P
3-0.3	200	238	2.60 70
0.6 0.6	1A 1A	212	3.00 75
8-0.9	100	13	2.30 70
0.9 0.9	330 330	235	2.15 70
0.8-9 0.8-9	500 500	207	2.75 75
0.8-9 0.8-9	1A 1A	208	3.85 75
0.15 0.15	200 200	236	2.15 70
0.20 0.20	300 300	214	2.75 90
20-12.0-12.20	700(DC)	221	3.50 90
0.15-20 0.15-20	1A 1A	206	4.80 1.05
0.15-27 0.15-27	500 500	203	4.05 85
0.15-27 0.15-27	1A 1A	204	5.10 1.05

12 AND/OR 24 VOLT			
Pr: 220-240 Volts			
12v	24V	Ref.	Price £ P&P
0.5	0.25	111	2.30 75
1.0	0.5	213	2.75 90
2	1	71	3.25 90
4	2	18	4.05 85
6	3	70	5.60 95
8	4	108	7.40 1.20
10	5	72	8.25 1.20
12	6	116	8.85 1.20
16	8	17	10.85 1.30
20	10	115	13.85 1.50
30	15	187	16.85 1.50
60	30	226	33.35 1.80

30 VOLT (Pr: 220-240V)			
Sec: 0-12-15-20-24-30V			
Amps	Ref. No.	Price £	P&P
0.5	112	2.85	90
1.0	79	3.80	90
2.0	3	5.90	1.05
3.0	20	6.30	1.20
4.0	21	6.60	1.20
5.0	51	9.60	1.20
6.0	117	11.10	1.20
8.0	88	14.35	1.50
10.0	89	16.60	1.50

50 VOLT (Pr: 220-240V)			
Sec: 0-19-25-33-40-50V			
Amps	Ref. No.	Price £	P&P
0.5	102	3.60	90
1.0	103	4.60	1.05
2.0	104	7.30	1.20
3.0	105	8.60	1.20
4.0	106	10.85	1.30
6.0	107	15.10	1.50
8.0	118	20.20	1.70
10.0	119	24.10	2.20

60 VOLT (Pr: 220-240)			
Sec: 0-24-30-40-48-60			
Amps	Ref. No.	Price £	P&P
0.5	124	3.85	90
1.0	126	5.60	1.05
2.0	127	7.55	1.20
3.0	125	11.10	1.30
4.0	123	12.35	1.50
5.0	40	14.15	1.60
6.0	120	17.60	1.60

AUTO TRANSFORMERS			
Input/Output Tapped 0-115-210-240V			
VA (Watts)	Ref. No.	Price £	P&P
20	113	2.85	90
75	64	4.10	90
150	4	5.60	1.05

Input/Output Tapped 0-115-210-220-240V			
Also 1500/2000/3000VA			
NAINS ISOLATING (Centre Tapped & Screened)			
Pr: 120/240V Sec: 120/240V			
VA (Watts)	Ref. No.	Price £	P&P
60	149	8.60	1.05
100	150	7.60	1.30
200	151	11.10	1.30
250	152	13.30	1.50
350	153	16.30	1.60
1000	156	37.10	3.20

Please add VAT at 15%.
Barclaycard and Access facilities
available
Trade and Education Welcome

BAYDIS

7a William Street
Herne Bay, Kent
Herne Bay G4586



Developing a Flat Screen TV

The recent announcement of a £5 million, four year, investment programme in the production of the Sinclair flat screen TV tube and Microvision pocket f.m. radio/television receiver prompts a look at the whole business of flat screen TV. It's always been a designer's dream to produce a TV set which can hang on a wall like a picture. Obviously an ordinary cathode ray tube can never be made flat enough to achieve this. The electron beam would have to scan over an angle approaching 180 degrees and this is electronically impractical.

Projection Systems

Since the 30's TV designers have achieved a flat screen effect by projection techniques. In most systems a small picture tube, with a very bright picture, is incorporated in a lens-mirror system which projects an enlarged image of the tube picture on a flat, or slightly curved, screen. This is how large pictures were achieved before large c.r.t.'s were practical.

In the USA and Japan there is now a new generation of large screen TV receivers, which look like ordinary sets, but in fact incorporate a projector which beams the picture onto the rear of a translucent screen. More commonly, however, projection is from the front onto a reflective screen.

To achieve a bright, colour picture three separate tubes are used, rather than a single conventional shadowmask tube. One tube reproduces only the red component of the picture, the second tube reproduces green and the third tube reproduces blue. The projection optics combine the red, green and blue images on the screen to produce a full colour picture. But you always need to use a projector in addition to the screen. Sometimes, as in a rear projection system, the projector is combined in the same cabinet as the screen. Sometimes the projector is disguised as a coffee table in front of the screen. But either way the end result is a cumbersome arrangement.

Matrix System

The long term answer to flat screen television is to use a matrix of light emitting cells instead of a cathode ray tube. In its simplest form, as already used in some vast sports arenas, the light cells are electric lamps. Many thousands of lamps are arranged in a grid of lines like a TV screen raster and their brilliance of illumination is continually modulated by a current which scans the grid.

In theory this replicates the effect of an electron beam scanning the phosphor screen of a TV tube. But in practice there are very real problems. Electric lamps have thermal inertia. You can't switch them on and off instantly. So the image smears on movement.

Neon lamps can be switched more quickly but they are very dim. It's also a very expensive business to build a matrix from large numbers of electric lamps, and they keep burning out so that maintenance is like painting the Forth Bridge. Also definition tends to be very coarse. So all over the world the race is on to find a matrix of fast acting light cells which can be made small enough to give reasonable definition.

Japanese Approach

At the 1980 Electronics Show in Tokyo, Toshiba showed a prototype pocket TV with a two inch screen made from a liquid crystal display matrix. The tiny screen contained 52800 individual picture elements, arranged in a matrix of 220 x 240 rows. The picture, in black and white only, was dim and disappointing with smearing on motion.

In the research laboratories of NHK, the Japanese radio station which is loosely equivalent to the BBC, I saw two prototype flat screen colour systems. The smallest, a ten inch diagonal display panel is formed from 36480 oblong gas discharge cells arranged with colour phosphors in a matrix of 95 x 384 rows.

The gas discharge cells generate ultraviolet radiation which excites phosphors to emit visible light of the three primary

colours, red, green and blue. The pictures were only moderately bright and of only reasonable colour rendition. Definition is coarse because the picture is effectively formed from only 12,160 elements.

The flat screen is also accompanied by a large stack of outboard electronics. Likewise the NHK 16 inch diagonal screen needs a substantial amount of additional electronics.

This uses a matrix of 240 x 320 cells and the phosphors are arranged as dot clusters rather than oblong strips. NHK engineers are the first to admit that both definition and brilliance must be improved before the system is workable.

Reducing the outboard electronics to manageable size is simply a matter of a large scale integration, and although expensive this presents no real practical problems. It's clear that NHK is looking ahead, perhaps to the next decade, and the production of a high definition wall screen built up from a matrix of microscopically fine multi-coloured light emitting cells.

American Answer

In the US, RCA has been looking at flat screen technology for the last 35 years but has now abandoned matrix techniques. RCA is instead developing a four inch thick cathode ray tube. In fact each of these tubes are really only a part picture tube.

A large TV screen is built up from a parallel series of long thin strips, each formed from an individual c.r.t. The electron beam is fired from guns at one end and turned through 90 degrees onto a phosphor screen by a series of deflector grids. Colour is achieved by normal shadowmask technique and multi-coloured phosphors.

The company claims that it will be able to produce a 50inch diagonal tube, made up from one inch wide individual tubes. This, says RCA, will be available towards the end of the decade.

Sinclair Recipe

In the UK, Sinclair is adopting a line more closely resembling the RCA approach than that being followed in Japan by NHK and Toshiba. The Sinclair tube, which measures around 4 x 2 x 1/2 inch in total size and has a 3 inch diagonal viewing screen, is made from a flat sandwich of two glass plates.

An electron beam fired from a gun at one end is bent, as in the RCA tube, through 90 degrees to strike a phosphor screen on the back plate. The image produced is viewed through a transparent tin oxide electrode on the front plate.

To keep power consumption of the scanning circuits down, the displayed image is of squashed aspect, rather like a cinemascope image on film before it is expanded by the special projection lens used for such films. A Fresnel lens on the front plate of the Sinclair tube restores the image to its normal 4 x 3 aspect ratio.

Although Sinclair has only recently disclosed these technical details, even fuller facts have actually been readily available through published patents for some time. For instance, French patent application number 78/14732, published under number 2 391 556, was available for anyone to read in the British Patent Office Library as far back as April 1979!

A recent press conference given by Sinclair did however clear up some other matters. Those who had studied the patents could not for instance see how the tube could possibly be made large, to produce reasonable size pictures. It also seemed impractical to convert the tube to colour, and still keep the cost down.

It now emerges that Sinclair plans to produce large screen pictures by using the tubes in a projection mode. Three tubes, one for red, one for green and one for blue, will be incorporated in an optical system to project a picture of up to 50 inches in size on a wall screen.

Even a 9inch picture in a portable set can, it is claimed, be most economically produced by using three tubes, a projection lens, and a back-projection screen. Only time will tell whether this extraordinary claim is justified.

Production and Reliability

In the meantime, Sinclair is to start producing tubes and Microvision

digital watches, has been overcome with the ZX80 computer "We have not been too proud to take a lesson from the Japanese" he says.

Quality control requirements on the raw components have tightened by a thousandfold but there are still a couple of question marks. Firstly the ZX80 is made for Sinclair by the Tek Group, not Timex. The latter company has already been named as the manufacturing base for the Nimslo 3-dimensional snapshot camera and for this is receiving £3 million in Government cash.

Much has been heard of this gadget, which is supposed to enable the home photographer to produce 3-D snapshots for not much more than the cost of ordinary photography. But so far nothing has been seen of a saleable product.

Incidentally Nimslo, like Sinclair, have been reticent over technical details concerning their products. But again, full details are already on the public record. US patent 3 852 787, for instance, gives a detailed break down of Nimslo 3-dimensional technology. Anyone calling at the

foreign section of the British Patent Office Library can look at a copy, free of charge.

Looking for a Market

Rather more important is the question of who actually *wants* a pocket TV set with a tiny black-and-white screen which they can carry round the world. Of course, some gadget-hungry executives will buy one simply because it is cheap and makes a good talking point.

In reality anyone who can afford to travel round the world can also afford to stay in a hotel and most modern hotel rooms have a TV set, usually a large screen colour receiver. And whereas it may be nice to listen to the sound from a radio or cassette recorder while on the move, or as aural wallpaper for work or play, any TV set (whether it's large screen colour or pocket sized flat black-and-white) needs watching. Also, however small the Microvision set may eventually be, it still needs a long aerial to receive pictures off-air.

At the London press conference Clive Sinclair showed an impressive looking pocket Microvision and pictures of this set were widely publicised by the media. In fact this set was a dummy. The only *working* system was a prototype, several years old, which sat on a large box of outboard electronics served by a long telescopic aerial. And it's pictures were certainly nothing special.

No one doubts Clive Sinclair's genius for innovation. And it may well be that the flat screen Microvision comes off the Timex production lines as cheaply and as reliably as he predicts. But no one can really predict whether sales will keep up with production.

Flat screen Microvision is a product looking for a market. As the British tax payer is contributing heavily to the development of that product—and 1,000 jobs hang on the results—we can only hope that the market is there.

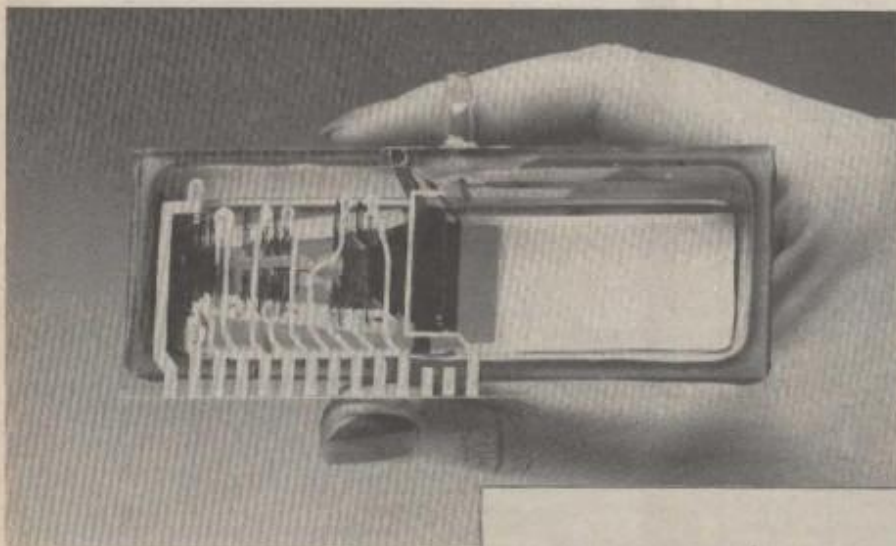

First prototype of the Sinclair flat-screen tube produced at St. Ives, Cambridge.

receivers, at the Timex Corporation's watch plant in Dundee. Over half the £5 million financial backing comes, one way or another, from the British tax payer. Although the investment is spread over the next 3 or 4 years, it is hoped soon to be producing tubes at the rate of one million a year.

Sinclair Microvision flat screen sets should start appearing in the shops for around £50 next year. These will be usable anywhere in the world except France, which is out of line with other TV standard systems on just about every count, for instance the sound is a.m. rather than f.m.

If all goes well around 1,000 people will eventually be employed by Timex on the project. It's obviously in the national interest, therefore, that all goes well!

Sinclair claims that the company's early bad reputation for poor reliability of product, for instance calculators and



Mock-up version of the new Sinclair multistandard 3in flat-screen Microvision pocket TV.

GREENWELD

443D MILLBROOK ROAD, SOUTHAMPTON SO1 0HX
All prices include VAT—just add 40p post. Tel (0703) 772501

THE SPECTACULAR 1981 GREENWELD

Component Catalogue

Bigger and better than ever!!!

- 60p discount vouchers
- First Class reply paid envelope
- Free Bargain List
- Priority Order Form
- VAT inclusive prices
- Quantity prices for bulk buyers

SEND 75p FOR YOUR COPY NOW!!!

VEROBLOC BREADBOARD

New from Vero, this versatile aid for building and testing circuits can accommodate any size of IC. Blocks can be joined together. Bus strips on X & X axis—total 380 connection points for just £4.15. (Photo shows 2 blocks)



TTL AND REED PANEL

Z829 74 Series ICs—Gates and complex logic. 20 assorted. ICs on panels £1.100 ICs £4.
Z827 9 x 8V reed relays, 6 x 2S030 or 2S230 6 x 400V reeds, + R's. Only 90p.

IN4006 DIODES

Special purchase of 1A reeds, Russian made. Packed in boxes of 300, £3.50 per box; 4 boxes £20.00; 10 boxes £78.00.

DISC CERAMICS

0-22uF 12V 9mm dia. Ideal for decoupling. 100 for £2.75; 1000 £20.00.
0-5uF 12V 15mm dia. 100 £1.90; 1000 £12.00.

TRANSISTOR PACK K516

Take advantage of this unbelievable offer!! Small signal NPN/PNP transistors in plastic package at an incredibly low, low price!! Almost all are marked with type number—almost all are full spec devices, some have bent leads. Over 30 different types have been found by us, including BC184/212/238/307/305; BF160/7; ZTX107/8/9/342/450/550 etc. Only available as a mixed pack at £3.100; £7.250; £25.1000.

CALC CHIPS 60p!!!

New full spec, supplied with data. Type MK90321—full function inc memory. Only 60p.

COMPONENT PACKS

K503 150 wirewound resistors from 1W to 12W, with a good range of values, £1.75.
K505 20 assorted potentiometers, all types including single, ganged, rotary and slider, £1.75.
K511 800 small value poly, mica, ceramic caps from a few pF to .05uF. Excellent variety, £1.20.
K514 100 silver mica caps from 5pF to a few thousand pF. Tolerances from 1% to 10%. £2.00.
K515 Transistor Pack. Small signal NPN/PNP transistors in plastic package. Almost all are marked, full spec devices, but some have bent leads. Over 30 different types have been found by us, inc. BC184/212/238/307/305; BF160/7; ZTX107/8/9/342/450/550 etc. Look at the low price 100 for £3.00; 250 for £7.00; 1000 for £25.
K520 Switch pack—20 different, rocker, slide, rotary, toggle, push, micro, etc. Only £2.00.
K521 Heatsink pack—5 diff. sizes, each 200mm, 50p.

2708 FULL SPEC £2

REGULATED PSU PANEL

Exclusive Greenweld design, fully variable 0-20V & 20mA-2A. Board contains all components except pots and transformer. Only £7.75. Suitable transformer and pots £8.00. Send SAE for fuller details.
TRANSFORMERS
Maine primary, 50V 20A sec. £20. Maine primary, 110V 15A sec. £30; 30A £40.
ALFAC PCB TRANSFERS
Lines, curves, dots, pads, DIL pads, etc. Pack of 13 different sheets, £9.15.
BARGAIN LIST 13
10 pages A4 list with 800 different items, many unusual, all at cut-price—switches, relays, pots, R's, C's, connectors, hardware, semiconductors, meters, displays, packs, panels, meters etc. etc. And its FREE!!—just send 9 x 4 stamped SAE.

4 TERMINAL REGS

LA78MG In power mini-dip case 5-35V at 1A, £1.00.
LA78MG Negative variation of above, £1.20.
Only 4 extra components required (50p extra) to make a fully variable supply!! Data supplied.

1W AMP PANELS

A011 Compact audio amp intended for record player on panel 95 x 65mm including vol. control and switch, complete with knobs. Apart from amp circuitry built around LM380N or TBA820M, there is a speed control circuit using 3 transistors. 8V operation, connexion data supplied. ONLY £1.50.

VU METERS

V006 Very attractive 55 x 45mm scaled -20 to +3dB, 250uA movement. Only £1.75, or £3.00 pair.

OP-AMP PSU KIT

A198 All parts + instructions to make a 50mA +15, 0, -15V supply from mains input. Only £1.95.

COPPER CLAD BOARD

K322 All pieces too small for our etching kits. Mostly double sided fibre-glass. 250gm (approx. 110 sq ins) for just £1.00.

JOB LOT OF COMPONENTS

9500 1N4000; 10000 .033/50; 22000 10pF/50; 15000 .22/12; 11000 270pF/50; 19000 66pF/50. 30000 various resistors. Total 112,500 components for £480 inc. VAT & cart.

12 VOLT INDICATORS

Ideal for light chasers, etc. Miniature 12V 75mA wire ended lamps in yellow, red, green, blue and clear. 100 each. 25 each colour, total 100 for £5.50.

PANELS

Z821 Panel with 16236 (2N3442) on small heat sink, 2N2222 dual transistor, 2 BC108, diodes, caps, resistors, etc. 60p.
Z482 Potted Oscillator Module works from 1-20V, can be used as LED flasher (3V min). Supplied with connection data, suitable R, C & LED. £1.00.

Z827 Reed relay panel—contains 2 x 8V reeds, 6 x 2S030 or 2S230, 6 x 400V reeds + Rs. 90p.
Z829 Pack of ex-computer panels containing 74 series ICs. Lots of different gates and complex logic. All ICs are marked with type no. or code for which an identification sheet is supplied. 20 ICs £1.90; 100 ICs £4.00.

A504 Black case 50 x 50 x 78mm with octal base. PCB inside has 24V reed relay, 200V 7A SCR, 4 x 5A 200V reeds, etc. 90p.

ODDS & ENDS

Transformer, mains in, 1770V 10mA out. £2.50.
W847 PCB relays, relay 11 x 33 x 20mm, 37V 5-10V SPCC 3A, 95p.
901A3 Pickering DIL relay 900R, 5P make, 3 7-10V, ex-equip on PCB, 75p.
X905 140 x 10mm ferrite rod with LW & MW windings, 45p.

10M 1W 5% CF Resistors—pack of 200 £1.
40W amp PCB + cct + layout. £1.00. All parts to make, £3.50.
1x 1W R's—111k, 33k, 500k, 900k, 950k. All 10 25p.
FNA5220 2 digit 1" 7-seg display on PCB, CC, With data £1.50.
7-seg displays: FND350, 357, 501, all 90p; 500, 947, 850, all £1.50.

Regs, TO3 cases: 7924 120p; 7805 100p; 7805 100p; 7912 100p; 78C5 230p. Others on B/L 13 Op-Amps; µA4136 130p; µA778 145p; µA777 300p; µA318 245p.
Isolators: FCD51, IL18, TIL118, all 80p.

P.C. ETCHING KIT Mk V

The best value in etching kits on the market—contains 100 sq ins copper clad board, Ferric Chloride, Etch resist pan, abrasive cleaner, two miniature drill bits, etching dish and instructions. All for £4.95.

ELECTRONICS

A NEW AND EXCITING HOBBY!!

BIG WELL ILLUSTRATED BOOK

Ideal for beginners — gives lots of general information — explains how to build lots of projects.

Projects: Radio Alarm, Radios, Organs, Parking Light etc. All parts supplied and can be removed on special deck provided.

NO SOLDERING is required. Just needs 4W battery.

£17.50 inc. VAT & Post

Also ADVENTURES WITH MICROELECTRONICS

— Explore the world of silicon chips — All components & Deck, £27.50 (inc. VAT & Post)

£17.50 inc. VAT & Post

Also ADVENTURES WITH MICROELECTRONICS

— Explore the world of silicon chips — All components & Deck, £27.50 (inc. VAT & Post)

£17.50 inc. VAT & Post

Also ADVENTURES WITH MICROELECTRONICS

— Explore the world of silicon chips — All components & Deck, £27.50 (inc. VAT & Post)

ELECTRON-KIT

Introducing our new CHIP SHOP KITS

Each **CHIP SHOP KIT** is complete in every way and contains all the components necessary to build and operate the project described. All you need is a Soldering Iron (see Kit No. 2) and a 9v battery. Each kit includes step-by-step instructions on construction and detailed educational notes about the individual circuit, together with advice about soldering techniques.

Kit No. 2—SOLDERING IRON—contains a high quality British soldering iron, a 1 Amp fuse and solder together with straightforward instructions upon how to handle your soldering iron and the best techniques for its use and maintenance.

Kit No. 3—ELECTRONICS TOOLS—contains a selection of useful tools for anyone starting in electronics, together with instructions about the use and care of your equipment.

SOLDER is included with every kit.

Kit No.	Description	Price
1 (a)	Morning Call plus	£5.00
1 (b)	Transistor Tester	
2	Soldering Iron	£5.00
3	Electronics Tools	£4.50
4	Electronic Organ	£3.50
5	Morse Code Trainer and Siren Oscillator	£4.00
6	Light Operated Burglar Alarm	£4.00
7	Buzzer—Aircraft	£3.00
8	Light and Sound Alarm	£3.00
9	Lie Detector	£3.00
10 (a)	Lamp Flasher plus	£4.50
10 (b)	Sleep Inducer	
11 (a)	Cat Sound plus	£4.50
11 (b)	Night Light Reminder	
12 (a)	Bicycle Horn plus	£5.00
12 (b)	Electronic Shocker	
13 (a)	Light Sensitive Alarm plus	£5.00
13 (b)	Electronic Lamp	
14	2-Transistor Radio	£4.00
15	Morning Alarm	£4.00
16	American Police Siren	£4.00
17	Flashing Dual-tone Horn	£3.50
18	Two-Way Interphone	£5.00
19	4-Transistor Radio	£5.00
20	Clicker—Helicopter Oscillator	£3.00

All kits packed individually in attractive boxes. Loudspeakers are included with each kit (except nos. 2, 3, 14 where they are not required).

Kit nos. 1, 10, 11, 12, 13 contain two separate projects.

These kits are becoming available in Hobby and Electronics Stores all over the Country—look out for the **CHIP SHOP DISPLAY** in your local store.

If you cannot locate a stockist please order direct from Electroni-Kit Ltd. Please add 50p per kit for postage and packing.

Trade and Educational Enquiries welcomed.

Cheque/P.O./Access/Barclaycard (or 23p for full-colour illustrated literature) to **DEPT. EECS**.

ELECTRONI-KIT LTD.
RECTORY COURT, CHALVINGTON,
E.SUSSEX, BN27 3TD (032 183 579)

SQUARE one FOR BEGINNERS

HAVING looked at the more common forms of non-polarised, fixed value capacitors last month, we now turn our attention to polarised types.

They are called polarised simply because it is essential to connect them up the correct way round as marked on the circuit diagram otherwise they will not work and may well fail with spectacular if not dangerous results.

The value of a capacitor depends on two factors—the size of the conductive plates and the nature of the dielectric. If you wish to obtain a very large value of capacitance and at the same time keep the physical size of the component manageable then it is necessary to use the dielec-

trics produced in a polarised capacitor.

Here a metal foil forms one of the plates. This is coated with an oxide which forms the dielectric. Another metal foil is separated from the first by a layer of porous paper impregnated with an electrolyte (hence the term electrolytic) and this combination forms the other plate. The action of the dielectric is maintained by making sure that the current always flows from the coated plate to the other. If this direction is reversed then the oxide layer breaks down and the component fails.

Recent advances in foil material have resulted in the tantalum capacitor becoming available.

A A selection of electrolytic capacitors. It can be seen that they are all in metal containers. This is to make construction easier as the actual casing of the capacitor often forms the negative connection. In fact this point can often be used to identify the different connections on an unknown capacitor. Remember however that there is usually a plastic coating on most capacitors for insulation purposes and some more modern electrolytics might be housed in plastic casings.

The most annoying drawback of electrolytics is their trend to instability. If one of these capacitors is left unused for a long time, it undergoes a process of deformation. Although it soon recovers when used again, it may fail if subjected to its maximum working voltage when re-used for the first time, a point worth remembering when a project doesn't work. Even "new" components may have been on the shelf some months.

On a more practical note, the tolerance of these capacitors is generally very wide, often +50, -25 per cent and the leakage current, that is the d.c. current flowing between the plates, is also high. Typical uses include smoothing in power supplies and inter-stage coupling in audio amplifiers.

Three case styles are common. The first, reserved for very high values and voltage ratings consists of a metal can with solder tags at one end as seen in the top left of the photo. Sometimes you find two or three capacitors actually inside the same container, as in this case, hence the three tags. Then there are axial types, that is with one wire coming from each end. These come in many sizes. Finally there is the radial type with both wires coming from the same end. These are often referred to as p.c.b. types. Each connection is identified as + or -. Usually only one is marked and it may be either one. Remember that the capacitor must be connected the right way round. Once again there is a trade off between value and voltage rating when it comes to case size.

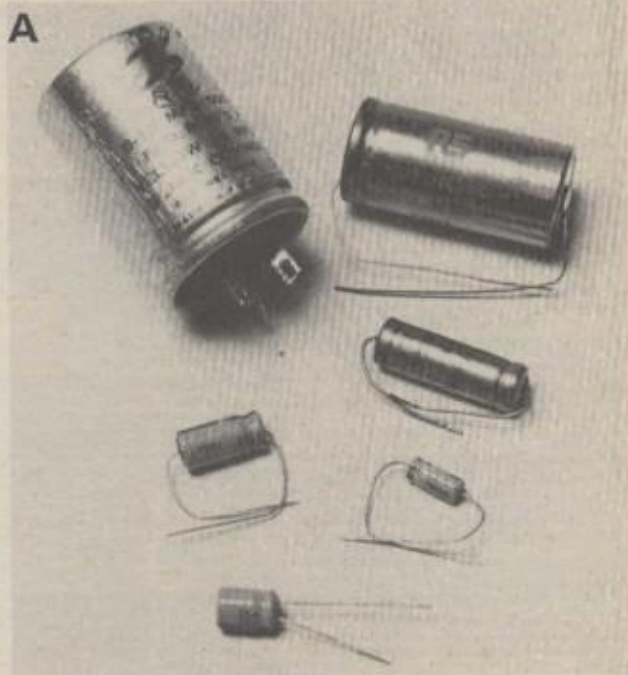

B

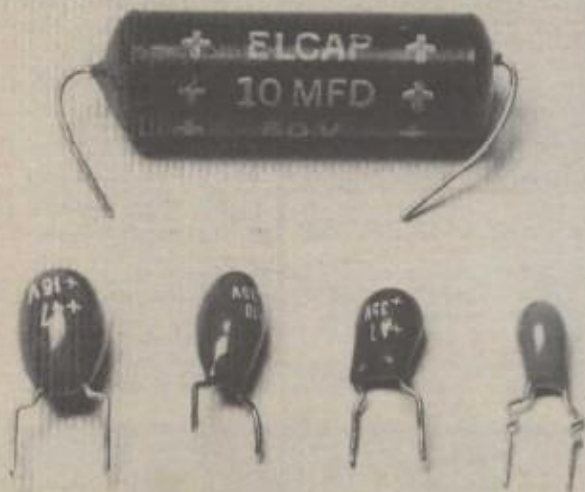

B Having said that all electrolytics have a + and - terminal and must be connected the correct way round, we can now contradict ourselves and say that in certain applications a non-polarised capacitor can be used. One of these is shown at the top of the photograph. It is distinguished by the fact that both ends are marked with + signs.

These devices differ in construction from a polarised electrolytic in that both plates inside the capacitor are made from metal foil coated with an oxide layer. These are then separated with the usual porous paper impregnated with electrolyte. Because of this construction method, non-polarised types are about twice as big as a comparable polarised type of the same value and voltage rating.

The most common application of this type of capacitor is in crossover networks for hi-fi speaker systems. These components suffer from the same tolerance and leakage problems as polarised types and are rarely used in other applications as it is possible to obtain other types of non-polarised capacitor that have the far superior leakage and tolerance characteristics necessary in other types of circuit.

Along the bottom of the photo we can see a row of tantalum bead capacitors. Although these are still polarised capacitors and therefore need connecting correctly, they offer distinct advantages over standard electrolytic types. The most striking feature is their size, the biggest being only the size of a man's little finger nail. They offer superior tolerances, typically ± 20 per cent and leakage current is less than one third of that of a comparable standard type. Of course all these advantages have to be paid for and tantalum capacitors tend to be anything up to three times the price of a comparable standard electrolytic.

COUNTER INTELLIGENCE



By PAUL YOUNG

Cheeky

Just imagine how a poor shop keeper feels after a particularly bad week, when someone enters his establishment and brightly informs him, "I have just bought this £300 music centre from Sparkos up the road, but he hasn't the right plug for it, so he sent me to you".

A few months ago I had another customer who I think would take first prize for cheek. We had a sale on at the time and as the sale items were displayed in a separate room, it was necessary just to keep an eye on them, which unfortunately stopped us working.

This particular nuisance would stand and read the books for 20 minutes and finally buy something for 10p. He would

then bring it back next day and want to change it. But it was his final effort that staggered me.

He had previously bought a small packet of bargain resistors for 20p. Next day he came in with the packet and a list of three resistors he required for a project. He asked me if I had them and I got them out. It was only then that his plan became clear. He was going to empty the packet on the counter, see if any colours matched up and if they did he knew he wouldn't have to buy them, in other words he just wanted to borrow them!!

I said to him "Why don't you buy a colour code calculator?" He asked me how much they were and I said 25p. He

then asked me the price of the three resistors, I said 18p so he said "In which case I'll take the resistors." Collapse of poor old Young!

Burning Matters

One of my many weaknesses is buying new fangled gadgets, especially if they are electronic. My automatic kettle was supposed to switch off automatically when it boiled, thus avoiding a room full of steam and finally a burnt-out element. Oh! it switched off all right, I would then heat the tea pot, put in the tea and attempt to switch it on again by pushing in the button. After almost breaking my thumb, I would give up and boil the water on the gas.

The one time I gave up completely in disgust and went away, the kettle obviously felt ashamed of itself and said, "I'm not fit to be an automatic kettle" promptly switched itself on again, filled the kitchen with steam and burnt out the element!!

Then the other day, I saw one of these new toasters that are timed with a chip. I just had to have one, I suppose Dr. Johnson would have called it, "The triumph of hope over experience." Well, I was fed up with toast that was either black or white, I've got to admit this is an improvement. My toast is now black one side and white the other. Well readers, I suggest you buy a good old fashioned toasting fork.

EVERY DOOR SHOULD HAVE ONE

As featured in E.E. May '81

Whatever kind of door you have, our New Electronic Combination Lock will enable you to open it easily but make things very difficult for unwelcome visitors. The unit, which comes complete with a 10-way keypad, requires an easily remembered 8 digit code to be entered before the door can be opened, while the intruder has over 5,000 combinations to choose from. The code can be easily changed by means of a pre-wired plug and a momentary or latched output version can be made. The kit has even more uses in a car where it may be used to disable the ignition. Another useful feature is the Save Button. This stores the combination number, enabling the car to be used by authorised persons such as garage personnel without disclosing the code. The complete kit measures 7 x 6 x 3 cms, deep and consumes a mere 45mA when not in use and will drive a 5V to 15V (750mA) solenoid or relay coil (not supplied) directly. So why not treat your door to a new lock for **ONLY £10.50** and think about all the keys you can lose or forget without ever locking yourself out.



DISCO LIGHTING KITS

Each unit has 4 channels (rated at 1KW at 240V per channel) which switch lamps to provide sequencing effects, controlled manually or by an optional opto-isolated audio input.

DL1090K
This kit features a bi-directional sequence, speed of sequence and frequency of direction change being variable by means of potentiometers. Incorporates master dimming control. **£14.00**

DL21600K
A lower cost version of the above, featuring unidirectional channel sequence with speed variable by means of a preset pot. Outputs switched only at mains zero crossing points to reduce radio interference to minimum. **£3.00**

Optional Opto Input
DLA1 80p

TRIACS

400V Plastic Case (Texas)	
3A TIC206D	48p
6A TIC206D	58p
6A TIC250D Sensitive gate	48p
12A TIC250D	55p
18A TIC248D	55p
25A TIC263D	190p
6A with trigger Q4064LT	80p
6A isolated tab TXAL225B	85p
Disc	18p

ALL COMPONENTS ARE BRAND NEW AND TO SPECIFICATION. ADD 50p P&P and 15% VAT TO TOTAL. OVERSEAS CUSTOMERS ADD £1.30 (Europe) £4 (elsewhere) for P&P.
Send s.a.s for price list and with all enquiries. Callers welcome
8.30-5.00 (Mon-Fri) 10.00-4.00 (Sat.)

TK Electronics

(EE), 11 BOSTON ROAD, LONDON W7 3SJ. TEL. 01-579 9794

ARE YOU SITTING COMFORTABLY?

Our new TDR300K Touch Dimmer Kit will ensure that you are. Based on our highly successful TD360K touch controlled dimmer kit, the TDR300K incorporates an infra red receiver, enabling the lamp brightness to be varied and switched on or off by touch or remotely by means of a small hand held transmitter.



The complete kit, which includes easy to follow instructions, will fit into a plaster depth box and the plastic front plate has no metal pads to touch, ensuring complete safety. Even a neon is included to help you locate the switch in the dark.

In years to come everyone will be selling remote control dimmers, but you can have your TDR300K kit now for **ONLY £14.20** for the dimmer unit and for **£4.20** for the transmitter. For the more athletic of you, the TD360K Touchdimmer kit is still available at **£8.50** and the TDEK Extension kit, for 2-way switching etc., is **£2.00**. **DONT FORGET** to add 50p P&P and 15% VAT to your total purchase.



NEW RIDICULOUSLY LOW PRICE FOR DVM THERMOMETER KIT

£13.50 + VAT



At this price you can use this kit in place of moving coil meters in virtually any application from bathroom scales to bicycle speedometers—the possibilities are endless.

VAMOS POWER FETS

VN10KM 0.5A, 80V (TO92)	52p
VN66AF 2A, 60V (TO220)	88p

Based on ICL7106 DVM chip and a 3 1/2 digit liquid crystal display. This kit will form the basis of a digital multimeter—only a few additional switches and resistors required (details supplied) or make a sensitive digital thermometer (-50° to 150°C) reading to 0.1°C. The basic kit has a sensitivity for full scale of 200mV, automatic polarity and runs from a 9V PP3 battery.

D.I.L. I.C. SOCKETS

8 pin	8p	18 pin	17p
14 pin	12p	20 pin	24p
18 pin	14p	40 pin	36p
Soldercon Pins			50p/100

INTEGRATED CIRCUITS

555 Timer	21p
741 Op Amp	19p
AY-5-1224 Clock	£2.60
AY-5-1230 Clock/Timer	£4.50
AY-3-1270 Thermometer	£8.20
CA3080 Transconductance Op. Amp.	72p
CA3130 CMOS Op. Amp.	75p
CA3140 CMOS Op. Amp.	49p
ICL7106 DVM (LCD Drive)	£7.00
LM377 Dual 2W Amp.	£1.45
LM375 Dual 5W Amp.	£3.50
LM330 2W Audio Amp.	80p
LM332 Dual low noise pre amp.	£1.00
LM386 250mW low voltage amp.	75p
LM1830 Fluid level Detector	£1.50
LM2917 F/V Converter (14 pin)	£1.60
LM3908 LED Flasher/oscillator	40p
LM3931 Thermometer	£1.50
LM3914 Dot/Bar Driver (linear)	£2.10
LM3915 Dot/Bar Driver (log)	£2.20
MM74C911 4-digit Display Controller	£6.90
MM74C926 4-digit counter with segment output	£4.50
S55682 Touchdimmer	£2.50
SL440 AC Power Control	£1.75
SN70477 Complex Sound Generator	£2.52
TBA805 5W Audio Amp.	98p
TBA810AS 7W Audio Amp.	£1.60
TCM7555 CMOS 555 Timer	70p
TDA 1024 Zero Voltage Switch	£1.20
TDA2020 20W Audio Amp	£1.98
TDA4900 D.C. Controlled Pre-amp.	£1.98
TL081 J-FET Op. Amp.	37p
TL084 Quad J-FET Op. Amp.	£1.90
TL082 Dual J-FET Op. Amp.	40p
TMS1121 Clock/7 day timer	£9.50
TMS1121 Data	50p
ZN1004E Timer	£1.80
ZN414 AM Radio	95p
All ICs supplied with Data Sheets	
Data Sheets only—per device	
10p	

CIRCUIT EXCHANGE

OPTO-ALARM ADDITION FOR INTRUDER ALARM

I built the intruder alarm published in your magazine (May 1979) and it proved highly successful. With this circuit, it can also be used as a very sensitive opto-alarm, as well as the loop switches. No modification is necessary to the original unit, the new wiring being connected to the parallel loop. The light source can be powered by battery, or from the intruder alarm power supply. The light source and PCC1 should be shielded from ambient light (mine were mounted inside two cigar tubes).

From the diagram, it can be seen that PCC1, R1 and VR1 form a potential divider chain. VR1 "trims" R1. With PCC1 illuminated from the light source, it exerts a low resistance; since this is lower than R1 and VR1 combined, the transistor does not conduct. Should the light beam be broken, PCC1 will then have a very high resistance, allowing current

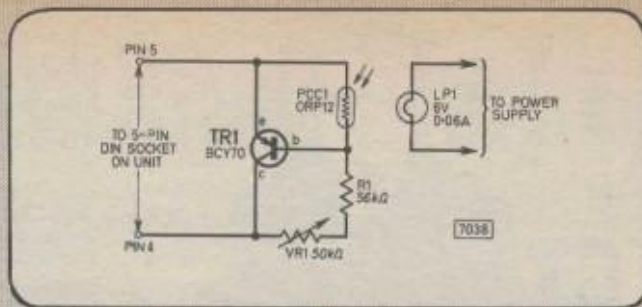

flowing through R1 and VR1 to turn TR1 on. The transistor then effectively "shorts" across the two terminals (4 and 5) "closing" the

normally open loop, and so sounding the alarm.

Paul Hemingway
Hull, North Humberside.

ZX80 P.S.U. IMPROVEMENT

My circuit should help to prevent the very common ZX80 fault of over heating. Many of your readers with a ZX80 may have problems with loading and saving due to the main circuit board getting too hot. The heat comes from the voltage regulator, the heat-sink fitted can't disperse all the heat so it heats up the board.

The computer needs about 10 volts, my Sinclair p.s.u. supplied 18 volts. The resistance needed to reduce the voltage can be calculated, in practice a resistance of 10Ω works best.

One watt resistors were used in the circuit but got rather hot. A strip of aluminium foil was placed around the ceramic area of the resistor R1 to help keep it cool. If 3 watt resistors are to hand they can be used. Of

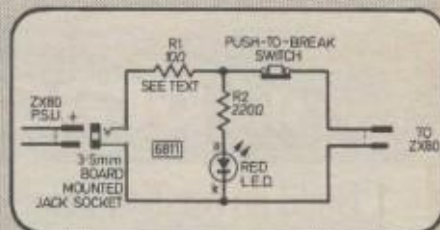

course resistors with integral heat-sink would be ideal, these are rather expensive.

A normal 0.2in red l.e.d. was used to show when the ZX80 is on. All the components were mounted on 0.1in stripboard. A push to break switch was mounted to allow instant clearing of memory.

A. R. Jones,
Loughborough,
Leicester.

CRYSTAL EARPIECE AMPLIFIER

I have designed a crystal earpiece amplifier. The circuit is connected to the crystal earpiece output socket of a piece of equipment and the gain of the transistor TR1 was found sufficient to drive a small loudspeaker via the output transformer.

The circuit could be used in many other projects, including the output stage of a simple radio tuner.

P. Patel,
Hornchurch,
Essex.

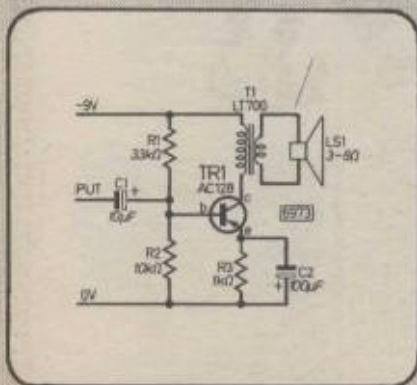

12V TO 9V CONVERTER WITH OVERLOAD PROTECTION

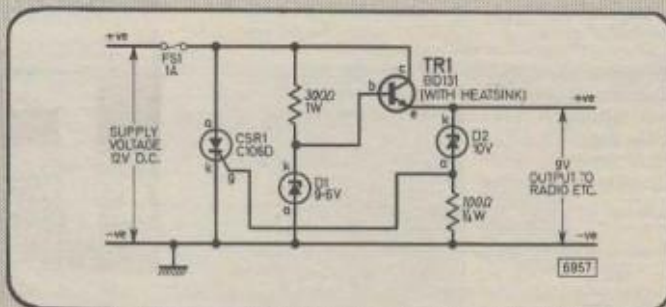

I enclose a circuit diagram for a simple device I built to step down the 12V d.c. supply from a car battery to 9V d.c., often used by portable radios. This is very useful for people who own cars with no installed radio, and also for campers.

It is a very simple circuit, which as well as stepping the voltage down, also blows the fuse FS1 if anything goes wrong with the rest of the circuit; this pre-

vents the load from becoming damaged.

M. D. Farrimond,
Eaton, Norwich.

CIRCUIT EXCHANGE

LOOK!

Here's how you master electronics.

.... the practical way.

This new style course will enable anyone to have a real understanding by a modern, practical and visual method. No previous knowledge is required, no maths, and an absolute minimum of theory.

You learn the practical way in easy steps mastering all the essentials of your hobby or to further your career in electronics or as a self-employed electronics engineer.

All the training can be carried out in the comfort of your own home and at your own pace. A tutor is available to whom you can write, at any time, for advice or help during your work. A Certificate is given at the end of every course.

1. Build an oscilloscope.

As the first stage of your training, you actually build your own Cathode ray oscilloscope! This is no toy, but a test instrument that you will need not only for the course's practical experiments, but also later if you decide to develop your knowledge and enter the profession. It remains your property and represents a very large saving over buying a similar piece of essential equipment.

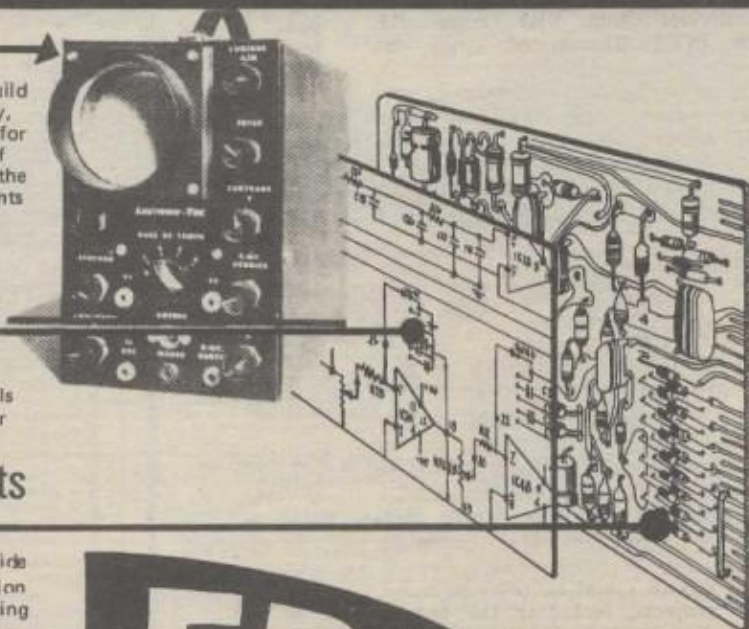

2. Read, draw and understand circuit diagrams.

In a short time you will be able to read and draw circuit diagrams, understand the very fundamentals of television, radio, computers and countless other electronic devices and their servicing procedures.

3. Carry out over 40 experiments on basic circuits.

We show you how to conduct experiments on a wide variety of different circuits and turn the information gained into a working knowledge of testing, servicing and maintaining all types of electronic equipment, radio, t.v. etc.

4. Free Gift.

All students enrolling in our courses receive a free circuit board originating from a computer and containing many different components that can be used in experiments and provide an excellent example of current electronic practice.

FREE

Post now, without obligation, to:-

BRITISH NATIONAL RADIO & ELECTRONICS SCHOOL

4, Cleveland Road, St. Helier, Jersey, Channel Islands.

NAME _____

ADDRESS _____

EE/8/81

Block caps please

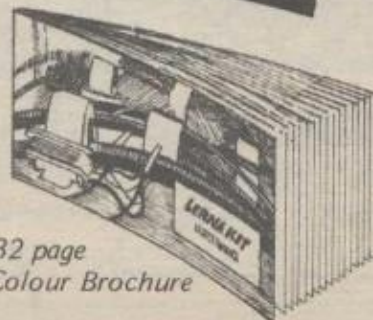

32 page
Colour Brochure

For
your
FREE
Catalogue
Send 30p to cover P&P

NEW DISTRIBUTORS WANTED

A fascinating new range of micro electronic Hobby Kits designed to bring the silicon chip into play! Using all the carefully selected electronic components* with our easy to follow step by step instructions, each kit builds into a different and absorbing game that fits into the original case.

Morse Code
Got the message?
Build this kit and you can send them!
Full morse alphabet enclosed

Quick Reaction
It's the fastest draw in the West -
Move at the speed of light!
Cheats are shown up!

Electronic Dice
Flashing Dice - a game of nerves
Throw a switch to win!

Digital Roulette
Monsieur et Madame -
place your bets -
your numbers up.



Telephone Amplifier
When everyone wants to listen!



Electronic Organ
Maestro of the keyboard - with
this kit you really do make the
music. A full scale to compose on.

ELECTROWARE*
SUTTON LANE, EASTLEIGH, S05 4AA TEL 0703610944/5

AVAILABLE FROM ALL LEADING ELECTRONIC DISTRIBUTORS

Cobbles Ltd.
London, 01-699-2282

Microdigital Ltd.
Liverpool, 051-227-2535

Electronic C.G. Ltd.
Manchester, 061-788-0656

Spectran Electronics (Manchester) Ltd.,
Salford, 061-834-4583

Jee Distribution Ltd.,
Middlesex, 01-897-3429

Wofford Electronics Ltd.,
Wofford, 0923-37774

Technomatic Ltd.,
London, 01-452-1500

New Bear Computing Store Ltd.,
Newbury, 0635-30505

Transam,
London, 01-402-8137

A. Marshall (London) Ltd.,
London, 01-624-0805

Interface Components Ltd.,
Amersham, 02403-22307

* A DIVISION OF OK MACHINE & TOOL CO. LIMITED



Wilmslow Audio

THE firm for speakers!

SEND 50p FOR THE WORLD'S BEST CATALOGUE OF SPEAKERS, DRIVE UNITS, KITS, CROSSOVERS ETC. AND DISCOUNT PRICE LIST

AUDAX ● AUDIOMASTER ● BAKER
BOWERS & WILKINS ● CASTLE
CELESTION ● CHARTWELL ● COLES
DALESFORD ● DECCA ● EAGLE ● ELAC
EMI ● FANE ● GAUSS ● GOODMAN'S
HARBETH ● ISOPHON ● I.M.F. ● JORDAN
JORDAN WATTS ● KEF ● LOWTHER
McKENZIE ● MISSION ● MONITOR AUDIO
MOTOROLA ● PEERLESS ● RADFORD
RAM ● ROGERS ● RICHARD ALLAN
SEAS ● SHACKMAN ● TANNOY
TANGENT ● VIDEOTONE ● WHARFEDALE

WILMSLOW AUDIO LTD. (Dept. EE)

35/39 CHURCH STREET, WILMSLOW,
CHESHIRE SK9 1AS

Tel: 0625-529599 FOR MAIL ORDER & EXPORT OF DRIVE UNITS, KITS ETC.

Tel: 0625-526213 (SWIFT OF WILMSLOW) FOR HI-FI & COMPLETE SPEAKERS

ELECTRONIC IGNITION SAVES PETROL



More and more new cars use electronic ignition to give the best performance and economy. Bring YOUR CAR up to top specification by fitting the latest TOTAL ENERGY DISCHARGE electronic system.

TOTAL ENERGY DISCHARGE gives all the advantages of the best capacitive discharge ignitions:

- ★ **Peak Performance**—higher output voltage.
- ★ **Improved Economy**—consistent high ignition performance.
- ★ **Better Starting**—full spark power even with low battery.
- ★ **Accurate Timing**—prevents contact wear without 'contactless' errors.
- ★ **Smooth Performance**—immune to contact bounce effects.

PLUS

SUPER HIGH POWER SPARK— $\frac{3}{4}$ times the energy of ordinary C.D. systems.

OPTIMUM SPARK DURATION—to get the very best performance and economy with today's lean carburettor settings.

DESIGNED IN RELIABILITY—with the 'ultimate insurance' of a change-over switch to revert instantly to standard ignition.

TECHNICAL DETAILS

HIGH EFFICIENCY INVERTER. A high-power, high efficiency, regulated inverter provides a 400-volt energy source—powerful enough to store twice the energy of other designs and regulated to provide full output even with the battery down to 4 volts.

SUPERB DISCHARGE CIRCUIT. A brand new technique prevents energy being reflected back to the storage capacitor, giving $\frac{3}{4}$ times the spark energy and 3 times the spark duration of ordinary C.D. systems, generating a spark powerful enough to cause rapid ignition of even the weakest fuel mixtures without the ignition delay associated with lower power 'long burn' inductive systems. In addition this circuit maintains the correct output polarity, thereby preventing unnecessary stress on the H.T. system.

SOPHISTICATED TRIGGER CIRCUIT. This circuit removes all unwanted signals caused by contact volt drop, contact shuffle, contact bounce, and external transients which, in many designs, can cause timing errors or damaging un-timed sparks. Only at the correct and precise contact opening is a spark produced. Contact wear is almost eliminated by reducing the contact breaker current to a low level—just sufficient to keep the contacts clean.

IN MONEY-SAVING KIT FORM at £14.85

ALSO MOTORCYCLE TWIN OUTPUT KIT £21.94 Plus £1 U.K. P.&P. All you need is a small soldering iron and a few basic tools — everything else is supplied with easy-to-follow instructions.

FITS ALL 6/12 volt NEGATIVE EARTH vehicles



ELECTRONIZE DESIGN
2 Hillside Road, Four Oaks
Sutton Coldfield, West Midlands, B74 4DQ
Phone 021-308 5877



ELECTRONIC GAMES

COLOUR CARTRIDGE T.V. GAME



SEMI-PROGRAMMABLE T.V. GAME
• 4 Cartridges + Mains Adaptor
Normal Price £73
NOW REDUCED TO: £39.50 (inc. VAT)

DATABASE T.V. GAME



FULLY PROGRAMMABLE CARTRIDGE T.V. GAME
14 Cartridges available
Normal Price £87.85
NOW REDUCED TO: £59 (inc. VAT)

ATARI T.V. GAME



The most popular T.V. Game on the market with a range of over 40 cartridges including SPACE INVADERS with over 112 games on one cartridge.
£95.45 (inc. VAT)

SPACE INVADERS



Hand-held Invaders Games available £19.95
• Invaders Cartridges available to fit ATARI/RADOFIN/ACTRONIC/PHILIPS G7000
• Cartridges also available for MATTEL/TELENG/ROWTRON/DATABASE/INTERTON

CHESS COMPUTERS



MANY UNITS ARE COVERED BY THE EXCLUSIVE SILICA SHOP 2-YEAR GUARANTEE

We carry a range of over 15 different Chess computers:

Electronic Chess £29.95
Chess Traveller £39.95
Chess Challenger 7 £79.00
Sensory 8 £119.00
Sensory Voice £259.00

SPECIAL OFFERS:
VOICE CHESS CHALLENGER
Normal Price £245 NOW £135.00
SARGON 2.5/BORIS 2.5
Normal Price £273.70 NOW £199.95
All prices include V.A.T.

TELETEXT



ADD-ON ADAPTOR £199

THE RADOFIN TELETEXT ADD-ON ADAPTOR

Plug the adaptor into the aerial socket of your colour T.V. and receive the CEEFAX and ORACLE television information services

THIS NEW MODEL INCORPORATES:

- Double height character facility
- True PAL Colour
- Meets latest BBC & IBA broadcast specifications
- Push button channel change
- Unnecessary to remove the unit to watch normal TV programmes
- Gold-plated circuit board for reliability
- New SUPERIMPOSE News Flash facility

SPEAK & SPELL



Normal Price £49.95
NOW REDUCED TO: £39.50 (inc. VAT)

Teach your child to spell properly with this unique learning aid. Fully automatic features and scoring. Additional word modules available to extend the range of words.

ADDING MACHINE OLYMPIA HHP 1010



Normal Price £57.21
NOW REDUCED TO: £34 (inc. VAT)

Uses ordinary paper! No need to buy expensive thermal paper!
Fast add listing PRINTER-CALCULATOR 2 lines per second, 10 digit capacity.
Users normal adding machine rolls. Battery or mains operated.
Size 9 1/2" x 4 1/2" x 2 1/2"
(Maine selector panel)

24 TUNE ELECTRONIC DOOR BELL



Normal Price £19.70
NOW REDUCED TO: £12.70 (inc. VAT)

Plays 24 different tunes with separate control and volume control. Select the most appropriate tune for your visitor, with appropriate tunes for different times of the year!

MATTEL T.V. GAME



The most advanced TV game in the world 20 cartridges available. Also on KEYBOARD gaming. £199.95 (inc. VAT)
MATTEL to a home computer with 16K RAM. Fully expandable and programmable in Microsoft Basic. Other accessories will be available later in the year.

HAND HELD GAMES EARTH INVADERS



These invaders are a breed of creature hitherto unknown to man. They cannot be killed by traditional methods — they must be buried. The battle is conducted in a maze where squads of alien chase home troops. The only way of alternating them is by digging holes and burying them.
£23.95 (inc. VAT)

HAND HELD GAMES GALAXY 1000



The 2nd generation Galaxy Invader. The invaders have re-grouped and have a seemingly endless supply of spacecraft whilst the player's arsenal is limited to just 250 missiles to be launched from 3 missile stations. You have to prevent the invaders landing on earth from destroying your home defences.
£19.95 (inc. VAT)

THE OLYMPIA — POST OFFICE APPROVED TELEPHONE ANSWERING MACHINE WITH REMOTE CALL-IN BLEEPER

This telephone answering machine is manufactured by Olympia Business Machines, one of the largest Office Equipment manufacturers in the UK. It is fully POST OFFICE APPROVED and will answer and record messages for 24 hours a day. With your remote call-in bleeper you can receive these messages by telephone wherever you are in the world. The remote call-in bleeper activates the Answer/Record Unit, which will at your command repeat messages, keep or erase them, and is activated from anywhere in the world, or on your return to your home or office. The machine can also be used for message referral, if you have an urgent appointment, but are expecting an important call, simply record the 'phone number' and location where you can be reached. With optional extra beepers (£13 each) this facility can be extended to colleagues and members of the family. Using a C90 standard cassette you can record as many as 45 messages. The announcement can be up to 16 seconds long and the incoming message up to 30 seconds long.



£135 (inc. VAT)

PRESTEL VIEWDATA



The ACE TELCOM VDX1000 Prestel Viewdata adaptor simply plugs into the aerial socket of your television and enables you to receive the Prestel-Viewdata service in colour or black & white.

- Features:
- Simplified controls for quick, easy operation
 - Special graphics feature for high resolution
 - State-of-the-art microprocessor control
 - Standard remote telephone keypad with Prestel only 'A' - 'Z'
 - Auto dialler incorporated for easy Prestel acquisition
 - True PAL colour encoder using satellite IC — chroma filter and data line incorporated for minimum picture interference maximum fidelity
 - Includes convenient TV — Prestel switchover
 - Easily connected to standard home or office telephone lines
 - Fully Post Office approved

SPECIAL PRICE £228.85 (inc. VAT)

FOR FREE BROCHURES — TEL: 01-301 1111



For free brochures and details on our range of electronic games, please telephone 01-301 1111. Free delivery service available. To order by telephone please quote a full home address and ACCESS/BARDLAY/CARD number, and leave the rest to us. Post and packing Free of Charge. CALLERS WELCOME. — Open every day of our Sidcup shop, open from Sun-Sun, Monday-Saturday (Sole Closing Thursday, 1pm — Late Opening Friday 6pm) 2-YEAR GUARANTEE — All goods are covered by a full year's guarantee and many are further covered by our exclusive Silica Shop 2-Year Guarantee.
MONEY BACK UNDERSTANDING — If you are unsatisfied with your purchase and return it within 7 days we will give you a full refund.
AFTER SALES SERVICE — available on all machines out of guarantee.
COMPETITIVE PRICES — We are keen to serve you best.
HELPFUL ADVICE — Available on the suitability of each machine.
CREDIT FACILITIES — Full range facilities available over 12, 24 or 36 months at competitive rates of interest.
PART EXCHANGE SCHEME — available on second-hand machines.
CREDIT CARDS WELCOME — Access Barclaycard, Direct Card, American Express.

SILICA SHOP LIMITED EE B
1-4 The Mews, Hatherley Road, Sidcup, Kent DA14 4DX
Telephone: 01-301 1111 or 01-309 1111



If you're into MICROPROCESSORS then they should be into an MP UroBreadBoard

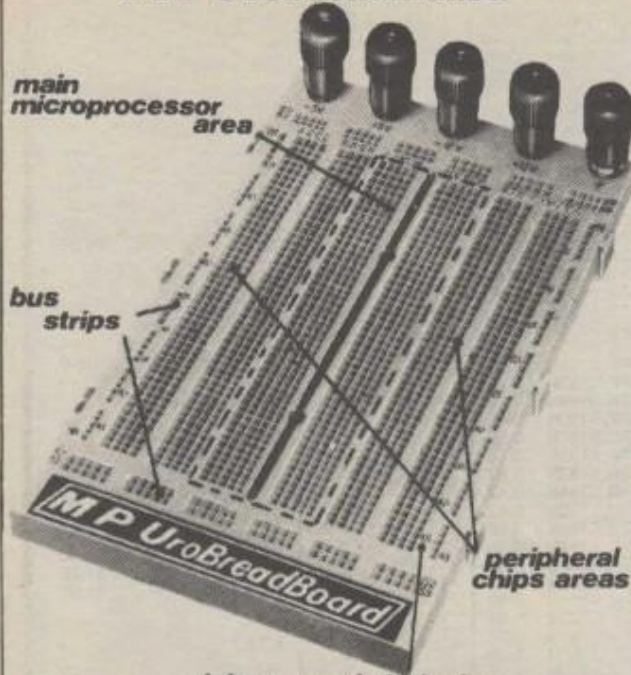

- * MPU Section accepts 24, 28, 40 & 64 pin DIL microprocessors
- * Auxiliary Areas accept any .3" or .6" RAM, ROM or peripheral chip
- * Power Bus Strips on all sides
- * 5 incoming turret Power Terminals
- * Component Support Bracket included
- * Over 1400 contact points
- * Alpha-Numeric column and row indexing
- * Eurocard size (160mm x 100mm)
- * Slots onto all BIMBOARDS
- * Non-Slip rubber backing
- * Ideal for schools and colleges
- * Long life, < 10m.ohms, nickel silver contacts

The PROFESSIONALS breadboard that BEGINNERS can start on

BOSS INDUSTRIAL MOULDINGS LTD

2 Herne Hill Rd, London SE24 0AU, England
Telephone 01-737 2383 Telex 919693
Cables & Telegrams: LITZEN LONDON SE24

Please send me . . . MPUroBreadBoard(s) @ £18.
This price includes VAT & PP, is applicable from Mar. 1, '81, but please add 15% for Overseas Orders, make cheques/P.O. payable to BOSS Industrial Mouldings Ltd and allow 10 days for order processing and cheque clearance etc.

I enclose a cheque/P.O. to the value of £.....

Name

Company

Address

Telephone Number

EE/8/81

INTERESTED IN ELECTRONICS?

TRY A ZEDPACK!
COMPONENTS AT A PRICE
EVERYONE CAN AFFORD

- Z1 300 mixed 1/2 and 1 watt resistors £1.95
 - Z2 150 mixed 1/2 and 1 watt resistors £1.95
 - Z3 300 mixed capacitors £2.95
 - Z4 100 mixed electrolytics £2.20
 - Z5 100 mixed polystyrene caps £2.20
 - Z6 300 mixed printed circuit components £1.95
 - Z7 300 mixed printed circuit resistors £1.45
 - Z9 100 mixed miniature ceramic and plate caps £1.20
 - Z10 25 assorted pots. £1.50
 - Z11 25 assorted presets, skeleton etc. £1
 - Z12 25 assorted vdr's and thermistors £1.20
 - Z13 11b mixed hardware. Nuts, bolts self-tappers, sleeving, etc. £1.20
 - Z14 100 mixed, new and marked, full spec. transistors. Pack includes:— BC148, BF154, BF274, BC212L, BC238, BC184L, PBC100 and, or lots of similar types £4.95
 - Z15 100 mixed diodes including:—zener, power, bridge, signal, germanium, silicon etc. All full spec. £4.25
 - Z16 20 1N4148 £1
 - Z17 20 1N4003/10D2 £1
 - Z18 20 zeners, 1 watt and 400mw £1.50
 - Z19 12 - 125" TIL 200 RED. LED'S £1
 - Z20 10 Assorted switches, including push button, slide, multipole, miniature etc. Fantastic value. £1.20.
- UHF MODULATORS**
Video in UHF out. Calibrated to channel 30 (625 line UHF) housed in metal box 2 1/2" x 2" x 1" with 9' coaxial lead, TV plug and connection data. £2.50 ea. 3 for £6.
Aluminium finish slider Anobs, standard fitting. 10 for £1
300µA Miniature level/batt. meters, as fitted to many cassette recorders. 50p
Deluxe FIBREGLASS printed circuit etching kits.
Includes 100 sq ins. of copperclad F/G board, 1lb ferric chloride, (made for U.S. army to MIL, SPEC.), 1 diao etch resist pen, abrasive cleaner, tweezers, etch resist dish and instructions. OUR PRICE £5.95
1lb of FeCl₃ £2.25.
100 Miniature reed switches. £3.20
100 Subminiature Reed Switches. £4.20

To: "GEMINI ELECTRONIC COMPONENTS" DEPT EE
"THE WAREHOUSE" SPEEDWELL ST. LONDON S.E.8.
Where shown. Send Cheque* or Postal Order. Plus 80p P&P, and 15% VAT.
Please Quote ZED Code. *Scholes etc. SEND OFFICIAL ORDER
ZED PACKS now available for Callers at 50 Deptford Broadway, London, S.E.8.

10,000uf. 35v Tag ended. 20" x 10" diam. with fixing stud and nut. High quality. £1 each, 3 for £2.50.

SMALL MAGNETS 8 for £1
With hole in

P/B SWITCH BANKS
These cost a fortune! Were made for various music centres. Includes independent and interdependent latching types multi pole etc etc. Can be modified. Can't be repeated. 2 Banks for £1. **KNOBS** for Switch Banks 10 for £1. Chrome or spun aluminium finish.

MINIATURE MAINS TRANSFORMERS
Top quality. Split bobbin construction will give 4.5V-0-4.5V at 250MA, 1 1/2" x 1 1/2" x 1 1/2", all sorts of uses. ONLY £1. 3 for £2.50.

PP3 Battery Connectors 10 for 50p.
Miniature Press to Make Switches, Red knob, 3 for 50p.

Subminiature S.P.C.O. Slide Switches. 8 for 50p.

Miniature D.P.C.O. Slide Switches. 8 for 50p.

Standard 2P. 3 Position Slide Switch. 4 for 30p.

Loudspeaker, 2 1/2" Round 8Ω. 60p ea. 3 for £1.50.

Assorted Fuse Holders including 20mm, P.C., Panel and chassis types. Pack of 7 for 50p.

3.5mm Jack Sockets, switched. Enclosed type. P.C. or panel mounting. With nuts and washers. 4 for 50p.

9 Section, Chrome on Brass Telescopic Aerial. Plugs into any 3.5mm socket. Approx 25" extended £1 each, 3 for £2.50.

Hi Power Infra. Red Transmitter 5mm LED. TIL 30 50p ea. 3 for £1.50.

Crystal Clear 3mm LEDs very pretty Red, Green, Yellow. 10 of one colour £1. 10 of each £2.50.

ALTERNATOR RECTIFIERS
Make lovely 60 amp bridges, ideal for High Power Battery Chargers. Type 4AFI. Set of 4 (2 neg. case + 2 pos. case) £2.

Special Purchase enables us to offer Mullard C266 Polyester Capacitors (Liquorice Allsorts) at the unbelievable price of £2 for 100 mixed. These consist of factory clearance lots i.e. soiled, floor sweepings, cosmetic rejects etc. Also Mullard miniature electrolytics 100 mixed £2.

Rapid Electronics

HILLCROFT HOUSE, STATION ROAD, EYNSFORD, KENT.

TRANSISTORS				LINEAR				
AC128 25	*BC182L 8	BD140 35	*741 15	LM380 80	NE555 55	CA3046 80	LM381 120	RC4155 50
AC176 25	*BC184L 7	ZTX300 14	CA3090 70	LM392 120	SN75477 150	*CA3130 75	LM455 40	TLO81 40
AD181 40	BC212L 10	2N2645 45	CA3140 45	LM3900 50	TLO84 110	BC107 10	BC247 10	2N3055 23
AD182 40	*BC214L 8	2N3053 23	*ICM7555 80	*LM3914 200	XR200 200	*BC108 8	BD131 35	2N3055 50
BC107 10	BC247 10	2N3055 50	LF351 45	*LM3915 200	ZN414 100	*BC108C 10	BD132 35	*2N3702 6
*BC108 8	BD131 35	2N3055 50	LF356 80	LM13600 120	ZN425E 200	*BC109 10	BD135 35	*2N3704 6
*BC109C 10	BD132 35	*2N3702 6	*LM324 40	NE555 17	TB480 30			
BC109 10	BD135 35	*2N3704 6						
CAPACITORS				CONNECTORS				
Polyester. Radial leads. C280 type. 0.01, 0.015, 0.022, 0.033, 50p; 0.047, 0.1, 70p; 0.15, 0.22, 50p; 0.33, 0.47, 130p; 1.0, 25p. Electrolytic. Radial leads. 1.63V, 2.2/25V, 4.7/33V, 10/25V, 70p; 22/25V, 47/25V, 80p; 100/25V, 50p; 220/25V, 14p; 470/250V 20p; 1000/25V, 28p.				Jack Plug skt. 2 pin 9p 9p 3.5mm 18p 9p 3 pin 12p 16p *Stand'rt 2p 15p 5 pin 180 13p 11p				
COMPONENT KITS				SUPER				
1W Resistor kit. Contains 10 of each value from 4.7Ω to 1M (650 resistors). 48p each. Ceramic capacitor kit. Contains 5 of each value 22pF to 0.01µF (135 caps.). 37p each. Polyester Capacitor kit. 5 of each value from 0.01 to 1µF (65 capacitors). 57p each. Nut and Bolt Kit. Total 300 items. 140p each. 25 6BA 1/2" bolts 25 4BA 1/2" bolts 25 8BA 1/2" bolts 25 4BA 1/2" bolts 50 8BA washers 50 4BA washers 50 8BA nuts 50 4BA nuts				All items marked * are our Summer Savers for '81. Send 28p in stamps for catalogue (free with orders over £3). Prices exclude VAT. Please add 50p carriage.				
SWITCHES				OPTO				
Subminiature toggle SPST 50p *DPDT 50p Standard toggle *SPST 25p DPDT 48p Slide switches DPDT *Miniature 10p Standard 18p Rotary switches 1P12W, 2P6W, 3P4W, or 4P3W 50p ea. Push to make 18p. Push to break 22p.				*3mm red 7p *3mm green 12p Size 0-1in. Matrix 3mm yellow 14p 2.5 x 1" 22p *5mm red 9p 2.5 x 3.75" 75p *5mm green 12p 2.5 x 5" 85p 5mm yellow 14p 3.75 x 5" 85p 10.3 or 5mm LED clips 30p Single sided 50p *FND500 70p Double sided 60p				
SOCKETS				BOXES				
*8 pin 7p Aluminium. With lid + screws. *14 pin 9p *16 pin 10p 3" x 2" x 1" 70p 100 Soldercon 4" x 3" x 1" 85p pins 45p 6" x 3" x 2" 100p 6" x 4" x 2" 120p								

★ Same day despatch ★ Competitive prices
★ Top quality components ★ In-depth stock

A PROFESSIONAL TOOLCASE FOR UNDER £40

Designed for the professional Electronics, T.V or Instrument Technician who needs to carry a large number of specialist tools.

The TL99 sets a standard as a low cost alternative to more expensive cases. It offers strength with a practical use of space and many other features.



Features

- 2 sided Reversible Multi-purpose tool pallet
- Document area
- 90° opening lock back stays
- 3" deep ABS lid and base
- Twin handles with 8 fixing points on aluminium frames
- Burst proof toggle locks with keys
- Moulded adjustable tray in base
- Heat sink for hot soldering iron

Dimensions TL 99 17" x 12" x 6" split (shown)

also available TL100 19" x 14" x 6" split

Tools NOT included. British made.

Money back guarantee. Allow 7-21 days for delivery.

Telemat Products Ltd, Ermine House, Post St, Godmanchester, Cambs. PE 18 8BA

Order Form

Telemat Products Ltd
Ermine House, Post St, Godmanchester, Cambs. PE 18 8BA (0480) 655334

Please send TL99 Professional Toolcases at £39.90 each.
also available TL100 Professional Toolcases at £43.70 each.
Both inc. VAT (P&P £2.60 extra)

Enclosed my cheque for £
Name
Company
Address

EE 7

MAIL ORDER ADVERTISING

British Code of Advertising Practice

Advertisements in this publication are required to conform to the British Code of Advertising Practice. In respect of mail order advertisements where money is paid in advance, the code requires advertisers to fulfil orders within 28 days, unless a longer delivery period is stated. Where goods are returned undamaged within seven days, the purchaser's money must be refunded. Please retain proof of postage/despatch, as this may be needed.

Mail order Protection Scheme

If you order goods from Mail Order advertisements in this magazine and pay by post in advance of delivery, EVERYDAY ELECTRONICS will consider you for compensation if the Advertiser should become insolvent or bankrupt, provided:

- (1) You have not received the goods or had your money returned; and
- (2) You write to the Publisher of EVERYDAY ELECTRONICS summarising the situation not earlier than 28 days from the date you sent your order and not later than two months from that day.

Please do not wait until the last moment to inform us. When you write, we will tell you how to make your claims and what evidence of payment is required.

We guarantee to meet claims from readers made in accordance with the above procedure as soon as possible after the Advertiser has been declared bankrupt or insolvent.

This guarantee covers only advance payment sent in direct response to an advertisement in this magazine not, for example, payment made in response to catalogues, etc., received as a result of answering such advertisements. Classified advertisements are excluded.

PM COMPONENTS LTD

VALVE & COMPONENT SPECIALISTS
CONINGSBY HOUSE, WROTHAM RD.,
MEOPHAM, KENT. Dept. EE

VALVES	PL500	1-48	9090	4-20	BC214	0-09	BU105	1-30
DY86	PL509	2-30	9146B	4-45	BC214L	0-09	BU200	1-30
DY802	PL802	2-50	7025	1-30	BC227	0-09	BU200A	1-52
E100F	PY788	0-74	7380	7-50	BC235	0-09	IAJ2340	0-48
EABC90	PY306A	1-35	7591	2-35	BC207	0-09	OC71	0-22
EBF80	PY801	0-85			BC327	0-10	R2008B	1-70
ECC81	QV002/6	10-50			BC337	0-10	R2010B	1-70
ECC82	QV003-20A				BC461	0-30	R2540	2-48
ECC83		12-23	AC126	0-22	BC478	0-20	TIP89	0-40
ECC85	QV06-40A		AC127	0-22	BC547	0-10	TIP29C	0-45
ECC88		12-95	AC128	0-28	BC548	0-10	TIP30C	0-40
ECC207	QV09-12	3-50	AC141K	0-34	BC549A	0-08	TIP31C	0-42
ECF80	TY2-125A	45-00	AC176	0-22	BC567	0-07	TIP32C	0-42
ECF82	U10	11-95	AC178K	0-31	BC558	0-07	TIP41C	0-45
ECH81	UCH81	0-85	AC187	0-26	BD131	0-32	TIP42C	0-47
ECL82	UCL82	0-78	AC187K	0-33	BD132	0-35	TIP47	0-65
ECL83	ULM	0-78	AC188	0-22	BD133	0-40	TIP268B	0-84
ECL86	UY85	0-70	AD149	0-79	BD135	0-30	TIP365B	0-60
EF37A	Z759	0-80	AD181	0-39	BD136	0-30	TIS91	0-20
EF80	ZD21	0-85	AD181/2	1-84	BD137	0-28	2N3054	0-59
EF86	ZK25	10-00	AD182	0-39	BD138	0-30	2N3055	0-59
EF88	4CX250B	28-00	AF127	0-32	BD139	0-32	2N3702	0-12
EF91	SU4G	0-85	AF139	0-42	BD140	0-30	2N3703	0-12
EF93	8CD8GA	4-00	AF239	0-42	BD144	1-30	2N3704	0-12
EF94	8GK8	2-30	BC107	0-16	BF115	0-35	2N3705	0-12
EF99	6J6	0-85	BC107B	0-16	BF167	0-24	2N3706	0-12
EF183	6J58C	2-35	BC109	0-18	BF179	0-34	2N3708	0-12
EF184	8KD6	2-35	BC108C	0-18	BF180	0-20	2N5294	0-38
EL34	6L6GC	1-75	BC109B	0-19	BF183	0-29	2N5296	0-48
EL84	8LD20	0-80	BC140	0-21	BF194	0-11	2N5298	0-38
EM64	8SN7GT	0-80	SC141	0-25	BF195	0-11	2SC1308	1-25
EZ20	8V6GT	0-90	BC182	0-21	BF198	0-11	2SC1307	1-25
EZ87	787	3-80	BC143	0-24	BF197	0-11		
G232	12AT7	0-55	BC147	0-06	BF198	0-10	I.C.'s	
G233	12AU7	0-60	BC148	0-09	BF199	0-14	MC1307	1-80
G234	12AX7	0-55	BC149	0-09	BF200	0-30	MC1350	1-00
KT61	12BA6	0-80	BC157	0-10	BF257	0-28	MC1405	3-00
KT66	12BE6	1-05	BC158	0-09	BF258	0-25	MC1405	3-00
KT77	12BH7	0-95	BC159	0-09	BF259	0-39	SN76020N	1-65
KT88	12HG7	3-25	BC160	0-28	BF336	0-34	SN76020N	1-65
N78	30FL2	0-95	BC170B	0-10	BFX29	0-30	SN76151N	1-30
OA5	85A2	1-20	BC171	0-08	BFX34	0-26	SN76227N	1-05
PCF80	90C1	1-60	BC172	0-09	BFX35	0-25	TA7205AP	0-88
PCF802		1-00	BC173B	0-07	BFX36	0-30	TAA661B	1-20
PCF808	148 811A	0-00	BC182	0-09	BFX38	0-25	TBA1205	0-70
PCL82	813	11-30	BC183	0-09	BFY30	0-21	TBA1205	0-70
PCL84	833A	47-85	BC184A	0-09	BFY31	0-21	TBA1205	0-70
PCL86	878 866A	3-80	BC212	0-09	BFY32	0-25	TBA1205	0-70
PCL805	2050A	3-00	BC212L	0-09	BFY30	0-25	TA7205AP	0-88
PFL200	1-12 5783	3-20	BC213	0-09	BU105	1-22	TA7205AP	0-88
PL504	1-20 5814A	2-75	BC213L	0-09	BU108	1-60	UPC0575C	2-85

P. & P. 50p per order.
Prices exclude VAT. Please add 15%.

Phone 0474 813225
24 hour Ansaphone service

Many other types available.
Full price list available.
Callers welcome.

Monday to Friday 9.30-5.30
Saturday 9.30-12.00



CLASSIFIED

The prepaid rate for classified advertisements is 24 pence per word (minimum 12 words), box number 60p extra. Semi-display setting £6.16 per single column centimetre (minimum 2.5cm). All cheques, postal orders, etc., to be made payable to Everyday Electronics and crossed "Lloyds Bank Ltd." Treasury

notes should always be sent registered post. Advertisements, together with remittance, should be sent to the Classified Advertisement Manager, Everyday Electronics, Room 2337, IPC Magazines Limited, King's Reach Tower, Stamford St., London SE1 9LS. (Telephone 01-261 5918).

When replying to Classified Advertisements please ensure:

- (A) That you have clearly stated your requirements.
- (B) That you have enclosed the right remittance.
- (C) That your name and address is written in block capitals, and
- (D) That your letter is correctly addressed to the advertiser.

This will assist advertisers in processing and despatching orders with the minimum of delay.

Receivers and Components

TURN YOUR SURPLUS capacitors, transistors etc., into cash. Contact Coles Harding & Co., 103 South Brink, Wisbech, Cambs. 0945 4188. Immediate settlement.

SILICON CELLAR

- CA3140E MOS Op Amp. Works with $V_{in} = V_{-}$ 45p
- LF351N FET Op Amp. Works with $V_{in} = V_{+}$ 41p
- LM324N QUAD Op Amp. 14-DIP. 3-32V Rail 48p
- LM334Z 3-Lead Constant Current Source 95p
- 1uA to 10mA Range. 1 to 30V drop. 40p
- 4 page DATA + our circuit suggestions 45p
- LM1458N Dual 741. 8-DIP. Common Rails 80p
- ZN404 Precision 2-45V Bandgap Reference 20p
- Full DATA + our circuit suggestions 36p
- DIODES IN4148 3p, 25p per 10. IN4003 5p
- 8-pin DIL IC SOCKETS 12p, 10 for 110p.
- Conductive FOAM for MOS ICs 3 x 3 inch

Prices INCLUDE VAT. Post 30p.

Send PO or Cheque to

SILICON CELLAR

(Dept 5)
21 West View Road, St. Albans, Herts

50 MIXED CONNECTORS £1. 100 mixed diodes £1. 4 section aerials 75p. Soldering irons £4. 10 different leds £1.30. 50 mixed ics 75p. Post 50p. Latest lists 25p SAE. 1000s components/items bargains. Sole Electronics, E/E, 37 Stanley Street, Ormskirk, Lancs L39 2DH.

VEROBOARD 0.1 stripboards average size $3\frac{1}{2} \times 5\frac{1}{2}$, 45p each. Orders to ALCO ELECTRONICS, 5 Sharon Road, West End, Southampton.

NEW ILLUSTRATED CATALOGUE of brand new, full spec electronic components, at very competitive prices. Send 45p plus S.A.E. to J. E. Harris, 9 Ivybridge, Broxbourne, Herts.

QUALITY $\pm 5\%$ CF resistors. Any 100 E12 values: 0.25W 95p, 0.5W 130p. Free postage. RKS Electronics, 13 Queens Terrace, Sherborne, Dorset.

300 SMALL COMPONENTS. Transistors, diodes £1.60. 7LBS ASSORTED COMPONENTS £5.95. 10lbs £5.25. FORTY 74 series ICs on panel £1.60. 500 capacitors £3.00. List 20p refundable. Post 50p optional insurance 20p. J. W. B. Radio, 2 Barnfield Crescent, Sale, Cheshire M33 1NL.

Software

CARDBOARD COMPUTER: Learn Assembly Language Programming and Computer Architecture. £8.97 inc VAT. Also Solar Cells, Science Kits, Energy Books, Stirling Engines, Space Blankets etc. etc. Send 25p for lists. Edenscombe Ltd., Dept PM., 34 Nathans Road, North Wembley, Middlesex HA0 3RX.

SIXTY ZX80/81 PROGRAMS. Specify which, listings only £4.95. Barclaycard accepted. Includes many games, utility programs, home finance, maths, chequebook, plus more in our "ZX80/81 Programs". Includes Hints/N/Tips, from Sussex Software, Wall-send House, Pevensey Bay, Sussex.

Service Sheets

BELL'S TELEVISION SERVICE for service sheets on Radio, TV etc. £1 plus SAE. Colour TV Service Manuals on request. SAE with enquiries to BTS, 190 King's Rd, Harrogate, N. Yorkshire. Tel: 0423 53885.

Any single service sheet £1/L.S.A.E. Thousands different Repair/Service Manuals/Sheets in stock. Repair data your named T.V. £5 (with circuits £8). S.A.E. Newsletter, Price Lists. Quotations.

AUSEE, 76 CHURCHES,
LARKHALL, LANARKSHIRE
(0698 833334).

SERVICE SHEETS from 50p and SAE. Catalogue 25p and SAE. Hamilton Radio, 47 Bohemia Road, St. Leonards, Sussex.

Books and Publications

BOOKS. BOOKS. BOOKS. Large range of radio and electronic books in stock. Send S.A.E. for lists. Servio Radio, Dept. EE8, 156-158 Merton Road, Wimbledon, London SW19 1EG.

OUT OF PRINT Book Service. 17 Fairwater Grove(E), Cardiff. Send S.A.E. for details.

PARAPHYSICS JOURNAL (Russian translations): Psychotronic Generators, Kirlianography, gravity lasers, telekinesis. Details: SAE 4in x 9in: Paralab, Downtown, Wilts.

PLEASE MENTION
EVERYDAY ELECTRONICS
WHEN REPLYING
TO ADVERTISEMENTS

ORDER FORM PLEASE WRITE IN BLOCK CAPITALS

Please insert the advertisement below in the next available issue of Everyday Electronics for insertions. I enclose Cheque/P.O. for £.....
(Cheques and Postal Orders should be crossed Lloyds Bank Ltd. and made payable to Everyday Electronics)

NAME

ADDRESS

Company registered in England. Registered No. 53606. Registered Office: King's Reach Tower, Stamford Street, London SE1 9LS.

Send to: Classified Advertisement Manager
EVERYDAY ELECTRONICS
Classified Advertisements Dept., Room 2337,
King's Reach Tower, Stamford Street, London SE1 9LS.
Telephone 01-261 5918
Rate:
24p per word, minimum 12 words. Box No. 60p extra.

Miscellaneous

PRINTED CIRCUITS. Make your own simply, cheaply and quickly! Golden Fotoka Light Sensitive Lacquer—now greatly improved and very much faster. Aerosol cans with full instructions. £2.25. Developer 35p. Ferric Chloride 55p. Clear Acetate sheet for master 14p. Copper-clad Fibre-glass Board approx. 1mm thick £1.70 sq.ft. Post/packing 75p. **WHITE HOUSE ELECTRONICS**, PO Box 19, Castle Drive, Penzance, Cornwall.

THE SCIENTIFIC WIRE COMPANY

PO Box 20, London E4, 01 531 1586.

ENAMELLED COPPER WIRE

SWG	1 lb.	8 oz.	4 oz.	2 oz.
8 to 28	2-76	1-50	0-90	0-60
30 to 34	3-50	1-80	0-90	0-70
35 to 39	3-40	2-00	1-10	0-80
40 to 43	4-75	2-60	2-00	1-42
44 to 47	5-90	3-40	2-39	2-00
48 to 49	15-98	9-58	6-38	3-68

SILVER PLATED COPPER WIRE

	14 to 30	8-90	3-75	2-20	1-40
	14 to 30	3-85	2-35	1-34	0-90

TINNED COPPER WIRE

	14 to 30	3-85	2-35	1-34	0-90
	14 to 30	3-85	2-35	1-34	0-90

Prices incl. P & P vat. Orders under £2 add 20p. SAE for List of Copper/Resistance wire. Dealer enquiries welcome.

Registered Office 22 Coningsby Gardens.

BALLARD'S OF TUNBRIDGE WELLS have moved to 54 Grosvenor Road, No lists. SAE. All enquiries phone T/Wells 31803.

GLASS FIBRE OPTIC LIGHT GUIDE multi-stranded 0.031 inch distal diameter, 80p per metre, 0.064 inch £1.20 per metre. Minimum order value £2.40 c.w.o. **D. LLOYD (NYEWOOD EQUIPMENT)**, 91 Tilmore Gardens, Petersfield, Hampshire.

DIGITAL WATCH BATTERY REPLACEMENT KIT



These watches all require battery (power cell) replacement at regular intervals. This kit provides the means. We supply eyeglass, non-magnetic tweezers, watch screwdriver, case knife and screwback case opener. Also one doz. assort. push-pieces, full instructions and battery identification chart. We then supply replacement batteries—you fit them. Begin now. Send £9 for complete kit and get into a fast growing business. Prompt despatch.

BOLSTER INSTRUMENT CO. (EE29)
11 Percy Avenue, Ashford, Middx., TW15 2PB

SUPER BUY Hioki 25W Soldering Iron £3-90 plus 30p P&P. Orders with cheque P.O. McDonald, M.O. Dept 72, Strawfrank Road, Carstairs Junction, Lanarks ML11 8RE.

LEARN ELECTRONICS WITHOUT SOLDER

Build electronic circuits without solder on a Roden S-Dec. This has built-in contacts and holes into which you plug your components. Suitable for all ages. Can be used time after time. Ideal gift for students or experimenters. Full instructions and 2 circuit diagrams with each S-Dec.

Send cheque or P.O. to:
Roden Products, Dept EE
High March, Daventry
Northants, NN11 4DE

£3.85

plus 40p p. & p. each

Wanted

ARMY WIRELESS SETS and instruction books on same. Hallicrafter receivers, and speakers. Will collect during my holidays in September. Please write to: A. Hulzer (PE1-DMN), Wilhelmisingel 16, 3135 JP Vlaardingen, Holland.

Veteran & Vintage

"SOUNDS VINTAGE"

The only magazine for all vintage sound enthusiasts, packed with articles by top writers, covering gramophones, phonographs, 78s, wireless, news, history, reviews, etc.

Bi-monthly. Annual subscription £6-50 (airmail extra). Send 75p for sample copy.

28 Chestwood Close, Billericay, Essex

For Sale

NEW BACK ISSUES OF "EVERYDAY ELECTRONICS". Available 85p each Post Free, cheque or uncrossed PO returned if not in stock. **BELL'S TELEVISION SERVICES**, 190 Kings Road, Harrogate, Yorkshire. Tel: (0423) 55865.

SECONDHAND ELECTRONIC TEST equipment including oscilloscopes, generators, psu's. **NORFAB PLANT AND MACHINERY**. Telephone Potter Heigham (069-27) 721.

TEACH IN 80 Tutor deck complete with all components. Built to good standard. £25. Phone: Stourport 6093.

The ONE catalogue you MUST have!



- About 2,000 items clearly listed.
- Profusely illustrated throughout.
- Large A-4 size pages.
- Bargain list, order form and 2 coupons each worth 25p if used as directed, all supplied free.

Price £1, plus 50p for post, packing and insurance.

Send cheque or P.O. for £1.50.

HOME RADIO Components Ltd
Dept. EE P.O. Box 82, 215 London Road,
Mitcham, Surrey. 01-543 5659

NEW REVISED EDITION

INTRODUCING AMATEUR ELECTRONICS IAN SINCLAIR

ONLY £3.95

* BARE ESSENTIALS * ABOUT ELECTRICITY * ACTIVE COMPONENTS
* CONNECTING UNITS * MEASURING & METERING * CIRCUITS

THE IDEAL INTRODUCTION TO ELECTRONICS FOR THE NOVICE OF ANY AGE £3.95 INC P&P

OTHER BOOKS AVAILABLE BY IAN SINCLAIR

- * UNDERSTANDING ELECTRONIC CIRCUITS £4-50
- * UNDERSTANDING ELECTRONIC COMPONENTS £4-50
- * REPAIRING POCKET TRANSISTOR RADIOS £2-95

KEITH DICKSON PUBLISHING LTD
17 HENDON LANE LONDON N3

ALL PRICES INCLUDE POSTAGE & PACKING

LED'S



125" & 2" ROUND RED YELLOW, GREEN or AMBER	8p 11p	TRIANGULAR Large, RED only Small, YELLOW or GREEN only	8p 11p
2" ONLY WHITE illuminated red	8p	DECIMAL POINT RED YELLOW or GREEN	8p 11p
RECTANGULAR RED YELLOW or GREEN	8p 11p	We also supply Alarm Equipment (Retail & Trade), PERSONAL CALLERS ONLY	
Clips for 125" or 2" Sorry no clips for rectangular and triangular LED's.	3p	Carbon potentiometers log or lin full range from 5K to 2MΩ 25p (unswitched) 45p (switched)	
Carbon resistors 1-5p (1-99), 1p 100 unmixd.			
DIP sockets 8 pin 14 pin 16 pin	8p 12p 12p	CMOS 4011 4017	15p 48p
Plugs 2.5mm 3mm 2 pin DIN	8p 8p 8p	BC106 10p LM330 88p OA30 4 5p	C105D 35p 8ZY88 8p 8p
TV plugs 1" mono jack	8p 12p	Loudspeakers 1 1/2" 8Ω	88p

ALARM DEVICES

Passive infra red detectors, pick up body heat up to 5m away. Unaffected by swinging curtains, falling stock, telephone bells, mains interference, fluorescent lights etc. To be used in conjunction with a burglar control panel. 12v supply £40
P.E. beams 20m range. Small neat units ideal for residential installations etc. £40

REQUIRED:- 12v "continental" relays new or ex equipment, minimum 10's must be in first class condition. State your price.

CB Components:-	MB3712	£2-20p	TA7130	£2-30p
AN214	TA7205	£2-95p	C2076	£1-80p
LC7130	TA7210	£2-40p		

All are top quality LED'S—compare price with any other Ad! P. & P. 60p. Add VAT 15% (carriage free over £5). Export P. & P. £1.00. Trade enquiries welcome.

WE ARE WARRINGTON'S SUPPLIERS OF CB GEAR!

SHOP HOURS 9.30-6 pm (5 pm Sat.). Closed every Thursday in June and July.

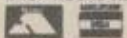

WEBB ELECTRONICS

41 WINWICK STREET, WARRINGTON, CHESHIRE. Tel. 54174

FAMOUS LOUDSPEAKERS Post £2					
Make	Model	Size	Watts	Ohms	Price
Seas	Tweeter	4in	50	8	£7.50
Goodmans	Tweeter	3½in	25	8	£4.00
Audat	Tweeter	3½in	50	8	£10.50
Seas	Mid-Range	4in	50	8	£7.50
Seas	Mid-Range	5in	50	8	£12.00
Seas	Mid-Range	4½in	100	8	£12.50
Goodmans	Full-Range	5½in	15	8	£6.50
Goodmans	Full-Range	8in	30	8	£12.50
Seas	Woofer	8in	30	8	£14.00
Rigonda	Full-Range	10½in	15	8	£5.50
Goodmans	Audion	12½in	50	8	£20.00
Goodmans	D12	12½in	90	9/15	£27.50
Goodmans	Audion	12½in	50	9/15	£20.00
Baker	Disc	12in	100	8/16	£24.00
Baker	Disc	15in	100	8/16	£30.00

BATTERY ELIMINATOR MAINS TO 9 VOLT
Stabilised output, 9 volt 400 m.a. UK made with terminals. Overload cut out. 5 x 31 x 2½in. Transformer Rectifier Unit. Suitable Radios, Cassettes, models, £4.50 post 50p.

E.M.I. 13½ x 8in Speaker Sale!

With tweeter. And crossover. £9.95
10W. State 3 or 8 ohm. Post £1

15W model £10.95
8 ohms Post £1

GOODMANS 20 Watt Woofer
Size 8in. 4 ohms £6.00
Rubber cone surround. Post £1

MATCHING TWEETER

4in square 4 ohm £3.25 Post 75p

R.C.S. MINI MODULE KIT 3-way

Loudspeaker System, EMI 5in Bass, 5in Middle, 3in Tweeter, with 3-way Crossover and Ready Cut Baffle, 15 x 8½in. Full assembly instructions. Response - 40 to 20,000 cps 12 watt RMS, 8 ohm. £10 each. £18.50 pair. Postage £1.50.

R.C.S. LOUDSPEAKER BARGAINS

3 ohm, 4in, 5in, 7 x 4in, £1.50; 8 x 5in, 6½in, £3; 8in, £3.50; 8 ohm, 2in, 2½in, 3in, 5in, £1.50; 8in, £4.50; 10in, £3; 12in, £6; 15 ohm, 2½in, 5 x 3in, 6 x 4in, 7 x 4in, £1.50; 25 ohm, 3in, 5 x 3in, 7 x 4in, £1.50; 125 ohm, 2½in dia., £1.50.

LOW VOLTAGE ELECTROLYTICS

1, 2, 4, 5, 8, 16, 25, 30, 50, 100, 200mF 15V 10p, 500mF 12V 15p; 25V 25p; 50V 30p; 100mF 12V 20p; 125V 25p; 30V 30p; 1200mF 76V 85p; 2200mF 8V 25p; 3000mF 25V 30p; 90V 55p; 3300mF 65V £1.30; 4700mF 63V £1.30; 2700mF 76V £1. 4700mF 40V 85p; 50V 85p; 3000mF 76V £1.75.

HIGH VOLTAGE ELECTROLYTICS

8/450V 45p 8+3/450V 75p 50+50/300V 50p
16/350V 45p 8+16/450V 75p 32+32+32/25V 75p
32/350V 75p 20+20/450V 75p 150+150/275V 85p
32/350V 85p 32+32/350V 90p 150+150/275V 70p
50/500V £1.20 32+32/500V £1.80 220/450V 85p

MANY OTHER ELECTROLYTICS IN STOCK

TRIMMERS 10pF, 30pF, 50pF, 5p, 100pF, 150pF, 15p.

CONDENSERS VARIOUS, 1pF to 0.01mF, 3p.

PAPER 300V-0 17p; 0-5 13p; 1mF 150V 25p; 2mF 150V 25p; 400V-0 001 to 0.05 5p; 0-1 15p; 0-25 25p; 0-47 35p.

MICRO SWITCHES SINGLE POLE CHANGE-OVER 30p.

SUB-MIN MICRO SWITCH, 30p. Single pole change over.

TWIN GANGS 100pF 50p; 500pF £1.

GEARED TWIN GANGS 25pF 85p; 350pF £1.

NEON PANEL INDICATORS 250V, Red 1½ x ½ 45p.

ILLUMINATED ROCKER SWITCH, Single pole, Red 65p.

RESISTORS, 10Ω to 10M, ½W 20% 2p; 2W, 10p.

HIGH STABILITY, ½W 2%, 10 ohms to 1 meg, 3p.

Ditto 5%. Preferred values 10 ohms to 10 meg, 3p.

WIRE-WOUND RESISTORS 5 watt, 10 watt, 15 watt 15p.

CASSETTE MOTOR, 8 volt £1.00.

ALUMINIUM CHASSIS 18 s.w.g. Undrilled, 4 sides, riveted corners; 6 x 4 x 2½in, £1.20; 8 x 6 x 2½in, £1.90; 10 x 7 x 2½in, £1.90; 14 x 9 x 2½in, £2.90; 16 x 9 x 2½in, £2.00; 12 x 3 x 2½in, £1.50; 12 x 3 x 2½in, £2.50; 16 x 10 x 2½in, £2.70. **ANGLE BRACKET** 6 x 2 ½ x 1½in, 25p.

ALUMINIUM PANELS 18 s.w.g., 12 x 12in, £1.30; 14 x 9in, £1.30; 6 x 4in, 25p; 12 x 9in, 50p; 10 x 7in, 60p; 8 x 8in, 60p; 14 x 9in, 60p; 12 x 9in, 60p; 16 x 18in, £1.40; 16 x 6in, 90p.

BLACK PLASTIC construction box with brushed aluminium face size 4½ x 4½ x 2" £1.50. Many other sizes.

BRIDGE RECTIFIER 200V PIV ½ amp 50p, 2 amp £1.90, 4 amp £1.50 62 50.

TOGGLE SWITCHES 5P 30p, DPST 40p, DPDT 50p.

MANY OTHER TOGGLES IN STOCK. Please enquire.

BSR 175/2 BUDGET SINGLE PLEAF ideal for disco or Hi-Fi system; stereo cartridge cueing device and bias compensator; 3 speeds Post £2 **£20**

BSR STEREO CARTRIDGES SC7 medium output £2. Sonotone BT-A-HC £2.50, V.100 Magnetic £7.

MAINS TRANSFORMERS

Post		Post	
6V, 500mA	£2.00 80p	6-0-6V 100mA	£1.80 80p
12V, 100mA	£1.20 80p	9-0-9V 50mA	£1.50 80p
12V, 750A	£1.75 80p	12V 3A	£2.50 80p
10-0-10V 2A	£3.00 £1	10V, 20V, 40V, 2x63 50	£2
20V, 5 amp and	£3.00 £1	20V, 1 amp	£3.00 £1
17V-0-17V, 2A, £4.00	£2	20V-0-20V, 1A	£3.50 £1
0, 5, 8, 10, 15V, 1A	£2.50 £1	2 of 18V, 6A	£11.00 £2
9V, 3 amp	£3.50 £1	12-0-12V, 2A	£3.50 £1
15-0-15V 2A	£3.00 £1	9V, 1 amp	£1.50 80p
35V, 2A	£3.50 £1	25V, 1A + 25V 1A	£3.00 £2
300V, 12A	£3.50 £1	32-0-32V 6.5A	£11.00 £2
20V, 40V, 60V, 1A	£4.00 £1	12V 2 amp	£3.00 £1

Radio Component Specialists
337, WHITEHORSE ROAD
CROYDON, SURREY, U.K. TEL: 01-484 1045
Post 85p Minimum, Callers Welcome,
Access-Barclay-Visa, Closed Wed, Lists 30p.

NO BATTERIES NO WIRES ONLY
£37.99
PER PAIR
+ VAT £5.70
+ P & P £1.95

The modern way of instant 2-way communications. Just plug into power socket. Ready to use. Crystal clear communications from room to room. Range ½-mile on the same mains phase. On/off switch. Volume control, with 'buzzer' call and light indicator. Useful as inter-office intercom, between office and warehouse, in surgery and in homes.
Also F.M. 2 channel "touch" model £55.95 per pair + VAT £8.40 + P&P £2.15.

NEW AMERICAN TYPE CRADLE TELEPHONE AMPLIFIER
£18.95
+ VAT £2.85
+ P & P £1.65

Latest transistorised Telephone Amplifier, with detached plug-in speaker. Placing the receiver on to the cradle activates a switch for immediate two-way conversation without holding the handset. Many people can listen at a time. Increase efficiency in office, shop, workshop. Perfect for "conference" calls; leaves the user's hands free to make notes, consult files. No long waiting, saves time with long-distance calls. On/off switch, volume control, Conversation recording, model at £20.95 + VAT £3.15, P&P £1.65.

DOOR ENTRY SYSTEM
No house/business/surgery should be without a DOOR ENTRY SYSTEM in this day and age. The modern way to answer the door in safety to unwanted callers. Talk to the caller and admit him only if satisfied by pressing a remote control button which will open the door electronically. A boon for the invalid, the aged, and busy housewife. Supplied complete d.i.y. kit with one internal Telephone, outside Speaker panel, electric door lock release (for Yale type surface latch lock); mains power unit, cable (4 pairs) 50ft and wiring diagram. Price £59.95 + VAT £9.00 + P&P £2.25. Kit with two phones £69.95 + VAT £10.50 + P&P £2.45.
10-day price refund guarantee on all items
Access and Barclaycard welcome.
WEST LONDON DIRECT SUPPLIES £1.8
169 KENSINGTON HIGH STREET,
LONDON, W8 Tel. 01-937 5548

POPS COMPONENTS
38/40 LOWER ADDISCOMBE ROAD
CROYDON, CR0 6AA
01-888-2950

*** POPS SPECIAL OFFERS THIS MONTH ***
Free LEDs + Cat. with every Order!

STEREO POWER AMPLIFIER MODULE
25W per channel into 8 ohms. In kit form. Really easy to build with fully comprehensive instructions at only £9.99.
Fully built and tested—only £11.99.
(Pre-Amp at £6 and Power Pack at £7 available.)

ARE YOU FULLY ADAPTABLE?
We have 12v Transformers at 400 mA on a panel with Rects. at only £1.10.
O.K. for 12v mains adaptor for radio, cassettes, etc.
Boxes suitable for above available at 50p each.

SOLAR CELLS ½" x ½". Give 20 mA at ½v. £1.50 each.
OFFER. Demo. Kit: 2 cells and motor for £4.50.

12v MINI RELAYS (Continental type)
2p x-over 700R—40p each.
4p x-over 430R—50p each.

100's more bargains. Full Cats. sent with orders received or send large S.A.E. P. & P. 50p.

PLEASE MENTION EVERYDAY ELECTRONICS WHEN REPLYING TO ADVERTISEMENTS

INDEX TO ADVERTISERS

Ambit	571
Baydis	560
Bi-Pak	573
B. K. Electronics	560
B.N.R.E.S.	569
Boss	570
Bull J.	559
Chordgate	516
Colour Print Express	Cov. II
Electroni-Kit	563
Electonize Design	568
Gemini	570
Greenweld	563
Home Radio	575
Intertext (ICS)	516
Keith Dickson	575
Magenta Electronics	514, 515
Maplin Electronic Supplies Ltd.	Cov. IV
Marshall's	515
OK Machine Tools	568
Phonosonics	554
PM Components	572
Pops Components	576
Powell T.	Cov. III
Radio Component Specialists	576
Radio TV Components	553
Rapid Electronics	570
Science of Cambridge	518, 519
Selray Book	560
Silica Shop	569
Teleman Products	572
Tempus	517
Titan Transformers	516
T. K. Electronics	565
Watford Electronics	513
Webb Electronics	575
West London Direct Supplies	576
Wilmslow Audio	568

E.E. PROJECT KITS

Intercom	ZB149	April 81	£19.25	Five Range Current Limiter	ZB53	March 80	£4.50
Digital Rule	ZB148	April 81	£28.00	Kitchen Timer	ZB55	March 80	£12.75
Freezer Alarm	ZB147	April 81	£11.75	Touch Switch	ZB56	March 80	£9.00
LED Dice	ZB146	March 81	£7.50	Micro Music Box	ZB45	Feb. 80	£17.00
Mini Siren	ZB145	March 81	£7.25	Simple Short Wave Receiver	ZB44	Feb. 80	£18.00
Modulated Tone Doorbell	ZB144	March 81	£6.25	Morse Practice Oscillator	ZB43	Feb. 80	£5.00
Bench Power Supply	ZB143	March 81	£48.50	Slide/Tape Synchroniser	ZB42	Feb. 80	£11.50
Car Actuated Driveway Light	ZB142	March 81	£22.00	Power Supply 3-9V	ZB47	Jan. 80	£4.50
3 Channel Stereo Mixer	ZB141	Feb. 81	£16.25	Burglar Alarm	ZB51	Dec. 79	£5.00
Signal Tracer	ZB140	Feb. 81	£7.50	Baby Alarm	ZB40	Nov. 79	£8.50
Nicad Battery Changer	ZB139	Feb. 81	£12.00	Opto Alarm	ZB41	Nov. 79	£5.00
Auto Slide Charger	ZB138	Jan. 81	£9.00	Radio Tuner MW/LW	ZB108	Nov. 79	£14.75
ICB Alarm	ZB137	Jan. 81	£7.25	3-Function Generator	ZB52	Nov. 79	£25.00
Phaser Sound Effects	ZB136	Jan. 81	£23.30	One Armed Bandit	ZB33	Oct. 79	£21.00
Mini I.C. Radio	ZB126	Nov. 80	£10.35	Lights-on Reminder	ZB34	Oct. 79	£4.60
Sound to Light	ZB127	Nov. 80	£19.00	Signal Level Indicator	ZB36	Oct. 79	£4.50
Guitar Practice Amplifier	ZB128	Nov. 80	£16.85	Universal Oscillator	ZB37	Oct. 79	£3.50
RG Action Tester	ZB129	Nov. 80	£10.25	Chaser Light	ZB4	Sept. 79	£17.50
Precision Timer	ZB130	Nov. 80	£21.00	Low Power Audio Amplifier	ZB3	Sept. 79	£3.75
Transistor Tester	ZB131	Nov. 80	£8.00	Simple Transistor Tester	ZB2	Sept. 79	£5.50
Soil Moisture Monitor	ZB132	Nov. 80	£5.00	Varicap MW Radio	ZB1	Sept. 79	£8.50
Audio Effects Unit	ZB122	Oct. 80	£12.25	Quiz Referee	ZB12	Aug. 79	£4.75
Phone Call Charge Jogger	ZB121	Oct. 80	£6.00	Trailer Flasher	ZB9	Aug. 79	£3.00
Darkroom Controller	ZB123	Oct. 80	£17.25	Electronic Tuning Fork	ZB7	Aug. 79	£8.90
Bicycle Alarm	ZB124	Oct. 80	£9.25	Power Supply 9V	ZB6	Aug. 79	£8.25
Lights Failure Monitor	ZB77	Sept. 80	£8.75	Warbling Timer	ZB5	Aug. 79	£5.80
TTL Power Supply Unit	ZB78	Sept. 80	£9.50	Water Level Indicator	ZB111	July 79	£4.50
Duo-Deci Timer	ZB75	Sept. 80	£8.50	Voltage Splitter	ZB15	July 79	£3.25
*TTL Logic Probe	ZB76	Sept. 80	£3.25	Electronic Canary	ZB19	June 79	£4.50
Bedside Radio	ZB74	Sept. 80	£14.25	Tremolo Unit	ZB18	June 79	£10.00
Auto Lighting-Up Warning	ZB71	Aug. 80	£5.65	Electronic Dice	ZB24	May 79	£13.50
Brakesafe Monitor	ZB68	Aug. 80	£7.50	Intruder Alarm	ZB23	May 79	£23.00
Cricketer Game	ZB69	Aug. 80	£14.95	Touch Bleeper	ZB27	April 79	£3.25
Zener Diode Tester	ZB79	July 80	£5.00	Transistor Tester	ZB100	April 79	£4.00
Signal Tracer	ZB80	July 80	£5.00	One Transistor Radio MW/LW	ZB104	March 79	£7.25
General Purpose Amplifier	ZB81	July 80	£6.00	Time Delay Indicator	ZB98	March 79	£4.00
Autowaa	ZB83	July 80	£19.25	Micro Chime	ZB96	Feb. 79	£12.00
A.F. Signal Generator	ZB84	July 80	£20.00	Lights Reminder for Car	ZB32	Jan. 79	£4.50
Courtesy Light Delay	ZB85	July 80	£5.25	Continuity Tester	ZB115	Jan. 79	£4.30
Auto Phase	ZB86	July 80	£19.25	Fuzz Box	ZB106	Dec. 78	£5.00
Battery Voltage Monitor	ZB64	May 80	£4.80	Vehicle Immobiliser	ZB110	Dec. 78	£5.00
Lights Warning System	ZB63	May 80	£3.60	Audio Effects Oscillator	ZB109	Nov. 78	£3.50
Autofade	ZB66	May 80	£10.25	Radio MW/LW	ZB116	Oct. 78	£7.00
*Dual Line Game	ZB65	May 80	£25.00	Sound to Light	ZB112	Sept. 78	£7.00
*Pre-tuned 4-Station Radio	ZB62	May 80	£14.00	Guitar Tone Booster	ZB117	Sept. 78	£5.00
Gas Sentinel	ZB61	April 80	£27.00	A.F. Signal Generator	ZB119	Aug. 78	£10.00
Cycle Direction Flasher	ZB59	April 80	£14.50	Weird Sound Effects Generator	ZB113	March 78	£3.50
Cable and Pipe Locator	ZB54	March 80	£3.75	Chaser Light Display	ZB97	Feb. 78	£22.00
Stereo Headphone Amplifier	ZB57	March 80	£15.25	Car System Alarm	ZB92	Feb. 78	£4.50
Doorbell Register	ZB58	March 80	£3.80				

★ TEACH-IN 80 ★

This popular monthly constructional series started in E.E. in 1979 and is a must for beginners to electronics. The sheer simplicity of the whole project experiments lends itself to be made by any beginner young or old. Basic technical principles and symbols explained in great detail. Start at the beginning with a hobby that could become a worthwhile career, our kit comes complete with all parts as specified by E.E.

List A, B and C £22.50. Monthly reprints from October 1979 available at 40p each per month extra or £4.50 for whole series.

*All E.E. project kits supplied with cases except items marked *. All kits come complete with items as specified plus Texas i.c. sockets where required, also veroboard connecting wire etc.

If you do not have the issue of E.E. which contains the project we can supply a reprint at 40p extra.

Personal callers please ring to check availability of kits.

All prices include post, packing and 15% V.A.T.

IONISER KIT

This negative ion generator gives you the power to saturate your home or office with millions of refreshing ions. Without fans or moving parts it puts out a pleasant breeze. A pure flow of ions pours out like water from a fountain, filling your room. The result? Your air feels fresh, pure, crisp and wonderfully refreshing. All parts, PCB and full instructions £12.50
A suitable case including front panel, neon switch etc... £10.50

Hours Mon-Friday 9-5.30 p.m. Sat. 9-4.30 p.m.
Callers by appointment only.
Telephone: 01-226 1489

T. POWELL

Advance Works, 44 Wallace Road, London N.1.

Visa/Access cards accepted
Minimum telephone Orders £5.00
Minimum Mail Order £1.00



MAPLIN make it easy...



in SOUTHEND
284 London Road
Westcliff-on-Sea
Essex
Tel: (0702) 554000
(Closed Mondays)



in HAMMERSMITH
159-161 King Street
Hammersmith
London W6
Tel: 01-748 0926
(Closed Mondays)

For personal service visit one of our stores.
Our new store at Hammersmith is conveniently situated near the end of the M4 and the North and South Circular Roads. There is excellent street parking on meters a few steps away and Hammersmith Underground Station is nearby. Call in and see us soon.



in our CATALOGUE

320 big pages packed with data and pictures of over 5,500 items

Over 100,000 copies sold already!
Don't miss out on your copy.

On sale now in all branches
WH Smith  price £1.

In case of difficulty check the coupon below.

by MAIL ORDER
A fast service you can rely on

- * Same day service on in-stock lines
- * Very large percentage of our stock lines in stock
- * All prices include VAT
- * Large range of all the most useful components
- * First class reply paid envelope with every order
- * Quality components—no rejects—no re-marks
- * Competitive prices
- * Your money is safe with a reputable company

On price, service, stock, quality and security it makes sense now more than ever to make **MAPLIN** your first choice for components every time!

make it easy... with MAPLIN

The Maplin Matinée

Amazing value for only £299.95 plus £99.50 for cabinet if required

Easy to build, superb specification.

Comparable with organs selling for up to £1,000. Full construction details in Electronics & Music Maker commencing March, 1981 issue. Back numbers available.



MAPLIN ELECTRONIC SUPPLIES LTD.

Post this coupon now.

Please send me a copy of your 320 page catalogue. I enclose £1.25 (incl. 25p p&p). If I am not completely satisfied I may return the catalogue to you and have my money refunded. If you live outside the U.K. send £1.68 or 12 International Reply Coupons.

Name

Address

EE/B/81

All mail to: P.O. Box 3, Rayleigh, Essex SS6 8LR. Tel: Southend (0702) 554155 Sales: (0702) 552911