

EVERYDAY

APRIL 1995

With

PRACTICAL

ELECTRONICS

INCORPORATING ELECTRONICS MONTHLY

FULLY S.O.R. £2.25

NATIONAL LOTTERY PREDICTOR

Generates numbers
for your entry using a
PIC Microcontroller

Plus *Three more
projects for last
month's FREE p.c.b.*

CONTINUITY TESTER

LIGHT ACTIVATED SWITCH

SWITCH ON/OFF TIMER



**THE No. 1 INDEPENDENT
MAGAZINE FOR
ELECTRONICS TECHNOLOGY
& COMPUTER PROJECTS**



A4 DTP MONITORS Brand new, 300 DPI. Complete with diagram but no interface details (so you will have to work it out!) Bargain at just £12.99 each!!!!

OPD MONITORS 9" mono monitor, fully cased complete with raster board, switched mode psu etc. CGA/TL input (15w ay D). IEC mains. £15.99 ref DEC23. Price including kit to convert to composite monitor for CCTV use etc £21.99 ref DEC24

LOW COST LASER NIGHT SIGHT Just £79!!!

Cheaper version of our £245 Cyclops model. Works ok in light levels or in complete darkness with the built in Laser ref 95/79 (please allow about 1 month delivery for these due to import difficulties)

PC CONTROLLED 4 CHANNEL TIMER Control (on/off times etc) up to 4 items (8A 240v each) with this kit. Complete with Software, relays, PCB etc £25.99 Ref 95/26

LOW COST RADAR DETECTOR Built and tested pocket radar detector, ideal for picking up speed traps etc. Why pay £70 or more? Ours is just £24.99 ref 95/25

COMPLETE PC 300 WATT UPS SYSTEM Top of the range UPS system providing protection for your computer system and valuable software against mains power fluctuations and cuts. New and boxed, UK made. Provides up to 5 mins running time in the event of complete power failure to allow you to run your system down correctly. **SALE PRICE** just £119.00.

RACAL MODEM BONANZA! 1 Racal MPS1223 1200/75 modem, telephone lead, mains lead, manual and comms software, the cheapest you onto the net! all this for just £13 ref DEC13

HOW LOW ARE YOUR FLOPPIES? 3.5" (1.44) unbranded. We have sold 100,000+ so ok! Pack of 50 £24.99 ref DEC16

BRITISH TELECOMM MULTIMETERS SA9083 These are 'returms' so they may have faults but look ok. Complete with new leads and leather case. Price for two meters & 1 case is £10 ref DEC89

5mw LASER POINTER. Supplied in kit form, complete with power adjuster, 1.5mw, and beam divergence adjuster. Runs on 2 AAA batteries. Produces thin red beam ideal for levels, gun sights, experiments etc. Cheapest in the UK! just £39.95 ref DEC49

SHOP WOBLERS! Small assemblies designed to take D size batteries and 'wobble' cardboard model signs about in shop windows! £3.99 Ref SEP42

RADIO PAGER Brand new, UK made pocket pager clearance price is just £4.99 each 100x40x15mm packed with bits! Ref SEP5

BULL TENS UNIT Fully built and tested TENS (Transcutaneous Electrical Nerve Stimulation) unit, complete with electrodes and full instructions. TENS is used for the relief of pain etc in up to 70% of sufferers. Drug free pain relief, safe and easy to use. Can be used in conjunction with analgesics etc. £49 Ref TEN1

STEREO MICROSCOPE 155X195MM, up to 600mm high, so items up to 10" will fit under lens. Rack and pinion focusing, 6 interchangeable rotating objective lenses, interchangeable eye pieces, +scaled eyepiece for accurate measuring etc. Powerful low voltage illumination system with green filter and variable intensity, 100mm black/white + ground glass stage plate, 70mm swivel mirror, adjustable eyepieces (both focus and width) Magnification range 4-100 X, field of view 39-2.4mm. Price is £299 for complete setup. Ref 95/300

3D 36MM CAMERA SYSTEM Complete kit to convert a standard 35mm camera into a 3D version! enable you to take 3D colour slides with your own camera! Kit contains a prism assembly for the front of your existing lens, a sample 3D slide, a 3D slide viewer and 2 different lens mounts 49mm and 52mm. (other sizes available from photo shops at about £3 ea) all you need is standard slide film. Price for the complete kit is £29.99 ref 95/30

COMPUTER RS232 TERMINALS. (LIBERTY) Excellent quality modem units (like wise 50, s) 2xRS232, 20 function keys, 50 thro to 38,400 baud, menu driven pop, screen cursor and keyboard setup menus (18 menu's) £29 Ref NOV4

OMRON TEMPERATURE CONTROLLERS (E6C2). Brand new controllers, adjustable from -50 deg C to +1,200 deg C using graduated dial, 2% accuracy, thermocouple input, long life relay output, 3A 240v o/p contacts. Perfect for exactly controlling a temperature. Normal trade £50+, ours £15. Ref E5C2

ELECTRIC MOTOR BONANZA! 110x60mm. Brand new precision, cap start (or spin to start) virtually silent and features a moving outer case that acts as a fly wheel. Because of their unusual design we think that 2 of these in a tube with some homemade fan blades could form the basis for a wind tunnel etc. Clearance price is just £4.99 FOR A PAIR! (note these will have to be wired in series for 240v operation Ref NOV1

MOTOR NO 2 BARGAIN 110x90mm. Similar to the above motor but more suitable for mounting vertically (ie turntable etc). Again you will have to wire 2 in series for 240v use. Bargain price is just £4.99 FOR A PAIR!! Ref NOV3

OMRON ELECTRONIC INTERVAL TIMERS.

Miniature adjustable timers, 4 pole c/o output 3A 240v.
HY1230S, 12VDC adjustable from 0-30 secs £9.99
HY1210M, 12VDC adjustable from 0-10 mins £9.99
HY1260M, 12VDC adjustable from 0-60 mins £9.99
HY2460M, 24VAC adjustable from 0-60 mins £5.99
HY241S, 24VAC adjustable from 0-1 secs £5.99
HY2460S, 24VAC adjustable from 0-60 secs £5.99
HY243H, 24VAC adjustable from 0-3 hours £8.99
HY2401S, 240v adjustable from 0-1 secs £9.99
HY2405S, 240v adjustable from 0-5 secs £9.99
HY24060M, 240v adjustable from 0-60 mins £12.99

PC PAL VGA TO TV CONVERTER Converts a colour TV into a basic VGA screen. Complete with built in psu, lead and s/ware £49.95 Ideal for laptops or a cheap upgrade

EMERGENCY LIGHTING UNIT Complete unit with 2 double bulb floodlights, built in charger and auto switch. Fully cased, 6v 8AH lead acid req'd (secondhand) £4 ref MAG4P11

GUIDED MISSILE WIRE. 4,200 metre reel of ultra thin 4 core insulated cable, 28lbs breaking strain, less than 1mm thick! Ideal alarms, intercoms, fishing, dolls houses etc. £14.99 ref MAG15P5

300v PANEL METER 70X60X50MM. AC, 90 degree scale. Good quality meter. £5.99 ref MAG 6P14. Ideal for monitoring mains etc.

ASTEC SWITCHED MODE PSU BM41012 Gives +5 @ 3.75A, +12 @ 1.5A, -12 @ 4A 230/110, cased, BM41012 £5.99 ref AUG6P3

TORRODIAL TX 30-0-30 480VA. Perfect for Mosfet amplifiers etc. 120mm dia 55mm thick. £18.99 ref APR19

AUTO SUNCHARGER 155x300mm solar panel with diode and 3 metre lead fitted with a cigar plug. 12v 2watt. £9.99 ea ref AUG10P3

FLOPPY DISCS D5DD Top quality 5.25" discs. These have been written to once and are unused. Pack of 20 is £4 ref AUG4P1

ECLATRON FLASH TUBE As used in police car flashing lights etc. full spec supplied, 60-100 flashes a min. £9.99 ref APR10P5

24v AC 96WATT Cased power supply. New £13.99 ref APR14

MILITARY SPEC GEIGER COUNTERS Unused anstrahthrom Her majesty's forces. £50 ref MAG 50P3

STETHOSCOPE Fully functioning stethoscope, ideal for listening to hearts, pipes, motors etc. £6 ref MAR6P6

OUTDOOR SOLAR PATH LIGHT Captures sunlight during the day and automatically switches on a built in lamp at dusk. Complete with sealed lead acid battery etc. £19.99 ref MAR20P1

ALARM VERSION Of above unit comes with built in alarm and pir to deter intruders. Good value at just £24.99 ref MAR25P4

CARETAKER VOLUMETRIC Alarm will cover the whole of the ground floor against forced entry. Includes mains power supply and integral battery backup. Powerful internal sander will take external bell if req'd. Retail £150+, ours? £49.99 ref MAR50P1

TELEPHONE CABLE White 6 core 100m reel complete with a pack of 100 dips. Ideal 'phone extns etc. £7.99 ref MAR8P3

MICRODRIVE STRIPPER Small cased tape drives ideal for stripping lots of useful goodies including a smart case, and lots of components. £2 each ref JUN2P3

SOLAR POWER LAB SPECIAL You get TWO 6"x6" 6v 130mA solar cells, 4 LED's, wire, buzzer, switch plus 1 relay or motor. Superb value kit just £5.99 REF. MAG6P8

SOLID STATE RELAYS Will switch 25A mains. Input 3.5-26V DC 57x43x21mm with terminal screws £3.99 REF. MAG4P10

300DPI A4 DTP MONITOR Brand new but shop soiled so hence bargain price! TTL/ECL inputs, 15" landscape, 1200x1664 pixel complete with circuit diag to help you interface with your projects. JUST £14.99 REF JUN15P2

BUGGING TAPE RECORDER Small voice activated recorder, uses micro cassette complete with head phones. £28.99 ref MAR29P1

ULTRAMINI BUG MIC 6mm x 3.5mm made by AKG. 5-12v electret condenser. Cost £12 ea. Ours? just four for £9.99 REF MAG10P2

RGB/CGA/EGA/TTL COLOUR MONITORS 12" in good condition. Back anodised metal case. £79 each REF JUN79

ANSWER PHONES Returns with 2 faults, we give you the bits for 1 fault, you have to find the other yourself! BT Response 200's £18 ea REF MAG18P1. PSU £5 ref MAG5P12

SWITCHED MODE PSU ex equip, 60w +5v @5A -5v @ 5A +12v @ 2A -12v @ 5A 120V/220v cased 245x88x55mm IEC input socket £6.99 REF MAG7P1

PLUG IN PSU 9V 200mA DC £2.99 each REF MAG3P9

PLUG IN ACORN PSU 19v AC 14w £2.99 REF MAG3P10

POWER SUPPLY fully cased with mains and o/p leads. 17v DC 900mA output. Bargain price £5.99 ref MAG6P9

ACORN ARCHIMEDES PSU +5v @ 4.4A on/off sw uncased, selectable mains input. 145x100x45mm £7 REF MAG7P2

GEIGER COUNTER KIT Low cost professional twin tube complete with PCB and components. Now only £19 REF AUG19

9v DC POWER SUPPLY Standard plug in type 150ma 9v DC with lead and DC power plug. price for two is £2.99 ref AUG3P4

AA NICAD PACK encapsulated pack of 8 AA nicad batteries (tagged) ex equip. 55x32x32mm £3 a pack. REF MAG3P11

13.8V 1.9A psu cased with leads. Just £9.99 REF MAG10P3

PPC MODEM CARDS These are high spec plugin cards made for the Amstrad laptop computers. 2400 baud dial up unit complete with leads. Clearance price is £5 REF: MAG5P1

INFRA RED REMOTE CONTROLLERS Originally made for hi spec satellite equipment but perfect for all sorts of remote control projects. Our clearance price is just £2 REF: MAG2

200 WATT INVERTER Converts 10-15v DC into either 110v or 240v AC. Fully cased 115x36x158mm complete with heavy duty power lead, cigar plug, AC outlet socket, Auto overload shutdown, auto short circuit shut down, auto input over voltage shutdown, auto input under voltage shut down (with audible alarm), auto temp control, unit shuts down if overheated and sounds audible alarm. Fused reversed polarity protected output frequency within 2% voltage within 10%. A extremely well built unit at an excellent price. Just £64.99 ref AUG6S

UNIVERSAL SPEED CONTROLLER KIT Designed by us for the C5 motor but ok for any 12v motor up to 30A. Complete with PCB etc. A heat sink may be required. £17.00 REF: MAG17

MAINS CABLE Precut black 2 core 2 metre lengths ideal for repairs, projects etc. 50 metres for £1.99 ref AUG2P7

COMPUTER COMMUNICATIONS PACK Kit contains 100m of 6 core cable, 100 cable clips, 2 line drivers with RS232 interfaces and all connectors etc. Ideal low cost method of communicating between PCs over a long distance. Complete kit £8.99

MINI CYCLOPS PIR 52x62x40mm runs on PP3 battery complete with shill sensor. Cheap protection at only £5.99 ref MAR6P4

ELECTRIC MOTOR KIT Comprehensive educational kit includes all you need to build an electric motor. £9.99 ref MAR10P4

VIDEO SENDER UNIT. Transmits both audio and video signals from either a video camera, video recorder, TV or Computer etc to a standard TV set in a 100' range! (tune TV to a spare channel) 12V DC op. Price is £15 REF: MAG15 12v psu is £5 extra REF: MAG5P2

***SOME OF OUR PRODUCTS MAY BE UNLICENSEABLE IN THE UK**

BULL ELECTRICAL
250 PORTLAND ROAD HOVE SUSSEX
BN3 5QT (ESTABLISHED 50 YEARS)
MAIL ORDER TERMS: CASH PO OR CHEQUE
WITH ORDER PLUS £3.00 POST PLUS VAT.
PLEASE ALLOW 7-10 DAYS FOR DELIVERY
TELEPHONE ORDERS WELCOME
TEL: 01273 203500
FAX: 01273 323077

***FM CORDLESS MICROPHONE** Small hand held unit with a 500' range! 2 transmit power levels. Reqs PP3 9v battery. Tuneable to any FM receiver. Price is £15 REF: MAG15P1

LOW COST WALKIE TALKIES. Pair of battery operated units with a range of about 200'. Ideal for garden use or as an educational toy. Price is £8 a pair. REF: MAG8P1 2 x PP3 req'd

***MINIATURE RADIO TRANSCEIVERS** A pair of walkie talkies with a range of up to 2km in open country. Units measure 22x52x155mm. Including cases and earpieces. 2xPP3 req'd. £30.00 pr. REF: MAG30

COMPOSITE VIDEO KIT. Converts composite video into separate H sync, V sync, and video. 12v DC. £8.00 REF: MAG8P2.

LQ3500 PRINTER ASSEMBLIES Made by Amstrad they are entire mechanical printer assemblies including printhead, stepper motors etc etc. In fact everything bar the case and electronics, a good stepper! £5 REF: MAG5P3 or 2 for £8 REF: MAG8P3

LED PACK of 100 standard red 5m leds £5 REF MAG5P4

UNIVERSAL PC POWER SUPPLY complete with flyleads, switch, fan etc. Two types available. 150w at £15 REF MAG15P2 (23x23x23mm) and 200w at £20 REF MAG20P3 (23x23x23mm)

***FM TRANSMITTER** housed in a standard working 13A adapter! the bug runs directly off the mains so lasts forever! why pay £700? or price is £26 REF: MAG26 Transmits to any FM radio

***FM BUG KIT** New design with PCB embedded coil for extra stability. Works to any FM radio. 9v battery req'd. £5 REF: MAG5P5

***FM BUG BUILT AND TESTED** superior design to kit. Supplied to detective agencies. 9v battery req'd. £14 REF: MAG14

TALKING COIN BOX STRIPPER originally made to retail at £79 each, these units are designed to convert an ordinary phone into a payphone. The units have the locks missing and sometimes broken hinges. However they can be adapted for their original use or used for something else?? Price is just £3 REF: MAG3P1

TOP QUALITY SPEAKERS Made for Hi Fi televisions these are 10 watt 4R Jap made 4" round with large shielded magnets. Good quality £2 each REF: MAG2P4 or 4 for £6 REF: MAG6P2

TWEETERS 2" diameter good quality tweeter 140R (ok with the above speaker) 2 for £2 REF: MAG2P5 or 4 for £3 REF: MAG3P4

AT KEYBOARDS Made by Apnort these quality keyboards need just a small mod to run on any AT. They work perfectly but you will have to put up with 1 or 2 foreign keycaps! Price £6 REF: MAG6P3

HEADPHONES Ex Virgin Atlantic. 8 pairs for £2 REF: MAG2P8

DOS PACKS Microsoft version 3.3 or higher complete with all manuals or price just £5 REF: MAG5P8. Worth it just for the very comprehensive manual! 5.25" only

DOS PACK Microsoft version 5.0 original software but no manuals hence only £5.99 3.5" only

PIR DETECTOR Made by famous UK alarm manufacturer these are hi spec long range internal units. 12v operation. Slight marks on case and unboxed (although brand new) £8 REF: MAG8P5

MOBILE CARPHONE £6.99 Well almost complete in car phone excluding the box of electronics normally hidden under seat. Can be made to illuminate with 12v also has built in light sensor so display only illuminates when dark. Totally convincing! REF: MAG6P6

ALARM BEACONS Zenon strobe made to mount on an external bell box but could be used for caravans etc. 12v operation. Just connect up and it flashes regularly! £5 REF: MAG5P11

6"X12" AMORPHOUS SOLAR PANEL 12v 155x310mm 130mA. Bargain price just £5.99 ea REF: MAG6P12

FIBRE OPTIC CABLE BUMPER PACK 10 metres for £4.99 ref MAG5P13. Ideal for experimenter! 30m for £12.99 ref MAG13P1

HEATSINKS (finned) TO220, designed to mount vertically on a pcb 50x40x25mm you can have a pack of 4 for £1 ref JUN1P11

INFRARED LASER NIGHT SCOPES
Image intensifier complete with hand grip attachment with built in adjustable laser lamp for zero light conditions. Supplied with Pentax 42mm camera mount and normal eye piece. 1.6kg uses 1xPP3 3xAAA's. Please allow us about 1 month for delivery on this product due to import problems! £245+Vat

NEW HIGH POWER LASERS
15mW Helium neon 3 switchable wavelengths 63um 1 15um 3 39um (2 of them are infrared) 500 1 polarizer built in so good for holography. Supplied complete with mains power supply 790x65mm. Use with EXTREME CAUTION AND QUALIFIED GUIDANCE £349+Vat

WE BUY SURPLUS STOCK FOR CASH!

1995 100 PAGE CATALOGUE NOW AVAILABLE, 45P STAMP OR FREE WITH ORDER.

3FT X 1FT 10WATT SOLAR PANELS
14.5v/700mA
£44.95

(PLUS £2.00 SPECIAL PACKAGING CHARGE)

TOP QUALITY AMORPHOUS SILICON CELLS HAVE ALMOST A TIMELESS LIFESPAN WITH AN INFINITE NUMBER OF POSSIBLE APPLICATIONS. SOME OF WHICH MAY BE CAR BATTERY CHARGING. FOR USE ON BOATS OR CARAVANS, OR ANYWHERE A PORTABLE 12V SUPPLY IS REQUIRED.

PORTABLE RADIATION DETECTOR
WITH NEW COMPUTER INTERFACE.

£59.00

A Hand held personal Gamma and X Ray detector. This unit contains two Geiger Tubes, has a 4 digit LCD display with a Piezo speaker, giving an audio visual indication. The unit detects high energy electromagnetic quanta with an energy from 30K eV to over 1.2M eV and a measuring range of 5-9999 UR/h or 10-99990 Nr/h. Supplied complete with handbook Ref. NOV18.

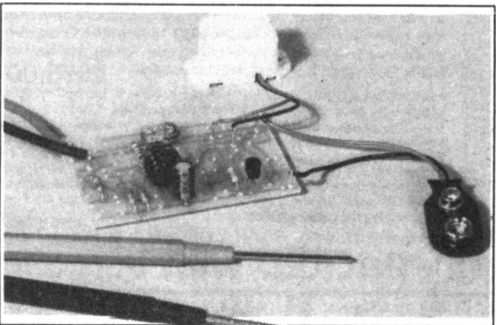
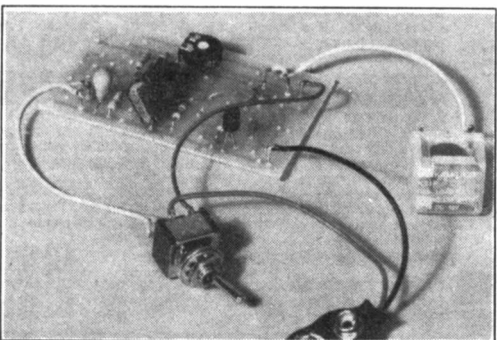
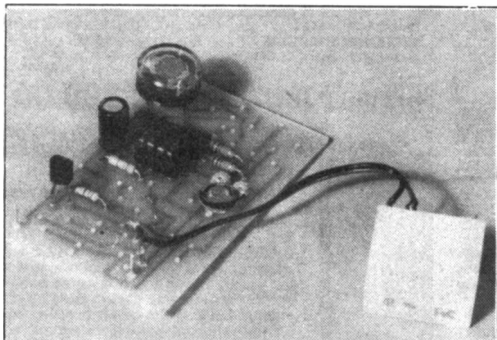

Projects

- NATIONAL LOTTERY PREDICTOR** by Julyan Ilett **266**
 A simple microcontroller project that could make your fortune
- AUTO BATTERY CHARGER** by Terry de Vaux-Balbirnie **280**
 Monitors the condition of lead-acid batteries
- LIGHT-ACTIVATED SWITCH** by Robert Penfold **298**
 A light-sensitive module that can be wired to switch when the light intensity varies from a pre-set level
- SWITCH ON/OFF TIMER** by Robert Penfold **302**
 Switch On or Off your equipment with this one to five minute (extendable) timer
- CONTINUITY TESTER** by Robert Penfold **304**
 A low-cost tester for your toolbox
- NAME OF THE GAME - 2 COUNTERSPIN** by Roy Bebbington **318**
 An easy-build module to set your party game or quiz spinning

Series

- CIRCUIT SURGERY** by Alan Winstanley **276**
 Doorbell Activated Lamp and more on heatsink calculations
- ELECTRONICS FROM THE GROUND UP - 7** **284**
 by Mike Tooley B.A.
 First steps in understanding electronics, with optional computer aided design software. Introducing Digital Logic
- INTERFACE** by Robert Penfold **316**
 The page for computer enthusiasts - Printer port interfacing
- TECHNIQUES - ACTUALLY DOING IT** by Robert Penfold **324**
 Making a connection
- AMATEUR RADIO** by Tony Smith G4FAI **332**
 Morse Tests; IARU Policy; Celebratory Satellite

Features

- EDITORIAL** **265**
- INNOVATIONS** **272**
 Everyday news from the world of electronics
- NEW TECHNOLOGY UPDATE** by Ian Poole **274**
 Emitter Coupled Logic and confocal microscopy, the latest method of detecting faulty wafers
- OHM SWEET OHM** by Max Fidling **278**
 Max and his devoted companion Piddles try their hand/paws at apiculture and taste the sweet life
- FOX REPORT** by Barry Fox **292**
 Digital TV broadcasting
- BACK ISSUES** Did you miss these? **297**
- ELECTRONICS SOFTWARE** **308**
 Educational software - Electronics Principles II, Electronics PC Toolbox 2.0, GCSE Electronics 2.0, and GCSE Mathematics
- ELECTRONICS VIDEOS** **309**
 Our range of educational videos
- THE HARD CELL** by Terry de Vaux-Balbirnie **310**
 What you should know about mobile telephones
- SHOPTALK** with David Barrington **326**
 Component buying for EPE projects
- PLEASE TAKE NOTE** **326**
 Moving Display Metronome
- DIRECT BOOK SERVICE** **327**
 A wide range of technical books available by mail order
- PRINTED CIRCUIT BOARD SERVICE** **330**
 PCBs for EPE projects - some at knock-down price!
- ADVERTISERS INDEX** **336**

© Wimborne Publishing Ltd 1995. Copyright in all drawings, photographs and articles published in **EVERYDAY with PRACTICAL ELECTRONICS** is fully protected, and reproduction or imitations in whole or in part are expressly forbidden.

Our May '95 Issue will be published on Friday, 7 April 1995. See page 255 for details.

Readers Service • Editorial and Advertisement Departments 265

Surplus always wanted for cash!

THE ORIGINAL SURPLUS WONDERLAND!

THIS MONTH'S SELECTION FROM OUR VAST EVER CHANGING STOCKS

Surplus always wanted for cash!

LOW COST PC's - ALL EXPANDABLE - ALL PC COMPATIBLE

SPECIAL OFFER

SPECIAL BUY

AT 286

40Mb HD + 3Mb Ram

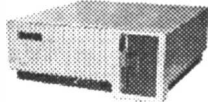

LIMITED QUANTITY only of these 12MHz HI GRADE 286 systems Made in the USA to an industrial specification, the system was designed for total reliability. The compact case houses the motherboard, PSU and EGA video card with single 5 1/4" 1.2 Mb floppy disk drive & integral 40Mb hard disk drive to the front. Real time clock with battery backup is provided as standard. Supplied in good used condition complete with enhanced keyboard, 640k + 2Mb RAM, DOS 4.01 and 90 DAY Full Guarantee. Ready to Run!
Order as HIGRADE 286 **ONLY £149.00 (E)**
CALL FOR QTY DISCOUNTS

Optional Fitted extras: VGA graphics card	£29.00
1.44Mb 3 1/2" floppy disk drive (instead of 1.2 Mb)	£32.95
NE2000 Ethernet (thick, thin or twisted) network card	£49.00

PC SCOOP COMPLETE COLOUR SYSTEM ONLY £99.00

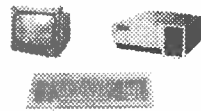

A massive bulk purchase enables us to bring you a COMPLETE ready to run colour PC system at an unheard of price! The Display Electronics PC99 system comprises of fully compatible and expandable XT PC with 256k of RAM, 5 1/4" 360k floppy disk drive, 12" CGA colour monitor, standard 84 key keyboard, MS DOS and all connecting cables - just plug in and go!! Ideal students, schools or anybody wishing to learn the world of PCs at an ultra low budget. Don't miss this opportunity. Fully guaranteed for 90 Days.
Order as PC99COL **£99.00 (E)**

Optional Fitted extras: 640k RAM	£29.00
2nd floppy drive, specify 5 1/4" 360k or 3 1/2" 720k	£29.95
Above prices for PC99 offer ONLY.	

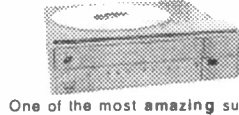

Computer Controlled Laser Video Disk Player

One of the most amazing surplus deals that we ever been able to offer you! The Philips VP410 LaserVision player, in as new condition, unit features full computer control, Plays standard 12" LaserVision disks with startling visual and audio quality in two channel stereo or mono. When controlled by a computer, it may also be used as a versatile high quality storage / retrieval medium. It will play back either LaserVision CAV (active play) or CLV (Long Play) discs (which covers most types of commercially available video discs) Some of the many features of this incredible machine are:
RS-232 INTERFACE RGB / COMPOSITE VIDEO OUTPUT
BNC-SCART INTERFACE PAL / RGB DECODER
IR-WIRED REMOTE CONTROL FAST RANDOM ACCESS

SPECIAL PURCHASE Only £399.00 (F)

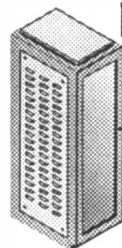

19" RACK CABINETS

Superb quality 6 foot 40U Virtually New, Ultra Smart Less than Half Price!

Top quality 19" rack cabinets made in UK by Optima Enclosures Ltd. Units feature designer, smoked acrylic lockable front door, full height lockable half louvered back door and removable side panels. Fully adjustable internal fixing struts, ready punched for any configuration of equipment mounting plus ready mounted integral 12 way 13 amp socket switched mains distribution strip make these racks some of the most versatile we have ever sold. Racks may be stacked side by side and therefore require only two side panels to stand singly or in bays. Overall dimensions are: 77-1/2" H x 32-1/2" D x 22" W. Order as:
Rack 1 Complete with removable side panels **£335.00 (G)**
Rack 2 Rack, Less side panels **£225.00 (G)**

Over 1000 racks in all sizes 19" 22" & 24" 3 to 44 U. Available from stock!! Call with your requirements.

TOUCH SCREEN SYSTEM

The ultimate in 'Touch Screen Technology' made by the experts - MicroTouch - but sold at a price below cost!! System consists of a flat translucent glass laminated panel measuring 29.5 x 23.5 cm connected to a PCB with on board sophisticated electronics. From the board comes a standard serial RS232 or TTL output. The output continuously gives simple serial data containing positional X & Y co-ordinates as to where a finger is touching the panel - as the finger moves, the data instantly changes. The X & Y information is given at an incredible matrix resolution of 1024 x 1024 positions over the screen size!!! So, no position, however small fails detection. A host of available translation software enables direct connection to a PC for a myriad of applications including: control panels, pointing devices, POS systems, controllers for the disabled or computer un-trained etc etc imagine using your finger in 'Windows' instead of a mouse!!! (a driver is indeed available!!) The applications for this amazing product are only limited by your imagination!! Supplied as a complete system including Controller, Power Supply and Data at an incredible price of only **£145.00 (B)** RFE. Full Software Support Available - Fully Guaranteed

LOW COST RAM UPGRADES

INTEL 'ABOVE' Memory Expansion Board. Full length PC-XT and PC-AT compatible card with 2 Mbytes of memory on board. Card is fully selectable for Expanded or Extended (286 processor and above) memory. Full data and driver disk supplied. In good used condition fully tested and guaranteed.
Windows compatible. Order as: ABOVE CARD **£59.95(A1)**
Half length 8 bit memory upgrade cards for PC AT XT expands memory either 256k or 512k in 64k steps. May also be used to fill in RAM above 640k DOS limit. Complete with data.
Order as: XT RAM UG. 256K **£32.95(A1)**
512K **£38.95(A1)**
1 MB x 9 SIMM 3 chip 80 ns only **£19.50(A)**
1 MB x 9 SIMM 9 chip 80 ns only **£23.50(A)**
1 MB x 9 SIMM 9 chip 80 ns only **£22.50(A)**

NO BREAK UNINTERRUPTIBLE PSU'S

Brand new and boxed 230 volts 1 KVA uninterruptible power supply from system from Densel. Model MUD 1085-AHBB. Complete with sealed lead acid batteries in matching case. Approx time from interrupt is 15 minutes. Complete with full manual **£575.00(G)**
EMERSON ACCUCARD UPS, brand new 8 Bit half length PC compatible card for all IBM XT/AT compatibles. Card provides DC power to all internal system components in the event of power supply failure. The Accusaver software provided uses only 6k of base RAM and automatically copies all system, expanded and video memory to the hard disk in the event of loss of power. When power is returned the machine is returned to the exact status when the power failed!! The unit features full self diagnostics on boot and is supplied brand new, with full, easy fitting instructions and manual.
Normally £189.00 NOW! **£69.00 or 2 for £120 (B)**

FLOPPY DISK DRIVES 3.5" - 8"

5.25" from £22.95 - 3.5" from £24.95

Massive purchases of standard 5.25" and 3.5" drives enables us to present prime product at industry beating low prices!! All units (unless stated) are BRAND NEW or removed from often brand new equipment and are fully tested, aligned and shipped to you with a 90 day guarantee and operate from standard voltages and are of standard size. All are IBM-PC compatible (if 3.5" supported on your PC).

3.5" Panasonic JU363/4 720k or equivalent	£24.95(B)
3.5" Mitsubishi MF355C-L. 1.4 Meg. Laptops only *	£36.95(B)
3.5" Mitsubishi MF355C-D. 1.4 Meg. Non laptop	£29.95(B)
5.25" Teac FD-55GFR 1.2 Meg	£29.95(B)
5.25" BRAND NEW Mitsubishi MF501B 360K	£22.95(B)
* Data cable included in price.	
Shugart 800/801 8" SS refurbished & tested	£195.00(E)
Shugart 851 8" double sided refurbished & tested	£250.00(E)
Mitsubishi M2894-63 8" double sided NEW	£275.00(E)
Mitsubishi M2896-63-02U 8" DS slimline NEW	£285.00(E)
Dual 8" drives with 2 mbyte capacity housed in a smart case with built in power supply. Ideal as exterior drives!	
	£499.00(F)

HARD DISK DRIVES

End of line purchase scoop! Brand new NEC D2246 8" 85 Mbyte of hard disk storage! Full industry standard SMD interface. Ultra hi speed data transfer and access time. replaces Fujitsu equivalent model. Complete with manual. Only **£299.00(E)**

3.5" FUJII FK-309-26 20mb MFM I/F RFE	£59.95(C)
3.5" CONNER CP3024 20 mb IDE I/F (or equiv.)RFE	£69.95(C)
3.5" CONNER CP3044 40mb IDE I/F (or equiv.)RFE	£89.00(C)
3.5" RODIME RO3057S 45mb SCSI I/F (Mac & Acorn)	£99.00(C)
5.25" MINISCRIBE 3425 20mb MFM I/F (or equiv.) RFE	£49.95(C)
5.25" SEAGATE ST-238R 30 mb RLL I/F Refurb	£69.95(C)
5.25" CDC 94205-51 40mb HH MFM I/F RFE tested	£69.95(C)
8" FUJITSU M2322K 160MB SMD I/F RFE tested	£195.00(E)
Hard disc controllers for MFM, IDE, SCSI, RLL etc. from £16.95	

THE AMAZING TELEBOX

Converts your colour monitor into a QUALITY COLOUR TV!!

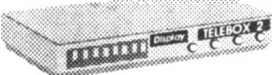

TV SOUND & VIDEO TUNER!

The TELEBOX consists of an attractive fully cased mains powered unit, containing all electronics ready to plug into a host of video monitors made by makers such as MICROVITEC, ATARI, SANYO, SONY, COMMODORE, PHILIPS, TATUNG, AMSTRAD etc. The composite video output will also plug directly into most video recorders, allowing reception of TV channels not normally receivable on most television receivers' (TELEBOX MB). Push button controls on the front panel allow reception of 8 fully louvered 'off air' UHF colour television channels. TELEBOX MB covers virtually all television frequencies VHF and UHF including the HYPERBAND as used by most cable TV operators. A composite video output is located on the rear panel for direct connection to most makes of monitor or desktop video systems. For complete compatibility - even for monitors without sound - an integral 4 watt audio amplifier and low level Hi Fi audio output are provided as standard.

TELEBOX ST for composite video input type monitors	£34.95
TELEBOX STL as ST but with integral speaker	£37.50
TELEBOX MB Multiband VHF-UHF-Cable- Hyperband tuner	£69.95
For overseas PAL versions state 5.5 or 6mhz sound specification	
*For cable / hyperband reception Telebox MB should be connected to cable type service. Shipping code on all Teleboxes is (B)	

FANS & BLOWERS

MITSUBISHI MMF-D6D12DL 60 x 25 mm 12v DC	£4.95 10 / £42
MITSUBISHI MMF-09B12DH 92 x 25 mm 12v DC	£5.95 10 / £53
PANCAKE I2-3.5 92 x 18 mm 12v DC	£7.95 10 / £69
EX-EQUIP 80 x 38mm AC fans - tested specify 110 or 240 v	£6.95
EX-EQUIP 80 x 38mm AC fans - tested specify 110 or 240 v	£5.95
VERO rack mount 1U x 19" fan tray specify 110 or 240v	£45.95 (A)
IMHOF B26 1900 rack mnt 3U x 19" Blower 110/240v NEW	£79.95
Shipping on all fans (A). Blowers (B) 50,000 Fans Ex Stock CALL	

IC's - TRANSISTORS - DIODES

OBsolete - SHORT SUPPLY - BULK

5,000,000 items EX STOCK

For MAJOR SAVINGS - SAE or CALL FOR LATEST LIST

Issue 13 of Display News now available - send large SAE - PACKED with bargains!



LONDON SHOP
Open Mon - Sat 9:00 - 5:30
215 Whitehorse Lane
South Norwood
On 88A Bus Route
N. Thornton Heath &
Selhurst Park SR Rail Stations

ALL MAIL & OFFICES
Open Mon-Fri 9.00-5:30
Dept EE. 32 Biggin Way
Upper Norwood
LONDON SE19 3XF

DISTEL © The Original
FREE On line Database
Info on 1000's of items
V21, V22, V22 BIS
0181 679 1888

ALL ENQUIRIES
0181 679 4414
FAX 0181 679 1927

All prices for UK Mainland. UK customers add 17.5% VAT to TOTAL order amount. Minimum order £10. Bona Fide account orders accepted from Government, Schools, Universities and Local Authorities - minimum account order £50. Cheques over £100 are subject to 10 working days clearance. Carnage charges (A)=£3.00, (S1)=£4.00, (B)=£5.50, (C)=£8.50, (D)=£12.00, (E)=£15.00, (F)=£18.00, (G)=CALL. Allow approx 6 days for shipping - faster CALL. Scotland surcharge CALL. All goods supplied to our Standard Conditions of Sale and unless stated guaranteed for 90 days. All guarantees on a return to base basis. All rights reserved to change prices / specifications without prior notice. Orders subject to stock. Discounts for volume. Top CASH prices paid for surplus goods. All trademarks etc acknowledged. © Display Electronics 1995. E & O.E. /11

PIC-DATS PIC Development and Training System

PIC-DATS enables in-circuit emulation of the PIC 16C5X family of microcontrollers. For educational purposes the system can be used as a classroom training aid

- ★ Enables real time emulation so the target system can be run and modified
- ★ Cross-assembler, communications program and editor in integrated software package
- ★ Simulator allows programs to be checked before using the hardware emulator
- ★ Uses a 16C55 microcontroller running at 4MHz
- ★ I/O and control lines accessed via 40-pin IDC connector
- ★ RS232 port
- ★ On board voltage regulation

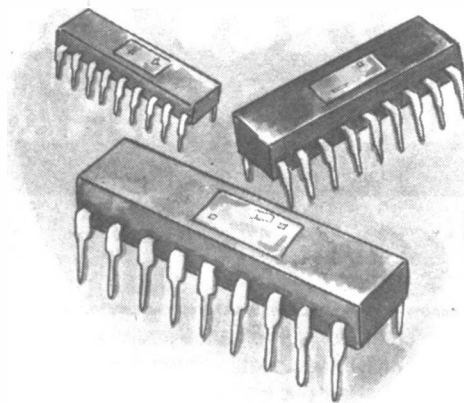

RF Signal Generator

A sophisticated design which can be calibrated to 2% accuracy and built for about one third of the price of an equivalent commercial generator. Covers 1-2MHz to 30MHz in three ranges with switched external or internal 30% modulation.

Midi Pedal

Midi Pedal units are often quite expensive and sophisticated, this basic design can be set up as a sustain, portamento or soft pedal and is relatively inexpensive and easy to build.

**DON'T MISS THIS IMPORTANT
"FIRST" FOR AN
ELECTRONICS MAGAZINE!**

EVERYDAY

With **PRACTICAL**

ELECTRONICS

MAY '95 ISSUE ON SALE FRIDAY, APRIL 7

NEXT MONTH

SEETRAX CAE - RANGER - PCB DESIGN

Ranger1 £100

- * Schematic capture linked to PCB
- * Parts and wiring list entry
- * Outline (footprint) library editor
- * Manual board layout
- * Full design rule checker
- * Back annotation (linked to schematic)
- * Power, m...y and signal autorouter - £50

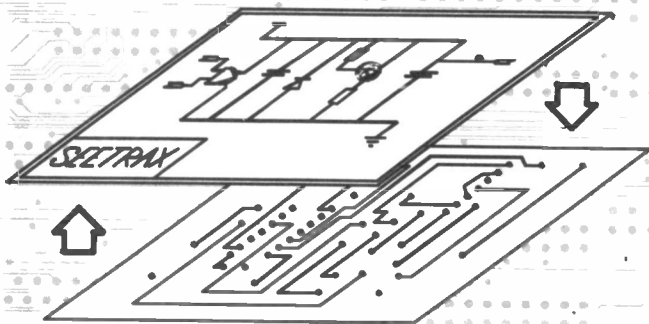

Ranger2 £599

- All the features of Ranger1 plus
- * Gate & pin swapping (linked to schematic)
 - * Track highlighting
 - * Auto track necking
 - * Copper flood fill
 - * Power planes (heat-relief & anti-pads)
 - * Rip-up & retry autorouter

Ranger3 £3500

- All the features of Ranger2 plus
- * UNIX or DOS versions
 - * 1 Micron resolution and angles to 1/10th degree
 - * Hierarchical or flat schematic
 - * Unlimited design size
 - * Any-shaped pad
 - * Split power planes
 - * Optional on-line DRC
 - * 100% rip-up & retry, push & shove autorouter

All systems upward compatible. Trade-in deals available.

Call Seetrax CAE for further information/demo packs.
Tel 0705 591037 Fax 0705 599036

Seetrax CAE, Hinton Daubnay House, Broadway Lane,
Lovedean, Hampshire, PO8 0SG

All trademarks acknowledged.

Outputs to:

- * 8/9 and 24 pin dot-matrix printers
- * HP Desk/Laser Jet, Canon BJet, Postscript (R3 only)
- * HP-GL, Houston Instruments plotters
- * Gerber photoplotters
- * NC Drill Excellon, Sieb & Meyer
- * AutoCAD DXF

SURVEILLANCE PROFESSIONAL QUALITY KITS

No. 1 for Kits

Whether your requirement for surveillance equipment is amateur, professional or you are just fascinated by this unique area of electronics SUMA DESIGNS has a kit to fit the bill. We have been designing electronic surveillance equipment for over 12 years and you can be sure that all our kits are very well tried, tested and proven and come complete with full instructions, circuit diagrams, assembly details and all high quality components including fibreglass PCB. Unless otherwise stated all transmitters are tuneable and can be received on an ordinary VHF FM radio.

Genuine SUMA kits available only direct from Suma Designs. Beware inferior imitations!

UTX Ultra-miniature Room Transmitter

Smallest room transmitter kit in the world! Incredible 10mm x 20mm including mic. 3-12V operation. 500m range.....£16.45

MTX Micro-miniature Room Transmitter

Best-selling micro-miniature Room Transmitter

Just 17mm x 17mm including mic. 3-12V operation. 1000m range.....£13.45

STX High-performance Room Transmitter

Hi performance transmitter with a buffered output stage for greater stability and range. Measures 22mm x 22mm including mic. 6-12V operation, 1500m range.....£15.45

VT500 High-power Room Transmitter

Powerful 250mW output providing excellent range and performance. Size 20mm x 40mm. 9-12V operation. 3000m range.....£16.45

VXT Voice Activated Transmitter

Triggers only when sounds are detected. Very low standby current. Variable sensitivity and delay with LED indicator. Size 20mm x 67mm. 9V operation. 1000m range..£19.45

HVX400 Mains Powered Room Transmitter

Connects directly to 240V AC supply for long-term monitoring. Size 30mm x 35mm. 500m range.....£19.45

SCRX Subcarrier Scrambled Room Transmitter

Scrambled output from this transmitter cannot be monitored without the SCDM decoder connected to the receiver. Size 20mm x 67mm. 9V operation. 1000m range.....£22.95

SC LX Subcarrier Telephone Transmitter

Connects to telephone line anywhere, requires no batteries. Output scrambled so requires SCDM connected to receiver. Size 32mm x 37mm. 1000m range.....£23.95

SCDM Subcarrier Decoder Unit for SCR X

Connects to receiver earphone socket and provides decoded audio output to headphones. Size 32mm x 70mm. 9-12V operation.....£22.95

ATR2 Micro Size Telephone Recording Interface

Connects between telephone line (anywhere) and cassette recorder. Switches tape automatically as phone is used. All conversations recorded. Size 16mm x 32mm. Powered from line.....£13.45

UTLX Ultra-miniature Telephone Transmitter

Smallest telephone transmitter kit available. Incredible size of 10mm x 20mm! Connects to line (anywhere) and switches on and off with phone use.

All conversation transmitted. Powered from line. 500m range.....£15.95

TLX700 Micro-miniature Telephone Transmitter

Best-selling telephone transmitter. Being 20mm x 20mm it is easier to assemble than UTLX. Connects to line (anywhere) and switches on and off with phone use. All conversations transmitted. Powered from line. 1000m range.....£13.45

STLX High-performance Telephone Transmitter

High performance transmitter with buffered output stage providing excellent stability and performance. Connects to line (anywhere) and switches on and off with phone use. All conversations transmitted. Powered from line. Size 22mm x 22mm. 1500m range.....£16.45

TKX900 Signalling/Tracking Transmitter

Transmits a continuous stream of audio pulses with variable tone and rate. Ideal for signalling or tracking purposes. High power output giving range up to 3000m. Size 25mm x 63mm. 9V operation.....£22.95

CD400 Pocket Bug Detector/Locator

LED and piezo bleeper pulse slowly, rate of pulse and pitch of tone increase as you approach signal. Gain control allows pinpointing of source. Size 45mm x 54mm. 9V operation.....£30.95

CD600 Professional Bug Detector/Locator

Multicolour readout of signal strength with variable rate bleeper and variable sensitivity used to detect and locate hidden transmitters. Switch to AUDIO CONFORM mode to distinguish between localised bug transmission and normal legitimate signals such as pagers, cellular, taxis etc. Size 70mm x 100mm. 9V operation.....£50.95

QTX180 Crystal Controlled Room Transmitter

Narrow band FM transmitter for the ultimate in privacy. Operates on 180 MHz and requires the use of a scanner receiver or our QRX180 kit (see catalogue). Size 20mm x 67mm. 9V operation. 1000m range.....£40.95

QLX180 Crystal Controlled Telephone Transmitter

As per QTX180 but connects to telephone line to monitor both sides of conversations. 20mm x 67mm. 9V operation. 1000m range.....£40.95

QSX180 Line Powered Crystal Controlled Phone Transmitter

As per QLX180 but draws power requirements from line. No batteries required. Size 32mm x 37mm. Range 500m.....£35.95

QRX180 Crystal Controlled FM Receiver

For monitoring any of the 'Q' range transmitters. High sensitivity unit. All RF section supplied as a pre-built and aligned module ready to connect on board so no difficulty setting up. Outpt to headphones. 60mm x 75mm. 9V operation.....£60.95

A build-up service is available on all our kits if required.

UK customers please send cheques, POs or registered cash. Please add £1.50 per order for P&P. Goods despatched ASAP allowing for cheque clearance. Overseas customers send sterling bank draft and add £5.00 per order for shipment. Credit card orders welcomed on 0827 714476.

OUR LATEST CATALOGUE CONTAINING MANY MORE NEW SURVEILLANCE KITS NOW AVAILABLE. SEND TWO FIRST CLASS STAMPS OR OVERSEAS SEND TWO IRCS.

★★★★ Specials ★★★★★

DLTX/DLRX Radio Control Switch

Remote control anything around your home or garden, outside lights, alarms, paging system etc. System consists of a small VHF transmitter with digital encoder and receiver unit with decoder and relay output, momentary or alternate, 8-way di1 switches on both boards set your own unique security code. TX size 45mm x 45mm. RX size 35mm x 90mm. Both 9V operation. Range up to 200m.

Complete System (2 kits).....£50.95

Individual Transmitter DLTX.....£19.95

Individual Receiver DLRX.....£37.95

MBX-1 Hi-Fi Micro Broadcaster

Not technically a surveillance device but a great idea! Connects to the headphone output of your Hi-Fi, tape or CD and transmits Hi-Fi quality to a nearby radio. Listen to your favourite music anywhere around the house, garden, in the bath or in the garage and you don't have to put up with the DJ's choice and boring waffle. Size 27mm x 60mm. 9V operation. 250m range.....£20.95

DEPT. EE

**SUMA
DESIGNS**

THE WORKSHOPS, 95 MAIN ROAD,
BAXTERLEY. NEAR AHERSTONE,
WARWICKSHIRE CV9 2LE

VISITORS STRICTLY BY APPOINTMENT ONLY



Tel/Fax:
0827 714476

A SELECTION OF SURPLUS FROM OUR LISTS



DIGITAL MULTIMETER

- ▶ Input Imp. 10M Ω
- ▶ 3½ digit 15mm LCD display
- ▶ 32 ranges including 20A ac/dc
- ▶ Transistor and diode test
- ▶ Continuity test with buzzer and LED
- ▶ Rugged yellow case
- ▶ Test leads with shrouded 4mm plugs
- ▶ Carrying case
- ▶ Fuse Protection
- ▶ Automatic polarity and zero

Usually
£36.95

£29.95

Battery and instruction manual included

Order Code
M3800

AC volts	0-200m-2-20-200-750Vaca±0.8%
DC volts	0-200m-2-20-200-1000Vdca±0.5%
AC current	0-20 μ -200 μ -2m-20m-200m-2A-20Aaca±1.0%
CD current	0-20 μ -200 μ -2m-20m-200m-2A-20Adca±0.5%
Resistance	0-200-2k-20k-200k-2M-20M Ω ±0.5%
Transistor hFE	0-1000 NPN/PNP
Dims	176x88x36mm

UNINTERRUPTIBLE POWER SUPPLIES

These are all in good working order, offered at a fraction of their original cost. Please note carriage is extra on these items only and will vary with distance; ring for details.



Z9298 Made by Sola, this UPS is rated 600VA and comes with a separately cased sealed lead acid battery of 36 cells.

£400

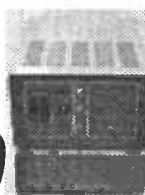

Z9297 Rated 1000VA, this UPS is made by Sola and is supplied with a separately cased sealed lead acid battery of 36 cells.

£500

BACK IN STOCK - MINIATURE DRILL PACKS!

REDUCED SHANKUNGSTEN CARBIDE

These were very popular when last advertised and sold out quite quickly. Don't miss out this time although we have plenty of 0.95mm, the other sizes are in short supply.

All have 3.15mm shank. They normally cost around £3 each.

Available in the following packs.
K901 8 drills - 0.35, 0.85, 4 x 0.95, 1.10 and 1.15mm for £5.95

These sizes only available separately
Z3233 0.95mm 75p; 25+ 0.40, 100+ 0.30
Z3234 1.10mm £1.00; 25+ 0.50; 100+ 0.40

ANOTHER SUPER DISK DEAL!

X6043 Star LC24-30/LC24-300 printer driver disk, individually packaged. There's also 15 TrueType Fonts for use with Windows 3.1, but we're just selling this for the media value - the software is free! It's a 3.5" 1.44M formatted high density disk.

10 for £3.95
100 for £30

VOLTAGE TESTER



YO238A Dual function screwdriver type circuit tester. Used as an inductance tester. It will detect buried live cables, breaks in cables etc. Touching a live part with the tip will indicate the voltage level on the LCD screen. AC or DC up to 250V max.

£3.50

FANS



Some ex-equip axial flow fans, all in good working order at substantial savings over new models.

Z3855 Smallest fan we've seen! 42x42 by just 10mm thick! Made by Nitev, model TA150DC. Rated 12V DC 0.11A. Only £3.00
X6015 Papst (mostly) 612L 60x60x25mm 12V DC (6-15V) 0.7W fans. List is 27.47. Our Price £3.00

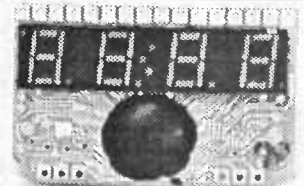

99P CLOCK

Z3873 Super Offer! A complete clock in a 40x25mm module. 9V operation with sleep & snooze, 24hr alarm, PM, colon and alarm indicators. Simple fast/slow setting controls. 5 display modes, 12/24hr selectable, display brightness control. Full info supplied. **All this for 99p!**

Wireless Doorbell

T071D Two part wireless doorbell. The transmitter is mounted by the front door and the receiver can be mounted or carried up to 16m (50 feet) away. Provided with self-adhesive pads and screws for mounting (if required). Transmitter requires a PP3 battery, receiver requires two AA batteries.

Dims: Transmitter 112x40x30mm
Receiver 93x70x30mm

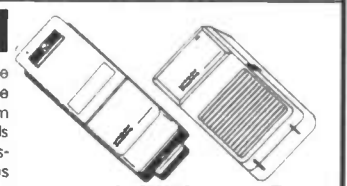

ONLY £8.95
SEEN ELSEWHERE FOR £14.95

RELAY PARCEL



Code	Man & Type	Size	V	R	Contacts	Pic	Qty	DP	Price	100+
Z3877	Omron G5A 234P-53/1	16x10x8	4.5	101R	DPCO 1A	A	2000	3.56	1.00	0.65
Z3899	Hamlin HE72 1A5262	19x6 5x7	5	500R	SPM	J	2500	2.55	1.00	0.65
Z3878	211NC D009-P	16x11x10	9	390R	SPCO	B	2600		1.00	0.65
Z3879	NEC MR24-12S	30x24x10	12	330R	4PCO	C	800	7.97	2.00	1.20
Z3880	KV23/9 FW	30x24x18	12	550R	DPCO	D	800	5.98	1.50	0.90
Z3881	National NF4-24	30x24x10	24	1200R	4PCO	C	100	7.97	2.00	1.20
Z3882	KV 1002-027	28x24x12	24	820R	DPCO 2A	E	300		1.00	0.65
Z3883	Omron LC1M-US	22x21x16	24	1500R	SPCO 10A	F	200	1.79	1.00	0.65
Z3884	AMF KAP14 DG	53x34x34	24	450R	3PCO 6A	G	900	5.86	2.00	1.20
Z3885	Omron PTO8 (FOR LY2)	29x22x12	8 PIN	BASE	2PCO	H	300	1.48	0.60	0.35
Z3886	Omron PT14 (FOR LY4)	42x29x12	14 PIN	BASE	4PCO	I	800	1.73	0.80	0.50

MINIATURE SWITCHES



Code	Type	Size	Contacts	Pos	Mntg	Qty	Price	100+
X3070	A13HAO	13x10x7	SPCO	NB	PCBH	1150	3/£1.00	0.15
X3071	A12GVAO	13x10x7	SPCO	NN	PCBH	1000	3/£1.00	0.15
X3072	A14SAO	13x10x7	SPCO	Push	PCBV	900	3/£1.00	0.15
X3073	A24AO	13x10x12	DPCO	NFN	ST	3600	5/£2.00	0.20
X3074	A22TSAO	13x10x12	DPCO	NN	PCBV	250	5/£2.00	0.20

UHF MODULATOR



X6035 Alps UHF modulator. Phono input, co-ax output, also switchable between co-ax input and output. £2.50

HEADPHONE OFFER



CD04 - Neat rectangular style CD Headphones, compact design with extremely good sound. These retail for up to £19.95 (depending on how posy the store is!) Spec 16-22,000Hz Sornarum cobalt transducers. Gold plated 3.5mm plug & adaptor. 32 Ω impedance.



MDR20 - Personal stereo headphones. Again top quality using sornarum cobalt transducers. Spec as CD04 alongside. Attractively packaged with spare covers.

SUPER PRICE £4.95 **SUPER PRICE £3.95**

Phone Nos: **SALES 01703 236363**; Technical 325999; Accounts 231003; Fax (All depts) 236307; FaxOnDemand 236315*

*To obtain latest lists, info etc, just dial 01703 236315 from any fax machine and follow instructions. Prices in this advert include VAT; Quantity prices don't. P&P £3 per order (£9.50 next day). Min Credit Card £12; Official Orders welcome from Education - min invoice charge £15. Payment accepted by cheque, PO, cash, book tokens, Access, Visa, Connect. Our stores (over 10,000 sq ft) have enormous stocks. We are open from 8-5.30 Mon-Sat. Come and see us!

GREENWELD
ELECTRONIC COMPONENTS



27D Park Road Southampton SO15 3UQ

£1 BARGAIN PACKS

You get another FREE if you order 10 of the same number.

- 1 x 12V Stepper Motor. 7.5 degree. Order Ref: 910.
- 1 x 10 pack Screwdrivers. Order Ref: 909.
- 2 x 5 Amp Pull Cord Ceiling Switches. Brown. Order Ref: 921.
- 5 x reels Insulation Tape. Order Ref: 911.
- 2 x 14mm Bull-races. Order Ref: 912.
- 2 x Cord Grip Switch Lamp Holders. Order Ref: 913.
- 1 x DC Voltage Reducer. 12V-6V. Order Ref: 916.
- 1 x 10 Amp 40V Bridge Rectifier. Order Ref: 889.
- Lightweight Stereo Headphones. Moving coil so superior sound. Order Ref: 896.
- 2 x 25W Crossovers. For 4ohm loudspeakers. Order Ref: 22.
- 2 x NiCad Constant Current Chargers. Easily adaptable to charge almost any NiCad battery. Order Ref: 30.
- 18V-0-18V 10VA mains transformer. Order Ref: 813.
- 2 x White Plastic Boxes. With lids, approx. 3" cube. Lid has square hole through the centre so these are ideal for light operated switch. Order Ref: 132.
- 2 x Reed Relay Kits. You get 8 reed switches and 2 coil sets. Order Ref: 148.
- 12V-0-12V 6VA mains transformer, p.c.b. mounting. Order Ref: 938.
- 1 x Big Pull Solenoid. Mains operated. Has 1/2" pull. Order Ref: 871.
- 1 x Big Push Solenoid. Mains operated. Has 1/2" push. Order Ref: 872.
- 1 x Mini Mono Amp. 3W into 4 ohm speaker or 1W into 8 ohm. Order Ref: 495.
- 1 x Mini Stereo 1W Amp. Order Ref: 870.
- 15V DC 150mA p.s.u., nicely cased. Order Ref: 942.
- 1 x In-Flight Stereo Unit is a stereo amp. Has two most useful mini moving coil speakers. Made for BOAC passengers. Order Ref: 29.
- 1 x 0-1mA Panel Meter. Full vision face 70mm square. Scaled 0-100. Order Ref: 756.
- 2 x Lithium Batteries. 2.5V pentlight size. Order Ref: 874.
- 2 x 3m Telephone Leads. With BT flat plug. Ideal for 'phone extensions, fax, etc. Order Ref: 552.
- 1 x 12V Solenoid. Has good 1/2" pull or could push if modified. Order Ref: 232.
- 4 x In-Flex Switches. With neon on/off lights, saves leaving things switched on. Order Ref: 7.
- 2 x 6V 1A Mains Transformers. Upright mounting with fixing clamps. Order Ref: 9.
- 2 x Humidity Switches. As the air becomes damper, the membrane stretches and operates a microswitch. Order Ref: 32.
- 5 x 13A Rocker Switch. Three tags so on/off, or changeover with centre off. Order Ref: 42.
- Mini Cassette Motor. 9V. Order Ref: 944.
- 1 x Suck or Blow-Operated Pressure Switch. Or it can be operated by any low pressure variation such as water level in tanks. Order Ref: 67.
- 1 x 6V 750mA Power Supply. Nicely cased with mains input and 6V output lead. Order Ref: 103A.
- 2 x Stripper Boards. Each contains a 400V 2A bridge rectifier and 14 other diodes and rectifiers as well as dozens of capacitors, etc. Order Ref: 120.
- 12 Very Fine Drills. For PCB boards etc. Normal cost about 80p each. Order Ref: 128.
- 5 x Motors for Model Aeroplanes. Spin to start so needs no switch. Order Ref: 134.
- 6 x Microphone Inserts. Magnetic 400 ohm, also act as speakers. Order Ref: 139.
- 6 x Neon Indicators. In panel mounting holders with lens. Order Ref: 180.
- 1 x In-Flex Solderstat. Keeps your soldering iron etc always at the ready. Order Ref: 196.
- 1 x Mains Solenoid. Very Powerful as 1/2" pull, or could push if modified. Order Ref: 199.
- 1 x Electric Clock. Mains operated. Put this in a box and you need never be late. Order Ref: 211.
- 4 x 12V Alarms. Makes a noise about as loud as a car horn. All brand new. Order Ref: 221.
- 2 x (6" x 4") Speakers. 16 ohm 5 watts, so can be joined in parallel to make a high wattage column. Order Ref: 243.
- 1 x Panostat. Controls output of boiling ring from simmer up to boil. Order Ref: 252.
- 2 x Oblong Push Switches. For bell or chimes, these can switch mains up to 5A so could be footswitch if fitted in pattress. Order Ref: 263.
- 50 x Mixed Silicon Diodes. Order Ref: 293.
- 1 x 6 Digit Mains Operated Counter. Standard size but counts in even numbers. Order Ref: 28.
- 2 x 6V Operated Reed Relays. One normally on, other normally closed. Order Ref: 48.
- 1 x Cabinet Lock. With two keys. Order Ref: 55.
- 6 1/2" 8Ω 5 Watt Speaker. Order Ref: 824.
- 1 x Shaded-Pole Mains Motor. 3/4" stack, so quite powerful. Order Ref: 85.
- 2 x 5 Aluminium Fan Blades. Could be fitted to the above motor. Order Ref: 86.
- 1 x Case, 3 1/2" x 2 1/4" x 1 3/4" with 13A socket pins. Order Ref: 845.
- 2 x Cases. 2 1/2" x 2 1/4" x 1 3/4" with 13A pins. Order Ref: 565.
- 4 x Luminous Rocker Switches. 10A mains. Order Ref: 793.
- 4 x Different Standard V3 Micro Switches. Order Ref: 340.
- 4 x Different Sub Min Micro Switches. Order Ref: 313.

BARGAINS GALORE

British Telecom Multimeter. It is a 20,000 OPV with a full vision scale, nicely cased, measuring approximately 6" x 4" x 2 1/4" deep. Has six D.C. volt ranges up to 250V, five A.C. ranges up to 1,000V, five D.C. current ranges up to 1A and three resistance ranges, one low resistance, one medium and the other up to one Megohm. All ranges are selected by one central control switch. Price complete with leads £8.50, Order Ref: 85P3. Carrying case with handle available and space for small tools, £2 extra.

Infra Red Controller. Made for Thorn TV sets but suitable for other control purposes. Fully built and ready to operate, real bargain, £2, Order Ref: 2P304.

Hall Effect. Give positive or negative pulses when magnet passes over. Mounted on small PCB, 2 for £1, Order Ref: 1032.

Digital Multi-Tester. 30 range, model no. 3800, normal price £40, our price £25, Order Ref: 25P14. Brand new and guaranteed.

Water Pump with spindle for operation by portable drill, £5, Order Ref: 5P240.

Three More Transformers. Order Ref: 4P81 is a 12V-0-12V 40W, clamp mounted, price £4 each less 10% for 10 or more. Order Ref: 5P236 is a 43V at 2-4A, frame mounted, heavy construction, will withstand considerable overloads, price £5. Order Ref: 3P181 is a 12V 3A frame mounting type but without the frames, price £3. We have tested this and find it quite suitable for 50W lamps

£1 Super Bargain

12V axial fan for only £1, ideal for equipment cooling, brand new, made by West German company. Brushless so virtually everlasting. Needs simple transistor drive circuit, we include diagram. Only £1. Order Ref: 919. When we supply this we will include a list of approximately 800 of our other £1 bargains.

Mains Klaxon Type Alarm. Very loud output but adjustable. Completely encased, shell or wall mounting, £5, Order Ref: 5P226.

12V 10A Switch Mode Power Supply for only £9.50 and a little bit of work because you have to convert your 135W PSU. Modifications are relatively simple - we supply instructions. Simply order PSU Ref: 9.5P2 and request modification details, price still £9.50.

1/4HP 12V Motor. The famous Sinclair C5 still available, price £29.50, VAT and carriage paid, Order Ref: 29.5P1

Speed Controller for 12V DC Motors. Suitable for motors with horse powers up to one third and drawing currents up to 30A. Gives very good control of speed. Uses MOSFETS and is based on a well tried circuit which appeared in the *Model Engineer* some time ago. The complete kit with case and on/off switch, price £18, Order Ref: 18P8

Figure-8 Flex. Figure-8 flat white pvc, flexible with 4 sq.mm cores. Ideal for speaker extensions and bell circuits. Also adequately insulated for mains lighting, 50m coil, £2, Order Ref: 2P345. 12m coil, £1, Order Ref: 1014

Friedland Underdoor Bell. Their ref: 792, a loud ringer but very neat, 3" diameter, complete with wall fixing screws, £5, Order Ref: 5P232.

Flashing Beacon. Ideal as a warning light, the fire alarm, etc. Xenon tube produces intense pulse of light. Operates from 12V DC and is supplied complete with mounting base. Price £7.50, Order Ref: 7.5P13.

12V 10A Switch Mode Power Supply. For only £9.50 and a little bit of work because you have to convert our 135W PSU. Modifications are relatively simple - we supply instructions. Simply order PSU Ref: 9.5P2 and request modification details, price still £9.50

Medicine Cupboard Alarm. Or it could be used to warn when any cupboard door is opened. The light shining on the unit makes the bell ring. Completely built and neatly cased, requires only a battery, £3, Order Ref: 3P155.

Don't Let it Overflow! Be it bath, sink, cellar, sump or any other thing that could flood. This device will tell you when the water has risen to the pre-set level. Adjustable over quite a useful range. Neatly cased for wall mounting, ready to work when battery fitted, £3, Order Ref: 3P156

Very Powerful Mains Motor. With extra long (2 1/2") shafts extending out each side. Makes it ideal for a reversing arrangement for, as you know, shaded-pole motors are not reversible, £3, Order Ref: 3P157

Solar Panel Bargain. Gives 3V at 200mA. Order Ref: 2P324

45A Double-Pole Mains Switch. Mounted on a 6" x 3 1/2" aluminium plate, beautifully finished in gold, with pilot light. Top quality, made by MEM, £2, Order Ref: 2P316

Lamp Dimmer. Suitable for up to 250W, on standard plate so fits directly in place of existing switch. Coloured red, blue, yellow or green but will take emulsion paint, £2 each, Order Ref: 2P380

Touch Dimmers. 40W-250W, no knob to turn, just finger on front plate, will give more, or less light, or off. Silver plate on white background, right size to replace normal switch, £5, Order Ref: 5P230

LCD 3 1/2 Digit Panel Meter

This is a multi-range voltmeter/ammeter using the A-D converter chip 7106 to provide five ranges each of volts and amps. Supplied with full data sheet. Special snip price of £12, Order Ref: 12P19

12/24V DC Solenoid. The construction of this is such that it will push or pull. With 24V this is terrifically powerful but is still quite good at 12V. £1, Order Ref: 877

Don't Stand Out In The Cold. Our 12m telephone extension lead has a flat BT socket one end and flat BT plug other end, £2, Order Ref: 2P338

20W 5" 4 Ohm Speaker. Mounted on baffle with front grille, £3, Order Ref: 3P145. Matching 4 ohm 20W tweeter on separate baffle, £1.50, Order Ref: 1.5P9

Telephone Extension Wire, 4-core correctly colour coded, intended for permanent extensions, 25m coil, £2, Order Ref: 2P339

High Power Switch Mode PSU. Normal mains input, three outputs: +12V at 4A, +5V at 16A and -12V at 1/2A. Completely enclosed in plated steel case. Brand new. Our special offer price of £9.50, Order Ref: 9.5P1

Philips 9" High Resolution Monitor. Black and white in metal frame for easy mounting. Brand new, still in maker's packing, offered at less than price of tube alone, only £15, Order Ref: 15P1

BARGAINS GALORE

3/4" Rubber Grommets for insulation through panel. Packet of 100, £1, Order Ref: 181

Mains Transformer 6V-0V-6V 6VA. £1, Order Ref: 330

Ceramic Wave Change Switch, 12-pole, 3-way with 1/4" spindle, £1, Order Ref: 303

Luminous Rocker Switches. Packet of 3, £1, Order Ref: 373

Cased Mains Power Supply with leads, ideal to operate doorbell, £1, Order Ref: 102

High Current A.C. Mains Relay. This has a 230V coil and changeover switch rated at 15A with PCB mounting with clear plastic cover, £1, Order Ref: 965

Ultra Thin Drills, actually 0.3mm. To buy these regular costs a fortune. However, these are packed in half dozens and the price to you is £1 per pack. Order Ref: 797B

You Can Stand On It! Made to house GPO telephone equipment, this box is extremely tough and would be ideal for keeping your small tools in. Internal size approx. 10 1/2" x 4 1/2" x 6" high. Complete with carrying strap, price £2. Order Ref: 2P283B

Ultra Sonic Transducers. Two metal cased units, one transmits, one receives. Built to operate around 40kHz. Price £1.50 the pair. Order Ref: 1.5P/4

Power Supply with Extras. Mains input is fused and filtered and the 12V DC output is voltage regulated. Intended for high class equipment, this is mounted on a PCB and, also mounted on the board, but easily removed, are two 12V relays and Piezo sander, £3, Order Ref: 3P80B

Insulation Tester with Multimeter. Internally generates voltages which enable you to read insulation directly in megohms. The multimeter has four ranges. AC/DC volts, three ranges DC milliamps, three ranges resistance and five ampere ranges. These instruments are ex-British Telecom but in very good condition, tested and guaranteed OK, probably cost at least £50, yours for only £7.50 with leads, carrying case £2 extra. Order Ref: 7.5P/4

Mains Isolation Transformer. Stops you getting "to earth" shocks. 230V in and 230V out. 150 watt. £7.50. Order Ref: 7.5P/5

Mains 230V Fan. Best make "PAPST", 1/4" square, metal blades, £8, Order Ref: 8P8

2MW Laser. Helium neon by Philips, full spec. £30. Order Ref: 30P1. Power supply for this in kit form with case is £15, Order Ref: 15P16, or in larger case to house tube as well £18, Order Ref: 18P2. The larger unit, made up, tested and ready to use, complete with laser tube £69, Order Ref: 69P1

12V 8ohm speaker, only £1.50 and waterproof.

Solar Charger. Holds 4AA NiCads and recharges these in eight hours, in very neat plastic case £6, Order Ref: 6P3

Ferrite Aerial Rod. 8" long x 3/8" diameter, made by Mullard. Complete with two coils, 2 for £1, Order Ref: 832P

Air Spaced Trimmer Caps. 2-20PF, ideal for precision tuning UHF circuits, 4 for £1, Order Ref: 818B

Modem Amstrad FM240. As new condition but customer return, so you may need to fault find, £6, Order Ref: 6P34

Amstrad Power Unit. 13.5V at 1.9A or 12V at 2A encased and with leads and output plug, normal mains input, £6, Order Ref: 6P23

80W Mains Transformer. Two available, good quality, both with normal primaries and upright mounting, one is 20V 4A, Order Ref: 3P106, the other 40V 2A, Order Ref: 3P107, only £3 each

Project Box. Size approx. 8" x 4" x 1/2" metal, sprayed grey, louvered ends for ventilation otherwise undrilled. Made for GPO so best quality, only £3 each. Order Ref: 3P74

Sintinel Component Board. Amongst hundreds of other parts, this has 15 I.C.s, all plug in so do not need desoldering. Cost well over £100, yours for £4, Order Ref: 4P67

Sinclair 9V 2-1A Power Supply. Made to operate the 138K Spectrum Plus 2, cased with input and output leads. Originally listed at around £15, are brand new, our price is only £3, Order Ref: 3P151

15W 8 Ohm 8" Speaker and 3" Tweeter. Made for a discontinued high quality music centre, gives real hi-fi and only £4 per pair. Order Ref: 4P57

Water Pump. Very powerful, mains operated, £10. Order Ref: 10P74

0-1mA Full Vision Panel Meter. 2 3/4" square, scaled 0-100 but scale easily removed for re-writing, £1 each. Order Ref: 756

Amstrad Keyboard Model KB5. This is a most comprehensive keyboard, having over 100 keys including, of course, full numerical and qwerty. Brand new, still in maker's packing, £5, Order Ref: 5P202

Unusual Solenoid. Solenoids normally have to be energised to pull in and hold the core, this is a disadvantage where the appliance is left on for most of the time. We now have magnetic solenoids which hold the core until a voltage is applied to release it. £2, Order Ref: 2P327

Mains Filter. Resin impregnated, nicely cased, p.c.b. mounting, £2, Order Ref: 2P315

Prices include VAT. Send cheque/postal order or ring and quote credit card number. Add £3 post and packing. Orders over £25 post free.

M & B ELECTRICAL SUPPLIES LTD
Pilgrim Works (Dept. E.E.)
Stairbridge Lane, Bolney,
Sussex RH17 5PA
Telephone: 0444 881965
(Also fax but phone first)
Callers to 12 Boundary Road,
Hove, Sussex.

EASY-PC, Schematic and PCB CAD

Over 18,000 Installations
in 80 Countries World-wide!

**Still
Only
£98.00!**

Plus P&P+VAT

**BRITISH
DESIGN
AWARD
1989**

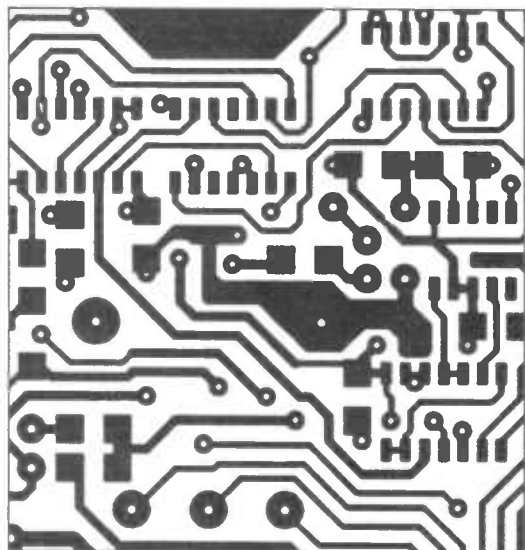

- Runs on:- PC/XT/AT/286/386/486 with Hercules, CGA, EGA or VGA display and many DOS emulations.
- Design:- Single sided, Double sided and Multi-layer (8) boards.
- Provides full Surface Mount support.
- Standard output includes Dot Matrix / Laser / Ink-jet Printer, Pen Plotter, Photo-plotter and N.C. Drill.
- Tech Support - free.
- Superbly easy to use.

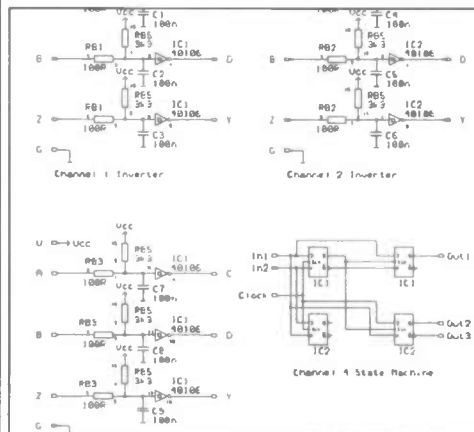

Options:-500 piece Surface Mount Symbol Library £48,
1000 piece Symbol Library £38, Gerber Import facility £98.

Electronic Designs Right First Time?

ELECTRO-MAGNETIC Simulation ONLY £495

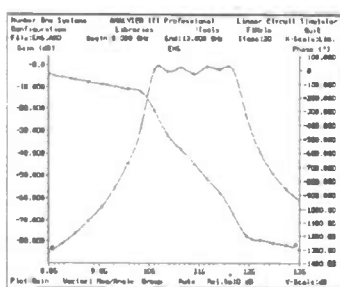
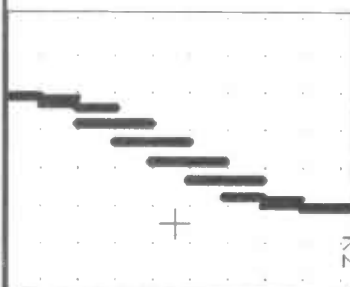
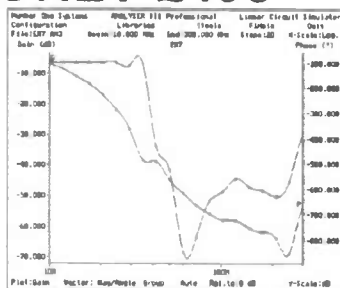
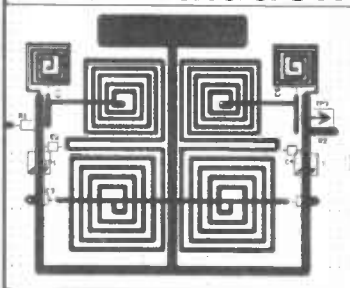

Affordable Electronics CAD

LAYAN: NEW, Electro-magnetic Layout Simulator. Includes the effects of the PCB LAYOUT into your simulation. Links to EASY-PC Professional XM and ANALYSER III Professional.	£495.00
STOCKIT: NEW, Comprehensive Stock Control program for the small or medium sized business	£145.00
EASY-PC Professional: Schematic Capture and PCB CAD. Links to ANALYSER III and PULSAR.	From £195.00
PULSAR / PULSAR Professional: Digital Circuit Simulators	From £98.00
ANALYSER III / ANALYSER III Professional: Linear Analogue Circuit Simulators	From £98.00
Z-MATCH for Windows: Smith Chart based problem solving program for R.F. Engineers	£245.00
FILTECH/ FILTECH Professional: Active and Passive Filter design programs.	From £145.00
EASY-PC: Entry level PCB and Schematic CAD	£98.00
Prices exclude P&P and VAT.	

For full information, please write, phone or fax:-

Number One Systems

UK/EEC: Ref. EVD, HARDING WAY, ST. IVES, CAMBS., ENGLAND, PE17 4WR.

Telephone UK: 01480 461778 (7 lines) Fax: 01480 494042

USA: Ref. EVD, 1795 Granger Avenue, Los Altos, CA 94024

Telephone/Fax: (415) 968 9306

International +44 1480 461778

MASTERCARD, VISA, DELTA, SWITCH Welcome.

- TECHNICAL SUPPORT FREE FOR LIFE
- PROGRAMS NOT COPY PROTECTED.
- SPECIAL PRICES FOR EDUCATION.

HEWLETT PACKARD HP71B

As easy to use as a calculator
but as powerful as a
computer



- A powerful set of basic functions, statements, and operators – over 230 in all – many larger computers don't have a set of basic instructions this complete.
- Advanced statistics functions enabling computations on up to 15 independent variables.
- Recursive subprograms and user defined functions.
- An advanced internal file system for storing programs and data. The HP71 has continuous memory – when you turn the computer off it retains programs and data.
- A keyboard that can be easily customized for your specific application.
- HP-IL Interface pre-installed to create a system that can print, plot, store, retrieve and display information. Control or read instruments or speak to other computers, 5000 bytes/sec. Built in ROM includes 46 separate commands, Interface to HP-IL, HP-B, RS232C, GPIO or series 80. Includes connection cables.

- Please rush me
- HP71B Powerful Calc/Computer (a £29.95)
- Bar-code Reader (a £12.95)
- Power Supply (a £4.95)
- Keyboard overlay (a £1.00)
- Memory module (a £3.00)
- Complete kit of HP71B, Bar-code Reader and Power Supply (a £39.50)

Total payment £..... + £3 delivery = £..... Tel.....
We accept Mastercard, Visa, Cheques or money orders – please post the above form to us, or Fax it, or Telephone with a verbal credit card order.

BARCODE READER

Smart wand

– Automatically recognises and decodes all major bar-code standards.

These are second users systems, ex NHS, are fully tested and working but have no programming (THAT IS UP TO YOU).

HP71B.....	£29.95
Bar-code Reader.....	£12.95
A.C. Power Supply.....	£4.95
(Works from batteries normally)	
Keyboard Overlay.....	£1.00
(Limited quantities)	
(Unknown Program – Memory Modules (2 different types).....	£3.00
(Limited quantities)	
Complete kit of HP71B, Bar-code Reader and power supply.....	£39.50

(Prices include VAT – Delivery Next day £3.00)
(Currently selling in US for over £500!)

INTERCONNECTIONS LTD
Unit 41, InShops, Wellington Centre
Aldershot, Hants, GU11 5DB
Tel: (01252) 341900 Fax: (01293) 822786

Please debit credit card

No..... Exp.....

Name.....

Address.....

Postcode.....

◆KITS◆KITS◆KITS◆KITS◆KITS◆KITS◆

A new range of high quality project kits from QUASAR ELECTRONICS that offer exceptional value for money. Supplied complete with all components, screen printed, solder resist fibre glass PCB's & comprehensive instructions (not just assembly notes!). The detailed explanation of circuit theory & operation, together with schematic circuit diagrams, really help you to understand how each circuit works.

SURVEILLANCE KITS



Don't be misled by the low price of our surveillance kits. They perform as well, if not better, than many we have seen that cost over twice the price! Transmitters can be received on an ordinary VHF FM radio.

KIT 7. 3V FM TRANSMITTER The most powerful 'bug' available for its size. 3V supply & number of components Guaranteed to transmit over 100 metres within buildings & to 500 metres in the open. Easily tunable in FM band. Greater range at higher voltage and better aural £4.95

KIT 13. SOUND ACTIVATED TAPE RECORDER SWITCH This is our new improved tape recorder switch which uses an FET to switch low voltage tape recorders as low as 1.5V. Tape recorder will turn on when the phone is used. Plugs into REMOTE & MIC sockets of recorder £6.25

KIT 16. FM TELEPHONE TRANSMITTER Miniature transmitter which attaches in series to one of the two lines of 'your' phone. Transmits over 200 metres to an ordinary FM receiver & further if the receiver is near phone line. Tune with ceramic trim cap. Uses phone line as an aerial and power source. Not for illegal use £4.95

KIT 18. 9V MINIATURE FM ROOM TRANSMITTER More powerful FM transmitter 'bug' than KIT 7. Tank oscillator coil built into the circuit board. Can be tuned anywhere in the FM band. 9V battery operation. Over 500 metre range in the open depending on aerial used. £5.95

KIT 28. SOUND ACTIVATED TRANSMITTER A sound activated switch and an FM transmitter joined together to make a sound activated FM TX. Set the level of sound that it will respond to. 2 stage transmitter needs tuning for best results. Tuning kit & instructions enclosed. Transmits up to 1 km in the open depending on aerial used. £8.95

KIT 32. TWO STAGE FM TRANSMITTER Our most powerful FM 'bug' to date. Two stage FM transmitter with an RF transistor (2N3563 or ZTX320) in its output stage. 9V operation. On/off switch mounted on PCB. £8.95

KIT 33. LOW VOLTAGE TAPE RECORDER SWITCH This is our new improved tape recorder switch which uses an FET to switch low voltage tape recorders as low as 1.5V. Tape recorder will turn on when the phone is used. Plugs into REMOTE & MIC sockets of recorder £6.25

OTHER KITS FROM THE RANGE

KIT 2. LCD TEMPERATURE METER/ BASIC MULTIMETER Introduces 3 1/2 digit LCD & the very popular 7105 IC. This IC has been used in low-cost multimeters for over 13 years. We use it to measure temperature using an ordinary signal transistor as the sensor. Data sheets provided. Breadboard area so you can extend circuit to build you own voltmeter, ammeter, resistance meter or extended-range temperature meter. Takes away the mystery of how multimeters work. Box powered 9V battery operated. £29.95

KIT 24. LOGIC PROBE This is the most important piece of equipment for testing and measuring digital equipment. It is usually used in fault finding and testing but can also assist in design work and to find out how digital equipment works. Switch for either TTL or CMOS. This modern design using a PUT. Includes detection circuit for very fast pulses. Gives visual (3 LEDs) & audio (piezo buzzer) response. £9.25

KIT 26. COMBINATION LOCK An introduction to a basic but fully working combination lock. Separate touch pad with 8 pads. Lock is reset if an incorrect digit is pressed. Relay capable of switching 240V supplied. 12V operation. Robust and versatile. £11.50

KIT 48. INTRODUCTION TO CLASS AB AMPLIFIERS Using amplifier modules is modern, quick and easy but teaches nothing about how they work. Here is a Class AB amplifier made from individual components which will deliver several watts of power into an ordinary 8 ohm speaker. Gives hands-on learning about cross-over distortion, bootstrapping, complementary pairs, and push-pull. Detailed explanation given. £10.95

KIT 63. ONE CHIP AM RADIO Complete AM radio on a PCB. Tuned radio frequency front-end, single chip RF amplifier & detector and two stages of amplification of the audio signal into a speaker. All components supplied. Cool pre-wound. Excellent for schools. £10.95

AUDIO◆LASER◆TEST GEAR◆FIBRE-OPTIC◆SECURITY◆TIMERS◆GAMES

Send 2 x 1st class stamps for our latest catalogue containing over 80 kits & publications. Mail order only. Please ADD £2.00 P. & P. per order & make cheques and postal orders payable to:

QUASAR ELECTRONICS

Dept. EPE Unit 14 Sunningdale BISHOP'S STORTFORD Hertfordshire CM23 2PA

VARIABLE VOLTAGE TRANSFORMERS

INPUT 220/240V AC 50/60
OUTPUT 0-260V

	Price	P&P
0.5KVA 2.5 amp max	£31.90	£6.00
	(£44.53 inc VAT)	£7.00
1KVA 5 amp max	£41.15	£7.00
	(£56.58 inc VAT)	£8.50
2KVA 10 amp max	£59.40	£8.50
	(£79.78 inc VAT)	£8.50
3KVA 15 amp max	£78.65	£8.50
	(£102.40 inc VAT)	
5KVA 25 amp max	£139.15	

(Plus Carriage)
Buy direct from the Importers. Keenest prices in the country
COMPREHENSIVE RANGE OF
TRANSFORMERS-LT-ISOLATION & AUTO
110 240V Auto transfer either cased with American socket and mains lead or open frame type. Available for immediate delivery

WIDE RANGE OF XENON FLASH TUBES

Write. Phone your enquiries

ULTRA VIOLET BLACK LIGHT FLOURESCENT TUBES

4ft 40 watt (£14.00 (callers only)	(£16.45 inc VAT)
2ft 20 watt (£9.00 (callers only)	(£10.58 inc VAT)
12in 8 watt (£4.80 + 75p p&p)	(£6.52 inc VAT)
9in 8 watt (£3.96 + 50p p&p)	(£5.24 inc VAT)
6in 4 watt (£3.96 + 50p p&p)	(£5.24 inc VAT)

For either 6in, 9in or 12in tubes £8.05 + £1.40 p&p (£8.75 inc VAT)
The above Tubes are suitable for Forged Bank Note detection, security marking etc.
Other Wave Lengths of U V TUBE available please telephone your enquiries

400 WATT UV LAMP

Only £38.00 + £4.00 p&p (£49.35 inc VAT)
160 WATT SELF BALLASTED BLACK LIGHT MERCURY BULB
Available with E S fitting
Price inc VAT & p&p £28.55



12V D.C. BILGE PUMPS

500 GPH 1 1/2" head 3 amp £19.98
1750 GPH 1 1/2" head 9 amp £34.55
Also now available
24V D.C. 1750 GPH 1 1/2" head
5 amp £35.55
All designed to be used submerged.
PRICES INCLUDE P&P & VAT

SUPER HY-LIGHT STROBE KIT

Designed for Disco, Theatrical use etc.
Approx 16 joules. Adjustable speed £50.00 + £3.00 p&p (£62.28 inc VAT)
Case and reflector £24.00 + £3.00 p&p (£31.73 inc VAT)
SAE for further details including Hy-Light and industrial Strobe Kits



SERVICE TRADING CO

57 BRIDGMAN ROAD, CHISWICK, LONDON W4 5BB

TEL: 081-995 1660

FAX: 081-995 0549

ACCOUNT CUSTOMERS MIN. ORDER £10



Ample Parking Space

"BOFFINS SPECIAL" – UNIQUE OFFER

Surplus Precision Medical Unit, internally in excellent condition. Designed primarily to eject a precise controllable amount of fluid from a medical syringe (latter not supplied). Contains the following removable components: Dual Micro Processor Boards and EPROMS. Escap Precision 12V DC Motor with 300:1 Gear Box and optical encoder coupled to a precision threaded drive mechanism. Mains supply with 6 x 1.5V Ni-Cad A.A. cells back-up. LCD Digital read-out 17mm high with legends. Audible warning.
These are sold for the dismantling of the exceptional quality components. Regret no Circuits available. Ridiculously low price. £20.00 + £4.00 p&p (£28.20 inc VAT)

3.5 KVA ISOLATION TRANSFORMER

New Manufacturers surplus, mounted in a solid metal enclosure with a surface mounted MK Residual Current Circuit Breaker. Internally fused 240V AC Input and Output. External SHA Ground Point. Ideal for work bench Isolation etc. Size: Width 44cm, Depth 44cm. Height incl. RCD 47cm. Weight 60 Kilos. Price EX-WAREHOUSE £120.00 + VAT)

240V AC CENTRIFUGAL BLOWER

New Manuf. Surplus Skeleton Blower suitable for mounting inside an enclosure to cool equipment. Overall size 130 x 110 x 85mm. Outlet 80 x 35mm. Impeller 60mm dia x 60mm long. Price £14.10 inc p&p & VAT)

SEWING MACHINE MOTOR

Brand new 220/240V AC/DC SEW-TRIC 2 lead Brush Motor. Size L 100mm x H 70mm x W 55mm. Spindle 1/4 in dia x 1 in long. Price £14.10 inc p&p & VAT)

GEARED MOTORS

71 RPM 20lb inch torque reversible 115V AC input including capacitor and transformer for 240V AC operation. Price inc VAT & p&p £27.73.

SOLID STATE EHT UNIT

Input 230/240V AC. Output approx 15KV. Producing 10mm spark. Built-in 10 sec timer. Easily modified for 20 sec. 30 sec. to continuous. Designed for boiler ignition. Dozens of uses in the field of physics and electronics, eg supplying neon or argon tubes etc. Price less case £8.50 + £2.40 p&p (£12.81 inc VAT) NMS

EPROM ERASURE KIT

Build your own EPROM ERASURE for a fraction of the price of a made-up unit kit of parts less case includes 12in 8 watt 2537 Angstrom Tube Ballast unit, pair of bi-pin leads, neon indicator, on/off switch, safety microswitch and circuit £15.00 + £2.00 p&p (£19.98 inc VAT)

MICROSWITCH

Pye 15 amp changeover lever microswitch, type S171. Brand new. Price 5 for £7.05 inc VAT & p&p

WASHING MACHINE WATER PUMP

Brand new 240V AC fan cooled. Can be used for a variety of purposes. Inlet 1 1/2 in, outlet 1 in dia. Price includes p&p & VAT £11.20 each or 2 for £20.50 inclusive

SYSTEM 200 DEVICE PROGRAMMER

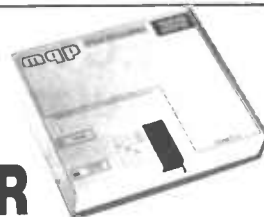

SYSTEM

Programs 24, 28, 32 pin EPROMS, EE-PROMS, FLASH and Emulators as standard, quickly, reliably and at low cost.

Expandable to cover virtually any programmable part including serial E², PALS, GALS, EPPLD's and microcontrollers from all manufacturers.

DESIGN

Not a plug in card but connects to the PC serial or parallel port; it comes complete with powerful yet easy to control software, cable and manual.

SUPPORT

UK design, manufacture and support. Same day dispatch, 12 month warranty. 10 day money back guarantee.

ASK FOR FREE INFORMATION PACK



MQP ELECTRONICS Ltd.

Unit 2, Park Road Centre, Malmesbury, Wiltshire, SN16 0BX UK
TEL. 0666 825146 FAX. 0666 825141

GERMANY 089/4602071; NORWAY 0702-17890; ITALY 02 92 10 3554
FRANCE (1)69.41.28.01; IRELAND 1-2800395; SWEDEN 08-590-32185;
Also from ELECTROSPEED UK

Pico Releases PC Potential

Pico's Virtual Instrumentation enable you to use your computer as a variety of useful test and measurement instruments or as an advanced data logger.

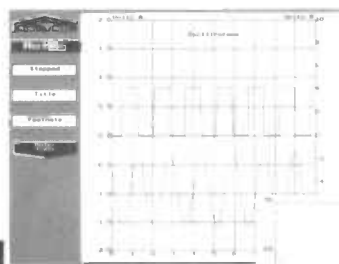

PicoScope
'Virtual instrument' software.

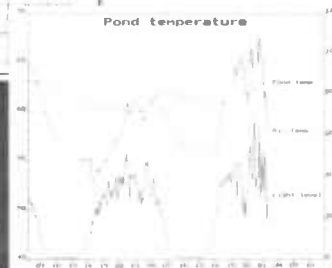

Hardware and software are supplied together as a package - no more worries about incompatibility or complex set-up procedures. Unlike traditional 'plug in' data acquisition cards, they simply plug into the PC's parallel or serial port, making them ideal for use with portable PC's.

PicoLog

Advanced data logging software.

Call for your Guide on 'Virtual Instrumentation'.

NEW SLA-16 Logic Analyser

Pocket sized 16 channel Logic Analyser



- Connects to PC serial port.
- High Speed - up to 50MHz sampling.
- Internal and external clock modes.
- 8K Trace Buffer.

SLA-16
with software, power supply and cables £ 219

NEW ADC-100 Virtual Instrument

Dual Channel 12 bit resolution



- Digital Storage Scope
- Spectrum Analyser
- Frequency Meter
- Chart Recorder
- Data Logger
- Voltmeter

The ADC-100 offers both a high sampling rate (100kHz) and a high resolution. It is ideal as a general purpose test instrument either in the lab or in the field. Flexible input ranges ($\pm 200\text{mV}$ to $\pm 20\text{V}$) allows the unit to connect directly to a wide variety of signals.

ADC-100 with PicoScope £199
with PicoScope & PicoLog £209

ADC-10

1 Channel 8 bit

- Lowest cost
- Up to 22kHz sampling
- 0 -5V input range

The ADC-10 gives your computer a single channel of analog input. Simply plug into the parallel port and your ready to go.

ADC-10 with PicoScope £49
PicoScope & PicoLog £59

Carriage UK free, Overseas £9
Oscilloscope Probes (x1, x10) £10
Existing ADC 10/11/12/100 users can add PicoLog for £25

ADC-11

11 Channel 10 bit

- Digital output
- Up to 18kHz sampling
- 0 -2.5V input range

The ADC-11 provides 11 channels of analog input in a case slightly larger than a matchbox. It is ideal for portable data logging using a "notebook" computer.

ADC-11 with PicoScope £85
PicoScope & PicoLog £95



ADC-12

1 Channel 12 bit

- High resolution
- Up to 17kHz sampling
- 0 -5V input range

The ADC-12 is similar to the ADC-10 but offers an improved 12 bit (1 part in 4096) resolution compared to the ADC-10's 8 bit (1 part in 256).

ADC-12 with PicoScope £85
PicoScope & PicoLog £95

ADC-10 Simply plug into the parallel port and your ready to go.

ADC-16

8 Channel 16 bit+sign

- Highest resolution
- 2Hz sampling - 16bit
- $\pm 2.5\text{V}$ input range

The ADC-16 has the highest resolution of the range, it is capable of detecting signal changes as small as $40\ \mu\text{V}$. Pairs of input channels can be used differentially to reject noise. Connects to serial port.

ADC-16 with PicoLog £115

PICO TECHNOLOGY



Pico Technology Ltd. Broadway House, 149-151 St Neots Rd, Hardwick, Cambridge. CB3 7QJ

Tel: 01954 - 211716 Fax: 01954 - 211880



Phone or FAX for sales, ordering information, data sheets, technical support. All prices exclusive of VAT



SHOP OPEN 9-5 MON-FRI. CLOSED SAT --- OFFICIAL ORDERS WELCOME

EPE MICROCONTROLLER P.I. TREASURE HUNTER

The latest MAGENTA DESIGN - highly stable & sensitive - with μ C control of all timing functions and advanced pulse separation techniques.

- New circuit design 1994
- High stability drift cancelling
- Easy to build & use
- No ground effect, works in seawater

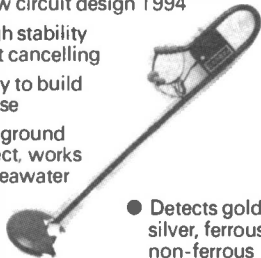

- Detects gold, silver, ferrous & non-ferrous metals

- Efficient quartz controlled microcontroller pulse generation.
- Full kit with headphones & all hardware

KIT 847.....£63.95

DIGITAL LCD THERMOSTAT

A versatile thermostat using a thermistor probe and having an l.c.d. display. MIN/MAX memories, -10 to 110 degrees celsius, or can be set to read in Fahrenheit. Individually settable upper and lower switching temperatures allow close control, or alternatively allow a wide 'dead band' to be set which can result in substantial energy savings when used with domestic hot water systems. Ideal for greenhouse ventilation or heating control, aquaria, home brewing, etc. Mains powered. 10A SPCO relay output. Punched and printed case.

KIT 841.....£29.95

PORTABLE ULTRASONIC PEST SCARER

A powerful 23kHz ultrasound generator in a compact hand-held case. MOSFET output drives a special sealed transducer with intense pulses via a special tuned transformer. Sweeping frequency output is designed to give maximum output without any special setting up.

KIT 842.....£22.56

DIGITAL CAPACITANCE METER

A really professional looking project. Kit is supplied with a punched and printed front panel, case, p.c.b. and all components. Quartz controlled accuracy of 1%. Large clear 5 digit display and high speed operation. Ideal for beginners - as the μ F, nF and pF ranges give clear unambiguous read out of marked and unmarked capacitors from a few pF up to thousands of μ F.

KIT 493.....£39.95

ACOUSTIC PROBE

A very popular project which picks up vibrations by means of a contact probe and passes them on to a pair of headphones or an amplifier. Sounds from engines, watches, and speech travelling through walls can be amplified and heard clearly. Useful for mechanics, instrument engineers, and nosy parkers!

KIT 740.....£19.98



1000V & 500V INSULATION TESTER

Superb new design. Regulated output, efficient circuit. Dual-scale meter, compact case. Reads up to 200 Megohms.

Kit includes wound coil, cut-out case, meter scale, PCB & ALL components.

KIT 848.....£32.95

MOSFET MkII VARIABLE BENCH POWER SUPPLY 0-25V 2.5A.

Based on our MkI design and preserving all the features, but now with switching pre-regulator for much higher efficiency. Panel meters indicate Volts and Amps. Fully variable down to zero. Toroidal mains transformer. Kit includes punched and printed case and all parts. As featured in April 1994 EPE. An essential piece of equipment.

KIT 845.....£64.95

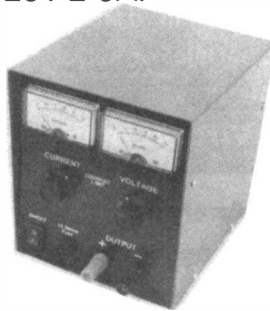

ULTRASONIC PEST SCARER

Keep pets/pests away from newly sown areas, fruit, vegetable and flower beds, children's play areas, patios etc. This project produces intense pulses of ultrasound which deter visiting animals.

- KIT INCLUDES ALL COMPONENTS, PCB & CASE
- EFFICIENT 100V TRANSDUCER OUTPUT
- COMPLETELY INAUDIBLE TO HUMANS

- UP TO 4 METRES RANGE
- LOW CURRENT DRAIN

KIT Ref. 812.....£14.81

'COMSTEP' P.C. COMPUTER STEPPING MOTOR INTERFACE

An exciting project supplied with two 200 step motors, interface board, and easy to use P.C. software. Allows independent control of both motors - speed, direction, number of steps, and half/full step mode. Connects to computer parallel port. Requires 12V 1A D.C. supply and printer lead.

KIT 846 (with 2 motors)£62.99 (Printer lead £5.00)

IONISER

A highly efficient mains powered Negative Ion Generator that clears the air by neutralising excess positive ions. Many claimed health benefits due to the ioniser removing dust and pollen from the air and clearing smoke particles. Costs virtually nothing to run and is completely safe in operation. Uses five point emitters.

KIT 707.....£17.75

BAT DETECTOR

An excellent circuit which reduces ultrasound frequencies between 20 and 100 kHz to the normal (human) audible range. Operating rather like a radio receiver the circuit allows the listener to tune-in to the ultrasonic frequencies of interest. Listening to Bats is fascinating, and it is possible to identify various different types using this project. Other uses have been found in industry for vibration monitoring etc.

KIT 814.....£21.44

SPACEWRITER

An innovative and exciting project. Wave the wand through the air and your message appears. Programmable to hold any message up to 16 digits long. Comes pre-loaded with "MERRY XMAS". Kit includes PCB, all components & tube + instructions for message loading.

KIT 849.....£16.99

12V EPROM ERASER

A safe low cost eraser for up to 4 EPROMS at a time in less than 20 minutes. Operates from a 12V supply (400mA). Used extensively for mobile work - updating equipment in the field etc. Also in educational situations where mains supplies are not allowed. Safety interlock prevents contact with UV.

KIT 790.....£28.51

MOSFET 25V 2.5A POWER SUPPLY

High performance design has made this one of our classic kits. Two panel meters indicate Volts and Amps. Variable from 0-25 Volts and current limit control from 0-2.5A. Rugged power MOSFET output stage. Toroidal mains transformer.

KIT 769.....£56.82

INSULATION TESTER

A reliable and neat electronic tester which checks insulation resistance of wiring and appliances etc., at 500 Volts. The unit is battery powered, simple and safe to operate. Leakage resistance of up to 100 Megohms can be read easily. A very popular college project.

KIT 444.....£22.37

DIGITAL COMBINATION LOCK

Digital lock with 12 key keypad. Entering a four digit code operates a 250V 16A relay. A special anti-tamper circuit permits the relay board to be mounted remotely. Ideal car immobiliser, operates from 12V. Drilled case, brushed aluminium keypad.

KIT 840.....£19.86

E.E. TREASURE HUNTER P.I. METAL DETECTOR MKI

Magenta's highly developed & acclaimed design. Quartz crystal controlled circuit MOSFET coil drive. D.C. coupled amplification. Full kit includes PCB, handle, case & search coil.



- KIT INC. HEADPHONES
- EFFICIENT CMOS DESIGN
- POWERFUL COIL DRIVE

- DETECTS FERROUS AND NON-FERROUS METAL - GOLD, SILVER, COPPER ETC.
- 190mm SEARCH COIL
- NO 'GROUND EFFECT'

KIT 815.....£45.95

HAMEG HM303 30 MHz DUAL TRACE OSCILLOSCOPE & COMPONENT CHECKER

Western Europe's best selling oscilloscope - now improved. It now features 30MHz bandwidth, triggering to 100MHz and 2mV/div sensitivity.

Sharp bright display on 8 x 10cm. screen with internal graticule. Special component tester built in - allows capacitors, resistors, transistors, diode, and many other components to be checked at a glance.

As with its predecessor, the QUALITY OF THIS INSTRUMENT IS OUTSTANDING. It is supported with a two year warranty covering parts and labour. If you are buying an oscilloscope, this is the one. It costs a fraction more than some others, but it is far far superior. Supplied with test probes, mains lead, and manual.

£392.00 + £68.60 VAT Includes FREE Next-day delivery (Cheques must be cleared)

EDUCATIONAL BOOKS & PACKS

ADVENTURES WITH ELECTRONICS

The classic book by Tom Duncan used throughout schools. Very well illustrated, ideal first book for age 10 on. No soldering. Uses an S.DEC breadboard.
Book & Components £28.95. Book only £7.25

FUN WITH ELECTRONICS

An Osborne book, wonderfully illustrated in colour. Component pack allows 6 projects to be built and kept. Soldering is necessary. Age 12 on, or younger with adult help.
Book & Components £28.88. Book only £2.95

30 SOLDERLESS BREADBOARD PROJECTS

A more advanced book to follow the others. No soldering. Circuits cover a wide range of interests.
Book & Components £30.69. Book only £2.95

DC MOTOR/GEARBOXES

Ideal for robots, buggies, and many other mechanical projects. Min. plastic gearbox with 1.5-4.5V DC motor. 6 ratios can be set up.

Small type MGS....£4.77

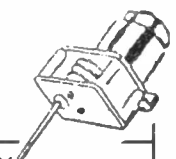

STEPPING MOTORS

For computer control via standard 4 pole unipolar drivers.

MD38 - miniature 48 steps per rev.....£9.15

MD35 1/2 - standard 48 steps per rev.....£12.99

Motors and Controllers

A range of kits and components for motion control and computer interfacing. Ideal for Design & Technical projects, and a whole range of up to the minute 'Home Automation' applications.

Comstep PC Computer Interface and driver board.

Drives two motors from PC parallel port. Supplied with comprehensive software. Needs 12Volt 1A supply.

With 2-200 Step Motors

Kit 846.....£67.00

Stepping Motors

MD38...Mini 48 step...£8.65
MD35...Std 48 step...£12.98
MD200...200 step...£16.80
MD24...Large 200 step...£22.95

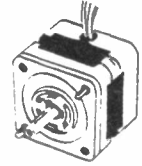

Power Booster for Comstep.

Adds to Comstep and allows motors up to 4 Amps to be driven. Two boosters drive two motors from a single Comstep. Uses standard Comstep software.

With MD24 Motors

Kit 850.....£39.95

DC Motor/Gearboxes.

Our Popular and Versatile DC motor/Gearbox sets. Ideal for Models, Robots, Buggies etc. 1.5 to 4.5V Multi ratio gearbox gives wide range of speeds.

LARGE TYPE - MGL £5.95
SMALL - MGS - £4.77

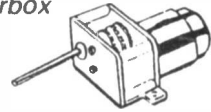

PC Communications Protocol for Comstep.

An interface board adding four switched inputs to the Comstep + All the code to develop your applications. Files in C, BASIC, FORTRAN & ASSEMBLER + demo.

Kit 851.....£26.98

Versatile Stepping motor Interface.

A Magenta design, gives Half and Full-Wave drive. Up to 1Amp and 24Volts. CMOS inputs - Drive from logic or computer port. Needs power supply.

Kit 816.....£9.82

PC Joystick Interface for Comstep.

Software for operating Comstep from a standard PC Joystick. Allows two Axis control, with acceleration, speed, and X-Y position control. Stores co-ordinates.

Kit 852.....£28.95

Stand-Alone Stepping motor Driver/Interface.

A Stand alone interface giving full control in all modes. Pushbutton operation with adjustable acceleration and speed. Ideal for demo and setting up. Then connect to computer port for full control.

Kit 850.....£39.95

BBC Computer Interface.

A versatile and easy to use interface giving 16 Power I/O lines from the User and Printer Ports. Use those old Beebs for control and Motor drive applications.

Kit 844...£37.95 or Built...£51.95

More Information:

All listed items come with data and instructions. For more information, including reprints of the appropriate magazine articles, send an SAE + £1.00 per kit - or phone and use Mastercard/Visa etc.

Mini-Lab & Micro Lab Electronics Teach-In 7

As featured in EPE and now published as Teach-In 7. All parts are supplied by Magenta. Teach-In 7 is £3.95 from us or EPE Full Mini Lab Kit - £119.95 - Power supply extra - £22.55 Full Micro Lab Kit - £155.95 Built Micro Lab - £189.95

MAGENTA

Tel: 0283 565435 Fax: 0283 546932 All prices include VAT. Add £3.00 p&p.

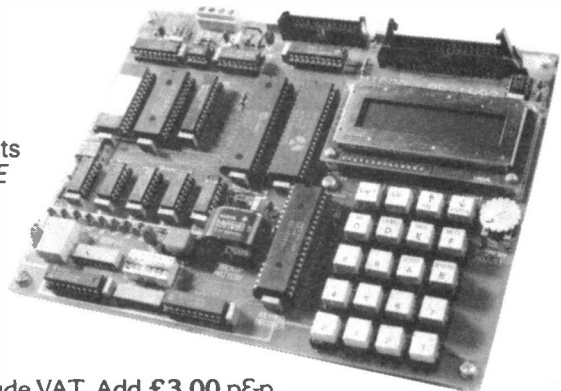

EVERYDAY With PRACTICAL ELECTRONICS

INCORPORATING ELECTRONICS MONTHLY

VOL. 24 No. 4

APRIL '95

NEW SERVICE

I quite often use this space to "plug" some of our forthcoming projects and articles. I am going to do that again this month but I also want to plug a new publication which is "hot off the press" – the new item is our *Electronics Service Manual*.

We are often asked by a wide variety of readers – everyone from novice hobbyists to university lecturers – if there is a publication which will show them how to go about repairing various items of electronic equipment. There used to be such a book: it was the *Electronics Repair Manual* published by WEKA Publishing before they closed their UK operation a few years ago.

When we bought the *Modern Electronics Manual* from them we also had the opportunity to buy the *Electronics Repair Manual* but we were not impressed with much of the original material in the Repair Manual and decided not to buy the title. However, we knew there was a strong demand for this type of information so, about a year ago, we set about producing our own entirely new *Electronics Service Manual*.

The new Manual has been written for us by Mike Tooley (who will be well known to *EPE* readers) so it comes from one of the best authors in the field, and we are proud of the finished product – which should be coming "off the press" as you read this. If you are interested in this fascinating and rewarding field of technology then see the centre pages in this issue for full details of this new Manual.

PROJECTS

Once again I believe we have a very exciting range of articles lined up for the next few months. These include a PIC Development and Training System which will enable students and hobbyists to develop PIC software, allowing the production of your own dedicated PIC Microcontroller projects. The system also forms an excellent classroom training aid and we believe it is another "first" in an electronics magazine.

In addition we will soon bring you an exciting and reasonably priced valve hi-fi amplifier design which is unlike anything ever published before; this will hopefully feature in our June issue. We also have a couple of Barry Fox features lined up for the next two issues, one of which is all about Smart Cards. Don't miss out!



SUBSCRIPTIONS

Annual Subscriptions for delivery direct to any address in the UK: £24. Overseas: £30 (£47.50 airmail). Cheques or bank drafts (in £ sterling only) payable to *Everyday with Practical Electronics* and sent to EPE Subscriptions Dept., Allen House, East

Borough, Wimborne, Dorset BH21 1PF. Tel: 01202 881749. Subscriptions start with the next available issue. We accept Access (MasterCard) or Visa.

BINDERS

Binders to hold one volume (12 issues) are now available from the above address. These are finished in blue p.v.c., printed with the magazine logo in gold on the spine. Price £5.95 plus £3.50 post and packing (for overseas readers the postage is £6.00 to everywhere except Australia and Papua New Guinea which cost £10.50). *Normally sent within seven days but please allow 28 days for delivery – more for overseas orders.*

Payment in £ sterling only please. Visa and Access (MasterCard) accepted, minimum credit card order £5. Send or phone your card number and card expiry date with your name, address etc.

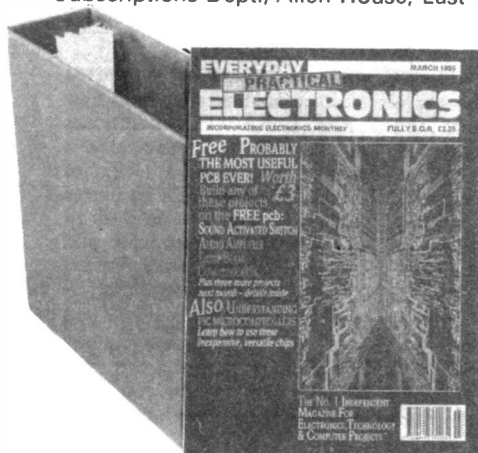

Editorial Offices:
EVERYDAY with PRACTICAL ELECTRONICS EDITORIAL
ALLEN HOUSE, EAST BOROUGH, WIMBORNE
DORSET BH21 1PF
Phone: Wimborne (01202) 881749
Fax: (01202) 841692. DX: Wimborne 45314
Due to the cost we cannot reply to orders or queries by Fax.

See notes on **Readers' Enquiries** below – we regret lengthy technical enquiries cannot be answered over the telephone.

Advertisement Offices:
EVERYDAY with PRACTICAL ELECTRONICS
ADVERTISEMENTS
HOLLAND WOOD HOUSE, CHURCH LANE
GREAT HOLLAND, ESSEX CO13 0JS
Phone/Fax: (01255) 850596

Editor: MIKE KENWARD

Secretary: PAM BROWN

Deputy Editor: DAVID BARRINGTON

Technical Editor: JOHN BECKER

Business Manager: DAVID J. LEAVER

Subscriptions: MARILYN GOLDBERG

Editorial: Wimborne (01202) 881749

Advertisement Manager:

PETER J. MEW, Frinton (01255) 850596

Advertisement Copy Controller:

DEREK NEW, Wimborne (01202) 882299

READERS' ENQUIRIES

We are unable to offer any advice on the use, purchase, repair or modification of commercial equipment or the incorporation or modification of designs published in the magazine. We regret that we cannot provide data or answer queries on articles or projects that are more than five years old. Letters requiring a personal reply *must* be accompanied by a **stamped self-addressed envelope or a self-addressed envelope and international reply coupons. Due to the cost we cannot reply to queries by Fax.**

All reasonable precautions are taken to ensure that the advice and data given to readers is reliable. We cannot, however, guarantee it and we cannot accept legal responsibility for it.

COMPONENT SUPPLIES

We do not supply electronic components or kits for building the projects featured, these can be supplied by advertisers.

We advise readers to check that all parts are still available before commencing any project in a back-dated issue.

We regret that we cannot provide data or answer queries on projects that are more than five years old.

ADVERTISEMENTS

Although the proprietors and staff of EVERYDAY with PRACTICAL ELECTRONICS take reasonable precautions to protect the interests of readers by ensuring as far as practicable that advertisements are *bona fide*, the magazine and its Publishers cannot give any undertakings in respect of statements or claims made by advertisers, whether these advertisements are printed as part of the magazine, or in inserts.

The Publishers regret that under no circumstances will the magazine accept liability for non-receipt of goods ordered, or for late delivery, or for faults in manufacture. Legal remedies are available in respect of some of these circumstances, and readers who have complaints should first address them to the advertiser.

TRANSMITTERS/BUGS/TELEPHONE EQUIPMENT

We advise readers that certain items of radio transmitting and telephone equipment which may be advertised in our pages cannot be legally used in the UK. Readers should check the law before buying any transmitting or telephone equipment as a fine, confiscation of equipment and/or imprisonment can result from illegal use or ownership. The laws vary from country to country; overseas readers should check local laws.

NATIONAL LOTTERY PREDICTOR

JULYAN ILETT

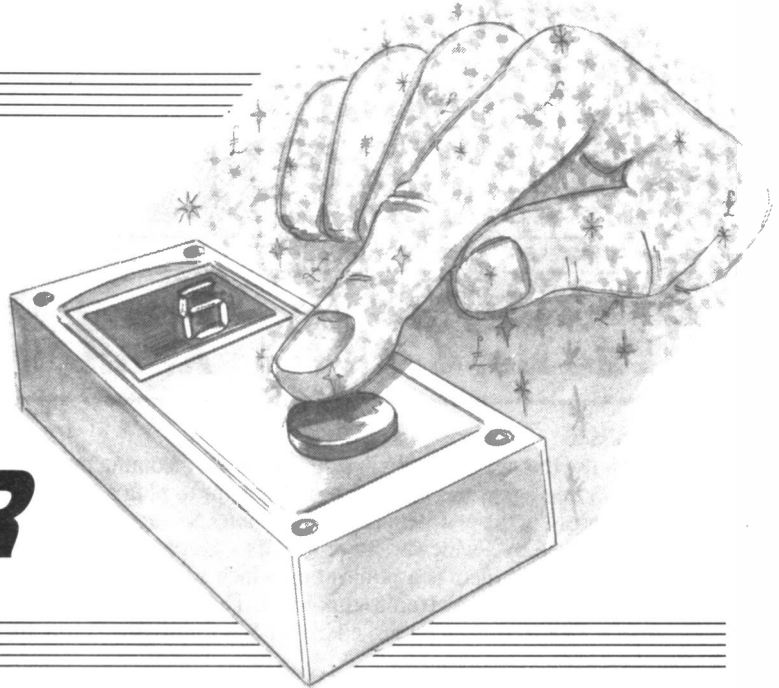

A simple PIC Microcontroller project that could make your fortune. This pocket-sized random number cruncher won't guarantee you win the National Lottery, but it is great fun to build - Who knows "it could be you!"

SINCE the introduction of the National Lottery back in November, a small number of people have become very rich. The rest of us, however, must have realised by now, what odds of "14 million-to-1 against" actually mean. So can anything be done to improve ones chances of winning?

The idea of accurately modelling the machine used by the lottery organisers is simply out of the question. The behaviour of a single ball, bouncing around inside a Perspex sphere, would be practically impossible to predict. The paths of forty nine balls, all colliding with each other, can be considered utterly random.

Would it be possible, then, to predict the next draw from analysis of previous draws? The mathematics of chance say no! The likelihood of any particular combination of numbers being drawn is precisely the same as all other combinations, and is not influenced in any way by any previous event.

PSYCHOLOGICAL FACTORS

So although it isn't possible to increase the chances of winning, it is possible to increase your share of the prize, if your numbers come up. The idea is to avoid combinations that other people are likely to select.

Choosing numbers in any other way than completely at random, will inevitably be affected by various psychological factors. A winning combination, for example, which consisted of four or more numbers greater than 31, would completely eliminate anyone who used birth dates to make their selection!

A random number generator is therefore essential, and if nothing else, it gives the electronics enthusiast a good excuse to get started on an interesting new gadget! The unit presented here, generates numbers between one and 49 in a random sequence, and displays them on a two digit, 7-segment l.e.d. display. A single pushbutton is used to switch the unit on, display all the

		Bit position							
		0	1	2	3	4	5	6	7
Reg No. (Hex)	10	1	2	3	4	5	6	7	8
	11	9	10	11	12	13	14	15	16
	12	17	18	19	20	21	22	23	24
	13	25	26	27	28	29	30	31	32
	14	33	34	35	36	37	38	39	40
	15	41	42	43	44	45	46	47	48
	16	49							

Fig. 1. Grid layout for the lottery numbers.

numbers, and reset the device, ready for a new number combination.

PRACTICAL DEVICE

One serious aim of this project is to demonstrate the design of a practical device using a PIC microcontroller. (See last month's feature *Understanding PIC Microcontrollers*.) Information is given about the software used, including a flowchart, and an example of how this is converted into actual assembly language instructions.

The microcontroller used is the Arizona Microchip PIC16C54, which is the smallest and simplest device in their current range. Even so, it still has a very impressive specification.

This remarkable 18-pin integrated circuit contains 512 bytes of ROM, 32 bytes of RAM, a real time counter, watchdog timer, code protection and more. It has a RISC architecture and is capable of operating at 20MHz, although in this design, it runs a good deal slower than that! It also has the ability to enter a very low power "sleep" mode, so this project needs no on/off switch.

Traditionally, the problem with designing microprocessor based projects has been software development. The microprocessor chip may only cost a few pounds, but the cost of all the development hardware and software can be considerable. A text editor, assembler, target development system, EPROM programmer and EPROM eraser are all essential tools, and if you want an in-circuit emulator and logic analyser, you'll need to win the lottery to pay for them! (We expect to publish a *PIC Development and Training System* as a project in the May issue - Ed.).

The PIC microcontrollers are supported by a realistically priced development system called PICSTART. This comprises assembler and simulator software, a neat little programmer unit and a stack of manuals. The system is readily available and costs under £200, but you do need to provide a PC compatible computer and an EPROM eraser. The software for the Predictor was developed on this system.

If you're not yet ready to rush out and buy the PICSTART development system, the author is able to supply a pre-programmed PIC16C54RC/P microcontroller for the project for £7. A floppy disk

containing the complete source code and other related files is also available for £1. For details, see *ShopTalk* page.

DESIGN BEGINNINGS

Generating a random number and displaying it as two 7-segment digits could be achieved using a handful of CMOS logic i.c.s. A complication arises, however, with the requirement that the National Lottery Predictor must not display any number more than once. This function can only be achieved by marking off the numbers that have been used, in an array, or grid.

This is where the logic circuit gets rather complicated, requiring an additional memory chip. The microcontroller has a small number of RAM locations or "registers" which can be used to form the array. Each element in the array only needs to indicate whether or not a certain number has been used, and can therefore be represented by a single bit.

Forty nine bits occupy just 7-bytes of memory (actually 6-bytes and 1-bit), which is just as well, as the microcontroller has a very limited number of registers, 32 in total, seven of which are reserved for special purposes. The arrangement of lottery numbers in the 7-byte grid is detailed in Fig. 1. For example, lottery number one is positioned in the first byte (register 10) in bit position zero.

To begin the design process, the operational requirements of the unit must be defined. Pressing the pushbutton for the first time, switches the National Lottery Predictor on. The display initially shows "—", indicating that it is reset, ready to start the number sequence.

Pressing the button again, displays the first random number, and subsequent presses generate further numbers until all 49 numbers have been displayed. With no more numbers available, the display shows "••", although normally, only the first six numbers will be required.

At any time, the pushbutton may be held down for a couple of seconds which will reset the grid ready for a new set of numbers. If the unit is left for more than about 2.5 minutes without the pushbutton being touched, the National Lottery Predictor goes into "sleep mode", effectively switching itself off. All these functions are achieved using just one button.

CIRCUIT DESCRIPTION

With the operational details worked out, the circuit design can begin. The complete circuit of the National Lottery Predictor is shown in Fig. 2. The PIC16C54 microcontroller IC1 is driven by a very simple clock circuit consisting of just one resistor and one capacitor, R3 and C2. The frequency of oscillation is about 800kHz using the values shown. The components R1, C1 and R2 generate the reset, and wake-up-from-sleep pulses.

There are two I/O (Input/Output) ports, one 8-bit and the other 4-bit. The 8-bit port, port B, is connected to the eight segments (seven plus decimal point) of both digits of the dual display, via resistors R6 to R13. Port A, the 4-bit port, is divided into one input bit and three output bits.

Outputs A1 and A0, pins 18, 17 are connected to the bases (b) of two pnp transistors, TR1 and TR2, via resistors R4 and R5. The display is a common anode type, which requires that current is sourced

through the common anode connection, and sunk via each individual cathode segment connection.

The pushbutton switch S1 is read by the microcontroller by first taking output A2, pin1, low. Then, input A3, pin 2, is read, after which A2 is taken high again. In this way, capacitor C1 is not discharged when the pushbutton is read, since output A2, does not go low for long enough.

When the microcontroller is in sleep mode, however, output A2 is left permanently low. Now, when the pushbutton is pressed, C1 discharges through resistor R1 and the microcontroller is reset, which wakes it up.

Much of the circuit design, in particular the clock, reset and wake-up circuitry, is taken straight from the applications handbook supplied with the PICSTART system. Details are also given on driving multiplexed displays and reading key switches.

SOFTWARE DESIGN

Software design is a very personal thing. Different people achieve the same result in different ways. The software developed for the National Lottery Predictor demonstrates just one method of providing the necessary functions, there are doubtless many others.

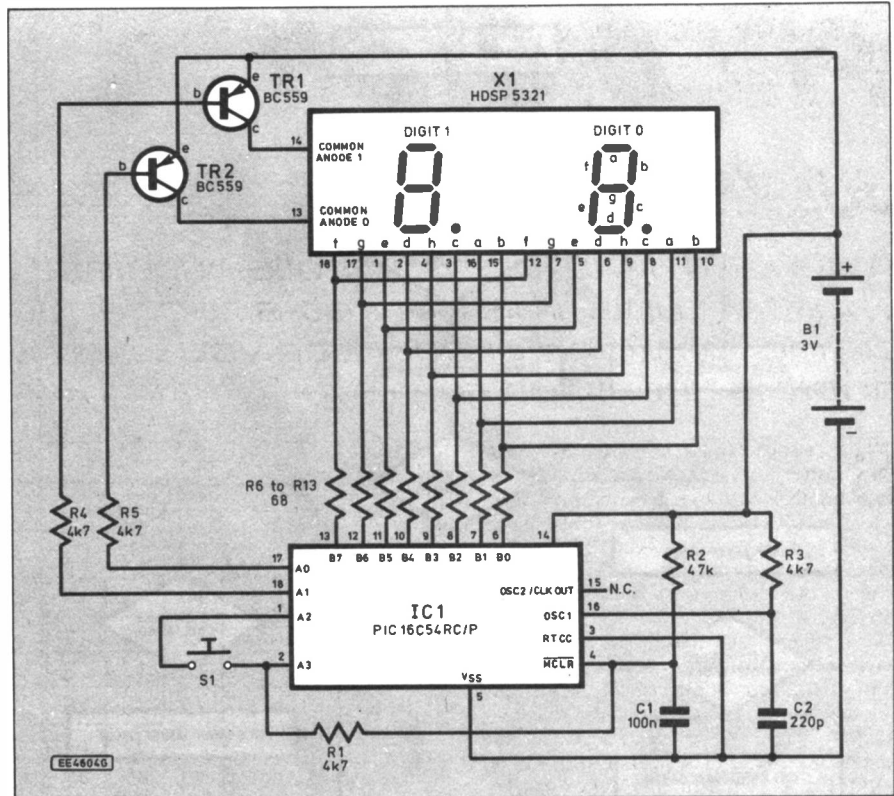

Fig. 2. Complete circuit diagram for the National Lottery Predictor.



In order to provide some insight into the design of this project, a flowchart has been provided, see Fig. 3, and a section of the source code has been reproduced, see Fig. 4.

The program performs several distinct functions, each of which is described below:

Display Multiplexing

Every time the software loop is executed, only one digit is displayed, both digits taking it in turns. The digit whose turn it is to be displayed, is identified by testing one bit in a register. The appropriate data is then taken from either of two digit registers, and the appropriate transistor turned on by lowering either bit 0 or bit 1 of port A.

As long as the software loop keeps running at a fast enough rate, both display digits appear to be lit up simultaneously.

Random Number Generation

The "random number" variable is incremented each time the loop is executed, unless it exceeds 49, whereupon it is set back to one. When the pushbutton is pressed, the current value of this variable is used as the random number.

The random behaviour results from the delay between presses of the pushbutton. The person operating the unit cannot see the value of the counter, so the random numbers cannot be influenced directly, although deliberate rhythmic button pushing can result in sequences of similar numbers.

Binary-to-Decimal Conversion

When the random number has been generated, it is converted into two decimal digits by repeatedly subtracting 10 from the number until it underflows (goes negative). Each time the subtraction is carried out, another register is incremented, indicating the number of times 10 has been subtracted. This number becomes the "tens" digit.

When the number does underflow, ten is added back restoring the remainder, which becomes the data for the "units" digit.

Digit Character Generation

Character data for the 7-segment display is taken from a table, indexed by the decimal number to be displayed. The table contains ten items corresponding with the digits 0 to 9.

The table is read twice, once for the "tens" digit and again for the "units" digit. Leading zero suppression is achieved by replacing the "tens" digit with a blank character whenever it is zero.

Number Grid Maintenance

Forty-nine bits of RAM hold the data indicating whether a number has already been used. When a number is displayed, the corresponding bit is set. If the unit attempts to use that number again, it must move on to the next available unused number. Two variables are used to address the grid.

A pointer is used to index one of the seven bytes in the grid, and a mask selects one bit out of the eight in each byte. Each time the random number is incremented, the mask bit is rotated into the next highest significant bit position. If the bit is rotated

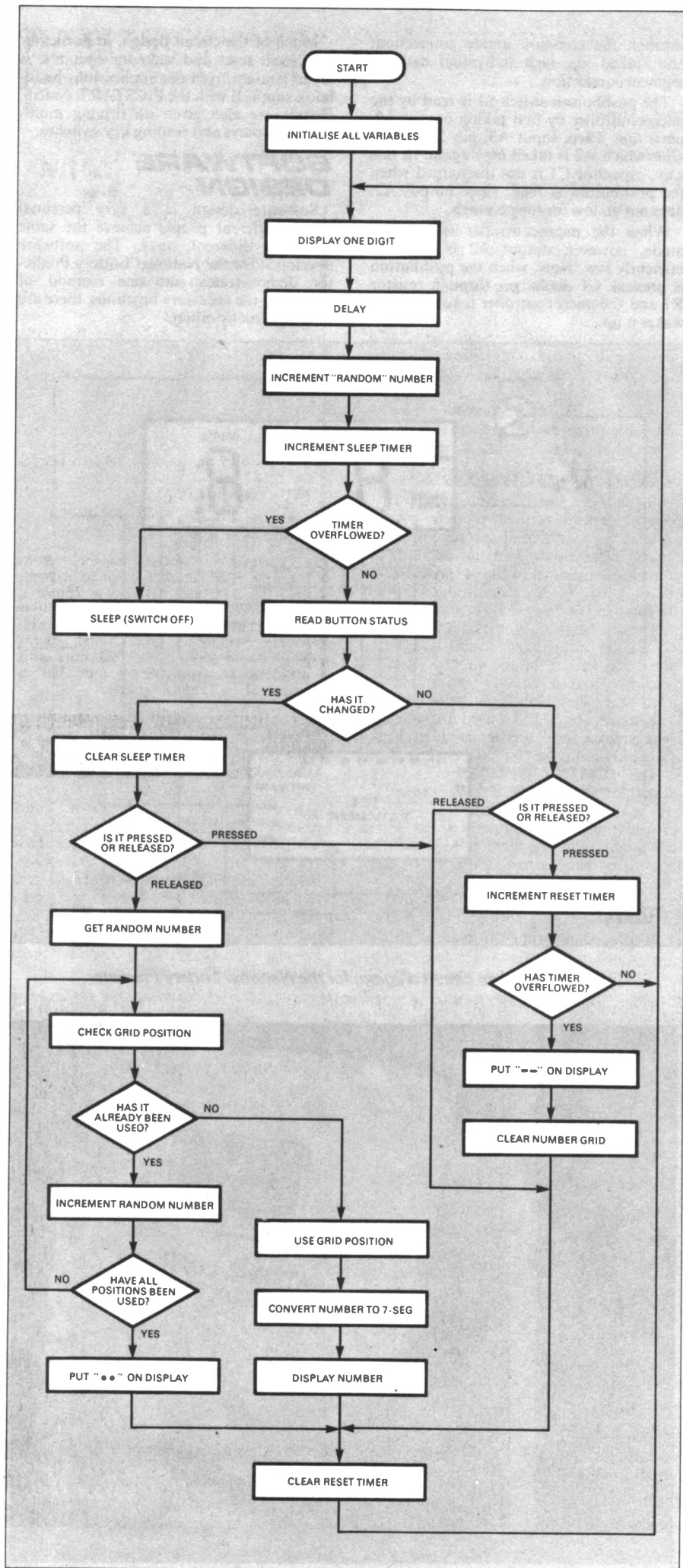

Fig. 3. (left) National Lottery Predictor flowchart.

```

reset      movlw 10          ;Subroutine to reset all bits in grid
          movwf fsr      ;set fsr to point at register 16
          movlw 07
          movwf gp_counter ;set gp_counter to 7, 7 registers to clear
clearreg   clrfsr      ;clear the register
          decf gp_counter,f ;decrement gp_counter
          btfscc status,z ;test gp_counter for zero
          goto alldone
          incf fsr,f      ;point to next register to be cleared
          goto clearreg
alldone    movlw 40      ;put two dashes on the display
          movwf digit0
          movwf digit1
          retlw 0

```

Fig. 4. Example of PIC Microcontroller assembly language.

out of bit seven, it is put back into bit zero and the pointer is incremented. This pair of variables operate like an octal (base-8) counter.

Pushbutton Reading and De-Bounce

The pushbutton has to be read in a special way so that it can also be used to bring the microcontroller out of sleep mode. One side of the button is connected to an input which is pulled high. The other side is connected to an output, see Fig. 2.

If the output is high, pressing the button has no effect. When the pushbutton is to be read, the output is briefly taken low, but only long enough for the read function and no more. This prevents the microcontroller being reset, even if the pushbutton is held down.

When the microcontroller is in sleep mode, however, the output is left at a low level. Pressing the button then causes the capacitor (C1) to discharge.

De-bounce is achieved by reading the pushbutton input at intervals of no less than about two milliseconds. This allows time for the bounce signals to stabilise between one read and the next.

Auto-Sleep Timing

A 16-bit counter increments continuously while the pushbutton remains inactive. When the counter eventually

overflows, after about 2.5 minutes, the I/O pins are all put into a condition which uses least power, after which the controller goes to sleep.

When the PIC microcontroller is woken up, the program is executed from the beginning.

Clearing the Grid

All bits in the number grid must be cleared or set to zero when the pushbutton is held for a couple of seconds. The program instructions used to achieve this function are shown in Fig. 4, providing an example of PIC microcontroller assembly language.

The file select register (fsr) is initially set to register 16 (or hexadecimal 10). This is the first register in the number grid. A general purpose counter (gp counter) is then given the value 7, as there are seven registers in the grid that need to be cleared. The indexed grid register is then cleared indirectly using the "fsr" as a pointer.

The counter is then decremented and tested for a zero value. If the counter is not yet zero, the "fsr" is incremented ready for the next grid register to be cleared. When all seven registers have been cleared, a "dash" symbol is put onto both digits of the display.

FUN!

Writing short programs in assembly language can be great fun. Piecing together the various different instructions is a bit

COMPONENTS

Resistors

R1, R3 to R5 4k7 (4 off)
R2 47k
R6 to R13 68 (8 off)
All 0.25W 5% carbon film

See
**SHOP
TALK**
Page

Capacitors

C1 100n disc ceramic
C2 220p ceramic

Semiconductors

X1 HDSP5321 dual 7-segment display (red), common anode
TR1, TR2 BC559 pnp silicon transistor (2 off)
IC1 PIC16C54RC/P ready-programmed microcontroller (see text)

Miscellaneous

S1 Min. round pushbutton switch (5mm pin spacings)

Printed circuit board available from the *EPE PCB Service*, code 935; plastic ABS box, size 102mm x 76mm x 38mm; red display filter; battery holder (2xAA type); battery clip; 18-pin d.i.l. socket; 1mm p.c.b. pins (2 off); 30mm M3 countersunk bolts; M3 nuts and washers; stick-on rubber feet; Velcro strip or sticky pads; solder etc.

Approx cost
guidance only

£19

like constructing a building out of "Lego" bricks.

There is one important difference, however. While building your multi-storey, luxury apartment block, you always seem to run out of one type of brick while having plenty of the others left over! There may only be 33 different instructions in the PIC assembly language, but you've got an unlimited supply of all of them!

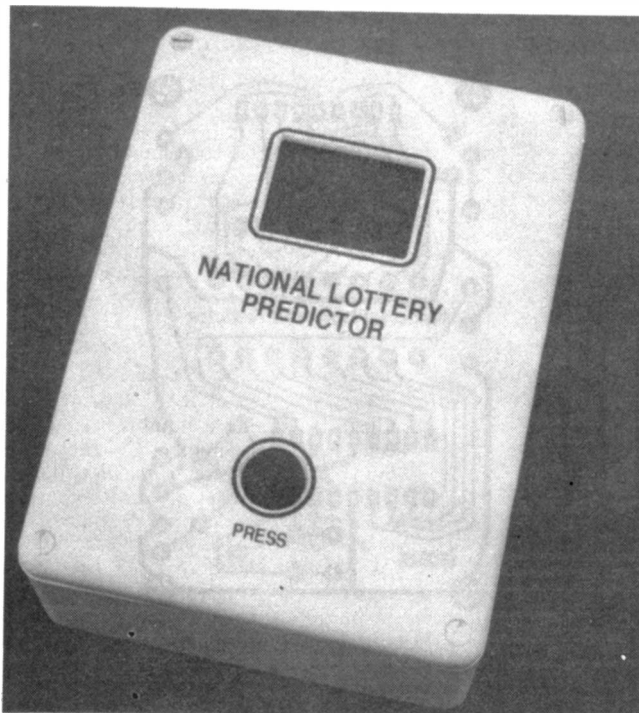

Front panel arrangement of the completed unit.

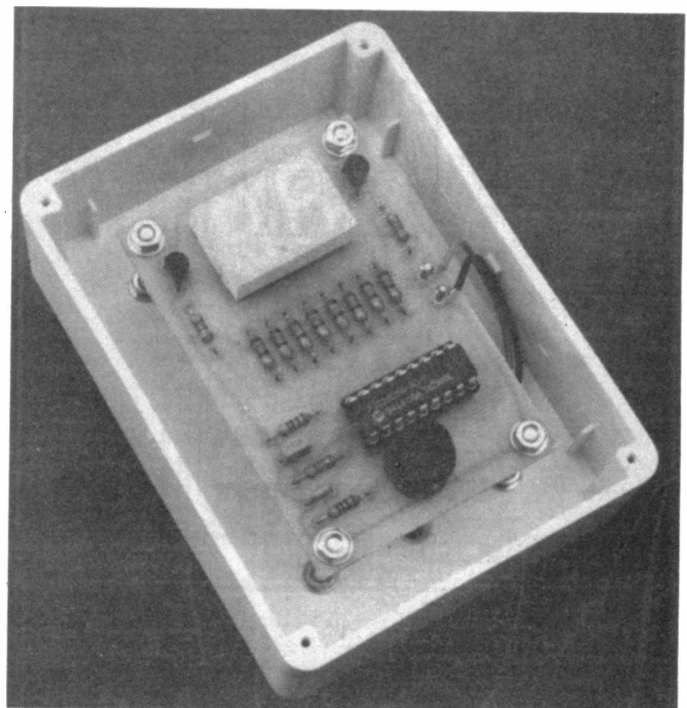

The completed circuit board mounted inside the small box.

CONSTRUCTION

Because the microcontroller integrates all the essential elements of a computer system into one tiny chip, the design of the printed circuit board (p.c.b.) layout is made very simple. All the components mount directly on the small single-sided p.c.b., including the double-digit display and the pushbutton, and there are no wire links.

The topside p.c.b. component layout and full size underside copper foil master pattern are shown in Fig. 5. This board is available from the *EPE PCB Service*, code 935. The battery connector is soldered directly onto two solder pins at the side of the board. Remember, there is no on/off switch.

Construction of the p.c.b. is very straightforward. The components can be fitted in any order, although a socket should be used for the microcontroller IC1, preferably a good quality, turned-pin type. The socket must have a low profile though, so that IC1 does not sit too high on the p.c.b.

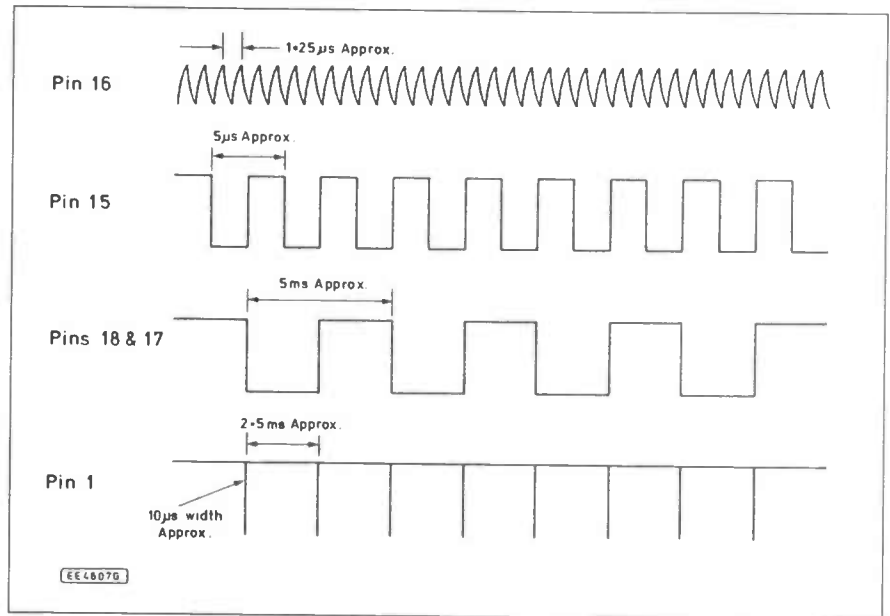

Fig. 6. Guide to test waveforms to be expected at the output pins of the microcontroller IC1.

TESTING TIME

Testing can be carried out using an oscilloscope if one is available, although a good quality logic probe will be perfectly suitable as an alternative. The waveforms in Fig. 6. should be referred to during the test procedure.

Check the output on pin 15, this should be a square wave of approximately 200kHz frequency (5µs period). On the adjacent pin, pin 16, the frequency should be four times higher and much less square.

The outputs on pins 17 and 18 should both be square waves of approximately 200Hz (5ms period), although one goes high when the other goes low. Finally, the output on pin 1 should show a brief, low going pulse (about 10µs width) at a frequency of approximately 400Hz (2.5ms period).

The logic probe, used to test the prototype unit, was capable of showing high and low logic levels as well as pulse waveforms. In addition, an indication was given of whether the pulse frequency was less than or greater than 100kHz, and whether the waveform was square (50 per cent mark space ratio) or was mainly high or mainly low. As such, it was an ideal tool with which to perform the tests mentioned above.

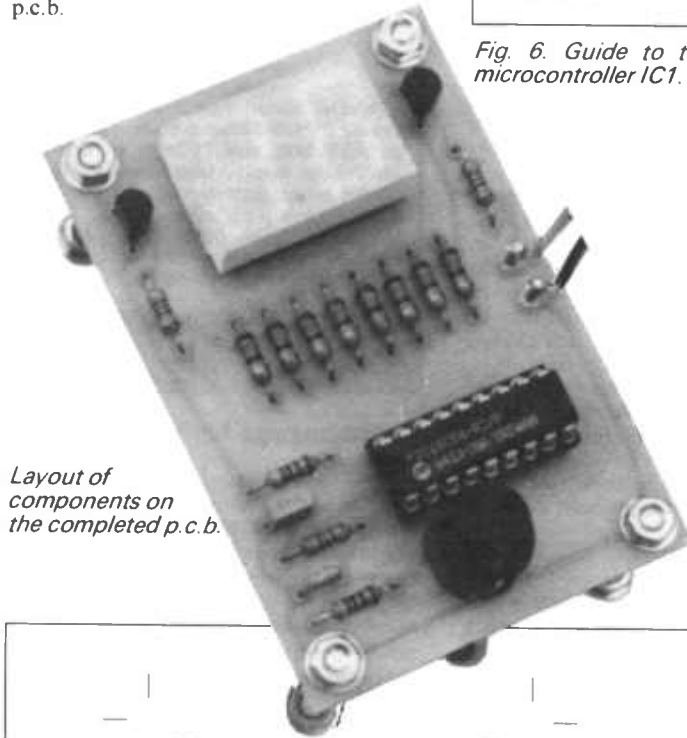

Layout of components on the completed p.c.b.

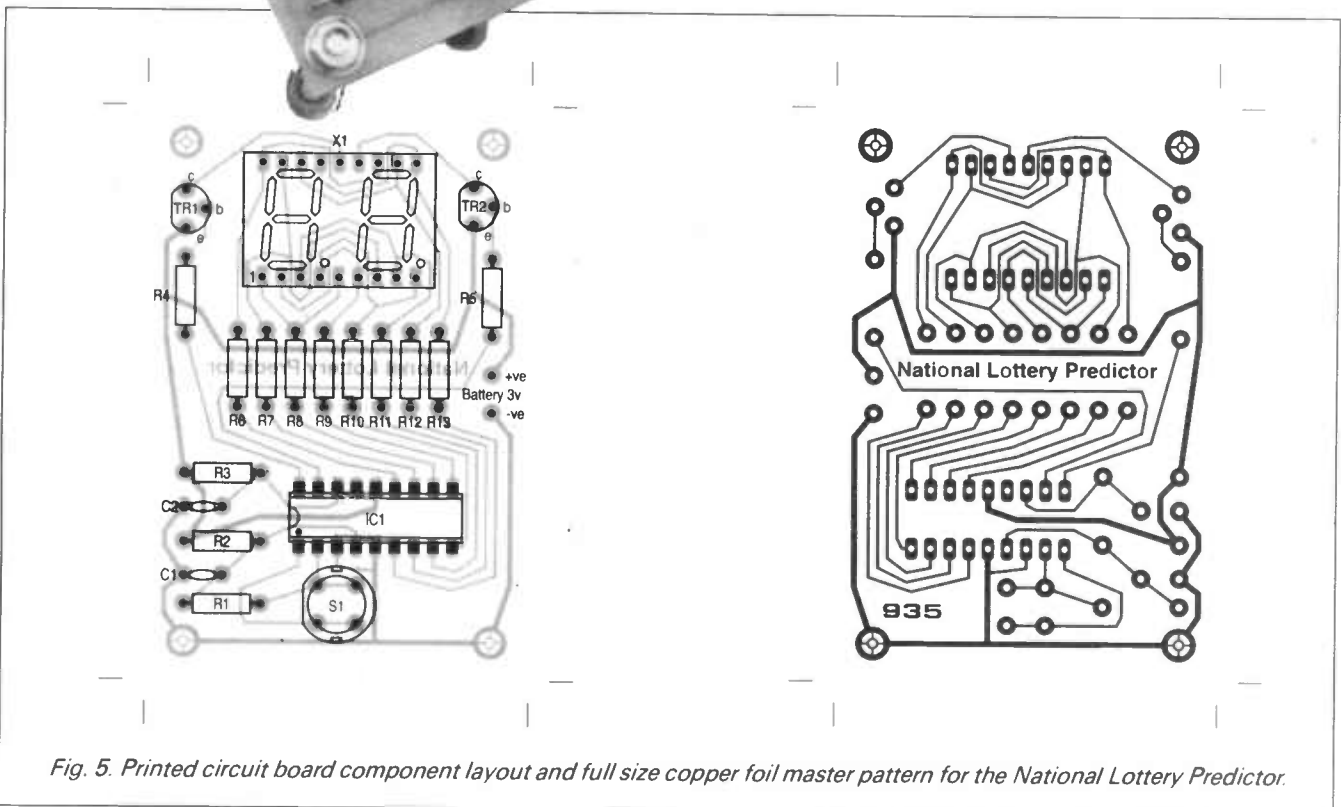

Fig. 5. Printed circuit board component layout and full size copper foil master pattern for the National Lottery Predictor.



IT COULD BE YOU!

Note that the logic probe may require TTL signals and a supply of around 5V. In this case, a 4.5V supply (three AA cells) may be used during testing, but *avoid* using 6V, as this might overload the microcontroller's outputs. All that remains is simply to confirm that the unit operates as expected.

ON THE CASE

The case, used to house the National Lottery Predictor, requires two cutouts on the front panel (i.e. the lid), and four holes in the base. The dimensions of the cutouts are detailed in Fig. 7. The cutout for the display is rectangular, but can be finished off with rounded corners to improve the appearance.

The p.c.b. is mounted on four countersunk M3 screws using nuts and washers to set it at the correct height. A piece of red transparent plastic filter material is attached to the inside of the case lid and should just touch the front of the display when the case is closed.

The battery holder can be attached to the inside of the case with self adhesive Velcro strips or double-sided sticky pads, and stick-on rubber feet can be attached to the bottom of the case, to cover the screw-heads.

IN SUMMARY

The PIC series microcontrollers are proving to be among the most popular devices of their type, and are widely used commercially. The range of devices includes such features as analogue-to-digital conversion and E²PROM non-volatile memory. More complex devices use a 16-bit bus and can make use of interrupts. The range is being added to all the time.

From the electronics hobbyists point of view, these devices represent an even more important innovation than microprocessors, when they became available in the late seventies. Microcontrollers are easier to use, have more flexible power requirements, require much less complex p.c.b. layouts and they often need no support logic at all.

If this project inspires you to equip yourself to get involved in this fascinating area of micro-electronics, you could be designing minaturised microcontroller devices in no time at all! □

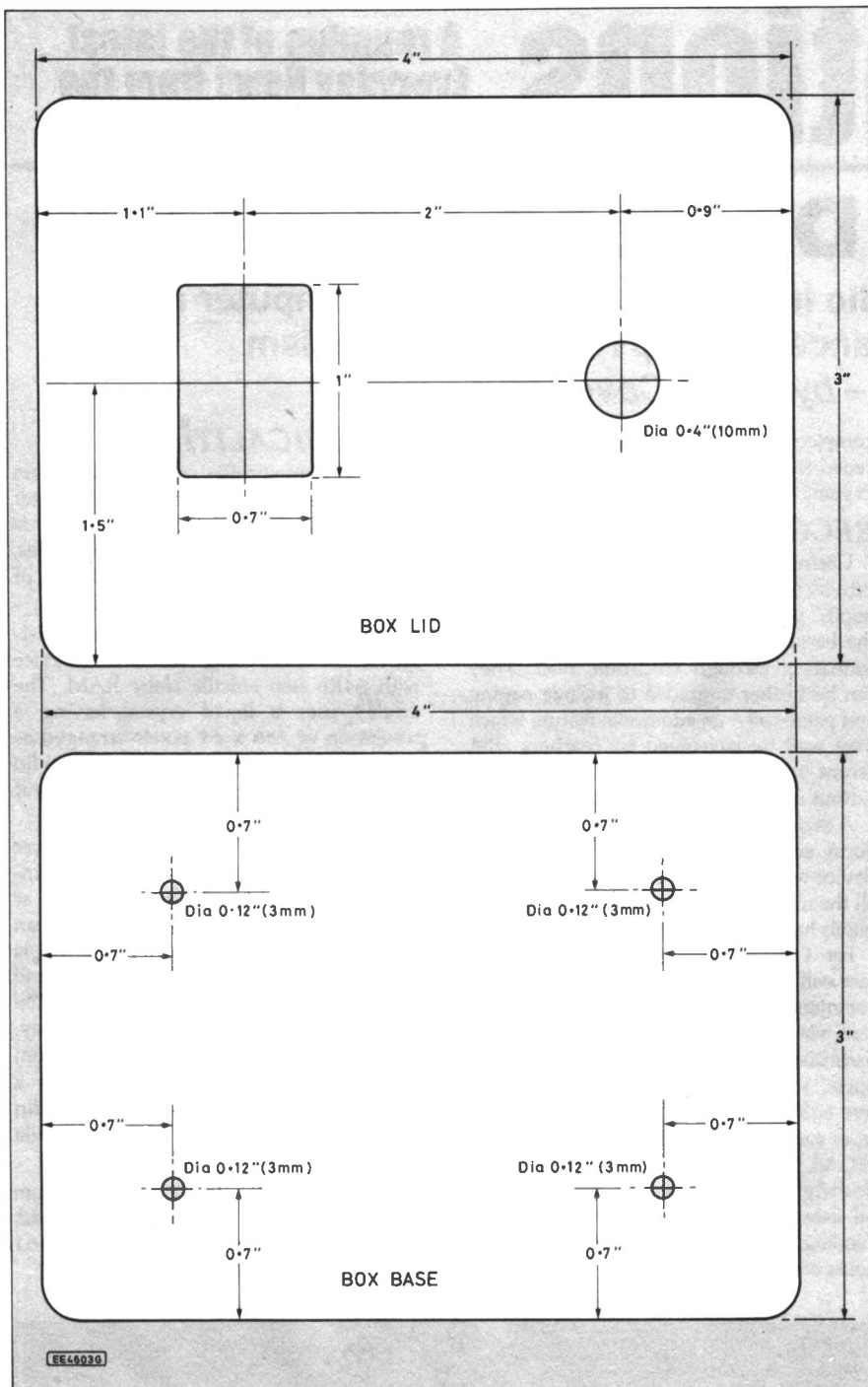
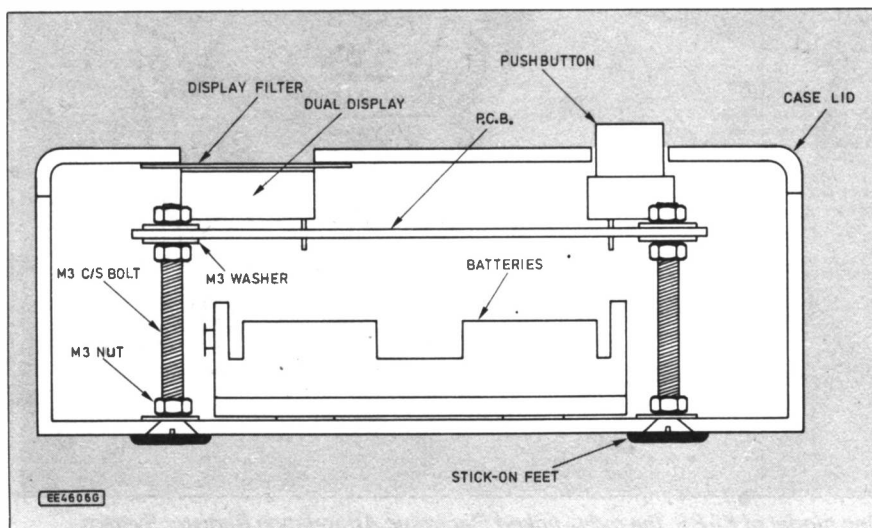

Fig. 7. Case dimensions and drilling details. The p.c.b. is mounted on M3 bolts and locked in position with nuts and washers, once the correct height has been found.



EARS TO DEFEAT SKIVERS

Intelligent key pads, radio interfaces and a central computer register class attendances to help reduce absenteeism

— by Hazel Cavendish

THEY are not going to get away with it any longer! Pupil drop-out days are numbered. "EARS", the £25,000 Electronic Attendance Registration System, works as an electronic register to reduce the administrative load on teachers and claims to save schools so much time that it can add two teaching periods to the school day.

Designed to provide the most advanced and effective system yet devised, the scheme has won numerous awards including the 1994 Educational Technology Gold Award and is already being used by 5,000 teachers not long after its introduction.

The brainchild of Bromcom Computers of Bromley, Kent, the system links key pads the size of a normal piece of A4 paper to a central computer by a two-way radio, modem links or broadband networks. Designed particularly for recording the presence or absence of pupils or college students, it has also been expanded to perform other valuable uses for schools and educational establishments.

KEY LIST

Teachers using the "Ears" system simply key in their name and the form they are about to teach, and it provides a list of names of those who should be attending that day. They can monitor the attendance of any class on a small screen, to see who is genuinely absent or playing hookey. It also records the reason for absence, where this is known, and records the attendance history of a pupil in his or her class.

The previous system most favoured by schools was based on the issue of cards to pupils which had to be inserted in card readers to record attendance. Alternatively, schools relied on specially prepared forms which were completed in the classroom, and subsequently inserted into an "optical mark reader" at a central point, which in turn transferred the information into the school's own system.

Apart from being labour-intensive, both these systems had specific weaknesses. Pupils were able to give their cards to others to register for them, and the "optical mark reader" increased a school's paper work considerably, and wasted staff time by requiring the transfer of records from classroom to school office.

Each teacher's "mobile data collection means" comprises a network of radio transmitters distributed over the area of the school or college premises and connected to a central computer. Radio links have the big advantage that the apparatus is then

completely portable, although it is conceded that modem links may be preferred in some cases.

RECORD PERFORMANCE

Usefully, the portable computers can be provided with further software for storing pupils' performance records and provides the basis of a network for exchanging information through electronic mail. They can be further upgraded to include paging and panic-call — an additional feature which may well be welcomed by teachers after recent reports of violent pupils causing serious injuries to staff in the classroom.

A staff member at the Portsmouth Sixth Form college remarked that the paging device would be particularly useful to route all the messages received from parents that pupils had forgotten their sandwiches!

For Colleges and Universities the system will be appreciated as affording greater communication between Tutors and College staff via use of Ears' one-way messaging, particularly in the case of "Split-site" Campuses, and interfaces with the administrative software currently used by most colleges such as SIMS, FEMIS, COVTECH and FECAS. It is anticipated that it will be particularly useful in the production of statistical data required by the Further Education Funding Council and is expected to save hours of administrative time.

TECHNICALITIES

The system consists of A4-sized folders with a built-in slim-line miniature computer and radio transmitter-receiver. The folder is battery-operated with no need for cables. Battery life is in excess of 120 hours of operation, lasting up to an academic year.

The microprocessor used for the registration folders is a Zilog Z180 6MHz device with 64Kb non-volatile static RAM. The display uses a liquid crystal having a resolution of 256 x 64 pixels arranged as eight lines by 42 characters. The radio transceiver is a MPT1340 UHF unit (licence exempt).

The central processor is a Mini-Tower Bromcom QC486/DX2 using an Intel 82486 microprocessor operating at 66MHz and having a 4Mb cache and an 8Mb RAM. A 540Mb capacity hard disk is used, which has a 15ms access time and 4Mb cache on its controller. The monitor used has a 14 inch SVGA display, and if a modem is preferred a Miracom Courier or equivalent is advised with a baud rate of up to 14,400. The radio transceivers are linked to the system via RS485 and RS232 interfaces.

For further information contact Bromcom Computers PLC, 417/421 Bromley Road, Downham, Bromley, Kent. Tel: 0181 461 3737. Fax: 0181 461 3993.

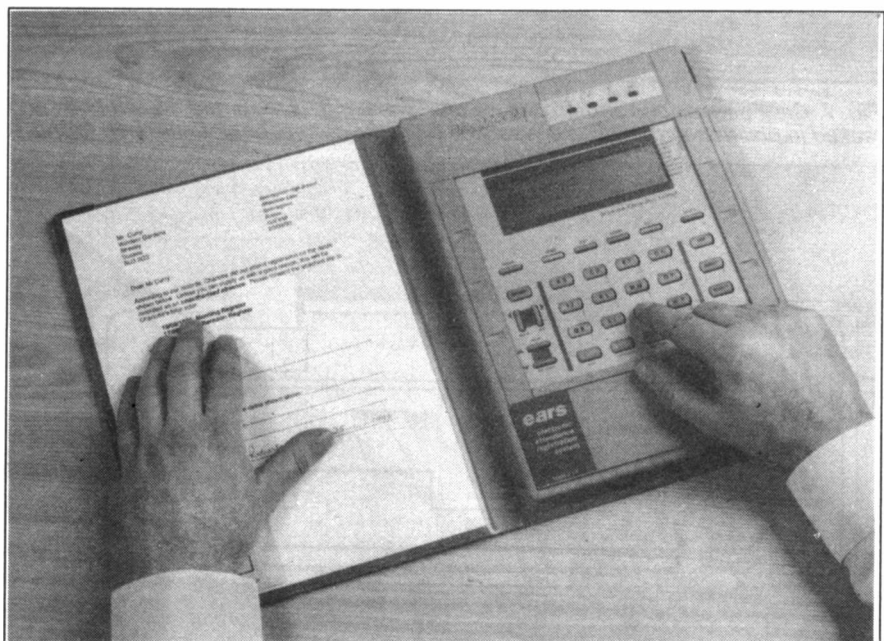

One model of EARS, the radio-linked Electronic Attendance Register System.

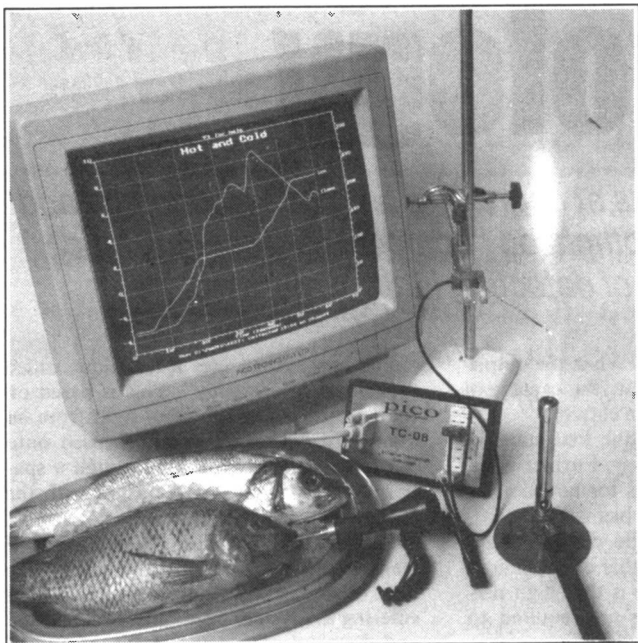

PC THERMOCOUPLING

Pico Technology has introduced an interface which allows thermocouples to be monitored by PC-compatible computers. The TC-08 is supplied with PicoLog datalogging software and is designed to allow simple yet accurate temperature recordings to be made. The interface accepts up to eight thermocouples (B, E, J, K, R, S and T types) and connects via the serial port. It does not require a power supply.

For type K thermocouples, resolution over the -270°C to $+1300^{\circ}\text{C}$ range is better than 0.1°C and accuracy is better than 0.5°C . Cold junction compensation is carried out within the unit and linearisation is carried out by the software.

Samples can be taken as fast as one per second and as slow as one per hour allowing recordings to be made for a few seconds or over several weeks as required. PicoLog offers advanced temperature processing functions including filtering, min/max detection and alarms. Data can be displayed in real time, in either graphical or text format, or printed out after collection.

The TC-08 interface comes complete with the PicoLog software, software drivers and connecting cable, for £199. A range of thermocouples/probes is available.

For further information contact Pico Technology Ltd., Broadway House, 149-151 St Neots Road, Hardwick, Cambridge, CB3 7QJ. Tel: 01954 211716. Fax: 01954 211880.

LOW POWER RADIO COMMS

Radio-Tech can help you to tune in to simple and affordable Low Power Radio data communications. The company has been involved in the design and supply of this type of equipment since the allocation of the deregulated radio bands by the DTI back in the mid-1980s.

A choice of over 20 affordable and high performance radio data modules is available off-the-shelf, including the new BIM high speed radio transceiver. Radio-Tech's aim is to make the use of Low Power Radio a viable alternative to cables for data communication applications, ranging from the traditional social and security alarms, through to wire-free EPOS (Electronic Point of Sale) terminals, remote controls, monitoring systems and radio LANs (Local Area Networks).

Undoubtedly, there are numerous other uses to which the various transceiving modules available can be put. Low Power Radio at affordable prices is a technology waiting to be explored by professional and hobbyist designers alike.

Manufacturers can also benefit from using one of the many DTI type-approved modules that Radio-Tech can offer. The procedure for obtaining type-approval for a product can be reduced to that of a paper exercise with only a nominal DTI registration fee involved. Exporters can also benefit since Radio-Tech can offer advice on which modules comply with European and other overseas specifications.

For further information, see Radio-Tech's full-page advert elsewhere in this issue, which also contains a FREE £15.00 introductory discount voucher offer. Alternatively, contact Radio-Tech Ltd. at Overbridge House, 41 Weald Hall Lane, Thornwood Common, Epping, CM16 6NB. Tel: 01992 561994. Fax: 01992 561994.

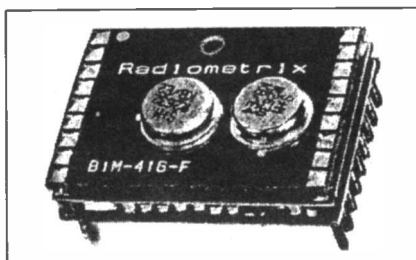

PLANE SPOTTING

Shortwave listeners to the HF Aeronautical frequencies will be interested to know that they can now automatically identify an aircraft's type and registration details. Seldec has introduced a Selcal decoder which, when linked to a suitable receiver tuned to one of the Oceanic Control Centres, will decipher a Selcal as it is transmitted, and present a clear visual display allowing identification of the aircraft by type, nationality, registration and airline.

Housed in a two-tone metal case, the Seldec Decoder displays the decoded Selcal codes on two rows of l.e.d.s correspondingly lettered A to S. Having logged and identified the Selcal, the display remains visible until reset by a pushbutton switch. The unit is then ready to receive and identify the next Selcal tones.

The decoder is compatible with all good quality, general coverage receivers and has been designed without the use of microprocessor technology in order to avoid electrical interference when used with sensitive HF receivers. Audio signals from short wave receivers are simply plugged into the decoder's audio input socket.

For further information contact Seldec, P.O. Box 3, Kidderminster, Worcestershire, DY12 1YZ. Tel: 01299 861372. Fax: 01299 861530.

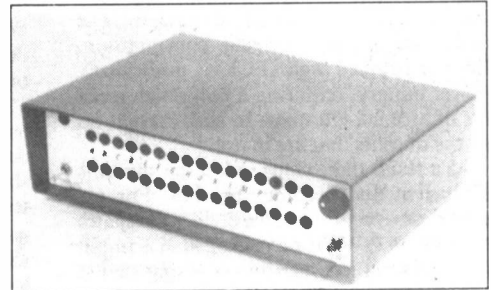

LIGHT CONVERSION

Texas Instruments has added another member to its family of light-to-frequency converters. These devices combine, on a single chip, photodiodes and a high resolution charge-to-frequency converter. The output is a pulse train having a frequency proportional to the incident light intensity. By counting pulses, or measuring the time between them, light intensity can be measured by a microcontroller without the use of analogue-to-digital converters.

The latest Texas device, the TSL235, is a low-cost precision opto-converter which typically delivers from 0.25Hz in darkness to 500kHz when fully saturated by light. The frequency output is highly linear to within 0.02% up to 100kHz, and the temperature coefficient is typically 100 ppm/°C. Power consumption is only about 5mW and the device can be run from voltages between 2.7V and 6.0V.

For further information contact Texas Instruments Ltd., Manton Lane, Bedford, MK41 7PA. Tel: 0234 270111.

GREEN PIECE

A new Energy Management Controller from Microchip can reduce electricity consumption by up to 30 per cent it is claimed. Their MTE1122 chip is ideal for all residential, commercial and industrial equipment which uses a.c. motors, including refrigerators, freezers, washing machines, dryers, swimming pool pumps, and heating, ventilation and air conditioning equipment.

Integrating Microchip's popular 8-bit RISC-based PIC16/17 microcontroller technology with proprietary power management firmware the new chip allows induction motor applications to be more energy efficient.

The controller operates by digitally monitoring the motor load and controlling power consumption thousands of times per second. Most a.c. induction motors require large currents under light or even no-load situations. The unique algorithm in the controller monitors the a.c. signal and senses when the motor is consuming more power than is required. The device modifies the a.c. signal allowing the motor to continue its rotational speed while consuming less power.

For further information contact Arizona Microchip Technology Ltd., Unit 6, The Courtyard, Furlong Road, Bourne End, Bucks, SL8 5AJ. Tel: 01628 851077.

New Technology Update

Ian Poole looks at upgrading an "old" technology and throws the spotlight on "confocal microscopy," the latest method of detecting faulty wafers.

EMITTER coupled logic has been available for many years and yet it still offers advantages over other types of logic technology. Its chief advantage is that it can offer operating speeds over 1GHz at affordable prices. This makes it a prime choice for a number of applications including the high speed dividers used in a number of radio frequency circuits like frequency synthesizers.

Power Hungry

However, it is hardly surprising that these chips have some disadvantages. The main one is their current consumption. Emitter coupled logic (ECL) is notoriously power hungry, requiring a pull-down resistor of around 470 ohms to sink current on all the outputs that are in use.

As a result these chips sink large amounts of current and become very hot. For example, one programmable divider dissipates as much as $\frac{1}{2}W$. Being packaged in a 16-pin d.i.l. package it is hardly surprising that it becomes very hot after a few minutes operation, and often it is too hot to handle.

Running at temperatures like this there is no chance of it being put into a surface mount package. It also means that the reliability figures obtained for a chip like this are lower than similar devices operating at lower temperatures.

A further problem is that they operate with voltage levels which do not conform to the normal logic standards. The best performance is obtained when they are run from 0V and $-5.2V$ lines i.e. the inverse of standard logic families.

Even then the supplies have to be more accurately maintained than those for other logic families. Fortunately, it is possible to run them from a 0V and +V supply but with a slight reduction in performance.

In addition to this the voltage swing of the output is small (just over 0.6V) and does not swing between both rails. This means that special translators are required to interface between ECL and conventional series of logic families or vice versa.

Active Service

In view of the high speed performance of ECL a number of developments are under way to improve the shortcomings of the technology. One of these involves the use of an active pull-down circuit. This is used to replace the external resistor which is standard on the existing circuits.

The use of the active pull-down circuit together with a.c. coupling between the devices produces significant improvements, allowing each chip to consume less current whilst being able to operate at higher speeds. When the output changes from low to high, the pull-down current is suppressed as it acts

against the rising voltage. When the output is falling from high to low, the capacitors help enhance the pull-down current.

This new idea is only the first stage in upgrading ECL technology. Further work is still required. The ideas for new devices still leave a number of problems.

The manufacture of the devices themselves incorporates a number of specialised structures. The main one is that high performance bipolar devices are required to give the speed.

In addition to this special capacitors need to be fabricated onto the chip. Also the additional circuitry required for the active pull-down facility places a number of restrictions on the remainder of the design.

However, with ECL still being deemed an important technology, research is being undertaken into resolving these problems. This should mean that ECL will remain a leading technology in use for many years to come.

Scanning Wafer Defects

As the size and complexity of i.c.s increases it is forcing the semiconductor manufacturers to meet increasingly high standards in their manufacturing processes. In large i.c.s even small defects can have disastrous results.

Previously it would have meant that a single chip in a wafer containing a large number of chips would have to be rejected. Now with the number of transistors increased by many orders of magnitude a single defect will make a much larger proportion of the whole wafer defective.

The problem is compounded by the fact that i.c. feature sizes are becoming smaller all the time. This means that even very small defects are very important. However, these small defects are very difficult to locate, putting more pressure on the equipment to locate them.

Current detection systems are based on either optical or scanning electron microscopes. These systems suffer from a number of disadvantages. Firstly they do not offer the types of throughput required by large production lines. In addition to this they are normally only used to scan the areas on the chip that are most likely to give defects. As such they do not fulfil all the requirements which are now being placed upon them.

Confocal Microscopy

As existing methods are becoming hard pressed to meet the ever increasing requirements, a company called Ultrapointe in San Jose, California has developed a new laser scanning system which is capable of locating defects which are as small as $0.1\mu m$ in diameter.

The new system uses a technique called "Confocal Microscopy". This is based on the use of a point source of light from an argon laser. This is sharply focused onto the wafer and then viewed through a spatial filter which exactly coincides with the illuminated area.

This means that the illuminated and viewing areas are exactly the same. The filter also ensures that any stray light entering the system from outside is rejected and does not reduce the clarity of any of the images produced.

The spot of light and the filter are scanned so that a picture can be built up of the whole of the surface of the wafer. In view of the very small depth of focus and the differences in height of various parts of the wafer, not every area will be in focus. As a result several passes are needed.

The information from each pass is stored and then a complete three dimensional picture is made of the whole of the wafer. The complete picture can then be examined for any defects.

The process can reveal a number of problems. It will show if there are any dimensional defects, unwanted particles, masking defects, and various pits and scratches. Also, in view of the three dimensional capability of the process, it is possible to see any problems below the surface when transparent layers are used. With conventional systems this would not always be easy because of the very narrow depth of focus which has to be used, and the time taken to refocus for each transparent site.

It is very important to be able to examine all of these aspects because some of the defects may reveal process or masking problems. These can then be cured to ensure that future batches do not suffer as well.

There are two main sections to the system: the computer unit with operator console and the laser optics unit. It has been designed so that the operator console can be located away from the optics unit. In this way the console can be kept out of the clean environment allowing for more convenient access to the system. It also means that less people have to enter the clean environment.

Another advantage of having two sections to the system is that it is easier to install the unit into an existing factory. With the extremely high costs of running an i.c. fabrication plant it is essential that down time is kept to a minimum.

In view of the requirements for ever higher yields and better reliability, this new system appears to be another valuable tool for the semiconductor industry. In the future, methods like this for locating defects and resolving problems will become increasingly important in ensuring that yields remain high and quality is maintained.

Is your PCB design package not quite as "professional" as you thought? Substantial trade-in discounts still available.

Board Capture

Schematic Capture Design Tool

- Direct netlist link to BoardMaker2
- Forward annotation with part values
- Full undo/redo facility (50 operations)
- Single-sheet, multi-paged and hierarchical designs
- Smooth scrolling
- Intelligent wires (automatic junctions)
- Dynamic connectivity information
- Automatic on-line annotation
- Integrated on-the-fly library editor
- Context sensitive editing
- Extensive component-based power control
- Back annotation from BoardMaker2

£395

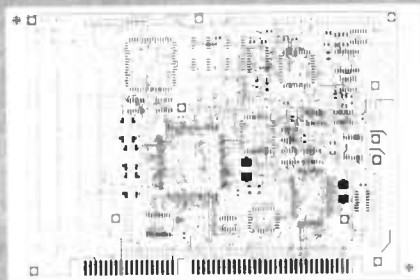
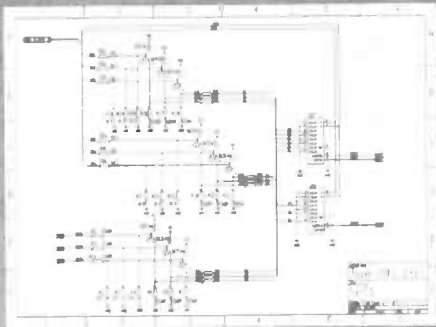

BoardMaker

BoardMaker1 - Entry level

- PCB and schematic drafting
- Easy and intuitive to use
- Surface mount and metric support
- 90, 45 and curved track corners
- Ground plane fill
- Copper highlight and clearance checking

£95

BoardMaker2 - Advanced level

- All the features of BoardMaker1
- Full netlist support- BoardCapture, OrCad, Schema, Tango, CadStar
- Full Design Rule Checking both mechanical and electrical
- Top down modification from the schematic
- Component renumber with back annotation
- Report generator- Database ASCII, BOM
- Thermal power plane support with full DRC

£395

BoardRouter

Gridless re-entrant autorouter

- Simultaneous multi-layer routing
- SMD and analogue support
- Full interrupt, resume, pan and zoom while routing

£200

Output drivers - Included as standard

- Printers - 9 & 24 pin Dot matrix, HPLaserjet and PostScript
- Penplotters - HP, Graphtec & Houston
- Photoplotters - All Gerber 3X00 and 4X00
- Excellon NC Drill and Annotated drill drawings (BM2)



For further information contact
Tsien (UK) Limited
 Aylesby House
 Wenny Road, Chatteris
 Cambridge, PE16 6UT
 Tel 01354 695959
 Fax 01354 695957
 E-mail Sales@tsien.demon.co.uk

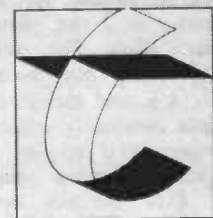

tsien

CIRCUIT SURGERY

ALAN WINSTANLEY

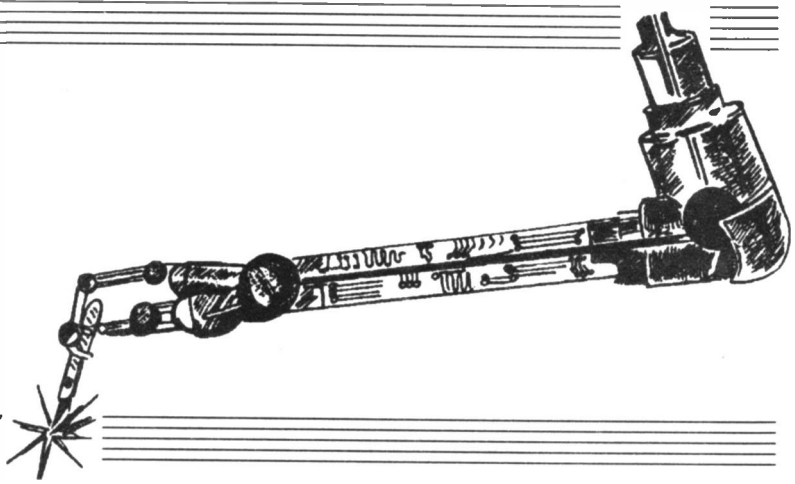

Our monthly round-up of enquiries, hints and tips offers a design for a doorbell which will shed some light on your night-time callers, and also looks at heatsink calculations in more detail.

Doorbell Activated Lamp

SOMETIMES I receive letters from readers asking, what is the point of building things yourself, when you can now buy so many consumer products more cheaply from the shops. It's certainly true that the constructor can no longer compete with mass-produced imported items such as digital clocks, radios or mains adapters, for example – OEMs (Original Equipment Manufacturers) have component purchase prices which we constructors can only dream about!

One of the advantages of being an electronics enthusiast, though, is the fact that you can design and assemble your own custom-made projects and gadgets to perform a specific function, especially useful if there isn't a ready-made solution available in the shops. You can either start from scratch or alternatively adapt existing designs to meet your needs. Not to mention, there's the ultimate satisfaction of building the project from scratch using your skills and your own bare hands.

As if to illustrate the point, from one of our overseas subscribers came this enquiry for a "doorbell with a difference". **Sumanadasa Namarathna** of Veyangoda, Sri Lanka writes:

Could you help me with a solution for a system which will help me to see callers who ring my doorbell at night? The idea is that when the doorbell is pressed during the day, the bell rings as normal but at night-time, a nearby outside lamp will illuminate for a few minutes so I can identify who's there. For this project I cannot buy parts from the UK and therefore please use commonly available components if you can.

My initial feeling was that a PIR (passive infra red detector) would fit the bill, detecting the body heat of callers and lighting the way whenever anyone approached, regardless of

whether they press the bell or not. Such lamps normally have built-in photocells to disable their operation in the day. (Indeed, my neighbour's cat takes advantage of my patio PIR floodlight to tackle my pond fish at night!) A basic and rather flimsy-looking floodlight fitted with a PIR can be purchased for under £15 here in the UK, but these are functional rather than ornamental, and they also dazzle oncomers.

If you already have an attractive outdoor lamp or a convenient porch light, then Fig. 1 may be of interest to experimenters: it's a circuit which enables your lamp to illuminate with a press of the doorbell pushswitch. It works at night-time only and will power the lamp for a few minutes through a timer circuit. The simple design is readily adaptable for other applications or configurations.

In Fig. 1, S1 is the bell pushswitch which completes the circuit to the solenoid of the existing Doorchime movement. When closed, the switch also triggers the 555 timer monostable built around IC2. This drives a mains relay RLA whose contacts can either be paralleled with an existing light switch, or wired in series with a live mains supply to feed a new lamp. When the switch is closed, the 555 triggers for a period equal to 1.1 VR2.C1 seconds, so the lamp will light for this period.

Let there be light

An electronic audible warning device could be used instead of the bell solenoid, or could be driven in parallel with an existing doorbell to add a second ringer elsewhere in the house. The diode D1 snubs the back e.m.f. generated by the solenoid coil.

In order to prevent the lamp from lighting during daylight hours, a cheap 741 op.amp (IC1) is configured as a Schmitt trigger, which is a circuit that converts a slowly-moving signal into a rapid snap-action edge. PCC1 is an ordinary ORP12-type photoconductive cell (light dependent resistor) forming one half of a potential divider with potentiometer VR1. The photocell is positioned where it can monitor ambient light levels but should be placed so that it will not be adversely affected by street-lights, headlights or light from the porch-lamp itself.

The non-inverting input (pin 3) of the op.amp is clamped at roughly half the supply rail by resistors R1 and R2, whilst a combination of VR1 and PCC1 sets the inverting input (pin 2) voltage. During daytime conditions, the resistance of the photocell is low (say a few hundred ohms) and so the inverting input is pulled down near to 0V.

The output of IC1 is high, and this is inverted by transistor TR1 which saturates hard on. Its collector is

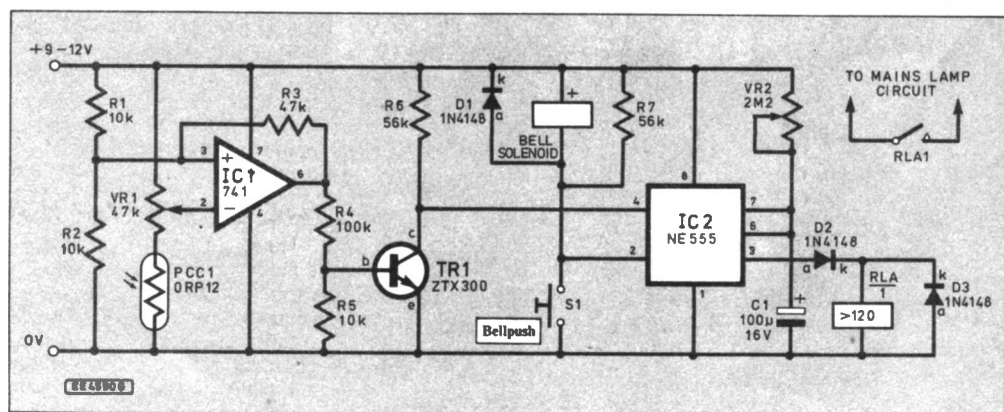

Fig. 1. Circuit diagram for a Doorbell-activated Porch Light.

therefore nearly 0V, which is sufficient to reset the 555 timer at pin 4 and prevent it operating. Adjust VR1 to obtain the desired switch-on level.

Thus, under daylight conditions, the timer is inhibited at pin 4 so the lamp can't illuminate – but the doorbell will still function as usual. Come nightfall, PCC1's resistance increases which pushes up the voltage at the inverting input until the op.amp output switches low and TR1 turns off. Now the 555 (IC2) will trigger when the doorbell is pressed, and the mains lamp will illuminate for a period determined by the setting of VR2.

Mr. Namarathna indicated in his letter that a power supply was available. Battery operation is not really feasible for this circuit due to the quiescent current requirements of the circuit, and no attempt was made to improve upon this using CMOS components. A simple smoothed power supply (approximately 12V) could be used, even a cheap 12V mains adapter might be suitable if it can handle the requirements of the Door-chime or sounder.

Take Note

Some other notes: component values are not at all critical and nearest junk box values will be fine. Similarly the transistor could be almost any *npn* small signal type, and you could try any other op.amp to hand just to see if it works.

The relay must be adequate for the mains loads, and it must have a coil resistance in the low hundreds of ohms or more. You could add an l.e.d. with 680 ohm series resistor to pin 6 of the op.amp, this will then indicate when IC1 is in its day or night setting – useful when initially testing the circuit.

If you have an existing doorbell, check internally that it can be switched from the negative rail, perhaps re-wiring it internally if necessary. Note that an existing bell mains transformer is likely to have an *a.c.* voltage output and *cannot* be used to power this circuit *directly*.

Finally, if you have any doubts or are inexperienced with mains wiring, please do not take risks but refer to a suitably qualified person for advice if needed.

Heatsink values

Last month we investigated regulator power supplies in some depth, noting that an "indestructible" three-terminal variable voltage device is likely to suffer thermal problems when used at extremes. If you dabble with power supplies or other higher power circuits yourself, eventually you will come across the requirement to use a *heatsink* to ensure that the heat produced by a device is removed away from the component quickly enough. Adequate heatsinking ensures that the maximum operating temperature of the device is not exceeded.

Where do you start when trying to calculate the requirements of a heatsink? What follows next might look a bit frightening to non-mathematicians (like myself), but it's actually very straightforward indeed.

There's an enormous variety of sizes and prices available, and often heatsinks

are conveniently pre-drilled to accept a particular semiconductor can size, such as TO-3 or TO-220 outlines. Heatsinks are measured in terms of their *thermal resistance*. This parameter is specified in Degrees Celsius per Watt ($^{\circ}\text{C}/\text{W}$), and is a very simple indication of how much the heatsink's temperature will rise for a given power "throughput".

In other words, an expensive heatsink with a very low thermal resistance (say $1^{\circ}\text{C}/\text{W}$) will hardly rise in temperature per watt of throughput, so it's very efficient at transferring heat to the surrounding fresh air. It's big! By contrast, the temperature rise of a small type (say $20^{\circ}\text{C}/\text{W}$) will be much higher and therefore they are only suited for lower power, less demanding applications.

The idea is that when a device (e.g. a regulator i.c.) becomes hot, we need to remove this heat away from the semiconductor chip or "junction" to ambient surroundings, otherwise the chip is liable to overheat. Think of a heatsink system as a "conveyor belt" shifting the heat away from the junction to the surrounding air. Anything which impedes the flow of heat from the junction (such as certain electrical insulation materials) is in effect contributing to the thermal resistance of the heatsink system – slowing down the conveyor so that heat builds up undesirably!

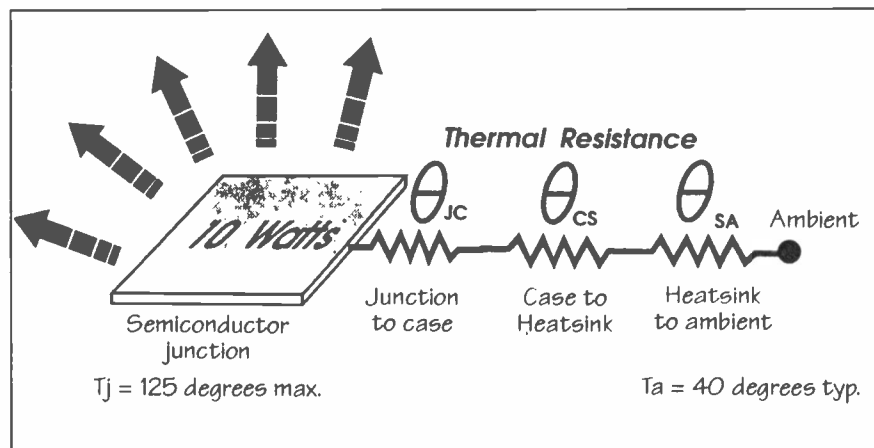

Fig. 2. Thermal resistance present in a heatsink system.

By carefully selecting heatsink ratings, we can ensure that the conveyor moves along at a speed to match the rate at which heat is being produced in the chip. Heat will then be conducted away efficiently, and the chip won't overheat.

A typical heatsink system consists of three "thermally resistive" elements, see Fig. 2. A semiconductor junction such as a transistor die or a regulator chip is embedded within a package. Imagine that the device is dissipating 10 watts and that its Absolute Maximum Temperature (as per its Data Sheet) is given as 125°C – typically for many semiconductors. How do we calculate the required thermal resistance of a heatsink? Firstly, we need to take into account *existing* thermal resistances before deciding upon a suitable heatsink value.

The symbol θ is used to denote thermal resistance. θ_{JC} is the thermal resistance between the semiconductor junction and the case wall of the package. This might represent the plastic resin of a TO-220

case, or heat-conducting grease within the steel case of a TO-3 device perhaps. (*Never* cut open such a device to see, because it may contain toxic materials.)

The thermal resistance from the case to the heatsink is shown as θ_{CS} . This could be an insulating washer or a smear of silicon heat-conductive grease. Finally, θ_{SA} is the thermal resistance between the heatsink and ambient temperature – it's the rating of the heatsink itself.

Heat conveyor

We can start by calculating the maximum allowable total thermal resistance in the system, also considering the ambient temperature likely to exist around the device, since this has a bearing on how efficient the system must be. For example, let's suppose the ambient temperature is likely to be 40°C . (This depends, though, on the general layout of any other components around the heatsink, and how adequate the existing ventilation might be.)

Therefore, the maximum permissible thermal resistance from junction to ambient (θ_{JA}) is $(125 - 40)^{\circ}\text{C}/10 \text{ Watts} = 8.5^{\circ}\text{C}/\text{W}$, otherwise the chip will overheat.

From Fig. 2, $\theta_{JA} = \theta_{JC} + \theta_{CS} + \theta_{SA}$. Buried in the Manufacturers' Data Sheet is the value of θ_{JC} – this depends

on the type of package. For example, National Semiconductor quote $2.3^{\circ}\text{C}/\text{W}$ for a TO-3 LM317K type, and a somewhat worse $4^{\circ}\text{C}/\text{W}$ for the TO-220 LM317T. Let's assume the latter.

Next, if you include an insulating washer with grease, this could introduce an estimated $0.4^{\circ}\text{C}/\text{W}$ thermal resistance between the case and the heatsink (θ_{CS}). You might even choose to ignore this element, since the figure for ambient temperature is already an estimate.

From the above formula, we can say that the heatsink rating θ_{SA} is therefore equal to $(8.5 - 4 - 0.4)^{\circ}\text{C}/\text{W} = 4.1^{\circ}\text{C}/\text{W}$. You could use anything lower than this (*a larger heatsink*) if you want. For hobbyist purposes, it's probably not necessary to go into so much detail but the above guide will at least give you a good idea of the sort of rating to go for when choosing a heatsink for your project. Ideally you would design for worse case conditions, though if you need to keep within a budget then a smaller heatsink might

be used – the thermal overload protection circuitry of a typical regulator will simply shut the device down at extreme temperature levels.

A brief computer listing written in Microsoft QBasic is offered this month to those who use a PC with MS-DOS. It's simple and you can elaborate upon it as you wish. It will calculate the maximum heatsink thermal resistance allowed, if you input the required data in response to a series of questions.

Power Supplies (Feb '95)

Unfortunately several gremlins crept into my Table 1 (Adjustable Voltage Regulators) in the February issue. The L200CV is good for 2A of course, and comes in a TO-220 5-pin style. Also, the "T" suffix in the (National Semiconductor) part numbers given, indicates TO-220 outlines, not TO-3 or TO-202 as printed. Sorry for the confusion.

Next Time: We check out the difference between *conventional current* and *electron flow* – a subject where in electronics, we're somewhat "backwards" compared with the rest of science.

Circuit Surgery is our column catering for feedback from readers. If you've

```

5 CLS
6 PRINT "HEATSINK CALCULATOR"
10 REM HEATSINK CALCULATOR UTILITY - ALAN WINSTANLEY FEB 1995
20 PRINT "MAXIMUM JUNCTION TEMPERATURE (Tj) = ";
30 INPUT TJ
40 PRINT "AMBIENT TEMPERATURE (Ta) = ";
50 INPUT TA
60 TEMPRISE = TJ - TA
70 PRINT "MAX PERMISSIBLE JUNCTION TEMP RISE OVER AMBIENT = "; TEMPRISE
80 PRINT
90 PRINT "INPUT MAXIMUM POWER DISSIPATED (WATTS)";
100 INPUT PT
110 PRINT "MAXIMUM PERMISSIBLE THERMAL RESISTANCE (0ja) IS ";
115 PRINT TEMPRISE / PT; "deg C per Watt"
120 PRINT
130 PRINT "INPUT THERMAL RESISTANCE 0jc (JUNCTION TO CASE) ";
140 INPUT Tjc
150 PRINT
160 PRINT "INPUT THERMAL RESISTANCE 0cs (CASE TO HEATSINK) ";
170 INPUT Tcs
180 PRINT
190 PRINT "MAXIMUM HEATSINK THERMAL RESISTANCE IS ";
200 PRINT (TEMPRISE / PT) - Tjc - Tcs; "deg C / Watt"

```

Computer listing for calculating maximum heatsink thermal resistance.

built an *EPE* constructional project and have any tips to pass on to your fellow constructors, why not write in to *Circuit Surgery* and we'll pass them on. Remember, this feature relies heavily on your input so if you have any comments or suggestions for future

topics, or any particularly puzzling problems which you'd like us to investigate, write to me at the usual address: Alan Winstanley, *Circuit Surgery*, Wimborne Publishing Ltd., Allen House, East Borough, Wimborne, Dorset, BH21 1PF., U.K.

Ohm Sweet Ohm

Max Fidling

The Honey Monster

RARE is the minute when the soldering iron's not plugged in and ready for action, with the smell of flux drifting into the workshop and the atmosphere occasionally punctuated by the odd electronic mishap or two. One particular day I was cleaning up a prototype after a small electrolytic capacitor had gone to meet its maker, accompanied by a disproportionately loud explosion of fluff and fumes. I was looking around for a replacement cap. when into the workshop walked one of my neighbours. Bob happened to be the local beekeeper, and as I started to solder in the new capacitor, he recounted a tale of woe.

Beekeeping has many fascinating aspects but the medieval technology associated with apiculture perhaps isn't one of them, not to a boffin like myself, at any rate. It seems that Bob's honey separator had suddenly expired and as he was in the middle of processing a batch of honeycombs, he desperately needed a hand to repair it, given that his electronics expertise was restricted to wiring a three-pin plug. (Which seems reasonable since my knowledge of honey was limited to scoffing it.)

Bob knew I was extremely partial to fresh honey and armed with this psychological weapon he had in the past managed to tempt me into "modernising" his equipment by installing several modest electronic gizmos to help with his honey processing.

Let me explain. When honey is produced within a bee-hive, it's necessary to extract the slurpy syrup from the wax honeycombs. This is effected by the simple technique of spinning the honey frames at

full pelt in something resembling a spin-drier. Bob's honey separator was a round stainless steel tank about the size of a Baby Burco boiler, and it held four frames at a time, flinging the honey out of the honeycombs like a centrifuge which could then be drained from a valve at the bottom of the tank. The yummy honey thus produced was then heated in a temperature-controlled warming box to remove any impurities or wax; hence the electronic thermostat I'd built for him some time ago... all scientific stuff!

The centrifuge had formerly been hand-powered but you can guess who, in exchange for some jars of fresh honey, had "automated it" by adding an old electric motor and speed controller! Bob explained that the motor had suddenly stopped working and hence he was in dire straits. Armed with my multimeter, Bob, myself and Piddles my feline apprentice walked round to the honey shed – which was in fact an almost derelict garden shack. The honey separator lay inside, silent.

Hurricane Honey

I removed the drive belts and pulleys and eventually tested the electric motor by running it gingerly from the mains. The motor ran perfectly so I guessed the fault lay in the speed controller which I'd constructed for him last season. It was a very simple design, using a very large triac and could probably power a London Underground train judging by the size of it. The theory had been to over-engineer the project a bit by using a 25A triac so I was a bit puzzled why it should fail on a mere quarter-horsepower washing machine motor. Perhaps the fact that the diecast box was full of honey which had leaked into it had some bearing on the matter, I mused.



Back at the workshop, I replaced the triac with another spare from the biscuit tin. Piddles assisted by licking out most of the honey from within the diecast box appreciatively, while I rummaged around for the solder. We soon had the controller bolted back into place on the separator and Bob filled the whirling dervish with more dripping honey frames. Clamping the lid down tightly, I plugged in and switched on the controller while Bob looked on. Meantime Piddles had started helping himself to a jar of freshly made honey he'd found open on the bench nearby.

The separator hummed into life and gathered speed like a hurricane mustering strength. Accelerating up to full speed, the steel lid on top started clattering like a milk pan lid about to boil over. The separator whirred at full tilt with me hanging on to it for all I was worth – the vibration rattling the timbers of the ancient shack and almost shaking my fillings out!

Mercifully, delicious liquid honey soon started to trickle out of the valve once more and into a gallon bucket, ready for the warming box. Eventually the separator slowed down to a halt, allowing me to gather my senses and with mission accomplished, a delighted Bob thanked me with more obligatory jars of honey. This job has its perks after all, I thought! Piddles seemed to agree, licking his lips and purring contentedly.

HART

HART AUDIO KITS – YOUR VALUE FOR MONEY ROUTE TO ULTIMATE HI-FI

HART KITS give you the opportunity to build the very best engineered hifi equipment there is, designed by the leaders in their field, using the best components that are available.

Every HART KIT is not just a new equipment acquisition but a valuable investment in knowledge, giving you guided hands-on experience of modern electronic techniques.

In short HART is your 'friend in the trade' giving you, as a knowledgeable constructor, access to better equipment at lower prices than the man in the street.

You can buy the reprints and construction manual for any kit to see how easy it is to build your own equipment the HART way. The FULL cost can be credited against your subsequent kit purchase.

Our list will give you full details of all our Audio Kits, components and special offers.

INTRODUCING

The Hart "Chiara"

Single-Ended Class "A" Headphone Amplifier.

Most modern high fidelity amplifiers either do not have a headphone output facility, or this may not be up to the highest standard.

The new Hart "Chiara" has been introduced as an add-on unit to remedy this situation, and will provide two ultra high quality headphone outlets. This is the first unit in our 2000 Range of modules to be introduced through the year. Housed in the neat, black finished, Hart Minibox it features the wide frequency response, low-distortion and "musicality" that one associates with designs from the renowned John Linsley Hood.

Both outputs will drive any standard high quality headphones with an impedance greater than 30 ohms and the unit is ideal for use with the Sennheiser range. A signal link-through makes it easy to incorporate into your system and two extra outputs, one at output level and one adjusted by the Volume control are available on the back panel. The high level output also makes a very useful long-line driver where remote mounted power amplifiers are used. Power requirements are very simple and can be provided by either of our new "Andante" power supplies. Use the K3565 to drive the "Chiara" on its own, K3550 if driving other modules as well.

Volume and Balance controls are provided and as befits any unit with serious aspirations to quality these are the ultra high quality Alps "Blue Velvet" components.

Very easily built, even by beginners, since all components fit directly on the single printed circuit board and there is no conventional wiring whatsoever. The kit has very detailed instructions, and even comes with a roll of Hart audiograde silver solder. It can also be supplied factory assembled and tested.

Selling for less than the total cost of all the components, if they were bought separately, this unit represents incredible value for money and makes an attractive and harmonious addition to any hifi system.

K2100 The total cost of a complete set of all components to build this unit is £126.37. Our special discount price for all parts bought together as a kit is.....**£109.50**

K2100SA Series Audiophile, with extra selected components.....**£112.46**

HART TC1D Triple Purpose TEST CASSETTE

Now available again and even better than before! Our famous triple purpose test cassette will help you set up your recorder for peak performance after fitting a new record/play head. This quality precision Test Cassette is digitally mastered in real time to give you an accurate standard to set the head azimuth, Dolby/VU level and tape speed, all easily done without test equipment.

TC1D Triple Purpose Test Cassette.....**£9.99**

Send or 'phone for your copy of our FREE List of these and many other Kits & Components. Enquiries from Overseas customers are equally welcome, but PLEASE send 2 IRCs if you want a list sent surface post, or 5 for Airmail.

Ordering is easy. Just write or telephone your requirements to sample the friendly and efficient HART service. Payment by cheque, cash or credit card. A telephoned order with your credit card number will get your order on its way to you THAT DAY.

Please add part cost of carriage and insurance as follows—INLAND Orders up to £20 - £1.50, Orders over £20 - £3.50. Express Courier, next working day £10.

OVERSEAS - Please see the ordering information with our lists.

INTRODUCING THE HART

"Andante"

20VA AUDIOPHILE POWER SUPPLIES

Specially designed for exacting audio use requiring absolute minimum noise, low hum field and total freedom from mechanical noise this unit is a logical development from our highly successful 1550 series.

Utilising linear technology throughout for smoothness and musicality makes it the perfect partner for any module, such as those in our new "2000" Range, requiring fully stabilised $\pm 15V$ supplies.

Two versions are available. K3550 has two $\pm 15V$ supplies and a single 15V for relays etc. and can be used with our K1400 preamp and our K1450 RIAA pickup preamp, as well as other useful modules soon to be introduced. The K3565 is identical in appearance but only has the $\pm 15V$ light current supply for use with the K1450 RIAA pickup preamplifier on its own.

K3550 Full Supply with all outputs.....**£89.75**

K3565 Power Supply for K1450 RIAA Pickup Preamp.....**£79.42**

ALPS "Blue Velvet" Precision Audio Controls



To fulfil the need for ultra high quality controls we import a special range of precision audio pots in values to cover most quality amplifier applications. All in 2-gang stereo format, with 20mm long 6mm diam. steel shafts, except for the 50K Log which is 25mm x 6mm. Overall size of the manual pot is 27W x 24H x 27Deep, motorised versions are 72-4mm Deep from the mounting face. Mounting bush for both types is 8mm diameter.

Now you can throw out those noisy ill-matched carbon pots and replace with the real hi-fi components only used selectively in the very top flight of World class amplifiers. The improvement in track accuracy and matching really is incredible giving better tonal balance between channels and rock solid image stability.

The motorised versions use a 5V DC motor coupled to the normal control shaft with a friction clutch so that the control can be operated manually or electrically. The idea of having electrically operated pots may seem odd, archaic even, but it is in fact the only way that remote control can be applied to any serious Hi-Fi system without loss of quality. The values chosen are the most suitable available for a low loss passive volume and balance control system, allowing armchair control of these two functions.

Our prices represent such super value for pots of this quality due to large purchases for our own kits.

MANUAL POTENTIOMETERS

2-Gang 100K Lin.....**£15.67**

2-Gang 10K, 50K or 100K Log.....**£16.40**

2-Gang 10K Special Balance, zero crosstalk and zero centre loss.....**£17.48**

MOTORISED POTENTIOMETERS

2-Gang 20K Log Volume Control.....**£26.20**

2-Gang 10K RD Special Balance, zero crosstalk and less than 10% loss in centre position.....**£26.98**

REEL TO REEL HEADS

999R 2/4 R/P 100mH.....**£16.84**

We have a few erase heads to suit which can only be supplied when 2 R/P heads are purchased **£36.80**

TAPE RECORDER CARE PRODUCTS

DEM1 Mains Powered Tape Head Demagnetizer, prevents noise on playback due to residual head magnetisation.....**£4.08**

DEM115 Electronic, Cassette Type, demagnetizer.....**£8.61**

LINSLEY HOOD 'SHUNT FEEDBACK' RIAA MOVING COIL & MOVING MAGNET PICKUP PREAMPLIFIERS



The HART K1450 Magnetic pickup preamplifier kit features a totally discrete component implementation with a specially designed low input impedance front end and the superior sound of the Shunt Feedback circuitry. High quality components fitting to an advanced double-sided printed circuit board make this a product at the leading edge of technology that you will be proud to own. Nevertheless with our step by step instructions it is very easy and satisfying to assemble. The higher current consumption of this unit means that it is best powered by our new Andante Audio Power Supply, itself an advanced piece of technology in a matching case. This supplies the superbly smoothed and stabilised supply lines needed by any sensitive preamplifier and features a fully potted Hi-grade toroidal transformer along with a special limited shift earth system for hum free operation. The K1450 is suitable for all moving coil and moving magnet transducers this unit is especially recommended for, and will extract the very best from the modern generation of low output high quality moving coil transducers.

K1450 Kit, complete with all parts ready to assemble inside the fully finished 228mm x 134mm x 63mm case. Kit includes full, easy to follow, assembly instructions as well as the Hart Guide to PCB Construction, we even throw in enough Hart Audiograde Silver Solder to construct your kit!.....**£111.58**

K1450SA Series Audiophile version with selected components.....**£133.94**

HIGH QUALITY REPLACEMENT CASSETTE HEADS



Do your tapes lack treble? A worn head could be the problem. For top performance cassette recorder heads should be replaced every 1,500 hours. Fitting one of our high quality replacement heads could restore performance to better than new! Standard inductances and mountings make fitting easy on nearly all machines (Sony are special dimensions, we do not stock) and our TC1 Test Cassette helps you set the azimuth spot on. As we are the actual importers you get prime parts at lower prices, compare our prices with other suppliers and see! All our heads are suitable for use with any Dolby system and are normally available ex-stock. We also stock a wide range of special heads for home construction and industrial users.

HC80 NEW RANGE High Beta Permalloy Stereo head. Modern space saver design for easy fitting and lower cost. Suitable for chrome, metal and ferric tapes, truly a universal replacement head for everything from hi-fi decks to car players and at an incredible price too!.....**£11.70**
HRP373 Downstream monitor combi head.....**£62.59**
HQ551A 4-Track R/P.....**£8.75**
HQ551S Sony Mount 4-Tr. R/P.....**£14.90**
HQR560 Rotary Base 12.5mm R/P/E.....**£21.90**
HQR570 Rotary Base 15mm R/P/E.....**£22.59**
HQR580 Rotary Base 12.5mm R/P.....**£14.29**

HART Classical CD's.

Top quality, Full Digital (DDD), over 100 titles from only **£1.99!** Ring or send for your list!

TECHNICAL BOOKSHELF

We stock a huge range of books of interest to the electronics and audio enthusiast, including many reprinted classics from the valve era. Some were in last months advertisement, but see our list for the full range.

New this month is the GEC Valve designs book at **£18.95**, and the VTL Book, a modern look at valve designs. **£17.95**.

QUALITY AUDIO KITS

24 hr. SALES LINE (0691) 652894

ALL PRICES INCLUDE UK/EC VAT

HART
HART ELECTRONIC KITS LTD
8 PENNY LANE BELL
OWESTRY, SHROPSHIRE
SY10 8AF

AUTO BATTERY CHARGER

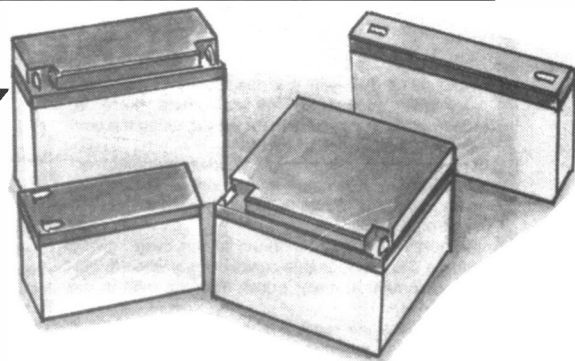

Terry de Vaux-Balbirnie

On-demand care for lead-acid batteries.

SMALL 12V lead-acid batteries are now used extensively as portable power sources and for back-up supplies. Their main advantage is a larger energy content for a given cost compared with nickel cadmium cells. Also, their self-discharge rate is much less.

The chief disadvantage is that they must be maintained more carefully than nickel-cadmium cells – particularly, to avoid discharging them below a certain level or leaving them in a discharged state. Such practice may cause irreversible damage.

NO DEMANDS

The Auto Battery Charger may be connected to the battery whatever its state of charge and left on continuously if desired. It will switch off automatically when the battery is fully charged.

Whenever the charge becomes less than a preset level (nominally 80 per cent), the unit will switch on again and the process repeat indefinitely – that is, it charges *on demand*. Since it is the mains supply which is switched on and off, the circuit draws current only during the process of charging.

Construction of the Auto Battery Charger is straightforward but you will need access to a digital multimeter for setting-up purposes at the end of construction.

DIRTY PLATES

When a nominal 12V lead-acid battery is on charge, its terminal voltage rises and eventually exceeds 14V. When taken off charge, this quickly drops to around 13V. In the absence of an external load it will then fall extremely slowly during the process of natural self-discharge. With a load applied, it falls at a rate dependent on the current drawn. Given time, the voltage would eventually fall to zero. However, allowing this to happen would prove very destructive and serious sulphation of the plates would occur.

In practice, the battery is said to be discharged when its terminal voltage drops below about 11.5V and it should never be allowed to fall much more than this. This charger constantly monitors the terminal voltage and switches on at 12.5V approximately (this corresponds to 80 per cent of maximum charge) and off again at 14.8V.

The design is innovative in that the circuit is powered by the battery itself. This allows the voltage to be monitored while the mains supply is off. Under these conditions, the current requirement of the prototype unit is only 90 μ A approximately so there is practically no drain on the battery – the natural leakage current being much greater.

The charging current is less than 1A which means that virtually any lead-acid battery can be accommodated without danger of overcharging. The prototype unit has been used successfully with batteries between 1Ah and 8Ah capacity.

This charger could be used as a module in any circuit where a 12V lead-acid battery is used in standby mode – in a burglar alarm system, for example. It may simply be connected up and forgotten. However, it is thought that most readers will wish to use it for cyclic operations where the battery is connected after a period of use and left on until needed again.

CIRCUIT DESCRIPTION

The complete circuit diagram for the Auto Battery Charger is shown in Fig. 1. While switch S1 is on and relay contacts RL1 “made”, the conventional arrangement of transformer T1, bridge rectifier D1-D4 and smoothing capacitor C1 provide a nominal 16V d.c. supply. Imagine for the moment that the relay contacts are *open* – that is, there is no power supply.

The battery (B1) to be charged is connected to the section of circuit based on the micropower op.amp IC2 and associated components. This op.amp has been specially chosen for its exceptionally low current requirement.

The inverting input, pin 2, of IC2 receives a precise 1.2V from IC1 – a precision reference i.c. Fixed resistor R3 allows a small current to flow through IC1 which is necessary for its operation. The non-inverting input pin 3 receives a proportion of the battery voltage derived from the potential divider consisting of resistors R1 and R2 in conjunction with preset potentiometer VR1.

Ignore the network comprising resistor R4 and preset potentiometer VR2 for the moment. While the battery voltage remains

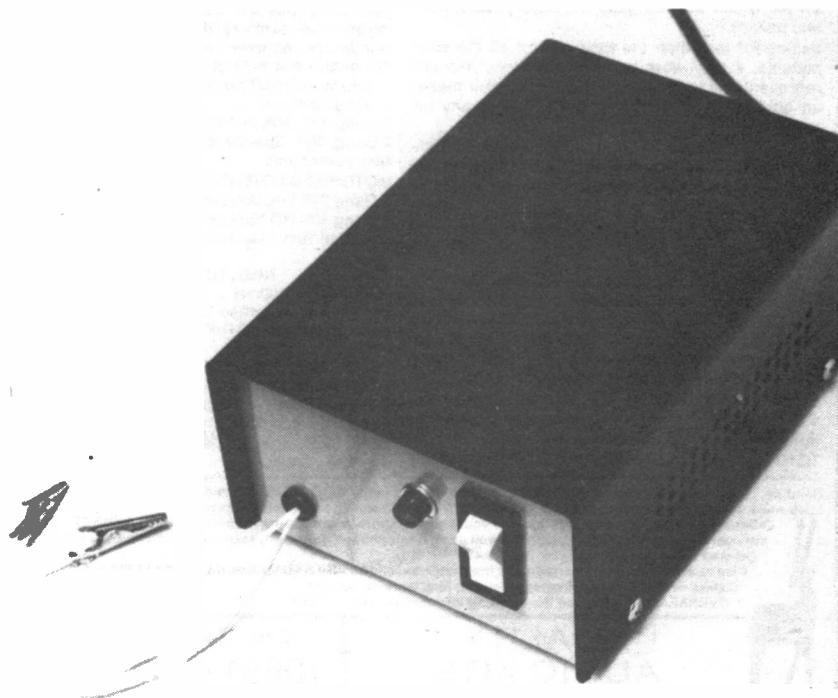

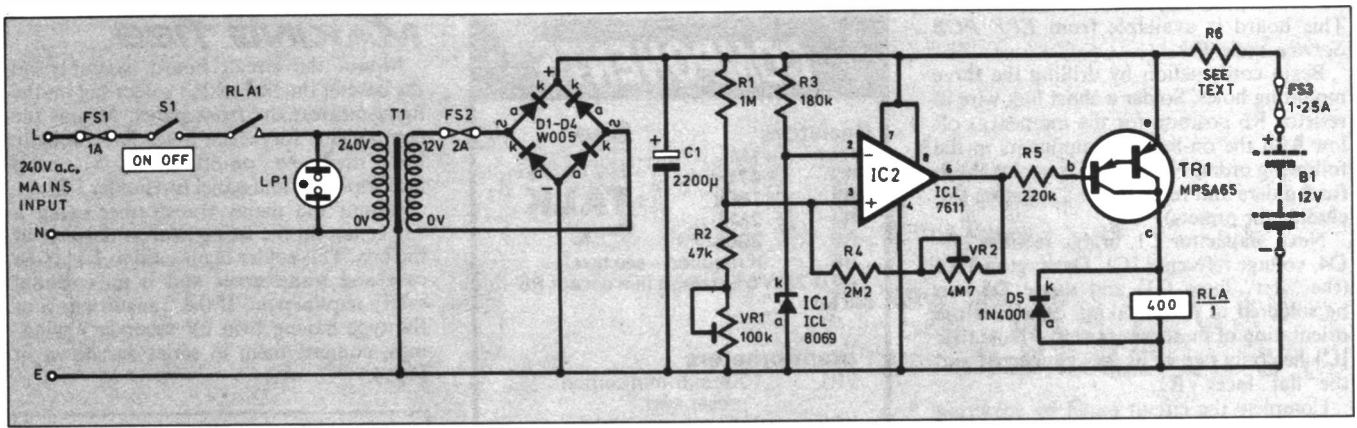

Fig. 1. Complete circuit diagram for the Auto Battery Charger.

above 14.5V, and with VR1 sliding contact at approximately mid-track position, there will be a voltage greater than 1.2V at the non-inverting input of IC2. Under these conditions, the op.amp will be *on* with its output pin 6 *high*.

This high state is applied, via resistor R5, to the base of Darlington transistor TR1. This turns it *off* (since it is a *pn*p transistor rather than the more familiar *npn* type) so no current flows through RLA relay coil. The normally-open contacts, RLA1, are therefore "broken" and the mains supply is *off* as previously supposed.

When the battery partly discharges, the voltage at the non-inverting input will drop below 1.2V. The conditions are now reversed and the voltage appearing at the non-inverting input will be less than that at the inverting one.

The op.amp output now switches *off* with the output becoming *low*. When this state is applied to TR1 base (b), it is switched on

and the relay coil in the collector (c) circuit is energized. The relay contacts RLA1 then "make" and establish a supply to the primary winding of transformer T1 and neon indicator LP1.

With a supply provided, the battery charges through resistor R6 and the terminal voltage rises. In fact R6 will probably not be needed. Its purpose, if present, is to limit the charging current to 1A. Its effect on threshold voltage monitoring is negligible.

OVER THE THRESHOLD

Without modification, this circuit would provide only one sharp switching voltage and this is not satisfactory. There need to be two well-defined levels – one for "on" and the other for "off".

This is achieved by introducing positive feedback via resistor R4 and preset potentiometer VR2. This provides Schmitt

trigger action so that once off, charging will not re-commence until the voltage has fallen below a certain lower value.

The difference between the "on" and "off" thresholds is set by VR2 adjustment. In the prototype unit, with VR2 sliding contact at mid-track position, the separation between the threshold voltages is approximately 2V. Thus, if the charger were to switch off as the voltage rose to 14.6V, it would need to fall to 12.6V for it to switch on again.

At the end of construction, VR1 will be adjusted to provide the required "on" voltage and VR2 the correct "off" one. Fuses FS1, FS2 and FS3 provide protection to all parts of the circuit.

CONSTRUCTION

Most of the components for the Auto Battery Charger are mounted on a single-sided printed circuit board (p.c.b.) The topside component layout and full-size copper foil track pattern are shown in Fig. 2.

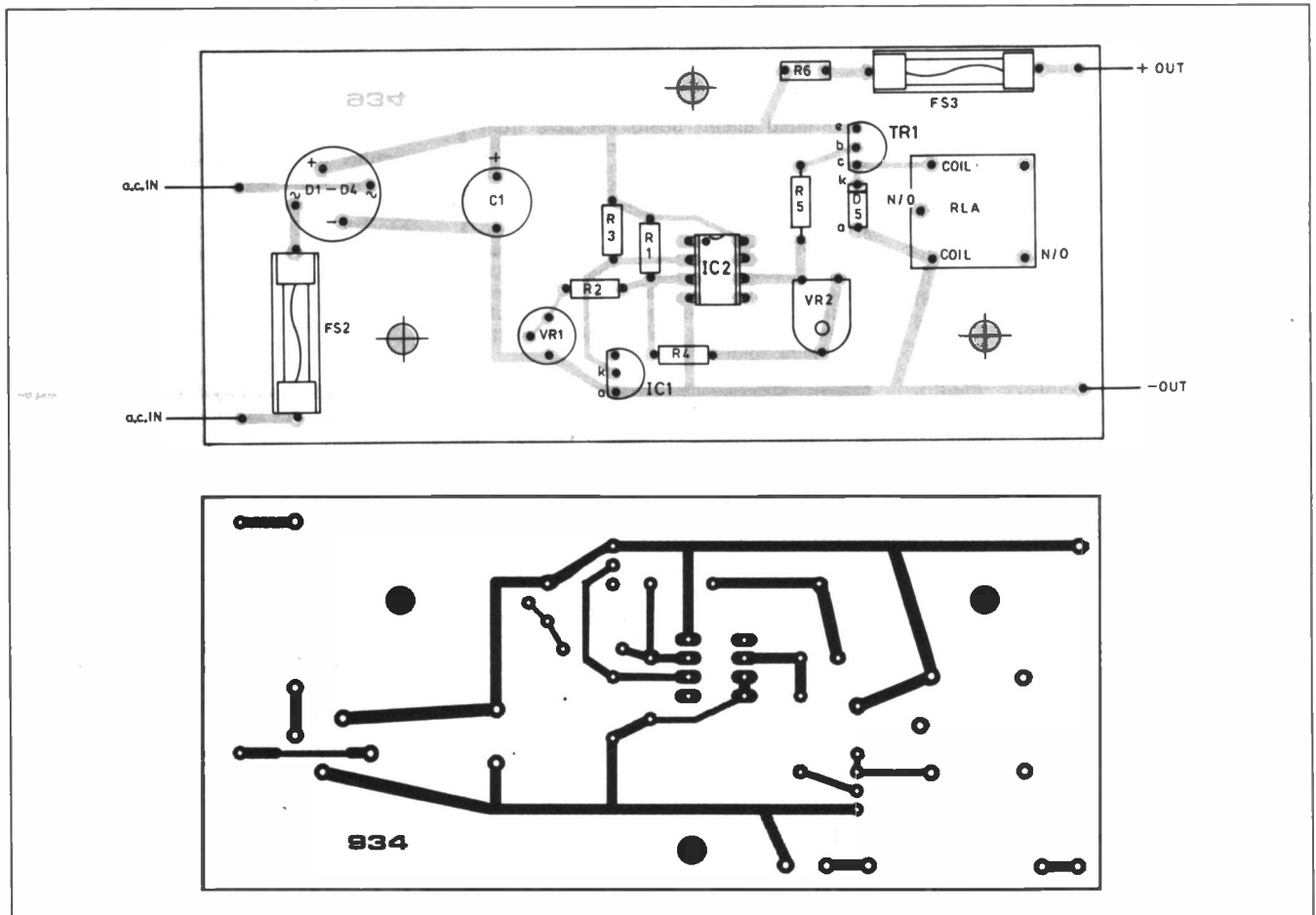

Fig. 2. Printed circuit board component layout and full size copper foil track pattern for the Auto Battery Charger.

This board is available from *EPE PCB Service*, code 934.

Begin construction by drilling the three mounting holes. Solder a short link wire in resistor R6 position for the moment. Follow with the on-board components in the following order. Firstly the i.c. socket, both fuseholders and relay then all resistors (including the presets).

Next, capacitor C1, bridge rectifier D1-D4, voltage reference IC1, Darlington TR1 (the "flat" faces C1) and diode D5 can be soldered in place, taking care over the orientation of these components. Note that IC1 has only two of its legs connected and the "flat" faces VR1.

Complete the circuit panel by soldering 15cm pieces of stranded connecting wire to the points marked "a.c. in" and "out". Solder a piece of similar wire 25cm long and red in colour to the point labelled "+ out".

Finally, solder 15cm pieces of 3A mains-type wire *direct* to the relay normally-open contacts on the underside of the board. Check that these connections are secure – **this is essential for safety reasons**. Adjust preset VR1 sliding contact fully anti-clockwise (as viewed from the relay) and VR2 to approximately mid-track position.

Note that an *aluminium or metal* case of the size stated in the parts list (or larger) **MUST be used** – a plastic enclosure is not suitable for this project. Drill holes in the front panel for ON-OFF switch S1, neon indicator LP1 and for the rubber grommet through which the output leads will be passed.

Make holes in the rear panel for fuseholder FS1 and for the strain relief bush to be used on the mains input lead. Note that a strain relief bush is essential here to prevent the wires pulling free which could be dangerous.

The printed circuit board is mounted on an aluminium panel cut and bent to the form shown in Fig. 3. Drill holes to correspond with those in the p.c.b. and one for the wires leading from the relay contacts to pass through – fit this latter one with a rubber grommet. Drill a further two holes to attach the aluminium panel to the base of the box.

Pass the relay wires through the grommeted hole and attach the circuit board to the aluminium panel using plastic stand-off insulators on the bolt shanks. These must maintain a minimum clearance of 5mm between the soldered joints on the reverse side of the p.c.b. and the metalwork. *Place a piece of plastic under the circuit panel in the region of the relay connections as an additional precaution.*

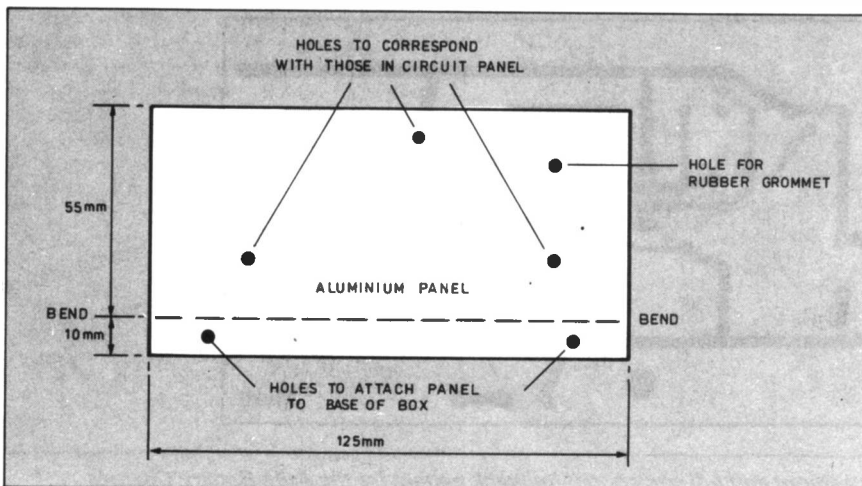

Fig. 3. Shaping the aluminium panel to which the p.c.b. is mounted.

COMPONENTS

Resistors

R1	1M
R2	47k
R3	180k
R4	2M2
R5	220k
R6	If required – see text.

All 0.25W 5% carbon film except R6 – see text.

See
**SHOP
TALK**
Page

Potentiometers

VR1	100k sub-min carbon preset, vert.
VR2	4M7 sub-min carbon preset, horiz.

Capacitor

C1	2200µ radial elect. 35V
----	-------------------------

Semiconductors

D1-D4	W005 50V 1.5A bridge rectifier
TR1	MPSA65 pnp Darlington transistor.
IC1	ICL8069CCZR 1.2V voltage reference i.c.
IC2	ICL7611 micropower op.amp.

Miscellaneous

T1	Mains transformer with 12V (or twin 6V secondaries) rated at 1A (12VA)
RLA	Miniature 12V 400ohm coil relay, with "make" contacts rated at 3A
S1	Mains rocker switch – 1A rating minimum
FS1	1A 20mm ceramic mains-type fuse and panel fuseholder
FS2	2A 20mm fuse and chassis fuseholder
FS3	1.25A 20mm fuse and chassis fuseholder
LP1	Mains neon indicator

Printed circuit board available from the *EPE PCB Service*, code 934; 8-pin d.i.l. socket; aluminium box, size 150mm x 100mm x 60mm minimum; crocodile clips (or spade-type connectors) (2 off); solder tags; 12V bulb, lampholder and crocodile clips for testing – see text; sheet aluminium for p.c.b. mounting; small fixings; strain-relief bush; rubber grommet; stand-off insulators (3 off); multistrand connecting wire; solder etc.

Approx cost
guidance only

£27

MAKING TIES

Mount the circuit board assembly on the base of the box with a solder tag on the fixing nearest the front panel. Mount the components for which holes have already been made i.e. on-off switch S1, neon indicator LP1 and panel fuseholder FS1.

Mount the mains transformer using a solder tag on the fixing nearest the rear of the box. This solder tag is used to Earth the case and transformer and is an essential safety requirement. If the transformer is of the type having twin 6V secondary windings, connect them in series as shown in Fig. 4.

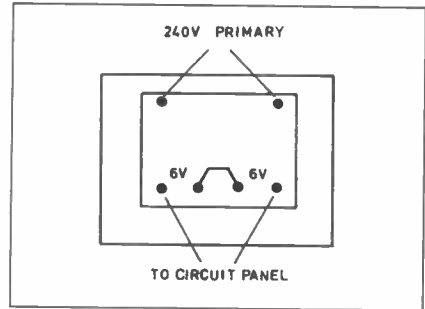

Fig. 4. Connections for transformer having twin 6V secondary windings.

Refer to Fig. 5, mount all remaining components and complete the interwiring shortening any wires as necessary. The use of small cable ties will keep the wiring neat.

Make up the input lead using three-core *mains-type* wire of 3A rating minimum. Secure the outer sheath using the strain relief bush and solder the wires as shown. Leave a little slack on the inside. Note that the Earth wire is soldered directly to the solder tag at the transformer. If the plug is of the standard UK type, fit a 2A or 3A fuse.

Cut a piece of *black* stranded wire similar in type to the existing red positive output lead and about 6cm longer. Solder one end to the solder tag at the aluminium panel together with the existing one. Secure the positive and negative output wires together, using a cable clamp pass them through the grommet checking that a little slack is left when they are pulled. Cut them to the same length and fit the ends with crocodile clips or spade-type connectors.

Insert a 20mm 1A *mains ceramic* fuse in FS1 fuseholder, a 2A fuse in FS2 and a 1.25A one in FS3 – these latter two may be of the glass type. Leave the lid of the case removed for the moment.

IMPORTANT WARNING

Make an insulating shield to cover the box on the transformer side of the circuit panel so that it is absolutely impossible to touch any mains connection when the lid of the case is removed. The photograph was taken with the shield removed to show internal components.

TESTING

You will need a 12V bulb to help with testing of the Charger – a 5W car sidelight type for a small battery or the 21W flashing indicator variety for a larger one. This will be used as a load. It should be placed in a lampholder and short wires attached with a crocodile clip on the end of each. Begin testing with the battery substantially discharged – check that the terminal voltage lies between 11.5V and 12V.

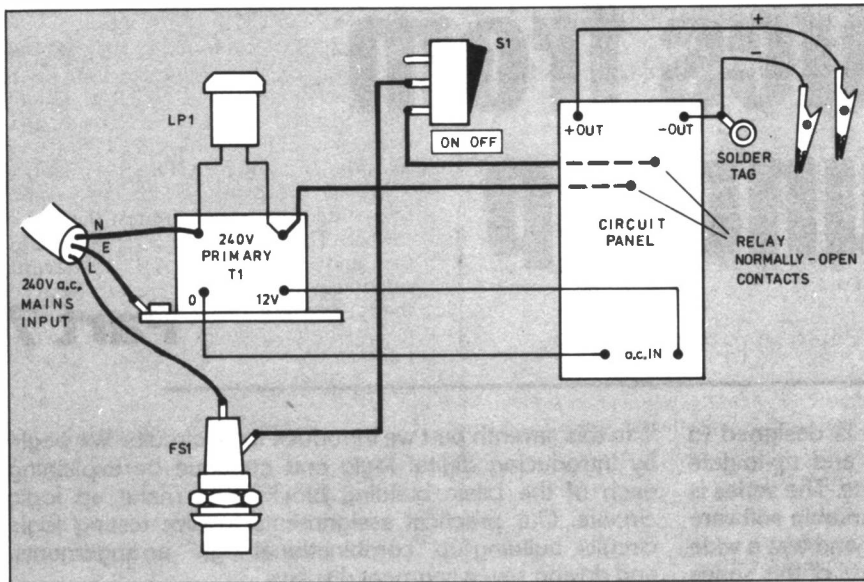

Fig. 5. Details of interwiring between the p.c.b. and other components.

Set the digital multimeter to a suitable current range and include it in the circuit as shown in Fig. 6. Take care to observe the polarity of the battery. Do not be surprised when the relay clicks as it should.

Keep the crocodile clips separated so that they cannot touch and plug the unit into the mains. The neon indicator should light. Check the current flowing into the battery – it is likely to be around 800mA.

If it is greater than 1A, fuse FS3 may blow and you will need a resistor in R6 position. This should have a power rating of **3W minimum** – a suitable value to begin with would be one ohm. To do this, snip through the link wire and solder the resistor to the free ends. Its value should be increased to reduce the current if necessary. With this test complete, switch off.

GIVING ATTENTION

You will need a trimming tool or very small screwdriver to enable quick and easy adjustment to preset VR1. Check that this is possible before continuing.

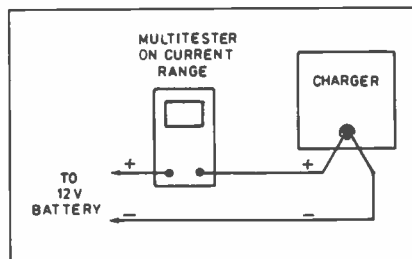

Fig. 6. Checking the current flow into a battery.

Remove the multimeter and adjust it to a suitable voltage range. Connect it directly across the battery terminals as shown in Fig. 7. Switch on and observe the reading at intervals. It should be seen that the voltage rises very slowly.

For the 6Ah battery used with the prototype unit this was about 0.3V per hour. This rate increases towards the end point so be particularly watchful after about 13.8V has been reached and have the trimming tool ready.

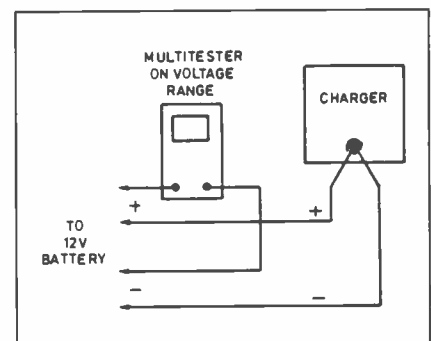

Fig. 7. Checking the actual voltage delivered to a battery.

so that when one is adjusted, the other may need attention too. You may therefore need to work in a series of small steps going from one to the other. Trying to speed matters up by using a higher-powered bulb could result in false voltage levels being set.

ALL CHARGED UP

With adjustments complete, test the charger under working conditions. The crocodile clips should always be connected to the battery *before* switching on the mains. If this precaution is not observed and they touch, a short-circuit will be caused and fuse FS3 may blow. Note also that if the battery is excessively discharged, either the mains will fail to switch on at all or FS3 may blow.

It is normal for the case to become warm with prolonged use. If there is a short interruption to the supply while charging is taking place, the lower threshold level will have to be reached before charging resumes.

When everything works correctly, the project may be put into permanent service. □

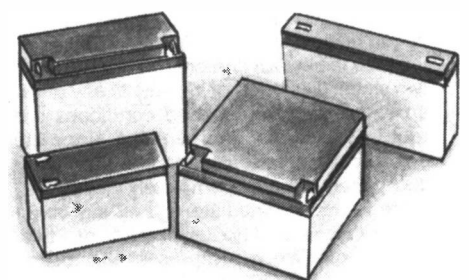
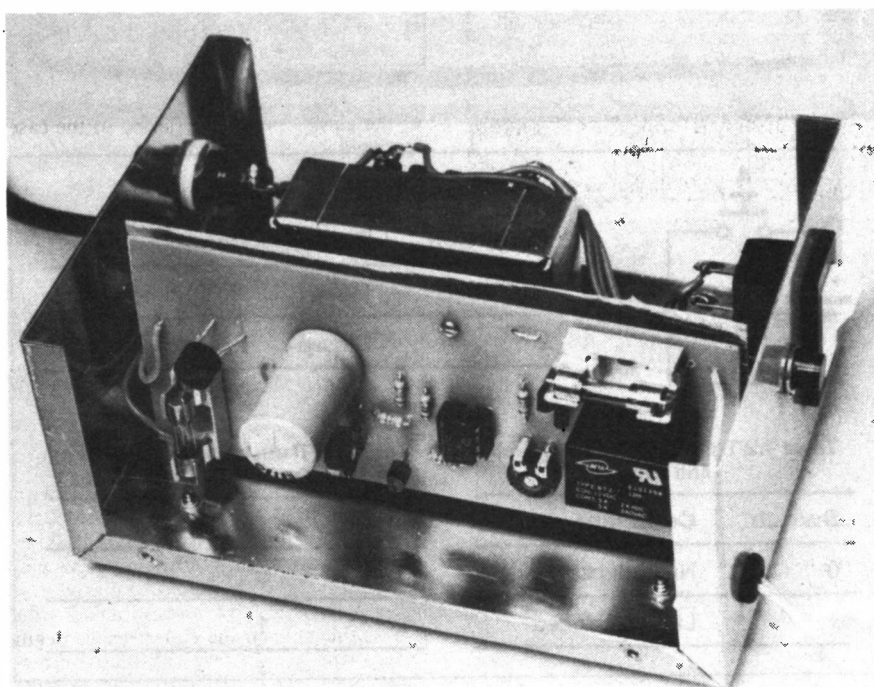

Electronics from the Ground Up

Mike Tooley, BA

Part 7

ELECTRONICS from the Ground Up is designed to provide you with a comprehensive and up-to-date introduction to the world of electronics. The series is based on *Electronics Workbench*, a remarkable software package that lets you use your PC to build and test a wide range of circuits. Back issues of earlier parts of this series are available – see *Back Issues* page.

In this seventh part we introduce logic circuits. We begin by introducing digital logic and continue by explaining each of the basic building blocks that make up logic circuits. Our practical assignments involve testing logic circuits, building up “combinational logic” arrangements, and driving seven-segment displays.

LOGIC

A basic requirement of many electronic circuits is that they should be able to make simple decisions based on a set of given conditions. Decisions are made on the basis of simple logical statements like:

If dark then put on the light

and

If temperature is less than 24°C then connect supply to the heater

and

If “hour” is greater than 11 and “24 hour clock” is not selected then display message “pm”.

All of these statements are similar in form. The first two are essentially:

If {condition} then {action}.

whilst the third is a compound statement of the form:

If {condition 1} and not {condition 2} then {action}.

All three of these statements can be readily implemented using straightforward electronic circuitry. Because this circuitry is based on discrete states and since the behaviour of the circuits can be described by a set of logical statements, the circuits that perform such tasks are referred to as “digital logic”.

SWITCHES AND LAMPS

To put this into context, let’s take a very simple example. Consider the circuit shown in Fig. 7.1 in which a battery is connected to a lamp via a switch. There are two possible states for the switch, *open* and *closed*. It should be obvious that the lamp will only operate when the switch is closed. We can summarise the operation of the circuit using a simple table as in Table 7.1.

Since the switch can only be in one of the two states (i.e., open or closed) at any given time, the open and closed conditions are mutually exclusive. Furthermore, since the switch cannot exist in any other state than completely open or completely closed (i.e., there is no intermediate or half-way state) the circuit is said to use binary or “two-state” logic. We can represent the logical state of the switch using the binary digits, 0

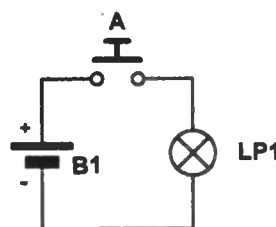
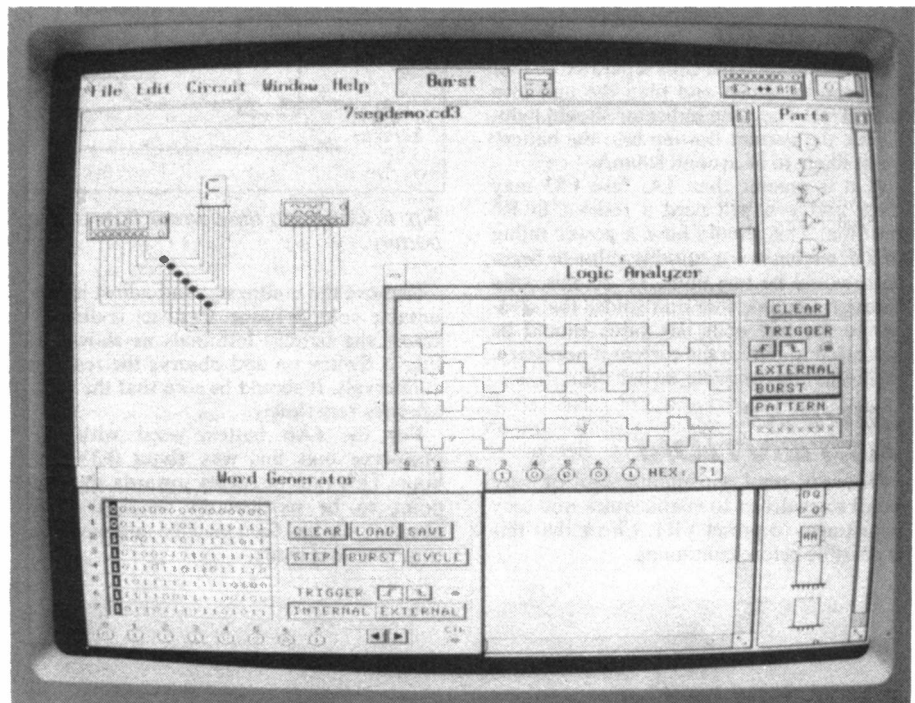

Table 7.1 Simple switching and logic

Condition	Switch	Comment
1	Open	No light produced
2	Closed	Light produced

Table 7.2 Truth table for the switch and lamp

Switch	Comment
0	No light produced
1	Light produced

Table 7.3 Truth table for the switch and lamp written in binary states

Input	Output
0	0
1	1

Fig. 7.1 Switch and lamp circuit, with truth tables.

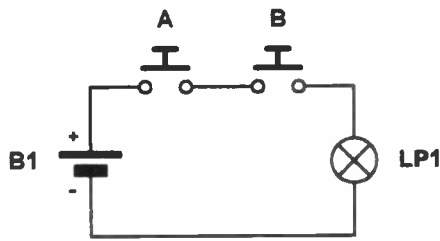

Table 7.4 Simple AND switching logic

Condition	Switch A	Switch B	Comment
1	Open	Open	No light produced
2	Open	Closed	No light produced
3	Closed	Open	No light produced
4	Closed	Closed	Light produced

Table 7.5 Truth table for AND switching logic

Switch A	Switch B	Comment
0	0	No light produced
0	1	No light produced
1	0	No light produced
1	1	Light produced

Table 7.6 Truth table for the AND function in terms of binary states

Input A	Input B	Output
0	0	0
0	1	0
1	0	0
1	1	1

Fig. 7.2 AND switching logic with truth tables.

and 1. We shall assume that a logical 0 is synonymous with open (or "off") and logical 1 is synonymous with closed (or "on"). Hence:

Switch open (off) = 0
Switch closed (on) = 1

We can now re-write the truth table in terms of the binary states as shown in Table 7.2.

We can take this process one stage further by re-writing the table in terms of the binary state of the circuit's "input" and "output" (see Table 7.3). We shall describe the binary state of the output by assuming that light corresponds to a logical 1 and no light corresponds to a logical 0. Hence:

No light (off) = 0
Light (on) = 1

AND LOGIC

Now consider the circuit with two switches shown in Fig. 7.2. Here the lamp will only operate when switch A is closed AND switch B is closed. However, let's look at the operation of the circuit in a little more detail. Since there are two switches (A and B) and there are two possible states for each switch (open or closed), there is a total of four possible conditions for the circuit. We can summarise these conditions in another table (see Table 7.4).

Since each switch can only be in one of the two states (i.e., open or closed) at any given time, the open and closed conditions are mutually exclusive. Furthermore, since the switches cannot exist in any other state

than completely open or completely closed (i.e., there are no intermediate states) the circuit uses "binary logic". We can thus represent the logical states of the two switches by the binary digits, 0 and 1.

Once again, if we adopt the obvious convention that an open switch can be represented by 0 and a closed switch by 1, we can re-write the truth table in terms of the binary states shown in Table 7.5 or in terms of inputs and outputs, as in Table 7.6.

OR LOGIC

Another circuit with two switches is shown in Fig. 7.3. This circuit differs from that shown in Fig. 7.2 by virtue of the fact that the two switches are connected in

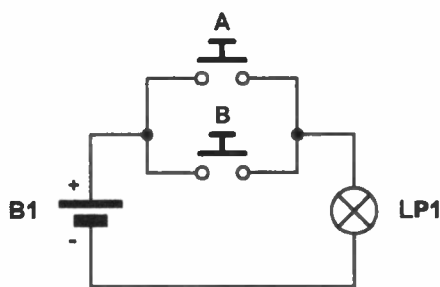

Table 7.7 Simple OR switching logic

Condition	Switch A	Switch B	Comment
1	Open	Open	No light produced
2	Open	Closed	Light produced
3	Closed	Open	Light produced
4	Closed	Closed	Light produced

Table 7.8 Truth table for OR switching logic

Switch A	Switch B	Comment
0	0	No light produced
0	1	Light produced
1	0	Light produced
1	1	Light produced

Table 7.9 Truth table for the OR function in terms of binary states

Input A	Input B	Output
0	0	0
0	1	1
1	0	1
1	1	1

Fig. 7.3 OR switching logic with truth tables.

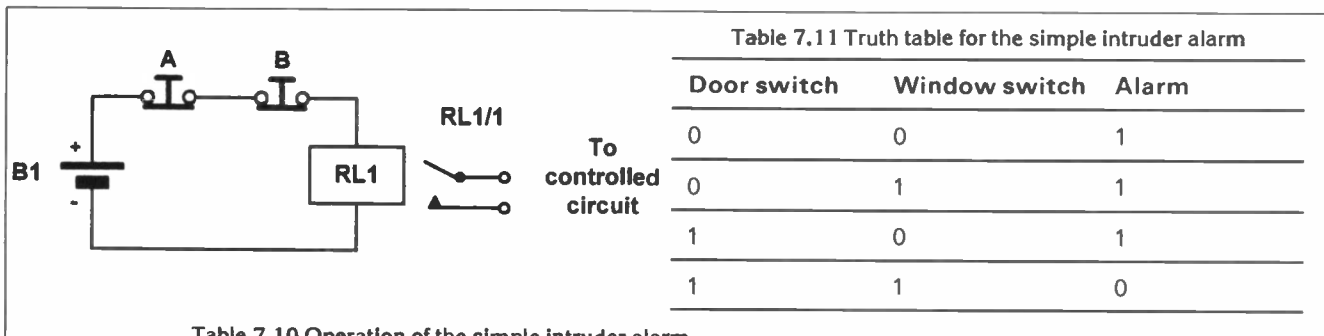

Table 7.11 Truth table for the simple intruder alarm

Door switch	Window switch	Alarm
0	0	1
0	1	1
1	0	1
1	1	0

Table 7.10 Operation of the simple intruder alarm

Door switch	Window switch	Relay coil	Alarm
open	open	not energised	sounding
open	closed	not energised	sounding
closed	open	not energised	sounding
closed	closed	energised	not sounding

B remain closed, the relay will operate and its contacts will remain open. When a door or window is opened, its respective switch will open. This, in turn, causes the circuit to be broken and the relay will cease to be energised. The relay contacts will then close and the alarm will sound (see Table 7.10).

Assuming the same logical convention as before (i.e., switch closed = 1, alarm sounding = 1), the truth table for the system is shown in Table 7.11.

It is worth comparing Table 7.11 with Table 7.6. The output column of each truth table is the same except for the fact that all the 0s have been replaced by 1s and vice versa. The logical function is thus the opposite (or "inverse") of AND. We call this function **NAND** (standing for **NOT-AND**).

Fig. 7.4 Intruder alarm based on normally-closed switches and its truth tables.

parallel rather than in series. In this case the lamp will operate when either of the two switches is closed, i.e. if switch A **OR** switch B is closed. As before, there is a total of four possible conditions for the circuit. We can summarise these conditions in another table, Table 7.7.

Once again, adopting the convention that an open switch can be represented by 0 and a closed switch by 1, we can re-write the truth table in terms of the binary states

or in terms of input and output states as shown in Table 7.8 and Table 7.9 respectively.

AND INVERSION

Now let's consider another situation. The circuit shown in Fig. 7.4 is a simple intruder alarm in which both door and a window switches are normally closed. The two switches are wired in series with a relay coil and battery. As long as switch A **AND** switch

BASIC LOGIC FUNCTIONS

To simplify the task of designing and building logic circuits, a range of standard devices is available to provide the basic logic functions, AND, OR, NAND,

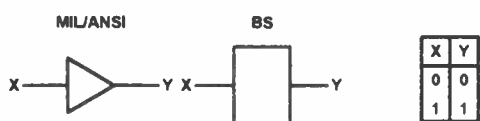

Fig. 7.5 Symbols and truth table for a buffer.

X	Y
0	0
1	1

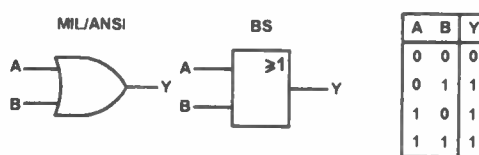

Fig. 7.9 Symbols and truth table for a two-input OR gate.

A	B	Y
0	0	0
0	1	1
1	0	1
1	1	1

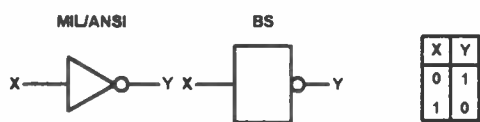

Fig. 7.6 Symbols and truth table for an inverter.

X	Y
0	1
1	0

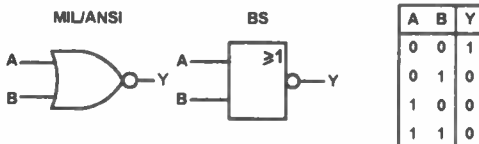

Fig. 7.10 Symbols and truth table for a two-input NOR gate.

A	B	Y
0	0	1
0	1	0
1	0	0
1	1	0

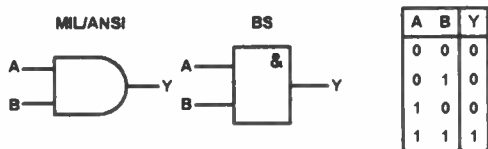

Fig. 7.7 Symbols and truth table for a two-input AND gate.

A	B	Y
0	0	0
0	1	0
1	0	0
1	1	1

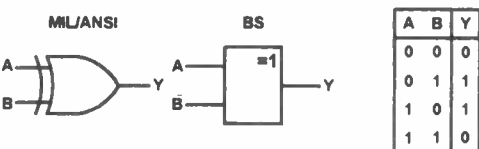

Fig. 7.11 Symbols and truth table for a two-input exclusive-OR gate.

A	B	Y
0	0	0
0	1	1
1	0	1
1	1	0

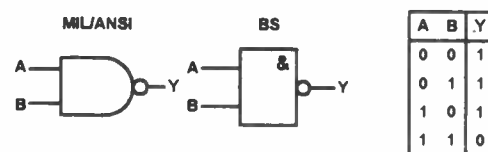

Fig. 7.8 Symbols and truth table for a two-input NAND gate.

A	B	Y
0	0	1
0	1	1
1	0	1
1	1	0

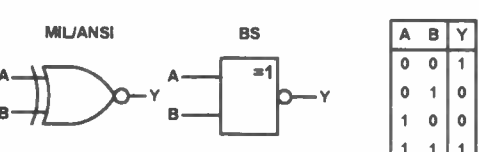

Fig. 7.12 Symbols and truth table for a two-input exclusive-NOR gate.

A	B	Y
0	0	1
0	1	0
1	0	0
1	1	1

NOR (inverted OR or NOT-OR, etc. These devices are commonly referred to as logic gates and are represented by symbols conforming to either British/European or MIL/ANSI standards. We shall briefly consider the action of each of the basic logic gates in turn (strictly speaking, buffers and inverters are not actually gates, although they are often assigned to this category). In each case, we have shown the BS and MIL/ANSI symbols side-by-side together with the truth table. (Note that *Electronics Workbench* supports both sets of symbols and you can choose which set you want to work with!). (Note also that *EPE* conventionally uses the MIL/ANSI symbols. Ed.).

Buffers

Buffers (see Fig. 7.5) don't actually affect the logical state of a digital signal (i.e., a logic 1 input results in a logic 1 output whereas a logic 0 input results in a logic 0 output). Despite this, they still have a useful function since they can be instrumental in regularising the logic levels at an interface or providing extra current drive to a load.

Inverters

Inverters (see Fig. 7.6) are used to complement the logic state (i.e., a logic 1 input results in a logic 0 output and vice versa). Inverters also provide extra current drive and, like buffers, are used in interfacing applications where they provide a means of regularising logic levels present at the input or output of a digital system. The circle shown at the output denotes the inversion function. (You may sometimes come across an inverter referred to as a NOT gate.)

AND gates

AND gates (see Fig. 7.7) will only produce a logic 1 output when all inputs are simultaneously at logic 1. Any other input combination results in a logic 0 output.

NAND gates

NAND gates (see Fig. 7.8) will only produce a logic 0 output when all inputs are simultaneously at logic 1. Any other input combination will produce a logic 1 output. A NAND gate, therefore, is nothing more than an AND gate with its output inverted! The circle shown at the output denotes this inversion.

OR gates

OR gates (see Fig. 7.9) will produce a logic 1 output whenever any one, or more, inputs are at logic 1. Putting this another way, an OR gate will only produce a logic 0 output whenever all of its inputs are simultaneously at logic 0.

NOR gates

NOR gates (see Fig. 7.10) will only produce a logic 1 output when all inputs are simultaneously at logic 0. Any other input combination will produce a logic 0 output. A NOR gate, therefore, is simply an OR gate with its output inverted. A circle is again used to indicate inversion.

Exclusive-OR gates

Exclusive-OR gates (see Fig. 7.11) will produce a logic 1 output whenever either one of the inputs is at logic 1 and the other is at logic 0. Exclusive-OR gates produce a logic 0 output whenever both inputs have the same logical state (i.e., when both are at logic 0 or both are at logic 1).

Exclusive-NOR gates

Exclusive-NOR gates (see Fig. 7.12) will produce a logic 0 output whenever either one of the inputs is at logic 0 and the other

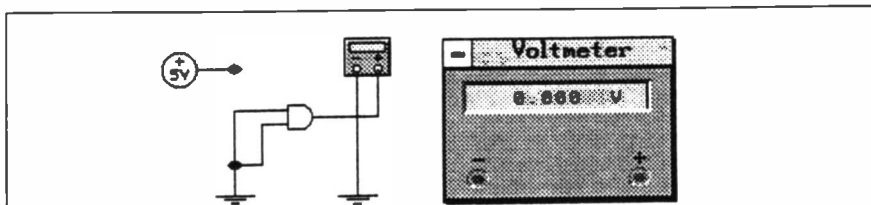

Fig. 7.13 Circuit for Assignment 7.1. Initial input connections (both A and B at logic 0).

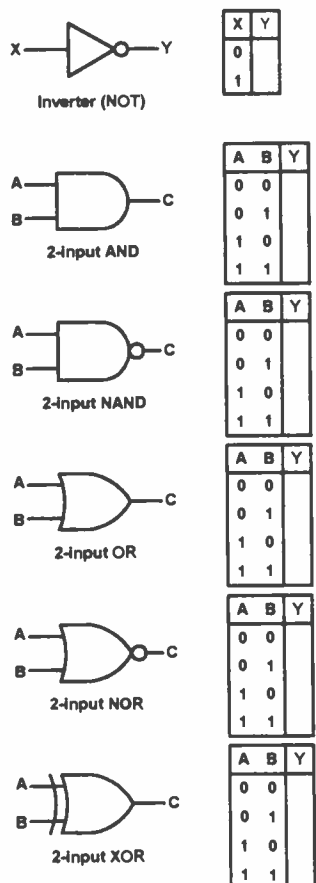

Fig. 7.14 Results for Assignment 7.1.

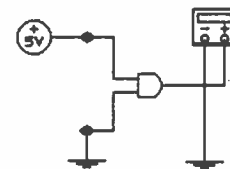

Fig. 7.15 Input connections for Assignment 7.1, A = 0 and B = 1.

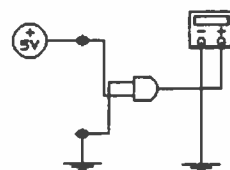

Fig. 7.16 Input connections for Assignment 7.1, A = 1 and B = 0.

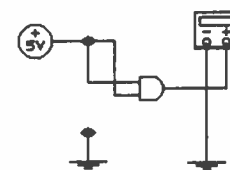

Fig. 7.17 Input connections for Assignment 7.1, A = 1 and B = 1.

Instructions:

1. Select the two-input AND gate and connect the circuit shown in Fig. 7.13. The voltmeter is to be used to measure and display the voltage produced at the output of the gate. The +5V sources and two ground connections are used to produce the input voltages for the gate.
2. With both of the inputs connected to ground (logic 0), as shown in Fig. 7.13, switch on the power to the circuit and note the output voltage indicated by the voltmeter. Convert this output to a logic state (either 0 or 1). Note that the voltmeter will read 0V for logic 0 and +5V for logic 1. Record the indication produced in the appropriate truth table in Fig. 7.14.
3. Repeat step 2 using each of the connections shown in Figs. 7.15, 7.16, and 7.17. For each circuit, record the logical state of the gate's output in the corresponding truth table in Fig. 7.14.
4. Repeat steps 1 to 3 for each of the logic gates provided.

Conclusions:

To what extent have the objectives for this assignment been met? Check that each truth table is correct for the particular type of gate under investigation, referring back earlier in the text if you are not entirely sure.

is at logic 1. Exclusive-NOR gates produce a logic 1 output whenever both inputs have the same logical state (i.e., when both are at logic 0 or both are at logic 1). Once more a circle is used to indicate the inversion function. An exclusive-NOR gate is thus an exclusive-OR gate with its output inverted.

Practical assignment 7.1:

Logic gates

In this practical assignment, and using the *Electronics Workbench* software, you will investigate the action of a variety of the most common types of logic gate.

Objectives:

- 7.1.1 To investigate the behaviour of each of the following types of logic gate:
 - (a) two-input AND
 - (b) two-input OR
 - (c) inverter (NOT gate)
 - (d) two-input NAND gate
 - (e) two-input NOR gate
- 7.1.2 To construct a truth table for each of the gates listed in 7.1.1.
- 7.1.3 To use a d.c. voltmeter to measure logic levels.

LOGIC FAMILIES

The integrated circuits (i.c.s) that provide the logic gate functions in modern digital circuitry are classified according to the semiconductor technology used in their fabrication. Indeed, the technology used is instrumental in determining the operational characteristics (such as power consumption, speed, and immunity to noise) of a device. The two basic logic families are CMOS (Complementary Metal Oxide Semiconductor) and TTL (Transistor Transistor Logic). Each of these principal families is then further divided into sub-families.

74-series TTL

The most common family of TTL logic devices is known as the 74-series. Devices from this family are coded with the prefix number 74. Variants within the family are identified by letters which follow the initial 74 prefix, as follows:

Infix	Meaning
None	Standard TTL device
ABT	Advanced bus interface logic
AC	Advanced CMOS
ACT	Advanced CMOS with TTL compatible inputs
ACTQ	Advanced CMOS with TTL compatible inputs
ALS	Advanced low-power Schottky
AS	Advanced Schottky TTL
BCT	Octal buffers/drivers
C	CMOS version of a TTL device
CBT	Crossbar technology
F	"Fast" – a high speed version of the device
FCT	High speed high output
GTL	Gunning transistor logic
H	High speed version
HC	High speed CMOS version (CMOS compatible inputs)
HCT	High speed CMOS version (TTL compatible inputs)
LS	Low-power Schottky
LV	Low voltage high speed CMOS
LVC	Low voltage CMOS
LVT	Low voltage technology
S	Schottky input configuration (improved speed and noise immunity).

4000-series CMOS

The most common family of CMOS devices is known as the 4000-series. Variants within the family are identified by suffix letters as follows:

Suffix	Meaning
None	Standard CMOS device.
A	Standard (unbuffered) CMOS device.
B, BE	Improved (buffered) CMOS device.
UB, UBE	Improved (unbuffered) CMOS device.

Examples

Fig. 7.18 shows the outlines of two digital integrated circuits. The device shown first in Fig. 7.18, coded 4001UBE, is an improved (unbuffered) version of a CMOS 4001 device whilst the chip shown second in Fig. 7.18, coded 74LS00, is the low-power Schottky version of a TTL 7400 device. Inside both chips there are four separate two-input gates, NOR in the case of the 4001UBE and NAND in the case of the 74LS00, as schematically shown in Fig. 7.19.

ELECTRICAL CHARACTERISTICS

In Assignment 7.1 you found that a logic 0 was represented by 0V whilst a logic 1 was represented by +5V. These voltages

Table 7.12 Logic levels for standard CMOS and TTL devices

Logic level	CMOS	TTL
Logic 1	more than $2/3 V_{DD}$	more than 2V
Logic 0	less than $1/3 V_{DD}$	less than 0.8V
Indeterminate	between $1/3 V_{DD}$ and $2/3 V_{DD}$	between 0.8V and 2V

(Note: V_{DD} is the positive supply associated with standard CMOS devices, this is often +5V but may take any value between +3V and +18V).

Table 7.13 Comparison of LS TTL and BE-series CMOS devices

Characteristic	Logic family	
	74LS	40BE
Maximum permissible supply voltage	5.25V	18V
Minimum permissible supply voltage	4.75V	3V
Quiescent power dissipation (per gate)	2mW	negligible
Dynamic power dissipation (per gate at 100kHz)	2mW	100µW
Typical delay experienced by a pulse passing through the gate	10ns	100ns
Maximum switching frequency	50MHz	12MHz
Minimum output current ($V_o = 0.4V$)	8mA	1.6mA
Number of LS-TTL loads that can be driven from a single output	20	4
Maximum input current (at $V_i = 0.4V$)	-0.4mA	-1µA

are idealised and, in practice, a range of voltages is used to represent the logic states 0 and 1. The logic levels for CMOS differ markedly from those associated with TTL. In particular, CMOS logic levels are relative to the supply voltage used whilst the logic levels associated with TTL devices tend to be absolute. Table 7.12 shows the logic levels for standard CMOS and TTL devices.

NOISE MARGIN

The noise margin of a logic device is a measure of its ability to reject noise; the larger the noise margin the better is its ability to perform in an environment in which noise is present. Noise margin is defined as the difference between the

minimum values of high state output and high state input voltage, and the maximum values of low state output and low state input voltage. Hence:

$$\text{Noise margin} = V_{OH(MIN)} - V_{IH(MIN)}$$

$$\text{or Noise margin} = V_{OL(MAX)} - V_{IL(MAX)}$$

where $V_{OH(MIN)}$ is the minimum value of high state (logic 1) output voltage, $V_{IH(MIN)}$ is the minimum value of high state (logic 1) input voltage, $V_{OL(MAX)}$ is the maximum value of low state (logic 0) output voltage, and $V_{IL(MIN)}$ is the minimum value of low state (logic 0) input voltage.

The noise margin for standard 7400 series TTL is typically 400mV whilst that for CMOS is $1/3 V_{DD}$, as shown comparatively in Fig. 7.20.

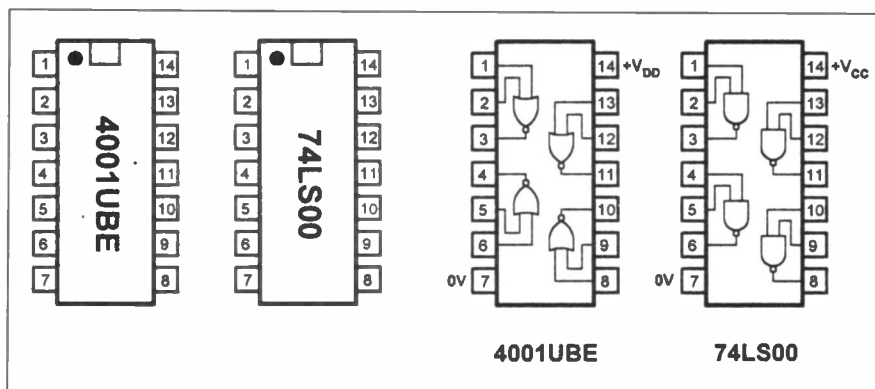

Fig. 7.18 Example of markings on digital integrated circuits.

Fig. 7.19 Logic gates available within the chips shown in Fig. 7.18.

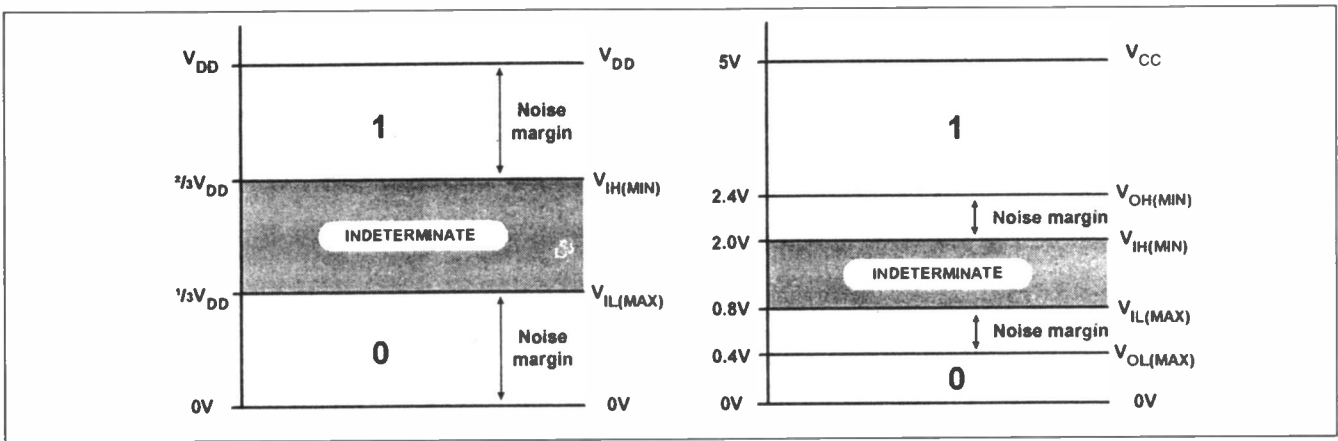

Fig. 7.20 Logic levels and noise margins for TTL and CMOS devices.

Table 7.13 compares the more important characteristics of the LS-TTL family with modern buffered CMOS logic. It is well worth taking a little time to study this table and decide which type of logic may be best suited to a particular application. For example, CMOS logic is ideal for use in battery operated low-power applications.

Practical assignment 7.2:
Combinational logic

In this practical assignment you will construct and test a variety of logic circuits based on standard logic gates.

Objectives:

- 7.2.1 To show how multiple-input AND and OR gates can be built using a number of two-input AND and OR gates, respectively.
- 7.2.2 To show how inverting the output of NAND and NOR gates produces AND and OR functions, respectively.
- 7.2.3 To show how inverting both of the inputs of a NAND gate produces an OR function.
- 7.2.4 To show how inverting both of the inputs of a NOR gate produces an AND function.
- 7.2.5 To show how an exclusive-OR gate can be built using basic logic gates.

Instructions:

1. Connect the circuit shown in Fig. 7.21. The output of the circuit is connected to a logic level indicator whilst the four inputs are derived from +5V and ground points. Switch on the power and test the circuit by constructing its truth table. Confirm that the circuit provides a four-input AND function.
2. Connect the circuit shown in Fig. 7.22. The output of the circuit is connected to a logic level indicator whilst the four inputs are derived from +5V and ground points. Switch on the power and test the circuit by constructing its truth table.
3. Connect the circuit shown in Fig. 7.23. The output of the circuit is connected to a logic level indicator whilst the two inputs are derived from +5V and ground points. Switch on the power and test the circuit by constructing its truth table.
4. Connect the circuit shown in Fig. 7.24. The output of the circuit is connected to a logic level indicator whilst the two inputs are derived from +5V and ground points. Switch on the power and test the circuit by constructing its truth table.
5. Connect the circuit shown in Fig. 7.25. The output of the circuit is connected to a logic level indicator whilst the two inputs are derived from +5V and ground points. Switch on the power and test the circuit by constructing its truth table.
6. Connect the circuit shown in Fig. 7.26. The output of the circuit is connected to a logic level indicator whilst the two inputs are derived from +5V and ground points. Switch on the power and test the circuit by constructing its truth table.
7. Connect the circuit shown in Fig. 7.27. The output of the circuit is connected to a logic level indicator whilst the two inputs are derived from +5V and ground points. Switch on the power and test the circuit by constructing its truth table.

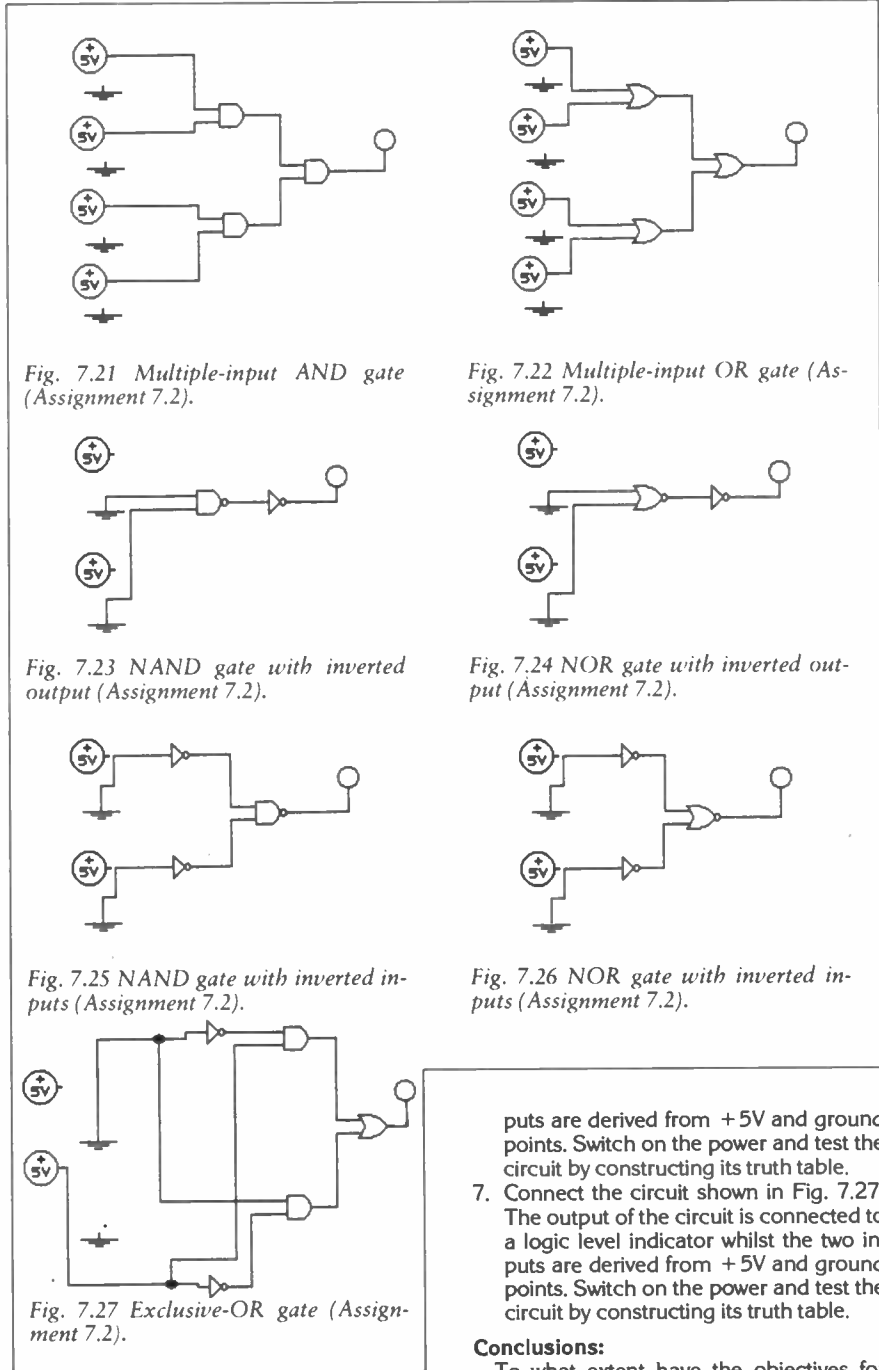

6. Connect the circuit shown in Fig. 7.26. The output of the circuit is connected to a logic level indicator whilst the two in-

puts are derived from +5V and ground points. Switch on the power and test the circuit by constructing its truth table.

7. Connect the circuit shown in Fig. 7.27. The output of the circuit is connected to a logic level indicator whilst the two inputs are derived from +5V and ground points. Switch on the power and test the circuit by constructing its truth table.

Conclusions:

To what extent have the objectives for this assignment been met? With reference to the truth tables, state the logical function for each logic symbol gate arrangement and identify the single gate symbol that can replace each combination.

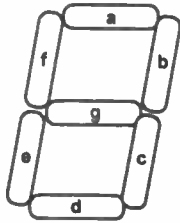

Fig. 7.28 Segment numbers for a seven-segment display.

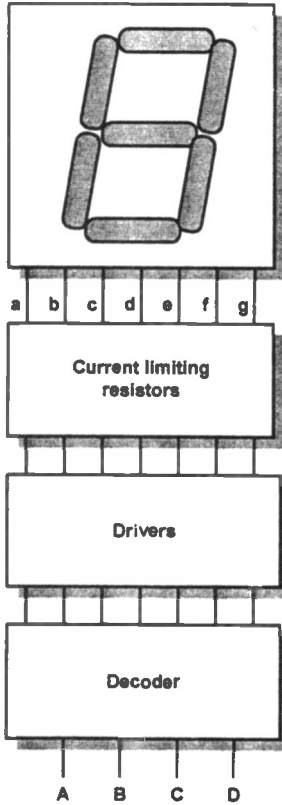

Fig. 7.30 Decoded seven-segment display showing binary-coded decimal (BCD) input (labelled A to D).

SEVEN-SEGMENT DISPLAYS

Seven-segment displays provide a means of displaying numbers (0 to 9) and some letters (e.g., A, b, C, d, E, F, H, etc.). Several different types of display are in common use but one of the most common is based on light emitting diodes (l.e.d.s). The arrangement of the segments in a typical seven-segment l.e.d. display is shown in Fig. 7.28.

Each of the segments is identified by a letter, a to g. In practice, two configurations are available; common-anode and common-cathode depending upon which of the segment connections is taken to a common point. Fig. 7.29 shows the connections to a common-anode display (note that, in practice the display would probably also be fitted with a decimal point). The seven fixed resistors in series with the segments are included to limit the current (usually in the region 5mA to 20mA per segment).

The problem of illuminating the correct segments of an l.e.d. display is greatly

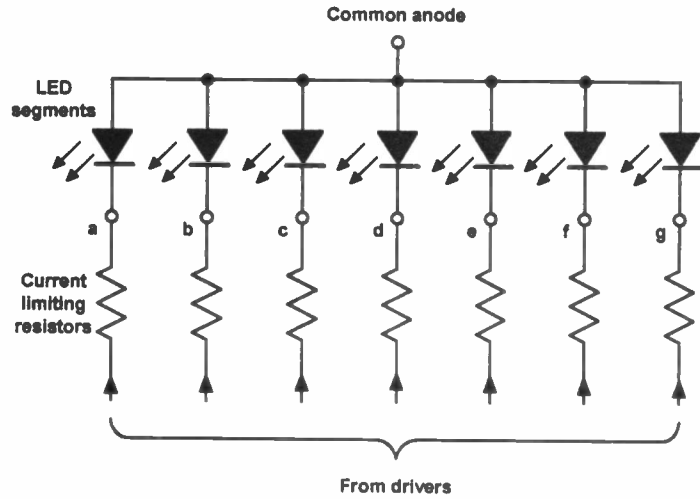

Fig. 7.29 Typical arrangement for a common-anode seven-segment display.

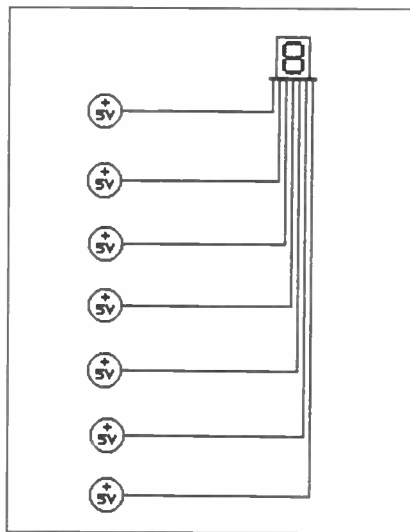

Fig. 7.31 Circuit for Assignment 7.3.

	a	b	c	d	e	f	g
0							
1							
2							
3							
4							
5							
6							
7							
8							
9							
A							
B							
C							
D							
E							
F							

Fig. 7.32 Results table for Assignment 7.3.

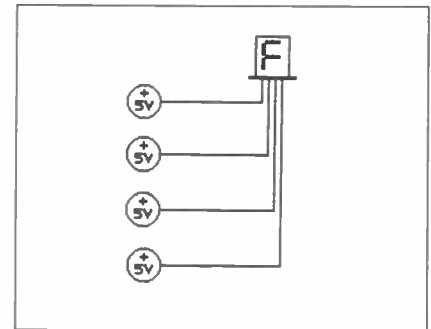

Fig. 7.33 Circuit for Assignment 7.3 (decoded display).

simplified by adding a decoder circuit, as shown in Fig. 7.30. This arrangement accepts a 4-bit binary code as its input (lines A to D) and it contains the necessary logic gate arrangements to ensure that the correct segments (a to g) are illuminated for each input code. You will investigate this arrangement in the next practical assignment.

Practical assignment 7.3: Seven-segment displays

In this practical assignment you will investigate the behaviour of seven-segment displays.

Objectives:

- 7.3.1 To investigate the behaviour of a seven-segment display.
- 7.3.2 To investigate the behaviour of a decoded seven-segment display.

Instructions:

1. Connect the circuit shown in Fig. 7.31.
2. Using Fig. 7.28, determine the segments that should be illuminated in order to produce the digits 0 to 9 and letters A to F (see Fig. 7.32).
3. Connect each arrangement in turn and check the display produced. Complete the truth table shown in Fig. 7.32.
4. Connect the circuit shown in Fig. 7.33. For each input combination (lines A to D) shade in the illuminated segments in Fig. 7.34. Hence determine the truth table for the decoded seven-segment display. Check that this conforms to standard binary-coded decimal.

Conclusions:

To what extent have the objectives for this assignment been met? How effective is

A	B	C	D	DISPLAY	A	B	C	D	DISPLAY
0	0	0	0		1	0	0	0	
0	0	0	1		1	0	0	1	
0	0	1	0		1	0	1	0	
0	0	1	1		1	0	1	1	
0	1	0	0		1	1	0	0	
0	1	0	1		1	1	0	1	
0	1	1	0		1	1	1	0	
0	1	1	1		1	1	1	1	

Fig. 7.34 Results for Assignment 7.3 (decoded display).

the seven-segment display at displaying alphanumeric characters? What are the advantages and disadvantages of a display which accepts binary-coded decimal? Can you suggest what the logic inside the decoder might look like? (Hint: consider what logic would be required to operate a single segment, e.g., segment a).

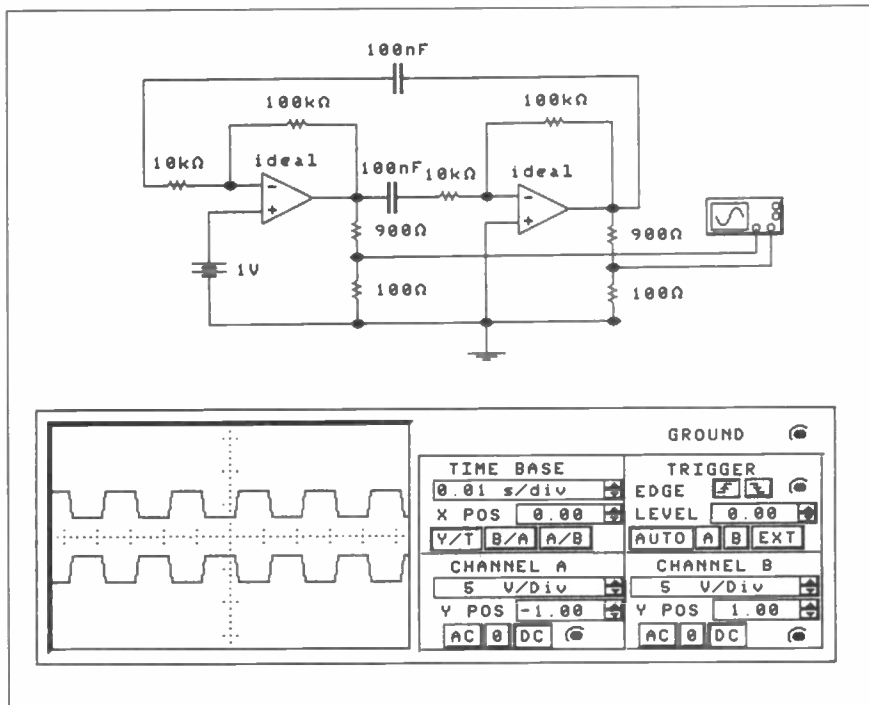

Fig. 7.35 Solution to last month's Brain Teaser.

BRAIN TEASER

This month's challenge for those of you who are using the full *Electronics Workbench* package is to design a logic arrangement with three inputs that will provide a "majority vote" (i.e., a logic 1 will be produced at the output provided that any two, or more, of the inputs are at logic 1. Build and test this circuit using *Electronics Workbench*.

Answer to last month's Brain Teaser

Last month's Brain Teaser involved the design of a circuit that produces complementary square wave outputs with an amplitude of 1V and a frequency of 50Hz. Fig. 7.35 shows one solution arrived at using the full version of *Electronics Workbench*.

PCB Designer

For Windows 3.1

Runs on any PC running Windows 3.1 in standard or enhanced mode with 2MB RAM
Will work with any Windows supported printer and monitor

PCB Designer - [c:\pcb\sample1.pcb]

File Edit Board Text Snap Window Help

Phone (01432) 355 414
FAX (01432) 264 800

Did you see this advert last month?
Were you looking for the price?
It's just £49.00 all inclusive!
No VAT, No Postage

- ✓ Produce Single or Double sided PCBs.
- ✓ Print out to any Windows supported printer.
- ✓ Toolbar for rapid access to commonly used components.
- ✓ Helpful prompts on screen as you work.
- ✓ Pad, track & IC sizes fully customisable.
- ✓ No charges for technical support.
- ✓ Snap-to grid sizes 0.1", 0.05" 0.025" and unrestricted.
- ✓ SMT pads and other pad shapes.
- ✓ Prints at the resolution of your printer - much higher than the screen shot shown here.

Internet
A working demo is available via FTP from [ftp.demon.co.uk](ftp://ftp.demon.co.uk/pub/bmpc/windows/pcbdemo/pcbdemo.zip)
as /pub/bmpc/windows/pcbdemo/pcbdemo.zip
e-mail enquiries to orders@niche.demon.co.uk

Niche Software (UK)

22 Tavistock Drive, Belmont, Hereford, HR2 7XN.

X: 1.000 Y: 0.000

Please Note: Since PCB designer is so easy to use, and to keep costs down, PCB Designer has an On-Line manual, in Windows Help format. A FREE tutorial is also supplied.

FOX REPORT by Barry Fox



MAC Grounded

Once Sky's budget PAL satellite service had killed off BSB's higher priced MAC service, the writing was on the wall. MAC was doomed, not just in the UK but the rest of Europe as well. There are still a few MAC services in Scandinavia, France and Germany but the transmission technology is used mainly for the encryption and widescreen distribution it offers.

To all intents and purposes, MAC is dead. So HD-MAC, the high definition upgrade which was due for commercial launch this year, is dead too.

This has turned out to be a blessing in disguise. Europe, and especially the UK, is now free to follow an all-digital route to future TV.

Digital TV

You will be hearing a lot about digital TV over the next few months, so it will help to have some hard facts on record. The situation changes almost daily but this was how it stood in early February.

In September 1993 manufacturers and broadcasters from all across Europe formed the voluntary DVB, Digital Video Broadcast group, to set agreed standards for digital satellite, cable or terrestrial TV. There are now over 150 members from all European countries. DVB gets no official funding.

The DVB drafts its standards and then passes them to ETSI, the European Telecommunications Standards Institute for rubber-stamping. But manufacturers feel free to start designing and building equipment once the DVB group has signed the standard off.

There are three main groups of standards, for cable, satellite and terrestrial TV. All are based on MPEG-2 coding. The differences are in the modulation.

The satellite system uses QPSK (Quadrature Phase Shift Keying) with guideline bit rate variable from 18.4Mbit/s to 48.4Mbit/s, and likely also to cover BPSK (Binary or two phase PSK) with guideline bit rate variable from 9.2Mbit/s to 24.3Mbit/s. The standard for cable distribution is 64 QAM (Quadrature Amplitude Modulation) with guideline bit rate variable from 9.6Mbit/s to 38.4Mbit/s.

Both these standards were agreed by January 1994 and ratified by ETSI exactly a year later.

The standard for terrestrial broadcasting (with COFDM, Coded Orthogonal Frequency Division Multiplex) should be

agreed by the end of 1995, with ratification by end of 1996. COFDM has been chosen because it provides resistance to multipath interference, and allows transmitters across the country to share a single frequency for a single network. Also a COFDM signal has a distribution of energy which makes any interference it causes look like analogue snow noise.

Split Decision

There is however an important split on the way COFDM will be implemented, and this split is between the BBC and NTL, National Transcommunications Ltd, the privatised company which provides transmitters for the UK's commercial TV broadcasting.

Both agree that Europe's 8MHz PAL channels can carry a net data rate of around 20Mbit/s, which will convey four or five programmes (depending on content and quality requirements). The BBC plans to split the 8MHz channel into 8000 discrete carriers. NTL argues that this triples the area of silicon, and relies on 0.35 micron technology.

Also if each transmitter is to use the same transmission frequency, all transmitters must carry exactly the same data stream, tightly synchronised to the others. This is technically difficult and it also blocks regional programme variations e.g. local news on a national network.

NTL's proposal is for uncorrelated transmission, with the data spread over 2000 carriers. Synchronisation is not necessary, so regional programme variations are possible. As long as the viewer's aerial can provide a 16dB difference between wanted and unwanted signal, decoding is error-free.

Conditional Access

The DVB is also working on encryption and conditional access. During 1994 the Group agreed on a common scrambling system for MPEG-2 video signals. With this, broadcasters can use their own chosen conditional access control system.

One option is for each programme service (e.g. Sky, the BBC, Eutelsat etc) to require viewers to buy a dedicated receiver. The other option is to agree a common interface for conditional access. This would be built into all receivers and have slots for control modules. A single receiver could then have several slots which could be used to decode a wide range of programmes, broadcast with different conditional access requirements.

The hidden benefit is that if any one encryption system is hacked by pirates, the broadcaster can swap it out by giving all subscribers a new plug in module for a new system.

This is an important consideration. After a few years of assurances that Videocrypt was pirate-proof, Sky had to go to court to stop pirates selling counterfeit smart cards that defeated the system.

First Broadcasts

So who will be first to the market with digital TV?

A special situation exists in the UK. Two frequencies in the middle of the UHF band (Channel 35 and 37) remain unused for broadcasting.

The UK government has now ordered that one of the two unused frequencies (Channel 35) be reserved for digital TV. The BBC hopes to use this frequency, along with some of the taboo channels between analogue broadcasts, for a new all-digital service to start by late 1997.

France has just launched six new analogue services, and only has one frequency that could perhaps be used for a digital service. Scandinavia has spare frequencies and wants to use them for terrestrial TV. Ostensibly, Germany has no spare frequencies. But there is talk of the military relinquishing its claim on UHF channels 61-68, to create some space for digital TV.

Continental subscriber TV stations Canal+ (for France) and Kinnevik (Scandinavia) look likely to be the first to use DVB standard systems for working services on air. Astra will soon launch extra satellites which are designed for digital transmission.

The Eutelsat organisation has already demonstrated that it is possible to split its 36MHz transmission channels into two halves, one 27MHz wide and carrying analogue pictures of similar quality to Astra, the other 9MHz wide and carrying a digital TV data stream running at 8 Mbit/second.

The half-channels can either carry the same programme, or two quite different programmes. Eutelsat is also in the process of launching higher powered "Hot Birds" which will bring dish size down to match Astra.

Giuliano Berretta, Eutelsat's Commercial Director, predicts that 1997 will be the year when Digital TV becomes accessible and affordable.

**“Electronics Workbench
is the best simulator to
design and verify circuits.”**

*Gordon MacDonald
Production Engineer Technician*

Electronics Workbench is a highly productive bench where you design and verify circuits in a fraction of the time. Connections are always perfect. Wires route themselves. And the simulated components and test instruments work just like the real thing.

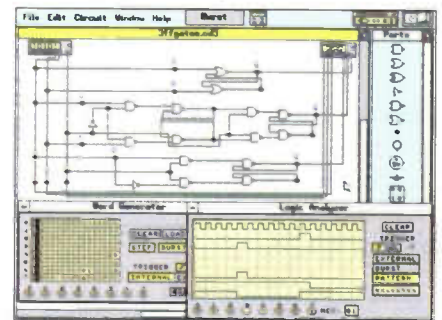

Digital Module: Analyzing a logic circuit.

It's faster than building with actual components because you change connections and component values instantly. And since the simulated components are free, you don't need to replace burnt-out parts or keep an extensive inventory. The result: You save precious time and money. Guaranteed!

The standard for simplicity and power for over six years, Electronics Workbench is the most popular tool of its kind. It has gained worldwide acclaim as the ideal complement to any test bench. **Fact: Over 90% of our customers recommend it to their friends and colleagues.**

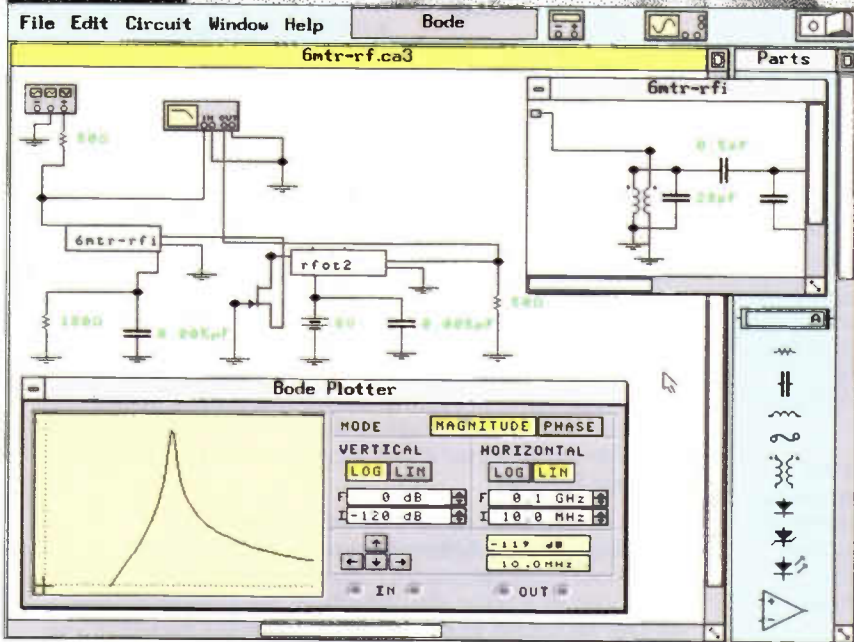
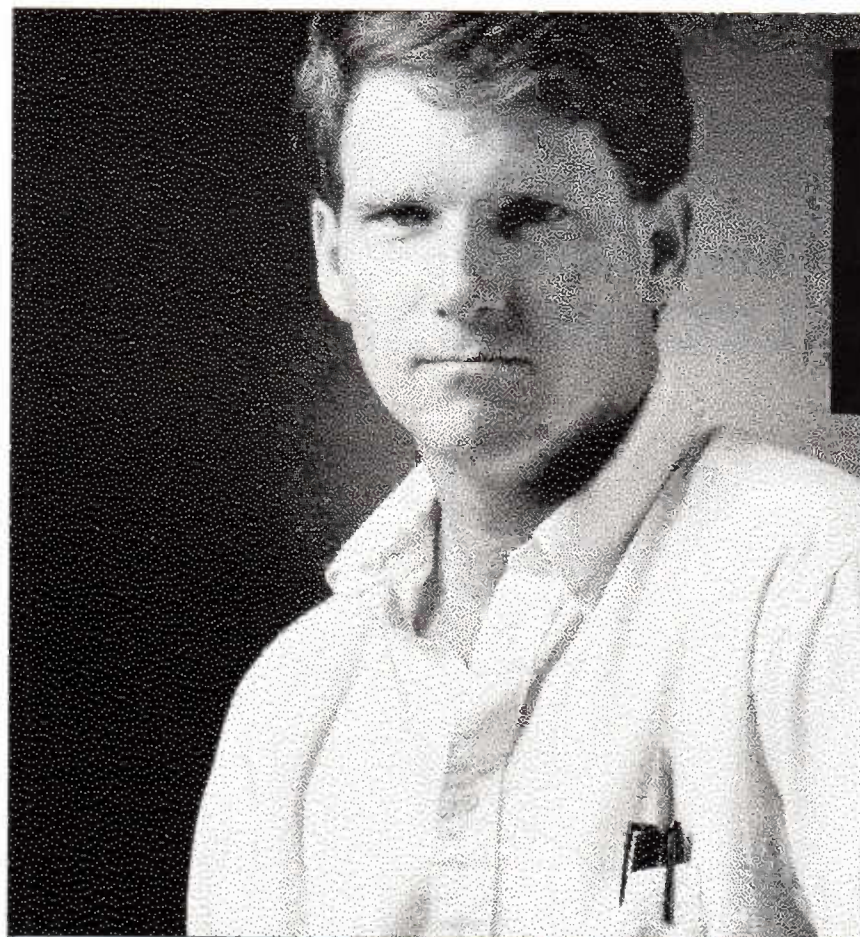

Analog Module: Tuning an RF front end.

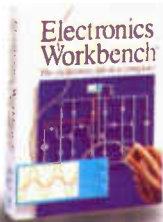

Just £199*

For DOS, Windows or Mac Version.



Electronics Workbench®

The electronics lab in a computer™

Call: 44 01203 233216

Robinson Marshall (Europe) PLC
Nadella Building, Progress Close, Leofric Business Park, Coventry, Warwickshire CV3 2TF
FAX: (44) 0203 233210

*30-day money-back guarantee.

Shipping charges - UK £4.99. All prices are plus V.A.T.
All trademarks are the property of their respective owners.

**With the purchase of Electronics Workbench. Offer valid until October 15, 1994.



**WHETHER ELECTRONICS IS YOUR HOBBY
OR YOUR LIVELIHOOD . . .
YOU NEED THE MODERN ELECTRONICS MANUAL
and the ELECTRONICS SERVICE MANUAL**

THE MODERN ELECTRONICS MANUAL



The essential reference work

- Easy-to-use format
- Clear and simple layout
- Comprehensive subject range
- Regular Supplements
- News of developments
- Sturdy ring-binder
- Projects to build
- Detailed assembly instructions
- Ready-to-transfer PCBs
- Full components checklists
- Extensive data tables
- Detailed supply information
- Professionally written

**ORDER NOW
and get a
FREE SUPPLEMENT
plus our
30 DAY MONEY BACK GUARANTEE**

EVERYTHING YOU NEED TO KNOW ABOUT ELECTRONICS!

The revised edition of the Modern Electronics Base Manual contains practical, easy-to-follow information on the following subjects:

BASIC PRINCIPLES: Symbols, components and their characteristics, active and passive component circuits, power supplies, acoustics and electroacoustics, the workshop, principles of metrology, measuring instruments, digital electronics, analogue electronics, physics for electronics.

CIRCUITS TO BUILD: There's nothing to beat the satisfaction of creating your own project. From basic principles to circuit-building, the Modern Electronics Manual and its Supplements describe clearly, with appropriate diagrams, how to assemble radios, loudspeakers, amplifiers, car projects, computer interfaces, measuring instruments, workshop equipment, security systems, etc.

REPAIRS AND MAINTENANCE: Basic circuit operation for radio, television, audio/hi-fi, telephones, computers.

ESSENTIAL DATA: Extensive tables on diodes, transistors, thyristors and triacs, digital and linear i.c.s, microprocessors.

EXTENSIVE GLOSSARY: Should you come across a technical word, phrase or abbreviation you're not familiar with, simply turn to the glossary included in the Manual and you'll find a comprehensive definition in plain English.

The Manual also covers **Safety, Specialist Vocabulary with Abbreviations and Suppliers.**

The most comprehensive reference work ever produced at a price you can afford, the revised edition of **THE MODERN ELECTRONICS MANUAL** provides you with all the essential information you need.

THE MODERN ELECTRONICS MANUAL

Revised Edition of Basic Work: Now contains over 1,000 pages of information.

Regular Supplements: Approximately 160-page Supplements of additional information which are forwarded to you immediately on publication. These are billed separately and can be discontinued at any time.

Presentation: Durable looseleaf system in large A4 format (297mm × 210mm)

Price of the Basic Work: £39.95 + £5.50 p&p (to include a recent Supplement free).

GUARANTEE

Our 30 day money back guarantee gives you **complete peace of mind**. If you are not entirely happy with either Manual, for whatever reason, simply return it to us in good condition within 30 days and we will make a **full refund of your payment** – no small print and no questions asked.

(Overseas buyers do have to pay the overseas postage charge).

Wimborne Publishing Ltd., Allen House, East Borough, Wimborne, Dorset BH21 1PF. Tel: 01202 881749. Fax: 01202 841692

ELECTRONICS SERVICE MANUAL

NEW

EVERYTHING YOU NEED TO KNOW TO GET STARTED IN REPAIRING AND SERVICING ELECTRONIC EQUIPMENT:

SAFETY: Be knowledgeable about Safety Regulations, Electrical Safety and First Aid.

UNDERPINNING KNOWLEDGE: Specific sections enable you to Understand Electrical and Electronic Principles, Active and Passive Components, Circuit Diagrams, Circuit Measurements, Radio, Logic Gates, Computers, Microprocessors, Valves and Manufacturers' Data, etc.

PRACTICAL SKILLS: Learn how to Identify Electronic Components, Avoid Static Hazards, Assemble a Toolkit, Set Up a Workshop, Carry Out Soldering and Wiring, Remove and Replace Components.

TEST EQUIPMENT: How to Choose and Use Test Equipment, and Get the Most out of your Multimeter and Oscilloscope, etc.

SERVICING TECHNIQUES: The regular Supplements will include vital guidelines on how to Service Audio Amplifiers, Radio Receivers, TV Receivers, Cassette Recorders, Video Recorders, Personal Computers, etc.

TECHNICAL NOTES: Commencing with the IBM PC, PC-XT, PC-AT, this section and the regular Supplements will deal with a very wide range of specific types of equipment.

REFERENCE DATA: Detailing vital parameters for Diodes, Small-Signal Transistors, Power Transistors, Thyristors, Triacs and Field Effect Transistors. Supplements will include Operational Amplifiers, Logic Circuits, Optoelectronic Devices, etc

The essential work for servicing and repairing.

- Easy-to-use format
- Clear and simple layout
- Regular Supplements
- Sturdy ring binder
- Vital safety precautions
- Troubleshooting techniques
- Fundamental principles
- Active and passive components
- Choosing and using test equipment
- Professionally written
- Servicing techniques
- Reference data

ELECTRONICS SERVICE MANUAL

TOTALLY NEW Basic Work: Contains around 900 pages of information. Edited by Mike Tooley BA.

Regular Supplements: Approximately 160-page Supplements of additional information which are forwarded to you immediately on publication. These are billed separately and can be discontinued at any time – the first Supplement is scheduled for publication in April '95.

Presentation: Durable looseleaf system in large A4 format (297mm x 210mm).

Price of the Basic Work: £39.95 + £5.50 p&p.

ORDER BOTH MANUALS TOGETHER AND SAVE OVER £15!

A mass of well-organised and clearly explained information is brought to you by expert editorial teams whose combined experience ensure the widest coverage

Regular Supplements to these unique publications, each around 160 pages, keep you abreast of the latest technology

REGULAR SUPPLEMENTS

Unlike a book or encyclopedia, these Manuals are living works – continuously extended with new material. Supplements are sent to you approximately every two to three months. Each Supplement contains around 160 pages – all for only £23.50 +

£2.50 p&p. You can of course return any Supplement (within ten days) which you feel is superfluous to your needs.

RESPONDING TO YOUR NEEDS

We are able to provide you with the most important and popular, up to date, features

in our Supplements. Our unique system is based on readers requests for new information. Through this service you are able to let us know exactly what information you require in your Manuals. You can also contact the editors directly in writing if you have a specific technical request or query relating to the Manuals.

PLEASE send me

THE MODERN ELECTRONICS MANUAL plus a FREE SUPPLEMENT

ELECTRONICS SERVICE MANUAL – Available mid January

I enclose payment of £45.45 (for one manual) or £75.45 for both manuals (saving over £15 by ordering both together). I shall also receive the appropriate Supplements several times a year. These are billed separately and can be discontinued at any time.

Should I decide not to keep the Manual/s I will return it/them to you within 30 days for a full refund.

FULL NAME
(PLEASE PRINT)

ADDRESS.....
.....
.....

..... POSTCODE

SIGNATURE.....

I enclose cheque/PO payable to Wimborne Publishing Ltd.

Please charge my Visa/Mastercard (Access)

Card No. Card Exp. Date

ORDER FORM

Simply complete and return the order form with your payment to the following address:

**Wimborne Publishing Ltd, Allen House,
East Borough, Wimborne, Dorset BH21 1PF**

We offer a 30 day MONEY BACK GUARANTEE
– If you are not happy with the Manual simply return it to us in good condition within 30 days for a full refund.

Overseas buyers do have to pay the overseas postage – see below.

OVERSEAS ORDERS: All overseas orders must be prepaid and are supplied under a money-back guarantee of satisfaction. If you are not entirely happy with the Manual return it within a month for a refund of the purchase price (you do have to pay the overseas postage). SEND £39.95 (or £64.45 for both manuals) PLUS THE POSTAGE SHOWN BELOW for EACH Manual:

EIRE	AIR MAIL ONLY £11
EUROPE (E.E.C. Countries)	AIR MAIL ONLY £20
EUROPE (non E.E.C.)	SURFACE MAIL £20, AIR MAIL £26
U.S.A. & CANADA	SURFACE MAIL £25, AIR MAIL £32
FAR EAST & AUSTRALIA	SURFACE MAIL £31, AIR MAIL £33
REST OF WORLD	SURFACE MAIL £25, AIR MAIL £44

Note surface mail can take over 10 weeks to some parts of the world. Each manual weighs around 4kg when packed.

All payments must be made in E's Sterling payable to Wimborne Publishing Ltd. We accept Mastercard (Access) and Visa credit cards.

PROFESSIONAL SCHEMATIC CAPTURE AND PCB SOFTWARE FOR WINDOWS *NEW!*

At last, professional schematic and PCB design software for Microsoft Windows is available at prices that won't break the bank. CADPAK for Windows offers entry level schematic and PCB drafting whilst PROPAK for Windows adds netlist integration, multi-sheet schematics, highly effective autorouting, power plane generation and much more.

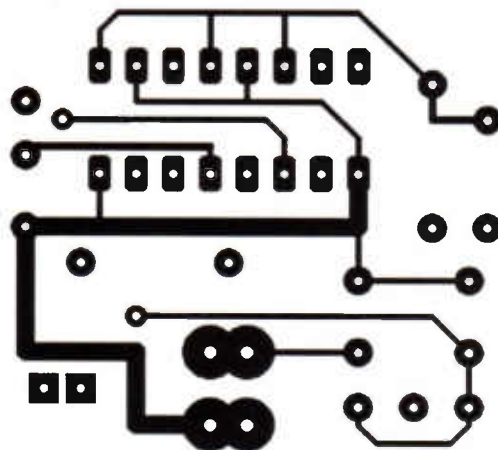

ISIS Illustrator

ISIS Illustrator was the first schematic drawing package for Windows and it's still the best. Illustrator's editing features will enable you to create circuit diagrams as attractive as the ones in the magazines.

- Runs under Windows 3.1.
- Full control of drawing appearance including line widths, fill styles, fonts, colours and more.
- Automatic wire routing and dot placement.
- Fully automatic annotator.
- Comes complete with component libraries; edit your own parts directly on the drawing.
- Full set of 2D drawing primitives + symbol library for logos etc.
- Exports diagrams to other applications via the clipboard.

ARES for Windows

ARES for Windows provides all the functionality you need to create top quality PCB layouts under Microsoft's GUI. Combining the best of our DOS based PCB layout technology with the best of Windows, this package is our most powerful and easy to use PCB design tool to date.

- True 32 bit application under Windows 3.1.
- Advanced route editing allows modification or deletion of any section of a track.
- Unlimited number of named pad/track styles.
- Comprehensive package library for both through hole and SMT parts.
- Full imperial & metric support including all dialogue forms.
- Gerber, Excellon and DXF outputs as well as output via Windows drivers. Also includes Gerber viewer.
- Multi-strategy autorouter gives high completion rates; power plane generator creates ground planes with ease.

LOW PRICES!

CADPAK for Windows	£149
CADPAK for DOS	£79
PROPAK for Windows	£495
PROPAK for DOS	£395

labcenter
E l e c t r o n i c s

Prices exclude postage (£5 for UK) and VAT. All manufacturers trademarks acknowledged.

Call us today on 01756 753440 or else fax 01756 752857 for a demo pack - please state DOS or Windows as these products are available for both platforms.

53-55 Main St. Grassington, N. Yorks. BD23 5AA

EVERYDAY WITH PRACTICAL ELECTRONICS BACK ISSUES

We can supply back issues of *EPE* by post, most issues from the past five years are available. An index for each year is also available – see order form. Alternatively, indexes are published in the December issue for that year. Where we are unable to provide a back issue a photostat of any *one article* (or *one part* of a series) can be purchased for the same price.

DID YOU MISS THESE?

NOV. '93

PROJECTS ● Portable Miniguard (PIR alarm) ● Tracktronic Projects (Thyristor Latched L.E.D. Display, Night Light, Twin Input Status Indicator) ● 20 Metre Direct Conversion Receiver ● Inside the Electric Guitar ● Multi Purpose Audio System, Part 2.
FEATURES ● Velleman View ● Electronics Principles, Special Software Supplement.

DEC. '93

PROJECTS ● Three-Way Christmas Tree Lights Flasher ● Auto Alarm ● 250W/600W Inverter and Uninterruptible Power Supply, Part 1 ● Multi-Purpose Audio System, Part 3 ● Waterproof Delay Switch.
FEATURES ● Safety First, Part 1 ● Index for Volume 22.

JAN. '94

PROJECTS ● Autolight (automatic nightlight) ● Timer and NiCad Capacity Checker ● 250W/600W Inverter and Uninterruptible Power Supply, Part 2 ● Multi-Purpose Audio System, Part 4 ● Pond Heater Thermostat.
FEATURES ● Safety First, Part 2 ● Calculation Corner, Part 1 ● Electronics Testing and Fault Diagnosis, Course Review.

FEB. '94

PROJECTS ● Whistle Controlled Light Switch ● Reviving the Valve Sound (rebuilding the Quad II power amp) ● Introduction to Microcontrollers – Timeout ● Battery To Mains Inverter and Uninterruptible Power Supply, Part 3 ● Multi-Purpose Audio System, Part 5.
FEATURES ● Calculation Corner, Part 2 ● Safety First, Part 3 ● European International Audio & Video Fair.

MARCH '94

PROJECTS ● Smart-Key Immobiliser ● Audio/R.F. Monitor ● CCD TV Camera, Part 1 ● Visual Doorbell ● Three-Phase Generator.
FEATURES ● Safety First, Part 4 ● Calculation Corner, Part 3 ● Free Wall Chart – Electronics Formulae 1.

APRIL '94

PROJECTS ● MOSFET Variable Bench Power Supply ● *EPE* Soundac PC sound output board ● CCD TV Camera, Part 2/Frame Grab ● Impulse Clock Master Unit ● Telephone Ring Detector.
FEATURES ● Best of British, Part 1 ● Calculation Corner, Part 4 ● Electronics Workbench Review ● Free Wall Chart – Electronics Formulae 2.

MAY '94

PROJECTS ● Simple TENS Unit (transcutaneous pain relief) ● Capacitance/Inductance Meter ● L.E.D. Matrix Message Display, Part 1 ● Stereo Noise Gate ● Dual Stepping Motor Driver for PCs.
FEATURES ● Calculation Corner, Part 5 ● Best of British, Part 2.



JUNE '94

PROJECTS ● Microcontroller P.I. Treasure Hunter ● Digital Water Meter ● Microprocessor Smart Switch ● Advanced TENS Unit (transcutaneous pain relief) ● L.E.D. Matrix Message Display, Part 2.
FEATURES ● Best of British, Part 3 ● Calculation Corner, Part 6.

JULY '94

PROJECTS ● Voxbox Voice Recording Board ● Simple NiCad Charger ● Watering Wizard (automatic garden watering) ● Pocket Print Timer ● Stereo HiFi Controller, Part 1.
FEATURES ● Best of British, Part 4 ● Calculation Corner, Part 7.

AUG. '94

PROJECTS ● Experimental Noise Cancelling Unit ● Dancing Fountains, Part 1 ● Charged-Up (PC battery tip) ● 6802 Development Board ● TV Camera Update ● Stereo HiFi Controller, Part 2.
FEATURES ● Calculation Corner, Part 8 ● Best of British, Part 5 ● I'll Be Seeing You (multimedia communications)

SEPT. '94

PROJECTS ● Protector Plus Car Alarm ● Greenhouse Watering System ● Experimental Seismograph, Part 1 ● Three-Channel Lamp Controller ● Dancing Fountains, Part 2.
FEATURES ● Calculation Corner, Part 9 ● The Invisible Force (magnetic force).

OCT. '94

PROJECTS ● Digilogue Clock ● Visual/Audio Guitar Tuner ● Hobby Power Supply ● Audio Auxilexer ● Experimental Seismograph, Part 2.
FEATURES ● Electronics from the Ground Up, Part 1 with Free PC Software ● Calculation Corner, Part 10.



NOV. '94

PROJECTS ● 1000V/500V Insulation Tester ● Video Modules, Part 1 (Simple Fader, Improved Fader, Video Enhancer) ● Active Guitar Tone Control ● Power Controller ● TV Off-er.
FEATURES ● Electronics from the Ground Up, Part 2 ● Consumer Electronics Show.

DEC. '94

PROJECTS ● Spacewriter Wand ● *EPE* Fruit Machine ● Universal Digital Code Lock ● Video Modules, Part 2 (Horizontal Wiper, Vertical Wiper, Audio Mixer) ● Rodent Repeller.
FEATURES ● Electronics from the Ground Up, Part 3 ● Embedded Controllers ● Index for Volume 23.

JAN. '95

PROJECTS ● Magnetic Field Detector ● Moving Display Metronome ● Model Railway Track Cleaner ● Beating the Christmas Lights ● *EPE* Fruit Machine, Part 2 ● Video Modules, Part 3 (Dynamic Noise Limiter, System Mains Power Supply).
FEATURES ● Electronics from the Ground Up, Part 4 ● Electromagnetic Compatibility ● Checking Transistors.



FEB. '95

PROJECTS ● 12V 35W PA Amplifier ● Foot-Operated Drill Controller ● The Ultimate Screen Saver ● MIDI Pedal Board ● Model Railway Signals.
FEATURES ● Electronics from the Ground Up, Part 5 ● Transformerless Power Supplies ● Quickroute 3.0 Review.

MARCH '95

PROJECTS ● Multi-Purpose Thermostat ● Name of the Game-1 Counterspell ● Sound Activated Switch ● Audio Amplifier ● Light Beam Communicator.
FEATURES ● Electronics from the Ground Up, Part 6 ● Understanding PIC Microcontrollers ● Visio Graphics Software Review. FREE Multi-Project PCB with this issue.

BACK ISSUES ONLY £2.50 each inc. UK p&p.

Overseas prices £3.10 each surface mail, £4.10 each airmail.

We can also supply the following issues from earlier years: 1989 (except March, June and Nov), 1990 (except March), 1991 (except Aug. and Sept.), 1992 (except April and Dec.), 1993 (except Jan., Feb. and March). Please note we are not able to supply copies of *Practical Electronics* prior to the merger of the two magazines in November 1992. Where we do not have an issue a photostat of any *one article* or *one part* of a series can be provided at the same price.

ORDER FORM – BACK ISSUES – PHOTOSTATS – INDEXES

- Send back issues dated
- Send photostats of (article title and issue date)
- Send copies of last five years indexes (£2.50 for five inc. p&p – Overseas £3.10 surface, £4.10 airmail)

Name

Address

I enclose cheque/P.O./bank draft to the value of £

Please charge my Visa/Mastercard £

Card No. Card Expiry Date

Note: Minimum order for credit cards £5. Please supply name and address of cardholder if different from that shown above.

SEND TO: Everyday with Practical Electronics, Allen House, East Borough, Wimborne, Dorset BH21 1PF.

Tel: 01202 881749. Fax: 01202 841692.

Send a copy of this form, or order by letter if you do not wish to cut your issue.

M4/95

LIGHT ACTIVATED SWITCH

ROBERT PENFOLD

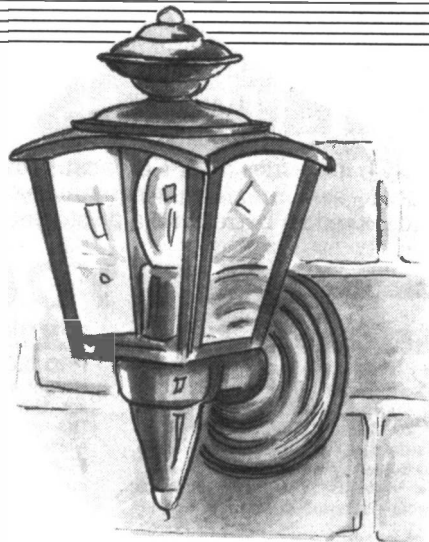

A light-sensitive switch that will find many uses in and around the home. An ideal project for the Multi-Project PCB.

THIS "light activated" circuit will automatically switch on a piece of electrical equipment when the detected light intensity falls below a preset threshold level. Alternatively, and by simply using the relay contacts in a different manner, it will switch on the controlled equipment when the detected light intensity goes above the preset threshold level.

Devices of this type are mainly used in automatic lighting applications. In particular, they are often used as a burglar deterrent.

By automatically operating a light the unit will give the appearance that a house, boat, or caravan is occupied, which is sufficient to deter most would-be intruders. No doubt there are other possible uses for an automatic switch of this type.

CIRCUIT OPERATION

The complete circuit diagram for the Light Activated Switch appears in Fig. 1. Operational amplifier IC1 is used in a simple trigger circuit.

Resistors R2 and R3 provide a reference potential of half the supply voltage to the non-inverting input (+), pin 3 of IC1. The inverting input (-), pin 2, is fed from a potential divider that has preset VR1 and resistor R1 as the upper arm, and R6, a light dependent resistor (l.d.r.) or photo conductive cell, as the lower arm.

The light sensor, R6, is an ORP12 cadmium sulphide photo-resistor. Its resistance is very high in total darkness, and the minimum dark resistance for the ORP12 is actually one megohm.

Higher light intensity produces reduced resistance, and in very bright conditions the ORP12 can exhibit a resistance of under 100 ohms. In an averagely lit room its resistance is typically a few kilohms.

With the l.d.r. in fairly bright conditions, the voltage fed to IC1's inverting input is lower than the reference voltage at the non-inverting input. This results in the output of IC1 going high, which biases transistor TR1 into conduction and switches on the relay.

The voltage fed to IC1's inverting input is relatively high if R6 is subjected to a very low light level. In fact it will be higher than the reference voltage at the non-inverting input. This results in IC1's output going low, which switches off transistor TR1 and the relay RLA.

The relay is therefore switched on if the detected light level is above a certain threshold level. This threshold level is controlled using a preset potentiometer VR1. The higher the resistance of VR1/R1, the lower the threshold level.

With the specified values for VR1 and R1 the unit covers a fairly low range of light levels. The range can be shifted higher by reducing the values of VR1 and R1 to 22 kilohms and 470 ohms respectively.

POSITIVE ACTION

Resistor R4 provides positive feedback over IC1 so that it triggers reliably from one state to the other, and does not tend to hover in an intermediate state when the light level is near the threshold level. It also introduces a small amount of hysteresis, which is a slight reluctance to change back again once the output of IC1 has switched from one state to the other.

The hysteresis occurs because resistor R4 tends to pull the reference voltage slightly below half the supply voltage when IC1's output is low, because it is effectively shunted across resistor R3. When IC1's output is high the reference voltage is pulled slightly above half the supply voltage, because R4 is then effectively in parallel with R2. The threshold level at which the relay switches on is slightly higher than that at which it switches off.

The purpose of the hysteresis is to prevent erratic operation when the light level nears the changeover point. Without the hysteresis it is virtually certain that the relay would switch on and off at a high rate when the light intensity was anywhere near the threshold level.

Even with the small amount of hysteresis provided by R4 the relay should switch "cleanly", but if necessary the amount of hysteresis can be increased by using a slightly lower value for R4. A protection diode D1 suppresses the high reverse voltage that would otherwise be produced across the relay coil each time it switched off.

POWER NEEDS

The current consumption of the circuit is only about 2mA when the relay is switched off, but it is approximately 30mA higher than this when the relay is switched on. The unit can be powered from batteries, such as eight HP7 size cells in a holder, but this is likely to prove rather expensive.

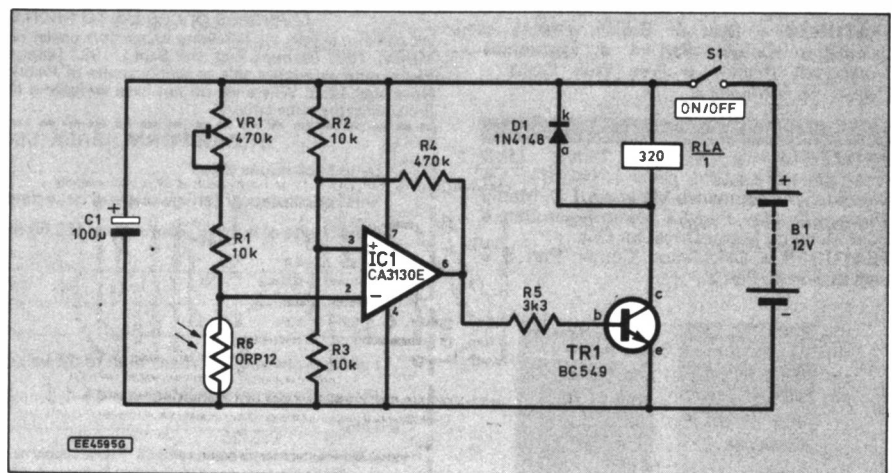

Fig. 1. Circuit diagram for the Light Activated Switch.

If the unit is used in a boat or motor vehicle which has a 12V battery supply, there should be no difficulty in powering it from this supply. The additional current consumption of the Light Activated Switch is likely to be insignificant in comparison to the very high capacity of a boat or vehicle battery. It is advisable to fit a 100mA fuse in series with the On/Off switch (S1) if the circuit is powered from a very low impedance source such as a car or boat battery.

For use in the home a 12V battery eliminator having a current rating of 50mA or more represents an inexpensive means of powering the circuit in the medium and long terms. The eliminator does not need to be a type having a well regulated or low ripple output.

CONSTRUCTION

If you have not already used last month's Free p.c.b., then this simple Light Activated Switch is another useful project for the specially designed Multi-Project PCB. If you require extra p.c.b.s these are available from the *EPE PCB Service*, code 932.

The printed circuit board component layout, together with details of the hard wiring and full size copper foil master is shown in Fig. 2. IC1 is a CMOS device, and the standard anti-static handling precautions should therefore be observed when dealing with this component. Fit IC1 in a holder, but do not plug it in place until the unit is complete in all other respects.

Do not overlook the link-wire just to the left of diode D1. This can be made from a piece of wire trimmed from a resistor leadout wire. Be careful to fit D1 the right way round, since both transistor TR1 and

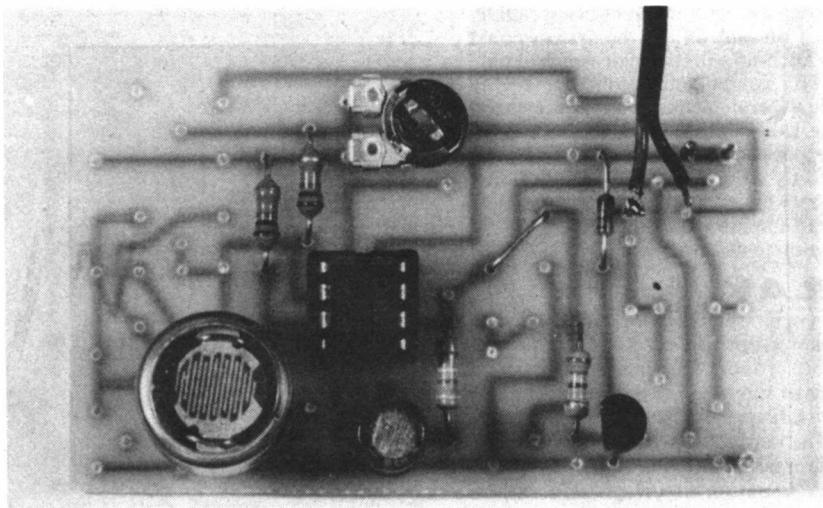

The completed circuit board with the l.d.r. (light sensitive resistor) mounted directly on the p.c.b.

diode D1 itself could be destroyed if a mistake is made here.

LIGHT SENSOR

In Fig. 2 and the photographs the light dependent resistor R6 is shown as being mounted on the printed circuit board. In practice it will often be necessary to mount this component off-board.

If the l.d.r. is fitted on the main unit, it must be mounted on the outside of the case, or a "window" for it to "look" through must be made at the appropriate position in the front panel of the case. The "window" can be hole about 12mm in diameter with a piece of clear plastic material glued in place behind the hole.

It is probably easier and more effective to mount the l.d.r. on the front panel. Drill a couple of small holes (about 2.5mm in dia.) and spaced 9mm apart to take the leadout wires, and then glue the photocell in place using any good quality general purpose adhesive. If the chosen case has a metal front panel, be careful not to get either leadout wire in contact with the panel.

In some applications it might be necessary to have the l.d.r. R6 located away from the main unit. Bear in mind that the unit might not function properly if it is used to control a light, and light from that source is allowed to shine directly on the surface of the l.d.r. Depending on the method of control used, the system

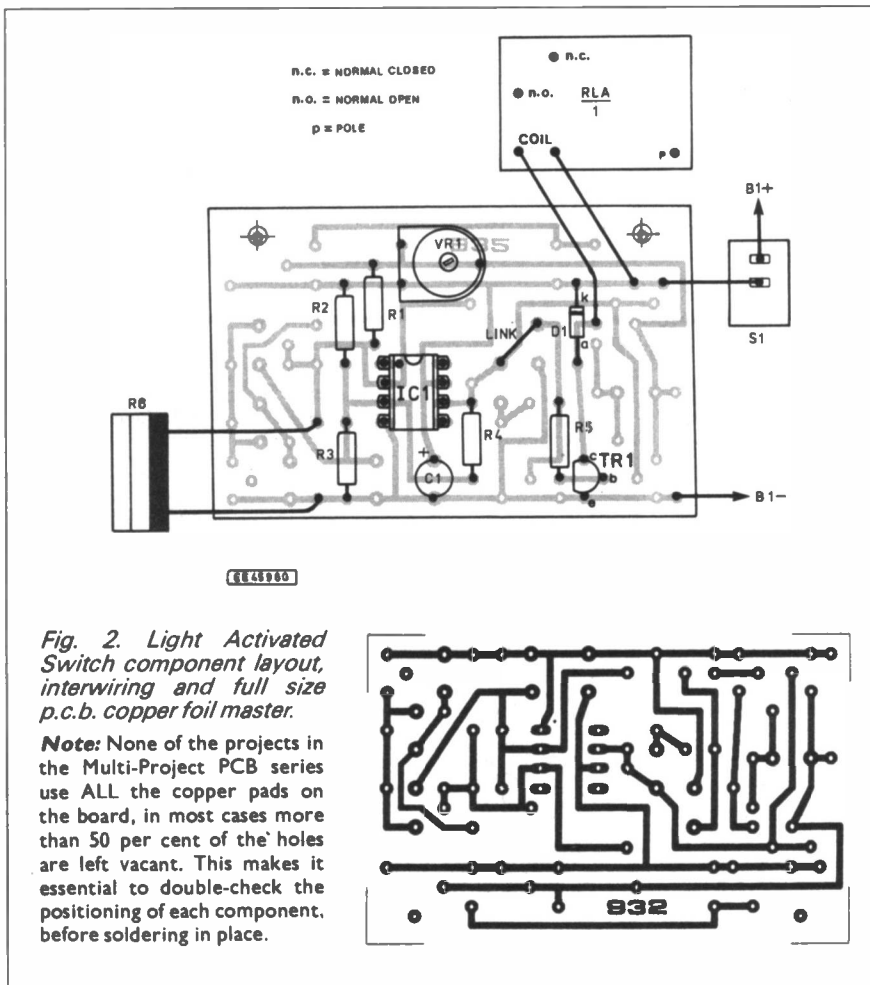

Fig. 2. Light Activated Switch component layout, interwiring and full size p.c.b. copper foil master.

Note: None of the projects in the Multi-Project PCB series use ALL the copper pads on the board, in most cases more than 50 per cent of the holes are left vacant. This makes it essential to double-check the positioning of each component, before soldering in place.

COMPONENTS

Resistors

R1, R2,	
R3	10k (3 off)
R4	470k
R5	3k3
R6	ORP12 light dependent resistor
All 0.25W 5% carbon film, except R6	

Potentiometer

VR1	470k min. carbon preset, horizontal
-----	-------------------------------------

Capacitor

C1	100µ radial elect. 16V
----	------------------------

Semiconductors

D1	1N4148 signal diode
TR1	BC549 npn silicon transistor
IC1	CA3130E CMOS op.amp

Miscellaneous

S1	On/Off toggle switch
RLA	12V 300 ohm coil (or more) relay, contacts as required (see text)
B1	12V battery pack (8 x HP7 in holder)

Printed circuit board available from the *EPE PCB Service*, code 932 (or Free with last month's issue); case, size and type to choice; 8-pin d.i.l. socket; PP3 type connector; multistrand connecting wire; solder, etc.

Approx cost guidance only

£10
excl. Batts.

could oscillate, with the light being rapidly switched on and off, or the system could simply latch-up with the light switched on.

The l.d.r. can be connected to the unit via a cable several metres long if necessary, but the cable should be a screened type. An inexpensive screened lead for audio use is perfectly adequate. The outer braiding must carry the connection to the 0V supply rail, with the inner conductor carrying the connection to resistor R1 and ICI pin 2.

RELAY

The circuit should work properly using any relay which has a 12V coil and a coil resistance of about 300 ohms or more. However, make sure that the relay has adequate contact ratings for your particular application. The connections shown in Fig.2 are correct for a Maplin "10A mains relay". The retailers' literature should provide connection details for other relays.

The specified relay, in common with virtually all modern relays, is only intended for printed circuit mounting. Unfortunately, there is no room for the relay on the circuit board. Probably the easiest way of mounting the relay is to glue it in

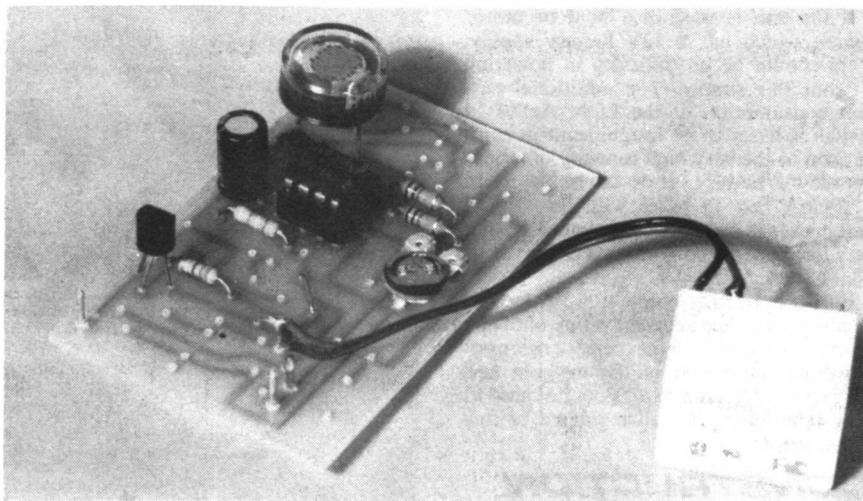

The completed circuit board showing connections to the relay coil. Connection to the relay contacts will depend on application.

place, "up-side-down", on the base panel of the case. Use a good quality adhesive such as an epoxy type.

The way in which the relay contacts are wired to the controlled equipment depends on whether this equipment must be switched on or off when the light threshold level is exceeded. Fig. 3 provides connection details for both methods of control when using the specified 10A relay.

It is assumed here that the relay will be used to control a 12V d.c. lamp. The relay can control mains powered equipment, but only those who have the requisite experience and expertise should use it in this way. *Projects that connect to the dangerous mains supply are definitely NOT suitable for beginners.*

IN USE

Preset control VR1 must be adjusted to give a suitable light threshold level. The easiest way of doing this is to first subject the l.d.r. to the light level at which the automatic switch on/off is required. Then adjust VR1 to the point where a slight to and fro adjustment results in the relay switching on and off.

If the required threshold brightness can not be reached, even with VR1 at minimum resistance (set fully clockwise), the values of VR1 and R1 must be reduced, as explained previously. □

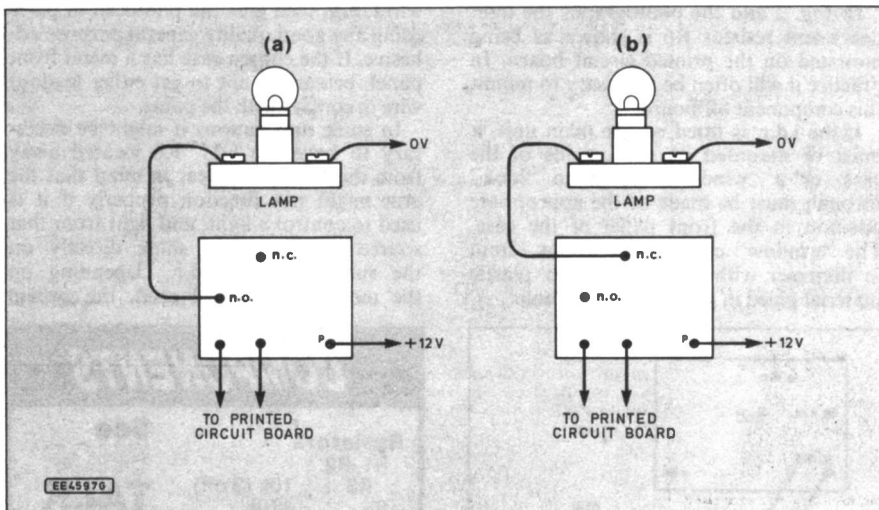

Fig. 3. Contact connection details when using the specified 10A relay. (a) to switch the lamp ON when the light threshold level is exceeded, and (b) to switch it OFF when the threshold level is exceeded.

RING BINDERS FOR EPE

This ring binder uses a special system to allow the issues to be easily removed and reinserted without any damage. A nylon strip slips over each issue and this passes over the four rings in the binder, thus holding the magazine in place (see photo).

The binders are finished in hard wearing royal blue p.v.c. with the magazine logo in gold on the spine. They will keep your issues neat and tidy but allow you to remove them for use easily.

The price is £5.95 plus £3.50 post and packing. If you order more than one binder add £1 postage for each binder after the initial £3.50 postage charge, (for overseas readers the postage is £6.00 each to everywhere except Australia and Papua New Guinea which costs £10.50 each).

Send your payment in £'s sterling cheque or PO (Overseas readers send £ sterling bank draft, or cheque drawn on a UK bank or pay by credit card), to Everyday with Practical Electronics, Allen House, East Borough, Wimborne, Dorset BH21 1PF. Tel: 01202 881749. Fax: 01202 841692 (We cannot reply to overseas queries or confirm orders by fax due to the high costs).

We also accept credit card payments. Mastercard (Access) or Visa (minimum credit card order £5). Send your card number and card expiry date plus cardholders address (if different to the delivery address).



Protects your valuable issues – keeps them together and tidy.



4. Mini FM transmitter, very high gain preamp, supplied complete with FET electret microphone. Designed to cover 88-108 Mhz but it is easy to change it to cover 63-130Mhz. Works with a common 9v (PP3) battery. 0.2W RF. £8.22 KIt no 1001.



Electronic siren kit with an impressive 5 watt power output. Ideal for car/bike alarms etc. 6-12vdc, max current 1A, tone frequency 1.2kHz. £7.05 KIt no 1003.



3-30v Power supply, variable, stabilized power supply for laboratory use. Shortcircuit protected, suitable for professional or amateur applications. 24v 3A transformer is also needed to complete the kit. £16.45 KIt 1007.



Powerful 1 watt FM transmitter supplied complete with piezoelectric microphone. 8-30vdc. At 25-30v you will get nearly 2 watts! £14.10 KIt no 1009.



FM/AM Scanner, well not quite you have to turn the knob yourself but you will hear things on this radio (even TV) that you would not hear on an ordinary radio! Receiver covers 50-160Mhz both AM and FM. Built in 5 watt amplifier. £17.62 KIt no 1013.



Mosquito repeller, modern way to keep midges at bay! Runs for about a month on a 1.5v battery. £8.22 KIt no 1015.



3 channel wireless sound to light system, mains operated, separate sensitivity adjustment for each channel, 1,200 watt power handling. Microphone included. £16.45 KIt no 1014.



Motorbike/cycle trembler alarm, adjustable sensitivity, preset alarm time, auto reset. Could be connected to bikes horn etc. £14.10 KIt no 1011



0-5 minute timer, adjustable from 0 to 5 mins, will switch up to 2A mains. Perfect for alarms, photographic laboratories etc. 12vdc. £8.22 KIt no 1020.



4 watt FM transmitter, small but powerful transmitter, 3 RF stages, microphone and an audio preamp include in kit. £23.50 KIt no 1028.



25 watt FM transmitter 4 RF stages, preamp required (our kit 1068 is suitable). Due to the complexity of the transmitter it is supplied in built up form only. £29.37 KIt no 1031.



Strobe light, adjustable frequency from 1- to 60 Hz (a lot faster than conventional strobes) mains operated. £18.80 KIt no 1037.



Ultrasonic radar ideal as a movement detector with a range of about 10 metres, automate your cat flap! 12v operation so ideal for cars, caravans etc. £16.45 KIt 1049.

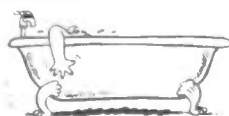

Liquid level detector useful for detecting fluid levels in tanks, fishponds, baths or as a rain or leak alarm. Will switch 2A mains. £5.87 KIt no 1081.



Combination lock 9 key, easily programmable, will switch 2A mains. Complete with keypad. 9v operation. £11.75 KIt 1114.

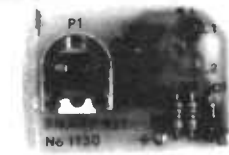

Phone bug detector, this device will warn you if somebody is eavesdropping on your phone line. £7.05 KIt no 1130.



Robot voice, interesting circuit that distorts your voice! adjustable, answer the phone with a different voice! 12vdc £10.57 KIt no 1131.

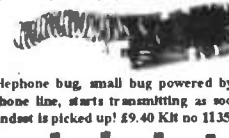

Telephone bug, small bug powered by the telephone line, starts transmitting as soon as the handset is picked up! £9.40 KIt no 1135.



Function generator, produces sinusoidal, saw tooth and square waves adjustable from 20hz-20khz, separate level controls for each shape. Will produce all 3 together. 24vac £17.62 KIt no 1008.



3 Channel light chaser, 800 watts per channel, speed and direction controls supplied with 12 leds and mains triacs, so you can use mains light bulbs if you want. 9-15vdc £19.97 KIt no 1026.



12v fluorescent. A useful kit that will enable you to light 4' fluorescent tubes from your car battery! (you will also need a 9v 2A transformer, not supplied) £9.40 KIt no 1069.



VOX switch, sound activated switch ideal for turning tape recorders on and off when sounds are heard. Makes the tape last a lot longer! adjustable sensitivity, built in delay. £9.40 KIt 1073.



Incar sound to light, Put some atmosphere in your car with this mini 3 channel sound to light. Each channel has 6 led's. £11.75 KIt no 1086.

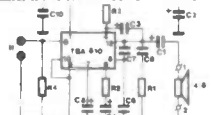

7 watt HI FI power amplifier useful, powerful, ideal for intercomms, audio systems, car use etc. 12-18vdc 500mA. £8.22 KIt No 1025.



Phone call relay, useful device that operates a relay when ever the 'phone rings, could be used to operate more bells or signalling lights etc. Will switch mains at 2A. £11.75 KIt no 1122.



Lead acid charger, two automatic charging rates, visual indication of battery state, ideal for alarm systems, emergency lighting etc. 100mA 12vdc. £14.10 KIt no 1095.



Car alarm system, works on voltage drop and/or vibration, entry and exit delays plus adjustable alarm duration. Good for cars, caravans etc. £14.10 KIt no 1019.

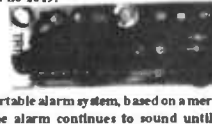

Portable alarm system, based on a mercury switch. The alarm continues to sound until the unit is disabled by the owner. Buzzer included. £12.92 KIt no 1150.

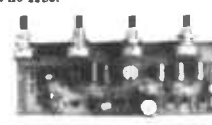

Preamp mixer, 3 input mono mixer, separate bass and treble controls plus independent level controls. 18vdc, input sens 150mv. 100mA. £17.62 KIt no 1052.

Mini metal detector, suitable for locating pipes in walls etc, range 15-20 cm, complete with case. 9v operation. £9.40 KIt no 1022.



800 watt single channel sound to light kit, mains operated, add rhythm to your party for only £9.40 KIt no 1006.



Sound effects generator, produce sounds ranging from bird chips to sirens, complete with speaker, add sound effects to your projects for just £10.57 KIt no 1045.



Guitar preamp with tone controls, small enough to fit inside any guitar, based on TL082 IC, 9-12vdc, 50mA. £9.40 KIt no 1091.



15 watt FM transmitter, 4 stage high power, preamp required. 12-18vdc. Can use either ground plane, open dipole, or Yagi. Supplied in built form only at £81.07 KIt 1021.



Telephone amplifier, Very sensitive amplifier which uses a 'phone pickup coil (supplied) will let you follow a conversation without holding the phone. £12.92 KIt no 1059.

TOP 10 BEST SELLING KITS CORNER

1. Variable speed control kit for 12v DC motors up to 30A! (you may need a heatsink for 30A) £19.97.
2. Composite video kit, converts composite signals into separate Hsync, Vsync and video £9.40.
3. Geiger counter kit, contains everything you need to build a working counter £22.32.
4. Solar energy kit, contains a solar panel, motor, buzzer and cable for experiments £5.87.
5. Electronic acupuncture kit, may help with migraine, poor circulation, backache etc. £8.22.
6. Electrifying apparatus kit, produces a weak adjustable high tension of 80-300v from a 9v battery, ideal for catching worms etc! £9.40.
7. A adapter bug kit, contains everything you need to build a professional bug built inside a standard 13A mains adapter! the bug is mains powered so it operates all the time the adapter is plugged in. Price is £16.45 for the complete kit including adapter. Hand tools and glue required.
8. Nicad charger kit automatic charger for cells from 1.2v to 15v, 7 settings 50600mA, transformer required 18-20v 600mA. £9.40.
- 9 & 10. Inverter kits, produce 240vac from a 12vdc supply, two versions are available a 15w one at £14.10, and an 80w version at £23.50.

EXPRESS COMPONENTS

how to order.....

Remember to add £1.50 p&p.
By phone with a credit card.
By post with either a cheque,
postal order or credit card details.
By fax with credit card details.
EXPRESS COMPONENTS, PO
BOX 517 HOVE SUSSEX BN3
5QZ. DEPT EE
TEL 01273 771156
FAX 01273 206875
Overseas orders please add £3.50
post and packing.

SWITCH ON/OFF TIMER



ROBERT PENFOLD

A low-cost, one to five minute timer (extendable) that can be wired to switch On or switch Off equipment. A project for last month's Free Multi-Project PCB.

THIS simple timer circuit can be used to automatically switch ON or switch OFF a piece of electronic equipment after a preset delay. For example, it could be used to provide a transistor radio with a "sleep" facility. In other words, it could be used to automatically switch off the radio after a delay of a few minutes.

Using the specified component values the timer provides a delay that is adjustable from just under one minute to about five minutes. As explained later, it is very easy to modify the circuit to cover different time ranges, but times of much more than about 10 minutes are not really practical with a simple CR timer circuit such as this.

CIRCUIT OPERATION

The full circuit diagram for the Switch On/Off Timer is shown in Fig. 1. IC1 is an operational amplifier (op.amp) which is used in a basic trigger circuit. Resistors R3 and R4 provide a reference potential to IC1's non-inverting input that is roughly equal to two-thirds of the supply voltage.

The CR timing circuit (VR1, R1, and C2) connects to the inverting input, pin 2 of IC1. At switch-on capacitor C2 starts to charge via preset VR1 and resistor R1, and the voltage fed to the inverting input of IC1 steadily increases. The charge on C2 will eventually rise to a potential that is greater than the reference level at the non-inverting input of IC1.

The output of IC1 is high while the inverting input is at a lower voltage than the non-inverting input. Transistor TR1 is a simple common emitter switch that drives the relay coil. With the output of IC1 high, TR1 is switched on, and the relay is therefore switched on or energised as well.

When the voltage at the inverting input starts to go above the reference potential, the output of IC1 swings lower in voltage. A small amount of positive feedback is applied to the circuit by resistor R5. As a result of this, once IC1's output starts to go lower in voltage, it rapidly triggers to the low state. Transistor TR1 and the relay are then switched off.

The time taken for the charge on C2 to reach the reference level is dependent on the values of R1, VR1, and C2. The delay time is approximately equal to $1.1 CR$ seconds, where C is the value of capacitor C2 in microfarads, and R is the series resistance of R1 and VR1 in megohms.

This gives a theoretical timing range of 51.7 to 294.69 seconds. In practice the tolerances of the components must be taken into account, and these can shift the timing range upwards or downwards by up to about 10 per cent. Also, leakage currents in the circuit are likely to extend the delay times by at least a few per cent.

CHANGING TIMES

This makes it impossible to accurately set a given delay time simply by using the mathematically correct timing component values. Instead, preset VR1 must be trimmed to give the required delay time using trial and error.

For shorter delay times simply make capacitor C2 lower in value. For example, a 30 second delay can be obtained using a value of $10\mu\text{F}$, which gives a theoretical timing range of 11 to 62.7 seconds.

Longer delays can be obtained by using a higher value for C2 and (or) R1. In practice there is only limited scope for producing longer times due to the leakage through capacitor C2.

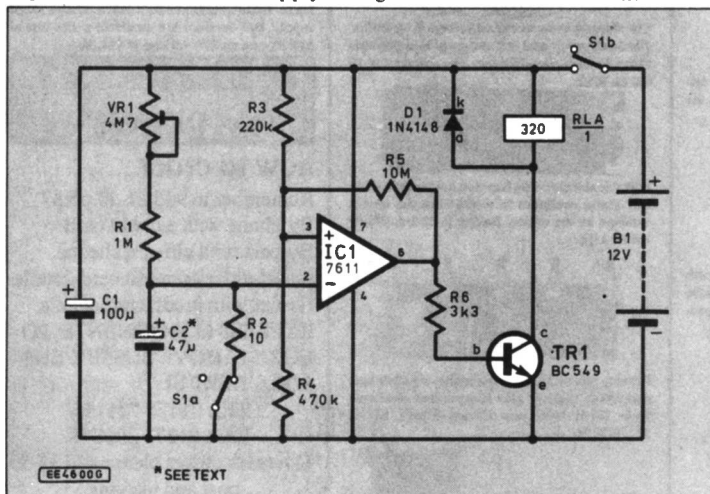
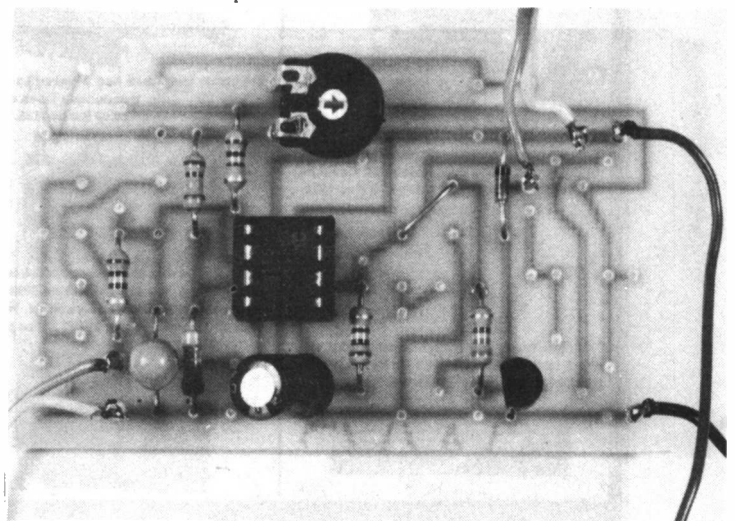

Fig. 1. Circuit diagram for the Switch On/Off Timer. Capacitor C2 must be a tantalum type.



Layout of components on the printed circuit board.

As the circuit stands, the current flow through VR1 and R1 is extremely low, and a small amount of leakage in capacitor C2 would be sufficient to prevent the charge on C2 from reaching the reference voltage. To avoid this it is essential to use a high quality component for C2, but its high value precludes the use of a non-polarised type.

A tantalum bead capacitor will provide good performance, and a superior grade electrolytic might also be suitable. With higher values for C2 it becomes increasingly difficult to obtain satisfactory results. A higher value for resistor R1 reduces the charge current, and also makes it difficult to obtain worthwhile performance. Realistic maximum values for C2 and R1 are 100µF and 10M respectively.

If a variable delay time is needed it is simply necessary to replace preset VR1 with an ordinary rotary potentiometer. This can be fitted with a calibrated scale, but the only way of finding the calibration points is by trial and error.

Switch S1a discharges capacitor C2 when the timer is switched off, so that it is almost instantly ready to start a new timing run again. Resistor R2 provides current limiting when S1a closes.

Without this current limiting there would be a lot of contact sparking, and S1 would soon fail. D1 is a protection diode that suppresses the high reverse voltage spike which would otherwise be generated across the relay coil each time it was switched off.

The low power CMOS op.amp, IC1, has an extremely high input resistance which ensures that the input current drawn from the timing network is far too low to have

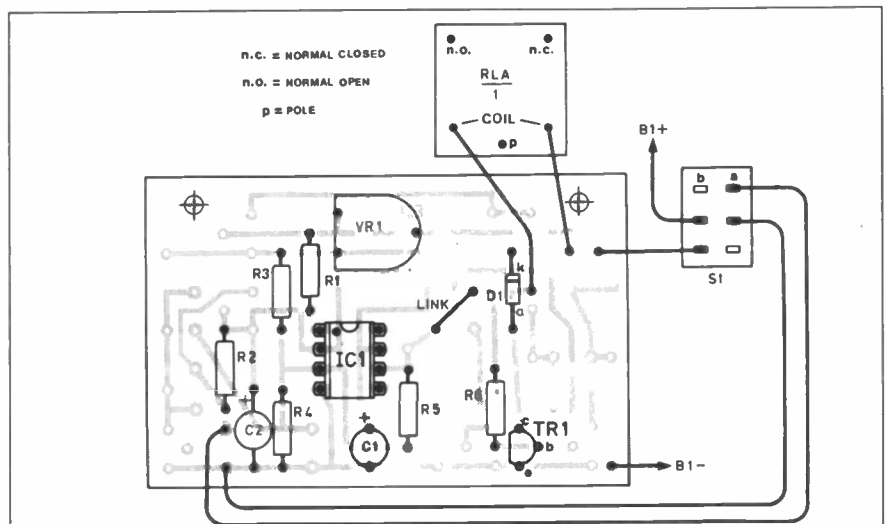
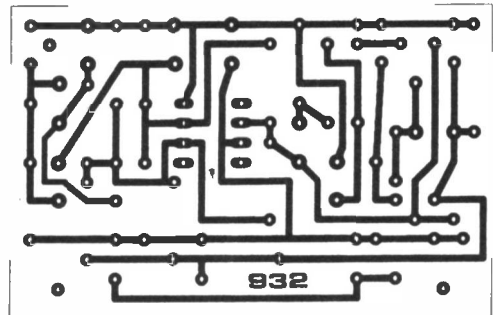

Fig. 2. Circuit board component layout, p.c.b. master and interwiring details for the Switch On/Off Timer.

Note: None of the projects in the Multi-Project PCB series use ALL the copper pads on the board, in most cases more than 50 per cent of the holes are left vacant. This makes it essential to double-check the positioning of each component, before soldering in place.



a significant effect on the charge rate. The current consumption of the circuit is around 30mA to 40mA initially, but this reduces to less than 50 microamps when the relay switches off.

This low current consumption is important, since in some applications the circuit will be left switched on for many hours after the relay has switched off. The HP7 battery pack will not run down significantly even if a current drain of 50 microamps is maintained for many days.

CONSTRUCTION

Using the Free printed circuit board (p.c.b.) from last month's issue should

make construction of the Switch On/Off Timer reasonably trouble free. If you missed last month's issue you can obtain extra p.c.b.s from the EPE PCB Service, code 932, for the sum of £3. The component overlay and copper foil master for the printed circuit board plus details of the hard wiring are provided in Fig. 2.

As IC1 is a CMOS device, the normal anti-static handling precautions should be taken when dealing with this component. Use a holder for this device, and do not fit it into place until all other connections have been completed. Do not handle IC1 any more than is really necessary, and try not to touch the pins.

COMPONENTS

Resistors

R1	1M
R2	10
R3	220k
R4	470k
R5	10M
R6	3k3
All 0.25W 5% carbon film	

See
**SHOP
TALK**
Page

Potentiometer

VR1	4M7 min. carbon preset, horizontal
-----	------------------------------------

Capacitors

C1	100µ radial elect. 16V
C2	47µ tantalum bead, 16V

Semiconductors

D1	1N4148 signal diode
TR1	BC549 npn silicon transistor
IC1	7611 low power op.amp

Miscellaneous

S1	d.p.d.t. min. toggle switch
RLA	12V 300 ohm (or more) coil relay, contacts as required (see text)
B1	12 volt battery pack (8 x HP7 size cells in holder)

Printed circuit board available from the EPE PCB Service, code 932 (or Free with last month's issue); case, size to suit; 8-pin d.i.l. socket; PP3 type battery clip; multistrand connecting wire; solder, etc.

Approx cost
guidance only

£9

excl. Batts.

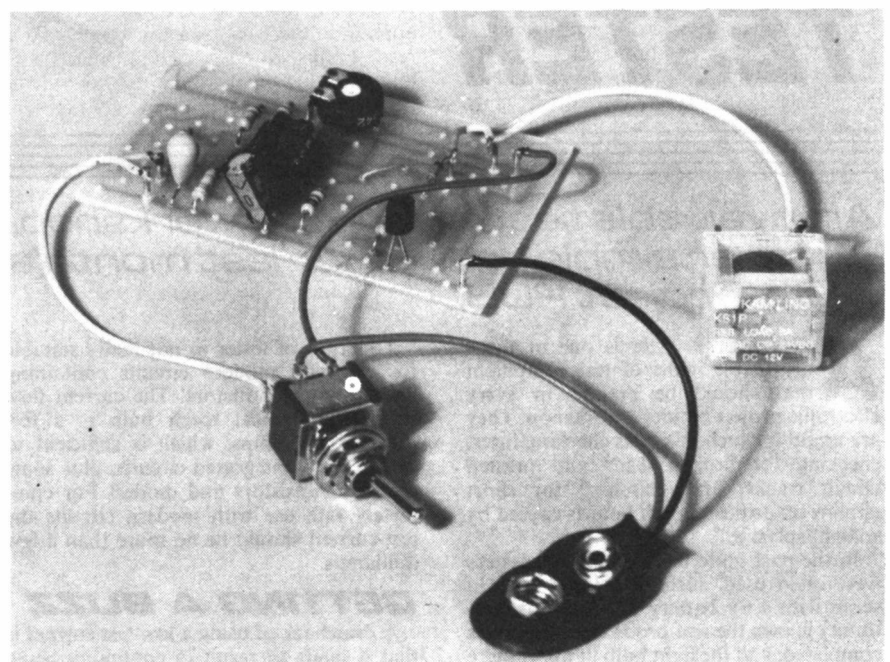

Wiring from the completed p.c.b. to the relay, battery connector and toggle switch.

Be very careful to get diode D1 the right way round as there could be dire consequences for both D1 and transistor TR1 if you get this wrong. Do not overlook the link-wire just to the left of D1.

The polarity of capacitor C2 should be marked by one or more "+" signs on the body of the component, but the markings are likely to be very small, and you may need the aid of a magnifier. The connections to the battery pack are made via an ordinary PP3 type battery clip.

RELAY

The relay can be any type which has a 12V coil with a resistance of about 300 ohms or more, plus suitable contacts for your application. Both the Maplin "10A Mains Relay" and the Electrovalue "Miniature SPDT 3A" types were found to work well. The connections shown in Fig. 2 are correct for the "miniature" 3A type.

There is no room for the relay on the circuit board, and it must therefore be mounted off-board on the case. Most modern relays are only intended for printed circuit mounting, and have no provision for chassis mounting. However, they can be glued in place using a good quality general purpose adhesive such as an epoxy type. Alternatively, it might be possible to fabricate a suitable clamp from a small piece of aluminium.

ON OR OFF

Although the relay switches off at the end of the timing period, the timer can automatically switch the controlled equipment on or off, depending on the way in which the relay's contacts are used. Fig.3 shows the two methods of connection.

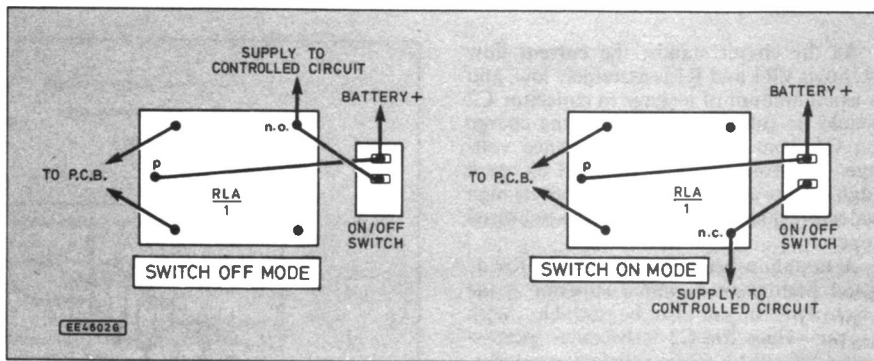

Fig. 3. Two methods of wiring the relay to the existing control equipment on/off switch.

It is assumed here that the relay is the miniature type, and that the unit is to be used with the relay contacts connected in parallel with the existing on/off switch. With the on/off switch set to the "off" position, the timer will then control the main item of equipment.

The exact way in which the unit is used must be varied to suit the prevailing circumstances. It might be necessary to add an s.p.s.t. switch in one lead from the relay to the existing on/off switch, so that the timer does not hold the main equipment switched on at inappropriate times.

This is most likely to be necessary with the switch-on mode, where the main equipment will otherwise be held switched on when the timer is switched off. Alternatively, simply wiring the relay in series with the on/off switch rather than in parallel with it might give the desired result.

The unit can be used to control mains powered equipment, but it should *only* be used in this way by those who have the necessary expertise and experience.

Beginners should only use the unit to control BATTERY POWERED equipment, and should NOT build any projects that involve connections to the dangerous mains supply.

TESTING

It is advisable to test the unit with preset VR1 initially set for minimum resistance (set fully clockwise). This should give a delay time of roughly one minute. Provided all is well, it is then a matter of trying higher values, and using trial and error to obtain the required delay time.

If the times obtained are much higher than expected, or the relay simply fails to switch off at all, it is likely that the problem is due to leakage through capacitor C2. First check to make quite sure that it is connected with the correct polarity. If it is connected properly, try replacing it with another capacitor.

It is worth emphasising again that the Timer can only work reliably if C2 is a high quality capacitor. □

Constructional Project

CONTINUITY TESTER

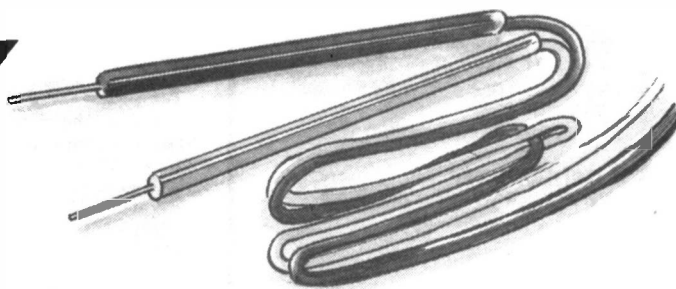

An invaluable tester for your workshop. Another simple project for last month's Multi-Project PCB.

A CONTINUITY tester is one of those invaluable items of test equipment that should be present in every electronic project builder's workshop. They are useful for such things as checking fuses, checking for broken leads and printed circuit tracks, and searching for short circuits on printed circuit boards caused by solder "splashes".

In the past quite basic continuity testers were often used, such as a torch bulb in series with a 6V battery. If there was continuity across the test prods the circuit was completed, and the light bulb lit up. If there was not, the lack of continuity was indicated by the bulb remaining switched off.

This type of tester is not really suitable for use with modern circuits containing delicate semiconductors. The current flow through a typical torch bulb is a few hundred milliamps, which is sufficient to "zap" many integrated circuits, plus some discrete transistors and diodes! For completely safe use with modern circuits the test current should be no more than a few milliamps.

GETTING A BUZZ

A drawback of using a low test current is that it tends to result in continuity being indicated even if there is actually a resistance of a hundred ohms or more across

the test probes. This can result in a lot of misleading results.

Many continuity testers, even some high current types, are also "fooled" by forward biased semiconductor junctions within the test circuit. These can be provided by diodes, or by diode junctions within transistors and integrated circuits.

Most modern circuits are liberally scattered with these hidden diode junctions. They are a frequent source of misleading results, with short circuits being indicated where none exist.

The Continuity Tester featured here provides an audible "buzz" when electrical continuity is present across the test prods. An audible indication is generally preferred to a visual type, as it avoids the need to keep looking away from the test prods (which tend to slip off the test points each time you look away).

The maximum voltage to be found across the test probes is about 6V, and the short circuit current is approximately 0.3mA. This ensures that the unit can be used safely with circuits that contain delicate semiconductors.

Reliable results are obtained because continuity is only indicated if the resistance across the test prods is no more than a few ohms. Also, the voltage drop across a forward biased silicon junction is sufficient to prevent the unit from being "fooled" into indicating proper continuity.

It will not indicate continuity due to germanium junctions or Schottky diodes either. This gives much greater reliability in use, but it does bring the minor drawback that the unit cannot be used to test any type of diode.

CIRCUIT DESCRIPTION

The complete circuit diagram for the Continuity Tester appears in Fig. 1. Operational amplifier IC1 is used here as a voltage comparator.

If the voltage at its inverting input (pin 2) is higher than the potential at its non-inverting input (pin 3), the output goes towards zero volts. Taking the inverting input to a lower voltage than that at the non-inverting input results in the output swinging more positive.

An operational amplifier has a very high open loop voltage gain, and the typical figure for the CA3130E is about 250,000 times. Consequently, only a minute voltage difference is needed across the inputs in order to send the output fully positive or negative.

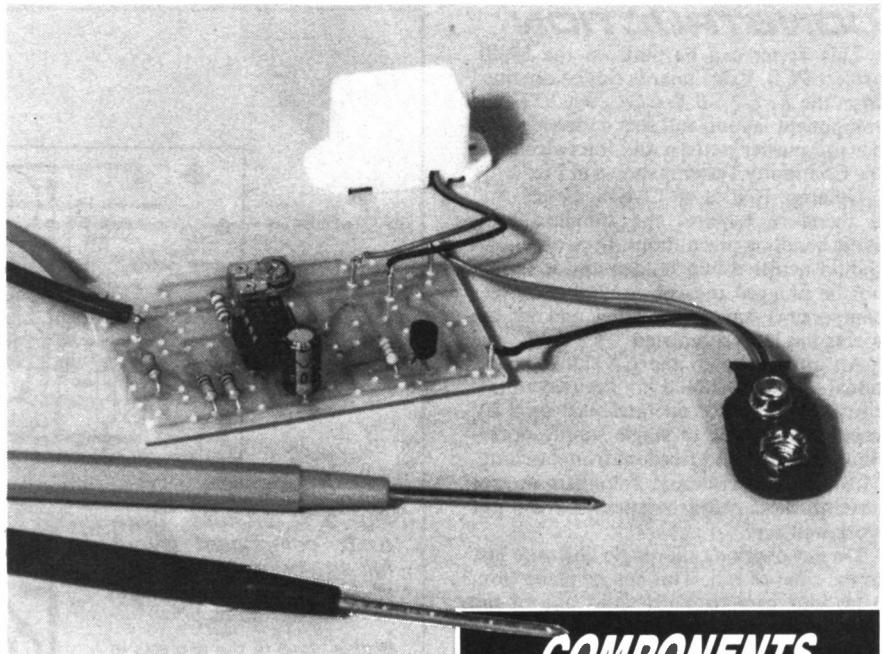

voltage. Under standby conditions there is an extremely high resistance across the test probes, giving zero volts at IC1's non-inverting input. The inverting input is therefore at the higher voltage, and the output of IC1 is low. This results in transistor TR1 being cut off, and the buzzer (WD1) is switched off.

If the test prods are shorted together, the voltage at the non-inverting input of IC1 goes to half the supply voltage, and it is then at a slightly higher potential than

(above)
Photograph of the completed unit showing the buzzer connected to the board.

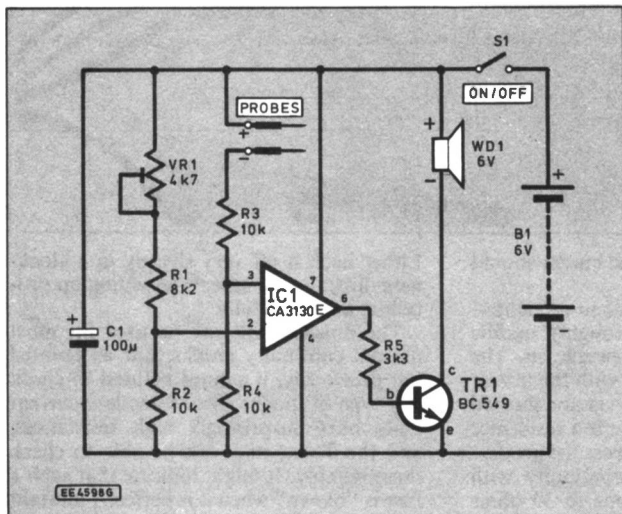

Fig. 1. (left). Circuit diagram for the Continuity Tester. The "test" buzzer is a miniature solid-state type and must be connected in-circuit with the correct polarity.

The two inputs of IC1 are fed from separate potential dividers. Preset VR1 and resistors R1 and R2 provide a reference potential to the inverting input, pin 2, and this voltage can be adjusted by means of VR1. Resistors R3 and R4 form the potential divider at the non-inverting input, pin 3, and these provide an output voltage equal to half the supply potential.

However, the test probes are connected in series with R3, and the half supply output voltage is only produced with the prods shorted together. A resistance between the prods, even a relatively low one, will give a slight reduction in the output voltage from R3 and R4.

IN ACTION

In practice preset VR1 is adjusted so that the reference voltage at the inverting input is fractionally lower than half the supply

the inverting input. This takes the output of IC1 high, which in turn results in TR1 being biased into conduction and the buzzer being activated.

If there is a small resistance across the test prods the voltage at the non-inverting input will be slightly less than half the supply voltage. This may be sufficient to take the non-inverting input to a higher voltage than the inverting input and activate the buzzer, or it might not.

This depends on the precise setting of VR1, and the resistance across the test probes. With careful adjustment of VR1 the circuit can be made to ignore resistances of less than about five to 10 ohms, which is good enough to avoid the vast majority of erroneous results.

The circuit could be made more sensitive by reducing the value of resistors R3 and R4. For example, using a value of one

COMPONENTS

Resistors

R1 8k2
R2, R3, R4 10k (3 off)
R5 3k3
All 0.25W 5% carbon film

See
SHOP
TALK
Page

Potentiometer

VR1 4k7 min. enclosed carbon preset, horizontal

Capacitors

C1 100µ radial elect. 10V

Semiconductors

TR1 BC549 npn silicon transistor
IC1 CA3130E CMOS op.amp

Miscellaneous

S1 s.p.s.t. min. toggle switch
B1 6V battery pack (4 x HP7 size cells in holder)
WD1 6V buzzer

Printed circuit board available from the EPE PCB Service, code 932 (or Free with last month's issue); case to choice; test probes and leads; 8-pin i.c. socket; PP3 type battery clip; multistrand connecting wire; solder, etc.

Approx cost
guidance only

£9
excl. Batts

kilohm would make the circuit ten times more discriminating, so that it would ignore resistances of more than about 0.5 to one ohm. The test current would still be quite low at only about 3mA.

In use it is not necessarily a good idea to have a very high degree of discrimination. It would probably not significantly reduce the number of "false alarms", and it could result in continuity being overlooked due to poor electrical contacts with the test prods. It is left to individual constructor's to select the degree of discrimination they require, but it would be advisable not to make resistors R3 and R4 less than about 560 ohms in value.

The current consumption of the circuit is less than one milliamp, but the consumption rises to about 20mA when the buzzer is activated. This still gives an extremely long life from the four HP7 size batteries.

CONSTRUCTION

This Tester can be built on the Multi-project PCB. Extra boards can be obtained from the *EPE PCB Service*, code 932. The component layout, full size underside copper foil master pattern and interwiring for the Continuity Tester is shown in Fig. 2.

Op.amp IC1 is a CMOS device and it therefore requires the standard anti-static handling precautions. In particular, it should be fitted in a holder, and it should not be plugged into place until the other components have been fitted and all the wiring has been completed.

An alternative to the CA3130E operational amplifier should *not* be used in this circuit. This device operates well on a 6V supply, is capable of single supply operation, and has good freedom from latch-up. Most other operational amplifiers do not have all these characteristics, and will not work well here.

Do not overlook the single link wire just to the right of IC1. This can be made from a leadout wire trimmed from one of the resistors.

The buzzer WD1 must be connected to the board with the correct polarity. The positive (+) and negative (-) leads are respectively identified by their red and black sleeving.

The buzzer requires a rectangular mounting hole in the front panel of the selected case. Probably the easiest way of making this is to first drill a hole of about 12mm in diameter, and then file it to shape and size using a miniature flat file.

The positions of the two small mounting holes can then be marked using the buzzer itself as a sort of template. The use of 8BA fixing bolts and nuts are required, and these are not supplied with the buzzer.

PROBES

Test probes are usually supplied complete with leads and plugs. The probes can therefore be connected to the circuit board via a pair of the appropriate sockets mounted on the front panel.

In practice it might be better to remove the plugs from the leads, drill an entrance hole for the leads in the front panel, and then solder the leads direct to the component board. This method ensures that there is always a low resistance connection between each prod and the circuit board, and that reliable results will be obtained.

IN USE

Preset potentiometer VR1 must be carefully adjusted to the correct setting if the Tester is to function well. Start with VR1 set at virtually minimum resistance (set almost fully clockwise). With the two test

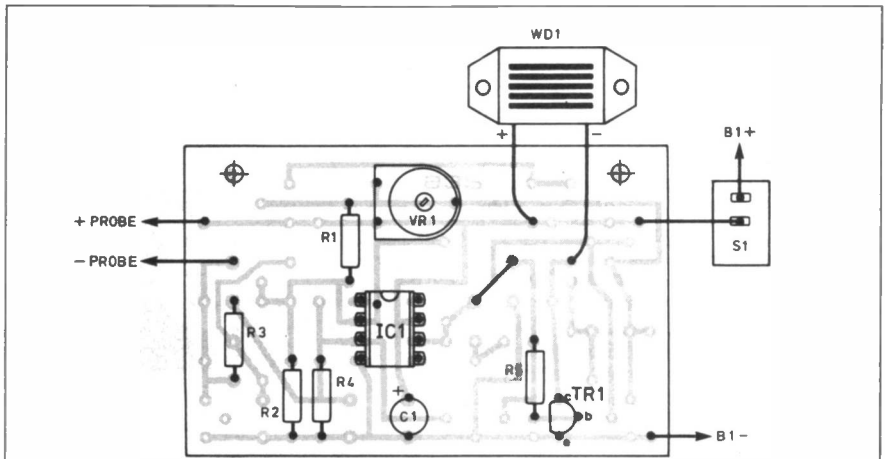
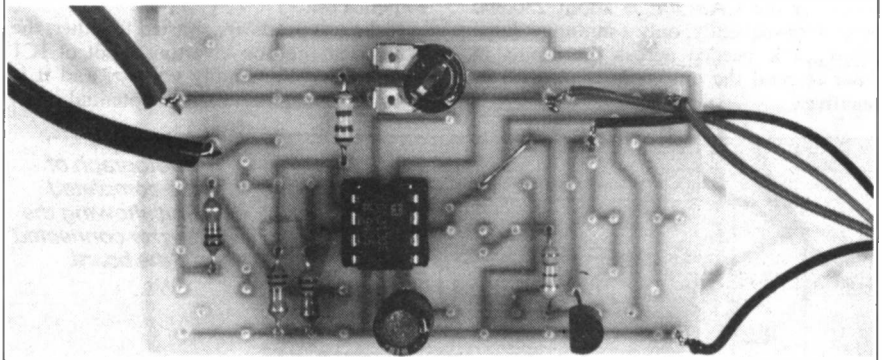
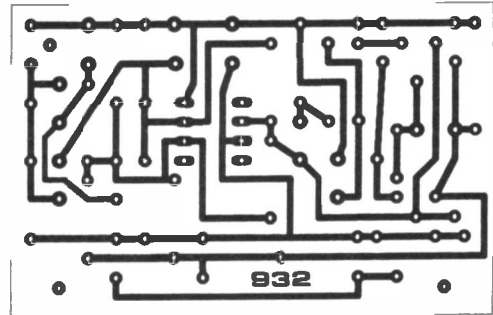

Fig. 2. Continuity Tester p.c.b. component layout, full size copper foil master and (below) photograph of finished board.

Note: None of the projects in the Multi-Project PCB series use ALL the copper pads on the board, in most cases more than 50 per cent of the holes are left vacant. This makes it essential to double-check the positioning of each component, before soldering in place.



prods connected together the buzzer should not operate.

If VR1 is steadily adjusted in a counter-clockwise direction, at a roughly middle setting the buzzer should switch on. The unit should then work well, with the buzzer operating when the test prods are shorted together, but not when there is a resistance of more than a few ohms across the prods.

If the circuit indicates continuity with resistances of about 10 ohms to 30 ohms across the prods, preset VR1, has been taken slightly beyond the optimum setting.

Either back it off very slightly in a clockwise direction, or repeat the setting up procedure more carefully.

The finished unit can be used for most normal continuity checks, but as pointed out previously, it cannot be used to check any type of diode. Also, some low current fuses have surprisingly high resistances, and the Tester may not be able to check these reliably. It might indicate that such a fuse is "blown" when it is perfectly all right (but not that it is all right when it is "blown"). □

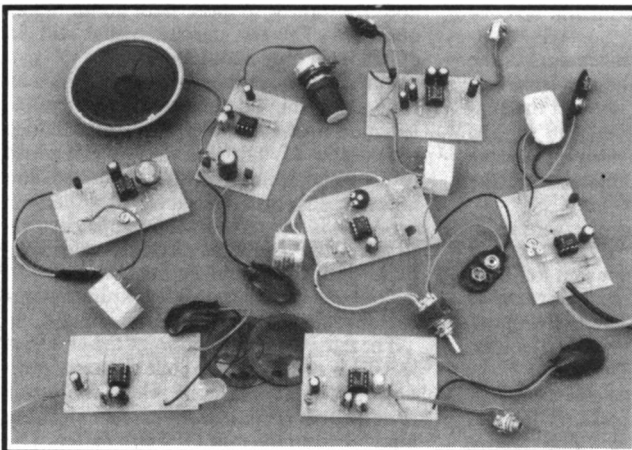

DON'T MISS OUT!

A FURTHER SELECTION OF PROJECTS "TAILORED" FOR YOUR FREE P.C.B. WILL BE APPEARING IN THE AUTUMN.

Plus ANOTHER IDENTICAL **FREE!** P.C.B. GIFT WILL BE ATTACHED TO AN ISSUE.

ORDER A REGULAR COPY FROM YOUR NEWSAGENT NOW, OR TAKE OUT A SUBSCRIPTION - PRESENTLY GREAT VALUE!!

Take the

Quickroute

from
£99.00

to successful PCB &
Schematic Design



Design PCBs and Schematics quickly

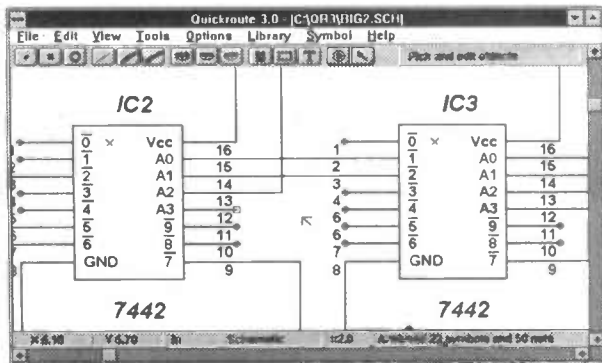

After schematic capture, components can be re-arranged prior to manual or automatic routing.

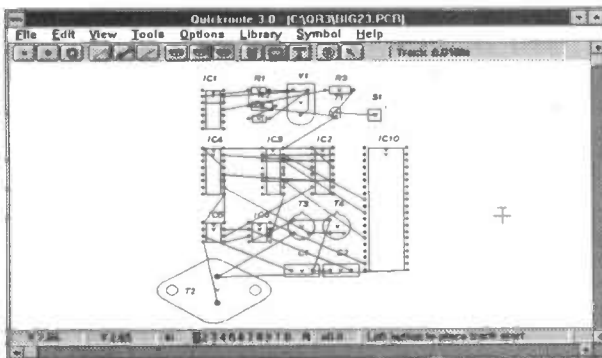

	Auto Router Max Layers	Schematic Capture	Gerber & NC-Drill	Design Size K nodes
DESIGNER	2 Standard	None	None	10
DESIGNER+	2 Medium	None	Export	20
PRO	8 Fast	Standard	Export	30
PRO+	8 Fast	Advanced	Export/ Import*	40

*PRO+ can import Gerber files

All versions include an auto-router.

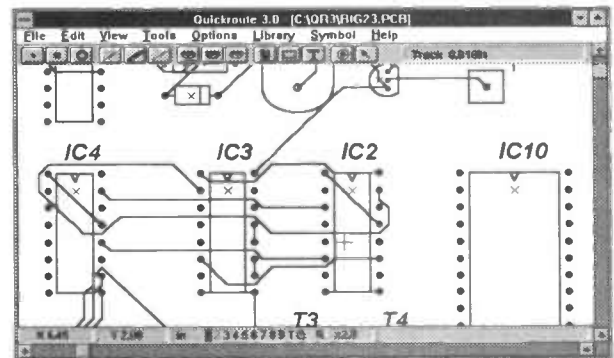

Telephone or FAX POWERware on 061 449 7101

POWERware, 14 Ley Lane,
Marple Bridge, Stockport,
SK6 5DD, UK.

Quickroute 3.0 for Windows 3.1
DESIGNER £99.00 DESIGNER+ £149.00
PRO £199.00 PRO+ £299.00
All prices exclude post & packing, and V.A.T.

DEMO
DISK
Available

ELECTRONICS SOFTWARE

from E.P.T. Educational Software
(Tel: 0376 514008)

If you are looking for a means of improving your knowledge of the basics of electronics then this software is for you.

ELECTRONICS PRINCIPLES II

- ★ Insulators, Conductors, Resistance ★ D.C. Circuits
- ★ Capacitance and Inductance ★ A.C. Series Circuits
- ★ A.C. Parallel Circuits ★ Reactance and Impedance
- ★ A.C. and D.C. Power ★ Frequency and Tuned Circuits
- ★ Using Numbers ★ Complex Numbers, Phase Angles
- ★ P.N. Junction Diode ★ Transistors ★ Operational Amplifiers
- ★ Logic Gates ★ Digital Number Systems ★ Combinational Logic
- ★ Flip Flops ★ Counters and Shift Registers ★ Memory
- ★ Microcomputer operation

Electronics Principles II is a major revision of the successful original version currently used by electronics hobbyists, schools, colleges, and for training within industry throughout the UK and overseas. Some of the modifications are as a result of feedback from teachers, but mostly the changes are due to making greater use of the available improvements in software development technology.

The individual sub-menus are changed to selection buttons, this makes all those topics available within a module, clearly visible to the user. The layout of the calculations is considerably enhanced, firstly by providing the formulae used and secondly by showing the calculation steps, exactly as in a textbook; the advantage here being that you can input your own values.

Having reviewed a dozen, or more, educational software packages designed to "teach" electronics, I was more than a little sceptical when I first heard about Electronics Principles: there seemed to be little that could be done that has not been done elsewhere. When I started to use the package my views changed. Indeed, I was so impressed with it that I quickly came to the conclusion that readers should have an opportunity to try the package out for themselves! – MIKE TOOLEY B.A. Dean of Faculty of Technology, Brooklands Technical College

Over 200 menu driven screens with interactive graphics enabling a learning by doing approach to encourage experimentation.

Complete package **Only £49.95** inc. VAT.

ELECTRONICS PC TOOLBOX VERSION 2.0

An extended and improved version of the popular Toolbox software. Presents commonly used formulae in a way that makes calculations easier thus encouraging experimentation in circuit design.

Covers D.C. Calculations from Ohm's Law to Loading a Potential Divider; Further D.C. Calculations from Power Ratio Decibels to Kirchhoff's Laws; A.C. Calculations from Average Peak Current to Filters and Admittance; Capacitance Calculations from Values to RC Time Constants; Inductance Calculations from Values to Selectivity; Binary Calculations from Addition to 2's Complement; Numbers and Phase Angles from Addition to Polar to Rectangular; Operational Amplifiers from Inverting Op.Amp to Op.Amp Differentiator.

Only £19.95 inc. VAT

These programs require a PC (or fully compatible system) running DOS with an 80286 or better processor and VGA (ideally colour) graphics. In addition you must have 4Mb of hard disk space, a high density (1.44Mb) floppy drive and at least 640K of RAM. We also recommend the use of a mouse. Site licences are available – please enquire.

Distributed by Direct Book Service, 33 Gravel Hill, Merley, Wimborne, Dorset, BH21 1RW. (Mail Order Only).

Add £1.50 per order for UK post and packing. Make cheques payable to Direct Book Service.

Direct Book Service is a division of Wimborne Publishing Ltd.

Tel: 01202 881749. Fax: 01202 841692.

Visa and Mastercard orders accepted (minimum credit card order £5) – please give card number, card expiry date and cardholders address if different from the delivery address. Orders are normally sent within seven days but please allow a maximum of 28 days – longer for overseas orders.

OVERSEAS ORDERS: Add £2.50 postage for countries in the E.E.C. Overseas readers, outside the E.E.C. countries add £3.50 for airmail postage.

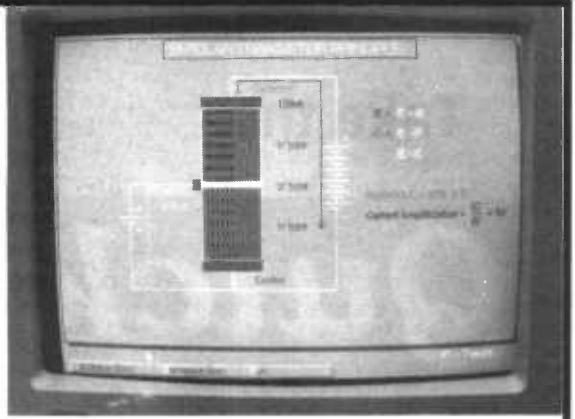

GCSE ELECTRONICS VERSION 2.0

Designed to complement our *Teach-In No. 7* publication, which contains a complete electronics course aimed at GCSE and A Level students, this software can also be used as a stand alone learning package for everyone interested in electronics. From simple d.c. current flow and Ohm's Law it covers the whole GCSE syllabus including a.c., semiconductors, op.amps, digital electronics, radio and fibre optic communications, digital numbering systems and goes on to look at microprocessor c.p.u.s, 6502 addressing modes and instruction sets. It even produces a program listing, which can be saved or retrieved from hard disk, when any of the instructions from the listed instruction set are input, thus allowing the user to monitor the registers for each of the addressing modes.

The original version is now widely used in schools and colleges throughout the UK.

An interactive, user friendly medium which assists learning in an enjoyable and interesting way.

Only £34.95 inc. VAT

Teach-In No 7 152-page A4 book £3.95 including a Special Limited Version of GCSE Electronics Software which covers the first two of the 12 parts of the course, thus enabling an assessment of the complete package. Both the book and software can be used on their own.

DEMONSTRATION DISK

Special demonstration disk containing Electronics Principles II, GCSE Maths and Mathematics Principles is available for £2.50 (Overseas orders send £3.50) – includes post and packing.

GCSE MATHS

A series of programs covering all the major topics required by the school syllabus. Designed to be user friendly enabling you to study or revise in what we believe is an interesting and enjoyable way. There are nearly one hundred and fifty menu driven screens with interactive graphics, enabling a "learning through doing" approach to encourage experimentation. Now being used in many schools throughout the UK.

Overseas customers or those with general interest in maths order *Mathematics Principle* – covers the same subjects without reference to GCSE.

Only £49.95 inc. VAT

VIDEOS ON ELECTRONICS

A range of videos designed to provide instruction on electronics theory. Each video gives a sound introduction and grounding in a specialised area of the subject. The tapes make learning both easier and more enjoyable than pure textbook or magazine study. They should prove particularly useful in schools, colleges, training departments and electronics clubs as well as to general hobbyists and those following distance learning courses etc.

VT201 to VT206 is a basic electronics course and is designed to be used as a complete series, if required.

VT201 54 minutes. Part One; D.C. Circuits. This video is an absolute must for the beginner. Series circuits, parallel circuits, Ohms law, how to use the digital multimeter and much more.
Order Code VT201

VT202 62 minutes. Part Two; A.C. Circuits. This is your next step in understanding the basics of electronics. You will learn about how coils, transformers, capacitors, etc are used in common circuits.
Order Code VT202

VT203 57 minutes. Part Three; Semiconductors. Gives you an exciting look into the world of semiconductors. With basic semiconductor theory. Plus 15 different semiconductor devices explained.
Order Code VT203

VT204 56 minutes. Part Four; Power Supplies. Guides you step-by-step through different sections of a power supply.
Order Code VT204

VT205 57 minutes. Part Five; Amplifiers. Shows you how amplifiers work as you have never seen them before. Class A, class B, class C, op.amps. etc.
Order Code VT205

VT206 54 minutes. Part Six; Oscillators. Oscillators are found in both linear and digital circuits. Gives a good basic background in oscillator circuits.
Order Code VT206

By the time you have completed VT206 you have completed the basic electronics course and should have a good understanding of the operation of basic circuit elements.

VCR MAINTENANCE

VT102 84 minutes: Introduction to VCR Repair. Warning, not for the beginner. Through the use of block diagrams this video will take you through the various circuits found in the NTSC VHS system. You will follow the signal from the input to the audio/video heads then from the heads back to the output.
Order Code VT102

VT103 35 minutes: A step-by-step easy to follow procedure for professionally cleaning the tape path and replacing many of the belts in most VHS VCR's. The viewer will also become familiar with the various parts found in the tape path.
Order Code VT103

Each video uses a mixture of animated current flow in circuits plus text, plus cartoon instruction etc., and a very full commentary to get the points across. The tapes are imported by us and originate from VCR Educational Products Co, an American supplier.
(All videos are to the UK PAL standard on VHS tapes)

Now for the digital series of six videos. This series is designed to provide a good grounding in computer technology.

VT301 54 minutes. Digital One; Gates begins with the basics as you learn about seven of the most common gates which are used in almost every digital circuit, plus Binary notation.
Order Code VT301

VT302 55 minutes. Digital Two; Flip Flops will further enhance your knowledge of digital basics. You will learn about Octal and Hexadecimal notation groups, flip-flops, counters, etc.
Order Code VT302

VT303 54 minutes. Digital Three; Registers and Displays is your next step in obtaining a solid understanding of the basic circuits found in today's digital designs. Gets into multiplexers, registers, display devices, etc.
Order Code VT303

VT304 59 minutes. Digital Four; DAC and ADC shows you how the computer is able to communicate with the real world. You will learn about digital-to-analogue and analogue-to-digital converter circuits.
Order Code VT304

VT305 56 minutes. Digital Five; Memory Devices introduces you to the technology used in many of today's memory devices. You will learn all about ROM devices and then proceed into PROM, EPROM, EEPROM, SRAM, DRAM, and MBM devices.
Order Code VT305

VT306 56 minutes. Digital Six; The CPU gives you a thorough understanding in the basics of the central processing unit and the input/output circuits used to make the system work.
Order Code VT306

By now you should have a good understanding of computer technology and what makes computers work. This series is also invaluable to the computer technician to understand the basics and thus aid troubleshooting.

VT401 61 minutes. A.M. Radio Theory. The most complete video ever produced on a.m. radio. Begins with the basics of a.m. transmission and proceeds to the five major stages of a.m. reception. Learn how the signal is detected, converted and reproduced. Also covers the Motorola C-QUAM a.m. stereo system.
Order Code VT401

VT402 58 minutes. F.M. Radio Part 1. F.M. basics including the functional blocks of a receiver. Plus r.f. amplifier, mixer oscillator, i.f. amplifier, limiter and f.m. decoder stages of a typical f.m. receiver.
Order Code VT402

VT403 58 minutes. F.M. Radio Part 2. A continuation of f.m. technology from Part 1. Begins with the detector stage output, proceeds to the 19kHz amplifier, frequency doubler, stereo demultiplexer and audio amplifier stages. Also covers RDS digital data encoding and decoding.
Order Code VT403

VT501 58 minutes. Fibre Optics. From the fundamentals of fibre optic technology through cable manufacture to connectors, transmitters and receivers.
Order Code VT501

ORDERING: Add £1.50 p&p per order for UK orders. **OVERSEAS ORDERS:** Add £3 postage for countries in the EEC. Overseas orders outside the EEC countries add £3 per tape airmail postage (or £6 per order surface mail postage).

All payments in £ sterling only (send cheque or money order drawn on a UK bank).

Visa and Mastercard orders accepted - please give card number, card expiry date and cardholder's address if different from the delivery address.

Orders are normally sent within seven days but please allow a maximum of 28 days - longer for overseas orders.

Send your order to: Direct Book Service, 33 Gravel Hill, Merley, Wimborne, Dorset BH21 1RW (Mail Order Only)

Direct Book Service is a division of

Wimborne Publishing Ltd.,

Tel: 01202 881749. Fax: 01202 841692

£29.95
each inc. VAT

UCAS
VCR EDUCATIONAL PRODUCTS COMPANY

Part 2
Alternating Current
VT202
Running Time 62 Min.

PHOTOTRANSISTOR

Emitter Base Collector



Showing Large Base Area

ORDER EIGHT OR MORE TOGETHER - GET ONE FREE (or order 16 together and get TWO FREE)

PHOTOTRANSISTOR



THE HARD CELL

TERRY de VAUX-BALBIRNIE



Are you itching to buy a mobile phone?
We look at the technology behind it.

FOR many years, people were content with fixed telephones in their homes and offices. It was a science fiction dream to be able to communicate from any location – perhaps while out walking or in the car.

Although we are still a little way from the comic-strip notion of a commercially-viable watch-strap telephone, most people are at least aware of the technology on offer even if they are confused by it. High Street hype would entice us into the shop and emerge with our new toy.

However, attracted by the price – highly discounted and offered at a fraction of its true value – let the buyer beware! There is a network connection charge, monthly line rental, cost of calls and details such as insurance to consider.

RAPID GROWTH

Mobile telephones constitute one of the most rapidly growing markets in the UK. In 1991 there were fewer than 400,000 units on air. By 1992 this had risen to over 500,000. By 1993 it was almost one million and by the end of 1994 it was expected to have reached 1.5 million – see Fig. 1. Estimates range between seven and 12 million mobile users by the year 2000.

The only way to provide a practical *wire-less* telephone is to use a two-way radio link. The basic techniques have been known for a long time – Marconi demonstrated the use of radio waves for communication purposes a hundred years ago. However, modern technology was needed to turn dreams into practical reality.

It also required a relaxation in the regulations regarding the use of radio transmitters. Traditionally, this has been the prerogative of broadcasting companies, emergency services, taxi operators, ships at sea and so on. General access was denied apart from licensed radio amateurs who needed (and still do) to pass a theory examination. There was some loosening of the rigid line when, in February 1981, the Home Secretary announced that he was willing to provide a Citizens Band service in the UK using the 27MHz band.

BRASS TACS

Early radio telephones were of the “taxi” kind and only able to talk to a base station some relatively short distance away. Messages to the public network had to be relayed by word of mouth. It became clear that, with emerging technology, a radio link could be established not only between mobile users but integrated with the national fixed system.

To this end, in 1982, the Department of Trade and Industry selected two organisations – Racal-Vodafone and Cellnet – to develop analogue networks to the British Standard *Total Access Communications System* (TACS) using the frequency range 890 to 960MHz. Operation began in January 1985.

To operate this service, 1000 duplex (two-way) radio channels were allocated (that is, 1000 frequencies for sending and 1000 for receiving). Each of the rival operators were allocated 300 channels with the remaining 400 reserved for the forthcoming digital pan European network called GSM (Group Systems for Mobile Communication) of which more will be said presently.

One method of use would be for mobile operators to employ high-powered transmitters and communicate with a single distant base station. This could then be patched into the public telephone network. To use this system, a caller would need exclusive use of one communication channel all the time he or she was talking.

With such a small number of possible users at any given time, this would be obviously impractical. A further problem with such

an idea is that a fairly low frequency of operation would be needed to provide the necessary long range and such frequencies have long since been allotted to other services.

The problem needed some lateral thinking. Space was available in the u.h.f. (ultra high frequency) region of the radio wave spectrum a little above that used for TV broadcasting (which extends to about 853MHz). Waves in this region behave rather like light and travel best over line-of-sight distances. For this reason, they would seem to be of little use for long-range communication. However, this very drawback gives a clue to their strength.

REPEAT, REPEAT

By exploiting the limited range, a process of *frequency re-use* is made possible. This means that the same frequencies may be employed by others a relatively short distance away without causing interference. In fact, over the entire nation, the same channels may be used many times over.

For a blanket system, therefore, all that is required is a network of very low-powered u.h.f. transmitters grouped in an arrangement

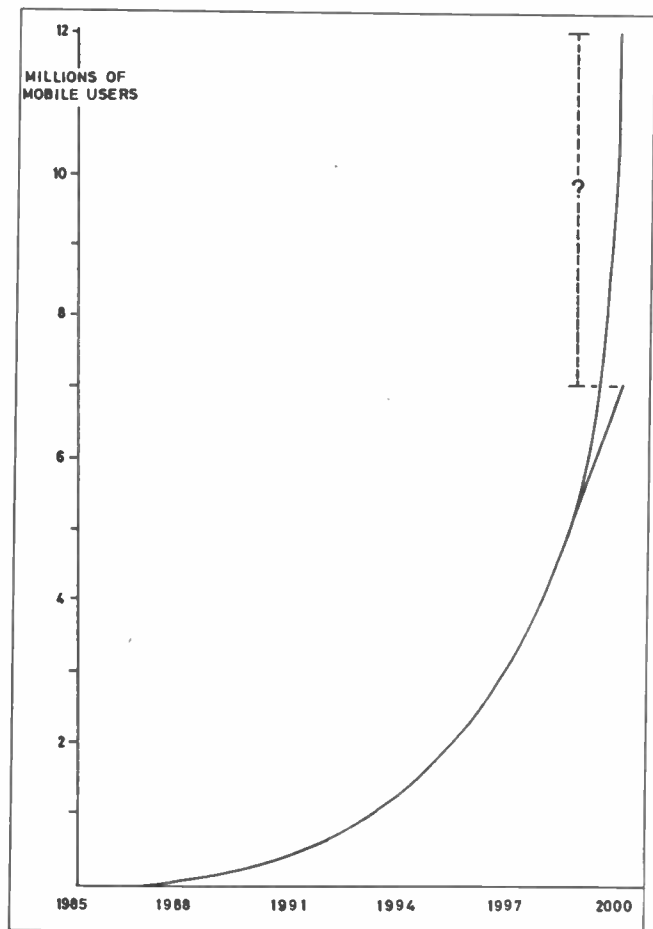

Fig. 1. How the increased use of mobile phones since 1985 is expected to rise by the year 2000.

of cells covering the whole country. As far as practicable, any mobile phone would be within the range of at least one cell. At present more than 98 per cent of the UK population is served by the analogue channels in this way.

In theory, signals should not extend beyond the boundary of the cell in which they are generated. However, this is impossible in practice and there is bound to be some overlap. If adjacent cells used the same frequencies, there would therefore be profound interference problems between them. To overcome this a *cell repeat pattern* is used. Fig. 2 shows one possible arrangement – the seven-cell pattern. Cells are represented by hexagons but this is only for the purpose of illustration.

Each cell in such a pattern will have at its disposal about 40 channels (i.e. the 300 allocated to the particular operator divided by seven). As a further safeguard against possible interference, adjacent cells do not share adjacent channels. In this way, the total channel allocation is recycled many times over throughout the nation by groups of such cell clusters.

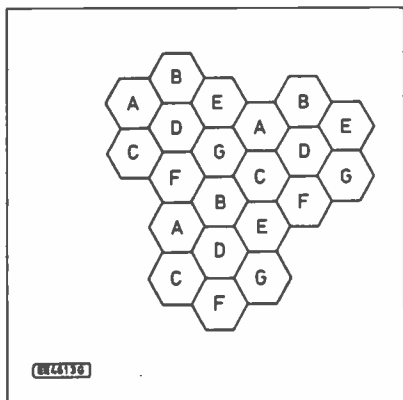

Fig. 2. 7-cell repeat pattern.

Cells are not all the same size because the distance over which they can effectively operate depends on the terrain. In the city, with tall buildings around, coverage will be small and there will be a need for many closely-spaced cells. Each will have a very low power output, perhaps 1W, and serve a 1km diameter circle. In rural areas, with fewer obstructions, cells will be made larger with a higher-power transmitter, perhaps 15W, serving a 20km circle.

There are twenty-one channels used as *control channels* and each base station will be allocated one of these. Control channels are used to send information to and from the mobile to monitor its status while idle (switched on but not actually in use). These also initiate a call and allocate the voice channel.

Additionally, there are two *guard channels*. These act as buffers between Vodafone and Cellnet frequencies to prevent possible interference. This provides 277 analogue speech channels for each network operator.

BRASS ETACS

More recently, the DTI has issued further frequencies adjoining the TACS allocation to cope with the ever increasing demand for the analogue service. These are called *extended channels* (ETACS). ETACS channels range from 872MHz to TACS at 890MHz (transmit) and 917MHz to TACS at 935MHz (receive). This provides an additional 320 channels for each operator.

ETACS channels are only used in certain urban areas and on major roads where the need for extra capacity is particularly important. Since ETACS is outside the normal TACS range, it can only be accessed by later equipment designed for its use. During the setting-up of a call, ETACS compatible equipment will be allocated an ETACS channel if one is available. If no such channel is free, a TACS one will be given instead. In this way, service is improved for all analogue mobiles.

The spectrum allocation including GSM, TACS and ETACS frequencies is shown in Fig. 3. It will be seen that the lower half of the frequency band is used for mobile to base communication and the top half for base to mobile. There is also a 2MHz gap (915MHz to 917MHz) between base station and mobile frequencies – a further guard against interference.

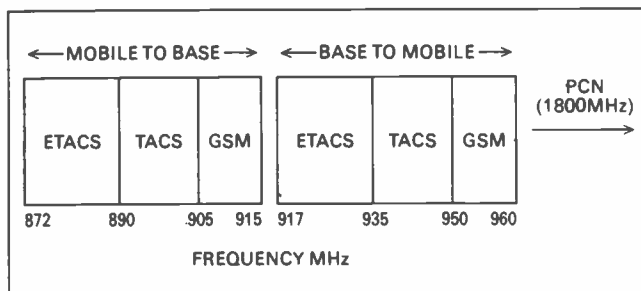
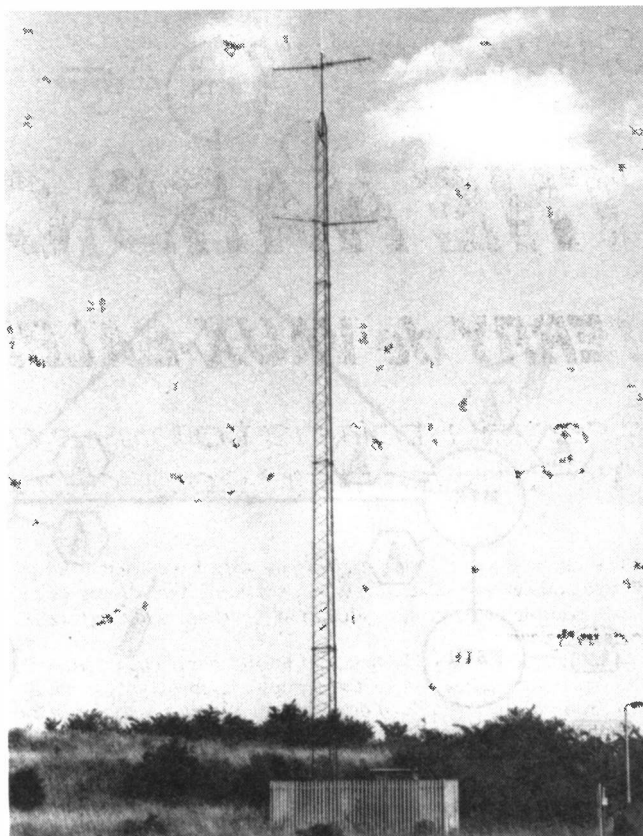

Fig. 3. Allocated frequency spectrum for the full mobile phone network.



Typical antenna mast in a rural area.

BASE STATION

Each base station has a set of aerials (antennas) together with transmitting and receiving equipment. In rural areas, a mast is generally used for the aerials (see photograph) but in towns they will be situated on tall buildings. Since communication is most effective over line-of-sight distances, mounting the aerial high will avoid the effects of intervening objects.

Depending on conditions and the need for selective coverage, some aerials will be omni-directional (covering the full 360 degrees) while others are directional covering perhaps 120 degrees. The transmitting and receiving equipment is sited in a small building or room beneath the aerial mast.

The base station is linked to a mobile telephone exchange (MTX) using conventional copper wire or fibre-optic cable. Although the radio section is *analogue*, this link is a *digital* one and often there will be two separate lines to each base station to guard against the failure of one. The line is provided by British Telecom or Mercury, being the only two fixed link operators.

The MTX is an electronic telephone exchange of the type used in the fixed network. One MTX has control over a number of base stations and all MTXs are interlinked to form a comprehensive grid covering the entire country. It is normal to operate two MTXs in parallel so that one can carry the total load in the event of the other failing.

The MTX sets up and connects calls. It also stores database information such as mobile identification numbers and any special features which the subscriber has paid for. The MTX also routes calls to operators who provide assistance, directory enquiries, etc. A simplified view of the system is shown in Fig. 4.

Each MTX is connected to the PSTN (Public Switched Telephone Network) operated by BT and Mercury. This means that mobiles can communicate with each other or to fixed telephones and vice-versa. One MTX can service many mobiles – for example, each Vodafone exchange can handle 60,000 units and more are added as the demand increases.

Whenever the mobile is switched on, it tunes to the strongest signal provided on a control channel (usually the one from the nearest base station). Before an outgoing call can be made, the MTX must "know" that the mobile is authorised to use it (that is, it is registered, has paid for the service and has not been disconnected for some reason).

This is carried out by two identification numbers. One is the actual telephone mobile number. The other is the ESN (Electronic Serial Number) which, on the analogue system, is a unique number programmed into the circuit.

When a call is made from the mobile, the telephone number to be called is entered on the keypad. The mobile number and ESN

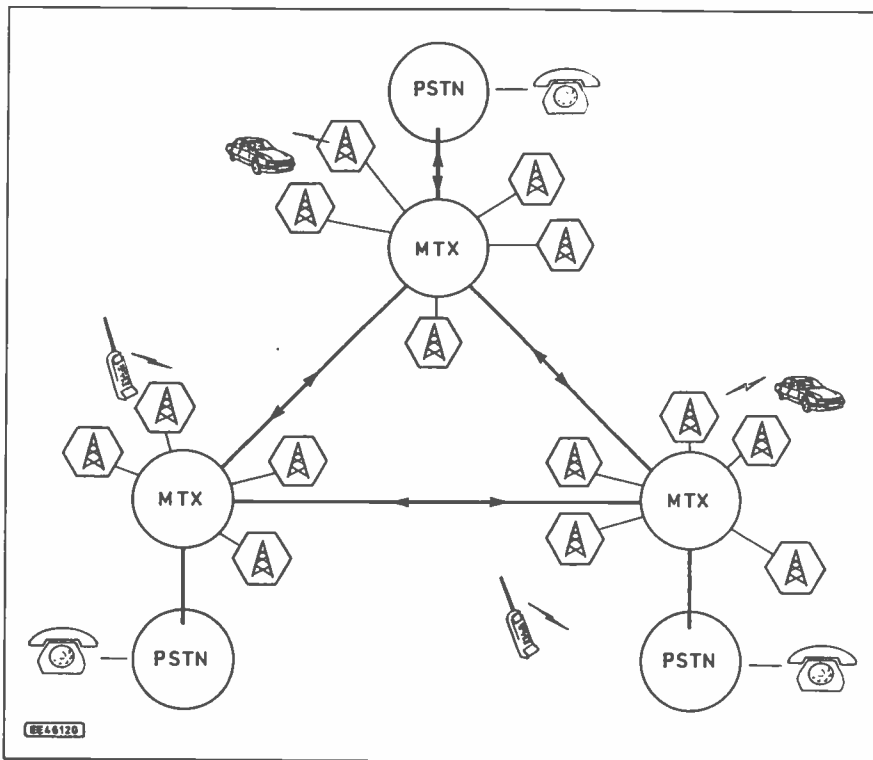

Fig. 4. How mobile telephone exchanges (MTX) are interlinked to form a comprehensive grid.

are automatically sent via the control channel to the MTX. The two numbers are then checked to ensure that they match, this takes about 350ms (a little over one-third of a second). A voice channel is then allocated (i.e. a pair of frequencies) and the call routed either to the PSTN or to another MTX and hence to another mobile.

If a Vodafone user wishes to make a call to a Cellnet subscriber or vice-versa, this was previously done by routing it via the PSTN. However, there is now a direct link between these two operators.

The output power of a mobile is controlled by the network. Each mobile unit has eight power settings and the MTX will select the most appropriate one according to distance and conditions.

THREE CATEGORIES

Whatever the manufacturer, all mobile equipment falls into one of three categories: *Mobile*, *Transportable* or *Hand Portable*. However, the term *mobile* is often used for any of these. The trend is towards the small hand-held variety and four out of five units now sold are of this type.

These are most versatile and can be carried virtually anywhere (but must not be used on aircraft, in petrol filling stations or in hospitals). Having the phone on the person also reduces the risk of theft. Generally, hand portables may be used hands-free in a car using a special kit.

The power output of a hand portable is generally only about 0.6W *e.r.p.* (effective radiated power) and in marginal signal strength areas the user may need to move around to achieve adequate communication. The prevailing signal strength (i.e. that received on the control channel) is shown on a display and is consulted before a call is made.

LOCAL GOSSIP

In the course of use, it is possible that the mobile will move from the management of one cell to another. The new cell will then take over and allocate a new channel. It is important that the system follows these changes at sufficient speed for the user to be unaware of it happening.

While the mobile is in use, adjacent base stations are checked to determine whether they will give a stronger signal. The moment this is so and, providing there is a free channel available, the instruction is relayed on the voice channel (not a control channel) to use the new one. This is all done in a fraction of a second.

All users should be aware that conversations made on analogue cellular networks are not secure. *Scanners* can tune in to the band of frequencies used for the service and rapidly check the spectrum pulling out the most powerful signals. Some people make a hobby out of this type of eavesdropping. Some may be mischief-makers – politicians and others in high office beware!

One of the disadvantages of owning a cellular phone is its desirability to the petty thief. The handheld variety is easily stolen

and quickly disposed of in a pub. Unfortunately, people tend to leave them in full view on the car parcel shelf, shop counter or similar place. There has even been some incidence of phone snatching in the street while it is being used.

As soon as the theft is discovered, the sensible user will inform the service provider (see *consumer advice* later) and the phone will be disconnected from the network. However, there may be some delay and the owner may be responsible for the cost of all calls made until then.

HAD THEIR CHIPS

Because the phone is easily disconnected, it may be thought that it is hardly worth stealing for the sake of a few calls. Unfortunately, it is a relatively simple job to change an analogue phone's ESN (and hence its identity) by a process known as "re-chipping". This is possible because the identification number is carried on an i.c. which can be replaced to provide a new number. The phone can then be sold on and re-connected to the network.

One particularly sneaky activity brought about by re-chipping is the fraudulent use of a customer's line without actually stealing the handset. This is done by using a little detective work to find out the genuine ESN. Another phone is then "cloned" by re-chipping with the same number. Phantom calls then turn up on the legitimate account holder's bill.

The network operators are aware of this and the problem is much less prevalent than it used to be. Computer programs oversee the system. If a phone appears to be making calls in two places at once or being used in widely different places with only a few minutes between, there is clearly a cloning problem and an alert is signalled. Digital phones overcome the problem by having the ESN on a smartcard which is removed from the handset when it is not in use. More will be said about this presently.

DIGITAL COMMUNICATIONS

The foregoing has been concerned with *analogue* cellular networks. These are still the workhorse of mobile communications in the UK and are expected to remain so until at least 1996. However, digital services are catching on fast and are gradually displacing the analogue ones.

Even so, much of what has been said is true for the new digital systems. In fact, there is a great deal of digital technology used in the operation of an analogue network. At the moment, most customers are buying analogue phones and these are perfectly adequate for day-to-day business and social use within the UK. Such users can be assured that the service will be available for many years – at least until 2015.

The defunct Hutchison Telecom *Rabbit* was an early *digital* system. This allowed for outgoing calls within a radius of some 100 metres of a base station. A network of such base stations were set up at garages, underground stations, banks and similar key locations where the Rabbit logo is still to be seen. It seemed like a good idea at the time but without blanket coverage, and with only outgoing calls possible, there proved to be insufficient appeal.

Of the present digital services, there are two families of equipment – GSM (mentioned earlier) which operates on frequencies adjoining those used for the analogue networks and PCN (personal communications system) which operates on a higher frequency range, around 1800MHz. Digital systems provide better sound quality, but this is not in itself very important. Analogue sound quality is as good as it needs to be. GSM was intended to provide uniformity.

The analogue systems being used in various countries operate to different standards and this can be a problem. Travelling businessmen needed to hire handsets and be connected to each national network on passing from one country to another. GSM removes this need and provides a standardised service. With GSM, there can be one phone number and one bill wherever calls are made. It will only be necessary to have the correct service agreement between the participating national networks.

An advantage of a digital system is that encryption is simple and this can make the conversation totally secure. By using a *Subscriber Identity Module* (SIM) card, security is greatly im-

proved. This card carries the ESN and other customer details. When the phone is used, the SIM is inserted and without this the phone is useless. By carrying the card on the person, theft of the phone is pointless.

By the end of 1993, all forms of cellular phones were available in GSM format – hand portables, car phones and transportables. GSM has a claimed UK coverage of 90 per cent. It will eventually span Europe and, ultimately, the whole world – at least, that is the dream. GSM followed the 1983 *Memorandum of Understanding* and is based on a European standard agreed between 22 operators in 19 countries.

The first GSM service in the UK was provided – albeit in a restricted service – by Vodafone in December 1991, with Mercury adding its own GSM offering *Eurodigital* in Autumn 1993. Cellnet's GSM came on stream in July 1994.

Other countries with GSM networks operating are Germany, Italy, Greece, Denmark, Sweden, Switzerland, Austria, Belgium and Norway. Luxembourg, France, Ireland, Portugal and Spain also became operational during 1994.

However, users report that many of these services are very fragmented. This is because, while analogue systems are well-established and have grown to provide excellent coverage, digital ones begin by covering major urban areas and follow with the less popular ones.

JUICY ORANGE

Personal Communication Networks came about from the Government's invitation in 1989 to apply for PCN operators' licences. PCN phones operate in conjunction with a SIM card which stores more personal information than with GSM – details of special services requested, etc.

PCN networks offer many optional services and potential customers will need to look carefully at those available to find the product which suits his or her needs best. They are far too numerous to be discussed in detail here.

Many of the services are free or provided at a reduced price compared with the analogue systems. Choosing a mix of such services can customise the phone to the individual's requirements. Unfortunately, detailed information about PCN services is changing so rapidly that several suppliers will probably need to be asked to be sure of obtaining correct and unbiased information.

The first PCN service to come on stream in the UK was Mercury *One-2-One* in Autumn 1993. With handsets manufactured by Siemens, Motorola and NEC the network originally extended to the boundaries of the M25 and was targeted at business users in London. Mercury is extending the service – the intention is to cover the South East and eventually become nationwide by the



The Nokia Orange phone which works exclusively with the Orange service from Hutchison Telecom.

late 90s. One-2-One had approximately 100,000 subscribers in late 1993 and coverage is about 24 per cent of the UK population at the time of writing.

Recently, Hutchison Telecom (UK) – owned by Hong Kong based Hutchison Whampoa (65 per cent), British Aerospace (30 per cent) and Barclays (5 per cent) – have announced their *Orange PCN* network with phones manufactured by Nokia (*Orange Phone*) and Motorola (*MRI*) now available in High Street stores such as Dixons, Currys, Rumbelows and Hutchison outlets. Some readers may have been mystified by the rather cryptic *Orange* advertising in the media. At the time of writing, the network covers over 65 per cent of the UK population (about 35 million) and was expected to be ahead of its target of 70 per cent (40 million) by the end of 1994 and 90 per cent (50 million) by mid-1995. The Nokia *Orange Phone* offers a two-line service whereby the same phone can have two numbers and two separate accounts – perhaps to separate private and business use. *Orange* charging is made by the second rather than the minute or half-minute as is the tradition with the analogue networks.

PCN systems are already well advanced in the UK but less well so in other countries. For reasonable European coverage GSM is therefore the preferred choice. At the time of writing, PCN networks were also operating in Germany and Thailand. Italy and France are scheduled to follow in the near future.

THE CELLULAR ROAD

Britain is fortunate in having had a comprehensive fixed telephone network for many years. Mobile systems are therefore seen as complementing the existing one.

This is not the case in certain other countries. These still use antiquated analogue equipment (sometimes a hand-me-down from a country going digital) and there may be no service at all outside the main urban areas. For such places, the direct jump to cellular can improve the country's infrastructure and provide the main service at minimum cost.

CONSUMER ADVICE

The unparalleled growth in mobile communications has come about by making a desirable product affordable to the masses. Even so, the best piece of advice is to ask yourself – do you *really* need a mobile phone? Is it just to impress your friends? Is it wanted merely as a status symbol?

Women who regularly travel at night will certainly find peace of mind in owning one. If you do decide to buy a cellular phone, look around and compare true costs. Perhaps you can wait for another year or so to allow the digital networks to increase their coverage.

Remember, you are buying a complete package (connection to a particular system, cost of monthly line rental, tariff, etc.) – not simply the purchase of a piece of hardware. There may be incentives such as free connection, free off-peak calls for a certain period, cashback schemes, etc. and these will change from time to time.

For general social and business use within the UK, you are likely to be advised to use the established analogue system offered by Cellnet or Vodafone. Cellnet is the UK's largest analogue network operator with over 1000 cell sites and about 750,000 subscribers making three million calls each day. They also have exclusive coverage of the Isle of Man and Channel Islands which may be important to some users.

There may be local weak spots on one system or the other and advice should be taken on this point. However, intense competition has led to there being little to choose between the two operators.

There is a bewildering range of tariffs and the user will need to look carefully for the one which suits his or her needs best. Some offer a lower fixed monthly charge but a higher call charge (low user rate). Others offer a higher charge and a lower rate per call (business rate).

There will be variations in the cost of peak and off-peak calls. Certain services may be requested such as three-way conversations, a facility for recording incoming messages while the user's phone is switched off, etc. There may be other options such as call diversion and international facilities.

POWER INSURANCE

Hand portables often have various battery options which allow different periods of use before the need for recharging. For some users this may be an important consideration. A typical nickel-cadmium battery pack will provide between 10 and 22 hours of standby use. While actually talking, the time is greatly reduced – to about 60 and 120 minutes respectively.

Usually a larger capacity nickel cadmium pack is available and a nickel hydride option, if available, will extend the time still further. A fast mains or car cigar lighter charger can restore the battery in

about 30 minutes. The standard "desktop" mains unit supplied with the phone may take around eight to 10 hours to charge the standard battery.

Remember to include insurance in your costs. That "£49" phone may be really worth £350. Profits will be made from the services you use and these will soon pay for the discounted hardware. However, the true price will have to be paid to replace the phone if it is lost or stolen. Your household insurance company may not be keen to include a mobile phone on your existing policy but it is worth asking.

It must be remembered that there is no local area service on the popular cellular systems. Calls to the BT or Mercury network are charged at the same rate regardless of distance and only depending on whether the time is peak or off-peak and the tariff selected. Thus, the full STD code must be entered each time even if the called party is just around the corner. Generally, calls are not charged for unless they are answered but, of course, "answering" includes any recorded message.

Users need to keep an eye on their itemised bills, however, since there have been reported errors. These are generally overseas calls made via old-technology fixed telephone exchanges at the distant end. These have been known to signal back a fee when the call was unsuccessful. Note that BT subscribers make calls to the mobile network at the "M" rate.

POWER TO THE PEOPLE

The dealer will use a *Licensed Service Provider* (or the shop may be a member of a chain owned by a service provider) who will access the network. The service provider will deal with all the day-to-day customer services such as billing and general enquiries. A contract will be signed to provide service for, say, one year at a certain monthly rate.

The Service Provider will enter the Mobile Number and ESN on to a terminal and data regarding any special services which the subscriber needs such as those mentioned previously. The information will be taken up by the network operator and programmed into the MTX. Note that not all special services are

available on all tariffs. For example, international calls may be barred. With luck, the mobile will be on-air before leaving the shop.

Peoples Phone is one of the UK's most well-known independent service providers supplying 10 per cent of new cellular customers with their airtime. Peoples Phone have more than 110,000 customers and a total turnover in excess of 100 million. Over the last six months alone, they have spent more than £5M on improvements and new equipment. With 60 High Street retail outlets throughout the UK, Peoples Phone has the second largest nationwide chain after the BT shops.

CRYSTAL BALL

It is fanciful to imagine that every spot on earth could be covered by a cellular network. What about travellers in the remote desert, the arctic, the Australian bush or the middle of the ocean? A satellite service could be the answer. The proposed system (the *Iridium* project being developed by Motorola in Phoenix, Arizona) involves placing rings of satellites around earth.

The signal from the phone would be passed to the nearest satellite and from there, it would hop from one to another until it lay above its destination. It would then pass to a ground station and be distributed via the national fixed or cellular network. Dual-use phones could switch automatically between cellular to satellite modes as required. Large sums of money have already been spent and pledged for development work.

Many of us now have several different telephone handsets. One is the familiar one for the fixed network. The second is a cordless telephone which is handy when gardening or working in the garage. This operates over a range of 100 metres or so from a base station situated in the house. There may also be a cellular handset in its various analogue and digital forms.

In the future, these may be integrated so that one handset provides all functions. It may also be that mobile costs fall in line with those on the fixed network with a single bill provided for all services.

Do you still want that mobile phone?

OMNI ELECTRONICS

174 Dalkeith Road, Edinburgh EH16 5DX ★ 031 667 2611

The supplier to use if you're looking for:-

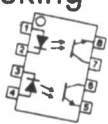
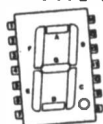

A WIDE RANGE OF

★ COMPONENTS AIMED AT THE ★
HOBBYIST



★ COMPETITIVE VAT INCLUSIVE ★
PRICES



★ MAIL ORDER – generally by ★
RETURN OF POST



★ FRIENDLY SERVICE ★



OPEN:

Monday-Thursday 9.15 - 6.00

Friday 9.15-5.00

Saturday 9.30-5.00



A SAMPLING OSCILLOSCOPE AND LOGIC ANALYSER

IN AN AFFORDABLE PORTABLE PACKAGE

- 10 Mega samples per second single channel DSO
- 1MHz analogue bandwidth
- 0.2V-50V input range
- Various Triggering options
- 10 Mega samples per second 8-channel logic analyser
- 5V TTL/4.5-15V CMOS logic level inputs
- Crisp, clear LCD screen
- Zoom and Scroll facilities (selected range only)
- Battery or mains adapter powered
- 12 Months Warranty (Built version only)
- "Get you working" service (kits only)

The Miniscope



MINISCOPE KIT £139

MINISCOPE BUILT £179

MAINS PSU £6 P&P £6

PLEASE ADD VAT AT 17.5%

Write or phone for a **FREE** Information Pack to:

AUDON AUDON ELECTRONICS

36 Attenborough Lane, Chilwell, Nottingham NG9 5JW

☎ 0115 9259737

BTEC
Certificated



TUTOR
Supported

N A T I O N A L
C O L L E G E O F
T E C H N O L O G Y

DISTANCE LEARNING COURSES

The National College of Technology offer a range of packaged learning short courses for study at home or in an industrial training environment which carry modular BTEC awards leading to a higher BTEC certificate. Study can commence at any time and at any level enabling you to create a study routine to fit around existing commitments. Courses on offer include:

Analogue Electronics
Digital Electronics
Fibre/Optoelectronics
Mechanics & Mechanisms
Programmable Logic Controllers
Electronic Testing & Fault Diagnosis

Tutor support and BTEC certification are available as options with no travelling or college attendance required. These very popular courses which are ideal for vocational training contain workbooks, audio cassette lecturates, PCB's, instruments, tools, components and leads as necessary to support the theoretical and practical training. Whether you are a newcomer to electronics or have some experience and simply need an update or certification, there is probably a distance learning course ready for you. Write or telephone for details to:

National College of Technology
NCT Ltd., PO Box 11
Wendover, Bucks
Tel: (0296) 624270

LÔÖKING FOR...

ICs ★
TRANSISTORS ★ SEMIs?
especially those hard to find?
Why not give us a buzz?

WE STOCK A MASSIVE RANGE

We specialise in devices with the following prefix
(to name but a few):

**2N 2SA 2SB 2SC 2SD 2SJ 2SK AN BA BC BD BDT BF
BFR BFY BFX BU BUK BUT BUV BUW BUZ CA DTA
HA IRF LA LB LC LFLM M MC MJ MJE MM MPS
MPSA MPSU NE RC SAA SAB SDA SI SL SN STA
STK STR TA TBA TC TDA TIP TEA TL UAA ULN UPC
XR ZN ZTX ... plus daily arrival of new numbers.**

ALSO

**RESISTORS ★ CAPACITORS ★ CHOKES ★ CABLES
LEADS ★ CONNECTORS ★ VIDEO HEADS ★ DRIVE BELTS
SWITCHES ★ TTL ★ CMOS ★ OP AMPS ★ VOLTAGE REGS
SPECIAL FUNCTION ★ TRANSFORMERS ETC ETC ETC**

**WE SPECIALISE IN PHONE & FAX MAIL ORDERS
BY CREDIT CARD**



Callers & Mail orders welcome



CRICKLEWOOD ELECTRONICS

40 CRICKLEWOOD BROADWAY, LONDON NW2 3ET
TEL: 081 452 0161 & 081 450 0995 FAX: 081 208 1441

!!! FULLY ILLUSTRATED CATALOGUE AVAILABLE !!!

New Kits from Cirkit



RX Board

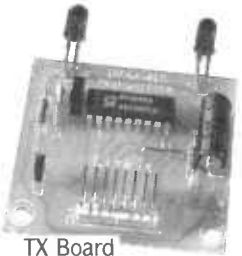

TX Board

IR Remote Control System

A complete Infra Red remote control system with a wide choice of outputs, both relay and transistor, configured for maximum flexibility for control of external systems.

- ▶ 5 relay outputs (mains rated)
- ▶ 3 transistor outputs (open collector)
- ▶ RX and TX boards available separately
- ▶ Ideal for use around the home
- ▶ 12 independent codes
- ▶ Range: 15m (approx)

IR Remote RX	41-05002	£13.20
IR Remote TX	41-05000	£9.10
Remote TX Case Kit	41-05001	£19.98
IR Control Board	41-05003	£15.99
Control Board Case Kit	41-05004	£8.99

Breath Alcohol Tester

Enjoy and have fun at parties with this interesting project giving indication of the amount of Alcohol on your breath.

N.B. The results from this tester must not be taken as proof of your fitness to drive a vehicle.

- ▶ LED indication of OK, caution and danger
- ▶ Components, case, tube, fitting and full instructions

41-05008
£37.99



Logic Chiptester

- ▶ Test those salvaged stocks of IC's (TTL & CMOS) provided they are less than 24 pins and operate from a 5V supply.
- ▶ IBM PC compatible
- ▶ Create test parameters
- ▶ PCB, components, software and comprehensive instructions

41-05022
£59.90



IR Stereo Headphones

- ▶ Keep those neighbours friendly and get rid of those unwanted leads with this useful project for all Hi-Fi buffs.
- ▶ No test equipment needed
- ▶ Excellent stereo sound
- ▶ TX and RX available separately

IR TX	41-05025	£25.75
IR RX	41-05024	£32.50

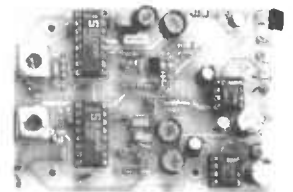

Full details of all the above are included in our comprehensive catalogue, £1.95 (plus 30p p&p)
All the above are currently in stock and available for immediate delivery. Standard p&p £1.50, next day delivery £5.29 (UK Mainland).

Cirkit

All prices include VAT (at 17.5%)



Cirkit Distribution Ltd

Park Lane · Broxbourne · Hertfordshire · EN10 7NQ
Telephone (01992) 448899 · Fax (01992) 471314

INTERFACE

Robert Penfold



THE TWO previous *Interface* articles covered the use of a PC printer port as a general purpose digital input/output port. This month we progress to the use of the printer port as an 8-bit analogue input/output port.

As the printer port has eight output lines as standard, and can provide eight input lines with the addition of the circuit described in the February issue, it is possible to have both analogue-to-digital and digital-to-analogue converters working simultaneously on this port. Of course, many applications only require one or other of these converters, but where both are needed the printer port handles the task remarkably well.

Analogue Output

Digital to analogue conversion is a more simple prospect than a conversion in the opposite direction. Interfacing this type of converter to a computer is usually very straightforward as there is little or no "handshaking" to contend with.

In this case the printer port provides eight latching outputs, and no handshaking at all is required. The values for the converter are simply written to the data lines of the printer port at address &H278 (LPT2) or &H378 (LPT1), and the converter produces the appropriate output voltage.

The only point that has to be kept in mind is that the converter will take a short time to adjust to each new value. In most cases the adjustment time is quite short, and is typically only a microsecond or two. Of course, any amplifiers, filters, or other stages that process the output of the converter are likely to extend this "settling" time.

Where eight latching outputs are available the Ferranti ZN426E probably represents the simplest means of providing an analogue output. Fig. 1 shows the circuit diagram for a PC analogue output port based on this chip.

The full scale output voltage is equal to the reference voltage fed to pin 5. This terminal can be fed from an external reference voltage of up to 3V, but in most cases the built-in 2.55V reference is perfectly adequate. In fact, the built-in reference voltage generator is a high quality type that is not easily bettered. R1 is the discrete load resistor for the voltage source, and C1 is its decoupling capacitor.

Output Voltage

The output voltage from IC1 (in volts) is equal to the value written to the printer port multiplied by 0.01. For example, a value of 147 would provide an output potential of 1.47V ($147 \times 0.01 = 1.47$).

In most practical applications this output voltage range will have to be modified using an amplifier or an attenuator. In virtually all

cases it will be a small amount of amplification that is required. This is the purpose of IC2, which also provides output buffering.

The non-inverting mode amplifier IC2 can have its closed loop voltage gain varied from unity to about 11 times by means of preset VR2. Maximum voltage gain is obtained with VR2's wiper at the bottom end of the track. Theoretically, maximum output voltages of between 2.55V and 28V can be achieved.

However, the maximum output voltage of IC2 is about 2V less than its supply potential, or about 3V if it is powered from a 5V supply. Therefore, maximum output voltages of more than 3V require IC2 to be powered from a higher supply potential of up to about 30V. This means using a separate supply for IC2, since the converter circuit must be powered from a 5V supply.

Preset potentiometer VR1 is the offset null control for IC1. This is only really needed if IC2 is used with VR2 set towards maximum gain, and a high degree of precision is required. Otherwise, it can simply be omitted.

If preset VR1 is included, the best way to find the correct setting is to first write a low value to the port, and adjust VR1 for the correct output voltage. Then write a high value to the port and adjust VR2 for the appropriate output voltage. Repeat this process a few times until no further adjustment is needed.

If VR1 is omitted, write a value of 255 to the port and then adjust VR2 for the required maximum output voltage. Reasonable accuracy should then be obtained over the full range of output voltages. The current consumption of the analogue input circuit is about 8mA, incidentally.

Writing to the port is very easy, and using GW BASIC it is just a matter of writing the values to the appropriate address using the OUT command. For example, "OUT &H378,123" would write a value of 123 to a digital-to-analogue converter connected to printer port LPT1.

Analogue Input

The circuit diagram for the analogue-to-digital converter is shown in Fig. 2. This is based on the Ferranti ZN448E, or the virtually identical ZN447E and ZN449E. The only difference between these three devices is their guaranteed accuracy.

The ZN448E is the most widely available version, and its accuracy of 0.5 l.s.b. (least significant bit) is good enough for virtually all practical applications. The ZN447E has a higher accuracy figure of 0.25 l.s.b., but tends to be quite expensive and is over-specified for most purposes. Although the least accurate of the three, the budget ZN449E is adequate for many applications, and it is relatively cheap if you can locate a source of supply.

These chips are successive approximation converters having built-in clock oscillators. The only discrete component required for the clock oscillator is a timing capacitor (C2). The specified value sets the clock frequency at a little under the maximum usable clock frequency of 1MHz.

In practice these chips invariably seem to perform properly with the clock oscillator operating well in excess of 1MHz. However, since only nine clock cycles are needed in order to complete a conversion, some 100,000 conversions per second are possible with the clock frequency at about 0.9MHz. Few real-world applications require a sampling rate as high as this.

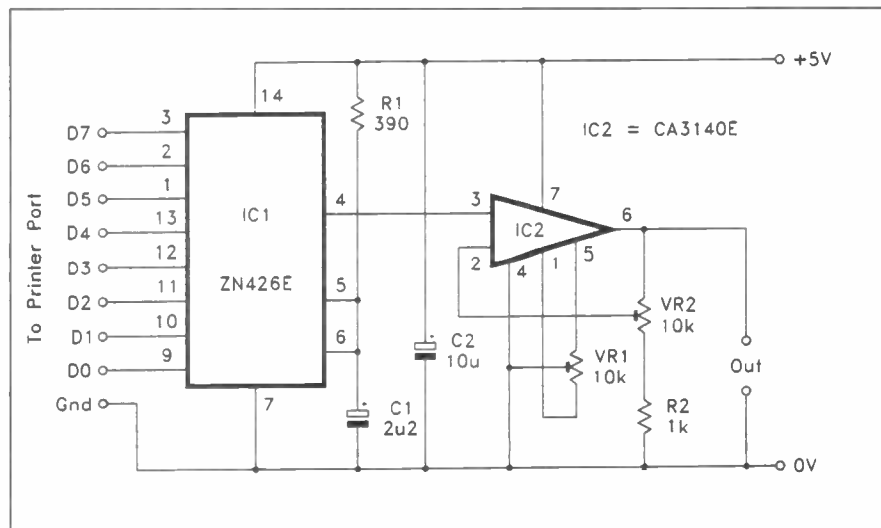

Fig. 1. The PC printer port D/A converter circuit diagram.

Voltage Generator

The full scale voltage is set by a reference potential, and like the ZN426E, the ZN448E has an integral 2.55V reference generator. This has R1 and C1 as its load resistor and decoupling capacitor. R2 is the "tail" resistor in the comparator stage at the input of the converter, and it must be driven from a negative supply rail.

If a suitable supply rail is not available it is possible to generate one using a couple of trigger/inverters in the circuit shown in Fig. 3. The PC input port (Fig. 2 EPE March 1995) uses one inverter from a 74LS14 package, and the negative supply generator can conveniently be based on two of the five unused sections of this device. Note that this circuit produces a negative output potential of just 3V, which requires the value of resistor R2 in the converter circuit to be reduced to a value of 47 kilohms.

Input Voltage

An input voltage in the range 0V to 2.55V can be applied direct to the analogue input at pin 6 of IC1 (Fig. 2), but this is not the recommended way of doing things. There is a small input offset voltage that will slightly reduce accuracy at low input voltages unless it is trimmed out.

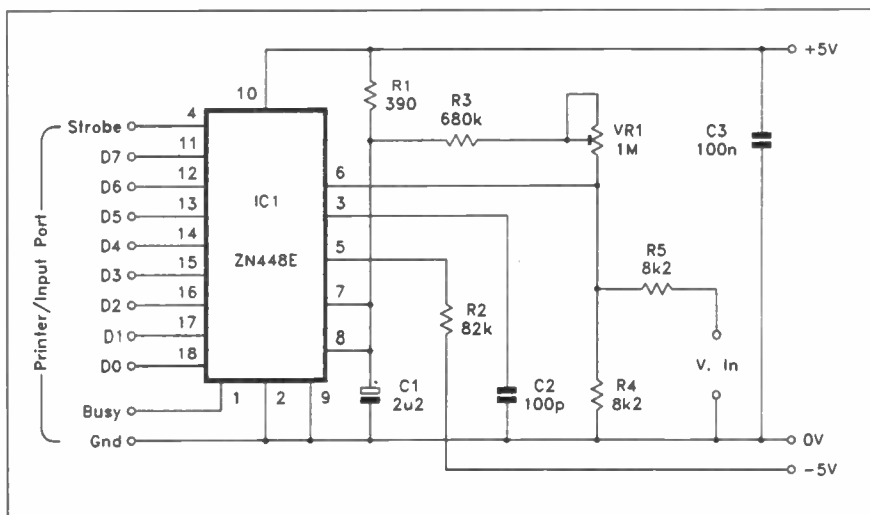

Fig. 2. Circuit diagram for the printer port A/D converter.

This offset can be nulled by applying a minute positive bias to the input signal. This is achieved by applying the input voltage to IC1 via a potential divider, and then using a resistance from the output of the reference source to the input of IC1 to provide the offset bias.

In this case resistors R4 and R5 act as a potential divider which attenuates the input signal by 50 per cent. This gives a full scale value of 5.1V. Resistor R3 and preset VR1 provide the positive offset bias, and VR1 is adjusted for optimum accuracy at low input voltages.

Obviously other full scale voltages can be obtained by using suitable values for R4 and R5, but the parallel resistance of these two resistors must be about 4 kilohm or it may not be possible to obtain a suitable offset voltage using VR1. In many practical applications R4 or R5 will have to be a preset resistor so that the full scale input voltage can be trimmed to precisely the required figure.

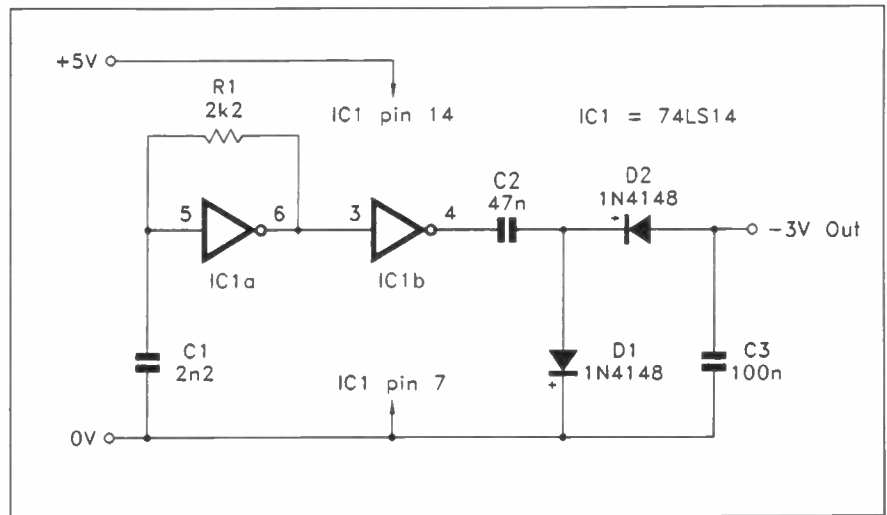

Fig. 3 The simple negative supply generator circuit diagram.

The ZN448E has tristate outputs, but this facility is not required here. Pin 2 is connected to the 0V rail so that the data outputs of IC1 are permanently enabled. These lines feed into the eight input lines of the add-on circuit featured in the February 1995 Interface article.

Pin 1 of IC4 goes high when the conversion has been completed, and this line can be monitored using the printer port's "busy" input. A software loop is then used to provide a hold-off until the conversion has been completed.

As the length of time taken for each conversion is constant at about 10 microseconds, it is possible to simply use a timing loop to prevent the port from being read prematurely. This is my preferred approach, as it leaves the "busy" handshake line free for other purposes. Of course, with a relatively slow language such as an interpreted BASIC there is no need to worry about a hold-off. Each conversion will be completed long before the program moves on to the routine that reads the port.

The following GW BASIC routine will read the analogue input port and write the returned value on the screen. It is basically just the same routine that is used to read the 8-bit input port, but line 5 has been added to provide a start conversion pulse on the "strobe" line. Bear in mind that the "strobe" line is inverted, so a value of 1 (not 0) is needed to set it low.

```

5 OUT &H37A,1
10 OUT &H37A,0
20 X = INP(&H379) AND 120
30 X = X/8
40 OUT &H37A,4
50 Y = INP(&H379) AND 120
60 Y = Y * 2
70 Z = X + Y
80 PRINT Z

```

**APPEARING
NEXT MONTH
DO-IT-YOURSELF
PIC-DATS
MICROCONTROLLER
DEVELOPMENT and
TRAINING SYSTEM**

THE NAME OF THE GAME COUNTERSPIN



ROY BEBBINGTON

PART 2

THE Name of the Game is a series of electronics projects based on party games or TV quiz games. Featuring something old, something new, there are electronic versions of popular, well-established TV games such as *Countdown* and *Catchword* with alphanumeric

displays, new games employing electronic word-making, and games of skill.

Accessories, used in various games, such as an interval timer, an electronic dice, a precedence switch, a heads/tails unit, are the subjects of later constructional articles.

COUNTERSPIN is an electronic selector for the numbers game of the popular TV quiz *Countdown*. In addition, it can be used for other games that need random number selection, or as a 0-999 counter. It features decade counters driving up to three 7-segment l.e.d. displays. By switch selection the displays are capable of randomly displaying:

- small number up to nine
- selection of four large numbers (25, 50, 75, 100)
- target number up to 999
- count number from 0 to 999 for timing purposes.

COUNTDOWN PRINCIPLE

In the TV game of *Countdown*, apart from the target number, all the numbers are selected by cards. However, *Counterspin*, as presented here, selects all numbers automatically using electronic counters. For those unfamiliar with the TV game, here are the general rules:

A contestant generally has a random selection of one large number (25, 50, 75, or 100) and five small numbers (one to nine). A target number is then selected by a counter. Any or all of the selected large and small numbers can then be added, subtracted, multiplied or divided in an attempt to obtain the target number, or as close to it as possible.

Contestants write down the large and small numbers as they appear, and then make their calculation. After a given time limit (say 30 seconds) a quizmaster ascertains whether they have achieved the target number, and the contestant with the nearest result shows how it was obtained. Scoring could be five points on target, reducing by the difference number for the player nearest to the target, e.g. four away from the target number could earn the winner one point.

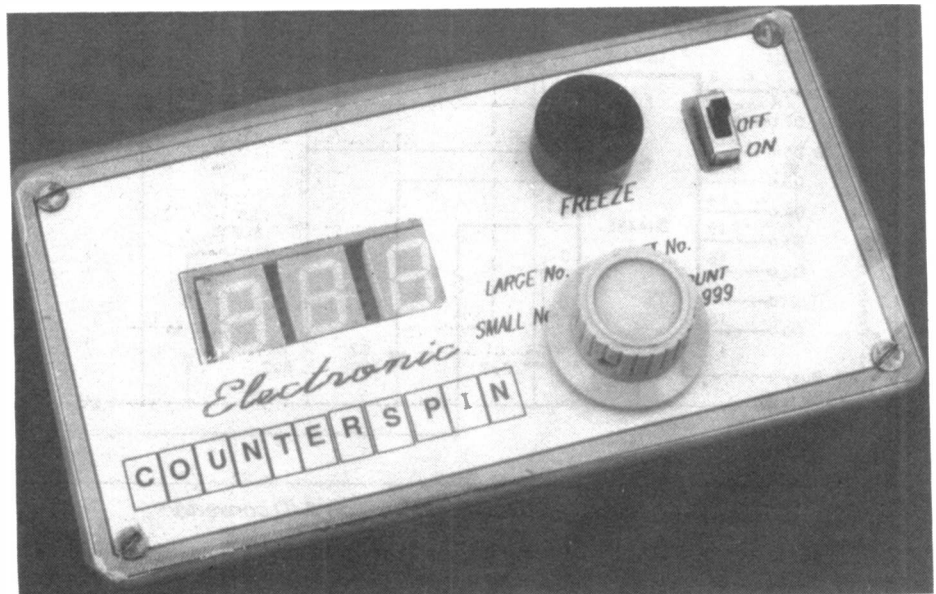

FRONT PANEL DISPLAY

The front panel, as shown in the photograph, houses the three 7-segment l.e.d. displays (X1, X2, X3 in Fig. 1), which serve as dual-purpose indicators for the two decade counters. The rotary *Select* switch, (S1), performs various functions. It *selects* the four number modes (Small, Large, Target and Count), and also switches the display constantly on in the *Count* position.

The right-hand on/off switch (S3) controls the +9V battery supply. In the *on* position the supply is connected to the clock generator and, depending on the position of the *Select* switch (S1), either the large number counter or the random number counter is also powered. To conserve battery power, although the clock pulses are activating the counters, the displays are inhibited (except in the count position) until a number is selected by the *Freeze* pushbutton switch (S2).

MODE SELECT

Switch S1 provides four switchable modes, as follows:

Small Number (S): counter IC5 in operation giving numbers between zero and nine when switch S2 is pressed. A zero can be ignored and another selection made if agreed.

Large Number (L): counter IC2 in operation giving numbers 25, 50, 75 or 100 when switch S2 is pressed.

Target Number (T): counters IC3 to IC5 in operation giving numbers from zero to 999 when switch S2 is pressed.

Count 0-999 (C): counters IC3 to IC5 in operation and a count number of up to 999 is displayed. The count can be started at zero by switching S3 off and then on again, and it can be stopped momentarily by pressing the *Freeze* pushbutton switch S2. When S2 is released, the count will continue from where it was interrupted, unless reset by the on/off switch.

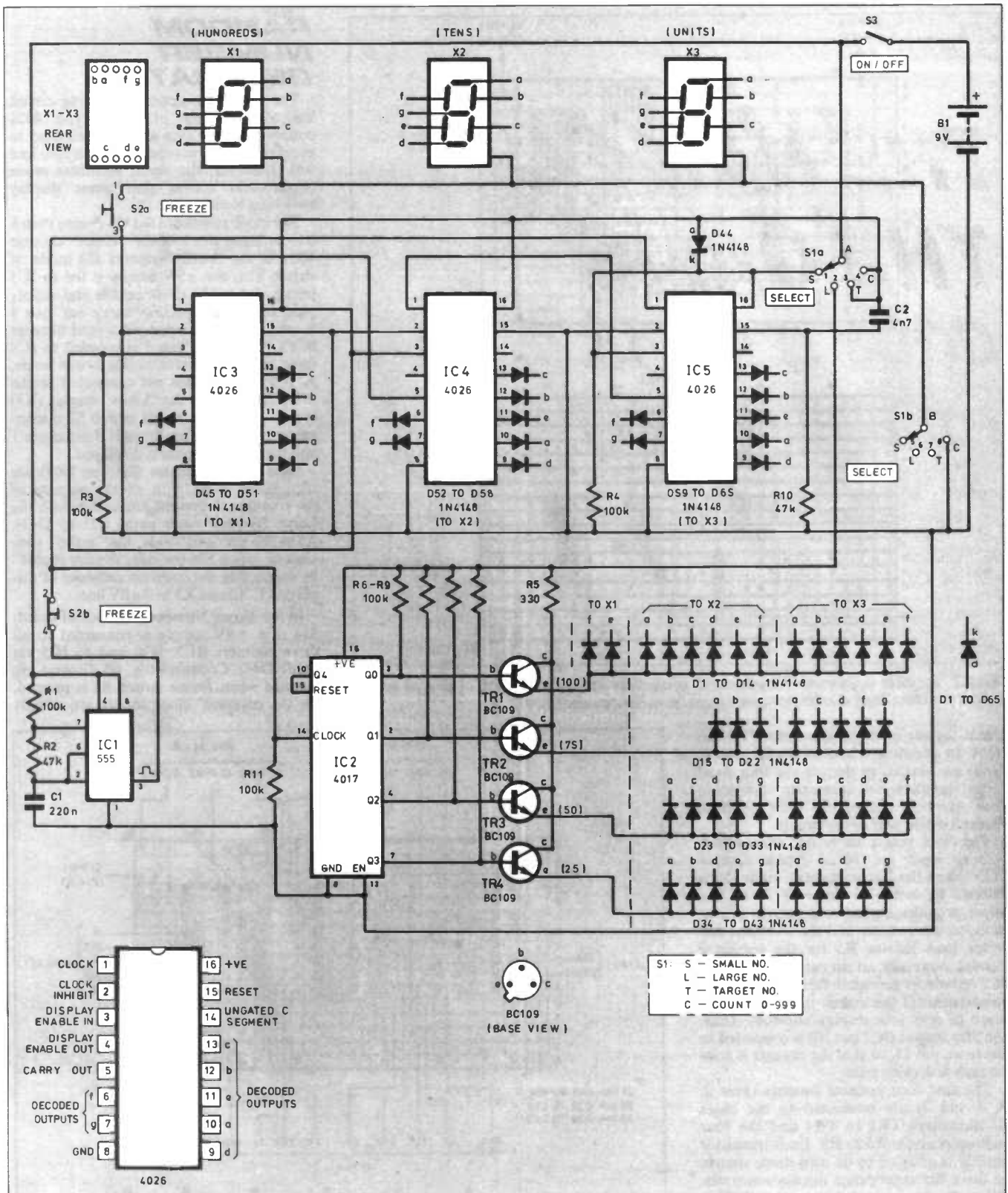

Fig. 1. Circuit diagram for the Counterspin games unit.

COUNTERSPIN CIRCUIT

The circuit diagram for the *Counterspin* unit is shown in Fig.1. Basically, it consists of three stages, namely, a clock generator (IC1) using a 555 timer to supply timing pulses for two counter arrays: a type 4017 counter (IC2) for the four large numbers, and three 4026 type counter-decoders (IC3 to IC5) for the small numbers, the target number and the zero to 999 count facility.

The clock pulses are supplied by the 555 timer, IC1, which is connected as an astable multivibrator. When the supply is switched

on by S3, pulses are present on IC1 output pin 3 at a frequency dependent on the values of resistors R1, R2 and capacitor C2.

For the values shown, the rate is about thirty pulses per second (30Hz), but this can be varied, if necessary, to suit individual requirements. For instance, for the count zero to 999 facility, resistor R1 could be replaced by a 500 kilohm panel mounting potentiometer, and capacitor C1 increased in value to about 2µ. The clock rate potentiometer could then be calibrated to give ten counts per second. The counter would then represent a total count-time of $999 \times 0.1 = 99$ seconds.

The output pulses available from IC1 pin 3 are fed to the break contacts of the *Freeze* push-button switch S2b, the output side of which is connected to the clock inputs of counters IC2 and IC5.

LARGE NUMBER COUNTER

Unlike the outputs of the 4026 counter-decoder chips, the outputs of the 4017 counter chip used to select one of the four large numbers must not sink or source a current exceeding 10mA and so cannot directly drive the 7-segment l.e.d. displays;

RANDOM NUMBER GENERATOR

The random number generating circuit basically consists of three type 4026 counter-decoder i.c.s serially connected to generate display numbers between zero and 999. However, the Small Numbers mode requirement means that some display switching is necessary.

The clock pulses are fed via Freeze switch S2b to input pin 1 of the "Units" counter IC5. In the Small Numbers (S) mode of switch S1a, the +9V supply is fed to IC5 pins 3 and 16, its clock enable and supply pins, respectively. IC5's "carry out" pin 5 is coupled to IC4 input pin 1 (and likewise IC4's "carry out" pin 5 is coupled to IC3 input pin 1). However, in this switch mode, as IC3 and IC4 are not connected to the +9V supply, only the "Units" display (X3) is active. Pressing Freeze switch S2 disconnects the clock pulses from IC3 input pin 1 and the active number is displayed.

Note that the diodes (D45 to D65) are required in series with all the outputs of the counters to prevent interaction with the Large Number diode paths (D1 to D43). As in the previous mode, the "make" contacts of switch S2a provide "display enable" by connecting the common cathodes of displays X1, X2 and X3 to the 0V line.

In the Target Number (T) mode of switch S1a, the +9V supply is connected to all three counters (IC3, IC4, and to IC5 via diode D44). Consequently, all displays are enabled when Freeze switch S2 is pressed. As the counters' clock inputs are serially

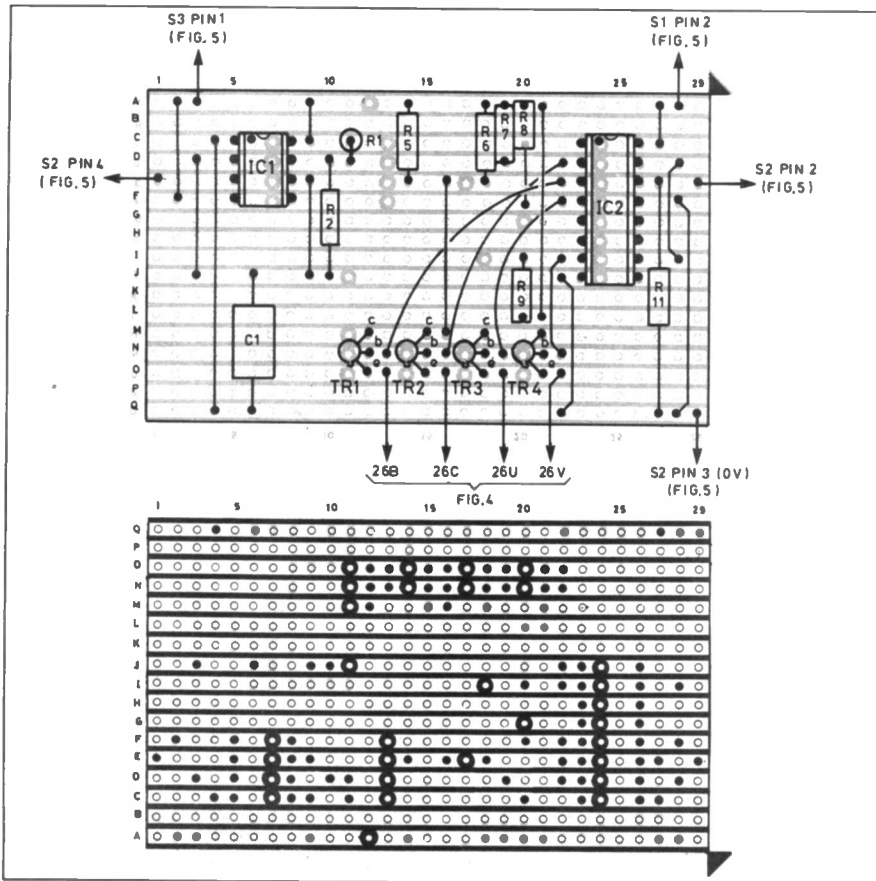

Fig. 2. Topside component layout and underside stripboard track cuts and solder joints for the Clock Generator and Large Number counter board.

hence the use of driver transistors TR1 to TR4. In addition, a host of diodes (D1 to D43) are needed to decode the four fixed large numbers so, ironically, providing four numbers out of the 1000 available forms a major part of the circuit.

The clock pulses are routed from switch S2b to input pin 14 of decade counter IC2. When the Large Number mode (L) is selected by switch S1 the +9V on its S1a wiper provides a positive supply to IC2 to activate this counter and the common collector load resistor R5 for the transistor drivers. Normally, all ten outputs of counter IC2 repeatedly go high in turn. However, the requirement in this circuit is for the generation of only four display numbers. Thus, the fifth output (IC2 pin 10) is connected to the reset, pin 15, so that the counter is reset on each fifth clock pulse.

The first four counter outputs (pins 2, 3, 4 and 7) are connected to the bases of transistors TR1 to TR4 and the four pull-up resistors R6 to R9. Each transistor emitter is coupled to its own diode matrix to drive the appropriate display segments. When the Freeze push-button switch S2 is operated, its S2b contacts open and pulses are disconnected from the input to counter IC2. Consequently, the particular IC2 output activated at that moment remains high.

Simultaneously, the "make" contacts of switch S2a close and the common cathodes of the displays are now connected to the 0V line. The relevant transistor is switched on by the counter's active output and current is supplied via the diodes in its emitter circuit to illuminate the designated segments of the displays. For example, if IC2 output pin 2 (designated "75") is frozen, TR2 is turned on and current flows through diodes D15 to D17 causing display X2 to show "7", and through diodes D18 to D22 causing display X3 to show "5".

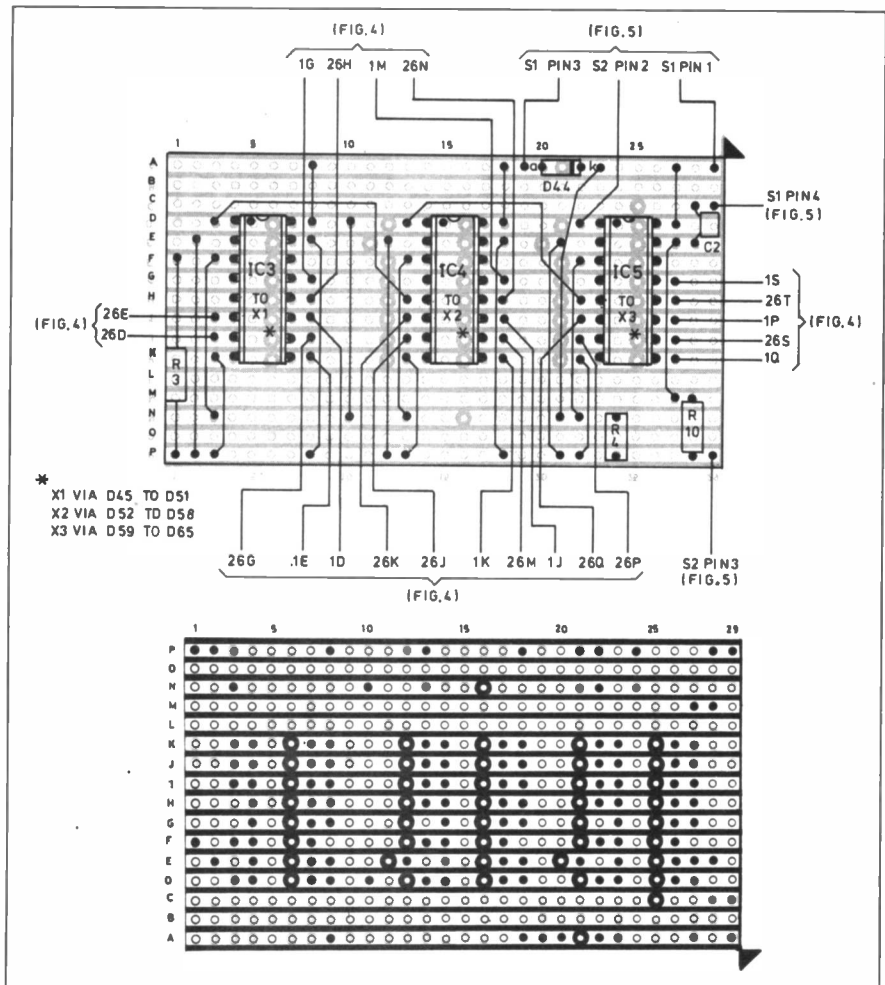

Fig. 3. Topside component layout and underside stripboard track cuts and solder joints for the Random Number Generator board.

connected, the count runs from zero to 999.

Strictly speaking, target numbers in the TV game *Countdown* are three figure numbers, but there seems no reason why numbers below 100 cannot be accepted. If a number is too low to make a reasonable calculation then the *Freeze* switch S2 button can be pressed again.

The count 0-999 (C) mode of switch S1 is similar to that of the Target mode in that all three counters (IC3 to IC5) are operative. This mode is not part of the TV *Countdown* game, but since the count to 999 facility is available, it can be used as a timing facility.

In the Count mode (C), switch S1b connects the common cathodes of displays X1, X2 and X3 to the 0V line, overriding the action of switch S2a. In this way, the time interval can be displayed and monitored. This facility is useful for

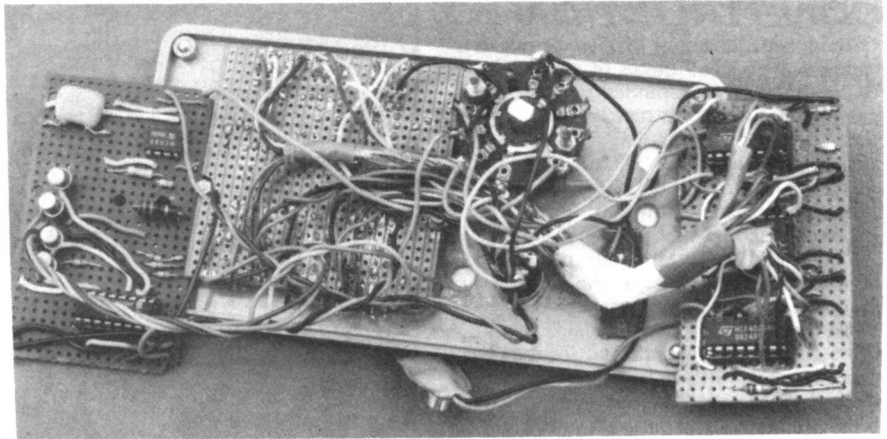

Photograph showing the interconnecting cabling between the three stripboard assemblies and the switches.

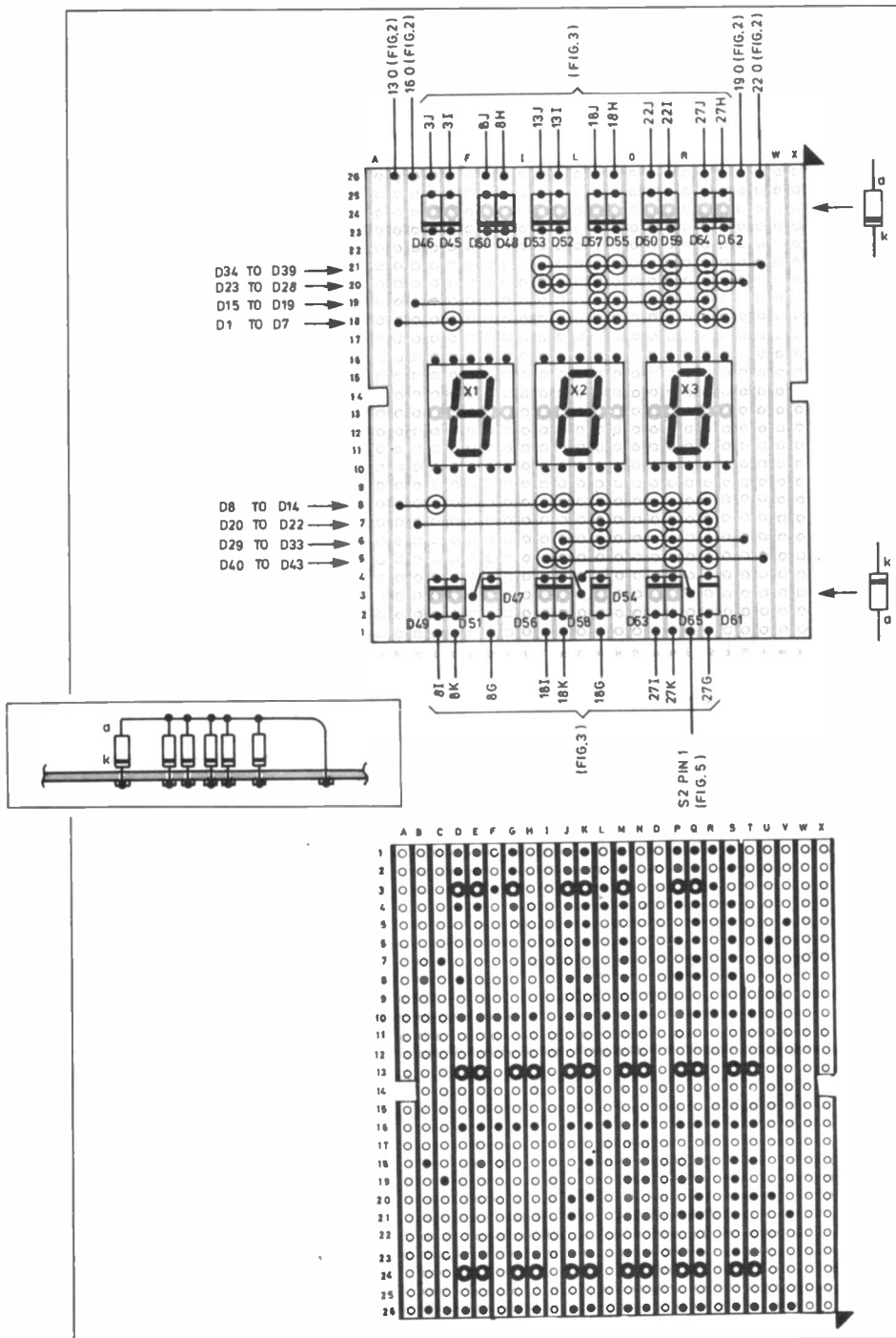

Fig. 4. Topside component layout and underside stripboard track cuts and solder joints for the Display/Matrix board. The insert shows an example of how the vertically mounted diodes should be connected.

checking the elapsed time and also allowing the count to be frozen from time to time; e.g. for "stopping the clock" when questions are being asked.

At switch-on, a small value capacitor, C2, connected to the +9V rail, provides a brief positive pulse to IC5's reset pin 15, to reset the count to zero. If necessary, *Freeze* switch S2 can be pushed in at switch-on by S3 to hold the zero ("000") until players are ready to start the count.

COMPONENTS

Resistors

R1, R3, R4
R6 to R9,
R11 100k (8 off)
R2, R10 47k (2 off)
R5 330
All 0.25W 5% carbon film

See
**SHOP
TALK**
Page

Capacitors

C1 220n polyester (see text)
C2 4n7 ceramic

Semiconductors

D1 to
D65 1N4148 signal diode
(65 off)
TR1 to
TR4 BC109 npn transistor
(4 off)
IC1 555 timer
IC2 4017 decade counter
IC3 to
IC5 4026 counter-decoder
(3 off)
X1 to X3 0.56in 7-segment l.e.d.
display, common cathode
(3 off)

Miscellaneous

S1 3-pole 4-way rotary switch
S2 2-pole make and break
pushbutton switch
S3 single-pole on/off slider
switch

Case, ABS plastic size 146mm x 76mm
x 46 mm (internal measurements); strip-
board 0.1in matrix, size 17 strips x 29
holes (Fig.2); stripboard 0.1in matrix, size
16 strips x 29 holes (Fig.3); stripboard
0.1in matrix, size 24 strips x 26 holes
(Fig.4); 8-pin d.i.l. socket, 16-pin d.i.l.
socket (4 off); knob; AA-type cell (6 off)
and holder with clip; 8BA nuts, bolts and
washers (2 off); stranded connecting
wire; solder, etc.

Approx cost
guidance only

£19
excl. batteries

CONSTRUCTION

Component assembly of *Counterspin* is made on three small pieces of stripboard. All components are mounted on these except for the three front panel switches S1, S2 and S3.

Stripboard assembly details for the Clock Generator and Large Number counter board are shown in Fig.2. The stripboard has a 0.1 inch matrix of 17 strips x 29 holes and the length is cut to slot into the grooves in the walls of the suggested plastic ABS box.

The stripboard copper underside layout shows all the solder points and the cuts to be made in the strips. Look out for any whiskers of copper that may be short-circuiting adjacent strips following track cutting. It is advisable to check for this with an ohmmeter or continuity tester at various stages during construction.

Sockets are recommended for all the i.c.s. Static charges can ruin CMOS chips, so it is a good policy to keep them in their original packing until ready for use, and fit them last.

Assembly details for the Random Number Generator board are shown in Fig.3. Again, the stripboard length is cut to slot into the grooves of the box and has a matrix of 16 strips x 29 holes. All components and fixed links are shown and the underside drawing indicates the soldered connections and cuts in the copper strips.

Assembly details for the Display/Matrix board are shown in Fig.4. The stripboard size is 24 strips by 26 holes. The most compact layout for the "large number" diodes (D1 to D43) is to mount them vertically as

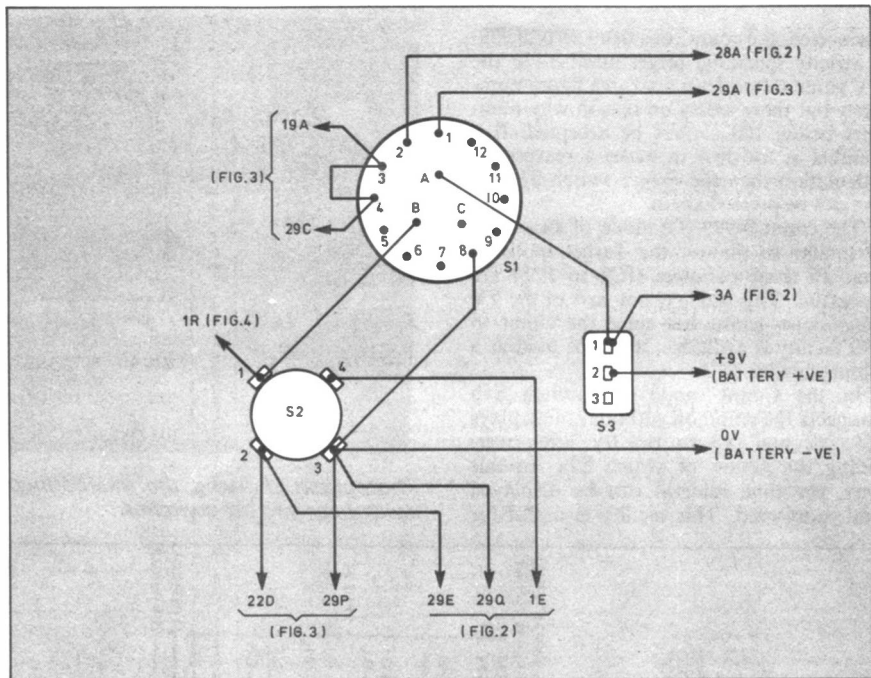

Fig. 5. Wiring details for the switches, showing stripboard destinations by figure number and matrix numbers.

shown in the inset figure example. If the leads are kept short, the diodes sit comfortably below the level of the displays and the front panel.

The Display/Matrix board is secured behind the front panel by two 8BA nuts, bolts and washers. Suitable viewing cut-outs are

of course, needed in the front panel. Holes also need to be drilled in the front panel to mount the three switches, S1 to S3.

Details of the connections between the switches and the stripboard assemblies are shown in Fig.5. The destinations of wires going to the stripboards are quoted as numeric-alpha codes indicating the matrix hole address. Multi-stranded insulated wire is recommended for all interconnections between the three stripboard assemblies and the switches.

The unit is powered at 9V by six type AA cells connected in series. Although the quiescent current is only about 5mA, the current consumption can vary between 60mA to over 100mA when the *Freeze* switch (S2) is pressed (about 10mA per display segment).

FURTHER ENLIGHTENMENT

Variations in the relative brilliances of the displays for different numbers may be noticed. This may be compensated for by inserting additional resistors, of about 330 ohms, between the diode matrix outputs and the inputs to the display segments, as described for *Counterspell*. In this case, resistor R5 should be replaced by a wire link. As with *Counterspell*, this technique is likely to result in increased current consumption.

Next Month: We introduce "On Your Marks buttons" to show Quizmaster who answered first.

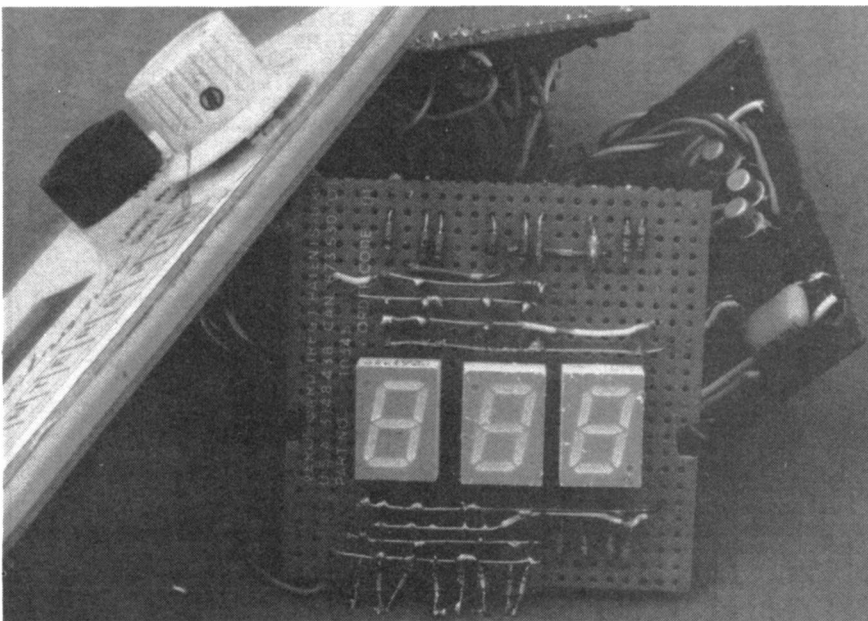

Close-up details of the prototype stripboard assembly for the *Counterspin* display module.

DON'T MISS OUT - ORDER YOUR COPY NOW!
EVERYDAY

With **PRACTICAL**

ELECTRONICS

INCORPORATING ELECTRONICS MONTHLY

NEWSAGENTS ORDER FORM

Please reserve/deliver a copy of *Everyday with Practical Electronics* for me each month.

Everyday with Practical Electronics is published on the first Friday of each month and distributed by Seymour.

Make sure of your copy of EPE each month - cut out or photostat this form, fill it in and hand it to your newsagent.

Signed

Name and Address
 (BLOCK CAPITALS PLEASE)

.....

High quality stepping motor kits (all including stepping motors). Comstep independent control of 2 stepping motors by PC (Via the Parallel Port) with 2 motors and software **£67.00** ready built **£99.00**

Software support and 4 digital inputs kit **£27.00**

Power interface 4A kit **£36.00** includes interface BA kit **£46.00**

Stepper kit 4 (manual control) powers 200 step stepping motor and control circuit **£23.00**

We are now stocking a range of stepping motors and kits to drive them - please ask for the stepping motor data sheet for full information

Inverter toroidal transformers 25VA 10 5.0-10 5V primary 0.260-285V secondary **£29.95**

LEDs 3mm or 5mm red or green 7 pack, yellow 11 pack

Cable Ties 1p each **£5.95** per 1000 **£49.50** per 10,000.

High quality photo resist copper clad epoxy glass boards

Dimensions	single-sided	double-sided
3x4 inches	£1.09	£1.23
4x8 inches	£2.75	£2.99
6x12 inches	£6.20	-
12x12 inches	£12.25	-

RECHARGEABLE BATTERIES

AA (HP7) 500mAh	£0.99
AA 700mAh	£1.75
C 2AH with solder tags	£3.60
D 4AH with solder tags	£4.95
1/2AA with solder tags	£1.75
AAA (HP16) 180mAh	£1.75
AA 500mAh with solder tags	£1.55
C (HP11) 1.8AH	£2.20
D (HP2) 1.2AH	£2.60
PP3 4V 110mAh	£4.95
Sub C with solder tags	£2.50
1/3 AA with tags (Philips CTV)	£1.95

Standard Charger, charges 4 AA cells in 5 hours, or 4 Cs or Ds in 12 to 14 hours plus 1xPP3 (1, 2, 3 or 4 cells may be charged at a time) **£5.95**

High power charger, as above but charges the Cs and Ds in 5 hours. AAs, Cs and Ds must be charged in twos or fours. **£10.95**

Nickel Metal Hydride AA cells, high capacity with no memory, 1000mAh **£3.50**, 1200mAh **£3.75**

SPECIAL OFFERS - PLEASE CHECK FOR AVAILABILITY

Stick of 4, 42mm x 16mm NiCad batteries, 171mm x 16mm dia., with red and black leads, 4 BV **£9.95**

Computer grade capacitors with screw terminals 53000F 60V **£4.95**

115V AC, 80V DC Motor, 4mm x 22mm shaft, 50mm dia. x 60mm long body (excluding shaft), it has a replaceable thermal fuse and brushes **£4.95** each, **£3.95** 100+

7-segment common anode LED display 12mm, 45p LM337K TO3 case variable regulator **£10.00** + **£1.44** each

GaAs F.E.T. low leakage current S8973 **£12.95** each, **£9.95** 10+, **£7.95** 100+

B5250 p-channel MOSFET **45p**

BC558 transistor **£3.95** per 100, **£10.00** per 1000

74LS05 Hex inverter **£10.00** per 100

Used 8748 Microcontroller **£3.50**

LS952 UHF Limiting amplifier, LC 16 surface mounting package with data sheet **£1.95**

AM27502 **£1.25** each, 90p 100+

CD4007UB **10p** 100+, **6p** 1000+

Stick Drive Boxes for a 5.25 disk drive, with room for power supply, light-grey plastic 67mm x 288mm x 247mm **£7.95** or **£49.50** for 10 Handheld Ultrasonic remote control **£3.95**

CV2486 gas laser 30mm x 10mm dia. with 3 wire terminals, will also work as a neon light **20p** each, **£7.50** per 100

All products advertised are new and unused unless otherwise stated

Wide range of CMOS TTL 74HC 74F Linear Transistors kits, rechargeable batteries, capacitors, tools etc. always in stock

Please add **£1.95** towards P&P VAT included in all prices

Sinclair light gun terminated with a jack plug and PP3 clip gives a signal when pointed at 50Hz flickering light, with output waveform chart **£3.95**

DC-DC converter, Reliability model, V12P5, 12V input 5V 200mA out, 300V input to output isolation, with data **£4.95** each or pack of 10 - **£39.50**

How counter uses 5V 100pF 240V, 50Hz **£1.45**

OWERTY keyboard, 58-key good quality switches, new **£6.00**

Airpac A82903-C large stepping motor 14V 7.5 step, 27 ohm, 68mm dia. body, 6.3mm shaft **£8.95** or **£20.00** for a box of 30

Polyester capacitors, box type, 22 5mm lead pitch 0.9uF 250V d.c. 18p each, 14p 100+ , 9p 1000+ , 1uF 250V d.c. 20p each, 15p 100+ , 10p 1000+ , 3-3uF 100V d.c. 30p each, 20p 100+ , 15p 1000+ , 1uF 50V bipolar electrolytic axial leads, 15p each, 7p 1000+

0.22uF 250V polyester axial leads, 15p each, 100+ 7.5p each

Polypropylene 1uF 400V d.c. (Wima MKP10) 27 5mm pitch 32 x 29 x 17mm case, 75p each, 60p 100+

Philips 12 series solid aluminium axial leads, 33uF 10V and 2uF 40V 40p each, 25p 100+ , Philips 108 series long life 22uF 63V axial, 30p each, 15p 1000+

Multilayer AVX ceramic capacitors, all 5mm pitch, 100V 100pF, 150pF 220pF, 1000pF (10n) 10p each, 5p 100+ , 3.5p 1000+ , 500pF compression trimmer **60p**

40uF 370V a.c. motor start capacitor (dialectro type containing no p.c.b.s) **£49.50** for 10

Solid carbon resistors, very low inductance, ideal for a.c. circuits, 27ohm 2W, 68ohm 2W 25p each, 15p each 100+

we have a range of 0.25W, 0.5W, 1W and 2W solid carbon resistors - please send SAE for list

P.C. 400W PSU (incl part 201035-001) with standard motherboard and 5 disk drive connectors, fan and mains inlet, 4 outlet connectors on back and switch on the side (top for tower case) dims 212 x 149 x 149mm excluding switch, **£26.00** each, **£138.00** for 6

MX180 Digital Multimeter, 17 ranges, 1000V d.c. 750V a.c. 2Mohm 200mA resistor Hi, 8V ac, 5V battery test **£7.95** or **£49.50** 100+

AMD 27256-3 EPROMs **£2.00** each, **£1.25** 95+ , DIP switch, 3PCO 12-pin (ERG SDC 3-023) **60p** each, **40p** 100+

Disk Drive Boxes for a 5.25 disk drive, with room for power supply, light-grey plastic 67mm x 288mm x 247mm **£7.95** or **£49.50** for 10 Handheld Ultrasonic remote control **£3.95**

CV2486 gas laser 30mm x 10mm dia. with 3 wire terminals, will also work as a neon light **20p** each, **£7.50** per 100

All products advertised are new and unused unless otherwise stated

Wide range of CMOS TTL 74HC 74F Linear Transistors kits, rechargeable batteries, capacitors, tools etc. always in stock

Please add **£1.95** towards P&P VAT included in all prices

JPG ELECTRONICS
276-278 Chatsworth Road
Chesterfield S40 2BH

Access: Visa Orders:
Tel: (01246) 211202 Fax: (01246) 550959
Callers welcome

revised edition TRANSMITTERS

AT LAST. A comprehensive, easy to follow guide to building short range transmitters and surveillance devices. Packed with useful information and circuits.

★ Only **£3.95** inc p&p.

(Some of the circuits included cannot be used legally in the UK)

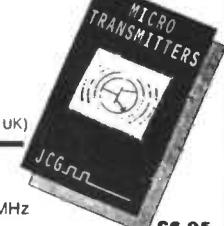

- RADIO KITS**
- All kits come with pre-drilled PCBs and high spec. components.
- MICRO FM TRANSMITTER (a)**, 1km range, 80-100MHz preset inc. mic., very small (2.3cm) **£6.95**
- MICRO FM TRANSMITTER (b)**, Variable mic. sens., tunable 90-110MHz, 1km range **£7.95**
- FM TRACKER**, Transmits an audio tone for direction finding, tracking etc. 80-110MHz **£8.50**
- ULTRA MINIATURE FM TRANSMITTER**, Runs off watch battery (inc), only 1x2cm, 200mtrs range, 80-100MHz **£8.95**
- FM RECEIVER (a)**, Tiny high quality FM radio. Will drive headphones direct (not inc) **£10.90**
- FM RECEIVER (b)**, As (a) but with 3 watt audio output and tuning LED **£13.50**
- CRYSTAL RADIO**, Includes tuner, earphone, ferrite aerial, etc. **£7.50**
- AM RADIO**, Single chip radio for headphones (not inc.) **£8.90**

- AUDIO POWER AMPS**
- 15 WATT** General purpose upgrade **£8.95**
- 40 WATT** High quality, HD 0-003%, switch on mute ideal for compact disc **£15.50**
- 150 WATT** Rugged and powerful MOSFET design. PA/sound systems **£22.95**

- PREAMPS ETC**
- GENERAL PURPOSE PREAMP**, Variable gain 9-25V 40mV max in **£4.00**
- ULTRA LOW NOISE**, For high quality mixers, mics etc 9-25V **£4.50**
- ACTIVE TONE**, 12dB C/B bass and treble with variable gain **£8.95**
- 7 BAND EQ**, 150Hz-18kHz for EQ units and tone control, includes on-board preamp and pots. Variable gain **£12.95**
- NOISE GATE**, Dynamic noise reduction system. Variable input and cut off level. Will accept instruments, tape decks etc **£15.95**
- MUSIC KITS**, Full range of on-board units for guitars and other instruments. Tone boosters, active circuits, delay lines, transducers. Send for list.

Prices include P&P. Mail Order Only. Make cheques and postal orders payable to:

JCG

PO Box HP79, Woodhouse Street, Leeds LS6 3XN

MEJDAF EUROPE LTD

JAPANESE TRANSISTORS

Type	U/Price	2SA 1051B	2B0	2SB 568	0.99
2SA 490	0.46	2SA 1075	0.80	2SB 595	0.52
2SA 495	0.50	2SA 1102	1.30	2SB 620	0.50
2SA 496	0.37	2SA 1103	1.00	2SB 621	0.75
2SA 497	1.30	2SA 1105	2.25	2SB 631	0.45
2SA 505	1.10	2SA 1106	1.50	2SB 633	0.50
2SA 539	0.46	2SA 1124	0.55	2SB 641	0.55
2SA 564	0.46	2SA 1138	0.70	2SB 642	0.58
2SA 608	0.24	2SA 1145	0.38	2SB 644	0.54
2SA 628	0.46	2SA 1162	20	2SB 647	0.75
2SA 638	0.50	2SA 1170	4.75	2SB 648	0.40
2SA 640	0.50	2SA 1175	0.25	2SB 649	0.30
2SA 659	0.60	2SA 1207	0.75	2SB 698	0.50
2SA 672	0.70	2SA 1220	0.70	2SB 733	0.75
2SA 673	0.25	2SA 1232	1.60	2SB 740	0.95
2SA 680	0.35	2SA 1263	2.50	2SB 743	0.35
2SA 682	0.70	2SA 1265	1.90	2SB 744	0.95
2SA 683	0.35	2SA 1309	0.45	2SB 754	0.80
2SA 684	0.96	2SB 407B	0.30	2SB 755	2.70
2SA 695	0.70	2SB 415	0.78	2SB 761	1.20
2SA 699	0.60	2SB 422	0.80	2SB 762	0.65
2SA 715	0.50	2SB 337	2.79	2SB 764	0.80
2SA 719	0.40	2SB 407	2.50	2SB 772	0.36
2SA 720	0.25	2SB 410	1.95	2SB 793	0.70
2SA 721	0.50	2SB 463	2.90	2SB 808	0.75
2SA 722	0.60	2SB 492	0.80	2SB 812	0.78
2SA 733	0.25	2SB 507	0.75	2SB 819	0.78
2SA 738	0.70	2SB 509	1.90	2SB 824	1.30
2SA 748	0.65	2SB 511	1.25	2SB 856	0.95
2SA 748	0.65	2SB 512	0.85	2SB 859	1.45
2SA 759	0.75	2SB 524	0.80	2SB 861	0.95
2SA 772	0.75	2SB 528	0.99	2SB 863	2.30
2SA 773	0.70	2SB 536	1.50	2SB 863	1.80
2SA 785	0.50	2SB 537	0.88	2SB 892	0.88
2SA 794	0.50	2SB 544	0.82	2SB 894	0.75
2SA 798	0.36	2SB 547	0.80	2SB 920	1.40
2SA 838	0.20	2SB 548	0.85	2SB 951	1.70
2SA 837	0.25	2SB 549	0.68	2SB 961	0.95
2SA 838	0.75	2SB 560	0.24	2SB 966	0.99
2SA 841	0.75	2SB 561	0.45	2SB 985	0.75
2SA 844	0.25	2SB 568	0.99	2SC 372	0.24
2SA 881	0.50	2SB 595	0.52	2SC 380	0.24
2SA 886	0.40	2SB 620	0.50	2SC 382	0.50
2SA 893	0.40	2SB 621	0.75	2SC 388	0.50
2SA 896	0.50	2SB 631	0.90	2SC 394	0.54
2SA 900	0.75	2SB 175	0.78	2SC 403	0.24
2SA 913	0.95	2SB 224	0.80	2SC 451	0.25
2SA 921	0.40	2SB 337	2.79	2SC 458	0.30
2SA 934	0.35	2SB 407	2.50	2SC 460	0.24
2SA 940	0.50	2SB 410	1.95	2SC 461	0.24
2SA 950	0.25	2SB 463	2.90	2SC 492	0.42
2SA 952	0.40	2SB 492	0.80	2SC 535	0.36
2SA 953	0.45	2SB 507	0.75	2SC 536	0.44
2SA 954	0.70	2SB 509	1.90	2SC 620	0.35
2SA 958	0.60	2SB 511	1.25	2SC 633	0.50
2SA 963	1.00	2SB 512	0.85	2SC 634	0.54
2SA 966	1.00	2SB 524	0.80	2SC 643	0.24
2SA 970	0.25	2SB 528	0.99	2SC 674	0.26
2SA 985	0.55	2SB 536	1.50	2SC 681	0.20
2SA 1012	0.75	2SB 537	0.88	2SC 682	0.75
2SA 1015	0.25	2SB 544	0.82	2SC 683	0.35
2SA 1020	0.20	2SB 547	0.80	2SC 710	0.15
2SA 1024	0.85	2SB 548	0.85	2SC 712	0.25
2SA 1026	0.85	2SB 549	0.68	2SC 714	0.25
2SA 1048	0.70	2SB 561	0.45	2SC 717	0.25

2SC 730	0.38	2SC 1623	0.50	2SC 2481	1.10	2SD 180	2.99	2SD 863	0.23
2SC 733	0.16	2SC 1625	0.60	2SC 2482	0.20	2SD 198	1.30	2SD 867	2.10
2SC 734	0.40	2SC 1637	0.70	2SC 2484	0.79	2SD 199	1.80	2SD 868	2.54
2SC 735	0.38	2SC 1652	0.55	2SC 2488	3.17	2SD 213	2.50	2SD 871	2.54
2SC 738	0.15	2SC 1667	2.25	2SC 2497	1.05	2SD 227	0.85	2SD 870	1.90
2SC 763	0.60	2SC 1674	0.15	2SC 2502	1.99	2SD 234	1.10	2SD 871	3.00
2SC 784	0.45	2SC 1675	0.90	2SC 2518	2.35	2SD 235	0.75	2SD 880	0.40
2SC 790	0.40	2SC 1678	0.70	2SC 2520	1.80	2SD 238	1.75	2SD 882	0.35
2SC 792	2.90	2SC 1683	0.90	2SC 2547	0.60	2SD 256	2.90	2SD 884	2.54
2SC 815	0.50	2SC 1684	0.29	2SC 2553	1.90	2SD 261	0.82	2SD 894	0.35
2SC 828	0.20	2SC 1685	0.28	2SC 2555	1.10	2SD 289	0.82	2SD 896	2.00
2SC 829	0.15	2SC 1687	0.75	2SC 2568	1.05	2SD 299	1.73	2SD 897	2.54
2SC 839	0.20	2SC 1730	0.10	2SC 2577	1.00	2SD 313	0.30	2SD 898	2.10
2SC 867	0.70	2SC 1740	0.10	2SC 2578	1.60	2SD 314	0.75	2SD 904	1.68
2SC 900	0.60	2SC 1741	0.30	2SC 2579	1.08	2SD 315	0.70	2SD 950	2.90
2SC 911	2.75	2SC 1749	0.70	2SC 2580	1.60	2SD 325	0.35	2SD 952	2.85
2SC 922	0.55	2SC 1755	0.80	2SC 2581	2.10	2SD 358	0.35	2SD 972	1.59
2SC 929	0.80	2SC 1756	0.35	2SC 2610	0.58	2SD 359	0.70	2SD 973	0.50
2SC 930	0.15	2SC 1815	0.10	2SC 2611	0.28	2SD 360	0.95	2SD 982	1.27
2SC 940	1.50	2SC 1826	0.60	2SC 2621	0.65	2SD 365	1.40	2SD 986	2.00
2SC 941	0.15	2SC 1827	0.60	2SC 2					

Techniques

ACTUALLY DOING IT!

by Robert Penfold

Over the years I must have received a few thousand readers' letters, and I cannot help noticing a steady trend. The general complexity of electronic projects has certainly increased over the years, and what is now an average sort of project would have been considered a fairly major undertaking twenty or thirty years ago.

You would have expected that the percentage of readers' letters asking for help with non-working projects to have increased, as it seems reasonable to assume that the greater complexity of modern projects gives more opportunity for something to go wrong. Surprisingly, the percentage of letters requesting help with non-working projects has, in fact, steadily reduced over the years. Letters of this type once accounted for the vast majority of the letters I received, but they are now a fairly small minority.

Possibly the general competence of electronics hobbyists has increased over the years, but I think it is more likely that improvements in methods of construction have reduced the chances of making mistakes. In particular, the vast majority of modern projects are based on a custom printed circuit board (p.c.b.). Using this method of construction it is comparatively easy to get everything right, and if a careless error should be made it will usually be spotted quite quickly.

Right Connections

This is not to say that building modern electronic projects is completely foolproof. Although there has been a trend towards having everything on the circuit board (including controls, sockets, etc.), most projects have at least a small amount of hard wiring, point-to-point wiring, or whatever other term you prefer. It is when completing this wiring that you find real opportunities to make mistakes.

Usually you will be working from a wiring diagram that provides good pictorial representations of the actual controls, sockets, transformers, or whatever, and the hard wiring should not, therefore, live up to its name. In practice it seems to be much easier to make the odd mistake when dealing with this wiring than when fitting the components to the printed circuit board.

One possible reason for this is that a printed circuit board normally has one

hole per leadout wire, but it is quite normal for some of the tags on controls and switches to be left unused. For example, if a 5-way 1-pole switch is required, there is a slight problem as switches having this contact arrangement are not readily available.

The most practical choice is a 6-way 2-pole rotary type having its adjustable end-stop set for 5-way operation, and one pole ignored. Six tags of the switch would then be used, and the other eight would be left unconnected.

Some constructors seem to get worried if any components in a project have tags or pins that are left unconnected. This is not usually indicative of anything missing from a circuit diagram or wiring diagram. It occurs simply because many controls, sockets, etc. have "extras" that are not needed in a particular design, so they are left connected to "thin air".

It is perhaps worth pointing out that many integrated circuits (i.c.s) also have pins that are not connected internally, or which are not normally utilized (pins 1, 5, and 8 of most operational amplifiers for example).

When wiring up a project that has a number of unused tags you need to take extra care. Be especially careful if there are components which have no connections to a large proportion of the tags.

Jack sockets seem to be one of the main causes of confusion, as many of these are fitted with switch contacts that are little used in modern designs. Fig. 1 provides connection details for

normal 3.5mm and 6.35mm (0.25 inch) switched jack sockets when the switch contact or contacts are not utilized.

Twining

There is an increasing problem with components that do not conform to the traditional shapes and sizes. If a components list calls for (say) a 10k log potentiometer, in one of the larger components catalogues you may well be able to find a choice of half a dozen components that fit this general description (standard, miniature, small slider, large slider, etc.). Many switches and sockets are now also available in a variety of styles.

We would strongly advise beginners to look carefully at any photographs of the prototype unit, and then search some component catalogues for components that physically match up with the components used in the prototype. This should save you the trouble of having to work out the correlation between the tags on the component you have obtained and the one illustrated in the article. I have pointed out many times that a selection of component catalogues is an essential part of the hobby, and this remains as true as it ever was.

From time to time you will inevitably end up with a component that is correct in every detail, but which is physically quite different to the one illustrated in the wiring diagram. In this situation a test meter, even a very basic one, is more than a little useful.

With the meter set to a resistance range (or the continuity tester setting) you can use it to check such things as which tags of a switch are interconnected at each setting, and which tag of a socket connects through to a given tag on the plug. Such is the diversity of modern sockets, switches, etc., I tend to routinely check practically all switches and sockets to make sure I have not jumped to any wrong conclusions.

Wires

Unless large currents are involved, a fairly thin type of multi-strand connecting wire is the best choice. I normally use 7/0.2 p.v.c. insulated connecting

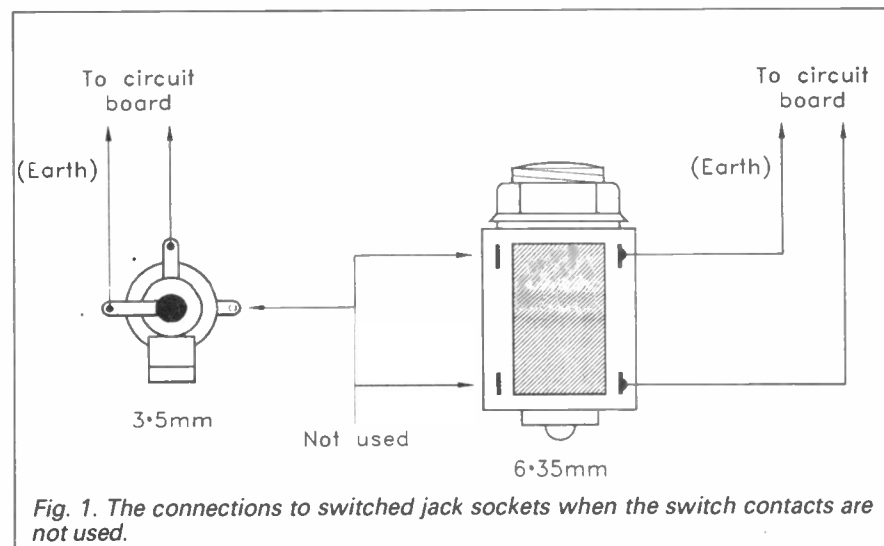

Fig. 1. The connections to switched jack sockets when the switch contacts are not used.

National Lottery Predictor

Apart from the ready-programmed PIC microcontroller, almost all the other components required to build the *National Lottery Predictor* could be classed as standard items. However, the dual 7-segment display and the pushbutton switch will have to be selected carefully if they are to fit on the small printed circuit board.

The pre-programmed PIC16C54RC/P microcontroller chip is available from the author, price £7. He also has a consignment of dual displays and pushbutton switches. These are being offered as a pack, one each of display and switch, for the sum of £4. A floppy disk containing the complete Source Code together with other related files is also available for just £1.

All orders (*Strictly Mail Order Only*) should be sent to: **Mr. J. Ilett, 99 Telford Way, Yeading, Hayes, Middlesex, UB4 9TH.** All monies should be made payable to *J. Ilett*. All prices include postage and packing. Overseas customers add £2 to order.

The specified case used in the prototype model was purchased from **Maplin** and is their type 3415 box, code FK74R. The red display filter material also came from the same supplier, code FR34M.

Most of our component advertisers carry various versions of 7-segment displays and no doubt many will work in this circuit but check they have an identical pinout arrangement first, to make sure they will fit on the small p.c.b. The printed circuit board is available from the *EPE PCB Service*, code 935.

Auto Battery Charger

To date, we have only come across two stockists listing the ICL8069 1.2V voltage

reference called for in the *Auto Battery Charger*. These are: **Maplin**, code YH39N and **Electromail**, code 428-969.

The ICL7611 micropower op.amp, chosen specially for its exceptionally low current requirement, should be available from most component suppliers. However, in case of difficulty it is listed by **Electromail** (☎ 0536 204555) and **Cricklewood** (☎ 081 452 0161).

The specified relay used in the prototype model has contacts rated 5A at 240V a.c. and comes from the 5A/10A miniature range sold by **Maplin**. The one suggested is the 12V version, coded JM18U 12V/5A Min. Relay. Other relays can, of course, be used but make sure that the contacts are adequately rated.

As the mains "live" connection is made directly to the relay contacts these pins MUST be covered with plastic insulation sleeving for added safety. It is also very important, for personal safety, that a well "Earthed" aluminium or metal case is used.

A further important point to note is that if resistor R6 is needed to complete the setting up, it must have a power rating of **3W minimum**. The Charger printed circuit board is available from the *EPE PCB Service*, code 934.

Light Activated Switch

Most of our component advertisers should carry the ORP12 light dependent resistor or its equivalent called for in the *Light Activated Switch*.

The circuit should work properly using almost any relay having a 12V coil with a resistance of about 300 ohms or more, but make sure you select one which has contacts rated for your intended application. The relay used in the prototype is the **Maplin "10A Mains"** type, code YX97F.

Switch On/Off Timer

Once again, the only item likely to cause concern for builders of the *Switch On/Off Timer* is the relay. This can be almost any 12V coil type with a resistance of 300 ohms or more, plus of course suitably rated contacts. Both the **Maplin "10A Mains Relay"** and the **Electrovalue "Min. S.P.D.T. 3A"** type worked successfully.

Continuity Tester

The CA3130E op.amp i.c. used in the *Continuity Tester* should not be replaced with a substitute op.amp. This i.c. operates well from a 6V supply, is capable of single supply operation and has good freedom from "latch-up." Most other op.amps do not match this specification and may not perform very well in this circuit.

The 6V buzzer used in this circuit was purchased from **Maplin**, code FL39N.

PLEASE TAKE NOTE

Moving Display Metronome Jan. '95

At the time of "going to press" we were unable to pass on a source of supply for the VN0610L f.e.t. specified for TR1 and TR2. We have since heard that **Farnell** (☎ 0532 636317) carry stocks of this *n*-channel device.

As this is an enhancement mode MOSFET device, it is suggested that a BS170 (available from **Electrovalue** - ☎ 0784 442253) would make a good substitute. The 2N5459 will not function in this circuit.

Alternatively, a reader has informed us that the circuit functions correctly with a ZTX300 *n*pn transistor, with a 220 kilohm resistor in its base connection, replacing the specified device. (i.e. base to gate, collector to drain and emitter to source). It has also been suggested (but not tried) that almost any *n*pn small signal transistor with an h_{fe} of around 300 (BC549C etc) would be OK, with a 10 kilohms resistor feeding the base, since the CMOS i.c.s are capable of sourcing the small amount of current required.

Our thanks to **Mr. R. K. Stephenson** and **Mr. B. J. Taylor**.

THE ONLY COMPANY ON FIRST NAME TERMS WITH THE NOISE POLLUTION AGENCY!

RTVC

PA 400 AMPLIFIER £129.99

- INPUT 0.75V-1.2V
- INPUT IMPEDANCE 47Kohms
- OUTPUT POWER 2 x 200 WATT MAX (4ohms)
- RMS OUTPUT POWER 2 x 125W RMS/MAX
- FREQUENCY RESPONSE 14Hz-26kHz (3db)
- S/N RATIO 10db
- SEPARATION 70db
- DIMS 482mm/308mm/132mm 3U
- WEIGHT 8.4kg

STANDARD FEATURES: BOTH AMPS HAVE INDEPENDENT LEFT/RIGHT VOLUME CONTROLS, VU METERS, AND ARE FAN COOLED.

BRITISH MADE

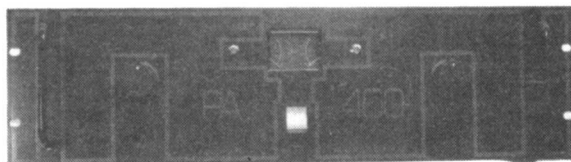

PA 700 BEEFY 700 WATT AMPLIFIER ONLY £204.95

- ★ ● INPUT 0.75V-1.2V VIA 1/4" (6.35mm) JACK SOCKETS
- ★ ● CHANNEL SEPARATION 85db
- ★ ● SIGNAL TO NOISE RATIO 100db
- ★ ● FREQUENCY RESPONSE 20Hz-30kHz
- ★ ● OUTPUT MAX 2 x 350W (4 ohms) VIA 3-PIN XLR FM
- ★ ● OUTPUT RMS 2 x 230W
- ★ ● SIZE 438mm (W) x 87mm (H) x 268mm (D) 2U
- WEIGHT 7.65kg (8.25kg boxed)

UTILISES 8 TO3 MOSFETS WITH DUAL TOROID TRANSFORMER P.S.U.

AUTHORISED DEALERS IN:- EMINENCE & RCF SPEAKERS, VESTAX, KAM, GEMINI & HW MIXERS, STANTON, ORTOFON, & SHURE CARTRIDGES.

RTVC

376 EDGWARE ROAD LONDON W2 1EB Tel: 071-723 8432/071-723 3462 Fax 071-723 3467
2 mins. from Edgware Road Tube Station.

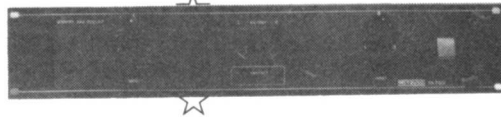

CRAZY PRICE!

DIRECT BOOK SERVICE

The books listed have been selected by *Everyday with Practical Electronics* editorial staff as being of special interest to everyone involved in electronics and computing. They are supplied by mail order direct to your door. Full ordering details are given on the last book page. For another selection of books see next month's issue.

ELECTRONIC PROJECTS - BOOK 1

Published by *Everyday Electronics* in association with *Magenta Electronics*.

Contains twenty of the best projects from previous issues of *EE* each backed with a kit of components. The projects are: Seashell Sea Synthesiser, EE Treasure Hunter, Mini Strobe, Digital Capacitance Meter, Three Channel Sound to Light, BBC 16K Sideways Ram, Simple Short Wave Radio, Insulation Tester, Stepper Motor interface, Eprom Eraser, 200MHz Digital Frequency Meter, Infra Red Alarm, EE Equaliser Ioniser, Bat Detector, Acoustic Probe, Mains Tester and Fuse Finder, Light Rider - (Lapel Badge, Disco Lights, Chaser Light), Musical Doorbell, Function Generator, Tilt Alarm, 10W Audio Amplifier, EE Buccaneer Induction Balance Metal Detector, BBC Midi Interface, Variable Bench Power Supply, Pet Scarer, Audio Signal Generator. 128 pages (A4 size) **Order code EPT1** £2.45

ELECTRONICS TEACH-IN 88/89 - INTRODUCING MICROPROCESSORS

Mike Tooley BA (published by *Everyday Electronics*)

A complete course that can lead successful readers to the award of a City and Guilds Certificate in Introductory Microprocessors (726/303). The book contains everything you need to know including full details on registering for assessment, etc. Starting with basic terminology, integrated circuits, logic families and numbering systems the text builds in stages, with revision and assessments built in, up to programming, languages, flow charts, etc. The course is ideal for the newcomer to the subject. 80 pages (A4 size) **Order code TI-88-89** £2.45

Special Everyday Electronics Books

ELECTRONICS TEACH-IN No. 5 GUIDE TO BUILDING ELECTRONIC PROJECTS

Published by *EVERYDAY ELECTRONICS*. Due to the demand from students, teachers and hobbyists we have put together a range of articles from previous issues of *Everyday Electronics* that will assist the reader with the construction of electronic projects.

The book contains the complete *Development for GCSE* series.

Contents: Features - Final Project Building; Building with Verob; Project Development for GCSE; Getting your Project Working; Printed Circuit Boards; Choosing and Using Components - The Multimeter; The Oscilloscope; Logic Probes; Digital Frequency Meters; Generators, etc; **Data -** Circuit Symbols; Component Codes; Resistors; Identifying Components; Component Codes; Resistor Codes; Understanding the Component Code; Component Codes; Mounting circuit components; Controls; Understanding Capacitors; Project: Detector; Personal Stereo Amplifier; Digital Expander's Unit; Quizmaster; Siren Effects Unit; UV Exposure Unit; Low-cost Capacitance Meter; Personal Radio. 88 pages (A4 size) **Order code T15** £2.95

ELECTRONICS TEACH-IN No. 6 DESIGN YOUR OWN CIRCUITS

(Published by *Everyday with Practical Electronics*)
Mike Tooley B.A.

This book is designed for the beginner and experienced reader alike, and aims to dispell some of the mystique associated with the design of electronic circuits. It shows how even the relative newcomer to electronics can, with the right approach, design and realise quite complex circuits.

Fourteen individual p.c.b. modules are described which, with various detailed modifications, should allow anyone to design and construct a very wide range of different projects. Nine "hands-on" complete DIY projects have also been included so readers can follow the thinking behind design, assembly, construction, testing and evaluation, together with suggested "mods" to meet individual needs. The practical projects have each been designed to stand on their own as complete items of

equipment. P.C.B.s for all the modules and projects are available by mail order.

The subjects covered in each chapter of the book are: Introduction and Power Supplies; Small Signal Amplifiers; Power Amplifiers; Oscillators; Logic Circuits; Timers; Radio; Power Control; Optoelectronics.

The nine complete constructional projects are: Versatile Bench Power Supply; Simple Intercom; Bench Amplifier/Signal Tracer; Waveform Generator; Electronic Die; Pulse Generator; Radio Receiver; Disco Lights Controller; Optical Communications Link. 136 pages **Order code T16** £3.45

TEACH-IN No. 7 plus FREE Software

ANALOGUE AND DIGITAL ELECTRONIC COURSE

(Published by *Everyday with Practical Electronics*)
Alan Winstanley and Keith Dye B. Eng(Tech)AMIEE
The highly acclaimed *Teach-In '92* series, which included the construction and use of the *Mini Lab* and *Micro Lab* test and development units, has been put together in book form. Additionally EPT Educational Software have developed a GCSE Electronics software program to complement the course and a FREE DISC covering the first two parts of the course is included with the book.

An interesting and thorough tutorial series aimed specifically at the novice or complete beginner in electronics. The series is designed to support those undertaking either GCSE Electronics or GCE Advanced Levels, and starts with fundamental principles.

If you are taking electronics or technology at school or college, this book is for you. If you just want to learn the basics of electronics then this book is for you. If you are teaching electronics or technology you must make sure you see it. *Teach-In No. 7* will be invaluable if you are considering a career in electronics or even if you are already training in one. The *Mini Lab* and software enable the construction and testing of both demonstration and development circuits. These learning aids bring electronics to life in an enjoyable and interesting way; you will both see and hear the electron in action! The *Micro Lab* microprocessor add-on system will appeal to higher level students and those developing microprocessor projects.

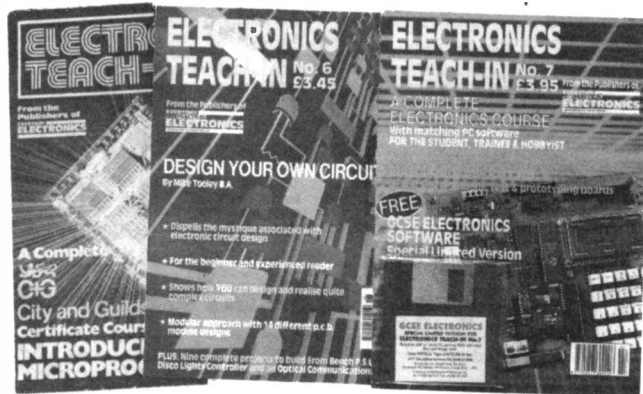

Computers and Computing

HOW TO CHOOSE A SMALL BUSINESS COMPUTER SYSTEM

D. Weale

This book is for anyone intending to buy an IBM compatible computer system, whether it is their first system or a replacement. There are sections on hardware, application and systems programs and how to actually make your choice as well as sections on the law, ergonomics and a glossary of common terms.

The text contains many useful tips and some warnings (which could save much effort and expense). 114 pages **Order code BP323** £4.95

UNDERSTANDING PC SPECIFICATIONS

R. A. Penfold

If you require a microcomputer for business applications, or a high quality home computer, an IBM PC or compatible is often the obvious choice. They are competitively priced, and are backed up by an enormous range of applications programs, hardware add-ons, etc. The main difficulty for the uninitiated is deciding on the specification that will best suit his or her needs. PCs range from simple systems of limited capabilities up to complex systems that can happily run applications that would have been considered beyond the abilities of a microcomputer not so long ago. It would be very easy to choose a PC system that is inadequate to run your applications efficiently, or one which goes beyond your needs and consequently represents poor value for money.

This book explains PC specifications in detail, and the subjects covered include the following: Differences between types of PC (XT, AT, 80386, etc); Maths co-processors; Input devices (keyboards, mice, and digitisers); Memory, including both expanded (EMS) and extended RAM; RAM disks and disk caches; Floppy disk drive formats and compatibility; Hard disk drives (including interleave factors and access times); Display adaptors, including all standard PC types (CGA, Hercules, Super VGA, etc); Contains everything you need to know if you can't tell your EMS from your EGA! 104 pages **Order code BP282** £4.95

AN INTRODUCTION TO 68000 ASSEMBLY LANGUAGE

R. A. & J. W. Penfold

Obtain a vast increase in running speed by writing programs for 6800 based micros such as the Commodore Amiga, Atari ST range or Apple Macintosh range etc., in assembly language. It is not as difficult as one might think and this book covers the fundamentals. 112 pages **Order code BP184** £2.95

MULTIMEDIA ON THE PC

Ian R. Sinclair

In this book, you'll find out what a CD ROM is, how it works, and why it is such a perfect add-on for a PC, allowing you to buy programmes, text, graphics and sound on a CD. It also describes the installation of a CD ROM drive and a sound card, pointing out the common problems that arise, and then shows how to use them to create a complete multimedia presentation that contains text, photos, a soundtrack with your own voice recorded as a commentary, even animation and edited video footage. 184 pages **Order code PC112** £11.95

A CONCISE INTRODUCTION TO MS-DOS

N. Kantaris

This guide is written with the non-expert, busy person in mind and, as such, it has an underlying structure based on "what you need to know first, appears first". Nonetheless, the guide is also designed to be circular, which means that you don't have to start at the beginning and go to the end. The more experienced user can start from any section.

The guide covers versions 3.0, 3.1 and 3.2 of both PC-DOS and MS-DOS as implemented by IBM and other manufacturers of "compatible" microcomputers. 64 pages **Order code BP322** £2.95

MAKING MS-DOS WORK FOR YOU (covers version 6.2)

N. Kantaris & P. R. M. Oliver

This book is written with the busy person in mind and, as such, it has an underlying structure based on "what you need to know first, appears first". Nonetheless, the

book has also been designed to be circular, which means that you don't have to start at the beginning and go to the end.

The book explains: How to write customised batch files which allow you to display what you want on your screen, and in the form and order you want it, instead of being forced to use the DOS prompt on a blank screen. How to design and set up a fast interactive and professional looking menu system, so that you or anyone else can run utility applications or commercial software packages easily. How the ANSI.SYS display and keyboard commands can be used to position the cursor on any part of the screen, change the intensity of the displayed characters or change their colour. How the Edit screen editor or the Edlin line editor can be used to enter ESCape (ANSI.SYS) commands into simple ASCII files to allow control of both your screen display and your printer. How to control the operation of the two main types of printers in use today, Epson compatible dot matrix and HP compatible laser printers. How to use several useful routines, such as moving and finding files, protecting files from accidental erasure, a simplified backup process, a screen saver, and a disc cataloguing system.

The Debug program and how it can be used to create, see and change the contents of any file, including those of programs written in assembler code. This includes how to find your way around the names and tasks of the CPU registers and the meaning of some simple assembler mnemonics. 182 pages **Order code BP319** £4.95

AN INTRODUCTION TO CP/M

R. A. Penfold

In order to run and use programs operating under CP/M it is not essential to have an understanding of the system, but a reasonable knowledge of the subject can certainly be of immense help when minor problems occur, and also in fully exploiting the possible potential of the system. This book tells the story! 84 pages **Order code BP183** £2.95

Audio and Music

ACOUSTIC FEEDBACK - HOW TO AVOID IT

Feedback is the bane of all public address systems. While feedback cannot be completely eliminated, many things can be done to reduce it to a level at which it is no longer a problem.

Much of the trouble is often the hall itself, not the equipment, but there is a simple and practical way of greatly improving acoustics. Some microphones are prone to feedback while others are not. Certain loudspeaker systems are much better than others, and the way the units are positioned can produce or reduce feedback. All these matters are fully explored as well as electronic aids such as equalizers, frequency-shifters and notch filters.

The special requirements of live group concerts are considered, and also the related problem of instability that is sometimes encountered with large set-ups. We even take a look at some unsuccessful attempts to cure feedback so as to save readers wasted time and effort duplicating them.

Also included is the circuit and layout of an inexpensive but highly successful twin-notch filter, and how to operate it. **92 pages** **Order code BP310** **£3.95**

PRACTICAL MIDI HANDBOOK

R. A. Penfold

The Musical Instrument Digital Interface (MIDI) is surrounded by a great deal of misunderstanding, and many of the user manuals that accompany MIDI equipment are quite incomprehensible to the reader.

The Practical MIDI Handbook is aimed primarily at musicians, enthusiasts and technicians who want to exploit the vast capabilities of MIDI, but who have no previous knowledge of electronics or computing. The majority of the book is devoted to an explanation of what MIDI can do and how to exploit it to the full, with practical advice on connecting up a MIDI system and getting it to work, as well as deciphering the technical information in those manuals. **128 pages** **Order code PC101** **£8.95**

PREAMPLIFIER AND FILTER CIRCUITS

R. A. Penfold

This book provides circuits and background information for a range of preamplifiers, plus tone controls, filters, mixers, etc. The use of modern low noise operational amplifiers and a specialist high performance audio preamplifier i.c. results in circuits that have excellent performance, but which are still quite simple. All the circuits featured can be built at quite low cost (just a few pounds in most cases).

The preamplifier circuits featured include:- Microphone preamplifiers (low impedance, high impedance, and crystal). Magnetic cartridge pick-up preamplifiers with R.I.A.A. equalisation. Crystal/ceramic pick-up preamplifier. Guitar pick-up preamplifier. Tape head preamplifier (for use with compact cassette systems).

Other circuits include:- Audio limiter to prevent overloading of power amplifiers. Passive tone controls. Active tone controls. PA filters (highpass and lowpass). Scratch and rumble filters. Loudness filter. Audio mixers. Volume and balance controls. **92 pages** **Order code BP309** **£3.95**

AN INTRODUCTION TO LOUSPEAKERS AND ENCLOSURE DESIGN

V. Capel

This book explores the various features, good points and snags of speaker designs. It examines the whys and wherefores so that the reader can understand the principles involved and so make an informed choice of design, or even design loudspeaker enclosures for him or herself. Crossover units are also explained, the various types, how they work, the distortions they produce and how to avoid them. Finally there is a step-by-step description of the construction of the *Kapellmeister* loudspeaker enclosure. **148 pages** **Order code BP256** **£2.95**

COMPUTERS AND MUSIC - AN INTRODUCTION

R. A. Penfold

Computers are playing an increasingly important part in the world of music, and the days when computerised music was strictly for the fanatical few are long gone.

If you are more used to the black and white keys of a synth keyboard than the QWERTY keyboard of a computer, you may be understandably confused by the jargon and terminology bandied about by computer buffs. But fear not, setting up and using a computer-based music making system is not as difficult as you might think.

This book will help you learn the basics of computing, running applications programs, wiring up a MIDI system and using the system to good effect, in fact just about everything you need to know about hardware and the programs, with no previous knowledge of computing needed or assumed. This book will help you to choose the right components for a system to suit your personal needs, and equip you to exploit that system fully. **174 pages** **Order code PC107** **£8.95**

ELECTRONIC PROJECTS FOR GUITAR

R. A. Penfold

This book contains a collection of guitar effects and some general purpose effects units, many of which are suitable for beginners to project building. An introductory chapter gives guidance on construction.

Each project has an introduction, an explanation of how it works, a circuit diagram, complete instructions on strip-board layout and assembly, as well as notes on setting up and using the units. Contents include: Guitar tuner; Guitar preamplifier; Guitar headphone amplifier; Soft distortion unit; Compressor; Envelope waa waa; Phaser; Dual tracking effects unit; Noise gate/expander; Treble booster; Dynamic treble booster; Envelope modifier; Tremolo unit; DI box. **110 pages** **Order code PC110** **£8.95**

HIGH POWER AUDIO AMPLIFIER CONSTRUCTION

R. A. Penfold

Practical constructional details of how to build a number of audio power amplifiers ranging from about 50 to 300/400 watts r.m.s. Includes MOSFET and bipolar transistor designs. **96 pages** **Order code BP277** **£3.95**

Theory and Reference

ELECTRONIC HOBBYISTS HANDBOOK

R. A. Penfold

Provides an inexpensive single source of easily located information that the amateur electronics enthusiast is likely to need for the day-to-day pursuance of this fascinating hobby. Covers common component colour codes. Details the characteristics and pinouts of many popular semiconductor devices, including various types of logic ICs, operational amplifiers, transistors, FETs, unijunctions, diodes, rectifiers, SCRs, diacs, triacs, regulators and SMDs, etc. Illustrates many useful types of circuits, such as timers and oscillators, audio amplifiers and filters, as well as including a separate section on power supplies. Also contains a multitude of other useful data. **88 pages** **Order code BP233** **£4.95**

FROM ATOMS TO AMPERES

F. A. Wilson

Explains in crystal clear terms the absolute fundamentals behind electricity and electronics. Really helps you to discover and understand the subject, perhaps for the first time ever.

Have you ever: Wondered about the true link between electricity and magnetism? Felt you could never understand the work of Einstein, Newton, Boltzmann, Planck and other early scientists? Just accepted that an electron is like a little black ball? Got mixed up with v.m.f. and p.d.? Thought the idea of holes in semiconductors is a bit much?

Then help is at hand with this inexpensive book, in as simple a way as possible and without too much complex mathematics and formulae. **244 pages** **Temporarily out of print**

ELECTRONICS - A "MADE SIMPLE" BOOK

G. H. Olsen

This book provides excellent background reading for our *Introducing Digital Electronics Teach-In Book* and will be of interest to everyone studying electronics. The subject is simply explained and well illustrated and the book assumes only a very basic knowledge of electricity. **330 pages** **Order code NE10** **£6.95**

A REFERENCE GUIDE TO PRACTICAL ELECTRONICS TERMS

F. A. Wilson

Electronic devices surround us on all sides and their numbers are increasing without mercy. Ours is the problem therefore in keeping up with this relentless expansion. Unfortunately we cannot know it all and most

of us do not wish to afford the cost of large reference books which explain many concepts in fair detail. Here is an answer, an inexpensive reference guide which explains briefly (but we hope, well) many of the underlying electronics features of practical devices, most of which, to a certain extent, control our lives.

This book is in effect more than just a dictionary of practical electronics terms, it goes a stage further in also getting down to fundamentals. Accordingly the number of terms may be limited but the explanations of the many which are included are designed to leave the reader more competent and satisfied - and this is without the use of complicated mathematics which often on first reading can even be confusing.

For those who also wish to get right down to the root of the matter, there is a second volume entitled *A Reference Guide to Basic Electronics Terms* (BP286), each of the books referring to its companion as necessary.

A reference guide for practically everybody concerned with electronics. **432 pages** **Order code BP287** **£5.95**

NEWNES ELECTRONICS POCKET BOOK

E. A. Parr

Newnes Electronics Pocket Book has been in print for over twenty years and has covered the development of electronics from valve to semiconductor technology and from transistors to LSI integrated circuits and microprocessors. To keep up to date with the rapidly changing world of electronics, continuous revision has been necessary. This new Fifth Edition takes account of recent changes and includes material suggested by readers of previous editions. New descriptions of op.amp. applications and the design of digital circuits have been added, along with a totally new chapter on computing, plus other revisions throughout. **315 pages (hard cover)** **Order code NE02** **£12.95**

ELECTRONIC MODULES AND SYSTEMS FOR BEGINNERS

Owen Bishop

This book describes over 60 modular electronic circuits - how they work, how to build them, and how to use them. The modules may be wired together to make hundreds of different electronic systems, both analogue and digital. To show the reader how to begin building systems from modules, a selection of over 25 electronic systems are described in detail, covering such widely differing applications as timing, home security, measurement, audio (including a simple radio receiver), games and remote control. **200 pages** **Order code BP266** **£3.95**

Project Building

HOW TO GET YOUR ELECTRONIC PROJECTS WORKING

R. A. Penfold

We have all built projects only to find that they did not work correctly, or at all, when first switched on. The aim of this book is to help the reader overcome just these problems by indicating how and where to start looking for many of the common faults that can occur when building up projects. **96 pages** **Order code BP110** **£2.95**

HOW TO DESIGN AND MAKE YOUR OWN P.C.B.s

R. A. Penfold

Deals with the simple methods of copying printed circuit board designs from magazines and books and covers all aspects of simple p.c.b. construction including photographic methods and designing your own p.c.b.s. **80 pages** **Order code BP121** **£2.50**

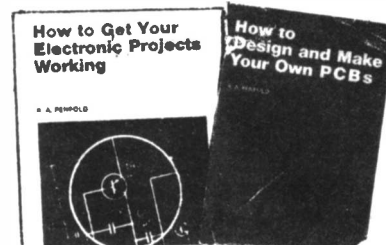

A BEGINNERS GUIDETO MODERN ELECTRONIC COMPONENTS

R. A. Penfold

The purpose of this book is to provide practical information to help the reader sort out the bewildering array of components currently on offer. An advanced knowledge of the theory of electronics is not needed, and this book is not intended to be a course in electronic theory. The main aim is to explain the differences between components of the same basic type (e.g. carbon, carbon film, metal film, and wire-wound resistors) so that the right component for a given application can be selected. A wide range of components are included, with the emphasis firmly on those components that are used a great deal in projects for the home constructor. **166 pages** **Order code BP285** **£3.95**

BEGINNER'S GUIDE TO BUILDING ELECTRONIC PROJECTS

R. A. Penfold

Shows the complete beginner how to tackle the practical side of electronics, so that he or she can confidently build the electronic projects that are regularly featured in magazines and books. Also include examples in the form of simple projects. **112 pages** **Order code 227** **£1.95**

ELECTRONICS SIMPLIFIED - CRYSTAL SET CONSTRUCTION

F. A. Wilson, C.G.I.A., C.Eng., F.I.E.E., F.I.E.R.E., F.B.I.M.

Especially written for those who wish to participate in the intricacies of electronics more through practical construction than by theoretical study. It is designed for all ages upwards from the day one can read intelligently and handle simple tools. **80 pages** **Order code BP92** **£1.75**

GUIDE TO BUILDING ELECTRONIC PROJECTS

Published by *Everyday Electronics*

See the first page of books - ELECTRONICS TEACH-IN No.5 - for full details.

ELECTRONICS PROJECT BOOK

Published by *Everyday Electronics* in association with *Magenta Electronics*.

See the first page of books for full details.

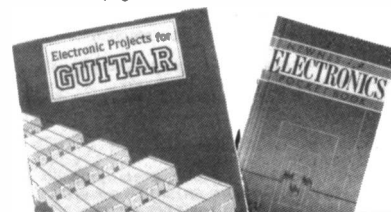

Testing and Test Gear

HOW TO USE OSCILLOSCOPES AND OTHER TEST EQUIPMENT

R. A. Penfold

This book explains the basic function of an oscilloscope, gives a detailed explanation of all the standard controls, and provides advice on buying. A separate chapter deals with using an oscilloscope for fault finding on linear and logic circuits, plenty of example waveforms help to illustrate the control functions and the effects of various fault conditions. The function and use of various other pieces of test equipment are also covered, including signal generators, logic probes, logic pulsed, and crystal calibrators. **104 pages** **Order code BP267** **£3.50**

Circuits and Design

Practical Electronic Filters

Owen Bishop

This book deals with the subject in a non-mathematical way. It reviews the main types of filter, explaining in simple terms how each type works and how it is used.

The book also presents a dozen filter-based projects with applications in and around the home or in the constructor's workshop. These include a number of audio projects such as a rhythm sequencer and a multi-voiced electronic organ.

Concluding the book is a practical step-by-step guide to designing simple filters for a wide range of purposes, with circuit diagrams and worked examples.

88 pages **Order code BP299** £4.95

Electronic Alarm Circuits Manual

R. M. Marston

One hundred and forty useful alarm circuits, of a variety of types, are shown in this volume. The operating principle of each one is explained in concise but comprehensive terms, and brief construction notes are given where necessary.

Aimed at the practical design engineer, technician and experimenter, as well as the electronics student and amateur.

124 pages **Order code NE11** £13.95

Digital Logic Gates and Flip-Flops

Ian R. Sinclair

This book, intended for enthusiasts, students and technicians, seeks to establish a firm foundation in digital electronics by treating the topics of gates and flip-flops thoroughly and from the beginning.

Topics such as Boolean algebra and Karnaugh mapping are explained, demonstrated and used extensively, and more attention is paid to the subject of synchronous counters than to the simple but less important ripple counters.

No background other than a basic knowledge of electronics is assumed, and the more theoretical topics are explained from the beginning, as also are many working practices. The book concludes with an explanation of microprocessor techniques as applied to digital logic.

200 pages **Order code PC106** £8.95

Electronic Circuits for the Computer Control of Robots

Robert Penfold

Robots and robotics offer one of the most interesting areas for the electronics hobbyist to experiment in. Today the mechanical side of robots is not too difficult, as there are robotics kit and a wide range of mechanical components available. The micro controller is not too much of a problem either, since the software need not be terribly complex and many inexpensive home computers are well suited to the task.

The main stumbling block for most would-be robot builders is the electronics to interface the computer to the motors, and the sensors which provide feedback from the

robot to the computer. The purpose of this book is to explain and provide some relatively simple electronic circuits which bridge this gap.

92 pages **Order code BP179** £2.95

Electronic Power Supply Handbook

Ian R. Sinclair

This book covers the often neglected topic of electronic power supplies. All types of supplies that are used for electronics purposes are covered in detail, starting with cells and batteries and extending by way of rectified supplies and linear stabilisers to modern switch-mode systems, IC switch-mode regulators, DC-DC converters and inverters.

The devices, their operating principles and typical circuits are all dealt with in detail. The action of rectifiers and the reservoir capacitor is emphasised, and the subject of stabilisation is covered. The book includes some useful formulae for assessing the likely hum level of a conventional rectifier reservoir supply.

136 pages **Order code PC108** £7.95

50 Simple LED Circuits

R. N. Soar

Contains 50 interesting and useful circuits and applications, covering many different branches of electronics, using one of the most inexpensive and freely available components - the light-emitting diode (LED). Also includes circuits for the 707 common anode display.

64 pages **Order code BP42** £1.95

Book 2 50 more I.e.d. circuits

Order code BP87 £1.95

Circuit Source Book 1

A. Penfold

Written to help you create and experiment with your own electronic designs by combining and using the various standard "building block" circuits provided. Where applicable, advice on how to alter the circuit parameters is given.

The circuits covered in this book are mainly concerned with analogue signal processing and include: Audio amplifiers (op.amp and bipolar transistors); audio power amplifiers; d.c. amplifiers; highpass, lowpass, bandpass and notch filters; tone controls; voltage controlled amplifiers and filters; triggers and voltage comparators; gates and electronic switching; bargraphs; mixers; phase shifters, current mirrors, hold circuits, etc.

Over 150 circuits are provided, which it is hoped will be useful to all those involved in circuit design and application, be they professionals, students or hobbyists.

182 pages **Order code BP321** £4.95

Circuit Source Book 2

R. A. Penfold

This book will help you to create and experiment with your own electronic designs by combining and using the various standard "building blocks" circuits provided. Where applicable, advice on how to alter the circuit parameters is provided.

The circuits covered are mainly concerned with signal generation, power supplies, and digital electronics.

The topics covered in this book include: 555 oscillators; sinewave oscillators; function generators; CMOS oscillators; voltage controlled oscillators; radio frequency oscillators; 555 monostables; CMOS monostables; TTL monostables; precision long timers; power supply and regulator circuits; negative supply generators and voltage boosters; digital dividers, decoders, etc.; counters and display drivers; D/A and A/D converters; opto-isolators, flip/flops, noise generators, tone decoders, etc.

Over 170 circuits are provided, which it is hoped will be useful to all those involved in circuit design and application, be they professionals, students or hobbyists.

192 pages **Order code BP322** £4.95

How to Use Op-Amps

E. A. Parr

This book has been written as a designer's guide covering many operational amplifiers, serving both as a source book of circuits and a reference book for design calculations. The approach has been made as non-mathematical as possible.

160 pages **Order code BP88** £2.95

A Beginners Guide to TTL Digital ICs

R. A. Penfold

This book first covers the basics of simple logic circuits in general, and then progresses to specific TTL logic integrated circuits. The devices covered include gates, oscillators, timers, flip/flops, dividers, and decoder circuits. Some practical circuits are used to illustrate the use of TTL devices in "real world" applications.

142 pages **Order code BP332** £4.95

DIRECT BOOK SERVICE

ORDERING DETAILS

Please state the title and order code clearly, print your name and address and add the required postage to the total order.

Add £1.50 to your total order for postage and packing (overseas readers add £3 for countries in Europe, or add £6 for all countries outside Europe, surface mail postage) and send a PO, cheque, international money order, (£ sterling only) made payable to Direct Book Service or credit card details (including the card expiry date), Visa or Mastercard (Access) - minimum credit card order is £5 - quoting your name and address, the order code and quantities required to DIRECT BOOK SERVICE, 33 GRAVEL HILL, MERLEY, WIMBORNE, DORSET BH21 1RW (mail order only).

Although books, videos and software are normally sent within seven days of receipt of your order, please allow a maximum of 28 days for delivery. Overseas readers allow extra time for surface mail post.

Please check price and availability (see latest issue of *Everyday with Practical Electronics*) before ordering from old lists.

Note - our postage charge is the same for one book or one hundred books!

MORE BOOKS NEXT MONTH
Direct Book Service is a division of Wimborne Publishing Ltd

Tel: 01202 881749
Fax: 01202 841692

Radio, TV, Satellite

Projects for Radio Amateurs and S.W.L.S.

R. A. Penfold

This book describes a number of electronic circuits, most of which are quite simple, which can be used to enhance the performance of most short wave radio systems.

The circuits covered include:- An aerial tuning unit; A simple active aerial; An add-on b.f.o. for portable sets; A wavetrapp for combat signals on spurious responses; An audio notch filter; A parametric equaliser; C.W. and S.S.B. audio filters; Simple noise limiters; A speech processor; A volume expander.

Other useful circuits include a crystal oscillator, and RTTY/C.W. tone decoder, and a RTTY serial to parallel converter. A full range of interesting and useful circuits for short wave enthusiasts.

92 pages **Order code BP304** £3.95

An Introduction to Amateur Radio

I. D. Poole

Amateur radio is a unique and fascinating hobby which has attracted thousands of people since it began at the turn of the century.

This book gives the newcomer a comprehensive and easy to understand guide through the subject so that the reader can gain the most from the hobby. It then remains an essential reference volume to be used time and again.

Topics covered include the basic aspects of the hobby, such as operating procedures, jargon and setting up a station. Technical topics covered include propagation, receivers, transmitters and aerials etc.

150 pages **Order code BP257** £3.50

Simple Short Wave Receiver Construction

R. A. Penfold

Short wave radio is a fascinating hobby, but one that seems to be regarded by many as an expensive pastime these days. In fact it is possible to pursue this hobby for a minimal monetary outlay if you are prepared to undertake a bit of d.i.y., and the receivers described in this book can all be built at low cost. All the sets are easy to construct, full wiring diagrams etc. are provided, and they are suitable for complete beginners. The receivers only require simple aerials, and do not need any complex alignment or other difficult setting up procedures.

The topics covered in this book include: The broadcast bands and their characteristics; The amateur bands and their characteristics; The propagation of radio signals; Simple aerials; Making an earth connection; Short wave crystal set; Simple t.r.f. receivers; Single sideband reception; Direct conversion receiver.

Contains everything you need to know in order to get started in this absorbing hobby.

88 pages **Order code BP275** £3.95

An Introduction to Amateur Communications Satellites

A. Pickford

Communications and broadcast satellites are normally inaccessible to individuals unless they are actively involved in their technicalities by working for organisations such as British Telecom, the various space agencies or military bodies, even those who possess a satellite television receiver system do not participate in the technical aspects of these highly technological systems.

There are a large number of amateur communications satellites in orbit around the world, traversing the globe continuously and they can be tracked and their signals received with relatively inexpensive equipment. This equipment can be connected to a home computer such as the BBC Micro or IBM compatible PCs, for the decoding of received signals.

This book describes several currently available systems, their connection to an appropriate computer and how they can be operated with suitable software.

102 pages **Order code BP290** £3.95

Aerial Projects

R. A. Penfold

The subject of aerials is vast but in this book the author has considered practical aerial designs, including active, loop and ferrite aerials which give good performances and are relatively simple and inexpensive to build. The complex theory and mathematics of aerial design have been avoided.

Also included are constructional details of a number of aerial accessories including a pre-selector, attenuator, filters and tuning unit.

96 pages **Order code BP105** £2.50

International Radio Stations Guide

P. Shore

Provides the casual listener, amateur radio DXer and the professional radio monitor with an essential reference work designed to guide him or her around the ever more complex radio bands. This new edition has been completely revised and rewritten and incorporates much more information which is divided into the following sections:

Listening to Short Wave Radio; Choosing a Short Wave Radio Receiver; How to Use the IRSG; Abbreviations; Country Codes; Worldwide Short Wave Radio Stations; European, Middle Eastern and African Long Wave Radio Stations; European, Near and Middle Eastern and African Medium Wave Radio Stations; Canadian Medium Wave Radio Stations; USA Medium Wave Radio Stations; Broadcasts in English; Programmes for DXers and Short Wave Listeners; UK FM Radio Stations; Time Differences From GMT; Wavelength/Frequency Conversion.

226 pages **Order code BP255** £5.95

WE HAVE THE WIDEST CHOICE OF USED OSCILLOSCOPES IN THE COUNTRY

TEKTRONIX 7000 SERIES OSCILLOSCOPES
Available from £200 - PLUG-INS SOLD SEPARATELY

TEKTRONIX 2246A 4 Channel 100MHz Cursors Voltmeter etc	£1250
TEKTRONIX 2245A 4 Channel 100MHz Cursors etc	£1000
TEKTRONIX 475 Dual Trace 100MHz Delay Sweep	£900
TEKTRONIX 465 Dual Trace 100MHz Delay Sweep	£400
TEKTRONIX SC504 Dual Trace 80MHz in TM503B	£300
WATSU 555711C 4 Channel 100MHz Delay Sweep with DMM	£300
TRO CS2070 4 Channel 70MHz Delay Sweep	£450
TEKTRONIX 2213 Dual Trace 60MHz	£350
HITACHI VS50F Dual Trace 60MHz Delay Sweep	£200
PHILIPS PM3217 Dual Trace 50MHz Delay Sweep	£200
TELEQUANTUM DB3 Dual Trace 50MHz Delay Sweep	£240
GOULD 051100 Dual Trace 30MHz with Delay	£200
GOULD 051100S1 Dual Trace 30MHz	£200
HITACHI 412 Dual Trace 20MHz Trig to 40MHz Delay	£225
GOULD 05300 Dual Trace 20MHz	£200
TEKTRONIX T992 Dual Trace 15MHz	£200
GOULD 0520B Dual Trace 15MHz	£125
WATSU 555702 Dual Trace 20MHz	£200
TRO CS1566A Dual Trace 20MHz	£200
LE CROY 9400 Dual Trace 125MHz Digital Storage	£1000
Hirachi VC6045 Dual Trace 100MHz 40MHz/5 Cursors Digital Storage	£1100
PHILIPS PM3305 4 Trace 25MHz Digital Storage	£650
TEKTRONIX 466 Dual Trace 100MHz Analogue Storage	£400
GOULD 054000 Dual Trace 100MHz Digital Storage	£200

HP 3458A 6 digit DC/True RMS AC Res HP/IB	£600
EP/DANA 3510 Microwave Frequency Counter 20Hz-18GHz	£900
HP 5341A Frequency Counter 50MHz-1.5GHz LED	£300
MARCONI 2435 Digital Frequency Meter 20Hz	£600
RACAL 1938F Freq Counter 1.5GHz 0.0005% CB/B High Stabl	£900
RACAL Dana 3520 Universal Counter/Timer 160MHz 8 digit	£500
MARCONI 2437 Universal Counter/Timer DC-100MHz 8 digit	£175
MARCONI 2431A Frequency Counter 10Hz-200MHz 8 digit	£150
MARCONI 2430A Frequency Counter 10Hz-80MHz 8 digit	£125
RACAL 9918 Frequency Counter 10Hz-520MHz 9 digit	£200
DATACON 9915 Frequency Meter/Timer 200kHz/8 digit	£125
DATACON 1061A 5.5 digit Autocal Multimeter True RMS AC/Current	£650
HP 3490A 5 digit Multimeter AC/DC Ohms	£200
HP 3455A 3.5 digit Multimeter AC/DC Ohms Current LED	£100
PHILIPS PM2334 Multi Function DMM 3.5-6.5 digit GPIB IEEE	£450
SOLAATRON 7150 6.5-3.5 digit DMM with IEEE	£600
SOLAATRON 7045 4.5 digit Multimeter Vrms/Amos/Ohms	£300
WAYNE KERR 8905 Automatic Precision Bridge 0.05%	£600
MARCONI TF2700 Universal Bridge Battery operated	from £150
MARCONI TF1315A Universal LCR Bridge 0.1%	£125
WAYNE KERR 8424 Digital Component Tester LCR	£200
HEATHKIT IB RLC Bridge	£80
BRADLEY 192 Oscilloscope Calibrator	£600
WILTRON 560 Scaler Network Analyser with Detectors	£1000
FARNELL H30100 0-30V 0-100A Metered	£800
FARNELL TV570 Mk2 70V 5A/35V 10A Metered	£200
FARNELL B5010 30V 10A Variable	£200
FARNELL L30E 0-30V 0-5A Metered	£95
THURLEY PL3200M0 50V 2A True Digital	£250
THURLEY PL320 30V 2A Digital	£120
MARCONI IWEIR TF2154 0-30V 1A 0-15V 2A 0-75V 4A Metered	£80
HP 8516A 0-3Kv 0-6mA Metered	£150
BRANDENBURG 472R PSU - 21V	£200
FEDERBACH F6200 Sine Sq/Tri 0.01Hz-100kHz	£30
BLACK STAR Meter 100-100MHz Freq Counter	£70
BLACK STAR Jupyter 500 500kHz Fun Gen Sine/Sq/Tri/WTZ	£70
LYONS PG71N Pulse Gen 100nsps 10MHz 11sec 1Hz	£75
FARNELL PGT01 Pulse Gen 100nsps 10MHz 11sec 1Hz	£125
LINDON LK1 Mk2 20 Audio Analyser	£500
UNIDUHI EP501 Audio Analyser	£100
PHILIPS PM5518 Colour TV Pattern Generator	£300
HP 4275A Multi Freq LCR Component Meter	£3500
HANDER TC501 Fun Gen 0.0005Hz-5MHz Sine/Sq/Tri/Ramp/Pulse etc	£200
MARCONI TF2331 Distortion Factor Meter 20Hz-20kHz 0.05%	£150

THIS IS JUST A SAMPLE - MANY OTHERS AVAILABLE

NEWEST FACED 1740A OSCILLOSCOPES
100MHz Dual Trace Delay Sweep For Only £350

MARCONI 2018 Synthesised AM/FM Sig Gen 80kHz-520MHz	£700
HP 8640B Sig Gen 500kHz-102MHz	£1000
HP 8620C Sweep Oscillator with 86245A 5.9-12.4GHz	£400
SYSTRON DDMER 1702 Synth AM/FM Sig Gen 100kHz-1GHz	£800
RACAL 9081 Synthesised Sig Gen 5-520MHz	£500
FARNELL S5C20 Synthesised AM/FM Sig Gen 10MHz-520MHz	£200
MARCONI TF2015 AM/FM Sig Gen 10kHz-510MHz	£200
MARCONI TF2015 With Synchronizer TF2171 (lock box)	£350
MARCONI SANDERS 6600A Microwave Sweep Osc 26.5-40GHz	£180
HP 3670B Microwave Sweep Osc 26.5-40GHz	£2000
HP SMTX ANTENNA Type 12 802.4	£400
RACAL INSTRUMENT RECORDER type Store 40N	£500
HP 3575A Gain Phase Meter 1Hz-13MHz	£400
MARCONI TF2337 Automatic Distortion Meter	£200
SAYROSA Automatic Modulation Meter type 252B	£125
BADFORD LDC Low Distortion Oscillator	£300
BADFORD LWS2 Low Distortion Measuring Set	£100

NEW EQUIPMENT

HAMEG OSCILLOSCOPE HM1005 Triple Trace 100MHz Delay Timebase	£847
HAMEG OSCILLOSCOPE HM604 Dual Trace 60MHz Delay Sweep	£653
HAMEG OSCILLOSCOPE HM303 Dual Trace 30MHz Comp Tester	£592
HAMEG OSCILLOSCOPE HM205-3 Dual Trace 20MHz Digital Storage	£663
*All other models available - oscilloscopes supplied with 2 probes	
BLACK STAR EQUIPMENT (P&P ALL UNITS £5)	
APOLLO 10 100MHz Counter Timer Ratio/Period/Time ant etc	£222
APOLLO 100 100MHz (as above with more functions)	£325
METER 100 FREQUENCY COUNTER 100MHz	£1700
METER 600 FREQUENCY COUNTER 600MHz	£145
METER 1000 FREQUENCY COUNTER 1GHz	£189
JUPITER 500 FUNCTION GEN 0.1Hz-500kHz Sine/Sq/Tri	£189
ORCON COLOUR BAR GENERATOR Pal/TV/Video	£229
OSCILLOSCOPE PROBES Switched X1 X10 (P&P £5)	£12

SPECTRUM ANALYSERS

HP 8558A 0.01-20MHz	£5000
HP 3580A LEO 0.5MHz-50kHz	£1000
POLAROID 641-1 10MHz-180Hz	£1500
ANCO ACB281 with ACB211 1700MHz	£1500
HP 182 with 8558B 100kHz-1500kHz	£1500
HP 141T with 8554B & 8552B 500kHz-1250MHz	£1200
HP 141T with 8553B & 8552A 1Hz-110MHz	£800
MARCONI TF2370 30Hz-110MHz	£1000
HP 8443 Tracking Gen/osc's available from	£300
HP 141T Main Frames Only Good Tubes	£700

Used Equipment - Guaranteed. Manuals supplied if possible.
This is a VERY SMALL SAMPLE OF STOCK. SAE or telephone for lists. Please check availability before ordering. CARRIAGE all units £18. VAT to be added to Total of Goods and Carriage.

STEWART OF READING
110 WYKHAM ROAD, READING, BERKS RG6 1PL
Tel: 01734 268041 Fax: 01734 351696 Callers welcome 9am to 5.30pm MON-FRI (UNTIL 8pm THURS)

NEWMARKET TRANSFORMERS LTD.
Unit 15, Craven Way Industrial Est., Newmarket, Suffolk, CB8 0AP
Telephone: (0638) 662989 Facsimile: (0683) 660799
TOROIDAL TRANSFORMER MANUFACTURERS
220/240V ANY Two Secondaries

VA	Price	Dimensions
30	£11.30	70 x 35mm
50	£12.40	80 x 45mm
80	£13.90	90 x 35mm
120	£14.80	90 x 45mm
160	£17.85	110 x 45mm
225	£19.20	110 x 50mm
300	£22.70	110 x 60mm
500	£29.85	140 x 60mm
625	£34.70	140 x 70mm
800	£39.80	125 x 90mm
1000	£45.70	160 x 70mm

Prices include VAT & Carriage
For further information and quantity discounts, contact Michael Dorman
Phone: 0638 662989 Fax: 0638 660799

SHERWOOD ELECTRONICS
7 William Street, Mansfield, Notts, NG19 6TD
CHOOSE 1 x £1 packs FREE with every 10 purchased

SP1 15 x 5mm Red Leds	SP37 15 x 100/35V radial elect caps
SP2 15 x 5mm Green Leds	SP42 200 x Mixed 0.25W C.F. resistors
SP3 12 x 5mm Yellow Leds	SP47 5 x Min push button switches
SP4 10 x 5mm Amber Leds	SP102 20 x 8 pin DIL sockets
SP10 100 x 1N4148 diodes	SP103 15 x 14 pin DIL sockets
SP11 30 x 1N4001 diodes	SP104 15 x 16 pin DIL sockets
SP12 30 x 1N4002 diodes	SP112 5 x Cmos 4093
SP18 20 x BC182 transistors	SP125 10 x 1000/40V radial elect caps
SP20 20 x BC184 transistors	SP130 100 x Mixed 0.5W C.F. resistors
SP22 20 x BC214 transistors	SP133 20 x 1N4004 diodes
SP23 20 x BC549 transistors	SP137 4 x W005 1.5A rectifiers
SP25 4 x 555 timers	SP142 2 x Cmos 4017
SP28 5 x Cmos 4011	SP147 5 x Stripboard 9 strips/25 holes
SP29 4 x Cmos 4013	SP156 3 x Stripboard 14 strips/27 holes
SP33 5 x Cmos 4081	SP167 6 x BC107 transistors
SP36 25 x 10/25V radial elect caps	SP183 20 x BC547 transistors

RESISTOR PACKS - 0.25W C.F. Film
RP3 5 each value - total 365 £2.75
RP7 10 each value - total 730 £4.15
RP10 1000 popular values £5.60

Catalogue available - £1 or FREE with first order over £5 goods value

Cheques or P.O. to **SHERWOOD ELECTRONICS** NO VAT
Please add £1.25 P&P to all orders

PCB SERVICE

Printed circuit boards for certain EPE constructional projects are available from the PCB Service, see list. These are fabricated in glass fibre, and are fully drilled and roller tinned. All prices include VAT and postage and packing. Add £1 per board for airmail outside of Europe. Remittances should be sent to The PCB Service, Everyday with Practical Electronics, Allen House, East Borough, Wimborne, Dorset BH21 1PF. Cheques should be crossed and made payable to Everyday with Practical Electronics (Payment in £ sterling only).

NOTE: While 95% of our boards are now held in stock and are dispatched within seven days of receipt of order, please allow a maximum of 28 days for delivery - overseas readers allow extra if ordered by surface mail.

Back numbers or photostats of articles are available if required - see the Back Numbers page for details.
Please check price and availability in the latest issue.
Boards can only be supplied on a payment with order basis.

Special KNOCK DOWN SALE of PCB's.
We have a few p.c.b.s left from past projects these are being offered at the knock down price of £1.00 each - no matter what size they are (some of these boards are worth over £8.00 each) while stocks last. This price includes VAT and UK post - overseas orders please add 50p postage (or £1 per board for airmail postage).

Tea Tune Thermostat 609; Suntan Timer 610; Time Switch 614; Doorbell Delay 616; Midi Pedal 639; Midi Merge 640; Audio Lead Tester 641; 4-Channel Auto Fader Interface 642; Music on Hold 646; Power Supply 25V 700mA 656; Stereo Noise Generator 681; Amstrad Speech Synthesiser 689; Hand Tally, main board 699 and display board 700; Ghost Waker 703; EE Muskteer TV/Video/Audio Remote Control 706; Amstrad PCW Sound Generator 715; Simple Basic Alarm 731; Model Train Controller 736; Digital LCD Thermostat, control board 740 and power relay board 741; Automatic Light Control - PSU board 747 and logic board 748; Modular Disco Lights - Simple Chaser 745 - Sweeper 746 - Masterlink 752 - Pattern Generator 760 - Dimmer Interface 765 - VU Sound Module 767 - Superchaser 771 - Supersweep 772; UV Exposure Unit 768; Bicycle Alarm 773; Knockerbox 775; Auto Nightlight 779.

Any of the above for just £1 each inc. VAT and p&p.
Back numbers or photostats of articles are available see the Back Numbers page for details.

PROJECT TITLE	Order Code	Cost
Mind Machine - Programmer Board	JAN '92	780
Transistor Checker	781	£7.39
Stepping Motor Driver/Interface	782	£4.63
Micro-Sense Alarm	783	£10.39
Telesound Programmable Timer	FEB '92	784
	785	£4.66
Auto Garage Light	MAR '92	786
Versatile BBC Computer Interface	787	£6.10
Economy Seven Timer	788	£11.59
		£5.20
Sonic Continuity Tester	APR '92	89
Telephone Ringer	790	£4.79
Experimental Weighing Scale	MAY '92	792
12V Drill Charger/PSU (both boards)	793	£5.17
Digital Servo Interface	JUNE '92	791
Tie Pulser	794	£4.73
CCD Reverb Unit	795	£5.19
Switch-Mode Power Supply	796	£6.39
		£7.01
UV Exposure Timer	JULY '92	797
Cricket Game	798	£5.33
Quick Prom	799	£6.77
Gas Alarm	AUG '92	800
Dual Metronome	801	£5.47
		£6.74
Ultrasonic Tape Measure	SEP '92	802
Quicktest	803	£6.06
		£4.82
Extended Range Capacitance Meter	OCT '92	804
Traffic Lights System	806	£5.63
		£5.04
Mini Lab	NOV '92	MINI LAB
EPE Altimet (Altimeter)	807	£14.95
Personal Stereo Amplifier	808	£6.30
		£6.47
Universal Infra-Red Remote Control	DEC '92	811T/811R
Combination Switch	812	£6.56
Christmas Lights Colour Spectrum	813	£5.68
		£5.97
TV/UHF Aerial Amp (double-sided)	JAN '93	814
Continuously Variable Balanced Power Supply	815	£7.23
Emergency Lighting Unit	816	£5.65
		£6.77
Biomet Pulse Monitor	FEB '93	817
Sensor	818	£6.30
Display		£6.30

REPORTING

AMATEUR RADIO

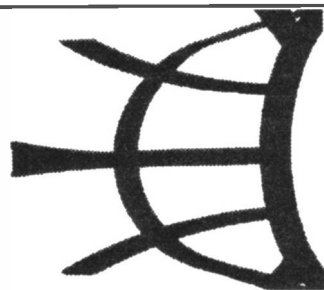

Tony Smith G4FAI

MORSE TEST DISCUSSIONS

In the February issue it was briefly reported that the International Amateur Radio Union's Administrative Council (AC) had decided to "neither propose nor support a change... at this time" in the current ITU Radio Regulations that require a Morse test for operation in the amateur frequencies below 30MHz.

The IARU has now issued a 26-page document which explains the background to this decision, and contains the report of the "CW Ad Hoc Committee", set up to make recommendations on this controversial issue.

The report begins with the definition of the Amateur Service as given by the International Telecommunication Union (ITU) in Article 1 of the International Radio Regulations:

"53. Amateur Service: A radiocommunication service for the purpose of self-training, *intercommunication* and technical investigations carried out by amateurs, that is, by duly authorized persons interested in radio technique solely with a personal aim and without pecuniary interest."

The word *intercommunication* in this definition (italics added) is given a special significance in the Committee's report, and it considers RR 2735 (in Article 32 of the Radio Regulations) specifically in terms of this definition:

"2735. Any person seeking a licence to operate the apparatus of an amateur station shall prove that he is able to send correctly by hand and to receive correctly by ear texts in Morse code signals. The administrations concerned may, however, waive this requirement in the case of stations making exclusive use of frequencies above 30 MHz."

FUTURE CHANGE NOT RULED OUT

In essence, the Committee came to the conclusion that the Morse code, with its use of Q-code and unique abbreviations - understood by operators in every country, irrespective of the spoken languages used, provides an effective common language for radio amateurs, and that at the present time this is the only practical way that intercommunication, as defined in RR53, can be practised by the Amateur Service.

It recommended, therefore that no change be made in the present regulations. However, it did not rule out the possibility that future technical developments may provide "an alternative means for ensuring that amateur stations can intercommunicate, and that these new means could become sufficiently universal to obviate the present requirement."

IARU POLICY

At its meeting in Singapore on 10 to 12 September 1994, the IARU Administrative Council received the report of the

CW Ad Hoc Committee and the following Resolution was adopted:

"Noting that the Morse code provides a means of intercommunication between peoples without regard to language barriers.

"Recognizing that the international radio regulations require that ability in the use of Morse code must be demonstrated before an operator's license for the use of amateur frequencies below 30MHz can be issued...

"Recognizing that support of this requirement has been affirmed at the most recent conference of each of the three IARU regional organizations...

"Further recognizing that future advances in communications technology may influence perceptions of the relevance of this requirement...

"Considering the report of the IARU CW Ad Hoc Committee, submitted to the Administrative Council in timely response to the Administrative Council's instruction at its Brussels meeting, September 1993...

"Decides to neither propose nor support any change to the international radio regulations pertaining to Morse code...

"Invites member-societies to consider the matter at future regional conferences and through this medium to communicate their views to the Administrative Council."

UNDERSTANDING NEEDED

Putting the question of licensing requirements aside, the Committee suggests that a wider understanding of the position of Morse code in amateur radio is needed in training courses for all grades of the amateur radio licence.

This includes an appreciation of the purpose of the Morse code and its place in amateur radio as a background during study for the "codeless" licences for operation above 30MHz. This, it says, may ensure that future discussion about the role of Morse code in amateur radio will be conducted on a factual rather than an emotional level.

The Committee concludes that competency in Morse code is essential real world preparation for operating on the world-wide HF amateur bands. That it is also a mandatory regulatory requirement necessary to sustain the control and the special characteristics of the Amateur Service in international working.

It also says, "Every entrant to Amateur Radio should have an understanding of these matters and an appreciation of the thrills and satisfaction that competency in the Morse code can bring."

ESTABLISHED MORSE POLICIES

The Committee reviewed recent decisions or developments in the IARU Regions and in some member-countries. In 1993, IARU Region 1 decided to maintain its present position regarding the need for a Morse test. Region 2, at its

conference in 1992, saw no need for any change to RR 2735, and Region 3, in 1994, unanimously supported the continuation of the Morse test as required by the ITU Radio Regulations.

The New Zealand Association of Radio Transmitters (NZART) after conducting a survey of its membership, developed a policy in 1994 supporting the continuation of the test under present circumstances. The Radio Society of Great Britain, in 1993, also conducted a survey in which support was two to one in favour of retention of the current Morse requirement.

The American Radio Relay League (ARRL), in January 1993, declared its support for the test, and instructed its representatives to insist before all national and international bodies that there be no modification to the present proficiency requirement.

OTHER BODIES

A seminar on Amateur Radio Communications, organised by the Asia-Pacific Telecommunity (APT), held in Tokyo in June 1994, agreed that the international Morse code should remain a basic requirement for amateur radio below 30MHz.

Finally, the Committee notes that within the ITU itself, the "Voluntary Group of Experts to study Allocation and Improved use of the Radio-frequency Spectrum and Simplification of the Radio Regulations", in its "Final Report to the Council and Administrations", proposes no change to the text content of Article 32 of the current Radio Regulations, indicating that no change is proposed to Regulation 2735 by the Group.

CELEBRATORY SATELLITE

On December 26, Russia launched its *RS15* amateur satellite to commemorate the 100th anniversary of the discovery of radio by Aleksandr Stepanovich Popov in 1895. Popov's work is the basis for the controversial Russian belief that he, and not Marconi, was the inventor of wireless communication.

The western world, of course, generally accepts that Marconi made his first transmissions in the same year, and is celebrating the centenary of that event also.

The basic details of the Russian satellite are: Uplink, 145.858MHz to 145.898MHz; Downlink, 29.354MHz to 29.394MHz; CW Beacon 1, 29.3525MHz; CW Beacon 2, 29.3987MHz.

Its weight is 70 kg; and it is orbiting the earth every 127.45 minutes. It is commanded by the RS3A control station at Moscow, headed by Leonid Maksakov, RA3AT. Comments and reception reports are requested, and should be sent to the RS3A Control Station, PO Box 59, Moscow 105122, Russia. (*W5YI Report*).



Transmitter TXM-418-A



Receiver SILRX-418-A



Transceiver BIM-418-F

NEW !

Transmitters :

PART No	MPT	Freq MHz	Data Rate	ERP mW	Power (Vs)	Price 1 +
TXM-418-A	1340	418	9600	0.25	6 - 9	£14.00
TXM-418-F	1340	418	19200	0.25	3.0	£15.64
TXM-433-A	N/A	433.92	9600	0.25	6 - 9	£15.64
TXM-433-F	N/A	433.92	19200	0.25	3.0	£15.64
TXM-4689-UK-00	1328 1344	173.250 173.225	1000	1.0	3.0	£25.48
TXM-4689-UK-03	1344	173.225	1000	10.0	3.0	£27.50
TXM-4688	1309	173.225	600	1/10	8 - 16	£31.27

Receivers :

PART No	Freq MHz	RSSI	CD	Data Rate	Power (V)	Price 1+
RXM-418-A	418	Yes	Yes	10000	5.0	29.05
RXM-433-A	433.92	Yes	Yes	10000	5.0	31.27
SILRX-418-A	418	No	Yes	5000	4.5 - 9	22.50
SILRX-433-A	433.92	No	Yes	5000	4.5 - 9	25.58
RXM-4666-60	173.225 173.250	Yes	Yes	1000	5.0	31.62

The BIM High Speed Transceiver :

Part No	MPT	Freq MHz	Data Rate	Power (V)	ERP mW	Price 1 +
BIM-418-F	1340	418	34000	5.0	0.25	49.95
BIM-433-F	ETS	433.92	34000	5.0	1.0	49.95

The NEW BIM Engineering Kit.

Only £149.95

To assist new customers unfamiliar with the BIM, we are offering an engineering kit comprising of two PCB's each containing a BIM-418-F transceiver, control logic, status LED's and a PIC microcontroller packed with test firmware. Using the kit you will be able to simulate data transfer at up to 34000bps, conduct range test, evaluate various data protocols and finally transmit your own data.

Order Code: BIM-418-DEV

Save £15.00 off your next order over £50.00

£15.00

Return this coupon with your next order: Valid until 6/95.

Name _____

Company _____

Address _____

PostCode _____

Tel: _____

Orders: Prices exclude carriage and VAT. Radio - Tech Limited, Overbridge House, 41 Weald Hall Lane, Thornwood Common, Epping, CM16 6NB. Telephone and credit card orders welcome.

Tel: London 0181-368-8277 Home Counties 01992 - 576107 Fax 01992 -561994



EVERYDAY CLASSIFIED

With **PRACTICAL**

ELECTRONICS

Everyday with Practical Electronics reaches twice as many UK readers as any other independent monthly hobby electronics magazine, our audited sales figures prove it. We have been the leading independent monthly magazine in this market for the last ten years

If you want your advertisements to be seen by the largest readership at the most economical price our classified and semi-display pages offer the best value. The prepaid rate for semi-display space is £8 (+VAT) per single column centimetre (minimum 2.5cm). The prepaid rate for classified adverts is 30p (+VAT) per word (minimum 12 words).

All cheques, postal orders, etc., to be made payable to Everyday with Practical Electronics. **VAT must be added.** Advertisements, together with remittance, should be sent to Everyday with Practical Electronics Advertisements, Holland Wood House, Church Lane, Great Holland, Essex CO13 0JS. Phone/Fax (01255) 850596.

For rates and information on display and classified advertising please contact our Advertisement Manager, Peter Mew as above.

Greenwell Micro Systems
Office Management Software

CIMS - Manage Customers and Invoices
SOMS - Manage Suppliers and Orders
CSMS - Manage Contacts and Sales

Available separately any combination or as a complete package. Ideal for any business. Also for sale floppy disks.

G.M.S., Unit 26, Wirral Business Park, Brassey Street, Birkenhead, Wirral, L41 8BY.
Tel: 0151 653 4515, Fax: 0151 651 0177.

THE BUG CONSTRUCTOR'S MANUAL

All you will ever need to know about Bugs. Over 40 Bug circuits for every application. Telephone, High Power, Crystal Controlled, and UHF Bugs and many pages of useful information. Many previously unavailable circuits. This is the very latest book, and the "ONLY" book of its kind in the UK. A valuable asset for the hobbyist and professional. Introductory offer price only £9.95 inc. P&P

For immediate despatch, send cheque or P.O.'s payable to:
GAINSFORD ELECTRONICS,
71 Gainsford Road, Southampton SO19 7AW.

MINI CCD CAMERA

Latest low-light (0.1lux), IR-sensitive mini camera from KOCOM #CA-H34C. 6 IR LEDs on board. 54mm x 38mm. 12V. Uncased. 33gm. Plugs direct into VCR or video monitor. £145 reg. airmail. Bank draft on any HK bank.

DIY ELECTRONICS
PO Box 88458, Sham Shui Po, Hong Kong.

THE BRITISH AMATEUR ELECTRONICS CLUB

exists to help electronics enthusiasts by personal contact and through a quarterly Newsletter.

For membership details, write to the Secretary:
Mr. J. F. Davies, 70 Ash Road, Cuddington, Northwich, Cheshire CW8 2PB.

Space donated by Everyday with Practical Electronics

No PLOTTER?

View, print or paste HP plotter files produced via CAD systems, scopes or received via modem etc. on your PC with this handy Windows utility.

Contact P. Handscomb at:
Silicon Vale Software
147 Manchester Road, Stockport SK4 1NL
Phone/Fax 0161 480 1451

YUGA ENTERPRISE
BA, LA, LB, LC, UP, A,
UPB, UPC, TA,
TBA, TDA, TEA,
2SA, 2SB, 2SC,
2SJ, 2SK, SAA,
STA, STK, STR,
HA, AC, KA, KIA,
IX, LM, MN, PA

Buy & Sell Japanese ICs & Transistors

TEL: (65) 741 0300
FAX: (65) 749 1048

705 Sims Drive #03-09
Shun Li Industrial Complex,
Singapore 1438.

BTEC ELECTRONICS TECHNICIAN FULL-TIME TRAINING

THOSE ELIGIBLE CAN APPLY FOR E.T. GRANT SUPPORT AN EQUAL OPPORTUNITIES PROGRAMME

O.N.C., O.N.D. and H.N.C.

Next course commences
Monday 24th April 1995
FULL PROSPECTUS FROM

LONDON ELECTRONICS COLLEGE
(Dept EPE) 20 PENYWERN ROAD
EARLS COURT, LONDON SW5 9SU
TEL: 071-373 8721

RCS VARIABLE VOLTAGE D.C. BENCH POWER SUPPLY

1 to 24 volts up to 1/2 amp. 1 to 20 volts up to 1 amp. 1 to 16 volts up to 1 1/2 amps d.c. Fully stabilised. Twin panel meters for instant voltage and current readings. Overload protection

Fully variable. Operates from 240V a.c. Compact unit. Size 9 x 5 1/2 x 3in.

NEW MODEL. Up to 30volts d.c. at 6 amps. 10 amps peak. Fully variable. Twin panel meters. Size 14 1/2 x 11 x 4 1/2in. £98 inc VAT. Carr £6

RADIO COMPONENT SPECIALISTS
337 WHITEHORSE ROAD, CROYDON SURREY, U.K. Tel: 0181-684 1665

Lots of transformers, high volt caps, valves, speakers, in stock. Phone or send your wants list for quote.

DIY ELECTRONICS
PO Box 88458, Sham Shui Po, Hong Kong.

Looking for a Job!

Are you too old, way over-qualified, got some capital and a little attitude? Interested in electronics? So was I. In 4 years I have set up my own, profitable electronic Kit business from nothing. Now I need people to work with me to sell into UK/Europe. Good designs, modern Kits. I can also supply electronic components.

Peter Crowcroft, **DIY ELECTRONICS**
PO Box 88458, Sham Shui Po, Hong Kong.
Fax: 852-2725 0610.

EVERYDAY
With **PRACTICAL**

ELECTRONICS

SUBSCRIPTION ORDER FORM

Annual subscription rates (1995):
UK £24.00.
Overseas £30.00 surface mail,
£47.50 airmail.

To:
Everyday with Practical Electronics,
Allen House, East Borough, Wimborne,
Dorset BH21 1PF

TEL: 01202 881749 Fax: 01202 841692

Miscellaneous

PROTOTYPE PRINTED CIRCUIT BOARDS one offs and quantities, for details send s.a.e. to B. M. Ansbro, 38 Poyning's Drive, Hove, Sussex BN3 8GR, or phone Brighton 883871.

G.C.S.E. ELECTRONICS KITS, at pocket money prices. S.A.E. for FREE catalogue. SIR-KIT Electronics, 70 Oxford Road, Clacton, CO15 3TE.

PLDs AND EPROMS copied or programmed. We supply logic devices/convert discrete logic to PLDs. Also PCBs designed. Send for details to PO Box 1561 Bath (0225 444467).

VALVE ENTHUSIASTS: Capacitors and other parts in stock. For free advice/lists please ring, Geoff Davies (Radio), Tel: 0788 574774.

PRINTED CIRCUIT BOARDS - QUICK SERVICE. Prototype and Small Production. We can raise your artwork from magazines or your draft designs at low cost. PCB's also designed from schematics. For details send to P. Agar, 36 Woodcot Avenue, Belfast, BT5 5JA or phone 01232 473533 (7 days).

LASER POINTERS 5mW 670nm (RED). German quality, £69.50 post paid. Also complete He-Ne Laser systems from £85.00. Telephone 01925 575848 for details. Cheques or PO to, English Scientific, 12 Orford Avenue, Warrington, Cheshire, WA2 7QL.

Typefit

The Typesetting program for all your Typesetting needs.

If you need typesetting for your Adverts, Brochures, etc. Typefit can help you.

Please telephone
01202 882299

Name

Address

.....

I enclose payment of £.....

(cheque/PO in £ sterling only, payable to Everyday with Practical Electronics). Alternatively send Access or Visa number and card expiry date.

Signature

Please supply name and address of cardholder if different from the subscription address shown above. Subscriptions can only start with the next available issue. For back numbers see the Editorial page.

M4/95

MAKE YOUR INTERESTS PAY!

Over the past 100 years more than 10 million students throughout the world have found it worth their while! An ICS home-study course can help you get a better job, make more money and have more fun out of life! ICS has over 100 years experience in home-study courses, and is the largest correspondence school in the world. You learn at your own pace, when and where you want under the guidance of expert 'personal' tutors. Find out how we can help YOU. Post or phone today for **FREE INFORMATION** on the course of your choice. (Tick one box only)

GCSE/A' LEVEL over 20 examination subjects to choose from. Ask for details.

Electronics <input type="checkbox"/>	TV, Video & Hi-Fi Servicing <input type="checkbox"/>
C & G Basic Electronic Engineering <input type="checkbox"/>	Refrigeration & Air Conditioning <input type="checkbox"/>
Electrical Engineering <input type="checkbox"/>	PC Repair <input type="checkbox"/>
Electrical Contracting/Installation <input type="checkbox"/>	Computer Programming <input type="checkbox"/>

Mr/Mrs/Miss/Ms

Address

P.Code

ICS International Correspondence Schools, Dept. ECS 45, 312/314 High Street, Sutton, Surrey SM1 1PR. Tel: 041-221 7373 (24 hours) Fax 041-221 8151

INFOTECH & STREE

76 Church St, Larkhall, Lanarks, ML9 1HE
Phone (0698) 883334/888343 or Fax (0698) 884825

Remember: Not only do we have every sheet ever produced, but we also have

The World's Largest Collection of SERVICE MANUALS & CIRCUITS

We are now successfully running a *Library Service* which allows you to borrow any manual you want for as long as you want, and when you need another manual, just return the one you have, plus a £4.95 exchange fee and tell us what you want next.

*Borrow any Service Manual for £4.95
regardless of its size or normal cost*

The cost of this service is a yearly subscription fee of only £59.95. Join now & get a free 'Data Ref Guide'.

N. R. BARDWELL LTD (EPE)

200 Signal diodes 1N4148.....	£1.00	25 3mm red LEDs.....	£1.00
75 Rectifier Diodes 1N4001.....	£1.00	25 Ass'd high brightness LEDs.....	£1.00
50 Rectifier Diodes 1N4007.....	£1.00	50 Axial LEDs (Diode package).....	£1.00
25 Rectifier Diodes 1N5401.....	£1.00	12 Ass'd 7-segment displays.....	£1.00
10 NE555 Timer ICs.....	£1.00	2 ORP12 light dependant resistors.....	£1.00
50 Ass'd Zener Diodes.....	£1.00	30 Ass'd IF transformers.....	£1.00
30 BC212L Transistors.....	£1.00	48 Ass'd coil formers.....	£1.00
30 BC213L Transistors.....	£1.00	100 Ass'd RF chokes (inductors).....	£1.00
20 BC327 Transistors.....	£1.00	30 Ass'd connectors edge.dill. etc.....	£1.00
20 BC328 Transistors.....	£1.00	30 Ass'd d.i.l. sockets up to 40-pin.....	£1.00
30 BC337 Transistors.....	£1.00	200 Ass'd disc ceramic capacitors.....	£1.00
30 BC478 Transistors.....	£1.00	80 Ass'd capacitors 1nF to 1µF.....	£1.00
30 BC547 Transistors.....	£1.00	80 Ass'd electrolytic capacitors.....	£1.00
30 BC548 Transistors.....	£1.00	10 4P3W MBB min rotary switches.....	£1.00
30 BC549 Transistors.....	£1.00	20 Min SP/CO slide switches.....	£1.00
30 BC550 Transistors.....	£1.00	20 1" glass reed switches.....	£1.00
25 BC557 Transistors.....	£1.00	200 4N7 mini axial capacitors.....	£1.00
30 BC558 Transistors.....	£1.00	24 24-pin d.i.l. wire wrap ic skts.....	£1.00
30 BC559 Transistors.....	£1.00	1 12V motorised volume control 50k.....	£1.00
25 BC640 Transistors.....	£1.00	50 Grommets 6.3mm id. 9.5mm od.....	£1.00
30 MPSA42 Transistors.....	£1.00	100 c/f 1/4W 5% resistors any one value, E24, range 1R to 10M.....	£0.45
30 MPSA92 Transistors.....	£1.00		
20 2N3702 Transistors.....	£1.00		
20 2N3904 Transistors.....	£1.00		
10 78M08 8V 500mA Pos Regulators.....	£1.00		
10 78M08 8V 500mA Neg Regulators.....	£1.00		
30 5mm red LEDs.....	£1.00		

Prices include VAT, postage £1.25. Stamp for Lists
288 Abbeydale Road, Sheffield S7 1FL
Phone (0114) 2552886 Fax (0114) 2500689

VISA



Cooke International

SUPPLIER OF QUALITY USED TEST INSTRUMENTS

ANALYSERS, BRIDGES, CALIBRATORS, VOLTMETERS, GENERATORS, OSCILLOSCOPES, POWER METERS, ETC. ALWAYS AVAILABLE

ORIGINAL SERVICE MANUALS FOR SALE
COPY SERVICE ALSO AVAILABLE

EXPORT, TRADE AND U.K. ENQUIRIES WELCOME
SEND LARGE S.A.E. (50p POSTAGE) FOR LISTS OF EQUIPMENT & MANUALS
ALL PRICES EXCLUDE VAT AND CARRIAGE
DISCOUNT FOR BULK ORDERS SHIPPING ARRANGED

OPEN MONDAY TO FRIDAY 9AM-5PM

Unit Four, Fordingbridge Site, Main Road, Barnham, Bognor Regis,
West Sussex, PO22 0EB

Tel (+ 44) 0243 545111/2 Fax (+ 44) 0243 542457

EQUIPMENT & ACCESSORIES PURCHASED

SERVICE MANUALS

We have what is probably the largest range of Service Information available anywhere.

From the Earliest Valve Wireless to the Latest Video Recorders. Colour Televisions, Test Gear, Audio, Computers, Amateur Radio in fact practically anything.

Write, Fax or Phone for immediate Quote.
Originals or Photostats as available.

Also available. Our **FREE** catalogue detailing Hundreds of Technical Books and Repair Guides available.

STOP PRESS

Now Available. Our Service Manuals Index on P.C. Disc (3.5") for use on your Computer. Just £3.50 with **FREE** everlasting Updates. Order MP-285.

MAURITRON TECHNICAL SERVICES (EPE),
8 Cherry Tree Road, Chinnor, Oxon, OX9 4QY.

Tel:- 01844-351694. Fax:- 01844 352554.

Please forward your latest catalogue for which I enclose 2 x 1st Class Stamps. or £3.50 for the Technical Books Catalogue plus Manuals Index on PC Disc(s).

NAME _____

ADDRESS _____

POSTCODE _____

If you do not wish to cut your magazine photocopy this coupon or use a separate sheet

COMPAC ELECTRONICS

3L WEYLONG ROAD, DAGENHAM, ESSEX RM8 3AB
Tel: 081 984 0831

L.O.P.T. TRANSFORMERS - WIDE RANGE AVAILABLE.
PHILIPS, FERGUSON etc.

Remote Controls: Amstrad, Toshiba, from £5. Ferguson, Philips, ITT, Sony from £10.

Universal Remote Control, operates TV, Video, Satellite, with Teletext buttons, £16.99 or non-Text £10.99.

We repair Philips hand sets, £5.00.

Pinch Rollers from £2.99.

Video Fig. 8 Mains Lead, Telefonken type, £1.00.

R.F. Video leads, 50p.

SCART to SCART leads, £1.75.

SCART to SCART leads, all pins connected, £2.33.

Aerial R.F. cable, RG62, 30p per mtr.

Aerial R.F. male plugs, 30p each.

TV on/off switches, from £1.95, most types.

Halogen Lamps, 240V, 500W, for outdoor floodlamps, £1.75.

Miniature Tool Kit, comprises: side cutters knife, screwdrivers, £7.00.

Ferguson TV TX100 Ni-Cad Battery, 2.4V, £1.20.

Sony Hi-Fi Tweeters, £2 a pair.

Loudspeakers, 8" x 5", 15 ohms, £1.

Power Supply AC adapters, universal 300mA, £4.99, 750mA, £7.99.

Philips Krypton Torches, £1.50.

Philips Television G11 line output panel, complete, £5 plus £2, post & carr.

Philips Soldering Iron, 240V, 25W, £5.99.

Voltage Regulators, LM340T, 44p.

Philips Audio Cassette Head Cleaning Kit, £2.

High quality loudspeaker cable, 50p per mtr.

Servicing Sprays £3.00 most types.

Ceramic Type Pulse Capacitors, 20 for £1.

SATELLITE

Marconi Blue Cap. ex-rental, £5 plus £2, post & carr.

Amstrad Compact black cap. LNB, voltage switching, 1dB, special price

£23.95 plus £2, post & carr.

Satellite dishes, £25.99 plus £5, post & carr.

Special offer, satellite owners upgrade to Astra 1D with our ADX frequency extender, £27.99. Can be used with standard or enhanced LNB.

Satellite cable, 30p mtr.

F. Connectors, 40p each.

MASPRO LNB FSS 1 3dB max. £13.33.

NOKIA LNB FSS 1.3. £13.33.

NOKIA Feed Horns, for offset antenna, £10.67.

NOKIA Electromagnetic, Polarizers, £8.00.

I.C.s: SAA3010P £3.40; TDA3651SI £1.10; TDA3654 £1.89; TDA3651A £2.85; TDA3652A £2.85; TDA2600 £5.73; TDA2578 £3.43; TDA2579 £2.86; TDA2030 £2.28; TDA3653 £3.43; TDA3651 £2.29; TDA3652 £3.44; TDA 3564 £4.59; TDA4500 £3.43; TDA8180 £5.48; TDA8190 £3.43; TDA8361, £19.99; STK4793 £9.00.

DIODES: Type RH1, £2.00.

TRANSISTORS: BU208A £1.20; BU508AF £1.75; BU11AF 55p; BC327 10p; BC337 10p; BC338 10p; BC548 10p; BC549 10p.

CAPACITORS ELECTROLYTIC: 0.22µ 50V 5p; 1µ 50V 5p; 2.2µ 50V 6p; 4.7µ 25V 10p; 47µ 100V 20p; 470µ 25V 20p; 680µ 63V 60p; 2,200µ 40V 60p; 3,300µ 25V 80p.

This is just a small sample of components available, please phone with your requirements.

Please add £1.00 postage & packing, all prices include VAT.

20 Amstrad Games	£5.00*
20 Spectrum Games	£5.00*
£1 PACKS	
50 BC184; 50 BC547A; 20 BS107;	
20 BSS92; 10 2N2907A; 20 2N5086;	
20 2N5551; 5 2N5657; 20 2N5769;	
4 2N6394; 5 2N6400; 12 BCY69;	
3 BD144; 3 BD145; 10 BD237;	
10 BD239A; 5 BDX42; 2 BDX94;	
5 BFW43; 10 BFX30; 3 BSU78;	
5 BSW68; 3 BSX59; 2 BUF410A;	
4 BUV26; 20 MPSA93;	
10 VN2010-L; 20 ZTX304; 20	
ZTX311; 20 ZTX510; 20 ZTX551; 5	
5V d.i.l. relays; 10 21-10MHz crystals;	
10 811MHz filters; 50 6-way i.c. skts.;	
50 14-way d.i.p. hors; 20 TO18	
heatsinks; 20 TO5 heatsinks; 200 TO5	
mounting pads; 200 TO18 mounting	
pads; 2 100Ω LOPT Tx; 5 12-way	
terminal blocks; 10 silver control	
knobs; 10 95V V.D.R.; 3 12V	
counters; 25 3-5mm jack plugs; 10	
PCB MT microswitch; 10 6-way d.i.l.	
switch; 10-1 pole 3-way rotary	
switch; 25 slide switches; 5 3A 250V	
power toggle switch; 50 4-7μF 25V	
caps; 15 2200μF 25V caps; 50 10μ	
16V caps; 10 0-047μF suppression	
caps; 25 neons; 10 1μF 250V	
polyesters.	
5¼" to 3½" floppy converter	
leads	£1.50 ea*
STC p.s.u. 240V Input; 5V 6A	
Output, (converts to 12V 3A,	
details supplied)	£5.95
Temperature probes, with	
data	£3.95*
Universal Timer (10 min. delay and	
20 min. cut-off functions)	£3.95*
12V 400mW Zeners, 100 off £1*	
UM1287 sound and video	
modulator	£2.50 ea*
3AMP mains filters	£1.00 ea*
40 Character x 1-line dot	
matrix display	£4.95 ea*
Car Dashboard Display (shows	
lights, indicators, doors,	
on picture of car)	£4.95*
4-digit clock display	£2.50*
4-digit i.c.d. with 7211 driver	£3.50*
17-digit v.f. display	£2.95*

Giant 2-digit v.f. display	£2.95*
12V stepper motors, 48 steps	
per rev., 7-3° step angle	£3.95*
250 off mixed electrolytic	
caps.	£4.95*
250 off polyester caps.	£4.95*
1000 off mixed resistors ¼W.	£4.95*
100 off phono plugs	£2.95*
50 off mixed terminal blocks	£2.50*
25 off buzzers & sounders	£3.50*
25 off mixed relays	£4.95*
50 off mixed switches	£7.50*
250 off i.c. sockets	£3.95*
1000 off Ceramic caps.	£7.50*
5 off 3V Lithium memory	
back-up batteries	£2.00*
100 off 2200μF 25V caps.	£6.00*
100 off 4-7μF 25V caps.	£2.50*
3lb mixed component pack	£4.95
Jumbo component pack	£10
Crystal oscillators 10/12MHz	£1 ea
5V DPCO D.I.L. relay	60p ea
5V SPCO S.I.L. reed relay	40p ea
12V Piezoelectric Sounders	50p ea
DIL Switches 3/4/6 and	
12-way	35p ea*
3-5mm jack plugs	10 for £1*
100 off Zener diodes, mixed	£2*
21-piece mini screwdriver set	£3.95*
Universal test lead kit	£3.95*
10 crocodile clip leads	£3.50*
20 off mixed R.F. Filters,	
Crystals, etc	£4.95*
100m P.V.C. sleeving	£4.50*

QUANTITY DISCOUNTS AVAILABLE PLEASE RING.
 We also buy all forms of electronic components, p.s.u.'s, disk drives etc. Lists to below address.

ALL PRICES INCLUDE V.A.T. PLEASE ADD £2.00 p&p EXCEPT ITEMS MARKED * WHICH ARE 50P. SAE FOR BULK BUYING LIST PAYMENT WITH ORDER TO:
Dept EE, COMPELEC,
14 Constable Road,
St. Ives, Huntingdon,
Cambs PE17 6EQ
Tel/Fax: 0480 300819

Mixed metal/carbon film resistors ¼W E12 series 10 ohms to 1 Megohm	2p
Carbon Film resistors ¼W 5% E24 series 0.51 R to 10M0	1p
100 off per value - 75p, even hundreds per value totalling 1000	£6.00p
Metal Film resistors ¼W 10R to 1 MO 5% E12 series - 1½p, 1% E24 series	2p
Mixed metal/carbon film resistors ¼W E24 series 1R0 to 10M0	1½p
1 watt mixed metal/Carbon Film 5% E12 series 4R7 to 10 Megohms	5p
Linear Carbon pre-sets 100mW and ¼W 100R to 2M2 E6 series	7p
Miniature polyester capacitors 250V working for vertical mounting	
015, 022, 033, 047, 068-4p 0.1 - 5p, 0.12, 0.15, 0.22 - 6p, 0.47 - 8p, 0.68 - 8p 1.0 - 12p	
Mylar (polyester) capacitors 100V working E12 series vertical mounting	
1000p to 8200p - 3p, 01 to 0.68 - 4p 0.1 - 5p, 0.12, 0.15, 0.22 - 6p, 0.47/50V - 8p	
Submin ceramic plate capacitors 100V wkg vertical mountings. E12 series	
2% 1.8pf to 47pf - 3p, 2% 56pf to 330pf - 4p, 10% 390p-4700p	4p
Disc/plate ceramics 50V E12 series 1P0 to 1000P, E6 Series 1500P to 47000P	2p
Polyethylene capacitors 63V working E12 series long axial wires	
10pf to 820pf - 5p, 1000pf to 10,000pf - 6p, 2,000pf	7p
741 Op Amp - 20p, 555 Timer - 20p, LM3900	80p
CMOS 4001 - 20p, 4011 - 22p, 4017 - 40p, 4069UB unbuffered	20p
DIL holders, 8-pin 9p; 14-, 16-, 18-pin 12p; 24-pin 18p; 28-pin 20p; 40-pin 25p	
ALUMINIUM ELECTROLYTICS (Mfuds/Volts)	
1/50, 2.2/50, 4.7/50, 10/25, 10/50	5p
22/16, 22/25, 22/50, 33/16, 47/16, 47/25, 47/50	6p
100/16, 100/25 7p, 100/50	12p
220/16 8p, 220/25, 220/50 10p; 470/16, 470/25	11p
1000/25 25p; 1000/35, 2200/25 35p; 4700/25	70p
Subminiature, tantalum bead electrolytics (Mfuds/Volts)	
0.1, 0.22, 0.47, 1.0, 2.2, 3.3 @ 35V - 4.7/16, 6.8/10, 10/6, 10p; 6.8/35, 12p	
4.7/25, 6.8/16, 10/6, 11p, 15/16, 22/6, 33/10, 15p; 10/25, 16p; 10/35, 22/16, 20p	
47/10, 20p; 47/16, 25p; 47/20, 30p; 47/35, 32p; 100/3, 18p; 100/6, 220/6, 20p	
VOLTAGE REGULATORS	
1A + or - 5V, 8V, 12V, 15V, 18V & 24V - 55p, 100mA, 5.8, 12, 15, V +	30p
DIODES (piv/amps)	
75/25mA 1N4148 2p, 800/1A 1N4006 4½p, 400/3A 1N5404 14p, 115/15mA OA91	8p
100/1A 1N4002 3½p, 1000/1A 1N4007 5p, 60/1.5A S1M1 5p, 100/1A bridge	25p
400/1A 1N4004 4p, 1250/1A BY 127 10p, 30/150mA OA47 gold bonded	18p
Zener diodes E24 series 3V3 to 33V 400mW - 6p, 1 watt	10p
Battery snaps for PP3 - 7p for PP9	12p
L.E.D.'s 3mm, & 5mm, Red, Green, Yellow - 10p, Grommets 3mm - 2p, 5mm	2p
Red flashing L.E.D.'s require 9-12V supply only, 5mm	50p
Mains indicator neons with 220k resistor	10p
20mm fuses 100mA to 5A, O. blow 6p, A/surge 10p, Holders, chassis, mounting	6p
High speed pc drill 0.8, 1.0, 1.3, 1.5, 2.0mm - 40p, Machines 12V dc	£15.00
HELPING HANDS 6 ball joints and 2 croc clips to hold awkward jobs	£4.50
AA/HP7 Nicad rechargeable cells 90p each, Universal charger unit	£6.50
AA/HP7 zinc/carbon batteries in packs of 4	£1.10 per pack
Glass reed switches with single pole make contacts - 8p, Magnets	20p
0.1" Stripboard 2½" x 1" 9 rows 25 holes - 25p, 3¼" x 2½" 24 rows 37 holes	70p
Jack plugs 2.5 & 3.5mm - 14p, Sockets Panel Mtg. 2.5 & 3.5mm	10p
Ear pieces 2.5 & 3.5mm, dynamic - 20p, 3.5mm crystal	£1.50
Multi cored solder, 22G - 8p yard, 18G - 14p yard	
TRANSISTORS	
BC107/8/9 - 12p, BC547/8/9 - 8p, BC557/8/9 - 8p, BC182, 182L, BC183, 183L,	
BC184, 184L, BC212, 212L - 10p,	
BC327, 337, 337L - 12p, BC727, 737 - 12p, BD135/6/7/8/9 - 25p, BCY70 - 18p,	
BFY50/51/52 - 20p,	
BFX88 - 15p, 2N3055 - 55p, TIP31, 32 - 30p, TIP41, 42 - 40p, BU208A - £1.50, BF195, 197 - 12p	
Ionisers with seven year guarantee, 240V AC, list price £16.95 or more	£12.50
Do not add VAT. Postage 30p (free over £5). Stamp for list.	
THE CR SUPPLY CO	
127 Chesterfield Rd., Sheffield S8 0RN Tel: 0742 557771 Return posting	

Millions of quality components at lowest ever prices!
 Plus Tools, Watches, Fancy Goods, Toys.
 Mail order UK only.
 All inclusive prices - **NO VAT** to add on.
 Send 43p stamped self addressed label or envelope for catalogue/clearance list.
 At least 2,100 offers to amaze you.
Brian J Reed
6 Queensmead Avenue, East Ewell
Epsom, Surrey KT17 3EQ
Tel: 0181-393 9055

ADVERTISERS INDEX

AUDON ELECTRONICS	314
N. R. BARDWELL	335
B. K. ELECTRONICS	Cover (iii)
BRIAN J. REED	336
BULL ELECTRICAL	Cover (ii)
CHATWIN GUITARS (JCG)	323
CIRKIT DISTRIBUTION	315
COMPAC ELECTRONICS	335
COMPELEC	336
COOKE INTERNATIONAL	335
CRICKLEWOOD ELECTRONICS	315
CR SUPPLY COMPANY	336
DISPLAY ELECTRONICS	254
ESR ELECTRONIC COMPONENTS	264
EXPRESS COMPONENTS	301
GREENWELD ELECTRONICS	257
HART ELECTRONIC KITS	279
ICS	335
INFOTECH & STREE	335
INTERCONNECTIONS	260
JPG ELECTRONICS	323
LABCENTER	296
MAGENTA ELECTRONICS	262/263
MAPLIN ELECTRONICS	Cover (iv)
MAURITRON	335
M&B ELECTRICAL SUPPLIES	258
MEJDAF EUROPE	323
MQP ELECTRONICS	260
NATIONAL COLLEGE OF TECHNOLOGY	315
NEWMARKET TRANSFORMERS	330
NICHE SOFTWARE	291
NUMBER ONE SYSTEMS	259
OMNI ELECTRONICS	314
PICO TECHNOLOGY	261
POWERWARE	307
QUASAR ELECTRONICS	260
RADIO-TECH	333
RADIO & TV	326
ROBINSON MARSHALL	293
SEETRAX CAE	255
SERVICE TRADING CO	260
SHERWOOD ELECTRONICS	330
STEWART OF READING	330
SUMA DESIGNS	256
TSIEN	275

ADVERTISEMENT MANAGER:
 PETER J. MEW
ADVERTISEMENT OFFICES:
 EVERYDAY with PRACTICAL ELECTRONICS, ADVERTISEMENTS, HOLLAND WOOD HOUSE, CHURCH LANE, GREAT HOLLAND, ESSEX CO13 0JS.
 Phone/Fax: (01255) 850596
 For Editorial address and phone numbers see page 265.

Published on approximately the first Friday of each month by Wimborne Publishing Ltd., Allen House, East Borough, Wimborne, Dorset BH21 1PF. Printed in England by Benham & Co. Ltd, Colchester, Essex. Distributed by Seymour, Windsor House, 1270 London Road, Norbury, London SW16 4DH. Sole Agents for Australia and New Zealand: Gordon & Gotch (Asia) Ltd., South Africa - Central News Agency Ltd. Subscriptions INLAND £24 and OVERSEAS £30 (£47.50 airmail) payable to "Everyday with Practical Electronics" Subs Dept, Allen House, East Borough, Wimborne, Dorset BH21 1PF. EVERYDAY with PRACTICAL ELECTRONICS is sold subject to the following conditions, namely that it shall not, without the written consent of the Publishers first having been given, be lent, resold, hired out or otherwise disposed of by way of Trade at more than the recommended selling price shown on the cover, and that it shall not be lent, resold, hired out or otherwise disposed of in a mutilated condition or in any unauthorised cover by way of Trade or affixed to or as part of any publication or advertising, literary or pictorial matter whatsoever.

OMP MOS-FET POWER AMPLIFIERS
HIGH POWER, TWO CHANNEL 19 INCH RACK

THOUSANDS PURCHASED BY PROFESSIONAL USERS



THE RENOWNED MXF SERIES OF POWER AMPLIFIERS
FOUR MODELS:- MXF200 (100W + 100W) MXF400 (200W + 200W)
MXF600 (300W + 300W) MXF900 (450W + 450W)
ALL POWER RATINGS R.M.S. INTO 4 OHMS, BOTH CHANNELS DRIVEN

FEATURES: ★ Independent power supplies with two toroidal transformers ★ Twin L.E.D. Vu meters ★ Level controls ★ Illuminated on/off switch ★ XLR connectors ★ Standard 775mV inputs ★ Open and short circuit proof ★ Latest Mos-Fets for stress free power delivery into virtually any load ★ High slew rate ★ Very low distortion ★ Aluminium cases ★ MXF600 & MXF900 fan cooled with D.C. loudspeaker and thermal protection.

USED THE WORLD OVER IN CLUBS, PUBS, CINEMAS, DISCOS ETC.

SIZES:- MXF200 W19" x H3 1/2" (2U) x D11"
MXF400 W19" x H5 1/2" (3U) x D12"
MXF600 W19" x H5 1/2" (3U) x D13"
MXF900 W19" x H5 1/2" (3U) x D14 1/2"

PRICES:- MXF200 £175.00 MXF400 £233.85
MXF600 £329.00 MXF900 £449.15
SPECIALIST CARRIER DEL. £12.50 EACH



OMP XO3 STEREO 3-WAY ACTIVE CROSS-OVER



Advanced 3-Way Stereo Active Cross-Over, housed in a 19" x 1U case. Each channel has three level controls, bass, mid & top. The removable front fascia allows access to the programmable DIL switches to adjust the cross-over frequency: Bass-Mid 250/500/800Hz, Mid-Top 1.8/3.5KHz, all at 24dB per octave. Bass invert switches on each bass channel. Nominal 775mV input/output. Fully compatible with OMP rack amplifier and modules.

Price £117.44 + £5.00 P&P

STEREO DISCO MIXER SDJ3400SE ★ ECHO & SOUND EFFECTS★

STEREO DISCO MIXER with 2 x 7 band L & R graphic equalisers with bar graph LED Vu meters. **MANY OUTSTANDING FEATURES:-** including Echo with repeat & speed control, DJ Mic with talk-over switch, 6 Channels with individual faders plus cross fade, Cue Headphone Monitor, 8 Sound Effects. Useful combination of the following inputs:- 3 turntables (mag), 3 mics, 5 Line for CD, Tape, Video etc.



Price £144.99 + £5.00 P&P

SIZE: 482 x 240 x 120mm

PIEZO ELECTRIC TWEETERS - MOTOROLA

Join the Piezo revolution! The low dynamic mass (no voice coil) of a Piezo tweeter produces an improved transient response with a lower distortion level than ordinary dynamic tweeters. As a crossover is not required these units can be added to existing speaker systems of up to 100 watts (more if two are put in series). **FREE EXPLANATORY LEAFLETS ARE SUPPLIED WITH EACH TWEETER.**

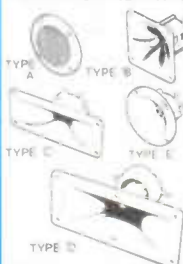

TYPE 'A' (KSN1036A) 3" round with protective wire mesh. Ideal for bookshelf and medium sized Hi-Fi speakers. Price £4.90 - 50p P&P.
TYPE 'B' (KSN1005A) 3 1/2" super horn for general purpose speakers, disco and P.A. systems etc. Price £5.99 - 50p P&P.
TYPE 'C' (KSN1016A) 2" x 5" wide dispersion horn for quality Hi-Fi systems and quality discos etc. Price £6.99 - 50p P&P.
TYPE 'D' (KSN1025A) 2" x 6" wide dispersion horn. Upper frequency response retained extending down to mid-range (2KHz). Suitable for high quality Hi-Fi systems and quality discos. Price £9.99 - 50p P&P.
TYPE 'E' (KSN1038A) 3 1/4" horn tweeter with attractive silver finish trim. Suitable for Hi-Fi monitor systems etc. Price £5.99 - 50p P&P.
LEVEL CONTROL Combines, on a recessed mounting plate, level control and cabinet input jack socket. 85x85mm. Price £4.10 - 50p P&P.

IBI FLIGHT CASED LOUDSPEAKERS

A new range of quality loudspeakers designed to take advantage of the latest speaker technology and enclosure designs. Both models utilize studio quality 12" cast aluminium loudspeakers with factory fitted grilles, wide dispersion constant directivity horns, extruded aluminium corner protection and steel ball corners, complemented with heavy duty black covering. The enclosures are fitted as standard with top hats for optional loudspeaker stands.



POWER RATINGS QUOTED IN WATTS RMS FOR EACH CABINET
FREQUENCY RESPONSE FULL RANGE 45Hz - 20KHz

IBI FC 12-100WATTS (100dB) PRICE £159.00 PER PAIR

IBI FC 12-200WATTS (100dB) PRICE £175.00 PER PAIR

SPECIALIST CARRIER DEL. £12.50 PER PAIR

OPTIONAL STANDS PRICE PER PAIR £49.00
Delivery £6.00 per pair

IN-CAR STEREO BOOSTER AMPS



PRICES: 150W £49.99 250W £99.99
400W £109.95 P&P £2.00 EACH

THREE SUPERB HIGH POWER CAR STEREO BOOSTER AMPLIFIERS

150 WATTS (75 + 75) Stereo, 150W Bridged Mono
250 WATTS (125 + 125) Stereo, 250W Bridged Mono
400 WATTS (200 + 200) Stereo, 400W Bridged Mono
ALL POWERS INTO 4 OHMS

Features:
★ Stereo, bridgable mono ★ Choice of high & low level inputs ★ L & R level controls ★ Remote on-off ★ Speaker & thermal protection.

POSTAL CHARGES PER ORDER £1.00 MINIMUM. OFFICIAL ORDERS FROM SCHOOLS, COLLEGES, GOVT. BOOIES, PLCs ETC. PRICES INCLUSIVE OF V.A.T., SALES COUNTER, VISA AND ACCESS ACCEPTED BY POST, PHONE OR FAX.

OMP MOS-FET POWER AMPLIFIER MODULES SUPPLIED READY BUILT AND TESTED.

These modules now enjoy a world-wide reputation for quality, reliability and performance at a realistic price. Four models are available to suit the needs of the professional and hobby market i.e. Industry, Leisure, Instrumental and Hi-Fi etc. When comparing prices, NOTE that all models include toroidal power supply, integral heat sink, glass fibre P.C.B. and drive circuits to power a compatible Vu meter. All models are open and short circuit proof.

THOUSANDS OF MODULES PURCHASED BY PROFESSIONAL USERS



OMP/MF 100 Mos-Fet Output power 110 watts
R.M.S. into 4 ohms, frequency response 1Hz - 100KHz
-3dB, Damping Factor > 300, Slew Rate 45V/uS,
T.H.D. typical 0.002%, Input Sensitivity 500mV, S.N.R.
-110 dB. Size 300 x 123 x 60mm.
PRICE £40.85 - £3.50 P&P



OMP/MF 200 Mos-Fet Output power 200 watts
R.M.S. into 4 ohms, frequency response 1Hz - 100KHz
-3dB, Damping Factor > 300, Slew Rate 50V/uS,
T.H.D. typical 0.001%, Input Sensitivity 500mV, S.N.R.
-110 dB. Size 300 x 155 x 100mm.
PRICE £64.35 - £4.00 P&P



OMP/MF 300 Mos-Fet Output power 300 watts
R.M.S. into 4 ohms, frequency response 1Hz - 100KHz
-3dB, Damping Factor > 300, Slew Rate 60V/uS,
T.H.D. typical 0.001%, Input Sensitivity 500mV, S.N.R.
-110 dB. Size 330 x 175 x 100mm.
PRICE £81.75 - £5.00 P&P



OMP/MF 450 Mos-Fet Output power 450 watts
R.M.S. into 4 ohms, frequency response 1Hz - 100KHz
-3dB, Damping Factor > 300, Slew Rate 75V/uS,
T.H.D. typical 0.001%, Input Sensitivity 500mV, S.N.R.
-110 dB, Fan Cooled, D.C. Loudspeaker Protection, 2
Second Anti-Thump Delay. Size 385 x 210 x 105mm.
PRICE £132.85 + £5.00 P&P



OMP/MF 1000 Mos-Fet Output power 1000 watts
R.M.S. into 2 ohms, 725 watts R.M.S. into 4 ohms,
frequency response 1Hz - 100KHz -3dB, Damping
Factor > 300, Slew Rate 75V/uS, T.H.D. typical
0.002%, Input Sensitivity 500mV, S.N.R. -110 dB, Fan
Cooled, D.C. Loudspeaker Protection, 2 Second
Anti-Thump Delay. Size 422 x 300 x 125mm.
PRICE £259.00 - £12.00 P&P

NOTE: MOS-FET MODULES ARE AVAILABLE IN TWO VERSIONS:
STANDARD - INPUT SENS 500mV, BAND WIDTH 100KHz.
PEC (PROFESSIONAL EQUIPMENT COMPATIBLE) - INPUT SENS
775mV, BAND WIDTH 50KHz. ORDER STANDARD OR PEC.

LOUDSPEAKERS

LARGE SELECTION OF SPECIALIST LOUDSPEAKERS AVAILABLE, INCLUDING CABINET FITTINGS, SPEAKER GRILLES, CROSS-OVERS AND HIGH POWER, HIGH FREQUENCY BULLETS AND HORNS, LARGE (A4) S.A.E. (60p STAMPED) FOR COMPLETE LIST.



McKenzie and Fane Loudspeakers are also available.

EMINENCE:- INSTRUMENTS, P.A., DISCO, ETC

ALL EMINENCE UNITS 8 OHMS IMPEDANCE
8" 100 WATT R.M.S. ME8-100 GEN. PURPOSE. LEAD GUITAR, EXCELLENT MID, DISCO. PRICE £32.71 £2.00 P&P
RES. FREQ. 72Hz, FREQ. RESP. TO 4KHz, SENS 97dB.
10" 100 WATT R.M.S. ME10-100 GUITAR, VOCAL, KEYBOARD, DISCO, EXCELLENT MID. PRICE £33.74 £2.50 P&P
RES. FREQ. 71Hz, FREQ. RESP. TO 7KHz, SENS 97dB.
10" 200 WATT R.M.S. ME10-200 GUITAR, KEYB'D, DISCO, VOCAL, EXCELLENT HIGH POWER MID. PRICE £43.47 £2.50 P&P
RES. FREQ. 65Hz, FREQ. RESP. TO 3.5KHz, SENS 99dB.
12" 100 WATT R.M.S. ME12-100LE GEN. PURPOSE. LEAD GUITAR, DISCO, STAGE MONITOR. PRICE £35.64 £3.50 P&P
RES. FREQ. 49Hz, FREQ. RESP. TO 6KHz, SENS 100dB.
12" 100 WATT R.M.S. ME12-100LT (TWIN CONE) WIDE RESPONSE, P.A., VOCAL, STAGE MONITOR. PRICE £36.67 £3.50 P&P
RES. FREQ. 42Hz, FREQ. RESP. TO 10KHz, SENS 98dB.
12" 200 WATT R.M.S. ME12-200 GEN. PURPOSE. GUITAR, DISCO, VOCAL, EXCELLENT MID. PRICE £46.71 £3.50 P&P
RES. FREQ. 58Hz, FREQ. RESP. TO 6KHz, SENS 98dB.
12" 300 WATT R.M.S. ME12-300GP HIGH POWER BASS, LEAD GUITAR, KEYBOARD, DISCO ETC. PRICE £70.19 £3.50 P&P
RES. FREQ. 47Hz, FREQ. RESP. TO 5KHz, SENS 103dB.
15" 200 WATT R.M.S. ME15-200 GEN. PURPOSE BASS, INCLUDING BASS GUITAR. PRICE £50.72 £4.00 P&P
RES. FREQ. 46Hz, FREQ. RESP. TO 5KHz, SENS 99dB.
15" 300 WATT R.M.S. ME15-300 HIGH POWER BASS, INCLUDING BASS GUITAR. PRICE £73.34 £4.00 P&P
RES. FREQ. 39Hz, FREQ. RESP. TO 3KHz, SENS 103dB.

EARBENDERS:- HI-FI, STUDIO, IN-CAR, ETC

ALL EARBENDER UNITS 8 OHMS (Except EB8-50 & EB10-50 which are dual impedance tapped @ 4 & 8 ohm)
BASS, SINGLE CONE, HIGH COMPLIANCE, ROLLED SURROUND
8" 50WATT EB8-50 OUAL IMPEDANCE, TAPPED 4/8 OHM BASS, HI-FI, IN-CAR. PRICE £8.90 £2.00 P&P
RES. FREQ. 40Hz, FREQ. RESP. TO 7KHz, SENS 97dB.
10" 50WATT EB10-50 DUAL IMPEDANCE, TAPPED 4/8 OHM BASS, HI-FI, IN-CAR. PRICE £13.65 £2.50 P&P
RES. FREQ. 40Hz, FREQ. RESP. TO 5KHz, SENS 99dB.
10" 100WATT EB10-100 BASS, HI-FI, STUDIO. PRICE £30.39 £3.50 P&P
RES. FREQ. 35Hz, FREQ. RESP. TO 3KHz, SENS 96dB.
12" 100WATT EB12-100 BASS, STUDIO, HI-FI, EXCELLENT DISCO. PRICE £42.12 £3.50 P&P
RES. FREQ. 26Hz, FREQ. RESP. TO 3 KHz, SENS 93dB.
FULL RANGE TWIN CONE, HIGH COMPLIANCE, ROLLED SURROUND
5 1/2" 60WATT EB5-60TC (TWIN CONE) HI-FI, MULTI-ARRAY DISCO ETC. PRICE £9.99 £1.50 P&P
RES. FREQ. 63Hz, FREQ. RESP. TO 20KHz, SENS 92dB.
6 1/2" 60WATT EB6-60TC (TWIN CONE) HI-FI, MULTI-ARRAY DISCO ETC. PRICE £10.99 £1.50 P&P
RES. FREQ. 38Hz, FREQ. RESP. TO 20KHz, SENS 94dB.
8" 60WATT EB8-60TC (TWIN CONE) HI-FI, MULTI-ARRAY DISCO ETC. PRICE £12.99 £1.50 P&P
RES. FREQ. 40Hz, FREQ. RESP. TO 18KHz, SENS 89dB.
10" 60WATT EB10-60TC (TWIN CONE) HI-FI, MULTI ARRAY DISCO ETC. PRICE £16.49 £2.00 P&P
RES. FREQ. 35Hz, FREQ. RESP. TO 12KHz, SENS 98dB.

TRANSMITTER HOBBY KITS

PROVEN TRANSMITTER DESIGNS INCLUDING GLASS FIBRE PRINTED CIRCUIT BOARD AND HIGH QUALITY COMPONENTS COMPLETE WITH CIRCUIT AND INSTRUCTIONS
3W TRANSMITTER 80-108MHz. VARICAP CONTROLLED PROFESSIONAL PERFORMANCE. RANGE UP TO 3 MILES. SIZE 38 x 123mm. SUPPLY 12V @ 0.5AMP. PRICE £14.85 £1.00 P&P
FM MICRO TRANSMITTER 100-108MHz. VARICAP TUNED, COMPLETE WITH VERY SENS FET MIC. RANGE 100-300m. SIZE 56 x 46mm. SUPPLY 9V BATTERY. PRICE £8.80 - £1.00 P&P



PHOTO: 3W FM TRANSMITTER

B.K. ELECTRONICS
UNITS 1 & 5 COMET WAY, SOUTHBEND-ON-SEA,
ESSEX, SS2 6TR.
Tel.: 0702 - 527572 Fax: 0702 - 420243

NEW

FULL COLOUR GUIDE TO ELECTRONIC PRODUCTS

Sept 1994–Aug 1995

Maplin



BS 5750
Part 2 1987

Level B:
Quality Assurance
RS12750

Order your copy of the New MAPLIN Catalogue on sale NOW!
Pick up a copy from any branch of WHSMITH, branches of John Menzies in Scotland ONLY, Eason & Son in N. Ireland ONLY, and Maplin stores nationwide for just £3.45 or post this coupon now to receive your copy for just £3.95 inc. p&p. If you live outside the U.K. send £7.30 or 18 IRCs for Airmail in Europe (including Republic of Ireland); £6.50 or 16 IRCs for surface mail outside Europe; or £12.30 or 30 IRCs for Airmail outside Europe.
I enclose £3.95/£7.30/£6.50/£12.30 (delete as applicable).

Name
Address
Post Code
Send to: Maplin Electronics,
P.O. Box 3, Rayleigh,
Essex, England
SS6 8LR

Over 800 colour packed pages
with hundreds of Brand New
Products at Super Low Prices.

**OUT OF THIS WORLD
ON SALE NOW
ONLY
£3.45**

Available from all branches of WHSMITH, John Menzies in Scotland ONLY, Eason & Son in N. Ireland ONLY, and Maplin stores nationwide.
The Maplin Electronics 1995 Catalogue – **OUT OF THIS WORLD!**

